

**MEASUREMENT REPORT****FCC 15.407 Dual Client Power Reduction Verification Supplemental Report****Applicant Name:**

Samsung Electronics Co., Ltd.  
129, Samsung-ro,  
Yeongtong-gu, Suwon-si  
Gyeonggi-do, 16677, Korea

**Date of Testing:**

5/23/2024 – 8/23/2024

**Test Report Issue Date:**

8/23/2024

**Test Site/Location:**

Element, Columbia, MD, USA

**Test Report Serial No.:**

1M2405140042-11-R1.A3L

**FCC ID:**

**A3LSMX920**

**APPLICANT:**

**Samsung Electronics Co., Ltd.**

**Application Type:**

Certification

**HVIN:**

SM-X920

**EUT Type:**

Portable Tablet

**FCC Classification:**

15E 6GHz Low Power Dual Client (6CD)

**FCC Rule Part(s):**

Part 15 Subpart E (15.407)

**Test Procedure(s):**

ANSI C.63.10-2013, KDB 987594 D02 v02r01,  
KDB 484596 D01 v02r03

This equipment has been shown to be capable of compliance with the applicable technical standards as indicated in the measurement report and was tested in accordance with the measurement procedures specified in §2.947. Test results reported herein relate only to the item(s) tested.

Note: This revised Test Report (S/N: 1M2405140042-11-R1.A3L) supersedes and replaces the previously issued test report on the same subject device for the same type of testing as indicated. Please discard or destroy the previously issued test report(s) and dispose of it accordingly.

I attest to the accuracy of data. All measurements reported herein were performed by me or were made under my supervision and are correct to the best of my knowledge and belief. I assume full responsibility for the completeness of these measurements and vouch for the qualifications of all persons taking them.



**RJ Ortanez**  
**Executive Vice President**



<b>FCC ID:</b> A3LSMX920	<b>MEASUREMENT REPORT (CERTIFICATION)</b>		<b>Approved by:</b> Technical Manager
<b>Test Report S/N:</b> 1M2405140042-11-R1.A3L	<b>Test Dates:</b> 5/23/2024 – 8/23/2024	<b>EUT Type:</b> Portable Tablet	Page 1 of 14

## TABLE OF CONTENTS

---

1.0	INTRODUCTION.....	3
1.1	Scope.....	3
1.2	Element Test Location .....	3
1.3	Test Facility / Accreditations .....	3
2.0	PRODUCT INFORMATION .....	4
2.1	Equipment Description.....	4
2.2	Antenna Description.....	4
2.3	Test Configuration .....	4
2.4	Software and Firmware.....	4
2.5	EMI Suppression Device(s)/Modifications.....	4
3.0	TEST EQUIPMENT CALIBRATION DATA.....	5
3.1	Measurement Procedure .....	5
3.2	Additional Requirements for Dual Client Devices .....	5
4.0	MEASUREMENT UNCERTAINTY .....	6
5.0	TEST EQUIPMENT CALIBRATION DATA.....	7
6.0	ENVIRONMENTAL CONDITIONS .....	8
7.0	TEST Summary.....	9
7.1	Summary .....	9
7.2	Dual Client Device Additional Requirement (AFC Protocol).....	10
8.0	CONCLUSION .....	14

<b>FCC ID:</b> A3LSMX920	<b>MEASUREMENT REPORT (CERTIFICATION)</b>		<b>Approved by:</b> Technical Manager
<b>Test Report S/N:</b> 1M2405140042-11-R1.A3L	<b>Test Dates:</b> 5/23/2024 – 8/23/2024	<b>EUT Type:</b> Portable Tablet	Page 2 of 14

## 1.0 INTRODUCTION

### 1.1 Scope

This is a supplemental test report provided to address the additional power adjustment test requirement outlined in RSS-248 Section 4.5.5(c) to demonstrate that the maximum power level of the dual client device remains at least 6 dB below the power levels authorized for the associated standard-power access point.

### 1.2 Element Test Location

These measurement tests were conducted at the Element laboratory located at 7185 Oakland Mills Road, Columbia, MD 21046.

### 1.3 Test Facility / Accreditations

Measurements were performed at Element laboratory located in Columbia, MD 21046, U.S.A.

- Element Washington DC LLC is an ISO 17025-2017 accredited test facility under the American Association for Laboratory Accreditation (A2LA) with Certificate number 2041.01 for Specific Absorption Rate (SAR), Hearing Aid Compatibility (HAC) testing, where applicable, and Electromagnetic Compatibility (EMC) testing for FCC and Innovation, Science, and Economic Development Canada rules.
- Element Washington DC LLC TCB is a Telecommunication Certification Body (TCB) accredited to ISO\IEC 17065-2012 by A2LA (Certificate number 2041.03) in all scopes of FCC Rules and ISED Standards (RSS).
- Element Washington DC LLC facility is a registered (2451B) test laboratory with the site description on file with ISED.
- Element Washington DC LLC is a Recognized U.S. Certification Assessment Body (CAB # US0110) for ISED Canada as designated by NIST under the U.S. and Canada Mutual Recognition Agreements (MRAs).

FCC ID: A3LSMX920	MEASUREMENT REPORT (CERTIFICATION)		Approved by: Technical Manager
Test Report S/N: 1M2405140042-11-R1.A3L	Test Dates: 5/23/2024 – 8/23/2024	EUT Type: Portable Tablet	Page 3 of 14

## 2.0 PRODUCT INFORMATION

### 2.1 Equipment Description

The Equipment Under Test (EUT) is the **Samsung Portable Tablet FCC ID: A3LSMX920**. The test data contained in this report pertains only to the additional requirements for standard power clients specified in 15.407 of the FCC rules for standard power operation in UNII bands 5 and 7.

**Test Device Serial Number(s):** 0009M

### 2.2 Antenna Description

The following antenna gains are used in this device per the "Unlicensed Band Antenna Gain" document provided by the client. This document is also included in the filing as a public exhibit.

	Ant1 Peak Gain [dBi]	Ant2 Peak Gain [dBi]	Directional Gain [dBi]
5925 – 6425 MHz	-4.47	-6.25	-2.30
6425 – 6525 MHz	-6.61	-7.87	-4.21
6525 – 6875 MHz	-8.23	-11.62	-6.75
6875 – 7125 MHz	-10.54	-11.56	-8.02

**Table 2-1. Antenna Peak Gain**

### 2.3 Test Configuration

The EUT was connected to a standard power 6GHz access point (Qualcomm Networking pro series). The standard power access point was connected to the AFC DUT Test Harness. The latest version of the AFC DUT Test Harness (V2.0.65) provided by the WiFi Alliance was used. For LPI verification, the EUT was connected to a low power 6GHz access point (TPLink Archer BE900).

### 2.4 Software and Firmware

Testing was performed on device(s) using software/firmware version installed on the EUT.

### 2.5 EMI Suppression Device(s)/Modifications

No EMI suppression device(s) were added, and no modifications were made during testing.

<b>FCC ID:</b> A3LSMX920	<b>MEASUREMENT REPORT (CERTIFICATION)</b>		<b>Approved by:</b> Technical Manager
<b>Test Report S/N:</b> 1M2405140042-11-R1.A3L	<b>Test Dates:</b> 5/23/2024 – 8/23/2024	<b>EUT Type:</b> Portable Tablet	Page 4 of 14

## 3.0 TEST EQUIPMENT CALIBRATION DATA

### 3.1 Measurement Procedure

The measurement procedures described in the American National Standard of Procedures for Compliance Testing of Unlicensed Wireless Devices (ANSI C63.10-2013), and the guidance provided in KDB 987594 D02 v02r01 were used in the measurement of the EUT to address the additional requirements for Dual Client Devices.

**Deviation from Measurement Procedure.....None**

### 3.2 Additional Requirements for Dual Client Devices

See Section 7.2 of this report for a description of the specific test(s) run in order to demonstrate compliance to this requirement under 15.407 of the FCC Rules.

<b>FCC ID:</b> A3LSMX920	<b>MEASUREMENT REPORT (CERTIFICATION)</b>		<b>Approved by:</b> Technical Manager
<b>Test Report S/N:</b> 1M2405140042-11-R1.A3L	<b>Test Dates:</b> 5/23/2024 – 8/23/2024	<b>EUT Type:</b> Portable Tablet	Page 5 of 14

## 4.0 MEASUREMENT UNCERTAINTY

The measurement uncertainties shown below were calculated in accordance with the requirements of ANSI C63.4-2014. All measurement uncertainty values are shown with a coverage factor of  $k = 2$  to indicate a 95% level of confidence. The measurement uncertainty shown below meets or exceeds the  $U_{\text{CISPR}}$  measurement uncertainty values specified in CISPR 16-4-2 and, thus, can be compared directly to specified limits to determine compliance.

Contribution	Expanded Uncertainty ( $\pm$ dB)
Conducted Bench Top Measurements	1.13
Radiated Disturbance (<1GHz)	4.98
Radiated Disturbance (>1GHz)	5.07
Radiated Disturbance (>18GHz)	5.09

FCC ID: A3LSMX920	MEASUREMENT REPORT (CERTIFICATION)		Approved by: Technical Manager
Test Report S/N: 1M2405140042-11-R1.A3L	Test Dates: 5/23/2024 – 8/23/2024	EUT Type: Portable Tablet	Page 6 of 14

## 5.0 TEST EQUIPMENT CALIBRATION DATA

Test Equipment Calibration is traceable to the National Institute of Standards and Technology (NIST).

Manufacturer	Model	Description	Cal Date	Cal Interval	Cal Due	Serial Number
Anritsu	MA24408A	8GHz Microwave Power Sensor	8/29/2023	Annual	8/29/2024	MY49430494
HP	EliteBook 850 G8	Test Harness Laptop	N/A	N/A	N/A	5CG1206NDH
Qualcomm	Networking Pro Series	Standard Power 6GHz AP	N/A	N/A	N/A	31822H240D5353
N/A	WL25-1	Conducted Cable Set (25GHz)	11/15/2023	Annual	11/15/2024	WL25-1
TPLink	Archer BE900	Quad-Band Wi-Fi 7 Router	N/A	N/A	N/A	22310J000044

**Table 5-1. Annual Test Equipment Calibration Schedule**

**Notes:**

Equipment with a calibration date of "N/A" shown in this list was not used to make direct calibrated measurements.

FCC ID: A3LSMX920	<b>MEASUREMENT REPORT (CERTIFICATION)</b>		<b>Approved by:</b> Technical Manager
<b>Test Report S/N:</b> 1M2405140042-11-R1.A3L	<b>Test Dates:</b> 5/23/2024 – 8/23/2024	<b>EUT Type:</b> Portable Tablet	Page 7 of 14

## 6.0 ENVIRONMENTAL CONDITIONS

The temperature is controlled within range of 15°C to 35°C. The relative humidity is controlled within range of 10% to 75%. The atmospheric pressure is monitored within the range 86-106kPa (860-1060mbar).

<b>FCC ID:</b> A3LSMX920	<b>MEASUREMENT REPORT (CERTIFICATION)</b>		<b>Approved by:</b> Technical Manager
<b>Test Report S/N:</b> 1M2405140042-11-R1.A3L	<b>Test Dates:</b> 5/23/2024 – 8/23/2024	<b>EUT Type:</b> Portable Tablet	Page 8 of 14



## 7.0 TEST SUMMARY

### 7.1 Summary

Company Name: Samsung Electronics Co., Ltd.

FCC ID: A3LSMX920

FCC Part Section(s)	Test Description	Test Limit	Test Condition	Test Result	Reference
15.407(a)(7)	Power Reduction Verification for standard client device	EUT must limit its power to no more than 6dB below its associated standard power access point's authorized transmit power. EUT must distinguish its associated access point as standard or low power and control its power levels accordingly.	Conducted	Pass	Section 7.2

**Table 7-1. Summary of Test Results**

FCC ID: A3LSMX920	MEASUREMENT REPORT (CERTIFICATION)		Approved by: Technical Manager
Test Report S/N: 1M2405140042-11-R1.A3L	Test Dates: 5/23/2024 – 8/23/2024	EUT Type: Portable Tablet	Page 9 of 14



## 7.2 Dual Client Device Additional Requirement (AFC Protocol) 15.407

### Test Overview and Limit

Dual Client Device additional requirements (AFC Protocol) are tested per the test procedures listed below. During testing, the EUT is connected to a standard power access point to show compliance with 15.407.

***The maximum power limits shall remain at least 6dB below the power levels authorized for the associated standard-power access point.***

***The EUT must distinguish its associated access point as standard or low power and control its power levels accordingly.***

### Test Procedure Used

ANSI C63.10.2013 – Section 12.3.3.2 Method PM-G  
ANSI C63.10.2013 – Section 14.2 Measure-and-Sum Technique  
KDB 987594 D02 v02r01

### Test Setup/Method

The EUT was connected via an RF cable to a power meter and connected wirelessly to a standard power 6GHz access point.

1. Standard power access point:
  - a. Setup Test Vector “CT\_AFC\_SP\_AP\_AFCDRSA31\_FrequencyChannel\_20MHz\_10625\_1
  - b. Run test vector using WFA AFC DUT test harness
  - c. Trigger Spectrum Inquiry Request from SP AP
  - d. Once SP AP has received the Spectrum Inquiry Response from the test harness, connect EUT to SP AP network and generate traffic via iPerf.
  - e. Measure output power at conducted ports of client EUT
2. Low power indoor access point:
  - a. Connect EUT to LPI AP network and generate traffic via iPerf.
  - b. Measure output power at conducted ports of client EUT

### Test Notes

- The EUT is a Dual Client Device.
- The test was executed with the SP AP authorized to transmit up to 14.5dBm, 25.25dBm, and 36dBm on Ch. 45 (6175MHz) as shown in the AFC Spectrum Mask outputs shown below. The LPI AP was operating on channel 45.
- The lowest 14.5dBm power level is based on the EIRP resulting from the conducted power targets specified in the manufacturer’s “WLAN and Bluetooth Maximum Power Document”.
- The EUT was connected via a conducted connection to the power meter. Simultaneously, the EUT was able to see and establish a radiated connection with the standard power access point and low power indoor access point.

### Test Setup Diagram

The testing was setup as shown in the diagram below:

FCC ID: A3LSMX920	MEASUREMENT REPORT (CERTIFICATION)		Approved by: Technical Manager
Test Report S/N: 1M2405140042-11-R1.A3L	Test Dates: 5/23/2024 – 8/23/2024	EUT Type: Portable Tablet	Page 10 of 14

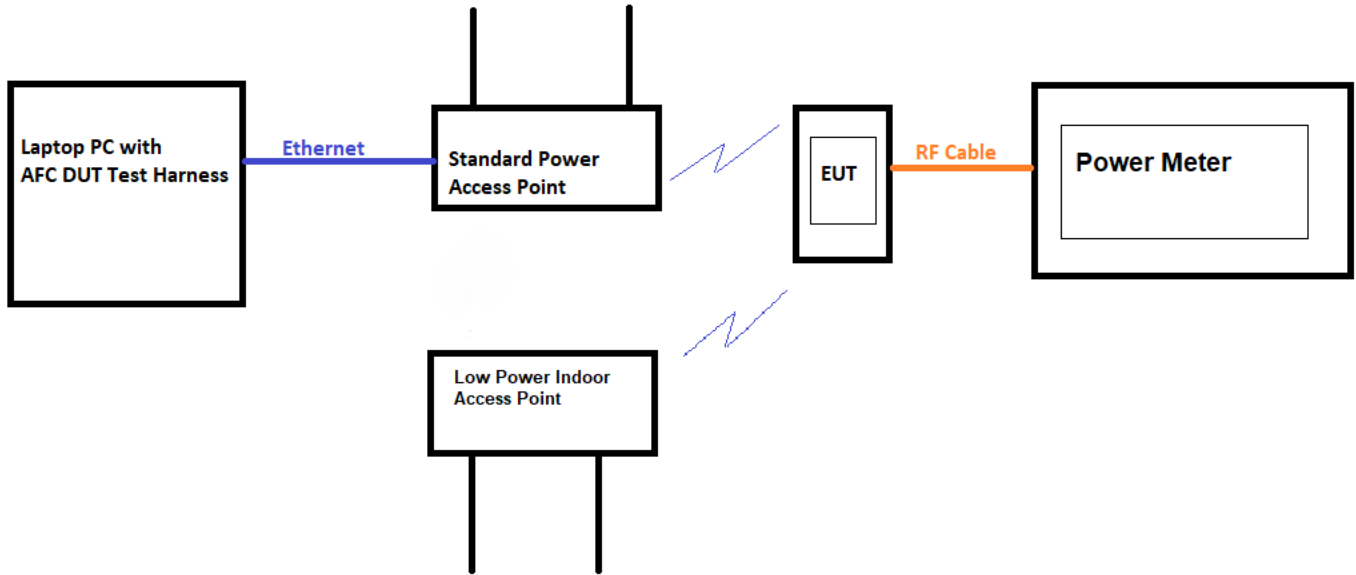

Figure 7-1. Test Setup Diagram for Power Reduction Verification Test

FCC ID: A3LSMX920	<b>MEASUREMENT REPORT (CERTIFICATION)</b>		Approved by: Technical Manager
Test Report S/N: 1M2405140042-11-R1.A3L	Test Dates: 5/23/2024 – 8/23/2024	EUT Type: Portable Tablet	Page 11 of 14

```
[DEBUG] : (08/Aug/2024 12:26:33) Randomized 20MHz channel mask len(16) (33: {'maxPsd': 23.0, 'maxEirp': 36.0}, 37: {'maxPsd': 23.0, 'maxEirp': 36.0}, 41: {'maxPsd': 23.0, 'maxEirp': 36.0}, 45: {'maxPsd': 23.0, 'maxEirp': 36.0}, 49: {'maxPsd': 23.0, 'maxEirp': 36.0}, 53: {'maxPsd': 23.0, 'maxEirp': 36.0}, 57: {'maxPsd': 23.0, 'maxEirp': 36.0}, 61: {'maxPsd': 23.0, 'maxEirp': 36.0}, 129: {'maxPsd': 23.0, 'maxEirp': 36.0}, 133: {'maxPsd': 23.0, 'maxEirp': 36.0}, 137: {'maxPsd': 23.0, 'maxEirp': 36.0}, 141: {'maxPsd': 23.0, 'maxEirp': 36.0}, 145: {'maxPsd': 23.0, 'maxEirp': 36.0}, 149: {'maxPsd': 23.0, 'maxEirp': 36.0}, 153: {'maxPsd': 23.0, 'maxEirp': 36.0}, 157: {'maxPsd': 23.0, 'maxEirp': 36.0})
```

**Figure 7-2. AFC Spectrum Mask including Ch.45 – EIRP/PSD Authorization by channel – 36dBm**

```
[DEBUG] : (08/Aug/2024 11:25:51) Randomized 20MHz channel mask len(16) (33: {'maxPsd': 12.25, 'maxEirp': 25.25}, 37: {'maxPsd': 12.25, 'maxEirp': 25.25}, 41: {'maxPsd': 12.25, 'maxEirp': 25.25}, 45: {'maxPsd': 12.25, 'maxEirp': 25.25}, 49: {'maxPsd': 12.25, 'maxEirp': 25.25}, 53: {'maxPsd': 12.25, 'maxEirp': 25.25}, 57: {'maxPsd': 12.25, 'maxEirp': 25.25}, 61: {'maxPsd': 12.25, 'maxEirp': 25.25}, 65: {'maxPsd': 12.25, 'maxEirp': 25.25}, 69: {'maxPsd': 12.25, 'maxEirp': 25.25}, 73: {'maxPsd': 12.25, 'maxEirp': 25.25}, 77: {'maxPsd': 12.25, 'maxEirp': 25.25}, 81: {'maxPsd': 12.25, 'maxEirp': 25.25}, 85: {'maxPsd': 12.25, 'maxEirp': 25.25}, 89: {'maxPsd': 12.25, 'maxEirp': 25.25}, 93: {'maxPsd': 12.25, 'maxEirp': 25.25})
```

**Figure 7-3. AFC Spectrum Mask including Ch.45 – EIRP/PSD Authorization by channel – 25.25dBm**

```
[DEBUG] : (08/Aug/2024 12:12:10) Randomized 20MHz channel mask len(8) (33: {'maxPsd': 1.5, 'maxEirp': 14.5}, 37: {'maxPsd': 1.5, 'maxEirp': 14.5}, 41: {'maxPsd': 1.5, 'maxEirp': 14.5}, 45: {'maxPsd': 1.5, 'maxEirp': 14.5}, 49: {'maxPsd': 1.5, 'maxEirp': 14.5}, 53: {'maxPsd': 1.5, 'maxEirp': 14.5}, 57: {'maxPsd': 1.5, 'maxEirp': 14.5}, 61: {'maxPsd': 1.5, 'maxEirp': 14.5})
```

**Figure 7-4. AFC Spectrum Mask including Ch.45 – EIRP/PSD Authorization by channel – 14.5dBm**

AFC Authorized EIRP for AP [dBm]	Dual Client ANT1 Conducted Power [dBm]	Dual Client ANT2 Conducted Power [dBm]	Dual Client MIMO Summed Conducted Power [dBm]	Directional Antenna Gain [dBi]	Dual Client MIMO EIRP [dBm]	Client EIRP Limit [dBm]	Margin [dB]
36.00	9.79	9.81	12.81	-2.30	10.51	30.00	-19.49
25.25	9.99	9.67	12.84	-2.30	10.54	19.25	-8.71
14.50	7.90	5.92	10.03	-2.30	7.73	8.50	-0.77

**Table 7-2. Dual Client Output Power Results – Ch.45**

AP	AFC Authorized EIRP for AP [dBm]	Dual Client ANT1 Conducted Power [dBm]	Dual Client ANT2 Conducted Power [dBm]	Dual Client MIMO Summed Conducted Power [dBm]	Directional Antenna Gain [dBi]	Dual Client MIMO EIRP [dBm]	Client EIRP Limit [dBm]	Margin [dB]
SP	36.00	9.79	9.81	12.81	-2.30	10.51	30.00	-19.49
LPI		9.32	9.98	12.67	-2.30	10.37	24.00	-13.63

**Table 7-3. Power Adjustment based on Associated AP Results – Ch.45**

**Sample Calculations**

At 6175MHz in 802.11ax (20MHz BW) mode, the average conducted output power was measured to be 9.79 dBm for Antenna-1 and 9.81 dBm for Antenna-2.

$$\text{Antenna 1} + \text{Antenna 2} = \text{MIMO}$$

$$(9.79 \text{ dBm} + 9.81 \text{ dBm}) = (9.528 \text{ mW} + 9.572 \text{ mW}) = 19.010 \text{ mW} = 12.81 \text{ dBm}$$

**Sample Directional Gain Calculation:**

Per ANSI C63.10-2013 Section 14.4.3, the directional gain is calculated using the following formula, where  $G_N$  is the gain of the nth antenna and  $N_{ANT}$  is the total number of antennas used.

$$\text{Directional gain} = 10 \log\left[\frac{10^{G_1/20} + 10^{G_2/20} + \dots + 10^{G_N/20}}{N_{ANT}}\right]^2 \text{ dBi}$$

FCC ID: A3LSMX920	MEASUREMENT REPORT (CERTIFICATION)		Approved by: Technical Manager
Test Report S/N: 1M2405140042-11-R1.A3L	Test Dates: 5/23/2024 – 8/23/2024	EUT Type: Portable Tablet	Page 12 of 14



**Sample e.i.r.p. Calculation:**

At 6175MHz in 802.11ax (20MHz BW) mode, the average MIMO conducted power was calculated to be 12.81 dBm with directional gain of -2.30 dBi.

$$\text{e.i.r.p. (dBm)} = \text{Conducted Power (dBm)} + \text{Ant gain (dBi)}$$

$$12.81 \text{ dBm} + -2.30\text{dBi} = 10.51\text{dBm}$$

<b>FCC ID:</b> A3LSMX920	<b>MEASUREMENT REPORT (CERTIFICATION)</b>		<b>Approved by:</b> Technical Manager
<b>Test Report S/N:</b> 1M2405140042-11-R1.A3L	<b>Test Dates:</b> 5/23/2024 – 8/23/2024	<b>EUT Type:</b> Portable Tablet	Page 13 of 14

## 8.0 CONCLUSION

The data collected relate only to the item(s) tested and show that the **Samsung Portable Tablet FCC ID: A3LSMX920** complies with the Additional Requirements for Dual Client Devices specified in 15.407 of the FCC rules.

FCC ID: A3LSMX920	<b>MEASUREMENT REPORT (CERTIFICATION)</b>		<b>Approved by:</b> Technical Manager
Test Report S/N: 1M2405140042-11-R1.A3L	Test Dates: 5/23/2024 – 8/23/2024	EUT Type: Portable Tablet	Page 14 of 14