



**FCC CFR47 PART 22 SUBPART H  
FCC CFR47 PART 24 SUBPART E  
FCC CFR47 PART 27 SUBPART H**

**WWAN**

**CERTIFICATION TEST REPORT**

**FOR**

**WCDMA/LTE Tablet + Bluetooth/BLE and DTS/UNII a/b/g/n/ac**

**MODEL NUMBER : SM-W728, SM-W728N0, SM-W727, SM-W727N0**

**FCC ID: A3LSMW728**

**REPORT NUMBER: 4787827147-E5V1**

**ISSUE DATE: FEB 17, 2017**

*Prepared for*  
**SAMSUNG ELECTRONICS CO., LTD.  
129 SAMSUNG-RO, YEONGTONG-GU, SUWON-SI,  
GYEONGGI-DO, 16677, KOREA**

*Prepared by*  
**UL Korea, Ltd. Suwon Laboratory  
218 Maeyeong-ro, Yeongtong-gu,  
Suwon-si, Gyeonggi-do, 16675, Korea  
TEL: (031) 337-9902  
FAX: (031) 213-5433**



Revision History

<u>Rev.</u>	<u>Issue Date</u>	<u>Revisions</u>	<u>Revised By</u>
V1	02/17/17	Initial issue	Junwhan Lee

## TABLE OF CONTENTS

<b>1. ATTESTATION OF TEST RESULTS</b> .....	<b>5</b>
<b>2. TEST METHODOLOGY</b> .....	<b>6</b>
<b>3. FACILITIES AND ACCREDITATION</b> .....	<b>6</b>
<b>4. CALIBRATION AND UNCERTAINTY</b> .....	<b>6</b>
4.1. <i>MEASURING INSTRUMENT CALIBRATION</i> .....	6
4.2. <i>SAMPLE CALCULATION</i> .....	6
4.3. <i>MEASUREMENT UNCERTAINTY</i> .....	7
<b>5. EQUIPMENT UNDER TEST</b> .....	<b>8</b>
5.1. <i>DESCRIPTION OF EUT</i> .....	8
5.2. <i>MAXIMUM OUTPUT POWER (WCDMA)</i> .....	8
5.3. <i>MAXIMUM OUTPUT POWER (LTE)</i> .....	9
5.4. <i>DESCRIPTION OF TEST SETUP</i> .....	11
<b>6. TEST AND MEASUREMENT EQUIPMENT</b> .....	<b>13</b>
<b>7. Summary Table</b> .....	<b>14</b>
<b>8. RF POWER OUTPUT VERIFICATION</b> .....	<b>15</b>
8.1. <i>UMTS REL 99</i> .....	15
8.1.1. <i>WCDMA OUTPUT POWER RESULT</i> .....	19
8.2. <i>LTE OUTPUT VERIFICATION</i> .....	21
8.2.1. <i>LTE OUTPUT POWER RESULT</i> .....	22
<b>9. PEAK TO AVERAGE RATIO</b> .....	<b>24</b>
9.1. <i>CONDUCTED PEAK TO AVERAGE RESULT</i> .....	24
9.2. <i>CONDUCTED PEAK TO AVERAGE PLOTS</i> .....	26
<b>10. LIMITS AND CONDUCTED RESULTS</b> .....	<b>29</b>
10.1. <i>OCCUPIED BANDWIDTH</i> .....	29
10.1.1. <i>OCCUPIED BANDWIDTH RESULTS</i> .....	30
10.1.2. <i>OCCUPIED BANDWIDTH PLOTS</i> .....	32
10.2. <i>BAND EDGE EMISSIONS</i> .....	40
10.2.1. <i>BAND EDGE PLOTS</i> .....	43
10.3. <i>OUT OF BAND EMISSIONS</i> .....	50
10.3.1. <i>OUT OF BAND EMISSIONS RESULT</i> .....	51
10.3.2. <i>OUT OF BAND EMISSIONS PLOTS</i> .....	53
10.4. <i>FREQUENCY STABILITY</i> .....	61
10.4.1. <i>FREQUENCY STABILITY RESULTS</i> .....	62

---

<b>11. RADIATED TEST RESULTS.....</b>	<b>66</b>
11.1. RADIATED POWER (ERP & EIRP).....	66
11.1.1. ERP/EIRP Results .....	67
11.1.2. ERP/EIRP DATA .....	70
11.2. FIELD STRENGTH OF SPURIOUS RADIATION.....	82
11.2.1. SPURIOUS RADIATION PLOTS.....	83
<b>12. SETUP PHOTOS.....</b>	<b>95</b>

# 1. ATTESTATION OF TEST RESULTS

**COMPANY NAME:** SAMSUNG ELECTRONICS CO., LTD.  
**EUT DESCRIPTION:** WCDMA/LTE Tablet + Bluetooth/BLE and DTS/UNII a/b/g/n/ac  
**MODEL NUMBER:** SM-W728, SM-W728N0, SM-W727, SM-W727N0  
**SERIAL NUMBER:** 9RKCR32HC000SJ (RADIATED);  
9RKCR32HC000Q8 (CONDUCTED)  
**DATE TESTED:** JAN 16, 2017 - FEB 17, 2017

APPLICABLE STANDARDS	
STANDARD	TEST RESULTS
FCC PART 22H, 24E and 27H	Pass

UL Korea, Ltd. tested the above equipment in accordance with the requirements set forth in the above standards. All indications of Pass/Fail in this report are opinions expressed by UL Korea, Ltd. based on interpretations and/or observations of test results. Measurement Uncertainties were not taken into account and are published for informational purposes only. The test results show that the equipment tested is capable of demonstrating compliance with the requirements as documented in this report.

**Note:** The results documented in this report apply only to the tested sample, under the conditions and modes of operation as described herein. This document may not be altered or revised in any way unless done so by UL Korea, Ltd. and all revisions are duly noted in the revisions section. Any alteration of this document not carried out by UL Korea, Ltd. will constitute fraud and shall nullify the document. This report must not be used by the client to claim product certification, approval, or endorsement by IAS, any agency of the Federal Government, or any agency of any government.

Approved & Released For  
UL Korea, Ltd. By:



SungGil Park  
Suwon Lab Engineer  
UL Korea, Ltd.

Tested By:



Junwhan Lee  
Suwon Lab Engineer  
UL Korea, Ltd.

## 2. TEST METHODOLOGY

The tests documented in this report were performed in accordance with following methods.

1. FCC CFR 47 Part 2.
2. FCC CFR 47 Part 22.
3. FCC CFR 47 Part 24.
4. FCC CFR 47 Part 27.
5. ANSI TIA-603-D
6. KDB 971168 D01 Power Meas License Digital Systems v02r02

## 3. FACILITIES AND ACCREDITATION

The test sites and measurement facilities used to collect data are located at 218 Maeyeong-ro, Yeongtong-gu, Suwon-si, Gyeonggi-do, 16675, Korea. Line conducted emissions are measured only at the 218 address. The following table identifies which facilities were utilized for radiated emission measurements documented in this report. Specific facilities are also identified in the test results sections.

218 Maeyeong-ro
<input checked="" type="checkbox"/> Chamber 1
<input checked="" type="checkbox"/> Chamber 2

UL Korea, Ltd. is accredited by IAS, Laboratory Code TL-637. The full scope of accreditation can be viewed at <http://www.iasonline.org/PDF/TL/TL-637.pdf>.

## 4. CALIBRATION AND UNCERTAINTY

### 4.1. MEASURING INSTRUMENT CALIBRATION

The measuring equipment utilized to perform the tests documented in this report has been calibrated in accordance with the manufacturer's recommendations, and is traceable to recognized national standards.

### 4.2. SAMPLE CALCULATION

Where relevant, the following sample calculation is provided:

EIRP = PSA reading with EUT worst orientation (dBm) + Path loss (dB) – cable loss( between the SG and substitution antenna) + Substitution Antenna Factor (dBi)

ERP = PSA reading with EUT worst orientation (dBm) + Path loss (dB) – cable loss( between the SG and substitution antenna)

(Path loss = Signal generator output – PSA reading with substitution antenna)

### 4.3. MEASUREMENT UNCERTAINTY

Where relevant, the following measurement uncertainty levels have been estimated for tests performed on the apparatus:

PARAMETER	UNCERTAINTY
Conducted Disturbance, 0.15 to 30 MHz	2.32 dB
Radiated Disturbance, Below 1GHz	4.14 dB
Radiated Disturbance, Above 1 GHz	5.97 dB

Uncertainty figures are valid to a confidence level of 95%.

## 5. EQUIPMENT UNDER TEST

### 5.1. DESCRIPTION OF EUT

The EUT is a WCDMA/LTE Tablet + Bluetooth/BLE and DTS/UNII a/b/g/n/ac.

SM-W728 and multi-models(SM-W727, SM-W727N0, SM-W728N0) are same hardware, but difference is Windows version and HSDPA categories. PED document described detail of difference. All compliance tests were performed using SM-W728 and HSDPA conducted power check for multi-models were performed.

### 5.2. MAXIMUM OUTPUT POWER (WCDMA)

The transmitter has a maximum peak conducted and radiated ERP / EIRP output powers as follows:

FCC Part 22/24						
Band	Frequency Range	Modulation	Conducted		Radiated	
	[MHz]		Peak	Avg [dBm]	Avg [mW]	Avg [dBm]
Band 5	824~849	REL99	22.50	177.83	20.45	110.92
		HSDPA	22.47	176.60	20.47	111.43
		HSUPA	22.36	172.19		
		DC-HSDPA	22.26	168.27		
Band 2	1850~1910	REL99	22.24	167.49	24.44	277.97
		HSDPA	22.19	165.58	24.19	262.42
		HSUPA	22.13	163.31		
		DC-HSDPA	22.03	159.59		

### 5.3. MAXIMUM OUTPUT POWER (LTE)

The transmitter has a maximum peak conducted and radiated ERP / EIRP output powers as follows:

#### LTE Band 17

FCC Part 27							
Band	Frequency Range [MHz]	BandWidth [MHz]	Modulation Peak	Conducted		Radiated	
				Avg [dBm]	Avg [mW]	Avg [dBm]	Avg [mW]
Band 17	704 ~ 716	10	QPSK	22.37	172.58	14.00	25.12
			16QAM	21.27	133.97	13.01	20.00
		5	QPSK	22.26	168.27	13.52	22.49
			16QAM	21.25	133.35	12.55	17.99

#### LTE Band 5

FCC Part 22							
Band	Frequency Range [MHz]	BandWidth [MHz]	Modulation Peak	Conducted		Radiated	
				Avg [dBm]	Avg [mW]	Avg [dBm]	Avg [mW]
Band 5	824 ~ 849	10	QPSK	23.62	230.14	19.41	87.30
			16QAM	23.20	208.93	17.82	60.53
		5	QPSK	23.53	225.42	19.66	92.47
			16QAM	23.30	213.80	18.19	65.92
		3	QPSK	23.71	234.96	19.71	93.54
			16QAM	23.22	209.89	18.18	65.77
		1.4	QPSK	23.59	228.56	17.36	54.45
			16QAM	23.19	208.45	15.89	38.82

**DESCRIPTION OF AVAILABLE ANTENNAS**

The radio utilizes internal antenna for the [List the bands supported with a maximum peak gain as follow:

Frequency (MHz)	Peak Gain (dBi)
WCDMA Band 5 / LTE Band 5 824 ~ 849 MHz	-0.3
WCDMA Band 2 1850 ~ 1910 MHz	4.8
LTE Band 17 704 ~ 716 MHz	-5.7

## 5.4. DESCRIPTION OF TEST SETUP

### SUPPORT EQUIPMENT

Support Equipment List				
Description	Manufacturer	Model	Serial Number	FCC ID
Adapter	SAMSUNG	EP-TA300	R37HCSB00A3SE3	N/A
Data Cable	SAMSUNG	EP-DW720CWE	N/A	N/A
Earphone	SAMSUNG	EO-EG920BW	N/A	N/A

### I/O CABLES

I/O Cable List						
Cable No	Port	# of identical ports	Connector Type	Cable Type	Cable Length (m)	Remarks
1	DC Power	1	C Type USB	Shielded	1.2m	N/A
2	Audio	2	Mini-Jack	Unshielded	1.1m	N/A

### ADDITIONAL EQUIPMENT

Support Equipment List				
Description	Manufacturer	Model	Serial Number	FCC ID
Keyboard	SAMSUNG	EJ-CW720	N/A	N/A
S-pen	SAMSUNG	EJ-PT820	N/A	N/A

Additional ERP/EIRP and radiated spurious emission measurements were performed on worst case condition (Max radiated power and spurious emission) equipped with keyboard. Test data shown on section 11 and setup photo shown on section 12.

### TEST SETUP

The EUT is continuously communicated to the call box during the tests.

**SETUP DIAGRAM FOR TESTS (CONDUCTED TEST SETUP)**

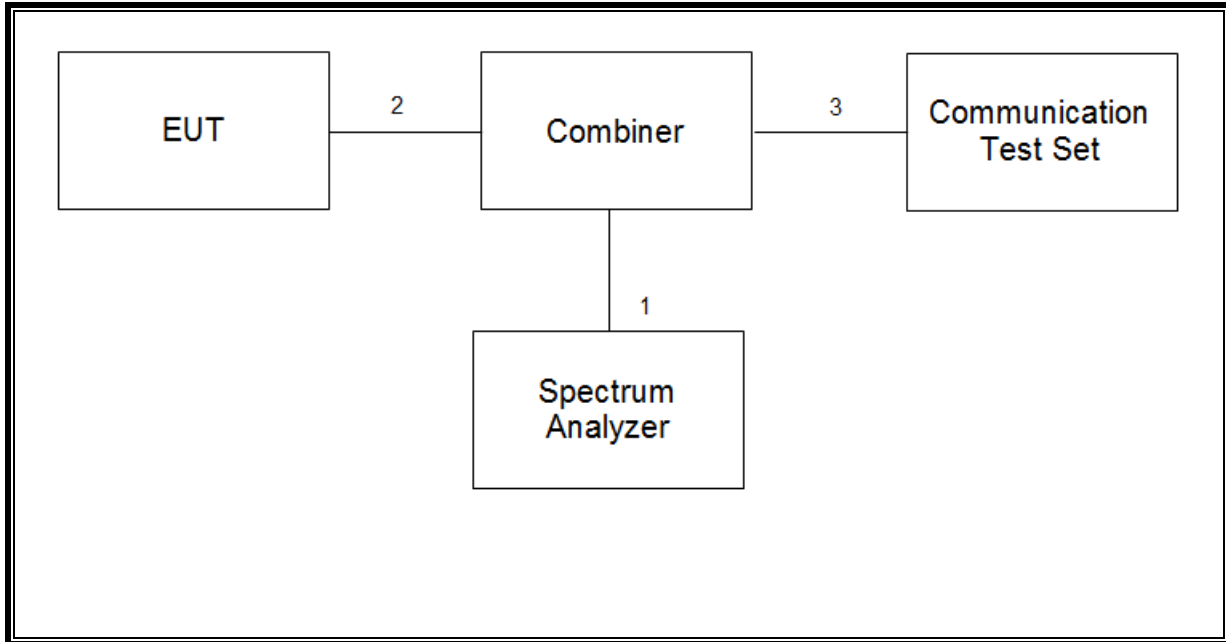

**SETUP DIAGRAM FOR TESTS (RADIATED TEST SETUP)**

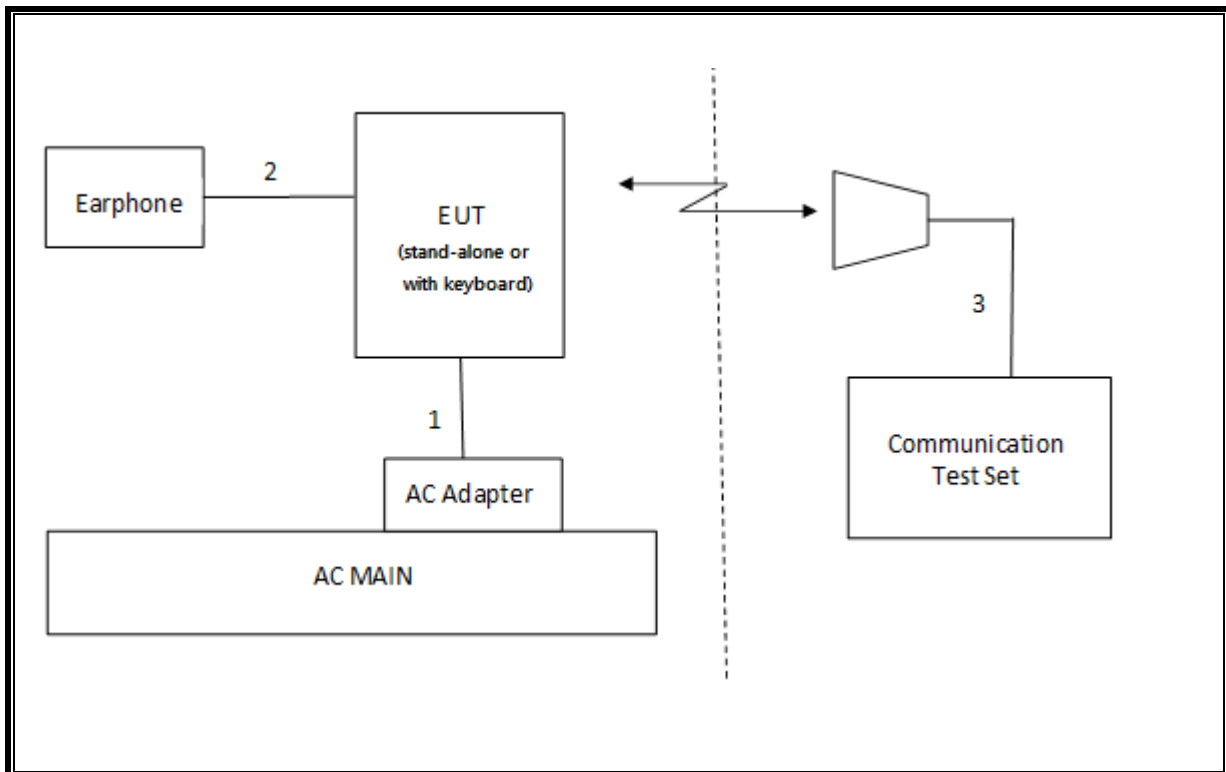

## 6. TEST AND MEASUREMENT EQUIPMENT

The following test and measurement equipment was utilized for the tests documented in this report:

Test Equipment List				
Description	Manufacturer	Model	S/N	Cal Due
Antenna, Tuned Dipole 400~1000 MHz	ETS	3121D DB4	00164753	07-28-17
Antenna, Horn, 40 GHz	ETS	3116C	00166155	11-30-17
Antenna, Horn, 40 GHz	ETS	3116C-PA	00168841	12-15-17
Antenna, Bilog, 30MHz-1GHz	SCHWARZBECK	VULB9163	750	10-14-18
Antenna, Bilog, 30MHz-1GHz	SCHWARZBECK	VULB9163	749	04-25-17
Antenna, Horn, 18 GHz	ETS	3115	00161451	05-17-17
Antenna, Horn, 18 GHz	ETS	3115	00167211	10-14-18
Antenna, Horn, 18 GHz	ETS	3117	00168724	06-17-17
Antenna, Horn, 18 GHz	ETS	3117	00168717	06-17-17
Combiner	WEINSCHL	1575	2150	08-16-17
Communications Test Set	R&S	CMW500	150312	08-17-17
Communications Test Set	R&S	CMW500	115331	08-17-17
DC Power Supply	Agilent / HP	E3640A	MY54226395	08-16-17
Preamplifier, 1000 MHz	Sonoma	310N	341282	08-17-17
Preamplifier, 1000 MHz	Sonoma	310N	351741	08-16-17
Preamplifier	ETS	3115-PA	00167475	08-17-17
Preamplifier, 18 GHz	Miteq	AFS42-00101800-25-S-42	1896138	08-16-17
Spectrum Analyzer, 44 GHz	Agilent / HP	N9030A	MY54170614	08-17-17
Spectrum Analyzer, 44 GHz	Agilent / HP	N9030A	MY54490312	08-16-17
Average Power Sensor	R&S	NRZ-Z91	102681	08-16-17
Average Power Sensor	Agilent / HP	U2000	MY54270007	08-17-17
EMI Test Receive, 40 GHz	R&S	ESU40	100439	08-17-17
EMI Test Receive, 40 GHz	R&S	ESU40	100457	08-16-17
EMI Test Receive, 3 GHz	R&S	ESR3	101832	08-16-17
Attenuator / Switch driver	HP	11713A	3748A04272	N/A
High Pass Filter 1.2GHz	Micro-Tronics	HPM50108-02	G005	08-17-17
High Pass Filter 1.2GHz	Micro-Tronics	HPM50108-02	G006	08-17-17
High Pass Filter 2.8GHz	Micro-Tronics	HPM50111-02	010	08-17-17
High Pass Filter 2.8GHz	Micro-Tronics	HPM50111-02	011	08-17-17
High Pass Filter 4GHz	Micro-Tronics	HPM50118-02	G001	08-17-17
High Pass Filter 4GHz	Micro-Tronics	HPM50118-02	G002	08-17-17
Attenuator	PASTERNAK	PE7087-10	A009	08-16-17
Temperature Chamber	ESPEC	SH-642	93001109	08-17-17
UL Software				
Description	Manufacturer	Model	Version	
Antenna port test software	UL	CLT	Ver 1.6 / 1.7	

## 7. Summary Table

FCC Part Section	Test Description	Test Limit	Test Condition	Test Result	Note
2.1049	Occupied Band width (99%)	N/A	Conducted	Pass	8.9969 MHz
22.917(a) 24.238(a) 27.53(g)	Band Edge / Conducted Spurious Emission	-13dBm		Pass	-14.117dBm
2.1046	Conducted output power	N/A		Pass	23.71 dBm
22.355 24.235 27.54	Frequency Stability	2.5PPM		Pass	-0.003 PPM
22.913(a)(2)	Effective Radiated Power	38.5 dBm	Radiated	Pass	20.47 dBm
27.50(c)(10)		34.77dBm		Pass	14.00 dBm
24.232(c)	Equivalent Isotropic Radiated Power	33dBm		Pass	24.44 dBm
22.917(a) 24.238(a) 27.53(g)	Radiated Spurious Emission	-13dBm		Pass	-43.0 dBm

FCC Rule Part	Frequency Range [MHz]	Output Power [W]	Frequency Tolerance	Emission Designator	Emission Bandwidth	Communication Type
WCDMA						
22H	826.4 - 846.6	0.111	2.5 ppm	4M07F9W		WCDMA BAND5
24E	1852.4 - 1907.6	0.278	2.5 ppm	4M07F9W		WCDMA BAND2
LTE Band 5						
22H	829.0 - 844.0	0.087	2.5 ppm	8M97G7W	10	QPSK
22H	829.0 - 844.0	0.061	2.5 ppm	9M00D7W	10	16QAM
22H	826.5 - 846.5	0.066	2.5 ppm	4M49D7W	5	16QAM
22H	825.5 - 847.5	0.094	2.5 ppm	2M68G7W	3	QPSK
LTE Band 17						
27H	709.0 - 711.0	0.025	2.5 ppm	8M97G7W	10	QPSK
27H	709.0 - 711.0	0.02	2.5 ppm	8M98D7W	10	16QAM

## 8. RF POWER OUTPUT VERIFICATION

### 8.1. UMTS REL 99

#### Release 99 Setup Procedures used to establish the test signals

The following tests were completed according to the test requirements outlined in section 5.2 of the 3GPP TS34.121-1 specification. The DUT supports power Class 3, which has a nominal maximum output power of 24 dBm (+1.7/-3.7).

Mode	Subtest	Rel99
WCDMA General Settings	Loopback Mode	Test Mode 2
	Rel99 RMC	12.2kbps RMC
	Power Control Algorithm	Algorithm2
	$\beta_c/\beta_d$	8/15

#### HSDPA Setup Procedures used to establish the test signals

The following 4 Sub-tests were completed according to Release 5 procedures in section 5.2 of 3GPP TS34.121. A summary of these settings are illustrated below:

	Mode	HSDPA	HSDPA	HSDPA	HSDPA
	Subtest	1	2	3	4
W-CDMA General Settings	Loopback Mode	Test Mode 1			
	Rel99 RMC	12.2kbps RMC			
	HSDPA FRC	H-Set 1			
	Power Control Algorithm	Algorithm 2			
	$\beta_c$	2/15	11/15	15/15	15/15
	$\beta_d$	15/15	15/15	8/15	4/15
	Bd (SF)	64			
	$\beta_c/\beta_d$	2/15	11/15	15/8	15/4
	$\beta_{hs}$	4/15	24/15	30/15	30/15
	MPR (dB)	0	0	0.5	0.5
HSDPA Specific Settings	$D_{ACK}$	8			
	$D_{NAK}$	8			
	DCQI	8			
	Ack-Nack repetition factor	3			
	CQI Feedback (Table 5.2B.4)	4ms			
	CQI Repetition Factor (Table 5.2B.4)	2			
	$A_{hs}=\beta_{hs}/\beta_c$	30/15			

**HSPA (HSDPA & HSUPA) Setup Procedures used to establish the test signals**

The following 5 Sub-tests were completed according to Release 6 procedures in section 5.2 of 3GPP TS34.121. A summary of these settings are illustrated below:

	Mode	HSPA				
	Subtest	1	2	3	4	5
WCDMA General Settings	Loopback Mode	Test Mode 1				
	Rel99 RMC	12.2 kbps RMC				
	HSDPA FRC	H-Set 1				
	HSUPA Test	HSPA				
	Power Control Algorithm	Algorithm 2				Algorithm 1
	$\beta_c$	11/15	6/15	15/15	2/15	15/15
	$\beta_d$	15/15	15/15	9/15	15/15	0
	$\beta_{ec}$	209/225	12/15	30/15	2/15	5/15
	$\beta_c/\beta_d$	11/15	6/15	15/9	2/15	15/1
	$\beta_{hs}$	22/15	12/15	30/15	4/15	5/15
	$\beta_{ed}$	1309/225	94/75	47/15	56/75	47/15
CM (dB)	1	3	2	3	1	
MPR (dB)	0	2	1	2	0	
HSDPA Specific Settings	DACK	8				0
	DNAK	8				0
	DCQI	8				0
	Ack-Nack repetition factor	3				
	CQI Feedback (Table 5.2B.4)	4ms				
	CQI Repetition Factor (Table 5.2B.4)	2				
	$A_{hs} = \beta_{hs}/\beta_c$	30/15				
HSUPA Specific Settings	E-DPDCCH	6	8	8	5	7
	DHARQ	0	0	0	0	0
	AG Index	20	12	15	17	21
	ETFCI (from 34.121 Table C.11.1.3)	75	67	92	71	81
	Associated Max UL Data Rate kbps	242.1	174.9	482.8	205.8	308.9
	Reference E-TFCIs	5	5	2	5	1
	Reference E-TFCI	11	11	11	11	67
	Reference E-TFCI PO	4	4	4	4	18
	Reference E-TFCI	67	67	92	67	67
	Reference E-TFCI PO	18	18	18	18	18
	Reference E-TFCI	71	71	71	71	71
	Reference E-TFCI PO	23	23	23	23	23
	Reference E-TFCI	75	75	75	75	75
	Reference E-TFCI PO	26	26	26	26	26
	Reference E-TFCI	81	81	81	81	81
Reference E-TFCI PO	27	27	27	27	27	
Maximum Channelisation Codes	2xSF2				SF4	

**DC-HSDPA Setup Procedures used to establish the test signals**

The following tests were completed according to procedures in section 7.3.13 of 3GPP TS34.108 v9.5.0. A summary of these settings are illustrated below:

Downlink Physical Channels are set as per 3GPP TS34.121-1 v9.0.0 E.5.0

Table E.5.0: Levels for HSDPA connection setup

Parameter During Connection setup	Unit	Value
P-CPICH_Ec/Ior	dB	-10
P-CCPCH and SCH_Ec/Ior	dB	-12
PICH_Ec/Ior	dB	-15
HS-PDSCH	dB	off
HS-SCCH_1	dB	off
DPCH_Ec/Ior	dB	-5
OCNS_Ec/Ior	dB	-3.1

Call is set up as per 3GPP TS34.108 v9.5.0 sub clause 7.3.13

The configurations of the fixed reference channels for HSDPA RF tests are described in 3GPP TS 34.121, annex C for FDD and 3GPP TS 34.122.

Table C.8.1.12: Fixed Reference Channel H-Set 12

Parameter	Unit	Value
Nominal Avg. Inf. Bit Rate	kbps	60
inter-TTI Distance	TTI's	1
Number of HARQ Processes	Processes	6
Information Bit Payload ( $N_{INF}$ )	Bits	120
Number Code Blocks	Blocks	1
Binary Channel Bits Per TTI	Bits	960
Total Available SML's in UE	SML's	19200
Number of SML's per HARQ Proc.	SML's	3200
Coding Rate		0.15
Number of Physical Channel Codes	Codes	1
Modulation		QPSK
Note 1: The RMC is intended to be used for DC-HSDPA mode and both cells shall transmit with identical parameters as listed in the table.		
Note 2: Maximum number of transmission is limited to 1, i.e., retransmission is not allowed. The redundancy and constellation version 0 shall be used.		

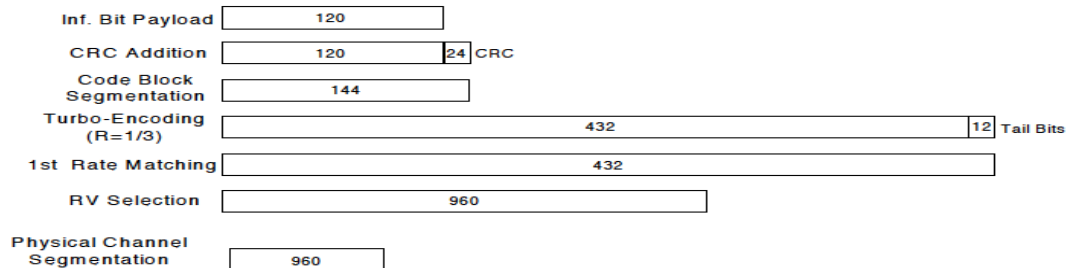

Figure C.8.19: Coding rate for Fixed reference Channel H-Set 12 (QPSK)

The following 4 Sub-tests for HSDPA were completed according to Release 8 procedures in section 5.2 of 3GPP TS34.121. A summary of subtest settings are illustrated below:

Mode	HSDPA	HSDPA	HSDPA	HSDPA	
Subtest	1	2	3	4	
WCDMA General Settings	Loopback Mode				
	Test Mode 1				
	Rel99 RMC				
	12.2kbps RMC				
	HSDPA FRC				
	H-Set 1				
	Power Control Algorithm				
	Algorithm2				
	$\beta_c$	2/15	11/15	15/15	15/15
	$\beta_d$	15/15	15/15	8/15	4/15
$\beta_d$ (SF)	64				
$\beta_c/\beta_d$	2/15	11/15	15/8	15/4	
$\beta_{hs}$	4/15	24/15	30/15	30/15	
MPR (dB)	0	0	0.5	0.5	
HSDPA Specific Settings	DACK				
	8				
	DNAK				
	8				
	DCQI				
	8				
	Ack-Nack Repetition factor				
3					
CQI Feedback					
4ms					
CQI Repetition Factor					
2					
A <sub>hs</sub> = $\beta_{hs} / \beta_c$					
30/15					

**HSPA+**

Since 16QAM is not used for uplink, the uplink Category and release is same as HSUPA, i.e., CAT 6 Rel 6. Therefore, the RF conducted power is not measured.

### 8.1.1. WCDMA OUTPUT POWER RESULT

#### WCDMA Band 5 Measured Results

Band	Mode		UL Ch No.	Freq. [MHz]	MPR [dB]	Avg Pwr [dBm]	
W-CDMA Band V	Rel 99	RMC, 12.2 kbps	4132	826.4	0.0	22.50	
			4183	836.6	0.0	22.48	
			4233	846.6	0.0	22.30	
	HSDPA	Subtest 1	4132	826.4	0.0	22.47	
			4183	836.6	0.0	22.29	
			4233	846.6	0.0	22.17	
		Subtest 2	4132	826.4	0.0	22.29	
			4183	836.6	0.0	22.18	
			4233	846.6	0.0	22.05	
		Subtest 3	4132	826.4	0.5	22.00	
			4183	836.6	0.5	21.96	
			4233	846.6	0.5	21.76	
		Subtest 4	4132	826.4	0.5	21.79	
			4183	836.6	0.5	21.75	
			4233	846.6	0.5	21.62	
		HSUPA	Subtest 1	4132	826.4	0.0	21.48
				4183	836.6	0.0	21.43
				4233	846.6	0.0	21.30
	Subtest 2		4132	826.4	2.0	20.56	
			4183	836.6	2.0	20.50	
			4233	846.6	2.0	20.31	
	Subtest 3		4132	826.4	1.0	21.30	
			4183	836.6	1.0	21.28	
			4233	846.6	1.0	21.13	
	Subtest 4		4132	826.4	2.0	20.95	
			4183	836.6	2.0	20.92	
			4233	846.6	2.0	20.76	
	Subtest 5		4132	826.4	0.0	22.36	
			4183	836.6	0.0	22.29	
			4233	846.6	0.0	22.14	
	DC-HSDPA	Subtest 1	4132	826.4	0.0	22.17	
			4183	836.6	0.0	22.26	
			4233	846.6	0.0	22.00	
		Subtest 2	4132	826.4	0.0	22.19	
			4183	836.6	0.0	22.14	
			4233	846.6	0.0	22.03	
		Subtest 3	4132	826.4	0.5	21.93	
			4183	836.6	0.5	21.88	
			4233	846.6	0.5	21.76	
		Subtest 4	4132	826.4	0.5	21.73	
			4183	836.6	0.5	21.68	
			4233	846.6	0.5	21.56	

**WCDMA Band 2 Measured Results**

Band	Mode		UL Ch No.	Freq. [MHz]	MPR [dB]	Avg Pwr [dBm]	
W-CDMA Band II	Rel 99	RMC, 12.2 kbps	9262	1852.4	0.0	22.24	
			9400	1880.0	0.0	21.93	
			9538	1907.6	0.0	22.00	
	HSDPA	Subtest 1	9262	1852.4	0.0	22.19	
			9400	1880.0	0.0	21.83	
			9538	1907.6	0.0	21.88	
		Subtest 2	9262	1852.4	0.0	22.04	
			9400	1880.0	0.0	21.75	
			9538	1907.6	0.0	21.86	
		Subtest 3	9262	1852.4	0.5	21.81	
			9400	1880.0	0.5	21.46	
			9538	1907.6	0.5	21.53	
		Subtest 4	9262	1852.4	0.5	21.58	
			9400	1880.0	0.5	21.26	
			9538	1907.6	0.5	21.32	
		HSUPA	Subtest 1	9262	1852.4	0.0	21.84
				9400	1880.0	0.0	21.64
				9538	1907.6	0.0	21.70
	Subtest 2		9262	1852.4	2.0	20.41	
			9400	1880.0	2.0	20.09	
			9538	1907.6	2.0	20.19	
	Subtest 3		9262	1852.4	1.0	21.00	
			9400	1880.0	1.0	20.80	
			9538	1907.6	1.0	20.91	
	Subtest 4		9262	1852.4	2.0	20.37	
			9400	1880.0	2.0	20.11	
			9538	1907.6	2.0	20.18	
	Subtest 5		9262	1852.4	0.0	22.13	
			9400	1880.0	0.0	21.81	
			9538	1907.6	0.0	21.86	
	DC-HSDPA	Subtest 1	9262	1852.4	0.0	21.70	
			9400	1880.0	0.0	21.64	
			9538	1907.6	0.0	21.87	
		Subtest 2	9262	1852.4	0.0	22.03	
			9400	1880.0	0.0	21.76	
			9538	1907.6	0.0	21.84	
		Subtest 3	9262	1852.4	0.5	21.79	
			9400	1880.0	0.5	21.52	
			9538	1907.6	0.5	21.46	
		Subtest 4	9262	1852.4	0.5	21.62	
			9400	1880.0	0.5	21.24	
			9538	1907.6	0.5	21.32	

## 8.2. LTE OUTPUT VERIFICATION

The following tests were conducted according to the test requirements outlined in section 6.2 of the 3GPP TS36.101 specification.

UE Power Class: 3 (23 +/- 2dBm). The allowed Maximum Power Reduction (MPR) for the maximum output power due to higher order modulation and transmit bandwidth configuration (resource blocks) is specified in Table 6.2.3-1 of the 3GPP TS36.101.

**Table 6.2.3-1: Maximum Power Reduction (MPR) for Power Class 3**

Modulation	Channel bandwidth / Transmission bandwidth (RB)						MPR (dB)
	1.4 MHz	3.0 MHz	5 MHz	10 MHz	15 MHz	20 MHz	
QPSK	> 5	> 4	> 8	> 12	> 16	> 18	≤ 1
16 QAM	≤ 5	≤ 4	≤ 8	≤ 12	≤ 16	≤ 18	≤ 1
16 QAM	> 5	> 4	> 8	> 12	> 16	> 18	≤ 2

The allowed A-MPR values specified below in Table 6.2.4.-1 of 3GPP TS36.101 are in addition to the allowed MPR requirements. All the measurements below were performed with A-MPR disabled, by using Network Signalling Value of "NS\_01".

**Table 6.2.4-1: Additional Maximum Power Reduction (A-MPR)**

Network Signalling value	Requirements (sub-clause)	E-UTRA Band	Channel bandwidth (MHz)	Resources Blocks ( $N_{RB}$ )	A-MPR (dB)
NS_01	6.6.2.1.1	Table 5.5-1	1.4, 3, 5, 10, 15, 20	Table 5.6-1	NA
NS_03	6.6.2.2.1	2, 4, 10, 23, 25, 35, 36	3	>5	≤ 1
			5	>6	≤ 1
			10	>6	≤ 1
			15	>8	≤ 1
			20	>10	≤ 1
NS_04	6.6.2.2.2	41	5	>6	≤ 1
			10, 15, 20	See Table 6.2.4-4	
NS_05	6.6.3.3.1	1	10,15,20	≥ 50	≤ 1
NS_06	6.6.2.2.3	12, 13, 14, 17	1.4, 3, 5, 10	Table 5.6-1	n/a
NS_07	6.6.2.2.3	13	10	Table 6.2.4-2	Table 6.2.4-2
	6.6.3.3.2				
NS_08	6.6.3.3.3	19	10, 15	> 44	≤ 3
NS_09	6.6.3.3.4	21	10, 15	> 40	≤ 1
				> 55	≤ 2
NS_10		20	15, 20	Table 6.2.4-3	Table 6.2.4-3
NS_11	6.6.2.2.1	23 <sup>1</sup>	1.4, 3, 5, 10	Table 6.2.4-5	Table 6.2.4-5
..					
NS_32	-	-	-	-	-

Note 1: Applies to the lower block of Band 23, i.e. a carrier placed in the 2000-2010 MHz region.

### 8.2.1. LTE OUTPUT POWER RESULT

#### LTE Band 17 Measured Results

BW (MHz)	Mode	RB Allocation	RB offset	Target MPR	Avg Pwr (dBm)	
					23790	710 MHz
					10	QPSK
		1	25	0	22.21	
		1	49	0	22.19	
		25	0	2	21.31	
		25	12	2	21.22	
		25	25	2	21.19	
		50	0	2	21.21	
	16QAM	1	0	1	21.27	
		1	25	1	21.11	
		1	49	1	21.07	
		25	0	2	20.37	
		25	12	2	20.24	
		25	25	2	20.23	
		50	0	2	20.26	
BW (MHz)	Mode	RB Allocation	RB offset	Target MPR	Avg Pwr (dBm)	
					23790	710 MHz
					5	QPSK
		1	12	0	22.26	
		1	24	0	22.15	
		12	0	2	21.32	
		12	7	2	21.24	
		12	13	2	21.20	
		25	0	2	21.19	
	16QAM	1	0	1	21.25	
		1	12	1	21.24	
		1	24	1	21.07	
		12	0	2	20.35	
		12	7	2	20.23	
		12	13	2	20.25	
		25	0	2	20.37	

**LTE Band 5 Measured Results**

Band	BW (MHz)	Mode	RB Allocation	RB offset	Target MPR	Avg Pwr [dBm]					
						Max. Power					
						829 MHz	836.5 MHz	844 MHz			
LTE Band 5	10	QPSK	1	0	0		23.62				
			1	25	0		23.46				
			1	49	0		23.39				
			25	0	1		22.32				
			25	12	1		22.19				
			25	25	1		22.11				
		16QAM	50	0	1		22.18				
			1	0	1		23.20				
			1	25	1		23.03				
			1	49	1		22.96				
			25	0	2		20.73				
			25	12	2		20.55				
			25	25	2		20.50				
			50	0	2		20.51				
Band	BW (MHz)	Mode	RB Allocation	RB offset	Target MPR	Avg Pwr [dBm]					
						Max. Power					
						826.5 MHz	836.5 MHz	846.5 MHz			
LTE Band 5	5	QPSK	1	0	0	23.46	23.42	23.13			
			1	12	0	23.53	23.39	23.23			
			1	24	0	23.49	23.24	23.13			
			12	0	1	22.38	22.22	22.08			
			12	7	1	22.32	22.11	22.02			
			12	13	1	22.42	22.10	22.04			
		16QAM	25	0	1	22.33	22.16	22.05			
			1	0	1	22.77	22.94	23.29			
			1	12	1	22.85	22.92	23.30			
			1	24	1	22.81	22.76	23.19			
			12	0	2	20.80	20.76	20.54			
			12	7	2	20.78	20.59	20.50			
			12	13	2	20.82	20.61	20.50			
			25	0	2	20.88	20.54	20.54			
			Band	BW (MHz)	Mode	RB Allocation	RB offset	Target MPR	Avg Pwr [dBm]		
									Max. Power		
825.5 MHz	836.5 MHz	847.5 MHz									
LTE Band 5	3	QPSK	1	0	0	23.63	23.65	23.44			
			1	8	0	23.71	23.64	23.51			
			1	14	0	23.59	23.56	23.37			
			8	0	1	22.42	22.28	22.18			
			8	4	1	22.42	22.33	22.18			
			8	7	1	22.40	22.32	22.16			
		16QAM	15	0	1	22.42	22.31	22.13			
			1	0	1	22.83	23.19	22.68			
			1	8	1	22.87	23.22	22.80			
			1	14	1	22.72	23.11	22.66			
			8	0	2	20.86	20.63	20.70			
			8	4	2	20.96	20.59	20.80			
			8	7	2	20.92	20.62	20.85			
			15	0	2	20.90	20.67	20.53			
			Band	BW (MHz)	Mode	RB Allocation	RB offset	Target MPR	Avg Pwr [dBm]		
									Max. Power		
824.7 MHz	836.5 MHz	848.3 MHz									
LTE Band 5	1.4	QPSK	1	0	0	23.49	23.48	23.45			
			1	3	0	23.49	23.52	23.45			
			1	5	0	23.50	23.56	23.49			
			3	0	0	23.54	23.53	23.39			
			3	1	0	23.55	23.55	23.40			
			3	3	0	23.54	23.59	23.41			
		16QAM	6	0	1	22.40	22.40	22.08			
			1	0	1	22.64	22.70	23.01			
			1	3	1	22.66	22.70	23.06			
			1	5	1	22.71	22.71	23.06			
			3	0	1	23.19	23.17	22.79			
			3	1	1	23.18	23.18	22.80			
			3	3	1	23.18	23.18	22.84			
			6	0	2	21.06	20.50	20.75			

## 9. PEAK TO AVERAGE RATIO

### Test Procedure

Per KDB 971168 D01 Power Meas License Digital Systems v02r02;

The transmitter output was connected to a CMW500 Test Set and configured to operate at maximum power. The PAR were measured on the Spectrum Analyzer.

### Test Spec

In addition, when the transmitter power is measured in terms of average value, the peak-to-average ratio of the power shall not exceed 13 dB.

### 9.1. CONDUCTED PEAK TO AVERAGE RESULT

#### WCDMA

Band	Channel	f [MHz]	Mode	Ratio [dB]	Limit [dB]
Band 5	4183	836.6	REL99	3.31	13.00
			HSDPA	3.36	
Band 2	9400	1880.0	REL99	3.28	
			HSDPA	3.34	

**LTE**

Band	BW [MHz]	Channel	f [MHz]	Mode	Ratio [dB]	Limit [dB]
Band 17	10	23790	710	QPSK	5.51	13.00
				16QAM	6.18	
	5			QPSK	6.08	
				16QAM	5.99	
Band 5	10	20525	836.5	QPSK	4.28	
				16QAM	4.89	
	5			QPSK	4.41	
				16QAM	4.82	
	3			QPSK	4.11	
				16QAM	4.72	
	1.4			QPSK	4.46	
				16QAM	5.15	

## 9.2. CONDUCTED PEAK TO AVERAGE PLOTS

### WCDMA

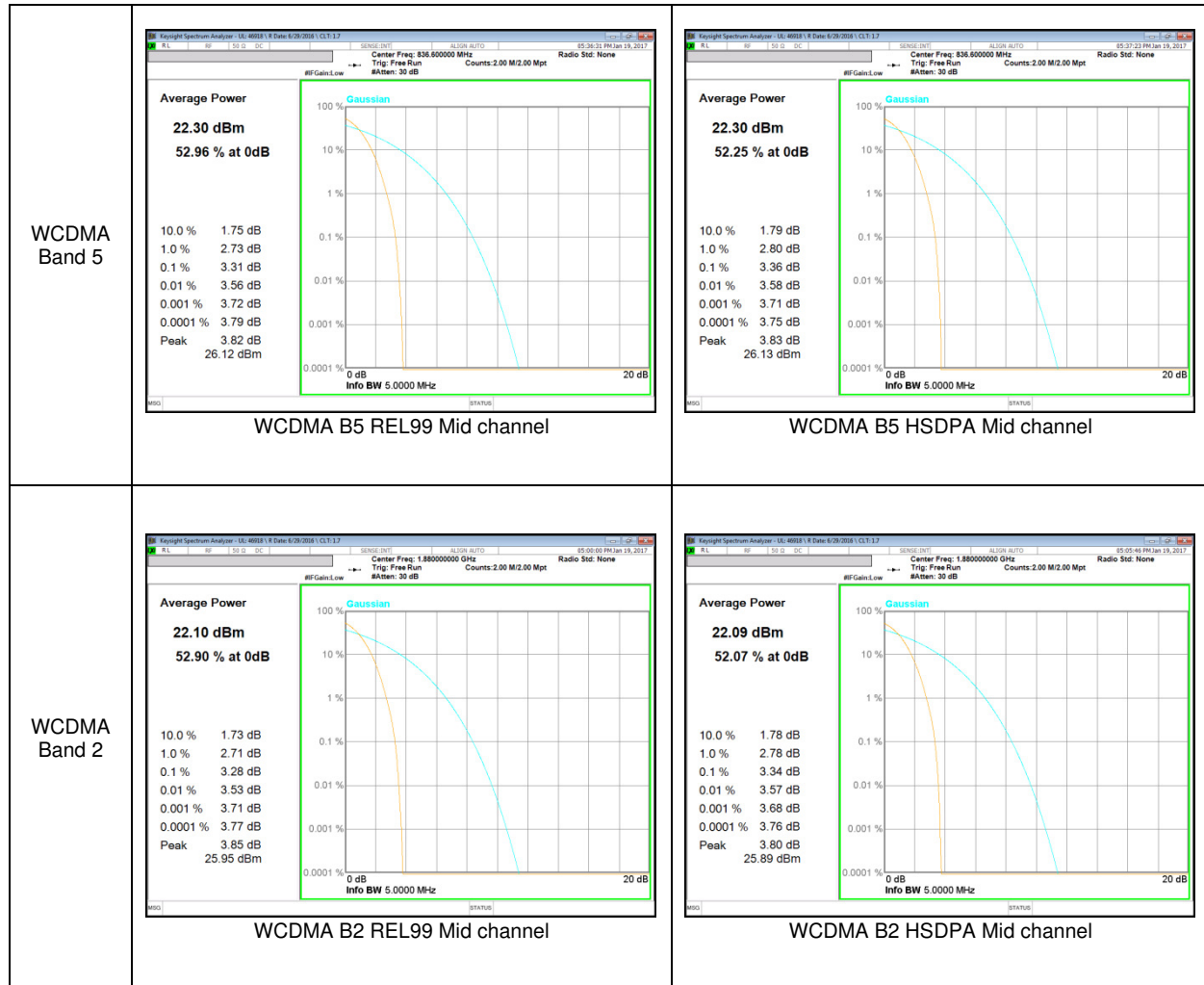

**LTE Band 17**

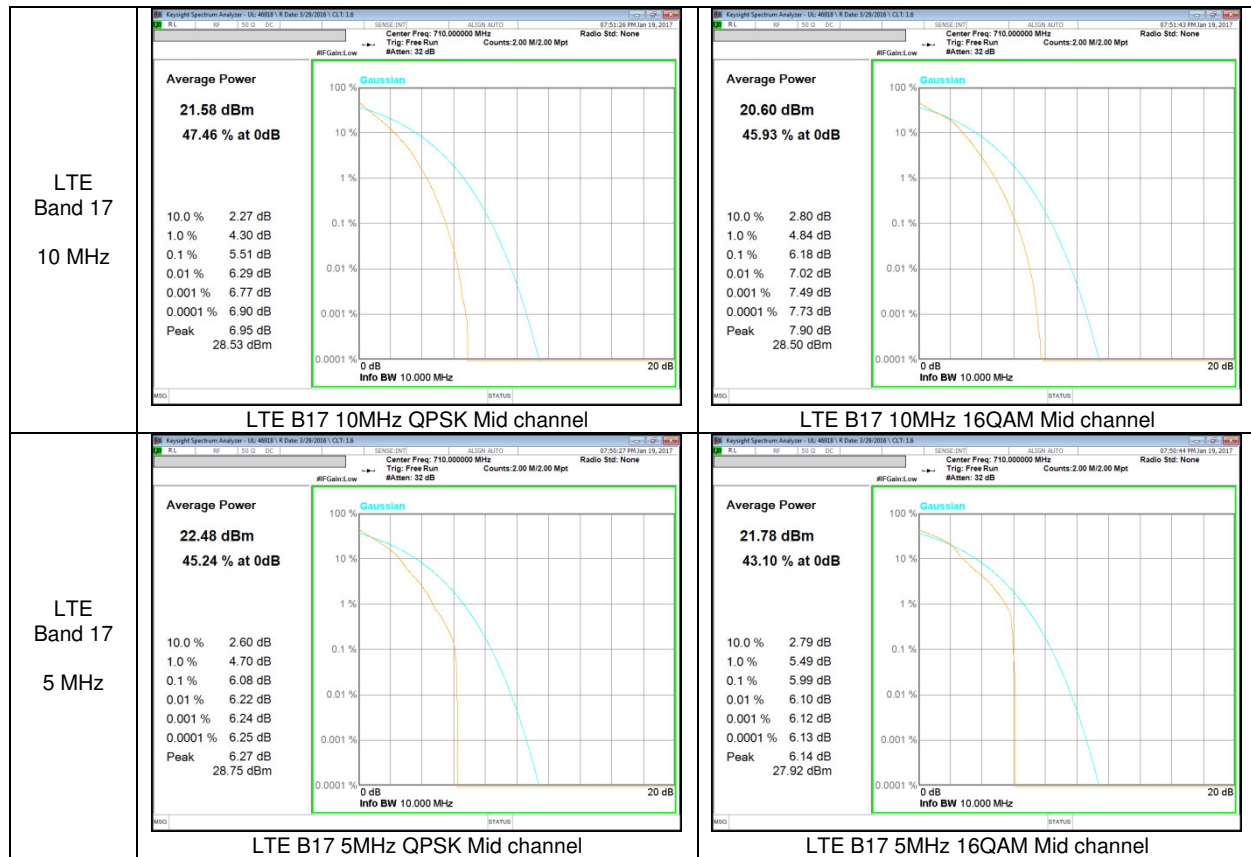

**LTE Band 5**

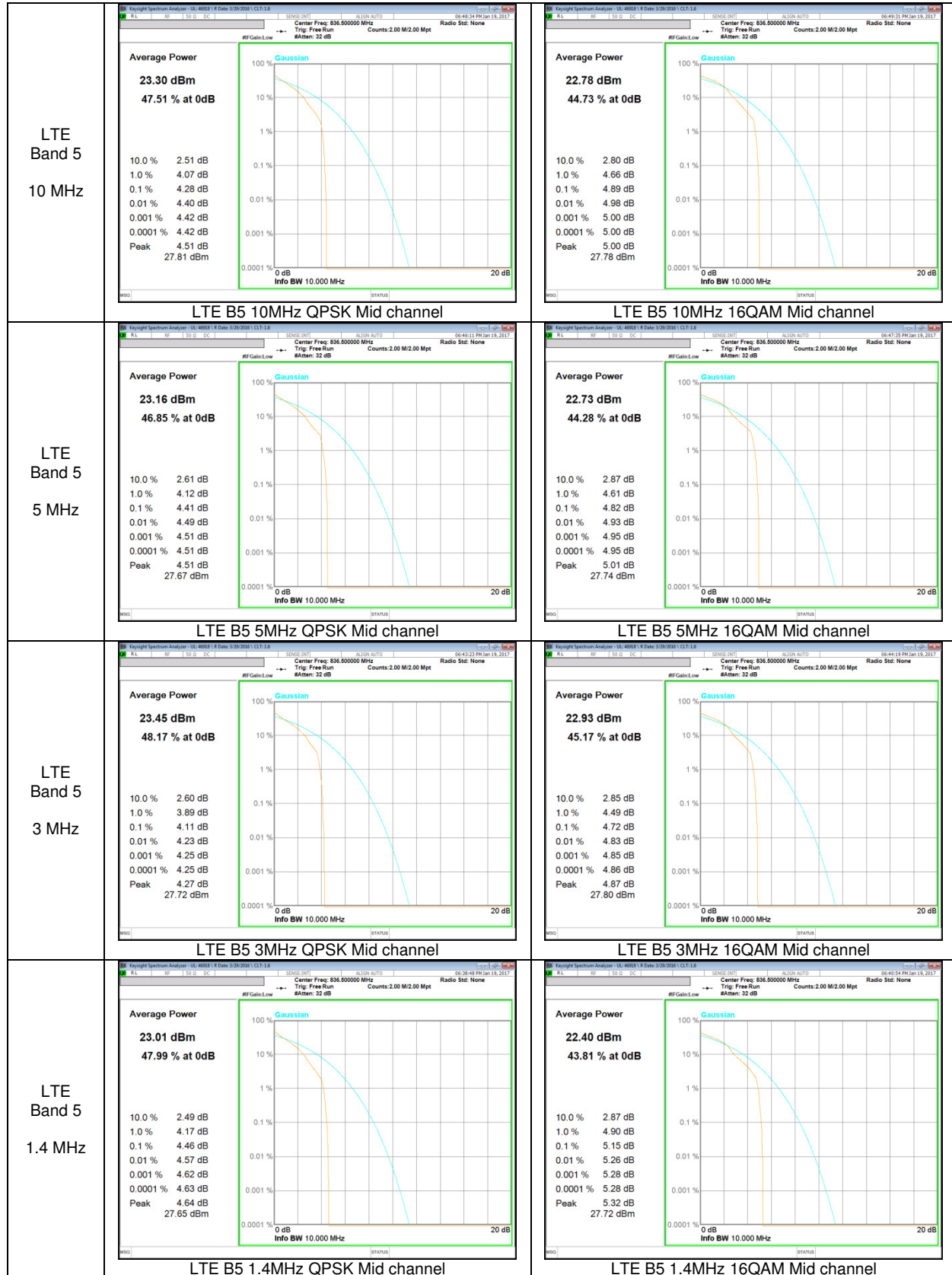

## 10. LIMITS AND CONDUCTED RESULTS

### 10.1. OCCUPIED BANDWIDTH

#### RULE PART(S)

FCC: §2.1049

#### LIMITS

For reporting purposes only

#### TEST PROCEDURE

The transmitter output was connected to a calibrated coaxial cable and coupler, the other end of which was connected to a spectrum analyzer. The occupied bandwidth was measured with the spectrum analyzer at the low, middle and high channel in each band. The -26dB bandwidth was also measured and recorded.

(KDB 971168 D01 Power Meas License Digital Systems v02r02)

**10.1.1. OCCUPIED BANDWIDTH RESULTS**

**WCDMA**

Band	Mode	Channel	f [MHz]	99% BW [MHz]	26dB BW [MHz]
Band 5	REL99	4132	826.4	4.0731	4.600
		4183	836.6	4.0604	4.597
		4233	846.6	4.0709	4.578
	HSDPA	4132	826.4	4.0706	4.586
		4183	836.6	4.0588	4.593
		4233	846.6	4.0626	4.580
Band 2	REL99	9262	1852.4	4.0594	4.609
		9400	1880.0	4.0699	4.616
		9538	1907.6	4.0566	4.599
	HSDPA	9262	1852.4	4.0518	4.587
		9400	1880.0	4.0678	4.602
		9538	1907.6	4.0673	4.564

**LTE Band 17**

Band	BW [MHz]	Channel	f [MHz]	Mode	99% BW [MHz]	26dB BW [MHz]
Band 17	10	23780	709.0	QPSK	8.9711	10.17
				16QAM	8.9686	10.19
		23790	710.0	QPSK	8.9698	10.10
				16QAM	8.9539	10.33
		23799	711.0	QPSK	8.9632	10.14
				16QAM	8.9829	10.21
	5	23755	706.5	QPSK	4.5060	5.028
				16QAM	4.4912	5.034
		23790	710.0	QPSK	4.4898	5.074
				16QAM	4.4875	5.055
		23824	713.5	QPSK	4.4766	5.000
				16QAM	4.4802	5.025

**LTE Band 5**

Band	BW [MHz]	Channel	f [MHz]	Mode	99% BW [MHz]	26dB BW [MHz]
Band 5	10	20450	829.0	QPSK	8.9692	10.21
				16QAM	8.9772	10.02
		20524	836.5	QPSK	8.9718	10.20
				16QAM	8.9496	10.23
		20599	844.0	QPSK	8.9707	10.12
				16QAM	8.9969	10.17
	5	20425	826.5	QPSK	4.5012	5.078
				16QAM	4.4911	5.068
		20524	836.5	QPSK	4.5023	5.038
				16QAM	4.4849	5.058
		20624	846.5	QPSK	4.4936	5.076
				16QAM	4.4891	5.021
	3	20415	825.5	QPSK	2.6818	2.958
				16QAM	2.6831	2.954
		20524	836.5	QPSK	2.6785	2.991
				16QAM	2.6828	2.968
		20634	847.5	QPSK	2.6848	2.978
				16QAM	2.6861	2.960
	1.4	20407	824.7	QPSK	1.0815	1.268
				16QAM	1.0843	1.304
		20524	836.5	QPSK	1.0836	1.286
				16QAM	1.0903	1.305
		20624	848.3	QPSK	1.0860	1.298
				16QAM	1.0837	1.306

## 10.1.2. OCCUPIED BANDWIDTH PLOTS

### WCDMA Band 5

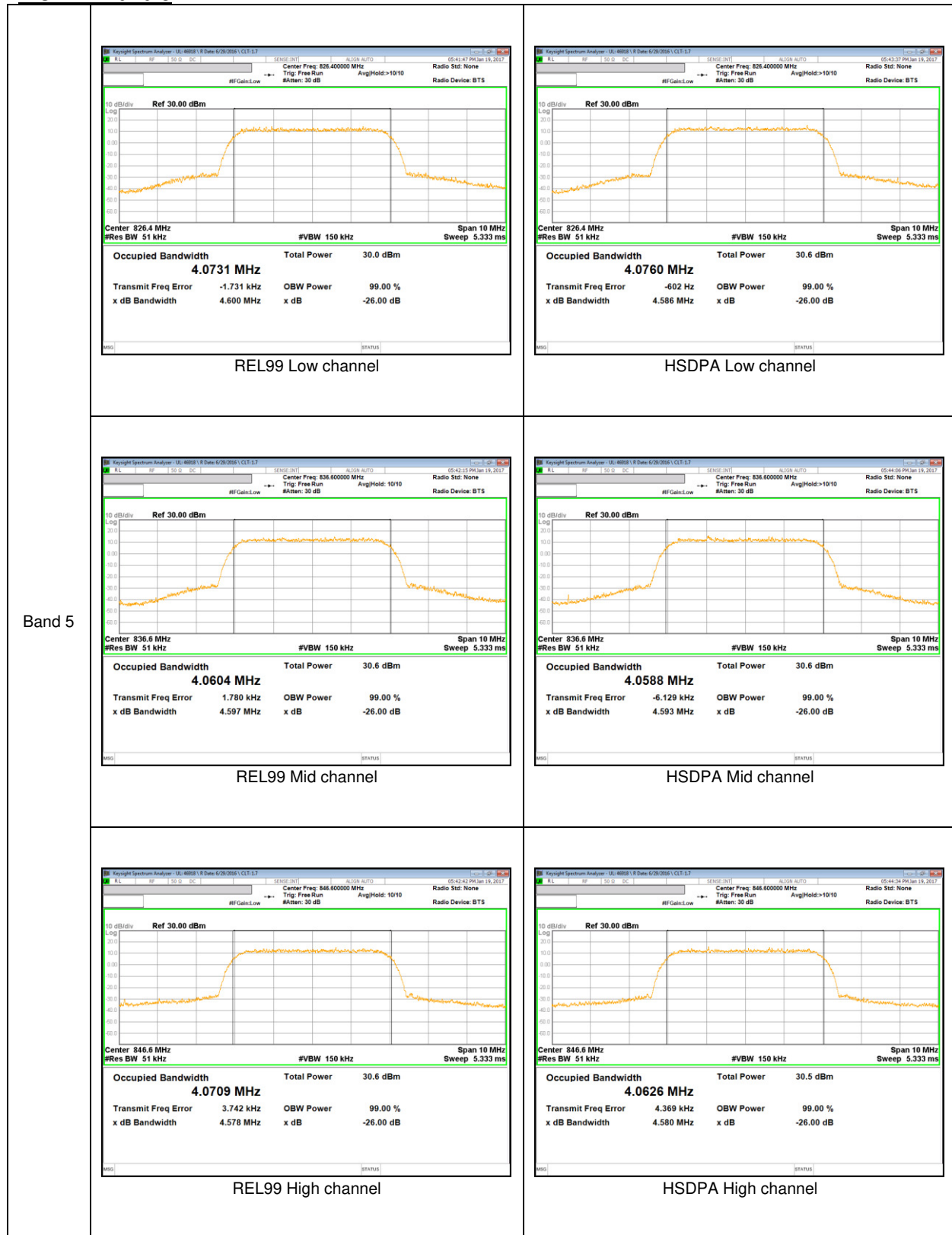

**WCDMA Band 2**

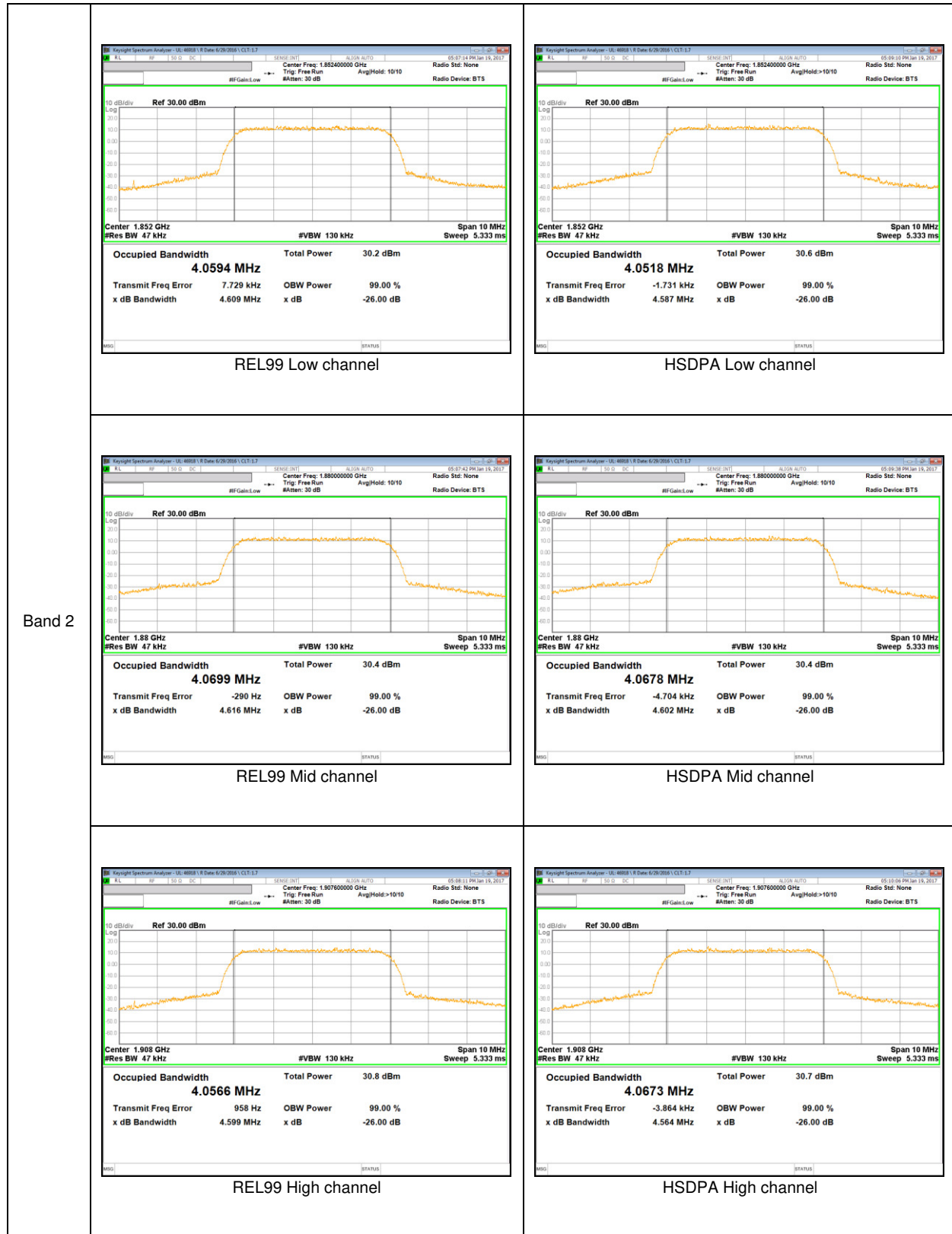

**LTE Band 17**

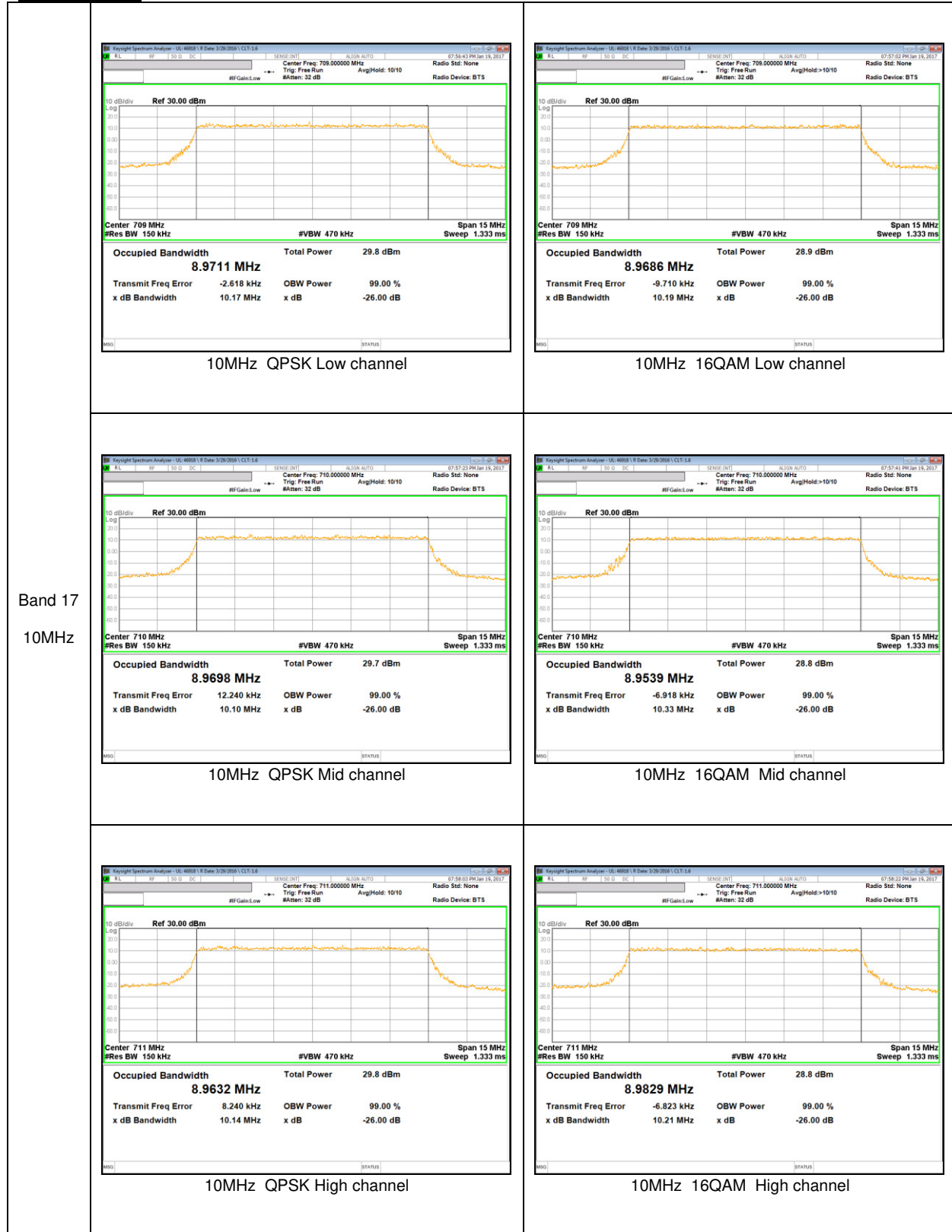

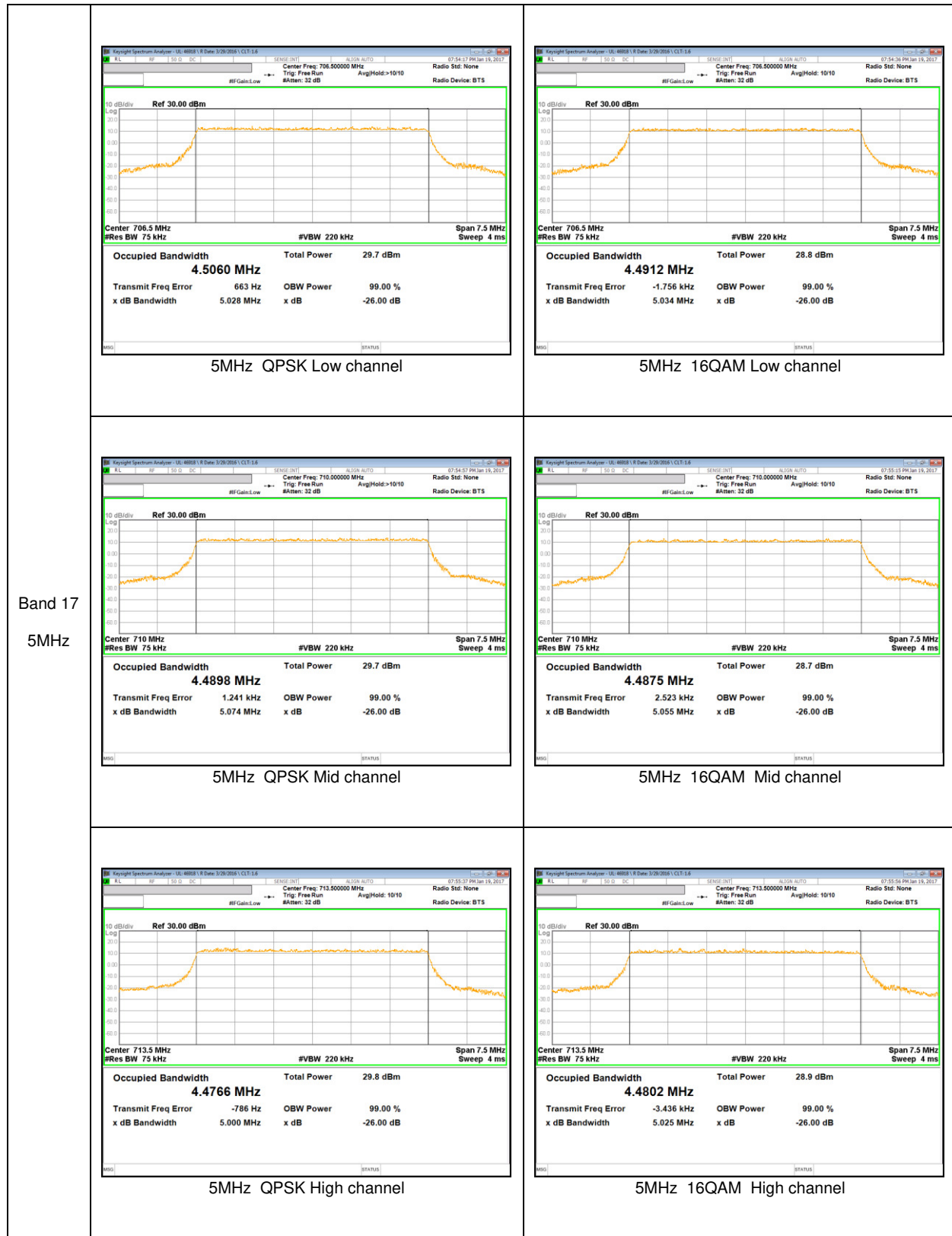

**LTE Band 5**

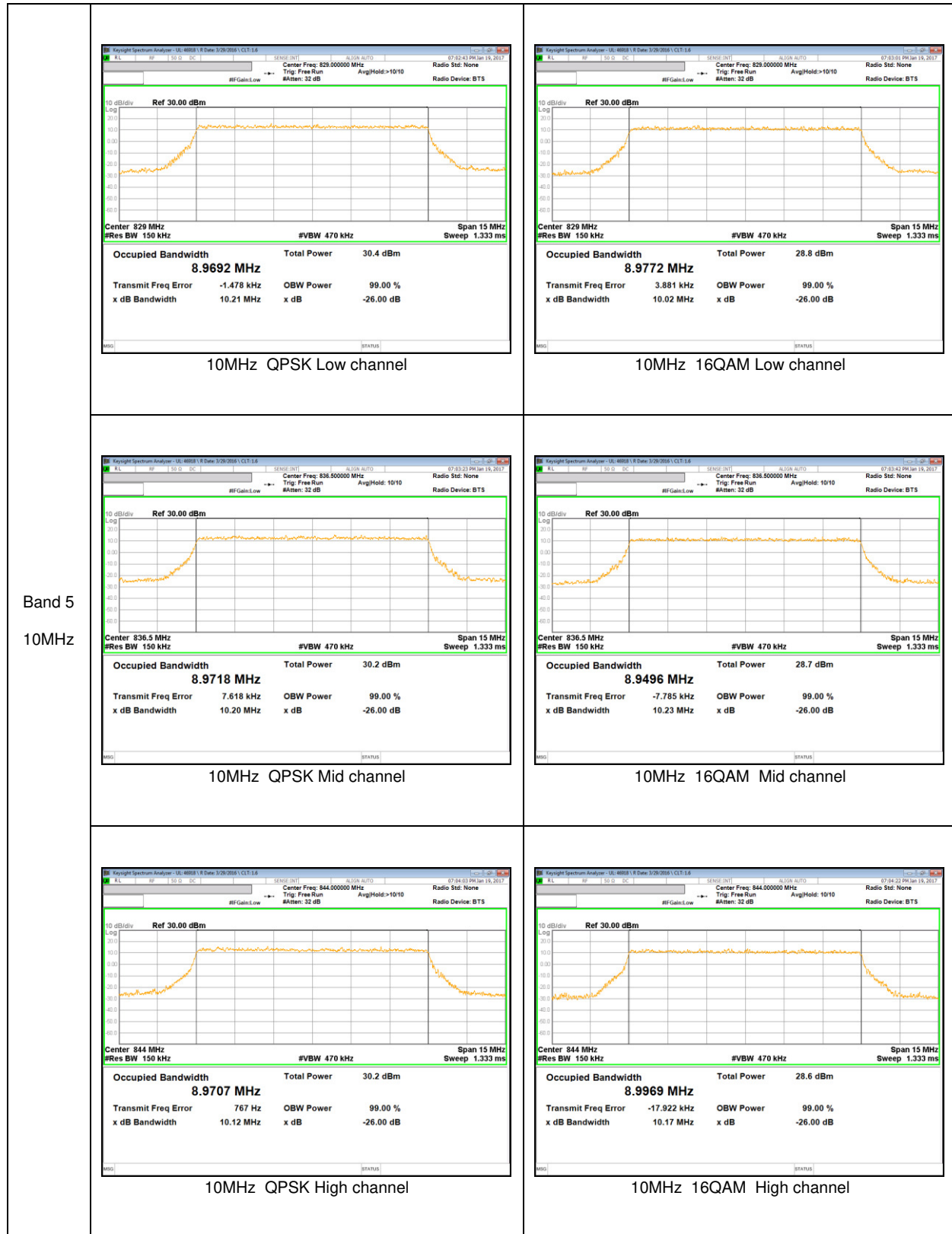

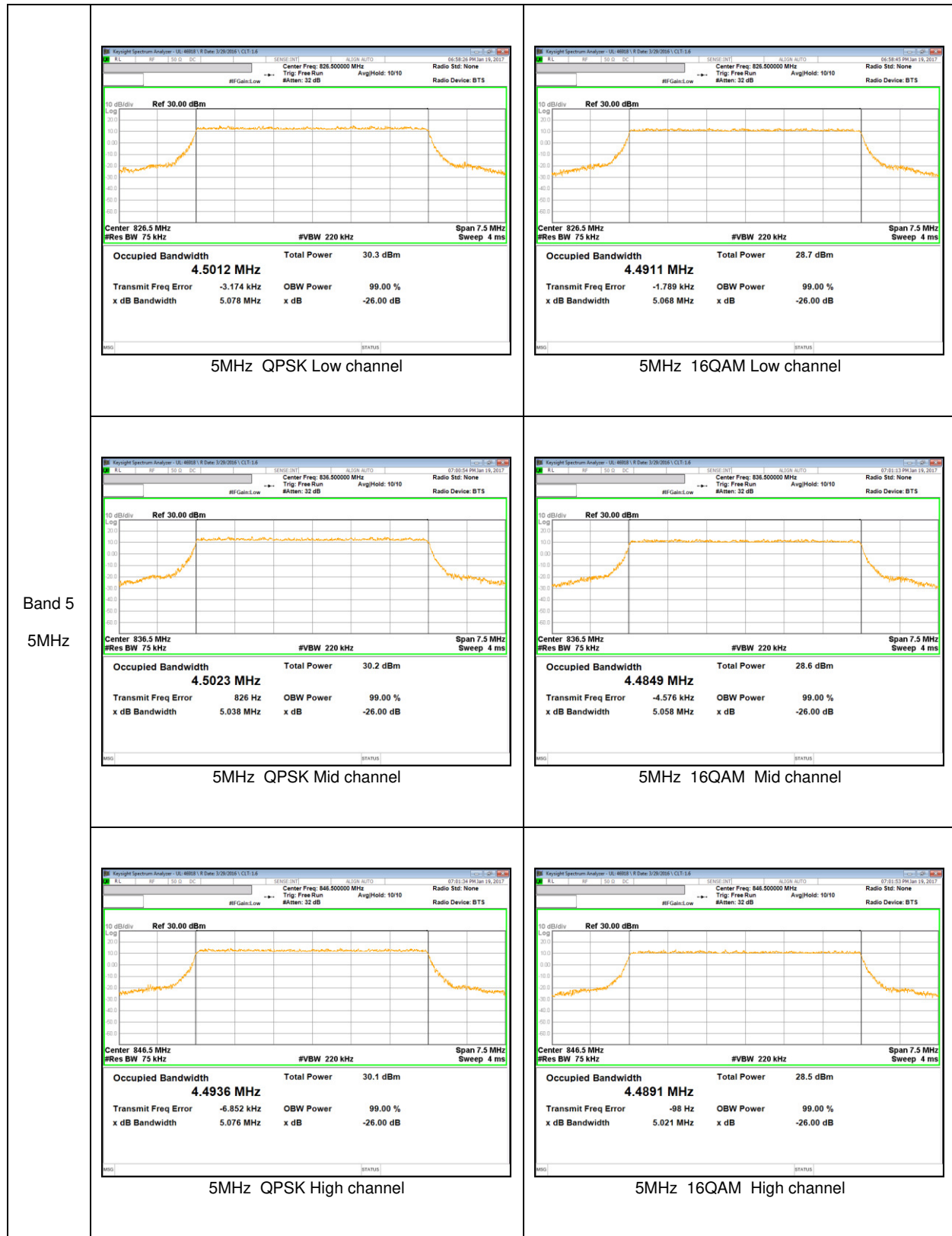

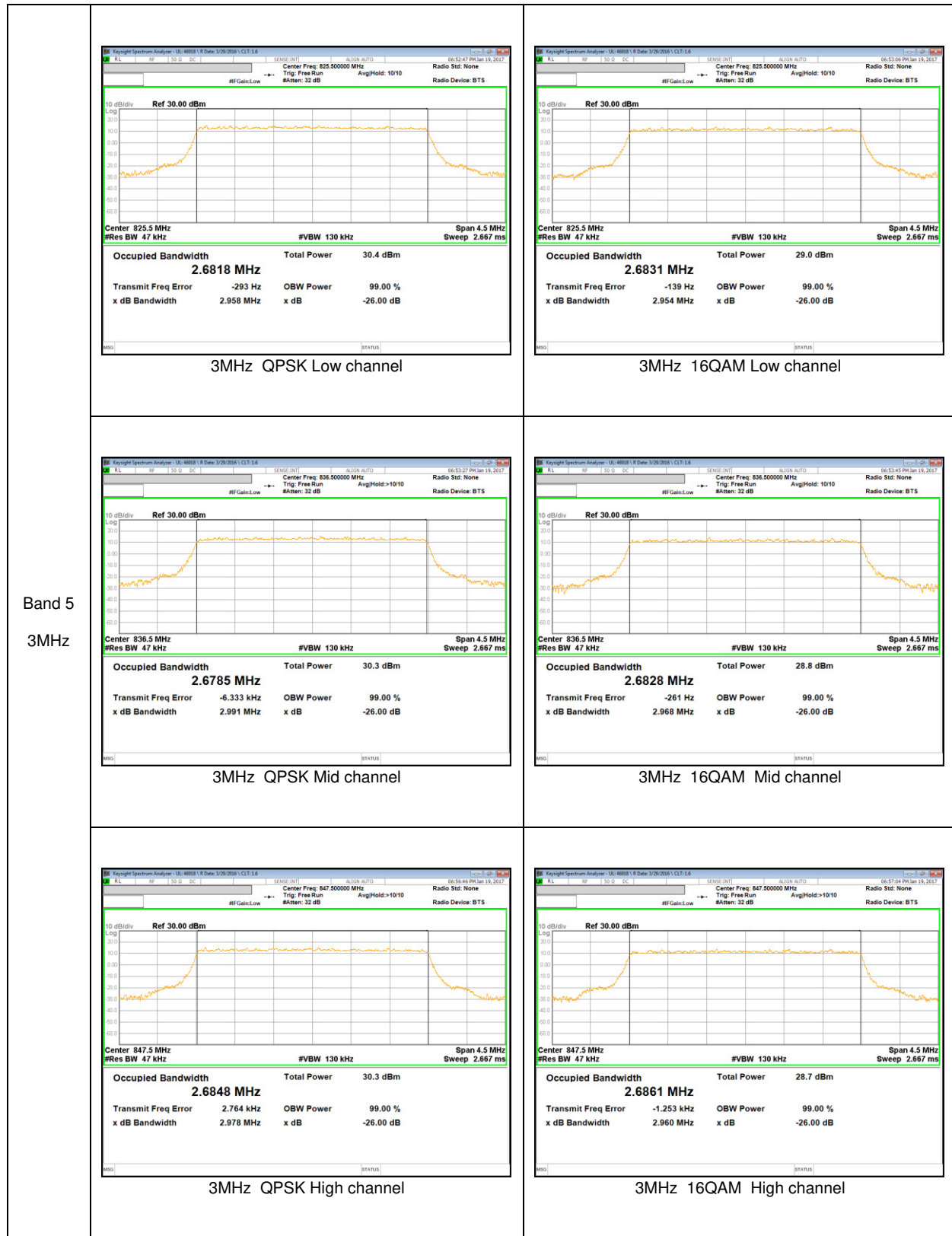

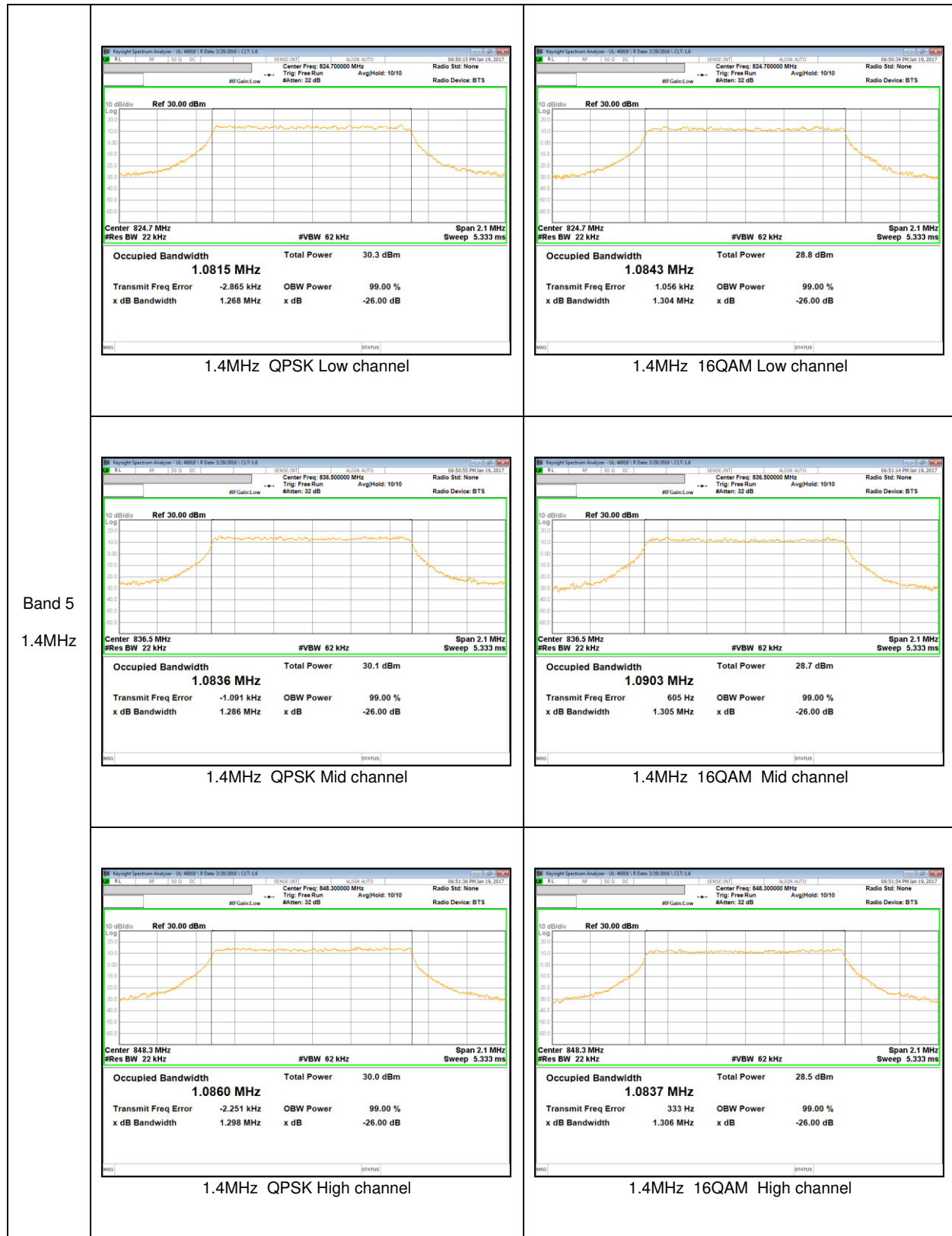

## 10.2. BAND EDGE EMISSIONS

### RULE PART(S)

FCC: §22.359, §24.238 and §27. 53

### LIMITS

The power of any emission outside of the authorized operating frequency ranges must be attenuated below the transmitting power (P) by a factor of at least  $43 + 10 \log (P)$  dB.

### TEST PROCEDURE

Per KDB 971168 D01 Power Meas License Digital Systems v02r02

The transmitter output was connected to a CMW500 Test Set and configured to operate at maximum power. The band edge emissions were measured at the required operating frequencies in each band on the Spectrum Analyzer.

### WCDMA/LTE

- a) Set the RBW = 1 ~ 1.5 % of OBW(Typically limited to a minimum RBW of 1% of the OBW)
- b) Set VBW  $\geq 3 \times$  RBW;
- c) Set span  $\geq 1.5$  times the OBW;
- d) Sweep time = Auto;
- e) Detector = RMS;
- f) Ensure that the number of measurement points  $\geq 2 \times$  Span/RBW;
- g) Trace mode = Average (100);

### RESULTS

#### WCDMA

Band	Mode	Side	f [MHz]	Level [dBm]	Limit [dBm]
Band 5	REL99	Lower	824	-30.565	-13.00
		Upper	849	-32.787	
	HSDPA	Lower	824	-30.216	
		Upper	849	-32.481	
Band 2	REL99	Lower	1850	-29.562	
		Upper	1910	-33.655	
	HSDPA	Lower	1850	-29.883	
		Upper	1910	-31.427	

**LTE 17**

Bandwidth	Mode	Side	RB Status	f [MHz]	Level [dBm]	Limit [dBm]
10 MHz	QPSK	Lower	1RB	704.000	-17.588	-13.00
			FRB	704.000	-27.118	
		Upper	1RB	716.000	-15.951	
			FRB	716.000	-27.299	
	16QAM	Lower	1RB	704.000	-16.667	
			FRB	704.000	-29.160	
		Upper	1RB	716.000	-15.683	
			FRB	716.000	-28.603	
5 MHz	QPSK	Lower	1RB	704.000	-15.872	-13.00
			FRB	704.000	-27.974	
		Upper	1RB	716.000	-16.641	
			FRB	716.000	-28.380	
	16QAM	Lower	1RB	704.000	-16.852	
			FRB	704.000	-29.314	
		Upper	1RB	716.000	-17.221	
			FRB	716.000	-28.901	

**LTE 5**

Bandwidth	Mode	Side	RB Status	f [MHz]	Level [dBm]	Limit [dBm]
10 MHz	QPSK	Lower	1RB	824.000	-14.739	-13.00
			FRB	824.000	-28.195	
		Upper	1RB	849.000	-15.086	
			FRB	849.000	-28.380	
	16QAM	Lower	1RB	824.000	-15.973	
			FRB	824.000	-29.658	
		Upper	1RB	849.000	-15.490	
			FRB	849.000	-31.136	
5 MHz	QPSK	Lower	1RB	824.000	-14.447	-13.00
			FRB	824.000	-26.144	
		Upper	1RB	849.000	-14.117	
			FRB	849.000	-27.086	
	16QAM	Lower	1RB	824.000	-15.677	
			FRB	824.000	-26.246	
		Upper	1RB	849.000	-14.266	
			FRB	849.000	-29.014	
3 MHz	QPSK	Lower	1RB	824.000	-14.933	-13.00
			FRB	824.000	-26.142	
		Upper	1RB	849.000	-14.213	
			FRB	849.000	-27.286	
	16QAM	Lower	1RB	824.000	-14.445	
			FRB	824.000	-26.463	
		Upper	1RB	849.000	-15.508	
			FRB	849.000	-27.995	
1.4 MHz	QPSK	Lower	1RB	824.000	-18.738	-13.00
			FRB	824.000	-27.472	
		Upper	1RB	849.000	-18.125	
			FRB	849.000	-26.722	
	16QAM	Lower	1RB	824.000	-19.019	
			FRB	824.000	-27.612	
		Upper	1RB	849.000	-20.468	
			FRB	849.000	-29.527	

### 10.2.1. BAND EDGE PLOTS

#### WCDMA

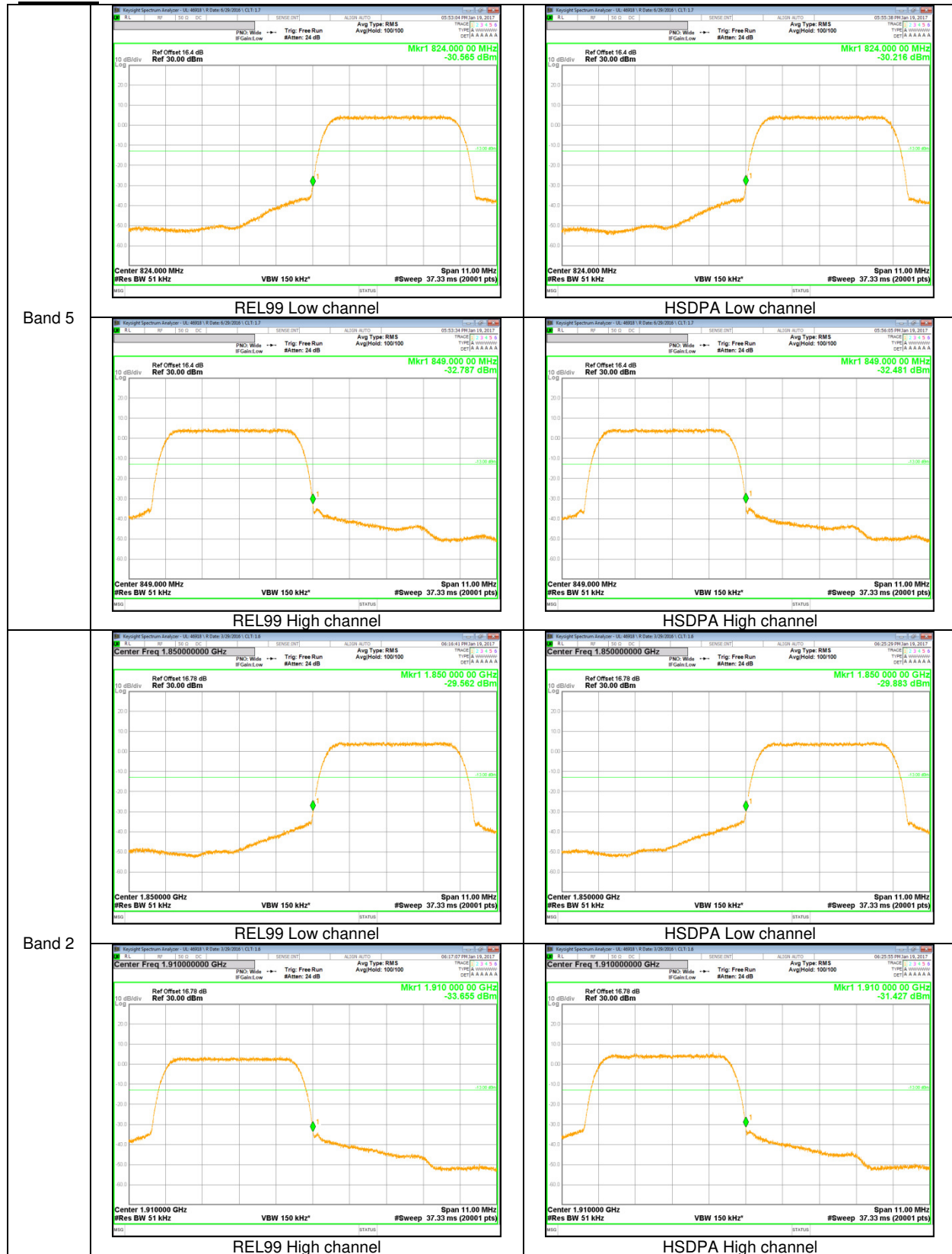

LTE Band 17

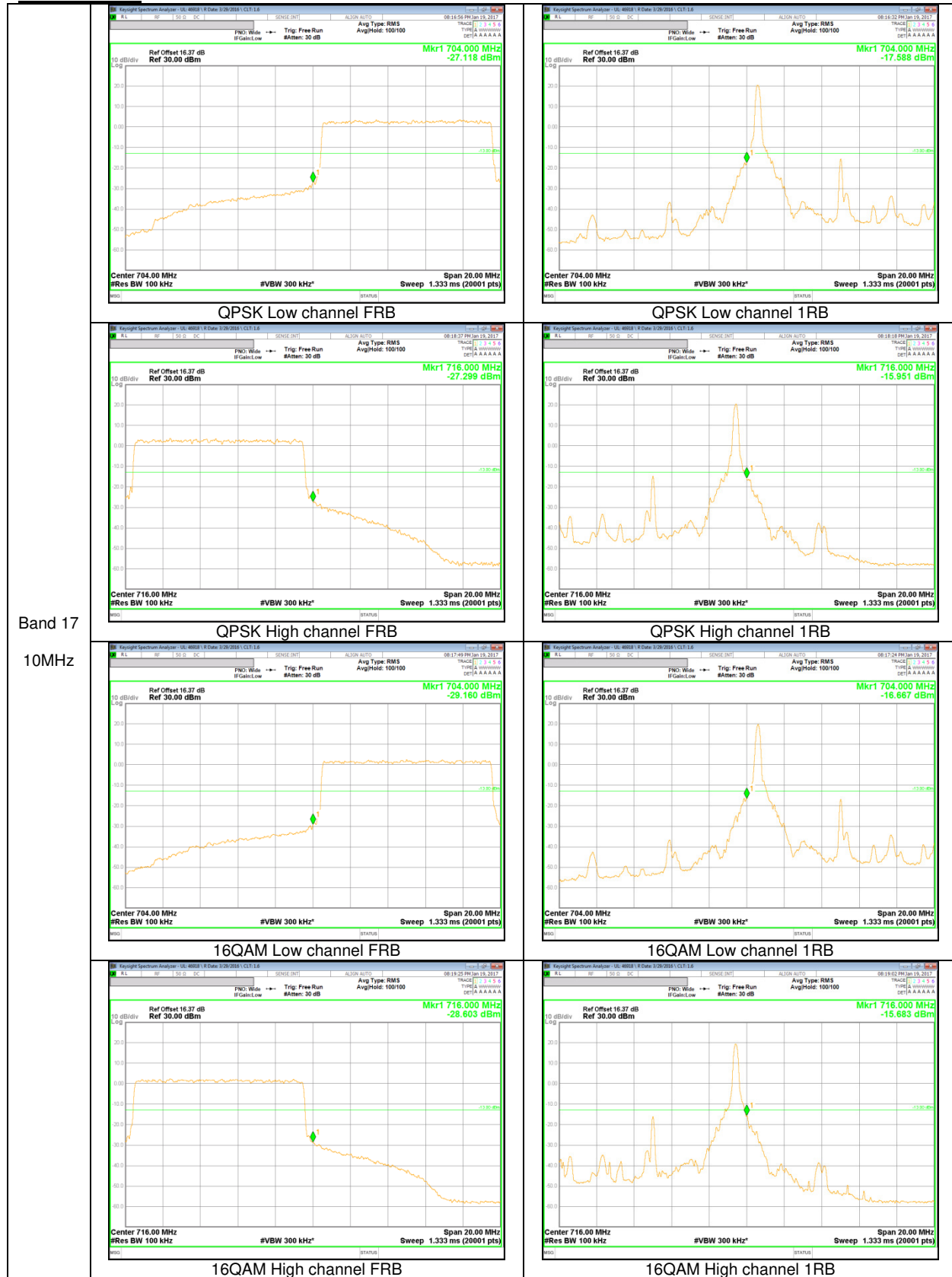

Band 17  
 10MHz

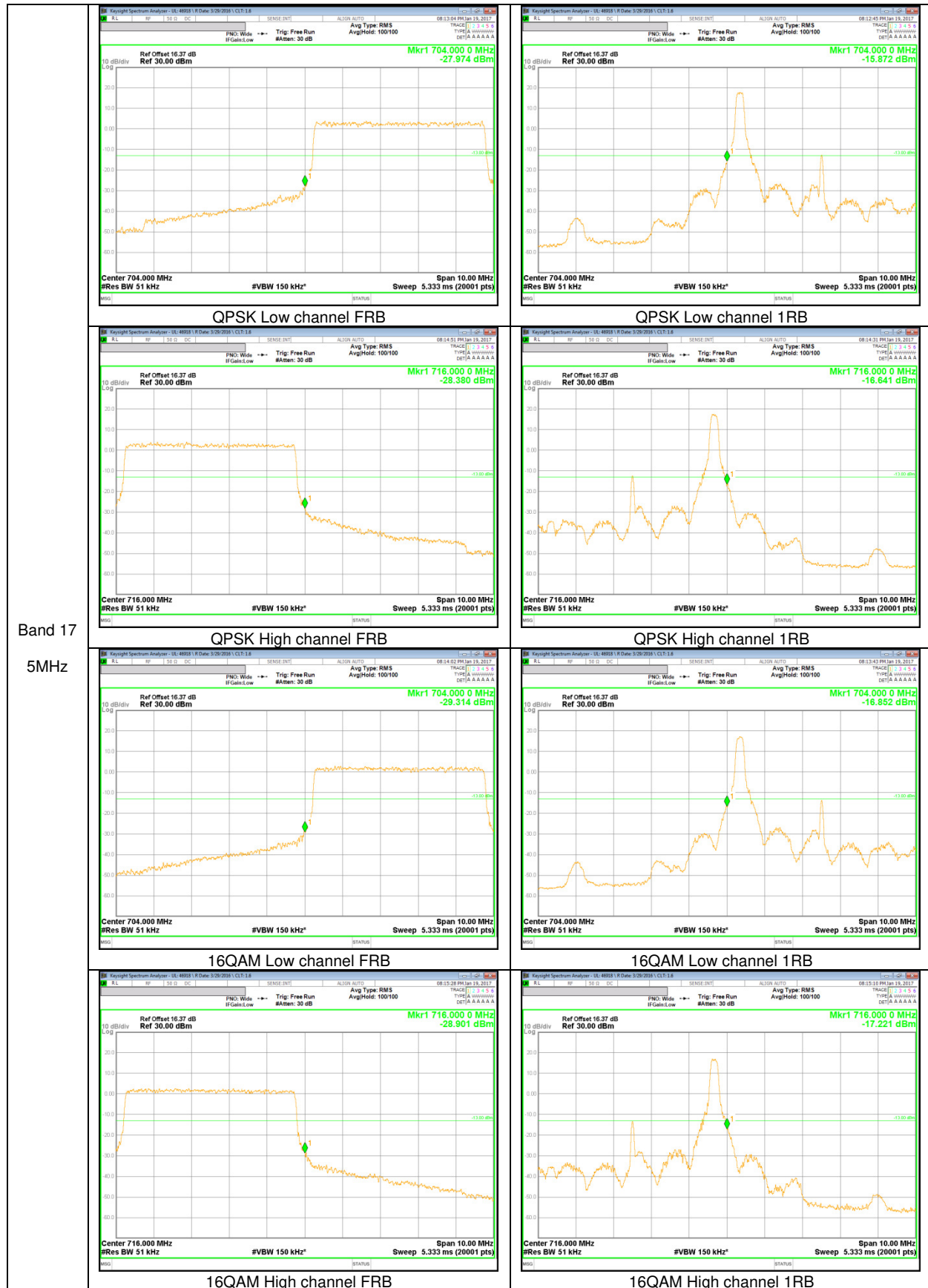

Band 17  
5MHz

LTE Band 5

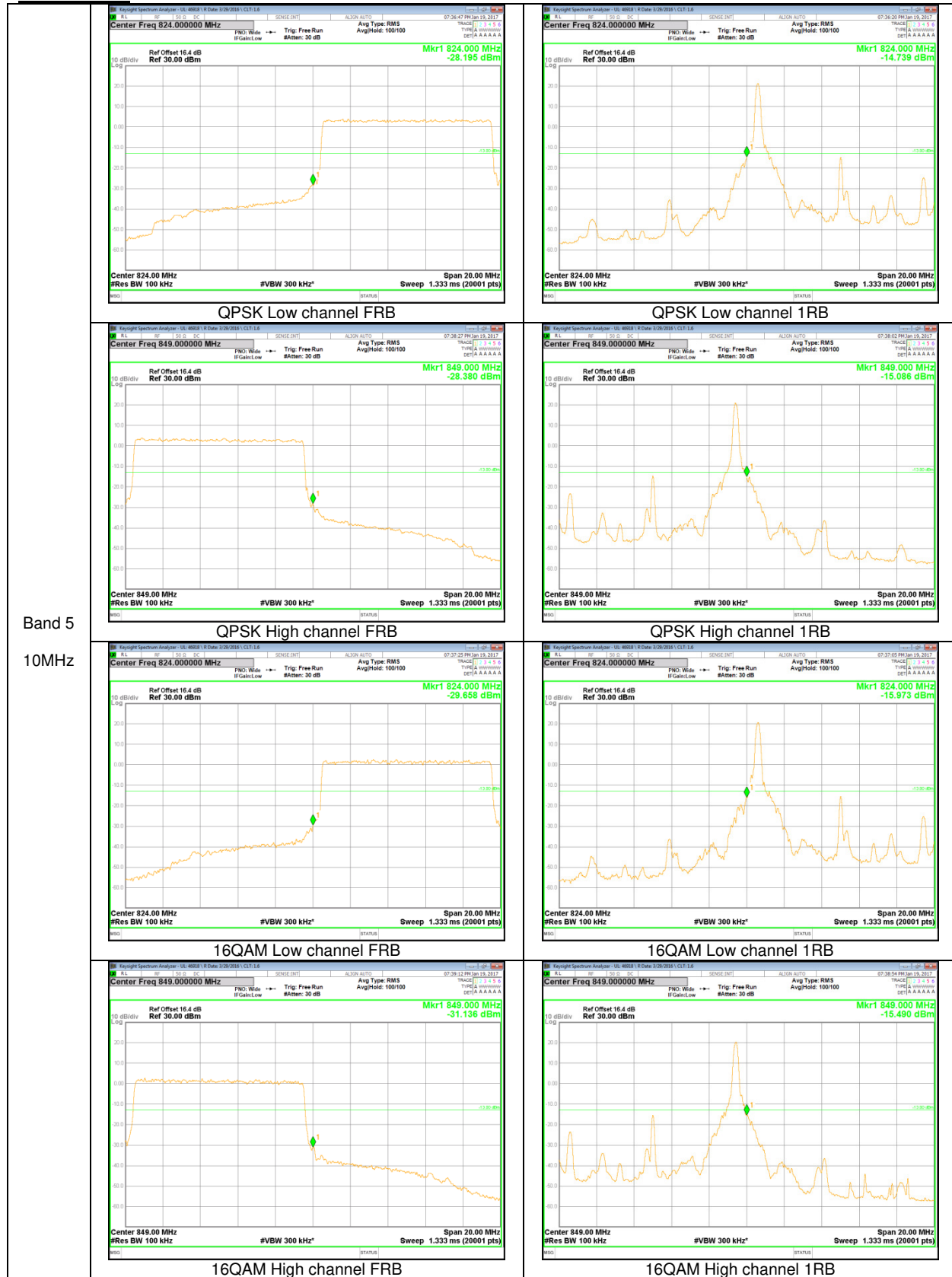

Band 5  
 10MHz