



**FCC 47 CFR PART 15 SUBPART E**

**UNII**

**CERTIFICATION TEST REPORT**

**FOR**

**WCDMA/LTE Tablet + BT/BLE and DTS/UNII a/b/g/n/ac**

**MODEL NUMBER : SM-W708Y**

**FCC ID: A3LSMW708Y**

**REPORT NUMBER: 16K22999-E4V1**

**ISSUE DATE: MAR 07, 2016**

*Prepared for*  
**SAMSUNG ELECTRONICS CO., LTD.**  
**129 SAMSUNG-RO, YEONGTONG-GU, SUWON-SI,**  
**GYEONGGI-DO, 443-742, KOREA**

*Prepared by*  
**UL Korea, Ltd. Suwon Laboratory**  
**218 Maeyeong-ro, Yeongtong-gu,**  
**Suwon-si, Gyeonggi-do, 443-823, Korea**  
**TEL: (031) 337-9902**  
**FAX: (031) 213-5433**



---

Revision History

<u>Rev.</u>	<u>Issue Date</u>	<u>Revisions</u>	<u>Revised By</u>
V1	03/07/16	Initial issue	SungGil Park

## TABLE OF CONTENTS

<b>1. ATTESTATION OF TEST RESULTS</b> .....	<b>5</b>
<b>2. TEST METHODOLOGY</b> .....	<b>6</b>
<b>3. FACILITIES AND ACCREDITATION</b> .....	<b>6</b>
<b>4. CALIBRATION AND UNCERTAINTY</b> .....	<b>6</b>
4.1. <i>MEASURING INSTRUMENT CALIBRATION</i> .....	6
4.2. <i>SAMPLE CALCULATION</i> .....	6
4.3. <i>MEASUREMENT UNCERTAINTY</i> .....	7
<b>5. EQUIPMENT UNDER TEST</b> .....	<b>8</b>
5.1. <i>DESCRIPTION OF EUT</i> .....	8
5.2. <i>MAXIMUM OUTPUT POWER</i> .....	9
5.3. <i>DESCRIPTION OF AVAILABLE ANTENNAS</i> .....	10
5.4. <i>List of test reduction and modes covering other modes:</i> .....	10
5.5. <i>WORST-CASE CONFIGURATION AND MODE</i> .....	12
5.6. <i>DESCRIPTION OF TEST SETUP</i> .....	13
<b>6. TEST AND MEASUREMENT EQUIPMENT</b> .....	<b>15</b>
<b>7. SUMMARY TABLE</b> .....	<b>16</b>
<b>8. ON TIME, DUTY CYCLE AND MEASUREMENT METHODS</b> .....	<b>17</b>
8.1. <i>ON TIME AND DUTY CYCLE RESULTS</i> .....	17
<b>9. MEASUREMENT METHOD</b> .....	<b>18</b>
<b>10. ANTENNA PORT TEST RESULTS</b> .....	<b>19</b>
10.1. <i>6 dB BANDWIDTH</i> .....	19
10.2. <i>26 dB BANDWIDTH</i> .....	19
10.3. <i>99% BANDWIDTH</i> .....	19
10.4. <i>OUTPUT POWER AND PPSD</i> .....	20
<b>11. TRANSMITTER ABOVE 1 GHz</b> .....	<b>21</b>
11.1. <i>5.2 GHz</i> .....	22
11.2. <i>5.3 GHz</i> .....	22
11.3. <i>5.5-5.6 GHz</i> .....	22
11.4. <i>5.8 GHz</i> .....	22

**12. WORST-CASE BELOW 1 GHz (in the 5.3 GHz Band) ..... 22**

**13. AC POWER LINE CONDUCTED EMISSIONS..... 23**

**14. DYNAMIC FREQUENCY SELECTION ..... 24**

    14.1. OVERVIEW ..... 24

        14.1.1. LIMITS..... 24

        14.1.1. TEST AND MEASUREMENT SYSTEM..... 28

        14.1.2. SETUP OF EUT ..... 31

        14.1.3. DESCRIPTION OF EUT ..... 32

    14.2. RESULTS FOR 20 MHz BANDWIDTH..... 33

        14.2.1. TEST CHANNEL..... 33

        14.2.2. RADAR WAVEFORM AND TRAFFIC..... 33

        14.2.3. OVERLAPPING CHANNEL TESTS ..... 33

        14.2.4. MOVE AND CLOSING TIME..... 33

    14.3. RESULTS FOR 40 MHz BANDWIDTH..... 34

        14.3.1. TEST CHANNEL..... 34

        14.3.2. RADAR WAVEFORM AND TRAFFIC..... 34

        14.3.3. OVERLAPPING CHANNEL TESTS ..... 34

        14.3.4. MOVE AND CLOSING TIME..... 34

    14.4. RESULTS FOR 80 MHz BANDWIDTH..... 35

        14.4.1. TEST CHANNEL..... 35

        14.4.2. RADAR WAVEFORM AND TRAFFIC..... 35

        14.4.3. OVERLAPPING CHANNEL TESTS ..... 35

        14.4.4. MOVE AND CLOSING TIME..... 35

**15. SETUP PHOTOS ..... 36**

# 1. ATTESTATION OF TEST RESULTS

**COMPANY NAME:** SAMSUNG ELECTRONICS CO., LTD.  
**EUT DESCRIPTION:** WCDMA/LTE Tablet + BT/BLE and DTS/UNII a/b/g/n/ac  
**MODEL NUMBER:** SM-W708Y  
**SERIAL NUMBER:** 8JA3R32GB000LST, 8JA3R32GB000MZ (RADIATED);  
123490EN400015 (CONDUCTED)  
**DATE TESTED:** FEB 27, 2016 - MAR 07, 2016

APPLICABLE STANDARDS	
STANDARD	TEST RESULTS
CFR 47 Part 15 Subpart E	Pass

UL Korea, Ltd. tested the above equipment in accordance with the requirements set forth in the above standards. All indications of Pass/Fail in this report are opinions expressed by UL Korea, Ltd. based on interpretations and/or observations of test results. Measurement Uncertainties were not taken into account and are published for informational purposes only. The test results show that the equipment tested is capable of demonstrating compliance with the requirements as documented in this report.

**Note:** The results documented in this report apply only to the tested sample, under the conditions and modes of operation as described herein. This document may not be altered or revised in any way unless done so by UL Korea, Ltd. and all revisions are duly noted in the revisions section. Any alteration of this document not carried out by UL Korea, Ltd. will constitute fraud and shall nullify the document. This report must not be used by the client to claim product certification, approval, or endorsement by IAS, any agency of the Federal Government, or any agency of any government.

Approved & Released For  
UL Korea, Ltd. By:



CY Choi  
Suwon Lab Engineer  
UL Korea, Ltd.

Tested By:



SungGil Park  
Suwon Lab Engineer  
UL Korea, Ltd.

## 2. TEST METHODOLOGY

The tests documented in this report were performed in accordance with FCC CFR 47 Part 2, FCC CFR 47 Part 15, FCC 06-96, FCC KDB 789033 D02 v01r01, ANSI C63.10-2009.

## 3. FACILITIES AND ACCREDITATION

The test sites and measurement facilities used to collect data are located at 218 Maeyeong-ro, Yeongtong-gu, Suwon-si, Gyeonggi-do, 443-823, Korea. Line conducted emissions are measured only at the 218 address. The following table identifies which facilities were utilized for radiated emission measurements documented in this report. Specific facilities are also identified in the test results sections.

218 Maeyeong-ro
<input checked="" type="checkbox"/> Chamber 1
<input checked="" type="checkbox"/> Chamber 2

UL Korea, Ltd. is accredited by IAS, Laboratory Code TL-637. The full scope of accreditation can be viewed at <http://www.iasonline.org/PDF/TL/TL-637.pdf>.

## 4. CALIBRATION AND UNCERTAINTY

### 4.1. MEASURING INSTRUMENT CALIBRATION

The measuring equipment utilized to perform the tests documented in this report has been calibrated in accordance with the manufacturer's recommendations, and is traceable to recognized national standards.

### 4.2. SAMPLE CALCULATION

Where relevant, the following sample calculation is provided:

$$\begin{aligned} \text{Field Strength (dBuV/m)} &= \text{Measured Voltage (dBuV)} + \text{Antenna Factor (dB/m)} + \\ &\text{Cable Loss (dB)} - \text{Preamp Gain (dB)} \\ 36.5 \text{ dBuV} + 18.7 \text{ dB/m} + 0.6 \text{ dB} - 26.9 \text{ dB} &= 28.9 \text{ dBuV/m} \end{aligned}$$

### 4.3. MEASUREMENT UNCERTAINTY

Where relevant, the following measurement uncertainty levels have been estimated for tests performed on the apparatus:

PARAMETER	UNCERTAINTY
Conducted Disturbance, 0.15 to 30 MHz	2.32 dB
Radiated Disturbance, Below 1GHz	4.14 dB
Radiated Disturbance, Above 1 GHz	5.97 dB

Uncertainty figures are valid to a confidence level of 95%.

## 5. EQUIPMENT UNDER TEST

### 5.1. DESCRIPTION OF EUT

The EUT is a WCDMA/LTE Tablet + BT/BLE and DTS/UNII a/b/g/n/ac.  
This test report addresses the NII (UNII) operational mode.

WiFi MIMO Condition

Frequency	Mode	Antenna 1	Antenna 2
2.4 GHz	802.11b	TX / RX	TX / RX
	802.11g	TX / RX	TX / RX
	802.11n	TX / RX	TX / RX
	802.11n MIMO	TX / RX	TX / RX
5 GHz	802.11a	TX / RX	TX / RX
	802.11n	TX / RX	TX / RX
	802.11ac	TX / RX	TX / RX
	802.11n/ac MIMO	TX / RX	TX / RX

## 5.2. MAXIMUM OUTPUT POWER

The transmitter has a maximum total conducted average output power as follows:

Frequency Range [MHz]	Mode	Output Power [dBm]		Output Power [mW]	
		Antenna1	Antenna2	Antenna1	Antenna2
5180 - 5240	802.11a SISO	12.95	12.65	19.74	18.40
	802.11a MIMO	15.81		38.14	
	802.11n HT20 SISO	13.15	13.24	20.64	21.10
	802.11n HT20 MIMO	16.21		41.74	
5190 - 5230	802.11n HT40 SISO	11.40	11.45	13.79	13.95
	802.11n HT40 MIMO	14.43		27.74	
5210	802.11ac VHT80 SISO	10.11	9.80	10.25	9.55
	802.11ac VHT80 MIMO	12.97		19.80	
5260 - 5320	802.11a SISO	13.27	12.69	21.25	18.56
	802.11a MIMO	16.00		39.81	
	802.11n HT20 SISO	13.14	13.41	20.59	21.92
	802.11n HT20 MIMO	16.29		42.51	
5270 - 5310	802.11n HT40 SISO	10.52	11.02	11.28	12.64
	802.11n HT40 MIMO	13.79		23.92	
5290	802.11ac VHT80 SISO	10.33	9.69	10.79	9.30
	802.11ac VHT80 MIMO	13.03		20.09	
5500 - 5720	802.11a SISO	12.78	12.97	18.96	19.83
	802.11a MIMO	15.89		38.79	
	802.11n HT20 SISO	13.33	12.76	21.52	18.89
	802.11n HT20 MIMO	16.07		40.42	
5510 - 5710	802.11n HT40 SISO	11.40	11.39	13.80	13.77
	802.11n HT40 MIMO	14.40		27.57	
5530 - 5690	802.11ac VHT80 SISO	9.77	10.07	9.48	10.16
	802.11ac VHT80 MIMO	12.93		19.63	
5745 - 5825	802.11a SISO	12.85	12.94	19.25	19.67
	802.11a MIMO	15.90		38.92	
	802.11n HT20 SISO	12.86	13.00	19.32	19.93
	802.11n HT20 MIMO	15.94		39.26	
5755 - 5795	802.11n HT40 SISO	11.38	11.46	13.75	13.98
	802.11n HT40 MIMO	14.43		27.73	
5775	802.11ac VHT80 SISO	10.02	10.47	10.04	11.15
	802.11ac VHT80 MIMO	13.26		21.19	

### 5.3. DESCRIPTION OF AVAILABLE ANTENNAS

The radio utilizes an FPCB antenna, with a maximum gain of:

Frequency Range [MHz]	Antenna Gain [dBi]	
	Antenna 1	Antenna 2
UNII 1 5150 – 5250	0.13	-4.65
UNII 2A 5250 – 5350	-1.23	-2.95
UNII 2C 5470 – 5725	-0.07	-4.45
UNII 3 5725 – 5850	-1.05	--1.94

### 5.4. List of test reduction and modes covering other modes:

The output power on covered modes is equal to or less than one referenced.

#### UNII 1

5150 - 5250 MHz Authorized Frequency Band (Antenna port & Radiated Testing)		
Frequency Range [MHz]	Mode	Covered by
5180 - 5240	802.11a legacy 1TX/STBC 2TX	802.11a 2TX CDD
5180 - 5240	802.11HT20 1TX	802.11n HT20 2TX CDD
5180 - 5240	802.11HT20 2TX STBC/SDM	802.11n HT20 2TX CDD
5180 - 5240	802.11ac VHT20 1TX	802.11n HT20 2TX CDD
5180 - 5240	802.11ac VHT20 2TX STBC/SDM	802.11n HT20 2TX CDD
5180 - 5240	802.11ac VHT20 2TX CDD/Tx BF	802.11n HT20 2TX CDD
5190 - 5230	802.11n HT40 1TX	802.11n HT40 2TX CDD
5190 - 5230	802.11n HT40 2TX STBC/SDM	802.11n HT40 2TX CDD
5190 - 5230	802.11ac VHT40 1TX	802.11n HT40 2TX CDD
5190 - 5230	802.11ac VHT40 2TX STBC/SDM	802.11n HT40 2TX CDD
5190 - 5230	802.11ac VHT40 2TX CDD/Tx BF	802.11n HT40 2TX CDD
5210	802.11ac VHT80 1TX	802.11ac VHT80 2TX CDD
5210	802.11ac VHT80 2TX STBC/SDM/Tx BF	802.11ac VHT80 2TX CDD

**UNII 2A**

<b>5250 - 5350 MHz Authorized Frequency Band (Antenna port &amp; Radiated Testing)</b>		
<b>Frequency Range [MHz]</b>	<b>Mode</b>	<b>Covered by</b>
5260 - 5320	802.11a legacy 1TX/STBC 2TX	802.11a 2TX CDD
5260 - 5320	802.11HT20 1TX	802.11n HT20 2TX CDD
5260 - 5320	802.11HT20 2TX STBC/SDM	802.11n HT20 2TX CDD
5260 - 5320	802.11ac VHT20 1TX	802.11n HT20 2TX CDD
5260 - 5320	802.11ac VHT20 2TX STBC/SDM	802.11n HT20 2TX CDD
5260 - 5320	802.11ac VHT20 2TX CDD/Tx BF	802.11n HT20 2TX CDD
5270 - 5310	802.11n HT40 1TX	802.11n HT40 2TX CDD
5270 - 5310	802.11n HT40 2TX STBC/SDM	802.11n HT40 2TX CDD
5270 - 5310	802.11ac VHT40 1TX	802.11n HT40 2TX CDD
5270 - 5310	802.11ac VHT40 2TX STBC/SDM	802.11n HT40 2TX CDD
5270 - 5310	802.11ac VHT40 2TX CDD/Tx BF	802.11n HT40 2TX CDD
5290	802.11ac VHT80 1TX	802.11ac VHT80 2TX CDD
5290	802.11ac VHT80 2TX STBC/SDM/Tx BF	802.11ac VHT80 2TX CDD

**UNII 2C**

<b>5470 - 5725 MHz Authorized Frequency Band (Antenna port &amp; Radiated Testing)</b>		
<b>Frequency Range [MHz]</b>	<b>Mode</b>	<b>Covered by</b>
5500 - 5720	802.11a legacy 1TX/STBC 2TX	802.11a 2TX CDD
5500 - 5720	802.11HT20 1TX	802.11n HT20 2TX CDD
5500 - 5720	802.11HT20 2TX STBC/SDM	802.11n HT20 2TX CDD
5500 - 5720	802.11ac VHT20 1TX	802.11n HT20 2TX CDD
5500 - 5720	802.11ac VHT20 2TX STBC/SDM	802.11n HT20 2TX CDD
5500 - 5720	802.11ac VHT20 2TX CDD/Tx BF	802.11n HT20 2TX CDD
5510 - 5710	802.11n HT40 1TX	802.11n HT40 2TX CDD
5510 - 5710	802.11n HT40 2TX STBC/SDM	802.11n HT40 2TX CDD
5510 - 5710	802.11ac VHT40 1TX	802.11n HT40 2TX CDD
5510 - 5710	802.11ac VHT40 2TX STBC/SDM	802.11n HT40 2TX CDD
5510 - 5710	802.11ac VHT40 2TX CDD/Tx BF	802.11n HT40 2TX CDD
5530 - 5690	802.11ac VHT80 1TX	802.11ac VHT80 2TX CDD
5530 - 5690	802.11ac VHT80 2TX STBC/SDM/Tx BF	802.11ac VHT80 2TX CDD

**UNII 3**

<b>5725 - 5850 MHz Authorized Frequency Band (Antenna port &amp; Radiated Testing)</b>		
<b>Frequency Range [MHz]</b>	<b>Mode</b>	<b>Covered by</b>
5745 - 5825	802.11a legacy 1TX/STBC 2TX	802.11a 2TX CDD
5745 - 5825	802.11HT20 1TX	802.11n HT20 2TX CDD
5745 - 5825	802.11HT20 2TX STBC/SDM	802.11n HT20 2TX CDD
5745 - 5825	802.11ac VHT20 1TX	802.11n HT20 2TX CDD
5745 - 5825	802.11ac VHT20 2TX STBC/SDM	802.11n HT20 2TX CDD
5745 - 5825	802.11ac VHT20 2TX CDD/Tx BF	802.11n HT20 2TX CDD
5755 - 5795	802.11n HT40 1TX	802.11n HT40 2TX CDD
5755 - 5795	802.11n HT40 2TX STBC/SDM	802.11n HT40 2TX CDD
5755 - 5795	802.11ac VHT40 1TX	802.11n HT40 2TX CDD
5755 - 5795	802.11ac VHT40 2TX STBC/SDM	802.11n HT40 2TX CDD
5755 - 5795	802.11ac VHT40 2TX CDD/Tx BF	802.11n HT40 2TX CDD
5775	802.11ac VHT80 1TX	802.11ac VHT80 2TX CDD
5775	802.11ac VHT80 2TX STBC/SDM/Tx BF	802.11ac VHT80 2TX CDD

**5.5. WORST-CASE CONFIGURATION AND MODE**

Radiated emission and power line conducted emission were performed with the EUT set to transmit at the channel with highest output power as worst-case scenario.

The fundamental of the EUT was investigated in three orthogonal orientations X,Y,Z, it was determined that the X orientation was worst-case orientation; therefore, all final radiated testing was performed with the EUT in the X orientation.

Based on the baseline scan, the worst-case data rates were:

- 802.11a mode: 6 Mbps
- 802.11n HT20mode: MCS0
- 802.11n HT40mode: MCS0
- 802.11ac VHT80mode: MCS0

## 5.6. DESCRIPTION OF TEST SETUP

### SUPPORT EQUIPMENT

Support Equipment List				
Description	Manufacturer	Model	Serial Number	FCC ID
Charger	SAMSUNG	EP-TA300	R37GALZGRB1SE3	N/A
Data Cable	SAMSUNG	EP-DW700CWE	N/A	N/A
Earphone	SAMSUNG	EO-EG900BW	N/A	N/A

### I/O CABLES

I/O Cable List						
Cable No	Port	# of identical ports	Connector Type	Cable Type	Cable Length (m)	Remarks
1	DC Power	1	Mini-USB	Shielded	0.8m	N/A
2	Audio	1	Mini-Jack	Unshielded	1.0m	N/A

### TEST SETUP

The EUT is a stand-alone unit during the tests. Test software exercised the radio card.

**SETUP DIAGRAM FOR TESTS**

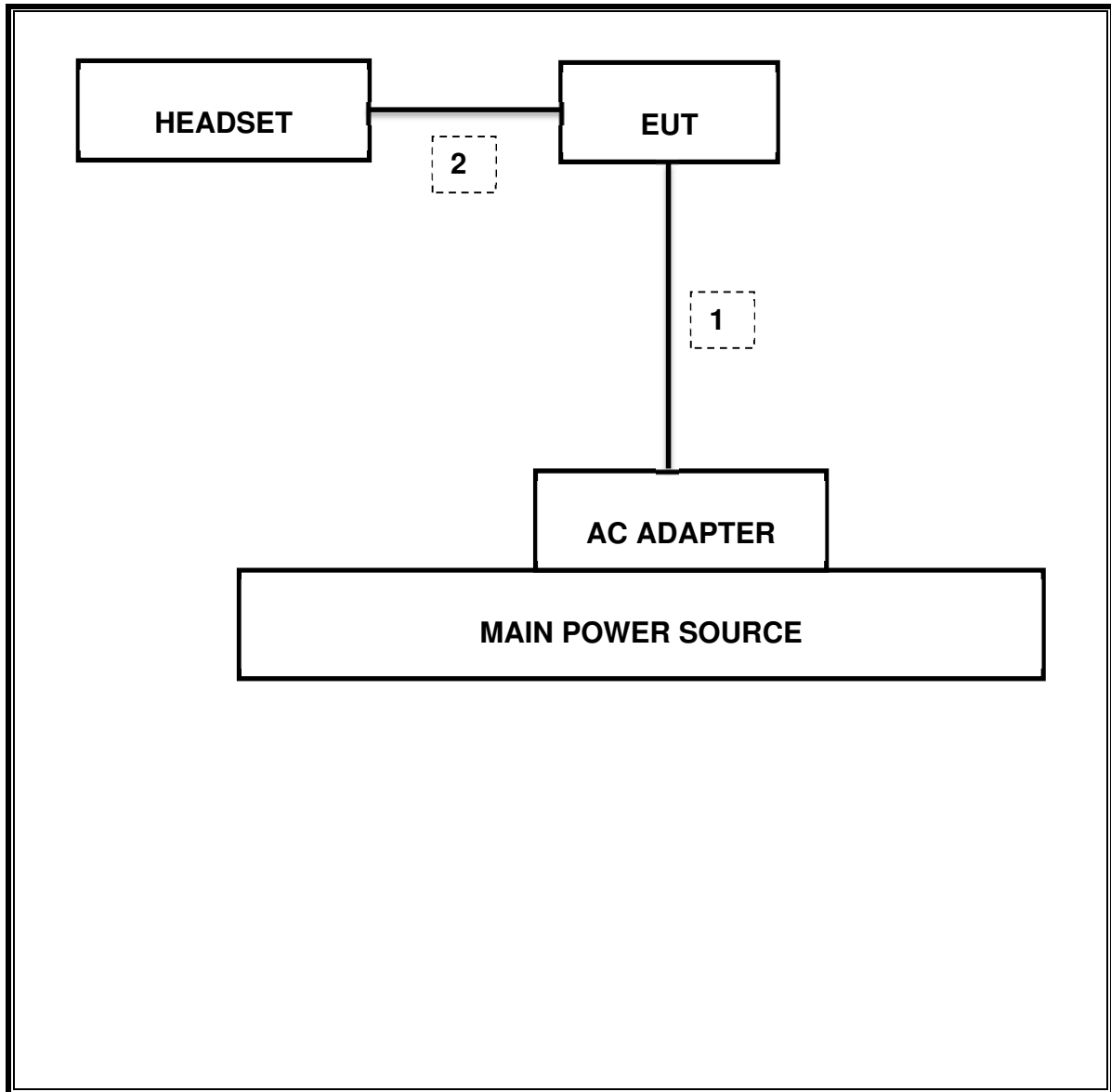

## 6. TEST AND MEASUREMENT EQUIPMENT

The following test and measurement equipment was utilized for the tests documented in this report:

Test Equipment List				
Description	Manufacturer	Model	S/N	Cal Due
Antenna, Bilog, 30MHz-1GHz	SCHWARZBECK	VULB9163	750	11-17-16
Antenna, Bilog, 30MHz-1GHz	SCHWARZBECK	VULB9163	749	04-25-17
Antenna, Horn, 18 GHz	ETS	3115	00167211	09-26-16
Antenna, Horn, 18 GHz	ETS	3115	00161451	05-17-17
Antenna, Horn, 18 GHz	ETS	3117	00168724	06-17-17
Antenna, Horn, 18 GHz	ETS	3117	00168717	06-17-17
Antenna, Horn, 40 GHz	ETS	3116C	00166155	09-23-16
Antenna, Horn, 40 GHz	ETS	3116C-PA	00168841	08-24-17
Preamplifier, 1000 MHz	Sonoma	310N	341282	08-18-16
Preamplifier, 1000 MHz	Sonoma	310N	351741	08-18-16
Preamplifier, 18 GHz	Miteq	AFS42-00101800-25-S-42	1876511	08-18-16
Preamplifier, 18 GHz	Miteq	AFS42-00101800-25-S-42	1896138	08-18-16
Spectrum Analyzer, 44 GHz	Agilent / HP	N9030A	MY54170614	08-19-16
Spectrum Analyzer, 44 GHz	Agilent / HP	N9030A	MY54490312	08-19-16
Bluetooth Tester	TESCOM	TC-3000C	3000C000546	08-18-16
Average Power Sensor	R&S	NRZ-Z91	102681	08-18-16
Average Power Sensor	Agilent / HP	U2000	MY54270007	08-18-16
EMI Test Receive, 40 GHz	R&S	ESU40	100439	08-19-16
EMI Test Receive, 40 GHz	R&S	ESU40	100457	08-19-16
EMI Test Receive, 3 GHz	R&S	ESR3	101832	08-19-16
Attenuator / Switch driver	HP	11713A	3748A04272	N/A
Low Pass Filter 3GHz	Micro-Tronics	LPS17541	009	08-18-16
Low Pass Filter 3GHz	Micro-Tronics	LPS17541	015	08-18-16
High Pass Filter 5GHz	Micro-Tronics	HPS17542	009	08-18-16
High Pass Filter 6GHz	Micro-Tronics	HPM17543	010	08-18-16
High Pass Filter 5GHz	Micro-Tronics	HPS17542	016	08-18-16
High Pass Filter 6GHz	Micro-Tronics	HPM17543	015	08-18-16
LISN	R&S	ENV-216	101836	08-19-16
LISN	R&S	ENV-216	101837	08-19-16

## 7. SUMMARY TABLE

The FCC ID: A3LSMW708Y shares the same enclosure and circuit board as FCC ID: A3LSMW700. The WLAN circuitry and layout, including antennas, are almost identical between the two units. The WLAN antennas and surrounding circuitry are the same between these two units.

After confirming through preliminary radiated emissions that the performance of the FCC ID: A3LSMW700 remains representative of FCC ID: A3LSMW708Y, test data for FCC ID: A3LSMW700 is being submitted for this application to cover WLAN features.

FCC Part Section	Test Description	Test Limit	Test Condition	Test Result	Worst Case
15.407 (a)	Occupied Band width (26dB)	N/A	Conducted	Pass	82.38 MHz
15.407	6dB Band width (5.8Ghz)	500KHz		Pass	1.93 MHz (Straddle)
15.407 (a)(2)	TX Cond. Power 5.15-2.25, 5.25-5.35 & 5.47-5.725	<24dBm or 11+10Log(OBW)		Pass	16.29 dBm
15.407 (a)(3)	TX Cond. Power 5.725-5.825	< 30dBm or 17+10Log(OBW)		Pass	15.94 dBm
15.407 (a)(5)	PSD (5.2,5.3,5.5GHz)	<11dBm		Pass	6.19 dBm
15.407 (a)(5)	PSD (5.8GHz)	30dBm per 500kHz		Pass	2.94 dBm
15.207 (a)	AC Power Line conducted emissions	Section 10	Radiated	Pass	41.36 dBuV (QP)
15.407 (b) & 15.209	Radiated Spurious Emission	< 54dBuV/m		Pass	50.93 BuV/m (AV)
15.407 (h)(2)	Dynamic Frequency Selection	N/A	Radiated / Condcuted	Pass	N/A

---

## 8. ON TIME, DUTY CYCLE AND MEASUREMENT METHODS

### LIMITS

None; for reporting purposes only.

### PROCEDURE

KDB 789033 D02 v01r01 Zero-Span Spectrum Analyzer Method.

### 8.1. ON TIME AND DUTY CYCLE RESULTS

### RESULTS

Please refer to the UNII test report of FCC ID : A3LSMW700

---

## 9. MEASUREMENT METHOD

KDB 789033 D02 General UNII Test Procedures New Rules v01r01  
KDB 905462 D03 Clients Without Radar Detection New Rules v01r01

The Duty Cycle is less than 98% and consistent therefore KDB 789033 Method SA-2 is used for power and PPSD

The Duty Cycle is less than 98% and consistent, KDB 789033 Method AD with Power RMS Averaging and duty cycle correction is used.

MIMO Device: KDB 662911 v02r01

Straddle Channels: KDB 644545 D03 v01

## 10. ANTENNA PORT TEST RESULTS

### 10.1. 6 dB BANDWIDTH

#### LIMITS

FCC §15.407

The minimum 6 dB bandwidth shall be at least 500 kHz.

#### TEST PROCEDURE

Reference to 789033 D02 General UNII Test Procedures New Rules v01r01: The transmitter output is connected to a spectrum analyzer with the RBW set to 100KHz, the VBW  $\geq 3 \times$  RBW, peak detector and max hold.

#### RESULTS

Please refer to the UNII test report of FCC ID : A3LSMW700

### 10.2. 26 dB BANDWIDTH

#### LIMITS

None; for reporting purposes only.

#### RESULTS

Please refer to the UNII test report of FCC ID : A3LSMW700

### 10.3. 99% BANDWIDTH

#### LIMITS

None; for reporting purposes only.

#### RESULTS

Please refer to the UNII test report of FCC ID : A3LSMW700

## 10.4. OUTPUT POWER AND PPSD

### LIMITS

FCC §15.407 (a) (1) (2) (3)

For the band 5.15–5.25 GHz, the maximum conducted output power over the frequency band of operation shall not exceed the lesser of 250 mW or 11 dBm + 10 log B, where B is the 26–dB emission bandwidth in MHz. In addition, the peak power spectral density shall not exceed 11 dBm in any 1–MHz band. If transmitting antennas of directional gain greater than 6 dBi are used, both the maximum conducted output power and the peak power spectral density shall be reduced by the amount in dB that the directional gain of the antenna exceeds 6 dBi.

For the 5.25-5.35 GHz and 5.47-5.725 GHz bands, the maximum conducted output power over the frequency bands of operation shall not exceed the lesser of 250 mW or 11 dBm + 10 log B, where B is the 26 dB emission bandwidth in megahertz. In addition, the maximum power spectral density shall not exceed 11 dBm in any 1 megahertz band. If transmitting antennas of directional gain greater than 6 dBi are used, both the maximum conducted output power and the maximum power spectral density shall be reduced by the amount in dB that the directional gain of the antenna exceeds 6 dBi.

For the band 5.725-5.85 GHz, the maximum conducted output power over the frequency band of operation shall not exceed 1 W. In addition, the maximum power spectral density shall not exceed 30 dBm in any 500-kHz band.

### DIRECTIONAL ANTENNA GAIN

For Power: The TX chains are uncorrelated and the antenna gain is the same for each chain. The directional gain is equal to the antenna gain.

For PSD: The TX chains are correlated and the antenna gain is unequal among the chains. The directional gain is:

5 GHz

Frequency Band [MHz]	Chain 0 Antenna Gain [dBi]	Chain 1 Antenna Gain [dBi]	Uncorrelated Directional Gain [dBi]	Correlated Directional Gain [dBi]
5150 - 5250	0.13	-4.65	-1.63	1.08
5250 - 5350	-1.23	-2.95	-2.01	0.96
5470 - 5725	-0.07	-4.45	-1.73	1.02
5725 - 5850	-1.05	-1.94	-1.47	1.53

### RESULTS

Please refer to the UNII test report of FCC ID : A3LSMW700

## 11. TRANSMITTER ABOVE 1 GHz

### LIMITS

FCC §15.205 and §15.209

Frequency Range (MHz)	Field Strength Limit (uV/m) at 3 m	Field Strength Limit (dBuV/m) at 3 m
30 - 88	100	40
88 - 216	150	43.5
216 - 960	200	46
Above 960	500	54

### TEST PROCEDURE

The EUT is placed on a non-conducting table 80 cm above the ground plane. The antenna to EUT distance is 3 meters.

For measurements below 1 GHz the resolution bandwidth is set to 100 kHz for peak detection measurements or 120 kHz for quasi-peak detection measurements. Peak detection is used unless otherwise noted as quasi-peak.

Reference to KDB 789033 D02 v01r01 UNII part G) 6) c) Method AD:

For measurements above 1 GHz the resolution bandwidth is set to 1 MHz; the video bandwidth is set to 3 MHz for peak measurements and add duty cycle factor to the reading offset for average measurements.

The spectrum from 30 MHz to 40 GHz is investigated with the transmitter set to the lowest, middle, and highest channels in each applicable band.

The frequency range of interest is monitored at a fixed antenna height and EUT azimuth. The EUT is rotated through 360 degrees to maximize emissions received. The antenna is scanned from 1 to 4 meters above the ground plane to further maximize the emission. Measurements are made with the antenna polarized in both the vertical and the horizontal positions.

### **11.1. 5.2 GHz**

#### **RESULTS**

Please refer to the UNII test report of FCC ID : A3LSMW700

### **11.2. 5.3 GHz**

#### **RESULTS**

Please refer to the UNII test report of FCC ID : A3LSMW700

### **11.3. 5.5-5.6 GHz**

#### **RESULTS**

Please refer to the UNII test report of FCC ID : A3LSMW700

### **11.4. 5.8 GHz**

#### **RESULTS**

Please refer to the UNII test report of FCC ID : A3LSMW700

## **12. WORST-CASE BELOW 1 GHz (in the 5.3 GHz Band)**

#### **RESULTS**

Please refer to the UNII test report of FCC ID : A3LSMW700

### 13. AC POWER LINE CONDUCTED EMISSIONS

#### LIMITS

FCC §15.207 (a)

Frequency of Emission (MHz)	Conducted Limit (dBuV)	
	Quasi-peak	Average
0.15-0.5	66 to 56*	56 to 46*
0.5-5	56	46
5-30	60	50

\*Decreases with the logarithm of the frequency.

#### TEST PROCEDURE

The EUT is placed on a non-conducting table 40 cm from the vertical ground plane and 80 cm above the horizontal ground plane. The EUT is configured in accordance with ANSI C63.10.

The receiver is set to a resolution bandwidth of 9 kHz. Peak detection is used unless otherwise noted as quasi-peak or average.

Line conducted data is recorded for both NEUTRAL and HOT lines.

#### RESULTS

Please refer to the UNII test report of FCC ID : A3LSMW700

## 14. DYNAMIC FREQUENCY SELECTION

### 14.1. OVERVIEW

#### 14.1.1. LIMITS

##### INDUSTRY CANADA

IC RSS-247 is closely harmonized with FCC Part 15 DFS rules. The deviations are as follows:

RSS-247 Issue §6.3

**Note:** For the band 5600–5650 MHz, no operation is permitted.

Until further notice, devices subject to this annex shall not be capable of transmitting in the band 5600–5650 MHz. This restriction is for the protection of Environment Canada weather radars operating in this band.

##### FCC

§15.407 (h), FCC KDB 905462 D02 “COMPLIANCE MEASUREMENT PROCEDURES FOR UNLICENSED-NATIONAL INFORMATION INFRASTRUCTURE DEVICES OPERATING IN THE 5250-5350 MHz AND 5470-5725 MHz BANDS INCORPORATING DYNAMIC FREQUENCY SELECTION” and KDB 905462 D03 “U-NII CLIENT DEVICES WITHOUT RADAR DETECTION CAPABILITY”.

**Table 1: Applicability of DFS requirements prior to use of a channel**

Requirement	Operational Mode		
	Master	Client (without radar detection)	Client (with radar detection)
Non-Occupancy Period	Yes	Not required	Yes
DFS Detection Threshold	Yes	Not required	Yes
Channel Availability Check Time	Yes	Not required	Not required
U-NII Detection Bandwidth	Yes	Not required	Yes

**Table 2: Applicability of DFS requirements during normal operation**

Requirement	Operational Mode		
	Master	Client (without DFS)	Client (with DFS)
DFS Detection Threshold	Yes	Not required	Yes
Channel Closing Transmission Time	Yes	Yes	Yes
Channel Move Time	Yes	Yes	Yes
U-NII Detection Bandwidth	Yes	Not required	Yes

Additional requirements for devices with multiple bandwidth modes	Master Device or Client with Radar DFS	Client (without DFS)
U-NII Detection Bandwidth and Statistical Performance Check	All BW modes must be tested	Not required
Channel Move Time and Channel Closing Transmission Time	Test using widest BW mode available	Test using the widest BW mode available for the link
All other tests	Any single BW mode	Not required

**Note:** Frequencies selected for statistical performance check (Section 7.8.4) should include several frequencies within the radar detection bandwidth and frequencies near the edge of the radar detection bandwidth. For 802.11 devices it is suggested to select frequencies in all 20 MHz channel blocks and a null frequency between the bonded 20 MHz channel blocks.

**Table 3: Interference Threshold values, Master or Client incorporating In-Service Monitoring**

Maximum Transmit Power	Value (see notes)
E.I.R.P. $\geq$ 200 mill watt	-64 dBm
E.I.R.P. < 200 mill watt and power spectral density < 10 dBm/MHz	-62 dBm
E.I.R.P. < 200 mill watt that do not meet power spectral density requirement	-64 dBm
<p><b>Note 1:</b> This is the level at the input of the receiver assuming a 0 dBi receive antenna  <b>Note 2:</b> Throughout these test procedures an additional 1 dB has been added to the amplitude of the test transmission waveforms to account for variations in measurement equipment. This will ensure that the test signal is at or above the detection threshold level to trigger a DFS response.  <b>Note 3:</b> E.I.R.P. is based on the highest antenna gain. For MIMO devices refer to KDB publication 662911 D01.</p>	

**Table 4: DFS Response requirement values**

Parameter	Value
<i>Non-occupancy period</i>	30 minutes
<i>Channel Availability Check Time</i>	60 seconds
<i>Channel Move Time</i>	10 seconds (See Note 1)
<i>Channel Closing Transmission Time</i>	200 milliseconds + approx. 60 milliseconds over remaining 10 second period. (See Notes 1 and 2)
<i>U-NII Detection Bandwidth</i>	Minimum 100% of the U-NII 99% transmission power bandwidth. (See Note 3)
<p><b>Note 1:</b> <i>Channel Move Time</i> and the <i>Channel Closing Transmission Time</i> should be performed with Radar Type 0. The measurement timing begins at the end of the Radar Type 0 burst.  <b>Note 2:</b> The <i>Channel Closing Transmission Time</i> is comprised of 200 milliseconds starting at the beginning of the <i>Channel Move Time</i> plus any additional intermittent control signals required to facilitate a <i>Channel</i> move (an aggregate of 60 milliseconds) during the remainder of the 10 second period. The aggregate duration of control signals will not count quiet periods in between transmissions.  <b>Note 3:</b> During the <i>U-NII Detection Bandwidth</i> detection test, radar type 0 should be used. For each frequency step the minimum percentage of detection is 90 percent. Measurements are performed with no data traffic.</p>	

**Table 5 – Short Pulse Radar Test Waveforms**

Radar Type	Pulse Width (usec)	PRI (usec)	Pulses	Minimum Percentage of Successful Detection	Minimum Trials
0	1	1428	18	See Note 1	See Note 1
1	1	Test A: 15 unique PRI values randomly selected from the list of 23 PRI values in table 5a	Roundup: $\{(1/360) \times (19 \times 10^6 \text{ PRI}_{\text{usec}})\}$	60%	30
		Test B: 15 unique PRI values randomly selected within the range of 518-3066 usec. With a minimum increment of 1 usec, excluding PRI values selected in Test A			
2	1-5	150-230	23-29	60%	30
3	6-10	200-500	16-18	60%	30
4	11-20	200-500	12-16	60%	30
Aggregate (Radar Types 1-4)				80%	120
<b>Note 1:</b> Short Pulse Radar Type 0 should be used for the <i>Detection Bandwidth</i> test, <i>Channel Move Time</i> , and <i>Channel Closing Time</i> tests.					

**Table 6 – Long Pulse Radar Test Signal**

Radar Waveform Type	Pulse Width (µsec)	Chirp Width (MHz)	PRI (µsec)	Pulses per Burst	Number of Bursts	Minimum Percentage of Successful Detection	Minimum Trials
5	50-100	5-20	1000-2000	1-3	8-20	80%	30

**Table 7 – Frequency Hopping Radar Test Signal**

Radar Waveform Type	Pulse Width (µsec)	PRI (µsec)	Pulses per Hop	Hopping Rate (kHz)	Hopping Sequence Length (msec)	Minimum Percentage of Successful Detection	Minimum Trials
6	1	333	9	0.333	300	70%	30

### 14.1.1. TEST AND MEASUREMENT SYSTEM

#### CONDUCTED METHOD SYSTEM BLOCK DIAGRAM

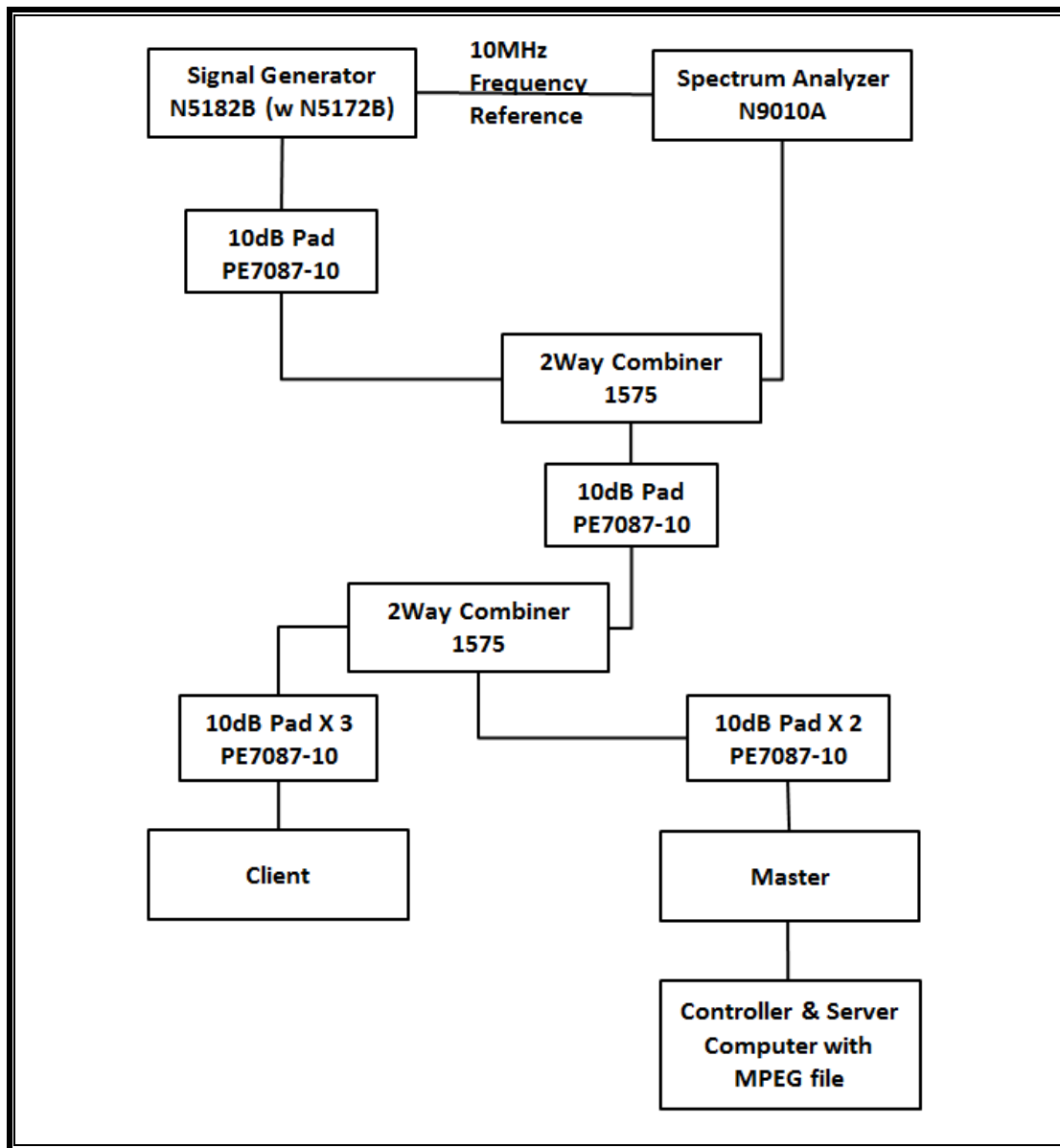

## **SYSTEM OVERVIEW**

The short pulse and long pulse signal generating system utilizes the Keysite Signal Studio for Pulse Building as N5172B. The Vector Signal Generator has been validated by the NTIA. The hopping signal generating system utilizes the CCS simulated hopping method and system, which has been validated by the DoD, FCC and NTIA. The software selects waveform parameters from within the bounds of the signal type on a random basis using uniform distribution.

The short pulse types 1, 2, 3 and 4, and the long pulse type 5 parameters are randomized at run-time.

The hopping type 6 pulse parameters are fixed while the hopping sequence is based on the August 2005 NTIA Hopping Frequency List. The initial starting point randomized at run-time and each subsequent starting point is incremented by 475. Each frequency in the 100-length segment is compared to the boundaries of the EUT Detection Bandwidth and the software creates a hopping burst pattern in accordance with Section 7.4.1.3 Method #2 Simulated Frequency Hopping Radar Waveform Generating Subsystem of KDB 905462 D02. The frequency of the signal generator is incremented in 1 MHz steps from  $F_L$  to  $F_H$  for each successive trial. This incremental sequence is repeated as required to generate a minimum of 30 total trials and to maintain a uniform frequency distribution over the entire Detection Bandwidth.

The signal monitoring equipment consists of a spectrum analyzer. The aggregate ON time is calculated by multiplying the number of bins above a threshold during a particular observation period by the dwell time per bin, with the analyzer set to peak detection and max hold.

## **SYSTEM CALIBRATION**

A 50-ohm load is connected in place of the spectrum analyzer, and the spectrum analyzer is connected to a horn antenna via a coaxial cable, with the reference level offset set to (horn antenna gain – coaxial cable loss). The signal generator is set to CW mode. The amplitude of the signal generator is adjusted to yield a level of –64 dBm as measured on the spectrum analyzer.

Without changing any of the instrument settings, the spectrum analyzer is reconnected to the Common port of the Spectrum Analyzer Combiner/Divider. The Reference Level Offset of the spectrum analyzer is adjusted so that the displayed amplitude of the signal is –64 dBm.

The spectrum analyzer displays the level of the signal generator as received at the antenna ports of the Master Device. The interference detection threshold may be varied from the calibrated value of –64 dBm and the spectrum analyzer will still indicate the level as received by the Master Device.

**ADJUSTMENT OF DISPLAYED TRAFFIC LEVEL**

A link is established between the Master and Slave and the distance between the units is adjusted as needed to provide a suitable received level at the Master and Slave devices. The video test file is streamed to generate WLAN traffic. The monitoring antenna is adjusted so that the WLAN traffic level, as displayed on the spectrum analyzer, is at lower amplitude than the radar detection threshold.

**TEST AND MEASUREMENT EQUIPMENT**

The following test and measurement equipment was utilized for the DFS tests documented in this report:

<b>TEST EQUIPMENT LIST</b>				
<b>Description</b>	<b>Manufacturer</b>	<b>Model</b>	<b>S/N</b>	<b>Cal Due</b>
Spectrum Analyzer, 7 GHz	Agilent / HP	N9010A	MY54200580	08-19-16
Vector Signal Generator, 6GHz	Agilent / HP	N5182B	MY53051241	08-19-16

**14.1.2. SETUP OF EUT**

**CONDUCTED METHOD EUT TEST SETUP**

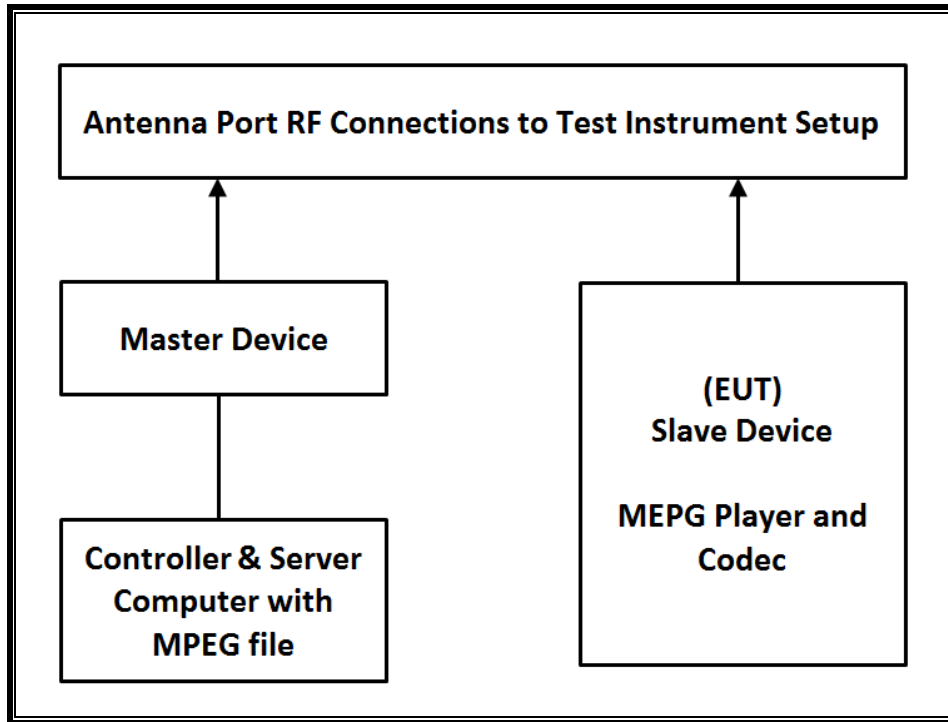

**SUPPORT EQUIPMENT**

The following support equipment was utilized for the DFS tests documented in this report:

PERIPHERAL SUPPORT EQUIPMENT LIST				
Description	Manufacturer	Model	Serial Number	FCC ID
Wireless Access Point	Cisco	AIR-CAP3702E-A-K9	FTX182276QX	LDK102087
Notebook PC (Controller/Server)	HP	HP EliteDesk 800 G1 TWR	CZC4125J25	DoC

### **14.1.3. DESCRIPTION OF EUT**

The EUT operates over the 5250-5350 MHz and 5470-5725 MHz ranges.

The EUT is a Slave Device without Radar Detection.

The highest power level within these bands is 16.29 dBm in the 5250-5350 MHz band and 16.07 dBm in the 5470-5725 MHz band.

The antenna assembly utilized two antenna with the EUT one is -0.17 dBi, and the other is -2.95 dBi.

The rated output power of the Master unit is > 23dBm (EIRP). Therefore the required interference threshold level is -64 dBm. After correction for procedural adjustments, the required conducted threshold at the antenna port is  $-64 + 1 = -63$  dBm.

The calibrated radiated DFS Detection Threshold level is set to -64 dBm. The tested level is lower than the required level hence it provides a margin to the limit.

The EUT uses one transmitter/receiver chain connected to an antenna to perform radiated tests.

WLAN traffic that meets or exceeds the minimum required loading was generated by transferring a data stream from the controller/server PC to the EUT using iPerf version 2.0.5 software package.

TPC is not required since the maximum EIRP is less than 500 mW (27 dBm).

The EUT utilizes the 802.11ac architecture. Three nominal channel bandwidths are implemented: 20 MHz, 40 MHz and 80 MHz.

The software installed in the access point is 12.4(25d)JA1.

### **UNIFORM CHANNEL SPREADING**

This requirement is not applicable to Slave radio devices.

### **OVERVIEW OF MASTER DEVICE WITH RESPECT TO §15.407 (h) REQUIREMENTS**

The Master Device is a Cisco Access Point, FCC ID: LDK102087. The minimum antenna gain for the Master Device is 6 dBi.

The rated output power of the Master unit is > 23dBm (EIRP). Therefore the required interference threshold level is -64 dBm. After correction for procedural adjustments, the required radiated threshold at the antenna port is  $-64 + 1 = -63$  dBm.

The calibrated radiated DFS Detection Threshold level is set to -64 dBm. The tested level is lower than the required level hence it provides a margin to the limit.

## 14.2. RESULTS FOR 20 MHz BANDWIDTH

### 14.2.1. TEST CHANNEL

All tests were performed at a channel center frequency of 5500 MHz.

### 14.2.2. RADAR WAVEFORM AND TRAFFIC

Please refer to the UNII test report of FCC ID : A3LSMW700

### 14.2.3. OVERLAPPING CHANNEL TESTS

#### RESULTS

These tests are not applicable.

### 14.2.4. MOVE AND CLOSING TIME

#### REPORTING NOTES

The reference marker is set at the end of last radar pulse.

The delta marker is set at the end of the last WLAN transmission following the radar pulse. This delta is the channel move time.

The aggregate channel closing transmission time is calculated as follows:

Aggregate Transmission Time =  
(Number of analyzer bins showing transmission) \* (dwell time per bin)

The observation period over which the aggregate time is calculated begins at (Reference Marker + 200 msec) and ends no earlier than (Reference Marker + 10 sec).

#### RESULTS

Please refer to the UNII test report of FCC ID : A3LSMW700

## 14.3. RESULTS FOR 40 MHz BANDWIDTH

### 14.3.1. TEST CHANNEL

All tests were performed at a channel center frequency of 5510 MHz.

### 14.3.2. RADAR WAVEFORM AND TRAFFIC

Please refer to the UNII test report of FCC ID : A3LSMW700

### 14.3.3. OVERLAPPING CHANNEL TESTS

#### RESULTS

These tests are not applicable.

### 14.3.4. MOVE AND CLOSING TIME

#### REPORTING NOTES

The reference marker is set at the end of last radar pulse.

The delta marker is set at the end of the last WLAN transmission following the radar pulse. This delta is the channel move time.

The aggregate channel closing transmission time is calculated as follows:

Aggregate Transmission Time =  
(Number of analyzer bins showing transmission) \* (dwell time per bin)

The observation period over which the aggregate time is calculated begins at (Reference Marker + 200 msec) and ends no earlier than (Reference Marker + 10 sec).

#### RESULTS

Please refer to the UNII test report of FCC ID : A3LSMW700

## 14.4. RESULTS FOR 80 MHz BANDWIDTH

### 14.4.1. TEST CHANNEL

All tests were performed at a channel center frequency of 5530 MHz.

### 14.4.2. RADAR WAVEFORM AND TRAFFIC

Please refer to the UNII test report of FCC ID : A3LSMW700

### 14.4.3. OVERLAPPING CHANNEL TESTS

#### RESULTS

These tests are not applicable.

### 14.4.4. MOVE AND CLOSING TIME

#### REPORTING NOTES

The reference marker is set at the end of last radar pulse.

The delta marker is set at the end of the last WLAN transmission following the radar pulse. This delta is the channel move time.

The aggregate channel closing transmission time is calculated as follows:

Aggregate Transmission Time =  
(Number of analyzer bins showing transmission) \* (dwell time per bin)

The observation period over which the aggregate time is calculated begins at (Reference Marker + 200 msec) and ends no earlier than (Reference Marker + 10 sec).

#### RESULTS

Please refer to the UNII test report of FCC ID : A3LSMW700