

SAR Test Report

Report No. : SF200609C06

Applicant : SAMSUNG ELECTRONICS CO. LTD.

Address : 129 Samsung-ro, Yeongtong-gu, Suwon-Si Gyeonggi-do 16677 Korea
(Republic Of)

Product : Tablet

FCC ID : A3LSMT970

Brand : Samsung

Model No. : SM-T970

Standards : FCC 47 CFR Part 2 (2.1093), IEEE C95.1:1992, IEEE Std 1528:2013
KDB 865664 D01 v01r04, KDB 865664 D02 v01r02
KDB 248227 D01 v02r02 , KDB 447498 D01 v06, KDB 616217 D04 v01r02

Sample Received Date : Jun. 09, 2020

Date of Testing : Jun. 10, 2020 ~ Jul. 01, 2020

Lab Address : No. 47-2, 14th Ling, Chia Pau Vil., Lin Kou Dist., New Taipei City, Taiwan

Test Location : No. 19, Hwa Ya 2nd Rd., Wen Hwa Vil., Kwei Shan Dist., Taoyuan City, Taiwan

CERTIFICATION: The above equipment have been tested by **Bureau Veritas Consumer Products Services (H.K.) Ltd., Taoyuan Branch–Lin Kou Laboratories**, and found compliance with the requirement of the above standards. The test record, data evaluation & Equipment Under Test (EUT) configurations represented herein are true and accurate accounts of the measurements of the sample’s SAR characteristics under the conditions specified in this report. It should not be reproduced except in full, without the written approval of our laboratory. The client should not use it to claim product certification, approval, or endorsement by TAF or any government agencies.

Prepared By : Vera Huang
Vera Huang / Specialist

Approved By : Gordon Lin
Gordon Lin / Manager



IC Site Registration No. : 7450F

This report is for your exclusive use. Any copying or replication of this report to or for any other person or entity, or use of our name or trademark, is permitted only with our prior written permission. This report sets forth our findings solely with respect to the test samples identified herein. The results set forth in this report are not indicative or representative of the quality or characteristics of the lot from which a test sample was taken or any similar or identical product unless specifically and expressly noted. Our report includes all of the tests requested by you and the results thereof based upon the information that you provided to us. You have 60 days from date of issuance of this report to notify us of any material error or omission caused by our negligence, provided, however, that such notice shall be in writing and shall specifically address the issue you wish to raise. A failure to raise such issue within the prescribed time shall constitute your unqualified acceptance of the completeness of this report, the tests conducted and the correctness of the report contents. Unless specific mention, the uncertainty of measurement has been explicitly taken into account to declare the compliance or non-compliance to the specification.

Table of Contents

Release Control Record	3
1. Summary of Maximum SAR Value	4
2. Description of Equipment Under Test	5
3. SAR Measurement System	6
3.1 Definition of Specific Absorption Rate (SAR)	6
3.2 SPEAG DASY6 System	6
3.2.1 Robot.....	7
3.2.2 Probes.....	8
3.2.3 Data Acquisition Electronics (DAE)	8
3.2.4 Phantoms	8
3.2.5 Device Holder.....	9
3.2.6 System Validation Dipoles	10
3.2.7 Power Source.....	10
3.2.8 Tissue Simulating Liquids.....	11
3.3 SAR System Verification	13
3.4 SAR Measurement Procedure	14
3.4.1 Area Scan and Zoom Scan Procedure.....	14
3.4.2 Volume Scan Procedure.....	15
3.4.3 Power Drift Monitoring.....	16
3.4.4 Spatial Peak SAR Evaluation	16
3.4.5 SAR Averaged Methods	16
4. SAR Measurement Evaluation	17
4.1 EUT Configuration and Setting.....	17
4.2 EUT Testing Position	24
4.2.1 Body Exposure Conditions	24
4.3 Tissue Verification	25
4.4 System Validation.....	26
4.5 System Verification.....	27
4.6 Maximum Output Power.....	27
4.6.1 Maximum Target Conducted Power	27
4.6.2 Measured Conducted Power Result.....	27
4.7 SAR Testing Results	28
4.7.1 SAR Test Reduction Considerations	28
4.7.2 SAR Results for Body Exposure Condition	29
4.7.3 SAR Measurement Variability.....	34
4.7.4 Simultaneous Multi-band Transmission Evaluation	35
5. Calibration of Test Equipment.....	40
6. Measurement Uncertainty	41
7. Information of the Testing Laboratories.....	45
Appendix A. SAR Plots of System Verification	
Appendix B. SAR Plots of SAR Measurement	
Appendix C. Maximum Target Conducted Power	
Appendix D. Measured Conducted Power	
Appendix E. Calibration Certificate for Probe and Dipole	
Appendix F. Photographs of EUT and Setup	

1. Summary of Maximum SAR Value

Equipment Class	Mode	Highest SAR-1g Body (W/kg)
DTS	2.4G WLAN	0.90
NII	5.3G WLAN	0.85
	5.6G WLAN	0.83
	5.8G WLAN	0.85
DSS	Bluetooth	0.77
Highest Simultaneous Transmission SAR		Body
		1.41

Note:

1. The SAR criteria (**Head & Body: SAR-1g 1.6 W/kg, and Extremity: SAR-10g 4.0 W/kg**) for general population/uncontrolled exposure is specified in FCC 47 CFR part 2 (2.1093) and ANSI/IEEE C95.1-1992.

SAR Test Report

2. Description of Equipment Under Test

EUT Type	Tablet
FCC ID	A3LSMT970
Brand Name	Samsung
Model Name	SM-T970
EUT Management No.	SAR01# SAR02#
HW Version	REV0.4
SW Version	T970.001
Tx Frequency Bands (Unit: MHz)	WLAN : 2412 ~ 2472, 5180 ~ 5240, 5260 ~ 5320, 5500 ~ 5720, 5745 ~ 5825 Bluetooth : 2402 ~ 2480
Uplink Modulations	802.11b : DSSS 802.11a/g/n/ac/ax : OFDM Bluetooth : GFSK, π/4-DQPSK, 8-DPSK
Maximum Tune-up Conducted Power (Unit: dBm)	Please refer to section 4.6.1 of this report
Antenna Type	Metal Antenna
EUT Stage	Engineering Sample

Note:

- The above EUT information is declared by manufacturer and for more detailed features description please refers to the manufacturer's specifications or User's Manual.

List of Accessory:

Battery	Brand Name	Samsung
	Manufacturer	Samsung
	Model Name	EB-BT975ABY
	Power Rating	3.86Vdc, 9800mAh, 37.83Wh
Keyboard	Brand Name	Samsung
	Manufacturer	Samsung
	Model Name	EF-DT970
	Specification	N/A
S-pen	Brand Name	Samsung
	Manufacturer	Samsung
	Model Name	EJ-PT870
	Specification	Bluetooth

3. SAR Measurement System

3.1 Definition of Specific Absorption Rate (SAR)

SAR is related to the rate at which energy is absorbed per unit mass in an object exposed to a radio field. The SAR distribution in a biological body is complicated and is usually carried out by experimental techniques or numerical modeling. The standard recommends limits for two tiers of groups, occupational/controlled and general population/uncontrolled, based on a person's awareness and ability to exercise control over his or her exposure. In general, occupational/controlled exposure limits are higher than the limits for general population/uncontrolled.

The SAR definition is the time derivative (rate) of the incremental energy (dW) absorbed by (dissipated in) an incremental mass (dm) contained in a volume element (dv) of a given density (ρ). The equation description is as below:

$$\text{SAR} = \frac{d}{dt} \left(\frac{dW}{dm} \right) = \frac{d}{dt} \left(\frac{dW}{\rho dv} \right)$$

SAR is expressed in units of Watts per kilogram (W/kg)

SAR measurement can be related to the electrical field in the tissue by

$$\text{SAR} = \frac{\sigma |E|^2}{\rho}$$

Where: σ is the conductivity of the tissue, ρ is the mass density of the tissue and E is the RMS electrical field strength.

3.2 SPEAG DASY6 System

DASY6 system consists of high precision robot, probe alignment sensor, phantom, robot controller, controlled measurement server and near-field probe. The robot includes six axes that can move to the precision position of the DASY6 software defined. The DASY6 software can define the area that is detected by the probe. The robot is connected to controlled box. Controlled measurement server is connected to the controlled robot box. The DAE includes amplifier, signal multiplexing, AD converter, offset measurement and surface detection. It is connected to the Electro-optical coupler (ECO). The ECO performs the conversion from the optical into digital electric signal of the DAE and transfers data to the PC.

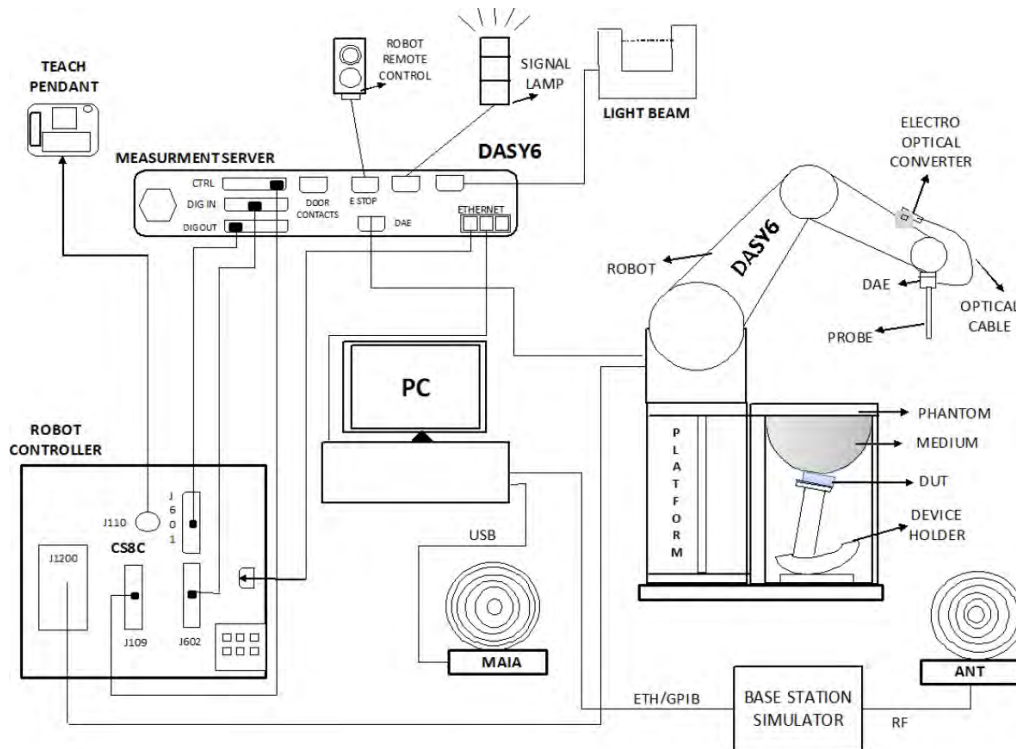

Fig-3.1 SPEAG DASY6 System Setup

3.2.1 Robot

The DASY6 system uses the high precision robots from Stäubli SA (France). For the 6-axis controller system, the robot controller version of CS8c from Stäubli is used. The Stäubli robot series have many features that are important for our application:

- High precision (repeatability ± 0.035 mm)
- High reliability (industrial design)
- Jerk-free straight movements
- Low ELF interference (the closed metallic construction shields against motor control fields)

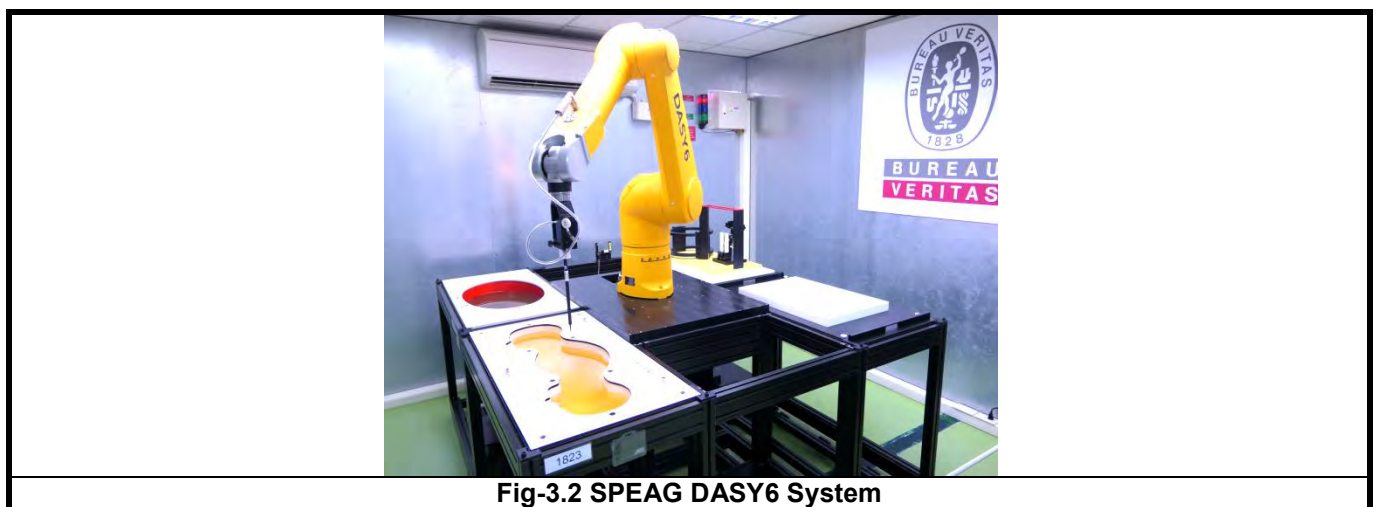



Fig-3.2 SPEAG DASY6 System

SAR Test Report

3.2.2 Probes

The SAR measurement is conducted with the dosimetric probe. The probe is specially designed and calibrated for use in liquid with high permittivity. The dosimetric probe has special calibration in liquid at different frequency.

Model	EX3DV4	
Construction	Symmetrical design with triangular core. Built-in shielding against static charges. PEEK enclosure material (resistant to organic solvents, e.g., DGBE).	
Frequency	4 MHz to 10 GHz Linearity: ± 0.2 dB	
Directivity	± 0.1 dB in TSL (rotation around probe axis) ± 0.3 dB in TSL (rotation normal to probe axis)	
Dynamic Range	10 μ W/g to 100 mW/g Linearity: ± 0.2 dB (noise: typically < 1 μ W/g)	
Dimensions	Overall length: 337 mm (Tip: 20 mm) Tip diameter: 2.5 mm (Body: 12 mm) Typical distance from probe tip to dipole centers: 1 mm	

3.2.3 Data Acquisition Electronics (DAE)

Model	DAE3, DAE4	
Construction	Signal amplifier, multiplexer, A/D converter and control logic. Serial optical link for communication with DASY embedded system (fully remote controlled). Two step probe touch detector for mechanical surface detection and emergency robot stop.	
Measurement Range	-100 to +300 mV (16 bit resolution and two range settings: 4mV, 400mV)	
Input Offset Voltage	$< 5\mu$ V (with auto zero)	
Input Bias Current	< 50 fA	
Dimensions	60 x 60 x 68 mm	

3.2.4 Phantoms

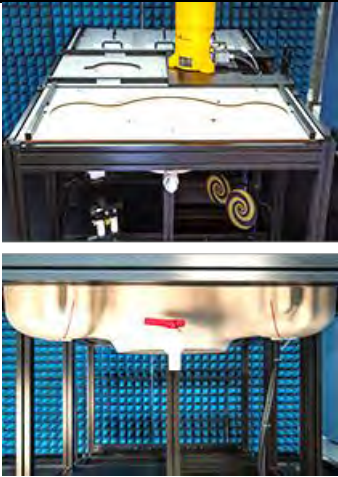
Model	SAM-Twin Phantom	
Construction	The shell corresponds to the specifications of the Specific Anthropomorphic Mannequin (SAM) phantom defined in IEEE Std 1528 and IEC 62209-1. It enables the dosimetric evaluation of left and right hand phone usage as well as body-mounted usage at the flat phantom region. A cover prevents evaporation of the liquid. Reference markings on the phantom allow the complete setup of all predefined phantom positions and measurement grids by teaching three points with the robot.	
Material	Vinylester, fiberglass reinforced (VE-GF)	
Shell Thickness	2 \pm 0.2 mm (6 \pm 0.2 mm at ear point)	
Dimensions	Length: 1000 mm Width: 500 mm Height: adjustable feet	
Filling Volume	approx. 25 liters	

SAR Test Report

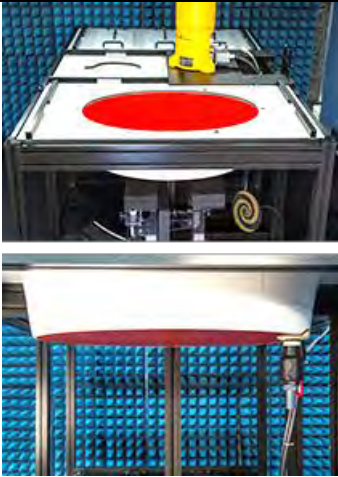
Model	ELI	
Construction	The ELI phantom is used for compliance testing of handheld and body-mounted wireless devices. ELI is fully compatible with the IEC 62209-2 standard and all known tissue simulating liquids. ELI has been optimized regarding its performance and can be integrated into our standard phantom tables. A cover prevents evaporation of the liquid. Reference markings on the phantom allow installation of the complete setup, including all predefined phantom positions and measurement grids, by teaching three points. The phantom is compatible with all SPEAG dosimetric probes and dipoles.	
Material	Vinylester, fiberglass reinforced (VE-GF)	
Shell Thickness	2.0 ± 0.2 mm (bottom plate)	
Dimensions	Major axis: 600 mm Minor axis: 400 mm	
Filling Volume	approx. 30 liters	

3.2.5 Device Holder

Model	MD4HHTV5 - Mounting Device for Hand-Held Transmitters	
Construction	In combination with the Twin SAM or ELI phantoms, the Mounting Device for Hand-Held Transmitters enables rotation of the mounted transmitter device to specified spherical coordinates. At the heads, the rotation axis is at the ear opening. Transmitter devices can be easily and accurately positioned according to IEC 62209-1, IEEE 1528, FCC, or other specifications. The device holder can be locked for positioning at different phantom sections (left head, right head, flat).	
Material	Polyoxymethylene (POM)	

Model	MDA4WTV5 - Mounting Device Adaptor for Ultra Wide Transmitters	
Construction	An upgrade kit to Mounting Device to enable easy mounting of wider devices like big smart-phones, e-books, small tablets, etc. It holds devices with width up to 140 mm.	
Material	Polyoxymethylene (POM)	

Model	MDA4SPV6 - Mounting Device Adaptor for Smart Phones	
Construction	The solid low-density MDA4SPV6 adaptor assuring no impact on the DUT radiation performance and is conform with any DUT design and shape.	
Material	ROHACELL	

SAR Test Report

Model	MD4LAPV5 - Mounting Device for Laptops and other Body-Worn Transmitters	
Construction	In combination with the Twin SAM or ELI phantoms, the Mounting Device (Body-Worn) enables testing of transmitter devices according to IEC 62209-2 specifications. The device holder can be locked for positioning at a flat phantom section.	
Material	Polyoxymethylene (POM), PET-G, Foam	

3.2.6 System Validation Dipoles

Model	D-Serial	
Construction	Symmetrical dipole with 1/4 balun. Enables measurement of feed point impedance with NWA. Matched for use near flat phantoms filled with tissue simulating solutions.	
Frequency	750 MHz to 5800 MHz	
Return Loss	> 20 dB	
Power Capability	> 100 W (f < 1GHz), > 40 W (f > 1GHz)	

3.2.7 Power Source

Model	Powersource1	
Signal Type	Continuous Wave	
Operating Frequencies	600 MHz to 5850 MHz	
Output Power	-5.0 dBm to +17.0 dBm	
Power Supply	5V DC, via USB jack	
Power Consumption	<3 W	
Applications	System performance check and validation with a CW signal.	

SAR Test Report

3.2.8 Tissue Simulating Liquids

For SAR measurement of the field distribution inside the phantom, the phantom must be filled with homogeneous tissue simulating liquid to a depth of at least 15 cm. For head SAR testing, the liquid height from the ear reference point (ERP) of the phantom to the liquid top surface is larger than 15 cm. For body SAR testing, the liquid height from the center of the flat phantom to the liquid top surface is larger than 15 cm. The nominal dielectric values of the tissue simulating liquids in the phantom and the tolerance of 10 % are listed in Table-3.1.

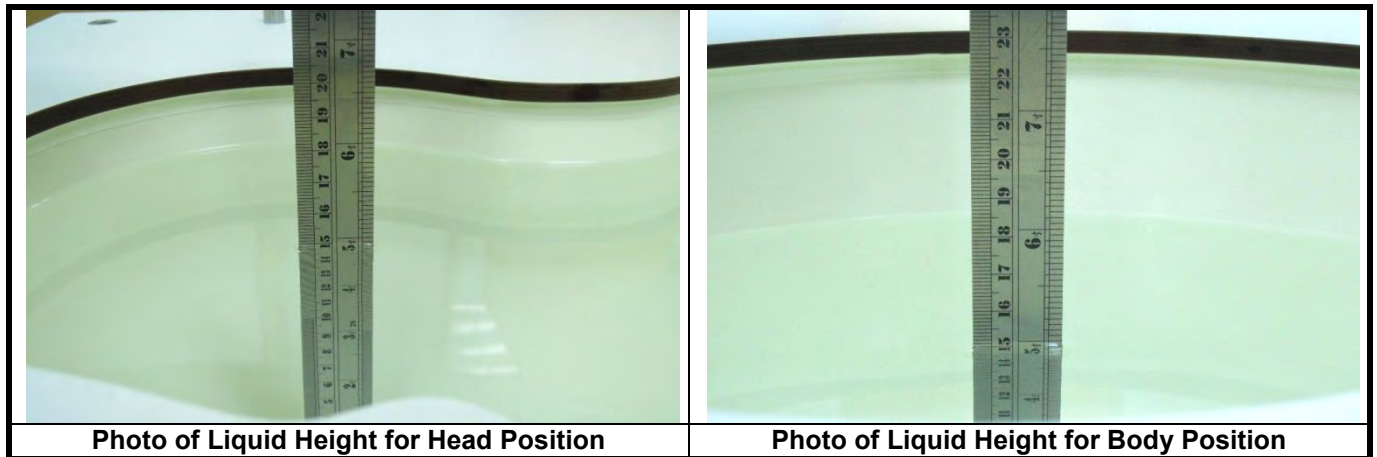

Table-3.1 Targets of Tissue Simulating Liquid

Frequency (MHz)	Target Permittivity	Range of $\pm 10\%$	Target Conductivity	Range of $\pm 10\%$
450	43.5	39.2 ~ 47.9	0.87	0.78 ~ 0.96
750	41.9	37.7 ~ 46.1	0.89	0.80 ~ 0.98
835	41.5	37.4 ~ 45.7	0.90	0.81 ~ 0.99
900	41.5	37.4 ~ 45.7	0.97	0.87 ~ 1.07
1450	40.5	36.5 ~ 44.6	1.20	1.08 ~ 1.32
1500	40.4	36.4 ~ 44.4	1.23	1.11 ~ 1.35
1640	40.2	36.2 ~ 44.2	1.31	1.18 ~ 1.44
1750	40.1	36.1 ~ 44.1	1.37	1.23 ~ 1.51
1800	40.0	36.0 ~ 44.0	1.40	1.26 ~ 1.54
1900	40.0	36.0 ~ 44.0	1.40	1.26 ~ 1.54
2000	40.0	36.0 ~ 44.0	1.40	1.26 ~ 1.54
2100	39.8	35.8 ~ 43.8	1.49	1.34 ~ 1.64
2300	39.5	35.6 ~ 43.5	1.67	1.50 ~ 1.84
2450	39.2	35.3 ~ 43.1	1.80	1.62 ~ 1.98
2600	39.0	35.1 ~ 42.9	1.96	1.76 ~ 2.16
3000	38.5	34.7 ~ 42.4	2.40	2.16 ~ 2.64
3500	37.9	34.1 ~ 41.7	2.91	2.62 ~ 3.20
4000	37.4	33.7 ~ 41.1	3.43	3.09 ~ 3.77
4500	36.8	33.1 ~ 40.5	3.94	3.55 ~ 4.33
5000	36.2	32.6 ~ 39.8	4.45	4.01 ~ 4.90
5200	36.0	32.4 ~ 39.6	4.66	4.19 ~ 5.13
5400	35.8	32.2 ~ 39.4	4.86	4.37 ~ 5.35
5600	35.5	32.0 ~ 39.1	5.07	4.56 ~ 5.58
5800	35.3	31.8 ~ 38.8	5.27	4.74 ~ 5.80
6000	35.1	31.6 ~ 38.6	5.48	4.93 ~ 6.03

SAR Test Report

The dielectric properties of the tissue simulating liquids are defined in IEC 62209-1 and IEC 62209-2. The dielectric properties of the tissue simulating liquids were verified prior to the SAR evaluation using a dielectric assessment kit and a network analyzer.

Since the range of $\pm 10\%$ of the required target values is used to measure relative permittivity and conductivity, the SAR correction procedure is applied to correct measured SAR for the deviations in permittivity and conductivity. Only positive correction has been used to scale up the measured SAR, and SAR result would not be corrected if the correction Δ SAR has a negative sign.

The following table gives the recipes for tissue simulating liquids.

Table-3.2 Recipes of Tissue Simulating Liquid

Tissue Type	Bactericide	DGBE	HEC	NaCl	Sucrose	Triton X-100	Water	Diethylene Glycol Mono-hexylether
H750	0.2	-	0.2	1.5	56.0	-	42.1	-
H835	0.2	-	0.2	1.5	57.0	-	41.1	-
H900	0.2	-	0.2	1.4	58.0	-	40.2	-
H1450	-	43.3	-	0.6	-	-	56.1	-
H1640	-	45.8	-	0.5	-	-	53.7	-
H1750	-	47.0	-	0.4	-	-	52.6	-
H1800	-	44.5	-	0.3	-	-	55.2	-
H1900	-	44.5	-	0.2	-	-	55.3	-
H2000	-	44.5	-	0.1	-	-	55.4	-
H2300	-	44.9	-	0.1	-	-	55.0	-
H2450	-	45.0	-	0.1	-	-	54.9	-
H2600	-	45.1	-	0.1	-	-	54.8	-
H3500	-	8.0	-	0.2	-	20.0	71.8	-
H5G	-	-	-	-	-	17.2	65.5	17.3

3.3 SAR System Verification

The system check verifies that the system operates within its specifications. It is performed daily or before every SAR measurement. The system check uses normal SAR measurements in the flat section of the phantom with a matched dipole at a specified distance. The system verification setup is shown as below.

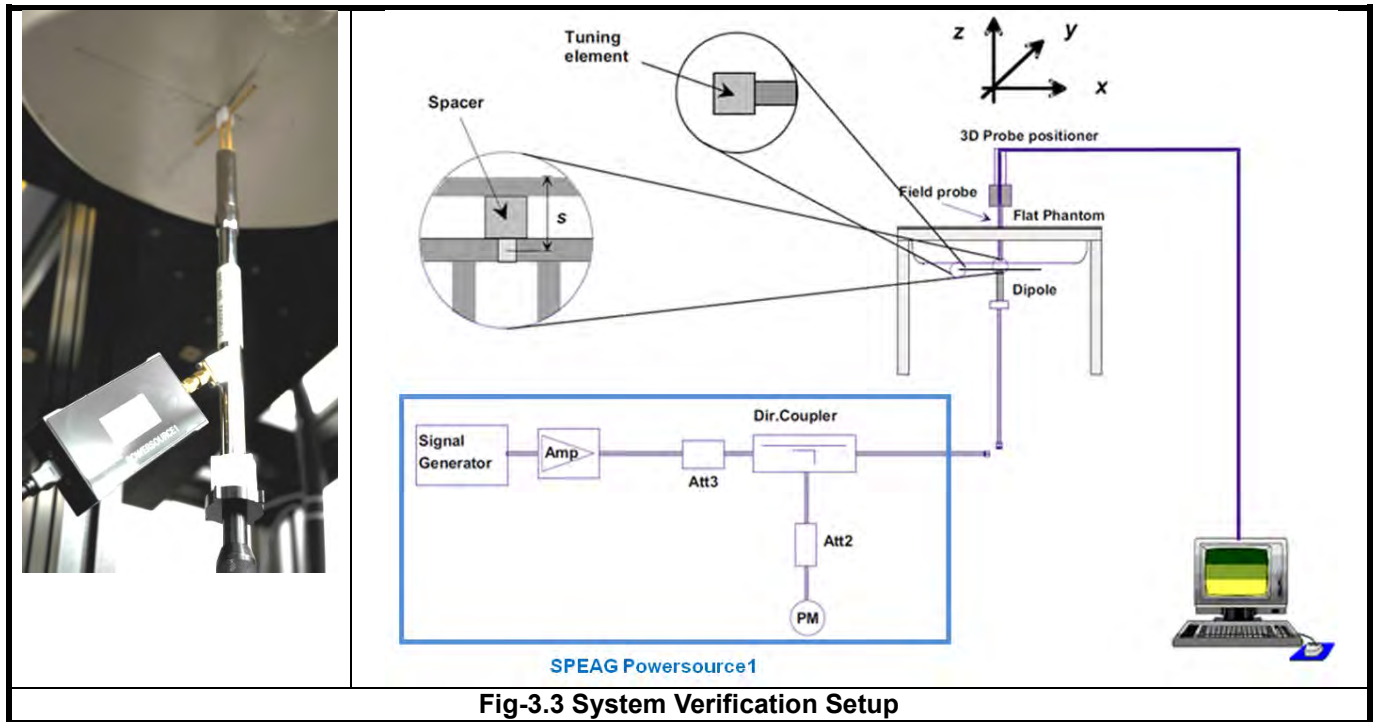

Fig-3.3 System Verification Setup

The SPEAG Powersource1 is a portable and very stable RF source providing a continuous wave (CW) signal. It is designed for conducting SAR system checks and SAR system validation of DASY and is compatible with IEC 62209-1, IEC 62209-2 and IEEE Std 1528 standards. The Powersource1 has been calibrated by SPEAG's ISO/IEC 17025-accredited calibration center. When using Powersource1, the setup can be simplified, as shown in Fig-3.3. The signal purity is warranted by design. Since the Powersource1 is calibrated, no additional equipment is needed and the Powersource1 can directly be connected to the SMA connector of the dipole without a cable as all separate components (signal generator, amplifier, coupler and power meter) are built into the unit.

The validation dipole is placed beneath the flat phantom with the specific spacer in place. The distance spacer is touch the phantom surface with a light pressure at the reference marking and be oriented parallel to the long side of the phantom. The Powersource1 is adjusted for the desired forward power of 17 dBm at the dipole connector and the RF output power would be turned on. After system check testing, the SAR result will be normalized to 1W forward input power and compared with the reference SAR value derived from validation dipole certificate report. The deviation of system check should be within 10 %.

3.4 SAR Measurement Procedure

According to the SAR test standard, the recommended procedure for assessing the peak spatial-average SAR value consists of the following steps:

- (a) Power reference measurement
- (b) Area scan
- (c) Zoom scan
- (d) Power drift measurement

The SAR measurement procedures for each of test conditions are as follows:

- (a) Make EUT to transmit maximum output power
- (b) Measure conducted output power through RF cable
- (c) Place the EUT in the specific position of phantom
- (d) Perform SAR testing steps on the DASY system
- (e) Record the SAR value

3.4.1 Area Scan and Zoom Scan Procedure

First area scan is used to locate the approximate location(s) of the local peak SAR value(s). The measurement grid within an area scan is defined by the grid extent, grid step size and grid offset. Next, in order to determine the EM field distribution in a three-dimensional spatial extension, zoom scan is required. The zoom scan is performed around the highest E-field value to determine the averaged SAR-distribution.

Measure the local SAR at a test point at 1.4 mm of the inner surface of the phantom recommended by SEPAG. The area scan (two-dimensional SAR distribution) is performed cover at least an area larger than the projection of the EUT or antenna. The measurement resolution and spatial resolution for interpolation shall be chosen to allow identification of the local peak locations to within one-half of the linear dimension of the corresponding side of the zoom scan volume. Following table provides the measurement parameters required for the area scan.

Parameter	$f \leq 3 \text{ GHz}$	$3 \text{ GHz} < f \leq 6 \text{ GHz}$
Maximum distance from closest measurement point to phantom surface	5 ± 1	$\delta \ln(2)/2 \pm 0.5$
Maximum probe angle from probe axis to phantom surface normal at the measurement location	$30^\circ \pm 1^\circ$	$20^\circ \pm 1^\circ$
Maximum area scan spatial resolution: $\Delta x_{\text{Area}}, \Delta y_{\text{Area}}$	$\leq 2 \text{ GHz: } \leq 15 \text{ mm}$ $2 - 3 \text{ GHz: } \leq 12 \text{ mm}$	$3 - 4 \text{ GHz: } \leq 12 \text{ mm}$ $4 - 6 \text{ GHz: } \leq 10 \text{ mm}$

From the scanned SAR distribution, identify the position of the maximum SAR value, in addition identify the positions of any local maxima with SAR values within 2 dB of the maximum value that will not be within the zoom scan of other peaks. Additional peaks shall be measured only when the primary peak is within 2 dB of the SAR compliance limit (e.g. 1 W/kg for 1.6 W/kg, 1 g limit; or 1.26 W/kg for 2 W/kg, 10 g limit).

SAR Test Report

The zoom scan (three-dimensional SAR distribution) is performed at the local maxima locations identified in previous area scan procedure. The zoom scan volume must be larger than the required minimum dimensions. When graded grids are used, which only applies in the direction normal to the phantom surface, the initial grid separation closest to the phantom surface and subsequent graded grid increment ratios must satisfy the required protocols. The 1-g SAR averaging volume must be fully contained within the zoom scan measurement volume boundaries; otherwise, the measurement must be repeated by shifting or expanding the zoom scan volume. The similar requirements also apply to 10-g SAR measurements. Following table provides the measurement parameters required for the zoom scan.

Parameter		$f \leq 3$ GHz	$3 \text{ GHz} < f \leq 6$ GHz
Maximum zoom scan spatial resolution: $\Delta x_{\text{Zoom}}, \Delta y_{\text{Zoom}}$		≤ 2 GHz: ≤ 8 mm 2 – 3 GHz: ≤ 5 mm	3 – 4 GHz: ≤ 5 mm 4 – 6 GHz: ≤ 4 mm
Maximum zoom scan spatial resolution, normal to phantom surface	<i>uniform grid:</i> $\Delta z_{\text{Zoom}}(n)$	≤ 5 mm	3 – 4 GHz: ≤ 4 mm 4 – 5 GHz: ≤ 3 mm 5 – 6 GHz: ≤ 2 mm
	<i>graded grids:</i> $\Delta z_{\text{Zoom}}(1)$	≤ 4 mm	3 – 4 GHz: ≤ 3.0 mm 4 – 5 GHz: ≤ 2.5 mm 5 – 6 GHz: ≤ 2.0 mm
	$\Delta z_{\text{Zoom}}(n>1)$	$\leq 1.5 \cdot \Delta z_{\text{Zoom}}(n-1)$ mm	
Minimum zoom scan volume (x, y, z)		≥ 30 mm	3 – 4 GHz: ≥ 28 mm 4 – 5 GHz: ≥ 25 mm 5 – 6 GHz: ≥ 22 mm

Per IEC 62209-2 AMD1, the successively higher resolution zoom scan is required if the zoom scan measured as defined above complies with both of the following criteria, or if the peak spatial-average SAR is below 0.1 W/kg, no additional measurements are needed:

- (1) The smallest horizontal distance from the local SAR peaks to all points 3 dB below the SAR peak shall be larger than the horizontal grid steps in both x and y directions ($\Delta x, \Delta y$). This shall be checked for the measured zoom scan plane conformal to the phantom at the distance z_{M1} .
- (2) The ratio of the SAR at the second measured point (M2) to the SAR at the closest measured point (M1) at the x-y location of the measured maximum SAR value shall be at least 30 %.

If one or both of the above criteria are not met, the zoom scan measurement shall be repeated using a finer resolution. New horizontal and vertical grid steps shall be determined from the measured SAR distribution so that the above criteria are met. Compliance with the above two criteria shall be demonstrated for the new measured zoom scan.

3.4.2 Volume Scan Procedure

The volume scan is used for assess overlapping SAR distributions for antennas transmitting in different frequency bands. It is equivalent to an oversized zoom scan used in standalone measurements. The measurement volume will be used to enclose all the simultaneous transmitting antennas. For antennas transmitting simultaneously in different frequency bands, the volume scan is measured separately in each frequency band. In order to sum correctly to compute the 1g aggregate SAR, the EUT remain in the same test position for all measurements and all volume scan use the same spatial resolution and grid spacing. When all volume scan were completed, the software, SEMCAD postprocessor can combine and subsequently superpose these measurement data to calculating the multiband SAR.

3.4.3 Power Drift Monitoring

All SAR testing is under the EUT install full charged battery and transmit maximum output power. In DASY measurement software, the power reference measurement and power drift measurement procedures are used for monitoring the power drift of EUT during SAR test. Both these procedures measure the field at a specified reference position before and after the SAR testing. The software will calculate the field difference in dB. If the power drift more than 5%, the SAR will be retested.

3.4.4 Spatial Peak SAR Evaluation

The procedure for spatial peak SAR evaluation has been implemented according to the test standard. It can be conducted for 1g and 10g, as well as for user-specific masses. The DASY software includes all numerical procedures necessary to evaluate the spatial peak SAR value.

The base for the evaluation is a "cube" measurement. The measured volume must include the 1g and 10g cubes with the highest averaged SAR values. For that purpose, the center of the measured volume is aligned to the interpolated peak SAR value of a previously performed area scan.

The entire evaluation of the spatial peak values is performed within the post-processing engine (SEMCAD). The system always gives the maximum values for the 1g and 10g cubes. The algorithm to find the cube with highest averaged SAR is divided into the following stages:

- (a) Extraction of the measured data (grid and values) from the Zoom Scan
- (b) Calculation of the SAR value at every measurement point based on all stored data (A/D values and measurement parameters)
- (c) Generation of a high-resolution mesh within the measured volume
- (d) Interpolation of all measured values from the measurement grid to the high-resolution grid
- (e) Extrapolation of the entire 3-D field distribution to the phantom surface over the distance from sensor to surface
- (f) Calculation of the averaged SAR within masses of 1g and 10g

3.4.5 SAR Averaged Methods

In DASY, the interpolation and extrapolation are both based on the modified Quadratic Shepard's method. The interpolation scheme combines a least-square fitted function method and a weighted average method which are the two basic types of computational interpolation and approximation.

Extrapolation routines are used to obtain SAR values between the lowest measurement points and the inner phantom surface. The extrapolation distance is determined by the surface detection distance and the probe sensor offset. The uncertainty increases with the extrapolation distance. To keep the uncertainty within 1% for the 1 g and 10 g cubes, the extrapolation distance should not be larger than 5 mm.

4. SAR Measurement Evaluation

4.1 EUT Configuration and Setting

<Considerations Related to Proximity Sensor>

The device supports WLAN, and Bluetooth capabilities. It is designed with a proximity sensor which can trigger/not trigger power reduction for WLAN 2.4G, 5G and Bluetooth on Rear Face, Top Side, Left Side, Left Corner, Right Side and Right Corner of EUT for SAR compliance. The power levels for all wireless technologies and the power reduction please refer to section 4.6 of this report.

Proximity Sensor Triggering Distances (KDB 616217 D04 §6.2)

The proximity sensor triggering distance was determined per KDB 616217 for rear face and applicable edge. Summary for power verification per distance was tabulated in the below table.

<Ant.1>

Output Power Verification in dBm for EUT Rear Face												
Band	Distance (mm)	14	15	16	17	18	19	20	21	22	23	24
WLAN2.4G	19	10.3	10.4	10.5	10.4	10.6	10.6	18.8	19.3	19.2	19.0	19.3
WLAN 5.3G	19	8.5	8.2	8.5	8.5	8.3	8.5	17.2	17.3	17.5	17.5	17.4
WLAN 5.6G	19	8.9	8.6	8.9	8.6	8.4	8.5	16.9	16.7	16.6	16.6	16.9
WLAN 5.8G	19	8.4	8.9	8.7	8.8	8.4	8.6	16.3	16.2	15.9	16.3	16.2
Bluetooth	19	11.4	11.9	11.7	11.6	11.5	11.6	12.3	12.0	12.1	12.2	12.1

Output Power Verification in dBm for EUT Top Side												
Band	Distance (mm)	15	16	17	18	19	20	21	22	23	24	25
WLAN2.4G	20	10.7	10.2	10.4	10.6	10.3	10.4	19.3	18.9	18.8	19.1	19.2
WLAN 5.3G	20	8.5	8.2	8.5	8.7	8.5	8.7	17.1	17.6	17.1	17.4	17.1
WLAN 5.6G	20	8.6	8.5	8.6	8.7	8.5	8.5	16.9	16.9	16.6	16.8	16.7
WLAN 5.8G	20	8.8	8.6	8.5	8.5	8.5	8.7	16.2	16.0	16.4	16.4	15.9
Bluetooth	20	11.4	11.7	11.9	11.4	11.4	11.5	12.3	12.3	12.5	12.3	12.1

Output Power Verification in dBm for EUT Right Side												
Band	Distance (mm)	3	4	5	6	7	8	9	10	11	12	13
WLAN2.4G	8	10.3	10.3	10.4	10.2	10.2	10.2	18.8	18.8	18.8	18.8	18.9
WLAN 5.3G	8	8.2	8.2	8.6	8.3	8.7	8.6	17.2	17.5	17.3	17.2	17.1
WLAN 5.6G	8	8.7	8.7	8.6	8.6	8.9	8.8	16.6	16.8	16.5	16.9	16.4
WLAN 5.8G	8	8.8	8.6	8.9	8.7	8.4	8.7	15.9	16.4	16.2	16.0	16.4
Bluetooth	8	11.6	11.8	11.8	11.5	11.8	11.9	12.5	12.2	12.1	12.5	12.3

Output Power Verification in dBm for EUT Right Corner												
Band	Distance (mm)	7	8	9	10	11	12	13	14	15	16	17
WLAN2.4G	12	10.6	10.4	10.7	10.2	10.3	10.7	19.3	19.1	19.3	19.1	19.1
WLAN 5.3G	12	8.5	8.3	8.7	8.6	8.5	8.4	17.1	17.5	17.4	17.1	17.2
WLAN 5.6G	12	8.9	8.9	8.8	8.7	8.9	8.4	16.5	16.6	16.6	16.5	16.5
WLAN 5.8G	12	8.4	8.6	8.9	8.6	8.8	8.8	15.9	16.0	15.9	16.2	16.3
Bluetooth	12	11.6	11.4	11.6	11.8	11.6	11.8	12.4	12.0	12.0	12.1	12.5

SAR Test Report

<Ant.2>

Output Power Verification in dBm for EUT Rear Face												
Band	Distance (mm)	6	7	8	9	10	11	12	13	14	15	16
WLAN 2.4G	11	11.8	12.0	11.5	11.9	12.0	11.5	19.6	19.6	19.6	19.3	19.5
WLAN 5.3G	11	8.5	8.5	8.2	8.4	8.4	8.2	17.2	16.9	16.9	17.3	16.9
WLAN 5.6G	11	8.4	8.2	8.4	8.3	8.4	8.1	16.7	16.5	16.2	16.6	16.5
WLAN 5.8G	11	7.7	7.7	7.9	8.2	7.7	7.8	16.6	16.1	16.5	16.6	16.5
Bluetooth	11	10.3	10.2	10.0	10.5	10.1	10.5	10.7	10.9	10.8	10.5	11.0

Output Power Verification in dBm for EUT Top Edge												
Band	Distance (mm)	10	11	12	13	14	15	16	17	18	19	20
WLAN 2.4G	15	11.7	12.0	11.9	11.8	11.5	11.7	19.1	19.5	19.2	19.1	19.5
WLAN 5.3G	15	8.0	8.4	8.1	8.4	8.3	8.2	17.1	17.1	16.9	17.1	17.1
WLAN 5.6G	15	8.3	8.1	8.4	8.3	8.3	8.6	16.6	16.7	16.7	16.7	16.5
WLAN 5.8G	15	7.9	8.0	8.1	8.2	8.0	7.9	16.6	16.1	16.3	16.1	16.6
Bluetooth	15	10.2	10.4	10.4	10.0	10.4	10.0	10.8	11.0	10.5	10.5	10.9

Output Power Verification in dBm for EUT Left Edge												
Band	Distance (mm)	0	1	2	3	4	5	6	7	8	9	10
WLAN 2.4G	5	11.5	11.6	11.9	11.7	11.5	11.9	19.3	19.1	19.2	19.5	19.2
WLAN 5.3G	5	8.1	8.4	8.3	8.0	8.2	8.1	17.1	17.1	17.1	17.3	17.2
WLAN 5.6G	5	8.6	8.6	8.4	8.2	8.5	8.5	16.4	16.7	16.2	16.6	16.6
WLAN 5.8G	5	7.8	7.9	8.0	8.2	7.9	7.8	16.1	16.6	16.5	16.5	16.1
Bluetooth	5	10.4	10.0	10.3	10.4	10.2	10.4	10.9	10.7	10.6	10.7	10.5

Output Power Verification in dBm for EUT Left Corner												
Band	Distance (mm)	5	6	7	8	9	10	11	12	13	14	15
WLAN 2.4G	10	11.6	11.6	12.0	12.0	11.5	11.9	19.1	19.5	19.1	19.4	19.2
WLAN 5.3G	10	8.5	8.2	8.3	8.1	8.1	8.4	16.8	16.8	17.0	17.0	16.8
WLAN 5.6G	10	8.5	8.6	8.5	8.4	8.5	8.6	16.2	16.6	16.4	16.7	16.2
WLAN 5.8G	10	8.1	7.8	7.9	8.2	7.9	7.7	16.1	16.4	16.1	16.6	16.1
Bluetooth	10	10.1	10.1	10.3	10.0	10.5	10.3	10.5	11.0	10.6	10.8	10.9

SAR Test Report

Proximity Sensor Coverage (KDB 616217 D04 §6.3)

Since the proximity sensor is collocated with antenna in one component, the procedure for proximity sensor coverage is not required.

Proximity Sensor Tilt Angle Influences (KDB 616217 D04 §6.4)

The proximity sensor tilt angle influence was determined per KDB 616217 for applicable edge. Summary for proximity sensor tilt angle influence is shown in below.

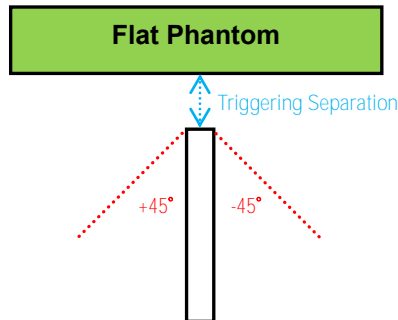

<Ant. 1>

Orientation	Separation Distance (mm)	Tilt Angle										
		-45°	-40°	-30°	-20°	-10°	0°	10°	20°	30°	40°	45°
Top Edge	20	On	On	On	On	On	On	On	On	On	On	On
Right Edge	8	On	On	On	On	On	On	On	On	On	On	On
Right Corner	12	On	On	On	On	On	On	On	On	On	On	On

<Ant. 2>

Orientation	Separation Distance (mm)	Tilt Angle										
		-45°	-40°	-30°	-20°	-10°	0°	10°	20°	30°	40°	45°
Top Edge	15	On	On	On	On	On	On	On	On	On	On	On
Left Edge	5	On	On	On	On	On	On	On	On	On	On	On
Left Corner	10	On	On	On	On	On	On	On	On	On	On	On

Summary for Proximity Sensor Triggering Test

According to the procedures noticed in KDB 616217 D04, the WLAN Ant 1 proximity sensor triggering distance is 19 mm for EUT Rear Face, 8 mm for EUT Right Side, 12 mm for EUT Right Corner and 20 mm for EUT Top Side, . The separation distance of 8 mm determined by the smallest triggering distance on Right Side, Right Corner is 12mm and Top Side is 20mm are used to access the tilt angle influence and the sensor does not release during ± 45 degree. Therefore, the smallest separation distance for tilt angle influence is 8 mm for the Right Side, 12mm for Right Corner and 20mm for Top Side. The conservation triggering distances based on the separation distance for the sensor trigger / not triggered as EUT with power reduction at 0 mm, and EUT without power reduction at 18 mm for EUT Rear Face, and 7 mm for Right Side, 11mm for Right Corner and 19mm for Top Side were used to test SAR.

SAR Test Report

The WLAN Ant 2 proximity sensor triggering distance is 11 mm for EUT Rear Face, 5 mm for EUT Left Side, 10 mm for EUT Left Corner and 15 mm for EUT Top Side, . The separation distance of 5 mm determined by the smallest triggering distance on Left Side, Left Corner is 10mm and Top Side is 15mm are used to access the tilt angle influence and the sensor does not release during ± 45 degree. Therefore, the smallest separation distance for tilt angle influence is 5 mm for the Left Side, 10mm for Left Corner and 15mm for Top Side. The conservation triggering distances based on the separation distance for the sensor trigger / not triggered as EUT with power reduction at 0 mm, and EUT without power reduction at 10 mm for EUT Rear Face, and 4 mm for Left Side, 9mm for Left Corner and 14mm for Top Side were used to test SAR.

For the WLAN MIMO mode the test distance, according to the WLAN Ant1 and Ant2 proximity sensor of test result, they used smaller distance to test SAR at same position.

The power reduction is depends on the proximity sensor input. For a steady SAR test, the power reduction was enabled or disabled manually by engineering software during SAR testing.

<Considerations Related to WLAN for Setup and Testing>

In general, various vendor specific external test software and chipset based internal test modes are typically used for SAR measurement. These chipset based test mode utilities are generally hardware and manufacturer dependent, and often include substantial flexibility to reconfigure or reprogram a device. A Wi-Fi device must be configured to transmit continuously at the required data rate, channel bandwidth and signal modulation, using the highest transmission duty factor supported by the test mode tools for SAR measurement. The test frequencies established using test mode must correspond to the actual channel frequencies. When 802.11 frame gaps are accounted for in the transmission, a maximum transmission duty factor of 92 - 96% is typically achievable in most test mode configurations. A minimum transmission duty factor of 85% is required to avoid certain hardware and device implementation issues related to wide range SAR scaling. In addition, a periodic transmission duty factor is required for current generation SAR systems to measure SAR correctly. The reported SAR must be scaled to 100% transmission duty factor to determine compliance at the maximum tune-up tolerance limit.

According to KDB 248227 D01, this device has installed WLAN engineering testing software which can provide continuous transmitting RF signal. During WLAN SAR testing, this device was operated to transmit continuously at the maximum transmission duty with specified transmission mode, operating frequency, lowest data rate, and maximum output power.

Initial Test Configuration

An initial test configuration is determined for OFDM transmission modes in 2.4 GHz and 5 GHz bands according to the channel bandwidth, modulation and data rate combination(s) with the highest maximum output power specified for production units in each standalone and aggregated frequency band. When the same maximum power is specified for multiple transmission modes in a frequency band, the largest channel bandwidth, lowest order modulation, lowest data rate and lowest order 802.11a/g/n/ac mode is used for SAR measurement, on the highest measured output power channel in the initial test configuration, for each frequency band.

Subsequent Test Configuration

SAR measurement requirements for the remaining 802.11 transmission mode configurations that have not been tested in the initial test configuration are determined separately for each standalone and aggregated frequency band, in each exposure condition, according to the maximum output power specified for production units. Additional power measurements may be required to determine if SAR measurements are required for subsequent highest output power channels in a subsequent test configuration. When the highest reported SAR for the initial test configuration according to the initial test position or fixed exposure position requirements, is adjusted by the ratio of the subsequent test configuration to initial test configuration specified maximum output power and the adjusted SAR is ≤ 1.2 W/kg, SAR is not required for that subsequent test configuration.

SAR Test Configuration and Channel Selection

When multiple channel bandwidth configurations in a frequency band have the same specified maximum output power, the initial test configuration is using largest channel bandwidth, lowest order modulation, lowest data rate, and lowest order 802.11 mode (i.e., 802.11a is chosen over 802.11n then 802.11ac or 802.11g is chosen over 802.11n). After an initial test configuration is determined, if multiple test channels have the same measured maximum output power, the channel chosen for SAR measurement is determined according to the following.

- 1) The channel closest to mid-band frequency is selected for SAR measurement.
- 2) For channels with equal separation from mid-band frequency; for example, high and low channels or two mid-band channels, the higher frequency (number) channel is selected for SAR measurement.

Test Reduction for U-NII-1 (5.2 GHz) and U-NII-2A (5.3 GHz) Bands

For devices that operate in both U-NII bands using the same transmitter and antenna(s), SAR test reduction is determined according to the following.

- 1) When the same maximum output power is specified for both bands, begin SAR measurement in U-NII-2A band by applying the OFDM SAR requirements. If the highest reported SAR for a test configuration is ≤ 1.2 W/kg, SAR is not required for U-NII-1 band for that configuration (802.11 mode and exposure condition).
- 2) When different maximum output power is specified for the bands, begin SAR measurement in the band with higher specified maximum output power. The highest reported SAR for the tested configuration is adjusted by the ratio of lower to higher specified maximum output power for the two bands. When the adjusted SAR is ≤ 1.2 W/kg, SAR is not required for the band with lower maximum output power in that test configuration.

SAR Test Report

<Considerations Related to Bluetooth for Setup and Testing>

This device has installed Bluetooth engineering testing software which can provide continuous transmitting RF signal. During Bluetooth SAR testing, this device was operated to transmit continuously at the maximum transmission duty with specified transmission mode, operating frequency, lowest data rate, and maximum output power.

The Bluetooth call box has been used during SAR measurement and the EUT was set to DH5 mode at the maximum output power. Its duty factor was calculated as below and the measured SAR for Bluetooth would be scaled to the 100% transmission duty factor to determine compliance.

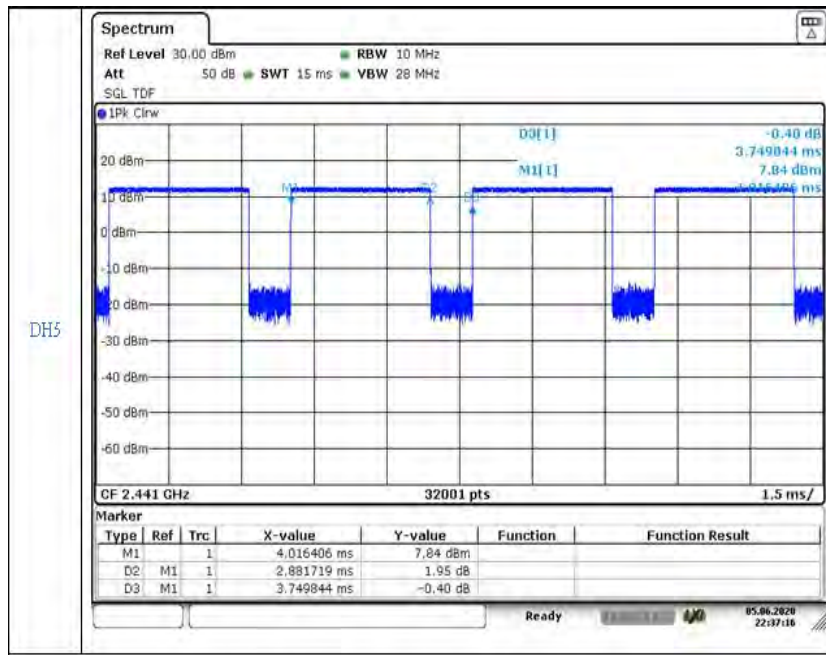

Time-domain plot for Bluetooth transmission signal

The duty factor of Bluetooth signal has been calculated as following.

$$\text{Duty Factor} = \text{Pulse Width} / \text{Total Period} = 2.881719 / 3.749844 = 76.85 \%$$

4.2 EUT Testing Position

4.2.1 Body Exposure Conditions

For full-size tablet, according to KDB 616217 D04, SAR evaluation is required for back surface and edges of the devices. The back surface and edges of the tablet are tested with the tablet touching the phantom. Exposures from antennas through the front surface of the display section of a tablet are generally limited to the user's hands. Exposures to hands for typical consumer transmitters used in tablets are not expected to exceed the extremity SAR limit; therefore, SAR evaluation for the front surface of tablet display screens are generally not necessary. When voice mode is supported on a tablet and it is limited to speaker mode or headset operations only, additional SAR testing for this type of voice use is not required.

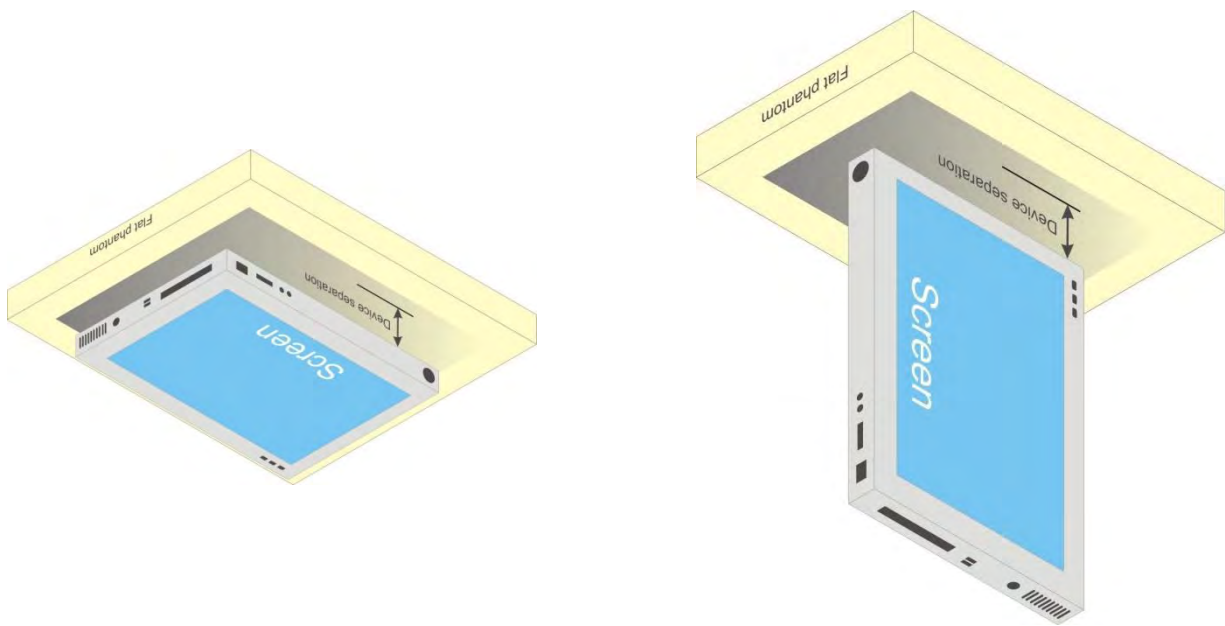

Fig-4.1 Illustration for Tablet Setup

4.3 Tissue Verification

The measuring results for tissue simulating liquid are shown as below.

Frequency (MHz)	Liquid Temp. (°C)	Measured Conductivity (σ)	Measured Permittivity (ϵ_r)	Target Conductivity (σ)	Target Permittivity (ϵ_r)	Conductivity Deviation (%)	Permittivity Deviation (%)	Test Date
2450	23.2	1.882	38.31	1.8	39.2	4.56	-2.27	Jun. 10, 2020
2450	23.3	1.865	37.815	1.8	39.2	3.61	-3.53	Jun. 12, 2020
2450	23.3	1.842	38.429	1.8	39.2	2.33	-1.97	Jun. 13, 2020
2450	23.4	1.869	39.083	1.8	39.2	3.83	-0.30	Jun. 19, 2020
2450	23.1	1.87	39.027	1.8	39.2	3.89	-0.44	Jun. 23, 2020
2450	23.1	1.861	39.172	1.8	39.2	3.39	-0.07	Jun. 27, 2020
2450	23.3	1.869	38.083	1.8	39.2	3.83	-2.85	Jul. 01, 2020
5250	23.2	4.78	35.347	4.71	35.9	1.49	-1.54	Jun. 10, 2020
5250	23.2	4.744	36.854	4.71	35.9	0.72	2.66	Jun. 14, 2020
5250	23.1	4.753	35.645	4.71	35.9	0.91	-0.71	Jun. 15, 2020
5250	23.5	4.513	37.007	4.71	35.9	-4.18	3.08	Jun. 17, 2020
5250	23.4	4.793	35.468	4.71	35.9	1.76	-1.20	Jun. 19, 2020
5600	23.5	4.854	36.544	5.07	35.5	-4.26	2.94	Jun. 17, 2020
5600	23.4	5.17	34.876	5.07	35.5	1.97	-1.76	Jun. 19, 2020
5600	23.4	4.889	35.563	5.07	35.5	-3.57	0.18	Jun. 20, 2020
5600	23.5	4.985	36.919	5.07	35.5	-1.68	4.00	Jun. 20, 2020
5600	23.1	5.12	34.235	5.07	35.5	0.99	-3.56	Jun. 23, 2020
5600	23.1	5.025	34.997	5.07	35.5	-0.89	-1.42	Jun. 24, 2020
5750	23.5	5.006	36.323	5.22	35.4	-4.10	2.61	Jun. 17, 2020
5750	23.4	5.331	34.529	5.22	35.4	2.13	-2.46	Jun. 19, 2020
5750	23.5	5.141	36.702	5.22	35.4	-1.51	3.68	Jun. 20, 2020
5750	23.1	5.282	33.95	5.22	35.4	1.19	-4.10	Jun. 23, 2020

Note:

The dielectric properties of the tissue simulating liquid have been measured within 24 hours before the SAR testing and within $\pm 10\%$ of the target values. Liquid temperature during the SAR testing has kept within $\pm 2^\circ\text{C}$.

SAR Test Report

4.4 System Validation

The SAR measurement system was validated according to procedures in KDB 865664 D01. The validation status in tabulated summary is as below.

Test Date	Probe S/N	Calibration Point	Measured Conductivity (σ)	Measured Permittivity (ϵ_r)	Validation for CW			Validation for Modulation		
					Sensitivity Range	Probe Linearity	Probe Isotropy	Modulation Type	Duty Factor	PAR
Jun. 10, 2020	3971	2450	1.882	38.31	Pass	Pass	Pass	OFDM	N/A	Pass
Jun. 12, 2020	7350	2450	1.865	37.815	Pass	Pass	Pass	OFDM	N/A	Pass
Jun. 13, 2020	7350	2450	1.842	38.429	Pass	Pass	Pass	OFDM	N/A	Pass
Jun. 19, 2020	7472	2450	1.869	39.083	Pass	Pass	Pass	OFDM	N/A	Pass
Jun. 23, 2020	7350	2450	1.87	39.027	Pass	Pass	Pass	OFDM	N/A	Pass
Jun. 27, 2020	7350	2450	1.861	39.172	Pass	Pass	Pass	OFDM	N/A	Pass
Jul. 01, 2020	7350	2450	1.869	38.083	Pass	Pass	Pass	OFDM	N/A	Pass
Jun. 10, 2020	3971	5250	4.78	35.347	Pass	Pass	Pass	OFDM	N/A	Pass
Jun. 14, 2020	7350	5250	4.744	36.854	Pass	Pass	Pass	OFDM	N/A	Pass
Jun. 15, 2020	3971	5250	4.753	35.645	Pass	Pass	Pass	OFDM	N/A	Pass
Jun. 17, 2020	3971	5250	4.513	37.007	Pass	Pass	Pass	OFDM	N/A	Pass
Jun. 19, 2020	7472	5250	4.793	35.468	Pass	Pass	Pass	OFDM	N/A	Pass
Jun. 17, 2020	3971	5600	4.854	36.544	Pass	Pass	Pass	OFDM	N/A	Pass
Jun. 19, 2020	7472	5600	5.17	34.876	Pass	Pass	Pass	OFDM	N/A	Pass
Jun. 20, 2020	7472	5600	4.889	35.563	Pass	Pass	Pass	OFDM	N/A	Pass
Jun. 20, 2020	7350	5600	4.985	36.919	Pass	Pass	Pass	OFDM	N/A	Pass
Jun. 23, 2020	7350	5600	5.12	34.235	Pass	Pass	Pass	OFDM	N/A	Pass
Jun. 24, 2020	7350	5600	5.025	34.997	Pass	Pass	Pass	OFDM	N/A	Pass
Jun. 17, 2020	3971	5750	5.006	36.323	Pass	Pass	Pass	OFDM	N/A	Pass
Jun. 19, 2020	7472	5750	5.331	34.529	Pass	Pass	Pass	OFDM	N/A	Pass
Jun. 20, 2020	7350	5750	5.141	36.702	Pass	Pass	Pass	OFDM	N/A	Pass
Jun. 23, 2020	7350	5750	5.282	33.95	Pass	Pass	Pass	OFDM	N/A	Pass

4.5 System Verification

The measuring result for system verification is tabulated as below.

Test Date	Frequency (MHz)	1W Target SAR-1g (W/kg)	Measured SAR-1g (W/kg)	Normalized to 1W SAR-1g (W/kg)	Deviation (%)	Dipole S/N	Probe S/N	DAE S/N
Jun. 10, 2020	2450	52.70	2.81	56.20	6.64	737	3971	1277
Jun. 12, 2020	2450	52.70	2.75	55.00	4.36	737	7350	917
Jun. 13, 2020	2450	52.70	2.45	49.00	-7.02	737	7350	917
Jun. 19, 2020	2450	52.70	2.69	53.80	2.09	737	7472	579
Jun. 23, 2020	2450	52.70	2.74	54.80	3.98	737	7350	917
Jun. 27, 2020	2450	52.70	2.67	53.40	1.33	737	7350	917
Jul. 01, 2020	2450	52.70	2.46	49.20	-6.64	737	7350	917
Jun. 10, 2020	5250	79.70	3.61	72.20	-9.41	1019	3971	1277
Jun. 14, 2020	5250	79.70	4.02	80.40	0.88	1019	7350	917
Jun. 15, 2020	5250	79.70	3.6	72.00	-9.66	1019	3971	1277
Jun. 17, 2020	5250	79.70	3.84	76.80	-3.64	1019	3971	1277
Jun. 19, 2020	5250	79.70	4.08	81.60	2.38	1019	7472	579
Jun. 17, 2020	5600	83.80	4.16	83.20	-0.72	1019	3971	1277
Jun. 19, 2020	5600	83.80	4.41	88.20	5.25	1019	7472	579
Jun. 20, 2020	5600	83.80	4.22	84.40	0.72	1019	7472	579
Jun. 20, 2020	5600	83.80	4.01	80.20	-4.30	1019	7350	917
Jun. 23, 2020	5600	83.80	4.11	82.20	-1.91	1019	7350	917
Jun. 24, 2020	5600	83.80	3.88	77.60	-7.40	1019	7350	917
Jun. 17, 2020	5750	80.40	3.95	79.00	-1.74	1019	3971	1277
Jun. 19, 2020	5750	80.40	4.1	82.00	1.99	1019	7472	579
Jun. 20, 2020	5750	80.40	3.94	78.80	-1.99	1019	7350	917
Jun. 23, 2020	5750	80.40	3.99	79.80	-0.75	1019	7350	917

Note:

Comparing to the reference SAR value provided by SPEAG in dipole calibration certificate, the deviation of system check results is within its specification of 10 %. The result indicates the system check can meet the variation criterion and the plots please refer to Appendix A of this report.

4.6 Maximum Output Power

4.6.1 Maximum Target Conducted Power

Refer to Appendix C.

4.6.2 Measured Conducted Power Result

Refer to Appendix D.

4.7 SAR Testing Results

4.7.1 SAR Test Reduction Considerations

<KDB 447498 D01, General RF Exposure Guidance>

Testing of other required channels within the operating mode of a frequency band is not required when the reported SAR for the mid-band or highest output power channel is:

- (1) ≤ 0.8 W/kg or 2.0 W/kg, for 1-g or 10-g respectively, when the transmission band is ≤ 100 MHz
- (2) ≤ 0.6 W/kg or 1.5 W/kg, for 1-g or 10-g respectively, when the transmission band is between 100 MHz and 200 MHz
- (3) ≤ 0.4 W/kg or 1.0 W/kg, for 1-g or 10-g respectively, when the transmission band is ≥ 200 MHz

When SAR is not measured at the maximum power level allowed for production units, the measured SAR will be scaled to the maximum tune-up tolerance limit to determine compliance. The scaling factor for the tune-up power is defined as maximum tune-up limit (mW) / measured conducted power (mW). The reported SAR would be calculated by measured SAR x tune-up power scaling factor.

The SAR has been measured with highest transmission duty factor supported by the test mode tools for WLAN and/or Bluetooth. When the transmission duty factor could not achieve 100%, the reported SAR will be scaled to 100% transmission duty factor to determine compliance at the maximum tune-up power. The scaling factor for the duty factor is defined as 100% / transmission duty cycle (%). The reported SAR would be calculated by measured SAR x tune-up power scaling factor x duty cycle scaling factor.

<KDB 248227 D01, SAR Guidance for Wi-Fi Transmitters>

- (1) For WLAN 2.4 GHz, the highest measured maximum output power channel for DSSS was selected for SAR measurement. When the reported SAR is ≤ 0.8 W/kg, no further SAR testing is required. Otherwise, SAR is evaluated at the next highest measured output power channel. When any reported SAR is > 1.2 W/kg, SAR is required for the third channel. For OFDM modes (802.11g/n), SAR is not required when the highest reported SAR for DSSS is adjusted by the ratio of OFDM to DSSS specified maximum output power and it is ≤ 1.2 W/kg.
- (2) For WLAN 5GHz, the initial test configuration was selected according to the transmission mode with the highest maximum output power. When the reported SAR of initial test configuration is > 0.8 W/kg, SAR is required for the subsequent highest measured output power channel until the reported SAR result is ≤ 1.2 W/kg or all required channels are measured. For other transmission modes, SAR is not required when the highest reported SAR for initial test configuration is adjusted by the ratio of subsequent test configuration to initial test configuration specified maximum output power and it is ≤ 1.2 W/kg.
- (3) For WLAN MIMO mode, the power-based standalone SAR test exclusion or the sum of SAR provision in KDB 447498 to determine simultaneous transmission SAR test exclusion should be applied. Otherwise, SAR for MIMO mode will be measured with all applicable antennas transmitting simultaneously at the specified maximum output power of MIMO operation.

SAR Test Report

4.7.2 SAR Results for Body Exposure Condition

Plot No.	Band	Mode	Test Position	Separation Distance (cm)	Ch.	P-sensor	Tx Antenna	Keyboard Cover	Duty Cycle	Crest Factor	Max. Tune-up Power (dBm)	Measured Conducted Power (dBm)	Scaling Factor	Power Drift (dB)	Measured SAR-1g (W/kg)	Scaled SAR-1g (W/kg)
	WLAN2.4G	802.11b	Rear Face	10	1	w/o	Ant 2		99.85	1.00	20.00	19.59	1.10	-0.07	0.279	0.31
	WLAN2.4G	802.11b	Left Side	4	1	w/o	Ant 2		99.85	1.00	20.00	19.59	1.10	0.09	0.673	0.74
	WLAN2.4G	802.11b	Left Corner	9	1	w/o	Ant 2		99.85	1.00	20.00	19.59	1.10	0.03	0.087	0.10
	WLAN2.4G	802.11b	Right Side	0	1	w/o	Ant 2		99.85	1.00	20.00	19.59	1.10	0	<0.001	0.00
	WLAN2.4G	802.11b	Top Side	14	1	w/o	Ant 2		99.85	1.00	20.00	19.59	1.10	-0.03	0.031	0.03
	WLAN2.4G	802.11b	Bottom Side	0	1	w/o	Ant 2		99.85	1.00	20.00	19.59	1.10	0	<0.001	0.00
	WLAN2.4G	802.11b	Rear Face	10	1	w/o	MIMO_Ant 1		99.85	1.00	20.00	19.10	1.23	0.03	0.456	0.56
							MIMO_Ant 2		99.85	1.00	20.00	19.91	1.02	0	<0.001	0.00
01	WLAN2.4G	802.11b	Left Side	4	1	w/o	MIMO_Ant 1		99.85	1.00	20.00	19.10	1.23	0	<0.001	0.00
							MIMO_Ant 2		99.85	1.00	20.00	19.91	1.02	-0.04	0.880	0.90
	WLAN2.4G	802.11b	Left Corner	9	1	w/o	MIMO_Ant 1		99.85	1.00	20.00	19.10	1.23	0	<0.001	0.00
							MIMO_Ant 2		99.85	1.00	20.00	19.91	1.02	-0.1	0.144	0.15
	WLAN2.4G	802.11b	Right Side	7	1	w/o	MIMO_Ant 1		99.85	1.00	20.00	19.10	1.23	-0.05	0.638	0.78
							MIMO_Ant 2		99.85	1.00	20.00	19.91	1.02	0	<0.001	0.00
	WLAN2.4G	802.11b	Right Corner	11	1	w/o	MIMO_Ant 1		99.85	1.00	20.00	19.10	1.23	0.08	0.196	0.24
							MIMO_Ant 2		99.85	1.00	20.00	19.91	1.02	0	<0.001	0.00
	WLAN2.4G	802.11b	Top Side	14	1	w/o	MIMO_Ant 1		99.85	1.00	20.00	19.10	1.23	-0.06	0.194	0.24
							MIMO_Ant 2		99.85	1.00	20.00	19.91	1.02	0	<0.001	0.00
	WLAN2.4G	802.11b	Bottom Side	0	1	w/o	MIMO_Ant 1		99.85	1.00	20.00	19.10	1.23	0	<0.001	0.00
							MIMO_Ant 2		99.85	1.00	20.00	19.91	1.02	0	<0.001	0.00
	WLAN2.4G	802.11b	Rear Face	0	1	w/	Ant 2		99.85	1.00	11.50	11.24	1.06	-0.12	0.384	0.41
	WLAN2.4G	802.11b	Left Side	0	1	w/	Ant 2		99.85	1.00	11.50	11.24	1.06	-0.03	0.484	0.51
	WLAN2.4G	802.11b	Left Corner	0	1	w/	Ant 2		99.85	1.00	11.50	11.24	1.06	-0.15	0.118	0.13
	WLAN2.4G	802.11b	Top Side	0	1	w/	Ant 2		99.85	1.00	11.50	11.24	1.06	0.02	0.132	0.14
	WLAN2.4G	802.11b	Rear Face	0	1	w/	MIMO_Ant 1		99.85	1.00	11.50	10.55	1.24	-0.12	0.333	0.41
							MIMO_Ant 2		99.85	1.00	11.50	11.20	1.07	-0.12	0.298	0.32
	WLAN2.4G	802.11b	Left Side	0	1	w/	MIMO_Ant 1		99.85	1.00	11.50	10.55	1.24	0	<0.001	0.00
							MIMO_Ant 2		99.85	1.00	11.50	11.20	1.07	-0.12	0.534	0.57
	WLAN2.4G	802.11b	Left Corner	0	1	w/	MIMO_Ant 1		99.85	1.00	11.50	10.55	1.24	0	<0.001	0.00
							MIMO_Ant 2		99.85	1.00	11.50	11.20	1.07	0.12	0.085	0.09
	WLAN2.4G	802.11b	Right Side	0	1	w/	MIMO_Ant 1		99.85	1.00	11.50	10.55	1.24	-0.18	0.244	0.30
							MIMO_Ant 2		99.85	1.00	11.50	11.20	1.07	0	<0.001	0.00
	WLAN2.4G	802.11b	Right Corner	0	1	w/	MIMO_Ant 1		99.85	1.00	11.50	10.55	1.24	0.07	0.182	0.23
							MIMO_Ant 2		99.85	1.00	11.50	11.20	1.07	0	<0.001	0.00
	WLAN2.4G	802.11b	Top Side	0	1	w/	MIMO_Ant 1		99.85	1.00	11.50	10.55	1.24	0.14	0.252	0.31
							MIMO_Ant 2		99.85	1.00	11.50	11.20	1.07	0	<0.001	0.00
	WLAN2.4G	802.11b	Left Side	4	6	w/o	MIMO_Ant 1		99.85	1.00	20.00	19.34	1.16	0	<0.001	0.00
							MIMO_Ant 2		99.85	1.00	20.00	19.52	1.12	0.15	0.684	0.77
	WLAN2.4G	802.11b	Left Side	4	11	w/o	MIMO_Ant 1		99.85	1.00	20.00	18.92	1.28	0	<0.001	0.00
							MIMO_Ant 2		99.85	1.00	20.00	19.75	1.06	0.13	0.683	0.72
	WLAN2.4G	802.11b	Left Side	4	12	w/o	MIMO_Ant 1		99.85	1.00	2.0	1.12	1.22	0	<0.001	0.00
							MIMO_Ant 2		99.85	1.00	2.0	1.95	1.01	0	<0.001	0.00
	WLAN2.4G	802.11b	Left Side	4	13	w/o	MIMO_Ant 1		99.85	1.00	2.0	1.33	1.17	0	<0.001	0.00
							MIMO_Ant 2		99.85	1.00	2.0	1.97	1.01	0	<0.001	0.00
	WLAN2.4G	802.11b	Left Side	4	1	w/o	MIMO_Ant 1		99.85	1.00	20.00	19.10	1.23	0	<0.001	0.00
							MIMO_Ant 2	v	99.85	1.00	20.00	19.91	1.02	0.1	0.265	0.27
	WLAN2.4G	802.11b	Left Side	4	1	w/o	MIMO_Ant 1		99.85	1.00	20.00	19.10	1.23	0	<0.001	0.00
							MIMO_Ant 2		99.85	1.00	20.00	19.91	1.02	-0.04	0.857	0.87

Note.

1. The "< 0.001" means there is no SAR value or the SAR is too low to be measured.
2. Zoom scan will interrupted the secondary hotspot if maximum SAR value is below 0.1 W/kg under WLAN MIMO mode.

SAR Test Report

Plot No.	Band	Mode	Test Position	Separation Distance (cm)	Ch.	P-sensor	Tx Antenna	Keyboard Cover	Duty Cycle	Crest Factor	Max. Tune-up Power (dBm)	Measured Conducted Power (dBm)	Scaling Factor	Power Drift (dB)	Measured SAR-1g (W/kg)	Scaled SAR-1g (W/kg)
	WLAN5.3G	802.11a	Rear Face	18	52	w/o	Ant 1		98.83	1.01	18.00	17.62	1.09	-0.08	0.086	0.09
	WLAN5.3G	802.11a	Left Side	0	52	w/o	Ant 1		98.83	1.01	18.00	17.62	1.09	0.16	0.0069	0.01
	WLAN5.3G	802.11a	Right Side	7	52	w/o	Ant 1		98.83	1.01	18.00	17.62	1.09	0.03	0.656	0.72
	WLAN5.3G	802.11a	Right Corner	11	52	w/o	Ant 1		98.83	1.01	18.00	17.62	1.09	0.14	0.287	0.32
	WLAN5.3G	802.11a	Top Side	19	52	w/o	Ant 1		98.83	1.01	18.00	17.62	1.09	0.12	0.089	0.10
	WLAN5.3G	802.11a	Bottom Side	0	52	w/o	Ant 1		98.83	1.01	18.00	17.62	1.09	0	<0.001	0.00
	WLAN5.3G	802.11a	Rear Face	10	52	w/o	Ant 2		98.83	1.01	18.00	17.34	1.16	-0.07	0.11	0.13
	WLAN5.3G	802.11a	Left Side	4	52	w/o	Ant 2		98.83	1.01	18.00	17.34	1.16	0.14	0.313	0.37
	WLAN5.3G	802.11a	Left Corner	9	52	w/o	Ant 2		98.83	1.01	18.00	17.34	1.16	-0.02	0.036	0.04
	WLAN5.3G	802.11a	Right Side	0	52	w/o	Ant 2		98.83	1.01	18.00	17.34	1.16	0.15	0.011	0.01
	WLAN5.3G	802.11a	Top Side	14	52	w/o	Ant 2		98.83	1.01	18.00	17.34	1.16	0.09	0.035	0.04
	WLAN5.3G	802.11a	Bottom Side	0	52	w/o	Ant 2		98.83	1.01	18.00	17.34	1.16	0	<0.001	0.00
	WLAN5.3G	802.11a	Rear Face	10	52	w/o	MIMO_Ant 1		98.83	1.01	18.00	17.89	1.03	0.11	0.261	0.27
							MIMO_Ant 2		98.83	1.01	18.00	17.66	1.08	0	<0.001	0.00
	WLAN5.3G	802.11a	Left Side	4	52	w/o	MIMO_Ant 1		98.83	1.01	18.00	17.89	1.03	0	<0.001	0.00
							MIMO_Ant 2		98.83	1.01	18.00	17.66	1.08	0.01	0.437	0.48
	WLAN5.3G	802.11a	Left Corner	9	52	w/o	MIMO_Ant 1		98.83	1.01	18.00	17.89	1.03	0	<0.001	0.00
							MIMO_Ant 2		98.83	1.01	18.00	17.66	1.08	0.03	0.077	0.08
	WLAN5.3G	802.11a	Right Side	7	52	w/o	MIMO_Ant 1		98.83	1.01	18.00	17.89	1.03	-0.05	0.673	0.70
							MIMO_Ant 2		98.83	1.01	18.00	17.66	1.08	0	<0.001	0.00
	WLAN5.3G	802.11a	Right Corner	11	52	w/o	MIMO_Ant 1		98.83	1.01	18.00	17.89	1.03	0.07	0.303	0.32
							MIMO_Ant 2		98.83	1.01	18.00	17.66	1.08	0	<0.001	0.00
	WLAN5.3G	802.11a	Top Side	14	52	w/o	MIMO_Ant 1		98.83	1.01	18.00	17.89	1.03	0.06	0.158	0.16
							MIMO_Ant 2		98.83	1.01	18.00	17.66	1.08	0	<0.001	0.00
	WLAN5.3G	802.11a	Bottom Side	0	52	w/o	MIMO_Ant 1		98.83	1.01	18.00	17.89	1.03	0	<0.001	0.00
							MIMO_Ant 2		98.83	1.01	18.00	17.66	1.08	0	<0.001	0.00
	WLAN5.3G	802.11ac VHT80	Rear Face	0	58	w/	Ant 1		99.69	1.00	9.00	8.74	1.06	0.02	0.385	0.41
	WLAN5.3G	802.11ac VHT80	Right Side	0	58	w/	Ant 1		99.69	1.00	9.00	8.74	1.06	-0.01	0.6	0.64
	WLAN5.3G	802.11ac VHT80	Right Corner	0	58	w/	Ant 1		99.69	1.00	9.00	8.74	1.06	-0.09	0.329	0.35
	WLAN5.3G	802.11ac VHT80	Top Side	0	58	w/	Ant 1		99.69	1.00	9.00	8.74	1.06	-0.19	0.363	0.38
02	WLAN5.3G	802.11ac VHT80	Rear Face	0	58	w/	Ant 2		99.69	1.00	9.00	8.53	1.11	0.09	0.768	0.85
	WLAN5.3G	802.11ac VHT80	Left Side	0	58	w/	Ant 2		99.69	1.00	9.00	8.53	1.11	0.05	0.402	0.45
	WLAN5.3G	802.11ac VHT80	Left Corner	0	58	w/	Ant 2		99.69	1.00	9.00	8.53	1.11	-0.03	0.113	0.13
	WLAN5.3G	802.11ac VHT80	Top Side	0	58	w/	Ant 2		99.69	1.00	9.00	8.53	1.11	0.1	0.237	0.26
	WLAN5.3G	802.11ac VHT80	Rear Face	0	58	w/	MIMO_Ant 1		99.69	1.00	9.00	8.44	1.14	0	<0.001	0.00
							MIMO_Ant 2		99.69	1.00	9.00	7.88	1.29	0.08	0.429	0.55
	WLAN5.3G	802.11ac VHT80	Left Side	0	58	w/	MIMO_Ant 1		99.69	1.00	9.00	8.44	1.14	0.11	0.364	0.41
							MIMO_Ant 2		99.69	1.00	9.00	7.88	1.29	0	<0.001	0.00
	WLAN5.3G	802.11ac VHT80	Left Corner	0	58	w/	MIMO_Ant 1		99.69	1.00	9.00	8.44	1.14	0	<0.001	0.00
							MIMO_Ant 2		99.69	1.00	9.00	7.88	1.29	-0.01	0.103	0.13
	WLAN5.3G	802.11ac VHT80	Right Side	0	58	w/	MIMO_Ant 1		99.69	1.00	9.00	8.44	1.14	-0.05	0.603	0.69
							MIMO_Ant 2		99.69	1.00	9.00	7.88	1.29	0	<0.001	0.00
	WLAN5.3G	802.11ac VHT80	Right Corner	0	58	w/	MIMO_Ant 1		99.69	1.00	9.00	8.44	1.14	0.08	0.316	0.36
							MIMO_Ant 2		99.69	1.00	9.00	7.88	1.29	0	<0.001	0.00
	WLAN5.3G	802.11ac VHT80	Top Side	0	58	w/	MIMO_Ant 1		99.69	1.00	9.00	8.44	1.14	0	<0.001	0.00
							MIMO_Ant 2		99.69	1.00	9.00	7.88	1.29	-0.05	0.211	0.27
	WLAN5.3G	802.11ac VHT80	Rear Face	0	58	w/	Ant 2	v	99.69	1.00	9.00	8.53	1.11	0.01	0.124	0.14

Note.

1. The "< 0.001" means there is no SAR value or the SAR is too low to be measured.
2. Zoom scan will interrupted the secondary hotspot if maximum SAR value is below 0.1 W/kg under WLAN MIMO mode.

SAR Test Report

Plot No.	Band	Mode	Test Position	Separation Distance (cm)	Ch.	P-sensor	Tx Antenna	Keyboard Cover	Duty Cycle	Crest Factor	Max. Tune-up Power (dBm)	Measured Conducted Power (dBm)	Scaling Factor	Power Drift (dB)	Measured SAR-1g (W/kg)	Scaled SAR-1g (W/kg)
	WLAN5.6G	802.11n HT40	Rear Face	18	134	w/o	Ant 1		99.67	1.00	17.00	16.89	1.03	-0.06	0.053	0.05
	WLAN5.6G	802.11n HT40	Left Side	0	134	w/o	Ant 1		99.67	1.00	17.00	16.89	1.03	0	<0.001	0.00
	WLAN5.6G	802.11n HT40	Right Side	7	134	w/o	Ant 1		99.67	1.00	17.00	16.89	1.03	-0.01	0.668	0.69
	WLAN5.6G	802.11n HT40	Right Corner	11	134	w/o	Ant 1		99.67	1.00	17.00	16.89	1.03	-0.13	0.24	0.25
	WLAN5.6G	802.11n HT40	Top Side	19	134	w/o	Ant 1		99.67	1.00	17.00	16.89	1.03	0.18	0.055	0.06
	WLAN5.6G	802.11n HT40	Bottom Side	0	134	w/o	Ant 1		99.67	1.00	17.00	16.89	1.03	0	<0.001	0.00
	WLAN5.6G	802.11n HT40	Rear Face	10	134	w/o	Ant 2		99.67	1.00	17.00	16.66	1.08	-0.1	0.207	0.22
	WLAN5.6G	802.11n HT40	Left Side	4	134	w/o	Ant 2		99.67	1.00	17.00	16.66	1.08	0.02	0.419	0.45
	WLAN5.6G	802.11n HT40	Left Corner	9	134	w/o	Ant 2		99.67	1.00	17.00	16.66	1.08	0.16	0.17	0.18
	WLAN5.6G	802.11n HT40	Right Side	0	134	w/o	Ant 2		99.67	1.00	17.00	16.66	1.08	0.14	0.02	0.02
	WLAN5.6G	802.11n HT40	Top Side	14	134	w/o	Ant 2		99.67	1.00	17.00	16.66	1.08	0.17	0.144	0.16
	WLAN5.6G	802.11n HT40	Bottom Side	0	134	w/o	Ant 2		99.67	1.00	17.00	16.66	1.08	0	<0.001	0.00
	WLAN5.6G	802.11n HT40	Rear Face	10	134	w/o	MIMO_Ant 1		99.67	1.00	17.00	16.83	1.04	0	<0.001	0.00
							MIMO_Ant 2		99.67	1.00	17.00	16.96	1.01	0.12	0.308	0.31
	WLAN5.6G	802.11n HT40	Left Side	4	134	w/o	MIMO_Ant 1		99.67	1.00	17.00	16.83	1.04	0	<0.001	0.00
							MIMO_Ant 2		99.67	1.00	17.00	16.96	1.01	0.09	0.472	0.48
	WLAN5.6G	802.11n HT40	Left Corner	9	134	w/o	MIMO_Ant 1		99.67	1.00	17.00	16.83	1.04	0	<0.001	0.00
							MIMO_Ant 2		99.67	1.00	17.00	16.96	1.01	0.04	0.19	0.19
	WLAN5.6G	802.11n HT40	Right Side	7	134	w/o	MIMO_Ant 1		99.67	1.00	17.00	16.83	1.04	-0.04	0.696	0.72
							MIMO_Ant 2		99.67	1.00	17.00	16.96	1.01	0	<0.001	0.00
	WLAN5.6G	802.11n HT40	Right Corner	11	134	w/o	MIMO_Ant 1		99.67	1.00	17.00	16.83	1.04	0.06	0.221	0.23
							MIMO_Ant 2		99.67	1.00	17.00	16.96	1.01	0	<0.001	0.00
	WLAN5.6G	802.11n HT40	Top Side	14	134	w/o	MIMO_Ant 1		99.67	1.00	17.00	16.83	1.04	0	<0.001	0.00
							MIMO_Ant 2		99.67	1.00	17.00	16.96	1.01	0.17	0.118	0.12
	WLAN5.6G	802.11n HT40	Bottom Side	0	134	w/o	MIMO_Ant 1		99.67	1.00	17.00	16.83	1.04	0	<0.001	0.00
							MIMO_Ant 2		99.67	1.00	17.00	16.96	1.01	0	<0.001	0.00
	WLAN5.6G	802.11ac VHT80	Rear Face	0	106	w/	Ant 1		99.69	1.00	9.00	8.86	1.03	0.06	0.390	0.40
	WLAN5.6G	802.11ac VHT80	Right Side	0	106	w/	Ant 1		99.69	1.00	9.00	8.86	1.03	-0.09	0.446	0.46
	WLAN5.6G	802.11ac VHT80	Right Corner	0	106	w/	Ant 1		99.69	1.00	9.00	8.86	1.03	0.19	0.395	0.41
	WLAN5.6G	802.11ac VHT80	Top Side	0	106	w/	Ant 1		99.69	1.00	9.00	8.86	1.03	0.16	0.368	0.38
03	WLAN5.6G	802.11ac VHT80	Rear Face	0	106	w/	Ant 2		99.69	1.00	9.00	8.60	1.10	0.06	0.752	0.83
	WLAN5.6G	802.11ac VHT80	Left Side	0	106	w/	Ant 2		99.69	1.00	9.00	8.60	1.10	-0.03	0.677	0.74
	WLAN5.6G	802.11ac VHT80	Left Corner	0	106	w/	Ant 2		99.69	1.00	9.00	8.60	1.10	0.15	0.198	0.22
	WLAN5.6G	802.11ac VHT80	Top Side	0	106	w/	Ant 2		99.69	1.00	9.00	8.60	1.10	-0.12	0.330	0.36
	WLAN5.6G	802.11ac VHT80	Rear Face	0	106	w/	MIMO_Ant 1		99.69	1.00	9.00	8.37	1.16	0	<0.001	0.00
							MIMO_Ant 2		99.69	1.00	9.00	8.29	1.18	-0.12	0.521	0.61
	WLAN5.6G	802.11ac VHT80	Left Side	0	106	w/	MIMO_Ant 1		99.69	1.00	9.00	8.37	1.16	-0.02	0.490	0.57
							MIMO_Ant 2		99.69	1.00	9.00	8.29	1.18	0	<0.001	0.00
	WLAN5.6G	802.11ac VHT80	Left Corner	0	106	w/	MIMO_Ant 1		99.69	1.00	9.00	8.37	1.16	0	<0.001	0.00
							MIMO_Ant 2		99.69	1.00	9.00	8.29	1.18	-0.19	0.187	0.22
	WLAN5.6G	802.11ac VHT80	Right Side	0	106	w/	MIMO_Ant 1		99.69	1.00	9.00	8.37	1.16	-0.09	0.368	0.43
							MIMO_Ant 2		99.69	1.00	9.00	8.29	1.18	0	<0.001	0.00
	WLAN5.6G	802.11ac VHT80	Right Corner	0	106	w/	MIMO_Ant 1		99.69	1.00	9.00	8.37	1.16	0.1	0.35	0.41
							MIMO_Ant 2		99.69	1.00	9.00	8.29	1.18	0	<0.001	0.00
	WLAN5.6G	802.11ac VHT80	Top Side	0	106	w/	MIMO_Ant 1		99.69	1.00	9.00	8.37	1.16	0.08	0.201	0.23
							MIMO_Ant 2		99.69	1.00	9.00	8.29	1.18	0	<0.001	0.00
	WLAN5.6G	802.11ac VHT80	Rear Face	0	122	w/	Ant 2		99.69	1.00	9.00	8.55	1.11	-0.04	0.56	0.62
	WLAN5.6G	802.11ac VHT80	Rear Face	0	138	w/	Ant 2		99.69	1.00	9.00	8.52	1.12	-0.01	0.627	0.70
	WLAN5.6G	802.11ac VHT80	Rear Face	0	106	w/	Ant 2	v	99.69	1.00	9.00	8.60	1.10	0.06	0.109	0.12

Note.

1. The "< 0.001" means there is no SAR value or the SAR is too low to be measured.
2. Zoom scan will interrupted the secondary hotspot if maximum SAR value is below 0.1 W/kg under WLAN MIMO mode.

SAR Test Report

Plot No.	Band	Mode	Test Position	Separation Distance (cm)	Ch.	P-sensor	Tx Antenna	Keyboard Cover	Duty Cycle	Crest Factor	Max. Tune-up Power (dBm)	Measured Conducted Power (dBm)	Scaling Factor	Power Drift (dB)	Measured SAR-1g (W/kg)	Scaled SAR-1g (W/kg)
	WLAN5.8G	802.11n HT40	Rear Face	18	151	w/o	Ant 1		99.67	1.00	17.00	16.44	1.14	0.08	0.048	0.05
	WLAN5.8G	802.11n HT40	Left Side	0	151	w/o	Ant 1		99.67	1.00	17.00	16.44	1.14	0.05	0.00487	0.01
	WLAN5.8G	802.11n HT40	Right Side	7	151	w/o	Ant 1		99.67	1.00	17.00	16.44	1.14	-0.05	0.706	0.80
	WLAN5.8G	802.11n HT40	Right Corner	11	151	w/o	Ant 1		99.67	1.00	17.00	16.44	1.14	0.06	0.392	0.45
	WLAN5.8G	802.11n HT40	Top Side	19	151	w/o	Ant 1		99.67	1.00	17.00	16.44	1.14	0.11	0.05	0.06
	WLAN5.8G	802.11n HT40	Bottom Side	0	151	w/o	Ant 1		99.67	1.00	17.00	16.44	1.14	0	<0.001	0.00
	WLAN5.8G	802.11n HT40	Rear Face	10	151	w/o	Ant 2		99.67	1.00	17.00	16.63	1.09	-0.05	0.15	0.16
	WLAN5.8G	802.11n HT40	Left Side	4	151	w/o	Ant 2		99.67	1.00	17.00	16.63	1.09	-0.07	0.211	0.23
	WLAN5.8G	802.11n HT40	Left Corner	9	151	w/o	Ant 2		99.67	1.00	17.00	16.63	1.09	0.06	0.123	0.13
	WLAN5.8G	802.11n HT40	Right Side	0	151	w/o	Ant 2		99.67	1.00	17.00	16.63	1.09	0.07	0.024	0.03
	WLAN5.8G	802.11n HT40	Top Side	14	151	w/o	Ant 2		99.67	1.00	17.00	16.63	1.09	0.08	0.094	0.10
	WLAN5.8G	802.11n HT40	Bottom Side	0	151	w/o	Ant 2		99.67	1.00	17.00	16.63	1.09	0	<0.001	0.00
	WLAN5.8G	802.11n HT40	Rear Face	10	151	w/o	MIMO_Ant 1		99.67	1.00	17.00	16.35	1.16	0	<0.001	0.00
							MIMO_Ant 2		99.67	1.00	17.00	16.95	1.01	-0.11	0.158	0.16
	WLAN5.8G	802.11n HT40	Left Side	4	151	w/o	MIMO_Ant 1		99.67	1.00	17.00	16.35	1.16	0	<0.001	0.00
							MIMO_Ant 2		99.67	1.00	17.00	16.95	1.01	0.12	0.215	0.22
	WLAN5.8G	802.11n HT40	Left Corner	9	151	w/o	MIMO_Ant 1		99.67	1.00	17.00	16.35	1.16	0	<0.001	0.00
							MIMO_Ant 2		99.67	1.00	17.00	16.95	1.01	0.09	0.056	0.06
	WLAN5.8G	802.11n HT40	Right Side	7	151	w/o	MIMO_Ant 1		99.67	1.00	17.00	16.35	1.16	-0.09	0.635	0.74
							MIMO_Ant 2		99.67	1.00	17.00	16.95	1.01	0	<0.001	0.00
	WLAN5.8G	802.11n HT40	Right Corner	11	151	w/o	MIMO_Ant 1		99.67	1.00	17.00	16.35	1.16	0.04	0.371	0.43
							MIMO_Ant 2		99.67	1.00	17.00	16.95	1.01	0	<0.001	0.00
	WLAN5.8G	802.11n HT40	Top Side	14	151	w/o	MIMO_Ant 1		99.67	1.00	17.00	16.35	1.16	0	<0.001	0.00
							MIMO_Ant 2		99.67	1.00	17.00	16.95	1.01	-0.08	0.102	0.10
	WLAN5.8G	802.11n HT40	Bottom Side	0	151	w/o	MIMO_Ant 1		99.67	1.00	17.00	16.35	1.16	0	<0.001	0.00
							MIMO_Ant 2		99.67	1.00	17.00	16.95	1.01	0	<0.001	0.00
	WLAN5.8G	802.11ac VHT80	Rear Face	0	155	w/	Ant 1		99.69	1.00	9.00	8.86	1.03	-0.06	0.393	0.40
	WLAN5.8G	802.11ac VHT80	Right Side	0	155	w/	Ant 1		99.69	1.00	9.00	8.86	1.03	0.17	0.574	0.59
	WLAN5.8G	802.11ac VHT80	Right Corner	0	155	w/	Ant 1		99.69	1.00	9.00	8.86	1.03	-0.09	0.545	0.56
	WLAN5.8G	802.11ac VHT80	Top Side	0	155	w/	Ant 1		99.69	1.00	9.00	8.86	1.03	0.19	0.23	0.24
	WLAN5.8G	802.11ac VHT80	Rear Face	0	155	w/	Ant 2		99.69	1.00	9.00	8.18	1.21	-0.07	0.634	0.77
	WLAN5.8G	802.11ac VHT80	Left Side	0	155	w/	Ant 2		99.69	1.00	9.00	8.18	1.21	-0.14	0.31	0.38
	WLAN5.8G	802.11ac VHT80	Left Corner	0	155	w/	Ant 2		99.69	1.00	9.00	8.18	1.21	0.11	0.251	0.30
	WLAN5.8G	802.11ac VHT80	Top Side	0	155	w/	Ant 2		99.69	1.00	9.00	8.18	1.21	0.09	0.324	0.39
	WLAN5.8G	802.11ac VHT80	Rear Face	0	155	w/	MIMO_Ant 1		99.69	1.00	9.00	8.06	1.24	0	<0.001	0.00
							MIMO_Ant 2		99.69	1.00	9.00	8.74	1.06	0.03	0.472	0.50
	WLAN5.8G	802.11ac VHT80	Left Side	0	155	w/	MIMO_Ant 1		99.69	1.00	9.00	8.06	1.24	0	<0.001	0.00
							MIMO_Ant 2		99.69	1.00	9.00	8.74	1.06	-0.11	0.34	0.36
	WLAN5.8G	802.11ac VHT80	Left Corner	0	155	w/	MIMO_Ant 1		99.69	1.00	9.00	8.06	1.24	0	<0.001	0.00
							MIMO_Ant 2		99.69	1.00	9.00	8.74	1.06	-0.14	0.165	0.17
	WLAN5.8G	802.11ac VHT80	Right Side	0	155	w/	MIMO_Ant 1		99.69	1.00	9.00	8.06	1.24	0.08	0.432	0.54
							MIMO_Ant 2		99.69	1.00	9.00	8.74	1.06	0	<0.001	0.00
	WLAN5.8G	802.11ac VHT80	Right Corner	0	155	w/	MIMO_Ant 1		99.69	1.00	9.00	8.06	1.24	0.19	0.351	0.44
							MIMO_Ant 2		99.69	1.00	9.00	8.74	1.06	0	<0.001	0.00
	WLAN5.8G	802.11ac VHT80	Top Side	0	155	w/	MIMO_Ant 1		99.69	1.00	9.00	8.06	1.24	0	<0.001	0.00
							MIMO_Ant 2		99.69	1.00	9.00	8.74	1.06	-0.19	0.267	0.28
04	WLAN5.8G	802.11n HT40	Right Side	7	159	w/o	Ant 1		99.67	1.00	17.00	15.35	1.46	-0.02	0.582	0.85
	WLAN5.8G	802.11n HT40	Right Side	7	159	w/o	Ant 1	v	99.67	1.00	17.00	15.35	1.46	0.01	0.094	0.14

Note.

1. The "< 0.001" means there is no SAR value or the SAR is too low to be measured.
2. Zoom scan will interrupted the secondary hotspot if maximum SAR value is below 0.1 W/kg under WLAN MIMO mode.

SAR Test Report

Plot No.	Band	Mode	Test Position	Separation Distance (cm)	Ch.	P-sensor	Tx Antenna	Keyboard Cover	Duty Cycle	Crest Factor	Max. Tune-up Power (dBm)	Measured Conducted Power (dBm)	Scaling Factor	Power Drift (dB)	Measured SAR-1g (W/kg)	Scaled SAR-1g (W/kg)
	BT	BDR	Rear Face	18	0	w/o	Ant 1		76.85	1.30	13.00	12.48	1.13	0	<0.001	0.00
	BT	BDR	Left Side	0	0	w/o	Ant 1		76.85	1.30	13.00	12.48	1.13	0	<0.001	0.00
	BT	BDR	Right Side	7	0	w/o	Ant 1		76.85	1.30	13.00	12.48	1.13	-0.06	0.105	0.15
	BT	BDR	Right Corner	11	0	w/o	Ant 1		76.85	1.30	13.00	12.48	1.13	0	<0.001	0.00
	BT	BDR	Top Side	14	0	w/o	Ant 1		76.85	1.30	13.00	12.48	1.13	0	<0.001	0.00
	BT	BDR	Bottom Side	0	0	w/o	Ant 1		76.85	1.30	13.00	12.48	1.13	0	<0.001	0.00
	BT	BDR	Rear Face	0	0	w/	Ant 1		76.85	1.30	12.50	11.94	1.14	-0.06	0.304	0.45
	BT	BDR	Right Side	0	0	w/	Ant 1		76.85	1.30	12.50	11.94	1.14	-0.06	0.452	0.67
	BT	BDR	Right Corner	0	0	w/	Ant 1		76.85	1.30	12.50	11.94	1.14	-0.04	0.212	0.31
	BT	BDR	Top Side	0	0	w/	Ant 1		76.85	1.30	12.50	11.94	1.14	0.04	0.219	0.32
05	BT	BDR	Right Side	0	39	w/	Ant 1		76.85	1.30	12.50	10.93	1.44	-0.03	0.411	0.77
	BT	BDR	Right Side	0	78	w/	Ant 1		76.85	1.30	12.50	10.18	1.71	-0.06	0.286	0.64
	BT	BDR	Rear Face	10	78	w/o	Ant 2		76.85	1.30	12.00	11.04	1.25	0	<0.001	0.00
	BT	BDR	Left Side	4	78	w/o	Ant 2		76.85	1.30	12.00	11.04	1.25	-0.01	0.060	0.10
	BT	BDR	Left Corner	9	78	w/o	Ant 2		76.85	1.30	12.00	11.04	1.25	0	<0.001	0.00
	BT	BDR	Right Side	0	78	w/o	Ant 2		76.85	1.30	12.00	11.04	1.25	0	<0.001	0.00
	BT	BDR	Top Side	14	78	w/o	Ant 2		76.85	1.30	12.00	11.04	1.25	0	<0.001	0.00
	BT	BDR	Bottom Side	0	78	w/o	Ant 2		76.85	1.30	12.00	11.04	1.25	0	<0.001	0.00
	BT	BDR	Rear Face	0	78	w/	Ant 2		76.85	1.30	11.00	10.49	1.12	0.04	0.117	0.17
	BT	BDR	Left Side	0	78	w/	Ant 2		76.85	1.30	11.00	10.49	1.12	0.01	0.248	0.36
	BT	BDR	Left Corner	0	78	w/	Ant 2		76.85	1.30	11.00	10.49	1.12	0.05	0.047	0.07
	BT	BDR	Top Side	0	78	w/	Ant 2		76.85	1.30	11.00	10.49	1.12	0	<0.001	0.00
	BT	BDR	Left Side	0	0	w/	Ant 2		76.85	1.30	11.00	9.42	1.44	-0.02	0.283	0.53
	BT	BDR	Left Side	0	39	w/	Ant 2		76.85	1.30	11.00	10.34	1.16	-0.11	0.243	0.37
	BT	BDR	Right Side	0	39	w/	Ant 1	V	76.85	1.30	12.50	10.93	1.44	0.04	0.252	0.47

Note. The “< 0.001” means there is no SAR value or the SAR is too low to be measured.

SAR Test Report

4.7.3 SAR Measurement Variability

According to KDB 865664 D01, SAR measurement variability was assessed for each frequency band, which is determined by the SAR probe calibration point and tissue-equivalent medium used for the device measurements. When both head and body tissue-equivalent media are required for SAR measurements in a frequency band, the variability measurement procedures should be applied to the tissue medium with the highest measured SAR, using the highest measured SAR configuration for that tissue-equivalent medium. Alternatively, if the highest measured SAR for both head and body tissue-equivalent media are ≤ 1.45 W/kg and the ratio of these highest SAR values, i.e., largest divided by smallest value, is ≤ 1.10 , the highest SAR configuration for either head or body tissue-equivalent medium maybe used to perform the repeated measurement. These additional measurements are repeated after the completion of all measurements requiring the same head or body tissue-equivalent medium in a frequency band. The test device should be returned to ambient conditions (normal room temperature) with the battery fully charged before it is re-mounted on the device holder for the repeated measurement(s) to minimize any unexpected variations in the repeated results.

SAR repeated measurement procedure:

1. When the highest measured SAR is < 0.80 W/kg, repeated measurement is not required.
2. When the highest measured SAR is ≥ 0.80 W/kg, repeat that measurement once.
3. If the ratio of largest to smallest SAR for the original and first repeated measurements is > 1.20 , or when the original or repeated measurement is ≥ 1.45 W/kg, perform a second repeated measurement.
4. If the ratio of largest to smallest SAR for the original, first and second repeated measurements is > 1.20 , and the original, first or second repeated measurement is ≥ 1.5 W/kg, perform a third repeated measurement.

Band	Mode	Test Position	Ch.	Original Measured SAR-1g (W/kg)	1st Repeated SAR-1g (W/kg)	L/S Ratio	2nd Repeated SAR-1g (W/kg)	L/S Ratio	3rd Repeated SAR-1g (W/kg)	L/S Ratio
WLAN2.4G	802.11b	Left Side	1	0.880	0.857	1.03	N/A	N/A	N/A	N/A

SAR Test Report

4.7.4 Simultaneous Multi-band Transmission Evaluation

<Possibilities of Simultaneous Transmission>

The simultaneous transmission possibilities for this device are listed as below.

Simultaneous TX Combination	Capable Transmit Configurations	Body Exposure Condition
1	WLAN 5G Ant1 + BT Ant. 1	Yes
2	WLAN 5G Ant2 + BT Ant. 2	Yes
3	WLAN 2.4G Ant1 + WLAN 5G Ant1 (RSDB)	Yes
4	WLAN 2.4G Ant2 +WLAN 5G Ant2 (RSDB)	Yes

Note :

Because WLAN Ant1 and WLAN Ant2 are spatially separated (per section 6.1 of KDB 248827 D01), there is no need to evaluate WWAN with both WLAN Ant1 and WLAN Ant2 simultaneously.

<SAR Summation Analysis>

Simultaneous transmission SAR test exclusion is determined for each operating configuration and exposure condition according to the reported standalone SAR of each applicable simultaneous transmitting antenna. When the sum of SAR_{1g} of all simultaneously transmitting antennas in an operating mode and exposure condition combination is within the SAR limit(SAR_{1g} 1.6 W/kg), the simultaneous transmission SAR is not required. When the sum of SAR_{1g} is greater than the SAR limit (SAR_{1g} 1.6 W/kg), SAR test exclusion is determined by the SPLSR.

Position	power	2.4GHz WLAN (W/kg)		2.4GHz WLAN (W/kg)		2.4GHz WLAN (W/kg)		2.4GHz WLAN (W/kg)		2.4GHz WLAN (W/kg)	
		Ant1	Ant2	Ant1	Ant2	Ant1	Ant2	Ant1	Ant2	Ant1	Ant2
Rear Face	reduced	0.41	0.41	0.41	0.85	0.40	0.83	0.40	0.77	0.45	0.17
	full	0.56	0.31	0.27	0.13	0.05	0.22	0.05	0.16	0.00	0.00
Left	reduced	0.00	0.57	0.01	0.45	0.00	0.74	0.01	0.38	0.00	0.53
	full	0.00	0.90	0.01	0.37	0.00	0.45	0.00	0.23	0.00	0.10
Right	reduced	0.30	0.00	0.64	0.01	0.46	0.02	0.59	0.03	0.77	0.00
	full	0.78	0.00	0.72	0.00	0.69	0.00	0.85	0.00	0.15	0.00
Top	reduced	0.31	0.14	0.38	0.26	0.38	0.36	0.24	0.39	0.32	0.00
	full	0.24	0.03	0.10	0.04	0.06	0.16	0.06	0.10	0.00	0.00
Bottom	full	0.00	0.00	0.00	0.00	0.00	0.00	0.00	0.00	0.00	0.00
Left Corner	reduced	0.00	0.13	0.00	0.13	0.00	0.22	0.00	0.30	0.00	0.07
	full	0.00	0.10	0.00	0.04	0.00	0.18	0.00	0.13	0.00	0.00
Right Corner	reduced	0.23	0.00	0.35	0.00	0.41	0.00	0.56	0.00	0.31	0.00
	full	0.24	0.00	0.32	0.00	0.25	0.00	0.45	0.00	0.00	0.00

Position	Combination #1	Combination #2	Combination #3	Combination #4
Rear Face	0.86	1.02	0.82	1.26
Left	0.01	1.27	0.01	1.35
Right	1.41	0.03	1.63	0.03
Top	0.70	0.39	0.69	0.53
Bottom	0.00	0.00	0.00	0.00

<SAR to Peak Location Separation Ratio Analysis>

The simultaneous transmitting antennas in each operating mode and exposure condition combination are considered one pair at a time to determine the SPLSR. When SAR is measured for both antennas in the pair, the peak location separation distance is computed by the following formula.

$$\text{Peak Location Separation Distance} = \sqrt{(x_1 - x_2)^2 + (y_1 - y_2)^2 + (z_1 - z_2)^2}$$

Where (x_1, y_1, z_1) and (x_2, y_2, z_2) are the coordinates of the extrapolated peak SAR locations in the area or zoom scans.

When standalone test exclusion applies, SAR is estimated; the peak location is assumed to be at the feed-point or geometric center of the antenna. Due to curvatures on the SAM phantom, when SAR is estimated for one of the antennas in an antenna pair, the measured peak SAR location will be translated onto the test device to determine the peak location separation for the antenna pair.

The SPLSR is determined by the following formula.

$$\text{SPLSR} = \frac{(\text{SAR}_1 + \text{SAR}_2)^{1.5}}{R_i}$$

Where SAR_1 and SAR_2 are the highest reported or estimated SAR for each antenna in the pair, and R_i is the separation distance between the peak SAR locations for the antenna pair in mm.

When the SPLSR is ≤ 0.04 , the simultaneous transmission SAR is not required. Otherwise, the enlarged zoom scan and volume scan post-processing procedures will be performed.

SAR Test Report

<SPLSR> Combination #3

Conditions	Exposure Condition	Test Position	SAR Value (W/kg)	Coordinates			Peak Location Separation Distance (R _i , mm)	SPLSR	Simultaneous Transmission SAR Test
				x	y	z			
WLAN2.4G_802.11b Ch1_MIMO Ant1	Body	Right Side	0.78	1.5	-123.5	1.17	11.1	0.18	required
WLAN5.8G_802.11n HT40_Ch151 Ant1			0.85	-2	-134	1.33			

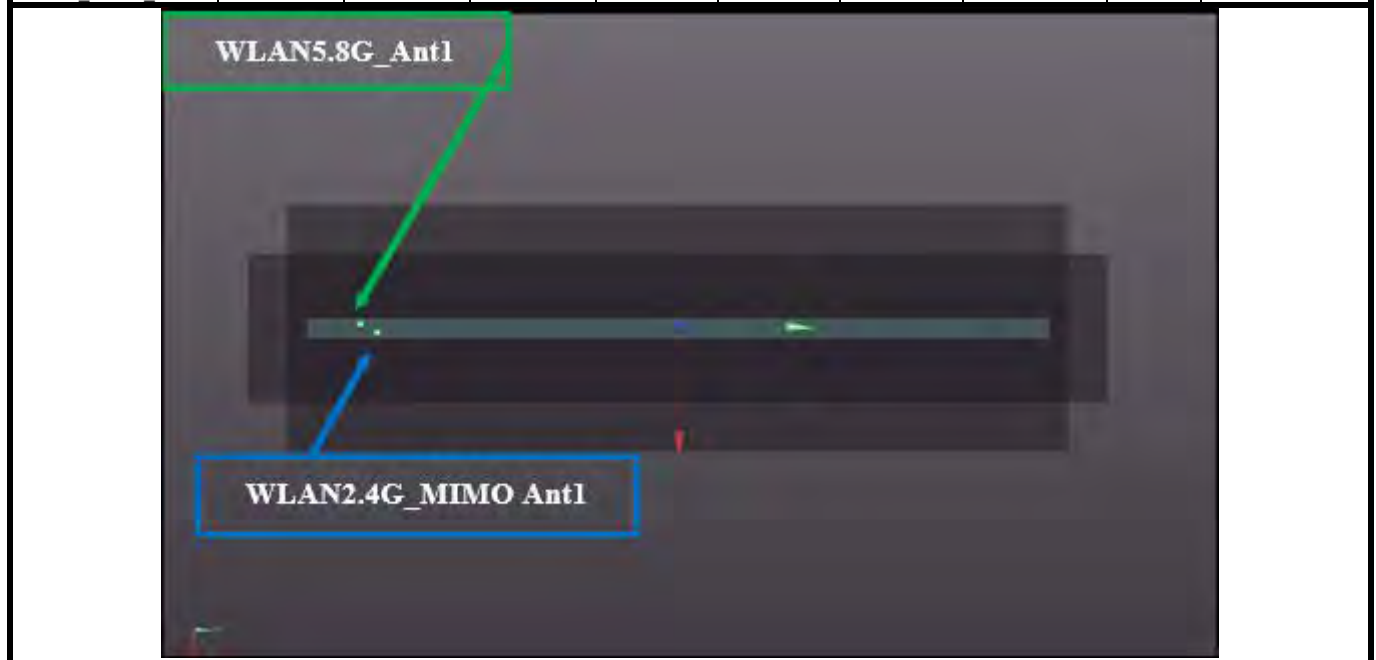

<Volume Scan> Combination #3

Combination #3	Photo
<p>WLAN2.4G_ 802.11b_Ch1_ MIMO Ant1</p> <p style="text-align: center;">+</p> <p>WLAN5.8G_ 802.11n HT40_ Ch151_Ant1</p>	<p>Multi Band Result: SAR(1 g) = 1.17 W/kg; SAR(10 g) = 0.481 W/kg (SAR corrected for target medium) Maximum value of SAR (interpolated) = 3.52 W/kg</p> 

SAR Test Report

<Additional Simultaneous Transmission Analysis>

The additional test applies to mixed simultaneous transmission.

According to the KDB 447498 D01v06, When one of the following test exclusion conditions is satisfied for all combinations of simultaneous transmission configurations, further equipment approval is not required to incorporate transmitter modules in host devices that operate in the mixed mobile and portable host platform exposure conditions.

a) The $[\Sigma \text{ of (the highest measured or estimated SAR for each standalone antenna configuration, adjusted for maximum tune-up tolerance) / 1.6 W/kg}] + [\Sigma \text{ of MPE ratios}] \leq 1.0$.

b) The SAR to peak location separation ratios of all simultaneously transmitting antenna pairs operating in portable device exposure conditions are all ≤ 0.04 , and the $[\Sigma \text{ of MPE ratios}] \leq 1.0$.

The worst of condition evaluation:

$(\text{Worst Volume scan}) / \text{Limit} + (\text{Field Strength Measured}) / \text{Limit} \leq 1.0$

$$1.17/1.6 + 0.052/1.63 = 0.763 \leq 1.0$$

Note. 0.052 is H-field of measurement result and the value is refer to BV CPS report no.SA200623C08-1.

Summary:

According to section 4.7.4 to evaluate the worst case, the results are all less than 1, so the rest of the configuration will not have the risk of failure.

Test Engineer : James Chu, and Zeke Wang

5. Calibration of Test Equipment

Equipment	Manufacturer	Model	SN	Cal. Date	Cal. Interval
System Validation Dipole	SPEAG	D2450V2	737	Aug. 26, 2019	1 Year
System Validation Dipole	SPEAG	D5GHzV2	1019	Mar. 13, 2020	1 Year
Dosimetric E-Field Probe	SPEAG	EX3DV4	3971	Jan. 27, 2020	1 Year
Dosimetric E-Field Probe	SPEAG	EX3DV4	7350	Dec. 16, 2019	1 Year
Dosimetric E-Field Probe	SPEAG	EX3DV4	7472	Aug. 30, 2019	1 Year
Data Acquisition Electronics	SPEAG	DAE3	579	Aug. 27, 2019	1 Year
Data Acquisition Electronics	SPEAG	DAE4	1277	Jan. 24, 2020	1 Year
Data Acquisition Electronics	SPEAG	DAE4	917	Dec. 17, 2019	1 Year
Spectrum Analyzer	R&S	FSL6	102006	Mar. 26, 2020	1 Year
Universal Wireless Test Set	Anritsu	MT8870A/MU8 87000A	6201699387	Oct. 07, 2019	1 Year
Thermometer	YFE	YF-160A	120702365	Aug. 06, 2019	1 Year
Dielectric Assessment Kit	SPEAG	DAK-3.5	1151	Aug. 20, 2019	1 Year
Powersource1	SPEAG	SE_UMS_160 BA	4010	Aug. 21, 2019	1 Year

SAR Test Report

6. Measurement Uncertainty

Source of Uncertainty	Uncertainty (± %)	Probability Distribution	Divisor	Ci (1g)	Ci (10g)	Standard Uncertainty (± %, 1g)	Standard Uncertainty (± %, 10g)	Vi
Measurement System								
Probe Calibration	6.0	Normal	1	1	1	6.0	6.0	∞
Axial Isotropy	4.7	Rectangular	√3	√0.5	√0.5	1.9	1.9	∞
Hemispherical Isotropy	9.6	Rectangular	√3	√0.5	√0.5	3.9	3.9	∞
Boundary Effect	1.0	Rectangular	√3	1	1	0.6	0.6	∞
Linearity	4.7	Rectangular	√3	1	1	2.7	2.7	∞
Detection Limits	0.25	Rectangular	√3	1	1	0.14	0.14	∞
Probe Modulation Response	4.8	Rectangular	√3	1	1	2.8	2.8	∞
Readout Electronics	0.3	Normal	1	1	1	0.3	0.3	∞
Response Time	0.0	Rectangular	√3	1	1	0.0	0.0	∞
Integration Time	1.7	Rectangular	√3	1	1	1.0	1.0	∞
RF Ambient Conditions – Noise	3.0	Rectangular	√3	1	1	1.7	1.7	∞
RF Ambient Conditions – Reflections	3.0	Rectangular	√3	1	1	1.7	1.7	∞
Probe Positioner Mechanical Tolerance	0.02	Rectangular	√3	1	1	0.01	0.01	∞
Probe Positioning with Respect to Phantom	0.4	Rectangular	√3	1	1	0.2	0.2	∞
Post-processing	2.0	Rectangular	√3	1	1	1.2	1.2	∞
Test Sample Related								
Test Sample Positioning	2.82 / 1.60	Normal	1	1	1	2.8	1.6	35
Device Holder Uncertainty	2.55 / 2.76	Normal	1	1	1	2.6	2.8	7
Power Drift of Measurement	5.0	Rectangular	√3	1	1	2.9	2.9	∞
PowerScaling	0.0	Rectangular	√3	1	1	0.0	0.0	∞
Phantom and Setup								
Phantom Uncertainty (Shape and Thickness Tolerances)	5.7	Rectangular	√3	1	1	3.3	3.3	∞
Liquid Conductivity (Temperature Uncertainty)	2.58	Rectangular	√3	0.78	0.71	1.2	1.1	∞
Liquid Conductivity (Measured)	2.95	Normal	1	0.78	0.71	2.3	2.1	61
Liquid Permittivity (Temperature Uncertainty)	1.97	Rectangular	√3	0.23	0.26	0.3	0.3	∞
Liquid Permittivity (Measured)	3.04	Normal	1	0.23	0.26	0.7	0.8	47
Combined Standard Uncertainty						± 10.9 %	± 10.7 %	
Expanded Uncertainty (K=2)						± 21.8 %	± 21.4 %	

Head SAR Uncertainty Budget for Frequency Range of 300 MHz to 3 GHz

SAR Test Report

Source of Uncertainty	Uncertainty (± %)	Probability Distribution	Divisor	Ci (1g)	Ci (10g)	Standard Uncertainty (± %, 1g)	Standard Uncertainty (± %, 10g)	Vi
Measurement System								
Probe Calibration	6.55	Normal	1	1	1	6.55	6.55	∞
Axial Isotropy	4.7	Rectangular	√3	0.7	0.7	1.9	1.9	∞
Hemispherical Isotropy	9.6	Rectangular	√3	0.7	0.7	3.9	3.9	∞
Boundary Effect	2.0	Rectangular	√3	1	1	1.2	1.2	∞
Linearity	4.7	Rectangular	√3	1	1	2.7	2.7	∞
Detection Limits	0.25	Rectangular	√3	1	1	0.14	0.14	∞
Probe Modulation Response	4.8	Rectangular	√3	1	1	2.8	2.8	∞
Readout Electronics	0.3	Normal	1	1	1	0.3	0.3	∞
Response Time	0.0	Rectangular	√3	1	1	0.0	0.0	∞
Integration Time	1.7	Rectangular	√3	1	1	1.0	1.0	∞
RF Ambient Conditions – Noise	3.0	Rectangular	√3	1	1	1.7	1.7	∞
RF Ambient Conditions – Reflections	3.0	Rectangular	√3	1	1	1.7	1.7	∞
Probe Positioner Mechanical Tolerance	0.04	Rectangular	√3	1	1	0.02	0.02	∞
Probe Positioning with Respect to Phantom	0.8	Rectangular	√3	1	1	0.5	0.5	∞
Post-processing	4.0	Rectangular	√3	1	1	2.3	2.3	∞
Test Sample Related								
Test Sample Positioning	2.82 / 1.60	Normal	1	1	1	2.8	1.6	35
Device Holder Uncertainty	2.55 / 2.76	Normal	1	1	1	2.6	2.8	7
Power Drift of Measurement	5.0	Rectangular	√3	1	1	2.9	2.9	∞
PowerScaling	0.0	Rectangular	√3	1	1	0.0	0.0	∞
Phantom and Setup								
Phantom Uncertainty (Shape and Thickness Tolerances)	6.2	Rectangular	√3	1	1	3.6	3.6	∞
Liquid Conductivity (Temperature Uncertainty)	2.58	Rectangular	√3	0.78	0.71	1.2	1.1	∞
Liquid Conductivity (Measured)	2.95	Normal	1	0.78	0.71	2.3	2.1	61
Liquid Permittivity (Temperature Uncertainty)	1.97	Rectangular	√3	0.23	0.26	0.3	0.3	∞
Liquid Permittivity (Measured)	3.04	Normal	1	0.23	0.26	0.7	0.8	47
Combined Standard Uncertainty						± 11.6 %	± 11.3 %	
Expanded Uncertainty (K=2)						± 23.2 %	± 22.6 %	

Head SAR Uncertainty Budget for Frequency Range of 3 GHz to 6 GHz

SAR Test Report

Source of Uncertainty	Uncertainty (± %)	Probability Distribution	Divisor	Ci (1g)	Ci (10g)	Standard Uncertainty (± %, 1g)	Standard Uncertainty (± %, 10g)	Vi
Measurement System								
Probe Calibration	6.0	Normal	1	1	1	6.0	6.0	∞
Axial Isotropy	4.7	Rectangular	√3	√0.5	√0.5	1.9	1.9	∞
Hemispherical Isotropy	9.6	Rectangular	√3	√0.5	√0.5	3.9	3.9	∞
Boundary Effect	1.0	Rectangular	√3	1	1	0.6	0.6	∞
Linearity	4.7	Rectangular	√3	1	1	2.7	2.7	∞
Detection Limits	0.25	Rectangular	√3	1	1	0.14	0.14	∞
Probe Modulation Response	4.8	Rectangular	√3	1	1	2.8	2.8	∞
Readout Electronics	0.3	Normal	1	1	1	0.3	0.3	∞
Response Time	0.0	Rectangular	√3	1	1	0.0	0.0	∞
Integration Time	1.7	Rectangular	√3	1	1	1.0	1.0	∞
RF Ambient Conditions – Noise	3.0	Rectangular	√3	1	1	1.7	1.7	∞
RF Ambient Conditions – Reflections	3.0	Rectangular	√3	1	1	1.7	1.7	∞
Probe Positioner Mechanical Tolerance	0.02	Rectangular	√3	1	1	0.01	0.01	∞
Probe Positioning with Respect to Phantom	0.4	Rectangular	√3	1	1	0.2	0.2	∞
Post-processing	2.0	Rectangular	√3	1	1	1.2	1.2	∞
Test Sample Related								
Test Sample Positioning	3.68 / 1.73	Normal	1	1	1	3.7	1.7	29
Device Holder Uncertainty	2.55 / 2.76	Normal	1	1	1	2.6	2.8	7
Power Drift of Measurement	5.0	Rectangular	√3	1	1	2.9	2.9	∞
PowerScaling	0.0	Rectangular	√3	1	1	0.0	0.0	∞
Phantom and Setup								
Phantom Uncertainty (Shape and Thickness Tolerances)	7.2	Rectangular	√3	1	1	4.2	4.2	∞
Liquid Conductivity (Temperature Uncertainty)	2.58	Rectangular	√3	0.78	0.71	1.2	1.1	∞
Liquid Conductivity (Measured)	2.95	Normal	1	0.78	0.71	2.3	2.1	61
Liquid Permittivity (Temperature Uncertainty)	1.97	Rectangular	√3	0.23	0.26	0.3	0.3	∞
Liquid Permittivity (Measured)	3.04	Normal	1	0.23	0.26	0.7	0.8	47
Combined Standard Uncertainty						± 11.5 %	± 11.0 %	
Expanded Uncertainty (K=2)						± 23.0 %	± 22.0 %	

Body SAR Uncertainty Budget for Frequency Range of 300 MHz to 3 GHz

SAR Test Report

Source of Uncertainty	Uncertainty (± %)	Probability Distribution	Divisor	Ci (1g)	Ci (10g)	Standard Uncertainty (± %, 1g)	Standard Uncertainty (± %, 10g)	Vi
Measurement System								
Probe Calibration	6.55	Normal	1	1	1	6.55	6.55	∞
Axial Isotropy	4.7	Rectangular	√3	0.7	0.7	1.9	1.9	∞
Hemispherical Isotropy	9.6	Rectangular	√3	0.7	0.7	3.9	3.9	∞
Boundary Effect	2.0	Rectangular	√3	1	1	1.2	1.2	∞
Linearity	4.7	Rectangular	√3	1	1	2.7	2.7	∞
Detection Limits	0.25	Rectangular	√3	1	1	0.14	0.14	∞
Probe Modulation Response	4.8	Rectangular	√3	1	1	2.8	2.8	∞
Readout Electronics	0.3	Normal	1	1	1	0.3	0.3	∞
Response Time	0.0	Rectangular	√3	1	1	0.0	0.0	∞
Integration Time	1.7	Rectangular	√3	1	1	1.0	1.0	∞
RF Ambient Conditions – Noise	3.0	Rectangular	√3	1	1	1.7	1.7	∞
RF Ambient Conditions – Reflections	3.0	Rectangular	√3	1	1	1.7	1.7	∞
Probe Positioner Mechanical Tolerance	0.04	Rectangular	√3	1	1	0.02	0.02	∞
Probe Positioning with Respect to Phantom	0.8	Rectangular	√3	1	1	0.5	0.5	∞
Post-processing	4.0	Rectangular	√3	1	1	2.3	2.3	∞
Test Sample Related								
Test Sample Positioning	3.68 / 1.73	Normal	1	1	1	3.7	1.7	29
Device Holder Uncertainty	2.55 / 2.76	Normal	1	1	1	2.6	2.8	7
Power Drift of Measurement	5.0	Rectangular	√3	1	1	2.9	2.9	∞
PowerScaling	0.0	Rectangular	√3	1	1	0.0	0.0	∞
Phantom and Setup								
Phantom Uncertainty (Shape and Thickness Tolerances)	7.6	Rectangular	√3	1	1	4.4	4.4	∞
Liquid Conductivity (Temperature Uncertainty)	2.58	Rectangular	√3	0.78	0.71	1.2	1.1	∞
Liquid Conductivity (Measured)	2.95	Normal	1	0.78	0.71	2.3	2.1	61
Liquid Permittivity (Temperature Uncertainty)	1.97	Rectangular	√3	0.23	0.26	0.3	0.3	∞
Liquid Permittivity (Measured)	3.04	Normal	1	0.23	0.26	0.7	0.8	47
Combined Standard Uncertainty						± 12.1 %	± 11.6 %	
Expanded Uncertainty (K=2)						± 24.2 %	± 23.2 %	

Body SAR Uncertainty Budget for Frequency Range of 3 GHz to 6 GHz

7. Information of the Testing Laboratories

We, Bureau Veritas Consumer Products Services (H.K.) Ltd., Taoyuan Branch, were founded in 1988 to provide our best service in EMC, Radio, Telecom and Safety consultation. Our laboratories are accredited and approved according to ISO/IEC 17025.

If you have any comments, please feel free to contact us at the following:

Taiwan Huaya Lab:

Add: No. 19, Huaya 2nd Rd., Guishan Dist., Taoyuan City 333, Taiwan

Tel: +886-(0)3-318-3232

Fax: +886-(0)3-211-5834

Taiwan Linkou Lab:

Add: No. 47-2, Baodoucuokeng, Linkou Dist., New Taipei City 244, Taiwan

Tel: +886-(0)2-2605-2180

Fax: +886-(0)2-2605-2943

Taiwan Hsinchu Lab1:

Add: E-2, No. 1, Lixing 1st Rd., East Dist., Hsinchu City 300, Taiwan

Tel: +886-(0)3-666-8565

Fax: +886-(0)3-666-8323

Taiwan Hsinchu Lab2:

Add: No. 49, Ln. 206, Wende Rd., Qionglin Township, Hsinchu County 307, Taiwan

Tel: +886-(0)3-512-0595

Fax: +886-(0)3-512-0568

Taiwan Xindian Lab:

Add: B2F., No. 215, Sec. 3, Beixin Rd., Xindian Dist., New Taipei City 231, Taiwan

Tel: +886-(0)2-8914-5882

Fax: +886-(0)2-8914-5840

Email: service.adt@tw.bureauveritas.com

Web Site: <https://ee.bureauveritas.com.tw/BVInternet/Default>

The road map of all our labs can be found in our web site also.

---END---

Appendix A. SAR Plots of System Verification

The plots for system verification with largest deviation for each SAR system combination are shown as follows.

System Check_H2450_200613

DUT: Dipole 2450 MHz; Type: D2450V2; SN: 737

Communication System: UID 0, CW; Frequency: 2450 MHz; Duty Cycle: 1:1
Medium: H19T27N1_0613 Medium parameters used (interpolated): $f = 2450$ MHz; $\sigma = 1.842$ S/m;
 $\epsilon_r = 38.429$; $\rho = 1000$ kg/m³
Ambient Temperature : 23.6 °C ; Liquid Temperature : 23.3 °C

DASY5 Configuration:

- Probe: EX3DV4 - SN7350; ConvF(7.7, 7.7, 7.7) @ 2450 MHz; Calibrated: 2019/12/16
- Sensor-Surface: 1.4mm (Mechanical Surface Detection)
- Electronics: DAE4 Sn917; Calibrated: 2019/12/17
- Phantom: ELI Phantom_1204; Type: QDOVA;
- Measurement SW: DASY52, Version 52.10 (4); SEMCAD X Version 14.6.14 (7483)

Pin=50mW/Area Scan (81x81x1): Interpolated grid: dx=1.200 mm, dy=1.200 mm
Maximum value of SAR (interpolated) = 4.24 W/kg

Pin=50mW/Zoom Scan (7x7x7)/Cube 0: Measurement grid: dx=5mm, dy=5mm, dz=5mm
Reference Value = 48.91 V/m; Power Drift = -0.05 dB
Peak SAR (extrapolated) = 4.99 W/kg
SAR(1 g) = 2.45 W/kg; SAR(10 g) = 1.18 W/kg (SAR corrected for target medium)
Maximum value of SAR (measured) = 4.08 W/kg

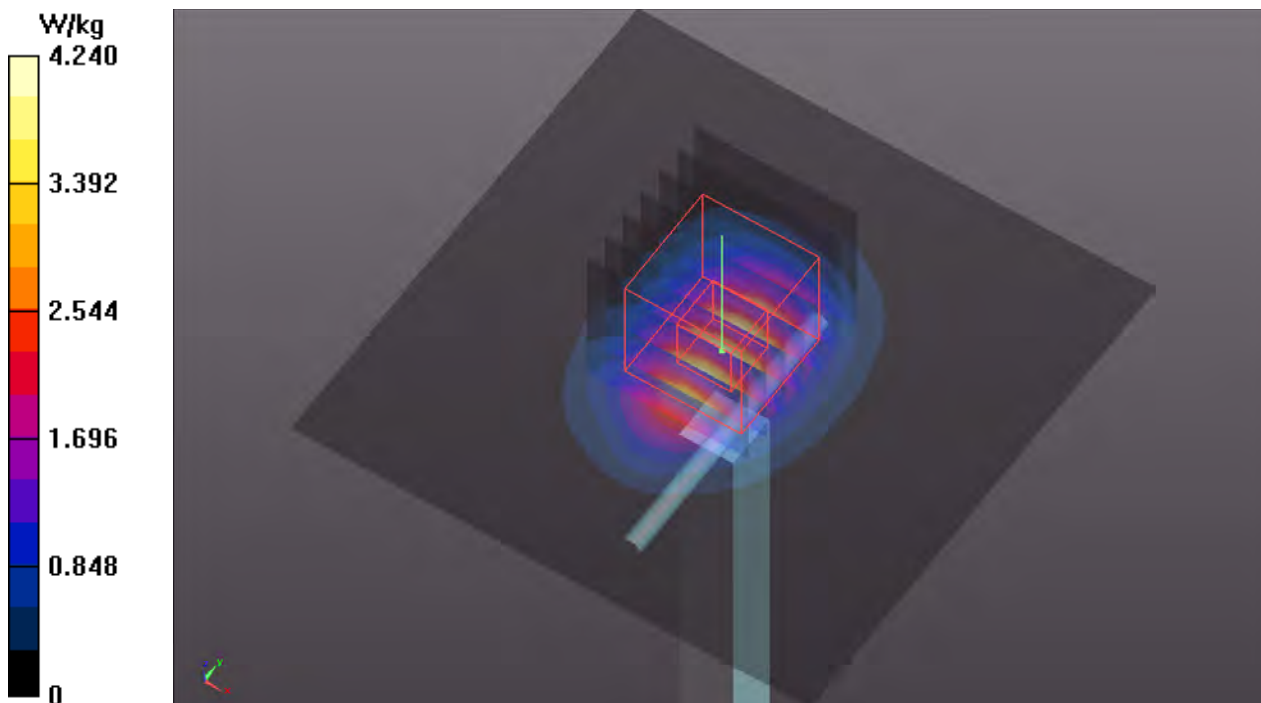

System Check_H5250_200615

DUT: Dipole 5 GHz; Type: D5GHzV2; SN: 1019

Communication System: UID 0, CW; Frequency: 5250 MHz; Duty Cycle: 1:1

Medium: H34T60N1_0615 Medium parameters used (interpolated): $f = 5250$ MHz; $\sigma = 4.753$ S/m;

$\epsilon_r = 35.645$; $\rho = 1000$ kg/m³

Ambient Temperature : 23.2 °C ; Liquid Temperature : 23.1 °C

DASY5 Configuration:

- Probe: EX3DV4 - SN3971; ConvF(5.28, 5.28, 5.28) @ 5250 MHz; Calibrated: 2020/01/27
- Sensor-Surface: 1.4mm (Mechanical Surface Detection)
- Electronics: DAE4 Sn1277; Calibrated: 2020/01/24
- Phantom: ELI Phantom_1043; Type: QDOVA;
- Measurement SW: DASY52, Version 52.10 (4); SEMCAD X Version 14.6.14 (7483)

Pin=50mW/Area Scan (91x91x1): Interpolated grid: dx=1.000 mm, dy=1.000 mm

Maximum value of SAR (interpolated) = 8.96 W/kg

Pin=50mW/Zoom Scan (7x7x7)/Cube 0: Measurement grid: dx=4mm, dy=4mm, dz=1.4mm

Reference Value = 47.26 V/m; Power Drift = 0.07 dB

Peak SAR (extrapolated) = 14.2 W/kg

SAR(1 g) = 3.6 W/kg; SAR(10 g) = 1.03 W/kg (SAR corrected for target medium)

Maximum value of SAR (measured) = 8.99 W/kg

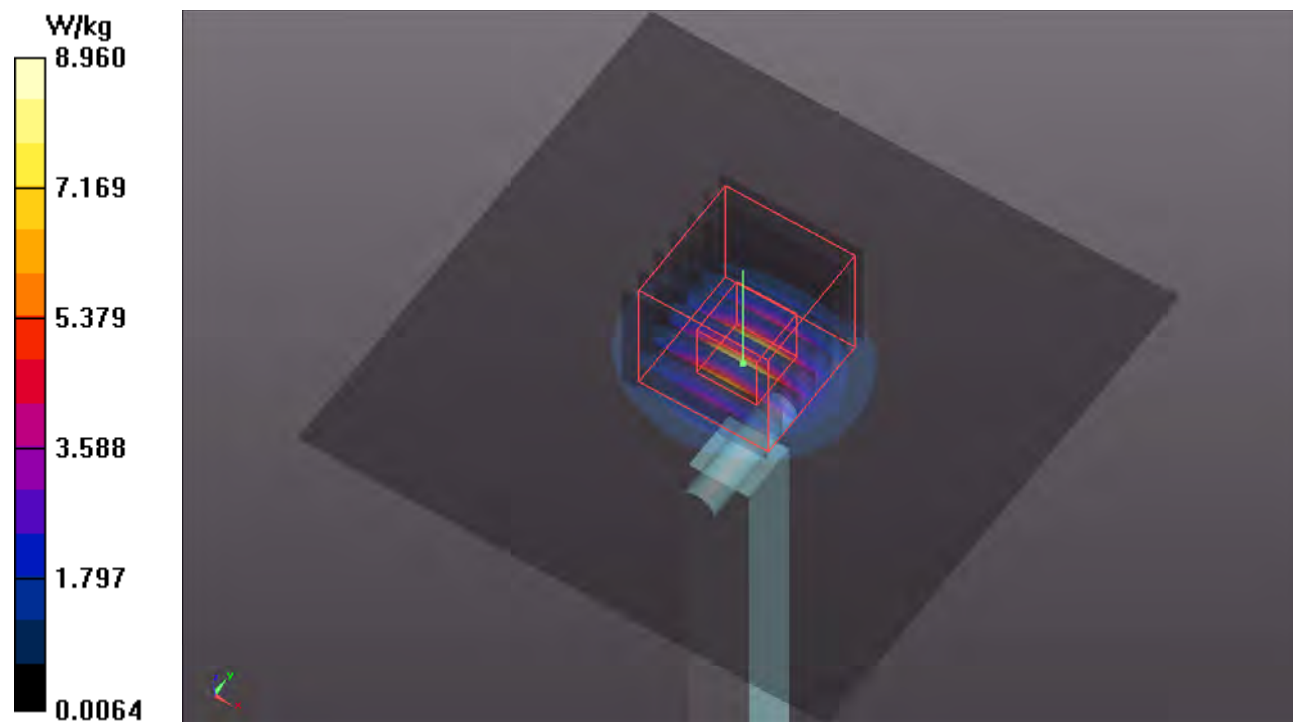

System Check_H5600_200624

DUT: Dipole 5 GHz; Type: D5GHzV2; SN: 1019

Communication System: UID 0, CW; Frequency: 5600 MHz; Duty Cycle: 1:1

Medium: H34T60N2_0624 Medium parameters used: $f = 5600$ MHz; $\sigma = 5.025$ S/m; $\epsilon_r = 34.997$; $\rho = 1000$ kg/m³

Ambient Temperature : 23.6 °C ; Liquid Temperature : 23.1 °C

DASY5 Configuration:

- Probe: EX3DV4 - SN7350; ConvF(4.55, 4.55, 4.55) @ 5600 MHz; Calibrated: 2019/12/16
- Sensor-Surface: 1.4mm (Mechanical Surface Detection)
- Electronics: DAE4 Sn917; Calibrated: 2019/12/17
- Phantom: ELI Phantom_1204; Type: QDOVA;
- Measurement SW: DASY52, Version 52.10 (4); SEMCAD X Version 14.6.14 (7483)

Pin=50mW/Area Scan (91x91x1): Interpolated grid: dx=1.000 mm, dy=1.000 mm
Maximum value of SAR (interpolated) = 8.97 W/kg

Pin=50mW/Zoom Scan (7x7x7)/Cube 0: Measurement grid: dx=4mm, dy=4mm, dz=1.4mm
Reference Value = 47.75 V/m; Power Drift = -0.01 dB
Peak SAR (extrapolated) = 16.3 W/kg
SAR(1 g) = 3.88 W/kg; SAR(10 g) = 1.01 W/kg (SAR corrected for target medium)
Maximum value of SAR (measured) = 9.47 W/kg

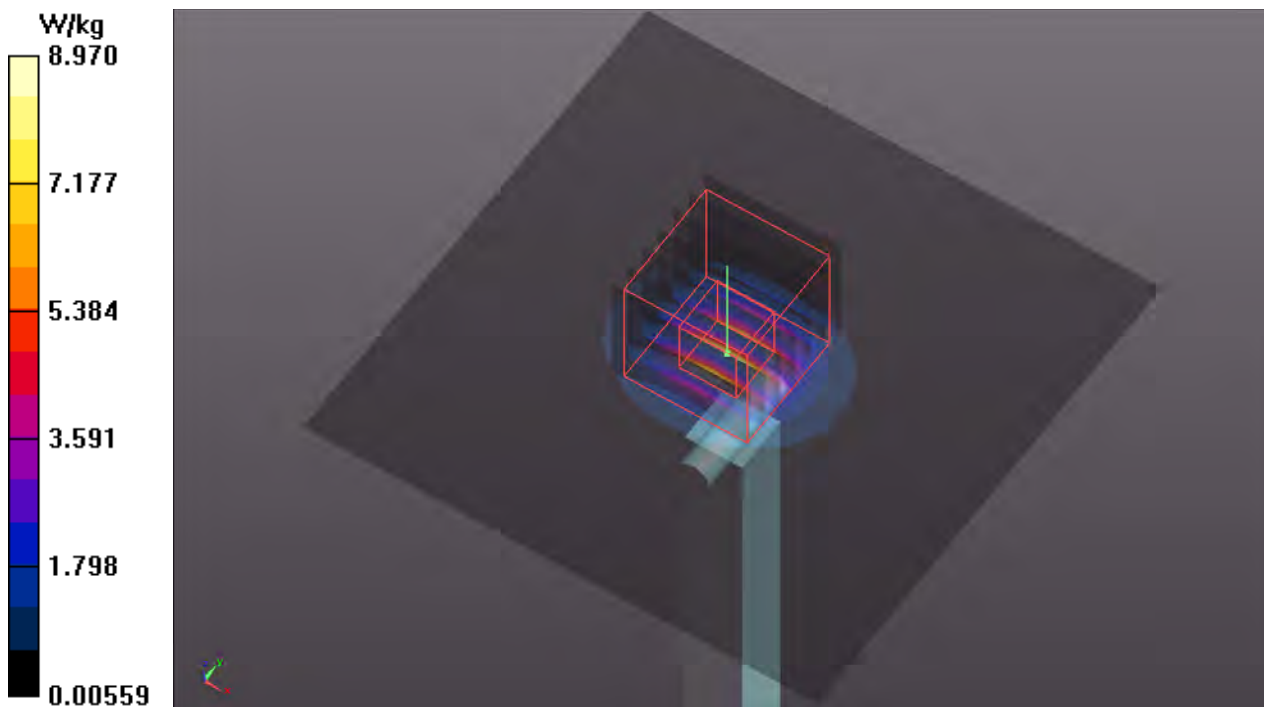

System Check_H5750_200619

DUT: Dipole 5 GHz; Type: D5GHzV2; SN: 1019

Communication System: UID 0, CW; Frequency: 5750 MHz; Duty Cycle: 1:1

Medium: H34T60N2_0619 Medium parameters used: $f = 5750$ MHz; $\sigma = 5.331$ S/m; $\epsilon_r = 34.529$; $\rho = 1000$ kg/m³

Ambient Temperature : 23.6 °C ; Liquid Temperature : 23.1 °C

DASY5 Configuration:

- Probe: EX3DV4 - SN7472; ConvF(5.23, 5.23, 5.23) @ 5750 MHz; Calibrated: 2019/08/30
- Sensor-Surface: 1.4mm (Mechanical Surface Detection)
- Electronics: DAE3 Sn579; Calibrated: 2019/08/27
- Phantom: ELI Phantom_1206; Type: QDOVA002AA;
- Measurement SW: DASY52, Version 52.10 (4); SEMCAD X Version 14.6.14 (7483)

Pin=50mW/Area Scan (91x91x1): Interpolated grid: dx=1.000 mm, dy=1.000 mm

Maximum value of SAR (interpolated) = 9.83 W/kg

Pin=50mW/Zoom Scan (7x7x7)/Cube 0: Measurement grid: dx=4mm, dy=4mm, dz=1.4mm

Reference Value = 45.62 V/m; Power Drift = -0.07 dB

Peak SAR (extrapolated) = 16.5 W/kg

SAR(1 g) = 4.1 W/kg; SAR(10 g) = 1.21 W/kg (SAR corrected for target medium)

Maximum value of SAR (measured) = 10.4 W/kg

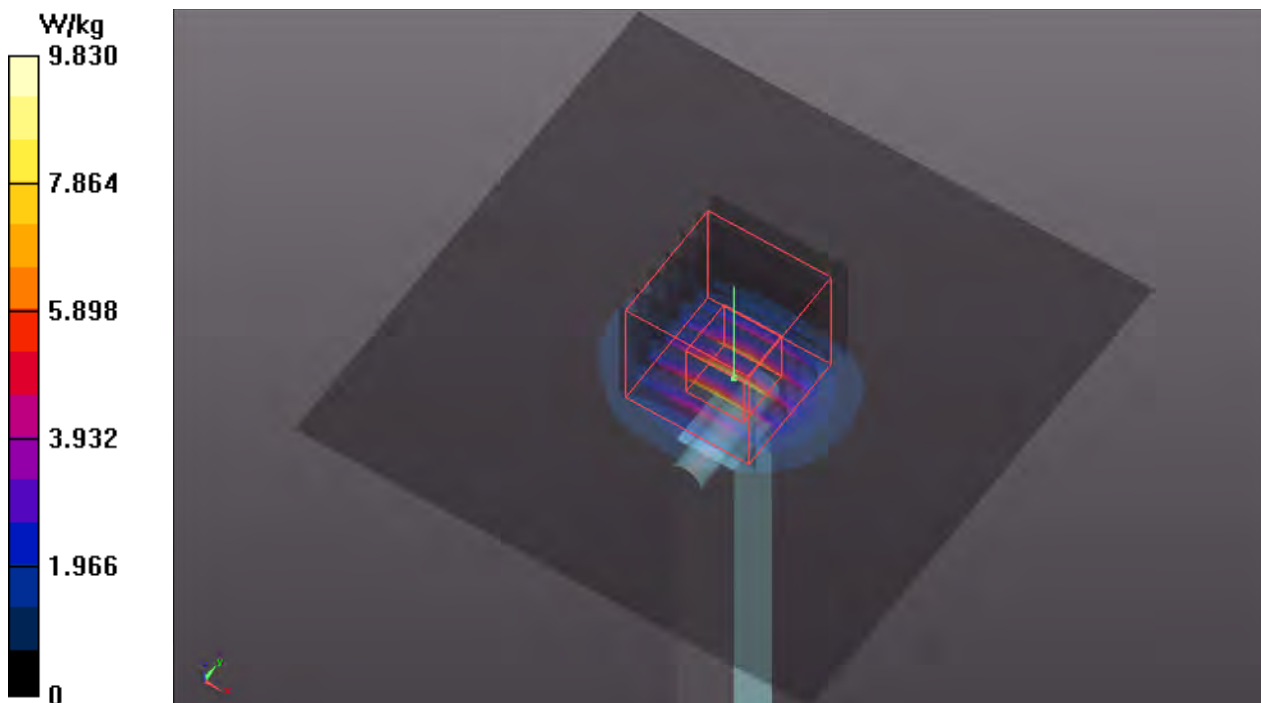

Appendix B. SAR Plots of SAR Measurement

The SAR plots for highest measured SAR in each exposure configuration, wireless mode and frequency band combination, and measured SAR > 1.5 W/kg are shown as follows.

P01 WLAN2.4G_802.11b_Left Side_4mm_Ch1_Ant0+1_Power Reduction_w_o

DUT: 200609C06

Communication System: UID 10315 - AAB, IEEE 802.11b WiFi 2.4 GHz (DSSS, 1 Mbps, 96pc duty cycle); Frequency: 2412 MHz; Duty Cycle: 1:1

Medium: H19T27N1_0610 Medium parameters used: $f = 2412 \text{ MHz}$; $\sigma = 1.842 \text{ S/m}$; $\epsilon_r = 38.48$; $\rho = 1000 \text{ kg/m}^3$

Ambient Temperature : 23.6 °C ; Liquid Temperature : 23.2 °C

DASY5 Configuration:

- Probe: EX3DV4 - SN3971; ConvF(8, 8, 8) @ 2412 MHz; Calibrated: 2020/01/27
- Sensor-Surface: 1.4mm (Mechanical Surface Detection)
- Electronics: DAE4 Sn1277; Calibrated: 2020/01/24
- Phantom: ELI Phantom_1043; Type: QDOVA;
- Measurement SW: DASY52, Version 52.10 (4); SEMCAD X Version 14.6.14 (7483)

Area Scan (41x251x1): Interpolated grid: dx=1.200 mm, dy=1.200 mm

Maximum value of SAR (interpolated) = 1.44 W/kg

Zoom Scan (7x7x7)/Cube 0: Measurement grid: dx=5mm, dy=5mm, dz=5mm

Reference Value = 25.44 V/m; Power Drift = -0.04 dB

Peak SAR (extrapolated) = 1.86 W/kg

SAR(1 g) = 0.880 W/kg; SAR(10 g) = 0.436 W/kg (SAR corrected for target medium)

Smallest distance from peaks to all points 3 dB below = 9 mm

Ratio of SAR at M2 to SAR at M1 = 47.4%

Maximum value of SAR (measured) = 1.51 W/kg

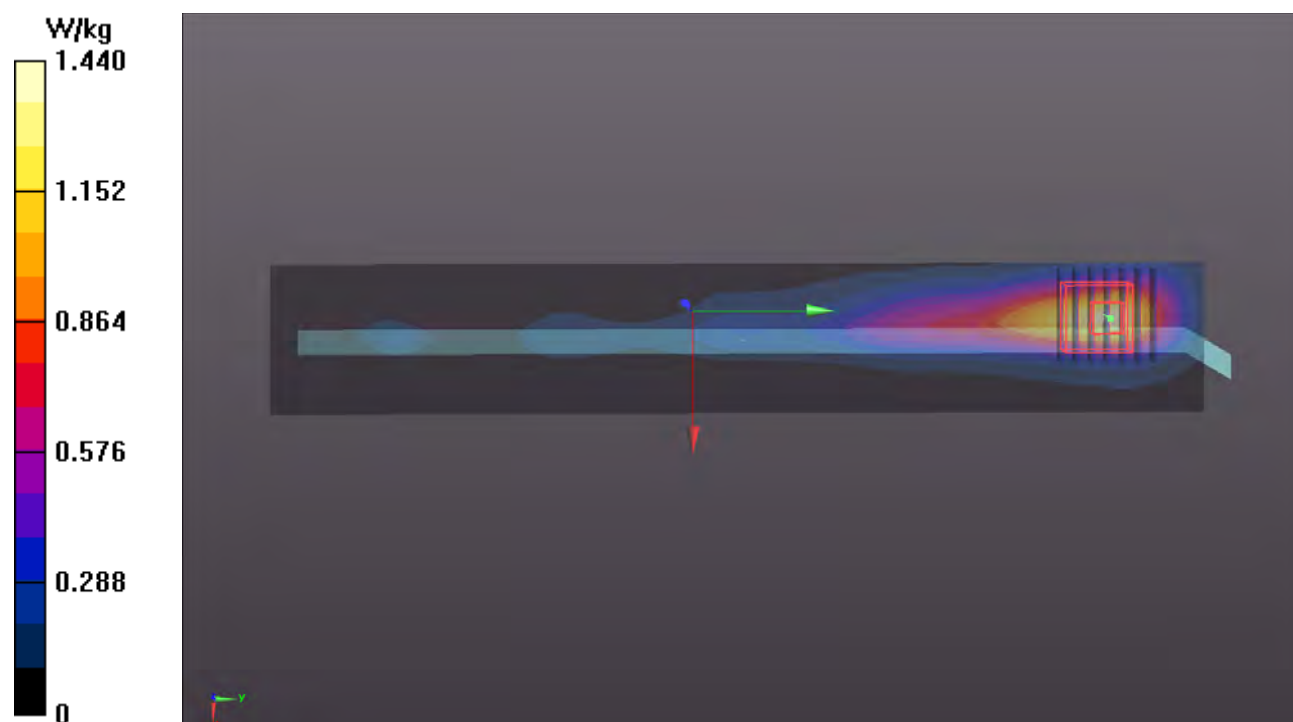

P02 WLAN5.3G_802.11ac VHT80_Rear Face_0mm_Ch58_Ant2_Power Reduction_w

DUT: 200609C06

Communication System: UID 10544 - AAB, IEEE 802.11ac WiFi (80MHz, MCS0, 99pc duty cycle); Frequency: 5290 MHz; Duty Cycle: 1:1
Medium: H34T60N1_0617 Medium parameters used (interpolated): $f = 5290 \text{ MHz}$; $\sigma = 4.549 \text{ S/m}$; $\epsilon_r = 36.945$; $\rho = 1000 \text{ kg/m}^3$
Ambient Temperature : $23.8 \text{ }^\circ\text{C}$; Liquid Temperature : $23.5 \text{ }^\circ\text{C}$

DASY5 Configuration:

- Probe: EX3DV4 - SN3971; ConvF(5.28, 5.28, 5.28) @ 5290 MHz; Calibrated: 2020/01/27
- Sensor-Surface: 1.4mm (Mechanical Surface Detection)
- Electronics: DAE4 Sn1277; Calibrated: 2020/01/24
- Phantom: ELI Phantom_1043; Type: QDOVA;
- Measurement SW: DASY52, Version 52.10 (4); SEMCAD X Version 14.6.14 (7483)

Area Scan (241x141x1): Interpolated grid: $dx=1.000 \text{ mm}$, $dy=1.000 \text{ mm}$
Maximum value of SAR (interpolated) = 1.19 W/kg

Zoom Scan (7x7x7)/Cube 0: Measurement grid: $dx=4\text{mm}$, $dy=4\text{mm}$, $dz=1.4\text{mm}$
Reference Value = 16.27 V/m ; Power Drift = 0.09 dB
Peak SAR (extrapolated) = 9.86 W/kg
SAR(1 g) = 0.768 W/kg ; SAR(10 g) = 0.189 W/kg (SAR corrected for target medium)
Smallest distance from peaks to all points 3 dB below = 4.2 mm
Ratio of SAR at M2 to SAR at M1 = 58.8%
Maximum value of SAR (measured) = 2.12 W/kg

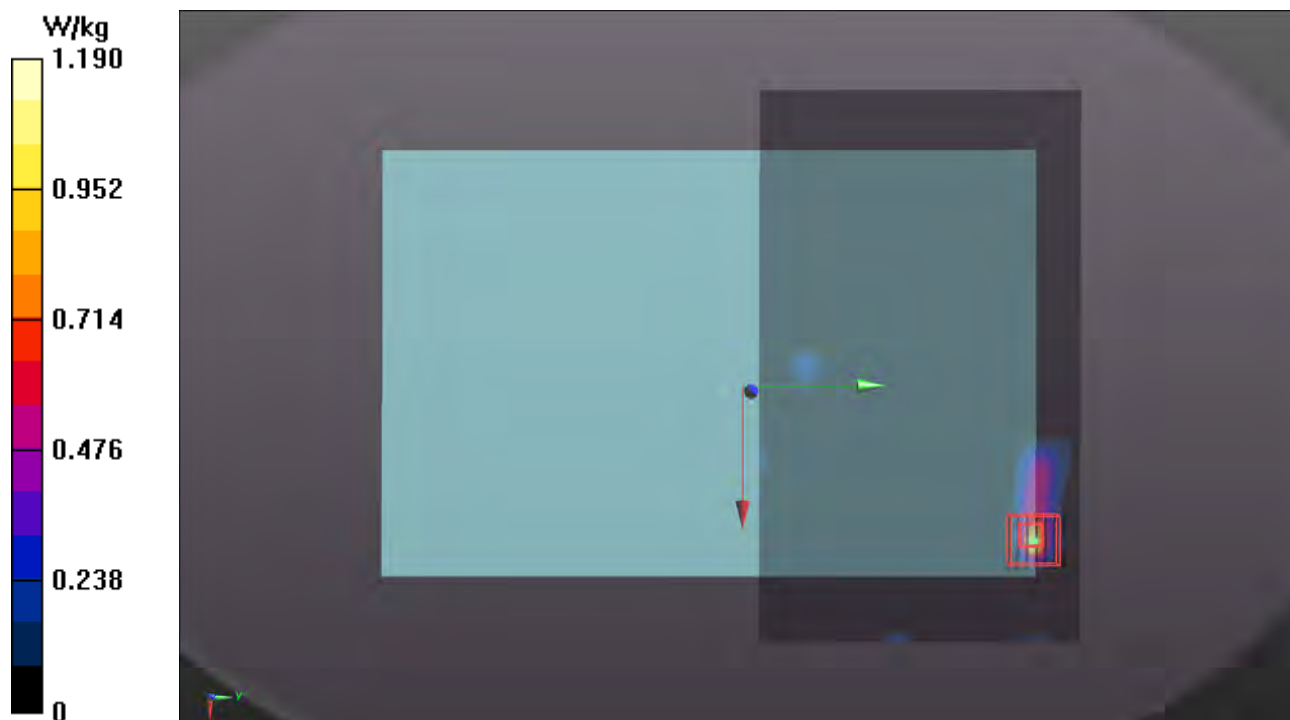

P03 WLAN5.6G_802.11ac VHT80_Rear Face_0mm_Ch106_Ant2_Power Reduction_w

DUT: 200609C06

Communication System: UID 10544 - AAB, IEEE 802.11ac WiFi (80MHz, MCS0, 99pc duty cycle); Frequency: 5530 MHz; Duty Cycle: 1:1

Medium: H34T60N1_0617 Medium parameters used: $f = 5530$ MHz; $\sigma = 4.823$ S/m; $\epsilon_r = 36.614$; $\rho = 1000$ kg/m³

Ambient Temperature : 23.8 °C ; Liquid Temperature : 23.5 °C

DASY5 Configuration:

- Probe: EX3DV4 - SN3971; ConvF(4.89, 4.89, 4.89) @ 5530 MHz; Calibrated: 2020/01/27
- Sensor-Surface: 1.4mm (Mechanical Surface Detection)
- Electronics: DAE4 Sn1277; Calibrated: 2020/01/24
- Phantom: ELI Phantom_1043; Type: QDOVA;
- Measurement SW: DASY52, Version 52.10 (4); SEMCAD X Version 14.6.14 (7483)

Area Scan (241x141x1): Interpolated grid: dx=1.000 mm, dy=1.000 mm

Maximum value of SAR (interpolated) = 1.79 W/kg

Zoom Scan (7x7x7)/Cube 0: Measurement grid: dx=4mm, dy=4mm, dz=1.4mm

Reference Value = 19.42 V/m; Power Drift = 0.06 dB

Peak SAR (extrapolated) = 3.25 W/kg

SAR(1 g) = 0.752 W/kg; SAR(10 g) = 0.207 W/kg (SAR corrected for target medium)

Smallest distance from peaks to all points 3 dB below = 4.3 mm

Ratio of SAR at M2 to SAR at M1 = 60%

Maximum value of SAR (measured) = 2.17 W/kg

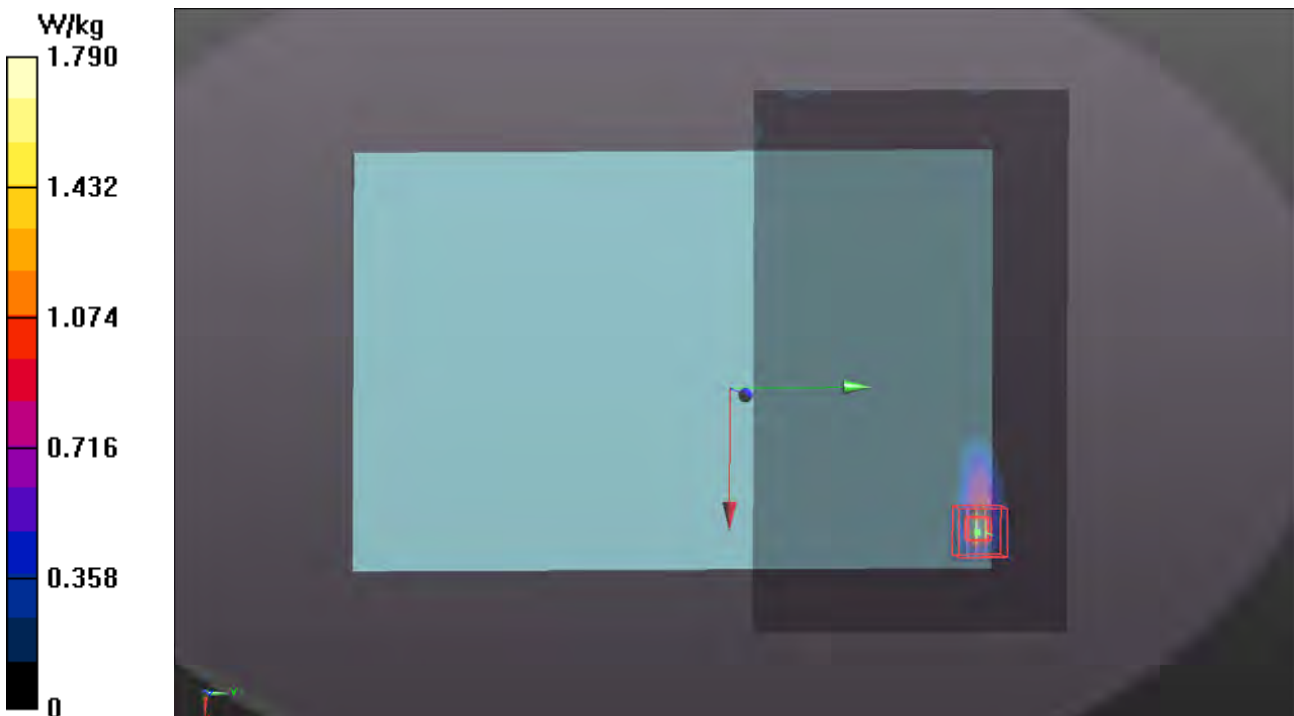

P04 WLAN5.8G_802.11n HT40_Right Side_7mm_Ch159_Ant1_Power Reduction_w_o

DUT: 200609C06

Communication System: UID 10599 - AAB, IEEE 802.11n (HT Mixed, 40MHz, MCS0, 90pc duty cycle); Frequency: 5795 MHz; Duty Cycle: 1:1
Medium: H34T60N2_0623 Medium parameters used: $f = 5795$ MHz; $\sigma = 5.335$ S/m; $\epsilon_r = 33.898$; $\rho = 1000$ kg/m³
Ambient Temperature : 23.6 °C ; Liquid Temperature : 23.1 °C

DASY5 Configuration:

- Probe: EX3DV4 - SN7350; ConvF(4.75, 4.75, 4.75) @ 5795 MHz; Calibrated: 2019/12/16
- Sensor-Surface: 1.4mm (Mechanical Surface Detection)
- Electronics: DAE4 Sn917; Calibrated: 2019/12/17
- Phantom: ELI Phantom_1204; Type: QDOVA;
- Measurement SW: DASY52, Version 52.10 (4); SEMCAD X Version 14.6.14 (7483)

Area Scan (101x301x1): Interpolated grid: dx=1.000 mm, dy=1.000 mm
Maximum value of SAR (interpolated) = 0.930 W/kg

Zoom Scan (7x7x7)/Cube 0: Measurement grid: dx=4mm, dy=4mm, dz=1.4mm
Reference Value = 12.79 V/m; Power Drift = -0.02 dB
Peak SAR (extrapolated) = 2.34 W/kg
SAR(1 g) = 0.582 W/kg; SAR(10 g) = 0.215 W/kg (SAR corrected for target medium)
Smallest distance from peaks to all points 3 dB below = 8.8 mm
Ratio of SAR at M2 to SAR at M1 = 62.1%
Maximum value of SAR (measured) = 1.34 W/kg

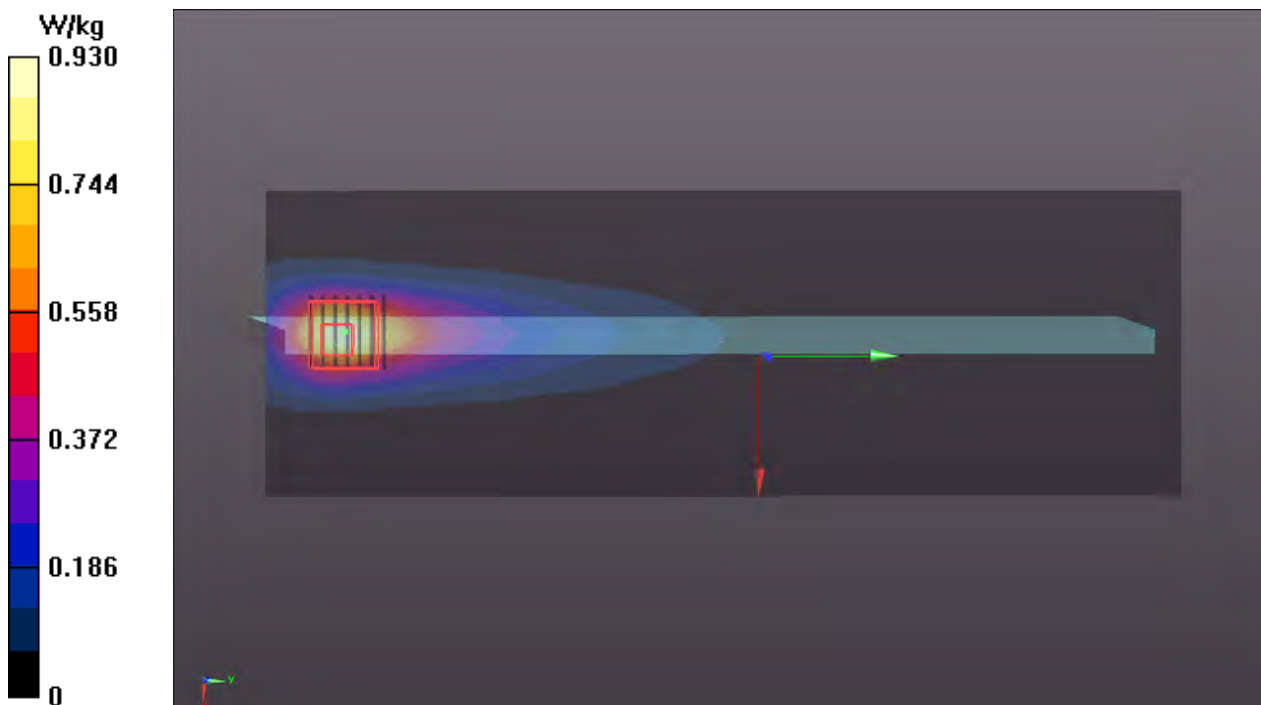

P05 BT_BDR_Right Side_0mm_Ch39_Ant1_Power Reduction_w

DUT: 200609C06

Communication System: UID 10032 - CAA, IEEE 802.15.1 Bluetooth (GFSK, DH5); Frequency: 2441 MHz; Duty Cycle: 1:1.3

Medium: H19T27N1_0623 Medium parameters used (interpolated): $f = 2441$ MHz; $\sigma = 1.86$ S/m; $\epsilon_r = 39.048$; $\rho = 1000$ kg/m³

Ambient Temperature : 23.6 °C ; Liquid Temperature : 23.1 °C

DASY5 Configuration:

- Probe: EX3DV4 - SN7350; ConvF(7.7, 7.7, 7.7) @ 2441 MHz; Calibrated: 2019/12/16
- Sensor-Surface: 1.4mm (Mechanical Surface Detection)
- Electronics: DAE4 Sn917; Calibrated: 2019/12/17
- Phantom: ELI Phantom_1204; Type: QDOVA;
- Measurement SW: DASY52, Version 52.10 (4); SEMCAD X Version 14.6.14 (7483)

Area Scan (51x251x1): Interpolated grid: dx=1.200 mm, dy=1.200 mm

Maximum value of SAR (interpolated) = 0.381 W/kg

Zoom Scan (7x7x7)/Cube 0: Measurement grid: dx=5mm, dy=5mm, dz=5mm

Reference Value = 12.53 V/m; Power Drift = -0.03 dB

Peak SAR (extrapolated) = 1.38 W/kg

SAR(1 g) = 0.411 W/kg; SAR(10 g) = 0.139 W/kg (SAR corrected for target medium)

Smallest distance from peaks to all points 3 dB below = 5.8 mm

Ratio of SAR at M2 to SAR at M1 = 36.8%

Maximum value of SAR (measured) = 0.938 W/kg

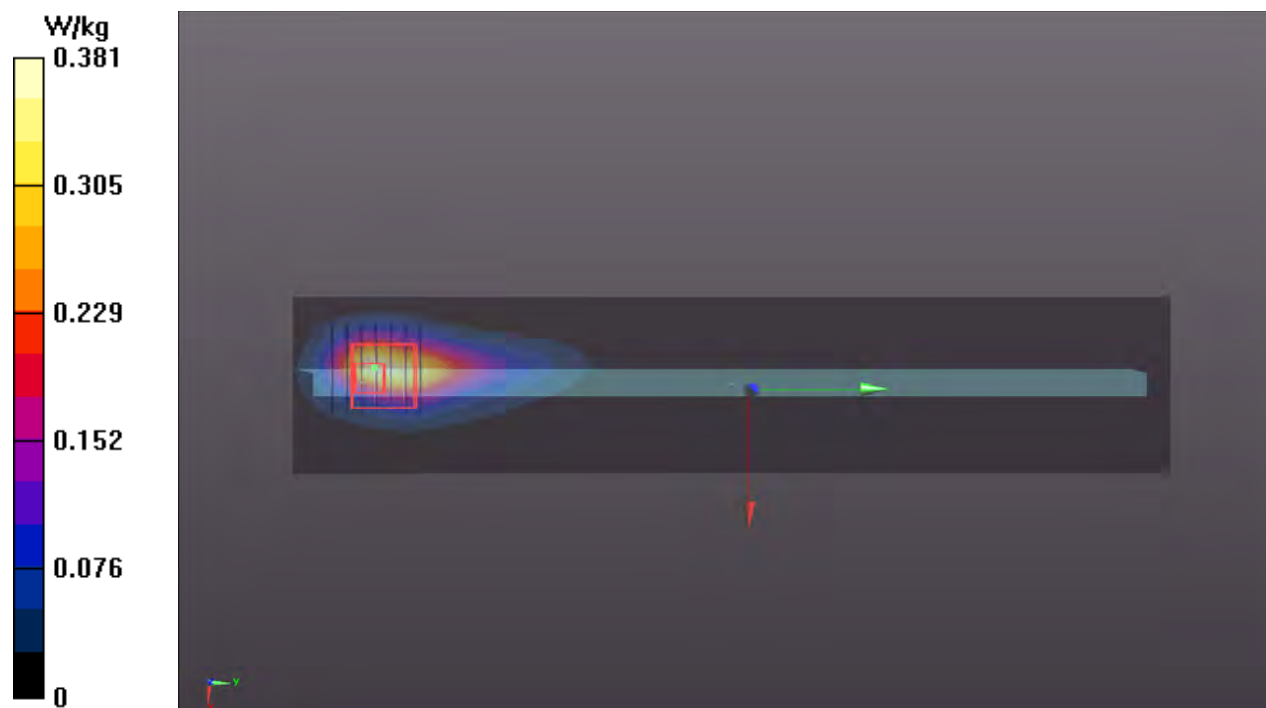

Appendix C. Maximum Target Conducted Power

The maximum conducted average power (Unit: dBm) including tune-up tolerance is shown as below.

WLAN Full Power										
WLAN2.4GHz										
Mode	Channel	Frequency	Ant 2			Ant 1+2				
			Target	Tolerance	Max Tune up	Target	Tolerance	Max Tune up		
802.11b	1	2412	19	+	1	20	22	+	1	23
	6	2437	19	+	1	20	22	+	1	23
	11	2462	19	+	1	20	22	+	1	23
	12	2467	4	+	1	5	4	+	1	5
	13	2472	-2.5	+	1	-1.5	-1	+	1	0
802.11g	1	2412	18	+	1	19	21	+	1	22
	6	2437	18	+	1	19	21	+	1	22
	11	2462	18	+	1	19	21	+	1	22
	12	2467	4	+	1	5	4	+	1	5
	13	2472	4	+	1	5	4	+	1	5
802.11n HT20	1	2412	17	+	1	18	20	+	1	21
	6	2437	17	+	1	18	20	+	1	21
	11	2462	17	+	1	18	20	+	1	21
	12	2467	4	+	1	5	4	+	1	5
	13	2472	4	+	1	5	4	+	1	5
802.11ac VHT20	1	2412	17	+	1	18	20	+	1	21
	6	2437	17	+	1	18	20	+	1	21
	11	2462	17	+	1	18	20	+	1	21
	12	2467	4	+	1	5	4	+	1	5
	13	2472	4	+	1	5	4	+	1	5
802.11ax HE20	1	2412	14	+	1	15	17	+	1	18
	6	2437	14	+	1	15	17	+	1	18
	11	2462	14	+	1	15	17	+	1	18
	12	2467	4	+	1	5	4	+	1	5
	13	2472	4	+	1	5	4	+	1	5

Bluetooth			Ant 1				Ant 2			
Mode	Channel	Frequency	Target	Tolerance	Max Tune up	Target	Tolerance	Max Tune up		
BR / EDR	0	2402	12	+	1	13	11	+	1	12
	39	2441	12	+	1	13	11	+	1	12
	78	2480	12	+	1	13	11	+	1	12
LE	0	2402				2.5	+	1	3.5	
	19	2440				2.5	+	1	3.5	
	39	2480				2.5	+	1	3.5	

WLAN Full Power														
WLAN 5.2GHz			Ant 1			Ant 2			Ant 1+2					
Mode	Channel	Frequency	Target	Tolerance	Max Tune up	Target	Tolerance	Max Tune up	Target	Tolerance	Max Tune up			
802.11a	36	5180	17	+	1	18	17	+	1	18	20	+	1	21
	40	5200	17	+	1	18	17	+	1	18	20	+	1	21
	44	5220	17	+	1	18	17	+	1	18	20	+	1	21
	48	5240	17	+	1	18	17	+	1	18	20	+	1	21
802.11n HT20	36	5180	16	+	1	17	16	+	1	17	19	+	1	20
	40	5200	16	+	1	17	16	+	1	17	19	+	1	20
	44	5220	16	+	1	17	16	+	1	17	19	+	1	20
	48	5240	16	+	1	17	16	+	1	17	19	+	1	20
802.11n HT40	38	5190	13	+	1	14	13	+	1	17	16	+	1	17
	46	5230	13	+	1	14	13	+	1	17	16	+	1	17
802.11ac VHT20	36	5180	16	+	1	17	16	+	1	17	19	+	1	20
	40	5200	16	+	1	17	16	+	1	17	19	+	1	20
	44	5220	16	+	1	17	16	+	1	17	19	+	1	20
	48	5240	16	+	1	17	16	+	1	17	19	+	1	20
802.11ac VHT40	38	5190	14	+	1	15	14	+	1	15	17	+	1	18
	46	5230	14	+	1	15	14	+	1	15	17	+	1	18
802.11ac VHT80	42	5210	13	+	1	14	13	+	1	14	16	+	1	17
802.11ax HE20	36	5180	13	+	1	14	13	+	1	17	16	+	1	17
	40	5200	13	+	1	14	13	+	1	17	16	+	1	17
	44	5220	13	+	1	14	13	+	1	17	16	+	1	17
	48	5240	13	+	1	14	13	+	1	17	16	+	1	17
802.11ax HE40	38	5190	11	+	1	12	11	+	1	15	14	+	1	15
	46	5230	11	+	1	12	11	+	1	15	14	+	1	15
802.11ax HE80	42	5210	10	+	1	11	10	+	1	14	13	+	1	14

WLAN Full Power														
WLAN 5.3GHz			Ant 1			Ant 2			Ant 1+2					
Mode	Channel	Frequency	Target	Tolerance	Max Tune up	Target	Tolerance	Max Tune up	Target	Tolerance	Max Tune up			
802.11a	52	5260	17	+	1	18	17	+	1	18	20	+	1	21
	56	5280	17	+	1	18	17	+	1	18	20	+	1	21
	60	5300	17	+	1	18	17	+	1	18	20	+	1	21
	64	5320	17	+	1	18	17	+	1	18	20	+	1	21
802.11n HT20	52	5260	16	+	1	17	16	+	1	17	19	+	1	20
	56	5280	16	+	1	17	16	+	1	17	19	+	1	20
	60	5300	16	+	1	17	16	+	1	17	19	+	1	20
	64	5320	16	+	1	17	16	+	1	17	19	+	1	20
802.11n HT40	54	5270	13	+	1	14	16	+	1	17	19	+	1	20
	62	5310	13	+	1	14	16	+	1	17	19	+	1	20
802.11ac VHT20	52	5260	16	+	1	17	16	+	1	17	19	+	1	20
	56	5280	16	+	1	17	16	+	1	17	19	+	1	20
	60	5300	16	+	1	17	16	+	1	17	19	+	1	20
	64	5320	16	+	1	17	16	+	1	17	19	+	1	20
802.11ac VHT40	54	5270	14	+	1	15	14	+	1	15	17	+	1	18
	62	5310	14	+	1	15	14	+	1	15	17	+	1	18
802.11ac VHT80	58	5290	13	+	1	14	13	+	1	14	16	+	1	17
802.11ax HE20	52	5260	14	+	1	15	14	+	1	17	17	+	1	18
	56	5280	14	+	1	15	14	+	1	17	17	+	1	18
	60	5300	14	+	1	15	14	+	1	17	17	+	1	18
	64	5320	14	+	1	15	14	+	1	17	17	+	1	18
802.11ax HE40	54	5270	11	+	1	12	11	+	1	15	14	+	1	15
	62	5310	11	+	1	12	11	+	1	15	14	+	1	15
802.11ax HE80	58	5290	10	+	1	11	10	+	1	14	13	+	1	14

WLAN Full Power														
WLAN 5.6GHz			Ant 1			Ant 2			Ant 1+2					
Mode	Channel	Frequency	Target	Tolerance	Max Tune up	Target	Tolerance	Max Tune up	Target	Tolerance	Max Tune up			
802.11a	100	5500	15.5	+	1	16.5	15.5	+	1	16.5	18.5	+	1	19.5
	116	5580	15.5	+	1	16.5	15.5	+	1	16.5	18.5	+	1	19.5
	120	5600	15.5	+	1	16.5	15.5	+	1	16.5	18.5	+	1	19.5
	124	5620	15.5	+	1	16.5	15.5	+	1	16.5	18.5	+	1	19.5
	132	5660	15.5	+	1	16.5	15.5	+	1	16.5	18.5	+	1	19.5
	140	5700	15.5	+	1	16.5	15.5	+	1	16.5	18.5	+	1	19.5
144	5720	15.5	+	1	16.5	15.5	+	1	16.5	18.5	+	1	19.5	
802.11n HT20	100	5500	16	+	1	17	16	+	1	17	19	+	1	20
	116	5580	16	+	1	17	16	+	1	17	19	+	1	20
	120	5600	16	+	1	17	16	+	1	17	19	+	1	20
	124	5620	16	+	1	17	16	+	1	17	19	+	1	20
	132	5660	16	+	1	17	16	+	1	17	19	+	1	20
	140	5700	16	+	1	17	16	+	1	17	19	+	1	20
144	5720	16	+	1	17	16	+	1	17	19	+	1	20	
802.11n HT40	102	5510	16	+	1	17	16	+	1	17	19	+	1	20
	110	5550	16	+	1	17	16	+	1	17	19	+	1	20
	118	5590	16	+	1	17	16	+	1	17	19	+	1	20
	126	5630	16	+	1	17	16	+	1	17	19	+	1	20
	134	5670	16	+	1	17	16	+	1	17	19	+	1	20
	142	5710	16	+	1	17	16	+	1	17	19	+	1	20
802.11ac VHT20	100	5500	16	+	1	17	16	+	1	17	19	+	1	20
	116	5580	16	+	1	17	16	+	1	17	19	+	1	20
	120	5600	16	+	1	17	16	+	1	17	19	+	1	20
	124	5620	16	+	1	17	16	+	1	17	19	+	1	20
	132	5660	16	+	1	17	16	+	1	17	19	+	1	20
	140	5700	16	+	1	17	16	+	1	17	19	+	1	20
144	5720	16	+	1	17	16	+	1	17	19	+	1	20	
802.11ac VHT40	102	5510	14	+	1	15	14	+	1	15	17	+	1	18
	110	5550	14	+	1	15	14	+	1	15	17	+	1	18
	118	5590	14	+	1	15	14	+	1	15	17	+	1	18
	126	5630	14	+	1	15	14	+	1	15	17	+	1	18
	134	5670	14	+	1	15	14	+	1	15	17	+	1	18
	142	5710	14	+	1	15	14	+	1	15	17	+	1	18
802.11ac VHT80	106	5530	13	+	1	14	13	+	1	14	16	+	1	17
	122	5610	13	+	1	14	13	+	1	14	16	+	1	17
	138	5690	13	+	1	14	13	+	1	14	16	+	1	17
802.11ax HE20	100	5500	13	+	1	14	13	+	1	14	16	+	1	17
	116	5580	13	+	1	14	13	+	1	14	16	+	1	17
	120	5600	13	+	1	14	13	+	1	14	16	+	1	17
	124	5620	13	+	1	14	13	+	1	14	16	+	1	17
	132	5660	13	+	1	14	13	+	1	14	16	+	1	17
	140	5700	13	+	1	14	13	+	1	14	16	+	1	17
144	5720	13	+	1	14	13	+	1	14	16	+	1	17	
802.11ax HE40	102	5510	11	+	1	12	11	+	1	12	14	+	1	15
	110	5550	11	+	1	12	11	+	1	12	14	+	1	15
	118	5590	11	+	1	12	11	+	1	12	14	+	1	15
	126	5630	11	+	1	12	11	+	1	12	14	+	1	15
	134	5670	11	+	1	12	11	+	1	12	14	+	1	15
142	5710	11	+	1	12	11	+	1	12	14	+	1	15	
802.11ax HE80	106	5530	10	+	1	11	10	+	1	11	13	+	1	14
	122	5610	10	+	1	11	10	+	1	11	13	+	1	14
	138	5690	10	+	1	11	10	+	1	11	13	+	1	14

WLAN Full Power														
WLAN 5.8GHz			Ant 1			Ant 2			Ant 1+2					
Mode	Channel	Frequency	Target	Tolerance	Max Tune up	Target	Tolerance	Max Tune up	Target	Tolerance	Max Tune up			
802.11a	149	5745	15.5	+	1	16.5	15.5	+	1	16.5	18.5	+	1	19.5
	153	5765	15.5	+	1	16.5	15.5	+	1	16.5	18.5	+	1	19.5
	157	5785	15.5	+	1	16.5	15.5	+	1	16.5	18.5	+	1	19.5
	161	5805	15.5	+	1	16.5	15.5	+	1	16.5	18.5	+	1	19.5
	165	5825	15.5	+	1	16.5	15.5	+	1	16.5	18.5	+	1	19.5
802.11n HT20	149	5745	16	+	1	17	16	+	1	17	19	+	1	20
	153	5765	16	+	1	17	16	+	1	17	19	+	1	20
	157	5785	16	+	1	17	16	+	1	17	19	+	1	20
	161	5805	16	+	1	17	16	+	1	17	19	+	1	20
	165	5825	16	+	1	17	16	+	1	17	19	+	1	20
802.11n HT40	151	5755	16	+	1	17	16	+	1	17	19	+	1	20
	159	5795	16	+	1	17	16	+	1	17	19	+	1	20
802.11ac VHT20	149	5745	16	+	1	17	16	+	1	17	19	+	1	20
	153	5765	16	+	1	17	16	+	1	17	19	+	1	20
	157	5785	16	+	1	17	16	+	1	17	19	+	1	20
	161	5805	16	+	1	17	16	+	1	17	19	+	1	20
	165	5825	16	+	1	17	16	+	1	17	19	+	1	20
802.11ac VHT40	151	5755	14	+	1	15	14	+	1	15	17	+	1	18
	159	5795	14	+	1	15	14	+	1	15	17	+	1	18
802.11ac VHT80	155	5775	13	+	1	14	13	+	1	14	16	+	1	17
802.11ax HE20	149	5745	13	+	1	14	13	+	1	14	16	+	1	17
	153	5765	13	+	1	14	13	+	1	14	16	+	1	17
	157	5785	13	+	1	14	13	+	1	14	16	+	1	17
	161	5805	13	+	1	14	13	+	1	14	16	+	1	17
	165	5825	13	+	1	14	13	+	1	14	16	+	1	17
802.11ax HE40	151	5755	11	+	1	12	11	+	1	12	14	+	1	15
	159	5795	11	+	1	12	11	+	1	12	14	+	1	15
802.11ax HE80	155	5775	10	+	1	11	10	+	1	11	13	+	1	14

WLAN Reduction Power														
WLAN 5.2GHz			Ant 1			Ant 2			Ant 1+2					
Mode	Channel	Frequency	Target	Tolerance	Max Tune up	Target	Tolerance	Max Tune up	Target	Tolerance	Max Tune up			
802.11a	36	5180	8	+	1	9	8	+	1	9	11	+	1	12
	40	5200	8	+	1	9	8	+	1	9	11	+	1	12
	44	5220	8	+	1	9	8	+	1	9	11	+	1	12
	48	5240	8	+	1	9	8	+	1	9	11	+	1	12
802.11n HT20	36	5180	8	+	1	9	8	+	1	9	11	+	1	12
	40	5200	8	+	1	9	8	+	1	9	11	+	1	12
	44	5220	8	+	1	9	8	+	1	9	11	+	1	12
	48	5240	8	+	1	9	8	+	1	9	11	+	1	12
802.11n HT40	38	5190	8	+	1	9	8	+	1	9	11	+	1	12
	46	5230	8	+	1	9	8	+	1	9	11	+	1	12
802.11ac VHT20	36	5180	8	+	1	9	8	+	1	9	11	+	1	12
	40	5200	8	+	1	9	8	+	1	9	11	+	1	12
	44	5220	8	+	1	9	8	+	1	9	11	+	1	12
	48	5240	8	+	1	9	8	+	1	9	11	+	1	12
802.11ac VHT40	38	5190	8	+	1	9	8	+	1	9	11	+	1	12
	46	5230	8	+	1	9	8	+	1	9	11	+	1	12
802.11ac VHT80	42	5210	8	+	1	9	8	+	1	9	11	+	1	12
802.11ax HE20	36	5180	8	+	1	9	8	+	1	9	11	+	1	12
	40	5200	8	+	1	9	8	+	1	9	11	+	1	12
	44	5220	8	+	1	9	8	+	1	9	11	+	1	12
	48	5240	8	+	1	9	8	+	1	9	11	+	1	12
802.11ax HE40	38	5190	8	+	1	9	8	+	1	9	11	+	1	12
	46	5230	8	+	1	9	8	+	1	9	11	+	1	12
802.11ax HE80	42	5210	8	+	1	9	8	+	1	9	11	+	1	12

WLAN Reduction Power														
WLAN 5.3GHz			Ant 1			Ant 2			Ant 1+2					
Mode	Channel	Frequency	Target	Tolerance	Max Tune up	Target	Tolerance	Max Tune up	Target	Tolerance	Max Tune up			
802.11a	52	5260	8	+	1	9	8	+	1	9	11	+	1	12
	56	5280	8	+	1	9	8	+	1	9	11	+	1	12
	60	5300	8	+	1	9	8	+	1	9	11	+	1	12
	64	5320	8	+	1	9	8	+	1	9	11	+	1	12
802.11n HT20	52	5260	8	+	1	9	8	+	1	9	11	+	1	12
	56	5280	8	+	1	9	8	+	1	9	11	+	1	12
	60	5300	8	+	1	9	8	+	1	9	11	+	1	12
	64	5320	8	+	1	9	8	+	1	9	11	+	1	12
802.11n HT40	54	5270	8	+	1	9	8	+	1	9	11	+	1	12
	62	5310	8	+	1	9	8	+	1	9	11	+	1	12
802.11ac VHT20	52	5260	8	+	1	9	8	+	1	9	11	+	1	12
	56	5280	8	+	1	9	8	+	1	9	11	+	1	12
	60	5300	8	+	1	9	8	+	1	9	11	+	1	12
	64	5320	8	+	1	9	8	+	1	9	11	+	1	12
802.11ac VHT40	54	5270	8	+	1	9	8	+	1	9	11	+	1	12
	62	5310	8	+	1	9	8	+	1	9	11	+	1	12
802.11ac VHT80	58	5290	8	+	1	9	8	+	1	9	11	+	1	12
802.11ax HE20	52	5260	8	+	1	9	8	+	1	9	11	+	1	12
	56	5280	8	+	1	9	8	+	1	9	11	+	1	12
	60	5300	8	+	1	9	8	+	1	9	11	+	1	12
	64	5320	8	+	1	9	8	+	1	9	11	+	1	12
802.11ax HE40	54	5270	8	+	1	9	8	+	1	9	11	+	1	12
	62	5310	8	+	1	9	8	+	1	9	11	+	1	12
802.11ax HE80	58	5290	8	+	1	9	8	+	1	9	11	+	1	12

WLAN Reduction Power														
WLAN 5.6GHz			Ant 1			Ant 2			Ant 1+2					
Mode	Channel	Frequency	Target	Tolerance	Max Tune up	Target	Tolerance	Max Tune up	Target	Tolerance	Max Tune up			
802.11a	100	5500	8	+	1	9	8	+	1	9	11	+	1	12
	116	5580	8	+	1	9	8	+	1	9	11	+	1	12
	120	5600	8	+	1	9	8	+	1	9	11	+	1	12
	124	5620	8	+	1	9	8	+	1	9	11	+	1	12
	132	5660	8	+	1	9	8	+	1	9	11	+	1	12
	140	5700	8	+	1	9	8	+	1	9	11	+	1	12
144	5720	8	+	1	9	8	+	1	9	11	+	1	12	
802.11n HT20	100	5500	8	+	1	9	8	+	1	9	11	+	1	12
	116	5580	8	+	1	9	8	+	1	9	11	+	1	12
	120	5600	8	+	1	9	8	+	1	9	11	+	1	12
	124	5620	8	+	1	9	8	+	1	9	11	+	1	12
	132	5660	8	+	1	9	8	+	1	9	11	+	1	12
	140	5700	8	+	1	9	8	+	1	9	11	+	1	12
144	5720	8	+	1	9	8	+	1	9	11	+	1	12	
802.11n HT40	102	5510	8	+	1	9	8	+	1	9	11	+	1	12
	110	5550	8	+	1	9	8	+	1	9	11	+	1	12
	118	5590	8	+	1	9	8	+	1	9	11	+	1	12
	126	5630	8	+	1	9	8	+	1	9	11	+	1	12
	134	5670	8	+	1	9	8	+	1	9	11	+	1	12
	142	5710	8	+	1	9	8	+	1	9	11	+	1	12
802.11ac VHT20	100	5500	8	+	1	9	8	+	1	9	11	+	1	12
	116	5580	8	+	1	9	8	+	1	9	11	+	1	12
	120	5600	8	+	1	9	8	+	1	9	11	+	1	12
	124	5620	8	+	1	9	8	+	1	9	11	+	1	12
	132	5660	8	+	1	9	8	+	1	9	11	+	1	12
	140	5700	8	+	1	9	8	+	1	9	11	+	1	12
144	5720	8	+	1	9	8	+	1	9	11	+	1	12	
802.11ac VHT40	102	5510	8	+	1	9	8	+	1	9	11	+	1	12
	110	5550	8	+	1	9	8	+	1	9	11	+	1	12
	118	5590	8	+	1	9	8	+	1	9	11	+	1	12
	126	5630	8	+	1	9	8	+	1	9	11	+	1	12
	134	5670	8	+	1	9	8	+	1	9	11	+	1	12
	142	5710	8	+	1	9	8	+	1	9	11	+	1	12
802.11ac VHT80	106	5530	8	+	1	9	8	+	1	9	11	+	1	12
	122	5610	8	+	1	9	8	+	1	9	11	+	1	12
	138	5690	8	+	1	9	8	+	1	9	11	+	1	12
802.11ax HE20	100	5500	8	+	1	9	8	+	1	9	11	+	1	12
	116	5580	8	+	1	9	8	+	1	9	11	+	1	12
	120	5600	8	+	1	9	8	+	1	9	11	+	1	12
	124	5620	8	+	1	9	8	+	1	9	11	+	1	12
	132	5660	8	+	1	9	8	+	1	9	11	+	1	12
	140	5700	8	+	1	9	8	+	1	9	11	+	1	12
144	5720	8	+	1	9	8	+	1	9	11	+	1	12	
802.11ax HE40	102	5510	8	+	1	9	8	+	1	9	11	+	1	12
	110	5550	8	+	1	9	8	+	1	9	11	+	1	12
	118	5590	8	+	1	9	8	+	1	9	11	+	1	12
	126	5630	8	+	1	9	8	+	1	9	11	+	1	12
	134	5670	8	+	1	9	8	+	1	9	11	+	1	12
142	5710	8	+	1	9	8	+	1	9	11	+	1	12	
802.11ax HE80	106	5530	8	+	1	9	8	+	1	9	11	+	1	12
	122	5610	8	+	1	9	8	+	1	9	11	+	1	12
	138	5690	8	+	1	9	8	+	1	9	11	+	1	12

WLAN Reduction Power														
WLAN 5.8GHz			Ant 1			Ant 2			Ant 1+2					
Mode	Channel	Frequency	Target	Tolerance	Max Tune up	Target	Tolerance	Max Tune up	Target	Tolerance	Max Tune up			
802.11a	149	5745	8	+	1	9	8	+	1	9	11	+	1	12
	153	5765	8	+	1	9	8	+	1	9	11	+	1	12
	157	5785	8	+	1	9	8	+	1	9	11	+	1	12
	161	5805	8	+	1	9	8	+	1	9	11	+	1	12
802.11n HT20	165	5825	8	+	1	9	8	+	1	9	11	+	1	12
	149	5745	8	+	1	9	8	+	1	9	11	+	1	12
	153	5765	8	+	1	9	8	+	1	9	11	+	1	12
	157	5785	8	+	1	9	8	+	1	9	11	+	1	12
802.11n HT40	161	5805	8	+	1	9	8	+	1	9	11	+	1	12
	165	5825	8	+	1	9	8	+	1	9	11	+	1	12
802.11ac VHT20	151	5755	8	+	1	9	8	+	1	9	11	+	1	12
	159	5795	8	+	1	9	8	+	1	9	11	+	1	12
	149	5745	8	+	1	9	8	+	1	9	11	+	1	12
	153	5765	8	+	1	9	8	+	1	9	11	+	1	12
802.11ac VHT40	157	5785	8	+	1	9	8	+	1	9	11	+	1	12
	161	5805	8	+	1	9	8	+	1	9	11	+	1	12
802.11ac VHT80	165	5825	8	+	1	9	8	+	1	9	11	+	1	12
	151	5755	8	+	1	9	8	+	1	9	11	+	1	12
802.11ax HE20	159	5795	8	+	1	9	8	+	1	9	11	+	1	12
	149	5745	8	+	1	9	8	+	1	9	11	+	1	12
	153	5765	8	+	1	9	8	+	1	9	11	+	1	12
	157	5785	8	+	1	9	8	+	1	9	11	+	1	12
802.11ax HE40	161	5805	8	+	1	9	8	+	1	9	11	+	1	12
	165	5825	8	+	1	9	8	+	1	9	11	+	1	12
802.11ax HE80	151	5755	8	+	1	9	8	+	1	9	11	+	1	12
	159	5795	8	+	1	9	8	+	1	9	11	+	1	12
802.11ax HE80	155	5775	8	+	1	9	8	+	1	9	11	+	1	12

Appendix D. Measured Conducted Power

The measuring conducted power (Unit: dBm) are shown as below.

WLAN Full Power			
Bluetooth Ant 1			
Mode	Channel	Frequency	SISO Ant 1 Avg. Power
BR / EDR	0	2402	12.48
	39	2441	11.52
	78	2480	10.62
LE	0	2402	
	19	2440	
	39	2480	

WLAN 5.3GHz Ant 1			
Mode	Channel	Frequency	SISO Ant 1 Avg. Power
802.11a	52	5260	17.62
	56	5280	17.55
	60	5300	17.28
	64	5320	17.09

WLAN 5.6GHz Ant 1			
Mode	Channel	Frequency	SISO Ant 1 Avg. Power
802.11n HT40	102	5510	16.1
	110	5550	16.05
	118	5590	16.07
	126	5630	16.42
	134	5670	16.89
	142	5710	16.16

WLAN 5.8GHz Ant 1			
Mode	Channel	Frequency	SISO Ant 1 Avg. Power
802.11n HT40	151	5755	16.44
	159	5795	15.35

WLAN Full Power			
WLAN2.4GHz Ant 2			
Mode	Channel	Frequency	SISO Ant 2 Avg. Power
802.11b	1	2412	19.59
	6	2437	19.39
	11	2462	19.52
	12	2467	4.1
	13	2472	-1.86

Bluetooth Ant 2			
Mode	Channel	Frequency	SISO Ant 2 Avg. Power
BR / EDR	0	2402	10.02
	39	2441	11.03
	78	2480	11.04
LE	0	2402	2.52
	19	2440	2.73
	39	2480	2.58

WLAN 5.3GHz Ant 2			
Mode	Channel	Frequency	SISO Ant 2 Avg. Power
802.11a	52	5260	17.34
	56	5280	17.14
	60	5300	17.28
	64	5320	17.14

WLAN 5.6GHz Ant 2			
Mode	Channel	Frequency	SISO Ant 2 Avg. Power
802.11n HT40	102	5510	16.01
	110	5550	16.21
	118	5590	16.35
	126	5630	16.54
	134	5670	16.66
	142	5710	16.62

WLAN 5.8GHz Ant 2			
Mode	Channel	Frequency	SISO Ant 2 Avg. Power
802.11n HT40	151	5755	16.63
	159	5795	16.5

WLAN Full Power					
WLAN2.4GHz Ant 1+2					
Mode	Channel	Frequency	MIMO Ant 1 Avg. Power	MIMO Ant 2 Avg. Power	MIMO Ant 1+2 Avg. Power
802.11b	1	2412	19.1	19.91	22.53
	6	2437	19.34	19.52	22.44
	11	2462	18.92	19.75	22.37
	12	2467	1.12	1.95	4.57
	13	2472	-3.87	-3.34	-0.59

WLAN 5.3GHz Ant 1+2					
Mode	Channel	Frequency	MIMO Ant 1 Avg. Power	MIMO Ant 2 Avg. Power	MIMO Ant 1+2 Avg. Power
802.11a	52	5260	17.89	17.66	20.79
	56	5280	17.84	17.53	20.7
	60	5300	17.63	17.62	20.64
	64	5320	17.43	17.56	20.51

WLAN 5.6GHz Ant 1+2					
Mode	Channel	Frequency	MIMO Ant 1 Avg. Power	MIMO Ant 2 Avg. Power	MIMO Ant 1+2 Avg. Power
802.11n HT40	102	5510	15.52	15.47	18.51
	110	5550	15.65	15.64	18.66
	118	5590	15.94	16.63	19.31
	126	5630	16.23	16.33	19.29
	134	5670	16.83	16.96	19.91
	142	5710	15.99	16.76	19.4

WLAN 5.8GHz Ant 1+2					
Mode	Channel	Frequency	MIMO Ant 1 Avg. Power	MIMO Ant 2 Avg. Power	MIMO Ant 1+2 Avg. Power
802.11n HT40	151	5755	16.35	16.95	19.99
	159	5795	16.01	16.89	19.72

WLAN Reduction Power			
Bluetooth Ant 1			
Mode	Channel	Frequency	SISO Ant 1 Avg. Power
BR / EDR	0	2402	11.94
	39	2441	10.93
	78	2480	10.18
LE	0	2402	
	19	2440	
	39	2480	

WLAN 5.3GHz Ant 1			
Mode	Channel	Frequency	SISO Ant 1 Avg. Power
802.11ac VHT80	58	5290	8.74

WLAN 5.6GHz Ant 1			
Mode	Channel	Frequency	SISO Ant 1 Avg. Power
802.11ac VHT80	106	5530	8.86
	122	5610	8.22
	138	5690	8.28

WLAN 5.8GHz Ant 1			
Mode	Channel	Frequency	SISO Ant 1 Avg. Power
802.11ac VHT80	155	5775	8.86

WLAN Reduction Power			
WLAN2.4GHz Ant 2			
Mode	Channel	Frequency	SISO Ant 2 Avg. Power
802.11b	1	2412	11.24
	6	2437	10.75
	11	2462	10.21

Bluetooth Ant 2			
Mode	Channel	Frequency	SISO Ant 2 Avg. Power
BR / EDR	0	2402	9.42
	39	2441	10.34
	78	2480	10.49
LE	0	2402	2.5
	19	2440	2.72
	39	2480	2.53

WLAN 5.3GHz Ant 2			
Mode	Channel	Frequency	SISO Ant 2 Avg. Power
802.11ac VHT80	58	5290	8.53

WLAN 5.6GHz Ant 2			
Mode	Channel	Frequency	SISO Ant 2 Avg. Power
802.11ac VHT80	106	5530	8.6
	122	5610	8.55
	138	5690	8.52

WLAN 5.8GHz Ant 2			
Mode	Channel	Frequency	SISO Ant 2 Avg. Power
802.11ac VHT80	155	5775	8.18

WLAN Reduction Power					
WLAN2.4GHz Ant 1+2					
Mode	Channel	Frequency	MIMO Ant 1 Avg. Power	MIMO Ant 2 Avg. Power	MIMO Ant 1+2 Avg. Power
802.11b	1	2412	10.55	11.2	13.9
	6	2437	10.73	10.96	13.86
	11	2462	9.88	10.45	13.18

WLAN 5.3GHz Ant 1+2					
Mode	Channel	Frequency	MIMO Ant 1 Avg. Power	MIMO Ant 2 Avg. Power	MIMO Ant 1+2 Avg. Power
802.11ac VHT80	58	5290	8.44	7.88	11.18

WLAN 5.6GHz Ant 1+2					
Mode	Channel	Frequency	MIMO Ant 1 Avg. Power	MIMO Ant 2 Avg. Power	MIMO Ant 1+2 Avg. Power
802.11ac VHT80	106	5530	8.37	8.29	11.34
	122	5610	7.69	8.66	11.21
	138	5690	7.36	8.42	10.93

WLAN 5.8GHz Ant 1+2					
Mode	Channel	Frequency	MIMO Ant 1 Avg. Power	MIMO Ant 2 Avg. Power	MIMO Ant 1+2 Avg. Power
802.11ac VHT80	155	5775	8.06	8.74	11.42

Appendix E. Calibration Certificate for Probe and Dipole

The SPEAG calibration certificates are shown as follows.



Accredited by the Swiss Accreditation Service (SAS)
The Swiss Accreditation Service is one of the signatories to the EA
Multilateral Agreement for the recognition of calibration certificates

Accreditation No.: **SCS 0108**

Client **B.V. ADT (Auden)**

Certificate No: **D2450V2-737_Aug19**

CALIBRATION CERTIFICATE

Object **D2450V2 - SN:737**

Calibration procedure(s) **QA CAL-05.v11
Calibration Procedure for SAR Validation Sources between 0.7-3 GHz**

Calibration date: **August 26, 2019**

This calibration certificate documents the traceability to national standards, which realize the physical units of measurements (SI).
The measurements and the uncertainties with confidence probability are given on the following pages and are part of the certificate.

All calibrations have been conducted in the closed laboratory facility: environment temperature (22 ± 3)°C and humidity < 70%.

Calibration Equipment used (M&TE critical for calibration)

Primary Standards	ID #	Cal Date (Certificate No.)	Scheduled Calibration
Power meter NRP	SN: 104778	03-Apr-19 (No. 217-02892/02893)	Apr-20
Power sensor NRP-Z91	SN: 103244	03-Apr-19 (No. 217-02892)	Apr-20
Power sensor NRP-Z91	SN: 103245	03-Apr-19 (No. 217-02893)	Apr-20
Reference 20 dB Attenuator	SN: 5058 (20k)	04-Apr-19 (No. 217-02894)	Apr-20
Type-N mismatch combination	SN: 5047.2 / 06327	04-Apr-19 (No. 217-02895)	Apr-20
Reference Probe EX3DV4	SN: 7349	29-May-19 (No. EX3-7349_May19)	May-20
DAE4	SN: 601	30-Apr-19 (No. DAE4-601_Apr19)	Apr-20
Secondary Standards	ID #	Check Date (in house)	Scheduled Check
Power meter E4419B	SN: GB39512475	30-Oct-14 (in house check Feb-19)	In house check: Oct-20
Power sensor HP 8481A	SN: US37292783	07-Oct-15 (in house check Oct-18)	In house check: Oct-20
Power sensor HP 8481A	SN: MY41092317	07-Oct-15 (in house check Oct-18)	In house check: Oct-20
RF generator R&S SMT-06	SN: 100972	15-Jun-15 (in house check Oct-18)	In house check: Oct-20
Network Analyzer Agilent E8358A	SN: US41080477	31-Mar-14 (in house check Oct-18)	In house check: Oct-19

Calibrated by: **Michael Weber** Name: **Michael Weber** Function: **Laboratory Technician**

Signature

Approved by: **Katja Pokovic** Name: **Katja Pokovic** Function: **Technical Manager**

Issued: August 26, 2019

This calibration certificate shall not be reproduced except in full without written approval of the laboratory.



Accredited by the Swiss Accreditation Service (SAS)

Accreditation No.: **SCS 0108**

The Swiss Accreditation Service is one of the signatories to the EA Multilateral Agreement for the recognition of calibration certificates

Glossary:

TSL	tissue simulating liquid
ConvF	sensitivity in TSL / NORM x,y,z
N/A	not applicable or not measured

Calibration is Performed According to the Following Standards:

- IEEE Std 1528-2013, "IEEE Recommended Practice for Determining the Peak Spatial-Averaged Specific Absorption Rate (SAR) in the Human Head from Wireless Communications Devices: Measurement Techniques", June 2013
- IEC 62209-1, "Measurement procedure for the assessment of Specific Absorption Rate (SAR) from hand-held and body-mounted devices used next to the ear (frequency range of 300 MHz to 6 GHz)", July 2016
- IEC 62209-2, "Procedure to determine the Specific Absorption Rate (SAR) for wireless communication devices used in close proximity to the human body (frequency range of 30 MHz to 6 GHz)", March 2010
- KDB 865664, "SAR Measurement Requirements for 100 MHz to 6 GHz"

Additional Documentation:

- DASY4/5 System Handbook

Methods Applied and Interpretation of Parameters:

- Measurement Conditions:** Further details are available from the Validation Report at the end of the certificate. All figures stated in the certificate are valid at the frequency indicated.
- Antenna Parameters with TSL:** The dipole is mounted with the spacer to position its feed point exactly below the center marking of the flat phantom section, with the arms oriented parallel to the body axis.
- Feed Point Impedance and Return Loss:** These parameters are measured with the dipole positioned under the liquid filled phantom. The impedance stated is transformed from the measurement at the SMA connector to the feed point. The Return Loss ensures low reflected power. No uncertainty required.
- Electrical Delay:** One-way delay between the SMA connector and the antenna feed point. No uncertainty required.
- SAR measured:** SAR measured at the stated antenna input power.
- SAR normalized:** SAR as measured, normalized to an input power of 1 W at the antenna connector.
- SAR for nominal TSL parameters:** The measured TSL parameters are used to calculate the nominal SAR result.

The reported uncertainty of measurement is stated as the standard uncertainty of measurement multiplied by the coverage factor $k=2$, which for a normal distribution corresponds to a coverage probability of approximately 95%.

Measurement Conditions

DASY system configuration, as far as not given on page 1.

DASY Version	DASY5	V52.10.2
Extrapolation	Advanced Extrapolation	
Phantom	Modular Flat Phantom	
Distance Dipole Center - TSL	10 mm	with Spacer
Zoom Scan Resolution	dx, dy, dz = 5 mm	
Frequency	2450 MHz ± 1 MHz	

Head TSL parameters

The following parameters and calculations were applied.

	Temperature	Permittivity	Conductivity
Nominal Head TSL parameters	22.0 °C	39.2	1.80 mho/m
Measured Head TSL parameters	(22.0 ± 0.2) °C	37.8 ± 6 %	1.83 mho/m ± 6 %
Head TSL temperature change during test	< 0.5 °C	----	----

SAR result with Head TSL

SAR averaged over 1 cm³ (1 g) of Head TSL	Condition	
SAR measured	250 mW input power	13.4 W/kg
SAR for nominal Head TSL parameters	normalized to 1W	52.7 W/kg ± 17.0 % (k=2)

SAR averaged over 10 cm³ (10 g) of Head TSL	condition	
SAR measured	250 mW input power	6.20 W/kg
SAR for nominal Head TSL parameters	normalized to 1W	24.5 W/kg ± 16.5 % (k=2)

Appendix (Additional assessments outside the scope of SCS 0108)

Antenna Parameters with Head TSL

Impedance, transformed to feed point	54.3 Ω + 4.5 j Ω
Return Loss	- 24.5 dB

General Antenna Parameters and Design

Electrical Delay (one direction)	1.162 ns
----------------------------------	----------

After long term use with 100W radiated power, only a slight warming of the dipole near the feedpoint can be measured.

The dipole is made of standard semirigid coaxial cable. The center conductor of the feeding line is directly connected to the second arm of the dipole. The antenna is therefore short-circuited for DC-signals. On some of the dipoles, small end caps are added to the dipole arms in order to improve matching when loaded according to the position as explained in the "Measurement Conditions" paragraph. The SAR data are not affected by this change. The overall dipole length is still according to the Standard.

No excessive force must be applied to the dipole arms, because they might bend or the soldered connections near the feedpoint may be damaged.

Additional EUT Data

Manufactured by	SPEAG
-----------------	-------

DASY5 Validation Report for Head TSL

Date: 26.08.2019

Test Laboratory: SPEAG, Zurich, Switzerland

DUT: Dipole 2450 MHz; Type: D2450V2; Serial: D2450V2 - SN:737

Communication System: UID 0 - CW; Frequency: 2450 MHz

Medium parameters used: $f = 2450$ MHz; $\sigma = 1.83$ S/m; $\epsilon_r = 37.8$; $\rho = 1000$ kg/m³

Phantom section: Flat Section

Measurement Standard: DASY5 (IEEE/IEC/ANSI C63.19-2011)

DASY52 Configuration:

- Probe: EX3DV4 - SN7349; ConvF(7.9, 7.9, 7.9) @ 2450 MHz; Calibrated: 29.05.2019
- Sensor-Surface: 1.4mm (Mechanical Surface Detection)
- Electronics: DAE4 Sn601; Calibrated: 30.04.2019
- Phantom: Flat Phantom 5.0 (front); Type: QD 000 P50 AA; Serial: 1001
- DASY52 52.10.2(1504); SEMCAD X 14.6.12(7470)

Dipole Calibration for Head Tissue/Pin=250 mW, d=10mm/Zoom Scan (7x7x7)/Cube 0:

Measurement grid: dx=5mm, dy=5mm, dz=5mm

Reference Value = 117.9 V/m; Power Drift = 0.00 dB

Peak SAR (extrapolated) = 26.7 W/kg

SAR(1 g) = 13.4 W/kg; SAR(10 g) = 6.2 W/kg

Maximum value of SAR (measured) = 22.1 W/kg

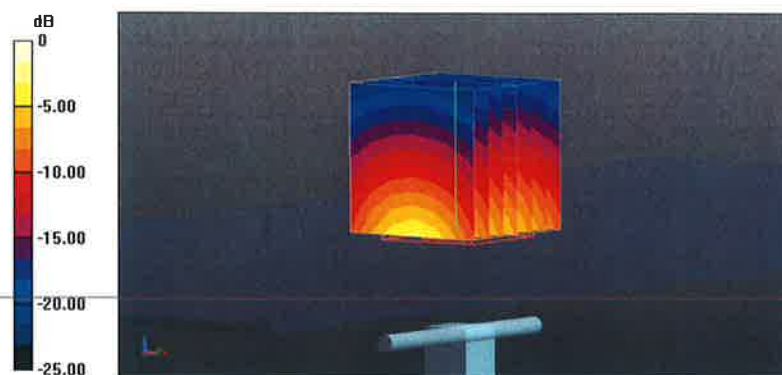

0 dB = 22.1 W/kg = 13.44 dBW/kg

Impedance Measurement Plot for Head TSL

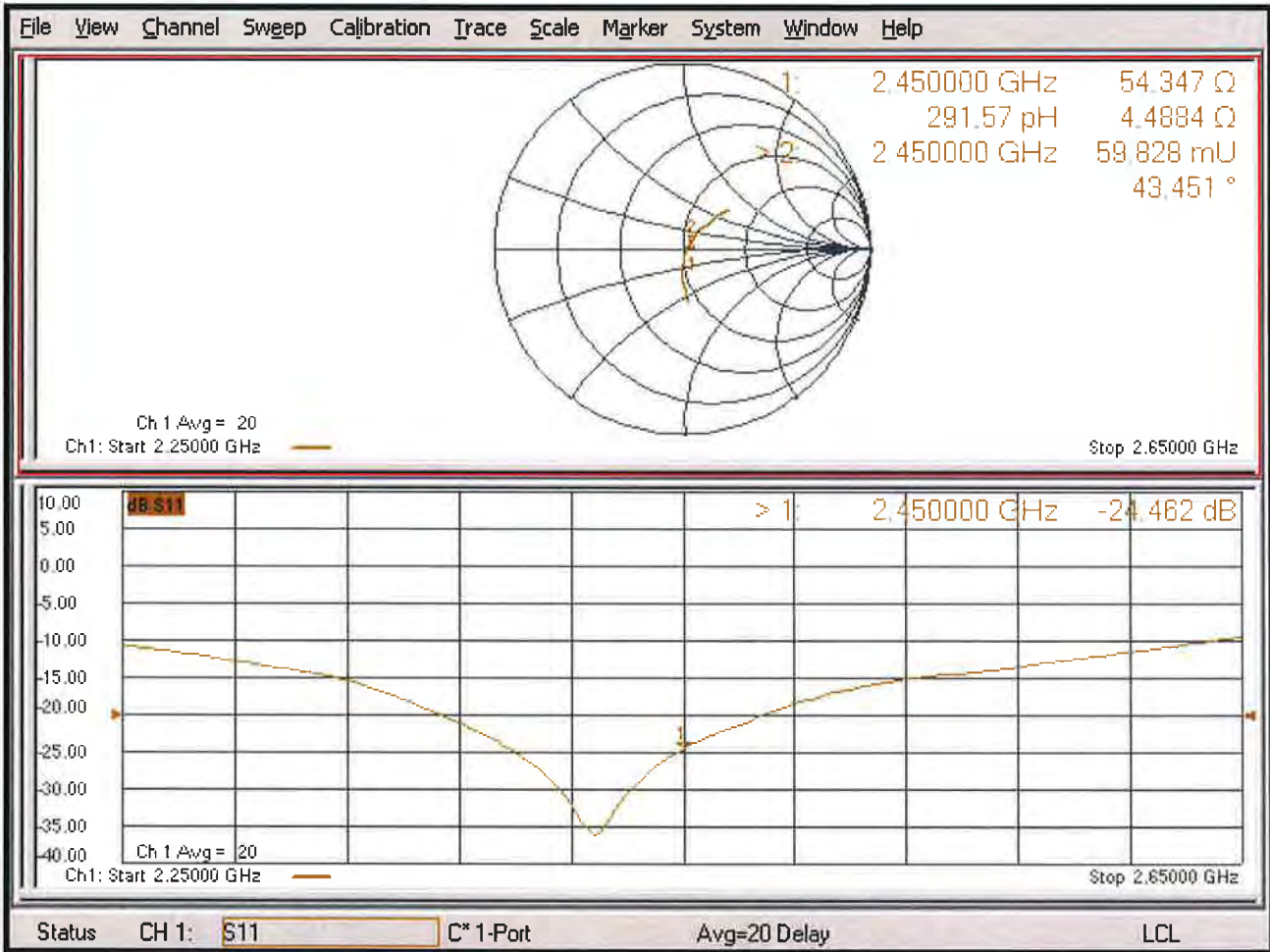



Accredited by the Swiss Accreditation Service (SAS)
The Swiss Accreditation Service is one of the signatories to the EA
Multilateral Agreement for the recognition of calibration certificates

Accreditation No.: **SCS 0108**

Client **B.V. ADT (Auden)**

Certificate No: **D5GHzV2-1019_Mar20**

CALIBRATION CERTIFICATE

Object **D5GHzV2 - SN:1019**

Calibration procedure(s) **QA CAL-22.v4
Calibration Procedure for SAR Validation Sources between 3-6 GHz**

Calibration date: **March 13, 2020**

This calibration certificate documents the traceability to national standards, which realize the physical units of measurements (SI).
The measurements and the uncertainties with confidence probability are given on the following pages and are part of the certificate.

All calibrations have been conducted in the closed laboratory facility: environment temperature (22 ± 3)°C and humidity < 70%.

Calibration Equipment used (M&TE critical for calibration)

Primary Standards	ID #	Cal Date (Certificate No.)	Scheduled Calibration
Power meter NRP	SN: 104778	03-Apr-19 (No. 217-02892/02893)	Apr-20
Power sensor NRP-Z91	SN: 103244	03-Apr-19 (No. 217-02892)	Apr-20
Power sensor NRP-Z91	SN: 103245	03-Apr-19 (No. 217-02893)	Apr-20
Reference 20 dB Attenuator	SN: 5058 (20k)	04-Apr-19 (No. 217-02894)	Apr-20
Type-N mismatch combination	SN: 5047.2 / 06327	04-Apr-19 (No. 217-02895)	Apr-20
Reference Probe EX3DV4	SN: 3503	31-Dec-19 (No. EX3-3503_Dec19)	Dec-20
DAE4	SN: 601	27-Dec-19 (No. DAE4-601_Dec19)	Dec-20

Secondary Standards	ID #	Check Date (in house)	Scheduled Check
Power meter E4419B	SN: GB39512475	30-Oct-14 (in house check Feb-19)	In house check: Oct-20
Power sensor HP 8481A	SN: US37292783	07-Oct-15 (in house check Oct-18)	In house check: Oct-20
Power sensor HP 8481A	SN: MY41092317	07-Oct-15 (in house check Oct-18)	In house check: Oct-20
RF generator R&S SMT-06	SN: 100972	15-Jun-15 (in house check Oct-18)	In house check: Oct-20
Network Analyzer Agilent E8358A	SN: US41080477	31-Mar-14 (in house check Oct-19)	In house check: Oct-20

Calibrated by: **Jeton Kastrati** **Function: Laboratory Technician** **Signature:**

Approved by: **Katja Pokovic** **Technical Manager**

Issued: March 13, 2020

This calibration certificate shall not be reproduced except in full without written approval of the laboratory.



Accredited by the Swiss Accreditation Service (SAS)

Accreditation No.: **SCS 0108**

The Swiss Accreditation Service is one of the signatories to the EA Multilateral Agreement for the recognition of calibration certificates

Glossary:

TSL	tissue simulating liquid
ConvF	sensitivity in TSL / NORM x,y,z
N/A	not applicable or not measured

Calibration is Performed According to the Following Standards:

- IEEE Std 1528-2013, "IEEE Recommended Practice for Determining the Peak Spatial-Averaged Specific Absorption Rate (SAR) in the Human Head from Wireless Communications Devices: Measurement Techniques", June 2013
- IEC 62209-1, "Measurement procedure for the assessment of Specific Absorption Rate (SAR) from hand-held and body-mounted devices used next to the ear (frequency range of 300 MHz to 6 GHz)", July 2016
- IEC 62209-2, "Procedure to determine the Specific Absorption Rate (SAR) for wireless communication devices used in close proximity to the human body (frequency range of 30 MHz to 6 GHz)", March 2010
- KDB 865664, "SAR Measurement Requirements for 100 MHz to 6 GHz"

Additional Documentation:

- DASY4/5 System Handbook

Methods Applied and Interpretation of Parameters:

- Measurement Conditions:* Further details are available from the Validation Report at the end of the certificate. All figures stated in the certificate are valid at the frequency indicated.
- Antenna Parameters with TSL:* The dipole is mounted with the spacer to position its feed point exactly below the center marking of the flat phantom section, with the arms oriented parallel to the body axis.
- Feed Point Impedance and Return Loss:* These parameters are measured with the dipole positioned under the liquid filled phantom. The impedance stated is transformed from the measurement at the SMA connector to the feed point. The Return Loss ensures low reflected power. No uncertainty required.
- Electrical Delay:* One-way delay between the SMA connector and the antenna feed point. No uncertainty required.
- SAR measured:* SAR measured at the stated antenna input power.
- SAR normalized:* SAR as measured, normalized to an input power of 1 W at the antenna connector.
- SAR for nominal TSL parameters:* The measured TSL parameters are used to calculate the nominal SAR result.

The reported uncertainty of measurement is stated as the standard uncertainty of measurement multiplied by the coverage factor $k=2$, which for a normal distribution corresponds to a coverage probability of approximately 95%.

Measurement Conditions

DASY system configuration, as far as not given on page 1.

DASY Version	DASY5	V52.10.4
Extrapolation	Advanced Extrapolation	
Phantom	Modular Flat Phantom V5.0	
Distance Dipole Center - TSL	10 mm	with Spacer
Zoom Scan Resolution	dx, dy = 4.0 mm, dz = 1.4 mm	Graded Ratio = 1.4 (Z direction)
Frequency	5250 MHz ± 1 MHz 5600 MHz ± 1 MHz 5750 MHz ± 1 MHz 5850 MHz ± 1 MHz	

Head TSL parameters at 5250 MHz

The following parameters and calculations were applied.

	Temperature	Permittivity	Conductivity
Nominal Head TSL parameters	22.0 °C	35.9	4.71 mho/m
Measured Head TSL parameters	(22.0 ± 0.2) °C	34.9 ± 6 %	4.49 mho/m ± 6 %
Head TSL temperature change during test	< 0.5 °C	---	----

SAR result with Head TSL at 5250 MHz

SAR averaged over 1 cm³ (1 g) of Head TSL	Condition	
SAR measured	100 mW input power	8.03 W/kg
SAR for nominal Head TSL parameters	normalized to 1W	79.7 W/kg ± 19.9 % (k=2)

SAR averaged over 10 cm³ (10 g) of Head TSL	condition	
SAR measured	100 mW input power	2.30 W/kg
SAR for nominal Head TSL parameters	normalized to 1W	22.8 W/kg ± 19.5 % (k=2)

Head TSL parameters at 5600 MHz

The following parameters and calculations were applied.

	Temperature	Permittivity	Conductivity
Nominal Head TSL parameters	22.0 °C	35.5	5.07 mho/m
Measured Head TSL parameters	(22.0 ± 0.2) °C	34.4 ± 6 %	4.84 mho/m ± 6 %
Head TSL temperature change during test	< 0.5 °C	----	----

SAR result with Head TSL at 5600 MHz

SAR averaged over 1 cm ³ (1 g) of Head TSL	Condition	
SAR measured	100 mW input power	8.45 W/kg
SAR for nominal Head TSL parameters	normalized to 1W	83.8 W/kg ± 19.9 % (k=2)

SAR averaged over 10 cm ³ (10 g) of Head TSL	condition	
SAR measured	100 mW input power	2.39 W/kg
SAR for nominal Head TSL parameters	normalized to 1W	23.7 W/kg ± 19.5 % (k=2)

Head TSL parameters at 5750 MHz

The following parameters and calculations were applied.

	Temperature	Permittivity	Conductivity
Nominal Head TSL parameters	22.0 °C	35.4	5.22 mho/m
Measured Head TSL parameters	(22.0 ± 0.2) °C	34.2 ± 6 %	4.99 mho/m ± 6 %
Head TSL temperature change during test	< 0.5 °C	----	----

SAR result with Head TSL at 5750 MHz

SAR averaged over 1 cm ³ (1 g) of Head TSL	Condition	
SAR measured	100 mW input power	8.11 W/kg
SAR for nominal Head TSL parameters	normalized to 1W	80.4 W/kg ± 19.9 % (k=2)

SAR averaged over 10 cm ³ (10 g) of Head TSL	condition	
SAR measured	100 mW input power	2.30 W/kg
SAR for nominal Head TSL parameters	normalized to 1W	22.8 W/kg ± 19.5 % (k=2)

Head TSL parameters at 5850 MHz

The following parameters and calculations were applied.

	Temperature	Permittivity	Conductivity
Nominal Head TSL parameters	22.0 °C	35.2	5.32 mho/m
Measured Head TSL parameters	(22.0 ± 0.2) °C	34.1 ± 6 %	5.10 mho/m ± 6 %
Head TSL temperature change during test	< 0.5 °C	----	----

SAR result with Head TSL at 5850 MHz

SAR averaged over 1 cm ³ (1 g) of Head TSL	Condition	
SAR measured	100 mW input power	8.24 W/kg
SAR for nominal Head TSL parameters	normalized to 1W	81.7 W/kg ± 19.9 % (k=2)

SAR averaged over 10 cm ³ (10 g) of Head TSL	condition	
SAR measured	100 mW input power	2.33 W/kg
SAR for nominal Head TSL parameters	normalized to 1W	23.1 W/kg ± 19.5 % (k=2)

Appendix (Additional assessments outside the scope of SCS 0108)

Antenna Parameters with Head TSL at 5250 MHz

Impedance, transformed to feed point	54.6 Ω - 5.1 j Ω
Return Loss	- 23.7 dB

Antenna Parameters with Head TSL at 5600 MHz

Impedance, transformed to feed point	58.1 Ω - 1.2 j Ω
Return Loss	- 22.4 dB

Antenna Parameters with Head TSL at 5750 MHz

Impedance, transformed to feed point	58.4 Ω + 3.9 j Ω
Return Loss	- 21.3 dB

Antenna Parameters with Head TSL at 5850 MHz

Impedance, transformed to feed point	55.8 Ω + 0.6 j Ω
Return Loss	- 25.1 dB

General Antenna Parameters and Design

Electrical Delay (one direction)	1.204 ns
----------------------------------	----------

After long term use with 100W radiated power, only a slight warming of the dipole near the feedpoint can be measured.

The dipole is made of standard semirigid coaxial cable. The center conductor of the feeding line is directly connected to the second arm of the dipole. The antenna is therefore short-circuited for DC-signals. On some of the dipoles, small end caps are added to the dipole arms in order to improve matching when loaded according to the position as explained in the "Measurement Conditions" paragraph. The SAR data are not affected by this change. The overall dipole length is still according to the Standard.

No excessive force must be applied to the dipole arms, because they might bend or the soldered connections near the feedpoint may be damaged.

Additional EUT Data

Manufactured by	SPEAG
-----------------	-------

DASY5 Validation Report for Head TSL

Date: 13.03.2020

Test Laboratory: SPEAG, Zurich, Switzerland

DUT: Dipole D5GHzV2; Type: D5GHzV2; Serial: D5GHzV2 - SN:1019

Communication System: UID 0 - CW; Frequency: 5250 MHz, Frequency: 5600 MHz, Frequency: 5750 MHz, Frequency: 5850 MHz

Medium parameters used: $f = 5250$ MHz; $\sigma = 4.49$ S/m; $\epsilon_r = 34.9$; $\rho = 1000$ kg/m³,

Medium parameters used: $f = 5600$ MHz; $\sigma = 4.84$ S/m; $\epsilon_r = 34.4$; $\rho = 1000$ kg/m³,

Medium parameters used: $f = 5750$ MHz; $\sigma = 4.99$ S/m; $\epsilon_r = 34.2$; $\rho = 1000$ kg/m³,

Medium parameters used: $f = 5850$ MHz; $\sigma = 5.1$ S/m; $\epsilon_r = 34.1$; $\rho = 1000$ kg/m³

Phantom section: Flat Section

Measurement Standard: DASY5 (IEEE/IEC/ANSI C63.19-2011)

DASY52 Configuration:

- Probe: EX3DV4 - SN3503; ConvF(5.5, 5.5, 5.5) @ 5250 MHz, ConvF(5.1, 5.1, 5.1) @ 5600 MHz, ConvF(5.08, 5.08, 5.08) @ 5750 MHz, ConvF(4.99, 4.99, 4.99) @ 5850 MHz; Calibrated: 31.12.2019
- Sensor-Surface: 1.4mm (Mechanical Surface Detection)
- Electronics: DAE4 Sn601; Calibrated: 27.12.2019
- Phantom: Flat Phantom 5.0 (front); Type: QD 000 P50 AA; Serial: 1001
- DASY52 52.10.4(1527); SEMCAD X 14.6.14(7483)

Dipole Calibration for Head Tissue/Pin=100mW, dist=10mm, f=5250 MHz/Zoom Scan, dist=1.4mm

(8x8x8)/Cube 0: Measurement grid: dx=4mm, dy=4mm, dz=1.4mm

Reference Value = 77.45 V/m; Power Drift = -0.08 dB

Peak SAR (extrapolated) = 27.9 W/kg

SAR(1 g) = 8.03 W/kg; SAR(10 g) = 2.30 W/kg

Smallest distance from peaks to all points 3 dB below = 7.2 mm

Ratio of SAR at M2 to SAR at M1 = 69.7%

Maximum value of SAR (measured) = 17.9 W/kg

Dipole Calibration for Head Tissue/Pin=100mW, dist=10mm, f=5600 MHz/Zoom Scan, dist=1.4mm

(8x8x8)/Cube 0: Measurement grid: dx=4mm, dy=4mm, dz=1.4mm

Reference Value = 77.30 V/m; Power Drift = -0.02 dB

Peak SAR (extrapolated) = 31.9 W/kg

SAR(1 g) = 8.45 W/kg; SAR(10 g) = 2.39 W/kg

Smallest distance from peaks to all points 3 dB below = 7.2 mm

Ratio of SAR at M2 to SAR at M1 = 67.1%

Maximum value of SAR (measured) = 19.4 W/kg

Dipole Calibration for Head Tissue/Pin=100mW, dist=10mm, f=5750 MHz/Zoom Scan, dist=1.4mm

(8x8x8)/Cube 0: Measurement grid: dx=4mm, dy=4mm, dz=1.4mm

Reference Value = 75.26 V/m; Power Drift = -0.02 dB

Peak SAR (extrapolated) = 32.0 W/kg

SAR(1 g) = 8.11 W/kg; SAR(10 g) = 2.30 W/kg

Smallest distance from peaks to all points 3 dB below = 7.2 mm

Ratio of SAR at M2 to SAR at M1 = 65.4%

Maximum value of SAR (measured) = 19.0 W/kg

Dipole Calibration for Head Tissue/Pin=100mW, dist=10mm, f=5850 MHz/Zoom Scan, dist=1.4mm
(8x8x8)/Cube 0: Measurement grid: dx=4mm, dy=4mm, dz=1.4mm
Reference Value = 75.08 V/m; Power Drift = -0.09 dB
Peak SAR (extrapolated) = 33.4 W/kg
SAR(1 g) = 8.24 W/kg; SAR(10 g) = 2.33 W/kg
Smallest distance from peaks to all points 3 dB below = 7.2 mm
Ratio of SAR at M2 to SAR at M1 = 64.7%
Maximum value of SAR (measured) = 19.4 W/kg

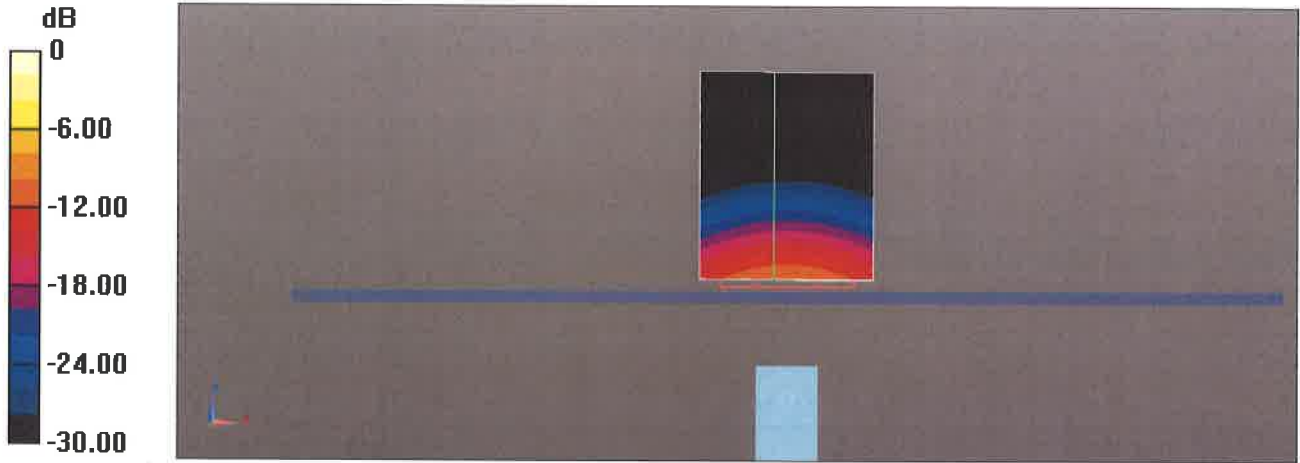

0 dB = 19.4 W/kg = 12.88 dBW/kg

Impedance Measurement Plot for Head TSL

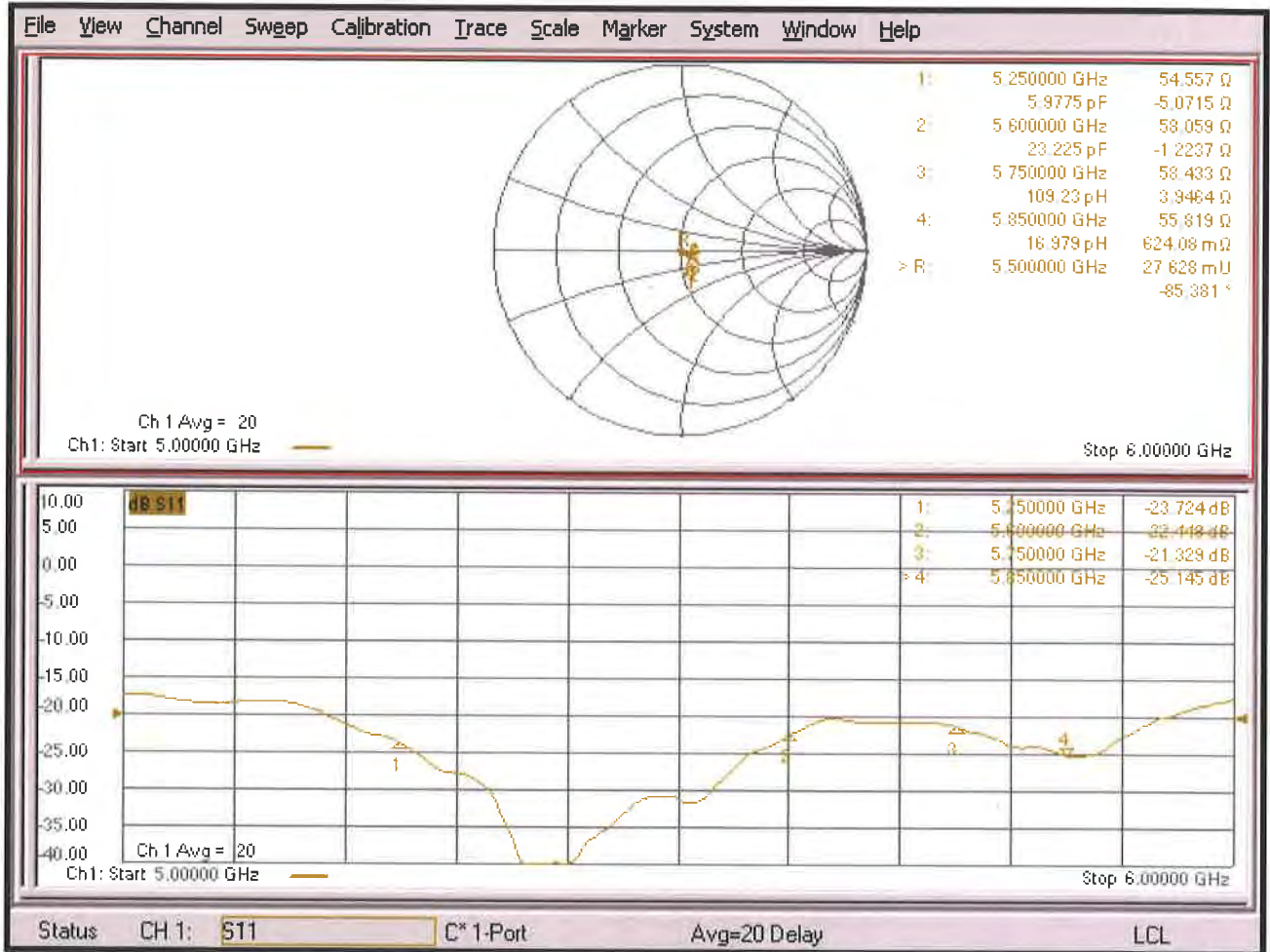



Accredited by the Swiss Accreditation Service (SAS)
The Swiss Accreditation Service is one of the signatories to the EA
Multilateral Agreement for the recognition of calibration certificates

Accreditation No.: **SCS 0108**

Client **B.V. ADT (Auden)**

Certificate No: **EX3-3971_Jan20**

CALIBRATION CERTIFICATE

Object **EX3DV4 - SN:3971**

Calibration procedure(s) **QA CAL-01.v9, QA CAL-14.v5, QA CAL-23.v5, QA CAL-25.v7
Calibration procedure for dosimetric E-field probes**

Calibration date: **January 27, 2020**

This calibration certificate documents the traceability to national standards, which realize the physical units of measurements (SI).
The measurements and the uncertainties with confidence probability are given on the following pages and are part of the certificate.

All calibrations have been conducted in the closed laboratory facility: environment temperature (22 ± 3)°C and humidity < 70%.

Calibration Equipment used (M&TE critical for calibration)

Primary Standards	ID	Cal Date (Certificate No.)	Scheduled Calibration
Power meter NRP	SN: 104778	03-Apr-19 (No. 217-02892/02893)	Apr-20
Power sensor NRP-Z91	SN: 103244	03-Apr-19 (No. 217-02892)	Apr-20
Power sensor NRP-Z91	SN: 103245	03-Apr-19 (No. 217-02893)	Apr-20
Reference 20 dB Attenuator	SN: S5277 (20x)	04-Apr-19 (No. 217-02894)	Apr-20
DAE4	SN: 660	27-Dec-19 (No. DAE4-660_Dec19)	Dec-20
Reference Probe ES3DV2	SN: 3013	31-Dec-19 (No. ES3-3013_Dec19)	Dec-20
Secondary Standards	ID	Check Date (in house)	Scheduled Check
Power meter E4419B	SN: GB41293874	06-Apr-16 (in house check Jun-18)	In house check: Jun-20
Power sensor E4412A	SN: MY41498087	06-Apr-16 (in house check Jun-18)	In house check: Jun-20
Power sensor E4412A	SN: 000110210	06-Apr-16 (in house check Jun-18)	In house check: Jun-20
RF generator HP 8648C	SN: US3642U01700	04-Aug-99 (in house check Jun-18)	In house check: Jun-20
Network Analyzer E8358A	SN: US41080477	31-Mar-14 (in house check Oct-19)	In house check: Oct-20

	Name	Function	Signature
Calibrated by:	Michael Weber	Laboratory Technician	
Approved by:	Katja Pokovic	Technical Manager	
			Issued: February 4, 2020

This calibration certificate shall not be reproduced except in full without written approval of the laboratory.



Accredited by the Swiss Accreditation Service (SAS)

Accreditation No.: **SCS 0108**

The Swiss Accreditation Service is one of the signatories to the EA
 Multilateral Agreement for the recognition of calibration certificates

Glossary:

TSL	tissue simulating liquid
NORM _{x,y,z}	sensitivity in free space
ConvF	sensitivity in TSL / NORM _{x,y,z}
DCP	diode compression point
CF	crest factor (1/duty_cycle) of the RF signal
A, B, C, D	modulation dependent linearization parameters
Polarization φ	φ rotation around probe axis
Polarization ϑ	ϑ rotation around an axis that is in the plane normal to probe axis (at measurement center), i.e., $\vartheta = 0$ is normal to probe axis
Connector Angle	information used in DASY system to align probe sensor X to the robot coordinate system

Calibration is Performed According to the Following Standards:

- a) IEEE Std 1528-2013, "IEEE Recommended Practice for Determining the Peak Spatial-Averaged Specific Absorption Rate (SAR) in the Human Head from Wireless Communications Devices: Measurement Techniques", June 2013
- b) IEC 62209-1, "Measurement procedure for the assessment of Specific Absorption Rate (SAR) from hand-held and body-mounted devices used next to the ear (frequency range of 300 MHz to 6 GHz)", July 2016
- c) IEC 62209-2, "Procedure to determine the Specific Absorption Rate (SAR) for wireless communication devices used in close proximity to the human body (frequency range of 30 MHz to 6 GHz)", March 2010
- d) KDB 865664, "SAR Measurement Requirements for 100 MHz to 6 GHz"

Methods Applied and Interpretation of Parameters:

- *NORM_{x,y,z}*: Assessed for E-field polarization $\vartheta = 0$ ($f \leq 900$ MHz in TEM-cell; $f > 1800$ MHz: R22 waveguide). *NORM_{x,y,z}* are only intermediate values, i.e., the uncertainties of *NORM_{x,y,z}* does not affect the E^2 -field uncertainty inside TSL (see below *ConvF*).
- *NORM(f)_{x,y,z} = NORM_{x,y,z} * frequency_response* (see Frequency Response Chart). This linearization is implemented in DASY4 software versions later than 4.2. The uncertainty of the frequency response is included in the stated uncertainty of *ConvF*.
- *DCP_{x,y,z}*: DCP are numerical linearization parameters assessed based on the data of power sweep with CW signal (no uncertainty required). DCP does not depend on frequency nor media.
- *PAR*: PAR is the Peak to Average Ratio that is not calibrated but determined based on the signal characteristics
- *A_{x,y,z}; B_{x,y,z}; C_{x,y,z}; D_{x,y,z}; VR_{x,y,z}; A, B, C, D* are numerical linearization parameters assessed based on the data of power sweep for specific modulation signal. The parameters do not depend on frequency nor media. *VR* is the maximum calibration range expressed in RMS voltage across the diode.
- *ConvF and Boundary Effect Parameters*: Assessed in flat phantom using E-field (or Temperature Transfer Standard for $f \leq 800$ MHz) and inside waveguide using analytical field distributions based on power measurements for $f > 800$ MHz. The same setups are used for assessment of the parameters applied for boundary compensation (alpha, depth) of which typical uncertainty values are given. These parameters are used in DASY4 software to improve probe accuracy close to the boundary. The sensitivity in TSL corresponds to *NORM_{x,y,z} * ConvF* whereby the uncertainty corresponds to that given for *ConvF*. A frequency dependent *ConvF* is used in DASY version 4.4 and higher which allows extending the validity from ± 50 MHz to ± 100 MHz.
- *Spherical isotropy (3D deviation from isotropy)*: in a field of low gradients realized using a flat phantom exposed by a patch antenna.
- *Sensor Offset*: The sensor offset corresponds to the offset of virtual measurement center from the probe tip (on probe axis). No tolerance required.
- *Connector Angle*: The angle is assessed using the information gained by determining the *NORM_x* (no uncertainty required).

DASY/EASY - Parameters of Probe: EX3DV4 - SN:3971

Basic Calibration Parameters

	Sensor X	Sensor Y	Sensor Z	Unc (k=2)
Norm ($\mu\text{V}/(\text{V}/\text{m})^2$) ^A	0.37	0.51	0.49	$\pm 10.1 \%$
DCP (mV) ^B	95.1	101.6	98.6	

Calibration Results for Modulation Response

UID	Communication System Name		A dB	B dB $\sqrt{\mu\text{V}}$	C	D dB	VR mV	Max dev.	Max Unc ^E (k=2)
0	CW	X	0.00	0.00	1.00	0.00	144.1	$\pm 3.5 \%$	$\pm 4.7 \%$
		Y	0.00	0.00	1.00		141.8		
		Z	0.00	0.00	1.00		144.4		
10352-AAA	Pulse Waveform (200Hz, 10%)	X	1.51	60.00	7.96	10.00	60.0	$\pm 3.0 \%$	$\pm 9.6 \%$
		Y	20.00	90.76	20.36		60.0		
		Z	20.00	89.78	19.97		60.0		
10353-AAA	Pulse Waveform (200Hz, 20%)	X	1.38	62.32	7.62	6.99	80.0	$\pm 1.8 \%$	$\pm 9.6 \%$
		Y	20.00	92.95	20.23		80.0		
		Z	20.00	91.08	19.21		80.0		
10354-AAA	Pulse Waveform (200Hz, 40%)	X	0.54	60.00	5.04	3.98	95.0	$\pm 1.1 \%$	$\pm 9.6 \%$
		Y	20.00	97.39	20.92		95.0		
		Z	20.00	92.72	18.33		95.0		
10355-AAA	Pulse Waveform (200Hz, 60%)	X	0.34	60.00	3.48	2.22	120.0	$\pm 1.2 \%$	$\pm 9.6 \%$
		Y	20.00	103.75	22.52		120.0		
		Z	20.00	88.97	15.17		120.0		
10387-AAA	QPSK Waveform, 1 MHz	X	8.00	70.00	7.00	0.00	150.0	$\pm 3.8 \%$	$\pm 9.6 \%$
		Y	0.73	62.53	9.36		150.0		
		Z	0.54	60.00	7.17		150.0		
10388-AAA	QPSK Waveform, 10 MHz	X	2.02	68.78	16.08	0.00	150.0	$\pm 1.2 \%$	$\pm 9.6 \%$
		Y	2.34	69.19	16.33		150.0		
		Z	2.01	66.73	14.91		150.0		
10396-AAA	64-QAM Waveform, 100 kHz	X	2.46	68.94	17.89	3.01	150.0	$\pm 0.7 \%$	$\pm 9.6 \%$
		Y	2.92	70.87	18.85		150.0		
		Z	2.73	68.90	17.96		150.0		
10399-AAA	64-QAM Waveform, 40 MHz	X	3.33	67.36	15.91	0.00	150.0	$\pm 2.3 \%$	$\pm 9.6 \%$
		Y	3.46	67.15	15.82		150.0		
		Z	3.37	66.52	15.40		150.0		
10414-AAA	WLAN CCDF, 64-QAM, 40MHz	X	4.56	65.89	15.68	0.00	150.0	$\pm 4.2 \%$	$\pm 9.6 \%$
		Y	4.78	65.60	15.52		150.0		
		Z	4.74	65.34	15.37		150.0		

Note: For details on UID parameters see Appendix

The reported uncertainty of measurement is stated as the standard uncertainty of measurement multiplied by the coverage factor k=2, which for a normal distribution corresponds to a coverage probability of approximately 95%.

^A The uncertainties of Norm X,Y,Z do not affect the E²-field uncertainty inside TSL (see Page 5).

^B Numerical linearization parameter; uncertainty not required.

^E Uncertainty is determined using the max. deviation from linear response applying rectangular distribution and is expressed for the square of the field value.

DASY/EASY - Parameters of Probe: EX3DV4 - SN:3971**Sensor Model Parameters**

	C1 fF	C2 fF	α V⁻¹	T1 ms.V⁻²	T2 ms.V⁻¹	T3 ms	T4 V⁻²	T5 V⁻¹	T6
X	28.7	214.41	35.61	5.27	0.71	4.98	0.56	0.30	1.00
Y	42.3	311.68	34.79	10.26	0.21	5.06	1.03	0.24	1.00
Z	41.8	318.91	36.85	8.44	0.38	5.08	0.50	0.42	1.01

Other Probe Parameters

Sensor Arrangement	Triangular
Connector Angle (°)	72
Mechanical Surface Detection Mode	enabled
Optical Surface Detection Mode	disabled
Probe Overall Length	337 mm
Probe Body Diameter	10 mm
Tip Length	9 mm
Tip Diameter	2.5 mm
Probe Tip to Sensor X Calibration Point	1 mm
Probe Tip to Sensor Y Calibration Point	1 mm
Probe Tip to Sensor Z Calibration Point	1 mm
Recommended Measurement Distance from Surface	1.4 mm

DASY/EASY - Parameters of Probe: EX3DV4 - SN:3971

Calibration Parameter Determined in Head Tissue Simulating Media

f (MHz) ^C	Relative Permittivity ^F	Conductivity (S/m) ^F	ConvF X	ConvF Y	ConvF Z	Alpha ^G	Depth ^G (mm)	Unc (k=2)
750	41.9	0.89	10.60	10.60	10.60	0.63	0.80	± 12.0 %
835	41.5	0.90	10.26	10.26	10.26	0.58	0.80	± 12.0 %
900	41.5	0.97	10.12	10.12	10.12	0.40	1.01	± 12.0 %
1450	40.5	1.20	9.09	9.09	9.09	0.26	0.80	± 12.0 %
1640	40.2	1.31	8.81	8.81	8.81	0.34	0.86	± 12.0 %
1750	40.1	1.37	8.73	8.73	8.73	0.34	0.86	± 12.0 %
1900	40.0	1.40	8.54	8.54	8.54	0.37	0.86	± 12.0 %
2000	40.0	1.40	8.48	8.48	8.48	0.39	0.90	± 12.0 %
2300	39.5	1.67	8.06	8.06	8.06	0.26	0.95	± 12.0 %
2450	39.2	1.80	8.00	8.00	8.00	0.38	0.86	± 12.0 %
2600	39.0	1.96	7.71	7.71	7.71	0.28	0.97	± 12.0 %
3300	38.2	2.71	7.42	7.42	7.42	0.35	1.30	± 13.1 %
3500	37.9	2.91	6.96	6.96	6.96	0.30	1.30	± 13.1 %
3700	37.7	3.12	6.99	6.99	6.99	0.30	1.30	± 13.1 %
3900	37.5	3.32	6.97	6.97	6.97	0.35	1.60	± 13.1 %
4100	37.2	3.53	6.44	6.44	6.44	0.35	1.60	± 13.1 %
4200	37.1	3.63	6.40	6.40	6.40	0.35	1.70	± 13.1 %
4400	36.9	3.84	6.17	6.17	6.17	0.40	1.70	± 13.1 %
4600	36.7	4.04	6.10	6.10	6.10	0.40	1.70	± 13.1 %
4800	36.4	4.25	6.08	6.08	6.08	0.40	1.80	± 13.1 %
4950	36.3	4.40	5.80	5.80	5.80	0.40	1.80	± 13.1 %
5250	35.9	4.71	5.28	5.28	5.28	0.40	1.80	± 13.1 %
5600	35.5	5.07	4.89	4.89	4.89	0.40	1.80	± 13.1 %
5750	35.4	5.22	5.05	5.05	5.05	0.40	1.80	± 13.1 %

^C Frequency validity above 300 MHz of ± 100 MHz only applies for DASY v4.4 and higher (see Page 2), else it is restricted to ± 50 MHz. The uncertainty is the RSS of the ConvF uncertainty at calibration frequency and the uncertainty for the indicated frequency band. Frequency validity below 300 MHz is ± 10, 25, 40, 50 and 70 MHz for ConvF assessments at 30, 64, 128, 150 and 220 MHz respectively. Validity of ConvF assessed at 6 MHz is 4-9 MHz, and ConvF assessed at 13 MHz is 9-19 MHz. Above 5 GHz frequency validity can be extended to ± 110 MHz.

^F At frequencies below 3 GHz, the validity of tissue parameters (ϵ and σ) can be relaxed to ± 10% if liquid compensation formula is applied to measured SAR values. At frequencies above 3 GHz, the validity of tissue parameters (ϵ and σ) is restricted to ± 5%. The uncertainty is the RSS of the ConvF uncertainty for indicated target tissue parameters.

^G Alpha/Depth are determined during calibration. SPEAG warrants that the remaining deviation due to the boundary effect after compensation is always less than ± 1% for frequencies below 3 GHz and below ± 2% for frequencies between 3-6 GHz at any distance larger than half the probe tip diameter from the boundary.

Frequency Response of E-Field (TEM-Cell:ifi110 EXX, Waveguide: R22)

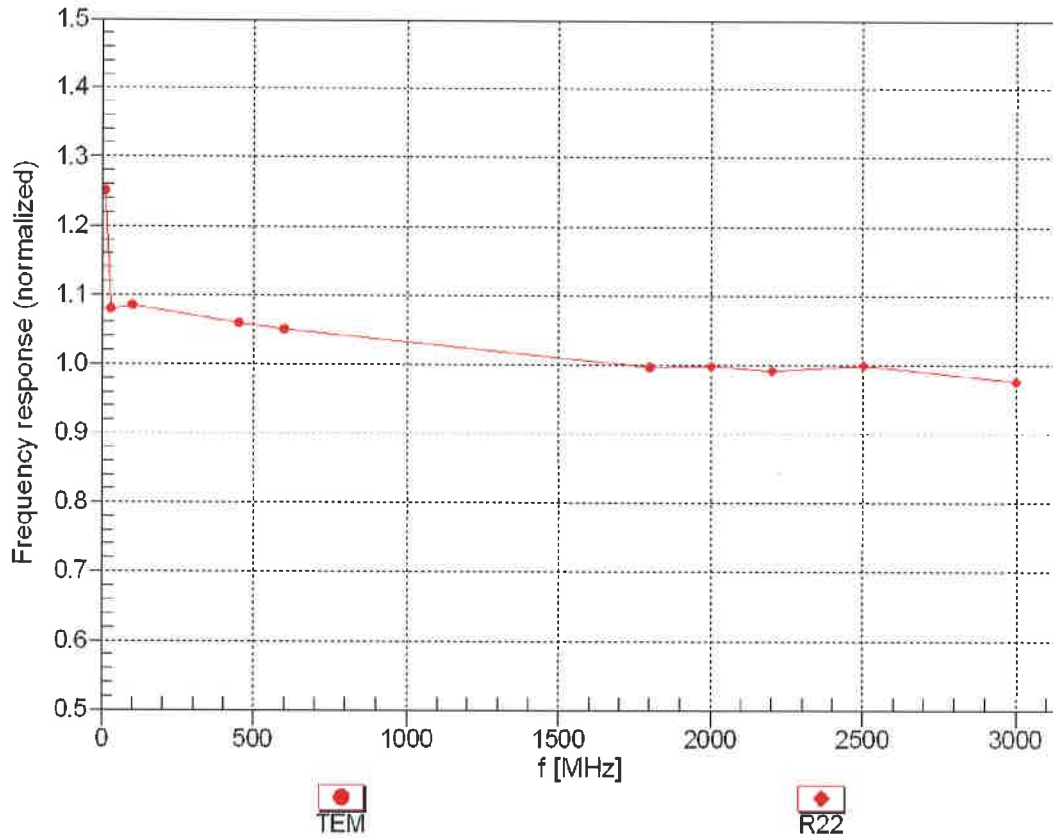

Uncertainty of Frequency Response of E-field: $\pm 6.3\%$ (k=2)

Receiving Pattern (ϕ), $\theta = 0^\circ$

f=600 MHz,TEM

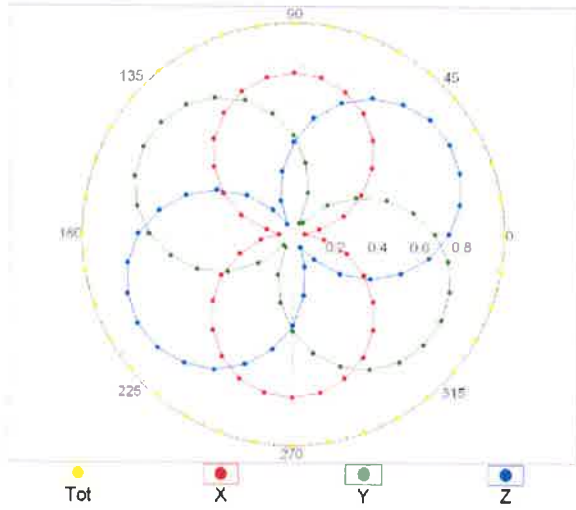

f=1800 MHz,R22

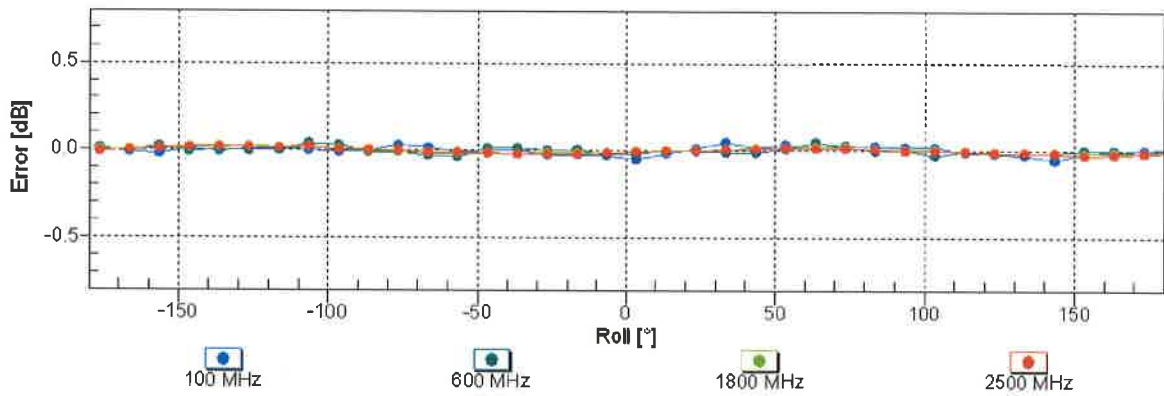
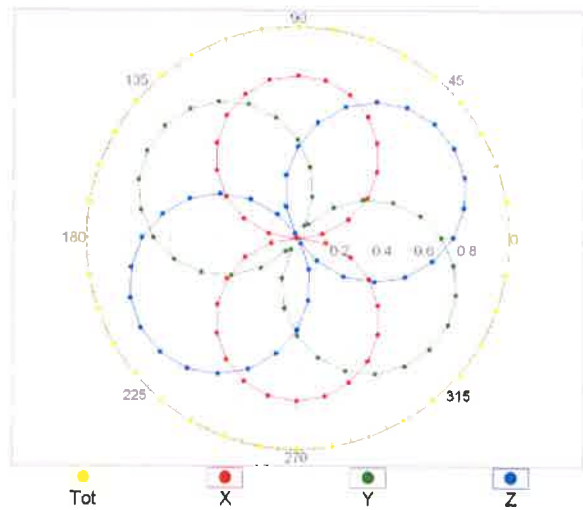

Uncertainty of Axial Isotropy Assessment: $\pm 0.5\%$ (k=2)

Dynamic Range f(SAR_{head}) (TEM cell , f_{eval}= 1900 MHz)

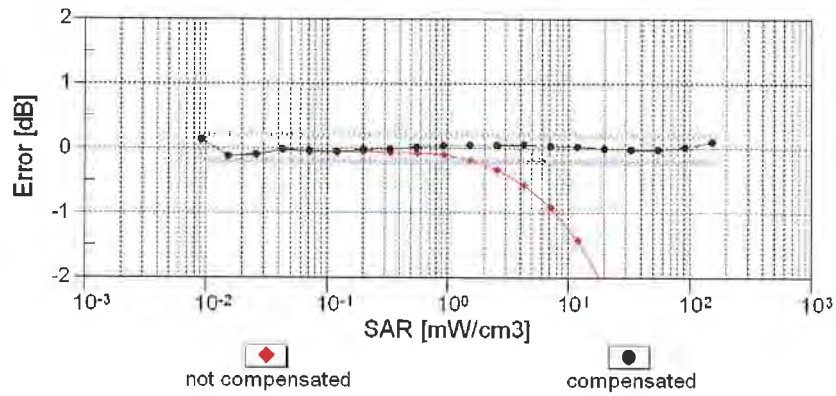
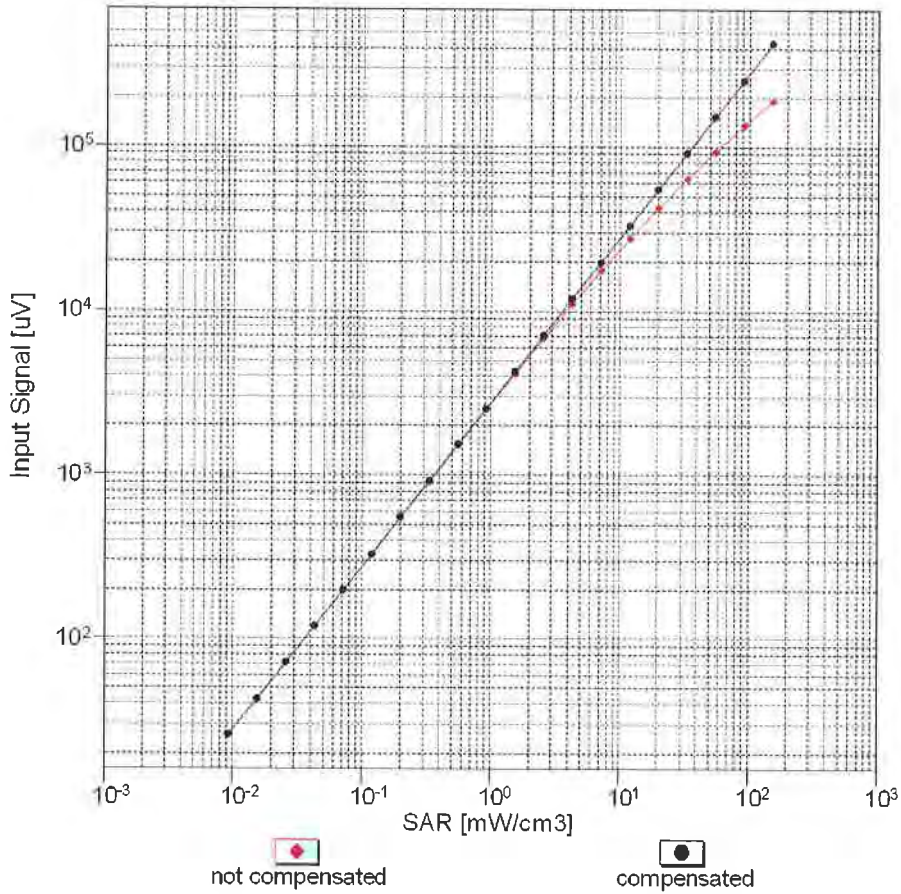

Uncertainty of Linearity Assessment: ± 0.6% (k=2)

Conversion Factor Assessment

f = 835 MHz, WGLS R9 (H_convF)

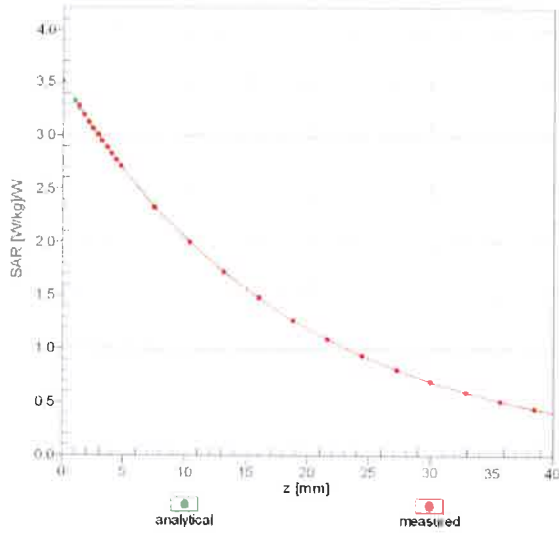

f = 1900 MHz, WGLS R22 (H_convF)

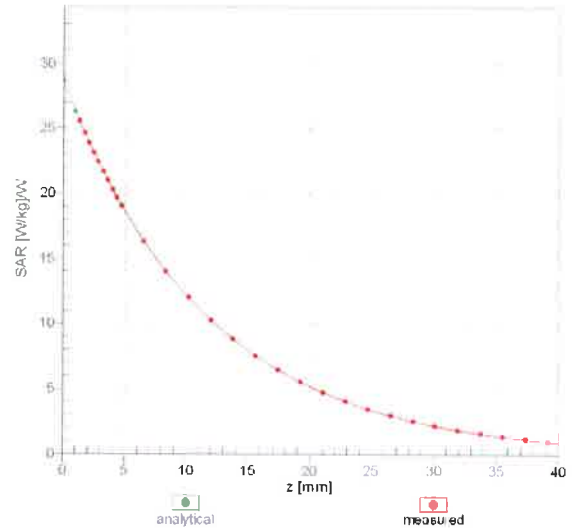

Deviation from Isotropy in Liquid Error (ϕ, ϑ), f = 900 MHz

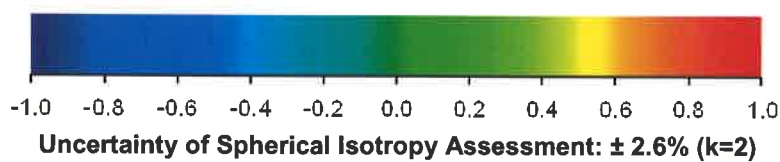
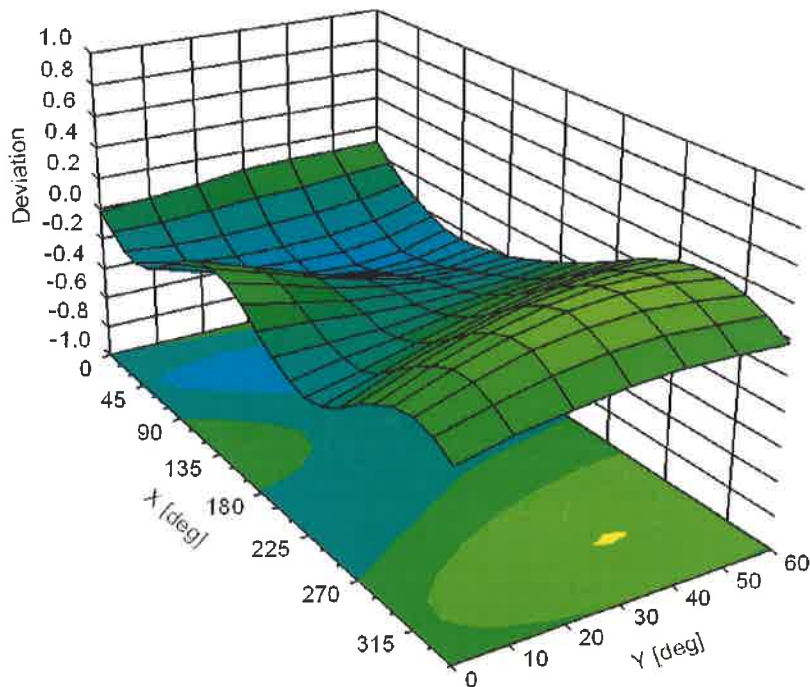

Appendix: Modulation Calibration Parameters

UID	Rev	Communication System Name	Group	PAR (dB)	Unc ^E (k=2)
0		CW	CW	0.00	± 4.7 %
10010	CAA	SAR Validation (Square, 100ms, 10ms)	Test	10.00	± 9.6 %
10011	CAB	UMTS-FDD (WCDMA)	WCDMA	2.91	± 9.6 %
10012	CAB	IEEE 802.11b WiFi 2.4 GHz (DSSS, 1 Mbps)	WLAN	1.87	± 9.6 %
10013	CAB	IEEE 802.11g WiFi 2.4 GHz (DSSS-OFDM, 6 Mbps)	WLAN	9.46	± 9.6 %
10021	DAC	GSM-FDD (TDMA, GMSK)	GSM	9.39	± 9.6 %
10023	DAC	GPRS-FDD (TDMA, GMSK, TN 0)	GSM	9.57	± 9.6 %
10024	DAC	GPRS-FDD (TDMA, GMSK, TN 0-1)	GSM	6.56	± 9.6 %
10025	DAC	EDGE-FDD (TDMA, 8PSK, TN 0)	GSM	12.62	± 9.6 %
10026	DAC	EDGE-FDD (TDMA, 8PSK, TN 0-1)	GSM	9.55	± 9.6 %
10027	DAC	GPRS-FDD (TDMA, GMSK, TN 0-1-2)	GSM	4.80	± 9.6 %
10028	DAC	GPRS-FDD (TDMA, GMSK, TN 0-1-2-3)	GSM	3.55	± 9.6 %
10029	DAC	EDGE-FDD (TDMA, 8PSK, TN 0-1-2)	GSM	7.78	± 9.6 %
10030	CAA	IEEE 802.15.1 Bluetooth (GFSK, DH1)	Bluetooth	5.30	± 9.6 %
10031	CAA	IEEE 802.15.1 Bluetooth (GFSK, DH3)	Bluetooth	1.87	± 9.6 %
10032	CAA	IEEE 802.15.1 Bluetooth (GFSK, DH5)	Bluetooth	1.16	± 9.6 %
10033	CAA	IEEE 802.15.1 Bluetooth (PI/4-DQPSK, DH1)	Bluetooth	7.74	± 9.6 %
10034	CAA	IEEE 802.15.1 Bluetooth (PI/4-DQPSK, DH3)	Bluetooth	4.53	± 9.6 %
10035	CAA	IEEE 802.15.1 Bluetooth (PI/4-DQPSK, DH5)	Bluetooth	3.83	± 9.6 %
10036	CAA	IEEE 802.15.1 Bluetooth (8-DPSK, DH1)	Bluetooth	8.01	± 9.6 %
10037	CAA	IEEE 802.15.1 Bluetooth (8-DPSK, DH3)	Bluetooth	4.77	± 9.6 %
10038	CAA	IEEE 802.15.1 Bluetooth (8-DPSK, DH5)	Bluetooth	4.10	± 9.6 %
10039	CAB	CDMA2000 (1xRTT, RC1)	CDMA2000	4.57	± 9.6 %
10042	CAB	IS-54 / IS-136 FDD (TDMA/FDM, PI/4-DQPSK, Halfrate)	AMPS	7.78	± 9.6 %
10044	CAA	IS-91/EIA/TIA-553 FDD (FDMA, FM)	AMPS	0.00	± 9.6 %
10048	CAA	DECT (TDD, TDMA/FDM, GFSK, Full Slot, 24)	DECT	13.80	± 9.6 %
10049	CAA	DECT (TDD, TDMA/FDM, GFSK, Double Slot, 12)	DECT	10.79	± 9.6 %
10056	CAA	UMTS-TDD (TD-SCDMA, 1.28 Mcps)	TD-SCDMA	11.01	± 9.6 %
10058	DAC	EDGE-FDD (TDMA, 8PSK, TN 0-1-2-3)	GSM	6.52	± 9.6 %
10059	CAB	IEEE 802.11b WiFi 2.4 GHz (DSSS, 2 Mbps)	WLAN	2.12	± 9.6 %
10060	CAB	IEEE 802.11b WiFi 2.4 GHz (DSSS, 5.5 Mbps)	WLAN	2.83	± 9.6 %
10061	CAB	IEEE 802.11b WiFi 2.4 GHz (DSSS, 11 Mbps)	WLAN	3.60	± 9.6 %
10062	CAC	IEEE 802.11a/h WiFi 5 GHz (OFDM, 6 Mbps)	WLAN	8.68	± 9.6 %
10063	CAC	IEEE 802.11a/h WiFi 5 GHz (OFDM, 9 Mbps)	WLAN	8.63	± 9.6 %
10064	CAC	IEEE 802.11a/h WiFi 5 GHz (OFDM, 12 Mbps)	WLAN	9.09	± 9.6 %
10065	CAC	IEEE 802.11a/h WiFi 5 GHz (OFDM, 18 Mbps)	WLAN	9.00	± 9.6 %
10066	CAC	IEEE 802.11a/h WiFi 5 GHz (OFDM, 24 Mbps)	WLAN	9.38	± 9.6 %
10067	CAC	IEEE 802.11a/h WiFi 5 GHz (OFDM, 36 Mbps)	WLAN	10.12	± 9.6 %
10068	CAC	IEEE 802.11a/h WiFi 5 GHz (OFDM, 48 Mbps)	WLAN	10.24	± 9.6 %
10069	CAC	IEEE 802.11a/h WiFi 5 GHz (OFDM, 54 Mbps)	WLAN	10.56	± 9.6 %
10071	CAB	IEEE 802.11g WiFi 2.4 GHz (DSSS/OFDM, 9 Mbps)	WLAN	9.83	± 9.6 %
10072	CAB	IEEE 802.11g WiFi 2.4 GHz (DSSS/OFDM, 12 Mbps)	WLAN	9.62	± 9.6 %
10073	CAB	IEEE 802.11g WiFi 2.4 GHz (DSSS/OFDM, 18 Mbps)	WLAN	9.94	± 9.6 %
10074	CAB	IEEE 802.11g WiFi 2.4 GHz (DSSS/OFDM, 24 Mbps)	WLAN	10.30	± 9.6 %
10075	CAB	IEEE 802.11g WiFi 2.4 GHz (DSSS/OFDM, 36 Mbps)	WLAN	10.77	± 9.6 %
10076	CAB	IEEE 802.11g WiFi 2.4 GHz (DSSS/OFDM, 48 Mbps)	WLAN	10.94	± 9.6 %
10077	CAB	IEEE 802.11g WiFi 2.4 GHz (DSSS/OFDM, 54 Mbps)	WLAN	11.00	± 9.6 %
10081	CAB	CDMA2000 (1xRTT, RC3)	CDMA2000	3.97	± 9.6 %
10082	CAB	IS-54 / IS-136 FDD (TDMA/FDM, PI/4-DQPSK, Fullrate)	AMPS	4.77	± 9.6 %
10090	DAC	GPRS-FDD (TDMA, GMSK, TN 0-4)	GSM	6.56	± 9.6 %
10097	CAB	UMTS-FDD (HSDPA)	WCDMA	3.98	± 9.6 %
10098	CAB	UMTS-FDD (HSUPA, Subtest 2)	WCDMA	3.98	± 9.6 %
10099	DAC	EDGE-FDD (TDMA, 8PSK, TN 0-4)	GSM	9.55	± 9.6 %
10100	CAE	LTE-FDD (SC-FDMA, 100% RB, 20 MHz, QPSK)	LTE-FDD	5.67	± 9.6 %
10101	CAE	LTE-FDD (SC-FDMA, 100% RB, 20 MHz, 16-QAM)	LTE-FDD	6.42	± 9.6 %
10102	CAE	LTE-FDD (SC-FDMA, 100% RB, 20 MHz, 64-QAM)	LTE-FDD	6.60	± 9.6 %
10103	CAG	LTE-TDD (SC-FDMA, 100% RB, 20 MHz, QPSK)	LTE-TDD	9.29	± 9.6 %
10104	CAG	LTE-TDD (SC-FDMA, 100% RB, 20 MHz, 16-QAM)	LTE-TDD	9.97	± 9.6 %
10105	CAG	LTE-TDD (SC-FDMA, 100% RB, 20 MHz, 64-QAM)	LTE-TDD	10.01	± 9.6 %
10108	CAG	LTE-FDD (SC-FDMA, 100% RB, 10 MHz, QPSK)	LTE-FDD	5.80	± 9.6 %

10109	CAG	LTE-FDD (SC-FDMA, 100% RB, 10 MHz, 16-QAM)	LTE-FDD	6.43	± 9.6 %
10110	CAG	LTE-FDD (SC-FDMA, 100% RB, 5 MHz, QPSK)	LTE-FDD	5.75	± 9.6 %
10111	CAG	LTE-FDD (SC-FDMA, 100% RB, 5 MHz, 16-QAM)	LTE-FDD	6.44	± 9.6 %
10112	CAG	LTE-FDD (SC-FDMA, 100% RB, 10 MHz, 64-QAM)	LTE-FDD	6.59	± 9.6 %
10113	CAG	LTE-FDD (SC-FDMA, 100% RB, 5 MHz, 64-QAM)	LTE-FDD	6.62	± 9.6 %
10114	CAC	IEEE 802.11n (HT Greenfield, 13.5 Mbps, BPSK)	WLAN	8.10	± 9.6 %
10115	CAC	IEEE 802.11n (HT Greenfield, 81 Mbps, 16-QAM)	WLAN	8.46	± 9.6 %
10116	CAC	IEEE 802.11n (HT Greenfield, 135 Mbps, 64-QAM)	WLAN	8.15	± 9.6 %
10117	CAC	IEEE 802.11n (HT Mixed, 13.5 Mbps, BPSK)	WLAN	8.07	± 9.6 %
10118	CAC	IEEE 802.11n (HT Mixed, 81 Mbps, 16-QAM)	WLAN	8.59	± 9.6 %
10119	CAC	IEEE 802.11n (HT Mixed, 135 Mbps, 64-QAM)	WLAN	8.13	± 9.6 %
10140	CAE	LTE-FDD (SC-FDMA, 100% RB, 15 MHz, 16-QAM)	LTE-FDD	6.49	± 9.6 %
10141	CAE	LTE-FDD (SC-FDMA, 100% RB, 15 MHz, 64-QAM)	LTE-FDD	6.53	± 9.6 %
10142	CAE	LTE-FDD (SC-FDMA, 100% RB, 3 MHz, QPSK)	LTE-FDD	5.73	± 9.6 %
10143	CAE	LTE-FDD (SC-FDMA, 100% RB, 3 MHz, 16-QAM)	LTE-FDD	6.35	± 9.6 %
10144	CAE	LTE-FDD (SC-FDMA, 100% RB, 3 MHz, 64-QAM)	LTE-FDD	6.65	± 9.6 %
10145	CAF	LTE-FDD (SC-FDMA, 100% RB, 1.4 MHz, QPSK)	LTE-FDD	5.76	± 9.6 %
10146	CAF	LTE-FDD (SC-FDMA, 100% RB, 1.4 MHz, 16-QAM)	LTE-FDD	6.41	± 9.6 %
10147	CAF	LTE-FDD (SC-FDMA, 100% RB, 1.4 MHz, 64-QAM)	LTE-FDD	6.72	± 9.6 %
10149	CAE	LTE-FDD (SC-FDMA, 50% RB, 20 MHz, 16-QAM)	LTE-FDD	6.42	± 9.6 %
10150	CAE	LTE-FDD (SC-FDMA, 50% RB, 20 MHz, 64-QAM)	LTE-FDD	6.60	± 9.6 %
10151	CAG	LTE-TDD (SC-FDMA, 50% RB, 20 MHz, QPSK)	LTE-TDD	9.28	± 9.6 %
10152	CAG	LTE-TDD (SC-FDMA, 50% RB, 20 MHz, 16-QAM)	LTE-TDD	9.92	± 9.6 %
10153	CAG	LTE-TDD (SC-FDMA, 50% RB, 20 MHz, 64-QAM)	LTE-TDD	10.05	± 9.6 %
10154	CAG	LTE-FDD (SC-FDMA, 50% RB, 10 MHz, QPSK)	LTE-FDD	5.75	± 9.6 %
10155	CAG	LTE-FDD (SC-FDMA, 50% RB, 10 MHz, 16-QAM)	LTE-FDD	6.43	± 9.6 %
10156	CAG	LTE-FDD (SC-FDMA, 50% RB, 5 MHz, QPSK)	LTE-FDD	5.79	± 9.6 %
10157	CAG	LTE-FDD (SC-FDMA, 50% RB, 5 MHz, 16-QAM)	LTE-FDD	6.49	± 9.6 %
10158	CAG	LTE-FDD (SC-FDMA, 50% RB, 10 MHz, 64-QAM)	LTE-FDD	6.62	± 9.6 %
10159	CAG	LTE-FDD (SC-FDMA, 50% RB, 5 MHz, 64-QAM)	LTE-FDD	6.56	± 9.6 %
10160	CAE	LTE-FDD (SC-FDMA, 50% RB, 15 MHz, QPSK)	LTE-FDD	5.82	± 9.6 %
10161	CAE	LTE-FDD (SC-FDMA, 50% RB, 15 MHz, 16-QAM)	LTE-FDD	6.43	± 9.6 %
10162	CAE	LTE-FDD (SC-FDMA, 50% RB, 15 MHz, 64-QAM)	LTE-FDD	6.58	± 9.6 %
10166	CAF	LTE-FDD (SC-FDMA, 50% RB, 1.4 MHz, QPSK)	LTE-FDD	5.46	± 9.6 %
10167	CAF	LTE-FDD (SC-FDMA, 50% RB, 1.4 MHz, 16-QAM)	LTE-FDD	6.21	± 9.6 %
10168	CAF	LTE-FDD (SC-FDMA, 50% RB, 1.4 MHz, 64-QAM)	LTE-FDD	6.79	± 9.6 %
10169	CAE	LTE-FDD (SC-FDMA, 1 RB, 20 MHz, QPSK)	LTE-FDD	5.73	± 9.6 %
10170	CAE	LTE-FDD (SC-FDMA, 1 RB, 20 MHz, 16-QAM)	LTE-FDD	6.52	± 9.6 %
10171	AAE	LTE-FDD (SC-FDMA, 1 RB, 20 MHz, 64-QAM)	LTE-FDD	6.49	± 9.6 %
10172	CAG	LTE-TDD (SC-FDMA, 1 RB, 20 MHz, QPSK)	LTE-TDD	9.21	± 9.6 %
10173	CAG	LTE-TDD (SC-FDMA, 1 RB, 20 MHz, 16-QAM)	LTE-TDD	9.48	± 9.6 %
10174	CAG	LTE-TDD (SC-FDMA, 1 RB, 20 MHz, 64-QAM)	LTE-TDD	10.25	± 9.6 %
10175	CAG	LTE-FDD (SC-FDMA, 1 RB, 10 MHz, QPSK)	LTE-FDD	5.72	± 9.6 %
10176	CAG	LTE-FDD (SC-FDMA, 1 RB, 10 MHz, 16-QAM)	LTE-FDD	6.52	± 9.6 %
10177	CAI	LTE-FDD (SC-FDMA, 1 RB, 5 MHz, QPSK)	LTE-FDD	5.73	± 9.6 %
10178	CAG	LTE-FDD (SC-FDMA, 1 RB, 5 MHz, 16-QAM)	LTE-FDD	6.52	± 9.6 %
10179	CAG	LTE-FDD (SC-FDMA, 1 RB, 10 MHz, 64-QAM)	LTE-FDD	6.50	± 9.6 %
10180	CAG	LTE-FDD (SC-FDMA, 1 RB, 5 MHz, 64-QAM)	LTE-FDD	6.50	± 9.6 %
10181	CAE	LTE-FDD (SC-FDMA, 1 RB, 15 MHz, QPSK)	LTE-FDD	5.72	± 9.6 %
10182	CAE	LTE-FDD (SC-FDMA, 1 RB, 15 MHz, 16-QAM)	LTE-FDD	6.52	± 9.6 %
10183	AAD	LTE-FDD (SC-FDMA, 1 RB, 15 MHz, 64-QAM)	LTE-FDD	6.50	± 9.6 %
10184	CAE	LTE-FDD (SC-FDMA, 1 RB, 3 MHz, QPSK)	LTE-FDD	5.73	± 9.6 %
10185	CAE	LTE-FDD (SC-FDMA, 1 RB, 3 MHz, 16-QAM)	LTE-FDD	6.51	± 9.6 %
10186	AAE	LTE-FDD (SC-FDMA, 1 RB, 3 MHz, 64-QAM)	LTE-FDD	6.50	± 9.6 %
10187	CAF	LTE-FDD (SC-FDMA, 1 RB, 1.4 MHz, QPSK)	LTE-FDD	5.73	± 9.6 %
10188	CAF	LTE-FDD (SC-FDMA, 1 RB, 1.4 MHz, 16-QAM)	LTE-FDD	6.52	± 9.6 %
10189	AAF	LTE-FDD (SC-FDMA, 1 RB, 1.4 MHz, 64-QAM)	LTE-FDD	6.50	± 9.6 %
10193	CAC	IEEE 802.11n (HT Greenfield, 6.5 Mbps, BPSK)	WLAN	8.09	± 9.6 %
10194	CAC	IEEE 802.11n (HT Greenfield, 39 Mbps, 16-QAM)	WLAN	8.12	± 9.6 %
10195	CAC	IEEE 802.11n (HT Greenfield, 65 Mbps, 64-QAM)	WLAN	8.21	± 9.6 %
10196	CAC	IEEE 802.11n (HT Mixed, 6.5 Mbps, BPSK)	WLAN	8.10	± 9.6 %
10197	CAC	IEEE 802.11n (HT Mixed, 39 Mbps, 16-QAM)	WLAN	8.13	± 9.6 %
10198	CAC	IEEE 802.11n (HT Mixed, 65 Mbps, 64-QAM)	WLAN	8.27	± 9.6 %
10219	CAC	IEEE 802.11n (HT Mixed, 7.2 Mbps, BPSK)	WLAN	8.03	± 9.6 %

10220	CAC	IEEE 802.11n (HT Mixed, 43.3 Mbps, 16-QAM)	WLAN	8.13	± 9.6 %
10221	CAC	IEEE 802.11n (HT Mixed, 72.2 Mbps, 64-QAM)	WLAN	8.27	± 9.6 %
10222	CAC	IEEE 802.11n (HT Mixed, 15 Mbps, BPSK)	WLAN	8.06	± 9.6 %
10223	CAC	IEEE 802.11n (HT Mixed, 90 Mbps, 16-QAM)	WLAN	8.48	± 9.6 %
10224	CAC	IEEE 802.11n (HT Mixed, 150 Mbps, 64-QAM)	WLAN	8.08	± 9.6 %
10225	CAB	UMTS-FDD (HSPA+)	WCDMA	5.97	± 9.6 %
10226	CAB	LTE-TDD (SC-FDMA, 1 RB, 1.4 MHz, 16-QAM)	LTE-TDD	9.49	± 9.6 %
10227	CAB	LTE-TDD (SC-FDMA, 1 RB, 1.4 MHz, 64-QAM)	LTE-TDD	10.26	± 9.6 %
10228	CAB	LTE-TDD (SC-FDMA, 1 RB, 1.4 MHz, QPSK)	LTE-TDD	9.22	± 9.6 %
10229	CAD	LTE-TDD (SC-FDMA, 1 RB, 3 MHz, 16-QAM)	LTE-TDD	9.48	± 9.6 %
10230	CAD	LTE-TDD (SC-FDMA, 1 RB, 3 MHz, 64-QAM)	LTE-TDD	10.25	± 9.6 %
10231	CAD	LTE-TDD (SC-FDMA, 1 RB, 3 MHz, QPSK)	LTE-TDD	9.19	± 9.6 %
10232	CAG	LTE-TDD (SC-FDMA, 1 RB, 5 MHz, 16-QAM)	LTE-TDD	9.48	± 9.6 %
10233	CAG	LTE-TDD (SC-FDMA, 1 RB, 5 MHz, 64-QAM)	LTE-TDD	10.25	± 9.6 %
10234	CAG	LTE-TDD (SC-FDMA, 1 RB, 5 MHz, QPSK)	LTE-TDD	9.21	± 9.6 %
10235	CAG	LTE-TDD (SC-FDMA, 1 RB, 10 MHz, 16-QAM)	LTE-TDD	9.48	± 9.6 %
10236	CAG	LTE-TDD (SC-FDMA, 1 RB, 10 MHz, 64-QAM)	LTE-TDD	10.25	± 9.6 %
10237	CAG	LTE-TDD (SC-FDMA, 1 RB, 10 MHz, QPSK)	LTE-TDD	9.21	± 9.6 %
10238	CAF	LTE-TDD (SC-FDMA, 1 RB, 15 MHz, 16-QAM)	LTE-TDD	9.48	± 9.6 %
10239	CAF	LTE-TDD (SC-FDMA, 1 RB, 15 MHz, 64-QAM)	LTE-TDD	10.25	± 9.6 %
10240	CAF	LTE-TDD (SC-FDMA, 1 RB, 15 MHz, QPSK)	LTE-TDD	9.21	± 9.6 %
10241	CAB	LTE-TDD (SC-FDMA, 50% RB, 1.4 MHz, 16-QAM)	LTE-TDD	9.82	± 9.6 %
10242	CAB	LTE-TDD (SC-FDMA, 50% RB, 1.4 MHz, 64-QAM)	LTE-TDD	9.86	± 9.6 %
10243	CAB	LTE-TDD (SC-FDMA, 50% RB, 1.4 MHz, QPSK)	LTE-TDD	9.46	± 9.6 %
10244	CAD	LTE-TDD (SC-FDMA, 50% RB, 3 MHz, 16-QAM)	LTE-TDD	10.06	± 9.6 %
10245	CAD	LTE-TDD (SC-FDMA, 50% RB, 3 MHz, 64-QAM)	LTE-TDD	10.06	± 9.6 %
10246	CAD	LTE-TDD (SC-FDMA, 50% RB, 3 MHz, QPSK)	LTE-TDD	9.30	± 9.6 %
10247	CAG	LTE-TDD (SC-FDMA, 50% RB, 5 MHz, 16-QAM)	LTE-TDD	9.91	± 9.6 %
10248	CAG	LTE-TDD (SC-FDMA, 50% RB, 5 MHz, 64-QAM)	LTE-TDD	10.09	± 9.6 %
10249	CAG	LTE-TDD (SC-FDMA, 50% RB, 5 MHz, QPSK)	LTE-TDD	9.29	± 9.6 %
10250	CAG	LTE-TDD (SC-FDMA, 50% RB, 10 MHz, 16-QAM)	LTE-TDD	9.81	± 9.6 %
10251	CAG	LTE-TDD (SC-FDMA, 50% RB, 10 MHz, 64-QAM)	LTE-TDD	10.17	± 9.6 %
10252	CAG	LTE-TDD (SC-FDMA, 50% RB, 10 MHz, QPSK)	LTE-TDD	9.24	± 9.6 %
10253	CAF	LTE-TDD (SC-FDMA, 50% RB, 15 MHz, 16-QAM)	LTE-TDD	9.90	± 9.6 %
10254	CAF	LTE-TDD (SC-FDMA, 50% RB, 15 MHz, 64-QAM)	LTE-TDD	10.14	± 9.6 %
10255	CAF	LTE-TDD (SC-FDMA, 50% RB, 15 MHz, QPSK)	LTE-TDD	9.20	± 9.6 %
10256	CAB	LTE-TDD (SC-FDMA, 100% RB, 1.4 MHz, 16-QAM)	LTE-TDD	9.96	± 9.6 %
10257	CAB	LTE-TDD (SC-FDMA, 100% RB, 1.4 MHz, 64-QAM)	LTE-TDD	10.08	± 9.6 %
10258	CAB	LTE-TDD (SC-FDMA, 100% RB, 1.4 MHz, QPSK)	LTE-TDD	9.34	± 9.6 %
10259	CAD	LTE-TDD (SC-FDMA, 100% RB, 3 MHz, 16-QAM)	LTE-TDD	9.98	± 9.6 %
10260	CAD	LTE-TDD (SC-FDMA, 100% RB, 3 MHz, 64-QAM)	LTE-TDD	9.97	± 9.6 %
10261	CAD	LTE-TDD (SC-FDMA, 100% RB, 3 MHz, QPSK)	LTE-TDD	9.24	± 9.6 %
10262	CAG	LTE-TDD (SC-FDMA, 100% RB, 5 MHz, 16-QAM)	LTE-TDD	9.83	± 9.6 %
10263	CAG	LTE-TDD (SC-FDMA, 100% RB, 5 MHz, 64-QAM)	LTE-TDD	10.16	± 9.6 %
10264	CAG	LTE-TDD (SC-FDMA, 100% RB, 5 MHz, QPSK)	LTE-TDD	9.23	± 9.6 %
10265	CAG	LTE-TDD (SC-FDMA, 100% RB, 10 MHz, 16-QAM)	LTE-TDD	9.92	± 9.6 %
10266	CAG	LTE-TDD (SC-FDMA, 100% RB, 10 MHz, 64-QAM)	LTE-TDD	10.07	± 9.6 %
10267	CAG	LTE-TDD (SC-FDMA, 100% RB, 10 MHz, QPSK)	LTE-TDD	9.30	± 9.6 %
10268	CAF	LTE-TDD (SC-FDMA, 100% RB, 15 MHz, 16-QAM)	LTE-TDD	10.06	± 9.6 %
10269	CAF	LTE-TDD (SC-FDMA, 100% RB, 15 MHz, 64-QAM)	LTE-TDD	10.13	± 9.6 %
10270	CAF	LTE-TDD (SC-FDMA, 100% RB, 15 MHz, QPSK)	LTE-TDD	9.58	± 9.6 %
10274	CAB	UMTS-FDD (HSUPA, Subtest 5, 3GPP Rel8.10)	WCDMA	4.87	± 9.6 %
10275	CAB	UMTS-FDD (HSUPA, Subtest 5, 3GPP Rel8.4)	WCDMA	3.96	± 9.6 %
10277	CAA	PHS (QPSK)	PHS	11.81	± 9.6 %
10278	CAA	PHS (QPSK, BW 884MHz, Rolloff 0.5)	PHS	11.81	± 9.6 %
10279	CAA	PHS (QPSK, BW 884MHz, Rolloff 0.38)	PHS	12.18	± 9.6 %
10290	AAB	CDMA2000, RC1, SO55, Full Rate	CDMA2000	3.91	± 9.6 %
10291	AAB	CDMA2000, RC3, SO55, Full Rate	CDMA2000	3.46	± 9.6 %
10292	AAB	CDMA2000, RC3, SO32, Full Rate	CDMA2000	3.39	± 9.6 %
10293	AAB	CDMA2000, RC3, SO3, Full Rate	CDMA2000	3.50	± 9.6 %
10295	AAB	CDMA2000, RC1, SO3, 1/8th Rate 25 fr.	CDMA2000	12.49	± 9.6 %
10297	AAD	LTE-FDD (SC-FDMA, 50% RB, 20 MHz, QPSK)	LTE-FDD	5.81	± 9.6 %
10298	AAD	LTE-FDD (SC-FDMA, 50% RB, 3 MHz, QPSK)	LTE-FDD	5.72	± 9.6 %
10299	AAD	LTE-FDD (SC-FDMA, 50% RB, 3 MHz, 16-QAM)	LTE-FDD	6.39	± 9.6 %

10300	AAD	LTE-FDD (SC-FDMA, 50% RB, 3 MHz, 64-QAM)	LTE-FDD	6.60	± 9.6 %
10301	AAA	IEEE 802.16e WiMAX (29:18, 5ms, 10MHz, QPSK, PUSC)	WiMAX	12.03	± 9.6 %
10302	AAA	IEEE 802.16e WiMAX (29:18, 5ms, 10MHz, QPSK, PUSC, 3 CTRL symbols)	WiMAX	12.57	± 9.6 %
10303	AAA	IEEE 802.16e WiMAX (31:15, 5ms, 10MHz, 64QAM, PUSC)	WiMAX	12.52	± 9.6 %
10304	AAA	IEEE 802.16e WiMAX (29:18, 5ms, 10MHz, 64QAM, PUSC)	WiMAX	11.86	± 9.6 %
10305	AAA	IEEE 802.16e WiMAX (31:15, 10ms, 10MHz, 64QAM, PUSC, 15 symbols)	WiMAX	15.24	± 9.6 %
10306	AAA	IEEE 802.16e WiMAX (29:18, 10ms, 10MHz, 64QAM, PUSC, 18 symbols)	WiMAX	14.67	± 9.6 %
10307	AAA	IEEE 802.16e WiMAX (29:18, 10ms, 10MHz, QPSK, PUSC, 18 symbols)	WiMAX	14.49	± 9.6 %
10308	AAA	IEEE 802.16e WiMAX (29:18, 10ms, 10MHz, 16QAM, PUSC)	WiMAX	14.46	± 9.6 %
10309	AAA	IEEE 802.16e WiMAX (29:18, 10ms, 10MHz, 16QAM, AMC 2x3, 18 symbols)	WiMAX	14.58	± 9.6 %
10310	AAA	IEEE 802.16e WiMAX (29:18, 10ms, 10MHz, QPSK, AMC 2x3, 18 symbols)	WiMAX	14.57	± 9.6 %
10311	AAD	LTE-FDD (SC-FDMA, 100% RB, 15 MHz, QPSK)	LTE-FDD	6.06	± 9.6 %
10313	AAA	iDEN 1:3	iDEN	10.51	± 9.6 %
10314	AAA	iDEN 1:6	iDEN	13.48	± 9.6 %
10315	AAB	IEEE 802.11b WiFi 2.4 GHz (DSSS, 1 Mbps, 96pc duty cycle)	WLAN	1.71	± 9.6 %
10316	AAB	IEEE 802.11g WiFi 2.4 GHz (ERP-OFDM, 6 Mbps, 96pc duty cycle)	WLAN	8.36	± 9.6 %
10317	AAC	IEEE 802.11a WiFi 5 GHz (OFDM, 6 Mbps, 96pc duty cycle)	WLAN	8.36	± 9.6 %
10352	AAA	Pulse Waveform (200Hz, 10%)	Generic	10.00	± 9.6 %
10353	AAA	Pulse Waveform (200Hz, 20%)	Generic	6.99	± 9.6 %
10354	AAA	Pulse Waveform (200Hz, 40%)	Generic	3.98	± 9.6 %
10355	AAA	Pulse Waveform (200Hz, 60%)	Generic	2.22	± 9.6 %
10356	AAA	Pulse Waveform (200Hz, 80%)	Generic	0.97	± 9.6 %
10387	AAA	QPSK Waveform, 1 MHz	Generic	5.10	± 9.6 %
10388	AAA	QPSK Waveform, 10 MHz	Generic	5.22	± 9.6 %
10396	AAA	64-QAM Waveform, 100 kHz	Generic	6.27	± 9.6 %
10399	AAA	64-QAM Waveform, 40 MHz	Generic	6.27	± 9.6 %
10400	AAD	IEEE 802.11ac WiFi (20MHz, 64-QAM, 99pc duty cycle)	WLAN	8.37	± 9.6 %
10401	AAD	IEEE 802.11ac WiFi (40MHz, 64-QAM, 99pc duty cycle)	WLAN	8.60	± 9.6 %
10402	AAD	IEEE 802.11ac WiFi (80MHz, 64-QAM, 99pc duty cycle)	WLAN	8.53	± 9.6 %
10403	AAB	CDMA2000 (1xEV-DO, Rev. 0)	CDMA2000	3.76	± 9.6 %
10404	AAB	CDMA2000 (1xEV-DO, Rev. A)	CDMA2000	3.77	± 9.6 %
10406	AAB	CDMA2000, RC3, SO32, SCH0, Full Rate	CDMA2000	5.22	± 9.6 %
10410	AAG	LTE-TDD (SC-FDMA, 1 RB, 10 MHz, QPSK, UL Subframe=2,3,4,7,8,9, Subframe Conf=4)	LTE-TDD	7.82	± 9.6 %
10414	AAA	WLAN CCDF, 64-QAM, 40MHz	Generic	8.54	± 9.6 %
10415	AAA	IEEE 802.11b WiFi 2.4 GHz (DSSS, 1 Mbps, 99pc duty cycle)	WLAN	1.54	± 9.6 %
10416	AAA	IEEE 802.11g WiFi 2.4 GHz (ERP-OFDM, 6 Mbps, 99pc duty cycle)	WLAN	8.23	± 9.6 %
10417	AAB	IEEE 802.11a/h WiFi 5 GHz (OFDM, 6 Mbps, 99pc duty cycle)	WLAN	8.23	± 9.6 %
10418	AAA	IEEE 802.11g WiFi 2.4 GHz (DSSS-OFDM, 6 Mbps, 99pc duty cycle, Long preamble)	WLAN	8.14	± 9.6 %
10419	AAA	IEEE 802.11g WiFi 2.4 GHz (DSSS-OFDM, 6 Mbps, 99pc duty cycle, Short preamble)	WLAN	8.19	± 9.6 %
10422	AAB	IEEE 802.11n (HT Greenfield, 7.2 Mbps, BPSK)	WLAN	8.32	± 9.6 %
10423	AAB	IEEE 802.11n (HT Greenfield, 43.3 Mbps, 16-QAM)	WLAN	8.47	± 9.6 %
10424	AAB	IEEE 802.11n (HT Greenfield, 72.2 Mbps, 64-QAM)	WLAN	8.40	± 9.6 %
10425	AAB	IEEE 802.11n (HT Greenfield, 15 Mbps, BPSK)	WLAN	8.41	± 9.6 %
10426	AAB	IEEE 802.11n (HT Greenfield, 90 Mbps, 16-QAM)	WLAN	8.45	± 9.6 %
10427	AAB	IEEE 802.11n (HT Greenfield, 150 Mbps, 64-QAM)	WLAN	8.41	± 9.6 %
10430	AAD	LTE-FDD (OFDMA, 5 MHz, E-TM 3.1)	LTE-FDD	8.28	± 9.6 %
10431	AAD	LTE-FDD (OFDMA, 10 MHz, E-TM 3.1)	LTE-FDD	8.38	± 9.6 %
10432	AAC	LTE-FDD (OFDMA, 15 MHz, E-TM 3.1)	LTE-FDD	8.34	± 9.6 %
10433	AAC	LTE-FDD (OFDMA, 20 MHz, E-TM 3.1)	LTE-FDD	8.34	± 9.6 %
10434	AAA	W-CDMA (BS Test Model 1, 64 DPCH)	WCDMA	8.60	± 9.6 %
10435	AAF	LTE-TDD (SC-FDMA, 1 RB, 20 MHz, QPSK, UL Subframe=2,3,4,7,8,9)	LTE-TDD	7.82	± 9.6 %
10447	AAD	LTE-FDD (OFDMA, 5 MHz, E-TM 3.1, Clipping 44%)	LTE-FDD	7.56	± 9.6 %
10448	AAD	LTE-FDD (OFDMA, 10 MHz, E-TM 3.1, Clipping 44%)	LTE-FDD	7.53	± 9.6 %
10449	AAC	LTE-FDD (OFDMA, 15 MHz, E-TM 3.1, Clipping 44%)	LTE-FDD	7.51	± 9.6 %
10450	AAC	LTE-FDD (OFDMA, 20 MHz, E-TM 3.1, Clipping 44%)	LTE-FDD	7.48	± 9.6 %

10451	AAA	W-CDMA (BS Test Model 1, 64 DPCH, Clipping 44%)	WCDMA	7.59	± 9.6 %
10453	AAD	Validation (Square, 10ms, 1ms)	Test	10.00	± 9.6 %
10456	AAB	IEEE 802.11ac WiFi (160MHz, 64-QAM, 99pc duty cycle)	WLAN	8.63	± 9.6 %
10457	AAA	UMTS-FDD (DC-HSDPA)	WCDMA	6.62	± 9.6 %
10458	AAA	CDMA2000 (1xEV-DO, Rev. B, 2 carriers)	CDMA2000	6.55	± 9.6 %
10459	AAA	CDMA2000 (1xEV-DO, Rev. B, 3 carriers)	CDMA2000	8.25	± 9.6 %
10460	AAA	UMTS-FDD (WCDMA, AMR)	WCDMA	2.39	± 9.6 %
10461	AAB	LTE-TDD (SC-FDMA, 1 RB, 1.4 MHz, QPSK, UL Subframe=2,3,4,7,8,9)	LTE-TDD	7.82	± 9.6 %
10462	AAB	LTE-TDD (SC-FDMA, 1 RB, 1.4 MHz, 16-QAM, UL Subframe=2,3,4,7,8,9)	LTE-TDD	8.30	± 9.6 %
10463	AAB	LTE-TDD (SC-FDMA, 1 RB, 1.4 MHz, 64-QAM, UL Subframe=2,3,4,7,8,9)	LTE-TDD	8.56	± 9.6 %
10464	AAC	LTE-TDD (SC-FDMA, 1 RB, 3 MHz, QPSK, UL Subframe=2,3,4,7,8,9)	LTE-TDD	7.82	± 9.6 %
10465	AAC	LTE-TDD (SC-FDMA, 1 RB, 3 MHz, 16-QAM, UL Subframe=2,3,4,7,8,9)	LTE-TDD	8.32	± 9.6 %
10466	AAC	LTE-TDD (SC-FDMA, 1 RB, 3 MHz, 64-QAM, UL Subframe=2,3,4,7,8,9)	LTE-TDD	8.57	± 9.6 %
10467	AAF	LTE-TDD (SC-FDMA, 1 RB, 5 MHz, QPSK, UL Subframe=2,3,4,7,8,9)	LTE-TDD	7.82	± 9.6 %
10468	AAF	LTE-TDD (SC-FDMA, 1 RB, 5 MHz, 16-QAM, UL Subframe=2,3,4,7,8,9)	LTE-TDD	8.32	± 9.6 %
10469	AAF	LTE-TDD (SC-FDMA, 1 RB, 5 MHz, 64-QAM, UL Subframe=2,3,4,7,8,9)	LTE-TDD	8.56	± 9.6 %
10470	AAF	LTE-TDD (SC-FDMA, 1 RB, 10 MHz, QPSK, UL Subframe=2,3,4,7,8,9)	LTE-TDD	7.82	± 9.6 %
10471	AAF	LTE-TDD (SC-FDMA, 1 RB, 10 MHz, 16-QAM, UL Subframe=2,3,4,7,8,9)	LTE-TDD	8.32	± 9.6 %
10472	AAF	LTE-TDD (SC-FDMA, 1 RB, 10 MHz, 64-QAM, UL Subframe=2,3,4,7,8,9)	LTE-TDD	8.57	± 9.6 %
10473	AAE	LTE-TDD (SC-FDMA, 1 RB, 15 MHz, QPSK, UL Subframe=2,3,4,7,8,9)	LTE-TDD	7.82	± 9.6 %
10474	AAE	LTE-TDD (SC-FDMA, 1 RB, 15 MHz, 16-QAM, UL Subframe=2,3,4,7,8,9)	LTE-TDD	8.32	± 9.6 %
10475	AAE	LTE-TDD (SC-FDMA, 1 RB, 15 MHz, 64-QAM, UL Subframe=2,3,4,7,8,9)	LTE-TDD	8.57	± 9.6 %
10477	AAF	LTE-TDD (SC-FDMA, 1 RB, 20 MHz, 16-QAM, UL Subframe=2,3,4,7,8,9)	LTE-TDD	8.32	± 9.6 %
10478	AAF	LTE-TDD (SC-FDMA, 1 RB, 20 MHz, 64-QAM, UL Subframe=2,3,4,7,8,9)	LTE-TDD	8.57	± 9.6 %
10479	AAB	LTE-TDD (SC-FDMA, 50% RB, 1.4 MHz, QPSK, UL Subframe=2,3,4,7,8,9)	LTE-TDD	7.74	± 9.6 %
10480	AAB	LTE-TDD (SC-FDMA, 50% RB, 1.4 MHz, 16-QAM, UL Subframe=2,3,4,7,8,9)	LTE-TDD	8.18	± 9.6 %
10481	AAB	LTE-TDD (SC-FDMA, 50% RB, 1.4 MHz, 64-QAM, UL Subframe=2,3,4,7,8,9)	LTE-TDD	8.45	± 9.6 %
10482	AAC	LTE-TDD (SC-FDMA, 50% RB, 3 MHz, QPSK, UL Subframe=2,3,4,7,8,9)	LTE-TDD	7.71	± 9.6 %
10483	AAC	LTE-TDD (SC-FDMA, 50% RB, 3 MHz, 16-QAM, UL Subframe=2,3,4,7,8,9)	LTE-TDD	8.39	± 9.6 %
10484	AAC	LTE-TDD (SC-FDMA, 50% RB, 3 MHz, 64-QAM, UL Subframe=2,3,4,7,8,9)	LTE-TDD	8.47	± 9.6 %
10485	AAF	LTE-TDD (SC-FDMA, 50% RB, 5 MHz, QPSK, UL Subframe=2,3,4,7,8,9)	LTE-TDD	7.59	± 9.6 %
10486	AAF	LTE-TDD (SC-FDMA, 50% RB, 5 MHz, 16-QAM, UL Subframe=2,3,4,7,8,9)	LTE-TDD	8.38	± 9.6 %
10487	AAF	LTE-TDD (SC-FDMA, 50% RB, 5 MHz, 64-QAM, UL Subframe=2,3,4,7,8,9)	LTE-TDD	8.60	± 9.6 %
10488	AAF	LTE-TDD (SC-FDMA, 50% RB, 10 MHz, QPSK, UL Subframe=2,3,4,7,8,9)	LTE-TDD	7.70	± 9.6 %
10489	AAF	LTE-TDD (SC-FDMA, 50% RB, 10 MHz, 16-QAM, UL Subframe=2,3,4,7,8,9)	LTE-TDD	8.31	± 9.6 %
10490	AAF	LTE-TDD (SC-FDMA, 50% RB, 10 MHz, 64-QAM, UL Subframe=2,3,4,7,8,9)	LTE-TDD	8.54	± 9.6 %

10491	AAE	LTE-TDD (SC-FDMA, 50% RB, 15 MHz, QPSK, UL Subframe=2,3,4,7,8,9)	LTE-TDD	7.74	± 9.6 %
10492	AAE	LTE-TDD (SC-FDMA, 50% RB, 15 MHz, 16-QAM, UL Subframe=2,3,4,7,8,9)	LTE-TDD	8.41	± 9.6 %
10493	AAE	LTE-TDD (SC-FDMA, 50% RB, 15 MHz, 64-QAM, UL Subframe=2,3,4,7,8,9)	LTE-TDD	8.55	± 9.6 %
10494	AAF	LTE-TDD (SC-FDMA, 50% RB, 20 MHz, QPSK, UL Subframe=2,3,4,7,8,9)	LTE-TDD	7.74	± 9.6 %
10495	AAF	LTE-TDD (SC-FDMA, 50% RB, 20 MHz, 16-QAM, UL Subframe=2,3,4,7,8,9)	LTE-TDD	8.37	± 9.6 %
10496	AAF	LTE-TDD (SC-FDMA, 50% RB, 20 MHz, 64-QAM, UL Subframe=2,3,4,7,8,9)	LTE-TDD	8.54	± 9.6 %
10497	AAB	LTE-TDD (SC-FDMA, 100% RB, 1.4 MHz, QPSK, UL Subframe=2,3,4,7,8,9)	LTE-TDD	7.67	± 9.6 %
10498	AAB	LTE-TDD (SC-FDMA, 100% RB, 1.4 MHz, 16-QAM, UL Subframe=2,3,4,7,8,9)	LTE-TDD	8.40	± 9.6 %
10499	AAB	LTE-TDD (SC-FDMA, 100% RB, 1.4 MHz, 64-QAM, UL Subframe=2,3,4,7,8,9)	LTE-TDD	8.68	± 9.6 %
10500	AAC	LTE-TDD (SC-FDMA, 100% RB, 3 MHz, QPSK, UL Subframe=2,3,4,7,8,9)	LTE-TDD	7.67	± 9.6 %
10501	AAC	LTE-TDD (SC-FDMA, 100% RB, 3 MHz, 16-QAM, UL Subframe=2,3,4,7,8,9)	LTE-TDD	8.44	± 9.6 %
10502	AAC	LTE-TDD (SC-FDMA, 100% RB, 3 MHz, 64-QAM, UL Subframe=2,3,4,7,8,9)	LTE-TDD	8.52	± 9.6 %
10503	AAF	LTE-TDD (SC-FDMA, 100% RB, 5 MHz, QPSK, UL Subframe=2,3,4,7,8,9)	LTE-TDD	7.72	± 9.6 %
10504	AAF	LTE-TDD (SC-FDMA, 100% RB, 5 MHz, 16-QAM, UL Subframe=2,3,4,7,8,9)	LTE-TDD	8.31	± 9.6 %
10505	AAF	LTE-TDD (SC-FDMA, 100% RB, 5 MHz, 64-QAM, UL Subframe=2,3,4,7,8,9)	LTE-TDD	8.54	± 9.6 %
10506	AAF	LTE-TDD (SC-FDMA, 100% RB, 10 MHz, QPSK, UL Subframe=2,3,4,7,8,9)	LTE-TDD	7.74	± 9.6 %
10507	AAF	LTE-TDD (SC-FDMA, 100% RB, 10 MHz, 16-QAM, UL Subframe=2,3,4,7,8,9)	LTE-TDD	8.36	± 9.6 %
10508	AAF	LTE-TDD (SC-FDMA, 100% RB, 10 MHz, 64-QAM, UL Subframe=2,3,4,7,8,9)	LTE-TDD	8.55	± 9.6 %
10509	AAE	LTE-TDD (SC-FDMA, 100% RB, 15 MHz, QPSK, UL Subframe=2,3,4,7,8,9)	LTE-TDD	7.99	± 9.6 %
10510	AAE	LTE-TDD (SC-FDMA, 100% RB, 15 MHz, 16-QAM, UL Subframe=2,3,4,7,8,9)	LTE-TDD	8.49	± 9.6 %
10511	AAE	LTE-TDD (SC-FDMA, 100% RB, 15 MHz, 64-QAM, UL Subframe=2,3,4,7,8,9)	LTE-TDD	8.51	± 9.6 %
10512	AAF	LTE-TDD (SC-FDMA, 100% RB, 20 MHz, QPSK, UL Subframe=2,3,4,7,8,9)	LTE-TDD	7.74	± 9.6 %
10513	AAF	LTE-TDD (SC-FDMA, 100% RB, 20 MHz, 16-QAM, UL Subframe=2,3,4,7,8,9)	LTE-TDD	8.42	± 9.6 %
10514	AAF	LTE-TDD (SC-FDMA, 100% RB, 20 MHz, 64-QAM, UL Subframe=2,3,4,7,8,9)	LTE-TDD	8.45	± 9.6 %
10515	AAA	IEEE 802.11b WiFi 2.4 GHz (DSSS, 2 Mbps, 99pc duty cycle)	WLAN	1.58	± 9.6 %
10516	AAA	IEEE 802.11b WiFi 2.4 GHz (DSSS, 5.5 Mbps, 99pc duty cycle)	WLAN	1.57	± 9.6 %
10517	AAA	IEEE 802.11b WiFi 2.4 GHz (DSSS, 11 Mbps, 99pc duty cycle)	WLAN	1.58	± 9.6 %
10518	AAB	IEEE 802.11a/h WiFi 5 GHz (OFDM, 9 Mbps, 99pc duty cycle)	WLAN	8.23	± 9.6 %
10519	AAB	IEEE 802.11a/h WiFi 5 GHz (OFDM, 12 Mbps, 99pc duty cycle)	WLAN	8.39	± 9.6 %
10520	AAB	IEEE 802.11a/h WiFi 5 GHz (OFDM, 18 Mbps, 99pc duty cycle)	WLAN	8.12	± 9.6 %
10521	AAB	IEEE 802.11a/h WiFi 5 GHz (OFDM, 24 Mbps, 99pc duty cycle)	WLAN	7.97	± 9.6 %
10522	AAB	IEEE 802.11a/h WiFi 5 GHz (OFDM, 36 Mbps, 99pc duty cycle)	WLAN	8.45	± 9.6 %
10523	AAB	IEEE 802.11a/h WiFi 5 GHz (OFDM, 48 Mbps, 99pc duty cycle)	WLAN	8.08	± 9.6 %
10524	AAB	IEEE 802.11a/h WiFi 5 GHz (OFDM, 54 Mbps, 99pc duty cycle)	WLAN	8.27	± 9.6 %
10525	AAB	IEEE 802.11ac WiFi (20MHz, MCS0, 99pc duty cycle)	WLAN	8.36	± 9.6 %
10526	AAB	IEEE 802.11ac WiFi (20MHz, MCS1, 99pc duty cycle)	WLAN	8.42	± 9.6 %
10527	AAB	IEEE 802.11ac WiFi (20MHz, MCS2, 99pc duty cycle)	WLAN	8.21	± 9.6 %
10528	AAB	IEEE 802.11ac WiFi (20MHz, MCS3, 99pc duty cycle)	WLAN	8.36	± 9.6 %
10529	AAB	IEEE 802.11ac WiFi (20MHz, MCS4, 99pc duty cycle)	WLAN	8.36	± 9.6 %
10531	AAB	IEEE 802.11ac WiFi (20MHz, MCS6, 99pc duty cycle)	WLAN	8.43	± 9.6 %
10532	AAB	IEEE 802.11ac WiFi (20MHz, MCS7, 99pc duty cycle)	WLAN	8.29	± 9.6 %
10533	AAB	IEEE 802.11ac WiFi (20MHz, MCS8, 99pc duty cycle)	WLAN	8.38	± 9.6 %

10534	AAB	IEEE 802.11ac WiFi (40MHz, MCS0, 99pc duty cycle)	WLAN	8.45	± 9.6 %
10535	AAB	IEEE 802.11ac WiFi (40MHz, MCS1, 99pc duty cycle)	WLAN	8.45	± 9.6 %
10536	AAB	IEEE 802.11ac WiFi (40MHz, MCS2, 99pc duty cycle)	WLAN	8.32	± 9.6 %
10537	AAB	IEEE 802.11ac WiFi (40MHz, MCS3, 99pc duty cycle)	WLAN	8.44	± 9.6 %
10538	AAB	IEEE 802.11ac WiFi (40MHz, MCS4, 99pc duty cycle)	WLAN	8.54	± 9.6 %
10540	AAB	IEEE 802.11ac WiFi (40MHz, MCS6, 99pc duty cycle)	WLAN	8.39	± 9.6 %
10541	AAB	IEEE 802.11ac WiFi (40MHz, MCS7, 99pc duty cycle)	WLAN	8.46	± 9.6 %
10542	AAB	IEEE 802.11ac WiFi (40MHz, MCS8, 99pc duty cycle)	WLAN	8.65	± 9.6 %
10543	AAB	IEEE 802.11ac WiFi (40MHz, MCS9, 99pc duty cycle)	WLAN	8.65	± 9.6 %
10544	AAB	IEEE 802.11ac WiFi (80MHz, MCS0, 99pc duty cycle)	WLAN	8.47	± 9.6 %
10545	AAB	IEEE 802.11ac WiFi (80MHz, MCS1, 99pc duty cycle)	WLAN	8.55	± 9.6 %
10546	AAB	IEEE 802.11ac WiFi (80MHz, MCS2, 99pc duty cycle)	WLAN	8.35	± 9.6 %
10547	AAB	IEEE 802.11ac WiFi (80MHz, MCS3, 99pc duty cycle)	WLAN	8.49	± 9.6 %
10548	AAB	IEEE 802.11ac WiFi (80MHz, MCS4, 99pc duty cycle)	WLAN	8.37	± 9.6 %
10550	AAB	IEEE 802.11ac WiFi (80MHz, MCS6, 99pc duty cycle)	WLAN	8.38	± 9.6 %
10551	AAB	IEEE 802.11ac WiFi (80MHz, MCS7, 99pc duty cycle)	WLAN	8.50	± 9.6 %
10552	AAB	IEEE 802.11ac WiFi (80MHz, MCS8, 99pc duty cycle)	WLAN	8.42	± 9.6 %
10553	AAB	IEEE 802.11ac WiFi (80MHz, MCS9, 99pc duty cycle)	WLAN	8.45	± 9.6 %
10554	AAC	IEEE 802.11ac WiFi (160MHz, MCS0, 99pc duty cycle)	WLAN	8.48	± 9.6 %
10555	AAC	IEEE 802.11ac WiFi (160MHz, MCS1, 99pc duty cycle)	WLAN	8.47	± 9.6 %
10556	AAC	IEEE 802.11ac WiFi (160MHz, MCS2, 99pc duty cycle)	WLAN	8.50	± 9.6 %
10557	AAC	IEEE 802.11ac WiFi (160MHz, MCS3, 99pc duty cycle)	WLAN	8.52	± 9.6 %
10558	AAC	IEEE 802.11ac WiFi (160MHz, MCS4, 99pc duty cycle)	WLAN	8.61	± 9.6 %
10560	AAC	IEEE 802.11ac WiFi (160MHz, MCS6, 99pc duty cycle)	WLAN	8.73	± 9.6 %
10561	AAC	IEEE 802.11ac WiFi (160MHz, MCS7, 99pc duty cycle)	WLAN	8.56	± 9.6 %
10562	AAC	IEEE 802.11ac WiFi (160MHz, MCS8, 99pc duty cycle)	WLAN	8.69	± 9.6 %
10563	AAC	IEEE 802.11ac WiFi (160MHz, MCS9, 99pc duty cycle)	WLAN	8.77	± 9.6 %
10564	AAA	IEEE 802.11g WiFi 2.4 GHz (DSSS-OFDM, 9 Mbps, 99pc duty cycle)	WLAN	8.25	± 9.6 %
10565	AAA	IEEE 802.11g WiFi 2.4 GHz (DSSS-OFDM, 12 Mbps, 99pc duty cycle)	WLAN	8.45	± 9.6 %
10566	AAA	IEEE 802.11g WiFi 2.4 GHz (DSSS-OFDM, 18 Mbps, 99pc duty cycle)	WLAN	8.13	± 9.6 %
10567	AAA	IEEE 802.11g WiFi 2.4 GHz (DSSS-OFDM, 24 Mbps, 99pc duty cycle)	WLAN	8.00	± 9.6 %
10568	AAA	IEEE 802.11g WiFi 2.4 GHz (DSSS-OFDM, 36 Mbps, 99pc duty cycle)	WLAN	8.37	± 9.6 %
10569	AAA	IEEE 802.11g WiFi 2.4 GHz (DSSS-OFDM, 48 Mbps, 99pc duty cycle)	WLAN	8.10	± 9.6 %
10570	AAA	IEEE 802.11g WiFi 2.4 GHz (DSSS-OFDM, 54 Mbps, 99pc duty cycle)	WLAN	8.30	± 9.6 %
10571	AAA	IEEE 802.11b WiFi 2.4 GHz (DSSS, 1 Mbps, 90pc duty cycle)	WLAN	1.99	± 9.6 %
10572	AAA	IEEE 802.11b WiFi 2.4 GHz (DSSS, 2 Mbps, 90pc duty cycle)	WLAN	1.99	± 9.6 %
10573	AAA	IEEE 802.11b WiFi 2.4 GHz (DSSS, 5.5 Mbps, 90pc duty cycle)	WLAN	1.98	± 9.6 %
10574	AAA	IEEE 802.11b WiFi 2.4 GHz (DSSS, 11 Mbps, 90pc duty cycle)	WLAN	1.98	± 9.6 %
10575	AAA	IEEE 802.11g WiFi 2.4 GHz (DSSS-OFDM, 6 Mbps, 90pc duty cycle)	WLAN	8.59	± 9.6 %
10576	AAA	IEEE 802.11g WiFi 2.4 GHz (DSSS-OFDM, 9 Mbps, 90pc duty cycle)	WLAN	8.60	± 9.6 %
10577	AAA	IEEE 802.11g WiFi 2.4 GHz (DSSS-OFDM, 12 Mbps, 90pc duty cycle)	WLAN	8.70	± 9.6 %
10578	AAA	IEEE 802.11g WiFi 2.4 GHz (DSSS-OFDM, 18 Mbps, 90pc duty cycle)	WLAN	8.49	± 9.6 %
10579	AAA	IEEE 802.11g WiFi 2.4 GHz (DSSS-OFDM, 24 Mbps, 90pc duty cycle)	WLAN	8.36	± 9.6 %
10580	AAA	IEEE 802.11g WiFi 2.4 GHz (DSSS-OFDM, 36 Mbps, 90pc duty cycle)	WLAN	8.76	± 9.6 %
10581	AAA	IEEE 802.11g WiFi 2.4 GHz (DSSS-OFDM, 48 Mbps, 90pc duty cycle)	WLAN	8.35	± 9.6 %
10582	AAA	IEEE 802.11g WiFi 2.4 GHz (DSSS-OFDM, 54 Mbps, 90pc duty cycle)	WLAN	8.67	± 9.6 %
10583	AAB	IEEE 802.11a/h WiFi 5 GHz (OFDM, 6 Mbps, 90pc duty cycle)	WLAN	8.59	± 9.6 %
10584	AAB	IEEE 802.11a/h WiFi 5 GHz (OFDM, 9 Mbps, 90pc duty cycle)	WLAN	8.60	± 9.6 %
10585	AAB	IEEE 802.11a/h WiFi 5 GHz (OFDM, 12 Mbps, 90pc duty cycle)	WLAN	8.70	± 9.6 %
10586	AAB	IEEE 802.11a/h WiFi 5 GHz (OFDM, 18 Mbps, 90pc duty cycle)	WLAN	8.49	± 9.6 %

10587	AAB	IEEE 802.11a/h WiFi 5 GHz (OFDM, 24 Mbps, 90pc duty cycle)	WLAN	8.36	± 9.6 %
10588	AAB	IEEE 802.11a/h WiFi 5 GHz (OFDM, 36 Mbps, 90pc duty cycle)	WLAN	8.76	± 9.6 %
10589	AAB	IEEE 802.11a/h WiFi 5 GHz (OFDM, 48 Mbps, 90pc duty cycle)	WLAN	8.35	± 9.6 %
10590	AAB	IEEE 802.11a/h WiFi 5 GHz (OFDM, 54 Mbps, 90pc duty cycle)	WLAN	8.67	± 9.6 %
10591	AAB	IEEE 802.11n (HT Mixed, 20MHz, MCS0, 90pc duty cycle)	WLAN	8.63	± 9.6 %
10592	AAB	IEEE 802.11n (HT Mixed, 20MHz, MCS1, 90pc duty cycle)	WLAN	8.79	± 9.6 %
10593	AAB	IEEE 802.11n (HT Mixed, 20MHz, MCS2, 90pc duty cycle)	WLAN	8.64	± 9.6 %
10594	AAB	IEEE 802.11n (HT Mixed, 20MHz, MCS3, 90pc duty cycle)	WLAN	8.74	± 9.6 %
10595	AAB	IEEE 802.11n (HT Mixed, 20MHz, MCS4, 90pc duty cycle)	WLAN	8.74	± 9.6 %
10596	AAB	IEEE 802.11n (HT Mixed, 20MHz, MCS5, 90pc duty cycle)	WLAN	8.71	± 9.6 %
10597	AAB	IEEE 802.11n (HT Mixed, 20MHz, MCS6, 90pc duty cycle)	WLAN	8.72	± 9.6 %
10598	AAB	IEEE 802.11n (HT Mixed, 20MHz, MCS7, 90pc duty cycle)	WLAN	8.50	± 9.6 %
10599	AAB	IEEE 802.11n (HT Mixed, 40MHz, MCS0, 90pc duty cycle)	WLAN	8.79	± 9.6 %
10600	AAB	IEEE 802.11n (HT Mixed, 40MHz, MCS1, 90pc duty cycle)	WLAN	8.88	± 9.6 %
10601	AAB	IEEE 802.11n (HT Mixed, 40MHz, MCS2, 90pc duty cycle)	WLAN	8.82	± 9.6 %
10602	AAB	IEEE 802.11n (HT Mixed, 40MHz, MCS3, 90pc duty cycle)	WLAN	8.94	± 9.6 %
10603	AAB	IEEE 802.11n (HT Mixed, 40MHz, MCS4, 90pc duty cycle)	WLAN	9.03	± 9.6 %
10604	AAB	IEEE 802.11n (HT Mixed, 40MHz, MCS5, 90pc duty cycle)	WLAN	8.76	± 9.6 %
10605	AAB	IEEE 802.11n (HT Mixed, 40MHz, MCS6, 90pc duty cycle)	WLAN	8.97	± 9.6 %
10606	AAB	IEEE 802.11n (HT Mixed, 40MHz, MCS7, 90pc duty cycle)	WLAN	8.82	± 9.6 %
10607	AAB	IEEE 802.11ac WiFi (20MHz, MCS0, 90pc duty cycle)	WLAN	8.64	± 9.6 %
10608	AAB	IEEE 802.11ac WiFi (20MHz, MCS1, 90pc duty cycle)	WLAN	8.77	± 9.6 %
10609	AAB	IEEE 802.11ac WiFi (20MHz, MCS2, 90pc duty cycle)	WLAN	8.57	± 9.6 %
10610	AAB	IEEE 802.11ac WiFi (20MHz, MCS3, 90pc duty cycle)	WLAN	8.78	± 9.6 %
10611	AAB	IEEE 802.11ac WiFi (20MHz, MCS4, 90pc duty cycle)	WLAN	8.70	± 9.6 %
10612	AAB	IEEE 802.11ac WiFi (20MHz, MCS5, 90pc duty cycle)	WLAN	8.77	± 9.6 %
10613	AAB	IEEE 802.11ac WiFi (20MHz, MCS6, 90pc duty cycle)	WLAN	8.94	± 9.6 %
10614	AAB	IEEE 802.11ac WiFi (20MHz, MCS7, 90pc duty cycle)	WLAN	8.59	± 9.6 %
10615	AAB	IEEE 802.11ac WiFi (20MHz, MCS8, 90pc duty cycle)	WLAN	8.82	± 9.6 %
10616	AAB	IEEE 802.11ac WiFi (40MHz, MCS0, 90pc duty cycle)	WLAN	8.82	± 9.6 %
10617	AAB	IEEE 802.11ac WiFi (40MHz, MCS1, 90pc duty cycle)	WLAN	8.81	± 9.6 %
10618	AAB	IEEE 802.11ac WiFi (40MHz, MCS2, 90pc duty cycle)	WLAN	8.58	± 9.6 %
10619	AAB	IEEE 802.11ac WiFi (40MHz, MCS3, 90pc duty cycle)	WLAN	8.86	± 9.6 %
10620	AAB	IEEE 802.11ac WiFi (40MHz, MCS4, 90pc duty cycle)	WLAN	8.87	± 9.6 %
10621	AAB	IEEE 802.11ac WiFi (40MHz, MCS5, 90pc duty cycle)	WLAN	8.77	± 9.6 %
10622	AAB	IEEE 802.11ac WiFi (40MHz, MCS6, 90pc duty cycle)	WLAN	8.68	± 9.6 %
10623	AAB	IEEE 802.11ac WiFi (40MHz, MCS7, 90pc duty cycle)	WLAN	8.82	± 9.6 %
10624	AAB	IEEE 802.11ac WiFi (40MHz, MCS8, 90pc duty cycle)	WLAN	8.96	± 9.6 %
10625	AAB	IEEE 802.11ac WiFi (40MHz, MCS9, 90pc duty cycle)	WLAN	8.96	± 9.6 %
10626	AAB	IEEE 802.11ac WiFi (80MHz, MCS0, 90pc duty cycle)	WLAN	8.83	± 9.6 %
10627	AAB	IEEE 802.11ac WiFi (80MHz, MCS1, 90pc duty cycle)	WLAN	8.88	± 9.6 %
10628	AAB	IEEE 802.11ac WiFi (80MHz, MCS2, 90pc duty cycle)	WLAN	8.71	± 9.6 %
10629	AAB	IEEE 802.11ac WiFi (80MHz, MCS3, 90pc duty cycle)	WLAN	8.85	± 9.6 %
10630	AAB	IEEE 802.11ac WiFi (80MHz, MCS4, 90pc duty cycle)	WLAN	8.72	± 9.6 %
10631	AAB	IEEE 802.11ac WiFi (80MHz, MCS5, 90pc duty cycle)	WLAN	8.81	± 9.6 %
10632	AAB	IEEE 802.11ac WiFi (80MHz, MCS6, 90pc duty cycle)	WLAN	8.74	± 9.6 %
10633	AAB	IEEE 802.11ac WiFi (80MHz, MCS7, 90pc duty cycle)	WLAN	8.83	± 9.6 %
10634	AAB	IEEE 802.11ac WiFi (80MHz, MCS8, 90pc duty cycle)	WLAN	8.80	± 9.6 %
10635	AAB	IEEE 802.11ac WiFi (80MHz, MCS9, 90pc duty cycle)	WLAN	8.81	± 9.6 %
10636	AAC	IEEE 802.11ac WiFi (160MHz, MCS0, 90pc duty cycle)	WLAN	8.83	± 9.6 %
10637	AAC	IEEE 802.11ac WiFi (160MHz, MCS1, 90pc duty cycle)	WLAN	8.79	± 9.6 %
10638	AAC	IEEE 802.11ac WiFi (160MHz, MCS2, 90pc duty cycle)	WLAN	8.86	± 9.6 %
10639	AAC	IEEE 802.11ac WiFi (160MHz, MCS3, 90pc duty cycle)	WLAN	8.85	± 9.6 %
10640	AAC	IEEE 802.11ac WiFi (160MHz, MCS4, 90pc duty cycle)	WLAN	8.98	± 9.6 %
10641	AAC	IEEE 802.11ac WiFi (160MHz, MCS5, 90pc duty cycle)	WLAN	9.06	± 9.6 %
10642	AAC	IEEE 802.11ac WiFi (160MHz, MCS6, 90pc duty cycle)	WLAN	9.06	± 9.6 %
10643	AAC	IEEE 802.11ac WiFi (160MHz, MCS7, 90pc duty cycle)	WLAN	8.89	± 9.6 %
10644	AAC	IEEE 802.11ac WiFi (160MHz, MCS8, 90pc duty cycle)	WLAN	9.05	± 9.6 %
10645	AAC	IEEE 802.11ac WiFi (160MHz, MCS9, 90pc duty cycle)	WLAN	9.11	± 9.6 %
10646	AAG	LTE-TDD (SC-FDMA, 1 RB, 5 MHz, QPSK, UL Subframe=2,7)	LTE-TDD	11.96	± 9.6 %
10647	AAF	LTE-TDD (SC-FDMA, 1 RB, 20 MHz, QPSK, UL Subframe=2,7)	LTE-TDD	11.96	± 9.6 %
10648	AAA	CDMA2000 (1x Advanced)	CDMA2000	3.45	± 9.6 %
10652	AAE	LTE-TDD (OFDMA, 5 MHz, E-TM 3.1, Clipping 44%)	LTE-TDD	6.91	± 9.6 %
10653	AAE	LTE-TDD (OFDMA, 10 MHz, E-TM 3.1, Clipping 44%)	LTE-TDD	7.42	± 9.6 %

10654	AAD	LTE-TDD (OFDMA, 15 MHz, E-TM 3.1, Clipping 44%)	LTE-TDD	6.96	± 9.6 %
10655	AAE	LTE-TDD (OFDMA, 20 MHz, E-TM 3.1, Clipping 44%)	LTE-TDD	7.21	± 9.6 %
10658	AAA	Pulse Waveform (200Hz, 10%)	Test	10.00	± 9.6 %
10659	AAA	Pulse Waveform (200Hz, 20%)	Test	6.99	± 9.6 %
10660	AAA	Pulse Waveform (200Hz, 40%)	Test	3.98	± 9.6 %
10661	AAA	Pulse Waveform (200Hz, 60%)	Test	2.22	± 9.6 %
10662	AAA	Pulse Waveform (200Hz, 80%)	Test	0.97	± 9.6 %
10670	AAA	Bluetooth Low Energy	Bluetooth	2.19	± 9.6 %
10671	AAA	IEEE 802.11ax (20MHz, MCS0, 90pc duty cycle)	WLAN	9.09	± 9.6 %
10672	AAA	IEEE 802.11ax (20MHz, MCS1, 90pc duty cycle)	WLAN	8.57	± 9.6 %
10673	AAA	IEEE 802.11ax (20MHz, MCS2, 90pc duty cycle)	WLAN	8.78	± 9.6 %
10674	AAA	IEEE 802.11ax (20MHz, MCS3, 90pc duty cycle)	WLAN	8.74	± 9.6 %
10675	AAA	IEEE 802.11ax (20MHz, MCS4, 90pc duty cycle)	WLAN	8.90	± 9.6 %
10676	AAA	IEEE 802.11ax (20MHz, MCS5, 90pc duty cycle)	WLAN	8.77	± 9.6 %
10677	AAA	IEEE 802.11ax (20MHz, MCS6, 90pc duty cycle)	WLAN	8.73	± 9.6 %
10678	AAA	IEEE 802.11ax (20MHz, MCS7, 90pc duty cycle)	WLAN	8.78	± 9.6 %
10679	AAA	IEEE 802.11ax (20MHz, MCS8, 90pc duty cycle)	WLAN	8.89	± 9.6 %
10680	AAA	IEEE 802.11ax (20MHz, MCS9, 90pc duty cycle)	WLAN	8.80	± 9.6 %
10681	AAA	IEEE 802.11ax (20MHz, MCS10, 90pc duty cycle)	WLAN	8.62	± 9.6 %
10682	AAA	IEEE 802.11ax (20MHz, MCS11, 90pc duty cycle)	WLAN	8.83	± 9.6 %
10683	AAA	IEEE 802.11ax (20MHz, MCS0, 99pc duty cycle)	WLAN	8.42	± 9.6 %
10684	AAA	IEEE 802.11ax (20MHz, MCS1, 99pc duty cycle)	WLAN	8.26	± 9.6 %
10685	AAA	IEEE 802.11ax (20MHz, MCS2, 99pc duty cycle)	WLAN	8.33	± 9.6 %
10686	AAA	IEEE 802.11ax (20MHz, MCS3, 99pc duty cycle)	WLAN	8.28	± 9.6 %
10687	AAA	IEEE 802.11ax (20MHz, MCS4, 99pc duty cycle)	WLAN	8.45	± 9.6 %
10688	AAA	IEEE 802.11ax (20MHz, MCS5, 99pc duty cycle)	WLAN	8.29	± 9.6 %
10689	AAA	IEEE 802.11ax (20MHz, MCS6, 99pc duty cycle)	WLAN	8.55	± 9.6 %
10690	AAA	IEEE 802.11ax (20MHz, MCS7, 99pc duty cycle)	WLAN	8.29	± 9.6 %
10691	AAA	IEEE 802.11ax (20MHz, MCS8, 99pc duty cycle)	WLAN	8.25	± 9.6 %
10692	AAA	IEEE 802.11ax (20MHz, MCS9, 99pc duty cycle)	WLAN	8.29	± 9.6 %
10693	AAA	IEEE 802.11ax (20MHz, MCS10, 99pc duty cycle)	WLAN	8.25	± 9.6 %
10694	AAA	IEEE 802.11ax (20MHz, MCS11, 99pc duty cycle)	WLAN	8.57	± 9.6 %
10695	AAA	IEEE 802.11ax (40MHz, MCS0, 90pc duty cycle)	WLAN	8.78	± 9.6 %
10696	AAA	IEEE 802.11ax (40MHz, MCS1, 90pc duty cycle)	WLAN	8.91	± 9.6 %
10697	AAA	IEEE 802.11ax (40MHz, MCS2, 90pc duty cycle)	WLAN	8.61	± 9.6 %
10698	AAA	IEEE 802.11ax (40MHz, MCS3, 90pc duty cycle)	WLAN	8.89	± 9.6 %
10699	AAA	IEEE 802.11ax (40MHz, MCS4, 90pc duty cycle)	WLAN	8.82	± 9.6 %
10700	AAA	IEEE 802.11ax (40MHz, MCS5, 90pc duty cycle)	WLAN	8.73	± 9.6 %
10701	AAA	IEEE 802.11ax (40MHz, MCS6, 90pc duty cycle)	WLAN	8.86	± 9.6 %
10702	AAA	IEEE 802.11ax (40MHz, MCS7, 90pc duty cycle)	WLAN	8.70	± 9.6 %
10703	AAA	IEEE 802.11ax (40MHz, MCS8, 90pc duty cycle)	WLAN	8.82	± 9.6 %
10704	AAA	IEEE 802.11ax (40MHz, MCS9, 90pc duty cycle)	WLAN	8.56	± 9.6 %
10705	AAA	IEEE 802.11ax (40MHz, MCS10, 90pc duty cycle)	WLAN	8.69	± 9.6 %
10706	AAA	IEEE 802.11ax (40MHz, MCS11, 90pc duty cycle)	WLAN	8.66	± 9.6 %
10707	AAA	IEEE 802.11ax (40MHz, MCS0, 99pc duty cycle)	WLAN	8.32	± 9.6 %
10708	AAA	IEEE 802.11ax (40MHz, MCS1, 99pc duty cycle)	WLAN	8.55	± 9.6 %
10709	AAA	IEEE 802.11ax (40MHz, MCS2, 99pc duty cycle)	WLAN	8.33	± 9.6 %
10710	AAA	IEEE 802.11ax (40MHz, MCS3, 99pc duty cycle)	WLAN	8.29	± 9.6 %
10711	AAA	IEEE 802.11ax (40MHz, MCS4, 99pc duty cycle)	WLAN	8.39	± 9.6 %
10712	AAA	IEEE 802.11ax (40MHz, MCS5, 99pc duty cycle)	WLAN	8.67	± 9.6 %
10713	AAA	IEEE 802.11ax (40MHz, MCS6, 99pc duty cycle)	WLAN	8.33	± 9.6 %
10714	AAA	IEEE 802.11ax (40MHz, MCS7, 99pc duty cycle)	WLAN	8.26	± 9.6 %
10715	AAA	IEEE 802.11ax (40MHz, MCS8, 99pc duty cycle)	WLAN	8.45	± 9.6 %
10716	AAA	IEEE 802.11ax (40MHz, MCS9, 99pc duty cycle)	WLAN	8.30	± 9.6 %
10717	AAA	IEEE 802.11ax (40MHz, MCS10, 99pc duty cycle)	WLAN	8.48	± 9.6 %
10718	AAA	IEEE 802.11ax (40MHz, MCS11, 99pc duty cycle)	WLAN	8.24	± 9.6 %
10719	AAA	IEEE 802.11ax (80MHz, MCS0, 90pc duty cycle)	WLAN	8.81	± 9.6 %
10720	AAA	IEEE 802.11ax (80MHz, MCS1, 90pc duty cycle)	WLAN	8.87	± 9.6 %
10721	AAA	IEEE 802.11ax (80MHz, MCS2, 90pc duty cycle)	WLAN	8.76	± 9.6 %
10722	AAA	IEEE 802.11ax (80MHz, MCS3, 90pc duty cycle)	WLAN	8.55	± 9.6 %
10723	AAA	IEEE 802.11ax (80MHz, MCS4, 90pc duty cycle)	WLAN	8.70	± 9.6 %
10724	AAA	IEEE 802.11ax (80MHz, MCS5, 90pc duty cycle)	WLAN	8.90	± 9.6 %
10725	AAA	IEEE 802.11ax (80MHz, MCS6, 90pc duty cycle)	WLAN	8.74	± 9.6 %
10726	AAA	IEEE 802.11ax (80MHz, MCS7, 90pc duty cycle)	WLAN	8.72	± 9.6 %

10727	AAA	IEEE 802.11ax (80MHz, MCS8, 90pc duty cycle)	WLAN	8.66	± 9.6 %
10728	AAA	IEEE 802.11ax (80MHz, MCS9, 90pc duty cycle)	WLAN	8.65	± 9.6 %
10729	AAA	IEEE 802.11ax (80MHz, MCS10, 90pc duty cycle)	WLAN	8.64	± 9.6 %
10730	AAA	IEEE 802.11ax (80MHz, MCS11, 90pc duty cycle)	WLAN	8.67	± 9.6 %
10731	AAA	IEEE 802.11ax (80MHz, MCS0, 99pc duty cycle)	WLAN	8.42	± 9.6 %
10732	AAA	IEEE 802.11ax (80MHz, MCS1, 99pc duty cycle)	WLAN	8.46	± 9.6 %
10733	AAA	IEEE 802.11ax (80MHz, MCS2, 99pc duty cycle)	WLAN	8.40	± 9.6 %
10734	AAA	IEEE 802.11ax (80MHz, MCS3, 99pc duty cycle)	WLAN	8.25	± 9.6 %
10735	AAA	IEEE 802.11ax (80MHz, MCS4, 99pc duty cycle)	WLAN	8.33	± 9.6 %
10736	AAA	IEEE 802.11ax (80MHz, MCS5, 99pc duty cycle)	WLAN	8.27	± 9.6 %
10737	AAA	IEEE 802.11ax (80MHz, MCS6, 99pc duty cycle)	WLAN	8.36	± 9.6 %
10738	AAA	IEEE 802.11ax (80MHz, MCS7, 99pc duty cycle)	WLAN	8.42	± 9.6 %
10739	AAA	IEEE 802.11ax (80MHz, MCS8, 99pc duty cycle)	WLAN	8.29	± 9.6 %
10740	AAA	IEEE 802.11ax (80MHz, MCS9, 99pc duty cycle)	WLAN	8.48	± 9.6 %
10741	AAA	IEEE 802.11ax (80MHz, MCS10, 99pc duty cycle)	WLAN	8.40	± 9.6 %
10742	AAA	IEEE 802.11ax (80MHz, MCS11, 99pc duty cycle)	WLAN	8.43	± 9.6 %
10743	AAA	IEEE 802.11ax (160MHz, MCS9, 90pc duty cycle)	WLAN	8.94	± 9.6 %
10744	AAA	IEEE 802.11ax (160MHz, MCS1, 90pc duty cycle)	WLAN	9.16	± 9.6 %
10745	AAA	IEEE 802.11ax (160MHz, MCS2, 90pc duty cycle)	WLAN	8.93	± 9.6 %
10746	AAA	IEEE 802.11ax (160MHz, MCS3, 90pc duty cycle)	WLAN	9.11	± 9.6 %
10747	AAA	IEEE 802.11ax (160MHz, MCS4, 90pc duty cycle)	WLAN	9.04	± 9.6 %
10748	AAA	IEEE 802.11ax (160MHz, MCS5, 90pc duty cycle)	WLAN	8.93	± 9.6 %
10749	AAA	IEEE 802.11ax (160MHz, MCS6, 90pc duty cycle)	WLAN	8.90	± 9.6 %
10750	AAA	IEEE 802.11ax (160MHz, MCS7, 90pc duty cycle)	WLAN	8.79	± 9.6 %
10751	AAA	IEEE 802.11ax (160MHz, MCS8, 90pc duty cycle)	WLAN	8.82	± 9.6 %
10752	AAA	IEEE 802.11ax (160MHz, MCS9, 90pc duty cycle)	WLAN	8.81	± 9.6 %
10753	AAA	IEEE 802.11ax (160MHz, MCS10, 90pc duty cycle)	WLAN	9.00	± 9.6 %
10754	AAA	IEEE 802.11ax (160MHz, MCS11, 90pc duty cycle)	WLAN	8.94	± 9.6 %
10755	AAA	IEEE 802.11ax (160MHz, MCS0, 99pc duty cycle)	WLAN	8.64	± 9.6 %
10756	AAA	IEEE 802.11ax (160MHz, MCS1, 99pc duty cycle)	WLAN	8.77	± 9.6 %
10757	AAA	IEEE 802.11ax (160MHz, MCS2, 99pc duty cycle)	WLAN	8.77	± 9.6 %
10758	AAA	IEEE 802.11ax (160MHz, MCS3, 99pc duty cycle)	WLAN	8.69	± 9.6 %
10759	AAA	IEEE 802.11ax (160MHz, MCS4, 99pc duty cycle)	WLAN	8.58	± 9.6 %
10760	AAA	IEEE 802.11ax (160MHz, MCS5, 99pc duty cycle)	WLAN	8.49	± 9.6 %
10761	AAA	IEEE 802.11ax (160MHz, MCS6, 99pc duty cycle)	WLAN	8.58	± 9.6 %
10762	AAA	IEEE 802.11ax (160MHz, MCS7, 99pc duty cycle)	WLAN	8.49	± 9.6 %
10763	AAA	IEEE 802.11ax (160MHz, MCS8, 99pc duty cycle)	WLAN	8.53	± 9.6 %
10764	AAA	IEEE 802.11ax (160MHz, MCS9, 99pc duty cycle)	WLAN	8.54	± 9.6 %
10765	AAA	IEEE 802.11ax (160MHz, MCS10, 99pc duty cycle)	WLAN	8.54	± 9.6 %
10766	AAA	IEEE 802.11ax (160MHz, MCS11, 99pc duty cycle)	WLAN	8.51	± 9.6 %
10767	AAB	5G NR (CP-OFDM, 1 RB, 5 MHz, QPSK, 15 kHz)	5G NR FR1 TDD	7.99	± 9.6 %
10768	AAB	5G NR (CP-OFDM, 1 RB, 10 MHz, QPSK, 15 kHz)	5G NR FR1 TDD	8.01	± 9.6 %
10769	AAB	5G NR (CP-OFDM, 1 RB, 15 MHz, QPSK, 15 kHz)	5G NR FR1 TDD	8.01	± 9.6 %
10770	AAB	5G NR (CP-OFDM, 1 RB, 20 MHz, QPSK, 15 kHz)	5G NR FR1 TDD	8.02	± 9.6 %
10771	AAB	5G NR (CP-OFDM, 1 RB, 25 MHz, QPSK, 15 kHz)	5G NR FR1 TDD	8.02	± 9.6 %
10772	AAB	5G NR (CP-OFDM, 1 RB, 30 MHz, QPSK, 15 kHz)	5G NR FR1 TDD	8.23	± 9.6 %
10773	AAB	5G NR (CP-OFDM, 1 RB, 40 MHz, QPSK, 15 kHz)	5G NR FR1 TDD	8.03	± 9.6 %
10774	AAB	5G NR (CP-OFDM, 1 RB, 50 MHz, QPSK, 15 kHz)	5G NR FR1 TDD	8.02	± 9.6 %
10776	AAB	5G NR (CP-OFDM, 50% RB, 10 MHz, QPSK, 15 kHz)	5G NR FR1 TDD	8.30	± 9.6 %
10778	AAB	5G NR (CP-OFDM, 50% RB, 20 MHz, QPSK, 15 kHz)	5G NR FR1 TDD	8.34	± 9.6 %
10780	AAB	5G NR (CP-OFDM, 50% RB, 30 MHz, QPSK, 15 kHz)	5G NR FR1 TDD	8.38	± 9.6 %
10781	AAB	5G NR (CP-OFDM, 50% RB, 40 MHz, QPSK, 15 kHz)	5G NR FR1 TDD	8.38	± 9.6 %

10782	AAB	5G NR (CP-OFDM, 50% RB, 50 MHz, QPSK, 15 kHz)	5G NR FR1 TDD	8.43	± 9.6 %
10783	AAB	5G NR (CP-OFDM, 100% RB, 5 MHz, QPSK, 15 kHz)	5G NR FR1 TDD	8.31	± 9.6 %
10784	AAB	5G NR (CP-OFDM, 100% RB, 10 MHz, QPSK, 15 kHz)	5G NR FR1 TDD	8.29	± 9.6 %
10785	AAB	5G NR (CP-OFDM, 100% RB, 15 MHz, QPSK, 15 kHz)	5G NR FR1 TDD	8.40	± 9.6 %
10786	AAB	5G NR (CP-OFDM, 100% RB, 20 MHz, QPSK, 15 kHz)	5G NR FR1 TDD	8.35	± 9.6 %
10787	AAB	5G NR (CP-OFDM, 100% RB, 25 MHz, QPSK, 15 kHz)	5G NR FR1 TDD	8.44	± 9.6 %
10788	AAB	5G NR (CP-OFDM, 100% RB, 30 MHz, QPSK, 15 kHz)	5G NR FR1 TDD	8.39	± 9.6 %
10789	AAB	5G NR (CP-OFDM, 100% RB, 40 MHz, QPSK, 15 kHz)	5G NR FR1 TDD	8.37	± 9.6 %
10790	AAB	5G NR (CP-OFDM, 100% RB, 50 MHz, QPSK, 15 kHz)	5G NR FR1 TDD	8.39	± 9.6 %
10791	AAB	5G NR (CP-OFDM, 1 RB, 5 MHz, QPSK, 30 kHz)	5G NR FR1 TDD	7.83	± 9.6 %
10792	AAB	5G NR (CP-OFDM, 1 RB, 10 MHz, QPSK, 30 kHz)	5G NR FR1 TDD	7.92	± 9.6 %
10793	AAB	5G NR (CP-OFDM, 1 RB, 15 MHz, QPSK, 30 kHz)	5G NR FR1 TDD	7.95	± 9.6 %
10794	AAB	5G NR (CP-OFDM, 1 RB, 20 MHz, QPSK, 30 kHz)	5G NR FR1 TDD	7.82	± 9.6 %
10795	AAB	5G NR (CP-OFDM, 1 RB, 25 MHz, QPSK, 30 kHz)	5G NR FR1 TDD	7.84	± 9.6 %
10796	AAB	5G NR (CP-OFDM, 1 RB, 30 MHz, QPSK, 30 kHz)	5G NR FR1 TDD	7.82	± 9.6 %
10797	AAB	5G NR (CP-OFDM, 1 RB, 40 MHz, QPSK, 30 kHz)	5G NR FR1 TDD	8.01	± 9.6 %
10798	AAB	5G NR (CP-OFDM, 1 RB, 50 MHz, QPSK, 30 kHz)	5G NR FR1 TDD	7.89	± 9.6 %
10799	AAB	5G NR (CP-OFDM, 1 RB, 60 MHz, QPSK, 30 kHz)	5G NR FR1 TDD	7.93	± 9.6 %
10801	AAB	5G NR (CP-OFDM, 1 RB, 80 MHz, QPSK, 30 kHz)	5G NR FR1 TDD	7.89	± 9.6 %
10802	AAB	5G NR (CP-OFDM, 1 RB, 90 MHz, QPSK, 30 kHz)	5G NR FR1 TDD	7.87	± 9.6 %
10803	AAB	5G NR (CP-OFDM, 1 RB, 100 MHz, QPSK, 30 kHz)	5G NR FR1 TDD	7.93	± 9.6 %
10805	AAB	5G NR (CP-OFDM, 50% RB, 10 MHz, QPSK, 30 kHz)	5G NR FR1 TDD	8.34	± 9.6 %
10806	AAB	5G NR (CP-OFDM, 50% RB, 15 MHz, QPSK, 30 kHz)	5G NR FR1 TDD	8.37	± 9.6 %
10809	AAB	5G NR (CP-OFDM, 50% RB, 30 MHz, QPSK, 30 kHz)	5G NR FR1 TDD	8.34	± 9.6 %
10810	AAB	5G NR (CP-OFDM, 50% RB, 40 MHz, QPSK, 30 kHz)	5G NR FR1 TDD	8.34	± 9.6 %
10812	AAB	5G NR (CP-OFDM, 50% RB, 60 MHz, QPSK, 30 kHz)	5G NR FR1 TDD	8.35	± 9.6 %
10817	AAB	5G NR (CP-OFDM, 100% RB, 5 MHz, QPSK, 30 kHz)	5G NR FR1 TDD	8.35	± 9.6 %
10818	AAB	5G NR (CP-OFDM, 100% RB, 10 MHz, QPSK, 30 kHz)	5G NR FR1 TDD	8.34	± 9.6 %
10819	AAB	5G NR (CP-OFDM, 100% RB, 15 MHz, QPSK, 30 kHz)	5G NR FR1 TDD	8.33	± 9.6 %
10820	AAB	5G NR (CP-OFDM, 100% RB, 20 MHz, QPSK, 30 kHz)	5G NR FR1 TDD	8.30	± 9.6 %
10821	AAB	5G NR (CP-OFDM, 100% RB, 25 MHz, QPSK, 30 kHz)	5G NR FR1 TDD	8.41	± 9.6 %
10822	AAB	5G NR (CP-OFDM, 100% RB, 30 MHz, QPSK, 30 kHz)	5G NR FR1 TDD	8.41	± 9.6 %
10823	AAB	5G NR (CP-OFDM, 100% RB, 40 MHz, QPSK, 30 kHz)	5G NR FR1 TDD	8.36	± 9.6 %

10824	AAB	5G NR (CP-OFDM, 100% RB, 50 MHz, QPSK, 30 kHz)	5G NR FR1 TDD	8.39	± 9.6 %
10825	AAB	5G NR (CP-OFDM, 100% RB, 60 MHz, QPSK, 30 kHz)	5G NR FR1 TDD	8.41	± 9.6 %
10827	AAB	5G NR (CP-OFDM, 100% RB, 80 MHz, QPSK, 30 kHz)	5G NR FR1 TDD	8.42	± 9.6 %
10828	AAB	5G NR (CP-OFDM, 100% RB, 90 MHz, QPSK, 30 kHz)	5G NR FR1 TDD	8.43	± 9.6 %
10829	AAB	5G NR (CP-OFDM, 100% RB, 100 MHz, QPSK, 30 kHz)	5G NR FR1 TDD	8.40	± 9.6 %
10830	AAB	5G NR (CP-OFDM, 1 RB, 10 MHz, QPSK, 60 kHz)	5G NR FR1 TDD	7.63	± 9.6 %
10831	AAB	5G NR (CP-OFDM, 1 RB, 15 MHz, QPSK, 60 kHz)	5G NR FR1 TDD	7.73	± 9.6 %
10832	AAB	5G NR (CP-OFDM, 1 RB, 20 MHz, QPSK, 60 kHz)	5G NR FR1 TDD	7.74	± 9.6 %
10833	AAB	5G NR (CP-OFDM, 1 RB, 25 MHz, QPSK, 60 kHz)	5G NR FR1 TDD	7.70	± 9.6 %
10834	AAB	5G NR (CP-OFDM, 1 RB, 30 MHz, QPSK, 60 kHz)	5G NR FR1 TDD	7.75	± 9.6 %
10835	AAB	5G NR (CP-OFDM, 1 RB, 40 MHz, QPSK, 60 kHz)	5G NR FR1 TDD	7.70	± 9.6 %
10836	AAB	5G NR (CP-OFDM, 1 RB, 50 MHz, QPSK, 60 kHz)	5G NR FR1 TDD	7.66	± 9.6 %
10837	AAB	5G NR (CP-OFDM, 1 RB, 60 MHz, QPSK, 60 kHz)	5G NR FR1 TDD	7.68	± 9.6 %
10839	AAB	5G NR (CP-OFDM, 1 RB, 80 MHz, QPSK, 60 kHz)	5G NR FR1 TDD	7.70	± 9.6 %
10840	AAB	5G NR (CP-OFDM, 1 RB, 90 MHz, QPSK, 60 kHz)	5G NR FR1 TDD	7.67	± 9.6 %
10841	AAB	5G NR (CP-OFDM, 1 RB, 100 MHz, QPSK, 60 kHz)	5G NR FR1 TDD	7.71	± 9.6 %
10843	AAB	5G NR (CP-OFDM, 50% RB, 15 MHz, QPSK, 60 kHz)	5G NR FR1 TDD	8.49	± 9.6 %
10844	AAB	5G NR (CP-OFDM, 50% RB, 20 MHz, QPSK, 60 kHz)	5G NR FR1 TDD	8.34	± 9.6 %
10846	AAB	5G NR (CP-OFDM, 50% RB, 30 MHz, QPSK, 60 kHz)	5G NR FR1 TDD	8.41	± 9.6 %
10854	AAB	5G NR (CP-OFDM, 100% RB, 10 MHz, QPSK, 60 kHz)	5G NR FR1 TDD	8.34	± 9.6 %
10855	AAB	5G NR (CP-OFDM, 100% RB, 15 MHz, QPSK, 60 kHz)	5G NR FR1 TDD	8.36	± 9.6 %
10856	AAB	5G NR (CP-OFDM, 100% RB, 20 MHz, QPSK, 60 kHz)	5G NR FR1 TDD	8.37	± 9.6 %
10857	AAB	5G NR (CP-OFDM, 100% RB, 25 MHz, QPSK, 60 kHz)	5G NR FR1 TDD	8.35	± 9.6 %
10858	AAB	5G NR (CP-OFDM, 100% RB, 30 MHz, QPSK, 60 kHz)	5G NR FR1 TDD	8.36	± 9.6 %
10859	AAB	5G NR (CP-OFDM, 100% RB, 40 MHz, QPSK, 60 kHz)	5G NR FR1 TDD	8.34	± 9.6 %
10860	AAB	5G NR (CP-OFDM, 100% RB, 50 MHz, QPSK, 60 kHz)	5G NR FR1 TDD	8.41	± 9.6 %
10861	AAB	5G NR (CP-OFDM, 100% RB, 60 MHz, QPSK, 60 kHz)	5G NR FR1 TDD	8.40	± 9.6 %
10863	AAB	5G NR (CP-OFDM, 100% RB, 80 MHz, QPSK, 60 kHz)	5G NR FR1 TDD	8.41	± 9.6 %
10864	AAB	5G NR (CP-OFDM, 100% RB, 90 MHz, QPSK, 60 kHz)	5G NR FR1 TDD	8.37	± 9.6 %
10865	AAB	5G NR (CP-OFDM, 100% RB, 100 MHz, QPSK, 60 kHz)	5G NR FR1 TDD	8.41	± 9.6 %
10866	AAB	5G NR (DFT-s-OFDM, 1 RB, 100 MHz, QPSK, 30 kHz)	5G NR FR1 TDD	5.68	± 9.6 %
10868	AAB	5G NR (DFT-s-OFDM, 100% RB, 100 MHz, QPSK, 30 kHz)	5G NR FR1 TDD	5.89	± 9.6 %
10869	AAC	5G NR (DFT-s-OFDM, 1 RB, 100 MHz, QPSK, 120 kHz)	5G NR FR2 TDD	5.75	± 9.6 %

10870	AAC	5G NR (DFT-s-OFDM, 100% RB, 100 MHz, QPSK, 120 kHz)	5G NR FR2 TDD	5.86	± 9.6 %
10871	AAC	5G NR (DFT-s-OFDM, 1 RB, 100 MHz, 16QAM, 120 kHz)	5G NR FR2 TDD	5.75	± 9.6 %
10872	AAC	5G NR (DFT-s-OFDM, 100% RB, 100 MHz, 16QAM, 120 kHz)	5G NR FR2 TDD	6.52	± 9.6 %
10873	AAC	5G NR (DFT-s-OFDM, 1 RB, 100 MHz, 64QAM, 120 kHz)	5G NR FR2 TDD	6.61	± 9.6 %
10874	AAC	5G NR (DFT-s-OFDM, 100% RB, 100 MHz, 64QAM, 120 kHz)	5G NR FR2 TDD	6.65	± 9.6 %
10875	AAC	5G NR (CP-OFDM, 1 RB, 100 MHz, QPSK, 120 kHz)	5G NR FR2 TDD	7.78	± 9.6 %
10876	AAC	5G NR (CP-OFDM, 100% RB, 100 MHz, QPSK, 120 kHz)	5G NR FR2 TDD	8.39	± 9.6 %
10877	AAC	5G NR (CP-OFDM, 1 RB, 100 MHz, 16QAM, 120 kHz)	5G NR FR2 TDD	7.95	± 9.6 %
10878	AAC	5G NR (CP-OFDM, 100% RB, 100 MHz, 16QAM, 120 kHz)	5G NR FR2 TDD	8.41	± 9.6 %
10879	AAC	5G NR (CP-OFDM, 1 RB, 100 MHz, 64QAM, 120 kHz)	5G NR FR2 TDD	8.12	± 9.6 %
10880	AAC	5G NR (CP-OFDM, 100% RB, 100 MHz, 64QAM, 120 kHz)	5G NR FR2 TDD	8.38	± 9.6 %
10881	AAC	5G NR (DFT-s-OFDM, 1 RB, 50 MHz, QPSK, 120 kHz)	5G NR FR2 TDD	5.75	± 9.6 %
10882	AAC	5G NR (DFT-s-OFDM, 100% RB, 50 MHz, QPSK, 120 kHz)	5G NR FR2 TDD	5.96	± 9.6 %
10883	AAC	5G NR (DFT-s-OFDM, 1 RB, 50 MHz, 16QAM, 120 kHz)	5G NR FR2 TDD	6.57	± 9.6 %
10884	AAC	5G NR (DFT-s-OFDM, 100% RB, 50 MHz, 16QAM, 120 kHz)	5G NR FR2 TDD	6.53	± 9.6 %
10885	AAC	5G NR (DFT-s-OFDM, 1 RB, 50 MHz, 64QAM, 120 kHz)	5G NR FR2 TDD	6.61	± 9.6 %
10886	AAC	5G NR (DFT-s-OFDM, 100% RB, 50 MHz, 64QAM, 120 kHz)	5G NR FR2 TDD	6.65	± 9.6 %
10887	AAC	5G NR (CP-OFDM, 1 RB, 50 MHz, QPSK, 120 kHz)	5G NR FR2 TDD	7.78	± 9.6 %
10888	AAC	5G NR (CP-OFDM, 100% RB, 50 MHz, QPSK, 120 kHz)	5G NR FR2 TDD	8.35	± 9.6 %
10889	AAC	5G NR (CP-OFDM, 1 RB, 50 MHz, 16QAM, 120 kHz)	5G NR FR2 TDD	8.02	± 9.6 %
10890	AAC	5G NR (CP-OFDM, 100% RB, 50 MHz, 16QAM, 120 kHz)	5G NR FR2 TDD	8.40	± 9.6 %
10891	AAC	5G NR (CP-OFDM, 1 RB, 50 MHz, 64QAM, 120 kHz)	5G NR FR2 TDD	8.13	± 9.6 %
10892	AAC	5G NR (CP-OFDM, 100% RB, 50 MHz, 64QAM, 120 kHz)	5G NR FR2 TDD	8.41	± 9.6 %

^E Uncertainty is determined using the max. deviation from linear response applying rectangular distribution and is expressed for the square of the field value.