



CERTIFICATION TEST REPORT

Report Number. : 12530276-E2V2

Applicant : Samsung Electronics Co., Ltd.
129 Samsung-Ro, Yeongtong-Gu,
Suwon-Si, Gyeonggi-Do, 16677, Korea

Model : SM-T927A

FCC ID : A3LSMT927A

EUT Description : WCDMA/LTE Tablet with BT, DTS/UNII a/b/g/n/ac

Test Standard(s) : FCC 47 CFR PART 15 SUBPART C

Date Of Issue:

January 09, 2019

Prepared by:

UL Verification Services Inc.
47173 Benicia Street
Fremont, CA 94538 U.S.A.
TEL: (510) 771-1000
FAX: (510) 661-0888



NVLAP Lab code: 200065-0

REPORT REVISION HISTORY

Rev.	Issue Date	Revisions	Revised By
V1	12/26/2018	Initial Issue	
V2	1/9/2019	Updated Section 6,8.5.2,10 and Removed GSM technology from the report.	K.Kedida

TABLE OF CONTENTS

REPORT REVISION HISTORY	2
TABLE OF CONTENTS	3
1. ATTESTATION OF TEST RESULTS	5
2. TEST METHODOLOGY	6
3. FACILITIES AND ACCREDITATION	6
4. CALIBRATION AND UNCERTAINTY	7
4.1. <i>MEASURING INSTRUMENT CALIBRATION</i>	<i>7</i>
4.2. <i>SAMPLE CALCULATION</i>	<i>7</i>
4.3. <i>MEASUREMENT UNCERTAINTY.....</i>	<i>7</i>
5. EQUIPMENT UNDER TEST.....	8
5.1. <i>EUT DESCRIPTION.....</i>	<i>8</i>
5.2. <i>MAXIMUM OUTPUT POWER.....</i>	<i>8</i>
5.3. <i>DESCRIPTION OF AVAILABLE ANTENNAS</i>	<i>8</i>
5.4. <i>SOFTWARE AND FIRMWARE.....</i>	<i>8</i>
5.5. <i>WORST-CASE CONFIGURATION AND MODE.....</i>	<i>8</i>
5.6. <i>DESCRIPTION OF TEST SETUP.....</i>	<i>9</i>
6. TEST AND MEASUREMENT EQUIPMENT	12
7. MEASUREMENT METHODS	13
8. ANTENNA PORT TEST RESULTS	14
8.1. <i>ON TIME AND DUTY CYCLE.....</i>	<i>14</i>
8.2. <i>20 dB AND 99% BANDWIDTH</i>	<i>16</i>
8.2.1. <i>BLUETOOTH BASIC DATA RATE GFSK MODULATION</i>	<i>17</i>
8.2.2. <i>BLUETOOTH ENHANCED DATA RATE 8PSK MODULATION.....</i>	<i>18</i>
8.3. <i>HOPPING FREQUENCY SEPARATION</i>	<i>19</i>
8.3.1. <i>BLUETOOTH BASIC DATA RATE GFSK MODULATION</i>	<i>20</i>
8.3.2. <i>BLUETOOTH ENHANCED DATA RATE 8PSK MODULATION.....</i>	<i>21</i>
8.4. <i>NUMBER OF HOPPING CHANNELS.....</i>	<i>22</i>
8.4.1. <i>BLUETOOTH BASIC DATA RATE GFSK MODULATION</i>	<i>23</i>
8.4.2. <i>BLUETOOTH ENHANCED DATA RATE 8PSK MODULATION.....</i>	<i>25</i>
8.5. <i>AVERAGE TIME OF OCCUPANCY.....</i>	<i>27</i>
8.5.1. <i>BLUETOOTH BASIC DATA RATE GFSK MODULATION</i>	<i>28</i>
8.5.2. <i>BLUETOOTH ENHANCED DATA RATE 8PSK MODULATION.....</i>	<i>30</i>
8.6. <i>OUTPUT POWER.....</i>	<i>32</i>
8.6.1. <i>BLUETOOTH BASIC DATA RATE GFSK MODULATION</i>	<i>33</i>
8.6.2. <i>BLUETOOTH ENHANCED DATA RATE 8PSK MODULATION.....</i>	<i>34</i>

8.7.	<i>AVERAGE POWER</i>	35
8.7.1.	BLUETOOTH BASIC DATA RATE GFSK MODULATION	36
8.7.2.	BLUETOOTH ENHANCED DATA RATE 8PSK MODULATION.....	37
8.8.	<i>CONDUCTED SPURIOUS EMISSIONS</i>	38
8.8.1.	BLUETOOTH BASIC DATA RATE GFSK MODULATION	39
8.8.2.	BLUETOOTH ENHANCED DATA RATE 8PSK MODULATION.....	41
9.	RADIATED TEST RESULTS	43
9.1.	<i>TRANSMITTER ABOVE 1 GHz</i>	44
9.1.1.	BLUETOOTH BASIC DATA RATE GFSK MODULATION	44
9.1.2.	BLUETOOTH ENHANCED DATA RATE 8PSK MODULATION.....	54
9.2.	<i>Worst Case Below 30 MHz</i>	64
9.3.	<i>Worst Case Below 1 GHz</i>	65
9.4.	<i>Worst Case 18-26 GHz</i>	67
10.	AC POWER LINE CONDUCTED EMISSIONS	69
10.1.1.	AC Power Line Norm.....	70
11.	SETUP PHOTOS	72

1. ATTESTATION OF TEST RESULTS

COMPANY NAME: Samsung Electronics Co., Ltd.
129 Samsung-Ro, Yeongtong-Gu,
Suwon-Si, Gyeonggi-Do, 16677, Korea

EUT DESCRIPTION: WCDMA/LTE Tablet with BT, DTS/UNII a/b/g/n/ac

MODEL: SM-T927A

SERIAL NUMBER: Conducted: R32K7002LNR, R32K7002LVV
Radiated: R32K7002M2M, R32K7002LCE

DATE TESTED: AUGUST 10 – 28, 2018

APPLICABLE STANDARDS	
STANDARD	TEST RESULTS
CFR 47 Part 15 Subpart C	Compliant

UL Verification Services Inc. tested the above equipment in accordance with the requirements set forth in the above standards. All indications of Pass/Fail in this report are opinions expressed by UL Verification Services Inc. based on interpretations and/or observations of test results. Measurement Uncertainties were not taken into account and are published for informational purposes only. The test results show that the equipment tested is capable of demonstrating compliance with the requirements as documented in this report.

Note: The results documented in this report apply only to the tested sample, under the conditions and modes of operation as described herein. This document may not be altered or revised in any way unless done so by UL Verification Services Inc. and all revisions are duly noted in the revisions section. Any alteration of this document not carried out by UL Verification Services Inc. will constitute fraud and shall nullify the document. This report must not be used by the client to claim product certification, approval, or endorsement by NVLAP, NIST, any agency of the Federal Government, or any agency of the U.S. government.

Approved & Released For
UL Verification Services Inc. By:

Reviewed By:



DAN CORONIA
CONSUMER TECHNOLOGY DIVISION
OPERATIONS LEADER
UL Verification Services Inc.

KIYA EDIDA
CONSUMER TECHNOLOGY DIVISION
SENIOR PROJECT ENGINEER
UL Verification Services Inc.

2. TEST METHODOLOGY

The tests documented in this report were performed in accordance with FCC CFR 47 Part 2, FCC CFR 47 Part 15, and ANSI C63.10-2013.

3. FACILITIES AND ACCREDITATION

The test sites and measurement facilities used to collect data are located at 47173 and 47266 Benicia Street, and 47658 Kato Road, Fremont, California, USA. Line conducted emissions are measured only at the 47173 address. The following table identifies which facilities were utilized for radiated emission measurements documented in this report. Specific facilities are also identified in the test results sections.

47173 Benicia Street	47266 Benicia Street	47658 Kato Rd.
<input checked="" type="checkbox"/> Chamber A (IC:2324B-1)	<input checked="" type="checkbox"/> Chamber D (IC:22541-1)	<input type="checkbox"/> Chamber I (IC: 2324A-5)
<input type="checkbox"/> Chamber B (IC:2324B-2)	<input type="checkbox"/> Chamber E (IC:22541-2)	<input type="checkbox"/> Chamber J (IC: 2324A-6)
<input type="checkbox"/> Chamber C (IC:2324B-3)	<input type="checkbox"/> Chamber F (IC:22541-3)	<input type="checkbox"/> Chamber K (IC: 2324A-1)
	<input type="checkbox"/> Chamber G (IC:22541-4)	<input type="checkbox"/> Chamber L (IC: 2324A-3)
	<input type="checkbox"/> Chamber H (IC:22541-5)	

The above test sites and facilities are covered under FCC Test Firm Registration # 208313. Chambers above are covered under Industry Canada company address and respective code.

UL Verification Services Inc. is accredited by NVLAP, Laboratory Code 200065-0

4. CALIBRATION AND UNCERTAINTY

4.1. MEASURING INSTRUMENT CALIBRATION

The measuring equipment utilized to perform the tests documented in this report has been calibrated in accordance with the manufacturer's recommendations, and is traceable to recognized national standards.

4.2. SAMPLE CALCULATION

Where relevant, the following sample calculation is provided:

$$\begin{aligned} \text{Field Strength (dBuV/m)} &= \text{Measured Voltage (dBuV)} + \text{Antenna Factor (dB/m)} + \\ &\text{Cable Loss (dB)} - \text{Preamp Gain (dB)} \\ 36.5 \text{ dBuV} + 18.7 \text{ dB/m} + 0.6 \text{ dB} - 26.9 \text{ dB} &= 28.9 \text{ dBuV/m} \end{aligned}$$

4.3. MEASUREMENT UNCERTAINTY

Where relevant, the following measurement uncertainty levels have been estimated for tests performed on the apparatus:

PARAMETER	UNCERTAINTY
Worst Case Conducted Disturbance, 9KHz to 0.15 MHz	3.84 dB
Worst Case Conducted Disturbance, 0.15 to 30 MHz	3.65 dB
Worst Case Radiated Disturbance, 9KHz to 30 MHz	3.15 dB
Worst Case Radiated Disturbance, 30 to 1000 MHz	5.36 dB
Worst Case Radiated Disturbance, 1000 to 18000 MHz	4.32 dB
Worst Case Radiated Disturbance, 18000 to 26000 MHz	4.45 dB
Worst Case Radiated Disturbance, 26000 to 40000 MHz	5.24 dB

Uncertainty figures are valid to a confidence level of 95%.

5. EQUIPMENT UNDER TEST

5.1. EUT DESCRIPTION

The EUT is a WCDMA/LTE Tablet with BT, DTS/UNII a/b/g/n/ac.

5.2. MAXIMUM OUTPUT POWER

The transmitter has a maximum peak conducted output power as follows:

Frequency Range (MHz)	Mode	Output Power (dBm)	Output Power (mW)
2402 - 2480	Basic GFSK	8.02	6.34
2402 - 2480	Enhanced 8PSK	8.24	6.67

Note: GFSK, DQPSK, 8PSK average Power are all investigated, The GFSK & 8PSK Power are the worst case. Testing is based on these modes to showing compliance.

5.3. DESCRIPTION OF AVAILABLE ANTENNAS

The radio utilizes an internal antenna, with a maximum gain of 1.71dBi.

5.4. SOFTWARE AND FIRMWARE

The test utility software used during testing was T927A.001

5.5. WORST-CASE CONFIGURATION AND MODE

Radiated emissions below 1GHz, above 18GHz, and power line conducted emission were performed with the EUT set to transmit at the channel with highest output power as worst-case scenario.

Band edge and radiated emissions between 1GHz and 18GHz were performed with the EUT set to transmit at the highest power on low, middle and high channels.

The fundamental of the EUT was investigated in three orthogonal orientations X,Y and Z it was determined that X orientation was worst-case orientation; therefore, all final radiated testing was performed with the EUT in X orientation.

Worst-case data rates as provided by the client were:

GFSK mode: DH5
8PSK mode: 3-DH5

5.6. DESCRIPTION OF TEST SETUP

SUPPORT EQUIPMENT

Support Equipment List				
Description	Manufacturer	Model	Serial Number	FCC ID
AC Adapter	Samsung	EP-TA300	R37K5PK1GA3SE3	N/A
Earphone	Samsung	N/A	N/A	N/A

I/O CABLES (CONDUCTED TEST)

I/O Cable List						
Cable No	Port	# of identical ports	Connector Type	Cable Type	Cable Length (m)	Remarks
1	Antenna	1	RF	Shielded	0.2	To PSA and BT Tester
2	USB Type C	1	USB Type C	Un-shielded	1	EUT to AC Mains

I/O CABLES (RADIATED AND CONDUCTED EMISSIONS)

I/O Cable List						
Cable No	Port	# of identical ports	Connector Type	Cable Type	Cable Length (m)	Remarks
1	USB Type C	1	USB Type C	Shielded	1	N/A
2	earphone	1	3.5mm	Un-shielded	1	N/A

TEST SETUP

The EUT is a stand alone. Test software exercised the radio card.

CONDCUTED TEST SETUP DIAGRAM

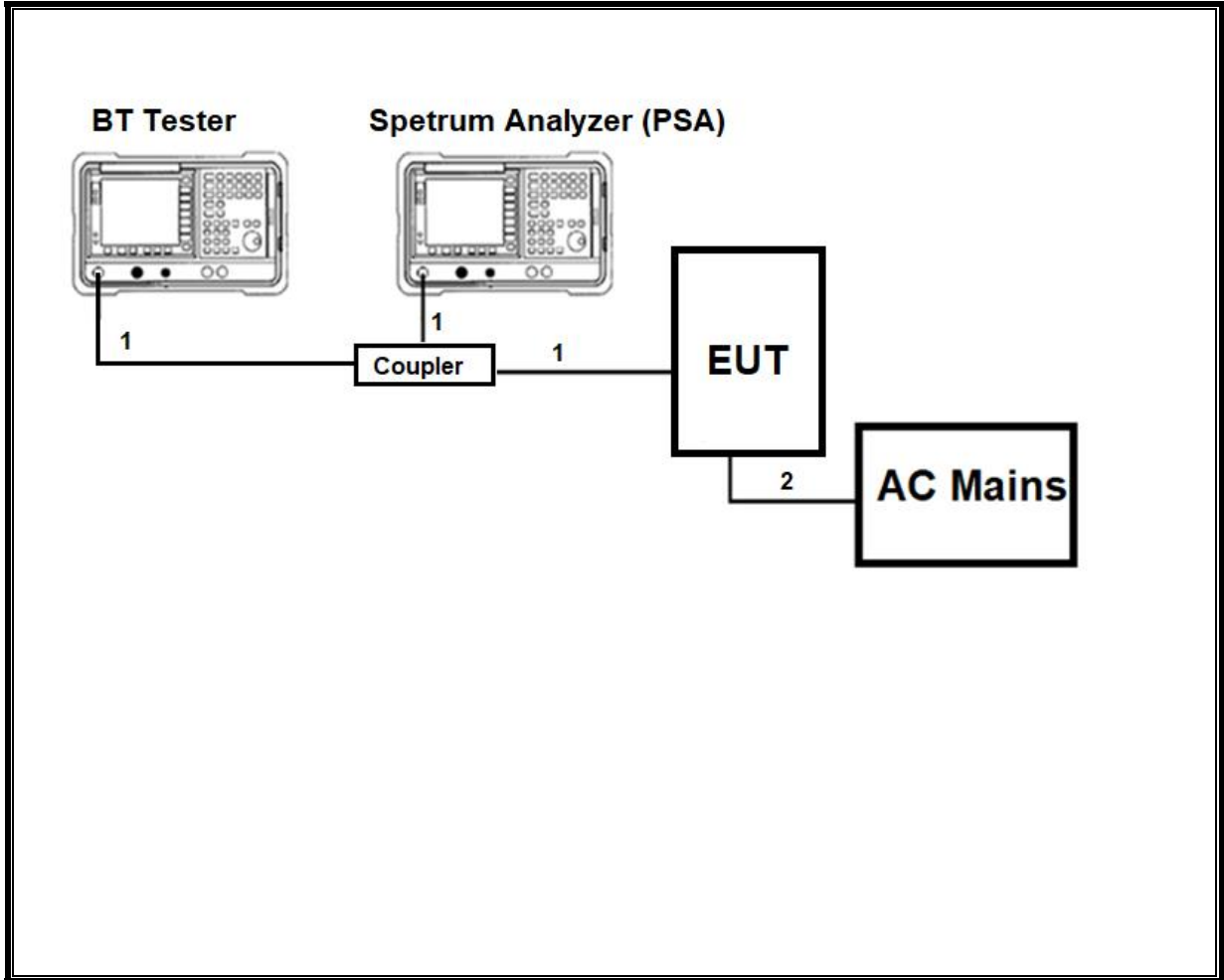

RADIATED AND AC LINE CONDUCTED EMISSIONS SETUP DIAGRAM

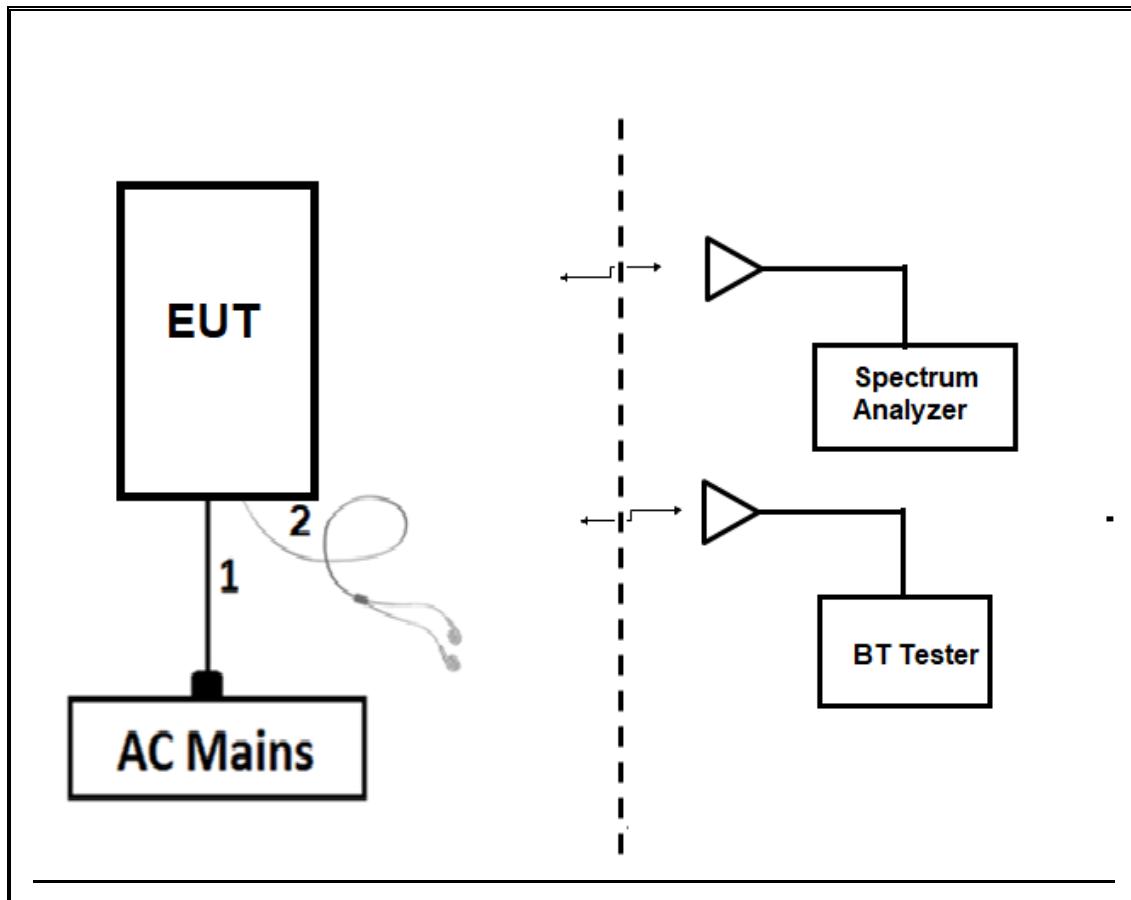

6. TEST AND MEASUREMENT EQUIPMENT

The following test and measurement equipment was utilized for the tests documented in this report:

TEST EQUIPMENT LIST					
Description	Manufacturer	Model	ID Num	Cal Due	Last Cal
Antenna, Broadband Hybrid, 30MHz to 2000MHz	Sunol Sciences Corp.	JB1	T130	10/26/2018	10/26/2017
Amplifier, 10kHz to 1GHz, 32dB	Sonoma Instrument Co.	8447D	T15	08/14/2019	08/14/2018
Antenna, Horn 1-18GHz	ETS-Lindgren	3117	T345	04/25/2019	04/25/2018
Antenna, Horn 1-18GHz	ETS-Lindgren	3117	T119	04/03/2019	05/24/2018
RF Amplifier, 1-18GHz	MITEQ	AFS42-00101800-25-S-42	T1165	06/12/2019	06/12/2018
RF Amplifier, 1-18GHz	AMPLICAL	AMP1G18-35	T1569	06/03/2019	06/03/2018
Antenna, Active Loop 9kHz-30MHz	Com-Power Corp.	AL-130R	T1866	10/10/2018	10/10/2017
Spectrum Analyzer	Agilent (Keysight) Technologies	N9030A	T200	11/18/2018	11/18/2017
Spectrum Analyzer, PXA, 3Hz to 44GHz	Agilent (Keysight) Technologies	N9030A	T1210	08/06/2019	08/06/2018
Spectrum Analyzer, PXA, 3Hz to 44GHz	Agilent (Keysight) Technologies	N9030A	T1466	04/16/2019	04/16/2018
EMI Test Reciever	Rohde & Schwarz	ESW44	PRE0179377	05/03/2019	05/03/2018
Spectrum Analyzer, PXA, 3Hz to 44GHz	Agilent (Keysight) Technologies	N9030A	T1113	12/21/2018	12/21/2017
18 - 26.5 GHz Horn Antenna	Seavey Division	MWH-1826/B	T89	01/18/2019	01/18/2018
Pre-Amp 1-26.5 GHz	Agilent	8449B	T404	03/09/2019	03/09/2018
EMI Reciever	Rohde & Schwarz	ESR	T1436	02/21/2019	02/21/2018
L.I.S.N.	FCC INC.	FCC LISN 50/250	T1310	06/15/2019	06/15/2018
L.I.S.N.	FCC INC.	FCC LISN 50/250	T24	03/06/2019	03/06/2018
Thermometer - Digital	Control Company	14-650-118	PRE0177861	02/26/2019	02/26/2018

Test Software List			
Description	Manufacturer	Model	Version
Radiated Software	UL	UL EMC	Ver 8.5, Aug 12, 2018
Antenna Port Software	UL	UL RF	Ver 9.5, Dec 1, 2016

7. MEASUREMENT METHODS

On Time and Duty Cycle: ANSI C63.10-2013 Section 11.6

Occupied BW (20dB): ANSI C63.10-2013 Section 6.9.2

Occupied BW (99%): ANSI C63.10-2013 Section 6.9.3

Carrier Frequency Separation: ANSI C63.10-2013 Section 7.8.2

Number of Hopping Frequencies: ANSI C63.10-2013 Section 7.8.3

Time of Occupancy (Dwell Time): ANSI C63.10-2013 Section 7.8.4

Peak Output Power: ANSI C63.10-2013 Section 7.8.5

Conducted Spurious Emissions: ANSI C63.10-2013 Section 7.8.8

Conducted Band-Edge: ANSI C63.10-2013 Section 6.10.4

Radiated Spurious Emissions 30-1000MHz: ANSI C63.10-2013 Section 6.3 and 6.5

Radiated Spurious Emissions above 1GHz: ANSI C63.10-2013 Section 6.3 and 6.6

Radiated Band-edge: ANSI C63.10-2013 Section 6.10.5

AC Power-line conducted emissions: ANSI C63.10-2013, Section 6.2.

8. ANTENNA PORT TEST RESULTS

8.1. ON TIME AND DUTY CYCLE

LIMITS

None; for reporting purposes only.

PROCEDURE

KDB 789033 Zero-Span Spectrum Analyzer Method.

ON TIME AND DUTY CYCLE RESULTS

Mode	ON Time B (msec)	Period (msec)	Duty Cycle x (linear)	Duty Cycle (%)	Duty Cycle Correction Factor (dB)	1/T Minimum VBW (kHz)
Bluetooth GFSK	2.879	3.745	0.769	76.9%	1.14	0.347
Bluetooth 8PSK	2.889	3.755	0.769	76.9%	1.14	0.346

DUTY CYCLE PLOTS

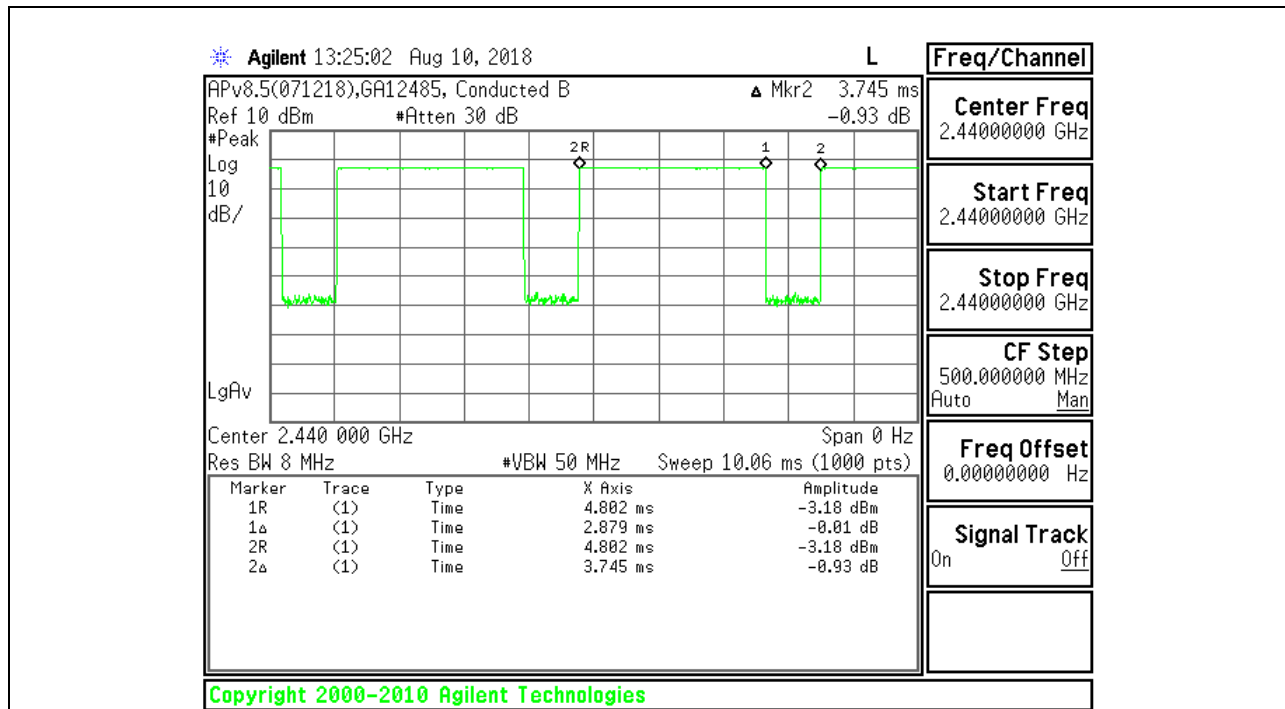

BLUETOOTH GFSK

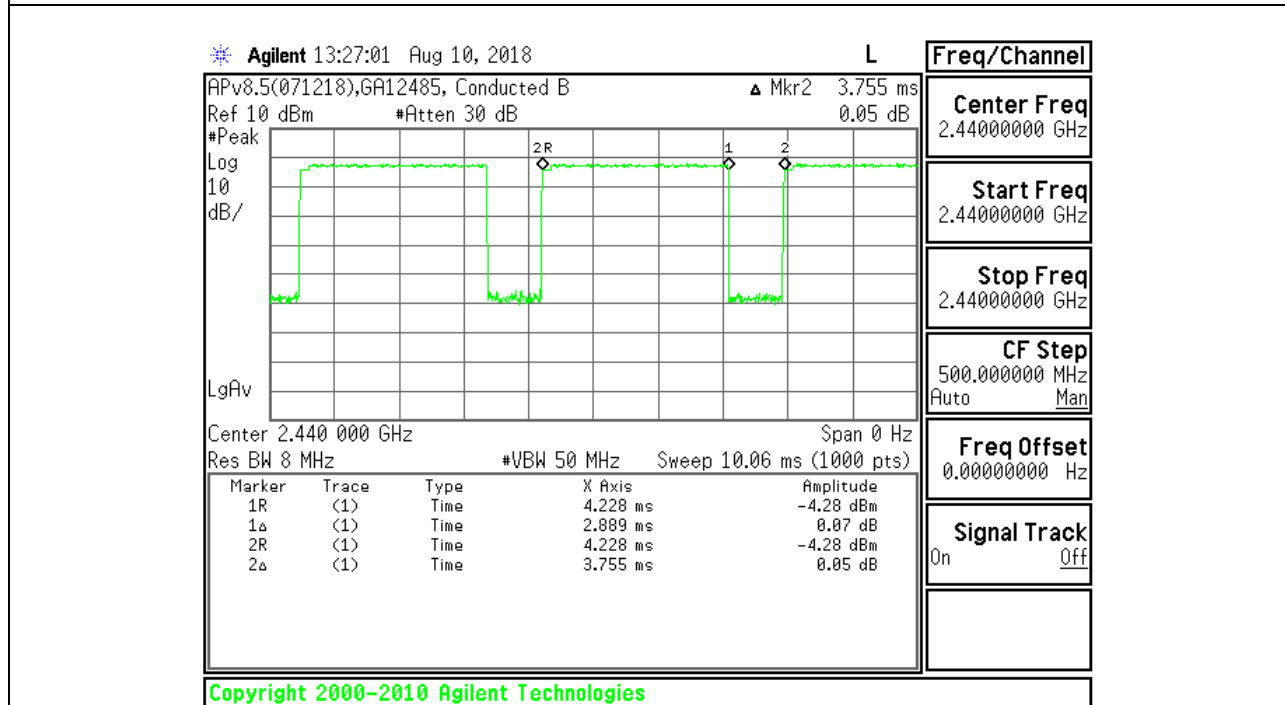

BLUETOOTH 8PSK

8.2. 20 dB AND 99% BANDWIDTH

LIMITS

None; for reporting purposes only.

TEST PROCEDURE

The transmitter output is connected to a spectrum analyzer. The RBW is set to $\geq 1\%$ of the 20 dB bandwidth. The VBW is set to \geq RBW. The sweep time is coupled.

RESULTS

8.2.1. BLUETOOTH BASIC DATA RATE GFSK MODULATION

Channel	Frequency (MHz)	20dB Bandwidth (MHz)	99% Bandwidth (MHz)
Low	2402	1.038	0.911
Mid	2441	1.031	0.91
High	2480	1.037	0.909

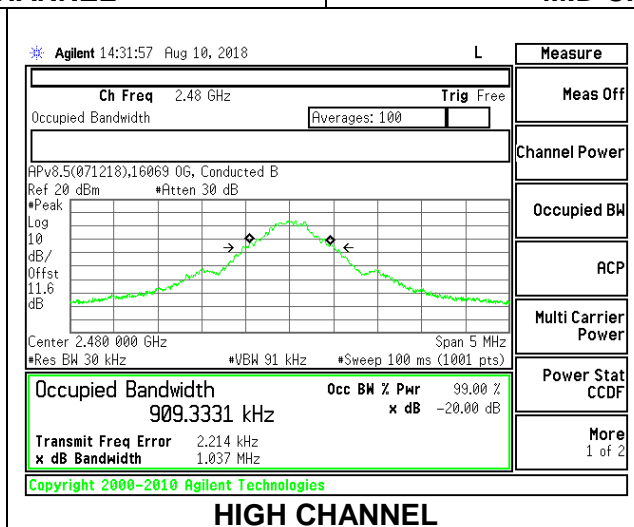
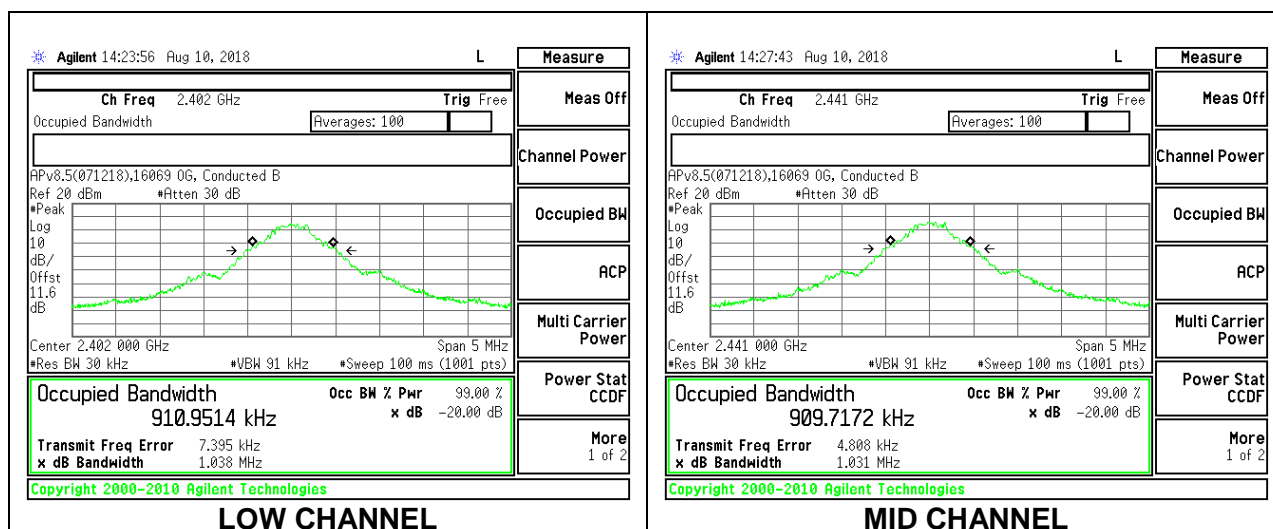

8.2.2. BLUETOOTH ENHANCED DATA RATE 8PSK MODULATION

Channel	Frequency (MHz)	20dB Bandwidth (MHz)	99% Bandwidth (MHz)
Low	2402	1.332	1.212
Mid	2441	1.332	1.215
High	2480	1.336	1.227

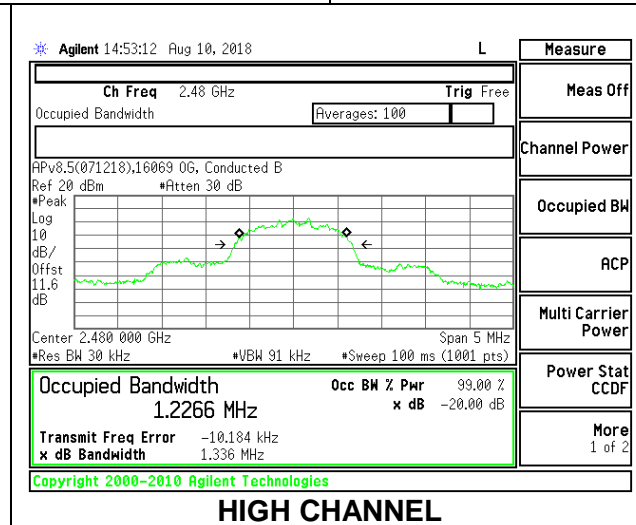
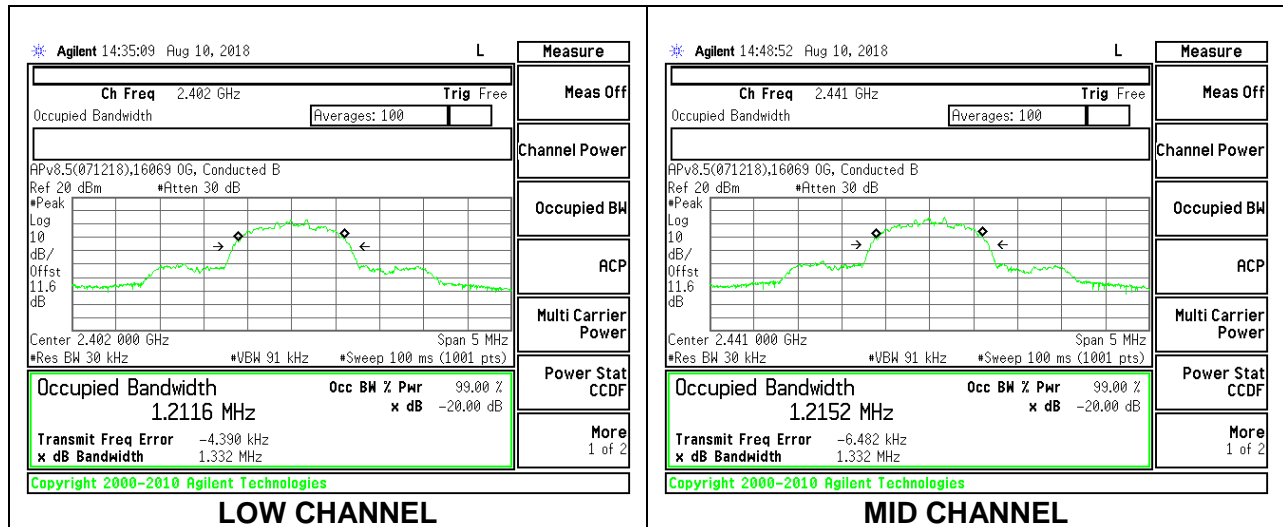

8.3. HOPPING FREQUENCY SEPARATION

LIMITS

FCC §15.247 (a) (1)

Frequency hopping systems shall have hopping channel carrier frequencies separated by a minimum of 25 kHz or the 20 dB bandwidth of the hopping channel, whichever is greater.

Alternatively, frequency hopping systems operating in the 2400-2483.5 MHz band may have hopping channel carrier frequencies that are separated by 25 kHz or two-thirds of the 20 dB bandwidth of the hopping channel, whichever is greater, provided the systems operate with an output power no greater than 125 mW.

TEST PROCEDURE

The transmitter output is connected to a spectrum analyzer. The RBW is set to 300 kHz and the VBW is set to 300 kHz. The sweep time is coupled.

RESULTS

8.3.1. BLUETOOTH BASIC DATA RATE GFSK MODULATION

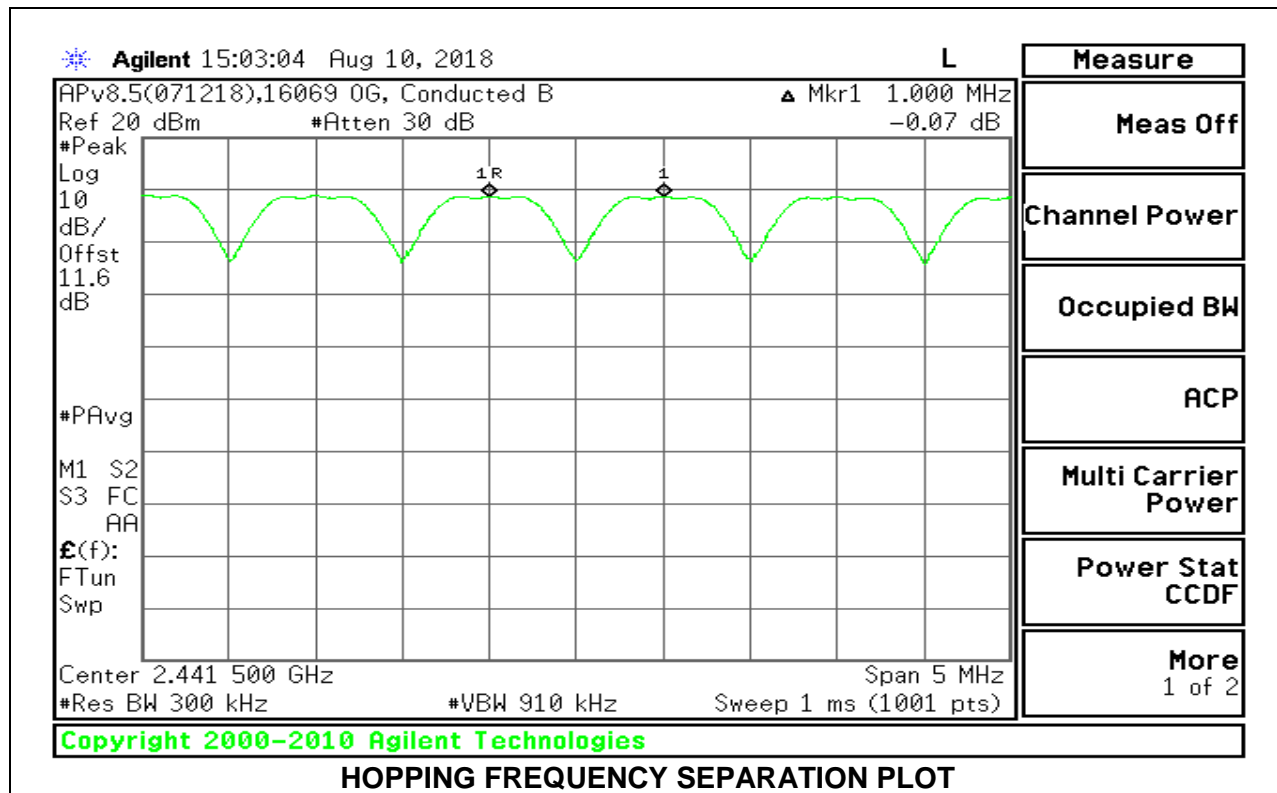

8.3.2. BLUETOOTH ENHANCED DATA RATE 8PSK MODULATION

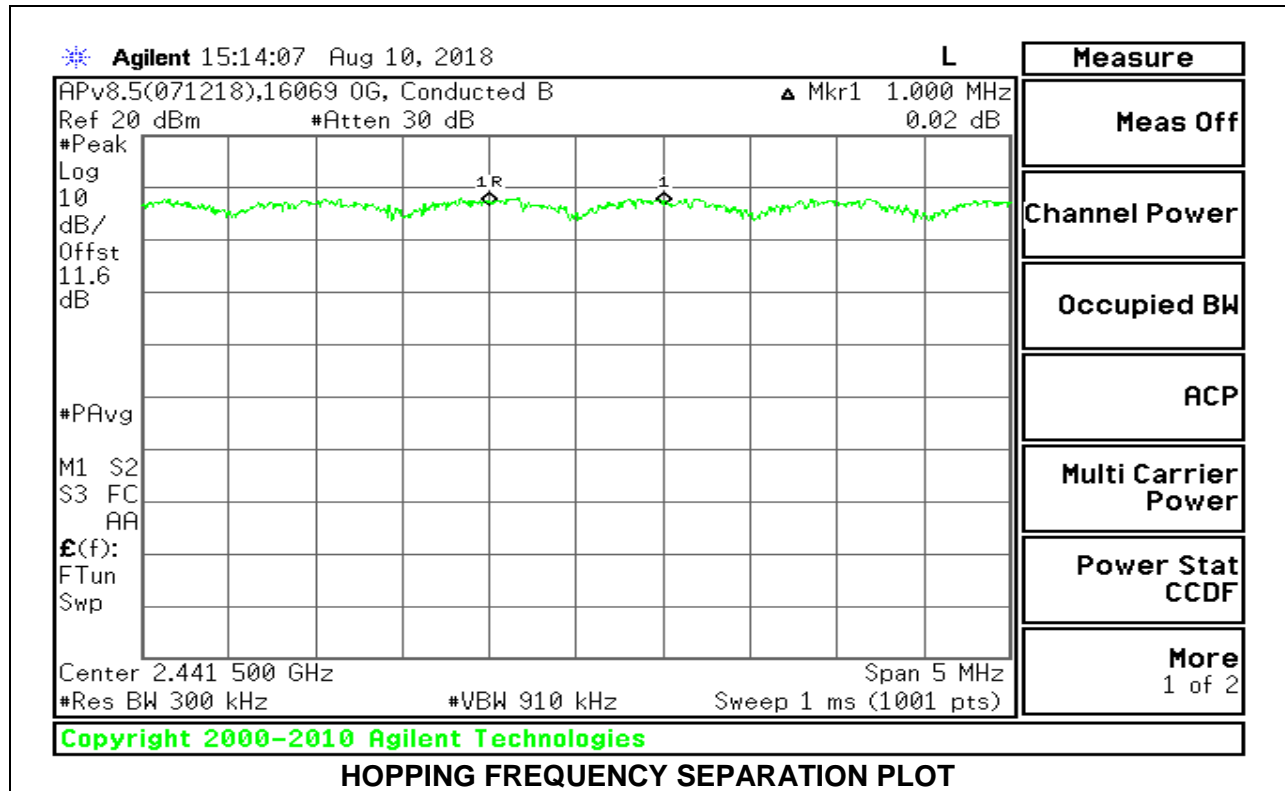

8.4. NUMBER OF HOPPING CHANNELS

LIMITS

FCC §15.247 (a) (1) (iii)

Frequency hopping systems in the 2400 – 2483.5 MHz band shall use at least 15 non-overlapping channels.

TEST PROCEDURE

The transmitter output is connected to a spectrum analyzer. The span is set to cover the entire authorized band, in either a single sweep or in multiple contiguous sweeps. The RBW is set to a maximum of 1 % of the span. The analyzer is set to Max Hold.

RESULTS

Normal Mode: 79 Channels Observed

8.4.1. BLUETOOTH BASIC DATA RATE GFSK MODULATION

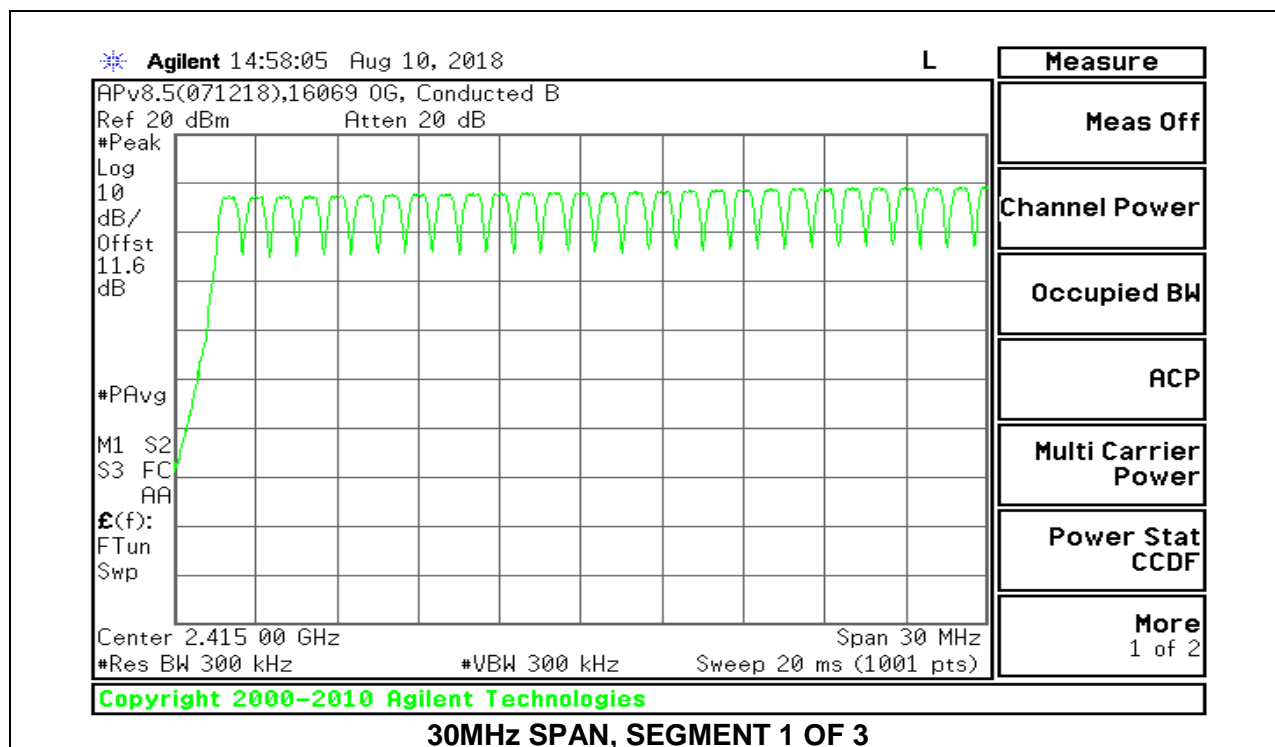
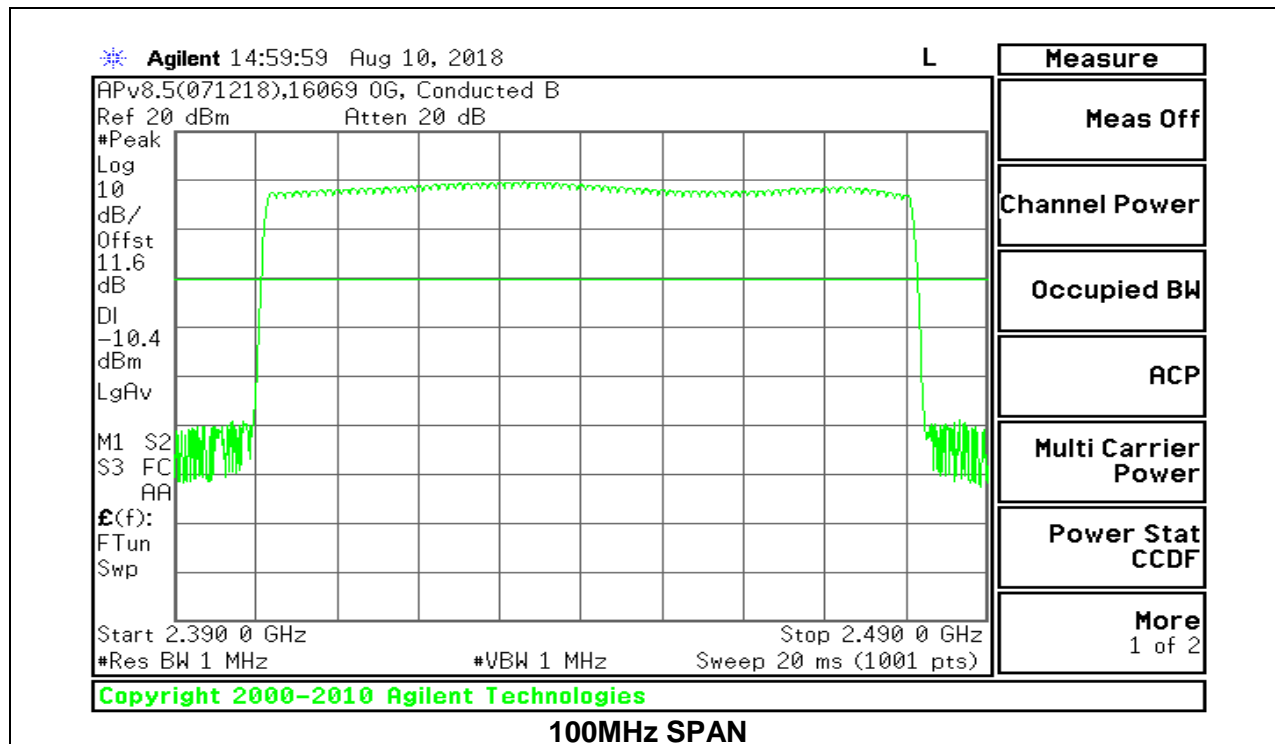

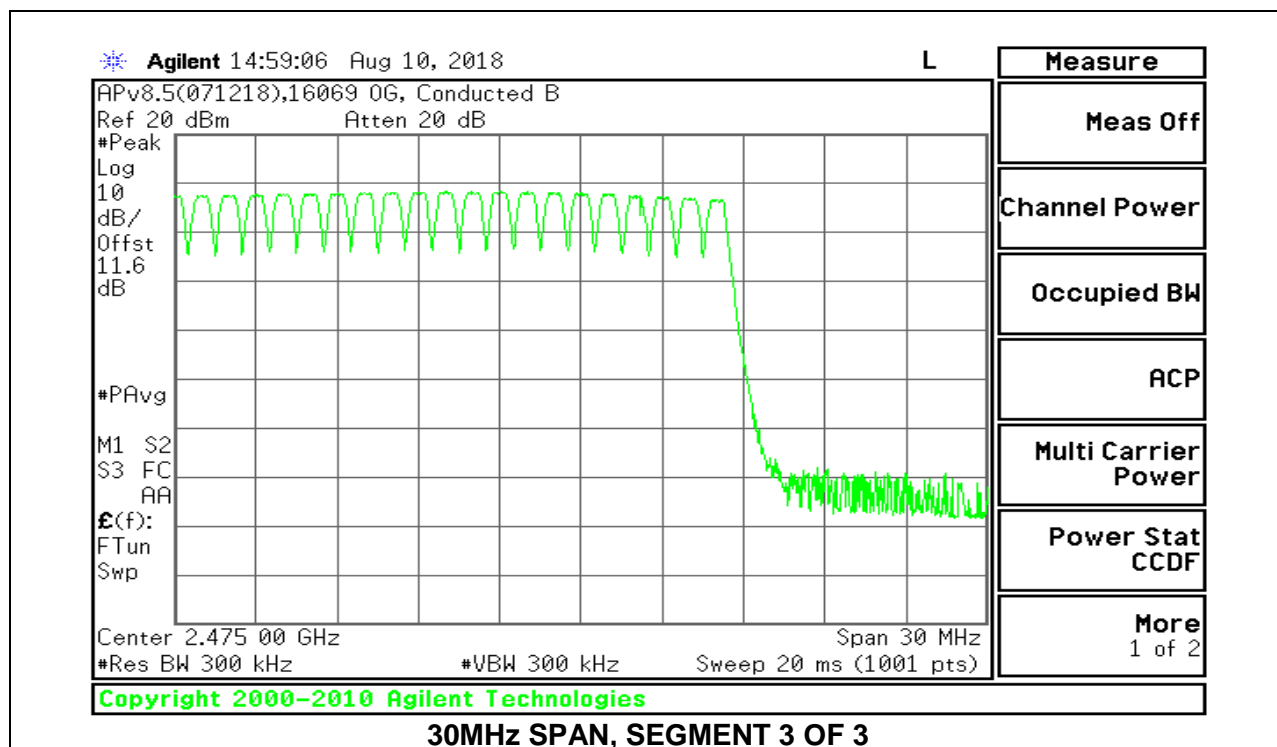
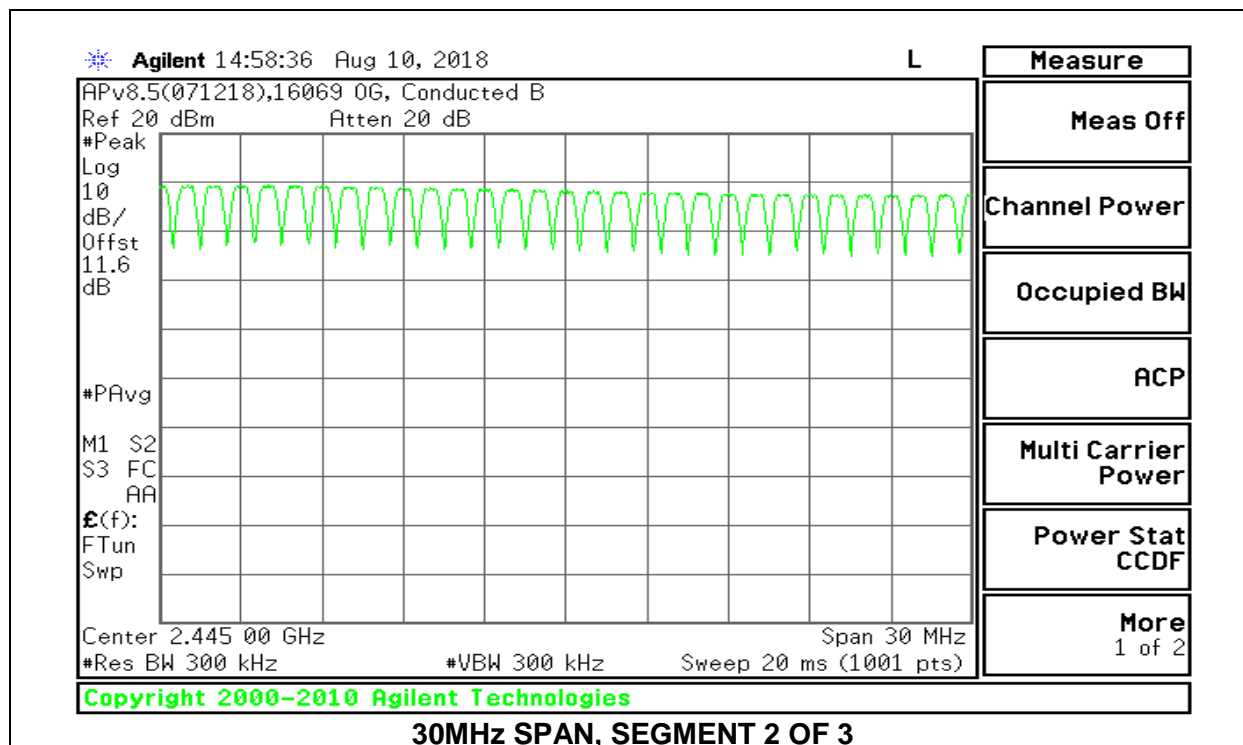

8.4.2. BLUETOOTH ENHANCED DATA RATE 8PSK MODULATION

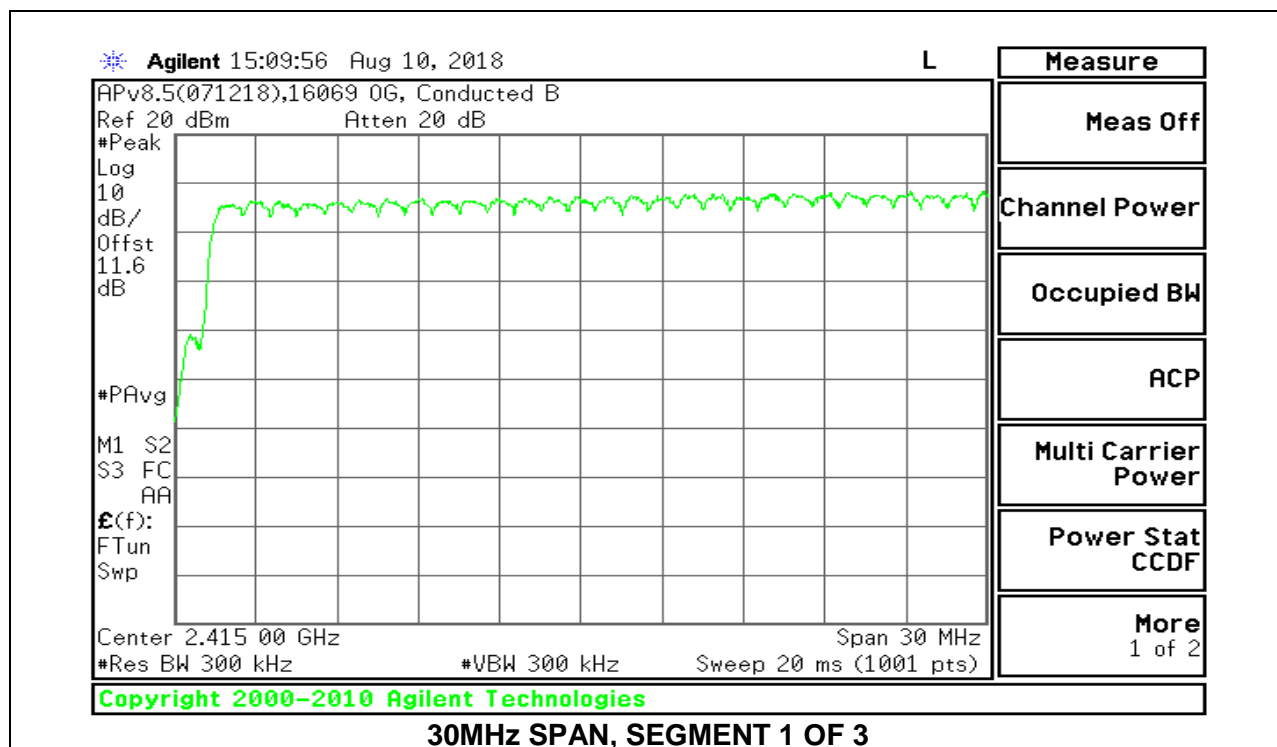
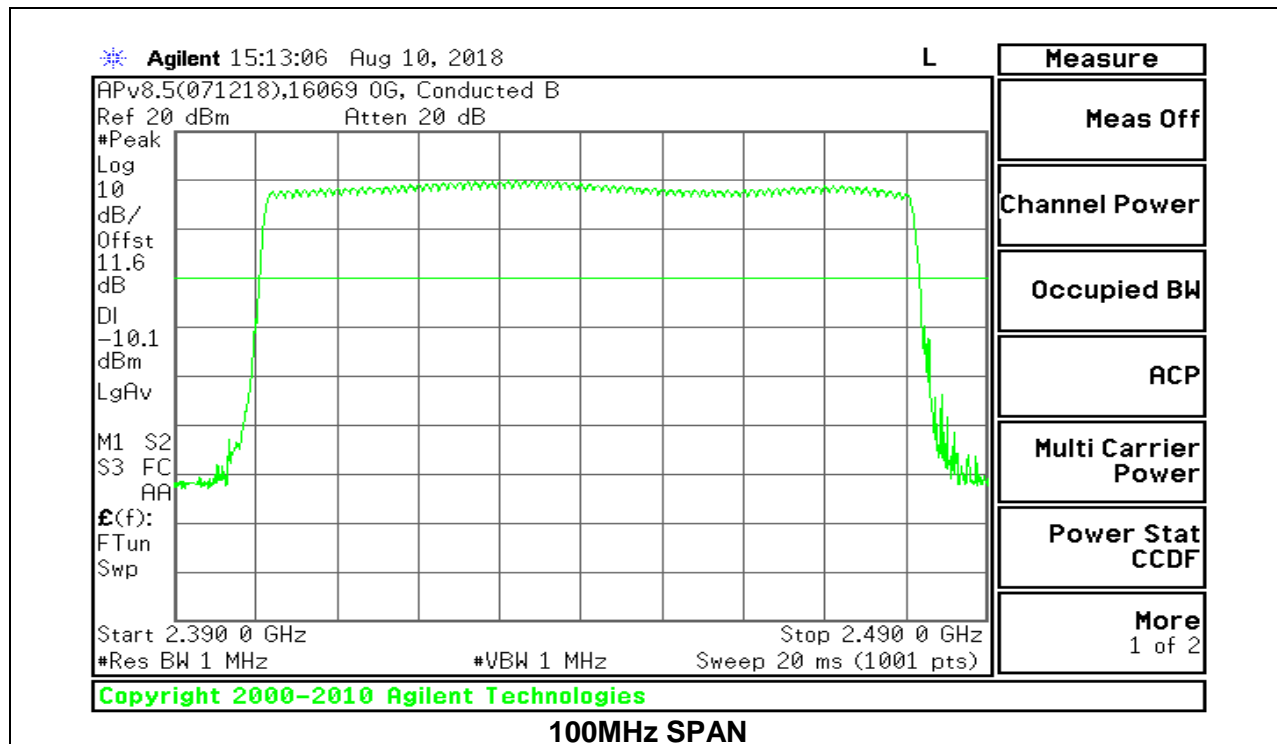

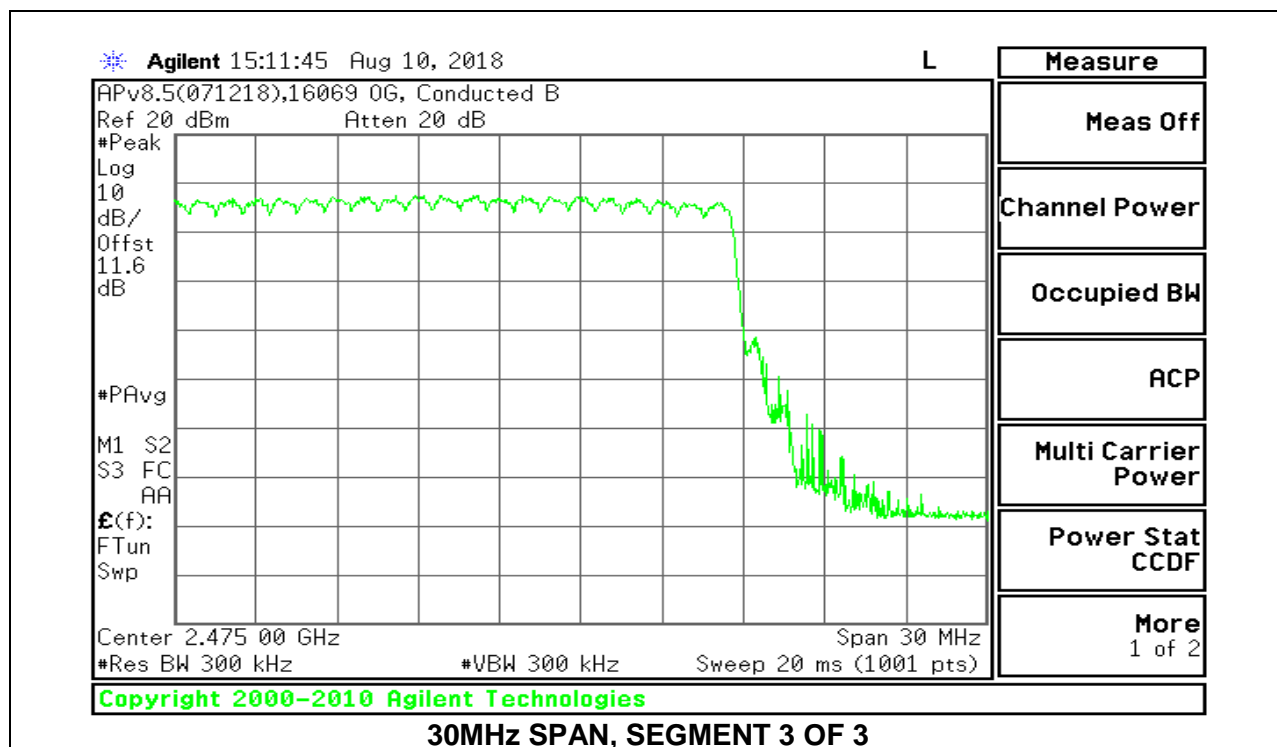
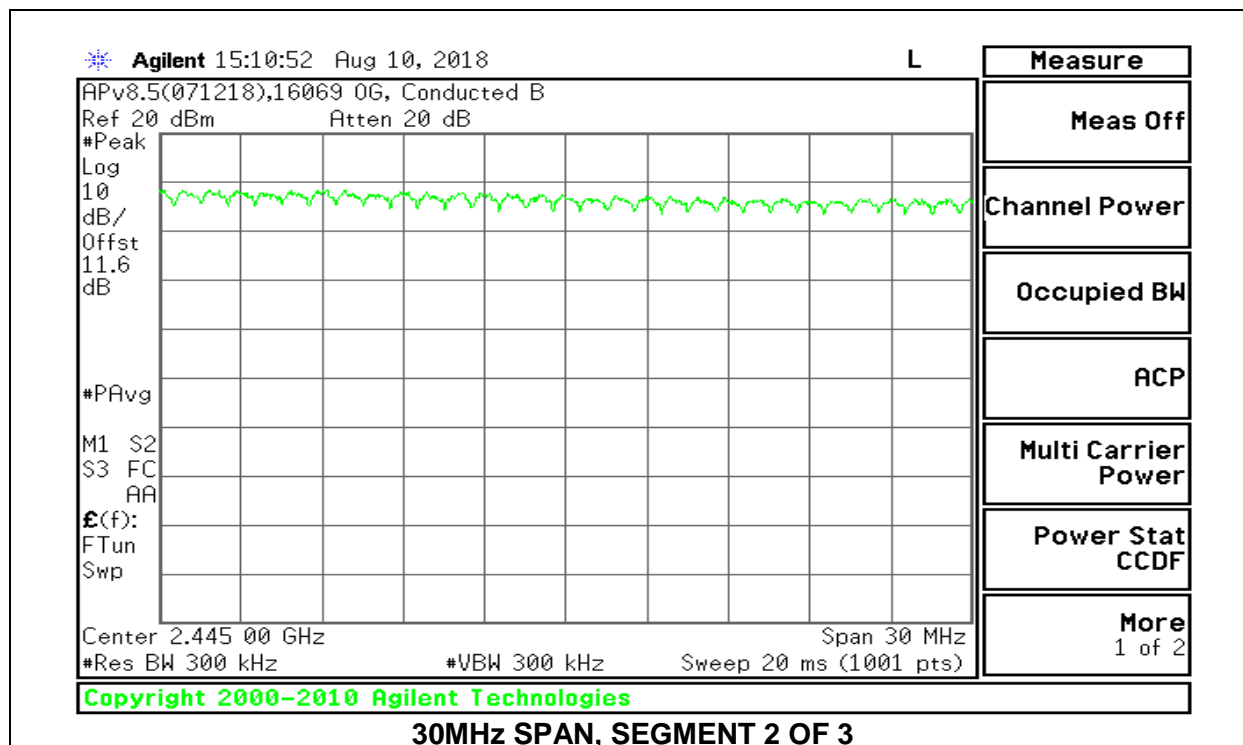

8.5. AVERAGE TIME OF OCCUPANCY

LIMITS

FCC §15.247 (a) (1) (iii)

The average time of occupancy on any channel shall not be greater than 0.4 seconds within a period of 0.4 seconds multiplied by the number of hopping channels employed.

TEST PROCEDURE

The transmitter output is connected to a spectrum analyzer. The span is set to 0 Hz, centered on a single, selected hopping channel. The width of a single pulse is measured in a fast scan. The number of pulses is measured in a 3.16 second scan, to enable resolution of each occurrence.

The average time of occupancy in the specified 3.16 second period (79 channels * 0.4 s) is equal to $10 * (\# \text{ of pulses in } 3.16 \text{ s}) * \text{ pulse width}$.

For AFH mode, the average time of occupancy in the specified 8 second period (20 channels * 0.4 seconds) is equal to $10 * (\# \text{ of pulses in } 0.8 \text{ s}) * \text{ pulse width}$.

RESULTS

8.5.1. BLUETOOTH BASIC DATA RATE GFSK MODULATION

DH Packet	Pulse Width (msec)	Number of Pulses in 3.16 seconds	Average Time of Occupancy (sec)	Limit (sec)	Margin (sec)
GFSK Normal Mode					
DH1	0.381	32	0.1219	0.4	-0.2781
DH3	1.637	18	0.2947	0.4	-0.1053
DH5	2.885	11	0.3174	0.4	-0.0827
DH Packet	Pulse Width (sec)	Number of Pulses in 0.8 seconds	Average Time of Occupancy (sec)	Limit (sec)	Margin (sec)
GFSK AFH Mode					
DH1	0.381	8	0.03048	0.4	-0.3695
DH3	1.637	4.5	0.07367	0.4	-0.3263
DH5	2.885	2.75	0.07934	0.4	-0.3207

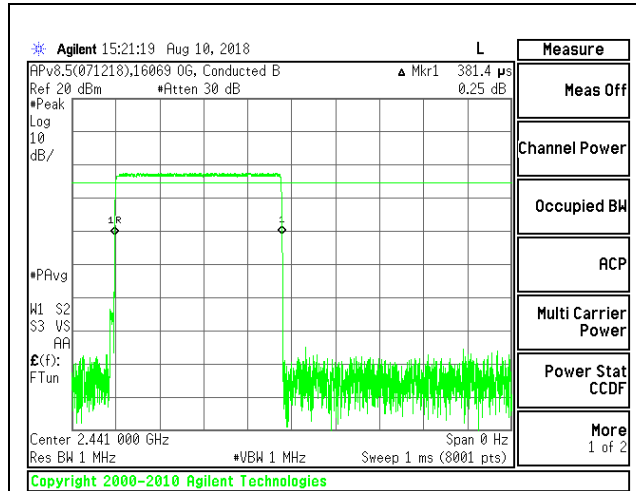

PULSE WIDTH - DH1

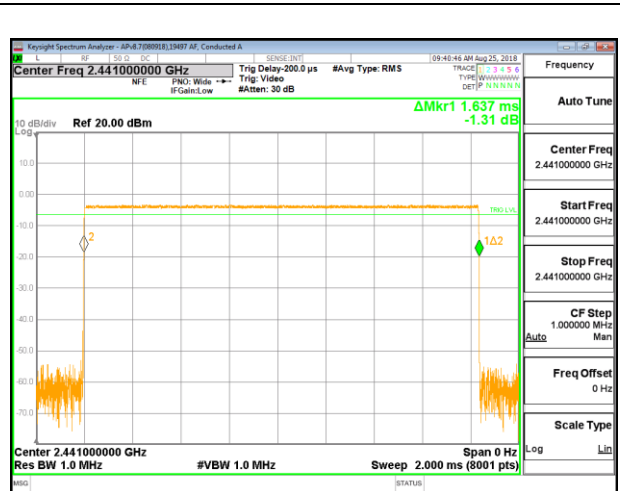

PULSE WIDTH - DH3

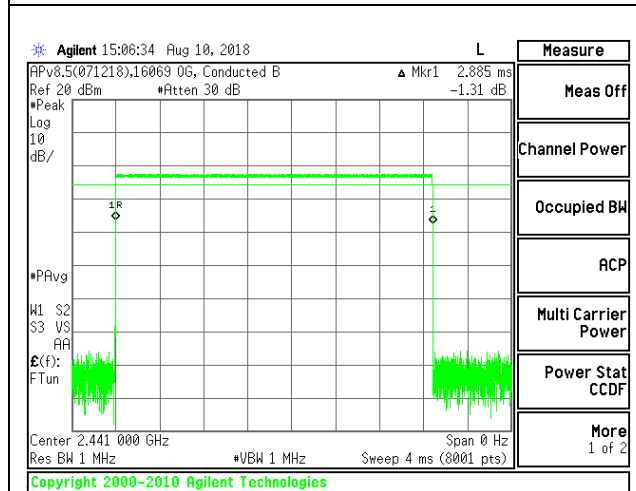

PULSE WIDTH - DH5

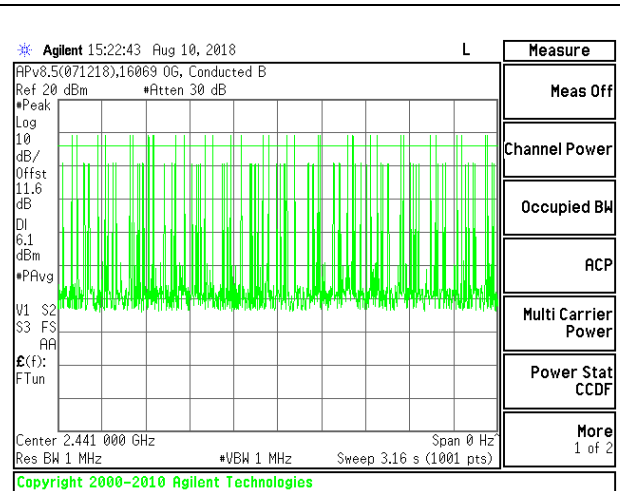

NUMBER OF PULSES IN 3.16 SECOND OBSERVATION PERIOD - DH1

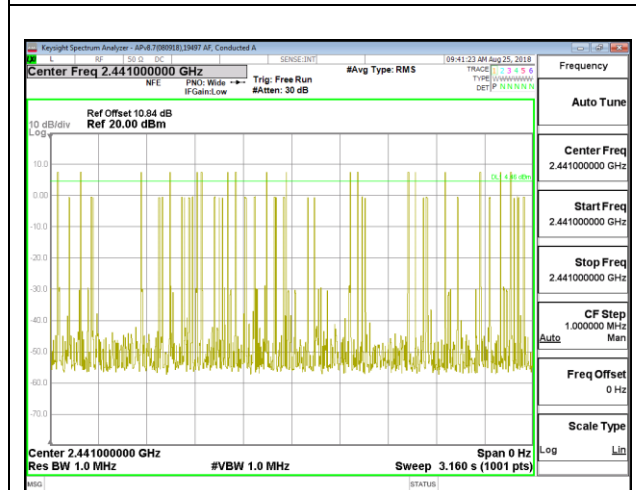

NUMBER OF PULSES IN 3.16 SECOND OBSERVATION PERIOD - DH3

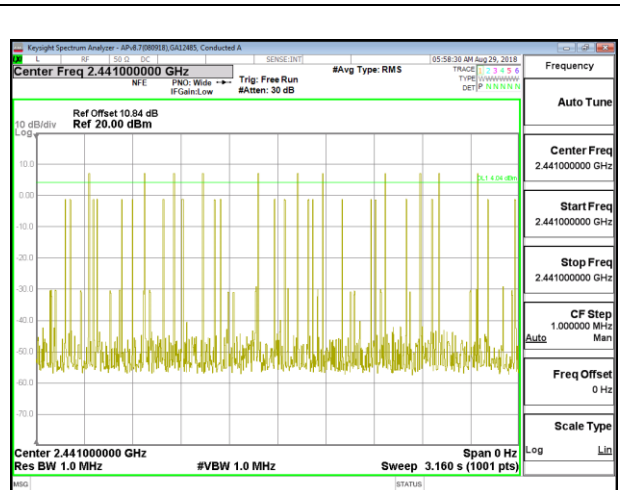

NUMBER OF PULSES IN 3.16 SECOND OBSERVATION PERIOD - DH5

8.5.2. BLUETOOTH ENHANCED DATA RATE 8PSK MODULATION

DH Packet	Pulse Width (msec)	Number of Pulses in 3.16 seconds	Average Time of Occupancy (sec)	Limit (sec)	Margin (sec)
8PSK Normal Mode					
DH1	0.393	33	0.12969	0.4	-0.2703
DH3	1.642	17	0.27914	0.4	-0.1209
DH5	2.882	11	0.31702	0.4	-0.083

Note: for AFH(8PSK) mode, please refer to the results of AFH(GFSK) mode; the channel selection and hopping rate are the same for both EDR and Basic Rate operation, data for Basic Rate in section 8.5.1 demonstrates compliance with channel occupancy when AFH is employed.

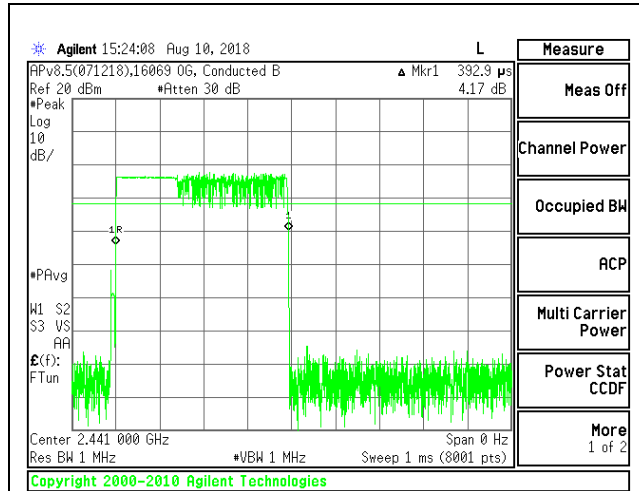

PULSE WIDTH – DH1

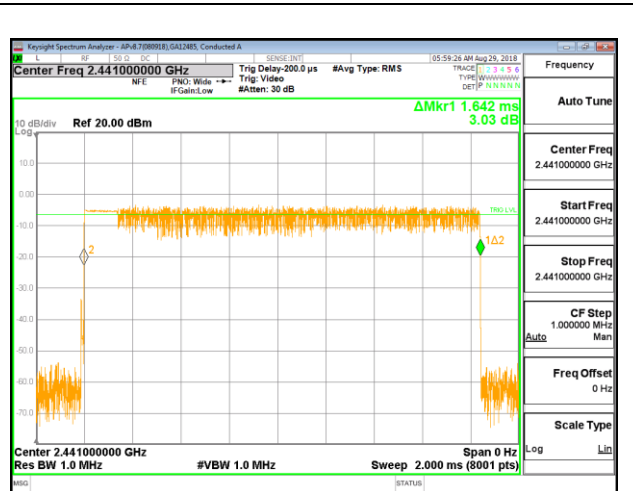

PULSE WIDTH – DH3

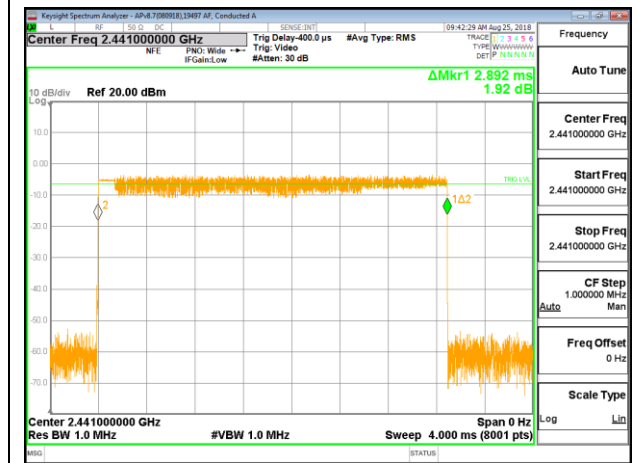

PULSE WIDTH – DH5

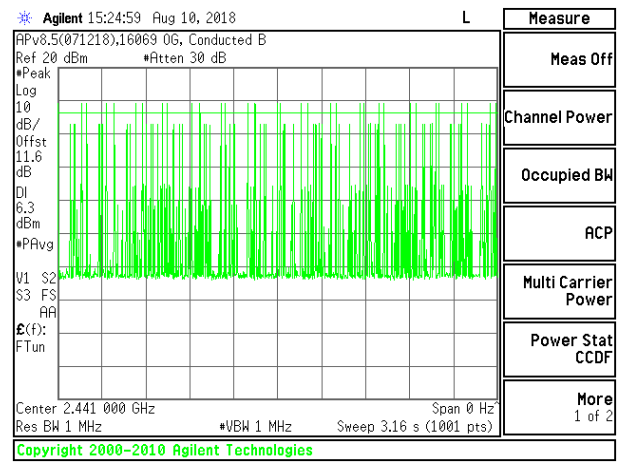

NUMBER OF PULSES IN 3.16 SECOND OBSERVATION PERIOD – DH1

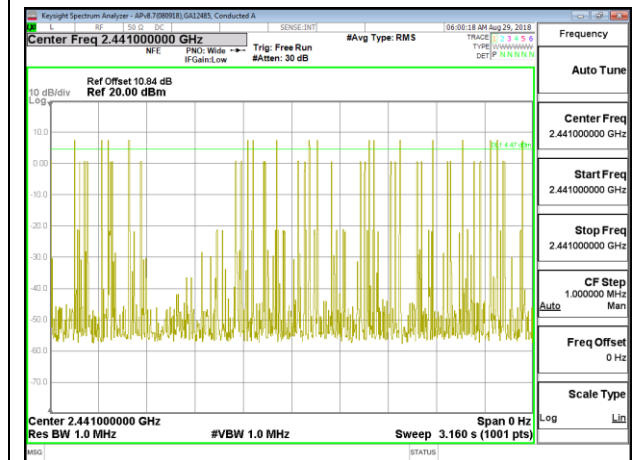

NUMBER OF PULSES IN 3.16 SECOND OBSERVATION PERIOD – DH3

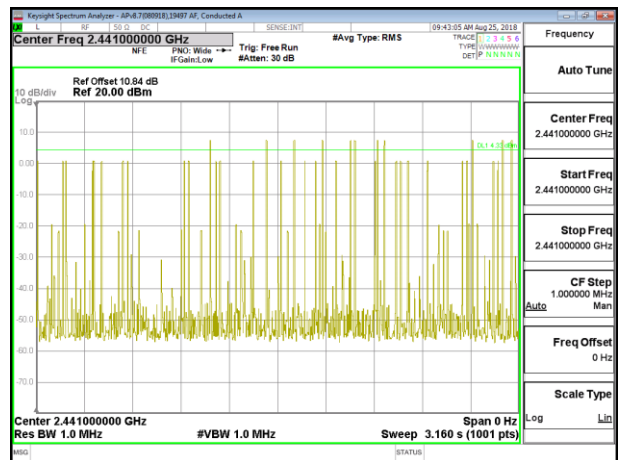

NUMBER OF PULSES IN 3.16 SECOND OBSERVATION PERIOD – DH5

8.6. OUTPUT POWER

LIMITS

§15.247 (b) (1)

The maximum antenna gain is less than 6 dBi, therefore the limit is 30 dBm. Alternatively, frequency hopping systems operating in the 2400-2483.5 MHz band may have hopping channel carrier frequencies that are separated by 25 kHz or two-thirds of the 20 dB bandwidth of the hopping channel, whichever is greater, provided the systems operate with an output power no greater than 125 mW.

TEST PROCEDURE

The transmitter output is connected to a power meter. The cable assembly insertion loss was entered as an offset in the power meter to allow for a peak reading of power.

RESULTS

8.6.1. BLUETOOTH BASIC DATA RATE GFSK MODULATION

Tested By:	16069 OG
Date:	8/10/2018

Channel	Frequency (MHz)	Output Power (dBm)	Limit (dBm)	Margin (dB)
Low	2402	6.79	30	-23.21
Middle	2441	8.02	30	-21.98
High	2480	5.95	30	-24.05

8.6.2. BLUETOOTH ENHANCED DATA RATE 8PSK MODULATION

Tested By:	16069 OG
Date:	8/10/2018

Channel	Frequency (MHz)	Output Power (dBm)	Limit (dBm)	Margin (dB)
Low	2402	6.93	21	-14.07
Middle	2441	8.24	21	-12.76
High	2480	6.07	21	-14.93

8.7. AVERAGE POWER

LIMITS

None; for reporting purposes only

TEST PROCEDURE

The transmitter output is connected to a power meter. The cable assembly insertion loss of was entered as an offset in the power meter to allow for a gated average reading of power.

RESULTS

8.7.1. BLUETOOTH BASIC DATA RATE GFSK MODULATION

Tested By:	16069 OG
Date	2/10/2018

Channel	Frequency (MHz)	Average Power (dBm)
Low	2402	6.13
Middle	2441	7.46
High	2480	5.39

8.7.2. BLUETOOTH ENHANCED DATA RATE 8PSK MODULATION

Tested By:	16069 OG
Date	8/10/2018

Channel	Frequency (MHz)	Average Power (dBm)
Low	2402	4.82
Middle	2441	6.15
High	2480	4.14

8.8. CONDUCTED SPURIOUS EMISSIONS

LIMITS

FCC §15.247 (d)

Limit = -20 dBc

TEST PROCEDURE

The transmitter output is connected to a spectrum analyzer. The resolution bandwidth is set to 100 kHz. The video bandwidth is set to 300 kHz.

The spectrum from 30 MHz to 26 GHz is investigated with the transmitter set to the lowest, middle, and highest channels.

The bandedges at 2.4 and 2.4835 GHz are investigated with the transmitter set to the normal hopping mode.

RESULTS

8.8.1. BLUETOOTH BASIC DATA RATE GFSK MODULATION

SPURIOUS EMISSIONS, NON-HOPPING

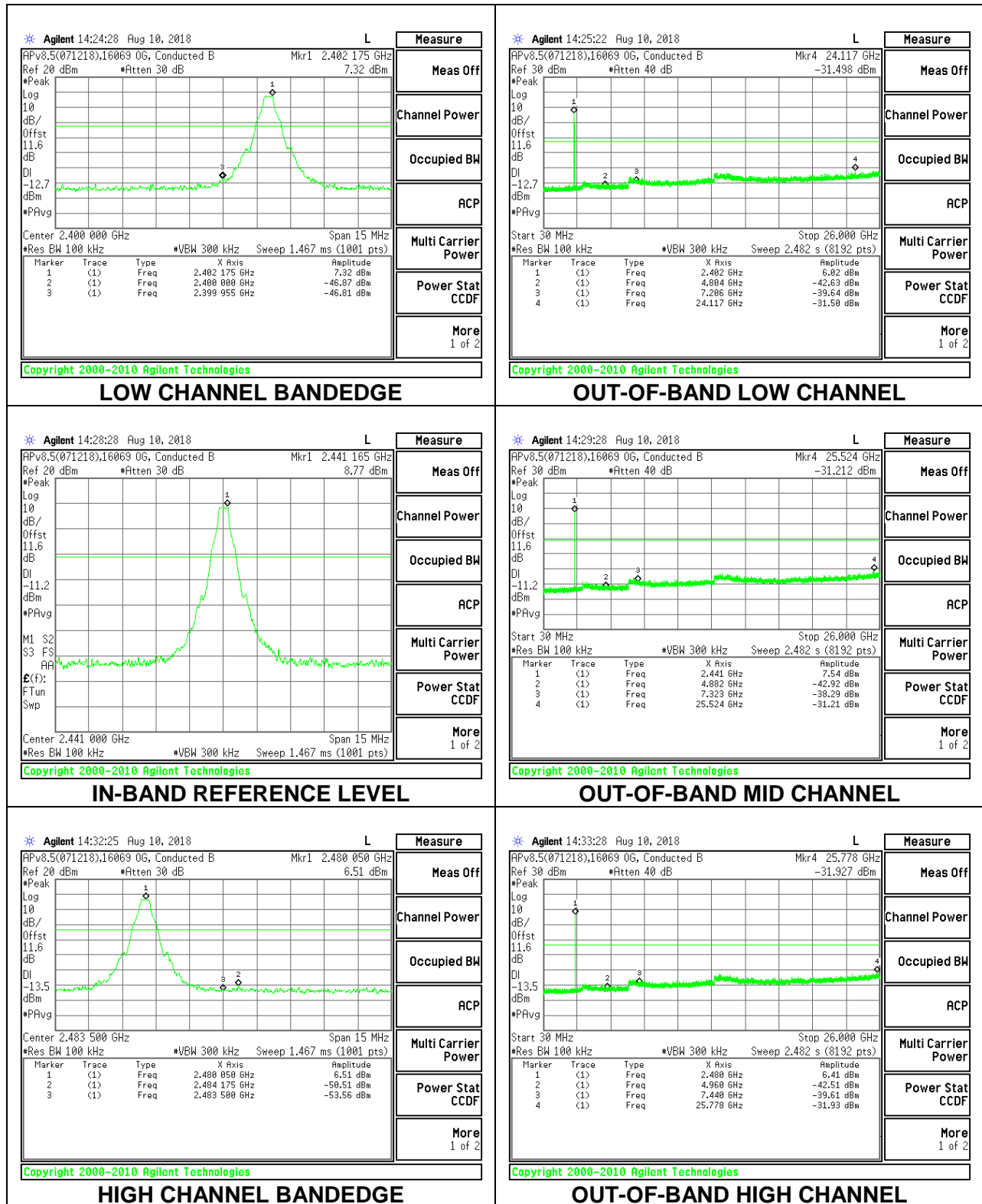

SPURIOUS BANDEGE EMISSIONS WITH HOPPING ON

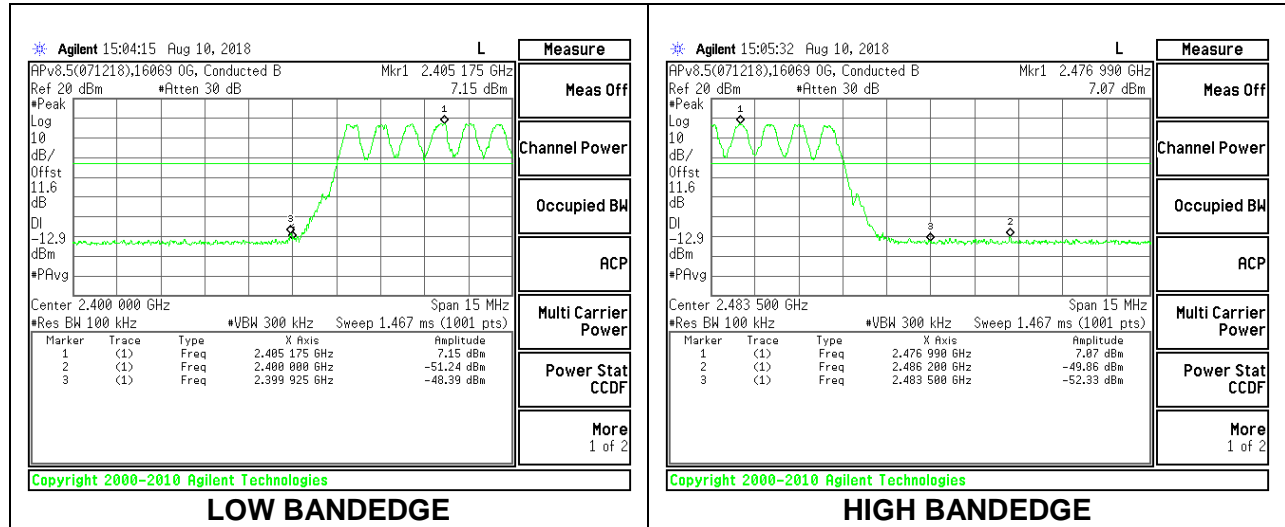

8.8.2. BLUETOOTH ENHANCED DATA RATE 8PSK MODULATION

SPURIOUS EMISSIONS, NON-HOPPING

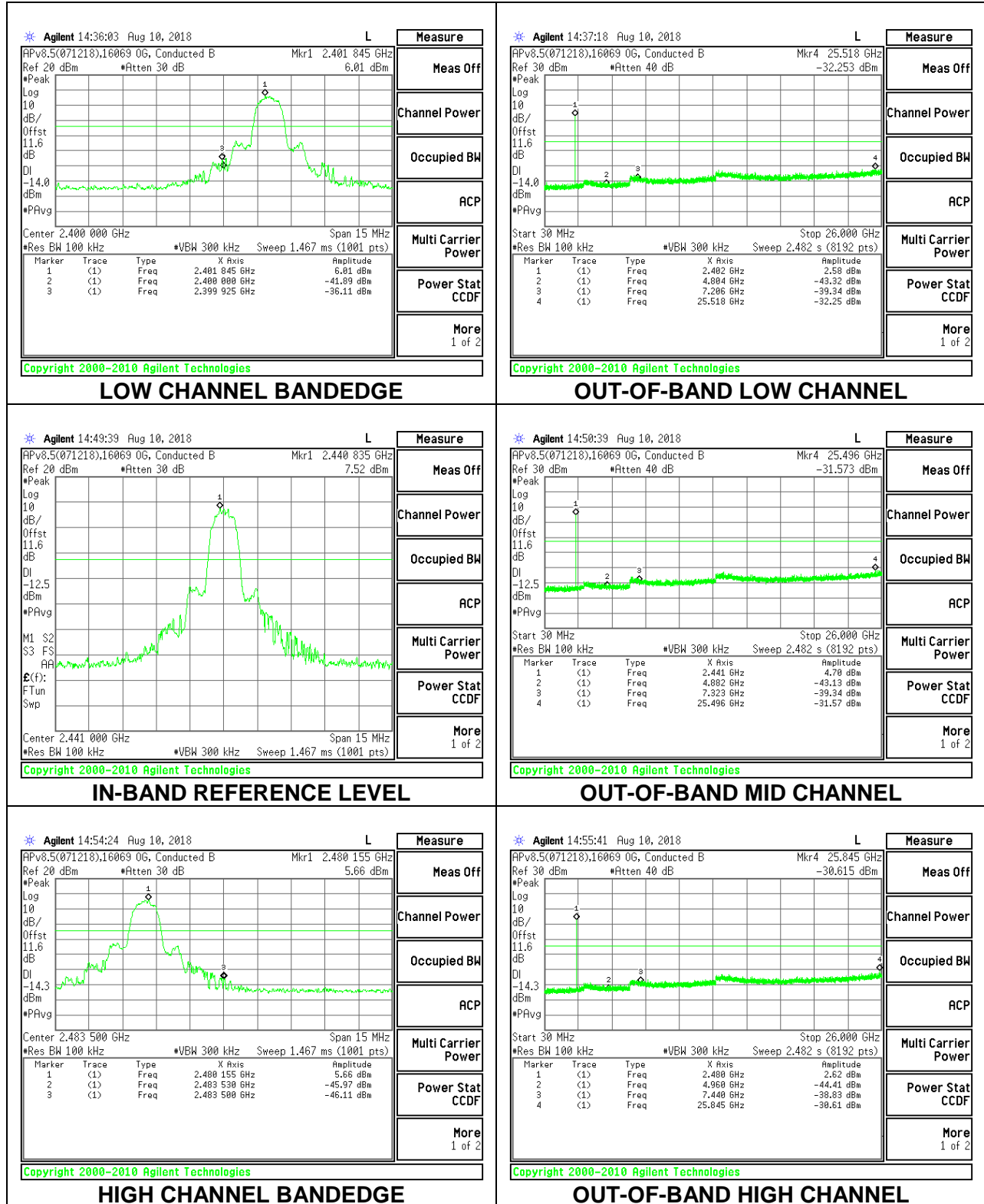

SPURIOUS BANDEGE EMISSIONS WITH HOPPING ON

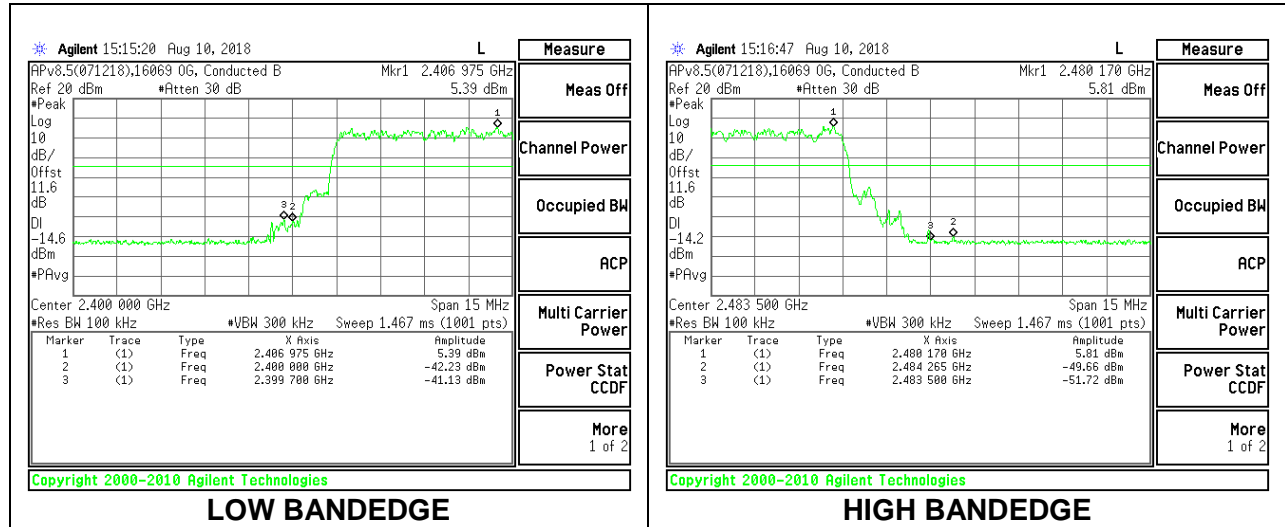

9. RADIATED TEST RESULTS

LIMITS

FCC §15.205 and §15.209

Frequency Range (MHz)	Field Strength Limit (uV/m) at 3 m	Field Strength Limit (dBuV/m) at 3 m
0.009-0.490	2400/F(kHz) @ 300 m	-
0.490-1.705	24000/F(kHz) @ 30 m	-
1.705 - 30	30 @ 30m	-
30 - 88	100	40
88 - 216	150	43.5
216 - 960	200	46
Above 960	500	54

TEST PROCEDURE

The EUT is placed on a non-conducting table 80 cm above the ground plane for measurement below 1GHz; 1.5 m above the ground plane for measurement above 1GHz. The antenna to EUT distance is 3 meters. The EUT is configured in accordance with ANSI C63.10. The EUT is set to transmit in a continuous mode.

For measurements below 1 GHz the resolution bandwidth is set to 100 kHz for peak detection measurements or 120 kHz for quasi-peak detection measurements. Peak detection is used unless otherwise noted as quasi-peak.

For pre-scans above 1 GHz the resolution bandwidth is set to 1 MHz; the video bandwidth is set to 30 KHz for peak measurements.

For measurements above 1 GHz the resolution bandwidth is set to 1 MHz, then the video bandwidth is set to 3 MHz for peak measurements and 1 MHz resolution bandwidth with 1/T (360Hz) video bandwidth with peak detector for average measurements.

The spectrum from 1 GHz to 18 GHz is investigated with the transmitter set to the lowest, middle, and highest channels in each applicable band. Below 1GHz and above 18GHz emissions, the channel with the highest output power was tested.

The frequency range of interest is monitored at a fixed antenna height and EUT azimuth. The EUT is rotated through 360 degrees to maximize emissions received. The antenna is scanned from 1 to 4 meters above the ground plane to further maximize the emission. Measurements are made with the antenna polarized in both the vertical and the horizontal positions.

9.1. TRANSMITTER ABOVE 1 GHz

9.1.1. BLUETOOTH BASIC DATA RATE GFSK MODULATION

BANDEDGE (LOW CHANNEL)

HORIZONTAL RESULT

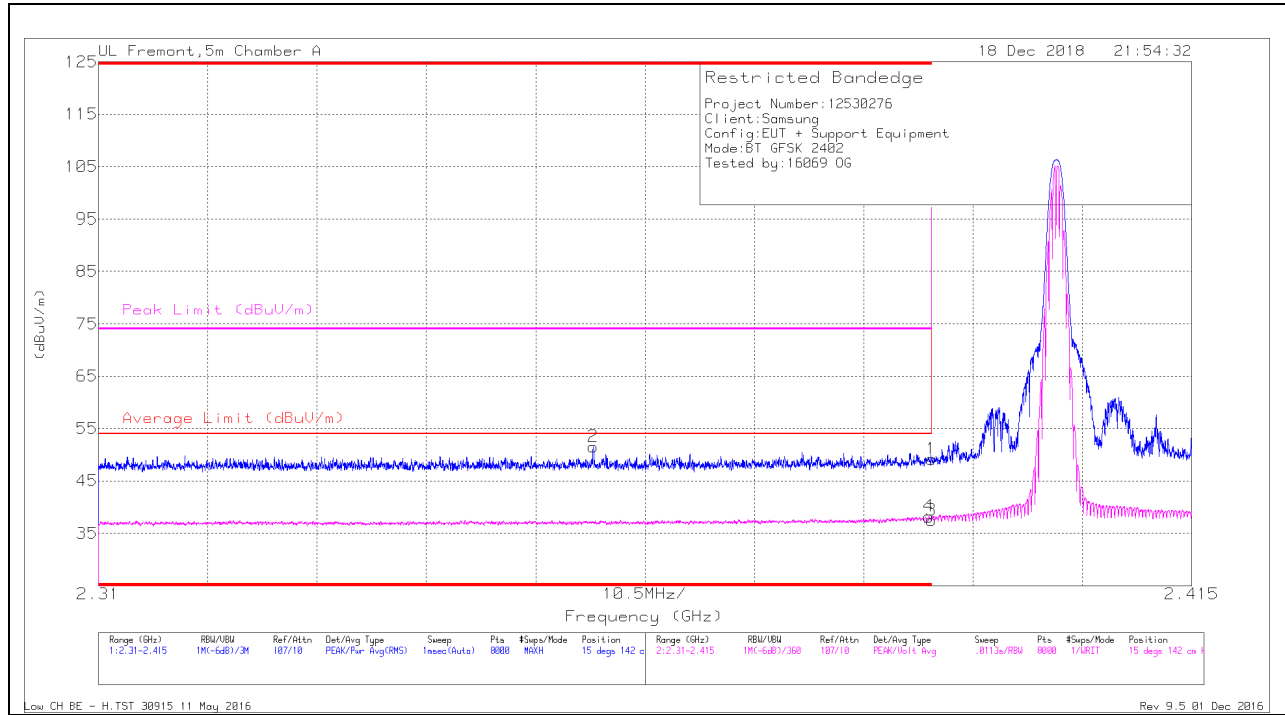

Trace Markers

Marker	Frequency (GHz)	Meter Reading (dBuV)	Det	AF T345 (dB/m)	Amp/Cb/Ftr/Pad (dB)	Corrected Reading (dBuV/m)	Average Limit (dBuV/m)	Margin (dB)	Peak Limit (dBuV/m)	PK Margin (dB)	Azimuth (Degs)	Height (cm)	Polarity
2	* 2.358	41.78	Pk	31.8	-22	51.58	-	-	74	-22.42	15	142	H
1	* 2.39	39.16	Pk	32	-22	49.16	-	-	74	-24.84	15	142	H
3	* 2.39	27.46	VA1T	32	-22	37.46	54	-16.54	-	-	15	142	H
4	* 2.39	28.19	VA1T	32	-22	38.19	54	-15.81	-	-	15	142	H

* - indicates frequency in CFR47 Pt 15 Restricted Band

Pk - Peak detector

VA1T - FHSS: Linear Voltage Average $V_B=1/T_{on}$ where: T_{on} is transmit duration

VERTICAL RESULT

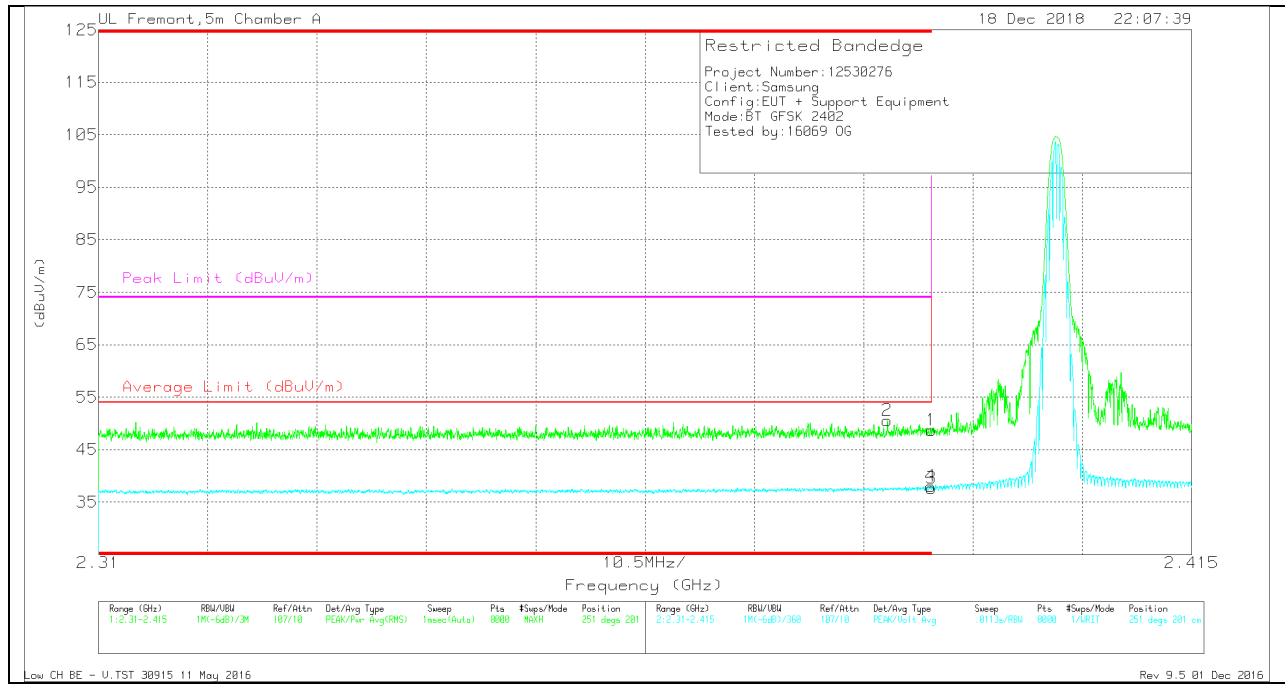

Trace Markers

Marker	Frequency (GHz)	Meter Reading (dBuV)	Det	AF T345 (dB/m)	Amp/Cb/Fltr/Pad (dB)	Corrected Reading (dBuV/m)	Average Limit (dBuV/m)	Margin (dB)	Peak Limit (dBuV/m)	PK Margin (dB)	Azimuth (Degs)	Height (cm)	Polarity
2	* 2.386	40.49	Pk	32	-22	50.49	-	-	74	-23.51	251	201	V
1	* 2.39	38.68	Pk	32	-22	48.68	-	-	74	-25.32	251	201	V
3	* 2.39	27.59	VA1T	32	-22	37.59	54	-16.41	-	-	251	201	V
4	* 2.39	28	VA1T	32	-22	38	54	-16	-	-	251	201	V

* - indicates frequency in CFR47 Pt 15 Restricted Band

Pk - Peak detector

VA1T - FHSS: Linear Voltage Average VB=1/Ton where: Ton is transmit duration

BANDEDGE (HIGH CHANNEL)

HORIZONTAL RESULT

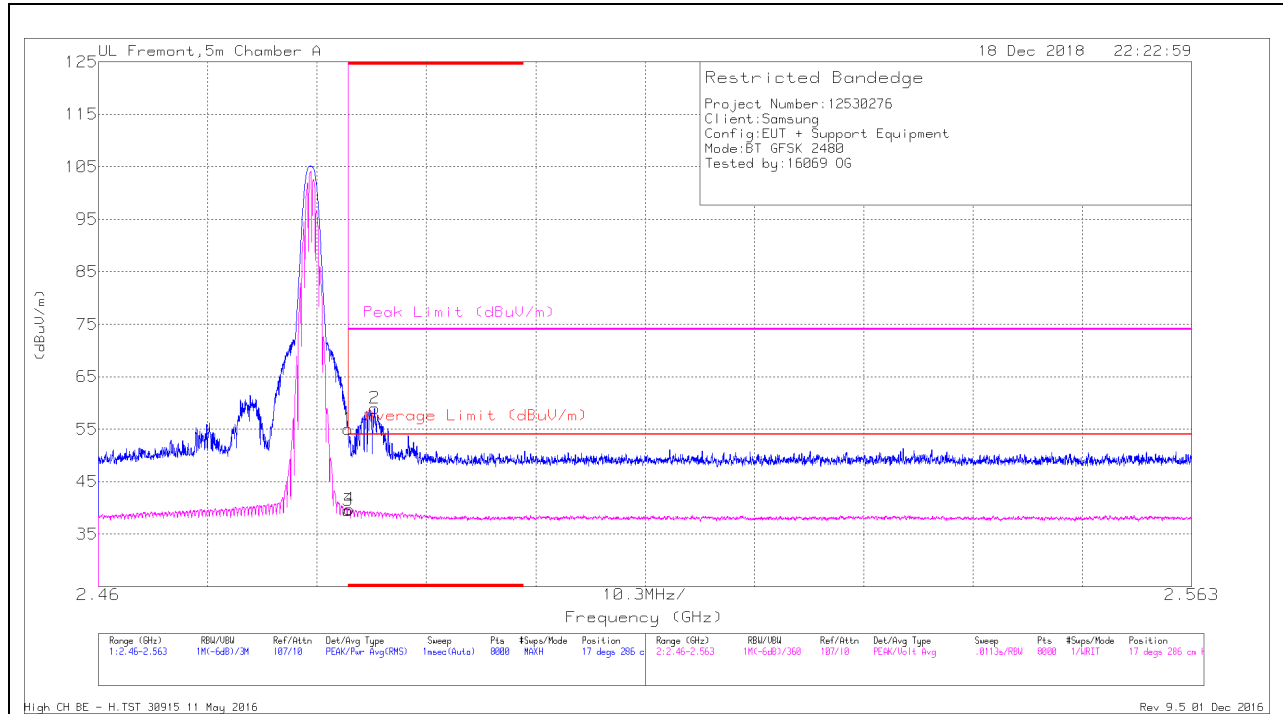

Trace Markers

Marker	Frequency (GHz)	Meter Reading (dBuV)	Det	AF T345 (dB/m)	Amp/Cb/Fitr/Pad (dB)	Corrected Reading (dBuV/m)	Average Limit (dBuV/m)	Margin (dB)	Peak Limit (dBuV/m)	PK Margin (dB)	Azimuth (Degs)	Height (cm)	Polarity
1	* 2.484	44.36	Pk	32.4	-21.7	55.06	-	-	74	-18.94	17	286	H
3	* 2.484	28.76	VA1T	32.4	-21.7	39.46	54	-14.54	-	-	17	286	H
4	* 2.484	29.05	VA1T	32.4	-21.7	39.75	54	-14.25	-	-	17	286	H
2	* 2.486	48.24	Pk	32.4	-21.7	58.94	-	-	74	-15.06	17	286	H

* - indicates frequency in CFR47 Pt 15 Restricted Band

Pk - Peak detector

VA1T - FHSS: Linear Voltage Average $V_B=1/T_{on}$ where: T_{on} is transmit duration

VERTICAL RESULT

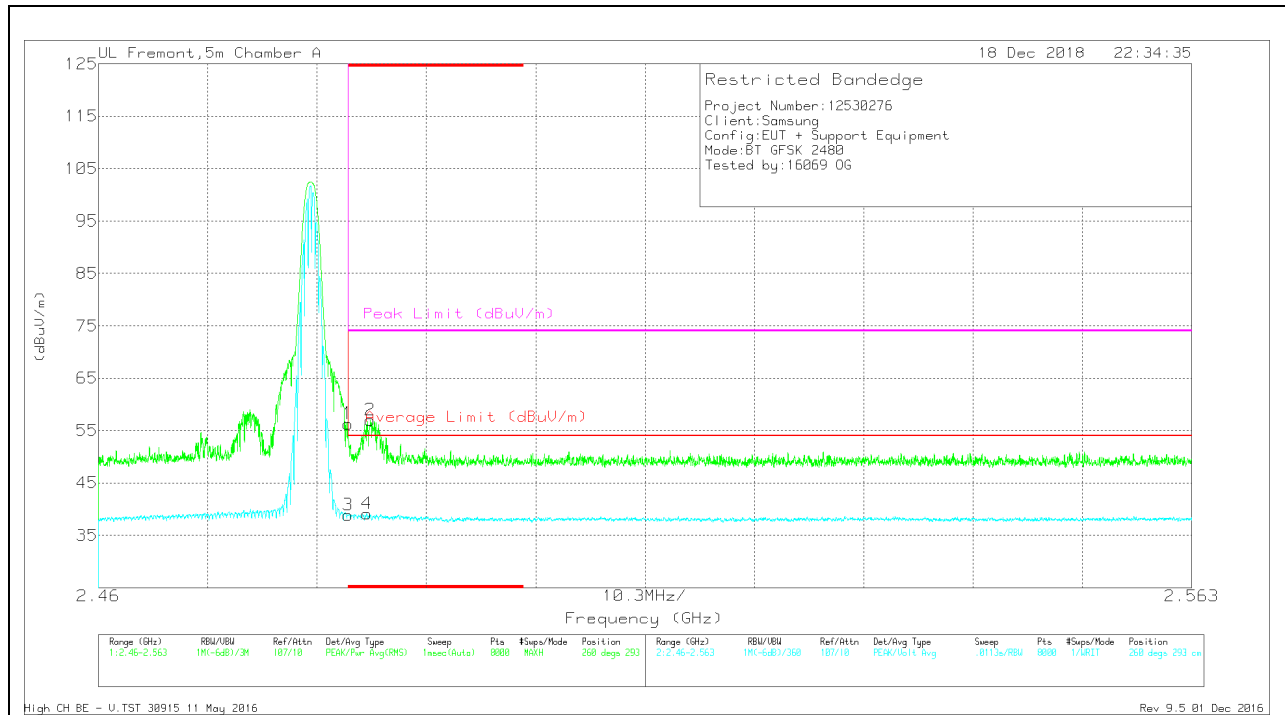

Trace Markers

Marker	Frequency (GHz)	Meter Reading (dBuV)	Det	AF T345 (dB/m)	Amp/Cb/Fltr/Pad (dB)	Corrected Reading (dBuV/m)	Average Limit (dBuV/m)	Margin (dB)	Peak Limit (dBuV/m)	PK Margin (dB)	Azimuth (Degs)	Height (cm)	Polarity
1	* 2.484	45.61	Pk	32.4	-21.7	56.31	-	-	74	-17.69	260	293	V
3	* 2.484	28.22	VA1T	32.4	-21.7	38.92	54	-15.08	-	-	260	293	V
4	* 2.485	28.4	VA1T	32.4	-21.7	39.1	54	-14.9	-	-	260	293	V
2	* 2.486	46.3	Pk	32.4	-21.7	57	-	-	74	-17	260	293	V

* - indicates frequency in CFR47 Pt 15 Restricted Band

Pk - Peak detector

VA1T - FHSS: Linear Voltage Average VB=1/Ton where: Ton is transmit duration

HARMONICS AND SPURIOUS EMISSIONS

LOW CHANNEL RESULTS

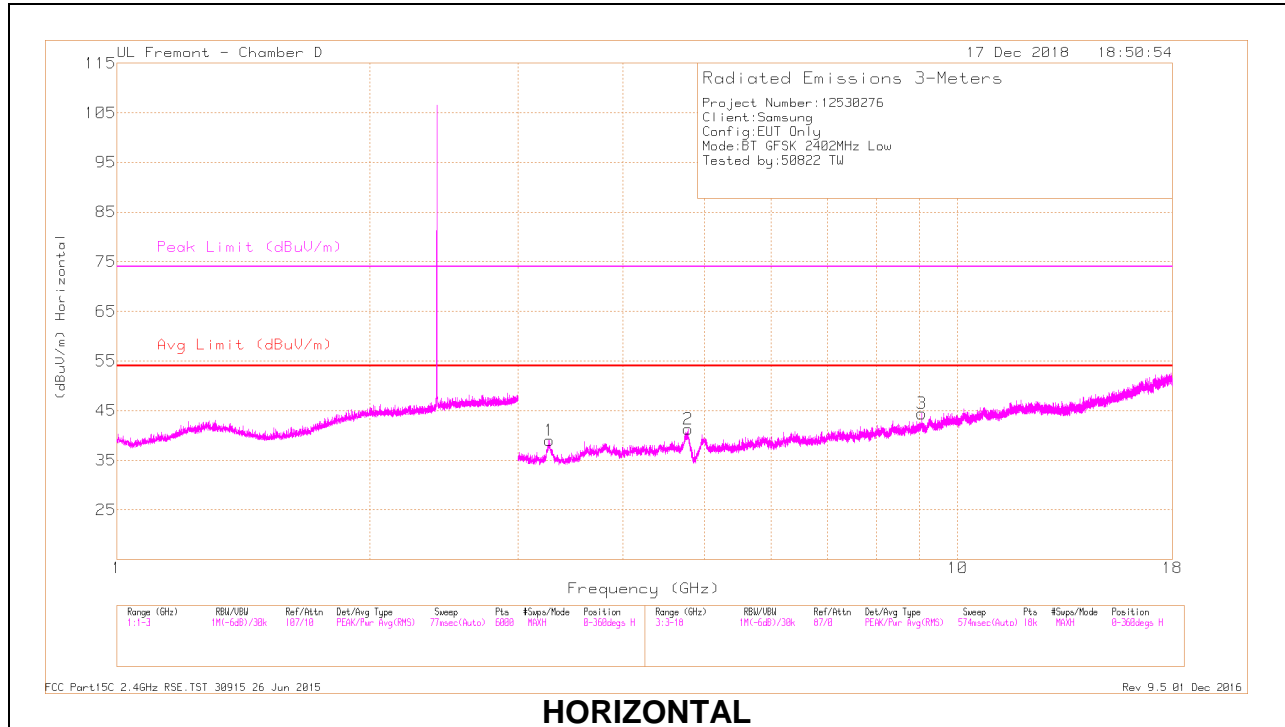

HORIZONTAL

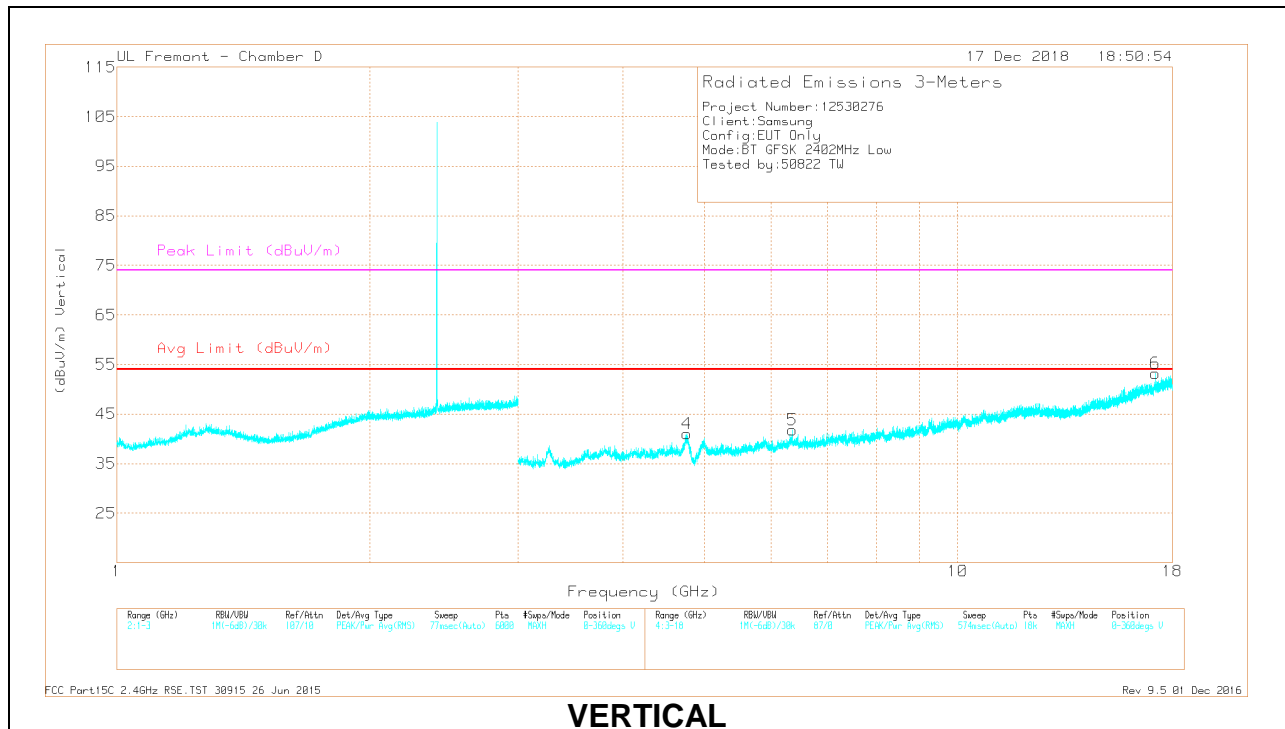

VERTICAL

RADIATED EMISSIONS

Frequency (GHz)	Meter Reading (dBuV)	Det	AF T119 (dB/m)	Amp/Cbl/Fitr/P ad (dB)	Corrected Reading (dBuV/m)	Avg Limit (dBuV/m)	Margin (dB)	Peak Limit (dBuV/m)	PK Margin (dB)	Azimuth (Degs)	Height (cm)	Polarity
* 4.778	36.64	PKFH	34.3	-25.3	45.64	-	-	74	-28.36	11	226	H
* 4.778	24.96	VA1T	34.3	-25.3	33.96	54	-20.04	-	-	11	226	H
* 9.059	32.95	PKFH	36.2	-20.6	48.55	-	-	74	-25.45	189	106	H
* 9.059	20.73	VA1T	36.2	-20.6	36.33	54	-17.67	-	-	189	106	H
* 4.762	37.35	PKFH	34.3	-25.4	46.25	-	-	74	-27.75	175	267	V
* 4.763	25.35	VA1T	34.3	-25.4	34.25	54	-19.75	-	-	175	267	V
3.269	23.71	VA1T	35.3	-27	32.01	-	-	-	-	53	199	H
3.271	35.01	PKFH	35.2	-27	43.21	-	-	-	-	53	199	H
6.357	34.8	PKFH	35.6	-25.1	45.3	-	-	-	-	183	212	V
6.359	23.31	VA1T	35.5	-25.2	33.61	-	-	-	-	183	212	V
17.171	19.96	VA1T	41.1	-16.6	44.46	-	-	-	-	236	348	V
17.173	32.55	PKFH	41.2	-16.6	57.15	-	-	-	-	236	348	V

* - indicates frequency in CFR47 Pt 15 Restricted Band

PKFH - FHSS: RB=100k/1MHz VB=3 x RB, Peak

VA1T - FHSS: Linear Voltage Average VB=1/Ton where: Ton is transmit duration

MID CHANNEL RESULTS

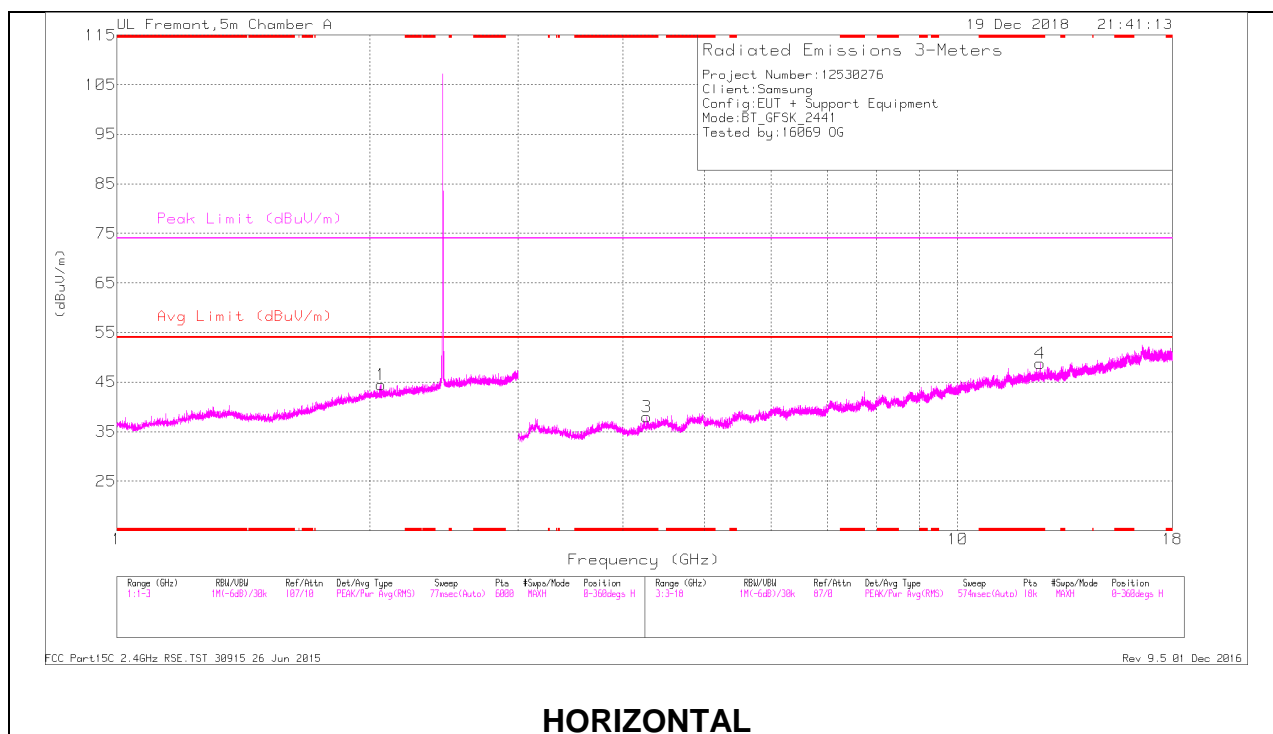

HORIZONTAL

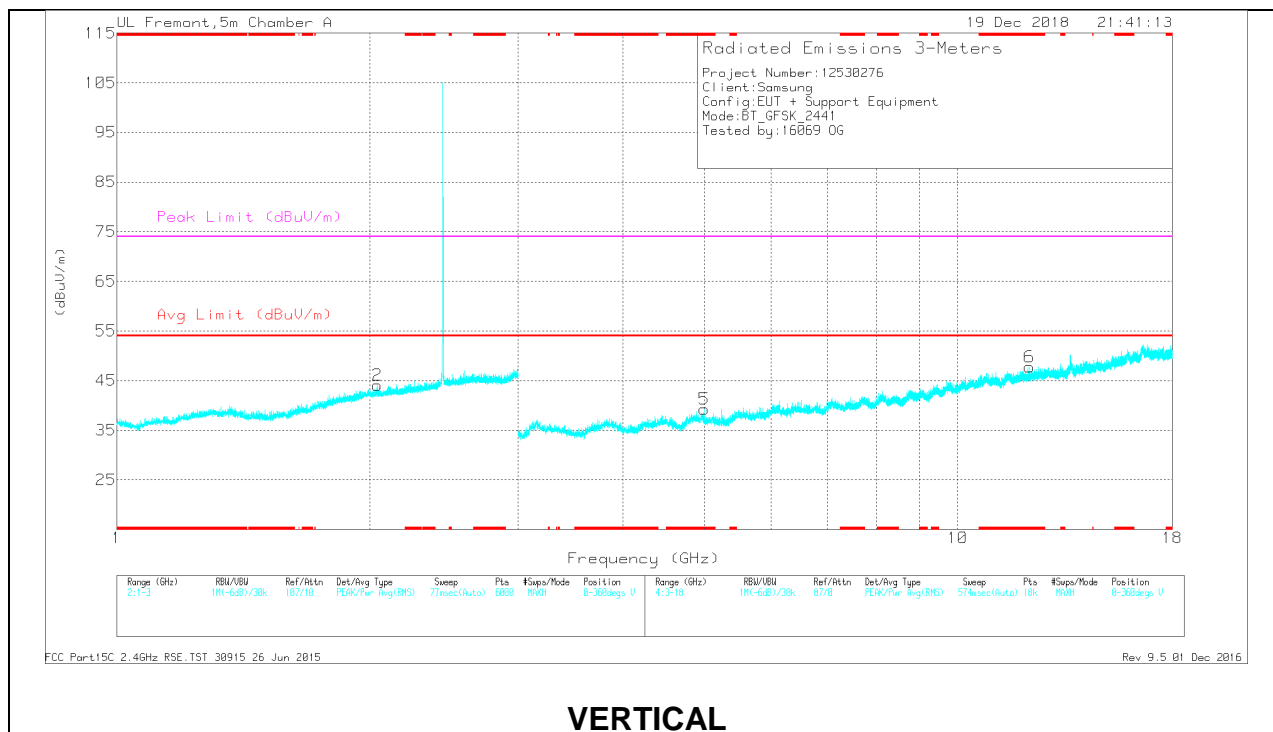

VERTICAL

RADIATED EMISSIONS

Frequency (GHz)	Meter Reading (dBuV)	Det	AF T345 (dB/m)	Amp/Cbl/Fitr/Prod (dB)	Corrected Reading (dBuV/m)	Avg Limit (dBuV/m)	Margin (dB)	Peak Limit (dBuV/m)	PK Margin (dB)	Azimuth (Degs)	Height (cm)	Polarity
* 4.263	35.07	PKFH	33.7	-26.6	42.17	-	-	74	-31.83	340	195	H
* 4.266	23.65	VA1T	33.7	-26.6	30.75	54	-23.25	-	-	340	195	H
* 12.529	30.47	PKFH	39.1	-17.2	52.37	-	-	74	-21.63	121	210	H
* 12.531	19.11	VA1T	39.1	-17.2	41.01	54	-12.99	-	-	121	210	H
* 4.996	35.01	PKFH	34.1	-26.9	42.21	-	-	74	-31.79	117	373	V
* 4.994	24.61	VA1T	34.1	-26.9	31.81	54	-22.19	-	-	117	373	V
* 12.172	30.2	PKFH	38.9	-17.8	51.3	-	-	74	-22.7	232	263	V
* 12.171	19.03	VA1T	39	-17.8	40.23	54	-13.77	-	-	232	263	V
2.041	38.48	PKFH	31.3	-22.4	47.38	-	-	-	-	178	221	V
2.061	38.83	PKFH	31.3	-22.4	47.73	-	-	-	-	7	126	H

* - indicates frequency in CFR47 Pt 15 Restricted Band

PKFH - FHSS: RB=100k/1MHz VB=3 x RB, Peak

VA1T - FHSS: Linear Voltage Average VB=1/Ton where: Ton is transmit duration

HIGH CHANNEL RESULTS

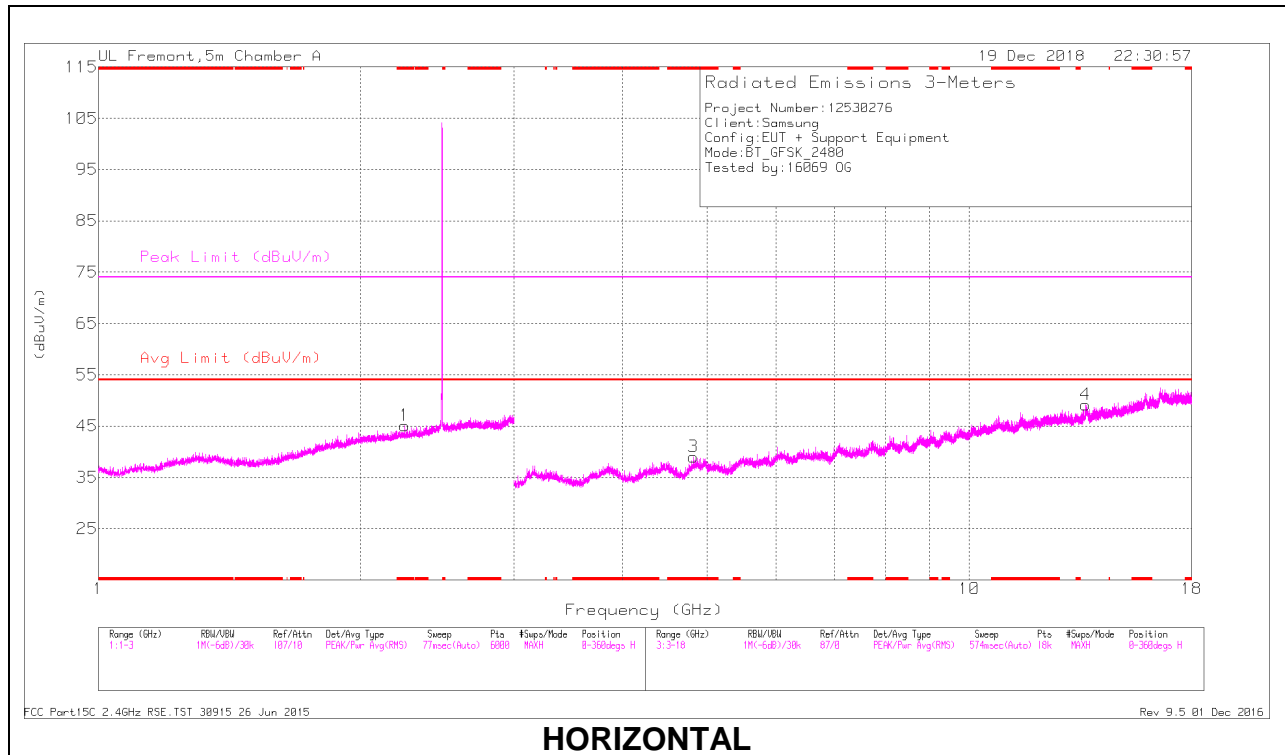

HORIZONTAL

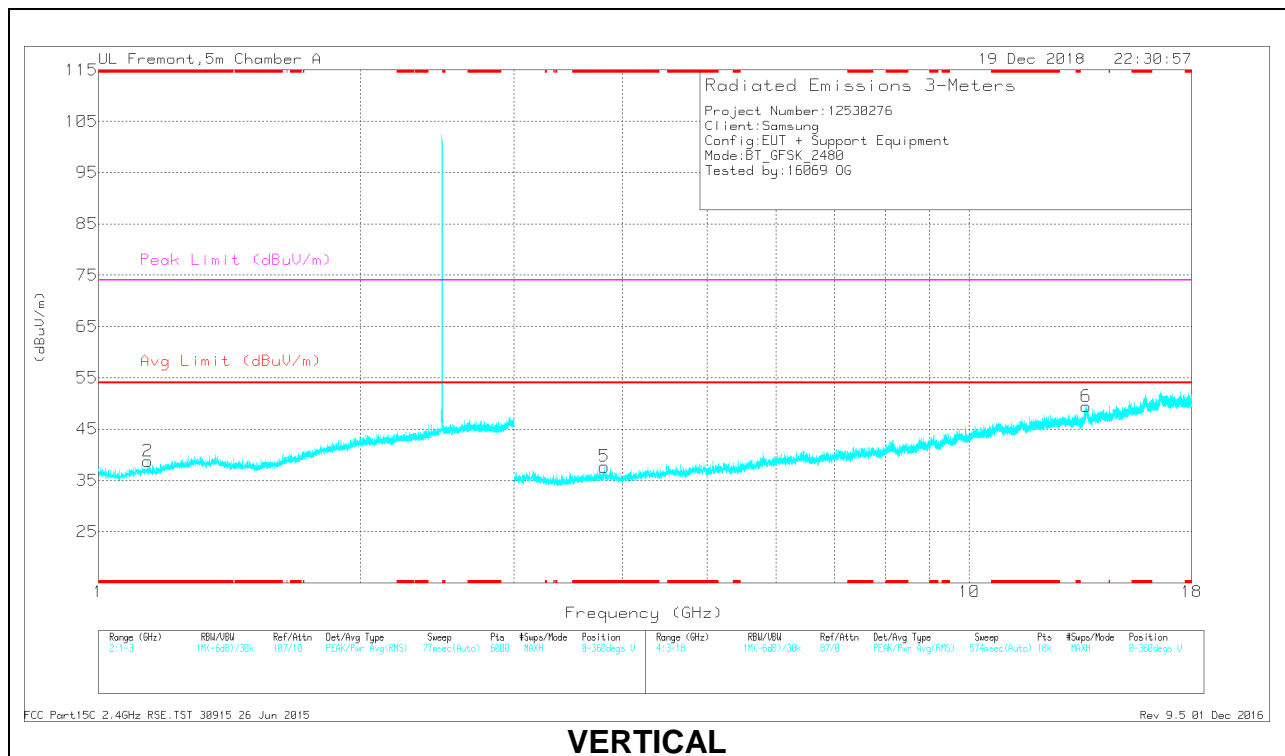

VERTICAL

RADIATED EMISSIONS

Frequency (GHz)	Meter Reading (dBuV)	Det	AF T345 (dB/m)	Amp/Cbl/Filtr/Pad (dB)	Corrected Reading (dBuV/m)	Avg Limit (dBuV/m)	Margin (dB)	Peak Limit (dBuV/m)	PK Margin (dB)	Azimuth (Degs)	Height (cm)	Polarity
* 2.249	38.9	PKFH	31.6	-21.9	48.6	-	-	74	-25.4	181	327	H
* 2.247	27.36	VA1T	31.6	-22	36.96	54	-17.04	-	-	181	327	H
* 1.14	39.79	PKFH	27.6	-24.4	42.99	-	-	74	-31.01	111	176	V
* 1.139	28.13	VA1T	27.6	-24.4	31.33	54	-22.67	-	-	111	176	V
* 4.821	34.25	PKFH	34.2	-25.6	42.85	-	-	74	-31.15	249	101	H
* 4.821	23.49	VA1T	34.2	-25.5	32.19	54	-21.81	-	-	249	101	H
* 3.806	36.9	PKFH	33.5	-27.8	42.6	-	-	74	-31.4	305	280	V
* 3.809	24.92	VA1T	33.5	-27.8	30.62	54	-23.38	-	-	305	280	V
13.603	31.72	PKFH	38.9	-16.2	54.42	-	-	-	-	107	105	H
13.619	31.43	PKFH	38.7	-16.6	53.53	-	-	-	-	344	250	V

* - indicates frequency in CFR47 Pt 15 Restricted Band

PKFH - FHSS: RB=100k/1MHz VB=3 x RB, Peak

VA1T - FHSS: Linear Voltage Average VB=1/Ton where: Ton is transmit duration

9.1.2. BLUETOOTH ENHANCED DATA RATE 8PSK MODULATION

BANDEDGE (LOW CHANNEL)

HORIZONTAL RESULT

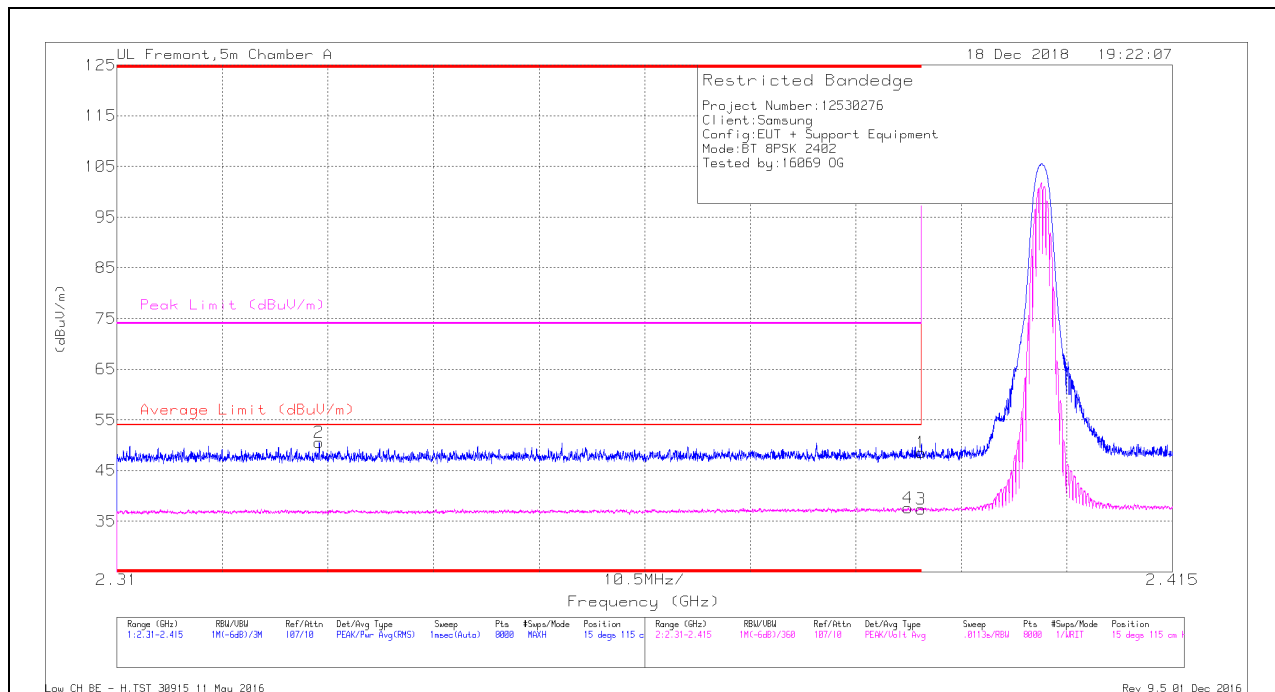

Trace Markers

Marker	Frequency (GHz)	Meter Reading (dBuV)	Det	AF T345 (dB/m)	Amp/Cb/Fltr/Pa d (dB)	Corrected Reading (dBuV/m)	Average Limit (dBuV/m)	Margin (dB)	Peak Limit (dBuV/m)	PK Margin (dB)	Azimuth (Degs)	Height (cm)	Polarity
1	* 2.39	38.53	Pk	32	-22	48.53	-	-	74	-25.47	15	115	H
2	* 2.33	40.87	Pk	31.7	-22	50.57	-	-	74	-23.43	15	115	H
3	* 2.39	27.37	VA1T	32	-22	37.37	54	-16.63	-	-	15	115	H
4	* 2.389	27.63	VA1T	32	-22	37.63	54	-16.37	-	-	15	115	H

* - indicates frequency in CFR47 Pt 15 Restricted Band

Pk - Peak detector

VA1T - FHSS: Linear Voltage Average $V_B=1/T_{on}$ where: T_{on} is transmit duration

VERTICAL RESULT

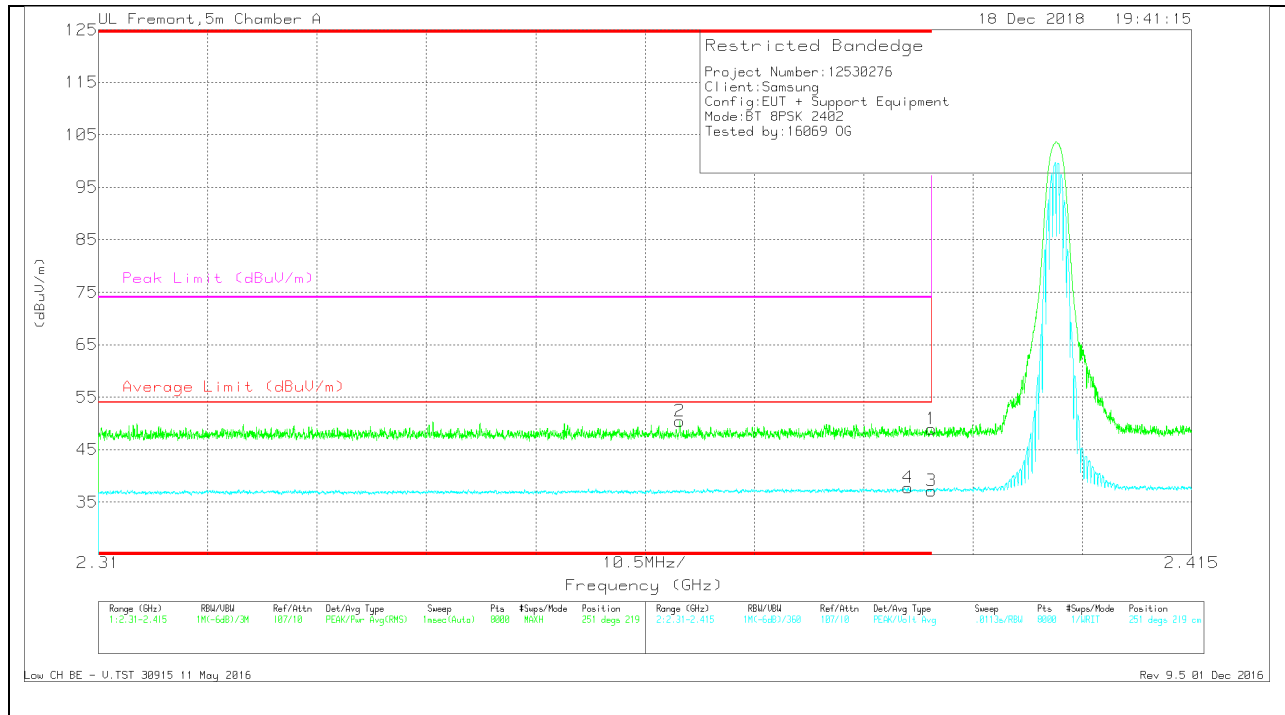

Trace Markers

Marker	Frequency (GHz)	Meter Reading (dBuV)	Det	AF T345 (dB/m)	Amp/Cb/Fltr/Pad (dB)	Corrected Reading (dBuV/m)	Average Limit (dBuV/m)	Margin (dB)	Peak Limit (dBuV/m)	PK Margin (dB)	Azimuth (Degs)	Height (cm)	Polarity
2	* 2.366	40.58	Pk	31.8	-22	50.38	-	-	74	-23.62	251	219	V
4	* 2.388	27.74	VA1T	32	-22	37.74	54	-16.26	-	-	251	219	V
1	* 2.39	38.88	Pk	32	-22	48.88	-	-	74	-25.12	251	219	V
3	* 2.39	27.11	VA1T	32	-22	37.11	54	-16.89	-	-	251	219	V

* - indicates frequency in CFR47 Pt 15 Restricted Band

Pk - Peak detector

VA1T - FHSS: Linear Voltage Average VB=1/Ton where: Ton is transmit duration

BANDEDGE (HIGH CHANNEL)

HORIZONTAL RESULT

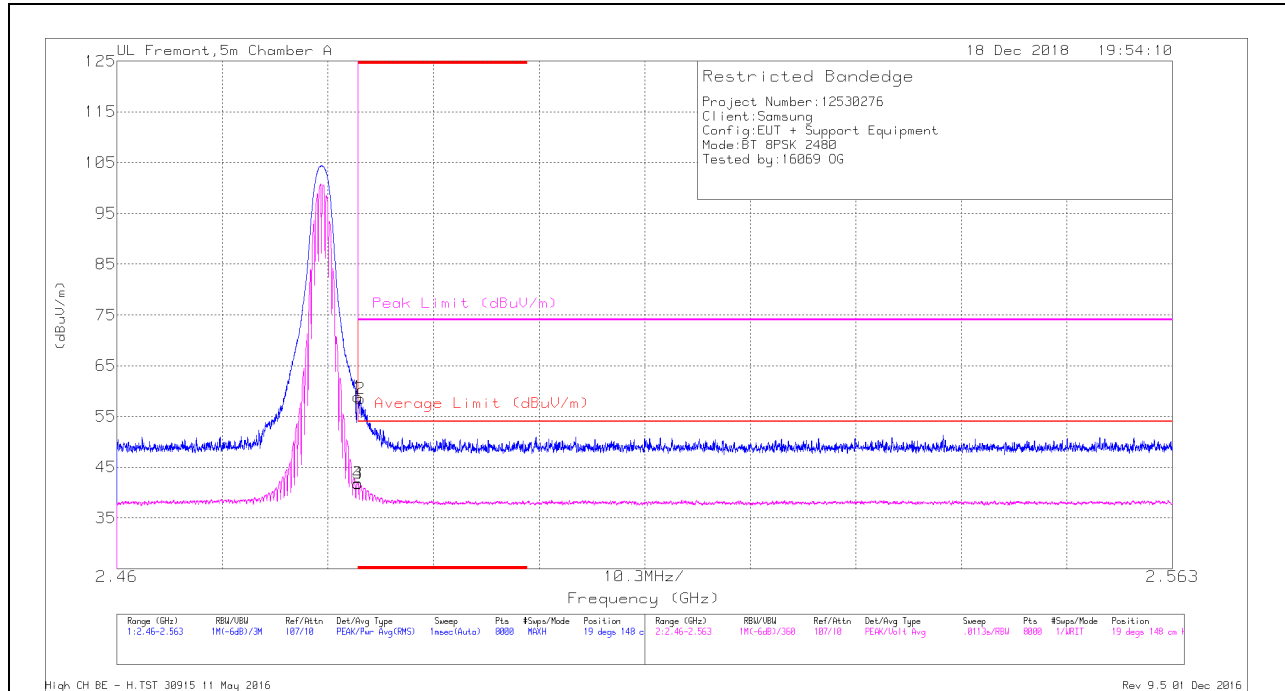

Trace Markers

Marker	Frequency (GHz)	Meter Reading (dBuV)	Det	AF T345 (dB/m)	Amp/Cb/Fltr/Pa d (dB)	Corrected Reading (dBuV/m)	Average Limit (dBuV/m)	Margin (dB)	Peak Limit (dBuV/m)	PK Margin (dB)	Azimuth (Degs)	Height (cm)	Polarity
1	* 2.484	48.21	Pk	32.4	-21.7	58.91	-	-	74	-15.09	19	148	H
2	* 2.484	47.78	Pk	32.4	-21.7	58.48	-	-	74	-15.52	19	148	H
3	* 2.484	31.11	VA1T	32.4	-21.7	41.81	54	-12.19	-	-	19	148	H
4	* 2.484	31.08	VA1T	32.4	-21.7	41.78	54	-12.22	-	-	19	148	H

* - indicates frequency in CFR47 Pt 15 Restricted Band

Pk - Peak detector

VA1T - FHSS: Linear Voltage Average VB=1/Ton where: Ton is transmit duration

VERTICAL RESULT

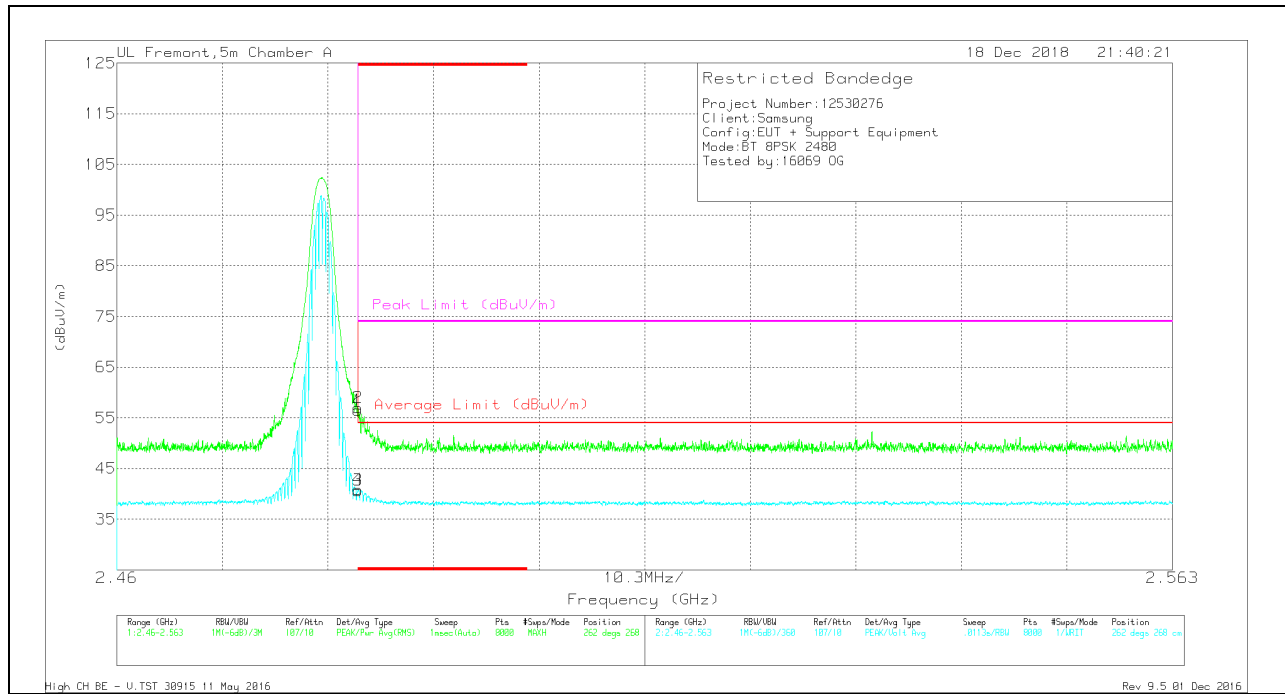

Trace Markers

Marker	Frequency (GHz)	Meter Reading (dBuV)	Det	AF T345 (dB/m)	Amp/Cbl/Fitr/Pad (dB)	Corrected Reading (dBuV/m)	Average Limit (dBuV/m)	Margin (dB)	Peak Limit (dBuV/m)	PK Margin (dB)	Azimuth (Degs)	Height (cm)	Polarity
1	* 2.484	45.81	Pk	32.4	-21.7	56.51	-	-	74	-17.49	262	268	V
2	* 2.484	46.32	Pk	32.4	-21.7	57.02	-	-	74	-16.98	262	268	V
3	* 2.484	29.97	VA1T	32.4	-21.7	40.67	54	-13.33	-	-	262	268	V
4	* 2.484	30.16	VA1T	32.4	-21.7	40.86	54	-13.14	-	-	262	268	V

* - indicates frequency in CFR47 Pt 15 Restricted Band

Pk - Peak detector

VA1T - FHSS: Linear Voltage Average $V_B=1/T_{on}$ where: T_{on} is transmit duration

HARMONICS AND SPURIOUS EMISSIONS

LOW CHANNEL RESULTS

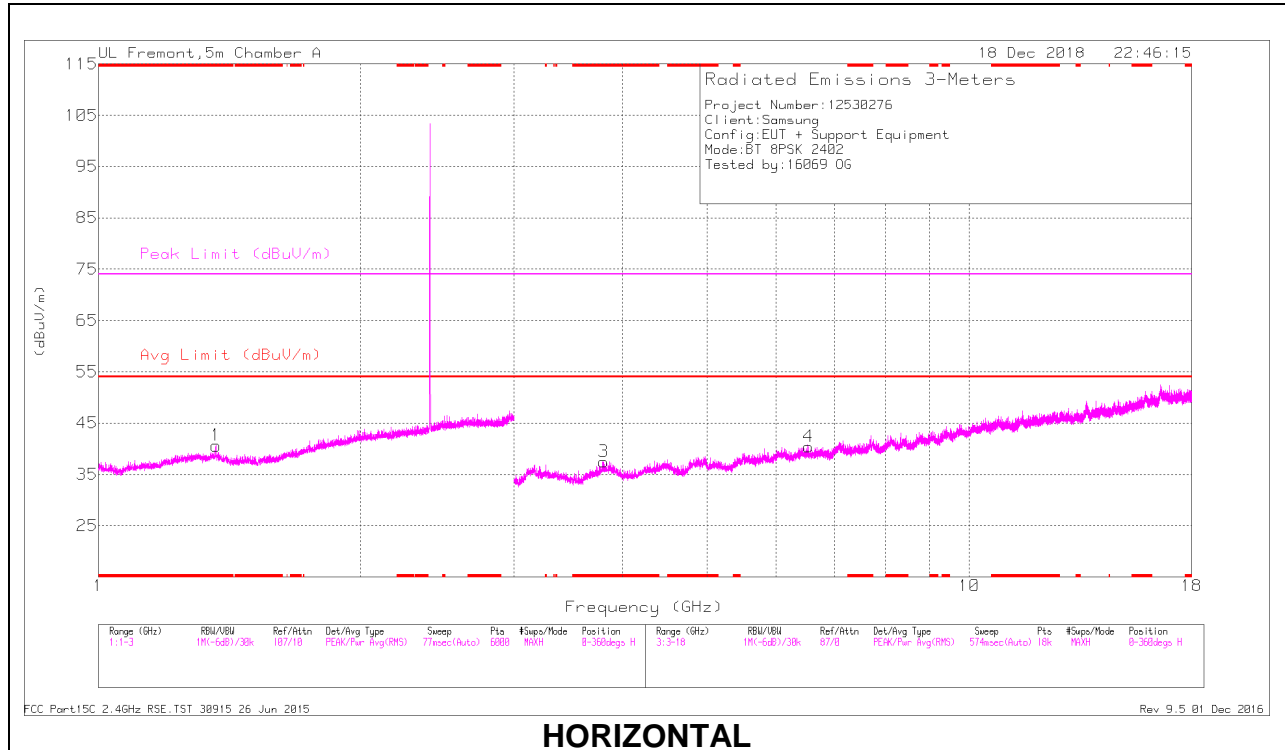

HORIZONTAL

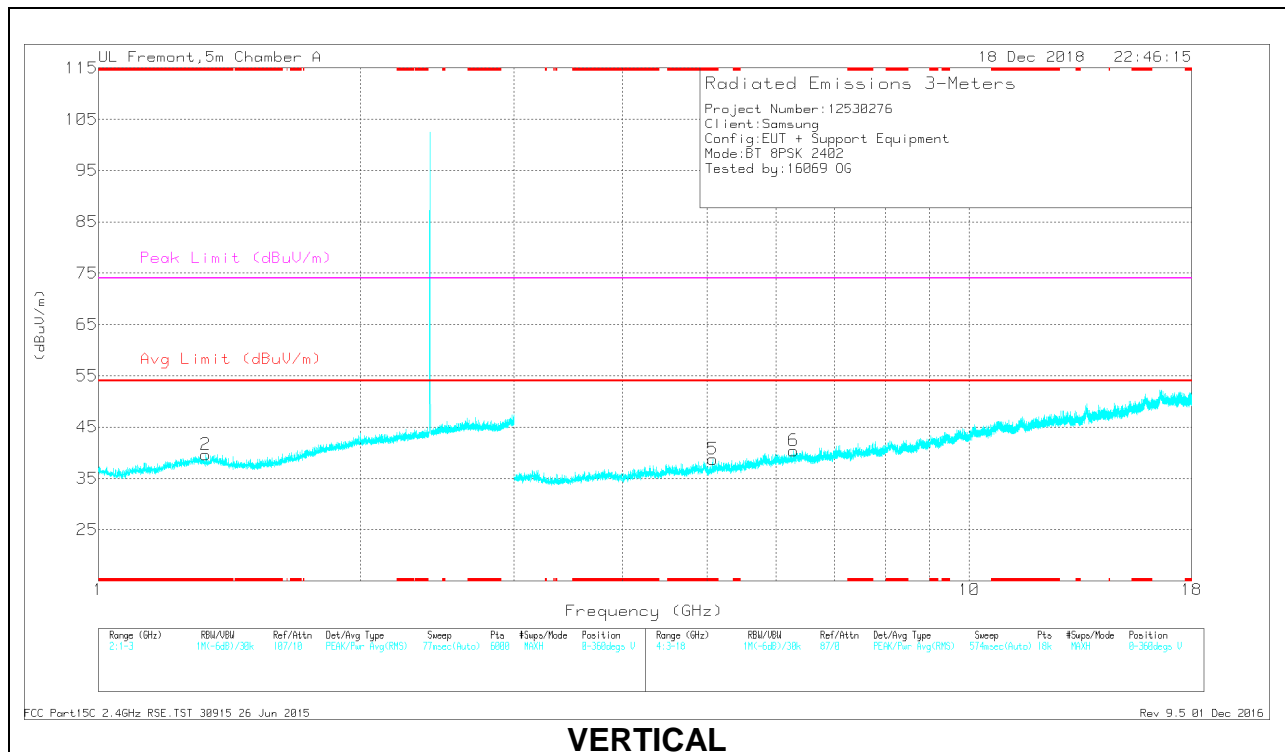

VERTICAL

RADIATED EMISSIONS

Frequency (GHz)	Meter Reading (dBuV)	Det	AF T345 (dB/m)	Amp/Cbl/Filtr/Pad (dB)	Corrected Reading (dBuV/m)	Avg Limit (dBuV/m)	Margin (dB)	Peak Limit (dBuV/m)	PK Margin (dB)	Azimuth (Degs)	Height (cm)	Polarity
* 1.362	38.8	PKFH	29.2	-24.2	43.8	-	-	74	-30.2	126	265	H
* 1.363	27.91	VA1T	29.2	-24.2	32.91	54	-21.09	-	-	126	265	H
* 1.328	39.08	PKFH	28.9	-24.2	43.78	-	-	74	-30.22	61	201	V
* 1.329	27.77	VA1T	28.9	-24.2	32.47	54	-21.53	-	-	61	201	V
* 3.808	35.85	PKFH	33.5	-27.8	41.55	-	-	74	-32.45	5	233	H
* 3.808	25.13	VA1T	33.5	-27.8	30.83	54	-23.17	-	-	5	233	H
* 5.075	34.62	PKFH	34.2	-26.6	42.22	-	-	74	-31.78	349	254	V
* 5.073	23.68	VA1T	34.2	-26.6	31.28	54	-22.72	-	-	349	254	V
6.278	33.89	PKFH	35.6	-24.6	44.89	-	-	-	-	210	214	V
6.534	31.39	PKFH	35.5	-23.3	43.59	-	-	-	-	264	102	H

* - indicates frequency in CFR47 Pt 15 Restricted Band

PKFH - FHSS: RB=100k/1MHz VB=3 x RB, Peak

VA1T - FHSS: Linear Voltage Average VB=1/Ton where: Ton is transmit duration

MID CHANNEL RESULTS

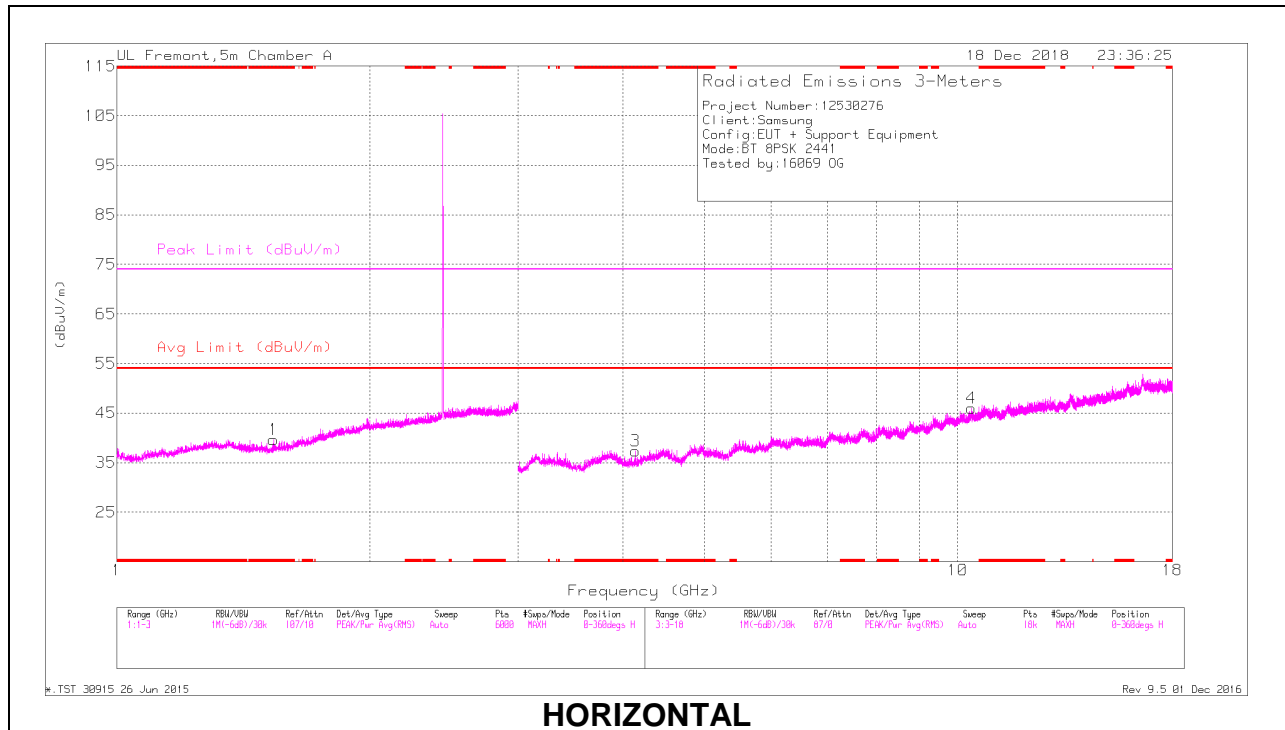

HORIZONTAL

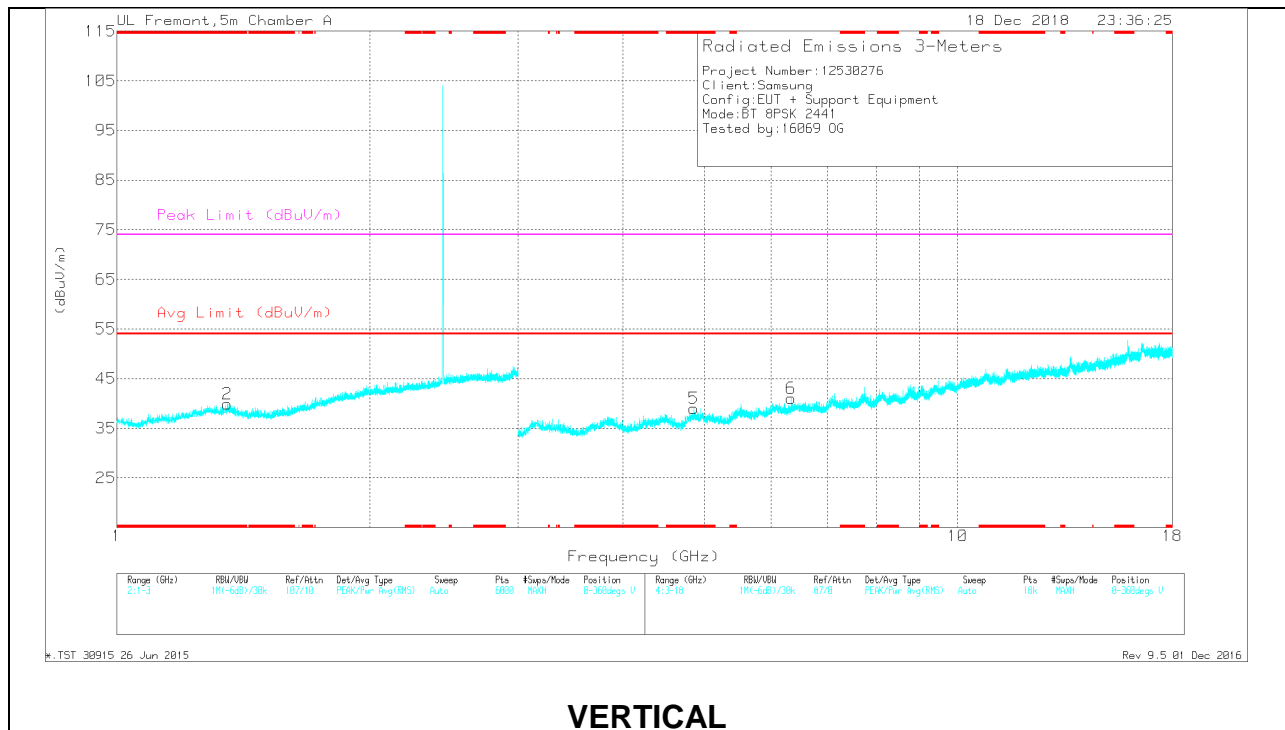

VERTICAL

RADIATED EMISSIONS

Frequency (GHz)	Meter Reading (dBuV)	Det	AF T345 (dB/m)	Amp/Cbl/Fitr/P ad (dB)	Corrected Reading (dBuV/m)	Avg Limit (dBuV/m)	Margin (dB)	Peak Limit (dBuV/m)	PK Margin (dB)	Azimuth (Degs)	Height (cm)	Polarity
* 1.536	38.4	PKFH	27.9	-23.7	42.6	-	-	74	-31.4	158	182	H
* 1.535	27.89	VA1T	27.9	-23.7	32.09	54	-21.91	-	-	158	182	H
* 1.353	39.26	PKFH	29.1	-24.1	44.26	-	-	74	-29.74	182	378	V
* 1.354	27.91	VA1T	29.1	-24.1	32.91	54	-21.09	-	-	182	378	V
* 4.137	34.15	PKFH	33.7	-27.3	40.55	-	-	74	-33.45	327	371	H
* 4.137	23.19	VA1T	33.7	-27.3	29.59	54	-24.41	-	-	327	371	H
* 4.858	33.94	PKFH	34.1	-25.6	42.44	-	-	74	-31.56	181	107	V
* 4.858	23.26	VA1T	34.1	-25.6	31.76	54	-22.24	-	-	181	107	V
6.339	32.89	PKFH	35.6	-24.3	44.19	-	-	-	-	107	151	V
10.386	30.43	PKFH	37.6	-18.2	49.83	-	-	-	-	296	156	H

* - indicates frequency in CFR47 Pt 15 Restricted Band

PKFH - FHSS: RB=100k/1MHz VB=3 x RB, Peak

VA1T - FHSS: Linear Voltage Average VB=1/Ton where: Ton is transmit duration

HIGH CHANNEL RESULTS

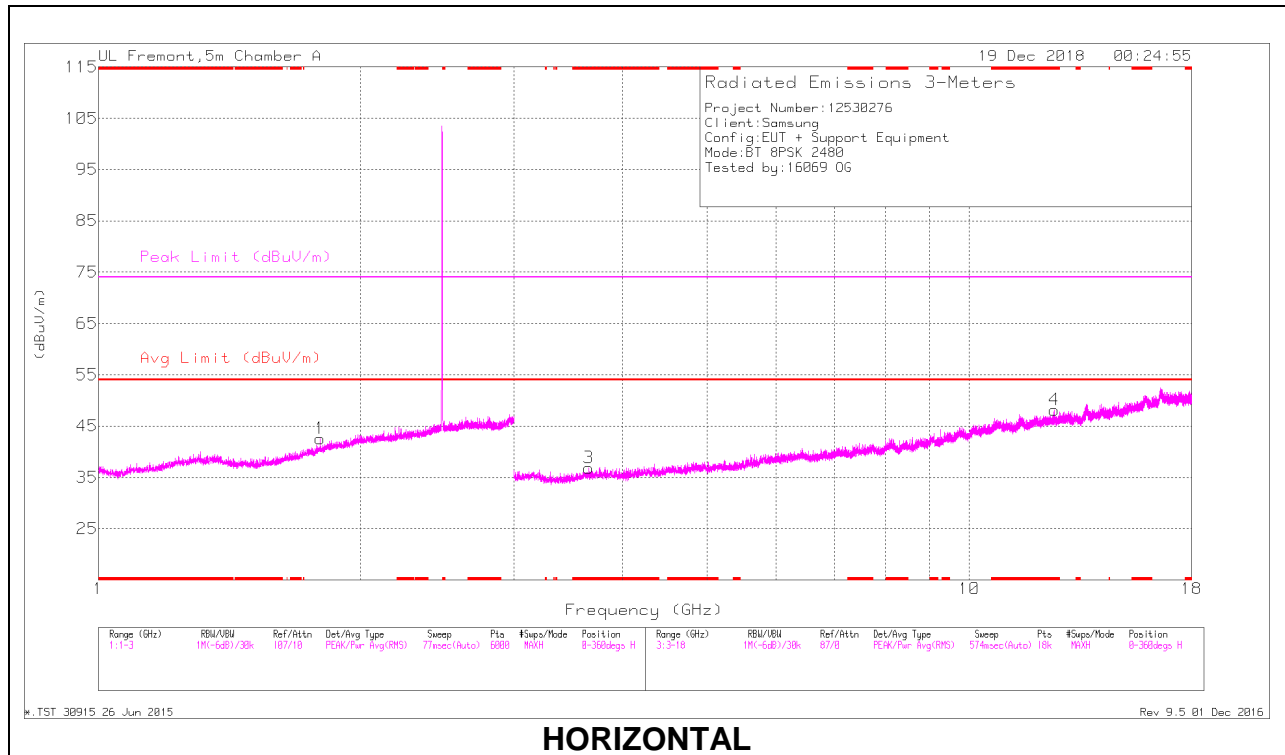

HORIZONTAL

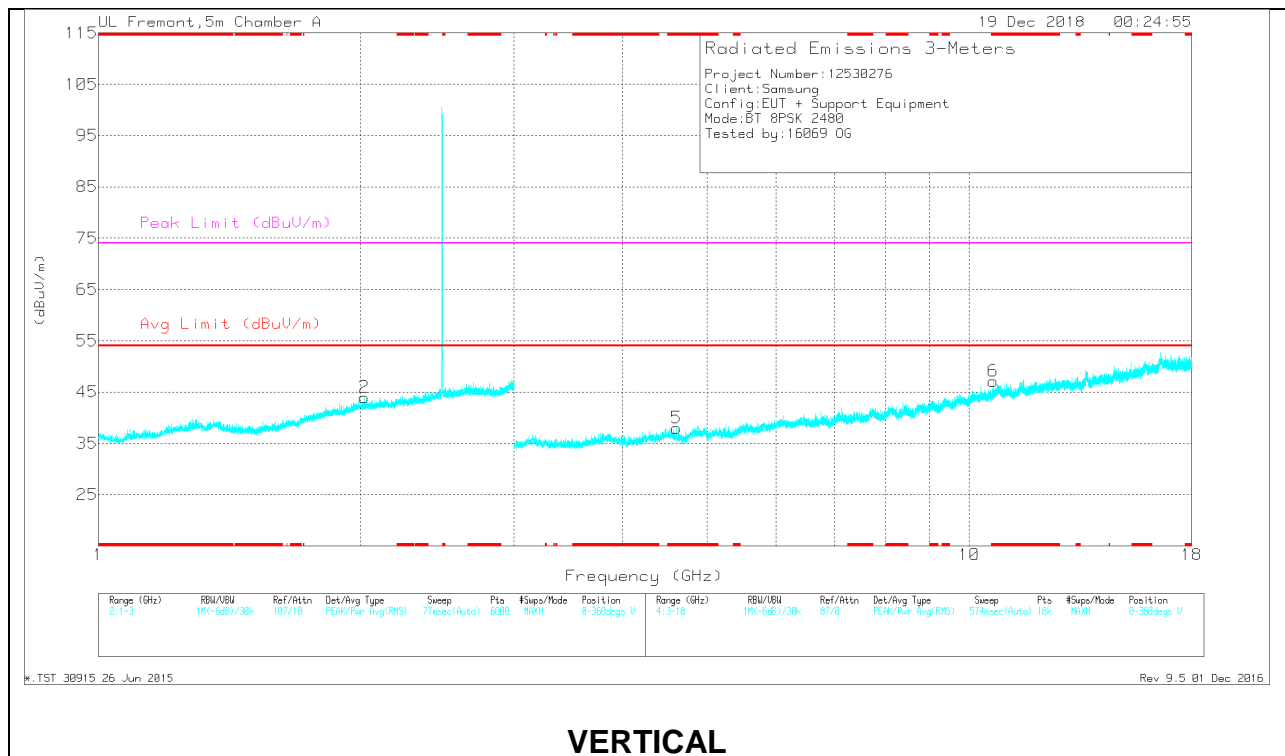

VERTICAL

RADIATED EMISSIONS

Frequency (GHz)	Meter Reading (dBuV)	Det	AF T345 (dB/m)	Amp/Cbl/Filtr/Pad (dB)	Corrected Reading (dBuV/m)	Avg Limit (dBuV/m)	Margin (dB)	Peak Limit (dBuV/m)	PK Margin (dB)	Azimuth (Degs)	Height (cm)	Polarity
* 3.656	34.58	PKFH	33.1	-27.7	39.98	-	-	74	-34.02	36	245	H
* 3.655	23.86	VA1T	33.1	-27.7	29.26	54	-24.74	-	-	36	245	H
* 12.522	29.82	PKFH	39.1	-17.3	51.62	-	-	74	-22.38	210	164	H
* 12.52	19.14	VA1T	39.1	-17.4	40.84	54	-13.16	-	-	210	164	H
* 4.61	35.77	PKFH	34.2	-27	42.97	-	-	74	-31.03	276	241	V
* 4.612	23.74	VA1T	34.2	-26.9	31.04	54	-22.96	-	-	276	241	V
* 10.656	31.71	PKFH	37.8	-18.5	51.01	-	-	74	-22.99	126	217	V
* 10.655	19.84	VA1T	37.8	-18.5	39.14	54	-14.86	-	-	126	217	V
1.794	39.04	PKFH	30.2	-23	46.24	-	-	-	-	316	193	H
2.02	39.69	PKFH	31.5	-22.6	48.59	-	-	-	-	213	383	V

* - indicates frequency in CFR47 Pt 15 Restricted Band

PKFH - FHSS: RB=100k/1MHz VB=3 x RB, Peak

VA1T - FHSS: Linear Voltage Average VB=1/Ton where: Ton is transmit duration

9.2. Worst Case Below 30 MHz

SPURIOUS EMISSIONS 9 kHz TO 30 MHz (WORST-CASE CONFIGURATION)

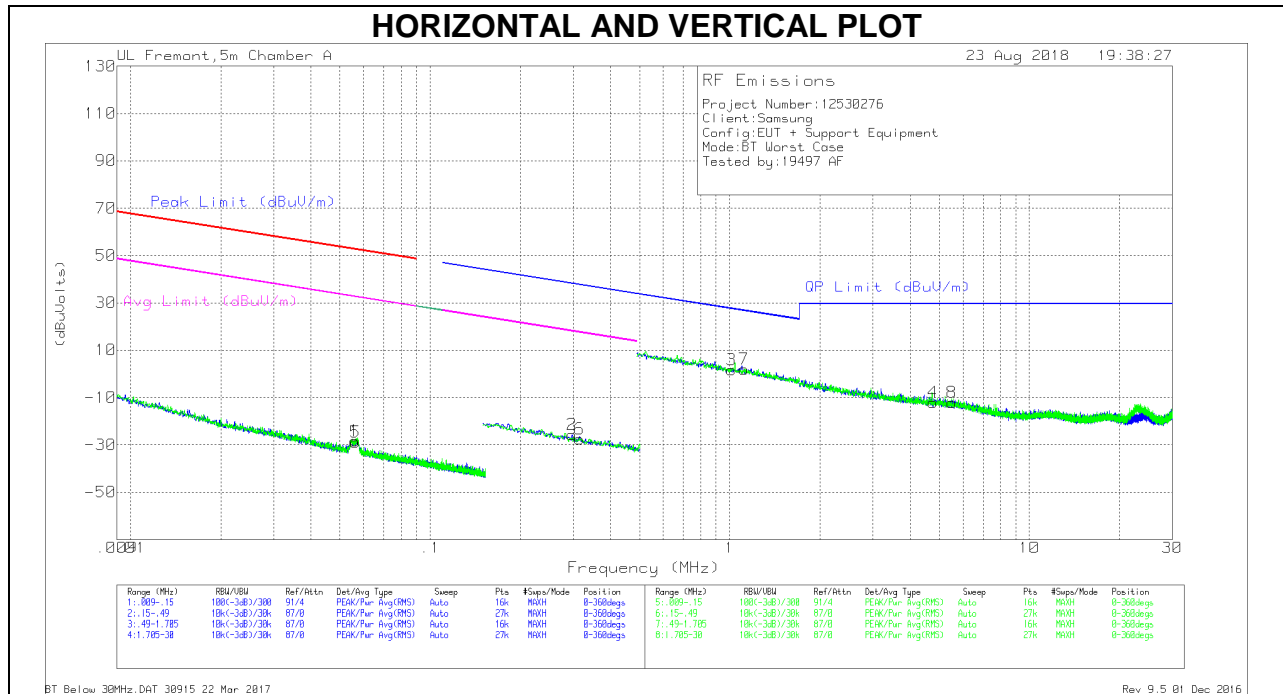

NOTE: KDB 414788 OATS and Chamber Correlation Justification

- Based on FCC 15.31 (f) (2): measurements may be performed at a distance closer than that specified in the regulations; however, an attempt should be made to avoid making measurements in the near field.
- OATs and chamber correlation testing had been performed and chamber measured test result is the worst case test result.

Below 30 MHz Data

Trace Markers

Marker	Frequency (MHz)	Meter Reading (dBuV)	Det	Loop Antenna (dB/m)	Cbl (dB)	Dist Corr 300m	Corrected Reading (dBuVolts)	Peak Limit (dBuV/m)	Margin (dB)	Avg Limit (dBuV/m)	Margin (dB)	Peak Limit (dBuV/m)	Margin (dB)	Avg Limit (dBuV/m)	Margin (dB)	Azimuth (Degs)
1	.05599	39.74	Pk	11.8	.1	-80	-28.36	52.62	-80.98	32.62	-60.98	-	-	-	-	0-360
5	.05627	39.17	Pk	11.8	.1	-80	-28.93	52.58	-81.51	32.58	-61.51	-	-	-	-	0-360
2	.2975	43.24	Pk	10.9	.1	-80	-25.76	-	-	-	-	38.14	-63.9	18.14	-43.9	0-360
6	.31511	41.47	Pk	10.9	.1	-80	-27.53	-	-	-	-	37.64	-65.17	17.64	-45.17	0-360

Pk - Peak detector

Marker	Frequency (MHz)	Meter Reading (dBuV)	Det	Loop Antenna (dB/m)	Cbl (dB)	Dist Corr 30m	Corrected Reading (dBuVolts)	QP Limit (dBuV/m)	Margin (dB)	Peak Limit (dBuV/m)	Margin (dB)	Avg Limit (dBuV/m)	Margin (dB)	Azimuth (Degs)
3	1.01273	30.23	Pk	11.3	.2	-40	1.73	27.51	-25.78	-	-	-	-	0-360
7	1.11616	30.47	Pk	11.3	.2	-40	1.97	26.67	-24.7	-	-	-	-	0-360
4	4.76516	16.45	Pk	11.2	.3	-40	-12.05	29.5	-41.55	-	-	-	-	0-360
8	5.515	16.5	Pk	11.1	.4	-40	-12	29.5	-41.5	-	-	-	-	0-360

Pk - Peak detector

9.3. Worst Case Below 1 GHz

SPURIOUS EMISSIONS 30 TO 1000 MHz (WORST-CASE CONFIGURATION)

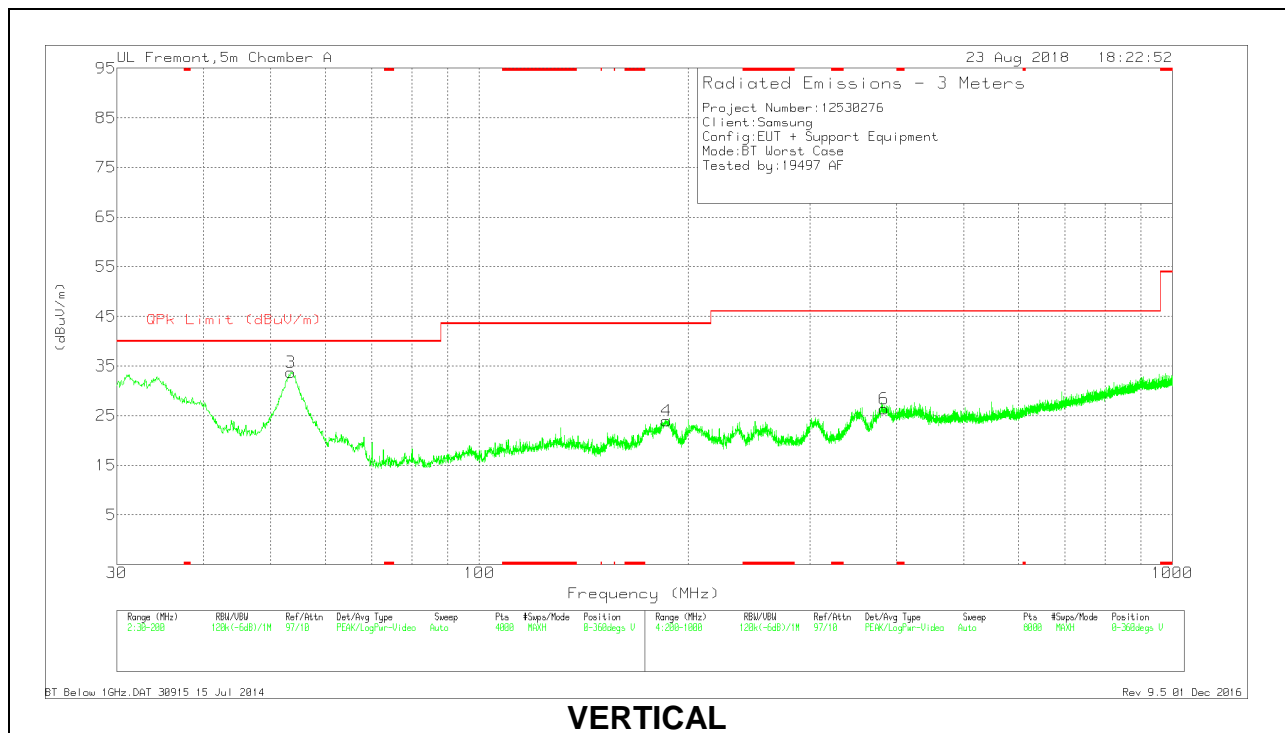
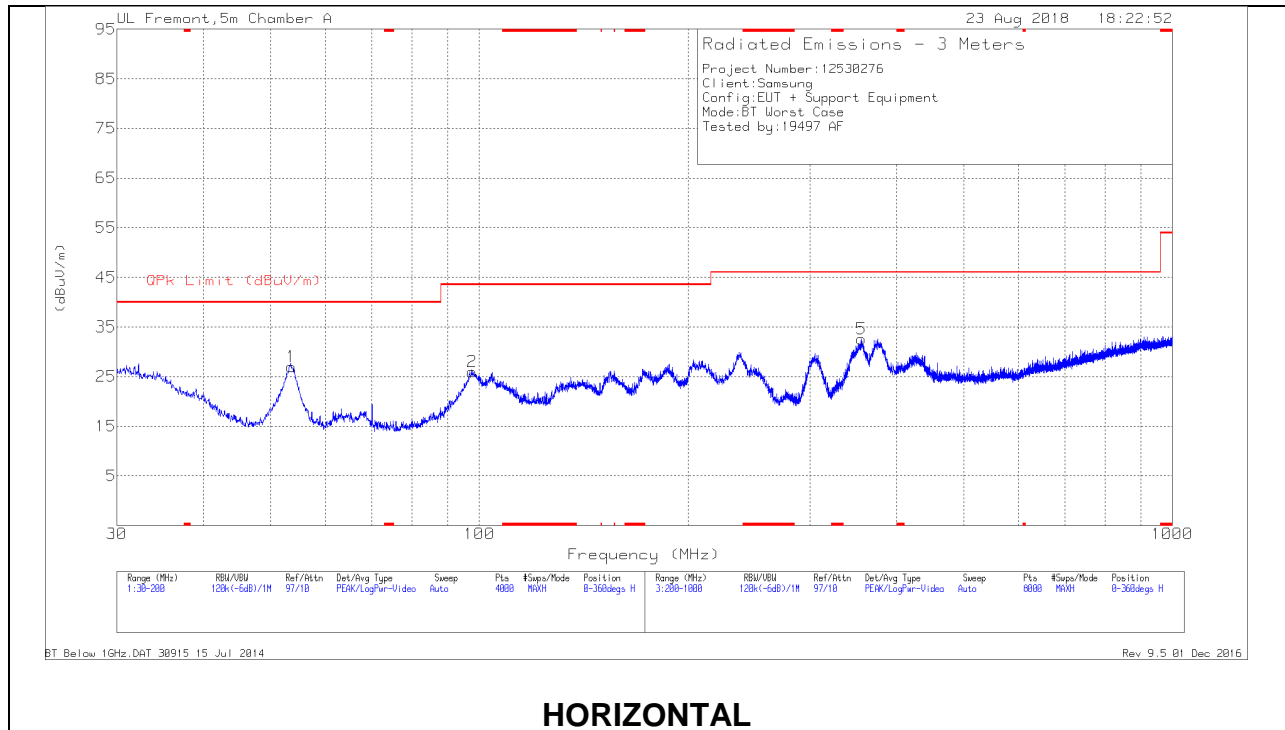

Below 1GHz Data

Marker	Frequency (MHz)	Meter Reading (dBuV)	Det	AFT130 (dB/m)	Amp/Cbl (dB/m)	Corrected Reading (dBuV/m)	QPk Limit (dBuV/m)	Margin (dB)	Azimuth (Degs)	Height (cm)	Polarity
3	53.4661	49.63	Pk	11.1	-27	33.73	40	-6.27	0-360	100	V
1	53.5936	42.83	Pk	11.1	-26.9	27.03	40	-12.97	0-360	400	H
2	97.72	38.84	Pk	13.6	-26.4	26.04	43.52	-17.48	0-360	300	H
4	186.2704	34.24	Pk	15.2	-25.5	23.94	43.52	-19.58	0-360	100	V
5	356.0203	38.89	Pk	18.5	-24.8	32.59	46.02	-13.43	0-360	101	H
6	384.1239	32.39	Pk	19	-25	26.39	46.02	-19.63	0-360	101	V

Pk - Peak detector

9.4. Worst Case 18-26 GHz

SPURIOUS EMISSIONS 18-26 GHz (WORST-CASE CONFIGURATION)

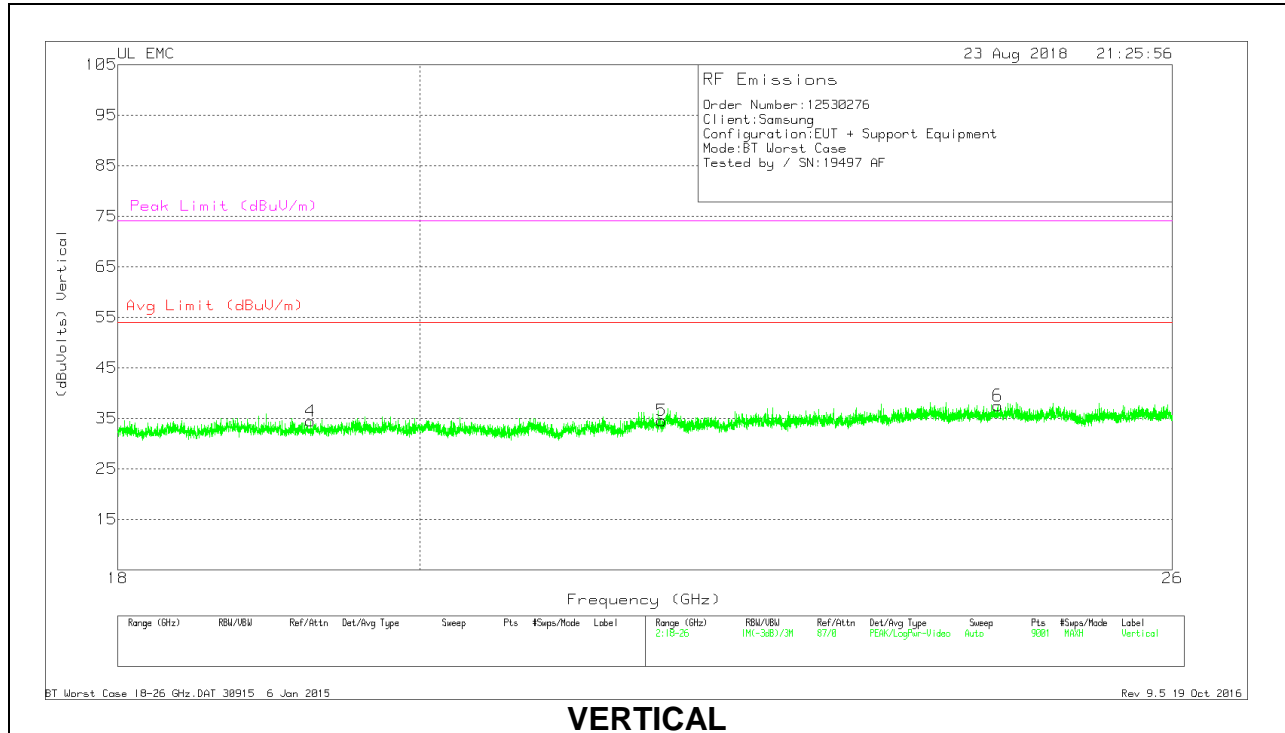
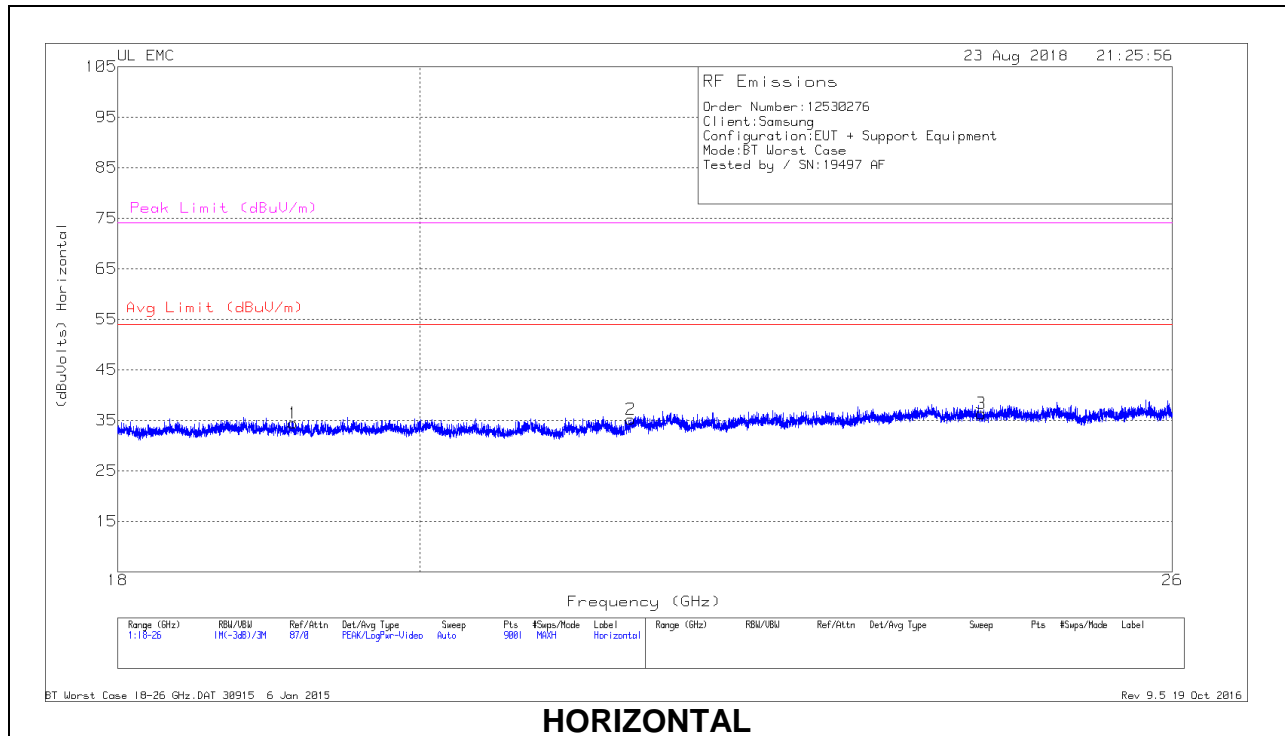

18 – 26GHz DATA

Marker	Frequency (GHz)	Meter Reading (dBuV)	Det	T89 AF (dB/m)	Amp/Cbl (dB)	Dist Corr (dB)	Corrected Reading (dBuVolts)	Avg Limit (dBuV/m)	Margin (dB)	Peak Limit (dBuV/m)	PK Margin (dB)
1	19.136	36.36	Pk	32.2	-24.6	-9.5	34.46	54	-19.54	74	-39.54
2	21.525	36.88	Pk	33	-25.2	-9.5	35.18	54	-18.82	74	-38.82
3	24.324	36.61	Pk	33.7	-24.5	-9.5	36.31	54	-17.69	74	-37.69
4	19.252	36.63	Pk	32.3	-25	-9.5	34.43	54	-19.57	74	-39.57
5	21.76	35.84	Pk	33.3	-25.1	-9.5	34.54	54	-19.46	74	-39.46
6	24.464	37.37	Pk	33.9	-24.3	-9.5	37.47	54	-16.53	74	-36.53

Pk - Peak detector

10. AC POWER LINE CONDUCTED EMISSIONS

LIMITS

FCC §15.207 (a)

Frequency of Emission (MHz)	Conducted Limit (dBuV)	
	Quasi-peak	Average
0.15-0.5	66 to 56*	56 to 46*
0.5-5	56	46
5-30	60	50

*Decreases with the logarithm of the frequency.

TEST PROCEDURE

The EUT is placed on a non-conducting table 40 cm from the vertical ground plane and 80 cm above the horizontal ground plane. The EUT is configured in accordance with ANSI C63.10.

The receiver is set to a resolution bandwidth of 9 kHz. Peak detection is used unless otherwise noted as quasi-peak or average.

Line conducted data is recorded for both NEUTRAL and HOT lines.

RESULTS

10.1.1. AC Power Line Norm

LINE 1 RESULTS

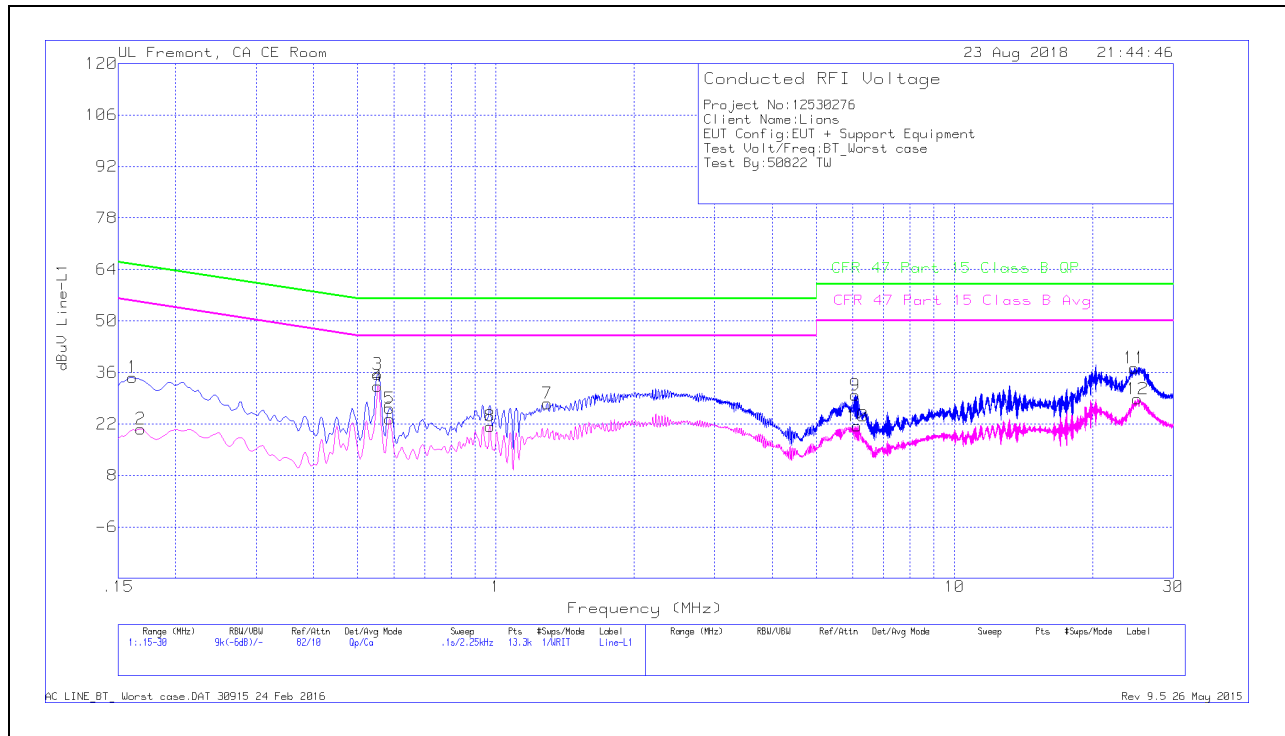

Trace Markers

Range 1: Line-L1 .15 - 30MHz											
Marker	Frequency (MHz)	Meter Reading (dBuV)	Det	LISN L1	LC Cables C1&C3	Limiter (dB)	Corrected Reading dBuV	CFR 47 Part 15 Class B QP	QP Margin (dB)	CFR 47 Part 15 Class B Avg	Av(CISPR) Margin (dB)
1	.16125	24.48	Qp	.1	0	10.1	34.68	65.4	-30.72	-	-
2	.168	10.41	Ca	.1	0	10.1	20.61	-	-	55.06	-34.45
3	.55275	25.39	Qp	0	0	10.1	35.49	56	-20.51	-	-
4	.55275	22.09	Ca	0	0	10.1	32.19	-	-	46	-13.81
5	.5865	16.1	Qp	0	0	10.1	26.2	56	-29.8	-	-
6	.5865	13.3	Ca	0	0	10.1	23.4	-	-	46	-22.6
7	1.29525	17.35	Qp	0	.1	10.1	27.55	56	-28.45	-	-
8	.97125	11.16	Ca	0	.1	10.1	21.36	-	-	46	-24.64
9	6.06975	19.4	Qp	0	.2	10.2	29.8	60	-30.2	-	-
10	6.1395	11	Ca	0	.2	10.2	21.4	-	-	50	-28.6
11	24.6705	26.3	Qp	.1	.3	10.5	37.2	60	-22.8	-	-
12	25.07325	17.85	Ca	.1	.3	10.5	28.75	-	-	50	-21.25

Qp - Quasi-Peak detector
 Ca - CISPR average detection

LINE 2 RESULTS

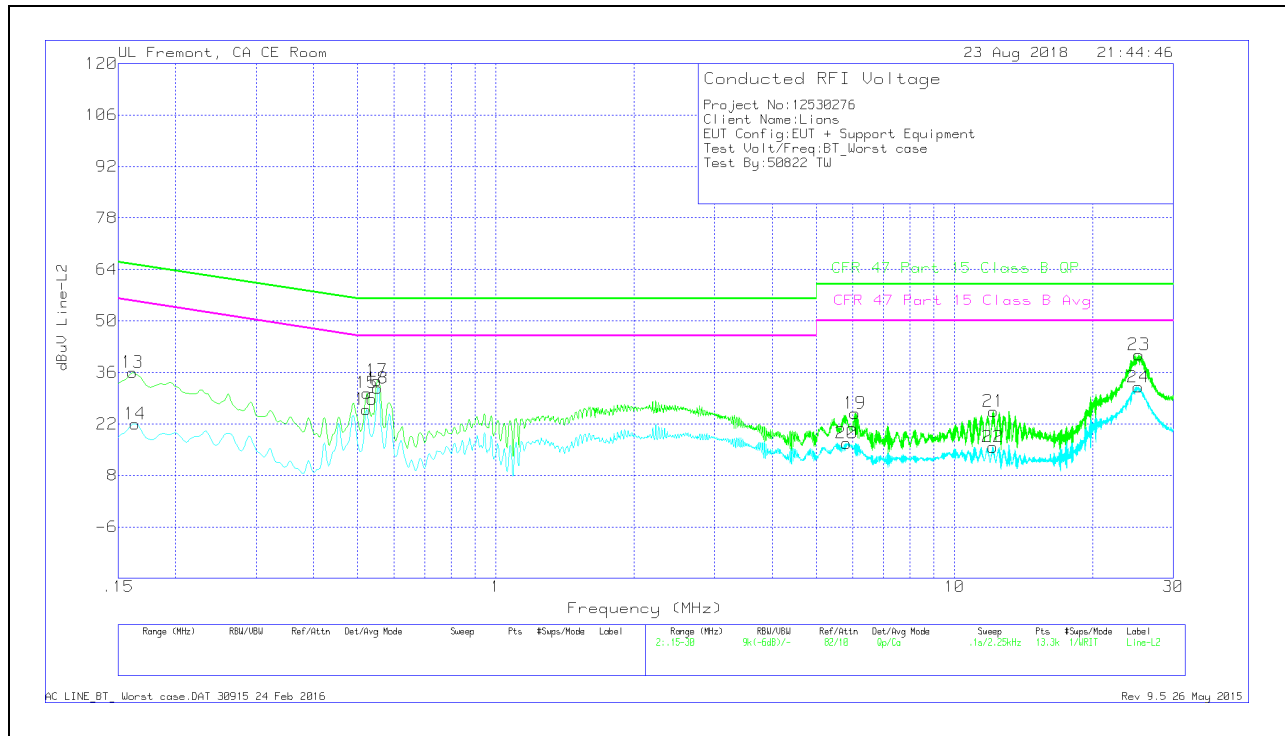

Trace Markers

Range 2: Line-L2 .15 - 30MHz											
Marker	Frequency (MHz)	Meter Reading (dBuV)	Det	LISN L2	LC Cables C2&C3	Limiter (dB)	Corrected Reading dBuV	CFR 47 Part 15 Class B QP	QP Margin (dB)	CFR 47 Part 15 Class B Avg	Av(CISPR) Margin (dB)
13	.16125	25.83	Qp	.1	0	10.1	36.03	65.4	-29.37	-	-
14	.1635	11.81	Ca	.1	0	10.1	22.01	-	-	55.28	-33.27
15	.5235	20.32	Qp	0	0	10.1	30.42	56	-25.58	-	-
16	.52125	15.86	Ca	0	0	10.1	25.96	-	-	46	-20.04
17	.5505	23.71	Qp	0	0	10.1	33.81	56	-22.19	-	-
18	.55275	21.6	Ca	0	0	10.1	31.7	-	-	46	-14.3
19	6.0675	14.53	Qp	0	.2	10.2	24.93	60	-35.07	-	-
20	5.81775	6.35	Ca	0	.2	10.2	16.75	-	-	50	-33.25
21	12.1605	14.94	Qp	.1	.2	10.2	25.44	60	-34.56	-	-
22	12.12675	5.23	Ca	.1	.2	10.2	15.73	-	-	50	-34.27
23	25.24425	29.93	Qp	.1	.3	10.5	40.83	60	-19.17	-	-
24	25.1745	21.13	Ca	.1	.3	10.5	32.03	-	-	50	-17.97

Qp - Quasi-Peak detector
 Ca - CISPR average detection