



SAR EVALUATION REPORT

Applicant Name:

Samsung Electronics Co., Ltd.
129, Samsung-ro, Maetan dong,
Yeongtong-gu, Suwon-si
Gyeonggi-do, 16677, Korea

Date of Testing:

06/27/19 - 07/07/19

Test Site/Location:

PCTEST Lab, Columbia, MD, USA

Document Serial No.:

1M1906170102-01.A3L

FCC ID:

A3LSMT860

APPLICANT:

SAMSUNG ELECTRONICS CO., LTD.

DUT Type:

Portable Tablet

Application Type:

Certification

FCC Rule Part(s):

CFR §2.1093

Model:

SM-T860

Additional Model(s):

SM-T860X

Equipment Class	Band & Mode	Tx Frequency	SAR
			1g Body (W/kg)
DTS	2.4 GHz WLAN	2412 - 2472 MHz	1.09
NII	U-NII-1	5180 - 5240 MHz	N/A
NII	U-NII-2A	5260 - 5320 MHz	0.56
NII	U-NII-2C	5500 - 5720 MHz	0.87
NII	U-NII-3	5745 - 5825 MHz	0.83
DSS/DTS	Bluetooth	2402 - 2480 MHz	0.69
Simultaneous SAR per KDB 690783 D01v01r03:			1.29

This wireless portable device has been shown to be capable of compliance for localized specific absorption rate (SAR) for uncontrolled environment/general population exposure limits specified in ANSI/IEEE C95.1-1992 and has been tested in accordance with the measurement procedures specified in Section 1.7 of this report; for North American frequency bands only.

I attest to the accuracy of data. All measurements reported herein were performed by me or were made under my supervision and are correct to the best of my knowledge and belief. I assume full responsibility for the completeness of these measurements and vouch for the qualifications of all persons taking them. Test results reported herein relate only to the item(s) tested.

Randy Ortanez
President



The SAR Tick is an initiative of the Mobile & Wireless Forum (MWF). While a product may be considered eligible, use of the SAR Tick logo requires an agreement with the MWF. Further details can be obtained by emailing: sartick@mwfai.info.





FCC ID A3LSMT860	 PCTEST ENGINEERING LABORATORY, INC.	SAR EVALUATION REPORT		Approved by: Quality Manager
Document S/N: 1M1906170102-01.A3L	Test Dates: 06/27/19 - 07/07/19	DUT Type: Portable Tablet	Page 1 of 34	

TABLE OF CONTENTS

1	DEVICE UNDER TEST	3
2	INTRODUCTION	7
3	DOSIMETRIC ASSESSMENT	8
4	TEST CONFIGURATION POSITIONS	9
5	RF EXPOSURE LIMITS	10
6	FCC MEASUREMENT PROCEDURES.....	11
7	RF CONDUCTED POWERS.....	14
8	SYSTEM VERIFICATION.....	19
9	SAR DATA SUMMARY	21
10	FCC MULTI-TX AND ANTENNA SAR CONSIDERATIONS.....	25
11	SAR MEASUREMENT VARIABILITY	29
12	EQUIPMENT LIST.....	30
13	MEASUREMENT UNCERTAINTIES.....	31
14	CONCLUSION.....	32
15	REFERENCES	33
APPENDIX A:	SAR TEST PLOTS	
APPENDIX B:	SAR DIPOLE VERIFICATION PLOTS	
APPENDIX C:	PROBE AND DIPOLE CALIBRATION CERTIFICATES	
APPENDIX D:	SAR TISSUE SPECIFICATIONS	
APPENDIX E:	SAR SYSTEM VALIDATION	
APPENDIX F:	DUT ANTENNA DIAGRAM & SAR TEST SETUP PHOTOGRAPHS	
APPENDIX G:	POWER REDUCTION VERIFICATION	

FCC ID A3LSMT860		SAR EVALUATION REPORT		Approved by: Quality Manager
Document S/N: 1M1906170102-01.A3L	Test Dates: 06/27/19 - 07/07/19	DUT Type: Portable Tablet	Page 2 of 34	

1 DEVICE UNDER TEST

1.1 Device Overview

Band & Mode	Operating Modes	Tx Frequency
2.4 GHz WLAN	Data	2412 - 2472 MHz
U-NII-1	Data	5180 - 5240 MHz
U-NII-2A	Data	5260 - 5320 MHz
U-NII-2C	Data	5500 - 5720 MHz
U-NII-3	Data	5745 - 5825 MHz
Bluetooth	Data	2402 - 2480 MHz
ANT+	Data	2402 - 2480 MHz

1.2 Power Reduction for SAR

This device uses a power reduction mechanism for SAR compliance. The power reduction mechanism is activated when the device is used in close proximity to the user's body. FCC KDB Publication 616217 D04v01r02 Section 6 was used as a guideline for selecting SAR test distances for this device. Detailed descriptions of the power reduction mechanism are included in the operational description.



1.3 Nominal and Maximum Output Power Specifications

This device operates using the following maximum and nominal output power specifications. SAR values were scaled to the maximum allowed power to determine compliance per KDB Publication 447498 D01v06.

1.3.1 Maximum SISO/MIMO WLAN and Bluetooth Output Power

Mode / Band	Channel	Modulated Average - Single Tx Chain (dBm)								
		1	2	3 - 8	9	10	11	12	13	
IEEE 802.11b (2.4 GHz)	Maximum	18.5	20.0			18.5	6.0	6.0		
	Nominal	17.5	19.0			17.5	5.0	5.0		
IEEE 802.11g (2.4 GHz)	Maximum	15.0	16.5	18.0	16.0	14.5	6.0	3.5		
	Nominal	14.0	15.5	17.0	15.0	13.5	5.0	2.5		
IEEE 802.11n (2.4 GHz)	Maximum	13.5	17.5	19.0	17.0	16.5	13.5	6.0	2.0	
	Nominal	12.5	16.5	18.0	16.0	15.5	12.5	5.0	1.0	

Mode / Band		Modulated Average - Single Tx Chain (dBm)		
		20 MHz Bandwidth	40 MHz Bandwidth	80 MHz Bandwidth
IEEE 802.11a (5 GHz)	Maximum	18.0		
	Nominal	17.0		
IEEE 802.11n (5 GHz)	Maximum	18.0	13.0	
	Nominal	17.0	12.0	
IEEE 802.11ac (5 GHz)	Maximum	13.0	13.0	13.0
	Nominal	12.0	12.0	12.0

FCC ID A3LSMT860	 PCTEST ENGINEERING LABORATORY, INC.	SAR EVALUATION REPORT		Approved by: Quality Manager
Document S/N: 1M1906170102-01.A3L	Test Dates: 06/27/19 - 07/07/19	DUT Type: Portable Tablet	Page 3 of 34	

Mode / Band		Modulated Average - MIMO (dBm)							
		20 MHz Bandwidth							
Channel		1	2	3 - 8	9	10	11	12	13
IEEE 802.11g (2.4 GHz)	Maximum	18.0	19.5	21.0	19.0	17.5	9.0	6.5	
	Nominal	17.0	18.5	20.0	18.0	16.5	8.0	5.5	
IEEE 802.11n (2.4 GHz)	Maximum	16.5	20.5	22.0	20.0	19.5	16.5	9.0	5.0
	Nominal	15.5	19.5	21.0	19.0	18.5	15.5	8.0	4.0



Mode / Band		Modulated Average - MIMO (dBm)		
		20 MHz Bandwidth	40 MHz Bandwidth	80 MHz Bandwidth
IEEE 802.11a (5 GHz)	Maximum	21.0		
	Nominal	20.0		
IEEE 802.11n (5 GHz)	Maximum	21.0	16.0	
	Nominal	20.0	15.0	
IEEE 802.11ac (5 GHz)	Maximum	16.0	16.0	16.0
	Nominal	15.0	15.0	15.0

Mode/Band		Modulated Average (dBm)
Bluetooth	Maximum	13.0
	Nominal	12.0
Bluetooth EDR	Maximum	11.0
	Nominal	10.0
Bluetooth LE	Maximum	6.0
	Nominal	5.0

1.3.1 Reduced SISO WLAN and Bluetooth Output Power

Mode / Band		Modulated Average (dBm)		
		Channel	1 - 11	12
IEEE 802.11b (2.4 GHz)	Maximum	13.5	6.0	6.0
	Nominal	12.5	5.0	5.0
IEEE 802.11g (2.4 GHz)	Maximum	13.5	6.0	3.5
	Nominal	12.5	5.0	2.5
IEEE 802.11n (2.4 GHz)	Maximum	13.5	6.0	2.0
	Nominal	12.5	5.0	1.0

Mode / Band		Modulated Average - Single Tx Chain (dBm)		
		20 MHz Bandwidth	40 MHz Bandwidth	80 MHz Bandwidth
IEEE 802.11a (5 GHz)	Maximum	10.0		
	Nominal	9.0		
IEEE 802.11n (5 GHz)	Maximum	10.0	10.0	
	Nominal	9.0	9.0	
IEEE 802.11ac (5 GHz)	Maximum	10.0	10.0	10.0
	Nominal	9.0	9.0	9.0

FCC ID A3LSMT860	 PCTEST ENGINEERING LABORATORY, INC.	SAR EVALUATION REPORT		Approved by: Quality Manager
Document S/N: 1M1906170102-01.A3L	Test Dates: 06/27/19 - 07/07/19	DUT Type: Portable Tablet		Page 4 of 34

Mode / Band		Modulated Average - MIMO (dBm)			
		20 MHz Bandwidth			
		Channel	1 - 11	12	13
IEEE 802.11g (2.4 GHz)	Maximum		16.5	9.0	6.5
	Nominal		15.5	8.0	5.5
IEEE 802.11n (2.4 GHz)	Maximum		16.5	9.0	5.0
	Nominal		15.5	8.0	4.0

Mode / Band		Modulated Average - MIMO (dBm)		
		20 MHz Bandwidth	40 MHz Bandwidth	80 MHz Bandwidth
IEEE 802.11a (5 GHz)	Maximum	10.0		
	Nominal	9.0		
IEEE 802.11n (5 GHz)	Maximum	10.0	10.0	
	Nominal	9.0	9.0	
IEEE 802.11ac (5 GHz)	Maximum	10.0	10.0	10.0
	Nominal	9.0	9.0	9.0

1.4 DUT Antenna Locations

The overall diagonal dimension of the device is > 200 mm. A diagram showing the location of the device antennas can be found in Appendix F. Exact antenna dimensions and separation distances are shown in the Technical Descriptions in the FCC filings.

**Table 1-1
Device Edges/Sides for SAR Testing**

Mode	Back	Top	Bottom	Right	Left
2.4 GHz WLAN Ant 1	Yes	Yes	No	No	Yes
2.4 GHz WLAN Ant 2	Yes	Yes	No	Yes	No
5 GHz WLAN Ant 1	Yes	Yes	No	No	Yes
5 GHz WLAN Ant 2	Yes	Yes	No	Yes	No
Bluetooth	Yes	Yes	No	No	Yes

Note: Per FCC KDB Publication 616217 D04v01r01, particular edges were not required to be evaluated for SAR based on the SAR exclusion threshold in KDB 447498 D01V06. Additional edges may have been evaluated for simultaneous transmission analysis.



1.5 Simultaneous Transmission Capabilities

According to FCC KDB Publication 447498 D01v06, transmitters are considered to be operating simultaneously when there is overlapping transmission, with the exception of transmissions during network hand-offs with maximum hand-off duration less than 30 seconds.

This device contains multiple transmitters that may operate simultaneously, and therefore requires a simultaneous transmission analysis according to FCC KDB Publication 447498 D01v06 4.3.2 procedures.

**Table 1-2
Simultaneous Transmission Scenarios**

No.	Capable Transmit Configuration	Body
1	2.4 GHz WI-FI MIMO	Yes
2	5 GHz WI-FI MIMO	Yes
3	2.4 GHz WI-FI Ant 1 + 5 GHz WI-FI Ant 2	Yes
4	2.4 GHz Bluetooth + 5 GHz WI-FI Ant 2	Yes

FCC ID A3LSMT860	 PCTEST ENGINEERING LABORATORY, INC.	SAR EVALUATION REPORT		Approved by: Quality Manager
Document S/N: 1M1906170102-01.A3L	Test Dates: 06/27/19 - 07/07/19	DUT Type: Portable Tablet	Page 5 of 34	

1. 2.4 GHz WLAN, and 2.4 GHz Bluetooth share the same antenna path and cannot transmit simultaneously.
2. This device supports 2x2 MIMO Tx for WLAN 802.11a/g/n/ac. 802.11a/g/n/ac supports CDD and STBC and 802.11n/ac additionally supports SDM. Each WLAN antenna can transmit independently or together when operating with MIMO.
3. This device supports Bluetooth Tethering.

1.6 Miscellaneous SAR Test Considerations

(A) WIFI/BT

Since U-NII-1 and U-NII-2A bands have the same maximum output power and the highest reported SAR for U-NII-2A is less than 1.2 W/kg, SAR is not required for U-NII-1 band according to FCC KDB Publication 248227 D01v02r02.

This device supports channel 1-13 for 2.4 GHz WLAN. However, since channels 12 and 13 have equal or less maximum output power, channels 1, 6, and 11 were considered for SAR testing per KDB 248227 D01v02r02.

This device supports IEEE 802.11ac with the following features:



- a) Up to 80 MHz Bandwidth only
- b) No aggregate channel configurations
- c) 2 Tx antenna output
- d) 256 QAM is supported
- e) TDWR and Band gap channels are supported

1.7 Guidance Applied

- FCC KDB Publication 248227 D01v02r02 (SAR Considerations for 802.11 Devices)
- FCC KDB Publication 447498 D01v06 (General SAR Guidance)
- FCC KDB Publication 865664 D01v01r04, D02v01r02 (SAR Measurements up to 6 GHz)
- FCC KDB Publication 616217 D04v01r02 (SAR tablets)

1.8 Device Serial Numbers

Several samples with identical hardware were used to support SAR testing. The manufacturer has confirmed that the device(s) tested have the same physical, mechanical and thermal characteristics and are within operational tolerances expected for production units. The serial numbers used for each test are indicated alongside the results in Section 9.

FCC ID A3LSMT860	 PCTEST ENGINEERING LABORATORY, INC.	SAR EVALUATION REPORT		Approved by: Quality Manager
Document S/N: 1M1906170102-01.A3L	Test Dates: 06/27/19 - 07/07/19	DUT Type: Portable Tablet	Page 6 of 34	

2 INTRODUCTION

The FCC and Innovation, Science, and Economic Development Canada have adopted the guidelines for evaluating the environmental effects of radio frequency (RF) radiation in ET Docket 93-62 on Aug. 6, 1996 and Health Canada Safety Code 6 to protect the public and workers from the potential hazards of RF emissions due to FCC-regulated portable devices. [1]

The safety limits used for the environmental evaluation measurements are based on the criteria published by the American National Standards Institute (ANSI) for localized specific absorption rate (SAR) in IEEE/ANSI C95.1-1992 Standard for Safety Levels with Respect to Human Exposure to Radio Frequency Electromagnetic Fields, 3 kHz to 300 GHz [3] and Health Canada RF Exposure Guidelines Safety Code 6 [22]. The measurement procedure described in IEEE/ANSI C95.3-2002 Recommended Practice for the Measurement of Potentially Hazardous Electromagnetic Fields - RF and Microwave [4] is used for guidance in measuring the Specific Absorption Rate (SAR) due to the RF radiation exposure from the Equipment Under Test (EUT). These criteria for SAR evaluation are similar to those recommended by the International Committee for Non-Ionizing Radiation Protection (ICNIRP) in Biological Effects and Exposure Criteria for Radiofrequency Electromagnetic Fields,” Report No. Vol 74. SAR is a measure of the rate of energy absorption due to exposure to an RF transmitting source. SAR values have been related to threshold levels for potential biological hazards.

2.1 SAR Definition

Specific Absorption Rate is defined as the time derivative (rate) of the incremental energy (dU) absorbed by (dissipated in) an incremental mass (dm) contained in a volume element (dV) of a given density (ρ). It is also defined as the rate of RF energy absorption per unit mass at a point in an absorbing body (see Equation 2-1).

Equation 2-1
SAR Mathematical Equation

$$SAR = \frac{d}{dt} \left(\frac{dU}{dm} \right) = \frac{d}{dt} \left(\frac{dU}{\rho dv} \right)$$



SAR is expressed in units of Watts per Kilogram (W/kg).

$$SAR = \frac{\sigma \cdot E^2}{\rho}$$

where:

- σ = conductivity of the tissue-simulating material (S/m)
- ρ = mass density of the tissue-simulating material (kg/m³)
- E = Total RMS electric field strength (V/m)

NOTE: The primary factors that control rate of energy absorption were found to be the wavelength of the incident field in relation to the dimensions and geometry of the irradiated organism, the orientation of the organism in relation to the polarity of field vectors, the presence of reflecting surfaces, and whether conductive contact is made by the organism with a ground plane.[6]

FCC ID A3LSMT860	 PCTEST ENGINEERING LABORATORY, INC.	SAR EVALUATION REPORT		Approved by: Quality Manager
Document S/N: 1M1906170102-01.A3L	Test Dates: 06/27/19 - 07/07/19	DUT Type: Portable Tablet	Page 7 of 34	

3 DOSIMETRIC ASSESSMENT

3.1 Measurement Procedure

The evaluation was performed using the following procedure compliant to FCC KDB Publication 865664 D01v01r04 and IEEE 1528-2013:

1. The SAR distribution at the exposed side of the head or body was measured at a distance no greater than 5.0 mm from the inner surface of the shell. The area covered the entire dimension of the device-head and body interface and the horizontal grid resolution was determined per FCC KDB Publication 865664 D01v01r04 (See Table 3-1) and IEEE 1528-2013.
2. The point SAR measurement was taken at the maximum SAR region determined from Step 1 to enable the monitoring of SAR fluctuations/drifts during the 1g/10g cube evaluation. SAR at this fixed point was measured and used as a reference value.
3. Based on the area scan data, the peak of the region with maximum SAR was determined by spline interpolation. Around this point, a volume was assessed according to the measurement resolution and volume size requirements of FCC KDB Publication 865664 D01v01r04 (See Table 3-1) and IEEE 1528-2013. On the basis of this data set, the spatial peak SAR value was evaluated with the following procedure (see references or the DASY manual online for more details):
 - a. SAR values at the inner surface of the phantom are extrapolated from the measured values along the line away from the surface with spacing no greater than that in Table 3-1. The extrapolation was based on a least-squares algorithm. A polynomial of the fourth order was calculated through the points in the z-axis (normal to the phantom shell).
 - b. After the maximum interpolated values were calculated between the points in the cube, the SAR was averaged over the spatial volume (1g or 10g) using a 3D-Spline interpolation algorithm. The 3D-spline is composed of three one-dimensional splines with the “Not a knot” condition (in x, y, and z directions). The volume was then integrated with the trapezoidal algorithm. One thousand points (10 x 10 x 10) were obtained through interpolation, in order to calculate the averaged SAR.
 - c. All neighboring volumes were evaluated until no neighboring volume with a higher average value was found.
4. The SAR reference value, at the same location as step 2, was re-measured after the zoom scan was complete to calculate the SAR drift. If the drift deviated by more than 5%, the SAR test and drift measurements were repeated.

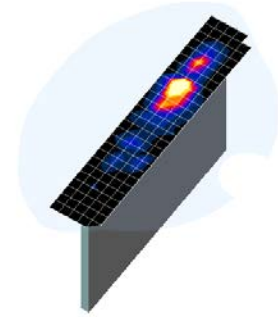



**Figure 3-1
Sample SAR Area
Scan**

**Table 3-1
Area and Zoom Scan Resolutions per FCC KDB Publication 865664 D01v01r04***

Frequency	Maximum Area Scan Resolution (mm) ($\Delta x_{area}, \Delta y_{area}$)	Maximum Zoom Scan Resolution (mm) ($\Delta x_{zoom}, \Delta y_{zoom}$)	Maximum Zoom Scan Spatial Resolution (mm)			Minimum Zoom Scan Volume (mm) (x,y,z)
			Uniform Grid	Graded Grid		
			$\Delta z_{zoom}(n)$	$\Delta z_{zoom}(1)^*$	$\Delta z_{zoom}(n-1)^*$	
≤ 2 GHz	≤ 15	≤ 8	≤ 5	≤ 4	≤ 1.5* $\Delta z_{zoom}(n-1)$	≥ 30
2-3 GHz	≤ 12	≤ 5	≤ 5	≤ 4	≤ 1.5* $\Delta z_{zoom}(n-1)$	≥ 30
3-4 GHz	≤ 12	≤ 5	≤ 4	≤ 3	≤ 1.5* $\Delta z_{zoom}(n-1)$	≥ 28
4-5 GHz	≤ 10	≤ 4	≤ 3	≤ 2.5	≤ 1.5* $\Delta z_{zoom}(n-1)$	≥ 25
5-6 GHz	≤ 10	≤ 4	≤ 2	≤ 2	≤ 1.5* $\Delta z_{zoom}(n-1)$	≥ 22

*Also compliant to IEEE 1528-2013 Table 6

FCC ID A3LSMT860		SAR EVALUATION REPORT		Approved by: Quality Manager
Document S/N: 1M1906170102-01.A3L	Test Dates: 06/27/19 - 07/07/19	DUT Type: Portable Tablet	Page 8 of 34	

4 TEST CONFIGURATION POSITIONS

4.1 Device Holder

The device holder is made out of low-loss POM material having the following dielectric parameters: relative permittivity $\epsilon = 3$ and loss tangent $\delta = 0.02$.

4.2 SAR Testing for Tablet per KDB Publication 616217 D04v01r02



Per FCC KDB Publication 616217 D04v01r02, the back surface and edges of the tablet should be tested for SAR compliance with the tablet touching the phantom. The SAR Exclusion Threshold in KDB 447498 D01v06 can be applied to determine SAR test exclusion for adjacent edge configurations. The closest distance from the antenna to an adjacent tablet edge is used to determine if SAR testing is required for the adjacent edges, with the adjacent edge positioned against the phantom and the edge containing the antenna positioned perpendicular to the phantom.

4.3 Proximity Sensor Considerations

This device uses a power reduction mechanism to reduce output powers in certain use conditions when the device is used close the user's body.

When the device's antenna is within a certain distance of the user, the sensor activates and reduces the maximum allowed output power. However, the sensor is not active when the device is moved beyond the sensor triggering distance and the maximum output power is no longer limited. Therefore, additional evaluation is needed in the vicinity of the triggering distance to ensure SAR is compliant when the device is allowed to operate at a non-reduced output power level. FCC KDB Publication 616217 D04v01r02 Section 6 was used as a guideline for selecting SAR test distances for this device at these additional test positions. Sensor triggering distance summary data is included in Appendix G.

The sensor is designed to support sufficient detection range and sensitivity to cover regions of the sensors in all applicable directions since the sensor entirely covers the antennas.

FCC ID A3LSMT860	 PCTEST ENGINEERING LABORATORY, INC.	SAR EVALUATION REPORT		Approved by: Quality Manager
Document S/N: 1M1906170102-01.A3L	Test Dates: 06/27/19 - 07/07/19	DUT Type: Portable Tablet		Page 9 of 34

5 RF EXPOSURE LIMITS

5.1 Uncontrolled Environment

UNCONTROLLED ENVIRONMENTS are defined as locations where there is the exposure of individuals who have no knowledge or control of their exposure. The general population/uncontrolled exposure limits are applicable to situations in which the general public may be exposed or in which persons who are exposed as a consequence of their employment may not be made fully aware of the potential for exposure or cannot exercise control over their exposure. Members of the general public would come under this category when exposure is not employment-related; for example, in the case of a wireless transmitter that exposes persons in its vicinity.



5.2 Controlled Environment

CONTROLLED ENVIRONMENTS are defined as locations where there is exposure that may be incurred by persons who are aware of the potential for exposure, (i.e. as a result of employment or occupation). In general, occupational/controlled exposure limits are applicable to situations in which persons are exposed as a consequence of their employment, who have been made fully aware of the potential for exposure and can exercise control over their exposure. This exposure category is also applicable when the exposure is of a transient nature due to incidental passage through a location where the exposure levels may be higher than the general population/uncontrolled limits, but the exposed person is fully aware of the potential for exposure and can exercise control over his or her exposure by leaving the area or by some other appropriate means.

**Table 5-1
SAR Human Exposure Specified in ANSI/IEEE C95.1-1992 and Health Canada Safety Code 6**

HUMAN EXPOSURE LIMITS		
	UNCONTROLLED ENVIRONMENT <i>General Population</i> (W/kg) or (mW/g)	CONTROLLED ENVIRONMENT <i>Occupational</i> (W/kg) or (mW/g)
Peak Spatial Average SAR Head	1.6	8.0
Whole Body SAR	0.08	0.4
Peak Spatial Average SAR Hands, Feet, Ankle, Wrists, etc.	4.0	20

1. The Spatial Peak value of the SAR averaged over any 1 gram of tissue (defined as a tissue volume in the shape of a cube) and over the appropriate averaging time.
2. The Spatial Average value of the SAR averaged over the whole body.
3. The Spatial Peak value of the SAR averaged over any 10 grams of tissue (defined as a tissue volume in the shape of a cube) and over the appropriate averaging time.

FCC ID A3LSMT860	 PCTEST ENGINEERING LABORATORY, INC.	SAR EVALUATION REPORT		Approved by: Quality Manager
Document S/N: 1M1906170102-01.A3L	Test Dates: 06/27/19 - 07/07/19	DUT Type: Portable Tablet		Page 10 of 34

6 FCC MEASUREMENT PROCEDURES

6.1 Measured and Reported SAR

Per FCC KDB Publication 447498 D01v06, when SAR is not measured at the maximum power level allowed for production units, the results must be scaled to the maximum tune-up tolerance limit according to the power applied to the individual channels tested to determine compliance. For simultaneous transmission, the measured aggregate SAR must be scaled according to the sum of the differences between the maximum tune-up tolerance and actual power used to test each transmitter. When SAR is measured at or scaled to the maximum tune-up tolerance limit, the results are referred to as *reported* SAR. The highest *reported* SAR results are identified on the grant of equipment authorization according to procedures in KDB 690783 D01v01r03.

6.2 Procedures Used to Establish RF Signal for SAR

The following procedures are according to FCC KDB Publication 941225 D01v03r01 “3G SAR Measurement Procedures.”

The device is placed into a simulated call using a base station simulator in a RF shielded chamber. Establishing connections in this manner ensure a consistent means for testing SAR and are recommended for evaluating SAR [4]. Devices under test are evaluated prior to testing, with a fully charged battery and were configured to operate at maximum output power. In order to verify that the device is tested throughout the SAR test at maximum output power, the SAR measurement system measures a “point SAR” at an arbitrary reference point at the start and end of the 1 gram SAR evaluation, to assess for any power drifts during the evaluation. If the power drift deviates by more than 5%, the SAR test and drift measurements are repeated.

6.3 SAR Testing with 802.11 Transmitters

The normal network operating configurations of 802.11 transmitters are not suitable for SAR measurements. Unpredictable fluctuations in network traffic and antenna diversity conditions can introduce undesirable variations in SAR results. The SAR for these devices should be measured using chipset based test mode software to ensure the results are consistent and reliable. See KDB Publication 248227 D01v02r02 for more details.



6.3.1 General Device Setup

Chipset based test mode software is hardware dependent and generally varies among manufacturers. The device operating parameters established in test mode for SAR measurements must be identical to those programmed in production units, including output power levels, amplifier gain settings and other RF performance tuning parameters.

A periodic duty factor is required for current generation SAR systems to measure SAR. When 802.11 frame gaps are accounted for in the transmission, a maximum transmission duty factor of 92 - 96% is typically achievable in most test mode configurations. A minimum transmission duty factor of 85% is required to avoid certain hardware and device implementation issues related to wide range SAR scaling. The reported SAR is scaled to 100% transmission duty factor to determine compliance at the maximum tune-up tolerance limit.

6.3.2 U-NII-1 and U-NII-2A

For devices that operate in both U-NII-1 and U-NII-2A bands, when the same maximum output power is specified for both bands, SAR measurement using OFDM SAR test procedures is not required for U-NII-1 unless the highest reported SAR for U-NII-2A is > 1.2 W/kg. When different maximum output powers are specified for the bands, SAR measurement for the U-NII band with the lower maximum output power is not required unless the highest reported SAR for the U-NII band with the higher maximum output power, adjusted by the ratio of lower to higher specified maximum output power for the two bands, is > 1.2 W/kg.

FCC ID A3LSMT860	 PCTEST ENGINEERING LABORATORY, INC.	SAR EVALUATION REPORT		Approved by: Quality Manager
Document S/N: 1M1906170102-01.A3L	Test Dates: 06/27/19 - 07/07/19	DUT Type: Portable Tablet		Page 11 of 34

6.3.3 U-NII-2C and U-NII-3

The frequency range covered by U-NII-2C and U-NII-3 is 380 MHz (5.47 – 5.85 GHz), which requires a minimum of at least two SAR probe calibration frequency points to support SAR measurements. When Terminal Doppler Weather Radar (TDWR) restriction applies, the channels at 5.60 – 5.65 GHz in U-NII-2C band must be disabled with acceptable mechanisms and documented in the equipment certification. Unless band gap channels are permanently disabled, SAR must be considered for these channels. Each band is tested independently according to the normally required OFDM SAR measurement and probe calibration frequency points requirements.

6.3.4 2.4 GHz SAR Test Requirements

SAR is measured for 2.4 GHz 802.11b DSSS using either the fixed test position or, when applicable, the initial test position procedure. SAR test reduction is determined according to the following:

- 1) When the reported SAR of the highest measured maximum output power channel for the exposure configuration is ≤ 0.8 W/kg, no further SAR testing is required for 802.11b DSSS in that exposure configuration.
- 2) When the reported SAR is > 0.8 W/kg, SAR is required for that position using the next highest measured output power channel. When any reported SAR is > 1.2 W/kg, SAR is required for the third channel; i.e., all channels require testing.



2.4 GHz 802.11 g/n OFDM are additionally evaluated for SAR if the highest reported SAR for 802.11b, adjusted by the ratio of the OFDM to DSSS specified maximum output power, is > 1.2 W/kg. When SAR is required for OFDM modes in 2.4 GHz band, the Initial Test Configuration Procedures should be followed.

6.3.5 OFDM Transmission Mode and SAR Test Channel Selection

When the same maximum output power was specified for multiple OFDM transmission mode configurations in a frequency band or aggregated band, SAR is measured using the configuration with the largest channel bandwidth, lowest order modulation and lowest data rate. When the maximum output power of a channel is the same for equivalent OFDM configurations; for example, 802.11a, 802.11n and 802.11ac or 802.11g and 802.11n with the same channel bandwidth, modulation and data rate etc., the lower order 802.11 mode i.e., 802.11a, then 802.11n and 802.11ac or 802.11g then 802.11n, is used for SAR measurement. When the maximum output power are the same for multiple test channels, either according to the default or additional power measurement requirements, SAR is measured using the channel closest to the middle of the frequency band or aggregated band. When there are multiple channels with the same maximum output power, SAR is measured using the higher number channel.

6.3.6 Initial Test Configuration Procedure

For OFDM, an initial test configuration is determined for each frequency band and aggregated band, according to the transmission mode with the highest maximum output power specified for SAR measurements. When the same maximum output power is specified for multiple OFDM transmission mode configurations in a frequency band or aggregated band, SAR is measured using the configuration(s) with the largest channel bandwidth, lowest order modulation, lowest data rate and lowest order IEEE 802.11 mode. The channel of the transmission mode with the highest average RF output conducted power will be the initial test configuration.

FCC ID A3LSMT860	 PCTEST ENGINEERING LABORATORY, INC.	SAR EVALUATION REPORT		Approved by: Quality Manager
Document S/N: 1M1906170102-01.A3L	Test Dates: 06/27/19 - 07/07/19	DUT Type: Portable Tablet	Page 12 of 34	



When the reported SAR is ≤ 0.8 W/kg, no additional measurements on other test channels are required. Otherwise, SAR is evaluated using the subsequent highest average RF output channel until the reported SAR result is ≤ 1.2 W/kg or all channels are measured. When there are multiple untested channels having the same subsequent highest average RF output power, the channel with higher frequency from the lowest 802.11 mode is considered for SAR measurements (See Section 6.3.5).

6.3.7 Subsequent Test Configuration Procedures

For OFDM configurations in each frequency band and aggregated band, SAR is evaluated for initial test configuration using the fixed test position or the initial test position procedure. When the highest reported SAR (for the initial test configuration), adjusted by the ratio of the specified maximum output power of the subsequent test configuration to initial test configuration, is ≤ 1.2 W/kg, no additional SAR tests for the subsequent test configurations are required.

6.3.8 MIMO SAR considerations

Per KDB Publication 248227 D01v02r02, the simultaneous SAR provisions in KDB Publication 447498 D01v06 should be applied to determine simultaneous transmission SAR test exclusion for WIFI MIMO. If the sum of 1g single transmission chain SAR measurements is < 1.6 W/kg, no additional SAR measurements for MIMO are required. Alternatively, SAR for MIMO can be measured with all antennas transmitting simultaneously at the specified maximum output power of MIMO operation.

FCC ID A3LSMT860		SAR EVALUATION REPORT		Approved by: Quality Manager
Document S/N: 1M1906170102-01.A3L	Test Dates: 06/27/19 - 07/07/19	DUT Type: Portable Tablet		Page 13 of 34

7 RF CONDUCTED POWERS

7.1 WLAN Conducted Powers

Table 7-1
2.4 GHz WLAN Maximum Average RF Power – Ant 1

2.4GHz Conducted Power [dBm]				
Freq [MHz]	Channel	IEEE Transmission Mode		
		802.11b	802.11g	802.11n
		Average	Average	Average
2412	1	17.84	14.75	12.35
2417	2	19.22	16.27	17.42
2422	3	N/A	17.34	18.84
2437	6	19.67	17.66	18.90
2447	8	N/A	N/A	18.86
2452	9	N/A	17.43	16.57
2457	10	19.53	15.58	16.28
2462	11	18.12	14.12	13.25

Table 7-2
2.4 GHz WLAN Maximum Average RF Power – Ant 2

2.4GHz Conducted Power [dBm]				
Freq [MHz]	Channel	IEEE Transmission Mode		
		802.11b	802.11g	802.11n
		Average	Average	Average
2412	1	18.49	14.96	12.82
2417	2	19.73	16.37	17.32
2422	3	N/A	17.51	18.81
2437	6	19.65	17.62	18.95
2447	8	N/A	N/A	18.91
2452	9	N/A	17.54	16.64
2457	10	19.86	15.79	16.44
2462	11	18.25	13.75	13.28



FCC ID A3LSMT860	 PCTEST ENGINEERING LABORATORY, INC.	SAR EVALUATION REPORT		Approved by: Quality Manager
Document S/N: 1M1906170102-01.A3L	Test Dates: 06/27/19 - 07/07/19	DUT Type: Portable Tablet	Page 14 of 34	

Table 7-3
5 GHz WLAN Maximum Average RF Power – Ant 1

5GHz (20MHz) Conducted Power [dBm]				
Freq [MHz]	Channel	IEEE Transmission Mode		
		802.11a	802.11n	802.11ac
		Average	Average	Average
5180	36	17.08	17.02	12.98
5200	40	17.02	17.02	12.44
5220	44	17.11	17.09	12.79
5240	48	17.16	17.16	12.71
5260	52	17.82	17.95	12.83
5280	56	17.62	17.83	12.98
5300	60	17.67	17.94	12.62
5320	64	17.81	17.92	12.77
5500	100	17.72	17.99	12.64
5600	120	17.38	17.84	12.94
5620	124	17.49	17.80	12.50
5720	144	17.40	17.61	12.46
5745	149	17.51	17.81	12.61
5785	157	17.77	17.94	12.76
5825	165	17.50	17.64	12.53

Table 7-4
5 GHz WLAN Maximum Average RF Power – Ant 2

5GHz (20MHz) Conducted Power [dBm]				
Freq [MHz]	Channel	IEEE Transmission Mode		
		802.11a	802.11n	802.11ac
		Average	Average	Average
5180	36	17.14	17.23	12.64
5200	40	17.22	17.15	12.91
5220	44	17.20	17.17	12.94
5240	48	17.08	17.08	12.90
5260	52	17.80	17.89	12.64
5280	56	17.93	17.97	12.85
5300	60	17.57	17.70	12.50
5320	64	17.71	17.85	12.55
5500	100	17.70	17.83	12.59
5600	120	17.64	17.65	12.51
5620	124	17.93	17.86	12.82
5720	144	17.96	17.93	12.53
5745	149	17.95	17.94	12.57
5785	157	17.95	17.96	12.57
5825	165	17.58	17.87	12.62

Table 7-5
2.4 GHz WLAN Reduced Average RF Power – Ant 1

2.4GHz Conducted Power [dBm]				
Freq [MHz]	Channel	IEEE Transmission Mode		
		802.11b	802.11g	802.11n
		Average	Average	Average
2412	1	12.84	12.86	12.74
2437	6	12.80	12.84	12.75
2462	11	13.46	13.36	13.24



FCC ID A3LSMT860		SAR EVALUATION REPORT		Approved by: Quality Manager
Document S/N: 1M1906170102-01.A3L	Test Dates: 06/27/19 - 07/07/19	DUT Type: Portable Tablet		Page 15 of 34

Table 7-6
2.4 GHz WLAN Reduced Average RF Power – Ant 2

2.4GHz Conducted Power [dBm]				
Freq [MHz]	Channel	IEEE Transmission Mode		
		802.11b	802.11g	802.11n
		Average	Average	Average
2412	1	13.03	13.00	12.90
2437	6	12.94	12.77	12.63
2462	11	12.87	12.84	12.67

Table 7-7
5 GHz WLAN Reduced Average RF Power – Ant 1

5GHz (80MHz) Conducted Power [dBm]		
Freq [MHz]	Channel	IEEE Transmission Mode
		802.11ac
		Average
5210	42	9.98
5290	58	9.94
5530	106	9.95
5610	122	9.79
5690	138	9.74
5775	155	9.90

Table 7-8
5 GHz WLAN Reduced Average RF Power – Ant 2

5GHz (80MHz) Conducted Power [dBm]		
Freq [MHz]	Channel	IEEE Transmission Mode
		802.11ac
		Average
5210	42	9.98
5290	58	9.99
5530	106	9.91
5610	122	9.87
5690	138	9.98
5775	155	9.99

Justification for test configurations for WLAN per KDB Publication 248227 D01v02r02:

- Power measurements were performed for the transmission mode configuration with the highest maximum output power specified for production units.
- For transmission modes with the same maximum output power specification, powers were measured for the largest channel bandwidth, lowest order modulation and lowest data rate.
- For transmission modes with identical maximum specified output power, channel bandwidth, modulation and data rates, power measurements were required for all identical configurations.
- For each transmission mode configuration, powers were measured for the highest and lowest channels; and at the mid-band channel(s) when there were at least 3 channels supported. For configurations with multiple mid-band channels, due to an even number of channels, both channels were measured.

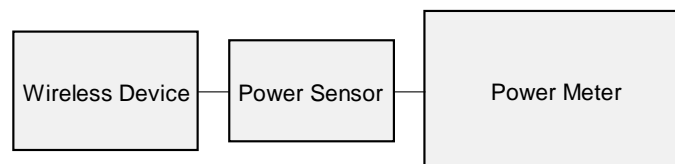



Figure 7-1
Power Measurement Setup

FCC ID A3LSMT860	PCTEST ENGINEERING LABORATORY, INC.	SAR EVALUATION REPORT		Approved by: Quality Manager
Document S/N: 1M1906170102-01.A3L	Test Dates: 06/27/19 - 07/07/19	DUT Type: Portable Tablet	Page 16 of 34	

7.2 Bluetooth Conducted Powers

Table 7-9
Bluetooth Average RF Power

Frequency [MHz]	Data Rate [Mbps]	Channel No.	Avg Conducted Power	
			[dBm]	[mW]
2402	1.0	0	12.82	19.157
2441	1.0	39	12.98	19.844
2480	1.0	78	12.48	17.683
2402	2.0	0	10.73	11.837
2441	2.0	39	10.37	10.883
2480	2.0	78	10.08	10.195
2402	3.0	0	10.78	11.979
2441	3.0	39	10.42	11.019
2480	3.0	78	10.14	10.326

FCC ID A3LSMT860	 PCTEST ENGINEERING LABORATORY, INC.	SAR EVALUATION REPORT		Approved by: Quality Manager
Document S/N: 1M1906170102-01.A3L	Test Dates: 06/27/19 - 07/07/19	DUT Type: Portable Tablet	Page 17 of 34	

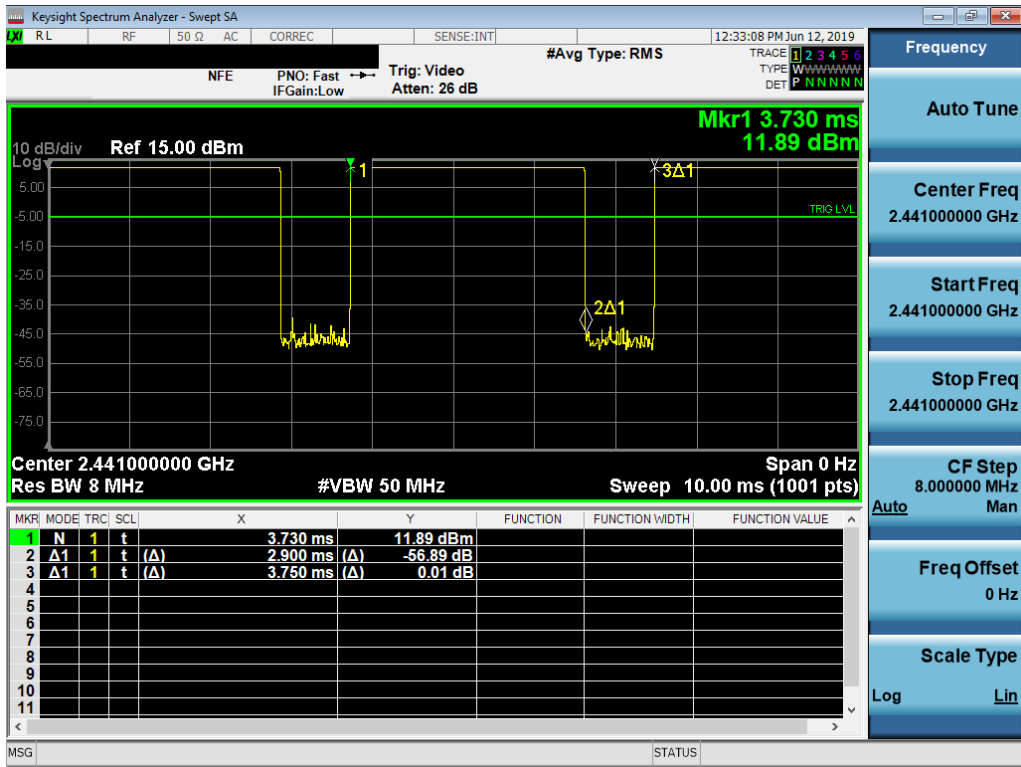

Figure 7-2
Bluetooth Transmission Plot

Equation 7-1
Bluetooth Duty Cycle Calculation

$$Duty\ Cycle = \frac{Pulse\ Width}{Period} * 100\% = \frac{2.90\ ms}{3.75\ ms} * 100\% = 77.3\%$$

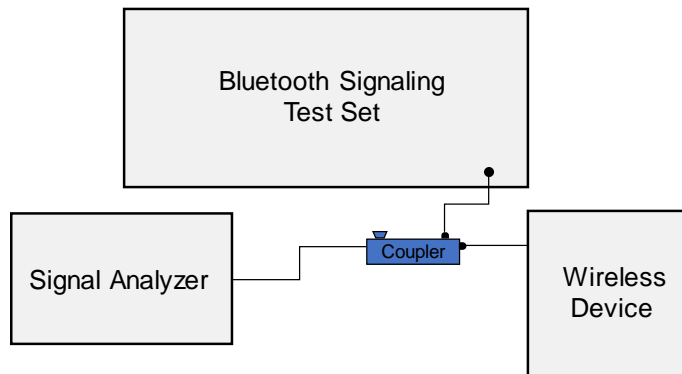

Figure 7-3
Power Measurement Setup

FCC ID A3LSMT860	PCTEST ENGINEERING LABORATORY, INC.	SAR EVALUATION REPORT	SAMSUNG	Approved by: Quality Manager
Document S/N: 1M1906170102-01.A3L	Test Dates: 06/27/19 - 07/07/19	DUT Type: Portable Tablet		Page 18 of 34



8 SYSTEM VERIFICATION

8.1 Tissue Verification

**Table 8-1
Measured Tissue Properties**

Calibrated for Tests Performed on:	Tissue Type	Tissue Temp During Calibration (°C)	Measured Frequency (MHz)	Measured Conductivity, σ (S/m)	Measured Dielectric Constant, ϵ	TARGET Conductivity, σ (S/m)	TARGET Dielectric Constant, ϵ	% dev σ	% dev ϵ
7/3/2019	2450B	23.7	2400	1.965	51.423	1.902	52.767	3.31%	-2.55%
			2450	2.022	51.296	1.950	52.700	3.69%	-2.66%
			2500	2.079	51.168	2.021	52.636	2.87%	-2.79%
7/7/2019	2450B	23.2	2400	1.956	51.375	1.902	52.767	2.84%	-2.64%
			2450	2.012	51.233	1.950	52.700	3.18%	-2.78%
			2500	2.072	51.073	2.021	52.636	2.52%	-2.97%
06/27/2019	5200B-5800B	22.1	5180	5.352	48.703	5.276	49.041	1.44%	-0.69%
			5200	5.385	48.659	5.299	49.014	1.62%	-0.72%
			5220	5.415	48.610	5.323	48.987	1.73%	-0.77%
			5240	5.442	48.567	5.346	48.960	1.80%	-0.80%
			5260	5.465	48.532	5.369	48.933	1.79%	-0.82%
			5280	5.493	48.504	5.393	48.906	1.85%	-0.82%
			5300	5.524	48.466	5.416	48.879	1.99%	-0.84%
			5320	5.560	48.429	5.439	48.851	2.22%	-0.86%
			5500	5.813	48.090	5.650	48.607	2.88%	-1.06%
			5520	5.850	48.051	5.673	48.580	3.12%	-1.09%
			5540	5.886	47.997	5.696	48.553	3.34%	-1.15%
			5560	5.917	47.968	5.720	48.526	3.44%	-1.15%
			5580	5.951	47.943	5.743	48.499	3.62%	-1.15%
			5600	5.972	47.912	5.766	48.471	3.57%	-1.15%
			5620	5.998	47.848	5.790	48.444	3.59%	-1.23%
			5640	6.033	47.789	5.813	48.417	3.78%	-1.30%
			5660	6.071	47.763	5.837	48.390	4.01%	-1.30%
			5680	6.102	47.735	5.860	48.363	4.13%	-1.30%
			5700	6.135	47.729	5.883	48.336	4.28%	-1.26%
			5745	6.197	47.605	5.936	48.275	4.40%	-1.39%
			5765	6.228	47.556	5.959	48.248	4.51%	-1.43%
5785	6.268	47.514	5.982	48.220	4.78%	-1.46%			
5800	6.292	47.512	6.000	48.200	4.87%	-1.43%			
5805	6.298	47.519	6.006	48.193	4.86%	-1.40%			
5825	6.323	47.483	6.029	48.166	4.88%	-1.42%			

The above measured tissue parameters were used in the DASY software. The DASY software was used to perform interpolation to determine the dielectric parameters at the SAR test device frequencies (per KDB Publication 865664 D01v01r04 and IEEE 1528-2013 6.6.1.2). The tissue parameters listed in the SAR test plots may slightly differ from the table above due to significant digit rounding in the software.

FCC ID A3LSMT860	 PCTEST ENGINEERING LABORATORY, INC.	SAR EVALUATION REPORT		Approved by: Quality Manager
Document S/N: 1M1906170102-01.A3L	Test Dates: 06/27/19 - 07/07/19	DUT Type: Portable Tablet		Page 19 of 34

8.2 Test System Verification

Prior to SAR assessment, the system is verified to $\pm 10\%$ of the SAR measurement on the reference dipole at the time of calibration by the calibration facility. Full system validation status and result summary can be found in Appendix E.

**Table 8-2
System Verification Results**

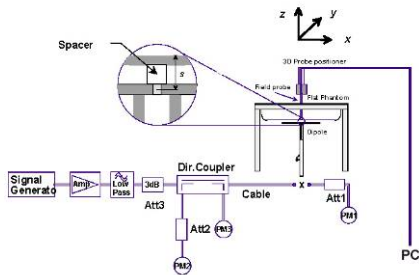

System Verification TARGET & MEASURED												
SAR System #	Tissue Frequency (MHz)	Tissue Type	Date	Amb. Temp (°C)	Liquid Temp (°C)	Input Power (W)	Source SN	Probe SN	Measured SAR _{1g} (W/kg)	1 W Target SAR _{1g} (W/kg)	1 W Normalized SAR _{1g} (W/kg)	Deviation _{1g} (%)
K	2450	BODY	07/03/2019	23.4	21.7	0.100	719	7417	4.950	50.100	49.500	-1.20%
K	2450	BODY	07/07/2019	23.0	22.1	0.100	719	7417	5.030	50.100	50.300	0.40%
L	5250	BODY	06/27/2019	23.5	21.1	0.050	1191	7308	3.710	77.000	74.200	-3.64%
L	5600	BODY	06/27/2019	23.5	21.1	0.050	1191	7308	3.890	79.200	77.800	-1.77%
L	5750	BODY	06/27/2019	23.5	21.1	0.050	1191	7308	3.580	76.100	71.600	-5.91%



**Figure 8-1
System Verification Setup Diagram**



**Figure 8-2
System Verification Setup Photo**

FCC ID A3LSMT860	 PCTEST ENGINEERING LABORATORY, INC.	SAR EVALUATION REPORT		Approved by: Quality Manager
Document S/N: 1M1906170102-01.A3L	Test Dates: 06/27/19 - 07/07/19	DUT Type: Portable Tablet	Page 20 of 34	



9 SAR DATA SUMMARY

9.1 Standalone Body SAR Data

**Table 9-1
2.4 GHz WIFI Body SAR Data**

MEASUREMENT RESULTS																		
FREQUENCY		Mode	Service	Bandwidth [MHz]	Maximum Allowed Power [dBm]	Conducted Power [dBm]	Power Drift [dB]	Spacing	Antenna Config.	Device Serial Number	Data Rate (Mbps)	Side	Duty Cycle (%)	SAR (1g)	Scaling Factor (Power)	Scaling Factor (Duty Cycle)	Reported SAR (1g)	Plot #
MHz	Ch.													(W/kg)			(W/kg)	
2437	6	802.11b	DSSS	22	20.0	19.67	0.01	15 mm	1	0AY9H	1	back	99.1	0.061	1.079	1.009	0.066	
2412	1	802.11b	DSSS	22	13.5	12.84	-0.16	0 mm	1	0AY9H	1	back	99.1	0.927	1.164	1.009	1.089	
2437	6	802.11b	DSSS	22	13.5	12.80	-0.12	0 mm	1	0AY9H	1	back	99.1	0.903	1.175	1.009	1.071	
2462	11	802.11b	DSSS	22	13.5	13.46	-0.16	0 mm	1	0AY9H	1	back	99.1	1.070	1.009	1.009	1.089	A1
2437	6	802.11b	DSSS	22	20.0	19.67	0.14	14 mm	1	0AY9H	1	top	99.1	0.028	1.079	1.009	0.030	
2462	11	802.11b	DSSS	22	13.5	13.46	-0.16	0 mm	1	0AY9H	1	top	99.1	0.166	1.009	1.009	0.169	
2437	6	802.11b	DSSS	22	20.0	19.67	0.04	6 mm	1	0AY9H	1	left	99.1	0.203	1.079	1.009	0.221	
2462	11	802.11b	DSSS	22	13.5	13.46	0.02	0 mm	1	0AY9H	1	left	99.1	0.783	1.009	1.009	0.797	
2457	10	802.11b	DSSS	22	20.0	19.86	0.10	15 mm	2	0AY9H	1	back	99.0	0.173	1.033	1.010	0.180	
2412	1	802.11b	DSSS	22	13.5	13.03	-0.04	0 mm	2	0AY9H	1	back	99.0	0.848	1.114	1.010	0.954	
2437	6	802.11b	DSSS	22	13.5	12.94	-0.08	0 mm	2	0AY9H	1	back	99.0	0.596	1.138	1.010	0.685	
2462	11	802.11b	DSSS	22	13.5	12.87	0.03	0 mm	2	0AY9H	1	back	99.0	0.735	1.156	1.010	0.858	
2457	10	802.11b	DSSS	22	20.0	19.86	-0.05	14 mm	2	0AY9H	1	top	99.0	0.204	1.033	1.010	0.213	
2412	1	802.11b	DSSS	22	13.5	13.03	-0.12	0 mm	2	0AY9H	1	top	99.0	0.420	1.114	1.010	0.473	
2457	10	802.11b	DSSS	22	20.0	19.86	-0.03	6 mm	2	0AY9H	1	right	99.0	0.661	1.033	1.010	0.690	
2412	1	802.11b	DSSS	22	13.5	13.03	-0.11	0 mm	2	0AY9H	1	right	99.0	0.762	1.114	1.010	0.857	
2437	6	802.11b	DSSS	22	13.5	12.94	-0.20	0 mm	2	0AY9H	1	right	99.0	0.774	1.138	1.010	0.890	
2462	11	802.11b	DSSS	22	13.5	13.46	-0.11	0 mm	1	0AY9H	1	back	99.1	0.976	1.009	1.009	0.994	
ANSI / IEEE C95.1 1992 - SAFETY LIMIT Spatial Peak Uncontrolled Exposure/General Population								Body 1.6 W/kg (mW/g) averaged over 1 gram										



Blue entries represent variability measurements.

FCC ID A3LSMT860	 PCTEST ENGINEERING LABORATORY, INC.	SAR EVALUATION REPORT		Approved by: Quality Manager
Document S/N: 1M1906170102-01.A3L	Test Dates: 06/27/19 - 07/07/19	DUT Type: Portable Tablet	Page 21 of 34	

**Table 9-2
5 GHz WIFI Body SAR Data**

MEASUREMENT RESULTS																		
FREQUENCY		Mode	Service	Bandwidth [MHz]	Maximum Allowed Power [dBm]	Conducted Power [dBm]	Power Drift [dB]	Spacing	Antenna Config.	Device Serial Number	Data Rate (Mbps)	Side	Duty Cycle (%)	SAR (1g)	Scaling Factor (Power)	Scaling Factor (Duty Cycle)	Reported SAR (1g)	Plot #
MHz	Ch.													(W/kg)			(W/kg)	
5260	52	802.11a	OFDM	20	18.0	17.82	0.18	15 mm	1	0AYBW	6	back	98.8	0.014	1.042	1.013	0.015	
5290	58	802.11ac	OFDM	80	10.0	9.94	-0.06	0 mm	1	0AYBW	29.3	back	94.5	0.262	1.014	1.058	0.281	
5260	52	802.11a	OFDM	20	18.0	17.82	0.11	14 mm	1	0AYBW	6	top	98.8	0.006	1.042	1.013	0.006	
5290	58	802.11ac	OFDM	80	10.0	9.94	0.09	0 mm	1	0AYBW	29.3	top	94.5	0.087	1.014	1.058	0.093	
5260	52	802.11a	OFDM	20	18.0	17.82	-0.10	6 mm	1	0AYBW	6	left	98.8	0.151	1.042	1.013	0.159	
5290	58	802.11ac	OFDM	80	10.0	9.94	-0.03	0 mm	1	0AYBW	29.3	left	94.5	0.280	1.014	1.058	0.300	
5280	56	802.11a	OFDM	20	18.0	17.93	0.11	15 mm	2	0AYBW	6	back	98.7	0.061	1.016	1.013	0.063	
5290	58	802.11ac	OFDM	80	10.0	9.99	-0.04	0 mm	2	0AYBW	29.3	back	94.5	0.391	1.002	1.058	0.415	
5280	56	802.11a	OFDM	20	18.0	17.93	0.14	14 mm	2	0AYBW	6	top	98.7	0.032	1.016	1.013	0.033	
5290	58	802.11ac	OFDM	80	10.0	9.99	-0.14	0 mm	2	0AYBW	29.3	top	94.5	0.155	1.002	1.058	0.164	
5280	56	802.11a	OFDM	20	18.0	17.93	0.07	6 mm	2	0AYBW	6	right	98.7	0.545	1.016	1.013	0.561	
5290	58	802.11ac	OFDM	80	10.0	9.99	-0.19	0 mm	2	0AYBW	29.3	right	94.5	0.315	1.002	1.058	0.334	
5280	56	802.11a	OFDM	20	18.0	17.93	-0.08	0 mm	2	0AYBW	6	left	98.7	0.010	1.016	1.013	0.010	
5500	100	802.11a	OFDM	20	18.0	17.72	0.15	15 mm	1	0AYBW	6	back	98.8	0.073	1.067	1.013	0.079	
5530	106	802.11ac	OFDM	80	10.0	9.95	-0.13	0 mm	1	0AYBW	29.3	back	94.5	0.604	1.012	1.058	0.647	
5500	100	802.11a	OFDM	20	18.0	17.72	-0.20	14 mm	1	0AYBW	6	top	98.8	0.049	1.067	1.013	0.053	
5530	106	802.11ac	OFDM	80	10.0	9.95	-0.20	0 mm	1	0AYBW	29.3	top	94.5	0.209	1.012	1.058	0.224	
5500	100	802.11a	OFDM	20	18.0	17.72	-0.08	6 mm	1	0AYBW	6	left	98.8	0.641	1.067	1.013	0.693	
5530	106	802.11ac	OFDM	80	10.0	9.95	0.04	0 mm	1	0AYBW	29.3	left	94.5	0.652	1.012	1.058	0.698	
5610	122	802.11ac	OFDM	80	10.0	9.79	0.19	0 mm	1	0AYBW	29.3	left	94.5	0.503	1.050	1.058	0.559	
5690	138	802.11ac	OFDM	80	10.0	9.74	-0.06	0 mm	1	0AYBW	29.3	left	94.5	0.465	1.062	1.058	0.545	
5720	144	802.11a	OFDM	20	18.0	17.96	-0.04	15 mm	2	0AYBW	6	back	98.7	0.078	1.009	1.013	0.080	
5690	138	802.11ac	OFDM	80	10.0	9.98	0.12	0 mm	2	0AYBW	29.3	back	94.5	0.545	1.005	1.058	0.579	
5720	144	802.11a	OFDM	20	18.0	17.96	-0.13	14 mm	2	0AYBW	6	top	98.7	0.057	1.009	1.013	0.058	
5690	138	802.11ac	OFDM	80	10.0	9.98	-0.12	0 mm	2	0AYBW	29.3	top	94.5	0.271	1.005	1.058	0.288	
5500	100	802.11a	OFDM	20	18.0	17.70	0.00	6 mm	2	0AYBW	6	right	98.7	0.725	1.072	1.013	0.787	
5620	124	802.11a	OFDM	20	18.0	17.93	0.02	6 mm	2	0AYBW	6	right	98.7	0.841	1.016	1.013	0.866	
5720	144	802.11a	OFDM	20	18.0	17.96	-0.03	6 mm	2	0AYBW	6	right	98.7	0.850	1.009	1.013	0.869	A2
5690	138	802.11ac	OFDM	80	10.0	9.98	-0.13	0 mm	2	0AYBW	29.3	right	94.5	0.640	1.005	1.058	0.681	
5720	144	802.11a	OFDM	20	18.0	17.96	-0.20	0 mm	2	0AYBW	6	left	98.7	0.012	1.009	1.013	0.012	
5785	157	802.11a	OFDM	20	18.0	17.77	-0.12	15 mm	1	0AYBW	6	back	98.8	0.021	1.054	1.013	0.022	
5775	155	802.11ac	OFDM	80	10.0	9.90	0.01	0 mm	1	0AYBW	29.3	back	94.5	0.342	1.023	1.058	0.370	
5785	157	802.11a	OFDM	20	18.0	17.77	-0.19	14 mm	1	0AYBW	6	top	98.8	0.024	1.054	1.013	0.026	
5775	155	802.11ac	OFDM	80	10.0	9.90	0.15	0 mm	1	0AYBW	29.3	top	94.5	0.049	1.023	1.058	0.053	
5785	157	802.11a	OFDM	20	18.0	17.77	-0.06	6 mm	1	0AYBW	6	left	98.8	0.293	1.054	1.013	0.313	
5775	155	802.11ac	OFDM	80	10.0	9.90	-0.09	0 mm	1	0AYBW	29.3	left	94.5	0.512	1.023	1.058	0.554	
5785	157	802.11a	OFDM	20	18.0	17.95	0.14	15 mm	2	0AYBW	6	back	98.7	0.069	1.012	1.013	0.071	
5775	155	802.11ac	OFDM	80	10.0	9.99	-0.14	0 mm	2	0AYBW	29.3	back	94.5	0.484	1.002	1.058	0.513	
5785	157	802.11a	OFDM	20	18.0	17.95	-0.08	14 mm	2	0AYBW	6	top	98.7	0.059	1.012	1.013	0.060	
5775	155	802.11ac	OFDM	80	10.0	9.99	-0.11	0 mm	2	0AYBW	29.3	top	94.5	0.235	1.002	1.058	0.249	
5745	149	802.11a	OFDM	20	18.0	17.95	-0.18	6 mm	2	0AYBW	6	right	98.7	0.737	1.012	1.013	0.756	
5785	157	802.11a	OFDM	20	18.0	17.95	-0.18	6 mm	2	0AYBW	6	right	98.7	0.810	1.012	1.013	0.830	
5775	155	802.11ac	OFDM	80	10.0	9.99	-0.14	0 mm	2	0AYBW	29.3	right	94.5	0.582	1.002	1.058	0.617	
5785	157	802.11a	OFDM	20	18.0	17.95	0.14	0 mm	2	0AYBW	6	left	98.7	0.010	1.012	1.013	0.010	
5620	124	802.11a	OFDM	20	18.0	17.93	-0.15	6 mm	2	0AYBW	6	right	98.7	0.809	1.016	1.013	0.833	
5720	144	802.11a	OFDM	20	18.0	17.96	-0.08	6 mm	2	0AYBW	6	right	98.7	0.798	1.009	1.013	0.816	
ANSI / IEEE C95.1 1992 - SAFETY LIMIT								Body										
Spatial Peak								1.6 W/kg (mW/g)										
Uncontrolled Exposure/General Population								averaged over 1 gram										

Blue entries represent variability measurements.

FCC ID A3LSMT860		SAR EVALUATION REPORT		Approved by: Quality Manager
Document S/N: 1M1906170102-01.A3L	Test Dates: 06/27/19 - 07/07/19	DUT Type: Portable Tablet		Page 22 of 34

**Table 9-3
2.4 GHz Bluetooth Body SAR Data**

MEASUREMENT RESULTS																
FREQUENCY		Mode	Service	Maximum Allowed Power [dBm]	Conducted Power [dBm]	Power Drift [dB]	Spacing	Device Serial Number	Data Rate (Mbps)	Side	Duty Cycle (%)	SAR (1g) (W/kg)	Scaling Factor (Cond Power)	Scaling Factor (Duty Cycle)	Reported SAR (1g) (W/kg)	Plot #
MHz	Ch.															
2441	39	Bluetooth	FHSS	13.0	12.98	0.05	0 mm	0AYCX	1	back	77.3	0.451	1.005	1.294	0.587	
2441	39	Bluetooth	FHSS	13.0	12.98	-0.15	0 mm	0AYCX	1	top	77.3	0.098	1.005	1.294	0.127	
2402	0	Bluetooth	FHSS	13.0	12.82	-0.05	0 mm	0AYCX	1	left	77.3	0.447	1.042	1.294	0.603	
2441	39	Bluetooth	FHSS	13.0	12.98	-0.08	0 mm	0AYCX	1	left	77.3	0.513	1.005	1.294	0.667	A3
2480	78	Bluetooth	FHSS	13.0	12.48	0.04	0 mm	0AYCX	1	left	77.3	0.473	1.128	1.294	0.690	
ANSI / IEEE C95.1 1992 - SAFETY LIMIT Spatial Peak Uncontrolled Exposure/General Population							Body 1.6 W/kg (mW/g) averaged over 1 gram									



9.2 SAR Test Notes

General Notes:

1. The test data reported are the worst-case SAR values according to test procedures specified in IEEE 1528-2013, and FCC KDB Publication 447498 D01v06.
2. Batteries are fully charged at the beginning of the SAR measurements.
3. Liquid tissue depth was at least 15.0 cm for all frequencies.
4. The manufacturer has confirmed that the device(s) tested have the same physical, mechanical and thermal characteristics and are within operational tolerances expected for production units.
5. SAR results were scaled to the maximum allowed power to demonstrate compliance per FCC KDB Publication 447498 D01v06.
6. Per FCC KDB 865664 D01v01r04, variability SAR tests were performed when the measured SAR results for a frequency band were greater than or equal to 0.8 W/kg. Repeated SAR measurements are highlighted in the tables above for clarity. Please see Section 11 for variability analysis.
7. FCC KDB Publication 616217 D04v01r02 Section 4.3, SAR tests are required for the back surface and edges of the tablet with the tablet touching the phantom. The SAR Exclusion Threshold in FCC KDB 447498 D01v06 was applied to determine SAR test exclusion for adjacent edge configurations.

WLAN Notes:



1. Justification for test configurations for WLAN per KDB Publication 248227 D01v02r02 for 2.4 GHz WIFI single transmission chain operations, the highest measured maximum output power channel for DSSS was selected for SAR measurement. SAR for OFDM modes (2.4 GHz 802.11g/n) was not required due to the maximum allowed powers and the highest reported DSSS SAR. See Section 6.3.4 for more information.
2. Justification for test configurations for WLAN per KDB Publication 248227 D01v02r02 for 5 GHz WIFI single transmission chain operations, the initial test configuration was selected according to the transmission mode with the highest maximum allowed powers. Other transmission modes were not investigated since the highest reported SAR for initial test configuration adjusted by the ratio of maximum output powers is less than 1.2 W/kg for 1g evaluations. See Section 6.3.5 for more information.
3. Per KDB Publication 248227 D01v02r02, SAR for MIMO was evaluated by following the simultaneous SAR provisions from KDB Publication 447498 D01v06 by either evaluating the sum of the 1g SAR values of each antenna transmitting independently or making a SAR measurement with both antennas transmitting simultaneously. Please see Section 10 for complete analysis.

FCC ID A3LSMT860	 PCTEST ENGINEERING LABORATORY, INC.	SAR EVALUATION REPORT		Approved by: Quality Manager
Document S/N: 1M1906170102-01.A3L	Test Dates: 06/27/19 - 07/07/19	DUT Type: Portable Tablet	Page 23 of 34	

4. When the maximum reported 1g averaged SAR is ≤ 0.8 W/kg, SAR testing on additional channels was not required. Otherwise, SAR for the next highest output power channel was required until the reported SAR result was ≤ 1.20 W/kg for 1g evaluations or all test channels were measured.
5. The device was configured to transmit continuously at the required data rate, channel bandwidth and signal modulation, using the highest transmission duty factor supported by the test mode tools. The reported SAR was scaled to the 100% transmission duty factor to determine compliance. Procedures used to measure the duty factor are identical to that in the associated EMC test reports.

Bluetooth Notes

1. Bluetooth SAR was measured with the device connected to a call box with hopping disabled with DH5 operation and Tx Tests test mode type. Per October 2016 TCB Workshop Notes, the reported SAR was scaled to the 100% transmission duty factor to determine compliance. See Section 7.2 for the time domain plot and calculation for the duty factor of the device.

FCC ID A3LSMT860	 PCTEST ENGINEERING LABORATORY, INC.	SAR EVALUATION REPORT		Approved by: Quality Manager
Document S/N: 1M1906170102-01.A3L	Test Dates: 06/27/19 - 07/07/19	DUT Type: Portable Tablet	Page 24 of 34	

10 FCC MULTI-TX AND ANTENNA SAR CONSIDERATIONS

10.1 Introduction

The following procedures adopted from FCC KDB Publication 447498 D01v06 are applicable to devices with built-in unlicensed transmitters such as 802.11 and Bluetooth devices which may simultaneously transmit with the licensed transmitter.

10.2 Simultaneous Transmission Procedures

This device contains transmitters that may operate simultaneously. Therefore, simultaneous transmission analysis is required. Per FCC KDB Publication 447498 D01v06 4.3.2 and IEEE 1528-2013 Section 6.3.4.1.2, simultaneous transmission SAR test exclusion may be applied when the sum of the 1g SAR for all the simultaneous transmitting antennas in a specific a physical test configuration is ≤ 1.6 W/kg. The different test positions in an exposure condition may be considered collectively to determine SAR test exclusion according to the sum of 1g or 10g SAR.

10.3 Body Simultaneous Transmission Analysis

Table 10-1
Simultaneous Transmission Scenario with 2.4 GHz WLAN

Simult Tx	Configuration	2.4 GHz WLAN Ant 1 SAR (W/kg)	2.4 GHz WLAN Ant 2 SAR (W/kg)	Σ SAR (W/kg)	SPLSR
		1	2	1+2	1+2
Body SAR	Back	1.089	0.954	See Note 1	0.02
	Top	0.169	0.473	0.642	N/A
	Bottom	0.400	0.400	0.800	N/A
	Right	0.400	0.890	1.290	N/A
	Left	0.797	0.400	1.197	N/A

Table 10-2
Simultaneous Transmission Scenario with 5 GHz WLAN

Simult Tx	Configuration	5 GHz WLAN Ant 1 SAR (W/kg)	5 GHz WLAN Ant 2 SAR (W/kg)	Σ SAR (W/kg)
		1	2	1+2
Body SAR	Back	0.647	0.579	1.226
	Top	0.224	0.288	0.512
	Bottom	0.400	0.400	0.800
	Right	0.400	0.869	1.269
	Left	0.698	0.012	0.710

Table 10-3
Simultaneous Transmission Scenario with 2.4 GHz WLAN Ant 1 and 5 GHz WLAN Ant 2

Simult Tx	Configuration	2.4 GHz WLAN Ant 1 SAR (W/kg)	5 GHz WLAN Ant 2 SAR (W/kg)	Σ SAR (W/kg)	SPLSR
		1	2	1+2	1+2
Body SAR	Back	1.089	0.579	See Note 1	0.02
	Top	0.169	0.288	0.457	N/A
	Bottom	0.400	0.400	0.800	N/A
	Right	0.400	0.869	1.269	N/A
	Left	0.797	0.012	0.809	N/A



FCC ID A3LSMT860	 PCTEST ENGINEERING LABORATORY, INC.	SAR EVALUATION REPORT		Approved by: Quality Manager
Document S/N: 1M1906170102-01.A3L	Test Dates: 06/27/19 - 07/07/19	DUT Type: Portable Tablet	Page 25 of 34	

Table 10-4
Simultaneous Transmission Scenario with 2.4 GHz Bluetooth and 5 GHz WLAN Ant 2

Simult Tx	Configuration	Bluetooth SAR (W/kg)	5 GHz WLAN Ant 2 SAR (W/kg)	Σ SAR (W/kg)
		1	2	1+2
Body SAR	Back	0.587	0.579	1.166
	Top	0.127	0.288	0.415
	Bottom	0.400	0.400	0.800
	Right	0.400	0.869	1.269
	Left	0.690	0.012	0.702

Note:



1. No evaluation was performed to determine the aggregate 1g SAR for these configurations as the SPLS ratio between the antenna pairs was not greater than 0.04 per FCC KDB 447498 D01v06. See Section 10.4 for detailed SPLS ratio analysis.
2. For SAR summation, the highest reported SAR across all test distances was used as the most conservative evaluation for simultaneous transmission analysis for each device edge.
3. When the antenna separation distance was > 50 mm, an estimated SAR of 0.4 W/kg was used to determine the simultaneous transmission SAR exclusion for test positions excluded per FCC KDB Publication 447498 D01v06.

10.4 SPLSR Evaluation and Analysis

Per FCC KDB Publication 447498 D01v06, when the sum of the standalone transmitters is more than 1.6 W/kg for 1g the SAR sum to peak locations can be analyzed to determine SAR distribution overlaps. When the SAR peak to location ratio (shown below) for each pair of antennas is ≤ 0.04 for 1g simultaneous SAR evaluation is not required. The distance between the transmitters was calculated using the following formula.

$$\text{Distance}_{\text{TX1} - \text{TX2}} = R_i = \sqrt{(x_1 - x_2)^2 + (y_1 - y_2)^2}$$

$$\text{SPLS Ratio} = \frac{(SAR_1 + SAR_2)^{1.5}}{R_i}$$

FCC ID A3LSMT860	 PCTEST ENGINEERING LABORATORY, INC.	SAR EVALUATION REPORT		Approved by: Quality Manager
Document S/N: 1M1906170102-01.A3L	Test Dates: 06/27/19 - 07/07/19	DUT Type: Portable Tablet	Page 26 of 34	

10.4.1 Back Side SPLSR Evaluation and Analysis

Table 10-5
Peak SAR Locations for Body Back Side



Mode/Band	x (mm)	y (mm)	Reported SAR (W/kg)
2.4 GHz WLAN Ant 1	1.60	-69.60	1.089
2.4 GHz WLAN Ant 2	6.00	73.40	0.954
5 GHz WLAN Ant 2	7.00	70.00	0.579

Table 10-6
Back Side SAR to Peak Location Separation Ratio Calculations

Antenna Pair		Standalone SAR (W/kg)		Standalone SAR Sum (W/kg)	Peak SAR Separation Distance (mm)	SPLSR Ratio	Plot Number
Ant "a"	Ant "b"	a	b	a+b	D _{a-b}	$(a+b)^{1.5}/D_{a-b}$	
2.4 GHz WLAN Ant 1	2.4 GHz WLAN Ant 2	1.089	0.954	2.043	143.07	0.02	1
2.4 GHz WLAN Ant 1	5 GHz WLAN Ant 2	1.089	0.579	1.668	139.70	0.02	2

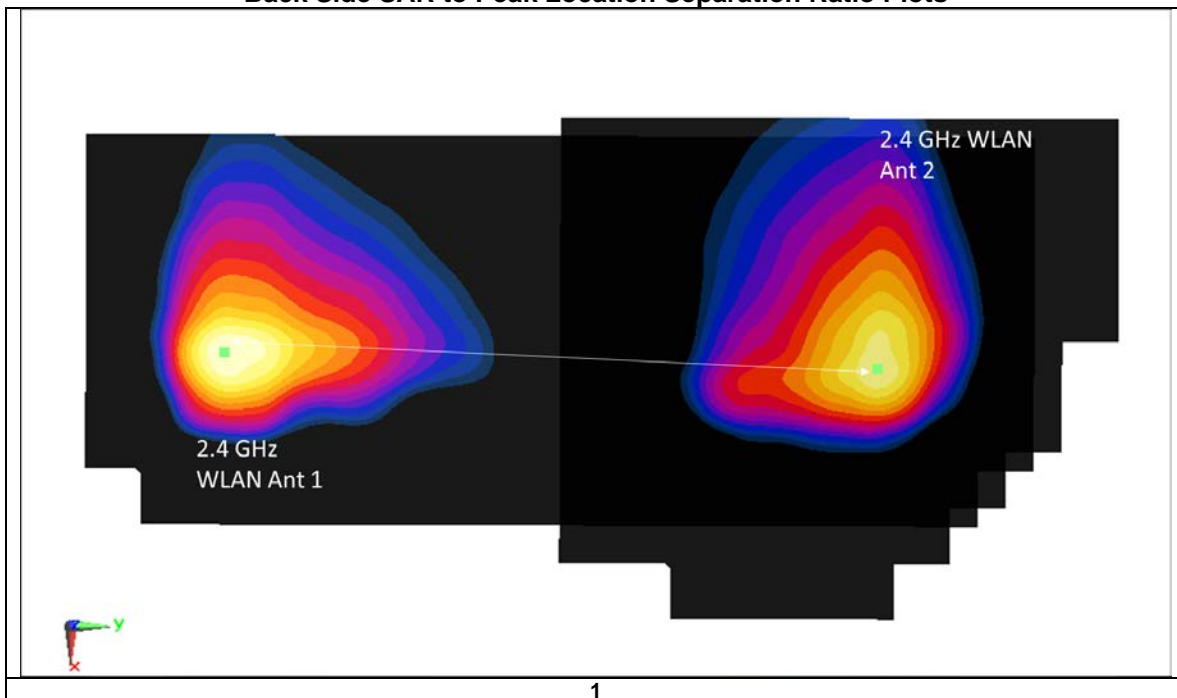
Table 10-7
Back Side SAR to Peak Location Separation Ratio Plots



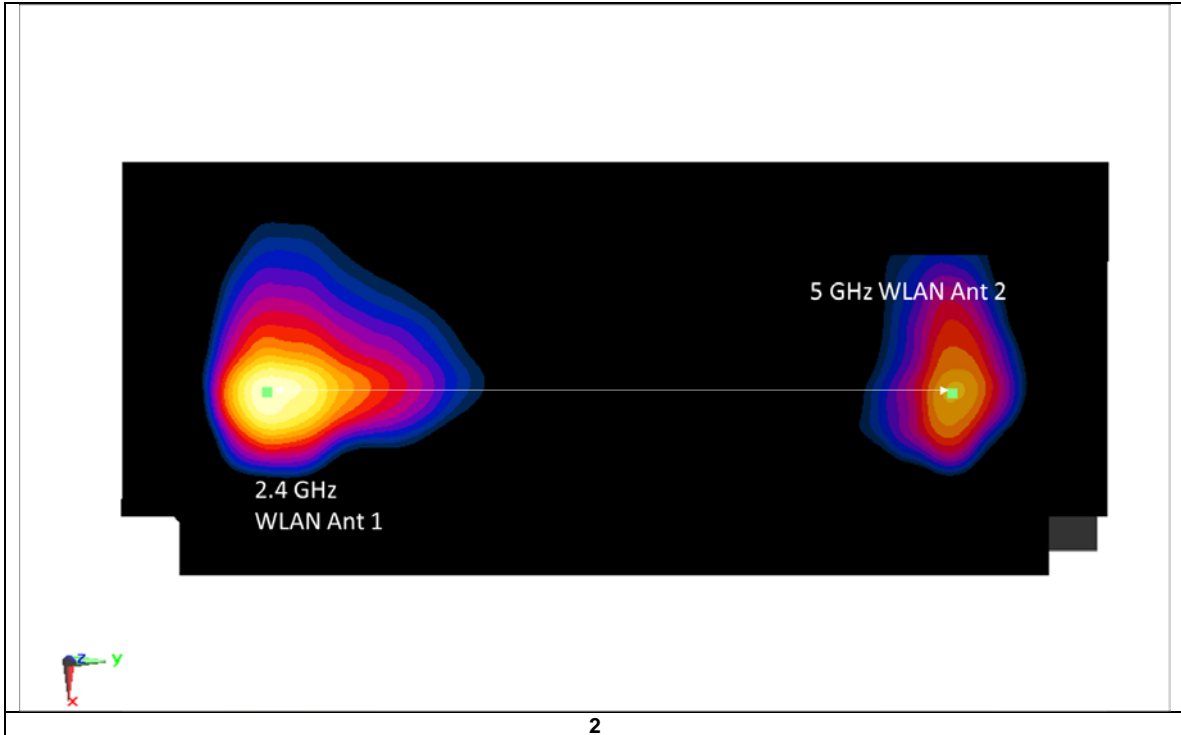

FCC ID A3LSMT860	 PCTEST ENGINEERING LABORATORY, INC.	SAR EVALUATION REPORT		Approved by: Quality Manager
Document S/N: 1M1906170102-01.A3L	Test Dates: 06/27/19 - 07/07/19	DUT Type: Portable Tablet		Page 27 of 34



10.5 Simultaneous Transmission Conclusion

The above numerical summed SAR results and SPLSR analysis are sufficient to determine that simultaneous transmission cases will not exceed the SAR limit and therefore no measured volumetric simultaneous SAR summation is required per FCC KDB Publication 447498 D01v06.

FCC ID A3LSMT860	 PCTEST ENGINEERING LABORATORY, INC.	SAR EVALUATION REPORT		Approved by: Quality Manager
Document S/N: 1M1906170102-01.A3L	Test Dates: 06/27/19 - 07/07/19	DUT Type: Portable Tablet	Page 28 of 34	

11 SAR MEASUREMENT VARIABILITY

11.1 Measurement Variability

Per FCC KDB Publication 865664 D01v01r04, SAR measurement variability was assessed for each frequency band, which was determined by the SAR probe calibration point and tissue-equivalent medium used for the device measurements. When both head and body tissue-equivalent media were required for SAR measurements in a frequency band, the variability measurement procedures were applied to the tissue medium with the highest measured SAR, using the highest measured SAR configuration for that tissue-equivalent medium. These additional measurements were repeated after the completion of all measurements requiring the same head or body tissue-equivalent medium in a frequency band. The test device was returned to ambient conditions (normal room temperature) with the battery fully charged before it was re-mounted on the device holder for the repeated measurement(s) to minimize any unexpected variations in the repeated results.

SAR Measurement Variability was assessed using the following procedures for each frequency band:



- 1) When the original highest measured SAR is ≥ 0.80 W/kg, the measurement was repeated once.
- 2) A second repeated measurement was performed only if the ratio of largest to smallest SAR for the original and first repeated measurements was > 1.20 or when the original or repeated measurement was ≥ 1.45 W/kg (~ 10% from the 1g SAR limit).
- 3) A third repeated measurement was performed only if the original, first or second repeated measurement was ≥ 1.5 W/kg and the ratio of largest to smallest SAR for the original, first and second repeated measurements is > 1.20 .
- 4) Repeated measurements are not required when the original highest measured SAR is < 0.80 W/kg

**Table 11-1
Body SAR Measurement Variability Results**

BODY VARIABILITY RESULTS														
Band	FREQUENCY		Mode	Service	Data Rate (Mbps)	Side	Spacing	Measured SAR (1g)	1st Repeated SAR (1g)	Ratio	2nd Repeated SAR (1g)	Ratio	3rd Repeated SAR (1g)	Ratio
	MHz	Ch.						(W/kg)	(W/kg)		(W/kg)		(W/kg)	
2450	2462.00	11	802.11b, 22 MHz Bandwidth	DSSS , ANT 1	1	back	0 mm	1.070	0.976	1.10	N/A	N/A	N/A	N/A
5600	5620.00	124	802.11a, 20 MHz Bandwidth	OFDM , ANT 2	6	right	6 mm	0.841	0.809	1.04	N/A	N/A	N/A	N/A
5750	5720.00	144	802.11a, 20 MHz Bandwidth	OFDM , ANT 2	6	right	6 mm	0.850	0.798	1.07	N/A	N/A	N/A	N/A
ANSI / IEEE C95.1 1992 - SAFETY LIMIT Spatial Peak Uncontrolled Exposure/General Population							Body 1.6 W/kg (mW/g) averaged over 1 gram							

11.2 Measurement Uncertainty



The measured SAR was < 1.5 W/kg for all frequency bands. Therefore, per KDB Publication 865664 D01v01r04, the extended measurement uncertainty analysis per IEEE 1528-2013 was not required.

FCC ID A3LSMT860	 PCTEST ENGINEERING LABORATORY, INC.	SAR EVALUATION REPORT		Approved by: Quality Manager
Document S/N: 1M1906170102-01.A3L	Test Dates: 06/27/19 - 07/07/19	DUT Type: Portable Tablet	Page 29 of 34	

12 EQUIPMENT LIST



Manufacturer	Model	Description	Cal Date	Cal Interval	Cal Due	Serial Number
Agilent	85033E	3.5mm Standard Calibration Kit	8/13/2018	Annual	8/13/2019	MY53402352
Agilent	8753E	(30kHz-6GHz) Network Analyzer	9/28/2018	Annual	9/28/2019	JP38020182
Agilent	8753ES	Network Analyzer	3/19/2019	Annual	3/19/2020	MY40001472
Agilent	8753ES	S-Parameter Vector Network Analyzer	8/30/2018	Annual	8/30/2019	MY40003841
Agilent	8753ES	S-Parameter Network Analyzer	10/2/2018	Annual	10/2/2019	US39170118
Agilent	E4438C	ESG Vector Signal Generator	3/8/2019	Biennial	3/8/2021	MY42082385
Agilent	E4440A	PSA Series Spectrum Analyzer	11/14/2018	Annual	11/14/2019	MY46186272
Agilent	N4010A	Wireless Connectivity Test Set	N/A	N/A	N/A	GB44450273
Agilent	N5182A	MXG Vector Signal Generator	11/28/2018	Annual	11/28/2019	MY47420603
Agilent	N9020A	MXA Signal Analyzer	4/20/2019	Annual	4/20/2020	US46470561
Amplifier Research	150A100C	Amplifier	CBT	N/A	CBT	350132
Amplifier Research	15S1G6	Amplifier	CBT	N/A	CBT	343971
Anritsu	MA24106A	USB Power Sensor	5/22/2019	Annual	5/22/2020	1231535
Anritsu	MA24106A	USB Power Sensor	5/6/2019	Annual	5/6/2020	1231538
Anritsu	MA24106A	USB Power Sensor	1/31/2019	Annual	1/31/2020	1244524
Anritsu	MA24106A	USB Power Sensor	9/20/2018	Annual	9/20/2019	1344545
Anritsu	MA2411B	Pulse Power Sensor	11/20/2018	Annual	11/20/2019	1339007
Anritsu	MA2411B	Pulse Power Sensor	11/20/2018	Annual	11/20/2019	1339008
Anritsu	MA2411B	Pulse Power Sensor	3/6/2019	Annual	3/6/2020	1339018
Anritsu	ML2495A	Power Meter	11/20/2018	Annual	11/20/2019	1039008
Anritsu	ML2496A	Power Meter	10/21/2018	Annual	10/21/2019	1138001
Control Company	4040	Therm./ Clock/ Humidity Monitor	10/9/2018	Biennial	10/9/2020	181647812
Control Company	4352	Ultra Long Stem Thermometer	11/29/2018	Biennial	11/29/2020	181766816
Keysight	772D	Dual Directional Coupler	CBT	N/A	CBT	MY52180215
MCL	BW-N6W5+	6dB Attenuator	CBT	N/A	CBT	1139
MiniCircuits	SLP-2400+	Low Pass Filter	CBT	N/A	CBT	R8979500903
MiniCircuits	VLF-6000+	Low Pass Filter	CBT	N/A	CBT	N/A
MiniCircuits	VLF-6000+	Low Pass Filter	CBT	N/A	CBT	N/A
Mini-Circuits	BW-N20W5	Power Attenuator	CBT	N/A	CBT	1226
Mini-Circuits	BW-N20W5+	DC to 18 GHz Precision Fixed 20 dB Attenuator	CBT	N/A	CBT	N/A
Mini-Circuits	NLP-2950+	Low Pass Filter DC to 2700 MHz	CBT	N/A	CBT	N/A
Mitutoyo	CD-6"CSX	Digital Caliper	4/18/2018	Biennial	4/18/2020	13264165
Narda	4014C-6	4 - 8 GHz SMA 6 dB Directional Coupler	CBT	N/A	CBT	N/A
Narda	4772-3	Attenuator (3dB)	CBT	N/A	CBT	9406
Narda	BW-S3W2	Attenuator (3dB)	CBT	N/A	CBT	120
Pasternack	NC-100	Torque Wrench	11/1/2017	Biennial	11/1/2019	N/A
Pasternack	NC-100	Torque Wrench	5/23/2018	Biennial	5/23/2020	N/A
Pasternack	NC-100	Torque Wrench	11/7/2017	Biennial	11/7/2019	N/A
Pasternack	PE2208-6	Bidirectional Coupler	CBT	N/A	CBT	N/A
Rohde & Schwarz	CMW500	Radio Communication Tester	11/14/2018	Annual	11/14/2019	100976
Rohde & Schwarz	CMW500	Radio Communication Tester	6/24/2019	Annual	6/24/2020	101699
Seekonk	NC-100	Torque Wrench	11/1/2017	Biennial	11/1/2019	22313
SPEAG	D2450V2	2450 MHz SAR Dipole	8/17/2017	Biennial	8/17/2019	719
SPEAG	D5GHzV2	5 GHz SAR Dipole	9/21/2016	Triennial	9/21/2019	1191
SPEAG	DAE4	Dasy Data Acquisition Electronics	2/13/2019	Annual	2/13/2020	665
SPEAG	DAE4	Dasy Data Acquisition Electronics	10/3/2018	Annual	10/3/2019	1558
SPEAG	DAK-3.5	Dielectric Assessment Kit	5/7/2019	Annual	5/7/2020	1070
SPEAG	DAK-3.5	Dielectric Parameter Probes	12/3/2018	Annual	12/3/2019	1278
SPEAG	EX3DV4	SAR Probe	8/23/2018	Annual	8/23/2019	7308
SPEAG	EX3DV4	SAR Probe	2/19/2019	Annual	2/19/2020	7417

Note: CBT (Calibrated Before Testing). Prior to testing, the measurement paths containing a cable, amplifier, attenuator, coupler or filter were connected to a calibrated source (i.e. a signal generator) to measure the losses of the measurement path. The power meter offset was then adjusted to compensate for the measurement system losses. This level offset is stored within the power meter before measurements are made. This calibration verification procedure applies to the system verification and output power measurements. The calibrated reading is then taken directly from the power meter after compensation of the losses for all final power measurements.

FCC ID A3LSMT860	 PCTEST ENGINEERING LABORATORY, INC.	SAR EVALUATION REPORT		Approved by: Quality Manager
Document S/N: 1M1906170102-01.A3L	Test Dates: 06/27/19 - 07/07/19	DUT Type: Portable Tablet		Page 30 of 34

13 MEASUREMENT UNCERTAINTIES

a	c	d	e= f(d,k)	f	g	h = c x f/e	i = c x g/e	k
Uncertainty Component	Tol. (± %)	Prob. Dist.	Div.	c _i 1gm	c _i 10 gms	1gm u _i (± %)	10gms u _i (± %)	v _i
Measurement System								
Probe Calibration	6.55	N	1	1.0	1.0	6.6	6.6	∞
Axial Isotropy	0.25	N	1	0.7	0.7	0.2	0.2	∞
Hemishperical Isotropy	1.3	N	1	0.7	0.7	0.9	0.9	∞
Boundary Effect	2.0	R	1.73	1.0	1.0	1.2	1.2	∞
Linearity	0.3	N	1	1.0	1.0	0.3	0.3	∞
System Detection Limits	0.25	R	1.73	1.0	1.0	0.1	0.1	∞
Readout Electronics	0.3	N	1	1.0	1.0	0.3	0.3	∞
Response Time	0.8	R	1.73	1.0	1.0	0.5	0.5	∞
Integration Time	2.6	R	1.73	1.0	1.0	1.5	1.5	∞
RF Ambient Conditions - Noise	3.0	R	1.73	1.0	1.0	1.7	1.7	∞
RF Ambient Conditions - Reflections	3.0	R	1.73	1.0	1.0	1.7	1.7	∞
Probe Positioner Mechanical Tolerance	0.4	R	1.73	1.0	1.0	0.2	0.2	∞
Probe Positioning w/ respect to Phantom	6.7	R	1.73	1.0	1.0	3.9	3.9	∞
Extrapolation, Interpolation & Integration algorithms for Max. SAR Evaluation	4.0	R	1.73	1.0	1.0	2.3	2.3	∞
Test Sample Related								
Test Sample Positioning	2.7	N	1	1.0	1.0	2.7	2.7	35
Device Holder Uncertainty	1.67	N	1	1.0	1.0	1.7	1.7	5
Output Power Variation - SAR drift measurement	5.0	R	1.73	1.0	1.0	2.9	2.9	∞
SAR Scaling	0.0	R	1.73	1.0	1.0	0.0	0.0	∞
Phantom & Tissue Parameters								
Phantom Uncertainty (Shape & Thickness tolerances)	7.6	R	1.73	1.0	1.0	4.4	4.4	∞
Liquid Conductivity - measurement uncertainty	4.2	N	1	0.78	0.71	3.3	3.0	10
Liquid Permittivity - measurement uncertainty	4.1	N	1	0.23	0.26	1.0	1.1	10
Liquid Conductivity - Temperature Uncertainty	3.4	R	1.73	0.78	0.71	1.5	1.4	∞
Liquid Permittivity - Temperature Uncertainty	0.6	R	1.73	0.23	0.26	0.1	0.1	∞
Liquid Conductivity - deviation from target values	5.0	R	1.73	0.64	0.43	1.8	1.2	∞
Liquid Permittivity - deviation from target values	5.0	R	1.73	0.60	0.49	1.7	1.4	∞
Combined Standard Uncertainty (k=1)	RSS					11.5	11.3	60
Expanded Uncertainty (95% CONFIDENCE LEVEL)	k=2					23.0	22.6	



FCC ID A3LSMT860	 PCTEST ENGINEERING LABORATORY, INC.	SAR EVALUATION REPORT		Approved by: Quality Manager
Document S/N: 1M1906170102-01.A3L	Test Dates: 06/27/19 - 07/07/19	DUT Type: Portable Tablet	Page 31 of 34	

14 CONCLUSION

14.1 Measurement Conclusion



The SAR evaluation indicates that the EUT complies with the RF radiation exposure limits of the FCC and Innovation, Science, and Economic Development Canada, with respect to all parameters subject to this test. These measurements were taken to simulate the RF effects of RF exposure under worst-case conditions. Precise laboratory measures were taken to assure repeatability of the tests. The results and statements relate only to the item(s) tested.

Please note that the absorption and distribution of electromagnetic energy in the body are very complex phenomena that depend on the mass, shape, and size of the body, the orientation of the body with respect to the field vectors, and the electrical properties of both the body and the environment. Other variables that may play a substantial role in possible biological effects are those that characterize the environment (e.g. ambient temperature, air velocity, relative humidity, and body insulation) and those that characterize the individual (e.g. age, gender, activity level, debilitation, or disease). Because various factors may interact with one another to vary the specific biological outcome of an exposure to electromagnetic fields, any protection guide should consider maximal amplification of biological effects as a result of field-body interactions, environmental conditions, and physiological variables. [3]



FCC ID A3LSMT860	 PCTEST ENGINEERING LABORATORY, INC.	SAR EVALUATION REPORT		Approved by: Quality Manager
Document S/N: 1M1906170102-01.A3L	Test Dates: 06/27/19 - 07/07/19	DUT Type: Portable Tablet	Page 32 of 34	

15 REFERENCES

- [1] Federal Communications Commission, ET Docket 93-62, Guidelines for Evaluating the Environmental Effects of Radiofrequency Radiation, Aug. 1996.
- [2] ANSI/IEEE C95.1-2005, American National Standard safety levels with respect to human exposure to radio frequency electromagnetic fields, 3kHz to 300GHz, New York: IEEE, 2006.
- [3] ANSI/IEEE C95.1-1992, American National Standard safety levels with respect to human exposure to radio frequency electromagnetic fields, 3kHz to 300GHz, New York: IEEE, Sept. 1992.
- [4] ANSI/IEEE C95.3-2002, IEEE Recommended Practice for the Measurement of Potentially Hazardous Electromagnetic Fields - RF and Microwave, New York: IEEE, December 2002.
- [5] IEEE Standards Coordinating Committee 39 –Standards Coordinating Committee 34 – IEEE Std. 1528-2013, IEEE Recommended Practice for Determining the Peak Spatial-Average Specific Absorption Rate (SAR) in the Human Head from Wireless Communications Devices: Measurement Techniques.
- [6] NCRP, National Council on Radiation Protection and Measurements, Biological Effects and Exposure Criteria for RadioFrequency Electromagnetic Fields, NCRP Report No. 86, 1986. Reprinted Feb. 1995.
- [7] T. Schmid, O. Egger, N. Kuster, Automated E-field scanning system for dosimetric assessments, IEEE Transaction on Microwave Theory and Techniques, vol. 44, Jan. 1996, pp. 105-113.
- [8] K. Pokovic, T. Schmid, N. Kuster, Robust setup for precise calibration of E-field probes in tissue simulating liquids at mobile communications frequencies, ICECOM97, Oct. 1997, pp. 1 -124.
- [9] K. Pokovic, T. Schmid, and N. Kuster, E-field Probe with improved isotropy in brain simulating liquids, Proceedings of the ELMAR, Zadar, Croatia, June 23-25, 1996, pp. 172-175.
- [10] Schmid & Partner Engineering AG, Application Note: Data Storage and Evaluation, June 1998, p2.
- [11] V. Hombach, K. Meier, M. Burkhardt, E. Kuhn, N. Kuster, The Dependence of EM Energy Absorption upon Human Modeling at 900 MHz, IEEE Transaction on Microwave Theory and Techniques, vol. 44 no. 10, Oct. 1996, pp. 1865-1873.
- [12] N. Kuster and Q. Balzano, Energy absorption mechanism by biological bodies in the near field of dipole antennas above 300MHz, IEEE Transaction on Vehicular Technology, vol. 41, no. 1, Feb. 1992, pp. 17-23.
- [13] G. Hartsgrove, A. Kraszewski, A. Surowiec, Simulated Biological Materials for Electromagnetic Radiation Absorption Studies, University of Ottawa, Bioelectromagnetics, Canada: 1987, pp. 29-36.
- [14] Q. Balzano, O. Garay, T. Manning Jr., Electromagnetic Energy Exposure of Simulated Users of Portable Cellular Telephones, IEEE Transactions on Vehicular Technology, vol. 44, no.3, Aug. 1995.
- [15] W. Gander, Computermathematick, Birkhaeuser, Basel, 1992.
- [16] W.H. Press, S.A. Teukolsky, W.T. Vetterling, and B.P. Flannery, Numerical Recipes in C, The Art of Scientific Computing, Second edition, Cambridge University Press, 1992.
- [17] N. Kuster, R. Kastle, T. Schmid, Dosimetric evaluation of mobile communications equipment with known precision, IEEE Transaction on Communications, vol. E80-B, no. 5, May 1997, pp. 645-652.

FCC ID A3LSMT860	 PCTEST ENGINEERING LABORATORY, INC.	SAR EVALUATION REPORT		Approved by: Quality Manager
Document S/N: 1M1906170102-01.A3L	Test Dates: 06/27/19 - 07/07/19	DUT Type: Portable Tablet	Page 33 of 34	

- [18] CENELEC CLC/SC111B, European Prestandard (prENV 50166-2), Human Exposure to Electromagnetic Fields High-frequency: 10kHz-300GHz, Jan. 1995.
- [19] Prof. Dr. Niels Kuster, ETH, Eidgenössische Technische Hochschule Zürich, Dosimetric Evaluation of the Cellular Phone.
- [20] IEC 62209-1, Measurement procedure for the assessment of specific absorption rate of human exposure to radio frequency fields from hand-held and body-mounted wireless communication devices - Part 1: Devices used next to the ear (Frequency range of 300 MHz to 6 GHz), July 2016.
- [21] Innovation, Science, Economic Development Canada RSS-102 Radio Frequency Exposure Compliance of Radiocommunication Apparatus (All Frequency Bands) Issue 5, March 2015.
- [22] Health Canada Safety Code 6 Limits of Human Exposure to Radio Frequency Electromagnetic Fields in the Frequency Range from 3 kHz – 300 GHz, 2015
- [23] FCC SAR Test Procedures for 2G-3G Devices, Mobile Hotspot and UMPC Devices KDB Publications 941225, D01-D07
- [24] SAR Measurement Guidance for IEEE 802.11 Transmitters, KDB Publication 248227 D01
- [25] FCC SAR Considerations for Handsets with Multiple Transmitters and Antennas, KDB Publications 648474 D03-D04
- [26] FCC SAR Evaluation Considerations for Laptop, Notebook, Netbook and Tablet Computers, FCC KDB Publication 616217 D04
- [27] FCC SAR Measurement and Reporting Requirements for 100MHz – 6 GHz, KDB Publications 865664 D01-D02
- [28] FCC General RF Exposure Guidance and SAR Procedures for Dongles, KDB Publication 447498, D01-D02
- [29] Anexo à Resolução No. 533, de 10 de Setembro de 2009.
- [30] IEC 62209-2, Human exposure to radio frequency fields from hand-held and body-mounted wireless communication devices - Human models, instrumentation, and procedures - Part 2: Procedure to determine the specific absorption rate (SAR) for wireless communication devices used in close proximity to the human body (frequency range of 30 MHz to 6 GHz), Mar. 2010.

FCC ID A3LSMT860	 PCTEST ENGINEERING LABORATORY, INC.	SAR EVALUATION REPORT		Approved by: Quality Manager
Document S/N: 1M1906170102-01.A3L	Test Dates: 06/27/19 - 07/07/19	DUT Type: Portable Tablet	Page 34 of 34	

APPENDIX A: SAR TEST DATA

PCTEST ENGINEERING LABORATORY, INC.

DUT: A3LSMT860; Type: Portable Tablet; Serial: 0AY9H

Communication System: UID 0, _IEEE 802.11b; Frequency: 2462 MHz; Duty Cycle: 1:1
Medium: 2450 Body Medium parameters used (interpolated):
 $f = 2462 \text{ MHz}$; $\sigma = 2.026 \text{ S/m}$; $\epsilon_r = 51.195$; $\rho = 1000 \text{ kg/m}^3$
Phantom section: Flat Section; Space: 0.0 cm

Test Date: 07-07-2019; Ambient Temp: 23.0°C; Tissue Temp: 22.1°C

Probe: EX3DV4 - SN7417; ConvF(7.51, 7.51, 7.51) @ 2462 MHz; Calibrated: 2/19/2019
Sensor-Surface: 1.4mm (Mechanical Surface Detection)
Electronics: DAE4 Sn665; Calibrated: 2/13/2019
Phantom: LeftTwin-SAM V5.0; Type: QD 000 P40 CD; Serial: TP1375
Measurement SW: DASY52, Version 52.10 (2);SEMCAD X Version 14.6.12 (7450)

**Mode: IEEE 802.11b, Antenna 1, 22 MHz Bandwidth, Body SAR,
Ch 11, 1 Mbps, Back Side**

Area Scan (8x18x1): Measurement grid: $dx=12\text{mm}$, $dy=12\text{mm}$
Zoom Scan (7x7x7)/Cube 0: Measurement grid: $dx=5\text{mm}$, $dy=5\text{mm}$, $dz=5\text{mm}$
Reference Value = 24.96 V/m; Power Drift = -0.16 dB
Peak SAR (extrapolated) = 3.54 W/kg
SAR(1 g) = 1.07 W/kg

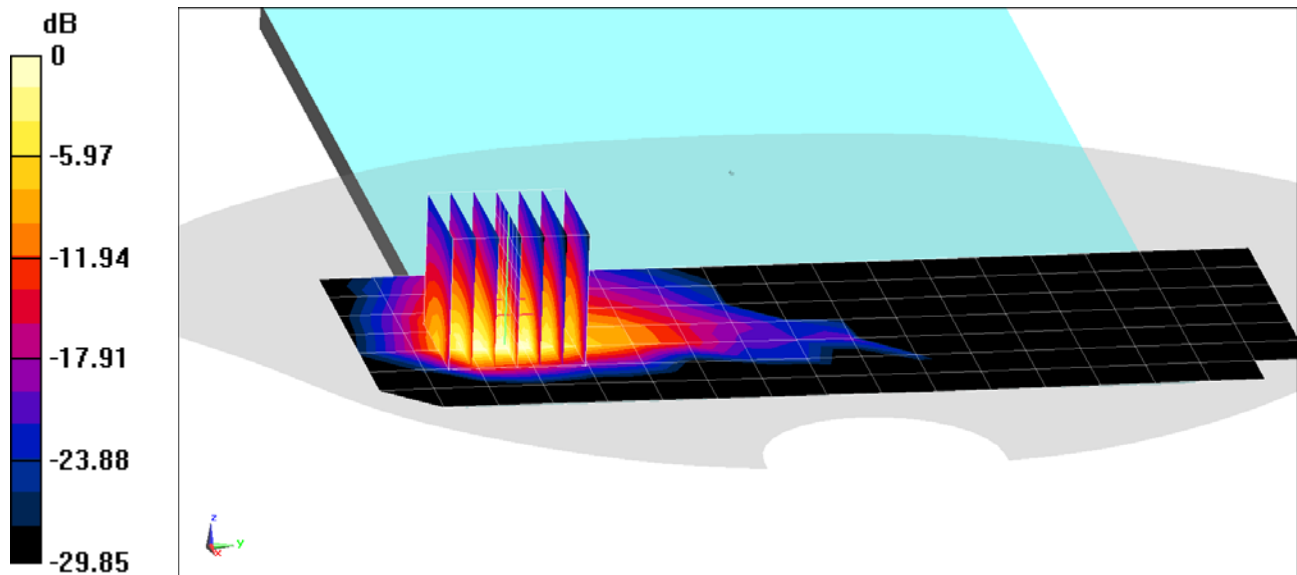

0 dB = 2.36 W/kg = 3.73 dBW/kg

PCTEST ENGINEERING LABORATORY, INC.

DUT: A3LSMT860; Type: Portable Tablet; Serial: 0AYBW

Communication System: UID 0, 802.11a 5.2-5.8 GHz Band; Frequency: 5720 MHz; Duty Cycle: 1:1
Medium: 5GHz Body Medium parameters used (interpolated):
 $f = 5720 \text{ MHz}$; $\sigma = 6.163 \text{ S/m}$; $\epsilon_r = 47.674$; $\rho = 1000 \text{ kg/m}^3$
Phantom section: Flat Section; Space: 0.6 cm

Test Date: 06-27-2019; Ambient Temp: 23.5°C; Tissue Temp: 21.1°C

Probe: EX3DV4 - SN7308; ConvF(4.18, 4.18, 4.18) @ 5720 MHz; Calibrated: 8/23/2018
Sensor-Surface: 1.4mm (Mechanical Surface Detection)
Electronics: DAE4 Sn1558; Calibrated: 10/3/2018
Phantom: Twin-SAM V5.0; Type: QD 000 P40 CD; Serial: 1630
Measurement SW: DASY52, Version 52.10 (2);SEMCAD X Version 14.6.12 (7450)

**Mode: IEEE 802.11a, U-NII-2C, Antenna 2, 20 MHz Bandwidth, Body SAR,
Ch 144, 6 Mbps, Right Edge**

Area Scan (9x27x1): Measurement grid: dx=5mm, dy=10mm

Zoom Scan (7x7x7)/Cube 0: Measurement grid: dx=4mm, dy=4mm, dz=1.4mm; Graded Ratio: 1.4

Reference Value = 12.17 V/m; Power Drift = -0.03 dB

Peak SAR (extrapolated) = 3.85 W/kg

SAR(1 g) = 0.850 W/kg

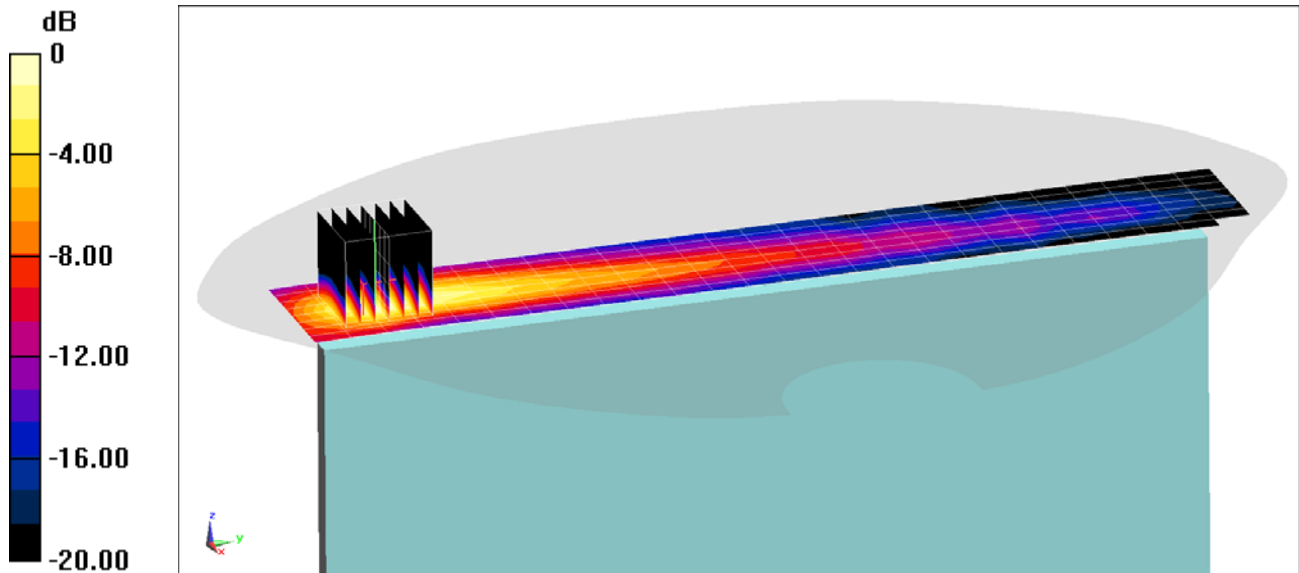

0 dB = 2.04 W/kg = 3.10 dBW/kg

PCTEST ENGINEERING LABORATORY, INC.

DUT: A3LSMT860; Type: Portable Tablet; Serial: 0AYCX

Communication System: UID 0, Bluetooth; Frequency: 2441 MHz; Duty Cycle: 1:1.294
Medium: 2450 Body Medium parameters used (interpolated):
 $f = 2441 \text{ MHz}$; $\sigma = 2.012 \text{ S/m}$; $\epsilon_r = 51.319$; $\rho = 1000 \text{ kg/m}^3$
Phantom section: Flat Section; Space: 0.0 cm

Test Date: 07-03-2019; Ambient Temp: 23.4°C; Tissue Temp: 21.7°C

Probe: EX3DV4 - SN7417; ConvF(7.51, 7.51, 7.51) @ 2441 MHz; Calibrated: 2/19/2019
Sensor-Surface: 1.4mm (Mechanical Surface Detection)
Electronics: DAE4 Sn665; Calibrated: 2/13/2019
Phantom: LeftTwin-SAM V5.0; Type: QD 000 P40 CD; Serial: TP1375
Measurement SW: DASY52, Version 52.10 (2);SEMCAD X Version 14.6.12 (7450)

Mode: Bluetooth, Body SAR, Ch 39, 1 Mbps, Left Edge

Area Scan (11x25x1): Measurement grid: dx=5mm, dy=12mm

Zoom Scan (7x9x7)/Cube 0: Measurement grid: dx=5mm, dy=5mm, dz=5mm

Reference Value = 17.06 V/m; Power Drift = -0.08 dB

Peak SAR (extrapolated) = 1.59 W/kg

SAR(1 g) = 0.513 W/kg

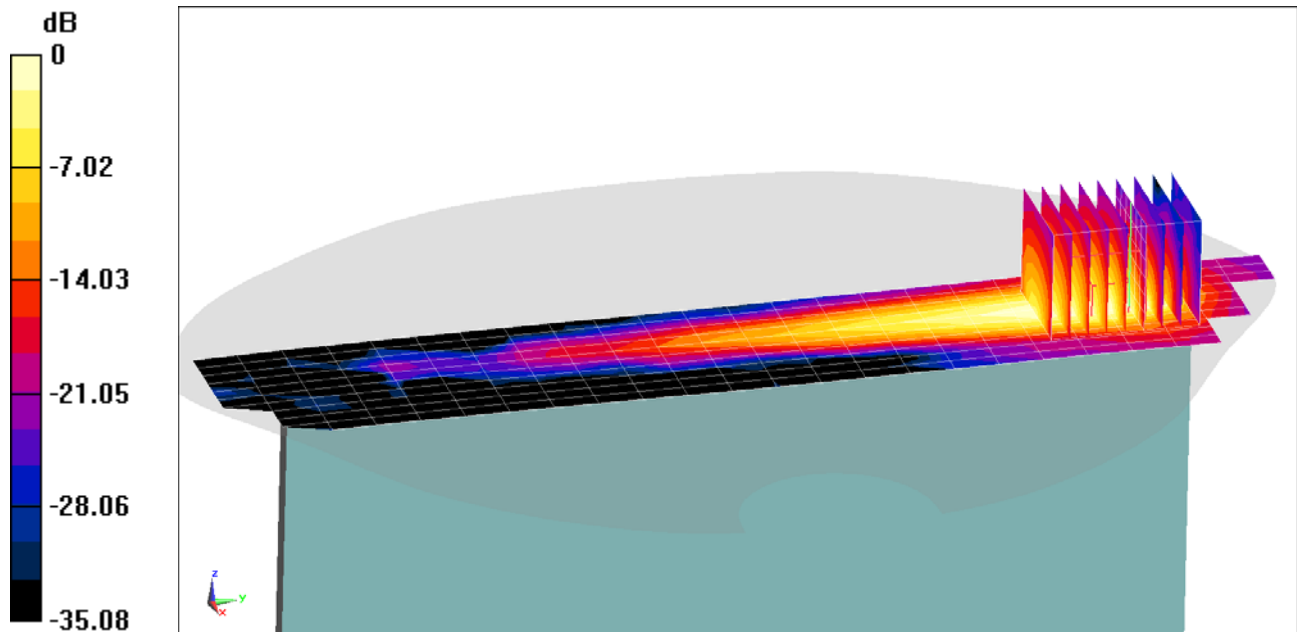

0 dB = 1.04 W/kg = 0.17 dBW/kg

APPENDIX B: SYSTEM VERIFICATION

PCTEST ENGINEERING LABORATORY, INC.

DUT: Dipole 2450 MHz; Type: D2450V2; Serial: 719

Communication System: UID 0, CW; Frequency: 2450 MHz; Duty Cycle: 1:1

Medium: 2450 Body; Medium parameters used:

$f = 2450$ MHz; $\sigma = 2.022$ S/m; $\epsilon_r = 51.296$; $\rho = 1000$ kg/m³

Phantom section: Flat Section; Space: 1.0 cm

Test Date: 07-03-2019; Ambient Temp: 23.4°C; Tissue Temp: 21.7°C

Probe: EX3DV4 - SN7417; ConvF(7.51, 7.51, 7.51) @ 2450 MHz; Calibrated: 2/19/2019

Sensor-Surface: 1.4mm (Mechanical Surface Detection)

Electronics: DAE4 Sn665; Calibrated: 2/13/2019

Phantom: LeftTwin-SAM V5.0; Type: QD 000 P40 CD; Serial: TP1375

Measurement SW: DASY52, Version 52.10 (2);SEMCAD X Version 14.6.12 (7450)

2450 MHz System Verification at 20.0 dBm (100 mW)

Area Scan (8x9x1): Measurement grid: dx=12mm, dy=12mm

Zoom Scan (7x7x7)/Cube 0: Measurement grid: dx=5mm, dy=5mm, dz=5mm

Peak SAR (extrapolated) = 10.4 W/kg

SAR(1 g) = 4.95 W/kg

Deviation(1 g) = -1.20%

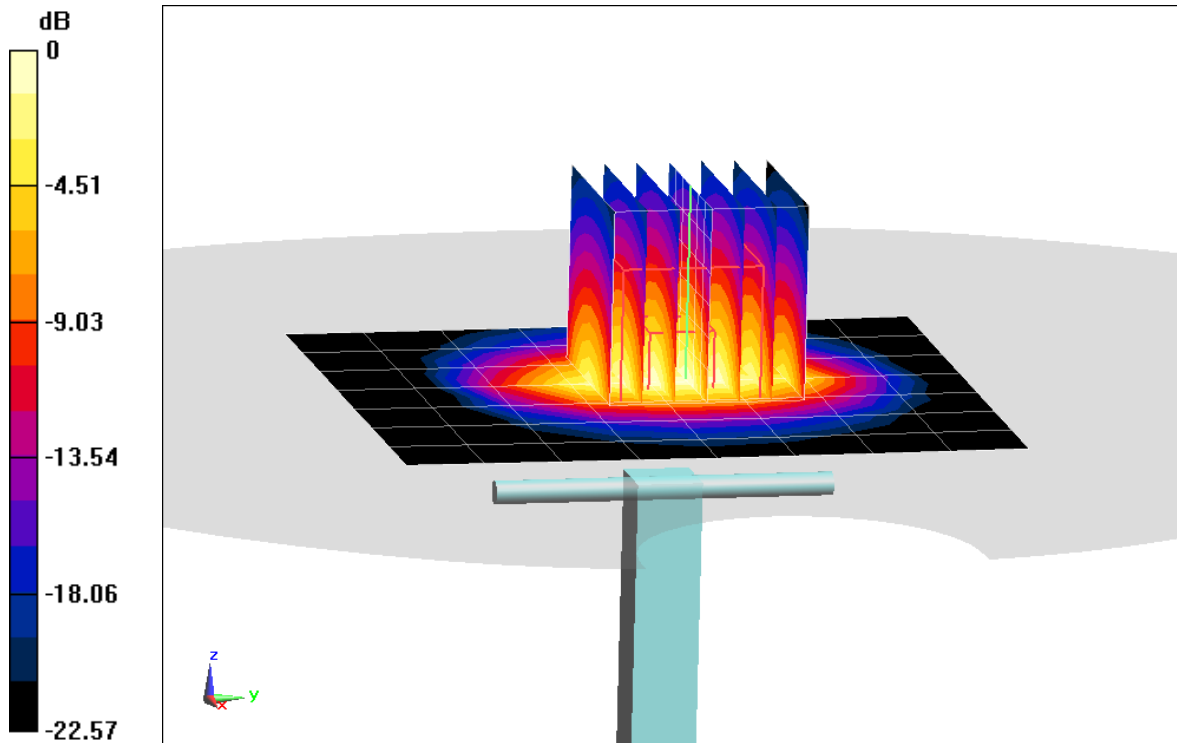

0 dB = 8.35 W/kg = 9.22 dBW/kg

PCTEST ENGINEERING LABORATORY, INC.

DUT: Dipole 2450 MHz; Type: D2450V2; Serial: 719

Communication System: UID 0, CW; Frequency: 2450 MHz; Duty Cycle: 1:1

Medium: 2450 Body; Medium parameters used:

$f = 2450$ MHz; $\sigma = 2.012$ S/m; $\epsilon_r = 51.233$; $\rho = 1000$ kg/m³

Phantom section: Flat Section; Space: 1.0 cm

Test Date: 07-07-2019; Ambient Temp: 23.0°C; Tissue Temp: 22.1°C

Probe: EX3DV4 - SN7417; ConvF(7.51, 7.51, 7.51) @ 2450 MHz; Calibrated: 2/19/2019

Sensor-Surface: 1.4mm (Mechanical Surface Detection)

Electronics: DAE4 Sn665; Calibrated: 2/13/2019

Phantom: LeftTwin-SAM V5.0; Type: QD 000 P40 CD; Serial: TP1375

Measurement SW: DASY52, Version 52.10 (2);SEMCAD X Version 14.6.12 (7450)

2450 MHz System Verification at 20.0 dBm (100 mW)

Area Scan (8x9x1): Measurement grid: dx=12mm, dy=12mm

Zoom Scan (7x7x7)/Cube 0: Measurement grid: dx=5mm, dy=5mm, dz=5mm

Peak SAR (extrapolated) = 10.3 W/kg

SAR(1 g) = 5.03 W/kg

Deviation(1 g) = 0.40%

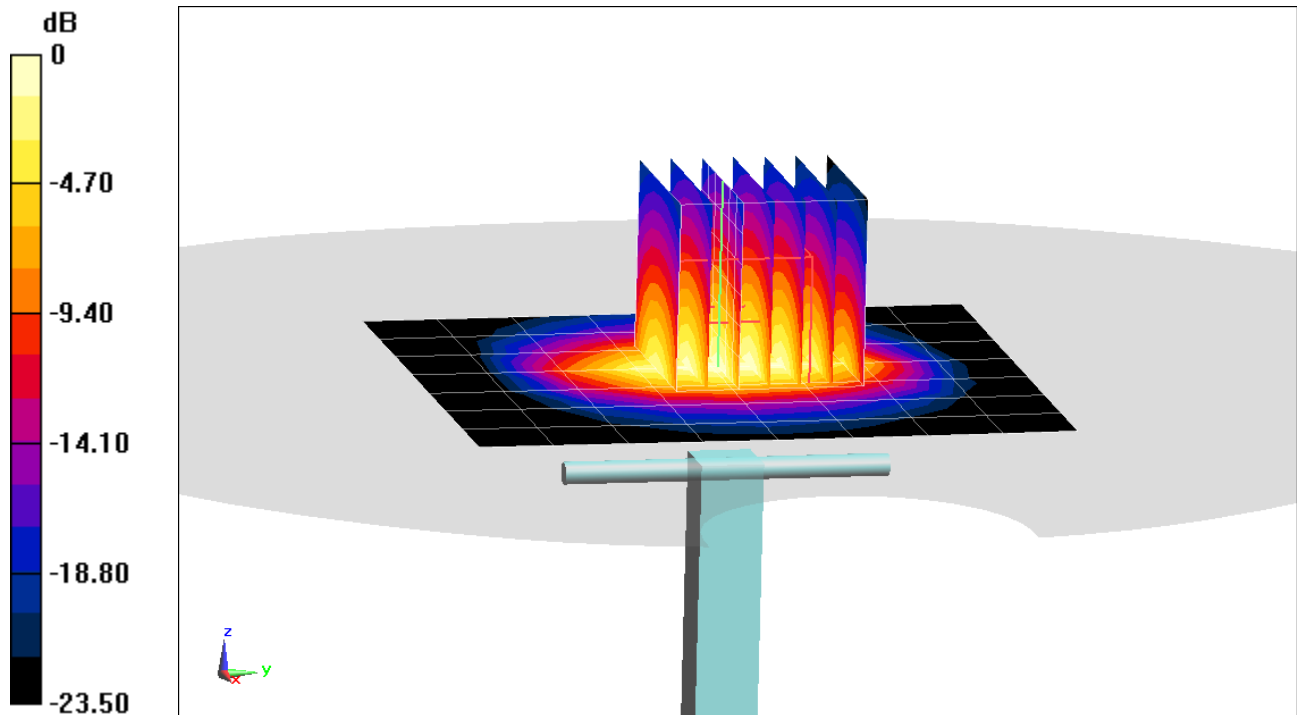

0 dB = 8.35 W/kg = 9.22 dBW/kg

PCTEST ENGINEERING LABORATORY, INC.

DUT: Dipole 5 GHz; Type: D5GHzV2; Serial: 1191

Communication System: UID 0, CW; Frequency: 5250 MHz; Duty Cycle: 1:1
Medium: 5GHz Body; Medium parameters used (interpolated):
 $f = 5250 \text{ MHz}$; $\sigma = 5.453 \text{ S/m}$; $\epsilon_r = 48.55$; $\rho = 1000 \text{ kg/m}^3$
Phantom section: Flat Section; Space: 1.0 cm

Test Date: 06-27-2019; Ambient Temp: 23.5°C; Tissue Temp: 21.1°C

Probe: EX3DV4 - SN7308; ConvF(4.48, 4.48, 4.48) @ 5250 MHz; Calibrated: 8/23/2018
Sensor-Surface: 1.4mm (Mechanical Surface Detection)
Electronics: DAE4 Sn1558; Calibrated: 10/3/2018
Phantom: Twin-SAM V5.0; Type: QD 000 P40 CD; Serial: 1630
Measurement SW: DASY52, Version 52.10 (2);SEMCAD X Version 14.6.12 (7450)

5250 MHz System Verification at 17.0 dBm (50 mW)

Area Scan (7x7x1): Measurement grid: dx=10mm, dy=10mm

Zoom Scan (8x8x7)/Cube 0: Measurement grid: dx=4mm, dy=4mm, dz=1.4mm; Graded Ratio: 1.4

Peak SAR (extrapolated) = 14.9 W/kg

SAR(1 g) = 3.71 W/kg

Deviation(1 g) = -3.64%

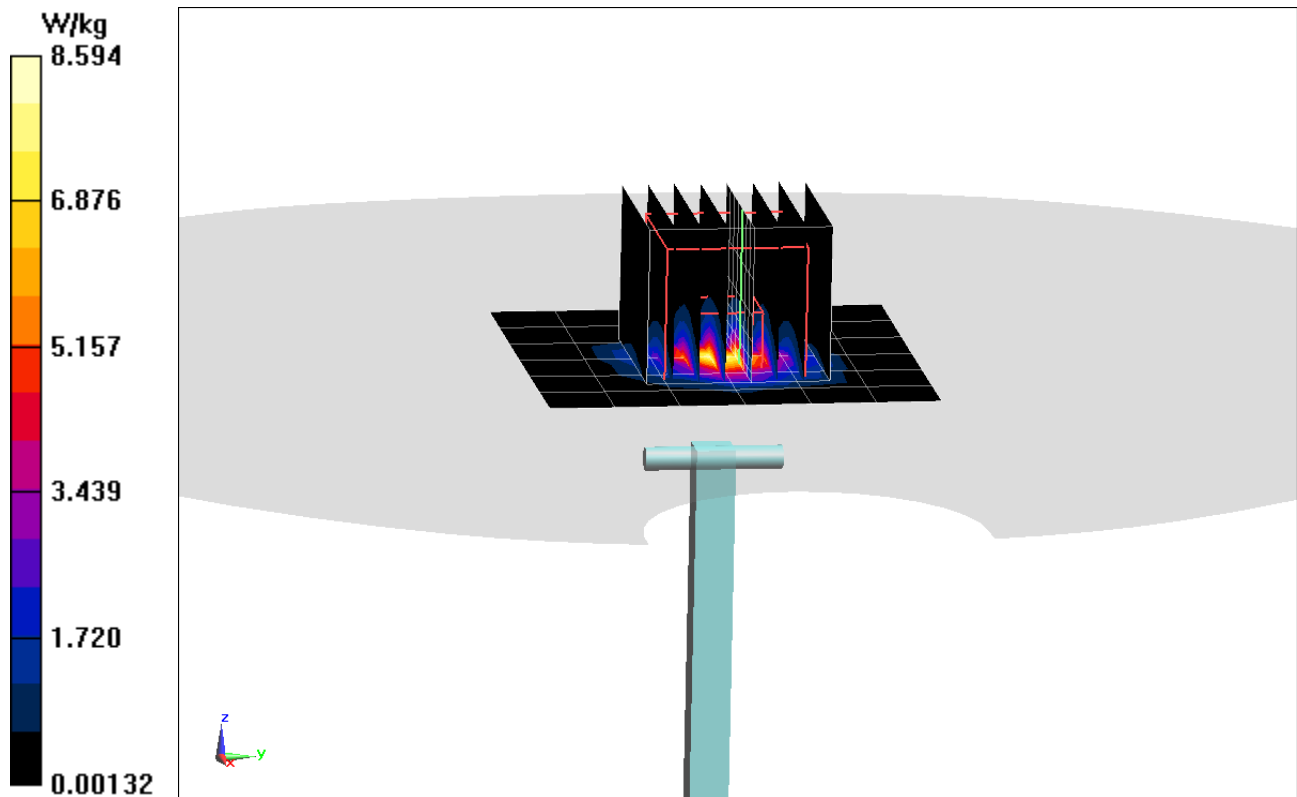

PCTEST ENGINEERING LABORATORY, INC.

DUT: Dipole 5 GHz; Type: D5GHzV2; Serial: 1191

Communication System: UID 0, CW; Frequency: 5600 MHz; Duty Cycle: 1:1

Medium: 5GHz Body; Medium parameters used:

$f = 5600$ MHz; $\sigma = 5.972$ S/m; $\epsilon_r = 47.912$; $\rho = 1000$ kg/m³

Phantom section: Flat Section; Space: 1.0 cm

Test Date: 06-27-2019; Ambient Temp: 23.5°C; Tissue Temp: 21.1°C

Probe: EX3DV4 - SN7308; ConvF(4, 4, 4) @ 5600 MHz; Calibrated: 8/23/2018

Sensor-Surface: 1.4mm (Mechanical Surface Detection)

Electronics: DAE4 Sn1558; Calibrated: 10/3/2018

Phantom: Twin-SAM V5.0; Type: QD 000 P40 CD; Serial: 1630

Measurement SW: DASY52, Version 52.10 (2);SEMCAD X Version 14.6.12 (7450)

5600 MHz System Verification at 17.0 dBm (50 mW)

Area Scan (7x7x1): Measurement grid: dx=10mm, dy=10mm

Zoom Scan (8x8x7)/Cube 0: Measurement grid: dx=4mm, dy=4mm, dz=1.4mm; Graded Ratio: 1.4

Peak SAR (extrapolated) = 17.3 W/kg

SAR(1 g) = 3.89 W/kg

Deviation(1 g) = -1.77%

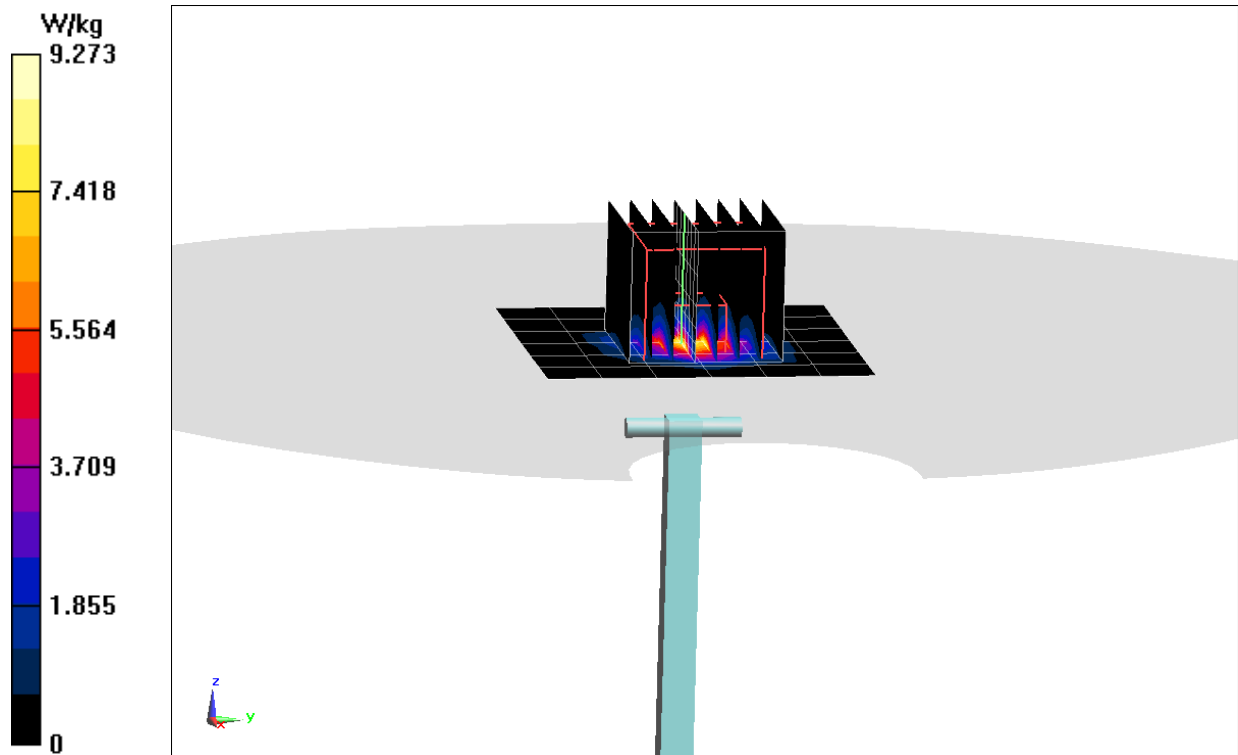

PCTEST ENGINEERING LABORATORY, INC.

DUT: Dipole 5 GHz; Type: D5GHzV2; Serial: 1191

Communication System: UID 0, CW; Frequency: 5750 MHz; Duty Cycle: 1:1
Medium: 5GHz Body; Medium parameters used (interpolated):
 $f = 5750 \text{ MHz}$; $\sigma = 6.205 \text{ S/m}$; $\epsilon_r = 47.593$; $\rho = 1000 \text{ kg/m}^3$
Phantom section: Flat Section; Space: 1.0 cm

Test Date: 06-27-2019; Ambient Temp: 23.5°C; Tissue Temp: 21.1°C

Probe: EX3DV4 - SN7308; ConvF(4.18, 4.18, 4.18) @ 5750 MHz; Calibrated: 8/23/2018
Sensor-Surface: 1.4mm (Mechanical Surface Detection)
Electronics: DAE4 Sn1558; Calibrated: 10/3/2018
Phantom: Twin-SAM V5.0; Type: QD 000 P40 CD; Serial: 1630
Measurement SW: DASY52, Version 52.10 (2);SEMCAD X Version 14.6.12 (7450)

5750 MHz System Verification at 17.0 dBm (50 mW)

Area Scan (7x7x1): Measurement grid: dx=10mm, dy=10mm

Zoom Scan (8x8x7)/Cube 0: Measurement grid: dx=4mm, dy=4mm, dz=1.4mm; Graded Ratio: 1.4

Peak SAR (extrapolated) = 16.7 W/kg

SAR(1 g) = 3.58 W/kg

Deviation(1 g) = -5.91%

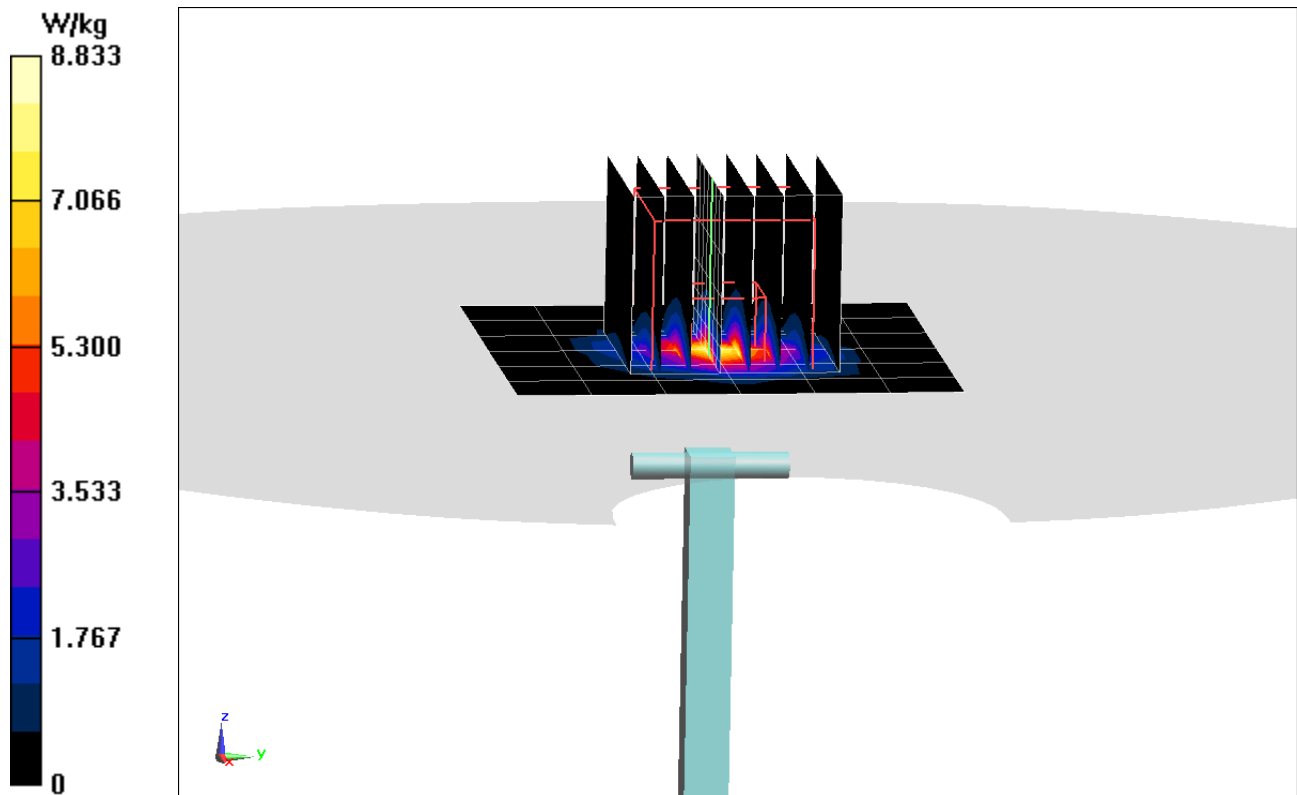

APPENDIX C: PROBE CALIBRATION

**Calibration Laboratory of
Schmid & Partner
Engineering AG**
Zeughausstrasse 43, 8004 Zurich, Switzerland



S Schweizerischer Kalibrierdienst
C Service suisse d'étalonnage
S Servizio svizzero di taratura
S Swiss Calibration Service

Accredited by the Swiss Accreditation Service (SAS)
The Swiss Accreditation Service is one of the signatories to the EA
Multilateral Agreement for the recognition of calibration certificates

Accreditation No.: **SCS 0108**

Client **PC Test**

Certificate No: **D2450V2-719_Aug17**

CALIBRATION CERTIFICATE

Object **D2450V2 - SN:719**

Calibration procedure(s) **QA CAL-05.v9**
Calibration procedure for dipole validation kits above 700 MHz

Calibration date: **August 17, 2017**

PMV ✓
8/27/17
Extended
BN ✓
7/19/2018

This calibration certificate documents the traceability to national standards, which realize the physical units of measurements (SI). The measurements and the uncertainties with confidence probability are given on the following pages and are part of the certificate.

All calibrations have been conducted in the closed laboratory facility: environment temperature (22 ± 3)°C and humidity < 70%.

Calibration Equipment used (M&TE critical for calibration)

Primary Standards	ID #	Cal Date (Certificate No.)	Scheduled Calibration
Power meter NRP	SN: 104778	04-Apr-17 (No. 217-02521/02522)	Apr-18
Power sensor NRP-Z91	SN: 103244	04-Apr-17 (No. 217-02521)	Apr-18
Power sensor NRP-Z91	SN: 103245	04-Apr-17 (No. 217-02522)	Apr-18
Reference 20 dB Attenuator	SN: 5058 (20k)	07-Apr-17 (No. 217-02528)	Apr-18
Type-N mismatch combination	SN: 5047.2 / 06327	07-Apr-17 (No. 217-02529)	Apr-18
Reference Probe EX3DV4	SN: 7349	31-May-17 (No. EX3-7349_May17)	May-18
DAE4	SN: 601	28-Mar-17 (No. DAE4-601_Mar17)	Mar-18

Secondary Standards	ID #	Check Date (in house)	Scheduled Check
Power meter EPM-442A	SN: GB37480704	07-Oct-15 (in house check Oct-16)	In house check: Oct-18
Power sensor HP 8481A	SN: US37292783	07-Oct-15 (in house check Oct-16)	In house check: Oct-18
Power sensor HP 8481A	SN: MY41092317	07-Oct-15 (in house check Oct-16)	In house check: Oct-18
RF generator R&S SMT-06	SN: 100972	15-Jun-15 (in house check Oct-16)	In house check: Oct-18
Network Analyzer HP 8753E	SN: US37390585	18-Oct-01 (in house check Oct-16)	In house check: Oct-17

Calibrated by: **Michael Weber** Name: Michael Weber Function: Laboratory Technician Signature: *M. Weber*

Approved by: **Katja Pokovic** Name: Katja Pokovic Function: Technical Manager Signature: *K. Pokovic*

Issued: August 17, 2017

This calibration certificate shall not be reproduced except in full without written approval of the laboratory.



Accredited by the Swiss Accreditation Service (SAS)

The Swiss Accreditation Service is one of the signatories to the EA
Multilateral Agreement for the recognition of calibration certificates

Accreditation No.: **SCS 0108**

Glossary:

TSL	tissue simulating liquid
ConvF	sensitivity in TSL / NORM x,y,z
N/A	not applicable or not measured

Calibration is Performed According to the Following Standards:

- IEEE Std 1528-2013, "IEEE Recommended Practice for Determining the Peak Spatial-Averaged Specific Absorption Rate (SAR) in the Human Head from Wireless Communications Devices: Measurement Techniques", June 2013
- IEC 62209-1, "Measurement procedure for the assessment of Specific Absorption Rate (SAR) from hand-held and body-mounted devices used next to the ear (frequency range of 300 MHz to 6 GHz)", July 2016
- IEC 62209-2, "Procedure to determine the Specific Absorption Rate (SAR) for wireless communication devices used in close proximity to the human body (frequency range of 30 MHz to 6 GHz)", March 2010
- KDB 865664, "SAR Measurement Requirements for 100 MHz to 6 GHz"

Additional Documentation:

- DASY4/5 System Handbook

Methods Applied and Interpretation of Parameters:

- Measurement Conditions:** Further details are available from the Validation Report at the end of the certificate. All figures stated in the certificate are valid at the frequency indicated.
- Antenna Parameters with TSL:** The dipole is mounted with the spacer to position its feed point exactly below the center marking of the flat phantom section, with the arms oriented parallel to the body axis.
- Feed Point Impedance and Return Loss:** These parameters are measured with the dipole positioned under the liquid filled phantom. The impedance stated is transformed from the measurement at the SMA connector to the feed point. The Return Loss ensures low reflected power. No uncertainty required.
- Electrical Delay:** One-way delay between the SMA connector and the antenna feed point. No uncertainty required.
- SAR measured:** SAR measured at the stated antenna input power.
- SAR normalized:** SAR as measured, normalized to an input power of 1 W at the antenna connector.
- SAR for nominal TSL parameters:** The measured TSL parameters are used to calculate the nominal SAR result.

The reported uncertainty of measurement is stated as the standard uncertainty of measurement multiplied by the coverage factor $k=2$, which for a normal distribution corresponds to a coverage probability of approximately 95%.

Measurement Conditions

DASY system configuration, as far as not given on page 1.

DASY Version	DASY5	V52.10.0
Extrapolation	Advanced Extrapolation	
Phantom	Modular Flat Phantom	
Distance Dipole Center - TSL	10 mm	with Spacer
Zoom Scan Resolution	dx, dy, dz = 5 mm	
Frequency	2450 MHz ± 1 MHz	

Head TSL parameters

The following parameters and calculations were applied.

	Temperature	Permittivity	Conductivity
Nominal Head TSL parameters	22.0 °C	39.2	1.80 mho/m
Measured Head TSL parameters	(22.0 ± 0.2) °C	37.8 ± 6 %	1.86 mho/m ± 6 %
Head TSL temperature change during test	< 0.5 °C	----	----

SAR result with Head TSL

SAR averaged over 1 cm³ (1 g) of Head TSL	Condition	
SAR measured	250 mW input power	13.3 W/kg
SAR for nominal Head TSL parameters	normalized to 1W	51.9 W/kg ± 17.0 % (k=2)

SAR averaged over 10 cm³ (10 g) of Head TSL	condition	
SAR measured	250 mW input power	6.15 W/kg
SAR for nominal Head TSL parameters	normalized to 1W	24.3 W/kg ± 16.5 % (k=2)

Body TSL parameters

The following parameters and calculations were applied.

	Temperature	Permittivity	Conductivity
Nominal Body TSL parameters	22.0 °C	52.7	1.95 mho/m
Measured Body TSL parameters	(22.0 ± 0.2) °C	51.9 ± 6 %	2.03 mho/m ± 6 %
Body TSL temperature change during test	< 0.5 °C	----	----

SAR result with Body TSL

SAR averaged over 1 cm³ (1 g) of Body TSL	Condition	
SAR measured	250 mW input power	12.8 W/kg
SAR for nominal Body TSL parameters	normalized to 1W	50.1 W/kg ± 17.0 % (k=2)

SAR averaged over 10 cm³ (10 g) of Body TSL	condition	
SAR measured	250 mW input power	6.00 W/kg
SAR for nominal Body TSL parameters	normalized to 1W	23.7 W/kg ± 16.5 % (k=2)

Appendix (Additional assessments outside the scope of SCS 0108)

Antenna Parameters with Head TSL

Impedance, transformed to feed point	55.7 Ω + 7.0 j Ω
Return Loss	- 21.4 dB

Antenna Parameters with Body TSL

Impedance, transformed to feed point	51.4 Ω + 8.1 j Ω
Return Loss	- 21.8 dB

General Antenna Parameters and Design

Electrical Delay (one direction)	1.150 ns
----------------------------------	----------

After long term use with 100W radiated power, only a slight warming of the dipole near the feedpoint can be measured.

The dipole is made of standard semirigid coaxial cable. The center conductor of the feeding line is directly connected to the second arm of the dipole. The antenna is therefore short-circuited for DC-signals. On some of the dipoles, small end caps are added to the dipole arms in order to improve matching when loaded according to the position as explained in the "Measurement Conditions" paragraph. The SAR data are not affected by this change. The overall dipole length is still according to the Standard.

No excessive force must be applied to the dipole arms, because they might bend or the soldered connections near the feedpoint may be damaged.

Additional EUT Data

Manufactured by	SPEAG
Manufactured on	September 10, 2002

DASY5 Validation Report for Head TSL

Date: 17.08.2017

Test Laboratory: SPEAG, Zurich, Switzerland

DUT: Dipole 2450 MHz; Type: D2450V2; Serial: D2450V2 - SN: 719

Communication System: UID 0 - CW; Frequency: 2450 MHz

Medium parameters used: $f = 2450$ MHz; $\sigma = 1.86$ S/m; $\epsilon_r = 37.8$; $\rho = 1000$ kg/m³

Phantom section: Flat Section

Measurement Standard: DASY5 (IEEE/IEC/ANSI C63.19-2011)

DASY52 Configuration:

- Probe: EX3DV4 - SN7349; ConvF(8.12, 8.12, 8.12); Calibrated: 31.05.2017;
- Sensor-Surface: 1.4mm (Mechanical Surface Detection)
- Electronics: DAE4 Sn601; Calibrated: 28.03.2017
- Phantom: Flat Phantom 5.0 (front); Type: QD 000 P50 AA; Serial: 1001
- DASY52 52.10.0(1446); SEMCAD X 14.6.10(7417)

Dipole Calibration for Head Tissue/Pin=250 mW, d=10mm/Zoom Scan (7x7x7)/Cube 0:

Measurement grid: dx=5mm, dy=5mm, dz=5mm

Reference Value = 112.8 V/m; Power Drift = -0.01 dB

Peak SAR (extrapolated) = 26.9 W/kg

SAR(1 g) = 13.3 W/kg; SAR(10 g) = 6.15 W/kg

Maximum value of SAR (measured) = 21.6 W/kg

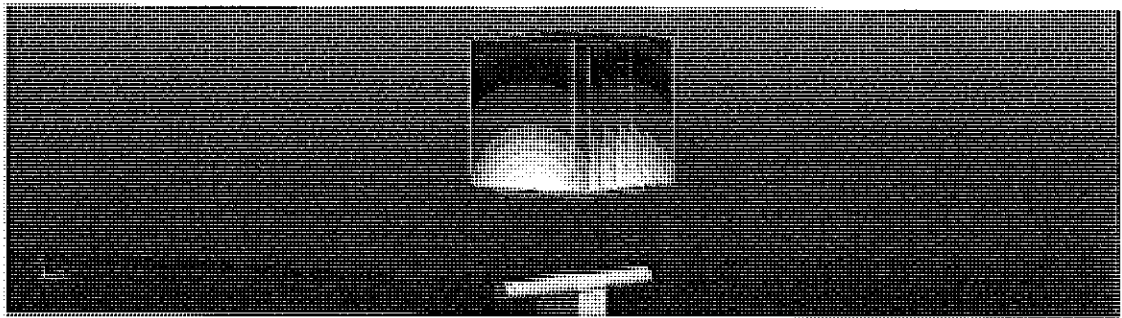
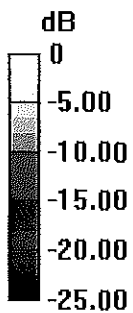

0 dB = 21.6 W/kg = 13.34 dBW/kg

Impedance Measurement Plot for Head TSL

17 Aug 2017 12:38:03
CH1 S11 1 U FS 1: 55.682 Ω 6.9766 Ω 453.21 μH 2 450.000 000 MHz

*
Oe1
CA

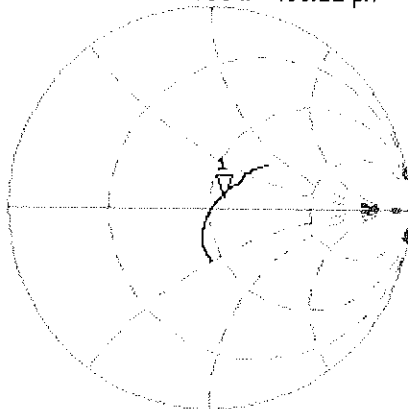

Avg
16

H1d

CH2 S11 LOG 5 dB/REF -20 dB 1: -21.413 dB 2 450.000 000 MHz

CA

Avg
16

H1d

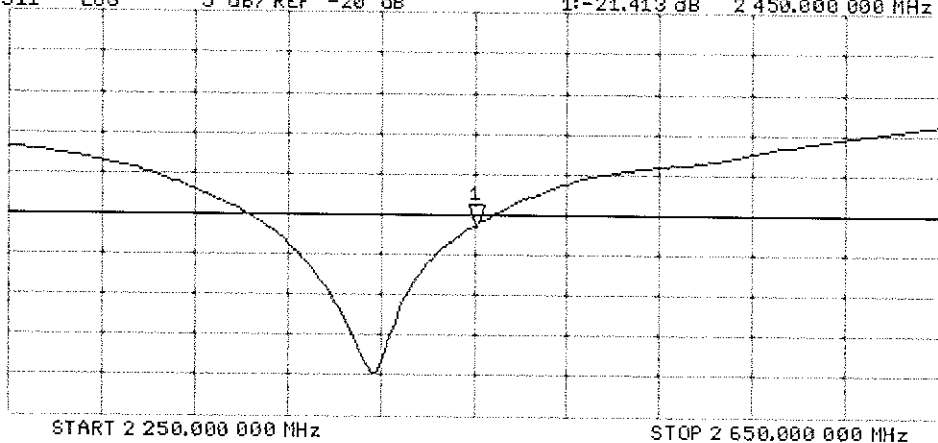

DASY5 Validation Report for Body TSL

Date: 17.08.2017

Test Laboratory: SPEAG, Zurich, Switzerland

DUT: Dipole 2450 MHz; Type: D2450V2; Serial: D2450V2 - SN: 719

Communication System: UID 0 - CW; Frequency: 2450 MHz

Medium parameters used: $f = 2450$ MHz; $\sigma = 2.03$ S/m; $\epsilon_r = 51.9$; $\rho = 1000$ kg/m³

Phantom section: Flat Section

Measurement Standard: DASY5 (IEEE/IEC/ANSI C63.19-2011)

DASY52 Configuration:

- Probe: EX3DV4 - SN7349; ConvF(8.1, 8.1, 8.1); Calibrated: 31.05.2017;
- Sensor-Surface: 1.4mm (Mechanical Surface Detection)
- Electronics: DAE4 Sn601; Calibrated: 28.03.2017
- Phantom: Flat Phantom 5.0 (back); Type: QD 000 P50 AA; Serial: 1002
- DASY52 52.10.0(1446); SEMCAD X 14.6.10(7417)

Dipole Calibration for Body Tissue/Pin=250 mW, d=10mm/Zoom Scan (7x7x7)/Cube 0:

Measurement grid: dx=5mm, dy=5mm, dz=5mm

Reference Value = 103.0 V/m; Power Drift = -0.07 dB

Peak SAR (extrapolated) = 25.2 W/kg

SAR(1 g) = 12.8 W/kg; SAR(10 g) = 6 W/kg

Maximum value of SAR (measured) = 19.8 W/kg

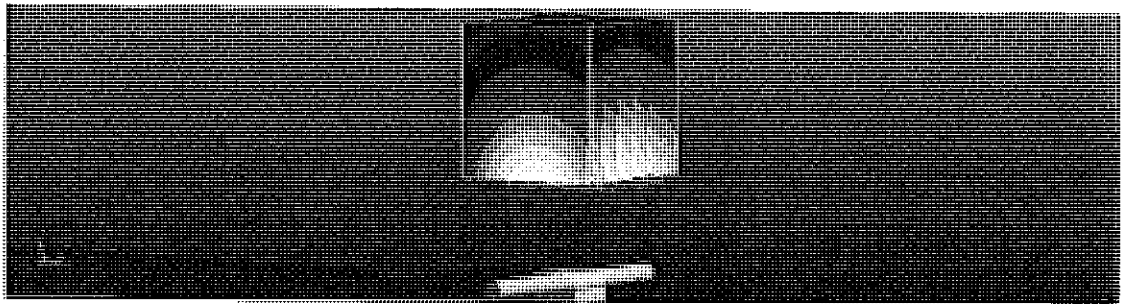
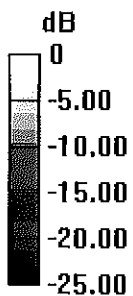

0 dB = 19.8 W/kg = 12.97 dBW/kg

Impedance Measurement Plot for Body TSL

17 Aug 2017 12:37:27
[CH1] S11 1 U FS 1: 51.379 Ω 8.1367 Ω 528.57 μ H 2 450.000 000 MHz

*
De1
C4

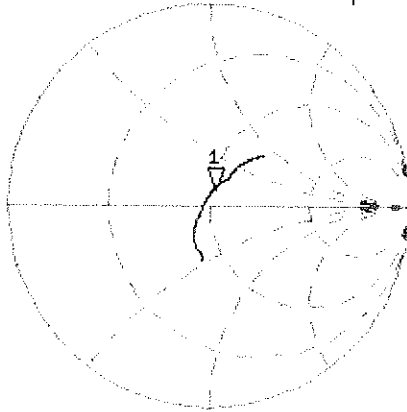

Avg
16

H1d

CH2 S11 LOG 5 dB/REF -20 dB 1: -21.809 dB 2 450.000 000 MHz

C4

Avg
16

H1d

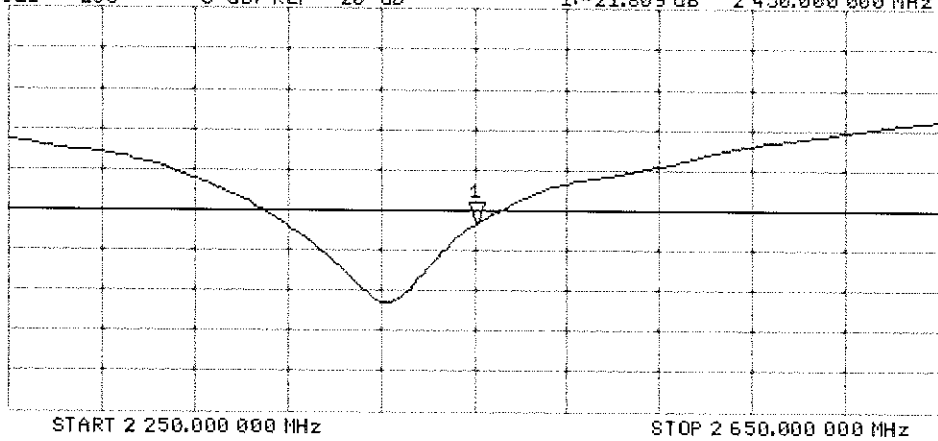

Certification of Calibration

Object: D2450V2 – SN: 719

Calibration procedure(s): Procedure for Calibration Extension for SAR Dipoles.

Extended Calibration date: 07/18/2018

Description: SAR Validation Dipole at 2450 MHz.

Calibration Equipment used:

Manufacturer	Model	Description	Cal Date	Cal Interval	Cal Due	Serial Number
Agilent	E4438C	ESG Vector Signal Generator	3/24/2017	Biennial	3/24/2019	MY42082385
Agilent	8753ES	S-Parameter Network Analyzer	9/14/2017	Annual	9/14/2018	US39170118
Amplifier Research	15S1G6	Amplifier	CBT	N/A	CBT	433971
Anritsu	ML2495A	Power Meter	11/28/2017	Annual	11/28/2018	1039008
Anritsu	MA2411B	Pulse Power Sensor	3/2/2018	Annual	3/2/2019	1207364
Anritsu	MA2411B	Pulse Power Sensor	11/15/2017	Annual	11/15/2018	1339007
Control Company	4040	Therm./Clock/Humidity Monitor	3/31/2017	Biennial	3/31/2019	170232394
Control Company	4352	Ultra Long Stem Thermometer	5/2/2017	Biennial	5/2/2019	170330156
Keysight	772D	Dual Directional Coupler	CBT	N/A	CBT	MY52180215
Keysight Technologies	85033E	Standard Mechanical Calibration Kit (DC to 9GHz, 3.5mm)	6/4/2018	Annual	6/4/2019	MY53401181
Mini-Circuits	BW-N20W5+	DC to 18 GHz Precision Fixed 20 dB Attenuator	CBT	N/A	CBT	N/A
Mini-Circuits	NLP-2950+	Low Pass Filter DC to 2700 MHz	CBT	N/A	CBT	N/A
Narda	4772-3	Attenuator (3dB)	CBT	N/A	CBT	9406
Pasternack	PE2209-10	Bidirectional Coupler	CBT	N/A	CBT	N/A
Pasternack	PE5011-1	Torque Wrench	7/19/2017	Biennial	7/19/2019	N/A
SPEAG	DAE4	Dasy Data Acquisition Electronics	3/7/2018	Annual	3/7/2019	1368
SPEAG	DAE4	Dasy Data Acquisition Electronics	8/9/2017	Annual	8/9/2018	1323
SPEAG	DAK-3.5	Dielectric Assessment Kit	9/12/2017	Annual	9/12/2018	1091
SPEAG	ES3DV3	SAR Probe	3/13/2018	Annual	3/13/2019	3319
SPEAG	ES3DV3	SAR Probe	8/14/2017	Annual	8/14/2018	3332

Measurement Uncertainty = $\pm 23\%$ (k=2)

	Name	Function	Signature
Calibrated By:	Brodie Halfoster	Test Engineer	<i>BRODIE HALFOSTER</i>
Approved By:	Kaitlin O'Keefe	Senior Technical Manager	<i>KOK</i>

DIPOLE CALIBRATION EXTENSION

Per KDB 865664 D01, calibration intervals of up to three years may be considered for reference dipoles when it is demonstrated that the SAR target, impedance and return loss of a dipole have remained stable according to the following requirements:

1. The measured SAR does not deviate more than 10% from the target on the calibration certificate.
2. The return-loss does not deviate more than 20% from the previous measurement and meets the required 20dB minimum return-loss requirement.
3. The measurement of real or imaginary parts of impedance does not deviate more than 5Ω from the previous measurement.

The following dipole was checked to pass the above 3 requirements to have 2-year calibration period from the calibration date:

Calibration Date	Extension Date	Certificate Electrical Delay (ns)	Certificate SAR Target Head (1g) W/kg @ 20.0 dBm	Measured Head SAR (1g) W/kg @ 20.0 dBm	Deviation 1g (%)	Certificate SAR Target Head (10g) W/kg @ 20.0 dBm	Measured Head SAR (10g) W/kg @ 20.0 dBm	Deviation 10g (%)	Certificate Impedance Head (Ohm) Real	Measured Impedance Head (Ohm) Real	Difference (Ohm) Real	Certificate Impedance Head (Ohm) Imaginary	Measured Impedance Head (Ohm) Imaginary	Difference (Ohm) Imaginary	Certificate Return Loss Head (dB)	Measured Return Loss Head (dB)	Deviation (%)	PASS/FAIL
8/17/2017	7/18/2018	1.150	5.19	5.46	5.20%	2.43	2.51	3.29%	55.7	53.9	1.8	7.0	2.9	4.1	-21.4	-25.4	-18.70%	PASS
Calibration Date	Extension Date	Certificate Electrical Delay (ns)	Certificate SAR Target Body (1g) W/kg @ 20.0 dBm	Measured Body SAR (1g) W/kg @ 20.0 dBm	Deviation 1g (%)	Certificate SAR Target Body (10g) W/kg @ 20.0 dBm	Measured Body SAR (10g) W/kg @ 20.0 dBm	Deviation 10g (%)	Certificate Impedance Body (Ohm) Real	Measured Impedance Body (Ohm) Real	Difference (Ohm) Real	Certificate Impedance Body (Ohm) Imaginary	Measured Impedance Body (Ohm) Imaginary	Difference (Ohm) Imaginary	Certificate Return Loss Body (dB)	Measured Return Loss Body (dB)	Deviation (%)	PASS/FAIL
8/17/2017	7/18/2018	1.150	5.01	5.19	3.59%	2.37	2.38	0.42%	51.4	50.2	1.2	8.1	5.9	2.2	-21.8	-24.6	-12.80%	PASS

Impedance & Return-Loss Measurement Plot for Head TSL

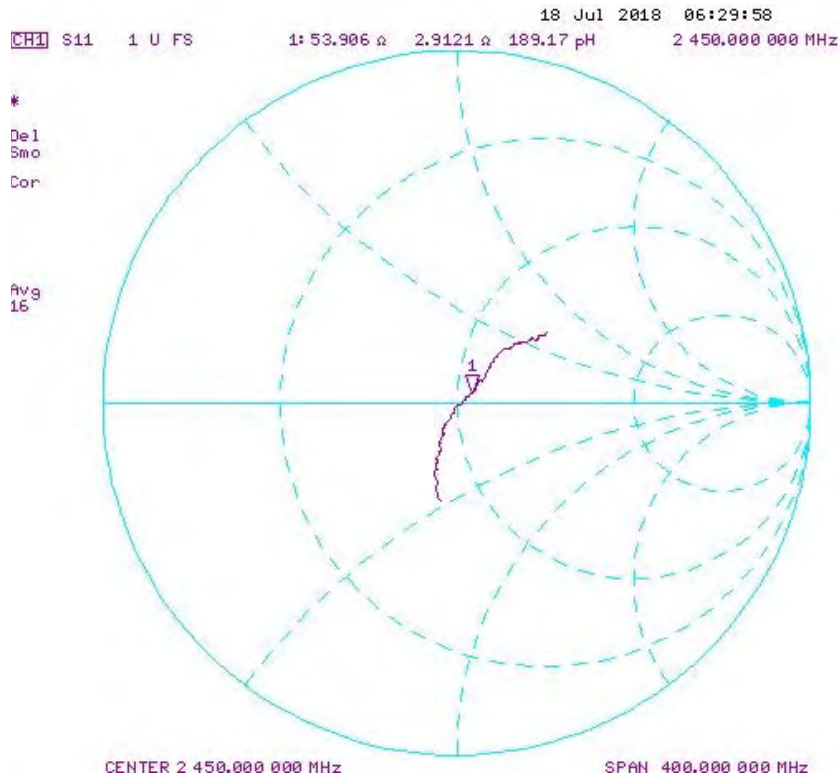

Impedance & Return-Loss Measurement Plot for Body TSL

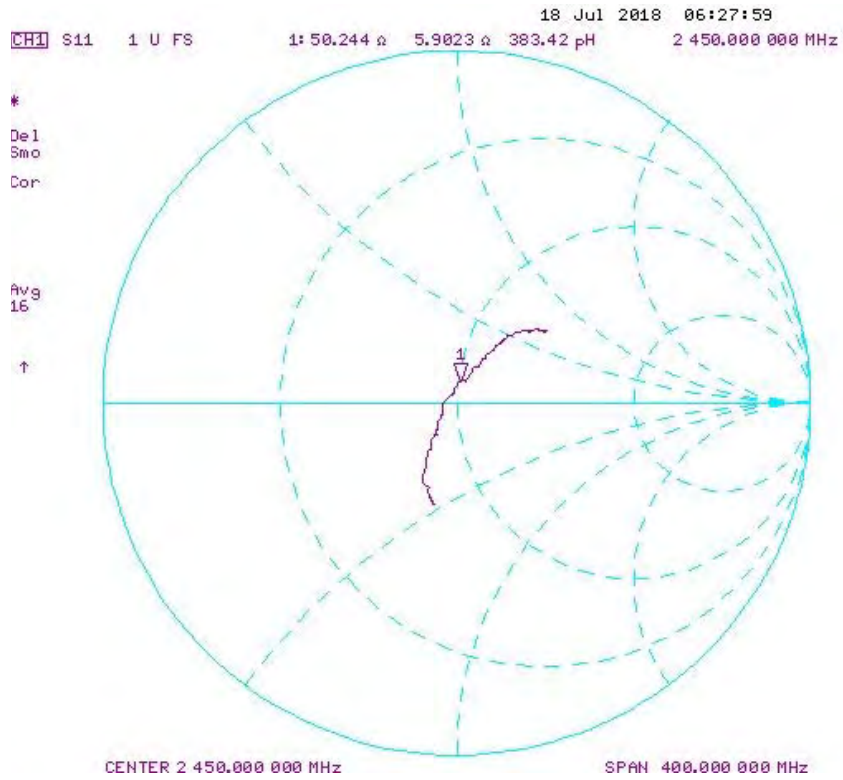



Accredited by the Swiss Accreditation Service (SAS)
The Swiss Accreditation Service is one of the signatories to the EA
Multilateral Agreement for the recognition of calibration certificates

Accreditation No.: **SCS 0108**

Client **PC Test**

Certificate No: **D5GHzV2-1191_Sep16**

CALIBRATION CERTIFICATE

Object **D5GHzV2 - SN:1191**

Calibration procedure(s) **QA CAL-22.v2**
Calibration procedure for dipole validation kits between 3-6 GHz

Calibration date: **September 21, 2016**

BNV
09-28-2016
Extended PMV
9/20/2018

This calibration certificate documents the traceability to national standards, which realize the physical units of measurements (SI).
The measurements and the uncertainties with confidence probability are given on the following pages and are part of the certificate.

All calibrations have been conducted in the closed laboratory facility: environment temperature (22 ± 3)°C and humidity < 70%.

Calibration Equipment used (M&TE critical for calibration)

Primary Standards	ID #	Cal Date (Certificate No.)	Scheduled Calibration
Power meter NRP	SN: 104778	06-Apr-16 (No. 217-02288/02289)	Apr-17
Power sensor NRP-Z91	SN: 103244	08-Apr-16 (No. 217-02288)	Apr-17
Power sensor NRP-Z91	SN: 103245	06-Apr-16 (No. 217-02289)	Apr-17
Reference 20 dB Attenuator	SN: 5058 (20k)	05-Apr-16 (No. 217-02292)	Apr-17
Type-N mismatch combination	SN: 5047.2 / 06327	05-Apr-16 (No. 217-02295)	Apr-17
Reference Probe EX3DV4	SN: 3503	30-Jun-16 (No. EX3-3503_Jun16)	Jun-17
DAE4	SN: 601	30-Dec-15 (No. DAE4-601_Dec15)	Dec-16

Secondary Standards	ID #	Check Date (in house)	Scheduled Check
Power meter EPM-442A	SN: GB37480704	07-Oct-15 (No. 217-02222)	In house check: Oct-16
Power sensor HP 8481A	SN: US37292783	07-Oct-15 (No. 217-02222)	In house check: Oct-16
Power sensor HP 8481A	SN: MY41092317	07-Oct-15 (No. 217-02223)	In house check: Oct-16
RF generator R&S SMT-06	SN: 100972	15-Jun-15 (in house check Jun-15)	In house check: Oct-16
Network Analyzer HP 8753E	SN: US37390585	18-Oct-01 (in house check Oct-15)	In house check: Oct-16

Calibrated by: **Leif Klysner** Name: **Leif Klysner** Function: **Laboratory Technician**

Approved by: **Katja Pokovic** Name: **Katja Pokovic** Function: **Technical Manager**

Signature
Leif Klysner
Katja Pokovic

Issued: September 22, 2016

This calibration certificate shall not be reproduced except in full without written approval of the laboratory.



Accredited by the Swiss Accreditation Service (SAS)
The Swiss Accreditation Service is one of the signatories to the EA
Multilateral Agreement for the recognition of calibration certificates

Accreditation No.: **SCS 0108**

Glossary:

TSL	tissue simulating liquid
ConvF	sensitivity in TSL / NORM x,y,z
N/A	not applicable or not measured

Calibration is Performed According to the Following Standards:

- IEEE Std 1528-2013, "IEEE Recommended Practice for Determining the Peak Spatial-Averaged Specific Absorption Rate (SAR) in the Human Head from Wireless Communications Devices: Measurement Techniques", June 2013
- IEC 62209-2, "Procedure to determine the Specific Absorption Rate (SAR) for wireless communication devices used in close proximity to the human body (frequency range of 30 MHz to 6 GHz)", March 2010
- KDB 865664, "SAR Measurement Requirements for 100 MHz to 6 GHz"

Additional Documentation:

- DASY4/5 System Handbook

Methods Applied and Interpretation of Parameters:

- Measurement Conditions:* Further details are available from the Validation Report at the end of the certificate. All figures stated in the certificate are valid at the frequency indicated.
- Antenna Parameters with TSL:* The dipole is mounted with the spacer to position its feed point exactly below the center marking of the flat phantom section, with the arms oriented parallel to the body axis.
- Feed Point Impedance and Return Loss:* These parameters are measured with the dipole positioned under the liquid filled phantom. The impedance stated is transformed from the measurement at the SMA connector to the feed point. The Return Loss ensures low reflected power. No uncertainty required.
- Electrical Delay:* One-way delay between the SMA connector and the antenna feed point. No uncertainty required.
- SAR measured:* SAR measured at the stated antenna input power.
- SAR normalized:* SAR as measured, normalized to an input power of 1 W at the antenna connector.
- SAR for nominal TSL parameters:* The measured TSL parameters are used to calculate the nominal SAR result.

The reported uncertainty of measurement is stated as the standard uncertainty of measurement multiplied by the coverage factor $k=2$, which for a normal distribution corresponds to a coverage probability of approximately 95%.

Measurement Conditions

DASY system configuration, as far as not given on page 1.

DASY Version	DASY5	V52.8.8
Extrapolation	Advanced Extrapolation	
Phantom	Modular Flat Phantom V5.0	
Distance Dipole Center - TSL	10 mm	with Spacer
Zoom Scan Resolution	dx, dy = 4.0 mm, dz = 1.4 mm	Graded Ratio = 1.4 (Z direction)
Frequency	5250 MHz ± 1 MHz 5600 MHz ± 1 MHz 5750 MHz ± 1 MHz	

Head TSL parameters at 5250 MHz

The following parameters and calculations were applied.

	Temperature	Permittivity	Conductivity
Nominal Head TSL parameters	22.0 °C	35.9	4.71 mho/m
Measured Head TSL parameters	(22.0 ± 0.2) °C	34.5 ± 6 %	4.59 mho/m ± 6 %
Head TSL temperature change during test	< 0.5 °C	----	----

SAR result with Head TSL at 5250 MHz

SAR averaged over 1 cm ³ (1 g) of Head TSL	Condition	
SAR measured	100 mW input power	7.96 W/kg
SAR for nominal Head TSL parameters	normalized to 1W	78.9 W/kg ± 19.9 % (k=2)

SAR averaged over 10 cm ³ (10 g) of Head TSL	condition	
SAR measured	100 mW input power	2.29 W/kg
SAR for nominal Head TSL parameters	normalized to 1W	22.6 W/kg ± 19.5 % (k=2)

Head TSL parameters at 5600 MHz

The following parameters and calculations were applied.

	Temperature	Permittivity	Conductivity
Nominal Head TSL parameters	22.0 °C	35.5	5.07 mho/m
Measured Head TSL parameters	(22.0 ± 0.2) °C	34.0 ± 6 %	4.93 mho/m ± 6 %
Head TSL temperature change during test	< 0.5 °C	----	----

SAR result with Head TSL at 5600 MHz

SAR averaged over 1 cm ³ (1 g) of Head TSL	Condition	
SAR measured	100 mW input power	8.45 W/kg
SAR for nominal Head TSL parameters	normalized to 1W	83.6 W / kg ± 19.9 % (k=2)

SAR averaged over 10 cm ³ (10 g) of Head TSL	condition	
SAR measured	100 mW input power	2.41 W/kg
SAR for nominal Head TSL parameters	normalized to 1W	23.8 W/kg ± 19.5 % (k=2)

Head TSL parameters at 5750 MHz

The following parameters and calculations were applied.

	Temperature	Permittivity	Conductivity
Nominal Head TSL parameters	22.0 °C	35.4	5.22 mho/m
Measured Head TSL parameters	(22.0 ± 0.2) °C	33.8 ± 6 %	5.08 mho/m ± 6 %
Head TSL temperature change during test	< 0.5 °C	----	----

SAR result with Head TSL at 5750 MHz

SAR averaged over 1 cm ³ (1 g) of Head TSL	Condition	
SAR measured	100 mW input power	7.99 W/kg
SAR for nominal Head TSL parameters	normalized to 1W	79.1 W/kg ± 19.9 % (k=2)

SAR averaged over 10 cm ³ (10 g) of Head TSL	condition	
SAR measured	100 mW input power	2.27 W/kg
SAR for nominal Head TSL parameters	normalized to 1W	22.4 W/kg ± 19.5 % (k=2)

Body TSL parameters at 5250 MHz

The following parameters and calculations were applied.

	Temperature	Permittivity	Conductivity
Nominal Body TSL parameters	22.0 °C	48.9	5.36 mho/m
Measured Body TSL parameters	(22.0 ± 0.2) °C	47.4 ± 6 %	5.52 mho/m ± 6 %
Body TSL temperature change during test	< 0.5 °C	----	----

SAR result with Body TSL at 5250 MHz

SAR averaged over 1 cm ³ (1 g) of Body TSL	Condition	
SAR measured	100 mW input power	7.74 W/kg
SAR for nominal Body TSL parameters	normalized to 1W	77.0 W/kg ± 19.9 % (k=2)

SAR averaged over 10 cm ³ (10 g) of Body TSL	condition	
SAR measured	100 mW input power	2.17 W/kg
SAR for nominal Body TSL parameters	normalized to 1W	21.6 W/kg ± 19.5 % (k=2)

Body TSL parameters at 5600 MHz

The following parameters and calculations were applied.

	Temperature	Permittivity	Conductivity
Nominal Body TSL parameters	22.0 °C	48.5	5.77 mho/m
Measured Body TSL parameters	(22.0 ± 0.2) °C	46.8 ± 6 %	6.00 mho/m ± 6 %
Body TSL temperature change during test	< 0.5 °C	----	----

SAR result with Body TSL at 5600 MHz

SAR averaged over 1 cm ³ (1 g) of Body TSL	Condition	
SAR measured	100 mW input power	7.96 W/kg
SAR for nominal Body TSL parameters	normalized to 1W	79.2 W/kg ± 19.9 % (k=2)

SAR averaged over 10 cm ³ (10 g) of Body TSL	condition	
SAR measured	100 mW input power	2.24 W/kg
SAR for nominal Body TSL parameters	normalized to 1W	22.2 W/kg ± 19.5 % (k=2)

Body TSL parameters at 5750 MHz

The following parameters and calculations were applied.

	Temperature	Permittivity	Conductivity
Nominal Body TSL parameters	22.0 °C	48.3	5.94 mho/m
Measured Body TSL parameters	(22.0 ± 0.2) °C	46.5 ± 6 %	6.21 mho/m ± 6 %
Body TSL temperature change during test	< 0.5 °C	----	----

SAR result with Body TSL at 5750 MHz

SAR averaged over 1 cm ³ (1 g) of Body TSL	Condition	
SAR measured	100 mW input power	7.65 W/kg
SAR for nominal Body TSL parameters	normalized to 1W	76.1 W/kg ± 19.9 % (k=2)

SAR averaged over 10 cm ³ (10 g) of Body TSL	condition	
SAR measured	100 mW input power	2.14 W/kg
SAR for nominal Body TSL parameters	normalized to 1W	21.2 W/kg ± 19.5 % (k=2)

Appendix (Additional assessments outside the scope of SCS 0108)

Antenna Parameters with Head TSL at 5250 MHz

Impedance, transformed to feed point	55.7 Ω - 4.3 j Ω
Return Loss	- 23.4 dB

Antenna Parameters with Head TSL at 5600 MHz

Impedance, transformed to feed point	58.3 Ω - 3.2 j Ω
Return Loss	- 21.8 dB

Antenna Parameters with Head TSL at 5750 MHz

Impedance, transformed to feed point	58.1 Ω + 4.8 j Ω
Return Loss	- 21.2 dB

Antenna Parameters with Body TSL at 5250 MHz

Impedance, transformed to feed point	56.1 Ω - 3.7 j Ω
Return Loss	- 23.4 dB

Antenna Parameters with Body TSL at 5600 MHz

Impedance, transformed to feed point	58.9 Ω - 1.7 j Ω
Return Loss	- 21.7 dB

Antenna Parameters with Body TSL at 5750 MHz

Impedance, transformed to feed point	59.5 Ω + 6.9 j Ω
Return Loss	- 19.4 dB

General Antenna Parameters and Design

Electrical Delay (one direction)	1.204 ns
----------------------------------	----------

After long term use with 100W radiated power, only a slight warming of the dipole near the feedpoint can be measured.

The dipole is made of standard semirigid coaxial cable. The center conductor of the feeding line is directly connected to the second arm of the dipole. The antenna is therefore short-circuited for DC-signals. On some of the dipoles, small end caps are added to the dipole arms in order to improve matching when loaded according to the position as explained in the "Measurement Conditions" paragraph. The SAR data are not affected by this change. The overall dipole length is still according to the Standard.

No excessive force must be applied to the dipole arms, because they might bend or the soldered connections near the feedpoint may be damaged.

Additional EUT Data

Manufactured by	SPEAG
Manufactured on	August 28, 2003

DASY5 Validation Report for Head TSL

Date: 21.09.2016

Test Laboratory: SPEAG, Zurich, Switzerland

DUT: Dipole D5GHzV2; Type: D5GHzV2; Serial: D5GHzV2 - SN:1191

Communication System: UID 0 - CW; Frequency: 5250 MHz, Frequency: 5600 MHz, Frequency: 5750 MHz
Medium parameters used: $f = 5250$ MHz; $\sigma = 4.59$ S/m; $\epsilon_r = 34.5$; $\rho = 1000$ kg/m³, Medium parameters used: $f = 5600$ MHz; $\sigma = 4.93$ S/m; $\epsilon_r = 34$; $\rho = 1000$ kg/m³, Medium parameters used: $f = 5750$ MHz; $\sigma = 5.08$ S/m; $\epsilon_r = 33.8$; $\rho = 1000$ kg/m³

Phantom section: Flat Section

Measurement Standard: DASY5 (IEEE/IEC/ANSI C63.19-2011)

DASY52 Configuration:

- Probe: EX3DV4 - SN3503; ConvF(5.42, 5.42, 5.42); Calibrated: 30.06.2016, ConvF(4.89, 4.89, 4.89); Calibrated: 30.06.2016, ConvF(4.85, 4.85, 4.85); Calibrated: 30.06.2016;
- Sensor-Surface: 1.4mm (Mechanical Surface Detection)
- Electronics: DAE4 Sn601; Calibrated: 30.12.2015
- Phantom: Flat Phantom 5.0 (front); Type: QD000P50AA; Serial: 1001
- DASY52 52.8.8(1258); SEMCAD X 14.6.10(7372)

Dipole Calibration for Head Tissue/Pin=100mW, dist=10mm, f=5250 MHz/Zoom Scan,

dist=1.4mm (8x8x7)/Cube 0: Measurement grid: dx=4mm, dy=4mm, dz=1.4mm

Reference Value = 68.49 V/m; Power Drift = 0.01 dB

Peak SAR (extrapolated) = 28.6 W/kg

SAR(1 g) = 7.96 W/kg; SAR(10 g) = 2.29 W/kg

Maximum value of SAR (measured) = 18.2 W/kg

Dipole Calibration for Head Tissue/Pin=100mW, dist=10mm, f=5600 MHz/Zoom Scan,

dist=1.4mm (8x8x7)/Cube 0: Measurement grid: dx=4mm, dy=4mm, dz=1.4mm

Reference Value = 69.34 V/m; Power Drift = -0.00 dB

Peak SAR (extrapolated) = 32.9 W/kg

SAR(1 g) = 8.45 W/kg; SAR(10 g) = 2.41 W/kg

Maximum value of SAR (measured) = 20.0 W/kg

Dipole Calibration for Head Tissue/Pin=100mW, dist=10mm, f=5750 MHz/Zoom Scan,

dist=1.4mm (8x8x7)/Cube 0: Measurement grid: dx=4mm, dy=4mm, dz=1.4mm

Reference Value = 67.15 V/m; Power Drift = 0.02 dB

Peak SAR (extrapolated) = 32.3 W/kg

SAR(1 g) = 7.99 W/kg; SAR(10 g) = 2.27 W/kg

Maximum value of SAR (measured) = 19.3 W/kg

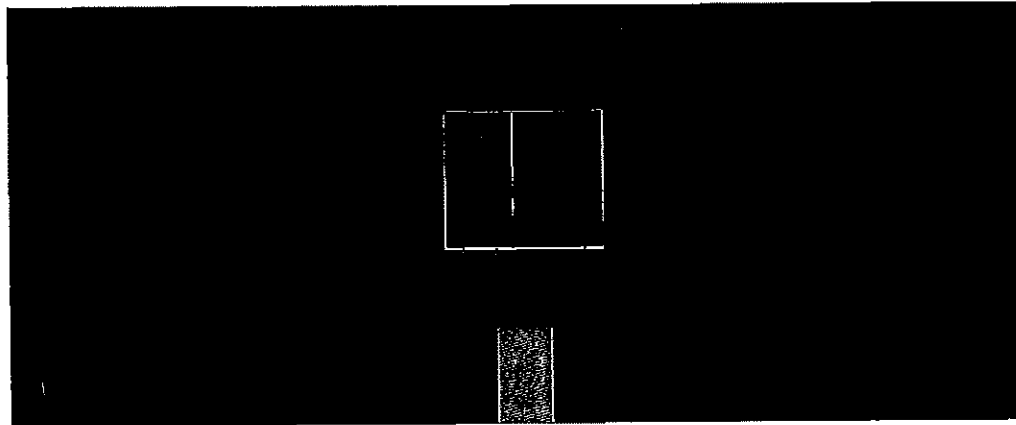
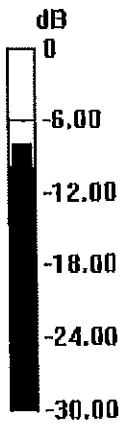

0 dB = 18.2 W/kg = 12.60 dBW/kg

Impedance Measurement Plot for Head TSL

20 Sep 2016 13:20:17
CH1 S11 1 U FS 1: 55.695 Ω -4.2793 Ω 7.0042 pF 5 250.000 000 MHz

*
 De1
 Cor
 Avg
 16
 H1d

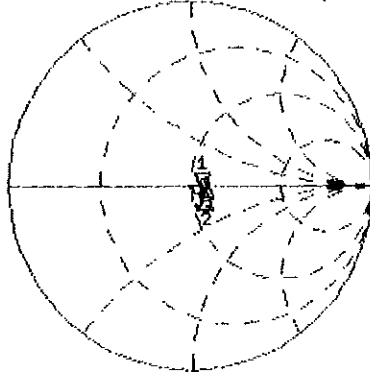

CH1 Markers
 2: 58.262 Ω
 -3.1738 Ω
 5.60000 GHz
 3: 58.078 Ω
 4.7969 Ω
 5.75000 GHz

CH2 S11 LOG 5 dB/REF -20 dB 1: -23.432 dB 5 250.000 000 MHz

Cor
 Avg
 16
 H1d

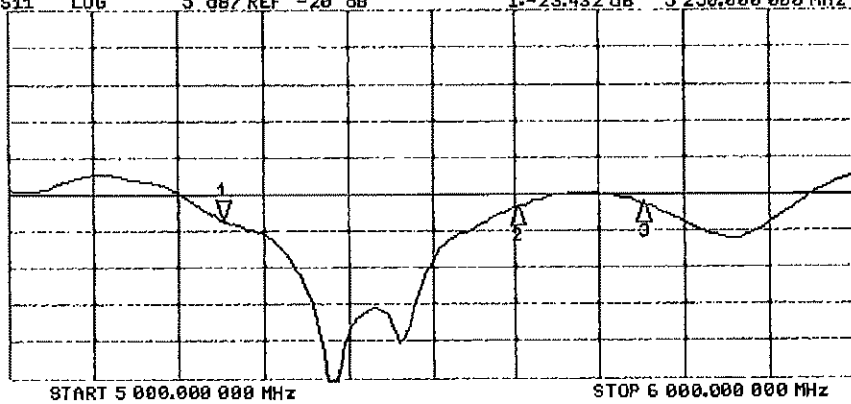

CH2 Markers
 2: -21.752 dB
 5.60000 GHz
 3: -21.226 dB
 5.75000 GHz

DASY5 Validation Report for Body TSL

Date: 20.09.2016

Test Laboratory: SPEAG, Zurich, Switzerland

DUT: Dipole D5GHzV2; Type: D5GHzV2; Serial: D5GHzV2 - SN:1191

Communication System: UID 0 - CW; Frequency: 5250 MHz, Frequency: 5600 MHz, Frequency: 5750 MHz
Medium parameters used: $f = 5250$ MHz; $\sigma = 5.52$ S/m; $\epsilon_r = 47.4$; $\rho = 1000$ kg/m³, Medium parameters used: $f = 5600$ MHz; $\sigma = 6$ S/m; $\epsilon_r = 46.8$; $\rho = 1000$ kg/m³, Medium parameters used: $f = 5750$ MHz; $\sigma = 6.21$ S/m; $\epsilon_r = 46.5$; $\rho = 1000$ kg/m³

Phantom section: Flat Section

Measurement Standard: DASY5 (IEEE/IEC/ANSI C63.19-2011)

DASY52 Configuration:

- Probe: EX3DV4 - SN3503; ConvF(4.85, 4.85, 4.85); Calibrated: 30.06.2016, ConvF(4.35, 4.35, 4.35); Calibrated: 30.06.2016, ConvF(4.3, 4.3, 4.3); Calibrated: 30.06.2016;
- Sensor-Surface: 1.4mm (Mechanical Surface Detection)
- Electronics: DAE4 Sn601; Calibrated: 30.12.2015
- Phantom: Flat Phantom 5.0 (back); Type: QD000P50AA; Serial: 1002
- DASY52 52.8.8(1258); SEMCAD X 14.6.10(7372)

Dipole Calibration for Body Tissue/Pin=100mW, dist=10mm, f=5250MHz/Zoom Scan, dist=1.4mm (8x8x7)/Cube 0: Measurement grid: dx=4mm, dy=4mm, dz=1.4mm

Reference Value = 66.49 V/m; Power Drift = -0.07 dB

Peak SAR (extrapolated) = 29.1 W/kg

SAR(1 g) = 7.74 W/kg; SAR(10 g) = 2.17 W/kg

Maximum value of SAR (measured) = 17.7 W/kg

Dipole Calibration for Body Tissue/Pin=100mW, dist=10mm, f=5600 MHz/Zoom Scan, dist=1.4mm (8x8x7)/Cube 0: Measurement grid: dx=4mm, dy=4mm, dz=1.4mm

Reference Value = 65.85 V/m; Power Drift = -0.09 dB

Peak SAR (extrapolated) = 32.5 W/kg

SAR(1 g) = 7.96 W/kg; SAR(10 g) = 2.24 W/kg

Maximum value of SAR (measured) = 18.8 W/kg

Dipole Calibration for Body Tissue/Pin=100mW, dist=10mm, f=5750 MHz/Zoom Scan, dist=1.4mm (8x8x7)/Cube 0: Measurement grid: dx=4mm, dy=4mm, dz=1.4mm

Reference Value = 64.21 V/m; Power Drift = -0.09 dB

Peak SAR (extrapolated) = 32.7 W/kg

SAR(1 g) = 7.65 W/kg; SAR(10 g) = 2.14 W/kg

Maximum value of SAR (measured) = 18.5 W/kg

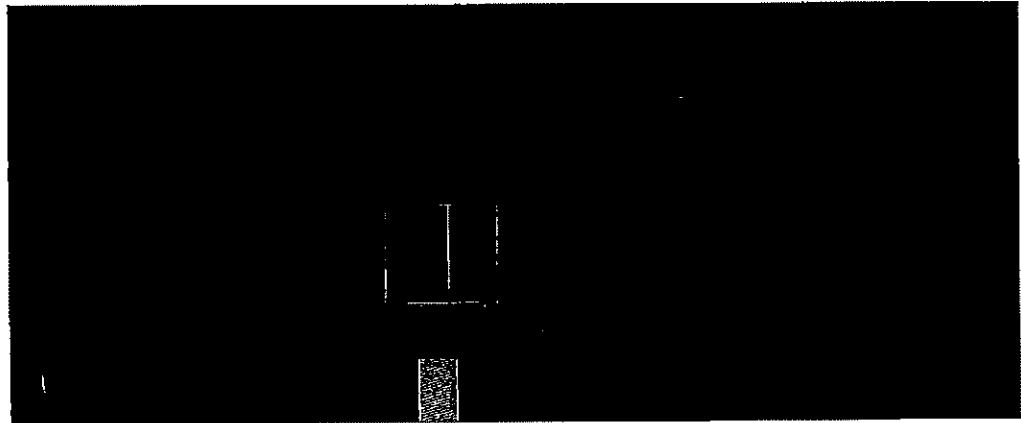
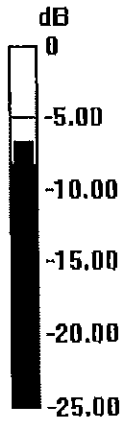

0 dB = 17.7 W/kg = 12.48 dBW/kg

Impedance Measurement Plot for Body TSL

20 Sep 2016 13:19:13

CH1 S11 1 U FS 1: 56.143 Ω -3.6992 Ω 8.1950 pF 5 250.000 000 MHz

De l
Cor
Avg
16
H1 d

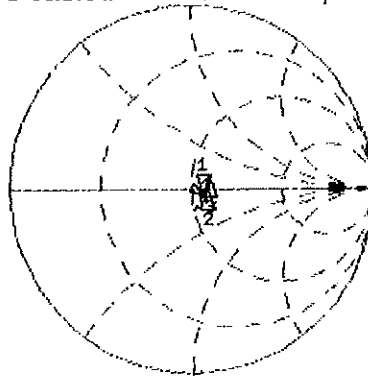

CH1 Markers
2: 58.887 Ω
-1.6504 Ω
5.60000 GHz
3: 59.510 Ω
6.9121 Ω
5.75000 GHz

CH2 S11 LOG 5 dB/ REF -20 dB 1: -23.406 dB 5 250.000 000 MHz

Cor
Avg
16
H1 d

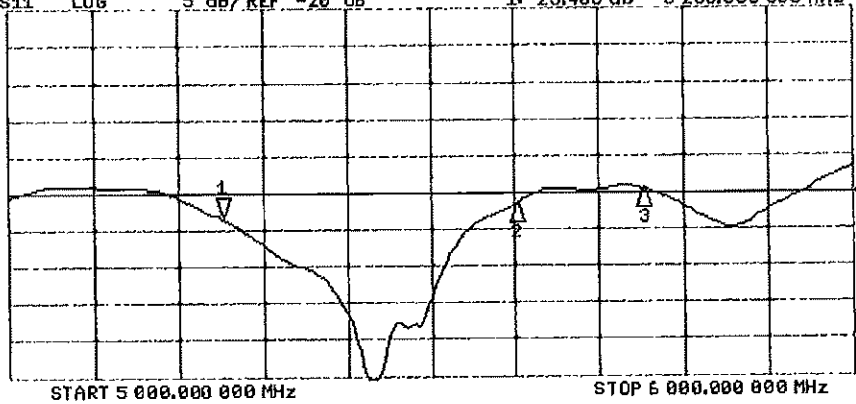

CH2 Markers
2: -21.616 dB
5.60000 GHz
3: -19.400 dB
5.75000 GHz

Certification of Calibration

Object: D5GHzV2 – SN: 1191

Calibration procedure(s): Procedure for Calibration Extension for SAR Dipoles.

Extension Calibration date: 9/19/2017

Description: SAR Validation Dipole at 5250, 5600, and 5750 MHz.

Calibration Equipment used:

Manufacturer	Model	Description	Cal Date	Cal Interval	Cal Due	Serial Number
Control Company	4040	Therm./Clock/Humidity Monitor	3/31/2017	Biennial	3/31/2019	170232394
Control Company	4352	Ultra Long Stem Thermometer	5/2/2017	Biennial	5/2/2019	170330156
Amplifier Research	15S1G6	Amplifier	CBT	N/A	CBT	433971
Narda	4772-3	Attenuator (3dB)	CBT	N/A	CBT	9406
Keysight	7720	Dual Directional Coupler	CBT	N/A	CBT	MYS2180215
Keysight Technologies	85033E	Standard Mechanical Calibration Kit (DC to 9GHz, 3.5mm)	6/1/2017	Annual	6/1/2018	MYS3401181
Agilent	8753ES	S-Parameter Network Analyzer	10/26/2016	Annual	10/26/2017	US39170118
Mini-Circuits	BW-N20W5+	DC to 18 GHz Precision Fixed 20 dB Attenuator	CBT	N/A	CBT	N/A
SPEAG	DAK-3.S	Dielectric Assessment Kit	5/10/2017	Annual	5/10/2018	1070
SPEAG	EX3DV4	SAR Probe	1/13/2017	Annual	1/13/2018	3589
SPEAG	EX3DV4	SAR Probe	2/13/2017	Annual	2/13/2018	3914
SPEAG	DAE4	Dasy Data Acquisition Electronics	1/16/2017	Annual	1/16/2018	1466
SPEAG	DAE4	Dasy Data Acquisition Electronics	2/9/2017	Annual	2/9/2018	665
Anritsu	MA2411B	Pulse Power Sensor	2/10/2017	Annual	2/10/2018	1207364
Anritsu	MA2411B	Pulse Power Sensor	2/10/2017	Annual	2/10/2018	1339018
Anritsu	ML2495A	Power Meter	10/16/2015	Biennial	10/16/2017	941001
Agilent	N5182A	MXG Vector Signal Generator	2/28/2017	Annual	2/28/2018	MY47420800
Seekonk	NC-100	Torque Wrench	11/6/2015	Biennial	11/6/2017	N/A
MiniCircuits	VLF-6000+	Low Pass Filter	CBT	N/A	CBT	N/A
Narda	4014C-6	4 - 8 GHz SMA 6 dB Directional Coupler	CBT	N/A	CBT	N/A

Measurement Uncertainty = $\pm 23\%$ (k=2)

	Name	Function	Signature
Calibrated By:	Brodie Halfoster	Test Engineer	<i>BRODIE HALFOSTER</i>
Approved By:	Kaitlin O'Keefe	Senior Technical Manager	<i>KOK</i>

DIPOLE CALIBRATION EXTENSION

Per KDB 865664 D01, calibration intervals of up to three years may be considered for reference dipoles when it is demonstrated that the SAR target, impedance and return loss of a dipole have remained stable according to the following requirements:

1. The measured SAR does not deviate more than 10% from the target on the calibration certificate.
2. The return-loss does not deviate more than 20% from the previous measurement and meets the required 20dB minimum return-loss requirement.
3. The measurement of real or imaginary parts of impedance does not deviate more than 5Ω from the previous measurement.

The following dipole was checked to pass the above 3 requirements to have 2-year calibration period from the calibration date:

Frequency (MHz)	Calibration Date	Extension Date	Certificate Electrical Delay (ns)	Certificate SAR Target Head (1g W/kg @ 17.0 dBm)	Measured Head SAR (1g) W/kg @ 17.0 dBm	Deviation 1g (%)	Certificate SAR Target Head (10g W/kg @ 17.0 dBm)	Measured Head SAR (10g) W/kg @ 17.0 dBm	Deviation 10g (%)	Certificate Impedance Head (Ohm) Real	Measured Impedance Head (Ohm) Real	Difference (Ohm) Real	Certificate Impedance Head (Ohm) Imaginary	Measured Impedance Head (Ohm) Imaginary	Difference (Ohm) Imaginary	Certificate Return Loss Head (dB)	Measured Return Loss Head (dB)	Deviation (%)	PASS/FAIL
5250	9/21/2016	9/19/2017	1.204	3.95	3.70	-6.21%	1.13	1.05	-7.08%	55.7	53.4	2.3	-4.3	-6.4	2.1	-23.4	-26.9	-15.00%	PASS
5600	9/21/2016	9/19/2017	1.204	4.18	4.03	-3.59%	1.19	1.13	-5.04%	58.3	55.8	2.7	-3.2	-1.2	2.0	-21.8	-26.1	-19.80%	PASS
5750	9/21/2016	9/19/2017	1.204	3.96	3.84	-3.08%	1.12	1.10	-1.79%	58.1	57.4	0.7	4.8	3.2	1.6	-21.2	-21.0	0.90%	PASS

Frequency (MHz)	Calibration Date	Extension Date	Certificate Electrical Delay (ns)	Certificate SAR Target Body (1g W/kg @ 17.0 dBm)	Measured Body SAR (1g) W/kg @ 17.0 dBm	Deviation 1g (%)	Certificate SAR Target Body (10g W/kg @ 17.0 dBm)	Measured Body SAR (10g) W/kg @ 17.0 dBm	Deviation 10g (%)	Certificate Impedance Body (Ohm) Real	Measured Impedance Body (Ohm) Real	Difference (Ohm) Real	Certificate Impedance Body (Ohm) Imaginary	Measured Impedance Body (Ohm) Imaginary	Difference (Ohm) Imaginary	Certificate Return Loss Body (dB)	Measured Return Loss Body (dB)	Deviation (%)	PASS/FAIL
5250	9/21/2016	9/19/2017	1.204	3.85	3.80	-1.30%	1.08	1.06	-1.85%	56.1	54.0	2.1	-3.7	-3.3	0.4	-23.4	-26.0	-11.10%	PASS
5600	9/21/2016	9/19/2017	1.204	3.96	4.06	2.53%	1.11	1.13	1.80%	58.9	56.5	2.4	-1.7	0.5	2.2	-21.7	-24.5	-12.80%	PASS
5750	9/21/2016	9/19/2017	1.204	3.81	3.66	-3.81%	1.06	1.02	-3.77%	59.5	58.0	1.5	6.9	5.2	1.7	-19.4	-21.1	-8.70%	PASS

Impedance & Return-Loss Measurement Plot for Head TSL

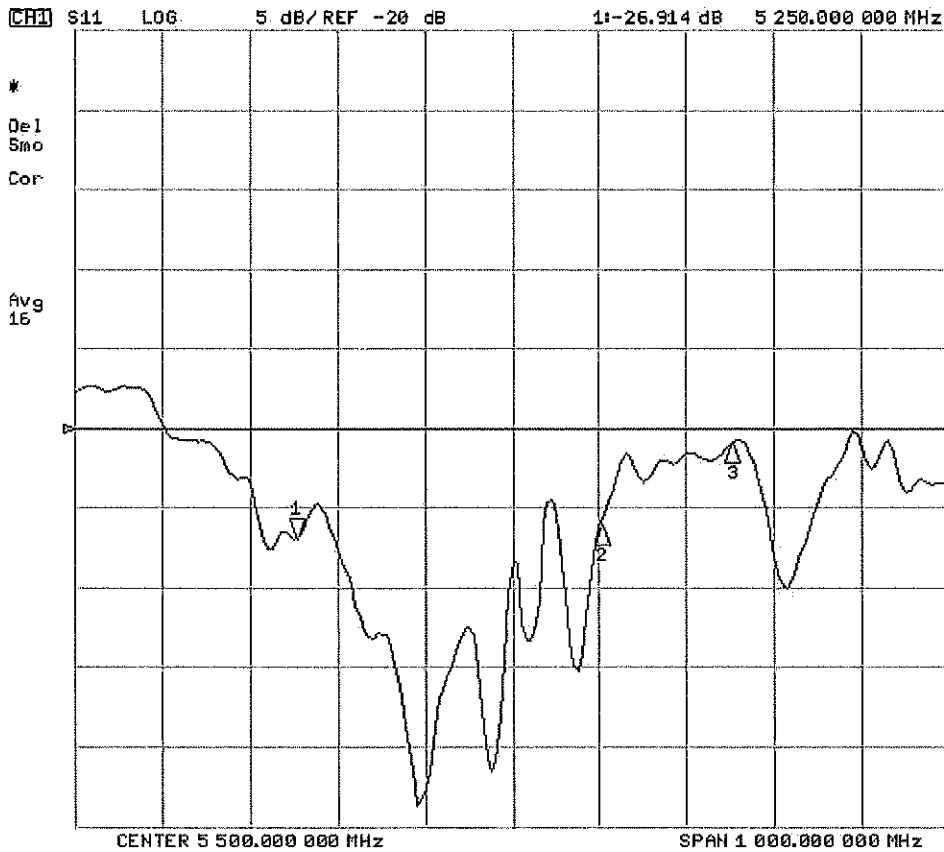
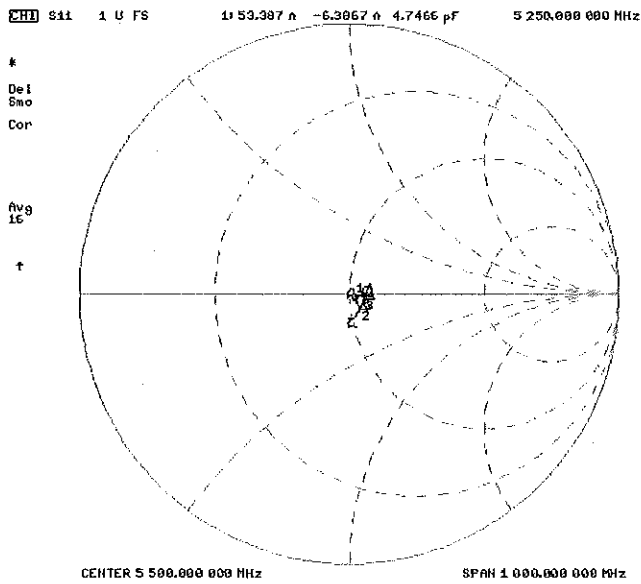

Impedance & Return-Loss Measurement Plot for Body TSL

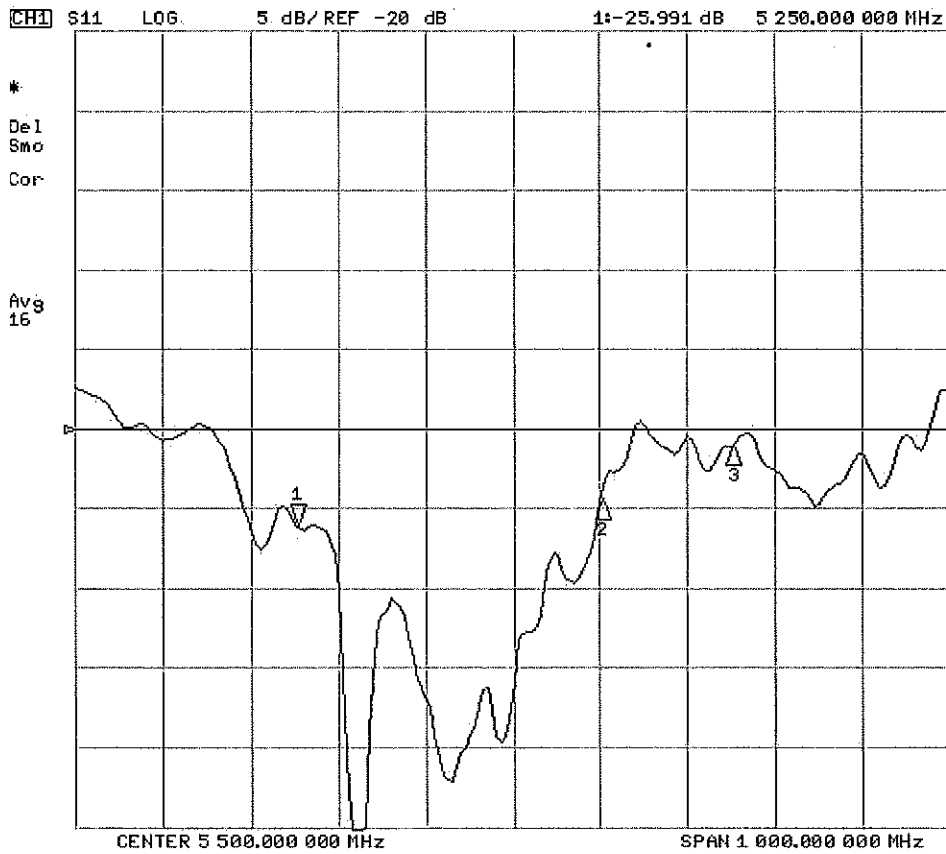
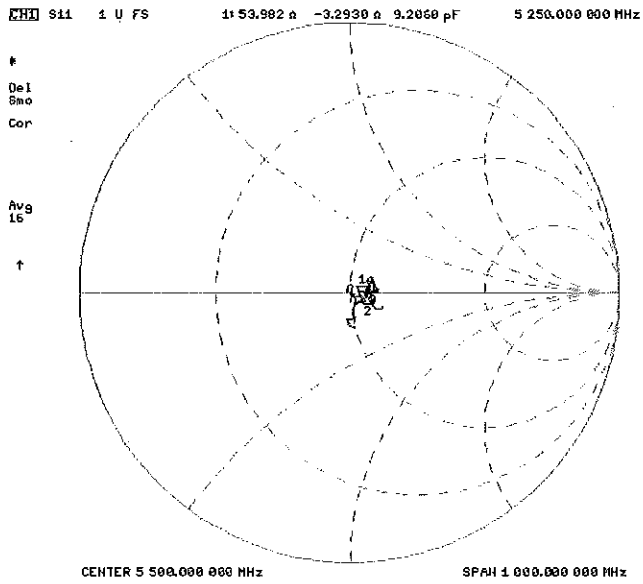

Certification of Calibration

Object: D5GHzV2 – SN: 1191

Calibration procedure(s): Procedure for Calibration Extension for SAR Dipoles.

Extension Calibration date: 9/11/2018

Description: SAR Validation Dipole at 5250, 5600, and 5750 MHz.

Calibration Equipment used:

Manufacturer	Model	Description	Cal Date	Cal Interval	Cal Due	Serial Number
Control Company	4040	Therm./Clock/Humidity Monitor	3/31/2017	Biennial	3/31/2019	170232394
Control Company	4352	Ultra Long Stem Thermometer	5/2/2017	Biennial	5/2/2019	170330156
Amplifier Research	1551G6	Amplifier	CBT	N/A	CBT	433971
Narda	4772-3	Attenuator (3dB)	CBT	N/A	CBT	9406
Keysight	772D	Dual Directional Coupler	CBT	N/A	CBT	MY52180215
Keysight Technologies	85033E	Standard Mechanical Calibration Kit (DC to 9GHz, 3.5mm)	6/4/2018	Annual	6/4/2019	MY53401181
Agilent	8753ES	S-Parameter Vector Network Analyzer	8/30/2018	Annual	8/30/2019	MY40003841
Mini-Circuits	BW-N20W5+	DC to 18 GHz Precision Fixed 20 dB Attenuator	CBT	N/A	CBT	N/A
SPEAG	DAK-3.5	Dielectric Assessment Kit	5/15/2018	Annual	5/15/2019	1070
SPEAG	EX3DV4	SAR Probe	6/25/2018	Annual	6/25/2019	7409
SPEAG	DAE4	Dasy Data Acquisition Electronics	6/18/2018	Annual	6/18/2019	1334
SPEAG	EX3DV4	SAR Probe	4/18/2018	Annual	4/18/2019	7357
SPEAG	DAE4	Dasy Data Acquisition Electronics	4/11/2018	Annual	4/11/2019	1407
Anritsu	MA2411B	Pulse Power Sensor	3/2/2018	Annual	3/2/2019	1207364
Anritsu	MA2411B	Pulse Power Sensor	3/2/2018	Annual	3/2/2019	1339018
Anritsu	ML2495A	Power Meter	10/22/2017	Annual	10/22/2018	1328004
Agilent	N5182A	MXG Vector Signal Generator	4/18/2018	Annual	4/18/2019	MY47420800
Seekonk	NC-100	Torque Wrench	7/11/2018	Annual	7/11/2019	N/A
MiniCircuits	VLF-6000+	Low Pass Filter	CBT	N/A	CBT	N/A
Narda	4014C-6	4 - 8 GHz SMA 6 dB Directional Coupler	CBT	N/A	CBT	N/A

Note: CBT (Calibrated Before Testing). Prior to testing, the measurement paths containing a cable, amplifier, attenuator, coupler or filter were connected to a calibrated source (i.e. a signal generator) to determine the losses of the measurement path.

Measurement Uncertainty = ±23% (k=2)

	Name	Function	Signature
Calibrated By:	Brodie Halfoster	Test Engineer	<i>BRODIE HALFOSTER</i>
Approved By:	Kaitlin O'Keefe	Senior Technical Manager	<i>KOK</i>

DIPOLE CALIBRATION EXTENSION

Per KDB 865664 D01, calibration intervals of up to three years may be considered for reference dipoles when it is demonstrated that the SAR target, impedance and return loss of a dipole have remained stable according to the following requirements:

1. The measured SAR does not deviate more than 10% from the target on the calibration certificate.
2. The return-loss does not deviate more than 20% from the previous measurement and meets the required 20dB minimum return-loss requirement.
3. The measurement of real or imaginary parts of impedance does not deviate more than 5Ω from the previous measurement.

The following dipole was checked to pass the above 3 requirements to have 3-year calibration period from the calibration date:

Frequency (MHz)	Calibration Date	Extension Date	Certificate Electrical Delay (ns)	Certificate SAR Target Head (1g) W/kg @ 17.0 dBm	Measured Head SAR (1g) W/kg @ 17.0 dBm	Deviation 1g (%)	Certificate SAR Target Head (10g) W/kg @ 17.0 dBm	Measured Head SAR (10g) W/kg @ 17.0 dBm	Deviation 10g (%)	Certificate Impedance Head (Ohm) Real	Measured Impedance Head (Ohm) Real	Difference (Ohm) Real	Certificate Impedance Head (Ohm) Imaginary	Measured Impedance Head (Ohm) Imaginary	Difference (Ohm) Imaginary	Certificate Return Loss Head (dB)	Measured Return Loss Head (dB)	Deviation (%)	PASS/FAIL
5250	9/21/2016	9/11/2018	1.204	3.945	3.9	-1.14%	1.13	1.11	-1.77%	55.7	54.9	0.8	-4.3	-7.7	3.4	-23.4	-21.3	9.10%	PASS
5600	9/21/2016	9/11/2018	1.204	4.18	4.19	0.24%	1.19	1.18	-0.84%	58.3	54.6	3.7	-3.2	-6.2	3	-21.8	-22.7	-4.30%	PASS
5750	9/21/2016	9/11/2018	1.204	3.955	3.82	-3.41%	1.12	1.08	-3.57%	58.1	58.7	0.6	4.8	7.4	2.6	-21.2	-19.5	7.80%	PASS
Frequency (MHz)	Calibration Date	Extension Date	Certificate Electrical Delay (ns)	Certificate SAR Target Body (1g) W/kg @ 17.0 dBm	Measured Body SAR (1g) W/kg @ 17.0 dBm	Deviation 1g (%)	Certificate SAR Target Body (10g) W/kg @ 17.0 dBm	Measured Body SAR (10g) W/kg @ 17.0 dBm	Deviation 10g (%)	Certificate Impedance Body (Ohm) Real	Measured Impedance Body (Ohm) Real	Difference (Ohm) Real	Certificate Impedance Body (Ohm) Imaginary	Measured Impedance Body (Ohm) Imaginary	Difference (Ohm) Imaginary	Certificate Return Loss Body (dB)	Measured Return Loss Body (dB)	Deviation (%)	PASS/FAIL
5250	9/21/2016	9/11/2018	1.204	3.85	3.6	-6.49%	1.08	1.01	-6.48%	56.1	53.6	2.5	-3.7	-5.5	1.8	-23.4	-24	-2.40%	PASS
5600	9/21/2016	9/11/2018	1.204	3.96	4.01	1.26%	1.11	1.1	-0.90%	58.9	57	1.9	-1.7	0.1	1.8	-21.7	-23.8	-9.70%	PASS
5750	9/21/2016	9/11/2018	1.204	3.805	3.88	1.97%	1.06	1.06	0.00%	59.5	60.3	0.8	6.9	6.1	0.8	-19.4	-19.2	1.00%	PASS

Impedance & Return-Loss Measurement Plot for Head TSL

11 Sep 2018 05:03:18
 [CH1] S11 1 U FS 1: 54.093 Ω -7.7207 Ω 3.9265 pF 5 250.000 000 MHz

*
 Del
 Smo
 Cor
 Avg
 16

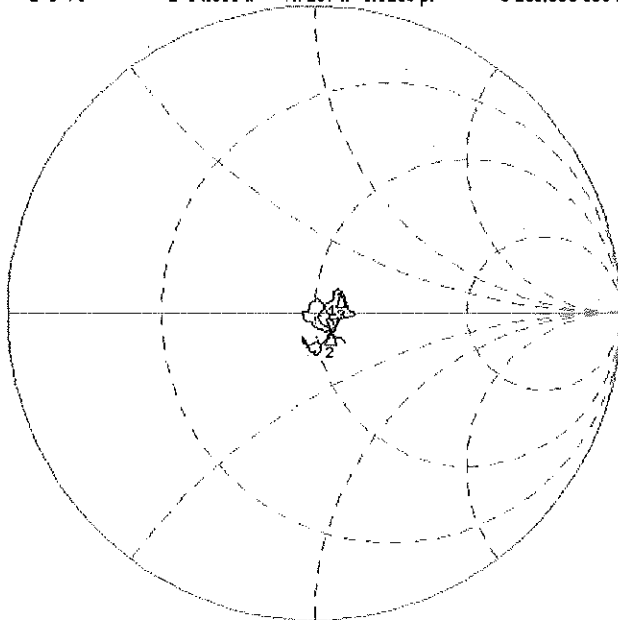

CH1 Markers
 2: 54.590 Ω
 -6.1797 Ω
 5.60000 GHz
 3: 50.559 Ω
 7.3097 Ω
 5.75000 GHz

CENTER 5 500.000 000 MHz SPAN 1 000.000 000 MHz
 11 Sep 2018 05:01:49

[CH1] S11 LOG 5 dB/REF -20 dB 1: -21.279 dB 5 250.000 000 MHz

*
 Del
 Smo
 Cor
 Avg
 16

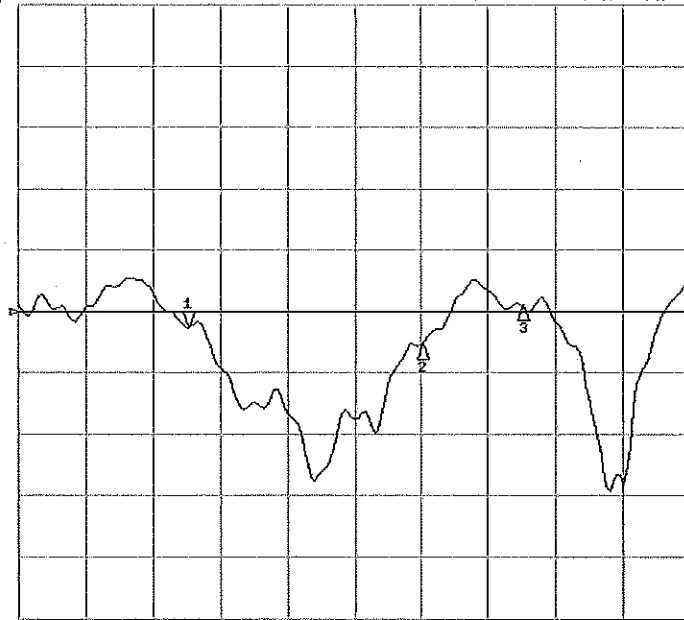

CH1 Markers
 2: -22.747 dB
 5.60000 GHz
 3: -19.546 dB
 5.75000 GHz

CENTER 5 500.000 000 MHz SPAN 1 000.000 000 MHz

Impedance & Return-Loss Measurement Plot for Body TSL

11 Sep 2018 05:00:12
 [CH1] S11 1 U F6 1: 53.613 n -5.4005 n 5.5315 pF 5 250.000 000 MHz

*
 Del
 Smo
 Cor
 Avg
 16

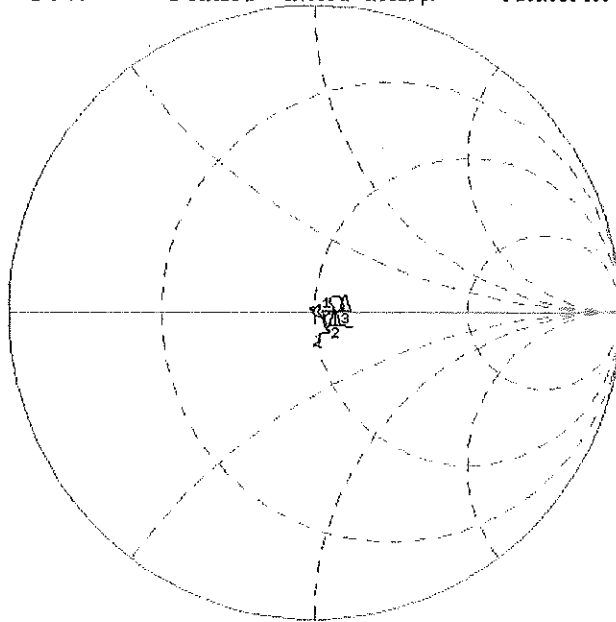

CH1 Markers
 2: 56.973 n
 0.0742 n
 5.60000 GHz
 3: 60.309 n
 5.0377 n
 5.75000 GHz

CENTER 5 500.000 000 MHz SPAN 1 000.000 000 MHz
 11 Sep 2018 05:00:43

[CH1] S11 LOG 5 dB/REF -20 dB 11-23.952 dB 5 250.000 000 MHz

*
 Del
 Smo
 Cor
 Avg
 16
 f

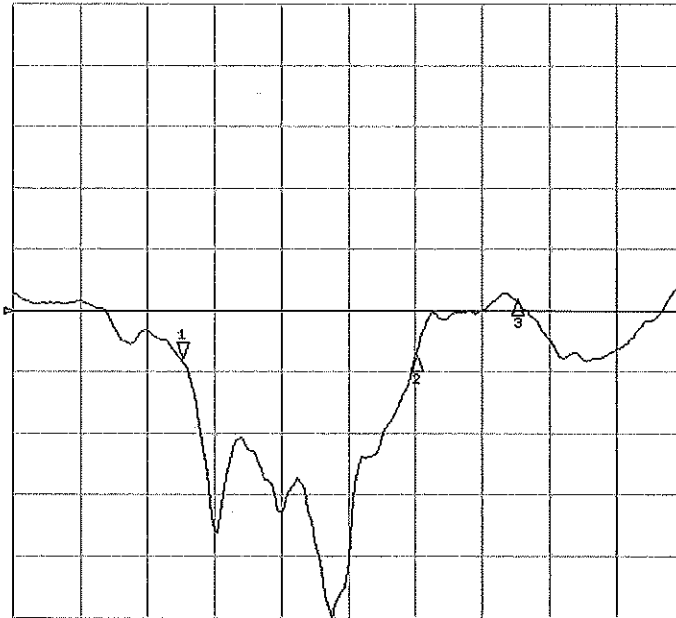

CH1 Markers
 2: -23.002 dB
 5.60000 GHz
 3: -19.200 dB
 5.75000 GHz

CENTER 5 500.000 000 MHz SPAN 1 000.000 000 MHz



Accredited by the Swiss Accreditation Service (SAS)
The Swiss Accreditation Service is one of the signatories to the EA
Multilateral Agreement for the recognition of calibration certificates

Accreditation No.: **SCS 0108**

Client **PC-Test**

Certificate No: **EX3-7308_Aug18**

CALIBRATION CERTIFICATE

Object: **EX3DV4 - SN:7308**

Calibration procedure(s): **QA CAL-01.v9, QA CAL-14.v4, QA CAL-23.v5, QA CAL-25.v6
Calibration procedure for dosimetric E-field probes**

Calibration date: **August 23, 2018**

*BN ✓
09-06-2018*

This calibration certificate documents the traceability to national standards, which realize the physical units of measurements (SI).
The measurements and the uncertainties with confidence probability are given on the following pages and are part of the certificate.

All calibrations have been conducted in the closed laboratory facility: environment temperature (22 ± 3)°C and humidity < 70%.

Calibration Equipment used (M&TE critical for calibration)

Primary Standards	ID	Cal Date (Certificate No.)	Scheduled Calibration
Power meter NRP	SN: 104778	04-Apr-18 (No. 217-02672/02673)	Apr-19
Power sensor NRP-Z91	SN: 103244	04-Apr-18 (No. 217-02672)	Apr-19
Power sensor NRP-Z91	SN: 103245	04-Apr-18 (No. 217-02673)	Apr-19
Reference 20 dB Attenuator	SN: S5277 (20x)	04-Apr-18 (No. 217-02682)	Apr-19
Reference Probe ES3DV2	SN: 3013	30-Dec-17 (No. ES3-3013_Dec17)	Dec-18
DAE4	SN: 660	21-Dec-17 (No. DAE4-660_Dec17)	Dec-18
Secondary Standards	ID	Check Date (in house)	Scheduled Check
Power meter E4419B	SN: GB41293874	06-Apr-16 (in house check Jun-18)	In house check: Jun-20
Power sensor E4412A	SN: MY41498087	06-Apr-16 (in house check Jun-18)	In house check: Jun-20
Power sensor E4412A	SN: 000110210	06-Apr-16 (in house check Jun-18)	In house check: Jun-20
RF generator HP 8648C	SN: US3642U01700	04-Aug-99 (in house check Jun-18)	In house check: Jun-20
Network Analyzer E8358A	SN: US41080477	31-Mar-14 (in house check Oct-17)	In house check: Oct-18

Calibrated by: **Jeton Kastrati** (Name), **Laboratory Technician** (Function), *[Signature]* (Signature)

Approved by: **Katja Pokovic** (Name), **Technical Manager** (Function), *[Signature]* (Signature)

Issued: August 24, 2018

This calibration certificate shall not be reproduced except in full without written approval of the laboratory.



Accredited by the Swiss Accreditation Service (SAS)

Accreditation No.: **SCS 0108**

The Swiss Accreditation Service is one of the signatories to the EA Multilateral Agreement for the recognition of calibration certificates

Glossary:

TSL	tissue simulating liquid
NORM _{x,y,z}	sensitivity in free space
ConvF	sensitivity in TSL / NORM _{x,y,z}
DCP	diode compression point
CF	crest factor (1/duty_cycle) of the RF signal
A, B, C, D	modulation dependent linearization parameters
Polarization φ	φ rotation around probe axis
Polarization ϑ	ϑ rotation around an axis that is in the plane normal to probe axis (at measurement center), i.e., ϑ = 0 is normal to probe axis
Connector Angle	information used in DASY system to align probe sensor X to the robot coordinate system

Calibration is Performed According to the Following Standards:

- a) IEEE Std 1528-2013, "IEEE Recommended Practice for Determining the Peak Spatial-Averaged Specific Absorption Rate (SAR) in the Human Head from Wireless Communications Devices: Measurement Techniques", June 2013
- b) IEC 62209-1, "Measurement procedure for the assessment of Specific Absorption Rate (SAR) from hand-held and body-mounted devices used next to the ear (frequency range of 300 MHz to 6 GHz)", July 2016
- c) IEC 62209-2, "Procedure to determine the Specific Absorption Rate (SAR) for wireless communication devices used in close proximity to the human body (frequency range of 30 MHz to 6 GHz)", March 2010
- d) KDB 865664, "SAR Measurement Requirements for 100 MHz to 6 GHz"

Methods Applied and Interpretation of Parameters:

- *NORM_{x,y,z}*: Assessed for E-field polarization ϑ = 0 (f ≤ 900 MHz in TEM-cell; f > 1800 MHz: R22 waveguide). *NORM_{x,y,z}* are only intermediate values, i.e., the uncertainties of *NORM_{x,y,z}* does not affect the E²-field uncertainty inside TSL (see below *ConvF*).
- *NORM(f)_{x,y,z}* = *NORM_{x,y,z}* * *frequency_response* (see Frequency Response Chart). This linearization is implemented in DASY4 software versions later than 4.2. The uncertainty of the frequency response is included in the stated uncertainty of *ConvF*.
- *DCP_{x,y,z}*: DCP are numerical linearization parameters assessed based on the data of power sweep with CW signal (no uncertainty required). DCP does not depend on frequency nor media.
- *PAR*: PAR is the Peak to Average Ratio that is not calibrated but determined based on the signal characteristics
- *A_{x,y,z}; B_{x,y,z}; C_{x,y,z}; D_{x,y,z}; VR_{x,y,z}*: A, B, C, D are numerical linearization parameters assessed based on the data of power sweep for specific modulation signal. The parameters do not depend on frequency nor media. VR is the maximum calibration range expressed in RMS voltage across the diode.
- *ConvF and Boundary Effect Parameters*: Assessed in flat phantom using E-field (or Temperature Transfer Standard for f ≤ 800 MHz) and inside waveguide using analytical field distributions based on power measurements for f > 800 MHz. The same setups are used for assessment of the parameters applied for boundary compensation (alpha, depth) of which typical uncertainty values are given. These parameters are used in DASY4 software to improve probe accuracy close to the boundary. The sensitivity in TSL corresponds to *NORM_{x,y,z}* * *ConvF* whereby the uncertainty corresponds to that given for *ConvF*. A frequency dependent *ConvF* is used in DASY version 4.4 and higher which allows extending the validity from ± 50 MHz to ± 100 MHz.
- *Spherical isotropy (3D deviation from isotropy)*: in a field of low gradients realized using a flat phantom exposed by a patch antenna.
- *Sensor Offset*: The sensor offset corresponds to the offset of virtual measurement center from the probe tip (on probe axis). No tolerance required.
- *Connector Angle*: The angle is assessed using the information gained by determining the *NORM_x* (no uncertainty required).

Probe EX3DV4

SN:7308

Manufactured: March 11, 2014
Calibrated: August 23, 2018

Calibrated for DASY/EASY Systems
(Note: non-compatible with DASY2 system!)

DASY/EASY - Parameters of Probe: EX3DV4 - SN:7308

Basic Calibration Parameters

	Sensor X	Sensor Y	Sensor Z	Unc (k=2)
Norm ($\mu\text{V}/(\text{V}/\text{m})^2$) ^A	0.49	0.60	0.44	$\pm 10.1 \%$
DCP (mV) ^B	99.6	97.1	102.5	

Modulation Calibration Parameters

UID	Communication System Name		A dB	B dB $\sqrt{\mu\text{V}}$	C	D dB	VR mV	Unc ^E (k=2)
0	CW	X	0.0	0.0	1.0	0.00	177.2	$\pm 3.5 \%$
		Y	0.0	0.0	1.0		165.4	
		Z	0.0	0.0	1.0		159.6	

Note: For details on UID parameters see Appendix.

Sensor Model Parameters

	C1 fF	C2 fF	α V ⁻¹	T1 ms.V ⁻²	T2 ms.V ⁻¹	T3 ms	T4 V ⁻²	T5 V ⁻¹	T6
X	53.71	401.2	35.76	12.80	0.351	5.077	0.717	0.413	1.005
Y	56.67	439.8	38.08	13.44	0.524	5.100	0.000	0.597	1.012
Z	40.98	304.1	35.29	8.573	0.334	5.045	1.531	0.174	1.005

The reported uncertainty of measurement is stated as the standard uncertainty of measurement multiplied by the coverage factor k=2, which for a normal distribution corresponds to a coverage probability of approximately 95%.

^A The uncertainties of Norm X,Y,Z do not affect the E²-field uncertainty inside TSL (see Pages 5 and 6).

^B Numerical linearization parameter: uncertainty not required.

^E Uncertainty is determined using the max. deviation from linear response applying rectangular distribution and is expressed for the square of the field value.

DASY/EASY - Parameters of Probe: EX3DV4 - SN:7308

Calibration Parameter Determined in Head Tissue Simulating Media

f (MHz) ^C	Relative Permittivity ^F	Conductivity (S/m) ^F	ConvF X	ConvF Y	ConvF Z	Alpha ^G	Depth ^G (mm)	Unc (k=2)
750	41.9	0.89	10.23	10.23	10.23	0.57	0.81	± 12.0 %
835	41.5	0.90	9.96	9.96	9.96	0.58	0.81	± 12.0 %
1750	40.1	1.37	8.66	8.66	8.66	0.36	0.80	± 12.0 %
1900	40.0	1.40	8.26	8.26	8.26	0.29	0.85	± 12.0 %
2300	39.5	1.67	7.81	7.81	7.81	0.29	0.85	± 12.0 %
2450	39.2	1.80	7.45	7.45	7.45	0.35	0.91	± 12.0 %
2600	39.0	1.96	7.30	7.30	7.30	0.35	0.87	± 12.0 %
5250	35.9	4.71	5.10	5.10	5.10	0.40	1.80	± 13.1 %
5600	35.5	5.07	4.85	4.85	4.85	0.40	1.80	± 13.1 %
5750	35.4	5.22	5.04	5.04	5.04	0.40	1.80	± 13.1 %

^C Frequency validity above 300 MHz of ± 100 MHz only applies for DASY v4.4 and higher (see Page 2), else it is restricted to ± 50 MHz. The uncertainty is the RSS of the ConvF uncertainty at calibration frequency and the uncertainty for the indicated frequency band. Frequency validity below 300 MHz is ± 10, 25, 40, 50 and 70 MHz for ConvF assessments at 30, 64, 128, 150 and 220 MHz respectively. Above 5 GHz frequency validity can be extended to ± 110 MHz.

^F At frequencies below 3 GHz, the validity of tissue parameters (ϵ and σ) can be relaxed to ± 10% if liquid compensation formula is applied to measured SAR values. At frequencies above 3 GHz, the validity of tissue parameters (ϵ and σ) is restricted to ± 5%. The uncertainty is the RSS of the ConvF uncertainty for indicated target tissue parameters.

^G Alpha/Depth are determined during calibration. SPEAG warrants that the remaining deviation due to the boundary effect after compensation is always less than ± 1% for frequencies below 3 GHz and below ± 2% for frequencies between 3-6 GHz at any distance larger than half the probe tip diameter from the boundary.

DASY/EASY - Parameters of Probe: EX3DV4 - SN:7308

Calibration Parameter Determined in Body Tissue Simulating Media

f (MHz) ^C	Relative Permittivity ^F	Conductivity (S/m) ^F	ConvF X	ConvF Y	ConvF Z	Alpha ^G	Depth ^G (mm)	Unc (k=2)
750	55.5	0.96	10.38	10.38	10.38	0.36	0.99	± 12.0 %
835	55.2	0.97	10.19	10.19	10.19	0.50	0.82	± 12.0 %
1750	53.4	1.49	8.13	8.13	8.13	0.27	1.04	± 12.0 %
1900	53.3	1.52	7.79	7.79	7.79	0.38	0.85	± 12.0 %
2300	52.9	1.81	7.73	7.73	7.73	0.37	0.80	± 12.0 %
2450	52.7	1.95	7.57	7.57	7.57	0.34	0.88	± 12.0 %
2600	52.5	2.16	7.40	7.40	7.40	0.29	0.95	± 12.0 %
5250	48.9	5.36	4.48	4.48	4.48	0.50	1.90	± 13.1 %
5600	48.5	5.77	4.00	4.00	4.00	0.50	1.90	± 13.1 %
5750	48.3	5.94	4.18	4.18	4.18	0.50	1.90	± 13.1 %

^C Frequency validity above 300 MHz of ± 100 MHz only applies for DASY v4.4 and higher (see Page 2), else it is restricted to ± 50 MHz. The uncertainty is the RSS of the ConvF uncertainty at calibration frequency and the uncertainty for the indicated frequency band. Frequency validity below 300 MHz is ± 10, 25, 40, 50 and 70 MHz for ConvF assessments at 30, 64, 128, 150 and 220 MHz respectively. Above 5 GHz frequency validity can be extended to ± 110 MHz.

^F At frequencies below 3 GHz, the validity of tissue parameters (ϵ and σ) can be relaxed to ± 10% if liquid compensation formula is applied to measured SAR values. At frequencies above 3 GHz, the validity of tissue parameters (ϵ and σ) is restricted to ± 5%. The uncertainty is the RSS of the ConvF uncertainty for indicated target tissue parameters.

^G Alpha/Depth are determined during calibration. SPEAG warrants that the remaining deviation due to the boundary effect after compensation is always less than ± 1% for frequencies below 3 GHz and below ± 2% for frequencies between 3-6 GHz at any distance larger than half the probe tip diameter from the boundary.

Frequency Response of E-Field

(TEM-Cell:ifi110 EXX, Waveguide: R22)

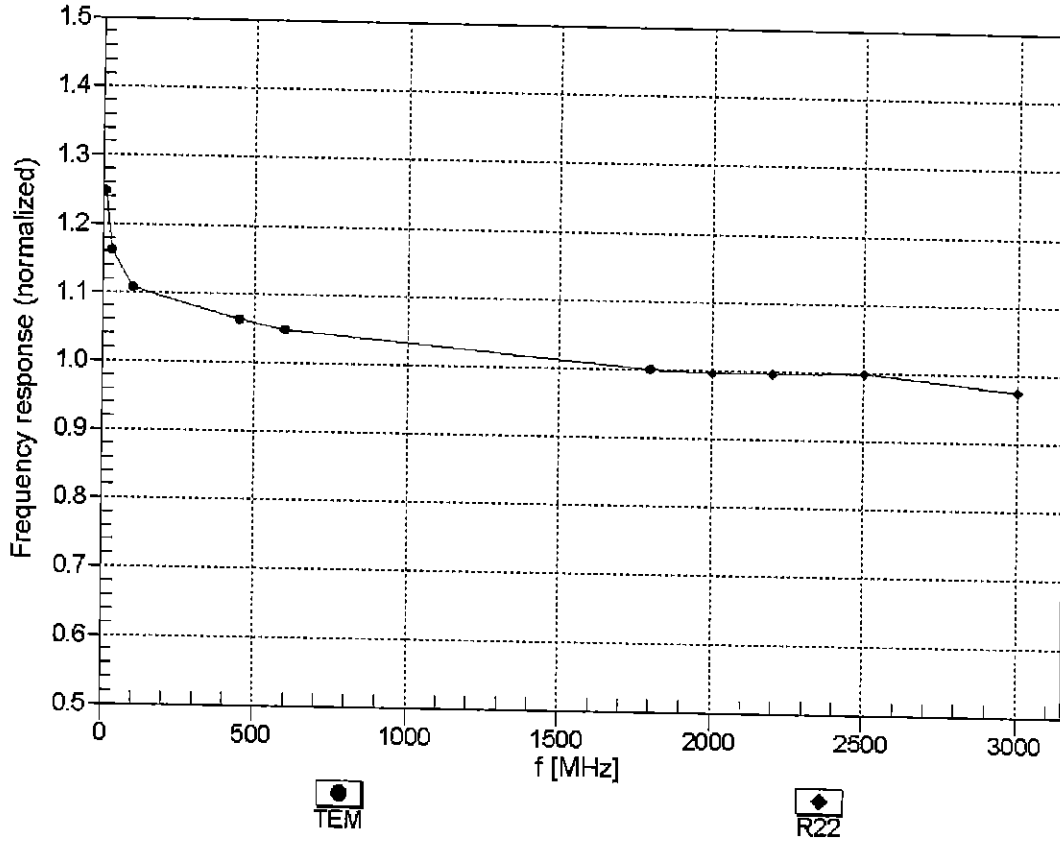

Uncertainty of Frequency Response of E-field: $\pm 6.3\%$ (k=2)

Receiving Pattern (ϕ), $\theta = 0^\circ$

f=600 MHz, TEM

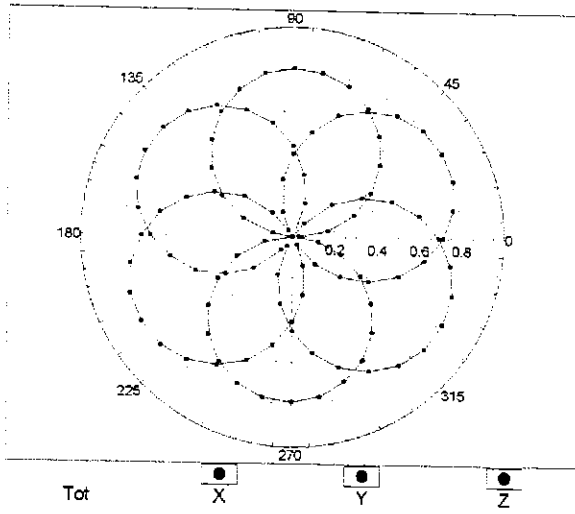

f=1800 MHz, R22

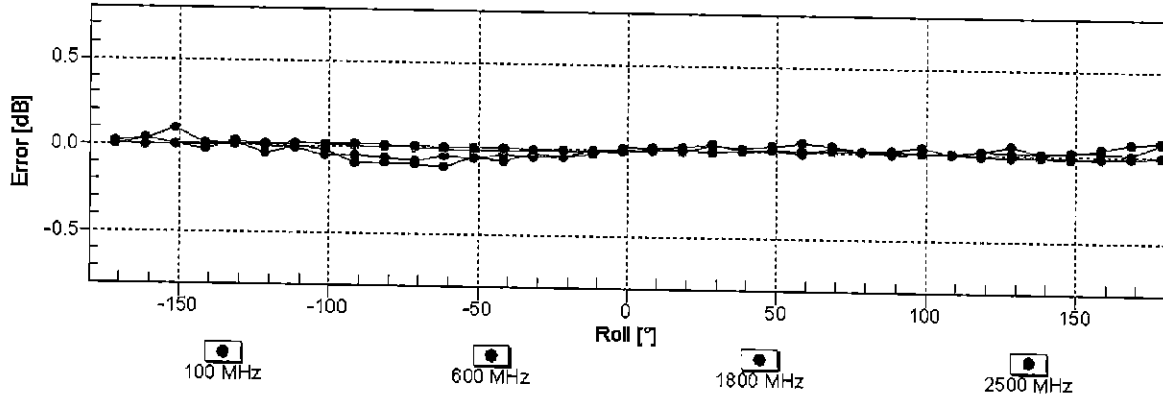
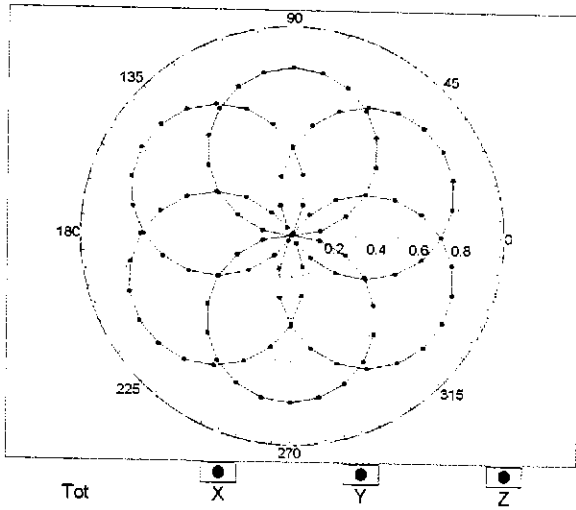

Uncertainty of Axial Isotropy Assessment: $\pm 0.5\%$ (k=2)

Dynamic Range $f(\text{SAR}_{\text{head}})$ (TEM cell, $f_{\text{eval}} = 1900 \text{ MHz}$)

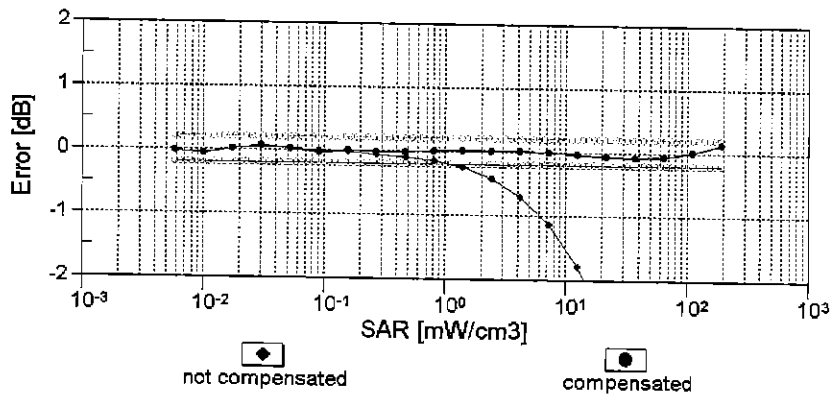
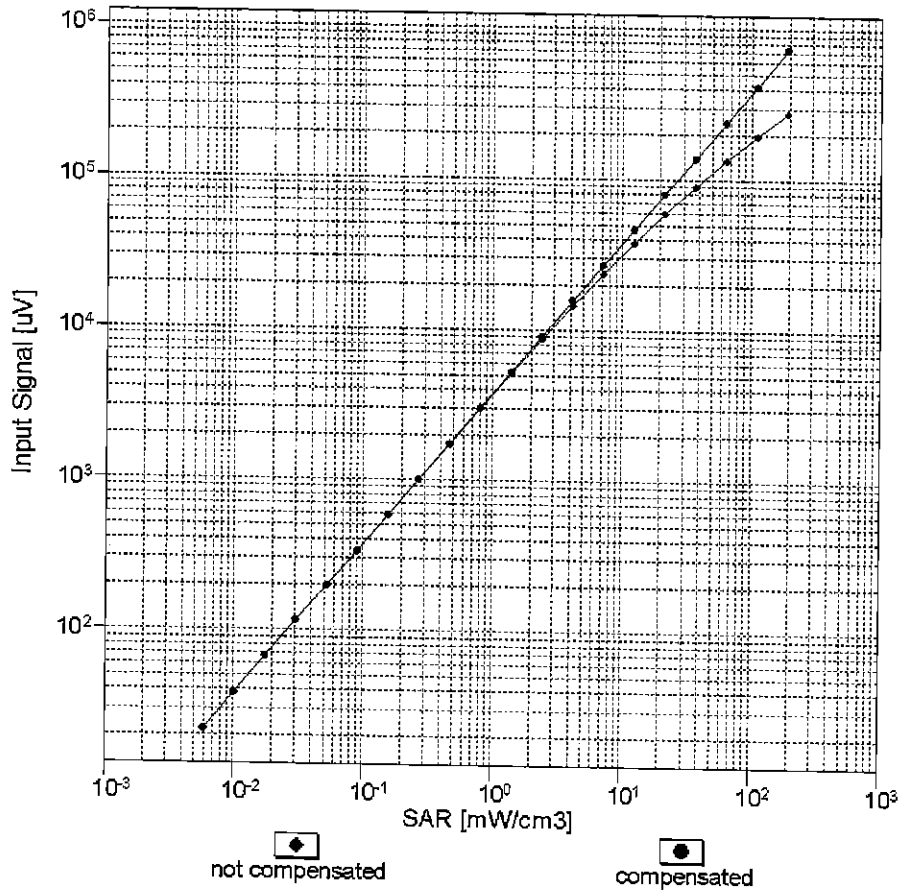

Uncertainty of Linearity Assessment: $\pm 0.6\%$ ($k=2$)

Conversion Factor Assessment

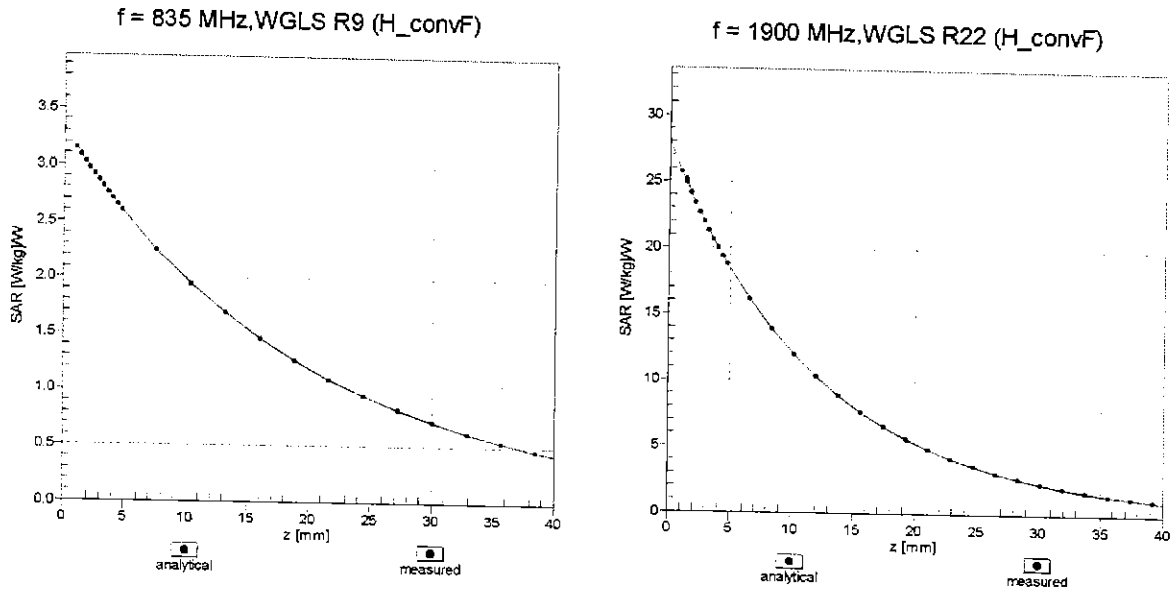

Deviation from Isotropy in Liquid Error (ϕ, θ), f = 900 MHz

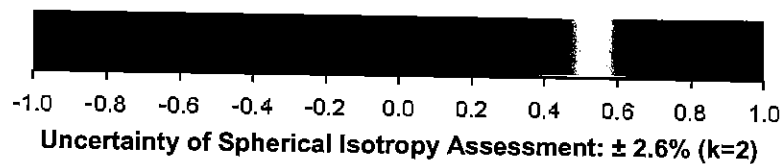
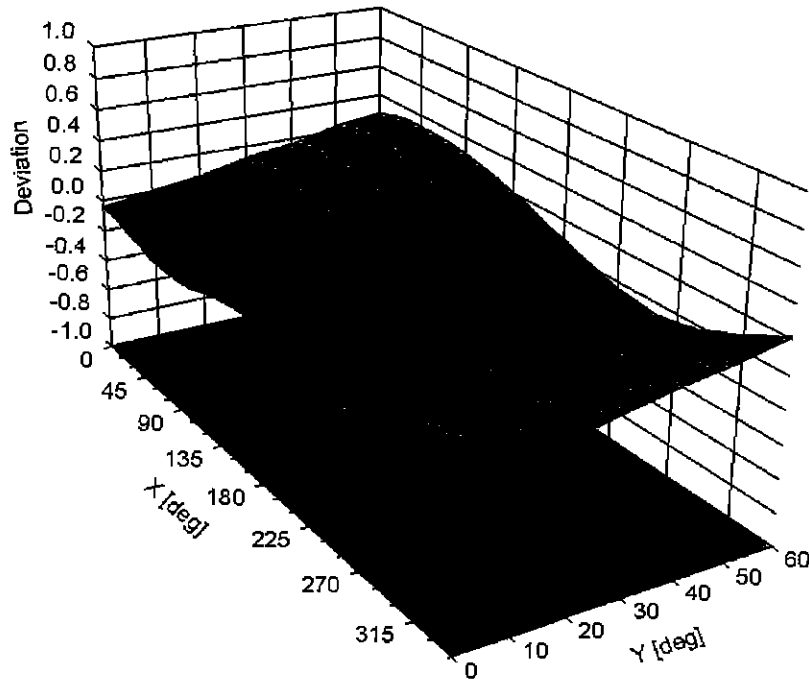

DASY/EASY - Parameters of Probe: EX3DV4 - SN:7308

Other Probe Parameters

Sensor Arrangement	Triangular
Connector Angle (°)	108.5
Mechanical Surface Detection Mode	enabled
Optical Surface Detection Mode	disabled
Probe Overall Length	337 mm
Probe Body Diameter	10 mm
Tip Length	9 mm
Tip Diameter	2.5 mm
Probe Tip to Sensor X Calibration Point	1 mm
Probe Tip to Sensor Y Calibration Point	1 mm
Probe Tip to Sensor Z Calibration Point	1 mm
Recommended Measurement Distance from Surface	1.4 mm

Appendix: Modulation Calibration Parameters

UID	Communication System Name		A dB	B dB $\sqrt{\mu}$ V	C	D dB	VR mV	Max Unc ^E (k=2)
0	CW	X	0.00	0.00	1.00	0.00	177.2	± 3.5 %
		Y	0.00	0.00	1.00		165.4	
		Z	0.00	0.00	1.00		159.6	
10010- CAA	SAR Validation (Square, 100ms, 10ms)	X	2.71	68.17	11.26	10.00	20.0	± 9.6 %
		Y	2.39	66.64	10.67		20.0	
		Z	1.90	64.26	9.03		20.0	
10011- CAB	UMTS-FDD (WCDMA)	X	1.19	70.37	17.06	0.00	150.0	± 9.6 %
		Y	0.96	66.50	14.51		150.0	
		Z	1.05	68.92	16.00		150.0	
10012- CAB	IEEE 802.11b WiFi 2.4 GHz (DSSS, 1 Mbps)	X	1.18	64.67	16.08	0.41	150.0	± 9.6 %
		Y	1.11	63.43	15.04		150.0	
		Z	1.13	64.11	15.48		150.0	
10013- CAB	IEEE 802.11g WiFi 2.4 GHz (DSSS-OFDM, 6 Mbps)	X	4.93	66.75	17.26	1.46	150.0	± 9.6 %
		Y	4.92	66.47	17.15		150.0	
		Z	4.74	66.75	17.08		150.0	
10021- DAC	GSM-FDD (TDMA, GMSK)	X	100.00	114.38	27.28	9.39	50.0	± 9.6 %
		Y	100.00	114.83	27.64		50.0	
		Z	100.00	109.69	24.90		50.0	
10023- DAC	GPRS-FDD (TDMA, GMSK, TN 0)	X	100.00	113.94	27.13	9.57	50.0	± 9.6 %
		Y	100.00	114.49	27.54		50.0	
		Z	100.00	109.21	24.74		50.0	
10024- DAC	GPRS-FDD (TDMA, GMSK, TN 0-1)	X	100.00	115.48	26.77	6.56	60.0	± 9.6 %
		Y	100.00	114.18	26.29		60.0	
		Z	100.00	109.85	23.86		60.0	
10025- DAC	EDGE-FDD (TDMA, 8PSK, TN 0)	X	6.22	84.66	34.29	12.57	50.0	± 9.6 %
		Y	4.94	76.24	29.94		50.0	
		Z	5.36	79.88	31.57		50.0	
10026- DAC	EDGE-FDD (TDMA, 8PSK, TN 0-1)	X	11.81	100.22	36.35	9.56	60.0	± 9.6 %
		Y	11.10	97.75	35.30		60.0	
		Z	7.89	90.81	32.78		60.0	
10027- DAC	GPRS-FDD (TDMA, GMSK, TN 0-1-2)	X	100.00	118.27	27.22	4.80	80.0	± 9.6 %
		Y	100.00	114.44	25.61		80.0	
		Z	100.00	111.67	23.86		80.0	
10028- DAC	GPRS-FDD (TDMA, GMSK, TN 0-1-2-3)	X	100.00	122.72	28.40	3.55	100.0	± 9.6 %
		Y	100.00	114.80	25.04		100.0	
		Z	100.00	114.83	24.49		100.0	
10029- DAC	EDGE-FDD (TDMA, 8PSK, TN 0-1-2)	X	6.56	85.50	29.56	7.80	80.0	± 9.6 %
		Y	6.53	84.80	29.16		80.0	
		Z	4.80	79.03	26.78		80.0	
10030- CAA	IEEE 802.15.1 Bluetooth (GFSK, DH1)	X	100.00	114.96	26.10	5.30	70.0	± 9.6 %
		Y	100.00	112.69	25.18		70.0	
		Z	100.00	108.37	22.73		70.0	
10031- CAA	IEEE 802.15.1 Bluetooth (GFSK, DH3)	X	100.00	126.84	28.53	1.88	100.0	± 9.6 %
		Y	100.00	105.21	19.68		100.0	
		Z	100.00	108.61	20.59		100.0	

10032-CAA	IEEE 802.15.1 Bluetooth (GFSK, DH5)	X	100.00	146.53	35.02	1.17	100.0	± 9.6 %
		Y	100.00	95.65	15.05		100.0	
		Z	100.00	112.23	21.08		100.0	
10033-CAA	IEEE 802.15.1 Bluetooth (PI/4-DQPSK, DH1)	X	100.00	133.98	36.90	5.30	70.0	± 9.6 %
		Y	94.91	132.14	36.35		70.0	
		Z	24.70	106.96	28.52		70.0	
10034-CAA	IEEE 802.15.1 Bluetooth (PI/4-DQPSK, DH3)	X	8.70	95.28	25.33	1.88	100.0	± 9.6 %
		Y	4.18	83.23	21.11		100.0	
		Z	3.97	82.01	19.44		100.0	
10035-CAA	IEEE 802.15.1 Bluetooth (PI/4-DQPSK, DH5)	X	3.83	83.82	21.38	1.17	100.0	± 9.6 %
		Y	2.23	74.99	17.69		100.0	
		Z	2.33	75.94	16.98		100.0	
10036-CAA	IEEE 802.15.1 Bluetooth (8-DPSK, DH1)	X	100.00	134.50	37.14	5.30	70.0	± 9.6 %
		Y	100.00	133.48	36.76		70.0	
		Z	56.60	119.91	31.85		70.0	
10037-CAA	IEEE 802.15.1 Bluetooth (8-DPSK, DH3)	X	7.69	93.53	24.78	1.88	100.0	± 9.6 %
		Y	3.89	82.31	20.76		100.0	
		Z	3.40	80.12	18.77		100.0	
10038-CAA	IEEE 802.15.1 Bluetooth (8-DPSK, DH5)	X	3.93	84.59	21.78	1.17	100.0	± 9.6 %
		Y	2.28	75.57	18.03		100.0	
		Z	2.38	76.51	17.34		100.0	
10039-CAB	CDMA2000 (1xRTT, RC1)	X	2.78	78.14	18.71	0.00	150.0	± 9.6 %
		Y	1.67	70.12	14.94		150.0	
		Z	2.00	74.01	15.76		150.0	
10042-CAB	IS-54 / IS-136 FDD (TDMA/FDM, PI/4-DQPSK, Halfrate)	X	100.00	110.92	24.96	7.78	50.0	± 9.6 %
		Y	100.00	110.22	24.75		50.0	
		Z	100.00	106.01	22.46		50.0	
10044-CAA	IS-91/EIA/TIA-553 FDD (FDMA, FM)	X	0.00	112.58	4.43	0.00	150.0	± 9.6 %
		Y	0.07	121.95	9.84		150.0	
		Z	0.01	118.94	9.83		150.0	
10048-CAA	DECT (TDD, TDMA/FDM, GFSK, Full Slot, 24)	X	100.00	111.48	27.44	13.80	25.0	± 9.6 %
		Y	100.00	112.85	28.28		25.0	
		Z	18.65	86.54	19.90		25.0	
10049-CAA	DECT (TDD, TDMA/FDM, GFSK, Double Slot, 12)	X	100.00	112.40	26.75	10.79	40.0	± 9.6 %
		Y	100.00	113.42	27.38		40.0	
		Z	46.23	99.19	22.45		40.0	
10056-CAA	UMTS-TDD (TD-SCDMA, 1.28 Mcps)	X	100.00	126.85	34.82	9.03	50.0	± 9.6 %
		Y	100.00	126.84	34.96		50.0	
		Z	73.14	116.99	30.84		50.0	
10058-DAC	EDGE-FDD (TDMA, 8PSK, TN 0-1-2-3)	X	4.87	79.06	26.07	6.55	100.0	± 9.6 %
		Y	4.89	78.72	25.82		100.0	
		Z	3.78	74.24	23.87		100.0	
10059-CAB	IEEE 802.11b WiFi 2.4 GHz (DSSS, 2 Mbps)	X	1.24	66.08	16.89	0.61	110.0	± 9.6 %
		Y	1.15	64.70	15.80		110.0	
		Z	1.15	65.12	16.08		110.0	
10060-CAB	IEEE 802.11b WiFi 2.4 GHz (DSSS, 5.5 Mbps)	X	100.00	145.11	38.67	1.30	110.0	± 9.6 %
		Y	100.00	138.14	35.54		110.0	
		Z	100.00	143.13	37.45		110.0	

10061-CAB	IEEE 802.11b WiFi 2.4 GHz (DSSS, 11 Mbps)	X	5.01	92.44	27.34	2.04	110.0	± 9.6 %
		Y	3.88	86.79	24.94		110.0	
		Z	2.64	81.37	23.02		110.0	
10062-CAC	IEEE 802.11a/h WiFi 5 GHz (OFDM, 6 Mbps)	X	4.74	66.80	16.70	0.49	100.0	± 9.6 %
		Y	4.72	66.44	16.52		100.0	
		Z	4.55	66.78	16.53		100.0	
10063-CAC	IEEE 802.11a/h WiFi 5 GHz (OFDM, 9 Mbps)	X	4.76	66.90	16.81	0.72	100.0	± 9.6 %
		Y	4.74	66.55	16.64		100.0	
		Z	4.57	66.86	16.62		100.0	
10064-CAC	IEEE 802.11a/h WiFi 5 GHz (OFDM, 12 Mbps)	X	5.07	67.18	17.05	0.86	100.0	± 9.6 %
		Y	5.06	66.88	16.91		100.0	
		Z	4.83	67.08	16.83		100.0	
10065-CAC	IEEE 802.11a/h WiFi 5 GHz (OFDM, 18 Mbps)	X	4.93	67.08	17.15	1.21	100.0	± 9.6 %
		Y	4.92	66.80	17.03		100.0	
		Z	4.69	66.95	16.91		100.0	
10066-CAC	IEEE 802.11a/h WiFi 5 GHz (OFDM, 24 Mbps)	X	4.95	67.11	17.33	1.46	100.0	± 9.6 %
		Y	4.94	66.84	17.22		100.0	
		Z	4.70	66.94	17.07		100.0	
10067-CAC	IEEE 802.11a/h WiFi 5 GHz (OFDM, 36 Mbps)	X	5.22	67.17	17.72	2.04	100.0	± 9.6 %
		Y	5.23	66.94	17.65		100.0	
		Z	4.99	67.15	17.52		100.0	
10068-CAC	IEEE 802.11a/h WiFi 5 GHz (OFDM, 48 Mbps)	X	5.28	67.31	17.99	2.55	100.0	± 9.6 %
		Y	5.30	67.12	17.95		100.0	
		Z	5.01	67.08	17.69		100.0	
10069-CAC	IEEE 802.11a/h WiFi 5 GHz (OFDM, 54 Mbps)	X	5.36	67.24	18.15	2.67	100.0	± 9.6 %
		Y	5.38	67.05	18.11		100.0	
		Z	5.09	67.11	17.88		100.0	
10071-CAB	IEEE 802.11g WiFi 2.4 GHz (DSSS/OFDM, 9 Mbps)	X	5.01	66.83	17.56	1.99	100.0	± 9.6 %
		Y	5.01	66.58	17.48		100.0	
		Z	4.83	66.80	17.36		100.0	
10072-CAB	IEEE 802.11g WiFi 2.4 GHz (DSSS/OFDM, 12 Mbps)	X	5.00	67.20	17.81	2.30	100.0	± 9.6 %
		Y	5.01	66.96	17.73		100.0	
		Z	4.79	67.07	17.56		100.0	
10073-CAB	IEEE 802.11g WiFi 2.4 GHz (DSSS/OFDM, 18 Mbps)	X	5.05	67.32	18.13	2.83	100.0	± 9.6 %
		Y	5.06	67.11	18.07		100.0	
		Z	4.84	67.21	17.87		100.0	
10074-CAB	IEEE 802.11g WiFi 2.4 GHz (DSSS/OFDM, 24 Mbps)	X	5.01	67.17	18.27	3.30	100.0	± 9.6 %
		Y	5.03	66.98	18.23		100.0	
		Z	4.82	67.10	18.01		100.0	
10075-CAB	IEEE 802.11g WiFi 2.4 GHz (DSSS/OFDM, 36 Mbps)	X	5.05	67.33	18.61	3.82	90.0	± 9.6 %
		Y	5.08	67.18	18.60		90.0	
		Z	4.84	67.13	18.28		90.0	
10076-CAB	IEEE 802.11g WiFi 2.4 GHz (DSSS/OFDM, 48 Mbps)	X	5.04	67.01	18.67	4.15	90.0	± 9.6 %
		Y	5.06	66.85	18.66		90.0	
		Z	4.86	66.95	18.41		90.0	
10077-CAB	IEEE 802.11g WiFi 2.4 GHz (DSSS/OFDM, 54 Mbps)	X	5.05	67.06	18.76	4.30	90.0	± 9.6 %
		Y	5.07	66.89	18.74		90.0	
		Z	4.89	67.03	18.52		90.0	

10081-CAB	CDMA2000 (1xRTT, RC3)	X	1.10	69.87	14.99	0.00	150.0	± 9.6 %
		Y	0.78	64.74	11.83		150.0	
		Z	0.78	66.34	11.97		150.0	
10082-CAB	IS-54 / IS-136 FDD (TDMA/FDM, PI/4-DQPSK, Fullrate)	X	0.69	60.00	4.39	4.77	80.0	± 9.6 %
		Y	0.71	60.00	4.39		80.0	
		Z	7.97	68.50	6.36		80.0	
10090-DAC	GPRS-FDD (TDMA, GMSK, TN 0-4)	X	100.00	115.53	26.81	6.56	60.0	± 9.6 %
		Y	100.00	114.29	26.36		60.0	
		Z	100.00	109.90	23.90		60.0	
10097-CAB	UMTS-FDD (HSDPA)	X	1.95	68.97	16.62	0.00	150.0	± 9.6 %
		Y	1.75	66.81	15.24		150.0	
		Z	1.87	68.90	16.13		150.0	
10098-CAB	UMTS-FDD (HSUPA, Subtest 2)	X	1.91	68.95	16.60	0.00	150.0	± 9.6 %
		Y	1.71	66.77	15.20		150.0	
		Z	1.83	68.86	16.11		150.0	
10099-DAC	EDGE-FDD (TDMA, 8PSK, TN 0-4)	X	11.93	100.45	36.42	9.56	60.0	± 9.6 %
		Y	11.20	97.95	35.37		60.0	
		Z	7.96	90.99	32.84		60.0	
10100-CAE	LTE-FDD (SC-FDMA, 100% RB, 20 MHz, QPSK)	X	3.40	71.76	17.45	0.00	150.0	± 9.6 %
		Y	3.10	69.82	16.33		150.0	
		Z	3.12	70.91	17.03		150.0	
10101-CAE	LTE-FDD (SC-FDMA, 100% RB, 20 MHz, 16-QAM)	X	3.36	68.15	16.35	0.00	150.0	± 9.6 %
		Y	3.24	67.23	15.77		150.0	
		Z	3.17	67.74	16.07		150.0	
10102-CAE	LTE-FDD (SC-FDMA, 100% RB, 20 MHz, 64-QAM)	X	3.45	68.05	16.42	0.00	150.0	± 9.6 %
		Y	3.34	67.19	15.87		150.0	
		Z	3.28	67.71	16.16		150.0	
10103-CAF	LTE-TDD (SC-FDMA, 100% RB, 20 MHz, QPSK)	X	6.86	77.75	21.56	3.98	65.0	± 9.6 %
		Y	6.56	76.62	21.10		65.0	
		Z	5.69	75.27	20.45		65.0	
10104-CAF	LTE-TDD (SC-FDMA, 100% RB, 20 MHz, 16-QAM)	X	6.41	74.58	21.07	3.98	65.0	± 9.6 %
		Y	6.33	74.04	20.86		65.0	
		Z	5.58	72.74	20.11		65.0	
10105-CAF	LTE-TDD (SC-FDMA, 100% RB, 20 MHz, 64-QAM)	X	6.09	73.43	20.88	3.98	65.0	± 9.6 %
		Y	6.03	72.95	20.69		65.0	
		Z	5.24	71.29	19.75		65.0	
10108-CAF	LTE-FDD (SC-FDMA, 100% RB, 10 MHz, QPSK)	X	2.97	70.94	17.29	0.00	150.0	± 9.6 %
		Y	2.72	69.08	16.17		150.0	
		Z	2.70	70.20	16.88		150.0	
10109-CAF	LTE-FDD (SC-FDMA, 100% RB, 10 MHz, 16-QAM)	X	3.02	68.05	16.32	0.00	150.0	± 9.6 %
		Y	2.90	67.02	15.66		150.0	
		Z	2.83	67.71	15.99		150.0	
10110-CAF	LTE-FDD (SC-FDMA, 100% RB, 5 MHz, QPSK)	X	2.42	70.09	17.00	0.00	150.0	± 9.6 %
		Y	2.21	68.14	15.78		150.0	
		Z	2.18	69.46	16.49		150.0	
10111-CAF	LTE-FDD (SC-FDMA, 100% RB, 5 MHz, 16-QAM)	X	2.76	69.06	16.78	0.00	150.0	± 9.6 %
		Y	2.59	67.59	15.88		150.0	
		Z	2.59	68.99	16.39		150.0	

10112-CAF	LTE-FDD (SC-FDMA, 100% RB, 10 MHz, 64-QAM)	X	3.14	67.97	16.35	0.00	150.0	± 9.6 %
		Y	3.03	67.00	15.72		150.0	
		Z	2.95	67.72	16.05		150.0	
10113-CAF	LTE-FDD (SC-FDMA, 100% RB, 5 MHz, 64-QAM)	X	2.92	69.11	16.87	0.00	150.0	± 9.6 %
		Y	2.75	67.72	16.02		150.0	
		Z	2.74	69.14	16.51		150.0	
10114-CAC	IEEE 802.11n (HT Greenfield, 13.5 Mbps, BPSK)	X	5.18	67.31	16.57	0.00	150.0	± 9.6 %
		Y	5.14	66.93	16.36		150.0	
		Z	5.02	67.26	16.48		150.0	
10115-CAC	IEEE 802.11n (HT Greenfield, 81 Mbps, 16-QAM)	X	5.52	67.57	16.70	0.00	150.0	± 9.6 %
		Y	5.51	67.29	16.56		150.0	
		Z	5.27	67.30	16.50		150.0	
10116-CAC	IEEE 802.11n (HT Greenfield, 135 Mbps, 64-QAM)	X	5.29	67.56	16.61	0.00	150.0	± 9.6 %
		Y	5.27	67.21	16.43		150.0	
		Z	5.10	67.44	16.50		150.0	
10117-CAC	IEEE 802.11n (HT Mixed, 13.5 Mbps, BPSK)	X	5.16	67.25	16.55	0.00	150.0	± 9.6 %
		Y	5.13	66.89	16.36		150.0	
		Z	4.99	67.15	16.44		150.0	
10118-CAC	IEEE 802.11n (HT Mixed, 81 Mbps, 16-QAM)	X	5.59	67.74	16.79	0.00	150.0	± 9.6 %
		Y	5.60	67.49	16.67		150.0	
		Z	5.34	67.49	16.60		150.0	
10119-CAC	IEEE 802.11n (HT Mixed, 135 Mbps, 64-QAM)	X	5.26	67.49	16.59	0.00	150.0	± 9.6 %
		Y	5.24	67.15	16.41		150.0	
		Z	5.09	67.40	16.49		150.0	
10140-CAE	LTE-FDD (SC-FDMA, 100% RB, 15 MHz, 16-QAM)	X	3.50	68.05	16.33	0.00	150.0	± 9.6 %
		Y	3.39	67.19	15.79		150.0	
		Z	3.30	67.72	16.07		150.0	
10141-CAE	LTE-FDD (SC-FDMA, 100% RB, 15 MHz, 64-QAM)	X	3.62	68.10	16.48	0.00	150.0	± 9.6 %
		Y	3.51	67.27	15.96		150.0	
		Z	3.43	67.85	16.25		150.0	
10142-CAE	LTE-FDD (SC-FDMA, 100% RB, 3 MHz, QPSK)	X	2.22	70.35	16.88	0.00	150.0	± 9.6 %
		Y	1.98	67.98	15.45		150.0	
		Z	1.97	69.67	16.10		150.0	
10143-CAE	LTE-FDD (SC-FDMA, 100% RB, 3 MHz, 16-QAM)	X	2.70	70.21	16.79	0.00	150.0	± 9.6 %
		Y	2.44	68.12	15.58		150.0	
		Z	2.48	69.97	16.00		150.0	
10144-CAE	LTE-FDD (SC-FDMA, 100% RB, 3 MHz, 64-QAM)	X	2.42	67.64	15.07	0.00	150.0	± 9.6 %
		Y	2.26	66.15	14.15		150.0	
		Z	2.13	66.86	13.96		150.0	
10145-CAF	LTE-FDD (SC-FDMA, 100% RB, 1.4 MHz, QPSK)	X	1.54	68.23	14.00	0.00	150.0	± 9.6 %
		Y	1.25	64.93	12.03		150.0	
		Z	1.00	63.72	10.21		150.0	
10146-CAF	LTE-FDD (SC-FDMA, 100% RB, 1.4 MHz, 16-QAM)	X	2.38	68.67	13.30	0.00	150.0	± 9.6 %
		Y	2.63	70.03	14.41		150.0	
		Z	1.37	62.94	8.80		150.0	
10147-CAF	LTE-FDD (SC-FDMA, 100% RB, 1.4 MHz, 64-QAM)	X	3.01	71.74	14.81	0.00	150.0	± 9.6 %
		Y	3.44	73.73	16.16		150.0	
		Z	1.50	63.86	9.38		150.0	

10149-CAE	LTE-FDD (SC-FDMA, 50% RB, 20 MHz, 16-QAM)	X	3.03	68.12	16.37	0.00	150.0	± 9.6 %
		Y	2.91	67.08	15.71		150.0	
		Z	2.84	67.78	16.04		150.0	
10150-CAE	LTE-FDD (SC-FDMA, 50% RB, 20 MHz, 64-QAM)	X	3.15	68.03	16.39	0.00	150.0	± 9.6 %
		Y	3.03	67.05	15.76		150.0	
		Z	2.96	67.78	16.09		150.0	
10151-CAF	LTE-TDD (SC-FDMA, 50% RB, 20 MHz, QPSK)	X	7.33	80.62	22.85	3.98	65.0	± 9.6 %
		Y	6.93	79.21	22.28		65.0	
		Z	6.07	78.22	21.74		65.0	
10152-CAF	LTE-TDD (SC-FDMA, 50% RB, 20 MHz, 16-QAM)	X	5.98	74.73	20.92	3.98	65.0	± 9.6 %
		Y	5.89	74.12	20.68		65.0	
		Z	5.12	72.74	19.78		65.0	
10153-CAF	LTE-TDD (SC-FDMA, 50% RB, 20 MHz, 64-QAM)	X	6.33	75.57	21.65	3.98	65.0	± 9.6 %
		Y	6.23	74.94	21.41		65.0	
		Z	5.49	73.78	20.61		65.0	
10154-CAF	LTE-FDD (SC-FDMA, 50% RB, 10 MHz, QPSK)	X	2.49	70.63	17.32	0.00	150.0	± 9.6 %
		Y	2.26	68.57	16.06		150.0	
		Z	2.24	69.92	16.77		150.0	
10155-CAF	LTE-FDD (SC-FDMA, 50% RB, 10 MHz, 16-QAM)	X	2.77	69.07	16.79	0.00	150.0	± 9.6 %
		Y	2.59	67.59	15.89		150.0	
		Z	2.59	69.02	16.41		150.0	
10156-CAF	LTE-FDD (SC-FDMA, 50% RB, 5 MHz, QPSK)	X	2.11	70.85	16.93	0.00	150.0	± 9.6 %
		Y	1.83	68.04	15.26		150.0	
		Z	1.82	69.80	15.80		150.0	
10157-CAF	LTE-FDD (SC-FDMA, 50% RB, 5 MHz, 16-QAM)	X	2.31	68.61	15.35	0.00	150.0	± 9.6 %
		Y	2.08	66.62	14.16		150.0	
		Z	1.98	67.47	13.92		150.0	
10158-CAF	LTE-FDD (SC-FDMA, 50% RB, 10 MHz, 64-QAM)	X	2.92	69.17	16.92	0.00	150.0	± 9.6 %
		Y	2.75	67.77	16.06		150.0	
		Z	2.75	69.22	16.57		150.0	
10159-CAF	LTE-FDD (SC-FDMA, 50% RB, 5 MHz, 64-QAM)	X	2.44	69.17	15.69	0.00	150.0	± 9.6 %
		Y	2.19	67.06	14.45		150.0	
		Z	2.09	67.96	14.21		150.0	
10160-CAE	LTE-FDD (SC-FDMA, 50% RB, 15 MHz, QPSK)	X	2.90	69.57	16.90	0.00	150.0	± 9.6 %
		Y	2.74	68.24	16.05		150.0	
		Z	2.70	69.25	16.60		150.0	
10161-CAE	LTE-FDD (SC-FDMA, 50% RB, 15 MHz, 16-QAM)	X	3.05	67.98	16.35	0.00	150.0	± 9.6 %
		Y	2.93	66.95	15.69		150.0	
		Z	2.86	67.77	16.01		150.0	
10162-CAE	LTE-FDD (SC-FDMA, 50% RB, 15 MHz, 64-QAM)	X	3.15	68.06	16.42	0.00	150.0	± 9.6 %
		Y	3.03	67.06	15.79		150.0	
		Z	2.97	67.96	16.14		150.0	
10166-CAF	LTE-FDD (SC-FDMA, 50% RB, 1.4 MHz, QPSK)	X	3.67	69.77	19.22	3.01	150.0	± 9.6 %
		Y	3.71	69.61	19.37		150.0	
		Z	3.45	70.11	19.35		150.0	
10167-CAF	LTE-FDD (SC-FDMA, 50% RB, 1.4 MHz, 16-QAM)	X	4.61	72.92	19.78	3.01	150.0	± 9.6 %
		Y	4.57	72.37	19.78		150.0	
		Z	4.42	74.02	20.14		150.0	

10168-CAF	LTE-FDD (SC-FDMA, 50% RB, 1.4 MHz, 64-QAM)	X	5.13	75.25	21.12	3.01	150.0	± 9.6 %
		Y	5.05	74.54	21.07		150.0	
		Z	5.13	77.22	21.87		150.0	
10169-CAE	LTE-FDD (SC-FDMA, 1 RB, 20 MHz, QPSK)	X	3.12	70.03	19.37	3.01	150.0	± 9.6 %
		Y	3.15	69.73	19.46		150.0	
		Z	2.86	69.57	19.15		150.0	
10170-CAE	LTE-FDD (SC-FDMA, 1 RB, 20 MHz, 16-QAM)	X	4.58	77.10	22.08	3.01	150.0	± 9.6 %
		Y	4.39	75.79	21.81		150.0	
		Z	4.44	78.23	22.53		150.0	
10171-AAE	LTE-FDD (SC-FDMA, 1 RB, 20 MHz, 64-QAM)	X	3.64	72.24	19.05	3.01	150.0	± 9.6 %
		Y	3.59	71.47	18.98		150.0	
		Z	3.36	72.39	19.02		150.0	
10172-CAF	LTE-TDD (SC-FDMA, 1 RB, 20 MHz, QPSK)	X	12.64	100.34	31.84	6.02	65.0	± 9.6 %
		Y	12.97	100.68	32.37		65.0	
		Z	5.77	87.24	27.51		65.0	
10173-CAF	LTE-TDD (SC-FDMA, 1 RB, 20 MHz, 16-QAM)	X	36.96	114.71	33.67	6.02	65.0	± 9.6 %
		Y	30.92	112.16	33.64		65.0	
		Z	22.36	108.00	31.61		65.0	
10174-CAF	LTE-TDD (SC-FDMA, 1 RB, 20 MHz, 64-QAM)	X	22.92	104.35	30.17	6.02	65.0	± 9.6 %
		Y	21.96	104.04	30.70		65.0	
		Z	11.65	95.24	27.25		65.0	
10175-CAF	LTE-FDD (SC-FDMA, 1 RB, 10 MHz, QPSK)	X	3.08	69.68	19.10	3.01	150.0	± 9.6 %
		Y	3.11	69.39	19.20		150.0	
		Z	2.82	69.22	18.88		150.0	
10176-CAF	LTE-FDD (SC-FDMA, 1 RB, 10 MHz, 16-QAM)	X	4.59	77.13	22.09	3.01	150.0	± 9.6 %
		Y	4.40	75.82	21.82		150.0	
		Z	4.45	78.26	22.55		150.0	
10177-CAH	LTE-FDD (SC-FDMA, 1 RB, 5 MHz, QPSK)	X	3.11	69.85	19.21	3.01	150.0	± 9.6 %
		Y	3.14	69.56	19.30		150.0	
		Z	2.84	69.38	18.97		150.0	
10178-CAF	LTE-FDD (SC-FDMA, 1 RB, 5 MHz, 16-QAM)	X	4.53	76.83	21.94	3.01	150.0	± 9.6 %
		Y	4.34	75.53	21.68		150.0	
		Z	4.39	77.99	22.42		150.0	
10179-CAF	LTE-FDD (SC-FDMA, 1 RB, 10 MHz, 64-QAM)	X	4.06	74.50	20.40	3.01	150.0	± 9.6 %
		Y	3.95	73.49	20.26		150.0	
		Z	3.83	75.09	20.61		150.0	
10180-CAF	LTE-FDD (SC-FDMA, 1 RB, 5 MHz, 64-QAM)	X	3.62	72.15	18.99	3.01	150.0	± 9.6 %
		Y	3.58	71.38	18.93		150.0	
		Z	3.35	72.32	18.97		150.0	
10181-CAE	LTE-FDD (SC-FDMA, 1 RB, 15 MHz, QPSK)	X	3.10	69.83	19.20	3.01	150.0	± 9.6 %
		Y	3.13	69.54	19.29		150.0	
		Z	2.84	69.36	18.97		150.0	
10182-CAE	LTE-FDD (SC-FDMA, 1 RB, 15 MHz, 16-QAM)	X	4.52	76.80	21.93	3.01	150.0	± 9.6 %
		Y	4.33	75.51	21.66		150.0	
		Z	4.38	77.96	22.40		150.0	
10183-AAE	LTE-FDD (SC-FDMA, 1 RB, 15 MHz, 64-QAM)	X	3.62	72.12	18.97	3.01	150.0	± 9.6 %
		Y	3.57	71.35	18.91		150.0	
		Z	3.34	72.29	18.96		150.0	

10184-CAE	LTE-FDD (SC-FDMA, 1 RB, 3 MHz, QPSK)	X	3.11	69.88	19.22	3.01	150.0	± 9.6 %
		Y	3.14	69.58	19.32		150.0	
		Z	2.85	69.41	18.99		150.0	
10185-CAE	LTE-FDD (SC-FDMA, 1 RB, 3 MHz, 16-QAM)	X	4.54	76.88	21.97	3.01	150.0	± 9.6 %
		Y	4.35	75.59	21.70		150.0	
		Z	4.41	78.06	22.45		150.0	
10186-AAE	LTE-FDD (SC-FDMA, 1 RB, 3 MHz, 64-QAM)	X	3.64	72.20	19.01	3.01	150.0	± 9.6 %
		Y	3.59	71.42	18.95		150.0	
		Z	3.36	72.37	19.00		150.0	
10187-CAF	LTE-FDD (SC-FDMA, 1 RB, 1.4 MHz, QPSK)	X	3.12	69.93	19.28	3.01	150.0	± 9.6 %
		Y	3.15	69.63	19.37		150.0	
		Z	2.86	69.48	19.07		150.0	
10188-CAF	LTE-FDD (SC-FDMA, 1 RB, 1.4 MHz, 16-QAM)	X	4.72	77.70	22.40	3.01	150.0	± 9.6 %
		Y	4.51	76.33	22.11		150.0	
		Z	4.61	78.98	22.92		150.0	
10189-AAF	LTE-FDD (SC-FDMA, 1 RB, 1.4 MHz, 64-QAM)	X	3.73	72.70	19.32	3.01	150.0	± 9.6 %
		Y	3.67	71.88	19.24		150.0	
		Z	3.46	72.92	19.33		150.0	
10193-CAC	IEEE 802.11n (HT Greenfield, 6.5 Mbps, BPSK)	X	4.59	66.76	16.33	0.00	150.0	± 9.6 %
		Y	4.55	66.31	16.09		150.0	
		Z	4.42	66.80	16.19		150.0	
10194-CAC	IEEE 802.11n (HT Greenfield, 39 Mbps, 16-QAM)	X	4.77	67.10	16.45	0.00	150.0	± 9.6 %
		Y	4.74	66.66	16.21		150.0	
		Z	4.58	67.08	16.32		150.0	
10195-CAC	IEEE 802.11n (HT Greenfield, 65 Mbps, 64-QAM)	X	4.82	67.12	16.46	0.00	150.0	± 9.6 %
		Y	4.78	66.69	16.22		150.0	
		Z	4.62	67.10	16.34		150.0	
10196-CAC	IEEE 802.11n (HT Mixed, 6.5 Mbps, BPSK)	X	4.60	66.84	16.36	0.00	150.0	± 9.6 %
		Y	4.56	66.40	16.12		150.0	
		Z	4.41	66.83	16.20		150.0	
10197-CAC	IEEE 802.11n (HT Mixed, 39 Mbps, 16-QAM)	X	4.79	67.12	16.46	0.00	150.0	± 9.6 %
		Y	4.75	66.69	16.22		150.0	
		Z	4.59	67.09	16.33		150.0	
10198-CAC	IEEE 802.11n (HT Mixed, 65 Mbps, 64-QAM)	X	4.82	67.14	16.47	0.00	150.0	± 9.6 %
		Y	4.78	66.71	16.24		150.0	
		Z	4.61	67.11	16.35		150.0	
10219-CAC	IEEE 802.11n (HT Mixed, 7.2 Mbps, BPSK)	X	4.55	66.86	16.33	0.00	150.0	± 9.6 %
		Y	4.51	66.41	16.08		150.0	
		Z	4.37	66.86	16.17		150.0	
10220-CAC	IEEE 802.11n (HT Mixed, 43.3 Mbps, 16-QAM)	X	4.79	67.10	16.45	0.00	150.0	± 9.6 %
		Y	4.75	66.67	16.22		150.0	
		Z	4.58	67.05	16.32		150.0	
10221-CAC	IEEE 802.11n (HT Mixed, 72.2 Mbps, 64-QAM)	X	4.83	67.06	16.45	0.00	150.0	± 9.6 %
		Y	4.79	66.64	16.23		150.0	
		Z	4.62	67.04	16.33		150.0	
10222-CAC	IEEE 802.11n (HT Mixed, 15 Mbps, BPSK)	X	5.14	67.26	16.55	0.00	150.0	± 9.6 %
		Y	5.11	66.90	16.36		150.0	
		Z	4.97	67.15	16.43		150.0	

10223-CAC	IEEE 802.11n (HT Mixed, 90 Mbps, 16-QAM)	X	5.45	67.43	16.65	0.00	150.0	± 9.6 %
		Y	5.45	67.18	16.52		150.0	
		Z	5.25	67.35	16.55		150.0	
10224-CAC	IEEE 802.11n (HT Mixed, 150 Mbps, 64-QAM)	X	5.19	67.37	16.53	0.00	150.0	± 9.6 %
		Y	5.15	66.99	16.33		150.0	
		Z	5.01	67.26	16.42		150.0	
10225-CAB	UMTS-FDD (HSPA+)	X	2.89	66.55	15.78	0.00	150.0	± 9.6 %
		Y	2.80	65.71	15.24		150.0	
		Z	2.72	66.49	15.32		150.0	
10226-CAA	LTE-TDD (SC-FDMA, 1 RB, 1.4 MHz, 16-QAM)	X	42.12	117.30	34.47	6.02	65.0	± 9.6 %
		Y	34.39	114.35	34.35		65.0	
		Z	25.78	110.75	32.49		65.0	
10227-CAA	LTE-TDD (SC-FDMA, 1 RB, 1.4 MHz, 64-QAM)	X	33.34	110.83	32.01	6.02	65.0	± 9.6 %
		Y	29.14	109.23	32.25		65.0	
		Z	23.91	107.08	30.63		65.0	
10228-CAA	LTE-TDD (SC-FDMA, 1 RB, 1.4 MHz, QPSK)	X	15.66	105.06	33.38	6.02	65.0	± 9.6 %
		Y	15.84	105.37	33.95		65.0	
		Z	7.75	93.33	29.68		65.0	
10229-CAC	LTE-TDD (SC-FDMA, 1 RB, 3 MHz, 16-QAM)	X	37.28	114.84	33.72	6.02	65.0	± 9.6 %
		Y	31.13	112.26	33.67		65.0	
		Z	22.62	108.17	31.67		65.0	
10230-CAC	LTE-TDD (SC-FDMA, 1 RB, 3 MHz, 64-QAM)	X	29.88	108.76	31.36	6.02	65.0	± 9.6 %
		Y	26.58	107.43	31.66		65.0	
		Z	20.85	104.61	29.86		65.0	
10231-CAC	LTE-TDD (SC-FDMA, 1 RB, 3 MHz, QPSK)	X	14.65	103.59	32.85	6.02	65.0	± 9.6 %
		Y	14.88	103.95	33.43		65.0	
		Z	7.34	92.15	29.19		65.0	
10232-CAE	LTE-TDD (SC-FDMA, 1 RB, 5 MHz, 16-QAM)	X	37.25	114.84	33.71	6.02	65.0	± 9.6 %
		Y	31.10	112.26	33.67		65.0	
		Z	22.58	108.16	31.67		65.0	
10233-CAE	LTE-TDD (SC-FDMA, 1 RB, 5 MHz, 64-QAM)	X	29.82	108.74	31.35	6.02	65.0	± 9.6 %
		Y	26.53	107.41	31.66		65.0	
		Z	20.76	104.56	29.85		65.0	
10234-CAE	LTE-TDD (SC-FDMA, 1 RB, 5 MHz, QPSK)	X	13.83	102.21	32.30	6.02	65.0	± 9.6 %
		Y	14.10	102.64	32.91		65.0	
		Z	7.03	91.14	28.71		65.0	
10235-CAE	LTE-TDD (SC-FDMA, 1 RB, 10 MHz, 16-QAM)	X	37.39	114.93	33.74	6.02	65.0	± 9.6 %
		Y	31.21	112.34	33.70		65.0	
		Z	22.65	108.24	31.69		65.0	
10236-CAE	LTE-TDD (SC-FDMA, 1 RB, 10 MHz, 64-QAM)	X	30.43	109.05	31.43	6.02	65.0	± 9.6 %
		Y	27.03	107.71	31.73		65.0	
		Z	21.22	104.87	29.93		65.0	
10237-CAE	LTE-TDD (SC-FDMA, 1 RB, 10 MHz, QPSK)	X	14.73	103.74	32.90	6.02	65.0	± 9.6 %
		Y	14.96	104.11	33.48		65.0	
		Z	7.35	92.21	29.22		65.0	
10238-CAE	LTE-TDD (SC-FDMA, 1 RB, 15 MHz, 16-QAM)	X	37.20	114.83	33.71	6.02	65.0	± 9.6 %
		Y	31.07	112.26	33.67		65.0	
		Z	22.51	108.13	31.66		65.0	

10239-CAE	LTE-TDD (SC-FDMA, 1 RB, 15 MHz, 64-QAM)	X	29.73	108.72	31.35	6.02	65.0	± 9.6 %
		Y	26.48	107.40	31.66		65.0	
		Z	20.66	104.50	29.83		65.0	
10240-CAE	LTE-TDD (SC-FDMA, 1 RB, 15 MHz, QPSK)	X	14.67	103.66	32.88	6.02	65.0	± 9.6 %
		Y	14.89	104.03	33.46		65.0	
		Z	7.33	92.17	29.20		65.0	
10241-CAA	LTE-TDD (SC-FDMA, 50% RB, 1.4 MHz, 16-QAM)	X	8.22	81.62	25.84	6.98	65.0	± 9.6 %
		Y	8.21	81.11	25.93		65.0	
		Z	7.55	81.89	25.74		65.0	
10242-CAA	LTE-TDD (SC-FDMA, 50% RB, 1.4 MHz, 64-QAM)	X	7.60	79.92	25.06	6.98	65.0	± 9.6 %
		Y	7.70	79.68	25.24		65.0	
		Z	6.63	79.21	24.57		65.0	
10243-CAA	LTE-TDD (SC-FDMA, 50% RB, 1.4 MHz, QPSK)	X	6.06	76.28	24.43	6.98	65.0	± 9.6 %
		Y	6.20	76.29	24.69		65.0	
		Z	5.27	75.02	23.70		65.0	
10244-CAC	LTE-TDD (SC-FDMA, 50% RB, 3 MHz, 16-QAM)	X	6.94	79.13	20.40	3.98	65.0	± 9.6 %
		Y	7.61	80.93	21.65		65.0	
		Z	4.63	73.01	16.54		65.0	
10245-CAC	LTE-TDD (SC-FDMA, 50% RB, 3 MHz, 64-QAM)	X	6.74	78.35	20.03	3.98	65.0	± 9.6 %
		Y	7.38	80.11	21.28		65.0	
		Z	4.46	72.20	16.14		65.0	
10246-CAC	LTE-TDD (SC-FDMA, 50% RB, 3 MHz, QPSK)	X	8.26	86.16	23.38	3.98	65.0	± 9.6 %
		Y	7.07	83.23	22.34		65.0	
		Z	4.76	77.46	19.00		65.0	
10247-CAE	LTE-TDD (SC-FDMA, 50% RB, 5 MHz, 16-QAM)	X	5.60	76.50	20.35	3.98	65.0	± 9.6 %
		Y	5.37	75.45	19.96		65.0	
		Z	4.29	72.64	17.71		65.0	
10248-CAE	LTE-TDD (SC-FDMA, 50% RB, 5 MHz, 64-QAM)	X	5.54	75.70	19.98	3.98	65.0	± 9.6 %
		Y	5.35	74.79	19.65		65.0	
		Z	4.24	71.91	17.36		65.0	
10249-CAE	LTE-TDD (SC-FDMA, 50% RB, 5 MHz, QPSK)	X	9.19	88.24	24.95	3.98	65.0	± 9.6 %
		Y	7.96	85.32	23.90		65.0	
		Z	6.28	82.28	22.02		65.0	
10250-CAE	LTE-TDD (SC-FDMA, 50% RB, 10 MHz, 16-QAM)	X	6.20	77.76	22.32	3.98	65.0	± 9.6 %
		Y	6.01	76.85	21.97		65.0	
		Z	5.20	75.42	20.86		65.0	
10251-CAE	LTE-TDD (SC-FDMA, 50% RB, 10 MHz, 64-QAM)	X	5.85	75.32	20.92	3.98	65.0	± 9.6 %
		Y	5.73	74.58	20.63		65.0	
		Z	4.92	73.12	19.45		65.0	
10252-CAE	LTE-TDD (SC-FDMA, 50% RB, 10 MHz, QPSK)	X	8.09	84.95	24.58	3.98	65.0	± 9.6 %
		Y	7.42	82.94	23.81		65.0	
		Z	6.31	81.52	22.96		65.0	
10253-CAE	LTE-TDD (SC-FDMA, 50% RB, 15 MHz, 16-QAM)	X	5.80	74.00	20.63	3.98	65.0	± 9.6 %
		Y	5.72	73.40	20.39		65.0	
		Z	5.04	72.28	19.52		65.0	
10254-CAE	LTE-TDD (SC-FDMA, 50% RB, 15 MHz, 64-QAM)	X	6.14	74.84	21.30	3.98	65.0	± 9.6 %
		Y	6.05	74.22	21.07		65.0	
		Z	5.36	73.21	20.25		65.0	

10255-CAE	LTE-TDD (SC-FDMA, 50% RB, 15 MHz, QPSK)	X	6.81	79.50	22.67	3.98	65.0	± 9.6 %
		Y	6.50	78.25	22.16		65.0	
		Z	5.72	77.37	21.59		65.0	
10256-CAA	LTE-TDD (SC-FDMA, 100% RB, 1.4 MHz, 16-QAM)	X	5.54	75.38	17.88	3.98	65.0	± 9.6 %
		Y	6.45	78.02	19.55		65.0	
		Z	3.15	67.52	12.83		65.0	
10257-CAA	LTE-TDD (SC-FDMA, 100% RB, 1.4 MHz, 64-QAM)	X	5.31	74.31	17.34	3.98	65.0	± 9.6 %
		Y	6.14	76.80	18.96		65.0	
		Z	3.05	66.79	12.37		65.0	
10258-CAA	LTE-TDD (SC-FDMA, 100% RB, 1.4 MHz, QPSK)	X	6.24	81.13	20.76	3.98	65.0	± 9.6 %
		Y	5.52	78.91	19.97		65.0	
		Z	3.09	70.62	15.05		65.0	
10259-CAC	LTE-TDD (SC-FDMA, 100% RB, 3 MHz, 16-QAM)	X	5.84	76.93	21.04	3.98	65.0	± 9.6 %
		Y	5.63	75.94	20.66		65.0	
		Z	4.68	73.82	18.92		65.0	
10260-CAC	LTE-TDD (SC-FDMA, 100% RB, 3 MHz, 64-QAM)	X	5.84	76.54	20.88	3.98	65.0	± 9.6 %
		Y	5.65	75.62	20.54		65.0	
		Z	4.68	73.47	18.76		65.0	
10261-CAC	LTE-TDD (SC-FDMA, 100% RB, 3 MHz, QPSK)	X	7.94	85.32	24.30	3.98	65.0	± 9.6 %
		Y	7.17	83.07	23.45		65.0	
		Z	5.90	80.89	22.01		65.0	
10262-CAE	LTE-TDD (SC-FDMA, 100% RB, 5 MHz, 16-QAM)	X	6.19	77.72	22.28	3.98	65.0	± 9.6 %
		Y	6.00	76.81	21.93		65.0	
		Z	5.19	75.36	20.81		65.0	
10263-CAE	LTE-TDD (SC-FDMA, 100% RB, 5 MHz, 64-QAM)	X	5.84	75.30	20.91	3.98	65.0	± 9.6 %
		Y	5.72	74.57	20.63		65.0	
		Z	4.91	73.09	19.44		65.0	
10264-CAE	LTE-TDD (SC-FDMA, 100% RB, 5 MHz, QPSK)	X	8.00	84.72	24.48	3.98	65.0	± 9.6 %
		Y	7.34	82.73	23.71		65.0	
		Z	6.24	81.28	22.84		65.0	
10265-CAE	LTE-TDD (SC-FDMA, 100% RB, 10 MHz, 16-QAM)	X	5.98	74.73	20.93	3.98	65.0	± 9.6 %
		Y	5.89	74.12	20.69		65.0	
		Z	5.12	72.74	19.78		65.0	
10266-CAE	LTE-TDD (SC-FDMA, 100% RB, 10 MHz, 64-QAM)	X	6.33	75.56	21.64	3.98	65.0	± 9.6 %
		Y	6.22	74.93	21.40		65.0	
		Z	5.49	73.76	20.60		65.0	
10267-CAE	LTE-TDD (SC-FDMA, 100% RB, 10 MHz, QPSK)	X	7.32	80.56	22.82	3.98	65.0	± 9.6 %
		Y	6.92	79.16	22.26		65.0	
		Z	6.05	78.17	21.72		65.0	
10268-CAE	LTE-TDD (SC-FDMA, 100% RB, 15 MHz, 16-QAM)	X	6.52	74.24	21.04	3.98	65.0	± 9.6 %
		Y	6.45	73.73	20.85		65.0	
		Z	5.74	72.63	20.16		65.0	
10269-CAE	LTE-TDD (SC-FDMA, 100% RB, 15 MHz, 64-QAM)	X	6.46	73.71	20.87	3.98	65.0	± 9.6 %
		Y	6.39	73.22	20.69		65.0	
		Z	5.73	72.22	20.02		65.0	
10270-CAE	LTE-TDD (SC-FDMA, 100% RB, 15 MHz, QPSK)	X	6.79	76.82	21.42	3.98	65.0	± 9.6 %
		Y	6.57	75.90	21.04		65.0	
		Z	5.88	75.11	20.59		65.0	

10274-CAB	UMTS-FDD (HSUPA, Subtest 5, 3GPP Rel8.10)	X	2.66	66.98	15.73	0.00	150.0	± 9.6 %
		Y	2.54	65.90	15.04		150.0	
		Z	2.55	67.07	15.35		150.0	
10275-CAB	UMTS-FDD (HSUPA, Subtest 5, 3GPP Rel8.4)	X	1.78	69.77	16.72	0.00	150.0	± 9.6 %
		Y	1.55	67.13	15.03		150.0	
		Z	1.62	69.04	16.02		150.0	
10277-CAA	PHS (QPSK)	X	2.12	61.97	7.55	9.03	50.0	± 9.6 %
		Y	2.25	62.30	7.96		50.0	
		Z	1.72	60.31	5.78		50.0	
10278-CAA	PHS (QPSK, BW 884MHz, Rolloff 0.5)	X	10.93	86.19	21.29	9.03	50.0	± 9.6 %
		Y	9.64	84.41	20.95		50.0	
		Z	3.57	69.00	13.15		50.0	
10279-CAA	PHS (QPSK, BW 884MHz, Rolloff 0.38)	X	11.22	86.49	21.46	9.03	50.0	± 9.6 %
		Y	9.91	84.71	21.11		50.0	
		Z	3.69	69.35	13.38		50.0	
10290-AAB	CDMA2000, RC1, SO55, Full Rate	X	1.95	72.86	16.32	0.00	150.0	± 9.6 %
		Y	1.38	67.46	13.46		150.0	
		Z	1.34	68.81	13.27		150.0	
10291-AAB	CDMA2000, RC3, SO55, Full Rate	X	1.06	69.47	14.79	0.00	150.0	± 9.6 %
		Y	0.76	64.53	11.71		150.0	
		Z	0.76	66.05	11.81		150.0	
10292-AAB	CDMA2000, RC3, SO32, Full Rate	X	1.83	78.35	18.94	0.00	150.0	± 9.6 %
		Y	0.91	67.73	13.68		150.0	
		Z	1.34	73.93	15.68		150.0	
10293-AAB	CDMA2000, RC3, SO3, Full Rate	X	4.73	93.04	24.47	0.00	150.0	± 9.6 %
		Y	1.31	72.72	16.40		150.0	
		Z	6.43	94.81	23.11		150.0	
10295-AAB	CDMA2000, RC1, SO3, 1/8th Rate 25 fr.	X	10.60	89.87	26.40	9.03	50.0	± 9.6 %
		Y	10.25	88.78	26.08		50.0	
		Z	12.25	89.80	24.68		50.0	
10297-AAD	LTE-FDD (SC-FDMA, 50% RB, 20 MHz, QPSK)	X	2.99	71.06	17.36	0.00	150.0	± 9.6 %
		Y	2.73	69.18	16.24		150.0	
		Z	2.72	70.32	16.96		150.0	
10298-AAD	LTE-FDD (SC-FDMA, 50% RB, 3 MHz, QPSK)	X	1.90	70.47	15.90	0.00	150.0	± 9.6 %
		Y	1.56	67.01	13.91		150.0	
		Z	1.44	67.67	13.50		150.0	
10299-AAD	LTE-FDD (SC-FDMA, 50% RB, 3 MHz, 16-QAM)	X	3.07	71.64	15.53	0.00	150.0	± 9.6 %
		Y	3.23	72.42	16.33		150.0	
		Z	2.17	67.61	12.32		150.0	
10300-AAD	LTE-FDD (SC-FDMA, 50% RB, 3 MHz, 64-QAM)	X	2.19	66.26	12.34	0.00	150.0	± 9.6 %
		Y	2.31	66.80	13.02		150.0	
		Z	1.57	63.33	9.50		150.0	
10301-AAA	IEEE 802.16e WiMAX (29:18, 5ms, 10MHz, QPSK, PUSC)	X	4.82	65.43	17.57	4.17	50.0	± 9.6 %
		Y	4.87	65.32	17.50		50.0	
		Z	4.60	65.72	17.49		50.0	
10302-AAA	IEEE 802.16e WiMAX (29:18, 5ms, 10MHz, QPSK, PUSC, 3 CTRL symbols)	X	5.31	66.17	18.35	4.96	50.0	± 9.6 %
		Y	5.36	66.00	18.25		50.0	
		Z	5.00	66.00	18.02		50.0	

10303-AAA	IEEE 802.16e WiMAX (31:15, 5ms, 10MHz, 64QAM, PUSC)	X	5.06	65.83	18.21	4.96	50.0	± 9.6 %
		Y	5.11	65.70	18.12		50.0	
		Z	4.75	65.61	17.82		50.0	
10304-AAA	IEEE 802.16e WiMAX (29:18, 5ms, 10MHz, 64QAM, PUSC)	X	4.87	65.69	17.69	4.17	50.0	± 9.6 %
		Y	4.90	65.47	17.55		50.0	
		Z	4.58	65.56	17.35		50.0	
10305-AAA	IEEE 802.16e WiMAX (31:15, 10ms, 10MHz, 64QAM, PUSC, 15 symbols)	X	4.43	67.35	19.83	6.02	35.0	± 9.6 %
		Y	4.56	67.70	19.98		35.0	
		Z	4.15	67.17	19.10		35.0	
10306-AAA	IEEE 802.16e WiMAX (29:18, 10ms, 10MHz, 64QAM, PUSC, 18 symbols)	X	4.77	66.43	19.36	6.02	35.0	± 9.6 %
		Y	4.86	66.61	19.45		35.0	
		Z	4.49	66.31	18.82		35.0	
10307-AAA	IEEE 802.16e WiMAX (29:18, 10ms, 10MHz, QPSK, PUSC, 18 symbols)	X	4.67	66.65	19.36	6.02	35.0	± 9.6 %
		Y	4.78	66.88	19.46		35.0	
		Z	4.37	66.39	18.75		35.0	
10308-AAA	IEEE 802.16e WiMAX (29:18, 10ms, 10MHz, 16QAM, PUSC)	X	4.64	66.81	19.48	6.02	35.0	± 9.6 %
		Y	4.74	67.03	19.58		35.0	
		Z	4.35	66.60	18.90		35.0	
10309-AAA	IEEE 802.16e WiMAX (29:18, 10ms, 10MHz, 16QAM, AMC 2x3, 18 symbols)	X	4.84	66.72	19.54	6.02	35.0	± 9.6 %
		Y	4.94	66.92	19.63		35.0	
		Z	4.52	66.47	18.95		35.0	
10310-AAA	IEEE 802.16e WiMAX (29:18, 10ms, 10MHz, QPSK, AMC 2x3, 18 symbols)	X	4.71	66.49	19.33	6.02	35.0	± 9.6 %
		Y	4.81	66.68	19.42		35.0	
		Z	4.43	66.37	18.80		35.0	
10311-AAD	LTE-FDD (SC-FDMA, 100% RB, 15 MHz, QPSK)	X	3.36	70.26	16.95	0.00	150.0	± 9.6 %
		Y	3.08	68.46	15.91		150.0	
		Z	3.08	69.51	16.57		150.0	
10313-AAA	IDEN 1:3	X	5.95	81.40	19.48	6.99	70.0	± 9.6 %
		Y	4.30	76.35	17.48		70.0	
		Z	3.21	73.80	16.43		70.0	
10314-AAA	IDEN 1:6	X	12.17	97.07	27.72	10.00	30.0	± 9.6 %
		Y	7.44	87.94	24.60		30.0	
		Z	6.18	85.76	23.72		30.0	
10315-AAB	IEEE 802.11b WiFi 2.4 GHz (DSSS, 1 Mbps, 96pc duty cycle)	X	1.10	64.61	16.02	0.17	150.0	± 9.6 %
		Y	1.01	63.21	14.85		150.0	
		Z	1.05	64.14	15.48		150.0	
10316-AAB	IEEE 802.11g WiFi 2.4 GHz (ERP-OFDM, 6 Mbps, 96pc duty cycle)	X	4.65	66.81	16.47	0.17	150.0	± 9.6 %
		Y	4.62	66.42	16.27		150.0	
		Z	4.46	66.78	16.31		150.0	
10317-AAC	IEEE 802.11a WiFi 5 GHz (OFDM, 6 Mbps, 96pc duty cycle)	X	4.65	66.81	16.47	0.17	150.0	± 9.6 %
		Y	4.62	66.42	16.27		150.0	
		Z	4.46	66.78	16.31		150.0	
10400-AAD	IEEE 802.11ac WiFi (20MHz, 64-QAM, 99pc duty cycle)	X	4.78	67.16	16.44	0.00	150.0	± 9.6 %
		Y	4.74	66.73	16.21		150.0	
		Z	4.55	67.11	16.31		150.0	
10401-AAD	IEEE 802.11ac WiFi (40MHz, 64-QAM, 99pc duty cycle)	X	5.43	67.23	16.53	0.00	150.0	± 9.6 %
		Y	5.42	66.92	16.38		150.0	
		Z	5.24	67.11	16.40		150.0	

10402-AAD	IEEE 802.11ac WiFi (80MHz, 64-QAM, 99pc duty cycle)	X	5.71	67.66	16.59	0.00	150.0	± 9.6 %
		Y	5.70	67.34	16.43		150.0	
		Z	5.52	67.48	16.45		150.0	
10403-AAB	CDMA2000 (1xEV-DO, Rev. 0)	X	1.95	72.86	16.32	0.00	115.0	± 9.6 %
		Y	1.38	67.46	13.46		115.0	
		Z	1.34	68.81	13.27		115.0	
10404-AAB	CDMA2000 (1xEV-DO, Rev. A)	X	1.95	72.86	16.32	0.00	115.0	± 9.6 %
		Y	1.38	67.46	13.46		115.0	
		Z	1.34	68.81	13.27		115.0	
10406-AAB	CDMA2000, RC3, SO32, SCH0, Full Rate	X	100.00	122.38	30.73	0.00	100.0	± 9.6 %
		Y	81.48	123.67	32.28		100.0	
		Z	100.00	114.83	26.66		100.0	
10410-AAE	LTE-TDD (SC-FDMA, 1 RB, 10 MHz, QPSK, UL Subframe=2,3,4,7,8,9, Subframe Conf=4)	X	100.00	123.65	31.04	3.23	80.0	± 9.6 %
		Y	100.00	127.30	33.02		80.0	
		Z	100.00	122.18	29.60		80.0	
10415-AAA	IEEE 802.11b WiFi 2.4 GHz (DSSS, 1 Mbps, 99pc duty cycle)	X	1.02	63.74	15.40	0.00	150.0	± 9.6 %
		Y	0.94	62.36	14.20		150.0	
		Z	0.99	63.49	14.99		150.0	
10416-AAA	IEEE 802.11g WiFi 2.4 GHz (ERP-OFDM, 6 Mbps, 99pc duty cycle)	X	4.59	66.79	16.39	0.00	150.0	± 9.6 %
		Y	4.55	66.36	16.15		150.0	
		Z	4.42	66.82	16.27		150.0	
10417-AAB	IEEE 802.11a/h WiFi 5 GHz (OFDM, 6 Mbps, 99pc duty cycle)	X	4.59	66.79	16.39	0.00	150.0	± 9.6 %
		Y	4.55	66.36	16.15		150.0	
		Z	4.42	66.82	16.27		150.0	
10418-AAA	IEEE 802.11g WiFi 2.4 GHz (DSSS-OFDM, 6 Mbps, 99pc duty cycle, Long preamble)	X	4.58	66.96	16.41	0.00	150.0	± 9.6 %
		Y	4.54	66.49	16.15		150.0	
		Z	4.42	67.01	16.31		150.0	
10419-AAA	IEEE 802.11g WiFi 2.4 GHz (DSSS-OFDM, 6 Mbps, 99pc duty cycle, Short preamble)	X	4.61	66.90	16.41	0.00	150.0	± 9.6 %
		Y	4.56	66.45	16.16		150.0	
		Z	4.43	66.95	16.30		150.0	
10422-AAB	IEEE 802.11n (HT Greenfield, 7.2 Mbps, BPSK)	X	4.73	66.90	16.41	0.00	150.0	± 9.6 %
		Y	4.69	66.47	16.18		150.0	
		Z	4.54	66.92	16.31		150.0	
10423-AAB	IEEE 802.11n (HT Greenfield, 43.3 Mbps, 16-QAM)	X	4.91	67.24	16.54	0.00	150.0	± 9.6 %
		Y	4.87	66.82	16.31		150.0	
		Z	4.68	67.21	16.40		150.0	
10424-AAB	IEEE 802.11n (HT Greenfield, 72.2 Mbps, 64-QAM)	X	4.82	67.19	16.51	0.00	150.0	± 9.6 %
		Y	4.79	66.76	16.28		150.0	
		Z	4.61	67.16	16.38		150.0	
10425-AAB	IEEE 802.11n (HT Greenfield, 15 Mbps, BPSK)	X	5.41	67.47	16.65	0.00	150.0	± 9.6 %
		Y	5.40	67.17	16.50		150.0	
		Z	5.21	67.35	16.53		150.0	
10426-AAB	IEEE 802.11n (HT Greenfield, 90 Mbps, 16-QAM)	X	5.41	67.47	16.65	0.00	150.0	± 9.6 %
		Y	5.40	67.19	16.50		150.0	
		Z	5.23	67.42	16.56		150.0	

10427-AAB	IEEE 802.11n (HT Greenfield, 150 Mbps, 64-QAM)	X	5.42	67.47	16.64	0.00	150.0	± 9.6 %
		Y	5.41	67.16	16.48		150.0	
		Z	5.22	67.32	16.51		150.0	
10430-AAC	LTE-FDD (OFDMA, 5 MHz, E-TM 3.1)	X	4.40	71.17	18.58	0.00	150.0	± 9.6 %
		Y	4.23	70.08	17.99		150.0	
		Z	4.30	72.10	18.56		150.0	
10431-AAC	LTE-FDD (OFDMA, 10 MHz, E-TM 3.1)	X	4.31	67.42	16.46	0.00	150.0	± 9.6 %
		Y	4.26	66.88	16.15		150.0	
		Z	4.07	67.45	16.24		150.0	
10432-AAC	LTE-FDD (OFDMA, 15 MHz, E-TM 3.1)	X	4.60	67.26	16.49	0.00	150.0	± 9.6 %
		Y	4.56	66.79	16.22		150.0	
		Z	4.38	67.26	16.33		150.0	
10433-AAC	LTE-FDD (OFDMA, 20 MHz, E-TM 3.1)	X	4.84	67.23	16.53	0.00	150.0	± 9.6 %
		Y	4.80	66.80	16.30		150.0	
		Z	4.63	67.20	16.40		150.0	
10434-AAA	W-CDMA (BS Test Model 1, 64 DPCH)	X	4.54	72.17	18.64	0.00	150.0	± 9.6 %
		Y	4.31	70.81	17.94		150.0	
		Z	4.47	73.20	18.53		150.0	
10435-AAE	LTE-TDD (SC-FDMA, 1 RB, 20 MHz, QPSK, UL Subframe=2,3,4,7,8,9)	X	100.00	123.43	30.93	3.23	80.0	± 9.6 %
		Y	100.00	127.09	32.93		80.0	
		Z	100.00	121.88	29.46		80.0	
10447-AAC	LTE-FDD (OFDMA, 5 MHz, E-TM 3.1, Clipping 44%)	X	3.63	67.60	15.97	0.00	150.0	± 9.6 %
		Y	3.55	66.82	15.51		150.0	
		Z	3.36	67.49	15.39		150.0	
10448-AAC	LTE-FDD (OFDMA, 10 MHz, E-TM 3.1, Clipping 44%)	X	4.14	67.21	16.33	0.00	150.0	± 9.6 %
		Y	4.08	66.64	16.00		150.0	
		Z	3.93	67.24	16.11		150.0	
10449-AAC	LTE-FDD (OFDMA, 15 MHz, E-TM 3.1, Clipping 44%)	X	4.40	67.10	16.39	0.00	150.0	± 9.6 %
		Y	4.35	66.60	16.11		150.0	
		Z	4.21	67.10	16.24		150.0	
10450-AAC	LTE-FDD (OFDMA, 20 MHz, E-TM 3.1, Clipping 44%)	X	4.59	67.00	16.40	0.00	150.0	± 9.6 %
		Y	4.54	66.54	16.14		150.0	
		Z	4.41	66.98	16.27		150.0	
10451-AAA	W-CDMA (BS Test Model 1, 64 DPCH, Clipping 44%)	X	3.56	67.91	15.68	0.00	150.0	± 9.6 %
		Y	3.45	67.01	15.16		150.0	
		Z	3.21	67.51	14.85		150.0	
10456-AAB	IEEE 802.11ac WiFi (160MHz, 64-QAM, 99pc duty cycle)	X	6.26	68.01	16.78	0.00	150.0	± 9.6 %
		Y	6.26	67.75	16.66		150.0	
		Z	6.13	67.97	16.72		150.0	
10457-AAA	UMTS-FDD (DC-HSDPA)	X	3.81	65.42	16.11	0.00	150.0	± 9.6 %
		Y	3.77	64.98	15.86		150.0	
		Z	3.73	65.50	15.98		150.0	
10458-AAA	CDMA2000 (1xEV-DO, Rev. B, 2 carriers)	X	4.16	71.37	18.08	0.00	150.0	± 9.6 %
		Y	3.92	69.91	17.32		150.0	
		Z	4.02	72.11	17.63		150.0	
10459-AAA	CDMA2000 (1xEV-DO, Rev. B, 3 carriers)	X	5.19	68.40	18.36	0.00	150.0	± 9.6 %
		Y	5.10	67.75	18.06		150.0	
		Z	5.01	69.18	18.25		150.0	

10460-AAA	UMTS-FDD (WCDMA, AMR)	X	1.07	72.05	18.39	0.00	150.0	± 9.6 %
		Y	0.81	67.05	15.17		150.0	
		Z	0.95	70.49	17.24		150.0	
10461-AAA	LTE-TDD (SC-FDMA, 1 RB, 1.4 MHz, QPSK, UL Subframe=2,3,4,7,8,9)	X	100.00	129.11	33.59	3.29	80.0	± 9.6 %
		Y	100.00	132.68	35.56		80.0	
		Z	100.00	128.17	32.38		80.0	
10462-AAA	LTE-TDD (SC-FDMA, 1 RB, 1.4 MHz, 16-QAM, UL Subframe=2,3,4,7,8,9)	X	29.76	94.39	20.32	3.23	80.0	± 9.6 %
		Y	100.00	112.07	25.94		80.0	
		Z	0.79	60.49	7.76		80.0	
10463-AAA	LTE-TDD (SC-FDMA, 1 RB, 1.4 MHz, 64-QAM, UL Subframe=2,3,4,7,8,9)	X	2.50	68.97	12.20	3.23	80.0	± 9.6 %
		Y	100.00	107.58	23.85		80.0	
		Z	0.77	60.00	6.89		80.0	
10464-AAB	LTE-TDD (SC-FDMA, 1 RB, 3 MHz, QPSK, UL Subframe=2,3,4,7,8,9)	X	100.00	126.29	32.12	3.23	80.0	± 9.6 %
		Y	100.00	130.29	34.26		80.0	
		Z	100.00	124.25	30.42		80.0	
10465-AAB	LTE-TDD (SC-FDMA, 1 RB, 3 MHz, 16-QAM, UL Subframe=2,3,4,7,8,9)	X	9.13	82.53	17.12	3.23	80.0	± 9.6 %
		Y	100.00	111.30	25.58		80.0	
		Z	0.75	60.00	7.44		80.0	
10466-AAB	LTE-TDD (SC-FDMA, 1 RB, 3 MHz, 64-QAM, UL Subframe=2,3,4,7,8,9)	X	1.98	66.71	11.27	3.23	80.0	± 9.6 %
		Y	99.88	106.88	23.53		80.0	
		Z	0.78	60.00	6.83		80.0	
10467-AAD	LTE-TDD (SC-FDMA, 1 RB, 5 MHz, QPSK, UL Subframe=2,3,4,7,8,9)	X	100.00	126.60	32.25	3.23	80.0	± 9.6 %
		Y	100.00	130.59	34.40		80.0	
		Z	100.00	124.67	30.60		80.0	
10468-AAD	LTE-TDD (SC-FDMA, 1 RB, 5 MHz, 16-QAM, UL Subframe=2,3,4,7,8,9)	X	11.66	85.00	17.83	3.23	80.0	± 9.6 %
		Y	100.00	111.53	25.68		80.0	
		Z	0.75	60.09	7.51		80.0	
10469-AAD	LTE-TDD (SC-FDMA, 1 RB, 5 MHz, 64-QAM, UL Subframe=2,3,4,7,8,9)	X	1.98	66.75	11.28	3.23	80.0	± 9.6 %
		Y	100.00	106.90	23.54		80.0	
		Z	0.77	60.00	6.83		80.0	
10470-AAD	LTE-TDD (SC-FDMA, 1 RB, 10 MHz, QPSK, UL Subframe=2,3,4,7,8,9)	X	100.00	126.64	32.26	3.23	80.0	± 9.6 %
		Y	100.00	130.65	34.41		80.0	
		Z	100.00	124.69	30.60		80.0	
10471-AAD	LTE-TDD (SC-FDMA, 1 RB, 10 MHz, 16-QAM, UL Subframe=2,3,4,7,8,9)	X	11.32	84.67	17.72	3.23	80.0	± 9.6 %
		Y	100.00	111.46	25.64		80.0	
		Z	0.75	60.04	7.47		80.0	
10472-AAD	LTE-TDD (SC-FDMA, 1 RB, 10 MHz, 64-QAM, UL Subframe=2,3,4,7,8,9)	X	1.96	66.63	11.22	3.23	80.0	± 9.6 %
		Y	100.00	106.82	23.49		80.0	
		Z	0.77	60.00	6.81		80.0	
10473-AAD	LTE-TDD (SC-FDMA, 1 RB, 15 MHz, QPSK, UL Subframe=2,3,4,7,8,9)	X	100.00	126.60	32.24	3.23	80.0	± 9.6 %
		Y	100.00	130.61	34.39		80.0	
		Z	100.00	124.64	30.58		80.0	
10474-AAD	LTE-TDD (SC-FDMA, 1 RB, 15 MHz, 16-QAM, UL Subframe=2,3,4,7,8,9)	X	11.06	84.45	17.66	3.23	80.0	± 9.6 %
		Y	100.00	111.47	25.64		80.0	
		Z	0.74	60.02	7.45		80.0	
10475-AAD	LTE-TDD (SC-FDMA, 1 RB, 15 MHz, 64-QAM, UL Subframe=2,3,4,7,8,9)	X	1.95	66.59	11.20	3.23	80.0	± 9.6 %
		Y	99.99	106.84	23.50		80.0	
		Z	0.77	60.00	6.81		80.0	

10477-AAE	LTE-TDD (SC-FDMA, 1 RB, 20 MHz, 16-QAM, UL Subframe=2,3,4,7,8,9)	X	9.10	82.47	17.07	3.23	80.0	± 9.6 %
		Y	100.00	111.24	25.54		80.0	
		Z	0.74	60.00	7.42		80.0	
10478-AAE	LTE-TDD (SC-FDMA, 1 RB, 20 MHz, 64-QAM, UL Subframe=2,3,4,7,8,9)	X	1.93	66.47	11.14	3.23	80.0	± 9.6 %
		Y	96.81	106.44	23.40		80.0	
		Z	0.77	60.00	6.80		80.0	
10479-AAA	LTE-TDD (SC-FDMA, 50% RB, 1.4 MHz, QPSK, UL Subframe=2,3,4,7,8,9)	X	9.68	90.97	25.10	3.23	80.0	± 9.6 %
		Y	13.83	97.37	27.65		80.0	
		Z	12.23	94.71	25.17		80.0	
10480-AAA	LTE-TDD (SC-FDMA, 50% RB, 1.4 MHz, 16-QAM, UL Subframe=2,3,4,7,8,9)	X	11.91	88.02	22.17	3.23	80.0	± 9.6 %
		Y	19.25	95.65	25.10		80.0	
		Z	7.50	81.30	18.54		80.0	
10481-AAA	LTE-TDD (SC-FDMA, 50% RB, 1.4 MHz, 64-QAM, UL Subframe=2,3,4,7,8,9)	X	9.15	83.59	20.38	3.23	80.0	± 9.6 %
		Y	15.12	91.18	23.39		80.0	
		Z	4.40	74.24	15.71		80.0	
10482-AAB	LTE-TDD (SC-FDMA, 50% RB, 3 MHz, QPSK, UL Subframe=2,3,4,7,8,9)	X	4.76	79.70	20.44	2.23	80.0	± 9.6 %
		Y	3.53	74.74	18.45		80.0	
		Z	2.62	71.60	16.13		80.0	
10483-AAB	LTE-TDD (SC-FDMA, 50% RB, 3 MHz, 16-QAM, UL Subframe=2,3,4,7,8,9)	X	5.87	78.17	19.16	2.23	80.0	± 9.6 %
		Y	8.24	83.44	21.55		80.0	
		Z	2.93	69.04	14.15		80.0	
10484-AAB	LTE-TDD (SC-FDMA, 50% RB, 3 MHz, 64-QAM, UL Subframe=2,3,4,7,8,9)	X	5.35	76.61	18.60	2.23	80.0	± 9.6 %
		Y	7.24	81.28	20.83		80.0	
		Z	2.73	67.94	13.69		80.0	
10485-AAD	LTE-TDD (SC-FDMA, 50% RB, 5 MHz, QPSK, UL Subframe=2,3,4,7,8,9)	X	4.47	78.87	21.04	2.23	80.0	± 9.6 %
		Y	3.68	75.23	19.49		80.0	
		Z	3.15	74.27	18.50		80.0	
10486-AAD	LTE-TDD (SC-FDMA, 50% RB, 5 MHz, 16-QAM, UL Subframe=2,3,4,7,8,9)	X	3.79	72.50	18.04	2.23	80.0	± 9.6 %
		Y	3.38	70.29	17.05		80.0	
		Z	2.84	69.02	15.57		80.0	
10487-AAD	LTE-TDD (SC-FDMA, 50% RB, 5 MHz, 64-QAM, UL Subframe=2,3,4,7,8,9)	X	3.74	71.89	17.77	2.23	80.0	± 9.6 %
		Y	3.37	69.86	16.85		80.0	
		Z	2.81	68.50	15.32		80.0	
10488-AAD	LTE-TDD (SC-FDMA, 50% RB, 10 MHz, QPSK, UL Subframe=2,3,4,7,8,9)	X	4.24	75.86	20.43	2.23	80.0	± 9.6 %
		Y	3.83	73.65	19.40		80.0	
		Z	3.28	72.72	18.85		80.0	
10489-AAD	LTE-TDD (SC-FDMA, 50% RB, 10 MHz, 16-QAM, UL Subframe=2,3,4,7,8,9)	X	3.72	70.49	18.27	2.23	80.0	± 9.6 %
		Y	3.53	69.26	17.66		80.0	
		Z	3.19	68.97	17.14		80.0	
10490-AAD	LTE-TDD (SC-FDMA, 50% RB, 10 MHz, 64-QAM, UL Subframe=2,3,4,7,8,9)	X	3.79	70.18	18.14	2.23	80.0	± 9.6 %
		Y	3.62	69.04	17.58		80.0	
		Z	3.27	68.77	17.05		80.0	
10491-AAD	LTE-TDD (SC-FDMA, 50% RB, 15 MHz, QPSK, UL Subframe=2,3,4,7,8,9)	X	4.23	73.19	19.42	2.23	80.0	± 9.6 %
		Y	3.95	71.65	18.67		80.0	
		Z	3.47	70.90	18.25		80.0	
10492-AAD	LTE-TDD (SC-FDMA, 50% RB, 15 MHz, 16-QAM, UL Subframe=2,3,4,7,8,9)	X	3.97	69.24	17.95	2.23	80.0	± 9.6 %
		Y	3.85	68.36	17.51		80.0	
		Z	3.50	68.04	17.11		80.0	

10493-AAD	LTE-TDD (SC-FDMA, 50% RB, 15 MHz, 64-QAM, UL Subframe=2,3,4,7,8,9)	X	4.03	69.04	17.87	2.23	80.0	± 9.6 %
		Y	3.92	68.21	17.46		80.0	
		Z	3.56	67.90	17.04		80.0	
10494-AAE	LTE-TDD (SC-FDMA, 50% RB, 20 MHz, QPSK, UL Subframe=2,3,4,7,8,9)	X	4.79	75.46	20.14	2.23	80.0	± 9.6 %
		Y	4.38	73.53	19.24		80.0	
		Z	3.78	72.48	18.78		80.0	
10495-AAE	LTE-TDD (SC-FDMA, 50% RB, 20 MHz, 16-QAM, UL Subframe=2,3,4,7,8,9)	X	4.03	69.76	18.19	2.23	80.0	± 9.6 %
		Y	3.90	68.85	17.73		80.0	
		Z	3.53	68.35	17.31		80.0	
10496-AAE	LTE-TDD (SC-FDMA, 50% RB, 20 MHz, 64-QAM, UL Subframe=2,3,4,7,8,9)	X	4.08	69.35	18.04	2.23	80.0	± 9.6 %
		Y	3.97	68.51	17.62		80.0	
		Z	3.60	68.09	17.22		80.0	
10497-AAA	LTE-TDD (SC-FDMA, 100% RB, 1.4 MHz, QPSK, UL Subframe=2,3,4,7,8,9)	X	3.72	75.87	18.08	2.23	80.0	± 9.6 %
		Y	2.64	70.76	15.98		80.0	
		Z	1.51	64.60	11.77		80.0	
10498-AAA	LTE-TDD (SC-FDMA, 100% RB, 1.4 MHz, 16-QAM, UL Subframe=2,3,4,7,8,9)	X	2.30	66.27	12.99	2.23	80.0	± 9.6 %
		Y	2.02	64.31	12.06		80.0	
		Z	1.20	60.00	8.21		80.0	
10499-AAA	LTE-TDD (SC-FDMA, 100% RB, 1.4 MHz, 64-QAM, UL Subframe=2,3,4,7,8,9)	X	2.18	65.35	12.41	2.23	80.0	± 9.6 %
		Y	1.97	63.70	11.62		80.0	
		Z	1.22	60.00	8.05		80.0	
10500-AAB	LTE-TDD (SC-FDMA, 100% RB, 3 MHz, QPSK, UL Subframe=2,3,4,7,8,9)	X	4.19	76.87	20.53	2.23	80.0	± 9.6 %
		Y	3.63	74.04	19.27		80.0	
		Z	3.15	73.35	18.54		80.0	
10501-AAB	LTE-TDD (SC-FDMA, 100% RB, 3 MHz, 16-QAM, UL Subframe=2,3,4,7,8,9)	X	3.74	71.57	18.07	2.23	80.0	± 9.6 %
		Y	3.44	69.83	17.26		80.0	
		Z	3.03	69.25	16.29		80.0	
10502-AAB	LTE-TDD (SC-FDMA, 100% RB, 3 MHz, 64-QAM, UL Subframe=2,3,4,7,8,9)	X	3.79	71.34	17.92	2.23	80.0	± 9.6 %
		Y	3.50	69.66	17.14		80.0	
		Z	3.07	69.05	16.12		80.0	
10503-AAD	LTE-TDD (SC-FDMA, 100% RB, 5 MHz, QPSK, UL Subframe=2,3,4,7,8,9)	X	4.18	75.62	20.32	2.23	80.0	± 9.6 %
		Y	3.77	73.43	19.30		80.0	
		Z	3.23	72.50	18.74		80.0	
10504-AAD	LTE-TDD (SC-FDMA, 100% RB, 5 MHz, 16-QAM, UL Subframe=2,3,4,7,8,9)	X	3.70	70.40	18.21	2.23	80.0	± 9.6 %
		Y	3.52	69.18	17.61		80.0	
		Z	3.17	68.86	17.07		80.0	
10505-AAD	LTE-TDD (SC-FDMA, 100% RB, 5 MHz, 64-QAM, UL Subframe=2,3,4,7,8,9)	X	3.77	70.08	18.09	2.23	80.0	± 9.6 %
		Y	3.60	68.95	17.53		80.0	
		Z	3.25	68.67	16.99		80.0	
10506-AAD	LTE-TDD (SC-FDMA, 100% RB, 10 MHz, QPSK, UL Subframe=2,3,4,7,8,9)	X	4.74	75.29	20.06	2.23	80.0	± 9.6 %
		Y	4.34	73.37	19.17		80.0	
		Z	3.74	72.32	18.70		80.0	
10507-AAD	LTE-TDD (SC-FDMA, 100% RB, 10 MHz, 16-QAM, UL Subframe=2,3,4,7,8,9)	X	4.01	69.69	18.15	2.23	80.0	± 9.6 %
		Y	3.88	68.79	17.69		80.0	
		Z	3.51	68.29	17.27		80.0	

10508-AAD	LTE-TDD (SC-FDMA, 100% RB, 10 MHz, 64-QAM, UL Subframe=2,3,4,7,8,9)	X	4.07	69.28	18.00	2.23	80.0	± 9.6 %
		Y	3.96	68.45	17.58		80.0	
		Z	3.59	68.02	17.17		80.0	
10509-AAD	LTE-TDD (SC-FDMA, 100% RB, 15 MHz, QPSK, UL Subframe=2,3,4,7,8,9)	X	4.87	73.12	19.15	2.23	80.0	± 9.6 %
		Y	4.57	71.69	18.46		80.0	
		Z	4.08	70.95	18.12		80.0	
10510-AAD	LTE-TDD (SC-FDMA, 100% RB, 15 MHz, 16-QAM, UL Subframe=2,3,4,7,8,9)	X	4.46	69.19	17.97	2.23	80.0	± 9.6 %
		Y	4.36	68.46	17.61		80.0	
		Z	3.98	67.93	17.23		80.0	
10511-AAD	LTE-TDD (SC-FDMA, 100% RB, 15 MHz, 64-QAM, UL Subframe=2,3,4,7,8,9)	X	4.49	68.83	17.85	2.23	80.0	± 9.6 %
		Y	4.40	68.15	17.52		80.0	
		Z	4.03	67.70	17.16		80.0	
10512-AAE	LTE-TDD (SC-FDMA, 100% RB, 20 MHz, QPSK, UL Subframe=2,3,4,7,8,9)	X	5.35	75.53	19.95	2.23	80.0	± 9.6 %
		Y	4.89	73.64	19.09		80.0	
		Z	4.27	72.56	18.64		80.0	
10513-AAE	LTE-TDD (SC-FDMA, 100% RB, 20 MHz, 16-QAM, UL Subframe=2,3,4,7,8,9)	X	4.37	69.62	18.15	2.23	80.0	± 9.6 %
		Y	4.26	68.83	17.75		80.0	
		Z	3.86	68.15	17.33		80.0	
10514-AAE	LTE-TDD (SC-FDMA, 100% RB, 20 MHz, 64-QAM, UL Subframe=2,3,4,7,8,9)	X	4.36	69.04	17.95	2.23	80.0	± 9.6 %
		Y	4.26	68.32	17.60		80.0	
		Z	3.89	67.75	17.20		80.0	
10515-AAA	IEEE 802.11b WiFi 2.4 GHz (DSSS, 2 Mbps, 99pc duty cycle)	X	0.98	64.01	15.52	0.00	150.0	± 9.6 %
		Y	0.90	62.52	14.23		150.0	
		Z	0.95	63.71	15.08		150.0	
10516-AAA	IEEE 802.11b WiFi 2.4 GHz (DSSS, 5.5 Mbps, 99pc duty cycle)	X	0.96	80.43	22.24	0.00	150.0	± 9.6 %
		Y	0.52	69.16	15.73		150.0	
		Z	0.74	75.71	19.80		150.0	
10517-AAA	IEEE 802.11b WiFi 2.4 GHz (DSSS, 11 Mbps, 99pc duty cycle)	X	0.87	66.95	16.73	0.00	150.0	± 9.6 %
		Y	0.75	64.30	14.64		150.0	
		Z	0.81	66.10	15.98		150.0	
10518-AAB	IEEE 802.11a/h WiFi 5 GHz (OFDM, 9 Mbps, 99pc duty cycle)	X	4.59	66.88	16.37	0.00	150.0	± 9.6 %
		Y	4.55	66.43	16.12		150.0	
		Z	4.41	66.91	16.25		150.0	
10519-AAB	IEEE 802.11a/h WiFi 5 GHz (OFDM, 12 Mbps, 99pc duty cycle)	X	4.79	67.13	16.49	0.00	150.0	± 9.6 %
		Y	4.75	66.71	16.26		150.0	
		Z	4.57	67.10	16.35		150.0	
10520-AAB	IEEE 802.11a/h WiFi 5 GHz (OFDM, 18 Mbps, 99pc duty cycle)	X	4.64	67.11	16.43	0.00	150.0	± 9.6 %
		Y	4.60	66.67	16.18		150.0	
		Z	4.43	67.05	16.27		150.0	
10521-AAB	IEEE 802.11a/h WiFi 5 GHz (OFDM, 24 Mbps, 99pc duty cycle)	X	4.57	67.12	16.42	0.00	150.0	± 9.6 %
		Y	4.53	66.66	16.16		150.0	
		Z	4.36	67.04	16.26		150.0	
10522-AAB	IEEE 802.11a/h WiFi 5 GHz (OFDM, 36 Mbps, 99pc duty cycle)	X	4.63	67.16	16.48	0.00	150.0	± 9.6 %
		Y	4.59	66.70	16.22		150.0	
		Z	4.42	67.17	16.36		150.0	

10523-AAB	IEEE 802.11a/h WiFi 5 GHz (OFDM, 48 Mbps, 99pc duty cycle)	X	4.51	67.05	16.34	0.00	150.0	± 9.6 %
		Y	4.46	66.56	16.06		150.0	
		Z	4.33	67.10	16.24		150.0	
10524-AAB	IEEE 802.11a/h WiFi 5 GHz (OFDM, 54 Mbps, 99pc duty cycle)	X	4.58	67.09	16.46	0.00	150.0	± 9.6 %
		Y	4.53	66.64	16.20		150.0	
		Z	4.37	67.10	16.33		150.0	
10525-AAB	IEEE 802.11ac WiFi (20MHz, MCS0, 99pc duty cycle)	X	4.55	66.14	16.05	0.00	150.0	± 9.6 %
		Y	4.50	65.66	15.78		150.0	
		Z	4.38	66.18	15.95		150.0	
10526-AAB	IEEE 802.11ac WiFi (20MHz, MCS1, 99pc duty cycle)	X	4.74	66.53	16.19	0.00	150.0	± 9.6 %
		Y	4.69	66.05	15.93		150.0	
		Z	4.52	66.50	16.07		150.0	
10527-AAB	IEEE 802.11ac WiFi (20MHz, MCS2, 99pc duty cycle)	X	4.66	66.50	16.15	0.00	150.0	± 9.6 %
		Y	4.61	66.01	15.87		150.0	
		Z	4.45	66.47	16.02		150.0	
10528-AAB	IEEE 802.11ac WiFi (20MHz, MCS3, 99pc duty cycle)	X	4.67	66.52	16.18	0.00	150.0	± 9.6 %
		Y	4.62	66.03	15.91		150.0	
		Z	4.47	66.48	16.05		150.0	
10529-AAB	IEEE 802.11ac WiFi (20MHz, MCS4, 99pc duty cycle)	X	4.67	66.52	16.18	0.00	150.0	± 9.6 %
		Y	4.62	66.03	15.91		150.0	
		Z	4.47	66.48	16.05		150.0	
10531-AAB	IEEE 802.11ac WiFi (20MHz, MCS6, 99pc duty cycle)	X	4.67	66.65	16.20	0.00	150.0	± 9.6 %
		Y	4.63	66.16	15.93		150.0	
		Z	4.44	66.54	16.04		150.0	
10532-AAB	IEEE 802.11ac WiFi (20MHz, MCS7, 99pc duty cycle)	X	4.53	66.51	16.14	0.00	150.0	± 9.6 %
		Y	4.48	66.01	15.86		150.0	
		Z	4.32	66.41	15.98		150.0	
10533-AAB	IEEE 802.11ac WiFi (20MHz, MCS8, 99pc duty cycle)	X	4.68	66.56	16.16	0.00	150.0	± 9.6 %
		Y	4.63	66.06	15.89		150.0	
		Z	4.48	66.56	16.05		150.0	
10534-AAB	IEEE 802.11ac WiFi (40MHz, MCS0, 99pc duty cycle)	X	5.19	66.60	16.20	0.00	150.0	± 9.6 %
		Y	5.16	66.20	15.99		150.0	
		Z	5.01	66.50	16.09		150.0	
10535-AAB	IEEE 802.11ac WiFi (40MHz, MCS1, 99pc duty cycle)	X	5.26	66.75	16.27	0.00	150.0	± 9.6 %
		Y	5.22	66.35	16.06		150.0	
		Z	5.06	66.65	16.16		150.0	
10536-AAB	IEEE 802.11ac WiFi (40MHz, MCS2, 99pc duty cycle)	X	5.13	66.73	16.24	0.00	150.0	± 9.6 %
		Y	5.09	66.32	16.02		150.0	
		Z	4.95	66.64	16.13		150.0	
10537-AAB	IEEE 802.11ac WiFi (40MHz, MCS3, 99pc duty cycle)	X	5.19	66.69	16.22	0.00	150.0	± 9.6 %
		Y	5.15	66.30	16.01		150.0	
		Z	5.00	66.59	16.11		150.0	
10538-AAB	IEEE 802.11ac WiFi (40MHz, MCS4, 99pc duty cycle)	X	5.28	66.73	16.28	0.00	150.0	± 9.6 %
		Y	5.26	66.36	16.08		150.0	
		Z	5.08	66.58	16.14		150.0	
10540-AAB	IEEE 802.11ac WiFi (40MHz, MCS6, 99pc duty cycle)	X	5.21	66.72	16.29	0.00	150.0	± 9.6 %
		Y	5.17	66.33	16.08		150.0	
		Z	5.01	66.56	16.15		150.0	

10541-AAB	IEEE 802.11ac WiFi (40MHz, MCS7, 99pc duty cycle)	X	5.18	66.60	16.22	0.00	150.0	± 9.6 %
		Y	5.14	66.20	16.01		150.0	
		Z	4.99	66.47	16.09		150.0	
10542-AAB	IEEE 802.11ac WiFi (40MHz, MCS8, 99pc duty cycle)	X	5.33	66.65	16.26	0.00	150.0	± 9.6 %
		Y	5.31	66.28	16.07		150.0	
		Z	5.14	66.55	16.15		150.0	
10543-AAB	IEEE 802.11ac WiFi (40MHz, MCS9, 99pc duty cycle)	X	5.41	66.68	16.29	0.00	150.0	± 9.6 %
		Y	5.39	66.31	16.11		150.0	
		Z	5.20	66.56	16.18		150.0	
10544-AAB	IEEE 802.11ac WiFi (80MHz, MCS0, 99pc duty cycle)	X	5.49	66.70	16.18	0.00	150.0	± 9.6 %
		Y	5.45	66.31	15.98		150.0	
		Z	5.34	66.58	16.07		150.0	
10545-AAB	IEEE 802.11ac WiFi (80MHz, MCS1, 99pc duty cycle)	X	5.68	67.09	16.32	0.00	150.0	± 9.6 %
		Y	5.66	66.76	16.15		150.0	
		Z	5.51	66.98	16.23		150.0	
10546-AAB	IEEE 802.11ac WiFi (80MHz, MCS2, 99pc duty cycle)	X	5.57	66.94	16.26	0.00	150.0	± 9.6 %
		Y	5.54	66.57	16.08		150.0	
		Z	5.38	66.73	16.11		150.0	
10547-AAB	IEEE 802.11ac WiFi (80MHz, MCS3, 99pc duty cycle)	X	5.64	66.98	16.27	0.00	150.0	± 9.6 %
		Y	5.63	66.66	16.11		150.0	
		Z	5.45	66.79	16.14		150.0	
10548-AAB	IEEE 802.11ac WiFi (80MHz, MCS4, 99pc duty cycle)	X	5.90	67.92	16.71	0.00	150.0	± 9.6 %
		Y	5.97	67.87	16.68		150.0	
		Z	5.63	67.50	16.47		150.0	
10550-AAB	IEEE 802.11ac WiFi (80MHz, MCS6, 99pc duty cycle)	X	5.59	66.92	16.26	0.00	150.0	± 9.6 %
		Y	5.55	66.54	16.07		150.0	
		Z	5.42	66.82	16.17		150.0	
10551-AAB	IEEE 802.11ac WiFi (80MHz, MCS7, 99pc duty cycle)	X	5.60	66.98	16.25	0.00	150.0	± 9.6 %
		Y	5.56	66.60	16.06		150.0	
		Z	5.40	66.75	16.10		150.0	
10552-AAB	IEEE 802.11ac WiFi (80MHz, MCS8, 99pc duty cycle)	X	5.51	66.77	16.16	0.00	150.0	± 9.6 %
		Y	5.47	66.37	15.96		150.0	
		Z	5.35	66.67	16.06		150.0	
10553-AAB	IEEE 802.11ac WiFi (80MHz, MCS9, 99pc duty cycle)	X	5.60	66.81	16.21	0.00	150.0	± 9.6 %
		Y	5.56	66.43	16.01		150.0	
		Z	5.41	66.65	16.08		150.0	
10554-AAC	IEEE 802.11ac WiFi (160MHz, MCS0, 99pc duty cycle)	X	5.89	67.05	16.26	0.00	150.0	± 9.6 %
		Y	5.86	66.69	16.08		150.0	
		Z	5.75	66.91	16.14		150.0	
10555-AAC	IEEE 802.11ac WiFi (160MHz, MCS1, 99pc duty cycle)	X	6.02	67.35	16.38	0.00	150.0	± 9.6 %
		Y	6.00	67.02	16.22		150.0	
		Z	5.86	67.17	16.25		150.0	
10556-AAC	IEEE 802.11ac WiFi (160MHz, MCS2, 99pc duty cycle)	X	6.04	67.39	16.40	0.00	150.0	± 9.6 %
		Y	6.02	67.06	16.23		150.0	
		Z	5.88	67.24	16.28		150.0	
10557-AAC	IEEE 802.11ac WiFi (160MHz, MCS3, 99pc duty cycle)	X	6.01	67.32	16.38	0.00	150.0	± 9.6 %
		Y	5.99	66.98	16.22		150.0	
		Z	5.85	67.13	16.24		150.0	

10558-AAC	IEEE 802.11ac WiFi (160MHz, MCS4, 99pc duty cycle)	X	6.07	67.49	16.48	0.00	150.0	± 9.6 %
		Y	6.05	67.17	16.33		150.0	
		Z	5.88	67.26	16.33		150.0	
10560-AAC	IEEE 802.11ac WiFi (160MHz, MCS6, 99pc duty cycle)	X	6.06	67.34	16.44	0.00	150.0	± 9.6 %
		Y	6.04	66.99	16.28		150.0	
		Z	5.88	67.13	16.30		150.0	
10561-AAC	IEEE 802.11ac WiFi (160MHz, MCS7, 99pc duty cycle)	X	5.98	67.30	16.46	0.00	150.0	± 9.6 %
		Y	5.96	66.96	16.30		150.0	
		Z	5.81	67.11	16.32		150.0	
10562-AAC	IEEE 802.11ac WiFi (160MHz, MCS8, 99pc duty cycle)	X	6.11	67.72	16.67	0.00	150.0	± 9.6 %
		Y	6.12	67.46	16.55		150.0	
		Z	5.89	67.37	16.45		150.0	
10563-AAC	IEEE 802.11ac WiFi (160MHz, MCS9, 99pc duty cycle)	X	6.43	68.23	16.87	0.00	150.0	± 9.6 %
		Y	6.50	68.16	16.85		150.0	
		Z	5.96	67.23	16.35		150.0	
10564-AAA	IEEE 802.11g WiFi 2.4 GHz (DSSS-OFDM, 9 Mbps, 99pc duty cycle)	X	4.91	66.93	16.51	0.46	150.0	± 9.6 %
		Y	4.88	66.54	16.31		150.0	
		Z	4.73	66.93	16.37		150.0	
10565-AAA	IEEE 802.11g WiFi 2.4 GHz (DSSS-OFDM, 12 Mbps, 99pc duty cycle)	X	5.16	67.40	16.83	0.46	150.0	± 9.6 %
		Y	5.13	67.02	16.64		150.0	
		Z	4.93	67.35	16.69		150.0	
10566-AAA	IEEE 802.11g WiFi 2.4 GHz (DSSS-OFDM, 18 Mbps, 99pc duty cycle)	X	4.99	67.26	16.66	0.46	150.0	± 9.6 %
		Y	4.96	66.87	16.45		150.0	
		Z	4.77	67.18	16.50		150.0	
10567-AAA	IEEE 802.11g WiFi 2.4 GHz (DSSS-OFDM, 24 Mbps, 99pc duty cycle)	X	5.02	67.67	17.02	0.46	150.0	± 9.6 %
		Y	4.98	67.25	16.79		150.0	
		Z	4.81	67.60	16.88		150.0	
10568-AAA	IEEE 802.11g WiFi 2.4 GHz (DSSS-OFDM, 36 Mbps, 99pc duty cycle)	X	4.90	67.00	16.42	0.46	150.0	± 9.6 %
		Y	4.87	66.62	16.22		150.0	
		Z	4.67	66.94	16.26		150.0	
10569-AAA	IEEE 802.11g WiFi 2.4 GHz (DSSS-OFDM, 48 Mbps, 99pc duty cycle)	X	4.97	67.73	17.07	0.46	150.0	± 9.6 %
		Y	4.93	67.29	16.83		150.0	
		Z	4.78	67.78	16.99		150.0	
10570-AAA	IEEE 802.11g WiFi 2.4 GHz (DSSS-OFDM, 54 Mbps, 99pc duty cycle)	X	5.01	67.57	17.00	0.46	150.0	± 9.6 %
		Y	4.97	67.15	16.77		150.0	
		Z	4.80	67.57	16.89		150.0	
10571-AAA	IEEE 802.11b WiFi 2.4 GHz (DSSS, 1 Mbps, 90pc duty cycle)	X	1.17	65.22	16.39	0.46	130.0	± 9.6 %
		Y	1.09	63.89	15.30		130.0	
		Z	1.10	64.48	15.68		130.0	
10572-AAA	IEEE 802.11b WiFi 2.4 GHz (DSSS, 2 Mbps, 90pc duty cycle)	X	1.19	65.91	16.81	0.46	130.0	± 9.6 %
		Y	1.10	64.45	15.65		130.0	
		Z	1.12	65.08	16.07		130.0	
10573-AAA	IEEE 802.11b WiFi 2.4 GHz (DSSS, 5.5 Mbps, 90pc duty cycle)	X	11.95	118.97	33.95	0.46	130.0	± 9.6 %
		Y	2.10	86.50	22.92		130.0	
		Z	2.78	93.83	26.37		130.0	
10574-AAA	IEEE 802.11b WiFi 2.4 GHz (DSSS, 11 Mbps, 90pc duty cycle)	X	1.42	73.69	20.72	0.46	130.0	± 9.6 %
		Y	1.20	70.19	18.52		130.0	
		Z	1.24	71.54	19.44		130.0	

10575-AAA	IEEE 802.11g WiFi 2.4 GHz (DSSS-OFDM, 6 Mbps, 90pc duty cycle)	X	4.69	66.71	16.57	0.46	130.0	± 9.6 %
		Y	4.67	66.34	16.38		130.0	
		Z	4.50	66.68	16.40		130.0	
10576-AAA	IEEE 802.11g WiFi 2.4 GHz (DSSS-OFDM, 9 Mbps, 90pc duty cycle)	X	4.72	66.88	16.64	0.46	130.0	± 9.6 %
		Y	4.69	66.50	16.44		130.0	
		Z	4.53	66.88	16.48		130.0	
10577-AAA	IEEE 802.11g WiFi 2.4 GHz (DSSS-OFDM, 12 Mbps, 90pc duty cycle)	X	4.94	67.20	16.81	0.46	130.0	± 9.6 %
		Y	4.91	66.83	16.62		130.0	
		Z	4.71	67.13	16.63		130.0	
10578-AAA	IEEE 802.11g WiFi 2.4 GHz (DSSS-OFDM, 18 Mbps, 90pc duty cycle)	X	4.83	67.37	16.92	0.46	130.0	± 9.6 %
		Y	4.81	66.98	16.72		130.0	
		Z	4.61	67.29	16.74		130.0	
10579-AAA	IEEE 802.11g WiFi 2.4 GHz (DSSS-OFDM, 24 Mbps, 90pc duty cycle)	X	4.60	66.66	16.24	0.46	130.0	± 9.6 %
		Y	4.57	66.30	16.05		130.0	
		Z	4.37	66.49	16.00		130.0	
10580-AAA	IEEE 802.11g WiFi 2.4 GHz (DSSS-OFDM, 36 Mbps, 90pc duty cycle)	X	4.64	66.67	16.25	0.46	130.0	± 9.6 %
		Y	4.62	66.31	16.06		130.0	
		Z	4.41	66.55	16.03		130.0	
10581-AAA	IEEE 802.11g WiFi 2.4 GHz (DSSS-OFDM, 48 Mbps, 90pc duty cycle)	X	4.73	67.42	16.87	0.46	130.0	± 9.6 %
		Y	4.70	67.02	16.65		130.0	
		Z	4.52	67.36	16.71		130.0	
10582-AAA	IEEE 802.11g WiFi 2.4 GHz (DSSS-OFDM, 54 Mbps, 90pc duty cycle)	X	4.54	66.41	16.03	0.46	130.0	± 9.6 %
		Y	4.53	66.07	15.85		130.0	
		Z	4.30	66.25	15.78		130.0	
10583-AAB	IEEE 802.11a/h WiFi 5 GHz (OFDM, 6 Mbps, 90pc duty cycle)	X	4.69	66.71	16.57	0.46	130.0	± 9.6 %
		Y	4.67	66.34	16.38		130.0	
		Z	4.50	66.68	16.40		130.0	
10584-AAB	IEEE 802.11a/h WiFi 5 GHz (OFDM, 9 Mbps, 90pc duty cycle)	X	4.72	66.88	16.64	0.46	130.0	± 9.6 %
		Y	4.69	66.50	16.44		130.0	
		Z	4.53	66.88	16.48		130.0	
10585-AAB	IEEE 802.11a/h WiFi 5 GHz (OFDM, 12 Mbps, 90pc duty cycle)	X	4.94	67.20	16.81	0.46	130.0	± 9.6 %
		Y	4.91	66.83	16.62		130.0	
		Z	4.71	67.13	16.63		130.0	
10586-AAB	IEEE 802.11a/h WiFi 5 GHz (OFDM, 18 Mbps, 90pc duty cycle)	X	4.83	67.37	16.92	0.46	130.0	± 9.6 %
		Y	4.81	66.98	16.72		130.0	
		Z	4.61	67.29	16.74		130.0	
10587-AAB	IEEE 802.11a/h WiFi 5 GHz (OFDM, 24 Mbps, 90pc duty cycle)	X	4.60	66.66	16.24	0.46	130.0	± 9.6 %
		Y	4.57	66.30	16.05		130.0	
		Z	4.37	66.49	16.00		130.0	
10588-AAB	IEEE 802.11a/h WiFi 5 GHz (OFDM, 36 Mbps, 90pc duty cycle)	X	4.64	66.67	16.25	0.46	130.0	± 9.6 %
		Y	4.62	66.31	16.06		130.0	
		Z	4.41	66.55	16.03		130.0	
10589-AAB	IEEE 802.11a/h WiFi 5 GHz (OFDM, 48 Mbps, 90pc duty cycle)	X	4.73	67.42	16.87	0.46	130.0	± 9.6 %
		Y	4.70	67.02	16.65		130.0	
		Z	4.52	67.36	16.71		130.0	
10590-AAB	IEEE 802.11a/h WiFi 5 GHz (OFDM, 54 Mbps, 90pc duty cycle)	X	4.54	66.41	16.03	0.46	130.0	± 9.6 %
		Y	4.53	66.07	15.85		130.0	
		Z	4.30	66.25	15.78		130.0	

10591-AAB	IEEE 802.11n (HT Mixed, 20MHz, MCS0, 90pc duty cycle)	X	4.84	66.77	16.66	0.46	130.0	± 9.6 %
		Y	4.82	66.41	16.48		130.0	
		Z	4.66	66.76	16.51		130.0	
10592-AAB	IEEE 802.11n (HT Mixed, 20MHz, MCS1, 90pc duty cycle)	X	5.01	67.12	16.79	0.46	130.0	± 9.6 %
		Y	4.99	66.76	16.61		130.0	
		Z	4.79	67.07	16.64		130.0	
10593-AAB	IEEE 802.11n (HT Mixed, 20MHz, MCS2, 90pc duty cycle)	X	4.93	67.04	16.68	0.46	130.0	± 9.6 %
		Y	4.91	66.69	16.51		130.0	
		Z	4.71	66.95	16.50		130.0	
10594-AAB	IEEE 802.11n (HT Mixed, 20MHz, MCS3, 90pc duty cycle)	X	4.98	67.20	16.83	0.46	130.0	± 9.6 %
		Y	4.96	66.84	16.65		130.0	
		Z	4.76	67.13	16.67		130.0	
10595-AAB	IEEE 802.11n (HT Mixed, 20MHz, MCS4, 90pc duty cycle)	X	4.95	67.16	16.73	0.46	130.0	± 9.6 %
		Y	4.93	66.80	16.55		130.0	
		Z	4.73	67.10	16.57		130.0	
10596-AAB	IEEE 802.11n (HT Mixed, 20MHz, MCS5, 90pc duty cycle)	X	4.89	67.16	16.74	0.46	130.0	± 9.6 %
		Y	4.87	66.79	16.55		130.0	
		Z	4.66	67.08	16.56		130.0	
10597-AAB	IEEE 802.11n (HT Mixed, 20MHz, MCS6, 90pc duty cycle)	X	4.84	67.08	16.63	0.46	130.0	± 9.6 %
		Y	4.82	66.71	16.44		130.0	
		Z	4.61	66.96	16.43		130.0	
10598-AAB	IEEE 802.11n (HT Mixed, 20MHz, MCS7, 90pc duty cycle)	X	4.82	67.33	16.90	0.46	130.0	± 9.6 %
		Y	4.80	66.95	16.70		130.0	
		Z	4.60	67.20	16.70		130.0	
10599-AAB	IEEE 802.11n (HT Mixed, 40MHz, MCS0, 90pc duty cycle)	X	5.51	67.30	16.83	0.46	130.0	± 9.6 %
		Y	5.50	67.04	16.72		130.0	
		Z	5.31	67.18	16.69		130.0	
10600-AAB	IEEE 802.11n (HT Mixed, 40MHz, MCS1, 90pc duty cycle)	X	5.66	67.75	17.03	0.46	130.0	± 9.6 %
		Y	5.70	67.66	17.00		130.0	
		Z	5.42	67.55	16.85		130.0	
10601-AAB	IEEE 802.11n (HT Mixed, 40MHz, MCS2, 90pc duty cycle)	X	5.54	67.49	16.91	0.46	130.0	± 9.6 %
		Y	5.55	67.29	16.83		130.0	
		Z	5.33	67.34	16.76		130.0	
10602-AAB	IEEE 802.11n (HT Mixed, 40MHz, MCS3, 90pc duty cycle)	X	5.62	67.47	16.82	0.46	130.0	± 9.6 %
		Y	5.64	67.27	16.74		130.0	
		Z	5.46	67.51	16.77		130.0	
10603-AAB	IEEE 802.11n (HT Mixed, 40MHz, MCS4, 90pc duty cycle)	X	5.72	67.83	17.13	0.46	130.0	± 9.6 %
		Y	5.72	67.56	17.01		130.0	
		Z	5.53	67.80	17.05		130.0	
10604-AAB	IEEE 802.11n (HT Mixed, 40MHz, MCS5, 90pc duty cycle)	X	5.51	67.26	16.84	0.46	130.0	± 9.6 %
		Y	5.51	67.00	16.72		130.0	
		Z	5.40	67.44	16.85		130.0	
10605-AAB	IEEE 802.11n (HT Mixed, 40MHz, MCS6, 90pc duty cycle)	X	5.62	67.58	16.99	0.46	130.0	± 9.6 %
		Y	5.63	67.37	16.91		130.0	
		Z	5.43	67.48	16.86		130.0	
10606-AAB	IEEE 802.11n (HT Mixed, 40MHz, MCS7, 90pc duty cycle)	X	5.39	67.04	16.59	0.46	130.0	± 9.6 %
		Y	5.38	66.75	16.46		130.0	
		Z	5.18	66.82	16.39		130.0	

10607-AAB	IEEE 802.11ac WiFi (20MHz, MCS0, 90pc duty cycle)	X	4.69	66.11	16.30	0.46	130.0	± 9.6 %
		Y	4.65	65.70	16.09		130.0	
		Z	4.51	66.12	16.16		130.0	
10608-AAB	IEEE 802.11ac WiFi (20MHz, MCS1, 90pc duty cycle)	X	4.89	66.54	16.47	0.46	130.0	± 9.6 %
		Y	4.86	66.13	16.26		130.0	
		Z	4.67	66.48	16.32		130.0	
10609-AAB	IEEE 802.11ac WiFi (20MHz, MCS2, 90pc duty cycle)	X	4.78	66.40	16.32	0.46	130.0	± 9.6 %
		Y	4.74	65.99	16.10		130.0	
		Z	4.56	66.32	16.14		130.0	
10610-AAB	IEEE 802.11ac WiFi (20MHz, MCS3, 90pc duty cycle)	X	4.83	66.56	16.48	0.46	130.0	± 9.6 %
		Y	4.80	66.15	16.27		130.0	
		Z	4.61	66.49	16.31		130.0	
10611-AAB	IEEE 802.11ac WiFi (20MHz, MCS4, 90pc duty cycle)	X	4.74	66.37	16.33	0.46	130.0	± 9.6 %
		Y	4.71	65.96	16.12		130.0	
		Z	4.52	66.28	16.15		130.0	
10612-AAB	IEEE 802.11ac WiFi (20MHz, MCS5, 90pc duty cycle)	X	4.76	66.53	16.38	0.46	130.0	± 9.6 %
		Y	4.73	66.12	16.16		130.0	
		Z	4.52	66.43	16.20		130.0	
10613-AAB	IEEE 802.11ac WiFi (20MHz, MCS6, 90pc duty cycle)	X	4.76	66.43	16.27	0.46	130.0	± 9.6 %
		Y	4.74	66.03	16.06		130.0	
		Z	4.52	66.26	16.05		130.0	
10614-AAB	IEEE 802.11ac WiFi (20MHz, MCS7, 90pc duty cycle)	X	4.70	66.62	16.50	0.46	130.0	± 9.6 %
		Y	4.67	66.19	16.28		130.0	
		Z	4.48	66.49	16.31		130.0	
10615-AAB	IEEE 802.11ac WiFi (20MHz, MCS8, 90pc duty cycle)	X	4.74	66.19	16.10	0.46	130.0	± 9.6 %
		Y	4.72	65.79	15.90		130.0	
		Z	4.52	66.11	15.92		130.0	
10616-AAB	IEEE 802.11ac WiFi (40MHz, MCS0, 90pc duty cycle)	X	5.34	66.61	16.47	0.46	130.0	± 9.6 %
		Y	5.32	66.28	16.32		130.0	
		Z	5.14	66.47	16.32		130.0	
10617-AAB	IEEE 802.11ac WiFi (40MHz, MCS1, 90pc duty cycle)	X	5.40	66.74	16.51	0.46	130.0	± 9.6 %
		Y	5.38	66.41	16.35		130.0	
		Z	5.21	66.65	16.39		130.0	
10618-AAB	IEEE 802.11ac WiFi (40MHz, MCS2, 90pc duty cycle)	X	5.29	66.79	16.56	0.46	130.0	± 9.6 %
		Y	5.27	66.46	16.39		130.0	
		Z	5.11	66.70	16.43		130.0	
10619-AAB	IEEE 802.11ac WiFi (40MHz, MCS3, 90pc duty cycle)	X	5.31	66.61	16.40	0.46	130.0	± 9.6 %
		Y	5.30	66.30	16.25		130.0	
		Z	5.11	66.46	16.24		130.0	
10620-AAB	IEEE 802.11ac WiFi (40MHz, MCS4, 90pc duty cycle)	X	5.41	66.67	16.47	0.46	130.0	± 9.6 %
		Y	5.41	66.38	16.34		130.0	
		Z	5.19	66.48	16.30		130.0	
10621-AAB	IEEE 802.11ac WiFi (40MHz, MCS5, 90pc duty cycle)	X	5.40	66.76	16.64	0.46	130.0	± 9.6 %
		Y	5.38	66.43	16.48		130.0	
		Z	5.21	66.64	16.50		130.0	
10622-AAB	IEEE 802.11ac WiFi (40MHz, MCS6, 90pc duty cycle)	X	5.41	66.91	16.70	0.46	130.0	± 9.6 %
		Y	5.39	66.60	16.55		130.0	
		Z	5.20	66.74	16.55		130.0	

10623-AAB	IEEE 802.11ac WiFi (40MHz, MCS7, 90pc duty cycle)	X	5.29	66.45	16.36	0.46	130.0	± 9.6 %
		Y	5.27	66.12	16.20		130.0	
		Z	5.08	66.28	16.19		130.0	
10624-AAB	IEEE 802.11ac WiFi (40MHz, MCS8, 90pc duty cycle)	X	5.48	66.64	16.51	0.46	130.0	± 9.6 %
		Y	5.47	66.35	16.38		130.0	
		Z	5.28	66.51	16.36		130.0	
10625-AAB	IEEE 802.11ac WiFi (40MHz, MCS9, 90pc duty cycle)	X	5.87	67.67	17.07	0.46	130.0	± 9.6 %
		Y	5.92	67.56	17.03		130.0	
		Z	5.48	66.99	16.66		130.0	
10626-AAB	IEEE 802.11ac WiFi (80MHz, MCS0, 90pc duty cycle)	X	5.62	66.65	16.41	0.46	130.0	± 9.6 %
		Y	5.59	66.32	16.26		130.0	
		Z	5.46	66.52	16.28		130.0	
10627-AAB	IEEE 802.11ac WiFi (80MHz, MCS1, 90pc duty cycle)	X	5.86	67.19	16.64	0.46	130.0	± 9.6 %
		Y	5.87	66.96	16.54		130.0	
		Z	5.68	67.07	16.52		130.0	
10628-AAB	IEEE 802.11ac WiFi (80MHz, MCS2, 90pc duty cycle)	X	5.67	66.78	16.37	0.46	130.0	± 9.6 %
		Y	5.65	66.49	16.24		130.0	
		Z	5.47	66.52	16.18		130.0	
10629-AAB	IEEE 802.11ac WiFi (80MHz, MCS3, 90pc duty cycle)	X	5.76	66.87	16.41	0.46	130.0	± 9.6 %
		Y	5.74	66.55	16.26		130.0	
		Z	5.55	66.62	16.22		130.0	
10630-AAB	IEEE 802.11ac WiFi (80MHz, MCS4, 90pc duty cycle)	X	6.21	68.41	17.17	0.46	130.0	± 9.6 %
		Y	6.36	68.57	17.26		130.0	
		Z	5.84	67.72	16.78		130.0	
10631-AAB	IEEE 802.11ac WiFi (80MHz, MCS5, 90pc duty cycle)	X	6.11	68.22	17.27	0.46	130.0	± 9.6 %
		Y	6.15	68.07	17.21		130.0	
		Z	5.81	67.73	16.97		130.0	
10632-AAB	IEEE 802.11ac WiFi (80MHz, MCS6, 90pc duty cycle)	X	5.83	67.26	16.81	0.46	130.0	± 9.6 %
		Y	5.82	66.98	16.68		130.0	
		Z	5.67	67.19	16.73		130.0	
10633-AAB	IEEE 802.11ac WiFi (80MHz, MCS7, 90pc duty cycle)	X	5.73	66.95	16.48	0.46	130.0	± 9.6 %
		Y	5.72	66.66	16.35		130.0	
		Z	5.54	66.74	16.32		130.0	
10634-AAB	IEEE 802.11ac WiFi (80MHz, MCS8, 90pc duty cycle)	X	5.72	66.98	16.56	0.46	130.0	± 9.6 %
		Y	5.70	66.65	16.41		130.0	
		Z	5.52	66.78	16.40		130.0	
10635-AAB	IEEE 802.11ac WiFi (80MHz, MCS9, 90pc duty cycle)	X	5.60	66.32	15.97	0.46	130.0	± 9.6 %
		Y	5.59	66.03	15.84		130.0	
		Z	5.39	66.04	15.76		130.0	
10636-AAC	IEEE 802.11ac WiFi (160MHz, MCS0, 90pc duty cycle)	X	6.03	67.02	16.50	0.46	130.0	± 9.6 %
		Y	6.02	66.74	16.37		130.0	
		Z	5.89	66.87	16.36		130.0	
10637-AAC	IEEE 802.11ac WiFi (160MHz, MCS1, 90pc duty cycle)	X	6.19	67.40	16.66	0.46	130.0	± 9.6 %
		Y	6.19	67.15	16.56		130.0	
		Z	6.02	67.21	16.51		130.0	
10638-AAC	IEEE 802.11ac WiFi (160MHz, MCS2, 90pc duty cycle)	X	6.19	67.38	16.63	0.46	130.0	± 9.6 %
		Y	6.19	67.12	16.52		130.0	
		Z	6.03	67.21	16.49		130.0	

10639-AAC	IEEE 802.11ac WiFi (160MHz, MCS3, 90pc duty cycle)	X	6.18	67.36	16.66	0.46	130.0	± 9.6 %
		Y	6.17	67.09	16.55		130.0	
		Z	6.00	67.13	16.50		130.0	
10640-AAC	IEEE 802.11ac WiFi (160MHz, MCS4, 90pc duty cycle)	X	6.19	67.39	16.62	0.46	130.0	± 9.6 %
		Y	6.20	67.16	16.53		130.0	
		Z	5.99	67.11	16.43		130.0	
10641-AAC	IEEE 802.11ac WiFi (160MHz, MCS5, 90pc duty cycle)	X	6.21	67.22	16.56	0.46	130.0	± 9.6 %
		Y	6.20	66.94	16.44		130.0	
		Z	6.05	67.08	16.43		130.0	
10642-AAC	IEEE 802.11ac WiFi (160MHz, MCS6, 90pc duty cycle)	X	6.27	67.52	16.87	0.46	130.0	± 9.6 %
		Y	6.26	67.23	16.75		130.0	
		Z	6.09	67.31	16.72		130.0	
10643-AAC	IEEE 802.11ac WiFi (160MHz, MCS7, 90pc duty cycle)	X	6.10	67.19	16.61	0.46	130.0	± 9.6 %
		Y	6.09	66.93	16.50		130.0	
		Z	5.93	67.00	16.46		130.0	
10644-AAC	IEEE 802.11ac WiFi (160MHz, MCS8, 90pc duty cycle)	X	6.29	67.77	16.92	0.46	130.0	± 9.6 %
		Y	6.32	67.61	16.86		130.0	
		Z	6.02	67.30	16.63		130.0	
10645-AAC	IEEE 802.11ac WiFi (160MHz, MCS9, 90pc duty cycle)	X	6.72	68.61	17.29	0.46	130.0	± 9.6 %
		Y	6.81	68.60	17.31		130.0	
		Z	6.13	67.29	16.58		130.0	
10646-AAE	LTE-TDD (SC-FDMA, 1 RB, 5 MHz, QPSK, UL Subframe=2,7)	X	26.22	119.06	40.53	9.30	60.0	± 9.6 %
		Y	23.98	116.77	40.23		60.0	
		Z	13.39	105.96	36.68		60.0	
10647-AAE	LTE-TDD (SC-FDMA, 1 RB, 20 MHz, QPSK, UL Subframe=2,7)	X	21.91	115.56	39.67	9.30	60.0	± 9.6 %
		Y	20.79	114.08	39.59		60.0	
		Z	11.12	102.25	35.63		60.0	
10648-AAA	CDMA2000 (1x Advanced)	X	0.80	65.60	12.34	0.00	150.0	± 9.6 %
		Y	0.65	62.69	10.17		150.0	
		Z	0.58	62.96	9.61		150.0	
10652-AAC	LTE-TDD (OFDMA, 5 MHz, E-TM 3.1, Clipping 44%)	X	3.70	67.38	17.08	2.23	80.0	± 9.6 %
		Y	3.59	66.56	16.66		80.0	
		Z	3.39	66.83	16.41		80.0	
10653-AAC	LTE-TDD (OFDMA, 10 MHz, E-TM 3.1, Clipping 44%)	X	4.17	66.50	17.03	2.23	80.0	± 9.6 %
		Y	4.11	65.95	16.76		80.0	
		Z	3.90	66.02	16.55		80.0	
10654-AAC	LTE-TDD (OFDMA, 15 MHz, E-TM 3.1, Clipping 44%)	X	4.13	66.12	17.00	2.23	80.0	± 9.6 %
		Y	4.07	65.60	16.75		80.0	
		Z	3.90	65.62	16.55		80.0	
10655-AAD	LTE-TDD (OFDMA, 20 MHz, E-TM 3.1, Clipping 44%)	X	4.19	66.12	17.04	2.23	80.0	± 9.6 %
		Y	4.13	65.62	16.79		80.0	
		Z	3.96	65.57	16.58		80.0	
10658-AAA	Pulse Waveform (200Hz, 10%)	X	100.00	111.27	26.15	10.00	50.0	± 9.6 %
		Y	100.00	112.15	26.71		50.0	
		Z	14.35	85.50	18.40		50.0	
10659-AAA	Pulse Waveform (200Hz, 20%)	X	100.00	110.66	24.83	6.99	60.0	± 9.6 %
		Y	100.00	110.25	24.76		60.0	
		Z	100.00	105.29	22.07		60.0	

10660-AAA	Pulse Waveform (200Hz, 40%)	X	100.00	112.93	24.53	3.98	80.0	± 9.6 %
		Y	100.00	108.47	22.64		80.0	
		Z	100.00	104.83	20.58		80.0	
10661-AAA	Pulse Waveform (200Hz, 60%)	X	100.00	118.71	25.68	2.22	100.0	± 9.6 %
		Y	100.00	104.33	19.70		100.0	
		Z	100.00	104.48	19.32		100.0	
10662-AAA	Pulse Waveform (200Hz, 80%)	X	100.00	138.66	31.49	0.97	120.0	± 9.6 %
		Y	0.19	60.00	4.09		120.0	
		Z	100.00	91.23	12.90		120.0	

^E Uncertainty is determined using the max. deviation from linear response applying rectangular distribution and is expressed for the square of the field value.



Accredited by the Swiss Accreditation Service (SAS)
The Swiss Accreditation Service is one of the signatories to the EA
Multilateral Agreement for the recognition of calibration certificates

Accreditation No.: **SCS 0108**

Client **PC Test**

Certificate No: **EX3-7417_Feb19**

CALIBRATION CERTIFICATE

Object **EX3DV4 - SN:7417**

Calibration procedure(s) **QA CAL-01-19 QA CAL-23-16 QA CAL-25-17
Calibration procedure for dielectric E-field probes**

Calibration date: **February 19, 2019**

HN
02-26-2019

This calibration certificate documents the traceability to national standards, which realize the physical units of measurements (SI).
The measurements and the uncertainties with confidence probability are given on the following pages and are part of the certificate.

All calibrations have been conducted in the closed laboratory facility: environment temperature (22 ± 3)°C and humidity < 70%.

Calibration Equipment used (M&TE critical for calibration)

Primary Standards	ID	Cal Date (Certificate No.)	Scheduled Calibration
Power meter NRP	SN: 104778	04-Apr-18 (No. 217-02672/02673)	Apr-19
Power sensor NRP-Z91	SN: 103244	04-Apr-18 (No. 217-02672)	Apr-19
Power sensor NRP-Z91	SN: 103245	04-Apr-18 (No. 217-02673)	Apr-19
Reference 20 dB Attenuator	SN: S5277 (20x)	04-Apr-18 (No. 217-02682)	Apr-19
DAE4	SN: 660	19-Dec-18 (No. DAE4-660_Dec18)	Dec-19
Reference Probe ES3DV2	SN: 3013	31-Dec-18 (No. ES3-3013_Dec18)	Dec-19
Secondary Standards	ID	Check Date (in house)	Scheduled Check
Power meter E4419B	SN: GB41293874	06-Apr-16 (in house check Jun-18)	In house check: Jun-20
Power sensor E4412A	SN: MY41498087	06-Apr-16 (in house check Jun-18)	In house check: Jun-20
Power sensor E4412A	SN: 000110210	06-Apr-16 (in house check Jun-18)	In house check: Jun-20
RF generator HP 8648C	SN: US3642U01700	04-Aug-99 (in house check Jun-18)	In house check: Jun-20
Network Analyzer E8358A	SN: US41080477	31-Mar-14 (in house check Oct-18)	In house check: Oct-19

Calibrated by:	Name Claudio Leubler	Function Laboratory Technician	Signature
Approved by:	Name Katja Pokovic	Function Technical Manager	Signature

Issued: February 20, 2019

This calibration certificate shall not be reproduced except in full without written approval of the laboratory.



Accredited by the Swiss Accreditation Service (SAS)

Accreditation No.: **SCS 0108**

The Swiss Accreditation Service is one of the signatories to the EA Multilateral Agreement for the recognition of calibration certificates

Glossary:

TSL	tissue simulating liquid
NORM _{x,y,z}	sensitivity in free space
ConvF	sensitivity in TSL / NORM _{x,y,z}
DCP	diode compression point
CF	crest factor (1/duty_cycle) of the RF signal
A, B, C, D	modulation dependent linearization parameters
Polarization φ	φ rotation around probe axis
Polarization §	§ rotation around an axis that is in the plane normal to probe axis (at measurement center), i.e., § = 0 is normal to probe axis
Connector Angle	information used in DASY system to align probe sensor X to the robot coordinate system

Calibration is Performed According to the Following Standards:

- a) IEEE Std 1528-2013, "IEEE Recommended Practice for Determining the Peak Spatial-Averaged Specific Absorption Rate (SAR) in the Human Head from Wireless Communications Devices: Measurement Techniques", June 2013
- b) IEC 62209-1, "Measurement procedure for the assessment of Specific Absorption Rate (SAR) from hand-held and body-mounted devices used next to the ear (frequency range of 300 MHz to 6 GHz)", July 2016
- c) IEC 62209-2, "Procedure to determine the Specific Absorption Rate (SAR) for wireless communication devices used in close proximity to the human body (frequency range of 30 MHz to 6 GHz)", March 2010
- d) KDB 865664, "SAR Measurement Requirements for 100 MHz to 6 GHz"

Methods Applied and Interpretation of Parameters:

- *NORM_{x,y,z}*: Assessed for E-field polarization § = 0 (f ≤ 900 MHz in TEM-cell; f > 1800 MHz: R22 waveguide). *NORM_{x,y,z}* are only intermediate values, i.e., the uncertainties of *NORM_{x,y,z}* does not affect the E²-field uncertainty inside TSL (see below *ConvF*).
- *NORM(f)_{x,y,z}* = *NORM_{x,y,z}* * *frequency_response* (see Frequency Response Chart). This linearization is implemented in DASY4 software versions later than 4.2. The uncertainty of the frequency response is included in the stated uncertainty of *ConvF*.
- *DCP_{x,y,z}*: DCP are numerical linearization parameters assessed based on the data of power sweep with CW signal (no uncertainty required). DCP does not depend on frequency nor media.
- *PAR*: PAR is the Peak to Average Ratio that is not calibrated but determined based on the signal characteristics
- *A_{x,y,z}*; *B_{x,y,z}*; *C_{x,y,z}*; *D_{x,y,z}*; *VR_{x,y,z}*: *A, B, C, D* are numerical linearization parameters assessed based on the data of power sweep for specific modulation signal. The parameters do not depend on frequency nor media. *VR* is the maximum calibration range expressed in RMS voltage across the diode.
- *ConvF and Boundary Effect Parameters*: Assessed in flat phantom using E-field (or Temperature Transfer Standard for f ≤ 800 MHz) and inside waveguide using analytical field distributions based on power measurements for f > 800 MHz. The same setups are used for assessment of the parameters applied for boundary compensation (alpha, depth) of which typical uncertainty values are given. These parameters are used in DASY4 software to improve probe accuracy close to the boundary. The sensitivity in TSL corresponds to *NORM_{x,y,z}* * *ConvF* whereby the uncertainty corresponds to that given for *ConvF*. A frequency dependent *ConvF* is used in DASY version 4.4 and higher which allows extending the validity from ± 50 MHz to ± 100 MHz.
- *Spherical isotropy (3D deviation from isotropy)*: in a field of low gradients realized using a flat phantom exposed by a patch antenna.
- *Sensor Offset*: The sensor offset corresponds to the offset of virtual measurement center from the probe tip (on probe axis). No tolerance required.
- *Connector Angle*: The angle is assessed using the information gained by determining the *NORM_x* (no uncertainty required).

DASY/EASY - Parameters of Probe: EX3DV4 - SN:7417

Basic Calibration Parameters

	Sensor X	Sensor Y	Sensor Z	Unc (k=2)
Norm ($\mu\text{V}/(\text{V}/\text{m})^2$) ^A	0.54	0.43	0.53	± 10.1 %
DCP (mV) ^B	98.7	97.4	100.4	

Calibration Results for Modulation Response

UID	Communication System Name		A dB	B dB $\sqrt{\mu\text{V}}$	C	D dB	VR mV	Max dev.	Max Unc ^E (k=2)
0	CW	X	0.00	0.00	1.00	0.00	144.6	± 3.3 %	± 4.7 %
		Y	0.00	0.00	1.00		149.7		
		Z	0.00	0.00	1.00		143.1		
10352-AAA	Pulse Waveform (200Hz, 10%)	X	15.00	88.38	19.65	10.00	60.0	± 3.3 %	± 9.6 %
		Y	4.33	71.38	13.30		60.0		
		Z	7.40	77.44	14.95		60.0		
10353-AAA	Pulse Waveform (200Hz, 20%)	X	15.00	92.19	20.43	6.99	80.0	± 2.2 %	± 9.6 %
		Y	5.53	76.01	13.64		80.0		
		Z	15.00	85.74	16.43		80.0		
10354-AAA	Pulse Waveform (200Hz, 40%)	X	15.00	107.68	26.54	3.98	95.0	± 1.3 %	± 9.6 %
		Y	9.05	79.53	12.66		95.0		
		Z	15.00	90.71	17.41		95.0		
10355-AAA	Pulse Waveform (200Hz, 60%)	X	15.00	127.17	33.83	2.22	120.0	± 1.2 %	± 9.6 %
		Y	0.26	60.00	4.45		120.0		
		Z	15.00	99.84	20.30		120.0		
10387-AAA	QPSK Waveform, 1 MHz	X	0.56	60.62	7.74	0.00	150.0	± 3.6 %	± 9.6 %
		Y	0.42	60.00	4.69		150.0		
		Z	0.44	60.00	5.48		150.0		
10388-AAA	QPSK Waveform, 10 MHz	X	2.27	69.09	16.46	0.00	150.0	± 1.3 %	± 9.6 %
		Y	1.94	67.43	15.43		150.0		
		Z	2.06	68.27	16.05		150.0		
10396-AAA	64-QAM Waveform, 100 kHz	X	3.15	72.71	19.95	3.01	150.0	± 2.5 %	± 9.6 %
		Y	2.04	67.08	18.19		150.0		
		Z	2.07	66.03	16.88		150.0		
10399-AAA	64-QAM Waveform, 40 MHz	X	3.52	67.53	16.10	0.00	150.0	± 2.4 %	± 9.6 %
		Y	3.32	66.83	15.68		150.0		
		Z	3.38	67.15	15.89		150.0		
10414-AAA	WLAN CCDF, 64-QAM, 40MHz	X	4.80	65.90	15.74	0.00	150.0	± 4.4 %	± 9.6 %
		Y	4.58	65.58	15.59		150.0		
		Z	4.60	65.76	15.65		150.0		

Note: For details on UID parameters see Appendix

The reported uncertainty of measurement is stated as the standard uncertainty of measurement multiplied by the coverage factor k=2, which for a normal distribution corresponds to a coverage probability of approximately 95%.

^A The uncertainties of Norm X,Y,Z do not affect the E²-field uncertainty inside TSL (see Pages 5 and 6).

^B Numerical linearization parameter: uncertainty not required.

^E Uncertainty is determined using the max. deviation from linear response applying rectangular distribution and is expressed for the square of the field value.

DASY/EASY - Parameters of Probe: EX3DV4 - SN:7417

Sensor Model Parameters

	C1 fF	C2 fF	α V ⁻¹	T1 ms.V ⁻²	T2 ms.V ⁻¹	T3 ms	T4 V ⁻²	T5 V ⁻¹	T6
X	37.6	279.10	35.33	9.45	0.00	5.09	1.69	0.14	1.01
Y	29.6	227.60	37.50	5.19	0.43	5.04	0.00	0.16	1.01
Z	28.8	214.34	35.37	6.91	0.00	5.04	0.00	0.24	1.00

Other Probe Parameters

Sensor Arrangement	Triangular
Connector Angle (°)	120.5
Mechanical Surface Detection Mode	enabled
Optical Surface Detection Mode	disabled
Probe Overall Length	337 mm
Probe Body Diameter	10 mm
Tip Length	9 mm
Tip Diameter	2.5 mm
Probe Tip to Sensor X Calibration Point	1 mm
Probe Tip to Sensor Y Calibration Point	1 mm
Probe Tip to Sensor Z Calibration Point	1 mm
Recommended Measurement Distance from Surface	1.4 mm

DASY/EASY - Parameters of Probe: EX3DV4 - SN:7417

Calibration Parameter Determined in Head Tissue Simulating Media

f (MHz) ^c	Relative Permittivity ^F	Conductivity (S/m) ^F	ConvF X	ConvF Y	ConvF Z	Alpha ^G	Depth ^G (mm)	Unc (k=2)
750	41.9	0.89	10.36	10.36	10.36	0.54	0.99	± 12.0 %
835	41.5	0.90	10.07	10.07	10.07	0.48	0.84	± 12.0 %
1750	40.1	1.37	8.39	8.39	8.39	0.38	0.85	± 12.0 %
1900	40.0	1.40	8.11	8.11	8.11	0.39	0.84	± 12.0 %
2300	39.5	1.67	7.73	7.73	7.73	0.30	0.93	± 12.0 %
2450	39.2	1.80	7.46	7.46	7.46	0.39	0.95	± 12.0 %
2600	39.0	1.96	7.17	7.17	7.17	0.31	1.05	± 12.0 %

^c Frequency validity above 300 MHz of ± 100 MHz only applies for DASY v4.4 and higher (see Page 2), else it is restricted to ± 50 MHz. The uncertainty is the RSS of the ConvF uncertainty at calibration frequency and the uncertainty for the indicated frequency band. Frequency validity below 300 MHz is ± 10, 25, 40, 50 and 70 MHz for ConvF assessments at 30, 64, 128, 150 and 220 MHz respectively. Validity of ConvF assessed at 6 MHz is 4-9 MHz, and ConvF assessed at 13 MHz is 9-19 MHz. Above 5 GHz frequency validity can be extended to ± 110 MHz.

^F At frequencies below 3 GHz, the validity of tissue parameters (ϵ and σ) can be relaxed to ± 10% if liquid compensation formula is applied to measured SAR values. At frequencies above 3 GHz, the validity of tissue parameters (ϵ and σ) is restricted to ± 5%. The uncertainty is the RSS of the ConvF uncertainty for indicated target tissue parameters.

^G Alpha/Depth are determined during calibration. SPEAG warrants that the remaining deviation due to the boundary effect after compensation is always less than ± 1% for frequencies below 3 GHz and below ± 2% for frequencies between 3-6 GHz at any distance larger than half the probe tip diameter from the boundary.

DASY/EASY - Parameters of Probe: EX3DV4 - SN:7417

Calibration Parameter Determined in Body Tissue Simulating Media

f (MHz) ^C	Relative Permittivity ^F	Conductivity (S/m) ^F	ConvF X	ConvF Y	ConvF Z	Alpha ^G	Depth ^G (mm)	Unc (k=2)
750	55.5	0.96	10.35	10.35	10.35	0.63	0.84	± 12.0 %
835	55.2	0.97	10.11	10.11	10.11	0.43	0.84	± 12.0 %
1750	53.4	1.49	8.21	8.21	8.21	0.43	0.88	± 12.0 %
1900	53.3	1.52	7.86	7.86	7.86	0.43	0.87	± 12.0 %
2300	52.9	1.81	7.64	7.64	7.64	0.41	0.93	± 12.0 %
2450	52.7	1.95	7.51	7.51	7.51	0.40	0.95	± 12.0 %
2600	52.5	2.16	7.37	7.37	7.37	0.33	1.05	± 12.0 %

^C Frequency validity above 300 MHz of ± 100 MHz only applies for DASY v4.4 and higher (see Page 2), else it is restricted to ± 50 MHz. The uncertainty is the RSS of the ConvF uncertainty at calibration frequency and the uncertainty for the indicated frequency band. Frequency validity below 300 MHz is ± 10, 25, 40, 50 and 70 MHz for ConvF assessments at 30, 64, 128, 150 and 220 MHz respectively. Validity of ConvF assessed at 6 MHz is 4-9 MHz, and ConvF assessed at 13 MHz is 9-19 MHz. Above 5 GHz frequency validity can be extended to ± 110 MHz.

^F At frequencies below 3 GHz, the validity of tissue parameters (ϵ and σ) can be relaxed to ± 10% if liquid compensation formula is applied to measured SAR values. At frequencies above 3 GHz, the validity of tissue parameters (ϵ and σ) is restricted to ± 5%. The uncertainty is the RSS of the ConvF uncertainty for indicated target tissue parameters.

^G Alpha/Depth are determined during calibration. SPEAG warrants that the remaining deviation due to the boundary effect after compensation is always less than ± 1% for frequencies below 3 GHz and below ± 2% for frequencies between 3-6 GHz at any distance larger than half the probe tip diameter from the boundary.

Frequency Response of E-Field (TEM-Cell:ifi110 EXX, Waveguide: R22)

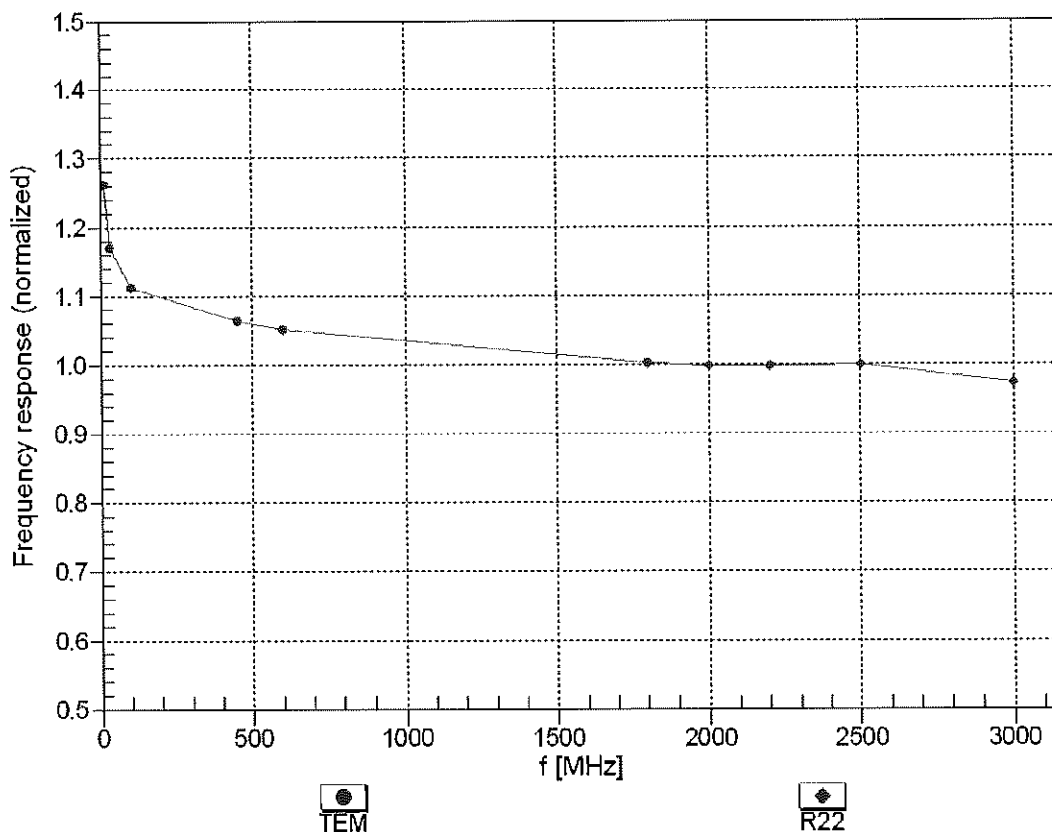

Uncertainty of Frequency Response of E-field: $\pm 6.3\%$ (k=2)

Receiving Pattern (ϕ), $\theta = 0^\circ$

f=600 MHz, TEM

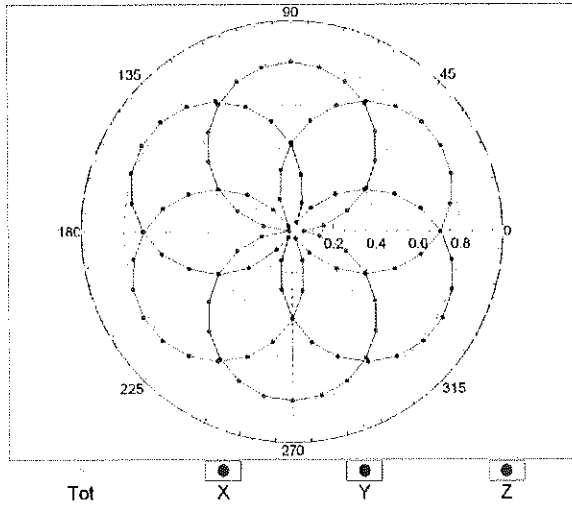

f=1800 MHz, R22

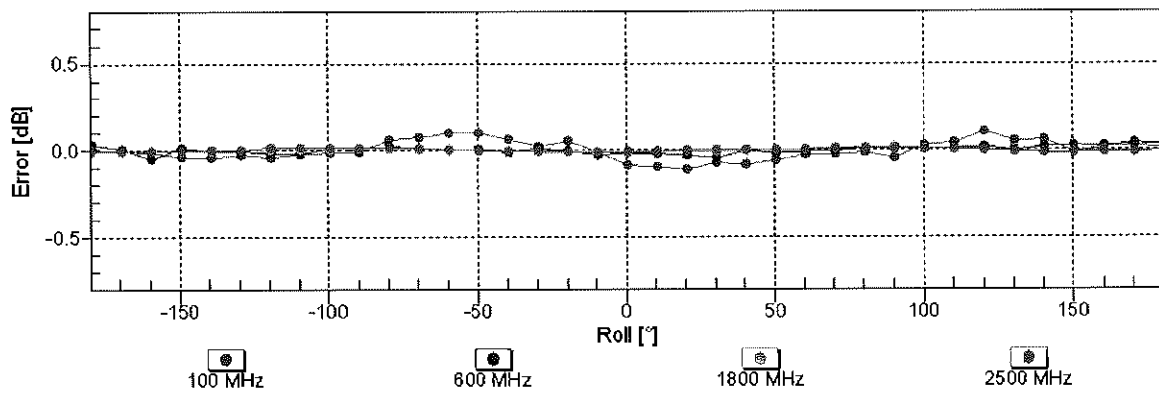
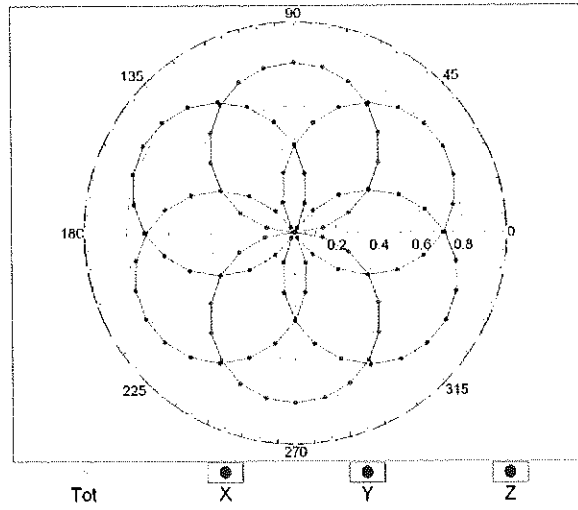

Uncertainty of Axial Isotropy Assessment: $\pm 0.5\%$ (k=2)

Dynamic Range f(SAR_{head}) (TEM cell , f_{eval}= 1900 MHz)

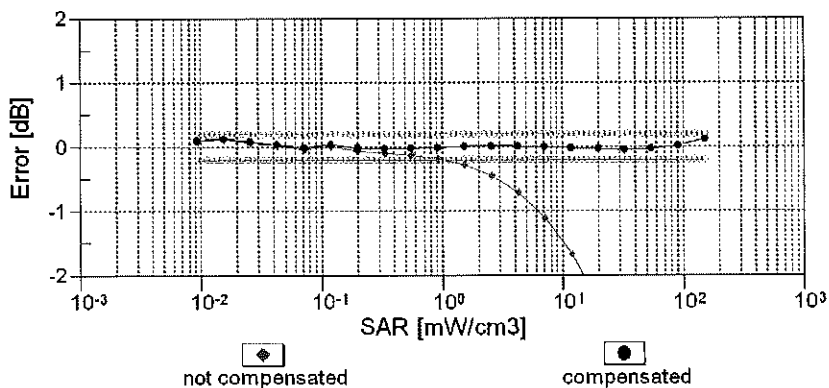
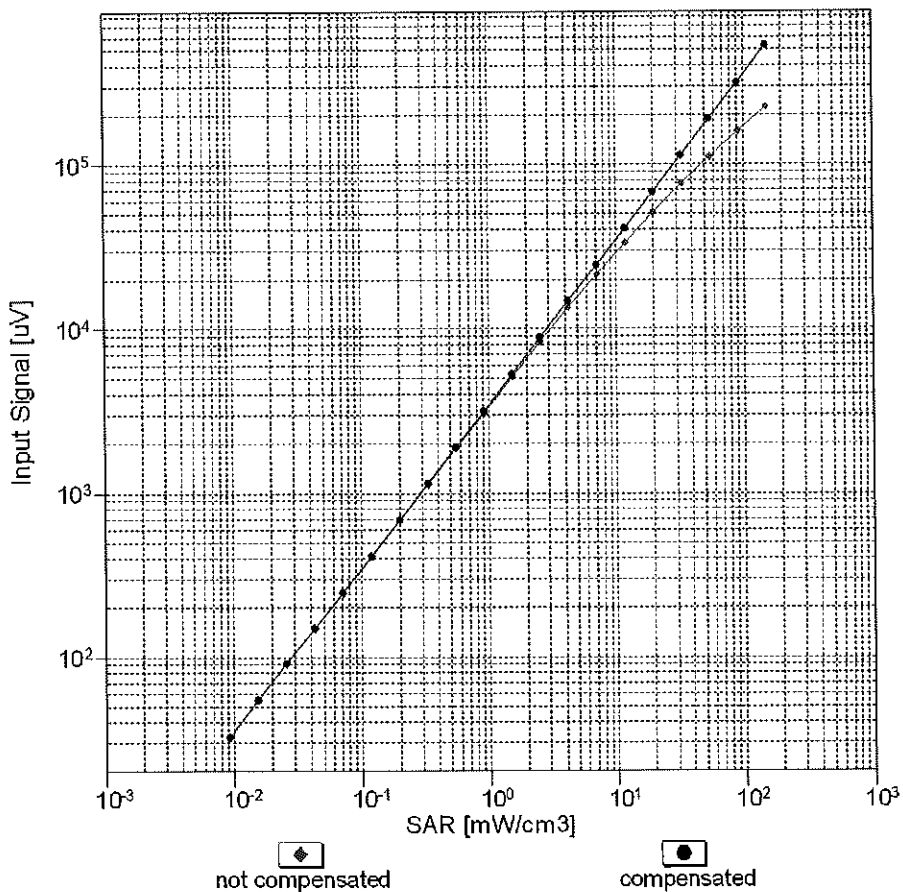

Uncertainty of Linearity Assessment: ± 0.6% (k=2)

Conversion Factor Assessment

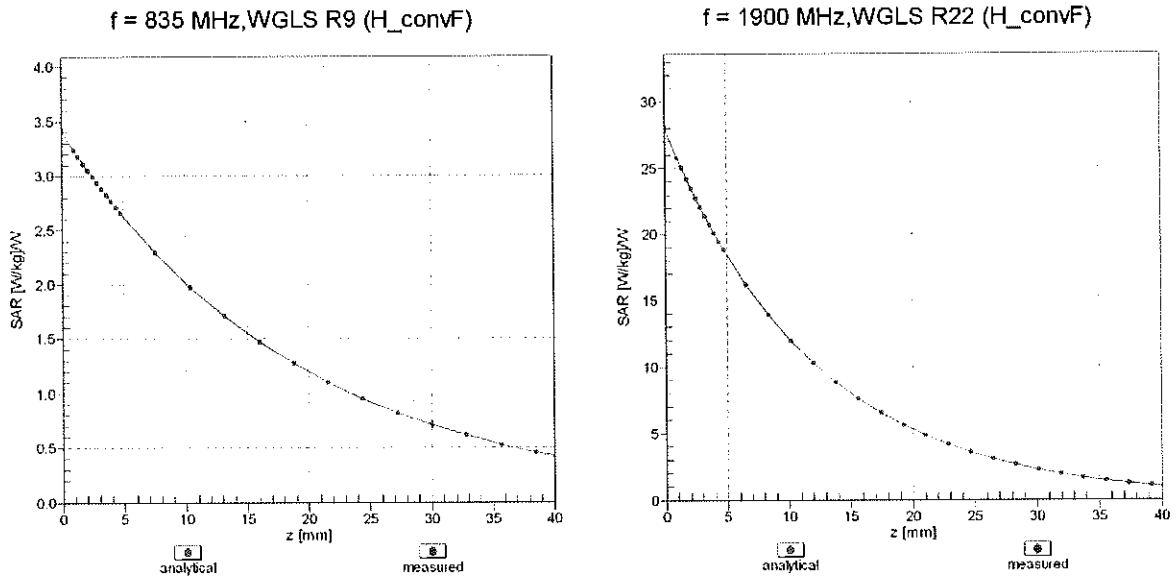

Deviation from Isotropy in Liquid

Error (ϕ, θ), f = 900 MHz

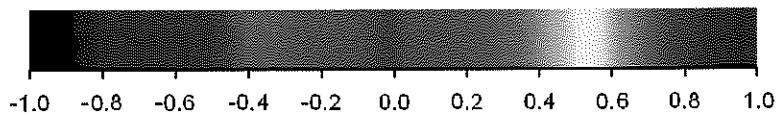
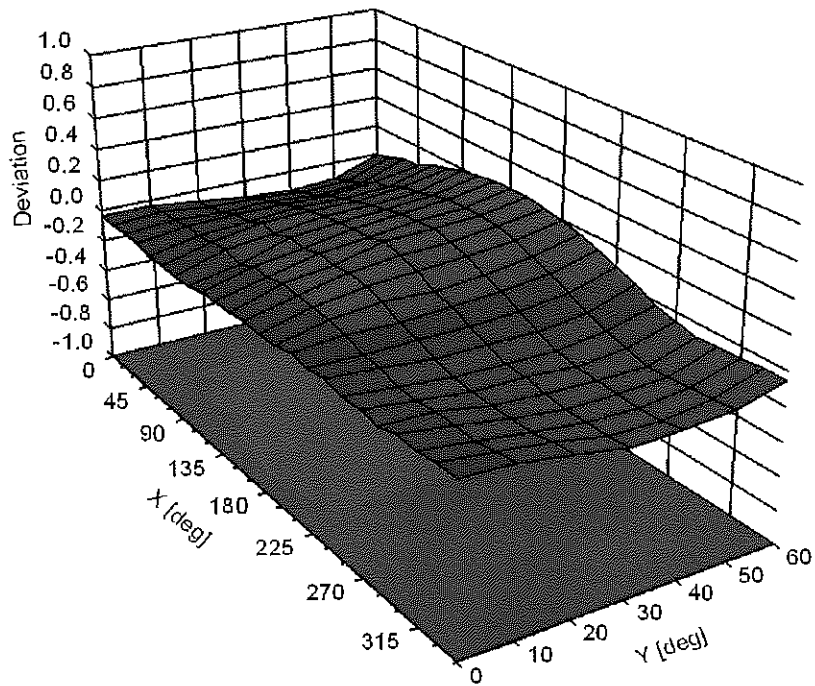

Uncertainty of Spherical Isotropy Assessment: $\pm 2.6\%$ (k=2)

Appendix: Modulation Calibration Parameters

UID	Rev	Communication System Name	Group	PAR (dB)	Unc ^F (k=2)
0		CW	CW	0.00	± 4.7 %
10010	CAA	SAR Validation (Square, 100ms, 10ms)	Test	10.00	± 9.6 %
10011	CAB	UMTS-FDD (WCDMA)	WCDMA	2.91	± 9.6 %
10012	CAB	IEEE 802.11b WiFi 2.4 GHz (DSSS, 1 Mbps)	WLAN	1.87	± 9.6 %
10013	CAB	IEEE 802.11g WiFi 2.4 GHz (DSSS-OFDM, 6 Mbps)	WLAN	9.46	± 9.6 %
10021	DAC	GSM-FDD (TDMA, GMSK)	GSM	9.39	± 9.6 %
10023	DAC	GPRS-FDD (TDMA, GMSK, TN 0)	GSM	9.57	± 9.6 %
10024	DAC	GPRS-FDD (TDMA, GMSK, TN 0-1)	GSM	6.56	± 9.6 %
10025	DAC	EDGE-FDD (TDMA, 8PSK, TN 0)	GSM	12.62	± 9.6 %
10026	DAC	EDGE-FDD (TDMA, 8PSK, TN 0-1)	GSM	9.55	± 9.6 %
10027	DAC	GPRS-FDD (TDMA, GMSK, TN 0-1-2)	GSM	4.80	± 9.6 %
10028	DAC	GPRS-FDD (TDMA, GMSK, TN 0-1-2-3)	GSM	3.55	± 9.6 %
10029	DAC	EDGE-FDD (TDMA, 8PSK, TN 0-1-2)	GSM	7.78	± 9.6 %
10030	CAA	IEEE 802.15.1 Bluetooth (GFSK, DH1)	Bluetooth	5.30	± 9.6 %
10031	CAA	IEEE 802.15.1 Bluetooth (GFSK, DH3)	Bluetooth	1.87	± 9.6 %
10032	CAA	IEEE 802.15.1 Bluetooth (GFSK, DH5)	Bluetooth	1.16	± 9.6 %
10033	CAA	IEEE 802.15.1 Bluetooth (PI/4-DQPSK, DH1)	Bluetooth	7.74	± 9.6 %
10034	CAA	IEEE 802.15.1 Bluetooth (PI/4-DQPSK, DH3)	Bluetooth	4.53	± 9.6 %
10035	CAA	IEEE 802.15.1 Bluetooth (PI/4-DQPSK, DH5)	Bluetooth	3.83	± 9.6 %
10036	CAA	IEEE 802.15.1 Bluetooth (8-DPSK, DH1)	Bluetooth	8.01	± 9.6 %
10037	CAA	IEEE 802.15.1 Bluetooth (8-DPSK, DH3)	Bluetooth	4.77	± 9.6 %
10038	CAA	IEEE 802.15.1 Bluetooth (8-DPSK, DH5)	Bluetooth	4.10	± 9.6 %
10039	CAB	CDMA2000 (1xRTT, RC1)	CDMA2000	4.57	± 9.6 %
10042	CAB	IS-54 / IS-136 FDD (TDMA/FDM, PI/4-DQPSK, Halfrate)	AMPS	7.78	± 9.6 %
10044	CAA	IS-91/EIA/TIA-553 FDD (FDMA, FM)	AMPS	0.00	± 9.6 %
10048	CAA	DECT (TDD, TDMA/FDM, GFSK, Full Slot, 24)	DECT	13.80	± 9.6 %
10049	CAA	DECT (TDD, TDMA/FDM, GFSK, Double Slot, 12)	DECT	10.79	± 9.6 %
10056	CAA	UMTS-TDD (TD-SCDMA, 1.28 Mcps)	TD-SCDMA	11.01	± 9.6 %
10058	DAC	EDGE-FDD (TDMA, 8PSK, TN 0-1-2-3)	GSM	6.52	± 9.6 %
10059	CAB	IEEE 802.11b WiFi 2.4 GHz (DSSS, 2 Mbps)	WLAN	2.12	± 9.6 %
10060	CAB	IEEE 802.11b WiFi 2.4 GHz (DSSS, 5.5 Mbps)	WLAN	2.83	± 9.6 %
10061	CAB	IEEE 802.11b WiFi 2.4 GHz (DSSS, 11 Mbps)	WLAN	3.60	± 9.6 %
10062	CAC	IEEE 802.11a/h WiFi 5 GHz (OFDM, 6 Mbps)	WLAN	8.68	± 9.6 %
10063	CAC	IEEE 802.11a/h WiFi 5 GHz (OFDM, 9 Mbps)	WLAN	8.63	± 9.6 %
10064	CAC	IEEE 802.11a/h WiFi 5 GHz (OFDM, 12 Mbps)	WLAN	9.09	± 9.6 %
10065	CAC	IEEE 802.11a/h WiFi 5 GHz (OFDM, 18 Mbps)	WLAN	9.00	± 9.6 %
10066	CAC	IEEE 802.11a/h WiFi 5 GHz (OFDM, 24 Mbps)	WLAN	9.38	± 9.6 %
10067	CAC	IEEE 802.11a/h WiFi 5 GHz (OFDM, 36 Mbps)	WLAN	10.12	± 9.6 %
10068	CAC	IEEE 802.11a/h WiFi 5 GHz (OFDM, 48 Mbps)	WLAN	10.24	± 9.6 %
10069	CAC	IEEE 802.11a/h WiFi 5 GHz (OFDM, 54 Mbps)	WLAN	10.56	± 9.6 %
10071	CAB	IEEE 802.11g WiFi 2.4 GHz (DSSS/OFDM, 9 Mbps)	WLAN	9.83	± 9.6 %
10072	CAB	IEEE 802.11g WiFi 2.4 GHz (DSSS/OFDM, 12 Mbps)	WLAN	9.62	± 9.6 %
10073	CAB	IEEE 802.11g WiFi 2.4 GHz (DSSS/OFDM, 18 Mbps)	WLAN	9.94	± 9.6 %
10074	CAB	IEEE 802.11g WiFi 2.4 GHz (DSSS/OFDM, 24 Mbps)	WLAN	10.30	± 9.6 %
10075	CAB	IEEE 802.11g WiFi 2.4 GHz (DSSS/OFDM, 36 Mbps)	WLAN	10.77	± 9.6 %
10076	CAB	IEEE 802.11g WiFi 2.4 GHz (DSSS/OFDM, 48 Mbps)	WLAN	10.94	± 9.6 %
10077	CAB	IEEE 802.11g WiFi 2.4 GHz (DSSS/OFDM, 54 Mbps)	WLAN	11.00	± 9.6 %
10081	CAB	CDMA2000 (1xRTT, RC3)	CDMA2000	3.97	± 9.6 %
10082	CAB	IS-54 / IS-136 FDD (TDMA/FDM, PI/4-DQPSK, Fullrate)	AMPS	4.77	± 9.6 %
10090	DAC	GPRS-FDD (TDMA, GMSK, TN 0-4)	GSM	6.56	± 9.6 %
10097	CAB	UMTS-FDD (HSDPA)	WCDMA	3.98	± 9.6 %
10098	CAB	UMTS-FDD (HSUPA, Subtest 2)	WCDMA	3.98	± 9.6 %
10099	DAC	EDGE-FDD (TDMA, 8PSK, TN 0-4)	GSM	9.55	± 9.6 %
10100	CAE	LTE-FDD (SC-FDMA, 100% RB, 20 MHz, QPSK)	LTE-FDD	5.67	± 9.6 %
10101	CAE	LTE-FDD (SC-FDMA, 100% RB, 20 MHz, 16-QAM)	LTE-FDD	6.42	± 9.6 %
10102	CAE	LTE-FDD (SC-FDMA, 100% RB, 20 MHz, 64-QAM)	LTE-FDD	6.60	± 9.6 %
10103	CAG	LTE-TDD (SC-FDMA, 100% RB, 20 MHz, QPSK)	LTE-TDD	9.29	± 9.6 %
10104	CAG	LTE-TDD (SC-FDMA, 100% RB, 20 MHz, 16-QAM)	LTE-TDD	9.97	± 9.6 %
10105	CAG	LTE-TDD (SC-FDMA, 100% RB, 20 MHz, 64-QAM)	LTE-TDD	10.01	± 9.6 %
10108	CAG	LTE-FDD (SC-FDMA, 100% RB, 10 MHz, QPSK)	LTE-FDD	5.80	± 9.6 %

10109	CAG	LTE-FDD (SC-FDMA, 100% RB, 10 MHz, 16-QAM)	LTE-FDD	6.43	± 9.6 %
10110	CAG	LTE-FDD (SC-FDMA, 100% RB, 5 MHz, QPSK)	LTE-FDD	5.75	± 9.6 %
10111	CAG	LTE-FDD (SC-FDMA, 100% RB, 5 MHz, 16-QAM)	LTE-FDD	6.44	± 9.6 %
10112	CAG	LTE-FDD (SC-FDMA, 100% RB, 10 MHz, 64-QAM)	LTE-FDD	6.59	± 9.6 %
10113	CAG	LTE-FDD (SC-FDMA, 100% RB, 5 MHz, 64-QAM)	LTE-FDD	6.62	± 9.6 %
10114	CAC	IEEE 802.11n (HT Greenfield, 13.5 Mbps, BPSK)	WLAN	8.10	± 9.6 %
10115	CAC	IEEE 802.11n (HT Greenfield, 81 Mbps, 16-QAM)	WLAN	8.46	± 9.6 %
10116	CAC	IEEE 802.11n (HT Greenfield, 135 Mbps, 64-QAM)	WLAN	8.15	± 9.6 %
10117	CAC	IEEE 802.11n (HT Mixed, 13.5 Mbps, BPSK)	WLAN	8.07	± 9.6 %
10118	CAC	IEEE 802.11n (HT Mixed, 81 Mbps, 16-QAM)	WLAN	8.59	± 9.6 %
10119	CAC	IEEE 802.11n (HT Mixed, 135 Mbps, 64-QAM)	WLAN	8.13	± 9.6 %
10140	CAE	LTE-FDD (SC-FDMA, 100% RB, 15 MHz, 16-QAM)	LTE-FDD	6.49	± 9.6 %
10141	CAE	LTE-FDD (SC-FDMA, 100% RB, 15 MHz, 64-QAM)	LTE-FDD	6.53	± 9.6 %
10142	CAE	LTE-FDD (SC-FDMA, 100% RB, 3 MHz, QPSK)	LTE-FDD	5.73	± 9.6 %
10143	CAE	LTE-FDD (SC-FDMA, 100% RB, 3 MHz, 16-QAM)	LTE-FDD	6.35	± 9.6 %
10144	CAE	LTE-FDD (SC-FDMA, 100% RB, 3 MHz, 64-QAM)	LTE-FDD	6.65	± 9.6 %
10145	CAF	LTE-FDD (SC-FDMA, 100% RB, 1.4 MHz, QPSK)	LTE-FDD	5.76	± 9.6 %
10146	CAF	LTE-FDD (SC-FDMA, 100% RB, 1.4 MHz, 16-QAM)	LTE-FDD	6.41	± 9.6 %
10147	CAF	LTE-FDD (SC-FDMA, 100% RB, 1.4 MHz, 64-QAM)	LTE-FDD	6.72	± 9.6 %
10149	CAE	LTE-FDD (SC-FDMA, 50% RB, 20 MHz, 16-QAM)	LTE-FDD	6.42	± 9.6 %
10150	CAE	LTE-FDD (SC-FDMA, 50% RB, 20 MHz, 64-QAM)	LTE-FDD	6.60	± 9.6 %
10151	CAG	LTE-TDD (SC-FDMA, 50% RB, 20 MHz, QPSK)	LTE-TDD	9.28	± 9.6 %
10152	CAG	LTE-TDD (SC-FDMA, 50% RB, 20 MHz, 16-QAM)	LTE-TDD	9.92	± 9.6 %
10153	CAG	LTE-TDD (SC-FDMA, 50% RB, 20 MHz, 64-QAM)	LTE-TDD	10.05	± 9.6 %
10154	CAG	LTE-FDD (SC-FDMA, 50% RB, 10 MHz, QPSK)	LTE-FDD	5.75	± 9.6 %
10155	CAG	LTE-FDD (SC-FDMA, 50% RB, 10 MHz, 16-QAM)	LTE-FDD	6.43	± 9.6 %
10156	CAG	LTE-FDD (SC-FDMA, 50% RB, 5 MHz, QPSK)	LTE-FDD	5.79	± 9.6 %
10157	CAG	LTE-FDD (SC-FDMA, 50% RB, 5 MHz, 16-QAM)	LTE-FDD	6.49	± 9.6 %
10158	CAG	LTE-FDD (SC-FDMA, 50% RB, 10 MHz, 64-QAM)	LTE-FDD	6.62	± 9.6 %
10159	CAG	LTE-FDD (SC-FDMA, 50% RB, 5 MHz, 64-QAM)	LTE-FDD	6.56	± 9.6 %
10160	CAE	LTE-FDD (SC-FDMA, 50% RB, 15 MHz, QPSK)	LTE-FDD	5.82	± 9.6 %
10161	CAE	LTE-FDD (SC-FDMA, 50% RB, 15 MHz, 16-QAM)	LTE-FDD	6.43	± 9.6 %
10162	CAE	LTE-FDD (SC-FDMA, 50% RB, 15 MHz, 64-QAM)	LTE-FDD	6.58	± 9.6 %
10166	CAF	LTE-FDD (SC-FDMA, 50% RB, 1.4 MHz, QPSK)	LTE-FDD	5.46	± 9.6 %
10167	CAF	LTE-FDD (SC-FDMA, 50% RB, 1.4 MHz, 16-QAM)	LTE-FDD	6.21	± 9.6 %
10168	CAF	LTE-FDD (SC-FDMA, 50% RB, 1.4 MHz, 64-QAM)	LTE-FDD	6.79	± 9.6 %
10169	CAE	LTE-FDD (SC-FDMA, 1 RB, 20 MHz, QPSK)	LTE-FDD	5.73	± 9.6 %
10170	CAE	LTE-FDD (SC-FDMA, 1 RB, 20 MHz, 16-QAM)	LTE-FDD	6.52	± 9.6 %
10171	AAE	LTE-FDD (SC-FDMA, 1 RB, 20 MHz, 64-QAM)	LTE-FDD	6.49	± 9.6 %
10172	CAG	LTE-TDD (SC-FDMA, 1 RB, 20 MHz, QPSK)	LTE-TDD	9.21	± 9.6 %
10173	CAG	LTE-TDD (SC-FDMA, 1 RB, 20 MHz, 16-QAM)	LTE-TDD	9.48	± 9.6 %
10174	CAG	LTE-TDD (SC-FDMA, 1 RB, 20 MHz, 64-QAM)	LTE-TDD	10.25	± 9.6 %
10175	CAG	LTE-FDD (SC-FDMA, 1 RB, 10 MHz, QPSK)	LTE-FDD	5.72	± 9.6 %
10176	CAG	LTE-FDD (SC-FDMA, 1 RB, 10 MHz, 16-QAM)	LTE-FDD	6.52	± 9.6 %
10177	CAI	LTE-FDD (SC-FDMA, 1 RB, 5 MHz, QPSK)	LTE-FDD	5.73	± 9.6 %
10178	CAG	LTE-FDD (SC-FDMA, 1 RB, 5 MHz, 16-QAM)	LTE-FDD	6.52	± 9.6 %
10179	CAG	LTE-FDD (SC-FDMA, 1 RB, 10 MHz, 64-QAM)	LTE-FDD	6.50	± 9.6 %
10180	CAG	LTE-FDD (SC-FDMA, 1 RB, 5 MHz, 64-QAM)	LTE-FDD	6.50	± 9.6 %
10181	CAE	LTE-FDD (SC-FDMA, 1 RB, 15 MHz, QPSK)	LTE-FDD	5.72	± 9.6 %
10182	CAE	LTE-FDD (SC-FDMA, 1 RB, 15 MHz, 16-QAM)	LTE-FDD	6.52	± 9.6 %
10183	AAD	LTE-FDD (SC-FDMA, 1 RB, 15 MHz, 64-QAM)	LTE-FDD	6.50	± 9.6 %
10184	CAE	LTE-FDD (SC-FDMA, 1 RB, 3 MHz, QPSK)	LTE-FDD	5.73	± 9.6 %
10185	CAE	LTE-FDD (SC-FDMA, 1 RB, 3 MHz, 16-QAM)	LTE-FDD	6.51	± 9.6 %
10186	AAE	LTE-FDD (SC-FDMA, 1 RB, 3 MHz, 64-QAM)	LTE-FDD	6.50	± 9.6 %
10187	CAF	LTE-FDD (SC-FDMA, 1 RB, 1.4 MHz, QPSK)	LTE-FDD	5.73	± 9.6 %
10188	CAF	LTE-FDD (SC-FDMA, 1 RB, 1.4 MHz, 16-QAM)	LTE-FDD	6.52	± 9.6 %
10189	AAF	LTE-FDD (SC-FDMA, 1 RB, 1.4 MHz, 64-QAM)	LTE-FDD	6.50	± 9.6 %
10193	CAC	IEEE 802.11n (HT Greenfield, 6.5 Mbps, BPSK)	WLAN	8.09	± 9.6 %
10194	CAC	IEEE 802.11n (HT Greenfield, 39 Mbps, 16-QAM)	WLAN	8.12	± 9.6 %
10195	CAC	IEEE 802.11n (HT Greenfield, 65 Mbps, 64-QAM)	WLAN	8.21	± 9.6 %
10196	CAC	IEEE 802.11n (HT Mixed, 6.5 Mbps, BPSK)	WLAN	8.10	± 9.6 %
10197	CAC	IEEE 802.11n (HT Mixed, 39 Mbps, 16-QAM)	WLAN	8.13	± 9.6 %
10198	CAC	IEEE 802.11n (HT Mixed, 65 Mbps, 64-QAM)	WLAN	8.27	± 9.6 %
10219	CAC	IEEE 802.11n (HT Mixed, 7.2 Mbps, BPSK)	WLAN	8.03	± 9.6 %

10220	CAC	IEEE 802.11n (HT Mixed, 43.3 Mbps, 16-QAM)	WLAN	8.13	±9.6 %
10221	CAC	IEEE 802.11n (HT Mixed, 72.2 Mbps, 64-QAM)	WLAN	8.27	±9.6 %
10222	CAC	IEEE 802.11n (HT Mixed, 15 Mbps, BPSK)	WLAN	8.06	±9.6 %
10223	CAC	IEEE 802.11n (HT Mixed, 90 Mbps, 16-QAM)	WLAN	8.48	±9.6 %
10224	CAC	IEEE 802.11n (HT Mixed, 150 Mbps, 64-QAM)	WLAN	8.08	±9.6 %
10225	CAB	UMTS-FDD (HSPA+)	WCDMA	5.97	±9.6 %
10226	CAA	LTE-TDD (SC-FDMA, 1 RB, 1.4 MHz, 16-QAM)	LTE-TDD	9.49	±9.6 %
10227	CAA	LTE-TDD (SC-FDMA, 1 RB, 1.4 MHz, 64-QAM)	LTE-TDD	10.26	±9.6 %
10228	CAA	LTE-TDD (SC-FDMA, 1 RB, 1.4 MHz, QPSK)	LTE-TDD	9.22	±9.6 %
10229	CAC	LTE-TDD (SC-FDMA, 1 RB, 3 MHz, 16-QAM)	LTE-TDD	9.48	±9.6 %
10230	CAC	LTE-TDD (SC-FDMA, 1 RB, 3 MHz, 64-QAM)	LTE-TDD	10.25	±9.6 %
10231	CAC	LTE-TDD (SC-FDMA, 1 RB, 3 MHz, QPSK)	LTE-TDD	9.19	±9.6 %
10232	CAF	LTE-TDD (SC-FDMA, 1 RB, 5 MHz, 16-QAM)	LTE-TDD	9.48	±9.6 %
10233	CAF	LTE-TDD (SC-FDMA, 1 RB, 5 MHz, 64-QAM)	LTE-TDD	10.25	±9.6 %
10234	CAF	LTE-TDD (SC-FDMA, 1 RB, 5 MHz, QPSK)	LTE-TDD	9.21	±9.6 %
10235	CAF	LTE-TDD (SC-FDMA, 1 RB, 10 MHz, 16-QAM)	LTE-TDD	9.48	±9.6 %
10236	CAF	LTE-TDD (SC-FDMA, 1 RB, 10 MHz, 64-QAM)	LTE-TDD	10.25	±9.6 %
10237	CAF	LTE-TDD (SC-FDMA, 1 RB, 10 MHz, QPSK)	LTE-TDD	9.21	±9.6 %
10238	CAF	LTE-TDD (SC-FDMA, 1 RB, 15 MHz, 16-QAM)	LTE-TDD	9.48	±9.6 %
10239	CAF	LTE-TDD (SC-FDMA, 1 RB, 15 MHz, 64-QAM)	LTE-TDD	10.25	±9.6 %
10240	CAF	LTE-TDD (SC-FDMA, 1 RB, 15 MHz, QPSK)	LTE-TDD	9.21	±9.6 %
10241	CAA	LTE-TDD (SC-FDMA, 50% RB, 1.4 MHz, 16-QAM)	LTE-TDD	9.82	±9.6 %
10242	CAA	LTE-TDD (SC-FDMA, 50% RB, 1.4 MHz, 64-QAM)	LTE-TDD	9.86	±9.6 %
10243	CAA	LTE-TDD (SC-FDMA, 50% RB, 1.4 MHz, QPSK)	LTE-TDD	9.46	±9.6 %
10244	CAC	LTE-TDD (SC-FDMA, 50% RB, 3 MHz, 16-QAM)	LTE-TDD	10.06	±9.6 %
10245	CAC	LTE-TDD (SC-FDMA, 50% RB, 3 MHz, 64-QAM)	LTE-TDD	10.06	±9.6 %
10246	CAC	LTE-TDD (SC-FDMA, 50% RB, 3 MHz, QPSK)	LTE-TDD	9.30	±9.6 %
10247	CAF	LTE-TDD (SC-FDMA, 50% RB, 5 MHz, 16-QAM)	LTE-TDD	9.91	±9.6 %
10248	CAF	LTE-TDD (SC-FDMA, 50% RB, 5 MHz, 64-QAM)	LTE-TDD	10.09	±9.6 %
10249	CAF	LTE-TDD (SC-FDMA, 50% RB, 5 MHz, QPSK)	LTE-TDD	9.29	±9.6 %
10250	CAF	LTE-TDD (SC-FDMA, 50% RB, 10 MHz, 16-QAM)	LTE-TDD	9.81	±9.6 %
10251	CAF	LTE-TDD (SC-FDMA, 50% RB, 10 MHz, 64-QAM)	LTE-TDD	10.17	±9.6 %
10252	CAF	LTE-TDD (SC-FDMA, 50% RB, 10 MHz, QPSK)	LTE-TDD	9.24	±9.6 %
10253	CAF	LTE-TDD (SC-FDMA, 50% RB, 15 MHz, 16-QAM)	LTE-TDD	9.90	±9.6 %
10254	CAF	LTE-TDD (SC-FDMA, 50% RB, 15 MHz, 64-QAM)	LTE-TDD	10.14	±9.6 %
10255	CAF	LTE-TDD (SC-FDMA, 50% RB, 15 MHz, QPSK)	LTE-TDD	9.20	±9.6 %
10256	CAA	LTE-TDD (SC-FDMA, 100% RB, 1.4 MHz, 16-QAM)	LTE-TDD	9.96	±9.6 %
10257	CAA	LTE-TDD (SC-FDMA, 100% RB, 1.4 MHz, 64-QAM)	LTE-TDD	10.08	±9.6 %
10258	CAA	LTE-TDD (SC-FDMA, 100% RB, 1.4 MHz, QPSK)	LTE-TDD	9.34	±9.6 %
10259	CAC	LTE-TDD (SC-FDMA, 100% RB, 3 MHz, 16-QAM)	LTE-TDD	9.98	±9.6 %
10260	CAC	LTE-TDD (SC-FDMA, 100% RB, 3 MHz, 64-QAM)	LTE-TDD	9.97	±9.6 %
10261	CAC	LTE-TDD (SC-FDMA, 100% RB, 3 MHz, QPSK)	LTE-TDD	9.24	±9.6 %
10262	CAF	LTE-TDD (SC-FDMA, 100% RB, 5 MHz, 16-QAM)	LTE-TDD	9.83	±9.6 %
10263	CAF	LTE-TDD (SC-FDMA, 100% RB, 5 MHz, 64-QAM)	LTE-TDD	10.16	±9.6 %
10264	CAF	LTE-TDD (SC-FDMA, 100% RB, 5 MHz, QPSK)	LTE-TDD	9.23	±9.6 %
10265	CAF	LTE-TDD (SC-FDMA, 100% RB, 10 MHz, 16-QAM)	LTE-TDD	9.92	±9.6 %
10266	CAF	LTE-TDD (SC-FDMA, 100% RB, 10 MHz, 64-QAM)	LTE-TDD	10.07	±9.6 %
10267	CAF	LTE-TDD (SC-FDMA, 100% RB, 10 MHz, QPSK)	LTE-TDD	9.30	±9.6 %
10268	CAF	LTE-TDD (SC-FDMA, 100% RB, 15 MHz, 16-QAM)	LTE-TDD	10.06	±9.6 %
10269	CAF	LTE-TDD (SC-FDMA, 100% RB, 15 MHz, 64-QAM)	LTE-TDD	10.13	±9.6 %
10270	CAF	LTE-TDD (SC-FDMA, 100% RB, 15 MHz, QPSK)	LTE-TDD	9.58	±9.6 %
10274	CAB	UMTS-FDD (HSUPA, Subtest 5, 3GPP Rel8.10)	WCDMA	4.87	±9.6 %
10275	CAB	UMTS-FDD (HSUPA, Subtest 5, 3GPP Rel8.4)	WCDMA	3.96	±9.6 %
10277	CAA	PHS (QPSK)	PHS	11.81	±9.6 %
10278	CAA	PHS (QPSK, BW 884MHz, Roll-off 0.5)	PHS	11.81	±9.6 %
10279	CAA	PHS (QPSK, BW 884MHz, Roll-off 0.38)	PHS	12.18	±9.6 %
10290	AAB	CDMA2000, RC1, SO55, Full Rate	CDMA2000	3.91	±9.6 %
10291	AAB	CDMA2000, RC3, SO55, Full Rate	CDMA2000	3.46	±9.6 %
10292	AAB	CDMA2000, RC3, SO32, Full Rate	CDMA2000	3.39	±9.6 %
10293	AAB	CDMA2000, RC3, SO3, Full Rate	CDMA2000	3.50	±9.6 %
10295	AAB	CDMA2000, RC1, SO3, 1/8th Rate 25 fr.	CDMA2000	12.49	±9.6 %
10297	AAD	LTE-FDD (SC-FDMA, 50% RB, 20 MHz, QPSK)	LTE-FDD	5.81	±9.6 %
10298	AAD	LTE-FDD (SC-FDMA, 50% RB, 3 MHz, QPSK)	LTE-FDD	5.72	±9.6 %
10299	AAD	LTE-FDD (SC-FDMA, 50% RB, 3 MHz, 16-QAM)	LTE-FDD	6.39	±9.6 %

10300	AAD	LTE-FDD (SC-FDMA, 50% RB, 3 MHz, 64-QAM)	LTE-FDD	6.60	± 9.6 %
10301	AAA	IEEE 802.16e WiMAX (29:18, 5ms, 10MHz, QPSK, PUSC)	WiMAX	12.03	± 9.6 %
10302	AAA	IEEE 802.16e WiMAX (29:18, 5ms, 10MHz, QPSK, PUSC, 3 CTRL symbols)	WiMAX	12.57	± 9.6 %
10303	AAA	IEEE 802.16e WiMAX (31:15, 5ms, 10MHz, 64QAM, PUSC)	WiMAX	12.52	± 9.6 %
10304	AAA	IEEE 802.16e WiMAX (29:18, 5ms, 10MHz, 64QAM, PUSC)	WiMAX	11.86	± 9.6 %
10305	AAA	IEEE 802.16e WiMAX (31:15, 10ms, 10MHz, 64QAM, PUSC, 15 symbols)	WiMAX	15.24	± 9.6 %
10306	AAA	IEEE 802.16e WiMAX (29:18, 10ms, 10MHz, 64QAM, PUSC, 18 symbols)	WiMAX	14.67	± 9.6 %
10307	AAA	IEEE 802.16e WiMAX (29:18, 10ms, 10MHz, QPSK, PUSC, 18 symbols)	WiMAX	14.49	± 9.6 %
10308	AAA	IEEE 802.16e WiMAX (29:18, 10ms, 10MHz, 16QAM, PUSC)	WiMAX	14.46	± 9.6 %
10309	AAA	IEEE 802.16e WiMAX (29:18, 10ms, 10MHz, 16QAM, AMC 2x3, 18 symbols)	WiMAX	14.58	± 9.6 %
10310	AAA	IEEE 802.16e WiMAX (29:18, 10ms, 10MHz, QPSK, AMC 2x3, 18 symbols)	WiMAX	14.57	± 9.6 %
10311	AAD	LTE-FDD (SC-FDMA, 100% RB, 15 MHz, QPSK)	LTE-FDD	6.06	± 9.6 %
10313	AAA	iDEN 1:3	iDEN	10.51	± 9.6 %
10314	AAA	iDEN 1:6	iDEN	13.48	± 9.6 %
10315	AAB	IEEE 802.11b WiFi 2.4 GHz (DSSS, 1 Mbps, 96pc duty cycle)	WLAN	1.71	± 9.6 %
10316	AAB	IEEE 802.11g WiFi 2.4 GHz (ERP-OFDM, 6 Mbps, 96pc duty cycle)	WLAN	8.36	± 9.6 %
10317	AAC	IEEE 802.11a WiFi 5 GHz (OFDM, 6 Mbps, 96pc duty cycle)	WLAN	8.36	± 9.6 %
10352	AAA	Pulse Waveform (200Hz, 10%)	Generic	10.00	± 9.6 %
10353	AAA	Pulse Waveform (200Hz, 20%)	Generic	6.99	± 9.6 %
10354	AAA	Pulse Waveform (200Hz, 40%)	Generic	3.98	± 9.6 %
10355	AAA	Pulse Waveform (200Hz, 60%)	Generic	2.22	± 9.6 %
10356	AAA	Pulse Waveform (200Hz, 80%)	Generic	0.97	± 9.6 %
10387	AAA	QPSK Waveform, 1 MHz	Generic	5.10	± 9.6 %
10388	AAA	QPSK Waveform, 10 MHz	Generic	5.22	± 9.6 %
10396	AAA	64-QAM Waveform, 100 kHz	Generic	6.27	± 9.6 %
10399	AAA	64-QAM Waveform, 40 MHz	Generic	6.27	± 9.6 %
10400	AAD	IEEE 802.11ac WiFi (20MHz, 64-QAM, 99pc duty cycle)	WLAN	8.37	± 9.6 %
10401	AAD	IEEE 802.11ac WiFi (40MHz, 64-QAM, 99pc duty cycle)	WLAN	8.60	± 9.6 %
10402	AAD	IEEE 802.11ac WiFi (80MHz, 64-QAM, 99pc duty cycle)	WLAN	8.53	± 9.6 %
10403	AAB	CDMA2000 (1xEV-DO, Rev. 0)	CDMA2000	3.76	± 9.6 %
10404	AAB	CDMA2000 (1xEV-DO, Rev. A)	CDMA2000	3.77	± 9.6 %
10406	AAB	CDMA2000, RC3, SO32, SCH0, Full Rate	CDMA2000	5.22	± 9.6 %
10410	AAF	LTE-TDD (SC-FDMA, 1 RB, 10 MHz, QPSK, UL Subframe=2,3,4,7,8,9, Subframe Conf=4)	LTE-TDD	7.82	± 9.6 %
10414	AAA	WLAN CCDF, 64-QAM, 40MHz	Generic	8.54	± 9.6 %
10415	AAA	IEEE 802.11b WiFi 2.4 GHz (DSSS, 1 Mbps, 99pc duty cycle)	WLAN	1.54	± 9.6 %
10416	AAA	IEEE 802.11g WiFi 2.4 GHz (ERP-OFDM, 6 Mbps, 99pc duty cycle)	WLAN	8.23	± 9.6 %
10417	AAB	IEEE 802.11a/h WiFi 5 GHz (OFDM, 6 Mbps, 99pc duty cycle)	WLAN	8.23	± 9.6 %
10418	AAA	IEEE 802.11g WiFi 2.4 GHz (DSSS-OFDM, 6 Mbps, 99pc duty cycle, Long preamble)	WLAN	8.14	± 9.6 %
10419	AAA	IEEE 802.11g WiFi 2.4 GHz (DSSS-OFDM, 6 Mbps, 99pc duty cycle, Short preamble)	WLAN	8.19	± 9.6 %
10422	AAB	IEEE 802.11n (HT Greenfield, 7.2 Mbps, BPSK)	WLAN	8.32	± 9.6 %
10423	AAB	IEEE 802.11n (HT Greenfield, 43.3 Mbps, 16-QAM)	WLAN	8.47	± 9.6 %
10424	AAB	IEEE 802.11n (HT Greenfield, 72.2 Mbps, 64-QAM)	WLAN	8.40	± 9.6 %
10425	AAB	IEEE 802.11n (HT Greenfield, 15 Mbps, BPSK)	WLAN	8.41	± 9.6 %
10426	AAB	IEEE 802.11n (HT Greenfield, 90 Mbps, 16-QAM)	WLAN	8.45	± 9.6 %
10427	AAB	IEEE 802.11n (HT Greenfield, 150 Mbps, 64-QAM)	WLAN	8.41	± 9.6 %
10430	AAD	LTE-FDD (OFDMA, 5 MHz, E-TM 3.1)	LTE-FDD	8.28	± 9.6 %
10431	AAD	LTE-FDD (OFDMA, 10 MHz, E-TM 3.1)	LTE-FDD	8.38	± 9.6 %
10432	AAC	LTE-FDD (OFDMA, 15 MHz, E-TM 3.1)	LTE-FDD	8.34	± 9.6 %
10433	AAC	LTE-FDD (OFDMA, 20 MHz, E-TM 3.1)	LTE-FDD	8.34	± 9.6 %
10434	AAA	W-CDMA (BS Test Model 1, 64 DPCH)	WCDMA	8.60	± 9.6 %
10435	AAF	LTE-TDD (SC-FDMA, 1 RB, 20 MHz, QPSK, UL Subframe=2,3,4,7,8,9)	LTE-TDD	7.82	± 9.6 %
10447	AAD	LTE-FDD (OFDMA, 5 MHz, E-TM 3.1, Clipping 44%)	LTE-FDD	7.56	± 9.6 %
10448	AAD	LTE-FDD (OFDMA, 10 MHz, E-TM 3.1, Clipping 44%)	LTE-FDD	7.53	± 9.6 %
10449	AAC	LTE-FDD (OFDMA, 15 MHz, E-TM 3.1, Clipping 44%)	LTE-FDD	7.51	± 9.6 %
10450	AAC	LTE-FDD (OFDMA, 20 MHz, E-TM 3.1, Clipping 44%)	LTE-FDD	7.48	± 9.6 %

10451	AAA	W-CDMA (BS Test Model 1, 64 DPCH, Clipping 44%)	WCDMA	7.59	± 9.6 %
10456	AAB	IEEE 802.11ac WiFi (160MHz, 64-QAM, 99pc duty cycle)	WLAN	8.63	± 9.6 %
10457	AAA	UMTS-FDD (DC-HSDPA)	WCDMA	6.62	± 9.6 %
10458	AAA	CDMA2000 (1xEV-DO, Rev. B, 2 carriers)	CDMA2000	6.55	± 9.6 %
10459	AAA	CDMA2000 (1xEV-DO, Rev. B, 3 carriers)	CDMA2000	8.25	± 9.6 %
10460	AAA	UMTS-FDD (WCDMA, AMR)	WCDMA	2.39	± 9.6 %
10461	AAA	LTE-TDD (SC-FDMA, 1 RB, 1.4 MHz, QPSK, UL Subframe=2,3,4,7,8,9)	LTE-TDD	7.82	± 9.6 %
10462	AAA	LTE-TDD (SC-FDMA, 1 RB, 1.4 MHz, 16-QAM, UL Subframe=2,3,4,7,8,9)	LTE-TDD	8.30	± 9.6 %
10463	AAA	LTE-TDD (SC-FDMA, 1 RB, 1.4 MHz, 64-QAM, UL Subframe=2,3,4,7,8,9)	LTE-TDD	8.56	± 9.6 %
10464	AAB	LTE-TDD (SC-FDMA, 1 RB, 3 MHz, QPSK, UL Subframe=2,3,4,7,8,9)	LTE-TDD	7.82	± 9.6 %
10465	AAB	LTE-TDD (SC-FDMA, 1 RB, 3 MHz, 16-QAM, UL Subframe=2,3,4,7,8,9)	LTE-TDD	8.32	± 9.6 %
10466	AAB	LTE-TDD (SC-FDMA, 1 RB, 3 MHz, 64-QAM, UL Subframe=2,3,4,7,8,9)	LTE-TDD	8.57	± 9.6 %
10467	AAE	LTE-TDD (SC-FDMA, 1 RB, 5 MHz, QPSK, UL Subframe=2,3,4,7,8,9)	LTE-TDD	7.82	± 9.6 %
10468	AAE	LTE-TDD (SC-FDMA, 1 RB, 5 MHz, 16-QAM, UL Subframe=2,3,4,7,8,9)	LTE-TDD	8.32	± 9.6 %
10469	AAE	LTE-TDD (SC-FDMA, 1 RB, 5 MHz, 64-QAM, UL Subframe=2,3,4,7,8,9)	LTE-TDD	8.56	± 9.6 %
10470	AAE	LTE-TDD (SC-FDMA, 1 RB, 10 MHz, QPSK, UL Subframe=2,3,4,7,8,9)	LTE-TDD	7.82	± 9.6 %
10471	AAE	LTE-TDD (SC-FDMA, 1 RB, 10 MHz, 16-QAM, UL Subframe=2,3,4,7,8,9)	LTE-TDD	8.32	± 9.6 %
10472	AAE	LTE-TDD (SC-FDMA, 1 RB, 10 MHz, 64-QAM, UL Subframe=2,3,4,7,8,9)	LTE-TDD	8.57	± 9.6 %
10473	AAE	LTE-TDD (SC-FDMA, 1 RB, 15 MHz, QPSK, UL Subframe=2,3,4,7,8,9)	LTE-TDD	7.82	± 9.6 %
10474	AAE	LTE-TDD (SC-FDMA, 1 RB, 15 MHz, 16-QAM, UL Subframe=2,3,4,7,8,9)	LTE-TDD	8.32	± 9.6 %
10475	AAE	LTE-TDD (SC-FDMA, 1 RB, 15 MHz, 64-QAM, UL Subframe=2,3,4,7,8,9)	LTE-TDD	8.57	± 9.6 %
10477	AAF	LTE-TDD (SC-FDMA, 1 RB, 20 MHz, 16-QAM, UL Subframe=2,3,4,7,8,9)	LTE-TDD	8.32	± 9.6 %
10478	AAF	LTE-TDD (SC-FDMA, 1 RB, 20 MHz, 64-QAM, UL Subframe=2,3,4,7,8,9)	LTE-TDD	8.57	± 9.6 %
10479	AAA	LTE-TDD (SC-FDMA, 50% RB, 1.4 MHz, QPSK, UL Subframe=2,3,4,7,8,9)	LTE-TDD	7.74	± 9.6 %
10480	AAA	LTE-TDD (SC-FDMA, 50% RB, 1.4 MHz, 16-QAM, UL Subframe=2,3,4,7,8,9)	LTE-TDD	8.18	± 9.6 %
10481	AAA	LTE-TDD (SC-FDMA, 50% RB, 1.4 MHz, 64-QAM, UL Subframe=2,3,4,7,8,9)	LTE-TDD	8.45	± 9.6 %
10482	AAB	LTE-TDD (SC-FDMA, 50% RB, 3 MHz, QPSK, UL Subframe=2,3,4,7,8,9)	LTE-TDD	7.71	± 9.6 %
10483	AAB	LTE-TDD (SC-FDMA, 50% RB, 3 MHz, 16-QAM, UL Subframe=2,3,4,7,8,9)	LTE-TDD	8.39	± 9.6 %
10484	AAB	LTE-TDD (SC-FDMA, 50% RB, 3 MHz, 64-QAM, UL Subframe=2,3,4,7,8,9)	LTE-TDD	8.47	± 9.6 %
10485	AAE	LTE-TDD (SC-FDMA, 50% RB, 5 MHz, QPSK, UL Subframe=2,3,4,7,8,9)	LTE-TDD	7.59	± 9.6 %
10486	AAE	LTE-TDD (SC-FDMA, 50% RB, 5 MHz, 16-QAM, UL Subframe=2,3,4,7,8,9)	LTE-TDD	8.38	± 9.6 %
10487	AAE	LTE-TDD (SC-FDMA, 50% RB, 5 MHz, 64-QAM, UL Subframe=2,3,4,7,8,9)	LTE-TDD	8.60	± 9.6 %
10488	AAE	LTE-TDD (SC-FDMA, 50% RB, 10 MHz, QPSK, UL Subframe=2,3,4,7,8,9)	LTE-TDD	7.70	± 9.6 %
10489	AAE	LTE-TDD (SC-FDMA, 50% RB, 10 MHz, 16-QAM, UL Subframe=2,3,4,7,8,9)	LTE-TDD	8.31	± 9.6 %
10490	AAE	LTE-TDD (SC-FDMA, 50% RB, 10 MHz, 64-QAM, UL Subframe=2,3,4,7,8,9)	LTE-TDD	8.54	± 9.6 %
10491	AAE	LTE-TDD (SC-FDMA, 50% RB, 15 MHz, QPSK, UL Subframe=2,3,4,7,8,9)	LTE-TDD	7.74	± 9.6 %

10492	AAE	LTE-TDD (SC-FDMA, 50% RB, 15 MHz, 16-QAM, UL Subframe=2,3,4,7,8,9)	LTE-TDD	8.41	± 9.6 %
10493	AAE	LTE-TDD (SC-FDMA, 50% RB, 15 MHz, 64-QAM, UL Subframe=2,3,4,7,8,9)	LTE-TDD	8.55	± 9.6 %
10494	AAF	LTE-TDD (SC-FDMA, 50% RB, 20 MHz, QPSK, UL Subframe=2,3,4,7,8,9)	LTE-TDD	7.74	± 9.6 %
10495	AAF	LTE-TDD (SC-FDMA, 50% RB, 20 MHz, 16-QAM, UL Subframe=2,3,4,7,8,9)	LTE-TDD	8.37	± 9.6 %
10496	AAF	LTE-TDD (SC-FDMA, 50% RB, 20 MHz, 64-QAM, UL Subframe=2,3,4,7,8,9)	LTE-TDD	8.54	± 9.6 %
10497	AAA	LTE-TDD (SC-FDMA, 100% RB, 1.4 MHz, QPSK, UL Subframe=2,3,4,7,8,9)	LTE-TDD	7.67	± 9.6 %
10498	AAA	LTE-TDD (SC-FDMA, 100% RB, 1.4 MHz, 16-QAM, UL Subframe=2,3,4,7,8,9)	LTE-TDD	8.40	± 9.6 %
10499	AAA	LTE-TDD (SC-FDMA, 100% RB, 1.4 MHz, 64-QAM, UL Subframe=2,3,4,7,8,9)	LTE-TDD	8.68	± 9.6 %
10500	AAB	LTE-TDD (SC-FDMA, 100% RB, 3 MHz, QPSK, UL Subframe=2,3,4,7,8,9)	LTE-TDD	7.67	± 9.6 %
10501	AAB	LTE-TDD (SC-FDMA, 100% RB, 3 MHz, 16-QAM, UL Subframe=2,3,4,7,8,9)	LTE-TDD	8.44	± 9.6 %
10502	AAB	LTE-TDD (SC-FDMA, 100% RB, 3 MHz, 64-QAM, UL Subframe=2,3,4,7,8,9)	LTE-TDD	8.52	± 9.6 %
10503	AAE	LTE-TDD (SC-FDMA, 100% RB, 5 MHz, QPSK, UL Subframe=2,3,4,7,8,9)	LTE-TDD	7.72	± 9.6 %
10504	AAE	LTE-TDD (SC-FDMA, 100% RB, 5 MHz, 16-QAM, UL Subframe=2,3,4,7,8,9)	LTE-TDD	8.31	± 9.6 %
10505	AAE	LTE-TDD (SC-FDMA, 100% RB, 5 MHz, 64-QAM, UL Subframe=2,3,4,7,8,9)	LTE-TDD	8.54	± 9.6 %
10506	AAE	LTE-TDD (SC-FDMA, 100% RB, 10 MHz, QPSK, UL Subframe=2,3,4,7,8,9)	LTE-TDD	7.74	± 9.6 %
10507	AAE	LTE-TDD (SC-FDMA, 100% RB, 10 MHz, 16-QAM, UL Subframe=2,3,4,7,8,9)	LTE-TDD	8.36	± 9.6 %
10508	AAE	LTE-TDD (SC-FDMA, 100% RB, 10 MHz, 64-QAM, UL Subframe=2,3,4,7,8,9)	LTE-TDD	8.55	± 9.6 %
10509	AAE	LTE-TDD (SC-FDMA, 100% RB, 15 MHz, QPSK, UL Subframe=2,3,4,7,8,9)	LTE-TDD	7.99	± 9.6 %
10510	AAE	LTE-TDD (SC-FDMA, 100% RB, 15 MHz, 16-QAM, UL Subframe=2,3,4,7,8,9)	LTE-TDD	8.49	± 9.6 %
10511	AAE	LTE-TDD (SC-FDMA, 100% RB, 15 MHz, 64-QAM, UL Subframe=2,3,4,7,8,9)	LTE-TDD	8.51	± 9.6 %
10512	AAF	LTE-TDD (SC-FDMA, 100% RB, 20 MHz, QPSK, UL Subframe=2,3,4,7,8,9)	LTE-TDD	7.74	± 9.6 %
10513	AAF	LTE-TDD (SC-FDMA, 100% RB, 20 MHz, 16-QAM, UL Subframe=2,3,4,7,8,9)	LTE-TDD	8.42	± 9.6 %
10514	AAF	LTE-TDD (SC-FDMA, 100% RB, 20 MHz, 64-QAM, UL Subframe=2,3,4,7,8,9)	LTE-TDD	8.45	± 9.6 %
10515	AAA	IEEE 802.11b WiFi 2.4 GHz (DSSS, 2 Mbps, 99pc duty cycle)	WLAN	1.58	± 9.6 %
10516	AAA	IEEE 802.11b WiFi 2.4 GHz (DSSS, 5.5 Mbps, 99pc duty cycle)	WLAN	1.57	± 9.6 %
10517	AAA	IEEE 802.11b WiFi 2.4 GHz (DSSS, 11 Mbps, 99pc duty cycle)	WLAN	1.58	± 9.6 %
10518	AAB	IEEE 802.11a/h WiFi 5 GHz (OFDM, 9 Mbps, 99pc duty cycle)	WLAN	8.23	± 9.6 %
10519	AAB	IEEE 802.11a/h WiFi 5 GHz (OFDM, 12 Mbps, 99pc duty cycle)	WLAN	8.39	± 9.6 %
10520	AAB	IEEE 802.11a/h WiFi 5 GHz (OFDM, 18 Mbps, 99pc duty cycle)	WLAN	8.12	± 9.6 %
10521	AAB	IEEE 802.11a/h WiFi 5 GHz (OFDM, 24 Mbps, 99pc duty cycle)	WLAN	7.97	± 9.6 %
10522	AAB	IEEE 802.11a/h WiFi 5 GHz (OFDM, 36 Mbps, 99pc duty cycle)	WLAN	8.45	± 9.6 %
10523	AAB	IEEE 802.11a/h WiFi 5 GHz (OFDM, 48 Mbps, 99pc duty cycle)	WLAN	8.08	± 9.6 %
10524	AAB	IEEE 802.11a/h WiFi 5 GHz (OFDM, 54 Mbps, 99pc duty cycle)	WLAN	8.27	± 9.6 %
10525	AAB	IEEE 802.11ac WiFi (20MHz, MCS0, 99pc duty cycle)	WLAN	8.36	± 9.6 %
10526	AAB	IEEE 802.11ac WiFi (20MHz, MCS1, 99pc duty cycle)	WLAN	8.42	± 9.6 %
10527	AAB	IEEE 802.11ac WiFi (20MHz, MCS2, 99pc duty cycle)	WLAN	8.21	± 9.6 %
10528	AAB	IEEE 802.11ac WiFi (20MHz, MCS3, 99pc duty cycle)	WLAN	8.36	± 9.6 %
10529	AAB	IEEE 802.11ac WiFi (20MHz, MCS4, 99pc duty cycle)	WLAN	8.36	± 9.6 %
10531	AAB	IEEE 802.11ac WiFi (20MHz, MCS6, 99pc duty cycle)	WLAN	8.43	± 9.6 %
10532	AAB	IEEE 802.11ac WiFi (20MHz, MCS7, 99pc duty cycle)	WLAN	8.29	± 9.6 %
10533	AAB	IEEE 802.11ac WiFi (20MHz, MCS8, 99pc duty cycle)	WLAN	8.38	± 9.6 %
10534	AAB	IEEE 802.11ac WiFi (40MHz, MCS0, 99pc duty cycle)	WLAN	8.45	± 9.6 %

10535	AAB	IEEE 802.11ac WiFi (40MHz, MCS1, 99pc duty cycle)	WLAN	8.45	± 9.6 %
10536	AAB	IEEE 802.11ac WiFi (40MHz, MCS2, 99pc duty cycle)	WLAN	8.32	± 9.6 %
10537	AAB	IEEE 802.11ac WiFi (40MHz, MCS3, 99pc duty cycle)	WLAN	8.44	± 9.6 %
10538	AAB	IEEE 802.11ac WiFi (40MHz, MCS4, 99pc duty cycle)	WLAN	8.54	± 9.6 %
10540	AAB	IEEE 802.11ac WiFi (40MHz, MCS6, 99pc duty cycle)	WLAN	8.39	± 9.6 %
10541	AAB	IEEE 802.11ac WiFi (40MHz, MCS7, 99pc duty cycle)	WLAN	8.46	± 9.6 %
10542	AAB	IEEE 802.11ac WiFi (40MHz, MCS8, 99pc duty cycle)	WLAN	8.65	± 9.6 %
10543	AAB	IEEE 802.11ac WiFi (40MHz, MCS9, 99pc duty cycle)	WLAN	8.65	± 9.6 %
10544	AAB	IEEE 802.11ac WiFi (80MHz, MCS0, 99pc duty cycle)	WLAN	8.47	± 9.6 %
10545	AAB	IEEE 802.11ac WiFi (80MHz, MCS1, 99pc duty cycle)	WLAN	8.55	± 9.6 %
10546	AAB	IEEE 802.11ac WiFi (80MHz, MCS2, 99pc duty cycle)	WLAN	8.35	± 9.6 %
10547	AAB	IEEE 802.11ac WiFi (80MHz, MCS3, 99pc duty cycle)	WLAN	8.49	± 9.6 %
10548	AAB	IEEE 802.11ac WiFi (80MHz, MCS4, 99pc duty cycle)	WLAN	8.37	± 9.6 %
10550	AAB	IEEE 802.11ac WiFi (80MHz, MCS6, 99pc duty cycle)	WLAN	8.38	± 9.6 %
10551	AAB	IEEE 802.11ac WiFi (80MHz, MCS7, 99pc duty cycle)	WLAN	8.50	± 9.6 %
10552	AAB	IEEE 802.11ac WiFi (80MHz, MCS8, 99pc duty cycle)	WLAN	8.42	± 9.6 %
10553	AAB	IEEE 802.11ac WiFi (80MHz, MCS9, 99pc duty cycle)	WLAN	8.45	± 9.6 %
10554	AAC	IEEE 802.11ac WiFi (160MHz, MCS0, 99pc duty cycle)	WLAN	8.48	± 9.6 %
10555	AAC	IEEE 802.11ac WiFi (160MHz, MCS1, 99pc duty cycle)	WLAN	8.47	± 9.6 %
10556	AAC	IEEE 802.11ac WiFi (160MHz, MCS2, 99pc duty cycle)	WLAN	8.50	± 9.6 %
10557	AAC	IEEE 802.11ac WiFi (160MHz, MCS3, 99pc duty cycle)	WLAN	8.52	± 9.6 %
10558	AAC	IEEE 802.11ac WiFi (160MHz, MCS4, 99pc duty cycle)	WLAN	8.61	± 9.6 %
10560	AAC	IEEE 802.11ac WiFi (160MHz, MCS6, 99pc duty cycle)	WLAN	8.73	± 9.6 %
10561	AAC	IEEE 802.11ac WiFi (160MHz, MCS7, 99pc duty cycle)	WLAN	8.56	± 9.6 %
10562	AAC	IEEE 802.11ac WiFi (160MHz, MCS8, 99pc duty cycle)	WLAN	8.69	± 9.6 %
10563	AAC	IEEE 802.11ac WiFi (160MHz, MCS9, 99pc duty cycle)	WLAN	8.77	± 9.6 %
10564	AAA	IEEE 802.11g WiFi 2.4 GHz (DSSS-OFDM, 9 Mbps, 99pc duty cycle)	WLAN	8.25	± 9.6 %
10565	AAA	IEEE 802.11g WiFi 2.4 GHz (DSSS-OFDM, 12 Mbps, 99pc duty cycle)	WLAN	8.45	± 9.6 %
10566	AAA	IEEE 802.11g WiFi 2.4 GHz (DSSS-OFDM, 18 Mbps, 99pc duty cycle)	WLAN	8.13	± 9.6 %
10567	AAA	IEEE 802.11g WiFi 2.4 GHz (DSSS-OFDM, 24 Mbps, 99pc duty cycle)	WLAN	8.00	± 9.6 %
10568	AAA	IEEE 802.11g WiFi 2.4 GHz (DSSS-OFDM, 36 Mbps, 99pc duty cycle)	WLAN	8.37	± 9.6 %
10569	AAA	IEEE 802.11g WiFi 2.4 GHz (DSSS-OFDM, 48 Mbps, 99pc duty cycle)	WLAN	8.10	± 9.6 %
10570	AAA	IEEE 802.11g WiFi 2.4 GHz (DSSS-OFDM, 54 Mbps, 99pc duty cycle)	WLAN	8.30	± 9.6 %
10571	AAA	IEEE 802.11b WiFi 2.4 GHz (DSSS, 1 Mbps, 90pc duty cycle)	WLAN	1.99	± 9.6 %
10572	AAA	IEEE 802.11b WiFi 2.4 GHz (DSSS, 2 Mbps, 90pc duty cycle)	WLAN	1.99	± 9.6 %
10573	AAA	IEEE 802.11b WiFi 2.4 GHz (DSSS, 5.5 Mbps, 90pc duty cycle)	WLAN	1.98	± 9.6 %
10574	AAA	IEEE 802.11b WiFi 2.4 GHz (DSSS, 11 Mbps, 90pc duty cycle)	WLAN	1.98	± 9.6 %
10575	AAA	IEEE 802.11g WiFi 2.4 GHz (DSSS-OFDM, 6 Mbps, 90pc duty cycle)	WLAN	8.59	± 9.6 %
10576	AAA	IEEE 802.11g WiFi 2.4 GHz (DSSS-OFDM, 9 Mbps, 90pc duty cycle)	WLAN	8.60	± 9.6 %
10577	AAA	IEEE 802.11g WiFi 2.4 GHz (DSSS-OFDM, 12 Mbps, 90pc duty cycle)	WLAN	8.70	± 9.6 %
10578	AAA	IEEE 802.11g WiFi 2.4 GHz (DSSS-OFDM, 18 Mbps, 90pc duty cycle)	WLAN	8.49	± 9.6 %
10579	AAA	IEEE 802.11g WiFi 2.4 GHz (DSSS-OFDM, 24 Mbps, 90pc duty cycle)	WLAN	8.36	± 9.6 %
10580	AAA	IEEE 802.11g WiFi 2.4 GHz (DSSS-OFDM, 36 Mbps, 90pc duty cycle)	WLAN	8.76	± 9.6 %
10581	AAA	IEEE 802.11g WiFi 2.4 GHz (DSSS-OFDM, 48 Mbps, 90pc duty cycle)	WLAN	8.35	± 9.6 %
10582	AAA	IEEE 802.11g WiFi 2.4 GHz (DSSS-OFDM, 54 Mbps, 90pc duty cycle)	WLAN	8.67	± 9.6 %
10583	AAB	IEEE 802.11a/h WiFi 5 GHz (OFDM, 6 Mbps, 90pc duty cycle)	WLAN	8.59	± 9.6 %
10584	AAB	IEEE 802.11a/h WiFi 5 GHz (OFDM, 9 Mbps, 90pc duty cycle)	WLAN	8.60	± 9.6 %
10585	AAB	IEEE 802.11a/h WiFi 5 GHz (OFDM, 12 Mbps, 90pc duty cycle)	WLAN	8.70	± 9.6 %
10586	AAB	IEEE 802.11a/h WiFi 5 GHz (OFDM, 18 Mbps, 90pc duty cycle)	WLAN	8.49	± 9.6 %
10587	AAB	IEEE 802.11a/h WiFi 5 GHz (OFDM, 24 Mbps, 90pc duty cycle)	WLAN	8.36	± 9.6 %

10588	AAB	IEEE 802.11a/h WiFi 5 GHz (OFDM, 36 Mbps, 90pc duty cycle)	WLAN	8.76	± 9.6 %
10589	AAB	IEEE 802.11a/h WiFi 5 GHz (OFDM, 48 Mbps, 90pc duty cycle)	WLAN	8.35	± 9.6 %
10590	AAB	IEEE 802.11a/h WiFi 5 GHz (OFDM, 54 Mbps, 90pc duty cycle)	WLAN	8.67	± 9.6 %
10591	AAB	IEEE 802.11n (HT Mixed, 20MHz, MCS0, 90pc duty cycle)	WLAN	8.63	± 9.6 %
10592	AAB	IEEE 802.11n (HT Mixed, 20MHz, MCS1, 90pc duty cycle)	WLAN	8.79	± 9.6 %
10593	AAB	IEEE 802.11n (HT Mixed, 20MHz, MCS2, 90pc duty cycle)	WLAN	8.64	± 9.6 %
10594	AAB	IEEE 802.11n (HT Mixed, 20MHz, MCS3, 90pc duty cycle)	WLAN	8.74	± 9.6 %
10595	AAB	IEEE 802.11n (HT Mixed, 20MHz, MCS4, 90pc duty cycle)	WLAN	8.74	± 9.6 %
10596	AAB	IEEE 802.11n (HT Mixed, 20MHz, MCS5, 90pc duty cycle)	WLAN	8.71	± 9.6 %
10597	AAB	IEEE 802.11n (HT Mixed, 20MHz, MCS6, 90pc duty cycle)	WLAN	8.72	± 9.6 %
10598	AAB	IEEE 802.11n (HT Mixed, 20MHz, MCS7, 90pc duty cycle)	WLAN	8.50	± 9.6 %
10599	AAB	IEEE 802.11n (HT Mixed, 40MHz, MCS0, 90pc duty cycle)	WLAN	8.79	± 9.6 %
10600	AAB	IEEE 802.11n (HT Mixed, 40MHz, MCS1, 90pc duty cycle)	WLAN	8.88	± 9.6 %
10601	AAB	IEEE 802.11n (HT Mixed, 40MHz, MCS2, 90pc duty cycle)	WLAN	8.82	± 9.6 %
10602	AAB	IEEE 802.11n (HT Mixed, 40MHz, MCS3, 90pc duty cycle)	WLAN	8.94	± 9.6 %
10603	AAB	IEEE 802.11n (HT Mixed, 40MHz, MCS4, 90pc duty cycle)	WLAN	9.03	± 9.6 %
10604	AAB	IEEE 802.11n (HT Mixed, 40MHz, MCS5, 90pc duty cycle)	WLAN	8.76	± 9.6 %
10605	AAB	IEEE 802.11n (HT Mixed, 40MHz, MCS6, 90pc duty cycle)	WLAN	8.97	± 9.6 %
10606	AAB	IEEE 802.11n (HT Mixed, 40MHz, MCS7, 90pc duty cycle)	WLAN	8.82	± 9.6 %
10607	AAB	IEEE 802.11ac WiFi (20MHz, MCS0, 90pc duty cycle)	WLAN	8.64	± 9.6 %
10608	AAB	IEEE 802.11ac WiFi (20MHz, MCS1, 90pc duty cycle)	WLAN	8.77	± 9.6 %
10609	AAB	IEEE 802.11ac WiFi (20MHz, MCS2, 90pc duty cycle)	WLAN	8.57	± 9.6 %
10610	AAB	IEEE 802.11ac WiFi (20MHz, MCS3, 90pc duty cycle)	WLAN	8.78	± 9.6 %
10611	AAB	IEEE 802.11ac WiFi (20MHz, MCS4, 90pc duty cycle)	WLAN	8.70	± 9.6 %
10612	AAB	IEEE 802.11ac WiFi (20MHz, MCS5, 90pc duty cycle)	WLAN	8.77	± 9.6 %
10613	AAB	IEEE 802.11ac WiFi (20MHz, MCS6, 90pc duty cycle)	WLAN	8.94	± 9.6 %
10614	AAB	IEEE 802.11ac WiFi (20MHz, MCS7, 90pc duty cycle)	WLAN	8.59	± 9.6 %
10615	AAB	IEEE 802.11ac WiFi (20MHz, MCS8, 90pc duty cycle)	WLAN	8.82	± 9.6 %
10616	AAB	IEEE 802.11ac WiFi (40MHz, MCS0, 90pc duty cycle)	WLAN	8.82	± 9.6 %
10617	AAB	IEEE 802.11ac WiFi (40MHz, MCS1, 90pc duty cycle)	WLAN	8.81	± 9.6 %
10618	AAB	IEEE 802.11ac WiFi (40MHz, MCS2, 90pc duty cycle)	WLAN	8.58	± 9.6 %
10619	AAB	IEEE 802.11ac WiFi (40MHz, MCS3, 90pc duty cycle)	WLAN	8.86	± 9.6 %
10620	AAB	IEEE 802.11ac WiFi (40MHz, MCS4, 90pc duty cycle)	WLAN	8.87	± 9.6 %
10621	AAB	IEEE 802.11ac WiFi (40MHz, MCS5, 90pc duty cycle)	WLAN	8.77	± 9.6 %
10622	AAB	IEEE 802.11ac WiFi (40MHz, MCS6, 90pc duty cycle)	WLAN	8.68	± 9.6 %
10623	AAB	IEEE 802.11ac WiFi (40MHz, MCS7, 90pc duty cycle)	WLAN	8.82	± 9.6 %
10624	AAB	IEEE 802.11ac WiFi (40MHz, MCS8, 90pc duty cycle)	WLAN	8.96	± 9.6 %
10625	AAB	IEEE 802.11ac WiFi (40MHz, MCS9, 90pc duty cycle)	WLAN	8.96	± 9.6 %
10626	AAB	IEEE 802.11ac WiFi (80MHz, MCS0, 90pc duty cycle)	WLAN	8.83	± 9.6 %
10627	AAB	IEEE 802.11ac WiFi (80MHz, MCS1, 90pc duty cycle)	WLAN	8.88	± 9.6 %
10628	AAB	IEEE 802.11ac WiFi (80MHz, MCS2, 90pc duty cycle)	WLAN	8.71	± 9.6 %
10629	AAB	IEEE 802.11ac WiFi (80MHz, MCS3, 90pc duty cycle)	WLAN	8.85	± 9.6 %
10630	AAB	IEEE 802.11ac WiFi (80MHz, MCS4, 90pc duty cycle)	WLAN	8.72	± 9.6 %
10631	AAB	IEEE 802.11ac WiFi (80MHz, MCS5, 90pc duty cycle)	WLAN	8.81	± 9.6 %
10632	AAB	IEEE 802.11ac WiFi (80MHz, MCS6, 90pc duty cycle)	WLAN	8.74	± 9.6 %
10633	AAB	IEEE 802.11ac WiFi (80MHz, MCS7, 90pc duty cycle)	WLAN	8.83	± 9.6 %
10634	AAB	IEEE 802.11ac WiFi (80MHz, MCS8, 90pc duty cycle)	WLAN	8.80	± 9.6 %
10635	AAB	IEEE 802.11ac WiFi (80MHz, MCS9, 90pc duty cycle)	WLAN	8.81	± 9.6 %
10636	AAC	IEEE 802.11ac WiFi (160MHz, MCS0, 90pc duty cycle)	WLAN	8.83	± 9.6 %
10637	AAC	IEEE 802.11ac WiFi (160MHz, MCS1, 90pc duty cycle)	WLAN	8.79	± 9.6 %
10638	AAC	IEEE 802.11ac WiFi (160MHz, MCS2, 90pc duty cycle)	WLAN	8.86	± 9.6 %
10639	AAC	IEEE 802.11ac WiFi (160MHz, MCS3, 90pc duty cycle)	WLAN	8.85	± 9.6 %
10640	AAC	IEEE 802.11ac WiFi (160MHz, MCS4, 90pc duty cycle)	WLAN	8.98	± 9.6 %
10641	AAC	IEEE 802.11ac WiFi (160MHz, MCS5, 90pc duty cycle)	WLAN	9.06	± 9.6 %
10642	AAC	IEEE 802.11ac WiFi (160MHz, MCS6, 90pc duty cycle)	WLAN	9.06	± 9.6 %
10643	AAC	IEEE 802.11ac WiFi (160MHz, MCS7, 90pc duty cycle)	WLAN	8.89	± 9.6 %
10644	AAC	IEEE 802.11ac WiFi (160MHz, MCS8, 90pc duty cycle)	WLAN	9.05	± 9.6 %
10645	AAC	IEEE 802.11ac WiFi (160MHz, MCS9, 90pc duty cycle)	WLAN	9.11	± 9.6 %
10646	AAF	LTE-TDD (SC-FDMA, 1 RB, 5 MHz, QPSK, UL Subframe=2,7)	LTE-TDD	11.96	± 9.6 %
10647	AAF	LTE-TDD (SC-FDMA, 1 RB, 20 MHz, QPSK, UL Subframe=2,7)	LTE-TDD	11.96	± 9.6 %
10648	AAA	CDMA2000 (1x Advanced)	CDMA2000	3.45	± 9.6 %
10652	AAD	LTE-TDD (OFDMA, 5 MHz, E-TM 3.1, Clipping 44%)	LTE-TDD	6.91	± 9.6 %
10653	AAD	LTE-TDD (OFDMA, 10 MHz, E-TM 3.1, Clipping 44%)	LTE-TDD	7.42	± 9.6 %
10654	AAD	LTE-TDD (OFDMA, 15 MHz, E-TM 3.1, Clipping 44%)	LTE-TDD	6.96	± 9.6 %

10655	AAE	LTE-TDD (OFDMA, 20 MHz, E-TM 3.1, Clipping 44%)	LTE-TDD	7.21	± 9.6 %
10658	AAA	Pulse Waveform (200Hz, 10%)	Test	10.00	± 9.6 %
10659	AAA	Pulse Waveform (200Hz, 20%)	Test	6.99	± 9.6 %
10660	AAA	Pulse Waveform (200Hz, 40%)	Test	3.98	± 9.6 %
10661	AAA	Pulse Waveform (200Hz, 60%)	Test	2.22	± 9.6 %
10662	AAA	Pulse Waveform (200Hz, 80%)	Test	0.97	± 9.6 %
10670	AAA	Bluetooth Low Energy	Bluetooth	2.19	± 9.6 %

^E Uncertainty is determined using the max. deviation from linear response applying rectangular distribution and is expressed for the square of the field value.

APPENDIX D: SAR TISSUE SPECIFICATIONS

Measurement Procedure for Tissue verification:

- 1) The network analyzer and probe system was configured and calibrated.
- 2) The probe was immersed in the tissue. The tissue was placed in a nonmetallic container. Trapped air bubbles beneath the flange were minimized by placing the probe at a slight angle.
- 3) The complex admittance with respect to the probe aperture was measured
- 4) The complex relative permittivity ϵ' can be calculated from the below equation (Pournaropoulos and Misra):

$$Y = \frac{j2\omega\epsilon_r\epsilon_0}{[\ln(b/a)]^2} \int_a^b \int_a^b \int_0^\pi \cos\phi' \frac{\exp[-j\omega r(\mu_0\epsilon_r'\epsilon_0)^{1/2}]}{r} d\phi' d\rho' d\rho$$

where Y is the admittance of the probe in contact with the sample, the primed and unprimed coordinates refer to source and observation points, respectively, $r^2 = \rho^2 + \rho'^2 - 2\rho\rho' \cos \phi'$, ω is the angular frequency, and $j = \sqrt{-1}$.

3 Composition / Information on ingredients

3.2 Mixtures

Description: Aqueous solution with surfactants and inhibitors

Declarable, or hazardous components:

CAS: 107-21-1 EINECS: 203-473-3 Reg.nr.: 01-2119456816-28-0000	Ethenediol STOT RE 2, H373; Acute Tox. 4, H302	>1.0-4.9%
CAS: 68608-26-4 EINECS: 271-781-5 Reg.nr.: 01-2119527859-22-0000	Sodium petroleum sulfonate Eye Irrit. 2, H319	< 2.9%
CAS: 107-41-5 EINECS: 203-489-0 Reg.nr.: 01-2119539582-35-0000	Hexylene Glycol / 2-Methyl-pentane-2,4-diol Skin Irrit. 2, H315; Eye Irrit. 2, H319	< 2.9%
CAS: 68920-66-1 NLP: 500-236-9 Reg.nr.: 01-2119489407-26-0000	Alkoxyated alcohol, > C₁₆ Aquatic Chronic 2, H411; Skin Irrit. 2, H315; Eye Irrit. 2, H319	< 2.0%

Additional information:



For the wording of the listed risk phrases refer to section 16.

Not mentioned CAS-, EINECS- or registration numbers are to be regarded as Proprietary/Confidential.

The specific chemical identity and/or exact percentage concentration of proprietary components is withheld as a trade secret.

Figure D-1
Composition of the Tissue Equivalent Matter

Note: Liquid recipes are proprietary SPEAG. Since the composition is approximate to the actual liquids utilized, the manufacturer tissue-equivalent liquid data sheets are provided below.

FCC ID A3LSMT860	 PCTEST ENGINEERING LABORATORY, INC.	SAR EVALUATION REPORT		Approved by: Quality Manager
Test Dates: 06/27/19 - 07/07/19	DUT Type: Portable Tablet			APPENDIX D: Page 1 of 2

Measurement Certificate / Material Test

Item Name	Body Tissue Simulating Liquid (MBBL600-6000V6)
Product No.	SL AAM U16 RC (Batch: 181029-1)
Manufacturer	SPEAG

Measurement Method
 TSL dielectric parameters measured using calibrated DAK probe.

Target Parameters
 Target parameters as defined in the KDB 865664 compliance standard.

Test Condition
 Ambient Condition 22°C ; 30% humidity
 TSL Temperature 22°C
 Test Date 30-Oct-18
 Operator CL

Additional Information
 TSL Density
 TSL Heat-capacity

Results		Measured		Target		Diff to Target [%]	
f [MHz]	e'	e''	sigma	eps	sigma	Δ-eps	Δ-sigma
800	55.1	21.3	0.95	55.3	0.97	-0.4	-2.1
825	55.1	20.8	0.95	55.2	0.98	-0.3	-2.0
835	55.1	20.0	0.95	55.1	0.99	0.0	-2.5
850	55.1	20.4	0.95	55.2	0.99	-0.1	-3.0
900	55.0	19.7	0.98	55.0	1.05	0.0	-6.7
1400	54.2	15.0	1.22	54.1	1.28	0.2	-4.7
1450	54.1	15.4	1.24	54.0	1.30	0.2	-4.8
1500	54.1	15.3	1.27	53.9	1.33	0.3	-4.5
1550	54.0	15.1	1.30	53.9	1.36	0.2	-1.4
1600	53.9	15.0	1.33	53.8	1.39	0.2	-4.3
1625	53.9	14.9	1.35	53.8	1.41	0.3	-4.3
1640	53.9	14.9	1.35	53.7	1.42	0.3	-4.2
1650	53.8	14.9	1.36	53.7	1.43	0.2	-4.9
1700	53.8	14.8	1.40	53.6	1.46	0.4	-4.1
1750	53.7	14.7	1.43	53.4	1.49	0.5	-8.0
1800	53.7	14.6	1.46	53.3	1.52	0.8	-3.9
1810	53.7	14.6	1.47	53.3	1.52	0.8	-3.3
1825	53.7	14.6	1.48	53.3	1.52	0.8	-2.6
1850	53.6	14.5	1.50	53.3	1.52	0.6	-1.3
1900	53.5	14.5	1.53	53.3	1.52	0.4	0.7
1950	53.5	14.5	1.57	53.3	1.52	0.4	3.3
2000	53.4	14.4	1.60	53.3	1.52	0.2	5.3
2050	53.4	14.4	1.64	53.2	1.57	0.3	4.5
2100	53.3	14.4	1.68	53.2	1.62	0.2	3.7
2150	53.3	14.4	1.72	53.1	1.66	0.4	3.6
2200	53.2	14.4	1.76	53.0	1.71	0.3	2.9
2250	53.1	14.4	1.81	53.0	1.76	0.2	2.8
2300	53.1	14.4	1.85	52.9	1.81	0.4	2.2
2350	53.0	14.5	1.89	52.8	1.85	0.3	2.2
2400	52.9	14.5	1.94	52.8	1.90	0.2	2.1
2450	52.9	14.5	1.98	52.7	1.95	0.4	1.5
2500	52.8	14.6	2.03	52.6	2.02	0.3	0.5
2550	52.7	14.6	2.07	52.6	2.09	0.2	-1.0
2600	52.6	14.7	2.12	52.5	2.16	0.2	-1.9

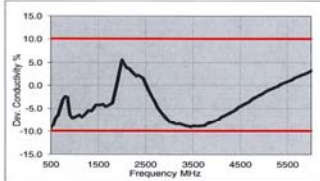
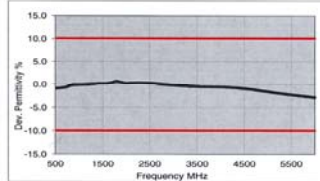

3500	51.1	15.5	3.02	51.3	3.31	-0.4	-8.8
3700	50.8	15.7	3.24	51.1	3.55	-0.5	-8.8
4200	46.1	18.2	5.27	49.0	6.20	-1.8	-0.6
5250	48.0	18.3	5.34	49.0	5.36	-1.9	-0.4
5300	47.9	18.4	5.41	48.9	5.42	-2.0	-0.2
5500	47.5	18.6	5.70	48.6	5.65	-2.2	0.9
5600	47.3	18.8	5.84	48.5	5.77	-2.3	1.3
5700	47.1	18.9	5.99	48.3	5.88	-2.5	1.8
5800	47.0	19.0	6.14	48.2	6.00	-2.6	2.3

TSL Dielectric Parameters

1

Figure D-II
750 – 5800 MHz Body Tissue Equivalent Matter

FCC ID A3LSMT860		SAR EVALUATION REPORT		Approved by: Quality Manager
Test Dates: 06/27/19 - 07/07/19	DUT Type: Portable Tablet			APPENDIX D: Page 2 of 2

APPENDIX E: SAR SYSTEM VALIDATION



Per FCC KDB Publication 865664 D02v01r02, SAR system validation status should be documented to confirm measurement accuracy. The SAR systems (including SAR probes, system components and software versions) used for this device were validated against its performance specifications prior to the SAR measurements. Reference dipoles were used with the required tissue- equivalent media for system validation, according to the procedures outlined in FCC KDB Publication 865664 D01v01r04 and IEEE 1528-2013. Since SAR probe calibrations are frequency dependent, each probe calibration point was validated at a frequency within the valid frequency range of the probe calibration point, using the system that normally operates with the probe for routine SAR measurements and according to the required tissue-equivalent media.

A tabulated summary of the system validation status including the validation date(s), measurement frequencies, SAR probes and tissue dielectric parameters has been included.

Table E-1
SAR System Validation Summary – 1g

SAR System	Freq. (MHz)	Date	Probe SN	Probe Cal Point		Cond. (σ)	Perm. (ϵ_r)	CW VALIDATION			MOD. VALIDATION		
								SENSITIVITY	PROBE LINEARITY	PROBE ISOTROPY	MOD. TYPE	DUTY FACTOR	PAR
K	2450	3/6/2019	7417	2450	Body	2.039	50.67	PASS	PASS	PASS	OFDM/TDD	PASS	PASS
L	5250	10/29/2018	7308	5250	Body	5.511	48.77	PASS	PASS	PASS	OFDM	N/A	PASS
L	5600	10/29/2018	7308	5600	Body	5.994	48.2	PASS	PASS	PASS	OFDM	N/A	PASS
L	5750	10/29/2018	7308	5750	Body	6.219	47.96	PASS	PASS	PASS	OFDM	N/A	PASS

NOTE: While the probes have been calibrated for both CW and modulated signals, all measurements were performed using communication systems calibrated for CW signals only. Modulations in the table above represent test configurations for which the measurement system has been validated per FCC KDB Publication 865664 D01v01r04 for scenarios when CW probe calibrations are used with other signal types. SAR systems were validated for modulated signals with a periodic duty cycle, such as GMSK, or with a high peak to average ratio (>5 dB), such as OFDM according to FCC KDB Publication 865664 D01v01r04.

FCC ID A3LSMT860		SAR EVALUATION REPORT		Approved by: Quality Manager
Test Dates: 06/27/19 - 07/07/19	DUT Type: Portable Tablet			APPENDIX E: Page 1 of 1

APPENDIX G POWER REDUCTION VERIFICATION

Per the May 2017 TCBC Workshop Notes, demonstration of proper functioning of the power reduction mechanisms is required to support the corresponding SAR configurations. The verification process was divided into two parts: (1) evaluation of output power levels for individual or multiple triggering mechanisms and (2) evaluation of the triggering distances for proximity-based sensors.

G.1 Power Verification Procedure



The power verification was performed according to the following procedure:

1. A base station simulator was used to establish a conducted RF connection and the output power was monitored. The power measurements were confirmed to be within expected tolerances for all states before and after a power reduction mechanism was triggered.
2. Step 1 was repeated for all relevant modes and frequency bands for the mechanism being investigated.
3. Steps 1 and 2 were repeated for all individual power reduction mechanisms and combinations thereof. For the combination cases, one mechanism was switched to a 'triggered' state at a time; powers were confirmed to be within tolerances after each additional mechanism was activated.

G.2 Distance Verification Procedure

The distance verification procedure was performed according to the following procedure:

1. A base station simulator was used to establish an RF connection and to monitor the power levels. The device being tested was placed below the relevant section of the phantom with the relevant side or edge of the device facing toward the phantom.
2. The device was moved toward and away from the phantom to determine the distance at which the mechanism triggers and the output power is reduced, per KDB Publication 616217 D04v01r02 and FCC Guidance. Each applicable test position was evaluated. The distances were confirmed to be the same or larger (more conservative) than the minimum distances provided by the manufacturer.
3. Steps 1 and 2 were repeated for each mode, as appropriate (see note below Table G-2 for more details).
4. Steps 1 through 3 were repeated for all distance-based power reduction mechanisms.

FCC ID: A3LSMT860	 PCTEST ENGINEERING LABORATORY, INC.	SAR EVALUATION REPORT		Reviewed by: Quality Manager
Test Dates: 06/27/19 – 07/07/19	DUT Type: Portable Tablet			APPENDIX G: Page 1 of 2

G.3 WIFI Verification Summary

**Table G-1
Power Measurement Verification WIFI**



Mechanism(s)	Mode/Band	Conducted Power (dBm)	
		Un-triggered (Max)	Mechanism #1 (Reduced)
1st			
Grip	802.11b	17.30	12.24
Grip	802.11g	16.05	12.30
Grip	802.11n (2.4GHz)	14.23	11.85
Grip	802.11a	16.13	9.18
Grip	802.11n (5GHz, 20MHz BW)	14.91	8.89
Grip	802.11ac (20MHz BW)	12.69	9.76
Grip	802.11n (5GHz, 40MHz BW)	12.73	9.16
Grip	802.11ac (40MHz BW)	12.65	9.51
Grip	802.11ac (80MHz BW)	12.28	9.37

*Note:

1. MIMO WIFI modes were not evaluated due to equipment limitations.
2. The above powers are within the tolerances expected by the manufacturer.

**Table G-2
Distance Measurement Verification for WIFI**

Mechanism(s)	Test Condition	Band	Distance Measurements (mm)		Minimum Distance per Manufacturer (mm)
			Moving Toward	Moving Away	
Grip	Body - Back Side	2.4GHz Ant1	16	19	16
Grip	Body - Back Side	2.4GHz Ant2	18	22	16
Grip	Body - Back Side	5GHz Ant1	16	19	16
Grip	Body - Back Side	5GHz Ant2	18	22	16
Grip	Body - Top Edge	2.4GHz Ant1	17	20	15
Grip	Body - Top Edge	2.4GHz Ant2	22	31	15
Grip	Body - Top Edge	5GHz Ant1	17	20	15
Grip	Body - Top Edge	5GHz Ant2	22	31	15
Grip	Body - Right Edge	2.4GHz Ant2	9	15	7
Grip	Body - Right Edge	5GHz Ant2	9	15	7
Grip	Body - Left Edge	2.4GHz Ant1	7	11	7
Grip	Body - Left Edge	5GHz Ant1	7	11	7

FCC ID: A3LSMT860	 PCTEST ENGINEERING LABORATORY, INC.	SAR EVALUATION REPORT		Reviewed by: Quality Manager
Test Dates: 06/27/19 – 07/07/19	DUT Type: Portable Tablet			APPENDIX G: Page 2 of 2