



SAR EVALUATION REPORT

Applicant Name:
 Samsung Electronics Co., Ltd.
 129, Samsung-ro, Maetan dong,
 Yeongtong-gu, Suwon-si
 Gyeonggi-do, 16677, Korea

Date of Testing:
 06/20/18 - 07/05/18
Test Site/Location:
 PCTEST Lab, Columbia, MD, USA
Document Serial No.:
 1M1806180124-01.A3L

FCC ID: A3LSMT837A

APPLICANT: SAMSUNG ELECTRONICS CO., LTD.

DUT Type: Portable Tablet
Application Type: Certification
FCC Rule Part(s): CFR §2.1093
Model: SM-T837A

Equipment Class	Band & Mode	Tx Frequency	SAR
			1g Body (W/kg)
PCB	UMTS 850	826.40 - 846.60 MHz	1.22
PCB	UMTS 1750	1712.4 - 1752.6 MHz	1.19
PCB	UMTS 1900	1852.4 - 1907.6 MHz	1.32
PCB	LTE Band 12	699.7 - 715.3 MHz	0.63
PCB	LTE Band 14	790.5 - 795.5 MHz	0.99
PCB	LTE Band 5 (Cell)	824.7 - 848.3 MHz	1.12
PCB	LTE Band 66 (AWS)	1710.7 - 1779.3 MHz	1.31
PCB	LTE Band 4 (AWS)	1710.7 - 1754.3 MHz	N/A
PCB	LTE Band 2 (PCS)	1850.7 - 1909.3 MHz	1.00
PCB	LTE Band 30	2307.5 - 2312.5 MHz	1.02
PCB	LTE Band 7	2502.5 - 2567.5 MHz	1.25
DTS	2.4 GHz WLAN	2412 - 2462 MHz	0.92
NII	U-NII-1	5180 - 5240 MHz	N/A
NII	U-NII-2A	5260 - 5320 MHz	0.90
NII	U-NII-2C	5500 - 5720 MHz	1.04
NII	U-NII-3	5745 - 5825 MHz	1.17
DSS/DTS	Bluetooth	2402 - 2480 MHz	0.34
Simultaneous SAR per KDB 690783 D01v01r03:			1.59

This wireless portable device has been shown to be capable of compliance for localized specific absorption rate (SAR) for uncontrolled environment/general population exposure limits specified in ANSI/IEEE C95.1-1992 and has been tested in accordance with the measurement procedures specified in Section 1.7 of this report; for North American frequency bands only.

I attest to the accuracy of data. All measurements reported herein were performed by me or were made under my supervision and are correct to the best of my knowledge and belief. I assume full responsibility for the completeness of these measurements and vouch for the qualifications of all persons taking them. Test results reported herein relate only to the item(s) tested.

Randy Ortanez
 President





The SAR Tick is an initiative of the Mobile & Wireless Forum (MWF). While a product may be considered eligible, use of the SAR Tick logo requires an agreement with the MWF. Further details can be obtained by emailing: sartick@mwfai.info.

FCC ID: A3LSMT837A		SAR EVALUATION REPORT		Approved by: Quality Manager
Document S/N: 1M1806180124-01.A3L	Test Dates: 06/20/18 - 07/05/18	DUT Type: Portable Tablet	Page 1 of 100	

TABLE OF CONTENTS

1	DEVICE UNDER TEST	3
2	LTE INFORMATION	11
3	INTRODUCTION	12
4	DOSIMETRIC ASSESSMENT	13
5	TEST CONFIGURATION POSITIONS.....	14
6	RF EXPOSURE LIMITS	15
7	FCC MEASUREMENT PROCEDURES.....	16
8	RF CONDUCTED POWERS.....	21
9	SYSTEM VERIFICATION.....	64
10	SAR DATA SUMMARY	66
11	FCC MULTI-TX AND ANTENNA SAR CONSIDERATIONS.....	76
12	SAR MEASUREMENT VARIABILITY	95
13	EQUIPMENT LIST.....	96
14	MEASUREMENT UNCERTAINTIES.....	97
15	CONCLUSION.....	98
16	REFERENCES	99
APPENDIX A: SAR TEST PLOTS		
APPENDIX B: SAR DIPOLE VERIFICATION PLOTS		
APPENDIX C: PROBE AND DIPOLE CALIBRATION CERTIFICATES		
APPENDIX D: SAR TISSUE SPECIFICATIONS		
APPENDIX E: SAR SYSTEM VALIDATION		
APPENDIX F: DUT ANTENNA DIAGRAM & SAR TEST SETUP PHOTOGRAPHS		
APPENDIX G: POWER REDUCTION VERIFICATION		
APPENDIX H: DOWNLINK LTE CA RF CONDUCTED POWERS		

FCC ID: A3LSMT837A		SAR EVALUATION REPORT		Approved by: Quality Manager
Document S/N: 1M1806180124-01.A3L	Test Dates: 06/20/18 - 07/05/18	DUT Type: Portable Tablet	Page 2 of 100	



1 DEVICE UNDER TEST

1.1 Device Overview

Band & Mode	Operating Modes	Tx Frequency
UMTS 850	Data	826.40 - 846.60 MHz
UMTS 1750	Data	1712.4 - 1752.6 MHz
UMTS 1900	Data	1852.4 - 1907.6 MHz
LTE Band 12	Data	699.7 - 715.3 MHz
LTE Band 14	Data	790.5 - 795.5 MHz
LTE Band 5 (Cell)	Data	824.7 - 848.3 MHz
LTE Band 66 (AWS)	Data	1710.7 - 1779.3 MHz
LTE Band 4 (AWS)	Data	1710.7 - 1754.3 MHz
LTE Band 2 (PCS)	Data	1850.7 - 1909.3 MHz
LTE Band 30	Data	2307.5 - 2312.5 MHz
LTE Band 7	Data	2502.5 - 2567.5 MHz
2.4 GHz WLAN	Data	2412 - 2462 MHz
U-NII-1	Data	5180 - 5240 MHz
U-NII-2A	Data	5260 - 5320 MHz
U-NII-2C	Data	5500 - 5720 MHz
U-NII-3	Data	5745 - 5825 MHz
Bluetooth	Data	2402 - 2480 MHz
ANT+	Data	2402 - 2480 MHz

1.2 Power Reduction for SAR

This device uses a power reduction mechanism for SAR compliance. The power reduction mechanism is activated when the device is used in close proximity to the user's body. FCC KDB Publication 616217 D04v01r02 Section 6 was used as a guideline for selecting SAR test distances for this device. Detailed descriptions of the power reduction mechanism are included in the operational description.

FCC ID: A3LSMT837A		SAR EVALUATION REPORT		Approved by: Quality Manager
Document S/N: 1M1806180124-01.A3L	Test Dates: 06/20/18 - 07/05/18	DUT Type: Portable Tablet	Page 3 of 100	



1.3 Nominal and Maximum Output Power Specifications

This device operates using the following maximum and nominal output power specifications. SAR values were scaled to the maximum allowed power to determine compliance per KDB Publication 447498 D01v06.

1.3.1 Maximum PCB Output Power

Mode / Band		Modulated Average (dBm)		
		3GPP WCDMA	3GPP HSDPA	3GPP HSUPA
UMTS Band 5 (850 MHz)	Maximum	25.0	25.0	25.0
	Nominal	24.0	24.0	24.0
UMTS Band 4 (1750 MHz)	Maximum	24.5	24.5	24.5
	Nominal	23.5	23.5	23.5
UMTS Band 2 (1900 MHz)	Maximum	25.0	25.0	25.0
	Nominal	24.0	24.0	24.0



Mode / Band		Modulated Average (dBm)
LTE Band 12	Maximum	25.0
	Nominal	24.0
LTE Band 14	Maximum	25.0
	Nominal	24.0
LTE Band 5 (Cell)	Maximum	25.0
	Nominal	24.0
LTE Band 66 (AWS)	Maximum	25.0
	Nominal	24.0
LTE Band 4 (AWS)	Maximum	25.0
	Nominal	24.0
LTE Band 2 (PCS)	Maximum	25.0
	Nominal	24.0
LTE Band 30	Maximum	24.2
	Nominal	23.2
LTE Band 7	Maximum	25.0
	Nominal	24.0

FCC ID: A3LSMT837A		SAR EVALUATION REPORT		Approved by: Quality Manager
Document S/N: 1M1806180124-01.A3L	Test Dates: 06/20/18 - 07/05/18	DUT Type: Portable Tablet	Page 4 of 100	

1.3.2 Reduced PCB Output Power

Mode / Band		Modulated Average (dBm)		
		3GPP WCDMA	3GPP HSDPA	3GPP HSUPA
UMTS Band 5 (850 MHz)	Maximum	17.0	17.0	17.0
	Nominal	16.0	16.0	16.0
UMTS Band 4 (1750 MHz)	Maximum	14.0	14.0	14.0
	Nominal	13.0	13.0	13.0
UMTS Band 2 (1900 MHz)	Maximum	14.0	14.0	14.0
	Nominal	13.0	13.0	13.0

Mode / Band		Modulated Average (dBm)
LTE Band 12	Maximum	14.0
	Nominal	13.0
LTE Band 14	Maximum	16.0
	Nominal	15.0
LTE Band 5 (Cell)	Maximum	16.0
	Nominal	15.0
LTE Band 66 (AWS)	Maximum	14.0
	Nominal	13.0
LTE Band 4 (AWS)	Maximum	13.0
	Nominal	12.0
LTE Band 2 (PCS)	Maximum	13.5
	Nominal	12.5
LTE Band 30	Maximum	14.5
	Nominal	13.5
LTE Band 7	Maximum	13.0
	Nominal	12.0

FCC ID: A3LSMT837A	 PCTEST ENGINEERING LABORATORY, INC.	SAR EVALUATION REPORT		Approved by: Quality Manager
Document S/N: 1M1806180124-01.A3L	Test Dates: 06/20/18 - 07/05/18	DUT Type: Portable Tablet		Page 5 of 100

1.3.3 Max WLAN and Bluetooth Output Power



Mode / Band		Modulated Average - Single Tx Chain (dBm)
IEEE 802.11b (2.4 GHz)	Maximum	14.0
	Nominal	13.0
IEEE 802.11g (2.4 GHz)	Maximum	14.0
	Nominal	13.0
IEEE 802.11n (2.4 GHz)	Maximum	14.0
	Nominal	13.0

Mode / Band		Modulated Average - Single Tx Chain (dBm)		
		20 MHz Bandwidth	40 MHz Bandwidth	80 MHz Bandwidth
IEEE 802.11a (5 GHz)	Maximum	14.0		
	Nominal	13.0		
IEEE 802.11n (5 GHz)	Maximum	14.0	14.0	
	Nominal	13.0	13.0	
IEEE 802.11ac (5 GHz)	Maximum	13.0	13.0	13.0
	Nominal	12.0	12.0	12.0

Mode / Band		Modulated Average - MIMO (dBm)	
		20 MHz Bandwidth	
IEEE 802.11n (2.4 GHz)	Maximum	17.0	
	Nominal	16.0	
IEEE 802.11g (2.4 GHz)	Maximum	17.0	
	Nominal	16.0	

Mode / Band		Modulated Average - MIMO (dBm)		
		20 MHz Bandwidth	40 MHz Bandwidth	80 MHz Bandwidth
IEEE 802.11a (5 GHz)	Maximum	17.0		
	Nominal	16.0		
IEEE 802.11n (5 GHz)	Maximum	17.0	17.0	
	Nominal	16.0	16.0	
IEEE 802.11ac (5 GHz)	Maximum	16.0	16.0	16.0
	Nominal	15.0	15.0	15.0

Mode / Band		Modulated Average - Single Tx Chain (dBm)
Bluetooth	Maximum	9.5
	Nominal	8.5
Bluetooth LE	Maximum	2.6
	Nominal	1.6

FCC ID: A3LSMT837A	 PCTEST ENGINEERING LABORATORY, INC.	SAR EVALUATION REPORT		Approved by: Quality Manager
Document S/N: 1M1806180124-01.A3L	Test Dates: 06/20/18 - 07/05/18	DUT Type: Portable Tablet		Page 6 of 100



1.3.4 Reduced WLAN Output Power

Mode / Band		Modulated Average - Single Tx Chain (dBm)
IEEE 802.11b (2.4 GHz)	Maximum	13.0
	Nominal	12.0
IEEE 802.11g (2.4 GHz)	Maximum	13.0
	Nominal	12.0
IEEE 802.11n (2.4 GHz)	Maximum	13.0
	Nominal	12.0

Mode / Band		Modulated Average - Single Tx Chain (dBm)		
		20 MHz Bandwidth	40 MHz Bandwidth	80 MHz Bandwidth
IEEE 802.11a (5 GHz)	Maximum	10.0		
	Nominal	9.0		
IEEE 802.11n (5 GHz)	Maximum	10.0	10.0	
	Nominal	9.0	9.0	
IEEE 802.11ac (5 GHz)	Maximum	10.0	10.0	10.0
	Nominal	9.0	9.0	9.0

Mode / Band		Modulated Average - MIMO (dBm)	
		20 MHz Bandwidth	
IEEE 802.11n (2.4 GHz)	Maximum	16.0	
	Nominal	15.0	
IEEE 802.11g (2.4 GHz)	Maximum	16.0	
	Nominal	15.0	

Mode / Band		Modulated Average - MIMO (dBm)		
		20 MHz Bandwidth	40 MHz Bandwidth	80 MHz Bandwidth
IEEE 802.11a (5 GHz)	Maximum	13.0		
	Nominal	12.0		
IEEE 802.11n (5 GHz)	Maximum	13.0	13.0	
	Nominal	12.0	12.0	
IEEE 802.11ac (5 GHz)	Maximum	13.0	13.0	13.0
	Nominal	12.0	12.0	12.0

FCC ID: A3LSMT837A		SAR EVALUATION REPORT		Approved by: Quality Manager
Document S/N: 1M1806180124-01.A3L	Test Dates: 06/20/18 - 07/05/18	DUT Type: Portable Tablet		Page 7 of 100



1.4 DUT Antenna Locations

The overall diagonal dimension of the device is > 200 mm. A diagram showing the location of the device antennas can be found in Appendix F. Exact antenna dimensions and separation distances are shown in the Technical Descriptions in the FCC filings.

**Table 1-1
Device Edges/Sides for SAR Testing**

Mode	Back	Top	Bottom	Right	Left
UMTS 850	Yes	Yes	No	Yes	Yes
UMTS 1750	Yes	Yes	No	Yes	Yes
UMTS 1900	Yes	Yes	No	Yes	Yes
LTE Band 12	Yes	Yes	No	Yes	Yes
LTE Band 14	Yes	Yes	No	Yes	Yes
LTE Band 5 (Cell)	Yes	Yes	No	Yes	Yes
LTE Band 66 (AWS)	Yes	Yes	No	Yes	Yes
LTE Band 2 (PCS)	Yes	Yes	No	Yes	Yes
LTE Band 30	Yes	Yes	No	Yes	Yes
LTE Band 7	Yes	Yes	No	Yes	Yes
2.4 GHz WLAN Ant 1	Yes	Yes	Yes	Yes	Yes
2.4 GHz WLAN Ant 2	Yes	Yes	Yes	Yes	Yes
5 GHz WLAN Ant 1	Yes	Yes	Yes	Yes	No
5 GHz WLAN Ant 2	Yes	Yes	Yes	Yes	Yes
Bluetooth	Yes	Yes	Yes	Yes	No

Note: Per FCC KDB Publication 616217 D04v01r01, particular edges were not required to be evaluated for SAR based on the SAR exclusion threshold in KDB 447498 D01V06. Additional edges may have been evaluated for simultaneous transmission analysis.

FCC ID: A3LSMT837A		SAR EVALUATION REPORT		Approved by: Quality Manager
Document S/N: 1M1806180124-01.A3L	Test Dates: 06/20/18 - 07/05/18	DUT Type: Portable Tablet	Page 8 of 100	

1.5 Simultaneous Transmission Capabilities

According to FCC KDB Publication 447498 D01v06, transmitters are considered to be transmitting simultaneously when there is overlapping transmission, with the exception of transmissions during network hand-offs with maximum hand-off duration less than 30 seconds.

This device contains multiple transmitters that may operate simultaneously, and therefore requires a simultaneous transmission analysis according to FCC KDB Publication 447498 D01v06 4.3.2 procedures.

**Table 1-2
Simultaneous Transmission Scenarios**

No.	Capable Transmit Configuration	Body
1	UMTS + 2.4 GHz WI-FI	Yes
2	UMTS + 5 GHz WI-FI	Yes
3	UMTS + 2.4 GHz Bluetooth	Yes
4	UMTS + 2.4 GHz WI-FI MIMO	Yes
5	UMTS + 5 GHz WI-FI MIMO	Yes
6	UMTS + 2.4 GHz WI-FI Ant 1 + 5 GHz WI-FI Ant 2	Yes
7	LTE + 2.4 GHz WI-FI	Yes
8	LTE + 5 GHz WI-FI	Yes
9	LTE + 2.4 GHz Bluetooth	Yes
10	LTE + 2.4 GHz WI-FI MIMO	Yes
11	LTE + 5 GHz WI-FI MIMO	Yes
12	LTE + 2.4 GHz WI-FI Ant 1 + 5 GHz WI-FI Ant 2	Yes

1. All licensed modes share the same antenna path and cannot transmit simultaneously.
2. This device supports 2x2 MIMO Tx for WLAN 802.11n/ac. 802.11a/g/n/ac supports CDD and STBC and 802.11n/ac additionally supports SDM. Each WLAN antenna can transmit independently or together when operating with MIMO.



1.6 Miscellaneous SAR Test Considerations

(A) WIFI/BT

Since U-NII-1 and U-NII-2A bands have the same maximum output power and the highest reported SAR for U-NII-2A is less than 1.2 W/kg, SAR is not required for U-NII-1 band according to FCC KDB Publication 248227 D01v02r02.

This device supports IEEE 802.11ac with the following features:

- a) Up to 80 MHz Bandwidth only
- b) No aggregate channel configurations
- c) 2 Tx antenna output
- d) 256 QAM is supported
- e) TDWR and Band gap channels are supported

FCC ID: A3LSMT837A	 PCTEST ENGINEERING LABORATORY, INC.	SAR EVALUATION REPORT		Approved by: Quality Manager
Document S/N: 1M1806180124-01.A3L	Test Dates: 06/20/18 - 07/05/18	DUT Type: Portable Tablet		Page 9 of 100

(B) Licensed Transmitter(s)

This device is only capable of QPSK HSUPA in the uplink. Therefore, no additional SAR tests are required beyond that described for devices with HSUPA in KDB 941225 D01v03r01.

LTE SAR for the higher modulations and lower bandwidths were not tested since the maximum average output power of all required channels and configurations was not more than 0.5 dB higher than the highest bandwidth; and the reported LTE SAR for the highest bandwidth was less than 1.45 W/kg for all configurations according to FCC KDB 941225 D05v02r04.

This device supports LTE Carrier Aggregation (CA) in the downlink only. All uplink communications are identical to Release 8 specifications. Per FCC KDB Publication 941225 D05A v01r02, SAR for LTE CA operations was not needed since the maximum average output power in LTE CA mode was not >0.25 dB higher than the maximum output power when downlink carrier aggregation was inactive. DLCA power measurements can be found in Appendix H.

This device supports downlink 4x4 MIMO operations for some LTE Bands. Per May 2017 TCB Workshop Guidance, SAR for downlink 4x4 MIMO was not needed since the maximum average output power in 4x4 downlink MIMO mode was not > 0.25 dB higher than the maximum output power with downlink 4x4 MIMO inactive.



This device supports LTE capabilities with overlapping transmission frequency ranges. When the supported frequency range of an LTE Band falls completely within an LTE band with a larger transmission frequency range, both LTE bands have the same target power (or the band with the larger transmission frequency range has a higher target power), and both LTE bands share the same transmission path and signal characteristics, SAR was only assessed for the band with the larger transmission frequency range.

1.7 Guidance Applied



- FCC KDB Publication 941225 D01v03r01, D05v02r04, D05Av01r02 (3G/4G)
- FCC KDB Publication 248227 D01v02r02 (SAR Considerations for 802.11 Devices)
- FCC KDB Publication 447498 D01v06 (General SAR Guidance)
- FCC KDB Publication 865664 D01v01r04, D02v01r02 (SAR Measurements up to 6 GHz)
- FCC KDB Publication 616217 D04v01r02 (Tablet)
- May 2017 TCB Workshop Notes (LTE 4x4 Downlink MIMO)
- April 2018 TCB Workshop Notes (LTE Carrier Aggregation)

1.8 Device Serial Numbers

Several samples with identical hardware were used to support SAR testing. The manufacturer has confirmed that the device(s) tested have the same physical, mechanical and thermal characteristics and are within operational tolerances expected for production units. The serial numbers used for each test are indicated alongside the results in Section 10.

FCC ID: A3LSMT837A		SAR EVALUATION REPORT		Approved by: Quality Manager
Document S/N: 1M1806180124-01.A3L	Test Dates: 06/20/18 - 07/05/18	DUT Type: Portable Tablet		Page 10 of 100

LTE Information			
FCC ID	A3LSMT837A		
Form Factor	Portable Tablet		
Frequency Range of each LTE transmission band	LTE Band 12 (699.7 - 715.3 MHz)		
	LTE Band 14 (790.5 - 795.5 MHz)		
	LTE Band 5 (Cell) (824.7 - 848.3 MHz)		
	LTE Band 66 (AWS) (1710.7 - 1779.3 MHz)		
	LTE Band 4 (AWS) (1710.7 - 1754.3 MHz)		
	LTE Band 2 (PCS) (1850.7 - 1909.3 MHz)		
	LTE Band 30 (2307.5 - 2312.5 MHz)		
	LTE Band 7 (2502.5 - 2567.5 MHz)		
Channel Bandwidths	LTE Band 12: 1.4 MHz, 3 MHz, 5 MHz, 10 MHz		
	LTE Band 14: 5 MHz, 10 MHz		
	LTE Band 5 (Cell): 1.4 MHz, 3 MHz, 5 MHz, 10 MHz		
	LTE Band 66 (AWS): 1.4 MHz, 3 MHz, 5 MHz, 10 MHz, 15 MHz, 20 MHz		
	LTE Band 4 (AWS): 1.4 MHz, 3 MHz, 5 MHz, 10 MHz, 15 MHz, 20 MHz		
	LTE Band 2 (PCS): 1.4 MHz, 3 MHz, 5 MHz, 10 MHz, 15 MHz, 20 MHz		
	LTE Band 30: 5 MHz, 10 MHz		
LTE Band 7: 5 MHz, 10 MHz, 15 MHz, 20 MHz			
Channel Numbers and Frequencies (MHz)	Low	Mid	High
LTE Band 12: 1.4 MHz	699.7 (23017)	707.5 (23095)	715.3 (23173)
LTE Band 12: 3 MHz	700.5 (23025)	707.5 (23095)	714.5 (23165)
LTE Band 12: 5 MHz	701.5 (23035)	707.5 (23095)	713.5 (23155)
LTE Band 12: 10 MHz	704 (23060)	707.5 (23095)	711 (23130)
LTE Band 14: 5 MHz	790.5 (23305)	793 (23330)	795.5 (23355)
LTE Band 14: 10 MHz	N/A	793 (23330)	N/A
LTE Band 5 (Cell): 1.4 MHz	824.7 (20407)	836.5 (20525)	848.3 (20643)
LTE Band 5 (Cell): 3 MHz	825.5 (20415)	836.5 (20525)	847.5 (20635)
LTE Band 5 (Cell): 5 MHz	826.5 (20425)	836.5 (20525)	846.5 (20625)
LTE Band 5 (Cell): 10 MHz	829 (20450)	836.5 (20525)	844 (20600)
LTE Band 66 (AWS): 1.4 MHz	1710.7 (131979)	1745 (132322)	1779.3 (132665)
LTE Band 66 (AWS): 3 MHz	1711.5 (131987)	1745 (132322)	1778.5 (132657)
LTE Band 66 (AWS): 5 MHz	1712.5 (131997)	1745 (132322)	1777.5 (132647)
LTE Band 66 (AWS): 10 MHz	1715 (132022)	1745 (132322)	1775 (132622)
LTE Band 66 (AWS): 15 MHz	1717.5 (132047)	1745 (132322)	1772.5 (132597)
LTE Band 66 (AWS): 20 MHz	1720 (132072)	1745 (132322)	1770 (132572)
LTE Band 4 (AWS): 1.4 MHz	1710.7 (19957)	1732.5 (20175)	1754.3 (20393)
LTE Band 4 (AWS): 3 MHz	1711.5 (19965)	1732.5 (20175)	1753.5 (20385)
LTE Band 4 (AWS): 5 MHz	1712.5 (19975)	1732.5 (20175)	1752.5 (20375)
LTE Band 4 (AWS): 10 MHz	1715 (20000)	1732.5 (20175)	1750 (20350)
LTE Band 4 (AWS): 15 MHz	1717.5 (20025)	1732.5 (20175)	1747.5 (20325)
LTE Band 4 (AWS): 20 MHz	1720 (20050)	1732.5 (20175)	1745 (20300)
LTE Band 2 (PCS): 1.4 MHz	1850.7 (18607)	1880 (18900)	1909.3 (19193)
LTE Band 2 (PCS): 3 MHz	1851.5 (18615)	1880 (18900)	1908.5 (19185)
LTE Band 2 (PCS): 5 MHz	1852.5 (18625)	1880 (18900)	1907.5 (19175)
LTE Band 2 (PCS): 10 MHz	1855 (18650)	1880 (18900)	1905 (19150)
LTE Band 2 (PCS): 15 MHz	1857.5 (18675)	1880 (18900)	1902.5 (19125)
LTE Band 2 (PCS): 20 MHz	1860 (18700)	1880 (18900)	1900 (19100)
LTE Band 30: 5 MHz	2307.5 (27685)	2310 (27710)	2312.5 (27735)
LTE Band 30: 10 MHz	N/A	2310 (27710)	N/A
LTE Band 7: 5 MHz	2502.5 (20775)	2535 (21100)	2567.5 (21425)
LTE Band 7: 10 MHz	2505 (20800)	2535 (21100)	2565 (21400)
LTE Band 7: 15 MHz	2507.5 (20825)	2535 (21100)	2562.5 (21375)
LTE Band 7: 20 MHz	2510 (20850)	2535 (21100)	2560 (21350)
UE Category	DL UE Cat 16 (QPSK, 16QAM, 64QAM, 256QAM) UL UE Cat 5 (QPSK, 16QAM, 64QAM)		
Modulations Supported in UL	QPSK, 16QAM, 64QAM		
LTE MPR Permanently implemented per 3GPP TS 36.101 section 6.2.3-6.2.5? (manufacturer attestation to be provided)	YES		
A-MPR (Additional MPR) disabled for SAR Testing?	YES		
LTE Carrier Aggregation Possible Combinations	The technical description includes all the possible carrier aggregation combinations		
LTE Additional Information	LTE Release 14 Information and this device does not support full CA features on 3GPP Release 14. It supports carrier aggregation and downlink MIMO and LAA features as shown in Section 9 and Appendix H. All other uplink communications are identical to the Release 8 specifications. Uplink communications are done on the PCC unless otherwise specified. The following LTE Release 14 Features are not supported: Relay, HetNet, Enhanced eICIC, MDH, eMBMS, Cross-Carrier Scheduling, Enhanced SC-FDMA.		

FCC ID: A3LSMT837A		SAR EVALUATION REPORT		Approved by: Quality Manager
Document S/N: 1M1806180124-01.A3L	Test Dates: 06/20/18 - 07/05/18	DUT Type: Portable Tablet	Page 11 of 100	

3 INTRODUCTION

The FCC and Innovation, Science, and Economic Development Canada have adopted the guidelines for evaluating the environmental effects of radio frequency (RF) radiation in ET Docket 93-62 on Aug. 6, 1996 and Health Canada Safety Code 6 to protect the public and workers from the potential hazards of RF emissions due to FCC-regulated portable devices. [1]

The safety limits used for the environmental evaluation measurements are based on the criteria published by the American National Standards Institute (ANSI) for localized specific absorption rate (SAR) in IEEE/ANSI C95.1-1992 Standard for Safety Levels with Respect to Human Exposure to Radio Frequency Electromagnetic Fields, 3 kHz to 300 GHz [3] and Health Canada RF Exposure Guidelines Safety Code 6 [22]. The measurement procedure described in IEEE/ANSI C95.3-2002 Recommended Practice for the Measurement of Potentially Hazardous Electromagnetic Fields - RF and Microwave [4] is used for guidance in measuring the Specific Absorption Rate (SAR) due to the RF radiation exposure from the Equipment Under Test (EUT). These criteria for SAR evaluation are similar to those recommended by the International Committee for Non-Ionizing Radiation Protection (ICNIRP) in Biological Effects and Exposure Criteria for Radiofrequency Electromagnetic Fields,” Report No. Vol 74. SAR is a measure of the rate of energy absorption due to exposure to an RF transmitting source. SAR values have been related to threshold levels for potential biological hazards.

3.1 SAR Definition

Specific Absorption Rate is defined as the time derivative (rate) of the incremental energy (dU) absorbed by (dissipated in) an incremental mass (dm) contained in a volume element (dV) of a given density (ρ). It is also defined as the rate of RF energy absorption per unit mass at a point in an absorbing body (see Equation 3-1).

Equation 3-1
SAR Mathematical Equation

$$SAR = \frac{d}{dt} \left(\frac{dU}{dm} \right) = \frac{d}{dt} \left(\frac{dU}{\rho dv} \right)$$



SAR is expressed in units of Watts per Kilogram (W/kg).

$$SAR = \frac{\sigma \cdot E^2}{\rho}$$

where:

- σ = conductivity of the tissue-simulating material (S/m)
- ρ = mass density of the tissue-simulating material (kg/m³)
- E = Total RMS electric field strength (V/m)

NOTE: The primary factors that control rate of energy absorption were found to be the wavelength of the incident field in relation to the dimensions and geometry of the irradiated organism, the orientation of the organism in relation to the polarity of field vectors, the presence of reflecting surfaces, and whether conductive contact is made by the organism with a ground plane.[6]

FCC ID: A3LSMT837A	 PCTEST ENGINEERING LABORATORY, INC.	SAR EVALUATION REPORT		Approved by: Quality Manager
Document S/N: 1M1806180124-01.A3L	Test Dates: 06/20/18 - 07/05/18	DUT Type: Portable Tablet	Page 12 of 100	

4 DOSIMETRIC ASSESSMENT

4.1 Measurement Procedure

The evaluation was performed using the following procedure compliant to FCC KDB Publication 865664 D01v01r04 and IEEE 1528-2013:

1. The SAR distribution at the exposed side of the head or body was measured at a distance no greater than 5.0 mm from the inner surface of the shell. The area covered the entire dimension of the device-head and body interface and the horizontal grid resolution was determined per FCC KDB Publication 865664 D01v01r04 (See Table 4-1) and IEEE 1528-2013.
2. The point SAR measurement was taken at the maximum SAR region determined from Step 1 to enable the monitoring of SAR fluctuations/drifts during the 1g/10g cube evaluation. SAR at this fixed point was measured and used as a reference value.
3. Based on the area scan data, the peak of the region with maximum SAR was determined by spline interpolation. Around this point, a volume was assessed according to the measurement resolution and volume size requirements of FCC KDB Publication 865664 D01v01r04 (See Table 4-1) and IEEE 1528-2013. On the basis of this data set, the spatial peak SAR value was evaluated with the following procedure (see references or the DASY manual online for more details):
 - a. SAR values at the inner surface of the phantom are extrapolated from the measured values along the line away from the surface with spacing no greater than that in Table 4-1. The extrapolation was based on a least-squares algorithm. A polynomial of the fourth order was calculated through the points in the z-axis (normal to the phantom shell).
 - b. After the maximum interpolated values were calculated between the points in the cube, the SAR was averaged over the spatial volume (1g or 10g) using a 3D-Spline interpolation algorithm. The 3D-spline is composed of three one-dimensional splines with the “Not a knot” condition (in x, y, and z directions). The volume was then integrated with the trapezoidal algorithm. One thousand points (10 x 10 x 10) were obtained through interpolation, in order to calculate the averaged SAR.
 - c. All neighboring volumes were evaluated until no neighboring volume with a higher average value was found.
4. The SAR reference value, at the same location as step 2, was re-measured after the zoom scan was complete to calculate the SAR drift. If the drift deviated by more than 5%, the SAR test and drift measurements were repeated.

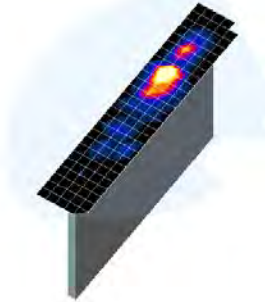



Figure 4-1
Sample SAR Area Scan

Table 4-1
Area and Zoom Scan Resolutions per FCC KDB Publication 865664 D01v01r04*

Frequency	Maximum Area Scan Resolution (mm) (Δx_{area} , Δy_{area})	Maximum Zoom Scan Resolution (mm) (Δx_{zoom} , Δy_{zoom})	Maximum Zoom Scan Spatial Resolution (mm)			Minimum Zoom Scan Volume (mm) (x,y,z)
			Uniform Grid	Graded Grid		
			$\Delta z_{zoom}(n)$	$\Delta z_{zoom}(1)^*$	$\Delta z_{zoom}(n>1)^*$	
≤ 2 GHz	≤ 15	≤ 8	≤ 5	≤ 4	≤ 1.5* $\Delta z_{zoom}(n-1)$	≥ 30
2-3 GHz	≤ 12	≤ 5	≤ 5	≤ 4	≤ 1.5* $\Delta z_{zoom}(n-1)$	≥ 30
3-4 GHz	≤ 12	≤ 5	≤ 4	≤ 3	≤ 1.5* $\Delta z_{zoom}(n-1)$	≥ 28
4-5 GHz	≤ 10	≤ 4	≤ 3	≤ 2.5	≤ 1.5* $\Delta z_{zoom}(n-1)$	≥ 25
5-6 GHz	≤ 10	≤ 4	≤ 2	≤ 2	≤ 1.5* $\Delta z_{zoom}(n-1)$	≥ 22

*Also compliant to IEEE 1528-2013 Table 6

FCC ID: A3LSMT837A		SAR EVALUATION REPORT		Approved by: Quality Manager
Document S/N: 1M1806180124-01.A3L	Test Dates: 06/20/18 - 07/05/18	DUT Type: Portable Tablet		Page 13 of 100

5 TEST CONFIGURATION POSITIONS

5.1 Device Holder

The device holder is made out of low-loss POM material having the following dielectric parameters: relative permittivity $\epsilon = 3$ and loss tangent $\delta = 0.02$.

5.2 SAR Testing for Tablet per KDB Publication 616217 D04v01r02



Per FCC KDB Publication 616217 D04v01r02, the back surface and edges of the tablet should be tested for SAR compliance with the tablet touching the phantom. The SAR Exclusion Threshold in KDB 447498 D01v06 can be applied to determine SAR test exclusion for adjacent edge configurations. The closest distance from the antenna to an adjacent tablet edge is used to determine if SAR testing is required for the adjacent edges, with the adjacent edge positioned against the phantom and the edge containing the antenna positioned perpendicular to the phantom.

5.3 Proximity Sensor Considerations

This device uses a power reduction mechanism to reduce output powers in certain use conditions when the device is used close the user's body.

When the device's antenna is within a certain distance of the user, the sensor activates and reduces the maximum allowed output power. However, the sensor is not active when the device is moved beyond the sensor triggering distance and the maximum output power is no longer limited. Therefore, additional evaluation is needed in the vicinity of the triggering distance to ensure SAR is compliant when the device is allowed to operate at a non-reduced output power level. FCC KDB Publication 616217 D04v01r02 Section 6 was used as a guideline for selecting SAR test distances for this device at these additional test positions. Sensor triggering distance summary data is included in Appendix G.

The sensor is designed to support sufficient detection range and sensitivity to cover regions of the sensors in all applicable directions since the sensor entirely covers the antennas.

FCC ID: A3LSMT837A		SAR EVALUATION REPORT		Approved by: Quality Manager
Document S/N: 1M1806180124-01.A3L	Test Dates: 06/20/18 - 07/05/18	DUT Type: Portable Tablet		Page 14 of 100

6 RF EXPOSURE LIMITS

6.1 Uncontrolled Environment

UNCONTROLLED ENVIRONMENTS are defined as locations where there is the exposure of individuals who have no knowledge or control of their exposure. The general population/uncontrolled exposure limits are applicable to situations in which the general public may be exposed or in which persons who are exposed as a consequence of their employment may not be made fully aware of the potential for exposure or cannot exercise control over their exposure. Members of the general public would come under this category when exposure is not employment-related; for example, in the case of a wireless transmitter that exposes persons in its vicinity.



6.2 Controlled Environment

CONTROLLED ENVIRONMENTS are defined as locations where there is exposure that may be incurred by persons who are aware of the potential for exposure, (i.e. as a result of employment or occupation). In general, occupational/controlled exposure limits are applicable to situations in which persons are exposed as a consequence of their employment, who have been made fully aware of the potential for exposure and can exercise control over their exposure. This exposure category is also applicable when the exposure is of a transient nature due to incidental passage through a location where the exposure levels may be higher than the general population/uncontrolled limits, but the exposed person is fully aware of the potential for exposure and can exercise control over his or her exposure by leaving the area or by some other appropriate means.

**Table 6-1
SAR Human Exposure Specified in ANSI/IEEE C95.1-1992 and Health Canada Safety Code 6**

HUMAN EXPOSURE LIMITS		
	UNCONTROLLED ENVIRONMENT <i>General Population</i> (W/kg) or (mW/g)	CONTROLLED ENVIRONMENT <i>Occupational</i> (W/kg) or (mW/g)
Peak Spatial Average SAR Head	1.6	8.0
Whole Body SAR	0.08	0.4
Peak Spatial Average SAR Hands, Feet, Ankle, Wrists, etc.	4.0	20

1. The Spatial Peak value of the SAR averaged over any 1 gram of tissue (defined as a tissue volume in the shape of a cube) and over the appropriate averaging time.
2. The Spatial Average value of the SAR averaged over the whole body.
3. The Spatial Peak value of the SAR averaged over any 10 grams of tissue (defined as a tissue volume in the shape of a cube) and over the appropriate averaging time.

FCC ID: A3LSMT837A	 PCTEST ENGINEERING LABORATORY, INC.	SAR EVALUATION REPORT	 SAMSUNG	Approved by: Quality Manager
Document S/N: 1M1806180124-01.A3L	Test Dates: 06/20/18 - 07/05/18	DUT Type: Portable Tablet	Page 15 of 100	

7 FCC MEASUREMENT PROCEDURES

Power measurements for licensed transmitters are performed using a base station simulator under digital average power.

7.1 Measured and Reported SAR

Per FCC KDB Publication 447498 D01v06, when SAR is not measured at the maximum power level allowed for production units, the results must be scaled to the maximum tune-up tolerance limit according to the power applied to the individual channels tested to determine compliance. For simultaneous transmission, the measured aggregate SAR must be scaled according to the sum of the differences between the maximum tune-up tolerance and actual power used to test each transmitter. When SAR is measured at or scaled to the maximum tune-up tolerance limit, the results are referred to as *reported* SAR. The highest *reported* SAR results are identified on the grant of equipment authorization according to procedures in KDB 690783 D01v01r03.

7.2 3G SAR Test Reduction Procedure

In FCC KDB Publication 941225 D01v03r01, certain transmission modes within a frequency band and wireless mode evaluated for SAR are defined as primary modes. The equivalent modes considered for SAR test reduction are denoted as secondary modes. When the maximum output power including tune-up tolerance specified for production units in a secondary mode is ≤ 0.25 dB higher than the primary mode or when the highest reported SAR of the primary mode, scaled by the ratio of specified maximum output power and tune-up tolerance of secondary to primary mode, is ≤ 1.2 W/kg, SAR measurements are not required for the secondary mode. These criteria are referred to as the 3G SAR test reduction procedure. When the 3G SAR test reduction procedure is not satisfied, SAR measurements are additionally required for the secondary mode.

7.3 Procedures Used to Establish RF Signal for SAR



The following procedures are according to FCC KDB Publication 941225 D01v03r01 “3G SAR Measurement Procedures.”

The device is placed into a simulated call using a base station simulator in a RF shielded chamber. Establishing connections in this manner ensure a consistent means for testing SAR and are recommended for evaluating SAR [4]. Devices under test are evaluated prior to testing, with a fully charged battery and were configured to operate at maximum output power. In order to verify that the device is tested throughout the SAR test at maximum output power, the SAR measurement system measures a “point SAR” at an arbitrary reference point at the start and end of the 1 gram SAR evaluation, to assess for any power drifts during the evaluation. If the power drift deviates by more than 5%, the SAR test and drift measurements are repeated.

7.4 SAR Measurement Conditions for UMTS

7.4.1 Output Power Verification

Maximum output power is verified on the High, Middle and Low channels according to the general descriptions in section 5.2 of 3GPP TS 34.121, using the appropriate RMC with TPC (transmit power control) set to all “1s” or applying the required inner loop power control procedures to maintain maximum output power while HSUPA is active. Results for all applicable physical channel configurations (DPCCH, DPDCHn and spreading codes, HS-DPCCH etc) are tabulated in this test report. All configurations that are not supported by the DUT or cannot be measured due to technical or equipment limitations are identified.

FCC ID: A3LSMT837A	 PCTEST ENGINEERING LABORATORY, INC.	SAR EVALUATION REPORT		Approved by: Quality Manager
Document S/N: 1M1806180124-01.A3L	Test Dates: 06/20/18 - 07/05/18	DUT Type: Portable Tablet		Page 16 of 100

7.4.2 Body SAR Measurements

SAR for body exposure configurations is measured using the 12.2 kbps RMC with the TPC bits all “1s”. The 3G SAR test reduction procedure is applied to other spreading codes and multiple DPDCH_n configurations supported by the handset with 12.2 kbps RMC as the primary mode. Otherwise, SAR is measured using an applicable RMC configuration with the corresponding spreading code or DPDCH_n, for the highest reported SAR configuration in 12.2 kbps RMC.

7.4.3 SAR Measurements with Rel 5 HSDPA

The 3G SAR test reduction procedure is applied to HSDPA body configurations with 12.2 kbps RMC as the primary mode. Otherwise, Body SAR for HSDPA is measured using an FRC with H-Set 1 in Sub-test 1 and a 12.2 kbps RMC configured in Test Loop Mode 1, for the highest reported SAR configuration in 12.2 kbps RMC without HSDPA. Handsets with both HSDPA and HSUPA are tested according to Release 6 HSPA test procedures.

7.4.4 SAR Measurements with Rel 6 HSUPA

The 3G SAR test reduction procedure is applied to HSPA (HSUPA/HSDPA with RMC) body configurations with 12.2 kbps RMC as the primary mode. Otherwise, Body SAR for HSPA is measured with E-DCH Sub-test 5, using H-Set 1 and QPSK for FRC and a 12.2 kbps RMC configured in Test Loop Mode 1 and power control algorithm 2, according to the highest reported body SAR configuration in 12.2 kbps RMC without HSPA.

When VOIP applies to head exposure, the 3G SAR test reduction procedure is applied with 12.2 kbps RMC as the primary mode; otherwise, the same HSPA configuration used for body SAR measurements are applied to head exposure testing.

7.5 SAR Measurement Conditions for LTE

LTE modes are tested according to FCC KDB 941225 D05v02r04 publication. Establishing connections with base station simulators ensure a consistent means for testing SAR and are recommended for evaluating SAR [4]. The R&S CMW500 or Anritsu MT8820C simulators are used for LTE output power measurements and SAR testing. Closed loop power control was used so the UE transmits with maximum output power during SAR testing. SAR tests were performed with the same number of RB and RB offsets transmitting on all TTI frames (maximum TTI).

7.5.1 Spectrum Plots for RB Configurations



A properly configured base station simulator was used for SAR tests and power measurements. Therefore, spectrum plots for RB configurations were not required to be included in this report.

7.5.2 MPR

MPR is permanently implemented for this device by the manufacturer. The specific manufacturer target MPR is indicated alongside the SAR results. MPR is enabled for this device, according to 3GPP TS36.101 Section 6.2.3 – 6.2.5 under Table 6.2.3-1.

7.5.3 A-MPR

A-MPR (Additional MPR) has been disabled for all SAR tests by setting NS=01 on the base station simulator.

FCC ID: A3LSMT837A		SAR EVALUATION REPORT		Approved by: Quality Manager
Document S/N: 1M1806180124-01.A3L	Test Dates: 06/20/18 - 07/05/18	DUT Type: Portable Tablet		Page 17 of 100

7.5.4 Required RB Size and RB Offsets for SAR Testing

According to FCC KDB 941225 D05v02r04:



- a. Per Section 5.2.1, SAR is required for QPSK 1 RB Allocation for the largest bandwidth
 - i. The required channel and offset combination with the highest maximum output power is required for SAR.
 - ii. When the reported SAR is ≤ 0.8 W/kg, testing of the remaining RB offset configurations and required test channels is not required. Otherwise, SAR is required for the remaining required test channels using the RB offset configuration with highest output power for that channel.
 - iii. When the reported SAR for a required test channel is > 1.45 W/kg, SAR is required for all RB offset configurations for that channel.
- b. Per Section 5.2.2, SAR is required for 50% RB allocation using the largest bandwidth following the same procedures outlined in Section 5.2.1.
- c. Per Section 5.2.3, QPSK SAR is not required for the 100% allocation when the highest maximum output power for the 100% allocation is less than the highest maximum output power of the 1 RB and 50% RB allocations and the reported SAR for the 1 RB and 50% RB allocations is < 0.8 W/kg.
- d. Per Section 5.2.4 and 5.3, SAR tests for higher order modulations and lower bandwidths configurations are not required when the conducted power of the required test configurations determined by Sections 5.2.1 through 5.2.3 is less than or equal to $\frac{1}{2}$ dB higher than the equivalent configuration using QPSK modulation and when the QPSK SAR for those configurations is < 1.45 W/kg.

7.5.5 Downlink Only Carrier Aggregation

Conducted power measurements with LTE Carrier Aggregation (CA) (downlink only) active are made in accordance to KDB Publication 941225 D05Av01r02. The RRC connection is only handled by one cell, the primary component carrier (PCC) for downlink and uplink communications. After making a data connection to the PCC, the UE device adds secondary component carrier(s) (SCC) on the downlink only. All uplink communications and acknowledgements remain identical to specifications when downlink carrier aggregation is inactive on the PCC. Additional conducted output powers are measured with the downlink carrier aggregation active for the configuration with highest measured maximum conducted power with downlink carrier aggregation inactive measured among the channel bandwidth, modulation, and RB combinations in each frequency band. Per FCC KDB Publication 941225 D05Av01r02, no SAR measurements are required for downlink only carrier aggregation configurations when the average output power with downlink only carrier aggregation active is not more than 0.25 dB higher than the average output power with downlink only carrier aggregation inactive.

7.6 SAR Testing with 802.11 Transmitters

The normal network operating configurations of 802.11 transmitters are not suitable for SAR measurements. Unpredictable fluctuations in network traffic and antenna diversity conditions can introduce undesirable variations in SAR results. The SAR for these devices should be measured using chipset based test mode software to ensure the results are consistent and reliable. See KDB Publication 248227 D01v02r02 for more details.

FCC ID: A3LSMT837A		SAR EVALUATION REPORT		Approved by: Quality Manager
Document S/N: 1M1806180124-01.A3L	Test Dates: 06/20/18 - 07/05/18	DUT Type: Portable Tablet	Page 18 of 100	

7.6.1 General Device Setup

Chipset based test mode software is hardware dependent and generally varies among manufacturers. The device operating parameters established in test mode for SAR measurements must be identical to those programmed in production units, including output power levels, amplifier gain settings and other RF performance tuning parameters.

A periodic duty factor is required for current generation SAR systems to measure SAR. When 802.11 frame gaps are accounted for in the transmission, a maximum transmission duty factor of 92 - 96% is typically achievable in most test mode configurations. A minimum transmission duty factor of 85% is required to avoid certain hardware and device implementation issues related to wide range SAR scaling. The reported SAR is scaled to 100% transmission duty factor to determine compliance at the maximum tune-up tolerance limit.

7.6.2 U-NII-1 and U-NII-2A

For devices that operate in both U-NII-1 and U-NII-2A bands, when the same maximum output power is specified for both bands, SAR measurement using OFDM SAR test procedures is not required for U-NII-1 unless the highest reported SAR for U-NII-2A is > 1.2 W/kg. When different maximum output powers are specified for the bands, SAR measurement for the U-NII band with the lower maximum output power is not required unless the highest reported SAR for the U-NII band with the higher maximum output power, adjusted by the ratio of lower to higher specified maximum output power for the two bands, is > 1.2 W/kg.

7.6.3 U-NII-2C and U-NII-3



The frequency range covered by U-NII-2C and U-NII-3 is 380 MHz (5.47 – 5.85 GHz), which requires a minimum of at least two SAR probe calibration frequency points to support SAR measurements. When Terminal Doppler Weather Radar (TDWR) restriction applies, the channels at 5.60 – 5.65 GHz in U-NII-2C band must be disabled with acceptable mechanisms and documented in the equipment certification. Unless band gap channels are permanently disabled, SAR must be considered for these channels. Each band is tested independently according to the normally required OFDM SAR measurement and probe calibration frequency points requirements.

7.6.4 2.4 GHz SAR Test Requirements

SAR is measured for 2.4 GHz 802.11b DSSS using either the fixed test position or, when applicable, the initial test position procedure. SAR test reduction is determined according to the following:

- 1) When the reported SAR of the highest measured maximum output power channel for the exposure configuration is ≤ 0.8 W/kg, no further SAR testing is required for 802.11b DSSS in that exposure configuration.
- 2) When the reported SAR is > 0.8 W/kg, SAR is required for that position using the next highest measured output power channel. When any reported SAR is > 1.2 W/kg, SAR is required for the third channel; i.e., all channels require testing.

2.4 GHz 802.11 g/n OFDM are additionally evaluated for SAR if the highest reported SAR for 802.11b, adjusted by the ratio of the OFDM to DSSS specified maximum output power, is > 1.2 W/kg. When SAR is required for OFDM modes in 2.4 GHz band, the Initial Test Configuration Procedures should be followed.

FCC ID: A3LSMT837A	 PCTEST PROFESSIONAL LABORATORY, INC.	SAR EVALUATION REPORT		Approved by: Quality Manager
Document S/N: 1M1806180124-01.A3L	Test Dates: 06/20/18 - 07/05/18	DUT Type: Portable Tablet		Page 19 of 100

7.6.5 OFDM Transmission Mode and SAR Test Channel Selection

When the same maximum output power was specified for multiple OFDM transmission mode configurations in a frequency band or aggregated band, SAR is measured using the configuration with the largest channel bandwidth, lowest order modulation and lowest data rate. When the maximum output power of a channel is the same for equivalent OFDM configurations; for example, 802.11a, 802.11n and 802.11ac or 802.11g and 802.11n with the same channel bandwidth, modulation and data rate etc., the lower order 802.11 mode i.e., 802.11a, then 802.11n and 802.11ac or 802.11g then 802.11n, is used for SAR measurement. When the maximum output power are the same for multiple test channels, either according to the default or additional power measurement requirements, SAR is measured using the channel closest to the middle of the frequency band or aggregated band. When there are multiple channels with the same maximum output power, SAR is measured using the higher number channel.

7.6.6 Initial Test Configuration Procedure

For OFDM, an initial test configuration is determined for each frequency band and aggregated band, according to the transmission mode with the highest maximum output power specified for SAR measurements. When the same maximum output power is specified for multiple OFDM transmission mode configurations in a frequency band or aggregated band, SAR is measured using the configuration(s) with the largest channel bandwidth, lowest order modulation, lowest data rate and lowest order IEEE 802.11 mode. The channel of the transmission mode with the highest average RF output conducted power will be the initial test configuration.



When the reported SAR is ≤ 0.8 W/kg, no additional measurements on other test channels are required. Otherwise, SAR is evaluated using the subsequent highest average RF output channel until the reported SAR result is ≤ 1.2 W/kg or all channels are measured. When there are multiple untested channels having the same subsequent highest average RF output power, the channel with higher frequency from the lowest 802.11 mode is considered for SAR measurements (See Section 7.6.5).

7.6.7 Subsequent Test Configuration Procedures

For OFDM configurations in each frequency band and aggregated band, SAR is evaluated for initial test configuration using the fixed test position or the initial test position procedure. When the highest reported SAR (for the initial test configuration), adjusted by the ratio of the specified maximum output power of the subsequent test configuration to initial test configuration, is ≤ 1.2 W/kg, no additional SAR tests for the subsequent test configurations are required.

7.6.8 MIMO SAR considerations

Per KDB Publication 248227 D01v02r02, the simultaneous SAR provisions in KDB Publication 447498 D01v06 should be applied to determine simultaneous transmission SAR test exclusion for WIFI MIMO. If the sum of 1g single transmission chain SAR measurements is < 1.6 W/kg, no additional SAR measurements for MIMO are required. Alternatively, SAR for MIMO can be measured with all antennas transmitting simultaneously at the specified maximum output power of MIMO operation.

FCC ID: A3LSMT837A	 PCTEST ENGINEERING LABORATORY, INC.	SAR EVALUATION REPORT		Approved by: Quality Manager
Document S/N: 1M1806180124-01.A3L	Test Dates: 06/20/18 - 07/05/18	DUT Type: Portable Tablet	Page 20 of 100	

8 RF CONDUCTED POWERS

8.1 UMTS Conducted Powers

**Table 8-1
Maximum Conducted Power**

3GPP Release Version	Mode	3GPP 34.121 Subtest	Cellular Band [dBm]			AWS Band [dBm]			PCS Band [dBm]			3GPP MPR [dB]
			4132	4183	4233	1312	1412	1513	9262	9400	9538	
99	WCDMA	12.2 kbps RMC	24.36	24.27	24.05	23.69	23.86	23.71	23.85	23.39	24.02	-
6	HSDPA	Subtest 1	23.31	23.19	22.94	22.58	22.76	22.60	22.74	22.46	23.08	0
6		Subtest 2	23.32	23.23	22.98	22.60	22.77	22.68	22.76	22.43	23.09	0
6		Subtest 3	22.85	22.72	22.49	22.08	22.29	22.17	22.21	21.92	22.59	0.5
6		Subtest 4	22.83	22.76	22.50	22.08	22.17	22.16	22.38	21.91	22.58	0.5
6	HSUPA	Subtest 1	23.35	23.21	22.96	22.59	22.77	22.69	22.99	22.61	22.37	0
6		Subtest 2	21.34	21.24	20.99	20.59	20.79	20.68	21.14	20.66	20.33	2
6		Subtest 3	22.33	22.20	21.97	21.59	21.78	21.67	22.08	21.66	21.38	1
6		Subtest 4	21.31	21.20	20.95	20.57	20.78	20.69	21.16	20.66	20.35	2
6		Subtest 5	22.64	22.51	22.29	22.57	22.77	22.67	23.01	22.67	22.42	0

**Table 8-2
Reduced Conducted Power**

3GPP Release Version	Mode	3GPP 34.121 Subtest	Cellular Band [dBm]			AWS Band [dBm]			PCS Band [dBm]			3GPP MPR [dB]
			4132	4183	4233	1312	1412	1513	9262	9400	9538	
99	WCDMA	12.2 kbps RMC	16.63	16.55	16.31	13.12	13.33	13.20	13.19	12.83	13.39	-
6	HSDPA	Subtest 1	15.84	15.35	15.68	12.58	12.53	12.49	12.70	12.14	12.42	0
6		Subtest 2	15.90	15.42	15.75	12.46	12.46	12.46	12.64	12.07	12.32	0
6		Subtest 3	15.43	14.94	15.27	11.99	11.97	11.91	12.14	11.56	11.86	0.5
6		Subtest 4	15.44	14.95	15.28	11.98	11.96	11.89	12.13	11.56	11.84	0.5
6	HSUPA	Subtest 1	16.00	15.64	16.00	12.60	12.57	12.52	12.77	12.17	12.46	0
6		Subtest 2	14.07	13.64	14.26	10.78	10.72	10.66	10.89	10.28	10.50	2
6		Subtest 3	15.10	14.59	14.96	11.64	11.59	11.55	11.76	11.17	11.42	1
6		Subtest 4	14.06	13.60	13.95	10.94	10.74	10.67	10.92	10.28	10.62	2
6		Subtest 5	16.00	15.60	15.98	12.59	12.58	12.56	12.76	12.18	12.46	0

This device does not support DC-HSDPA.

It is expected by the manufacturer that MPR for some HSPA subtests may be up to 2 dB more than specified by 3GPP, but also as low as 0 dB according to the chipset implementation in this model.

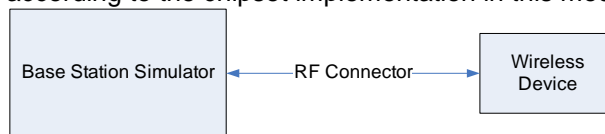

**Figure 8-1
Power Measurement Setup**

FCC ID: A3LSMT837A		SAR EVALUATION REPORT		Approved by: Quality Manager
Document S/N: 1M1806180124-01.A3L	Test Dates: 06/20/18 - 07/05/18	DUT Type: Portable Tablet	Page 21 of 100	

8.2 LTE Conducted Powers

8.2.1

LTE Band 12

Table 8-3
LTE Band 12 Maximum Conducted Powers - 10 MHz Bandwidth

LTE Band 12 10 MHz Bandwidth					
Modulation	RB Size	RB Offset	Mid Channel	MPR Allowed per 3GPP [dB]	MPR [dB]
			23095 (707.5 MHz)		
			Conducted Power [dBm]		
QPSK	1	0	23.89	0	0
	1	25	23.87		0
	1	49	23.87		0
	25	0	23.00	0-1	1
	25	12	23.03		1
	25	25	22.99		1
	50	0	22.98		1
16QAM	1	0	23.23	0-1	1
	1	25	23.17		1
	1	49	23.16		1
	25	0	22.02	0-2	2
	25	12	22.06		2
	25	25	22.00		2
	50	0	21.99		2
64QAM	1	0	22.13	0-2	2
	1	25	22.10		2
	1	49	22.10		2
	25	0	21.05	0-3	3
	25	12	21.04		3
	25	25	21.00		3
	50	0	21.01		3

Note: LTE Band 12 at 10 MHz bandwidth does not support three non-overlapping channels. Per KDB Publication 941225 D05v02, when a device supports overlapping channel assignment in a channel bandwidth configuration, the middle channel of the group of overlapping channels should be selected for testing.



FCC ID: A3LSMT837A		SAR EVALUATION REPORT		Approved by: Quality Manager
Document S/N: 1M1806180124-01.A3L	Test Dates: 06/20/18 - 07/05/18	DUT Type: Portable Tablet		Page 22 of 100

Table 8-4
LTE Band 12 Maximum Conducted Powers - 5 MHz Bandwidth

LTE Band 12 5 MHz Bandwidth								
Modulation	RB Size	RB Offset	Low Channel	Mid Channel	High Channel	MPR Allowed per 3GPP [dB]	MPR [dB]	
			23035 (701.5 MHz)	23095 (707.5 MHz)	23155 (713.5 MHz)			
			Conducted Power [dBm]					
QPSK	1	0	23.95	23.79	23.63	0	0	
	1	12	23.93	23.75	23.58		0	
	1	24	23.93	23.76	23.58		0	
	QPSK	12	0	23.17	22.98	22.82	0-1	1
		12	6	23.16	23.02	22.87		1
		12	13	23.16	22.99	22.79		1
		25	0	23.15	22.99	22.81		1
12		6	22.21	22.05	21.88	2		
16QAM	1	0	23.40	23.25	23.01	0-1	1	
	1	12	23.36	23.18	22.98		1	
	1	24	23.36	23.15	22.95		1	
	16QAM	12	0	22.20	22.07	21.85	0-2	2
		12	6	22.21	22.05	21.88		2
		12	13	22.17	22.01	21.82		2
		25	0	22.16	22.00	21.83		2
64QAM	1	0	22.31	22.11	21.94	0-2	2	
	1	12	22.29	22.10	21.93		2	
	1	24	22.27	22.09	21.90		2	
	64QAM	12	0	21.18	21.06	20.83	0-3	3
		12	6	21.19	21.03	20.85		3
		12	13	21.16	20.99	20.81		3
		25	0	21.16	20.98	20.83		3

Table 8-5
LTE Band 12 Maximum Conducted Powers - 3 MHz Bandwidth

LTE Band 12 3 MHz Bandwidth								
Modulation	RB Size	RB Offset	Low Channel	Mid Channel	High Channel	MPR Allowed per 3GPP [dB]	MPR [dB]	
			23025 (700.5 MHz)	23095 (707.5 MHz)	23165 (714.5 MHz)			
			Conducted Power [dBm]					
QPSK	1	0	24.04	23.85	23.56	0	0	
	1	7	24.14	23.95	23.65		0	
	1	14	24.06	23.85	23.53		0	
	QPSK	8	0	23.11	22.92	22.58	0-1	1
		8	4	23.10	22.93	22.58		1
		8	7	23.07	22.88	22.57		1
		15	0	23.09	22.90	22.56		1
16QAM	1	0	23.31	23.10	22.77	0-1	1	
	1	7	23.39	23.21	22.86		1	
	1	14	23.29	23.12	22.80		1	
	16QAM	8	0	22.15	21.93	21.62	0-2	2
		8	4	22.17	21.98	21.62		2
		8	7	22.16	21.95	21.60		2
		15	0	22.10	21.91	21.55		2
64QAM	1	0	22.20	22.00	21.73	0-2	2	
	1	7	22.33	22.12	21.85		2	
	1	14	22.20	21.99	21.68		2	
	64QAM	8	0	21.10	20.94	20.58	0-3	3
		8	4	21.13	20.94	20.60		3
		8	7	21.10	20.92	20.57		3
		15	0	21.08	20.92	20.55		3





FCC ID: A3LSMT837A	 PCTEST <small>ENGINEERING LABORATORY, INC.</small>	SAR EVALUATION REPORT		Approved by: Quality Manager
Document S/N: 1M1806180124-01.A3L	Test Dates: 06/20/18 - 07/05/18	DUT Type: Portable Tablet	Page 23 of 100	

Table 8-6
LTE Band 12 Maximum Conducted Powers -1.4 MHz Bandwidth

LTE Band 12 1.4 MHz Bandwidth							
Modulation	RB Size	RB Offset	Low Channel	Mid Channel	High Channel	MPR Allowed per 3GPP [dB]	MPR [dB]
			23017 (699.7 MHz)	23095 (707.5 MHz)	23173 (715.3 MHz)		
			Conducted Power [dBm]				
QPSK	1	0	24.03	23.83	23.52	0	0
	1	2	24.10	23.88	23.58		0
	1	5	24.01	23.84	23.49		0
	3	0	24.06	23.84	23.54		0
	3	2	24.09	23.89	23.57		0
	3	3	24.04	23.81	23.55		0
16QAM	6	0	23.09	22.89	22.52	0-1	1
	1	0	23.29	23.07	22.76	0-1	1
	1	2	23.35	23.14	22.82		1
	1	5	23.27	23.06	22.77		1
	3	0	23.17	22.95	22.66		1
	3	2	23.19	23.03	22.70		1
3	3	23.16	22.97	22.66	1		
64QAM	6	0	22.14	21.92	21.56	0-2	2
	1	0	22.18	21.97	21.66	0-2	2
	1	2	22.26	22.04	21.71		2
	1	5	22.17	21.97	21.64		2
	3	0	22.11	21.91	21.59		2
	3	2	22.17	21.96	21.65		2
3	3	22.13	21.90	21.61	2		
	6	0	21.07	20.87	20.52	0-3	3

FCC ID: A3LSMT837A		SAR EVALUATION REPORT		Approved by: Quality Manager
Document S/N: 1M1806180124-01.A3L	Test Dates: 06/20/18 - 07/05/18	DUT Type: Portable Tablet	Page 24 of 100	

**Table 8-7
LTE Band 12 Reduced Conducted Powers - 10 MHz Bandwidth**

LTE Band 12 10 MHz Bandwidth					
Modulation	RB Size	RB Offset	Mid Channel	MPR Allowed per 3GPP [dB]	MPR [dB]
			23095 (707.5 MHz)		
			Conducted Power [dBm]		
QPSK	1	0	13.14	0	0
	1	25	13.05		0
	1	49	13.04		0
	25	0	13.19	0-1	0
	25	12	13.20		0
	25	25	13.09		0
	50	0	13.12		0
16QAM	1	0	13.54	0-1	0
	1	25	13.50		0
	1	49	13.49		0
	25	0	13.17	0-2	0
	25	12	13.20		0
	25	25	13.13		0
	50	0	13.06		0
64QAM	1	0	13.62	0-2	0
	1	25	13.58		0
	1	49	13.47		0
	25	0	13.12	0-3	0
	25	12	13.12		0
	25	25	13.11		0
	50	0	13.14		0

Note: LTE Band 12 at 10 MHz bandwidth does not support three non-overlapping channels. Per KDB Publication 941225 D05v02, when a device supports overlapping channel assignment in a channel bandwidth configuration, the middle channel of the group of overlapping channels should be selected for testing.



FCC ID: A3LSMT837A		SAR EVALUATION REPORT		Approved by: Quality Manager
Document S/N: 1M1806180124-01.A3L	Test Dates: 06/20/18 - 07/05/18	DUT Type: Portable Tablet		Page 25 of 100

Table 8-8
LTE Band 12 Reduced Conducted Powers - 5 MHz Bandwidth

LTE Band 12 5 MHz Bandwidth								
Modulation	RB Size	RB Offset	Low Channel	Mid Channel	High Channel	MPR Allowed per 3GPP [dB]	MPR [dB]	
			23035 (701.5 MHz)	23095 (707.5 MHz)	23155 (713.5 MHz)			
			Conducted Power [dBm]					
QPSK	1	0	13.37	13.18	13.05	0	0	
	1	12	13.30	13.10	12.96		0	
	1	24	13.23	13.10	12.91		0	
	QPSK	12	0	13.35	13.20	13.02	0-1	0
		12	6	13.37	13.20	13.03		0
		12	13	13.28	13.14	12.96		0
		25	0	13.34	13.16	13.03		0
1		0	13.58	13.47	13.33	0-1		0
1	12	13.50	13.39	13.18	0			
1	24	13.50	13.39	13.19	0			
16QAM	12	0	13.38	13.29	13.09	0-2	0	
	12	6	13.38	13.24	13.05		0	
	12	13	13.33	13.19	13.02		0	
	25	0	13.37	13.19	13.03		0	
	1	0	13.62	13.43	13.28		0-2	0
1	12	13.57	13.32	13.22	0			
1	24	13.46	13.31	13.16	0			
64QAM	12	0	13.44	13.29	13.09	0-3	0	
	12	6	13.39	13.24	13.09		0	
	12	13	13.37	13.19	13.01		0	
	25	0	13.37	13.24	13.04		0	

Table 8-9
LTE Band 12 Reduced Conducted Powers - 3 MHz Bandwidth

LTE Band 12 3 MHz Bandwidth									
Modulation	RB Size	RB Offset	Low Channel	Mid Channel	High Channel	MPR Allowed per 3GPP [dB]	MPR [dB]		
			23025 (700.5 MHz)	23095 (707.5 MHz)	23165 (714.5 MHz)				
			Conducted Power [dBm]						
QPSK	1	0	13.35	13.16	12.90	0	0		
	1	7	13.38	13.20	12.94		0		
	1	14	13.27	13.10	12.81		0		
	QPSK	8	0	13.32	13.21	12.90	0-1	0	
		8	4	13.34	13.19	12.87		0	
		8	7	13.29	13.16	12.86		0	
16QAM	15	0	13.33	13.14	12.88	0-1	0		
	1	0	13.59	13.40	13.22		0		
	1	7	13.60	13.52	13.25		0		
	1	14	13.49	13.33	13.14		0		
	16QAM	8	0	13.41	13.22		12.96	0-2	0
		8	4	13.43	13.26		12.95		0
8		7	13.35	13.21	12.91	0			
64QAM	15	0	13.30	13.16	12.89	0-2	0		
	1	0	13.59	13.35	13.09		0		
	1	7	13.64	13.45	13.22		0		
	1	14	13.53	13.32	13.07		0		
	64QAM	8	0	13.42	13.22		12.96	0-3	0
		8	4	13.43	13.23		12.95		0
		8	7	13.39	13.19		12.96		0
	15	0	13.38	13.15	12.91		0		





FCC ID: A3LSMT837A	 PCTEST <small>ENGINEERING LABORATORY, INC.</small>	SAR EVALUATION REPORT		Approved by: Quality Manager
Document S/N: 1M1806180124-01.A3L	Test Dates: 06/20/18 - 07/05/18	DUT Type: Portable Tablet	Page 26 of 100	

Table 8-10
LTE Band 12 Reduced Conducted Powers -1.4 MHz Bandwidth

LTE Band 12 1.4 MHz Bandwidth							
Modulation	RB Size	RB Offset	Low Channel	Mid Channel	High Channel	MPR Allowed per 3GPP [dB]	MPR [dB]
			23017 (699.7 MHz)	23095 (707.5 MHz)	23173 (715.3 MHz)		
			Conducted Power [dBm]				
QPSK	1	0	13.26	13.07	12.78	0	0
	1	2	13.32	13.08	12.82		0
	1	5	13.23	13.02	12.73		0
	3	0	13.28	13.07	12.79		0
	3	2	13.29	13.14	12.84		0
	3	3	13.26	13.06	12.78		0
16QAM	6	0	13.27	13.12	12.80	0-1	0
	1	0	13.56	13.35	13.08	0-1	0
	1	2	13.57	13.38	13.17		0
	1	5	13.47	13.29	13.02		0
	3	0	13.35	13.24	12.94		0
	3	2	13.40	13.23	12.97		0
3	3	13.34	13.25	12.92	0		
64QAM	6	0	13.35	13.17	12.92	0-2	0
	1	0	13.48	13.28	13.05	0-2	0
	1	2	13.54	13.36	13.11		0
	1	5	13.45	13.27	13.02		0
	3	0	13.42	13.23	12.93		0
	3	2	13.46	13.25	13.00		0
3	3	13.38	13.17	12.90	0		
	6	0	13.34	13.14	12.89	0-3	0



FCC ID: A3LSMT837A		SAR EVALUATION REPORT		Approved by: Quality Manager
Document S/N: 1M1806180124-01.A3L	Test Dates: 06/20/18 - 07/05/18	DUT Type: Portable Tablet		Page 27 of 100

8.2.2

LTE Band 14

Table 8-11
 LTE Band 14 Maximum Conducted Powers - 10 MHz Bandwidth



LTE Band 14 10 MHz Bandwidth					
Modulation	RB Size	RB Offset	Mid Channel	MPR Allowed per 3GPP [dB]	MPR [dB]
			23330 (793.0 MHz)		
			Conducted Power [dBm]		
QPSK	1	0	23.91	0	0
	1	25	23.82		0
	1	49	23.76		0
	25	0	22.92	0-1	1
	25	12	22.91		1
	25	25	22.84		1
	50	0	22.91		1
16QAM	1	0	23.16	0-1	1
	1	25	23.10		1
	1	49	23.03		1
	25	0	21.94	0-2	2
	25	12	21.93		2
	25	25	21.83		2
	50	0	21.91		2
64QAM	1	0	22.11	0-2	2
	1	25	22.02		2
	1	49	21.97		2
	25	0	20.97	0-3	3
	25	12	20.96		3
	25	25	20.88		3
	50	0	20.93		3

FCC ID: A3LSMT837A	 PCTEST ENGINEERING LABORATORY, INC.	SAR EVALUATION REPORT		Approved by: Quality Manager
Document S/N: 1M1806180124-01.A3L	Test Dates: 06/20/18 - 07/05/18	DUT Type: Portable Tablet		Page 28 of 100

**Table 8-12
LTE Band 14 Maximum Conducted Powers - 5 MHz Bandwidth**

LTE Band 14 5 MHz Bandwidth					
Modulation	RB Size	RB Offset	Mid Channel	MPR Allowed per 3GPP [dB]	MPR [dB]
			23330 (793.0 MHz)		
			Conducted Power [dBm]		
QPSK	1	0	23.88	0	0
	1	12	23.83		0
	1	24	23.81		0
	12	0	22.89	0-1	1
	12	6	22.90		1
	12	13	22.86		1
	25	0	22.89		1
16QAM	1	0	23.15	0-1	1
	1	12	23.08		1
	1	24	23.07		1
	12	0	21.93	0-2	2
	12	6	21.93		2
	12	13	21.92		2
	25	0	21.88		2
64QAM	1	0	22.08	0-2	2
	1	12	22.06		2
	1	24	22.00		2
	12	0	20.95	0-3	3
	12	6	20.95		3
	12	13	20.91		3
	25	0	20.91		3

Note: LTE Band 14 at 5 MHz bandwidth does not support three non-overlapping channels. Per KDB Publication 941225 D05v02, when a device supports overlapping channel assignment in a channel bandwidth configuration, the middle channel of the group of overlapping channels should be selected for testing.

FCC ID: A3LSMT837A		SAR EVALUATION REPORT		Approved by: Quality Manager
Document S/N: 1M1806180124-01.A3L	Test Dates: 06/20/18 - 07/05/18	DUT Type: Portable Tablet		Page 29 of 100

**Table 8-13
LTE Band 14 Reduced Conducted Powers - 10 MHz Bandwidth**

LTE Band 14 10 MHz Bandwidth					
Modulation	RB Size	RB Offset	Mid Channel	MPR Allowed per 3GPP [dB]	MPR [dB]
			23330 (793.0 MHz)		
			Conducted Power [dBm]		
QPSK	1	0	15.01	0	0
	1	25	14.86		0
	1	49	14.81		0
	25	0	14.99	0-1	0
	25	12	14.96		0
	25	25	14.91		0
	50	0	14.90		0
16QAM	1	0	15.32	0-1	0
	1	25	15.20		0
	1	49	15.14		0
	25	0	15.09	0-2	0
	25	12	15.08		0
	25	25	15.03		0
	50	0	14.92		0
64QAM	1	0	14.83	0-2	0
	1	25	14.98		0
	1	49	14.89		0
	25	0	15.06	0-3	0
	25	12	15.05		0
	25	25	14.98		0
	50	0	14.98		0





FCC ID: A3LSMT837A	 PCTEST ENGINEERING LABORATORY, INC.	SAR EVALUATION REPORT		Approved by: Quality Manager
Document S/N: 1M1806180124-01.A3L	Test Dates: 06/20/18 - 07/05/18	DUT Type: Portable Tablet		Page 30 of 100

Table 8-14
LTE Band 14 Reduced Conducted Powers - 5 MHz Bandwidth

LTE Band 14 5 MHz Bandwidth					
Modulation	RB Size	RB Offset	Mid Channel	MPR Allowed per 3GPP [dB]	MPR [dB]
			23330 (793.0 MHz)		
			Conducted Power [dBm]		
QPSK	1	0	15.11	0	0
	1	12	15.12		0
	1	24	14.92		0
	12	0	15.03	0-1	0
	12	6	15.14		0
	12	13	15.06		0
	25	0	15.03		0
16QAM	1	0	15.11	0-1	0
	1	12	15.23		0
	1	24	15.06		0
	12	0	15.03	0-2	0
	12	6	15.15		0
	12	13	15.06		0
	25	0	15.02		0
64QAM	1	0	15.14	0-2	0
	1	12	15.19		0
	1	24	15.10		0
	12	0	15.16	0-3	0
	12	6	15.15		0
	12	13	15.12		0
	25	0	15.10		0

Note: LTE Band 14 at 5 MHz bandwidth does not support three non-overlapping channels. Per KDB Publication 941225 D05v02, when a device supports overlapping channel assignment in a channel bandwidth configuration, the middle channel of the group of overlapping channels should be selected for testing.

FCC ID: A3LSMT837A		SAR EVALUATION REPORT		Approved by: Quality Manager
Document S/N: 1M1806180124-01.A3L	Test Dates: 06/20/18 - 07/05/18	DUT Type: Portable Tablet	Page 31 of 100	

8.2.3

LTE Band 5 (Cell)

Table 8-15
LTE Band 5 (Cell) Maximum Conducted Powers - 10 MHz Bandwidth

LTE Band 5 (Cell) 10 MHz Bandwidth					
Modulation	RB Size	RB Offset	Mid Channel	MPR Allowed per 3GPP [dB]	MPR [dB]
			20525 (836.5 MHz)		
			Conducted Power [dBm]		
QPSK	1	0	24.15	0	0
	1	25	24.06		0
	1	49	24.01		0
	25	0	23.15	0-1	1
	25	12	23.14		1
	25	25	23.05		1
	50	0	23.10		1
16QAM	1	0	23.40	0-1	1
	1	25	23.33		1
	1	49	23.26		1
	25	0	22.16	0-2	2
	25	12	22.14		2
	25	25	22.04		2
	50	0	22.13		2
64QAM	1	0	22.33	0-2	2
	1	25	22.27		2
	1	49	22.21		2
	25	0	21.16	0-3	3
	25	12	21.15		3
	25	25	21.09		3
	50	0	21.13		3

Note: LTE Band 5 (Cell) at 10 MHz bandwidth does not support three non-overlapping channels. Per KDB Publication 941225 D05v02, when a device supports overlapping channel assignment in a channel bandwidth configuration, the middle channel of the group of overlapping channels should be selected for testing.



FCC ID: A3LSMT837A	 PCTEST ENGINEERING LABORATORY, INC.	SAR EVALUATION REPORT		Approved by: Quality Manager
Document S/N: 1M1806180124-01.A3L	Test Dates: 06/20/18 - 07/05/18	DUT Type: Portable Tablet	Page 32 of 100	

Table 8-16
LTE Band 5 (Cell) Maximum Conducted Powers - 5 MHz Bandwidth

LTE Band 5 (Cell) 5 MHz Bandwidth								
Modulation	RB Size	RB Offset	Low Channel	Mid Channel	High Channel	MPR Allowed per 3GPP [dB]	MPR [dB]	
			20425 (826.5 MHz)	20525 (836.5 MHz)	20625 (846.5 MHz)			
			Conducted Power [dBm]					
QPSK	1	0	24.11	24.07	24.00	0	0	
	1	12	24.05	24.04	23.93		0	
	1	24	24.03	24.03	23.90		0	
	12	0	23.13	23.13	22.98	0-1	1	
	12	6	23.13	23.10	22.99		1	
	12	13	23.07	23.05	22.93		1	
16QAM	25	0	23.09	23.10	22.96	0-1	1	
	1	0	23.41	23.36	23.24		0-1	1
	1	12	23.35	23.33	23.19			1
	1	24	23.30	23.29	23.15	0-2		1
	12	0	22.18	22.12	22.01		2	
	12	6	22.17	22.17	22.03		2	
64QAM	12	13	22.14	22.09	21.98	0-2	2	
	25	0	22.11	22.11	21.98		2	
	1	0	22.34	22.33	22.21		0-2	2
	1	12	22.30	22.26	22.14	2		
	1	24	22.26	22.24	22.10	0-3		2
	12	0	21.19	21.15	21.04		3	
	12	6	21.18	21.15	21.04		3	
	12	13	21.15	21.11	20.98	0-3	3	
25	0	21.13	21.13	21.00	3			

Table 8-17
LTE Band 5 (Cell) Maximum Conducted Powers - 3 MHz Bandwidth

LTE Band 5 (Cell) 3 MHz Bandwidth								
Modulation	RB Size	RB Offset	Low Channel	Mid Channel	High Channel	MPR Allowed per 3GPP [dB]	MPR [dB]	
			20415 (825.5 MHz)	20525 (836.5 MHz)	20635 (847.5 MHz)			
			Conducted Power [dBm]					
QPSK	1	0	24.14	24.08	23.98	0	0	
	1	7	24.19	24.17	24.03		0	
	1	14	24.11	24.09	23.92		0	
	8	0	23.15	23.08	22.94	0-1	1	
	8	4	23.14	23.09	22.97		1	
	8	7	23.14	23.09	22.96		1	
16QAM	15	0	23.11	23.08	22.96	0-1	1	
	1	0	23.36	23.35	23.20		0-1	1
	1	7	23.45	23.43	23.28			1
	1	14	23.34	23.30	23.17	0-2		1
	8	0	22.16	22.15	22.00		2	
	8	4	22.19	22.17	22.02		2	
64QAM	8	7	22.15	22.11	21.99	0-2	2	
	15	0	22.09	22.05	21.94		2	
	1	0	22.32	22.27	22.13		0-2	2
	1	7	22.40	22.40	22.24	2		
	1	14	22.27	22.25	22.09	0-3		2
	8	0	21.13	21.11	20.98		3	
	8	4	21.17	21.13	21.00		3	
	8	7	21.11	21.08	20.95	0-3	3	
15	0	21.16	21.10	20.98	3			





FCC ID: A3LSMT837A		SAR EVALUATION REPORT		Approved by: Quality Manager
Document S/N: 1M1806180124-01.A3L	Test Dates: 06/20/18 - 07/05/18	DUT Type: Portable Tablet	Page 33 of 100	

Table 8-18
LTE Band 5 (Cell) Maximum Conducted Powers -1.4 MHz Bandwidth

LTE Band 5 (Cell) 1.4 MHz Bandwidth							
Modulation	RB Size	RB Offset	Low Channel	Mid Channel	High Channel	MPR Allowed per 3GPP [dB]	MPR [dB]
			20407 (824.7 MHz)	20525 (836.5 MHz)	20643 (848.3 MHz)		
			Conducted Power [dBm]				
QPSK	1	0	24.04	24.00	23.86	0	0
	1	2	24.10	24.06	23.91		0
	1	5	24.04	23.98	23.82		0
	3	0	24.07	24.04	23.88		0
	3	2	24.11	24.06	23.93		0
	3	3	24.07	24.02	23.87	0	
	6	0	23.08	23.03	22.88	0-1	1
16QAM	1	0	23.30	23.28	23.13	0-1	1
	1	2	23.38	23.34	23.18		1
	1	5	23.28	23.24	23.11		1
	3	0	23.19	23.16	22.98		1
	3	2	23.25	23.20	23.05		1
	3	3	23.16	23.14	23.01	1	
	6	0	22.11	22.08	21.93	0-2	2
64QAM	1	0	22.24	22.20	22.06	0-2	2
	1	2	22.29	22.24	22.11		2
	1	5	22.21	22.17	22.03		2
	3	0	22.15	22.13	21.96		2
	3	2	22.20	22.17	22.02		2
	3	3	22.15	22.14	21.95	2	
	6	0	21.10	21.03	20.88	0-3	3

FCC ID: A3LSMT837A		SAR EVALUATION REPORT		Approved by: Quality Manager
Document S/N: 1M1806180124-01.A3L	Test Dates: 06/20/18 - 07/05/18	DUT Type: Portable Tablet	Page 34 of 100	

**Table 8-19
LTE Band 5 (Cell) Reduced Conducted Powers - 10 MHz Bandwidth**

LTE Band 5 (Cell) 10 MHz Bandwidth					
Modulation	RB Size	RB Offset	Mid Channel	MPR Allowed per 3GPP [dB]	MPR [dB]
			20525 (836.5 MHz)		
			Conducted Power [dBm]		
QPSK	1	0	15.51	0	0
	1	25	15.42		0
	1	49	15.34		0
	25	0	15.50	0-1	0
	25	12	15.47		0
	25	25	15.42		0
	50	0	15.46		0
16QAM	1	0	15.67	0-1	0
	1	25	15.66		0
	1	49	15.58		0
	25	0	15.49	0-2	0
	25	12	15.48		0
	25	25	15.42		0
	50	0	15.53		0
64QAM	1	0	15.57	0-2	0
	1	25	15.45		0
	1	49	15.39		0
	25	0	15.47	0-3	0
	25	12	15.52		0
	25	25	15.47		0
	50	0	15.38		0

Note: LTE Band 5 (Cell) at 10 MHz bandwidth does not support three non-overlapping channels. Per KDB Publication 941225 D05v02, when a device supports overlapping channel assignment in a channel bandwidth configuration, the middle channel of the group of overlapping channels should be selected for testing.



FCC ID: A3LSMT837A		SAR EVALUATION REPORT		Approved by: Quality Manager
Document S/N: 1M1806180124-01.A3L	Test Dates: 06/20/18 - 07/05/18	DUT Type: Portable Tablet		Page 35 of 100

Table 8-20
LTE Band 5 (Cell) Reduced Conducted Powers - 5 MHz Bandwidth

LTE Band 5 (Cell) 5 MHz Bandwidth								
Modulation	RB Size	RB Offset	Low Channel	Mid Channel	High Channel	MPR Allowed per 3GPP [dB]	MPR [dB]	
			20425 (826.5 MHz)	20525 (836.5 MHz)	20625 (846.5 MHz)			
			Conducted Power [dBm]					
QPSK	1	0	15.40	15.39	15.24	0	0	
	1	12	15.36	15.32	15.16		0	
	1	24	15.31	15.28	15.13		0	
	12	0	15.40	15.41	15.26	0-1	0	
	12	6	15.45	15.43	15.29		0	
	12	13	15.35	15.36	15.23		0	
16QAM	25	0	15.42	15.38	15.23	0-1	0	
	1	0	15.62	15.66	15.42		0-2	0
	1	12	15.64	15.53	15.44			0
	1	24	15.61	15.54	15.33	0-2		0
	12	0	15.47	15.43	15.27		0	
	12	6	15.46	15.41	15.29		0	
64QAM	12	13	15.43	15.36	15.23	0-2	0	
	25	0	15.43	15.36	15.23		0	
	1	0	15.64	15.59	15.45		0-2	0
	1	12	15.57	15.54	15.32	0		
	1	24	15.49	15.51	15.37	0		
	64QAM	12	0	15.45	15.44	15.31	0-3	0
		12	6	15.47	15.43	15.30		0
		12	13	15.39	15.37	15.24		0
25		0	15.42	15.38	15.27	0-3	0	
							0	
							0	

Table 8-21
LTE Band 5 (Cell) Reduced Conducted Powers - 3 MHz Bandwidth

LTE Band 5 (Cell) 3 MHz Bandwidth								
Modulation	RB Size	RB Offset	Low Channel	Mid Channel	High Channel	MPR Allowed per 3GPP [dB]	MPR [dB]	
			20415 (825.5 MHz)	20525 (836.5 MHz)	20635 (847.5 MHz)			
			Conducted Power [dBm]					
QPSK	1	0	15.42	15.35	15.19	0	0	
	1	7	15.47	15.40	15.26		0	
	1	14	15.32	15.30	15.12		0	
	8	0	15.44	15.40	15.21	0-1	0	
	8	4	15.41	15.39	15.24		0	
	8	7	15.40	15.30	15.18		0	
16QAM	15	0	15.43	15.38	15.18	0-1	0	
	1	0	15.69	15.61	15.41		0-1	0
	1	7	15.80	15.72	15.58			0
	1	14	15.51	15.57	15.38	0-2		0
	8	0	15.45	15.38	15.24		0	
	8	4	15.46	15.41	15.26		0	
64QAM	8	7	15.42	15.38	15.22	0-2	0	
	15	0	15.41	15.32	15.16		0	
	1	0	15.61	15.50	15.38		0-2	0
	1	7	15.66	15.64	15.44	0		
	1	14	15.56	15.47	15.30	0		
	64QAM	8	0	15.43	15.38	15.24	0-3	0
8		4	15.44	15.41	15.23	0		
8		7	15.40	15.36	15.21	0		
15		0	15.42	15.36	15.21	0-3	0	
							0	





FCC ID: A3LSMT837A		SAR EVALUATION REPORT		Approved by: Quality Manager
Document S/N: 1M1806180124-01.A3L	Test Dates: 06/20/18 - 07/05/18	DUT Type: Portable Tablet		Page 36 of 100

Table 8-22
LTE Band 5 (Cell) Reduced Conducted Powers -1.4 MHz Bandwidth

LTE Band 5 (Cell) 1.4 MHz Bandwidth							
Modulation	RB Size	RB Offset	Low Channel	Mid Channel	High Channel	MPR Allowed per 3GPP [dB]	MPR [dB]
			20407 (824.7 MHz)	20525 (836.5 MHz)	20643 (848.3 MHz)		
			Conducted Power [dBm]				
QPSK	1	0	15.23	15.21	15.05	0	0
	1	2	15.35	15.25	15.12		0
	1	5	15.22	15.20	15.00		0
	3	0	15.32	15.26	15.11		0
	3	2	15.34	15.29	15.10		0
	3	3	15.27	15.24	15.09	0	
	6	0	15.30	15.26	15.08	0-1	0
16QAM	1	0	15.54	15.50	15.37	0-1	0
	1	2	15.62	15.60	15.40		0
	1	5	15.50	15.44	15.23		0
	3	0	15.37	15.33	15.17		0
	3	2	15.41	15.40	15.23		0
	3	3	15.37	15.31	15.22	0	
	6	0	15.35	15.30	15.12	0-2	0
64QAM	1	0	15.41	15.47	15.27	0-2	0
	1	2	15.47	15.46	15.34		0
	1	5	15.47	15.36	15.23		0
	3	0	15.35	15.35	15.17		0
	3	2	15.41	15.36	15.19		0
	3	3	15.36	15.34	15.15	0	
	6	0	15.32	15.28	15.12	0-3	0

FCC ID: A3LSMT837A		SAR EVALUATION REPORT		Approved by: Quality Manager
Document S/N: 1M1806180124-01.A3L	Test Dates: 06/20/18 - 07/05/18	DUT Type: Portable Tablet		Page 37 of 100

8.2.4

LTE Band 66 (AWS)

Table 8-23
LTE Band 66 (AWS) Maximum Conducted Powers - 20 MHz Bandwidth

LTE Band 66 (AWS) 20 MHz Bandwidth								
Modulation	RB Size	RB Offset	Low Channel	Mid Channel	High Channel	MPR Allowed per 3GPP [dB]	MPR [dB]	
			132072 (1720.0 MHz)	132322 (1745.0 MHz)	132572 (1770.0 MHz)			
			Conducted Power [dBm]					
QPSK	1	0	24.14	24.38	24.44	0	0	
	1	50	23.90	24.09	24.14		0	
	1	99	23.83	24.00	24.06		0	
	QPSK	50	0	23.12	23.27	23.33	0-1	1
		50	25	23.00	23.20	23.22		1
		50	50	22.94	23.11	23.12		1
		100	0	23.01	23.19	23.24		1
16QAM	1	0	23.39	23.62	23.70	0-1	1	
	1	50	23.16	23.33	23.40		1	
	1	99	23.09	23.28	23.35		1	
	16QAM	50	0	22.09	22.27	22.31	0-2	2
		50	25	22.02	22.20	22.24		2
		50	50	21.94	22.11	22.14		2
		100	0	22.02	22.19	22.24		2
64QAM	1	0	22.25	22.47	22.54	0-2	2	
	1	50	22.03	22.23	22.20		2	
	1	99	22.01	22.13	22.17		2	
	64QAM	50	0	21.03	21.21	21.24	0-3	3
		50	25	21.02	21.17	21.22		3
		50	50	20.96	21.12	21.14		3
		100	0	21.03	21.22	21.26		3

Table 8-24
LTE Band 66 (AWS) Maximum Conducted Powers - 15 MHz Bandwidth

LTE Band 66 (AWS) 15 MHz Bandwidth								
Modulation	RB Size	RB Offset	Low Channel	Mid Channel	High Channel	MPR Allowed per 3GPP [dB]	MPR [dB]	
			132047 (1717.5 MHz)	132322 (1745.0 MHz)	132597 (1772.5 MHz)			
			Conducted Power [dBm]					
QPSK	1	0	24.13	24.31	24.39	0	0	
	1	36	23.91	24.11	24.15		0	
	1	74	23.89	24.06	24.10		0	
	QPSK	36	0	23.08	23.22	23.29	0-1	1
		36	18	23.03	23.16	23.19		1
		36	37	22.94	23.14	23.14		1
		75	0	22.99	23.20	23.21		1
16QAM	1	0	23.38	23.58	23.68	0-1	1	
	1	36	23.17	23.35	23.41		1	
	1	74	23.15	23.32	23.36		1	
	16QAM	36	0	22.10	22.22	22.28	0-2	2
		36	18	22.02	22.17	22.22		2
		36	37	21.96	22.11	22.15		2
		75	0	22.00	22.17	22.21		2
64QAM	1	0	22.31	22.52	22.58	0-2	2	
	1	36	22.11	22.29	22.33		2	
	1	74	22.07	22.24	22.28		2	
	64QAM	36	0	21.08	21.26	21.28	0-3	3
		36	18	21.02	21.17	21.24		3
		36	37	20.97	21.12	21.15		3
		75	0	21.02	21.15	21.22		3



FCC ID: A3LSMT837A		SAR EVALUATION REPORT		Approved by: Quality Manager
Document S/N: 1M1806180124-01.A3L	Test Dates: 06/20/18 - 07/05/18	DUT Type: Portable Tablet	Page 38 of 100	

Table 8-25
LTE Band 66 (AWS) Maximum Conducted Powers - 10 MHz Bandwidth

LTE Band 66 (AWS) 10 MHz Bandwidth								
Modulation	RB Size	RB Offset	Low Channel	Mid Channel	High Channel	MPR Allowed per 3GPP [dB]	MPR [dB]	
			132022 (1715.0 MHz)	132322 (1745.0 MHz)	132622 (1775.0 MHz)			
			Conducted Power [dBm]					
QPSK	1	0	24.24	24.41	24.46	0	0	
	1	25	24.10	24.27	24.31		0	
	1	49	24.06	24.25	24.28		0	
	25	0	23.23	23.40	23.42	0-1	1	
	25	12	23.21	23.38	23.38		1	
	25	25	23.15	23.28	23.31		1	
16QAM	50	0	23.19	23.35	23.36	0-1	1	
	1	0	23.48	23.66	23.73		0-1	1
	1	25	23.36	23.54	23.57			1
	1	49	23.35	23.51	23.55	0-2		1
	25	0	22.24	22.40	22.42		2	
	25	12	22.21	22.37	22.41		2	
64QAM	25	25	22.16	22.29	22.32	0-2	2	
	50	0	22.18	22.35	22.39		2	
	1	0	22.42	22.60	22.65		0-2	2
	1	25	22.31	22.48	22.49	0-3		2
	1	49	22.28	22.45	22.46			2
	25	0	21.25	21.40	21.44		3	
64QAM	25	12	21.22	21.38	21.41	0-3	3	
	25	25	21.17	21.31	21.35		3	
	50	0	21.21	21.34	21.40		3	

Table 8-26
LTE Band 66 (AWS) Maximum Conducted Powers - 5 MHz Bandwidth

LTE Band 66 (AWS) 5 MHz Bandwidth								
Modulation	RB Size	RB Offset	Low Channel	Mid Channel	High Channel	MPR Allowed per 3GPP [dB]	MPR [dB]	
			131997 (1712.5 MHz)	132322 (1745.0 MHz)	132647 (1777.5 MHz)			
			Conducted Power [dBm]					
QPSK	1	0	23.67	23.97	23.97	0	0	
	1	12	23.61	23.89	23.91		0	
	1	24	23.62	23.88	23.90		0	
	12	0	22.68	22.96	22.97	0-1	1	
	12	6	22.72	22.93	22.96		1	
	12	13	22.64	22.91	22.89		1	
16QAM	25	0	22.68	22.91	22.90	0-1	1	
	1	0	22.95	23.23	23.24		0-1	1
	1	12	22.87	23.16	23.18			1
	1	24	22.86	23.13	23.16	0-2		1
	12	0	21.72	21.99	21.99		2	
	12	6	21.70	21.97	21.98		2	
64QAM	12	13	21.72	21.96	21.99	0-2	2	
	25	0	21.68	21.91	21.94		2	
	1	0	21.88	22.16	22.19		0-2	2
	1	12	21.84	22.09	22.10	0-3		2
	1	24	21.81	22.06	22.08			2
	12	0	20.72	20.97	20.99		0-3	3
12	6	20.71	20.97	20.99	3			
12	13	20.74	20.97	20.99	3			
25	0	20.71	20.95	20.96	3			



FCC ID: A3LSMT837A		SAR EVALUATION REPORT		Approved by: Quality Manager
Document S/N: 1M1806180124-01.A3L	Test Dates: 06/20/18 - 07/05/18	DUT Type: Portable Tablet	Page 39 of 100	

Table 8-27
LTE Band 66 (AWS) Maximum Conducted Powers - 3 MHz Bandwidth

LTE Band 66 (AWS) 3 MHz Bandwidth							
Modulation	RB Size	RB Offset	Low Channel	Mid Channel	High Channel	MPR Allowed per 3GPP [dB]	MPR [dB]
			131987 (1711.5 MHz)	132322 (1745.0 MHz)	132657 (1778.5 MHz)		
Conducted Power [dBm]							
QPSK	1	0	24.03	24.30	24.31	0	0
	1	7	24.08	24.35	24.37		0
	1	14	24.00	24.21	24.24		0
	8	0	23.06	23.30	23.29	0-1	1
	8	4	23.04	23.32	23.30		1
	8	7	23.02	23.27	23.28		1
16QAM	15	0	23.01	23.27	23.28	0-1	1
	1	0	23.29	23.53	23.56		1
	1	7	23.37	23.64	23.65		1
	1	14	23.27	23.51	23.51	0-2	1
	8	0	22.10	22.35	22.35		2
	8	4	22.11	22.36	22.36		2
64QAM	8	7	22.06	22.31	22.34	0-2	2
	15	0	22.03	22.28	22.28		2
	1	0	22.22	22.49	22.51		0-2
	1	7	22.33	22.58	22.58	2	
	1	14	22.18	22.43	22.47	2	
	64QAM	8	0	21.09	21.33	21.33	0-3
8		4	21.11	21.34	21.35	3	
8		7	21.05	21.32	21.32	3	
15		0	21.05	21.30	21.33	3	

Table 8-28
LTE Band 66 (AWS) Maximum Conducted Powers -1.4 MHz Bandwidth

LTE Band 66 (AWS) 1.4 MHz Bandwidth							
Modulation	RB Size	RB Offset	Low Channel	Mid Channel	High Channel	MPR Allowed per 3GPP [dB]	MPR [dB]
			131979 (1710.7 MHz)	132322 (1745.0 MHz)	132665 (1779.3 MHz)		
Conducted Power [dBm]							
QPSK	1	0	23.69	23.96	23.97	0	0
	1	2	23.77	24.03	24.04		0
	1	5	23.69	23.97	23.96		0
	3	0	23.72	23.98	24.01	0-1	0
	3	2	23.76	24.04	24.04		0
	3	3	23.71	23.98	23.99		0
16QAM	6	0	22.75	22.98	23.00	0-1	1
	1	0	22.98	23.25	23.31		1
	1	2	23.06	23.31	23.34		1
	1	5	22.95	23.23	23.22	0-1	1
	3	0	22.85	23.13	23.14		1
	3	2	22.91	23.14	23.17		1
64QAM	3	3	22.85	23.10	23.12	0-2	1
	6	0	21.82	22.05	22.05		2
	1	0	21.93	22.17	22.18		0-2
	1	2	21.97	22.24	22.25	2	
	1	5	21.90	22.15	22.18	2	
	3	0	21.85	22.11	22.13	0-2	2
3	2	21.89	22.16	22.18	2		
3	3	21.83	22.09	22.10	2		
6	0	20.77	21.02	21.03	0-3	3	



FCC ID: A3LSMT837A		SAR EVALUATION REPORT		Approved by: Quality Manager
Document S/N: 1M1806180124-01.A3L	Test Dates: 06/20/18 - 07/05/18	DUT Type: Portable Tablet	Page 40 of 100	

Table 8-29
LTE Band 66 (AWS) Reduced Conducted Powers - 20 MHz Bandwidth

LTE Band 66 (AWS) 20 MHz Bandwidth							
Modulation	RB Size	RB Offset	Low Channel	Mid Channel	High Channel	MPR Allowed per 3GPP [dB]	MPR [dB]
			132072 (1720.0 MHz)	132322 (1745.0 MHz)	132572 (1770.0 MHz)		
			Conducted Power [dBm]				
QPSK	1	0	13.09	13.38	13.39	0	0
	1	50	12.93	13.23	13.13		0
	1	99	12.96	13.17	13.12		0
	50	0	13.18	13.36	13.42	0-1	0
	50	25	13.12	13.25	13.33		0
	50	50	13.11	13.24	13.28		0
16QAM	100	0	13.15	13.30	13.36	0-1	0
	1	0	13.59	13.37	13.71		0
	1	50	13.30	13.17	13.58		0
	1	99	13.38	13.08	13.53	0-2	0
	50	0	13.24	13.38	13.46		0
	50	25	13.22	13.32	13.38		0
64QAM	50	50	13.16	13.27	13.35	0-2	0
	100	0	13.23	13.33	13.34		0
	1	0	13.27	13.72	13.50		0-2
	1	50	13.21	13.59	13.42	0	
	1	99	13.07	13.57	13.40	0	
	64QAM	50	0	13.27	13.36	13.21	0-3
50		25	13.14	13.31	13.42	0	
50		50	13.19	13.23	13.37	0	
100		0	13.21	13.36	13.44	0	

Table 8-30
LTE Band 66 (AWS) Reduced Conducted Powers - 15 MHz Bandwidth

LTE Band 66 (AWS) 15 MHz Bandwidth							
Modulation	RB Size	RB Offset	Low Channel	Mid Channel	High Channel	MPR Allowed per 3GPP [dB]	MPR [dB]
			132047 (1717.5 MHz)	132322 (1745.0 MHz)	132597 (1772.5 MHz)		
			Conducted Power [dBm]				
QPSK	1	0	13.09	13.18	13.36	0	0
	1	36	12.92	12.99	13.12		0
	1	74	12.86	12.98	13.07		0
	36	0	13.05	13.15	13.27	0-1	0
	36	18	13.00	13.12	13.19		0
	36	37	12.96	13.06	13.16		0
16QAM	75	0	13.02	13.11	13.23	0-1	0
	1	0	13.28	13.44	13.52		0
	1	36	13.18	13.28	13.34		0
	1	74	13.12	13.23	13.31	0-2	0
	36	0	13.11	13.18	13.25		0
	36	18	13.04	13.12	13.22		0
64QAM	36	37	13.01	13.08	13.18	0-2	0
	75	0	13.05	13.14	13.17		0
	1	0	13.36	13.43	13.51		0-2
	1	36	13.12	13.24	13.34	0	
	1	74	13.13	13.24	13.29	0	
	64QAM	36	0	13.06	13.18	13.27	0-3
36		18	13.02	13.11	13.24	0	
36		37	12.95	13.05	13.17	0	
75		0	13.01	13.10	13.21	0	



FCC ID: A3LSMT837A		SAR EVALUATION REPORT		Approved by: Quality Manager
Document S/N: 1M1806180124-01.A3L	Test Dates: 06/20/18 - 07/05/18	DUT Type: Portable Tablet	Page 41 of 100	

Table 8-31
LTE Band 66 (AWS) Reduced Conducted Powers - 10 MHz Bandwidth

LTE Band 66 (AWS) 10 MHz Bandwidth							
Modulation	RB Size	RB Offset	Low Channel	Mid Channel	High Channel	MPR Allowed per 3GPP [dB]	MPR [dB]
			132022 (1715.0 MHz)	132322 (1745.0 MHz)	132622 (1775.0 MHz)		
			Conducted Power [dBm]				
QPSK	1	0	13.01	13.12	13.24	0	0
	1	25	12.91	13.02	13.09		0
	1	49	12.90	12.97	13.05		0
	25	0	13.04	13.13	13.20	0-1	0
	25	12	13.01	13.12	13.17		0
	25	25	12.99	13.06	13.16		0
16QAM	50	0	12.99	13.11	13.16	0-1	0
	1	0	13.26	13.43	13.45		0
	1	25	13.13	13.18	13.28		0
	25	0	13.08	13.14	13.26	0-2	0
	25	12	13.06	13.16	13.19		0
	25	25	12.98	13.08	13.10		0
64QAM	50	0	13.05	13.18	13.22	0-2	0
	1	0	13.22	13.34	13.39		0
	1	25	13.10	13.22	13.29		0
	1	49	13.07	13.18	13.22	0-3	0
	25	0	13.08	13.15	13.26		0
	25	12	13.07	13.16	13.24		0
	25	25	12.99	13.12	13.17	0	
	50	0	13.06	13.17	13.25	0	

Table 8-32
LTE Band 66 (AWS) Reduced Conducted Powers - 5 MHz Bandwidth

LTE Band 66 (AWS) 5 MHz Bandwidth							
Modulation	RB Size	RB Offset	Low Channel	Mid Channel	High Channel	MPR Allowed per 3GPP [dB]	MPR [dB]
			131997 (1712.5 MHz)	132322 (1745.0 MHz)	132647 (1777.5 MHz)		
			Conducted Power [dBm]				
QPSK	1	0	12.91	13.11	13.19	0	0
	1	12	12.85	13.04	13.08		0
	1	24	12.87	13.00	13.09		0
	12	0	12.93	13.12	13.20	0-1	0
	12	6	12.93	13.15	13.17		0
	12	13	12.88	13.11	13.15		0
16QAM	25	0	12.92	13.08	13.18	0-1	0
	1	0	13.12	13.35	13.35		0
	1	12	13.08	13.24	13.29		0
	1	24	13.03	13.30	13.36	0-2	0
	12	0	13.00	13.16	13.23		0
	12	6	12.99	13.18	13.23		0
64QAM	12	13	12.99	13.18	13.22	0-2	0
	25	0	12.95	13.10	13.13		0
	1	0	13.12	13.26	13.33		0-3
	1	12	13.07	13.27	13.33	0	
	1	24	13.04	13.22	13.29	0	
	12	0	12.94	13.17	13.23	0-3	0
12	6	12.97	13.16	13.23	0		
12	13	12.98	13.16	13.22	0		
	25	0	12.96	13.16	13.19	0	





FCC ID: A3LSMT837A	 PCTEST <small>ENGINEERING LABORATORY, INC.</small>	SAR EVALUATION REPORT		Approved by: Quality Manager
Document S/N: 1M1806180124-01.A3L	Test Dates: 06/20/18 - 07/05/18	DUT Type: Portable Tablet	Page 42 of 100	

Table 8-33
LTE Band 66 (AWS) Reduced Conducted Powers - 3 MHz Bandwidth

LTE Band 66 (AWS) 3 MHz Bandwidth								
Modulation	RB Size	RB Offset	Low Channel	Mid Channel	High Channel	MPR Allowed per 3GPP [dB]	MPR [dB]	
			131987 (1711.5 MHz)	132322 (1745.0 MHz)	132657 (1778.5 MHz)			
			Conducted Power [dBm]					
QPSK	1	0	12.89	13.06	13.12	0	0	
	1	7	12.96	13.14	13.21		0	
	1	14	12.82	13.02	13.06		0	
	8	0	12.89	13.12	13.14	0-1	0	
	8	4	12.91	13.13	13.14		0	
	8	7	12.91	13.09	13.11		0	
16QAM	15	0	12.91	13.10	13.12	0-1	0	
	1	0	13.08	13.30	13.32		0	
	1	7	13.21	13.34	13.37		0	
	1	14	13.04	13.30	13.25	0-2	0	
	8	0	13.03	13.16	13.21		0	
	8	4	13.03	13.15	13.21		0	
64QAM	8	7	12.99	13.16	13.19	0-2	0	
	8	0	12.95	13.08	13.15		0	
	15	0	12.95	13.08	13.15		0	
	1	0	12.98	13.21	13.28	0-2	0	
	1	7	13.12	13.31	13.38		0	
	1	14	13.02	13.20	13.25		0	
	64QAM	8	0	12.92	13.11	13.15	0-3	0
		8	4	12.93	13.10	13.18		0
8		7	12.90	13.07	13.15	0		
15		0	12.90	13.10	13.13	0		

Table 8-34
LTE Band 66 (AWS) Reduced Conducted Powers -1.4 MHz Bandwidth

LTE Band 66 (AWS) 1.4 MHz Bandwidth							
Modulation	RB Size	RB Offset	Low Channel	Mid Channel	High Channel	MPR Allowed per 3GPP [dB]	MPR [dB]
			131979 (1710.7 MHz)	132322 (1745.0 MHz)	132665 (1779.3 MHz)		
			Conducted Power [dBm]				
QPSK	1	0	12.81	12.98	13.04	0	0
	1	2	12.83	13.02	13.10		0
	1	5	12.79	12.96	13.03		0
	3	0	12.82	12.99	13.04	0-1	0
	3	2	12.85	13.04	13.10		0
	3	3	12.79	13.00	13.04		0
16QAM	6	0	12.82	13.01	13.03	0-1	0
	1	0	12.99	13.22	13.27		0
	1	2	13.15	13.31	13.26		0
	1	5	13.04	13.21	13.28	0-1	0
	3	0	12.98	13.13	13.18		0
	3	2	13.00	13.17	13.23		0
64QAM	3	3	12.96	13.13	13.19	0-2	0
	6	0	12.92	13.05	13.09		0
	1	0	12.99	13.15	13.22		0-2
	1	2	13.05	13.13	13.26	0	
	1	5	12.89	13.15	13.20	0	
	3	0	12.90	13.10	13.09	0	
	3	2	12.95	13.13	13.17	0	
	3	3	12.85	13.03	13.15	0-3	0
6	0	12.82	13.01	13.06	0		

FCC ID: A3LSMT837A		SAR EVALUATION REPORT		Approved by: Quality Manager
Document S/N: 1M1806180124-01.A3L	Test Dates: 06/20/18 - 07/05/18	DUT Type: Portable Tablet	Page 43 of 100	

8.2.5

LTE Band 2 (PCS)

Table 8-35
LTE Band 2 (PCS) Maximum Conducted Powers - 20 MHz Bandwidth

LTE Band 2 (PCS) 20 MHz Bandwidth							
Modulation	RB Size	RB Offset	Low Channel	Mid Channel	High Channel	MPR Allowed per 3GPP [dB]	MPR [dB]
			18700 (1860.0 MHz)	18900 (1880.0 MHz)	19100 (1900.0 MHz)		
			Conducted Power [dBm]				
QPSK	1	0	24.04	23.77	24.21	0	0
	1	50	23.79	23.53	23.94		0
	1	99	23.75	23.52	23.95		0
	50	0	22.99	22.70	23.18	0-1	1
	50	25	22.89	22.60	23.09		1
	50	50	22.83	22.54	23.05		1
	100	0	22.92	22.61	23.12		1
16QAM	1	0	23.31	23.02	23.45	0-1	1
	1	50	23.04	22.80	23.20		1
	1	99	23.01	22.80	23.24		1
	50	0	22.01	21.71	22.15	0-2	2
	50	25	21.89	21.61	22.10		2
	50	50	21.83	21.57	22.05		2
	100	0	21.92	21.62	22.10		2
64QAM	1	0	22.24	21.94	22.39	0-2	2
	1	50	21.95	21.72	22.12		2
	1	99	21.92	21.70	22.14		2
	50	0	21.04	20.73	21.22	0-3	3
	50	25	20.94	20.66	21.12		3
	50	50	20.87	20.60	21.08		3
	100	0	20.94	20.66	21.14		3

Table 8-36
LTE Band 2 (PCS) Maximum Conducted Powers - 15 MHz Bandwidth

LTE Band 2 (PCS) 15 MHz Bandwidth							
Modulation	RB Size	RB Offset	Low Channel	Mid Channel	High Channel	MPR Allowed per 3GPP [dB]	MPR [dB]
			18675 (1857.5 MHz)	18900 (1880.0 MHz)	19125 (1902.5 MHz)		
			Conducted Power [dBm]				
QPSK	1	0	24.15	23.73	24.27	0	0
	1	36	23.90	23.53	24.05		0
	1	74	23.90	23.53	24.09		0
	36	0	23.06	22.67	23.21	0-1	1
	36	18	23.03	22.61	23.17		1
	36	37	22.93	22.57	23.13		1
	75	0	23.00	22.62	23.20		1
16QAM	1	0	23.41	22.97	23.52	0-1	1
	1	36	23.20	22.80	23.28		1
	1	74	23.14	22.79	23.38		1
	36	0	22.09	21.69	22.24	0-2	2
	36	18	22.00	21.63	22.19		2
	36	37	21.97	21.57	22.16		2
	75	0	22.00	21.59	22.17		2
64QAM	1	0	22.33	21.91	22.47	0-2	2
	1	36	22.13	21.74	22.27		2
	1	74	22.08	21.70	22.27		2
	36	0	21.08	20.69	21.24	0-3	3
	36	18	21.04	20.63	21.20		3
	36	37	20.96	20.58	21.15		3
	75	0	21.03	20.62	21.18		3



FCC ID: A3LSMT837A		SAR EVALUATION REPORT		Approved by: Quality Manager
Document S/N: 1M1806180124-01.A3L	Test Dates: 06/20/18 - 07/05/18	DUT Type: Portable Tablet		Page 44 of 100

Table 8-37
LTE Band 2 (PCS) Maximum Conducted Powers - 10 MHz Bandwidth

LTE Band 2 (PCS) 10 MHz Bandwidth								
Modulation	RB Size	RB Offset	Low Channel	Mid Channel	High Channel	MPR Allowed per 3GPP [dB]	MPR [dB]	
			18650 (1855.0 MHz)	18900 (1880.0 MHz)	19150 (1905.0 MHz)			
			Conducted Power [dBm]					
QPSK	1	0	24.02	23.63	24.15	0	0	
	1	25	23.90	23.50	24.02		0	
	1	49	23.88	23.49	24.03		0	
	25	0	23.03	22.61	23.16	0-1	1	
	25	12	22.98	22.59	23.14		1	
	25	25	22.93	22.53	23.10		1	
16QAM	50	0	22.96	22.57	23.13	0-1	1	
	1	0	23.30	22.88	23.36		0-1	1
	1	25	23.16	22.75	23.24			1
	1	49	23.14	22.79	23.32	0-2		1
	25	0	22.04	21.62	22.16		2	
	25	12	22.03	21.63	22.17		2	
64QAM	25	25	21.96	21.55	22.11	0-2	2	
	50	0	22.00	21.58	22.13		2	
	1	0	22.22	21.81	22.30		0-2	2
	1	25	22.11	21.71	22.22	2		
	1	49	22.08	21.69	22.22	0-3		2
	25	0	21.06	20.63	21.17		3	
	25	12	21.03	20.62	21.17		3	
	25	25	20.97	20.58	21.12	0-3	3	
50	0	21.01	20.61	21.17	3			

Table 8-38
LTE Band 2 (PCS) Maximum Conducted Powers - 5 MHz Bandwidth

LTE Band 2 (PCS) 5 MHz Bandwidth								
Modulation	RB Size	RB Offset	Low Channel	Mid Channel	High Channel	MPR Allowed per 3GPP [dB]	MPR [dB]	
			18625 (1852.5 MHz)	18900 (1880.0 MHz)	19175 (1907.5 MHz)			
			Conducted Power [dBm]					
QPSK	1	0	23.98	23.57	24.18	0	0	
	1	12	23.91	23.51	24.11		0	
	1	24	23.90	23.49	24.14		0	
	12	0	22.97	22.57	23.20	0-1	1	
	12	6	23.00	22.59	23.20		1	
	12	13	22.95	22.53	23.16		1	
16QAM	25	0	22.94	22.52	23.16	0-1	1	
	1	0	23.28	22.85	23.39		0-1	1
	1	12	23.19	22.78	23.38			1
	1	24	23.18	22.74	23.38	0-2		1
	12	0	22.02	21.59	22.23		2	
	12	6	22.04	21.59	22.24		2	
64QAM	12	13	21.97	21.57	22.18	0-2	2	
	25	0	21.98	21.55	22.18		2	
	1	0	22.19	21.77	22.34		0-2	2
	1	12	22.14	21.72	22.33	2		
	1	24	22.11	21.70	22.31	0-3		2
	12	0	21.04	20.62	21.23		3	
	12	6	21.04	20.62	21.23		3	
12	13	21.04	20.61	21.23	3			
25	0	20.98	20.56	21.19	0-3	3		



FCC ID: A3LSMT837A	 PCTEST <small>ENGINEERING LABORATORY, INC.</small>	SAR EVALUATION REPORT		Approved by: Quality Manager
Document S/N: 1M1806180124-01.A3L	Test Dates: 06/20/18 - 07/05/18	DUT Type: Portable Tablet	Page 45 of 100	

Table 8-39
LTE Band 2 (PCS) Maximum Conducted Powers - 3 MHz Bandwidth

LTE Band 2 (PCS) 3 MHz Bandwidth							
Modulation	RB Size	RB Offset	Low Channel	Mid Channel	High Channel	MPR Allowed per 3GPP [dB]	MPR [dB]
			18615 (1851.5 MHz)	18900 (1880.0 MHz)	19185 (1908.5 MHz)		
			Conducted Power [dBm]				
QPSK	1	0	23.95	23.52	24.14	0	0
	1	7	24.02	23.60	24.21		0
	1	14	23.93	23.49	24.08		0
	8	0	22.94	22.55	23.15	0-1	1
	8	4	22.99	22.57	23.18		1
	8	7	22.93	22.52	23.15		1
16QAM	15	0	22.94	22.56	23.17	0-1	1
	1	0	23.18	22.78	23.37		1
	1	7	23.28	22.88	23.49		1
	1	14	23.17	22.76	23.37	0-2	1
	8	0	22.03	21.60	22.21		2
	8	4	22.02	21.59	22.23		2
64QAM	8	7	22.03	21.59	22.20	0-2	2
	15	0	21.93	21.52	22.13		2
	1	0	22.11	21.71	22.32		0-3
	1	7	22.25	21.83	22.43	2	
	1	14	22.11	21.69	22.30	2	
	8	0	21.01	20.60	21.22	0-3	3
8	4	21.02	20.61	21.22	3		
8	7	21.02	20.60	21.21	3		
	15	0	20.96	20.54	21.16		3

Table 8-40
LTE Band 2 (PCS) Maximum Conducted Powers -1.4 MHz Bandwidth

LTE Band 2 (PCS) 1.4 MHz Bandwidth							
Modulation	RB Size	RB Offset	Low Channel	Mid Channel	High Channel	MPR Allowed per 3GPP [dB]	MPR [dB]
			18607 (1850.7 MHz)	18900 (1880.0 MHz)	19193 (1909.3 MHz)		
			Conducted Power [dBm]				
QPSK	1	0	23.87	23.44	24.05	0	0
	1	2	23.94	23.52	24.11		0
	1	5	23.87	23.42	24.03		0
	3	0	23.90	23.46	24.09	0-1	0
	3	2	23.95	23.51	24.12		0
	3	3	23.91	23.46	24.06		0
16QAM	6	0	22.92	22.48	23.07	0-1	1
	1	0	23.13	22.72	23.32		1
	1	2	23.21	22.77	23.37		1
	1	5	23.10	22.69	23.28	0-1	1
	3	0	23.04	22.59	23.21		1
	3	2	23.07	22.65	23.24		1
64QAM	3	3	23.03	22.60	23.20	0-2	1
	6	0	21.97	21.53	22.15		2
	1	0	22.05	21.64	22.24		0-2
	1	2	22.12	21.70	22.31	2	
	1	5	22.04	21.61	22.22	2	
	3	0	21.99	21.54	22.18	0-3	2
3	2	22.00	21.56	22.19	2		
3	3	21.98	21.56	22.20	2		
	6	0	20.93	20.50	21.13		3



FCC ID: A3LSMT837A	 PCTEST <small>ENGINEERING LABORATORY, INC.</small>	SAR EVALUATION REPORT		Approved by: Quality Manager
Document S/N: 1M1806180124-01.A3L	Test Dates: 06/20/18 - 07/05/18	DUT Type: Portable Tablet	Page 46 of 100	

Table 8-41
LTE Band 2 (PCS) Reduced Conducted Powers - 20 MHz Bandwidth

LTE Band 2 (PCS) 20 MHz Bandwidth							
Modulation	RB Size	RB Offset	Low Channel	Mid Channel	High Channel	MPR Allowed per 3GPP [dB]	MPR [dB]
			18700 (1860.0 MHz)	18900 (1880.0 MHz)	19100 (1900.0 MHz)		
			Conducted Power [dBm]				
QPSK	1	0	13.18	12.90	13.40	0	0
	1	50	12.94	12.73	13.14		0
	1	99	12.97	12.72	13.13		0
	50	0	13.12	12.92	13.31	0-1	0
	50	25	13.04	12.80	13.30		0
	50	50	12.98	12.79	13.19		0
16QAM	100	0	13.12	12.86	13.28	0-1	0
	1	0	13.22	13.20	13.36		0
	1	50	12.92	12.97	13.13		0
	1	99	12.90	12.91	13.16	0-2	0
	50	0	13.13	12.90	13.32		0
	50	25	13.03	12.86	13.25		0
64QAM	50	50	13.02	12.77	13.19	0-2	0
	100	0	13.05	12.80	13.31		0
	1	0	13.45	12.73	13.50		0-2
	1	50	13.29	12.56	13.39	0	
	1	99	13.31	12.53	13.25	0-3	
	50	0	13.11	12.86	13.31		0
50	25	13.09	12.79	13.32	0		
50	50	13.00	12.80	13.24	0-3	0	
100	0	13.10	12.80	13.30		0	

Table 8-42
LTE Band 2 (PCS) Reduced Conducted Powers - 15 MHz Bandwidth

LTE Band 2 (PCS) 15 MHz Bandwidth							
Modulation	RB Size	RB Offset	Low Channel	Mid Channel	High Channel	MPR Allowed per 3GPP [dB]	MPR [dB]
			18675 (1857.5 MHz)	18900 (1880.0 MHz)	19125 (1902.5 MHz)		
			Conducted Power [dBm]				
QPSK	1	0	13.23	12.82	13.43	0	0
	1	36	13.02	12.70	13.26		0
	1	74	12.97	12.61	13.23		0
	36	0	13.15	12.85	13.42	0-1	0
	36	18	13.09	12.78	13.34		0
	36	37	13.09	12.74	13.32		0
16QAM	75	0	13.10	12.78	13.35	0-1	0
	1	0	13.43	13.02	13.50		0
	1	36	13.22	12.83	13.47		0
	1	74	13.24	12.81	13.47	0-2	0
	36	0	13.15	12.81	13.43		0
	36	18	13.11	12.74	13.37		0
64QAM	36	37	13.09	12.70	13.34	0-2	0
	75	0	13.14	12.74	13.32		0
	1	0	13.44	12.98	13.50		0-2
	1	36	13.26	12.86	13.45	0	
	1	74	13.21	12.84	13.48	0-3	
	36	0	13.20	12.78	13.40		0
36	18	13.15	12.73	13.34	0		
36	37	13.05	12.68	13.36	0-3	0	
75	0	13.12	12.72	13.37		0	



FCC ID: A3LSMT837A		SAR EVALUATION REPORT		Approved by: Quality Manager
Document S/N: 1M1806180124-01.A3L	Test Dates: 06/20/18 - 07/05/18	DUT Type: Portable Tablet	Page 47 of 100	

Table 8-43
LTE Band 2 (PCS) Reduced Conducted Powers - 10 MHz Bandwidth

LTE Band 2 (PCS) 10 MHz Bandwidth							
Modulation	RB Size	RB Offset	Low Channel	Mid Channel	High Channel	MPR Allowed per 3GPP [dB]	MPR [dB]
			18650 (1855.0 MHz)	18900 (1880.0 MHz)	19150 (1905.0 MHz)		
Conducted Power [dBm]							
QPSK	1	0	13.17	12.77	13.33	0	0
	1	25	13.05	12.63	13.24		0
	1	49	13.02	12.59	13.17		0
	25	0	13.15	12.79	13.37	0-1	0
	25	12	13.10	12.72	13.31		0
	25	25	13.10	12.71	13.30		0
16QAM	50	0	13.11	12.71	13.33	0-1	0
	1	0	13.26	12.89	13.49		0
	1	25	13.13	12.86	13.47		0
	1	49	13.21	12.78	13.43	0-2	0
	25	0	13.12	12.72	13.30		0
	25	12	13.11	12.70	13.31		0
64QAM	25	25	13.05	12.62	13.20	0-2	0
	50	0	13.13	12.72	13.31		0
	1	0	13.30	12.85	13.50		0
	1	25	13.22	12.79	13.41	0-2	0
	1	49	13.17	12.76	13.40		0
	25	0	13.16	12.78	13.38		0-3
25	12	13.18	12.76	13.37	0		
25	25	13.09	12.70	13.31	0		
50	0	13.13	12.72	13.37	0	0	

Table 8-44
LTE Band 2 (PCS) Reduced Conducted Powers - 5 MHz Bandwidth

LTE Band 2 (PCS) 5 MHz Bandwidth							
Modulation	RB Size	RB Offset	Low Channel	Mid Channel	High Channel	MPR Allowed per 3GPP [dB]	MPR [dB]
			18625 (1852.5 MHz)	18900 (1880.0 MHz)	19175 (1907.5 MHz)		
Conducted Power [dBm]							
QPSK	1	0	13.10	12.67	13.37	0	0
	1	12	13.02	12.63	13.32		0
	1	24	13.05	12.60	13.29		0
	12	0	13.12	12.75	13.41	0-1	0
	12	6	13.12	12.71	13.39		0
	12	13	13.06	12.70	13.37		0
16QAM	25	0	13.12	12.71	13.39	0-1	0
	1	0	13.30	12.87	13.50		0
	1	12	13.17	12.85	13.49		0
	1	24	13.23	12.75	13.48	0-2	0
	12	0	13.12	12.74	13.43		0
	12	6	13.13	12.70	13.42		0
64QAM	12	13	13.08	12.68	13.39	0-2	0
	25	0	13.06	12.64	13.34		0
	1	0	13.30	12.85	13.50		0-2
	1	12	13.23	12.84	13.46	0	
	1	24	13.16	12.72	13.47	0-3	
	12	0	13.15	12.71	13.42		0
12	6	13.14	12.73	13.44	0		
12	13	13.15	12.74	13.46	0	0	
25	0	13.12	12.70	13.42	0	0	





FCC ID: A3LSMT837A		SAR EVALUATION REPORT		Approved by: Quality Manager
Document S/N: 1M1806180124-01.A3L	Test Dates: 06/20/18 - 07/05/18	DUT Type: Portable Tablet	Page 48 of 100	

Table 8-45
LTE Band 2 (PCS) Reduced Conducted Powers - 3 MHz Bandwidth

LTE Band 2 (PCS) 3 MHz Bandwidth							
Modulation	RB Size	RB Offset	Low Channel	Mid Channel	High Channel	MPR Allowed per 3GPP [dB]	MPR [dB]
			18615 (1851.5 MHz)	18900 (1880.0 MHz)	19185 (1908.5 MHz)		
			Conducted Power [dBm]				
QPSK	1	0	12.98	12.65	13.31	0	0
	1	7	13.14	12.76	13.41		0
	1	14	13.02	12.59	13.26		0
	8	0	13.09	12.71	13.40	0-1	0
	8	4	13.08	12.67	13.38		0
	8	7	13.05	12.68	13.37		0
16QAM	15	0	13.11	12.70	13.33	0-1	0
	1	0	13.22	12.83	13.50		0
	1	7	13.34	12.90	13.48		0
	1	14	13.18	12.75	13.43	0-2	0
	8	0	13.10	12.71	13.39		0
	8	4	13.12	12.71	13.41		0
64QAM	8	7	13.09	12.69	13.39	0-2	0
	15	0	13.05	12.66	13.36		0
	1	0	13.21	12.78	13.50		0
	1	7	13.33	12.89	13.49	0-2	0
	1	14	13.18	12.76	13.50		0
	8	0	13.09	12.68	13.40		0-3
8	4	13.10	12.67	13.39	0		
8	7	13.09	12.68	13.41	0		
	15	0	13.08	12.64	13.40		0

Table 8-46
LTE Band 2 (PCS) Reduced Conducted Powers -1.4 MHz Bandwidth

LTE Band 2 (PCS) 1.4 MHz Bandwidth							
Modulation	RB Size	RB Offset	Low Channel	Mid Channel	High Channel	MPR Allowed per 3GPP [dB]	MPR [dB]
			18607 (1850.7 MHz)	18900 (1880.0 MHz)	19193 (1909.3 MHz)		
			Conducted Power [dBm]				
QPSK	1	0	12.95	12.58	13.24	0	0
	1	2	13.00	12.63	13.25		0
	1	5	12.96	12.55	13.23		0
	3	0	12.99	12.58	13.27	0-1	0
	3	2	13.04	12.65	13.29		0
	3	3	13.00	12.59	13.27		0
16QAM	6	0	13.03	12.62	13.24	0-1	0
	1	0	13.10	12.72	13.49		0
	1	2	13.24	12.82	13.47		0
	1	5	13.16	12.71	13.41	0-1	0
	3	0	13.07	12.71	13.41		0
	3	2	13.14	12.78	13.44		0
64QAM	3	3	13.04	12.65	13.47	0-2	0
	6	0	13.00	12.61	13.33		0
	1	0	13.16	12.78	13.47		0-2
	1	2	13.20	12.79	13.50	0	
	1	5	13.12	12.67	13.41	0	
	3	0	13.06	12.67	13.35	0-2	0
3	2	13.08	12.63	13.35	0		
3	3	13.04	12.64	13.36	0		
	6	0	13.02	12.60	13.35	0-3	0

FCC ID: A3LSMT837A	 PCTEST <small>ENGINEERING LABORATORY, INC.</small>	SAR EVALUATION REPORT		Approved by: Quality Manager
Document S/N: 1M1806180124-01.A3L	Test Dates: 06/20/18 - 07/05/18	DUT Type: Portable Tablet	Page 49 of 100	

8.2.6

LTE Band 30

Table 8-47
 LTE Band 30 Maximum Conducted Powers - 10 MHz Bandwidth

LTE Band 30 10 MHz Bandwidth					
Modulation	RB Size	RB Offset	Mid Channel	MPR Allowed per 3GPP [dB]	MPR [dB]
			27710 (2310.0 MHz)		
			Conducted Power [dBm]		
QPSK	1	0	24.09	0	0
	1	25	23.30		0
	1	49	24.08		0
	25	0	22.88	0-1	1
	25	12	22.93		1
	25	25	22.95		1
	50	0	22.77		1
16QAM	1	0	23.19	0-1	1
	1	25	22.30		1
	1	49	23.20		1
	25	0	21.97	0-2	2
	25	12	21.91		2
	25	25	21.72		2
	50	0	21.96		2
64QAM	1	0	22.18	0-2	2
	1	25	21.34		2
	1	49	21.84		2
	25	0	21.18	0-3	3
	25	12	20.63		3
	25	25	20.61		3
	50	0	20.98		3





FCC ID: A3LSMT837A	 PCTEST ENGINEERING LABORATORY, INC.	SAR EVALUATION REPORT			Approved by: Quality Manager
Document S/N: 1M1806180124-01.A3L	Test Dates: 06/20/18 - 07/05/18	DUT Type: Portable Tablet		Page 50 of 100	

Table 8-48
LTE Band 30 Maximum Conducted Powers - 5 MHz Bandwidth

LTE Band 30 5 MHz Bandwidth					
Modulation	RB Size	RB Offset	Mid Channel	MPR Allowed per 3GPP [dB]	MPR [dB]
			27710 (2310.0 MHz)		
			Conducted Power [dBm]		
QPSK	1	0	23.67	0	0
	1	12	23.28		0
	1	24	23.15		0
	12	0	22.78	0-1	1
	12	6	22.67		1
	12	13	22.59		1
	25	0	22.61		1
16QAM	1	0	22.54	0-1	1
	1	12	22.43		1
	1	24	22.27		1
	12	0	22.06	0-2	2
	12	6	21.87		2
	12	13	21.75		2
	25	0	21.81		2
64QAM	1	0	21.93	0-2	2
	1	12	21.34		2
	1	24	21.46		2
	12	0	21.06	0-3	3
	12	6	20.41		3
	12	13	20.92		3
	25	0	20.88		3

Note: LTE Band 30 at 5 MHz bandwidth does not support three non-overlapping channels. Per KDB Publication 941225 D05v02, when a device supports overlapping channel assignment in a channel bandwidth configuration, the middle channel of the group of overlapping channels should be selected for testing.

FCC ID: A3LSMT837A		SAR EVALUATION REPORT		Approved by: Quality Manager
Document S/N: 1M1806180124-01.A3L	Test Dates: 06/20/18 - 07/05/18	DUT Type: Portable Tablet		Page 51 of 100

**Table 8-49
LTE Band 30 Reduced Conducted Powers - 10 MHz Bandwidth**

LTE Band 30 10 MHz Bandwidth					
Modulation	RB Size	RB Offset	Mid Channel	MPR Allowed per 3GPP [dB]	MPR [dB]
			27710 (2310.0 MHz)		
			Conducted Power [dBm]		
QPSK	1	0	14.03	0	0
	1	25	14.15		0
	1	49	14.37		0
	25	0	14.12	0-1	0
	25	12	14.22		0
	25	25	14.37		0
	50	0	14.26		0
16QAM	1	0	14.33	0-1	0
	1	25	14.42		0
	1	49	14.49		0
	25	0	14.16	0-2	0
	25	12	14.26		0
	25	25	14.40		0
	50	0	14.27		0
64QAM	1	0	14.09	0-2	0
	1	25	14.33		0
	1	49	14.45		0
	25	0	14.14	0-3	0
	25	12	14.28		0
	25	25	14.36		0
	50	0	14.27		0





FCC ID: A3LSMT837A		SAR EVALUATION REPORT		Approved by: Quality Manager
Document S/N: 1M1806180124-01.A3L	Test Dates: 06/20/18 - 07/05/18	DUT Type: Portable Tablet		Page 52 of 100

Table 8-50
LTE Band 30 Reduced Conducted Powers - 5 MHz Bandwidth

LTE Band 30 5 MHz Bandwidth					
Modulation	RB Size	RB Offset	Mid Channel	MPR Allowed per 3GPP [dB]	MPR [dB]
			27710 (2310.0 MHz)		
			Conducted Power [dBm]		
QPSK	1	0	14.02	0	0
	1	12	14.11		0
	1	24	14.21		0
	12	0	14.14	0-1	0
	12	6	14.15		0
	12	13	14.18		0
	25	0	14.13		0
16QAM	1	0	14.29	0-1	0
	1	12	14.19		0
	1	24	14.37		0
	12	0	14.12	0-2	0
	12	6	14.18		0
	12	13	14.22		0
	25	0	14.19		0
64QAM	1	0	14.18	0-2	0
	1	12	14.27		0
	1	24	14.35		0
	12	0	14.09	0-3	0
	12	6	14.18		0
	12	13	14.14		0
	25	0	14.11		0

Note: LTE Band 30 at 5 MHz bandwidth does not support three non-overlapping channels. Per KDB Publication 941225 D05v02, when a device supports overlapping channel assignment in a channel bandwidth configuration, the middle channel of the group of overlapping channels should be selected for testing.

FCC ID: A3LSMT837A		SAR EVALUATION REPORT		Approved by: Quality Manager
Document S/N: 1M1806180124-01.A3L	Test Dates: 06/20/18 - 07/05/18	DUT Type: Portable Tablet		Page 53 of 100

8.2.7

LTE Band 7

Table 8-51
LTE Band 7 Maximum Conducted Powers - 20 MHz Bandwidth

LTE Band 7 20 MHz Bandwidth								
Modulation	RB Size	RB Offset	Low Channel	Mid Channel	High Channel	MPR Allowed per 3GPP [dB]	MPR [dB]	
			20850 (2510.0 MHz)	21100 (2535.0 MHz)	21350 (2560.0 MHz)			
			Conducted Power [dBm]					
QPSK	1	0	24.57	24.32	24.11	0	0	
	1	50	24.30	24.04	23.84		0	
	1	99	24.18	24.01	23.76		0	
	50	0	23.52	23.23	23.09	0-1	1	
	50	25	23.40	23.13	22.97		1	
	50	50	23.29	23.05	22.91		1	
16QAM	100	0	23.41	23.14	22.96	0-1	1	
	1	0	23.82	23.48	23.37		0-1	1
	1	50	23.63	23.36	23.12			1
	1	99	23.48	23.19	23.03	0-2		1
	50	0	22.53	22.20	22.04		2	
	50	25	22.39	22.14	21.98		2	
64QAM	50	50	22.31	22.05	21.92	0-2	2	
	100	0	22.42	22.11	21.97		2	
	1	0	22.79	22.49	22.29		0-2	2
	1	50	22.49	22.26	22.07	2		
	1	99	22.36	22.19	22.02	0-3		2
	50	0	21.53	21.24	21.07		3	
50	25	21.44	21.19	21.01	3			
64QAM	50	50	21.35	21.12	20.93	0-3	3	
	100	0	21.45	21.18	21.02		3	

Table 8-52
LTE Band 7 Maximum Conducted Powers - 15 MHz Bandwidth

LTE Band 7 15 MHz Bandwidth								
Modulation	RB Size	RB Offset	Low Channel	Mid Channel	High Channel	MPR Allowed per 3GPP [dB]	MPR [dB]	
			20825 (2507.5 MHz)	21100 (2535.0 MHz)	21375 (2562.5 MHz)			
			Conducted Power [dBm]					
QPSK	1	0	24.46	24.26	23.92	0	0	
	1	36	24.24	24.05	23.72		0	
	1	74	24.12	23.97	23.65		0	
	36	0	23.42	23.20	22.89	0-1	1	
	36	18	23.35	23.13	22.82		1	
	36	37	23.29	23.07	22.74		1	
16QAM	75	0	23.34	23.09	22.81	0-1	1	
	1	0	23.69	23.45	23.16		0-1	1
	1	36	23.47	23.28	22.96			1
	1	74	23.33	23.30	22.87	0-2		1
	36	0	22.41	22.19	21.90		2	
	36	18	22.36	22.14	21.86		2	
64QAM	36	37	22.29	22.08	21.77	0-2	2	
	75	0	22.35	22.13	21.82		2	
	1	0	22.65	22.44	22.10		0-2	2
	1	36	22.43	22.23	22.01	2		
	1	74	22.34	22.20	21.88	0-3		2
	36	0	21.44	21.20	20.91		3	
36	18	21.39	21.16	20.87	3			
64QAM	36	37	21.29	21.09	20.77	0-3	3	
	75	0	21.35	21.13	20.83		3	





FCC ID: A3LSMT837A		SAR EVALUATION REPORT		Approved by: Quality Manager
Document S/N: 1M1806180124-01.A3L	Test Dates: 06/20/18 - 07/05/18	DUT Type: Portable Tablet		Page 54 of 100

Table 8-53
LTE Band 7 Maximum Conducted Powers - 10 MHz Bandwidth

LTE Band 7 10 MHz Bandwidth								
Modulation	RB Size	RB Offset	Low Channel	Mid Channel	High Channel	MPR Allowed per 3GPP [dB]	MPR [dB]	
			20800 (2505.0 MHz)	21100 (2535.0 MHz)	21400 (2565.0 MHz)			
			Conducted Power [dBm]					
QPSK	1	0	24.40	24.16	23.88	0	0	
	1	25	24.27	24.07	23.77		0	
	1	49	24.19	24.00	23.71		0	
	25	0	23.41	23.14	22.83	0-1	1	
	25	12	23.37	23.12	22.85		1	
	25	25	23.29	23.03	22.76		1	
16QAM	50	0	23.31	23.10	22.79	0-1	1	
	1	0	23.62	23.39	23.15		0-1	1
	1	25	23.49	23.36	23.01			1
	1	49	23.45	23.21	22.94	0-2		1
	25	0	22.39	22.15	21.85		2	
	25	12	22.39	22.12	21.84		2	
64QAM	25	25	22.29	22.07	21.74	0-2	2	
	50	0	22.37	22.13	21.79		2	
	1	0	22.57	22.36	22.00		0-2	2
	1	25	22.49	22.30	21.92	2		
	1	49	22.36	22.18	21.87	2		
	64QAM	25	0	21.44	21.15	20.88	0-3	3
25		12	21.39	21.17	20.87	3		
25		25	21.31	21.10	20.78	3		
50		0	21.38	21.17	20.84	3		

Table 8-54
LTE Band 7 Maximum Conducted Powers - 5 MHz Bandwidth

LTE Band 7 5 MHz Bandwidth								
Modulation	RB Size	RB Offset	Low Channel	Mid Channel	High Channel	MPR Allowed per 3GPP [dB]	MPR [dB]	
			20775 (2502.5 MHz)	21100 (2535.0 MHz)	21425 (2567.5 MHz)			
			Conducted Power [dBm]					
QPSK	1	0	24.35	24.11	23.89	0	0	
	1	12	24.31	24.08	23.91		0	
	1	24	24.25	24.01	23.81		0	
	12	0	23.39	23.13	22.95	0-1	1	
	12	6	23.38	23.12	22.92		1	
	12	13	23.32	23.09	22.86		1	
16QAM	25	0	23.36	23.11	22.90	0-1	1	
	1	0	23.54	23.36	23.16		0-1	1
	1	12	23.55	23.34	23.06			1
	1	24	23.44	23.23	23.01	0-2		1
	12	0	22.45	22.13	21.93		2	
	12	6	22.42	22.16	21.99		2	
64QAM	12	13	22.39	22.12	21.92	0-2	2	
	25	0	22.37	22.08	21.87		2	
	1	0	22.51	22.27	22.07		0-2	2
	1	12	22.48	22.28	22.07	2		
	1	24	22.41	22.22	21.99	2		
	64QAM	12	0	21.44	21.17	20.97	0-3	3
12		6	21.44	21.17	20.98	3		
12		13	21.39	21.11	20.93	3		
25		0	21.40	21.11	20.91	3		

FCC ID: A3LSMT837A		SAR EVALUATION REPORT		Approved by: Quality Manager
Document S/N: 1M1806180124-01.A3L	Test Dates: 06/20/18 - 07/05/18	DUT Type: Portable Tablet	Page 55 of 100	

**Table 8-55
LTE Band 7 Reduced Conducted Powers - 20 MHz Bandwidth**

LTE Band 7 20 MHz Bandwidth							
Modulation	RB Size	RB Offset	Low Channel	Mid Channel	High Channel	MPR Allowed per 3GPP [dB]	MPR [dB]
			20850 (2510.0 MHz)	21100 (2535.0 MHz)	21350 (2560.0 MHz)		
			Conducted Power [dBm]				
QPSK	1	0	12.34	12.27	12.11	0	0
	1	50	12.19	12.18	11.90		0
	1	99	12.17	12.15	11.93		0
	50	0	12.33	12.23	12.01	0-1	0
	50	25	12.26	12.29	12.00		0
	50	50	12.23	12.23	11.93		0
16QAM	100	0	12.20	12.16	11.96	0-1	0
	1	0	12.35	12.50	12.08		0
	1	50	12.21	12.47	11.91		0
	1	99	12.20	12.42	11.89	0-2	0
	50	0	12.27	12.25	12.04		0
	50	25	12.29	12.25	11.98		0
64QAM	50	50	12.27	12.29	11.95	0-2	0
	100	0	12.31	12.19	11.96		0
	1	0	12.49	12.14	12.50		0-3
	1	50	12.36	11.98	12.35	0	
	1	99	12.27	12.10	12.27	0	
	50	0	12.40	12.30	12.06	0	
50	25	12.29	12.32	12.01	0		
50	50	12.25	12.26	11.93	0		
100	0	12.25	12.17	11.98	0		

**Table 8-56
LTE Band 7 Reduced Conducted Powers - 15 MHz Bandwidth**

LTE Band 7 15 MHz Bandwidth							
Modulation	RB Size	RB Offset	Low Channel	Mid Channel	High Channel	MPR Allowed per 3GPP [dB]	MPR [dB]
			20825 (2507.5 MHz)	21100 (2535.0 MHz)	21375 (2562.5 MHz)		
			Conducted Power [dBm]				
QPSK	1	0	12.34	12.17	12.07	0	0
	1	36	12.16	11.98	11.89		0
	1	74	12.08	11.88	11.81		0
	36	0	12.32	12.13	12.02	0-1	0
	36	18	12.26	12.09	11.97		0
	36	37	12.18	12.00	11.91		0
16QAM	75	0	12.25	12.08	11.95	0-1	0
	1	0	12.58	12.30	12.29		0
	1	36	12.37	12.15	12.06		0
	1	74	12.27	12.12	12.01	0-2	0
	36	0	12.29	12.07	11.98		0
	36	18	12.24	12.04	11.98		0
64QAM	36	37	12.16	12.00	11.85	0-2	0
	75	0	12.20	12.04	11.97		0
	1	0	12.56	12.28	12.20		0-3
	1	36	12.36	12.12	12.06	0	
	1	74	12.27	12.03	11.97	0	
	36	0	12.35	12.08	11.99	0	
36	18	12.30	12.05	11.97	0		
36	37	12.21	11.98	11.89	0		
75	0	12.27	12.04	11.96	0		





FCC ID: A3LSMT837A	 PCTEST <small>ENGINEERING LABORATORY, INC.</small>	SAR EVALUATION REPORT		Approved by: Quality Manager
Document S/N: 1M1806180124-01.A3L	Test Dates: 06/20/18 - 07/05/18	DUT Type: Portable Tablet	Page 56 of 100	

Table 8-57
LTE Band 7 Reduced Conducted Powers - 10 MHz Bandwidth

LTE Band 7 10 MHz Bandwidth							
Modulation	RB Size	RB Offset	Low Channel	Mid Channel	High Channel	MPR Allowed per 3GPP [dB]	MPR [dB]
			20800 (2505.0 MHz)	21100 (2535.0 MHz)	21400 (2565.0 MHz)		
			Conducted Power [dBm]				
QPSK	1	0	12.28	12.07	11.92	0	0
	1	25	12.17	11.97	11.77		0
	1	49	12.12	11.92	11.73		0
	25	0	12.31	12.08	11.86	0-1	0
	25	12	12.23	12.06	11.83		0
	25	25	12.16	12.00	11.79		0
16QAM	50	0	12.23	12.02	11.85	0-1	0
	1	0	12.51	12.24	12.08		0
	1	25	12.42	12.21	12.02		0
	1	49	12.31	12.17	11.97	0-2	0
	25	0	12.28	12.07	11.86		0
	25	12	12.29	12.05	11.84		0
64QAM	25	25	12.17	11.97	11.75	0-2	0
	50	0	12.25	12.02	11.81		0
	1	0	12.48	12.22	12.08		0
	1	25	12.38	12.15	12.00	0-3	0
	1	49	12.31	12.05	11.86		0
	25	0	12.32	12.08	11.88		0
64QAM	25	12	12.31	12.06	11.86	0-3	0
	25	25	12.23	12.00	11.80		0
	50	0	12.27	12.05	11.85		0

Table 8-58
LTE Band 7 Reduced Conducted Powers - 5 MHz Bandwidth

LTE Band 7 5 MHz Bandwidth							
Modulation	RB Size	RB Offset	Low Channel	Mid Channel	High Channel	MPR Allowed per 3GPP [dB]	MPR [dB]
			20775 (2502.5 MHz)	21100 (2535.0 MHz)	21425 (2567.5 MHz)		
			Conducted Power [dBm]				
QPSK	1	0	12.23	12.01	11.91	0	0
	1	12	12.22	11.98	11.90		0
	1	24	12.16	11.92	11.82		0
	12	0	12.26	12.02	11.91	0-1	0
	12	6	12.27	12.09	11.94		0
	12	13	12.20	12.01	11.90		0
16QAM	25	0	12.22	11.99	11.93	0-1	0
	1	0	12.40	12.25	12.15		0
	1	12	12.45	12.19	12.14		0
	1	24	12.40	12.18	12.05	0-2	0
	12	0	12.28	12.05	11.96		0
	12	6	12.30	12.08	11.98		0
64QAM	12	13	12.23	12.06	11.92	0-2	0
	25	0	12.24	12.01	11.89		0
	1	0	12.43	12.17	12.10		0-3
	1	12	12.36	12.14	12.04	0	
	1	24	12.35	12.12	11.99	0	
	64QAM	12	0	12.32	12.06	11.95	0-3
12		6	12.34	12.05	11.96	0	
12		13	12.23	12.03	11.94	0	
25		0	12.29	12.04	11.94	0	

FCC ID: A3LSMT837A		SAR EVALUATION REPORT		Approved by: Quality Manager
Document S/N: 1M1806180124-01.A3L	Test Dates: 06/20/18 - 07/05/18	DUT Type: Portable Tablet	Page 57 of 100	

8.3 WLAN Conducted Powers

**Table 8-59
2.4 GHz WLAN Maximum Average RF Power – Ant 1**

2.4GHz Conducted Power [dBm]				
Freq [MHz]	Channel	IEEE Transmission Mode		
		802.11b	802.11g	802.11n
		Average	Average	Average
2412	1	13.32	13.10	12.94
2437	6	12.99	12.79	12.67
2462	11	13.31	13.37	13.19

**Table 8-60
2.4 GHz WLAN Maximum Average RF Power – Ant 2**

2.4GHz Conducted Power [dBm]				
Freq [MHz]	Channel	IEEE Transmission Mode		
		802.11b	802.11g	802.11n
		Average	Average	Average
2412	1	13.32	13.17	13.05
2437	6	12.89	12.73	12.51
2462	11	12.97	12.85	12.66





FCC ID: A3LSMT837A		SAR EVALUATION REPORT		Approved by: Quality Manager
Document S/N: 1M1806180124-01.A3L	Test Dates: 06/20/18 - 07/05/18	DUT Type: Portable Tablet		Page 58 of 100

Table 8-61
5 GHz WLAN Maximum Average RF Power – Ant 1

5GHz (40MHz) Conducted Power [dBm]		
Freq [MHz]	Channel	IEEE Transmission Mode
		802.11n
		Average
5190	38	13.43
5230	46	13.29
5270	54	12.98
5310	62	13.19
5510	102	13.14
5590	118	12.87
5630	126	13.06
5710	142	12.73
5755	151	12.92
5795	159	12.45

Table 8-62
5 GHz WLAN Maximum Average RF Power – Ant 2

5GHz (40MHz) Conducted Power [dBm]		
Freq [MHz]	Channel	IEEE Transmission Mode
		802.11n
		Average
5190	38	13.54
5230	46	12.69
5270	54	12.61
5310	62	13.12
5510	102	13.37
5590	118	13.48
5630	126	13.42
5710	142	13.36
5755	151	13.10
5795	159	13.42

FCC ID: A3LSMT837A		SAR EVALUATION REPORT		Approved by: Quality Manager
Document S/N: 1M1806180124-01.A3L	Test Dates: 06/20/18 - 07/05/18	DUT Type: Portable Tablet	Page 59 of 100	

**Table 8-63
2.4 GHz WLAN Reduced Average RF Power – Ant 1**

2.4GHz Conducted Power [dBm]				
Freq [MHz]	Channel	IEEE Transmission Mode		
		802.11b	802.11g	802.11n
		Average	Average	Average
2412	1	12.45	12.32	12.16
2437	6	12.14	12.04	11.85
2462	11	12.44	12.46	12.41

**Table 8-64
2.4 GHz WLAN Reduced Average RF Power – Ant 2**

2.4GHz Conducted Power [dBm]				
Freq [MHz]	Channel	IEEE Transmission Mode		
		802.11b	802.11g	802.11n
		Average	Average	Average
2412	1	11.60	12.47	12.34
2437	6	12.48	12.26	12.11
2462	11	11.87	11.77	12.45

**Table 8-65
5 GHz WLAN Reduced Average RF Power – Ant 1**

5GHz (80MHz) Conducted Power [dBm]		
Freq [MHz]	Channel	IEEE Transmission Mode
		802.11ac
		Average
5210	42	9.43
5290	58	8.47
5530	106	9.04
5610	122	9.16
5690	138	8.77
5775	155	9.26



FCC ID: A3LSMT837A		SAR EVALUATION REPORT		Approved by: Quality Manager
Document S/N: 1M1806180124-01.A3L	Test Dates: 06/20/18 - 07/05/18	DUT Type: Portable Tablet		Page 60 of 100

Table 8-66
5 GHz WLAN Reduced Average RF Power – Ant 2

5GHz (80MHz) Conducted Power [dBm]		
Freq [MHz]	Channel	IEEE Transmission Mode
		802.11ac
		Average
5210	42	9.21
5290	58	9.47
5530	106	9.17
5610	122	9.13
5690	138	8.78
5775	155	8.88

Justification for test configurations for WLAN per KDB Publication 248227 D01v02r02:

- Power measurements were performed for the transmission mode configuration with the highest maximum output power specified for production units.
- For transmission modes with the same maximum output power specification, powers were measured for the largest channel bandwidth, lowest order modulation and lowest data rate.
- For transmission modes with identical maximum specified output power, channel bandwidth, modulation and data rates, power measurements were required for all identical configurations.
- For each transmission mode configuration, powers were measured for the highest and lowest channels; and at the mid-band channel(s) when there were at least 3 channels supported. For configurations with multiple mid-band channels, due to an even number of channels, both channels were measured.
- The bolded data rate and channel above were tested for SAR.

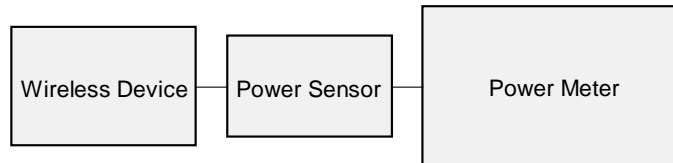



Figure 8-2
Power Measurement Setup



FCC ID: A3LSMT837A		SAR EVALUATION REPORT		Approved by: Quality Manager
Document S/N: 1M1806180124-01.A3L	Test Dates: 06/20/18 - 07/05/18	DUT Type: Portable Tablet	Page 61 of 100	

8.4 Bluetooth Conducted Powers

Table 8-67
Bluetooth Average RF Power

Frequency [MHz]	Data Rate [Mbps]	Channel No.	Avg Conducted Power	
			[dBm]	[mW]
2402	1.0	0	7.44	5.551
2441	1.0	39	6.92	4.921
2480	1.0	78	8.32	6.787
2402	2.0	0	6.82	4.808
2441	2.0	39	6.36	4.328
2480	2.0	78	7.75	5.955
2402	3.0	0	6.87	4.862
2441	3.0	39	6.41	4.378
2480	3.0	78	7.80	6.027

Note: The bolded data rates and channel above were tested for SAR.

FCC ID: A3LSMT837A		SAR EVALUATION REPORT		Approved by: Quality Manager
Document S/N: 1M1806180124-01.A3L	Test Dates: 06/20/18 - 07/05/18	DUT Type: Portable Tablet		Page 62 of 100

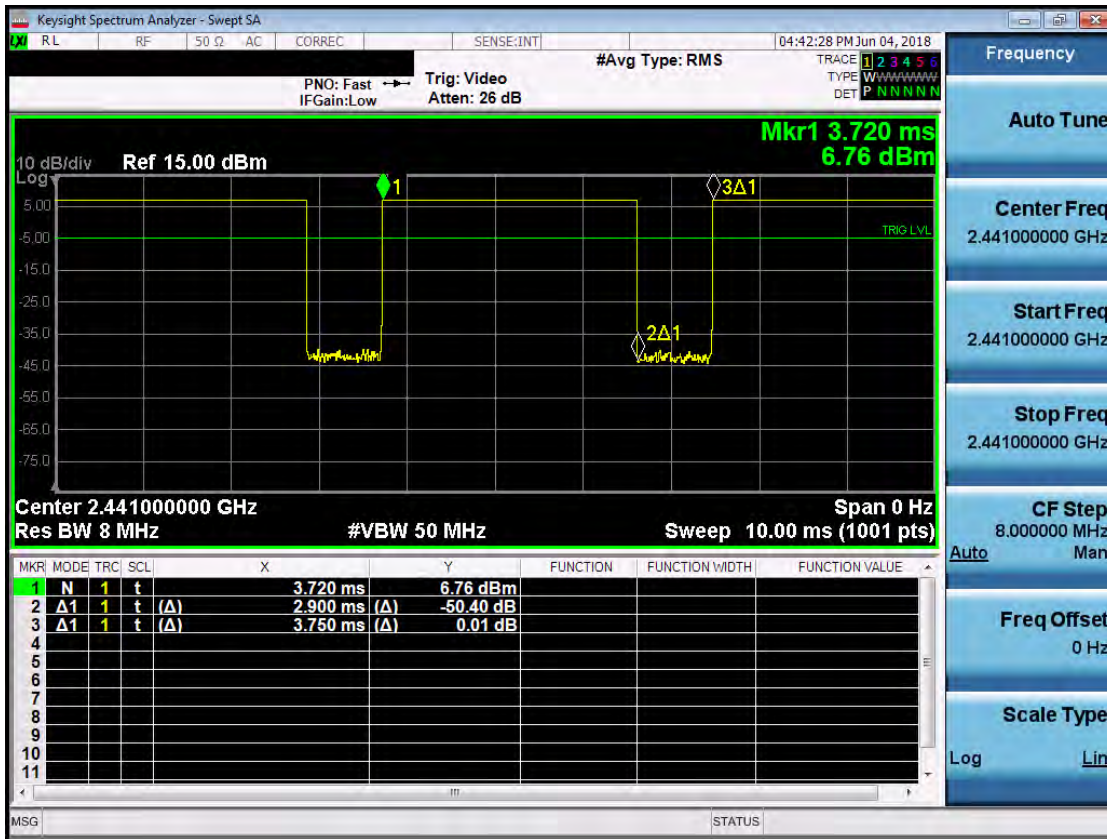

Figure 8-3
Bluetooth Transmission Plot

Equation 8-1
Bluetooth Duty Cycle Calculation

$$Duty\ Cycle = \frac{Pulse\ Width}{Period} * 100\% = \frac{2.90ms}{3.75ms} * 100\% = 77.3\%$$

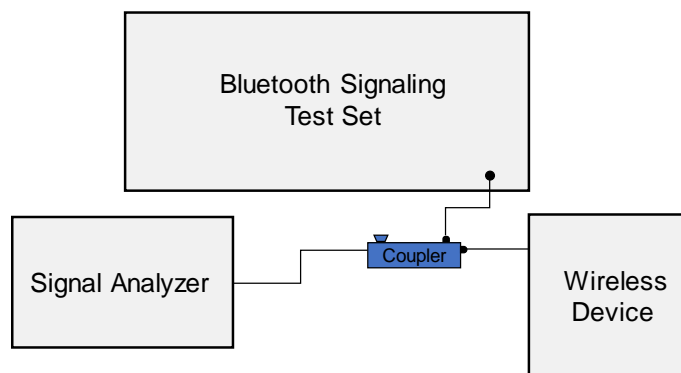

Figure 8-4
Power Measurement Setup

FCC ID: A3LSMT837A		SAR EVALUATION REPORT		Approved by: Quality Manager
Document S/N: 1M1806180124-01.A3L	Test Dates: 06/20/18 - 07/05/18	DUT Type: Portable Tablet		Page 63 of 100



9 SYSTEM VERIFICATION

9.1 Tissue Verification

**Table 9-1
Measured Tissue Properties**

Calibrated for Tests Performed on:	Tissue Type	Tissue Temp During Calibration (°C)	Measured Frequency (MHz)	Measured Conductivity, σ (S/m)	Measured Dielectric Constant, ϵ	TARGET Conductivity, σ (S/m)	TARGET Dielectric Constant, ϵ	% dev σ	% dev ϵ
6/25/2018	750B	22.0	700	0.967	53.869	0.959	55.726	0.83%	-3.33%
			710	0.972	53.770	0.960	55.687	1.25%	-3.44%
			740	0.982	53.724	0.963	55.570	1.97%	-3.32%
			755	0.989	53.606	0.964	55.512	2.59%	-3.43%
			785	0.999	53.600	0.966	55.395	3.42%	-3.24%
7/2/2018	835B	20.3	800	1.003	53.507	0.967	55.336	3.72%	-3.31%
			820	0.975	54.021	0.969	55.258	0.62%	-2.24%
			835	0.980	53.985	0.970	55.200	1.03%	-2.20%
			850	0.985	53.937	0.988	55.154	-0.30%	-2.21%
6/25/2018	1750B	21.5	1710	1.466	51.875	1.463	53.537	0.21%	-3.10%
			1750	1.510	51.719	1.488	53.432	1.48%	-3.21%
			1790	1.552	51.568	1.514	53.326	2.51%	-3.30%
6/28/2018	1900B	22.0	1850	1.519	51.681	1.520	53.300	-0.07%	-3.04%
			1880	1.553	51.643	1.520	53.300	2.17%	-3.11%
			1910	1.586	51.538	1.520	53.300	4.34%	-3.31%
7/5/2018	1900B	22.1	1850	1.497	53.392	1.520	53.300	-1.51%	0.17%
			1880	1.529	53.307	1.520	53.300	0.59%	0.01%
			1910	1.562	53.206	1.520	53.300	2.76%	-0.18%
6/20/2018	2450B	23.0	2400	1.955	50.963	1.902	52.767	2.79%	-3.42%
			2450	2.013	50.825	1.950	52.700	3.23%	-3.56%
			2500	2.074	50.676	2.021	52.636	2.62%	-3.72%
			2550	2.131	50.556	2.092	52.573	1.86%	-3.84%
			2600	2.190	50.386	2.163	52.509	1.25%	-4.04%
7/2/2018	2450B	21.7	2400	1.968	50.714	1.902	52.767	3.47%	-3.89%
			2450	2.025	50.558	1.950	52.700	3.85%	-4.06%
			2500	2.084	50.421	2.021	52.636	3.12%	-4.21%
7/4/2018	2450B	22.5	2300	1.837	52.084	1.809	52.900	1.55%	-1.54%
			2310	1.849	52.048	1.816	52.887	1.82%	-1.59%
			2320	1.861	52.008	1.826	52.873	1.92%	-1.64%
			2400	1.970	51.717	1.902	52.767	3.58%	-1.99%
			2450	2.038	51.523	1.950	52.700	4.51%	-2.23%
06/25/2018	5200B-5800B	21.5	2500	2.110	51.334	2.021	52.636	4.40%	-2.47%
			5240	5.473	47.393	5.346	48.960	2.38%	-3.20%
			5260	5.476	47.373	5.369	48.933	1.99%	-3.19%
			5280	5.517	47.296	5.393	48.906	2.30%	-3.29%
			5300	5.540	47.314	5.416	48.879	2.29%	-3.20%
			5320	5.571	47.250	5.439	48.851	2.43%	-3.28%
			5500	5.808	46.954	5.650	48.607	2.80%	-3.40%
			5520	5.844	46.925	5.673	48.580	3.01%	-3.41%
			5540	5.870	46.904	5.696	48.553	3.05%	-3.40%
			5560	5.899	46.853	5.720	48.526	3.13%	-3.45%
			5580	5.931	46.829	5.743	48.499	3.27%	-3.44%
			5600	5.949	46.790	5.766	48.471	3.17%	-3.47%
			5620	5.992	46.748	5.790	48.444	3.49%	-3.50%
			5640	6.011	46.722	5.813	48.417	3.41%	-3.50%
			5660	6.046	46.664	5.837	48.390	3.58%	-3.57%
			5680	6.066	46.677	5.860	48.363	3.52%	-3.49%
			5700	6.089	46.626	5.883	48.336	3.50%	-3.54%
			5745	6.155	46.525	5.936	48.275	3.69%	-3.63%
			5765	6.188	46.527	5.959	48.248	3.84%	-3.57%
			5785	6.209	46.501	5.982	48.220	3.79%	-3.56%
			5800	6.237	46.439	6.000	48.200	3.95%	-3.65%
			5805	6.249	46.425	6.006	48.193	4.05%	-3.67%
			5825	6.253	46.384	6.029	48.166	3.72%	-3.70%

The above measured tissue parameters were used in the DASY software. The DASY software was used to perform interpolation to determine the dielectric parameters at the SAR test device frequencies (per KDB Publication 865664 D01v01r04 and IEEE 1528-2013 6.6.1.2). The tissue parameters listed in the SAR test plots may slightly differ from the table above due to significant digit rounding in the software.

FCC ID: A3LSMT837A		SAR EVALUATION REPORT		Approved by: Quality Manager
Document S/N: 1M1806180124-01.A3L	Test Dates: 06/20/18 - 07/05/18	DUT Type: Portable Tablet	Page 64 of 100	

9.2 Test System Verification

Prior to SAR assessment, the system is verified to $\pm 10\%$ of the SAR measurement on the reference dipole at the time of calibration by the calibration facility. Full system validation status and result summary can be found in Appendix E.

**Table 9-2
System Verification Results**

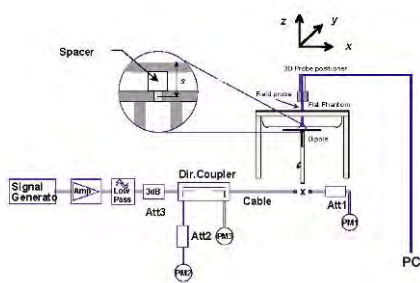

System Verification TARGET & MEASURED												
SAR System #	Tissue Frequency (MHz)	Tissue Type	Date:	Amb. Temp (°C)	Liquid Temp (°C)	Input Power (W)	Source SN	Probe SN	Measured SAR _{1g} (W/kg)	1 W Target SAR _{1g} (W/kg)	1 W Normalized SAR _{1g} (W/kg)	Deviation _{1g} (%)
J	750	BODY	06/25/2018	21.5	22.0	0.200	1003	3914	1.860	8.580	9.300	8.39%
J	835	BODY	07/02/2018	20.3	20.3	0.200	4d132	3914	2.010	9.710	10.050	3.50%
G	1750	BODY	06/25/2018	23.1	21.3	0.100	1051	3332	3.920	37.200	39.200	5.38%
I	1900	BODY	06/28/2018	22.6	22.0	0.100	5d141	7406	4.140	40.000	41.400	3.50%
I	1900	BODY	07/05/2018	23.5	22.1	0.100	5d141	7406	4.180	40.000	41.800	4.50%
G	2300	BODY	07/04/2018	23.5	22.5	0.100	1008	3332	4.650	47.100	46.500	-1.27%
K	2450	BODY	06/20/2018	23.3	22.2	0.100	882	3319	5.130	50.200	51.300	2.19%
K	2450	BODY	07/02/2018	22.2	21.7	0.100	882	3319	5.100	50.200	51.000	1.59%
G	2450	BODY	07/04/2018	23.5	22.5	0.100	882	3332	4.850	50.200	48.500	-3.39%
K	2600	BODY	06/20/2018	23.3	22.2	0.100	1004	3319	5.680	54.800	56.800	3.65%
D	5250	BODY	06/25/2018	22.5	21.3	0.050	1237	7357	3.570	76.900	71.400	-7.15%
D	5600	BODY	06/25/2018	22.5	21.3	0.050	1237	7357	3.900	78.500	78.000	-0.64%
D	5750	BODY	06/25/2018	22.5	21.3	0.050	1237	7357	3.730	77.100	74.600	-3.24%



**Figure 9-1
System Verification Setup Diagram**



**Figure 9-2
System Verification Setup Photo**

FCC ID: A3LSMT837A		SAR EVALUATION REPORT		Approved by: Quality Manager
Document S/N: 1M1806180124-01.A3L	Test Dates: 06/20/18 - 07/05/18	DUT Type: Portable Tablet	Page 65 of 100	



10 SAR DATA SUMMARY

10.1 Standalone Body SAR Data

**Table 10-1
UMTS Body SAR Data**

MEASUREMENT RESULTS														
FREQUENCY		Mode	Service	Maximum Allowed Power [dBm]	Conducted Power [dBm]	Power Drift [dB]	Spacing	Device Serial Number	Duty Cycle	Side	SAR (1g)	Scaling Factor	Reported SAR (1g)	Plot #
MHz	Ch.										(W/kg)		(W/kg)	
836.60	4183	UMTS 850	RMC	25.0	24.27	-0.04	16 mm	05866	1:1	back	0.627	1.183	0.742	
826.40	4132	UMTS 850	RMC	25.0	24.36	0.04	16 mm	05866	1:1	top	1.050	1.159	1.217	A1
836.60	4183	UMTS 850	RMC	25.0	24.27	0.14	16 mm	05866	1:1	top	0.962	1.183	1.138	
846.60	4233	UMTS 850	RMC	25.0	24.05	0.04	16 mm	05866	1:1	top	0.924	1.245	1.150	
836.60	4183	UMTS 850	RMC	25.0	24.27	-0.05	0 mm	05866	1:1	right	0.179	1.183	0.212	
836.60	4183	UMTS 850	RMC	25.0	24.27	0.12	0 mm	05866	1:1	left	0.118	1.183	0.140	
826.40	4132	UMTS 850	RMC	17.0	16.63	-0.04	0 mm	05866	1:1	back	0.819	1.089	0.892	
836.60	4183	UMTS 850	RMC	17.0	16.55	-0.13	0 mm	05866	1:1	back	0.766	1.109	0.849	
846.60	4233	UMTS 850	RMC	17.0	16.31	-0.06	0 mm	05866	1:1	back	0.735	1.172	0.861	
826.40	4132	UMTS 850	RMC	17.0	16.63	0.03	0 mm	05866	1:1	top	0.959	1.089	1.044	
836.60	4183	UMTS 850	RMC	17.0	16.55	-0.03	0 mm	05866	1:1	top	0.959	1.109	1.064	
846.60	4233	UMTS 850	RMC	17.0	16.31	0.02	0 mm	05866	1:1	top	0.877	1.172	1.028	
826.40	4132	UMTS 850	RMC	25.0	24.36	0.10	16 mm	05866	1:1	top	1.050	1.159	1.217	
1732.40	1412	UMTS 1750	RMC	24.5	23.86	-0.02	16 mm	05031	1:1	back	0.427	1.159	0.495	
1732.40	1412	UMTS 1750	RMC	24.5	23.86	-0.02	16 mm	05031	1:1	top	0.449	1.159	0.520	
1712.40	1312	UMTS 1750	RMC	24.5	23.69	-0.02	0 mm	05031	1:1	right	0.765	1.205	0.922	
1732.40	1412	UMTS 1750	RMC	24.5	23.86	0.07	0 mm	05031	1:1	right	0.712	1.159	0.825	
1752.60	1513	UMTS 1750	RMC	24.5	23.71	0.03	0 mm	05031	1:1	right	0.854	1.199	1.024	
1732.40	1412	UMTS 1750	RMC	24.5	23.86	0.00	0 mm	05031	1:1	left	0.351	1.159	0.407	
1712.40	1312	UMTS 1750	RMC	14.0	13.12	-0.02	0 mm	05031	1:1	back	0.840	1.225	1.029	
1732.40	1412	UMTS 1750	RMC	14.0	13.33	-0.04	0 mm	05031	1:1	back	0.913	1.167	1.065	
1752.60	1513	UMTS 1750	RMC	14.0	13.20	0.01	0 mm	05031	1:1	back	0.989	1.202	1.189	A2
1712.40	1312	UMTS 1750	RMC	14.0	13.12	0.02	0 mm	05031	1:1	top	0.733	1.225	0.898	
1732.40	1412	UMTS 1750	RMC	14.0	13.33	-0.03	0 mm	05031	1:1	top	0.717	1.167	0.837	
1752.60	1513	UMTS 1750	RMC	14.0	13.20	0.04	0 mm	05031	1:1	top	0.838	1.202	1.007	
1907.60	9538	UMTS 1900	RMC	25.0	24.02	0.02	16 mm	05866	1:1	back	0.602	1.253	0.754	
1907.60	9538	UMTS 1900	RMC	25.0	24.02	-0.02	16 mm	05866	1:1	top	0.614	1.253	0.769	
1852.40	9262	UMTS 1900	RMC	25.0	23.85	0.01	0 mm	05866	1:1	right	0.795	1.303	1.036	
1880.00	9400	UMTS 1900	RMC	25.0	23.39	-0.02	0 mm	05866	1:1	right	0.872	1.449	1.264	
1907.60	9538	UMTS 1900	RMC	25.0	24.02	0.00	0 mm	05866	1:1	right	0.834	1.253	1.045	
1907.60	9538	UMTS 1900	RMC	25.0	24.02	0.00	0 mm	05866	1:1	left	0.337	1.253	0.422	
1852.40	9262	UMTS 1900	RMC	14.0	13.19	0.13	0 mm	05866	1:1	back	0.974	1.205	1.174	
1880.00	9400	UMTS 1900	RMC	14.0	12.83	0.14	0 mm	05866	1:1	back	1.010	1.309	1.322	
1907.60	9538	UMTS 1900	RMC	14.0	13.39	0.12	0 mm	05866	1:1	back	1.050	1.151	1.209	
1852.40	9262	UMTS 1900	RMC	14.0	13.19	0.02	0 mm	05866	1:1	top	0.828	1.205	0.998	
1880.00	9400	UMTS 1900	RMC	14.0	12.83	0.00	0 mm	05866	1:1	top	0.840	1.309	1.100	
1907.60	9538	UMTS 1900	RMC	14.0	13.39	0.00	0 mm	05866	1:1	top	0.903	1.151	1.039	
1907.60	9538	UMTS 1900	RMC	14.0	13.39	0.10	0 mm	05866	1:1	back	1.100	1.151	1.266	A3
ANSI / IEEE C95.1 1992 - SAFETY LIMIT Spatial Peak Uncontrolled Exposure/General Population							Body 1.6 W/kg (mW/g) averaged over 1 gram							

Note: Blue entry indicates variability measurements.



FCC ID: A3LSMT837A		SAR EVALUATION REPORT		Approved by: Quality Manager
Document S/N: 1M1806180124-01.A3L	Test Dates: 06/20/18 - 07/05/18	DUT Type: Portable Tablet	Page 66 of 100	

**Table 10-2
LTE Band 12 Body SAR**

MEASUREMENT RESULTS																			
FREQUENCY		Mode	Bandwidth [MHz]	Maximum Allowed Power [dBm]	Conducted Power [dBm]	Power Drift [dB]	MPR [dB]	Device Serial Number	Modulation	RB Size	RB Offset	Spacing	Side	Duty Cycle	SAR (1g)	Scaling Factor	Reported SAR (1g)	Plot #	
MHz	Ch.														(W/kg)		(W/kg)		
707.50	23095	Mid	LTE Band 12	10	25.0	23.89	0.00	0	05358	QPSK	1	0	16 mm	back	1:1	0.319	1.291	0.412	
707.50	23095	Mid	LTE Band 12	10	24.0	23.03	-0.02	1	05358	QPSK	25	12	16 mm	back	1:1	0.247	1.250	0.309	
707.50	23095	Mid	LTE Band 12	10	25.0	23.89	0.16	0	05358	QPSK	1	0	16 mm	top	1:1	0.488	1.291	0.630	A4
707.50	23095	Mid	LTE Band 12	10	24.0	23.03	0.19	1	05358	QPSK	25	12	16 mm	top	1:1	0.384	1.250	0.480	
707.50	23095	Mid	LTE Band 12	10	25.0	23.89	0.04	0	05358	QPSK	1	0	0 mm	right	1:1	0.145	1.291	0.187	
707.50	23095	Mid	LTE Band 12	10	24.0	23.03	-0.10	1	05358	QPSK	25	12	0 mm	right	1:1	0.126	1.250	0.158	
707.50	23095	Mid	LTE Band 12	10	25.0	23.89	0.14	0	05358	QPSK	1	0	0 mm	left	1:1	0.102	1.291	0.132	
707.50	23095	Mid	LTE Band 12	10	24.0	23.03	0.16	1	05358	QPSK	25	12	0 mm	left	1:1	0.086	1.250	0.108	
707.50	23095	Mid	LTE Band 12	10	14.0	13.14	-0.05	0	05358	QPSK	1	0	0 mm	back	1:1	0.388	1.219	0.473	
707.50	23095	Mid	LTE Band 12	10	14.0	13.20	-0.03	0	05358	QPSK	25	12	0 mm	back	1:1	0.390	1.202	0.469	
707.50	23095	Mid	LTE Band 12	10	14.0	13.14	-0.03	0	05358	QPSK	1	0	0 mm	top	1:1	0.395	1.219	0.482	
707.50	23095	Mid	LTE Band 12	10	14.0	13.20	-0.03	0	05358	QPSK	25	12	0 mm	top	1:1	0.399	1.202	0.480	
ANSI / IEEE C95.1 1992 - SAFETY LIMIT Spatial Peak Uncontrolled Exposure/General Population										Body 1.6 W/kg (mW/g) averaged over 1 gram									



**Table 10-3
LTE Band 14 Body SAR**

MEASUREMENT RESULTS																			
FREQUENCY		Mode	Bandwidth [MHz]	Maximum Allowed Power [dBm]	Conducted Power [dBm]	Power Drift [dB]	MPR [dB]	Device Serial Number	Modulation	RB Size	RB Offset	Spacing	Side	Duty Cycle	SAR (1g)	Scaling Factor	Reported SAR (1g)	Plot #	
MHz	Ch.														(W/kg)		(W/kg)		
793.00	23330	Mid	LTE Band 14	10	25.0	23.91	-0.07	0	05358	QPSK	1	0	16 mm	back	1:1	0.412	1.285	0.529	
793.00	23330	Mid	LTE Band 14	10	24.0	22.92	-0.01	1	05358	QPSK	25	0	16 mm	back	1:1	0.322	1.282	0.413	
793.00	23330	Mid	LTE Band 14	10	25.0	23.91	0.18	0	05358	QPSK	1	0	16 mm	top	1:1	0.773	1.285	0.993	A5
793.00	23330	Mid	LTE Band 14	10	24.0	22.92	0.07	1	05358	QPSK	25	0	16 mm	top	1:1	0.633	1.282	0.812	
793.00	23330	Mid	LTE Band 14	10	24.0	22.91	0.01	1	05358	QPSK	50	0	16 mm	top	1:1	0.645	1.285	0.829	
793.00	23330	Mid	LTE Band 14	10	25.0	23.91	0.08	0	05358	QPSK	1	0	0 mm	right	1:1	0.188	1.285	0.242	
793.00	23330	Mid	LTE Band 14	10	24.0	22.92	-0.10	1	05358	QPSK	25	0	0 mm	right	1:1	0.153	1.282	0.196	
793.00	23330	Mid	LTE Band 14	10	25.0	23.91	-0.03	0	05358	QPSK	1	0	0 mm	left	1:1	0.102	1.285	0.131	
793.00	23330	Mid	LTE Band 14	10	24.0	22.92	0.09	1	05358	QPSK	25	0	0 mm	left	1:1	0.077	1.282	0.099	
793.00	23330	Mid	LTE Band 14	10	16.0	15.01	0.05	0	05358	QPSK	1	0	0 mm	back	1:1	0.703	1.256	0.883	
793.00	23330	Mid	LTE Band 14	10	16.0	14.99	-0.21	0	05358	QPSK	25	0	0 mm	back	1:1	0.715	1.262	0.902	
793.00	23330	Mid	LTE Band 14	10	16.0	14.90	-0.07	0	05358	QPSK	50	0	0 mm	back	1:1	0.704	1.288	0.907	
793.00	23330	Mid	LTE Band 14	10	16.0	15.01	0.01	0	05358	QPSK	1	0	0 mm	top	1:1	0.717	1.256	0.901	
793.00	23330	Mid	LTE Band 14	10	16.0	14.99	-0.04	0	05358	QPSK	25	0	0 mm	top	1:1	0.723	1.262	0.912	
793.00	23330	Mid	LTE Band 14	10	16.0	14.90	0.13	0	05358	QPSK	50	0	0 mm	top	1:1	0.704	1.288	0.907	
ANSI / IEEE C95.1 1992 - SAFETY LIMIT Spatial Peak Uncontrolled Exposure/General Population										Body 1.6 W/kg (mW/g) averaged over 1 gram									

FCC ID: A3LSMT837A		SAR EVALUATION REPORT		Approved by: Quality Manager
Document S/N: 1M1806180124-01.A3L	Test Dates: 06/20/18 - 07/05/18	DUT Type: Portable Tablet	Page 67 of 100	

**Table 10-4
LTE Band 5 (Cell) Body SAR**



MEASUREMENT RESULTS																			
FREQUENCY		Mode	Bandwidth [MHz]	Maximum Allowed Power [dBm]	Conducted Power [dBm]	Power Drift [dB]	MPR [dB]	Device Serial Number	Modulation	RB Size	RB Offset	Spacing	Side	Duty Cycle	SAR (1g)	Scaling Factor	Reported SAR (1g)	Plot #	
MHz	Ch.														(W/kg)		(W/kg)		
836.50	20525	Mid	LTE Band 5 (Cell)	10	25.0	24.15	-0.02	0	05866	QPSK	1	0	16 mm	back	1:1	0.702	1.216	0.854	
836.50	20525	Mid	LTE Band 5 (Cell)	10	24.0	23.15	0.00	1	05866	QPSK	25	0	16 mm	back	1:1	0.565	1.216	0.687	
836.50	20525	Mid	LTE Band 5 (Cell)	10	24.0	23.10	0.02	1	05866	QPSK	50	0	16 mm	back	1:1	0.553	1.230	0.680	
836.50	20525	Mid	LTE Band 5 (Cell)	10	25.0	24.15	0.13	0	05866	QPSK	1	0	16 mm	top	1:1	0.924	1.216	1.124	A6
836.50	20525	Mid	LTE Band 5 (Cell)	10	24.0	23.15	-0.01	1	05866	QPSK	25	0	16 mm	top	1:1	0.735	1.216	0.894	
836.50	20525	Mid	LTE Band 5 (Cell)	10	24.0	23.10	-0.02	1	05866	QPSK	50	0	16 mm	top	1:1	0.765	1.230	0.941	
836.50	20525	Mid	LTE Band 5 (Cell)	10	25.0	24.15	0.15	0	05866	QPSK	1	0	0 mm	right	1:1	0.168	1.216	0.204	
836.50	20525	Mid	LTE Band 5 (Cell)	10	24.0	23.15	-0.09	1	05866	QPSK	25	0	0 mm	right	1:1	0.137	1.216	0.167	
836.50	20525	Mid	LTE Band 5 (Cell)	10	25.0	24.15	-0.05	0	05866	QPSK	1	0	0 mm	left	1:1	0.101	1.216	0.123	
836.50	20525	Mid	LTE Band 5 (Cell)	10	24.0	23.15	-0.10	1	05866	QPSK	25	0	0 mm	left	1:1	0.087	1.216	0.106	
836.50	20525	Mid	LTE Band 5 (Cell)	10	16.0	15.51	0.00	0	05866	QPSK	1	0	0 mm	back	1:1	0.647	1.119	0.724	
836.50	20525	Mid	LTE Band 5 (Cell)	10	16.0	15.50	-0.01	0	05866	QPSK	25	0	0 mm	back	1:1	0.644	1.122	0.723	
836.50	20525	Mid	LTE Band 5 (Cell)	10	16.0	15.51	-0.16	0	05866	QPSK	1	0	0 mm	top	1:1	0.673	1.119	0.753	
836.50	20525	Mid	LTE Band 5 (Cell)	10	16.0	15.50	-0.19	0	05866	QPSK	25	0	0 mm	top	1:1	0.686	1.122	0.770	
ANSI / IEEE C95.1 1992 - SAFETY LIMIT Spatial Peak Uncontrolled Exposure/General Population							Body 1.6 W/kg (mW/g) averaged over 1 gram												

FCC ID: A3LSMT837A		SAR EVALUATION REPORT		Approved by: Quality Manager
Document S/N: 1M1806180124-01.A3L	Test Dates: 06/20/18 - 07/05/18	DUT Type: Portable Tablet	Page 68 of 100	

**Table 10-5
LTE Band 66 (AWS) Body SAR**



MEASUREMENT RESULTS																			
FREQUENCY		Mode	Bandwidth [MHz]	Maximum Allowed Power [dBm]	Conducted Power [dBm]	Power Drift [dB]	MPR [dB]	Device Serial Number	Modulation	RB Size	RB Offset	Spacing	Side	Duty Cycle	SAR (1g)	Scaling Factor	Reported SAR (1g)	Plot #	
MHz	Ch.														(W/kg)		(W/kg)		
1770.00	132572	High	LTE Band 66 (AWS)	20	25.0	24.44	0.01	0	05106	QPSK	1	0	16 mm	back	1:1	0.570	1.138	0.649	
1770.00	132572	High	LTE Band 66 (AWS)	20	24.0	23.33	-0.04	1	05106	QPSK	50	0	16 mm	back	1:1	0.449	1.167	0.524	
1770.00	132572	High	LTE Band 66 (AWS)	20	25.0	24.44	-0.09	0	05106	QPSK	1	0	16 mm	top	1:1	0.615	1.138	0.700	
1770.00	132572	High	LTE Band 66 (AWS)	20	24.0	23.33	-0.02	1	05106	QPSK	50	0	16 mm	top	1:1	0.487	1.167	0.568	
1720.00	132072	Low	LTE Band 66 (AWS)	20	25.0	24.14	-0.04	0	05106	QPSK	1	0	0 mm	right	1:1	1.060	1.219	1.292	
1745.00	132322	Mid	LTE Band 66 (AWS)	20	25.0	24.38	-0.11	0	05106	QPSK	1	0	0 mm	right	1:1	1.110	1.153	1.280	
1770.00	132572	High	LTE Band 66 (AWS)	20	25.0	24.44	-0.07	0	05106	QPSK	1	0	0 mm	right	1:1	1.120	1.138	1.275	
1720.00	132072	Low	LTE Band 66 (AWS)	20	24.0	23.12	0.00	1	05106	QPSK	50	0	0 mm	right	1:1	0.826	1.225	1.012	
1745.00	132322	Mid	LTE Band 66 (AWS)	20	24.0	23.27	-0.02	1	05106	QPSK	50	0	0 mm	right	1:1	0.871	1.183	1.030	
1770.00	132572	High	LTE Band 66 (AWS)	20	24.0	23.33	-0.13	1	05106	QPSK	50	0	0 mm	right	1:1	0.897	1.167	1.047	
1770.00	132572	High	LTE Band 66 (AWS)	20	24.0	23.24	-0.03	1	05106	QPSK	100	0	0 mm	right	1:1	0.868	1.191	1.034	
1770.00	132572	High	LTE Band 66 (AWS)	20	25.0	24.44	0.00	0	05106	QPSK	1	0	0 mm	left	1:1	0.499	1.138	0.568	
1770.00	132572	High	LTE Band 66 (AWS)	20	24.0	23.33	0.14	1	05106	QPSK	50	0	0 mm	left	1:1	0.347	1.167	0.405	
1720.00	132072	Low	LTE Band 66 (AWS)	20	14.0	13.09	0.00	0	05106	QPSK	1	0	0 mm	back	1:1	0.777	1.233	0.958	
1745.00	132322	Mid	LTE Band 66 (AWS)	20	14.0	13.38	0.02	0	05106	QPSK	1	0	0 mm	back	1:1	0.855	1.153	0.986	
1770.00	132572	High	LTE Band 66 (AWS)	20	14.0	13.39	0.00	0	05106	QPSK	1	0	0 mm	back	1:1	0.909	1.151	1.046	
1720.00	132072	Low	LTE Band 66 (AWS)	20	14.0	13.18	0.00	0	05106	QPSK	50	0	0 mm	back	1:1	0.769	1.208	0.929	
1745.00	132322	Mid	LTE Band 66 (AWS)	20	14.0	13.36	0.02	0	05106	QPSK	50	0	0 mm	back	1:1	0.845	1.159	0.979	
1770.00	132572	High	LTE Band 66 (AWS)	20	14.0	13.42	0.00	0	05106	QPSK	50	0	0 mm	back	1:1	0.904	1.143	1.033	
1770.00	132572	High	LTE Band 66 (AWS)	20	14.0	13.36	0.01	0	05106	QPSK	100	0	0 mm	back	1:1	0.894	1.159	1.036	
1720.00	132072	Low	LTE Band 66 (AWS)	20	14.0	13.09	-0.13	0	05106	QPSK	1	0	0 mm	top	1:1	0.771	1.233	0.951	
1745.00	132322	Mid	LTE Band 66 (AWS)	20	14.0	13.38	-0.14	0	05106	QPSK	1	0	0 mm	top	1:1	0.817	1.153	0.942	
1770.00	132572	High	LTE Band 66 (AWS)	20	14.0	13.39	-0.13	0	05106	QPSK	1	0	0 mm	top	1:1	0.821	1.151	0.945	
1720.00	132072	Low	LTE Band 66 (AWS)	20	14.0	13.18	-0.15	0	05106	QPSK	50	0	0 mm	top	1:1	0.760	1.208	0.918	
1745.00	132322	Mid	LTE Band 66 (AWS)	20	14.0	13.36	-0.12	0	05106	QPSK	50	0	0 mm	top	1:1	0.800	1.159	0.927	
1770.00	132572	High	LTE Band 66 (AWS)	20	14.0	13.42	-0.13	0	05106	QPSK	50	0	0 mm	top	1:1	0.811	1.143	0.927	
1770.00	132572	High	LTE Band 66 (AWS)	20	14.0	13.36	-0.11	0	05106	QPSK	100	0	0 mm	top	1:1	0.793	1.159	0.919	
1770.00	132572	High	LTE Band 66 (AWS)	20	25.0	24.44	0.15	0	05106	QPSK	1	0	0 mm	right	1:1	1.150	1.138	1.309	A7
ANSI / IEEE C95.1 1992 - SAFETY LIMIT Spatial Peak Uncontrolled Exposure/General Population								Body 1.6 W/kg (mW/g) averaged over 1 gram											

Note: Blue entry indicates variability measurements.

FCC ID: A3LSMT837A		SAR EVALUATION REPORT		Approved by: Quality Manager
Document S/N: 1M1806180124-01.A3L	Test Dates: 06/20/18 - 07/05/18	DUT Type: Portable Tablet	Page 69 of 100	

**Table 10-6
LTE Band 2 (PCS) Body SAR**

MEASUREMENT RESULTS																			
FREQUENCY		Mode	Bandwidth [MHz]	Maximum Allowed Power [dBm]	Conducted Power [dBm]	Power Drift [dB]	MPR [dB]	Device Serial Number	Modulation	RB Size	RB Offset	Spacing	Side	Duty Cycle	SAR (1g)	Scaling Factor	Reported SAR (1g)	Plot #	
MHz	Ch.														(W/kg)		(W/kg)		
1860.00	18700	Low	LTE Band 2 (PCS)	20	25.0	24.04	0.15	0	05866	QPSK	1	0	16 mm	back	1:1	0.584	1.247	0.728	
1880.00	18900	Mid	LTE Band 2 (PCS)	20	25.0	23.77	0.04	0	05866	QPSK	1	0	16 mm	back	1:1	0.628	1.327	0.833	
1900.00	19100	High	LTE Band 2 (PCS)	20	25.0	24.21	0.03	0	05866	QPSK	1	0	16 mm	back	1:1	0.714	1.199	0.856	
1900.00	19100	High	LTE Band 2 (PCS)	20	24.0	23.18	0.02	1	05866	QPSK	50	0	16 mm	back	1:1	0.562	1.208	0.679	
1900.00	19100	High	LTE Band 2 (PCS)	20	24.0	23.12	0.04	1	05866	QPSK	100	0	16 mm	back	1:1	0.553	1.225	0.677	
1900.00	19100	High	LTE Band 2 (PCS)	20	25.0	24.21	-0.03	0	05866	QPSK	1	0	16 mm	top	1:1	0.592	1.199	0.710	
1900.00	19100	High	LTE Band 2 (PCS)	20	24.0	23.18	-0.01	1	05866	QPSK	50	0	16 mm	top	1:1	0.467	1.208	0.564	
1900.00	19100	High	LTE Band 2 (PCS)	20	25.0	24.21	-0.01	0	05866	QPSK	1	0	0 mm	right	1:1	0.626	1.199	0.751	
1900.00	19100	High	LTE Band 2 (PCS)	20	24.0	23.18	-0.01	1	05866	QPSK	50	0	0 mm	right	1:1	0.553	1.208	0.688	
1900.00	19100	High	LTE Band 2 (PCS)	20	25.0	24.21	0.01	0	05866	QPSK	1	0	0 mm	left	1:1	0.371	1.199	0.445	
1900.00	19100	High	LTE Band 2 (PCS)	20	24.0	23.18	0.05	1	05866	QPSK	50	0	0 mm	left	1:1	0.293	1.208	0.354	
1860.00	18700	Low	LTE Band 2 (PCS)	20	13.5	13.18	0.12	0	05866	QPSK	1	0	0 mm	back	1:1	0.870	1.076	0.936	
1880.00	18900	Mid	LTE Band 2 (PCS)	20	13.5	12.90	0.19	0	05866	QPSK	1	0	0 mm	back	1:1	0.873	1.148	1.002	
1900.00	19100	High	LTE Band 2 (PCS)	20	13.5	13.40	0.21	0	05866	QPSK	1	0	0 mm	back	1:1	0.936	1.023	0.958	A8
1860.00	18700	Low	LTE Band 2 (PCS)	20	13.5	13.12	0.20	0	05866	QPSK	50	0	0 mm	back	1:1	0.864	1.091	0.943	
1880.00	18900	Mid	LTE Band 2 (PCS)	20	13.5	12.92	0.13	0	05866	QPSK	50	0	0 mm	back	1:1	0.871	1.143	0.996	
1900.00	19100	High	LTE Band 2 (PCS)	20	13.5	13.31	0.21	0	05866	QPSK	50	0	0 mm	back	1:1	0.924	1.045	0.966	
1900.00	19100	High	LTE Band 2 (PCS)	20	13.5	13.28	0.20	0	05866	QPSK	100	0	0 mm	back	1:1	0.923	1.052	0.971	
1860.00	18700	Low	LTE Band 2 (PCS)	20	13.5	13.18	-0.03	0	05866	QPSK	1	0	0 mm	top	1:1	0.667	1.076	0.718	
1880.00	18900	Mid	LTE Band 2 (PCS)	20	13.5	12.90	0.02	0	05866	QPSK	1	0	0 mm	top	1:1	0.736	1.148	0.845	
1900.00	19100	High	LTE Band 2 (PCS)	20	13.5	13.40	0.01	0	05866	QPSK	1	0	0 mm	top	1:1	0.881	1.023	0.901	
1860.00	18700	Low	LTE Band 2 (PCS)	20	13.5	13.12	0.00	0	05866	QPSK	50	0	0 mm	top	1:1	0.673	1.091	0.734	
1880.00	18900	Mid	LTE Band 2 (PCS)	20	13.5	12.92	0.01	0	05866	QPSK	50	0	0 mm	top	1:1	0.765	1.143	0.874	
1900.00	19100	High	LTE Band 2 (PCS)	20	13.5	13.31	0.02	0	05866	QPSK	50	0	0 mm	top	1:1	0.891	1.045	0.931	
1900.00	19100	High	LTE Band 2 (PCS)	20	13.5	13.28	0.02	0	05866	QPSK	100	0	0 mm	top	1:1	0.884	1.052	0.930	
ANSI / IEEE C95.1 1992 - SAFETY LIMIT Spatial Peak Uncontrolled Exposure/General Population								Body 1.6 W/kg (mW/g) averaged over 1 gram											

FCC ID: A3LSMT837A		SAR EVALUATION REPORT		Approved by: Quality Manager
Document S/N: 1M1806180124-01.A3L	Test Dates: 06/20/18 - 07/05/18	DUT Type: Portable Tablet	Page 70 of 100	

**Table 10-7
LTE Band 30 Body SAR**



MEASUREMENT RESULTS																			
FREQUENCY		Mode	Bandwidth [MHz]	Maximum Allowed Power [dBm]	Conducted Power [dBm]	Power Drift [dB]	MPR [dB]	Device Serial Number	Modulation	RB Size	RB Offset	Spacing	Side	Duty Cycle	SAR (1g)	Scaling Factor	Reported SAR (1g)	Plot #	
MHz	Ch.														(W/kg)		(W/kg)		
2310.00	27710	Mid	LTE Band 30	10	24.2	24.09	-0.06	0	05080	QPSK	1	0	16 mm	back	1:1	0.459	1.026	0.471	
2310.00	27710	Mid	LTE Band 30	10	23.2	22.95	-0.05	1	05080	QPSK	25	25	16 mm	back	1:1	0.361	1.059	0.382	
2310.00	27710	Mid	LTE Band 30	10	24.2	24.09	-0.02	0	05080	QPSK	1	0	16 mm	top	1:1	0.365	1.026	0.374	
2310.00	27710	Mid	LTE Band 30	10	23.2	22.95	-0.03	1	05080	QPSK	25	25	16 mm	top	1:1	0.286	1.059	0.303	
2310.00	27710	Mid	LTE Band 30	10	24.2	24.09	0.00	0	05080	QPSK	1	0	0 mm	right	1:1	0.744	1.026	0.763	
2310.00	27710	Mid	LTE Band 30	10	23.2	22.95	-0.11	1	05080	QPSK	25	25	0 mm	right	1:1	0.564	1.059	0.597	
2310.00	27710	Mid	LTE Band 30	10	24.2	24.09	0.02	0	05080	QPSK	1	0	0 mm	left	1:1	0.163	1.026	0.167	
2310.00	27710	Mid	LTE Band 30	10	23.2	22.95	0.07	1	05080	QPSK	25	25	0 mm	left	1:1	0.132	1.059	0.140	
2310.00	27710	Mid	LTE Band 30	10	14.5	14.37	-0.04	0	05080	QPSK	1	49	0 mm	back	1:1	0.893	1.030	0.920	
2310.00	27710	Mid	LTE Band 30	10	14.5	14.37	-0.05	0	05080	QPSK	25	25	0 mm	back	1:1	0.902	1.030	0.929	
2310.00	27710	Mid	LTE Band 30	10	14.5	14.26	-0.04	0	05080	QPSK	50	0	0 mm	back	1:1	0.902	1.057	0.953	
2310.00	27710	Mid	LTE Band 30	10	14.5	14.37	-0.13	0	05080	QPSK	1	49	0 mm	top	1:1	0.568	1.030	0.585	
2310.00	27710	Mid	LTE Band 30	10	14.5	14.37	-0.15	0	05080	QPSK	25	25	0 mm	top	1:1	0.578	1.030	0.595	
2310.00	27710	Mid	LTE Band 30	10	14.5	14.26	0.10	0	05080	QPSK	50	0	0 mm	back	1:1	0.963	1.057	1.018	A9
ANSI / IEEE C95.1 1992 - SAFETY LIMIT Spatial Peak Uncontrolled Exposure/General Population								Body 1.6 W/kg (mW/g) averaged over 1 gram											

Note: Blue entry indicates variability measurements.

**Table 10-8
LTE Band 7 Body SAR**



MEASUREMENT RESULTS																			
FREQUENCY		Mode	Bandwidth [MHz]	Maximum Allowed Power [dBm]	Conducted Power [dBm]	Power Drift [dB]	MPR [dB]	Device Serial Number	Modulation	RB Size	RB Offset	Spacing	Side	Duty Cycle	SAR (1g)	Scaling Factor	Reported SAR (1g)	Plot #	
MHz	Ch.														(W/kg)		(W/kg)		
2510.00	20850	Low	LTE Band 7	20	25.0	24.57	0.03	0	05767	QPSK	1	0	16 mm	back	1:1	0.714	1.104	0.788	
2510.00	20850	Low	LTE Band 7	20	24.0	23.52	-0.02	1	05767	QPSK	50	0	16 mm	back	1:1	0.650	1.117	0.726	
2510.00	20850	Low	LTE Band 7	20	25.0	24.57	-0.07	0	05767	QPSK	1	0	16 mm	top	1:1	0.500	1.104	0.552	
2510.00	20850	Low	LTE Band 7	20	24.0	23.52	-0.02	1	05767	QPSK	50	0	16 mm	top	1:1	0.492	1.117	0.550	
2510.00	20850	Low	LTE Band 7	20	25.0	24.57	0.15	0	05767	QPSK	1	0	0 mm	right	1:1	0.275	1.104	0.304	
2510.00	20850	Low	LTE Band 7	20	24.0	23.52	0.10	1	05767	QPSK	50	0	0 mm	right	1:1	0.270	1.117	0.302	
2510.00	20850	Low	LTE Band 7	20	25.0	24.57	0.21	0	05767	QPSK	1	0	0 mm	left	1:1	0.288	1.104	0.318	
2510.00	20850	Low	LTE Band 7	20	24.0	23.52	-0.19	1	05767	QPSK	50	0	0 mm	left	1:1	0.242	1.117	0.270	
2510.00	20850	Low	LTE Band 7	20	13.0	12.34	-0.01	0	05767	QPSK	1	0	0 mm	back	1:1	0.918	1.164	1.069	
2535.00	21100	Mid	LTE Band 7	20	13.0	12.27	0.01	0	05767	QPSK	1	0	0 mm	back	1:1	0.987	1.183	1.168	
2560.00	21350	High	LTE Band 7	20	13.0	12.11	0.07	0	05767	QPSK	1	0	0 mm	back	1:1	0.992	1.227	1.217	
2510.00	20850	Low	LTE Band 7	20	13.0	12.33	0.00	0	05767	QPSK	50	0	0 mm	back	1:1	0.912	1.167	1.064	
2535.00	21100	Mid	LTE Band 7	20	13.0	12.29	0.06	0	05767	QPSK	50	25	0 mm	back	1:1	0.980	1.178	1.154	
2560.00	21350	High	LTE Band 7	20	13.0	12.01	0.09	0	05767	QPSK	50	0	0 mm	back	1:1	0.994	1.256	1.248	A10
2510.00	20850	Low	LTE Band 7	20	13.0	12.20	0.10	0	05767	QPSK	100	0	0 mm	back	1:1	0.863	1.202	1.037	
2510.00	20850	Low	LTE Band 7	20	13.0	12.34	-0.02	0	05767	QPSK	1	0	0 mm	top	1:1	0.515	1.164	0.599	
2510.00	20850	Low	LTE Band 7	20	13.0	12.33	-0.04	0	05767	QPSK	50	0	0 mm	top	1:1	0.514	1.167	0.600	
2510.00	20850	Low	LTE Band 7	20	13.0	12.34	0.13	0	05767	QPSK	1	0	0 mm	back	1:1	0.888	1.164	1.034	
2560.00	21350	High	LTE Band 7	20	13.0	12.01	0.16	0	05767	QPSK	50	0	0 mm	back	1:1	0.975	1.256	1.225	
ANSI / IEEE C95.1 1992 - SAFETY LIMIT Spatial Peak Uncontrolled Exposure/General Population								Body 1.6 W/kg (mW/g) averaged over 1 gram											

Note: Blue entry indicates variability measurements.

FCC ID: A3LSMT837A		SAR EVALUATION REPORT		Approved by: Quality Manager
Document S/N: 1M1806180124-01.A3L	Test Dates: 06/20/18 - 07/05/18	DUT Type: Portable Tablet	Page 71 of 100	

**Table 10-9
2.4 GHz WLAN Body SAR**



MEASUREMENT RESULTS																		
FREQUENCY		Mode	Service	Bandwidth [MHz]	Maximum Allowed Power [dBm]	Conducted Power [dBm]	Power Drift [dB]	Spacing	Antenna Config.	Device Serial Number	Data Rate (Mbps)	Side	Duty Cycle (%)	SAR (1g)	Scaling Factor (Power)	Scaling Factor (Duty Cycle)	Reported SAR (1g)	Plot #
MHz	Ch.													(W/kg)			(W/kg)	
2412	1	802.11b	DSSS	22	14.0	13.32	-0.01	5 mm	1	04992	1	back	98.9	0.112	1.169	1.011	0.132	
2412	1	802.11b	DSSS	22	13.0	12.45	-0.14	0 mm	1	04992	1	back	98.9	0.803	1.135	1.011	0.921	A11
2437	6	802.11b	DSSS	22	13.0	12.14	-0.12	0 mm	1	04992	1	back	98.9	0.662	1.219	1.011	0.816	
2462	11	802.11b	DSSS	22	13.0	12.44	-0.19	0 mm	1	04992	1	back	98.9	0.729	1.138	1.011	0.839	
2412	1	802.11b	DSSS	22	14.0	13.32	0.18	0 mm	1	04992	1	top	98.9	0.008	1.169	1.011	0.009	
2412	1	802.11b	DSSS	22	14.0	13.32	-0.01	0 mm	1	04992	1	bottom	98.9	0.289	1.169	1.011	0.342	
2412	1	802.11b	DSSS	22	14.0	13.32	0.12	0 mm	1	04992	1	right	98.9	0.067	1.169	1.011	0.079	
2412	1	802.11b	DSSS	22	14.0	13.32	0.02	0 mm	1	04992	1	left	98.9	0.000	1.169	1.011	0.000	
2412	1	802.11b	DSSS	22	14.0	13.32	0.09	5 mm	2	04992	1	back	99.0	0.304	1.169	1.010	0.359	
2412	1	802.11b	DSSS	22	13.0	11.60	-0.05	0 mm	2	04992	1	back	99.0	0.604	1.380	1.010	0.842	
2437	6	802.11b	DSSS	22	13.0	12.48	0.07	0 mm	2	04992	1	back	99.0	0.706	1.127	1.010	0.804	
2462	11	802.11b	DSSS	22	13.0	11.87	0.03	0 mm	2	04992	1	back	99.0	0.618	1.297	1.010	0.810	
2412	1	802.11b	DSSS	22	14.0	13.32	0.04	0 mm	2	04992	1	top	99.0	0.004	1.169	1.010	0.005	
2412	1	802.11b	DSSS	22	14.0	13.32	0.07	0 mm	2	04992	1	bottom	99.0	0.147	1.169	1.010	0.174	
2412	1	802.11b	DSSS	22	14.0	13.32	0.11	0 mm	2	04992	1	right	99.0	0.006	1.169	1.010	0.007	
2412	1	802.11b	DSSS	22	14.0	13.32	0.14	0 mm	2	04992	1	left	99.0	0.015	1.169	1.010	0.018	
ANSI / IEEE C95.1 1992 - SAFETY LIMIT Spatial Peak Uncontrolled Exposure/General Population								Body 1.6 W/kg (mW/g) averaged over 1 gram										

FCC ID: A3LSMT837A	 PCTEST <small>ENGINEERING LABORATORY, INC.</small>	SAR EVALUATION REPORT		Approved by: Quality Manager
Document S/N: 1M1806180124-01.A3L	Test Dates: 06/20/18 - 07/05/18	DUT Type: Portable Tablet	Page 72 of 100	

**Table 10-10
5 GHz WLAN Body SAR**

MEASUREMENT RESULTS																		
FREQUENCY		Mode	Service	Bandwidth [MHz]	Maximum Allowed Power [dBm]	Conducted Power [dBm]	Power Drift [dB]	Spacing	Antenna Config.	Device Serial Number	Data Rate (Mbps)	Side	Duty Cycle (%)	SAR (1g)	Scaling Factor (Power)	Scaling Factor (Duty Cycle)	Reported SAR (1g)	Plot #
MHz	Ch.													(W/kg)			(W/kg)	
5310	62	802.11n	OFDM	40	14.0	13.19	0.12	5 mm	1	04992	13.5	back	94.2	0.305	1.205	1.062	0.390	
5290	58	802.11ac	OFDM	80	10.0	8.47	0.00	0 mm	1	04992	29.3	back	87.3	0.551	1.422	1.145	0.897	
5310	62	802.11n	OFDM	40	14.0	13.19	0.09	0 mm	1	04992	13.5	top	94.2	0.000	1.205	1.062	0.000	
5310	62	802.11n	OFDM	40	14.0	13.19	0.00	0 mm	1	04992	13.5	bottom	94.2	0.431	1.205	1.062	0.552	
5310	62	802.11n	OFDM	40	14.0	13.19	0.13	0 mm	1	04992	13.5	right	94.2	0.059	1.205	1.062	0.076	
5310	62	802.11n	OFDM	40	14.0	13.12	0.16	5 mm	2	04992	13.5	back	94.4	0.215	1.225	1.059	0.279	
5290	58	802.11ac	OFDM	80	10.0	9.47	-0.04	0 mm	2	04992	29.3	back	89.2	0.307	1.130	1.121	0.389	
5310	62	802.11n	OFDM	40	14.0	13.12	0.14	0 mm	2	04992	13.5	top	94.4	0.000	1.225	1.059	0.000	
5310	62	802.11n	OFDM	40	14.0	13.12	-0.04	0 mm	2	04992	13.5	bottom	94.4	0.306	1.225	1.059	0.397	
5310	62	802.11n	OFDM	40	14.0	13.12	0.00	0 mm	2	04992	13.5	right	94.4	0.000	1.225	1.059	0.000	
5310	62	802.11n	OFDM	40	14.0	13.12	0.15	0 mm	2	04992	13.5	left	94.4	0.088	1.225	1.059	0.114	
5510	102	802.11n	OFDM	40	14.0	13.14	0.13	5 mm	1	04992	13.5	back	94.2	0.285	1.219	1.062	0.369	
5530	106	802.11ac	OFDM	80	10.0	9.04	0.21	0 mm	1	04992	29.3	back	87.3	0.671	1.247	1.145	0.958	
5610	122	802.11ac	OFDM	80	10.0	9.16	-0.11	0 mm	1	04992	29.3	back	87.3	0.748	1.213	1.145	1.039	
5510	102	802.11n	OFDM	40	14.0	13.14	0.01	0 mm	1	04992	13.5	top	94.2	0.000	1.219	1.062	0.000	
5510	102	802.11n	OFDM	40	14.0	13.14	-0.01	0 mm	1	04992	13.5	bottom	94.2	0.294	1.219	1.062	0.381	
5510	102	802.11n	OFDM	40	14.0	13.14	0.12	0 mm	1	04992	13.5	right	94.2	0.036	1.219	1.062	0.047	
5590	118	802.11n	OFDM	40	14.0	13.48	-0.16	5 mm	2	04992	13.5	back	94.4	0.325	1.127	1.059	0.388	
5530	106	802.11ac	OFDM	80	10.0	9.17	-0.14	0 mm	2	04992	29.3	back	89.2	0.374	1.211	1.121	0.508	
5590	118	802.11n	OFDM	40	14.0	13.48	0.00	0 mm	2	04992	13.5	top	94.4	0.000	1.127	1.059	0.000	
5590	118	802.11n	OFDM	40	14.0	13.48	-0.08	0 mm	2	04992	13.5	bottom	94.4	0.467	1.127	1.059	0.557	
5590	118	802.11n	OFDM	40	14.0	13.48	0.09	0 mm	2	04992	13.5	right	94.4	0.000	1.127	1.059	0.000	
5590	118	802.11n	OFDM	40	14.0	13.48	0.11	0 mm	2	04992	13.5	left	94.4	0.082	1.127	1.059	0.098	
5755	151	802.11n	OFDM	40	14.0	12.92	0.17	5 mm	1	04992	13.5	back	94.2	0.241	1.282	1.062	0.328	
5775	155	802.11ac	OFDM	80	10.0	9.26	-0.01	0 mm	1	04992	29.3	back	87.3	0.859	1.186	1.145	1.166	A12
5755	151	802.11n	OFDM	40	14.0	12.92	0.00	0 mm	1	04992	13.5	top	94.2	0.000	1.282	1.062	0.000	
5755	151	802.11n	OFDM	40	14.0	12.92	0.18	0 mm	1	04992	13.5	bottom	94.2	0.203	1.282	1.062	0.276	
5755	151	802.11n	OFDM	40	14.0	12.92	0.10	0 mm	1	04992	13.5	right	94.2	0.016	1.282	1.062	0.022	
5795	159	802.11n	OFDM	40	14.0	13.42	-0.01	5 mm	2	04992	13.5	back	94.4	0.247	1.143	1.059	0.299	
5775	155	802.11ac	OFDM	80	10.0	8.88	-0.11	0 mm	2	04992	29.3	back	89.2	0.313	1.294	1.121	0.454	
5795	159	802.11n	OFDM	40	14.0	13.42	0.19	0 mm	2	04992	13.5	top	94.4	0.006	1.143	1.059	0.007	
5795	159	802.11n	OFDM	40	14.0	13.42	0.14	0 mm	2	04992	13.5	bottom	94.4	0.340	1.143	1.059	0.412	
5795	159	802.11n	OFDM	40	14.0	13.42	0.00	0 mm	2	04992	13.5	right	94.4	0.000	1.143	1.059	0.000	
5795	159	802.11n	OFDM	40	14.0	13.42	-0.17	0 mm	2	04992	13.5	left	94.4	0.046	1.143	1.059	0.056	
5775	155	802.11ac	OFDM	80	10.0	9.26	-0.13	0 mm	1	04992	29.3	back	87.3	0.847	1.186	1.145	1.150	
ANSI / IEEE C95.1 1992 - SAFETY LIMIT								Body										
Spatial Peak								1.6 W/kg (mW/g)										
Uncontrolled Exposure/General Population								averaged over 1 gram										

Note: Blue entry indicates variability measurements.

FCC ID: A3LSMT837A		SAR EVALUATION REPORT		Approved by: Quality Manager
Document S/N: 1M1806180124-01.A3L	Test Dates: 06/20/18 - 07/05/18	DUT Type: Portable Tablet	Page 73 of 100	

**Table 10-11
DSS Body SAR**

MEASUREMENT RESULTS																
FREQUENCY		Mode	Service	Maximum Allowed Power [dBm]	Conducted Power [dBm]	Power Drift [dB]	Spacing	Device Serial Number	Data Rate (Mbps)	Side	Duty Cycle (%)	SAR (1g)	Scaling Factor (Cond Power)	Scaling Factor (Duty Cycle)	Reported SAR (1g)	Plot #
MHz	Ch.											(W/kg)			(W/kg)	
2480	78	Bluetooth	FHSS	9.5	8.32	-0.09	0 mm	04893	1	back	77.3	0.202	1.312	1.294	0.343	A13
2480	78	Bluetooth	FHSS	9.5	8.32	0.02	0 mm	04893	1	top	77.3	0.000	1.312	1.294	0.000	
2480	78	Bluetooth	FHSS	9.5	8.32	0.15	0 mm	04893	1	bottom	77.3	0.091	1.312	1.294	0.154	
2480	78	Bluetooth	FHSS	9.5	8.32	0.12	0 mm	04893	1	right	77.3	0.024	1.312	1.294	0.041	
ANSI / IEEE C95.1 1992 - SAFETY LIMIT Spatial Peak Uncontrolled Exposure/General Population							Body 1.6 W/kg (mW/g) averaged over 1 gram									

10.2 SAR Test Notes

General Notes:



- The test data reported are the worst-case SAR values according to test procedures specified in FCC KDB Publication 616217 D04v01r02 and FCC KDB Publication 447498 D01v06.
- Batteries are fully charged at the beginning of the SAR measurements.
- Liquid tissue depth was at least 15.0 cm for all frequencies.
- The manufacturer has confirmed that the device(s) tested have the same physical, mechanical and thermal characteristics and are within operational tolerances expected for production units.
- SAR results were scaled to the maximum allowed power to demonstrate compliance per FCC KDB Publication 447498 D01v06.
- Per FCC KDB 865664 D01v01r04, variability SAR tests were performed when the measured SAR results for a frequency band were greater than or equal to 0.8 W/kg. Repeated SAR measurements are highlighted in the tables above for clarity. Please see Section 12 for variability analysis.
- FCC KDB Publication 616217 D04v01r02 Section 4.3, SAR tests are required for the back surface and edges of the tablet with the tablet touching the phantom. The SAR Exclusion Threshold in FCC KDB 447498 D01v06 was applied to determine SAR test exclusion for adjacent edge configurations.

UMTS Notes:

- UMTS mode in was tested under RMC 12.2 kbps with HSPA Inactive per KDB Publication 941225 D01v03r01. AMR and HSPA SAR was not required per the 3G Test Reduction Procedure in KDB Publication 941225 D01v03r01.
- Per FCC KDB Publication 447498 D01v06, if the reported (scaled) SAR measured at the middle channel or highest output power channel for each test configuration is ≤ 0.8 W/kg for 1g evaluations then testing at the other channels is not required for such test configuration(s). When the maximum output power variation across the required test channels is $> \frac{1}{2}$ dB, instead of the middle channel, the highest output power channel was used.

LTE Notes:

- LTE Considerations: LTE test configurations are determined according to SAR Evaluation Considerations for LTE Devices in FCC KDB Publication 941225 D05v02r04. The general test procedures used for testing can be found in Section 7.5.4.

FCC ID: A3LSMT837A		SAR EVALUATION REPORT		Approved by: Quality Manager
Document S/N: 1M1806180124-01.A3L	Test Dates: 06/20/18 - 07/05/18	DUT Type: Portable Tablet	Page 74 of 100	



2. MPR is permanently implemented for this device by the manufacturer. The specific manufacturer target MPR is indicated alongside the SAR results. MPR is enabled for this device, according to 3GPP TS36.101 Section 6.2.3 – 6.2.5 under Table 6.2.3-1.
3. A-MPR was disabled for all SAR tests by setting NS=01 on the base station simulator. SAR tests were performed with the same number of RB and RB offsets transmitting on all TTI frames (maximum TTI).
4. Per KDB Publication 941225 D05Av01r02, SAR for downlink only LTE CA operations was not needed since the maximum average output power in LTE CA mode was not >0.25 dB higher than the maximum output power when downlink carrier aggregation was inactive.

WLAN Notes:

1. Justification for test configurations for WLAN per KDB Publication 248227 D01v02r02 for 2.4 GHz WIFI single transmission chain operations, the highest measured maximum output power channel for DSSS was selected for SAR measurement. SAR for OFDM modes (2.4 GHz 802.11g/n) was not required due to the maximum allowed powers and the highest reported DSSS SAR. See Section 7.6.4 for more information.
2. Justification for test configurations for WLAN per KDB Publication 248227 D01v02r02 for 5 GHz WIFI single transmission chain operations, the initial test configuration was selected according to the transmission mode with the highest maximum allowed powers. Other transmission modes were not investigated since the highest reported SAR for initial test configuration adjusted by the ratio of maximum output powers is less than 1.2 W/kg for 1g evaluations. See Section 7.6.5 for more information.
3. Per KDB Publication 248227 D01v02r02, SAR for MIMO was evaluated by following the simultaneous SAR provisions from KDB Publication 447498 D01v06 by either evaluating the sum of the 1g SAR values of each antenna transmitting independently or making a SAR measurement with both antennas transmitting simultaneously. Please see Section 11 for complete analysis.
4. When the maximum reported 1g averaged SAR is ≤ 0.8 W/kg, SAR testing on additional channels was not required. Otherwise, SAR for the next highest output power channel was required until the reported SAR result was ≤ 1.20 W/kg for 1g evaluations or all test channels were measured.
5. The device was configured to transmit continuously at the required data rate, channel bandwidth and signal modulation, using the highest transmission duty factor supported by the test mode tools. The reported SAR was scaled to the 100% transmission duty factor to determine compliance. Procedures used to measure the duty factor are identical to that in the associated EMC test reports.

Bluetooth Notes

1. Bluetooth SAR was measured with the device connected to a call box with hopping disabled with DH5 operation and Tx Tests test mode type. Per October 2016 TCB Workshop Notes, the reported SAR was scaled to the 100% transmission duty factor to determine compliance. See Section 8.4 for the time domain plot and calculation for the duty factor of the device.

FCC ID: A3LSMT837A	 PCTEST ENGINEERING LABORATORY, INC.	SAR EVALUATION REPORT		Approved by: Quality Manager
Document S/N: 1M1806180124-01.A3L	Test Dates: 06/20/18 - 07/05/18	DUT Type: Portable Tablet	Page 75 of 100	



11 FCC MULTI-TX AND ANTENNA SAR CONSIDERATIONS

11.1 Introduction

The following procedures adopted from FCC KDB Publication 447498 D01v06 are applicable to devices with built-in unlicensed transmitters such as 802.11 and Bluetooth devices which may simultaneously transmit with the licensed transmitter.

11.2 Simultaneous Transmission Procedures



This device contains transmitters that may operate simultaneously. Therefore simultaneous transmission analysis is required. Per FCC KDB Publication 447498 D01v06 4.3.2 and IEEE 1528-2013 Section 6.3.4.1.2, simultaneous transmission SAR test exclusion may be applied when the sum of the 1g SAR for all the simultaneous transmitting antennas in a specific a physical test configuration is ≤ 1.6 W/kg. The different test positions in an exposure condition may be considered collectively to determine SAR test exclusion according to the sum of 1g SAR.

FCC ID: A3LSMT837A		SAR EVALUATION REPORT		Approved by: Quality Manager
Document S/N: 1M1806180124-01.A3L	Test Dates: 06/20/18 - 07/05/18	DUT Type: Portable Tablet		Page 76 of 100

11.3 Body SAR Simultaneous Transmission Analysis

Table 11-1
Simultaneous Transmission Scenario with 2.4 GHz WLAN

Simult Tx	Configuration	UMTS 850 SAR (W/kg)	2.4 GHz WLAN Ant 1 SAR (W/kg)	2.4 GHz WLAN Ant 2 SAR (W/kg)	Σ SAR (W/kg)			SPLSR		
		1	2	3	1+2	1+3	1+2+3	1+2	1+3	2+3
Body SAR	Back	0.892	0.921	0.842	See Note 1	See Note 1	See Note 1	0.01	0.01	0.02
	Top	1.217	0.009	0.005	1.226	1.222	1.231	N/A	N/A	N/A
	Bottom	0.400	0.342	0.174	0.742	0.574	0.916	N/A	N/A	N/A
	Right	0.212	0.079	0.007	0.291	0.219	0.298	N/A	N/A	N/A
	Left	0.140	0.000	0.018	0.140	0.158	0.158	N/A	N/A	N/A
Simult Tx	Configuration	UMTS 1750 SAR (W/kg)	2.4 GHz WLAN Ant 1 SAR (W/kg)	2.4 GHz WLAN Ant 2 SAR (W/kg)	Σ SAR (W/kg)			SPLSR		
		1	2	3	1+2	1+3	1+2+3	1+2	1+3	2+3
Body SAR	Back	1.189	0.921	0.842	See Note 1	See Note 1	See Note 1	0.01	0.01	0.02
	Top	1.007	0.009	0.005	1.016	1.012	1.021	N/A	N/A	N/A
	Bottom	0.400	0.342	0.174	0.742	0.574	0.916	N/A	N/A	N/A
	Right	1.024	0.079	0.007	1.103	1.031	1.110	N/A	N/A	N/A
	Left	0.407	0.000	0.018	0.407	0.425	0.425	N/A	N/A	N/A
Simult Tx	Configuration	UMTS 1900 SAR (W/kg)	2.4 GHz WLAN Ant 1 SAR (W/kg)	2.4 GHz WLAN Ant 2 SAR (W/kg)	Σ SAR (W/kg)			SPLSR		
		1	2	3	1+2	1+3	1+2+3	1+2	1+3	2+3
Body SAR	Back	1.322	0.921	0.842	See Note 1	See Note 1	See Note 1	0.01	0.01	0.02
	Top	1.100	0.009	0.005	1.109	1.105	1.114	N/A	N/A	N/A
	Bottom	0.400	0.342	0.174	0.742	0.574	0.916	N/A	N/A	N/A
	Right	1.264	0.079	0.007	1.343	1.271	1.350	N/A	N/A	N/A
	Left	0.422	0.000	0.018	0.422	0.440	0.440	N/A	N/A	N/A
Simult Tx	Configuration	LTE Band 12 SAR (W/kg)	2.4 GHz WLAN Ant 1 SAR (W/kg)	2.4 GHz WLAN Ant 2 SAR (W/kg)	Σ SAR (W/kg)			SPLSR		
		1	2	3	1+2	1+3	1+2+3	1+2	1+3	2+3
Body SAR	Back	0.473	0.921	0.842	1.394	1.315	See Note 1	0.01	0.01	0.02
	Top	0.630	0.009	0.005	0.639	0.635	0.644	N/A	N/A	N/A
	Bottom	0.400	0.342	0.174	0.742	0.574	0.916	N/A	N/A	N/A
	Right	0.187	0.079	0.007	0.266	0.194	0.273	N/A	N/A	N/A
	Left	0.132	0.000	0.018	0.132	0.150	0.150	N/A	N/A	N/A
Simult Tx	Configuration	LTE Band 14 SAR (W/kg)	2.4 GHz WLAN Ant 1 SAR (W/kg)	2.4 GHz WLAN Ant 2 SAR (W/kg)	Σ SAR (W/kg)			SPLSR		
		1	2	3	1+2	1+3	1+2+3	1+2	1+3	2+3
Body SAR	Back	0.907	0.921	0.842	See Note 1	See Note 1	See Note 1	0.01	0.01	0.02
	Top	0.993	0.009	0.005	1.002	0.998	1.007	N/A	N/A	N/A
	Bottom	0.400	0.342	0.174	0.742	0.574	0.916	N/A	N/A	N/A
	Right	0.242	0.079	0.007	0.321	0.249	0.328	N/A	N/A	N/A
	Left	0.131	0.000	0.018	0.131	0.149	0.149	N/A	N/A	N/A

FCC ID: A3LSMT837A		SAR EVALUATION REPORT		Approved by: Quality Manager
Document S/N: 1M1806180124-01.A3L	Test Dates: 06/20/18 - 07/05/18	DUT Type: Portable Tablet	Page 77 of 100	

Simult Tx	Configuration	LTE Band 5 (Cell) SAR (W/kg)	2.4 GHz WLAN Ant 1 SAR (W/kg)	2.4 GHz WLAN Ant 2 SAR (W/kg)	Σ SAR (W/kg)			SPLSR		
		1	2	3	1+2	1+3	1+2+3	1+2	1+3	2+3
Body SAR	Back	0.854	0.921	0.842	See Note 1	See Note 1	See Note 1	0.01	0.01	0.02
	Top	1.124	0.009	0.005	1.133	1.129	1.138	N/A	N/A	N/A
	Bottom	0.400	0.342	0.174	0.742	0.574	0.916	N/A	N/A	N/A
	Right	0.204	0.079	0.007	0.283	0.211	0.290	N/A	N/A	N/A
	Left	0.123	0.000	0.018	0.123	0.141	0.141	N/A	N/A	N/A
Simult Tx	Configuration	LTE Band 66 (AWS) SAR (W/kg)	2.4 GHz WLAN Ant 1 SAR (W/kg)	2.4 GHz WLAN Ant 2 SAR (W/kg)	Σ SAR (W/kg)			SPLSR		
		1	2	3	1+2	1+3	1+2+3	1+2	1+3	2+3
Body SAR	Back	1.046	0.921	0.842	See Note 1	See Note 1	See Note 1	0.01	0.01	0.02
	Top	0.951	0.009	0.005	0.960	0.956	0.965	N/A	N/A	N/A
	Bottom	0.400	0.342	0.174	0.742	0.574	0.916	N/A	N/A	N/A
	Right	1.309	0.079	0.007	1.388	1.316	1.395	N/A	N/A	N/A
	Left	0.568	0.000	0.018	0.568	0.586	0.586	N/A	N/A	N/A
Simult Tx	Configuration	LTE Band 2 (PCS) SAR (W/kg)	2.4 GHz WLAN Ant 1 SAR (W/kg)	2.4 GHz WLAN Ant 2 SAR (W/kg)	Σ SAR (W/kg)			SPLSR		
		1	2	3	1+2	1+3	1+2+3	1+2	1+3	2+3
Body SAR	Back	1.002	0.921	0.842	See Note 1	See Note 1	See Note 1	0.01	0.01	0.02
	Top	0.931	0.009	0.005	0.940	0.936	0.945	N/A	N/A	N/A
	Bottom	0.400	0.342	0.174	0.742	0.574	0.916	N/A	N/A	N/A
	Right	0.751	0.079	0.007	0.830	0.758	0.837	N/A	N/A	N/A
	Left	0.445	0.000	0.018	0.445	0.463	0.463	N/A	N/A	N/A
Simult Tx	Configuration	LTE Band 30 SAR (W/kg)	2.4 GHz WLAN Ant 1 SAR (W/kg)	2.4 GHz WLAN Ant 2 SAR (W/kg)	Σ SAR (W/kg)			SPLSR		
		1	2	3	1+2	1+3	1+2+3	1+2	1+3	2+3
Body SAR	Back	1.018	0.921	0.842	See Note 1	See Note 1	See Note 1	0.01	0.01	0.02
	Top	0.595	0.009	0.005	0.604	0.600	0.609	N/A	N/A	N/A
	Bottom	0.400	0.342	0.174	0.742	0.574	0.916	N/A	N/A	N/A
	Right	0.763	0.079	0.007	0.842	0.770	0.849	N/A	N/A	N/A
	Left	0.167	0.000	0.018	0.167	0.185	0.185	N/A	N/A	N/A
Simult Tx	Configuration	LTE Band 7 SAR (W/kg)	2.4 GHz WLAN Ant 1 SAR (W/kg)	2.4 GHz WLAN Ant 2 SAR (W/kg)	Σ SAR (W/kg)			SPLSR		
		1	2	3	1+2	1+3	1+2+3	1+2	1+3	2+3
Body SAR	Back	1.248	0.921	0.842	See Note 1	See Note 1	See Note 1	0.01	0.01	0.02
	Top	0.600	0.009	0.005	0.609	0.605	0.614	N/A	N/A	N/A
	Bottom	0.400	0.342	0.174	0.742	0.574	0.916	N/A	N/A	N/A
	Right	0.304	0.079	0.007	0.383	0.311	0.390	N/A	N/A	N/A
	Left	0.318	0.000	0.018	0.318	0.336	0.336	N/A	N/A	N/A





FCC ID: A3LSMT837A		SAR EVALUATION REPORT		Approved by: Quality Manager
Document S/N: 1M1806180124-01.A3L	Test Dates: 06/20/18 - 07/05/18	DUT Type: Portable Tablet	Page 78 of 100	

Table 11-2
Simultaneous Transmission Scenario with 5 GHz WLAN

Simult Tx	Configuration	UMTS 850 SAR (W/kg)	5 GHz WLAN Ant 1 SAR (W/kg)	5 GHz WLAN Ant 2 SAR (W/kg)	Σ SAR (W/kg)			SPLSR		
		1	2	3	1+2	1+3	1+2+3	1+2	1+3	2+3
Body SAR	Back	0.892	1.166	0.508	See Note 1	1.400	See Note 1	0.01	0.01	0.02
	Top	1.217	0.000	0.007	1.217	1.224	1.224	N/A	N/A	N/A
	Bottom	0.400	0.552	0.557	0.952	0.957	1.509	N/A	N/A	N/A
	Right	0.212	0.076	0.000	0.288	0.212	0.288	N/A	N/A	N/A
	Left	0.140	0.400	0.114	0.540	0.254	0.654	N/A	N/A	N/A
Simult Tx	Configuration	UMTS 1750 SAR (W/kg)	5 GHz WLAN Ant 1 SAR (W/kg)	5 GHz WLAN Ant 2 SAR (W/kg)	Σ SAR (W/kg)			SPLSR		
		1	2	3	1+2	1+3	1+2+3	1+2	1+3	2+3
Body SAR	Back	1.189	1.166	0.508	See Note 1	See Note 1	See Note 1	0.02	0.01	0.02
	Top	1.007	0.000	0.007	1.007	1.014	1.014	N/A	N/A	N/A
	Bottom	0.400	0.552	0.557	0.952	0.957	1.509	N/A	N/A	N/A
	Right	1.024	0.076	0.000	1.100	1.024	1.100	N/A	N/A	N/A
	Left	0.407	0.400	0.114	0.807	0.521	0.921	N/A	N/A	N/A
Simult Tx	Configuration	UMTS 1900 SAR (W/kg)	5 GHz WLAN Ant 1 SAR (W/kg)	5 GHz WLAN Ant 2 SAR (W/kg)	Σ SAR (W/kg)			SPLSR		
		1	2	3	1+2	1+3	1+2+3	1+2	1+3	2+3
Body SAR	Back	1.322	1.166	0.508	See Note 1	See Note 1	See Note 1	0.02	0.01	0.02
	Top	1.100	0.000	0.007	1.100	1.107	1.107	N/A	N/A	N/A
	Bottom	0.400	0.552	0.557	0.952	0.957	1.509	N/A	N/A	N/A
	Right	1.264	0.076	0.000	1.340	1.264	1.340	N/A	N/A	N/A
	Left	0.422	0.400	0.114	0.822	0.536	0.936	N/A	N/A	N/A
Simult Tx	Configuration	LTE Band 12 SAR (W/kg)	5 GHz WLAN Ant 1 SAR (W/kg)	5 GHz WLAN Ant 2 SAR (W/kg)	Σ SAR (W/kg)			SPLSR		
		1	2	3	1+2	1+3	1+2+3	1+2	1+3	2+3
Body SAR	Back	0.473	1.166	0.508	See Note 1	0.981	See Note 1	0.01	0.00	0.02
	Top	0.630	0.000	0.007	0.630	0.637	0.637	N/A	N/A	N/A
	Bottom	0.400	0.552	0.557	0.952	0.957	1.509	N/A	N/A	N/A
	Right	0.187	0.076	0.000	0.263	0.187	0.263	N/A	N/A	N/A
	Left	0.132	0.400	0.114	0.532	0.246	0.646	N/A	N/A	N/A
Simult Tx	Configuration	LTE Band 14 SAR (W/kg)	5 GHz WLAN Ant 1 SAR (W/kg)	5 GHz WLAN Ant 2 SAR (W/kg)	Σ SAR (W/kg)			SPLSR		
		1	2	3	1+2	1+3	1+2+3	1+2	1+3	2+3
Body SAR	Back	0.907	1.166	0.508	See Note 1	1.415	See Note 1	0.01	0.01	0.02
	Top	0.993	0.000	0.007	0.993	1.000	1.000	N/A	N/A	N/A
	Bottom	0.400	0.552	0.557	0.952	0.957	1.509	N/A	N/A	N/A
	Right	0.242	0.076	0.000	0.318	0.242	0.318	N/A	N/A	N/A
	Left	0.131	0.400	0.114	0.531	0.245	0.645	N/A	N/A	N/A

FCC ID: A3LSMT837A		SAR EVALUATION REPORT		Approved by: Quality Manager
Document S/N: 1M1806180124-01.A3L	Test Dates: 06/20/18 - 07/05/18	DUT Type: Portable Tablet	Page 79 of 100	

Simult Tx	Configuration	LTE Band 5 (Cell) SAR (W/kg)	5 GHz WLAN Ant 1 SAR (W/kg)	5 GHz WLAN Ant 2 SAR (W/kg)	Σ SAR (W/kg)			SPLSR		
		1	2	3	1+2	1+3	1+2+3	1+2	1+3	2+3
Body SAR	Back	0.854	1.166	0.508	See Note 1	1.362	See Note 1	0.01	0.01	0.02
	Top	1.124	0.000	0.007	1.124	1.131	1.131	N/A	N/A	N/A
	Bottom	0.400	0.552	0.557	0.952	0.957	1.509	N/A	N/A	N/A
	Right	0.204	0.076	0.000	0.280	0.204	0.280	N/A	N/A	N/A
	Left	0.123	0.400	0.114	0.523	0.237	0.637	N/A	N/A	N/A
Simult Tx	Configuration	LTE Band 66 (AWS) SAR (W/kg)	5 GHz WLAN Ant 1 SAR (W/kg)	5 GHz WLAN Ant 2 SAR (W/kg)	Σ SAR (W/kg)			SPLSR		
		1	2	3	1+2	1+3	1+2+3	1+2	1+3	2+3
Body SAR	Back	1.046	1.166	0.508	See Note 1	1.554	See Note 1	0.01	0.01	0.02
	Top	0.951	0.000	0.007	0.951	0.958	0.958	N/A	N/A	N/A
	Bottom	0.400	0.552	0.557	0.952	0.957	1.509	N/A	N/A	N/A
	Right	1.309	0.076	0.000	1.385	1.309	1.385	N/A	N/A	N/A
	Left	0.568	0.400	0.114	0.968	0.682	1.082	N/A	N/A	N/A
Simult Tx	Configuration	LTE Band 2 (PCS) SAR (W/kg)	5 GHz WLAN Ant 1 SAR (W/kg)	5 GHz WLAN Ant 2 SAR (W/kg)	Σ SAR (W/kg)			SPLSR		
		1	2	3	1+2	1+3	1+2+3	1+2	1+3	2+3
Body SAR	Back	1.002	1.166	0.508	See Note 1	1.510	See Note 1	0.01	0.01	0.02
	Top	0.931	0.000	0.007	0.931	0.938	0.938	N/A	N/A	N/A
	Bottom	0.400	0.552	0.557	0.952	0.957	1.509	N/A	N/A	N/A
	Right	0.751	0.076	0.000	0.827	0.751	0.827	N/A	N/A	N/A
	Left	0.445	0.400	0.114	0.845	0.559	0.959	N/A	N/A	N/A
Simult Tx	Configuration	LTE Band 30 SAR (W/kg)	5 GHz WLAN Ant 1 SAR (W/kg)	5 GHz WLAN Ant 2 SAR (W/kg)	Σ SAR (W/kg)			SPLSR		
		1	2	3	1+2	1+3	1+2+3	1+2	1+3	2+3
Body SAR	Back	1.018	1.166	0.508	See Note 1	1.526	See Note 1	0.01	0.01	0.02
	Top	0.595	0.000	0.007	0.595	0.602	0.602	N/A	N/A	N/A
	Bottom	0.400	0.552	0.557	0.952	0.957	1.509	N/A	N/A	N/A
	Right	0.763	0.076	0.000	0.839	0.763	0.839	N/A	N/A	N/A
	Left	0.167	0.400	0.114	0.567	0.281	0.681	N/A	N/A	N/A
Simult Tx	Configuration	LTE Band 7 SAR (W/kg)	5 GHz WLAN Ant 1 SAR (W/kg)	5 GHz WLAN Ant 2 SAR (W/kg)	Σ SAR (W/kg)			SPLSR		
		1	2	3	1+2	1+3	1+2+3	1+2	1+3	2+3
Body SAR	Back	1.248	1.166	0.508	See Note 1	See Note 1	See Note 1	0.02	0.01	0.02
	Top	0.600	0.000	0.007	0.600	0.607	0.607	N/A	N/A	N/A
	Bottom	0.400	0.552	0.557	0.952	0.957	1.509	N/A	N/A	N/A
	Right	0.304	0.076	0.000	0.380	0.304	0.380	N/A	N/A	N/A
	Left	0.318	0.400	0.114	0.718	0.432	0.832	N/A	N/A	N/A







FCC ID: A3LSMT837A	 PCTEST ENGINEERING LABORATORY, INC.	SAR EVALUATION REPORT		Approved by: Quality Manager
Document S/N: 1M1806180124-01.A3L	Test Dates: 06/20/18 - 07/05/18	DUT Type: Portable Tablet		Page 80 of 100

Table 11-3
Simultaneous Transmission Scenario with 2.4 GHz WLAN Ant 1 and 5 GHz WLAN Ant 2



Simult Tx	Configuration	UMTS 850 SAR (W/kg)	2.4 GHz WLAN Ant 1 SAR (W/kg)	5 GHz WLAN Ant 2 SAR (W/kg)	Σ SAR (W/kg)	SPLSR		
		1	2	3		1+2+3	1+2	1+3
Body SAR	Back	0.892	0.921	0.508	See Note 1	0.01	0.01	0.02
	Top	1.217	0.009	0.007	1.233	N/A	N/A	N/A
	Bottom	0.400	0.342	0.557	1.299	N/A	N/A	N/A
	Right	0.212	0.079	0.000	0.291	N/A	N/A	N/A
	Left	0.140	0.000	0.114	0.254	N/A	N/A	N/A
Simult Tx	Configuration	UMTS 1750 SAR (W/kg)	2.4 GHz WLAN Ant 1 SAR (W/kg)	5 GHz WLAN Ant 2 SAR (W/kg)	Σ SAR (W/kg)	SPLSR		
		1	2	3		1+2+3	1+2	1+3
Body SAR	Back	1.189	0.921	0.508	See Note 1	0.01	0.01	0.02
	Top	1.007	0.009	0.007	1.023	N/A	N/A	N/A
	Bottom	0.400	0.342	0.557	1.299	N/A	N/A	N/A
	Right	1.024	0.079	0.000	1.103	N/A	N/A	N/A
	Left	0.407	0.000	0.114	0.521	N/A	N/A	N/A
Simult Tx	Configuration	UMTS 1900 SAR (W/kg)	2.4 GHz WLAN Ant 1 SAR (W/kg)	5 GHz WLAN Ant 2 SAR (W/kg)	Σ SAR (W/kg)	SPLSR		
		1	2	3		1+2+3	1+2	1+3
Body SAR	Back	1.322	0.921	0.508	See Note 1	0.01	0.01	0.02
	Top	1.100	0.009	0.007	1.116	N/A	N/A	N/A
	Bottom	0.400	0.342	0.557	1.299	N/A	N/A	N/A
	Right	1.264	0.079	0.000	1.343	N/A	N/A	N/A
	Left	0.422	0.000	0.114	0.536	N/A	N/A	N/A
Simult Tx	Configuration	LTE Band 12 SAR (W/kg)	2.4 GHz WLAN Ant 1 SAR (W/kg)	5 GHz WLAN Ant 2 SAR (W/kg)	Σ SAR (W/kg)	SPLSR		
		1	2	3		1+2+3	1+2	1+3
Body SAR	Back	0.473	0.921	0.508	See Note 1	0.01	0.00	0.02
	Top	0.630	0.009	0.007	0.646	N/A	N/A	N/A
	Bottom	0.400	0.342	0.557	1.299	N/A	N/A	N/A
	Right	0.187	0.079	0.000	0.266	N/A	N/A	N/A
	Left	0.132	0.000	0.114	0.246	N/A	N/A	N/A

FCC ID: A3LSMT837A		SAR EVALUATION REPORT		Approved by: Quality Manager
Document S/N: 1M1806180124-01.A3L	Test Dates: 06/20/18 - 07/05/18	DUT Type: Portable Tablet		Page 81 of 100

Simult Tx	Configuration	LTE Band 14 SAR (W/kg)	2.4 GHz WLAN Ant 1 SAR (W/kg)	5 GHz WLAN Ant 2 SAR (W/kg)	Σ SAR (W/kg)	SPLSR		
		1	2	3		1+2+3	1+2	1+3
Body SAR	Back	0.907	0.921	0.508	See Note 1	0.01	0.01	0.02
	Top	0.993	0.009	0.007	1.009	N/A	N/A	N/A
	Bottom	0.400	0.342	0.557	1.299	N/A	N/A	N/A
	Right	0.242	0.079	0.000	0.321	N/A	N/A	N/A
	Left	0.131	0.000	0.114	0.245	N/A	N/A	N/A
Simult Tx	Configuration	LTE Band 5 (Cell) SAR (W/kg)	2.4 GHz WLAN Ant 1 SAR (W/kg)	5 GHz WLAN Ant 2 SAR (W/kg)	Σ SAR (W/kg)	SPLSR		
		1	2	3		1+2+3	1+2	1+3
Body SAR	Back	0.854	0.921	0.508	See Note 1	0.01	0.01	0.02
	Top	1.124	0.009	0.007	1.140	N/A	N/A	N/A
	Bottom	0.400	0.342	0.557	1.299	N/A	N/A	N/A
	Right	0.204	0.079	0.000	0.283	N/A	N/A	N/A
	Left	0.123	0.000	0.114	0.237	N/A	N/A	N/A
Simult Tx	Configuration	LTE Band 66 (AWS) SAR (W/kg)	2.4 GHz WLAN Ant 1 SAR (W/kg)	5 GHz WLAN Ant 2 SAR (W/kg)	Σ SAR (W/kg)	SPLSR		
		1	2	3		1+2+3	1+2	1+3
Body SAR	Back	1.046	0.921	0.508	See Note 1	0.01	0.01	0.02
	Top	0.951	0.009	0.007	0.967	N/A	N/A	N/A
	Bottom	0.400	0.342	0.557	1.299	N/A	N/A	N/A
	Right	1.309	0.079	0.000	1.388	N/A	N/A	N/A
	Left	0.568	0.000	0.114	0.682	N/A	N/A	N/A
Simult Tx	Configuration	LTE Band 2 (PCS) SAR (W/kg)	2.4 GHz WLAN Ant 1 SAR (W/kg)	5 GHz WLAN Ant 2 SAR (W/kg)	Σ SAR (W/kg)	SPLSR		
		1	2	3		1+2+3	1+2	1+3
Body SAR	Back	1.002	0.921	0.508	See Note 1	0.01	0.01	0.02
	Top	0.931	0.009	0.007	0.947	N/A	N/A	N/A
	Bottom	0.400	0.342	0.557	1.299	N/A	N/A	N/A
	Right	0.751	0.079	0.000	0.830	N/A	N/A	N/A
	Left	0.445	0.000	0.114	0.559	N/A	N/A	N/A

FCC ID: A3LSMT837A	 PCTEST ENGINEERING LABORATORY, INC.	SAR EVALUATION REPORT		Approved by: Quality Manager
Document S/N: 1M1806180124-01.A3L	Test Dates: 06/20/18 - 07/05/18	DUT Type: Portable Tablet		Page 82 of 100

Simult Tx	Configuration	LTE Band 30 SAR (W/kg)	2.4 GHz WLAN Ant 1 SAR (W/kg)	5 GHz WLAN Ant 2 SAR (W/kg)	Σ SAR (W/kg)	SPLSR		
		1	2	3		1+2+3	1+2	1+3
Body SAR	Back	1.018	0.921	0.508	See Note 1	0.01	0.01	0.02
	Top	0.595	0.009	0.007	0.611	N/A	N/A	N/A
	Bottom	0.400	0.342	0.557	1.299	N/A	N/A	N/A
	Right	0.763	0.079	0.000	0.842	N/A	N/A	N/A
	Left	0.167	0.000	0.114	0.281	N/A	N/A	N/A
Simult Tx	Configuration	LTE Band 7 SAR (W/kg)	2.4 GHz WLAN Ant 1 SAR (W/kg)	5 GHz WLAN Ant 2 SAR (W/kg)	Σ SAR (W/kg)	SPLSR		
		1	2	3		1+2+3	1+2	1+3
Body SAR	Back	1.248	0.921	0.508	See Note 1	0.01	0.01	0.02
	Top	0.600	0.009	0.007	0.616	N/A	N/A	N/A
	Bottom	0.400	0.342	0.557	1.299	N/A	N/A	N/A
	Right	0.304	0.079	0.000	0.383	N/A	N/A	N/A
	Left	0.318	0.000	0.114	0.432	N/A	N/A	N/A

FCC ID: A3LSMT837A	 PCTEST ENGINEERING LABORATORY, INC.	SAR EVALUATION REPORT		Approved by: Quality Manager
Document S/N: 1M1806180124-01.A3L	Test Dates: 06/20/18 - 07/05/18	DUT Type: Portable Tablet		Page 83 of 100



**Table 11-4
Simultaneous Transmission Scenario with Bluetooth**

Simult Tx	Configuration	UMTS 850 SAR (W/kg)	Bluetooth SAR (W/kg)	Σ SAR (W/kg)
		1	2	1+2
Body SAR	Back	0.892	0.343	1.235
	Top	1.217	0.000	1.217
	Bottom	0.400	0.154	0.554
	Right	0.212	0.041	0.253
	Left	0.140	0.400	0.540



Simult Tx	Configuration	UMTS 1750 SAR (W/kg)	Bluetooth SAR (W/kg)	Σ SAR (W/kg)
		1	2	1+2
Body SAR	Back	1.189	0.343	1.532
	Top	1.007	0.000	1.007
	Bottom	0.400	0.154	0.554
	Right	1.024	0.041	1.065
	Left	0.407	0.400	0.807

Simult Tx	Configuration	UMTS 1900 SAR (W/kg)	Bluetooth SAR (W/kg)	Σ SAR (W/kg)	SPLSR
		1	2	1+2	1+2
Body SAR	Back	1.322	0.343	See Note 1	0.01
	Top	1.100	0.000	1.100	N/A
	Bottom	0.400	0.154	0.554	N/A
	Right	1.264	0.041	1.305	N/A
	Left	0.422	0.400	0.822	N/A

Simult Tx	Configuration	LTE Band 12 SAR (W/kg)	Bluetooth SAR (W/kg)	Σ SAR (W/kg)
		1	2	1+2
Body SAR	Back	0.473	0.343	0.816
	Top	0.630	0.000	0.630
	Bottom	0.400	0.154	0.554
	Right	0.187	0.041	0.228
	Left	0.132	0.400	0.532

FCC ID: A3LSMT837A		SAR EVALUATION REPORT		Approved by: Quality Manager
Document S/N: 1M1806180124-01.A3L	Test Dates: 06/20/18 - 07/05/18	DUT Type: Portable Tablet		Page 84 of 100



Simult Tx	Configuration	LTE Band 14 SAR (W/kg)	Bluetooth SAR (W/kg)	Σ SAR (W/kg)
		1	2	1+2
Body SAR	Back	0.907	0.343	1.250
	Top	0.993	0.000	0.993
	Bottom	0.400	0.154	0.554
	Right	0.242	0.041	0.283
	Left	0.131	0.400	0.531
Simult Tx	Configuration	LTE Band 5 (Cell) SAR (W/kg)	Bluetooth SAR (W/kg)	Σ SAR (W/kg)
		1	2	1+2
Body SAR	Back	0.854	0.343	1.197
	Top	1.124	0.000	1.124
	Bottom	0.400	0.154	0.554
	Right	0.204	0.041	0.245
	Left	0.123	0.400	0.523
Simult Tx	Configuration	LTE Band 66 (AWS) SAR (W/kg)	Bluetooth SAR (W/kg)	Σ SAR (W/kg)
		1	2	1+2
Body SAR	Back	1.046	0.343	1.389
	Top	0.951	0.000	0.951
	Bottom	0.400	0.154	0.554
	Right	1.309	0.041	1.350
	Left	0.568	0.400	0.968
Simult Tx	Configuration	LTE Band 2 (PCS) SAR (W/kg)	Bluetooth SAR (W/kg)	Σ SAR (W/kg)
		1	2	1+2
Body SAR	Back	1.002	0.343	1.345
	Top	0.931	0.000	0.931
	Bottom	0.400	0.154	0.554
	Right	0.751	0.041	0.792
	Left	0.445	0.400	0.845

FCC ID: A3LSMT837A	 PCTEST ENGINEERING LABORATORY, INC.	SAR EVALUATION REPORT		Approved by: Quality Manager
Document S/N: 1M1806180124-01.A3L	Test Dates: 06/20/18 - 07/05/18	DUT Type: Portable Tablet	Page 85 of 100	

Simult Tx	Configuration	LTE Band 30 SAR (W/kg)	Bluetooth SAR (W/kg)	Σ SAR (W/kg)
		1	2	1+2
Body SAR	Back	1.018	0.343	1.361
	Top	0.595	0.000	0.595
	Bottom	0.400	0.154	0.554
	Right	0.763	0.041	0.804
	Left	0.167	0.400	0.567
Simult Tx	Configuration	LTE Band 7 SAR (W/kg)	Bluetooth SAR (W/kg)	Σ SAR (W/kg)
		1	2	1+2
Body SAR	Back	1.248	0.343	1.591
	Top	0.600	0.000	0.600
	Bottom	0.400	0.154	0.554
	Right	0.304	0.041	0.345
	Left	0.318	0.400	0.718

Notes:

1. No evaluation was performed to determine the aggregate 1g SAR for these configurations as the SPLS ratio between the antenna pairs was not greater than 0.04 per FCC KDB 447498 D01v06. See Section 11.4 for detailed SPLS ratio analysis.
2. For SAR summation, the highest reported SAR across all test distances was used as the most conservative evaluation for simultaneous transmission analysis for each device edge.
3. When the antenna separation distance was > 50 mm, an estimated SAR of 0.4 W/kg was used to determine the simultaneous transmission SAR exclusion for test positions excluded per FCC KDB Publication 447498 D01v06.

FCC ID: A3LSMT837A		SAR EVALUATION REPORT		Approved by: Quality Manager
Document S/N: 1M1806180124-01.A3L	Test Dates: 06/20/18 - 07/05/18	DUT Type: Portable Tablet	Page 86 of 100	

11.4 Body SAR Simultaneous Transmission Analysis

Per FCC KDB Publication 447498 D01v06, when the sum of the standalone transmitters is more than 1.6 W/kg for 1g, the SAR sum to peak locations can be analyzed to determine SAR distribution overlaps. When the SAR peak to location ratio (shown below) for each pair of antennas is ≤ 0.04 for 1g, simultaneous SAR evaluation is not required. The distance between the transmitters was calculated using the following formula.



$$\text{Distance}_{T_{X1} - T_{X2}} = R_i = \sqrt{(x_1 - x_2)^2 + (y_1 - y_2)^2} \text{ (Body)}$$

$$\text{SPLS Ratio} = \frac{(SAR_1 + SAR_2)^{1.5}}{R_i}$$

11.4.1 Back Side SPLSR Evaluation and Analysis



**Table 11-5
Peak SAR Locations for Body Back Side**

Mode/Band	x (mm)	y (mm)
2.4 GHz WLAN Ant 1	-66.80	-109.60
2.4 GHz WLAN Ant 2	29.20	-113.20
5 GHz WLAN Ant 1	-65.00	-116.00
5 GHz WLAN Ant 2	36.00	-119.00
UMTS 850	-21.50	124.00
UMTS 1750	-38.00	116.50
UMTS 1900	-38.00	115.00
LTE Band 12	-23.00	124.00
LTE Band 14	-21.50	124.00
LTE Band 5 (Cell)	-20.50	127.00
LTE Band 66 (AWS)	-38.00	116.50
LTE Band 2 (PCS)	-38.00	115.00
LTE Band 30	-44.20	119.20
LTE Band 7	-46.60	119.20
Bluetooth	-60.80	-114.40

FCC ID: A3LSMT837A		SAR EVALUATION REPORT		Approved by: Quality Manager
Document S/N: 1M1806180124-01.A3L	Test Dates: 06/20/18 - 07/05/18	DUT Type: Portable Tablet	Page 87 of 100	



**Table 11-6
Back Side SAR to Peak Location Separation Ratio Calculations**

Antenna Pair		Standalone SAR (W/kg)		Standalone SAR Sum (W/kg)	Peak SAR Separation Distance (mm)	SPLS Ratio	Plot Number
Ant "a"	Ant "b"	a	b	a+b	D _{a-b}	$(a+b)^{1.5}/D_{a-b}$	
2.4 GHz WLAN Ant 1	2.4 GHz WLAN Ant 2	0.921	0.842	1.763	96.07	0.02	1
5 GHz WLAN Ant 1	5 GHz WLAN Ant 2	1.166	0.508	1.674	101.04	0.02	2
2.4 GHz WLAN Ant 1	5 GHz WLAN Ant 2	0.921	0.508	1.429	103.23	0.02	3
2.4 GHz WLAN Ant 1	UMTS 850	0.921	0.892	1.813	237.95	0.01	4, 6
2.4 GHz WLAN Ant 2	UMTS 850	0.842	0.892	1.734	242.56	0.01	4
5 GHz WLAN Ant 1	UMTS 850	1.166	0.892	2.058	243.91	0.01	5
5 GHz WLAN Ant 2	UMTS 850	0.508	0.892	1.400	249.71	0.01	5, 6
2.4 GHz WLAN Ant 1	UMTS 1750	0.921	1.189	2.110	227.93	0.01	7, 9
2.4 GHz WLAN Ant 2	UMTS 1750	0.842	1.189	2.031	239.33	0.01	7
5 GHz WLAN Ant 1	UMTS 1750	1.166	1.189	2.355	234.06	0.02	8
5 GHz WLAN Ant 2	UMTS 1750	0.508	1.189	1.697	246.85	0.01	8, 9
2.4 GHz WLAN Ant 1	UMTS 1900	0.921	1.322	2.243	226.44	0.01	10, 12
2.4 GHz WLAN Ant 2	UMTS 1900	0.842	1.322	2.164	237.89	0.01	10
5 GHz WLAN Ant 1	UMTS 1900	1.166	1.322	2.488	232.57	0.02	11
5 GHz WLAN Ant 2	UMTS 1900	0.508	1.322	1.830	245.42	0.01	11, 12
2.4 GHz WLAN Ant 1	LTE Band 12	0.921	0.473	1.394	237.67	0.01	13, 15
2.4 GHz WLAN Ant 2	LTE Band 12	0.842	0.473	1.315	242.88	0.01	13
5 GHz WLAN Ant 1	LTE Band 12	1.166	0.473	1.639	243.65	0.01	14
5 GHz WLAN Ant 2	LTE Band 12	0.508	0.473	0.981	250.06	0.00	14, 15
2.4 GHz WLAN Ant 1	LTE Band 14	0.921	0.907	1.828	237.95	0.01	16, 18
2.4 GHz WLAN Ant 2	LTE Band 14	0.842	0.907	1.749	242.56	0.01	16
5 GHz WLAN Ant 1	LTE Band 14	1.166	0.907	2.073	243.91	0.01	17
5 GHz WLAN Ant 2	LTE Band 14	0.508	0.907	1.415	249.71	0.01	17, 18
2.4 GHz WLAN Ant 1	LTE Band 5 (Cell)	0.921	0.854	1.775	241.09	0.01	19, 21
2.4 GHz WLAN Ant 2	LTE Band 5 (Cell)	0.842	0.854	1.696	245.29	0.01	19
5 GHz WLAN Ant 1	LTE Band 5 (Cell)	1.166	0.854	2.020	247.04	0.01	20
5 GHz WLAN Ant 2	LTE Band 5 (Cell)	0.508	0.854	1.362	252.40	0.01	20, 21
2.4 GHz WLAN Ant 1	LTE Band 66 (AWS)	0.921	1.046	1.967	227.93	0.01	22, 24
2.4 GHz WLAN Ant 2	LTE Band 66 (AWS)	0.842	1.046	1.888	239.33	0.01	22
5 GHz WLAN Ant 1	LTE Band 66 (AWS)	1.166	1.046	2.212	234.06	0.01	23
5 GHz WLAN Ant 2	LTE Band 66 (AWS)	0.508	1.046	1.554	246.85	0.01	23, 24
2.4 GHz WLAN Ant 1	LTE Band 2 (PCS)	0.921	1.002	1.923	226.44	0.01	25, 27
2.4 GHz WLAN Ant 2	LTE Band 2 (PCS)	0.842	1.002	1.844	237.89	0.01	25
5 GHz WLAN Ant 1	LTE Band 2 (PCS)	1.166	1.002	2.168	232.57	0.01	26
5 GHz WLAN Ant 2	LTE Band 2 (PCS)	0.508	1.002	1.51	245.42	0.01	26, 27
2.4 GHz WLAN Ant 1	LTE Band 30	0.921	1.018	1.939	229.91	0.01	28, 30
2.4 GHz WLAN Ant 2	LTE Band 30	0.842	1.018	1.86	243.72	0.01	28
5 GHz WLAN Ant 1	LTE Band 30	1.166	1.018	2.184	236.12	0.01	29
5 GHz WLAN Ant 2	LTE Band 30	0.508	1.018	1.526	251.34	0.01	29, 30
2.4 GHz WLAN Ant 1	LTE Band 7	0.921	1.248	2.169	229.69	0.01	31, 33
2.4 GHz WLAN Ant 2	LTE Band 7	0.842	1.248	2.09	244.45	0.01	31
5 GHz WLAN Ant 1	LTE Band 7	1.166	1.248	2.414	235.92	0.02	32
5 GHz WLAN Ant 2	LTE Band 7	0.508	1.248	1.756	252.12	0.01	32, 33
UMTS 1900	Bluetooth	1.322	0.343	1.665	230.53	0.01	34

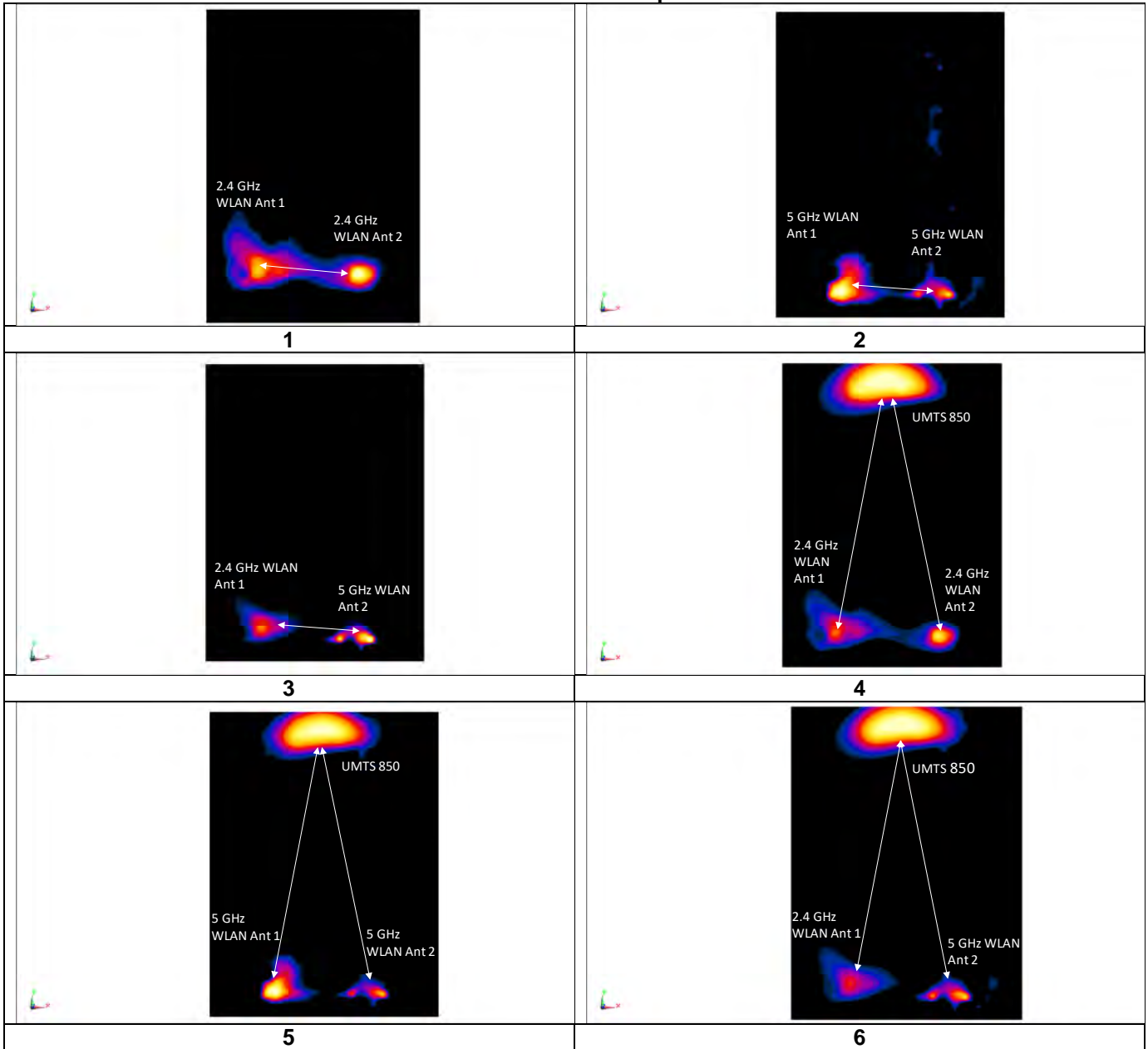

FCC ID: A3LSMT837A		SAR EVALUATION REPORT		Approved by: Quality Manager
Document S/N: 1M1806180124-01.A3L	Test Dates: 06/20/18 - 07/05/18	DUT Type: Portable Tablet		Page 88 of 100

**Table 11-7
Back Side SAR to Peak Location Separation Ratio Plots**



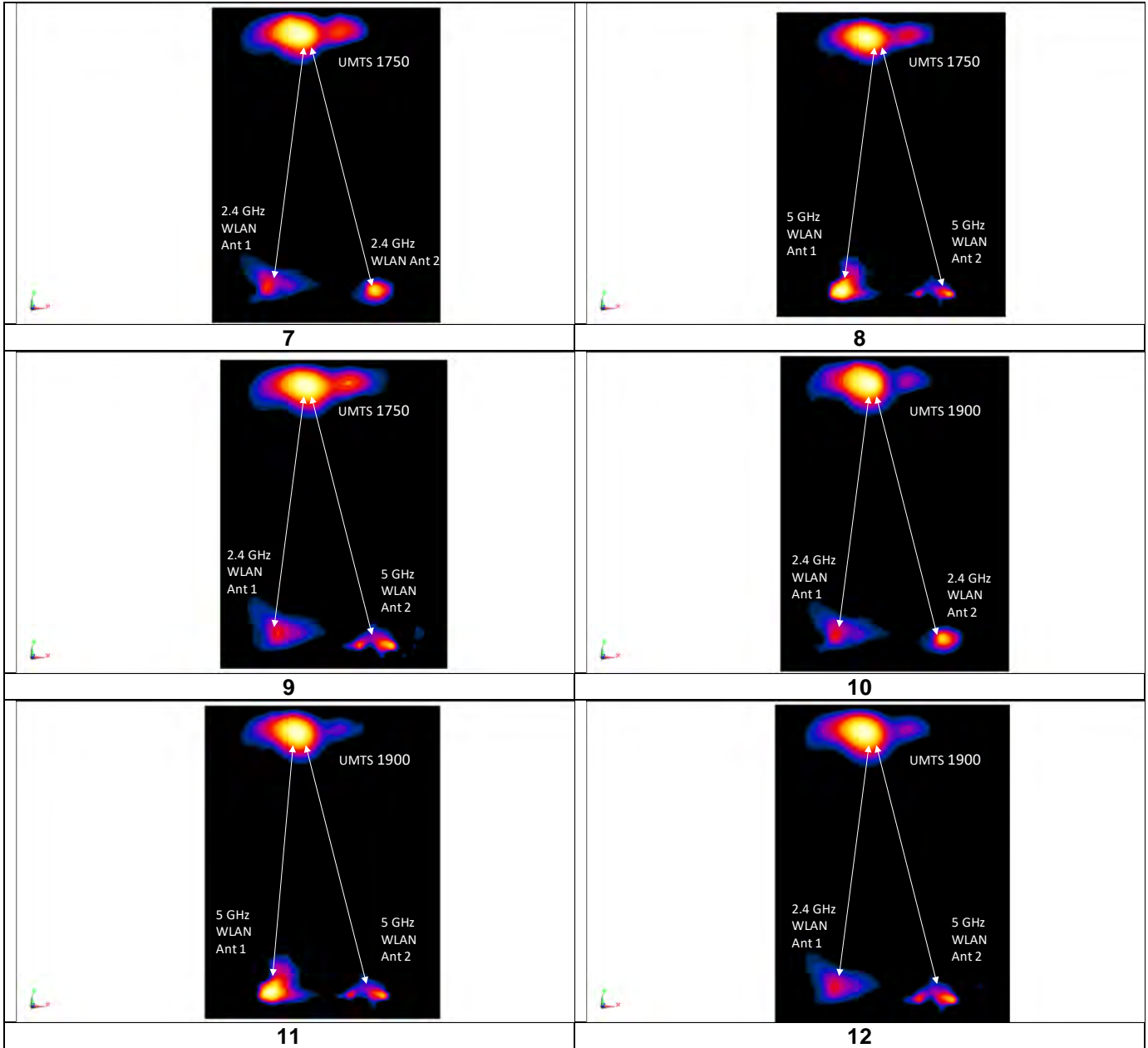

FCC ID: A3LSMT837A		SAR EVALUATION REPORT		Approved by: Quality Manager
Document S/N: 1M1806180124-01.A3L	Test Dates: 06/20/18 - 07/05/18	DUT Type: Portable Tablet		Page 89 of 100



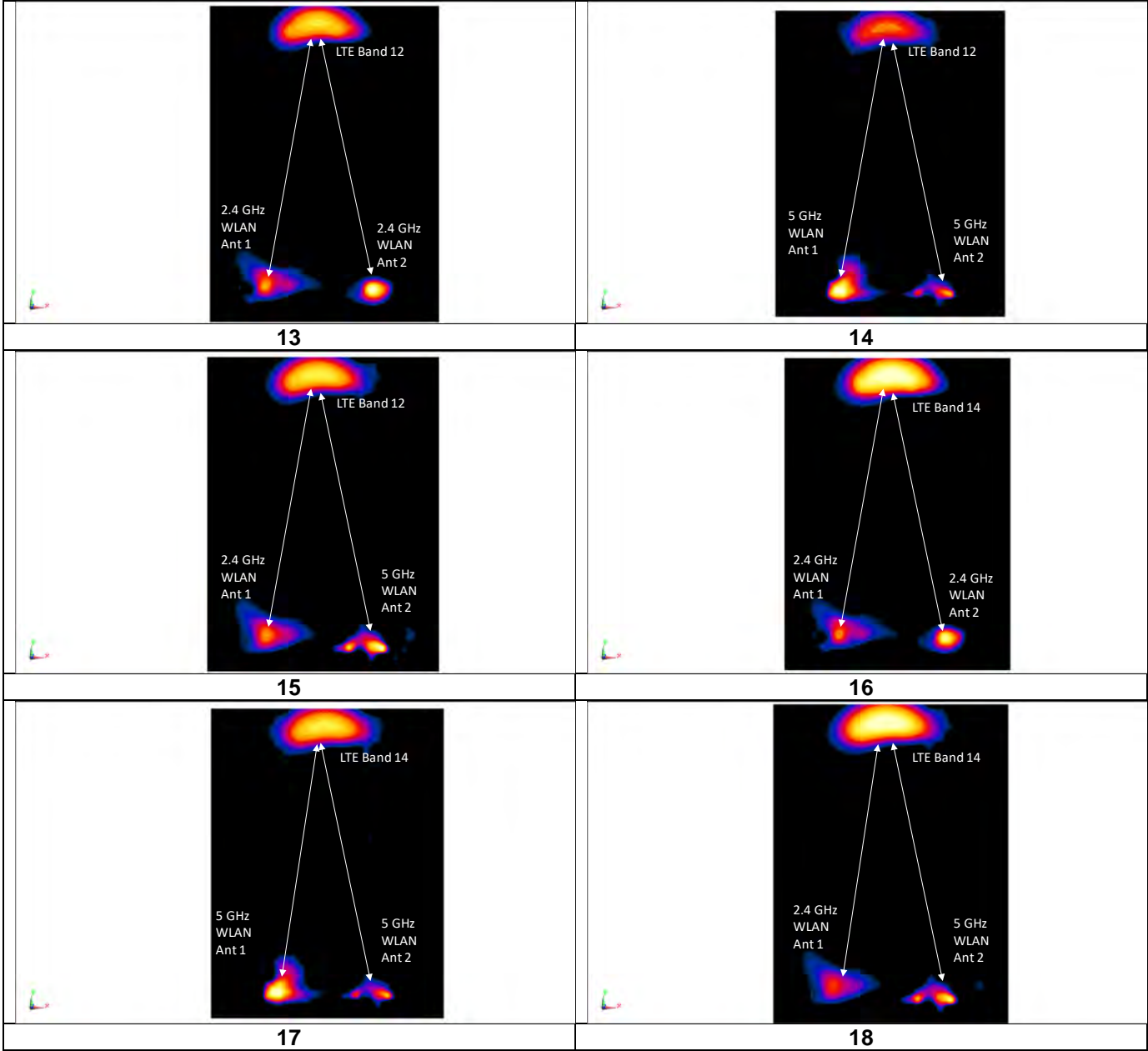

FCC ID: A3LSMT837A		SAR EVALUATION REPORT		Approved by: Quality Manager
Document S/N: 1M1806180124-01.A3L	Test Dates: 06/20/18 - 07/05/18	DUT Type: Portable Tablet		Page 90 of 100



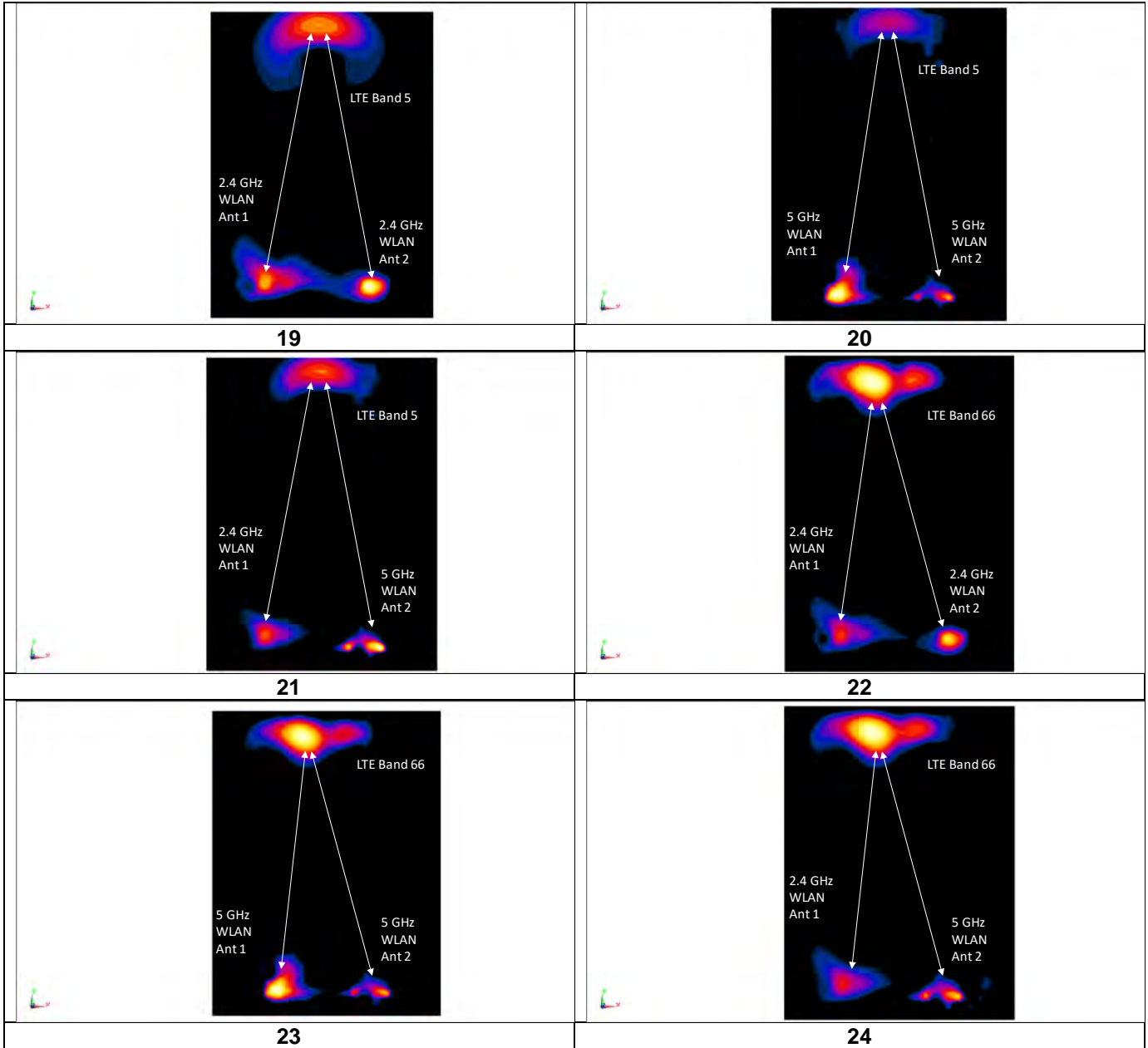

FCC ID: A3LSMT837A		SAR EVALUATION REPORT		Approved by: Quality Manager
Document S/N: 1M1806180124-01.A3L	Test Dates: 06/20/18 - 07/05/18	DUT Type: Portable Tablet		Page 91 of 100

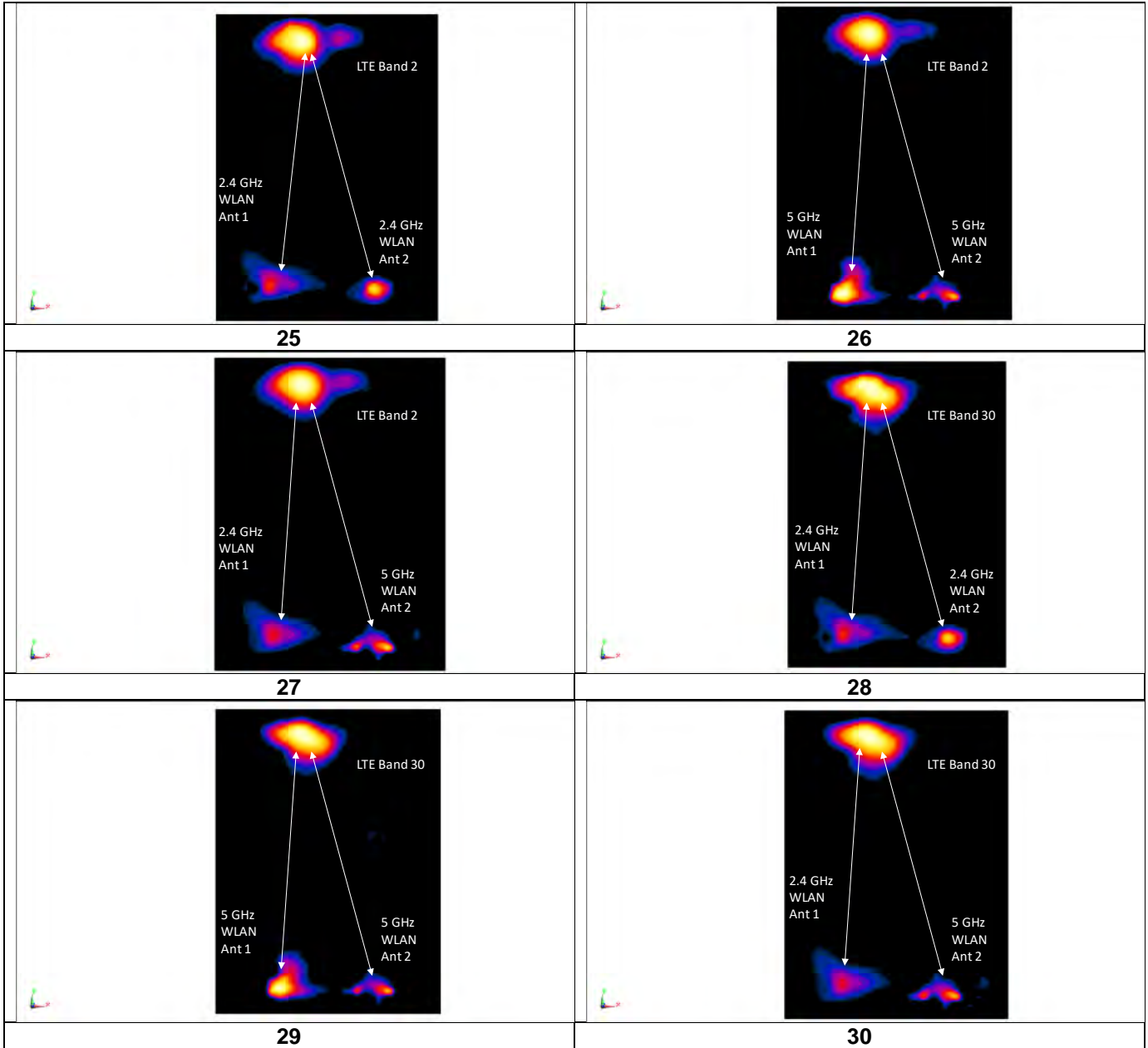

FCC ID: A3LSMT837A		SAR EVALUATION REPORT		Approved by: Quality Manager
Document S/N: 1M1806180124-01.A3L	Test Dates: 06/20/18 - 07/05/18	DUT Type: Portable Tablet	Page 92 of 100	



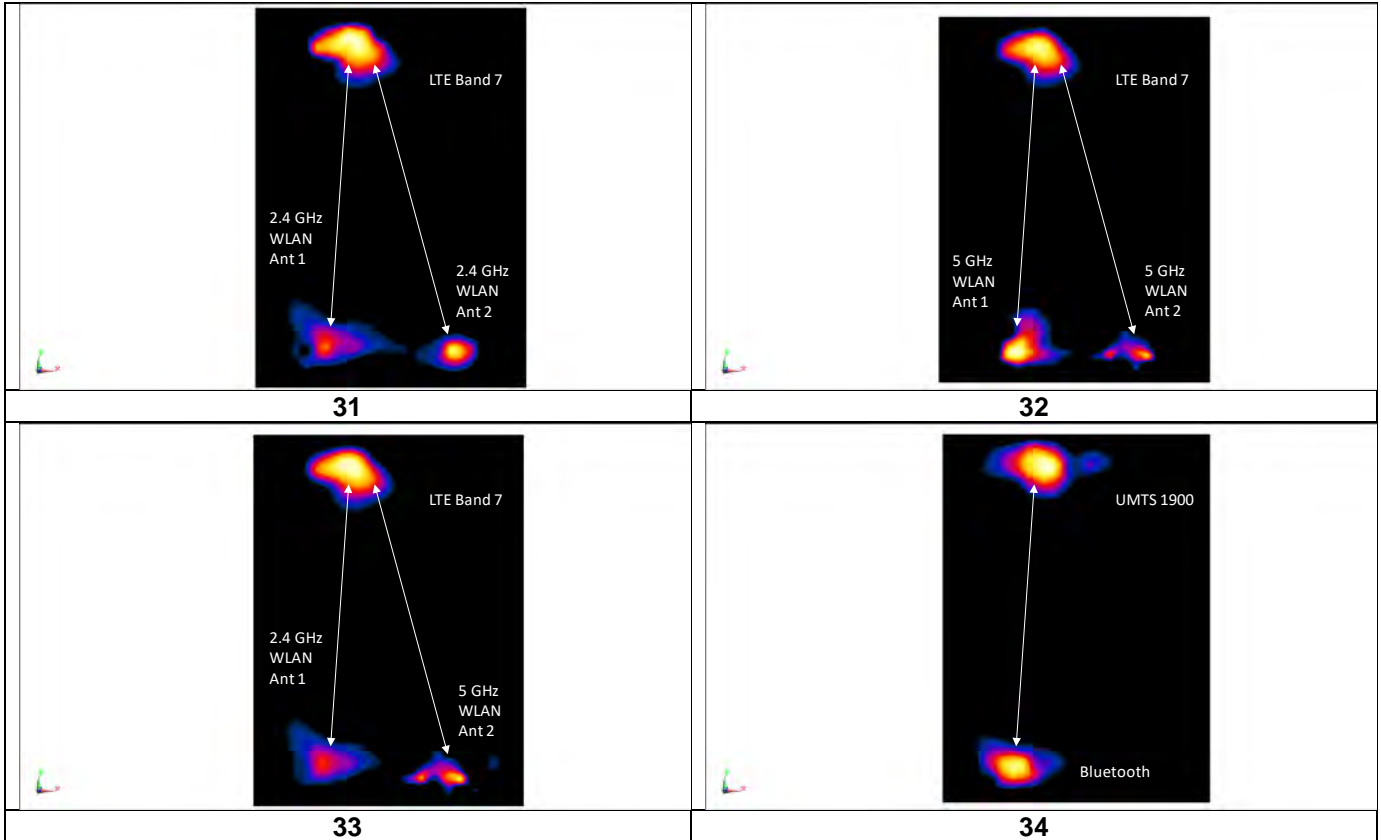

FCC ID: A3LSMT837A	 PCTEST ENGINEERING LABORATORY, INC.	SAR EVALUATION REPORT	 SAMSUNG	Approved by: Quality Manager
Document S/N: 1M1806180124-01.A3L	Test Dates: 06/20/18 - 07/05/18	DUT Type: Portable Tablet		Page 93 of 100



11.5 Simultaneous Transmission Conclusion

The above numerical summed SAR results and SPLSR analysis are sufficient to determine that simultaneous transmission cases will not exceed the SAR limit and therefore no measured volumetric simultaneous SAR summation is required per FCC KDB Publication 447498 D01v06 and IEEE 1528- 2013 Section 6.3.4.1.

FCC ID: A3LSMT837A		SAR EVALUATION REPORT		Approved by: Quality Manager
Document S/N: 1M1806180124-01.A3L	Test Dates: 06/20/18 - 07/05/18	DUT Type: Portable Tablet		Page 94 of 100

12 SAR MEASUREMENT VARIABILITY

12.1 Measurement Variability

Per FCC KDB Publication 865664 D01v01r04, SAR measurement variability was assessed for each frequency band, which was determined by the SAR probe calibration point and tissue-equivalent medium used for the device measurements. When both head and body tissue-equivalent media were required for SAR measurements in a frequency band, the variability measurement procedures were applied to the tissue medium with the highest measured SAR, using the highest measured SAR configuration for that tissue-equivalent medium. These additional measurements were repeated after the completion of all measurements requiring the same head or body tissue-equivalent medium in a frequency band. The test device was returned to ambient conditions (normal room temperature) with the battery fully charged before it was re-mounted on the device holder for the repeated measurement(s) to minimize any unexpected variations in the repeated results.

SAR Measurement Variability was assessed using the following procedures for each frequency band:



- 1) When the original highest measured SAR is ≥ 0.80 W/kg, the measurement was repeated once.
- 2) A second repeated measurement was performed only if the ratio of largest to smallest SAR for the original and first repeated measurements was > 1.20 or when the original or repeated measurement was ≥ 1.45 W/kg (~ 10% from the 1g SAR limit).
- 3) A third repeated measurement was performed only if the original, first or second repeated measurement was ≥ 1.5 W/kg and the ratio of largest to smallest SAR for the original, first and second repeated measurements is > 1.20 .
- 4) Repeated measurements are not required when the original highest measured SAR is < 0.80 W/kg

**Table 12-1
Body SAR Measurement Variability Results**

BODY VARIABILITY RESULTS														
Band	FREQUENCY		Mode	Service	Data Rate (Mbps)	Side	Spacing	Measured SAR (1g)	1st Repeated SAR (1g)	Ratio	2nd Repeated SAR (1g)	Ratio	3rd Repeated SAR (1g)	Ratio
	MHz	Ch.						(W/kg)	(W/kg)		(W/kg)		(W/kg)	
835	826.40	4132	UMTS 850	RMC	N/A	top	16 mm	1.050	1.050	1.00	N/A	N/A	N/A	N/A
1750	1770.00	132572	LTE Band 66 (AWS), 20 MHz Bandwidth	QPSK, 1 RB, 0 RB Offset	N/A	right	0 mm	1.120	1.150	1.03	N/A	N/A	N/A	N/A
1900	1907.60	9538	UMTS 1900	RMC	N/A	back	0 mm	1.050	1.100	1.05	N/A	N/A	N/A	N/A
2300	2310.00	27710	LTE Band 30, 10 MHz Bandwidth	QPSK, 50 RB, 0 RB Offset	N/A	back	0 mm	0.902	0.963	1.07	N/A	N/A	N/A	N/A
2450	2510.00	20850	LTE Band 7, 20 MHz Bandwidth	QPSK, 1 RB, 0 RB Offset	N/A	back	0 mm	0.918	0.888	1.03	N/A	N/A	N/A	N/A
2600	2560.00	21350	LTE Band 7, 20 MHz Bandwidth	QPSK, 50 RB, 0 RB Offset	N/A	back	0 mm	0.994	0.975	1.02	N/A	N/A	N/A	N/A
5750	5775.00	155	802.11ac, 80 MHz Bandwidth	OFDM, ANT 1	29.3	back	0 mm	0.859	0.847	1.01	N/A	N/A	N/A	N/A
ANSI / IEEE C95.1 1992 - SAFETY LIMIT							Body							
Spatial Peak							1.6 W/kg (mW/g)							
Uncontrolled Exposure/General Population							averaged over 1 gram							

12.2 Measurement Uncertainty



The measured SAR was < 1.5 W/kg for all frequency bands. Therefore, per KDB Publication 865664 D01v01r04, the extended measurement uncertainty analysis per IEEE 1528-2013 was not required.

FCC ID: A3LSMT837A		SAR EVALUATION REPORT		Approved by: Quality Manager
Document S/N: 1M1806180124-01.A3L	Test Dates: 06/20/18 - 07/05/18	DUT Type: Portable Tablet	Page 95 of 100	

13 EQUIPMENT LIST



Manufacturer	Model	Description	Cal Date	Cal Interval	Cal Due	Serial Number
Agilent	8753ES	S-Parameter Vector Network Analyzer	8/17/2017	Annual	8/17/2018	MY4003841
Agilent	8753ES	S-Parameter Network Analyzer	2/8/2018	Annual	2/8/2019	US39170122
Agilent	E4438C	ESG Vector Signal Generator	3/21/2017	Biennial	3/21/2019	MY45090700
Agilent	E5515C	8960 Series 10 Wireless Communications Test Set	11/15/2017	Annual	11/15/2018	GB42230325
Agilent	E5515C	Wireless Communications Test Set	1/24/2018	Annual	1/24/2019	GB44400860
Agilent	N4010A	Wireless Connectivity Test Set	N/A	N/A	N/A	GB44450273
Agilent	N5182A	MXG Vector Signal Generator	4/18/2018	Annual	4/18/2019	MY47420800
Agilent	N9020A	MXA Signal Analyzer	1/24/2018	Annual	1/24/2019	US46470561
Amplifier Research	15S1G6	Amplifier	CBT	N/A	CBT	433971
Amplifier Research	15S1G6	Amplifier	CBT	N/A	CBT	433972
Anritsu	MA24106A	USB Power Sensor	6/5/2018	Annual	6/5/2019	1244515
Anritsu	MA24106A	USB Power Sensor	6/5/2018	Annual	6/5/2019	1248508
Anritsu	MA2411B	Pulse Power Sensor	3/2/2018	Annual	3/2/2019	1207364
Anritsu	MA2411B	Pulse Power Sensor	3/2/2018	Annual	3/2/2019	1339018
Anritsu	ML2496A	Power Meter	5/21/2018	Annual	5/21/2019	1351001
Anritsu	MT8821C	Radio Communication Analyzer	11/17/2017	Annual	11/17/2018	6201381794
COMTECH	AR85729-5	Solid State Amplifier	CBT	N/A	CBT	M155A00-009
COMTECH	AR85729-5/5759B	Solid State Amplifier	CBT	N/A	CBT	M3W1A00-1002
Control Company	4040	Therm./ Clock/ Humidity Monitor	3/1/2017	Biennial	3/1/2019	170152009
Control Company	4040	Therm./Clock/Humidity Monitor	3/31/2017	Biennial	3/31/2019	170232394
Control Company	4352	Ultra Long Stem Thermometer	5/2/2017	Biennial	5/2/2019	170330147
Control Company	4352	Ultra Long Stem Thermometer	5/2/2017	Biennial	5/2/2019	170330156
Keysight	772D	Dual Directional Coupler	CBT	N/A	CBT	MY52180215
MCL	BW-N6W5+	6dB Attenuator	CBT	N/A	CBT	1139
Mini Circuits	PWR-4GHS	USB Power Sensor	1/20/2018	Annual	1/20/2019	11710030063
Mini Circuits	PWR-4GHS	USB Power Sensor	1/22/2018	Annual	1/22/2019	11710030062
MiniCircuits	SLP-2400+	Low Pass Filter	CBT	N/A	CBT	R8979500903
MiniCircuits	VLF-6000+	Low Pass Filter	CBT	N/A	CBT	N/A
Mini-Circuits	BW-N20W5	Power Attenuator	CBT	N/A	CBT	1226
Mini-Circuits	BW-N20W5+	DC to 18 GHz Precision Fixed 20 dB Attenuator	CBT	N/A	CBT	N/A
Mini-Circuits	NLP-1200+	Low Pass Filter DC to 1000 MHz	CBT	N/A	CBT	N/A
Mini-Circuits	NLP-2950+	Low Pass Filter DC to 2700 MHz	CBT	N/A	CBT	N/A
Mitutoyo	CD-6"CSX	Digital Caliper	4/18/2018	Biennial	4/18/2020	13264165
Narda	4014C-6	4 - 8 GHz SMA 6 dB Directional Coupler	CBT	N/A	CBT	N/A
Narda	4772-3	Attenuator (3dB)	CBT	N/A	CBT	9406
Narda	BW-S3W2	Attenuator (3dB)	CBT	N/A	CBT	120
Pasternack	NC-100	Torque Wrench	5/23/2018	Biennial	5/23/2020	N/A
Pasternack	PE2209-10	Bidirectional Coupler	CBT	N/A	CBT	N/A
Rohde & Schwarz	CMW500	Radio Communication tester	7/14/2017	Annual	7/14/2018	140144
Rohde & Schwarz	CMW500	Wideband Radio Communication Tester	7/20/2017	Annual	7/20/2018	132885
Rohde & Schwarz	CMW500	Radio Communication Tester	11/3/2017	Annual	11/3/2018	100976
Rohde & Schwarz	CMW500	Wideband Radio Communication Tester	1/19/2018	Annual	1/19/2019	164948
SPEAG	D1750V2	1750 MHz SAR Dipole	4/19/2018	Annual	4/19/2019	1051
SPEAG	D1900V2	1900 MHz SAR Dipole	4/12/2018	Annual	4/12/2019	5d141
SPEAG	D2300V2	2300 MHz SAR Dipole	2/7/2018	Annual	2/7/2019	1008
SPEAG	D2450V2	2450 MHz SAR Dipole	2/7/2018	Annual	2/7/2019	882
SPEAG	D2600V2	2600 MHz SAR Dipole	4/11/2018	Annual	4/11/2019	1004
SPEAG	D5GHzV2	5 GHz SAR Dipole	8/15/2017	Annual	8/15/2018	1237
SPEAG	D750V3	750 MHz SAR Dipole	1/15/2018	Annual	1/15/2019	1003
SPEAG	D835V2	835 MHz SAR Dipole	1/15/2018	Annual	1/15/2019	4d132
SPEAG	DAE4	Dasy Data Acquisition Electronics	2/15/2018	Annual	2/15/2019	665
SPEAG	DAE4	Dasy Data Acquisition Electronics	8/9/2017	Annual	8/9/2018	1323
SPEAG	DAE4	Dasy Data Acquisition Electronics	5/22/2018	Annual	5/22/2019	859
SPEAG	DAE4	Dasy Data Acquisition Electronics	3/7/2018	Annual	3/7/2019	1368
SPEAG	DAE4	Dasy Data Acquisition Electronics	4/11/2018	Annual	4/11/2019	1407
SPEAG	DAK-12	Dielectric Assessment Kit (10MHz - 3GHz)	3/13/2018	Annual	3/13/2019	1102
SPEAG	DAK-3.5	Dielectric Assessment Kit	9/12/2017	Annual	9/12/2018	1091
SPEAG	ES3DV3	SAR Probe	3/13/2018	Annual	3/13/2019	3319
SPEAG	ES3DV3	SAR Probe	8/14/2017	Annual	8/14/2018	3332
SPEAG	EX3DV4	SAR Probe	2/14/2018	Annual	2/14/2019	3914
SPEAG	EX3DV4	SAR Probe	5/22/2018	Annual	5/22/2019	7406
SPEAG	EX3DV4	SAR Probe	4/18/2018	Annual	4/18/2019	7357

Note: CBT (Calibrated Before Testing). Prior to testing, the measurement paths containing a cable, amplifier, attenuator, coupler or filter were connected to a calibrated source (i.e. a signal generator) to determine the losses of the measurement path. The power meter offset was then adjusted to compensate for the measurement system losses. This level offset is stored within the power meter before measurements are made. This calibration verification procedure applies to the system verification and output power measurements. The calibrated reading is then taken directly from the power meter after compensation of the losses for all final power measurements.

FCC ID: A3LSMT837A		SAR EVALUATION REPORT		Approved by: Quality Manager
Document S/N: 1M1806180124-01.A3L	Test Dates: 06/20/18 - 07/05/18	DUT Type: Portable Tablet	Page 96 of 100	

14 MEASUREMENT UNCERTAINTIES

a	c	d	e= f(d,k)	f	g	h = c x f/e	i = c x g/e	k
Uncertainty Component	Tol. (± %)	Prob. Dist.	Div.	c _i 1gm	c _i 10 gms	1gm u _i (± %)	10gms u _i (± %)	v _i
Measurement System								
Probe Calibration	6.55	N	1	1.0	1.0	6.6	6.6	∞
Axial Isotropy	0.25	N	1	0.7	0.7	0.2	0.2	∞
Hemishperical Isotropy	1.3	N	1	0.7	0.7	0.9	0.9	∞
Boundary Effect	2.0	R	1.73	1.0	1.0	1.2	1.2	∞
Linearity	0.3	N	1	1.0	1.0	0.3	0.3	∞
System Detection Limits	0.25	R	1.73	1.0	1.0	0.1	0.1	∞
Readout Electronics	0.3	N	1	1.0	1.0	0.3	0.3	∞
Response Time	0.8	R	1.73	1.0	1.0	0.5	0.5	∞
Integration Time	2.6	R	1.73	1.0	1.0	1.5	1.5	∞
RF Ambient Conditions - Noise	3.0	R	1.73	1.0	1.0	1.7	1.7	∞
RF Ambient Conditions - Reflections	3.0	R	1.73	1.0	1.0	1.7	1.7	∞
Probe Positioner Mechanical Tolerance	0.4	R	1.73	1.0	1.0	0.2	0.2	∞
Probe Positioning w/ respect to Phantom	6.7	R	1.73	1.0	1.0	3.9	3.9	∞
Extrapolation, Interpolation & Integration algorithms for Max. SAR Evaluation	4.0	R	1.73	1.0	1.0	2.3	2.3	∞
Test Sample Related								
Test Sample Positioning	2.7	N	1	1.0	1.0	2.7	2.7	35
Device Holder Uncertainty	1.67	N	1	1.0	1.0	1.7	1.7	5
Output Power Variation - SAR drift measurement	5.0	R	1.73	1.0	1.0	2.9	2.9	∞
SAR Scaling	0.0	R	1.73	1.0	1.0	0.0	0.0	∞
Phantom & Tissue Parameters								
Phantom Uncertainty (Shape & Thickness tolerances)	7.6	R	1.73	1.0	1.0	4.4	4.4	∞
Liquid Conductivity - measurement uncertainty	4.2	N	1	0.78	0.71	3.3	3.0	10
Liquid Permittivity - measurement uncertainty	4.1	N	1	0.23	0.26	1.0	1.1	10
Liquid Conductivity - Temperature Uncertainty	3.4	R	1.73	0.78	0.71	1.5	1.4	∞
Liquid Permittivity - Temperature Uncertainty	0.6	R	1.73	0.23	0.26	0.1	0.1	∞
Liquid Conductivity - deviation from target values	5.0	R	1.73	0.64	0.43	1.8	1.2	∞
Liquid Permittivity - deviation from target values	5.0	R	1.73	0.60	0.49	1.7	1.4	∞
Combined Standard Uncertainty (k=1)	RSS					11.5	11.3	60
Expanded Uncertainty (95% CONFIDENCE LEVEL)	k=2					23.0	22.6	



FCC ID: A3LSMT837A		SAR EVALUATION REPORT		Approved by: Quality Manager
Document S/N: 1M1806180124-01.A3L	Test Dates: 06/20/18 - 07/05/18	DUT Type: Portable Tablet	Page 97 of 100	

15 CONCLUSION

15.1 Measurement Conclusion



The SAR evaluation indicates that the EUT complies with the RF radiation exposure limits of the FCC and Innovation, Science, and Economic Development Canada, with respect to all parameters subject to this test. These measurements were taken to simulate the RF effects of RF exposure under worst-case conditions. Precise laboratory measures were taken to assure repeatability of the tests. The results and statements relate only to the item(s) tested.

Please note that the absorption and distribution of electromagnetic energy in the body are very complex phenomena that depend on the mass, shape, and size of the body, the orientation of the body with respect to the field vectors, and the electrical properties of both the body and the environment. Other variables that may play a substantial role in possible biological effects are those that characterize the environment (e.g. ambient temperature, air velocity, relative humidity, and body insulation) and those that characterize the individual (e.g. age, gender, activity level, debilitation, or disease). Because various factors may interact with one another to vary the specific biological outcome of an exposure to electromagnetic fields, any protection guide should consider maximal amplification of biological effects as a result of field-body interactions, environmental conditions, and physiological variables. [3]



FCC ID: A3LSMT837A		SAR EVALUATION REPORT		Approved by: Quality Manager
Document S/N: 1M1806180124-01.A3L	Test Dates: 06/20/18 - 07/05/18	DUT Type: Portable Tablet		Page 98 of 100

16 REFERENCES

- [1] Federal Communications Commission, ET Docket 93-62, Guidelines for Evaluating the Environmental Effects of Radiofrequency Radiation, Aug. 1996.
- [2] ANSI/IEEE C95.1-2005, American National Standard safety levels with respect to human exposure to radio frequency electromagnetic fields, 3kHz to 300GHz, New York: IEEE, 2006.
- [3] ANSI/IEEE C95.1-1992, American National Standard safety levels with respect to human exposure to radio frequency electromagnetic fields, 3kHz to 300GHz, New York: IEEE, Sept. 1992.
- [4] ANSI/IEEE C95.3-2002, IEEE Recommended Practice for the Measurement of Potentially Hazardous Electromagnetic Fields - RF and Microwave, New York: IEEE, December 2002.
- [5] IEEE Standards Coordinating Committee 39 –Standards Coordinating Committee 34 – IEEE Std. 1528-2013, IEEE Recommended Practice for Determining the Peak Spatial-Average Specific Absorption Rate (SAR) in the Human Head from Wireless Communications Devices: Measurement Techniques.
- [6] NCRP, National Council on Radiation Protection and Measurements, Biological Effects and Exposure Criteria for RadioFrequency Electromagnetic Fields, NCRP Report No. 86, 1986. Reprinted Feb. 1995.
- [7] T. Schmid, O. Egger, N. Kuster, Automated E-field scanning system for dosimetric assessments, IEEE Transaction on Microwave Theory and Techniques, vol. 44, Jan. 1996, pp. 105-113.
- [8] K. Pokovic, T. Schmid, N. Kuster, Robust setup for precise calibration of E-field probes in tissue simulating liquids at mobile communications frequencies, ICECOM97, Oct. 1997, pp. 1 -124.
- [9] K. Pokovic, T. Schmid, and N. Kuster, E-field Probe with improved isotropy in brain simulating liquids, Proceedings of the ELMAR, Zadar, Croatia, June 23-25, 1996, pp. 172-175.
- [10] Schmid & Partner Engineering AG, Application Note: Data Storage and Evaluation, June 1998, p2.
- [11] V. Hombach, K. Meier, M. Burkhardt, E. Kuhn, N. Kuster, The Dependence of EM Energy Absorption upon Human Modeling at 900 MHz, IEEE Transaction on Microwave Theory and Techniques, vol. 44 no. 10, Oct. 1996, pp. 1865-1873.
- [12] N. Kuster and Q. Balzano, Energy absorption mechanism by biological bodies in the near field of dipole antennas above 300MHz, IEEE Transaction on Vehicular Technology, vol. 41, no. 1, Feb. 1992, pp. 17-23.
- [13] G. Hartsgrove, A. Kraszewski, A. Surowiec, Simulated Biological Materials for Electromagnetic Radiation Absorption Studies, University of Ottawa, Bioelectromagnetics, Canada: 1987, pp. 29-36.
- [14] Q. Balzano, O. Garay, T. Manning Jr., Electromagnetic Energy Exposure of Simulated Users of Portable Cellular Telephones, IEEE Transactions on Vehicular Technology, vol. 44, no.3, Aug. 1995.
- [15] W. Gander, Computermathematick, Birkhaeuser, Basel, 1992.
- [16] W.H. Press, S.A. Teukolsky, W.T. Vetterling, and B.P. Flannery, Numerical Recipes in C, The Art of Scientific Computing, Second edition, Cambridge University Press, 1992.
- [17] N. Kuster, R. Kastle, T. Schmid, Dosimetric evaluation of mobile communications equipment with known precision, IEEE Transaction on Communications, vol. E80-B, no. 5, May 1997, pp. 645-652.

FCC ID: A3LSMT837A	 PCTEST ENGINEERING LABORATORY, INC.	SAR EVALUATION REPORT		Approved by: Quality Manager
Document S/N: 1M1806180124-01.A3L	Test Dates: 06/20/18 - 07/05/18	DUT Type: Portable Tablet		Page 99 of 100

- [18] CENELEC CLC/SC111B, European Prestandard (prENV 50166-2), Human Exposure to Electromagnetic Fields High-frequency: 10kHz-300GHz, Jan. 1995.
- [19] Prof. Dr. Niels Kuster, ETH, Eidgenössische Technische Hochschule Zürich, Dosimetric Evaluation of the Cellular Phone.
- [20] IEC 62209-1, Measurement procedure for the assessment of specific absorption rate of human exposure to radio frequency fields from hand-held and body-mounted wireless communication devices - Part 1: Devices used next to the ear (Frequency range of 300 MHz to 6 GHz), July 2016.
- [21] Innovation, Science, Economic Development Canada RSS-102 Radio Frequency Exposure Compliance of Radiocommunication Apparatus (All Frequency Bands) Issue 5, March 2015.
- [22] Health Canada Safety Code 6 Limits of Human Exposure to Radio Frequency Electromagnetic Fields in the Frequency Range from 3 kHz – 300 GHz, 2015
- [23] FCC SAR Test Procedures for 2G-3G Devices, Mobile Hotspot and UMPC Devices KDB Publications 941225, D01-D07
- [24] SAR Measurement Guidance for IEEE 802.11 Transmitters, KDB Publication 248227 D01
- [25] FCC SAR Considerations for Handsets with Multiple Transmitters and Antennas, KDB Publications 648474 D03-D04
- [26] FCC SAR Evaluation Considerations for Laptop, Notebook, Netbook and Tablet Computers, FCC KDB Publication 616217 D04
- [27] FCC SAR Measurement and Reporting Requirements for 100MHz – 6 GHz, KDB Publications 865664 D01-D02
- [28] FCC General RF Exposure Guidance and SAR Procedures for Dongles, KDB Publication 447498, D01-D02
- [29] Anexo à Resolução No. 533, de 10 de Setembro de 2009.
- [30] IEC 62209-2, Human exposure to radio frequency fields from hand-held and body-mounted wireless communication devices - Human models, instrumentation, and procedures - Part 2: Procedure to determine the specific absorption rate (SAR) for wireless communication devices used in close proximity to the human body (frequency range of 30 MHz to 6 GHz), Mar. 2010.

FCC ID: A3LSMT837A		SAR EVALUATION REPORT		Approved by: Quality Manager
Document S/N: 1M1806180124-01.A3L	Test Dates: 06/20/18 - 07/05/18	DUT Type: Portable Tablet	Page 100 of 100	

APPENDIX A: SAR TEST DATA

PCTEST ENGINEERING LABORATORY, INC.

DUT: A3LSMT837A; Type: Portable Tablet; Serial: 05866

Communication System: UID 0, UMTS; Frequency: 826.4 MHz; Duty Cycle: 1:1
Medium: 835 Body Medium parameters used (interpolated):
 $f = 826.4 \text{ MHz}$; $\sigma = 0.977 \text{ S/m}$; $\epsilon_r = 54.006$; $\rho = 1000 \text{ kg/m}^3$
Phantom section: Flat Section; Space: 1.6 cm

Test Date: 07-02-2018; Ambient Temp: 20.3°C; Tissue Temp: 20.3°C

Probe: EX3DV4 - SN3914; ConvF(9.57, 9.57, 9.57); Calibrated: 2/14/2018;
Sensor-Surface: 1.4mm (Mechanical Surface Detection)

Electronics: DAE4 Sn665; Calibrated: 2/15/2018

Phantom: Twin-SAM V5.0 Right; Type: QD 000 P40 CD; Serial: 1800

Measurement SW: DASY52, Version 52.10;SEMCAD X Version 14.6.10 (7417)

Mode: UMTS 850, Body SAR, Top Edge, Low.ch

Area Scan (10x13x1): Measurement grid: dx=5mm, dy=15mm

Zoom Scan (5x5x7)/Cube 0: Measurement grid: dx=8mm, dy=8mm, dz=5mm

Reference Value = 33.73 V/m; Power Drift = 0.04 dB

Peak SAR (extrapolated) = 1.57 W/kg

SAR(1 g) = 1.05 W/kg

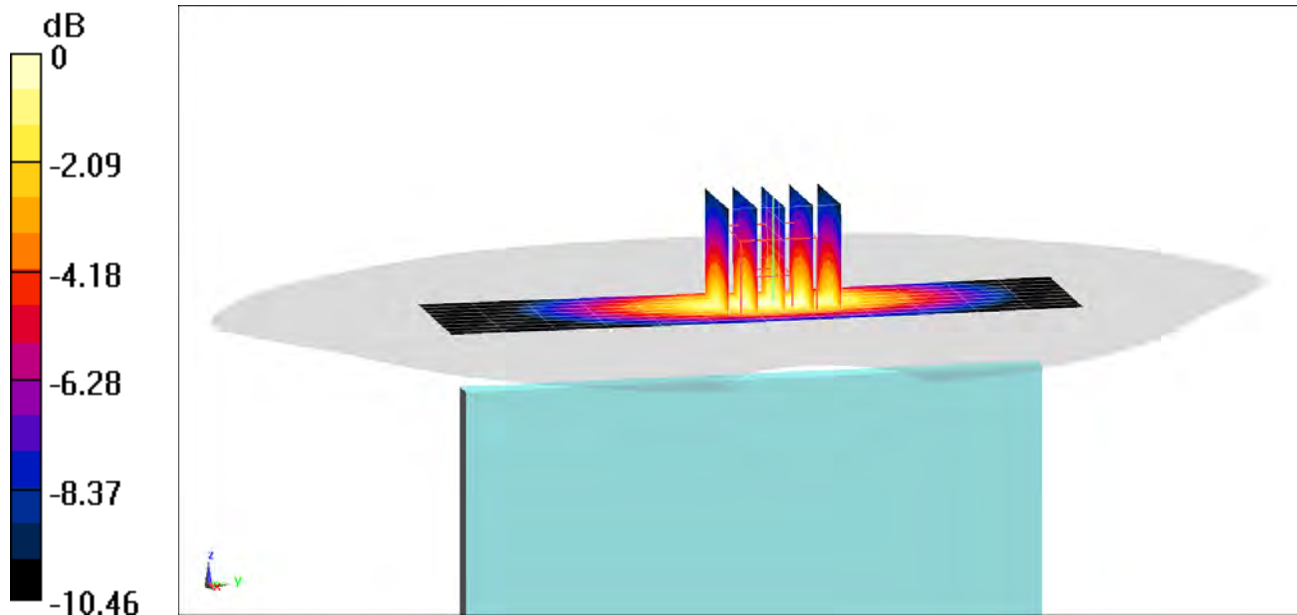

0 dB = 1.39 W/kg = 1.43 dBW/kg

PCTEST ENGINEERING LABORATORY, INC.

DUT: A3LSMT837A; Type: Portable Tablet; Serial: 05031

Communication System: UID 0, _UMTS; Frequency: 1752.6 MHz; Duty Cycle: 1:1
Medium: 1750 Body Medium parameters used (interpolated):
 $f = 1752.6$ MHz; $\sigma = 1.513$ S/m; $\epsilon_r = 51.709$; $\rho = 1000$ kg/m³
Phantom section: Flat Section; Space: 0.0 cm

Test Date: 06-25-2018; Ambient Temp: 23.1°C; Tissue Temp: 21.3°C

Probe: ES3DV3 - SN3332; ConvF(5.16, 5.16, 5.16); Calibrated: 8/14/2017;
Sensor-Surface: 3mm (Mechanical Surface Detection)
Electronics: DAE4 Sn1323; Calibrated: 8/9/2017
Phantom: SAM Front; Type: SAM; Serial: 1686
Measurement SW: DASY52, Version 52.10;SEMCAD X Version 14.6.10 (7417)

Mode: UMTS 1750, Body SAR, Back side, High.ch

Area Scan (15x11x1): Measurement grid: dx=15mm, dy=15mm
Zoom Scan (5x5x7)/Cube 0: Measurement grid: dx=8mm, dy=8mm, dz=5mm
Reference Value = 28.87 V/m; Power Drift = 0.01 dB
Peak SAR (extrapolated) = 2.28 W/kg
SAR(1 g) = 0.989 W/kg

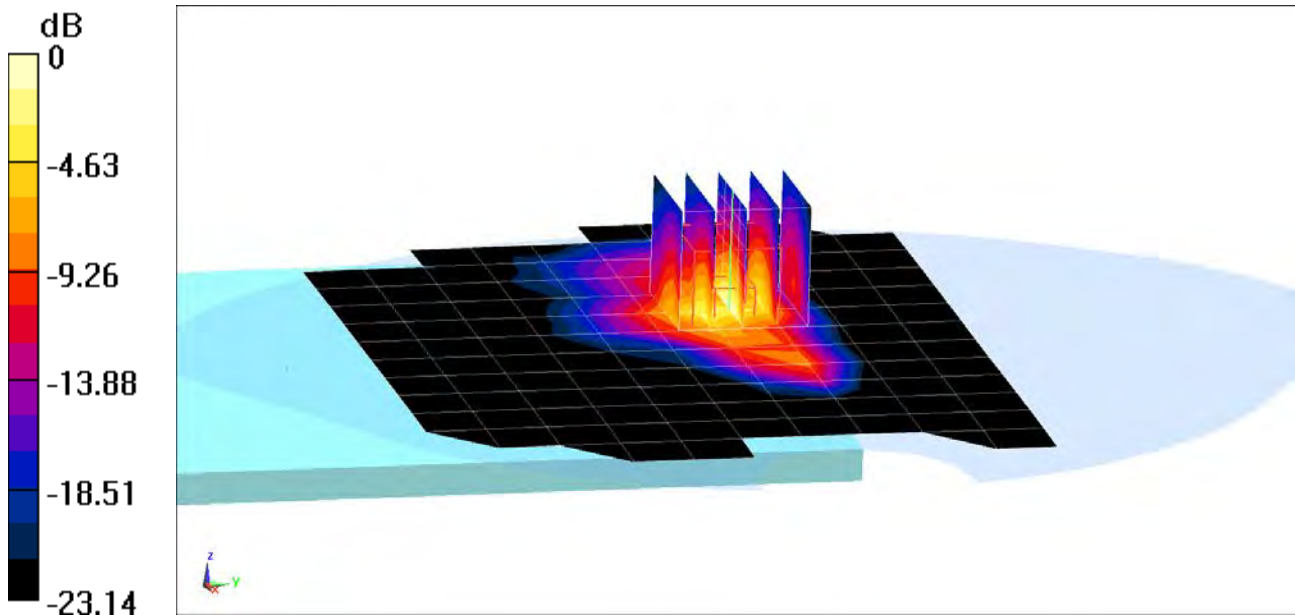

0 dB = 1.47 W/kg = 1.67 dBW/kg

PCTEST ENGINEERING LABORATORY, INC.

DUT: A3LSMT837A; Type: Portable Tablet; Serial: 05866

Communication System: UID 0, UMTS; Frequency: 1907.6 MHz; Duty Cycle: 1:1
Medium: 1900 Body Medium parameters used (interpolated):
 $f = 1907.6$ MHz; $\sigma = 1.559$ S/m; $\epsilon_r = 53.214$; $\rho = 1000$ kg/m³
Phantom section: Flat Section; Space: 0.0 cm

Test Date: 07-05-2018; Ambient Temp: 23.5°C; Tissue Temp: 22.1°C

Probe: EX3DV4 - SN7406; ConvF(7.74, 7.74, 7.74); Calibrated: 5/22/2018;
Sensor-Surface: 1.4mm (Mechanical Surface Detection)
Electronics: DAE4 Sn859; Calibrated: 5/22/2018
Phantom: Twin-SAM V4.0; Type: QD 000 P40 CC; Serial: 1167
Measurement SW: DASY52, Version 52.10; SEMCAD X Version 14.6.10 (7417)

Mode: UMTS 1900, Body SAR, Back side, High.ch

Area Scan (15x11x1): Measurement grid: dx=15mm, dy=15mm
Zoom Scan (5x5x7)/Cube 0: Measurement grid: dx=8mm, dy=8mm, dz=5mm
Reference Value = 28.82 V/m; Power Drift = 0.10 dB
Peak SAR (extrapolated) = 2.75 W/kg
SAR(1 g) = 1.1 W/kg

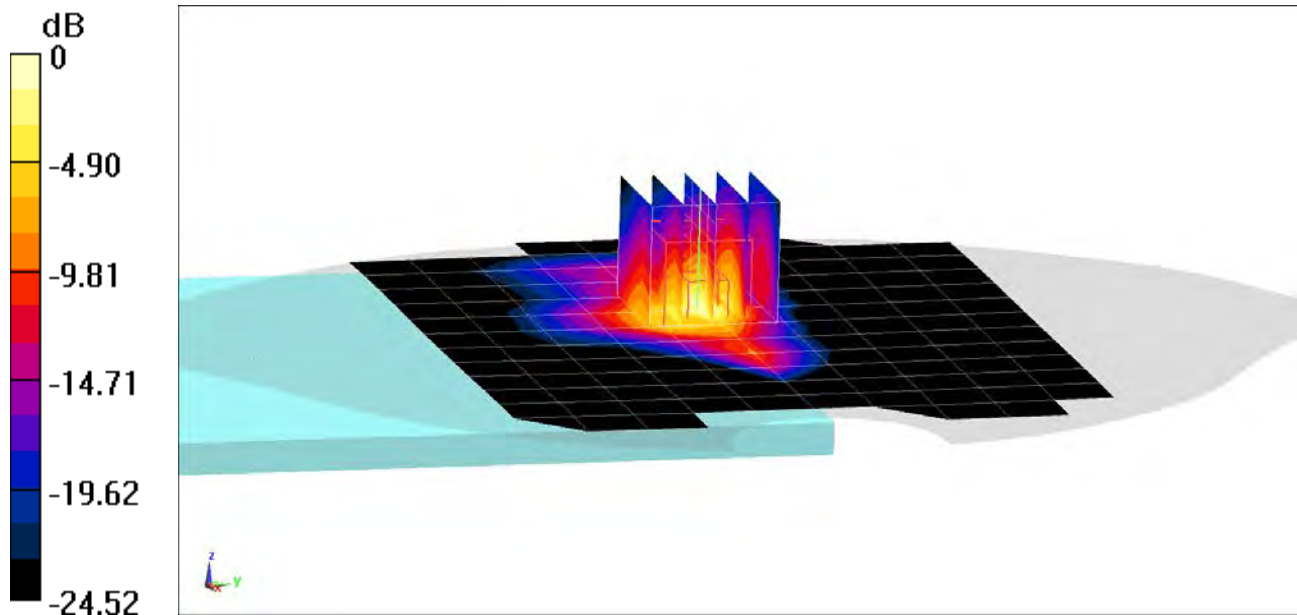

0 dB = 2.16 W/kg = 3.34 dBW/kg

PCTEST ENGINEERING LABORATORY, INC.

DUT: A3LSMT837A; Type: Portable Tablet; Serial: 05358

Communication System: UID 0, LTE Band 12; Frequency: 707.5 MHz; Duty Cycle: 1:1
Medium: 750 Body Medium parameters used (interpolated):
 $f = 707.5 \text{ MHz}$; $\sigma = 0.971 \text{ S/m}$; $\epsilon_r = 53.795$; $\rho = 1000 \text{ kg/m}^3$
Phantom section: Flat Section; Space: 1.6 cm

Test Date: 06-25-2018; Ambient Temp: 21.5°C; Tissue Temp: 22.0°C

Probe: EX3DV4 - SN3914; ConvF(9.75, 9.75, 9.75); Calibrated: 2/14/2018;
Sensor-Surface: 1.4mm (Mechanical Surface Detection)

Electronics: DAE4 Sn665; Calibrated: 2/15/2018

Phantom: Twin-SAM V5.0 Right; Type: QD 000 P40 CD; Serial: 1800

Measurement SW: DASY52, Version 52.10;SEMCAD X Version 14.6.10 (7417)

**Mode: LTE Band 12, Body SAR, Top Edge, Mid.ch,
10 MHz Bandwidth, QPSK, 1 RB, 0 RB Offset**

Area Scan (10x13x1): Measurement grid: dx=5mm, dy=15mm

Zoom Scan (5x5x7)/Cube 0: Measurement grid: dx=8mm, dy=8mm, dz=5mm

Reference Value = 22.73 V/m; Power Drift = 0.16 dB

Peak SAR (extrapolated) = 0.684 W/kg

SAR(1 g) = 0.488 W/kg

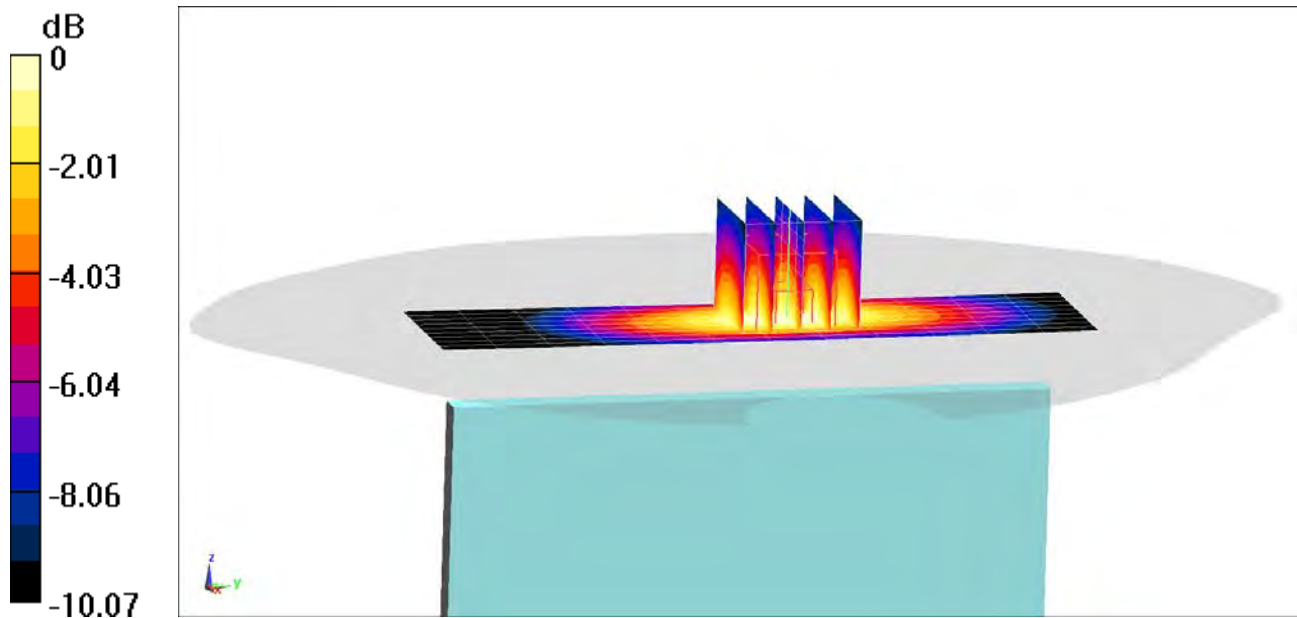

0 dB = 0.621 W/kg = -2.07 dBW/kg

PCTEST ENGINEERING LABORATORY, INC.

DUT: A3LSMT837A; Type: Portable Tablet; Serial: 05358

Communication System: UID 0, LTE Band 14; Frequency: 793 MHz; Duty Cycle: 1:1
Medium: 750 Body Medium parameters used (interpolated):
 $f = 793 \text{ MHz}$; $\sigma = 1.001 \text{ S/m}$; $\epsilon_r = 53.55$; $\rho = 1000 \text{ kg/m}^3$
Phantom section: Flat Section; Space: 1.6 cm

Test Date: 06-25-2018; Ambient Temp: 21.5°C; Tissue Temp: 22.0°C

Probe: EX3DV4 - SN3914; ConvF(9.75, 9.75, 9.75); Calibrated: 2/14/2018;
Sensor-Surface: 1.4mm (Mechanical Surface Detection)

Electronics: DAE4 Sn665; Calibrated: 2/15/2018

Phantom: Twin-SAM V5.0 Right; Type: QD 000 P40 CD; Serial: 1800

Measurement SW: DASY52, Version 52.10;SEMCAD X Version 14.6.10 (7417)

**Mode: LTE Band 14, Body SAR, Top Edge, Mid.ch,
10 MHz Bandwidth, QPSK, 1 RB, 0 RB Offset**

Area Scan (10x13x1): Measurement grid: dx=5mm, dy=15mm

Zoom Scan (5x5x7)/Cube 0: Measurement grid: dx=8mm, dy=8mm, dz=5mm

Reference Value = 27.29 V/m; Power Drift = 0.18 dB

Peak SAR (extrapolated) = 1.03 W/kg

SAR(1 g) = 0.773 W/kg

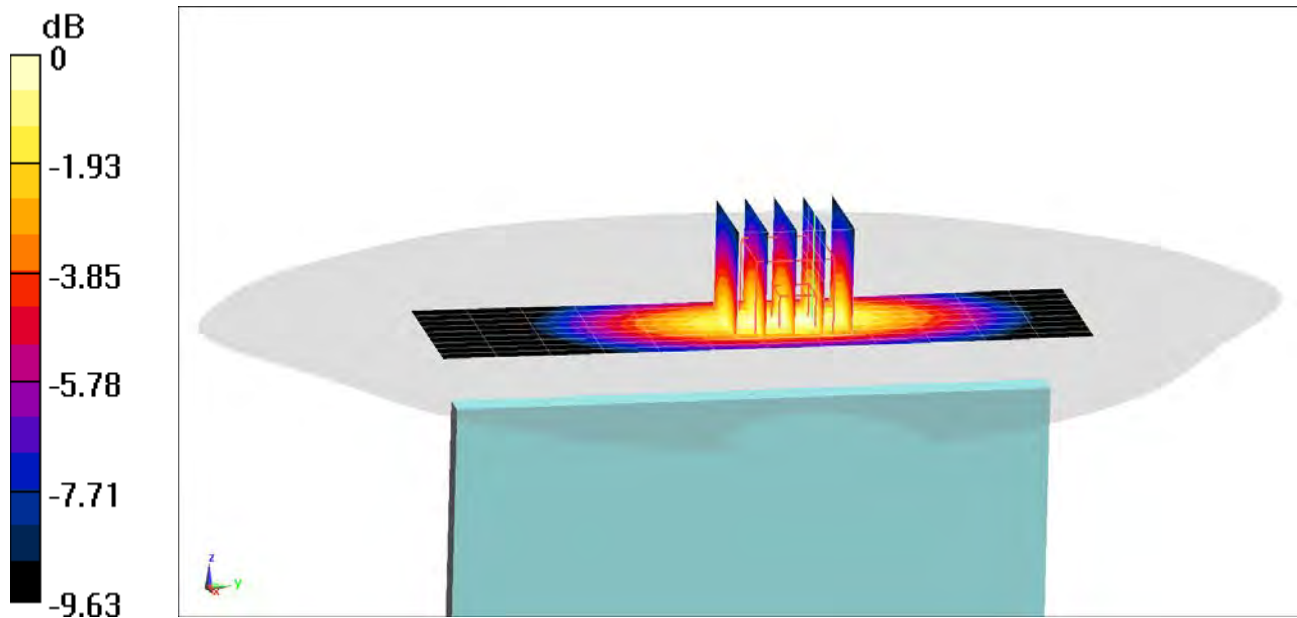

0 dB = 0.969 W/kg = -0.14 dBW/kg

PCTEST ENGINEERING LABORATORY, INC.

DUT: A3LSMT837A; Type: Portable Tablet; Serial: 05866

Communication System: UID 0, LTE Band 5 (Cell.); Frequency: 836.5 MHz; Duty Cycle: 1:1
Medium: 835 Body Medium parameters used (interpolated):
 $f = 836.5 \text{ MHz}$; $\sigma = 0.981 \text{ S/m}$; $\epsilon_r = 53.98$; $\rho = 1000 \text{ kg/m}^3$
Phantom section: Flat Section; Space: 1.6 cm

Test Date: 07-02-2018; Ambient Temp: 20.3°C; Tissue Temp: 20.3°C

Probe: EX3DV4 - SN3914; ConvF(9.57, 9.57, 9.57); Calibrated: 2/14/2018;

Sensor-Surface: 1.4mm (Mechanical Surface Detection)

Electronics: DAE4 Sn665; Calibrated: 2/15/2018

Phantom: Twin-SAM V5.0 Right; Type: QD 000 P40 CD; Serial: 1800

Measurement SW: DASY52, Version 52.10;SEMCAD X Version 14.6.10 (7417)

**Mode: LTE Band 5 (Cell.), Body SAR, Top Edge, Mid.ch,
10 MHz Bandwidth, QPSK, 1 RB, 0 RB Offset**

Area Scan (10x13x1): Measurement grid: dx=5mm, dy=15mm

Zoom Scan (5x5x7)/Cube 0: Measurement grid: dx=8mm, dy=8mm, dz=5mm

Reference Value = 31.61 V/m; Power Drift = 0.13 dB

Peak SAR (extrapolated) = 1.36 W/kg

SAR(1 g) = 0.924 W/kg

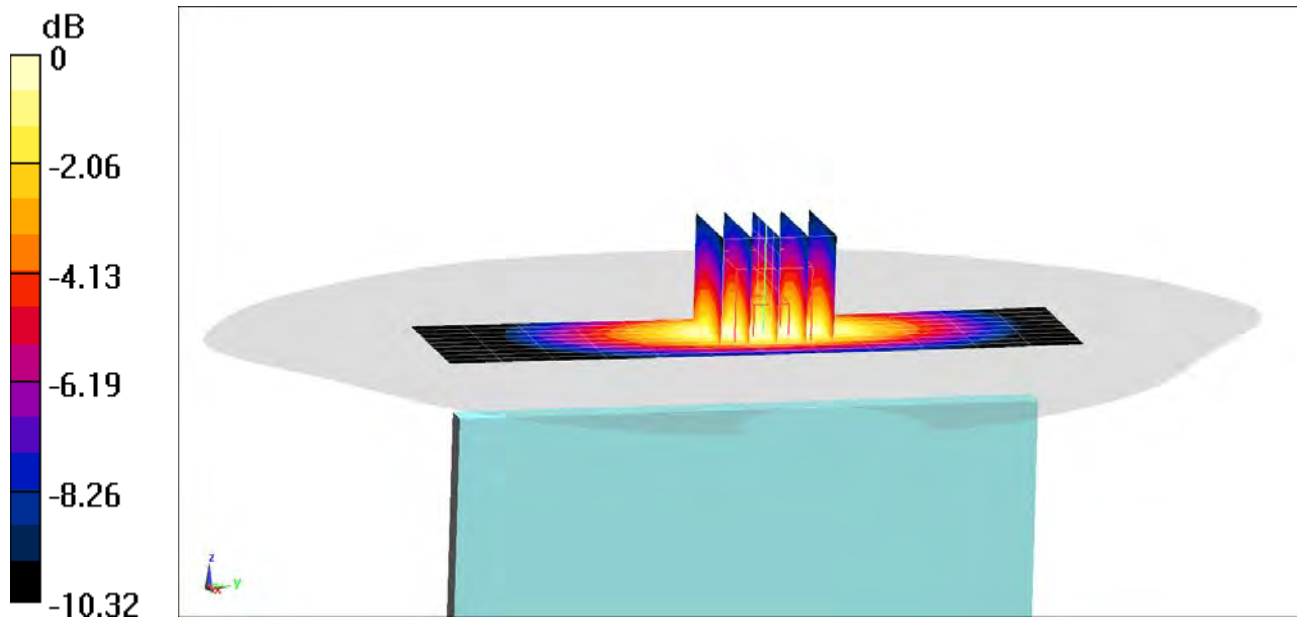

0 dB = 1.21 W/kg = 0.83 dBW/kg

PCTEST ENGINEERING LABORATORY, INC.

DUT: A3LSMT837A; Type: Portable Tablet; Serial: 05106

Communication System: UID 0, _LTE Band 66 (AWS); Frequency: 1770 MHz; Duty Cycle: 1:1
Medium: 1750 Body Medium parameters used (interpolated):
 $f = 1770 \text{ MHz}$; $\sigma = 1.531 \text{ S/m}$; $\epsilon_r = 51.644$; $\rho = 1000 \text{ kg/m}^3$
Phantom section: Flat Section; Space: 0.0 cm

Test Date: 06-25-2018; Ambient Temp: 23.1°C; Tissue Temp: 21.3°C

Probe: ES3DV3 - SN3332; ConvF(5.16, 5.16, 5.16); Calibrated: 8/14/2017;
Sensor-Surface: 3mm (Mechanical Surface Detection)
Electronics: DAE4 Sn1323; Calibrated: 8/9/2017
Phantom: SAM Front; Type: SAM; Serial: 1686
Measurement SW: DASY52, Version 52.10;SEMCAD X Version 14.6.10 (7417)

**Mode: LTE Band 66 (AWS), Body SAR, Right Edge, High.ch,
20 MHz Bandwidth, QPSK, 1 RB, 0 RB Offset**

Area Scan (10x19x1): Measurement grid: dx=5mm, dy=15mm
Zoom Scan (5x5x7)/Cube 0: Measurement grid: dx=8mm, dy=8mm, dz=5mm
Reference Value = 29.77 V/m; Power Drift = 0.15 dB
Peak SAR (extrapolated) = 2.47 W/kg
SAR(1 g) = 1.15 W/kg

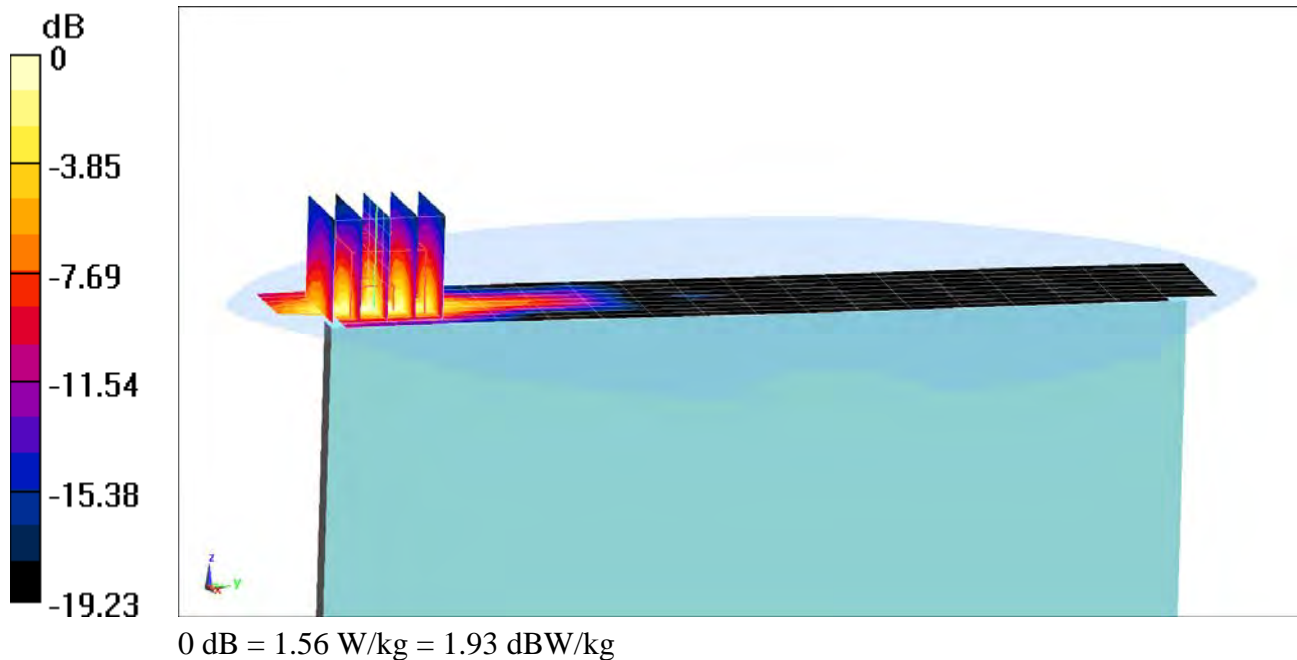

PCTEST ENGINEERING LABORATORY, INC.

DUT: A3LSMT837A; Type: Portable Tablet; Serial: 05866

Communication System: UID 0, LTE Band 2 (PCS); Frequency: 1900 MHz; Duty Cycle: 1:1
Medium: 1900 Body Medium parameters used (interpolated):
 $f = 1900 \text{ MHz}$; $\sigma = 1.575 \text{ S/m}$; $\epsilon_r = 51.573$; $\rho = 1000 \text{ kg/m}^3$
Phantom section: Flat Section; Space: 0.0 cm

Test Date: 06-28-2018; Ambient Temp: 22.6°C; Tissue Temp: 22.0°C

Probe: EX3DV4 - SN7406; ConvF(7.74, 7.74, 7.74); Calibrated: 5/22/2018;
Sensor-Surface: 1.4mm (Mechanical Surface Detection)
Electronics: DAE4 Sn859; Calibrated: 5/22/2018
Phantom: Twin-SAM V4.0; Type: QD 000 P40 CC; Serial: 1167
Measurement SW: DASY52, Version 52.10; SEMCAD X Version 14.6.10 (7417)

**Mode: LTE Band 2 (PCS), Body SAR, Back side, High.ch,
20 MHz Bandwidth, QPSK, 1 RB, 0 RB Offset**

Area Scan (15x11x1): Measurement grid: dx=15mm, dy=15mm
Zoom Scan (5x5x7)/Cube 0: Measurement grid: dx=8mm, dy=8mm, dz=5mm
Reference Value = 24.31 V/m; Power Drift = 0.21 dB
Peak SAR (extrapolated) = 2.10 W/kg
SAR(1 g) = 0.936 W/kg

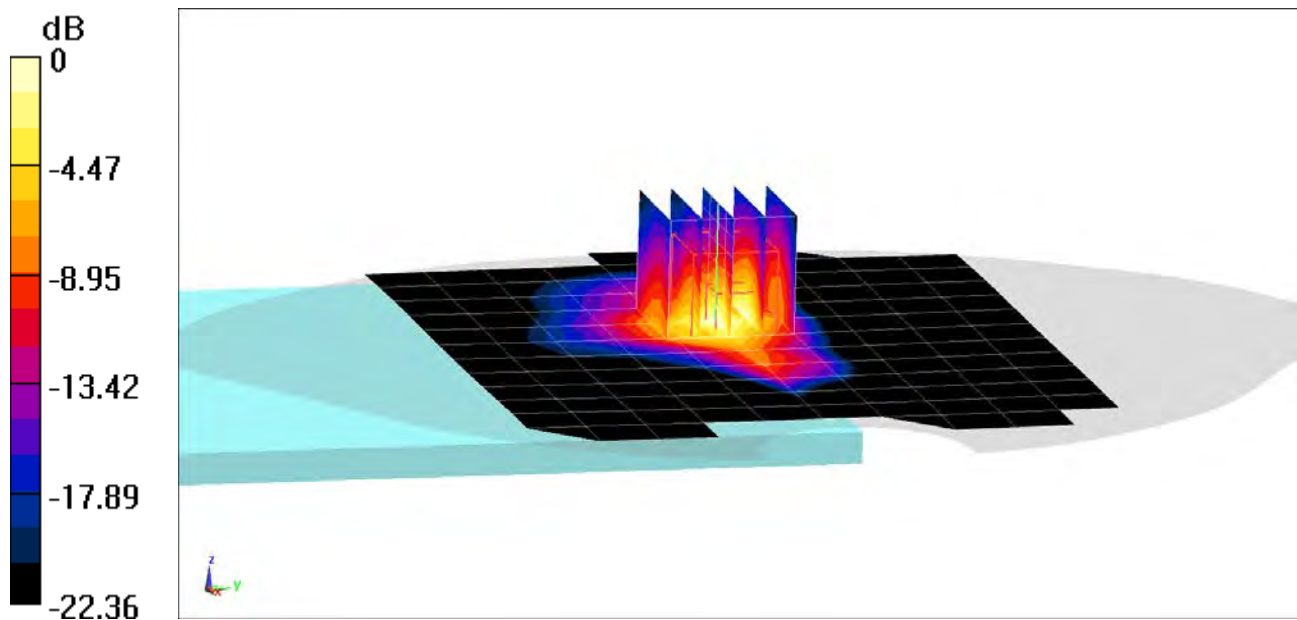

0 dB = 1.46 W/kg = 1.64 dBW/kg

PCTEST ENGINEERING LABORATORY, INC.

DUT: A3LSMT837A; Type: Portable Tablet; Serial: 05080

Communication System: UID 0, LTE Band 30; Frequency: 2310 MHz; Duty Cycle: 1:1

Medium: 2450 Body Medium parameters used:

$f = 2310$ MHz; $\sigma = 1.849$ S/m; $\epsilon_r = 52.048$; $\rho = 1000$ kg/m³

Phantom section: Flat Section; Space: 0.0 cm

Test Date: 07-04-2018; Ambient Temp: 23.5°C; Tissue Temp: 22.5°C

Probe: ES3DV3 - SN3332; ConvF(4.74, 4.74, 4.74); Calibrated: 8/14/2017;

Sensor-Surface: 3mm (Mechanical Surface Detection)

Electronics: DAE4 Sn1323; Calibrated: 8/9/2017

Phantom: SAM Left; Type: QD000P40CA; Serial: TP:82355

Measurement SW: DASY52, Version 52.10;SEMCAD X Version 14.6.10 (7417)

**Mode: LTE Band 30, Body SAR, Back side, Mid.ch,
10 MHz Bandwidth, QPSK, 50 RB, 0 RB Offset**

Area Scan (16x15x1): Measurement grid: dx=12mm, dy=12mm

Zoom Scan (8x8x7)/Cube 0: Measurement grid: dx=5mm, dy=5mm, dz=5mm

Reference Value = 25.32 V/m; Power Drift = 0.10 dB

Peak SAR (extrapolated) = 2.42 W/kg

SAR(1 g) = 0.963 W/kg

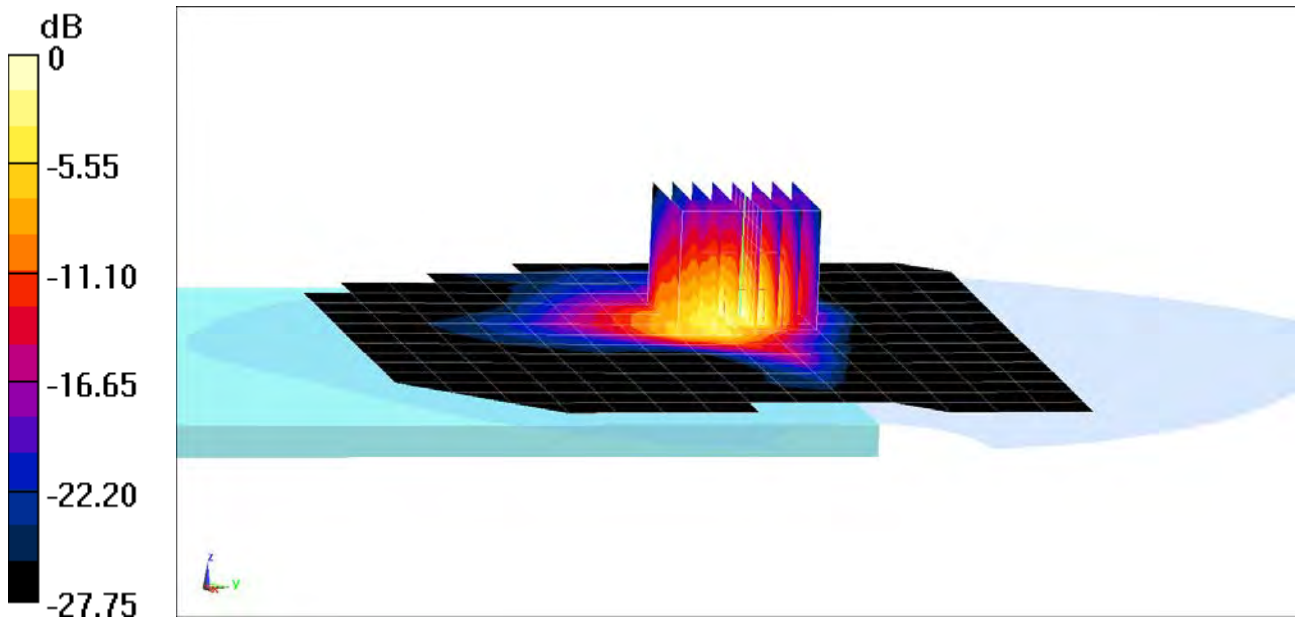

0 dB = 1.44 W/kg = 1.58 dBW/kg

PCTEST ENGINEERING LABORATORY, INC.

DUT: A3LSMT837A; Type: Portable Tablet; Serial: 05767

Communication System: UID 0, LTE Band 7; Frequency: 2560 MHz; Duty Cycle: 1:1

Medium: 2450 Body Medium parameters used (interpolated):

$f = 2560$ MHz; $\sigma = 2.143$ S/m; $\epsilon_r = 50.522$; $\rho = 1000$ kg/m³

Phantom section: Flat Section; Space: 0.0 cm

Test Date: 06-20-2018; Ambient Temp: 23.3°C; Tissue Temp: 22.2°C

Probe: ES3DV3 - SN3319; ConvF(4.33, 4.33, 4.33); Calibrated: 3/13/2018;

Sensor-Surface: 3mm (Mechanical Surface Detection)

Electronics: DAE4 Sn1368; Calibrated: 3/7/2018

Phantom: LeftTwin-SAM V5.0; Type: QD 000 P40 CD; Serial: 1375

Measurement SW: DASY52, Version 52.10;SEMCAD X Version 14.6.10 (7417)

**Mode: LTE Band 7, Body SAR, Back side, High.ch,
20 MHz Bandwidth, QPSK, 50 RB, 0 RB Offset**

Area Scan (19x25x1): Measurement grid: dx=12mm, dy=12mm

Zoom Scan (7x7x7)/Cube 0: Measurement grid: dx=5mm, dy=5mm, dz=5mm

Reference Value = 24.14 V/m; Power Drift = 0.09 dB

Peak SAR (extrapolated) = 3.08 W/kg

SAR(1 g) = 0.994 W/kg

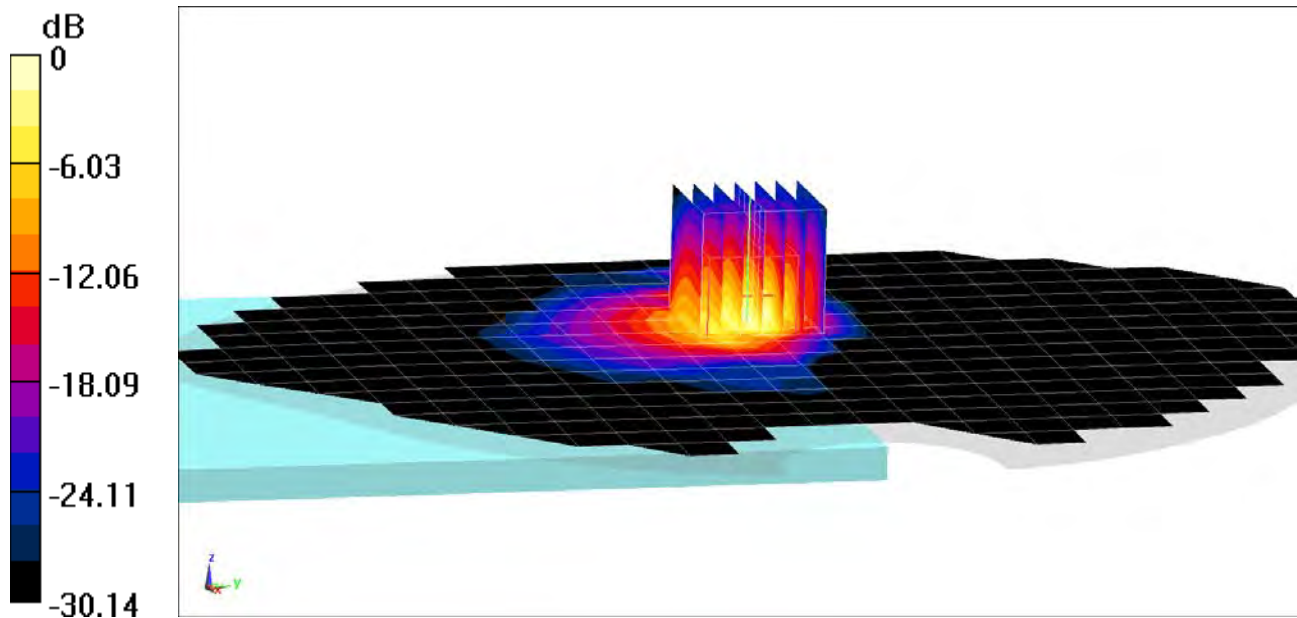

0 dB = 1.47 W/kg = 1.67 dBW/kg

PCTEST ENGINEERING LABORATORY, INC.

DUT: A3LSMT837A; Type: Portable Tablet; Serial: 04992

Communication System: UID 0, _IEEE 802.11b; Frequency: 2412 MHz; Duty Cycle: 1:1
Medium: 2450 Body Medium parameters used (interpolated):
 $f = 2412 \text{ MHz}$; $\sigma = 1.982 \text{ S/m}$; $\epsilon_r = 50.677$; $\rho = 1000 \text{ kg/m}^3$
Phantom section: Flat Section; Space: 0.0 cm

Test Date: 07-02-2018; Ambient Temp: 22.2°C; Tissue Temp: 21.7°C

Probe: ES3DV3 - SN3319; ConvF(4.51, 4.51, 4.51); Calibrated: 3/13/2018;
Sensor-Surface: 3mm (Mechanical Surface Detection)
Electronics: DAE4 Sn1368; Calibrated: 3/7/2018
Phantom: LeftTwin-SAM V5.0; Type: QD 000 P40 CD; Serial: 1375
Measurement SW: DASY52, Version 52.10;SEMCAD X Version 14.6.10 (7417)

**Mode: IEEE 802.11b, 22 MHz Bandwidth, Body SAR,
Ch 1, 1 Mbps, Back Side, Antenna 1**

Area Scan (16x20x1): Measurement grid: dx=12mm, dy=12mm
Zoom Scan (7x7x7)/Cube 0: Measurement grid: dx=5mm, dy=5mm, dz=5mm
Reference Value = 23.15 V/m; Power Drift = -0.14 dB
Peak SAR (extrapolated) = 2.69 W/kg
SAR(1 g) = 0.803 W/kg

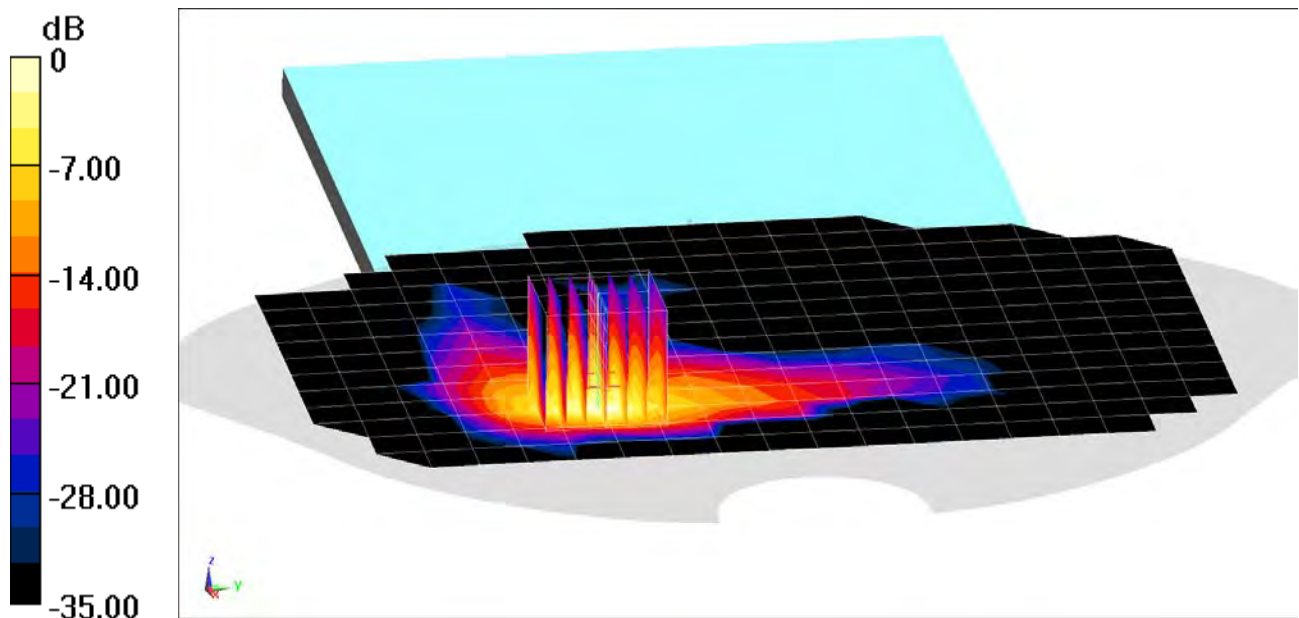

0 dB = 1.27 W/kg = 1.04 dBW/kg

PCTEST ENGINEERING LABORATORY, INC.

DUT: A3LSMT837A; Type: Portable Tablet; Serial: 04992

Communication System: UID 0, 802.11ac 5.2-5.8 GHz Band; Frequency: 5775 MHz; Duty Cycle: 1:1
Medium: 5 GHz Body Medium parameters used (interpolated):
 $f = 5775 \text{ MHz}$; $\sigma = 6.198 \text{ S/m}$; $\epsilon_r = 46.514$; $\rho = 1000 \text{ kg/m}^3$
Phantom section: Flat Section; Space: 0.0 cm

Test Date: 06-25-2018; Ambient Temp: 22.5°C; Tissue Temp: 21.3°C

Probe: EX3DV4 - SN7357; ConvF(4.21, 4.21, 4.21); Calibrated: 4/18/2018;

Sensor-Surface: 1.4mm (Mechanical Surface Detection)

Electronics: DAE4 Sn1407; Calibrated: 4/11/2018

Phantom: SAM with CRP v5.0 Left; Type: QD000P40CD; Serial: 1687

Measurement SW: DASY52, Version 52.10;SEMCAD X Version 14.6.10 (7417)

**Mode: IEEE 802.11ac, U-NII-3, 80 MHz Bandwidth, Body SAR,
Ch 155, 29.3 Mbps, Back Side, Antenna 1**

Area Scan (15x21x1): Measurement grid: dx=10mm, dy=10mm

Zoom Scan (9x9x7)/Cube 0: Measurement grid: dx=4mm, dy=4mm, dz=1.4mm; Graded Ratio: 1.4

Reference Value = 11.55 V/m; Power Drift = -0.01 dB

Peak SAR (extrapolated) = 7.84 W/kg

SAR(1 g) = 0.859 W/kg

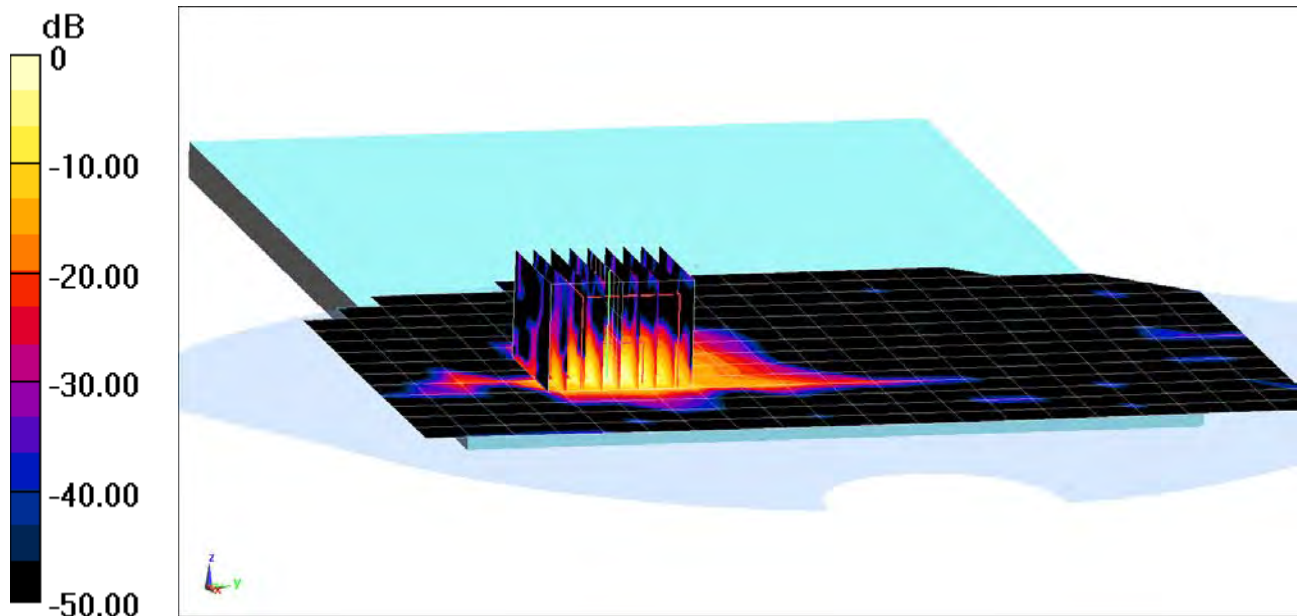

0 dB = 3.23 W/kg = 5.09 dBW/kg

PCTEST ENGINEERING LABORATORY, INC.

DUT: A3LSMT837A; Type: Portable Tablet; Serial: 04893

Communication System: UID 0, Bluetooth; Frequency: 2480 MHz; Duty Cycle: 1:1.294

Medium: 2450 Body Medium parameters used (interpolated):

$f = 2480 \text{ MHz}$; $\sigma = 2.081 \text{ S/m}$; $\epsilon_r = 51.41$; $\rho = 1000 \text{ kg/m}^3$

Phantom section: Flat Section; Space: 0.0 cm

Test Date: 07-04-2018; Ambient Temp: 23.5°C; Tissue Temp: 22.5°C

Probe: ES3DV3 - SN3332; ConvF(4.55, 4.55, 4.55); Calibrated: 8/14/2017;

Sensor-Surface: 3mm (Mechanical Surface Detection)

Electronics: DAE4 Sn1323; Calibrated: 8/9/2017

Phantom: SAM Left; Type: QD000P40CA; Serial: TP:82355

Measurement SW: DASY52, Version 52.10; SEMCAD X Version 14.6.10 (7417)

Mode: Bluetooth, Body SAR, Ch 78, 1 Mbps, Back Side

Area Scan (16x11x1): Measurement grid: dx=12mm, dy=12mm

Zoom Scan (7x7x7)/Cube 0: Measurement grid: dx=5mm, dy=5mm, dz=5mm

Reference Value = 9.382 V/m; Power Drift = -0.09 dB

Peak SAR (extrapolated) = 0.696 W/kg

SAR(1 g) = 0.202 W/kg

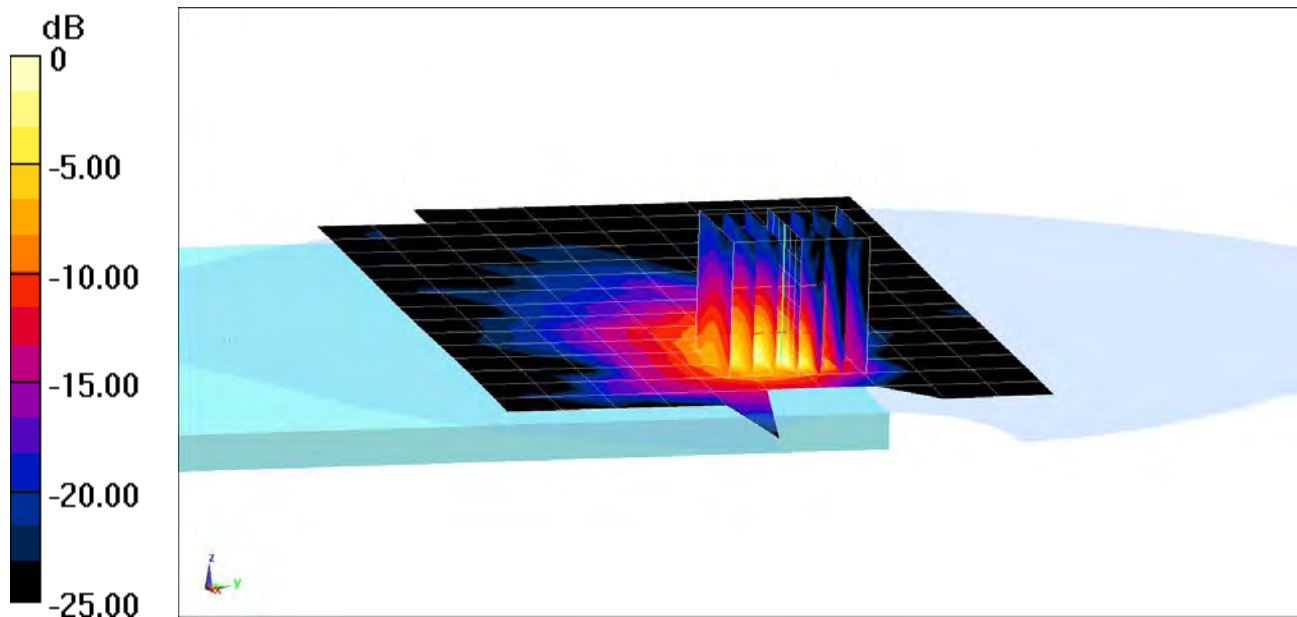

0 dB = 0.311 W/kg = -5.07 dBW/kg

APPENDIX B: SYSTEM VERIFICATION

PCTEST ENGINEERING LABORATORY, INC.

DUT: Dipole 750 MHz; Type: D750V3; Serial: 1003

Communication System: UID 0, CW; Frequency: 750 MHz; Duty Cycle: 1:1

Medium: 750 Body Medium parameters used (interpolated):

$f = 750 \text{ MHz}$; $\sigma = 0.987 \text{ S/m}$; $\epsilon_r = 53.645$; $\rho = 1000 \text{ kg/m}^3$

Phantom section: Flat Section; Space: 1.5 cm

Test Date: 06-25-2018; Ambient Temp: 21.5°C; Tissue Temp: 22.0°C

Probe: EX3DV4 - SN3914; ConvF(9.75, 9.75, 9.75); Calibrated: 2/14/2018;

Sensor-Surface: 1.4mm (Mechanical Surface Detection)

Electronics: DAE4 Sn665; Calibrated: 2/15/2018

Phantom: Twin-SAM V5.0 Right; Type: QD 000 P40 CD; Serial: 1800

Measurement SW: DASY52, Version 52.10; SEMCAD X Version 14.6.10 (7417)

750 MHz System Verification at 23.0 dBm (200 mW)

Area Scan (7x15x1): Measurement grid: dx=15mm, dy=15mm

Zoom Scan (5x5x7)/Cube 0: Measurement grid: dx=8mm, dy=8mm, dz=5mm

Peak SAR (extrapolated) = 2.80 W/kg

SAR(1 g) = 1.86 W/kg

Deviation(1 g) = 8.39%

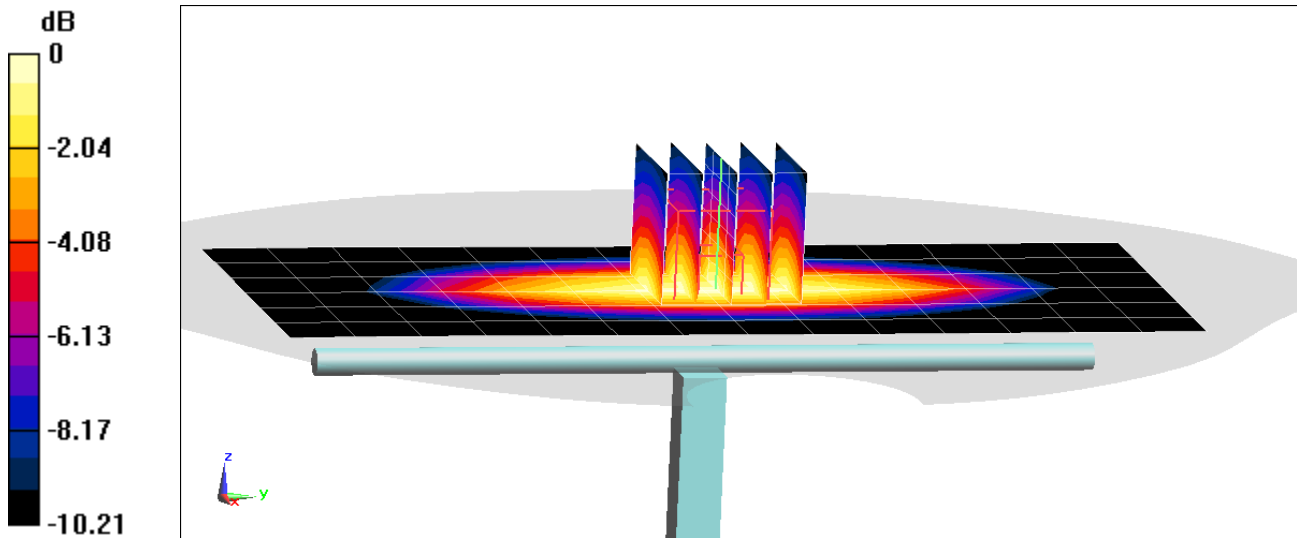

PCTEST ENGINEERING LABORATORY, INC.

DUT: Dipole 835 MHz; Type: D835V2; Serial: 4d132

Communication System: UID 0, CW; Frequency: 835 MHz; Duty Cycle: 1:1

Medium: 835 Body Medium parameters used:

$f = 835 \text{ MHz}$; $\sigma = 0.98 \text{ S/m}$; $\epsilon_r = 53.985$; $\rho = 1000 \text{ kg/m}^3$

Phantom section: Flat Section; Space: 1.5 cm

Test Date: 07-02-2018; Ambient Temp: 20.3°C; Tissue Temp: 20.3°C

Probe: EX3DV4 - SN3914; ConvF(9.57, 9.57, 9.57); Calibrated: 2/14/2018;

Sensor-Surface: 1.4mm (Mechanical Surface Detection)

Electronics: DAE4 Sn665; Calibrated: 2/15/2018

Phantom: Twin-SAM V5.0 Right; Type: QD 000 P40 CD; Serial: 1800

Measurement SW: DASY52, Version 52.10; SEMCAD X Version 14.6.10 (7417)

835 MHz System Verification at 23.0 dBm (200 mW)

Area Scan (7x14x1): Measurement grid: dx=15mm, dy=15mm

Zoom Scan (5x5x7)/Cube 0: Measurement grid: dx=8mm, dy=8mm, dz=5mm

Peak SAR (extrapolated) = 3.04 W/kg

SAR(1 g) = 2.01 W/kg

Deviation(1 g) = 3.50%

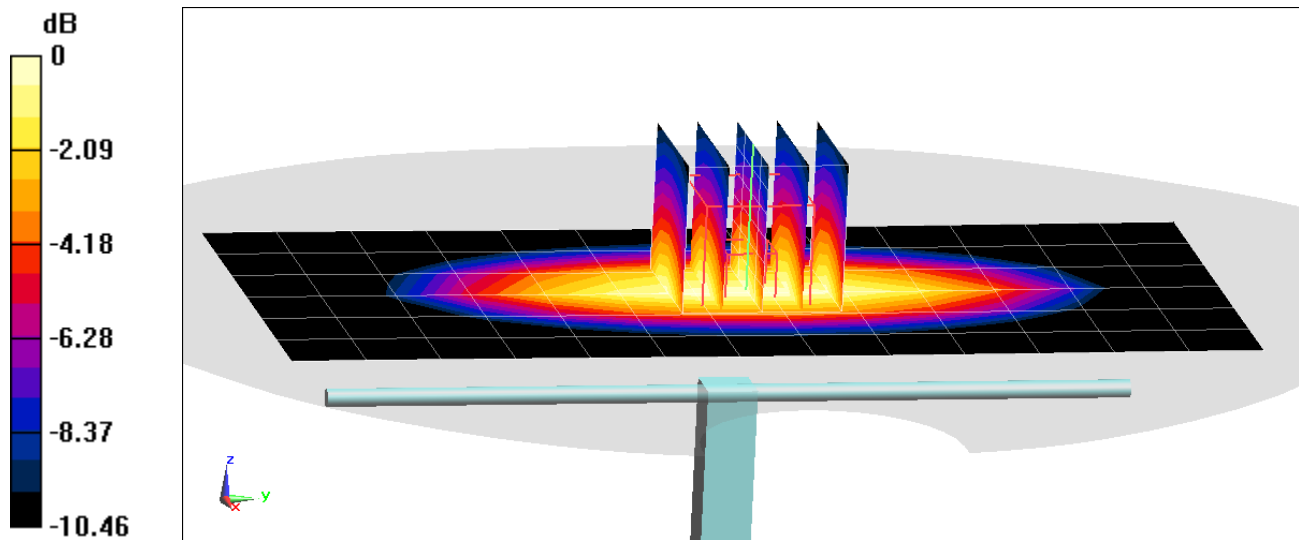

0 dB = 2.69 W/kg = 4.30 dBW/kg

PCTEST ENGINEERING LABORATORY, INC.

DUT: Dipole 1750 MHz; Type: D1750V2; Serial: 1051

Communication System: UID 0, CW; Frequency: 1750 MHz; Duty Cycle: 1:1

Medium: 1750 Body Medium parameters used:

$f = 1750 \text{ MHz}$; $\sigma = 1.51 \text{ S/m}$; $\epsilon_r = 51.719$; $\rho = 1000 \text{ kg/m}^3$

Phantom section: Flat Section; Space: 1.0 cm

Test Date: 06-25-2018; Ambient Temp: 23.1°C; Tissue Temp: 21.3°C

Probe: ES3DV3 - SN3332; ConvF(5.16, 5.16, 5.16); Calibrated: 8/14/2017;

Sensor-Surface: 3mm (Mechanical Surface Detection)

Electronics: DAE4 Sn1323; Calibrated: 8/9/2017

Phantom: SAM Front; Type: SAM; Serial: 1686

Measurement SW: DASY52, Version 52.10;SEMCAD X Version 14.6.10 (7417)

1750 MHz System Verification at 20.0 dBm (100 mW)

Area Scan (7x9x1): Measurement grid: dx=15mm, dy=15mm

Zoom Scan (5x5x7)/Cube 0: Measurement grid: dx=8mm, dy=8mm, dz=5mm

Peak SAR (extrapolated) = 6.98 W/kg

SAR(1 g) = 3.92 W/kg

Deviation(1 g) = 5.38%

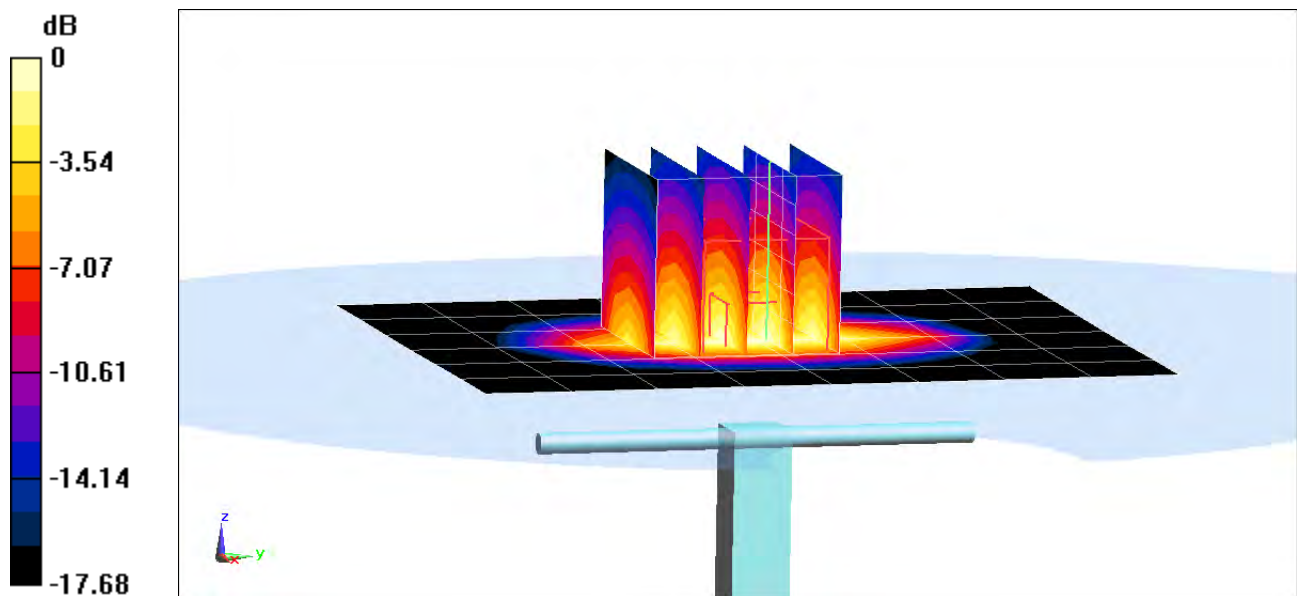

0 dB = 4.91 W/kg = 6.91 dBW/kg

PCTEST ENGINEERING LABORATORY, INC.

DUT: Dipole 1900 MHz; Type: D1900V2; Serial: 5d141

Communication System: UID 0, CW; Frequency: 1900 MHz; Duty Cycle: 1:1

Medium: 1900 Body Medium parameters used (interpolated):

$f = 1900 \text{ MHz}$; $\sigma = 1.551 \text{ S/m}$; $\epsilon_r = 53.24$; $\rho = 1000 \text{ kg/m}^3$

Phantom section: Flat Section; Space: 1.0 cm

Test Date: 07-05-2018; Ambient Temp: 23.5°C; Tissue Temp: 22.1°C

Probe: EX3DV4 - SN7406; ConvF(7.74, 7.74, 7.74); Calibrated: 5/22/2018;

Sensor-Surface: 1.4mm (Mechanical Surface Detection)

Electronics: DAE4 Sn859; Calibrated: 5/22/2018

Phantom: Twin-SAM V4.0; Type: QD 000 P40 CC; Serial: 1167

Measurement SW: DASY52, Version 52.10;SEMCAD X Version 14.6.10 (7417)

1900 MHz System Verification at 20.0 dBm (100 mW)

Area Scan (7x11x1): Measurement grid: dx=15mm, dy=15mm

Zoom Scan (5x5x7)/Cube 0: Measurement grid: dx=8mm, dy=8mm, dz=5mm

Peak SAR (extrapolated) = 7.64 W/kg

SAR(1 g) = 4.18 W/kg

Deviation(1 g) = 4.50%

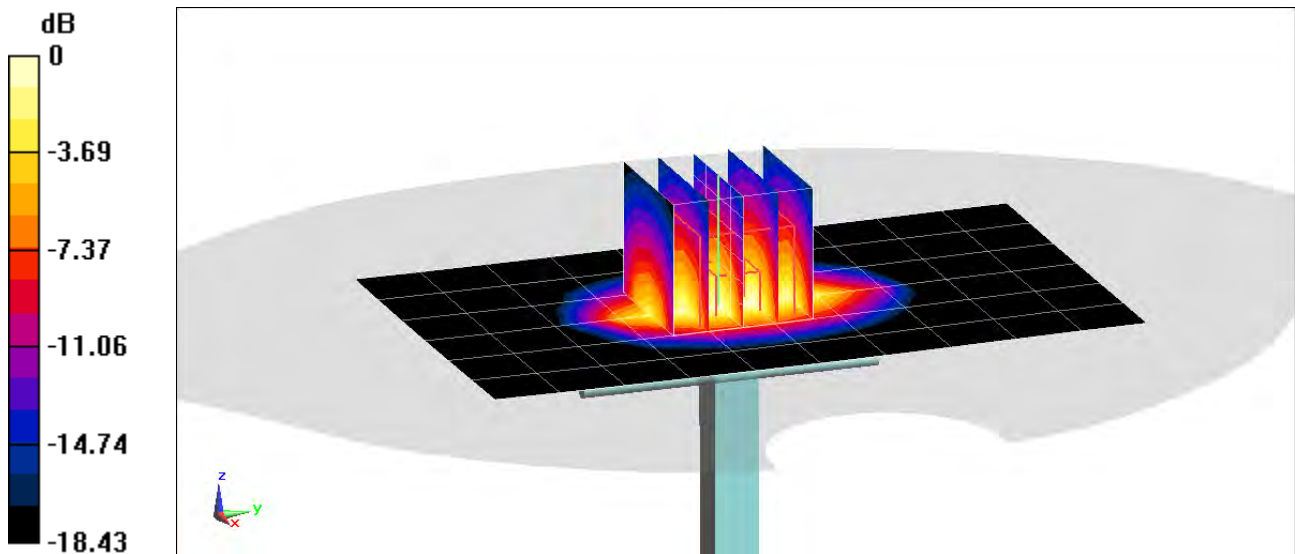

0 dB = 6.36 W/kg = 8.03 dBW/kg

PCTEST ENGINEERING LABORATORY, INC.

DUT: Dipole 2300 MHz; Type: D2300V2; Serial: 1008

Communication System: UID 0, CW; Frequency: 2300 MHz; Duty Cycle: 1:1

Medium: 2450 Body Medium parameters used:

$f = 2300$ MHz; $\sigma = 1.837$ S/m; $\epsilon_r = 52.084$; $\rho = 1000$ kg/m³

Phantom section: Flat Section; Space: 1.0 cm

Test Date: 07-04-2018; Ambient Temp: 23.5°C; Tissue Temp: 22.5°C

Probe: ES3DV3 - SN3332; ConvF(4.74, 4.74, 4.74); Calibrated: 8/14/2017;

Sensor-Surface: 3mm (Mechanical Surface Detection)

Electronics: DAE4 Sn1323; Calibrated: 8/9/2017

Phantom: SAM Left; Type: QD000P40CA; Serial: TP:82355

Measurement SW: DASY52, Version 52.10; SEMCAD X Version 14.6.10 (7417)

2300 MHz System Verification at 20.0 dBm (100 mW)

Area Scan (8x9x1): Measurement grid: dx=12mm, dy=12mm

Zoom Scan (7x7x7)/Cube 0: Measurement grid: dx=5mm, dy=5mm, dz=5mm

Peak SAR (extrapolated) = 8.96 W/kg

SAR(1 g) = 4.65 W/kg

Deviation(1 g) = -1.27%

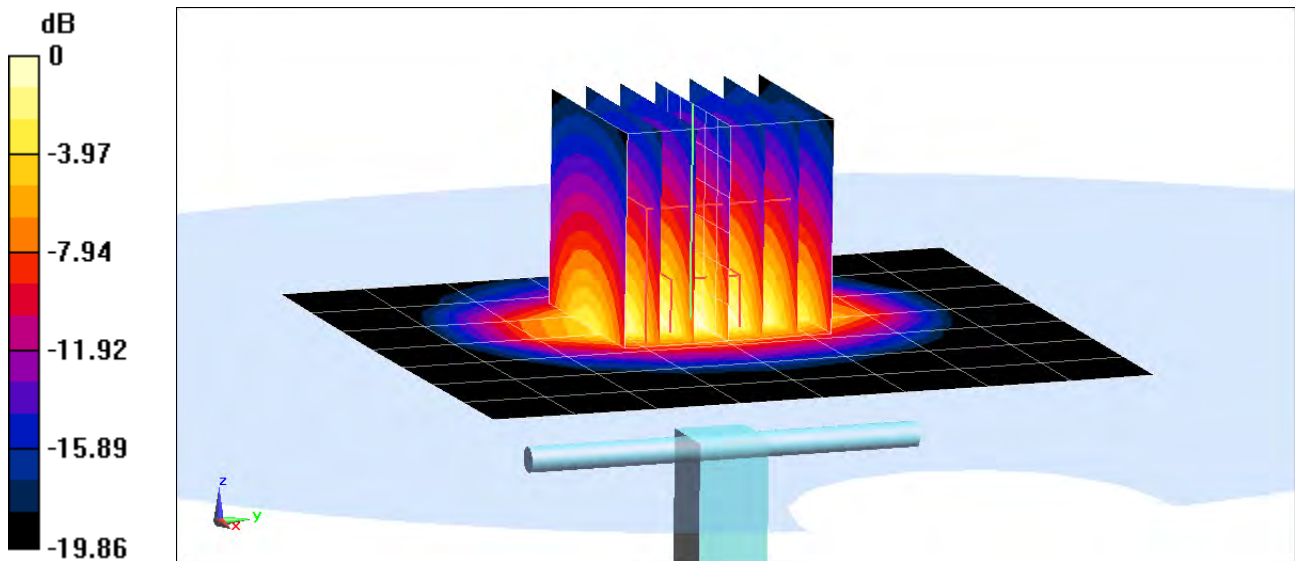

0 dB = 6.08 W/kg = 7.84 dBW/kg

PCTEST ENGINEERING LABORATORY, INC.

DUT: Dipole 2450 MHz; Type: D2450V2; Serial: 882

Communication System: UID 0, CW; Frequency: 2450 MHz; Duty Cycle: 1:1

Medium: 2450 Body Medium parameters used:

$f = 2450 \text{ MHz}$; $\sigma = 2.013 \text{ S/m}$; $\epsilon_r = 50.825$; $\rho = 1000 \text{ kg/m}^3$

Phantom section: Flat Section; Space: 1.0 cm

Test Date: 06-20-2018; Ambient Temp: 23.3°C; Tissue Temp: 22.2°C

Probe: ES3DV3 - SN3319; ConvF(4.51, 4.51, 4.51); Calibrated: 3/13/2018;

Sensor-Surface: 3mm (Mechanical Surface Detection)

Electronics: DAE4 Sn1368; Calibrated: 3/7/2018

Phantom: LeftTwin-SAM V5.0; Type: QD 000 P40 CD; Serial: 1375

Measurement SW: DASY52, Version 52.10; SEMCAD X Version 14.6.10 (7417)

2450 MHz System Verification at 20.0 dBm (100 mW)

Area Scan (8x9x1): Measurement grid: dx=12mm, dy=12mm

Zoom Scan (7x7x7)/Cube 0: Measurement grid: dx=5mm, dy=5mm, dz=5mm

Peak SAR (extrapolated) = 10.6 W/kg

SAR(1 g) = 5.13 W/kg

Deviation(1 g) = 2.19%

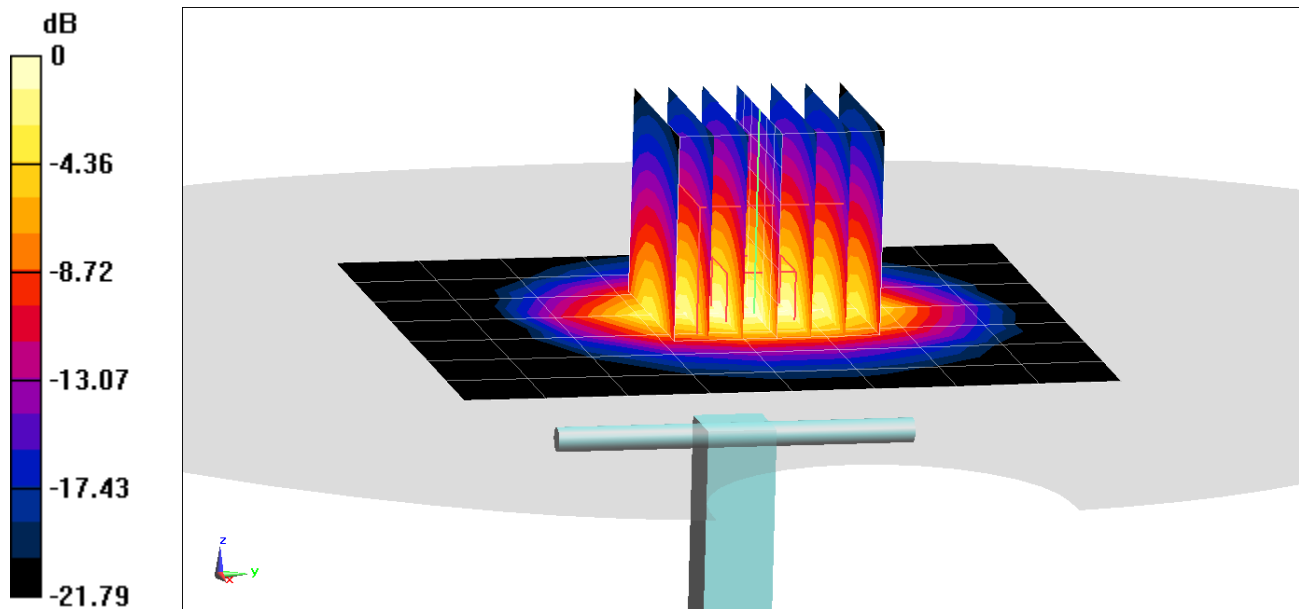

0 dB = 6.80 W/kg = 8.33 dBW/kg

PCTEST ENGINEERING LABORATORY, INC.

DUT: Dipole 2450 MHz; Type: D2450V2; Serial: 882

Communication System: UID 0, CW; Frequency: 2450 MHz; Duty Cycle: 1:1
Medium: 2450 Body Medium parameters used:
 $f = 2450 \text{ MHz}$; $\sigma = 2.038 \text{ S/m}$; $\epsilon_r = 51.523$; $\rho = 1000 \text{ kg/m}^3$
Phantom section: Flat Section; Space: 1.0 cm

Test Date: 07-04-2018; Ambient Temp: 23.5°C; Tissue Temp: 22.5°C

Probe: ES3DV3 - SN3332; ConvF(4.55, 4.55, 4.55); Calibrated: 8/14/2017;
Sensor-Surface: 3mm (Mechanical Surface Detection)
Electronics: DAE4 Sn1323; Calibrated: 8/9/2017
Phantom: SAM Left; Type: QD000P40CA; Serial: TP:82355
Measurement SW: DASY52, Version 52.10; SEMCAD X Version 14.6.10 (7417)

2450 MHz System Verification at 20.0 dBm (100 mW)

Area Scan (8x9x1): Measurement grid: dx=12mm, dy=12mm
Zoom Scan (7x7x7)/Cube 0: Measurement grid: dx=5mm, dy=5mm, dz=5mm
Peak SAR (extrapolated) = 10.1 W/kg
SAR(1 g) = 4.85 W/kg
Deviation(1 g) = -3.39%

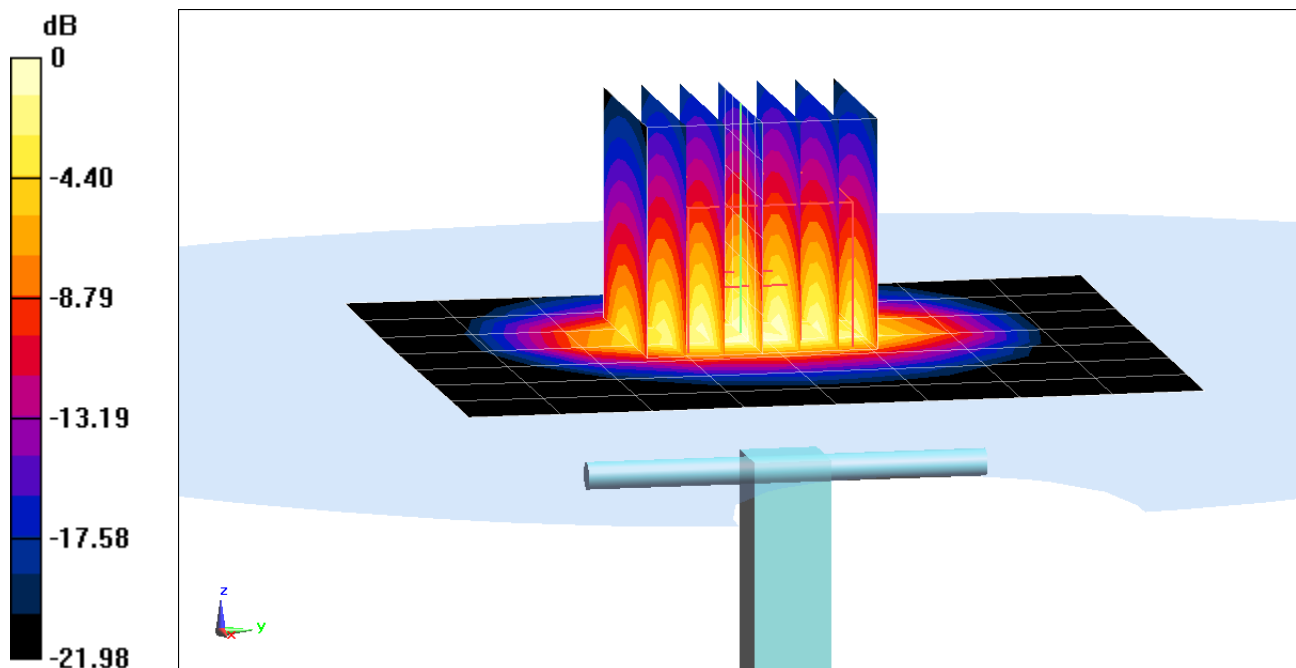

0 dB = 6.37 W/kg = 8.04 dBW/kg

PCTEST ENGINEERING LABORATORY, INC.

DUT: Dipole 2600 MHz; Type: D2600V2; Serial: 1004

Communication System: UID 0, CW; Frequency: 2600 MHz; Duty Cycle: 1:1
Medium: 2450 Body Medium parameters used:
 $f = 2600 \text{ MHz}$; $\sigma = 2.19 \text{ S/m}$; $\epsilon_r = 50.386$; $\rho = 1000 \text{ kg/m}^3$
Phantom section: Flat Section; Space: 1.0 cm

Test Date: 06-20-2018; Ambient Temp: 23.3°C; Tissue Temp: 22.2°C

Probe: ES3DV3 - SN3319; ConvF(4.33, 4.33, 4.33); Calibrated: 3/13/2018;
Sensor-Surface: 3mm (Mechanical Surface Detection)
Electronics: DAE4 Sn1368; Calibrated: 3/7/2018
Phantom: LeftTwin-SAM V5.0; Type: QD 000 P40 CD; Serial: 1375
Measurement SW: DASY52, Version 52.10; SEMCAD X Version 14.6.10 (7417)

2600 MHz System Verification at 20.0 dBm (100 mW)

Area Scan (8x9x1): Measurement grid: dx=12mm, dy=12mm
Zoom Scan (7x7x7)/Cube 0: Measurement grid: dx=5mm, dy=5mm, dz=5mm
Peak SAR (extrapolated) = 12.4 W/kg
SAR(1 g) = 5.68 W/kg
Deviation(1 g) = 3.65%

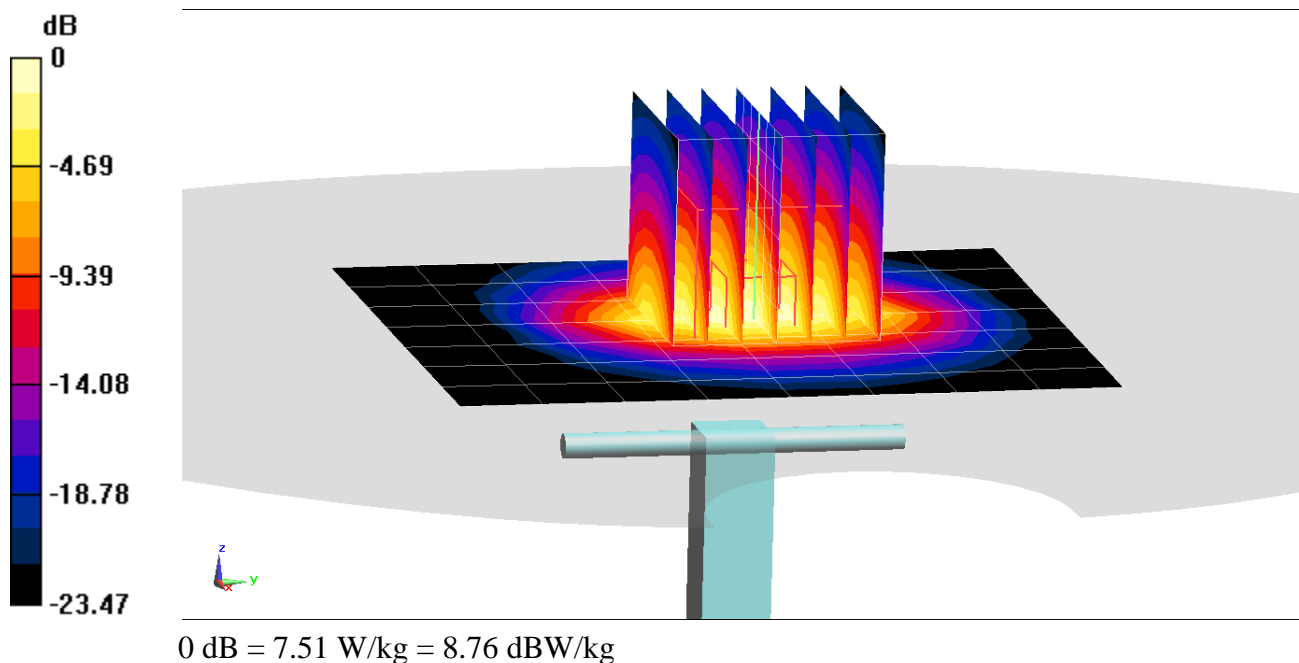

PCTEST ENGINEERING LABORATORY, INC.

DUT: Dipole 5 GHz; Type: D5GHzV2; Serial: 1237

Communication System: UID 0, CW; Frequency: 5250 MHz; Duty Cycle: 1:1
Medium: 5 GHz Body Medium parameters used (interpolated):
 $f = 5250 \text{ MHz}$; $\sigma = 5.475 \text{ S/m}$; $\epsilon_r = 47.383$; $\rho = 1000 \text{ kg/m}^3$
Phantom section: Flat Section; Space: 1.0 cm

Test Date: 06-25-2018; Ambient Temp: 22.5°C; Tissue Temp: 21.3°C

Probe: EX3DV4 - SN7357; ConvF(4.78, 4.78, 4.78); Calibrated: 4/18/2018;
Sensor-Surface: 1.4mm (Mechanical Surface Detection)

Electronics: DAE4 Sn1407; Calibrated: 4/11/2018

Phantom: SAM with CRP v5.0 Left; Type: QD000P40CD; Serial: 1687

Measurement SW: DASY52, Version 52.10;SEMCAD X Version 14.6.10 (7417)

5250 MHz System Verification at 17.0 dBm (50 mW)

Area Scan (7x7x1): Measurement grid: dx=10mm, dy=10mm

Zoom Scan (8x8x7)/Cube 0: Measurement grid: dx=4mm, dy=4mm, dz=1.4mm; Graded Ratio: 1.4

Peak SAR (extrapolated) = 14.2 W/kg

SAR(1 g) = 3.57 W/kg

Deviation(1 g) = -7.15%

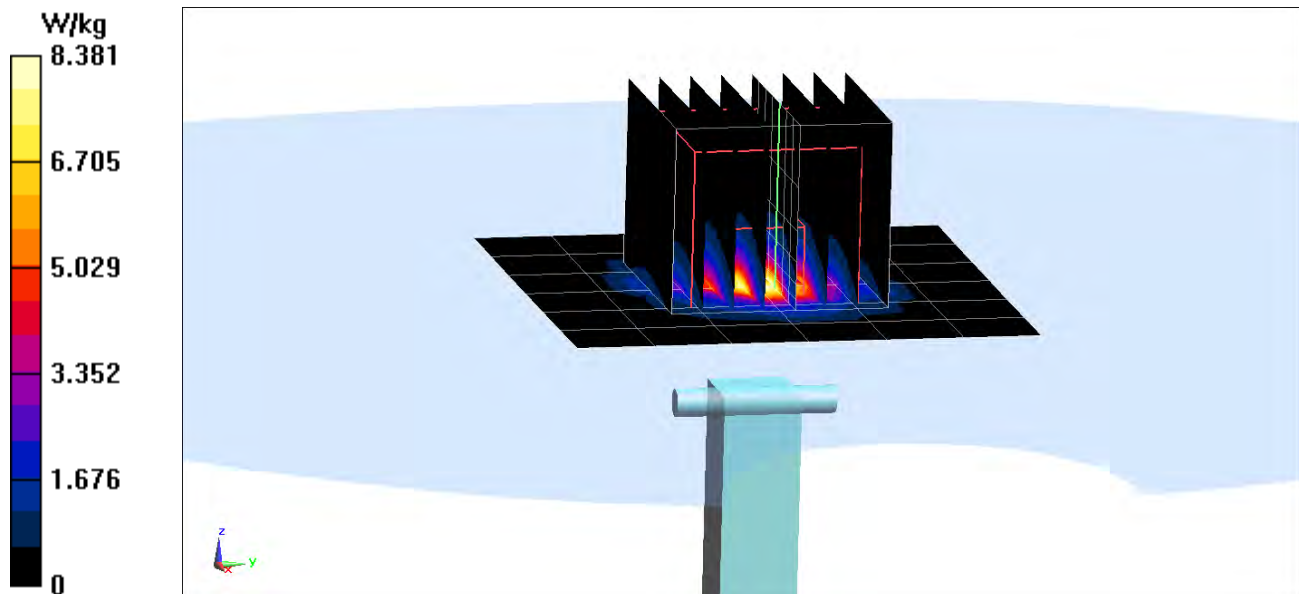

PCTEST ENGINEERING LABORATORY, INC.

DUT: Dipole 5 GHz; Type: D5GHzV2; Serial: 1237

Communication System: UID 0, CW; Frequency: 5600 MHz; Duty Cycle: 1:1

Medium: 5 GHz Body Medium parameters used:

$f = 5600 \text{ MHz}$; $\sigma = 5.949 \text{ S/m}$; $\epsilon_r = 46.79$; $\rho = 1000 \text{ kg/m}^3$

Phantom section: Flat Section; Space: 1.0 cm

Test Date: 06-25-2018; Ambient Temp: 22.5°C; Tissue Temp: 21.3°C

Probe: EX3DV4 - SN7357; ConvF(4.2, 4.2, 4.2); Calibrated: 4/18/2018;

Sensor-Surface: 1.4mm (Mechanical Surface Detection)

Electronics: DAE4 Sn1407; Calibrated: 4/11/2018

Phantom: SAM with CRP v5.0 Left; Type: QD000P40CD; Serial: 1687

Measurement SW: DASY52, Version 52.10;SEMCAD X Version 14.6.10 (7417)

5600 MHz System Verification at 17.0 dBm (50 mW)

Area Scan (7x7x1): Measurement grid: dx=10mm, dy=10mm

Zoom Scan (8x8x7)/Cube 0: Measurement grid: dx=4mm, dy=4mm, dz=1.4mm; Graded Ratio: 1.4

Peak SAR (extrapolated) = 17.1 W/kg

SAR(1 g) = 3.9 W/kg

Deviation(1 g) = -0.64%

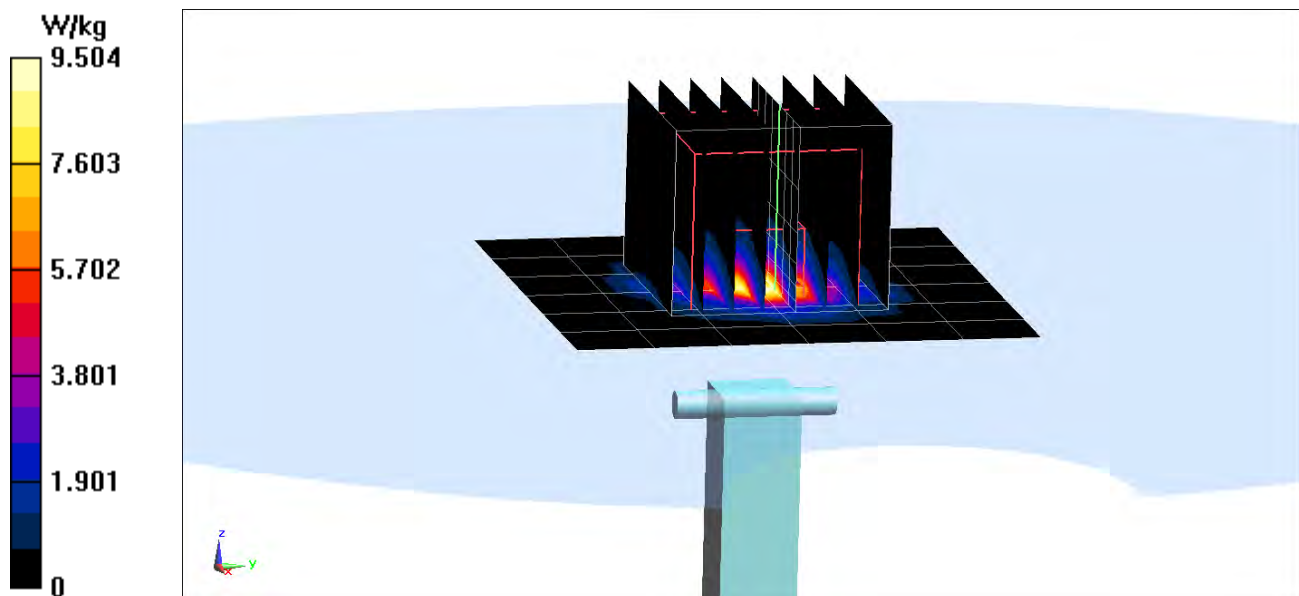

PCTEST ENGINEERING LABORATORY, INC.

DUT: Dipole 5 GHz; Type: D5GHzV2; Serial: 1237

Communication System: UID 0, CW; Frequency: 5750 MHz; Duty Cycle: 1:1
Medium: 5 GHz Body Medium parameters used (interpolated):
 $f = 5750 \text{ MHz}$; $\sigma = 6.163 \text{ S/m}$; $\epsilon_r = 46.526$; $\rho = 1000 \text{ kg/m}^3$
Phantom section: Flat Section; Space: 1.0 cm

Test Date: 06-25-2018; Ambient Temp: 22.5°C; Tissue Temp: 21.3°C

Probe: EX3DV4 - SN7357; ConvF(4.21, 4.21, 4.21); Calibrated: 4/18/2018;
Sensor-Surface: 1.4mm (Mechanical Surface Detection)

Electronics: DAE4 Sn1407; Calibrated: 4/11/2018

Phantom: SAM with CRP v5.0 Left; Type: QD000P40CD; Serial: 1687

Measurement SW: DASY52, Version 52.10;SEMCAD X Version 14.6.10 (7417)

5750 MHz System Verification at 17.0 dBm (50 mW)

Area Scan (7x7x1): Measurement grid: dx=10mm, dy=10mm

Zoom Scan (8x8x7)/Cube 0: Measurement grid: dx=4mm, dy=4mm, dz=1.4mm; Graded Ratio: 1.4

Peak SAR (extrapolated) = 17.2 W/kg

SAR(1 g) = 3.73 W/kg

Deviation(1 g) = -3.24%

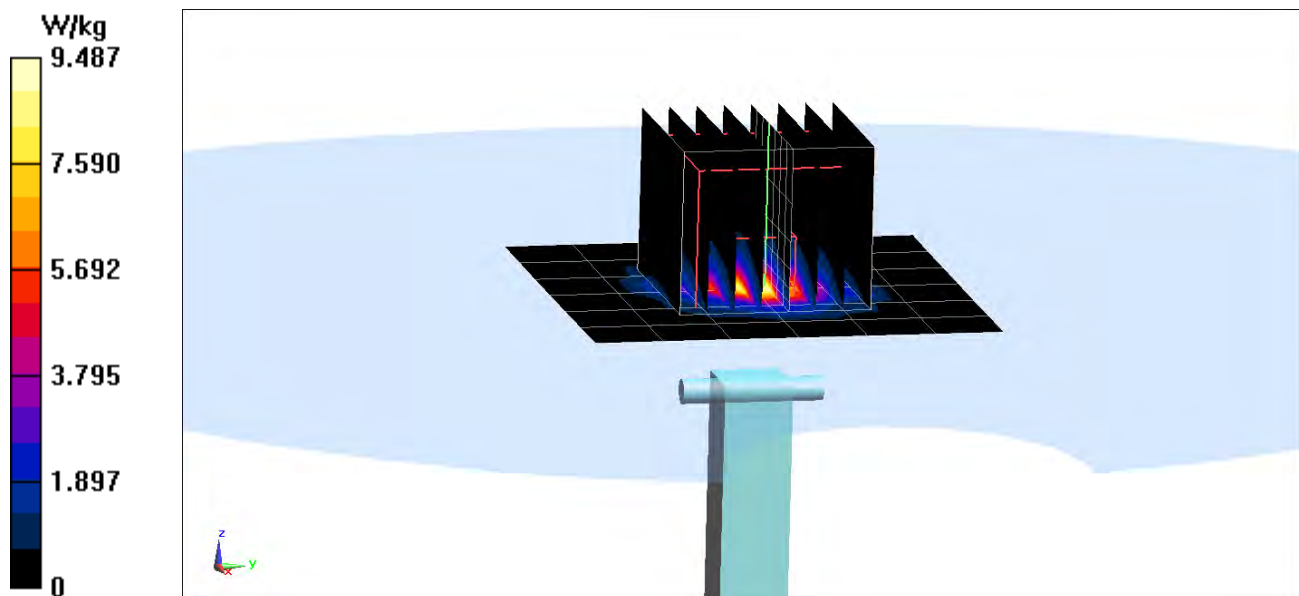

APPENDIX C: PROBE CALIBRATION



Accredited by the Swiss Accreditation Service (SAS)
The Swiss Accreditation Service is one of the signatories to the EA
Multilateral Agreement for the recognition of calibration certificates

Accreditation No.: **SCS 0108**

Client **PC Test**

Certificate No: **D750V3-1003_Jan18**

CALIBRATION CERTIFICATE

Object **D750V3 - SN:1003**

Calibration procedure(s) **QA CAL-05.v9**
Calibration procedure for dipole validation kits above 700 MHz

Calibration date: **January 15, 2018**

BN
01-25-2018

This calibration certificate documents the traceability to national standards, which realize the physical units of measurements (SI).
The measurements and the uncertainties with confidence probability are given on the following pages and are part of the certificate.

All calibrations have been conducted in the closed laboratory facility: environment temperature (22 ± 3)°C and humidity < 70%.

Calibration Equipment used (M&TE critical for calibration)

Primary Standards	ID #	Cal Date (Certificate No.)	Scheduled Calibration
Power meter NRP	SN: 104778	04-Apr-17 (No. 217-02521/02522)	Apr-18
Power sensor NRP-Z91	SN: 103244	04-Apr-17 (No. 217-02521)	Apr-18
Power sensor NRP-Z91	SN: 103245	04-Apr-17 (No. 217-02522)	Apr-18
Reference 20 dB Attenuator	SN: 5058 (20k)	07-Apr-17 (No. 217-02528)	Apr-18
Type-N mismatch combination	SN: 5047.2 / 06327	07-Apr-17 (No. 217-02529)	Apr-18
Reference Probe EX3DV4	SN: 7349	30-Dec-17 (No. EX3-7349_Dec17)	Dec-18
DAE4	SN: 601	26-Oct-17 (No. DAE4-601_Oct17)	Oct-18
Secondary Standards	ID #	Check Date (in house)	Scheduled Check
Power meter EPM-442A	SN: GB37480704	07-Oct-15 (in house check Oct-16)	In house check: Oct-18
Power sensor HP 8481A	SN: US37292783	07-Oct-15 (in house check Oct-16)	In house check: Oct-18
Power sensor HP 8481A	SN: MY41092317	07-Oct-15 (in house check Oct-16)	In house check: Oct-18
RF generator R&S SMT-06	SN: 100972	15-Jun-15 (in house check Oct-16)	In house check: Oct-18
Network Analyzer HP 8753E	SN: US37390585	18-Oct-01 (in house check Oct-17)	In house check: Oct-18

Calibrated by: **Leif Klysner** Function: **Laboratory Technician**

Signature
Leif Klysner

Approved by: **Katja Pokovic** Technical Manager

Katja Pokovic

Issued: January 15, 2018

This calibration certificate shall not be reproduced except in full without written approval of the laboratory.



Accredited by the Swiss Accreditation Service (SAS)
The Swiss Accreditation Service is one of the signatories to the EA
Multilateral Agreement for the recognition of calibration certificates

Accreditation No.: **SCS 0108**

Glossary:

TSL	tissue simulating liquid
ConvF	sensitivity in TSL / NORM x,y,z
N/A	not applicable or not measured

Calibration is Performed According to the Following Standards:

- IEEE Std 1528-2013, "IEEE Recommended Practice for Determining the Peak Spatial-Averaged Specific Absorption Rate (SAR) in the Human Head from Wireless Communications Devices: Measurement Techniques", June 2013
- IEC 62209-1, "Measurement procedure for the assessment of Specific Absorption Rate (SAR) from hand-held and body-mounted devices used next to the ear (frequency range of 300 MHz to 6 GHz)", July 2016
- IEC 62209-2, "Procedure to determine the Specific Absorption Rate (SAR) for wireless communication devices used in close proximity to the human body (frequency range of 30 MHz to 6 GHz)", March 2010
- KDB 865664, "SAR Measurement Requirements for 100 MHz to 6 GHz"

Additional Documentation:

- DASY4/5 System Handbook

Methods Applied and Interpretation of Parameters:

- Measurement Conditions:** Further details are available from the Validation Report at the end of the certificate. All figures stated in the certificate are valid at the frequency indicated.
- Antenna Parameters with TSL:** The dipole is mounted with the spacer to position its feed point exactly below the center marking of the flat phantom section, with the arms oriented parallel to the body axis.
- Feed Point Impedance and Return Loss:** These parameters are measured with the dipole positioned under the liquid filled phantom. The impedance stated is transformed from the measurement at the SMA connector to the feed point. The Return Loss ensures low reflected power. No uncertainty required.
- Electrical Delay:** One-way delay between the SMA connector and the antenna feed point. No uncertainty required.
- SAR measured:** SAR measured at the stated antenna input power.
- SAR normalized:** SAR as measured, normalized to an input power of 1 W at the antenna connector.
- SAR for nominal TSL parameters:** The measured TSL parameters are used to calculate the nominal SAR result.

The reported uncertainty of measurement is stated as the standard uncertainty of measurement multiplied by the coverage factor $k=2$, which for a normal distribution corresponds to a coverage probability of approximately 95%.

Measurement Conditions

DASY system configuration, as far as not given on page 1.

DASY Version	DASY5	V52.10.0
Extrapolation	Advanced Extrapolation	
Phantom	Modular Flat Phantom	
Distance Dipole Center - TSL	15 mm	with Spacer
Zoom Scan Resolution	dx, dy, dz = 5.0 mm	
Frequency	750 MHz \pm 1 MHz	

Head TSL parameters

The following parameters and calculations were applied.

	Temperature	Permittivity	Conductivity
Nominal Head TSL parameters	22.0 °C	41.9	0.89 mho/m
Measured Head TSL parameters	(22.0 \pm 0.2) °C	40.9 \pm 6 %	0.90 mho/m \pm 6 %
Head TSL temperature change during test	< 0.5 °C	----	----

SAR result with Head TSL

SAR averaged over 1 cm³ (1 g) of Head TSL	Condition	
SAR measured	250 mW input power	2.10 W/kg
SAR for nominal Head TSL parameters	normalized to 1W	8.28 W/kg \pm 17.0 % (k=2)

SAR averaged over 10 cm³ (10 g) of Head TSL	condition	
SAR measured	250 mW input power	1.37 W/kg
SAR for nominal Head TSL parameters	normalized to 1W	5.42 W/kg \pm 16.5 % (k=2)

Body TSL parameters

The following parameters and calculations were applied.

	Temperature	Permittivity	Conductivity
Nominal Body TSL parameters	22.0 °C	55.5	0.96 mho/m
Measured Body TSL parameters	(22.0 \pm 0.2) °C	55.0 \pm 6 %	0.96 mho/m \pm 6 %
Body TSL temperature change during test	< 0.5 °C	----	----

SAR result with Body TSL

SAR averaged over 1 cm³ (1 g) of Body TSL	Condition	
SAR measured	250 mW input power	2.15 W/kg
SAR for nominal Body TSL parameters	normalized to 1W	8.58 W/kg \pm 17.0 % (k=2)

SAR averaged over 10 cm³ (10 g) of Body TSL	condition	
SAR measured	250 mW input power	1.43 W/kg
SAR for nominal Body TSL parameters	normalized to 1W	5.71 W/kg \pm 16.5 % (k=2)

Appendix (Additional assessments outside the scope of SCS 0108)

Antenna Parameters with Head TSL

Impedance, transformed to feed point	53.8 Ω - 2.1 j Ω
Return Loss	- 27.6 dB

Antenna Parameters with Body TSL

Impedance, transformed to feed point	49.2 Ω - 6.2 j Ω
Return Loss	- 24.0 dB

General Antenna Parameters and Design

Electrical Delay (one direction)	1.043 ns
----------------------------------	----------

After long term use with 100W radiated power, only a slight warming of the dipole near the feedpoint can be measured.

The dipole is made of standard semirigid coaxial cable. The center conductor of the feeding line is directly connected to the second arm of the dipole. The antenna is therefore short-circuited for DC-signals. On some of the dipoles, small end caps are added to the dipole arms in order to improve matching when loaded according to the position as explained in the "Measurement Conditions" paragraph. The SAR data are not affected by this change. The overall dipole length is still according to the Standard.

No excessive force must be applied to the dipole arms, because they might bend or the soldered connections near the feedpoint may be damaged.

Additional EUT Data

Manufactured by	SPEAG
Manufactured on	January 21, 2009

Appendix (Additional assessments outside the scope of SCS 0108)

Measurement Conditions

DASY system configuration, as far as not given on page 1 and 3.

Phantom	SAM Head Phantom	For usage with cSAR3DV2-R/L
---------	------------------	-----------------------------

SAR result with SAM Head (Top)

SAR averaged over 1 cm ³ (1 g) of Head TSL	Condition	
SAR measured	250 mW input power	1.98 W/kg
SAR for nominal Head TSL parameters	normalized to 1W	7.94 W/kg ± 17.5 % (k=2)

SAR averaged over 10 cm ³ (10 g) of Head TSL	condition	
SAR measured	250 mW input power	1.33 W/kg
SAR for nominal Head TSL parameters	normalized to 1W	5.32 W/kg ± 16.9 % (k=2)

SAR result with SAM Head (Mouth)

SAR averaged over 1 cm ³ (1 g) of Head TSL	Condition	
SAR measured	250 mW input power	2.05 W/kg
SAR for nominal Head TSL parameters	normalized to 1W	8.22 W/kg ± 17.5 % (k=2)

SAR averaged over 10 cm ³ (10 g) of Head TSL	condition	
SAR measured	250 mW input power	1.38 W/kg
SAR for nominal Head TSL parameters	normalized to 1W	5.52 W/kg ± 16.9 % (k=2)

SAR result with SAM Head (Neck)

SAR averaged over 1 cm ³ (1 g) of Head TSL	Condition	
SAR measured	250 mW input power	2.01 W/kg
SAR for nominal Head TSL parameters	normalized to 1W	8.06 W/kg ± 17.5 % (k=2)

SAR averaged over 10 cm ³ (10 g) of Head TSL	condition	
SAR measured	250 mW input power	1.38 W/kg
SAR for nominal Head TSL parameters	normalized to 1W	5.52 W/kg ± 16.9 % (k=2)

SAR result with SAM Head (Ear)

SAR averaged over 1 cm ³ (1 g) of Head TSL	Condition	
SAR measured	250 mW input power	1.67 W/kg
SAR for nominal Head TSL parameters	normalized to 1W	6.70 W/kg ± 17.5 % (k=2)

SAR averaged over 10 cm ³ (10 g) of Head TSL	condition	
SAR measured	250 mW input power	1.15 W/kg
SAR for nominal Head TSL parameters	normalized to 1W	4.60 W/kg ± 16.9 % (k=2)

DASY5 Validation Report for Head TSL

Date: 12.01.2018

Test Laboratory: SPEAG, Zurich, Switzerland

DUT: Dipole 750 MHz; Type: D750V3; Serial: D750V3 - SN:1003

Communication System: UID 0 - CW; Frequency: 750 MHz

Medium parameters used: $f = 750$ MHz; $\sigma = 0.9$ S/m; $\epsilon_r = 40.9$; $\rho = 1000$ kg/m³

Phantom section: Flat Section

Measurement Standard: DASY5 (IEEE/IEC/ANSI C63.19-2011)

DASY52 Configuration:

- Probe: EX3DV4 - SN7349; ConvF(10.22, 10.22, 10.22); Calibrated: 30.12.2017;
- Sensor-Surface: 1.4mm (Mechanical Surface Detection)
- Electronics: DAE4 Sn601; Calibrated: 26.10.2017
- Phantom: Flat Phantom 4.9 (front); Type: QD 00L P49 AA; Serial: 1001
- DASY52 52.10.0(1446); SEMCAD X 14.6.10(7417)

Dipole Calibration for Head Tissue/Pin=250 mW, d=15mm/Zoom Scan (7x7x7)/Cube 0:

Measurement grid: dx=5mm, dy=5mm, dz=5mm

Reference Value = 59.11 V/m; Power Drift = -0.04 dB

Peak SAR (extrapolated) = 3.15 W/kg

SAR(1 g) = 2.1 W/kg; SAR(10 g) = 1.37 W/kg

Maximum value of SAR (measured) = 2.80 W/kg

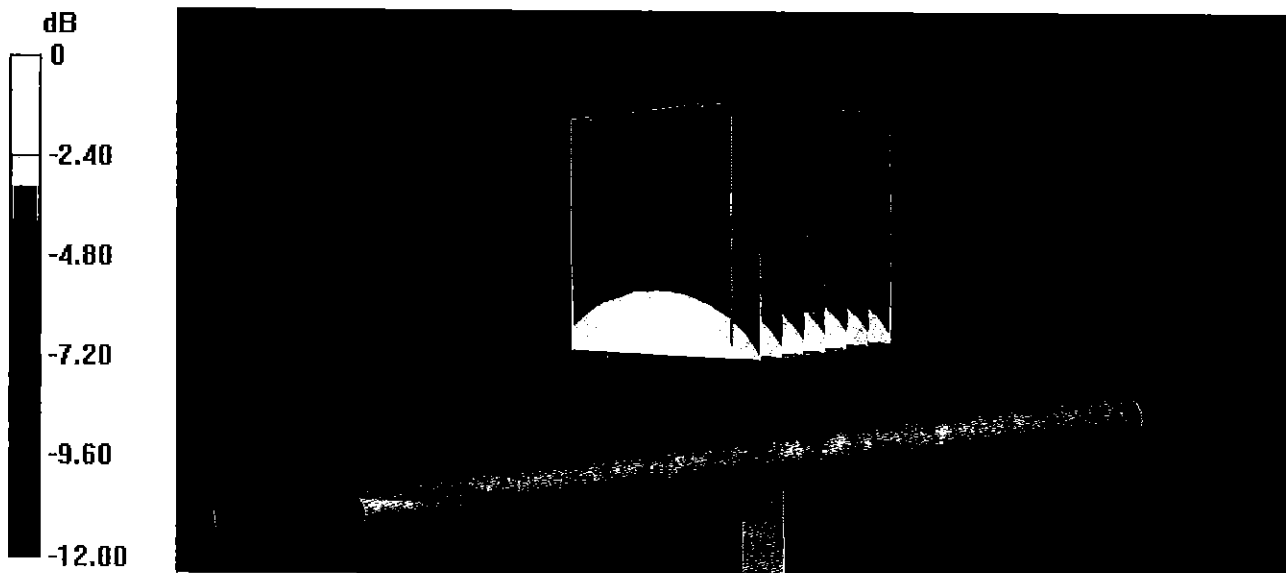

0 dB = 2.80 W/kg = 4.47 dBW/kg

Impedance Measurement Plot for Head TSL

12 Jan 2018 13:14:07
CH1 S11 1 U FS 1: 53.754 Ω -2.0996 Ω 101.07 pF 750.000 000 MHz

*
Del
CA

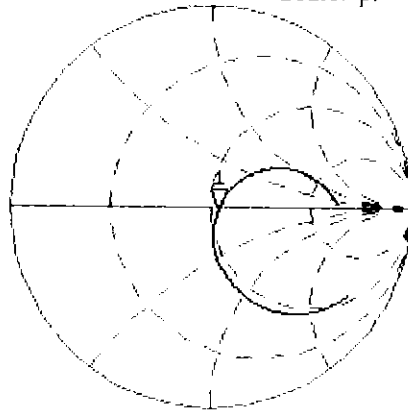

Avg
16

H1d

CH2 S11 LOG 5 dB/REF -20 dB 1: -27.643 dB 750.000 000 MHz

CA

Avg
16

H1d

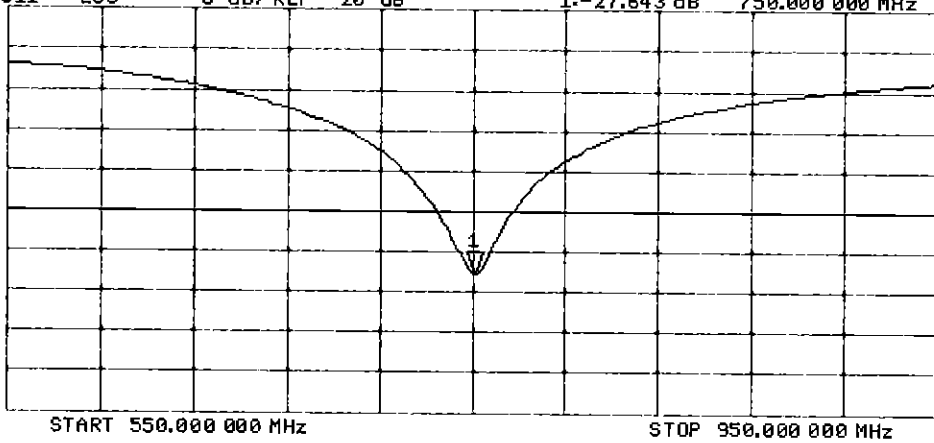

DASY5 Validation Report for Body TSL

Date: 12.01.2018

Test Laboratory: SPEAG, Zurich, Switzerland

DUT: Dipole 750 MHz; Type: D750V3; Serial: D750V3 - SN:1003

Communication System: UID 0 - CW; Frequency: 750 MHz

Medium parameters used: $f = 750$ MHz; $\sigma = 0.96$ S/m; $\epsilon_r = 55$; $\rho = 1000$ kg/m³

Phantom section: Flat Section

Measurement Standard: DASY5 (IEEE/IEC/ANSI C63.19-2011)

DASY52 Configuration:

- Probe: EX3DV4 - SN7349; ConvF(10.19, 10.19, 10.19); Calibrated: 30.12.2017;
- Sensor-Surface: 1.4mm (Mechanical Surface Detection)
- Electronics: DAE4 Sn601; Calibrated: 26.10.2017
- Phantom: Flat Phantom 4.9 (Back); Type: QD 00R P49 AA; Serial: 1005
- DASY52 52.10.0(1446); SEMCAD X 14.6.10(7417)

Dipole Calibration for Body Tissue/Pin=250 mW, d=15mm/Zoom Scan (7x8x7)/Cube 0:

Measurement grid: dx=5mm, dy=5mm, dz=5mm

Reference Value = 57.31 V/m; Power Drift = -0.01 dB

Peak SAR (extrapolated) = 3.17 W/kg

SAR(1 g) = 2.15 W/kg; SAR(10 g) = 1.43 W/kg

Maximum value of SAR (measured) = 2.83 W/kg

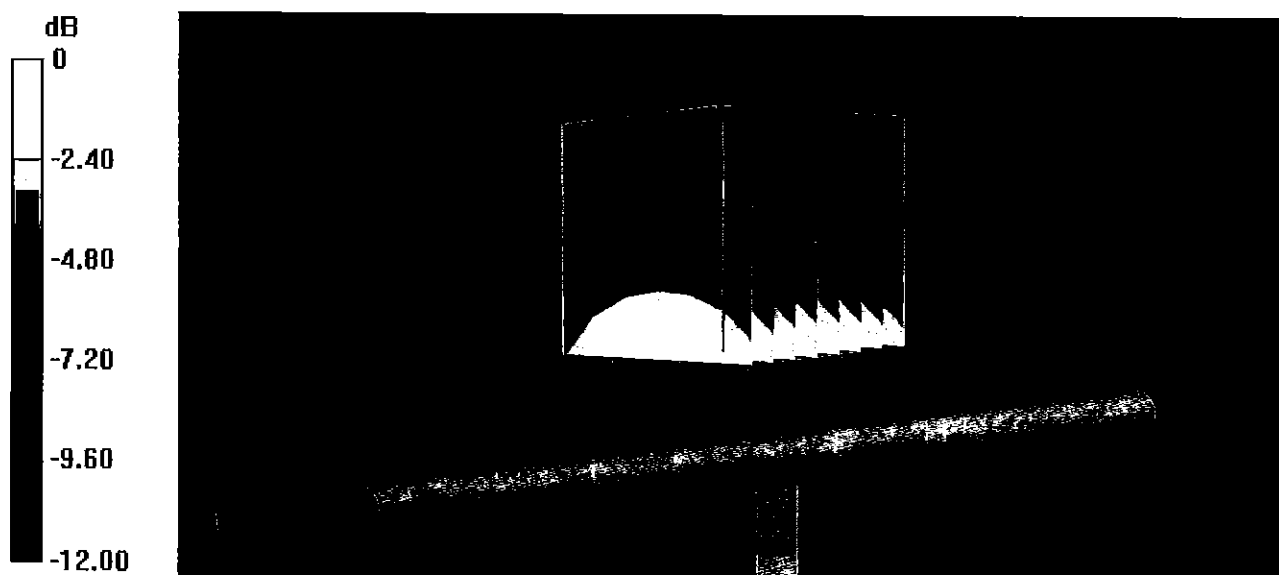

Impedance Measurement Plot for Body TSL

12 Jan 2018 13:13:21
CH1 S11 1 U FS 1: 49.234 Ω -6.1934 Ω 34.264 pF 750.000 000 MHz

*
De1

CA

Avg
16

H1d

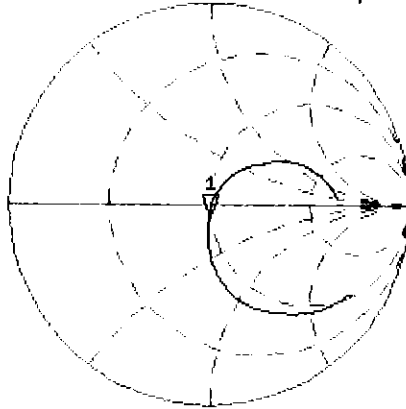

CH2 S11 LOG 5 dB/REF -20 dB 1:-24.047 dB 750.000 000 MHz

CA

Avg
16

H1d

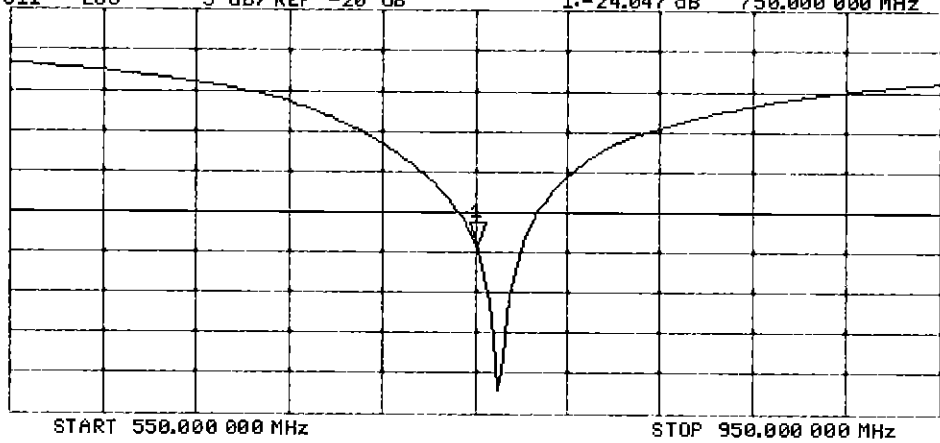

DASY5 Validation Report for SAM Head

Date: 15.01.2018

Test Laboratory: SPEAG, Zurich, Switzerland

DUT: Dipole 750 MHz; Type: D750V3; Serial: D750V3 - SN:1003

Communication System: UID 0 - CW; Frequency: 750 MHz

Medium parameters used: $f = 750$ MHz; $\sigma = 0.9$ S/m; $\epsilon_r = 44.2$; $\rho = 1000$ kg/m³

Measurement Standard: DASY5 (IEEE/IEC/ANSI C63.19-2011)

DASY52 Configuration:

- Probe: EX3DV4 - SN7349; ConvF(10.22, 10.22, 10.22); Calibrated: 30.12.2017;
- Sensor-Surface: 1.4mm (Mechanical Surface Detection)
- Electronics: DAE4 Sn601; Calibrated: 26.10.2017
- Phantom: SAM Head
- DASY52 52.10.0(1446); SEMCAD X 14.6.10(7417)

SAM Head/Top/Zoom Scan (7x7x7)/Cube 0: Measurement grid: dx=5mm, dy=5mm, dz=5mm

Reference Value = 56.79 V/m; Power Drift = -0.01 dB

Peak SAR (extrapolated) = 2.89 W/kg

SAR(1 g) = 1.98 W/kg; SAR(10 g) = 1.33 W/kg

Maximum value of SAR (measured) = 2.58 W/kg

SAM Head/Mouth/Zoom Scan (7x7x7)/Cube 0: Measurement grid: dx=5mm, dy=5mm, dz=5mm

Reference Value = 56.85 V/m; Power Drift = -0.06 dB

Peak SAR (extrapolated) = 2.94 W/kg

SAR(1 g) = 2.05 W/kg; SAR(10 g) = 1.38 W/kg

Maximum value of SAR (measured) = 2.62 W/kg

SAM Head/Neck/Zoom Scan (7x7x7)/Cube 0: Measurement grid: dx=5mm, dy=5mm, dz=5mm

Reference Value = 56.29 V/m; Power Drift = 0.04 dB

Peak SAR (extrapolated) = 2.78 W/kg

SAR(1 g) = 2.01 W/kg; SAR(10 g) = 1.38 W/kg

Maximum value of SAR (measured) = 2.56 W/kg

SAM Head/Ear/Zoom Scan (7x7x7)/Cube 0: Measurement grid: dx=5mm, dy=5mm, dz=5mm

Reference Value = 51.01 V/m; Power Drift = 0.02 dB

Peak SAR (extrapolated) = 2.31 W/kg

SAR(1 g) = 1.67 W/kg; SAR(10 g) = 1.15 W/kg

Maximum value of SAR (measured) = 2.11 W/kg

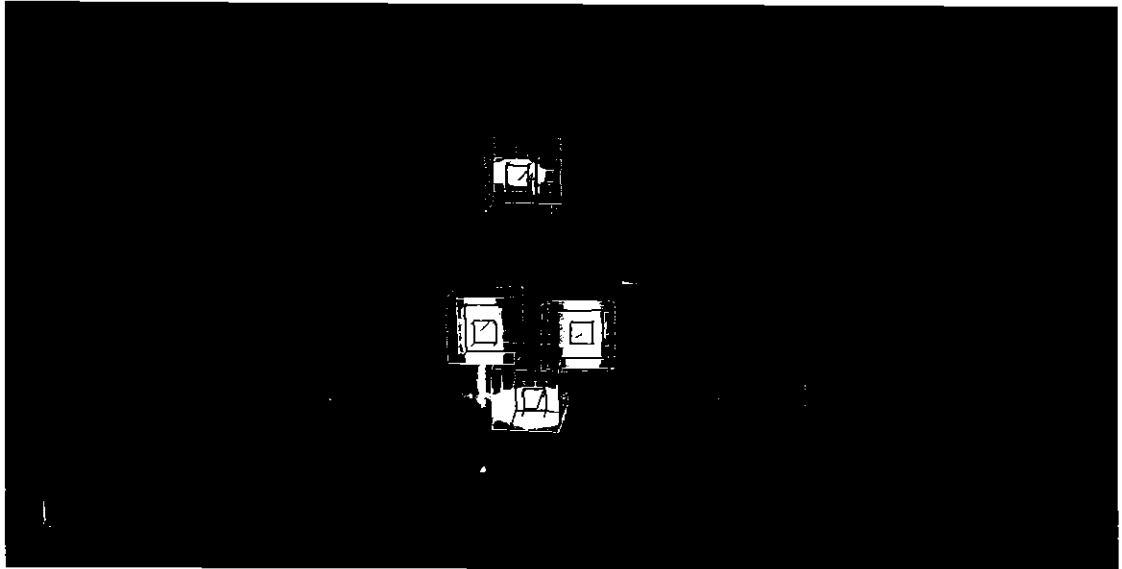
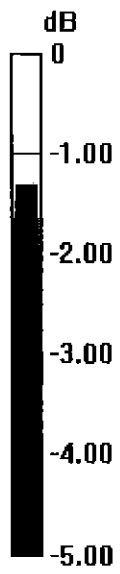

0 dB = 2.58 W/kg = 4.12 dBW/kg



Accredited by the Swiss Accreditation Service (SAS)
The Swiss Accreditation Service is one of the signatories to the EA
Multilateral Agreement for the recognition of calibration certificates

Accreditation No.: **SCS 0108**

Client **PC Test**

Certificate No: **D835V2-4d132_Jan18**

CALIBRATION CERTIFICATE

Object **D835V2 - SN:4d132**

Calibration procedure(s) **QA CAL-05.v9**
Calibration procedure for dipole validation kits above 700 MHz

Calibration date: **January 15, 2018**

BNV
01-25-2018

This calibration certificate documents the traceability to national standards, which realize the physical units of measurements (SI).
The measurements and the uncertainties with confidence probability are given on the following pages and are part of the certificate.

All calibrations have been conducted in the closed laboratory facility: environment temperature $(22 \pm 3)^\circ\text{C}$ and humidity $< 70\%$.

Calibration Equipment used (M&TE critical for calibration)

Primary Standards	ID #	Cal Date (Certificate No.)	Scheduled Calibration
Power meter NRP	SN: 104778	04-Apr-17 (No. 217-02521/02522)	Apr-18
Power sensor NRP-Z91	SN: 103244	04-Apr-17 (No. 217-02521)	Apr-18
Power sensor NRP-Z91	SN: 103245	04-Apr-17 (No. 217-02522)	Apr-18
Reference 20 dB Attenuator	SN: 5058 (20k)	07-Apr-17 (No. 217-02528)	Apr-18
Type-N mismatch combination	SN: 5047.2 / 06327	07-Apr-17 (No. 217-02529)	Apr-18
Reference Probe EX3DV4	SN: 7349	30-Dec-17 (No. EX3-7349_Dec17)	Dec-18
DAE4	SN: 601	26-Oct-17 (No. DAE4-601_Oct17)	Oct-18
Secondary Standards	ID #	Check Date (in house)	Scheduled Check
Power meter EPM-442A	SN: GB37480704	07-Oct-15 (in house check Oct-16)	In house check: Oct-18
Power sensor HP 8481A	SN: US37292783	07-Oct-15 (in house check Oct-16)	In house check: Oct-18
Power sensor HP 8481A	SN: MY41092317	07-Oct-15 (in house check Oct-16)	In house check: Oct-18
RF generator R&S SMT-06	SN: 100972	15-Jun-15 (in house check Oct-16)	In house check: Oct-18
Network Analyzer HP 8753E	SN: US37390585	18-Oct-01 (in house check Oct-17)	In house check: Oct-18

Calibrated by: **Leif Klysner** Name: **Leif Klysner** Function: **Laboratory Technician**

Signature: *Leif Klysner*

Approved by: **Katja Pokovic** Name: **Katja Pokovic** Function: **Technical Manager**

Signature: *Katja Pokovic*

Issued: January 15, 2018

This calibration certificate shall not be reproduced except in full without written approval of the laboratory.



Accredited by the Swiss Accreditation Service (SAS)
The Swiss Accreditation Service is one of the signatories to the EA
Multilateral Agreement for the recognition of calibration certificates

Accreditation No.: **SCS 0108**

Glossary:

TSL	tissue simulating liquid
ConvF	sensitivity in TSL / NORM x,y,z
N/A	not applicable or not measured

Calibration is Performed According to the Following Standards:

- IEEE Std 1528-2013, "IEEE Recommended Practice for Determining the Peak Spatial-Averaged Specific Absorption Rate (SAR) in the Human Head from Wireless Communications Devices: Measurement Techniques", June 2013
- IEC 62209-1, "Measurement procedure for the assessment of Specific Absorption Rate (SAR) from hand-held and body-mounted devices used next to the ear (frequency range of 300 MHz to 6 GHz)", July 2016
- IEC 62209-2, "Procedure to determine the Specific Absorption Rate (SAR) for wireless communication devices used in close proximity to the human body (frequency range of 30 MHz to 6 GHz)", March 2010
- KDB 865664, "SAR Measurement Requirements for 100 MHz to 6 GHz"

Additional Documentation:

- DASY4/5 System Handbook

Methods Applied and Interpretation of Parameters:

- Measurement Conditions:** Further details are available from the Validation Report at the end of the certificate. All figures stated in the certificate are valid at the frequency indicated.
- Antenna Parameters with TSL:** The dipole is mounted with the spacer to position its feed point exactly below the center marking of the flat phantom section, with the arms oriented parallel to the body axis.
- Feed Point Impedance and Return Loss:** These parameters are measured with the dipole positioned under the liquid filled phantom. The impedance stated is transformed from the measurement at the SMA connector to the feed point. The Return Loss ensures low reflected power. No uncertainty required.
- Electrical Delay:** One-way delay between the SMA connector and the antenna feed point. No uncertainty required.
- SAR measured:** SAR measured at the stated antenna input power.
- SAR normalized:** SAR as measured, normalized to an input power of 1 W at the antenna connector.
- SAR for nominal TSL parameters:** The measured TSL parameters are used to calculate the nominal SAR result.

The reported uncertainty of measurement is stated as the standard uncertainty of measurement multiplied by the coverage factor $k=2$, which for a normal distribution corresponds to a coverage probability of approximately 95%.

Measurement Conditions

DASY system configuration, as far as not given on page 1.

DASY Version	DASY5	V52.10.0
Extrapolation	Advanced Extrapolation	
Phantom	Modular Flat Phantom	
Distance Dipole Center - TSL	10 mm	with Spacer
Zoom Scan Resolution	dx, dy, dz = 5.0 mm	
Frequency	835 MHz \pm 1 MHz	

Head TSL parameters

The following parameters and calculations were applied.

	Temperature	Permittivity	Conductivity
Nominal Head TSL parameters	22.0 °C	41.5	0.90 mho/m
Measured Head TSL parameters	(22.0 \pm 0.2) °C	40.7 \pm 6 %	0.92 mho/m \pm 6 %
Head TSL temperature change during test	< 0.5 °C	----	----

SAR result with Head TSL

SAR averaged over 1 cm³ (1 g) of Head TSL	Condition	
SAR measured	250 mW input power	2.39 W/kg
SAR for nominal Head TSL parameters	normalized to 1W	9.36 W/kg \pm 17.0 % (k=2)

SAR averaged over 10 cm³ (10 g) of Head TSL	condition	
SAR measured	250 mW input power	1.55 W/kg
SAR for nominal Head TSL parameters	normalized to 1W	6.10 W/kg \pm 16.5 % (k=2)

Body TSL parameters

The following parameters and calculations were applied.

	Temperature	Permittivity	Conductivity
Nominal Body TSL parameters	22.0 °C	55.2	0.97 mho/m
Measured Body TSL parameters	(22.0 \pm 0.2) °C	54.8 \pm 6 %	0.99 mho/m \pm 6 %
Body TSL temperature change during test	< 0.5 °C	----	----

SAR result with Body TSL

SAR averaged over 1 cm³ (1 g) of Body TSL	Condition	
SAR measured	250 mW input power	2.47 W/kg
SAR for nominal Body TSL parameters	normalized to 1W	9.71 W/kg \pm 17.0 % (k=2)

SAR averaged over 10 cm³ (10 g) of Body TSL	condition	
SAR measured	250 mW input power	1.62 W/kg
SAR for nominal Body TSL parameters	normalized to 1W	6.39 W/kg \pm 16.5 % (k=2)

Appendix (Additional assessments outside the scope of SCS 0108)

Antenna Parameters with Head TSL

Impedance, transformed to feed point	51.8 Ω - 2.9 j Ω
Return Loss	- 29.5 dB

Antenna Parameters with Body TSL

Impedance, transformed to feed point	47.4 Ω - 5.7 j Ω
Return Loss	- 23.9 dB

General Antenna Parameters and Design

Electrical Delay (one direction)	1.386 ns
----------------------------------	----------

After long term use with 100W radiated power, only a slight warming of the dipole near the feedpoint can be measured.

The dipole is made of standard semirigid coaxial cable. The center conductor of the feeding line is directly connected to the second arm of the dipole. The antenna is therefore short-circuited for DC-signals. On some of the dipoles, small end caps are added to the dipole arms in order to improve matching when loaded according to the position as explained in the "Measurement Conditions" paragraph. The SAR data are not affected by this change. The overall dipole length is still according to the Standard.

No excessive force must be applied to the dipole arms, because they might bend or the soldered connections near the feedpoint may be damaged.

Additional EUT Data

Manufactured by	SPEAG
Manufactured on	July 22, 2011

Appendix (Additional assessments outside the scope of SCS 0108)

Measurement Conditions

DASY system configuration, as far as not given on page 1 and 3.

Phantom	SAM Head Phantom	For usage with cSAR3DV2-R/L
---------	------------------	-----------------------------

SAR result with SAM Head (Top)

SAR averaged over 1 cm ³ (1 g) of Head TSL	Condition	
SAR measured	250 mW input power	2.40 W/kg
SAR for nominal Head TSL parameters	normalized to 1W	9.41 W/kg ± 17.5 % (k=2)

SAR averaged over 10 cm ³ (10 g) of Head TSL	condition	
SAR measured	250 mW input power	1.58 W/kg
SAR for nominal Head TSL parameters	normalized to 1W	6.21 W/kg ± 16.9 % (k=2)

SAR result with SAM Head (Mouth)

SAR averaged over 1 cm ³ (1 g) of Head TSL	Condition	
SAR measured	250 mW input power	2.47 W/kg
SAR for nominal Head TSL parameters	normalized to 1W	9.69 W/kg ± 17.5 % (k=2)

SAR averaged over 10 cm ³ (10 g) of Head TSL	condition	
SAR measured	250 mW input power	1.64 W/kg
SAR for nominal Head TSL parameters	normalized to 1W	6.45 W/kg ± 16.9 % (k=2)

SAR result with SAM Head (Neck)

SAR averaged over 1 cm ³ (1 g) of Head TSL	Condition	
SAR measured	250 mW input power	2.35 W/kg
SAR for nominal Head TSL parameters	normalized to 1W	9.22 W/kg ± 17.5 % (k=2)

SAR averaged over 10 cm ³ (10 g) of Head TSL	condition	
SAR measured	250 mW input power	1.59 W/kg
SAR for nominal Head TSL parameters	normalized to 1W	6.25 W/kg ± 16.9 % (k=2)

SAR result with SAM Head (Ear)

SAR averaged over 1 cm ³ (1 g) of Head TSL	Condition	
SAR measured	250 mW input power	2.03 W/kg
SAR for nominal Head TSL parameters	normalized to 1W	7.96 W/kg ± 17.5 % (k=2)

SAR averaged over 10 cm ³ (10 g) of Head TSL	condition	
SAR measured	250 mW input power	1.37 W/kg
SAR for nominal Head TSL parameters	normalized to 1W	5.39 W/kg ± 16.9 % (k=2)

DASY5 Validation Report for Head TSL

Date: 08.01.2018

Test Laboratory: SPEAG, Zurich, Switzerland

DUT: Dipole 835 MHz; Type: D835V2; Serial: D835V2 - SN:4d132

Communication System: UID 0 - CW; Frequency: 835 MHz

Medium parameters used: $f = 835 \text{ MHz}$; $\sigma = 0.92 \text{ S/m}$; $\epsilon_r = 40.7$; $\rho = 1000 \text{ kg/m}^3$

Phantom section: Flat Section

Measurement Standard: DASY5 (IEEE/IEC/ANSI C63.19-2011)

DASY52 Configuration:

- Probe: EX3DV4 - SN7349; ConvF(9.9, 9.9, 9.9); Calibrated: 30.12.2017;
- Sensor-Surface: 1.4mm (Mechanical Surface Detection)
- Electronics: DAE4 Sn601; Calibrated: 26.10.2017
- Phantom: Flat Phantom 4.9 (front); Type: QD 00L P49 AA; Serial: 1001
- DASY52 52.10.0(1446); SEMCAD X 14.6.10(7417)

Dipole Calibration for Head Tissue/ $P_{in}=250 \text{ mW}$, $d=10\text{mm}$ /Zoom Scan (7x7x7)/Cube 0:

Measurement grid: $dx=5\text{mm}$, $dy=5\text{mm}$, $dz=5\text{mm}$

Reference Value = 63.23 V/m ; Power Drift = -0.04 dB

Peak SAR (extrapolated) = 3.64 W/kg

SAR(1 g) = 2.39 W/kg ; SAR(10 g) = 1.55 W/kg

Maximum value of SAR (measured) = 3.22 W/kg



0 dB = $3.22 \text{ W/kg} = 5.08 \text{ dBW/kg}$

Impedance Measurement Plot for Head TSL

8 Jan 2018 16:29:07

CH1 S11 1 U FS

1: 51.768 Ω -2.8984 Ω 65.761 pF

835.000 000 MHz

De1

Cor

Avg
16

H1d

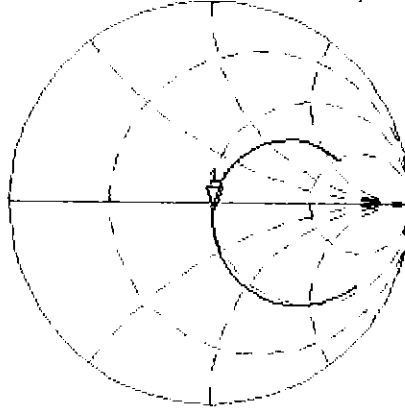

CH2 S11 LOG

5 dB/REF -20 dB

1:-29.535 dB

835.000 000 MHz

Cor

Avg
16

H1d

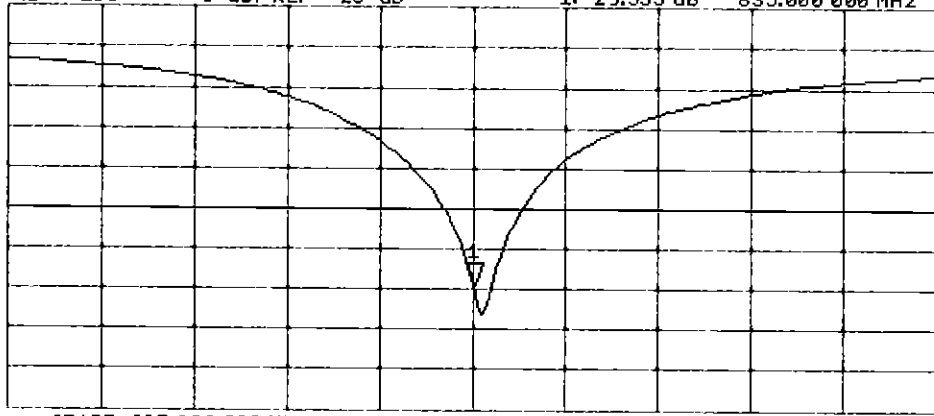

START 635.000 000 MHz

STOP 1 035.000 000 MHz

DASY5 Validation Report for Body TSL

Date: 08.01.2018

Test Laboratory: SPEAG, Zurich, Switzerland

DUT: Dipole 835 MHz; Type: D835V2; Serial: D835V2 - SN:4d132

Communication System: UID 0 - CW; Frequency: 835 MHz

Medium parameters used: $f = 835$ MHz; $\sigma = 0.99$ S/m; $\epsilon_r = 54.8$; $\rho = 1000$ kg/m³

Phantom section: Flat Section

Measurement Standard: DASY5 (IEEE/IEC/ANSI C63.19-2011)

DASY52 Configuration:

- Probe: EX3DV4 - SN7349; ConvF(10.05, 10.05, 10.05); Calibrated: 30.12.2017;
- Sensor-Surface: 1.4mm (Mechanical Surface Detection)
- Electronics: DAE4 Sn601; Calibrated: 26.10.2017
- Phantom: Flat Phantom 4.9 (Back); Type: QD 00R P49 AA; Serial: 1005
- DASY52 52.10.0(1446); SEMCAD X 14.6.10(7417)

Dipole Calibration for Body Tissue/Pin=250 mW, d=10mm/Zoom Scan (7x7x7)/Cube 0:

Measurement grid: dx=5mm, dy=5mm, dz=5mm

Reference Value = 60.55 V/m; Power Drift = -0.06 dB

Peak SAR (extrapolated) = 3.66 W/kg

SAR(1 g) = 2.47 W/kg; SAR(10 g) = 1.62 W/kg

Maximum value of SAR (measured) = 3.24 W/kg

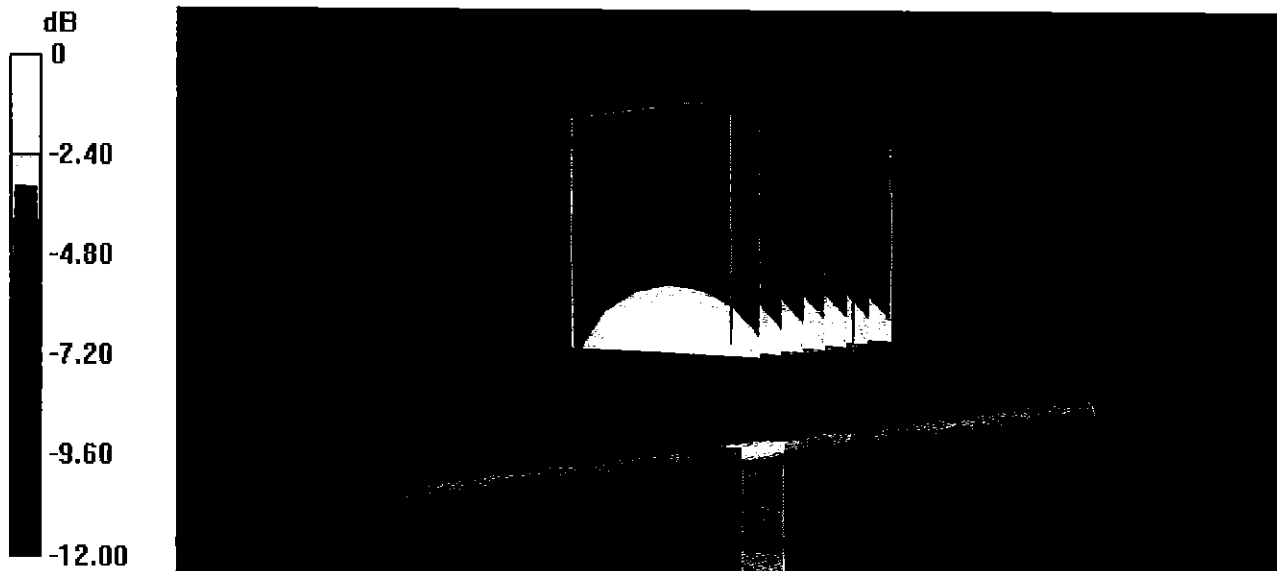

0 dB = 3.24 W/kg = 5.11 dBW/kg

Impedance Measurement Plot for Body TSL

8 Jan 2018 16:27:09
[CH1] S11 1 U FS 1: 47.447 Ω -5.6680 Ω 33.628 pF 835.000 000 MHz

*
De1
Cor

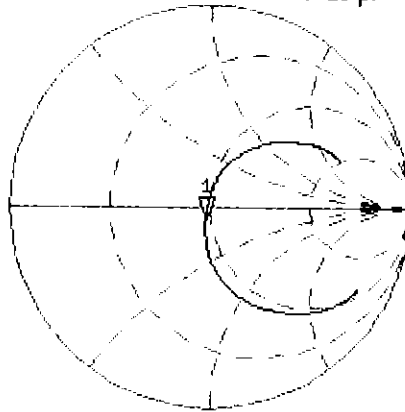

Avg
16

H1d

CH2 S11 LOG 5 dB/REF -20 dB 1:-23.922 dB 835.000 000 MHz

Cor

Avg
16

H1d

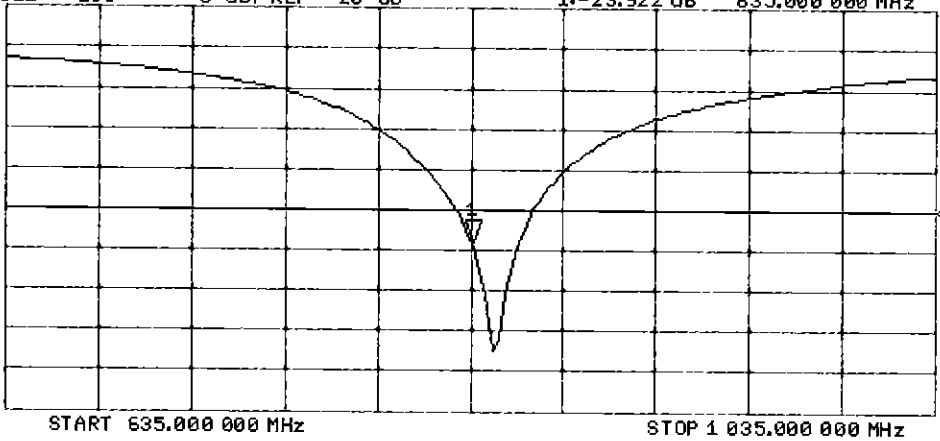

DASY5 Validation Report for SAM Head

Date: 15.01.2018

Test Laboratory: SPEAG, Zurich, Switzerland

DUT: Dipole 835 MHz; Type: D835V2; Serial: D835V2 - SN:4d132

Communication System: UID 0 - CW; Frequency: 835 MHz

Medium parameters used: $f = 835$ MHz; $\sigma = 0.94$ S/m; $\epsilon_r = 44.1$; $\rho = 1000$ kg/m³

Measurement Standard: DASY5 (IEEE/IEC/ANSI C63.19-2011)

DASY52 Configuration:

- Probe: EX3DV4 - SN7349; ConvF(9.9, 9.9, 9.9); Calibrated: 30.12.2017;
- Sensor-Surface: 1.4mm (Mechanical Surface Detection)
- Electronics: DAE4 Sn601; Calibrated: 26.10.2017
- Phantom: SAM Head
- DASY52 52.10.0(1446); SEMCAD X 14.6.10(7417)

SAM Head/Top/Zoom Scan (7x7x7)/Cube 0: Measurement grid: dx=5mm, dy=5mm, dz=5mm

Reference Value = 61.00 V/m; Power Drift = 0.01 dB

Peak SAR (extrapolated) = 3.56 W/kg

SAR(1 g) = 2.4 W/kg; SAR(10 g) = 1.58 W/kg

Maximum value of SAR (measured) = 3.16 W/kg

SAM Head/Mouth/Zoom Scan (7x7x7)/Cube 0: Measurement grid: dx=5mm, dy=5mm, dz=5mm

Reference Value = 60.99 V/m; Power Drift = -0.04 dB

Peak SAR (extrapolated) = 3.65 W/kg

SAR(1 g) = 2.47 W/kg; SAR(10 g) = 1.64 W/kg

Maximum value of SAR (measured) = 3.19 W/kg

SAM Head/Neck/Zoom Scan (7x7x7)/Cube 0: Measurement grid: dx=5mm, dy=5mm, dz=5mm

Reference Value = 59.20 V/m; Power Drift = 0.05 dB

Peak SAR (extrapolated) = 3.33 W/kg

SAR(1 g) = 2.35 W/kg; SAR(10 g) = 1.59 W/kg

Maximum value of SAR (measured) = 3.04 W/kg

SAM Head/Ear/Zoom Scan (7x7x7)/Cube 0: Measurement grid: dx=5mm, dy=5mm, dz=5mm

Reference Value = 55.03 V/m; Power Drift = 0.01 dB

Peak SAR (extrapolated) = 2.90 W/kg

SAR(1 g) = 2.03 W/kg; SAR(10 g) = 1.37 W/kg

Maximum value of SAR (measured) = 2.61 W/kg

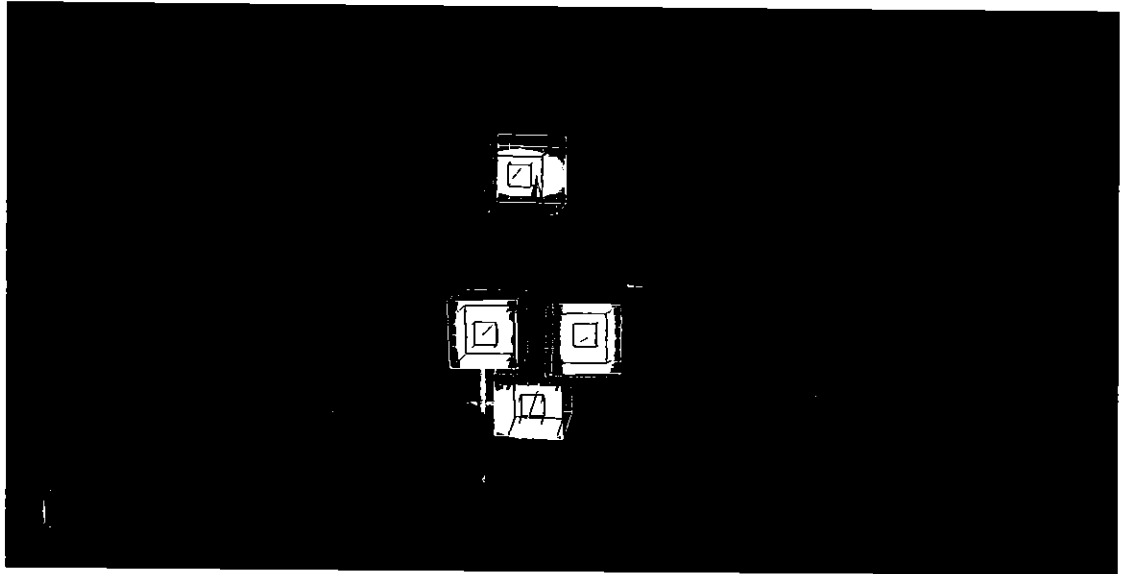
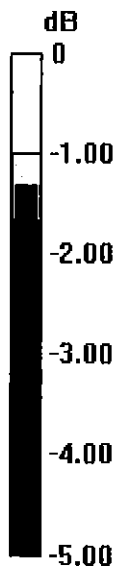

0 dB = 2.61 W/kg = 4.17 dBW/kg



Accredited by the Swiss Accreditation Service (SAS)
The Swiss Accreditation Service is one of the signatories to the EA
Multilateral Agreement for the recognition of calibration certificates

Accreditation No.: **SCS 0108**

Client **PC Test**

Certificate No: **D1750V2-1051_Apr18**

CALIBRATION CERTIFICATE

Object **D1750V2 - SN: 1051**

Calibration procedure(s) **QA CAL-05.v10
Calibration procedure for dipole validation kits above 700 MHz**

Calibration date: **April 19, 2018**

*BN ✓
05-01-2018*

This calibration certificate documents the traceability to national standards, which realize the physical units of measurements (SI).
The measurements and the uncertainties with confidence probability are given on the following pages and are part of the certificate.

All calibrations have been conducted in the closed laboratory facility: environment temperature (22 ± 3)°C and humidity < 70%.

Calibration Equipment used (M&TE critical for calibration)

Primary Standards	ID #	Cal Date (Certificate No.)	Scheduled Calibration
Power meter NRP	SN: 104778	04-Apr-18 (No. 217-02672/02673)	Apr-19
Power sensor NRP-Z91	SN: 103244	04-Apr-18 (No. 217-02672)	Apr-19
Power sensor NRP-Z91	SN: 103245	04-Apr-18 (No. 217-02673)	Apr-19
Reference 20 dB Attenuator	SN: 5058 (20k)	04-Apr-18 (No. 217-02682)	Apr-19
Type-N mismatch combination	SN: 5047.2 / 06327	04-Apr-18 (No. 217-02683)	Apr-19
Reference Probe EX3DV4	SN: 7349	30-Dec-17 (No. EX3-7349_Dec17)	Dec-18
DAE4	SN: 601	26-Oct-17 (No. DAE4-601_Oct17)	Oct-18
Secondary Standards	ID #	Check Date (in house)	Scheduled Check
Power meter EPM-442A	SN: GB37480704	07-Oct-15 (in house check Oct-16)	In house check: Oct-18
Power sensor HP 8481A	SN: US37292783	07-Oct-15 (in house check Oct-16)	In house check: Oct-18
Power sensor HP 8481A	SN: MY41092317	07-Oct-15 (in house check Oct-16)	In house check: Oct-18
RF generator R&S SMT-06	SN: 100972	15-Jun-15 (in house check Oct-16)	In house check: Oct-18
Network Analyzer HP 8753E	SN: US37390585	18-Oct-01 (in house check Oct-17)	In house check: Oct-18

Calibrated by: **Name** Michael Weber **Function** Laboratory Technician

Signature
M. Weber

Approved by: **Name** Katja Pokovic **Function** Technical Manager

K. Pokovic

Issued: April 19, 2018

This calibration certificate shall not be reproduced except in full without written approval of the laboratory.



Accredited by the Swiss Accreditation Service (SAS)

The Swiss Accreditation Service is one of the signatories to the EA
Multilateral Agreement for the recognition of calibration certificates

Glossary:

TSL	tissue simulating liquid
ConvF	sensitivity in TSL / NORM x,y,z
N/A	not applicable or not measured

Calibration is Performed According to the Following Standards:

- IEEE Std 1528-2013, "IEEE Recommended Practice for Determining the Peak Spatial-Averaged Specific Absorption Rate (SAR) in the Human Head from Wireless Communications Devices: Measurement Techniques", June 2013
- IEC 62209-1, "Measurement procedure for the assessment of Specific Absorption Rate (SAR) from hand-held and body-mounted devices used next to the ear (frequency range of 300 MHz to 6 GHz)", July 2016
- IEC 62209-2, "Procedure to determine the Specific Absorption Rate (SAR) for wireless communication devices used in close proximity to the human body (frequency range of 30 MHz to 6 GHz)", March 2010
- KDB 865664, "SAR Measurement Requirements for 100 MHz to 6 GHz"

Additional Documentation:

- DASY4/5 System Handbook

Methods Applied and Interpretation of Parameters:

- Measurement Conditions:** Further details are available from the Validation Report at the end of the certificate. All figures stated in the certificate are valid at the frequency indicated.
- Antenna Parameters with TSL:** The dipole is mounted with the spacer to position its feed point exactly below the center marking of the flat phantom section, with the arms oriented parallel to the body axis.
- Feed Point Impedance and Return Loss:** These parameters are measured with the dipole positioned under the liquid filled phantom. The impedance stated is transformed from the measurement at the SMA connector to the feed point. The Return Loss ensures low reflected power. No uncertainty required.
- Electrical Delay:** One-way delay between the SMA connector and the antenna feed point. No uncertainty required.
- SAR measured:** SAR measured at the stated antenna input power.
- SAR normalized:** SAR as measured, normalized to an input power of 1 W at the antenna connector.
- SAR for nominal TSL parameters:** The measured TSL parameters are used to calculate the nominal SAR result.

The reported uncertainty of measurement is stated as the standard uncertainty of measurement multiplied by the coverage factor $k=2$, which for a normal distribution corresponds to a coverage probability of approximately 95%.

Measurement Conditions

DASY system configuration, as far as not given on page 1.

DASY Version	DASY5	V52.10.0
Extrapolation	Advanced Extrapolation	
Phantom	Modular Flat Phantom	
Distance Dipole Center - TSL	10 mm	with Spacer
Zoom Scan Resolution	dx, dy, dz = 5 mm	
Frequency	1750 MHz ± 1 MHz	

Head TSL parameters

The following parameters and calculations were applied.

	Temperature	Permittivity	Conductivity
Nominal Head TSL parameters	22.0 °C	40.1	1.37 mho/m
Measured Head TSL parameters	(22.0 ± 0.2) °C	39.2 ± 6 %	1.35 mho/m ± 6 %
Head TSL temperature change during test	< 0.5 °C	----	----

SAR result with Head TSL

SAR averaged over 1 cm ³ (1 g) of Head TSL	Condition	
SAR measured	250 mW input power	9.10 W/kg
SAR for nominal Head TSL parameters	normalized to 1W	36.5 W/kg ± 17.0 % (k=2)

SAR averaged over 10 cm ³ (10 g) of Head TSL	condition	
SAR measured	250 mW input power	4.82 W/kg
SAR for nominal Head TSL parameters	normalized to 1W	19.3 W/kg ± 16.5 % (k=2)

Body TSL parameters

The following parameters and calculations were applied.

	Temperature	Permittivity	Conductivity
Nominal Body TSL parameters	22.0 °C	53.4	1.49 mho/m
Measured Body TSL parameters	(22.0 ± 0.2) °C	52.4 ± 6 %	1.46 mho/m ± 6 %
Body TSL temperature change during test	< 0.5 °C	----	----

SAR result with Body TSL

SAR averaged over 1 cm ³ (1 g) of Body TSL	Condition	
SAR measured	250 mW input power	9.21 W/kg
SAR for nominal Body TSL parameters	normalized to 1W	37.2 W/kg ± 17.0 % (k=2)

SAR averaged over 10 cm ³ (10 g) of Body TSL	condition	
SAR measured	250 mW input power	4.94 W/kg
SAR for nominal Body TSL parameters	normalized to 1W	19.9 W/kg ± 16.5 % (k=2)

Appendix (Additional assessments outside the scope of SCS 0108)

Antenna Parameters with Head TSL

Impedance, transformed to feed point	51.7 Ω + 2.5 j Ω
Return Loss	- 30.4 dB

Antenna Parameters with Body TSL

Impedance, transformed to feed point	47.6 Ω + 1.3 j Ω
Return Loss	- 31.1 dB

General Antenna Parameters and Design

Electrical Delay (one direction)	1.222 ns
----------------------------------	----------

After long term use with 100W radiated power, only a slight warming of the dipole near the feedpoint can be measured.

The dipole is made of standard semirigid coaxial cable. The center conductor of the feeding line is directly connected to the second arm of the dipole. The antenna is therefore short-circuited for DC-signals. On some of the dipoles, small end caps are added to the dipole arms in order to improve matching when loaded according to the position as explained in the "Measurement Conditions" paragraph. The SAR data are not affected by this change. The overall dipole length is still according to the Standard.

No excessive force must be applied to the dipole arms, because they might bend or the soldered connections near the feedpoint may be damaged.

Additional EUT Data

Manufactured by	SPEAG
Manufactured on	February 19, 2010

DASY5 Validation Report for Head TSL

Date: 19.04.2018

Test Laboratory: SPEAG, Zurich, Switzerland

DUT: Dipole 1750 MHz; Type: D1750V2; Serial: D1750V2 - SN:1051

Communication System: UID 0 - CW; Frequency: 1750 MHz

Medium parameters used: $f = 1750$ MHz; $\sigma = 1.35$ S/m; $\epsilon_r = 39.2$; $\rho = 1000$ kg/m³

Phantom section: Flat Section

Measurement Standard: DASY5 (IEEE/IEC/ANSI C63.19-2011)

DASY52 Configuration:

- Probe: EX3DV4 - SN7349; ConvF(8.5, 8.5, 8.5); Calibrated: 30.12.2017;
- Sensor-Surface: 1.4mm (Mechanical Surface Detection)
- Electronics: DAE4 Sn601; Calibrated: 26.10.2017
- Phantom: Flat Phantom 5.0 (front); Type: QD 000 P50 AA; Serial: 1001
- DASY52 52.10.0(1446); SEMCAD X 14.6.10(7417)

Dipole Calibration for Head Tissue/Pin=250 mW, d=10mm/Zoom Scan (7x7x7)/Cube 0:

Measurement grid: dx=5mm, dy=5mm, dz=5mm

Reference Value = 107.3 V/m; Power Drift = -0.08 dB

Peak SAR (extrapolated) = 16.7 W/kg

SAR(1 g) = 9.1 W/kg; SAR(10 g) = 4.82 W/kg

Maximum value of SAR (measured) = 14.0 W/kg

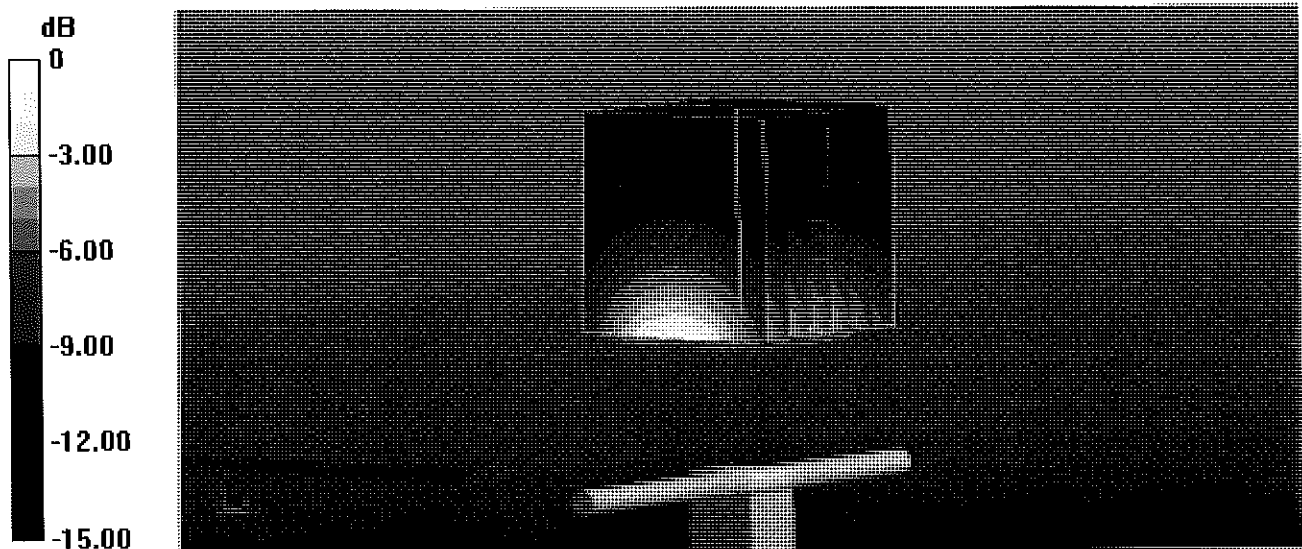

0 dB = 14.0 W/kg = 11.46 dBW/kg

Impedance Measurement Plot for Head TSL

19 Apr 2018 16:34:28

CH1 S11 1 U FS 1: 51.703 Ω 2.5391 Ω 230.92 pF 1 750.000 000 MHz

*
Del
CA
Avg
16
H1 d

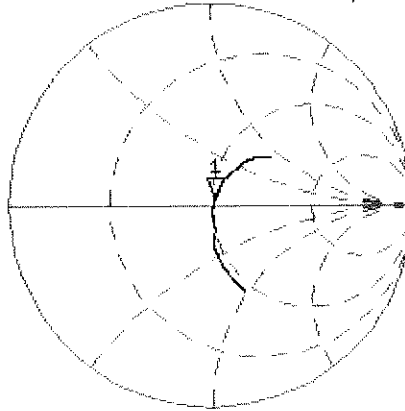

CH2 S11 LOG 5 dB/REF -20 dB 1:-30.440 dB 1 750.000 000 MHz

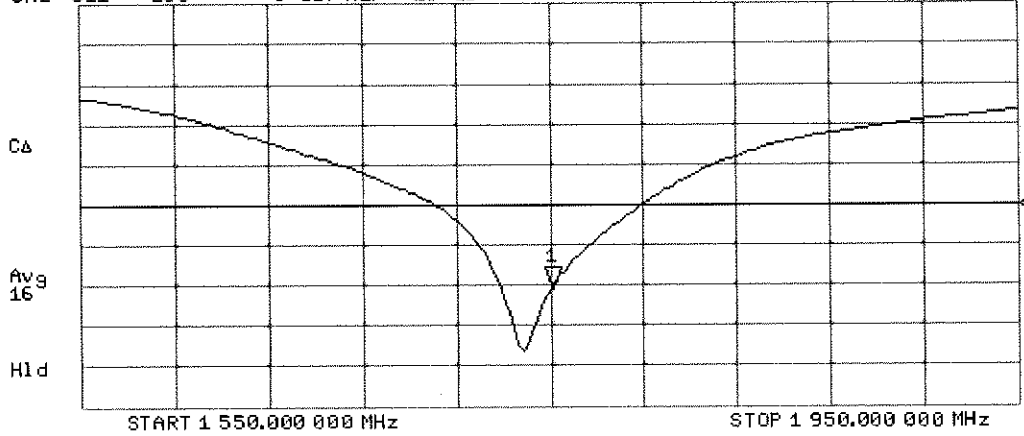

DASY5 Validation Report for Body TSL

Date: 19.04.2018

Test Laboratory: SPEAG, Zurich, Switzerland

DUT: Dipole 1750 MHz; Type: D1750V2; Serial: D1750V2 - SN:1051

Communication System: UID 0 - CW; Frequency: 1750 MHz

Medium parameters used: $f = 1750$ MHz; $\sigma = 1.46$ S/m; $\epsilon_r = 52.4$; $\rho = 1000$ kg/m³

Phantom section: Flat Section

Measurement Standard: DASY5 (IEEE/IEC/ANSI C63.19-2011)

DASY52 Configuration:

- Probe: EX3DV4 - SN7349; ConvF(8.35, 8.35, 8.35); Calibrated: 30.12.2017;
- Sensor-Surface: 1.4mm (Mechanical Surface Detection)
- Electronics: DAE4 Sn601; Calibrated: 26.10.2017
- Phantom: Flat Phantom 5.0 (back); Type: QD 000 P50 AA; Serial: 1002
- DASY52 52.10.0(1446); SEMCAD X 14.6.10(7417)

Dipole Calibration for Body Tissue/Pin=250 mW, d=10mm/Zoom Scan (7x7x7)/Cube 0:

Measurement grid: dx=5mm, dy=5mm, dz=5mm

Reference Value = 99.30 V/m; Power Drift = -0.09 dB

Peak SAR (extrapolated) = 16.2 W/kg

SAR(1 g) = 9.21 W/kg; SAR(10 g) = 4.94 W/kg

Maximum value of SAR (measured) = 13.3 W/kg

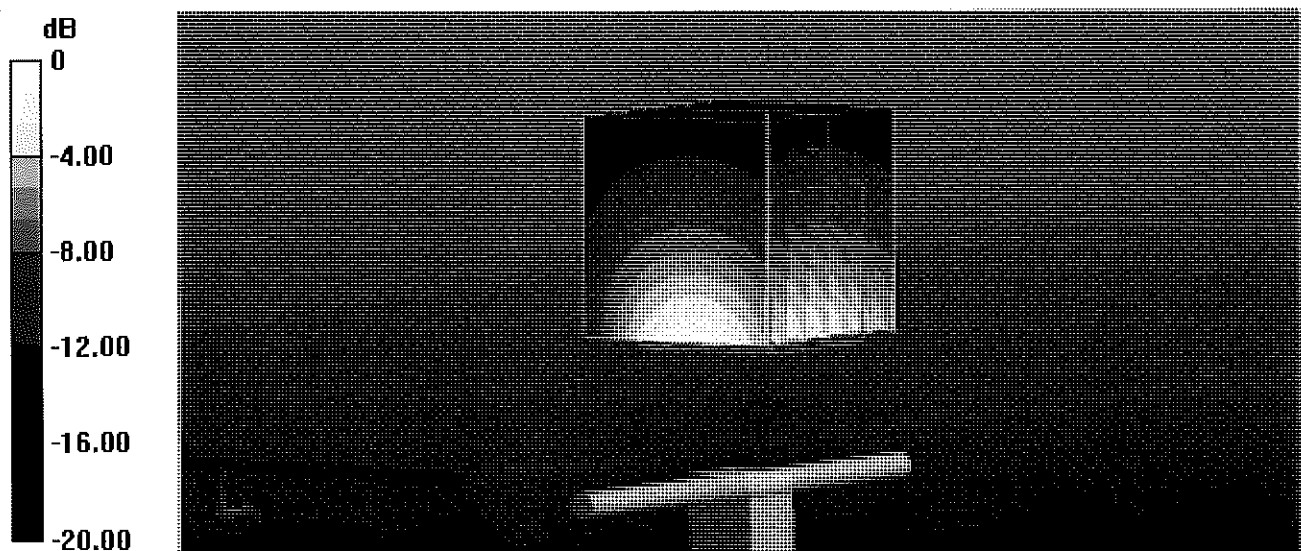

0 dB = 13.3 W/kg = 11.24 dBW/kg

Impedance Measurement Plot for Body TSL

19 Apr 2018 17:21:05

CH1 S11 1 U FS 1: 47.590 Ω 1.2520 Ω 113.86 μ H 1 750.000 000 MHz

*
Del
CA

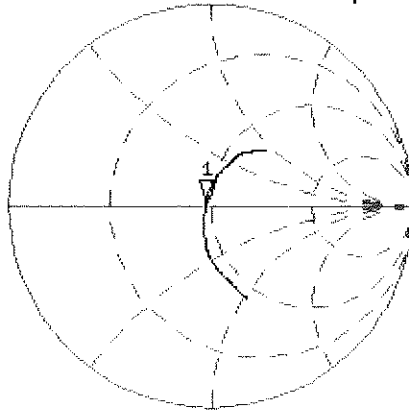

Avg
16

H1d

CH2 S11 LOG 5 dB/REF -20 dB 1:-31.120 dB 1 750.000 000 MHz

CA

Avg
16

H1d

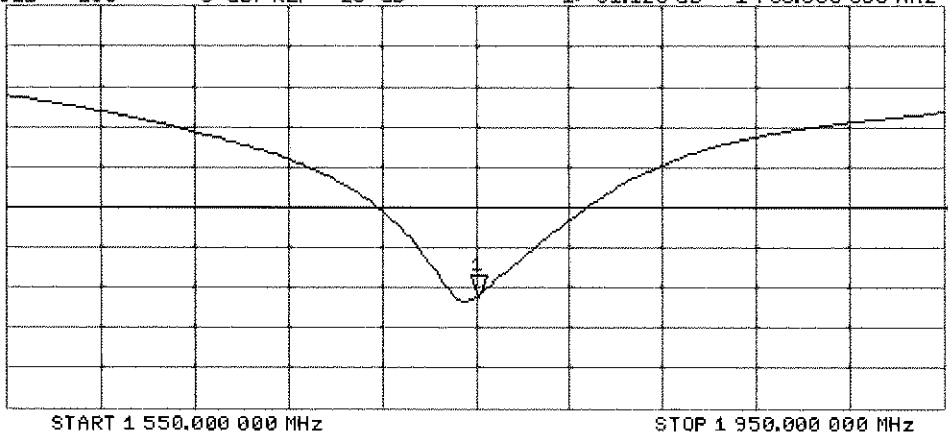



Accredited by the Swiss Accreditation Service (SAS)
The Swiss Accreditation Service is one of the signatories to the EA
Multilateral Agreement for the recognition of calibration certificates

Accreditation No.: **SCS 0108**

Client **PC Test**

Certificate No: **D1900V2-5d141_Apr18**

CALIBRATION CERTIFICATE

Object **D1900V2 - SN:5d141**

Calibration procedure(s) **QA CAL-05.v10
Calibration procedure for dipole validation kits above 700 MHz**

Calibration date: **April 12, 2018**

*BNV
05-01-2018*

This calibration certificate documents the traceability to national standards, which realize the physical units of measurements (SI).
The measurements and the uncertainties with confidence probability are given on the following pages and are part of the certificate.

All calibrations have been conducted in the closed laboratory facility: environment temperature (22 ± 3)°C and humidity < 70%.

Calibration Equipment used (M&TE critical for calibration)

Primary Standards	ID #	Cal Date (Certificate No.)	Scheduled Calibration
Power meter NRP	SN: 104778	04-Apr-18 (No. 217-02672/02673)	Apr-19
Power sensor NRP-Z91	SN: 103244	04-Apr-18 (No. 217-02672)	Apr-19
Power sensor NRP-Z91	SN: 103245	04-Apr-18 (No. 217-02673)	Apr-19
Reference 20 dB Attenuator	SN: 5058 (20k)	04-Apr-18 (No. 217-02682)	Apr-19
Type-N mismatch combination	SN: 5047.2 / 06327	04-Apr-18 (No. 217-02683)	Apr-19
Reference Probe EX3DV4	SN: 7349	30-Dec-17 (No. EX3-7349_Dec17)	Dec-18
DAE4	SN: 601	26-Oct-17 (No. DAE4-601_Oct17)	Oct-18

Secondary Standards	ID #	Check Date (in house)	Scheduled Check
Power meter EPM-442A	SN: GB37480704	07-Oct-15 (in house check Oct-16)	In house check: Oct-18
Power sensor HP 8481A	SN: US37292783	07-Oct-15 (in house check Oct-16)	In house check: Oct-18
Power sensor HP 8481A	SN: MY41092317	07-Oct-15 (in house check Oct-16)	In house check: Oct-18
RF generator R&S SMT-06	SN: 100972	15-Jun-15 (in house check Oct-16)	In house check: Oct-18
Network Analyzer HP 8753E	SN: US37390585	18-Oct-01 (in house check Oct-17)	In house check: Oct-18

Calibrated by:	Name Jeton Kastrali	Function Laboratory Technician	Signature
Approved by:	Name Katja Pokovic	Function Technical Manager	

Issued: April 13, 2018

This calibration certificate shall not be reproduced except in full without written approval of the laboratory.



Accredited by the Swiss Accreditation Service (SAS)

The Swiss Accreditation Service is one of the signatories to the EA
Multilateral Agreement for the recognition of calibration certificates

Accreditation No.: **SCS 0108**

Glossary:

TSL	tissue simulating liquid
ConvF	sensitivity in TSL / NORM x,y,z
N/A	not applicable or not measured

Calibration is Performed According to the Following Standards:

- IEEE Std 1528-2013, "IEEE Recommended Practice for Determining the Peak Spatial-Averaged Specific Absorption Rate (SAR) in the Human Head from Wireless Communications Devices: Measurement Techniques", June 2013
- IEC 62209-1, "Measurement procedure for the assessment of Specific Absorption Rate (SAR) from hand-held and body-mounted devices used next to the ear (frequency range of 300 MHz to 6 GHz)", July 2016
- IEC 62209-2, "Procedure to determine the Specific Absorption Rate (SAR) for wireless communication devices used in close proximity to the human body (frequency range of 30 MHz to 6 GHz)", March 2010
- KDB 865664, "SAR Measurement Requirements for 100 MHz to 6 GHz"

Additional Documentation:

- DASY4/5 System Handbook

Methods Applied and Interpretation of Parameters:

- Measurement Conditions:** Further details are available from the Validation Report at the end of the certificate. All figures stated in the certificate are valid at the frequency indicated.
- Antenna Parameters with TSL:** The dipole is mounted with the spacer to position its feed point exactly below the center marking of the flat phantom section, with the arms oriented parallel to the body axis.
- Feed Point Impedance and Return Loss:** These parameters are measured with the dipole positioned under the liquid filled phantom. The impedance stated is transformed from the measurement at the SMA connector to the feed point. The Return Loss ensures low reflected power. No uncertainty required.
- Electrical Delay:** One-way delay between the SMA connector and the antenna feed point. No uncertainty required.
- SAR measured:** SAR measured at the stated antenna input power.
- SAR normalized:** SAR as measured, normalized to an input power of 1 W at the antenna connector.
- SAR for nominal TSL parameters:** The measured TSL parameters are used to calculate the nominal SAR result.

The reported uncertainty of measurement is stated as the standard uncertainty of measurement multiplied by the coverage factor $k=2$, which for a normal distribution corresponds to a coverage probability of approximately 95%.

Measurement Conditions

DASY system configuration, as far as not given on page 1.

DASY Version	DASY5	V52.10.0
Extrapolation	Advanced Extrapolation	
Phantom	Modular Flat Phantom	
Distance Dipole Center - TSL	10 mm	with Spacer
Zoom Scan Resolution	dx, dy, dz = 5 mm	
Frequency	1900 MHz \pm 1 MHz	

Head TSL parameters

The following parameters and calculations were applied.

	Temperature	Permittivity	Conductivity
Nominal Head TSL parameters	22.0 °C	40.0	1.40 mho/m
Measured Head TSL parameters	(22.0 \pm 0.2) °C	41.1 \pm 6 %	1.35 mho/m \pm 6 %
Head TSL temperature change during test	< 0.5 °C	----	----

SAR result with Head TSL

SAR averaged over 1 cm³ (1 g) of Head TSL	Condition	
SAR measured	250 mW input power	9.55 W/kg
SAR for nominal Head TSL parameters	normalized to 1W	39.3 W/kg \pm 17.0 % (k=2)

SAR averaged over 10 cm³ (10 g) of Head TSL	condition	
SAR measured	250 mW input power	5.05 W/kg
SAR for nominal Head TSL parameters	normalized to 1W	20.6 W/kg \pm 16.5 % (k=2)

Body TSL parameters

The following parameters and calculations were applied.

	Temperature	Permittivity	Conductivity
Nominal Body TSL parameters	22.0 °C	53.3	1.52 mho/m
Measured Body TSL parameters	(22.0 \pm 0.2) °C	55.3 \pm 6 %	1.47 mho/m \pm 6 %
Body TSL temperature change during test	< 0.5 °C	----	----

SAR result with Body TSL

SAR averaged over 1 cm³ (1 g) of Body TSL	Condition	
SAR measured	250 mW input power	9.73 W/kg
SAR for nominal Body TSL parameters	normalized to 1W	40.0 W/kg \pm 17.0 % (k=2)

SAR averaged over 10 cm³ (10 g) of Body TSL	condition	
SAR measured	250 mW input power	5.20 W/kg
SAR for nominal Body TSL parameters	normalized to 1W	21.2 W/kg \pm 16.5 % (k=2)

Appendix (Additional assessments outside the scope of SCS 0108)

Antenna Parameters with Head TSL

Impedance, transformed to feed point	53.4 Ω + 5.9 j Ω
Return Loss	- 23.6 dB

Antenna Parameters with Body TSL

Impedance, transformed to feed point	48.8 Ω + 7.2 j Ω
Return Loss	- 22.6 dB

General Antenna Parameters and Design

Electrical Delay (one direction)	1.198 ns
----------------------------------	----------

After long term use with 100W radiated power, only a slight warming of the dipole near the feedpoint can be measured.

The dipole is made of standard semirigid coaxial cable. The center conductor of the feeding line is directly connected to the second arm of the dipole. The antenna is therefore short-circuited for DC-signals. On some of the dipoles, small end caps are added to the dipole arms in order to improve matching when loaded according to the position as explained in the "Measurement Conditions" paragraph. The SAR data are not affected by this change. The overall dipole length is still according to the Standard.

No excessive force must be applied to the dipole arms, because they might bend or the soldered connections near the feedpoint may be damaged.

Additional EUT Data

Manufactured by	SPEAG
Manufactured on	March 11, 2011

DASY5 Validation Report for Head TSL

Date: 12.04.2018

Test Laboratory: SPEAG, Zurich, Switzerland

DUT: Dipole 1900 MHz; Type: D1900V2; Serial: D1900V2 - SN:5d141

Communication System: UID 0 - CW; Frequency: 1900 MHz

Medium parameters used: $f = 1900$ MHz; $\sigma = 1.35$ S/m; $\epsilon_r = 41.1$; $\rho = 1000$ kg/m³

Phantom section: Flat Section

Measurement Standard: DASY5 (IEEE/IEC/ANSI C63.19-2011)

DASY52 Configuration:

- Probe: EX3DV4 - SN7349; ConvF(8.18, 8.18, 8.18); Calibrated: 30.12.2017;
- Sensor-Surface: 1.4mm (Mechanical Surface Detection)
- Electronics: DAE4 Sn601; Calibrated: 26.10.2017
- Phantom: Flat Phantom 5.0 (front); Type: QD 000 P50 AA; Serial: 1001
- DASY52 52.10.0(1446); SEMCAD X 14.6.10(7417)

Dipole Calibration for Head Tissue/Pin=250 mW, d=10mm/Zoom Scan (7x7x7)/Cube 0:

Measurement grid: dx=5mm, dy=5mm, dz=5mm

Reference Value = 108.9 V/m; Power Drift = -0.03 dB

Peak SAR (extrapolated) = 17.5 W/kg

SAR(1 g) = 9.55 W/kg; SAR(10 g) = 5.05 W/kg

Maximum value of SAR (measured) = 14.7 W/kg

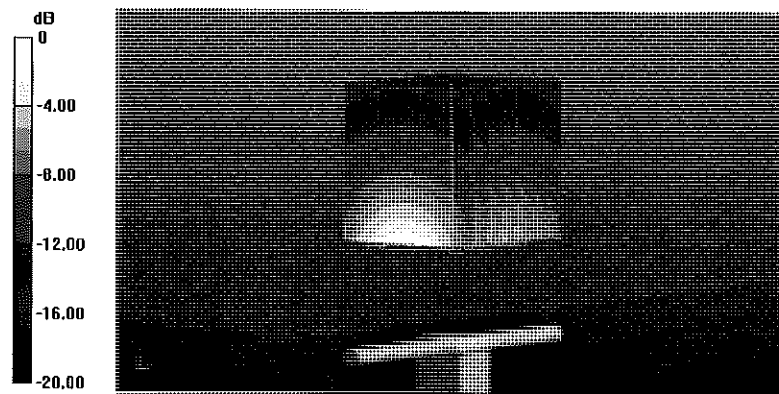

0 dB = 14.7 W/kg = 11.67 dBW/kg

Impedance Measurement Plot for Head TSL

12 Apr 2018 13:57:42

CH1 S11 1 U FS

1: 53.406 Ω 5.9336 Ω 497.03 μ H

1 900.000 000 MHz

*
De1

CA

Avg
16

H1d

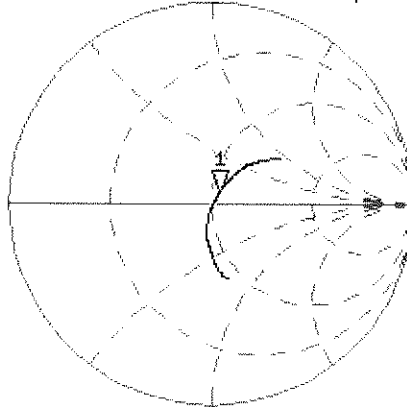

CH2 S11

LOG

5 dB/REF -20 dB

1: -23.594 dB

1 900.000 000 MHz

CA

Avg
16

H1d

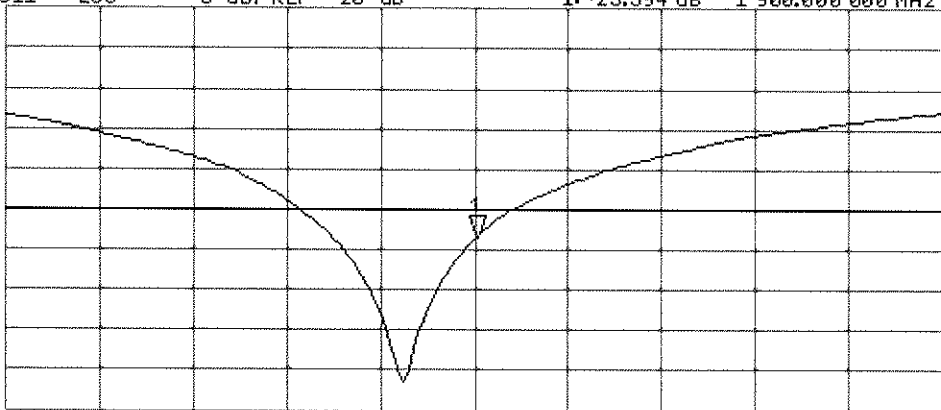

START 1 700.000 000 MHz

STOP 2 100.000 000 MHz

DASY5 Validation Report for Body TSL

Date: 12.04.2018

Test Laboratory: SPEAG, Zurich, Switzerland

DUT: Dipole 1900 MHz; Type: D1900V2; Serial: D1900V2 - SN:5d141

Communication System: UID 0 - CW; Frequency: 1900 MHz

Medium parameters used: $f = 1900$ MHz; $\sigma = 1.47$ S/m; $\epsilon_r = 55.3$; $\rho = 1000$ kg/m³

Phantom section: Flat Section

Measurement Standard: DASY5 (IEEE/IEC/ANSI C63.19-2011)

DASY52 Configuration:

- Probe: EX3DV4 - SN7349; ConvF(8.15, 8.15, 8.15); Calibrated: 30.12.2017;
- Sensor-Surface: 1.4mm (Mechanical Surface Detection)
- Electronics: DAE4 Sn601; Calibrated: 26.10.2017
- Phantom: Flat Phantom 5.0 (back); Type: QD 000 P50 AA; Serial: 1002
- DASY52 52.10.0(1446); SEMCAD X 14.6.10(7417)

Dipole Calibration for Body Tissue/ $P_{in}=250$ mW, $d=10$ mm/Zoom Scan (7x7x7)/Cube 0:

Measurement grid: $dx=5$ mm, $dy=5$ mm, $dz=5$ mm

Reference Value = 103.8 V/m; Power Drift = -0.05 dB

Peak SAR (extrapolated) = 17.1 W/kg

SAR(1 g) = 9.73 W/kg; SAR(10 g) = 5.2 W/kg

Maximum value of SAR (measured) = 14.5 W/kg

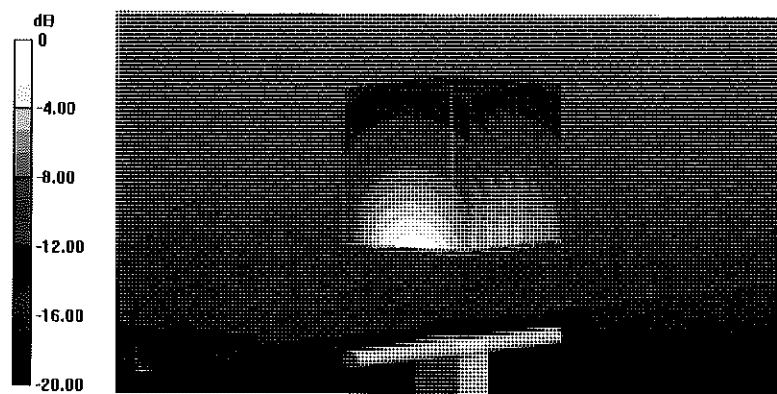

0 dB = 14.5 W/kg = 11.61 dBW/kg

Impedance Measurement Plot for Body TSL

CH1 S11 1 U FS 12 Apr 2018 13:56:24
 1: 48.797 Ω 7.2422 Ω 606.65 μ H 1 900.000 000 MHz

*
Del

CA

Avg
16

H1d

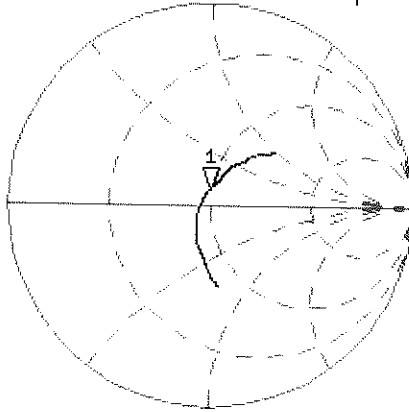

CH2 S11 LOG 5 dB/REF -20 dB 1:-22.604 dB 1 900.000 000 MHz

CA

Avg
16

H1d

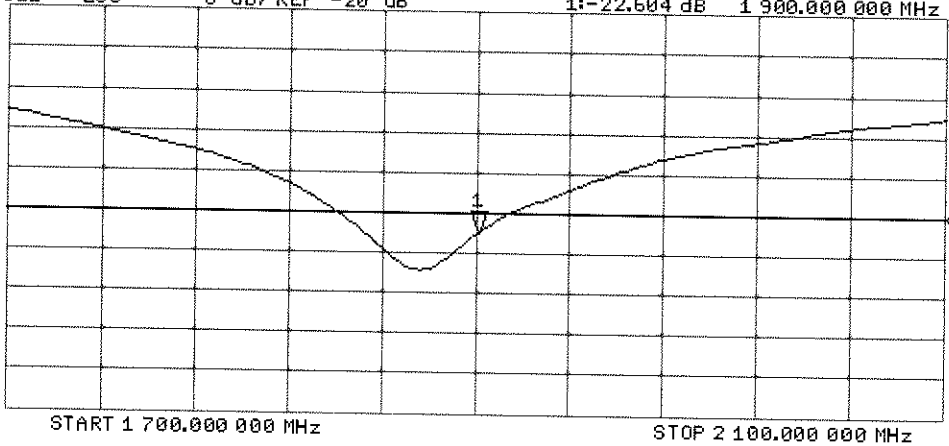



Accredited by the Swiss Accreditation Service (SAS)
The Swiss Accreditation Service is one of the signatories to the EA
Multilateral Agreement for the recognition of calibration certificates

Accreditation No.: **SCS 0108**

Client **PC Test**

Certificate No: **D2300V2-1008_Feb18**

CALIBRATION CERTIFICATE

Object **D2300V2 - SN:1008**

Calibration procedure(s) **QA CAL-05.v9
Calibration procedure for dipole validation kits above 700 MHz**

BNV
03-02-2018

Calibration date: **February 07, 2018**

This calibration certificate documents the traceability to national standards, which realize the physical units of measurements (SI).
The measurements and the uncertainties with confidence probability are given on the following pages and are part of the certificate.

All calibrations have been conducted in the closed laboratory facility: environment temperature (22 ± 3)°C and humidity < 70%.

Calibration Equipment used (M&TE critical for calibration)

Primary Standards	ID #	Cal Date (Certificate No.)	Scheduled Calibration
Power meter NRP	SN: 104778	04-Apr-17 (No. 217-02521/02522)	Apr-18
Power sensor NRP-Z91	SN: 103244	04-Apr-17 (No. 217-02521)	Apr-18
Power sensor NRP-Z91	SN: 103245	04-Apr-17 (No. 217-02522)	Apr-18
Reference 20 dB Attenuator	SN: 5058 (20k)	07-Apr-17 (No. 217-02528)	Apr-18
Type-N mismatch combination	SN: 5047.2 / 06327	07-Apr-17 (No. 217-02529)	Apr-18
Reference Probe EX3DV4	SN: 7349	30-Dec-17 (No. EX3-7349_Dec17)	Dec-18
DAE4	SN: 601	26-Oct-17 (No. DAE4-601_Oct17)	Oct-18

Secondary Standards	ID #	Check Date (in house)	Scheduled Check
Power meter EPM-442A	SN: GB37480704	07-Oct-15 (in house check Oct-16)	In house check: Oct-18
Power sensor HP 8481A	SN: US37292783	07-Oct-15 (in house check Oct-16)	In house check: Oct-18
Power sensor HP 8481A	SN: MY41092317	07-Oct-15 (in house check Oct-16)	In house check: Oct-18
RF generator R&S SMT-06	SN: 100972	15-Jun-15 (in house check Oct-16)	In house check: Oct-18
Network Analyzer HP 8753E	SN: US37390585	18-Oct-01 (in house check Oct-17)	In house check: Oct-18

Calibrated by: **Claudio Leubler** Name: Claudio Leubler Function: Laboratory Technician

Signature

Approved by: **Katja Pokovic** Name: Katja Pokovic Function: Technical Manager

Issued: February 7, 2018

This calibration certificate shall not be reproduced except in full without written approval of the laboratory.



Accredited by the Swiss Accreditation Service (SAS)

The Swiss Accreditation Service is one of the signatories to the EA
Multilateral Agreement for the recognition of calibration certificates

Accreditation No.: **SCS 0108**

Glossary:

TSL	tissue simulating liquid
ConvF	sensitivity in TSL / NORM x,y,z
N/A	not applicable or not measured

Calibration is Performed According to the Following Standards:

- IEEE Std 1528-2013, "IEEE Recommended Practice for Determining the Peak Spatial-Averaged Specific Absorption Rate (SAR) in the Human Head from Wireless Communications Devices: Measurement Techniques", June 2013
- IEC 62209-1, "Measurement procedure for the assessment of Specific Absorption Rate (SAR) from hand-held and body-mounted devices used next to the ear (frequency range of 300 MHz to 6 GHz)", July 2016
- IEC 62209-2, "Procedure to determine the Specific Absorption Rate (SAR) for wireless communication devices used in close proximity to the human body (frequency range of 30 MHz to 6 GHz)", March 2010
- KDB 865664, "SAR Measurement Requirements for 100 MHz to 6 GHz"

Additional Documentation:

- DASY4/5 System Handbook

Methods Applied and Interpretation of Parameters:

- Measurement Conditions:* Further details are available from the Validation Report at the end of the certificate. All figures stated in the certificate are valid at the frequency indicated.
- Antenna Parameters with TSL:* The dipole is mounted with the spacer to position its feed point exactly below the center marking of the flat phantom section, with the arms oriented parallel to the body axis.
- Feed Point Impedance and Return Loss:* These parameters are measured with the dipole positioned under the liquid filled phantom. The impedance stated is transformed from the measurement at the SMA connector to the feed point. The Return Loss ensures low reflected power. No uncertainty required.
- Electrical Delay:* One-way delay between the SMA connector and the antenna feed point. No uncertainty required.
- SAR measured:* SAR measured at the stated antenna input power.
- SAR normalized:* SAR as measured, normalized to an input power of 1 W at the antenna connector.
- SAR for nominal TSL parameters:* The measured TSL parameters are used to calculate the nominal SAR result.

The reported uncertainty of measurement is stated as the standard uncertainty of measurement multiplied by the coverage factor $k=2$, which for a normal distribution corresponds to a coverage probability of approximately 95%.

Measurement Conditions

DASY system configuration, as far as not given on page 1.

DASY Version	DASY5	V52.10.0
Extrapolation	Advanced Extrapolation	
Phantom	Modular Flat Phantom	
Distance Dipole Center - TSL	10 mm	with Spacer
Zoom Scan Resolution	dx, dy, dz = 5 mm	
Frequency	2300 MHz \pm 1 MHz	

Head TSL parameters

The following parameters and calculations were applied.

	Temperature	Permittivity	Conductivity
Nominal Head TSL parameters	22.0 °C	39.5	1.67 mho/m
Measured Head TSL parameters	(22.0 \pm 0.2) °C	38.4 \pm 6 %	1.70 mho/m \pm 6 %
Head TSL temperature change during test	< 0.5 °C	----	----

SAR result with Head TSL

SAR averaged over 1 cm³ (1 g) of Head TSL	Condition	
SAR measured	250 mW input power	12.6 W/kg
SAR for nominal Head TSL parameters	normalized to 1W	49.6 W/kg \pm 17.0 % (k=2)

SAR averaged over 10 cm³ (10 g) of Head TSL	condition	
SAR measured	250 mW input power	6.00 W/kg
SAR for nominal Head TSL parameters	normalized to 1W	23.8 W/kg \pm 16.5 % (k=2)

Body TSL parameters

The following parameters and calculations were applied.

	Temperature	Permittivity	Conductivity
Nominal Body TSL parameters	22.0 °C	52.9	1.81 mho/m
Measured Body TSL parameters	(22.0 \pm 0.2) °C	51.8 \pm 6 %	1.86 mho/m \pm 6 %
Body TSL temperature change during test	< 0.5 °C	----	----

SAR result with Body TSL

SAR averaged over 1 cm³ (1 g) of Body TSL	Condition	
SAR measured	250 mW input power	12.0 W/kg
SAR for nominal Body TSL parameters	normalized to 1W	47.1 W/kg \pm 17.0 % (k=2)

SAR averaged over 10 cm³ (10 g) of Body TSL	condition	
SAR measured	250 mW input power	5.75 W/kg
SAR for nominal Body TSL parameters	normalized to 1W	22.7 W/kg \pm 16.5 % (k=2)

Appendix (Additional assessments outside the scope of SCS 0108)

Antenna Parameters with Head TSL

Impedance, transformed to feed point	49.1 Ω - 2.8 j Ω
Return Loss	- 30.7 dB

Antenna Parameters with Body TSL

Impedance, transformed to feed point	45.8 Ω - 1.6 j Ω
Return Loss	- 26.6 dB

General Antenna Parameters and Design

Electrical Delay (one direction)	1.169 ns
----------------------------------	----------

After long term use with 100W radiated power, only a slight warming of the dipole near the feedpoint can be measured.

The dipole is made of standard semirigid coaxial cable. The center conductor of the feeding line is directly connected to the second arm of the dipole. The antenna is therefore short-circuited for DC-signals. On some of the dipoles, small end caps are added to the dipole arms in order to improve matching when loaded according to the position as explained in the "Measurement Conditions" paragraph. The SAR data are not affected by this change. The overall dipole length is still according to the Standard.

No excessive force must be applied to the dipole arms, because they might bend or the soldered connections near the feedpoint may be damaged.

Additional EUT Data

Manufactured by	SPEAG
Manufactured on	October 30, 2007

DASY5 Validation Report for Head TSL

Date: 07.02.2018

Test Laboratory: SPEAG, Zurich, Switzerland

DUT: Dipole 2300 MHz; Type: D2300V2; Serial: D2300V2 - SN:1008

Communication System: UID 0 - CW; Frequency: 2300 MHz

Medium parameters used: $f = 2300$ MHz; $\sigma = 1.7$ S/m; $\epsilon_r = 38.4$; $\rho = 1000$ kg/m³

Phantom section: Flat Section

Measurement Standard: DASY5 (IEEE/IEC/ANSI C63.19-2011)

DASY52 Configuration:

- Probe: EX3DV4 - SN7349; ConvF(8.08, 8.08, 8.08); Calibrated: 30.12.2017;
- Sensor-Surface: 1.4mm (Mechanical Surface Detection)
- Electronics: DAE4 Sn601; Calibrated: 26.10.2017
- Phantom: Flat Phantom 5.0 (front); Type: QD 000 P50 AA; Serial: 1001
- DASY52 52.10.0(1446); SEMCAD X 14.6.10(7417)

Dipole Calibration for Head Tissue/Pin=250 mW, d=10mm/Zoom Scan (7x7x7)/Cube 0:

Measurement grid: dx=5mm, dy=5mm, dz=5mm

Reference Value = 115.2 V/m; Power Drift = -0.07 dB

Peak SAR (extrapolated) = 24.7 W/kg

SAR(1 g) = 12.6 W/kg; SAR(10 g) = 6 W/kg

Maximum value of SAR (measured) = 20.1 W/kg

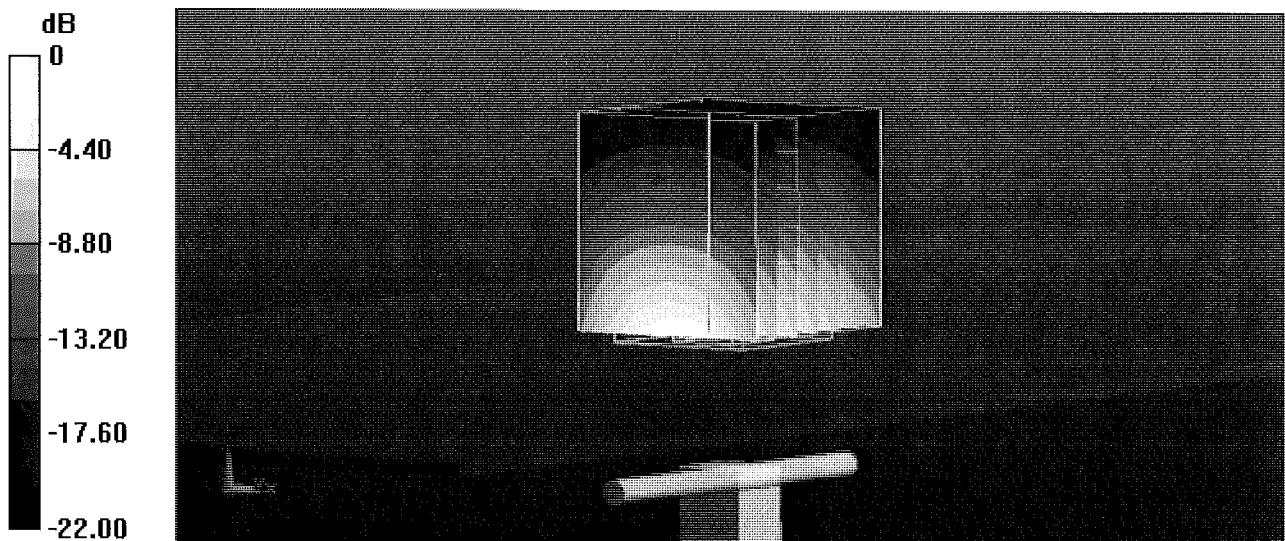

0 dB = 20.1 W/kg = 13.03 dBW/kg

Impedance Measurement Plot for Head TSL

7 Feb 2018 15:33:40

CH1 S11 1 U FS 1: 49.119 Ω -2.7578 Ω 25.092 pF 2 300.000 000 MHz

*
De1
Ca

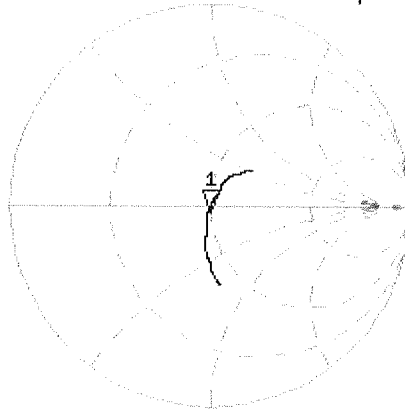

Avg
16

H1d

CH2 S11 LOG 5 dB/REF -20 dB 1:-30.697 dB 2 300.000 000 MHz

Ca

Avg
16

H1d

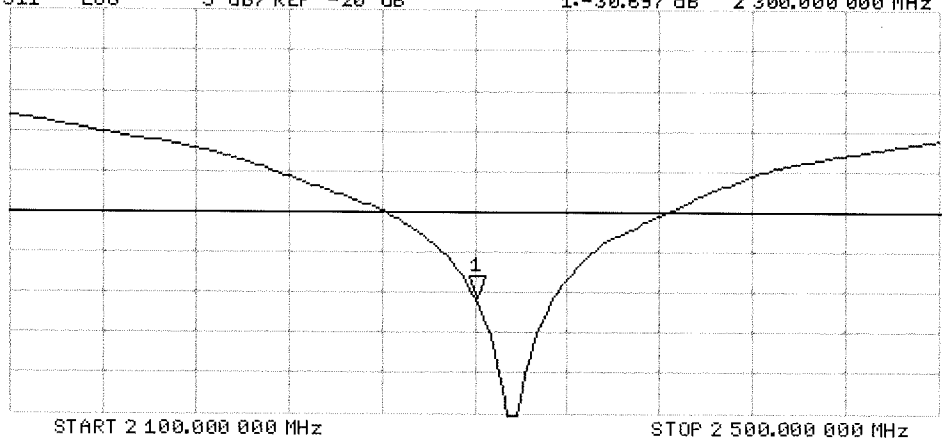

DASY5 Validation Report for Body TSL

Date: 07.02.2018

Test Laboratory: SPEAG, Zurich, Switzerland

DUT: Dipole 2300 MHz; Type: D2300V2; Serial: D2300V2 - SN:1008

Communication System: UID 0 - CW; Frequency: 2300 MHz

Medium parameters used: $f = 2300 \text{ MHz}$; $\sigma = 1.86 \text{ S/m}$; $\epsilon_r = 51.8$; $\rho = 1000 \text{ kg/m}^3$

Phantom section: Flat Section

Measurement Standard: DASY5 (IEEE/IEC/ANSI C63.19-2011)

DASY52 Configuration:

- Probe: EX3DV4 - SN7349; ConvF(8.08, 8.08, 8.08); Calibrated: 30.12.2017;
- Sensor-Surface: 1.4mm (Mechanical Surface Detection)
- Electronics: DAE4 Sn601; Calibrated: 26.10.2017
- Phantom: Flat Phantom 5.0 (back); Type: QD 000 P50 AA; Serial: 1002
- DASY52 52.10.0(1446); SEMCAD X 14.6.10(7417)

Dipole Calibration for Body Tissue/Pin=250 mW, d=10mm/Zoom Scan (7x7x7)/Cube 0:

Measurement grid: $dx=5\text{mm}$, $dy=5\text{mm}$, $dz=5\text{mm}$

Reference Value = 106.7 V/m; Power Drift = -0.08 dB

Peak SAR (extrapolated) = 23.3 W/kg

SAR(1 g) = 12 W/kg; SAR(10 g) = 5.75 W/kg

Maximum value of SAR (measured) = 19.0 W/kg

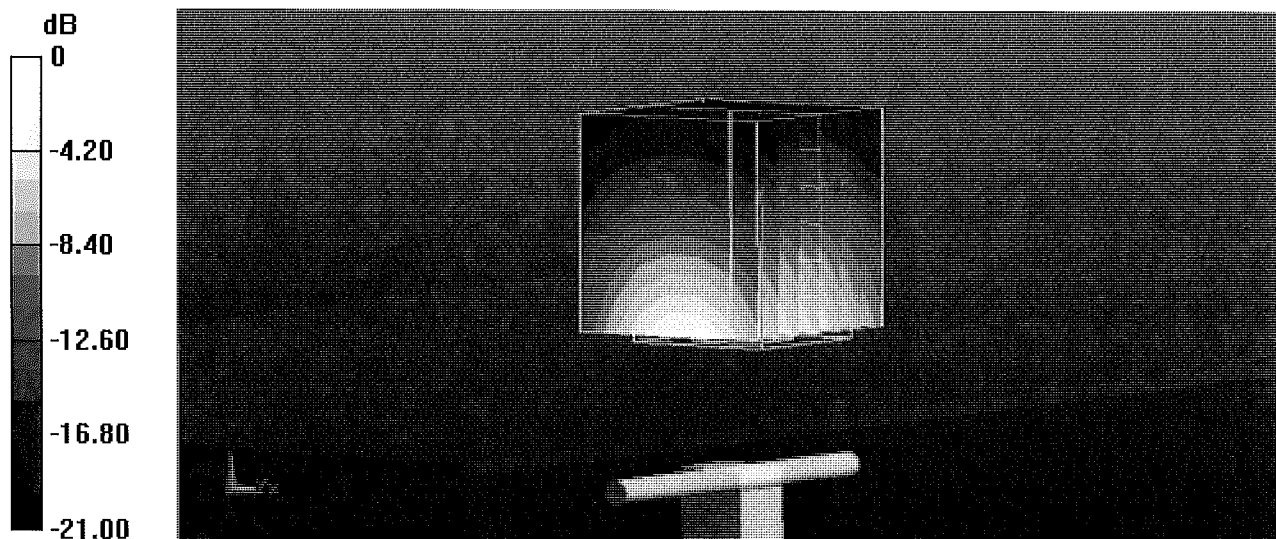

0 dB = 19.0 W/kg = 12.79 dBW/kg

Impedance Measurement Plot for Body TSL

7 Feb 2018 15:33:10

CH1 S11 1 U FS 1: 45.795 Ω -1.5664 Ω 44.176 μ F 2 300.000 000 MHz

*
De1
CA
Avg
16
H1d

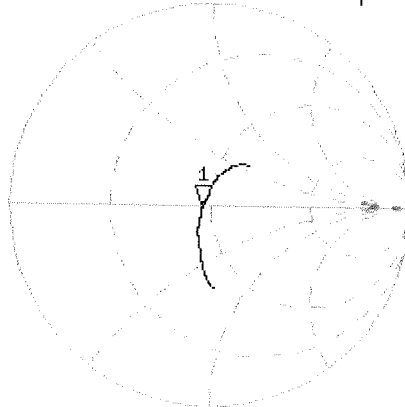

CH2 S11 LOG 5 dB/REF -20 dB 1:-26.585 dB 2 300.000 000 MHz

CA
Avg
16
H1d

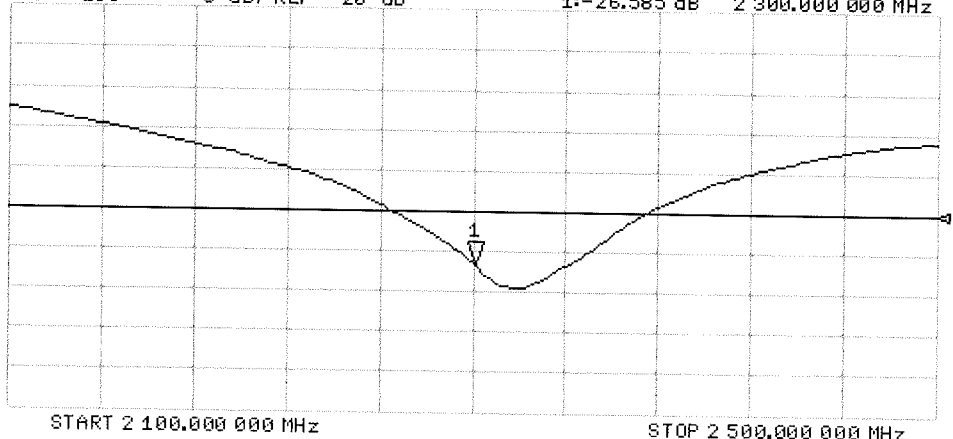



Accredited by the Swiss Accreditation Service (SAS)
The Swiss Accreditation Service is one of the signatories to the EA
Multilateral Agreement for the recognition of calibration certificates

Accreditation No.: **SCS 0108**

Client **PC Test**

Certificate No: **D2450V2-882_Feb18**

CALIBRATION CERTIFICATE

Object **D2450V2 - SN:882**

Calibration procedure(s) **QA CAL-05.v9
Calibration procedure for dipole validation kits above 700 MHz**

*BN ✓
03-02-2018*

Calibration date: **February 07, 2018**

This calibration certificate documents the traceability to national standards, which realize the physical units of measurements (SI).
The measurements and the uncertainties with confidence probability are given on the following pages and are part of the certificate.

All calibrations have been conducted in the closed laboratory facility: environment temperature (22 ± 3)°C and humidity < 70%.

Calibration Equipment used (M&TE critical for calibration)

Primary Standards	ID #	Cal Date (Certificate No.)	Scheduled Calibration
Power meter NRP	SN: 104778	04-Apr-17 (No. 217-02521/02522)	Apr-18
Power sensor NRP-Z91	SN: 103244	04-Apr-17 (No. 217-02521)	Apr-18
Power sensor NRP-Z91	SN: 103245	04-Apr-17 (No. 217-02522)	Apr-18
Reference 20 dB Attenuator	SN: 5058 (20k)	07-Apr-17 (No. 217-02528)	Apr-18
Type-N mismatch combination	SN: 5047.2 / 06327	07-Apr-17 (No. 217-02529)	Apr-18
Reference Probe EX3DV4	SN: 7349	30-Dec-17 (No. EX3-7349_Dec17)	Dec-18
DAE4	SN: 601	26-Oct-17 (No. DAE4-601_Oct17)	Oct-18

Secondary Standards	ID #	Check Date (in house)	Scheduled Check
Power meter EPM-442A	SN: GB37480704	07-Oct-15 (in house check Oct-16)	In house check: Oct-18
Power sensor HP 8481A	SN: US37292783	07-Oct-15 (in house check Oct-16)	In house check: Oct-18
Power sensor HP 8481A	SN: MY41092317	07-Oct-15 (in house check Oct-16)	In house check: Oct-18
RF generator R&S SMT-06	SN: 100972	15-Jun-15 (in house check Oct-16)	In house check: Oct-18
Network Analyzer HP 8753E	SN: US37390585	18-Oct-01 (in house check Oct-17)	In house check: Oct-18

Calibrated by: **Claudio Leubler** Name: Claudio Leubler Function: Laboratory Technician

Signature *[Handwritten Signature]*

Approved by: **Katja Pokovic** Name: Katja Pokovic Function: Technical Manager

Signature *[Handwritten Signature]*

Issued: February 7, 2018

This calibration certificate shall not be reproduced except in full without written approval of the laboratory.



Accredited by the Swiss Accreditation Service (SAS)

The Swiss Accreditation Service is one of the signatories to the EA
Multilateral Agreement for the recognition of calibration certificates

Accreditation No.: **SCS 0108**

Glossary:

TSL	tissue simulating liquid
ConvF	sensitivity in TSL / NORM x,y,z
N/A	not applicable or not measured

Calibration is Performed According to the Following Standards:

- IEEE Std 1528-2013, "IEEE Recommended Practice for Determining the Peak Spatial-Averaged Specific Absorption Rate (SAR) in the Human Head from Wireless Communications Devices: Measurement Techniques", June 2013
- IEC 62209-1, "Measurement procedure for the assessment of Specific Absorption Rate (SAR) from hand-held and body-mounted devices used next to the ear (frequency range of 300 MHz to 6 GHz)", July 2016
- IEC 62209-2, "Procedure to determine the Specific Absorption Rate (SAR) for wireless communication devices used in close proximity to the human body (frequency range of 30 MHz to 6 GHz)", March 2010
- KDB 865664, "SAR Measurement Requirements for 100 MHz to 6 GHz"

Additional Documentation:

- DASY4/5 System Handbook

Methods Applied and Interpretation of Parameters:

- Measurement Conditions:** Further details are available from the Validation Report at the end of the certificate. All figures stated in the certificate are valid at the frequency indicated.
- Antenna Parameters with TSL:** The dipole is mounted with the spacer to position its feed point exactly below the center marking of the flat phantom section, with the arms oriented parallel to the body axis.
- Feed Point Impedance and Return Loss:** These parameters are measured with the dipole positioned under the liquid filled phantom. The impedance stated is transformed from the measurement at the SMA connector to the feed point. The Return Loss ensures low reflected power. No uncertainty required.
- Electrical Delay:** One-way delay between the SMA connector and the antenna feed point. No uncertainty required.
- SAR measured:** SAR measured at the stated antenna input power.
- SAR normalized:** SAR as measured, normalized to an input power of 1 W at the antenna connector.
- SAR for nominal TSL parameters:** The measured TSL parameters are used to calculate the nominal SAR result.

The reported uncertainty of measurement is stated as the standard uncertainty of measurement multiplied by the coverage factor $k=2$, which for a normal distribution corresponds to a coverage probability of approximately 95%.

Measurement Conditions

DASY system configuration, as far as not given on page 1.

DASY Version	DASY5	V52.10.0
Extrapolation	Advanced Extrapolation	
Phantom	Modular Flat Phantom	
Distance Dipole Center - TSL	10 mm	with Spacer
Zoom Scan Resolution	dx, dy, dz = 5 mm	
Frequency	2450 MHz \pm 1 MHz	

Head TSL parameters

The following parameters and calculations were applied.

	Temperature	Permittivity	Conductivity
Nominal Head TSL parameters	22.0 °C	39.2	1.80 mho/m
Measured Head TSL parameters	(22.0 \pm 0.2) °C	37.9 \pm 6 %	1.87 mho/m \pm 6 %
Head TSL temperature change during test	< 0.5 °C	----	----

SAR result with Head TSL

SAR averaged over 1 cm³ (1 g) of Head TSL	Condition	
SAR measured	250 mW input power	13.4 W/kg
SAR for nominal Head TSL parameters	normalized to 1W	52.2 W/kg \pm 17.0 % (k=2)

SAR averaged over 10 cm³ (10 g) of Head TSL	condition	
SAR measured	250 mW input power	6.22 W/kg
SAR for nominal Head TSL parameters	normalized to 1W	24.5 W/kg \pm 16.5 % (k=2)

Body TSL parameters

The following parameters and calculations were applied.

	Temperature	Permittivity	Conductivity
Nominal Body TSL parameters	22.0 °C	52.7	1.95 mho/m
Measured Body TSL parameters	(22.0 \pm 0.2) °C	51.4 \pm 6 %	2.04 mho/m \pm 6 %
Body TSL temperature change during test	< 0.5 °C	----	----

SAR result with Body TSL

SAR averaged over 1 cm³ (1 g) of Body TSL	Condition	
SAR measured	250 mW input power	12.9 W/kg
SAR for nominal Body TSL parameters	normalized to 1W	50.2 W/kg \pm 17.0 % (k=2)

SAR averaged over 10 cm³ (10 g) of Body TSL	condition	
SAR measured	250 mW input power	5.98 W/kg
SAR for nominal Body TSL parameters	normalized to 1W	23.6 W/kg \pm 16.5 % (k=2)

Appendix (Additional assessments outside the scope of SCS 0108)

Antenna Parameters with Head TSL

Impedance, transformed to feed point	52.0 Ω + 1.3 j Ω
Return Loss	- 32.6 dB

Antenna Parameters with Body TSL

Impedance, transformed to feed point	48.8 Ω + 3.7 j Ω
Return Loss	- 28.1 dB

General Antenna Parameters and Design

Electrical Delay (one direction)	1.156 ns
----------------------------------	----------

After long term use with 100W radiated power, only a slight warming of the dipole near the feedpoint can be measured.

The dipole is made of standard semirigid coaxial cable. The center conductor of the feeding line is directly connected to the second arm of the dipole. The antenna is therefore short-circuited for DC-signals. On some of the dipoles, small end caps are added to the dipole arms in order to improve matching when loaded according to the position as explained in the "Measurement Conditions" paragraph. The SAR data are not affected by this change. The overall dipole length is still according to the Standard.

No excessive force must be applied to the dipole arms, because they might bend or the soldered connections near the feedpoint may be damaged.

Additional EUT Data

Manufactured by	SPEAG
Manufactured on	October 06, 2011

DASY5 Validation Report for Head TSL

Date: 07.02.2018

Test Laboratory: SPEAG, Zurich, Switzerland

DUT: Dipole 2450 MHz; Type: D2450V2; Serial: D2450V2 - SN:882

Communication System: UID 0 - CW; Frequency: 2450 MHz

Medium parameters used: $f = 2450$ MHz; $\sigma = 1.87$ S/m; $\epsilon_r = 37.9$; $\rho = 1000$ kg/m³

Phantom section: Flat Section

Measurement Standard: DASY5 (IEEE/IEC/ANSI C63.19-2011)

DASY52 Configuration:

- Probe: EX3DV4 - SN7349; ConvF(7.88, 7.88, 7.88); Calibrated: 30.12.2017;
- Sensor-Surface: 1.4mm (Mechanical Surface Detection)
- Electronics: DAE4 Sn601; Calibrated: 26.10.2017
- Phantom: Flat Phantom 5.0 (front); Type: QD 000 P50 AA; Serial: 1001
- DASY52 52.10.0(1446); SEMCAD X 14.6.10(7417)

Dipole Calibration for Head Tissue/Pin=250 mW, d=10mm/Zoom Scan (7x7x7)/Cube 0:

Measurement grid: dx=5mm, dy=5mm, dz=5mm

Reference Value = 112.2 V/m; Power Drift = -0.03 dB

Peak SAR (extrapolated) = 27.1 W/kg

SAR(1 g) = 13.4 W/kg; SAR(10 g) = 6.22 W/kg

Maximum value of SAR (measured) = 21.6 W/kg

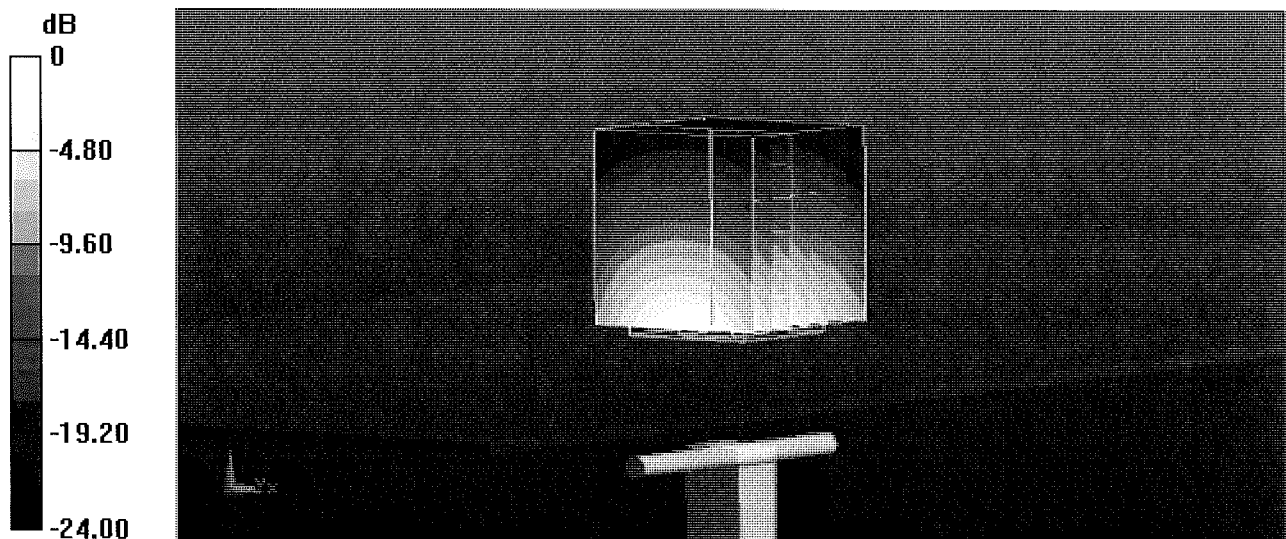

0 dB = 21.6 W/kg = 13.34 dBW/kg

Impedance Measurement Plot for Head TSL

7 Feb 2018 15:38:37

[CH1] S11 1 U FS 1: 52.023 Ω 1.2734 Ω 82.724 pF 2 450.000 000 MHz

*
Del

CA

Avg
16

H1d

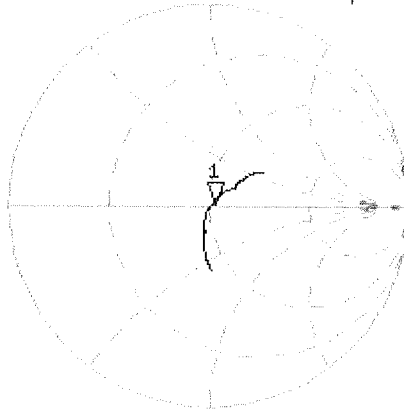

CH2 S11 LOG 5 dB/ REF -20 dB 1: -32.606 dB 2 450.000 000 MHz

CA

Avg
16

H1d

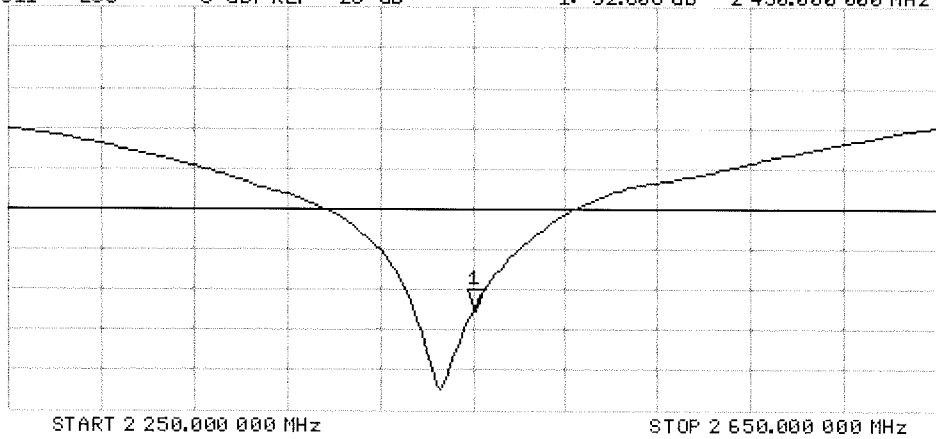

DASY5 Validation Report for Body TSL

Date: 07.02.2018

Test Laboratory: SPEAG, Zurich, Switzerland

DUT: Dipole 2450 MHz; Type: D2450V2; Serial: D2450V2 - SN:882

Communication System: UID 0 - CW; Frequency: 2450 MHz

Medium parameters used: $f = 2450$ MHz; $\sigma = 2.04$ S/m; $\epsilon_r = 51.4$; $\rho = 1000$ kg/m³

Phantom section: Flat Section

Measurement Standard: DASY5 (IEEE/IEC/ANSI C63.19-2011)

DASY52 Configuration:

- Probe: EX3DV4 - SN7349; ConvF(8.01, 8.01, 8.01); Calibrated: 30.12.2017;
- Sensor-Surface: 1.4mm (Mechanical Surface Detection)
- Electronics: DAE4 Sn601; Calibrated: 26.10.2017
- Phantom: Flat Phantom 5.0 (back); Type: QD 000 P50 AA; Serial: 1002
- DASY52 52.10.0(1446); SEMCAD X 14.6.10(7417)

Dipole Calibration for Body Tissue/Pin=250 mW, d=10mm/Zoom Scan (7x7x7)/Cube 0:

Measurement grid: dx=5mm, dy=5mm, dz=5mm

Reference Value = 107.8 V/m; Power Drift = -0.01 dB

Peak SAR (extrapolated) = 25.9 W/kg

SAR(1 g) = 12.9 W/kg; SAR(10 g) = 5.98 W/kg

Maximum value of SAR (measured) = 21.2 W/kg

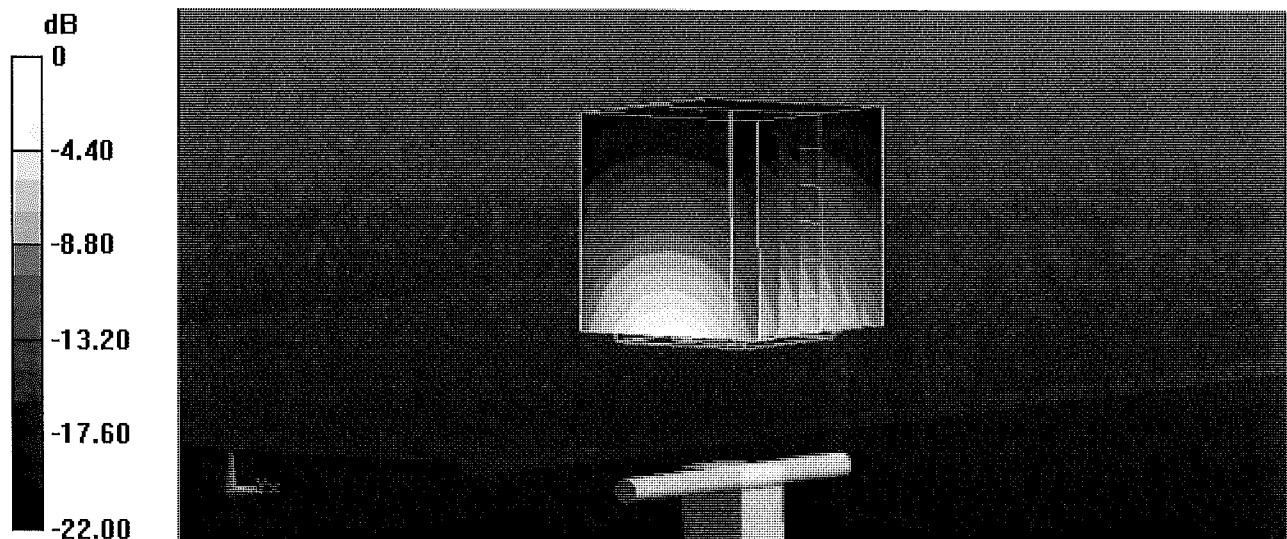

0 dB = 21.2 W/kg = 13.26 dBW/kg

Impedance Measurement Plot for Body TSL

7 Feb 2018 15:38:06

CH1 S11 1 U FS 1: 48.838 Ω 3.7051 Ω 240.69 μH 2 450.000 000 MHz

*
De1
CA



Avg
16

H1d

CH2 S11 LOG 5 dB/REF -20 dB 1:-28.126 dB 2 450.000 000 MHz

CA

Avg
16

H1d

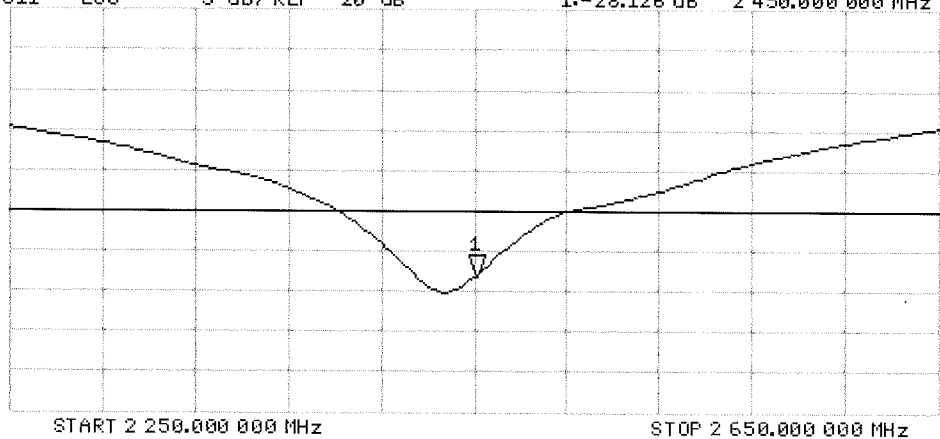



Accredited by the Swiss Accreditation Service (SAS)
The Swiss Accreditation Service is one of the signatories to the EA
Multilateral Agreement for the recognition of calibration certificates

Accreditation No.: **SCS 0108**

Client **PC Test**

Certificate No: **D2600V2-1004_Apr18**

CALIBRATION CERTIFICATE

Object **D2600V2 - SN:1004**

Calibration procedure(s) **QA CAL-05.v10
Calibration procedure for dipole validation kits above 700 MHz**

*BN ✓
05-01-2018*

Calibration date: **April 11, 2018**

This calibration certificate documents the traceability to national standards, which realize the physical units of measurements (SI).
The measurements and the uncertainties with confidence probability are given on the following pages and are part of the certificate.

All calibrations have been conducted in the closed laboratory facility: environment temperature (22 ± 3)°C and humidity < 70%.

Calibration Equipment used (M&TE critical for calibration)

Primary Standards	ID #	Cal Date (Certificate No.)	Scheduled Calibration
Power meter NRP	SN: 104778	04-Apr-18 (No. 217-02672/02673)	Apr-19
Power sensor NRP-Z91	SN: 103244	04-Apr-18 (No. 217-02672)	Apr-19
Power sensor NRP-Z91	SN: 103245	04-Apr-18 (No. 217-02673)	Apr-19
Reference 20 dB Attenuator	SN: 5058 (20k)	04-Apr-18 (No. 217-02682)	Apr-19
Type-N mismatch combination	SN: 5047.2 / 06327	04-Apr-18 (No. 217-02683)	Apr-19
Reference Probe EX3DV4	SN: 7349	30-Dec-17 (No. EX3-7349_Dec17)	Dec-18
DAE4	SN: 601	26-Oct-17 (No. DAE4-601_Oct17)	Oct-18

Secondary Standards	ID #	Check Date (in house)	Scheduled Check
Power meter EPM-442A	SN: GB37480704	07-Oct-15 (in house check Oct-16)	In house check: Oct-18
Power sensor HP 8481A	SN: US37292783	07-Oct-15 (in house check Oct-16)	In house check: Oct-18
Power sensor HP 8481A	SN: MY41092317	07-Oct-15 (in house check Oct-16)	In house check: Oct-18
RF generator R&S SMT-06	SN: 100972	15-Jun-15 (in house check Oct-16)	In house check: Oct-18
Network Analyzer HP 8753E	SN: US37390585	18-Oct-01 (in house check Oct-17)	In house check: Oct-18

Calibrated by: **Michael Weber** Name: Michael Weber Function: Laboratory Technician

M. Weber

Approved by: **Katja Pokovic** Name: Katja Pokovic Function: Technical Manager

Katja Pokovic

Issued: April 12, 2018

This calibration certificate shall not be reproduced except in full without written approval of the laboratory.



Accredited by the Swiss Accreditation Service (SAS)

Accreditation No.: **SCS 0108**

The Swiss Accreditation Service is one of the signatories to the EA Multilateral Agreement for the recognition of calibration certificates

Glossary:

TSL	tissue simulating liquid
ConvF	sensitivity in TSL / NORM x,y,z
N/A	not applicable or not measured

Calibration is Performed According to the Following Standards:

- IEEE Std 1528-2013, "IEEE Recommended Practice for Determining the Peak Spatial-Averaged Specific Absorption Rate (SAR) in the Human Head from Wireless Communications Devices: Measurement Techniques", June 2013
- IEC 62209-1, "Measurement procedure for the assessment of Specific Absorption Rate (SAR) from hand-held and body-mounted devices used next to the ear (frequency range of 300 MHz to 6 GHz)", July 2016
- IEC 62209-2, "Procedure to determine the Specific Absorption Rate (SAR) for wireless communication devices used in close proximity to the human body (frequency range of 30 MHz to 6 GHz)", March 2010
- KDB 865664, "SAR Measurement Requirements for 100 MHz to 6 GHz"

Additional Documentation:

- DASY4/5 System Handbook

Methods Applied and Interpretation of Parameters:

- Measurement Conditions:** Further details are available from the Validation Report at the end of the certificate. All figures stated in the certificate are valid at the frequency indicated.
- Antenna Parameters with TSL:** The dipole is mounted with the spacer to position its feed point exactly below the center marking of the flat phantom section, with the arms oriented parallel to the body axis.
- Feed Point Impedance and Return Loss:** These parameters are measured with the dipole positioned under the liquid filled phantom. The impedance stated is transformed from the measurement at the SMA connector to the feed point. The Return Loss ensures low reflected power. No uncertainty required.
- Electrical Delay:** One-way delay between the SMA connector and the antenna feed point. No uncertainty required.
- SAR measured:** SAR measured at the stated antenna input power.
- SAR normalized:** SAR as measured, normalized to an input power of 1 W at the antenna connector.
- SAR for nominal TSL parameters:** The measured TSL parameters are used to calculate the nominal SAR result.

The reported uncertainty of measurement is stated as the standard uncertainty of measurement multiplied by the coverage factor $k=2$, which for a normal distribution corresponds to a coverage probability of approximately 95%.

Measurement Conditions

DASY system configuration, as far as not given on page 1.

DASY Version	DASY5	V52.10.0
Extrapolation	Advanced Extrapolation	
Phantom	Modular Flat Phantom	
Distance Dipole Center - TSL	10 mm	with Spacer
Zoom Scan Resolution	dx, dy, dz = 5 mm	
Frequency	2600 MHz \pm 1 MHz	

Head TSL parameters

The following parameters and calculations were applied.

	Temperature	Permittivity	Conductivity
Nominal Head TSL parameters	22.0 °C	39.0	1.96 mho/m
Measured Head TSL parameters	(22.0 \pm 0.2) °C	37.8 \pm 6 %	2.03 mho/m \pm 6 %
Head TSL temperature change during test	< 0.5 °C	----	----

SAR result with Head TSL

SAR averaged over 1 cm³ (1 g) of Head TSL	Condition	
SAR measured	250 mW input power	14.3 W/kg
SAR for nominal Head TSL parameters	normalized to 1W	55.9 W/kg \pm 17.0 % (k=2)

SAR averaged over 10 cm³ (10 g) of Head TSL	condition	
SAR measured	250 mW input power	6.35 W/kg
SAR for nominal Head TSL parameters	normalized to 1W	25.1 W/kg \pm 16.5 % (k=2)

Body TSL parameters

The following parameters and calculations were applied.

	Temperature	Permittivity	Conductivity
Nominal Body TSL parameters	22.0 °C	52.5	2.16 mho/m
Measured Body TSL parameters	(22.0 \pm 0.2) °C	52.1 \pm 6 %	2.19 mho/m \pm 6 %
Body TSL temperature change during test	< 0.5 °C	----	----

SAR result with Body TSL

SAR averaged over 1 cm³ (1 g) of Body TSL	Condition	
SAR measured	250 mW input power	13.8 W/kg
SAR for nominal Body TSL parameters	normalized to 1W	54.8 W/kg \pm 17.0 % (k=2)

SAR averaged over 10 cm³ (10 g) of Body TSL	condition	
SAR measured	250 mW input power	6.20 W/kg
SAR for nominal Body TSL parameters	normalized to 1W	24.7 W/kg \pm 16.5 % (k=2)

Appendix (Additional assessments outside the scope of SCS 0108)

Antenna Parameters with Head TSL

Impedance, transformed to feed point	47.7 Ω - 5.7 j Ω
Return Loss	- 24.1 dB

Antenna Parameters with Body TSL

Impedance, transformed to feed point	46.0 Ω - 3.8 j Ω
Return Loss	- 24.9 dB

General Antenna Parameters and Design

Electrical Delay (one direction)	1.149 ns
----------------------------------	----------

After long term use with 100W radiated power, only a slight warming of the dipole near the feedpoint can be measured.

The dipole is made of standard semirigid coaxial cable. The center conductor of the feeding line is directly connected to the second arm of the dipole. The antenna is therefore short-circuited for DC-signals. On some of the dipoles, small end caps are added to the dipole arms in order to improve matching when loaded according to the position as explained in the "Measurement Conditions" paragraph. The SAR data are not affected by this change. The overall dipole length is still according to the Standard.

No excessive force must be applied to the dipole arms, because they might bend or the soldered connections near the feedpoint may be damaged.

Additional EUT Data

Manufactured by	SPEAG
Manufactured on	December 23, 2006

DASY5 Validation Report for Head TSL

Date: 11.04.2018

Test Laboratory: SPEAG, Zurich, Switzerland

DUT: Dipole 2600 MHz; Type: D2600V2; Serial: D2600V2 - SN: 1004

Communication System: UID 0 - CW; Frequency: 2600 MHz

Medium parameters used: $f = 2600$ MHz; $\sigma = 2.03$ S/m; $\epsilon_r = 37.8$; $\rho = 1000$ kg/m³

Phantom section: Flat Section

Measurement Standard: DASY5 (IEEE/IEC/ANSI C63.19-2011)

DASY52 Configuration:

- Probe: EX3DV4 - SN7349; ConvF(7.7, 7.7, 7.7); Calibrated: 30.12.2017;
- Sensor-Surface: 1.4mm (Mechanical Surface Detection)
- Electronics: DAE4 Sn601; Calibrated: 26.10.2017
- Phantom: Flat Phantom 5.0 (front); Type: QD 000 P50 AA; Serial: 1001
- DASY52 52.10.0(1446); SEMCAD X 14.6.10(7417)

Dipole Calibration for Head Tissue/Pin=250 mW, d=10mm/Zoom Scan (7x7x7)/Cube 0:

Measurement grid: dx=5mm, dy=5mm, dz=5mm

Reference Value = 118.5 V/m; Power Drift = -0.04 dB

Peak SAR (extrapolated) = 28.6 W/kg

SAR(1 g) = 14.3 W/kg; SAR(10 g) = 6.35 W/kg

Maximum value of SAR (measured) = 23.9 W/kg

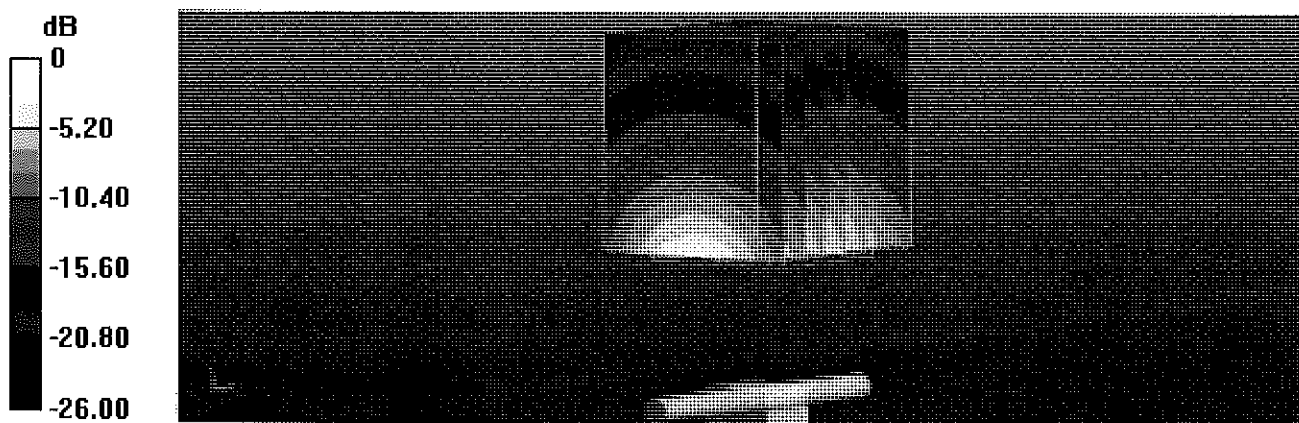

0 dB = 23.9 W/kg = 13.78 dBW/kg

Impedance Measurement Plot for Head TSL

11 Apr 2018 11:25:16

[CH1] S11 1 U FS 1: 47.721 Ω -5.6836 Ω 10.770 pF 2 500.000 000 MHz

*

De1

CA

Avg
16

H1 d

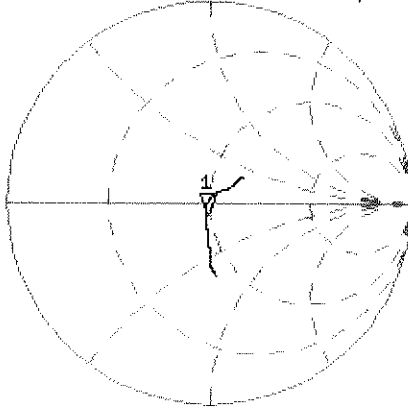

CH2 S11 LOG 5 dB/REF -20 dB 1:-24.073 dB 2 500.000 000 MHz

CA

Avg
16

H1 d

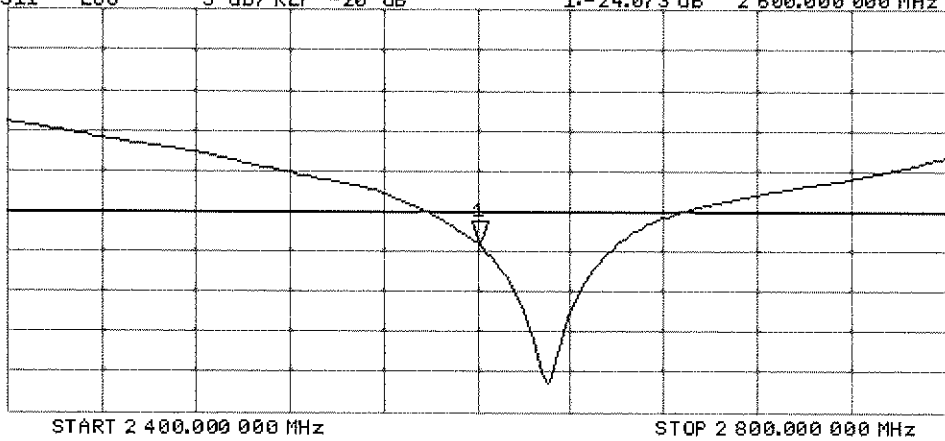

DASY5 Validation Report for Body TSL

Date: 11.04.2018

Test Laboratory: SPEAG, Zurich, Switzerland

DUT: Dipole 2600 MHz; Type: D2600V2; Serial: D2600V2 - SN: 1004

Communication System: UID 0 - CW; Frequency: 2600 MHz

Medium parameters used: $f = 2600$ MHz; $\sigma = 2.19$ S/m; $\epsilon_r = 52.1$; $\rho = 1000$ kg/m³

Phantom section: Flat Section

Measurement Standard: DASY5 (IEEE/IEC/ANSI C63.19-2011)

DASY52 Configuration:

- Probe: EX3DV4 - SN7349; ConvF(7.81, 7.81, 7.81); Calibrated: 30.12.2017;
- Sensor-Surface: 1.4mm (Mechanical Surface Detection)
- Electronics: DAE4 Sn601; Calibrated: 26.10.2017
- Phantom: Flat Phantom 5.0 (back); Type: QD 000 P50 AA; Serial: 1002
- DASY52 52.10.0(1446); SEMCAD X 14.6.10(7417)

Dipole Calibration for Body Tissue/ $P_{in}=250$ mW, $d=10$ mm/Zoom Scan (7x7x7)/Cube 0:

Measurement grid: $dx=5$ mm, $dy=5$ mm, $dz=5$ mm

Reference Value = 108.5 V/m; Power Drift = -0.09 dB

Peak SAR (extrapolated) = 28.3 W/kg

SAR(1 g) = 13.8 W/kg; SAR(10 g) = 6.2 W/kg

Maximum value of SAR (measured) = 22.9 W/kg

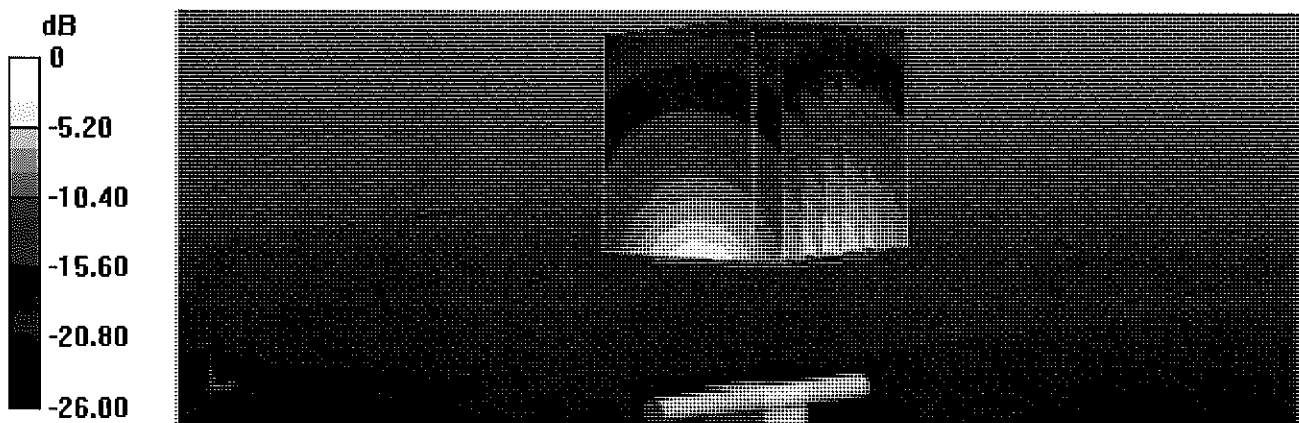

0 dB = 22.9 W/kg = 13.60 dBW/kg

Impedance Measurement Plot for Body TSL

11 Apr 2018 11:24:36

CH1 S11 1 U FS 1: 46.039 Ω -3.7520 Ω 16.315 pF 2 600.000 000 MHz

*
De1

CA

Avg
16

H1 d

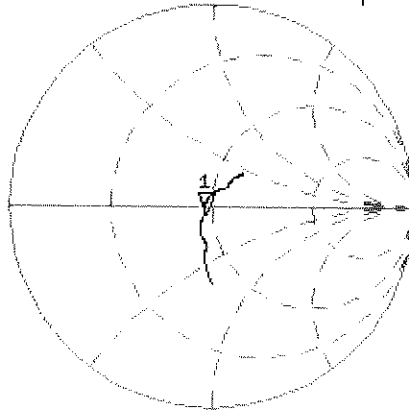

CH2 S11 LOG 5 dB/REF -20 dB 1:-24.921 dB 2 600.000 000 MHz

CA

Avg
16

H1 d

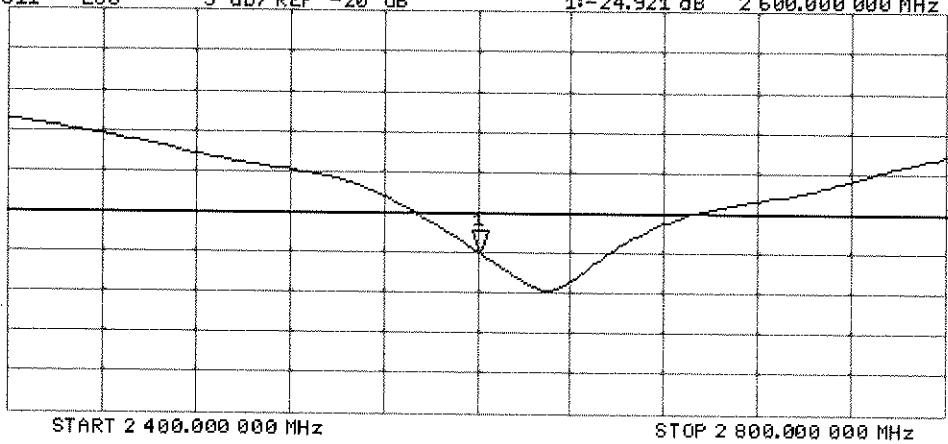



Accredited by the Swiss Accreditation Service (SAS)
The Swiss Accreditation Service is one of the signatories to the EA
Multilateral Agreement for the recognition of calibration certificates

Accreditation No.: **SCS 0108**

Client **PC Test**

Certificate No: **D5GHzV2-1237_Aug17**

CALIBRATION CERTIFICATE

Object **D5GHzV2 - SN:1237**

Calibration procedure(s) **QA CAL-22.v2
Calibration procedure for dipole validation kits between 3-6 GHz**

Calibration date: **August 15, 2017**

PMV
8/27/17

This calibration certificate documents the traceability to national standards, which realize the physical units of measurements (SI).
The measurements and the uncertainties with confidence probability are given on the following pages and are part of the certificate.

All calibrations have been conducted in the closed laboratory facility: environment temperature (22 ± 3)°C and humidity < 70%.

Calibration Equipment used (M&TE critical for calibration)

Primary Standards	ID #	Cal Date (Certificate No.)	Scheduled Calibration
Power meter NRP	SN: 104778	04-Apr-17 (No. 217-02521/02522)	Apr-18
Power sensor NRP-Z91	SN: 103244	04-Apr-17 (No. 217-02521)	Apr-18
Power sensor NRP-Z91	SN: 103245	04-Apr-17 (No. 217-02522)	Apr-18
Reference 20 dB Attenuator	SN: 5058 (20k)	07-Apr-17 (No. 217-02528)	Apr-18
Type-N mismatch combination	SN: 5047.2 / 06327	07-Apr-17 (No. 217-02529)	Apr-18
Reference Probe EX3DV4	SN: 3503	31-Dec-16 (No. EX3-3503_Dec16)	Dec-17
DAE4	SN: 601	28-Mar-17 (No. DAE4-601_Mar17)	Mar-18

Secondary Standards	ID #	Check Date (in house)	Scheduled Check
Power meter EPM-442A	SN: GB37480704	07-Oct-15 (in house check Oct-16)	In house check: Oct-18
Power sensor HP 8481A	SN: US37292783	07-Oct-15 (in house check Oct-16)	In house check: Oct-18
Power sensor HP 8481A	SN: MY41092317	07-Oct-15 (in house check Oct-16)	In house check: Oct-18
RF generator R&S SMT-06	SN: 100972	15-Jun-15 (in house check Oct-16)	In house check: Oct-18
Network Analyzer HP 8753E	SN: US37390585	18-Oct-01 (in house check Oct-16)	In house check: Oct-17

Calibrated by: **Johannes Kurikka** Function: **Laboratory Technician**

Approved by: **Katja Pokovic** Technical Manager

Signature
[Handwritten Signature]
[Handwritten Signature]

Issued: August 16, 2017

This calibration certificate shall not be reproduced except in full without written approval of the laboratory.



Accredited by the Swiss Accreditation Service (SAS)
The Swiss Accreditation Service is one of the signatories to the EA
Multilateral Agreement for the recognition of calibration certificates

Accreditation No.: **SCS 0108**

Glossary:

TSL	tissue simulating liquid
ConvF	sensitivity in TSL / NORM x,y,z
N/A	not applicable or not measured

Calibration is Performed According to the Following Standards:

- IEEE Std 1528-2013, "IEEE Recommended Practice for Determining the Peak Spatial-Averaged Specific Absorption Rate (SAR) in the Human Head from Wireless Communications Devices: Measurement Techniques", June 2013
- IEC 62209-1, "Measurement procedure for the assessment of Specific Absorption Rate (SAR) from hand-held and body-mounted devices used next to the ear (frequency range of 300 MHz to 6 GHz)", July 2016
- IEC 62209-2, "Procedure to determine the Specific Absorption Rate (SAR) for wireless communication devices used in close proximity to the human body (frequency range of 30 MHz to 6 GHz)", March 2010
- KDB 865664, "SAR Measurement Requirements for 100 MHz to 6 GHz"

Additional Documentation:

- DASY4/5 System Handbook

Methods Applied and Interpretation of Parameters:

- Measurement Conditions:** Further details are available from the Validation Report at the end of the certificate. All figures stated in the certificate are valid at the frequency indicated.
- Antenna Parameters with TSL:** The dipole is mounted with the spacer to position its feed point exactly below the center marking of the flat phantom section, with the arms oriented parallel to the body axis.
- Feed Point Impedance and Return Loss:** These parameters are measured with the dipole positioned under the liquid filled phantom. The impedance stated is transformed from the measurement at the SMA connector to the feed point. The Return Loss ensures low reflected power. No uncertainty required.
- Electrical Delay:** One-way delay between the SMA connector and the antenna feed point. No uncertainty required.
- SAR measured:** SAR measured at the stated antenna input power.
- SAR normalized:** SAR as measured, normalized to an input power of 1 W at the antenna connector.
- SAR for nominal TSL parameters:** The measured TSL parameters are used to calculate the nominal SAR result.

The reported uncertainty of measurement is stated as the standard uncertainty of measurement multiplied by the coverage factor $k=2$, which for a normal distribution corresponds to a coverage probability of approximately 95%.

Measurement Conditions

DASY system configuration, as far as not given on page 1.

DASY Version	DASY5	V52.10.0
Extrapolation	Advanced Extrapolation	
Phantom	Modular Flat Phantom V5.0	
Distance Dipole Center - TSL	10 mm	with Spacer
Zoom Scan Resolution	dx, dy = 4.0 mm, dz = 1.4 mm	Graded Ratio = 1.4 (Z direction)
Frequency	5250 MHz ± 1 MHz 5600 MHz ± 1 MHz 5750 MHz ± 1 MHz	

Head TSL parameters at 5250 MHz

The following parameters and calculations were applied.

	Temperature	Permittivity	Conductivity
Nominal Head TSL parameters	22.0 °C	35.9	4.71 mho/m
Measured Head TSL parameters	(22.0 ± 0.2) °C	34.7 ± 6 %	4.49 mho/m ± 6 %
Head TSL temperature change during test	< 0.5 °C	----	----

SAR result with Head TSL at 5250 MHz

SAR averaged over 1 cm ³ (1 g) of Head TSL	Condition	
SAR measured	100 mW input power	8.14 W/kg
SAR for nominal Head TSL parameters	normalized to 1W	80.7 W/kg ± 19.9 % (k=2)

SAR averaged over 10 cm ³ (10 g) of Head TSL	condition	
SAR measured	100 mW input power	2.33 W/kg
SAR for nominal Head TSL parameters	normalized to 1W	23.0 W/kg ± 19.5 % (k=2)

Head TSL parameters at 5600 MHz

The following parameters and calculations were applied.

	Temperature	Permittivity	Conductivity
Nominal Head TSL parameters	22.0 °C	35.5	5.07 mho/m
Measured Head TSL parameters	(22.0 ± 0.2) °C	34.2 ± 6 %	4.84 mho/m ± 6 %
Head TSL temperature change during test	< 0.5 °C	----	----

SAR result with Head TSL at 5600 MHz

SAR averaged over 1 cm ³ (1 g) of Head TSL	Condition	
SAR measured	100 mW input power	8.33 W/kg
SAR for nominal Head TSL parameters	normalized to 1W	82.5 W / kg ± 19.9 % (k=2)

SAR averaged over 10 cm ³ (10 g) of Head TSL	condition	
SAR measured	100 mW input power	2.38 W/kg
SAR for nominal Head TSL parameters	normalized to 1W	23.5 W/kg ± 19.5 % (k=2)

Head TSL parameters at 5750 MHz

The following parameters and calculations were applied.

	Temperature	Permittivity	Conductivity
Nominal Head TSL parameters	22.0 °C	35.4	5.22 mho/m
Measured Head TSL parameters	(22.0 ± 0.2) °C	34.0 ± 6 %	4.99 mho/m ± 6 %
Head TSL temperature change during test	< 0.5 °C	----	----

SAR result with Head TSL at 5750 MHz

SAR averaged over 1 cm ³ (1 g) of Head TSL	Condition	
SAR measured	100 mW input power	8.10 W/kg
SAR for nominal Head TSL parameters	normalized to 1W	80.2 W/kg ± 19.9 % (k=2)

SAR averaged over 10 cm ³ (10 g) of Head TSL	condition	
SAR measured	100 mW input power	2.31 W/kg
SAR for nominal Head TSL parameters	normalized to 1W	22.8 W/kg ± 19.5 % (k=2)

Body TSL parameters at 5250 MHz

The following parameters and calculations were applied.

	Temperature	Permittivity	Conductivity
Nominal Body TSL parameters	22.0 °C	48.9	5.36 mho/m
Measured Body TSL parameters	(22.0 ± 0.2) °C	47.0 ± 6 %	5.46 mho/m ± 6 %
Body TSL temperature change during test	< 0.5 °C	----	----

SAR result with Body TSL at 5250 MHz

SAR averaged over 1 cm ³ (1 g) of Body TSL	Condition	
SAR measured	100 mW input power	7.75 W/kg
SAR for nominal Body TSL parameters	normalized to 1W	76.9 W/kg ± 19.9 % (k=2)

SAR averaged over 10 cm ³ (10 g) of Body TSL	condition	
SAR measured	100 mW input power	2.17 W/kg
SAR for nominal Body TSL parameters	normalized to 1W	21.5 W/kg ± 19.5 % (k=2)

Body TSL parameters at 5600 MHz

The following parameters and calculations were applied.

	Temperature	Permittivity	Conductivity
Nominal Body TSL parameters	22.0 °C	48.5	5.77 mho/m
Measured Body TSL parameters	(22.0 ± 0.2) °C	46.4 ± 6 %	5.93 mho/m ± 6 %
Body TSL temperature change during test	< 0.5 °C	----	----

SAR result with Body TSL at 5600 MHz

SAR averaged over 1 cm ³ (1 g) of Body TSL	Condition	
SAR measured	100 mW input power	7.91 W/kg
SAR for nominal Body TSL parameters	normalized to 1W	78.5 W/kg ± 19.9 % (k=2)

SAR averaged over 10 cm ³ (10 g) of Body TSL	condition	
SAR measured	100 mW input power	2.23 W/kg
SAR for nominal Body TSL parameters	normalized to 1W	22.1 W/kg ± 19.5 % (k=2)

Body TSL parameters at 5750 MHz

The following parameters and calculations were applied.

	Temperature	Permittivity	Conductivity
Nominal Body TSL parameters	22.0 °C	48.3	5.94 mho/m
Measured Body TSL parameters	(22.0 ± 0.2) °C	46.2 ± 6 %	6.13 mho/m ± 6 %
Body TSL temperature change during test	< 0.5 °C	----	----

SAR result with Body TSL at 5750 MHz

SAR averaged over 1 cm ³ (1 g) of Body TSL	Condition	
SAR measured	100 mW input power	7.77 W/kg
SAR for nominal Body TSL parameters	normalized to 1W	77.1 W/kg ± 19.9 % (k=2)

SAR averaged over 10 cm ³ (10 g) of Body TSL	condition	
SAR measured	100 mW input power	2.16 W/kg
SAR for nominal Body TSL parameters	normalized to 1W	21.4 W/kg ± 19.5 % (k=2)

Appendix (Additional assessments outside the scope of SCS 0108)

Antenna Parameters with Head TSL at 5250 MHz

Impedance, transformed to feed point	49.9 Ω - 5.3 j Ω
Return Loss	- 25.5 dB

Antenna Parameters with Head TSL at 5600 MHz

Impedance, transformed to feed point	51.9 Ω + 2.3 j Ω
Return Loss	- 30.7 dB

Antenna Parameters with Head TSL at 5750 MHz

Impedance, transformed to feed point	55.6 Ω - 0.5 j Ω
Return Loss	- 25.5 dB

Antenna Parameters with Body TSL at 5250 MHz

Impedance, transformed to feed point	46.9 Ω - 4.2 j Ω
Return Loss	- 25.4 dB

Antenna Parameters with Body TSL at 5600 MHz

Impedance, transformed to feed point	50.2 Ω + 3.0 j Ω
Return Loss	- 30.4 dB

Antenna Parameters with Body TSL at 5750 MHz

Impedance, transformed to feed point	53.4 Ω + 0.2 j Ω
Return Loss	- 29.7 dB

General Antenna Parameters and Design

Electrical Delay (one direction)	1.194 ns
----------------------------------	----------

After long term use with 100W radiated power, only a slight warming of the dipole near the feedpoint can be measured.

The dipole is made of standard semirigid coaxial cable. The center conductor of the feeding line is directly connected to the second arm of the dipole. The antenna is therefore short-circuited for DC-signals. On some of the dipoles, small end caps are added to the dipole arms in order to improve matching when loaded according to the position as explained in the "Measurement Conditions" paragraph. The SAR data are not affected by this change. The overall dipole length is still according to the Standard.

No excessive force must be applied to the dipole arms, because they might bend or the soldered connections near the feedpoint may be damaged.

Additional EUT Data

Manufactured by	SPEAG
Manufactured on	May 04, 2015

DASY5 Validation Report for Head TSL

Date: 15.08.2017

Test Laboratory: SPEAG, Zurich, Switzerland

DUT: Dipole D5GHzV2; Type: D5GHzV2; Serial: D5GHzV2 - SN: 1237

Communication System: UID 0 - CW; Frequency: 5250 MHz, Frequency: 5600 MHz, Frequency: 5750 MHz
Medium parameters used: $f = 5250$ MHz; $\sigma = 4.49$ S/m; $\epsilon_r = 34.7$; $\rho = 1000$ kg/m³,
Medium parameters used: $f = 5600$ MHz; $\sigma = 4.84$ S/m; $\epsilon_r = 34.2$; $\rho = 1000$ kg/m³,
Medium parameters used: $f = 5750$ MHz; $\sigma = 4.99$ S/m; $\epsilon_r = 34$; $\rho = 1000$ kg/m³
Phantom section: Flat Section
Measurement Standard: DASY5 (IEEE/IEC/ANSI C63.19-2011)

DASY52 Configuration:

- Probe: EX3DV4 - SN3503; ConvF(5.58, 5.58, 5.58); Calibrated: 31.12.2016, ConvF(5.09, 5.09, 5.09); Calibrated: 31.12.2016, ConvF(5.02, 5.02, 5.02); Calibrated: 31.12.2016;
- Sensor-Surface: 1.4mm (Mechanical Surface Detection)
- Electronics: DAE4 Sn601; Calibrated: 28.03.2017
- Phantom: Flat Phantom 5.0 (front); Type: QD 000 P50 AA; Serial: 1001
- DASY52 52.10.0(1446); SEMCAD X 14.6.10(7417)

Dipole Calibration for Head Tissue/Pin=100mW, dist=10mm, f=5250 MHz/Zoom Scan, dist=1.4mm (8x8x7)/Cube 0: Measurement grid: dx=4mm, dy=4mm, dz=1.4mm

Reference Value = 70.08 V/m; Power Drift = -0.06 dB

Peak SAR (extrapolated) = 30.6 W/kg

SAR(1 g) = 8.14 W/kg; SAR(10 g) = 2.33 W/kg

Maximum value of SAR (measured) = 19.2 W/kg

Dipole Calibration for Head Tissue/Pin=100mW, dist=10mm, f=5600 MHz/Zoom Scan, dist=1.4mm (8x8x7)/Cube 0: Measurement grid: dx=4mm, dy=4mm, dz=1.4mm

Reference Value = 70.04 V/m; Power Drift = -0.06 dB

Peak SAR (extrapolated) = 32.7 W/kg

SAR(1 g) = 8.33 W/kg; SAR(10 g) = 2.38 W/kg

Maximum value of SAR (measured) = 19.8 W/kg

Dipole Calibration for Head Tissue/Pin=100mW, dist=10mm, f=5750 MHz/Zoom Scan, dist=1.4mm (8x8x7)/Cube 0: Measurement grid: dx=4mm, dy=4mm, dz=1.4mm

Reference Value = 69.11 V/m; Power Drift = -0.09 dB

Peak SAR (extrapolated) = 32.4 W/kg

SAR(1 g) = 8.1 W/kg; SAR(10 g) = 2.31 W/kg

Maximum value of SAR (measured) = 19.6 W/kg

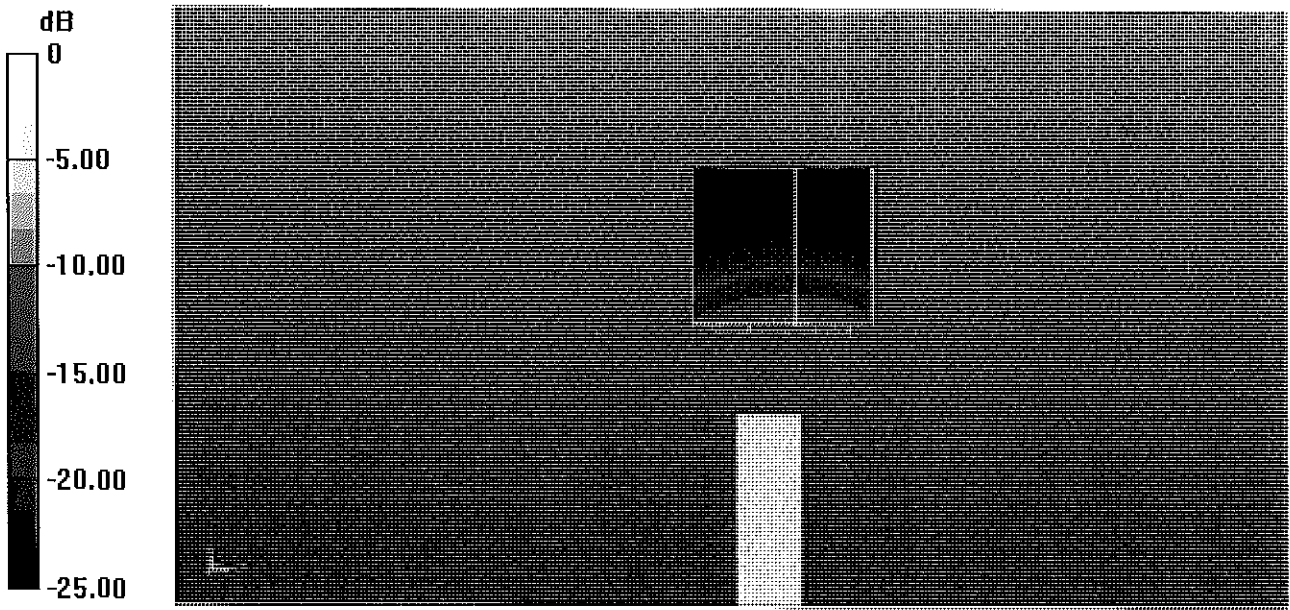

0 dB = 19.2 W/kg = 12.83 dBW/kg

Impedance Measurement Plot for Head TSL

9 Aug 2017 12:04:29

CH1 S11 1 U FS 1: 49.920 Ω -5.3223 Ω 5.6959 μ F 5 250.000 000 MHz

*
De1
Cor
Avg
16
H1d

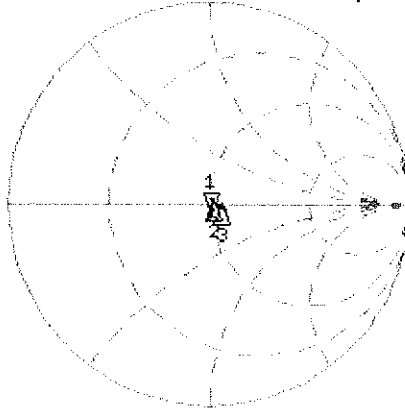

CH1 Markers
2: 51.904 Ω
2.3008 Ω
5.60000 GHz
3: 55.609 Ω
-492.19 $m\Omega$
5.75000 GHz

CH2 S11 LOG 5 dB/ REF -20 dB 1: -25.482 dB 5 250.000 000 MHz

Cor
Avg
16
H1d

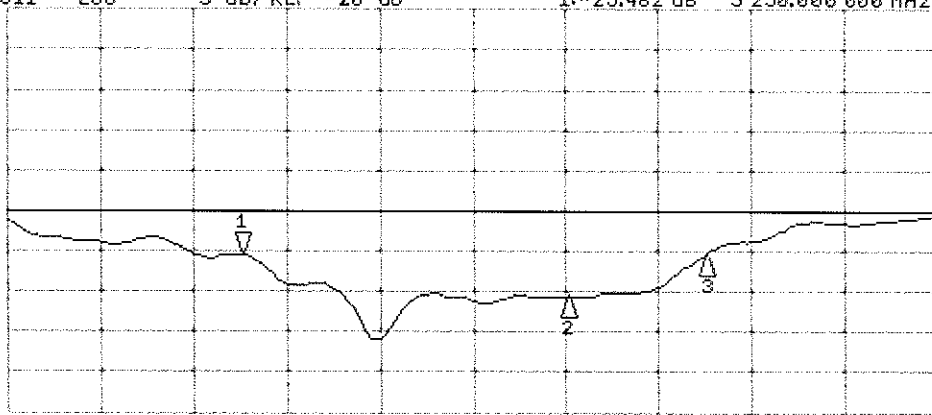

CH2 Markers
2: -30.654 dB
5.60000 GHz
3: -25.460 dB
5.75000 GHz

START 5 000.000 000 MHz

STOP 6 000.000 000 MHz

DASY5 Validation Report for Body TSL

Date: 08.08.2017

Test Laboratory: SPEAG, Zurich, Switzerland

DUT: Dipole D5GHzV2; Type: D5GHzV2; Serial: D5GHzV2 - SN: 1237

Communication System: UID 0 - CW; Frequency: 5250 MHz, Frequency: 5600 MHz, Frequency: 5750 MHz
Medium parameters used: $f = 5250$ MHz; $\sigma = 5.46$ S/m; $\epsilon_r = 47$; $\rho = 1000$ kg/m³,
Medium parameters used: $f = 5600$ MHz; $\sigma = 5.93$ S/m; $\epsilon_r = 46.4$; $\rho = 1000$ kg/m³,
Medium parameters used: $f = 5750$ MHz; $\sigma = 6.13$ S/m; $\epsilon_r = 46.2$; $\rho = 1000$ kg/m³
Phantom section: Flat Section
Measurement Standard: DASY5 (IEEE/IEC/ANSI C63.19-2011)

DASY52 Configuration:

- Probe: EX3DV4 - SN3503; ConvF(5.14, 5.14, 5.14); Calibrated: 31.12.2016, ConvF(4.57, 4.57, 4.57); Calibrated: 31.12.2016, ConvF(4.51, 4.51, 4.51); Calibrated: 31.12.2016;
- Sensor-Surface: 1.4mm (Mechanical Surface Detection)
- Electronics: DAE4 Sn601; Calibrated: 28.03.2017
- Phantom: Flat Phantom 5.0 (back); Type: QD 000 P50 AA; Serial: 1002
- DASY52 52.10.0(1446); SEMCAD X 14.6.10(7417)

Dipole Calibration for Body Tissue/Pin=100mW, dist=10mm, f=5250MHz/Zoom Scan, dist=1.4mm (8x8x7)/Cube 0: Measurement grid: dx=4mm, dy=4mm, dz=1.4mm
Reference Value = 65.87 V/m; Power Drift = -0.05 dB
Peak SAR (extrapolated) = 29.9 W/kg
SAR(1 g) = 7.75 W/kg; SAR(10 g) = 2.17 W/kg
Maximum value of SAR (measured) = 18.4 W/kg

Dipole Calibration for Body Tissue/Pin=100mW, dist=10mm, f=5600 MHz/Zoom Scan, dist=1.4mm (8x8x7)/Cube 0: Measurement grid: dx=4mm, dy=4mm, dz=1.4mm
Reference Value = 65.11 V/m; Power Drift = -0.05 dB
Peak SAR (extrapolated) = 33.0 W/kg
SAR(1 g) = 7.91 W/kg; SAR(10 g) = 2.23 W/kg
Maximum value of SAR (measured) = 19.3 W/kg

Dipole Calibration for Body Tissue/Pin=100mW, dist=10mm, f=5750 MHz/Zoom Scan, dist=1.4mm (8x8x7)/Cube 0: Measurement grid: dx=4mm, dy=4mm, dz=1.4mm
Reference Value = 63.64 V/m; Power Drift = -0.08 dB
Peak SAR (extrapolated) = 33.8 W/kg
SAR(1 g) = 7.77 W/kg; SAR(10 g) = 2.16 W/kg
Maximum value of SAR (measured) = 19.1 W/kg

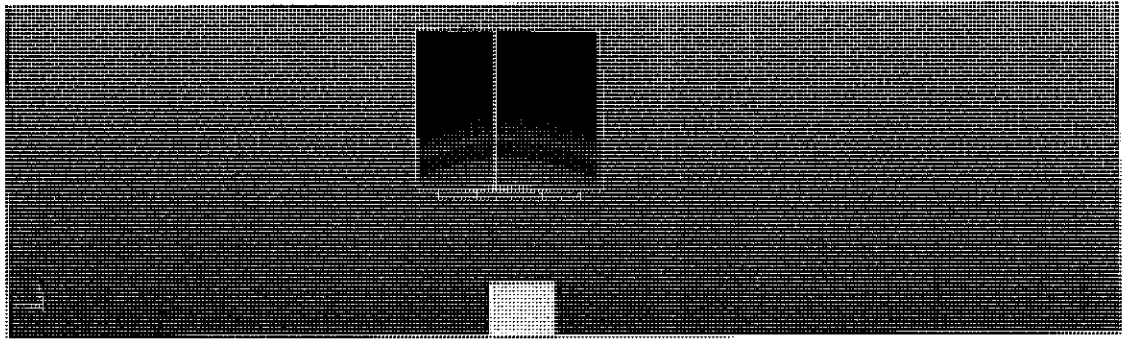
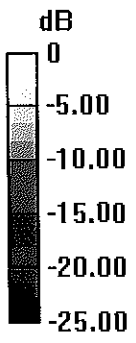

0 dB = 18.4 W/kg = 12.65 dBW/kg

Impedance Measurement Plot for Body TSL

8 Aug 2017 15:23:50

CH1 S11 1 U FS 1: 46.885 Ω -4.1973 Ω 7.2226 pF 5 250.000 000 MHz

*
De1
Cor
Avg
16
H1d

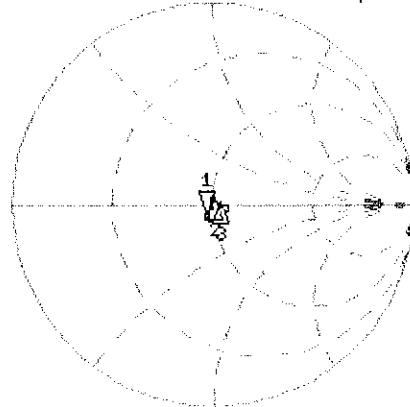

CH1 Markers
2: 50.184 Ω
3: 0.215 Ω
5.60000 GHz
3: 53.363 Ω
0.1719 Ω
5.75000 GHz

CH2 S11 LOG 5 dB/REF -20 dB 1: -25.364 dB 5 250.000 000 MHz

Cor
Avg
16
H1d

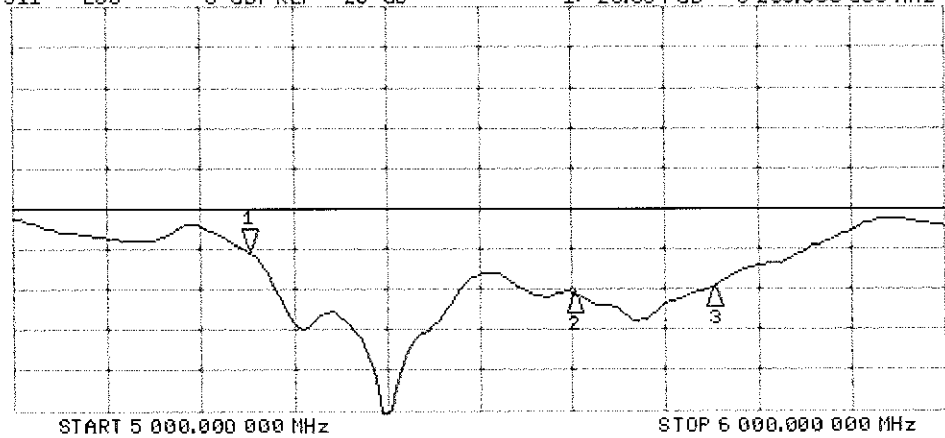

CH2 Markers
2: -30.389 dB
5.60000 GHz
3: -29.742 dB
5.75000 GHz



Accredited by the Swiss Accreditation Service (SAS)
The Swiss Accreditation Service is one of the signatories to the EA
Multilateral Agreement for the recognition of calibration certificates

Accreditation No.: **SCS 0108**

Client **PC Test**

Certificate No: **EX3-3914_Feb18**

CALIBRATION CERTIFICATE

Object **EX3DV4 - SN:3914**

Calibration procedure(s) **QA CAL-01.v9, QA CAL-12.v9, QA CAL-14.v4, QA CAL-23.v5,
QA CAL-25.v6
Calibration procedure for dosimetric E-field probes**

*BN
02-29-2018*

Calibration date: **February 14, 2018**

This calibration certificate documents the traceability to national standards, which realize the physical units of measurements (SI).
The measurements and the uncertainties with confidence probability are given on the following pages and are part of the certificate.

All calibrations have been conducted in the closed laboratory facility: environment temperature $(22 \pm 3)^\circ\text{C}$ and humidity $< 70\%$.

Calibration Equipment used (M&TE critical for calibration)

Primary Standards	ID	Cal Date (Certificate No.)	Scheduled Calibration
Power meter NRP	SN: 104778	04-Apr-17 (No. 217-02521/02522)	Apr-18
Power sensor NRP-Z91	SN: 103244	04-Apr-17 (No. 217-02521)	Apr-18
Power sensor NRP-Z91	SN: 103245	04-Apr-17 (No. 217-02525)	Apr-18
Reference 20 dB Attenuator	SN: S5277 (20x)	07-Apr-17 (No. 217-02528)	Apr-18
Reference Probe ES3DV2	SN: 3013	30-Dec-17 (No. ES3-3013_Dec17)	Dec-18
DAE4	SN: 660	21-Dec-17 (No. DAE4-660_Dec17)	Dec-18
Secondary Standards	ID	Check Date (in house)	Scheduled Check
Power meter E4419B	SN: GB41293874	06-Apr-16 (in house check Jun-16)	In house check: Jun-18
Power sensor E4412A	SN: MY41498087	06-Apr-16 (in house check Jun-16)	In house check: Jun-18
Power sensor E4412A	SN: 000110210	06-Apr-16 (in house check Jun-16)	In house check: Jun-18
RF generator HP 8648C	SN: US3642U01700	04-Aug-99 (in house check Jun-16)	In house check: Jun-18
Network Analyzer HP 8753E	SN: US37390585	18-Oct-01 (in house check Oct-17)	In house check: Oct-18

Calibrated by:	Name Jeton Kastrati	Function Laboratory Technician	Signature
Approved by:	Name Katja Pokovic	Function Technical Manager	Signature

Issued: February 14, 2018

This calibration certificate shall not be reproduced except in full without written approval of the laboratory.



Accredited by the Swiss Accreditation Service (SAS)

Accreditation No.: **SCS 0108**

The Swiss Accreditation Service is one of the signatories to the EA
Multilateral Agreement for the recognition of calibration certificates

Glossary:

TSL	tissue simulating liquid
NORM _{x,y,z}	sensitivity in free space
ConvF	sensitivity in TSL / NORM _{x,y,z}
DCP	diode compression point
CF	crest factor (1/duty_cycle) of the RF signal
A, B, C, D	modulation dependent linearization parameters
Polarization φ	φ rotation around probe axis
Polarization ϑ	ϑ rotation around an axis that is in the plane normal to probe axis (at measurement center), i.e., $\vartheta = 0$ is normal to probe axis
Connector Angle	information used in DASY system to align probe sensor X to the robot coordinate system

Calibration is Performed According to the Following Standards:

- IEEE Std 1528-2013, "IEEE Recommended Practice for Determining the Peak Spatial-Averaged Specific Absorption Rate (SAR) in the Human Head from Wireless Communications Devices: Measurement Techniques", June 2013
- IEC 62209-1, "Measurement procedure for the assessment of Specific Absorption Rate (SAR) from hand-held and body-mounted devices used next to the ear (frequency range of 300 MHz to 6 GHz)", July 2016
- IEC 62209-2, "Procedure to determine the Specific Absorption Rate (SAR) for wireless communication devices used in close proximity to the human body (frequency range of 30 MHz to 6 GHz)", March 2010
- KDB 865664, "SAR Measurement Requirements for 100 MHz to 6 GHz"

Methods Applied and Interpretation of Parameters:

- NORM_{x,y,z}**: Assessed for E-field polarization $\vartheta = 0$ ($f \leq 900$ MHz in TEM-cell; $f > 1800$ MHz: R22 waveguide). NORM_{x,y,z} are only intermediate values, i.e., the uncertainties of NORM_{x,y,z} does not affect the E²-field uncertainty inside TSL (see below ConvF).
- NORM(f)_{x,y,z}** = NORM_{x,y,z} * frequency_response (see Frequency Response Chart). This linearization is implemented in DASY4 software versions later than 4.2. The uncertainty of the frequency response is included in the stated uncertainty of ConvF.
- DCP_{x,y,z}**: DCP are numerical linearization parameters assessed based on the data of power sweep with CW signal (no uncertainty required). DCP does not depend on frequency nor media.
- PAR**: PAR is the Peak to Average Ratio that is not calibrated but determined based on the signal characteristics
- A_{x,y,z}; B_{x,y,z}; C_{x,y,z}; D_{x,y,z}; VR_{x,y,z}**: A, B, C, D are numerical linearization parameters assessed based on the data of power sweep for specific modulation signal. The parameters do not depend on frequency nor media. VR is the maximum calibration range expressed in RMS voltage across the diode.
- ConvF and Boundary Effect Parameters**: Assessed in flat phantom using E-field (or Temperature Transfer Standard for $f \leq 800$ MHz) and inside waveguide using analytical field distributions based on power measurements for $f > 800$ MHz. The same setups are used for assessment of the parameters applied for boundary compensation (alpha, depth) of which typical uncertainty values are given. These parameters are used in DASY4 software to improve probe accuracy close to the boundary. The sensitivity in TSL corresponds to NORM_{x,y,z} * ConvF whereby the uncertainty corresponds to that given for ConvF. A frequency dependent ConvF is used in DASY version 4.4 and higher which allows extending the validity from ± 50 MHz to ± 100 MHz.
- Spherical isotropy (3D deviation from isotropy)**: in a field of low gradients realized using a flat phantom exposed by a patch antenna.
- Sensor Offset**: The sensor offset corresponds to the offset of virtual measurement center from the probe tip (on probe axis). No tolerance required.
- Connector Angle**: The angle is assessed using the information gained by determining the NORM_x (no uncertainty required).

Probe EX3DV4

SN:3914

Manufactured: December 18, 2012
Calibrated: February 14, 2018

Calibrated for DASY/EASY Systems
(Note: non-compatible with DASY2 system!)

DASY/EASY - Parameters of Probe: EX3DV4 - SN:3914

Basic Calibration Parameters

	Sensor X	Sensor Y	Sensor Z	Unc (k=2)
Norm ($\mu\text{V}/(\text{V}/\text{m})^2$) ^A	0.47	0.41	0.44	$\pm 10.1\%$
DCP (mV) ^B	98.1	103.5	99.1	

Modulation Calibration Parameters

UID	Communication System Name		A dB	B dB $\sqrt{\mu\text{V}}$	C	D dB	VR mV	Unc ^E (k=2)
0	CW	X	0.0	0.0	1.0	0.00	157.3	$\pm 3.5\%$
		Y	0.0	0.0	1.0		143.4	
		Z	0.0	0.0	1.0		153.1	

Note: For details on UID parameters see Appendix.

Sensor Model Parameters

	C1 fF	C2 fF	α V ⁻¹	T1 ms.V ⁻²	T2 ms.V ⁻¹	T3 ms	T4 V ⁻²	T5 V ⁻¹	T6
X	44.52	338.7	36.78	11.30	0.699	5.054	0.000	0.544	1.006
Y	43.63	317.9	34.18	13.04	0.623	5.031	2.000	0.164	1.007
Z	41.48	314.2	36.51	10.96	0.847	5.054	0.251	0.494	1.008

The reported uncertainty of measurement is stated as the standard uncertainty of measurement multiplied by the coverage factor k=2, which for a normal distribution corresponds to a coverage probability of approximately 95%.

^A The uncertainties of Norm X,Y,Z do not affect the E²-field uncertainty inside TSL (see Pages 5 and 6).

^B Numerical linearization parameter: uncertainty not required.

^E Uncertainty is determined using the max. deviation from linear response applying rectangular distribution and is expressed for the square of the field value.

DASY/EASY - Parameters of Probe: EX3DV4 - SN:3914

Calibration Parameter Determined in Head Tissue Simulating Media

f (MHz) ^C	Relative Permittivity ^F	Conductivity (S/m) ^F	ConvF X	ConvF Y	ConvF Z	Alpha ^G	Depth (mm) ^G	Unc (k=2)
6	55.5	0.75	21.06	21.06	21.06	0.00	1.00	± 13.3 %
13	55.5	0.75	17.97	17.97	17.97	0.00	1.00	± 13.3 %
750	41.9	0.89	10.18	10.18	10.18	0.58	0.80	± 12.0 %
835	41.5	0.90	9.70	9.70	9.70	0.52	0.80	± 12.0 %
1750	40.1	1.37	8.34	8.34	8.34	0.40	0.80	± 12.0 %
1900	40.0	1.40	7.98	7.98	7.98	0.41	0.84	± 12.0 %
2300	39.5	1.67	7.58	7.58	7.58	0.37	0.87	± 12.0 %
2450	39.2	1.80	7.26	7.26	7.26	0.43	0.84	± 12.0 %
2600	39.0	1.96	7.04	7.04	7.04	0.29	0.86	± 12.0 %
3500	37.9	2.91	6.99	6.99	6.99	0.25	1.20	± 13.1 %
3700	37.7	3.12	6.72	6.72	6.72	0.23	1.20	± 13.1 %
5250	35.9	4.71	5.41	5.41	5.41	0.30	1.80	± 13.1 %
5600	35.5	5.07	4.79	4.79	4.79	0.40	1.80	± 13.1 %
5750	35.4	5.22	4.78	4.78	4.78	0.40	1.80	± 13.1 %

^C Frequency validity above 300 MHz of ± 100 MHz only applies for DASY v4.4 and higher (see Page 2), else it is restricted to ± 50 MHz. The uncertainty is the RSS of the ConvF uncertainty at calibration frequency and the uncertainty for the indicated frequency band. Frequency validity below 300 MHz is ± 10, 25, 40, 50 and 70 MHz for ConvF assessments at 30, 64, 128, 150 and 220 MHz respectively. Validity of ConvF assessed at 6 MHz is 4-9 MHz, and ConvF assessed at 13 MHz is 9-19 MHz. Above 5 GHz frequency validity can be extended to ± 110 MHz.

^F At frequencies below 3 GHz, the validity of tissue parameters (ϵ and σ) can be relaxed to ± 10% if liquid compensation formula is applied to measured SAR values. At frequencies above 3 GHz, the validity of tissue parameters (ϵ and σ) is restricted to ± 5%. The uncertainty is the RSS of the ConvF uncertainty for indicated target tissue parameters.

^G Alpha/Depth are determined during calibration. SPEAG warrants that the remaining deviation due to the boundary effect after compensation is always less than ± 1% for frequencies below 3 GHz and below ± 2% for frequencies between 3-6 GHz at any distance larger than half the probe tip diameter from the boundary.

DASY/EASY - Parameters of Probe: EX3DV4 - SN:3914

Calibration Parameter Determined in Body Tissue Simulating Media

f (MHz) ^C	Relative Permittivity ^F	Conductivity (S/m) ^F	ConvF X	ConvF Y	ConvF Z	Alpha ^G	Depth ^G (mm)	Unc (k=2)
750	55.5	0.96	9.75	9.75	9.75	0.47	0.80	± 12.0 %
835	55.2	0.97	9.57	9.57	9.57	0.44	0.89	± 12.0 %
1750	53.4	1.49	7.91	7.91	7.91	0.37	0.80	± 12.0 %
1900	53.3	1.52	7.62	7.62	7.62	0.29	1.01	± 12.0 %
2300	52.9	1.81	7.46	7.46	7.46	0.40	0.88	± 12.0 %
2450	52.7	1.95	7.39	7.39	7.39	0.39	0.86	± 12.0 %
2600	52.5	2.16	7.05	7.05	7.05	0.28	1.05	± 12.0 %
3500	51.3	3.31	6.81	6.81	6.81	0.30	1.25	± 13.1 %
3700	51.0	3.55	6.64	6.64	6.64	0.30	1.25	± 13.1 %
5250	48.9	5.36	4.81	4.81	4.81	0.35	1.90	± 13.1 %
5600	48.5	5.77	4.09	4.09	4.09	0.40	1.90	± 13.1 %
5750	48.3	5.94	4.22	4.22	4.22	0.40	1.90	± 13.1 %

^C Frequency validity above 300 MHz of ± 100 MHz only applies for DASY v4.4 and higher (see Page 2), else it is restricted to ± 50 MHz. The uncertainty is the RSS of the ConvF uncertainty at calibration frequency and the uncertainty for the indicated frequency band. Frequency validity below 300 MHz is ± 10, 25, 40, 50 and 70 MHz for ConvF assessments at 30, 64, 128, 150 and 220 MHz respectively. Above 5 GHz frequency validity can be extended to ± 110 MHz.

^F At frequencies below 3 GHz, the validity of tissue parameters (ϵ and σ) can be relaxed to ± 10% if liquid compensation formula is applied to measured SAR values. At frequencies above 3 GHz, the validity of tissue parameters (ϵ and σ) is restricted to ± 5%. The uncertainty is the RSS of the ConvF uncertainty for indicated target tissue parameters.

^G Alpha/Depth are determined during calibration. SPEAG warrants that the remaining deviation due to the boundary effect after compensation is always less than ± 1% for frequencies below 3 GHz and below ± 2% for frequencies between 3-6 GHz at any distance larger than half the probe tip diameter from the boundary.

Frequency Response of E-Field (TEM-Cell:ifi110 EXX, Waveguide: R22)

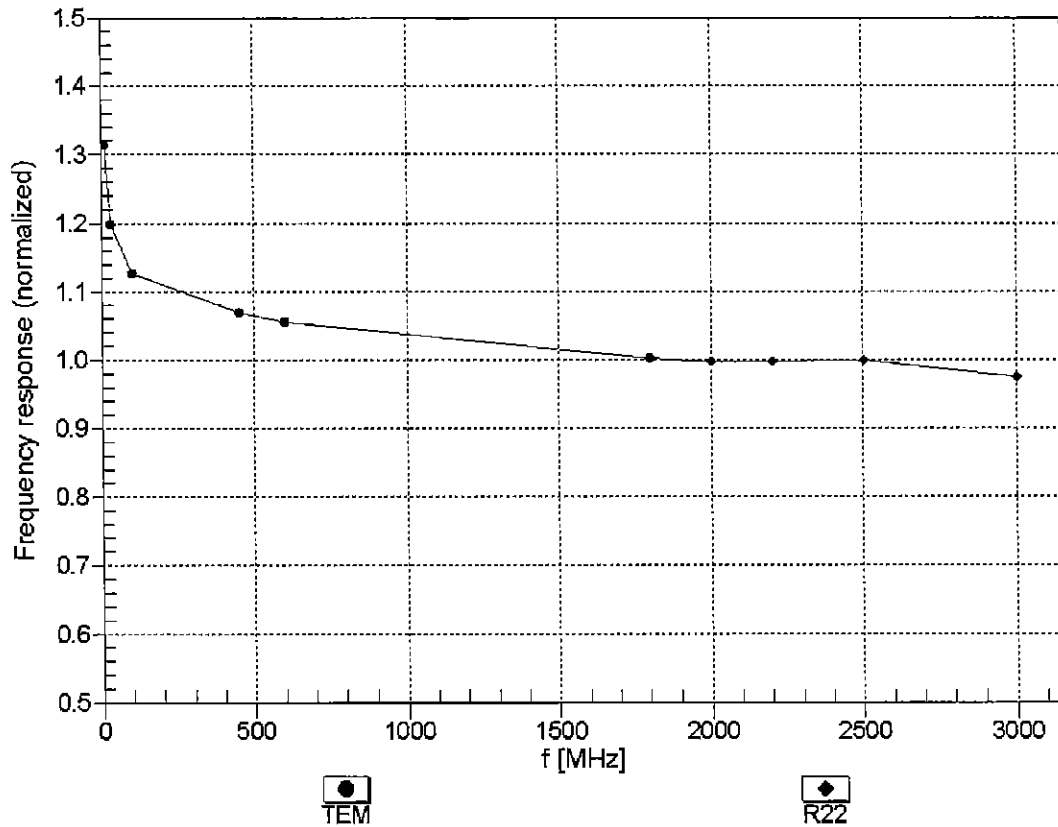

Uncertainty of Frequency Response of E-field: $\pm 6.3\%$ (k=2)

Receiving Pattern (ϕ), $\theta = 0^\circ$

f=600 MHz,TEM

f=1800 MHz,R22

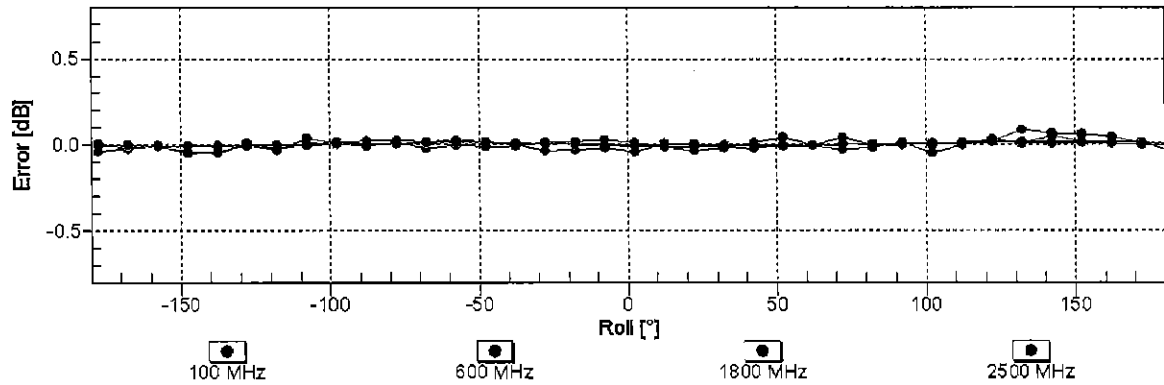
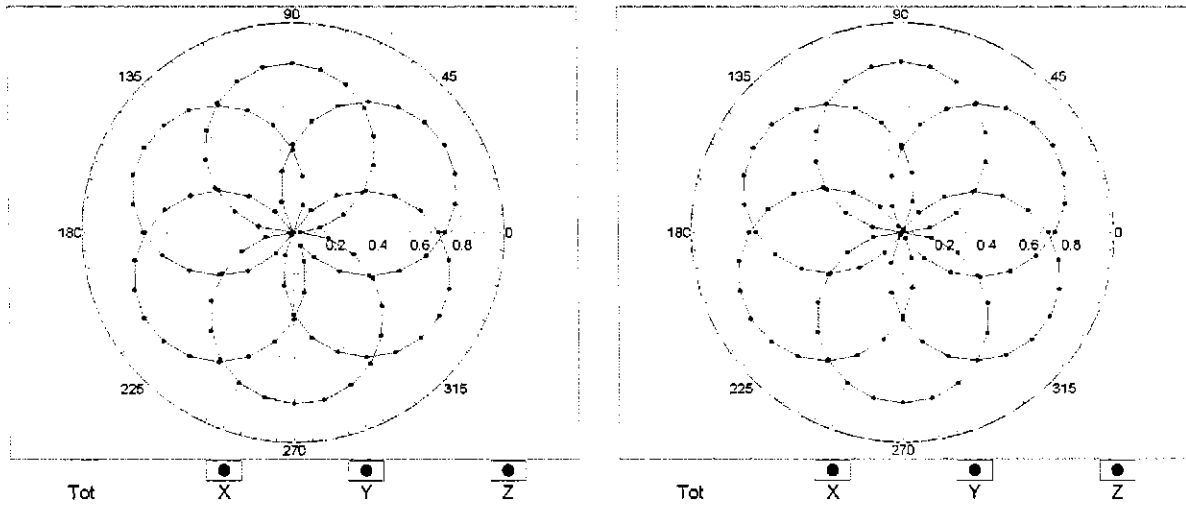

Uncertainty of Axial Isotropy Assessment: $\pm 0.5\%$ (k=2)

Dynamic Range $f(SAR_{head})$ (TEM cell , $f_{eval}= 1900$ MHz)

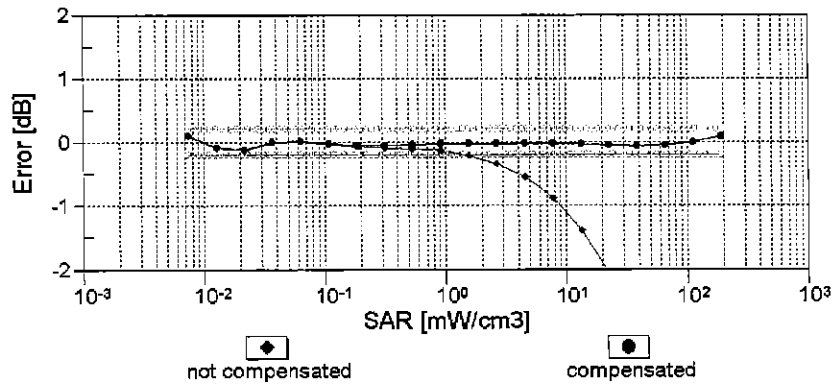
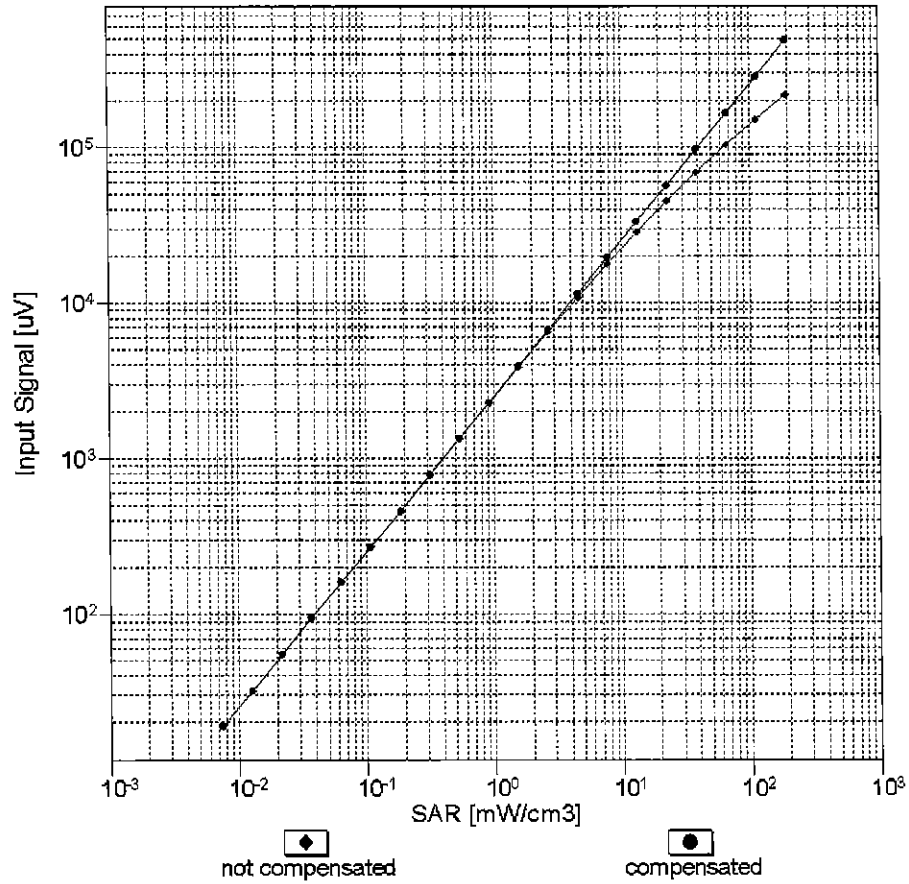

Uncertainty of Linearity Assessment: $\pm 0.6\%$ (k=2)

Conversion Factor Assessment

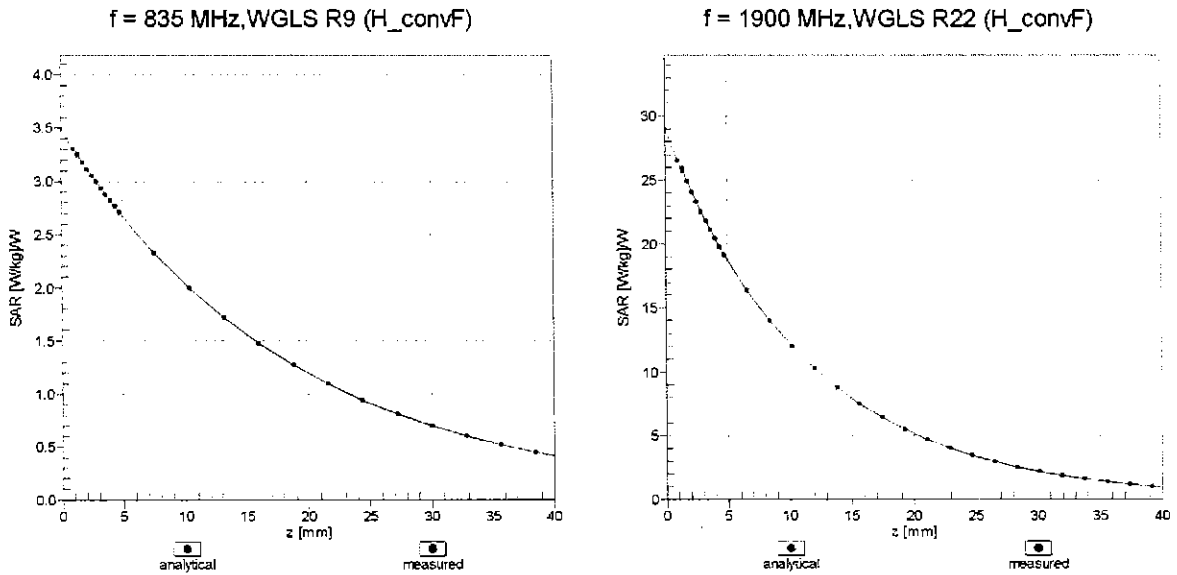

Deviation from Isotropy in Liquid Error (ϕ, θ), f = 900 MHz

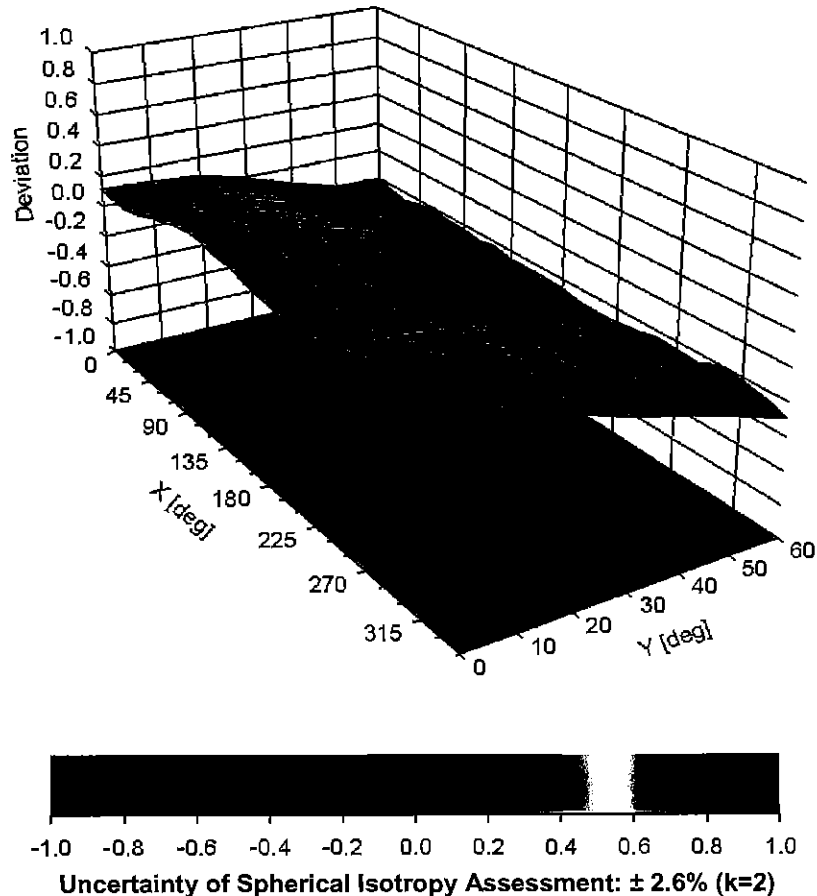

DASY/EASY - Parameters of Probe: EX3DV4 - SN:3914

Other Probe Parameters

Sensor Arrangement	Triangular
Connector Angle (°)	132.3
Mechanical Surface Detection Mode	enabled
Optical Surface Detection Mode	disabled
Probe Overall Length	337 mm
Probe Body Diameter	10 mm
Tip Length	9 mm
Tip Diameter	2.5 mm
Probe Tip to Sensor X Calibration Point	1 mm
Probe Tip to Sensor Y Calibration Point	1 mm
Probe Tip to Sensor Z Calibration Point	1 mm
Recommended Measurement Distance from Surface	1.4 mm

Appendix: Modulation Calibration Parameters

UID	Communication System Name		A dB	B dB μ V	C	D dB	VR mV	Max Unc ^E (k=2)
0	CW	X	0.00	0.00	1.00	0.00	157.3	$\pm 3.5\%$
		Y	0.00	0.00	1.00		143.4	
		Z	0.00	0.00	1.00		153.1	
10010- CAA	SAR Validation (Square, 100ms, 10ms)	X	2.02	63.97	9.10	10.00	20.0	$\pm 9.6\%$
		Y	2.59	66.85	10.84		20.0	
		Z	2.31	65.14	9.98		20.0	
10011- CAB	UMTS-FDD (WCDMA)	X	0.89	66.39	14.20	0.00	150.0	$\pm 9.6\%$
		Y	1.06	68.74	16.01		150.0	
		Z	0.90	66.80	14.44		150.0	
10012- CAB	IEEE 802.11b WiFi 2.4 GHz (DSSS, 1 Mbps)	X	1.06	63.38	14.79	0.41	150.0	$\pm 9.6\%$
		Y	1.17	64.37	15.54		150.0	
		Z	1.07	63.61	14.94		150.0	
10013- CAB	IEEE 802.11g WiFi 2.4 GHz (DSSS-OFDM, 6 Mbps)	X	4.75	66.53	16.97	1.46	150.0	$\pm 9.6\%$
		Y	4.80	66.78	17.02		150.0	
		Z	4.73	66.65	17.01		150.0	
10021- DAC	GSM-FDD (TDMA, GMSK)	X	100.00	110.09	25.45	9.39	50.0	$\pm 9.6\%$
		Y	100.00	112.00	26.43		50.0	
		Z	100.00	111.93	26.50		50.0	
10023- DAC	GPRS-FDD (TDMA, GMSK, TN 0)	X	100.00	109.83	25.39	9.57	50.0	$\pm 9.6\%$
		Y	100.00	111.69	26.33		50.0	
		Z	100.00	111.63	26.42		50.0	
10024- DAC	GPRS-FDD (TDMA, GMSK, TN 0-1)	X	100.00	107.43	23.14	6.56	60.0	$\pm 9.6\%$
		Y	100.00	110.61	24.77		60.0	
		Z	100.00	109.57	24.26		60.0	
10025- DAC	EDGE-FDD (TDMA, 8PSK, TN 0)	X	4.03	68.96	25.05	12.57	50.0	$\pm 9.6\%$
		Y	5.30	77.15	29.41		50.0	
		Z	4.06	68.52	24.65		50.0	
10026- DAC	EDGE-FDD (TDMA, 8PSK, TN 0-1)	X	8.87	91.28	32.17	9.56	60.0	$\pm 9.6\%$
		Y	10.08	94.25	33.27		60.0	
		Z	8.65	90.32	31.77		60.0	
10027- DAC	GPRS-FDD (TDMA, GMSK, TN 0-1-2)	X	100.00	105.82	21.66	4.80	80.0	$\pm 9.6\%$
		Y	100.00	111.09	24.24		80.0	
		Z	100.00	108.42	22.93		80.0	
10028- DAC	GPRS-FDD (TDMA, GMSK, TN 0-1-2-3)	X	100.00	104.11	20.26	3.55	100.0	$\pm 9.6\%$
		Y	100.00	112.84	24.34		100.0	
		Z	100.00	107.37	21.76		100.0	
10029- DAC	EDGE-FDD (TDMA, 8PSK, TN 0-1-2)	X	5.57	80.93	27.02	7.80	80.0	$\pm 9.6\%$
		Y	6.11	82.68	27.69		80.0	
		Z	5.53	80.55	26.85		80.0	
10030- CAA	IEEE 802.15.1 Bluetooth (GFSK, DH1)	X	100.00	104.99	21.59	5.30	70.0	$\pm 9.6\%$
		Y	100.00	109.04	23.62		70.0	
		Z	100.00	107.17	22.68		70.0	
10031- CAA	IEEE 802.15.1 Bluetooth (GFSK, DH3)	X	0.46	62.47	6.17	1.88	100.0	$\pm 9.6\%$
		Y	100.00	111.97	22.67		100.0	
		Z	100.00	95.35	15.52		100.0	

10032-CAA	IEEE 802.15.1 Bluetooth (GFSK, DH5)	X	0.19	60.00	3.78	1.17	100.0	± 9.6 %
		Y	100.00	120.03	24.95		100.0	
		Z	0.19	60.00	4.15		100.0	
10033-CAA	IEEE 802.15.1 Bluetooth (PI/4-DQPSK, DH1)	X	13.55	95.45	24.90	5.30	70.0	± 9.6 %
		Y	18.76	100.49	26.60		70.0	
		Z	13.36	94.67	24.55		70.0	
10034-CAA	IEEE 802.15.1 Bluetooth (PI/4-DQPSK, DH3)	X	2.70	75.51	16.71	1.88	100.0	± 9.6 %
		Y	4.49	82.47	19.70		100.0	
		Z	2.90	76.09	16.70		100.0	
10035-CAA	IEEE 802.15.1 Bluetooth (PI/4-DQPSK, DH5)	X	1.71	70.85	14.56	1.17	100.0	± 9.6 %
		Y	2.70	76.95	17.56		100.0	
		Z	1.78	71.24	14.48		100.0	
10036-CAA	IEEE 802.15.1 Bluetooth (8-DPSK, DH1)	X	22.62	103.29	27.18	5.30	70.0	± 9.6 %
		Y	32.35	108.98	28.96		70.0	
		Z	21.86	102.15	26.73		70.0	
10037-CAA	IEEE 802.15.1 Bluetooth (8-DPSK, DH3)	X	2.48	74.51	16.30	1.88	100.0	± 9.6 %
		Y	3.96	80.90	19.14		100.0	
		Z	2.61	74.90	16.23		100.0	
10038-CAA	IEEE 802.15.1 Bluetooth (8-DPSK, DH5)	X	1.74	71.34	14.88	1.17	100.0	± 9.6 %
		Y	2.75	77.52	17.90		100.0	
		Z	1.82	71.77	14.82		100.0	
10039-CAB	CDMA2000 (1xRTT, RC1)	X	1.34	68.49	13.13	0.00	150.0	± 9.6 %
		Y	2.27	75.66	16.89		150.0	
		Z	1.29	68.35	12.80		150.0	
10042-CAB	IS-54 / IS-136 FDD (TDMA/FDM, PI/4-DQPSK, Halfrate)	X	34.99	94.66	19.93	7.78	50.0	± 9.6 %
		Y	100.00	108.11	23.89		50.0	
		Z	100.00	107.01	23.40		50.0	
10044-CAA	IS-91/EIA/TIA-553 FDD (FDMA, FM)	X	0.17	126.30	3.13	0.00	150.0	± 9.6 %
		Y	0.00	107.81	5.46		150.0	
		Z	0.15	126.17	2.27		150.0	
10048-CAA	DECT (TDD, TDMA/FDM, GFSK, Full Slot, 24)	X	10.11	79.88	18.52	13.80	25.0	± 9.6 %
		Y	23.48	91.75	22.45		25.0	
		Z	12.25	82.71	19.92		25.0	
10049-CAA	DECT (TDD, TDMA/FDM, GFSK, Double Slot, 12)	X	11.72	83.69	18.67	10.79	40.0	± 9.6 %
		Y	40.84	100.05	23.71		40.0	
		Z	15.78	87.97	20.48		40.0	
10056-CAA	UMTS-TDD (TD-SCDMA, 1.28 Mcps)	X	18.86	95.31	25.05	9.03	50.0	± 9.6 %
		Y	26.98	101.35	27.04		50.0	
		Z	17.19	93.67	24.60		50.0	
10058-DAC	EDGE-FDD (TDMA, 8PSK, TN 0-1-2-3)	X	4.30	76.01	24.21	6.55	100.0	± 9.6 %
		Y	4.66	77.31	24.71		100.0	
		Z	4.30	75.85	24.15		100.0	
10059-CAB	IEEE 802.11b WiFi 2.4 GHz (DSSS, 2 Mbps)	X	1.10	64.51	15.41	0.61	110.0	± 9.6 %
		Y	1.22	65.59	16.19		110.0	
		Z	1.11	64.78	15.58		110.0	
10060-CAB	IEEE 802.11b WiFi 2.4 GHz (DSSS, 5.5 Mbps)	X	40.70	121.16	30.62	1.30	110.0	± 9.6 %
		Y	100.00	138.01	35.59		110.0	
		Z	76.47	130.66	32.92		110.0	

10061-CAB	IEEE 802.11b WiFi 2.4 GHz (DSSS, 11 Mbps)	X	2.97	81.68	22.34	2.04	110.0	± 9.6 %
		Y	3.52	84.01	23.42		110.0	
		Z	3.16	82.63	22.73		110.0	
10062-CAC	IEEE 802.11a/h WiFi 5 GHz (OFDM, 6 Mbps)	X	4.54	66.50	16.38	0.49	100.0	± 9.6 %
		Y	4.60	66.81	16.49		100.0	
		Z	4.51	66.59	16.41		100.0	
10063-CAC	IEEE 802.11a/h WiFi 5 GHz (OFDM, 9 Mbps)	X	4.56	66.59	16.48	0.72	100.0	± 9.6 %
		Y	4.62	66.89	16.58		100.0	
		Z	4.53	66.70	16.52		100.0	
10064-CAC	IEEE 802.11a/h WiFi 5 GHz (OFDM, 12 Mbps)	X	4.84	66.85	16.71	0.86	100.0	± 9.6 %
		Y	4.89	67.12	16.79		100.0	
		Z	4.80	66.93	16.74		100.0	
10065-CAC	IEEE 802.11a/h WiFi 5 GHz (OFDM, 18 Mbps)	X	4.71	66.74	16.80	1.21	100.0	± 9.6 %
		Y	4.76	67.01	16.87		100.0	
		Z	4.67	66.83	16.83		100.0	
10066-CAC	IEEE 802.11a/h WiFi 5 GHz (OFDM, 24 Mbps)	X	4.72	66.77	16.97	1.46	100.0	± 9.6 %
		Y	4.77	67.02	17.03		100.0	
		Z	4.69	66.86	17.00		100.0	
10067-CAC	IEEE 802.11a/h WiFi 5 GHz (OFDM, 36 Mbps)	X	5.02	66.97	17.43	2.04	100.0	± 9.6 %
		Y	5.06	67.18	17.45		100.0	
		Z	4.99	67.10	17.47		100.0	
10068-CAC	IEEE 802.11a/h WiFi 5 GHz (OFDM, 48 Mbps)	X	5.06	66.99	17.64	2.55	100.0	± 9.6 %
		Y	5.10	67.19	17.65		100.0	
		Z	5.03	67.09	17.67		100.0	
10069-CAC	IEEE 802.11a/h WiFi 5 GHz (OFDM, 54 Mbps)	X	5.14	67.01	17.83	2.67	100.0	± 9.6 %
		Y	5.18	67.19	17.83		100.0	
		Z	5.11	67.11	17.86		100.0	
10071-CAB	IEEE 802.11g WiFi 2.4 GHz (DSSS/OFDM, 9 Mbps)	X	4.84	66.62	17.27	1.99	100.0	± 9.6 %
		Y	4.89	66.85	17.31		100.0	
		Z	4.83	66.75	17.32		100.0	
10072-CAB	IEEE 802.11g WiFi 2.4 GHz (DSSS/OFDM, 12 Mbps)	X	4.82	66.93	17.48	2.30	100.0	± 9.6 %
		Y	4.86	67.16	17.51		100.0	
		Z	4.80	67.06	17.53		100.0	
10073-CAB	IEEE 802.11g WiFi 2.4 GHz (DSSS/OFDM, 18 Mbps)	X	4.88	67.11	17.81	2.83	100.0	± 9.6 %
		Y	4.92	67.32	17.83		100.0	
		Z	4.87	67.25	17.87		100.0	
10074-CAB	IEEE 802.11g WiFi 2.4 GHz (DSSS/OFDM, 24 Mbps)	X	4.87	67.01	17.95	3.30	100.0	± 9.6 %
		Y	4.91	67.22	17.97		100.0	
		Z	4.87	67.19	18.02		100.0	
10075-CAB	IEEE 802.11g WiFi 2.4 GHz (DSSS/OFDM, 36 Mbps)	X	4.90	67.11	18.25	3.82	90.0	± 9.6 %
		Y	4.95	67.32	18.26		90.0	
		Z	4.91	67.27	18.31		90.0	
10076-CAB	IEEE 802.11g WiFi 2.4 GHz (DSSS/OFDM, 48 Mbps)	X	4.92	66.92	18.38	4.15	90.0	± 9.6 %
		Y	4.97	67.13	18.38		90.0	
		Z	4.94	67.11	18.46		90.0	
10077-CAB	IEEE 802.11g WiFi 2.4 GHz (DSSS/OFDM, 54 Mbps)	X	4.95	66.99	18.48	4.30	90.0	± 9.6 %
		Y	5.00	67.21	18.49		90.0	
		Z	4.97	67.20	18.56		90.0	

10081-CAB	CDMA2000 (1xRTT, RC3)	X	0.61	63.26	9.90	0.00	150.0	± 9.6 %
		Y	0.87	67.43	13.01		150.0	
		Z	0.58	63.10	9.56		150.0	
10082-CAB	IS-54 / IS-136 FDD (TDMA/FDM, PI/4-DQPSK, Fullrate)	X	2.50	65.17	5.97	4.77	80.0	± 9.6 %
		Y	0.75	60.00	4.55		80.0	
		Z	0.72	60.00	4.31		80.0	
10090-DAC	GPRS-FDD (TDMA, GMSK, TN 0-4)	X	100.00	107.54	23.21	6.56	60.0	± 9.6 %
		Y	100.00	110.64	24.80		60.0	
		Z	100.00	109.67	24.33		60.0	
10097-CAB	UMTS-FDD (HSDPA)	X	1.69	67.19	15.08	0.00	150.0	± 9.6 %
		Y	1.88	68.79	16.18		150.0	
		Z	1.71	67.59	15.23		150.0	
10098-CAB	UMTS-FDD (HSUPA, Subtest 2)	X	1.65	67.13	15.04	0.00	150.0	± 9.6 %
		Y	1.84	68.75	16.15		150.0	
		Z	1.67	67.53	15.19		150.0	
10099-DAC	EDGE-FDD (TDMA, 8PSK, TN 0-4)	X	8.93	91.41	32.21	9.56	60.0	± 9.6 %
		Y	10.16	94.39	33.31		60.0	
		Z	8.70	90.44	31.80		60.0	
10100-CAD	LTE-FDD (SC-FDMA, 100% RB, 20 MHz, QPSK)	X	2.94	69.72	16.26	0.00	150.0	± 9.6 %
		Y	3.18	71.08	17.07		150.0	
		Z	2.94	69.89	16.39		150.0	
10101-CAD	LTE-FDD (SC-FDMA, 100% RB, 20 MHz, 16-QAM)	X	3.09	67.13	15.64	0.00	150.0	± 9.6 %
		Y	3.21	67.85	16.08		150.0	
		Z	3.07	67.21	15.70		150.0	
10102-CAD	LTE-FDD (SC-FDMA, 100% RB, 20 MHz, 64-QAM)	X	3.20	67.14	15.76	0.00	150.0	± 9.6 %
		Y	3.32	67.82	16.17		150.0	
		Z	3.18	67.23	15.82		150.0	
10103-CAD	LTE-TDD (SC-FDMA, 100% RB, 20 MHz, QPSK)	X	5.93	75.11	20.17	3.98	65.0	± 9.6 %
		Y	6.63	76.82	20.78		65.0	
		Z	5.91	75.14	20.21		65.0	
10104-CAD	LTE-TDD (SC-FDMA, 100% RB, 20 MHz, 16-QAM)	X	5.89	73.03	20.08	3.98	65.0	± 9.6 %
		Y	6.25	73.91	20.36		65.0	
		Z	5.90	73.09	20.11		65.0	
10105-CAD	LTE-TDD (SC-FDMA, 100% RB, 20 MHz, 64-QAM)	X	5.51	71.58	19.75	3.98	65.0	± 9.6 %
		Y	6.10	73.31	20.41		65.0	
		Z	5.86	72.81	20.30		65.0	
10108-CAE	LTE-FDD (SC-FDMA, 100% RB, 10 MHz, QPSK)	X	2.55	69.01	16.09	0.00	150.0	± 9.6 %
		Y	2.75	70.30	16.89		150.0	
		Z	2.54	69.20	16.22		150.0	
10109-CAE	LTE-FDD (SC-FDMA, 100% RB, 10 MHz, 16-QAM)	X	2.74	66.99	15.50	0.00	150.0	± 9.6 %
		Y	2.87	67.79	16.01		150.0	
		Z	2.72	67.11	15.56		150.0	
10110-CAE	LTE-FDD (SC-FDMA, 100% RB, 5 MHz, QPSK)	X	2.04	68.09	15.59	0.00	150.0	± 9.6 %
		Y	2.23	69.47	16.51		150.0	
		Z	2.03	68.32	15.72		150.0	
10111-CAE	LTE-FDD (SC-FDMA, 100% RB, 5 MHz, 16-QAM)	X	2.46	67.87	15.72	0.00	150.0	± 9.6 %
		Y	2.64	69.03	16.47		150.0	
		Z	2.45	68.15	15.81		150.0	

10112-CAE	LTE-FDD (SC-FDMA, 100% RB, 10 MHz, 64-QAM)	X	2.87	67.02	15.59	0.00	150.0	± 9.6 %
		Y	3.00	67.79	16.07		150.0	
		Z	2.85	67.16	15.65		150.0	
10113-CAE	LTE-FDD (SC-FDMA, 100% RB, 5 MHz, 64-QAM)	X	2.61	68.07	15.89	0.00	150.0	± 9.6 %
		Y	2.79	69.17	16.59		150.0	
		Z	2.61	68.36	15.98		150.0	
10114-CAC	IEEE 802.11n (HT Greenfield, 13.5 Mbps, BPSK)	X	5.01	67.03	16.34	0.00	150.0	± 9.6 %
		Y	5.06	67.33	16.45		150.0	
		Z	4.97	67.05	16.35		150.0	
10115-CAC	IEEE 802.11n (HT Greenfield, 81 Mbps, 16-QAM)	X	5.27	67.10	16.38	0.00	150.0	± 9.6 %
		Y	5.32	67.38	16.48		150.0	
		Z	5.22	67.11	16.39		150.0	
10116-CAC	IEEE 802.11n (HT Greenfield, 135 Mbps, 64-QAM)	X	5.09	67.20	16.35	0.00	150.0	± 9.6 %
		Y	5.14	67.50	16.46		150.0	
		Z	5.06	67.23	16.37		150.0	
10117-CAC	IEEE 802.11n (HT Mixed, 13.5 Mbps, BPSK)	X	4.97	66.87	16.27	0.00	150.0	± 9.6 %
		Y	5.03	67.20	16.40		150.0	
		Z	4.94	66.93	16.31		150.0	
10118-CAC	IEEE 802.11n (HT Mixed, 81 Mbps, 16-QAM)	X	5.35	67.31	16.50	0.00	150.0	± 9.6 %
		Y	5.39	67.55	16.57		150.0	
		Z	5.30	67.32	16.50		150.0	
10119-CAC	IEEE 802.11n (HT Mixed, 135 Mbps, 64-QAM)	X	5.08	67.16	16.34	0.00	150.0	± 9.6 %
		Y	5.12	67.45	16.45		150.0	
		Z	5.04	67.20	16.36		150.0	
10140-CAD	LTE-FDD (SC-FDMA, 100% RB, 15 MHz, 16-QAM)	X	3.23	67.13	15.67	0.00	150.0	± 9.6 %
		Y	3.35	67.82	16.08		150.0	
		Z	3.21	67.22	15.73		150.0	
10141-CAD	LTE-FDD (SC-FDMA, 100% RB, 15 MHz, 64-QAM)	X	3.36	67.28	15.87	0.00	150.0	± 9.6 %
		Y	3.48	67.94	16.26		150.0	
		Z	3.34	67.38	15.93		150.0	
10142-CAD	LTE-FDD (SC-FDMA, 100% RB, 3 MHz, QPSK)	X	1.80	67.92	15.04	0.00	150.0	± 9.6 %
		Y	2.02	69.71	16.23		150.0	
		Z	1.78	68.19	15.11		150.0	
10143-CAD	LTE-FDD (SC-FDMA, 100% RB, 3 MHz, 16-QAM)	X	2.28	68.33	15.13	0.00	150.0	± 9.6 %
		Y	2.56	70.16	16.27		150.0	
		Z	2.27	68.61	15.13		150.0	
10144-CAD	LTE-FDD (SC-FDMA, 100% RB, 3 MHz, 64-QAM)	X	2.03	65.81	13.36	0.00	150.0	± 9.6 %
		Y	2.22	67.14	14.29		150.0	
		Z	1.98	65.83	13.22		150.0	
10145-CAE	LTE-FDD (SC-FDMA, 100% RB, 1.4 MHz, QPSK)	X	0.92	62.55	9.46	0.00	150.0	± 9.6 %
		Y	1.17	65.32	11.54		150.0	
		Z	0.84	61.98	8.80		150.0	
10146-CAE	LTE-FDD (SC-FDMA, 100% RB, 1.4 MHz, 16-QAM)	X	1.39	62.93	9.23	0.00	150.0	± 9.6 %
		Y	1.99	66.57	11.19		150.0	
		Z	1.31	62.53	8.72		150.0	
10147-CAE	LTE-FDD (SC-FDMA, 100% RB, 1.4 MHz, 64-QAM)	X	1.52	63.83	9.83	0.00	150.0	± 9.6 %
		Y	2.52	69.22	12.51		150.0	
		Z	1.42	63.36	9.28		150.0	

10149-CAD	LTE-FDD (SC-FDMA, 50% RB, 20 MHz, 16-QAM)	X	2.75	67.05	15.55	0.00	150.0	± 9.6 %
		Y	2.88	67.86	16.07		150.0	
		Z	2.73	67.18	15.62		150.0	
10150-CAD	LTE-FDD (SC-FDMA, 50% RB, 20 MHz, 64-QAM)	X	2.88	67.08	15.63	0.00	150.0	± 9.6 %
		Y	3.01	67.85	16.12		150.0	
		Z	2.86	67.22	15.70		150.0	
10151-CAD	LTE-TDD (SC-FDMA, 50% RB, 20 MHz, QPSK)	X	6.32	77.90	21.36	3.98	65.0	± 9.6 %
		Y	6.91	79.14	21.77		65.0	
		Z	6.41	78.22	21.50		65.0	
10152-CAD	LTE-TDD (SC-FDMA, 50% RB, 20 MHz, 16-QAM)	X	5.42	72.95	19.71	3.98	65.0	± 9.6 %
		Y	5.78	73.88	20.03		65.0	
		Z	5.43	73.04	19.72		65.0	
10153-CAD	LTE-TDD (SC-FDMA, 50% RB, 20 MHz, 64-QAM)	X	5.81	74.06	20.59	3.98	65.0	± 9.6 %
		Y	6.20	74.97	20.87		65.0	
		Z	5.84	74.21	20.62		65.0	
10154-CAE	LTE-FDD (SC-FDMA, 50% RB, 10 MHz, QPSK)	X	2.09	68.53	15.87	0.00	150.0	± 9.6 %
		Y	2.29	69.96	16.81		150.0	
		Z	2.08	68.78	15.99		150.0	
10155-CAE	LTE-FDD (SC-FDMA, 50% RB, 10 MHz, 16-QAM)	X	2.46	67.89	15.74	0.00	150.0	± 9.6 %
		Y	2.64	69.05	16.49		150.0	
		Z	2.46	68.18	15.84		150.0	
10156-CAE	LTE-FDD (SC-FDMA, 50% RB, 5 MHz, QPSK)	X	1.63	67.76	14.61	0.00	150.0	± 9.6 %
		Y	1.89	69.98	16.07		150.0	
		Z	1.61	67.98	14.81		150.0	
10157-CAE	LTE-FDD (SC-FDMA, 50% RB, 5 MHz, 16-QAM)	X	1.84	66.10	13.16	0.00	150.0	± 9.6 %
		Y	2.08	67.93	14.40		150.0	
		Z	1.79	66.07	12.96		150.0	
10158-CAE	LTE-FDD (SC-FDMA, 50% RB, 10 MHz, 64-QAM)	X	2.62	68.14	15.95	0.00	150.0	± 9.6 %
		Y	2.80	69.25	16.65		150.0	
		Z	2.62	68.44	16.04		150.0	
10159-CAE	LTE-FDD (SC-FDMA, 50% RB, 5 MHz, 64-QAM)	X	1.94	66.53	13.44	0.00	150.0	± 9.6 %
		Y	2.21	68.50	14.73		150.0	
		Z	1.88	66.49	13.23		150.0	
10160-CAD	LTE-FDD (SC-FDMA, 50% RB, 15 MHz, QPSK)	X	2.59	68.31	15.97	0.00	150.0	± 9.6 %
		Y	2.73	69.19	16.57		150.0	
		Z	2.58	68.51	16.08		150.0	
10161-CAD	LTE-FDD (SC-FDMA, 50% RB, 15 MHz, 16-QAM)	X	2.77	67.03	15.54	0.00	150.0	± 9.6 %
		Y	2.91	67.84	16.05		150.0	
		Z	2.75	67.18	15.60		150.0	
10162-CAD	LTE-FDD (SC-FDMA, 50% RB, 15 MHz, 64-QAM)	X	2.88	67.21	15.67	0.00	150.0	± 9.6 %
		Y	3.02	68.01	16.17		150.0	
		Z	2.86	67.38	15.74		150.0	
10166-CAE	LTE-FDD (SC-FDMA, 50% RB, 1.4 MHz, QPSK)	X	3.37	69.04	18.77	3.01	150.0	± 9.6 %
		Y	3.72	71.09	19.82		150.0	
		Z	3.38	69.53	19.11		150.0	
10167-CAE	LTE-FDD (SC-FDMA, 50% RB, 1.4 MHz, 16-QAM)	X	4.04	71.49	19.00	3.01	150.0	± 9.6 %
		Y	5.05	75.77	20.88		150.0	
		Z	4.12	72.30	19.44		150.0	

10168-CAE	LTE-FDD (SC-FDMA, 50% RB, 1.4 MHz, 64-QAM)	X	4.56	74.09	20.53	3.01	150.0	± 9.6 %
		Y	5.99	79.40	22.74		150.0	
		Z	4.72	75.27	21.13		150.0	
10169-CAD	LTE-FDD (SC-FDMA, 1 RB, 20 MHz, QPSK)	X	2.74	67.94	18.26	3.01	150.0	± 9.6 %
		Y	3.25	71.55	20.05		150.0	
		Z	2.77	68.38	18.59		150.0	
10170-CAD	LTE-FDD (SC-FDMA, 1 RB, 20 MHz, 16-QAM)	X	3.65	73.29	20.42	3.01	150.0	± 9.6 %
		Y	6.00	83.03	24.31		150.0	
		Z	3.81	74.44	21.04		150.0	
10171-AAD	LTE-FDD (SC-FDMA, 1 RB, 20 MHz, 64-QAM)	X	2.98	69.09	17.51	3.01	150.0	± 9.6 %
		Y	4.17	75.40	20.24		150.0	
		Z	3.05	69.77	17.92		150.0	
10172-CAD	LTE-TDD (SC-FDMA, 1 RB, 20 MHz, QPSK)	X	6.26	85.95	26.48	6.02	65.0	± 9.6 %
		Y	13.49	101.43	31.66		65.0	
		Z	6.07	85.72	26.58		65.0	
10173-CAD	LTE-TDD (SC-FDMA, 1 RB, 20 MHz, 16-QAM)	X	11.36	93.09	26.93	6.02	65.0	± 9.6 %
		Y	61.90	122.46	34.86		65.0	
		Z	13.00	96.00	28.02		65.0	
10174-CAD	LTE-TDD (SC-FDMA, 1 RB, 20 MHz, 64-QAM)	X	8.36	86.77	24.30	6.02	65.0	± 9.6 %
		Y	35.10	110.72	31.17		65.0	
		Z	8.86	88.32	24.99		65.0	
10175-CAE	LTE-FDD (SC-FDMA, 1 RB, 10 MHz, QPSK)	X	2.71	67.63	18.00	3.01	150.0	± 9.6 %
		Y	3.19	71.11	19.75		150.0	
		Z	2.74	68.04	18.32		150.0	
10176-CAE	LTE-FDD (SC-FDMA, 1 RB, 10 MHz, 16-QAM)	X	3.66	73.32	20.43	3.01	150.0	± 9.6 %
		Y	6.01	83.07	24.33		150.0	
		Z	3.81	74.46	21.05		150.0	
10177-CAG	LTE-FDD (SC-FDMA, 1 RB, 5 MHz, QPSK)	X	2.73	67.78	18.10	3.01	150.0	± 9.6 %
		Y	3.23	71.31	19.86		150.0	
		Z	2.76	68.20	18.41		150.0	
10178-CAE	LTE-FDD (SC-FDMA, 1 RB, 5 MHz, 16-QAM)	X	3.63	73.10	20.31	3.01	150.0	± 9.6 %
		Y	5.90	82.67	24.15		150.0	
		Z	3.78	74.24	20.93		150.0	
10179-CAE	LTE-FDD (SC-FDMA, 1 RB, 10 MHz, 64-QAM)	X	3.28	71.01	18.80	3.01	150.0	± 9.6 %
		Y	4.94	78.87	22.07		150.0	
		Z	3.38	71.91	19.31		150.0	
10180-CAE	LTE-FDD (SC-FDMA, 1 RB, 5 MHz, 64-QAM)	X	2.98	69.03	17.47	3.01	150.0	± 9.6 %
		Y	4.15	75.28	20.17		150.0	
		Z	3.04	69.71	17.88		150.0	
10181-CAD	LTE-FDD (SC-FDMA, 1 RB, 15 MHz, QPSK)	X	2.73	67.76	18.09	3.01	150.0	± 9.6 %
		Y	3.22	71.29	19.85		150.0	
		Z	2.75	68.18	18.41		150.0	
10182-CAD	LTE-FDD (SC-FDMA, 1 RB, 15 MHz, 16-QAM)	X	3.62	73.08	20.30	3.01	150.0	± 9.6 %
		Y	5.88	82.63	24.13		150.0	
		Z	3.77	74.21	20.92		150.0	
10183-AAC	LTE-FDD (SC-FDMA, 1 RB, 15 MHz, 64-QAM)	X	2.97	69.01	17.46	3.01	150.0	± 9.6 %
		Y	4.14	75.24	20.16		150.0	
		Z	3.04	69.68	17.87		150.0	

10184-CAD	LTE-FDD (SC-FDMA, 1 RB, 3 MHz, QPSK)	X	2.74	67.80	18.11	3.01	150.0	± 9.6 %
		Y	3.24	71.35	19.88		150.0	
		Z	2.77	68.22	18.43		150.0	
10185-CAD	LTE-FDD (SC-FDMA, 1 RB, 3 MHz, 16-QAM)	X	3.64	73.15	20.34	3.01	150.0	± 9.6 %
		Y	5.93	82.75	24.19		150.0	
		Z	3.79	74.29	20.96		150.0	
10186-AAD	LTE-FDD (SC-FDMA, 1 RB, 3 MHz, 64-QAM)	X	2.99	69.07	17.49	3.01	150.0	± 9.6 %
		Y	4.16	75.34	20.20		150.0	
		Z	3.05	69.75	17.90		150.0	
10187-CAE	LTE-FDD (SC-FDMA, 1 RB, 1.4 MHz, QPSK)	X	2.75	67.86	18.18	3.01	150.0	± 9.6 %
		Y	3.25	71.43	19.96		150.0	
		Z	2.78	68.29	18.51		150.0	
10188-CAE	LTE-FDD (SC-FDMA, 1 RB, 1.4 MHz, 16-QAM)	X	3.76	73.83	20.74	3.01	150.0	± 9.6 %
		Y	6.30	84.02	24.77		150.0	
		Z	3.92	75.04	21.38		150.0	
10189-AAE	LTE-FDD (SC-FDMA, 1 RB, 1.4 MHz, 64-QAM)	X	3.05	69.47	17.77	3.01	150.0	± 9.6 %
		Y	4.32	76.05	20.59		150.0	
		Z	3.12	70.18	18.19		150.0	
10193-CAC	IEEE 802.11n (HT Greenfield, 6.5 Mbps, BPSK)	X	4.39	66.44	16.00	0.00	150.0	± 9.6 %
		Y	4.46	66.83	16.18		150.0	
		Z	4.36	66.53	16.02		150.0	
10194-CAC	IEEE 802.11n (HT Greenfield, 39 Mbps, 16-QAM)	X	4.55	66.74	16.13	0.00	150.0	± 9.6 %
		Y	4.63	67.12	16.30		150.0	
		Z	4.51	66.81	16.16		150.0	
10195-CAC	IEEE 802.11n (HT Greenfield, 65 Mbps, 64-QAM)	X	4.59	66.77	16.15	0.00	150.0	± 9.6 %
		Y	4.67	67.15	16.32		150.0	
		Z	4.55	66.84	16.18		150.0	
10196-CAC	IEEE 802.11n (HT Mixed, 6.5 Mbps, BPSK)	X	4.39	66.48	16.01	0.00	150.0	± 9.6 %
		Y	4.46	66.87	16.19		150.0	
		Z	4.35	66.57	16.03		150.0	
10197-CAC	IEEE 802.11n (HT Mixed, 39 Mbps, 16-QAM)	X	4.56	66.75	16.14	0.00	150.0	± 9.6 %
		Y	4.64	67.14	16.31		150.0	
		Z	4.53	66.83	16.17		150.0	
10198-CAC	IEEE 802.11n (HT Mixed, 65 Mbps, 64-QAM)	X	4.59	66.78	16.16	0.00	150.0	± 9.6 %
		Y	4.67	67.16	16.33		150.0	
		Z	4.55	66.85	16.19		150.0	
10219-CAC	IEEE 802.11n (HT Mixed, 7.2 Mbps, BPSK)	X	4.34	66.50	15.97	0.00	150.0	± 9.6 %
		Y	4.41	66.90	16.15		150.0	
		Z	4.30	66.59	15.99		150.0	
10220-CAC	IEEE 802.11n (HT Mixed, 43.3 Mbps, 16-QAM)	X	4.56	66.72	16.13	0.00	150.0	± 9.6 %
		Y	4.63	67.10	16.30		150.0	
		Z	4.52	66.79	16.15		150.0	
10221-CAC	IEEE 802.11n (HT Mixed, 72.2 Mbps, 64-QAM)	X	4.60	66.71	16.14	0.00	150.0	± 9.6 %
		Y	4.67	67.09	16.31		150.0	
		Z	4.56	66.79	16.17		150.0	
10222-CAC	IEEE 802.11n (HT Mixed, 15 Mbps, BPSK)	X	4.94	66.87	16.27	0.00	150.0	± 9.6 %
		Y	5.00	67.20	16.40		150.0	
		Z	4.91	66.93	16.30		150.0	

10223-CAC	IEEE 802.11n (HT Mixed, 90 Mbps, 16-QAM)	X	5.26	67.15	16.43	0.00	150.0	± 9.6 %
		Y	5.29	67.39	16.51		150.0	
		Z	5.21	67.16	16.44		150.0	
10224-CAC	IEEE 802.11n (HT Mixed, 150 Mbps, 64-QAM)	X	4.98	66.98	16.25	0.00	150.0	± 9.6 %
		Y	5.05	67.32	16.38		150.0	
		Z	4.95	67.03	16.28		150.0	
10225-CAB	UMTS-FDD (HSPA+)	X	2.65	65.82	14.94	0.00	150.0	± 9.6 %
		Y	2.77	66.54	15.42		150.0	
		Z	2.63	65.96	14.93		150.0	
10226-CAA	LTE-TDD (SC-FDMA, 1 RB, 1.4 MHz, 16-QAM)	X	12.29	94.61	27.52	6.02	65.0	± 9.6 %
		Y	76.74	126.49	35.96		65.0	
		Z	14.23	97.75	28.67		65.0	
10227-CAA	LTE-TDD (SC-FDMA, 1 RB, 1.4 MHz, 64-QAM)	X	11.60	92.16	26.09	6.02	65.0	± 9.6 %
		Y	58.51	119.10	33.33		65.0	
		Z	13.58	95.42	27.28		65.0	
10228-CAA	LTE-TDD (SC-FDMA, 1 RB, 1.4 MHz, QPSK)	X	8.07	91.29	28.44	6.02	65.0	± 9.6 %
		Y	14.98	103.75	32.45		65.0	
		Z	8.37	92.43	29.01		65.0	
10229-CAB	LTE-TDD (SC-FDMA, 1 RB, 3 MHz, 16-QAM)	X	11.46	93.21	26.98	6.02	65.0	± 9.6 %
		Y	62.74	122.68	34.92		65.0	
		Z	13.11	96.13	28.07		65.0	
10230-CAB	LTE-TDD (SC-FDMA, 1 RB, 3 MHz, 64-QAM)	X	10.78	90.84	25.59	6.02	65.0	± 9.6 %
		Y	48.68	115.84	32.42		65.0	
		Z	12.46	93.85	26.71		65.0	
10231-CAB	LTE-TDD (SC-FDMA, 1 RB, 3 MHz, QPSK)	X	7.66	90.18	27.97	6.02	65.0	± 9.6 %
		Y	13.86	102.08	31.86		65.0	
		Z	7.92	91.24	28.52		65.0	
10232-CAD	LTE-TDD (SC-FDMA, 1 RB, 5 MHz, 16-QAM)	X	11.44	93.19	26.97	6.02	65.0	± 9.6 %
		Y	62.67	122.68	34.92		65.0	
		Z	13.08	96.11	28.07		65.0	
10233-CAD	LTE-TDD (SC-FDMA, 1 RB, 5 MHz, 64-QAM)	X	10.75	90.81	25.58	6.02	65.0	± 9.6 %
		Y	48.50	115.79	32.41		65.0	
		Z	12.42	93.82	26.70		65.0	
10234-CAD	LTE-TDD (SC-FDMA, 1 RB, 5 MHz, QPSK)	X	7.34	89.19	27.51	6.02	65.0	± 9.6 %
		Y	12.98	100.59	31.27		65.0	
		Z	7.57	90.21	28.04		65.0	
10235-CAD	LTE-TDD (SC-FDMA, 1 RB, 10 MHz, 16-QAM)	X	11.45	93.23	26.99	6.02	65.0	± 9.6 %
		Y	63.03	122.79	34.95		65.0	
		Z	13.11	96.15	28.08		65.0	
10236-CAD	LTE-TDD (SC-FDMA, 1 RB, 10 MHz, 64-QAM)	X	10.87	90.96	25.62	6.02	65.0	± 9.6 %
		Y	49.65	116.13	32.49		65.0	
		Z	12.57	93.99	26.75		65.0	
10237-CAD	LTE-TDD (SC-FDMA, 1 RB, 10 MHz, QPSK)	X	7.67	90.24	28.00	6.02	65.0	± 9.6 %
		Y	13.91	102.19	31.90		65.0	
		Z	7.93	91.30	28.54		65.0	
10238-CAD	LTE-TDD (SC-FDMA, 1 RB, 15 MHz, 16-QAM)	X	11.41	93.16	26.96	6.02	65.0	± 9.6 %
		Y	62.56	122.66	34.91		65.0	
		Z	13.06	96.08	28.06		65.0	

10239-CAD	LTE-TDD (SC-FDMA, 1 RB, 15 MHz, 64-QAM)	X	10.72	90.78	25.57	6.02	65.0	± 9.6 %
		Y	48.29	115.74	32.40		65.0	
		Z	12.38	93.78	26.69		65.0	
10240-CAD	LTE-TDD (SC-FDMA, 1 RB, 15 MHz, QPSK)	X	7.65	90.20	27.98	6.02	65.0	± 9.6 %
		Y	13.86	102.14	31.88		65.0	
		Z	7.91	91.26	28.53		65.0	
10241-CAA	LTE-TDD (SC-FDMA, 50% RB, 1.4 MHz, 16-QAM)	X	7.49	79.94	24.73	6.98	65.0	± 9.6 %
		Y	9.15	84.52	26.53		65.0	
		Z	7.78	81.10	25.24		65.0	
10242-CAA	LTE-TDD (SC-FDMA, 50% RB, 1.4 MHz, 64-QAM)	X	6.76	77.82	23.76	6.98	65.0	± 9.6 %
		Y	8.56	83.16	25.93		65.0	
		Z	7.57	80.56	24.94		65.0	
10243-CAA	LTE-TDD (SC-FDMA, 50% RB, 1.4 MHz, QPSK)	X	5.55	74.73	23.33	6.98	65.0	± 9.6 %
		Y	6.44	78.27	24.91		65.0	
		Z	5.56	75.03	23.50		65.0	
10244-CAB	LTE-TDD (SC-FDMA, 50% RB, 3 MHz, 16-QAM)	X	4.91	73.06	16.84	3.98	65.0	± 9.6 %
		Y	6.23	76.34	18.14		65.0	
		Z	4.96	73.17	16.71		65.0	
10245-CAB	LTE-TDD (SC-FDMA, 50% RB, 3 MHz, 64-QAM)	X	4.78	72.39	16.50	3.98	65.0	± 9.6 %
		Y	5.96	75.43	17.72		65.0	
		Z	4.79	72.41	16.32		65.0	
10246-CAB	LTE-TDD (SC-FDMA, 50% RB, 3 MHz, QPSK)	X	4.86	76.58	18.54	3.98	65.0	± 9.6 %
		Y	5.74	78.81	19.49		65.0	
		Z	4.75	76.10	18.16		65.0	
10247-CAD	LTE-TDD (SC-FDMA, 50% RB, 5 MHz, 16-QAM)	X	4.54	72.63	17.68	3.98	65.0	± 9.6 %
		Y	5.00	73.89	18.23		65.0	
		Z	4.50	72.44	17.41		65.0	
10248-CAD	LTE-TDD (SC-FDMA, 50% RB, 5 MHz, 64-QAM)	X	4.51	72.01	17.39	3.98	65.0	± 9.6 %
		Y	4.93	73.18	17.90		65.0	
		Z	4.45	71.77	17.09		65.0	
10249-CAD	LTE-TDD (SC-FDMA, 50% RB, 5 MHz, QPSK)	X	6.38	81.20	21.41	3.98	65.0	± 9.6 %
		Y	7.34	83.11	22.13		65.0	
		Z	6.46	81.34	21.34		65.0	
10250-CAD	LTE-TDD (SC-FDMA, 50% RB, 10 MHz, 16-QAM)	X	5.54	75.67	20.83	3.98	65.0	± 9.6 %
		Y	5.99	76.71	21.17		65.0	
		Z	5.60	75.87	20.83		65.0	
10251-CAD	LTE-TDD (SC-FDMA, 50% RB, 10 MHz, 64-QAM)	X	5.22	73.28	19.41	3.98	65.0	± 9.6 %
		Y	5.60	74.26	19.76		65.0	
		Z	5.22	73.35	19.34		65.0	
10252-CAD	LTE-TDD (SC-FDMA, 50% RB, 10 MHz, QPSK)	X	6.60	81.03	22.49	3.98	65.0	± 9.6 %
		Y	7.35	82.49	22.99		65.0	
		Z	6.74	81.46	22.63		65.0	
10253-CAD	LTE-TDD (SC-FDMA, 50% RB, 15 MHz, 16-QAM)	X	5.32	72.45	19.46	3.98	65.0	± 9.6 %
		Y	5.67	73.38	19.78		65.0	
		Z	5.34	72.58	19.46		65.0	
10254-CAD	LTE-TDD (SC-FDMA, 50% RB, 15 MHz, 64-QAM)	X	5.67	73.46	20.23	3.98	65.0	± 9.6 %
		Y	6.04	74.36	20.52		65.0	
		Z	5.70	73.62	20.25		65.0	

10255-CAD	LTE-TDD (SC-FDMA, 50% RB, 15 MHz, QPSK)	X	6.00	77.17	21.28	3.98	65.0	± 9.6 %
		Y	6.54	78.36	21.67		65.0	
		Z	6.09	77.51	21.41		65.0	
10256-CAA	LTE-TDD (SC-FDMA, 100% RB, 1.4 MHz, 16-QAM)	X	3.55	68.31	13.56	3.98	65.0	± 9.6 %
		Y	4.31	70.70	14.63		65.0	
		Z	3.47	67.95	13.18		65.0	
10257-CAA	LTE-TDD (SC-FDMA, 100% RB, 1.4 MHz, 64-QAM)	X	3.46	67.65	13.15	3.98	65.0	± 9.6 %
		Y	4.12	69.78	14.12		65.0	
		Z	3.37	67.24	12.73		65.0	
10258-CAA	LTE-TDD (SC-FDMA, 100% RB, 1.4 MHz, QPSK)	X	3.31	70.56	15.03	3.98	65.0	± 9.6 %
		Y	3.93	72.68	16.08		65.0	
		Z	3.14	69.68	14.40		65.0	
10259-CAB	LTE-TDD (SC-FDMA, 100% RB, 3 MHz, 16-QAM)	X	4.95	73.85	18.86	3.98	65.0	± 9.6 %
		Y	5.40	75.01	19.32		65.0	
		Z	4.95	73.84	18.70		65.0	
10260-CAB	LTE-TDD (SC-FDMA, 100% RB, 3 MHz, 64-QAM)	X	4.97	73.54	18.73	3.98	65.0	± 9.6 %
		Y	5.40	74.66	19.18		65.0	
		Z	4.96	73.50	18.55		65.0	
10261-CAB	LTE-TDD (SC-FDMA, 100% RB, 3 MHz, QPSK)	X	6.09	80.15	21.50	3.98	65.0	± 9.6 %
		Y	6.88	81.79	22.11		65.0	
		Z	6.20	80.42	21.51		65.0	
10262-CAD	LTE-TDD (SC-FDMA, 100% RB, 5 MHz, 16-QAM)	X	5.53	75.60	20.77	3.98	65.0	± 9.6 %
		Y	5.97	76.64	21.12		65.0	
		Z	5.58	75.79	20.77		65.0	
10263-CAD	LTE-TDD (SC-FDMA, 100% RB, 5 MHz, 64-QAM)	X	5.21	73.26	19.40	3.98	65.0	± 9.6 %
		Y	5.59	74.24	19.76		65.0	
		Z	5.21	73.32	19.33		65.0	
10264-CAD	LTE-TDD (SC-FDMA, 100% RB, 5 MHz, QPSK)	X	6.52	80.79	22.38	3.98	65.0	± 9.6 %
		Y	7.26	82.25	22.87		65.0	
		Z	6.65	81.20	22.51		65.0	
10265-CAD	LTE-TDD (SC-FDMA, 100% RB, 10 MHz, 16-QAM)	X	5.42	72.95	19.72	3.98	65.0	± 9.6 %
		Y	5.78	73.89	20.03		65.0	
		Z	5.43	73.04	19.72		65.0	
10266-CAD	LTE-TDD (SC-FDMA, 100% RB, 10 MHz, 64-QAM)	X	5.81	74.04	20.57	3.98	65.0	± 9.6 %
		Y	6.19	74.96	20.86		65.0	
		Z	5.84	74.19	20.60		65.0	
10267-CAD	LTE-TDD (SC-FDMA, 100% RB, 10 MHz, QPSK)	X	6.31	77.85	21.33	3.98	65.0	± 9.6 %
		Y	6.90	79.09	21.75		65.0	
		Z	6.39	78.16	21.48		65.0	
10268-CAD	LTE-TDD (SC-FDMA, 100% RB, 15 MHz, 16-QAM)	X	6.05	72.91	20.14	3.98	65.0	± 9.6 %
		Y	6.40	73.76	20.40		65.0	
		Z	6.06	73.00	20.17		65.0	
10269-CAD	LTE-TDD (SC-FDMA, 100% RB, 15 MHz, 64-QAM)	X	6.03	72.50	20.01	3.98	65.0	± 9.6 %
		Y	6.37	73.34	20.27		65.0	
		Z	6.05	72.60	20.04		65.0	
10270-CAD	LTE-TDD (SC-FDMA, 100% RB, 15 MHz, QPSK)	X	6.14	75.03	20.36	3.98	65.0	± 9.6 %
		Y	6.59	76.06	20.69		65.0	
		Z	6.19	75.26	20.47		65.0	

10274-CAB	UMTS-FDD (HSUPA, Subtest 5, 3GPP Rel8.10)	X	2.45	66.18	14.83	0.00	150.0	± 9.6 %
		Y	2.58	67.05	15.42		150.0	
		Z	2.44	66.39	14.86		150.0	
10275-CAB	UMTS-FDD (HSUPA, Subtest 5, 3GPP Rel8.4)	X	1.45	67.15	14.79	0.00	150.0	± 9.6 %
		Y	1.65	68.98	16.07		150.0	
		Z	1.46	67.49	14.94		150.0	
10277-CAA	PHS (QPSK)	X	2.05	60.99	6.61	9.03	50.0	± 9.6 %
		Y	2.14	61.42	6.98		50.0	
		Z	2.15	61.21	6.84		50.0	
10278-CAA	PHS (QPSK, BW 884MHz, Rolloff 0.5)	X	3.88	69.24	13.58	9.03	50.0	± 9.6 %
		Y	4.38	71.00	14.54		50.0	
		Z	3.84	68.69	13.30		50.0	
10279-CAA	PHS (QPSK, BW 884MHz, Rolloff 0.38)	X	4.00	69.55	13.78	9.03	50.0	± 9.6 %
		Y	4.51	71.31	14.73		50.0	
		Z	3.94	68.96	13.47		50.0	
10290-AAB	CDMA2000, RC1, SO55, Full Rate	X	1.07	65.69	11.52	0.00	150.0	± 9.6 %
		Y	1.53	70.26	14.37		150.0	
		Z	1.01	65.37	11.10		150.0	
10291-AAB	CDMA2000, RC3, SO55, Full Rate	X	0.60	63.10	9.79	0.00	150.0	± 9.6 %
		Y	0.85	67.12	12.84		150.0	
		Z	0.57	62.93	9.45		150.0	
10292-AAB	CDMA2000, RC3, SO32, Full Rate	X	0.74	66.24	11.75	0.00	150.0	± 9.6 %
		Y	1.46	75.17	16.76		150.0	
		Z	0.73	66.36	11.54		150.0	
10293-AAB	CDMA2000, RC3, SO3, Full Rate	X	1.24	72.67	15.10	0.00	150.0	± 9.6 %
		Y	5.17	93.05	23.35		150.0	
		Z	1.42	74.33	15.45		150.0	
10295-AAB	CDMA2000, RC1, SO3, 1/8th Rate 25 fr.	X	9.92	85.20	23.12	9.03	50.0	± 9.6 %
		Y	9.50	84.91	23.23		50.0	
		Z	10.83	86.02	23.20		50.0	
10297-AAC	LTE-FDD (SC-FDMA, 50% RB, 20 MHz, QPSK)	X	2.57	69.12	16.16	0.00	150.0	± 9.6 %
		Y	2.77	70.42	16.97		150.0	
		Z	2.55	69.32	16.30		150.0	
10298-AAC	LTE-FDD (SC-FDMA, 50% RB, 3 MHz, QPSK)	X	1.27	65.66	12.33	0.00	150.0	± 9.6 %
		Y	1.58	68.64	14.32		150.0	
		Z	1.21	65.43	11.98		150.0	
10299-AAC	LTE-FDD (SC-FDMA, 50% RB, 3 MHz, 16-QAM)	X	2.00	66.49	12.18	0.00	150.0	± 9.6 %
		Y	3.31	72.57	14.96		150.0	
		Z	1.99	66.70	12.06		150.0	
10300-AAC	LTE-FDD (SC-FDMA, 50% RB, 3 MHz, 64-QAM)	X	1.58	63.09	9.74	0.00	150.0	± 9.6 %
		Y	1.99	65.54	11.08		150.0	
		Z	1.51	62.92	9.42		150.0	
10301-AAA	IEEE 802.16e WiMAX (29:18, 5ms, 10MHz, QPSK, PUSC)	X	4.69	65.76	17.48	4.17	50.0	± 9.6 %
		Y	4.64	65.55	17.37		50.0	
		Z	4.67	65.93	17.49		50.0	
10302-AAA	IEEE 802.16e WiMAX (29:18, 5ms, 10MHz, QPSK, PUSC, 3 CTRL symbols)	X	5.09	65.93	17.93	4.96	50.0	± 9.6 %
		Y	5.12	66.18	18.09		50.0	
		Z	5.09	66.17	17.98		50.0	

10303-AAA	IEEE 802.16e WiMAX (31:15, 5ms, 10MHz, 64QAM, PUSC)	X	4.84	65.58	17.76	4.96	50.0	± 9.6 %
		Y	4.88	65.83	17.92		50.0	
		Z	4.85	65.84	17.81		50.0	
10304-AAA	IEEE 802.16e WiMAX (29:18, 5ms, 10MHz, 64QAM, PUSC)	X	4.65	65.44	17.26	4.17	50.0	± 9.6 %
		Y	4.69	65.73	17.44		50.0	
		Z	4.65	65.69	17.31		50.0	
10305-AAA	IEEE 802.16e WiMAX (31:15, 10ms, 10MHz, 64QAM, PUSC, 15 symbols)	X	4.44	68.14	19.56	6.02	35.0	± 9.6 %
		Y	4.41	68.01	19.60		35.0	
		Z	4.62	69.17	19.86		35.0	
10306-AAA	IEEE 802.16e WiMAX (29:18, 10ms, 10MHz, 64QAM, PUSC, 18 symbols)	X	4.68	66.85	19.08	6.02	35.0	± 9.6 %
		Y	4.67	66.81	19.12		35.0	
		Z	4.77	67.53	19.30		35.0	
10307-AAA	IEEE 802.16e WiMAX (29:18, 10ms, 10MHz, QPSK, PUSC, 18 symbols)	X	4.59	67.04	19.05	6.02	35.0	± 9.6 %
		Y	4.58	66.99	19.09		35.0	
		Z	4.69	67.75	19.27		35.0	
10308-AAA	IEEE 802.16e WiMAX (29:18, 10ms, 10MHz, 16QAM, PUSC)	X	4.57	67.28	19.21	6.02	35.0	± 9.6 %
		Y	4.56	67.23	19.25		35.0	
		Z	4.69	68.04	19.45		35.0	
10309-AAA	IEEE 802.16e WiMAX (29:18, 10ms, 10MHz, 16QAM, AMC 2x3, 18 symbols)	X	4.73	67.04	19.22	6.02	35.0	± 9.6 %
		Y	4.72	66.99	19.24		35.0	
		Z	4.82	67.69	19.42		35.0	
10310-AAA	IEEE 802.16e WiMAX (29:18, 10ms, 10MHz, QPSK, AMC 2x3, 18 symbols)	X	4.63	66.94	19.07	6.02	35.0	± 9.6 %
		Y	4.63	66.90	19.11		35.0	
		Z	4.74	67.65	19.30		35.0	
10311-AAC	LTE-FDD (SC-FDMA, 100% RB, 15 MHz, QPSK)	X	2.92	68.38	15.85	0.00	150.0	± 9.6 %
		Y	3.14	69.67	16.60		150.0	
		Z	2.91	68.56	15.97		150.0	
10313-AAA	iDEN 1:3	X	2.95	70.69	14.66	6.99	70.0	± 9.6 %
		Y	3.98	74.43	16.48		70.0	
		Z	3.15	71.48	15.14		70.0	
10314-AAA	iDEN 1:6	X	5.04	79.92	21.00	10.00	30.0	± 9.6 %
		Y	6.78	84.92	23.16		30.0	
		Z	5.73	81.64	21.73		30.0	
10315-AAB	IEEE 802.11b WiFi 2.4 GHz (DSSS, 1 Mbps, 96pc duty cycle)	X	0.97	63.25	14.68	0.17	150.0	± 9.6 %
		Y	1.08	64.33	15.52		150.0	
		Z	0.98	63.49	14.85		150.0	
10316-AAB	IEEE 802.11g WiFi 2.4 GHz (ERP-OFDM, 6 Mbps, 96pc duty cycle)	X	4.44	66.48	16.13	0.17	150.0	± 9.6 %
		Y	4.51	66.82	16.27		150.0	
		Z	4.41	66.56	16.16		150.0	
10317-AAC	IEEE 802.11a WiFi 5 GHz (OFDM, 6 Mbps, 96pc duty cycle)	X	4.44	66.48	16.13	0.17	150.0	± 9.6 %
		Y	4.51	66.82	16.27		150.0	
		Z	4.41	66.56	16.16		150.0	
10400-AAD	IEEE 802.11ac WiFi (20MHz, 64-QAM, 99pc duty cycle)	X	4.53	66.78	16.11	0.00	150.0	± 9.6 %
		Y	4.61	67.15	16.28		150.0	
		Z	4.49	66.84	16.14		150.0	
10401-AAD	IEEE 802.11ac WiFi (40MHz, 64-QAM, 99pc duty cycle)	X	5.27	67.03	16.34	0.00	150.0	± 9.6 %
		Y	5.28	67.17	16.36		150.0	
		Z	5.22	67.01	16.33		150.0	

10402-AAD	IEEE 802.11ac WiFi (80MHz, 64-QAM, 99pc duty cycle)	X	5.50	67.24	16.31	0.00	150.0	± 9.6 %
		Y	5.56	67.57	16.43		150.0	
		Z	5.47	67.27	16.33		150.0	
10403-AAB	CDMA2000 (1xEV-DO, Rev. 0)	X	1.07	65.69	11.52	0.00	115.0	± 9.6 %
		Y	1.53	70.26	14.37		115.0	
		Z	1.01	65.37	11.10		115.0	
10404-AAB	CDMA2000 (1xEV-DO, Rev. A)	X	1.07	65.69	11.52	0.00	115.0	± 9.6 %
		Y	1.53	70.26	14.37		115.0	
		Z	1.01	65.37	11.10		115.0	
10406-AAB	CDMA2000, RC3, SO32, SCH0, Full Rate	X	23.46	102.23	25.39	0.00	100.0	± 9.6 %
		Y	100.00	115.29	27.21		100.0	
		Z	100.00	120.73	29.57		100.0	
10410-AAD	LTE-TDD (SC-FDMA, 1 RB, 10 MHz, QPSK, UL Subframe=2,3,4,7,8,9, Subframe Conf=4)	X	55.06	113.36	27.76	3.23	80.0	± 9.6 %
		Y	100.00	120.25	29.20		80.0	
		Z	100.00	122.59	30.17		80.0	
10415-AAA	IEEE 802.11b WiFi 2.4 GHz (DSSS, 1 Mbps, 99pc duty cycle)	X	0.91	62.47	14.11	0.00	150.0	± 9.6 %
		Y	1.00	63.52	14.99		150.0	
		Z	0.91	62.68	14.27		150.0	
10416-AAA	IEEE 802.11g WiFi 2.4 GHz (ERP-OFDM, 6 Mbps, 99pc duty cycle)	X	4.39	66.47	16.07	0.00	150.0	± 9.6 %
		Y	4.46	66.85	16.24		150.0	
		Z	4.36	66.56	16.10		150.0	
10417-AAB	IEEE 802.11a/h WiFi 5 GHz (OFDM, 6 Mbps, 99pc duty cycle)	X	4.39	66.47	16.07	0.00	150.0	± 9.6 %
		Y	4.46	66.85	16.24		150.0	
		Z	4.36	66.56	16.10		150.0	
10418-AAA	IEEE 802.11g WiFi 2.4 GHz (DSSS-OFDM, 6 Mbps, 99pc duty cycle, Long preamble)	X	4.38	66.64	16.10	0.00	150.0	± 9.6 %
		Y	4.46	67.04	16.28		150.0	
		Z	4.35	66.74	16.14		150.0	
10419-AAA	IEEE 802.11g WiFi 2.4 GHz (DSSS-OFDM, 6 Mbps, 99pc duty cycle, Short preamble)	X	4.40	66.59	16.10	0.00	150.0	± 9.6 %
		Y	4.48	66.98	16.27		150.0	
		Z	4.37	66.68	16.13		150.0	
10422-AAB	IEEE 802.11n (HT Greenfield, 7.2 Mbps, BPSK)	X	4.51	66.58	16.11	0.00	150.0	± 9.6 %
		Y	4.59	66.96	16.28		150.0	
		Z	4.48	66.67	16.14		150.0	
10423-AAB	IEEE 802.11n (HT Greenfield, 43.3 Mbps, 16-QAM)	X	4.67	66.88	16.22	0.00	150.0	± 9.6 %
		Y	4.74	67.25	16.38		150.0	
		Z	4.62	66.95	16.24		150.0	
10424-AAB	IEEE 802.11n (HT Greenfield, 72.2 Mbps, 64-QAM)	X	4.59	66.83	16.19	0.00	150.0	± 9.6 %
		Y	4.67	67.21	16.36		150.0	
		Z	4.55	66.90	16.22		150.0	
10425-AAB	IEEE 802.11n (HT Greenfield, 15 Mbps, BPSK)	X	5.20	67.12	16.39	0.00	150.0	± 9.6 %
		Y	5.25	67.39	16.48		150.0	
		Z	5.17	67.16	16.41		150.0	
10426-AAB	IEEE 802.11n (HT Greenfield, 90 Mbps, 16-QAM)	X	5.23	67.21	16.43	0.00	150.0	± 9.6 %
		Y	5.26	67.44	16.50		150.0	
		Z	5.19	67.25	16.45		150.0	

10427-AAB	IEEE 802.11n (HT Greenfield, 150 Mbps, 64-QAM)	X	5.23	67.14	16.39	0.00	150.0	± 9.6 %
		Y	5.27	67.40	16.48		150.0	
		Z	5.18	67.14	16.40		150.0	
10430-AAB	LTE-FDD (OFDMA, 5 MHz, E-TM 3.1)	X	4.20	71.33	18.23	0.00	150.0	± 9.6 %
		Y	4.38	72.12	18.67		150.0	
		Z	4.24	71.88	18.40		150.0	
10431-AAB	LTE-FDD (OFDMA, 10 MHz, E-TM 3.1)	X	4.04	67.01	16.00	0.00	150.0	± 9.6 %
		Y	4.14	67.47	16.25		150.0	
		Z	4.00	67.12	16.01		150.0	
10432-AAB	LTE-FDD (OFDMA, 15 MHz, E-TM 3.1)	X	4.35	66.89	16.12	0.00	150.0	± 9.6 %
		Y	4.44	67.29	16.32		150.0	
		Z	4.31	66.97	16.15		150.0	
10433-AAB	LTE-FDD (OFDMA, 20 MHz, E-TM 3.1)	X	4.61	66.86	16.21	0.00	150.0	± 9.6 %
		Y	4.68	67.24	16.38		150.0	
		Z	4.57	66.94	16.24		150.0	
10434-AAA	W-CDMA (BS Test Model 1, 64 DPCH)	X	4.31	72.22	18.13	0.00	150.0	± 9.6 %
		Y	4.57	73.29	18.72		150.0	
		Z	4.37	72.83	18.28		150.0	
10435-AAC	LTE-TDD (SC-FDMA, 1 RB, 20 MHz, QPSK, UL Subframe=2,3,4,7,8,9)	X	46.38	110.94	27.14	3.23	80.0	± 9.6 %
		Y	100.00	119.98	29.08		80.0	
		Z	100.00	122.32	30.05		80.0	
10447-AAB	LTE-FDD (OFDMA, 5 MHz, E-TM 3.1, Clipping 44%)	X	3.31	66.87	15.09	0.00	150.0	± 9.6 %
		Y	3.44	67.57	15.54		150.0	
		Z	3.26	66.97	15.03		150.0	
10448-AAB	LTE-FDD (OFDMA, 10 MHz, E-TM 3.1, Clipping 44%)	X	3.89	66.79	15.86	0.00	150.0	± 9.6 %
		Y	3.98	67.27	16.12		150.0	
		Z	3.85	66.90	15.88		150.0	
10449-AAB	LTE-FDD (OFDMA, 15 MHz, E-TM 3.1, Clipping 44%)	X	4.17	66.71	16.01	0.00	150.0	± 9.6 %
		Y	4.26	67.14	16.23		150.0	
		Z	4.14	66.80	16.04		150.0	
10450-AAB	LTE-FDD (OFDMA, 20 MHz, E-TM 3.1, Clipping 44%)	X	4.38	66.63	16.06	0.00	150.0	± 9.6 %
		Y	4.46	67.03	16.25		150.0	
		Z	4.35	66.71	16.09		150.0	
10451-AAA	W-CDMA (BS Test Model 1, 64 DPCH, Clipping 44%)	X	3.16	66.87	14.55	0.00	150.0	± 9.6 %
		Y	3.31	67.71	15.09		150.0	
		Z	3.09	66.88	14.41		150.0	
10456-AAB	IEEE 802.11ac WiFi (160MHz, 64-QAM, 99pc duty cycle)	X	6.10	67.71	16.58	0.00	150.0	± 9.6 %
		Y	6.13	67.95	16.63		150.0	
		Z	6.10	67.81	16.63		150.0	
10457-AAA	UMTS-FDD (DC-HSDPA)	X	3.68	65.12	15.78	0.00	150.0	± 9.6 %
		Y	3.75	65.52	15.96		150.0	
		Z	3.67	65.23	15.81		150.0	
10458-AAA	CDMA2000 (1xEV-DO, Rev. B, 2 carriers)	X	3.88	71.11	17.24	0.00	150.0	± 9.6 %
		Y	4.15	72.36	17.96		150.0	
		Z	3.88	71.47	17.22		150.0	
10459-AAA	CDMA2000 (1xEV-DO, Rev. B, 3 carriers)	X	5.03	68.93	18.26	0.00	150.0	± 9.6 %
		Y	5.12	69.27	18.40		150.0	
		Z	5.02	69.28	18.31		150.0	

10460-AAA	UMTS-FDD (WCDMA, AMR)	X	0.76	67.21	14.98	0.00	150.0	± 9.6 %
		Y	0.95	70.10	17.17		150.0	
		Z	0.78	67.84	15.35		150.0	
10461-AAA	LTE-TDD (SC-FDMA, 1 RB, 1.4 MHz, QPSK, UL Subframe=2,3,4,7,8,9)	X	100.00	124.22	31.05	3.29	80.0	± 9.6 %
		Y	100.00	126.59	32.12		80.0	
		Z	100.00	126.67	32.13		80.0	
10462-AAA	LTE-TDD (SC-FDMA, 1 RB, 1.4 MHz, 16-QAM, UL Subframe=2,3,4,7,8,9)	X	1.13	62.20	9.29	3.23	80.0	± 9.6 %
		Y	1.76	66.14	10.65		80.0	
		Z	1.32	63.88	10.13		80.0	
10463-AAA	LTE-TDD (SC-FDMA, 1 RB, 1.4 MHz, 64-QAM, UL Subframe=2,3,4,7,8,9)	X	0.91	60.00	7.67	3.23	80.0	± 9.6 %
		Y	0.95	60.52	7.63		80.0	
		Z	0.89	60.00	7.73		80.0	
10464-AAA	LTE-TDD (SC-FDMA, 1 RB, 3 MHz, QPSK, UL Subframe=2,3,4,7,8,9)	X	47.59	111.65	27.34	3.23	80.0	± 9.6 %
		Y	100.00	123.29	30.45		80.0	
		Z	100.00	123.26	30.40		80.0	
10465-AAA	LTE-TDD (SC-FDMA, 1 RB, 3 MHz, 16-QAM, UL Subframe=2,3,4,7,8,9)	X	1.05	61.52	8.89	3.23	80.0	± 9.6 %
		Y	1.46	64.47	9.90		80.0	
		Z	1.18	62.83	9.59		80.0	
10466-AAA	LTE-TDD (SC-FDMA, 1 RB, 3 MHz, 64-QAM, UL Subframe=2,3,4,7,8,9)	X	0.91	60.00	7.62	3.23	80.0	± 9.6 %
		Y	0.90	60.08	7.36		80.0	
		Z	0.89	60.00	7.68		80.0	
10467-AAC	LTE-TDD (SC-FDMA, 1 RB, 5 MHz, QPSK, UL Subframe=2,3,4,7,8,9)	X	72.09	117.06	28.59	3.23	80.0	± 9.6 %
		Y	100.00	123.66	30.60		80.0	
		Z	100.00	123.63	30.56		80.0	
10468-AAC	LTE-TDD (SC-FDMA, 1 RB, 5 MHz, 16-QAM, UL Subframe=2,3,4,7,8,9)	X	1.07	61.70	9.00	3.23	80.0	± 9.6 %
		Y	1.53	64.89	10.09		80.0	
		Z	1.22	63.12	9.74		80.0	
10469-AAC	LTE-TDD (SC-FDMA, 1 RB, 5 MHz, 64-QAM, UL Subframe=2,3,4,7,8,9)	X	0.91	60.00	7.62	3.23	80.0	± 9.6 %
		Y	0.90	60.09	7.36		80.0	
		Z	0.89	60.00	7.68		80.0	
10470-AAC	LTE-TDD (SC-FDMA, 1 RB, 10 MHz, QPSK, UL Subframe=2,3,4,7,8,9)	X	74.02	117.39	28.66	3.23	80.0	± 9.6 %
		Y	100.00	123.68	30.61		80.0	
		Z	100.00	123.65	30.56		80.0	
10471-AAC	LTE-TDD (SC-FDMA, 1 RB, 10 MHz, 16-QAM, UL Subframe=2,3,4,7,8,9)	X	1.07	61.65	8.96	3.23	80.0	± 9.6 %
		Y	1.51	64.78	10.03		80.0	
		Z	1.21	63.05	9.70		80.0	
10472-AAC	LTE-TDD (SC-FDMA, 1 RB, 10 MHz, 64-QAM, UL Subframe=2,3,4,7,8,9)	X	0.91	60.00	7.61	3.23	80.0	± 9.6 %
		Y	0.89	60.04	7.32		80.0	
		Z	0.89	60.00	7.66		80.0	
10473-AAC	LTE-TDD (SC-FDMA, 1 RB, 15 MHz, QPSK, UL Subframe=2,3,4,7,8,9)	X	72.58	117.11	28.59	3.23	80.0	± 9.6 %
		Y	100.00	123.64	30.59		80.0	
		Z	100.00	123.61	30.54		80.0	
10474-AAC	LTE-TDD (SC-FDMA, 1 RB, 15 MHz, 16-QAM, UL Subframe=2,3,4,7,8,9)	X	1.06	61.62	8.95	3.23	80.0	± 9.6 %
		Y	1.50	64.73	10.01		80.0	
		Z	1.20	63.02	9.68		80.0	
10475-AAC	LTE-TDD (SC-FDMA, 1 RB, 15 MHz, 64-QAM, UL Subframe=2,3,4,7,8,9)	X	0.91	60.00	7.61	3.23	80.0	± 9.6 %
		Y	0.89	60.02	7.32		80.0	
		Z	0.89	60.00	7.66		80.0	

10477-AAC	LTE-TDD (SC-FDMA, 1 RB, 20 MHz, 16-QAM, UL Subframe=2,3,4,7,8,9)	X	1.04	61.46	8.85	3.23	80.0	± 9.6 %
		Y	1.44	64.36	9.83		80.0	
		Z	1.17	62.77	9.54		80.0	
10478-AAC	LTE-TDD (SC-FDMA, 1 RB, 20 MHz, 64-QAM, UL Subframe=2,3,4,7,8,9)	X	0.91	60.00	7.60	3.23	80.0	± 9.6 %
		Y	0.89	60.00	7.29		80.0	
		Z	0.89	60.00	7.65		80.0	
10479-AAA	LTE-TDD (SC-FDMA, 50% RB, 1.4 MHz, QPSK, UL Subframe=2,3,4,7,8,9)	X	8.21	87.49	22.94	3.23	80.0	± 9.6 %
		Y	20.18	101.14	27.13		80.0	
		Z	18.46	99.74	26.54		80.0	
10480-AAA	LTE-TDD (SC-FDMA, 50% RB, 1.4 MHz, 16-QAM, UL Subframe=2,3,4,7,8,9)	X	5.14	76.02	17.14	3.23	80.0	± 9.6 %
		Y	17.56	91.22	21.83		80.0	
		Z	8.18	81.93	19.01		80.0	
10481-AAA	LTE-TDD (SC-FDMA, 50% RB, 1.4 MHz, 64-QAM, UL Subframe=2,3,4,7,8,9)	X	3.78	71.70	15.15	3.23	80.0	± 9.6 %
		Y	9.36	82.53	18.82		80.0	
		Z	4.98	75.18	16.32		80.0	
10482-AAA	LTE-TDD (SC-FDMA, 50% RB, 3 MHz, QPSK, UL Subframe=2,3,4,7,8,9)	X	2.35	69.25	15.02	2.23	80.0	± 9.6 %
		Y	3.01	72.46	16.59		80.0	
		Z	2.33	69.25	14.80		80.0	
10483-AAA	LTE-TDD (SC-FDMA, 50% RB, 3 MHz, 16-QAM, UL Subframe=2,3,4,7,8,9)	X	3.09	69.06	14.42	2.23	80.0	± 9.6 %
		Y	4.90	74.92	16.84		80.0	
		Z	3.31	69.99	14.61		80.0	
10484-AAA	LTE-TDD (SC-FDMA, 50% RB, 3 MHz, 64-QAM, UL Subframe=2,3,4,7,8,9)	X	2.93	68.12	14.03	2.23	80.0	± 9.6 %
		Y	4.36	73.23	16.22		80.0	
		Z	3.05	68.75	14.10		80.0	
10485-AAC	LTE-TDD (SC-FDMA, 50% RB, 5 MHz, QPSK, UL Subframe=2,3,4,7,8,9)	X	2.95	72.33	17.49	2.23	80.0	± 9.6 %
		Y	3.47	74.53	18.53		80.0	
		Z	3.08	73.09	17.68		80.0	
10486-AAC	LTE-TDD (SC-FDMA, 50% RB, 5 MHz, 16-QAM, UL Subframe=2,3,4,7,8,9)	X	2.76	67.89	15.02	2.23	80.0	± 9.6 %
		Y	3.16	69.70	15.94		80.0	
		Z	2.75	68.00	14.88		80.0	
10487-AAC	LTE-TDD (SC-FDMA, 50% RB, 5 MHz, 64-QAM, UL Subframe=2,3,4,7,8,9)	X	2.75	67.50	14.83	2.23	80.0	± 9.6 %
		Y	3.13	69.21	15.71		80.0	
		Z	2.74	67.55	14.66		80.0	
10488-AAC	LTE-TDD (SC-FDMA, 50% RB, 10 MHz, QPSK, UL Subframe=2,3,4,7,8,9)	X	3.27	71.87	18.23	2.23	80.0	± 9.6 %
		Y	3.61	73.22	18.84		80.0	
		Z	3.35	72.44	18.47		80.0	
10489-AAC	LTE-TDD (SC-FDMA, 50% RB, 10 MHz, 16-QAM, UL Subframe=2,3,4,7,8,9)	X	3.21	68.44	16.77	2.23	80.0	± 9.6 %
		Y	3.45	69.44	17.24		80.0	
		Z	3.25	68.82	16.89		80.0	
10490-AAC	LTE-TDD (SC-FDMA, 50% RB, 10 MHz, 64-QAM, UL Subframe=2,3,4,7,8,9)	X	3.29	68.29	16.72	2.23	80.0	± 9.6 %
		Y	3.53	69.24	17.16		80.0	
		Z	3.33	68.65	16.82		80.0	
10491-AAC	LTE-TDD (SC-FDMA, 50% RB, 15 MHz, QPSK, UL Subframe=2,3,4,7,8,9)	X	3.51	70.39	17.81	2.23	80.0	± 9.6 %
		Y	3.78	71.45	18.28		80.0	
		Z	3.55	70.76	17.99		80.0	
10492-AAC	LTE-TDD (SC-FDMA, 50% RB, 15 MHz, 16-QAM, UL Subframe=2,3,4,7,8,9)	X	3.56	67.76	16.86	2.23	80.0	± 9.6 %
		Y	3.76	68.54	17.20		80.0	
		Z	3.58	68.03	16.97		80.0	

10493-AAC	LTE-TDD (SC-FDMA, 50% RB, 15 MHz, 64-QAM, UL Subframe=2,3,4,7,8,9)	X	3.62	67.64	16.82	2.23	80.0	± 9.6 %
		Y	3.82	68.40	17.14		80.0	
		Z	3.64	67.90	16.91		80.0	
10494-AAC	LTE-TDD (SC-FDMA, 50% RB, 20 MHz, QPSK, UL Subframe=2,3,4,7,8,9)	X	3.79	71.83	18.26	2.23	80.0	± 9.6 %
		Y	4.13	73.06	18.79		80.0	
		Z	3.85	72.23	18.46		80.0	
10495-AAC	LTE-TDD (SC-FDMA, 50% RB, 20 MHz, 16-QAM, UL Subframe=2,3,4,7,8,9)	X	3.59	68.11	17.06	2.23	80.0	± 9.6 %
		Y	3.79	68.91	17.40		80.0	
		Z	3.61	68.36	17.17		80.0	
10496-AAC	LTE-TDD (SC-FDMA, 50% RB, 20 MHz, 64-QAM, UL Subframe=2,3,4,7,8,9)	X	3.67	67.87	17.00	2.23	80.0	± 9.6 %
		Y	3.86	68.62	17.31		80.0	
		Z	3.69	68.11	17.10		80.0	
10497-AAA	LTE-TDD (SC-FDMA, 100% RB, 1.4 MHz, QPSK, UL Subframe=2,3,4,7,8,9)	X	1.45	63.41	11.17	2.23	80.0	± 9.6 %
		Y	1.92	66.56	12.95		80.0	
		Z	1.35	62.71	10.54		80.0	
10498-AAA	LTE-TDD (SC-FDMA, 100% RB, 1.4 MHz, 16-QAM, UL Subframe=2,3,4,7,8,9)	X	1.28	60.00	8.33	2.23	80.0	± 9.6 %
		Y	1.38	60.59	8.91		80.0	
		Z	1.25	60.00	8.01		80.0	
10499-AAA	LTE-TDD (SC-FDMA, 100% RB, 1.4 MHz, 64-QAM, UL Subframe=2,3,4,7,8,9)	X	1.30	60.00	8.19	2.23	80.0	± 9.6 %
		Y	1.33	60.08	8.49		80.0	
		Z	1.27	60.00	7.87		80.0	
10500-AAA	LTE-TDD (SC-FDMA, 100% RB, 3 MHz, QPSK, UL Subframe=2,3,4,7,8,9)	X	3.04	71.93	17.72	2.23	80.0	± 9.6 %
		Y	3.46	73.67	18.54		80.0	
		Z	3.15	72.64	17.94		80.0	
10501-AAA	LTE-TDD (SC-FDMA, 100% RB, 3 MHz, 16-QAM, UL Subframe=2,3,4,7,8,9)	X	2.98	68.33	15.79	2.23	80.0	± 9.6 %
		Y	3.31	69.74	16.50		80.0	
		Z	3.01	68.63	15.79		80.0	
10502-AAA	LTE-TDD (SC-FDMA, 100% RB, 3 MHz, 64-QAM, UL Subframe=2,3,4,7,8,9)	X	3.03	68.16	15.65	2.23	80.0	± 9.6 %
		Y	3.36	69.55	16.35		80.0	
		Z	3.05	68.42	15.63		80.0	
10503-AAC	LTE-TDD (SC-FDMA, 100% RB, 5 MHz, QPSK, UL Subframe=2,3,4,7,8,9)	X	3.23	71.65	18.12	2.23	80.0	± 9.6 %
		Y	3.56	73.00	18.74		80.0	
		Z	3.30	72.21	18.35		80.0	
10504-AAC	LTE-TDD (SC-FDMA, 100% RB, 5 MHz, 16-QAM, UL Subframe=2,3,4,7,8,9)	X	3.19	68.33	16.71	2.23	80.0	± 9.6 %
		Y	3.43	69.33	17.17		80.0	
		Z	3.23	68.71	16.82		80.0	
10505-AAC	LTE-TDD (SC-FDMA, 100% RB, 5 MHz, 64-QAM, UL Subframe=2,3,4,7,8,9)	X	3.27	68.19	16.66	2.23	80.0	± 9.6 %
		Y	3.51	69.14	17.10		80.0	
		Z	3.31	68.54	16.75		80.0	
10506-AAC	LTE-TDD (SC-FDMA, 100% RB, 10 MHz, QPSK, UL Subframe=2,3,4,7,8,9)	X	3.76	71.67	18.18	2.23	80.0	± 9.6 %
		Y	4.10	72.90	18.71		80.0	
		Z	3.81	72.07	18.38		80.0	
10507-AAC	LTE-TDD (SC-FDMA, 100% RB, 10 MHz, 16-QAM, UL Subframe=2,3,4,7,8,9)	X	3.57	68.04	17.02	2.23	80.0	± 9.6 %
		Y	3.78	68.84	17.36		80.0	
		Z	3.59	68.29	17.13		80.0	

10508-AAC	LTE-TDD (SC-FDMA, 100% RB, 10 MHz, 64-QAM, UL Subframe=2,3,4,7,8,9)	X	3.65	67.79	16.95	2.23	80.0	± 9.6 %
		Y	3.85	68.55	17.26		80.0	
		Z	3.67	68.04	17.05		80.0	
10509-AAC	LTE-TDD (SC-FDMA, 100% RB, 15 MHz, QPSK, UL Subframe=2,3,4,7,8,9)	X	4.11	70.47	17.71	2.23	80.0	± 9.6 %
		Y	4.41	71.52	18.16		80.0	
		Z	4.14	70.76	17.87		80.0	
10510-AAC	LTE-TDD (SC-FDMA, 100% RB, 15 MHz, 16-QAM, UL Subframe=2,3,4,7,8,9)	X	4.05	67.79	17.05	2.23	80.0	± 9.6 %
		Y	4.24	68.50	17.33		80.0	
		Z	4.06	67.96	17.14		80.0	
10511-AAC	LTE-TDD (SC-FDMA, 100% RB, 15 MHz, 64-QAM, UL Subframe=2,3,4,7,8,9)	X	4.11	67.57	17.00	2.23	80.0	± 9.6 %
		Y	4.30	68.25	17.26		80.0	
		Z	4.12	67.74	17.08		80.0	
10512-AAC	LTE-TDD (SC-FDMA, 100% RB, 20 MHz, QPSK, UL Subframe=2,3,4,7,8,9)	X	4.27	71.92	18.15	2.23	80.0	± 9.6 %
		Y	4.64	73.17	18.68		80.0	
		Z	4.32	72.22	18.32		80.0	
10513-AAC	LTE-TDD (SC-FDMA, 100% RB, 20 MHz, 16-QAM, UL Subframe=2,3,4,7,8,9)	X	3.94	68.01	17.14	2.23	80.0	± 9.6 %
		Y	4.13	68.75	17.43		80.0	
		Z	3.95	68.18	17.23		80.0	
10514-AAC	LTE-TDD (SC-FDMA, 100% RB, 20 MHz, 64-QAM, UL Subframe=2,3,4,7,8,9)	X	3.97	67.63	17.03	2.23	80.0	± 9.6 %
		Y	4.15	68.33	17.30		80.0	
		Z	3.98	67.79	17.12		80.0	
10515-AAA	IEEE 802.11b WiFi 2.4 GHz (DSSS, 2 Mbps, 99pc duty cycle)	X	0.87	62.63	14.14	0.00	150.0	± 9.6 %
		Y	0.97	63.74	15.08		150.0	
		Z	0.87	62.85	14.30		150.0	
10516-AAA	IEEE 802.11b WiFi 2.4 GHz (DSSS, 5.5 Mbps, 99pc duty cycle)	X	0.49	69.66	15.70	0.00	150.0	± 9.6 %
		Y	0.68	73.95	19.23		150.0	
		Z	0.52	70.86	16.45		150.0	
10517-AAA	IEEE 802.11b WiFi 2.4 GHz (DSSS, 11 Mbps, 99pc duty cycle)	X	0.71	64.33	14.51	0.00	150.0	± 9.6 %
		Y	0.83	66.01	15.95		150.0	
		Z	0.72	64.67	14.76		150.0	
10518-AAB	IEEE 802.11a/h WiFi 5 GHz (OFDM, 9 Mbps, 99pc duty cycle)	X	4.38	66.55	16.05	0.00	150.0	± 9.6 %
		Y	4.46	66.94	16.23		150.0	
		Z	4.35	66.64	16.08		150.0	
10519-AAB	IEEE 802.11a/h WiFi 5 GHz (OFDM, 12 Mbps, 99pc duty cycle)	X	4.55	66.77	16.16	0.00	150.0	± 9.6 %
		Y	4.62	67.14	16.33		150.0	
		Z	4.51	66.84	16.19		150.0	
10520-AAB	IEEE 802.11a/h WiFi 5 GHz (OFDM, 18 Mbps, 99pc duty cycle)	X	4.40	66.71	16.07	0.00	150.0	± 9.6 %
		Y	4.48	67.10	16.26		150.0	
		Z	4.37	66.78	16.10		150.0	
10521-AAB	IEEE 802.11a/h WiFi 5 GHz (OFDM, 24 Mbps, 99pc duty cycle)	X	4.34	66.70	16.06	0.00	150.0	± 9.6 %
		Y	4.42	67.10	16.25		150.0	
		Z	4.30	66.76	16.08		150.0	
10522-AAB	IEEE 802.11a/h WiFi 5 GHz (OFDM, 36 Mbps, 99pc duty cycle)	X	4.40	66.82	16.16	0.00	150.0	± 9.6 %
		Y	4.48	67.21	16.34		150.0	
		Z	4.36	66.90	16.19		150.0	

10523-AAB	IEEE 802.11a/h WiFi 5 GHz (OFDM, 48 Mbps, 99pc duty cycle)	X	4.29	66.70	16.01	0.00	150.0	± 9.6 %
		Y	4.37	67.12	16.22		150.0	
		Z	4.26	66.81	16.06		150.0	
10524-AAB	IEEE 802.11a/h WiFi 5 GHz (OFDM, 54 Mbps, 99pc duty cycle)	X	4.34	66.74	16.12	0.00	150.0	± 9.6 %
		Y	4.42	67.13	16.31		150.0	
		Z	4.30	66.82	16.16		150.0	
10525-AAB	IEEE 802.11ac WiFi (20MHz, MCS0, 99pc duty cycle)	X	4.34	65.80	15.73	0.00	150.0	± 9.6 %
		Y	4.43	66.22	15.92		150.0	
		Z	4.32	65.90	15.77		150.0	
10526-AAB	IEEE 802.11ac WiFi (20MHz, MCS1, 99pc duty cycle)	X	4.50	66.14	15.86	0.00	150.0	± 9.6 %
		Y	4.58	66.55	16.05		150.0	
		Z	4.46	66.22	15.90		150.0	
10527-AAB	IEEE 802.11ac WiFi (20MHz, MCS2, 99pc duty cycle)	X	4.42	66.09	15.80	0.00	150.0	± 9.6 %
		Y	4.50	66.52	16.00		150.0	
		Z	4.38	66.18	15.84		150.0	
10528-AAB	IEEE 802.11ac WiFi (20MHz, MCS3, 99pc duty cycle)	X	4.44	66.11	15.83	0.00	150.0	± 9.6 %
		Y	4.52	66.53	16.03		150.0	
		Z	4.40	66.19	15.87		150.0	
10529-AAB	IEEE 802.11ac WiFi (20MHz, MCS4, 99pc duty cycle)	X	4.44	66.11	15.83	0.00	150.0	± 9.6 %
		Y	4.52	66.53	16.03		150.0	
		Z	4.40	66.19	15.87		150.0	
10531-AAB	IEEE 802.11ac WiFi (20MHz, MCS6, 99pc duty cycle)	X	4.42	66.18	15.83	0.00	150.0	± 9.6 %
		Y	4.50	66.61	16.03		150.0	
		Z	4.37	66.25	15.86		150.0	
10532-AAB	IEEE 802.11ac WiFi (20MHz, MCS7, 99pc duty cycle)	X	4.29	66.04	15.76	0.00	150.0	± 9.6 %
		Y	4.37	66.48	15.97		150.0	
		Z	4.25	66.11	15.79		150.0	
10533-AAB	IEEE 802.11ac WiFi (20MHz, MCS8, 99pc duty cycle)	X	4.44	66.17	15.83	0.00	150.0	± 9.6 %
		Y	4.53	66.60	16.03		150.0	
		Z	4.41	66.26	15.87		150.0	
10534-AAB	IEEE 802.11ac WiFi (40MHz, MCS0, 99pc duty cycle)	X	4.98	66.20	15.91	0.00	150.0	± 9.6 %
		Y	5.05	66.57	16.06		150.0	
		Z	4.95	66.26	15.95		150.0	
10535-AAB	IEEE 802.11ac WiFi (40MHz, MCS1, 99pc duty cycle)	X	5.05	66.39	16.00	0.00	150.0	± 9.6 %
		Y	5.11	66.72	16.13		150.0	
		Z	5.01	66.43	16.03		150.0	
10536-AAB	IEEE 802.11ac WiFi (40MHz, MCS2, 99pc duty cycle)	X	4.92	66.34	15.95	0.00	150.0	± 9.6 %
		Y	4.99	66.70	16.10		150.0	
		Z	4.89	66.40	15.99		150.0	
10537-AAB	IEEE 802.11ac WiFi (40MHz, MCS3, 99pc duty cycle)	X	4.98	66.30	15.94	0.00	150.0	± 9.6 %
		Y	5.04	66.66	16.08		150.0	
		Z	4.95	66.35	15.97		150.0	
10538-AAB	IEEE 802.11ac WiFi (40MHz, MCS4, 99pc duty cycle)	X	5.06	66.31	15.98	0.00	150.0	± 9.6 %
		Y	5.12	66.65	16.12		150.0	
		Z	5.02	66.35	16.01		150.0	
10540-AAB	IEEE 802.11ac WiFi (40MHz, MCS6, 99pc duty cycle)	X	4.99	66.30	16.00	0.00	150.0	± 9.6 %
		Y	5.05	66.64	16.13		150.0	
		Z	4.95	66.33	16.02		150.0	

10541-AAB	IEEE 802.11ac WiFi (40MHz, MCS7, 99pc duty cycle)	X	4.97	66.19	15.93	0.00	150.0	± 9.6 %
		Y	5.03	66.55	16.07		150.0	
		Z	4.93	66.22	15.95		150.0	
10542-AAB	IEEE 802.11ac WiFi (40MHz, MCS8, 99pc duty cycle)	X	5.12	66.28	15.99	0.00	150.0	± 9.6 %
		Y	5.19	66.62	16.12		150.0	
		Z	5.09	66.32	16.02		150.0	
10543-AAB	IEEE 802.11ac WiFi (40MHz, MCS9, 99pc duty cycle)	X	5.19	66.29	16.02	0.00	150.0	± 9.6 %
		Y	5.25	66.63	16.15		150.0	
		Z	5.15	66.34	16.05		150.0	
10544-AAB	IEEE 802.11ac WiFi (80MHz, MCS0, 99pc duty cycle)	X	5.31	66.31	15.91	0.00	150.0	± 9.6 %
		Y	5.37	66.66	16.05		150.0	
		Z	5.28	66.35	15.94		150.0	
10545-AAB	IEEE 802.11ac WiFi (80MHz, MCS1, 99pc duty cycle)	X	5.50	66.75	16.09	0.00	150.0	± 9.6 %
		Y	5.54	67.02	16.18		150.0	
		Z	5.47	66.79	16.11		150.0	
10546-AAB	IEEE 802.11ac WiFi (80MHz, MCS2, 99pc duty cycle)	X	5.36	66.48	15.97	0.00	150.0	± 9.6 %
		Y	5.42	66.83	16.10		150.0	
		Z	5.33	66.50	15.98		150.0	
10547-AAB	IEEE 802.11ac WiFi (80MHz, MCS3, 99pc duty cycle)	X	5.43	66.54	15.99	0.00	150.0	± 9.6 %
		Y	5.49	66.87	16.11		150.0	
		Z	5.40	66.57	16.01		150.0	
10548-AAB	IEEE 802.11ac WiFi (80MHz, MCS4, 99pc duty cycle)	X	5.66	67.42	16.40	0.00	150.0	± 9.6 %
		Y	5.65	67.55	16.42		150.0	
		Z	5.60	67.37	16.38		150.0	
10550-AAB	IEEE 802.11ac WiFi (80MHz, MCS6, 99pc duty cycle)	X	5.40	66.56	16.02	0.00	150.0	± 9.6 %
		Y	5.45	66.87	16.13		150.0	
		Z	5.37	66.62	16.05		150.0	
10551-AAB	IEEE 802.11ac WiFi (80MHz, MCS7, 99pc duty cycle)	X	5.39	66.55	15.97	0.00	150.0	± 9.6 %
		Y	5.45	66.88	16.09		150.0	
		Z	5.35	66.53	15.97		150.0	
10552-AAB	IEEE 802.11ac WiFi (80MHz, MCS8, 99pc duty cycle)	X	5.32	66.38	15.89	0.00	150.0	± 9.6 %
		Y	5.38	66.76	16.04		150.0	
		Z	5.29	66.43	15.92		150.0	
10553-AAB	IEEE 802.11ac WiFi (80MHz, MCS9, 99pc duty cycle)	X	5.39	66.39	15.93	0.00	150.0	± 9.6 %
		Y	5.45	66.75	16.07		150.0	
		Z	5.36	66.42	15.95		150.0	
10554-AAC	IEEE 802.11ac WiFi (160MHz, MCS0, 99pc duty cycle)	X	5.72	66.67	16.01	0.00	150.0	± 9.6 %
		Y	5.77	67.00	16.12		150.0	
		Z	5.70	66.69	16.02		150.0	
10555-AAC	IEEE 802.11ac WiFi (160MHz, MCS1, 99pc duty cycle)	X	5.84	66.96	16.13	0.00	150.0	± 9.6 %
		Y	5.88	67.25	16.23		150.0	
		Z	5.81	66.97	16.14		150.0	
10556-AAC	IEEE 802.11ac WiFi (160MHz, MCS2, 99pc duty cycle)	X	5.87	67.02	16.15	0.00	150.0	± 9.6 %
		Y	5.91	67.31	16.25		150.0	
		Z	5.84	67.04	16.17		150.0	
10557-AAC	IEEE 802.11ac WiFi (160MHz, MCS3, 99pc duty cycle)	X	5.83	66.90	16.11	0.00	150.0	± 9.6 %
		Y	5.87	67.22	16.22		150.0	
		Z	5.80	66.91	16.13		150.0	

10558-AAC	IEEE 802.11ac WiFi (160MHz, MCS4, 99pc duty cycle)	X	5.87	67.06	16.20	0.00	150.0	± 9.6 %
		Y	5.91	67.36	16.31		150.0	
		Z	5.83	67.06	16.21		150.0	
10560-AAC	IEEE 802.11ac WiFi (160MHz, MCS6, 99pc duty cycle)	X	5.86	66.91	16.17	0.00	150.0	± 9.6 %
		Y	5.92	67.23	16.28		150.0	
		Z	5.83	66.92	16.18		150.0	
10561-AAC	IEEE 802.11ac WiFi (160MHz, MCS7, 99pc duty cycle)	X	5.80	66.89	16.20	0.00	150.0	± 9.6 %
		Y	5.84	67.19	16.30		150.0	
		Z	5.77	66.91	16.21		150.0	
10562-AAC	IEEE 802.11ac WiFi (160MHz, MCS8, 99pc duty cycle)	X	5.89	67.20	16.35	0.00	150.0	± 9.6 %
		Y	5.93	67.48	16.44		150.0	
		Z	5.84	67.16	16.34		150.0	
10563-AAC	IEEE 802.11ac WiFi (160MHz, MCS9, 99pc duty cycle)	X	6.00	67.15	16.29	0.00	150.0	± 9.6 %
		Y	6.02	67.38	16.35		150.0	
		Z	5.93	67.06	16.25		150.0	
10564-AAA	IEEE 802.11g WiFi 2.4 GHz (DSSS-OFDM, 9 Mbps, 99pc duty cycle)	X	4.70	66.60	16.19	0.46	150.0	± 9.6 %
		Y	4.77	66.96	16.34		150.0	
		Z	4.67	66.68	16.22		150.0	
10565-AAA	IEEE 802.11g WiFi 2.4 GHz (DSSS-OFDM, 12 Mbps, 99pc duty cycle)	X	4.92	67.06	16.53	0.46	150.0	± 9.6 %
		Y	4.99	67.39	16.67		150.0	
		Z	4.88	67.12	16.55		150.0	
10566-AAA	IEEE 802.11g WiFi 2.4 GHz (DSSS-OFDM, 18 Mbps, 99pc duty cycle)	X	4.75	66.88	16.33	0.46	150.0	± 9.6 %
		Y	4.82	67.22	16.47		150.0	
		Z	4.71	66.94	16.35		150.0	
10567-AAA	IEEE 802.11g WiFi 2.4 GHz (DSSS-OFDM, 24 Mbps, 99pc duty cycle)	X	4.79	67.31	16.72	0.46	150.0	± 9.6 %
		Y	4.86	67.67	16.87		150.0	
		Z	4.75	67.38	16.75		150.0	
10568-AAA	IEEE 802.11g WiFi 2.4 GHz (DSSS-OFDM, 36 Mbps, 99pc duty cycle)	X	4.66	66.64	16.08	0.46	150.0	± 9.6 %
		Y	4.73	66.98	16.23		150.0	
		Z	4.62	66.69	16.09		150.0	
10569-AAA	IEEE 802.11g WiFi 2.4 GHz (DSSS-OFDM, 48 Mbps, 99pc duty cycle)	X	4.76	67.45	16.81	0.46	150.0	± 9.6 %
		Y	4.83	67.82	16.96		150.0	
		Z	4.73	67.57	16.86		150.0	
10570-AAA	IEEE 802.11g WiFi 2.4 GHz (DSSS-OFDM, 54 Mbps, 99pc duty cycle)	X	4.78	67.26	16.71	0.46	150.0	± 9.6 %
		Y	4.85	67.62	16.86		150.0	
		Z	4.74	67.35	16.75		150.0	
10571-AAA	IEEE 802.11b WiFi 2.4 GHz (DSSS, 1 Mbps, 90pc duty cycle)	X	1.05	63.78	14.98	0.46	130.0	± 9.6 %
		Y	1.16	64.84	15.77		130.0	
		Z	1.06	64.03	15.14		130.0	
10572-AAA	IEEE 802.11b WiFi 2.4 GHz (DSSS, 2 Mbps, 90pc duty cycle)	X	1.06	64.35	15.34	0.46	130.0	± 9.6 %
		Y	1.17	65.47	16.16		130.0	
		Z	1.07	64.63	15.52		130.0	
10573-AAA	IEEE 802.11b WiFi 2.4 GHz (DSSS, 5.5 Mbps, 90pc duty cycle)	X	1.81	84.33	21.65	0.46	130.0	± 9.6 %
		Y	2.93	92.85	25.80		130.0	
		Z	2.19	87.52	22.91		130.0	
10574-AAA	IEEE 802.11b WiFi 2.4 GHz (DSSS, 11 Mbps, 90pc duty cycle)	X	1.15	70.21	18.29	0.46	130.0	± 9.6 %
		Y	1.33	72.12	19.55		130.0	
		Z	1.19	70.90	18.68		130.0	

10575-AAA	IEEE 802.11g WiFi 2.4 GHz (DSSS-OFDM, 6 Mbps, 90pc duty cycle)	X	4.49	66.39	16.24	0.46	130.0	± 9.6 %
		Y	4.55	66.72	16.36		130.0	
		Z	4.46	66.48	16.26		130.0	
10576-AAA	IEEE 802.11g WiFi 2.4 GHz (DSSS-OFDM, 9 Mbps, 90pc duty cycle)	X	4.51	66.57	16.31	0.46	130.0	± 9.6 %
		Y	4.58	66.91	16.44		130.0	
		Z	4.48	66.67	16.34		130.0	
10577-AAA	IEEE 802.11g WiFi 2.4 GHz (DSSS-OFDM, 12 Mbps, 90pc duty cycle)	X	4.70	66.85	16.48	0.46	130.0	± 9.6 %
		Y	4.77	67.17	16.60		130.0	
		Z	4.67	66.93	16.51		130.0	
10578-AAA	IEEE 802.11g WiFi 2.4 GHz (DSSS-OFDM, 18 Mbps, 90pc duty cycle)	X	4.60	67.01	16.59	0.46	130.0	± 9.6 %
		Y	4.67	67.35	16.72		130.0	
		Z	4.57	67.10	16.62		130.0	
10579-AAA	IEEE 802.11g WiFi 2.4 GHz (DSSS-OFDM, 24 Mbps, 90pc duty cycle)	X	4.36	66.21	15.83	0.46	130.0	± 9.6 %
		Y	4.42	66.54	15.97		130.0	
		Z	4.32	66.26	15.84		130.0	
10580-AAA	IEEE 802.11g WiFi 2.4 GHz (DSSS-OFDM, 36 Mbps, 90pc duty cycle)	X	4.40	66.27	15.86	0.46	130.0	± 9.6 %
		Y	4.46	66.59	16.00		130.0	
		Z	4.36	66.33	15.88		130.0	
10581-AAA	IEEE 802.11g WiFi 2.4 GHz (DSSS-OFDM, 48 Mbps, 90pc duty cycle)	X	4.50	67.05	16.53	0.46	130.0	± 9.6 %
		Y	4.57	67.39	16.67		130.0	
		Z	4.47	67.15	16.57		130.0	
10582-AAA	IEEE 802.11g WiFi 2.4 GHz (DSSS-OFDM, 54 Mbps, 90pc duty cycle)	X	4.29	65.96	15.60	0.46	130.0	± 9.6 %
		Y	4.35	66.28	15.74		130.0	
		Z	4.25	66.00	15.61		130.0	
10583-AAB	IEEE 802.11a/h WiFi 5 GHz (OFDM, 6 Mbps, 90pc duty cycle)	X	4.49	66.39	16.24	0.46	130.0	± 9.6 %
		Y	4.55	66.72	16.36		130.0	
		Z	4.46	66.48	16.26		130.0	
10584-AAB	IEEE 802.11a/h WiFi 5 GHz (OFDM, 9 Mbps, 90pc duty cycle)	X	4.51	66.57	16.31	0.46	130.0	± 9.6 %
		Y	4.58	66.91	16.44		130.0	
		Z	4.48	66.67	16.34		130.0	
10585-AAB	IEEE 802.11a/h WiFi 5 GHz (OFDM, 12 Mbps, 90pc duty cycle)	X	4.70	66.85	16.48	0.46	130.0	± 9.6 %
		Y	4.77	67.17	16.60		130.0	
		Z	4.67	66.93	16.51		130.0	
10586-AAB	IEEE 802.11a/h WiFi 5 GHz (OFDM, 18 Mbps, 90pc duty cycle)	X	4.60	67.01	16.59	0.46	130.0	± 9.6 %
		Y	4.67	67.35	16.72		130.0	
		Z	4.57	67.10	16.62		130.0	
10587-AAB	IEEE 802.11a/h WiFi 5 GHz (OFDM, 24 Mbps, 90pc duty cycle)	X	4.36	66.21	15.83	0.46	130.0	± 9.6 %
		Y	4.42	66.54	15.97		130.0	
		Z	4.32	66.26	15.84		130.0	
10588-AAB	IEEE 802.11a/h WiFi 5 GHz (OFDM, 36 Mbps, 90pc duty cycle)	X	4.40	66.27	15.86	0.46	130.0	± 9.6 %
		Y	4.46	66.59	16.00		130.0	
		Z	4.36	66.33	15.88		130.0	
10589-AAB	IEEE 802.11a/h WiFi 5 GHz (OFDM, 48 Mbps, 90pc duty cycle)	X	4.50	67.05	16.53	0.46	130.0	± 9.6 %
		Y	4.57	67.39	16.67		130.0	
		Z	4.47	67.15	16.57		130.0	
10590-AAB	IEEE 802.11a/h WiFi 5 GHz (OFDM, 54 Mbps, 90pc duty cycle)	X	4.29	65.96	15.60	0.46	130.0	± 9.6 %
		Y	4.35	66.28	15.74		130.0	
		Z	4.25	66.00	15.61		130.0	

10591-AAB	IEEE 802.11n (HT Mixed, 20MHz, MCS0, 90pc duty cycle)	X	4.64	66.47	16.35	0.46	130.0	± 9.6 %
		Y	4.70	66.79	16.47		130.0	
		Z	4.61	66.56	16.38		130.0	
10592-AAB	IEEE 802.11n (HT Mixed, 20MHz, MCS1, 90pc duty cycle)	X	4.78	66.80	16.49	0.46	130.0	± 9.6 %
		Y	4.84	67.11	16.60		130.0	
		Z	4.75	66.87	16.51		130.0	
10593-AAB	IEEE 802.11n (HT Mixed, 20MHz, MCS2, 90pc duty cycle)	X	4.70	66.68	16.35	0.46	130.0	± 9.6 %
		Y	4.76	67.00	16.47		130.0	
		Z	4.66	66.75	16.37		130.0	
10594-AAB	IEEE 802.11n (HT Mixed, 20MHz, MCS3, 90pc duty cycle)	X	4.76	66.86	16.52	0.46	130.0	± 9.6 %
		Y	4.82	67.18	16.63		130.0	
		Z	4.72	66.94	16.54		130.0	
10595-AAB	IEEE 802.11n (HT Mixed, 20MHz, MCS4, 90pc duty cycle)	X	4.72	66.81	16.41	0.46	130.0	± 9.6 %
		Y	4.78	67.13	16.53		130.0	
		Z	4.68	66.89	16.44		130.0	
10596-AAB	IEEE 802.11n (HT Mixed, 20MHz, MCS5, 90pc duty cycle)	X	4.66	66.80	16.40	0.46	130.0	± 9.6 %
		Y	4.72	67.12	16.53		130.0	
		Z	4.62	66.87	16.43		130.0	
10597-AAB	IEEE 802.11n (HT Mixed, 20MHz, MCS6, 90pc duty cycle)	X	4.60	66.68	16.27	0.46	130.0	± 9.6 %
		Y	4.67	67.01	16.40		130.0	
		Z	4.57	66.74	16.29		130.0	
10598-AAB	IEEE 802.11n (HT Mixed, 20MHz, MCS7, 90pc duty cycle)	X	4.59	66.93	16.55	0.46	130.0	± 9.6 %
		Y	4.66	67.26	16.68		130.0	
		Z	4.56	67.00	16.58		130.0	
10599-AAB	IEEE 802.11n (HT Mixed, 40MHz, MCS0, 90pc duty cycle)	X	5.32	67.00	16.59	0.46	130.0	± 9.6 %
		Y	5.34	67.19	16.62		130.0	
		Z	5.28	67.04	16.61		130.0	
10600-AAB	IEEE 802.11n (HT Mixed, 40MHz, MCS1, 90pc duty cycle)	X	5.45	67.42	16.77	0.46	130.0	± 9.6 %
		Y	5.44	67.51	16.75		130.0	
		Z	5.41	67.45	16.79		130.0	
10601-AAB	IEEE 802.11n (HT Mixed, 40MHz, MCS2, 90pc duty cycle)	X	5.34	67.16	16.66	0.46	130.0	± 9.6 %
		Y	5.36	67.35	16.69		130.0	
		Z	5.30	67.21	16.68		130.0	
10602-AAB	IEEE 802.11n (HT Mixed, 40MHz, MCS3, 90pc duty cycle)	X	5.45	67.27	16.63	0.46	130.0	± 9.6 %
		Y	5.48	67.47	16.67		130.0	
		Z	5.43	67.37	16.68		130.0	
10603-AAB	IEEE 802.11n (HT Mixed, 40MHz, MCS4, 90pc duty cycle)	X	5.52	67.55	16.90	0.46	130.0	± 9.6 %
		Y	5.54	67.72	16.93		130.0	
		Z	5.50	67.66	16.96		130.0	
10604-AAB	IEEE 802.11n (HT Mixed, 40MHz, MCS5, 90pc duty cycle)	X	5.38	67.16	16.70	0.46	130.0	± 9.6 %
		Y	5.41	67.36	16.73		130.0	
		Z	5.38	67.32	16.78		130.0	
10605-AAB	IEEE 802.11n (HT Mixed, 40MHz, MCS6, 90pc duty cycle)	X	5.44	67.34	16.78	0.46	130.0	± 9.6 %
		Y	5.45	67.47	16.78		130.0	
		Z	5.41	67.37	16.80		130.0	
10606-AAB	IEEE 802.11n (HT Mixed, 40MHz, MCS7, 90pc duty cycle)	X	5.17	66.57	16.25	0.46	130.0	± 9.6 %
		Y	5.21	66.82	16.32		130.0	
		Z	5.14	66.65	16.29		130.0	

10607-AAB	IEEE 802.11ac WiFi (20MHz, MCS0, 90pc duty cycle)	X	4.48	65.79	15.98	0.46	130.0	± 9.6 %
		Y	4.55	66.14	16.12		130.0	
		Z	4.46	65.89	16.02		130.0	
10608-AAB	IEEE 802.11ac WiFi (20MHz, MCS1, 90pc duty cycle)	X	4.65	66.17	16.14	0.46	130.0	± 9.6 %
		Y	4.72	66.52	16.28		130.0	
		Z	4.61	66.26	16.18		130.0	
10609-AAB	IEEE 802.11ac WiFi (20MHz, MCS2, 90pc duty cycle)	X	4.54	66.00	15.96	0.46	130.0	± 9.6 %
		Y	4.61	66.36	16.11		130.0	
		Z	4.51	66.08	15.99		130.0	
10610-AAB	IEEE 802.11ac WiFi (20MHz, MCS3, 90pc duty cycle)	X	4.59	66.17	16.14	0.46	130.0	± 9.6 %
		Y	4.66	66.53	16.28		130.0	
		Z	4.56	66.26	16.17		130.0	
10611-AAB	IEEE 802.11ac WiFi (20MHz, MCS4, 90pc duty cycle)	X	4.51	65.97	15.97	0.46	130.0	± 9.6 %
		Y	4.57	66.32	16.12		130.0	
		Z	4.47	66.05	16.01		130.0	
10612-AAB	IEEE 802.11ac WiFi (20MHz, MCS5, 90pc duty cycle)	X	4.51	66.11	16.01	0.46	130.0	± 9.6 %
		Y	4.58	66.46	16.16		130.0	
		Z	4.47	66.19	16.05		130.0	
10613-AAB	IEEE 802.11ac WiFi (20MHz, MCS6, 90pc duty cycle)	X	4.51	65.96	15.88	0.46	130.0	± 9.6 %
		Y	4.57	66.31	16.02		130.0	
		Z	4.46	66.02	15.90		130.0	
10614-AAB	IEEE 802.11ac WiFi (20MHz, MCS7, 90pc duty cycle)	X	4.46	66.18	16.13	0.46	130.0	± 9.6 %
		Y	4.53	66.55	16.29		130.0	
		Z	4.43	66.26	16.17		130.0	
10615-AAB	IEEE 802.11ac WiFi (20MHz, MCS8, 90pc duty cycle)	X	4.50	65.78	15.73	0.46	130.0	± 9.6 %
		Y	4.57	66.13	15.88		130.0	
		Z	4.46	65.86	15.76		130.0	
10616-AAB	IEEE 802.11ac WiFi (40MHz, MCS0, 90pc duty cycle)	X	5.13	66.23	16.19	0.46	130.0	± 9.6 %
		Y	5.18	66.52	16.28		130.0	
		Z	5.10	66.28	16.22		130.0	
10617-AAB	IEEE 802.11ac WiFi (40MHz, MCS1, 90pc duty cycle)	X	5.21	66.44	16.26	0.46	130.0	± 9.6 %
		Y	5.24	66.68	16.33		130.0	
		Z	5.17	66.48	16.29		130.0	
10618-AAB	IEEE 802.11ac WiFi (40MHz, MCS2, 90pc duty cycle)	X	5.09	66.44	16.28	0.46	130.0	± 9.6 %
		Y	5.14	66.73	16.37		130.0	
		Z	5.07	66.51	16.32		130.0	
10619-AAB	IEEE 802.11ac WiFi (40MHz, MCS3, 90pc duty cycle)	X	5.10	66.22	16.10	0.46	130.0	± 9.6 %
		Y	5.14	66.49	16.19		130.0	
		Z	5.07	66.27	16.13		130.0	
10620-AAB	IEEE 802.11ac WiFi (40MHz, MCS4, 90pc duty cycle)	X	5.19	66.25	16.17	0.46	130.0	± 9.6 %
		Y	5.23	66.52	16.25		130.0	
		Z	5.15	66.30	16.20		130.0	
10621-AAB	IEEE 802.11ac WiFi (40MHz, MCS5, 90pc duty cycle)	X	5.20	66.42	16.38	0.46	130.0	± 9.6 %
		Y	5.25	66.70	16.46		130.0	
		Z	5.17	66.46	16.41		130.0	
10622-AAB	IEEE 802.11ac WiFi (40MHz, MCS6, 90pc duty cycle)	X	5.21	66.59	16.46	0.46	130.0	± 9.6 %
		Y	5.25	66.84	16.53		130.0	
		Z	5.16	66.58	16.46		130.0	

10623-AAB	IEEE 802.11ac WiFi (40MHz, MCS7, 90pc duty cycle)	X	5.08	66.07	16.06	0.46	130.0	± 9.6 %
		Y	5.13	66.35	16.15		130.0	
		Z	5.04	66.08	16.07		130.0	
10624-AAB	IEEE 802.11ac WiFi (40MHz, MCS8, 90pc duty cycle)	X	5.27	66.29	16.24	0.46	130.0	± 9.6 %
		Y	5.32	66.55	16.31		130.0	
		Z	5.24	66.33	16.26		130.0	
10625-AAB	IEEE 802.11ac WiFi (40MHz, MCS9, 90pc duty cycle)	X	5.56	67.05	16.67	0.46	130.0	± 9.6 %
		Y	5.57	67.20	16.69		130.0	
		Z	5.45	66.85	16.58		130.0	
10626-AAB	IEEE 802.11ac WiFi (80MHz, MCS0, 90pc duty cycle)	X	5.45	66.29	16.15	0.46	130.0	± 9.6 %
		Y	5.49	66.58	16.24		130.0	
		Z	5.42	66.33	16.18		130.0	
10627-AAB	IEEE 802.11ac WiFi (80MHz, MCS1, 90pc duty cycle)	X	5.69	66.90	16.42	0.46	130.0	± 9.6 %
		Y	5.70	67.08	16.45		130.0	
		Z	5.66	66.94	16.45		130.0	
10628-AAB	IEEE 802.11ac WiFi (80MHz, MCS2, 90pc duty cycle)	X	5.46	66.33	16.07	0.46	130.0	± 9.6 %
		Y	5.50	66.60	16.14		130.0	
		Z	5.42	66.33	16.07		130.0	
10629-AAB	IEEE 802.11ac WiFi (80MHz, MCS3, 90pc duty cycle)	X	5.54	66.41	16.10	0.46	130.0	± 9.6 %
		Y	5.57	66.66	16.17		130.0	
		Z	5.51	66.44	16.12		130.0	
10630-AAB	IEEE 802.11ac WiFi (80MHz, MCS4, 90pc duty cycle)	X	5.93	67.80	16.79	0.46	130.0	± 9.6 %
		Y	5.86	67.72	16.70		130.0	
		Z	5.85	67.67	16.74		130.0	
10631-AAB	IEEE 802.11ac WiFi (80MHz, MCS5, 90pc duty cycle)	X	5.84	67.65	16.92	0.46	130.0	± 9.6 %
		Y	5.86	67.82	16.94		130.0	
		Z	5.79	67.61	16.91		130.0	
10632-AAB	IEEE 802.11ac WiFi (80MHz, MCS6, 90pc duty cycle)	X	5.66	66.99	16.61	0.46	130.0	± 9.6 %
		Y	5.68	67.19	16.65		130.0	
		Z	5.64	67.07	16.66		130.0	
10633-AAB	IEEE 802.11ac WiFi (80MHz, MCS7, 90pc duty cycle)	X	5.53	66.52	16.20	0.46	130.0	± 9.6 %
		Y	5.57	66.82	16.28		130.0	
		Z	5.50	66.56	16.22		130.0	
10634-AAB	IEEE 802.11ac WiFi (80MHz, MCS8, 90pc duty cycle)	X	5.51	66.55	16.27	0.46	130.0	± 9.6 %
		Y	5.56	66.86	16.37		130.0	
		Z	5.48	66.58	16.29		130.0	
10635-AAB	IEEE 802.11ac WiFi (80MHz, MCS9, 90pc duty cycle)	X	5.38	65.83	15.63	0.46	130.0	± 9.6 %
		Y	5.42	66.12	15.72		130.0	
		Z	5.34	65.82	15.63		130.0	
10636-AAC	IEEE 802.11ac WiFi (160MHz, MCS0, 90pc duty cycle)	X	5.87	66.66	16.24	0.46	130.0	± 9.6 %
		Y	5.90	66.93	16.31		130.0	
		Z	5.85	66.69	16.27		130.0	
10637-AAC	IEEE 802.11ac WiFi (160MHz, MCS1, 90pc duty cycle)	X	6.02	67.05	16.42	0.46	130.0	± 9.6 %
		Y	6.04	67.25	16.46		130.0	
		Z	5.99	67.06	16.43		130.0	
10638-AAC	IEEE 802.11ac WiFi (160MHz, MCS2, 90pc duty cycle)	X	6.02	67.01	16.38	0.46	130.0	± 9.6 %
		Y	6.04	67.26	16.44		130.0	
		Z	5.99	67.04	16.40		130.0	

10639-AAC	IEEE 802.11ac WiFi (160MHz, MCS3, 90pc duty cycle)	X	5.99	66.94	16.39	0.46	130.0	± 9.6 %
		Y	6.02	67.20	16.45		130.0	
		Z	5.96	66.96	16.40		130.0	
10640-AAC	IEEE 802.11ac WiFi (160MHz, MCS4, 90pc duty cycle)	X	5.99	66.93	16.32	0.46	130.0	± 9.6 %
		Y	6.01	67.17	16.38		130.0	
		Z	5.95	66.93	16.33		130.0	
10641-AAC	IEEE 802.11ac WiFi (160MHz, MCS5, 90pc duty cycle)	X	6.05	66.90	16.33	0.46	130.0	± 9.6 %
		Y	6.06	67.10	16.36		130.0	
		Z	6.02	66.93	16.35		130.0	
10642-AAC	IEEE 802.11ac WiFi (160MHz, MCS6, 90pc duty cycle)	X	6.08	67.13	16.62	0.46	130.0	± 9.6 %
		Y	6.11	67.39	16.68		130.0	
		Z	6.05	67.15	16.64		130.0	
10643-AAC	IEEE 802.11ac WiFi (160MHz, MCS7, 90pc duty cycle)	X	5.92	66.82	16.35	0.46	130.0	± 9.6 %
		Y	5.94	67.04	16.40		130.0	
		Z	5.89	66.84	16.37		130.0	
10644-AAC	IEEE 802.11ac WiFi (160MHz, MCS8, 90pc duty cycle)	X	6.04	67.19	16.56	0.46	130.0	± 9.6 %
		Y	6.06	67.41	16.60		130.0	
		Z	5.99	67.13	16.53		130.0	
10645-AAC	IEEE 802.11ac WiFi (160MHz, MCS9, 90pc duty cycle)	X	6.20	67.30	16.58	0.46	130.0	± 9.6 %
		Y	6.18	67.42	16.57		130.0	
		Z	6.12	67.19	16.53		130.0	
10646-AAD	LTE-TDD (SC-FDMA, 1 RB, 5 MHz, QPSK, UL Subframe=2,7)	X	13.97	103.27	34.96	9.30	60.0	± 9.6 %
		Y	20.81	112.89	38.12		60.0	
		Z	13.67	103.09	35.06		60.0	
10647-AAC	LTE-TDD (SC-FDMA, 1 RB, 20 MHz, QPSK, UL Subframe=2,7)	X	12.30	101.10	34.41	9.30	60.0	± 9.6 %
		Y	17.37	109.51	37.26		60.0	
		Z	12.00	100.85	34.49		60.0	
10648-AAA	CDMA2000 (1x Advanced)	X	0.49	61.28	8.20	0.00	150.0	± 9.6 %
		Y	0.65	63.85	10.60		150.0	
		Z	0.46	61.03	7.80		150.0	
10652-AAB	LTE-TDD (OFDMA, 5 MHz, E-TM 3.1, Clipping 44%)	X	3.40	66.41	16.15	2.23	80.0	± 9.6 %
		Y	3.58	67.18	16.52		80.0	
		Z	3.42	66.69	16.22		80.0	
10653-AAB	LTE-TDD (OFDMA, 10 MHz, E-TM 3.1, Clipping 44%)	X	3.94	65.81	16.40	2.23	80.0	± 9.6 %
		Y	4.08	66.40	16.64		80.0	
		Z	3.94	66.00	16.46		80.0	
10654-AAB	LTE-TDD (OFDMA, 15 MHz, E-TM 3.1, Clipping 44%)	X	3.93	65.47	16.42	2.23	80.0	± 9.6 %
		Y	4.06	66.03	16.64		80.0	
		Z	3.94	65.63	16.48		80.0	
10655-AAB	LTE-TDD (OFDMA, 20 MHz, E-TM 3.1, Clipping 44%)	X	3.99	65.43	16.46	2.23	80.0	± 9.6 %
		Y	4.13	65.99	16.67		80.0	
		Z	4.01	65.58	16.52		80.0	
10658-AAA	Pulse Waveform (200Hz, 10%)	X	7.13	77.36	16.21	10.00	50.0	± 9.6 %
		Y	16.32	87.94	19.95		50.0	
		Z	9.11	80.61	17.72		50.0	
10659-AAA	Pulse Waveform (200Hz, 20%)	X	35.68	94.53	19.76	6.99	60.0	± 9.6 %
		Y	100.00	107.23	23.45		60.0	
		Z	100.00	106.51	23.11		60.0	

10660- AAA	Pulse Waveform (200Hz, 40%)	X	100.00	100.10	18.83	3.98	80.0	± 9.6 %
		Y	100.00	106.47	21.86		80.0	
		Z	100.00	102.58	20.01		80.0	
10661- AAA	Pulse Waveform (200Hz, 60%)	X	1.25	67.33	8.37	2.22	100.0	± 9.6 %
		Y	100.00	108.17	21.47		100.0	
		Z	100.00	96.28	16.23		100.0	
10662- AAA	Pulse Waveform (200Hz, 80%)	X	0.30	60.00	2.55	0.97	120.0	± 9.6 %
		Y	100.00	113.09	21.91		120.0	
		Z	0.20	60.00	3.18		120.0	

^E Uncertainty is determined using the max. deviation from linear response applying rectangular distribution and is expressed for the square of the field value.



Accredited by the Swiss Accreditation Service (SAS)
The Swiss Accreditation Service is one of the signatories to the EA
Multilateral Agreement for the recognition of calibration certificates

Accreditation No.: **SCS 0108**

Client **PC Test**

Certificate No: **ES3-3332_Aug17**

CALIBRATION CERTIFICATE

Object **ES3DV3 - SN:3332**

Calibration procedure(s) **QA CAL-01.v9, QA CAL-23.v5, QA CAL-25.v6
Calibration procedure for dosimetric E-field probes**

Calibration date: **August 14, 2017**

This calibration certificate documents the traceability to national standards, which realize the physical units of measurements (SI).
The measurements and the uncertainties with confidence probability are given on the following pages and are part of the certificate.

All calibrations have been conducted in the closed laboratory facility: environment temperature (22 ± 3)°C and humidity < 70%.

Calibration Equipment used (M&TE critical for calibration)

PHY
8/27/17

Primary Standards	ID	Cal Date (Certificate No.)	Scheduled Calibration
Power meter NRP	SN: 104778	04-Apr-17 (No. 217-02521/02522)	Apr-18
Power sensor NRP-Z91	SN: 103244	04-Apr-17 (No. 217-02521)	Apr-18
Power sensor NRP-Z91	SN: 103245	04-Apr-17 (No. 217-02525)	Apr-18
Reference 20 dB Attenuator	SN: S5277 (20x)	07-Apr-17 (No. 217-02528)	Apr-18
Reference Probe ES3DV2	SN: 3013	31-Dec-16 (No. ES3-3013_Dec16)	Dec-17
DAE4	SN: 660	7-Dec-16 (No. DAE4-660_Dec16)	Dec-17
Secondary Standards	ID	Check Date (in house)	Scheduled Check
Power meter E4419B	SN: GB41293874	06-Apr-16 (in house check Jun-16)	In house check: Jun-18
Power sensor E4412A	SN: MY41498087	06-Apr-16 (in house check Jun-16)	In house check: Jun-18
Power sensor E4412A	SN: 000110210	06-Apr-16 (in house check Jun-16)	In house check: Jun-18
RF generator HP 8648C	SN: US3642U01700	04-Aug-99 (in house check Jun-16)	In house check: Jun-18
Network Analyzer HP 8753E	SN: US37390585	18-Oct-01 (in house check Oct-16)	In house check: Oct-17

Calibrated by:	Name Jeton Kastrati	Function Laboratory Technician	Signature
Approved by:	Name Katja Pokovic	Function Technical Manager	Signature
			Issued: August 16, 2017
This calibration certificate shall not be reproduced except in full without written approval of the laboratory.			



Accredited by the Swiss Accreditation Service (SAS)

Accreditation No.: **SCS 0108**

The Swiss Accreditation Service is one of the signatories to the EA
Multilateral Agreement for the recognition of calibration certificates

Glossary:

TSL	tissue simulating liquid
NORM _{x,y,z}	sensitivity in free space
ConvF	sensitivity in TSL / NORM _{x,y,z}
DCP	diode compression point
CF	crest factor (1/duty_cycle) of the RF signal
A, B, C, D	modulation dependent linearization parameters
Polarization φ	φ rotation around probe axis
Polarization ϑ	ϑ rotation around an axis that is in the plane normal to probe axis (at measurement center), i.e., $\vartheta = 0$ is normal to probe axis
Connector Angle	information used in DASY system to align probe sensor X to the robot coordinate system

Calibration is Performed According to the Following Standards:

- a) IEEE Std 1528-2013, "IEEE Recommended Practice for Determining the Peak Spatial-Averaged Specific Absorption Rate (SAR) in the Human Head from Wireless Communications Devices: Measurement Techniques", June 2013
- b) IEC 62209-1, "Measurement procedure for the assessment of Specific Absorption Rate (SAR) from hand-held and body-mounted devices used next to the ear (frequency range of 300 MHz to 6 GHz)", July 2016
- c) IEC 62209-2, "Procedure to determine the Specific Absorption Rate (SAR) for wireless communication devices used in close proximity to the human body (frequency range of 30 MHz to 6 GHz)", March 2010
- d) KDB 865664, "SAR Measurement Requirements for 100 MHz to 6 GHz"

Methods Applied and Interpretation of Parameters:

- *NORM_{x,y,z}*: Assessed for E-field polarization $\vartheta = 0$ ($f \leq 900$ MHz in TEM-cell; $f > 1800$ MHz: R22 waveguide). *NORM_{x,y,z}* are only intermediate values, i.e., the uncertainties of *NORM_{x,y,z}* does not affect the E^2 -field uncertainty inside TSL (see below *ConvF*).
- *NORM(f)_{x,y,z}* = *NORM_{x,y,z}* * *frequency_response* (see Frequency Response Chart). This linearization is implemented in DASY4 software versions later than 4.2. The uncertainty of the frequency response is included in the stated uncertainty of *ConvF*.
- *DCP_{x,y,z}*: DCP are numerical linearization parameters assessed based on the data of power sweep with CW signal (no uncertainty required). DCP does not depend on frequency nor media.
- *PAR*: *PAR* is the Peak to Average Ratio that is not calibrated but determined based on the signal characteristics
- *A_{x,y,z}*; *B_{x,y,z}*; *C_{x,y,z}*; *D_{x,y,z}*; *VR_{x,y,z}*; *A, B, C, D* are numerical linearization parameters assessed based on the data of power sweep for specific modulation signal. The parameters do not depend on frequency nor media. *VR* is the maximum calibration range expressed in RMS voltage across the diode.
- *ConvF* and *Boundary Effect Parameters*: Assessed in flat phantom using E-field (or Temperature Transfer Standard for $f \leq 800$ MHz) and inside waveguide using analytical field distributions based on power measurements for $f > 800$ MHz. The same setups are used for assessment of the parameters applied for boundary compensation (alpha, depth) of which typical uncertainty values are given. These parameters are used in DASY4 software to improve probe accuracy close to the boundary. The sensitivity in TSL corresponds to *NORM_{x,y,z}* * *ConvF* whereby the uncertainty corresponds to that given for *ConvF*. A frequency dependent *ConvF* is used in DASY version 4.4 and higher which allows extending the validity from ± 50 MHz to ± 100 MHz.
- *Spherical isotropy (3D deviation from isotropy)*: in a field of low gradients realized using a flat phantom exposed by a patch antenna.
- *Sensor Offset*: The sensor offset corresponds to the offset of virtual measurement center from the probe tip (on probe axis). No tolerance required.
- *Connector Angle*: The angle is assessed using the information gained by determining the *NORM_x* (no uncertainty required).

Probe ES3DV3

SN:3332

Manufactured: January 24, 2012
Calibrated: August 14, 2017

Calibrated for DASY/EASY Systems
(Note: non-compatible with DASY2 system!)

DASY/EASY - Parameters of Probe: ES3DV3 - SN:3332

Basic Calibration Parameters

	Sensor X	Sensor Y	Sensor Z	Unc (k=2)
Norm ($\mu\text{V}/(\text{V}/\text{m})^2$) ^A	1.00	0.93	0.88	$\pm 10.1 \%$
DCP (mV) ^B	104.0	103.0	103.0	

Modulation Calibration Parameters

UID	Communication System Name		A dB	B dB $\sqrt{\mu\text{V}}$	C	D dB	VR mV	Unc ^E (k=2)
0	CW	X	0.0	0.0	1.0	0.00	192.0	$\pm 3.5 \%$
		Y	0.0	0.0	1.0		194.3	
		Z	0.0	0.0	1.0		179.9	

Note: For details on UID parameters see Appendix.

Sensor Model Parameters

	C1 fF	C2 fF	α V ⁻¹	T1 ms.V ⁻²	T2 ms.V ⁻¹	T3 ms	T4 V ⁻²	T5 V ⁻¹	T6
X	76.72	548.9	35.46	56.44	4.600	5.1	0.000	0.903	1.011
Y	44.78	323.3	35.85	29.01	2.529	5.1	0.000	0.546	1.009
Z	38.01	268.3	34.56	26.38	1.777	5.1	0.096	0.424	1.004

The reported uncertainty of measurement is stated as the standard uncertainty of measurement multiplied by the coverage factor k=2, which for a normal distribution corresponds to a coverage probability of approximately 95%.

^A The uncertainties of Norm X,Y,Z do not affect the E²-field uncertainty inside TSL (see Pages 5 and 6).

^B Numerical linearization parameter: uncertainty not required.

^E Uncertainty is determined using the max. deviation from linear response applying rectangular distribution and is expressed for the square of the field value.

DASY/EASY - Parameters of Probe: ES3DV3 - SN:3332

Calibration Parameter Determined in Head Tissue Simulating Media

f (MHz) ^C	Relative Permittivity ^F	Conductivity (S/m) ^F	ConvF X	ConvF Y	ConvF Z	Alpha ^G	Depth ^G (mm)	Unc (k=2)
750	41.9	0.89	6.81	6.81	6.81	0.72	1.31	± 12.0 %
835	41.5	0.90	6.64	6.64	6.64	0.80	1.21	± 12.0 %
1750	40.1	1.37	5.56	5.56	5.56	0.80	1.20	± 12.0 %
1900	40.0	1.40	5.33	5.33	5.33	0.76	1.26	± 12.0 %
2300	39.5	1.67	4.99	4.99	4.99	0.70	1.36	± 12.0 %
2450	39.2	1.80	4.68	4.68	4.68	0.63	1.48	± 12.0 %
2600	39.0	1.96	4.56	4.56	4.56	0.80	1.23	± 12.0 %

^C Frequency validity above 300 MHz of ± 100 MHz only applies for DASY v4.4 and higher (see Page 2), else it is restricted to ± 50 MHz. The uncertainty is the RSS of the ConvF uncertainty at calibration frequency and the uncertainty for the indicated frequency band. Frequency validity below 300 MHz is ± 10, 25, 40, 50 and 70 MHz for ConvF assessments at 30, 64, 128, 150 and 220 MHz respectively. Above 5 GHz frequency validity can be extended to ± 110 MHz.

^F At frequencies below 3 GHz, the validity of tissue parameters (ϵ and σ) can be relaxed to ± 10% if liquid compensation formula is applied to measured SAR values. At frequencies above 3 GHz, the validity of tissue parameters (ϵ and σ) is restricted to ± 5%. The uncertainty is the RSS of the ConvF uncertainty for indicated target tissue parameters.

^G Alpha/Depth are determined during calibration. SPEAG warrants that the remaining deviation due to the boundary effect after compensation is always less than ± 1% for frequencies below 3 GHz and below ± 2% for frequencies between 3-6 GHz at any distance larger than half the probe tip diameter from the boundary.

DASY/EASY - Parameters of Probe: ES3DV3 - SN:3332

Calibration Parameter Determined in Body Tissue Simulating Media

f (MHz) ^C	Relative Permittivity ^F	Conductivity (S/m) ^F	ConvF X	ConvF Y	ConvF Z	Alpha ^G	Depth ^G (mm)	Unc (k=2)
750	55.5	0.96	6.54	6.54	6.54	0.55	1.43	± 12.0 %
835	55.2	0.97	6.47	6.47	6.47	0.71	1.27	± 12.0 %
1750	53.4	1.49	5.16	5.16	5.16	0.80	1.22	± 12.0 %
1900	53.3	1.52	4.95	4.95	4.95	0.54	1.56	± 12.0 %
2300	52.9	1.81	4.74	4.74	4.74	0.80	1.30	± 12.0 %
2450	52.7	1.95	4.55	4.55	4.55	0.80	1.17	± 12.0 %
2600	52.5	2.16	4.43	4.43	4.43	0.80	1.12	± 12.0 %

^C Frequency validity above 300 MHz of ± 100 MHz only applies for DASY v4.4 and higher (see Page 2), else it is restricted to ± 50 MHz. The uncertainty is the RSS of the ConvF uncertainty at calibration frequency and the uncertainty for the indicated frequency band. Frequency validity below 300 MHz is ± 10, 25, 40, 50 and 70 MHz for ConvF assessments at 30, 64, 128, 150 and 220 MHz respectively. Above 5 GHz frequency validity can be extended to ± 110 MHz.

^F At frequencies below 3 GHz, the validity of tissue parameters (ϵ and σ) can be relaxed to ± 10% if liquid compensation formula is applied to measured SAR values. At frequencies above 3 GHz, the validity of tissue parameters (ϵ and σ) is restricted to ± 5%. The uncertainty is the RSS of the ConvF uncertainty for indicated target tissue parameters.

^G Alpha/Depth are determined during calibration. SPEAG warrants that the remaining deviation due to the boundary effect after compensation is always less than ± 1% for frequencies below 3 GHz and below ± 2% for frequencies between 3-6 GHz at any distance larger than half the probe tip diameter from the boundary.

Frequency Response of E-Field

(TEM-Cell:ifi110 EXX, Waveguide: R22)

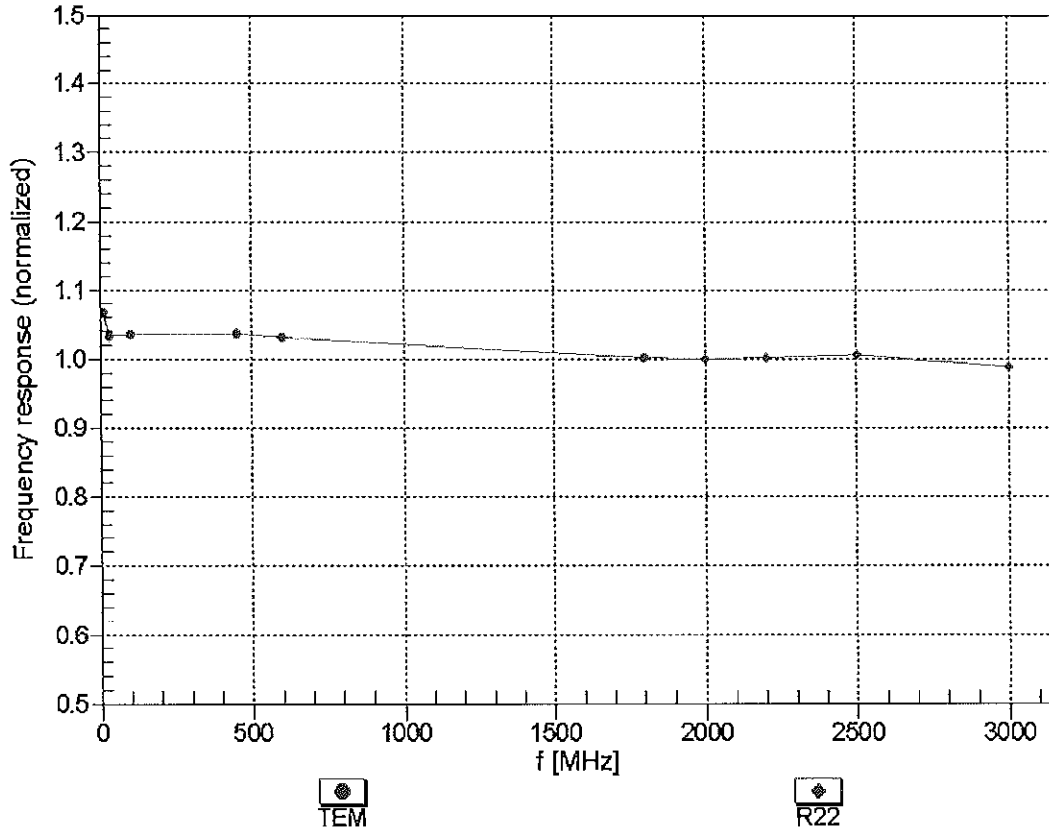

Uncertainty of Frequency Response of E-field: $\pm 6.3\%$ (k=2)

Receiving Pattern (ϕ), $\vartheta = 0^\circ$

f=600 MHz,TEM

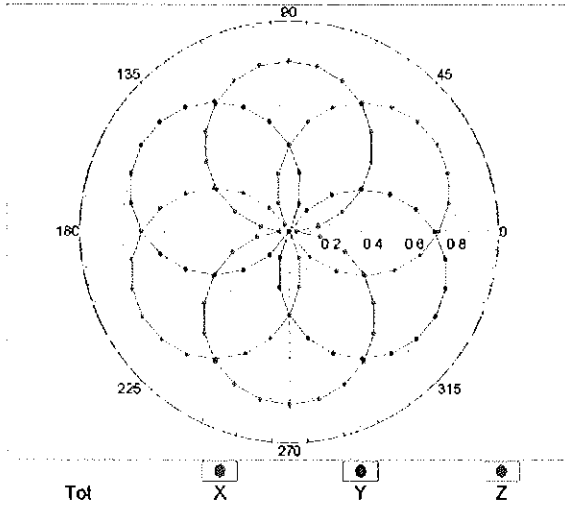

f=1800 MHz,R22

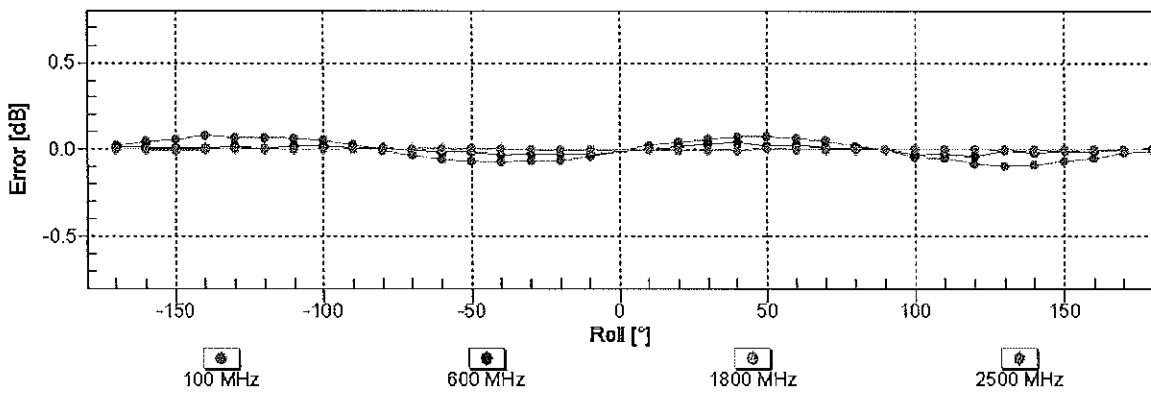
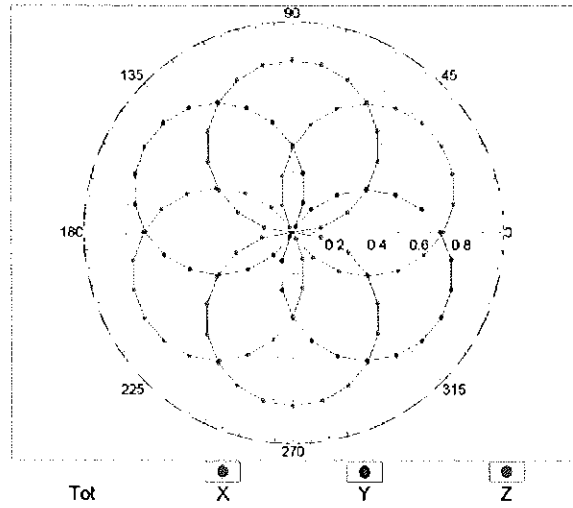

Uncertainty of Axial Isotropy Assessment: $\pm 0.5\%$ (k=2)

Dynamic Range f(SAR_{head}) (TEM cell , f_{eval}= 1900 MHz)

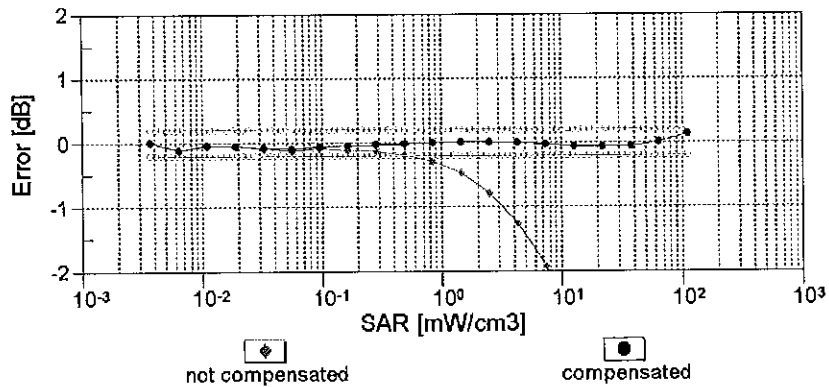
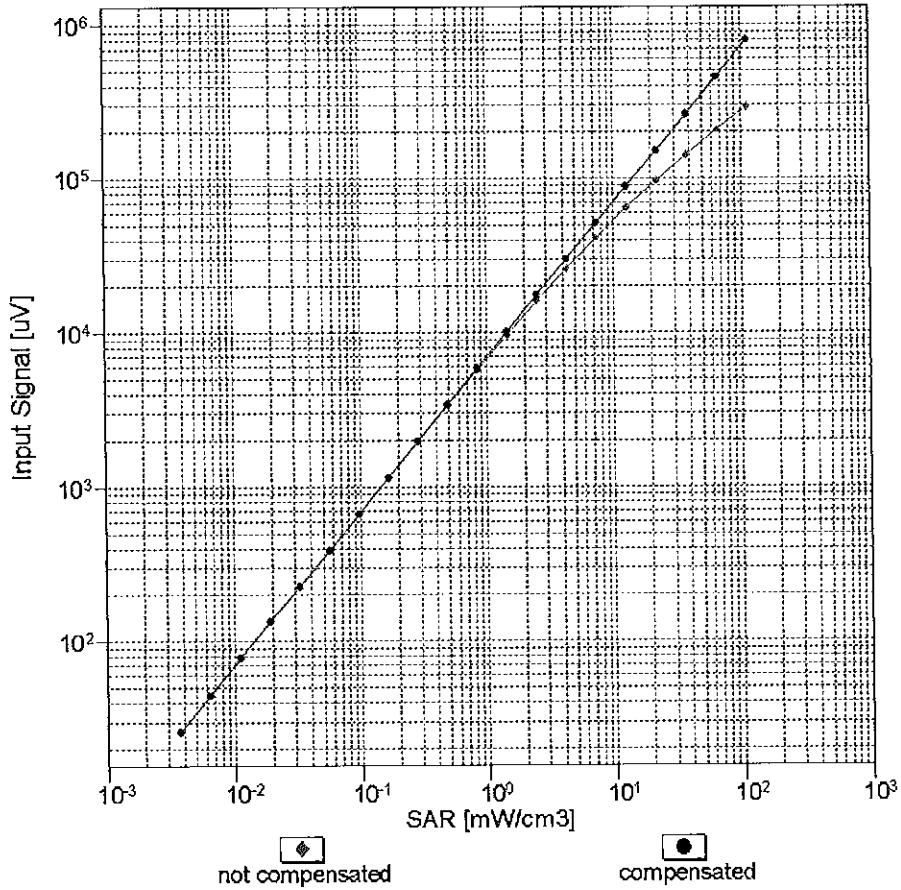

Uncertainty of Linearity Assessment: ± 0.6% (k=2)

Conversion Factor Assessment

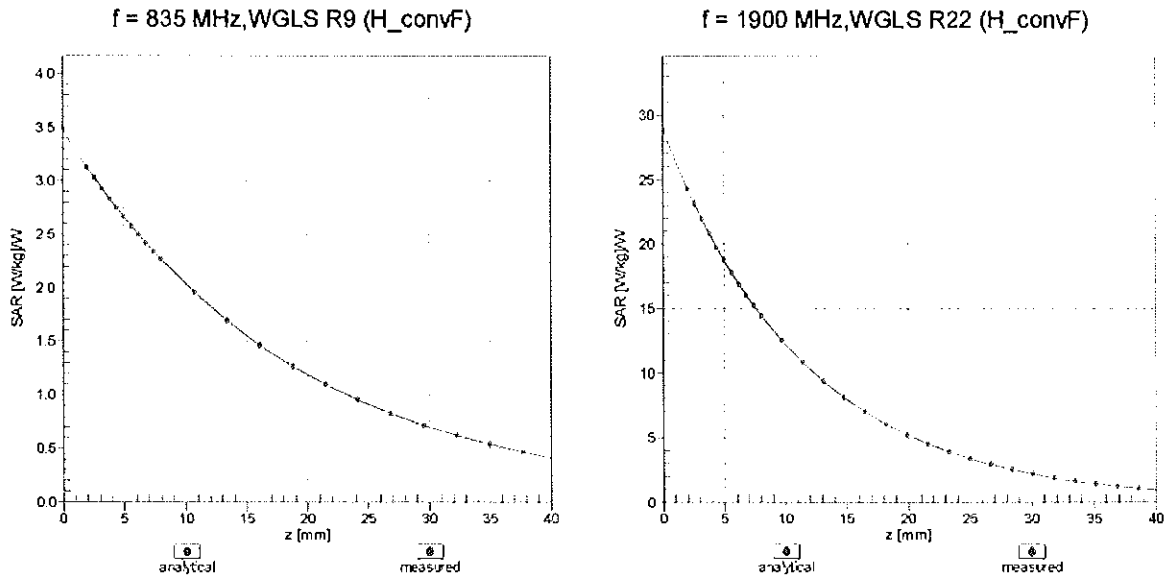

Deviation from Isotropy in Liquid Error (ϕ, ϑ), f = 900 MHz

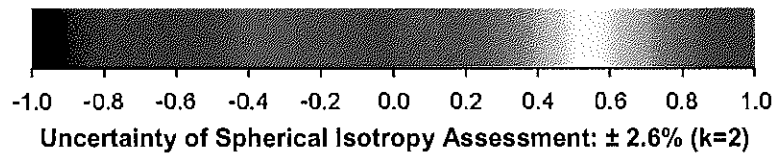
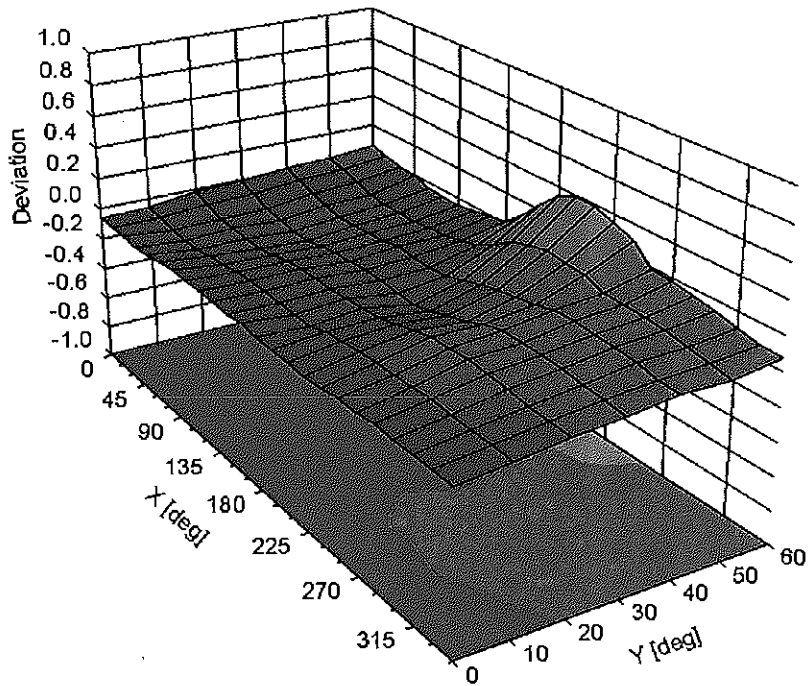

DASY/EASY - Parameters of Probe: ES3DV3 - SN:3332

Other Probe Parameters

Sensor Arrangement	Triangular
Connector Angle (°)	50
Mechanical Surface Detection Mode	enabled
Optical Surface Detection Mode	disabled
Probe Overall Length	337 mm
Probe Body Diameter	10 mm
Tip Length	10 mm
Tip Diameter	4 mm
Probe Tip to Sensor X Calibration Point	2 mm
Probe Tip to Sensor Y Calibration Point	2 mm
Probe Tip to Sensor Z Calibration Point	2 mm
Recommended Measurement Distance from Surface	3 mm

Appendix: Modulation Calibration Parameters

UID	Communication System Name		A dB	B dB $\sqrt{\mu V}$	C	D dB	VR mV	Max Unc ^E (k=2)
0	CW	X	0.00	0.00	1.00	0.00	192.0	$\pm 3.5\%$
		Y	0.00	0.00	1.00		194.3	
		Z	0.00	0.00	1.00		179.9	
10010- CAA	SAR Validation (Square, 100ms, 10ms)	X	9.02	77.08	18.94	10.00	25.0	$\pm 9.6\%$
		Y	12.19	85.73	21.41		25.0	
		Z	23.02	95.31	23.86		25.0	
10011- CAB	UMTS-FDD (WCDMA)	X	1.60	76.05	19.77	0.00	150.0	$\pm 9.6\%$
		Y	1.08	68.15	15.73		150.0	
		Z	1.25	71.36	17.60		150.0	
10012- CAB	IEEE 802.11b WiFi 2.4 GHz (DSSS, 1 Mbps)	X	1.52	68.53	17.98	0.41	150.0	$\pm 9.6\%$
		Y	1.33	65.39	16.06		150.0	
		Z	1.37	66.35	16.79		150.0	
10013- CAB	IEEE 802.11g WiFi 2.4 GHz (DSSS-OFDM, 6 Mbps)	X	5.37	67.71	17.82	1.46	150.0	$\pm 9.6\%$
		Y	5.07	67.50	17.57		150.0	
		Z	4.99	67.81	17.71		150.0	
10021- DAC	GSM-FDD (TDMA, GMSK)	X	11.16	81.48	22.11	9.39	50.0	$\pm 9.6\%$
		Y	61.59	115.23	32.13		50.0	
		Z	100.00	122.78	33.35		50.0	
10023- DAC	GPRS-FDD (TDMA, GMSK, TN 0)	X	11.07	81.20	22.06	9.57	50.0	$\pm 9.6\%$
		Y	43.11	109.07	30.52		50.0	
		Z	100.00	122.63	33.33		50.0	
10024- DAC	GPRS-FDD (TDMA, GMSK, TN 0-1)	X	12.88	85.34	22.06	6.56	60.0	$\pm 9.6\%$
		Y	100.00	120.15	31.36		60.0	
		Z	100.00	120.25	30.99		60.0	
10025- DAC	EDGE-FDD (TDMA, 8PSK, TN 0)	X	19.49	99.22	36.41	12.57	50.0	$\pm 9.6\%$
		Y	15.67	100.74	38.44		50.0	
		Z	29.43	124.69	47.97		50.0	
10026- DAC	EDGE-FDD (TDMA, 8PSK, TN 0-1)	X	18.92	96.32	32.19	9.56	60.0	$\pm 9.6\%$
		Y	17.33	101.02	35.08		60.0	
		Z	24.89	113.23	39.81		60.0	
10027- DAC	GPRS-FDD (TDMA, GMSK, TN 0-1-2)	X	24.19	95.70	24.33	4.80	80.0	$\pm 9.6\%$
		Y	100.00	119.30	30.03		80.0	
		Z	100.00	120.36	30.17		80.0	
10028- DAC	GPRS-FDD (TDMA, GMSK, TN 0-1-2-3)	X	100.00	115.36	28.49	3.55	100.0	$\pm 9.6\%$
		Y	100.00	119.83	29.45		100.0	
		Z	100.00	122.10	30.18		100.0	
10029- DAC	EDGE-FDD (TDMA, 8PSK, TN 0-1-2)	X	16.27	93.78	30.32	7.80	80.0	$\pm 9.6\%$
		Y	11.67	92.24	30.90		80.0	
		Z	13.37	97.80	33.46		80.0	
10030- CAA	IEEE 802.15.1 Bluetooth (GFSK, DH1)	X	15.68	88.86	22.54	5.30	70.0	$\pm 9.6\%$
		Y	100.00	118.49	29.99		70.0	
		Z	100.00	118.88	29.80		70.0	
10031- CAA	IEEE 802.15.1 Bluetooth (GFSK, DH3)	X	100.00	116.01	27.12	1.88	100.0	$\pm 9.6\%$
		Y	100.00	121.13	28.42		100.0	
		Z	100.00	126.03	30.32		100.0	

10032-CAA	IEEE 802.15.1 Bluetooth (GFSK, DH5)	X	100.00	119.38	27.36	1.17	100.0	± 9.6 %
		Y	100.00	126.54	29.58		100.0	
		Z	100.00	136.16	33.43		100.0	
10033-CAA	IEEE 802.15.1 Bluetooth (PI/4-DQPSK, DH1)	X	13.27	88.21	24.10	5.30	70.0	± 9.6 %
		Y	20.91	99.02	27.13		70.0	
		Z	58.05	115.59	31.27		70.0	
10034-CAA	IEEE 802.15.1 Bluetooth (PI/4-DQPSK, DH3)	X	16.18	96.67	25.44	1.88	100.0	± 9.6 %
		Y	10.83	91.57	22.94		100.0	
		Z	52.78	113.06	28.24		100.0	
10035-CAA	IEEE 802.15.1 Bluetooth (PI/4-DQPSK, DH5)	X	12.45	95.04	24.79	1.17	100.0	± 9.6 %
		Y	5.49	83.70	20.10		100.0	
		Z	18.62	100.06	24.56		100.0	
10036-CAA	IEEE 802.15.1 Bluetooth (8-DPSK, DH1)	X	14.34	89.63	24.62	5.30	70.0	± 9.6 %
		Y	26.79	103.24	28.41		70.0	
		Z	95.10	123.67	33.30		70.0	
10037-CAA	IEEE 802.15.1 Bluetooth (8-DPSK, DH3)	X	15.98	96.45	25.32	1.88	100.0	± 9.6 %
		Y	9.62	89.98	22.43		100.0	
		Z	37.04	108.35	27.08		100.0	
10038-CAA	IEEE 802.15.1 Bluetooth (8-DPSK, DH5)	X	13.91	96.94	25.41	1.17	100.0	± 9.6 %
		Y	5.69	84.50	20.47		100.0	
		Z	19.52	101.18	25.01		100.0	
10039-CAB	CDMA2000 (1xRTT, RC1)	X	3.28	80.46	20.53	0.00	150.0	± 9.6 %
		Y	1.92	73.09	15.89		150.0	
		Z	3.08	80.13	18.22		150.0	
10042-CAB	IS-54 / IS-136 FDD (TDMA/FDM, PI/4-DQPSK, Halfrate)	X	11.60	82.51	21.10	7.78	50.0	± 9.6 %
		Y	100.00	118.83	31.00		50.0	
		Z	100.00	118.47	30.39		50.0	
10044-CAA	IS-91/EIA/TIA-553 FDD (FDMA, FM)	X	0.02	128.88	9.05	0.00	150.0	± 9.6 %
		Y	0.00	96.92	0.26		150.0	
		Z	0.02	60.00	140.78		150.0	
10048-CAA	DECT (TDD, TDMA/FDM, GFSK, Full Slot, 24)	X	10.75	78.30	22.86	13.80	25.0	± 9.6 %
		Y	15.61	90.30	26.65		25.0	
		Z	32.75	104.57	30.45		25.0	
10049-CAA	DECT (TDD, TDMA/FDM, GFSK, Double Slot, 12)	X	10.92	80.23	22.15	10.79	40.0	± 9.6 %
		Y	20.87	96.36	27.22		40.0	
		Z	64.62	115.72	32.06		40.0	
10056-CAA	UMTS-TDD (TD-SCDMA, 1.28 Mcps)	X	11.51	81.76	22.84	9.03	50.0	± 9.6 %
		Y	15.28	90.93	25.77		50.0	
		Z	25.94	101.11	28.65		50.0	
10058-DAC	EDGE-FDD (TDMA, 8PSK, TN 0-1-2-3)	X	14.19	91.88	29.00	6.55	100.0	± 9.6 %
		Y	8.68	86.53	28.09		100.0	
		Z	9.12	89.51	29.70		100.0	
10059-CAB	IEEE 802.11b WiFi 2.4 GHz (DSSS, 2 Mbps)	X	2.01	72.72	19.70	0.61	110.0	± 9.6 %
		Y	1.51	67.62	17.16		110.0	
		Z	1.56	68.78	17.99		110.0	
10060-CAB	IEEE 802.11b WiFi 2.4 GHz (DSSS, 5.5 Mbps)	X	100.00	126.29	32.07	1.30	110.0	± 9.6 %
		Y	100.00	132.71	34.39		110.0	
		Z	100.00	137.07	36.21		110.0	

10061-CAB	IEEE 802.11b WiFi 2.4 GHz (DSSS, 11 Mbps)	X	36.66	112.50	30.92	2.04	110.0	± 9.6 %
		Y	11.07	98.15	27.76		110.0	
		Z	22.12	112.16	32.18		110.0	
10062-CAB	IEEE 802.11a/h WiFi 5 GHz (OFDM, 6 Mbps)	X	5.03	67.33	17.05	0.49	100.0	± 9.6 %
		Y	4.77	67.19	16.82		100.0	
		Z	4.70	67.51	16.97		100.0	
10063-CAB	IEEE 802.11a/h WiFi 5 GHz (OFDM, 9 Mbps)	X	5.09	67.56	17.23	0.72	100.0	± 9.6 %
		Y	4.81	67.36	16.96		100.0	
		Z	4.74	67.68	17.11		100.0	
10064-CAB	IEEE 802.11a/h WiFi 5 GHz (OFDM, 12 Mbps)	X	5.47	67.93	17.49	0.86	100.0	± 9.6 %
		Y	5.10	67.63	17.20		100.0	
		Z	5.00	67.90	17.32		100.0	
10065-CAB	IEEE 802.11a/h WiFi 5 GHz (OFDM, 18 Mbps)	X	5.40	68.08	17.70	1.21	100.0	± 9.6 %
		Y	5.02	67.68	17.39		100.0	
		Z	4.92	67.92	17.50		100.0	
10066-CAB	IEEE 802.11a/h WiFi 5 GHz (OFDM, 24 Mbps)	X	5.49	68.31	17.98	1.46	100.0	± 9.6 %
		Y	5.08	67.82	17.62		100.0	
		Z	4.97	68.04	17.73		100.0	
10067-CAB	IEEE 802.11a/h WiFi 5 GHz (OFDM, 36 Mbps)	X	5.84	68.47	18.45	2.04	100.0	± 9.6 %
		Y	5.42	68.13	18.14		100.0	
		Z	5.31	68.42	18.28		100.0	
10068-CAB	IEEE 802.11a/h WiFi 5 GHz (OFDM, 48 Mbps)	X	6.07	69.08	18.91	2.55	100.0	± 9.6 %
		Y	5.53	68.32	18.44		100.0	
		Z	5.39	68.51	18.54		100.0	
10069-CAB	IEEE 802.11a/h WiFi 5 GHz (OFDM, 54 Mbps)	X	6.13	68.90	19.06	2.67	100.0	± 9.6 %
		Y	5.61	68.37	18.66		100.0	
		Z	5.48	68.58	18.76		100.0	
10071-CAB	IEEE 802.11g WiFi 2.4 GHz (DSSS/OFDM, 9 Mbps)	X	5.56	68.08	18.26	1.99	100.0	± 9.6 %
		Y	5.22	67.75	17.96		100.0	
		Z	5.14	68.03	18.10		100.0	
10072-CAB	IEEE 802.11g WiFi 2.4 GHz (DSSS/OFDM, 12 Mbps)	X	5.71	68.87	18.66	2.30	100.0	± 9.6 %
		Y	5.28	68.28	18.29		100.0	
		Z	5.18	68.53	18.42		100.0	
10073-CAB	IEEE 802.11g WiFi 2.4 GHz (DSSS/OFDM, 18 Mbps)	X	5.93	69.43	19.17	2.83	100.0	± 9.6 %
		Y	5.43	68.68	18.74		100.0	
		Z	5.32	68.95	18.89		100.0	
10074-CAB	IEEE 802.11g WiFi 2.4 GHz (DSSS/OFDM, 24 Mbps)	X	6.04	69.75	19.56	3.30	100.0	± 9.6 %
		Y	5.49	68.80	18.99		100.0	
		Z	5.38	69.07	19.15		100.0	
10075-CAB	IEEE 802.11g WiFi 2.4 GHz (DSSS/OFDM, 36 Mbps)	X	6.35	70.65	20.23	3.82	90.0	± 9.6 %
		Y	5.63	69.18	19.44		90.0	
		Z	5.49	69.37	19.56		90.0	
10076-CAB	IEEE 802.11g WiFi 2.4 GHz (DSSS/OFDM, 48 Mbps)	X	6.37	70.50	20.38	4.15	90.0	± 9.6 %
		Y	5.68	69.10	19.63		90.0	
		Z	5.56	69.34	19.78		90.0	
10077-CAB	IEEE 802.11g WiFi 2.4 GHz (DSSS/OFDM, 54 Mbps)	X	6.43	70.65	20.50	4.30	90.0	± 9.6 %
		Y	5.73	69.22	19.75		90.0	
		Z	5.61	69.48	19.91		90.0	

10081-CAB	CDMA2000 (1xRTT, RC3)	X	1.62	75.66	18.40	0.00	150.0	± 9.6 %
		Y	0.87	66.71	12.69		150.0	
		Z	1.13	71.02	14.45		150.0	
10082-CAB	IS-54 / IS-136 FDD (TDMA/FDM, PI/4-DQPSK, Fullrate)	X	3.53	66.20	10.93	4.77	80.0	± 9.6 %
		Y	2.19	64.40	9.18		80.0	
		Z	1.96	64.15	8.74		80.0	
10090-DAC	GPRS-FDD (TDMA, GMSK, TN 0-4)	X	12.79	85.25	22.06	6.56	60.0	± 9.6 %
		Y	100.00	120.23	31.42		60.0	
		Z	100.00	120.31	31.04		60.0	
10097-CAB	UMTS-FDD (HSDPA)	X	2.06	70.06	17.46	0.00	150.0	± 9.6 %
		Y	1.88	68.31	15.96		150.0	
		Z	2.04	70.38	16.98		150.0	
10098-CAB	UMTS-FDD (HSUPA, Subtest 2)	X	2.02	70.12	17.47	0.00	150.0	± 9.6 %
		Y	1.84	68.27	15.94		150.0	
		Z	2.00	70.37	16.98		150.0	
10099-DAC	EDGE-FDD (TDMA, 8PSK, TN 0-4)	X	18.80	96.14	32.13	9.56	60.0	± 9.6 %
		Y	17.28	100.91	35.04		60.0	
		Z	24.81	113.10	39.77		60.0	
10100-CAD	LTE-FDD (SC-FDMA, 100% RB, 20 MHz, QPSK)	X	3.84	73.61	18.19	0.00	150.0	± 9.6 %
		Y	3.15	70.58	16.91		150.0	
		Z	3.25	71.69	17.61		150.0	
10101-CAD	LTE-FDD (SC-FDMA, 100% RB, 20 MHz, 16-QAM)	X	3.58	69.11	16.83	0.00	150.0	± 9.6 %
		Y	3.26	67.74	16.10		150.0	
		Z	3.26	68.29	16.47		150.0	
10102-CAD	LTE-FDD (SC-FDMA, 100% RB, 20 MHz, 64-QAM)	X	3.66	68.88	16.84	0.00	150.0	± 9.6 %
		Y	3.36	67.71	16.19		150.0	
		Z	3.36	68.23	16.52		150.0	
10103-CAD	LTE-TDD (SC-FDMA, 100% RB, 20 MHz, QPSK)	X	9.75	77.78	20.81	3.98	65.0	± 9.6 %
		Y	8.78	79.16	21.83		65.0	
		Z	9.34	81.38	22.82		65.0	
10104-CAD	LTE-TDD (SC-FDMA, 100% RB, 20 MHz, 16-QAM)	X	9.87	77.22	21.49	3.98	65.0	± 9.6 %
		Y	8.42	77.09	21.77		65.0	
		Z	8.44	78.16	22.31		65.0	
10105-CAD	LTE-TDD (SC-FDMA, 100% RB, 20 MHz, 64-QAM)	X	9.19	75.82	21.15	3.98	65.0	± 9.6 %
		Y	8.07	76.20	21.66		65.0	
		Z	8.27	77.70	22.41		65.0	
10108-CAE	LTE-FDD (SC-FDMA, 100% RB, 10 MHz, QPSK)	X	3.37	72.69	18.02	0.00	150.0	± 9.6 %
		Y	2.75	69.90	16.77		150.0	
		Z	2.82	71.09	17.51		150.0	
10109-CAE	LTE-FDD (SC-FDMA, 100% RB, 10 MHz, 16-QAM)	X	3.26	68.97	16.85	0.00	150.0	± 9.6 %
		Y	2.91	67.66	16.01		150.0	
		Z	2.92	68.36	16.42		150.0	
10110-CAE	LTE-FDD (SC-FDMA, 100% RB, 5 MHz, QPSK)	X	2.79	71.81	17.85	0.00	150.0	± 9.6 %
		Y	2.23	69.12	16.39		150.0	
		Z	2.31	70.62	17.23		150.0	
10111-CAE	LTE-FDD (SC-FDMA, 100% RB, 5 MHz, 16-QAM)	X	2.96	69.58	17.27	0.00	150.0	± 9.6 %
		Y	2.63	68.64	16.31		150.0	
		Z	2.69	69.84	16.85		150.0	

10112-CAE	LTE-FDD (SC-FDMA, 100% RB, 10 MHz, 64-QAM)	X	3.36	68.71	16.80	0.00	150.0	± 9.6 %
		Y	3.03	67.66	16.06		150.0	
		Z	3.04	68.35	16.45		150.0	
10113-CAE	LTE-FDD (SC-FDMA, 100% RB, 5 MHz, 64-QAM)	X	3.10	69.46	17.27	0.00	150.0	± 9.6 %
		Y	2.78	68.78	16.44		150.0	
		Z	2.83	69.92	16.93		150.0	
10114-CAB	IEEE 802.11n (HT Greenfield, 13.5 Mbps, BPSK)	X	5.34	67.65	16.76	0.00	150.0	± 9.6 %
		Y	5.17	67.50	16.64		150.0	
		Z	5.08	67.64	16.74		150.0	
10115-CAB	IEEE 802.11n (HT Greenfield, 81 Mbps, 16-QAM)	X	5.80	68.17	17.01	0.00	150.0	± 9.6 %
		Y	5.44	67.60	16.69		150.0	
		Z	5.33	67.71	16.77		150.0	
10116-CAB	IEEE 802.11n (HT Greenfield, 135 Mbps, 64-QAM)	X	5.47	67.90	16.79	0.00	150.0	± 9.6 %
		Y	5.25	67.68	16.65		150.0	
		Z	5.17	67.85	16.77		150.0	
10117-CAB	IEEE 802.11n (HT Mixed, 13.5 Mbps, BPSK)	X	5.34	67.65	16.78	0.00	150.0	± 9.6 %
		Y	5.12	67.32	16.56		150.0	
		Z	5.07	67.59	16.73		150.0	
10118-CAB	IEEE 802.11n (HT Mixed, 81 Mbps, 16-QAM)	X	5.79	68.04	16.95	0.00	150.0	± 9.6 %
		Y	5.52	67.82	16.81		150.0	
		Z	5.42	67.93	16.89		150.0	
10119-CAB	IEEE 802.11n (HT Mixed, 135 Mbps, 64-QAM)	X	5.44	67.84	16.78	0.00	150.0	± 9.6 %
		Y	5.24	67.66	16.65		150.0	
		Z	5.17	67.84	16.77		150.0	
10140-CAD	LTE-FDD (SC-FDMA, 100% RB, 15 MHz, 16-QAM)	X	3.72	68.86	16.76	0.00	150.0	± 9.6 %
		Y	3.39	67.72	16.10		150.0	
		Z	3.39	68.26	16.45		150.0	
10141-CAD	LTE-FDD (SC-FDMA, 100% RB, 15 MHz, 64-QAM)	X	3.82	68.79	16.84	0.00	150.0	± 9.6 %
		Y	3.51	67.83	16.27		150.0	
		Z	3.51	68.36	16.60		150.0	
10142-CAD	LTE-FDD (SC-FDMA, 100% RB, 3 MHz, QPSK)	X	2.57	71.96	17.88	0.00	150.0	± 9.6 %
		Y	2.01	69.21	16.02		150.0	
		Z	2.13	71.18	16.95		150.0	
10143-CAD	LTE-FDD (SC-FDMA, 100% RB, 3 MHz, 16-QAM)	X	2.89	70.53	17.42	0.00	150.0	± 9.6 %
		Y	2.49	69.45	15.95		150.0	
		Z	2.62	71.11	16.52		150.0	
10144-CAD	LTE-FDD (SC-FDMA, 100% RB, 3 MHz, 64-QAM)	X	2.69	68.52	16.05	0.00	150.0	± 9.6 %
		Y	2.23	66.92	14.20		150.0	
		Z	2.23	67.85	14.42		150.0	
10145-CAE	LTE-FDD (SC-FDMA, 100% RB, 1.4 MHz, QPSK)	X	2.07	72.06	16.97	0.00	150.0	± 9.6 %
		Y	1.17	64.90	11.31		150.0	
		Z	1.08	64.84	10.72		150.0	
10146-CAE	LTE-FDD (SC-FDMA, 100% RB, 1.4 MHz, 16-QAM)	X	4.64	77.66	18.95	0.00	150.0	± 9.6 %
		Y	1.89	66.33	11.57		150.0	
		Z	1.28	62.78	8.70		150.0	
10147-CAE	LTE-FDD (SC-FDMA, 100% RB, 1.4 MHz, 64-QAM)	X	5.86	81.36	20.54	0.00	150.0	± 9.6 %
		Y	2.26	68.50	12.73		150.0	
		Z	1.39	63.59	9.24		150.0	

10149-CAD	LTE-FDD (SC-FDMA, 50% RB, 20 MHz, 16-QAM)	X	3.27	69.03	16.89	0.00	150.0	± 9.6 %
		Y	2.92	67.72	16.06		150.0	
		Z	2.93	68.43	16.47		150.0	
10150-CAD	LTE-FDD (SC-FDMA, 50% RB, 20 MHz, 64-QAM)	X	3.37	68.76	16.84	0.00	150.0	± 9.6 %
		Y	3.04	67.71	16.11		150.0	
		Z	3.05	68.41	16.50		150.0	
10151-CAD	LTE-TDD (SC-FDMA, 50% RB, 20 MHz, QPSK)	X	9.88	78.98	21.39	3.98	65.0	± 9.6 %
		Y	9.54	82.00	22.98		65.0	
		Z	10.52	85.01	24.21		65.0	
10152-CAD	LTE-TDD (SC-FDMA, 50% RB, 20 MHz, 16-QAM)	X	9.59	77.49	21.44	3.98	65.0	± 9.6 %
		Y	8.05	77.33	21.53		65.0	
		Z	8.15	78.63	22.11		65.0	
10153-CAD	LTE-TDD (SC-FDMA, 50% RB, 20 MHz, 64-QAM)	X	9.88	78.01	21.96	3.98	65.0	± 9.6 %
		Y	8.51	78.32	22.28		65.0	
		Z	8.64	79.68	22.87		65.0	
10154-CAE	LTE-FDD (SC-FDMA, 50% RB, 10 MHz, QPSK)	X	2.88	72.43	18.21	0.00	150.0	± 9.6 %
		Y	2.28	69.53	16.65		150.0	
		Z	2.36	71.01	17.47		150.0	
10155-CAE	LTE-FDD (SC-FDMA, 50% RB, 10 MHz, 16-QAM)	X	2.96	69.57	17.27	0.00	150.0	± 9.6 %
		Y	2.63	68.66	16.33		150.0	
		Z	2.70	69.87	16.88		150.0	
10156-CAE	LTE-FDD (SC-FDMA, 50% RB, 5 MHz, QPSK)	X	2.50	72.75	18.17	0.00	150.0	± 9.6 %
		Y	1.86	69.32	15.77		150.0	
		Z	2.00	71.53	16.72		150.0	
10157-CAE	LTE-FDD (SC-FDMA, 50% RB, 5 MHz, 16-QAM)	X	2.58	69.56	16.46	0.00	150.0	± 9.6 %
		Y	2.07	67.52	14.21		150.0	
		Z	2.11	68.66	14.46		150.0	
10158-CAE	LTE-FDD (SC-FDMA, 50% RB, 10 MHz, 64-QAM)	X	3.11	69.51	17.31	0.00	150.0	± 9.6 %
		Y	2.79	68.85	16.49		150.0	
		Z	2.84	70.00	16.99		150.0	
10159-CAE	LTE-FDD (SC-FDMA, 50% RB, 5 MHz, 64-QAM)	X	2.70	69.94	16.71	0.00	150.0	± 9.6 %
		Y	2.17	67.94	14.47		150.0	
		Z	2.21	69.05	14.68		150.0	
10160-CAD	LTE-FDD (SC-FDMA, 50% RB, 15 MHz, QPSK)	X	3.17	70.70	17.47	0.00	150.0	± 9.6 %
		Y	2.80	69.22	16.63		150.0	
		Z	2.84	70.27	17.24		150.0	
10161-CAD	LTE-FDD (SC-FDMA, 50% RB, 15 MHz, 16-QAM)	X	3.25	68.62	16.80	0.00	150.0	± 9.6 %
		Y	2.93	67.68	16.03		150.0	
		Z	2.94	68.43	16.42		150.0	
10162-CAD	LTE-FDD (SC-FDMA, 50% RB, 15 MHz, 64-QAM)	X	3.34	68.54	16.80	0.00	150.0	± 9.6 %
		Y	3.04	67.85	16.15		150.0	
		Z	3.05	68.62	16.54		150.0	
10166-CAE	LTE-FDD (SC-FDMA, 50% RB, 1.4 MHz, QPSK)	X	4.29	71.19	20.11	3.01	150.0	± 9.6 %
		Y	3.58	69.86	19.45		150.0	
		Z	3.34	69.55	19.26		150.0	
10167-CAE	LTE-FDD (SC-FDMA, 50% RB, 1.4 MHz, 16-QAM)	X	5.65	74.34	20.64	3.01	150.0	± 9.6 %
		Y	4.34	72.64	19.86		150.0	
		Z	3.97	72.28	19.65		150.0	

10168-CAE	LTE-FDD (SC-FDMA, 50% RB, 1.4 MHz, 64-QAM)	X	6.08	75.90	21.58	3.01	150.0	± 9.6 %
		Y	4.83	75.01	21.26		150.0	
		Z	4.38	74.50	20.98		150.0	
10169-CAD	LTE-FDD (SC-FDMA, 1 RB, 20 MHz, QPSK)	X	4.41	74.54	21.42	3.01	150.0	± 9.6 %
		Y	2.96	68.83	19.02		150.0	
		Z	2.72	67.99	18.57		150.0	
10170-CAD	LTE-FDD (SC-FDMA, 1 RB, 20 MHz, 16-QAM)	X	6.70	80.82	23.44	3.01	150.0	± 9.6 %
		Y	3.91	74.17	21.18		150.0	
		Z	3.42	72.70	20.49		150.0	
10171-AAD	LTE-FDD (SC-FDMA, 1 RB, 20 MHz, 64-QAM)	X	5.50	76.54	20.93	3.01	150.0	± 9.6 %
		Y	3.29	70.45	18.57		150.0	
		Z	2.94	69.58	18.14		150.0	
10172-CAD	LTE-TDD (SC-FDMA, 1 RB, 20 MHz, QPSK)	X	25.76	101.07	30.32	6.02	65.0	± 9.6 %
		Y	18.45	102.75	32.10		65.0	
		Z	20.86	107.70	33.85		65.0	
10173-CAD	LTE-TDD (SC-FDMA, 1 RB, 20 MHz, 16-QAM)	X	19.21	92.24	26.33	6.02	65.0	± 9.6 %
		Y	26.29	105.14	31.12		65.0	
		Z	28.49	108.55	32.12		65.0	
10174-CAD	LTE-TDD (SC-FDMA, 1 RB, 20 MHz, 64-QAM)	X	17.46	89.68	25.13	6.02	65.0	± 9.6 %
		Y	21.35	100.13	29.12		65.0	
		Z	22.92	103.28	30.05		65.0	
10175-CAE	LTE-FDD (SC-FDMA, 1 RB, 10 MHz, QPSK)	X	4.34	74.12	21.15	3.01	150.0	± 9.6 %
		Y	2.93	68.55	18.79		150.0	
		Z	2.70	67.77	18.36		150.0	
10176-CAE	LTE-FDD (SC-FDMA, 1 RB, 10 MHz, 16-QAM)	X	6.71	80.84	23.45	3.01	150.0	± 9.6 %
		Y	3.92	74.20	21.19		150.0	
		Z	3.42	72.72	20.50		150.0	
10177-CAG	LTE-FDD (SC-FDMA, 1 RB, 5 MHz, QPSK)	X	4.38	74.32	21.26	3.01	150.0	± 9.6 %
		Y	2.95	68.69	18.87		150.0	
		Z	2.71	67.87	18.43		150.0	
10178-CAE	LTE-FDD (SC-FDMA, 1 RB, 5 MHz, 16-QAM)	X	6.59	80.50	23.29	3.01	150.0	± 9.6 %
		Y	3.89	74.02	21.09		150.0	
		Z	3.41	72.61	20.43		150.0	
10179-CAE	LTE-FDD (SC-FDMA, 1 RB, 10 MHz, 64-QAM)	X	6.03	78.45	22.01	3.01	150.0	± 9.6 %
		Y	3.58	72.24	19.76		150.0	
		Z	3.16	71.11	19.23		150.0	
10180-CAE	LTE-FDD (SC-FDMA, 1 RB, 5 MHz, 64-QAM)	X	5.47	76.42	20.86	3.01	150.0	± 9.6 %
		Y	3.28	70.40	18.53		150.0	
		Z	2.94	69.55	18.12		150.0	
10181-CAD	LTE-FDD (SC-FDMA, 1 RB, 15 MHz, QPSK)	X	4.38	74.30	21.25	3.01	150.0	± 9.6 %
		Y	2.95	68.67	18.87		150.0	
		Z	2.71	67.86	18.43		150.0	
10182-CAD	LTE-FDD (SC-FDMA, 1 RB, 15 MHz, 16-QAM)	X	6.58	80.48	23.29	3.01	150.0	± 9.6 %
		Y	3.88	74.00	21.08		150.0	
		Z	3.40	72.59	20.42		150.0	
10183-AAC	LTE-FDD (SC-FDMA, 1 RB, 15 MHz, 64-QAM)	X	5.46	76.40	20.85	3.01	150.0	± 9.6 %
		Y	3.28	70.38	18.52		150.0	
		Z	2.93	69.53	18.11		150.0	

10184-CAD	LTE-FDD (SC-FDMA, 1 RB, 3 MHz, QPSK)	X	4.39	74.34	21.27	3.01	150.0	± 9.6 %
		Y	2.96	68.71	18.89		150.0	
		Z	2.72	67.89	18.44		150.0	
10185-CAD	LTE-FDD (SC-FDMA, 1 RB, 3 MHz, 16-QAM)	X	6.61	80.55	23.32	3.01	150.0	± 9.6 %
		Y	3.90	74.06	21.11		150.0	
		Z	3.42	72.64	20.45		150.0	
10186-AAD	LTE-FDD (SC-FDMA, 1 RB, 3 MHz, 64-QAM)	X	5.49	76.46	20.88	3.01	150.0	± 9.6 %
		Y	3.29	70.44	18.55		150.0	
		Z	2.95	69.59	18.14		150.0	
10187-CAE	LTE-FDD (SC-FDMA, 1 RB, 1.4 MHz, QPSK)	X	4.40	74.38	21.31	3.01	150.0	± 9.6 %
		Y	2.97	68.77	18.95		150.0	
		Z	2.73	67.95	18.51		150.0	
10188-CAE	LTE-FDD (SC-FDMA, 1 RB, 1.4 MHz, 16-QAM)	X	6.86	81.30	23.70	3.01	150.0	± 9.6 %
		Y	4.01	74.64	21.46		150.0	
		Z	3.49	73.09	20.74		150.0	
10189-AAE	LTE-FDD (SC-FDMA, 1 RB, 1.4 MHz, 64-QAM)	X	5.63	76.95	21.16	3.01	150.0	± 9.6 %
		Y	3.36	70.82	18.81		150.0	
		Z	3.00	69.90	18.37		150.0	
10193-CAB	IEEE 802.11n (HT Greenfield, 6.5 Mbps, BPSK)	X	4.76	66.98	16.56	0.00	150.0	± 9.6 %
		Y	4.53	66.89	16.29		150.0	
		Z	4.48	67.27	16.46		150.0	
10194-CAB	IEEE 802.11n (HT Greenfield, 39 Mbps, 16-QAM)	X	4.98	67.40	16.66	0.00	150.0	± 9.6 %
		Y	4.70	67.19	16.42		150.0	
		Z	4.63	67.53	16.59		150.0	
10195-CAB	IEEE 802.11n (HT Greenfield, 65 Mbps, 64-QAM)	X	5.02	67.38	16.65	0.00	150.0	± 9.6 %
		Y	4.74	67.22	16.44		150.0	
		Z	4.67	67.55	16.61		150.0	
10196-CAB	IEEE 802.11n (HT Mixed, 6.5 Mbps, BPSK)	X	4.79	67.12	16.61	0.00	150.0	± 9.6 %
		Y	4.53	66.94	16.30		150.0	
		Z	4.47	67.29	16.46		150.0	
10197-CAB	IEEE 802.11n (HT Mixed, 39 Mbps, 16-QAM)	X	5.00	67.41	16.67	0.00	150.0	± 9.6 %
		Y	4.71	67.21	16.43		150.0	
		Z	4.64	67.54	16.60		150.0	
10198-CAB	IEEE 802.11n (HT Mixed, 65 Mbps, 64-QAM)	X	5.02	67.39	16.66	0.00	150.0	± 9.6 %
		Y	4.74	67.23	16.45		150.0	
		Z	4.67	67.55	16.61		150.0	
10219-CAB	IEEE 802.11n (HT Mixed, 7.2 Mbps, BPSK)	X	4.75	67.15	16.58	0.00	150.0	± 9.6 %
		Y	4.48	66.96	16.27		150.0	
		Z	4.43	67.33	16.43		150.0	
10220-CAB	IEEE 802.11n (HT Mixed, 43.3 Mbps, 16-QAM)	X	5.00	67.42	16.67	0.00	150.0	± 9.6 %
		Y	4.70	67.17	16.42		150.0	
		Z	4.63	67.50	16.58		150.0	
10221-CAB	IEEE 802.11n (HT Mixed, 72.2 Mbps, 64-QAM)	X	5.03	67.33	16.65	0.00	150.0	± 9.6 %
		Y	4.75	67.16	16.44		150.0	
		Z	4.68	67.49	16.60		150.0	
10222-CAB	IEEE 802.11n (HT Mixed, 15 Mbps, BPSK)	X	5.32	67.70	16.79	0.00	150.0	± 9.6 %
		Y	5.10	67.32	16.56		150.0	
		Z	5.04	67.57	16.71		150.0	

10223-CAB	IEEE 802.11n (HT Mixed, 90 Mbps, 16-QAM)	X	5.69	67.90	16.90	0.00	150.0	± 9.6 %
		Y	5.41	67.62	16.73		150.0	
		Z	5.32	67.79	16.83		150.0	
10224-CAB	IEEE 802.11n (HT Mixed, 150 Mbps, 64-QAM)	X	5.40	67.86	16.79	0.00	150.0	± 9.6 %
		Y	5.14	67.44	16.54		150.0	
		Z	5.08	67.68	16.69		150.0	
10225-CAB	UMTS-FDD (HSPA+)	X	3.04	66.91	16.27	0.00	150.0	± 9.6 %
		Y	2.80	66.45	15.40		150.0	
		Z	2.79	67.13	15.62		150.0	
10226-CAA	LTE-TDD (SC-FDMA, 1 RB, 1.4 MHz, 16-QAM)	X	19.62	92.68	26.54	6.02	65.0	± 9.6 %
		Y	28.14	106.53	31.60		65.0	
		Z	30.74	110.09	32.63		65.0	
10227-CAA	LTE-TDD (SC-FDMA, 1 RB, 1.4 MHz, 64-QAM)	X	17.31	89.65	25.20	6.02	65.0	± 9.6 %
		Y	25.62	103.45	30.17		65.0	
		Z	27.71	106.63	31.05		65.0	
10228-CAA	LTE-TDD (SC-FDMA, 1 RB, 1.4 MHz, QPSK)	X	25.12	101.14	30.46	6.02	65.0	± 9.6 %
		Y	22.85	107.40	33.58		65.0	
		Z	23.56	110.42	34.69		65.0	
10229-CAB	LTE-TDD (SC-FDMA, 1 RB, 3 MHz, 16-QAM)	X	19.21	92.22	26.33	6.02	65.0	± 9.6 %
		Y	26.37	105.18	31.14		65.0	
		Z	28.56	108.58	32.13		65.0	
10230-CAB	LTE-TDD (SC-FDMA, 1 RB, 3 MHz, 64-QAM)	X	16.99	89.27	25.02	6.02	65.0	± 9.6 %
		Y	24.08	102.25	29.76		65.0	
		Z	25.76	105.25	30.60		65.0	
10231-CAB	LTE-TDD (SC-FDMA, 1 RB, 3 MHz, QPSK)	X	24.47	100.57	30.23	6.02	65.0	± 9.6 %
		Y	21.54	106.10	33.13		65.0	
		Z	22.10	109.02	34.22		65.0	
10232-CAD	LTE-TDD (SC-FDMA, 1 RB, 5 MHz, 16-QAM)	X	19.21	92.23	26.33	6.02	65.0	± 9.6 %
		Y	26.35	105.17	31.13		65.0	
		Z	28.56	108.59	32.14		65.0	
10233-CAD	LTE-TDD (SC-FDMA, 1 RB, 5 MHz, 64-QAM)	X	16.99	89.29	25.03	6.02	65.0	± 9.6 %
		Y	24.05	102.24	29.76		65.0	
		Z	25.73	105.25	30.60		65.0	
10234-CAD	LTE-TDD (SC-FDMA, 1 RB, 5 MHz, QPSK)	X	23.75	99.87	29.94	6.02	65.0	± 9.6 %
		Y	20.44	104.88	32.66		65.0	
		Z	20.94	107.73	33.73		65.0	
10235-CAD	LTE-TDD (SC-FDMA, 1 RB, 10 MHz, 16-QAM)	X	19.23	92.26	26.34	6.02	65.0	± 9.6 %
		Y	26.43	105.24	31.16		65.0	
		Z	28.68	108.68	32.16		65.0	
10236-CAD	LTE-TDD (SC-FDMA, 1 RB, 10 MHz, 64-QAM)	X	17.05	89.34	25.04	6.02	65.0	± 9.6 %
		Y	24.28	102.38	29.79		65.0	
		Z	26.05	105.43	30.64		65.0	
10237-CAD	LTE-TDD (SC-FDMA, 1 RB, 10 MHz, QPSK)	X	24.65	100.72	30.28	6.02	65.0	± 9.6 %
		Y	21.67	106.26	33.17		65.0	
		Z	22.28	109.22	34.28		65.0	
10238-CAD	LTE-TDD (SC-FDMA, 1 RB, 15 MHz, 16-QAM)	X	19.21	92.24	26.33	6.02	65.0	± 9.6 %
		Y	26.34	105.18	31.13		65.0	
		Z	28.55	108.60	32.14		65.0	

10239-CAD	LTE-TDD (SC-FDMA, 1 RB, 15 MHz, 64-QAM)	X	17.00	89.31	25.04	6.02	65.0	± 9.6 %
		Y	24.00	102.22	29.75		65.0	
		Z	25.68	105.23	30.60		65.0	
10240-CAD	LTE-TDD (SC-FDMA, 1 RB, 15 MHz, QPSK)	X	24.60	100.69	30.26	6.02	65.0	± 9.6 %
		Y	21.61	106.21	33.16		65.0	
		Z	22.24	109.18	34.27		65.0	
10241-CAA	LTE-TDD (SC-FDMA, 50% RB, 1.4 MHz, 16-QAM)	X	14.83	87.15	27.43	6.98	65.0	± 9.6 %
		Y	11.87	87.25	27.69		65.0	
		Z	12.27	89.81	28.71		65.0	
10242-CAA	LTE-TDD (SC-FDMA, 50% RB, 1.4 MHz, 64-QAM)	X	14.03	85.86	26.85	6.98	65.0	± 9.6 %
		Y	11.07	85.73	27.03		65.0	
		Z	11.88	89.15	28.39		65.0	
10243-CAA	LTE-TDD (SC-FDMA, 50% RB, 1.4 MHz, QPSK)	X	12.50	85.61	27.61	6.98	65.0	± 9.6 %
		Y	8.91	82.53	26.67		65.0	
		Z	9.40	85.62	28.06		65.0	
10244-CAB	LTE-TDD (SC-FDMA, 50% RB, 3 MHz, 16-QAM)	X	10.84	80.28	21.46	3.98	65.0	± 9.6 %
		Y	8.60	79.06	19.82		65.0	
		Z	7.30	76.79	18.14		65.0	
10245-CAB	LTE-TDD (SC-FDMA, 50% RB, 3 MHz, 64-QAM)	X	10.80	80.00	21.33	3.98	65.0	± 9.6 %
		Y	8.32	78.30	19.47		65.0	
		Z	7.01	75.95	17.75		65.0	
10246-CAB	LTE-TDD (SC-FDMA, 50% RB, 3 MHz, QPSK)	X	10.19	81.67	21.72	3.98	65.0	± 9.6 %
		Y	9.19	82.92	21.40		65.0	
		Z	10.28	85.26	21.82		65.0	
10247-CAD	LTE-TDD (SC-FDMA, 50% RB, 5 MHz, 16-QAM)	X	9.24	78.33	20.99	3.98	65.0	± 9.6 %
		Y	7.42	77.41	19.87		65.0	
		Z	7.44	78.18	19.81		65.0	
10248-CAD	LTE-TDD (SC-FDMA, 50% RB, 5 MHz, 64-QAM)	X	9.29	78.02	20.88	3.98	65.0	± 9.6 %
		Y	7.28	76.69	19.57		65.0	
		Z	7.17	77.21	19.40		65.0	
10249-CAD	LTE-TDD (SC-FDMA, 50% RB, 5 MHz, QPSK)	X	10.52	82.18	22.29	3.98	65.0	± 9.6 %
		Y	10.94	86.37	23.51		65.0	
		Z	13.59	90.89	24.82		65.0	
10250-CAD	LTE-TDD (SC-FDMA, 50% RB, 10 MHz, 16-QAM)	X	9.84	79.38	22.27	3.98	65.0	± 9.6 %
		Y	8.59	80.24	22.59		65.0	
		Z	8.91	81.95	23.17		65.0	
10251-CAD	LTE-TDD (SC-FDMA, 50% RB, 10 MHz, 64-QAM)	X	9.48	77.77	21.45	3.98	65.0	± 9.6 %
		Y	7.96	77.76	21.28		65.0	
		Z	8.06	79.03	21.69		65.0	
10252-CAD	LTE-TDD (SC-FDMA, 50% RB, 10 MHz, QPSK)	X	10.35	81.23	22.32	3.98	65.0	± 9.6 %
		Y	10.67	85.75	24.25		65.0	
		Z	12.80	90.26	25.85		65.0	
10253-CAD	LTE-TDD (SC-FDMA, 50% RB, 15 MHz, 16-QAM)	X	9.41	77.10	21.37	3.98	65.0	± 9.6 %
		Y	7.89	76.83	21.30		65.0	
		Z	7.98	78.11	21.82		65.0	
10254-CAD	LTE-TDD (SC-FDMA, 50% RB, 15 MHz, 64-QAM)	X	9.73	77.64	21.86	3.98	65.0	± 9.6 %
		Y	8.31	77.74	21.96		65.0	
		Z	8.42	79.03	22.48		65.0	

10255-CAD	LTE-TDD (SC-FDMA, 50% RB, 15 MHz, QPSK)	X	9.76	78.98	21.63	3.98	65.0	± 9.6 %
		Y	9.21	81.58	22.99		65.0	
		Z	10.10	84.50	24.17		65.0	
10256-CAA	LTE-TDD (SC-FDMA, 100% RB, 1.4 MHz, 16-QAM)	X	10.36	79.33	20.55	3.98	65.0	± 9.6 %
		Y	6.89	75.10	17.29		65.0	
		Z	5.38	71.84	15.02		65.0	
10257-CAA	LTE-TDD (SC-FDMA, 100% RB, 1.4 MHz, 64-QAM)	X	10.33	78.98	20.36	3.98	65.0	± 9.6 %
		Y	6.60	74.15	16.79		65.0	
		Z	5.14	70.90	14.50		65.0	
10258-CAA	LTE-TDD (SC-FDMA, 100% RB, 1.4 MHz, QPSK)	X	9.84	80.89	21.06	3.98	65.0	± 9.6 %
		Y	6.93	77.80	18.67		65.0	
		Z	6.67	77.68	18.06		65.0	
10259-CAB	LTE-TDD (SC-FDMA, 100% RB, 3 MHz, 16-QAM)	X	9.48	78.65	21.42	3.98	65.0	± 9.6 %
		Y	7.89	78.48	20.85		65.0	
		Z	8.05	79.67	21.05		65.0	
10260-CAB	LTE-TDD (SC-FDMA, 100% RB, 3 MHz, 64-QAM)	X	9.52	78.48	21.39	3.98	65.0	± 9.6 %
		Y	7.84	78.08	20.70		65.0	
		Z	7.93	79.11	20.83		65.0	
10261-CAB	LTE-TDD (SC-FDMA, 100% RB, 3 MHz, QPSK)	X	10.28	81.56	22.27	3.98	65.0	± 9.6 %
		Y	10.28	85.25	23.51		65.0	
		Z	12.40	89.51	24.85		65.0	
10262-CAD	LTE-TDD (SC-FDMA, 100% RB, 5 MHz, 16-QAM)	X	9.83	79.35	22.25	3.98	65.0	± 9.6 %
		Y	8.56	80.18	22.55		65.0	
		Z	8.88	81.87	23.12		65.0	
10263-CAD	LTE-TDD (SC-FDMA, 100% RB, 5 MHz, 64-QAM)	X	9.48	77.78	21.46	3.98	65.0	± 9.6 %
		Y	7.94	77.74	21.28		65.0	
		Z	8.05	79.01	21.68		65.0	
10264-CAD	LTE-TDD (SC-FDMA, 100% RB, 5 MHz, QPSK)	X	10.32	81.15	22.28	3.98	65.0	± 9.6 %
		Y	10.57	85.55	24.15		65.0	
		Z	12.63	90.00	25.74		65.0	
10265-CAD	LTE-TDD (SC-FDMA, 100% RB, 10 MHz, 16-QAM)	X	9.59	77.50	21.45	3.98	65.0	± 9.6 %
		Y	8.04	77.33	21.54		65.0	
		Z	8.14	78.63	22.11		65.0	
10266-CAD	LTE-TDD (SC-FDMA, 100% RB, 10 MHz, 64-QAM)	X	9.89	78.01	21.96	3.98	65.0	± 9.6 %
		Y	8.50	78.31	22.27		65.0	
		Z	8.64	79.67	22.86		65.0	
10267-CAD	LTE-TDD (SC-FDMA, 100% RB, 10 MHz, QPSK)	X	9.88	78.96	21.38	3.98	65.0	± 9.6 %
		Y	9.52	81.96	22.96		65.0	
		Z	10.50	84.95	24.19		65.0	
10268-CAD	LTE-TDD (SC-FDMA, 100% RB, 15 MHz, 16-QAM)	X	9.95	76.96	21.54	3.98	65.0	± 9.6 %
		Y	8.52	76.88	21.79		65.0	
		Z	8.53	77.92	22.30		65.0	
10269-CAD	LTE-TDD (SC-FDMA, 100% RB, 15 MHz, 64-QAM)	X	9.89	76.68	21.52	3.98	65.0	± 9.6 %
		Y	8.46	76.46	21.67		65.0	
		Z	8.45	77.44	22.15		65.0	
10270-CAD	LTE-TDD (SC-FDMA, 100% RB, 15 MHz, QPSK)	X	9.66	77.24	20.86	3.98	65.0	± 9.6 %
		Y	8.81	78.78	21.90		65.0	
		Z	9.16	80.58	22.73		65.0	

10274-CAB	UMTS-FDD (HSUPA, Subtest 5, 3GPP Rel8.10)	X	2.74	67.26	16.17	0.00	150.0	± 9.6 %
		Y	2.61	66.92	15.38		150.0	
		Z	2.66	67.94	15.80		150.0	
10275-CAB	UMTS-FDD (HSUPA, Subtest 5, 3GPP Rel8.4)	X	2.05	72.21	18.03	0.00	150.0	± 9.6 %
		Y	1.65	68.50	15.87		150.0	
		Z	1.80	70.74	17.08		150.0	
10277-CAA	PHS (QPSK)	X	8.03	72.61	16.76	9.03	50.0	± 9.6 %
		Y	5.31	69.07	13.45		50.0	
		Z	4.52	67.70	12.08		50.0	
10278-CAA	PHS (QPSK, BW 884MHz, Rolloff 0.5)	X	10.53	79.27	21.29	9.03	50.0	± 9.6 %
		Y	8.21	77.64	19.35		50.0	
		Z	7.62	76.93	18.36		50.0	
10279-CAA	PHS (QPSK, BW 884MHz, Rolloff 0.38)	X	10.71	79.48	21.37	9.03	50.0	± 9.6 %
		Y	8.29	77.74	19.41		50.0	
		Z	7.68	77.01	18.42		50.0	
10290-AAB	CDMA2000, RC1, SO55, Full Rate	X	2.46	75.92	18.53	0.00	150.0	± 9.6 %
		Y	1.45	69.17	13.90		150.0	
		Z	1.74	72.52	15.01		150.0	
10291-AAB	CDMA2000, RC3, SO55, Full Rate	X	1.54	75.02	18.13	0.00	150.0	± 9.6 %
		Y	0.85	66.46	12.55		150.0	
		Z	1.09	70.54	14.22		150.0	
10292-AAB	CDMA2000, RC3, SO32, Full Rate	X	2.85	86.00	22.76	0.00	150.0	± 9.6 %
		Y	1.20	72.00	15.52		150.0	
		Z	3.37	86.48	20.58		150.0	
10293-AAB	CDMA2000, RC3, SO3, Full Rate	X	6.08	98.98	27.50	0.00	150.0	± 9.6 %
		Y	2.38	81.80	19.81		150.0	
		Z	91.77	132.75	32.89		150.0	
10295-AAB	CDMA2000, RC1, SO3, 1/8th Rate 25 fr.	X	11.42	82.00	23.75	9.03	50.0	± 9.6 %
		Y	13.54	88.04	25.23		50.0	
		Z	20.14	95.71	27.34		50.0	
10297-AAC	LTE-FDD (SC-FDMA, 50% RB, 20 MHz, QPSK)	X	3.39	72.81	18.09	0.00	150.0	± 9.6 %
		Y	2.76	70.00	16.84		150.0	
		Z	2.84	71.20	17.58		150.0	
10298-AAC	LTE-FDD (SC-FDMA, 50% RB, 3 MHz, QPSK)	X	2.33	72.89	17.78	0.00	150.0	± 9.6 %
		Y	1.54	67.89	13.96		150.0	
		Z	1.61	69.51	14.40		150.0	
10299-AAC	LTE-FDD (SC-FDMA, 50% RB, 3 MHz, 16-QAM)	X	4.61	76.96	19.19	0.00	150.0	± 9.6 %
		Y	2.70	70.48	14.61		150.0	
		Z	1.96	66.96	12.10		150.0	
10300-AAC	LTE-FDD (SC-FDMA, 50% RB, 3 MHz, 64-QAM)	X	3.49	71.59	16.26	0.00	150.0	± 9.6 %
		Y	1.91	65.24	11.36		150.0	
		Z	1.47	63.13	9.40		150.0	
10301-AAA	IEEE 802.16e WiMAX (29:18, 5ms, 10MHz, QPSK, PUSC)	X	6.59	70.34	20.04	4.17	80.0	± 9.6 %
		Y	5.68	68.74	18.85		80.0	
		Z	5.70	69.67	19.26		80.0	
10302-AAA	IEEE 802.16e WiMAX (29:18, 5ms, 10MHz, QPSK, PUSC, 3 CTRL symbols)	X	7.28	71.73	21.22	4.96	80.0	± 9.6 %
		Y	6.10	69.04	19.43		80.0	
		Z	6.04	69.77	19.77		80.0	

10303-AAA	IEEE 802.16e WiMAX (31:15, 5ms, 10MHz, 64QAM, PUSC)	X	7.35	72.51	21.62	4.96	80.0	± 9.6 %
		Y	5.94	69.06	19.41		80.0	
		Z	5.89	69.82	19.76		80.0	
10304-AAA	IEEE 802.16e WiMAX (29:18, 5ms, 10MHz, 64QAM, PUSC)	X	6.69	70.97	20.39	4.17	80.0	± 9.6 %
		Y	5.59	68.42	18.66		80.0	
		Z	5.56	69.20	19.00		80.0	
10305-AAA	IEEE 802.16e WiMAX (31:15, 10ms, 10MHz, 64QAM, PUSC, 15 symbols)	X	14.75	90.64	29.58	6.02	50.0	± 9.6 %
		Y	10.18	84.38	26.41		50.0	
		Z	10.30	85.54	26.72		50.0	
10306-AAA	IEEE 802.16e WiMAX (29:18, 10ms, 10MHz, 64QAM, PUSC, 18 symbols)	X	9.44	79.58	25.56	6.02	50.0	± 9.6 %
		Y	7.33	75.98	23.40		50.0	
		Z	6.44	73.04	21.64		50.0	
10307-AAA	IEEE 802.16e WiMAX (29:18, 10ms, 10MHz, QPSK, PUSC, 18 symbols)	X	10.22	81.50	26.08	6.02	50.0	± 9.6 %
		Y	7.67	77.32	23.80		50.0	
		Z	7.49	77.77	23.93		50.0	
10308-AAA	IEEE 802.16e WiMAX (29:18, 10ms, 10MHz, 16QAM, PUSC)	X	10.67	82.66	26.55	6.02	50.0	± 9.6 %
		Y	7.93	78.29	24.23		50.0	
		Z	7.77	78.85	24.42		50.0	
10309-AAA	IEEE 802.16e WiMAX (29:18, 10ms, 10MHz, 16QAM, AMC 2x3, 18 symbols)	X	9.59	79.83	25.67	6.02	50.0	± 9.6 %
		Y	7.43	76.26	23.57		50.0	
		Z	6.50	73.23	21.79		50.0	
10310-AAA	IEEE 802.16e WiMAX (29:18, 10ms, 10MHz, QPSK, AMC 2x3, 18 symbols)	X	9.69	80.24	25.70	6.02	50.0	± 9.6 %
		Y	7.48	76.59	23.59		50.0	
		Z	7.35	77.19	23.79		50.0	
10311-AAC	LTE-FDD (SC-FDMA, 100% RB, 15 MHz, QPSK)	X	3.76	71.88	17.62	0.00	150.0	± 9.6 %
		Y	3.12	69.22	16.46		150.0	
		Z	3.20	70.27	17.11		150.0	
10313-AAA	IDEN 1:3	X	8.04	75.55	17.71	6.99	70.0	± 9.6 %
		Y	8.89	81.65	20.17		70.0	
		Z	12.54	87.83	22.26		70.0	
10314-AAA	IDEN 1:6	X	10.06	79.94	21.38	10.00	30.0	± 9.6 %
		Y	12.66	89.89	25.48		30.0	
		Z	20.06	99.62	28.65		30.0	
10315-AAB	IEEE 802.11b WiFi 2.4 GHz (DSSS, 1 Mbps, 96pc duty cycle)	X	1.30	67.68	17.69	0.17	150.0	± 9.6 %
		Y	1.18	64.90	15.80		150.0	
		Z	1.23	65.94	16.59		150.0	
10316-AAB	IEEE 802.11g WiFi 2.4 GHz (ERP-OFDM, 6 Mbps, 96pc duty cycle)	X	4.90	67.26	16.78	0.17	150.0	± 9.6 %
		Y	4.64	67.10	16.54		150.0	
		Z	4.58	67.43	16.69		150.0	
10317-AAB	IEEE 802.11a WiFi 5 GHz (OFDM, 6 Mbps, 96pc duty cycle)	X	4.90	67.26	16.78	0.17	150.0	± 9.6 %
		Y	4.64	67.10	16.54		150.0	
		Z	4.58	67.43	16.69		150.0	
10400-AAC	IEEE 802.11ac WiFi (20MHz, 64-QAM, 99pc duty cycle)	X	5.01	67.47	16.66	0.00	150.0	± 9.6 %
		Y	4.68	67.24	16.42		150.0	
		Z	4.61	67.58	16.60		150.0	
10401-AAC	IEEE 802.11ac WiFi (40MHz, 64-QAM, 99pc duty cycle)	X	5.58	67.43	16.66	0.00	150.0	± 9.6 %
		Y	5.46	67.62	16.70		150.0	
		Z	5.29	67.47	16.64		150.0	

10402-AAC	IEEE 802.11ac WiFi (80MHz, 64-QAM, 99pc duty cycle)	X	5.90	68.07	16.80	0.00	150.0	± 9.6 %
		Y	5.66	67.67	16.59		150.0	
		Z	5.60	67.87	16.71		150.0	
10403-AAB	CDMA2000 (1xEV-DO, Rev. 0)	X	2.46	75.92	18.53	0.00	115.0	± 9.6 %
		Y	1.45	69.17	13.90		115.0	
		Z	1.74	72.52	15.01		115.0	
10404-AAB	CDMA2000 (1xEV-DO, Rev. A)	X	2.46	75.92	18.53	0.00	115.0	± 9.6 %
		Y	1.45	69.17	13.90		115.0	
		Z	1.74	72.52	15.01		115.0	
10406-AAB	CDMA2000, RC3, SO32, SCH0, Full Rate	X	38.96	111.40	30.01	0.00	100.0	± 9.6 %
		Y	96.63	125.46	32.24		100.0	
		Z	100.00	123.89	30.87		100.0	
10410-AAC	LTE-TDD (SC-FDMA, 1 RB, 10 MHz, QPSK, UL Subframe=2,3,4,7,8,9)	X	79.33	113.95	29.40	3.23	80.0	± 9.6 %
		Y	100.00	123.80	32.02		80.0	
		Z	100.00	124.20	31.74		80.0	
10415-AAA	IEEE 802.11b WiFi 2.4 GHz (DSSS, 1 Mbps, 99pc duty cycle)	X	1.01	64.64	16.23	0.00	150.0	± 9.6 %
		Y	1.03	63.36	14.90		150.0	
		Z	1.08	64.37	15.69		150.0	
10416-AAA	IEEE 802.11g WiFi 2.4 GHz (ERP-OFDM, 6 Mbps, 99pc duty cycle)	X	4.76	67.00	16.58	0.00	150.0	± 9.6 %
		Y	4.53	66.92	16.37		150.0	
		Z	4.48	67.28	16.53		150.0	
10417-AAA	IEEE 802.11a/h WiFi 5 GHz (OFDM, 6 Mbps, 99pc duty cycle)	X	4.76	67.00	16.58	0.00	150.0	± 9.6 %
		Y	4.53	66.92	16.37		150.0	
		Z	4.48	67.28	16.53		150.0	
10418-AAA	IEEE 802.11g WiFi 2.4 GHz (DSSS-OFDM, 6 Mbps, 99pc duty cycle, Long preamble)	X	4.74	67.14	16.57	0.00	150.0	± 9.6 %
		Y	4.53	67.10	16.40		150.0	
		Z	4.48	67.49	16.59		150.0	
10419-AAA	IEEE 802.11g WiFi 2.4 GHz (DSSS-OFDM, 6 Mbps, 99pc duty cycle, Short preamble)	X	4.77	67.10	16.59	0.00	150.0	± 9.6 %
		Y	4.55	67.04	16.39		150.0	
		Z	4.49	67.42	16.58		150.0	
10422-AAA	IEEE 802.11n (HT Greenfield, 7.2 Mbps, BPSK)	X	4.90	67.10	16.59	0.00	150.0	± 9.6 %
		Y	4.66	67.03	16.41		150.0	
		Z	4.60	67.38	16.58		150.0	
10423-AAA	IEEE 802.11n (HT Greenfield, 43.3 Mbps, 16-QAM)	X	5.14	67.54	16.75	0.00	150.0	± 9.6 %
		Y	4.81	67.33	16.51		150.0	
		Z	4.74	67.65	16.67		150.0	
10424-AAA	IEEE 802.11n (HT Greenfield, 72.2 Mbps, 64-QAM)	X	5.04	67.47	16.71	0.00	150.0	± 9.6 %
		Y	4.74	67.28	16.49		150.0	
		Z	4.66	67.61	16.65		150.0	
10425-AAA	IEEE 802.11n (HT Greenfield, 15 Mbps, BPSK)	X	5.61	67.86	16.86	0.00	150.0	± 9.6 %
		Y	5.36	67.59	16.69		150.0	
		Z	5.29	67.80	16.81		150.0	
10426-AAA	IEEE 802.11n (HT Greenfield, 90 Mbps, 16-QAM)	X	5.62	67.87	16.86	0.00	150.0	± 9.6 %
		Y	5.40	67.74	16.76		150.0	
		Z	5.31	67.91	16.86		150.0	

10427-AAA	IEEE 802.11n (HT Greenfield, 150 Mbps, 64-QAM)	X	5.65	67.92	16.88	0.00	150.0	± 9.6 %
		Y	5.39	67.63	16.70		150.0	
		Z	5.28	67.70	16.75		150.0	
10430-AAB	LTE-FDD (OFDMA, 5 MHz, E-TM 3.1)	X	4.50	70.33	18.46	0.00	150.0	± 9.6 %
		Y	4.28	71.46	18.38		150.0	
		Z	4.28	72.32	18.56		150.0	
10431-AAB	LTE-FDD (OFDMA, 10 MHz, E-TM 3.1)	X	4.56	67.66	16.75	0.00	150.0	± 9.6 %
		Y	4.19	67.51	16.33		150.0	
		Z	4.12	67.97	16.50		150.0	
10432-AAB	LTE-FDD (OFDMA, 15 MHz, E-TM 3.1)	X	4.83	67.55	16.72	0.00	150.0	± 9.6 %
		Y	4.50	67.35	16.43		150.0	
		Z	4.43	67.74	16.61		150.0	
10433-AAB	LTE-FDD (OFDMA, 20 MHz, E-TM 3.1)	X	5.06	67.54	16.75	0.00	150.0	± 9.6 %
		Y	4.75	67.32	16.51		150.0	
		Z	4.68	67.64	16.67		150.0	
10434-AAA	W-CDMA (BS Test Model 1, 64 DPCH)	X	4.58	70.97	18.48	0.00	150.0	± 9.6 %
		Y	4.39	72.38	18.32		150.0	
		Z	4.42	73.36	18.48		150.0	
10435-AAC	LTE-TDD (SC-FDMA, 1 RB, 20 MHz, QPSK, UL Subframe=2,3,4,7,8,9)	X	73.07	112.66	29.06	3.23	80.0	± 9.6 %
		Y	100.00	123.60	31.93		80.0	
		Z	100.00	123.98	31.64		80.0	
10447-AAB	LTE-FDD (OFDMA, 5 MHz, E-TM 3.1, Clipping 44%)	X	3.91	67.87	16.49	0.00	150.0	± 9.6 %
		Y	3.47	67.50	15.53		150.0	
		Z	3.41	68.08	15.62		150.0	
10448-AAB	LTE-FDD (OFDMA, 10 MHz, E-TM 3.1, Clipping 44%)	X	4.36	67.43	16.61	0.00	150.0	± 9.6 %
		Y	4.04	67.29	16.20		150.0	
		Z	3.99	67.77	16.38		150.0	
10449-AAB	LTE-FDD (OFDMA, 15 MHz, E-TM 3.1, Clipping 44%)	X	4.59	67.37	16.63	0.00	150.0	± 9.6 %
		Y	4.32	67.18	16.33		150.0	
		Z	4.27	67.58	16.51		150.0	
10450-AAB	LTE-FDD (OFDMA, 20 MHz, E-TM 3.1, Clipping 44%)	X	4.75	67.29	16.62	0.00	150.0	± 9.6 %
		Y	4.52	67.08	16.36		150.0	
		Z	4.47	67.43	16.54		150.0	
10451-AAA	W-CDMA (BS Test Model 1, 64 DPCH, Clipping 44%)	X	3.88	68.25	16.35	0.00	150.0	± 9.6 %
		Y	3.34	67.60	15.06		150.0	
		Z	3.25	68.08	15.03		150.0	
10456-AAA	IEEE 802.11ac WiFi (160MHz, 64-QAM, 99pc duty cycle)	X	6.45	68.48	17.01	0.00	150.0	± 9.6 %
		Y	6.28	68.20	16.88		150.0	
		Z	6.24	68.43	17.01		150.0	
10457-AAA	UMTS-FDD (DC-HSDPA)	X	3.87	65.68	16.38	0.00	150.0	± 9.6 %
		Y	3.81	65.57	16.07		150.0	
		Z	3.81	65.98	16.26		150.0	
10458-AAA	CDMA2000 (1xEV-DO, Rev. B, 2 carriers)	X	3.63	67.17	15.82	0.00	150.0	± 9.6 %
		Y	3.13	66.82	14.32		150.0	
		Z	2.97	66.93	13.99		150.0	
10459-AAA	CDMA2000 (1xEV-DO, Rev. B, 3 carriers)	X	4.79	65.36	16.37	0.00	150.0	± 9.6 %
		Y	4.24	65.27	15.46		150.0	
		Z	4.13	65.72	15.38		150.0	

10460-AAA	UMTS-FDD (WCDMA, AMR)	X	1.54	79.74	21.99	0.00	150.0	± 9.6 %
		Y	0.95	69.06	16.64		150.0	
		Z	1.16	73.20	19.00		150.0	
10461-AAA	LTE-TDD (SC-FDMA, 1 RB, 1.4 MHz, QPSK, UL Subframe=2,3,4,7,8,9)	X	100.00	118.00	30.59	3.29	80.0	± 9.6 %
		Y	100.00	127.27	33.69		80.0	
		Z	100.00	128.13	33.61		80.0	
10462-AAA	LTE-TDD (SC-FDMA, 1 RB, 1.4 MHz, 16-QAM, UL Subframe=2,3,4,7,8,9)	X	100.00	108.76	26.18	3.23	80.0	± 9.6 %
		Y	100.00	111.69	26.26		80.0	
		Z	100.00	109.78	24.92		80.0	
10463-AAA	LTE-TDD (SC-FDMA, 1 RB, 1.4 MHz, 64-QAM, UL Subframe=2,3,4,7,8,9)	X	61.06	101.21	23.94	3.23	80.0	± 9.6 %
		Y	100.00	108.45	24.70		80.0	
		Z	9.38	82.48	17.38		80.0	
10464-AAA	LTE-TDD (SC-FDMA, 1 RB, 3 MHz, QPSK, UL Subframe=2,3,4,7,8,9)	X	100.00	116.66	29.84	3.23	80.0	± 9.6 %
		Y	100.00	125.35	32.64		80.0	
		Z	100.00	125.94	32.43		80.0	
10465-AAA	LTE-TDD (SC-FDMA, 1 RB, 3 MHz, 16-QAM, UL Subframe=2,3,4,7,8,9)	X	100.00	108.47	26.02	3.23	80.0	± 9.6 %
		Y	100.00	111.17	26.01		80.0	
		Z	44.16	100.58	22.73		80.0	
10466-AAA	LTE-TDD (SC-FDMA, 1 RB, 3 MHz, 64-QAM, UL Subframe=2,3,4,7,8,9)	X	42.58	96.75	22.75	3.23	80.0	± 9.6 %
		Y	42.99	98.93	22.41		80.0	
		Z	5.89	77.61	15.84		80.0	
10467-AAC	LTE-TDD (SC-FDMA, 1 RB, 5 MHz, QPSK, UL Subframe=2,3,4,7,8,9)	X	100.00	116.79	29.90	3.23	80.0	± 9.6 %
		Y	100.00	125.60	32.75		80.0	
		Z	100.00	126.22	32.56		80.0	
10468-AAC	LTE-TDD (SC-FDMA, 1 RB, 5 MHz, 16-QAM, UL Subframe=2,3,4,7,8,9)	X	100.00	108.56	26.07	3.23	80.0	± 9.6 %
		Y	100.00	111.35	26.09		80.0	
		Z	61.74	104.33	23.64		80.0	
10469-AAC	LTE-TDD (SC-FDMA, 1 RB, 5 MHz, 64-QAM, UL Subframe=2,3,4,7,8,9)	X	43.83	97.08	22.83	3.23	80.0	± 9.6 %
		Y	46.06	99.70	22.59		80.0	
		Z	6.04	77.89	15.93		80.0	
10470-AAC	LTE-TDD (SC-FDMA, 1 RB, 10 MHz, QPSK, UL Subframe=2,3,4,7,8,9)	X	100.00	116.81	29.90	3.23	80.0	± 9.6 %
		Y	100.00	125.63	32.76		80.0	
		Z	100.00	126.25	32.56		80.0	
10471-AAC	LTE-TDD (SC-FDMA, 1 RB, 10 MHz, 16-QAM, UL Subframe=2,3,4,7,8,9)	X	100.00	108.53	26.05	3.23	80.0	± 9.6 %
		Y	100.00	111.31	26.07		80.0	
		Z	61.64	104.26	23.61		80.0	
10472-AAC	LTE-TDD (SC-FDMA, 1 RB, 10 MHz, 64-QAM, UL Subframe=2,3,4,7,8,9)	X	44.10	97.14	22.84	3.23	80.0	± 9.6 %
		Y	46.39	99.73	22.59		80.0	
		Z	6.02	77.83	15.90		80.0	
10473-AAC	LTE-TDD (SC-FDMA, 1 RB, 15 MHz, QPSK, UL Subframe=2,3,4,7,8,9)	X	100.00	116.79	29.89	3.23	80.0	± 9.6 %
		Y	100.00	125.60	32.74		80.0	
		Z	100.00	126.23	32.55		80.0	
10474-AAC	LTE-TDD (SC-FDMA, 1 RB, 15 MHz, 16-QAM, UL Subframe=2,3,4,7,8,9)	X	100.00	108.54	26.05	3.23	80.0	± 9.6 %
		Y	100.00	111.32	26.07		80.0	
		Z	60.20	104.02	23.55		80.0	
10475-AAC	LTE-TDD (SC-FDMA, 1 RB, 15 MHz, 64-QAM, UL Subframe=2,3,4,7,8,9)	X	43.66	97.03	22.81	3.23	80.0	± 9.6 %
		Y	44.87	99.39	22.51		80.0	
		Z	5.94	77.72	15.87		80.0	

10477-AAC	LTE-TDD (SC-FDMA, 1 RB, 20 MHz, 16-QAM, UL Subframe=2,3,4,7,8,9)	X	100.00	108.43	26.00	3.23	80.0	± 9.6 %
		Y	100.00	111.14	25.99		80.0	
		Z	48.11	101.47	22.92		80.0	
10478-AAC	LTE-TDD (SC-FDMA, 1 RB, 20 MHz, 64-QAM, UL Subframe=2,3,4,7,8,9)	X	43.04	96.84	22.76	3.23	80.0	± 9.6 %
		Y	43.24	98.94	22.39		80.0	
		Z	5.86	77.55	15.80		80.0	
10479-AAA	LTE-TDD (SC-FDMA, 50% RB, 1.4 MHz, QPSK, UL Subframe=2,3,4,7,8,9)	X	18.43	95.26	26.62	3.23	80.0	± 9.6 %
		Y	47.63	113.17	30.89		80.0	
		Z	79.42	120.84	32.18		80.0	
10480-AAA	LTE-TDD (SC-FDMA, 50% RB, 1.4 MHz, 16-QAM, UL Subframe=2,3,4,7,8,9)	X	15.38	87.90	23.16	3.23	80.0	± 9.6 %
		Y	35.80	101.51	25.84		80.0	
		Z	33.10	99.76	24.57		80.0	
10481-AAA	LTE-TDD (SC-FDMA, 50% RB, 1.4 MHz, 64-QAM, UL Subframe=2,3,4,7,8,9)	X	14.20	86.14	22.35	3.23	80.0	± 9.6 %
		Y	23.64	94.76	23.60		80.0	
		Z	17.83	90.68	21.64		80.0	
10482-AAA	LTE-TDD (SC-FDMA, 50% RB, 3 MHz, QPSK, UL Subframe=2,3,4,7,8,9)	X	11.00	86.13	22.59	2.23	80.0	± 9.6 %
		Y	6.54	80.66	19.81		80.0	
		Z	10.00	86.91	21.46		80.0	
10483-AAA	LTE-TDD (SC-FDMA, 50% RB, 3 MHz, 16-QAM, UL Subframe=2,3,4,7,8,9)	X	11.81	84.53	22.26	2.23	80.0	± 9.6 %
		Y	9.59	82.56	20.08		80.0	
		Z	5.79	75.74	16.81		80.0	
10484-AAA	LTE-TDD (SC-FDMA, 50% RB, 3 MHz, 64-QAM, UL Subframe=2,3,4,7,8,9)	X	11.16	83.50	21.93	2.23	80.0	± 9.6 %
		Y	8.15	80.18	19.27		80.0	
		Z	5.05	73.86	16.10		80.0	
10485-AAC	LTE-TDD (SC-FDMA, 50% RB, 5 MHz, QPSK, UL Subframe=2,3,4,7,8,9)	X	11.03	86.44	23.15	2.23	80.0	± 9.6 %
		Y	6.87	82.16	21.41		80.0	
		Z	9.87	88.59	23.41		80.0	
10486-AAC	LTE-TDD (SC-FDMA, 50% RB, 5 MHz, 16-QAM, UL Subframe=2,3,4,7,8,9)	X	6.95	77.02	19.85	2.23	80.0	± 9.6 %
		Y	4.98	74.27	17.96		80.0	
		Z	5.53	76.50	18.48		80.0	
10487-AAC	LTE-TDD (SC-FDMA, 50% RB, 5 MHz, 64-QAM, UL Subframe=2,3,4,7,8,9)	X	6.82	76.43	19.65	2.23	80.0	± 9.6 %
		Y	4.85	73.54	17.65		80.0	
		Z	5.25	75.41	18.04		80.0	
10488-AAC	LTE-TDD (SC-FDMA, 50% RB, 10 MHz, QPSK, UL Subframe=2,3,4,7,8,9)	X	9.46	82.96	22.30	2.23	80.0	± 9.6 %
		Y	5.99	78.96	21.12		80.0	
		Z	6.82	82.33	22.47		80.0	
10489-AAC	LTE-TDD (SC-FDMA, 50% RB, 10 MHz, 16-QAM, UL Subframe=2,3,4,7,8,9)	X	6.62	75.52	19.96	2.23	80.0	± 9.6 %
		Y	4.91	73.20	18.90		80.0	
		Z	5.11	74.84	19.54		80.0	
10490-AAC	LTE-TDD (SC-FDMA, 50% RB, 10 MHz, 64-QAM, UL Subframe=2,3,4,7,8,9)	X	6.56	74.88	19.76	2.23	80.0	± 9.6 %
		Y	4.94	72.82	18.76		80.0	
		Z	5.10	74.33	19.33		80.0	
10491-AAC	LTE-TDD (SC-FDMA, 50% RB, 15 MHz, QPSK, UL Subframe=2,3,4,7,8,9)	X	7.98	78.75	20.93	2.23	80.0	± 9.6 %
		Y	5.56	75.73	20.09		80.0	
		Z	5.84	77.68	21.00		80.0	
10492-AAC	LTE-TDD (SC-FDMA, 50% RB, 15 MHz, 16-QAM, UL Subframe=2,3,4,7,8,9)	X	6.52	73.74	19.47	2.23	80.0	± 9.6 %
		Y	5.01	71.66	18.63		80.0	
		Z	5.04	72.68	19.10		80.0	

10493-AAC	LTE-TDD (SC-FDMA, 50% RB, 15 MHz, 64-QAM, UL Subframe=2,3,4,7,8,9)	X	6.52	73.38	19.36	2.23	80.0	± 9.6 %
		Y	5.05	71.42	18.55		80.0	
		Z	5.05	72.38	18.97		80.0	
10494-AAC	LTE-TDD (SC-FDMA, 50% RB, 20 MHz, QPSK, UL Subframe=2,3,4,7,8,9)	X	9.30	81.16	21.56	2.23	80.0	± 9.6 %
		Y	6.19	77.55	20.65		80.0	
		Z	6.63	79.81	21.68		80.0	
10495-AAC	LTE-TDD (SC-FDMA, 50% RB, 20 MHz, 16-QAM, UL Subframe=2,3,4,7,8,9)	X	6.75	74.54	19.74	2.23	80.0	± 9.6 %
		Y	5.09	72.10	18.86		80.0	
		Z	5.10	73.07	19.34		80.0	
10496-AAC	LTE-TDD (SC-FDMA, 50% RB, 20 MHz, 64-QAM, UL Subframe=2,3,4,7,8,9)	X	6.67	73.87	19.53	2.23	80.0	± 9.6 %
		Y	5.11	71.66	18.72		80.0	
		Z	5.11	72.57	19.16		80.0	
10497-AAA	LTE-TDD (SC-FDMA, 100% RB, 1.4 MHz, QPSK, UL Subframe=2,3,4,7,8,9)	X	9.58	84.00	21.43	2.23	80.0	± 9.6 %
		Y	4.27	74.12	16.39		80.0	
		Z	5.12	76.54	16.66		80.0	
10498-AAA	LTE-TDD (SC-FDMA, 100% RB, 1.4 MHz, 16-QAM, UL Subframe=2,3,4,7,8,9)	X	6.19	75.19	17.72	2.23	80.0	± 9.6 %
		Y	2.33	64.39	11.23		80.0	
		Z	1.83	62.54	9.68		80.0	
10499-AAA	LTE-TDD (SC-FDMA, 100% RB, 1.4 MHz, 64-QAM, UL Subframe=2,3,4,7,8,9)	X	6.08	74.60	17.40	2.23	80.0	± 9.6 %
		Y	2.20	63.55	10.68		80.0	
		Z	1.70	61.64	9.07		80.0	
10500-AAA	LTE-TDD (SC-FDMA, 100% RB, 3 MHz, QPSK, UL Subframe=2,3,4,7,8,9)	X	9.69	83.97	22.50	2.23	80.0	± 9.6 %
		Y	6.26	80.30	21.12		80.0	
		Z	7.99	85.23	22.80		80.0	
10501-AAA	LTE-TDD (SC-FDMA, 100% RB, 3 MHz, 16-QAM, UL Subframe=2,3,4,7,8,9)	X	6.73	76.14	19.79	2.23	80.0	± 9.6 %
		Y	4.97	73.89	18.33		80.0	
		Z	5.41	76.03	18.94		80.0	
10502-AAA	LTE-TDD (SC-FDMA, 100% RB, 3 MHz, 64-QAM, UL Subframe=2,3,4,7,8,9)	X	6.66	75.65	19.59	2.23	80.0	± 9.6 %
		Y	4.97	73.54	18.13		80.0	
		Z	5.36	75.51	18.67		80.0	
10503-AAC	LTE-TDD (SC-FDMA, 100% RB, 5 MHz, QPSK, UL Subframe=2,3,4,7,8,9)	X	9.33	82.74	22.21	2.23	80.0	± 9.6 %
		Y	5.90	78.70	21.01		80.0	
		Z	6.71	82.03	22.35		80.0	
10504-AAC	LTE-TDD (SC-FDMA, 100% RB, 5 MHz, 16-QAM, UL Subframe=2,3,4,7,8,9)	X	6.59	75.44	19.92	2.23	80.0	± 9.6 %
		Y	4.88	73.08	18.84		80.0	
		Z	5.07	74.71	19.47		80.0	
10505-AAC	LTE-TDD (SC-FDMA, 100% RB, 5 MHz, 64-QAM, UL Subframe=2,3,4,7,8,9)	X	6.52	74.79	19.72	2.23	80.0	± 9.6 %
		Y	4.91	72.71	18.70		80.0	
		Z	5.07	74.21	19.27		80.0	
10506-AAC	LTE-TDD (SC-FDMA, 100% RB, 10 MHz, QPSK, UL Subframe=2,3,4,7,8,9)	X	9.21	81.00	21.50	2.23	80.0	± 9.6 %
		Y	6.13	77.37	20.57		80.0	
		Z	6.56	79.62	21.60		80.0	
10507-AAC	LTE-TDD (SC-FDMA, 100% RB, 10 MHz, 16-QAM, UL Subframe=2,3,4,7,8,9)	X	6.72	74.48	19.71	2.23	80.0	± 9.6 %
		Y	5.07	72.03	18.82		80.0	
		Z	5.08	73.01	19.31		80.0	

10508-AAC	LTE-TDD (SC-FDMA, 100% RB, 10 MHz, 64-QAM, UL Subframe=2,3,4,7,8,9)	X	6.65	73.80	19.50	2.23	80.0	± 9.6 %
		Y	5.09	71.58	18.67		80.0	
		Z	5.09	72.48	19.12		80.0	
10509-AAC	LTE-TDD (SC-FDMA, 100% RB, 15 MHz, QPSK, UL Subframe=2,3,4,7,8,9)	X	8.15	77.43	20.26	2.23	80.0	± 9.6 %
		Y	5.99	74.82	19.62		80.0	
		Z	6.17	76.24	20.35		80.0	
10510-AAC	LTE-TDD (SC-FDMA, 100% RB, 15 MHz, 16-QAM, UL Subframe=2,3,4,7,8,9)	X	6.94	73.36	19.32	2.23	80.0	± 9.6 %
		Y	5.42	71.16	18.60		80.0	
		Z	5.37	71.81	18.97		80.0	
10511-AAC	LTE-TDD (SC-FDMA, 100% RB, 15 MHz, 64-QAM, UL Subframe=2,3,4,7,8,9)	X	6.87	72.87	19.19	2.23	80.0	± 9.6 %
		Y	5.44	70.83	18.50		80.0	
		Z	5.39	71.45	18.85		80.0	
10512-AAC	LTE-TDD (SC-FDMA, 100% RB, 20 MHz, QPSK, UL Subframe=2,3,4,7,8,9)	X	9.41	80.22	21.09	2.23	80.0	± 9.6 %
		Y	6.52	76.83	20.24		80.0	
		Z	6.84	78.58	21.10		80.0	
10513-AAC	LTE-TDD (SC-FDMA, 100% RB, 20 MHz, 16-QAM, UL Subframe=2,3,4,7,8,9)	X	7.03	74.19	19.61	2.23	80.0	± 9.6 %
		Y	5.36	71.56	18.76		80.0	
		Z	5.31	72.21	19.14		80.0	
10514-AAC	LTE-TDD (SC-FDMA, 100% RB, 20 MHz, 64-QAM, UL Subframe=2,3,4,7,8,9)	X	6.85	73.42	19.39	2.23	80.0	± 9.6 %
		Y	5.32	71.03	18.59		80.0	
		Z	5.27	71.61	18.94		80.0	
10515-AAA	IEEE 802.11b WiFi 2.4 GHz (DSSS, 2 Mbps, 99pc duty cycle)	X	0.98	65.05	16.44	0.00	150.0	± 9.6 %
		Y	1.00	63.56	14.97		150.0	
		Z	1.05	64.66	15.82		150.0	
10516-AAA	IEEE 802.11b WiFi 2.4 GHz (DSSS, 5.5 Mbps, 99pc duty cycle)	X	100.00	168.11	45.87	0.00	150.0	± 9.6 %
		Y	0.67	71.83	18.15		150.0	
		Z	1.04	80.65	22.82		150.0	
10517-AAA	IEEE 802.11b WiFi 2.4 GHz (DSSS, 11 Mbps, 99pc duty cycle)	X	0.96	70.11	18.69	0.00	150.0	± 9.6 %
		Y	0.85	65.61	15.70		150.0	
		Z	0.93	67.57	17.12		150.0	
10518-AAA	IEEE 802.11a/h WiFi 5 GHz (OFDM, 9 Mbps, 99pc duty cycle)	X	4.76	67.10	16.57	0.00	150.0	± 9.6 %
		Y	4.53	67.01	16.35		150.0	
		Z	4.47	67.38	16.53		150.0	
10519-AAA	IEEE 802.11a/h WiFi 5 GHz (OFDM, 12 Mbps, 99pc duty cycle)	X	5.02	67.44	16.72	0.00	150.0	± 9.6 %
		Y	4.70	67.22	16.46		150.0	
		Z	4.63	67.55	16.62		150.0	
10520-AAA	IEEE 802.11a/h WiFi 5 GHz (OFDM, 18 Mbps, 99pc duty cycle)	X	4.86	67.45	16.66	0.00	150.0	± 9.6 %
		Y	4.55	67.17	16.38		150.0	
		Z	4.48	67.50	16.54		150.0	
10521-AAA	IEEE 802.11a/h WiFi 5 GHz (OFDM, 24 Mbps, 99pc duty cycle)	X	4.79	67.47	16.66	0.00	150.0	± 9.6 %
		Y	4.48	67.16	16.36		150.0	
		Z	4.42	67.48	16.53		150.0	
10522-AAA	IEEE 802.11a/h WiFi 5 GHz (OFDM, 36 Mbps, 99pc duty cycle)	X	4.82	67.32	16.63	0.00	150.0	± 9.6 %
		Y	4.55	67.29	16.46		150.0	
		Z	4.47	67.62	16.63		150.0	

10523-AAA	IEEE 802.11a/h WiFi 5 GHz (OFDM, 48 Mbps, 99pc duty cycle)	X	4.69	67.31	16.53	0.00	150.0	± 9.6 %
		Y	4.44	67.17	16.32		150.0	
		Z	4.39	67.59	16.54		150.0	
10524-AAA	IEEE 802.11a/h WiFi 5 GHz (OFDM, 54 Mbps, 99pc duty cycle)	X	4.78	67.32	16.64	0.00	150.0	± 9.6 %
		Y	4.49	67.20	16.43		150.0	
		Z	4.42	67.57	16.62		150.0	
10525-AAA	IEEE 802.11ac WiFi (20MHz, MCS0, 99pc duty cycle)	X	4.72	66.35	16.23	0.00	150.0	± 9.6 %
		Y	4.49	66.26	16.02		150.0	
		Z	4.45	66.66	16.22		150.0	
10526-AAA	IEEE 802.11ac WiFi (20MHz, MCS1, 99pc duty cycle)	X	4.95	66.78	16.37	0.00	150.0	± 9.6 %
		Y	4.64	66.60	16.16		150.0	
		Z	4.58	66.96	16.34		150.0	
10527-AAA	IEEE 802.11ac WiFi (20MHz, MCS2, 99pc duty cycle)	X	4.86	66.80	16.35	0.00	150.0	± 9.6 %
		Y	4.57	66.56	16.10		150.0	
		Z	4.51	66.93	16.29		150.0	
10528-AAA	IEEE 802.11ac WiFi (20MHz, MCS3, 99pc duty cycle)	X	4.89	66.82	16.38	0.00	150.0	± 9.6 %
		Y	4.58	66.57	16.13		150.0	
		Z	4.52	66.94	16.32		150.0	
10529-AAA	IEEE 802.11ac WiFi (20MHz, MCS4, 99pc duty cycle)	X	4.89	66.82	16.38	0.00	150.0	± 9.6 %
		Y	4.58	66.57	16.13		150.0	
		Z	4.52	66.94	16.32		150.0	
10531-AAA	IEEE 802.11ac WiFi (20MHz, MCS6, 99pc duty cycle)	X	4.92	67.00	16.42	0.00	150.0	± 9.6 %
		Y	4.57	66.66	16.14		150.0	
		Z	4.49	66.99	16.31		150.0	
10532-AAA	IEEE 802.11ac WiFi (20MHz, MCS7, 99pc duty cycle)	X	4.76	66.93	16.40	0.00	150.0	± 9.6 %
		Y	4.43	66.51	16.07		150.0	
		Z	4.37	66.85	16.25		150.0	
10533-AAA	IEEE 802.11ac WiFi (20MHz, MCS8, 99pc duty cycle)	X	4.90	66.82	16.35	0.00	150.0	± 9.6 %
		Y	4.59	66.64	16.13		150.0	
		Z	4.53	67.03	16.33		150.0	
10534-AAA	IEEE 802.11ac WiFi (40MHz, MCS0, 99pc duty cycle)	X	5.38	66.99	16.41	0.00	150.0	± 9.6 %
		Y	5.14	66.65	16.20		150.0	
		Z	5.08	66.89	16.34		150.0	
10535-AAA	IEEE 802.11ac WiFi (40MHz, MCS1, 99pc duty cycle)	X	5.47	67.13	16.46	0.00	150.0	± 9.6 %
		Y	5.21	66.87	16.30		150.0	
		Z	5.13	67.05	16.42		150.0	
10536-AAA	IEEE 802.11ac WiFi (40MHz, MCS2, 99pc duty cycle)	X	5.32	67.12	16.45	0.00	150.0	± 9.6 %
		Y	5.08	66.81	16.25		150.0	
		Z	5.02	67.06	16.40		150.0	
10537-AAA	IEEE 802.11ac WiFi (40MHz, MCS3, 99pc duty cycle)	X	5.39	67.07	16.42	0.00	150.0	± 9.6 %
		Y	5.13	66.76	16.23		150.0	
		Z	5.08	67.03	16.39		150.0	
10538-AAA	IEEE 802.11ac WiFi (40MHz, MCS4, 99pc duty cycle)	X	5.52	67.19	16.52	0.00	150.0	± 9.6 %
		Y	5.21	66.77	16.27		150.0	
		Z	5.14	66.99	16.41		150.0	
10540-AAA	IEEE 802.11ac WiFi (40MHz, MCS6, 99pc duty cycle)	X	5.40	67.10	16.49	0.00	150.0	± 9.6 %
		Y	5.15	66.79	16.30		150.0	
		Z	5.07	66.96	16.41		150.0	

10541-AAA	IEEE 802.11ac WiFi (40MHz, MCS7, 99pc duty cycle)	X	5.41	67.10	16.49	0.00	150.0	± 9.6 %
		Y	5.12	66.64	16.21		150.0	
		Z	5.05	66.85	16.34		150.0	
10542-AAA	IEEE 802.11ac WiFi (40MHz, MCS8, 99pc duty cycle)	X	5.53	67.02	16.46	0.00	150.0	± 9.6 %
		Y	5.28	66.73	16.27		150.0	
		Z	5.21	66.95	16.40		150.0	
10543-AAA	IEEE 802.11ac WiFi (40MHz, MCS9, 99pc duty cycle)	X	5.65	67.09	16.50	0.00	150.0	± 9.6 %
		Y	5.35	66.75	16.31		150.0	
		Z	5.28	67.01	16.46		150.0	
10544-AAA	IEEE 802.11ac WiFi (80MHz, MCS0, 99pc duty cycle)	X	5.63	67.05	16.36	0.00	150.0	± 9.6 %
		Y	5.46	66.75	16.19		150.0	
		Z	5.42	66.95	16.31		150.0	
10545-AAA	IEEE 802.11ac WiFi (80MHz, MCS1, 99pc duty cycle)	X	5.85	67.43	16.48	0.00	150.0	± 9.6 %
		Y	5.67	67.24	16.39		150.0	
		Z	5.61	67.44	16.52		150.0	
10546-AAA	IEEE 802.11ac WiFi (80MHz, MCS2, 99pc duty cycle)	X	5.76	67.40	16.49	0.00	150.0	± 9.6 %
		Y	5.52	66.93	16.25		150.0	
		Z	5.45	67.09	16.35		150.0	
10547-AAA	IEEE 802.11ac WiFi (80MHz, MCS3, 99pc duty cycle)	X	5.86	67.50	16.53	0.00	150.0	± 9.6 %
		Y	5.59	67.00	16.28		150.0	
		Z	5.54	67.20	16.40		150.0	
10548-AAA	IEEE 802.11ac WiFi (80MHz, MCS4, 99pc duty cycle)	X	6.21	68.68	17.08	0.00	150.0	± 9.6 %
		Y	5.87	68.02	16.76		150.0	
		Z	5.72	67.95	16.76		150.0	
10550-AAA	IEEE 802.11ac WiFi (80MHz, MCS6, 99pc duty cycle)	X	5.77	67.31	16.45	0.00	150.0	± 9.6 %
		Y	5.57	67.05	16.32		150.0	
		Z	5.52	67.30	16.47		150.0	
10551-AAA	IEEE 802.11ac WiFi (80MHz, MCS7, 99pc duty cycle)	X	5.80	67.45	16.48	0.00	150.0	± 9.6 %
		Y	5.55	67.00	16.26		150.0	
		Z	5.45	67.07	16.32		150.0	
10552-AAA	IEEE 802.11ac WiFi (80MHz, MCS8, 99pc duty cycle)	X	5.69	67.19	16.37	0.00	150.0	± 9.6 %
		Y	5.47	66.81	16.17		150.0	
		Z	5.43	67.06	16.31		150.0	
10553-AAA	IEEE 802.11ac WiFi (80MHz, MCS9, 99pc duty cycle)	X	5.78	67.21	16.40	0.00	150.0	± 9.6 %
		Y	5.54	66.82	16.20		150.0	
		Z	5.48	67.01	16.32		150.0	
10554-AAB	IEEE 802.11ac WiFi (160MHz, MCS0, 99pc duty cycle)	X	6.03	67.43	16.45	0.00	150.0	± 9.6 %
		Y	5.89	67.12	16.28		150.0	
		Z	5.84	67.28	16.38		150.0	
10555-AAB	IEEE 802.11ac WiFi (160MHz, MCS1, 99pc duty cycle)	X	6.22	67.88	16.64	0.00	150.0	± 9.6 %
		Y	6.02	67.44	16.43		150.0	
		Z	5.95	67.54	16.50		150.0	
10556-AAB	IEEE 802.11ac WiFi (160MHz, MCS2, 99pc duty cycle)	X	6.20	67.79	16.59	0.00	150.0	± 9.6 %
		Y	6.04	67.49	16.44		150.0	
		Z	5.99	67.66	16.55		150.0	
10557-AAB	IEEE 802.11ac WiFi (160MHz, MCS3, 99pc duty cycle)	X	6.21	67.81	16.62	0.00	150.0	± 9.6 %
		Y	5.99	67.35	16.39		150.0	
		Z	5.93	67.50	16.49		150.0	

10558-AAB	IEEE 802.11ac WiFi (160MHz, MCS4, 99pc duty cycle)	X	6.28	68.03	16.75	0.00	150.0	± 9.6 %
		Y	6.04	67.52	16.49		150.0	
		Z	5.95	67.59	16.55		150.0	
10560-AAB	IEEE 802.11ac WiFi (160MHz, MCS6, 99pc duty cycle)	X	6.28	67.87	16.71	0.00	150.0	± 9.6 %
		Y	6.03	67.35	16.44		150.0	
		Z	5.96	67.49	16.53		150.0	
10561-AAB	IEEE 802.11ac WiFi (160MHz, MCS7, 99pc duty cycle)	X	6.18	67.80	16.71	0.00	150.0	± 9.6 %
		Y	5.96	67.36	16.48		150.0	
		Z	5.90	67.49	16.57		150.0	
10562-AAB	IEEE 802.11ac WiFi (160MHz, MCS8, 99pc duty cycle)	X	6.37	68.38	17.01	0.00	150.0	± 9.6 %
		Y	6.06	67.66	16.63		150.0	
		Z	5.96	67.67	16.66		150.0	
10563-AAB	IEEE 802.11ac WiFi (160MHz, MCS9, 99pc duty cycle)	X	6.58	68.54	17.02	0.00	150.0	± 9.6 %
		Y	6.18	67.65	16.59		150.0	
		Z	6.05	67.62	16.60		150.0	
10564-AAA	IEEE 802.11g WiFi 2.4 GHz (DSSS-OFDM, 9 Mbps, 99pc duty cycle)	X	5.11	67.26	16.76	0.46	150.0	± 9.6 %
		Y	4.86	67.10	16.52		150.0	
		Z	4.80	67.44	16.68		150.0	
10565-AAA	IEEE 802.11g WiFi 2.4 GHz (DSSS-OFDM, 12 Mbps, 99pc duty cycle)	X	5.41	67.77	17.08	0.46	150.0	± 9.6 %
		Y	5.08	67.53	16.83		150.0	
		Z	5.00	67.82	16.97		150.0	
10566-AAA	IEEE 802.11g WiFi 2.4 GHz (DSSS-OFDM, 18 Mbps, 99pc duty cycle)	X	5.23	67.67	16.93	0.46	150.0	± 9.6 %
		Y	4.92	67.38	16.66		150.0	
		Z	4.84	67.67	16.80		150.0	
10567-AAA	IEEE 802.11g WiFi 2.4 GHz (DSSS-OFDM, 24 Mbps, 99pc duty cycle)	X	5.26	68.03	17.24	0.46	150.0	± 9.6 %
		Y	4.95	67.77	17.01		150.0	
		Z	4.87	68.04	17.15		150.0	
10568-AAA	IEEE 802.11g WiFi 2.4 GHz (DSSS-OFDM, 36 Mbps, 99pc duty cycle)	X	5.14	67.36	16.67	0.46	150.0	± 9.6 %
		Y	4.84	67.19	16.45		150.0	
		Z	4.75	67.49	16.60		150.0	
10569-AAA	IEEE 802.11g WiFi 2.4 GHz (DSSS-OFDM, 48 Mbps, 99pc duty cycle)	X	5.19	68.02	17.24	0.46	150.0	± 9.6 %
		Y	4.92	67.92	17.11		150.0	
		Z	4.86	68.27	17.29		150.0	
10570-AAA	IEEE 802.11g WiFi 2.4 GHz (DSSS-OFDM, 54 Mbps, 99pc duty cycle)	X	5.23	67.81	17.17	0.46	150.0	± 9.6 %
		Y	4.94	67.74	17.02		150.0	
		Z	4.86	68.06	17.18		150.0	
10571-AAA	IEEE 802.11b WiFi 2.4 GHz (DSSS, 1 Mbps, 90pc duty cycle)	X	1.68	70.36	18.73	0.46	130.0	± 9.6 %
		Y	1.37	66.32	16.49		130.0	
		Z	1.41	67.39	17.29		130.0	
10572-AAA	IEEE 802.11b WiFi 2.4 GHz (DSSS, 2 Mbps, 90pc duty cycle)	X	1.75	71.47	19.28	0.46	130.0	± 9.6 %
		Y	1.40	67.01	16.89		130.0	
		Z	1.45	68.17	17.74		130.0	
10573-AAA	IEEE 802.11b WiFi 2.4 GHz (DSSS, 5.5 Mbps, 90pc duty cycle)	X	100.00	142.31	37.38	0.46	130.0	± 9.6 %
		Y	5.69	99.12	27.30		130.0	
		Z	66.26	143.73	39.41		130.0	
10574-AAA	IEEE 802.11b WiFi 2.4 GHz (DSSS, 11 Mbps, 90pc duty cycle)	X	3.57	87.71	25.60	0.46	130.0	± 9.6 %
		Y	1.70	74.22	20.29		130.0	
		Z	1.88	76.94	21.86		130.0	

10575-AAA	IEEE 802.11g WiFi 2.4 GHz (DSSS-OFDM, 6 Mbps, 90pc duty cycle)	X	4.95	67.19	16.89	0.46	130.0	± 9.6 %
		Y	4.69	67.03	16.64		130.0	
		Z	4.63	67.35	16.80		130.0	
10576-AAA	IEEE 802.11g WiFi 2.4 GHz (DSSS-OFDM, 9 Mbps, 90pc duty cycle)	X	4.98	67.35	16.96	0.46	130.0	± 9.6 %
		Y	4.72	67.20	16.72		130.0	
		Z	4.66	67.55	16.88		130.0	
10577-AAA	IEEE 802.11g WiFi 2.4 GHz (DSSS-OFDM, 12 Mbps, 90pc duty cycle)	X	5.24	67.69	17.13	0.46	130.0	± 9.6 %
		Y	4.90	67.46	16.87		130.0	
		Z	4.82	67.76	17.01		130.0	
10578-AAA	IEEE 802.11g WiFi 2.4 GHz (DSSS-OFDM, 18 Mbps, 90pc duty cycle)	X	5.14	67.89	17.23	0.46	130.0	± 9.6 %
		Y	4.81	67.63	16.98		130.0	
		Z	4.73	67.92	17.12		130.0	
10579-AAA	IEEE 802.11g WiFi 2.4 GHz (DSSS-OFDM, 24 Mbps, 90pc duty cycle)	X	4.94	67.39	16.68	0.46	130.0	± 9.6 %
		Y	4.58	66.91	16.29		130.0	
		Z	4.50	67.21	16.45		130.0	
10580-AAA	IEEE 802.11g WiFi 2.4 GHz (DSSS-OFDM, 36 Mbps, 90pc duty cycle)	X	4.98	67.29	16.65	0.46	130.0	± 9.6 %
		Y	4.62	66.97	16.32		130.0	
		Z	4.54	67.27	16.48		130.0	
10581-AAA	IEEE 802.11g WiFi 2.4 GHz (DSSS-OFDM, 48 Mbps, 90pc duty cycle)	X	5.07	68.07	17.23	0.46	130.0	± 9.6 %
		Y	4.72	67.70	16.95		130.0	
		Z	4.65	68.04	17.12		130.0	
10582-AAA	IEEE 802.11g WiFi 2.4 GHz (DSSS-OFDM, 54 Mbps, 90pc duty cycle)	X	4.90	67.13	16.49	0.46	130.0	± 9.6 %
		Y	4.51	66.68	16.07		130.0	
		Z	4.43	67.00	16.24		130.0	
10583-AAA	IEEE 802.11a/h WiFi 5 GHz (OFDM, 6 Mbps, 90pc duty cycle)	X	4.95	67.19	16.89	0.46	130.0	± 9.6 %
		Y	4.69	67.03	16.64		130.0	
		Z	4.63	67.35	16.80		130.0	
10584-AAA	IEEE 802.11a/h WiFi 5 GHz (OFDM, 9 Mbps, 90pc duty cycle)	X	4.98	67.35	16.96	0.46	130.0	± 9.6 %
		Y	4.72	67.20	16.72		130.0	
		Z	4.66	67.55	16.88		130.0	
10585-AAA	IEEE 802.11a/h WiFi 5 GHz (OFDM, 12 Mbps, 90pc duty cycle)	X	5.24	67.69	17.13	0.46	130.0	± 9.6 %
		Y	4.90	67.46	16.87		130.0	
		Z	4.82	67.76	17.01		130.0	
10586-AAA	IEEE 802.11a/h WiFi 5 GHz (OFDM, 18 Mbps, 90pc duty cycle)	X	5.14	67.89	17.23	0.46	130.0	± 9.6 %
		Y	4.81	67.63	16.98		130.0	
		Z	4.73	67.92	17.12		130.0	
10587-AAA	IEEE 802.11a/h WiFi 5 GHz (OFDM, 24 Mbps, 90pc duty cycle)	X	4.94	67.39	16.68	0.46	130.0	± 9.6 %
		Y	4.58	66.91	16.29		130.0	
		Z	4.50	67.21	16.45		130.0	
10588-AAA	IEEE 802.11a/h WiFi 5 GHz (OFDM, 36 Mbps, 90pc duty cycle)	X	4.98	67.29	16.65	0.46	130.0	± 9.6 %
		Y	4.62	66.97	16.32		130.0	
		Z	4.54	67.27	16.48		130.0	
10589-AAA	IEEE 802.11a/h WiFi 5 GHz (OFDM, 48 Mbps, 90pc duty cycle)	X	5.07	68.07	17.23	0.46	130.0	± 9.6 %
		Y	4.72	67.70	16.95		130.0	
		Z	4.65	68.04	17.12		130.0	
10590-AAA	IEEE 802.11a/h WiFi 5 GHz (OFDM, 54 Mbps, 90pc duty cycle)	X	4.90	67.13	16.49	0.46	130.0	± 9.6 %
		Y	4.51	66.68	16.07		130.0	
		Z	4.43	67.00	16.24		130.0	

10591-AAA	IEEE 802.11n (HT Mixed, 20MHz, MCS0, 90pc duty cycle)	X	5.10	67.21	16.96	0.46	130.0	± 9.6 %
		Y	4.84	67.07	16.74		130.0	
		Z	4.77	67.39	16.89		130.0	
10592-AAA	IEEE 802.11n (HT Mixed, 20MHz, MCS1, 90pc duty cycle)	X	5.29	67.56	17.07	0.46	130.0	± 9.6 %
		Y	4.98	67.40	16.87		130.0	
		Z	4.90	67.69	17.01		130.0	
10593-AAA	IEEE 802.11n (HT Mixed, 20MHz, MCS2, 90pc duty cycle)	X	5.23	67.57	17.01	0.46	130.0	± 9.6 %
		Y	4.90	67.30	16.75		130.0	
		Z	4.82	67.59	16.88		130.0	
10594-AAA	IEEE 802.11n (HT Mixed, 20MHz, MCS3, 90pc duty cycle)	X	5.28	67.68	17.13	0.46	130.0	± 9.6 %
		Y	4.96	67.47	16.91		130.0	
		Z	4.88	67.75	17.04		130.0	
10595-AAA	IEEE 802.11n (HT Mixed, 20MHz, MCS4, 90pc duty cycle)	X	5.27	67.71	17.06	0.46	130.0	± 9.6 %
		Y	4.93	67.44	16.81		130.0	
		Z	4.85	67.75	16.96		130.0	
10596-AAA	IEEE 802.11n (HT Mixed, 20MHz, MCS5, 90pc duty cycle)	X	5.21	67.70	17.06	0.46	130.0	± 9.6 %
		Y	4.86	67.44	16.81		130.0	
		Z	4.78	67.74	16.97		130.0	
10597-AAA	IEEE 802.11n (HT Mixed, 20MHz, MCS6, 90pc duty cycle)	X	5.16	67.68	17.00	0.46	130.0	± 9.6 %
		Y	4.81	67.32	16.68		130.0	
		Z	4.73	67.61	16.83		130.0	
10598-AAA	IEEE 802.11n (HT Mixed, 20MHz, MCS7, 90pc duty cycle)	X	5.15	67.96	17.27	0.46	130.0	± 9.6 %
		Y	4.80	67.55	16.95		130.0	
		Z	4.72	67.82	17.08		130.0	
10599-AAA	IEEE 802.11n (HT Mixed, 40MHz, MCS0, 90pc duty cycle)	X	5.77	67.84	17.13	0.46	130.0	± 9.6 %
		Y	5.52	67.58	16.96		130.0	
		Z	5.45	67.81	17.10		130.0	
10600-AAA	IEEE 802.11n (HT Mixed, 40MHz, MCS1, 90pc duty cycle)	X	6.05	68.67	17.52	0.46	130.0	± 9.6 %
		Y	5.68	68.13	17.21		130.0	
		Z	5.58	68.26	17.30		130.0	
10601-AAA	IEEE 802.11n (HT Mixed, 40MHz, MCS2, 90pc duty cycle)	X	5.85	68.16	17.28	0.46	130.0	± 9.6 %
		Y	5.55	67.80	17.06		130.0	
		Z	5.46	67.98	17.17		130.0	
10602-AAA	IEEE 802.11n (HT Mixed, 40MHz, MCS3, 90pc duty cycle)	X	5.99	68.30	17.27	0.46	130.0	± 9.6 %
		Y	5.68	67.95	17.06		130.0	
		Z	5.60	68.17	17.19		130.0	
10603-AAA	IEEE 802.11n (HT Mixed, 40MHz, MCS4, 90pc duty cycle)	X	6.09	68.64	17.55	0.46	130.0	± 9.6 %
		Y	5.74	68.19	17.31		130.0	
		Z	5.66	68.42	17.44		130.0	
10604-AAA	IEEE 802.11n (HT Mixed, 40MHz, MCS5, 90pc duty cycle)	X	5.79	67.86	17.16	0.46	130.0	± 9.6 %
		Y	5.59	67.76	17.08		130.0	
		Z	5.54	68.06	17.25		130.0	
10605-AAA	IEEE 802.11n (HT Mixed, 40MHz, MCS6, 90pc duty cycle)	X	5.90	68.15	17.31	0.46	130.0	± 9.6 %
		Y	5.67	68.01	17.21		130.0	
		Z	5.56	68.12	17.28		130.0	
10606-AAA	IEEE 802.11n (HT Mixed, 40MHz, MCS7, 90pc duty cycle)	X	5.65	67.59	16.91	0.46	130.0	± 9.6 %
		Y	5.37	67.19	16.65		130.0	
		Z	5.33	67.51	16.83		130.0	

10607-AAA	IEEE 802.11ac WiFi (20MHz, MCS0, 90pc duty cycle)	X	4.92	66.49	16.57	0.46	130.0	± 9.6 %
		Y	4.68	66.39	16.37		130.0	
		Z	4.62	66.76	16.54		130.0	
10608-AAA	IEEE 802.11ac WiFi (20MHz, MCS1, 90pc duty cycle)	X	5.16	66.93	16.72	0.46	130.0	± 9.6 %
		Y	4.85	66.77	16.53		130.0	
		Z	4.77	67.10	16.69		130.0	
10609-AAA	IEEE 802.11ac WiFi (20MHz, MCS2, 90pc duty cycle)	X	5.06	66.87	16.62	0.46	130.0	± 9.6 %
		Y	4.74	66.62	16.36		130.0	
		Z	4.67	66.96	16.53		130.0	
10610-AAA	IEEE 802.11ac WiFi (20MHz, MCS3, 90pc duty cycle)	X	5.11	67.01	16.76	0.46	130.0	± 9.6 %
		Y	4.79	66.78	16.53		130.0	
		Z	4.72	67.11	16.69		130.0	
10611-AAA	IEEE 802.11ac WiFi (20MHz, MCS4, 90pc duty cycle)	X	5.05	66.92	16.66	0.46	130.0	± 9.6 %
		Y	4.71	66.59	16.38		130.0	
		Z	4.64	66.93	16.55		130.0	
10612-AAA	IEEE 802.11ac WiFi (20MHz, MCS5, 90pc duty cycle)	X	5.07	67.04	16.68	0.46	130.0	± 9.6 %
		Y	4.72	66.76	16.43		130.0	
		Z	4.64	67.09	16.61		130.0	
10613-AAA	IEEE 802.11ac WiFi (20MHz, MCS6, 90pc duty cycle)	X	5.09	66.98	16.60	0.46	130.0	± 9.6 %
		Y	4.71	66.61	16.29		130.0	
		Z	4.63	66.91	16.45		130.0	
10614-AAA	IEEE 802.11ac WiFi (20MHz, MCS7, 90pc duty cycle)	X	5.02	67.21	16.84	0.46	130.0	± 9.6 %
		Y	4.67	66.81	16.53		130.0	
		Z	4.59	67.11	16.69		130.0	
10615-AAA	IEEE 802.11ac WiFi (20MHz, MCS8, 90pc duty cycle)	X	5.05	66.70	16.43	0.46	130.0	± 9.6 %
		Y	4.71	66.43	16.16		130.0	
		Z	4.64	66.79	16.34		130.0	
10616-AAA	IEEE 802.11ac WiFi (40MHz, MCS0, 90pc duty cycle)	X	5.58	67.10	16.74	0.46	130.0	± 9.6 %
		Y	5.33	66.79	16.55		130.0	
		Z	5.25	67.00	16.67		130.0	
10617-AAA	IEEE 802.11ac WiFi (40MHz, MCS1, 90pc duty cycle)	X	5.66	67.25	16.77	0.46	130.0	± 9.6 %
		Y	5.41	67.04	16.65		130.0	
		Z	5.31	67.19	16.74		130.0	
10618-AAA	IEEE 802.11ac WiFi (40MHz, MCS2, 90pc duty cycle)	X	5.54	67.29	16.82	0.46	130.0	± 9.6 %
		Y	5.29	67.03	16.66		130.0	
		Z	5.22	67.24	16.78		130.0	
10619-AAA	IEEE 802.11ac WiFi (40MHz, MCS3, 90pc duty cycle)	X	5.56	67.09	16.66	0.46	130.0	± 9.6 %
		Y	5.30	66.81	16.48		130.0	
		Z	5.23	67.05	16.63		130.0	
10620-AAA	IEEE 802.11ac WiFi (40MHz, MCS4, 90pc duty cycle)	X	5.71	67.30	16.81	0.46	130.0	± 9.6 %
		Y	5.38	66.84	16.54		130.0	
		Z	5.30	67.04	16.67		130.0	
10621-AAA	IEEE 802.11ac WiFi (40MHz, MCS5, 90pc duty cycle)	X	5.66	67.28	16.90	0.46	130.0	± 9.6 %
		Y	5.39	66.98	16.73		130.0	
		Z	5.30	67.12	16.82		130.0	
10622-AAA	IEEE 802.11ac WiFi (40MHz, MCS6, 90pc duty cycle)	X	5.65	67.37	16.94	0.46	130.0	± 9.6 %
		Y	5.40	67.13	16.80		130.0	
		Z	5.30	67.22	16.87		130.0	

10623-AAA	IEEE 802.11ac WiFi (40MHz, MCS7, 90pc duty cycle)	X	5.58	67.14	16.73	0.46	130.0	± 9.6 %
		Y	5.28	66.65	16.43		130.0	
		Z	5.18	66.78	16.52		130.0	
10624-AAA	IEEE 802.11ac WiFi (40MHz, MCS8, 90pc duty cycle)	X	5.72	67.10	16.77	0.46	130.0	± 9.6 %
		Y	5.47	66.85	16.60		130.0	
		Z	5.38	67.03	16.70		130.0	
10625-AAA	IEEE 802.11ac WiFi (40MHz, MCS9, 90pc duty cycle)	X	6.05	67.87	17.19	0.46	130.0	± 9.6 %
		Y	5.77	67.66	17.06		130.0	
		Z	5.49	67.24	16.87		130.0	
10626-AAA	IEEE 802.11ac WiFi (80MHz, MCS0, 90pc duty cycle)	X	5.80	67.08	16.64	0.46	130.0	± 9.6 %
		Y	5.63	66.82	16.50		130.0	
		Z	5.57	66.99	16.60		130.0	
10627-AAA	IEEE 802.11ac WiFi (80MHz, MCS1, 90pc duty cycle)	X	6.05	67.56	16.82	0.46	130.0	± 9.6 %
		Y	5.90	67.51	16.81		130.0	
		Z	5.83	67.67	16.91		130.0	
10628-AAA	IEEE 802.11ac WiFi (80MHz, MCS2, 90pc duty cycle)	X	5.89	67.33	16.66	0.46	130.0	± 9.6 %
		Y	5.66	66.90	16.43		130.0	
		Z	5.58	67.01	16.51		130.0	
10629-AAA	IEEE 802.11ac WiFi (80MHz, MCS3, 90pc duty cycle)	X	6.01	67.46	16.71	0.46	130.0	± 9.6 %
		Y	5.74	67.00	16.48		130.0	
		Z	5.68	67.19	16.60		130.0	
10630-AAA	IEEE 802.11ac WiFi (80MHz, MCS4, 90pc duty cycle)	X	6.66	69.52	17.74	0.46	130.0	± 9.6 %
		Y	6.23	68.64	17.29		130.0	
		Z	5.99	68.32	17.17		130.0	
10631-AAA	IEEE 802.11ac WiFi (80MHz, MCS5, 90pc duty cycle)	X	6.51	69.16	17.72	0.46	130.0	± 9.6 %
		Y	6.05	68.21	17.27		130.0	
		Z	5.91	68.16	17.27		130.0	
10632-AAA	IEEE 802.11ac WiFi (80MHz, MCS6, 90pc duty cycle)	X	6.07	67.76	17.04	0.46	130.0	± 9.6 %
		Y	5.87	67.57	16.97		130.0	
		Z	5.81	67.79	17.10		130.0	
10633-AAA	IEEE 802.11ac WiFi (80MHz, MCS7, 90pc duty cycle)	X	6.04	67.71	16.86	0.46	130.0	± 9.6 %
		Y	5.71	67.04	16.54		130.0	
		Z	5.62	67.14	16.61		130.0	
10634-AAA	IEEE 802.11ac WiFi (80MHz, MCS8, 90pc duty cycle)	X	6.01	67.64	16.89	0.46	130.0	± 9.6 %
		Y	5.69	67.06	16.60		130.0	
		Z	5.63	67.23	16.71		130.0	
10635-AAA	IEEE 802.11ac WiFi (80MHz, MCS9, 90pc duty cycle)	X	5.88	66.99	16.33	0.46	130.0	± 9.6 %
		Y	5.57	66.39	16.00		130.0	
		Z	5.49	66.55	16.11		130.0	
10636-AAB	IEEE 802.11ac WiFi (160MHz, MCS0, 90pc duty cycle)	X	6.20	67.47	16.73	0.46	130.0	± 9.6 %
		Y	6.06	67.19	16.58		130.0	
		Z	6.01	67.33	16.67		130.0	
10637-AAB	IEEE 802.11ac WiFi (160MHz, MCS1, 90pc duty cycle)	X	6.43	68.00	16.96	0.46	130.0	± 9.6 %
		Y	6.23	67.63	16.79		130.0	
		Z	6.14	67.69	16.84		130.0	
10638-AAB	IEEE 802.11ac WiFi (160MHz, MCS2, 90pc duty cycle)	X	6.38	67.82	16.85	0.46	130.0	± 9.6 %
		Y	6.23	67.59	16.75		130.0	
		Z	6.16	67.71	16.83		130.0	

10639-AAB	IEEE 802.11ac WiFi (160MHz, MCS3, 90pc duty cycle)	X	6.40	67.91	16.95	0.46	130.0	± 9.6 %
		Y	6.18	67.47	16.73		130.0	
		Z	6.11	67.58	16.80		130.0	
10640-AAB	IEEE 802.11ac WiFi (160MHz, MCS4, 90pc duty cycle)	X	6.45	68.06	16.97	0.46	130.0	± 9.6 %
		Y	6.19	67.49	16.68		130.0	
		Z	6.09	67.54	16.73		130.0	
10641-AAB	IEEE 802.11ac WiFi (160MHz, MCS5, 90pc duty cycle)	X	6.42	67.72	16.82	0.46	130.0	± 9.6 %
		Y	6.26	67.48	16.70		130.0	
		Z	6.18	67.60	16.78		130.0	
10642-AAB	IEEE 802.11ac WiFi (160MHz, MCS6, 90pc duty cycle)	X	6.51	68.09	17.16	0.46	130.0	± 9.6 %
		Y	6.27	67.64	16.94		130.0	
		Z	6.19	67.74	17.01		130.0	
10643-AAB	IEEE 802.11ac WiFi (160MHz, MCS7, 90pc duty cycle)	X	6.33	67.78	16.92	0.46	130.0	± 9.6 %
		Y	6.13	67.39	16.71		130.0	
		Z	6.05	67.49	16.79		130.0	
10644-AAB	IEEE 802.11ac WiFi (160MHz, MCS8, 90pc duty cycle)	X	6.62	68.66	17.38	0.46	130.0	± 9.6 %
		Y	6.24	67.74	16.91		130.0	
		Z	6.11	67.69	16.91		130.0	
10645-AAB	IEEE 802.11ac WiFi (160MHz, MCS9, 90pc duty cycle)	X	6.82	68.76	17.37	0.46	130.0	± 9.6 %
		Y	6.42	67.94	16.97		130.0	
		Z	6.29	67.89	16.97		130.0	
10646-AAD	LTE-TDD (SC-FDMA, 1 RB, 5 MHz, QPSK, UL Subframe=2,7)	X	22.37	99.45	32.18	9.30	60.0	± 9.6 %
		Y	34.93	118.52	39.50		60.0	
		Z	65.31	137.01	45.15		60.0	
10647-AAC	LTE-TDD (SC-FDMA, 1 RB, 20 MHz, QPSK, UL Subframe=2,7)	X	23.87	101.54	32.95	9.30	60.0	± 9.6 %
		Y	35.03	119.53	39.96		60.0	
		Z	61.92	136.93	45.35		60.0	
10648-AAA	CDMA2000 (1x Advanced)	X	1.11	70.04	15.37	0.00	150.0	± 9.6 %
		Y	0.68	63.85	10.64		150.0	
		Z	0.72	65.39	11.21		150.0	
10652-AAB	LTE-TDD (OFDMA, 5 MHz, E-TM 3.1, Clipping 44%)	X	5.43	70.91	18.53	2.23	80.0	± 9.6 %
		Y	4.44	69.41	17.59		80.0	
		Z	4.46	70.35	17.94		80.0	
10653-AAB	LTE-TDD (OFDMA, 10 MHz, E-TM 3.1, Clipping 44%)	X	5.75	69.79	18.37	2.23	80.0	± 9.6 %
		Y	4.85	68.29	17.59		80.0	
		Z	4.80	68.81	17.83		80.0	
10654-AAB	LTE-TDD (OFDMA, 15 MHz, E-TM 3.1, Clipping 44%)	X	5.63	69.47	18.36	2.23	80.0	± 9.6 %
		Y	4.81	67.88	17.59		80.0	
		Z	4.76	68.31	17.81		80.0	
10655-AAB	LTE-TDD (OFDMA, 20 MHz, E-TM 3.1, Clipping 44%)	X	5.69	69.55	18.41	2.23	80.0	± 9.6 %
		Y	4.87	67.81	17.62		80.0	
		Z	4.82	68.18	17.82		80.0	

^F Uncertainty is determined using the max. deviation from linear response applying rectangular distribution and is expressed for the square of the field value.



Accredited by the Swiss Accreditation Service (SAS)
The Swiss Accreditation Service is one of the signatories to the EA
Multilateral Agreement for the recognition of calibration certificates

Accreditation No.: **SCS 0108**

Client **PC Test**

Certificate No: **EX3-7406_May18**

CALIBRATION CERTIFICATE

Object: **EX3DV4 - SN:7406**

Calibration procedure(s): **QA CAL-01.v9, QA CAL-12.v9, QA CAL-23.v5, QA CAL-25.v6
Calibration procedure for dosimetric E-field probes**

Calibration date: **May 22, 2018**

*BNV
06-25-2018*

This calibration certificate documents the traceability to national standards, which realize the physical units of measurements (SI).
The measurements and the uncertainties with confidence probability are given on the following pages and are part of the certificate.

All calibrations have been conducted in the closed laboratory facility: environment temperature (22 ± 3)°C and humidity < 70%.

Calibration Equipment used (M&TE critical for calibration)

Primary Standards	ID	Cal Date (Certificate No.)	Scheduled Calibration
Power meter NRP	SN: 104778	04-Apr-18 (No. 217-02672/02673)	Apr-19
Power sensor NRP-Z91	SN: 103244	04-Apr-18 (No. 217-02672)	Apr-19
Power sensor NRP-Z91	SN: 103245	04-Apr-18 (No. 217-02673)	Apr-19
Reference 20 dB Attenuator	SN: S5277 (20x)	04-Apr-18 (No. 217-02682)	Apr-19
Reference Probe ES3DV2	SN: 3013	30-Dec-17 (No. ES3-3013_Dec17)	Dec-18
DAE4	SN: 660	21-Dec-17 (No. DAE4-660_Dec17)	Dec-18
Secondary Standards	ID	Check Date (in house)	Scheduled Check
Power meter E4419B	SN: GB41293874	06-Apr-16 (in house check Jun-16)	In house check: Jun-18
Power sensor E4412A	SN: MY41498087	06-Apr-16 (in house check Jun-16)	In house check: Jun-18
Power sensor E4412A	SN: 000110210	06-Apr-16 (in house check Jun-16)	In house check: Jun-18
RF generator HP 8648C	SN: US3642U01700	04-Aug-99 (in house check Jun-16)	In house check: Jun-18
Network Analyzer HP 8753E	SN: US37390585	18-Oct-01 (in house check Oct-17)	In house check: Oct-18

	Name	Function	Signature
Calibrated by:	Jeton Kastrati	Laboratory Technician	
Approved by:	Katja Pokovic	Technical Manager	

Issued: May 22, 2018

This calibration certificate shall not be reproduced except in full without written approval of the laboratory.



Accredited by the Swiss Accreditation Service (SAS)

Accreditation No.: **SCS 0108**

The Swiss Accreditation Service is one of the signatories to the EA
Multilateral Agreement for the recognition of calibration certificates

Glossary:

TSL	tissue simulating liquid
NORM _{x,y,z}	sensitivity in free space
ConvF	sensitivity in TSL / NORM _{x,y,z}
DCP	diode compression point
CF	crest factor (1/duty_cycle) of the RF signal
A, B, C, D	modulation dependent linearization parameters
Polarization φ	φ rotation around probe axis
Polarization ϑ	ϑ rotation around an axis that is in the plane normal to probe axis (at measurement center), i.e., $\vartheta = 0$ is normal to probe axis
Connector Angle	information used in DASY system to align probe sensor X to the robot coordinate system

Calibration is Performed According to the Following Standards:

- IEEE Std 1528-2013, "IEEE Recommended Practice for Determining the Peak Spatial-Averaged Specific Absorption Rate (SAR) in the Human Head from Wireless Communications Devices: Measurement Techniques", June 2013
- IEC 62209-1, "Measurement procedure for the assessment of Specific Absorption Rate (SAR) from hand-held and body-mounted devices used next to the ear (frequency range of 300 MHz to 6 GHz)", July 2016
- IEC 62209-2, "Procedure to determine the Specific Absorption Rate (SAR) for wireless communication devices used in close proximity to the human body (frequency range of 30 MHz to 6 GHz)", March 2010
- KDB 865664, "SAR Measurement Requirements for 100 MHz to 6 GHz"

Methods Applied and Interpretation of Parameters:

- NORM_{x,y,z}**: Assessed for E-field polarization $\vartheta = 0$ ($f \leq 900$ MHz in TEM-cell; $f > 1800$ MHz: R22 waveguide). NORM_{x,y,z} are only intermediate values, i.e., the uncertainties of NORM_{x,y,z} does not affect the E²-field uncertainty inside TSL (see below ConvF).
- NORM(f)_{x,y,z}** = NORM_{x,y,z} * frequency_response (see Frequency Response Chart). This linearization is implemented in DASY4 software versions later than 4.2. The uncertainty of the frequency response is included in the stated uncertainty of ConvF.
- DCP_{x,y,z}**: DCP are numerical linearization parameters assessed based on the data of power sweep with CW signal (no uncertainty required). DCP does not depend on frequency nor media.
- PAR**: PAR is the Peak to Average Ratio that is not calibrated but determined based on the signal characteristics
- A_{x,y,z}; B_{x,y,z}; C_{x,y,z}; D_{x,y,z}; VR_{x,y,z}**: A, B, C, D are numerical linearization parameters assessed based on the data of power sweep for specific modulation signal. The parameters do not depend on frequency nor media. VR is the maximum calibration range expressed in RMS voltage across the diode.
- ConvF and Boundary Effect Parameters**: Assessed in flat phantom using E-field (or Temperature Transfer Standard for $f \leq 800$ MHz) and inside waveguide using analytical field distributions based on power measurements for $f > 800$ MHz. The same setups are used for assessment of the parameters applied for boundary compensation (alpha, depth) of which typical uncertainty values are given. These parameters are used in DASY4 software to improve probe accuracy close to the boundary. The sensitivity in TSL corresponds to NORM_{x,y,z} * ConvF whereby the uncertainty corresponds to that given for ConvF. A frequency dependent ConvF is used in DASY version 4.4 and higher which allows extending the validity from ± 50 MHz to ± 100 MHz.
- Spherical isotropy (3D deviation from isotropy)**: in a field of low gradients realized using a flat phantom exposed by a patch antenna.
- Sensor Offset**: The sensor offset corresponds to the offset of virtual measurement center from the probe tip (on probe axis). No tolerance required.
- Connector Angle**: The angle is assessed using the information gained by determining the NORM_x (no uncertainty required).

Probe EX3DV4

SN:7406

Manufactured: November 24, 2015
Calibrated: May 22, 2018

Calibrated for DASY/EASY Systems
(Note: non-compatible with DASY2 system!)

DASY/EASY - Parameters of Probe: EX3DV4 - SN:7406

Basic Calibration Parameters

	Sensor X	Sensor Y	Sensor Z	Unc (k=2)
Norm ($\mu\text{V}/(\text{V}/\text{m})^2$) ^A	0.47	0.43	0.46	$\pm 10.1 \%$
DCP (mV) ^B	98.8	100.2	97.1	

Modulation Calibration Parameters

UID	Communication System Name		A dB	B dB $\sqrt{\mu\text{V}}$	C	D dB	VR mV	Unc ^E (k=2)
0	CW	X	0.0	0.0	1.0	0.00	159.0	$\pm 3.3 \%$
		Y	0.0	0.0	1.0		176.8	
		Z	0.0	0.0	1.0		172.1	

Note: For details on UID parameters see Appendix.

Sensor Model Parameters

	C1 fF	C2 fF	α V ⁻¹	T1 ms.V ⁻²	T2 ms.V ⁻¹	T3 ms	T4 V ⁻²	T5 V ⁻¹	T6
X	40.51	308.1	36.65	8.462	0.498	5.057	0.000	0.453	1.008
Y	20.79	155.9	36.07	8.177	0.281	5.026	0.312	0.202	1.000
Z	39.96	308.6	37.72	7.122	0.556	5.056	0.094	0.485	1.007

The reported uncertainty of measurement is stated as the standard uncertainty of measurement multiplied by the coverage factor k=2, which for a normal distribution corresponds to a coverage probability of approximately 95%.

^A The uncertainties of Norm X,Y,Z do not affect the E²-field uncertainty inside TSL (see Pages 5 and 6).

^B Numerical linearization parameter: uncertainty not required.

^E Uncertainty is determined using the max. deviation from linear response applying rectangular distribution and is expressed for the square of the field value.

DASY/EASY - Parameters of Probe: EX3DV4 - SN:7406

Calibration Parameter Determined in Head Tissue Simulating Media

f (MHz) ^C	Relative Permittivity ^F	Conductivity (S/m) ^F	ConvF X	ConvF Y	ConvF Z	Alpha ^G	Depth ^G (mm)	Unc (k=2)
30	55.0	0.75	16.52	16.52	16.52	0.00	1.00	± 13.3 %
750	41.9	0.89	10.09	10.09	10.09	0.48	0.90	± 12.0 %
835	41.5	0.90	9.70	9.70	9.70	0.43	0.91	± 12.0 %
1750	40.1	1.37	8.58	8.58	8.58	0.35	0.80	± 12.0 %
1900	40.0	1.40	8.22	8.22	8.22	0.39	0.84	± 12.0 %
2300	39.5	1.67	7.95	7.95	7.95	0.30	0.84	± 12.0 %
2450	39.2	1.80	7.54	7.54	7.54	0.31	0.87	± 12.0 %
2600	39.0	1.96	7.40	7.40	7.40	0.25	0.95	± 12.0 %

^C Frequency validity above 300 MHz of ± 100 MHz only applies for DASY v4.4 and higher (see Page 2), else it is restricted to ± 50 MHz. The uncertainty is the RSS of the ConvF uncertainty at calibration frequency and the uncertainty for the indicated frequency band. Frequency validity below 300 MHz is ± 10, 25, 40, 50 and 70 MHz for ConvF assessments at 30, 64, 128, 150 and 220 MHz respectively. Above 5 GHz frequency validity can be extended to ± 110 MHz.

^F At frequencies below 3 GHz, the validity of tissue parameters (ϵ and σ) can be relaxed to ± 10% if liquid compensation formula is applied to measured SAR values. At frequencies above 3 GHz, the validity of tissue parameters (ϵ and σ) is restricted to ± 5%. The uncertainty is the RSS of the ConvF uncertainty for indicated target tissue parameters.

^G Alpha/Depth are determined during calibration. SPEAG warrants that the remaining deviation due to the boundary effect after compensation is always less than ± 1% for frequencies below 3 GHz and below ± 2% for frequencies between 3-6 GHz at any distance larger than half the probe tip diameter from the boundary.

DASY/EASY - Parameters of Probe: EX3DV4 - SN:7406

Calibration Parameter Determined in Body Tissue Simulating Media

f (MHz) ^C	Relative Permittivity ^F	Conductivity (S/m) ^F	ConvF X	ConvF Y	ConvF Z	Alpha ^G	Depth ^G (mm)	Unc (k=2)
750	55.5	0.96	9.91	9.91	9.91	0.52	0.80	± 12.0 %
835	55.2	0.97	9.61	9.61	9.61	0.52	0.80	± 12.0 %
1750	53.4	1.49	8.04	8.04	8.04	0.43	0.84	± 12.0 %
1900	53.3	1.52	7.74	7.74	7.74	0.39	0.84	± 12.0 %
2300	52.9	1.81	7.46	7.46	7.46	0.41	0.86	± 12.0 %
2450	52.7	1.95	7.30	7.30	7.30	0.43	0.88	± 12.0 %
2600	52.5	2.16	7.27	7.27	7.27	0.33	0.98	± 12.0 %

^C Frequency validity above 300 MHz of ± 100 MHz only applies for DASY v4.4 and higher (see Page 2), else it is restricted to ± 50 MHz. The uncertainty is the RSS of the ConvF uncertainty at calibration frequency and the uncertainty for the indicated frequency band. Frequency validity below 300 MHz is ± 10, 25, 40, 50 and 70 MHz for ConvF assessments at 30, 64, 128, 150 and 220 MHz respectively. Above 5 GHz frequency validity can be extended to ± 110 MHz.

^F At frequencies below 3 GHz, the validity of tissue parameters (ϵ and σ) can be relaxed to ± 10% if liquid compensation formula is applied to measured SAR values. At frequencies above 3 GHz, the validity of tissue parameters (ϵ and σ) is restricted to ± 5%. The uncertainty is the RSS of the ConvF uncertainty for indicated target tissue parameters.

^G Alpha/Depth are determined during calibration. SPEAG warrants that the remaining deviation due to the boundary effect after compensation is always less than ± 1% for frequencies below 3 GHz and below ± 2% for frequencies between 3-6 GHz at any distance larger than half the probe tip diameter from the boundary.

Frequency Response of E-Field (TEM-Cell:ifi110 EXX, Waveguide: R22)

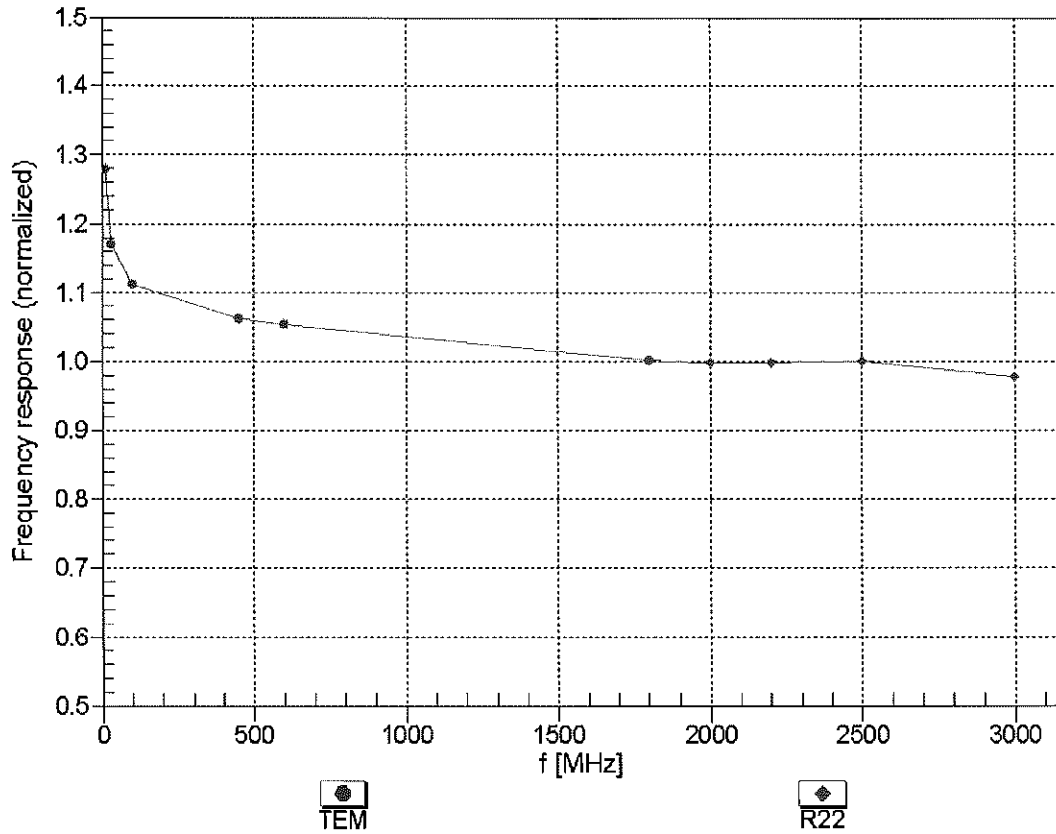

Uncertainty of Frequency Response of E-field: $\pm 6.3\%$ (k=2)

Receiving Pattern (ϕ), $\theta = 0^\circ$

f=600 MHz, TEM

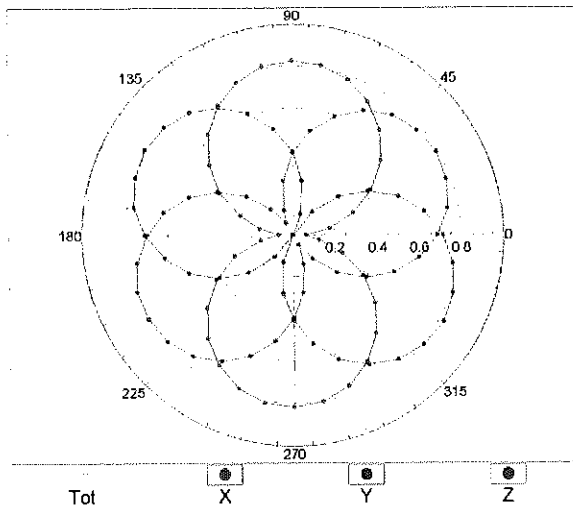

f=1800 MHz, R22

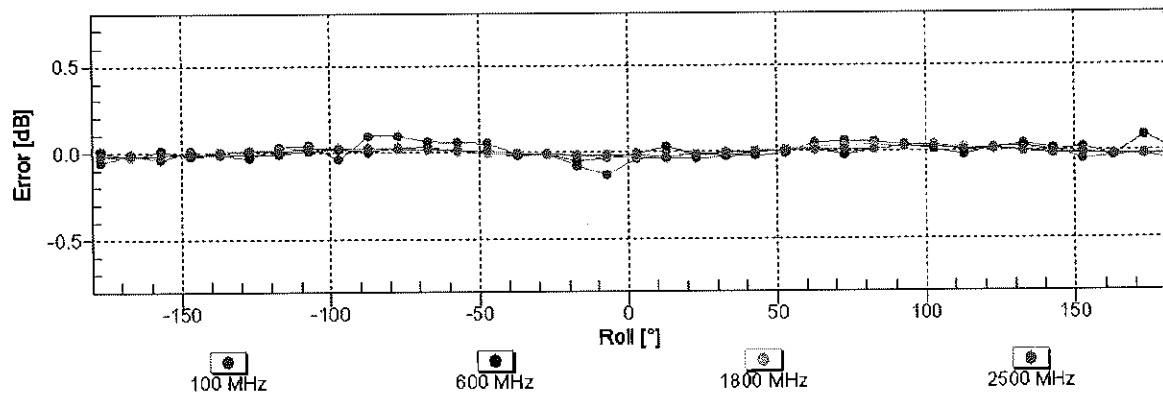
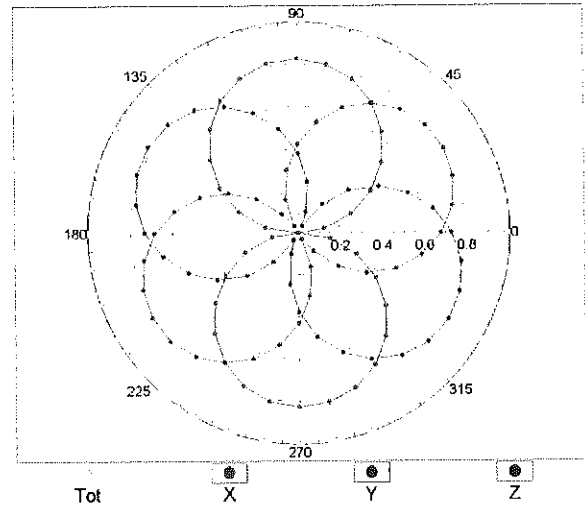

Uncertainty of Axial Isotropy Assessment: $\pm 0.5\%$ ($k=2$)

Dynamic Range $f(SAR_{head})$ (TEM cell , $f_{eval} = 1900$ MHz)

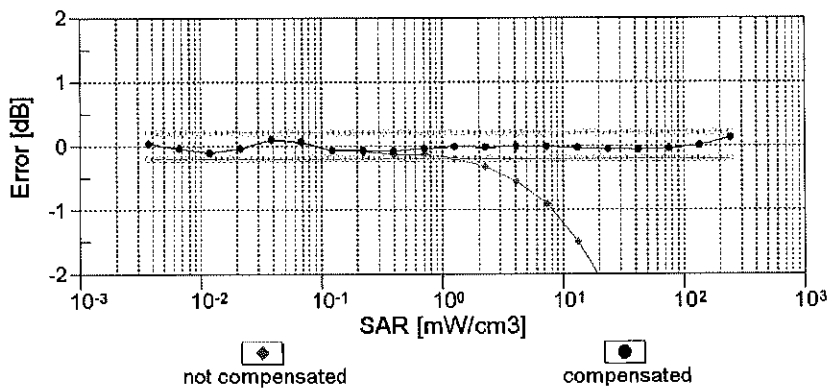
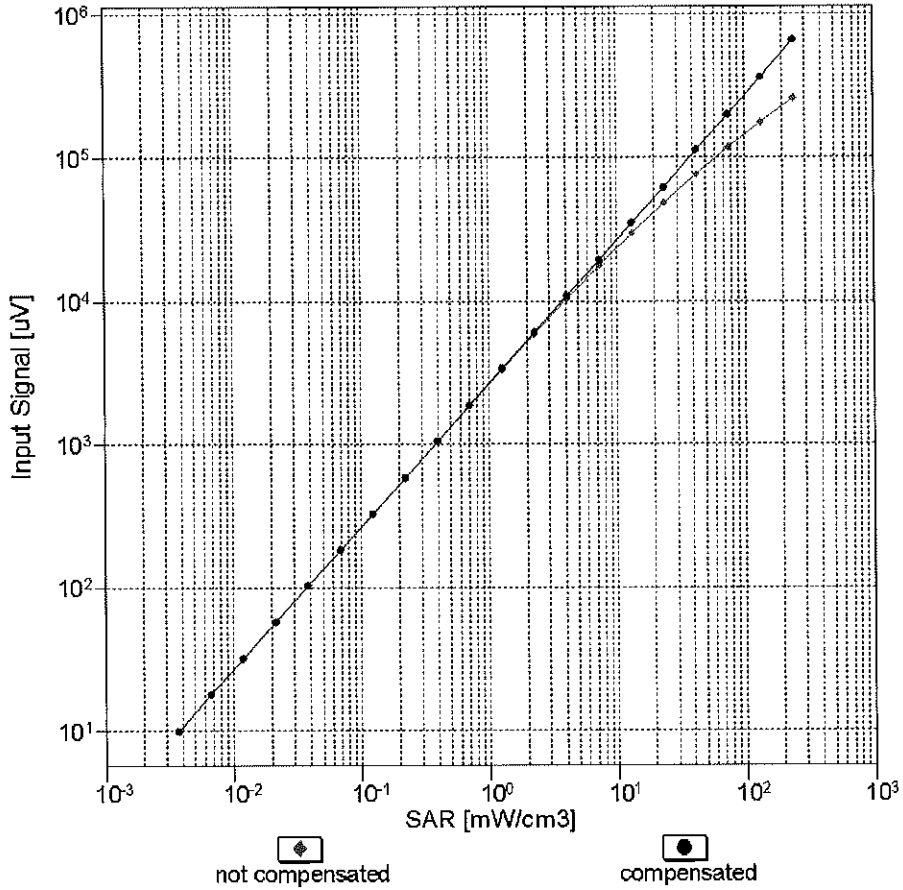

Uncertainty of Linearity Assessment: $\pm 0.6\%$ (k=2)

Conversion Factor Assessment

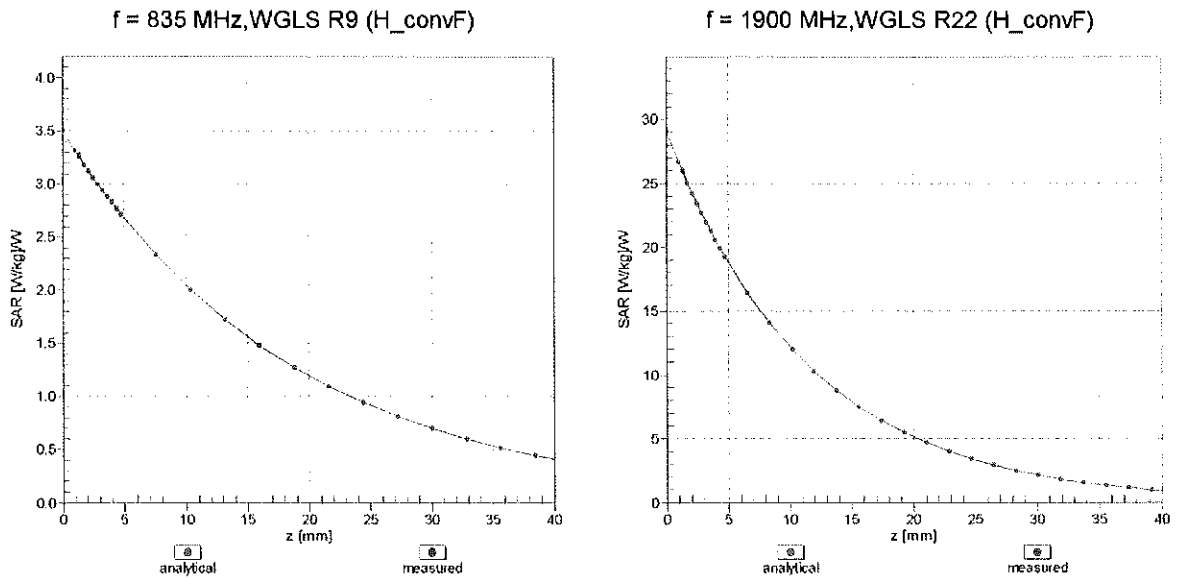

Deviation from Isotropy in Liquid Error (ϕ, θ), f = 900 MHz

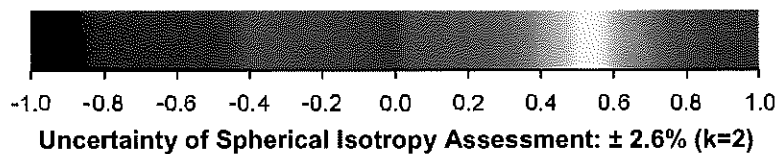
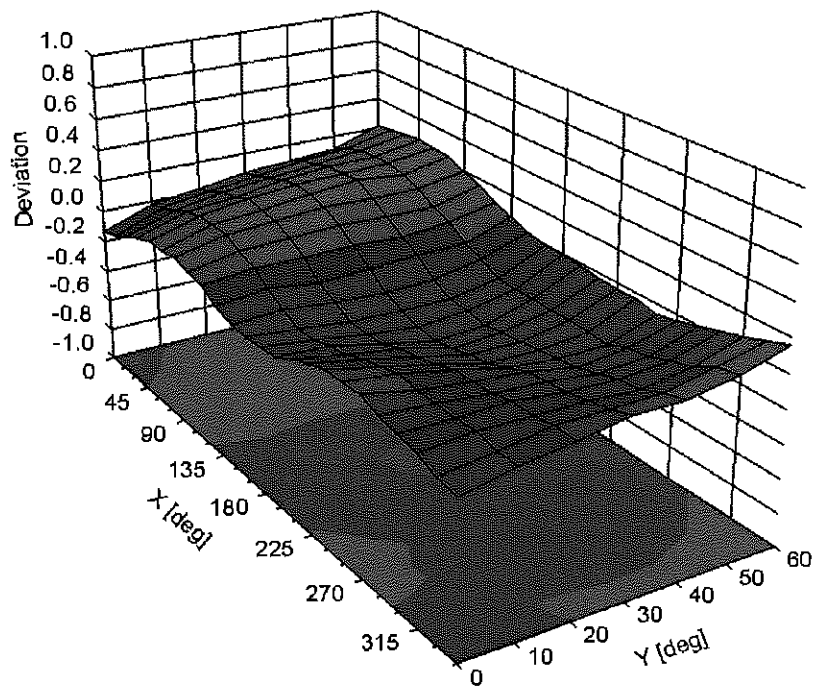

DASY/EASY - Parameters of Probe: EX3DV4 - SN:7406

Other Probe Parameters

Sensor Arrangement	Triangular
Connector Angle (°)	2.9
Mechanical Surface Detection Mode	enabled
Optical Surface Detection Mode	disabled
Probe Overall Length	337 mm
Probe Body Diameter	10 mm
Tip Length	9 mm
Tip Diameter	2.5 mm
Probe Tip to Sensor X Calibration Point	1 mm
Probe Tip to Sensor Y Calibration Point	1 mm
Probe Tip to Sensor Z Calibration Point	1 mm
Recommended Measurement Distance from Surface	1.4 mm

Appendix: Modulation Calibration Parameters

UID	Communication System Name		A dB	B dB $\sqrt{\mu V}$	C	D dB	VR mV	Max Unc ^E (k=2)
0	CW	X	0.00	0.00	1.00	0.00	159.0	$\pm 3.3 \%$
		Y	0.00	0.00	1.00		176.8	
		Z	0.00	0.00	1.00		172.1	
10010- CAA	SAR Validation (Square, 100ms, 10ms)	X	2.08	64.96	9.67	10.00	20.0	$\pm 9.6 \%$
		Y	1.53	62.37	7.61		20.0	
		Z	1.91	63.93	9.02		20.0	
10011- CAB	UMTS-FDD (WCDMA)	X	0.84	64.72	13.20	0.00	150.0	$\pm 9.6 \%$
		Y	2.29	84.03	21.49		150.0	
		Z	0.87	65.77	13.83		150.0	
10012- CAB	IEEE 802.11b WiFi 2.4 GHz (DSSS, 1 Mbps)	X	1.07	62.64	14.17	0.41	150.0	$\pm 9.6 \%$
		Y	1.16	66.58	16.90		150.0	
		Z	1.05	62.95	14.54		150.0	
10013- CAB	IEEE 802.11g WiFi 2.4 GHz (DSSS-OFDM, 6 Mbps)	X	4.71	66.44	16.84	1.46	150.0	$\pm 9.6 \%$
		Y	4.37	67.68	17.36		150.0	
		Z	4.70	66.50	16.96		150.0	
10021- DAC	GSM-FDD (TDMA, GMSK)	X	100.00	111.67	26.02	9.39	50.0	$\pm 9.6 \%$
		Y	100.00	105.88	22.91		50.0	
		Z	100.00	110.56	25.48		50.0	
10023- DAC	GPRS-FDD (TDMA, GMSK, TN 0)	X	100.00	111.18	25.86	9.57	50.0	$\pm 9.6 \%$
		Y	100.00	104.93	22.52		50.0	
		Z	100.00	110.10	25.33		50.0	
10024- DAC	GPRS-FDD (TDMA, GMSK, TN 0-1)	X	100.00	110.92	24.51	6.56	60.0	$\pm 9.6 \%$
		Y	100.00	104.17	21.07		60.0	
		Z	100.00	109.40	23.71		60.0	
10025- DAC	EDGE-FDD (TDMA, 8PSK, TN 0)	X	3.97	69.08	25.47	12.57	50.0	$\pm 9.6 \%$
		Y	6.34	86.82	35.22		50.0	
		Z	3.66	66.66	24.05		50.0	
10026- DAC	EDGE-FDD (TDMA, 8PSK, TN 0-1)	X	6.82	85.96	30.56	9.56	60.0	$\pm 9.6 \%$
		Y	6.90	89.59	32.84		60.0	
		Z	6.52	85.14	30.29		60.0	
10027- DAC	GPRS-FDD (TDMA, GMSK, TN 0-1-2)	X	100.00	111.11	23.76	4.80	80.0	$\pm 9.6 \%$
		Y	100.00	105.05	20.71		80.0	
		Z	100.00	108.99	22.68		80.0	
10028- DAC	GPRS-FDD (TDMA, GMSK, TN 0-1-2-3)	X	100.00	111.34	23.14	3.55	100.0	$\pm 9.6 \%$
		Y	100.00	107.81	21.20		100.0	
		Z	100.00	108.15	21.58		100.0	
10029- DAC	EDGE-FDD (TDMA, 8PSK, TN 0-1-2)	X	4.51	76.74	25.54	7.80	80.0	$\pm 9.6 \%$
		Y	4.44	78.91	27.21		80.0	
		Z	4.34	76.19	25.41		80.0	
10030- CAA	IEEE 802.15.1 Bluetooth (GFSK, DH1)	X	100.00	108.75	23.04	5.30	70.0	$\pm 9.6 \%$
		Y	100.00	100.28	18.89		70.0	
		Z	100.00	106.90	22.09		70.0	
10031- CAA	IEEE 802.15.1 Bluetooth (GFSK, DH3)	X	100.00	99.67	17.08	1.88	100.0	$\pm 9.6 \%$
		Y	50.08	84.31	11.26		100.0	
		Z	0.35	62.17	5.86		100.0	

10032-CAA	IEEE 802.15.1 Bluetooth (GFSK, DH5)	X	28.56	85.45	12.04	1.17	100.0	± 9.6 %
		Y	0.15	60.00	3.24		100.0	
		Z	0.16	60.00	3.46		100.0	
10033-CAA	IEEE 802.15.1 Bluetooth (PI/4-DQPSK, DH1)	X	8.12	89.17	23.19	5.30	70.0	± 9.6 %
		Y	5.53	78.60	16.12		70.0	
		Z	8.77	90.41	23.45		70.0	
10034-CAA	IEEE 802.15.1 Bluetooth (PI/4-DQPSK, DH3)	X	1.89	71.18	14.91	1.88	100.0	± 9.6 %
		Y	0.70	61.17	6.54		100.0	
		Z	1.94	71.91	15.07		100.0	
10035-CAA	IEEE 802.15.1 Bluetooth (PI/4-DQPSK, DH5)	X	1.33	67.78	13.07	1.17	100.0	± 9.6 %
		Y	0.50	60.00	5.45		100.0	
		Z	1.34	68.27	13.15		100.0	
10036-CAA	IEEE 802.15.1 Bluetooth (8-DPSK, DH1)	X	11.58	94.76	24.99	5.30	70.0	± 9.6 %
		Y	7.92	82.80	17.55		70.0	
		Z	13.45	97.05	25.53		70.0	
10037-CAA	IEEE 802.15.1 Bluetooth (8-DPSK, DH3)	X	1.76	70.41	14.56	1.88	100.0	± 9.6 %
		Y	0.67	60.87	6.38		100.0	
		Z	1.78	71.00	14.68		100.0	
10038-CAA	IEEE 802.15.1 Bluetooth (8-DPSK, DH5)	X	1.33	68.01	13.29	1.17	100.0	± 9.6 %
		Y	0.50	60.00	5.57		100.0	
		Z	1.35	68.60	13.42		100.0	
10039-CAB	CDMA2000 (1xRTT, RC1)	X	1.09	65.82	11.60	0.00	150.0	± 9.6 %
		Y	0.33	60.00	4.54		150.0	
		Z	1.10	66.30	11.64		150.0	
10042-CAB	IS-54 / IS-136 FDD (TDMA/FDM, PI/4-DQPSK, Halfrate)	X	100.00	107.41	23.26	7.78	50.0	± 9.6 %
		Y	57.23	96.27	18.96		50.0	
		Z	100.00	105.97	22.54		50.0	
10044-CAA	IS-91/EIA/TIA-553 FDD (FDMA, FM)	X	0.03	118.97	9.94	0.00	150.0	± 9.6 %
		Y	0.05	129.23	11.15		150.0	
		Z	0.09	122.00	10.41		150.0	
10048-CAA	DECT (TDD, TDMA/FDM, GFSK, Full Slot, 24)	X	21.95	89.61	21.44	13.80	25.0	± 9.6 %
		Y	5.10	70.47	13.72		25.0	
		Z	12.15	81.59	18.87		25.0	
10049-CAA	DECT (TDD, TDMA/FDM, GFSK, Double Slot, 12)	X	43.64	100.12	23.34	10.79	40.0	± 9.6 %
		Y	5.90	74.58	14.22		40.0	
		Z	17.31	88.39	19.94		40.0	
10056-CAA	UMTS-TDD (TD-SCDMA, 1.28 Mcps)	X	25.07	100.73	26.75	9.03	50.0	± 9.6 %
		Y	12.75	86.31	19.79		50.0	
		Z	22.08	98.32	25.86		50.0	
10058-DAC	EDGE-FDD (TDMA, 8PSK, TN 0-1-2-3)	X	3.64	72.69	22.94	6.55	100.0	± 9.6 %
		Y	3.58	74.51	24.46		100.0	
		Z	3.51	72.30	22.90		100.0	
10059-CAB	IEEE 802.11b WiFi 2.4 GHz (DSSS, 2 Mbps)	X	1.08	63.42	14.64	0.61	110.0	± 9.6 %
		Y	1.21	68.14	17.70		110.0	
		Z	1.06	63.79	15.05		110.0	
10060-CAB	IEEE 802.11b WiFi 2.4 GHz (DSSS, 5.5 Mbps)	X	2.61	84.17	21.25	1.30	110.0	± 9.6 %
		Y	100.00	147.02	38.69		110.0	
		Z	5.12	95.07	24.77		110.0	

10061-CAB	IEEE 802.11b WiFi 2.4 GHz (DSSS, 11 Mbps)	X	1.89	74.28	19.62	2.04	110.0	± 9.6 %
		Y	6.72	99.45	28.86		110.0	
		Z	1.98	76.00	20.54		110.0	
10062-CAC	IEEE 802.11a/h WiFi 5 GHz (OFDM, 6 Mbps)	X	4.50	66.38	16.23	0.49	100.0	± 9.6 %
		Y	4.17	67.64	16.77		100.0	
		Z	4.49	66.45	16.37		100.0	
10063-CAC	IEEE 802.11a/h WiFi 5 GHz (OFDM, 9 Mbps)	X	4.52	66.46	16.33	0.72	100.0	± 9.6 %
		Y	4.19	67.78	16.90		100.0	
		Z	4.51	66.54	16.46		100.0	
10064-CAC	IEEE 802.11a/h WiFi 5 GHz (OFDM, 12 Mbps)	X	4.78	66.72	16.56	0.86	100.0	± 9.6 %
		Y	4.37	67.91	17.05		100.0	
		Z	4.77	66.78	16.69		100.0	
10065-CAC	IEEE 802.11a/h WiFi 5 GHz (OFDM, 18 Mbps)	X	4.65	66.59	16.65	1.21	100.0	± 9.6 %
		Y	4.25	67.66	17.08		100.0	
		Z	4.64	66.65	16.78		100.0	
10066-CAC	IEEE 802.11a/h WiFi 5 GHz (OFDM, 24 Mbps)	X	4.67	66.60	16.82	1.46	100.0	± 9.6 %
		Y	4.25	67.56	17.16		100.0	
		Z	4.65	66.66	16.94		100.0	
10067-CAC	IEEE 802.11a/h WiFi 5 GHz (OFDM, 36 Mbps)	X	4.96	66.87	17.31	2.04	100.0	± 9.6 %
		Y	4.45	67.61	17.49		100.0	
		Z	4.95	66.92	17.43		100.0	
10068-CAC	IEEE 802.11a/h WiFi 5 GHz (OFDM, 48 Mbps)	X	5.00	66.83	17.50	2.55	100.0	± 9.6 %
		Y	4.58	67.92	17.91		100.0	
		Z	4.98	66.87	17.60		100.0	
10069-CAC	IEEE 802.11a/h WiFi 5 GHz (OFDM, 54 Mbps)	X	5.07	66.86	17.70	2.67	100.0	± 9.6 %
		Y	4.58	67.73	17.95		100.0	
		Z	5.05	66.90	17.80		100.0	
10071-CAB	IEEE 802.11g WiFi 2.4 GHz (DSSS/OFDM, 9 Mbps)	X	4.80	66.52	17.15	1.99	100.0	± 9.6 %
		Y	4.47	67.76	17.67		100.0	
		Z	4.79	66.57	17.27		100.0	
10072-CAB	IEEE 802.11g WiFi 2.4 GHz (DSSS/OFDM, 12 Mbps)	X	4.77	66.78	17.34	2.30	100.0	± 9.6 %
		Y	4.40	67.85	17.80		100.0	
		Z	4.75	66.83	17.46		100.0	
10073-CAB	IEEE 802.11g WiFi 2.4 GHz (DSSS/OFDM, 18 Mbps)	X	4.82	66.94	17.68	2.83	100.0	± 9.6 %
		Y	4.48	68.17	18.22		100.0	
		Z	4.81	66.99	17.79		100.0	
10074-CAB	IEEE 802.11g WiFi 2.4 GHz (DSSS/OFDM, 24 Mbps)	X	4.82	66.85	17.82	3.30	100.0	± 9.6 %
		Y	4.56	68.39	18.51		100.0	
		Z	4.80	66.90	17.93		100.0	
10075-CAB	IEEE 802.11g WiFi 2.4 GHz (DSSS/OFDM, 36 Mbps)	X	4.84	66.90	18.10	3.82	90.0	± 9.6 %
		Y	4.62	68.53	18.81		90.0	
		Z	4.82	66.93	18.20		90.0	
10076-CAB	IEEE 802.11g WiFi 2.4 GHz (DSSS/OFDM, 48 Mbps)	X	4.87	66.75	18.26	4.15	90.0	± 9.6 %
		Y	4.66	68.36	18.96		90.0	
		Z	4.85	66.78	18.35		90.0	
10077-CAB	IEEE 802.11g WiFi 2.4 GHz (DSSS/OFDM, 54 Mbps)	X	4.90	66.83	18.36	4.30	90.0	± 9.6 %
		Y	4.70	68.52	19.13		90.0	
		Z	4.88	66.86	18.46		90.0	

10081-CAB	CDMA2000 (1xRTT, RC3)	X	0.57	62.19	9.13	0.00	150.0	± 9.6 %
		Y	27.42	131.24	12.30		150.0	
		Z	0.55	62.22	8.90		150.0	
10082-CAB	IS-54 / IS-136 FDD (TDMA/FDM, PI/4-DQPSK, Fullrate)	X	5.02	67.53	6.38	4.77	80.0	± 9.6 %
		Y	1.48	62.15	3.83		80.0	
		Z	0.60	60.00	3.69		80.0	
10090-DAC	GPRS-FDD (TDMA, GMSK, TN 0-4)	X	100.00	110.99	24.56	6.56	60.0	± 9.6 %
		Y	100.00	104.24	21.12		60.0	
		Z	100.00	109.50	23.78		60.0	
10097-CAB	UMTS-FDD (HSDPA)	X	1.62	66.19	14.37	0.00	150.0	± 9.6 %
		Y	2.77	77.65	18.43		150.0	
		Z	1.66	66.92	14.80		150.0	
10098-CAB	UMTS-FDD (HSUPA, Subtest 2)	X	1.59	66.12	14.32	0.00	150.0	± 9.6 %
		Y	2.75	77.82	18.53		150.0	
		Z	1.63	66.85	14.76		150.0	
10099-DAC	EDGE-FDD (TDMA, 8PSK, TN 0-4)	X	6.86	86.10	30.61	9.56	60.0	± 9.6 %
		Y	6.96	89.80	32.91		60.0	
		Z	6.57	85.27	30.34		60.0	
10100-CAD	LTE-FDD (SC-FDMA, 100% RB, 20 MHz, QPSK)	X	2.79	68.67	15.73	0.00	150.0	± 9.6 %
		Y	3.01	72.73	18.31		150.0	
		Z	2.85	69.21	16.10		150.0	
10101-CAD	LTE-FDD (SC-FDMA, 100% RB, 20 MHz, 16-QAM)	X	3.03	66.63	15.32	0.00	150.0	± 9.6 %
		Y	2.95	68.63	16.67		150.0	
		Z	3.05	66.87	15.55		150.0	
10102-CAD	LTE-FDD (SC-FDMA, 100% RB, 20 MHz, 64-QAM)	X	3.14	66.68	15.45	0.00	150.0	± 9.6 %
		Y	3.05	68.65	16.75		150.0	
		Z	3.16	66.90	15.67		150.0	
10103-CAD	LTE-TDD (SC-FDMA, 100% RB, 20 MHz, QPSK)	X	5.48	74.24	19.94	3.98	65.0	± 9.6 %
		Y	5.83	78.05	21.80		65.0	
		Z	5.16	73.46	19.72		65.0	
10104-CAD	LTE-TDD (SC-FDMA, 100% RB, 20 MHz, 16-QAM)	X	5.43	71.87	19.65	3.98	65.0	± 9.6 %
		Y	5.15	73.23	20.29		65.0	
		Z	5.30	71.66	19.65		65.0	
10105-CAD	LTE-TDD (SC-FDMA, 100% RB, 20 MHz, 64-QAM)	X	5.28	71.13	19.61	3.98	65.0	± 9.6 %
		Y	5.09	72.76	20.36		65.0	
		Z	5.27	71.32	19.81		65.0	
10108-CAE	LTE-FDD (SC-FDMA, 100% RB, 10 MHz, QPSK)	X	2.42	67.95	15.52	0.00	150.0	± 9.6 %
		Y	2.65	73.21	18.48		150.0	
		Z	2.47	68.55	15.91		150.0	
10109-CAE	LTE-FDD (SC-FDMA, 100% RB, 10 MHz, 16-QAM)	X	2.67	66.43	15.11	0.00	150.0	± 9.6 %
		Y	2.65	69.54	16.65		150.0	
		Z	2.69	66.74	15.37		150.0	
10110-CAE	LTE-FDD (SC-FDMA, 100% RB, 5 MHz, QPSK)	X	1.92	66.97	14.92	0.00	150.0	± 9.6 %
		Y	2.27	74.05	18.03		150.0	
		Z	1.96	67.64	15.34		150.0	
10111-CAE	LTE-FDD (SC-FDMA, 100% RB, 5 MHz, 16-QAM)	X	2.36	67.07	15.14	0.00	150.0	± 9.6 %
		Y	2.72	73.04	17.01		150.0	
		Z	2.39	67.59	15.47		150.0	

10112-CAE	LTE-FDD (SC-FDMA, 100% RB, 10 MHz, 64-QAM)	X	2.80	66.52	15.22	0.00	150.0	± 9.6 %
		Y	2.78	69.65	16.71		150.0	
		Z	2.82	66.81	15.47		150.0	
10113-CAE	LTE-FDD (SC-FDMA, 100% RB, 5 MHz, 64-QAM)	X	2.51	67.31	15.33	0.00	150.0	± 9.6 %
		Y	2.80	72.79	16.92		150.0	
		Z	2.54	67.82	15.65		150.0	
10114-CAC	IEEE 802.11n (HT Greenfield, 13.5 Mbps, BPSK)	X	4.96	66.85	16.19	0.00	150.0	± 9.6 %
		Y	4.63	67.53	16.79		150.0	
		Z	4.96	66.92	16.33		150.0	
10115-CAC	IEEE 802.11n (HT Greenfield, 81 Mbps, 16-QAM)	X	5.22	66.93	16.24	0.00	150.0	± 9.6 %
		Y	4.88	67.74	16.83		150.0	
		Z	5.22	67.01	16.38		150.0	
10116-CAC	IEEE 802.11n (HT Greenfield, 135 Mbps, 64-QAM)	X	5.05	67.03	16.21	0.00	150.0	± 9.6 %
		Y	4.70	67.78	16.83		150.0	
		Z	5.05	67.12	16.36		150.0	
10117-CAC	IEEE 802.11n (HT Mixed, 13.5 Mbps, BPSK)	X	4.94	66.75	16.16	0.00	150.0	± 9.6 %
		Y	4.61	67.43	16.76		150.0	
		Z	4.95	66.84	16.31		150.0	
10118-CAC	IEEE 802.11n (HT Mixed, 81 Mbps, 16-QAM)	X	5.30	67.13	16.35	0.00	150.0	± 9.6 %
		Y	4.86	67.63	16.79		150.0	
		Z	5.31	67.24	16.51		150.0	
10119-CAC	IEEE 802.11n (HT Mixed, 135 Mbps, 64-QAM)	X	5.04	67.00	16.20	0.00	150.0	± 9.6 %
		Y	4.69	67.70	16.79		150.0	
		Z	5.05	67.10	16.36		150.0	
10140-CAD	LTE-FDD (SC-FDMA, 100% RB, 15 MHz, 16-QAM)	X	3.17	66.68	15.36	0.00	150.0	± 9.6 %
		Y	3.04	68.72	16.64		150.0	
		Z	3.18	66.91	15.58		150.0	
10141-CAD	LTE-FDD (SC-FDMA, 100% RB, 15 MHz, 64-QAM)	X	3.30	66.85	15.57	0.00	150.0	± 9.6 %
		Y	3.18	69.04	16.88		150.0	
		Z	3.31	67.07	15.79		150.0	
10142-CAD	LTE-FDD (SC-FDMA, 100% RB, 3 MHz, QPSK)	X	1.67	66.60	14.19	0.00	150.0	± 9.6 %
		Y	1.87	72.33	15.40		150.0	
		Z	1.70	67.34	14.60		150.0	
10143-CAD	LTE-FDD (SC-FDMA, 100% RB, 3 MHz, 16-QAM)	X	2.12	67.16	14.28	0.00	150.0	± 9.6 %
		Y	1.56	66.54	11.72		150.0	
		Z	2.16	67.74	14.58		150.0	
10144-CAD	LTE-FDD (SC-FDMA, 100% RB, 3 MHz, 64-QAM)	X	1.92	65.03	12.70	0.00	150.0	± 9.6 %
		Y	1.13	62.33	8.88		150.0	
		Z	1.92	65.29	12.82		150.0	
10145-CAE	LTE-FDD (SC-FDMA, 100% RB, 1.4 MHz, QPSK)	X	0.84	61.53	8.53	0.00	150.0	± 9.6 %
		Y	0.42	60.00	3.23		150.0	
		Z	0.80	61.27	8.17		150.0	
10146-CAE	LTE-FDD (SC-FDMA, 100% RB, 1.4 MHz, 16-QAM)	X	1.25	62.09	8.49	0.00	150.0	± 9.6 %
		Y	15.63	136.67	2.52		150.0	
		Z	1.18	61.53	7.92		150.0	
10147-CAE	LTE-FDD (SC-FDMA, 100% RB, 1.4 MHz, 64-QAM)	X	1.33	62.76	8.97	0.00	150.0	± 9.6 %
		Y	175.53	59.57	0.91		150.0	
		Z	1.25	62.05	8.31		150.0	

10149-CAD	LTE-FDD (SC-FDMA, 50% RB, 20 MHz, 16-QAM)	X	2.68	66.49	15.16	0.00	150.0	± 9.6 %
		Y	2.67	69.66	16.73		150.0	
		Z	2.70	66.80	15.42		150.0	
10150-CAD	LTE-FDD (SC-FDMA, 50% RB, 20 MHz, 64-QAM)	X	2.81	66.57	15.26	0.00	150.0	± 9.6 %
		Y	2.79	69.76	16.78		150.0	
		Z	2.82	66.87	15.51		150.0	
10151-CAD	LTE-TDD (SC-FDMA, 50% RB, 20 MHz, QPSK)	X	5.57	76.26	20.83	3.98	65.0	± 9.6 %
		Y	6.54	82.28	23.19		65.0	
		Z	5.47	76.32	20.97		65.0	
10152-CAD	LTE-TDD (SC-FDMA, 50% RB, 20 MHz, 16-QAM)	X	4.95	71.73	19.22	3.98	65.0	± 9.6 %
		Y	4.69	73.27	19.41		65.0	
		Z	4.83	71.56	19.23		65.0	
10153-CAD	LTE-TDD (SC-FDMA, 50% RB, 20 MHz, 64-QAM)	X	5.31	72.79	20.07	3.98	65.0	± 9.6 %
		Y	5.16	74.91	20.53		65.0	
		Z	5.19	72.65	20.11		65.0	
10154-CAE	LTE-FDD (SC-FDMA, 50% RB, 10 MHz, QPSK)	X	1.96	67.30	15.14	0.00	150.0	± 9.6 %
		Y	2.37	74.79	18.39		150.0	
		Z	2.00	68.02	15.59		150.0	
10155-CAE	LTE-FDD (SC-FDMA, 50% RB, 10 MHz, 16-QAM)	X	2.36	67.10	15.16	0.00	150.0	± 9.6 %
		Y	2.75	73.23	17.11		150.0	
		Z	2.39	67.62	15.50		150.0	
10156-CAE	LTE-FDD (SC-FDMA, 50% RB, 5 MHz, QPSK)	X	1.48	66.22	13.61	0.00	150.0	± 9.6 %
		Y	1.17	67.13	11.92		150.0	
		Z	1.51	66.95	13.98		150.0	
10157-CAE	LTE-FDD (SC-FDMA, 50% RB, 5 MHz, 16-QAM)	X	1.71	65.06	12.34	0.00	150.0	± 9.6 %
		Y	0.82	60.69	7.08		150.0	
		Z	1.71	65.33	12.43		150.0	
10158-CAE	LTE-FDD (SC-FDMA, 50% RB, 10 MHz, 64-QAM)	X	2.51	67.38	15.38	0.00	150.0	± 9.6 %
		Y	2.84	73.04	17.05		150.0	
		Z	2.55	67.90	15.71		150.0	
10159-CAE	LTE-FDD (SC-FDMA, 50% RB, 5 MHz, 64-QAM)	X	1.79	65.38	12.55	0.00	150.0	± 9.6 %
		Y	0.84	60.64	7.05		150.0	
		Z	1.79	65.65	12.65		150.0	
10160-CAD	LTE-FDD (SC-FDMA, 50% RB, 15 MHz, QPSK)	X	2.49	67.50	15.47	0.00	150.0	± 9.6 %
		Y	2.56	71.83	17.66		150.0	
		Z	2.54	68.10	15.86		150.0	
10161-CAD	LTE-FDD (SC-FDMA, 50% RB, 15 MHz, 16-QAM)	X	2.70	66.49	15.13	0.00	150.0	± 9.6 %
		Y	2.68	69.90	16.49		150.0	
		Z	2.71	66.81	15.39		150.0	
10162-CAD	LTE-FDD (SC-FDMA, 50% RB, 15 MHz, 64-QAM)	X	2.81	66.70	15.28	0.00	150.0	± 9.6 %
		Y	2.80	70.26	16.67		150.0	
		Z	2.82	67.03	15.53		150.0	
10166-CAE	LTE-FDD (SC-FDMA, 50% RB, 1.4 MHz, QPSK)	X	3.24	68.52	18.59	3.01	150.0	± 9.6 %
		Y	2.46	67.16	18.36		150.0	
		Z	3.27	68.87	18.81		150.0	
10167-CAE	LTE-FDD (SC-FDMA, 50% RB, 1.4 MHz, 16-QAM)	X	3.78	70.80	18.80	3.01	150.0	± 9.6 %
		Y	2.65	69.44	18.59		150.0	
		Z	3.87	71.35	19.05		150.0	

10168-CAE	LTE-FDD (SC-FDMA, 50% RB, 1.4 MHz, 64-QAM)	X	4.22	73.24	20.28	3.01	150.0	± 9.6 %
		Y	2.98	72.19	20.36		150.0	
		Z	4.38	74.05	20.65		150.0	
10169-CAD	LTE-FDD (SC-FDMA, 1 RB, 20 MHz, QPSK)	X	2.60	66.96	17.88	3.01	150.0	± 9.6 %
		Y	2.17	66.08	17.74		150.0	
		Z	2.64	67.39	18.13		150.0	
10170-CAD	LTE-FDD (SC-FDMA, 1 RB, 20 MHz, 16-QAM)	X	3.25	71.58	19.84	3.01	150.0	± 9.6 %
		Y	2.55	70.69	19.84		150.0	
		Z	3.42	72.54	20.26		150.0	
10171-AAD	LTE-FDD (SC-FDMA, 1 RB, 20 MHz, 64-QAM)	X	2.73	68.00	17.17	3.01	150.0	± 9.6 %
		Y	2.14	67.11	17.01		150.0	
		Z	2.83	68.55	17.41		150.0	
10172-CAD	LTE-TDD (SC-FDMA, 1 RB, 20 MHz, QPSK)	X	4.83	82.25	25.65	6.02	65.0	± 9.6 %
		Y	3.25	78.99	24.66		65.0	
		Z	4.17	79.62	24.62		65.0	
10173-CAD	LTE-TDD (SC-FDMA, 1 RB, 20 MHz, 16-QAM)	X	7.80	88.67	26.11	6.02	65.0	± 9.6 %
		Y	4.97	85.33	24.86		65.0	
		Z	8.07	89.25	26.21		65.0	
10174-CAD	LTE-TDD (SC-FDMA, 1 RB, 20 MHz, 64-QAM)	X	6.67	84.99	24.27	6.02	65.0	± 9.6 %
		Y	3.85	80.27	22.34		65.0	
		Z	5.89	82.90	23.46		65.0	
10175-CAE	LTE-FDD (SC-FDMA, 1 RB, 10 MHz, QPSK)	X	2.57	66.69	17.64	3.01	150.0	± 9.6 %
		Y	2.15	65.85	17.52		150.0	
		Z	2.61	67.10	17.88		150.0	
10176-CAE	LTE-FDD (SC-FDMA, 1 RB, 10 MHz, 16-QAM)	X	3.26	71.60	19.85	3.01	150.0	± 9.6 %
		Y	2.56	70.71	19.85		150.0	
		Z	3.43	72.56	20.27		150.0	
10177-CAG	LTE-FDD (SC-FDMA, 1 RB, 5 MHz, QPSK)	X	2.59	66.81	17.73	3.01	150.0	± 9.6 %
		Y	2.16	65.91	17.56		150.0	
		Z	2.63	67.23	17.97		150.0	
10178-CAE	LTE-FDD (SC-FDMA, 1 RB, 5 MHz, 16-QAM)	X	3.23	71.44	19.75	3.01	150.0	± 9.6 %
		Y	2.55	70.64	19.81		150.0	
		Z	3.40	72.38	20.17		150.0	
10179-CAE	LTE-FDD (SC-FDMA, 1 RB, 10 MHz, 64-QAM)	X	2.96	69.67	18.37	3.01	150.0	± 9.6 %
		Y	2.32	68.83	18.31		150.0	
		Z	3.09	70.38	18.68		150.0	
10180-CAE	LTE-FDD (SC-FDMA, 1 RB, 5 MHz, 64-QAM)	X	2.73	67.95	17.14	3.01	150.0	± 9.6 %
		Y	2.14	67.11	17.00		150.0	
		Z	2.82	68.50	17.37		150.0	
10181-CAD	LTE-FDD (SC-FDMA, 1 RB, 15 MHz, QPSK)	X	2.59	66.80	17.72	3.01	150.0	± 9.6 %
		Y	2.15	65.90	17.56		150.0	
		Z	2.63	67.21	17.96		150.0	
10182-CAD	LTE-FDD (SC-FDMA, 1 RB, 15 MHz, 16-QAM)	X	3.23	71.42	19.74	3.01	150.0	± 9.6 %
		Y	2.55	70.62	19.79		150.0	
		Z	3.40	72.36	20.16		150.0	
10183-AAC	LTE-FDD (SC-FDMA, 1 RB, 15 MHz, 64-QAM)	X	2.73	67.93	17.12	3.01	150.0	± 9.6 %
		Y	2.14	67.09	16.99		150.0	
		Z	2.82	68.48	17.36		150.0	

10184-CAD	LTE-FDD (SC-FDMA, 1 RB, 3 MHz, QPSK)	X	2.60	66.84	17.74	3.01	150.0	± 9.6 %
		Y	2.16	65.93	17.57		150.0	
		Z	2.64	67.25	17.98		150.0	
10185-CAD	LTE-FDD (SC-FDMA, 1 RB, 3 MHz, 16-QAM)	X	3.24	71.49	19.78	3.01	150.0	± 9.6 %
		Y	2.56	70.68	19.83		150.0	
		Z	3.41	72.43	20.20		150.0	
10186-AAD	LTE-FDD (SC-FDMA, 1 RB, 3 MHz, 64-QAM)	X	2.74	67.99	17.16	3.01	150.0	± 9.6 %
		Y	2.14	67.14	17.02		150.0	
		Z	2.83	68.54	17.39		150.0	
10187-CAE	LTE-FDD (SC-FDMA, 1 RB, 1.4 MHz, QPSK)	X	2.60	66.90	17.81	3.01	150.0	± 9.6 %
		Y	2.17	66.04	17.68		150.0	
		Z	2.65	67.32	18.06		150.0	
10188-CAE	LTE-FDD (SC-FDMA, 1 RB, 1.4 MHz, 16-QAM)	X	3.33	72.04	20.13	3.01	150.0	± 9.6 %
		Y	2.61	71.14	20.14		150.0	
		Z	3.51	73.05	20.58		150.0	
10189-AAE	LTE-FDD (SC-FDMA, 1 RB, 1.4 MHz, 64-QAM)	X	2.79	68.33	17.41	3.01	150.0	± 9.6 %
		Y	2.18	67.45	17.26		150.0	
		Z	2.89	68.91	17.66		150.0	
10193-CAC	IEEE 802.11n (HT Greenfield, 6.5 Mbps, BPSK)	X	4.35	66.32	15.83	0.00	150.0	± 9.6 %
		Y	4.08	67.94	16.57		150.0	
		Z	4.35	66.41	15.97		150.0	
10194-CAC	IEEE 802.11n (HT Greenfield, 39 Mbps, 16-QAM)	X	4.50	66.59	15.97	0.00	150.0	± 9.6 %
		Y	4.17	67.97	16.67		150.0	
		Z	4.50	66.68	16.11		150.0	
10195-CAC	IEEE 802.11n (HT Greenfield, 65 Mbps, 64-QAM)	X	4.54	66.63	15.99	0.00	150.0	± 9.6 %
		Y	4.18	67.89	16.64		150.0	
		Z	4.54	66.71	16.13		150.0	
10196-CAC	IEEE 802.11n (HT Mixed, 6.5 Mbps, BPSK)	X	4.34	66.34	15.84	0.00	150.0	± 9.6 %
		Y	4.05	67.87	16.52		150.0	
		Z	4.34	66.43	15.98		150.0	
10197-CAC	IEEE 802.11n (HT Mixed, 39 Mbps, 16-QAM)	X	4.52	66.61	15.98	0.00	150.0	± 9.6 %
		Y	4.17	67.97	16.68		150.0	
		Z	4.51	66.70	16.12		150.0	
10198-CAC	IEEE 802.11n (HT Mixed, 65 Mbps, 64-QAM)	X	4.54	66.63	16.00	0.00	150.0	± 9.6 %
		Y	4.17	67.88	16.63		150.0	
		Z	4.53	66.72	16.14		150.0	
10219-CAC	IEEE 802.11n (HT Mixed, 7.2 Mbps, BPSK)	X	4.29	66.36	15.79	0.00	150.0	± 9.6 %
		Y	4.02	68.01	16.56		150.0	
		Z	4.29	66.45	15.94		150.0	
10220-CAC	IEEE 802.11n (HT Mixed, 43.3 Mbps, 16-QAM)	X	4.51	66.57	15.97	0.00	150.0	± 9.6 %
		Y	4.17	67.92	16.66		150.0	
		Z	4.50	66.66	16.11		150.0	
10221-CAC	IEEE 802.11n (HT Mixed, 72.2 Mbps, 64-QAM)	X	4.55	66.57	15.99	0.00	150.0	± 9.6 %
		Y	4.19	67.87	16.64		150.0	
		Z	4.55	66.66	16.13		150.0	
10222-CAC	IEEE 802.11n (HT Mixed, 15 Mbps, BPSK)	X	4.91	66.74	16.14	0.00	150.0	± 9.6 %
		Y	4.61	67.46	16.76		150.0	
		Z	4.92	66.81	16.28		150.0	

10223-CAC	IEEE 802.11n (HT Mixed, 90 Mbps, 16-QAM)	X	5.20	66.98	16.29	0.00	150.0	± 9.6 %
		Y	4.78	67.52	16.75		150.0	
		Z	5.21	67.07	16.44		150.0	
10224-CAC	IEEE 802.11n (HT Mixed, 150 Mbps, 64-QAM)	X	4.95	66.84	16.12	0.00	150.0	± 9.6 %
		Y	4.64	67.65	16.77		150.0	
		Z	4.95	66.92	16.26		150.0	
10225-CAB	UMTS-FDD (HSPA+)	X	2.60	65.43	14.52	0.00	150.0	± 9.6 %
		Y	2.31	67.01	13.92		150.0	
		Z	2.60	65.66	14.70		150.0	
10226-CAA	LTE-TDD (SC-FDMA, 1 RB, 1.4 MHz, 16-QAM)	X	8.30	89.91	26.63	6.02	65.0	± 9.6 %
		Y	5.39	86.92	25.51		65.0	
		Z	8.64	90.59	26.77		65.0	
10227-CAA	LTE-TDD (SC-FDMA, 1 RB, 1.4 MHz, 64-QAM)	X	8.42	88.94	25.65	6.02	65.0	± 9.6 %
		Y	4.82	84.03	23.72		65.0	
		Z	8.66	89.39	25.69		65.0	
10228-CAA	LTE-TDD (SC-FDMA, 1 RB, 1.4 MHz, QPSK)	X	5.33	84.56	26.61	6.02	65.0	± 9.6 %
		Y	3.51	80.74	25.42		65.0	
		Z	5.37	85.04	26.79		65.0	
10229-CAB	LTE-TDD (SC-FDMA, 1 RB, 3 MHz, 16-QAM)	X	7.86	88.78	26.15	6.02	65.0	± 9.6 %
		Y	5.00	85.42	24.89		65.0	
		Z	8.13	89.36	26.26		65.0	
10230-CAB	LTE-TDD (SC-FDMA, 1 RB, 3 MHz, 64-QAM)	X	7.90	87.76	25.18	6.02	65.0	± 9.6 %
		Y	4.45	82.60	23.15		65.0	
		Z	8.08	88.11	25.19		65.0	
10231-CAB	LTE-TDD (SC-FDMA, 1 RB, 3 MHz, QPSK)	X	5.13	83.76	26.22	6.02	65.0	± 9.6 %
		Y	3.36	79.77	24.94		65.0	
		Z	5.16	84.16	26.37		65.0	
10232-CAD	LTE-TDD (SC-FDMA, 1 RB, 5 MHz, 16-QAM)	X	7.85	88.76	26.15	6.02	65.0	± 9.6 %
		Y	4.99	85.41	24.89		65.0	
		Z	8.11	89.34	26.25		65.0	
10233-CAD	LTE-TDD (SC-FDMA, 1 RB, 5 MHz, 64-QAM)	X	7.87	87.73	25.17	6.02	65.0	± 9.6 %
		Y	4.44	82.56	23.14		65.0	
		Z	8.06	88.08	25.18		65.0	
10234-CAD	LTE-TDD (SC-FDMA, 1 RB, 5 MHz, QPSK)	X	4.98	83.08	25.85	6.02	65.0	± 9.6 %
		Y	3.27	79.15	24.57		65.0	
		Z	5.00	83.43	25.98		65.0	
10235-CAD	LTE-TDD (SC-FDMA, 1 RB, 10 MHz, 16-QAM)	X	7.85	88.79	26.16	6.02	65.0	± 9.6 %
		Y	5.00	85.44	24.91		65.0	
		Z	8.12	89.37	26.27		65.0	
10236-CAD	LTE-TDD (SC-FDMA, 1 RB, 10 MHz, 64-QAM)	X	7.96	87.89	25.21	6.02	65.0	± 9.6 %
		Y	4.49	82.70	23.18		65.0	
		Z	8.15	88.24	25.23		65.0	
10237-CAD	LTE-TDD (SC-FDMA, 1 RB, 10 MHz, QPSK)	X	5.13	83.78	26.24	6.02	65.0	± 9.6 %
		Y	3.35	79.76	24.95		65.0	
		Z	5.16	84.20	26.39		65.0	
10238-CAD	LTE-TDD (SC-FDMA, 1 RB, 15 MHz, 16-QAM)	X	7.83	88.73	26.14	6.02	65.0	± 9.6 %
		Y	4.99	85.40	24.89		65.0	
		Z	8.09	89.31	26.24		65.0	

10239-CAD	LTE-TDD (SC-FDMA, 1 RB, 15 MHz, 64-QAM)	X	7.84	87.68	25.15	6.02	65.0	± 9.6 %
		Y	4.43	82.52	23.13		65.0	
		Z	8.03	88.04	25.17		65.0	
10240-CAD	LTE-TDD (SC-FDMA, 1 RB, 15 MHz, QPSK)	X	5.12	83.75	26.22	6.02	65.0	± 9.6 %
		Y	3.35	79.78	24.95		65.0	
		Z	5.14	84.16	26.38		65.0	
10241-CAA	LTE-TDD (SC-FDMA, 50% RB, 1.4 MHz, 16-QAM)	X	6.74	78.78	24.52	6.98	65.0	± 9.6 %
		Y	5.69	81.27	25.87		65.0	
		Z	6.76	79.00	24.59		65.0	
10242-CAA	LTE-TDD (SC-FDMA, 50% RB, 1.4 MHz, 64-QAM)	X	6.37	77.64	23.95	6.98	65.0	± 9.6 %
		Y	5.22	79.69	25.18		65.0	
		Z	6.58	78.48	24.29		65.0	
10243-CAA	LTE-TDD (SC-FDMA, 50% RB, 1.4 MHz, QPSK)	X	5.29	74.44	23.43	6.98	65.0	± 9.6 %
		Y	4.45	76.12	24.64		65.0	
		Z	4.96	73.24	22.88		65.0	
10244-CAB	LTE-TDD (SC-FDMA, 50% RB, 3 MHz, 16-QAM)	X	4.30	71.80	16.21	3.98	65.0	± 9.6 %
		Y	1.55	60.92	7.03		65.0	
		Z	4.03	70.91	15.66		65.0	
10245-CAB	LTE-TDD (SC-FDMA, 50% RB, 3 MHz, 64-QAM)	X	4.18	71.11	15.84	3.98	65.0	± 9.6 %
		Y	1.55	60.79	6.91		65.0	
		Z	3.92	70.24	15.30		65.0	
10246-CAB	LTE-TDD (SC-FDMA, 50% RB, 3 MHz, QPSK)	X	3.86	73.77	17.33	3.98	65.0	± 9.6 %
		Y	1.55	63.11	9.15		65.0	
		Z	3.72	73.55	17.17		65.0	
10247-CAD	LTE-TDD (SC-FDMA, 50% RB, 5 MHz, 16-QAM)	X	3.97	70.99	16.82	3.98	65.0	± 9.6 %
		Y	2.28	64.64	10.82		65.0	
		Z	3.84	70.75	16.69		65.0	
10248-CAD	LTE-TDD (SC-FDMA, 50% RB, 5 MHz, 64-QAM)	X	3.96	70.43	16.55	3.98	65.0	± 9.6 %
		Y	2.25	64.13	10.55		65.0	
		Z	3.83	70.16	16.40		65.0	
10249-CAD	LTE-TDD (SC-FDMA, 50% RB, 5 MHz, QPSK)	X	5.06	78.16	20.28	3.98	65.0	± 9.6 %
		Y	3.58	73.72	16.05		65.0	
		Z	5.04	78.50	20.42		65.0	
10250-CAD	LTE-TDD (SC-FDMA, 50% RB, 10 MHz, 16-QAM)	X	4.92	73.99	20.11	3.98	65.0	± 9.6 %
		Y	4.91	76.06	19.61		65.0	
		Z	4.82	73.98	20.18		65.0	
10251-CAD	LTE-TDD (SC-FDMA, 50% RB, 10 MHz, 64-QAM)	X	4.70	71.93	18.79	3.98	65.0	± 9.6 %
		Y	4.06	71.69	17.17		65.0	
		Z	4.58	71.78	18.78		65.0	
10252-CAD	LTE-TDD (SC-FDMA, 50% RB, 10 MHz, QPSK)	X	5.51	78.57	21.66	3.98	65.0	± 9.6 %
		Y	7.63	86.68	23.81		65.0	
		Z	5.47	78.89	21.88		65.0	
10253-CAD	LTE-TDD (SC-FDMA, 50% RB, 15 MHz, 16-QAM)	X	4.88	71.33	18.98	3.98	65.0	± 9.6 %
		Y	4.55	72.63	18.75		65.0	
		Z	4.76	71.16	18.98		65.0	
10254-CAD	LTE-TDD (SC-FDMA, 50% RB, 15 MHz, 64-QAM)	X	5.20	72.27	19.72	3.98	65.0	± 9.6 %
		Y	4.94	73.95	19.64		65.0	
		Z	5.08	72.13	19.74		65.0	

10255-CAD	LTE-TDD (SC-FDMA, 50% RB, 15 MHz, QPSK)	X	5.31	75.57	20.73	3.98	65.0	± 9.6 %
		Y	6.09	81.09	22.63		65.0	
		Z	5.22	75.61	20.85		65.0	
10256-CAA	LTE-TDD (SC-FDMA, 100% RB, 1.4 MHz, 16-QAM)	X	3.08	67.09	12.82	3.98	65.0	± 9.6 %
		Y	1.10	59.01	4.61		65.0	
		Z	2.85	66.14	12.16		65.0	
10257-CAA	LTE-TDD (SC-FDMA, 100% RB, 1.4 MHz, 64-QAM)	X	3.00	66.43	12.39	3.98	65.0	± 9.6 %
		Y	1.10	58.89	4.44		65.0	
		Z	2.79	65.56	11.75		65.0	
10258-CAA	LTE-TDD (SC-FDMA, 100% RB, 1.4 MHz, QPSK)	X	2.70	68.34	13.85	3.98	65.0	± 9.6 %
		Y	1.08	60.00	5.96		65.0	
		Z	2.52	67.66	13.41		65.0	
10259-CAB	LTE-TDD (SC-FDMA, 100% RB, 3 MHz, 16-QAM)	X	4.36	72.23	18.07	3.98	65.0	± 9.6 %
		Y	3.05	68.29	13.76		65.0	
		Z	4.25	72.11	18.03		65.0	
10260-CAB	LTE-TDD (SC-FDMA, 100% RB, 3 MHz, 64-QAM)	X	4.39	71.97	17.95	3.98	65.0	± 9.6 %
		Y	3.03	67.89	13.54		65.0	
		Z	4.27	71.82	17.89		65.0	
10261-CAB	LTE-TDD (SC-FDMA, 100% RB, 3 MHz, QPSK)	X	5.00	77.54	20.53	3.98	65.0	± 9.6 %
		Y	4.86	78.27	18.84		65.0	
		Z	4.96	77.83	20.69		65.0	
10262-CAD	LTE-TDD (SC-FDMA, 100% RB, 5 MHz, 16-QAM)	X	4.91	73.93	20.06	3.98	65.0	± 9.6 %
		Y	4.87	75.90	19.51		65.0	
		Z	4.80	73.90	20.13		65.0	
10263-CAD	LTE-TDD (SC-FDMA, 100% RB, 5 MHz, 64-QAM)	X	4.69	71.90	18.78	3.98	65.0	± 9.6 %
		Y	4.05	71.68	17.17		65.0	
		Z	4.57	71.76	18.77		65.0	
10264-CAD	LTE-TDD (SC-FDMA, 100% RB, 5 MHz, QPSK)	X	5.45	78.36	21.55	3.98	65.0	± 9.6 %
		Y	7.43	86.19	23.60		65.0	
		Z	5.41	78.66	21.76		65.0	
10265-CAD	LTE-TDD (SC-FDMA, 100% RB, 10 MHz, 16-QAM)	X	4.95	71.73	19.22	3.98	65.0	± 9.6 %
		Y	4.69	73.28	19.42		65.0	
		Z	4.83	71.56	19.24		65.0	
10266-CAD	LTE-TDD (SC-FDMA, 100% RB, 10 MHz, 64-QAM)	X	5.30	72.77	20.06	3.98	65.0	± 9.6 %
		Y	5.16	74.89	20.52		65.0	
		Z	5.18	72.63	20.09		65.0	
10267-CAD	LTE-TDD (SC-FDMA, 100% RB, 10 MHz, QPSK)	X	5.56	76.21	20.81	3.98	65.0	± 9.6 %
		Y	6.50	82.16	23.14		65.0	
		Z	5.46	76.27	20.95		65.0	
10268-CAD	LTE-TDD (SC-FDMA, 100% RB, 15 MHz, 16-QAM)	X	5.60	71.84	19.73	3.98	65.0	± 9.6 %
		Y	5.34	73.47	20.38		65.0	
		Z	5.47	71.64	19.74		65.0	
10269-CAD	LTE-TDD (SC-FDMA, 100% RB, 15 MHz, 64-QAM)	X	5.61	71.49	19.61	3.98	65.0	± 9.6 %
		Y	5.38	73.21	20.25		65.0	
		Z	5.48	71.28	19.61		65.0	
10270-CAD	LTE-TDD (SC-FDMA, 100% RB, 15 MHz, QPSK)	X	5.61	73.88	19.99	3.98	65.0	± 9.6 %
		Y	5.96	77.92	21.88		65.0	
		Z	5.49	73.78	20.05		65.0	

10274-CAB	UMTS-FDD (HSUPA, Subtest 5, 3GPP Rel8.10)	X	2.40	65.75	14.40	0.00	150.0	± 9.6 %
		Y	2.28	68.52	14.52		150.0	
		Z	2.41	66.07	14.63		150.0	
10275-CAB	UMTS-FDD (HSUPA, Subtest 5, 3GPP Rel8.4)	X	1.37	65.89	14.00	0.00	150.0	± 9.6 %
		Y	2.24	77.18	18.60		150.0	
		Z	1.41	66.69	14.48		150.0	
10277-CAA	PHS (QPSK)	X	1.83	60.56	6.14	9.03	50.0	± 9.6 %
		Y	1.18	58.25	3.31		50.0	
		Z	1.78	60.31	5.89		50.0	
10278-CAA	PHS (QPSK, BW 884MHz, Rolloff 0.5)	X	3.52	68.49	13.06	9.03	50.0	± 9.6 %
		Y	1.90	61.19	6.81		50.0	
		Z	3.28	67.42	12.39		50.0	
10279-CAA	PHS (QPSK, BW 884MHz, Rolloff 0.38)	X	3.63	68.79	13.26	9.03	50.0	± 9.6 %
		Y	1.93	61.26	6.89		50.0	
		Z	3.38	67.71	12.59		50.0	
10290-AAB	CDMA2000, RC1, SO55, Full Rate	X	0.93	64.00	10.40	0.00	150.0	± 9.6 %
		Y	0.33	60.00	4.23		150.0	
		Z	0.92	64.13	10.27		150.0	
10291-AAB	CDMA2000, RC3, SO55, Full Rate	X	0.56	62.08	9.05	0.00	150.0	± 9.6 %
		Y	0.25	60.00	3.73		150.0	
		Z	0.54	62.09	8.81		150.0	
10292-AAB	CDMA2000, RC3, SO32, Full Rate	X	0.64	64.04	10.45	0.00	150.0	± 9.6 %
		Y	0.23	60.00	3.99		150.0	
		Z	0.63	64.48	10.42		150.0	
10293-AAB	CDMA2000, RC3, SO3, Full Rate	X	0.84	67.30	12.52	0.00	150.0	± 9.6 %
		Y	0.24	60.00	4.44		150.0	
		Z	0.95	69.16	13.11		150.0	
10295-AAB	CDMA2000, RC1, SO3, 1/8th Rate 25 fr.	X	11.34	87.79	23.91	9.03	50.0	± 9.6 %
		Y	100.00	106.64	24.70		50.0	
		Z	13.04	89.56	24.26		50.0	
10297-AAC	LTE-FDD (SC-FDMA, 50% RB, 20 MHz, QPSK)	X	2.43	68.04	15.58	0.00	150.0	± 9.6 %
		Y	2.68	73.41	18.60		150.0	
		Z	2.48	68.65	15.99		150.0	
10298-AAC	LTE-FDD (SC-FDMA, 50% RB, 3 MHz, QPSK)	X	1.13	64.13	11.23	0.00	150.0	± 9.6 %
		Y	0.47	60.00	5.40		150.0	
		Z	1.12	64.36	11.24		150.0	
10299-AAC	LTE-FDD (SC-FDMA, 50% RB, 3 MHz, 16-QAM)	X	1.79	65.44	11.45	0.00	150.0	± 9.6 %
		Y	0.62	60.00	4.41		150.0	
		Z	1.72	64.98	11.00		150.0	
10300-AAC	LTE-FDD (SC-FDMA, 50% RB, 3 MHz, 64-QAM)	X	1.44	62.46	9.17	0.00	150.0	± 9.6 %
		Y	0.61	60.00	3.80		150.0	
		Z	1.39	62.14	8.79		150.0	
10301-AAA	IEEE 802.16e WIMAX (29:18, 5ms, 10MHz, QPSK, PUSC)	X	4.49	65.00	16.96	4.17	50.0	± 9.6 %
		Y	4.09	66.69	17.12		50.0	
		Z	4.52	65.33	17.21		50.0	
10302-AAA	IEEE 802.16e WIMAX (29:18, 5ms, 10MHz, QPSK, PUSC, 3 CTRL symbols)	X	4.99	65.68	17.71	4.96	50.0	± 9.6 %
		Y	4.49	66.84	17.65		50.0	
		Z	4.97	65.74	17.79		50.0	

10303-AAA	IEEE 802.16e WiMAX (31:15, 5ms, 10MHz, 64QAM, PUSC)	X	4.74	65.30	17.51	4.96	50.0	± 9.6 %
		Y	4.42	67.46	17.88		50.0	
		Z	4.72	65.36	17.59		50.0	
10304-AAA	IEEE 802.16e WiMAX (29:18, 5ms, 10MHz, 64QAM, PUSC)	X	4.55	65.18	17.01	4.17	50.0	± 9.6 %
		Y	4.17	66.84	17.11		50.0	
		Z	4.53	65.26	17.11		50.0	
10305-AAA	IEEE 802.16e WiMAX (31:15, 10ms, 10MHz, 64QAM, PUSC, 15 symbols)	X	4.22	67.24	18.89	6.02	35.0	± 9.6 %
		Y	3.80	67.97	17.01		35.0	
		Z	4.24	67.52	19.03		35.0	
10306-AAA	IEEE 802.16e WiMAX (29:18, 10ms, 10MHz, 64QAM, PUSC, 18 symbols)	X	4.53	66.32	18.64	6.02	35.0	± 9.6 %
		Y	4.12	67.69	17.81		35.0	
		Z	4.53	66.50	18.76		35.0	
10307-AAA	IEEE 802.16e WiMAX (29:18, 10ms, 10MHz, QPSK, PUSC, 18 symbols)	X	4.42	66.39	18.56	6.02	35.0	± 9.6 %
		Y	4.01	67.62	17.64		35.0	
		Z	4.42	66.59	18.68		35.0	
10308-AAA	IEEE 802.16e WiMAX (29:18, 10ms, 10MHz, 16QAM, PUSC)	X	4.40	66.60	18.70	6.02	35.0	± 9.6 %
		Y	4.05	68.08	17.93		35.0	
		Z	4.40	66.81	18.83		35.0	
10309-AAA	IEEE 802.16e WiMAX (29:18, 10ms, 10MHz, 16QAM, AMC 2x3, 18 symbols)	X	4.57	66.46	18.76	6.02	35.0	± 9.6 %
		Y	4.15	67.86	18.00		35.0	
		Z	4.57	66.64	18.88		35.0	
10310-AAA	IEEE 802.16e WiMAX (29:18, 10ms, 10MHz, QPSK, AMC 2x3, 18 symbols)	X	4.48	66.38	18.62	6.02	35.0	± 9.6 %
		Y	4.11	67.92	17.93		35.0	
		Z	4.48	66.57	18.74		35.0	
10311-AAC	LTE-FDD (SC-FDMA, 100% RB, 15 MHz, QPSK)	X	2.77	67.40	15.33	0.00	150.0	± 9.6 %
		Y	2.94	71.44	17.85		150.0	
		Z	2.83	67.92	15.69		150.0	
10313-AAA	iDEN 1:3	X	2.63	70.72	15.17	6.99	70.0	± 9.6 %
		Y	4.78	79.70	18.53		70.0	
		Z	2.45	70.15	14.87		70.0	
10314-AAA	iDEN 1:6	X	4.23	78.95	21.28	10.00	30.0	± 9.6 %
		Y	21.13	105.84	29.54		30.0	
		Z	4.50	79.98	21.54		30.0	
10315-AAB	IEEE 802.11b WiFi 2.4 GHz (DSSS, 1 Mbps, 96pc duty cycle)	X	0.98	62.52	14.02	0.17	150.0	± 9.6 %
		Y	1.09	67.04	17.16		150.0	
		Z	0.97	62.89	14.44		150.0	
10316-AAB	IEEE 802.11g WiFi 2.4 GHz (ERP-OFDM, 6 Mbps, 96pc duty cycle)	X	4.40	66.34	15.98	0.17	150.0	± 9.6 %
		Y	4.07	67.64	16.55		150.0	
		Z	4.39	66.42	16.11		150.0	
10317-AAC	IEEE 802.11a WiFi 5 GHz (OFDM, 6 Mbps, 96pc duty cycle)	X	4.40	66.34	15.98	0.17	150.0	± 9.6 %
		Y	4.07	67.64	16.55		150.0	
		Z	4.39	66.42	16.11		150.0	
10400-AAD	IEEE 802.11ac WiFi (20MHz, 64-QAM, 99pc duty cycle)	X	4.48	66.62	15.95	0.00	150.0	± 9.6 %
		Y	4.04	67.65	16.49		150.0	
		Z	4.47	66.71	16.10		150.0	
10401-AAD	IEEE 802.11ac WiFi (40MHz, 64-QAM, 99pc duty cycle)	X	5.21	66.82	16.17	0.00	150.0	± 9.6 %
		Y	4.85	67.54	16.72		150.0	
		Z	5.22	66.92	16.32		150.0	

10402-AAD	IEEE 802.11ac WiFi (80MHz, 64-QAM, 99pc duty cycle)	X	5.47	67.11	16.20	0.00	150.0	± 9.6 %
		Y	5.17	67.73	16.77		150.0	
		Z	5.47	67.15	16.32		150.0	
10403-AAB	CDMA2000 (1xEV-DO, Rev. 0)	X	0.93	64.00	10.40	0.00	115.0	± 9.6 %
		Y	0.33	60.00	4.23		115.0	
		Z	0.92	64.13	10.27		115.0	
10404-AAB	CDMA2000 (1xEV-DO, Rev. A)	X	0.93	64.00	10.40	0.00	115.0	± 9.6 %
		Y	0.33	60.00	4.23		115.0	
		Z	0.92	64.13	10.27		115.0	
10406-AAB	CDMA2000, RC3, SO32, SCH0, Full Rate	X	16.67	98.68	24.47	0.00	100.0	± 9.6 %
		Y	7.21	81.11	14.31		100.0	
		Z	37.53	107.95	26.47		100.0	
10410-AAD	LTE-TDD (SC-FDMA, 1 RB, 10 MHz, QPSK, UL Subframe=2,3,4,7,8,9, Subframe Conf=4)	X	24.48	107.00	27.24	3.23	80.0	± 9.6 %
		Y	15.52	100.17	23.54		80.0	
		Z	35.49	111.31	27.96		80.0	
10415-AAA	IEEE 802.11b WiFi 2.4 GHz (DSSS, 1 Mbps, 99pc duty cycle)	X	0.93	61.94	13.54	0.00	150.0	± 9.6 %
		Y	1.01	66.17	16.61		150.0	
		Z	0.92	62.29	13.95		150.0	
10416-AAA	IEEE 802.11g WiFi 2.4 GHz (ERP-OFDM, 6 Mbps, 99pc duty cycle)	X	4.35	66.34	15.91	0.00	150.0	± 9.6 %
		Y	4.05	67.74	16.57		150.0	
		Z	4.35	66.43	16.05		150.0	
10417-AAB	IEEE 802.11a/h WiFi 5 GHz (OFDM, 6 Mbps, 99pc duty cycle)	X	4.35	66.34	15.91	0.00	150.0	± 9.6 %
		Y	4.05	67.74	16.57		150.0	
		Z	4.35	66.43	16.05		150.0	
10418-AAA	IEEE 802.11g WiFi 2.4 GHz (DSSS-OFDM, 6 Mbps, 99pc duty cycle, Long preamble)	X	4.34	66.51	15.94	0.00	150.0	± 9.6 %
		Y	4.03	68.00	16.69		150.0	
		Z	4.34	66.61	16.09		150.0	
10419-AAA	IEEE 802.11g WiFi 2.4 GHz (DSSS-OFDM, 6 Mbps, 99pc duty cycle, Short preamble)	X	4.36	66.46	15.94	0.00	150.0	± 9.6 %
		Y	4.05	67.90	16.64		150.0	
		Z	4.36	66.55	16.08		150.0	
10422-AAB	IEEE 802.11n (HT Greenfield, 7.2 Mbps, BPSK)	X	4.47	66.46	15.96	0.00	150.0	± 9.6 %
		Y	4.14	67.79	16.63		150.0	
		Z	4.47	66.54	16.10		150.0	
10423-AAB	IEEE 802.11n (HT Greenfield, 43.3 Mbps, 16-QAM)	X	4.61	66.73	16.06	0.00	150.0	± 9.6 %
		Y	4.22	68.01	16.69		150.0	
		Z	4.61	66.82	16.20		150.0	
10424-AAB	IEEE 802.11n (HT Greenfield, 72.2 Mbps, 64-QAM)	X	4.54	66.68	16.03	0.00	150.0	± 9.6 %
		Y	4.16	67.92	16.66		150.0	
		Z	4.53	66.77	16.18		150.0	
10425-AAB	IEEE 802.11n (HT Greenfield, 15 Mbps, BPSK)	X	5.17	66.99	16.27	0.00	150.0	± 9.6 %
		Y	4.80	67.69	16.83		150.0	
		Z	5.17	67.08	16.41		150.0	
10426-AAB	IEEE 802.11n (HT Greenfield, 90 Mbps, 16-QAM)	X	5.19	67.07	16.30	0.00	150.0	± 9.6 %
		Y	4.84	67.85	16.90		150.0	
		Z	5.20	67.19	16.47		150.0	

10427-AAB	IEEE 802.11n (HT Greenfield, 150 Mbps, 64-QAM)	X	5.17	66.95	16.24	0.00	150.0	± 9.6 %
		Y	4.81	67.67	16.81		150.0	
		Z	5.17	67.02	16.38		150.0	
10430-AAB	LTE-FDD (OFDMA, 5 MHz, E-TM 3.1)	X	4.04	70.70	17.69	0.00	150.0	± 9.6 %
		Y	5.18	78.06	19.24		150.0	
		Z	4.12	71.34	18.06		150.0	
10431-AAB	LTE-FDD (OFDMA, 10 MHz, E-TM 3.1)	X	3.97	66.79	15.75	0.00	150.0	± 9.6 %
		Y	3.59	68.58	16.14		150.0	
		Z	3.97	66.94	15.91		150.0	
10432-AAB	LTE-FDD (OFDMA, 15 MHz, E-TM 3.1)	X	4.30	66.71	15.93	0.00	150.0	± 9.6 %
		Y	3.93	68.25	16.56		150.0	
		Z	4.29	66.83	16.08		150.0	
10433-AAB	LTE-FDD (OFDMA, 20 MHz, E-TM 3.1)	X	4.56	66.71	16.05	0.00	150.0	± 9.6 %
		Y	4.18	67.98	16.70		150.0	
		Z	4.55	66.80	16.19		150.0	
10434-AAA	W-CDMA (BS Test Model 1, 64 DPCH)	X	4.08	71.35	17.45	0.00	150.0	± 9.6 %
		Y	4.19	74.65	16.76		150.0	
		Z	4.19	72.07	17.82		150.0	
10435-AAC	LTE-TDD (SC-FDMA, 1 RB, 20 MHz, QPSK, UL Subframe=2,3,4,7,8,9)	X	22.01	105.36	26.76	3.23	80.0	± 9.6 %
		Y	12.26	97.11	22.67		80.0	
		Z	30.46	109.05	27.35		80.0	
10447-AAB	LTE-FDD (OFDMA, 5 MHz, E-TM 3.1, Clipping 44%)	X	3.20	66.45	14.65	0.00	150.0	± 9.6 %
		Y	2.49	66.31	12.90		150.0	
		Z	3.20	66.65	14.79		150.0	
10448-AAB	LTE-FDD (OFDMA, 10 MHz, E-TM 3.1, Clipping 44%)	X	3.83	66.57	15.61	0.00	150.0	± 9.6 %
		Y	3.50	68.44	16.07		150.0	
		Z	3.83	66.72	15.77		150.0	
10449-AAB	LTE-FDD (OFDMA, 15 MHz, E-TM 3.1, Clipping 44%)	X	4.13	66.53	15.82	0.00	150.0	± 9.6 %
		Y	3.82	68.12	16.50		150.0	
		Z	4.12	66.65	15.98		150.0	
10450-AAB	LTE-FDD (OFDMA, 20 MHz, E-TM 3.1, Clipping 44%)	X	4.34	66.47	15.89	0.00	150.0	± 9.6 %
		Y	4.03	67.78	16.58		150.0	
		Z	4.33	66.57	16.04		150.0	
10451-AAA	W-CDMA (BS Test Model 1, 64 DPCH, Clipping 44%)	X	3.02	66.30	14.00	0.00	150.0	± 9.6 %
		Y	1.96	63.95	10.66		150.0	
		Z	3.02	66.48	14.10		150.0	
10456-AAB	IEEE 802.11ac WiFi (160MHz, 64-QAM, 99pc duty cycle)	X	6.11	67.70	16.53	0.00	150.0	± 9.6 %
		Y	6.19	69.21	17.55		150.0	
		Z	6.14	67.81	16.68		150.0	
10457-AAA	UMTS-FDD (DC-HSDPA)	X	3.68	65.04	15.61	0.00	150.0	± 9.6 %
		Y	3.54	66.84	16.42		150.0	
		Z	3.67	65.12	15.76		150.0	
10458-AAA	CDMA2000 (1xEV-DO, Rev. B, 2 carriers)	X	3.62	70.05	16.39	0.00	150.0	± 9.6 %
		Y	1.73	62.72	9.51		150.0	
		Z	3.68	70.56	16.64		150.0	
10459-AAA	CDMA2000 (1xEV-DO, Rev. B, 3 carriers)	X	4.87	68.53	17.80	0.00	150.0	± 9.6 %
		Y	3.66	66.63	14.39		150.0	
		Z	4.93	68.95	18.05		150.0	

10460-AAA	UMTS-FDD (WCDMA, AMR)	X	0.72	64.98	13.65	0.00	150.0	± 9.6 %
		Y	8.89	109.57	29.93		150.0	
		Z	0.75	66.41	14.51		150.0	
10461-AAA	LTE-TDD (SC-FDMA, 1 RB, 1.4 MHz, QPSK, UL Subframe=2,3,4,7,8,9)	X	13.94	101.67	26.79	3.29	80.0	± 9.6 %
		Y	100.00	127.12	30.86		80.0	
		Z	40.31	115.94	29.98		80.0	
10462-AAA	LTE-TDD (SC-FDMA, 1 RB, 1.4 MHz, 16-QAM, UL Subframe=2,3,4,7,8,9)	X	1.11	63.17	10.06	3.23	80.0	± 9.6 %
		Y	0.26	55.58	3.51		80.0	
		Z	0.94	61.56	9.02		80.0	
10463-AAA	LTE-TDD (SC-FDMA, 1 RB, 1.4 MHz, 64-QAM, UL Subframe=2,3,4,7,8,9)	X	0.81	60.00	7.90	3.23	80.0	± 9.6 %
		Y	1.89	63.59	6.01		80.0	
		Z	0.81	60.00	7.64		80.0	
10464-AAA	LTE-TDD (SC-FDMA, 1 RB, 3 MHz, QPSK, UL Subframe=2,3,4,7,8,9)	X	10.27	95.95	24.48	3.23	80.0	± 9.6 %
		Y	10.37	95.51	22.29		80.0	
		Z	21.85	105.27	26.52		80.0	
10465-AAA	LTE-TDD (SC-FDMA, 1 RB, 3 MHz, 16-QAM, UL Subframe=2,3,4,7,8,9)	X	1.01	62.26	9.56	3.23	80.0	± 9.6 %
		Y	0.26	55.51	3.41		80.0	
		Z	0.88	60.92	8.64		80.0	
10466-AAA	LTE-TDD (SC-FDMA, 1 RB, 3 MHz, 64-QAM, UL Subframe=2,3,4,7,8,9)	X	0.81	60.00	7.85	3.23	80.0	± 9.6 %
		Y	2.94	64.67	6.15		80.0	
		Z	0.81	60.00	7.59		80.0	
10467-AAC	LTE-TDD (SC-FDMA, 1 RB, 5 MHz, QPSK, UL Subframe=2,3,4,7,8,9)	X	12.26	98.51	25.22	3.23	80.0	± 9.6 %
		Y	17.71	102.01	24.01		80.0	
		Z	30.02	109.65	27.64		80.0	
10468-AAC	LTE-TDD (SC-FDMA, 1 RB, 5 MHz, 16-QAM, UL Subframe=2,3,4,7,8,9)	X	1.04	62.52	9.70	3.23	80.0	± 9.6 %
		Y	0.26	55.56	3.48		80.0	
		Z	0.90	61.11	8.75		80.0	
10469-AAC	LTE-TDD (SC-FDMA, 1 RB, 5 MHz, 64-QAM, UL Subframe=2,3,4,7,8,9)	X	0.81	60.00	7.85	3.23	80.0	± 9.6 %
		Y	0.90	60.91	5.15		80.0	
		Z	0.81	60.00	7.59		80.0	
10470-AAC	LTE-TDD (SC-FDMA, 1 RB, 10 MHz, QPSK, UL Subframe=2,3,4,7,8,9)	X	12.39	98.68	25.27	3.23	80.0	± 9.6 %
		Y	18.66	102.62	24.14		80.0	
		Z	30.74	109.98	27.71		80.0	
10471-AAC	LTE-TDD (SC-FDMA, 1 RB, 10 MHz, 16-QAM, UL Subframe=2,3,4,7,8,9)	X	1.03	62.46	9.66	3.23	80.0	± 9.6 %
		Y	0.26	55.54	3.46		80.0	
		Z	0.89	61.06	8.72		80.0	
10472-AAC	LTE-TDD (SC-FDMA, 1 RB, 10 MHz, 64-QAM, UL Subframe=2,3,4,7,8,9)	X	0.81	60.00	7.83	3.23	80.0	± 9.6 %
		Y	1.83	63.55	6.01		80.0	
		Z	0.81	60.00	7.57		80.0	
10473-AAC	LTE-TDD (SC-FDMA, 1 RB, 15 MHz, QPSK, UL Subframe=2,3,4,7,8,9)	X	12.30	98.56	25.23	3.23	80.0	± 9.6 %
		Y	17.97	102.17	24.03		80.0	
		Z	30.28	109.75	27.65		80.0	
10474-AAC	LTE-TDD (SC-FDMA, 1 RB, 15 MHz, 16-QAM, UL Subframe=2,3,4,7,8,9)	X	1.02	62.43	9.65	3.23	80.0	± 9.6 %
		Y	0.26	55.54	3.45		80.0	
		Z	0.89	61.04	8.70		80.0	
10475-AAC	LTE-TDD (SC-FDMA, 1 RB, 15 MHz, 64-QAM, UL Subframe=2,3,4,7,8,9)	X	0.81	60.00	7.83	3.23	80.0	± 9.6 %
		Y	3.14	65.15	6.35		80.0	
		Z	0.81	60.00	7.57		80.0	

10477-AAC	LTE-TDD (SC-FDMA, 1 RB, 20 MHz, 16-QAM, UL Subframe=2,3,4,7,8,9)	X	1.00	62.22	9.52	3.23	80.0	± 9.6 %
		Y	0.26	55.50	3.40		80.0	
		Z	0.88	60.88	8.60		80.0	
10478-AAC	LTE-TDD (SC-FDMA, 1 RB, 20 MHz, 64-QAM, UL Subframe=2,3,4,7,8,9)	X	0.81	60.00	7.82	3.23	80.0	± 9.6 %
		Y	3.81	65.69	6.44		80.0	
		Z	0.81	60.00	7.56		80.0	
10479-AAA	LTE-TDD (SC-FDMA, 50% RB, 1.4 MHz, QPSK, UL Subframe=2,3,4,7,8,9)	X	6.59	85.50	22.56	3.23	80.0	± 9.6 %
		Y	100.00	124.45	30.64		80.0	
		Z	8.59	89.42	23.62		80.0	
10480-AAA	LTE-TDD (SC-FDMA, 50% RB, 1.4 MHz, 16-QAM, UL Subframe=2,3,4,7,8,9)	X	4.79	76.18	17.27	3.23	80.0	± 9.6 %
		Y	0.79	60.53	7.96		80.0	
		Z	4.72	75.80	16.90		80.0	
10481-AAA	LTE-TDD (SC-FDMA, 50% RB, 1.4 MHz, 64-QAM, UL Subframe=2,3,4,7,8,9)	X	3.50	71.72	15.20	3.23	80.0	± 9.6 %
		Y	0.75	60.00	7.10		80.0	
		Z	3.26	70.74	14.59		80.0	
10482-AAA	LTE-TDD (SC-FDMA, 50% RB, 3 MHz, QPSK, UL Subframe=2,3,4,7,8,9)	X	1.78	66.01	13.40	2.23	80.0	± 9.6 %
		Y	0.80	60.00	6.87		80.0	
		Z	1.80	66.49	13.54		80.0	
10483-AAA	LTE-TDD (SC-FDMA, 50% RB, 3 MHz, 16-QAM, UL Subframe=2,3,4,7,8,9)	X	2.59	67.30	13.51	2.23	80.0	± 9.6 %
		Y	1.09	60.00	5.52		80.0	
		Z	2.37	66.27	12.85		80.0	
10484-AAA	LTE-TDD (SC-FDMA, 50% RB, 3 MHz, 64-QAM, UL Subframe=2,3,4,7,8,9)	X	2.46	66.44	13.12	2.23	80.0	± 9.6 %
		Y	1.12	60.00	5.52		80.0	
		Z	2.26	65.46	12.48		80.0	
10485-AAC	LTE-TDD (SC-FDMA, 50% RB, 5 MHz, QPSK, UL Subframe=2,3,4,7,8,9)	X	2.31	69.06	16.01	2.23	80.0	± 9.6 %
		Y	2.52	71.75	14.63		80.0	
		Z	2.43	70.26	16.55		80.0	
10486-AAC	LTE-TDD (SC-FDMA, 50% RB, 5 MHz, 16-QAM, UL Subframe=2,3,4,7,8,9)	X	2.35	65.93	13.92	2.23	80.0	± 9.6 %
		Y	1.10	60.00	7.99		80.0	
		Z	2.35	66.25	14.03		80.0	
10487-AAC	LTE-TDD (SC-FDMA, 50% RB, 5 MHz, 64-QAM, UL Subframe=2,3,4,7,8,9)	X	2.36	65.64	13.75	2.23	80.0	± 9.6 %
		Y	1.13	60.00	7.94		80.0	
		Z	2.36	65.89	13.84		80.0	
10488-AAC	LTE-TDD (SC-FDMA, 50% RB, 10 MHz, QPSK, UL Subframe=2,3,4,7,8,9)	X	2.76	69.44	17.18	2.23	80.0	± 9.6 %
		Y	4.34	80.02	20.91		80.0	
		Z	2.84	70.33	17.68		80.0	
10489-AAC	LTE-TDD (SC-FDMA, 50% RB, 10 MHz, 16-QAM, UL Subframe=2,3,4,7,8,9)	X	2.91	67.08	16.06	2.23	80.0	± 9.6 %
		Y	3.28	71.79	16.98		80.0	
		Z	2.93	67.51	16.34		80.0	
10490-AAC	LTE-TDD (SC-FDMA, 50% RB, 10 MHz, 64-QAM, UL Subframe=2,3,4,7,8,9)	X	3.00	67.01	16.04	2.23	80.0	± 9.6 %
		Y	3.19	70.91	16.56		80.0	
		Z	3.01	67.40	16.29		80.0	
10491-AAC	LTE-TDD (SC-FDMA, 50% RB, 15 MHz, QPSK, UL Subframe=2,3,4,7,8,9)	X	3.11	68.64	17.05	2.23	80.0	± 9.6 %
		Y	3.62	74.69	19.64		80.0	
		Z	3.15	69.19	17.41		80.0	
10492-AAC	LTE-TDD (SC-FDMA, 50% RB, 15 MHz, 16-QAM, UL Subframe=2,3,4,7,8,9)	X	3.31	66.73	16.33	2.23	80.0	± 9.6 %
		Y	3.42	70.36	17.49		80.0	
		Z	3.30	66.98	16.55		80.0	

10493-AAC	LTE-TDD (SC-FDMA, 50% RB, 15 MHz, 64-QAM, UL Subframe=2,3,4,7,8,9)	X	3.37	66.65	16.30	2.23	80.0	± 9.6 %
		Y	3.42	69.99	17.28		80.0	
		Z	3.37	66.89	16.51		80.0	
10494-AAC	LTE-TDD (SC-FDMA, 50% RB, 20 MHz, QPSK, UL Subframe=2,3,4,7,8,9)	X	3.29	69.76	17.41	2.23	80.0	± 9.6 %
		Y	3.96	76.26	20.40		80.0	
		Z	3.36	70.43	17.82		80.0	
10495-AAC	LTE-TDD (SC-FDMA, 50% RB, 20 MHz, 16-QAM, UL Subframe=2,3,4,7,8,9)	X	3.32	66.99	16.51	2.23	80.0	± 9.6 %
		Y	3.45	70.58	17.96		80.0	
		Z	3.32	67.26	16.75		80.0	
10496-AAC	LTE-TDD (SC-FDMA, 50% RB, 20 MHz, 64-QAM, UL Subframe=2,3,4,7,8,9)	X	3.41	66.83	16.48	2.23	80.0	± 9.6 %
		Y	3.49	70.20	17.79		80.0	
		Z	3.41	67.07	16.70		80.0	
10497-AAA	LTE-TDD (SC-FDMA, 100% RB, 1.4 MHz, QPSK, UL Subframe=2,3,4,7,8,9)	X	1.18	61.39	9.87	2.23	80.0	± 9.6 %
		Y	0.42	53.98	1.19		80.0	
		Z	1.11	61.01	9.51		80.0	
10498-AAA	LTE-TDD (SC-FDMA, 100% RB, 1.4 MHz, 16-QAM, UL Subframe=2,3,4,7,8,9)	X	1.22	60.00	7.98	2.23	80.0	± 9.6 %
		Y	99.99	258.49	1.69		80.0	
		Z	1.20	60.00	7.80		80.0	
10499-AAA	LTE-TDD (SC-FDMA, 100% RB, 1.4 MHz, 64-QAM, UL Subframe=2,3,4,7,8,9)	X	1.24	60.00	7.83	2.23	80.0	± 9.6 %
		Y	99.95	273.67	5.17		80.0	
		Z	1.21	60.00	7.64		80.0	
10500-AAA	LTE-TDD (SC-FDMA, 100% RB, 3 MHz, QPSK, UL Subframe=2,3,4,7,8,9)	X	2.48	69.15	16.47	2.23	80.0	± 9.6 %
		Y	4.15	78.35	18.23		80.0	
		Z	2.59	70.22	16.99		80.0	
10501-AAA	LTE-TDD (SC-FDMA, 100% RB, 3 MHz, 16-QAM, UL Subframe=2,3,4,7,8,9)	X	2.62	66.65	14.86	2.23	80.0	± 9.6 %
		Y	1.65	63.40	10.90		80.0	
		Z	2.64	67.08	15.07		80.0	
10502-AAA	LTE-TDD (SC-FDMA, 100% RB, 3 MHz, 64-QAM, UL Subframe=2,3,4,7,8,9)	X	2.66	66.53	14.74	2.23	80.0	± 9.6 %
		Y	1.59	62.74	10.46		80.0	
		Z	2.68	66.92	14.92		80.0	
10503-AAC	LTE-TDD (SC-FDMA, 100% RB, 5 MHz, QPSK, UL Subframe=2,3,4,7,8,9)	X	2.73	69.26	17.09	2.23	80.0	± 9.6 %
		Y	4.21	79.52	20.70		80.0	
		Z	2.81	70.13	17.57		80.0	
10504-AAC	LTE-TDD (SC-FDMA, 100% RB, 5 MHz, 16-QAM, UL Subframe=2,3,4,7,8,9)	X	2.89	66.99	16.00	2.23	80.0	± 9.6 %
		Y	3.22	71.53	16.84		80.0	
		Z	2.91	67.41	16.27		80.0	
10505-AAC	LTE-TDD (SC-FDMA, 100% RB, 5 MHz, 64-QAM, UL Subframe=2,3,4,7,8,9)	X	2.98	66.92	15.98	2.23	80.0	± 9.6 %
		Y	3.15	70.69	16.45		80.0	
		Z	3.00	67.30	16.23		80.0	
10506-AAC	LTE-TDD (SC-FDMA, 100% RB, 10 MHz, QPSK, UL Subframe=2,3,4,7,8,9)	X	3.27	69.63	17.34	2.23	80.0	± 9.6 %
		Y	3.91	76.02	20.28		80.0	
		Z	3.33	70.28	17.74		80.0	
10507-AAC	LTE-TDD (SC-FDMA, 100% RB, 10 MHz, 16-QAM, UL Subframe=2,3,4,7,8,9)	X	3.31	66.93	16.47	2.23	80.0	± 9.6 %
		Y	3.43	70.48	17.90		80.0	
		Z	3.31	67.19	16.70		80.0	

10508-AAC	LTE-TDD (SC-FDMA, 100% RB, 10 MHz, 64-QAM, UL Subframe=2,3,4,7,8,9)	X	3.40	66.77	16.43	2.23	80.0	± 9.6 %
		Y	3.47	70.07	17.72		80.0	
		Z	3.40	67.00	16.65		80.0	
10509-AAC	LTE-TDD (SC-FDMA, 100% RB, 15 MHz, QPSK, UL Subframe=2,3,4,7,8,9)	X	3.71	68.99	17.10	2.23	80.0	± 9.6 %
		Y	3.93	72.91	19.23		80.0	
		Z	3.74	69.39	17.40		80.0	
10510-AAC	LTE-TDD (SC-FDMA, 100% RB, 15 MHz, 16-QAM, UL Subframe=2,3,4,7,8,9)	X	3.81	66.87	16.61	2.23	80.0	± 9.6 %
		Y	3.70	69.03	17.73		80.0	
		Z	3.80	67.02	16.79		80.0	
10511-AAC	LTE-TDD (SC-FDMA, 100% RB, 15 MHz, 64-QAM, UL Subframe=2,3,4,7,8,9)	X	3.88	66.72	16.58	2.23	80.0	± 9.6 %
		Y	3.77	68.83	17.64		80.0	
		Z	3.87	66.85	16.75		80.0	
10512-AAC	LTE-TDD (SC-FDMA, 100% RB, 20 MHz, QPSK, UL Subframe=2,3,4,7,8,9)	X	3.76	70.05	17.41	2.23	80.0	± 9.6 %
		Y	4.13	74.35	19.72		80.0	
		Z	3.82	70.57	17.75		80.0	
10513-AAC	LTE-TDD (SC-FDMA, 100% RB, 20 MHz, 16-QAM, UL Subframe=2,3,4,7,8,9)	X	3.69	66.99	16.66	2.23	80.0	± 9.6 %
		Y	3.62	69.07	17.83		80.0	
		Z	3.68	67.16	16.86		80.0	
10514-AAC	LTE-TDD (SC-FDMA, 100% RB, 20 MHz, 64-QAM, UL Subframe=2,3,4,7,8,9)	X	3.74	66.70	16.58	2.23	80.0	± 9.6 %
		Y	3.66	68.68	17.67		80.0	
		Z	3.72	66.84	16.77		80.0	
10515-AAA	IEEE 802.11b WiFi 2.4 GHz (DSSS, 2 Mbps, 99pc duty cycle)	X	0.89	62.04	13.53	0.00	150.0	± 9.6 %
		Y	0.99	66.72	16.88		150.0	
		Z	0.88	62.43	13.97		150.0	
10516-AAA	IEEE 802.11b WiFi 2.4 GHz (DSSS, 5.5 Mbps, 99pc duty cycle)	X	0.42	65.22	13.44	0.00	150.0	± 9.6 %
		Y	100.00	170.44	46.50		150.0	
		Z	0.47	67.93	14.90		150.0	
10517-AAA	IEEE 802.11b WiFi 2.4 GHz (DSSS, 11 Mbps, 99pc duty cycle)	X	0.71	63.10	13.56	0.00	150.0	± 9.6 %
		Y	0.99	72.70	19.61		150.0	
		Z	0.71	63.90	14.21		150.0	
10518-AAB	IEEE 802.11a/h WiFi 5 GHz (OFDM, 9 Mbps, 99pc duty cycle)	X	4.34	66.42	15.89	0.00	150.0	± 9.6 %
		Y	4.04	67.95	16.62		150.0	
		Z	4.34	66.52	16.03		150.0	
10519-AAB	IEEE 802.11a/h WiFi 5 GHz (OFDM, 12 Mbps, 99pc duty cycle)	X	4.50	66.62	16.00	0.00	150.0	± 9.6 %
		Y	4.14	68.05	16.67		150.0	
		Z	4.49	66.71	16.14		150.0	
10520-AAB	IEEE 802.11a/h WiFi 5 GHz (OFDM, 18 Mbps, 99pc duty cycle)	X	4.35	66.54	15.90	0.00	150.0	± 9.6 %
		Y	4.01	67.95	16.60		150.0	
		Z	4.35	66.64	16.05		150.0	
10521-AAB	IEEE 802.11a/h WiFi 5 GHz (OFDM, 24 Mbps, 99pc duty cycle)	X	4.29	66.51	15.88	0.00	150.0	± 9.6 %
		Y	3.94	67.81	16.52		150.0	
		Z	4.28	66.61	16.02		150.0	
10522-AAB	IEEE 802.11a/h WiFi 5 GHz (OFDM, 36 Mbps, 99pc duty cycle)	X	4.34	66.65	15.98	0.00	150.0	± 9.6 %
		Y	3.95	67.80	16.52		150.0	
		Z	4.34	66.75	16.13		150.0	

10523-AAB	IEEE 802.11a/h WiFi 5 GHz (OFDM, 48 Mbps, 99pc duty cycle)	X	4.25	66.56	15.85	0.00	150.0	± 9.6 %
		Y	3.96	68.17	16.68		150.0	
		Z	4.25	66.67	16.01		150.0	
10524-AAB	IEEE 802.11a/h WiFi 5 GHz (OFDM, 54 Mbps, 99pc duty cycle)	X	4.29	66.57	15.95	0.00	150.0	± 9.6 %
		Y	3.92	67.94	16.65		150.0	
		Z	4.28	66.68	16.11		150.0	
10525-AAB	IEEE 802.11ac WiFi (20MHz, MCS0, 99pc duty cycle)	X	4.30	65.65	15.56	0.00	150.0	± 9.6 %
		Y	4.04	67.23	16.37		150.0	
		Z	4.30	65.76	15.72		150.0	
10526-AAB	IEEE 802.11ac WiFi (20MHz, MCS1, 99pc duty cycle)	X	4.44	65.96	15.69	0.00	150.0	± 9.6 %
		Y	4.10	67.36	16.43		150.0	
		Z	4.44	66.06	15.84		150.0	
10527-AAB	IEEE 802.11ac WiFi (20MHz, MCS2, 99pc duty cycle)	X	4.36	65.91	15.62	0.00	150.0	± 9.6 %
		Y	4.06	67.43	16.42		150.0	
		Z	4.36	66.02	15.78		150.0	
10528-AAB	IEEE 802.11ac WiFi (20MHz, MCS3, 99pc duty cycle)	X	4.38	65.93	15.65	0.00	150.0	± 9.6 %
		Y	4.05	67.35	16.40		150.0	
		Z	4.38	66.04	15.81		150.0	
10529-AAB	IEEE 802.11ac WiFi (20MHz, MCS4, 99pc duty cycle)	X	4.38	65.93	15.65	0.00	150.0	± 9.6 %
		Y	4.05	67.35	16.40		150.0	
		Z	4.38	66.04	15.81		150.0	
10531-AAB	IEEE 802.11ac WiFi (20MHz, MCS6, 99pc duty cycle)	X	4.35	65.97	15.64	0.00	150.0	± 9.6 %
		Y	4.01	67.35	16.37		150.0	
		Z	4.35	66.08	15.79		150.0	
10532-AAB	IEEE 802.11ac WiFi (20MHz, MCS7, 99pc duty cycle)	X	4.23	65.82	15.56	0.00	150.0	± 9.6 %
		Y	3.93	67.27	16.33		150.0	
		Z	4.23	65.93	15.72		150.0	
10533-AAB	IEEE 802.11ac WiFi (20MHz, MCS8, 99pc duty cycle)	X	4.39	65.99	15.65	0.00	150.0	± 9.6 %
		Y	4.07	67.57	16.46		150.0	
		Z	4.39	66.11	15.81		150.0	
10534-AAB	IEEE 802.11ac WiFi (40MHz, MCS0, 99pc duty cycle)	X	4.94	66.05	15.78	0.00	150.0	± 9.6 %
		Y	4.64	66.91	16.43		150.0	
		Z	4.95	66.13	15.92		150.0	
10535-AAB	IEEE 802.11ac WiFi (40MHz, MCS1, 99pc duty cycle)	X	5.00	66.21	15.85	0.00	150.0	± 9.6 %
		Y	4.65	66.98	16.47		150.0	
		Z	5.00	66.29	16.00		150.0	
10536-AAB	IEEE 802.11ac WiFi (40MHz, MCS2, 99pc duty cycle)	X	4.88	66.17	15.81	0.00	150.0	± 9.6 %
		Y	4.56	66.99	16.45		150.0	
		Z	4.88	66.26	15.96		150.0	
10537-AAB	IEEE 802.11ac WiFi (40MHz, MCS3, 99pc duty cycle)	X	4.93	66.14	15.80	0.00	150.0	± 9.6 %
		Y	4.65	67.13	16.53		150.0	
		Z	4.94	66.23	15.95		150.0	
10538-AAB	IEEE 802.11ac WiFi (40MHz, MCS4, 99pc duty cycle)	X	5.01	66.14	15.84	0.00	150.0	± 9.6 %
		Y	4.66	66.91	16.44		150.0	
		Z	5.02	66.22	15.99		150.0	
10540-AAB	IEEE 802.11ac WiFi (40MHz, MCS6, 99pc duty cycle)	X	4.94	66.12	15.84	0.00	150.0	± 9.6 %
		Y	4.60	66.83	16.43		150.0	
		Z	4.95	66.20	15.99		150.0	

10541-AAB	IEEE 802.11ac WiFi (40MHz, MCS7, 99pc duty cycle)	X	4.92	66.01	15.78	0.00	150.0	± 9.6 %
		Y	4.61	66.86	16.41		150.0	
		Z	4.92	66.07	15.91		150.0	
10542-AAB	IEEE 802.11ac WiFi (40MHz, MCS8, 99pc duty cycle)	X	5.08	66.12	15.85	0.00	150.0	± 9.6 %
		Y	4.74	66.92	16.46		150.0	
		Z	5.08	66.19	15.99		150.0	
10543-AAB	IEEE 802.11ac WiFi (40MHz, MCS9, 99pc duty cycle)	X	5.14	66.15	15.90	0.00	150.0	± 9.6 %
		Y	4.79	66.97	16.52		150.0	
		Z	5.15	66.24	16.04		150.0	
10544-AAB	IEEE 802.11ac WiFi (80MHz, MCS0, 99pc duty cycle)	X	5.28	66.17	15.79	0.00	150.0	± 9.6 %
		Y	5.02	66.72	16.34		150.0	
		Z	5.29	66.22	15.92		150.0	
10545-AAB	IEEE 802.11ac WiFi (80MHz, MCS1, 99pc duty cycle)	X	5.46	66.60	15.97	0.00	150.0	± 9.6 %
		Y	5.15	67.11	16.50		150.0	
		Z	5.48	66.70	16.12		150.0	
10546-AAB	IEEE 802.11ac WiFi (80MHz, MCS2, 99pc duty cycle)	X	5.32	66.30	15.83	0.00	150.0	± 9.6 %
		Y	5.04	66.80	16.35		150.0	
		Z	5.32	66.36	15.96		150.0	
10547-AAB	IEEE 802.11ac WiFi (80MHz, MCS3, 99pc duty cycle)	X	5.39	66.39	15.87	0.00	150.0	± 9.6 %
		Y	5.17	67.18	16.54		150.0	
		Z	5.41	66.46	16.01		150.0	
10548-AAB	IEEE 802.11ac WiFi (80MHz, MCS4, 99pc duty cycle)	X	5.58	67.13	16.21	0.00	150.0	± 9.6 %
		Y	5.08	67.06	16.46		150.0	
		Z	5.61	67.28	16.39		150.0	
10550-AAB	IEEE 802.11ac WiFi (80MHz, MCS6, 99pc duty cycle)	X	5.37	66.44	15.91	0.00	150.0	± 9.6 %
		Y	5.20	67.46	16.69		150.0	
		Z	5.39	66.55	16.06		150.0	
10551-AAB	IEEE 802.11ac WiFi (80MHz, MCS7, 99pc duty cycle)	X	5.33	66.33	15.82	0.00	150.0	± 9.6 %
		Y	5.00	66.73	16.30		150.0	
		Z	5.34	66.38	15.94		150.0	
10552-AAB	IEEE 802.11ac WiFi (80MHz, MCS8, 99pc duty cycle)	X	5.29	66.25	15.78	0.00	150.0	± 9.6 %
		Y	5.03	66.95	16.40		150.0	
		Z	5.29	66.30	15.90		150.0	
10553-AAB	IEEE 802.11ac WiFi (80MHz, MCS9, 99pc duty cycle)	X	5.35	66.24	15.81	0.00	150.0	± 9.6 %
		Y	5.04	66.77	16.32		150.0	
		Z	5.35	66.28	15.93		150.0	
10554-AAC	IEEE 802.11ac WiFi (160MHz, MCS0, 99pc duty cycle)	X	5.70	66.53	15.89	0.00	150.0	± 9.6 %
		Y	5.48	66.93	16.36		150.0	
		Z	5.71	66.58	16.01		150.0	
10555-AAC	IEEE 802.11ac WiFi (160MHz, MCS1, 99pc duty cycle)	X	5.81	66.79	16.00	0.00	150.0	± 9.6 %
		Y	5.55	67.14	16.45		150.0	
		Z	5.82	66.86	16.13		150.0	
10556-AAC	IEEE 802.11ac WiFi (160MHz, MCS2, 99pc duty cycle)	X	5.84	66.87	16.04	0.00	150.0	± 9.6 %
		Y	5.59	67.27	16.51		150.0	
		Z	5.85	66.94	16.17		150.0	
10557-AAC	IEEE 802.11ac WiFi (160MHz, MCS3, 99pc duty cycle)	X	5.79	66.74	15.99	0.00	150.0	± 9.6 %
		Y	5.53	67.10	16.44		150.0	
		Z	5.80	66.79	16.11		150.0	