



**FCC 47 CFR PART 15 SUBPART E**

**UNII**

**CERTIFICATION TEST REPORT**

**FOR**

**GSM/WCDMA/LTE Tablet + BT/BLE, DTS/UNII a/b/g/n/ac and ANT+**

**MODEL NUMBER : SM-T835C**

**FCC ID: A3LSMT835C**

**REPORT NUMBER: 4788506351-E4V1**

**ISSUE DATE: JUL 10, 2018**

*Prepared for*  
**SAMSUNG ELECTRONICS CO., LTD.**  
**129 SAMSUNG-RO, YEONGTONG-GU, SUWON-SI,**  
**GYEONGGI-DO, 16677, KOREA**

*Prepared by*  
**UL Korea, Ltd.**  
**26th floor, 152, Teheran-ro, Gangnam-gu Seoul, 06236, Korea**

**Suwon Test Site: UL Korea, Ltd. Suwon Laboratory**  
**218 Maeyeong-ro, Yeongtong-gu,**  
**Suwon-si, Gyeonggi-do, 16675, Korea**  
**TEL: (031) 337-9902**  
**FAX: (031) 213-5433**



**ACCREDITED\***

Testing  
Laboratory

**TL-637**

Revision History

<u>Rev.</u>	<u>Issue Date</u>	<u>Revisions</u>	<u>Revised By</u>
V1	07/10/18	Initial issue	Junwhan Lee

## TABLE OF CONTENTS

<b>1. ATTESTATION OF TEST RESULTS .....</b>	<b>7</b>
1.1. INTRODUCTION OF TEST DATA REUSE.....	8
1.2. DIFFERENCE.....	8
1.3. SPOT CHECK VERIFICATION DATA .....	8
1.4. REFERENCE DETAIL .....	9
<b>2. TEST METHODOLOGY .....</b>	<b>10</b>
<b>3. FACILITIES AND ACCREDITATION .....</b>	<b>10</b>
<b>4. CALIBRATION AND UNCERTAINTY .....</b>	<b>10</b>
4.1. MEASURING INSTRUMENT CALIBRATION .....	10
4.2. SAMPLE CALCULATION .....	10
4.3. MEASUREMENT UNCERTAINTY.....	11
<b>5. EQUIPMENT UNDER TEST .....</b>	<b>12</b>
5.1. DESCRIPTION OF EUT .....	12
5.2. MAXIMUM OUTPUT POWER.....	13
5.3. DESCRIPTION OF AVAILABLE ANTENNAS .....	14
5.4. List of test reduction and modes covering other modes: .....	14
5.5. WORST-CASE CONFIGURATION AND MODE.....	16
5.6. DESCRIPTION OF TEST SETUP.....	17
<b>6. TEST AND MEASUREMENT EQUIPMENT .....</b>	<b>19</b>
<b>7. SUMMARY TABLE .....</b>	<b>20</b>
<b>8. MEASUREMENT METHODS .....</b>	<b>21</b>
<b>9. REFERENCE MEASUREMENTS RESULTS .....</b>	<b>22</b>
9.1. ON TIME AND DUTY CYCLE RESULTS.....	22
9.2. DUTY CYCLE PLOTS .....	22
9.3. 26 dB BANDWIDTH.....	25
9.3.1. 802.11a MODE IN THE 5.2 GHz BAND.....	26
9.3.2. 802.11n HT20 MODE IN THE 5.2 GHz BAND .....	26
9.3.3. 802.11n HT40 MODE IN THE 5.2 GHz BAND .....	26
9.3.4. 802.11ac VHT80 MODE IN THE 5.2 GHz BAND .....	26
9.3.5. 802.11a MODE IN THE 5.3 GHz BAND.....	27
9.3.6. 802.11n HT20 MODE IN THE 5.3 GHz BAND .....	27
9.3.7. 802.11n HT40 MODE IN THE 5.3 GHz BAND .....	27
9.3.8. 802.11ac VHT80 MODE IN THE 5.3 GHz BAND .....	27
9.3.9. 802.11a MODE IN THE 5.5 GHz BAND.....	28

9.3.10.	802.11n HT20 MODE IN THE 5.5 GHz BAND .....	28
9.3.11.	802.11n HT40 MODE IN THE 5.5 GHz BAND .....	28
9.3.12.	802.11ac VHT80 MODE IN THE 5.5 GHz BAND .....	28
9.3.13.	802.11a MODE IN THE 5.8 GHz BAND .....	29
9.3.14.	802.11n HT20 MODE IN THE 5.8 GHz BAND .....	29
9.3.15.	802.11n HT40 MODE IN THE 5.8 GHz BAND .....	29
9.3.16.	802.11ac VHT80 MODE IN THE 5.8 GHz BAND .....	29
9.3.17.	26 dB BANDWIDTH PLOTS .....	30
9.4.	<b>99% BANDWIDTH</b> .....	<b>43</b>
9.4.1.	802.11a MODE IN THE 5.2 GHz BAND .....	43
9.4.2.	802.11n HT20 MODE IN THE 5.2 GHz BAND .....	44
9.4.3.	802.11n HT40 MODE IN THE 5.2 GHz BAND .....	44
9.4.4.	802.11ac VHT80 MODE IN THE 5.2 GHz BAND .....	44
9.4.5.	802.11a MODE IN THE 5.3 GHz BAND .....	44
9.4.6.	802.11n HT20 MODE IN THE 5.3 GHz BAND .....	45
9.4.7.	802.11n HT40 MODE IN THE 5.3 GHz BAND .....	45
9.4.8.	802.11ac VHT80 MODE IN THE 5.3 GHz BAND .....	45
9.4.9.	802.11a MODE IN THE 5.5 GHz BAND .....	46
9.4.10.	802.11n HT20 MODE IN THE 5.5 GHz BAND .....	46
9.4.11.	802.11n HT40 MODE IN THE 5.5 GHz BAND .....	46
9.4.12.	802.11ac VHT80 MODE IN THE 5.5 GHz BAND .....	46
9.4.13.	802.11a MODE IN THE 5.8 GHz BAND .....	47
9.4.14.	802.11n HT20 MODE IN THE 5.8 GHz BAND .....	47
9.4.15.	802.11n HT40 MODE IN THE 5.8 GHz BAND .....	47
9.4.16.	802.11ac VHT80 MODE IN THE 5.8 GHz BAND .....	47
9.4.17.	99% BANDWIDTH PLOTS .....	48
<b>10.</b>	<b>ANTENNA PORT TEST RESULTS</b> .....	<b>61</b>
10.1.	<b>6 dB BANDWIDTH</b> .....	<b>61</b>
10.1.1.	802.11a MODE IN THE 5.8 GHz BAND .....	62
10.1.2.	802.11n HT20 MODE IN THE 5.8 GHz BAND .....	62
10.1.3.	802.11n HT40 MODE IN THE 5.8 GHz BAND .....	62
10.1.4.	802.11n VHT80 MODE IN THE 5.8 GHz BAND .....	62
10.1.5.	6 dB BANDWIDTH PLOTS .....	63
10.2.	<b>OUTPUT POWER AND PPSD</b> .....	<b>67</b>
10.2.1.	802.11a MODE IN THE 5.2 GHz BAND .....	68
10.2.2.	802.11n HT20 MODE IN THE 5.2 GHz BAND .....	69
10.2.3.	802.11n HT40 MODE IN THE 5.2 GHz BAND .....	70
10.2.4.	802.11ac VHT80 MODE IN THE 5.2 GHz BAND .....	71
10.2.5.	802.11a MODE IN THE 5.3 GHz BAND .....	72
10.2.6.	802.11n HT20 MODE IN THE 5.3 GHz BAND .....	73
10.2.7.	802.11n HT40 MODE IN THE 5.3 GHz BAND .....	74
10.2.8.	802.11ac VHT80 MODE IN THE 5.3 GHz BAND .....	75
10.2.9.	802.11a MODE IN THE 5.5 GHz BAND .....	76
10.2.10.	802.11n HT20 MODE IN THE 5.5 GHz BAND .....	77
10.2.11.	802.11n HT40 MODE IN THE 5.5 GHz BAND .....	78
10.2.12.	802.11ac VHT80 MODE IN THE 5.5 GHz BAND .....	79
10.2.13.	802.11a MODE IN THE 5.8 GHz BAND .....	80
10.2.14.	802.11n HT20 MODE IN THE 5.8 GHz BAND .....	81
10.2.15.	802.11n HT40 MODE IN THE 5.8 GHz BAND .....	82

10.2.16.	802.11ac VHT80 MODE IN THE 5.8 GHz BAND .....	83
10.2.17.	802.11a MODE IN THE STRADDLE CHANNEL .....	84
10.2.18.	802.11n HT20 MODE IN THE STRADDLE CHANNEL .....	85
10.2.19.	802.11n HT40 MODE IN THE STRADDLE CHANNEL .....	86
10.2.20.	802.11ac VHT80 MODE IN THE STRADDLE CHANNEL .....	87
10.2.21.	OUTPUT POWER AND PPSD PLOTS .....	88
<b>11.</b>	<b>TRANSMITTER ABOVE 1 GHz.....</b>	<b>105</b>
11.1.	5.2 GHz.....	108
11.1.1.	TX Above 1GHz 802.11a 2Tx CDD MODE IN THE 5.2GHz BAND .....	108
11.1.2.	TX Above 1GHz 802.11n HT20 2Tx CDD MODE IN THE 5.2GHz BAND.....	116
11.1.3.	TX Above 1GHz 802.11n HT40 2Tx CDD MODE IN THE 5.2GHz BAND.....	124
11.1.4.	TX ABOVE 1GHz 802.11ac VHT80 2Tx CDD MODE IN THE 5.2GHz BAND.....	130
11.2.	5.3 GHz.....	134
11.2.1.	TX ABOVE 1 GHz 802.11a 2Tx CDD MODE IN THE 5.3 GHz BAND .....	134
11.2.2.	TX ABOVE 1GHz 802.11n HT20 2Tx CDD MODE IN THE 5.3GHz BAND .....	142
11.2.3.	TX ABOVE 1GHz 802.11n HT40 2Tx CDD MODE IN THE 5.3GHz BAND .....	150
11.2.4.	TX ABOVE 1GHz 802.11ac VHT80 2Tx CDD MODE IN THE 5.3GHz BAND .....	156
	RESTRICTED BANDEDGE (High CHANNEL).....	156
11.3.	5.5-5.6 GHz.....	160
11.3.1.	TX ABOVE 1 GHz 802.11a 2Tx CDD MODE IN THE 5.5 GHz BAND .....	160
11.3.2.	TX ABOVE 1GHz 802.11n HT20 2Tx CDD MODE IN THE 5.5GHz BAND .....	170
11.3.3.	TX ABOVE 1GHz 802.11n HT40 2Tx CDD MODE IN THE 5.5GHz BAND .....	180
11.3.4.	TX ABOVE 1GHz 802.11ac VHT80 2Tx CDD MODE IN THE 5.5GHz BAND.....	190
11.3.5.	TX ABOVE 1GHz 802.11a 2Tx CDD MODE IN THE STRADDLE CHANNEL .....	198
11.3.6.	TX ABOVE 1GHz 802.11n HT20 2Tx CDD MODE IN THE STRADDLE CHANNEL	200
11.3.7.	TX ABOVE 1GHz 802.11n HT40 2Tx CDD MODE IN THE STRADDLE CHANNEL	202
11.3.8.	TX ABOVE 1GHz 802.11ac VHT80 2Tx CDD MODE IN THE STRADDLE CHANNEL	204
11.4.	5.8 GHz.....	206
11.4.1.	TX ABOVE 1GHz 802.11a 2Tx CDD MODE IN THE 5.8GHz BAND .....	206
11.4.2.	TX ABOVE 1GHz 802.11n HT20 2Tx CDD MODE IN THE 5.8GHz BAND .....	216
11.4.3.	TX ABOVE 1GHz 802.11n HT40 2Tx CDD MODE IN THE 5.8GHz BAND .....	226
11.4.4.	TX ABOVE 1GHz 802.11ac VHT80 2Tx CDD MODE IN THE 5.8GHz BAND.....	234
11.5.	Spurious Emissions for Simultaneous Transmission .....	240
11.5.1.	Worst test case condition .....	240
<b>12.</b>	<b>WORST-CASE BELOW 1 GHz .....</b>	<b>247</b>
<b>13.</b>	<b>AC POWER LINE CONDUCTED EMISSIONS .....</b>	<b>251</b>
<b>14.</b>	<b>DYNAMIC FREQUENCY SELECTION.....</b>	<b>256</b>
14.1.	OVERVIEW.....	256
14.1.1.	LIMITS.....	256
14.1.1.	TEST AND MEASUREMENT SYSTEM.....	260
14.1.2.	SETUP OF EUT.....	263
14.1.3.	DESCRIPTION OF EUT .....	264
14.2.	RESULTS FOR 20 MHz BANDWIDTH.....	265

---

14.2.1.	TEST CHANNEL .....	265
14.2.2.	RADAR WAVEFORM AND TRAFFIC .....	265
14.2.3.	OVERLAPPING CHANNEL TESTS.....	267
14.2.4.	MOVE AND CLOSING TIME .....	267
14.3.	<i>RESULTS FOR 40 MHz BANDWIDTH</i> .....	270
14.3.1.	TEST CHANNEL .....	270
14.3.2.	RADAR WAVEFORM AND TRAFFIC .....	270
14.3.3.	OVERLAPPING CHANNEL TESTS.....	272
14.3.4.	MOVE AND CLOSING TIME .....	272
14.4.	<i>RESULTS FOR 80 MHz BANDWIDTH</i> .....	275
14.4.1.	TEST CHANNEL .....	275
14.4.2.	RADAR WAVEFORM AND TRAFFIC .....	275
14.4.3.	OVERLAPPING CHANNEL TESTS.....	277
14.4.4.	MOVE AND CLOSING TIME .....	277
<b>15.</b>	<b>SETUP PHOTOS.....</b>	<b>280</b>

# 1. ATTESTATION OF TEST RESULTS

**COMPANY NAME:** SAMSUNG ELECTRONICS CO., LTD.  
**EUT DESCRIPTION:** GSM/WCDMA/LTE Tablet + BT/BLE, DTS/UNII a/b/g/n/ac and ANT+  
**MODEL NUMBER:** SM-T835C  
**SERIAL NUMBER:** R32K10045KW (RADIATED, Original);  
R32K10044PB (CONDUCTED, Original)  
R22K4004M1Z, R22K500LEAW  
(RADIATED, Spot check and additional test)  
**DATE TESTED:** APR 11, 2018 - JUN 08, 2018 (Original)  
JUN 29, 2018 - JUL 10, 2018 (Spot check and additional test)

APPLICABLE STANDARDS	
STANDARD	TEST RESULTS
CFR 47 Part 15 Subpart E	Pass

UL Korea, Ltd. tested the above equipment in accordance with the requirements set forth in the above standards. All indications of Pass/Fail in this report are opinions expressed by UL Korea, Ltd. based on interpretations and/or observations of test results. Measurement Uncertainties were not taken into account and are published for informational purposes only. The test results show that the equipment tested is capable of demonstrating compliance with the requirements as documented in this report.

**Note:** The results documented in this report apply only to the tested sample, under the conditions and modes of operation as described herein. This document may not be altered or revised in any way unless done so by UL Korea, Ltd. and all revisions are duly noted in the revisions section. Any alteration of this document not carried out by UL Korea, Ltd. will constitute fraud and shall nullify the document. This report must not be used by the client to claim product certification, approval, or endorsement by IAS, any agency of the Federal Government, or any agency of any government.

Approved & Released For  
UL Korea, Ltd. By:

Tested By:



SungGil Park  
Suwon Lab Engineer  
UL Korea, Ltd.

Junwhan Lee  
Suwon Lab Engineer  
UL Korea, Ltd.

## 1.1. INTRODUCTION OF TEST DATA REUSE

This report referenced from the FCC ID: A3LSMT835 NII WLAN(FCC CFR 47 Part 15E). And the applicant takes full responsibility that the test data as referenced in this report represent compliance for this FCC ID.

## 1.2. DIFFERENCE

The FCC ID: A3LSMT835C, shares the same enclosure and circuit board as FCC ID: A3LSMT835. The WLAN antennas and surrounding circuitry and layout are identical between these two units.

After confirming through preliminary radiated emissions that the performance of the FCC ID: A3LSMT835 remains representative of FCC ID: A3LSMT835C. The test data of FCC ID: A3LSMT835 being submitted for this application to cover WLAN features.

Because DTS WLAN test data of FCC ID: A3LSMT835 didn't re-use for FCC ID: A3LSMT835C, so spurious emissions for simultaneous transmission were performed newly on section 11.5.

## 1.3. SPOT CHECK VERIFICATION DATA (Worst case of the radiated spurious and band edge emissions)

Band	Test Item	Mode	Frequency	Test Limit	Original model		Deviation	Remark
					SM-T835 Results	Spot check model		
					FCC ID : A3LSMT835	SM-T835C Results FCC ID : A3LSMT835C		
UNII WLAN (5GHz)	Band Edge	802.11ac VHT80	5210 MHz	54 dBuV/m	46.09 dBuV/m	45.74 dBuV/m	-0.35 dB	
	RSE	802.11 a	5240 MHz	54 dBuV/m	40.14 dBuV/m	42.77 dBuV/m	2.63 dB	
	Band Edge	802.11ac VHT80	5290 MHz	54 dBuV/m	46.55 dBuV/m	47.02 dBuV/m	0.47 dB	
	RSE	802.11ac VHT80	5290 MHz	54 dBuV/m	40.11 dBuV/m	43.09 dBuV/m	2.98 dB	
	Band Edge	802.11ac VHT80	5530 MHz	54 dBuV/m	45.64 dBuV/m	45.07 dBuV/m	-0.57 dB	
	RSE	802.11ac VHT80	5690 MHz	54 dBuV/m	41.76 dBuV/m	42.91 dBuV/m	1.15 dB	
	Band Edge	802.11 a	5825 MHz	-27 dBm	-35.13 dBm	-35.77 dBm	-0.64 dB	
	RSE	802.11 n HT20	5745 MHz	54 dBuV/m	40.53 dBuV/m	42.91 dBuV/m	2.38 dB	

Comparison of two models, upper deviation is within 3dB range and all test results are under FCC Technical Limits.

## 1.4. REFERENCE DETAIL

Reference application that contains the reused reference data.

Equipment Class	Reference FCC ID	Type Grant/Permissive Change	Reference Application	Folder Test/RF Exposure	Report Title / Section
DXX	A3LSMT835	Grant	4788429415-E5V1	Test	FCC Report ANT+ / All sections
NII	A3LSMT835	Grant	4788429415-E4V1	Test	FCC Report UNII WLAN / All sections (Except section 11.5)

## 2. TEST METHODOLOGY

The tests documented in this report were performed in accordance with following methods.

1. FCC CFR 47 Part 2.
2. FCC CFR 47 Part 15.
3. KDB 789033 D02 General UNII Test Procedures New Rules v02r01
4. KDB 905462 D02 UNII DFS Compliance Procedures New Rules v02
5. KDB 905462 D03 UNII Clients Without Radar Detection New Rules v01r02
6. KDB 662911 D01 v02r01
7. ANSI C63.10-2013.

## 3. FACILITIES AND ACCREDITATION

The test sites and measurement facilities used to collect data are located at 218 Maeyeong-ro, Yeongtong-gu, Suwon-si, Gyeonggi-do, 16675, Korea. Line conducted emissions are measured only at the 218 address. The following table identifies which facilities were utilized for radiated emission measurements documented in this report. Specific facilities are also identified in the test results sections.

218 Maeyeong-ro	
<input checked="" type="checkbox"/>	Chamber 1
<input type="checkbox"/>	Chamber 2
<input checked="" type="checkbox"/>	Chamber 3

UL Korea, Ltd. is accredited by IAS, Laboratory Code TL-637. The full scope of accreditation can be viewed at <http://www.iasonline.org/PDF/TL/TL-637.pdf>.

## 4. CALIBRATION AND UNCERTAINTY

### 4.1. MEASURING INSTRUMENT CALIBRATION

The measuring equipment utilized to perform the tests documented in this report has been calibrated in accordance with the manufacturer's recommendations, and is traceable to recognized national standards.

### 4.2. SAMPLE CALCULATION

Where relevant, the following sample calculation is provided:

$$\begin{aligned} \text{Field Strength (dBuV/m)} &= \text{Measured Voltage (dBuV)} + \text{Antenna Factor (dB/m)} + \\ &\text{Cable Loss (dB)} - \text{Preamp Gain (dB)} \\ 36.5 \text{ dBuV} + 18.7 \text{ dB/m} + 0.6 \text{ dB} - 26.9 \text{ dB} &= 28.9 \text{ dBuV/m} \end{aligned}$$

### 4.3. MEASUREMENT UNCERTAINTY

Where relevant, the following measurement uncertainty levels have been estimated for tests performed on the apparatus:

PARAMETER	UNCERTAINTY
Conducted Disturbance, 0.15 to 30 MHz	2.32 dB
Radiated Disturbance, Below 1GHz	3.86 dB
Radiated Disturbance, Above 1 GHz	5.97 dB

Uncertainty figures are valid to a confidence level of 95%.

## 5. EQUIPMENT UNDER TEST

### 5.1. DESCRIPTION OF EUT

The EUT is a GSM/WCDMA/LTE Tablet + BT/BLE, DTS/UNII a/b/g/n/ac and ANT+. This test report addresses the NII (UNII) operational mode.

WiFi MIMO Condition

Frequency	Mode	Antenna 1	Antenna 2
2.4 GHz	802.11b	TX / RX	TX / RX
	802.11g	TX / RX	TX / RX
	802.11g MIMO	TX / RX	TX / RX
	802.11n	TX / RX	TX / RX
	802.11n MIMO	TX / RX	TX / RX
5 GHz	802.11a	TX / RX	TX / RX
	802.11a MIMO	TX / RX	TX / RX
	802.11n	TX / RX	TX / RX
	802.11n MIMO	TX / RX	TX / RX
	802.11ac	TX / RX	TX / RX
	802.11ac MIMO	TX / RX	TX / RX

Simultaneous TX Condition

Frequency	Supported
2.4 GHz Antenna 1 + 5 GHz Antenna 2	Yes
2.4 GHz Antenna 2 + 5 GHz Antenna 1	No
2.4 GHz Antenna 1 + 5 GHz Antenna 1	No
2.4 GHz Antenna 2 + 5 GHz Antenna 2	No

Spurious Emissions for Simultaneous Transmission were reported on the section 11.5.

## 5.2. MAXIMUM OUTPUT POWER

The transmitter has a maximum total conducted average output power as follows:

Frequency Range [MHz]	Mode	Output Power [dBm]		Output Power [mW]	
		Antenna1	Antenna2	Antenna1	Antenna2
5180 - 5240	802.11a MIMO	12.57		18.07	
	802.11n HT20 MIMO	12.40		17.38	
5190 - 5230	802.11n HT40 MIMO	12.80		19.05	
5210	802.11ac VHT80 MIMO	12.60		18.20	
5260 - 5320	802.11a MIMO	12.62		18.28	
	802.11n HT20 MIMO	12.44		17.54	
5270 - 5310	802.11n HT40 MIMO	12.31		17.02	
5290	802.11ac VHT80 MIMO	12.22		16.67	
5500 - 5720	802.11a MIMO	12.41		17.42	
	802.11n HT20 MIMO	12.25		16.79	
5510 - 5710	802.11n HT40 MIMO	12.81		19.10	
5530 - 5690	802.11ac VHT80 MIMO	12.63		18.32	
5745 - 5825	802.11a MIMO	12.51		17.82	
	802.11n HT20 MIMO	12.60		18.20	
5755 - 5795	802.11n HT40 MIMO	12.79		19.01	
5775	802.11ac VHT80 MIMO	12.62		18.28	

### 5.3. DESCRIPTION OF AVAILABLE ANTENNAS

The radio utilizes a internal antenna, with a maximum gain of:

Frequency Range [MHz]	Antenna Gain [dBi]	
	Antenna 1	Antenna 2
UNII 1 5150 – 5250	-3.62	-5.37
UNII 2A 5250 – 5350	-3.62	-5.37
UNII 2C 5470 – 5725	-3.62	-5.37
UNII 3 5725 – 5850	-3.62	-5.37

### 5.4. List of test reduction and modes covering other modes:

The output power on covered modes is equal to or less than one referenced.

#### UNII 1

5150 - 5250 MHz Authorized Frequency Band (Radiated Testing)		
Frequency Range [MHz]	Mode	Covered by
5180 - 5240	802.11a legacy 1TX/CDD 2TX	802.11a 2TX CDD
5180 - 5240	802.11HT20 1TX	802.11n HT20 2TX CDD
5180 - 5240	802.11HT20 2TX SDM/CDD	802.11n HT20 2TX CDD
5180 - 5240	802.11ac VHT20 1TX	802.11n HT20 2TX CDD
5180 - 5240	802.11ac VHT20 2TX SDM/CDD	802.11n HT20 2TX CDD
5190 - 5230	802.11n HT40 1TX	802.11n HT40 2TX CDD
5190 - 5230	802.11n HT40 2TX SDM/CDD	802.11n HT40 2TX CDD
5190 - 5230	802.11ac VHT40 1TX	802.11n HT40 2TX CDD
5190 - 5230	802.11ac VHT40 2TX SDM/CDD	802.11n HT40 2TX CDD
5210	802.11ac VHT80 1TX	802.11ac VHT80 2TX CDD
5210	802.11ac VHT80 2TX SDM/CDD	802.11ac VHT80 2TX CDD

**UNII 2A**

<b>5250 - 5350 MHz Authorized Frequency Band (Radiated Testing)</b>		
<b>Frequency Range [MHz]</b>	<b>Mode</b>	<b>Covered by</b>
5260 - 5320	802.11a legacy 1TX/CDD 2TX	802.11a 2TX CDD
5260 - 5320	802.11HT20 1TX	802.11n HT20 2TX CDD
5260 - 5320	802.11HT20 2TX SDM/CDD	802.11n HT20 2TX CDD
5260 - 5320	802.11ac VHT20 1TX	802.11n HT20 2TX CDD
5260 - 5320	802.11ac VHT20 2TX SDM/CDD	802.11n HT20 2TX CDD
5270 - 5310	802.11n HT40 1TX	802.11n HT40 2TX CDD
5270 - 5310	802.11n HT40 2TX SDM/CDD	802.11n HT40 2TX CDD
5270 - 5310	802.11ac VHT40 1TX	802.11n HT40 2TX CDD
5270 - 5310	802.11ac VHT40 2TX SDM/CDD	802.11n HT40 2TX CDD
5290	802.11ac VHT80 1TX	802.11ac VHT80 2TX CDD
5290	802.11ac VHT80 2TX SDM/CDD	802.11ac VHT80 2TX CDD

**UNII 2C**

<b>5470 - 5725 MHz Authorized Frequency Band (Radiated Testing)</b>		
<b>Frequency Range [MHz]</b>	<b>Mode</b>	<b>Covered by</b>
5500 - 5720	802.11a legacy 1TX/CDD 2TX	802.11a 2TX CDD
5500 - 5720	802.11HT20 1TX	802.11n HT20 2TX CDD
5500 - 5720	802.11HT20 2TX SDM/CDD	802.11n HT20 2TX CDD
5500 - 5720	802.11ac VHT20 1TX	802.11n HT20 2TX CDD
5500 - 5720	802.11ac VHT20 2TX SDM/CDD	802.11n HT20 2TX CDD
5510 - 5710	802.11n HT40 1TX	802.11n HT40 2TX CDD
5510 - 5710	802.11n HT40 2TX SDM/CDD	802.11n HT40 2TX CDD
5510 - 5710	802.11ac VHT40 1TX	802.11n HT40 2TX CDD
5510 - 5710	802.11ac VHT40 2TX SDM/CDD	802.11n HT40 2TX CDD
5530 - 5690	802.11ac VHT80 1TX	802.11ac VHT80 2TX CDD
5530 - 5690	802.11ac VHT80 2TX SDM/CDD	802.11ac VHT80 2TX CDD

**UNII 3**

<b>5725 - 5850 MHz Authorized Frequency Band (Radiated Testing)</b>		
<b>Frequency Range [MHz]</b>	<b>Mode</b>	<b>Covered by</b>
5745 - 5825	802.11a legacy 1TX/CDD 2TX	802.11a 2TX CDD
5745 - 5825	802.11HT20 1TX	802.11n HT20 2TX CDD
5745 - 5825	802.11HT20 2TX SDM/CDD	802.11n HT20 2TX CDD
5745 - 5825	802.11ac VHT20 1TX	802.11n HT20 2TX CDD
5745 - 5825	802.11ac VHT20 2TX SDM/CDD	802.11n HT20 2TX CDD
5755 - 5795	802.11n HT40 1TX	802.11n HT40 2TX CDD
5755 - 5795	802.11n HT40 2TX SDM/CDD	802.11n HT40 2TX CDD
5755 - 5795	802.11ac VHT40 1TX	802.11n HT40 2TX CDD
5755 - 5795	802.11ac VHT40 2TX SDM/CDD	802.11n HT40 2TX CDD
5775	802.11ac VHT80 1TX	802.11ac VHT80 2TX CDD
5775	802.11ac VHT80 2TX SDM/CDD	802.11ac VHT80 2TX CDD

**5.5. WORST-CASE CONFIGURATION AND MODE**

Radiated emission below 1GHz and power line conducted emission were performed with the EUT set to transmit at the channel with highest output power as worst-case scenario.

Radiated emission above 1GHz was performed with the EUT set to transmit low/mid/high channels.

The fundamental of the EUT was investigated in three orthogonal orientations X, Y and Z it was determined that Z orientation was worst-case orientation; therefore, all final radiated testing was performed with the EUT in Z orientation.

Based on the baseline scan, the worst-case data rates were:

- 802.11a mode: 6 Mbps (2Tx CDD)
- 802.11n HT20mode: MCS0 (2Tx CDD)
- 802.11n HT40mode: MCS0 (2Tx CDD)
- 802.11ac VHT80mode: MCS0 (2Tx CDD)

## 5.6. DESCRIPTION OF TEST SETUP

### SUPPORT EQUIPMENT

Support Equipment List				
Description	Manufacturer	Model	Serial Number	FCC ID
Charger	SAMSUNG	EP-TA200	R37K49A2631DK3	N/A
Data Cable	SAMSUNG	EP-DN930CWE	N/A	N/A
Earphone	SAMSUNG	EO-EG920BW	N/A	N/A

### I/O CABLES

I/O Cable List						
Cable No	Port	# of identical ports	Connector Type	Cable Type	Cable Length (m)	Remarks
1	DC Power	1	C Type	Shielded	1.1m	N/A
2	Audio	2	Mini-Jack	Unshielded	1.2m	N/A

### TEST SETUP

The EUT is a stand-alone unit during the tests.  
Test software exercised the EUT to enable NII mode.

### NOTE

Additional tests under 1 GHz were performed with the keyboard attached to check on all port terminated conditions. Keyboard is not an in-box item.

**SETUP DIAGRAM FOR TESTS (CONDUCTED TEST SETUP)**

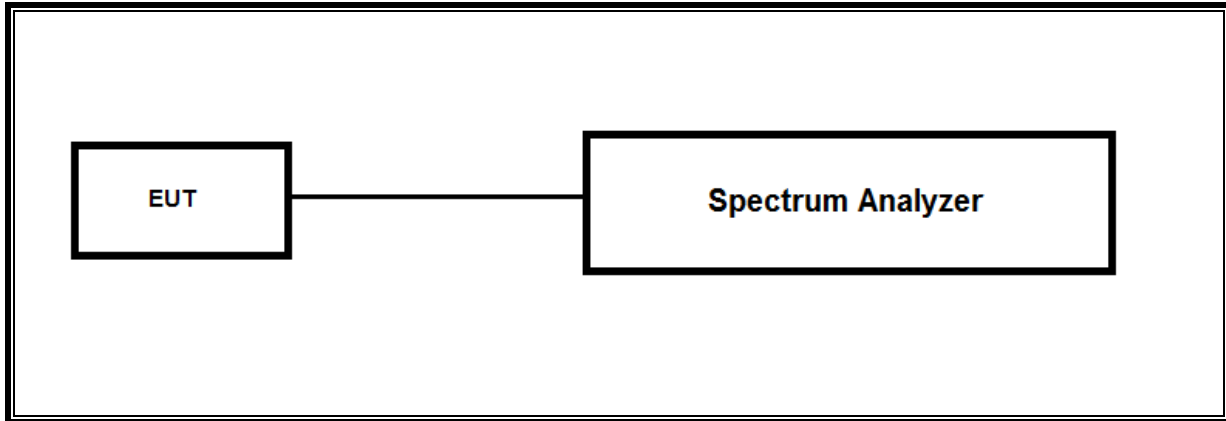

**SETUP DIAGRAM FOR TESTS (RADIATED TEST SETUP)**

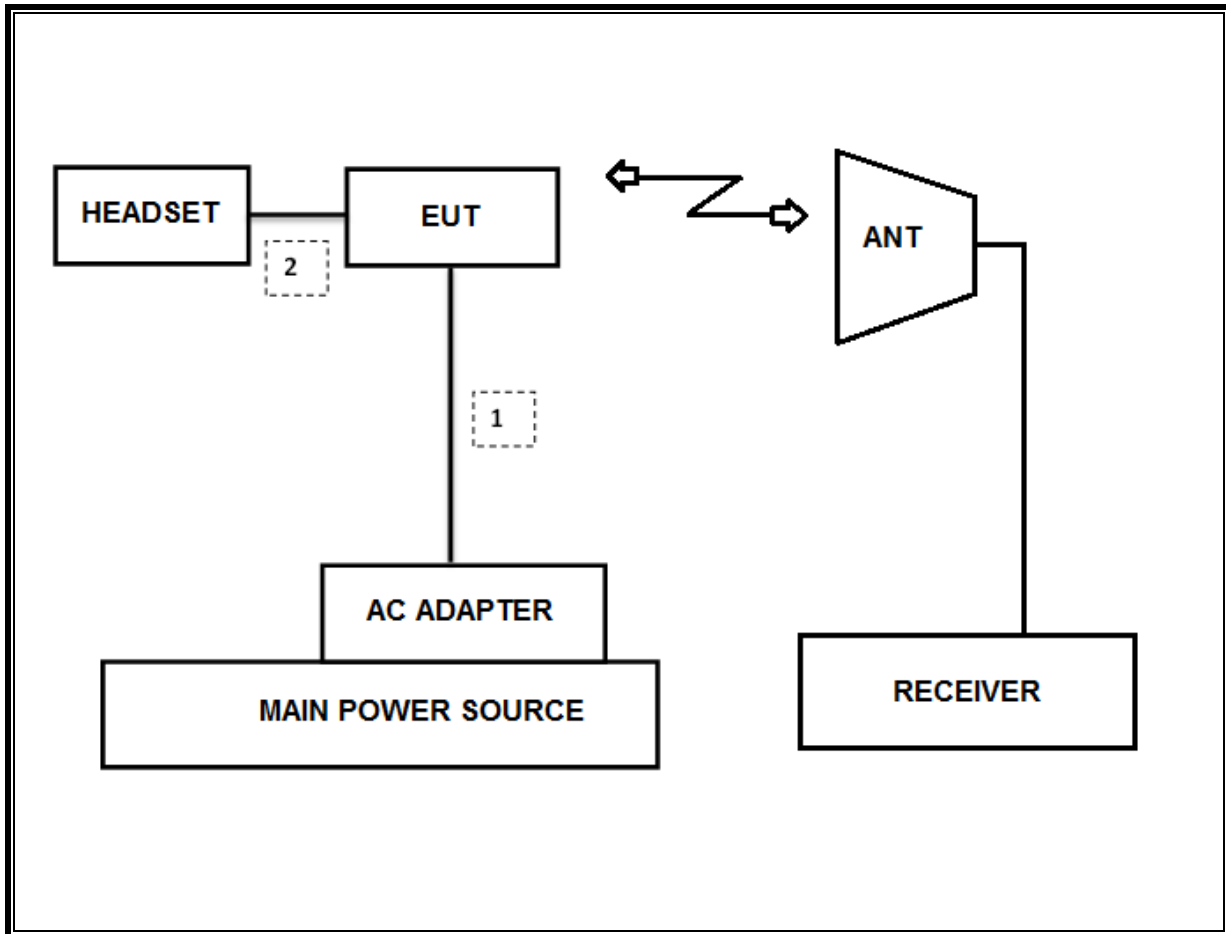

## 6. TEST AND MEASUREMENT EQUIPMENT

The following test and measurement equipment was utilized for the tests documented in this report:

Test Equipment List				
Description	Manufacturer	Model	S/N	Cal Due
Antenna, Bilog, 30MHz-1GHz	SCHWARZBECK	VULB9163	750	08-31-19
Antenna, Bilog, 30MHz-1GHz	SCHWARZBECK	VULB9163	749	09-14-19
Antenna, Bilog, 30MHz-1GHz	SCHWARZBECK	VULB9163	845	08-31-19
Antenna, Horn, 18 GHz	ETS	3115	00167211	10-14-18
Antenna, Horn, 18 GHz	ETS	3115	00161451	03-10-19
Antenna, Horn, 18 GHz	ETS	3117	00168724	05-31-19
Antenna, Horn, 18 GHz	ETS	3117	00168717	05-31-19
Antenna, Horn, 18 GHz	ETS	3117	00205959	11-29-18
Antenna, Horn, 40 GHz	ETS	3116C	00166155	12-04-19
Antenna, Horn, 40 GHz	ETS	3116C	00168645	12-04-19
Antenna, Horn, 40 GHz	ETS	3116C-PA	00168841	11-13-19
Preamplifier, 1000 MHz	Sonoma	310N	341282	08-09-18
Preamplifier, 1000 MHz	Sonoma	310N	351741	08-07-18
Preamplifier, 1000 MHz	Sonoma	310N	370599	08-10-18
Preamplifier, 18 GHz	Miteq	AFS42-00101800-25-S-42	1876511	08-08-18
Preamplifier, 18 GHz	Miteq	AFS42-00101800-25-S-42	1896138	08-08-18
Preamplifier, 18 GHz	Miteq	AFS42-00101800-25-S-42	2029169	08-11-18
Spectrum Analyzer, 44 GHz	Agilent / HP	N9030A	MY54170614	08-08-18
Spectrum Analyzer, 44 GHz	Agilent / HP	N9030A	MY54490312	08-08-18
Spectrum Analyzer, 43.5 GHz	R&S	FSW43	104089	08-11-18
Average Power Sensor	Agilent / HP	U2000	MY54270007	08-08-18
Attenuator	PASTERNAK	PE7087-10	A001	08-08-18
Attenuator	PASTERNAK	PE7087-10	A008	08-08-18
Attenuator	PASTERNAK	PE7087-10	2	08-10-18
Attenuator	PASTERNAK	PE7087-10	A009	08-08-18
EMI Test Receive, 40 GHz	R&S	ESU40	100439	08-08-18
EMI Test Receive, 40 GHz	R&S	ESU40	100457	08-08-18
EMI Test Receive, 44 GHz	R&S	ESW44	101590	08-09-18
EMI Test Receive, 3 GHz	R&S	ESR3	101832	08-07-18
Low Pass Filter 5GHz	Micro-Tronics	LPS17541	009	08-08-18
Low Pass Filter 5GHz	Micro-Tronics	LPS17541	015	08-08-18
Low Pass Filter 5GHz	Micro-Tronics	LPS17541	020	08-11-18
High Pass Filter 3GHz	Micro-Tronics	HPM17543	010	08-08-18
High Pass Filter 3GHz	Micro-Tronics	HPM17543	015	08-08-18
High Pass Filter 3GHz	Micro-Tronics	HPM17543	020	08-11-18
High Pass Filter 6GHz	Micro-Tronics	HPS17542	009	08-08-18
High Pass Filter 6GHz	Micro-Tronics	HPS17542	016	08-08-18
High Pass Filter 6GHz	Micro-Tronics	HPS17542	021	08-11-18
LISN	R&S	ENV-216	101837	08-09-18
UL Software				
Description	Manufacturer	Model	Version	
Radiated software	UL	UL EMC	Ver 9.5	
AC Line Conducted software	UL	UL EMC	Ver 9.5	

## 7. SUMMARY TABLE

FCC Part Section	Test Description	Test Limit	Test Condition	Test Result
15.407(e)	6dB Band width (5.8Ghz)	500KHz	Condcuted	PASS
15.407 (a)(2)	TX Cond. Power 5.15-2.25, 5.25-5.35 & 5.47-5.725	<24dBm or 11+10Log(OBW)		PASS
15.407 (a)(3)	TX Cond. Power 5.725-5.825	< 30dBm or 17+10Log(OBW)		PASS
15.407 (a)(5)	PSD (5.2,5.3,5.5GHz)	<11dBm		PASS
15.407 (a)(5)	PSD (5.8GHz)	30dBm per 500kHz		PASS
15.207 (a)	AC Power Line conducted emissions	Section 10	Radiated	PASS
15.407 (b) & 15.209	Radiated Spurious Emission	< 54dBuV/m		PASS
15.407 (h)(2)	Dynamic Frequency Selection	N/A	Condcuted	PASS

## 8. MEASUREMENT METHODS

On-Time and Duty Cycle : KDB 789033 D02 v02r01, Section B.

6dB Emission BW : KDB 789033 D02 v02r01, Section C.2.

26dB Emission BW : KDB 789033 D02 v02r01, Section C.1.

99% Occupied BW : KDB 789033 D02 v02r01, Section D.

Conducted Output Power : KDB 789033 D02 v02r01, Section E.3.a(Method PM)

Conducted Output Power for Straddle Channel (ch144/142/138 for 20/40/80MHz BW):

KDB 789033 D02 v02r01, Section E.2.d(Method SA-2)

Power Spectral Density : KDB 789033 D02 v02r01, Section F.

Unwanted emissions in restricted bands : KDB 789033 D02 v02r01, Section G.

Unwanted emissions in non-restricted bands : KDB 789033 D02 v02r01, Section G.

AC Power Line Conducted Emission : ANSI C63.10-2013, Section 6.2.

## 9. REFERENCE MEASUREMENTS RESULTS

### 9.1. ON TIME AND DUTY CYCLE RESULTS

Mode	ON Time B [msec]	Period [msec]	Duty Cycle x [linear]	Duty Cycle [%]	Duty Cycle Correction Factor [dB]	1/T Minimum VBW [kHz]
802.11a	3.049	3.138	0.972	97.2%	0.12	0.328
802.11n HT20	2.835	2.925	0.969	96.9%	0.14	0.353
802.11n HT40	1.383	1.463	0.945	94.5%	0.24	0.723
802.11ac VHT80	0.664	0.750	0.884	88.4%	0.53	1.507

### LIMITS

None; for reporting purposes only.

### PROCEDURE

KDB 789033 D02 v02r01 Zero-Span Spectrum Analyzer Method.

### 9.2. DUTY CYCLE PLOTS

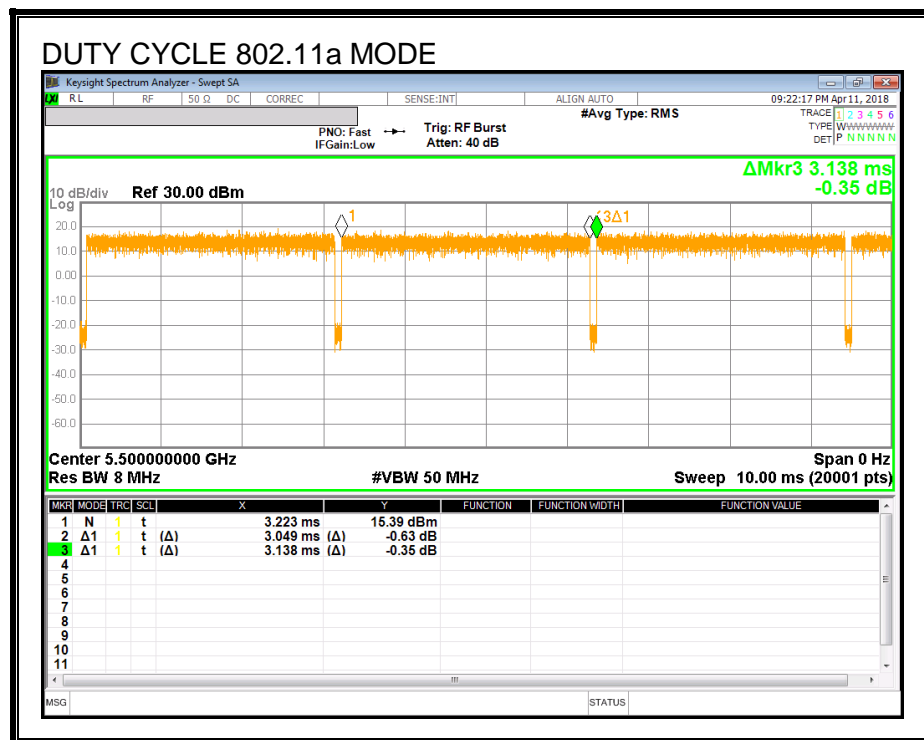

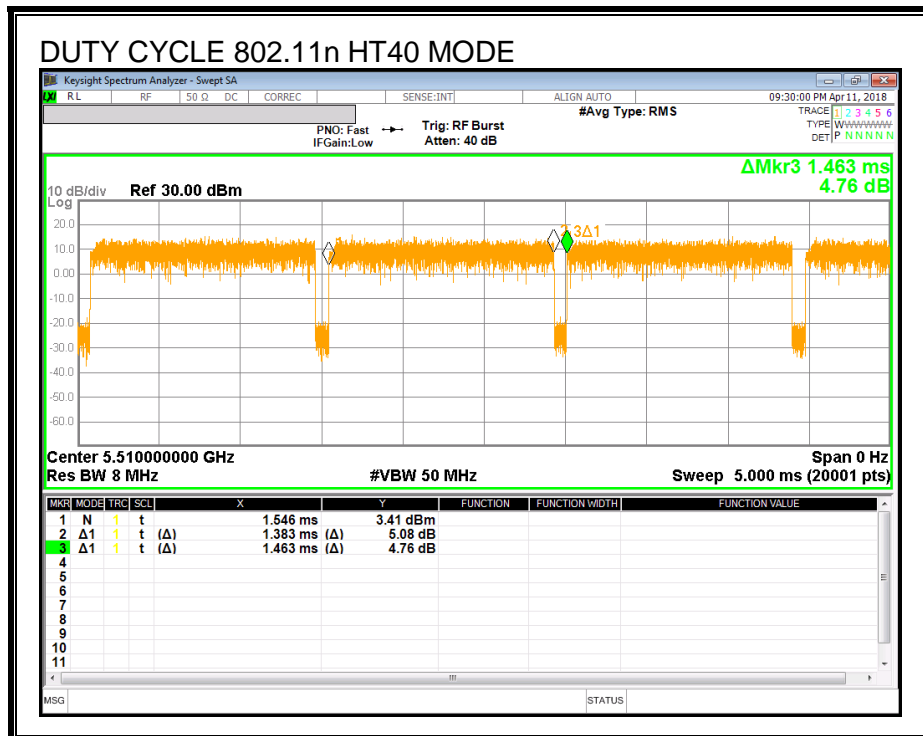
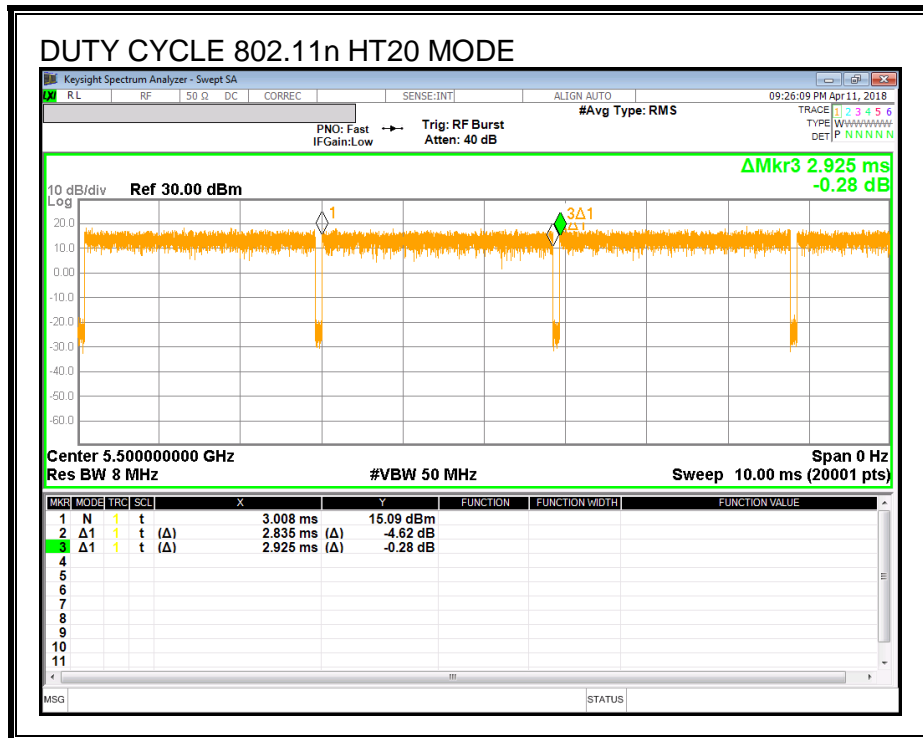

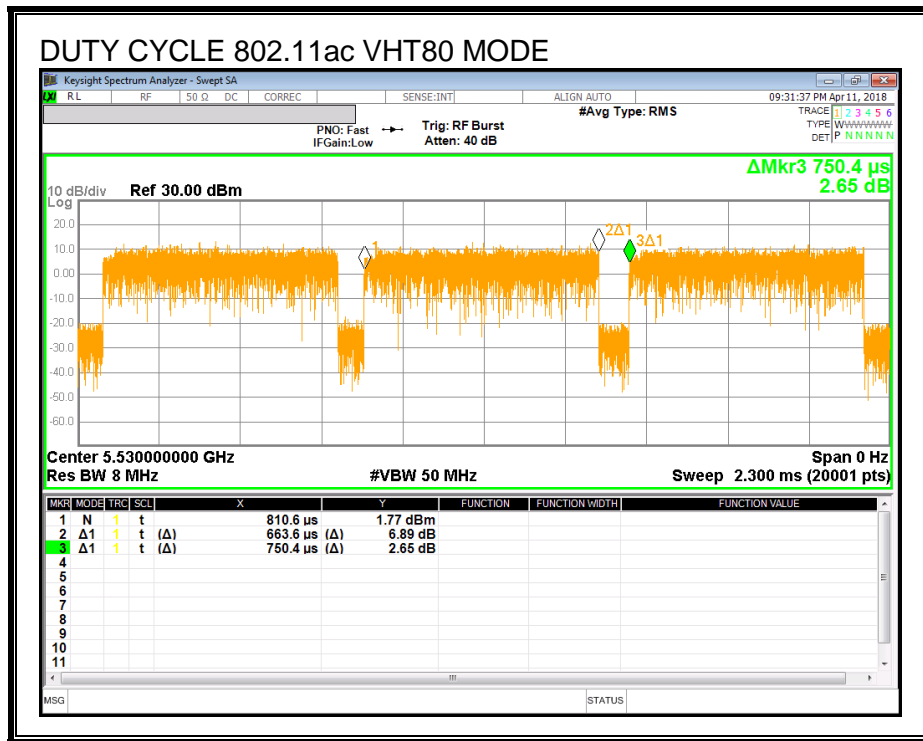

### 9.3. 26 dB BANDWIDTH

#### LIMITS

None; for reporting purposes only.

#### TEST PROCEDURE

Reference to 789033 D02 General UNII Test Procedures New Rules v02r01: The transmitter output is connected to a spectrum analyzer with the RBW set to approximately 1% of EBW, the VBW > RBW, peak detector and max hold.

#### NOTE

- Calculation for 26dB Bandwidth of UNII-2C and UNII-3 Straddle Channel

ex) Fundamental frequency : 5720MHz

- 26dB BW : 20.58MHz
- Turning Frequency : 5725MHz
- 26dB Bandwidth of UNII-2C band Portion  
=  $(5725 - (5720 - (20.58 / 2))) = 15.29 \text{ MHz}$
- 26dB Bandwidth of UNII-3 band Portion  
=  $(5720 + (20.58 / 2) - 5725) = 5.29 \text{ MHz}$

**RESULTS**

**9.3.1.802.11a MODE IN THE 5.2 GHz BAND**

Channel	Frequency [MHz]	26 dB Bandwidth [MHz]	
		Antenna 1	Antenna 2
Low	5180	20.91	18.95
Mid	5200	20.08	20.24
High	5240	20.96	19.66
Worst		20.96	

**9.3.2.802.11n HT20 MODE IN THE 5.2 GHz BAND**

Channel	Frequency [MHz]	26 dB Bandwidth [MHz]	
		Antenna 1	Antenna 2
Low	5180	20.27	20.22
Mid	5200	20.88	21.10
High	5240	20.55	20.51
Worst		21.10	

**9.3.3.802.11n HT40 MODE IN THE 5.2 GHz BAND**

Channel	Frequency [MHz]	26 dB Bandwidth [MHz]	
		Antenna 1	Antenna 2
Low	5190	39.57	39.77
High	5230	40.03	39.98
Worst		40.03	

**9.3.4. 802.11ac VHT80 MODE IN THE 5.2 GHz BAND**

Channel	Frequency [MHz]	26 dB Bandwidth [MHz]	
		Antenna 1	Antenna 2
Middle	5210	81.08	81.77
Worst		81.77	

**9.3.5.802.11a MODE IN THE 5.3 GHz BAND**

Channel	Frequency [MHz]	26 dB Bandwidth [MHz]	
		Antenna 1	Antenna 2
Low	5260	20.55	20.43
Mid	5300	21.00	20.15
High	5320	21.27	20.68
Worst		21.27	

**9.3.6.802.11n HT20 MODE IN THE 5.3 GHz BAND**

Channel	Frequency [MHz]	26 dB Bandwidth [MHz]	
		Antenna 1	Antenna 2
Low	5260	21.12	21.21
Mid	5300	21.10	20.29
High	5320	20.57	21.88
Worst		21.88	

**9.3.7.802.11n HT40 MODE IN THE 5.3 GHz BAND**

Channel	Frequency [MHz]	26 dB Bandwidth [MHz]	
		Antenna 1	Antenna 2
Low	5270	39.66	39.17
High	5310	39.65	39.53
Worst		39.66	

**9.3.8. 802.11ac VHT80 MODE IN THE 5.3 GHz BAND**

Channel	Frequency [MHz]	26 dB Bandwidth [MHz]	
		Antenna 1	Antenna 2
Middle	5290	81.67	81.49
Worst		81.67	

**9.3.9. 802.11a MODE IN THE 5.5 GHz BAND**

Channel	Frequency [MHz]	26 dB Bandwidth [MHz]	
		Antenna 1	Antenna 2
Low	5500	20.20	20.30
Mid	5580	20.89	19.98
High	5700	21.24	20.56
Straddle	5720	15.31	15.00
Worst		21.24	

**9.3.10. 802.11n HT20 MODE IN THE 5.5 GHz BAND**

Channel	Frequency [MHz]	26 dB Bandwidth [MHz]	
		Antenna 1	Antenna 2
Low	5500	20.93	21.50
Mid	5580	21.73	20.88
High	5700	21.64	20.95
Straddle	5720	15.44	16.13
Worst		21.73	

**9.3.11. 802.11n HT40 MODE IN THE 5.5 GHz BAND**

Channel	Frequency [MHz]	26 dB Bandwidth [MHz]	
		Antenna 1	Antenna 2
Low	5510	40.39	40.05
Mid	5590	40.21	39.85
High	5670	39.87	39.77
Straddle	5710	35.06	34.88
Worst		40.39	

**9.3.12. 802.11ac VHT80 MODE IN THE 5.5 GHz BAND**

Channel	Frequency [MHz]	26 dB Bandwidth [MHz]	
		Antenna 1	Antenna 2
Low	5530	81.15	81.85
High	5610	81.79	81.32
Staddle	5690	75.44	75.67
Worst		81.85	

**9.3.13. 802.11a MODE IN THE 5.8 GHz BAND**

Channel	Frequency [MHz]	26 dB Bandwidth [MHz]	
		Antenna 1	Antenna 2
Straddle	5720	5.31	5.00
Low	5745	20.79	19.94
Mid	5785	20.63	21.70
High	5825	20.89	21.79
Worst		21.79	

**9.3.14. 802.11n HT20 MODE IN THE 5.8 GHz BAND**

Channel	Frequency [MHz]	26 dB Bandwidth [MHz]	
		Antenna 1	Antenna 2
Straddle	5720	5.44	6.13
Low	5745	21.66	21.46
Mid	5785	21.86	20.39
High	5825	20.70	19.98
Worst		21.86	

**9.3.15. 802.11n HT40 MODE IN THE 5.8 GHz BAND**

Channel	Frequency [MHz]	26 dB Bandwidth [MHz]	
		Antenna 1	Antenna 2
Straddle	5710	5.06	4.88
Low	5755	39.69	39.67
High	5795	40.18	40.42
Worst		40.42	

**9.3.16. 802.11ac VHT80 MODE IN THE 5.8 GHz BAND**

Channel	Frequency [MHz]	26 dB Bandwidth [MHz]	
		Antenna 1	Antenna 2
Straddle	5690	5.44	5.67
Middle	5775	80.19	80.40
Worst		80.40	

### 9.3.17. 26 dB BANDWIDTH PLOTS

#### UNII 5.2 GHz IEEE 802.11a mode

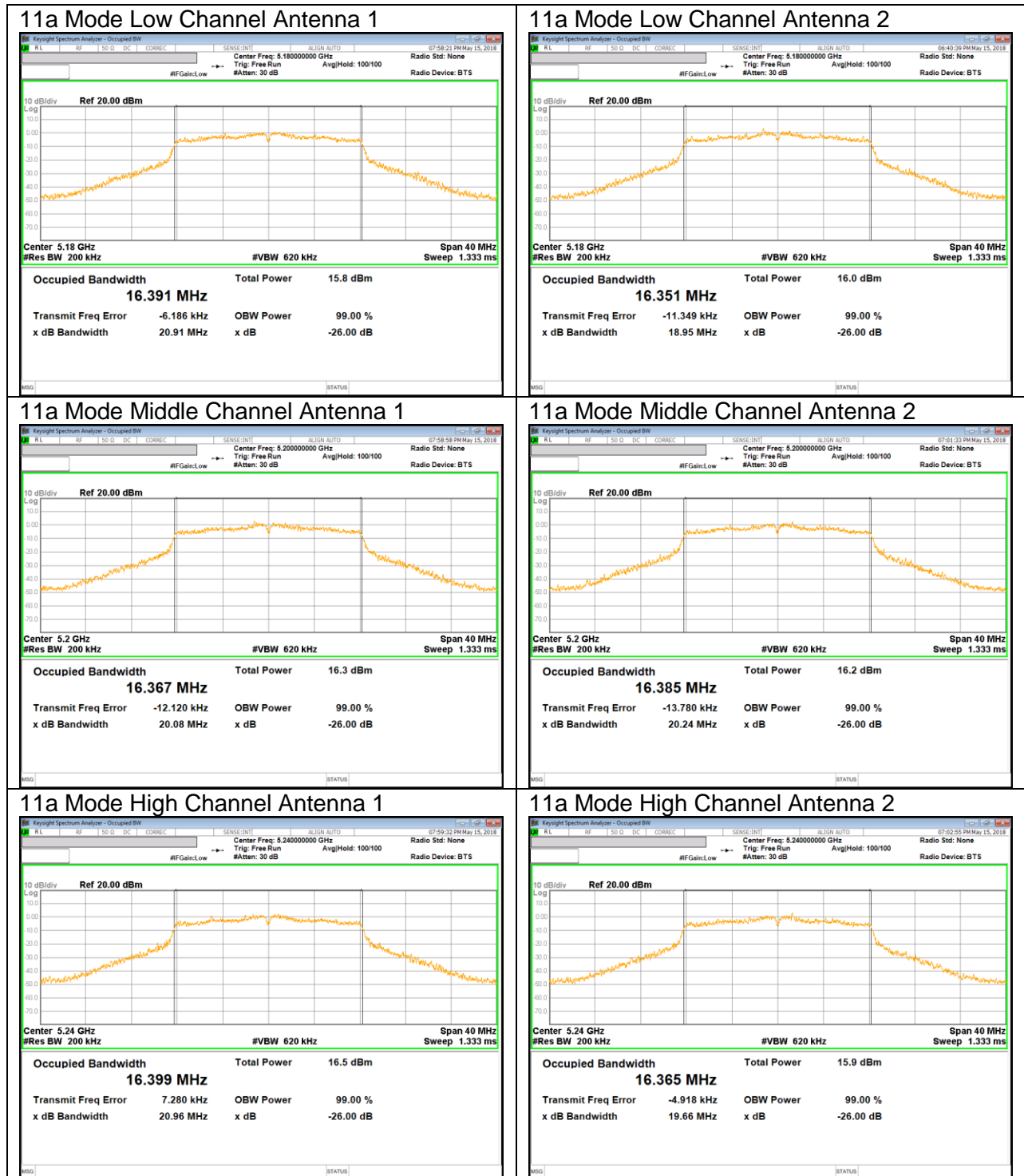

**UNII 5.2 GHz IEEE 802.11n HT20 mode**

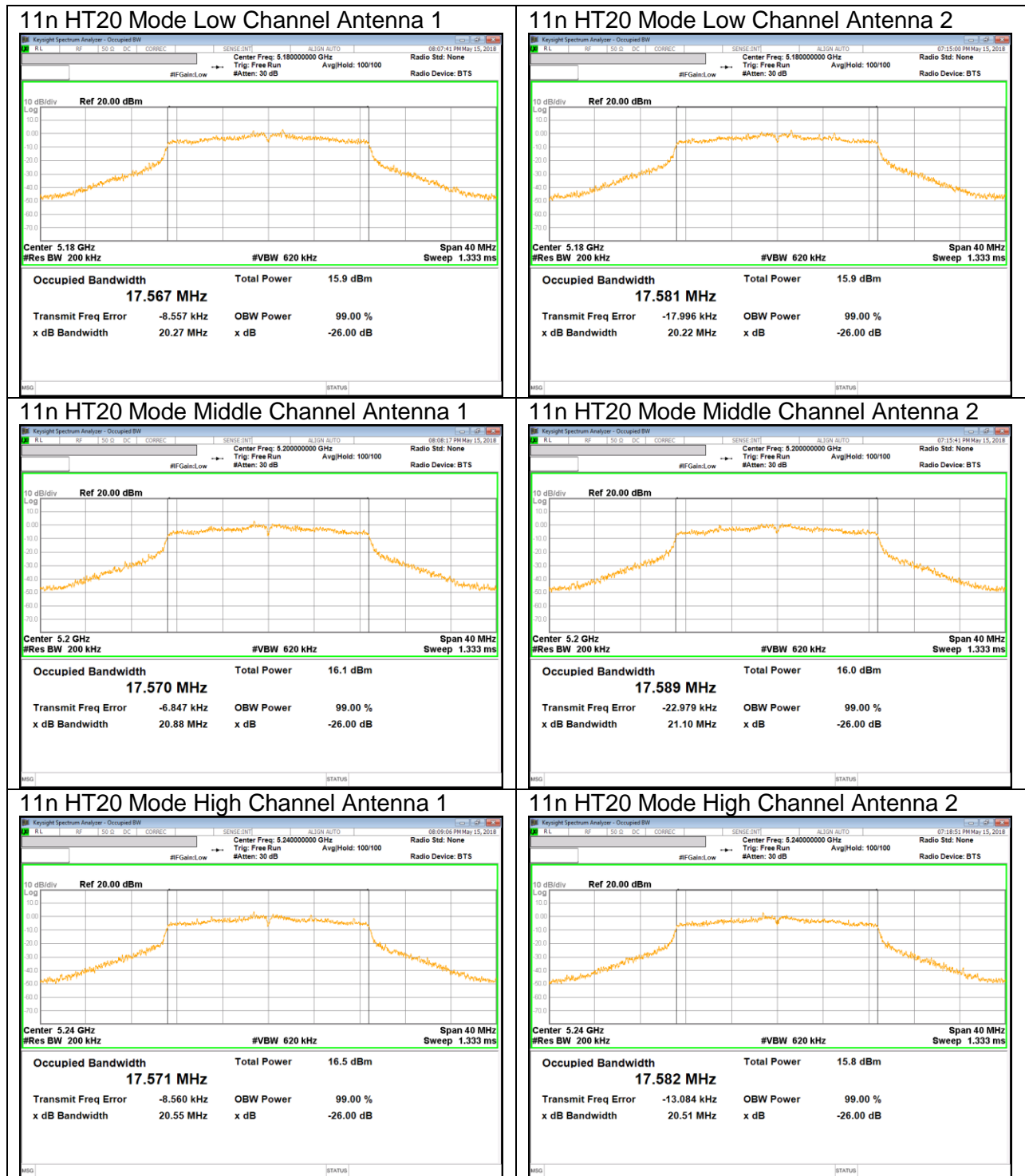

**UNII 5.2 GHz IEEE 802.11n HT40 mode**

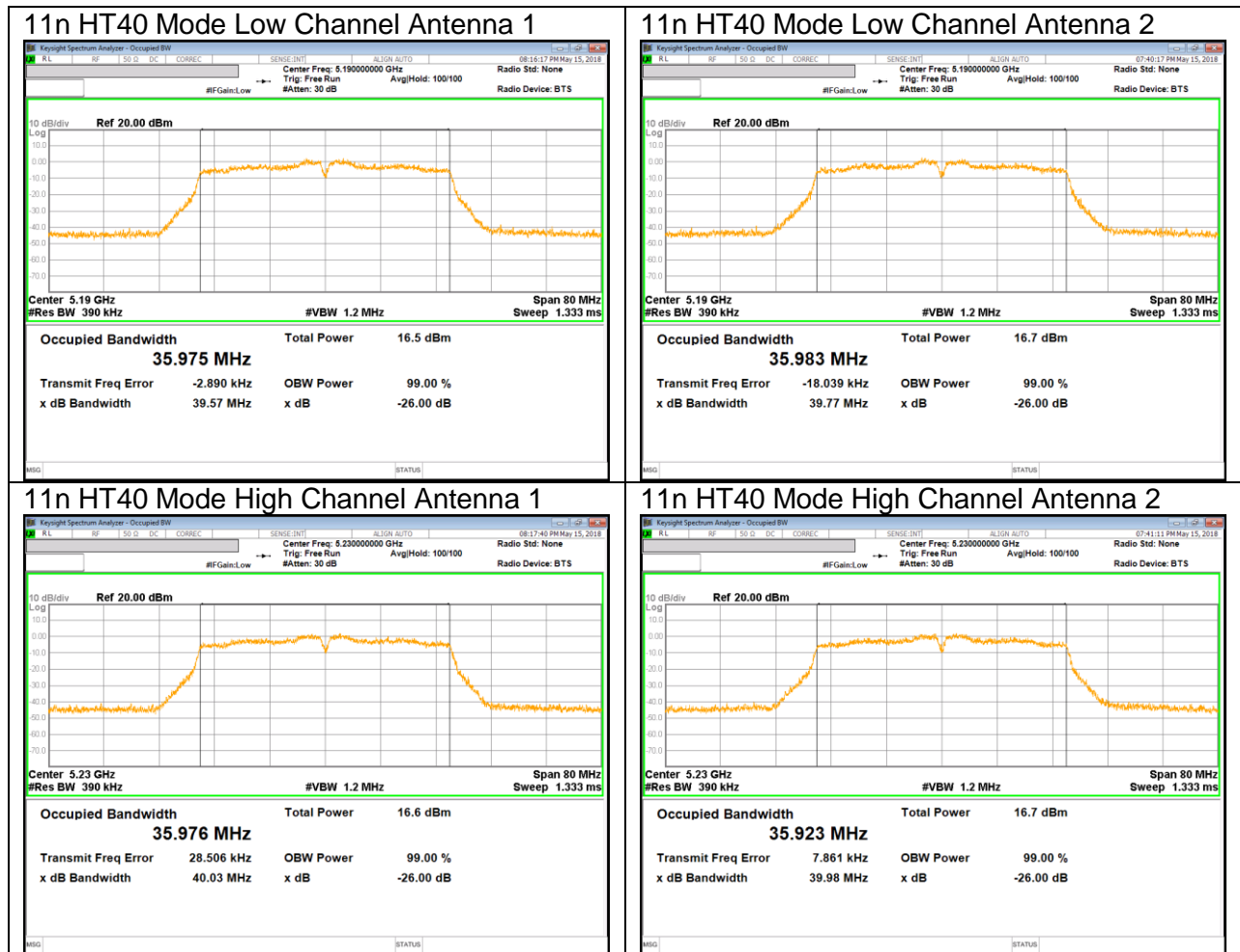

**UNII 5.2 GHz IEEE 802.11ac VHT80 mode**

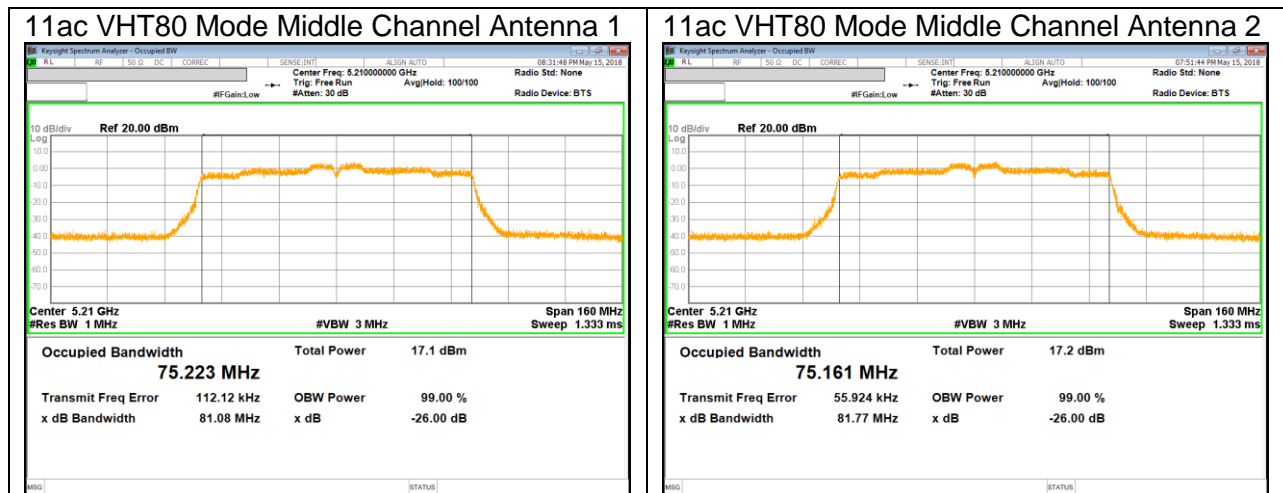

**UNII 5.3 GHz IEEE 802.11a mode**

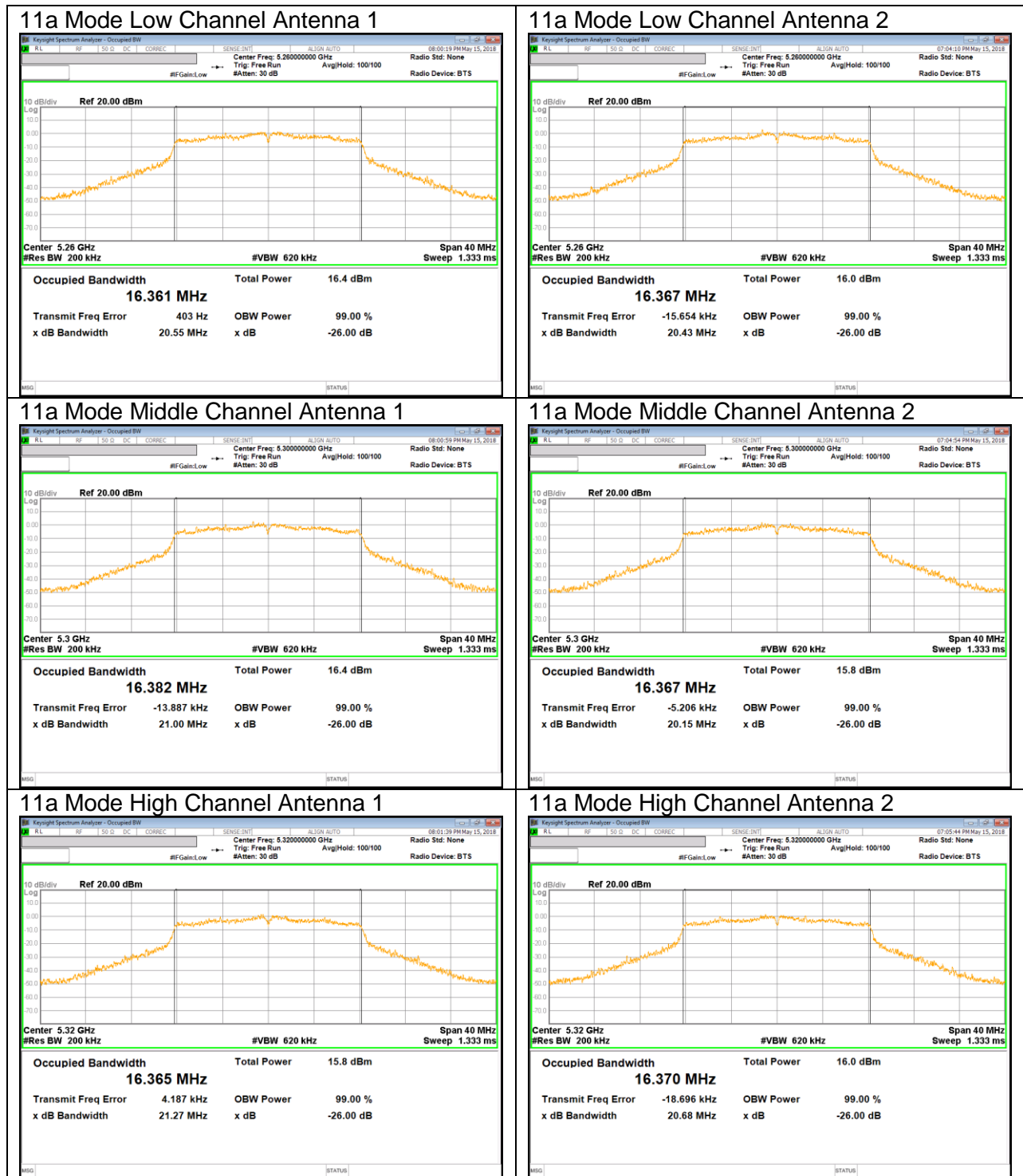

**UNII 5.3 GHz IEEE 802.11n HT20 mode**

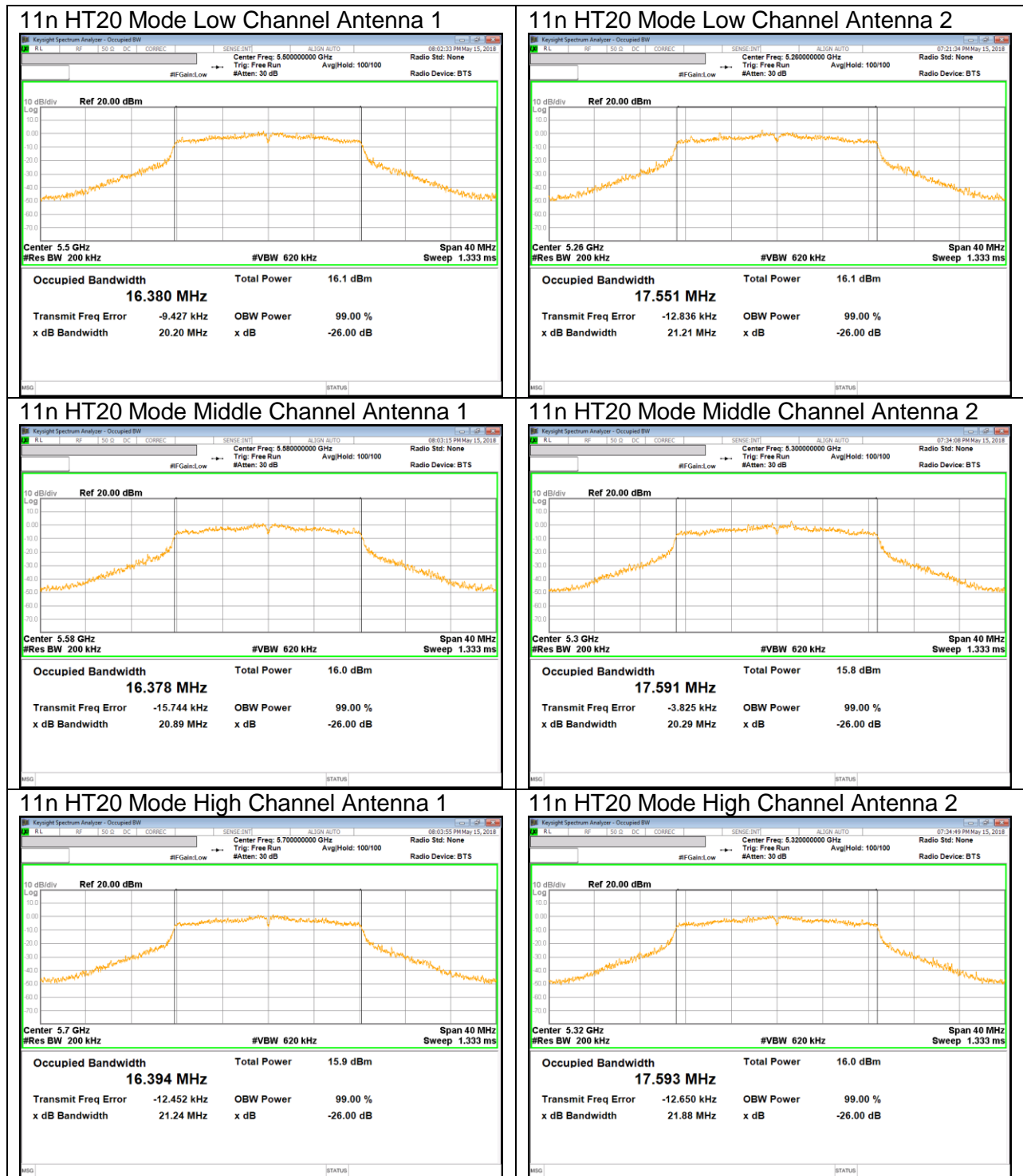

**UNII 5.3 GHz IEEE 802.11n HT40 mode**

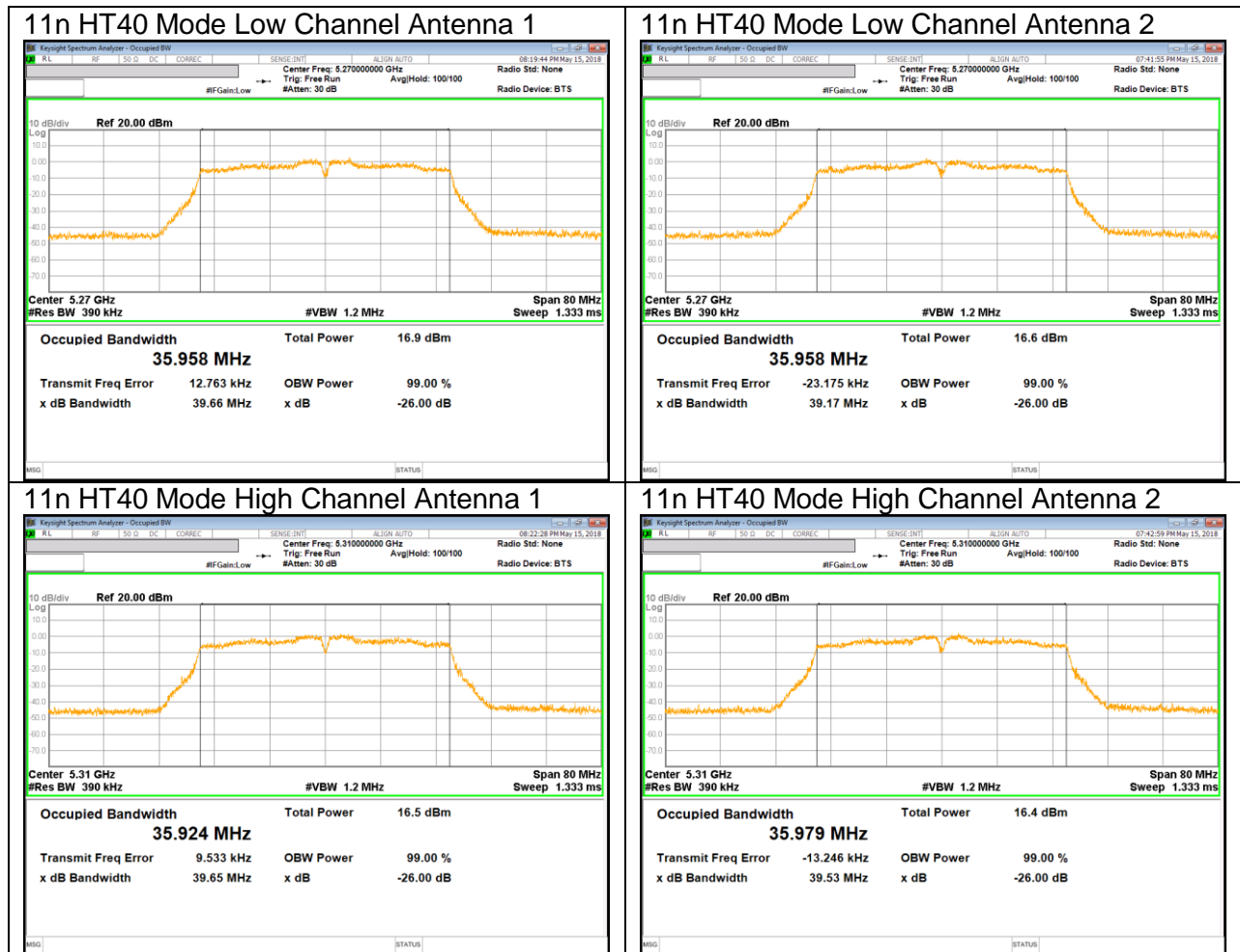

**UNII 5.3 GHz IEEE 802.11ac VHT80 mode**

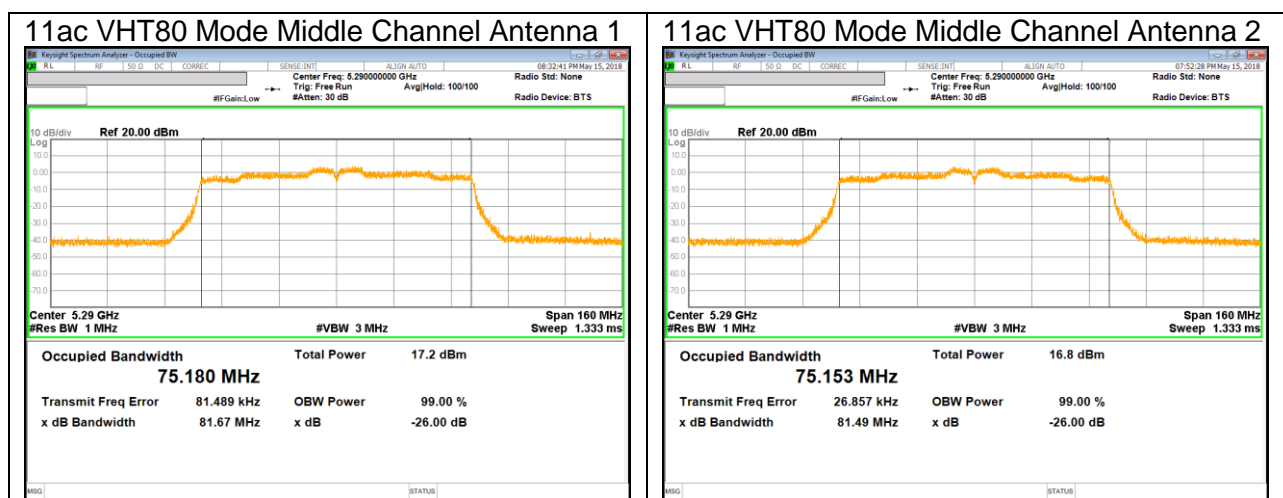

**UNII 5.5 GHz IEEE 802.11a mode**

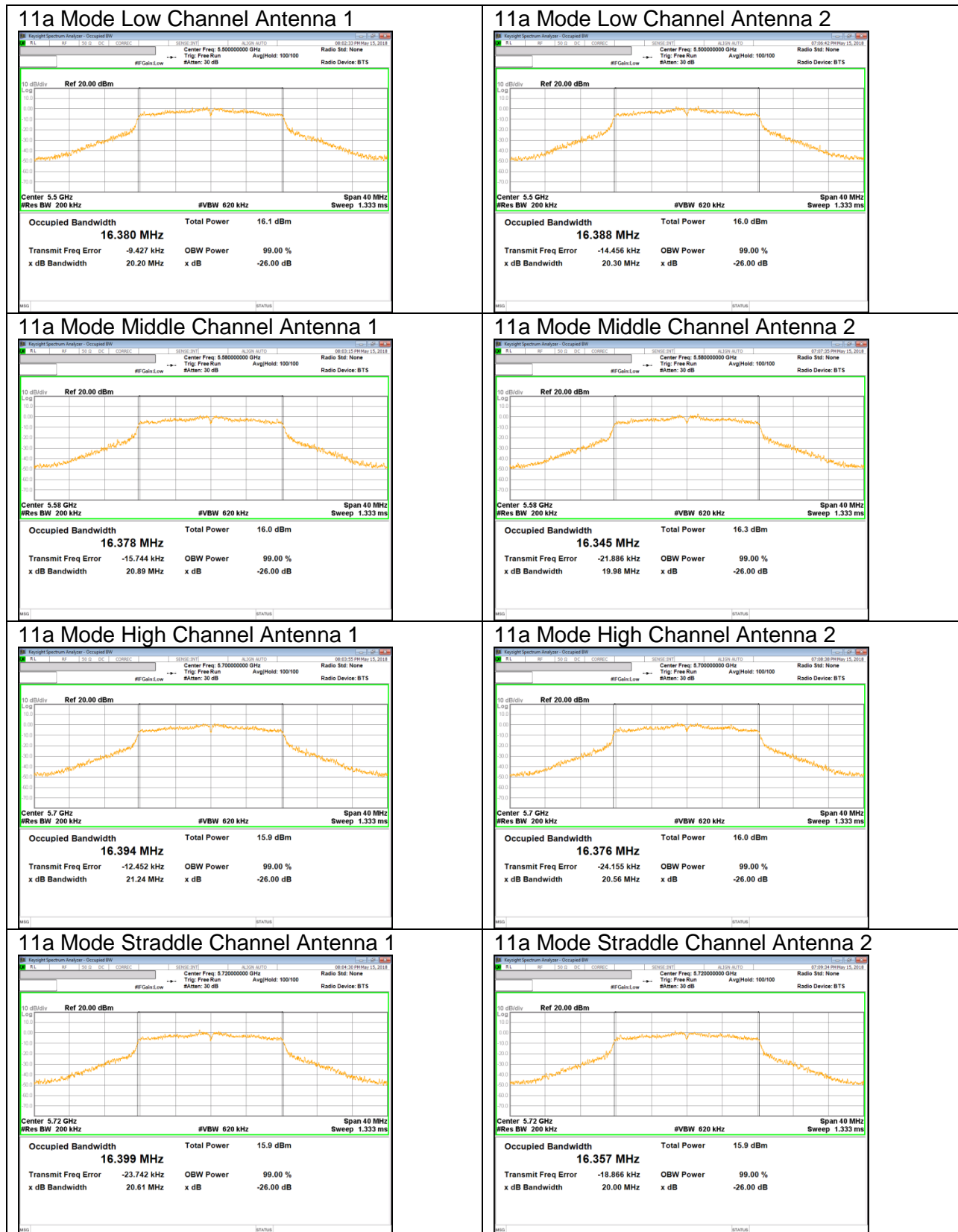

**UNII 5.5 GHz IEEE 802.11n HT20 mode**

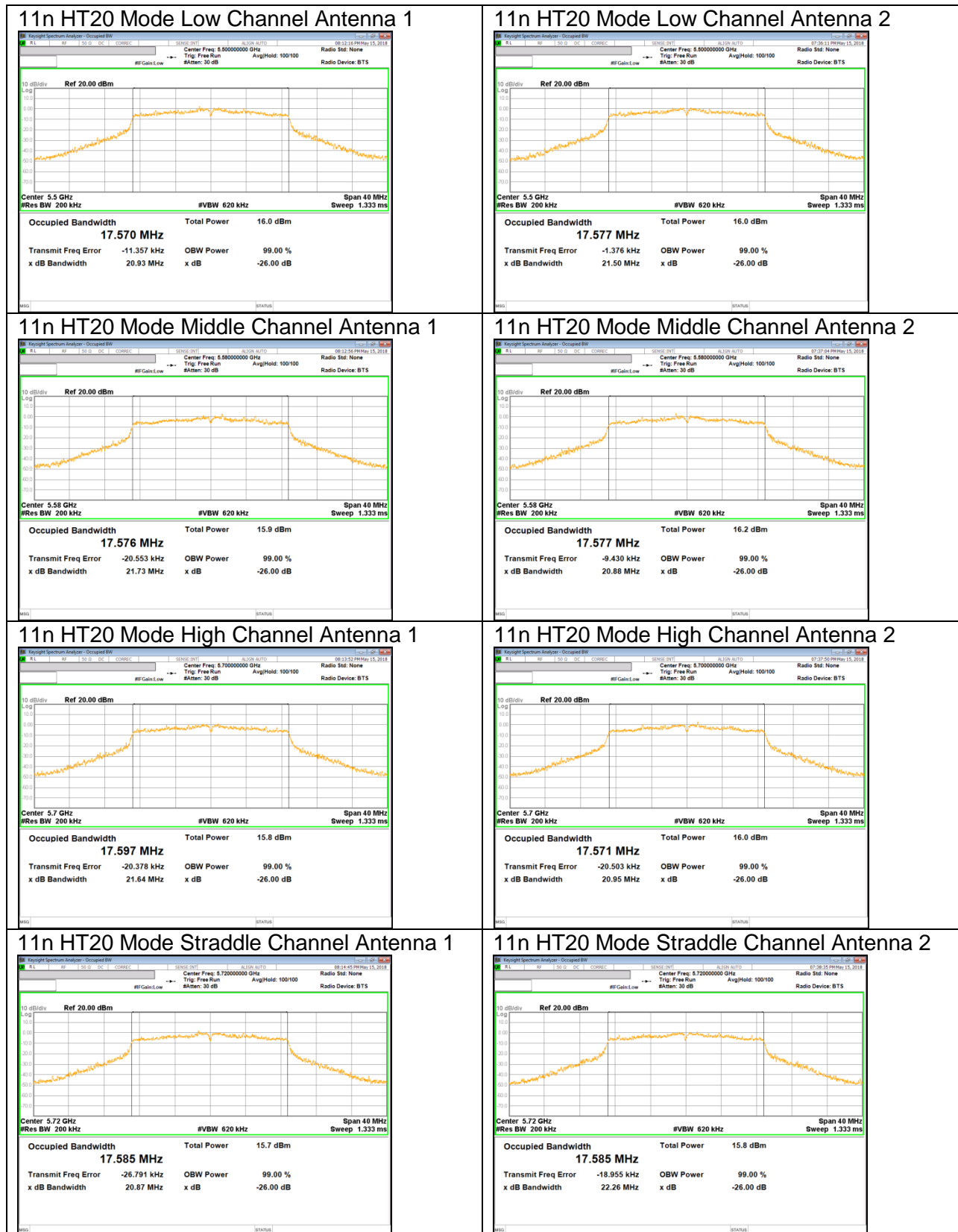

**UNII 5.5 GHz IEEE 802.11n HT40 mode**



**UNII 5.5 GHz IEEE 802.11ac VHT80 mode**

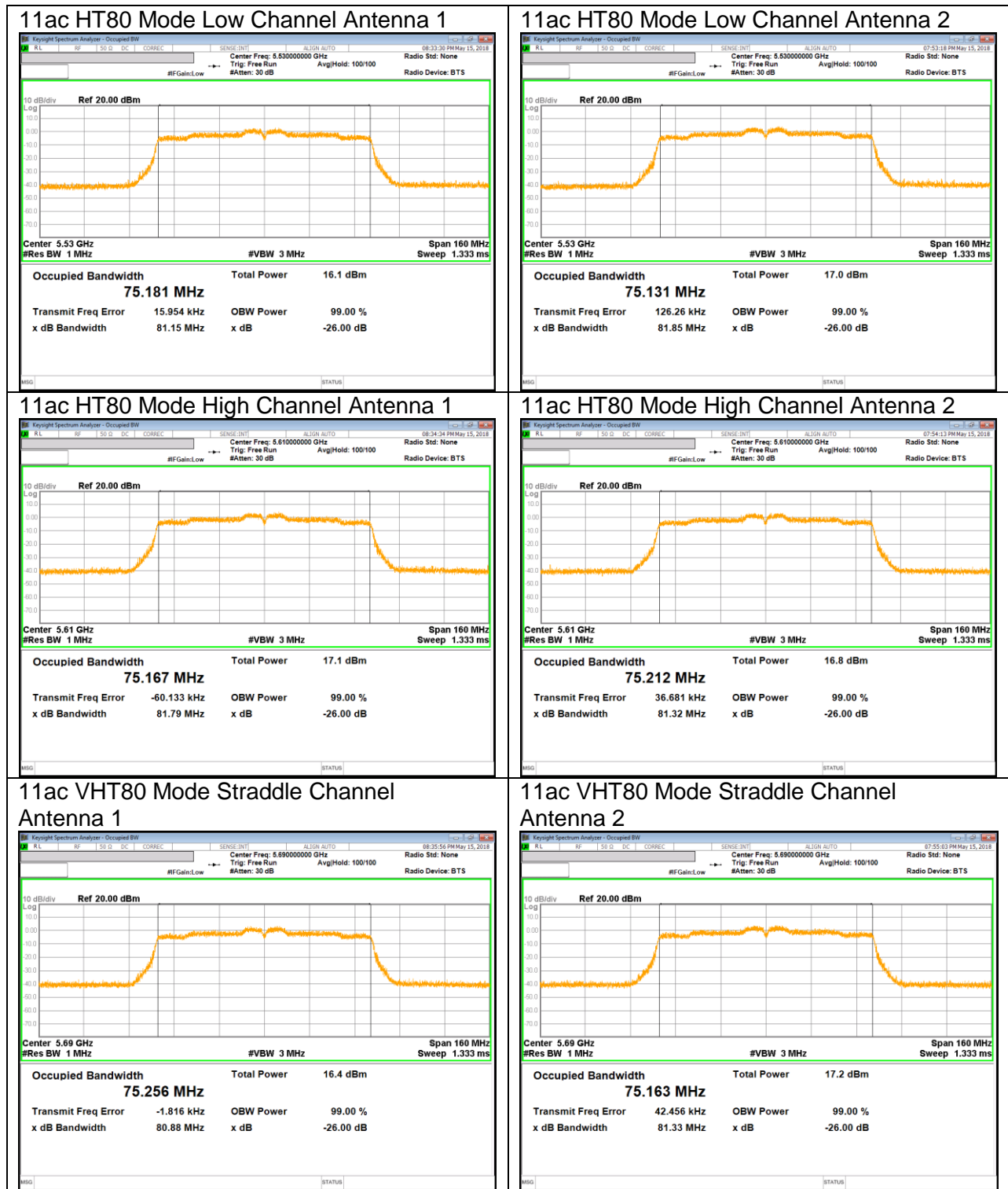

**UNII 5.8 GHz IEEE 802.11a mode**

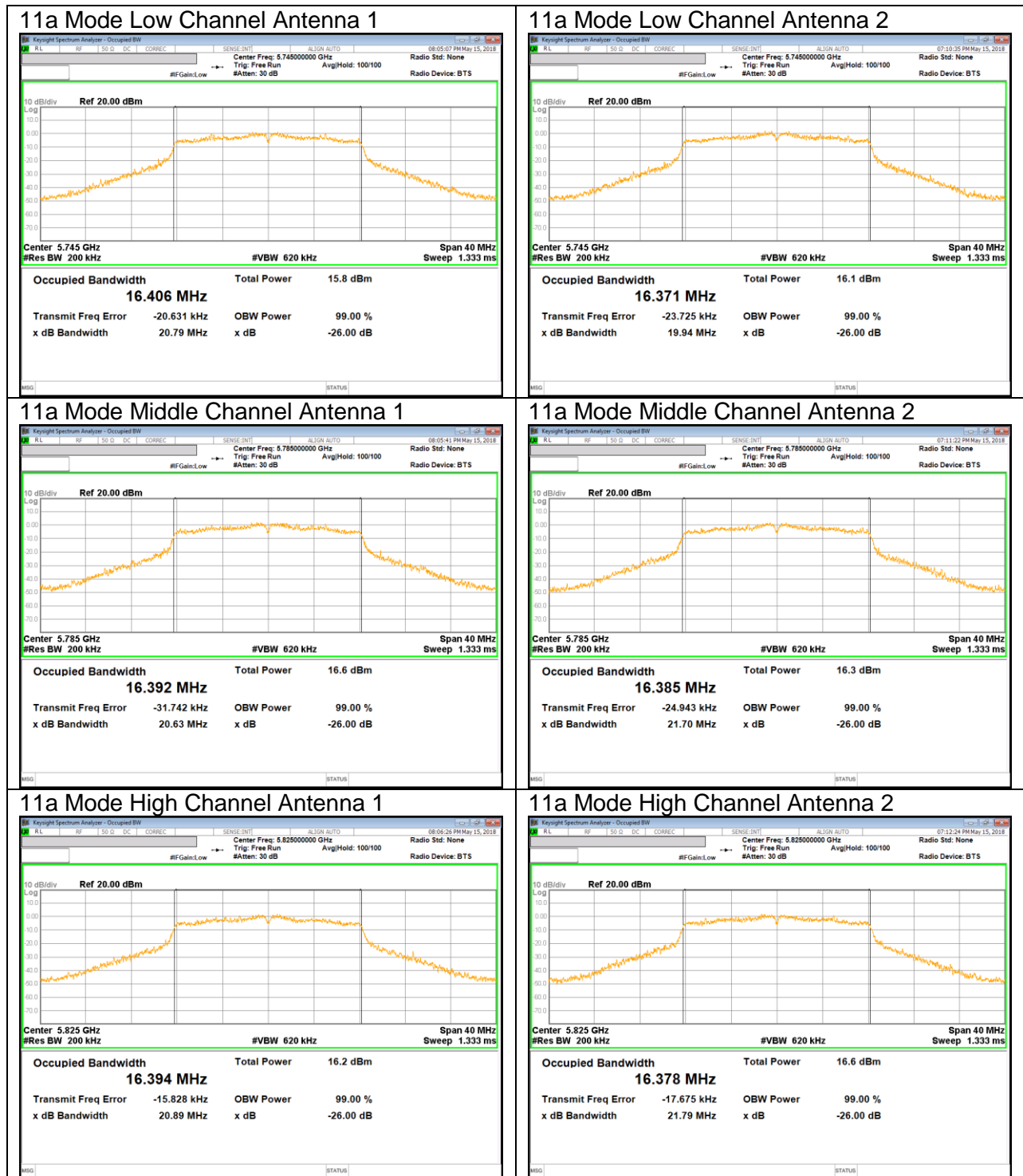

**UNII 5.8 GHz IEEE 802.11n HT20 mode**

