

11.1. 5.2 GHz

11.1.1. TX Above 1GHz 802.11a 2TX CDD MODE IN THE 5.2GHz BAND

RESTRICTED BANDEDGE (LOW CHANNEL)

HORIZONTAL PEAK AND AVERAGE PLOT

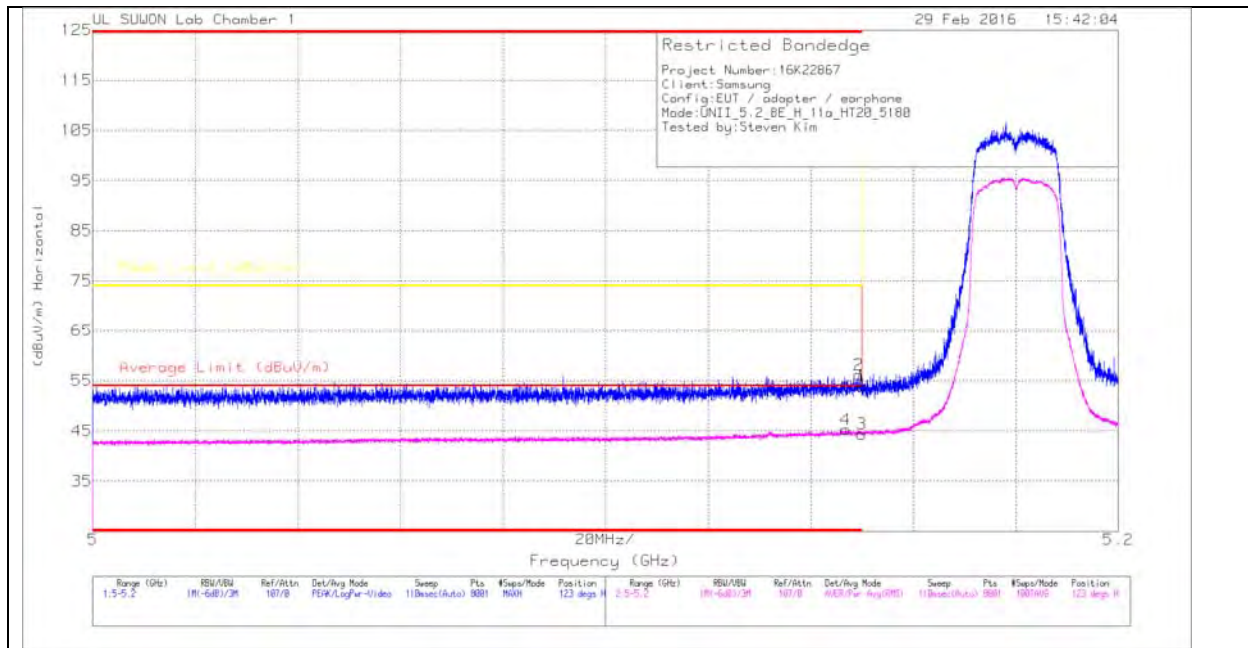

HORIZONTAL DATA

TRACE MARKERS

| Marker | Frequency (GHz) | Meter Reading (dBuV) | Det | 3117(001687 17)_150619 | Path_2 | DC Corr (dB) | Corrected Reading (dBuV/m) | Average Limit (dBuV/m) | Margin (dB) | Peak Limit (dBuV/m) | PK Margin (dB) | Azimuth (Degs) | Height (cm) | Polarity |
|--------|-----------------|----------------------|-----|------------------------|--------|--------------|----------------------------|------------------------|-------------|---------------------|----------------|----------------|-------------|----------|
| 1 | * 5.15 | 43.77 | PK | 34.2 | -24.1 | 0 | 53.87 | - | - | 74 | -20.13 | 123 | 202 | H |
| 2 | * 5.149 | 46.07 | PK | 34.2 | -24.1 | 0 | 56.17 | - | - | 74 | -17.83 | 123 | 202 | H |
| 3 | * 5.15 | 33.99 | RMS | 34.2 | -24.1 | .29 | 44.38 | 54 | -9.62 | - | - | 123 | 202 | H |
| 4 | * 5.147 | 34.91 | RMS | 34.2 | -24.1 | .29 | 45.3 | 54 | -8.7 | - | - | 123 | 202 | H |

* - indicates frequency in CFR15.205/IC7.2.2 Restricted Band

PK - Peak detector

RMS - RMS detection

VERTICAL PEAK AND AVERAGE PLOT

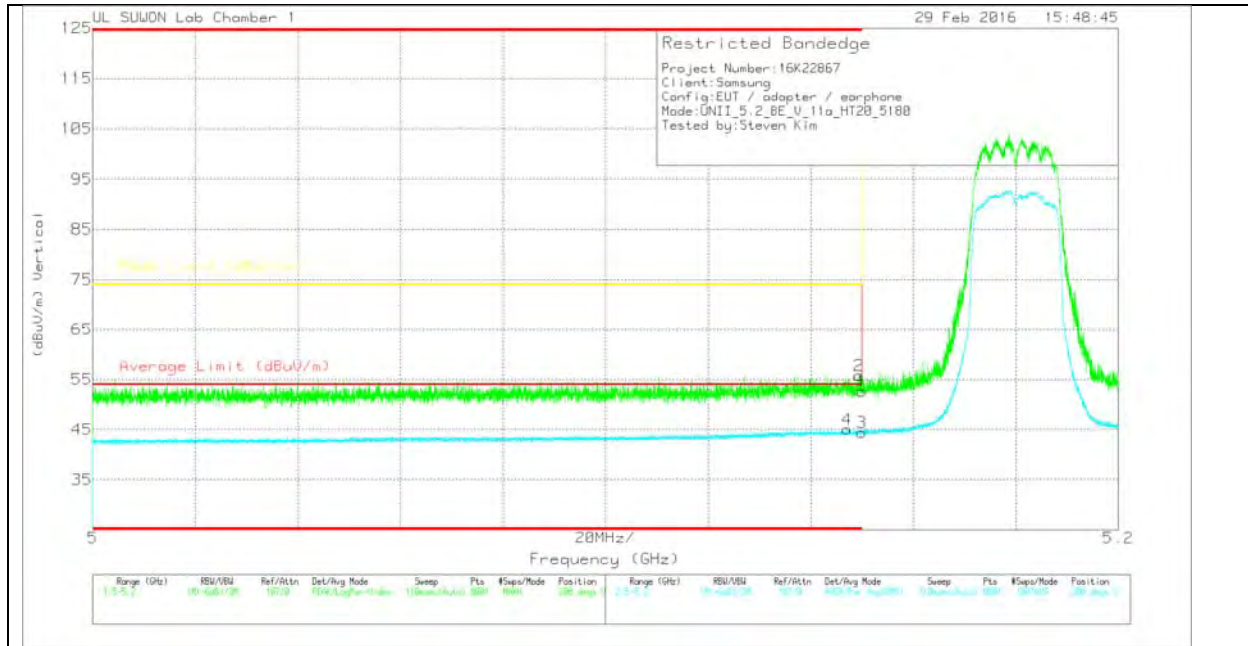

VERTICAL DATA

TRACE MARKERS

| Marker | Frequency (GHz) | Meter Reading (dBuV) | Det | 3117(001687 17_150619) | Path_2 | DC Corr (dB) | Corrected Reading (dBuV/m) | Average Limit (dBuV/m) | Margin (dB) | Peak Limit (dBuV/m) | PK Margin (dB) | Azimuth (Degs) | Height (cm) | Polarity |
|--------|-----------------|----------------------|-----|------------------------|--------|--------------|----------------------------|------------------------|-------------|---------------------|----------------|----------------|-------------|----------|
| 1 | * 5.15 | 42.5 | PK | 34.2 | -24.1 | 0 | 52.6 | - | - | 74 | -21.4 | 208 | 153 | V |
| 2 | * 5.149 | 45.67 | PK | 34.2 | -24.1 | 0 | 55.77 | - | - | 74 | -18.23 | 208 | 153 | V |
| 3 | * 5.15 | 34.01 | RMS | 34.2 | -24.1 | .29 | 44.4 | 54 | -9.6 | - | - | 208 | 153 | V |
| 4 | * 5.147 | 34.63 | RMS | 34.2 | -24.1 | .29 | 45.02 | 54 | -8.98 | - | - | 208 | 153 | V |

* - indicates frequency in CFR15.205/IC7.2.2 Restricted Band

Pk - Peak detector

RMS - RMS detection

HARMONICS AND SPURIOUS EMISSIONS

LOW CHANNEL HORIZONTAL

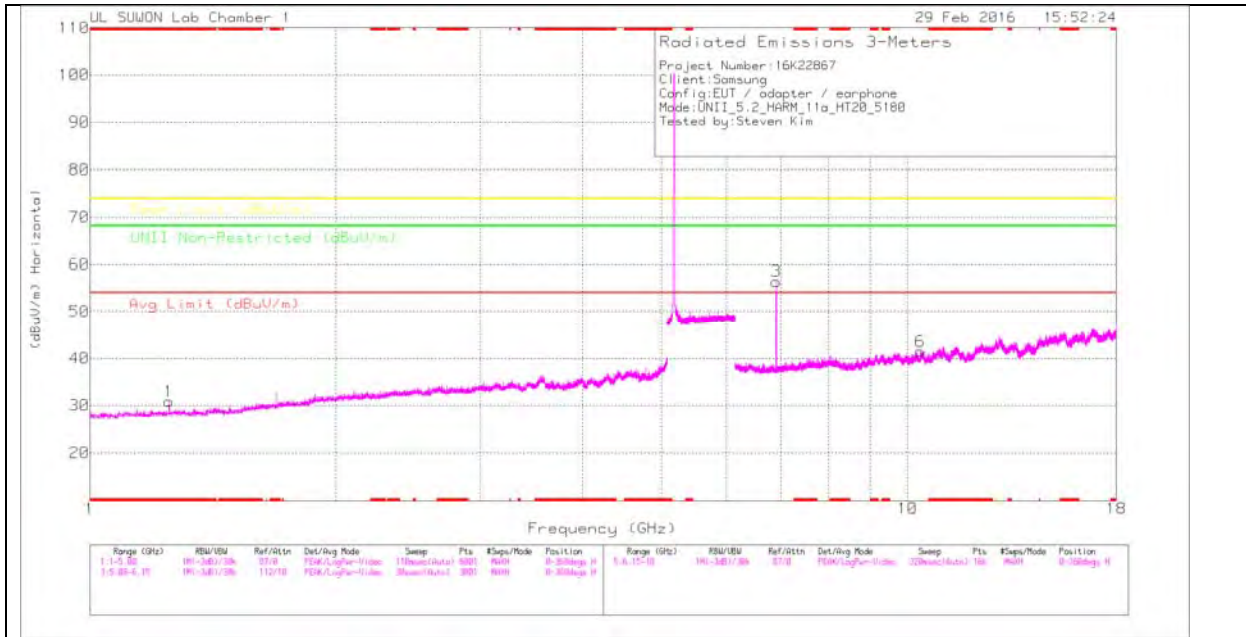

LOW CHANNEL VERTICAL

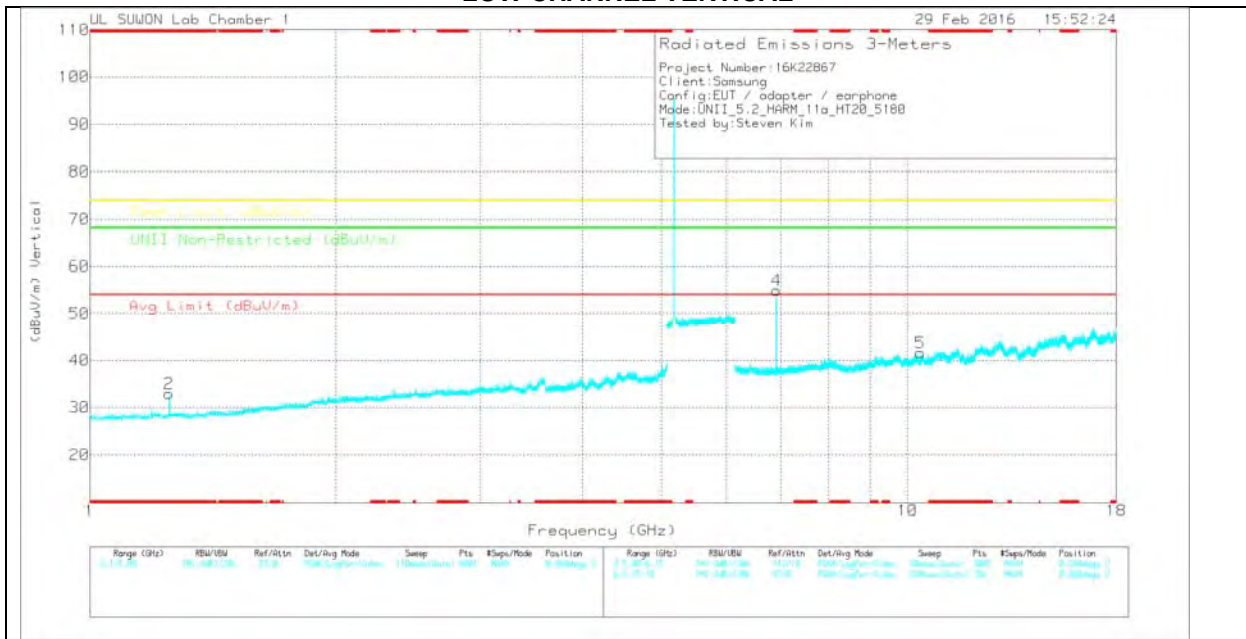

Note: Emission was scanned up to 40GHz; No emissions were detected above the noise floor which was at least 20dB below the specification limit.

LOW CHANNEL DATA

TRACE MARKERS

| Marker | Frequency (GHz) | Meter Reading (dBuV) | Det | 3117(0016 8717)_150 619 | Path_4 | DC Corr (dB) | Corrected Reading (dBuV/m) | Avg Limit (dBuV/m) | Margin (dB) | Peak Limit (dBuV/m) | Margin (dB) | UNII Non-Restricted (dBuV/m) | Margin (dB) | Azimuth (Degs) | Height (cm) | Polarity |
|--------|-----------------|----------------------|-----|-------------------------|--------|--------------|----------------------------|--------------------|-------------|---------------------|-------------|------------------------------|-------------|----------------|-------------|----------|
| 1 | * 1.25 | 42.75 | PK | 28.3 | -40.2 | 0 | 30.85 | - | - | 74 | -43.15 | - | - | 0-360 | 200 | H |
| 2 | * 1.25 | 44.9 | PK | 28.3 | -40.2 | 0 | 33 | - | - | 74 | -41 | - | - | 0-360 | 200 | V |
| 3 | 6.906 | 51.63 | PK | 35.6 | -30.8 | 0 | 56.43 | - | - | - | - | 68.2 | -11.77 | 0-360 | 100 | H |
| 6 | 10.36 | 31.01 | PK | 37.8 | -27.3 | 0 | 41.51 | - | - | - | - | 68.2 | -26.69 | 0-360 | 200 | H |
| 4 | 6.907 | 50.12 | PK | 35.6 | -30.8 | 0 | 54.92 | - | - | - | - | 68.2 | -13.28 | 0-360 | 100 | V |
| 5 | 10.359 | 31.25 | PK | 37.8 | -27.4 | 0 | 41.65 | - | - | - | - | 68.2 | -26.55 | 0-360 | 200 | V |

* - indicates frequency in CFR15.205/IC7.2.2 Restricted Band

PK – Peak detector

Radiated Emissions

| Frequency (GHz) | Meter Reading (dBuV) | Det | 3117(0016871 7)_150619 | Path_5 | DC Corr (dB) | Corrected Reading (dBuV/m) | Avg Limit (dBuV/m) | Margin (dB) | Peak Limit (dBuV/m) | Margin (dB) | UNII Non-Restricted (dBuV/m) | Margin (dB) | Azimuth (Degs) | Height (cm) | Polarity |
|-----------------|----------------------|------|------------------------|--------|--------------|----------------------------|--------------------|-------------|---------------------|-------------|------------------------------|-------------|----------------|-------------|----------|
| 6.907 | 53.76 | PK-U | 35.6 | -30.8 | 0 | 58.56 | - | - | - | - | 68.2 | -9.64 | 111 | 100 | H |
| 6.907 | 53 | PK-U | 35.6 | -30.8 | 0 | 57.8 | - | - | - | - | 68.2 | -10.4 | 146 | 100 | V |

* - indicates frequency in CFR15.205/IC7.2.2 Restricted Band

PK-U - U-NII: Maximum Peak

MID CHANNEL HORIZONTAL

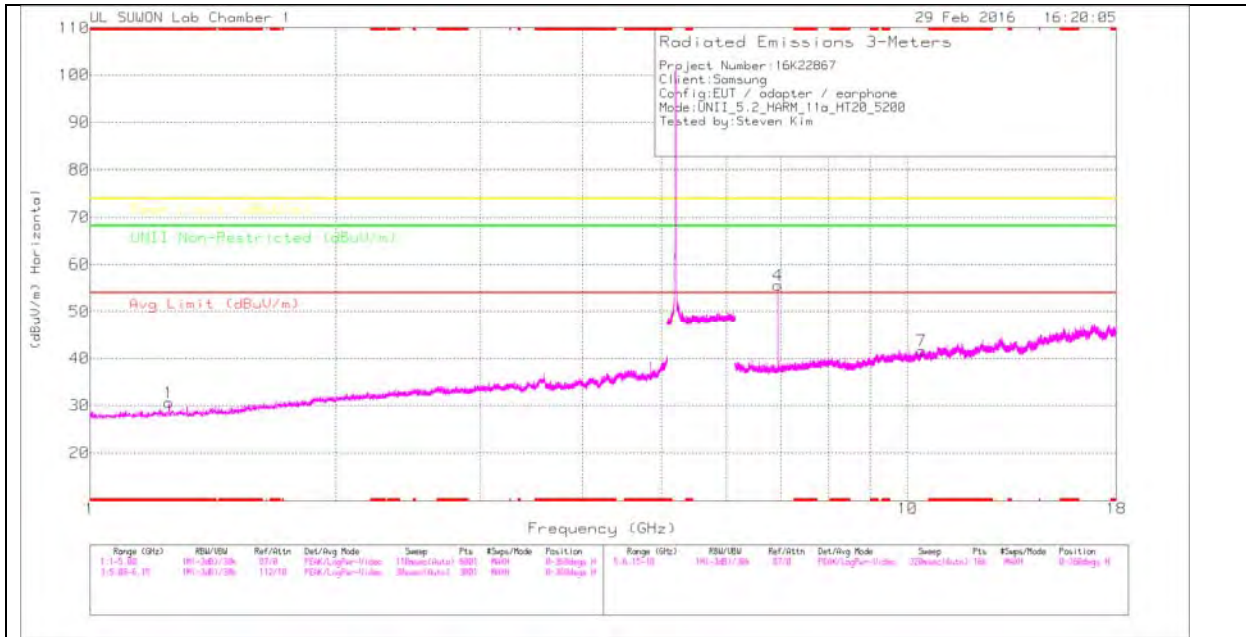

MID CHANNEL VERTICAL

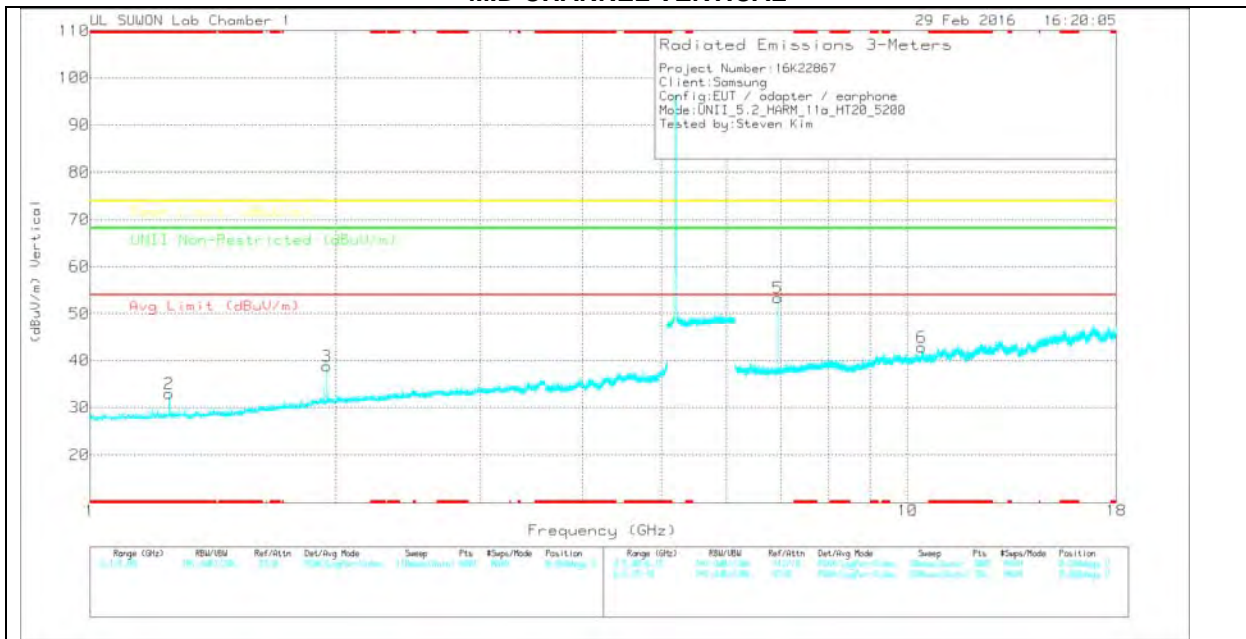

Note: Emission was scanned up to 40GHz; No emissions were detected above the noise floor which was at least 20dB below the specification limit.

MID CHANNEL DATA

TRACE MARKERS

| Marker | Frequency (GHz) | Meter Reading (dBuV) | Det | 3117(0016 8717)_150 619 | Path_4 | DC Corr (dB) | Corrected Reading (dBuV/m) | Avg Limit (dBuV/m) | Margin (dB) | Peak Limit (dBuV/m) | Margin (dB) | UNII Non-Restricted (dBuV/m) | Margin (dB) | Azimuth (Degs) | Height (cm) | Polarity |
|--------|-----------------|----------------------|-----|-------------------------|--------|--------------|----------------------------|--------------------|-------------|---------------------|-------------|------------------------------|-------------|----------------|-------------|----------|
| 1 | * 1.25 | 42.47 | PK | 28.3 | -40.2 | 0 | 30.57 | - | - | 74 | -43.43 | - | - | 0-360 | 200 | H |
| 2 | * 1.25 | 44.81 | PK | 28.3 | -40.2 | 0 | 32.91 | - | - | 74 | -41.09 | - | - | 0-360 | 200 | V |
| 3 | 1.949 | 46.87 | PK | 30.9 | -39 | 0 | 38.77 | - | - | - | - | 68.2 | -29.43 | 0-360 | 200 | V |
| 4 | 6.933 | 50.63 | PK | 35.7 | -30.7 | 0 | 55.63 | - | - | - | - | 68.2 | -12.57 | 0-360 | 100 | H |
| 7 | 10.4 | 30.55 | PK | 37.8 | -26.7 | 0 | 41.65 | - | - | - | - | 68.2 | -26.55 | 0-360 | 100 | H |
| 5 | 6.933 | 48.39 | PK | 35.7 | -30.7 | 0 | 53.39 | - | - | - | - | 68.2 | -14.81 | 0-360 | 100 | V |
| 6 | 10.4 | 31.65 | PK | 37.8 | -26.7 | 0 | 42.75 | - | - | - | - | 68.2 | -25.45 | 0-360 | 200 | V |

* - indicates frequency in CFR15.205/IC7.2.2 Restricted Band

PK – Peak detector

Radiated Emissions

| Frequency (GHz) | Meter Reading (dBuV) | Det | 3117(001687 17)_150619 | Path_5 | DC Corr (dB) | Corrected Reading (dBuV/m) | Avg Limit (dBuV/m) | Margin (dB) | Peak Limit (dBuV/m) | Margin (dB) | UNII Non-Restricted (dBuV/m) | Margin (dB) | Azimuth (Degs) | Height (cm) | Polarity |
|-----------------|----------------------|------|------------------------|--------|--------------|----------------------------|--------------------|-------------|---------------------|-------------|------------------------------|-------------|----------------|-------------|----------|
| 6.933 | 52.95 | PK-U | 35.7 | -30.7 | 0 | 57.95 | - | - | - | - | 68.2 | -10.25 | 112 | 100 | H |
| 6.933 | 51.44 | PK-U | 35.7 | -30.7 | 0 | 56.44 | - | - | - | - | 68.2 | -11.76 | 143 | 102 | V |

* - indicates frequency in CFR15.205/IC7.2.2 Restricted Band

PK-U - U-NII: Maximum Peak

HIGH CHANNEL HORIZONTAL

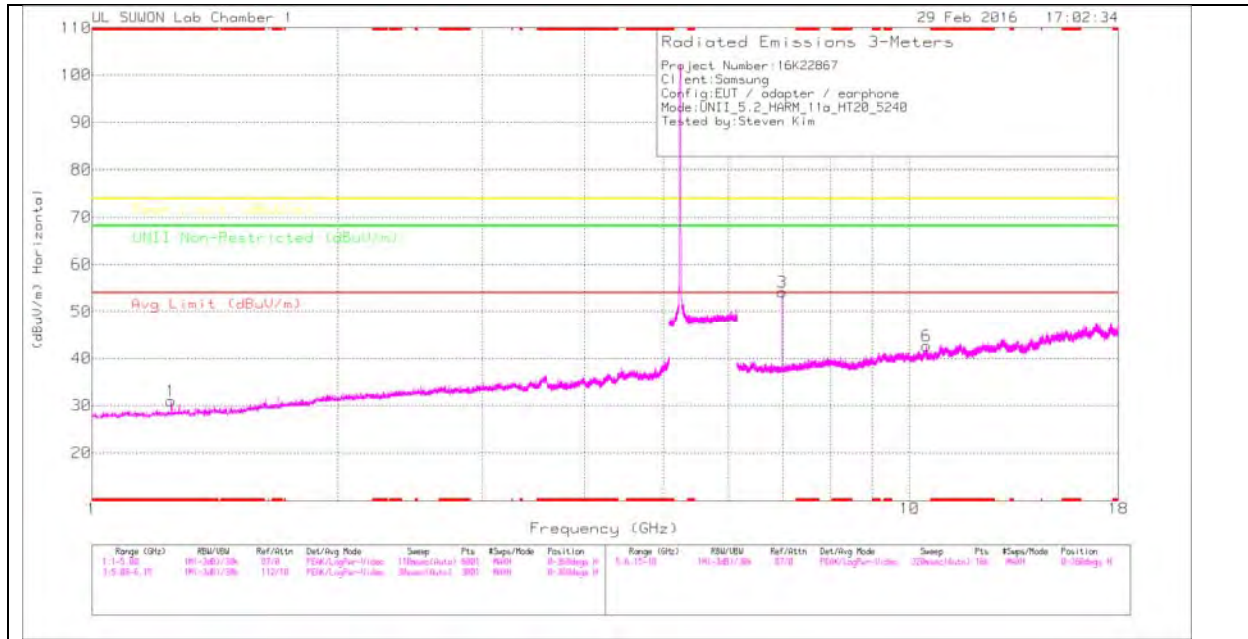

HIGH CHANNEL VERTICAL

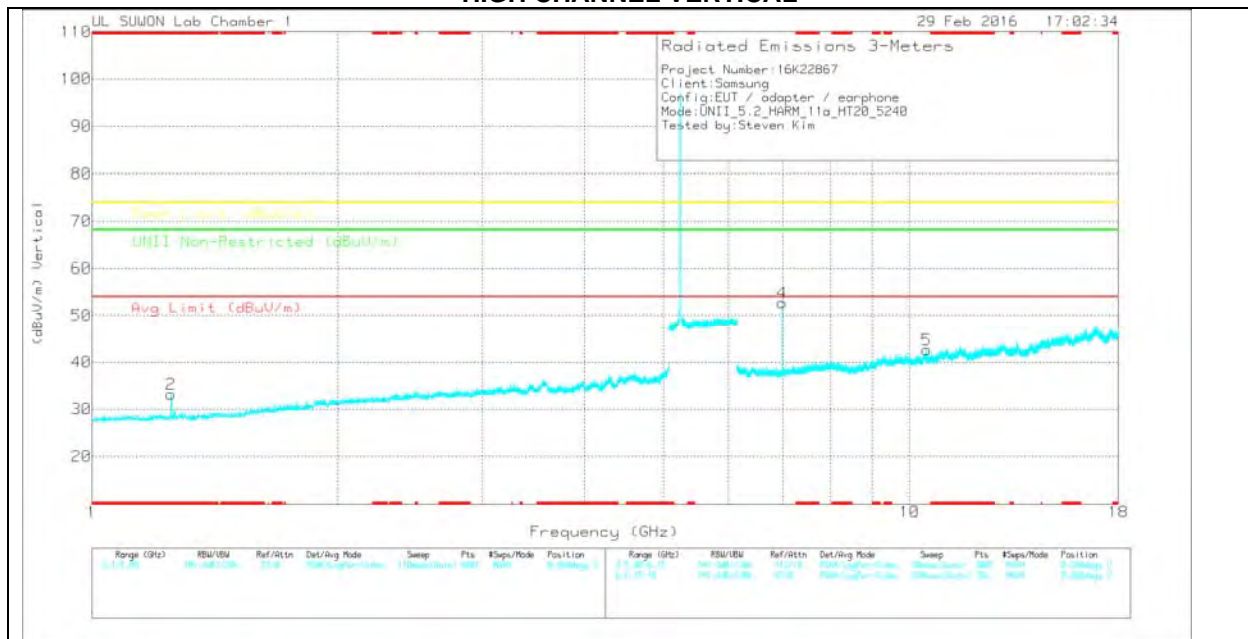

Note: Emission was scanned up to 40GHz; No emissions were detected above the noise floor which was at least 20dB below the specification limit.

HIGH CHANNEL DATA

TRACE MARKERS

| Marker | Frequency (GHz) | Meter Reading (dBuV) | Det | 3117(0016 8717)_150 619 | Path_4 | DC Corr (dB) | Corrected Reading (dBuV/m) | Avg Limit (dBuV/m) | Margin (dB) | Peak Limit (dBuV/m) | Margin (dB) | UNII Non-Restricted (dBuV/m) | Margin (dB) | Azimuth (Degs) | Height (cm) | Polarity |
|--------|-----------------|----------------------|-----|-------------------------|--------|--------------|----------------------------|--------------------|-------------|---------------------|-------------|------------------------------|-------------|----------------|-------------|----------|
| 1 | * 1.25 | 42.92 | PK | 28.3 | -40.2 | 0 | 31.02 | - | - | 74 | -42.98 | - | - | 0-360 | 200 | H |
| 2 | * 1.25 | 45.08 | PK | 28.3 | -40.2 | 0 | 33.18 | - | - | 74 | -40.82 | - | - | 0-360 | 200 | V |
| 3 | 6.986 | 49.07 | PK | 35.7 | -30.6 | 0 | 54.17 | - | - | - | - | 68.2 | -14.03 | 0-360 | 100 | H |
| 6 | 10.48 | 32.56 | PK | 37.8 | -27.7 | 0 | 42.66 | - | - | - | - | 68.2 | -25.54 | 0-360 | 200 | H |
| 4 | 6.986 | 47.6 | PK | 35.7 | -30.6 | 0 | 52.7 | - | - | - | - | 68.2 | -15.5 | 0-360 | 200 | V |
| 5 | 10.48 | 32.57 | PK | 37.8 | -27.7 | 0 | 42.67 | - | - | - | - | 68.2 | -25.53 | 0-360 | 100 | V |

* - indicates frequency in CFR15.205/IC7.2.2 Restricted Band

PK – Peak detector

Radiated Emissions

| Frequency (GHz) | Meter Reading (dBuV) | Det | 3117(001687 17)_150619 | Path_5 | DC Corr (dB) | Corrected Reading (dBuV/m) | Avg Limit (dBuV/m) | Margin (dB) | Peak Limit (dBuV/m) | Margin (dB) | UNII Non-Restricted (dBuV/m) | Margin (dB) | Azimuth (Degs) | Height (cm) | Polarity |
|-----------------|----------------------|------|------------------------|--------|--------------|----------------------------|--------------------|-------------|---------------------|-------------|------------------------------|-------------|----------------|-------------|----------|
| 6.987 | 52 | PK-U | 35.7 | -30.6 | 0 | 57.1 | - | - | - | - | 68.2 | -11.1 | 114 | 138 | H |
| 6.987 | 50.67 | PK-U | 35.7 | -30.6 | 0 | 55.77 | - | - | - | - | 68.2 | -12.43 | 146 | 135 | V |

* - indicates frequency in CFR15.205/IC7.2.2 Restricted Band

PK-U - U-NII: Maximum Peak

**11.1.2. TX Above 1GHz 802.11n HT20 2TX CDD MODE IN THE 5.2GHz BAND
 RESTRICTED BANDEDGE (LOW CHANNEL)**

HORIZONTAL PEAK AND AVERAGE PLOT

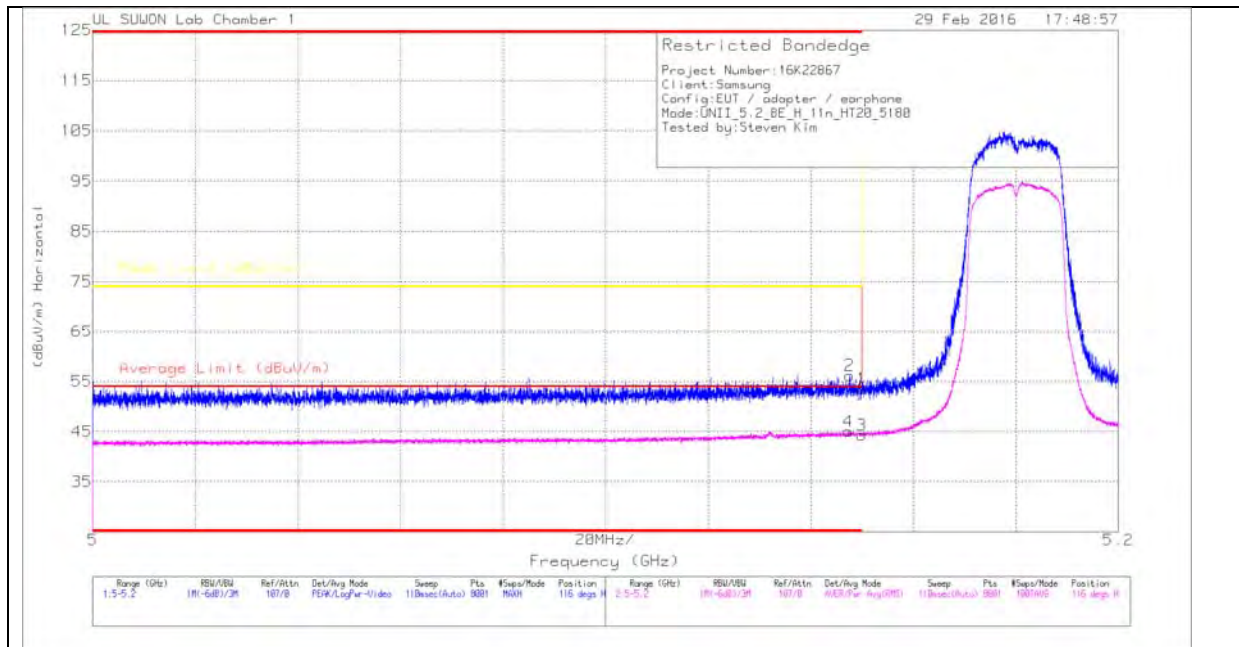

HORIZONTAL DATA

TRACE MARKERS

| Marker | Frequency (GHz) | Meter Reading (dBuV) | Det | 3117(00168 717_15061 9) | Path_2 | DC Corr (dB) | Corrected Reading (dBuV/m) | Average Limit (dBuV/m) | Margin (dB) | Peak Limit (dBuV/m) | PK Margin (dB) | Azimuth (Degs) | Height (cm) | Polarity |
|--------|-----------------|----------------------|-----|-------------------------|--------|--------------|----------------------------|------------------------|-------------|---------------------|----------------|----------------|-------------|----------|
| 1 | * 5.15 | 43.46 | Pk | 34.2 | -24.1 | 0 | 53.56 | - | - | 74 | -20.44 | 116 | 151 | H |
| 2 | * 5.148 | 46.09 | Pk | 34.2 | -24.1 | 0 | 56.19 | - | - | 74 | -17.81 | 116 | 151 | H |
| 3 | * 5.15 | 33.89 | RMS | 34.2 | -24.1 | .31 | 44.3 | 54 | -9.7 | - | - | 116 | 151 | H |
| 4 | * 5.147 | 34.62 | RMS | 34.2 | -24.1 | .31 | 45.03 | 54 | -8.97 | - | - | 116 | 151 | H |

* - indicates frequency in CFR15.205/IC7.2.2 Restricted Band

Pk - Peak detector

RMS - RMS detection

VERTICAL PEAK AND AVERAGE PLOT

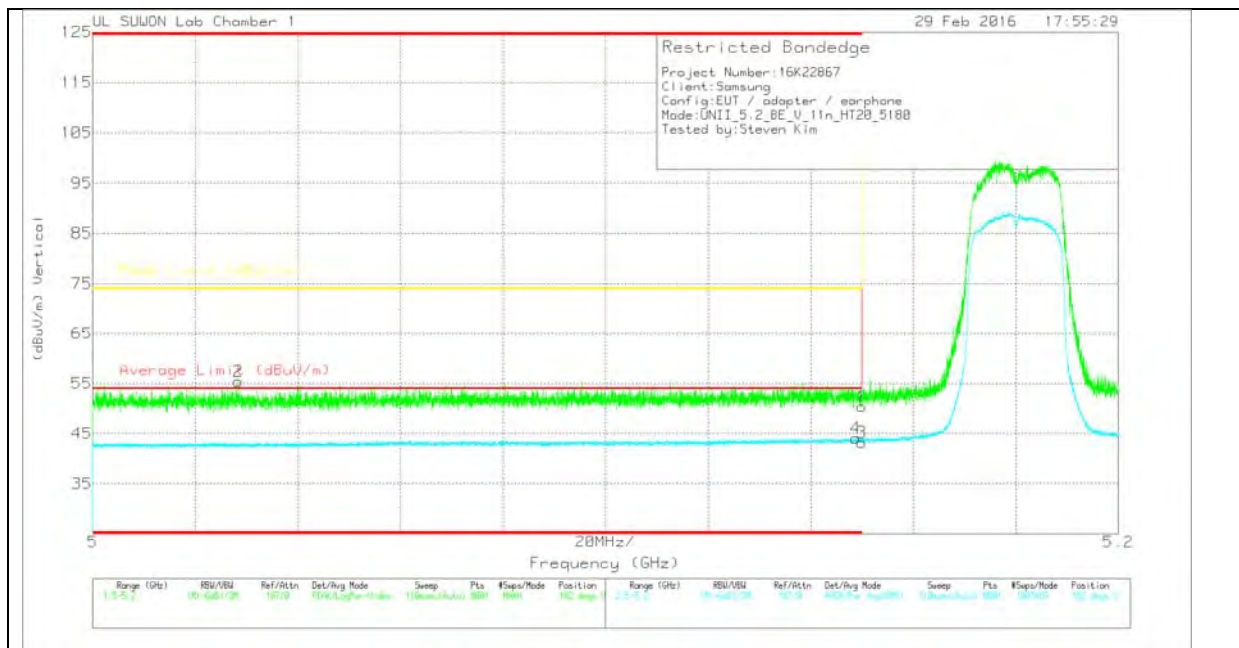

VERTICAL DATA

TRACE MARKERS

| Marker | Frequency (GHz) | Meter Reading (dBuV) | Det | 3117(001687 17_150619) | Path_2 | DC Corr (dB) | Corrected Reading (dBuV/m) | Average Limit (dBuV/m) | Margin (dB) | Peak Limit (dBuV/m) | PK Margin (dB) | Azimuth (Degs) | Height (cm) | Polarity |
|--------|-----------------|----------------------|-----|------------------------|--------|--------------|----------------------------|------------------------|-------------|---------------------|----------------|----------------|-------------|----------|
| 1 | * 5.15 | 40.34 | PK | 34.2 | -24.1 | 0 | 50.44 | - | - | 74 | -23.56 | 182 | 130 | V |
| 2 | * 5.028 | 45.64 | PK | 34.1 | -24.3 | 0 | 55.44 | - | - | 74 | -18.56 | 182 | 130 | V |
| 3 | * 5.15 | 32.84 | RMS | 34.2 | -24.1 | .31 | 43.25 | 54 | -10.75 | - | - | 182 | 130 | V |
| 4 | * 5.149 | 33.69 | RMS | 34.2 | -24.1 | .31 | 44.1 | 54 | -9.9 | - | - | 182 | 130 | V |

* - indicates frequency in CFR15.205/IC7.2.2 Restricted Band

Pk - Peak detector

RMS - RMS detection

HARMONICS AND SPURIOUS EMISSIONS

LOW CHANNEL HORIZONTAL

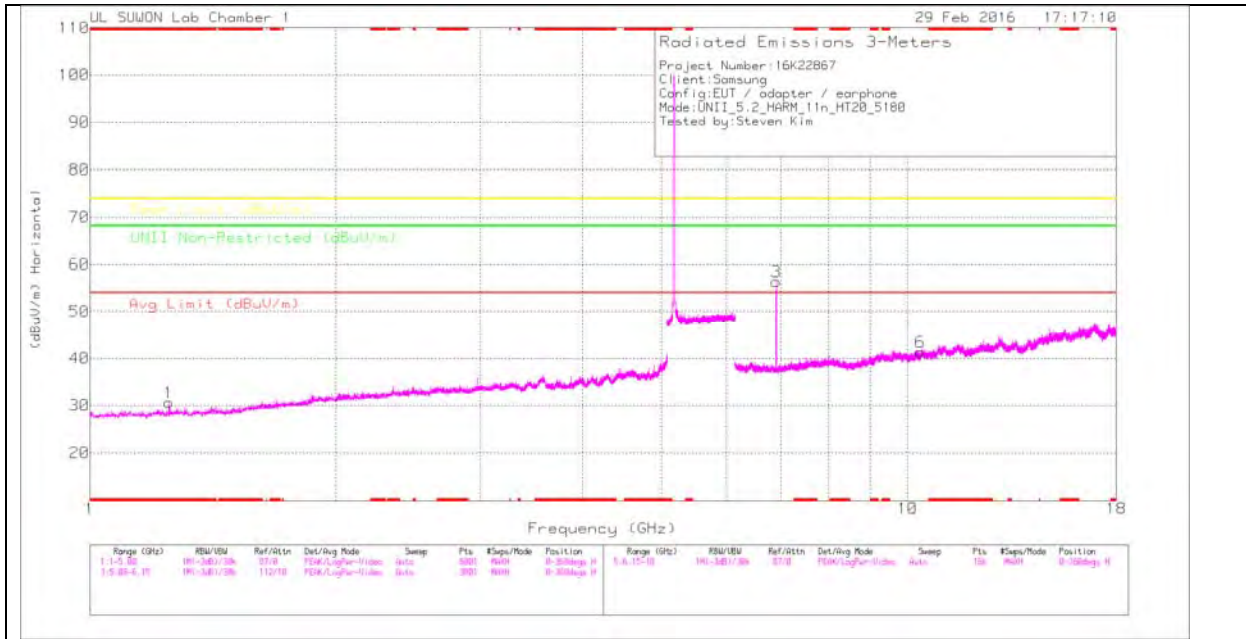

LOW CHANNEL VERTICAL

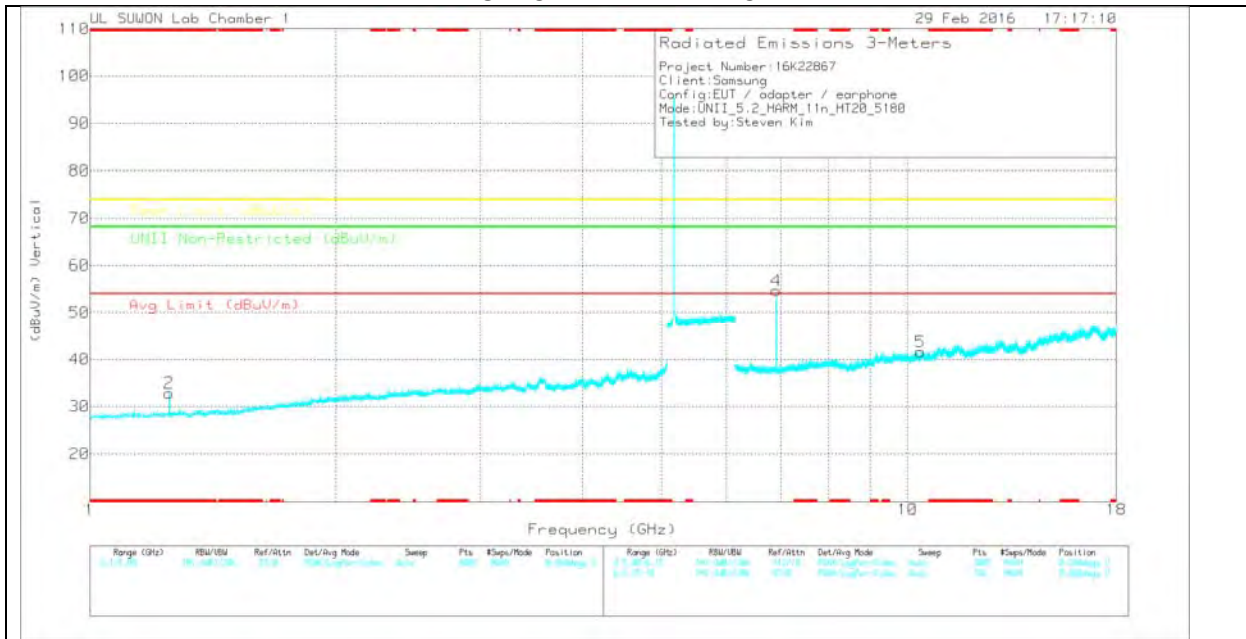

Note: Emission was scanned up to 40GHz; No emissions were detected above the noise floor which was at least 20dB below the specification limit.

LOW CHANNEL DATA

TRACE MARKERS

| Marker | Frequency (GHz) | Meter Reading (dBuV) | Det | 3117(0016 8717)_150 619 | Path_4 | DC Corr (dB) | Corrected Reading (dBuV/m) | Avg Limit (dBuV/m) | Margin (dB) | Peak Limit (dBuV/m) | Margin (dB) | UNII Non-Restricted (dBuV/m) | Margin (dB) | Azimuth (Degs) | Height (cm) | Polarity |
|--------|-----------------|----------------------|-----|-------------------------|--------|--------------|----------------------------|--------------------|-------------|---------------------|-------------|------------------------------|-------------|----------------|-------------|----------|
| 1 | * 1.25 | 42.58 | PK | 28.3 | -40.2 | 0 | 30.68 | - | - | 74 | -43.32 | - | - | 0-360 | 200 | H |
| 2 | * 1.25 | 44.79 | PK | 28.3 | -40.2 | 0 | 32.89 | - | - | 74 | -41.11 | - | - | 0-360 | 200 | V |
| 3 | 6.906 | 51.58 | PK | 35.6 | -30.8 | 0 | 56.38 | - | - | - | - | 68.2 | -11.82 | 0-360 | 100 | H |
| 6 | 10.36 | 30.84 | PK | 37.8 | -27.3 | 0 | 41.34 | - | - | - | - | 68.2 | -26.86 | 0-360 | 100 | H |
| 4 | 6.906 | 49.87 | PK | 35.6 | -30.8 | 0 | 54.67 | - | - | - | - | 68.2 | -13.53 | 0-360 | 100 | V |
| 5 | 10.36 | 31.12 | PK | 37.8 | -27.3 | 0 | 41.62 | - | - | - | - | 68.2 | -26.58 | 0-360 | 100 | V |

* - indicates frequency in CFR15.205/IC7.2.2 Restricted Band

PK – Peak detector

Radiated Emissions

| Frequency (GHz) | Meter Reading (dBuV) | Det | 3117(001687 17)_150619 | Path_5 | DC Corr (dB) | Corrected Reading (dBuV/m) | Avg Limit (dBuV/m) | Margin (dB) | Peak Limit (dBuV/m) | Margin (dB) | UNII Non-Restricted (dBuV/m) | Margin (dB) | Azimuth (Degs) | Height (cm) | Polarity |
|-----------------|----------------------|------|------------------------|--------|--------------|----------------------------|--------------------|-------------|---------------------|-------------|------------------------------|-------------|----------------|-------------|----------|
| 6.907 | 52.61 | PK-U | 35.6 | -30.8 | 0 | 57.41 | - | - | - | - | 68.2 | -10.79 | 109 | 180 | H |
| 6.907 | 52.32 | PK-U | 35.6 | -30.8 | 0 | 57.12 | - | - | - | - | 68.2 | -11.08 | 143 | 132 | V |

* - indicates frequency in CFR15.205/IC7.2.2 Restricted Band

PK-U - U-NII: Maximum Peak

MID CHANNEL HORIZONTAL

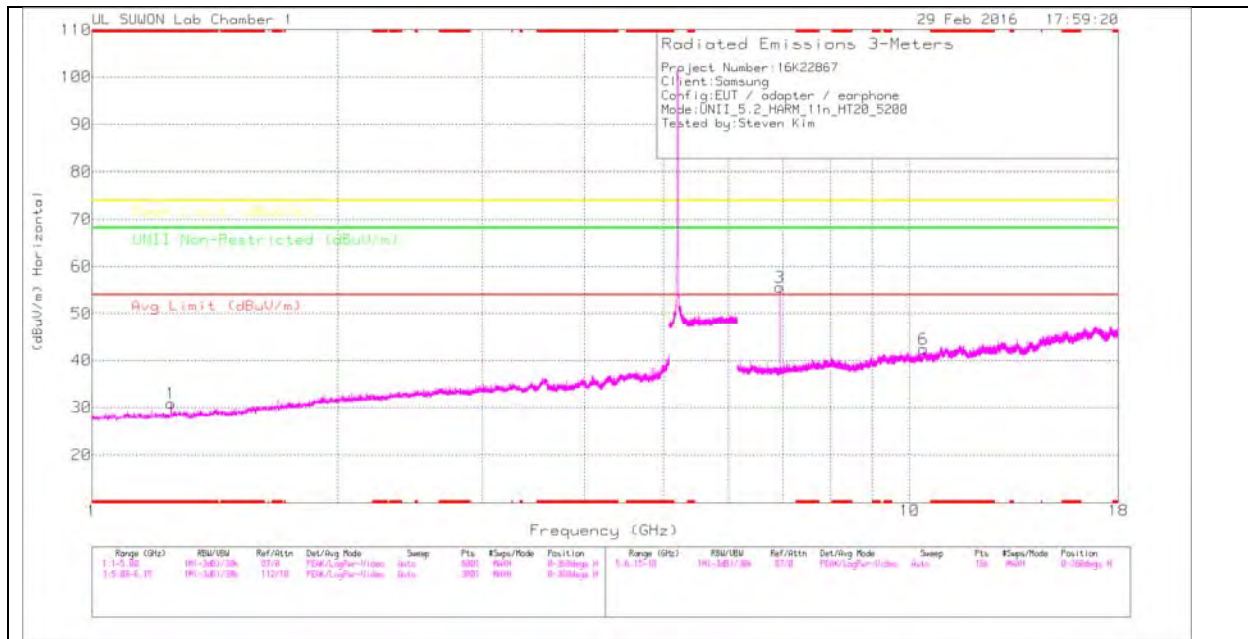

MID CHANNEL VERTICAL

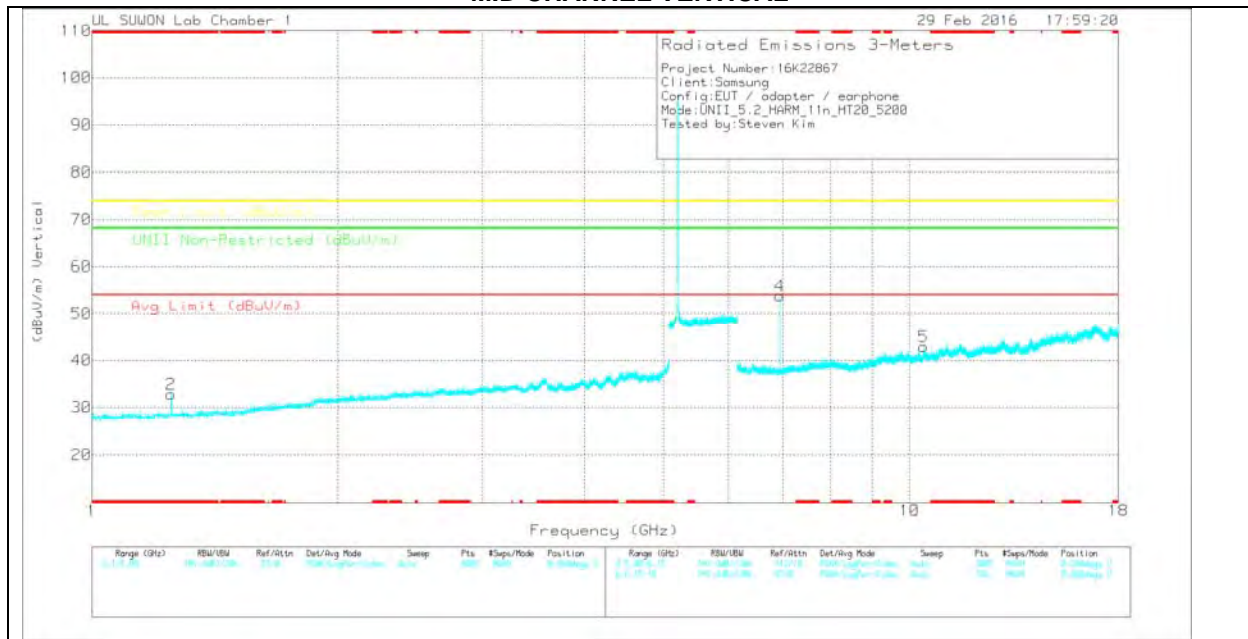

Note: Emission was scanned up to 40GHz; No emissions were detected above the noise floor which was at least 20dB below the specification limit.

MID CHANNEL DATA

TRACE MARKERS

| Marker | Frequency (GHz) | Meter Reading (dBuV) | Det | 3117(0016 8717)_150 619 | Path_4 | DC Corr (dB) | Corrected Reading (dBuV/m) | Avg Limit (dBuV/m) | Margin (dB) | Peak Limit (dBuV/m) | Margin (dB) | UNII Non-Restricted (dBuV/m) | Margin (dB) | Azimuth (Degs) | Height (cm) | Polarity |
|--------|-----------------|----------------------|-----|-------------------------|--------|--------------|----------------------------|--------------------|-------------|---------------------|-------------|------------------------------|-------------|----------------|-------------|----------|
| 1 | * 1.25 | 42.73 | PK | 28.3 | -40.2 | 0 | 30.83 | - | - | 74 | -43.17 | - | - | 0-360 | 200 | H |
| 2 | * 1.25 | 44.7 | PK | 28.3 | -40.2 | 0 | 32.8 | - | - | 74 | -41.2 | - | - | 0-360 | 200 | V |
| 3 | 6.933 | 50.53 | PK | 35.7 | -30.7 | 0 | 55.53 | - | - | - | - | 68.2 | -12.67 | 0-360 | 100 | H |
| 6 | 10.4 | 31.28 | PK | 37.8 | -26.7 | 0 | 42.38 | - | - | - | - | 68.2 | -25.82 | 0-360 | 100 | H |
| 4 | 6.933 | 48.82 | PK | 35.7 | -30.7 | 0 | 53.82 | - | - | - | - | 68.2 | -14.38 | 0-360 | 100 | V |
| 5 | 10.399 | 31.83 | PK | 37.8 | -26.7 | 0 | 42.93 | - | - | - | - | 68.2 | -25.27 | 0-360 | 200 | V |

* - indicates frequency in CFR15.205/IC7.2.2 Restricted Band

PK – Peak Detector

Radiated Emissions

| Frequency (GHz) | Meter Reading (dBuV) | Det | 3117(0016871 7)_150619 | Path_5 | DC Corr (dB) | Corrected Reading (dBuV/m) | Avg Limit (dBuV/m) | Margin (dB) | Peak Limit (dBuV/m) | Margin (dB) | UNII Non-Restricted (dBuV/m) | Margin (dB) | Azimuth (Degs) | Height (cm) | Polarity |
|-----------------|----------------------|------|------------------------|--------|--------------|----------------------------|--------------------|-------------|---------------------|-------------|------------------------------|-------------|----------------|-------------|----------|
| 6.933 | 52.89 | PK-U | 35.7 | -30.7 | 0 | 57.89 | - | - | - | - | 68.2 | -10.31 | 112 | 139 | H |
| 6.933 | 51.25 | PK-U | 35.7 | -30.7 | 0 | 56.25 | - | - | - | - | 68.2 | -11.95 | 143 | 129 | V |

* - indicates frequency in CFR15.205/IC7.2.2 Restricted Band

PK-U - U-NII: Maximum Peak

HIGH CHANNEL HORIZONTAL

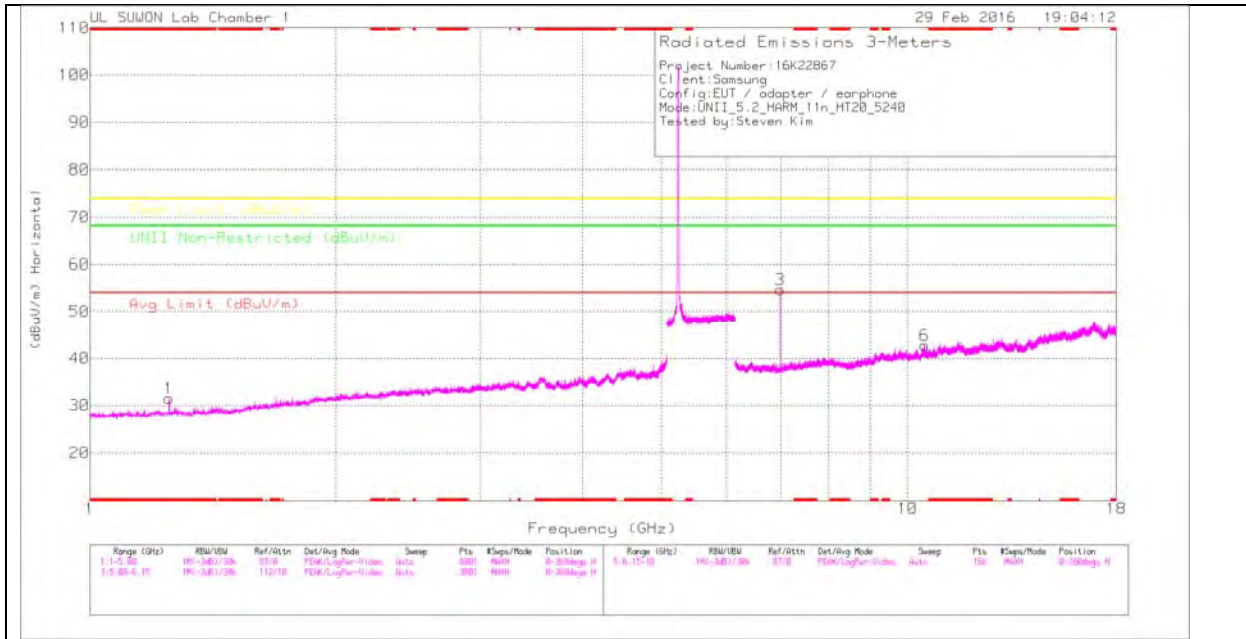

HIGH CHANNEL VERTICAL

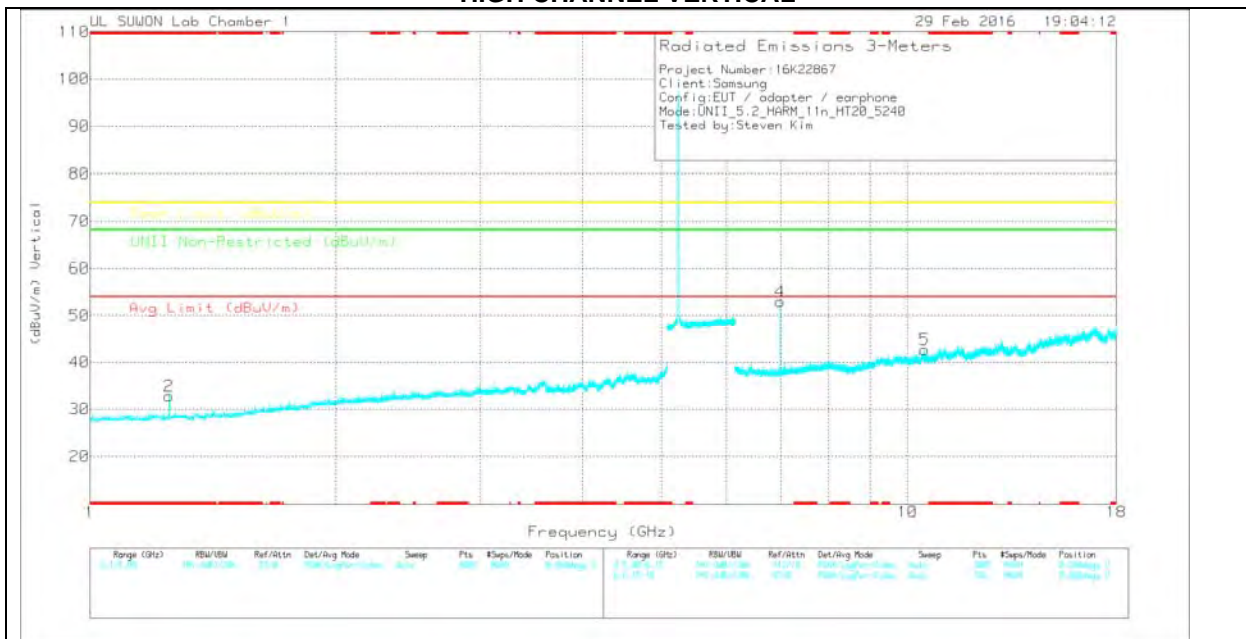

Note: Emission was scanned up to 40GHz; No emissions were detected above the noise floor which was at least 20dB below the specification limit.

HIGH CHANNEL DATA

TRACE MARKERS

| Marker | Frequency (GHz) | Meter Reading (dBuV) | Det | 3117(0016 8717)_150 619 | Path_4 | DC Corr (dB) | Corrected Reading (dBuV/m) | Avg Limit (dBuV/m) | Margin (dB) | Peak Limit (dBuV/m) | Margin (dB) | UNII Non-Restricted (dBuV/m) | Margin (dB) | Azimuth (Degs) | Height (cm) | Polarity |
|--------|-----------------|----------------------|-----|-------------------------|--------|--------------|----------------------------|--------------------|-------------|---------------------|-------------|------------------------------|-------------|----------------|-------------|----------|
| 1 | * 1.25 | 43.46 | PK | 28.3 | -40.2 | 0 | 31.56 | - | - | 74 | -42.44 | - | - | 0-360 | 200 | H |
| 2 | * 1.25 | 44.7 | PK | 28.3 | -40.2 | 0 | 32.8 | - | - | 74 | -41.2 | - | - | 0-360 | 200 | V |
| 3 | 6.986 | 49.62 | PK | 35.7 | -30.6 | 0 | 54.72 | - | - | - | - | 68.2 | -13.48 | 0-360 | 100 | H |
| 6 | 10.48 | 32.67 | PK | 37.8 | -27.7 | 0 | 42.77 | - | - | - | - | 68.2 | -25.43 | 0-360 | 100 | H |
| 4 | 6.986 | 47.94 | PK | 35.7 | -30.6 | 0 | 53.04 | - | - | - | - | 68.2 | -15.16 | 0-360 | 200 | V |
| 5 | 10.48 | 32.62 | PK | 37.8 | -27.7 | 0 | 42.72 | - | - | - | - | 68.2 | -25.48 | 0-360 | 200 | V |

* - indicates frequency in CFR15.205/IC7.2.2 Restricted Band

PK – Peak detector

Radiated Emissions

| Frequency (GHz) | Meter Reading (dBuV) | Det | 3117(001687 17)_150619 | Path_5 | DC Corr (dB) | Corrected Reading (dBuV/m) | Avg Limit (dBuV/m) | Margin (dB) | Peak Limit (dBuV/m) | Margin (dB) | UNII Non-Restricted (dBuV/m) | Margin (dB) | Azimuth (Degs) | Height (cm) | Polarity |
|-----------------|----------------------|------|------------------------|--------|--------------|----------------------------|--------------------|-------------|---------------------|-------------|------------------------------|-------------|----------------|-------------|----------|
| 6.987 | 52.01 | PK-U | 35.7 | -30.6 | 0 | 57.11 | - | - | - | - | 68.2 | -11.09 | 114 | 139 | H |
| 6.987 | 51.36 | PK-U | 35.7 | -30.6 | 0 | 56.46 | - | - | - | - | 68.2 | -11.74 | 146 | 141 | V |

* - indicates frequency in CFR15.205/IC7.2.2 Restricted Band

PK-U - U-NII: Maximum Peak

11.1.3. TX Above 1GHz 802.11n HT40 2TX CDD MODE IN THE 5.2GHz BAND RESTRICTED BANDEDGE (LOW CHANNEL)

HORIZONTAL PEAK AND AVERAGE PLOT

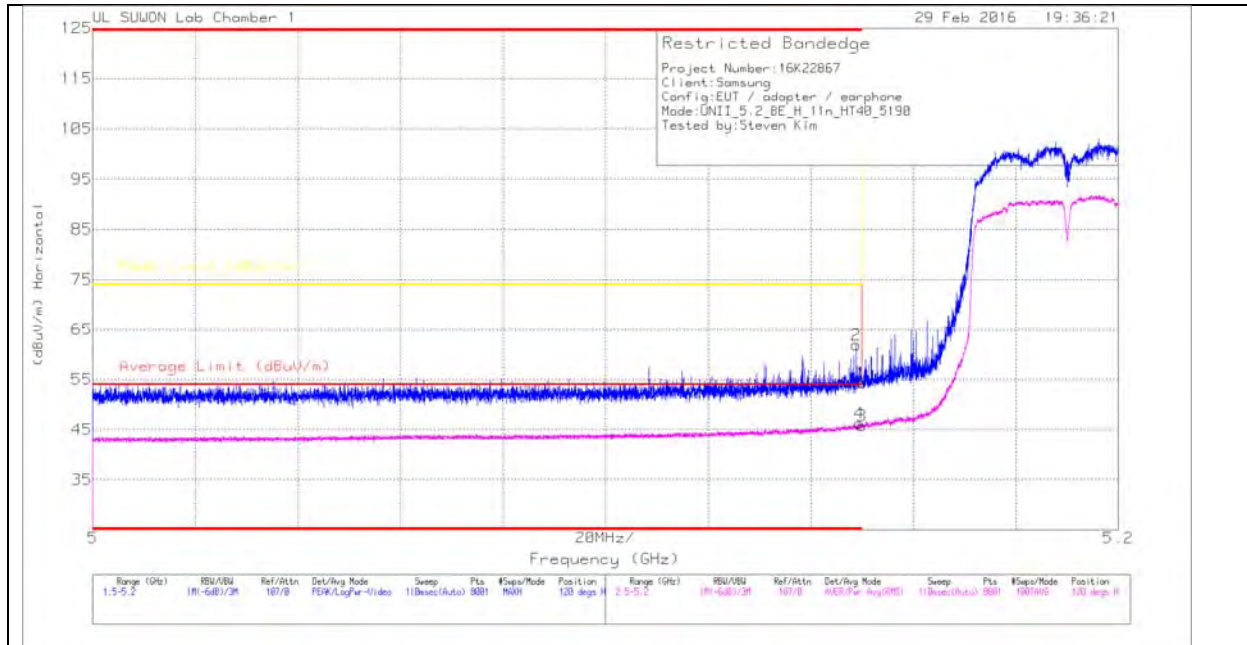

HORIZONTAL DATA

TRACE MARKERS

| Marker | Frequency (GHz) | Meter Reading (dBuV) | Det | 3117(001687 17_150619) | Path_2 | DC Corr (dB) | Corrected Reading (dBuV/m) | Average Limit (dBuV/m) | Margin (dB) | Peak Limit (dBuV/m) | PK Margin (dB) | Azimuth (Degs) | Height (cm) | Polarity |
|--------|-----------------|----------------------|-----|------------------------|--------|--------------|----------------------------|------------------------|-------------|---------------------|----------------|----------------|-------------|----------|
| 1 | * 5.15 | 44.19 | PK | 34.2 | -24.1 | 0 | 54.29 | - | - | 74 | -19.71 | 120 | 103 | H |
| 2 | * 5.149 | 51.77 | PK | 34.2 | -24.1 | 0 | 61.87 | - | - | 74 | -12.13 | 120 | 103 | H |
| 3 | * 5.15 | 35.04 | RMS | 34.2 | -24.1 | .59 | 45.73 | 54 | -8.27 | - | - | 120 | 103 | H |
| 4 | * 5.15 | 35.55 | RMS | 34.2 | -24.1 | .59 | 46.24 | 54 | -7.76 | - | - | 120 | 103 | H |

* - indicates frequency in CFR15.205/IC7.2.2 Restricted Band

PK - Peak detector

RMS - RMS detection

VERTICAL PEAK AND AVERAGE PLOT

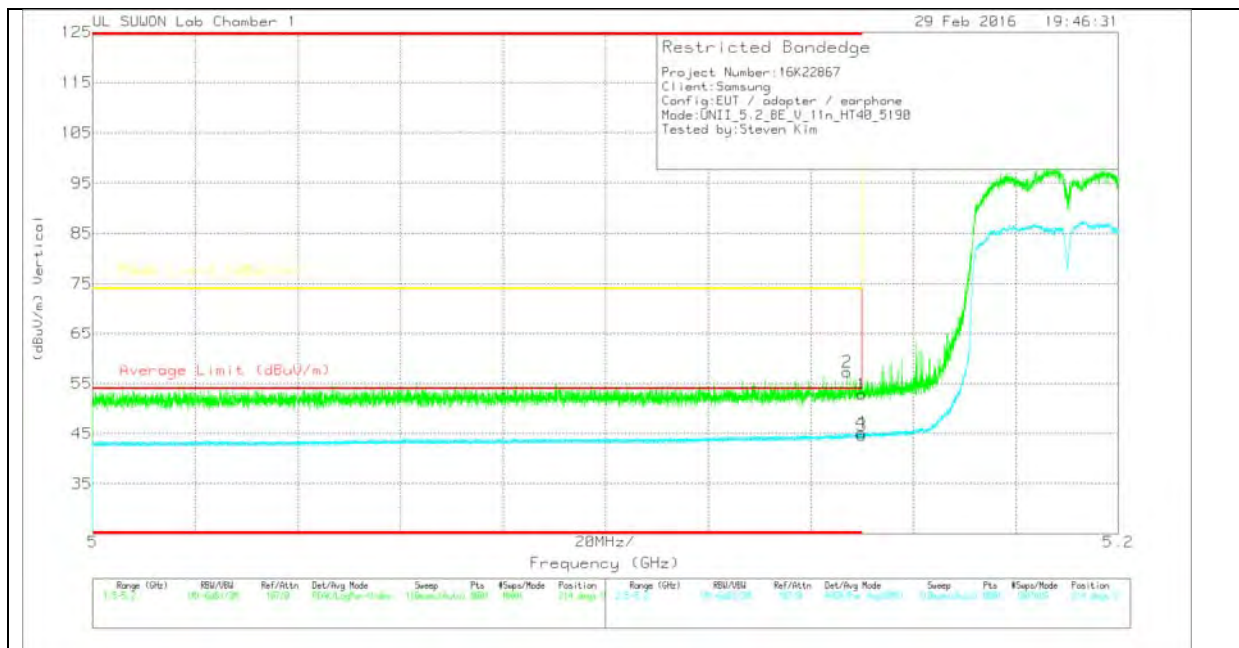

VERTICAL DATA

TRACE MARKERS

| Marker | Frequency (GHz) | Meter Reading (dBuV) | Det | 3117(001687 17_150619) | Path_2 | DC Corr (dB) | Corrected Reading (dBuV/m) | Average Limit (dBuV/m) | Margin (dB) | Peak Limit (dBuV/m) | PK Margin (dB) | Azimuth (Degs) | Height (cm) | Polarity |
|--------|-----------------|----------------------|-----|------------------------|--------|--------------|----------------------------|------------------------|-------------|---------------------|----------------|----------------|-------------|----------|
| 1 | * 5.15 | 42.75 | Pk | 34.2 | -24.1 | 0 | 52.85 | - | - | 74 | -21.15 | 214 | 112 | V |
| 2 | * 5.147 | 47.19 | Pk | 34.2 | -24.1 | 0 | 57.29 | - | - | 74 | -16.71 | 214 | 112 | V |
| 3 | * 5.15 | 34.01 | RMS | 34.2 | -24.1 | .59 | 44.7 | 54 | -9.3 | - | - | 214 | 112 | V |
| 4 | * 5.15 | 34.51 | RMS | 34.2 | -24.1 | .59 | 45.2 | 54 | -8.8 | - | - | 214 | 112 | V |

* - indicates frequency in CFR15.205/IC7.2.2 Restricted Band

Pk - Peak detector

RMS - RMS detection

HARMONICS AND SPURIOUS EMISSIONS

LOW CHANNEL HORIZONTAL

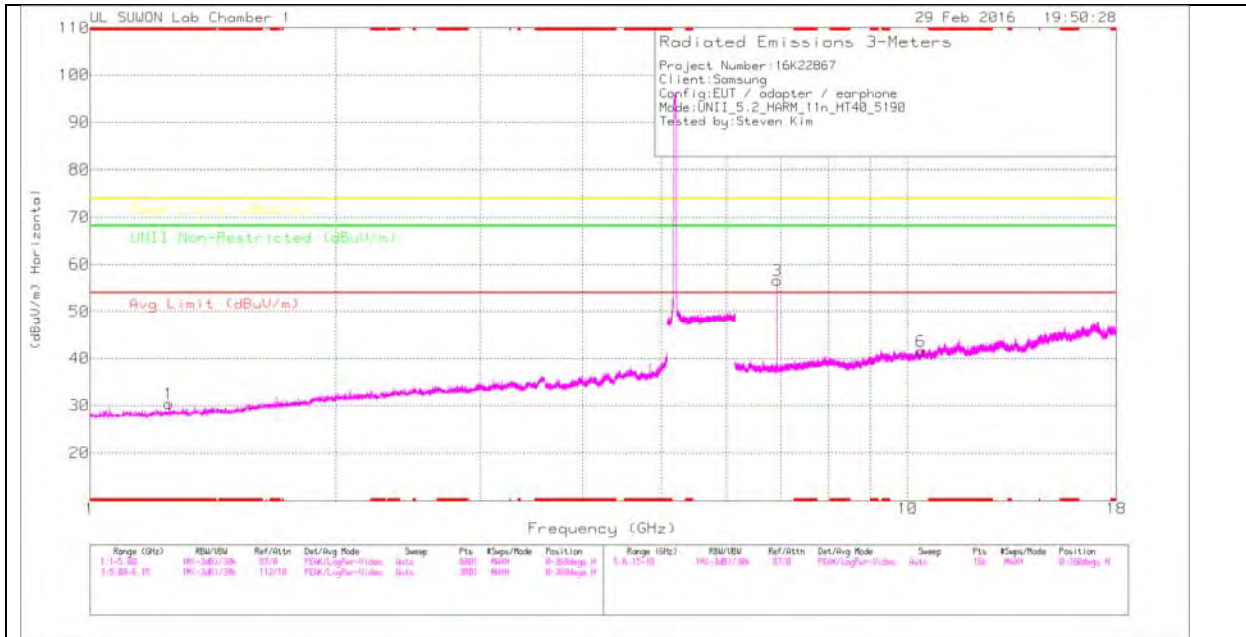

LOW CHANNEL VERTICAL

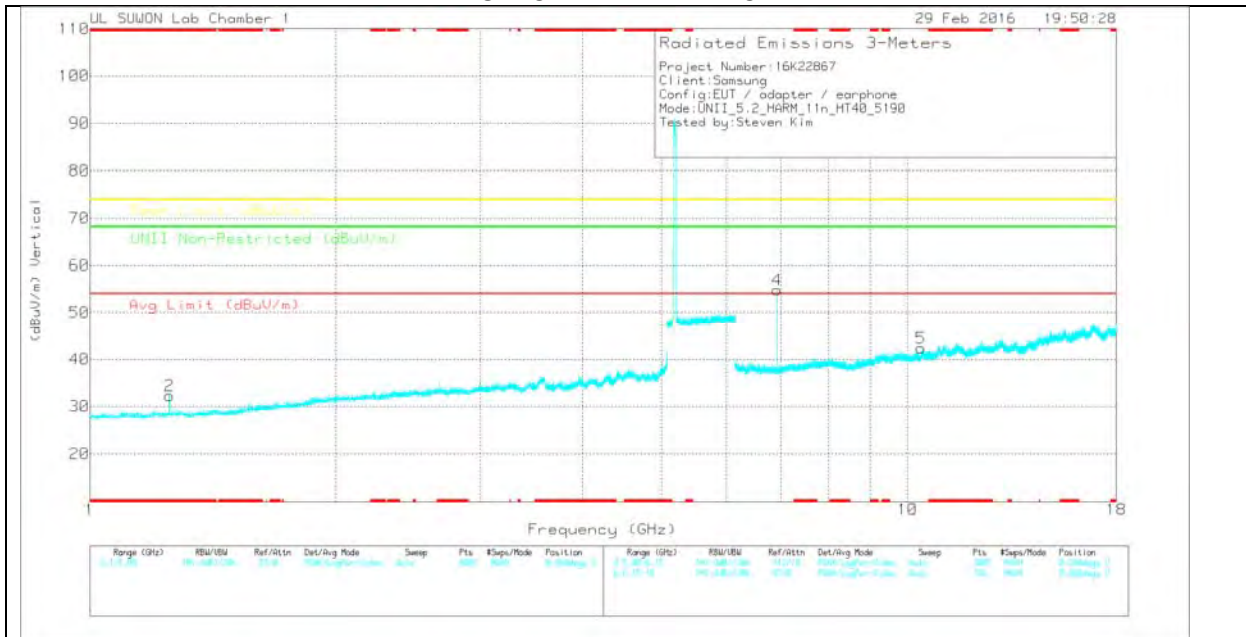

Note: Emission was scanned up to 40GHz; No emissions were detected above the noise floor which was at least 20dB below the specification limit.

LOW CHANNEL DATA

TRACE MARKERS

| Marker | Frequency (GHz) | Meter Reading (dBuV) | Det | 3117(0016 8717)_150 619 | Path_4 | DC Corr (dB) | Corrected Reading (dBuV/m) | Avg Limit (dBuV/m) | Margin (dB) | Peak Limit (dBuV/m) | Margin (dB) | UNII Non-Restricted (dBuV/m) | Margin (dB) | Azimuth (Degs) | Height (cm) | Polarity |
|--------|-----------------|----------------------|-----|-------------------------|--------|--------------|----------------------------|--------------------|-------------|---------------------|-------------|------------------------------|-------------|----------------|-------------|----------|
| 1 | * 1.25 | 42.25 | PK | 28.3 | -40.2 | 0 | 30.35 | - | - | 74 | -43.65 | - | - | 0-360 | 200 | H |
| 2 | * 1.25 | 44.2 | PK | 28.3 | -40.2 | 0 | 32.3 | - | - | 74 | -41.7 | - | - | 0-360 | 200 | V |
| 3 | 6.919 | 51.66 | PK | 35.7 | -30.7 | 0 | 56.66 | - | - | - | - | 68.2 | -11.54 | 0-360 | 100 | H |
| 6 | 10.38 | 30.64 | PK | 37.8 | -27 | 0 | 41.44 | - | - | - | - | 68.2 | -26.76 | 0-360 | 100 | H |
| 4 | 6.919 | 49.77 | PK | 35.7 | -30.7 | 0 | 54.77 | - | - | - | - | 68.2 | -13.43 | 0-360 | 100 | V |
| 5 | 10.38 | 31.63 | PK | 37.8 | -27 | 0 | 42.43 | - | - | - | - | 68.2 | -25.77 | 0-360 | 100 | V |

* - indicates frequency in CFR15.205/IC7.2.2 Restricted Band

PK – Peak detector

Radiated Emissions

| Frequency (GHz) | Meter Reading (dBuV) | Det | 3117(0016871 7)_150619 | Path_5 | DC Corr (dB) | Corrected Reading (dBuV/m) | Avg Limit (dBuV/m) | Margin (dB) | Peak Limit (dBuV/m) | Margin (dB) | UNII Non-Restricted (dBuV/m) | Margin (dB) | Azimuth (Degs) | Height (cm) | Polarity |
|-----------------|----------------------|------|------------------------|--------|--------------|----------------------------|--------------------|-------------|---------------------|-------------|------------------------------|-------------|----------------|-------------|----------|
| 6.92 | 53.71 | PK-U | 35.7 | -30.7 | 0 | 58.71 | - | - | - | - | 68.2 | -9.49 | 111 | 140 | H |
| 6.92 | 52.29 | PK-U | 35.7 | -30.7 | 0 | 57.29 | - | - | - | - | 68.2 | -10.91 | 143 | 142 | V |

* - indicates frequency in CFR15.205/IC7.2.2 Restricted Band

PK-U - U-NII: Maximum Peak

HIGH CHANNEL HORIZONTAL

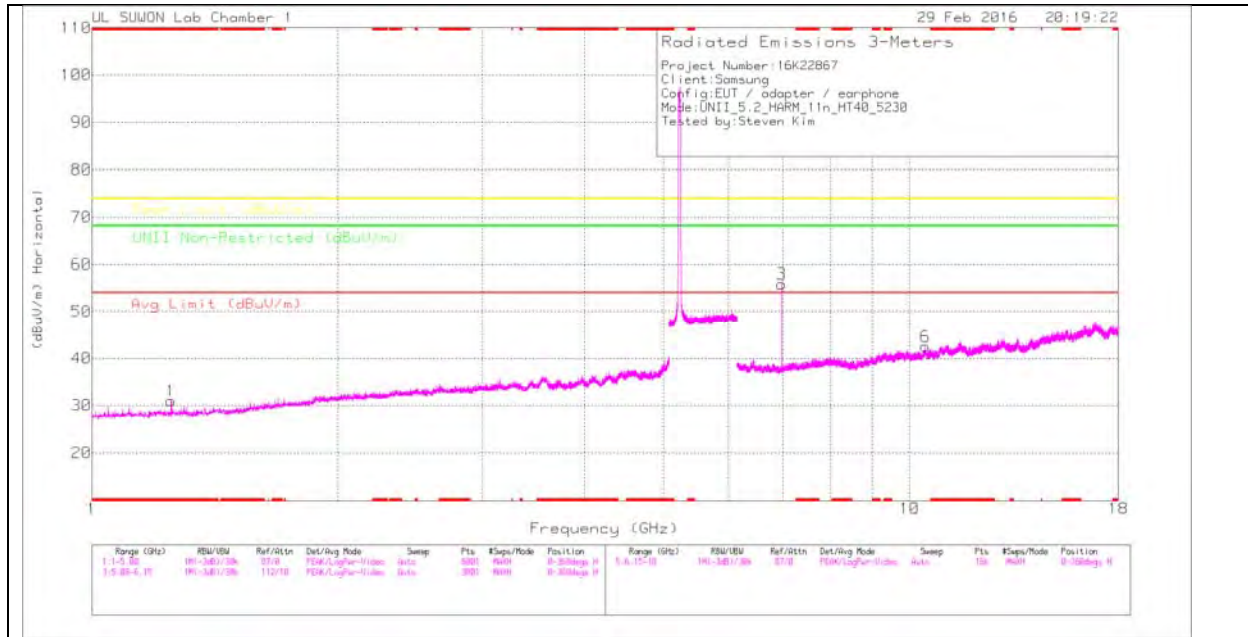

HIGH CHANNEL VERTICAL

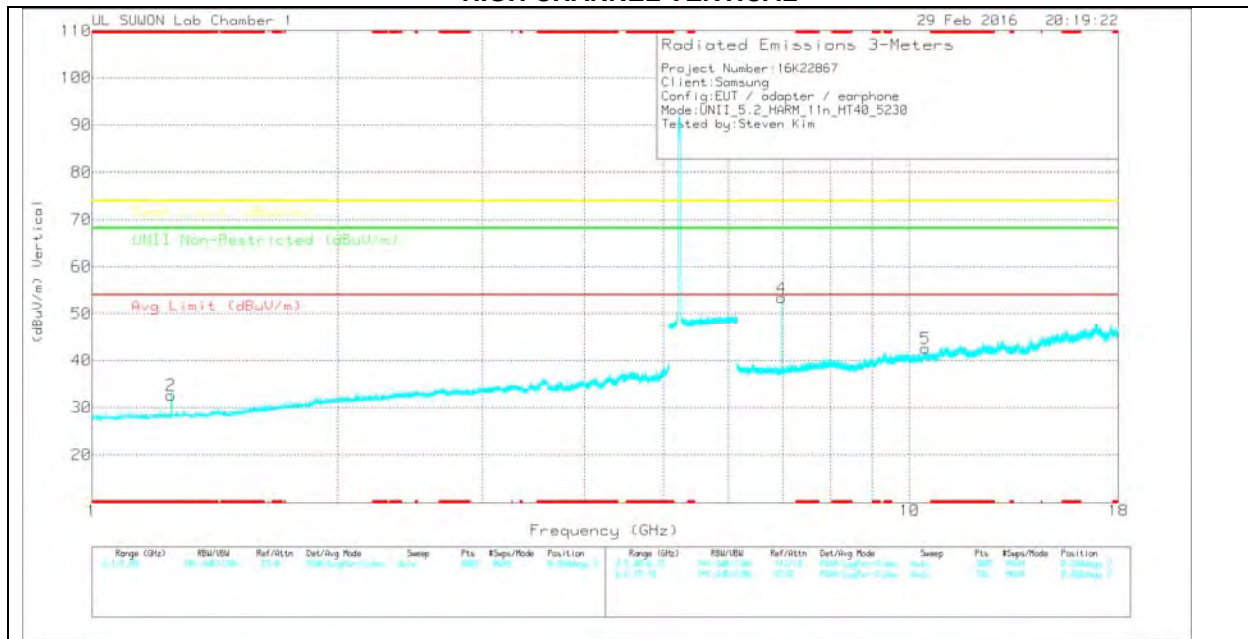

Note: Emission was scanned up to 40GHz; No emissions were detected above the noise floor which was at least 20dB below the specification limit.

HIGH CHANNEL DATA

TRACE MARKERS

| Marker | Frequency (GHz) | Meter Reading (dBuV) | Det | 3117(0016 8717)_150 619 | Path_4 | DC Corr (dB) | Corrected Reading (dBuV/m) | Avg Limit (dBuV/m) | Margin (dB) | Peak Limit (dBuV/m) | Margin (dB) | UNII Non-Restricted (dBuV/m) | Margin (dB) | Azimuth (Degs) | Height (cm) | Polarity |
|--------|-----------------|----------------------|-----|-------------------------|--------|--------------|----------------------------|--------------------|-------------|---------------------|-------------|------------------------------|-------------|----------------|-------------|----------|
| 1 | * 1.25 | 42.97 | PK | 28.3 | -40.2 | 0 | 31.07 | - | - | 74 | -42.93 | - | - | 0-360 | 200 | H |
| 2 | * 1.25 | 44.53 | PK | 28.3 | -40.2 | 0 | 32.63 | - | - | 74 | -41.37 | - | - | 0-360 | 200 | V |
| 3 | 6.973 | 50.71 | PK | 35.7 | -30.5 | 0 | 55.91 | - | - | - | - | 68.2 | -12.29 | 0-360 | 100 | H |
| 6 | 10.46 | 32.22 | PK | 37.8 | -27.5 | 0 | 42.52 | - | - | - | - | 68.2 | -25.68 | 0-360 | 100 | H |
| 4 | 6.973 | 48.2 | PK | 35.7 | -30.5 | 0 | 53.4 | - | - | - | - | 68.2 | -14.8 | 0-360 | 200 | V |
| 5 | 10.459 | 32.19 | PK | 37.8 | -27.5 | 0 | 42.49 | - | - | - | - | 68.2 | -25.71 | 0-360 | 100 | V |

* - indicates frequency in CFR15.205/IC7.2.2 Restricted Band

PK – Peak detector

Radiated Emissions

| Frequency (GHz) | Meter Reading (dBuV) | Det | 3117(001687 17)_150619 | Path_5 | DC Corr (dB) | Corrected Reading (dBuV/m) | Avg Limit (dBuV/m) | Margin (dB) | Peak Limit (dBuV/m) | Margin (dB) | UNII Non-Restricted (dBuV/m) | Margin (dB) | Azimuth (Degs) | Height (cm) | Polarity |
|-----------------|----------------------|------|------------------------|--------|--------------|----------------------------|--------------------|-------------|---------------------|-------------|------------------------------|-------------|----------------|-------------|----------|
| 6.973 | 52.53 | PK-U | 35.7 | -30.5 | 0 | 57.73 | - | - | - | - | 68.2 | -10.47 | 107 | 138 | H |
| 6.973 | 51.28 | PK-U | 35.7 | -30.5 | 0 | 56.48 | - | - | - | - | 68.2 | -11.72 | 146 | 140 | V |

* - indicates frequency in CFR15.205/IC7.2.2 Restricted Band

PK-U - U-NII: Maximum Peak

**11.1.4. TX ABOVE 1GHz 802.11ac HT80 2TX CDD MODE IN THE 5.2GHz BAND
 RESTRICTED BANDEDGE (LOW CHANNEL)**

HORIZONTAL PEAK AND AVERAGE PLOT

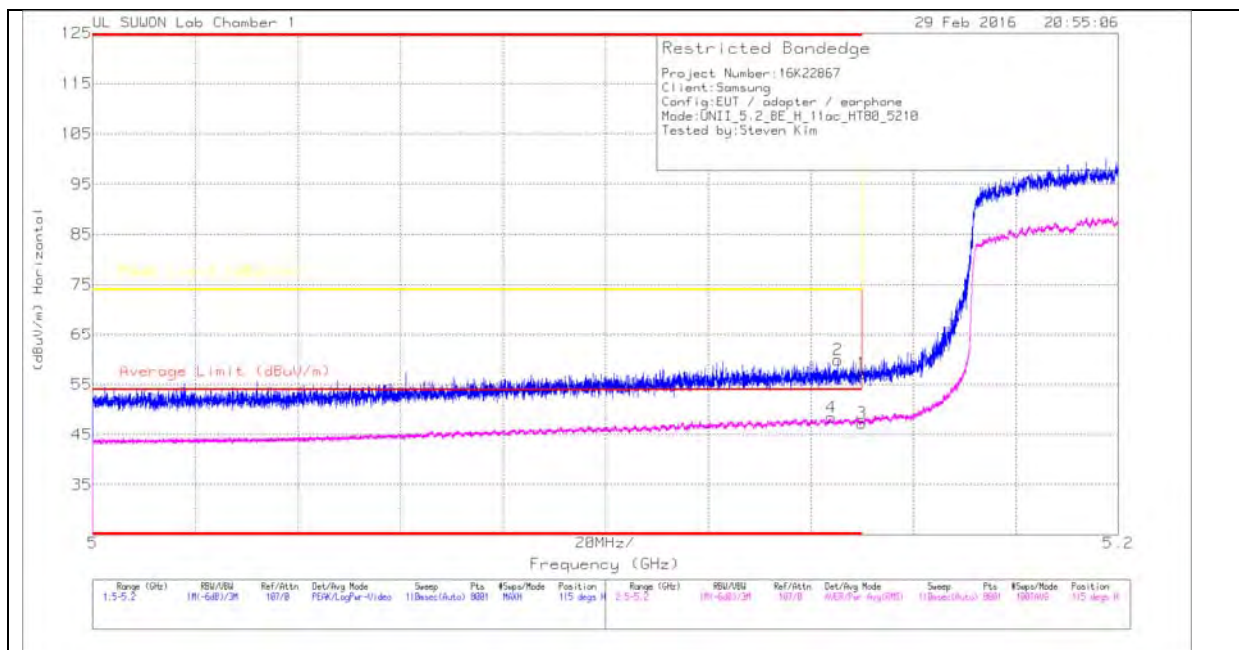

HORIZONTAL DATA

TRACE MARKERS

| Marker | Frequency (GHz) | Meter Reading (dBuV) | Det | 3117/001687 17_150619 | Path_2 | DC Corr (dB) | Corrected Reading (dBuV/m) | Average Limit (dBuV/m) | Margin (dB) | Peak Limit (dBuV/m) | PK Margin (dB) | Azimuth (Degs) | Height (cm) | Polarity |
|--------|-----------------|----------------------|-----|--------------------------|--------|--------------|----------------------------|------------------------|-------------|---------------------|----------------|----------------|-------------|----------|
| 1 | * 5.15 | 47.07 | Pk | 34.2 | -24.1 | 0 | 57.17 | - | - | 74 | -16.83 | 115 | 160 | H |
| 2 | * 5.145 | 49.79 | Pk | 34.2 | -24.1 | 0 | 59.89 | - | - | 74 | -14.11 | 115 | 160 | H |
| 3 | * 5.15 | 36.08 | RMS | 34.2 | -24.1 | 1.11 | 47.29 | 54 | -6.71 | - | - | 115 | 160 | H |
| 4 | * 5.144 | 37.22 | RMS | 34.2 | -24.1 | 1.11 | 48.43 | 54 | -5.57 | - | - | 115 | 160 | H |

* - indicates frequency in CFR15.205/IC7.2.2 Restricted Band

Pk - Peak detector

RMS - RMS detection

VERTICAL PEAK AND AVERAGE PLOT

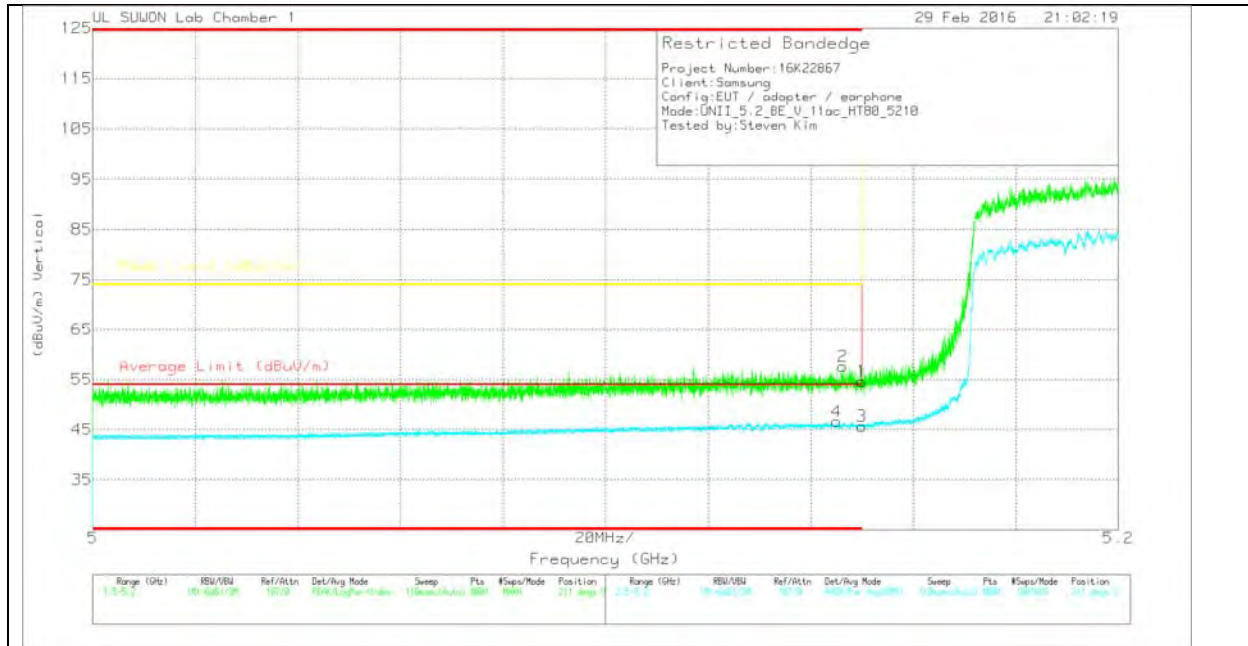

VERTICAL DATA

TRACE MARKERS

| Marker | Frequency (GHz) | Meter Reading (dBuV) | Det | 3117(001687 17_150619) | Path_2 | DC Corr (dB) | Corrected Reading (dBuV/m) | Average Limit (dBuV/m) | Margin (dB) | Peak Limit (dBuV/m) | PK Margin (dB) | Azimuth (Degs) | Height (cm) | Polarity |
|--------|-----------------|----------------------|-----|------------------------|--------|--------------|----------------------------|------------------------|-------------|---------------------|----------------|----------------|-------------|----------|
| 1 | * 5.15 | 44.53 | PK | 34.2 | -24.1 | 0 | 54.63 | - | - | 74 | -19.37 | 211 | 153 | V |
| 2 | * 5.146 | 47.54 | PK | 34.2 | -24.1 | 0 | 57.64 | - | - | 74 | -16.36 | 211 | 153 | V |
| 3 | * 5.15 | 34.47 | RMS | 34.2 | -24.1 | 1.11 | 45.68 | 54 | -8.32 | - | - | 211 | 153 | V |
| 4 | * 5.145 | 35.4 | RMS | 34.2 | -24.1 | 1.11 | 46.61 | 54 | -7.39 | - | - | 211 | 153 | V |

* - indicates frequency in CFR15.205/IC7.2.2 Restricted Band

Pk - Peak detector

RMS - RMS detection

HARMONICS AND SPURIOUS EMISSIONS

MID CHANNEL HORIZONTAL

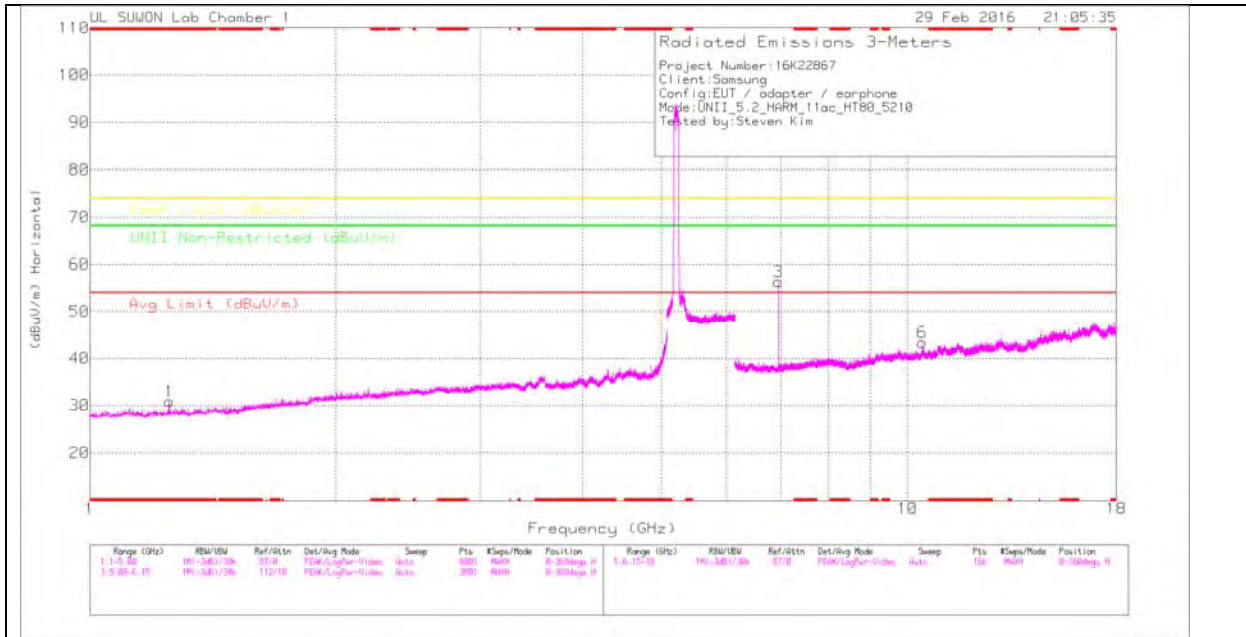

MID CHANNEL VERTICAL

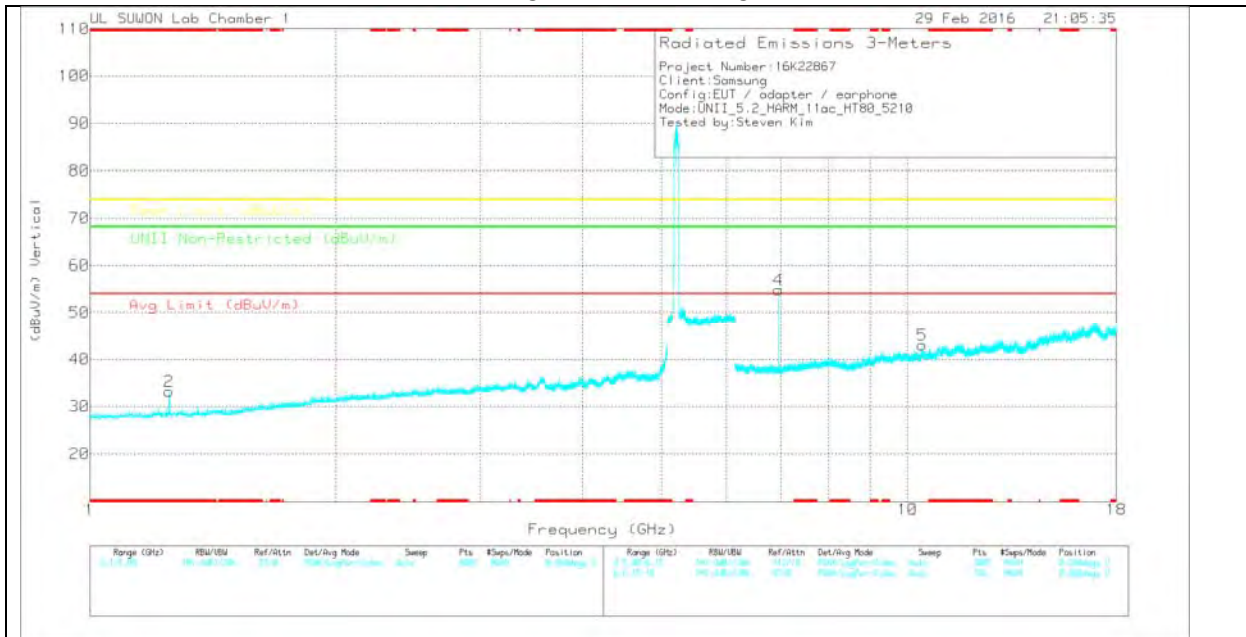

Note: Emission was scanned up to 40GHz; No emissions were detected above the noise floor which was at least 20dB below the specification limit.

MID CHANNEL DATA

TRACE MARKERS

| Marker | Frequency (GHz) | Meter Reading (dBuV) | Det | 3117(0016 8717)_150 619 | Path_4 | DC Corr (dB) | Corrected Reading (dBuV/m) | Avg Limit (dBuV/m) | Margin (dB) | Peak Limit (dBuV/m) | Margin (dB) | UNII Non-Restricted (dBuV/m) | Margin (dB) | Azimuth (Degs) | Height (cm) | Polarity |
|--------|-----------------|----------------------|-----|-------------------------|--------|--------------|----------------------------|--------------------|-------------|---------------------|-------------|------------------------------|-------------|----------------|-------------|----------|
| 1 | * 1.25 | 42.74 | PK | 28.3 | -40.2 | 0 | 30.84 | - | - | 74 | -43.16 | - | - | 0-360 | 200 | H |
| 2 | * 1.25 | 45.06 | PK | 28.3 | -40.2 | 0 | 33.16 | - | - | 74 | -40.84 | - | - | 0-360 | 200 | V |
| 3 | 6.946 | 51.28 | PK | 35.7 | -30.6 | 0 | 56.38 | - | - | - | - | 68.2 | -11.82 | 0-360 | 100 | H |
| 6 | 10.42 | 32.27 | PK | 37.8 | -26.7 | 0 | 43.37 | - | - | - | - | 68.2 | -24.83 | 0-360 | 200 | H |
| 4 | 6.946 | 49.72 | PK | 35.7 | -30.6 | 0 | 54.82 | - | - | - | - | 68.2 | -13.38 | 0-360 | 100 | V |
| 5 | 10.419 | 31.98 | PK | 37.8 | -26.7 | 0 | 43.08 | - | - | - | - | 68.2 | -25.12 | 0-360 | 100 | V |

* - indicates frequency in CFR15.205/IC7.2.2 Restricted Band

PK – Peak detector

Radiated Emissions

| Frequency (GHz) | Meter Reading (dBuV) | Det | 3117(001687 17)_150619 | Path_5 | DC Corr (dB) | Corrected Reading (dBuV/m) | Avg Limit (dBuV/m) | Margin (dB) | Peak Limit (dBuV/m) | Margin (dB) | UNII Non-Restricted (dBuV/m) | Margin (dB) | Azimuth (Degs) | Height (cm) | Polarity |
|-----------------|----------------------|------|------------------------|--------|--------------|----------------------------|--------------------|-------------|---------------------|-------------|------------------------------|-------------|----------------|-------------|----------|
| 6.947 | 53.03 | PK-U | 35.7 | -30.6 | 0 | 58.13 | - | - | - | - | 68.2 | -10.07 | 115 | 141 | H |
| 6.947 | 52.42 | PK-U | 35.7 | -30.6 | 0 | 57.52 | - | - | - | - | 68.2 | -10.68 | 146 | 139 | V |

* - indicates frequency in CFR15.205/IC7.2.2 Restricted Band

PK-U - U-NII: Maximum Peak

11.2. 5.3 GHz

11.2.1. TX ABOVE 1 GHz 802.11a 2TX CDD MODE IN THE 5.3 GHz BAND AUTHORIZED BANDEDGE (HIGH CHANNEL)

HORIZONTAL PEAK AND AVERAGE PLOT

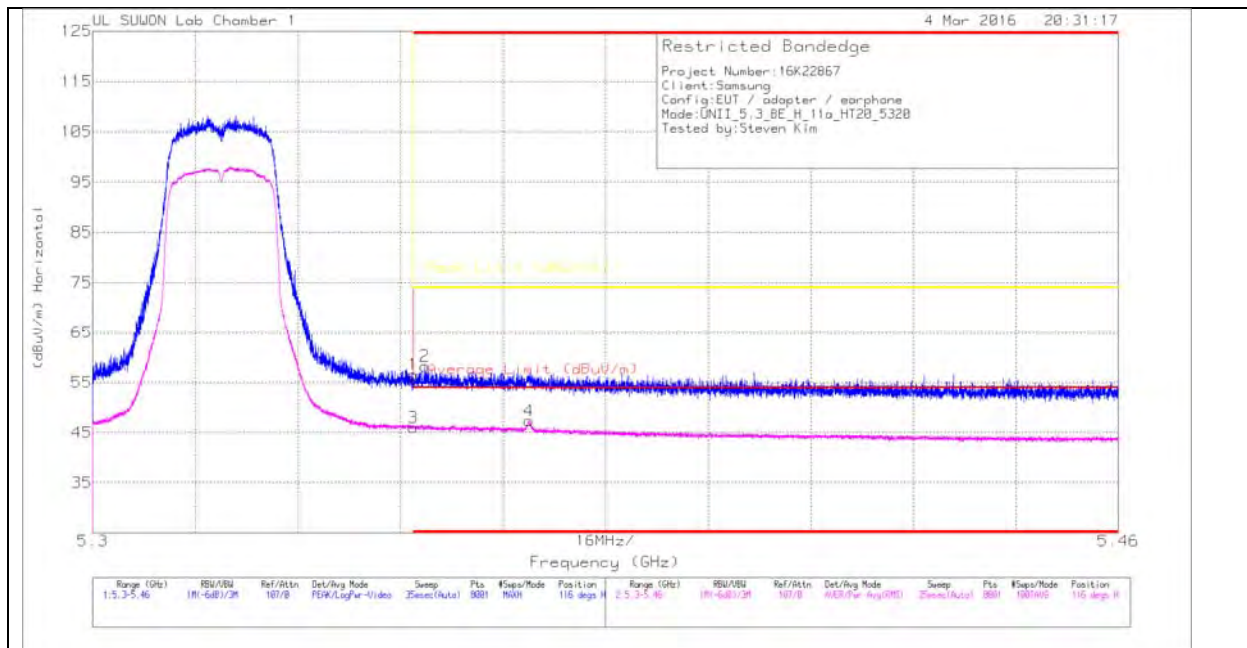

HORIZONTAL DATA

TRACE MARKERS

| Marker | Frequency (GHz) | Meter Reading (dBuV) | Det | 3117(001687 17)_150619 | Path_2 | DC Corr (dB) | Corrected Reading (dBuV/m) | Average Limit (dBuV/m) | Margin (dB) | Peak Limit (dBuV/m) | PK Margin (dB) | Azimuth (Degs) | Height (cm) | Polarity |
|--------|-----------------|----------------------|-----|------------------------|--------|--------------|----------------------------|------------------------|-------------|---------------------|----------------|----------------|-------------|----------|
| 1 | * 5.35 | 45.38 | Pk | 34.5 | -23.3 | 0 | 56.58 | - | - | 74 | -17.42 | 116 | 198 | H |
| 2 | * 5.352 | 47.07 | Pk | 34.5 | -23.3 | 0 | 58.27 | - | - | 74 | -15.73 | 116 | 198 | H |
| 3 | * 5.35 | 34.54 | RMS | 34.5 | -23.3 | .29 | 46.03 | 54 | -7.97 | - | - | 116 | 198 | H |
| 4 | * 5.368 | 35.87 | RMS | 34.5 | -23.3 | .29 | 47.36 | 54 | -6.64 | - | - | 116 | 198 | H |

* - indicates frequency in CFR15.205/IC7.2.2 Restricted Band

Pk - Peak detector

RMS - RMS detection

VERTICAL PEAK AND AVERAGE PLOT

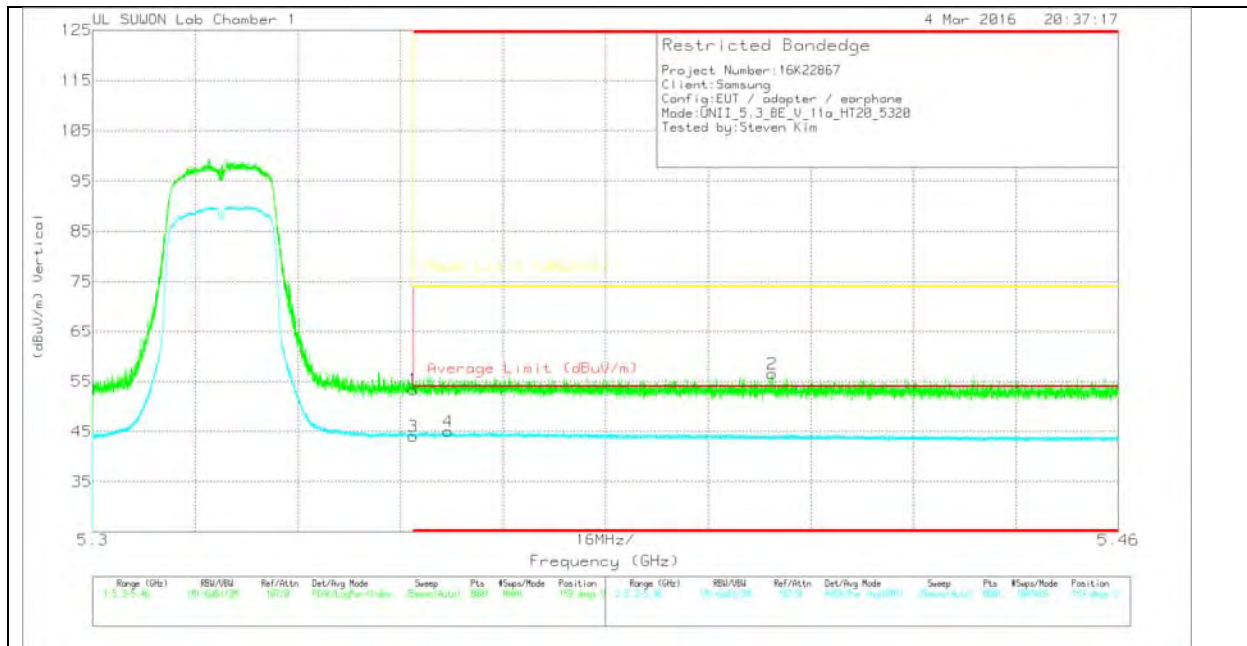

VERTICAL DATA

TRACE MARKERS

| Marker | Frequency (GHz) | Meter Reading (dBuV) | Det | 3117(001687 17_150619) | Path_2 | DC Corr (dB) | Corrected Reading (dBuV/m) | Average Limit (dBuV/m) | Margin (dB) | Peak Limit (dBuV/m) | PK Margin (dB) | Azimuth (Degs) | Height (cm) | Polarity |
|--------|-----------------|----------------------|-----|------------------------|--------|--------------|----------------------------|------------------------|-------------|---------------------|----------------|----------------|-------------|----------|
| 1 | * 5.35 | 42.18 | PK | 34.5 | -23.3 | 0 | 53.38 | - | - | 74 | -20.62 | 159 | 252 | V |
| 2 | * 5.406 | 45.23 | PK | 34.6 | -23.3 | 0 | 56.53 | - | - | 74 | -17.47 | 159 | 252 | V |
| 3 | * 5.35 | 32.54 | RMS | 34.5 | -23.3 | .29 | 44.03 | 54 | -9.97 | - | - | 159 | 252 | V |
| 4 | * 5.355 | 33.57 | RMS | 34.5 | -23.3 | .29 | 45.06 | 54 | -8.94 | - | - | 159 | 252 | V |

* - indicates frequency in CFR15.205/IC7.2.2 Restricted Band

PK - Peak detector

RMS - RMS detection

HARMONICS AND SPURIOUS EMISSIONS

LOW CHANNEL HORIZONTAL

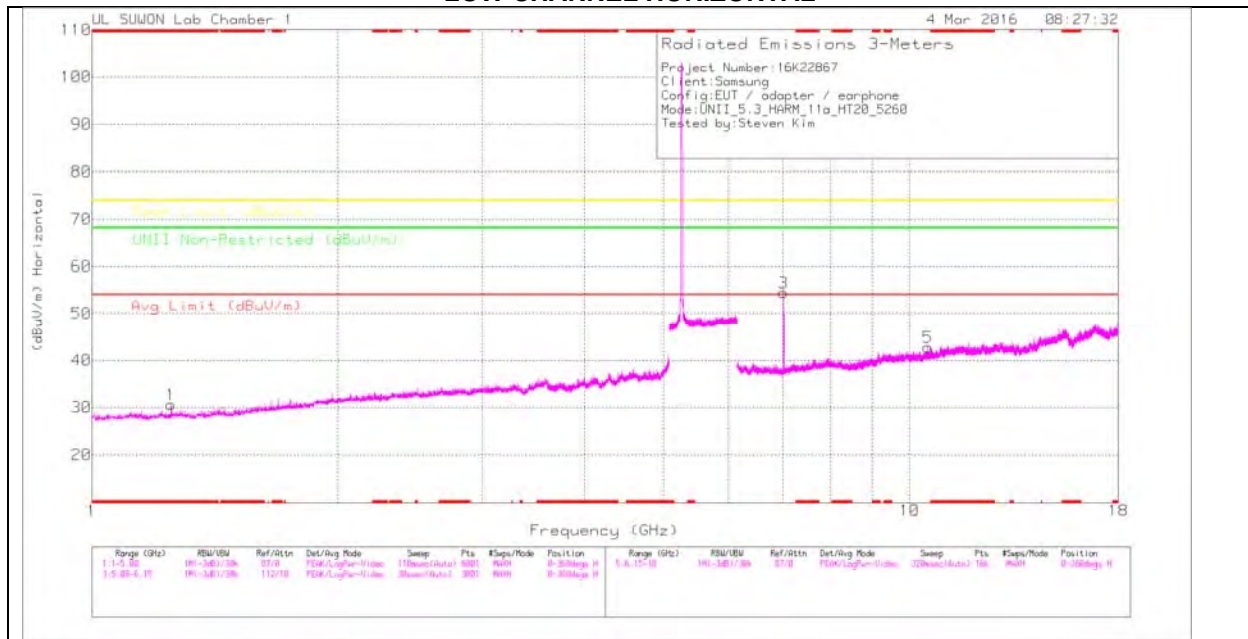

LOW CHANNEL VERTICAL

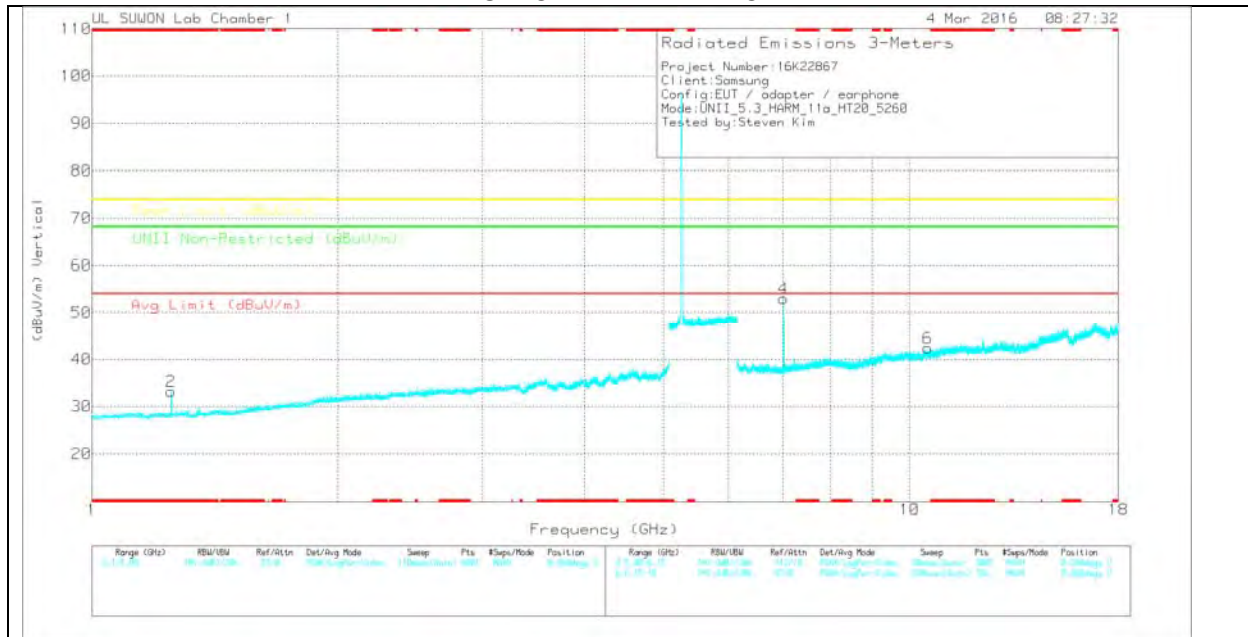

Note: Emission was scanned up to 40GHz; No emissions were detected above the noise floor which was at least 20dB below the specification limit.

LOW CHANNEL DATA

TRACE MARKERS

| Marker | Frequency (GHz) | Meter Reading (dBuV) | Det | 3117(0016 8717)_150 619 | Path_4 | DC Corr (dB) | Corrected Reading (dBuV/m) | Avg Limit (dBuV/m) | Margin (dB) | Peak Limit (dBuV/m) | Margin (dB) | UNII Non-Restricted (dBuV/m) | Margin (dB) | Azimuth (Degs) | Height (cm) | Polarity |
|--------|-----------------|----------------------|-----|-------------------------|--------|--------------|----------------------------|--------------------|-------------|---------------------|-------------|------------------------------|-------------|----------------|-------------|----------|
| 1 | * 1.25 | 42.53 | PK | 28.3 | -40.2 | 0 | 30.63 | - | - | 74 | -43.37 | - | - | 0-360 | 200 | H |
| 2 | * 1.25 | 45.08 | PK | 28.3 | -40.2 | 0 | 33.18 | - | - | 74 | -40.82 | - | - | 0-360 | 200 | V |
| 3 | 7.013 | 49.35 | PK | 35.7 | -30.6 | 0 | 54.45 | - | - | - | - | 68.2 | -13.75 | 0-360 | 100 | H |
| 5 | 10.52 | 32.07 | PK | 37.9 | -27.2 | 0 | 42.77 | - | - | - | - | 68.2 | -25.43 | 0-360 | 100 | H |
| 4 | 7.013 | 47.87 | PK | 35.7 | -30.6 | 0 | 52.97 | - | - | - | - | 68.2 | -15.23 | 0-360 | 100 | V |
| 6 | 10.52 | 31.73 | PK | 37.9 | -27.2 | 0 | 42.43 | - | - | - | - | 68.2 | -25.77 | 0-360 | 100 | V |

* - indicates frequency in CFR15.205/IC7.2.2 Restricted Band

PK – Peak detector

Radiated Emissions

| Frequency (GHz) | Meter Reading (dBuV) | Det | 3117(001687 17)_150619 | Path_5 | DC Corr (dB) | Corrected Reading (dBuV/m) | Avg Limit (dBuV/m) | Margin (dB) | Peak Limit (dBuV/m) | Margin (dB) | UNII Non-Restricted (dBuV/m) | Margin (dB) | Azimuth (Degs) | Height (cm) | Polarity |
|-----------------|----------------------|------|------------------------|--------|--------------|----------------------------|--------------------|-------------|---------------------|-------------|------------------------------|-------------|----------------|-------------|----------|
| 7.013 | 51.78 | PK-U | 35.7 | -30.6 | 0 | 56.88 | - | - | - | - | 68.2 | -11.32 | 108 | 134 | H |
| 7.013 | 50.58 | PK-U | 35.7 | -30.6 | 0 | 55.68 | - | - | - | - | 68.2 | -12.52 | 141 | 128 | V |

* - indicates frequency in CFR15.205/IC7.2.2 Restricted Band

PK-U - U-NII: Maximum Peak

MID CHANNEL HORIZONTAL

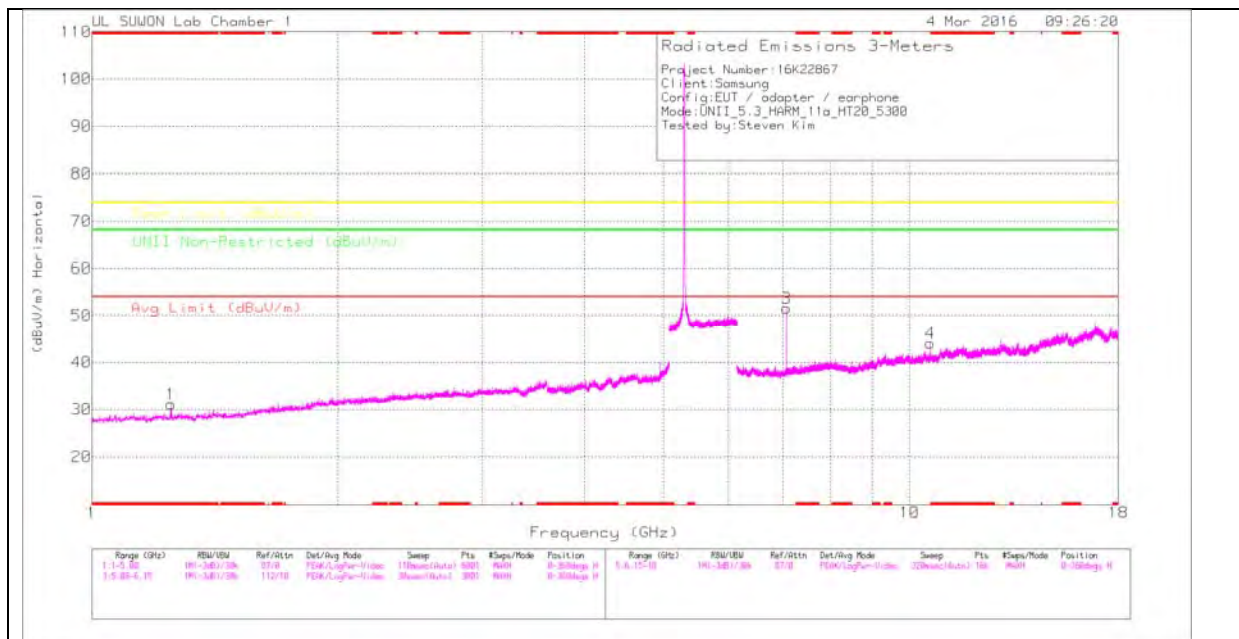

MID CHANNEL VERTICAL

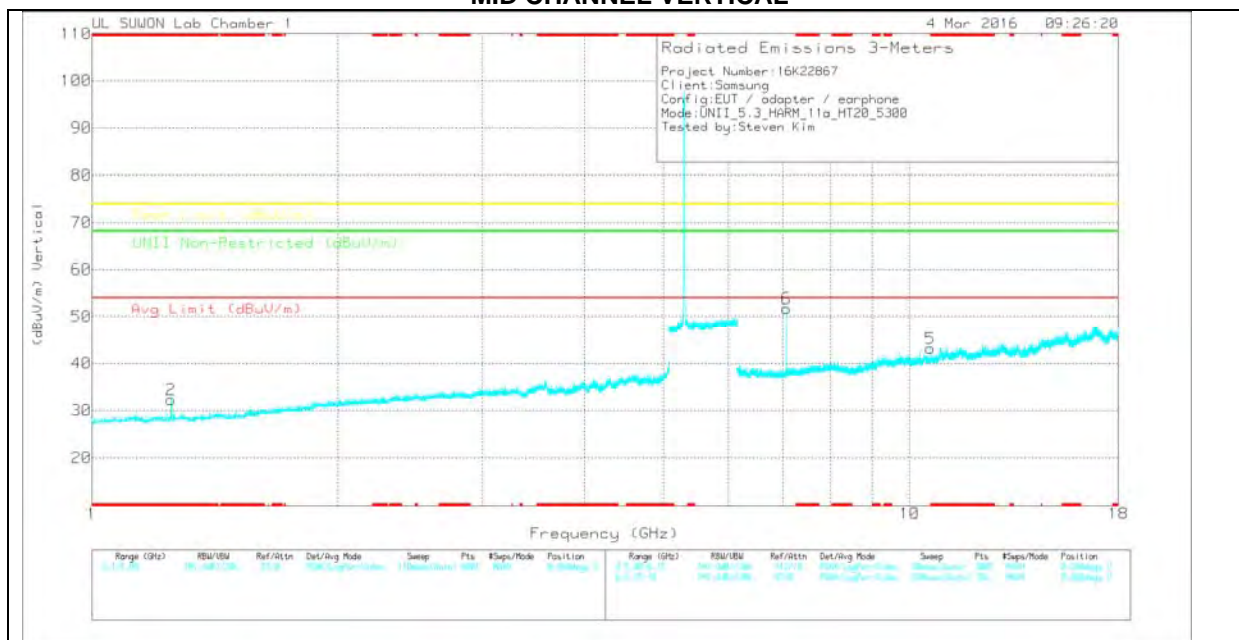

Note: Emission was scanned up to 40GHz; No emissions were detected above the noise floor which was at least 20dB below the specification limit.

MID CHANNEL DATA

TRACE MARKERS

| Marker | Frequency (GHz) | Meter Reading (dBuV) | Det | 3117(0016 8717)_150 619 | Path_4 | DC Corr (dB) | Corrected Reading (dBuV/m) | Avg Limit (dBuV/m) | Margin (dB) | Peak Limit (dBuV/m) | Margin (dB) | UNII Non-Restricted (dBuV/m) | Margin (dB) | Azimuth (Degs) | Height (cm) | Polarity |
|--------|-----------------|----------------------|-----|-------------------------|--------|--------------|----------------------------|--------------------|-------------|---------------------|-------------|------------------------------|-------------|----------------|-------------|----------|
| 1 | * 1.25 | 43.08 | PK | 28.3 | -40.2 | 0 | 31.18 | - | - | 74 | -42.82 | - | - | 0-360 | 200 | H |
| 2 | * 1.25 | 44.18 | PK | 28.3 | -40.2 | 0 | 32.28 | - | - | 74 | -41.72 | - | - | 0-360 | 200 | V |
| 3 | 7.066 | 46.42 | PK | 35.7 | -30.5 | 0 | 51.62 | - | - | - | - | 68.2 | -16.58 | 0-360 | 100 | H |
| 4 | * 10.6 | 33.19 | PK | 37.9 | -27 | 0 | 44.09 | - | - | 74 | -29.91 | - | - | 0-360 | 200 | H |
| 5 | * 10.6 | 32.27 | PK | 37.9 | -27 | 0 | 43.17 | - | - | 74 | -30.83 | - | - | 0-360 | 100 | V |
| 6 | 7.066 | 46.57 | PK | 35.7 | -30.5 | 0 | 51.77 | - | - | - | - | 68.2 | -16.43 | 0-360 | 100 | V |

* - indicates frequency in CFR15.205/IC7.2.2 Restricted Band

PK – Peak detector

Radiated Emissions

| Frequency (GHz) | Meter Reading (dBuV) | Det | 3117(001687 17)_150619 | Path_5 | DC Corr (dB) | Corrected Reading (dBuV/m) | Avg Limit (dBuV/m) | Margin (dB) | Peak Limit (dBuV/m) | Margin (dB) | UNII Non-Restricted (dBuV/m) | Margin (dB) | Azimuth (Degs) | Height (cm) | Polarity |
|-----------------|----------------------|------|------------------------|--------|--------------|----------------------------|--------------------|-------------|---------------------|-------------|------------------------------|-------------|----------------|-------------|----------|
| 7.067 | 51.09 | PK-U | 35.7 | -30.5 | 0 | 56.29 | - | - | - | - | 68.2 | -11.91 | 174 | 123 | H |
| 7.067 | 50.58 | PK-U | 35.7 | -30.5 | 0 | 55.78 | - | - | - | - | 68.2 | -12.42 | 190 | 103 | V |

* - indicates frequency in CFR15.205/IC7.2.2 Restricted Band

PK-U - U-NII: Maximum Peak

HIGH CHANNEL HORIZONTAL

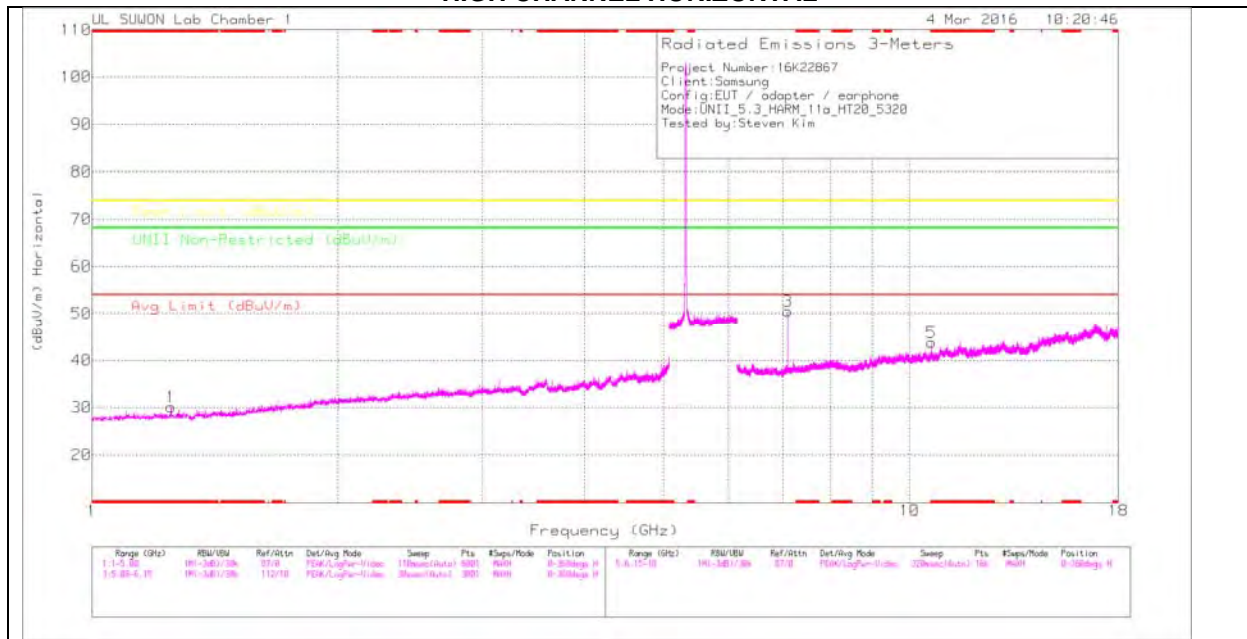

HIGH CHANNEL VERTICAL

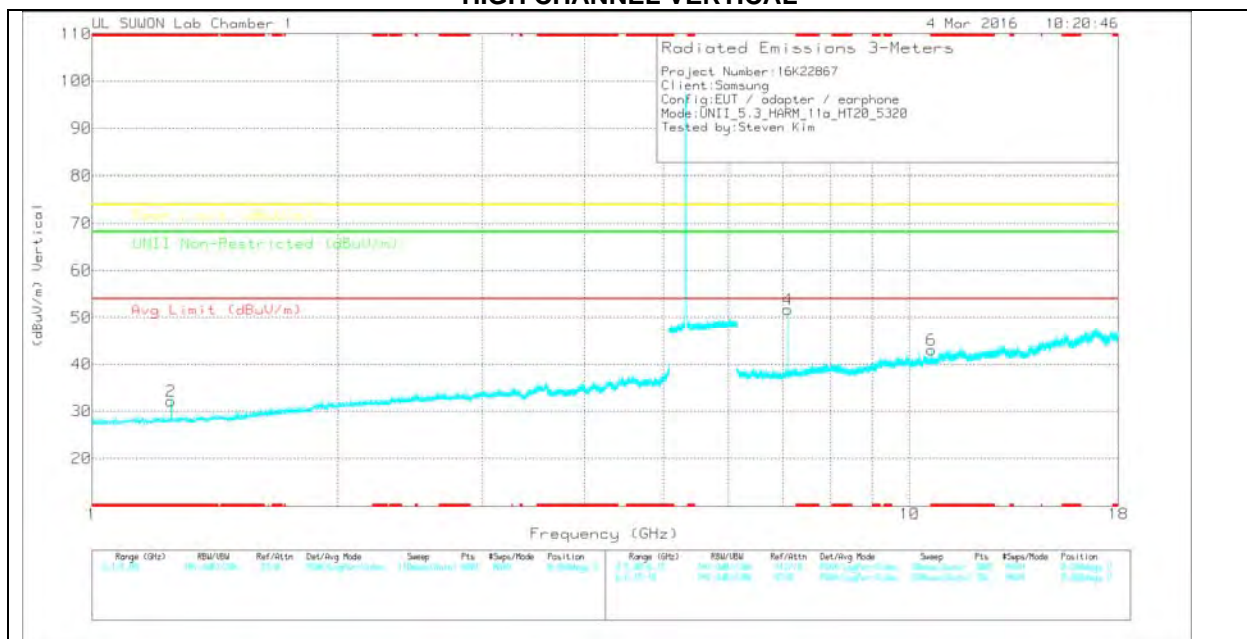

Note: Emission was scanned up to 40GHz; No emissions were detected above the noise floor which was at least 20dB below the specification limit.

HIGH CHANNEL DATA

TRACE MARKERS

| Marker | Frequency (GHz) | Meter Reading (dBuV) | Det | 3117(0016 8717)_150 619 | Path_4 | DC Corr (dB) | Corrected Reading (dBuV/m) | Avg Limit (dBuV/m) | Margin (dB) | Peak Limit (dBuV/m) | Margin (dB) | UNII Non-Restricted (dBuV/m) | Margin (dB) | Azimuth (Degs) | Height (cm) | Polarity |
|--------|-----------------|----------------------|-----|-------------------------|--------|--------------|----------------------------|--------------------|-------------|---------------------|-------------|------------------------------|-------------|----------------|-------------|----------|
| 1 | * 1.25 | 42.01 | PK | 28.3 | -40.2 | 0 | 30.11 | - | - | 74 | -43.89 | - | - | 0-360 | 200 | H |
| 2 | * 1.25 | 44.12 | PK | 28.3 | -40.2 | 0 | 32.22 | - | - | 74 | -41.78 | - | - | 0-360 | 200 | V |
| 3 | 7.093 | 45.36 | PK | 35.7 | -30.5 | 0 | 50.56 | - | - | - | - | 68.2 | -17.64 | 0-360 | 100 | H |
| 5 | * 10.64 | 33.56 | PK | 37.9 | -27.6 | 0 | 43.86 | - | - | 74 | -30.14 | - | - | 0-360 | 100 | H |
| 4 | 7.093 | 46.53 | PK | 35.7 | -30.5 | 0 | 51.73 | - | - | - | - | 68.2 | -16.47 | 0-360 | 100 | V |
| 6 | * 10.64 | 32.7 | PK | 37.9 | -27.6 | 0 | 43 | - | - | 74 | -31 | - | - | 0-360 | 200 | V |

* - indicates frequency in CFR15.205/IC7.2.2 Restricted Band

PK – Peak detector

Radiated Emissions

| Frequency (GHz) | Meter Reading (dBuV) | Det | 3117(001687 17)_150619 | Path_5 | DC Corr (dB) | Corrected Reading (dBuV/m) | Avg Limit (dBuV/m) | Margin (dB) | Peak Limit (dBuV/m) | Margin (dB) | UNII Non-Restricted (dBuV/m) | Margin (dB) | Azimuth (Degs) | Height (cm) | Polarity |
|-----------------|----------------------|------|------------------------|--------|--------------|----------------------------|--------------------|-------------|---------------------|-------------|------------------------------|-------------|----------------|-------------|----------|
| 7.093 | 50.94 | PK-U | 35.7 | -30.5 | 0 | 56.14 | - | - | - | - | 68.2 | -12.06 | 175 | 122 | H |
| 7.093 | 50.75 | PK-U | 35.7 | -30.5 | 0 | 55.95 | - | - | - | - | 68.2 | -12.25 | 188 | 320 | V |

* - indicates frequency in CFR15.205/IC7.2.2 Restricted Band

PK-U - U-NII: Maximum Peak

11.2.2. TX ABOVE 1GHz 802.11n HT20 2TX CDD MODE IN THE 5.3GHz BAND

AUTHORIZED BANDEDGE (HIGH CHANNEL)

HORIZONTAL PEAK AND AVERAGE PLOT

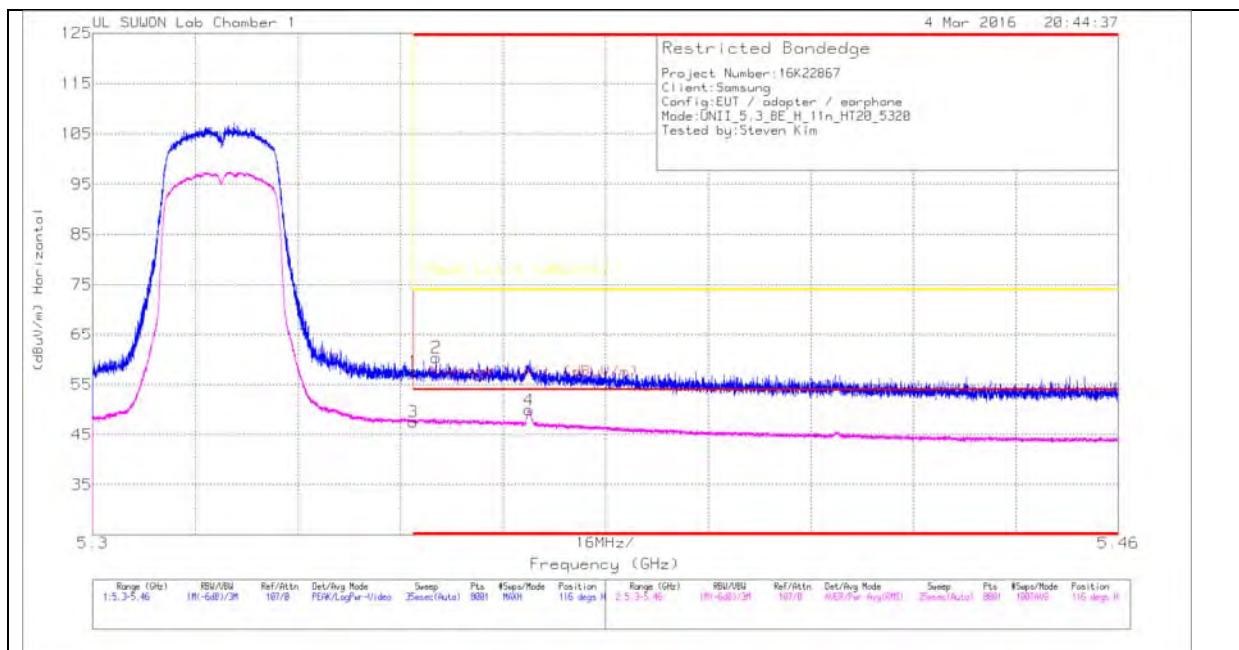

HORIZONTAL DATA

TRACE MARKERS

| Marker | Frequency (GHz) | Meter Reading (dBuV) | Det | 3117(00168 717_15061 9 | Path_2 | DC Corr (dB) | Corrected Reading (dBuV/m) | Average Limit (dBuV/m) | Margin (dB) | Peak Limit (dBuV/m) | PK Margin (dB) | Azimuth (Degs) | Height (cm) | Polarity |
|--------|-----------------|----------------------|-----|------------------------|--------|--------------|----------------------------|------------------------|-------------|---------------------|----------------|----------------|-------------|----------|
| 1 | * 5.35 | 46.41 | Pk | 34.5 | -23.3 | 0 | 57.61 | - | - | 74 | -16.39 | 116 | 198 | H |
| 2 | * 5.354 | 49.14 | Pk | 34.5 | -23.3 | 0 | 60.34 | - | - | 74 | -13.66 | 116 | 198 | H |
| 3 | * 5.35 | 36.03 | RMS | 34.5 | -23.3 | .31 | 47.54 | 54 | -6.46 | - | - | 116 | 198 | H |
| 4 | * 5.368 | 38.39 | RMS | 34.5 | -23.3 | .31 | 49.9 | 54 | -4.1 | - | - | 116 | 198 | H |

* - indicates frequency in CFR15.205/IC7.2.2 Restricted Band

Pk - Peak detector

RMS - RMS detection

VERTICAL PEAK AND AVERAGE PLOT

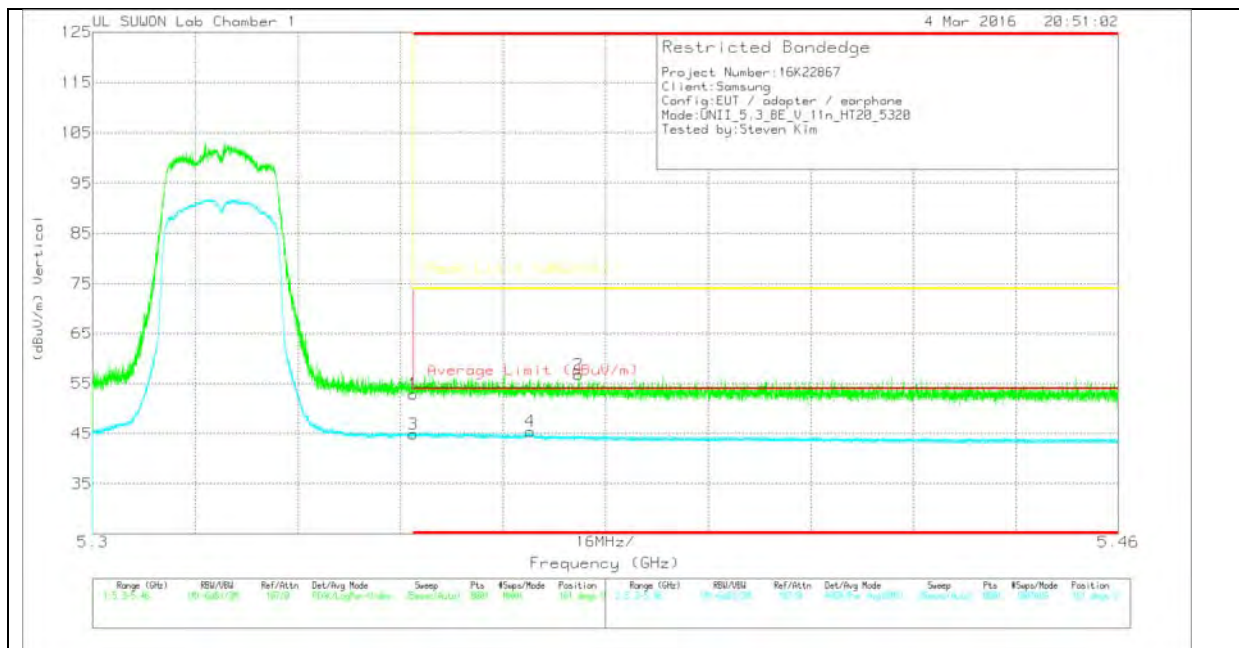

VERTICAL DATA

TRACE MARKERS

| Marker | Frequency (GHz) | Meter Reading (dBuV) | Det | 3117(001687 17_150619) | Path_2 | DC Corr (dB) | Corrected Reading (dBuV/m) | Average Limit (dBuV/m) | Margin (dB) | Peak Limit (dBuV/m) | PK Margin (dB) | Azimuth (Degs) | Height (cm) | Polarity |
|--------|-----------------|----------------------|-----|------------------------|--------|--------------|----------------------------|------------------------|-------------|---------------------|----------------|----------------|-------------|----------|
| 1 | * 5.35 | 41.71 | PK | 34.5 | -23.3 | 0 | 52.91 | - | - | 74 | -21.09 | 161 | 100 | V |
| 2 | * 5.376 | 45.58 | PK | 34.5 | -23.3 | 0 | 56.78 | - | - | 74 | -17.22 | 161 | 100 | V |
| 3 | * 5.35 | 33.39 | RMS | 34.5 | -23.3 | .31 | 44.9 | 54 | -9.1 | - | - | 161 | 100 | V |
| 4 | * 5.368 | 33.94 | RMS | 34.5 | -23.3 | .31 | 45.45 | 54 | -8.55 | - | - | 161 | 100 | V |

* - indicates frequency in CFR15.205/IC7.2.2 Restricted Band

PK - Peak detector

RMS - RMS detection

HARMONICS AND SPURIOUS EMISSIONS

LOW CHANNEL HORIZONTAL

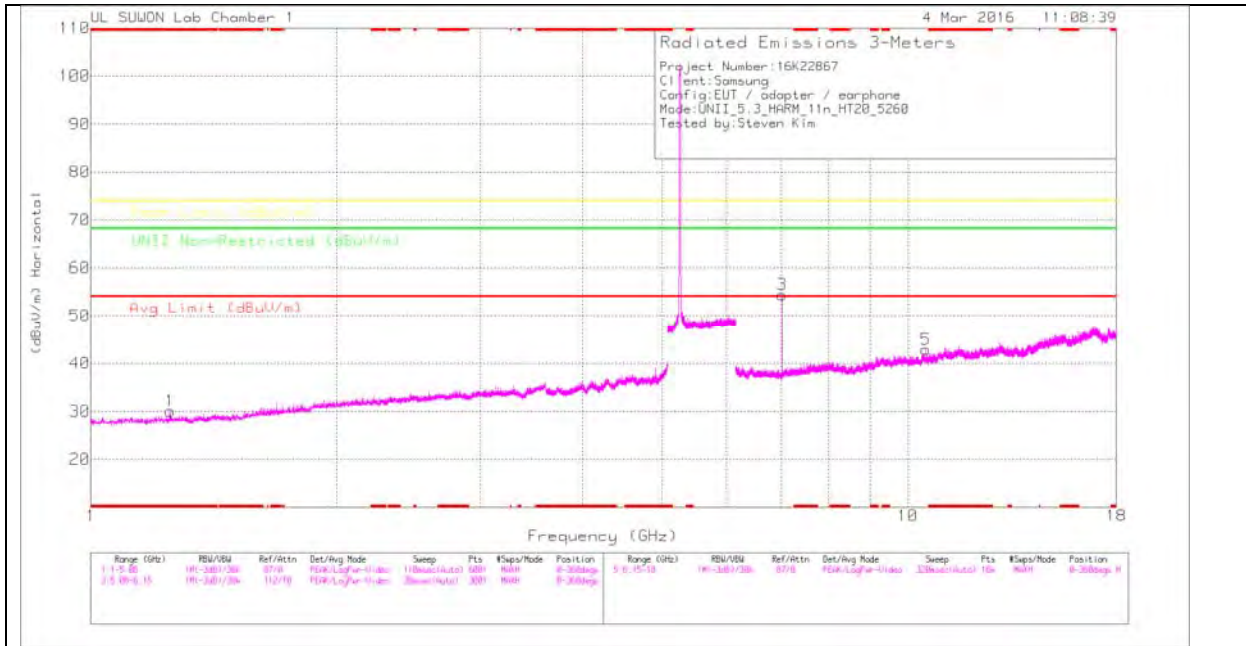

LOW CHANNEL VERTICAL

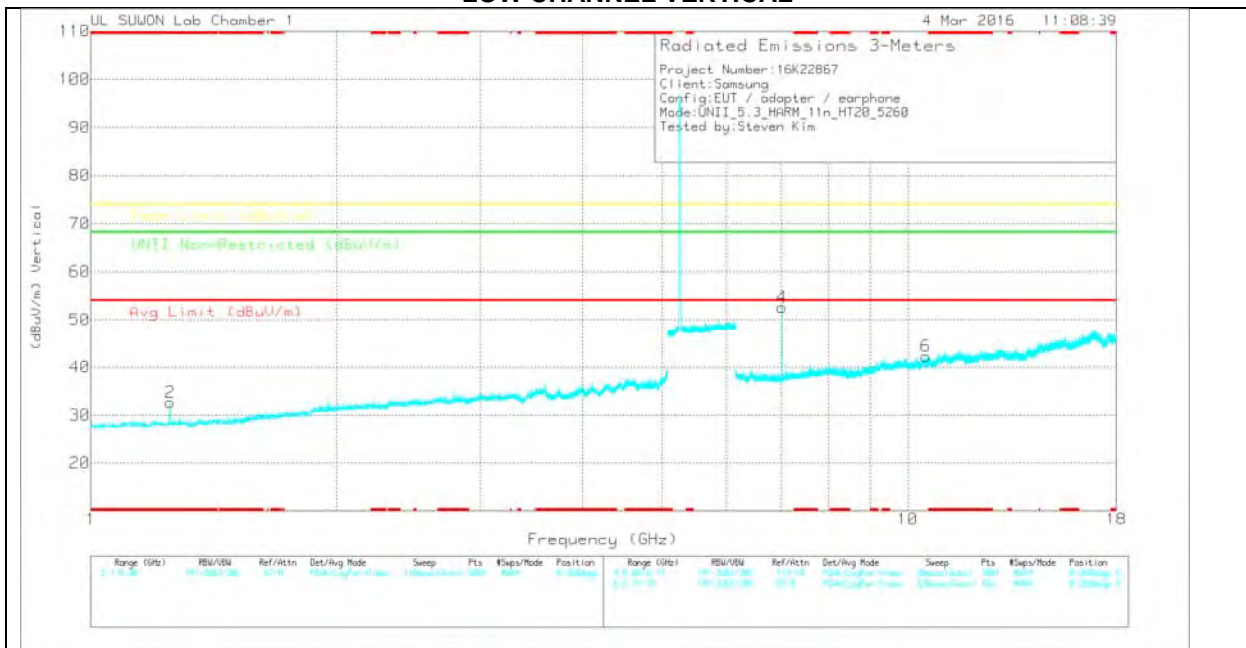

Note: Emission was scanned up to 40GHz; No emissions were detected above the noise floor which was at least 20dB below the specification limit.

LOW CHANNEL DATA

TRACE MARKERS

| Marker | Frequency (GHz) | Meter Reading (dBuV) | Det | 3117(0016 8717)_150 619 | Path_4 | DC Corr (dB) | Corrected Reading (dBuV/m) | Avg Limit (dBuV/m) | Margin (dB) | Peak Limit (dBuV/m) | Margin (dB) | UNII Non-Restricted (dBuV/m) | Margin (dB) | Azimuth (Degs) | Height (cm) | Polarity |
|--------|-----------------|----------------------|-----|-------------------------|--------|--------------|----------------------------|--------------------|-------------|---------------------|-------------|------------------------------|-------------|----------------|-------------|----------|
| 1 | * 1.25 | 41.95 | PK | 28.3 | -40.2 | 0 | 30.05 | - | - | 74 | -43.95 | - | - | 0-360 | 200 | H |
| 2 | * 1.25 | 44.58 | PK | 28.3 | -40.2 | 0 | 32.68 | - | - | 74 | -41.32 | - | - | 0-360 | 200 | V |
| 3 | 7.013 | 49.34 | PK | 35.7 | -30.6 | 0 | 54.44 | - | - | - | - | 68.2 | -13.76 | 0-360 | 100 | H |
| 5 | 10.52 | 32.19 | PK | 37.9 | -27.2 | 0 | 42.89 | - | - | - | - | 68.2 | -25.31 | 0-360 | 100 | H |
| 4 | 7.013 | 47.52 | PK | 35.7 | -30.6 | 0 | 52.62 | - | - | - | - | 68.2 | -15.58 | 0-360 | 100 | V |
| 6 | 10.519 | 31.6 | PK | 37.9 | -27.2 | 0 | 42.3 | - | - | - | - | 68.2 | -25.9 | 0-360 | 200 | V |

* - indicates frequency in CFR15.205/IC7.2.2 Restricted Band

PK – Peak detector

Radiated Emissions

| Frequency (GHz) | Meter Reading (dBuV) | Det | 3117(001687 17)_150619 | Path_5 | DC Corr (dB) | Corrected Reading (dBuV/m) | Avg Limit (dBuV/m) | Margin (dB) | Peak Limit (dBuV/m) | Margin (dB) | UNII Non-Restricted (dBuV/m) | Margin (dB) | Azimuth (Degs) | Height (cm) | Polarity |
|-----------------|----------------------|------|------------------------|--------|--------------|----------------------------|--------------------|-------------|---------------------|-------------|------------------------------|-------------|----------------|-------------|----------|
| 7.013 | 52.33 | PK-U | 35.7 | -30.6 | 0 | 57.43 | - | - | - | - | 68.2 | -10.77 | 115 | 135 | H |
| 7.013 | 51.25 | PK-U | 35.7 | -30.6 | 0 | 56.35 | - | - | - | - | 68.2 | -11.85 | 141 | 100 | V |

* - indicates frequency in CFR15.205/IC7.2.2 Restricted Band

PK-U - U-NII: Maximum Peak

MID CHANNEL HORIZONTAL

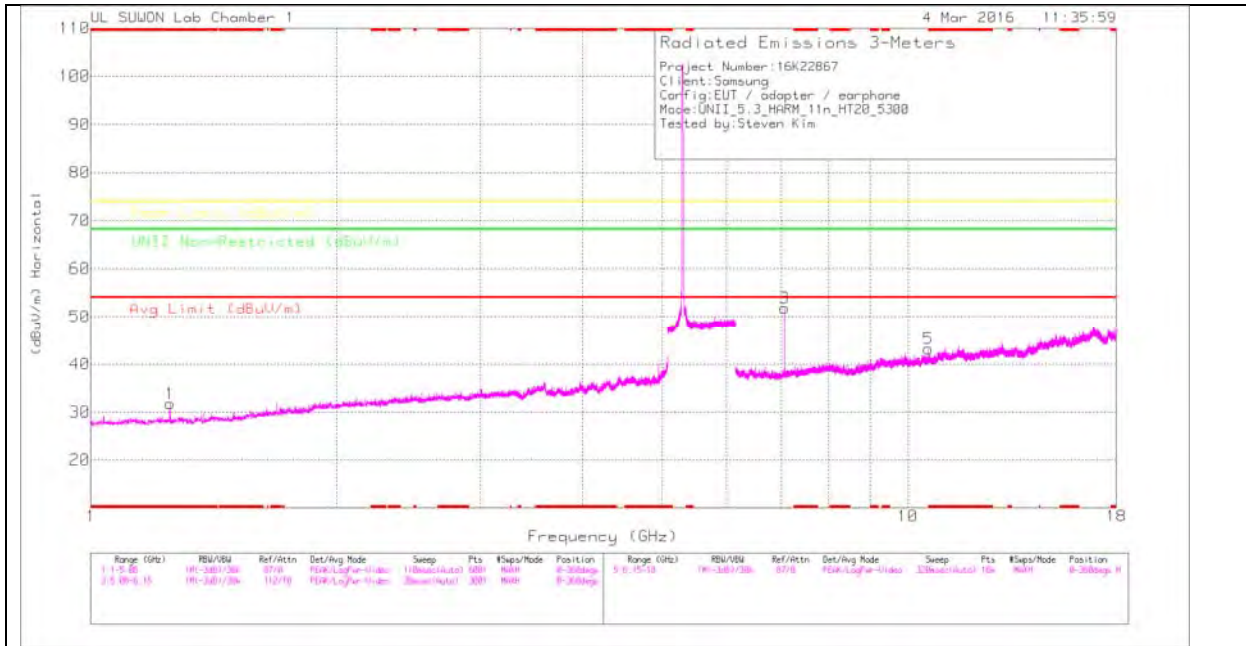

MID CHANNEL VERTICAL

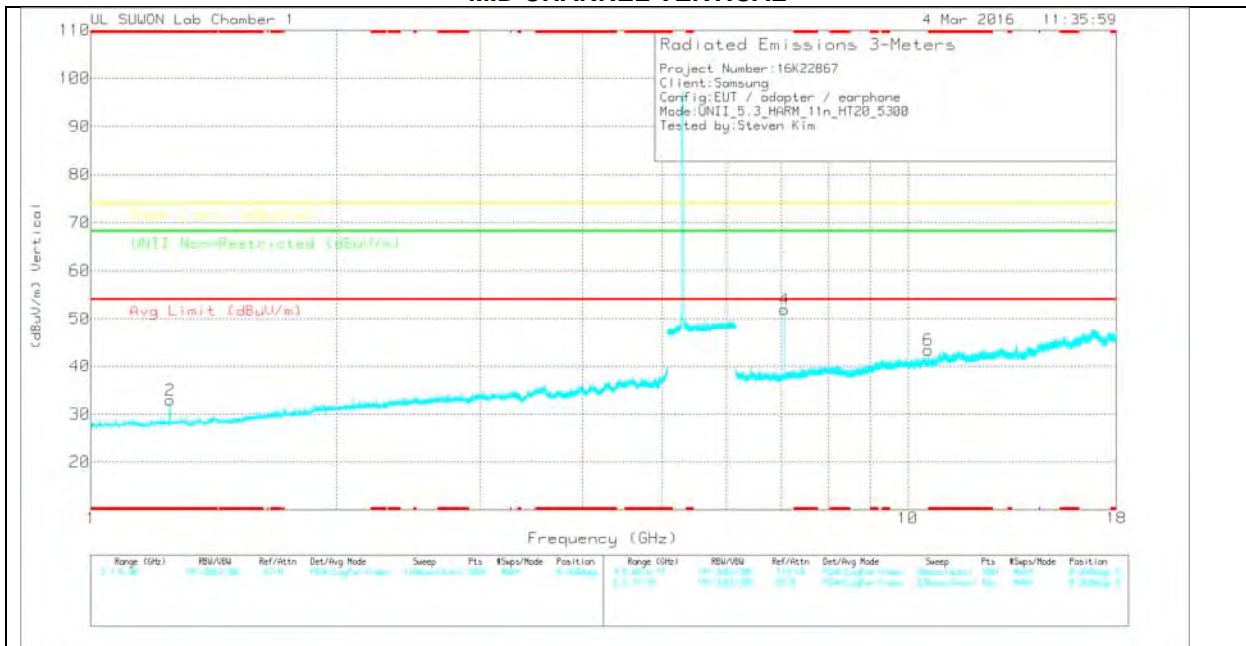

Note: Emission was scanned up to 40GHz; No emissions were detected above the noise floor which was at least 20dB below the specification limit.

MID CHANNEL DATA

TRACE MARKERS

| Marker | Frequency (GHz) | Meter Reading (dBuV) | Det | 3117/0016 87171_150 619 | Path_4 | DC Corr (dB) | Corrected Reading (dBuV/m) | Avg Limit (dBuV/m) | Margin (dB) | Peak Limit (dBuV/m) | Margin (dB) | UNII Non-Restricted (dBuV/m) | Margin (dB) | Azimuth (Degs) | Height (cm) | Polarity |
|--------|-----------------|----------------------|-----|-------------------------|--------|--------------|----------------------------|--------------------|-------------|---------------------|-------------|------------------------------|-------------|----------------|-------------|----------|
| 1 | * 1.25 | 43.62 | PK | 28.3 | -40.2 | 0 | 31.72 | - | - | 74 | -42.28 | - | - | 0-360 | 200 | H |
| 2 | * 1.25 | 44.83 | PK | 28.3 | -40.2 | 0 | 32.93 | - | - | 74 | -41.07 | - | - | 0-360 | 200 | V |
| 3 | 7.066 | 46.58 | PK | 35.7 | -30.5 | 0 | 51.78 | - | - | - | - | 68.2 | -16.42 | 0-360 | 100 | H |
| 5 | * 10.6 | 32.3 | PK | 37.9 | -27 | 0 | 43.2 | - | - | 74 | -30.8 | - | - | 0-360 | 100 | H |
| 4 | 7.066 | 46.71 | PK | 35.7 | -30.5 | 0 | 51.91 | - | - | - | - | 68.2 | -16.29 | 0-360 | 100 | V |
| 6 | * 10.6 | 32.43 | PK | 37.9 | -27 | 0 | 43.33 | - | - | 74 | -30.67 | - | - | 0-360 | 200 | V |

* - indicates frequency in CFR15.205/IC7.2.2 Restricted Band

PK – Peak detector

Radiated Emissions

| Frequency (GHz) | Meter Reading (dBuV) | Det | 3117/001687 171_150619 | Path_5 | DC Corr (dB) | Corrected Reading (dBuV/m) | Avg Limit (dBuV/m) | Margin (dB) | Peak Limit (dBuV/m) | Margin (dB) | UNII Non-Restricted (dBuV/m) | Margin (dB) | Azimuth (Degs) | Height (cm) | Polarity |
|-----------------|----------------------|------|------------------------|--------|--------------|----------------------------|--------------------|-------------|---------------------|-------------|------------------------------|-------------|----------------|-------------|----------|
| 7.067 | 50.59 | PK-U | 35.7 | -30.5 | 0 | 55.79 | - | - | - | - | 68.2 | -12.41 | 168 | 113 | H |
| 7.067 | 51.07 | PK-U | 35.7 | -30.5 | 0 | 56.27 | - | - | - | - | 68.2 | -11.93 | 190 | 103 | V |

* - indicates frequency in CFR15.205/IC7.2.2 Restricted Band

PK-U - U-NII: Maximum Peak

HIGH CHANNEL HORIZONTAL

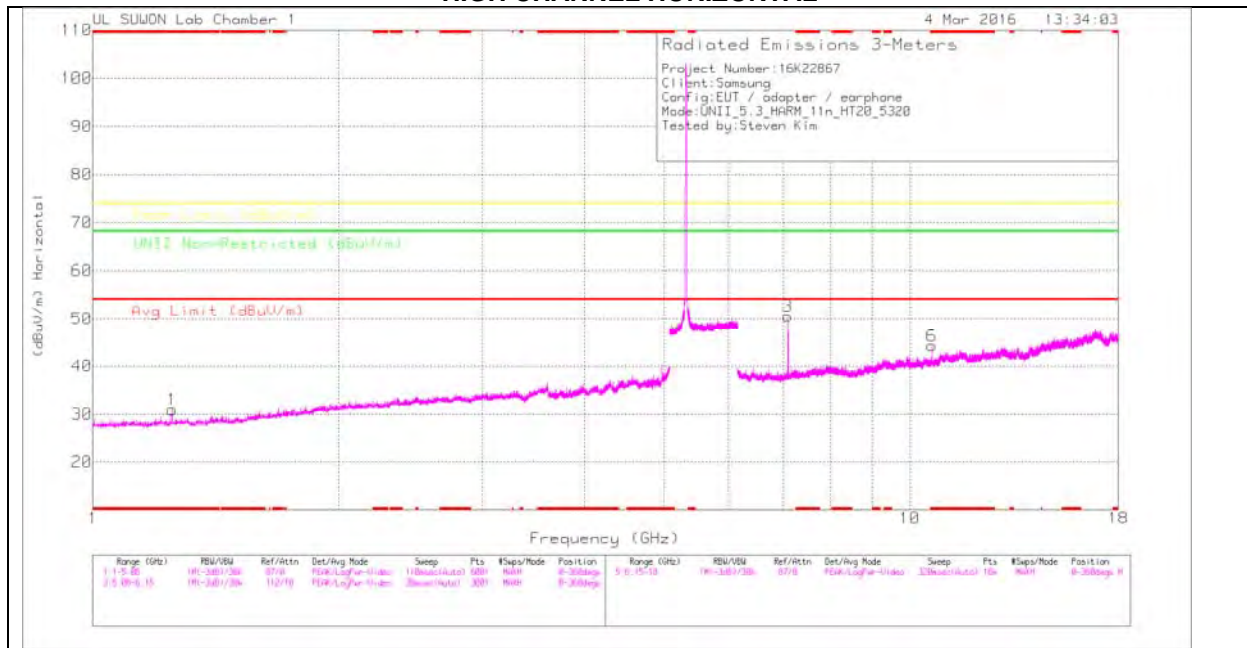

HIGH CHANNEL VERTICAL

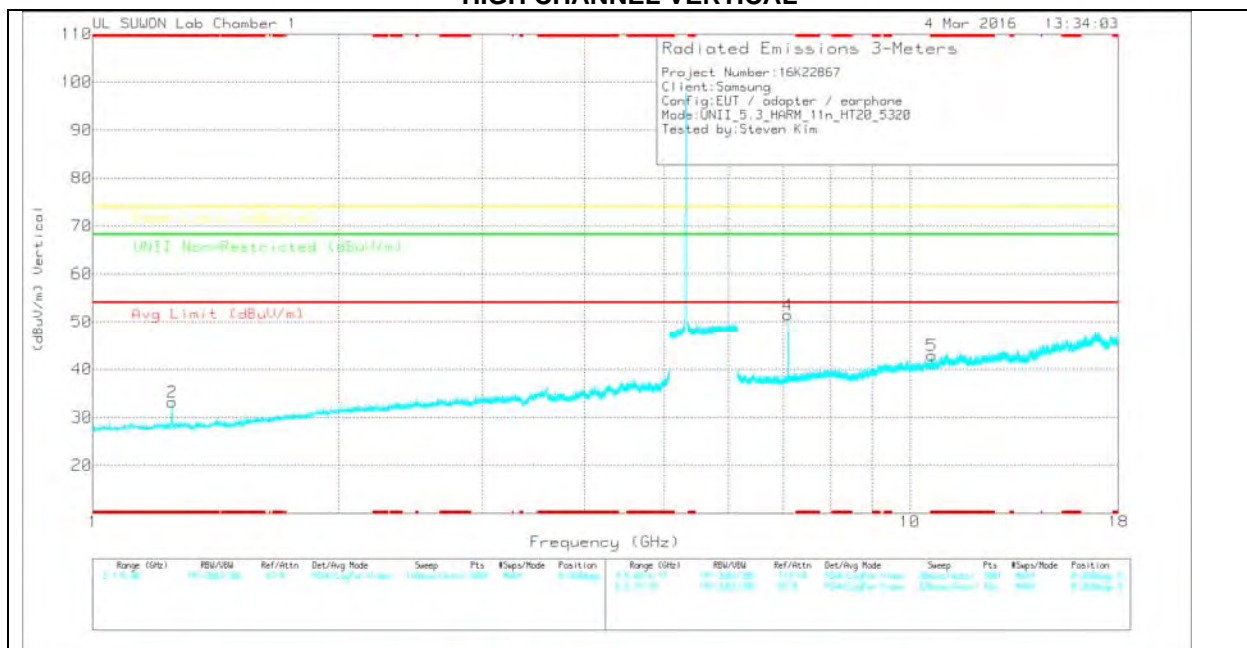

Note: Emission was scanned up to 40GHz; No emissions were detected above the noise floor which was at least 20dB below the specification limit.

HIGH CHANNEL DATA

TRACE MARKERS

| Marker | Frequency (GHz) | Meter Reading (dBuV) | Det | 3117(0016 8717)_150 619 | Path_4 | DC Corr (dB) | Corrected Reading (dBuV/m) | Avg Limit (dBuV/m) | Margin (dB) | Peak Limit (dBuV/m) | Margin (dB) | UNII Non-Restricted (dBuV/m) | Margin (dB) | Azimuth (Degs) | Height (cm) | Polarity |
|--------|-----------------|----------------------|-----|-------------------------|--------|--------------|----------------------------|--------------------|-------------|---------------------|-------------|------------------------------|-------------|----------------|-------------|----------|
| 1 | * 1.25 | 42.84 | PK | 28.3 | -40.2 | 0 | 30.94 | - | - | 74 | -43.06 | - | - | 0-360 | 200 | H |
| 2 | * 1.25 | 45.03 | PK | 28.3 | -40.2 | 0 | 33.13 | - | - | 74 | -40.87 | - | - | 0-360 | 200 | V |
| 3 | 7.093 | 45.37 | PK | 35.7 | -30.5 | 0 | 50.57 | - | - | - | - | 68.2 | -17.63 | 0-360 | 100 | H |
| 6 | * 10.64 | 33.96 | PK | 37.9 | -27.6 | 0 | 44.26 | - | - | 74 | -29.74 | - | - | 0-360 | 100 | H |
| 4 | 7.093 | 46.21 | PK | 35.7 | -30.5 | 0 | 51.41 | - | - | - | - | 68.2 | -16.79 | 0-360 | 100 | V |
| 5 | * 10.64 | 32.56 | PK | 37.9 | -27.6 | 0 | 42.86 | - | - | 74 | -31.14 | - | - | 0-360 | 200 | V |

* - indicates frequency in CFR15.205/IC7.2.2 Restricted Band

PK – Peak detector

Radiated Emissions

| Frequency (GHz) | Meter Reading (dBuV) | Det | 3117(001687 17)_150619 | Path_5 | DC Corr (dB) | Corrected Reading (dBuV/m) | Avg Limit (dBuV/m) | Margin (dB) | Peak Limit (dBuV/m) | Margin (dB) | UNII Non-Restricted (dBuV/m) | Margin (dB) | Azimuth (Degs) | Height (cm) | Polarity |
|-----------------|----------------------|------|------------------------|--------|--------------|----------------------------|--------------------|-------------|---------------------|-------------|------------------------------|-------------|----------------|-------------|----------|
| 7.093 | 50.81 | PK-U | 35.7 | -30.5 | 0 | 56.01 | - | - | - | - | 68.2 | -12.19 | 170 | 123 | H |
| 7.093 | 49.95 | PK-U | 35.7 | -30.5 | 0 | 55.15 | - | - | - | - | 68.2 | -13.05 | 190 | 318 | V |
| * 10.64 | 41.98 | PK-U | 37.9 | -27.6 | 0 | 52.28 | - | - | 74 | -21.72 | - | - | 178 | 122 | V |
| * 10.64 | 32.62 | ADR | 37.9 | -27.6 | .31 | 43.23 | 54 | -10.77 | - | - | - | - | 178 | 122 | V |
| * 10.64 | 42.94 | PK-U | 37.9 | -27.6 | 0 | 53.24 | - | - | 74 | -20.76 | - | - | 100 | 271 | H |
| * 10.64 | 34.77 | ADR | 37.9 | -27.6 | .31 | 45.38 | 54 | -8.62 | - | - | - | - | 100 | 271 | H |

* - indicates frequency in CFR15.205/IC7.2.2 Restricted Band

PK-U - U-NII: Maximum Peak

11.2.3. TX ABOVE 1GHz 802.11n HT40 2TX CDD MODE IN THE 5.3GHz BAND AUTHORIZED BANDEDGE (HIGH CHANNEL)

HORIZONTAL PEAK AND AVERAGE PLOT

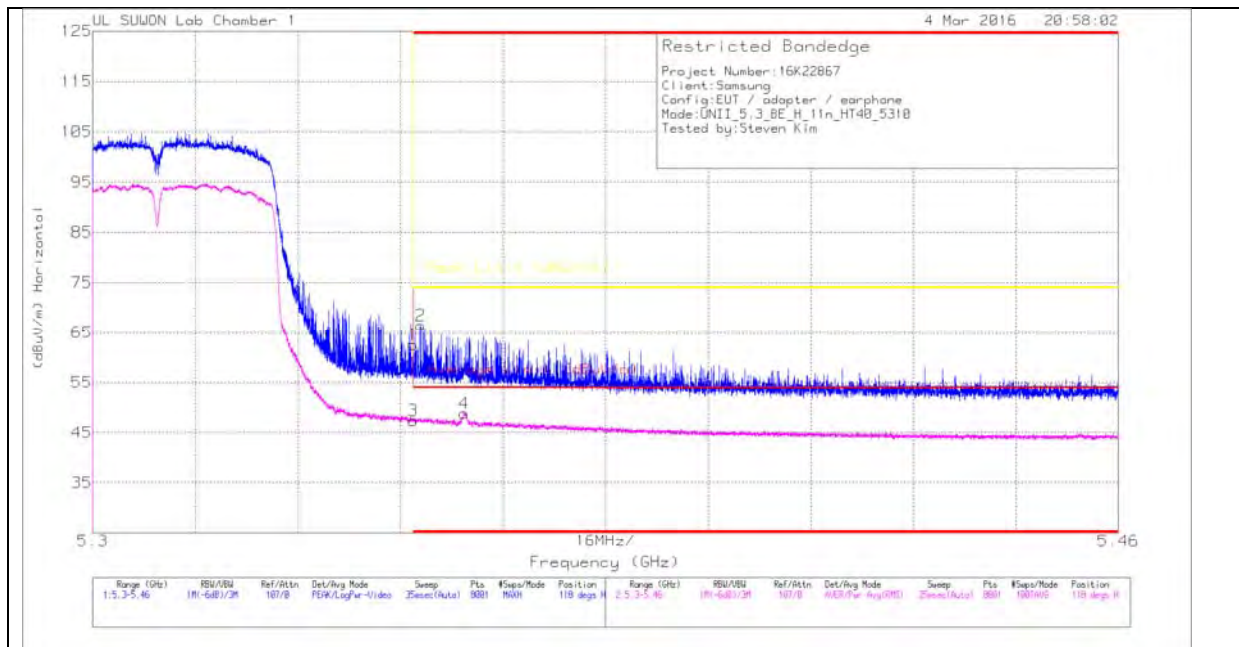

HORIZONTAL DATA

TRACE MARKERS

| Marker | Frequency (GHz) | Meter Reading (dBuV) | Det | 3117(001687 17_150619) | Path_2 | DC Corr (dB) | Corrected Reading (dBuV/m) | Average Limit (dBuV/m) | Margin (dB) | Peak Limit (dBuV/m) | PK Margin (dB) | Azimuth (Degs) | Height (cm) | Polarity |
|--------|-----------------|----------------------|-----|------------------------|--------|--------------|----------------------------|------------------------|-------------|---------------------|----------------|----------------|-------------|----------|
| 1 | * 5.35 | 51.36 | PK | 34.5 | -23.3 | 0 | 62.56 | - | - | 74 | -11.44 | 118 | 202 | H |
| 2 | * 5.351 | 55.25 | Pk | 34.5 | -23.3 | 0 | 66.45 | - | - | 74 | -7.55 | 118 | 202 | H |
| 3 | * 5.35 | 35.61 | RMS | 34.5 | -23.3 | .59 | 47.4 | 54 | -6.6 | - | - | 118 | 202 | H |
| 4 | * 5.358 | 37.05 | RMS | 34.5 | -23.3 | .59 | 48.84 | 54 | -5.16 | - | - | 118 | 202 | H |

* - indicates frequency in CFR15.205/IC7.2.2 Restricted Band

Pk - Peak detector

RMS - RMS detection

VERTICAL PEAK AND AVERAGE PLOT

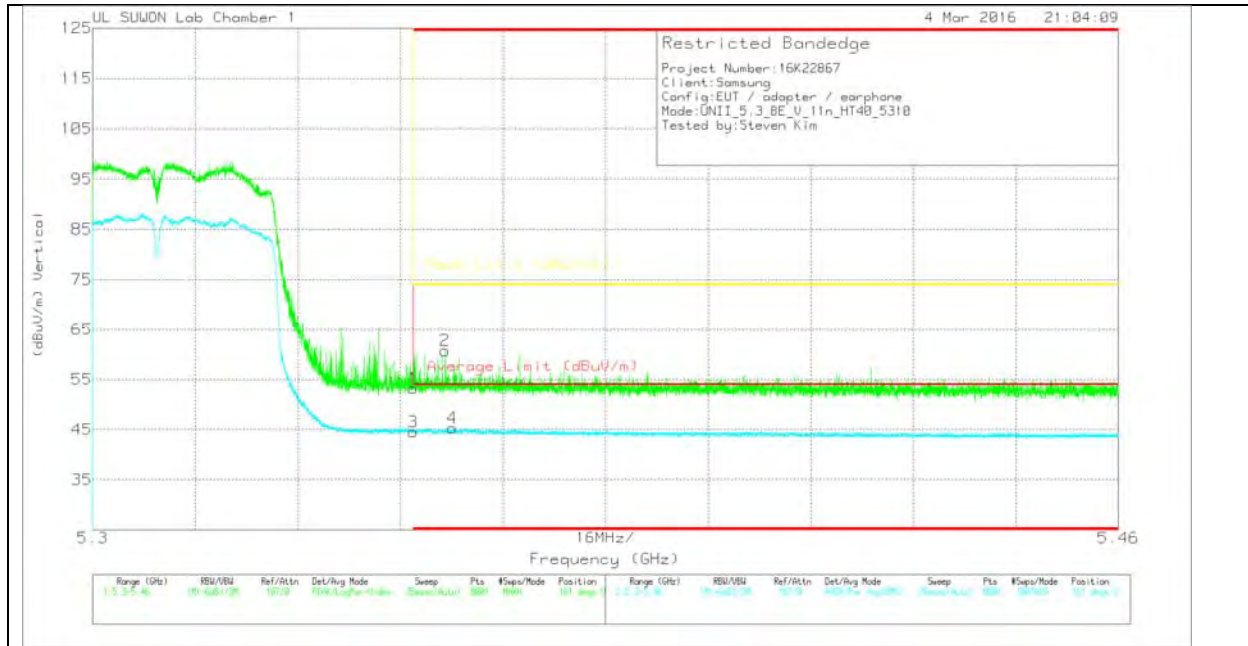

VERTICAL DATA

TRACE MARKERS

| Marker | Frequency (GHz) | Meter Reading (dBuV) | Det | 3117(001687 17_150619) | Path_2 | DC Corr (dB) | Corrected Reading (dBuV/m) | Average Limit (dBuV/m) | Margin (dB) | Peak Limit (dBuV/m) | PK Margin (dB) | Azimuth (Degs) | Height (cm) | Polarity |
|--------|-----------------|----------------------|-----|------------------------|--------|--------------|----------------------------|------------------------|-------------|---------------------|----------------|----------------|-------------|----------|
| 1 | * 5.35 | 42.01 | PK | 34.5 | -23.3 | 0 | 53.21 | - | - | 74 | -20.79 | 161 | 100 | V |
| 2 | * 5.355 | 49.56 | PK | 34.5 | -23.3 | 0 | 60.76 | - | - | 74 | -13.24 | 161 | 100 | V |
| 3 | * 5.35 | 32.77 | RMS | 34.5 | -23.3 | .59 | 44.56 | 54 | -9.44 | - | - | 161 | 100 | V |
| 4 | * 5.356 | 33.52 | RMS | 34.5 | -23.3 | .59 | 45.31 | 54 | -8.69 | - | - | 161 | 100 | V |

* - indicates frequency in CFR15.205/IC7.2.2 Restricted Band

PK - Peak detector

RMS - RMS detection

HARMONICS AND SPURIOUS EMISSIONS

LOW CHANNEL HORIZONTAL

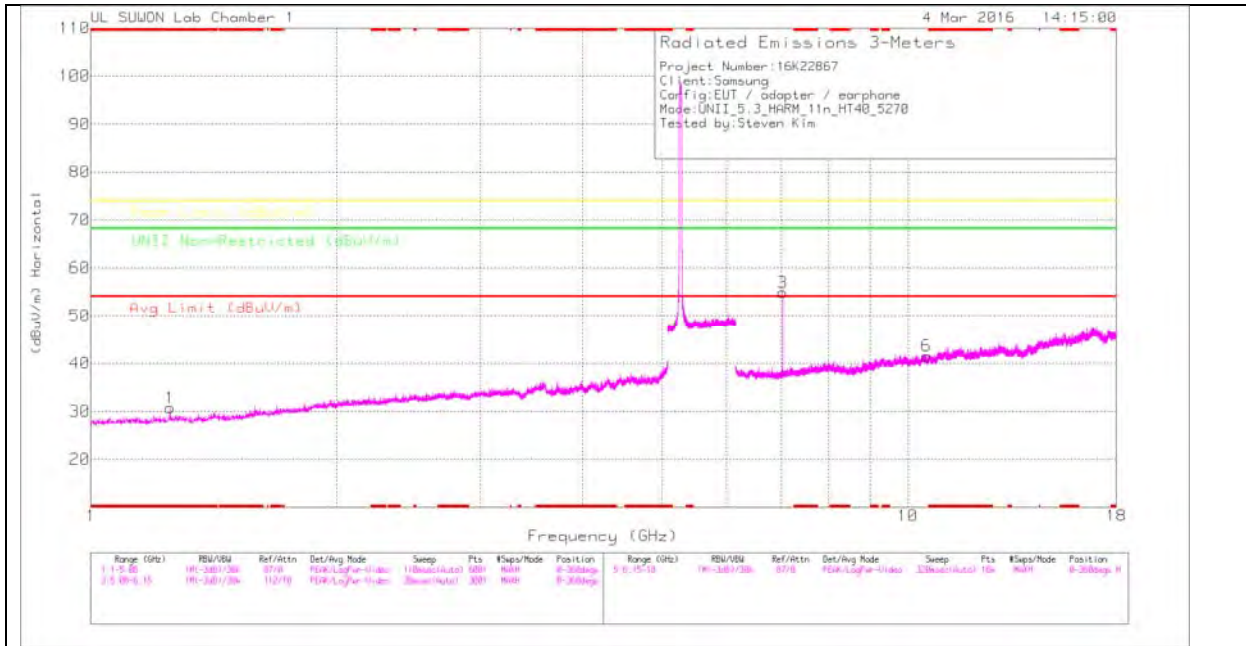

LOW CHANNEL VERTICAL

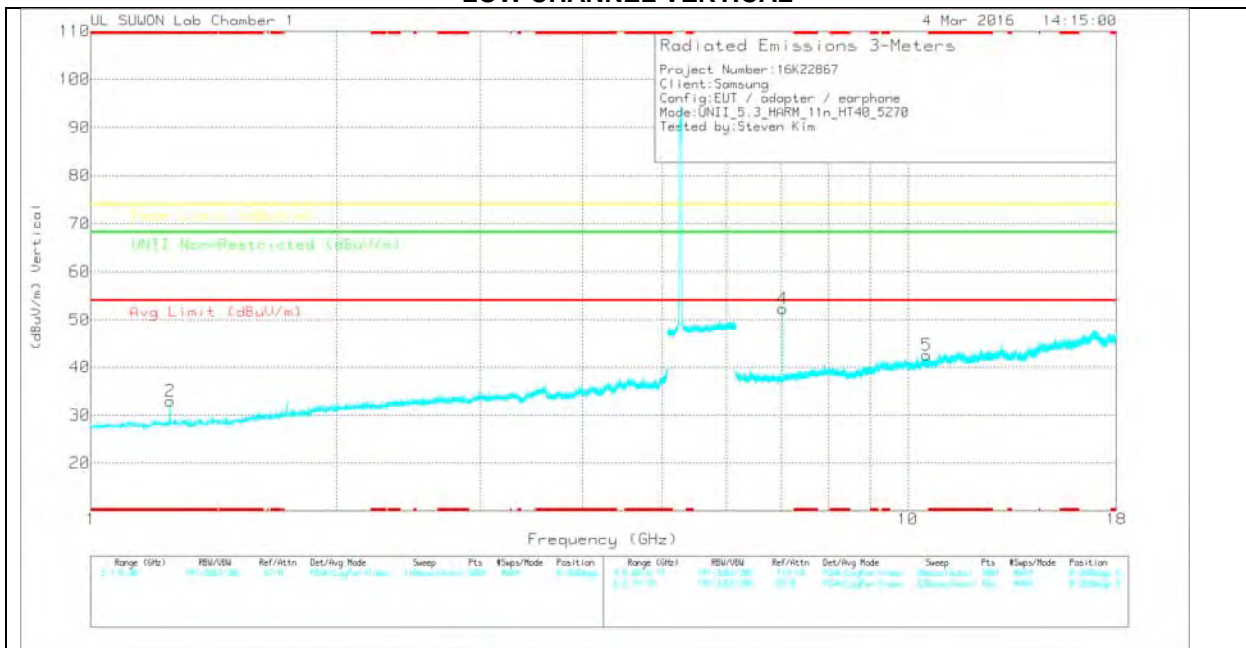

Note: Emission was scanned up to 40GHz; No emissions were detected above the noise floor which was at least 20dB below the specification limit.

LOW CHANNEL DATA

TRACE MARKERS

| Marker | Frequency (GHz) | Meter Reading (dBuV) | Det | 3117(0016 8717)_150 619 | Path_4 | DC Corr (dB) | Corrected Reading (dBuV/m) | Avg Limit (dBuV/m) | Margin (dB) | Peak Limit (dBuV/m) | Margin (dB) | UNII Non-Restricted (dBuV/m) | Margin (dB) | Azimuth (Degs) | Height (cm) | Polarity |
|--------|-----------------|----------------------|-----|-------------------------|--------|--------------|----------------------------|--------------------|-------------|---------------------|-------------|------------------------------|-------------|----------------|-------------|----------|
| 1 | * 1.25 | 42.63 | PK | 28.3 | -40.2 | 0 | 30.73 | - | - | 74 | -43.27 | - | - | 0-360 | 200 | H |
| 2 | * 1.25 | 44.85 | PK | 28.3 | -40.2 | 0 | 32.95 | - | - | 74 | -41.05 | - | - | 0-360 | 200 | V |
| 3 | 7.027 | 49.79 | PK | 35.7 | -30.6 | 0 | 54.89 | - | - | - | - | 68.2 | -13.31 | 0-360 | 100 | H |
| 6 | 10.539 | 30.73 | PK | 37.9 | -27.1 | 0 | 41.53 | - | - | - | - | 68.2 | -26.67 | 0-360 | 100 | H |
| 4 | 7.027 | 47.26 | PK | 35.7 | -30.6 | 0 | 52.36 | - | - | - | - | 68.2 | -15.84 | 0-360 | 100 | V |
| 5 | 10.54 | 31.74 | PK | 37.9 | -27.1 | 0 | 42.54 | - | - | - | - | 68.2 | -25.66 | 0-360 | 100 | V |

* - indicates frequency in CFR15.205/IC7.2.2 Restricted Band

PK – Peak detector

Radiated Emissions

| Frequency (GHz) | Meter Reading (dBuV) | Det | 3117(001687 17)_150619 | Path_5 | DC Corr (dB) | Corrected Reading (dBuV/m) | Avg Limit (dBuV/m) | Margin (dB) | Peak Limit (dBuV/m) | Margin (dB) | UNII Non-Restricted (dBuV/m) | Margin (dB) | Azimuth (Degs) | Height (cm) | Polarity |
|-----------------|----------------------|------|------------------------|--------|--------------|----------------------------|--------------------|-------------|---------------------|-------------|------------------------------|-------------|----------------|-------------|----------|
| 7.027 | 51.77 | PK-U | 35.7 | -30.6 | 0 | 56.87 | - | - | - | - | 68.2 | -11.33 | 107 | 135 | H |
| 7.027 | 50.77 | PK-U | 35.7 | -30.6 | 0 | 55.87 | - | - | - | - | 68.2 | -12.33 | 142 | 100 | V |

* - indicates frequency in CFR15.205/IC7.2.2 Restricted Band

PK-U - U-NII: Maximum Peak

HIGH CHANNEL HORIZONTAL

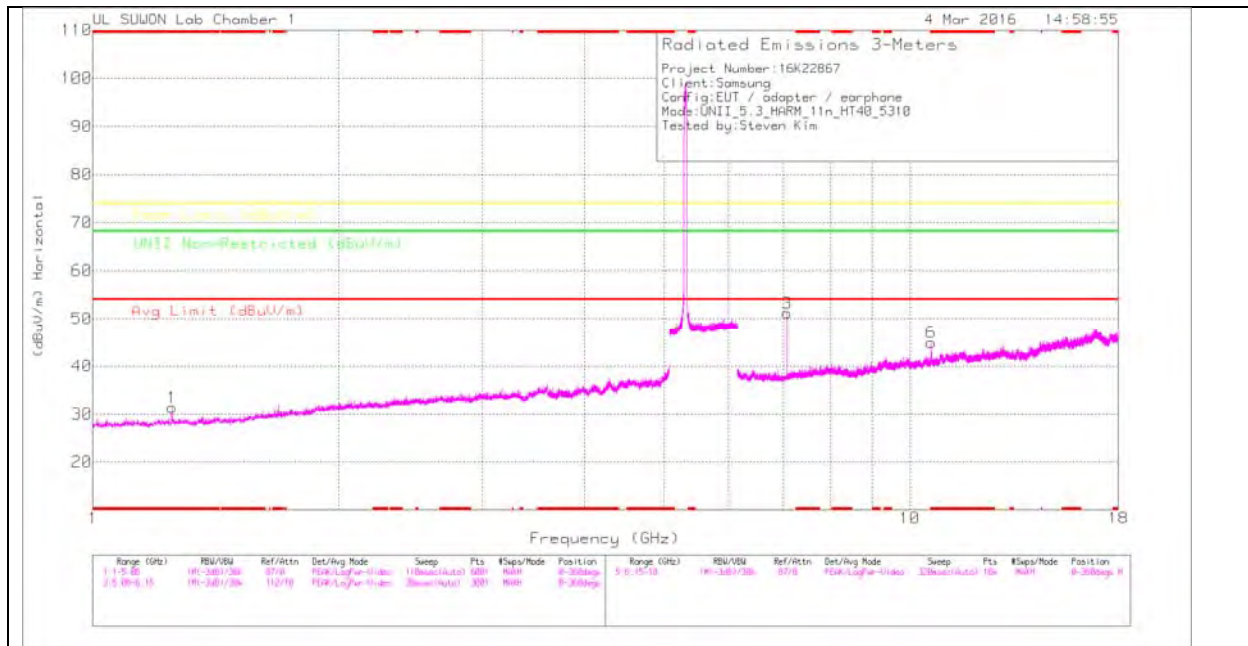

HIGH CHANNEL VERTICAL

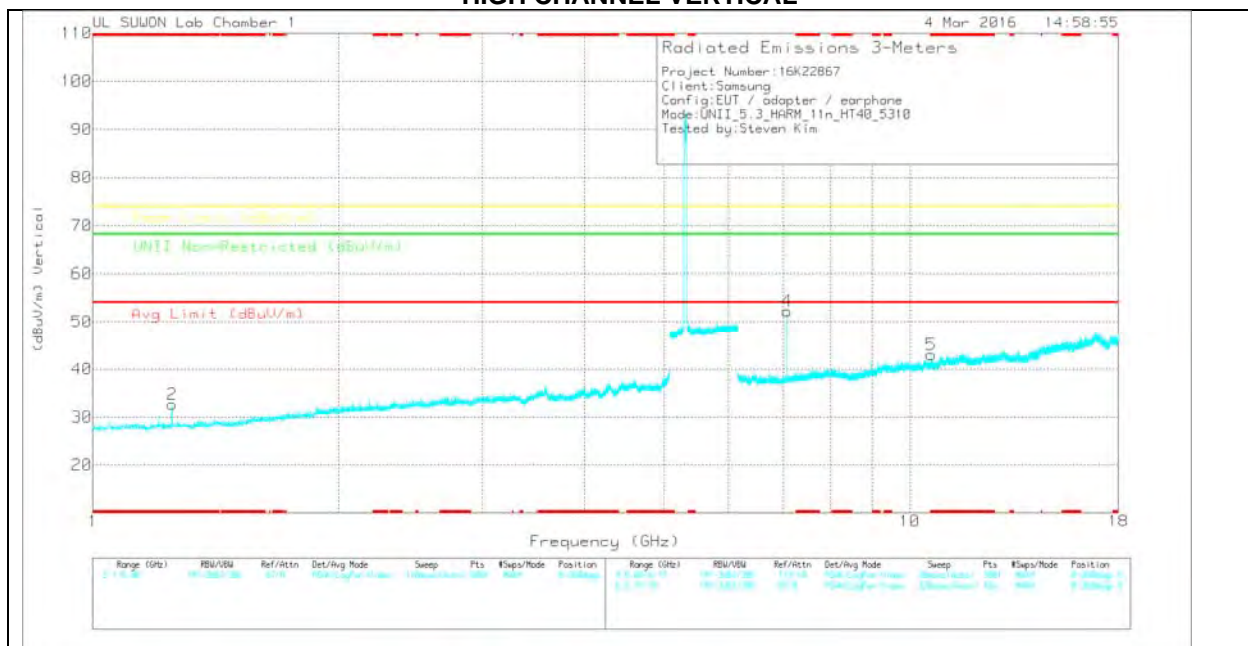

Note: Emission was scanned up to 40GHz; No emissions were detected above the noise floor which was at least 20dB below the specification limit.

HIGH CHANNEL DATA

TRACE MARKERS

| Marker | Frequency (GHz) | Meter Reading (dBuV) | Det | 3117(00168717)_150619 | Path_4 | DC Corr (dB) | Corrected Reading (dBuV/m) | Avg Limit (dBuV/m) | Margin (dB) | Peak Limit (dBuV/m) | Margin (dB) | UNII Non-Restricted (dBuV/m) | Margin (dB) | Azimuth (Degs) | Height (cm) | Polarity |
|--------|-----------------|----------------------|-----|-----------------------|--------|--------------|----------------------------|--------------------|-------------|---------------------|-------------|------------------------------|-------------|----------------|-------------|----------|
| 1 | * 1.25 | 43.27 | PK | 28.3 | -40.2 | 0 | 31.37 | - | - | 74 | -42.63 | - | - | 0-360 | 200 | H |
| 2 | * 1.25 | 44.58 | PK | 28.3 | -40.2 | 0 | 32.68 | - | - | 74 | -41.32 | - | - | 0-360 | 200 | V |
| 3 | 7.079 | 45.99 | PK | 35.7 | -30.5 | 0 | 51.19 | - | - | - | - | 68.2 | -17.01 | 0-360 | 100 | H |
| 6 | * 10.62 | 34.18 | PK | 37.9 | -27.1 | 0 | 44.98 | - | - | 74 | -29.02 | - | - | 0-360 | 200 | H |
| 4 | 7.079 | 47.03 | PK | 35.7 | -30.5 | 0 | 52.23 | - | - | - | - | 68.2 | -15.97 | 0-360 | 200 | V |
| 5 | * 10.62 | 32.24 | PK | 37.9 | -27.1 | 0 | 43.04 | - | - | 74 | -30.96 | - | - | 0-360 | 200 | V |

* - indicates frequency in CFR15.205/IC7.2.2 Restricted Band

PK – Peak detector

Radiated Emissions

| Frequency (GHz) | Meter Reading (dBuV) | Det | 3117(00168717)_150619 | Path_5 | DC Corr (dB) | Corrected Reading (dBuV/m) | Avg Limit (dBuV/m) | Margin (dB) | Peak Limit (dBuV/m) | Margin (dB) | UNII Non-Restricted (dBuV/m) | Margin (dB) | Azimuth (Degs) | Height (cm) | Polarity |
|-----------------|----------------------|------|-----------------------|--------|--------------|----------------------------|--------------------|-------------|---------------------|-------------|------------------------------|-------------|----------------|-------------|----------|
| 7.08 | 50.39 | PK-U | 35.7 | -30.5 | 0 | 55.59 | - | - | - | - | 68.2 | -12.61 | 169 | 111 | H |
| 7.08 | 49.19 | PK-U | 35.7 | -30.5 | 0 | 54.39 | - | - | - | - | 68.2 | -13.81 | 188 | 300 | V |
| * 10.633 | 40.98 | PK-U | 37.9 | -27.4 | 0 | 51.48 | - | - | 74 | -22.52 | - | - | 47 | 379 | V |
| * 10.62 | 29.47 | ADR | 37.9 | -27.1 | .59 | 40.86 | 54 | -13.14 | - | - | - | - | 47 | 379 | V |
| * 10.62 | 41.58 | PK-U | 37.9 | -27.1 | 0 | 52.38 | - | - | 74 | -21.62 | - | - | 105 | 271 | H |
| * 10.62 | 32.19 | ADR | 37.9 | -27.1 | .59 | 43.58 | 54 | -10.42 | - | - | - | - | 105 | 271 | H |

* - indicates frequency in CFR15.205/IC7.2.2 Restricted Band

PK-U - U-NII: Maximum Peak

ADR - U-NII AD primary method, RMS average

11.2.4. TX ABOVE 1GHz 802.11ac HT80 2TX CDD MODE IN THE 5.3GHz BAND RESTRICTED BANDEDGE (High CHANNEL)

HORIZONTAL PEAK AND AVERAGE PLOT

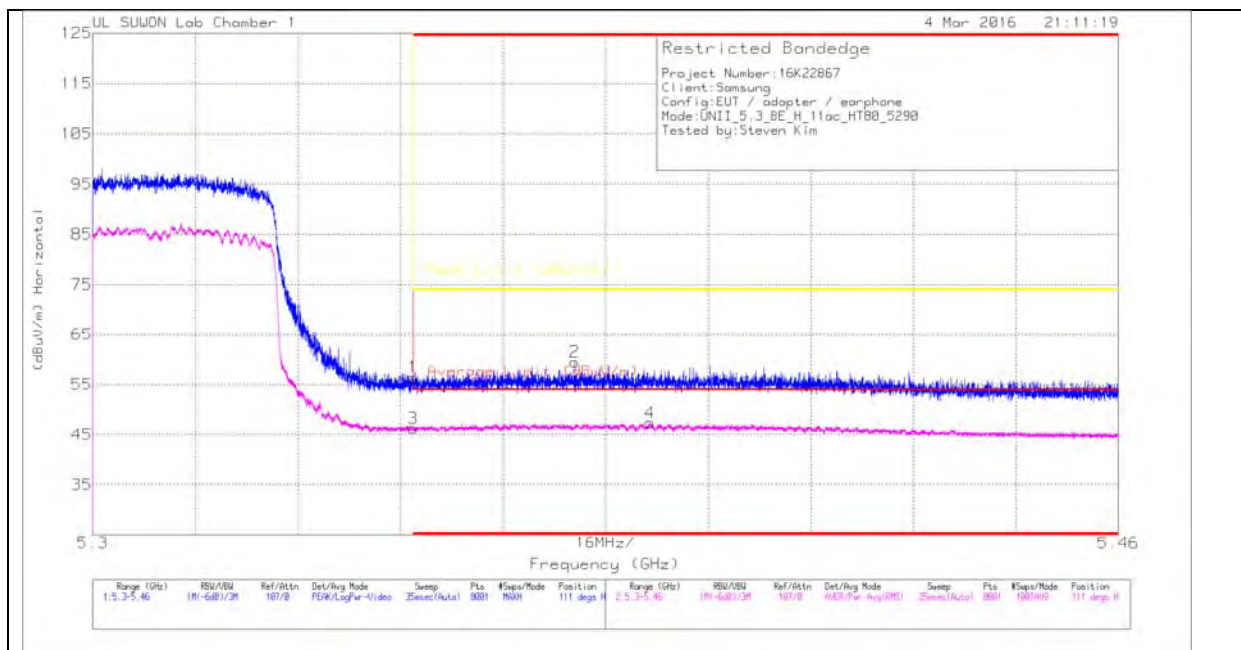

HORIZONTAL DATA

TRACE MARKERS

| Marker | Frequency (GHz) | Meter Reading (dBuV) | Det | 3117(001687 17_150619) | Path_2 | DC Corr (dB) | Corrected Reading (dBuV/m) | Average Limit (dBuV/m) | Margin (dB) | Peak Limit (dBuV/m) | PK Margin (dB) | Azimuth (Degs) | Height (cm) | Polarity |
|--------|-----------------|----------------------|-----|------------------------|--------|--------------|----------------------------|------------------------|-------------|---------------------|----------------|----------------|-------------|----------|
| 1 | * 5.35 | 45.26 | PK | 34.5 | -23.3 | 0 | 56.46 | - | - | 74 | -17.54 | 111 | 147 | H |
| 2 | * 5.375 | 48.3 | PK | 34.5 | -23.3 | 0 | 59.5 | - | - | 74 | -14.5 | 111 | 147 | H |
| 3 | * 5.35 | 33.94 | RMS | 34.5 | -23.3 | 1.11 | 46.25 | 54 | -7.75 | - | - | 111 | 147 | H |
| 4 | * 5.387 | 35.06 | RMS | 34.5 | -23.3 | 1.11 | 47.37 | 54 | -6.63 | - | - | 111 | 147 | H |

* - indicates frequency in CFR15.205/IC7.2.2 Restricted Band

PK - Peak detector

RMS - RMS detection

VERTICAL PEAK AND AVERAGE PLOT

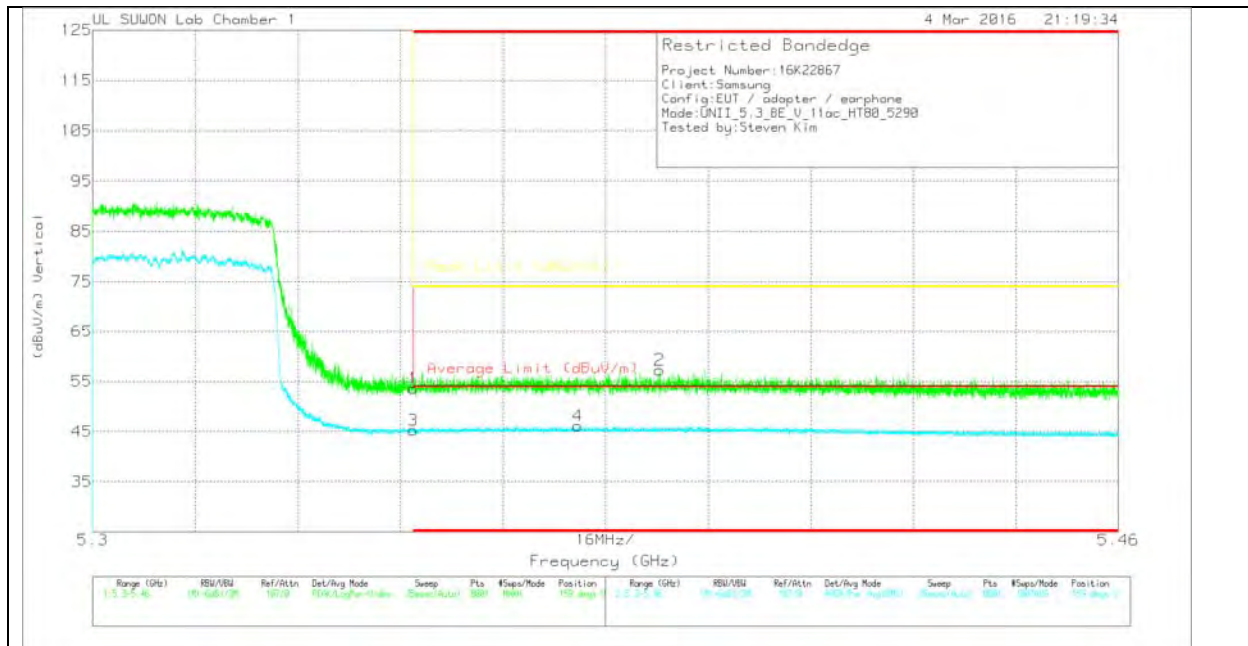

VERTICAL DATA

TRACE MARKERS

| Marker | Frequency (GHz) | Meter Reading (dBuV) | Det | 3117(001687 17_150619) | Path_2 | DC Corr (dB) | Corrected Reading (dBuV/m) | Average Limit (dBuV/m) | Margin (dB) | Peak Limit (dBuV/m) | PK Margin (dB) | Azimuth (Degs) | Height (cm) | Polarity |
|--------|-----------------|----------------------|-----|------------------------|--------|--------------|----------------------------|------------------------|-------------|---------------------|----------------|----------------|-------------|----------|
| 1 | * 5.35 | 42.42 | Pk | 34.5 | -23.3 | 0 | 53.62 | - | - | 74 | -20.38 | 159 | 275 | V |
| 2 | * 5.388 | 46.09 | Pk | 34.5 | -23.3 | 0 | 57.29 | - | - | 74 | -16.71 | 159 | 275 | V |
| 3 | * 5.35 | 32.96 | RMS | 34.5 | -23.3 | 1.11 | 45.27 | 54 | -8.73 | - | - | 159 | 275 | V |
| 4 | * 5.376 | 33.81 | RMS | 34.5 | -23.3 | 1.11 | 46.12 | 54 | -7.88 | - | - | 159 | 275 | V |

* - indicates frequency in CFR15.205/IC7.2.2 Restricted Band

Pk - Peak detector

RMS - RMS detection

HARMONICS AND SPURIOUS EMISSIONS

MID CHANNEL HORIZONTAL

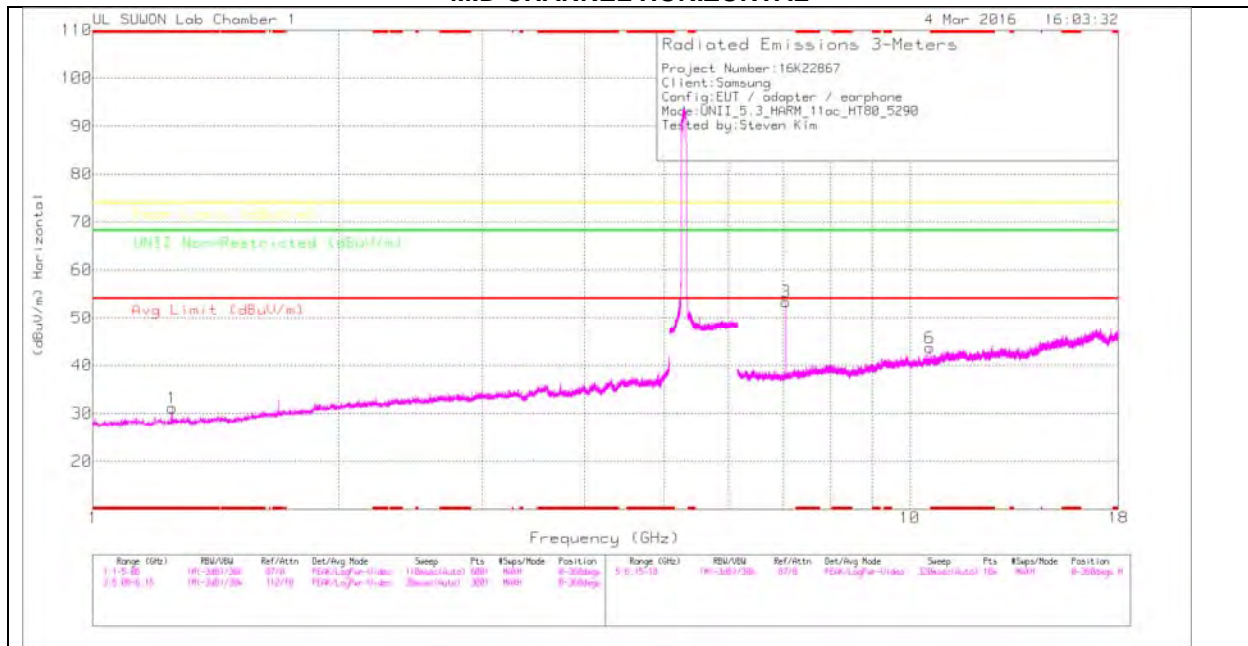

MID CHANNEL VERTICAL

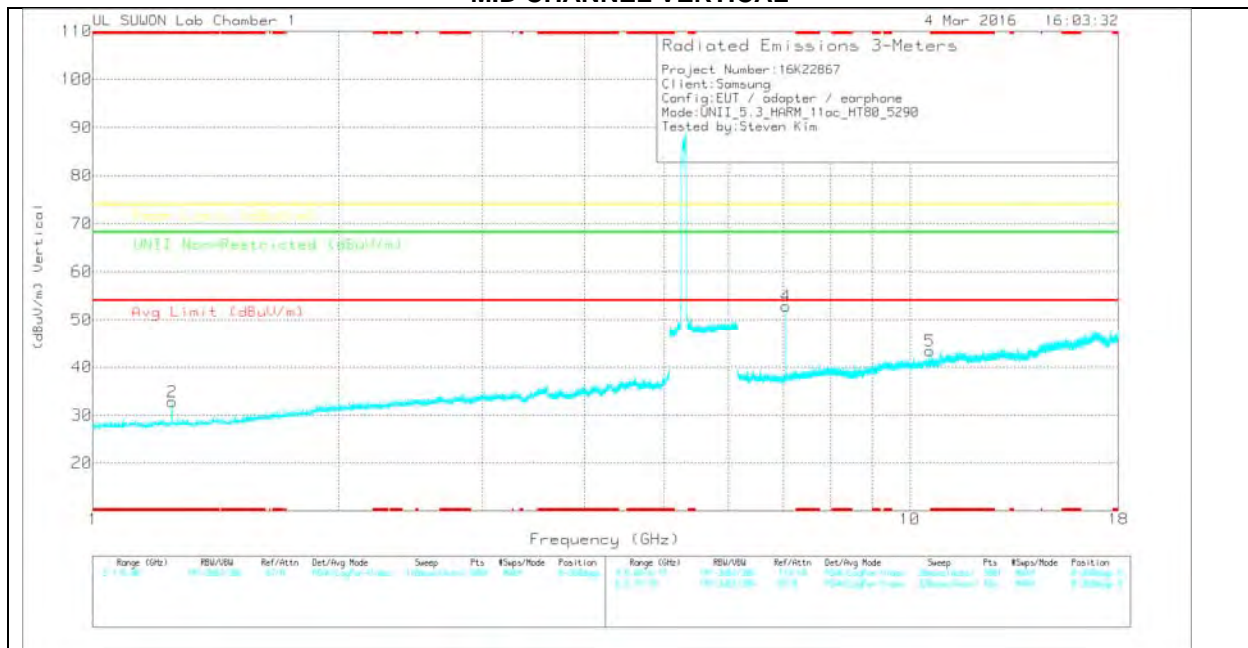

Note: Emission was scanned up to 40GHz; No emissions were detected above the noise floor which was at least 20dB below the specification limit.

MID CHANNEL DATA

TRACE MARKERS

| Marker | Frequency (GHz) | Meter Reading (dBuV) | Det | 3117(0016 8717)_150 619 | Path_4 | DC Corr (dB) | Corrected Reading (dBuV/m) | Avg Limit (dBuV/m) | Margin (dB) | Peak Limit (dBuV/m) | Margin (dB) | UNII Non-Restricted (dBuV/m) | Margin (dB) | Azimuth (Degs) | Height (cm) | Polarity |
|--------|-----------------|----------------------|-----|-------------------------|--------|--------------|----------------------------|--------------------|-------------|---------------------|-------------|------------------------------|-------------|----------------|-------------|----------|
| 1 | * 1.25 | 42.99 | PK | 28.3 | -40.2 | 0 | 31.09 | - | - | 74 | -42.91 | - | - | 0-360 | 200 | H |
| 2 | * 1.25 | 44.69 | PK | 28.3 | -40.2 | 0 | 32.79 | - | - | 74 | -41.21 | - | - | 0-360 | 200 | V |
| 3 | 7.053 | 48.18 | PK | 35.7 | -30.5 | 0 | 53.38 | - | - | - | - | 68.2 | -14.82 | 0-360 | 100 | H |
| 6 | 10.58 | 32.51 | PK | 37.9 | -26.8 | 0 | 43.61 | - | - | - | - | 68.2 | -24.59 | 0-360 | 100 | H |
| 4 | 7.053 | 47.65 | PK | 35.7 | -30.5 | 0 | 52.85 | - | - | - | - | 68.2 | -15.35 | 0-360 | 200 | V |
| 5 | 10.58 | 32.28 | PK | 37.9 | -26.8 | 0 | 43.38 | - | - | - | - | 68.2 | -24.82 | 0-360 | 200 | V |

* - indicates frequency in CFR15.205/IC7.2.2 Restricted Band

PK – Peak detector

Radiated Emissions

| Frequency (GHz) | Meter Reading (dBuV) | Det | 3117(001687 17)_150619 | Path_5 | DC Corr (dB) | Corrected Reading (dBuV/m) | Avg Limit (dBuV/m) | Margin (dB) | Peak Limit (dBuV/m) | Margin (dB) | UNII Non-Restricted (dBuV/m) | Margin (dB) | Azimuth (Degs) | Height (cm) | Polarity |
|-----------------|----------------------|------|------------------------|--------|--------------|----------------------------|--------------------|-------------|---------------------|-------------|------------------------------|-------------|----------------|-------------|----------|
| 7.053 | 51.4 | PK-U | 35.7 | -30.5 | 0 | 56.6 | - | - | - | - | 68.2 | -11.6 | 58 | 173 | H |
| 7.053 | 49.84 | PK-U | 35.7 | -30.5 | 0 | 55.04 | - | - | - | - | 68.2 | -13.16 | 185 | 303 | V |

* - indicates frequency in CFR15.205/IC7.2.2 Restricted Band

PK-U - U-NII: Maximum Peak

11.3. 5.5-5.6 GHz

11.3.1. TX ABOVE 1 GHz 802.11a 2TX CDD MODE IN THE 5.5 GHz BAND

RESTRICTED BANDEDGE (LOW CHANNEL)

HORIZONTAL PEAK AND AVERAGE PLOT

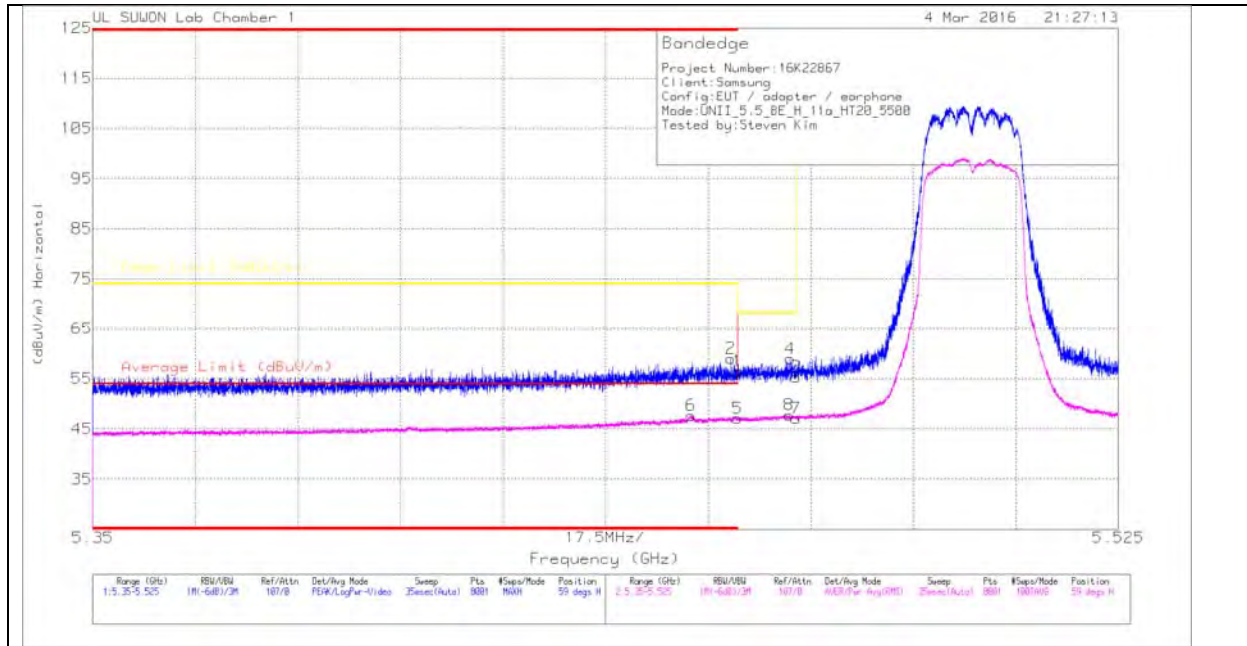

HORIZONTAL DATA

TRACE MARKERS

| Marker | Frequency (GHz) | Meter Reading (dBuV) | Det | 3117(001687 17)_150619 | Path_2 | DC Corr (dB) | Corrected Reading (dBuV/m) | Average Limit (dBuV/m) | Margin (dB) | Peak Limit (dBuV/m) | PK Margin (dB) | Azimuth (Degs) | Height (cm) | Polarity |
|--------|-----------------|----------------------|-----|------------------------|--------|--------------|----------------------------|------------------------|-------------|---------------------|----------------|----------------|-------------|----------|
| 1 | * 5.46 | 45.11 | PK | 34.6 | -23.2 | 0 | 56.51 | - | - | 74 | -17.49 | 59 | 101 | H |
| 2 | * 5.459 | 47.61 | PK | 34.6 | -23.2 | 0 | 59.01 | - | - | 74 | -14.99 | 59 | 101 | H |
| 3 | 5.47 | 43.83 | PK | 34.6 | -23.1 | 0 | 55.33 | - | - | 68.2 | -12.87 | 59 | 101 | H |
| 4 | 5.469 | 47.47 | PK | 34.6 | -23.1 | 0 | 58.97 | - | - | 68.2 | -9.23 | 59 | 101 | H |
| 5 | * 5.46 | 35.43 | RMS | 34.6 | -23.2 | .29 | 47.12 | 54 | -6.88 | - | - | 59 | 101 | H |
| 6 | * 5.452 | 35.97 | RMS | 34.6 | -23.2 | .29 | 47.66 | 54 | -6.34 | - | - | 59 | 101 | H |
| 7 | 5.47 | 35.31 | RMS | 34.6 | -23.1 | .29 | 47.1 | - | - | - | - | 59 | 101 | H |
| 8 | 5.469 | 36 | RMS | 34.6 | -23.1 | .29 | 47.79 | - | - | - | - | 59 | 101 | H |

* - indicates frequency in CFR15.205/IC7.2.2 Restricted Band

Pk - Peak detector

RMS - RMS detection

VERTICAL PEAK AND AVERAGE PLOT

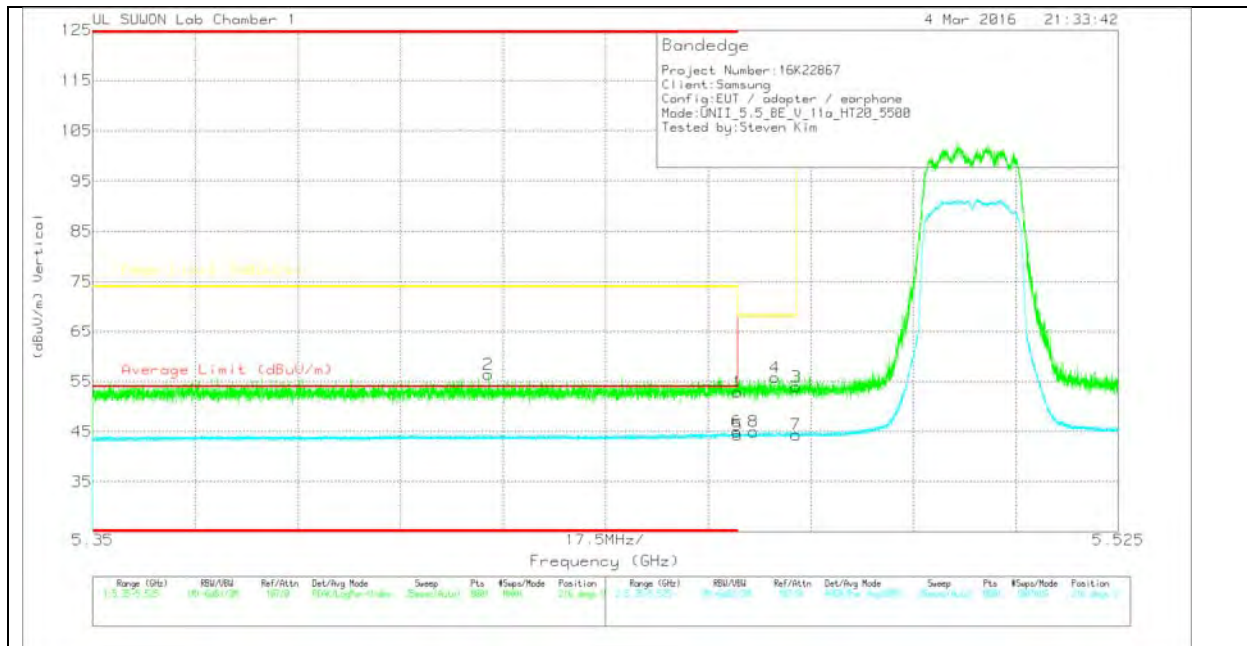

VERTICAL DATA

TRACE MARKERS

| Marker | Frequency (GHz) | Meter Reading (dBuV) | Det | 3117(001687 17_150619) | Path_2 | DC Corr (dB) | Corrected Reading (dBuV/m) | Average Limit (dBuV/m) | Margin (dB) | Peak Limit (dBuV/m) | PK Margin (dB) | Azimuth (Degs) | Height (cm) | Polarity |
|--------|-----------------|----------------------|-----|------------------------|--------|--------------|----------------------------|------------------------|-------------|---------------------|----------------|----------------|-------------|----------|
| 1 | * 5.46 | 41.44 | Pk | 34.6 | -23.2 | 0 | 52.84 | - | - | 74 | -21.16 | 216 | 130 | V |
| 2 | * 5.417 | 45.08 | Pk | 34.6 | -23.3 | 0 | 56.38 | - | - | 74 | -17.62 | 216 | 130 | V |
| 3 | 5.47 | 42.43 | Pk | 34.6 | -23.1 | 0 | 53.93 | - | - | 68.2 | -14.27 | 216 | 130 | V |
| 4 | 5.466 | 44.27 | Pk | 34.6 | -23.1 | 0 | 55.77 | - | - | 68.2 | -12.43 | 216 | 130 | V |
| 5 | * 5.46 | 32.61 | RMS | 34.6 | -23.2 | 29 | 44.3 | 54 | -9.7 | - | - | 216 | 130 | V |
| 6 | * 5.46 | 33.28 | RMS | 34.6 | -23.2 | 29 | 44.97 | 54 | -9.03 | - | - | 216 | 130 | V |
| 7 | 5.47 | 32.58 | RMS | 34.6 | -23.1 | 29 | 44.37 | - | - | - | - | 216 | 130 | V |
| 8 | 5.463 | 33.2 | RMS | 34.6 | -23.1 | 29 | 44.99 | - | - | - | - | 216 | 130 | V |

* - indicates frequency in CFR15.205/IC7.2.2 Restricted Band

Pk - Peak detector

RMS - RMS detection

AUTHORIZED BANDEDGE (HIGH CHANNEL)

HORIZONTAL PEAK AND AVERAGE PLOT

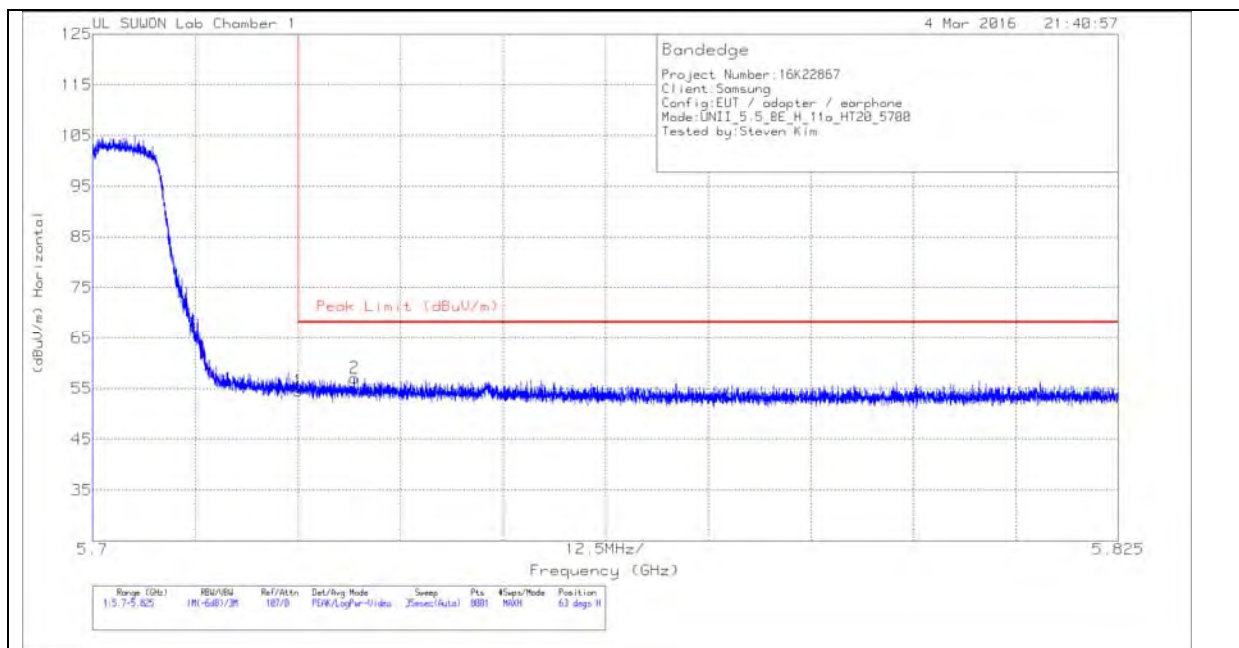

HORIZONTAL DATA

TRACE MARKERS

| Marker | Frequency (GHz) | Meter Reading (dBuV) | Det | 3117(0016 8717)_150 619 | Path_2 | DC Corr (dB) | Corrected Reading (dBuV/m) | Peak Limit (dBuV/m) | PK Margin (dB) | Azimuth (Degs) | Height (cm) | Polarity |
|--------|-----------------|----------------------|-----|-------------------------|--------|--------------|----------------------------|---------------------|----------------|----------------|-------------|----------|
| 1 | 5.725 | 42.56 | Pk | 34.8 | -22.8 | 0 | 54.56 | 68.2 | -13.64 | 63 | 188 | H |
| 2 | 5.732 | 45.07 | Pk | 34.8 | -22.8 | 0 | 57.07 | 68.2 | -11.13 | 63 | 188 | H |

Pk - Peak detector

VERTICAL PEAK AND AVERAGE PLOT

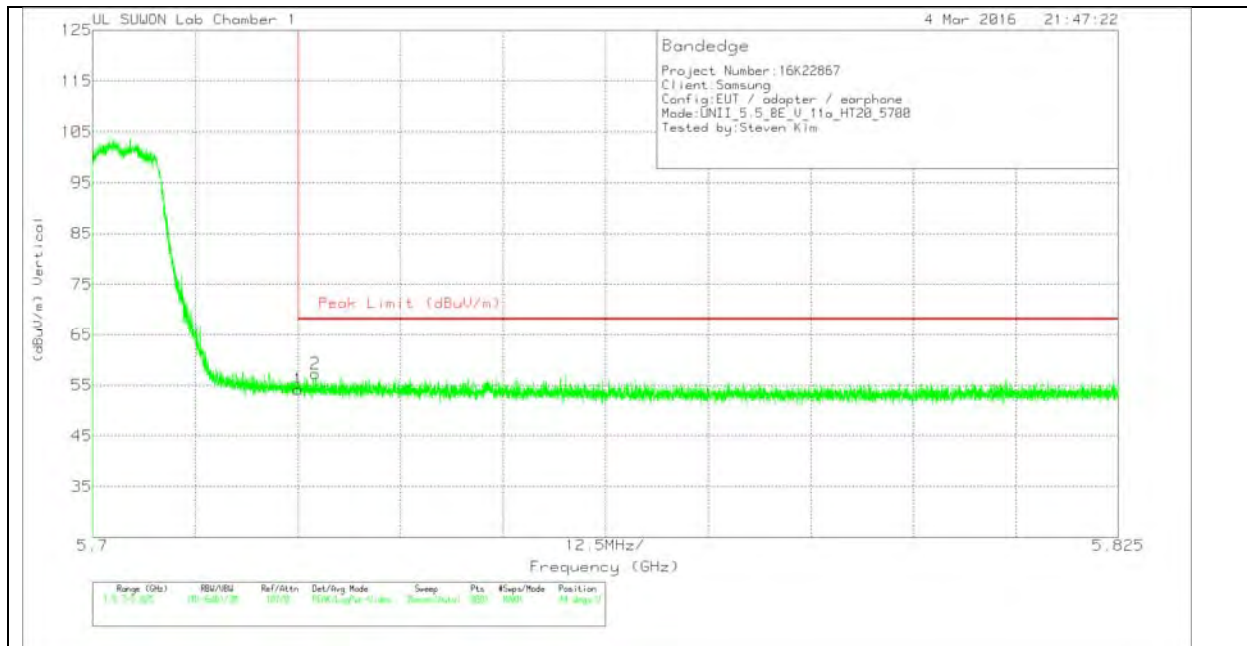

VERTICAL DATA

TRACE MARKERS

| Marker | Frequency (GHz) | Meter Reading (dBuV) | Det | 3117(0016 8717)_150 619 | Path_2 | DC Corr (dB) | Corrected Reading (dBuV/m) | Peak Limit (dBuV/m) | PK Margin (dB) | Azimuth (Degs) | Height (cm) | Polarity |
|--------|-----------------|----------------------|-----|-------------------------|--------|--------------|----------------------------|---------------------|----------------|----------------|-------------|----------|
| 1 | 5.725 | 42.16 | Pk | 34.8 | -22.8 | 0 | 54.16 | 68.2 | -14.04 | 44 | 136 | V |
| 2 | 5.727 | 45.29 | Pk | 34.8 | -22.8 | 0 | 57.29 | 68.2 | -10.91 | 44 | 136 | V |

Pk - Peak detector

HARMONICS AND SPURIOUS EMISSIONS

LOW CHANNEL HORIZONTAL

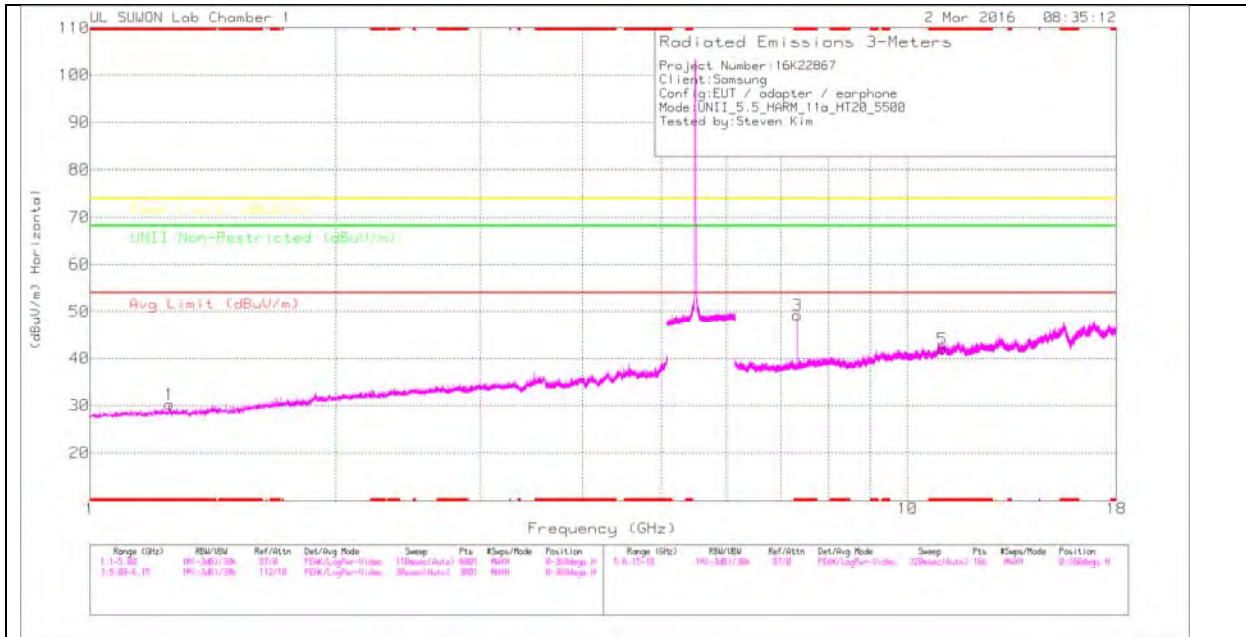

LOW CHANNEL VERTICAL

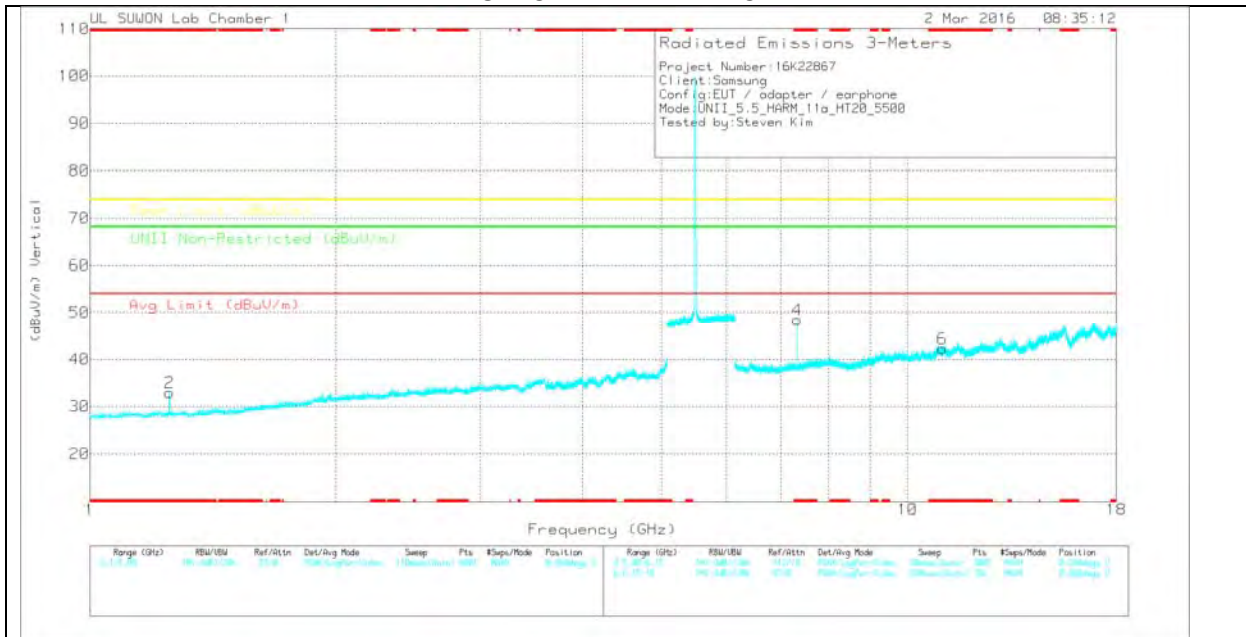

Note: Emission was scanned up to 40GHz; No emissions were detected above the noise floor which was at least 20dB below the specification limit.

LOW CHANNEL DATA

TRACE MARKERS

| Marker | Frequency (GHz) | Meter Reading (dBuV) | Det | 3117(0016 8717)_150 619 | Path_4 | DC Corr (dB) | Corrected Reading (dBuV/m) | Avg Limit (dBuV/m) | Margin (dB) | Peak Limit (dBuV/m) | Margin (dB) | UNII Non-Restricted (dBuV/m) | Margin (dB) | Azimuth (Degs) | Height (cm) | Polarity |
|--------|-----------------|----------------------|-----|-------------------------|--------|--------------|----------------------------|--------------------|-------------|---------------------|-------------|------------------------------|-------------|----------------|-------------|----------|
| 1 | * 1.25 | 42.09 | PK | 28.3 | -40.2 | 0 | 30.19 | - | - | 74 | -43.81 | - | - | 0-360 | 200 | H |
| 2 | * 1.25 | 44.84 | PK | 28.3 | -40.2 | 0 | 32.94 | - | - | 74 | -41.06 | - | - | 0-360 | 200 | V |
| 3 | * 7.333 | 43.99 | PK | 35.8 | -30.5 | 0 | 49.29 | - | - | 74 | -24.71 | - | - | 0-360 | 100 | H |
| 5 | * 11.024 | 31.06 | PK | 38.2 | -27.2 | 0 | 42.06 | - | - | 74 | -31.94 | - | - | 0-360 | 200 | H |
| 4 | * 7.333 | 43.21 | PK | 35.8 | -30.5 | 0 | 48.51 | - | - | 74 | -25.49 | - | - | 0-360 | 100 | V |
| 6 | * 11.023 | 31.29 | PK | 38.2 | -27.2 | 0 | 42.29 | - | - | 74 | -31.71 | - | - | 0-360 | 100 | V |

* - indicates frequency in CFR15.205/IC7.2.2 Restricted Band

PK – Peak detector

Radiated Emissions

| Frequency (GHz) | Meter Reading (dBuV) | Det | 3117(001687 17)_150619 | Path_5 | DC Corr (dB) | Corrected Reading (dBuV/m) | Avg Limit (dBuV/m) | Margin (dB) | Peak Limit (dBuV/m) | Margin (dB) | UNII Non-Restricted (dBuV/m) | Margin (dB) | Azimuth (Degs) | Height (cm) | Polarity |
|-----------------|----------------------|------|------------------------|--------|--------------|----------------------------|--------------------|-------------|---------------------|-------------|------------------------------|-------------|----------------|-------------|----------|
| * 7.333 | 49.62 | PK-U | 35.8 | -30.5 | 0 | 54.92 | - | - | 74 | -19.08 | - | - | 168 | 109 | H |
| * 7.333 | 43.55 | ADR | 35.8 | -30.5 | 0 | 48.85 | 54 | -5.15 | - | - | - | - | 168 | 109 | H |
| * 7.333 | 49.59 | PK-U | 35.8 | -30.5 | 0 | 54.89 | - | - | 74 | -19.11 | - | - | 164 | 257 | V |
| * 7.333 | 44.46 | ADR | 35.8 | -30.5 | 0 | 49.76 | 54 | -4.24 | - | - | - | - | 164 | 257 | V |

* - indicates frequency in CFR15.205/IC7.2.2 Restricted Band

PK-U - U-NII: Maximum Peak

ADR - U-NII AD primary method, RMS average

MID CHANNEL HORIZONTAL

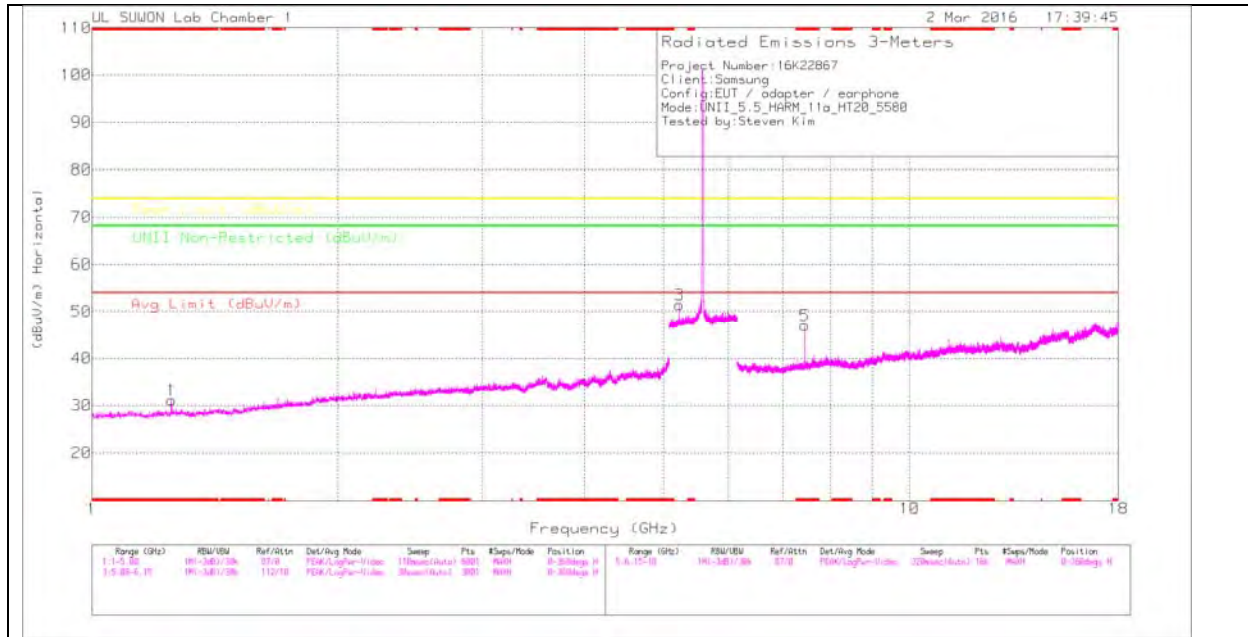

MID CHANNEL VERTICAL

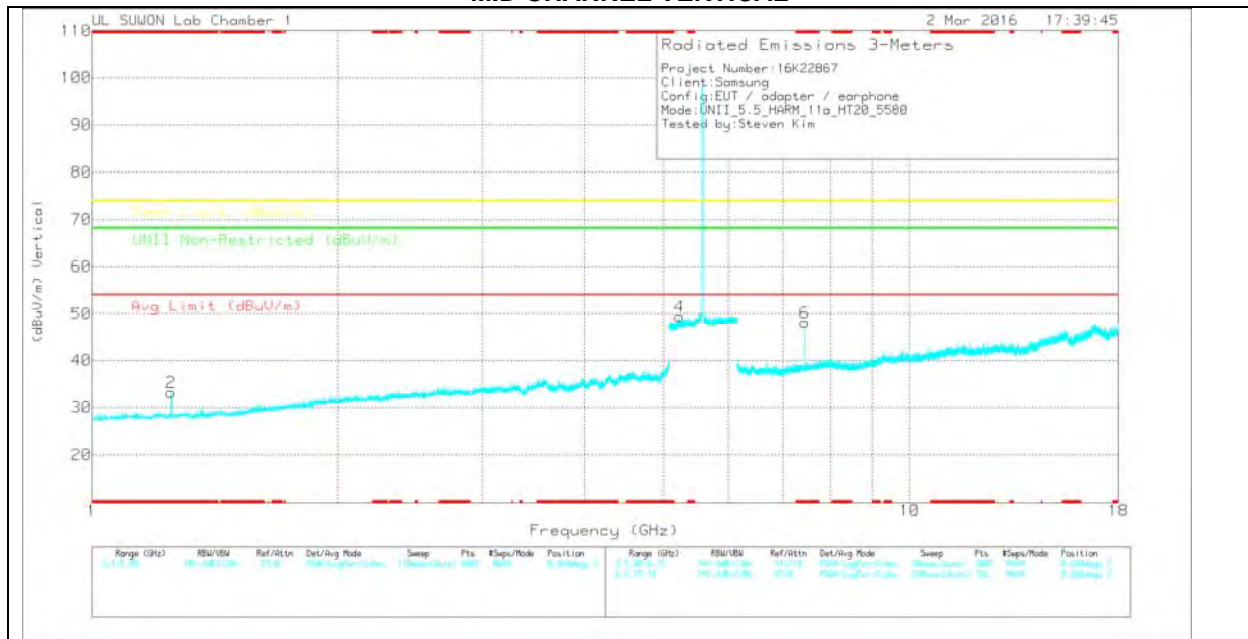

Note: Emission was scanned up to 40GHz; No emissions were detected above the noise floor which was at least 20dB below the specification limit.

MID CHANNEL DATA

TRACE MARKERS

| Marker | Frequency (GHz) | Meter Reading (dBuV) | Det | 3117(0016 8717)_150 619 | Path_4 | DC Corr (dB) | Corrected Reading (dBuV/m) | Avg Limit (dBuV/m) | Margin (dB) | Peak Limit (dBuV/m) | Margin (dB) | UNII Non-Restricted (dBuV/m) | Margin (dB) | Azimuth (Degs) | Height (cm) | Polarity |
|--------|-----------------|----------------------|-----|-------------------------|--------|--------------|----------------------------|--------------------|-------------|---------------------|-------------|------------------------------|-------------|----------------|-------------|----------|
| 1 | * 1.25 | 43.09 | PK | 28.3 | -40.2 | 0 | 31.19 | - | - | 74 | -42.81 | - | - | 0-360 | 200 | H |
| 2 | * 1.25 | 45.11 | PK | 28.3 | -40.2 | 0 | 33.21 | - | - | 74 | -40.79 | - | - | 0-360 | 200 | V |
| 3 | 5.228 | 40.83 | PK | 34.3 | -23.7 | 0 | 51.43 | - | - | - | - | 68.2 | -16.77 | 0-360 | 100 | H |
| 4 | 5.228 | 38.79 | PK | 34.3 | -23.7 | 0 | 49.39 | - | - | - | - | 68.2 | -18.81 | 0-360 | 100 | V |
| 5 | * 7.439 | 41.85 | PK | 35.8 | -30.6 | 0 | 47.05 | - | - | 74 | -26.95 | - | - | 0-360 | 100 | H |
| 6 | * 7.439 | 42.83 | PK | 35.8 | -30.6 | 0 | 48.03 | - | - | 74 | -25.97 | - | - | 0-360 | 200 | V |

* - indicates frequency in CFR15.205/IC7.2.2 Restricted Band

PK – Peak detector

Radiated Emissions

| Frequency (GHz) | Meter Reading (dBuV) | Det | 3117(001687 17)_150619 | Path_2 | DC Corr (dB) | Corrected Reading (dBuV/m) | Avg Limit (dBuV/m) | Margin (dB) | Peak Limit (dBuV/m) | Margin (dB) | UNII Non-Restricted (dBuV/m) | Margin (dB) | Azimuth (Degs) | Height (cm) | Polarity |
|-----------------|----------------------|------|------------------------|--------|--------------|----------------------------|--------------------|-------------|---------------------|-------------|------------------------------|-------------|----------------|-------------|----------|
| 5.228 | 49.07 | PK-U | 34.3 | -23.7 | 0 | 59.67 | - | - | - | - | 68.2 | -8.53 | 114 | 214 | H |
| 5.229 | 47.98 | PK-U | 34.3 | -23.7 | 0 | 58.58 | - | - | - | - | 68.2 | -9.62 | 205 | 123 | V |
| * 7.44 | 42.47 | ADR | 35.8 | -30.5 | 0 | 47.77 | 54 | -6.23 | - | - | - | - | 167 | 237 | V |
| * 7.44 | 40.65 | ADR | 35.8 | -30.5 | 0 | 45.95 | 54 | -8.05 | - | - | - | - | 166 | 102 | H |
| * 7.44 | 48.94 | PK-U | 35.8 | -30.5 | 0 | 54.24 | - | - | 74 | -19.76 | - | - | 167 | 237 | V |
| * 7.44 | 47.98 | PK-U | 35.8 | -30.5 | 0 | 53.28 | - | - | 74 | -20.72 | - | - | 166 | 102 | H |

* - indicates frequency in CFR15.205/IC7.2.2 Restricted Band

PK-U - U-NII: Maximum Peak

ADR - U-NII AD primary method, RMS average

HIGH CHANNEL HORIZONTAL

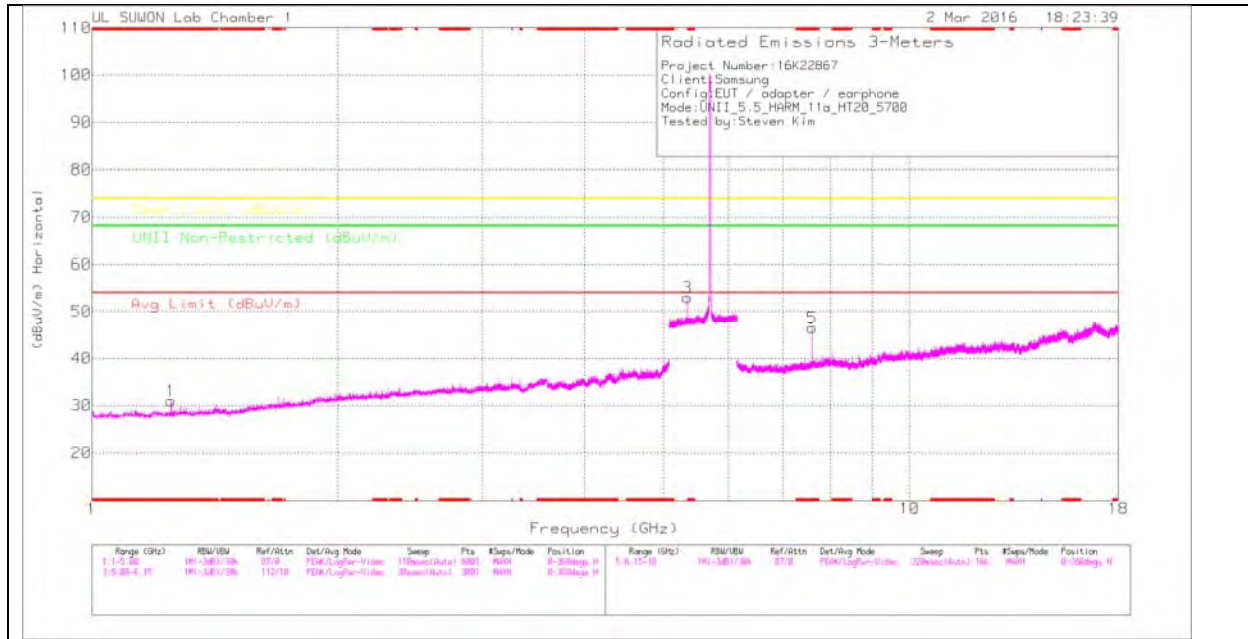

HIGH CHANNEL VERTICAL

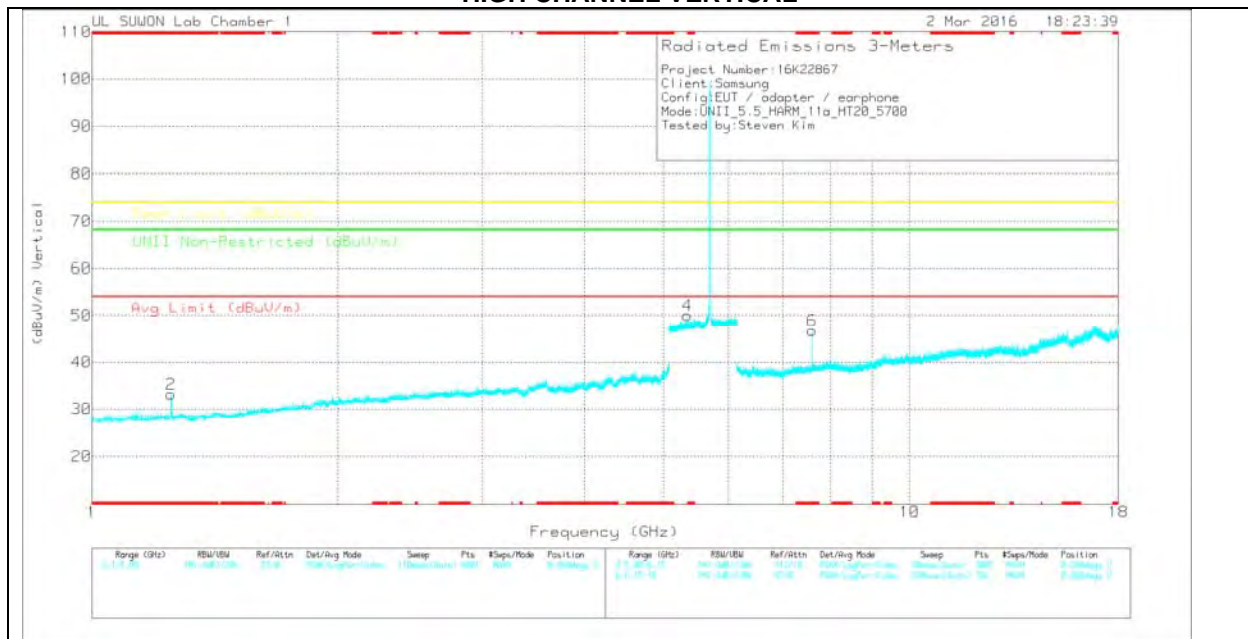

Note: Emission was scanned up to 40GHz; No emissions were detected above the noise floor which was at least 20dB below the specification limit.

HIGH CHANNEL DATA

TRACE MARKERS

| Marker | Frequency (GHz) | Meter Reading (dBuV) | Det | 3117(0016 8717)_150 619 | Path_4 | DC Corr (dB) | Corrected Reading (dBuV/m) | Avg Limit (dBuV/m) | Margin (dB) | Peak Limit (dBuV/m) | Margin (dB) | UNII Non-Restricted (dBuV/m) | Margin (dB) | Azimuth (Degs) | Height (cm) | Polarity |
|--------|-----------------|----------------------|-----|-------------------------|--------|--------------|----------------------------|--------------------|-------------|---------------------|-------------|------------------------------|-------------|----------------|-------------|----------|
| 1 | * 1.25 | 42.86 | PK | 28.3 | -40.2 | 0 | 30.96 | - | - | 74 | -43.04 | - | - | 0-360 | 200 | H |
| 2 | * 1.25 | 45.11 | PK | 28.3 | -40.2 | 0 | 33.21 | - | - | 74 | -40.79 | - | - | 0-360 | 200 | V |
| 3 | 5.348 | 41.76 | PK | 34.5 | -23.3 | 0 | 52.96 | - | - | - | - | 68.2 | -15.24 | 0-360 | 100 | H |
| 4 | 5.348 | 38.79 | PK | 34.5 | -23.3 | 0 | 49.99 | - | - | - | - | 68.2 | -18.21 | 0-360 | 100 | V |
| 5 | * 7.599 | 40.95 | PK | 35.9 | -30.3 | 0 | 46.55 | - | - | 74 | -27.45 | - | - | 0-360 | 100 | H |
| 6 | * 7.6 | 41.25 | PK | 35.9 | -30.3 | 0 | 46.85 | - | - | 74 | -27.15 | - | - | 0-360 | 100 | V |

* - indicates frequency in CFR15.205/IC7.2.2 Restricted Band

PK – Peak detector

Radiated Emissions

| Frequency (GHz) | Meter Reading (dBuV) | Det | 3117(001687 17)_150619 | Path_2 | DC Corr (dB) | Corrected Reading (dBuV/m) | Avg Limit (dBuV/m) | Margin (dB) | Peak Limit (dBuV/m) | Margin (dB) | UNII Non-Restricted (dBuV/m) | Margin (dB) | Azimuth (Degs) | Height (cm) | Polarity |
|-----------------|----------------------|------|------------------------|--------|--------------|----------------------------|--------------------|-------------|---------------------|-------------|------------------------------|-------------|----------------|-------------|----------|
| 5.348 | 49.67 | PK-U | 34.5 | -23.3 | 0 | 60.87 | - | - | - | - | 68.2 | -7.33 | 120 | 206 | H |
| 5.348 | 48.94 | PK-U | 34.5 | -23.3 | 0 | 60.14 | - | - | - | - | 68.2 | -8.06 | 210 | 136 | V |
| * 7.6 | 38.23 | ADR | 35.9 | -30.3 | 0 | 43.83 | 54 | -10.17 | - | - | - | - | 203 | 114 | V |
| * 7.6 | 40.26 | ADR | 35.9 | -30.3 | 0 | 45.86 | 54 | -8.14 | - | - | - | - | 172 | 103 | H |
| * 7.6 | 47.02 | PK-U | 35.9 | -30.3 | 0 | 52.62 | - | - | 74 | -21.38 | - | - | 203 | 114 | V |
| * 7.6 | 47.36 | PK-U | 35.9 | -30.3 | 0 | 52.96 | - | - | 74 | -21.04 | - | - | 172 | 103 | H |

* - indicates frequency in CFR15.205/IC7.2.2 Restricted Band

PK-U - U-NII: Maximum Peak

ADR - U-NII AD primary method, RMS average

11.3.2. TX ABOVE 1GHz 802.11n HT20 2TX CDD MODE IN THE 5.5GHz BAND RESTRICTED BANDEDGE (LOW CHANNEL)

HORIZONTAL PEAK AND AVERAGE PLOT

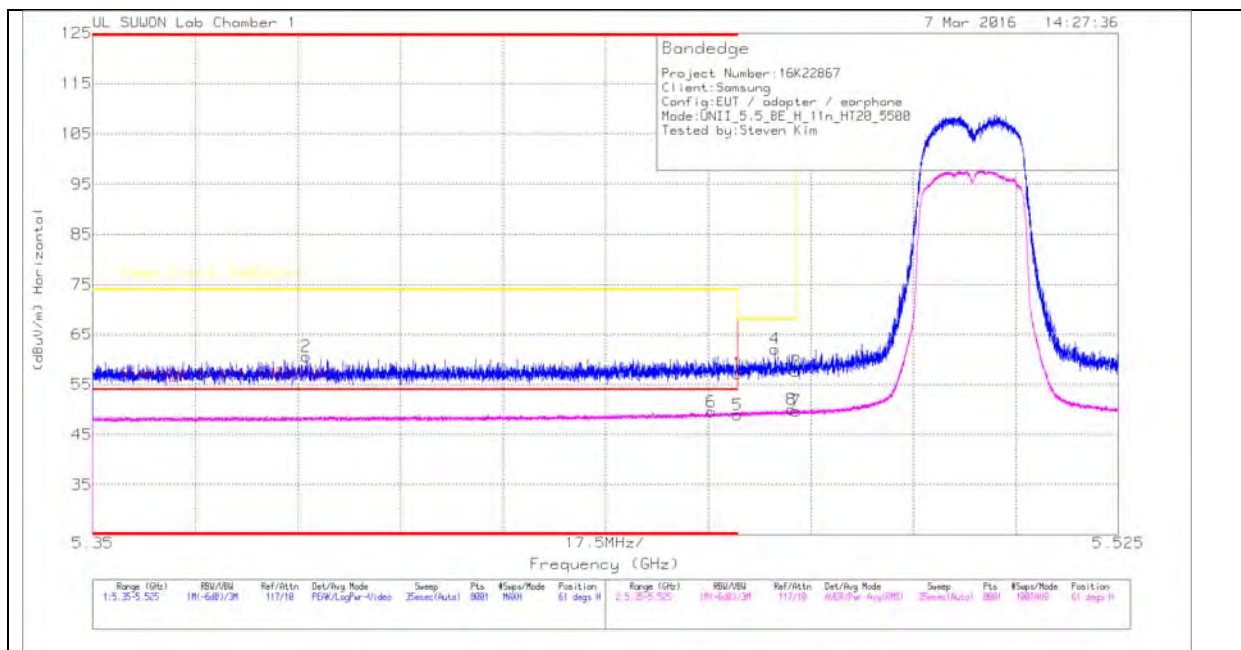

HORIZONTAL DATA

TRACE MARKERS

| Marker | Frequency (GHz) | Meter Reading (dBUV) | Det | 3117(001687 17_150619) | Path_2 | DC Corr (dB) | Corrected Reading (dBUV/m) | Average Limit (dBUV/m) | Margin (dB) | Peak Limit (dBUV/m) | PK Margin (dB) | Azimuth (Degs) | Height (cm) | Polarity |
|--------|-----------------|----------------------|-----|------------------------|--------|--------------|----------------------------|------------------------|-------------|---------------------|----------------|----------------|-------------|----------|
| 1 | * 5.46 | 45.79 | PK | 34.6 | -23.2 | 0 | 57.19 | - | - | 74 | -16.81 | 61 | 207 | H |
| 2 | * 5.386 | 49.41 | PK | 34.5 | -23.3 | 0 | 60.61 | - | - | 74 | -13.39 | 61 | 207 | H |
| 3 | 5.47 | 46.1 | PK | 34.6 | -23.1 | 0 | 57.6 | - | - | 68.2 | -10.6 | 61 | 207 | H |
| 4 | 5.466 | 50.58 | PK | 34.6 | -23.1 | 0 | 62.08 | - | - | 68.2 | -6.12 | 61 | 207 | H |
| 5 | * 5.46 | 37.23 | RMS | 34.6 | -23.2 | .31 | 48.94 | 54 | -5.06 | - | - | 61 | 207 | H |
| 6 | * 5.455 | 37.86 | RMS | 34.6 | -23.2 | .31 | 49.57 | 54 | -4.43 | - | - | 61 | 207 | H |
| 7 | 5.47 | 37.9 | RMS | 34.6 | -23.1 | .31 | 49.71 | - | - | - | - | 61 | 207 | H |
| 8 | 5.469 | 38.2 | RMS | 34.6 | -23.1 | .31 | 50.01 | - | - | - | - | 61 | 207 | H |

* - indicates frequency in CFR15.205/IC7.2.2 Restricted Band

Pk - Peak detector

RMS - RMS detection

AUTHORIZED BANDEDGE (HIGH CHANNEL)

HORIZONTAL PEAK AND AVERAGE PLOT

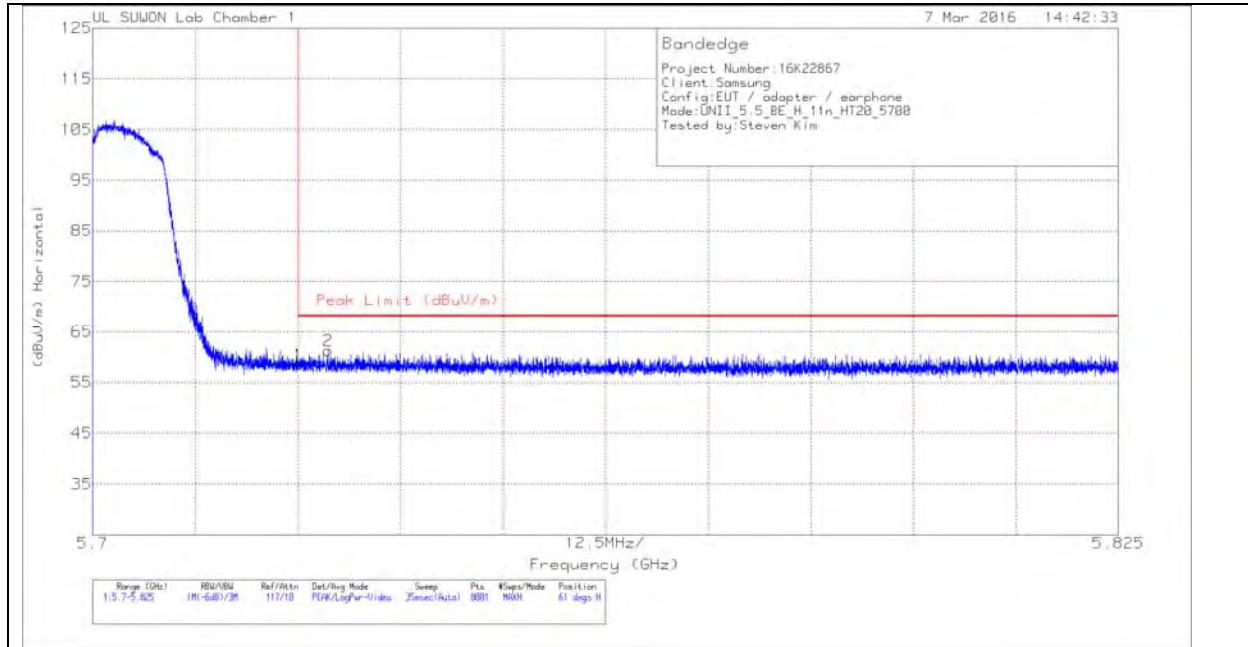

HORIZONTAL DATA

TRACE MARKERS

| Marker | Frequency (GHz) | Meter Reading (dBuV) | Det | 3117(0016 8717)_150 619 | Path_2 | DC Corr (dB) | Corrected Reading (dBuV/m) | Peak Limit (dBuV/m) | PK Margin (dB) | Azimuth (Degs) | Height (cm) | Polarity |
|--------|-----------------|----------------------|-----|-------------------------|--------|--------------|----------------------------|---------------------|----------------|----------------|-------------|----------|
| 1 | 5.725 | 46.46 | Pk | 34.8 | -22.8 | 0 | 58.46 | 68.2 | -9.74 | 61 | 145 | H |
| 2 | 5.729 | 49.27 | Pk | 34.8 | -22.8 | 0 | 61.27 | 68.2 | -6.93 | 61 | 145 | H |

Pk - Peak detector

VERTICAL PEAK AND AVERAGE PLOT

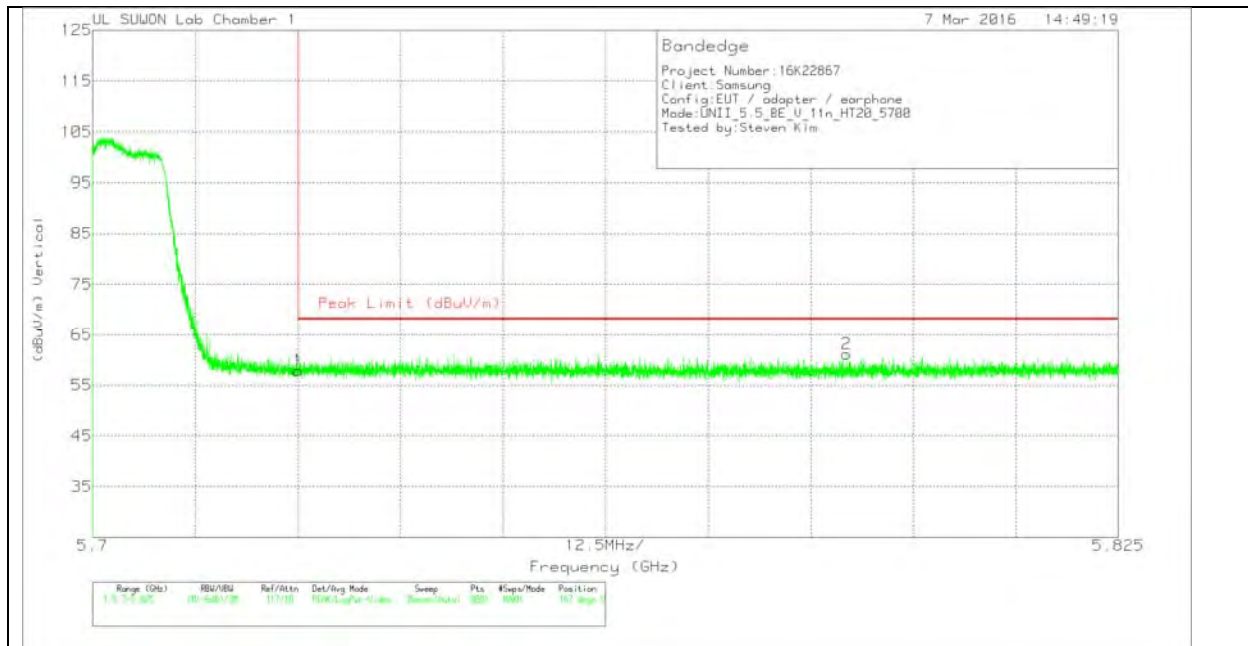

VERTICAL DATA

TRACE MARKERS

| Marker | Frequency (GHz) | Meter Reading (dBuV) | Det | 3117(0016 8717)_150 619 | Path_2 | DC Corr (dB) | Corrected Reading (dBuV/m) | Peak Limit (dBuV/m) | PK Margin (dB) | Azimuth (Degs) | Height (cm) | Polarity |
|--------|-----------------|----------------------|-----|-------------------------|--------|--------------|----------------------------|---------------------|----------------|----------------|-------------|----------|
| 1 | 5.725 | 45.93 | Pk | 34.8 | -22.8 | 0 | 57.93 | 68.2 | -10.27 | 167 | 120 | V |
| 2 | 5.792 | 48.99 | Pk | 34.8 | -22.6 | 0 | 61.19 | 68.2 | -7.01 | 167 | 120 | V |

Pk - Peak detector

HARMONICS AND SPURIOUS EMISSIONS

LOW CHANNEL HORIZONTAL

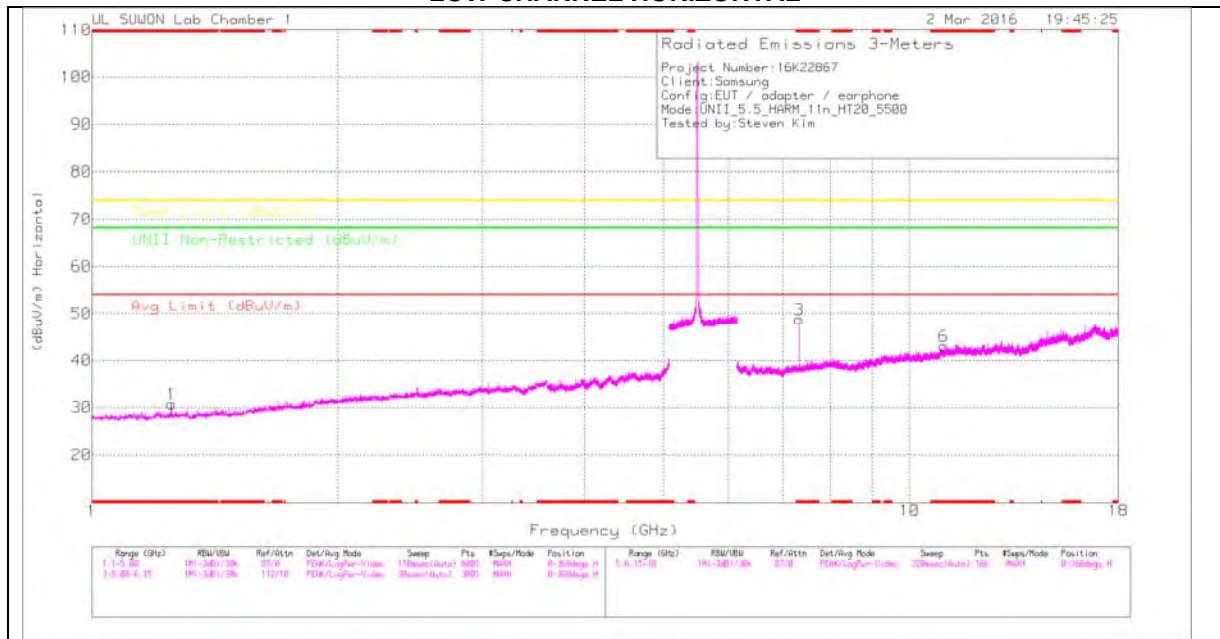

LOW CHANNEL VERTICAL

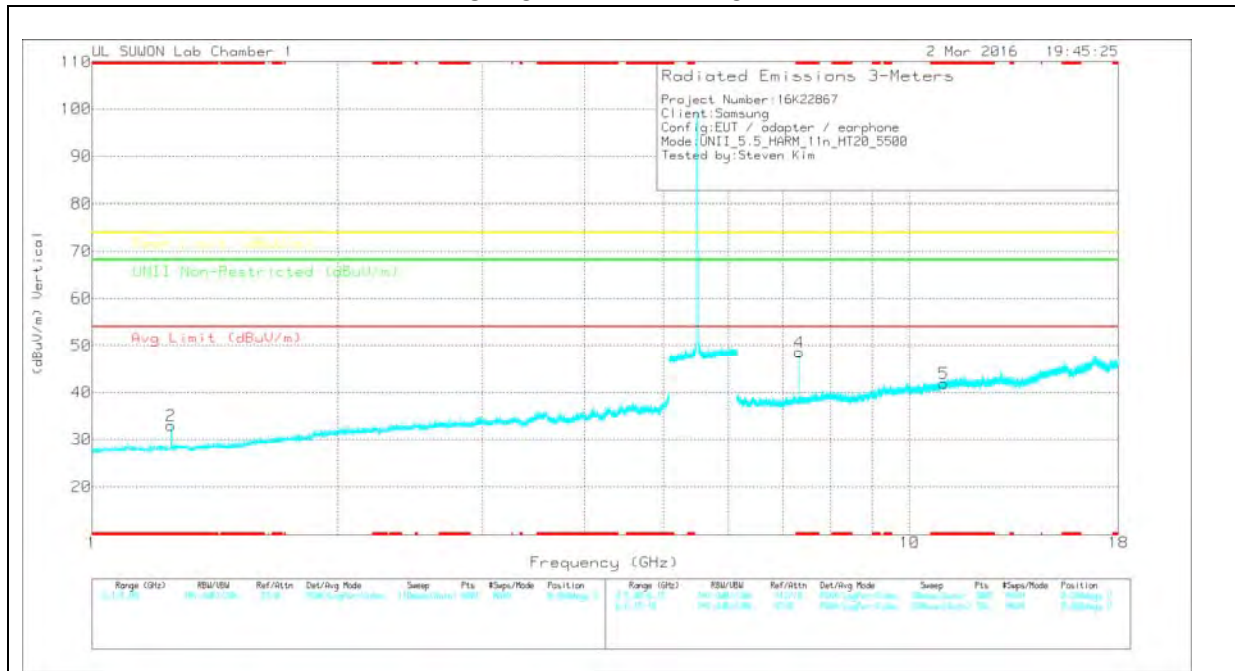

Note: Emission was scanned up to 40GHz; No emissions were detected above the noise floor which was at least 20dB below the specification limit.

LOW CHANNEL DATA

TRACE MARKERS

| Marker | Frequency (GHz) | Meter Reading (dBuV) | Det | 3117(00168717)_150619 | Path_4 | DC Corr (dB) | Corrected Reading (dBuV/m) | Avg Limit (dBuV/m) | Margin (dB) | Peak Limit (dBuV/m) | Margin (dB) | UNII Non-Restricted (dBuV/m) | Margin (dB) | Azimuth (Degs) | Height (cm) | Polarity |
|--------|-----------------|----------------------|-----|-----------------------|--------|--------------|----------------------------|--------------------|-------------|---------------------|-------------|------------------------------|-------------|----------------|-------------|----------|
| 1 | * 1.25 | 42.63 | PK | 28.3 | -40.2 | 0 | 30.73 | - | - | 74 | -43.27 | - | - | 0-360 | 200 | H |
| 2 | * 1.25 | 44.83 | PK | 28.3 | -40.2 | 0 | 32.93 | - | - | 74 | -41.07 | - | - | 0-360 | 200 | V |
| 3 | * 7.333 | 43.4 | PK | 35.8 | -30.5 | 0 | 48.7 | - | - | 74 | -25.3 | - | - | 0-360 | 100 | H |
| 6 | * 11 | 32.23 | PK | 38.2 | -27.4 | 0 | 43.03 | - | - | 74 | -30.97 | - | - | 0-360 | 200 | H |
| 4 | * 7.333 | 43.35 | PK | 35.8 | -30.5 | 0 | 48.65 | - | - | 74 | -25.35 | - | - | 0-360 | 100 | V |
| 5 | * 11 | 31.1 | PK | 38.2 | -27.4 | 0 | 41.9 | - | - | 74 | -32.1 | - | - | 0-360 | 100 | V |

* - indicates frequency in CFR15.205/IC7.2.2 Restricted Band

PK – Peak detector

Radiated Emissions

| Frequency (GHz) | Meter Reading (dBuV) | Det | 3117(00168717)_150619 | Path_5 | DC Corr (dB) | Corrected Reading (dBuV/m) | Avg Limit (dBuV/m) | Margin (dB) | Peak Limit (dBuV/m) | Margin (dB) | UNII Non-Restricted (dBuV/m) | Margin (dB) | Azimuth (Degs) | Height (cm) | Polarity |
|-----------------|----------------------|------|-----------------------|--------|--------------|----------------------------|--------------------|-------------|---------------------|-------------|------------------------------|-------------|----------------|-------------|----------|
| * 7.333 | 49.12 | PK-U | 35.8 | -30.5 | 0 | 54.42 | - | - | 74 | -19.58 | - | - | 173 | 109 | H |
| * 7.333 | 43.93 | ADR | 35.8 | -30.5 | 0 | 49.23 | 54 | -4.77 | - | - | - | - | 173 | 109 | H |
| * 7.333 | 49.58 | PK-U | 35.8 | -30.5 | 0 | 54.88 | - | - | 74 | -19.12 | - | - | 169 | 215 | V |
| * 7.333 | 42.16 | ADR | 35.8 | -30.5 | 0 | 47.46 | 54 | -6.54 | - | - | - | - | 169 | 215 | V |

* - indicates frequency in CFR15.205/IC7.2.2 Restricted Band

PK-U - U-NII: Maximum Peak

ADR - U-NII AD primary method, RMS average

MID CHANNEL HORIZONTAL

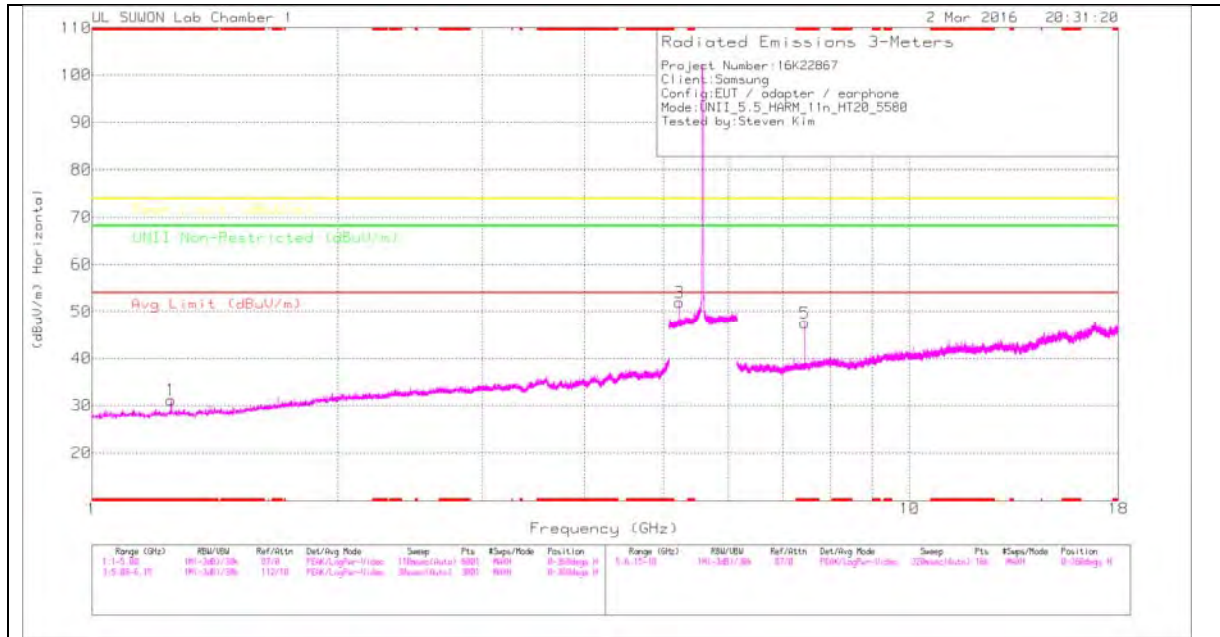

MID CHANNEL VERTICAL

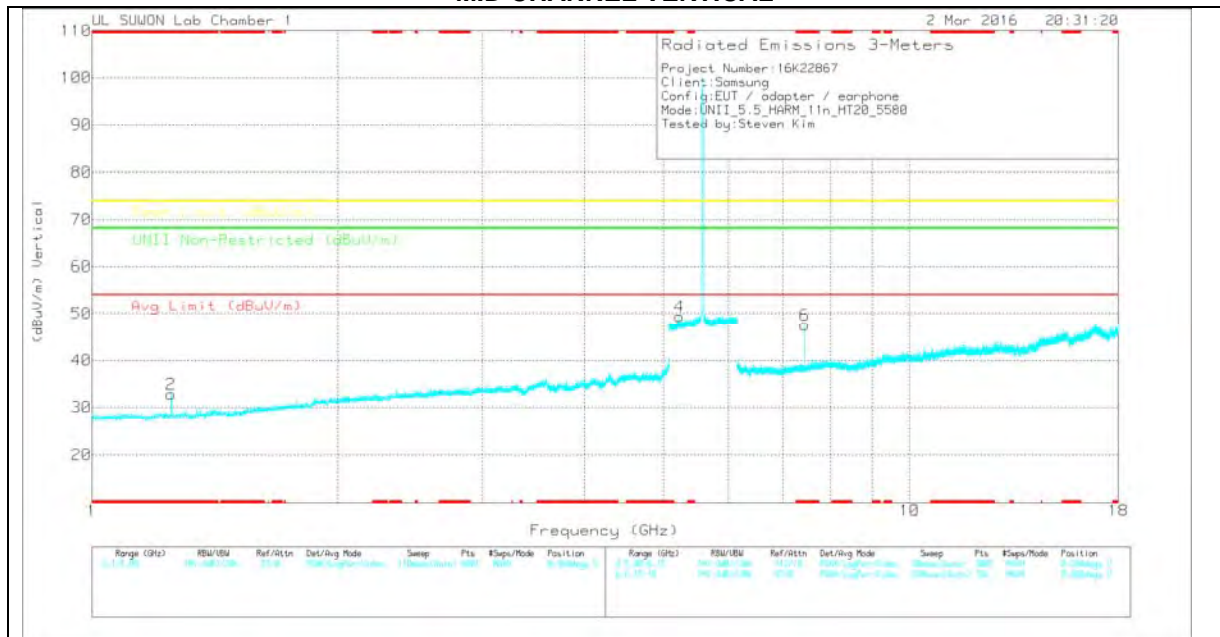

Note: Emission was scanned up to 40GHz; No emissions were detected above the noise floor which was at least 20dB below the specification limit.

MID CHANNEL DATA

TRACE MARKERS

| Marker | Frequency (GHz) | Meter Reading (dBuV) | Det | 3117(0016 8717_150 619) | Path_4 | DC Corr (dB) | Corrected Reading (dBuV/m) | Avg Limit (dBuV/m) | Margin (dB) | Peak Limit (dBuV/m) | Margin (dB) | UNII Non-Restricted (dBuV/m) | Margin (dB) | Azimuth (Degs) | Height (cm) | Polarity |
|--------|-----------------|----------------------|-----|-------------------------|--------|--------------|----------------------------|--------------------|-------------|---------------------|-------------|------------------------------|-------------|----------------|-------------|----------|
| 1 | * 1.25 | 43.11 | PK | 28.3 | -40.2 | 0 | 31.21 | - | - | 74 | -42.79 | - | - | 0-360 | 200 | H |
| 2 | * 1.25 | 44.77 | PK | 28.3 | -40.2 | 0 | 32.87 | - | - | 74 | -41.13 | - | - | 0-360 | 200 | V |
| 3 | 5.228 | 41.31 | PK | 34.3 | -23.7 | 0 | 51.91 | - | - | - | - | 68.2 | -16.29 | 0-360 | 100 | H |
| 4 | 5.228 | 38.84 | PK | 34.3 | -23.7 | 0 | 49.44 | - | - | - | - | 68.2 | -18.76 | 0-360 | 200 | V |
| 5 | * 7.439 | 42.35 | PK | 35.8 | -30.6 | 0 | 47.55 | - | - | 74 | -26.45 | - | - | 0-360 | 100 | H |
| 6 | * 7.439 | 42.33 | PK | 35.8 | -30.6 | 0 | 47.53 | - | - | 74 | -26.47 | - | - | 0-360 | 200 | V |

* - indicates frequency in CFR15.205/IC7.2.2 Restricted Band

PK – Peak detector

Radiated Emissions

| Frequency (GHz) | Meter Reading (dBuV) | Det | 3117(001687 17_150619) | Path_2 | DC Corr (dB) | Corrected Reading (dBuV/m) | Avg Limit (dBuV/m) | Margin (dB) | Peak Limit (dBuV/m) | Margin (dB) | UNII Non-Restricted (dBuV/m) | Margin (dB) | Azimuth (Degs) | Height (cm) | Polarity |
|-----------------|----------------------|------|------------------------|--------|--------------|----------------------------|--------------------|-------------|---------------------|-------------|------------------------------|-------------|----------------|-------------|----------|
| 5.228 | 49.99 | PK-U | 34.3 | -23.7 | 0 | 60.59 | - | - | - | - | 68.2 | -7.61 | 117 | 100 | H |
| 5.228 | 48.27 | PK-U | 34.3 | -23.7 | 0 | 58.87 | - | - | - | - | 68.2 | -9.33 | 209 | 108 | V |
| * 7.44 | 40.71 | ADR | 35.8 | -30.5 | 0 | 46.01 | 54 | -7.99 | - | - | - | - | 161 | 236 | V |
| * 7.44 | 41.84 | ADR | 35.8 | -30.5 | 0 | 47.14 | 54 | -6.86 | - | - | - | - | 166 | 103 | H |
| * 7.44 | 48.41 | PK-U | 35.8 | -30.5 | 0 | 53.71 | - | - | 74 | -20.29 | - | - | 161 | 236 | V |
| * 7.44 | 47.77 | PK-U | 35.8 | -30.5 | 0 | 53.07 | - | - | 74 | -20.93 | - | - | 166 | 103 | H |

* - indicates frequency in CFR15.205/IC7.2.2 Restricted Band

PK-U - U-NII: Maximum Peak

ADR - U-NII AD primary method, RMS average

HIGH CHANNEL HORIZONTAL

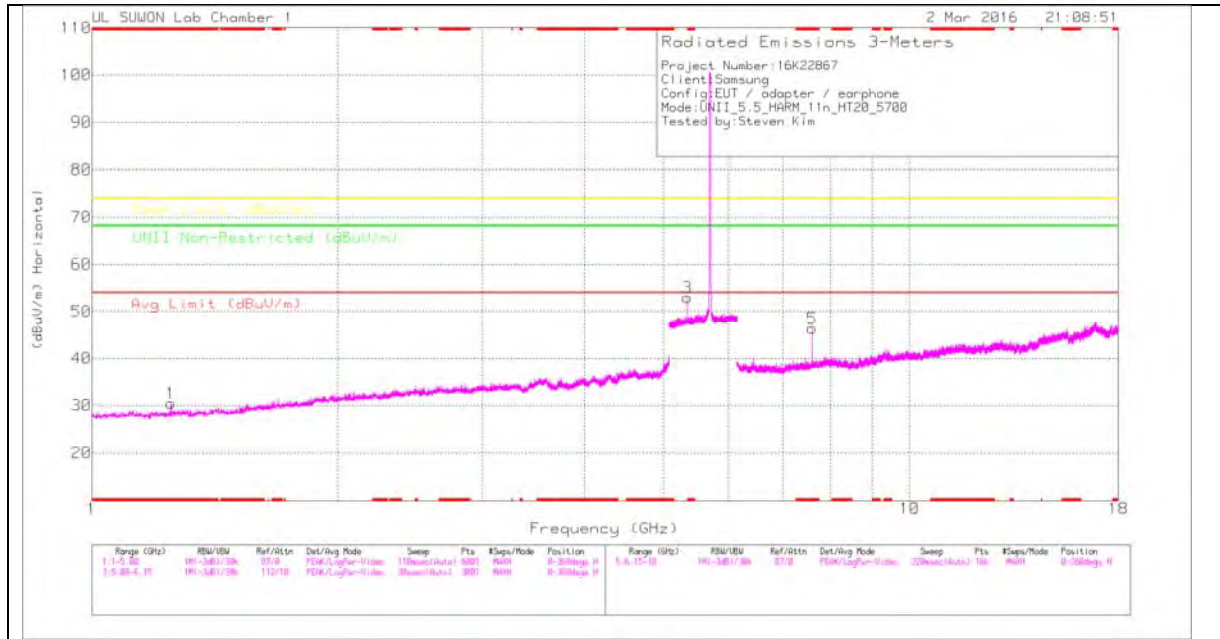

HIGH CHANNEL VERTICAL

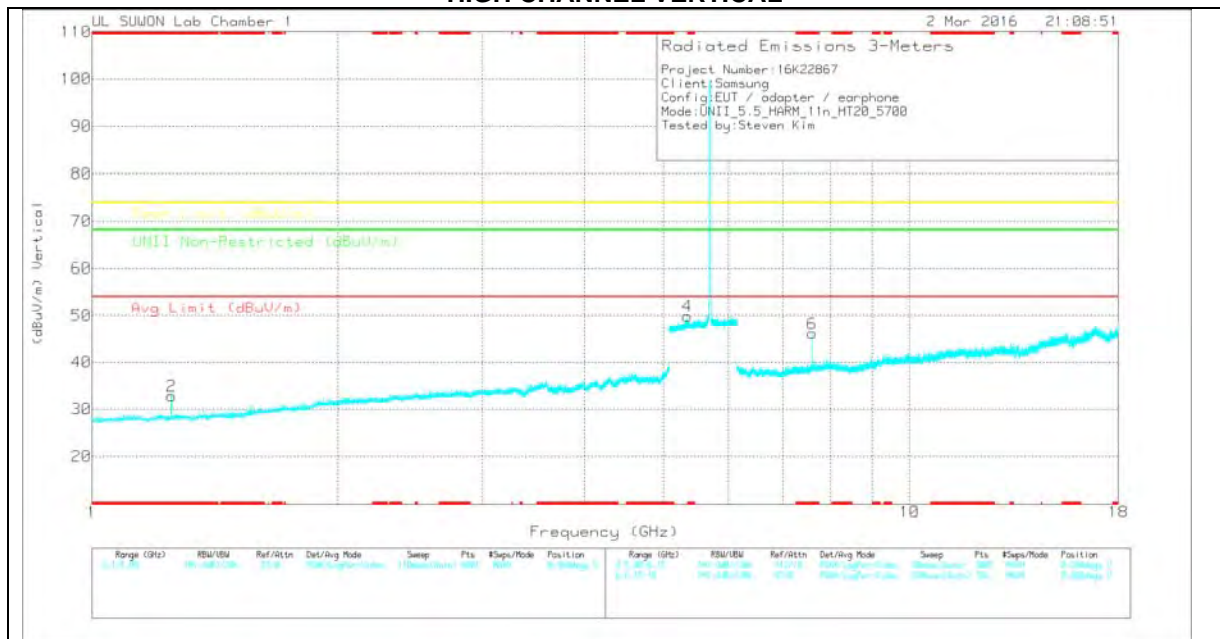

Note: Emission was scanned up to 40GHz; No emissions were detected above the noise floor which was at least 20dB below the specification limit.

HIGH CHANNEL DATA

TRACE MARKERS

| Marker | Frequency (GHz) | Meter Reading (dBuV) | Det | 3117/0016 8717_150 619 | Path_4 | DC Corr (dB) | Corrected Reading (dBuV/m) | Avg Limit (dBuV/m) | Margin (dB) | Peak Limit (dBuV/m) | Margin (dB) | UNII Non-Restricted (dBuV/m) | Margin (dB) | Azimuth (Degs) | Height (cm) | Polarity |
|--------|-----------------|----------------------|-----|------------------------|--------|--------------|----------------------------|--------------------|-------------|---------------------|-------------|------------------------------|-------------|----------------|-------------|----------|
| 1 | * 1.25 | 42.4 | PK | 28.3 | -40.2 | 0 | 30.5 | - | - | 74 | -43.5 | - | - | 0-360 | 200 | H |
| 2 | * 1.25 | 44.74 | PK | 28.3 | -40.2 | 0 | 32.84 | - | - | 74 | -41.16 | - | - | 0-360 | 200 | V |
| 3 | 5.348 | 41.77 | PK | 34.5 | -23.3 | 0 | 52.97 | - | - | - | - | 68.2 | -15.23 | 0-360 | 100 | H |
| 4 | 5.348 | 38.71 | PK | 34.5 | -23.3 | 0 | 49.91 | - | - | - | - | 68.2 | -18.29 | 0-360 | 200 | V |
| 5 | * 7.6 | 40.75 | PK | 35.9 | -30.3 | 0 | 46.35 | - | - | 74 | -27.65 | - | - | 0-360 | 100 | H |
| 6 | * 7.6 | 40.51 | PK | 35.9 | -30.3 | 0 | 46.11 | - | - | 74 | -27.89 | - | - | 0-360 | 100 | V |

* - indicates frequency in CFR15.205/IC7.2.2 Restricted Band

PK – Peak Detector

Radiated Emissions

| Frequency (GHz) | Meter Reading (dBuV) | Det | 3117/001687 17_150619 | Path_2 | DC Corr (dB) | Corrected Reading (dBuV/m) | Avg Limit (dBuV/m) | Margin (dB) | Peak Limit (dBuV/m) | Margin (dB) | UNII Non-Restricted (dBuV/m) | Margin (dB) | Azimuth (Degs) | Height (cm) | Polarity |
|-----------------|----------------------|------|-----------------------|--------|--------------|----------------------------|--------------------|-------------|---------------------|-------------|------------------------------|-------------|----------------|-------------|----------|
| 5.348 | 49.93 | PK-U | 34.5 | -23.3 | 0 | 61.13 | - | - | - | - | 68.2 | -7.07 | 122 | 206 | H |
| 5.348 | 48.68 | PK-U | 34.5 | -23.3 | 0 | 59.88 | - | - | - | - | 68.2 | -8.32 | 199 | 113 | V |
| * 7.6 | 38.23 | ADR | 35.9 | -30.3 | 0 | 43.83 | 54 | -10.17 | - | - | - | - | 166 | 283 | V |
| * 7.6 | 40.23 | ADR | 35.9 | -30.3 | 0 | 45.83 | 54 | -8.17 | - | - | - | - | 170 | 100 | H |
| * 7.6 | 46.3 | PK-U | 35.9 | -30.3 | 0 | 51.9 | - | - | 74 | -22.1 | - | - | 166 | 283 | V |
| * 7.6 | 46.89 | PK-U | 35.9 | -30.3 | 0 | 52.49 | - | - | 74 | -21.51 | - | - | 170 | 100 | H |

* - indicates frequency in CFR15.205/IC7.2.2 Restricted Band

PK-U - U-NII: Maximum Peak

ADR - U-NII AD primary method, RMS average

11.3.3. TX ABOVE 1GHz 802.11n HT40 2TX CDD MODE IN THE 5.5GHz BAND RESTRICTED BANDEDGE (LOW CHANNEL)

HORIZONTAL PEAK AND AVERAGE PLOT

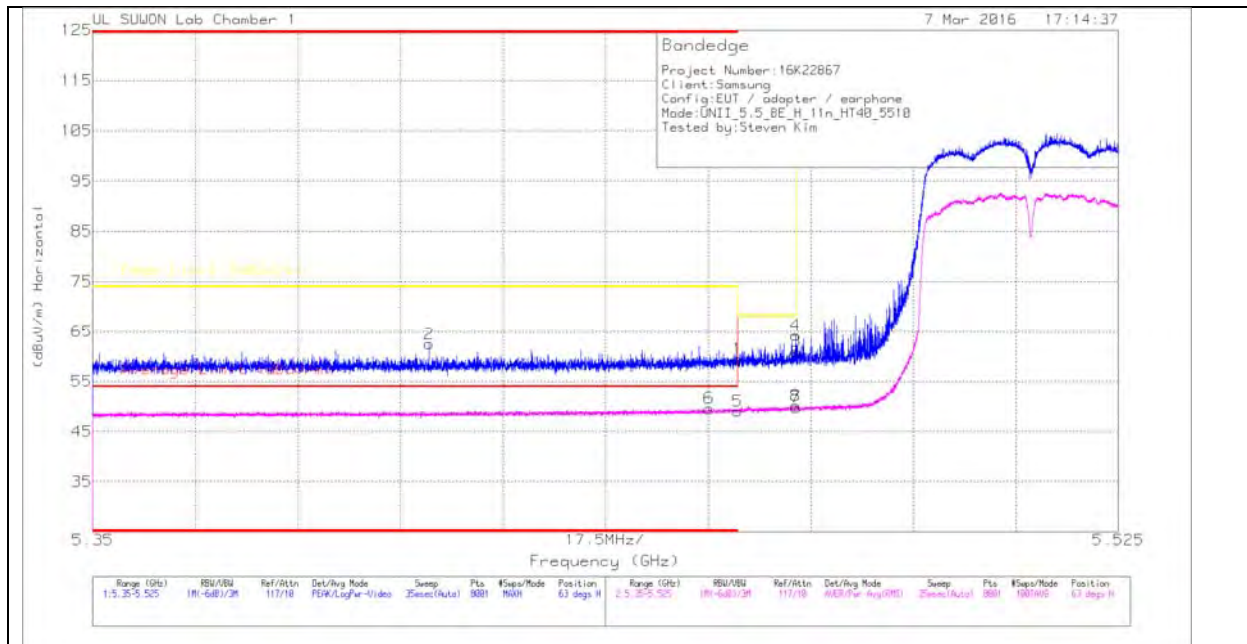

HORIZONTAL DATA

TRACE MARKERS

| Marker | Frequency (GHz) | Meter Reading (dBuV) | Det | 3117(001687 17_150619) | Path_2 | DC Corr (dB) | Corrected Reading (dBuV/m) | Average Limit (dBuV/m) | Margin (dB) | Peak Limit (dBuV/m) | PK Margin (dB) | Azimuth (Degs) | Height (cm) | Polarity |
|--------|-----------------|----------------------|-----|------------------------|--------|--------------|----------------------------|------------------------|-------------|---------------------|----------------|----------------|-------------|----------|
| 1 | * 5.46 | 48.12 | PK | 34.6 | -23.2 | 0 | 59.52 | - | - | 74 | -14.48 | 63 | 204 | H |
| 2 | * 5.407 | 51.2 | PK | 34.6 | -23.3 | 0 | 62.5 | - | - | 74 | -11.5 | 63 | 204 | H |
| 3 | 5.47 | 49.48 | PK | 34.6 | -23.1 | 0 | 60.98 | - | - | 68.2 | -7.22 | 63 | 204 | H |
| 4 | 5.47 | 52.77 | PK | 34.6 | -23.1 | 0 | 64.27 | - | - | 68.2 | -3.93 | 63 | 204 | H |
| 5 | * 5.46 | 37.1 | RMS | 34.6 | -23.2 | .59 | 49.09 | 54 | -4.91 | - | - | 63 | 204 | H |
| 6 | * 5.455 | 37.63 | RMS | 34.6 | -23.2 | .59 | 49.62 | 54 | -4.38 | - | - | 63 | 204 | H |
| 7 | 5.47 | 37.77 | RMS | 34.6 | -23.1 | .59 | 49.86 | - | - | - | - | 63 | 204 | H |
| 8 | 5.47 | 38.06 | RMS | 34.6 | -23.1 | .59 | 50.15 | - | - | - | - | 63 | 204 | H |

* - indicates frequency in CFR15.205/IC7.2.2 Restricted Band

Pk - Peak detector

RMS - RMS detection

VERTICAL PEAK AND AVERAGE PLOT

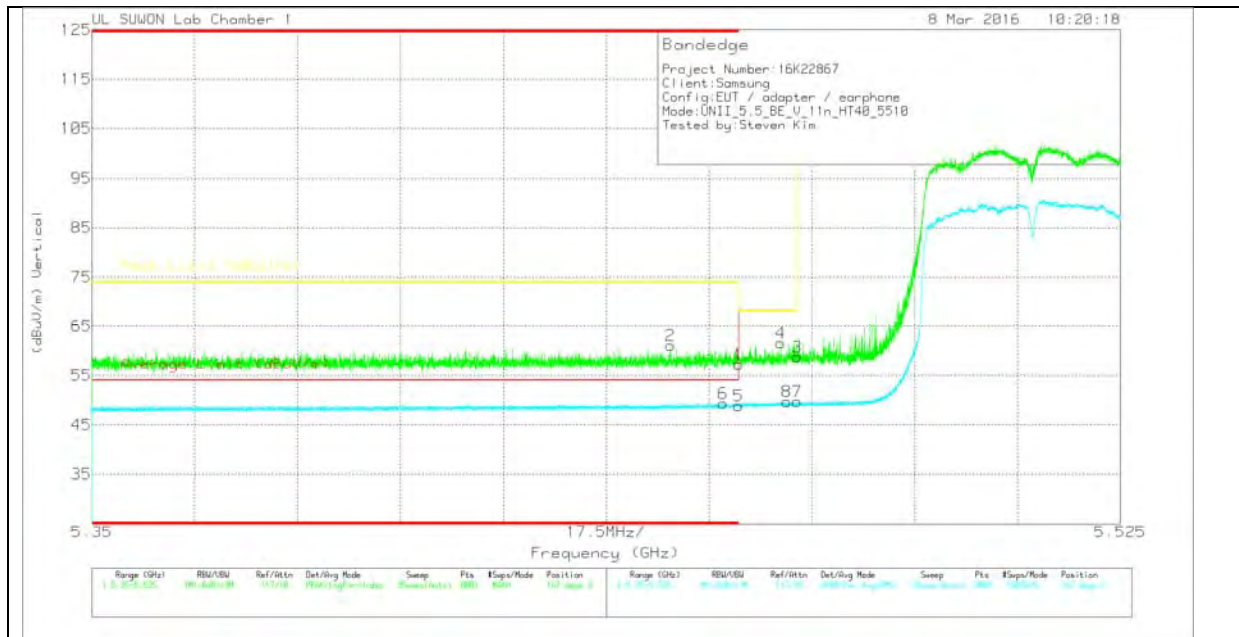

VERTICAL DATA

TRACE MARKERS

| Marker | Frequency (GHz) | Meter Reading (dBuV) | Det | 3117(001687 17)_150619 | Path_2 | DC Corr (dB) | Corrected Reading (dBuV/m) | Average Limit (dBuV/m) | Margin (dB) | Peak Limit (dBuV/m) | PK Margin (dB) | Azimuth (Degs) | Height (cm) | Polarity |
|--------|-----------------|----------------------|-----|------------------------|--------|--------------|----------------------------|------------------------|-------------|---------------------|----------------|----------------|-------------|----------|
| 1 | * 5.46 | 45.84 | PK | 34.6 | -23.2 | 0 | 57.24 | - | - | 74 | -16.76 | 167 | 116 | V |
| 2 | * 5.448 | 49.72 | PK | 34.6 | -23.2 | 0 | 61.12 | - | - | 74 | -12.88 | 167 | 116 | V |
| 3 | 5.47 | 47.19 | PK | 34.6 | -23.1 | 0 | 58.69 | - | - | 68.2 | -9.51 | 167 | 116 | V |
| 4 | 5.467 | 50.08 | PK | 34.6 | -23.1 | 0 | 61.58 | - | - | 68.2 | -6.62 | 167 | 116 | V |
| 5 | * 5.46 | 36.87 | RMS | 34.6 | -23.2 | .59 | 48.86 | 54 | -5.14 | - | - | 167 | 116 | V |
| 6 | * 5.457 | 37.35 | RMS | 34.6 | -23.2 | .59 | 49.34 | 54 | -4.66 | - | - | 167 | 116 | V |
| 7 | 5.47 | 37.58 | RMS | 34.6 | -23.1 | .59 | 49.67 | - | - | - | - | 167 | 116 | V |
| 8 | 5.468 | 37.65 | RMS | 34.6 | -23.1 | .59 | 49.74 | - | - | - | - | 167 | 116 | V |

* - indicates frequency in CFR15.205/IC7.2.2 Restricted Band

PK - Peak detector

RMS - RMS detection

AUTHORIZED BANDEDGE (HIGH CHANNEL)

HORIZONTAL PEAK AND AVERAGE PLOT

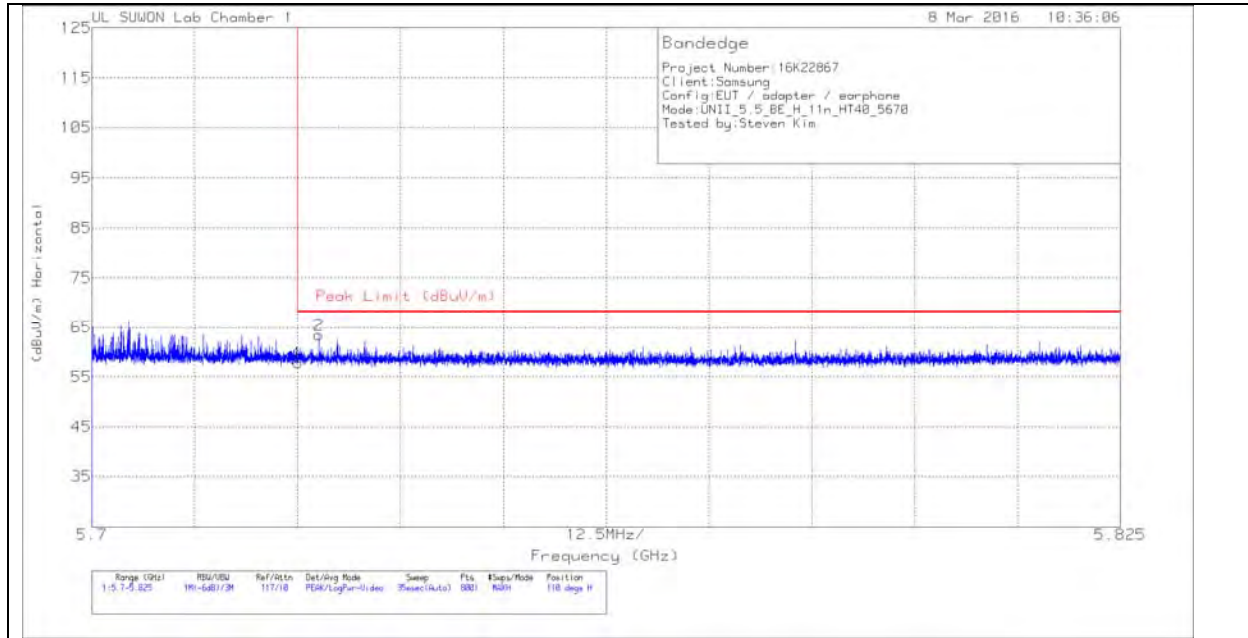

HORIZONTAL DATA

TRACE MARKERS

| Marker | Frequency (GHz) | Meter Reading (dBuV) | Det | 3117(0016 8717)_150 619 | Path_2 | DC Corr (dB) | Corrected Reading (dBuV/m) | Peak Limit (dBuV/m) | PK Margin (dB) | Azimuth (Degs) | Height (cm) | Polarity |
|--------|-----------------|----------------------|-----|-------------------------|--------|--------------|----------------------------|---------------------|----------------|----------------|-------------|----------|
| 1 | 5.725 | 45.87 | Pk | 34.8 | -22.8 | 0 | 57.87 | 68.2 | -10.33 | 110 | 140 | H |
| 2 | 5.728 | 51.47 | Pk | 34.8 | -22.8 | 0 | 63.47 | 68.2 | -4.73 | 110 | 140 | H |

Pk - Peak detector

VERTICAL PEAK AND AVERAGE PLOT

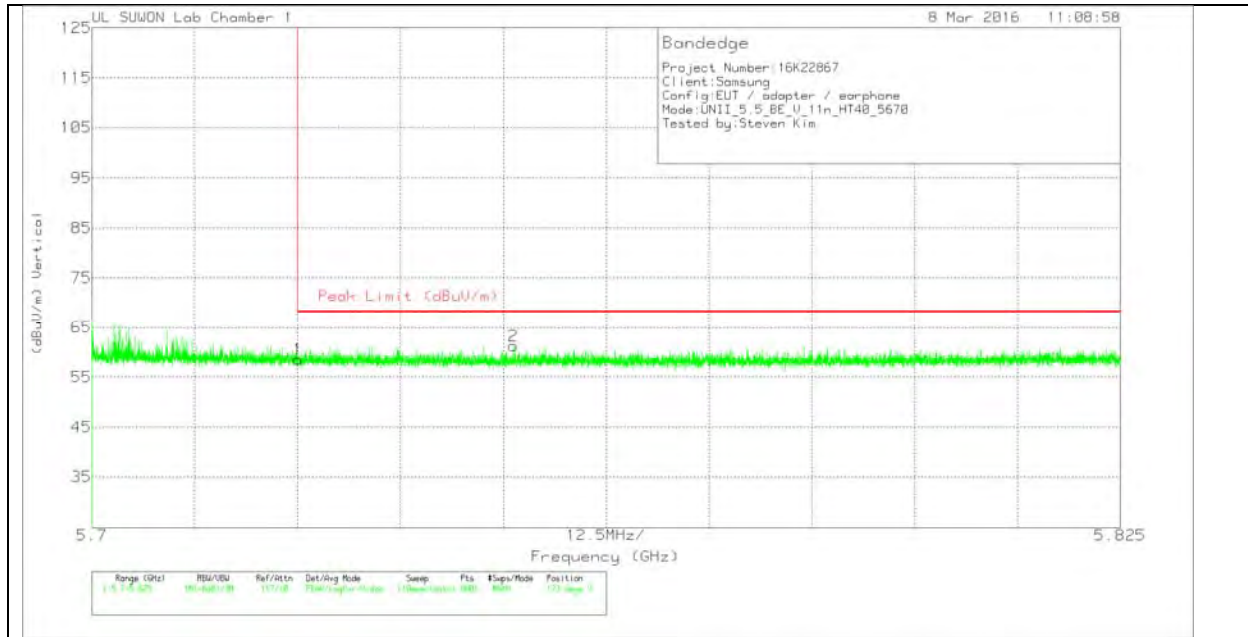

VERTICAL DATA

TRACE MARKERS

| Marker | Frequency (GHz) | Meter Reading (dBuV) | Det | 3117(001 68717)_15 0619 | Path_2 | Corrected Reading (dBuV/m) | Peak Limit (dBuV/m) | PK Margin (dB) | Azimuth (Degs) | Height (cm) | Polarity | Marker |
|--------|-----------------|----------------------|-----|-------------------------|--------|----------------------------|---------------------|----------------|----------------|-------------|----------|--------|
| 1 | 5.725 | 46.61 | Pk | 34.8 | -22.8 | 58.61 | 68.2 | -9.59 | 173 | 136 | V | 1 |
| 2 | 5.751 | 49.18 | Pk | 34.8 | -22.7 | 61.28 | 68.2 | -6.92 | 173 | 136 | V | 2 |

Pk - Peak detector

HARMONICS AND SPURIOUS EMISSIONS

LOW CHANNEL HORIZONTAL

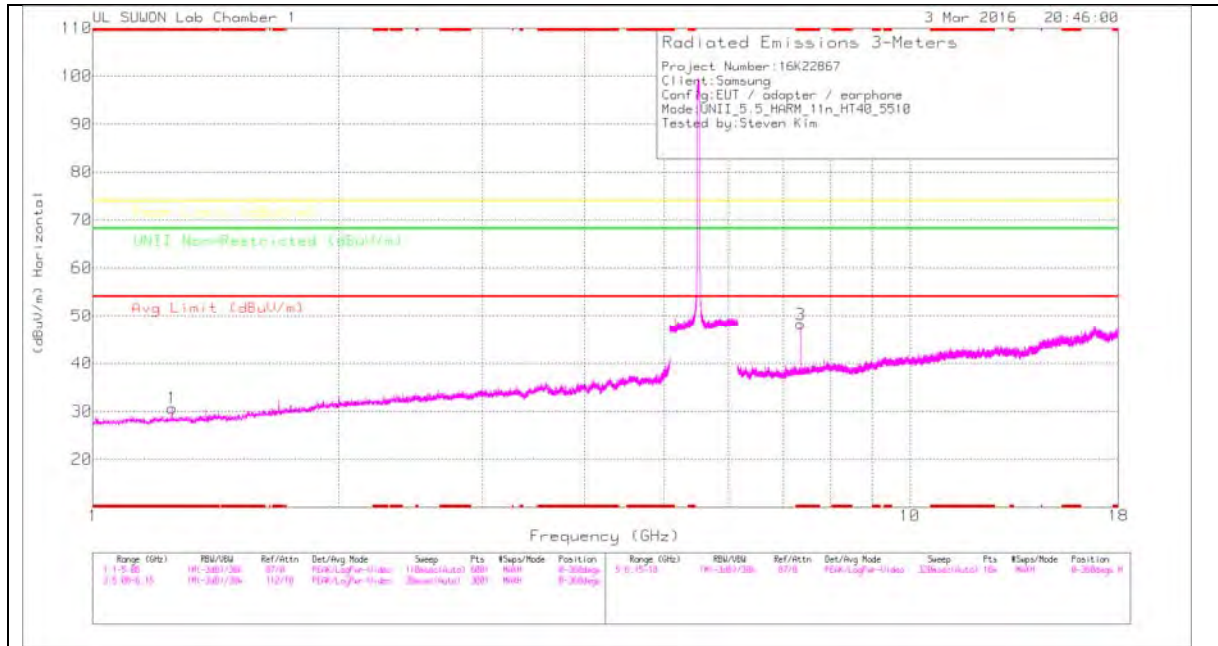

LOW CHANNEL VERTICAL

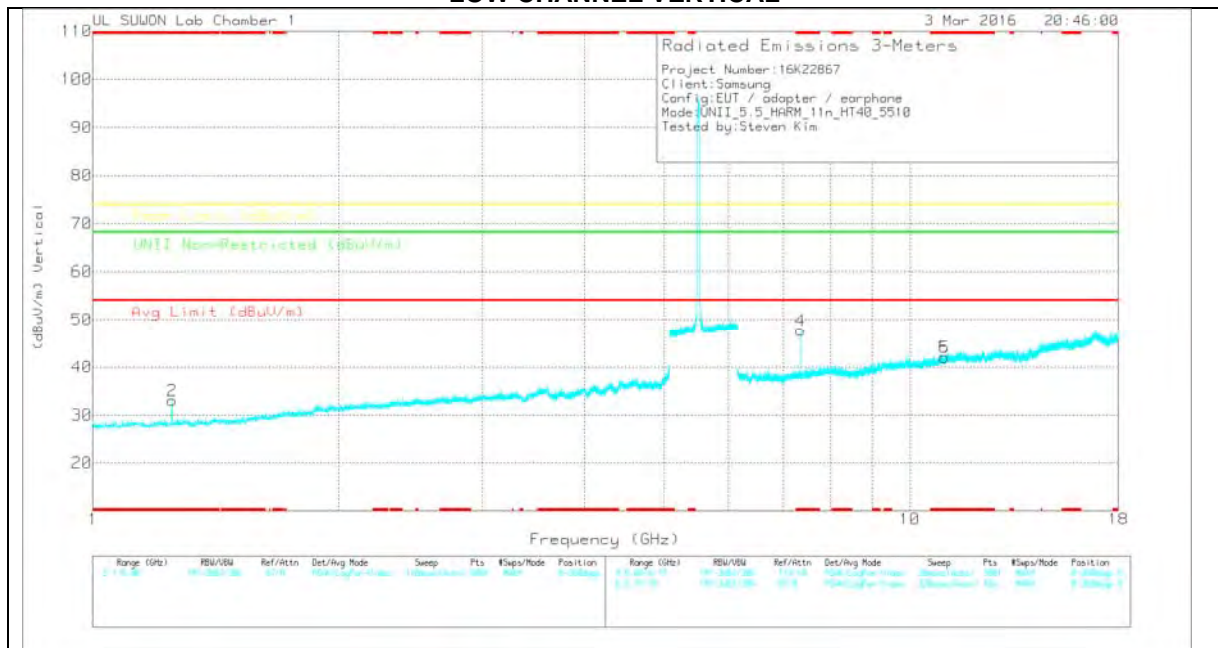

Note: Emission was scanned up to 40GHz; No emissions were detected above the noise floor which was at least 20dB below the specification limit.

LOW CHANNEL DATA

TRACE MARKERS

| Marker | Frequency (GHz) | Meter Reading (dBuV) | Det | 3117(0016 8717)_150 619 | Path_4 | DC Corr (dB) | Corrected Reading (dBuV/m) | Avg Limit (dBuV/m) | Margin (dB) | Peak Limit (dBuV/m) | Margin (dB) | UNII Non-Restricted (dBuV/m) | Margin (dB) | Azimuth (Degs) | Height (cm) | Polarity |
|--------|-----------------|----------------------|-----|-------------------------|--------|--------------|----------------------------|--------------------|-------------|---------------------|-------------|------------------------------|-------------|----------------|-------------|----------|
| 1 | * 1.25 | 42.57 | PK | 28.3 | -40.2 | 0 | 30.67 | - | - | 74 | -43.33 | - | - | 0-360 | 200 | H |
| 2 | * 1.25 | 44.95 | PK | 28.3 | -40.2 | 0 | 33.05 | - | - | 74 | -40.95 | - | - | 0-360 | 200 | V |
| 3 | * 7.346 | 42.93 | PK | 35.8 | -30.5 | 0 | 48.23 | - | - | 74 | -25.77 | - | - | 0-360 | 200 | H |
| 4 | * 7.346 | 42.44 | PK | 35.8 | -30.5 | 0 | 47.74 | - | - | 74 | -26.26 | - | - | 0-360 | 200 | V |
| 5 | * 11.02 | 31.05 | PK | 38.2 | -27.2 | 0 | 42.05 | - | - | 74 | -31.95 | - | - | 0-360 | 100 | V |
| 6 | * 11.02 | 31.05 | PK | 38.2 | -27.2 | 0 | 42.05 | - | - | 74 | -31.95 | - | - | 0-360 | 100 | V |

* - indicates frequency in CFR15.205/IC7.2.2 Restricted Band

PK – Peak detector

Radiated Emissions

| Frequency (GHz) | Meter Reading (dBuV) | Det | 3117(001687 17)_150619 | Path_5 | DC Corr (dB) | Corrected Reading (dBuV/m) | Avg Limit (dBuV/m) | Margin (dB) | Peak Limit (dBuV/m) | Margin (dB) | UNII Non-Restricted (dBuV/m) | Margin (dB) | Azimuth (Degs) | Height (cm) | Polarity |
|-----------------|----------------------|------|------------------------|--------|--------------|----------------------------|--------------------|-------------|---------------------|-------------|------------------------------|-------------|----------------|-------------|----------|
| * 7.347 | 49.24 | PK-U | 35.8 | -30.5 | 0 | 54.54 | - | - | 74 | -19.46 | - | - | 171 | 108 | H |
| * 7.347 | 42.97 | ADR | 35.8 | -30.5 | 0 | 48.27 | 54 | -5.73 | - | - | - | - | 171 | 108 | H |
| * 7.347 | 49.86 | PK-U | 35.8 | -30.5 | 0 | 55.16 | - | - | 74 | -18.84 | - | - | 171 | 245 | V |
| * 7.347 | 43.98 | ADR | 35.8 | -30.5 | 0 | 49.28 | 54 | -4.72 | - | - | - | - | 171 | 245 | V |

* - indicates frequency in CFR15.205/IC7.2.2 Restricted Band

PK-U - U-NII: Maximum Peak

ADR - U-NII AD primary method, RMS average

MID CHANNEL HORIZONTAL

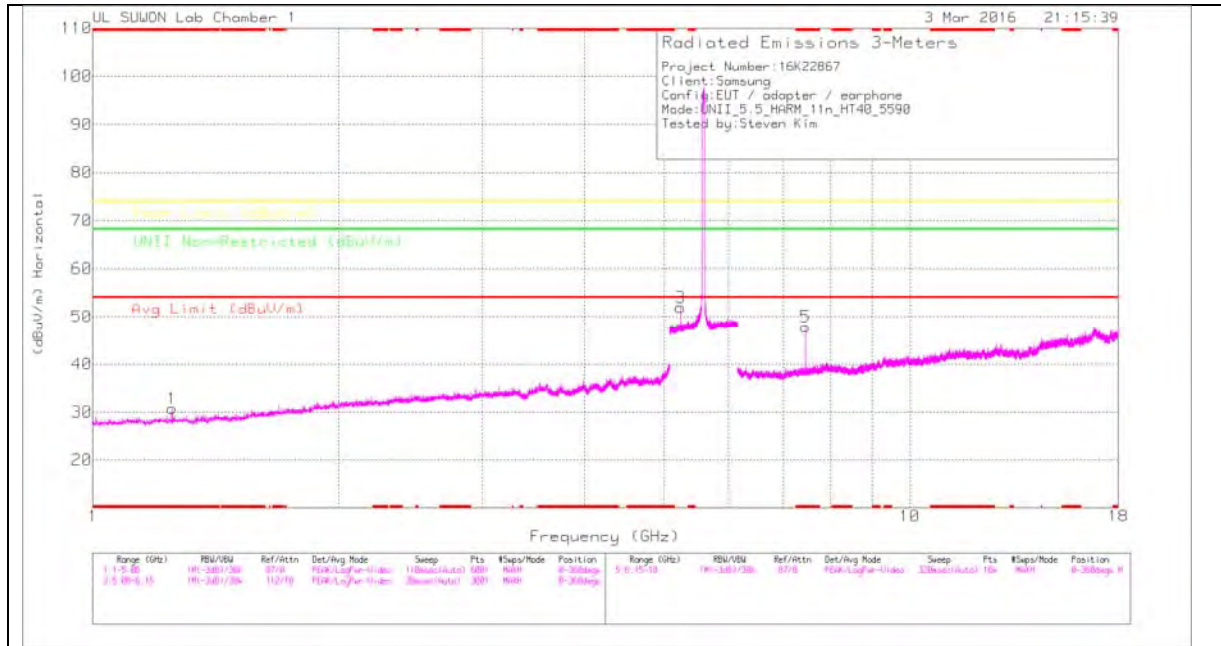

MID CHANNEL VERTICAL

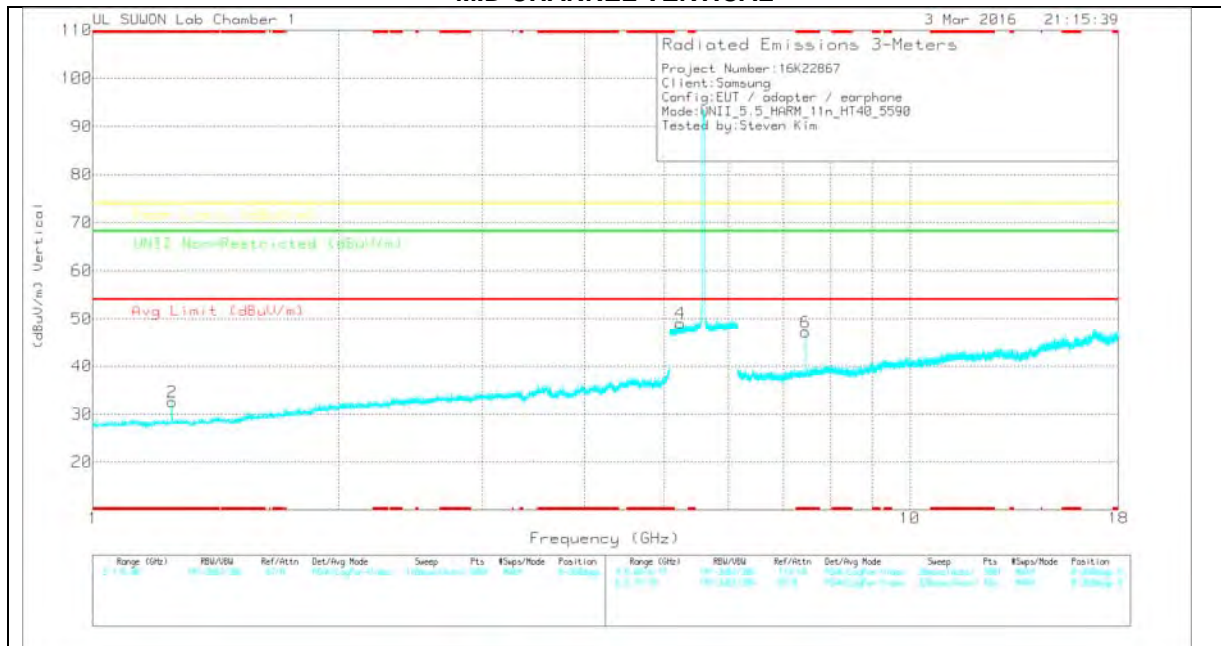

Note: Emission was scanned up to 40GHz; No emissions were detected above the noise floor which was at least 20dB below the specification limit.

MID CHANNEL DATA

TRACE MARKERS

| Marker | Frequency (GHz) | Meter Reading (dBuV) | Det | 3117(0016 8717)_150 619 | Path_4 | DC Corr (dB) | Corrected Reading (dBuV/m) | Avg Limit (dBuV/m) | Margin (dB) | Peak Limit (dBuV/m) | Margin (dB) | UNII Non-Restricted (dBuV/m) | Margin (dB) | Azimuth (Degs) | Height (cm) | Polarity |
|--------|-----------------|----------------------|-----|-------------------------|--------|--------------|----------------------------|--------------------|-------------|---------------------|-------------|------------------------------|-------------|----------------|-------------|----------|
| 1 | * 1.25 | 42.62 | PK | 28.3 | -40.2 | 0 | 30.72 | - | - | 74 | -43.28 | - | - | 0-360 | 200 | H |
| 2 | * 1.25 | 44.4 | PK | 28.3 | -40.2 | 0 | 32.5 | - | - | 74 | -41.5 | - | - | 0-360 | 200 | V |
| 3 | 5.238 | 41.21 | PK | 34.4 | -23.7 | 0 | 51.91 | - | - | - | - | 68.2 | -16.29 | 0-360 | 100 | H |
| 4 | 5.238 | 38.36 | PK | 34.4 | -23.7 | 0 | 49.06 | - | - | - | - | 68.2 | -19.14 | 0-360 | 100 | V |
| 5 | * 7.453 | 42.61 | PK | 35.8 | -30.5 | 0 | 47.91 | - | - | 74 | -26.09 | - | - | 0-360 | 100 | H |
| 6 | * 7.453 | 41.86 | PK | 35.8 | -30.5 | 0 | 47.16 | - | - | 74 | -26.84 | - | - | 0-360 | 200 | V |

* - indicates frequency in CFR15.205/IC7.2.2 Restricted Band

PK – Peak detector

Radiated Emissions

| Frequency (GHz) | Meter Reading (dBuV) | Det | 3117(001687 17)_150619 | Path_2 | DC Corr (dB) | Corrected Reading (dBuV/m) | Avg Limit (dBuV/m) | Margin (dB) | Peak Limit (dBuV/m) | Margin (dB) | UNII Non-Restricted (dBuV/m) | Margin (dB) | Azimuth (Degs) | Height (cm) | Polarity |
|-----------------|----------------------|------|------------------------|--------|--------------|----------------------------|--------------------|-------------|---------------------|-------------|------------------------------|-------------|----------------|-------------|----------|
| 5.238 | 48.68 | PK-U | 34.4 | -23.7 | 0 | 59.38 | - | - | - | - | 68.2 | -8.82 | 114 | 149 | H |
| 5.237 | 48.16 | PK-U | 34.4 | -23.7 | 0 | 58.86 | - | - | - | - | 68.2 | -9.34 | 209 | 353 | V |
| * 7.453 | 42.49 | ADR | 35.8 | -30.5 | 0 | 47.79 | 54 | -6.21 | - | - | - | - | 205 | 172 | V |
| * 7.453 | 41.9 | ADR | 35.8 | -30.5 | 0 | 47.2 | 54 | -6.8 | - | - | - | - | 174 | 105 | H |
| * 7.453 | 49.2 | PK-U | 35.8 | -30.5 | 0 | 54.5 | - | - | 74 | -19.5 | - | - | 205 | 172 | V |
| * 7.453 | 49.12 | PK-U | 35.8 | -30.5 | 0 | 54.42 | - | - | 74 | -19.58 | - | - | 174 | 105 | H |

* - indicates frequency in CFR15.205/IC7.2.2 Restricted Band

PK-U - U-NII: Maximum Peak

ADR - U-NII AD primary method, RMS average

HIGH CHANNEL HORIZONTAL

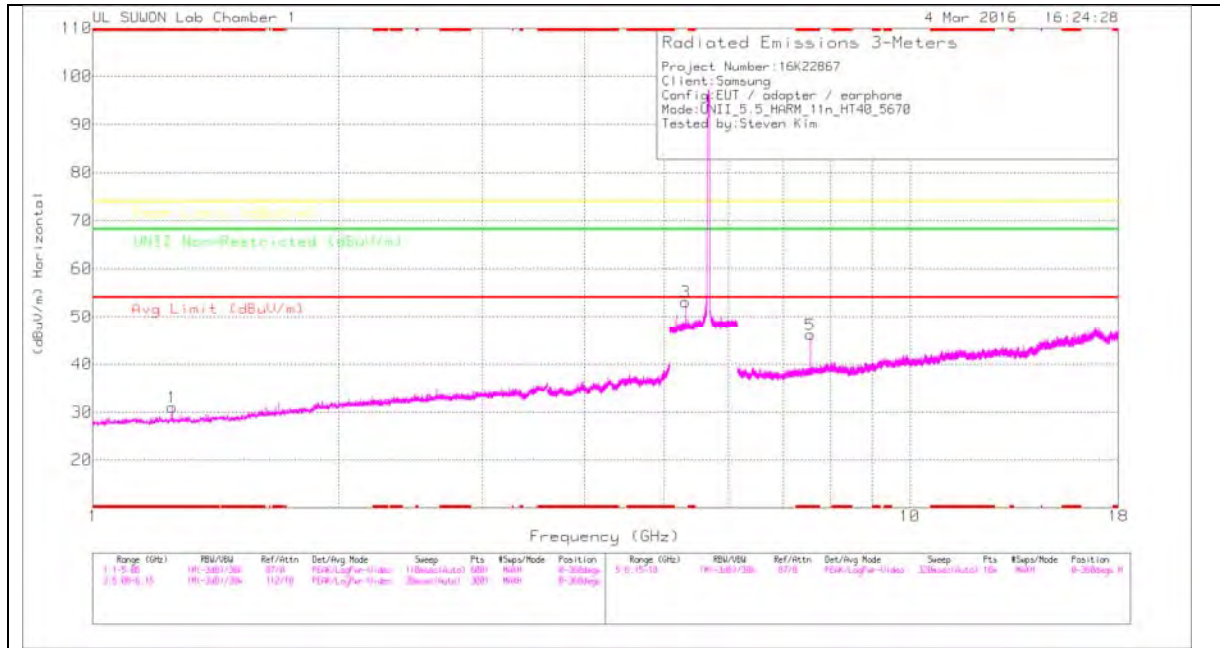

HIGH CHANNEL VERTICAL

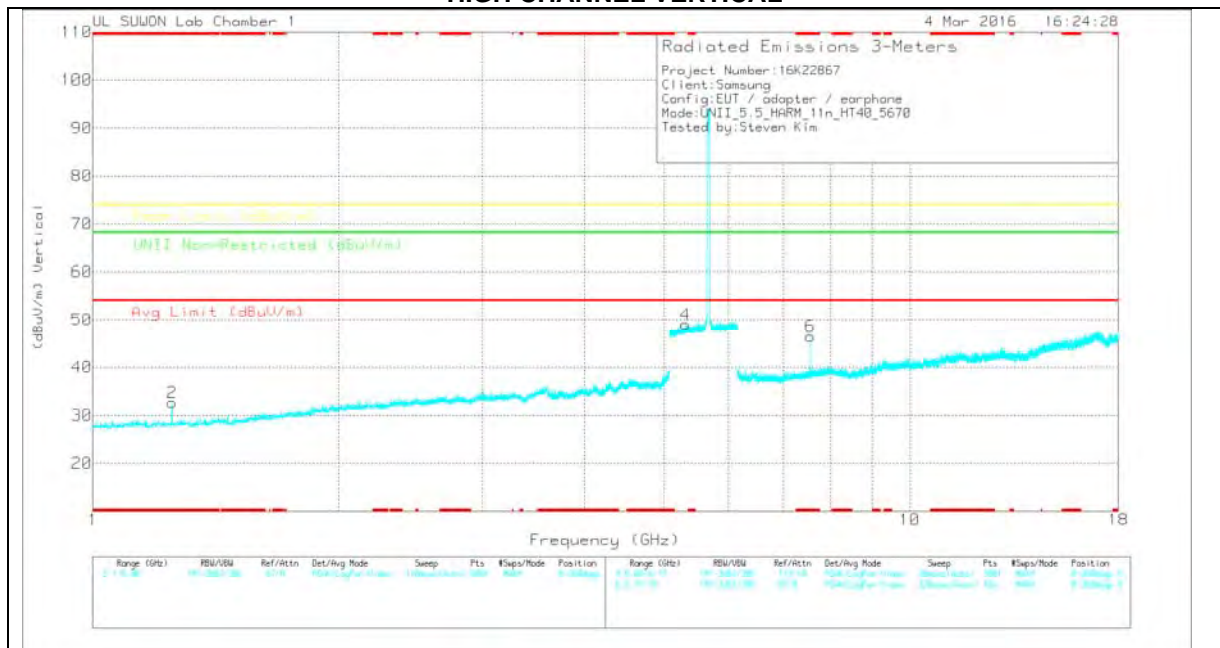

Note: Emission was scanned up to 40GHz; No emissions were detected above the noise floor which was at least 20dB below the specification limit.

HIGH CHANNEL DATA

TRACE MARKERS

| Marker | Frequency (GHz) | Meter Reading (dBuV) | Det | 3117(0016 8717)_150 619 | Path_4 | DC Corr (dB) | Corrected Reading (dBuV/m) | Avg Limit (dBuV/m) | Margin (dB) | Peak Limit (dBuV/m) | Margin (dB) | UNII Non-Restricted (dBuV/m) | Margin (dB) | Azimuth (Degs) | Height (cm) | Polarity |
|--------|-----------------|----------------------|-----|-------------------------|--------|--------------|----------------------------|--------------------|-------------|---------------------|-------------|------------------------------|-------------|----------------|-------------|----------|
| 1 | * 1.25 | 42.89 | PK | 28.3 | -40.2 | 0 | 30.99 | - | - | 74 | -43.01 | - | - | 0-360 | 200 | H |
| 2 | * 1.25 | 44.54 | PK | 28.3 | -40.2 | 0 | 32.64 | - | - | 74 | -41.36 | - | - | 0-360 | 200 | V |
| 3 | 5.318 | 41.89 | PK | 34.5 | -23.3 | 0 | 53.09 | - | - | - | - | 68.2 | -15.11 | 0-360 | 100 | H |
| 4 | 5.318 | 37.79 | PK | 34.5 | -23.3 | 0 | 48.99 | - | - | - | - | 68.2 | -19.21 | 0-360 | 200 | V |
| 5 | * 7.559 | 40.28 | PK | 35.9 | -30 | 0 | 46.18 | - | - | 74 | -27.82 | - | - | 0-360 | 100 | H |
| 6 | * 7.559 | 40.6 | PK | 35.9 | -30 | 0 | 46.5 | - | - | 74 | -27.5 | - | - | 0-360 | 100 | V |

* - indicates frequency in CFR15.205/IC7.2.2 Restricted Band

PK – Peak detector

Radiated Emissions

| Frequency (GHz) | Meter Reading (dBuV) | Det | 3117(001687 17)_150619 | Path_2 | DC Corr (dB) | Corrected Reading (dBuV/m) | Avg Limit (dBuV/m) | Margin (dB) | Peak Limit (dBuV/m) | Margin (dB) | UNII Non-Restricted (dBuV/m) | Margin (dB) | Azimuth (Degs) | Height (cm) | Polarity |
|-----------------|----------------------|------|------------------------|--------|--------------|----------------------------|--------------------|-------------|---------------------|-------------|------------------------------|-------------|----------------|-------------|----------|
| 5.318 | 49.48 | PK-U | 34.5 | -23.3 | 0 | 60.68 | - | - | - | - | 68.2 | -7.52 | 61 | 101 | H |
| * 7.56 | 39.67 | ADR | 35.9 | -30 | 0 | 45.57 | 54 | -8.43 | - | - | - | - | 172 | 112 | H |
| * 7.56 | 41.07 | ADR | 35.9 | -30 | 0 | 46.97 | 54 | -7.03 | - | - | - | - | 201 | 105 | V |
| * 7.56 | 46.98 | PK-U | 35.9 | -30 | 0 | 52.88 | - | - | 74 | -21.12 | - | - | 172 | 112 | H |
| * 7.56 | 47.41 | PK-U | 35.9 | -30 | 0 | 53.31 | - | - | 74 | -20.69 | - | - | 201 | 105 | V |

* - indicates frequency in CFR15.205/IC7.2.2 Restricted Band

PK-U - U-NII: Maximum Peak

ADR - U-NII AD primary method, RMS average

11.3.4. TX ABOVE 1GHz 802.11ac HT80 2TX CDD MODE IN THE 5.5GHz BAND RESTRICTED BANDEDGE (LOW CHANNEL)

HORIZONTAL PEAK AND AVERAGE PLOT

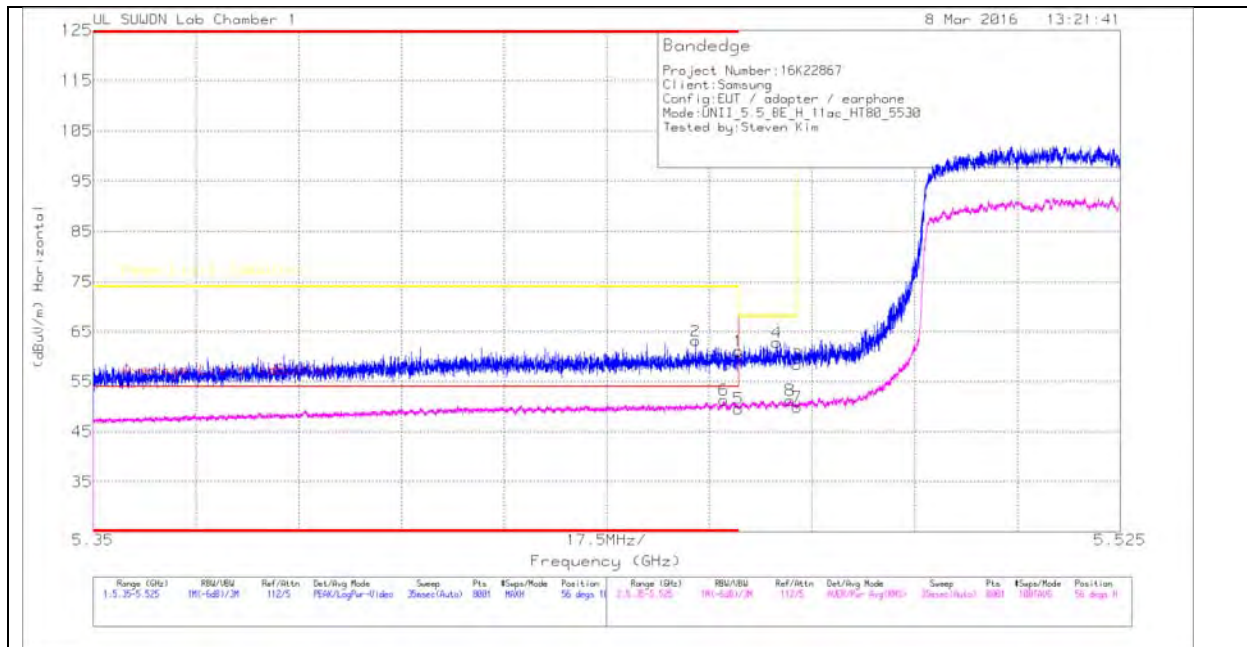

HORIZONTAL DATA

TRACE MARKERS

| Marker | Frequency (GHz) | Meter Reading (dBuV) | Det | 3117(001687 17_150619) | Path_2 | DC Corr (dB) | Corrected Reading (dBuV/m) | Average Limit (dBuV/m) | Margin (dB) | Peak Limit (dBuV/m) | PK Margin (dB) | Azimuth (Degs) | Height (cm) | Polarity |
|--------|-----------------|----------------------|-----|------------------------|--------|--------------|----------------------------|------------------------|-------------|---------------------|----------------|----------------|-------------|----------|
| 1 | * 5.46 | 49.67 | Pk | 34.6 | -23.2 | 0 | 61.07 | - | - | 74 | -12.93 | 56 | 101 | H |
| 2 | * 5.453 | 51.75 | Pk | 34.6 | -23.2 | 0 | 63.15 | - | - | 74 | -10.85 | 56 | 101 | H |
| 3 | 5.47 | 46.9 | Pk | 34.6 | -23.1 | 0 | 58.4 | - | - | 68.2 | -9.8 | 56 | 101 | H |
| 4 | 5.466 | 51.31 | Pk | 34.6 | -23.1 | 0 | 62.81 | - | - | 68.2 | -5.39 | 56 | 101 | H |
| 5 | * 5.46 | 37.08 | RMS | 34.6 | -23.2 | 1.11 | 49.59 | 54 | -4.41 | - | - | 56 | 101 | H |
| 6 | * 5.457 | 38.77 | RMS | 34.6 | -23.2 | 1.11 | 51.28 | 54 | -2.72 | - | - | 56 | 101 | H |
| 7 | 5.47 | 37.23 | RMS | 34.6 | -23.1 | 1.11 | 49.84 | - | - | - | - | 56 | 101 | H |
| 8 | 5.469 | 38.63 | RMS | 34.6 | -23.1 | 1.11 | 51.24 | - | - | - | - | 56 | 101 | H |

* - indicates frequency in CFR15.205/IC7.2.2 Restricted Band

Pk - Peak detector

RMS - RMS detection

VERTICAL PEAK AND AVERAGE PLOT

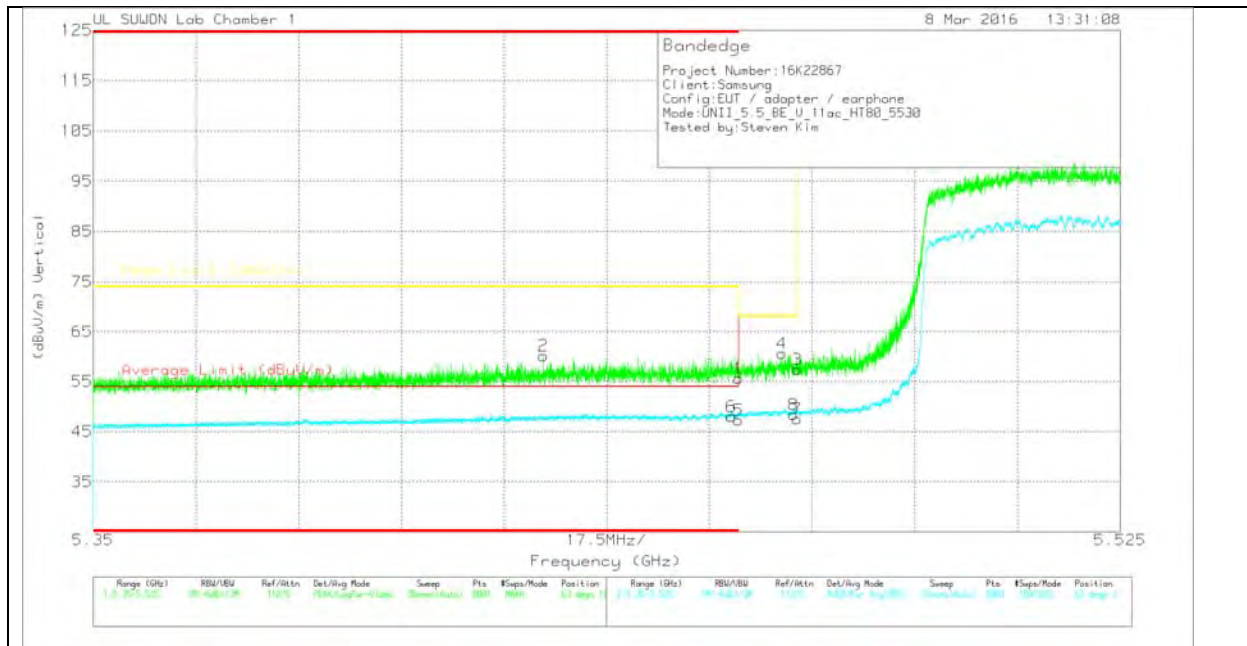

VERTICAL DATA

TRACE MARKERS

| Marker | Frequency (GHz) | Meter Reading (dBuV) | Det | 3117(001687 17_150619) | Path_2 | DC Corr (dB) | Corrected Reading (dBuV/m) | Average Limit (dBuV/m) | Margin (dB) | Peak Limit (dBuV/m) | PK Margin (dB) | Azimuth (Degs) | Height (cm) | Polarity |
|--------|-----------------|----------------------|-----|------------------------|--------|--------------|----------------------------|------------------------|-------------|---------------------|----------------|----------------|-------------|----------|
| 1 | * 5.46 | 44.25 | Pk | 34.6 | -23.2 | 0 | 55.65 | - | - | 74 | -18.35 | 63 | 100 | V |
| 2 | * 5.427 | 48.75 | Pk | 34.6 | -23.2 | 0 | 60.15 | - | - | 74 | -13.85 | 63 | 100 | V |
| 3 | 5.47 | 45.91 | Pk | 34.6 | -23.1 | 0 | 57.41 | - | - | 68.2 | -10.79 | 63 | 100 | V |
| 4 | 5.467 | 49.09 | Pk | 34.6 | -23.1 | 0 | 60.59 | - | - | 68.2 | -7.61 | 63 | 100 | V |
| 5 | * 5.46 | 35.93 | RMS | 34.6 | -23.2 | 1.11 | 48.44 | 54 | -5.56 | - | - | 63 | 100 | V |
| 6 | * 5.459 | 36.66 | RMS | 34.6 | -23.2 | 1.11 | 49.17 | 54 | -4.83 | - | - | 63 | 100 | V |
| 7 | 5.47 | 36.06 | RMS | 34.6 | -23.1 | 1.11 | 48.67 | - | - | - | - | 63 | 100 | V |
| 8 | 5.469 | 36.89 | RMS | 34.6 | -23.1 | 1.11 | 49.5 | - | - | - | - | 63 | 100 | V |

* - indicates frequency in CFR15.205/IC7.2.2 Restricted Band

Pk - Peak detector

RMS - RMS detection

HARMONICS AND SPURIOUS EMISSIONS

LOW CHANNEL HORIZONTAL

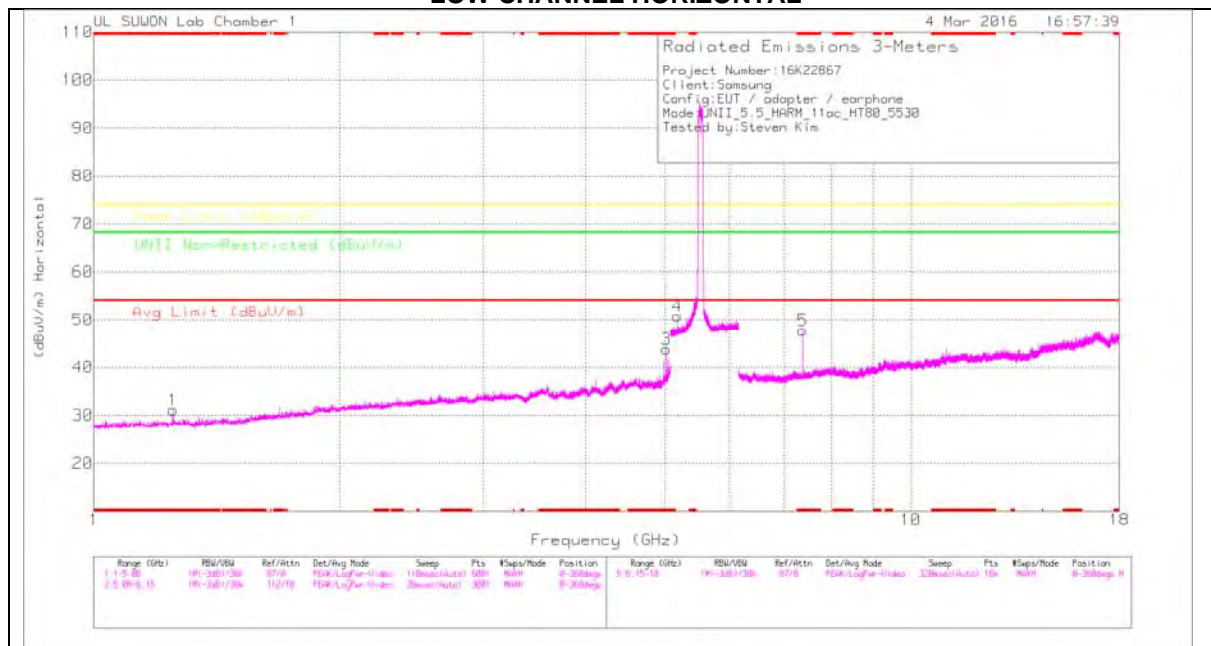

LOW CHANNEL VERTICAL

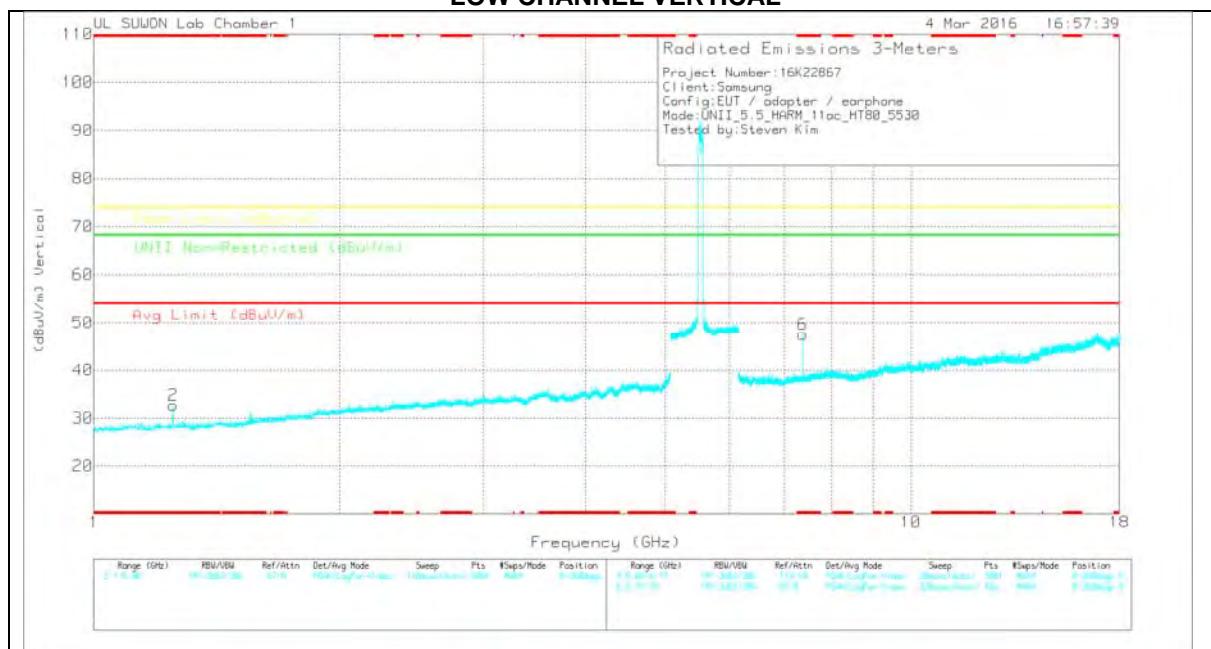

Note: Emission was scanned up to 40GHz; No emissions were detected above the noise floor which was at least 20dB below the specification limit.

LOW CHANNEL DATA

TRACE MARKERS

| Marker | Frequency (GHz) | Meter Reading (dBuV) | Det | 3117(0016 8717)_150 619 | Path_4 | DC Corr (dB) | Corrected Reading (dBuV/m) | Avg Limit (dBuV/m) | Margin (dB) | Peak Limit (dBuV/m) | Margin (dB) | UNII Non-Restricted (dBuV/m) | Margin (dB) | Azimuth (Degs) | Height (cm) | Polarity |
|--------|-----------------|----------------------|-----|-------------------------|--------|--------------|----------------------------|--------------------|-------------|---------------------|-------------|------------------------------|-------------|----------------|-------------|----------|
| 1 | * 1.25 | 42.99 | PK | 28.3 | -40.2 | 0 | 31.09 | - | - | 74 | -42.91 | - | - | 0-360 | 200 | H |
| 3 | * 5.019 | 41.92 | PK | 34.1 | -32.2 | 0 | 43.82 | - | - | 74 | -30.18 | - | - | 0-360 | 100 | H |
| 2 | * 1.25 | 44.61 | PK | 28.3 | -40.2 | 0 | 32.71 | - | - | 74 | -41.29 | - | - | 0-360 | 200 | V |
| 4 | 5.178 | 40.4 | PK | 34.3 | -23.9 | 0 | 50.8 | - | - | - | - | 68.2 | -17.4 | 0-360 | 100 | H |
| 5 | * 7.373 | 42.37 | PK | 35.8 | -30.4 | 0 | 47.77 | - | - | 74 | -26.23 | - | - | 0-360 | 100 | H |
| 6 | * 7.373 | 42.15 | PK | 35.8 | -30.4 | 0 | 47.55 | - | - | 74 | -26.45 | - | - | 0-360 | 200 | V |

* - indicates frequency in CFR15.205/IC7.2.2 Restricted Band

PK – Peak detector

Radiated Emissions

| Frequency (GHz) | Meter Reading (dBuV) | Det | 3117(001687 17)_150619 | Path_4 | DC Corr (dB) | Corrected Reading (dBuV/m) | Avg Limit (dBuV/m) | Margin (dB) | Peak Limit (dBuV/m) | Margin (dB) | UNII Non-Restricted (dBuV/m) | Margin (dB) | Azimuth (Degs) | Height (cm) | Polarity |
|-----------------|----------------------|------|------------------------|--------|--------------|----------------------------|--------------------|-------------|---------------------|-------------|------------------------------|-------------|----------------|-------------|----------|
| * 5.018 | 48.69 | PK-U | 34.1 | -32.2 | 0 | 50.59 | - | - | 74 | -23.41 | - | - | 69 | 107 | H |
| * 5.018 | 34.74 | ADR | 34.1 | -32.2 | 0 | 36.64 | 54 | -17.36 | - | - | - | - | 69 | 107 | H |
| 5.178 | 49.66 | PK-U | 34.3 | -23.9 | 0 | 60.06 | - | - | - | - | 68.2 | -8.14 | 113 | 107 | H |
| * 7.373 | 39.89 | ADR | 35.8 | -30.4 | 0 | 45.29 | 54 | -8.71 | - | - | - | - | 168 | 111 | H |
| * 7.373 | 39.92 | ADR | 35.8 | -30.4 | 0 | 45.32 | 54 | -8.68 | - | - | - | - | 200 | 169 | V |
| * 7.373 | 48.56 | PK-U | 35.8 | -30.4 | 0 | 53.96 | - | - | 74 | -20.04 | - | - | 168 | 111 | H |
| * 7.373 | 47.95 | PK-U | 35.8 | -30.4 | 0 | 53.35 | - | - | 74 | -20.65 | - | - | 200 | 169 | V |

* - indicates frequency in CFR15.205/IC7.2.2 Restricted Band

PK-U - U-NII: Maximum Peak

ADR - U-NII AD primary method, RMS average

HIGH CHANNEL HORIZONTAL

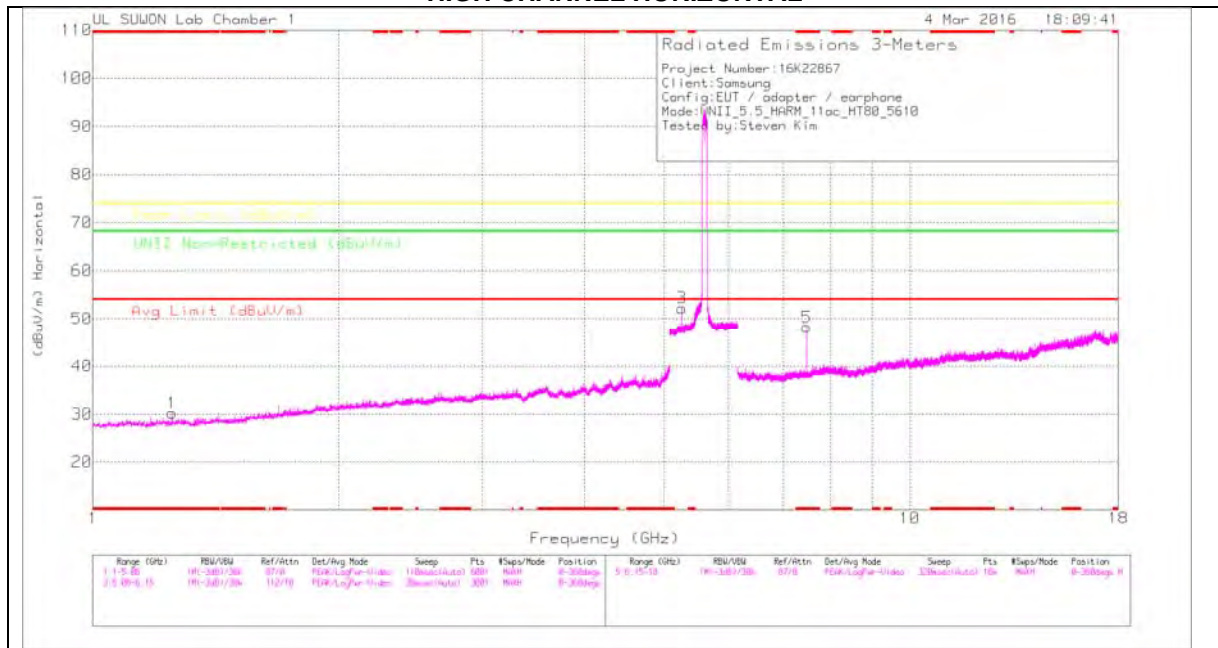

HIGH CHANNEL VERTICAL

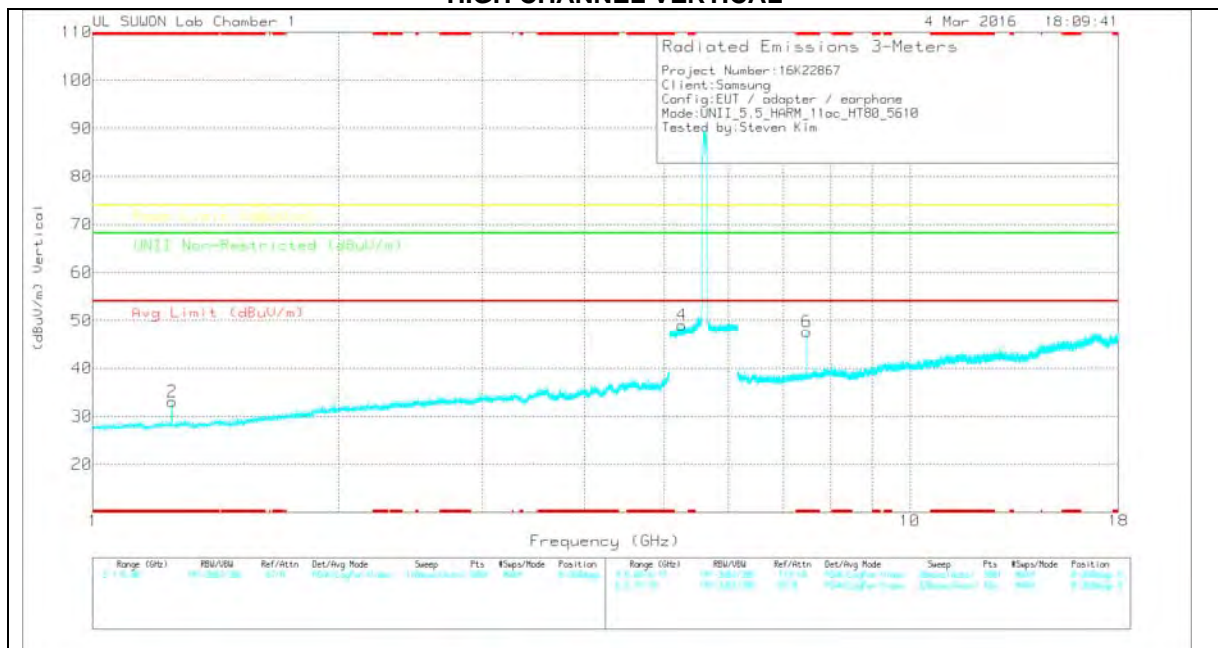

Note: Emission was scanned up to 40GHz; No emissions were detected above the noise floor which was at least 20dB below the specification limit.

HIGH CHANNEL DATA

TRACE MARKERS

| Marker | Frequency (GHz) | Meter Reading (dBuV) | Det | 3117(0016 8717)_150 619 | Path_4 | DC Corr (dB) | Corrected Reading (dBuV/m) | Avg Limit (dBuV/m) | Margin (dB) | Peak Limit (dBuV/m) | Margin (dB) | UNII Non-Restricted (dBuV/m) | Margin (dB) | Azimuth (Degs) | Height (cm) | Polarity |
|--------|-----------------|----------------------|-----|-------------------------|--------|--------------|----------------------------|--------------------|-------------|---------------------|-------------|------------------------------|-------------|----------------|-------------|----------|
| 1 | * 1.25 | 42.13 | PK | 28.3 | -40.2 | 0 | 30.23 | - | - | 74 | -43.77 | - | - | 0-360 | 200 | H |
| 2 | * 1.25 | 44.98 | PK | 28.3 | -40.2 | 0 | 33.08 | - | - | 74 | -40.92 | - | - | 0-360 | 200 | V |
| 3 | 5.258 | 41.47 | PK | 34.4 | -23.6 | 0 | 52.27 | - | - | - | - | 68.2 | -15.93 | 0-360 | 100 | H |
| 4 | 5.258 | 38.27 | PK | 34.4 | -23.6 | 0 | 49.07 | - | - | - | - | 68.2 | -19.13 | 0-360 | 100 | V |
| 5 | * 7.48 | 42.76 | PK | 35.8 | -30.3 | 0 | 48.26 | - | - | 74 | -25.74 | - | - | 0-360 | 100 | H |
| 6 | * 7.48 | 42.17 | PK | 35.8 | -30.3 | 0 | 47.67 | - | - | 74 | -26.33 | - | - | 0-360 | 100 | V |

* - indicates frequency in CFR15.205/IC7.2.2 Restricted Band

PK – Peak detector

Radiated Emissions

| Frequency (GHz) | Meter Reading (dBuV) | Det | 3117(001687 17)_150619 | Path_2 | DC Corr (dB) | Corrected Reading (dBuV/m) | Avg Limit (dBuV/m) | Margin (dB) | Peak Limit (dBuV/m) | Margin (dB) | UNII Non-Restricted (dBuV/m) | Margin (dB) | Azimuth (Degs) | Height (cm) | Polarity |
|-----------------|----------------------|------|------------------------|--------|--------------|----------------------------|--------------------|-------------|---------------------|-------------|------------------------------|-------------|----------------|-------------|----------|
| 5.258 | 50.57 | PK-U | 34.4 | -23.6 | 0 | 61.37 | - | - | - | - | 68.2 | -6.83 | 112 | 101 | H |
| * 7.48 | 39.39 | ADR | 35.8 | -30.3 | 0 | 44.89 | 54 | -9.11 | - | - | - | - | 172 | 159 | H |
| * 7.48 | 37.79 | ADR | 35.8 | -30.3 | 0 | 43.29 | 54 | -10.71 | - | - | - | - | 163 | 295 | V |
| * 7.48 | 48.09 | PK-U | 35.8 | -30.3 | 0 | 53.59 | - | - | 74 | -20.41 | - | - | 172 | 159 | H |
| * 7.48 | 48.74 | PK-U | 35.8 | -30.3 | 0 | 54.24 | - | - | 74 | -19.76 | - | - | 163 | 295 | V |

* - indicates frequency in CFR15.205/IC7.2.2 Restricted Band

PK-U - U-NII: Maximum Peak

ADR - U-NII AD primary method, RMS average

11.4. 5.8 GHz

11.4.1. TX ABOVE 1GHz 802.11a 2TX CDD MODE IN THE 5.8GHz BAND HARMONICS AND SPURIOUS EMISSIONS HORIZONTAL PEAK PLOT

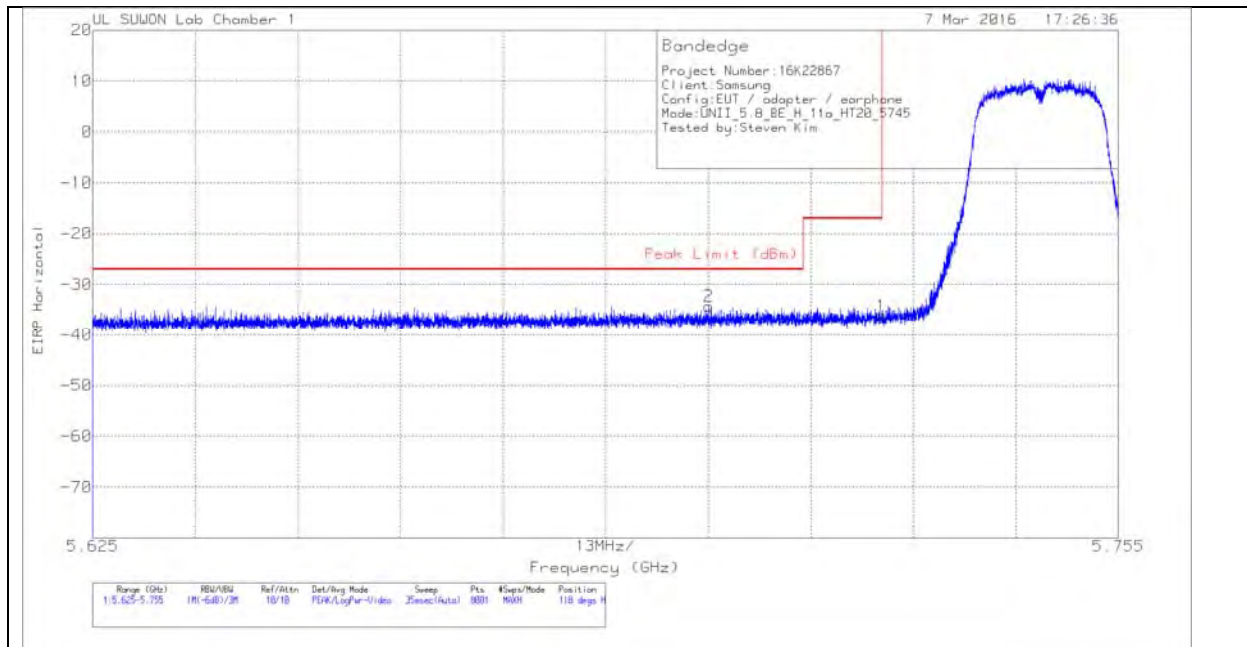

HORIZONTAL DATA

TRACE MARKERS

| Marker | Frequency (GHz) | Meter Reading (dBm) | Det | 3117(0016 8717)_150 619 | Path_2 | Conversion Factor (dB) | DC Corr (dB) | Corrected Reading EIRP | Peak Limit (dBm) | PK Margin (dB) | Azimuth (Degs) | Height (cm) | Polarity |
|--------|-----------------|---------------------|-----|-------------------------|--------|------------------------|--------------|------------------------|------------------|----------------|----------------|-------------|----------|
| 1 | 5.725 | -59.95 | Pk | 34.8 | -22.8 | 11.8 | 0 | -36.15 | -17 | -19.15 | 118 | 187 | H |
| 2 | 5.703 | -57.98 | Pk | 34.8 | -22.9 | 11.8 | 0 | -34.28 | -27 | -7.28 | 118 | 187 | H |

Pk - Peak detector

VERTICAL PEAK PLOT

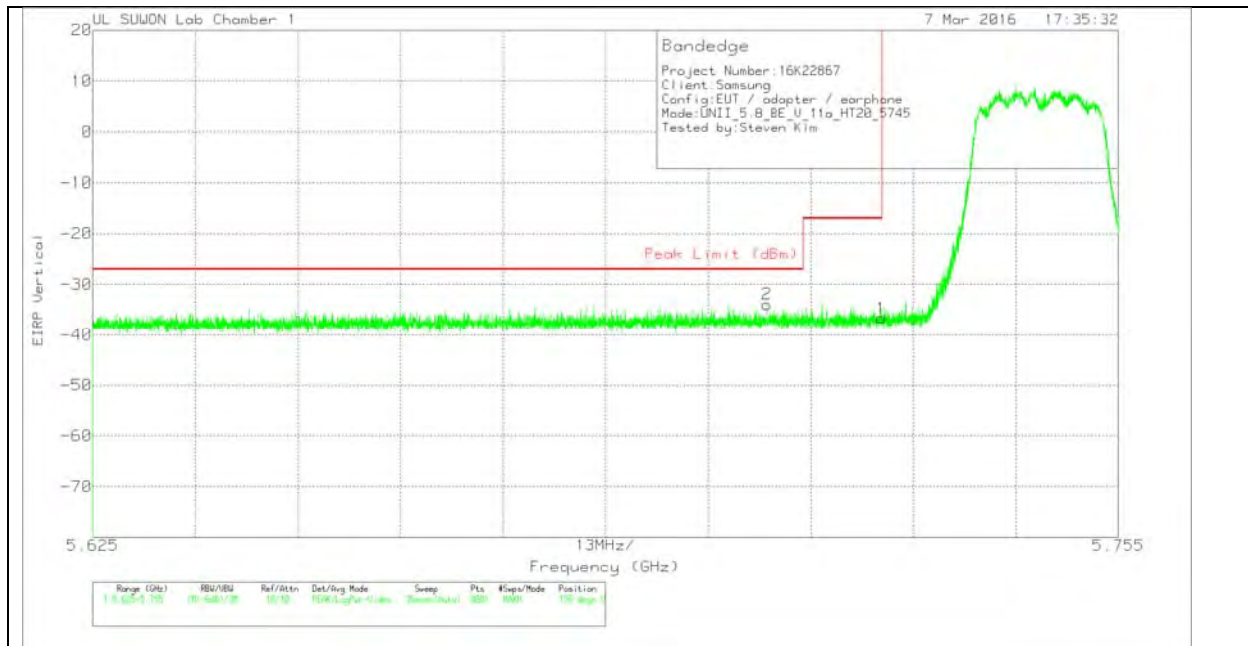

VERTICAL DATA

TRACE MARKERS

| Marker | Frequency (GHz) | Meter Reading (dBm) | Det | 3117(0016 8717)_150 619 | Path_2 | Conversion Factor (dB) | DC Corr (dB) | Corrected Reading EIRP | Peak Limit (dBm) | PK Margin (dB) | Azimuth (Degs) | Height (cm) | Polarity |
|--------|-----------------|---------------------|-----|-------------------------|--------|------------------------|--------------|------------------------|------------------|----------------|----------------|-------------|----------|
| 1 | 5.725 | -60.44 | Pk | 34.8 | -22.8 | 11.8 | 0 | -36.64 | -17 | -19.64 | 159 | 101 | V |
| 2 | 5.71 | -57.7 | Pk | 34.8 | -22.8 | 11.8 | 0 | -33.9 | -27 | -6.9 | 159 | 101 | V |

Pk - Peak detector

AUTHORIZED BANDEDGE (HIGH CHANNEL)

HORIZONTAL PEAK PLOT

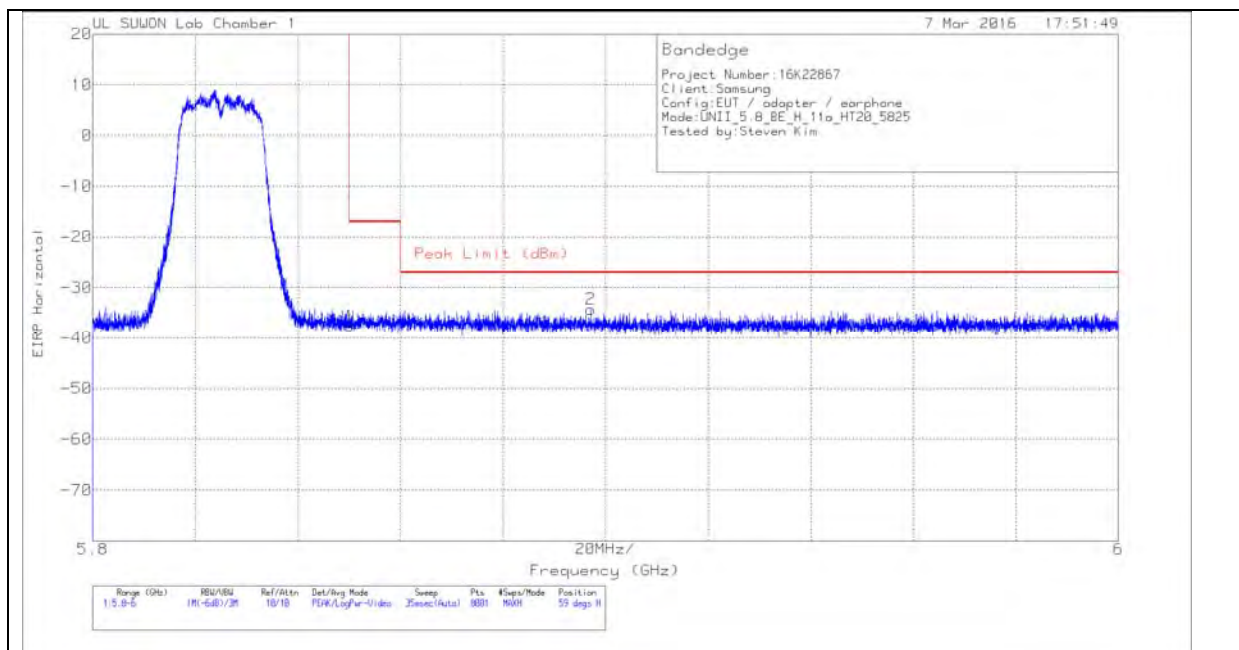

HORIZONTAL DATA

TRACE MARKERS

| Marker | Frequency (GHz) | Meter Reading (dBm) | Det | 3117(0016 8717)_150 619 | Path_2 | Conversion Factor (dB) | DC Corr (dB) | Corrected Reading EIRP | Peak Limit (dBm) | PK Margin (dB) | Azimuth (Degs) | Height (cm) | Polarity |
|--------|-----------------|---------------------|-----|-------------------------|--------|------------------------|--------------|------------------------|------------------|----------------|----------------|-------------|----------|
| 1 | 5.85 | -62.12 | PK | 34.9 | -22.2 | 11.8 | 0 | -37.62 | -17 | -20.62 | 59 | 181 | H |
| 2 | 5.897 | -58.66 | PK | 34.9 | -22.3 | 11.8 | 0 | -34.26 | -27 | -7.26 | 59 | 181 | H |

Pk - Peak detector

VERTICAL PEAK PLOT

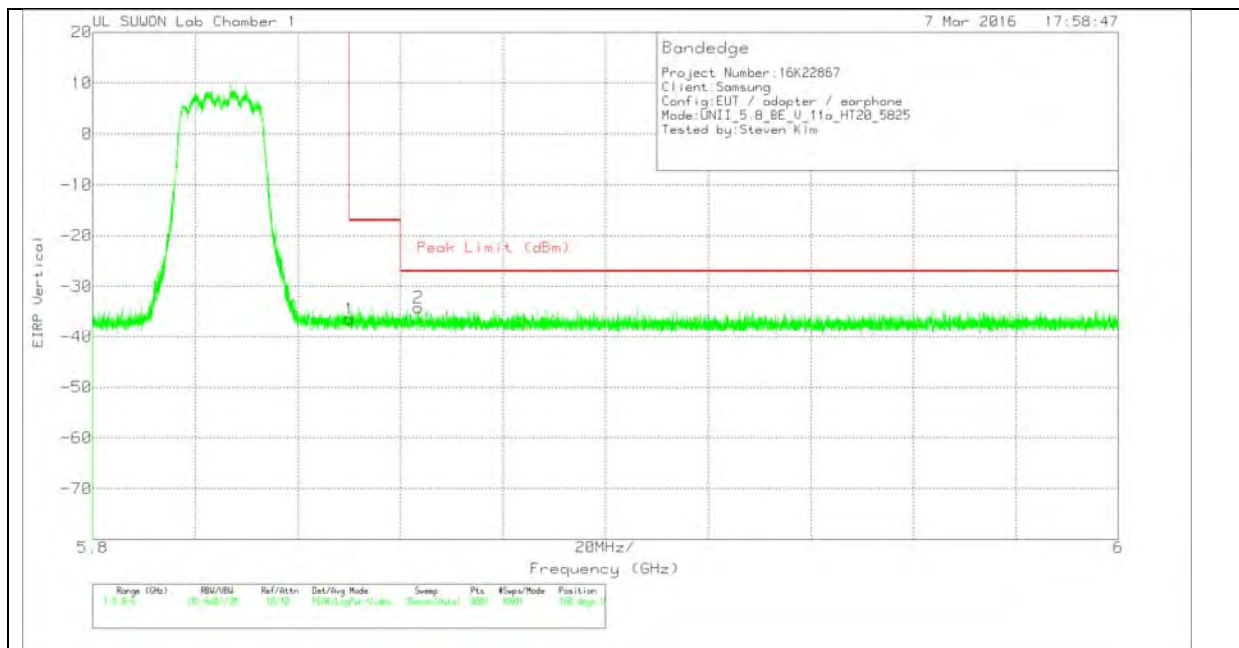

VERTICAL DATA

TRACE MARKERS

| Marker | Frequency (GHz) | Meter Reading (dBm) | Det | 3117(0016 8717)_150 619 | Path_2 | Conversion Factor (dB) | DC Corr (dB) | Corrected Reading EIRP | Peak Limit (dBm) | PK Margin (dB) | Azimuth (Degs) | Height (cm) | Polarity |
|--------|-----------------|---------------------|-----|-------------------------|--------|------------------------|--------------|------------------------|------------------|----------------|----------------|-------------|----------|
| 1 | 5.85 | -60.92 | Pk | 34.9 | -22.2 | 11.8 | 0 | -36.42 | -17 | -19.42 | 160 | 100 | V |
| 2 | 5.864 | -58.56 | Pk | 34.9 | -22.3 | 11.8 | 0 | -34.16 | -27 | -7.16 | 160 | 100 | V |

Pk - Peak detector

Straddle CHANNEL(144) HORIZONTAL

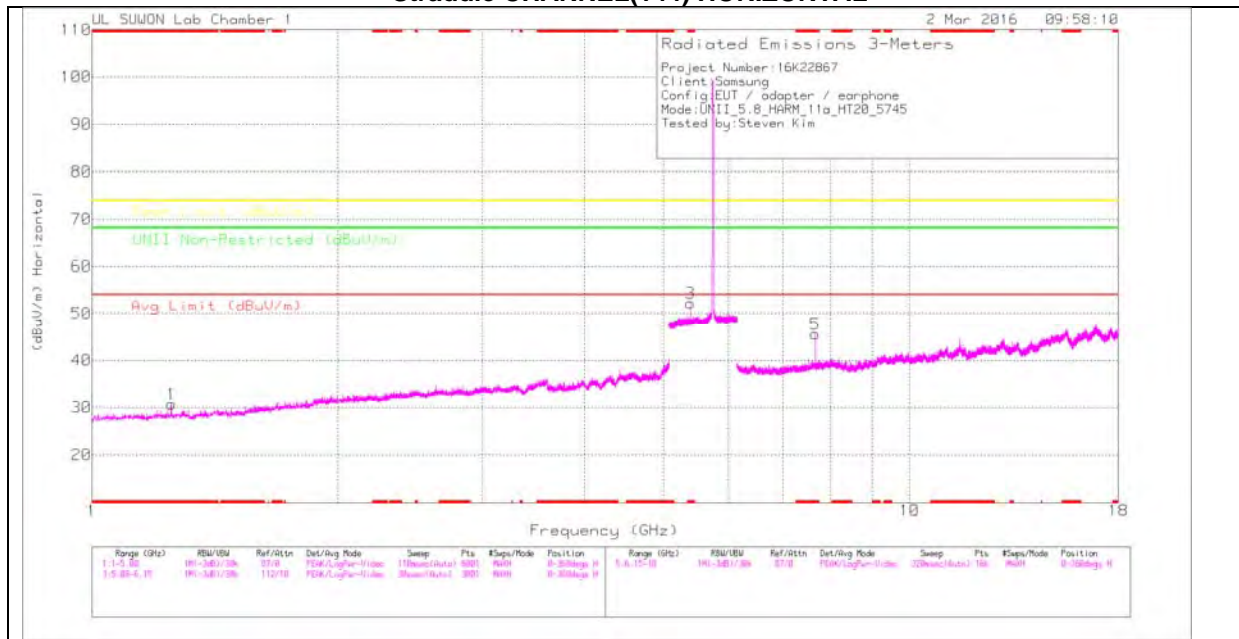

Straddle CHANNEL(144) VERTICAL

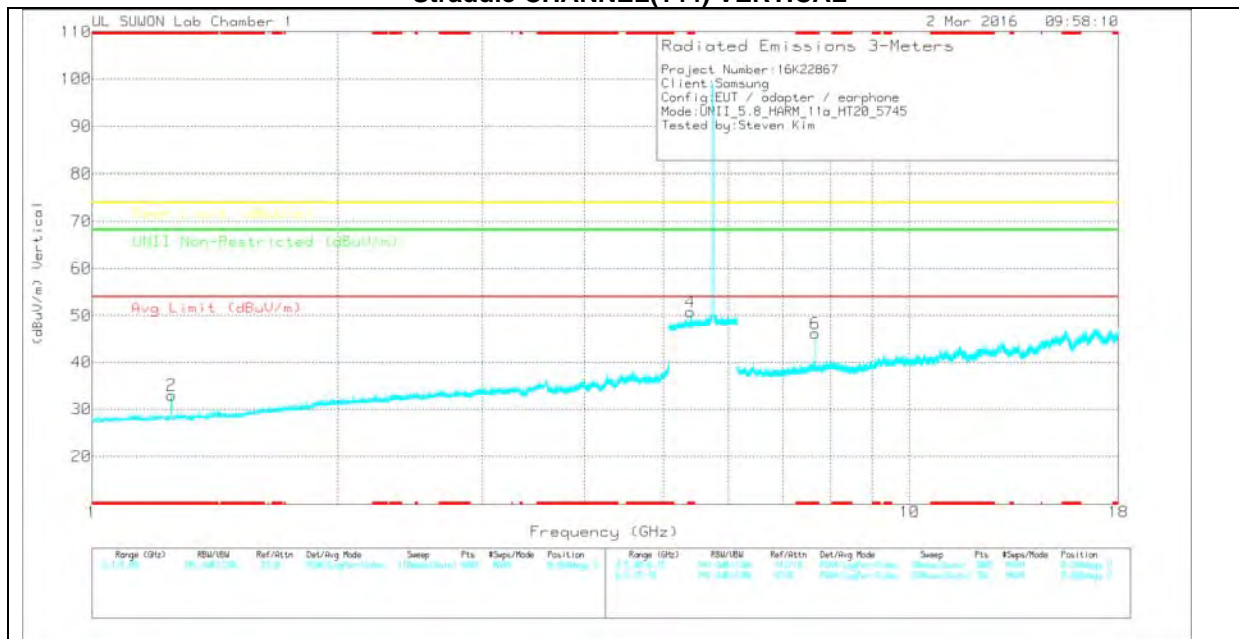

Note: Emission was scanned up to 40GHz; No emissions were detected above the noise floor which was at least 20dB below the specification limit.

Straddle CHANNEL(144) DATA

TRACE MARKERS

| Marker | Frequency (GHz) | Meter Reading (dBuV) | Det | 3117(0016 8717)_150 619 | Path_4 | DC Corr (dB) | Corrected Reading (dBuV/m) | Avg Limit (dBuV/m) | Margin (dB) | Peak Limit (dBuV/m) | Margin (dB) | UNII Non-Restricted (dBuV/m) | Margin (dB) | Azimuth (Degs) | Height (cm) | Polarity |
|--------|-----------------|----------------------|-----|-------------------------|--------|--------------|----------------------------|--------------------|-------------|---------------------|-------------|------------------------------|-------------|----------------|-------------|----------|
| 1 | * 1.25 | 42.71 | PK | 28.3 | -40.2 | 0 | 30.81 | - | - | 74 | -43.19 | - | - | 0-360 | 200 | H |
| 2 | * 1.25 | 44.92 | PK | 28.3 | -40.2 | 0 | 33.02 | - | - | 74 | -40.98 | - | - | 0-360 | 200 | V |
| 3 | * 5.393 | 41.04 | PK | 34.5 | -23.3 | 0 | 52.24 | - | - | 74 | -21.76 | - | - | 0-360 | 100 | H |
| 4 | * 5.393 | 39.62 | PK | 34.5 | -23.3 | 0 | 50.82 | - | - | 74 | -23.18 | - | - | 0-360 | 200 | V |
| 5 | * 7.66 | 39.97 | PK | 36 | -30.3 | 0 | 45.67 | - | - | 74 | -28.33 | - | - | 0-360 | 100 | H |
| 6 | * 7.66 | 40.51 | PK | 36 | -30.3 | 0 | 46.21 | - | - | 74 | -27.79 | - | - | 0-360 | 100 | V |

* - indicates frequency in CFR15.205/IC7.2.2 Restricted Band

PK – Peak Detector

Radiated Emissions

| Frequency (GHz) | Meter Reading (dBuV) | Det | 3117(001687 17)_150619 | Path_2 | DC Corr (dB) | Corrected Reading (dBuV/m) | Avg Limit (dBuV/m) | Margin (dB) | Peak Limit (dBuV/m) | Margin (dB) | UNII Non-Restricted (dBuV/m) | Margin (dB) | Azimuth (Degs) | Height (cm) | Polarity |
|-----------------|----------------------|------|------------------------|--------|--------------|----------------------------|--------------------|-------------|---------------------|-------------|------------------------------|-------------|----------------|-------------|----------|
| * 5.393 | 50.78 | PK-U | 34.5 | -23.3 | 0 | 61.98 | - | - | 74 | -12.02 | - | - | 61 | 215 | H |
| * 5.393 | 38.22 | ADR | 34.5 | -23.3 | 0 | 49.42 | 54 | -4.58 | - | - | - | - | 61 | 215 | H |
| * 5.393 | 38.49 | ADR | 34.5 | -23.3 | 0 | 49.69 | 54 | -4.31 | - | - | - | - | 202 | 108 | V |
| * 5.393 | 49.16 | PK-U | 34.5 | -23.3 | 0 | 60.36 | - | - | 74 | -13.64 | - | - | 202 | 108 | V |
| * 7.66 | 40.09 | ADR | 36 | -30.3 | 0 | 45.79 | 54 | -8.21 | - | - | - | - | 172 | 102 | H |
| * 7.66 | 38.41 | ADR | 36 | -30.3 | 0 | 44.11 | 54 | -9.89 | - | - | - | - | 201 | 115 | V |
| * 7.66 | 47.55 | PK-U | 36 | -30.3 | 0 | 53.25 | - | - | 74 | -20.75 | - | - | 172 | 102 | H |
| * 7.66 | 47.16 | PK-U | 36 | -30.3 | 0 | 52.86 | - | - | 74 | -21.14 | - | - | 201 | 115 | V |

* - indicates frequency in CFR15.205/IC7.2.2 Restricted Band

PK-U - U-NII: Maximum Peak

ADR - U-NII AD primary method, RMS average

LOW CHANNEL HORIZONTAL

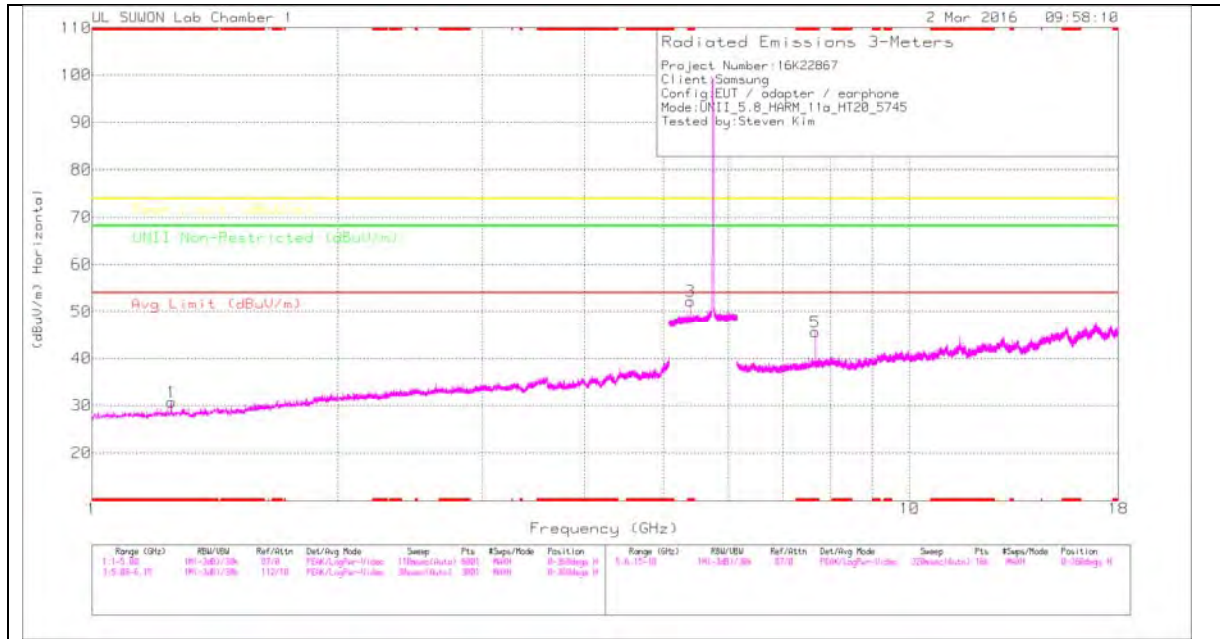

LOW CHANNEL VERTICAL

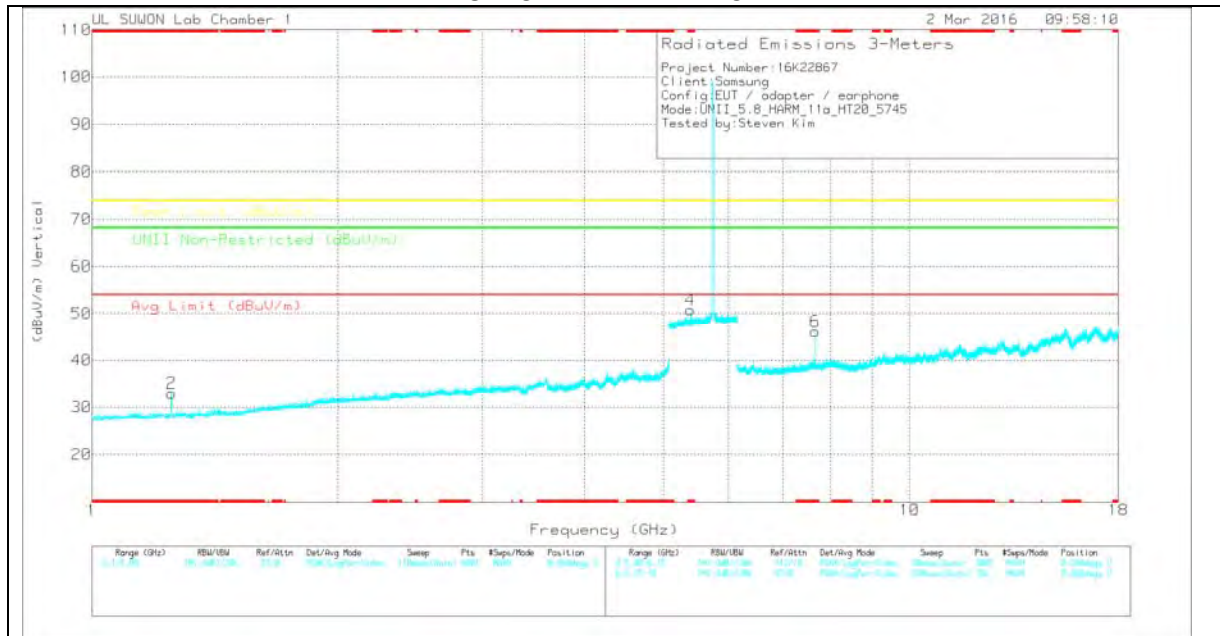

Note: Emission was scanned up to 40GHz; No emissions were detected above the noise floor which was at least 20dB below the specification limit.

LOW CHANNEL DATA

TRACE MARKERS

| Marker | Frequency (GHz) | Meter Reading (dBuV) | Det | 3117(0016 8717)_150 619 | Path_4 | DC Corr (dB) | Corrected Reading (dBuV/m) | Avg Limit (dBuV/m) | Margin (dB) | Peak Limit (dBuV/m) | Margin (dB) | UNII Non-Restricted (dBuV/m) | Margin (dB) | Azimuth (Degs) | Height (cm) | Polarity |
|--------|-----------------|----------------------|-----|-------------------------|--------|--------------|----------------------------|--------------------|-------------|---------------------|-------------|------------------------------|-------------|----------------|-------------|----------|
| 1 | * 1.25 | 42.71 | PK | 28.3 | -40.2 | 0 | 30.81 | - | - | 74 | -43.19 | - | - | 0-360 | 200 | H |
| 2 | * 1.25 | 44.92 | PK | 28.3 | -40.2 | 0 | 33.02 | - | - | 74 | -40.98 | - | - | 0-360 | 200 | V |
| 3 | * 5.393 | 41.04 | PK | 34.5 | -23.3 | 0 | 52.24 | - | - | 74 | -21.76 | - | - | 0-360 | 100 | H |
| 4 | * 5.393 | 39.62 | PK | 34.5 | -23.3 | 0 | 50.82 | - | - | 74 | -23.18 | - | - | 0-360 | 200 | V |
| 5 | * 7.66 | 39.97 | PK | 36 | -30.3 | 0 | 45.67 | - | - | 74 | -28.33 | - | - | 0-360 | 100 | H |
| 6 | * 7.66 | 40.51 | PK | 36 | -30.3 | 0 | 46.21 | - | - | 74 | -27.79 | - | - | 0-360 | 100 | V |

* - indicates frequency in CFR15.205/IC7.2.2 Restricted Band

PK – Peak Detector

Radiated Emissions

| Frequency (GHz) | Meter Reading (dBuV) | Det | 3117(001687 17)_150619 | Path_2 | DC Corr (dB) | Corrected Reading (dBuV/m) | Avg Limit (dBuV/m) | Margin (dB) | Peak Limit (dBuV/m) | Margin (dB) | UNII Non-Restricted (dBuV/m) | Margin (dB) | Azimuth (Degs) | Height (cm) | Polarity |
|-----------------|----------------------|------|------------------------|--------|--------------|----------------------------|--------------------|-------------|---------------------|-------------|------------------------------|-------------|----------------|-------------|----------|
| * 5.393 | 50.78 | PK-U | 34.5 | -23.3 | 0 | 61.98 | - | - | 74 | -12.02 | - | - | 61 | 215 | H |
| * 5.393 | 38.22 | ADR | 34.5 | -23.3 | 0 | 49.42 | 54 | -4.58 | - | - | - | - | 61 | 215 | H |
| * 5.393 | 38.49 | ADR | 34.5 | -23.3 | 0 | 49.69 | 54 | -4.31 | - | - | - | - | 202 | 108 | V |
| * 5.393 | 49.16 | PK-U | 34.5 | -23.3 | 0 | 60.36 | - | - | 74 | -13.64 | - | - | 202 | 108 | V |
| * 7.66 | 40.09 | ADR | 36 | -30.3 | 0 | 45.79 | 54 | -8.21 | - | - | - | - | 172 | 102 | H |
| * 7.66 | 38.41 | ADR | 36 | -30.3 | 0 | 44.11 | 54 | -9.89 | - | - | - | - | 201 | 115 | V |
| * 7.66 | 47.55 | PK-U | 36 | -30.3 | 0 | 53.25 | - | - | 74 | -20.75 | - | - | 172 | 102 | H |
| * 7.66 | 47.16 | PK-U | 36 | -30.3 | 0 | 52.86 | - | - | 74 | -21.14 | - | - | 201 | 115 | V |

* - indicates frequency in CFR15.205/IC7.2.2 Restricted Band

PK-U - U-NII: Maximum Peak

ADR - U-NII AD primary method, RMS average

MID CHANNEL HORIZONTAL

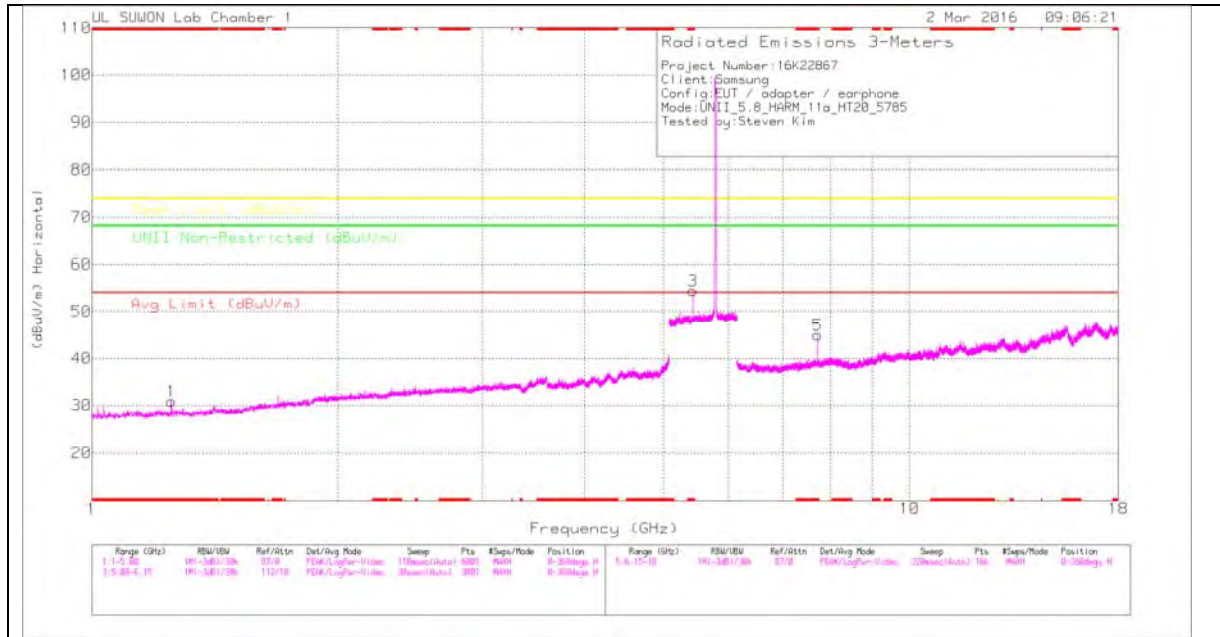

MID CHANNEL VERTICAL

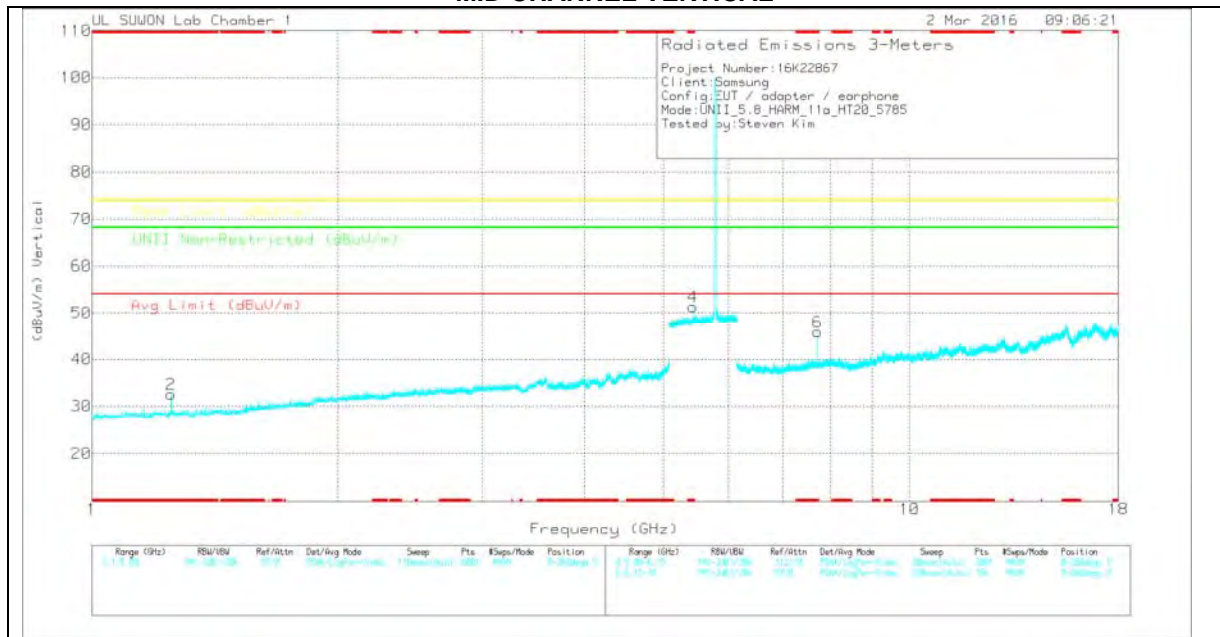

Note: Emission was scanned up to 40GHz; No emissions were detected above the noise floor which was at least 20dB below the specification limit.

MID CHANNEL DATA

TRACE MARKERS

| Marker | Frequency (GHz) | Meter Reading (dBuV) | Det | 3117(0016 8717)_150 619 | Path_4 | DC Corr (dB) | Corrected Reading (dBuV/m) | Avg Limit (dBuV/m) | Margin (dB) | Peak Limit (dBuV/m) | Margin (dB) | UNII Non-Restricted (dBuV/m) | Margin (dB) | Azimuth (Degs) | Height (cm) | Polarity |
|--------|-----------------|----------------------|-----|-------------------------|--------|--------------|----------------------------|--------------------|-------------|---------------------|-------------|------------------------------|-------------|----------------|-------------|----------|
| 1 | * 1.25 | 42.76 | PK | 28.3 | -40.2 | 0 | 30.86 | - | - | 74 | -43.14 | - | - | 0-360 | 200 | H |
| 2 | * 1.25 | 44.49 | PK | 28.3 | -40.2 | 0 | 32.59 | - | - | 74 | -41.41 | - | - | 0-360 | 200 | V |
| 3 | * 5.433 | 43.08 | PK | 34.6 | -23.2 | 0 | 54.48 | - | - | 74 | -19.52 | - | - | 0-360 | 100 | H |
| 4 | * 5.433 | 39.9 | PK | 34.6 | -23.2 | 0 | 51.3 | - | - | 74 | -22.7 | - | - | 0-360 | 200 | V |
| 5 | * 7.713 | 39.19 | PK | 36.1 | -30.3 | 0 | 44.99 | - | - | 74 | -29.01 | - | - | 0-360 | 100 | H |
| 6 | * 7.713 | 40.07 | PK | 36.1 | -30.3 | 0 | 45.87 | - | - | 74 | -28.13 | - | - | 0-360 | 100 | V |

* - indicates frequency in CFR15.205/IC7.2.2 Restricted Band

PK – Peak Detector

Radiated Emissions

| Frequency (GHz) | Meter Reading (dBuV) | Det | 3117(001687 17)_150619 | Path_2 | DC Corr (dB) | Corrected Reading (dBuV/m) | Avg Limit (dBuV/m) | Margin (dB) | Peak Limit (dBuV/m) | Margin (dB) | UNII Non-Restricted (dBuV/m) | Margin (dB) | Azimuth (Degs) | Height (cm) | Polarity |
|-----------------|----------------------|------|------------------------|--------|--------------|----------------------------|--------------------|-------------|---------------------|-------------|------------------------------|-------------|----------------|-------------|----------|
| * 5.433 | 50.89 | PK-U | 34.6 | -23.2 | 0 | 62.29 | - | - | 74 | -11.71 | - | - | 57 | 208 | H |
| * 5.433 | 39.41 | ADR | 34.6 | -23.2 | 0 | 50.81 | 54 | -3.19 | - | - | - | - | 57 | 208 | H |
| * 5.433 | 49.31 | PK-U | 34.6 | -23.2 | 0 | 60.71 | - | - | 74 | -13.29 | - | - | 198 | 103 | V |
| * 5.433 | 37.68 | ADR | 34.6 | -23.2 | 0 | 49.08 | 54 | -4.92 | - | - | - | - | 198 | 103 | V |
| * 7.713 | 39.89 | ADR | 36.1 | -30.3 | 0 | 45.69 | 54 | -8.31 | - | - | - | - | 168 | 317 | H |
| * 7.713 | 38.96 | ADR | 36.1 | -30.3 | 0 | 44.76 | 54 | -9.24 | - | - | - | - | 156 | 107 | V |
| * 7.713 | 47.2 | PK-U | 36.1 | -30.3 | 0 | 53 | - | - | 74 | -21 | - | - | 168 | 317 | H |
| * 7.714 | 46.4 | PK-U | 36.1 | -30.3 | 0 | 52.2 | - | - | 74 | -21.8 | - | - | 156 | 107 | V |

* - indicates frequency in CFR15.205/IC7.2.2 Restricted Band

PK-U - U-NII: Maximum Peak

ADR - U-NII AD primary method, RMS average

HIGH CHANNEL HORIZONTAL

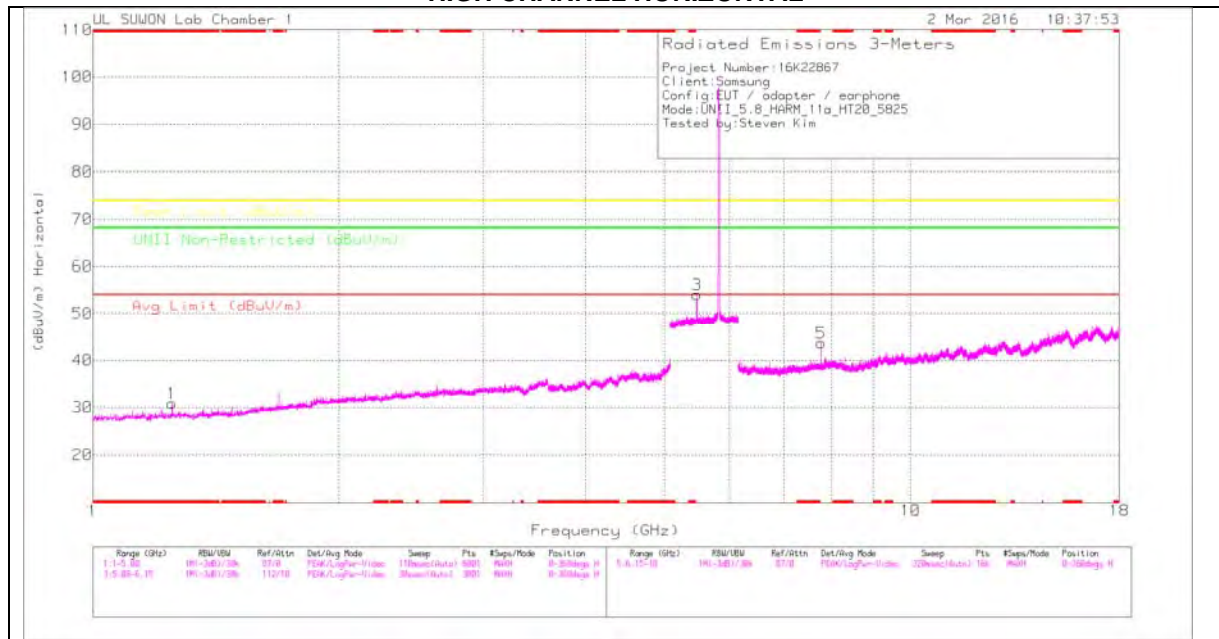

HIGH CHANNEL VERTICAL

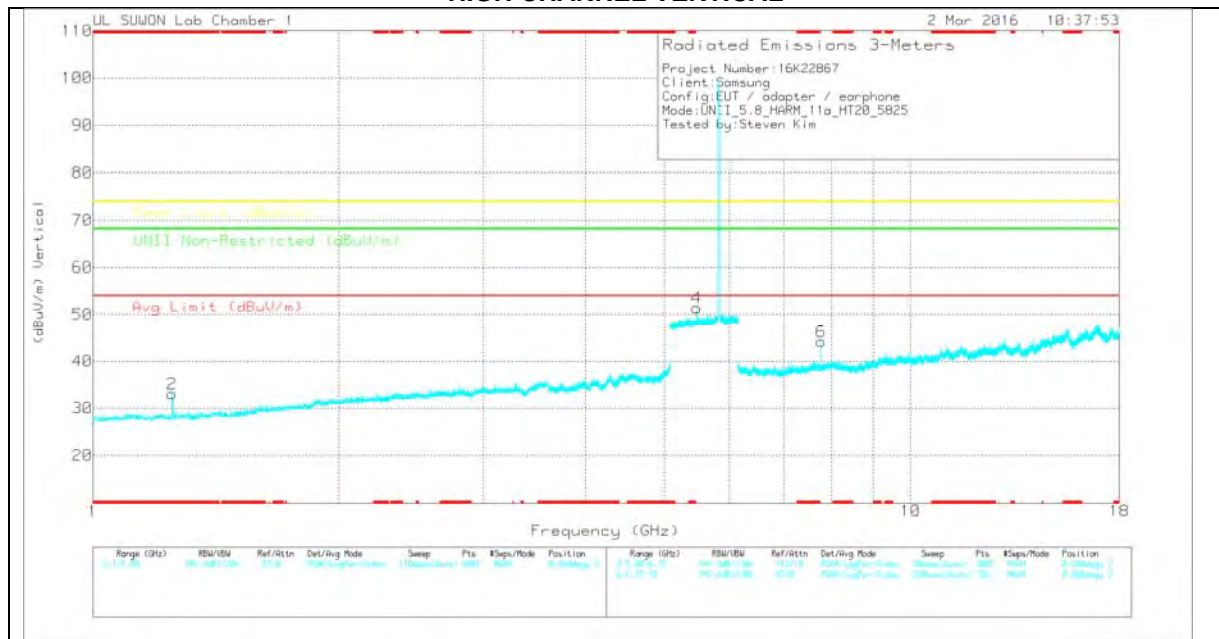

Note: Emission was scanned up to 40GHz; No emissions were detected above the noise floor which was at least 20dB below the specification limit.

HIGH CHANNEL DATA

TRACE MARKERS

| Marker | Frequency (GHz) | Meter Reading (dBuV) | Det | 3117(0016 8717)_150 619 | Path_4 | DC Corr (dB) | Corrected Reading (dBuV/m) | Avg Limit (dBuV/m) | Margin (dB) | Peak Limit (dBuV/m) | Margin (dB) | UNII Non-Restricted (dBuV/m) | Margin (dB) | Azimuth (Degs) | Height (cm) | Polarity |
|--------|-----------------|----------------------|-----|-------------------------|--------|--------------|----------------------------|--------------------|-------------|---------------------|-------------|------------------------------|-------------|----------------|-------------|----------|
| 1 | * 1.25 | 42.79 | PK | 28.3 | -40.2 | 0 | 30.89 | - | - | 74 | -43.11 | - | - | 0-360 | 200 | H |
| 2 | * 1.25 | 44.93 | PK | 28.3 | -40.2 | 0 | 33.03 | - | - | 74 | -40.97 | - | - | 0-360 | 200 | V |
| 3 | 5.473 | 42.56 | PK | 34.6 | -23.1 | 0 | 54.06 | - | - | - | - | 68.2 | -14.14 | 0-360 | 100 | H |
| 4 | 5.473 | 40 | PK | 34.6 | -23.1 | 0 | 51.5 | - | - | - | - | 68.2 | -16.7 | 0-360 | 100 | V |
| 5 | 7.767 | 37.76 | PK | 36.2 | -30.3 | 0 | 43.66 | - | - | - | - | 68.2 | -24.54 | 0-360 | 100 | H |
| 6 | 7.767 | 38.33 | PK | 36.2 | -30.3 | 0 | 44.23 | - | - | - | - | 68.2 | -23.97 | 0-360 | 100 | V |

* - indicates frequency in CFR15.205/IC7.2.2 Restricted Band

PK – Peak Detector

Radiated Emissions

| Frequency (GHz) | Meter Reading (dBuV) | Det | 3117(0016871 7)_150619 | Path_2 | DC Corr (dB) | Corrected Reading (dBuV/m) | Avg Limit (dBuV/m) | Margin (dB) | Peak Limit (dBuV/m) | Margin (dB) | UNII Non-Restricted (dBuV/m) | Margin (dB) | Azimuth (Degs) | Height (cm) | Polarity |
|-----------------|----------------------|------|------------------------|--------|--------------|----------------------------|--------------------|-------------|---------------------|-------------|------------------------------|-------------|----------------|-------------|----------|
| 5.473 | 50.89 | PK-U | 34.6 | -23.1 | 0 | 62.39 | - | - | - | - | 68.2 | -5.81 | 59 | 157 | H |
| 5.472 | 48.84 | PK-U | 34.6 | -23.1 | 0 | 60.34 | - | - | - | - | 68.2 | -7.86 | 205 | 160 | V |
| 7.766 | 46.41 | PK-U | 36.2 | -30.3 | 0 | 52.31 | - | - | - | - | 68.2 | -15.89 | 172 | 311 | H |
| 7.766 | 46.51 | PK-U | 36.2 | -30.3 | 0 | 52.41 | - | - | - | - | 68.2 | -15.79 | 202 | 187 | V |

* - indicates frequency in CFR15.205/IC7.2.2 Restricted Band

PK-U - U-NII: Maximum Peak

**11.4.2. TX ABOVE 1GHz 802.11n HT20 2TX CDD MODE IN THE 5.8GHz BAND
 HARMONICS AND SPURIOUS EMISSIONS
 HORIZONTAL PEAK PLOT**

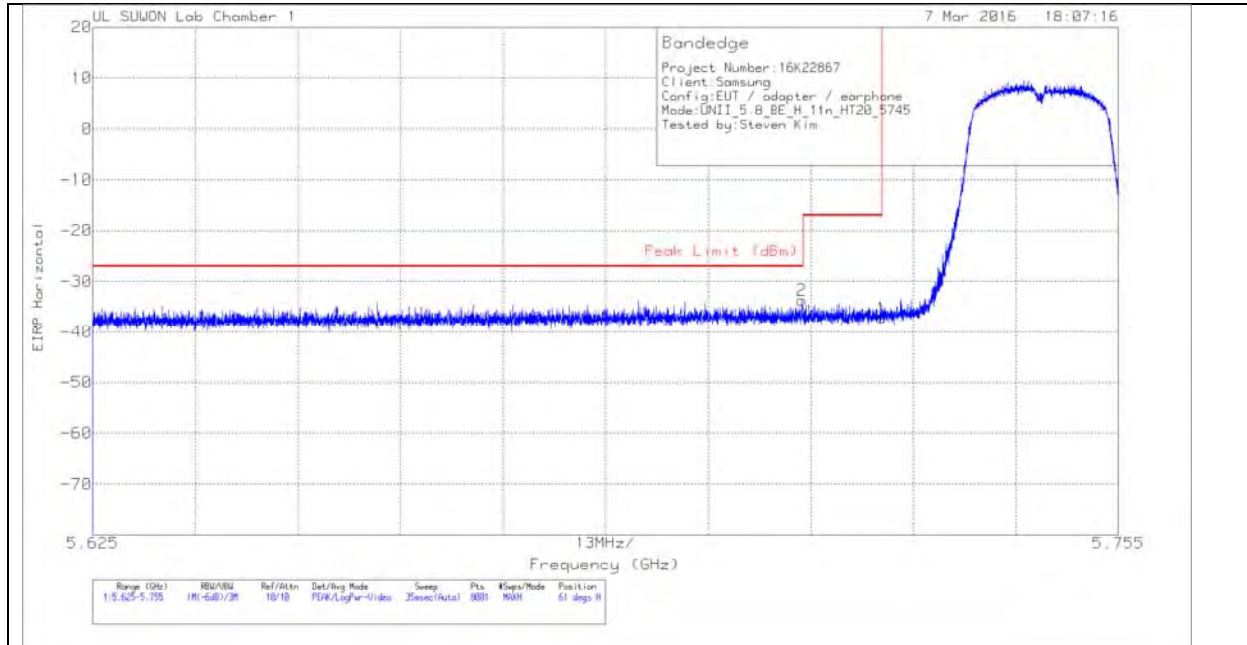

HORIZONTAL DATA

TRACE MARKERS

| Marker | Frequency (GHz) | Meter Reading (dBm) | Det | 3117(0016 8717)_150 619 | Path_2 | Conversion Factor (dB) | DC Corr (dB) | Corrected Reading EIRP | Peak Limit (dBm) | PK Margin (dB) | Azimuth (Degs) | Height (cm) | Polarity |
|--------|-----------------|---------------------|-----|-------------------------|--------|------------------------|--------------|------------------------|------------------|----------------|----------------|-------------|----------|
| 1 | 5.725 | -61.01 | Pk | 34.8 | -22.8 | 11.8 | 0 | -37.21 | -17 | -20.21 | 61 | 186 | H |
| 2 | 5.715 | -57.49 | Pk | 34.8 | -22.8 | 11.8 | 0 | -33.69 | -27 | -6.69 | 61 | 186 | H |

Pk - Peak detector

VERTICAL PEAK PLOT

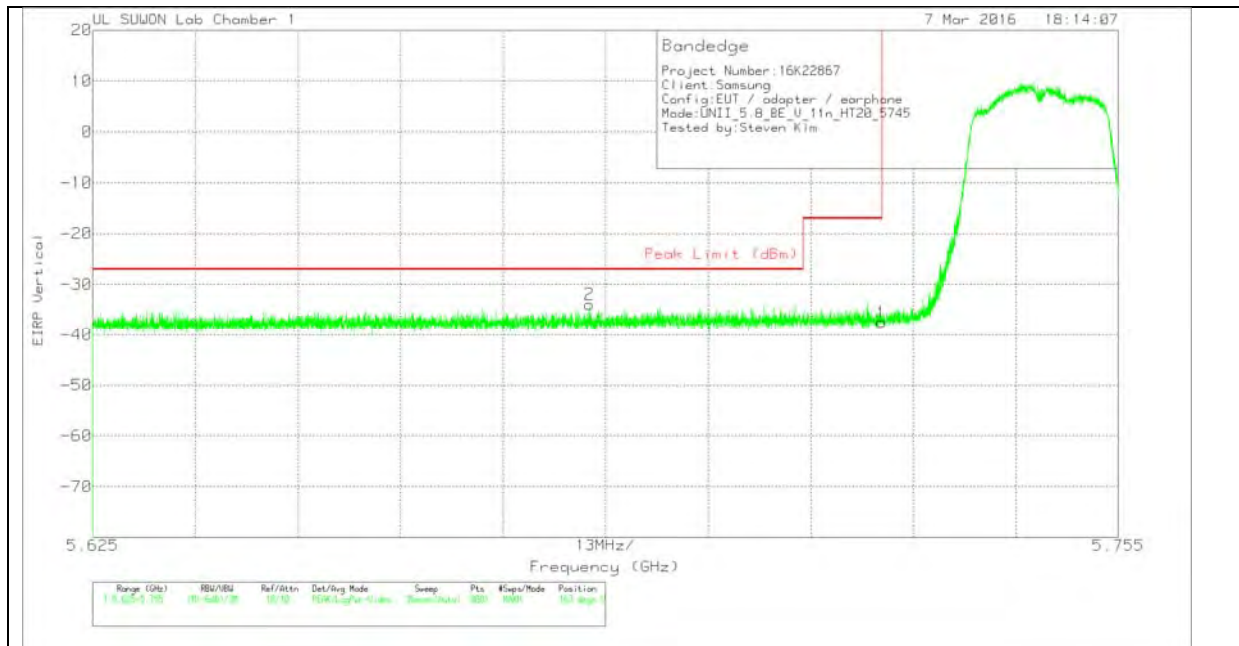

VERTICAL DATA

TRACE MARKERS

| Marker | Frequency (GHz) | Meter Reading (dBm) | Det | 3117(0016 8717)_150 619 | Path_2 | Conversion Factor (dB) | DC Corr (dB) | Corrected Reading EIRP | Peak Limit (dBm) | PK Margin (dB) | Azimuth (Degs) | Height (cm) | Polarity |
|--------|-----------------|---------------------|-----|-------------------------|--------|------------------------|--------------|------------------------|------------------|----------------|----------------|-------------|----------|
| 1 | 5.725 | -61.25 | Pk | 34.8 | -22.8 | 11.8 | 0 | -37.45 | -17 | -20.45 | 163 | 134 | V |
| 2 | 5.688 | -57.61 | Pk | 34.8 | -22.9 | 11.8 | 0 | -33.91 | -27 | -6.91 | 163 | 134 | V |

Pk - Peak detector

AUTHORIZED BANDEDGE (HIGH CHANNEL)

HORIZONTAL PEAK AND AVERAGE PLOT

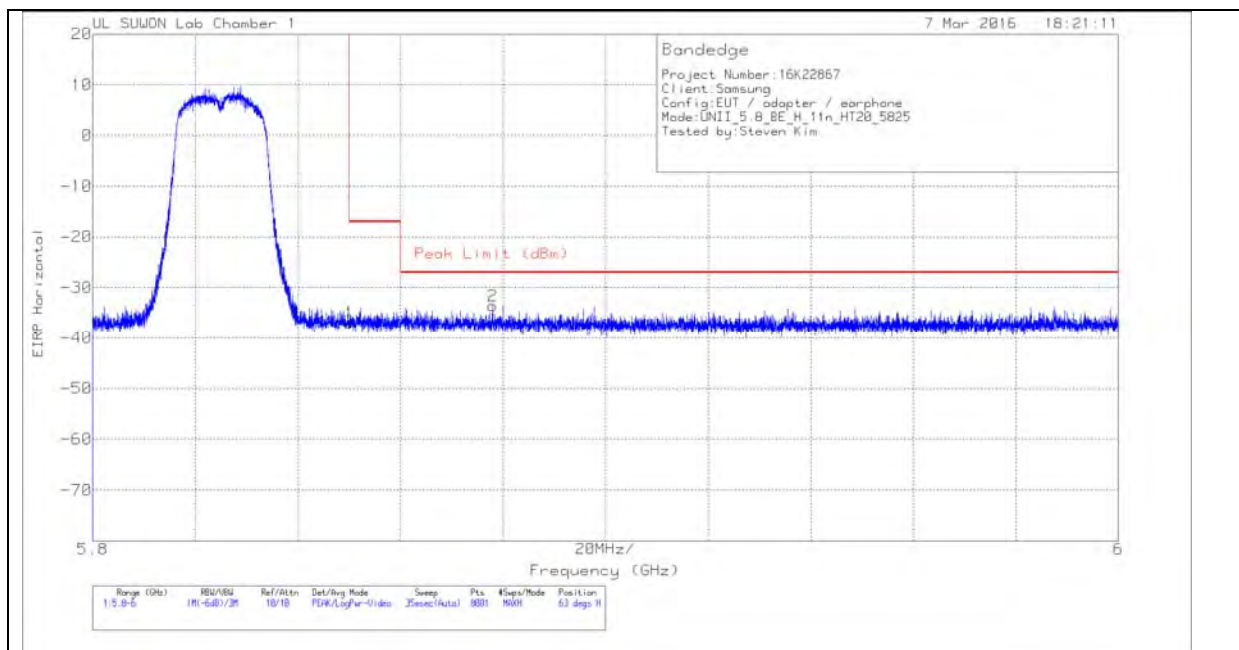

HORIZONTAL DATA

TRACE MARKERS

| Marker | Frequency (GHz) | Meter Reading (dBm) | Det | 3117(0016 8717)_150 619 | Path_2 | Conversion Factor (dB) | DC Corr (dB) | Corrected Reading EIRP | Peak Limit (dBm) | PK Margin (dB) | Azimuth (Degs) | Height (cm) | Polarity |
|--------|-----------------|---------------------|-----|-------------------------|--------|------------------------|--------------|------------------------|------------------|----------------|----------------|-------------|----------|
| 1 | 5.85 | -61.45 | PK | 34.9 | -22.2 | 11.8 | 0 | -36.95 | -17 | -19.95 | 63 | 182 | H |
| 2 | 5.878 | -57.98 | PK | 34.9 | -22.3 | 11.8 | 0 | -33.58 | -27 | -6.58 | 63 | 182 | H |

Pk - Peak detector

VERTICAL PEAK PLOT

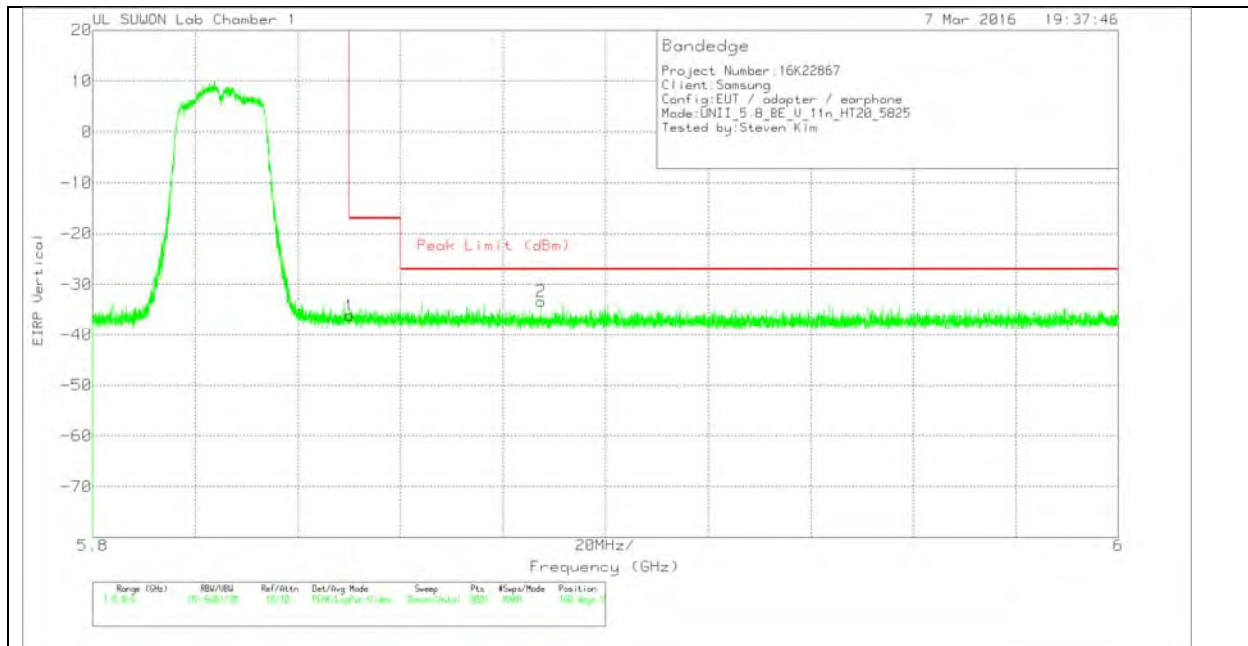

VERTICAL DATA

TRACE MARKERS

| Marker | Frequency (GHz) | Meter Reading (dBm) | Det | 3117(0016 8717)_150 619 | Path_2 | Conversion Factor (dB) | DC Corr (dB) | Corrected Reading EIRP | Peak Limit (dBm) | PK Margin (dB) | Azimuth (Degs) | Height (cm) | Polarity |
|--------|-----------------|---------------------|-----|-------------------------|--------|------------------------|--------------|------------------------|------------------|----------------|----------------|-------------|----------|
| 1 | 5.85 | -60.64 | Pk | 34.9 | -22.2 | 11.8 | 0 | -36.14 | -17 | -19.14 | 160 | 105 | V |
| 2 | 5.887 | -57.72 | Pk | 34.9 | -22.3 | 11.8 | 0 | -33.32 | -27 | -6.32 | 160 | 105 | V |

Pk - Peak detector

LOW CHANNEL HORIZONTAL

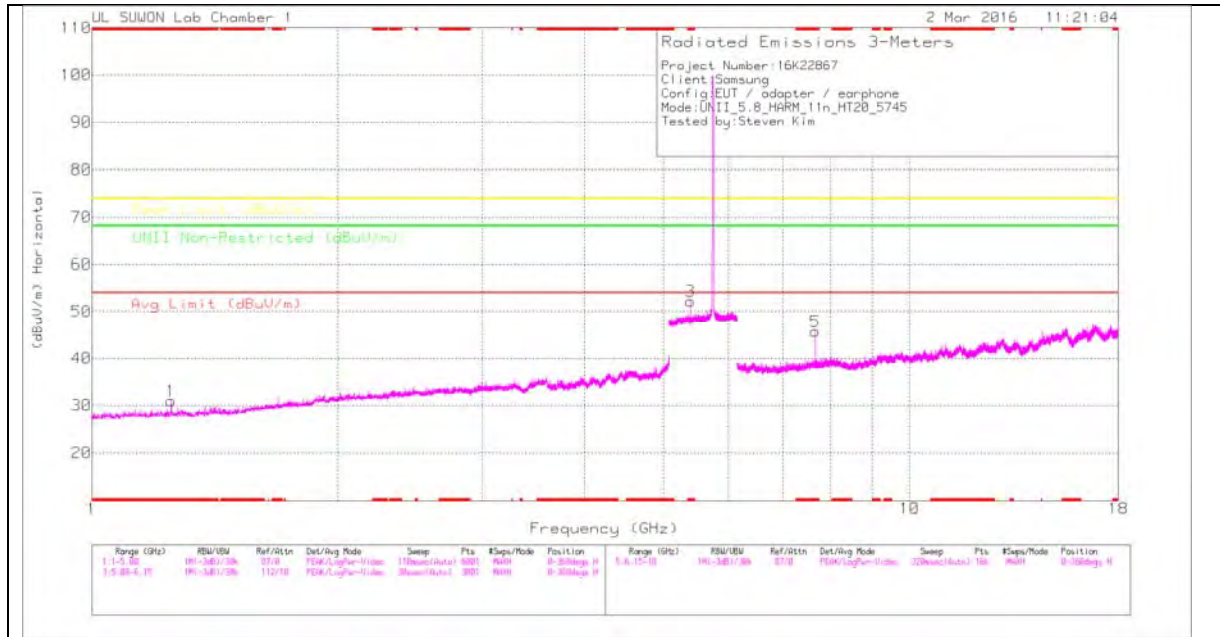

LOW CHANNEL VERTICAL

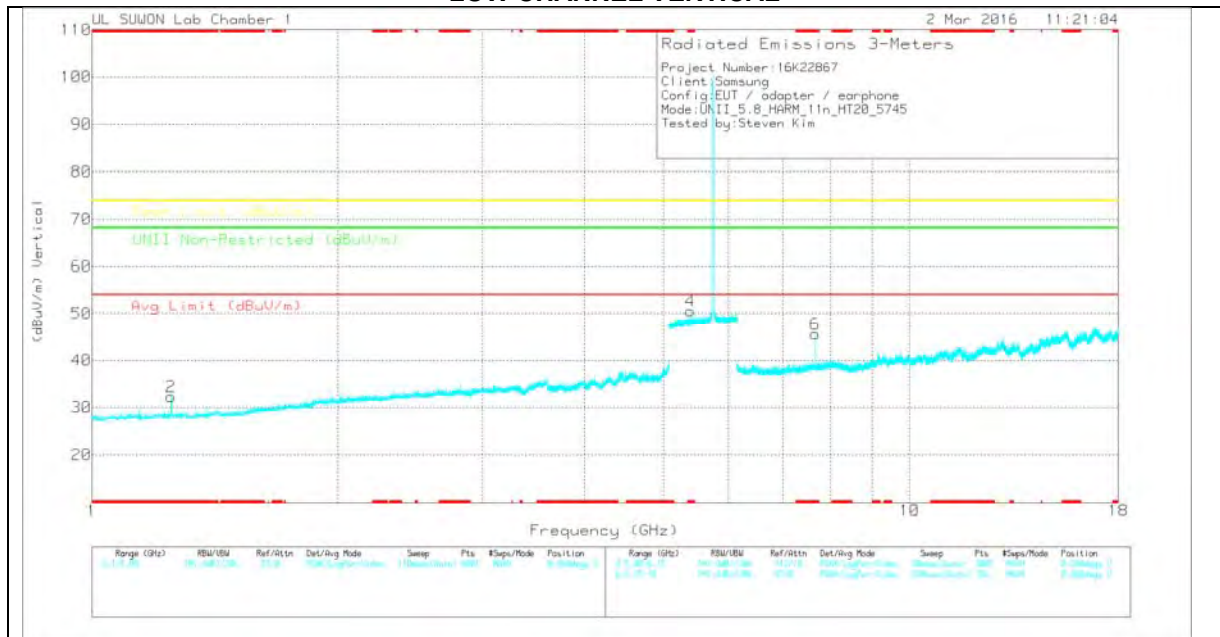

Note: Emission was scanned up to 40GHz; No emissions were detected above the noise floor which was at least 20dB below the specification limit.

LOW CHANNEL DATA

TRACE MARKERS

| Marker | Frequency (GHz) | Meter Reading (dBuV) | Det | 3117(0016 8717)_150 619 | Path_4 | DC Corr (dB) | Corrected Reading (dBuV/m) | Avg Limit (dBuV/m) | Margin (dB) | Peak Limit (dBuV/m) | Margin (dB) | UNII Non-Restricted (dBuV/m) | Margin (dB) | Azimuth (Degs) | Height (cm) | Polarity |
|--------|-----------------|----------------------|-----|-------------------------|--------|--------------|----------------------------|--------------------|-------------|---------------------|-------------|------------------------------|-------------|----------------|-------------|----------|
| 1 | * 1.25 | 42.88 | PK | 28.3 | -40.2 | 0 | 30.98 | - | - | 74 | -43.02 | - | - | 0-360 | 200 | H |
| 2 | * 1.25 | 44.23 | PK | 28.3 | -40.2 | 0 | 32.33 | - | - | 74 | -41.67 | - | - | 0-360 | 200 | V |
| 3 | * 5.393 | 41.01 | PK | 34.5 | -23.3 | 0 | 52.21 | - | - | 74 | -21.79 | - | - | 0-360 | 100 | H |
| 4 | * 5.393 | 39.29 | PK | 34.5 | -23.3 | 0 | 50.49 | - | - | 74 | -23.51 | - | - | 0-360 | 200 | V |
| 5 | * 7.66 | 40.07 | PK | 36 | -30.3 | 0 | 45.77 | - | - | 74 | -28.23 | - | - | 0-360 | 100 | H |
| 6 | * 7.659 | 39.89 | PK | 36 | -30.3 | 0 | 45.59 | - | - | 74 | -28.41 | - | - | 0-360 | 100 | V |

* - indicates frequency in CFR15.205/IC7.2.2 Restricted Band

PK – Peak Detector

Radiated Emissions

| Frequency (GHz) | Meter Reading (dBuV) | Det | 3117(001687 17)_150619 | Path_2 | DC Corr (dB) | Corrected Reading (dBuV/m) | Avg Limit (dBuV/m) | Margin (dB) | Peak Limit (dBuV/m) | Margin (dB) | UNII Non-Restricted (dBuV/m) | Margin (dB) | Azimuth (Degs) | Height (cm) | Polarity |
|-----------------|----------------------|------|------------------------|--------|--------------|----------------------------|--------------------|-------------|---------------------|-------------|------------------------------|-------------|----------------|-------------|----------|
| * 5.393 | 51.02 | PK-U | 34.5 | -23.3 | 0 | 62.22 | - | - | 74 | -11.78 | - | - | 56 | 211 | H |
| * 5.393 | 39.66 | ADR | 34.5 | -23.3 | 0 | 50.86 | 54 | -3.14 | - | - | - | - | 56 | 211 | H |
| * 5.393 | 49.36 | PK-U | 34.5 | -23.3 | 0 | 60.56 | - | - | 74 | -13.44 | - | - | 209 | 135 | V |
| * 5.393 | 37.37 | ADR | 34.5 | -23.3 | 0 | 48.57 | 54 | -5.43 | - | - | - | - | 209 | 135 | V |
| * 7.66 | 39.2 | ADR | 36 | -30.3 | 0 | 44.9 | 54 | -9.1 | - | - | - | - | 172 | 110 | H |
| * 7.66 | 38.99 | ADR | 36 | -30.3 | 0 | 44.69 | 54 | -9.31 | - | - | - | - | 200 | 122 | V |
| * 7.66 | 46.82 | PK-U | 36 | -30.3 | 0 | 52.52 | - | - | 74 | -21.48 | - | - | 172 | 110 | H |
| * 7.66 | 46.75 | PK-U | 36 | -30.3 | 0 | 52.45 | - | - | 74 | -21.55 | - | - | 200 | 122 | V |

* - indicates frequency in CFR15.205/IC7.2.2 Restricted Band

PK-U - U-NII: Maximum Peak

ADR - U-NII AD primary method, RMS average

MID CHANNEL HORIZONTAL

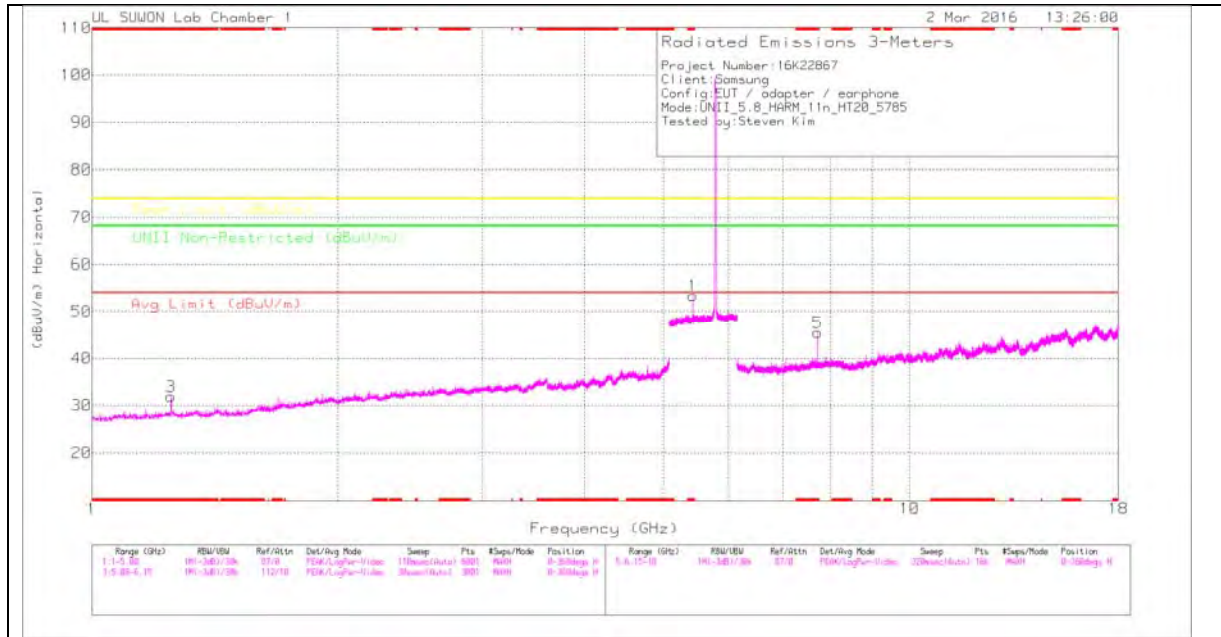

MID CHANNEL VERTICAL

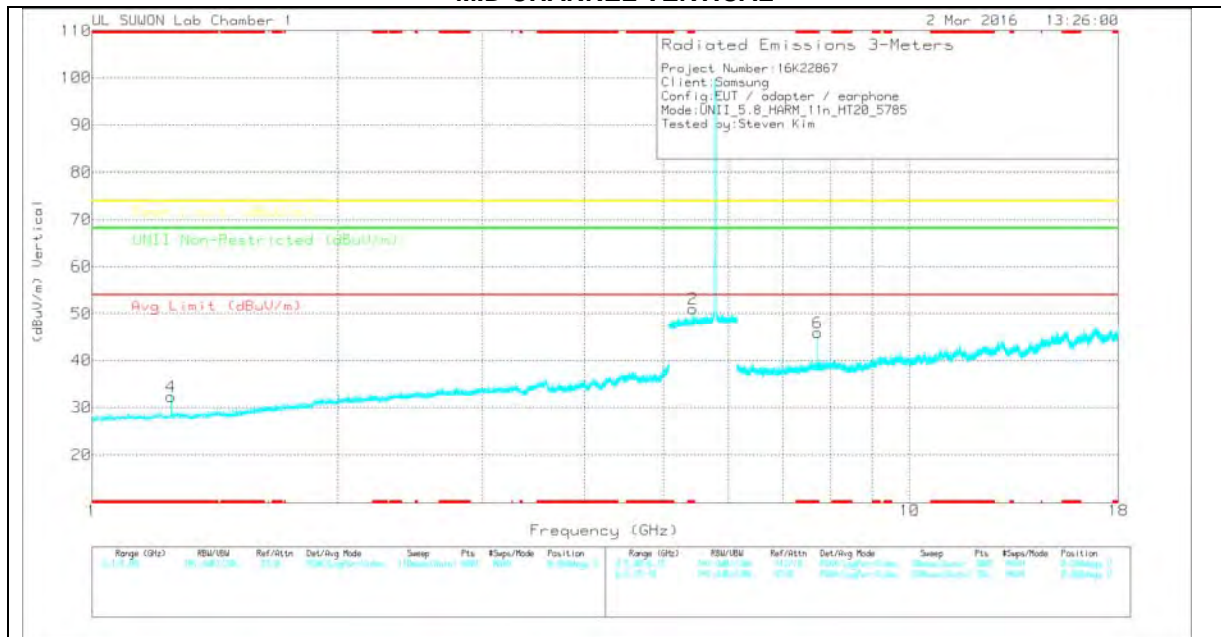

Note: Emission was scanned up to 40GHz; No emissions were detected above the noise floor which was at least 20dB below the specification limit.

MID CHANNEL DATA

TRACE MARKERS

| Marker | Frequency (GHz) | Meter Reading (dBuV) | Det | 3117(0016 8717)_150 619 | Path_4 | DC Corr (dB) | Corrected Reading (dBuV/m) | Avg Limit (dBuV/m) | Margin (dB) | Peak Limit (dBuV/m) | Margin (dB) | UNII Non-Restricted (dBuV/m) | Margin (dB) | Azimuth (Degs) | Height (cm) | Polarity |
|--------|-----------------|----------------------|-----|-------------------------|--------|--------------|----------------------------|--------------------|-------------|---------------------|-------------|------------------------------|-------------|----------------|-------------|----------|
| 3 | * 1.25 | 43.81 | PK | 28.3 | -40.2 | 0 | 31.91 | - | - | 74 | -42.09 | - | - | 0-360 | 200 | H |
| 4 | * 1.25 | 44.21 | PK | 28.3 | -40.2 | 0 | 32.31 | - | - | 74 | -41.69 | - | - | 0-360 | 200 | V |
| 1 | * 5.433 | 41.99 | PK | 34.6 | -23.2 | 0 | 53.39 | - | - | 74 | -20.61 | - | - | 0-360 | 100 | H |
| 2 | * 5.433 | 39.69 | PK | 34.6 | -23.2 | 0 | 51.09 | - | - | 74 | -22.91 | - | - | 0-360 | 200 | V |
| 5 | * 7.713 | 39.74 | PK | 36.1 | -30.3 | 0 | 45.54 | - | - | 74 | -28.46 | - | - | 0-360 | 100 | H |
| 6 | * 7.713 | 40.11 | PK | 36.1 | -30.3 | 0 | 45.91 | - | - | 74 | -28.09 | - | - | 0-360 | 100 | V |

* - indicates frequency in CFR15.205/IC7.2.2 Restricted Band

PK – Peak Detector

Radiated Emissions

| Frequency (GHz) | Meter Reading (dBuV) | Det | 3117(001687 17)_150619 | Path_2 | DC Corr (dB) | Corrected Reading (dBuV/m) | Avg Limit (dBuV/m) | Margin (dB) | Peak Limit (dBuV/m) | Margin (dB) | UNII Non-Restricted (dBuV/m) | Margin (dB) | Azimuth (Degs) | Height (cm) | Polarity |
|-----------------|----------------------|------|------------------------|--------|--------------|----------------------------|--------------------|-------------|---------------------|-------------|------------------------------|-------------|----------------|-------------|----------|
| * 5.433 | 49.81 | PK-U | 34.6 | -23.2 | 0 | 61.21 | - | - | 74 | -12.79 | - | - | 57 | 203 | H |
| * 5.433 | 38.68 | ADR | 34.6 | -23.2 | 0 | 50.08 | 54 | -3.92 | - | - | - | - | 57 | 203 | H |
| * 5.433 | 49.23 | PK-U | 34.6 | -23.2 | 0 | 60.63 | - | - | 74 | -13.37 | - | - | 205 | 133 | V |
| * 5.433 | 38.48 | ADR | 34.6 | -23.2 | 0 | 49.88 | 54 | -4.12 | - | - | - | - | 205 | 133 | V |
| * 7.713 | 38.29 | ADR | 36.1 | -30.3 | 0 | 44.09 | 54 | -9.91 | - | - | - | - | 174 | 269 | H |
| * 7.713 | 39.17 | ADR | 36.1 | -30.3 | 0 | 44.97 | 54 | -9.03 | - | - | - | - | 161 | 100 | V |
| * 7.713 | 46.55 | PK-U | 36.1 | -30.3 | 0 | 52.35 | - | - | 74 | -21.65 | - | - | 174 | 269 | H |
| * 7.713 | 46.55 | PK-U | 36.1 | -30.3 | 0 | 52.35 | - | - | 74 | -21.65 | - | - | 161 | 100 | V |

* - indicates frequency in CFR15.205/IC7.2.2 Restricted Band

PK-U - U-NII: Maximum Peak

ADR - U-NII AD primary method, RMS average

HIGH CHANNEL HORIZONTAL

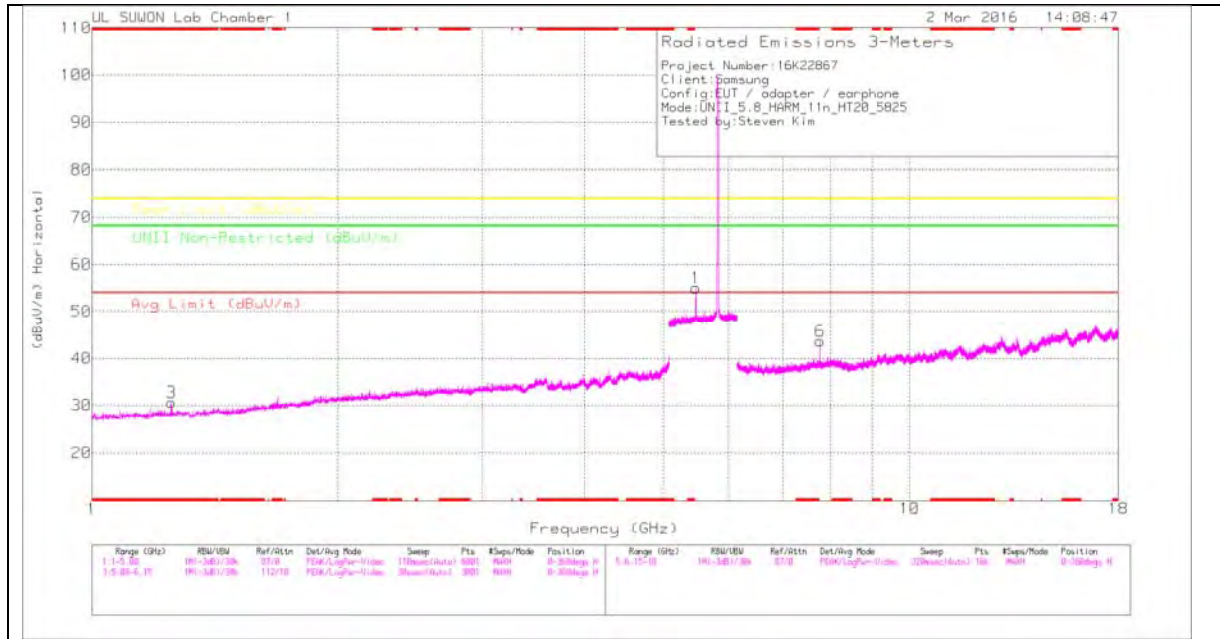

HIGH CHANNEL VERTICAL

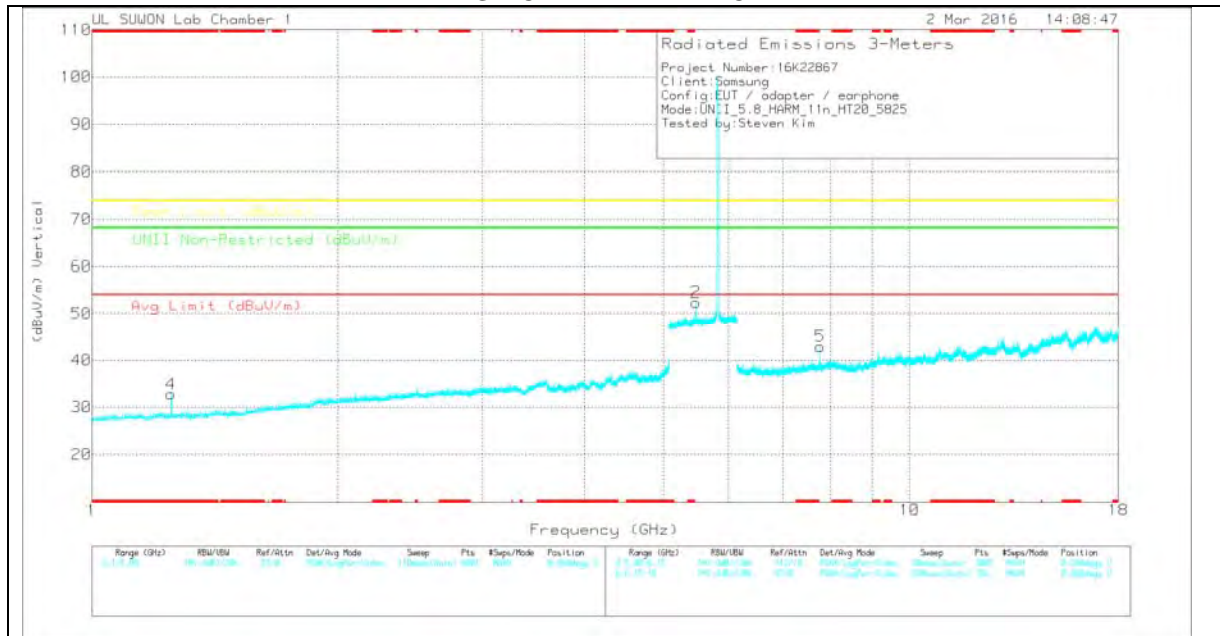

Note: Emission was scanned up to 40GHz; No emissions were detected above the noise floor which was at least 20dB below the specification limit.

HIGH CHANNEL DATA

TRACE MARKERS

| Marker | Frequency (GHz) | Meter Reading (dBuV) | Det | 3117/0016 8717_150 619 | Path_4 | DC Corr (dB) | Corrected Reading (dBuV/m) | Avg Limit (dBuV/m) | Margin (dB) | Peak Limit (dBuV/m) | Margin (dB) | UNII Non-Restricted (dBuV/m) | Margin (dB) | Azimuth (Degs) | Height (cm) | Polarity |
|--------|-----------------|----------------------|-----|------------------------|--------|--------------|----------------------------|--------------------|-------------|---------------------|-------------|------------------------------|-------------|----------------|-------------|----------|
| 3 | * 1.25 | 42.59 | PK | 28.3 | -40.2 | 0 | 30.69 | - | - | 74 | -43.31 | - | - | 0-360 | 200 | H |
| 4 | * 1.25 | 44.74 | PK | 28.3 | -40.2 | 0 | 32.84 | - | - | 74 | -41.16 | - | - | 0-360 | 200 | V |
| 1 | 5.473 | 43.51 | PK | 34.6 | -23.1 | 0 | 55.01 | - | - | - | - | 68.2 | -13.19 | 0-360 | 100 | H |
| 2 | 5.473 | 40.92 | PK | 34.6 | -23.1 | 0 | 52.42 | - | - | - | - | 68.2 | -15.78 | 0-360 | 200 | V |
| 6 | 7.767 | 37.79 | PK | 36.2 | -30.3 | 0 | 43.69 | - | - | - | - | 68.2 | -24.51 | 0-360 | 200 | H |
| 5 | 7.766 | 37.08 | PK | 36.2 | -30.3 | 0 | 42.98 | - | - | - | - | 68.2 | -25.22 | 0-360 | 100 | V |

* - indicates frequency in CFR15.205/IC7.2.2 Restricted Band

PK – Peak Detector

Radiated Emissions

| Frequency (GHz) | Meter Reading (dBuV) | Det | 3117/001687 17_150619 | Path_2 | DC Corr (dB) | Corrected Reading (dBuV/m) | Avg Limit (dBuV/m) | Margin (dB) | Peak Limit (dBuV/m) | Margin (dB) | UNII Non-Restricted (dBuV/m) | Margin (dB) | Azimuth (Degs) | Height (cm) | Polarity |
|-----------------|----------------------|------|-----------------------|--------|--------------|----------------------------|--------------------|-------------|---------------------|-------------|------------------------------|-------------|----------------|-------------|----------|
| 5.473 | 50.56 | PK-U | 34.6 | -23.1 | 0 | 62.06 | - | - | - | - | 68.2 | -6.14 | 57 | 104 | H |
| 5.473 | 49.58 | PK-U | 34.6 | -23.1 | 0 | 61.08 | - | - | - | - | 68.2 | -7.12 | 207 | 101 | V |
| 7.767 | 46.02 | PK-U | 36.2 | -30.3 | 0 | 51.92 | - | - | - | - | 68.2 | -16.28 | 170 | 310 | H |
| 7.767 | 46 | PK-U | 36.2 | -30.3 | 0 | 51.9 | - | - | - | - | 68.2 | -16.3 | 154 | 127 | V |

* - indicates frequency in CFR15.205/IC7.2.2 Restricted Band

PK-U - U-NII: Maximum Peak

**11.4.3. TX ABOVE 1GHz 802.11n HT40 2TX CDD MODE IN THE 5.8GHz BAND
 HARMONICS AND SPURIOUS EMISSIONS
 HORIZONTAL PEAK PLOT**

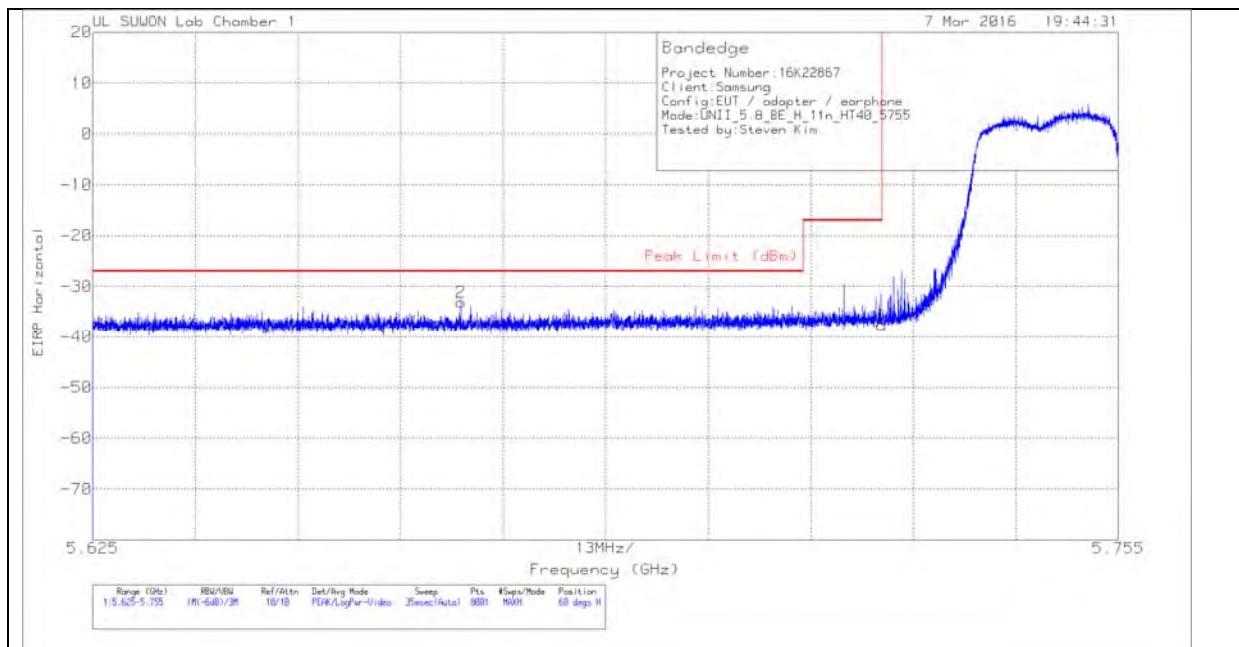

HORIZONTAL DATA

TRACE MARKERS

| Marker | Frequency (GHz) | Meter Reading (dBm) | Det | 3117(0016 8717)_150 619 | Path_2 | Conversion Factor (dB) | DC Corr (dB) | Corrected Reading EIRP | Peak Limit (dBm) | PK Margin (dB) | Azimuth (Degs) | Height (cm) | Polarity |
|--------|-----------------|---------------------|-----|-------------------------|--------|------------------------|--------------|------------------------|------------------|----------------|----------------|-------------|----------|
| 1 | 5.725 | -61.38 | Pk | 34.8 | -22.8 | 11.8 | 0 | -37.58 | -17 | -20.58 | 60 | 289 | H |
| 2 | 5.672 | -56.7 | Pk | 34.8 | -23 | 11.8 | 0 | -33.1 | -27 | -6.1 | 60 | 289 | H |

Pk - Peak detector

VERTICAL PEAK PLOT

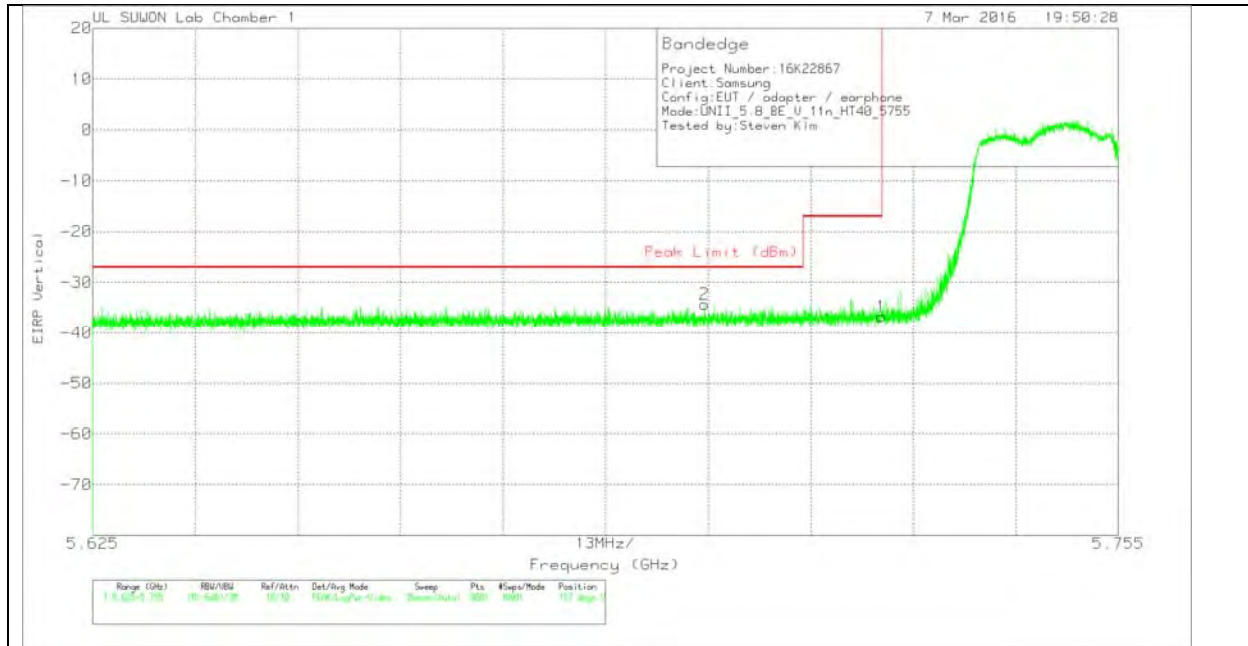

VERTICAL DATA

TRACE MARKERS

| Marker | Frequency (GHz) | Meter Reading (dBm) | Det | 3117(0016 8717)_150 619 | Path_2 | Conversion Factor (dB) | DC Corr (dB) | Corrected Reading EIRP | Peak Limit (dBm) | PK Margin (dB) | Azimuth (Degs) | Height (cm) | Polarity |
|--------|-----------------|---------------------|-----|-------------------------|--------|------------------------|--------------|------------------------|------------------|----------------|----------------|-------------|----------|
| 1 | 5.725 | -60.51 | Pk | 34.8 | -22.8 | 11.8 | 0 | -36.71 | -17 | -19.71 | 157 | 222 | V |
| 2 | 5.703 | -57.98 | Pk | 34.8 | -22.9 | 11.8 | 0 | -34.28 | -27 | -7.28 | 157 | 222 | V |

Pk - Peak detector

AUTHORIZED BANDEDGE (HIGH CHANNEL)

HORIZONTAL PEAK PLOT

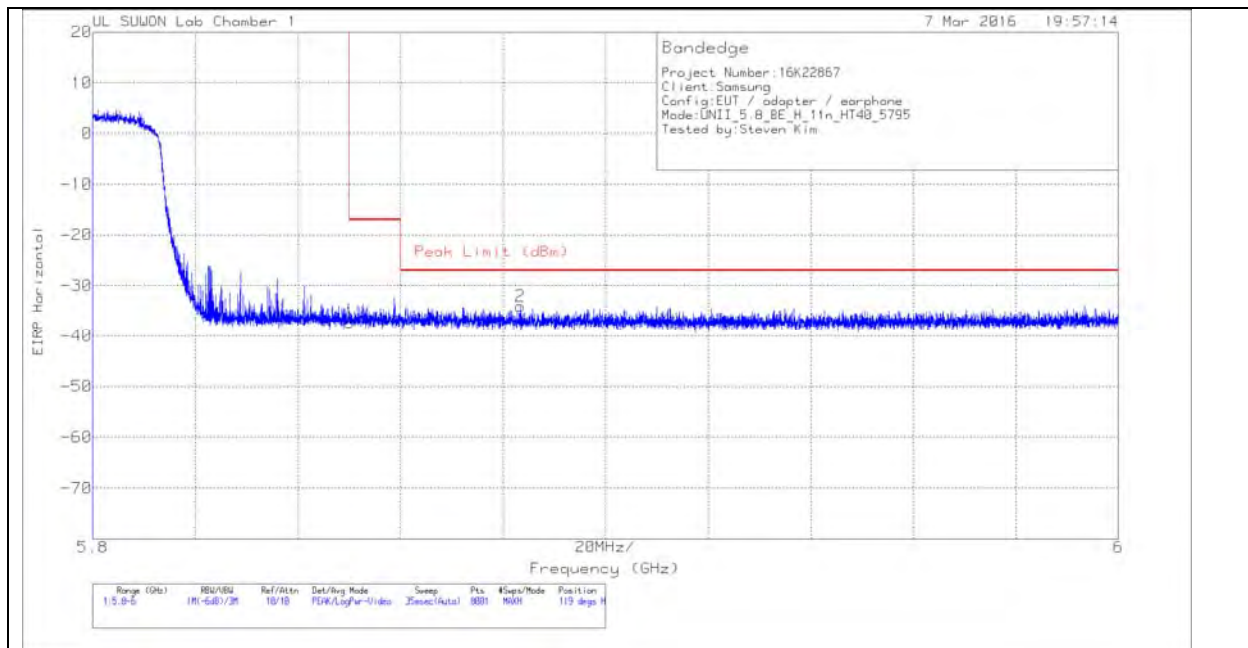

HORIZONTAL DATA

TRACE MARKERS

| Marker | Frequency (GHz) | Meter Reading (dBm) | Det | 3117(0016 8717)_150 619 | Path_2 | Conversion Factor (dB) | DC Corr (dB) | Corrected Reading EIRP | Peak Limit (dBm) | PK Margin (dB) | Azimuth (Degs) | Height (cm) | Polarity |
|--------|-----------------|---------------------|-----|-------------------------|--------|------------------------|--------------|------------------------|------------------|----------------|----------------|-------------|----------|
| 1 | 5.85 | -61.86 | PK | 34.9 | -22.2 | 11.8 | 0 | -37.36 | -17 | -20.36 | 119 | 183 | H |
| 2 | 5.883 | -58.45 | PK | 34.9 | -22.3 | 11.8 | 0 | -34.05 | -27 | -7.05 | 119 | 183 | H |

Pk - Peak detector

VERTICAL PEAK PLOT

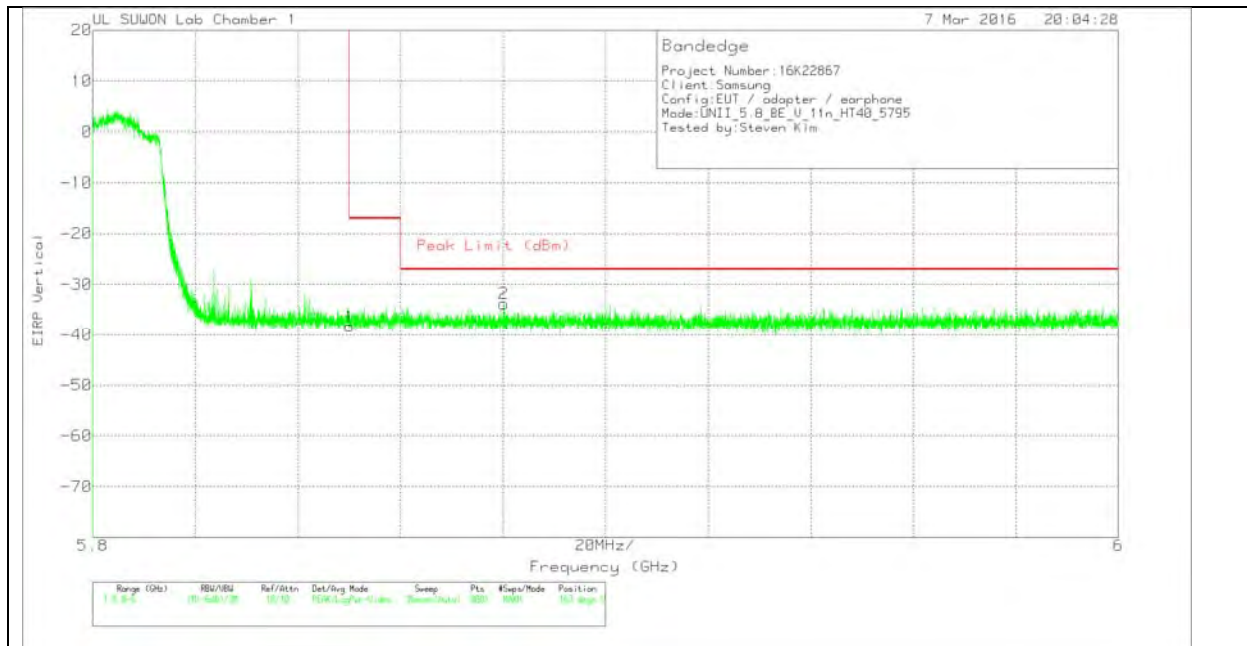

VERTICAL DATA

TRACE MARKERS

| Marker | Frequency (GHz) | Meter Reading (dBm) | Det | 3117(0016 8717)_150 619 | Path_2 | Conversion Factor (dB) | DC Corr (dB) | Corrected Reading EIRP | Peak Limit (dBm) | PK Margin (dB) | Azimuth (Degs) | Height (cm) | Polarity |
|--------|-----------------|---------------------|-----|-------------------------|--------|------------------------|--------------|------------------------|------------------|----------------|----------------|-------------|----------|
| 1 | 5.85 | -62.81 | Pk | 34.9 | -22.2 | 11.8 | 0 | -38.31 | -17 | -21.31 | 163 | 100 | V |
| 2 | 5.88 | -58.16 | Pk | 34.9 | -22.3 | 11.8 | 0 | -33.76 | -27 | -6.76 | 163 | 100 | V |

Pk - Peak detector

LOW CHANNEL HORIZONTAL

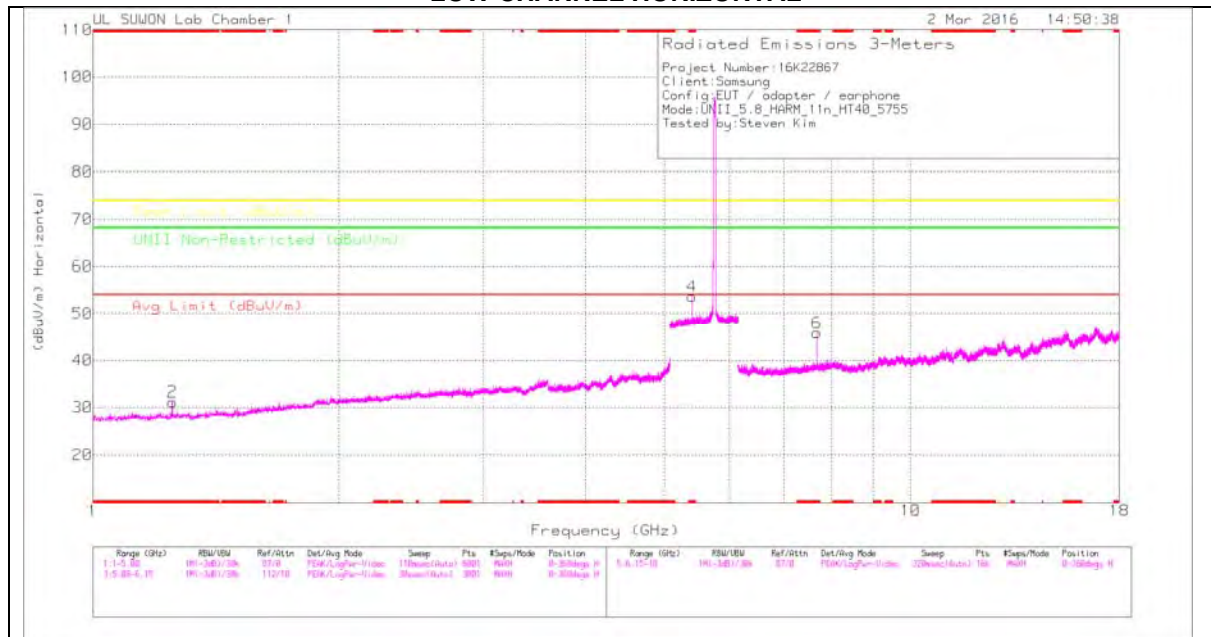

LOW CHANNEL VERTICAL

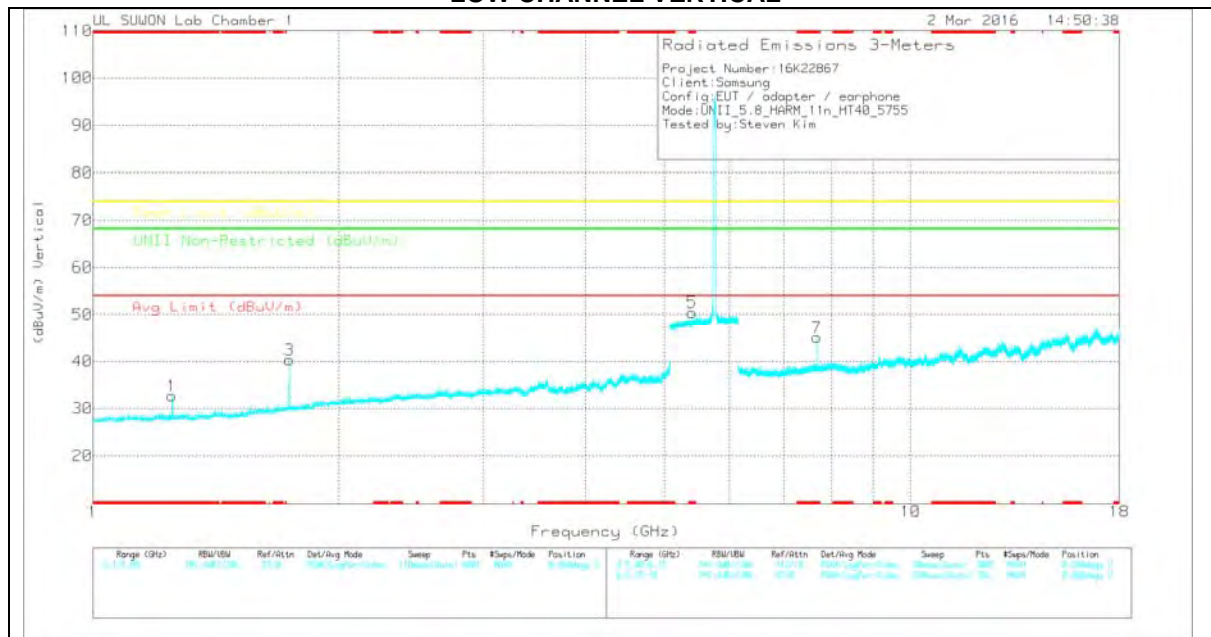

Note: Emission was scanned up to 40GHz; No emissions were detected above the noise floor which was at least 20dB below the specification limit.

LOW CHANNEL DATA

TRACE MARKERS

| Marker | Frequency (GHz) | Meter Reading (dBuV) | Det | 3117(001687 8717)_150 619 | Path_4 | DC Corr (dB) | Corrected Reading (dBuV/m) | Avg Limit (dBuV/m) | Margin (dB) | Peak Limit (dBuV/m) | Margin (dB) | UNII Non-Restricted (dBuV/m) | Margin (dB) | Azimuth (Degs) | Height (cm) | Polarity |
|--------|-----------------|----------------------|-----|---------------------------|--------|--------------|----------------------------|--------------------|-------------|---------------------|-------------|------------------------------|-------------|----------------|-------------|----------|
| 2 | * 1.25 | 43.11 | PK | 28.3 | -40.2 | 0 | 31.21 | - | - | 74 | -42.79 | - | - | 0-360 | 200 | H |
| 1 | * 1.25 | 44.65 | PK | 28.3 | -40.2 | 0 | 32.75 | - | - | 74 | -41.25 | - | - | 0-360 | 200 | V |
| 3 | 1.738 | 49.79 | PK | 29.8 | -39.3 | 0 | 40.29 | - | - | - | - | 68.2 | -27.91 | 0-360 | 200 | V |
| 4 | * 5.403 | 42.37 | PK | 34.6 | -23.3 | 0 | 53.67 | - | - | 74 | -20.33 | - | - | 0-360 | 100 | H |
| 5 | * 5.403 | 39.18 | PK | 34.6 | -23.3 | 0 | 50.48 | - | - | 74 | -23.52 | - | - | 0-360 | 200 | V |
| 6 | * 7.673 | 40.24 | PK | 36 | -30.3 | 0 | 45.94 | - | - | 74 | -28.06 | - | - | 0-360 | 100 | H |

* - indicates frequency in CFR15.205/IC7.2.2 Restricted Band

PK – Peak Detector

Radiated Emissions

| Frequency (GHz) | Meter Reading (dBuV) | Det | 3117(001687 17)_150619 | Path_4 | DC Corr (dB) | Corrected Reading (dBuV/m) | Avg Limit (dBuV/m) | Margin (dB) | Peak Limit (dBuV/m) | Margin (dB) | UNII Non-Restricted (dBuV/m) | Margin (dB) | Azimuth (Degs) | Height (cm) | Polarity |
|-----------------|----------------------|------|------------------------|--------|--------------|----------------------------|--------------------|-------------|---------------------|-------------|------------------------------|-------------|----------------|-------------|----------|
| 1.738 | 50.72 | PK-U | 29.8 | -39.3 | 0 | 41.22 | - | - | - | - | 68.2 | -26.98 | 74 | 351 | V |
| * 5.403 | 39.54 | ADR | 34.6 | -23.3 | 0 | 50.84 | 54 | -3.16 | - | - | - | - | 61 | 209 | H |
| * 5.403 | 38.99 | ADR | 34.6 | -23.3 | 0 | 50.29 | 54 | -3.71 | - | - | - | - | 207 | 110 | V |
| * 5.403 | 49.94 | PK-U | 34.6 | -23.3 | 0 | 61.24 | - | - | 74 | -12.76 | - | - | 61 | 209 | H |
| * 5.403 | 49.81 | PK-U | 34.6 | -23.3 | 0 | 61.11 | - | - | 74 | -12.89 | - | - | 207 | 110 | V |
| * 7.673 | 37.62 | ADR | 36 | -30.3 | 0 | 43.32 | 54 | -10.68 | - | - | - | - | 152 | 106 | V |
| * 7.673 | 38.28 | ADR | 36 | -30.3 | 0 | 43.98 | 54 | -10.02 | - | - | - | - | 170 | 318 | H |
| * 7.673 | 47.44 | PK-U | 36 | -30.3 | 0 | 53.14 | - | - | 74 | -20.86 | - | - | 152 | 106 | V |
| * 7.674 | 46.95 | PK-U | 36 | -30.3 | 0 | 52.65 | - | - | 74 | -21.35 | - | - | 170 | 318 | H |

* - indicates frequency in CFR15.205/IC7.2.2 Restricted Band

PK-U - U-NII: Maximum Peak

ADR - U-NII AD primary method, RMS average

HIGH CHANNEL HORIZONTAL

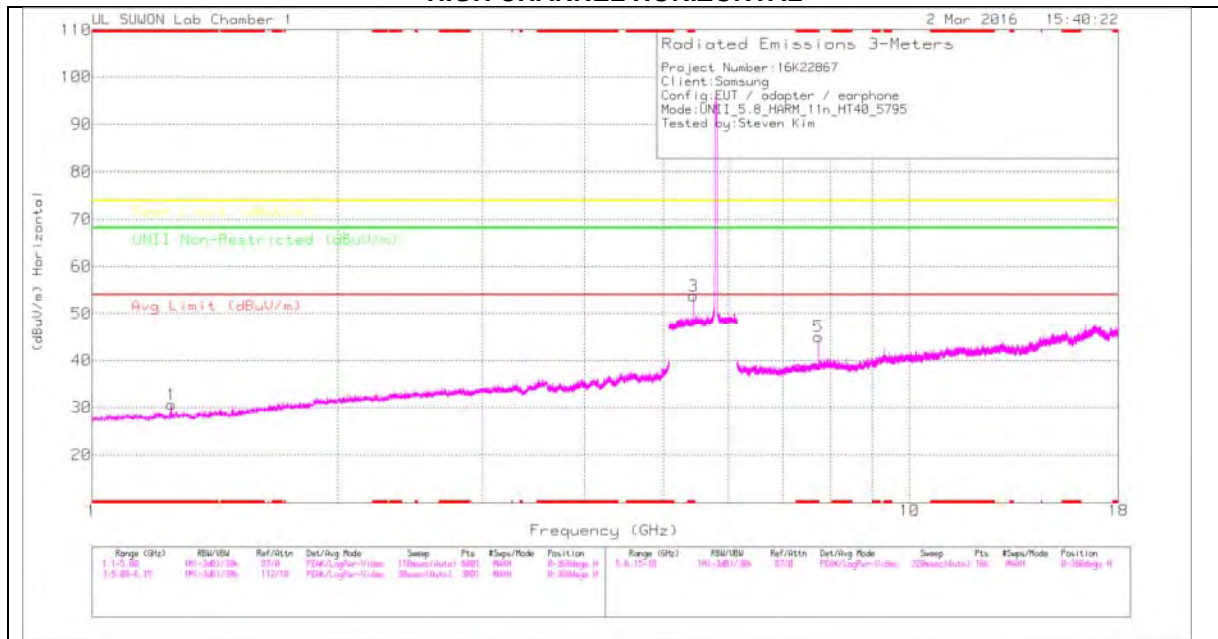

HIGH CHANNEL VERTICAL

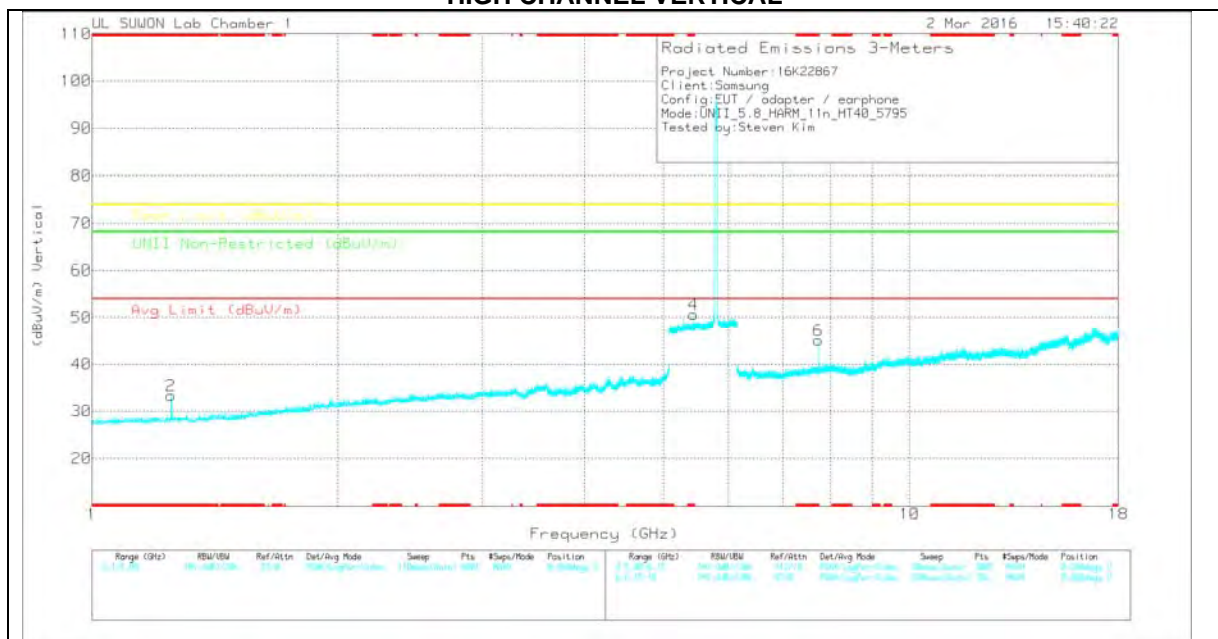

Note: Emission was scanned up to 40GHz; No emissions were detected above the noise floor which was at least 20dB below the specification limit.

HIGH CHANNEL DATA

TRACE MARKERS

| Marker | Frequency (GHz) | Meter Reading (dBuV) | Det | 3117(0016 8717)_150 619 | Path_4 | DC Corr (dB) | Corrected Reading (dBuV/m) | Avg Limit (dBuV/m) | Margin (dB) | Peak Limit (dBuV/m) | Margin (dB) | UNII Non-Restricted (dBuV/m) | Margin (dB) | Azimuth (Degs) | Height (cm) | Polarity |
|--------|-----------------|----------------------|-----|-------------------------|--------|--------------|----------------------------|--------------------|-------------|---------------------|-------------|------------------------------|-------------|----------------|-------------|----------|
| 1 | * 1.25 | 42.52 | PK | 28.3 | -40.2 | 0 | 30.62 | - | - | 74 | -43.38 | - | - | 0-360 | 200 | H |
| 2 | * 1.25 | 45.23 | PK | 28.3 | -40.2 | 0 | 33.33 | - | - | 74 | -40.67 | - | - | 0-360 | 200 | V |
| 3 | * 5.443 | 42.38 | PK | 34.6 | -23.2 | 0 | 53.78 | - | - | 74 | -20.22 | - | - | 0-360 | 100 | H |
| 4 | * 5.443 | 39.31 | PK | 34.6 | -23.2 | 0 | 50.71 | - | - | 74 | -23.29 | - | - | 0-360 | 100 | V |
| 5 | * 7.727 | 39.25 | PK | 36.1 | -30.3 | 0 | 45.05 | - | - | 74 | -28.95 | - | - | 0-360 | 200 | H |
| 6 | * 7.726 | 39.31 | PK | 36.1 | -30.3 | 0 | 45.11 | - | - | 74 | -28.89 | - | - | 0-360 | 100 | V |

* - indicates frequency in CFR15.205/IC7.2.2 Restricted Band

PK – Peak Detector

Radiated Emissions

| Frequency (GHz) | Meter Reading (dBuV) | Det | 3117(001687 17)_150619 | Path_2 | DC Corr (dB) | Corrected Reading (dBuV/m) | Avg Limit (dBuV/m) | Margin (dB) | Peak Limit (dBuV/m) | Margin (dB) | UNII Non-Restricted (dBuV/m) | Margin (dB) | Azimuth (Degs) | Height (cm) | Polarity |
|-----------------|----------------------|------|------------------------|--------|--------------|----------------------------|--------------------|-------------|---------------------|-------------|------------------------------|-------------|----------------|-------------|----------|
| * 5.443 | 49.49 | PK-U | 34.6 | -23.2 | 0 | 60.89 | - | - | 74 | -13.11 | - | - | 57 | 151 | H |
| * 5.443 | 38.81 | ADR | 34.6 | -23.2 | 0 | 50.21 | 54 | -3.79 | - | - | - | - | 57 | 151 | H |
| * 5.443 | 49.04 | PK-U | 34.6 | -23.2 | 0 | 60.44 | - | - | 74 | -13.56 | - | - | 200 | 107 | V |
| * 5.443 | 38.62 | ADR | 34.6 | -23.2 | 0 | 50.02 | 54 | -3.98 | - | - | - | - | 200 | 107 | V |
| * 7.727 | 38.25 | ADR | 36.1 | -30.3 | 0 | 44.05 | 54 | -9.95 | - | - | - | - | 163 | 249 | V |
| * 7.727 | 33.92 | ADR | 36.1 | -30.3 | 0 | 39.72 | 54 | -14.28 | - | - | - | - | 172 | 315 | H |
| * 7.727 | 46.74 | PK-U | 36.1 | -30.3 | 0 | 52.54 | - | - | 74 | -21.46 | - | - | 163 | 249 | V |
| * 7.727 | 46.51 | PK-U | 36.1 | -30.3 | 0 | 52.31 | - | - | 74 | -21.69 | - | - | 172 | 315 | H |

* - indicates frequency in CFR15.205/IC7.2.2 Restricted Band

PK-U - U-NII: Maximum Peak

ADR - U-NII AD primary method, RMS average

**11.4.4. TX ABOVE 1GHz 802.11ac HT80 2TX CDD MODE IN THE 5.8GHz BAND
 HARMONICS AND SPURIOUS EMISSIONS
 HORIZONTAL PEAK PLOT**

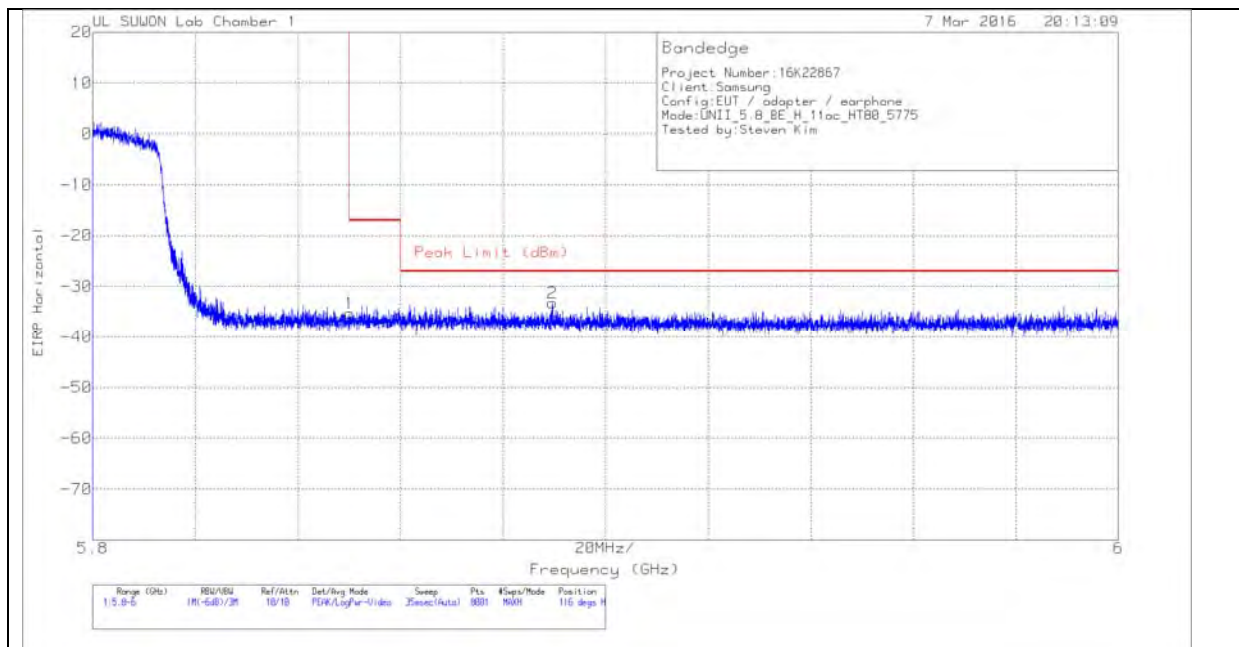

HORIZONTAL DATA

TRACE MARKERS

| Marker | Frequency (GHz) | Meter Reading (dBm) | Det | 3117(0016 8717)_150 619 | Path_2 | Conversion Factor (dB) | DC Corr (dB) | Corrected Reading EIRP | Peak Limit (dBm) | PK Margin (dB) | Azimuth (Degs) | Height (cm) | Polarity |
|--------|-----------------|---------------------|-----|-------------------------|--------|------------------------|--------------|------------------------|------------------|----------------|----------------|-------------|----------|
| 1 | 5.85 | -59.79 | Pk | 34.9 | -22.2 | 11.8 | 0 | -35.29 | -17 | -18.29 | 116 | 141 | H |
| 2 | 5.89 | -57.65 | PK | 34.9 | -22.3 | 11.8 | 0 | -33.25 | -27 | -6.25 | 116 | 141 | H |

Pk - Peak detector

VERTICAL PEAK PLOT

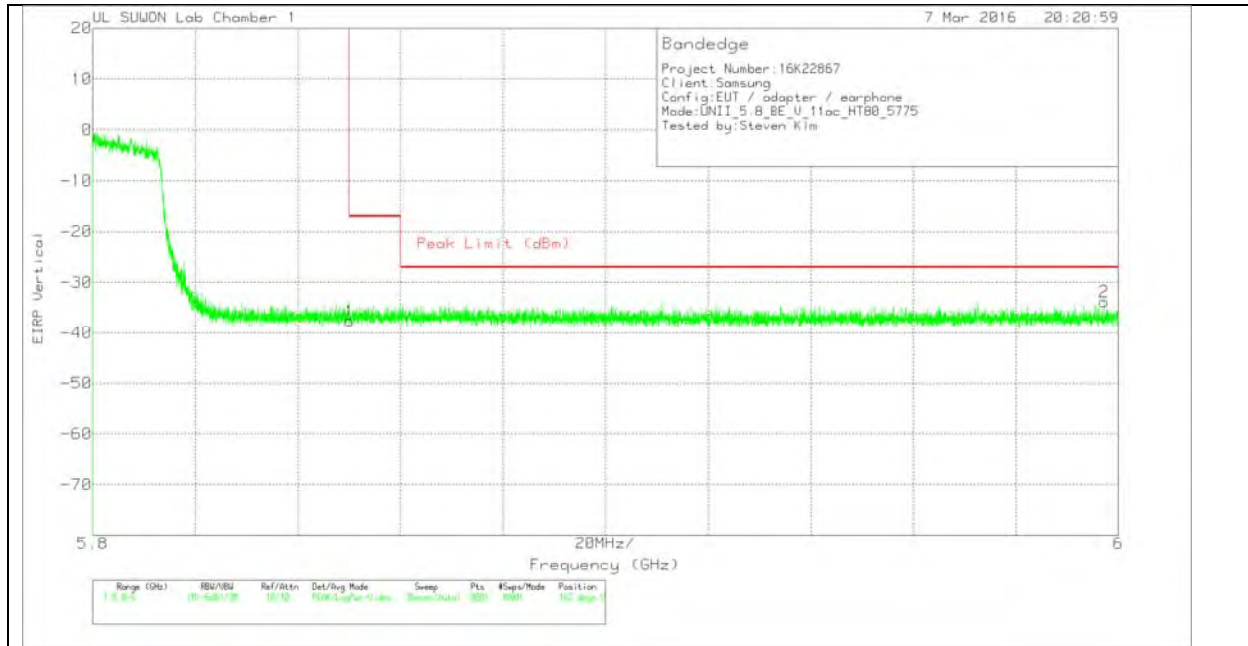

VERTICAL DATA

TRACE MARKERS

| Marker | Frequency (GHz) | Meter Reading (dBm) | Det | 3117(0016 8717)_150 619 | Path_2 | Conversion Factor (dB) | DC Corr (dB) | Corrected Reading EIRP | Peak Limit (dBm) | PK Margin (dB) | Azimuth (Degs) | Height (cm) | Polarity |
|--------|-----------------|---------------------|-----|-------------------------|--------|------------------------|--------------|------------------------|------------------|----------------|----------------|-------------|----------|
| 1 | 5.85 | -62.09 | Pk | 34.9 | -22.2 | 11.8 | 0 | -37.59 | -17 | -20.59 | 162 | 101 | V |
| 2 | 5.997 | -58.31 | Pk | 34.9 | -22.2 | 11.8 | 0 | -33.81 | -27 | -6.81 | 162 | 101 | V |

Pk - Peak detector

LOW CHANNEL HORIZONTAL

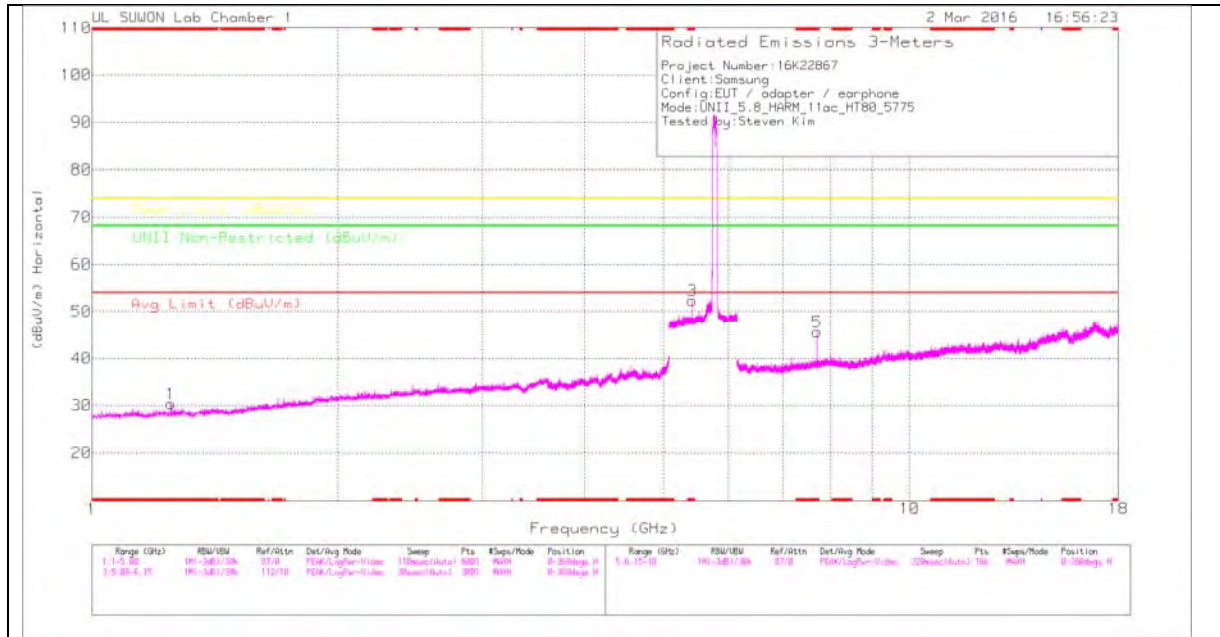

LOW CHANNEL VERTICAL

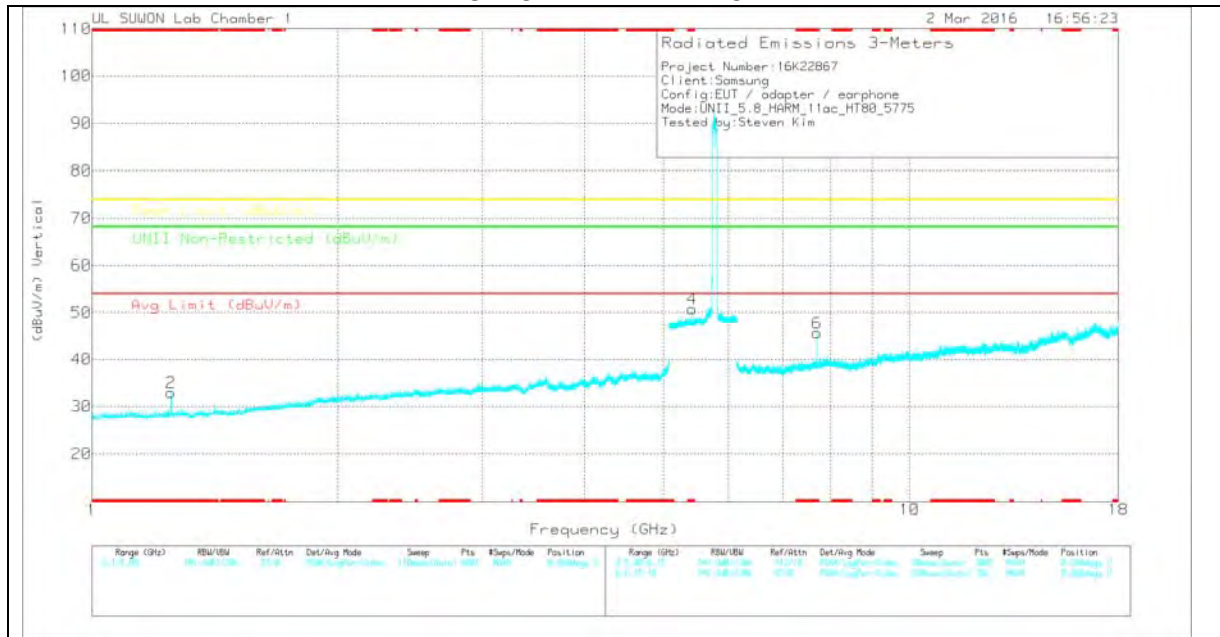

Note: Emission was scanned up to 40GHz; No emissions were detected above the noise floor which was at least 20dB below the specification limit.

LOW CHANNEL DATA

TRACE MARKERS

| Marker | Frequency (GHz) | Meter Reading (dBuV) | Det | 3117(0016 8717)_150 619 | Path_4 | DC Corr (dB) | Corrected Reading (dBuV/m) | Avg Limit (dBuV/m) | Margin (dB) | Peak Limit (dBuV/m) | Margin (dB) | UNII Non-Restricted (dBuV/m) | Margin (dB) | Azimuth (Degs) | Height (cm) | Polarity |
|--------|-----------------|----------------------|-----|-------------------------|--------|--------------|----------------------------|--------------------|-------------|---------------------|-------------|------------------------------|-------------|----------------|-------------|----------|
| 1 | * 1.25 | 42.32 | PK | 28.3 | -40.2 | 0 | 30.42 | - | - | 74 | -43.58 | - | - | 0-360 | 200 | H |
| 2 | * 1.25 | 44.9 | PK | 28.3 | -40.2 | 0 | 33 | - | - | 74 | -41 | - | - | 0-360 | 200 | V |
| 3 | * 5.423 | 40.94 | PK | 34.6 | -23.2 | 0 | 52.34 | - | - | 74 | -21.66 | - | - | 0-360 | 100 | H |
| 4 | * 5.423 | 39.39 | PK | 34.6 | -23.2 | 0 | 50.79 | - | - | 74 | -23.21 | - | - | 0-360 | 100 | V |
| 5 | * 7.699 | 39.79 | PK | 36.1 | -30.3 | 0 | 45.59 | - | - | 74 | -28.41 | - | - | 0-360 | 100 | H |
| 6 | * 7.699 | 39.82 | PK | 36.1 | -30.3 | 0 | 45.62 | - | - | 74 | -28.38 | - | - | 0-360 | 100 | V |

* - indicates frequency in CFR15.205/IC7.2.2 Restricted Band

PK – Peak Detector

Radiated Emissions

| Frequency (GHz) | Meter Reading (dBuV) | Det | 3117(001687 17)_150619 | Path_2 | DC Corr (dB) | Corrected Reading (dBuV/m) | Avg Limit (dBuV/m) | Margin (dB) | Peak Limit (dBuV/m) | Margin (dB) | UNII Non-Restricted (dBuV/m) | Margin (dB) | Azimuth (Degs) | Height (cm) | Polarity |
|-----------------|----------------------|------|------------------------|--------|--------------|----------------------------|--------------------|-------------|---------------------|-------------|------------------------------|-------------|----------------|-------------|----------|
| * 5.423 | 50.11 | PK-U | 34.6 | -23.2 | 0 | 61.51 | - | - | 74 | -12.49 | - | - | 59 | 105 | H |
| * 5.423 | 39.37 | ADR | 34.6 | -23.2 | 0 | 50.77 | 54 | -3.23 | - | - | - | - | 59 | 105 | H |
| * 5.423 | 49.53 | PK-U | 34.6 | -23.2 | 0 | 60.93 | - | - | 74 | -13.07 | - | - | 207 | 106 | V |
| * 5.423 | 38.2 | ADR | 34.6 | -23.2 | 0 | 49.6 | 54 | -4.4 | - | - | - | - | 207 | 106 | V |
| * 7.7 | 37.39 | ADR | 36.1 | -30.3 | 0 | 43.19 | 54 | -10.81 | - | - | - | - | 166 | 247 | V |
| * 7.7 | 38.48 | ADR | 36.1 | -30.3 | 0 | 44.28 | 54 | -9.72 | - | - | - | - | 174 | 316 | H |
| * 7.7 | 45.69 | PK-U | 36.1 | -30.3 | 0 | 51.49 | - | - | 74 | -22.51 | - | - | 166 | 247 | V |
| * 7.7 | 46.55 | PK-U | 36.1 | -30.3 | 0 | 52.35 | - | - | 74 | -21.65 | - | - | 174 | 316 | H |

* - indicates frequency in CFR15.205/IC7.2.2 Restricted Band

PK-U - U-NII: Maximum Peak

ADR - U-NII AD primary method, RMS average

12. WORST-CASE BELOW 1 GHz (in the 5.3 GHz Band)

SPURIOUS EMISSIONS 30 TO 1000 MHz (WORST-CASE CONFIGURATION, HORIZONTAL)

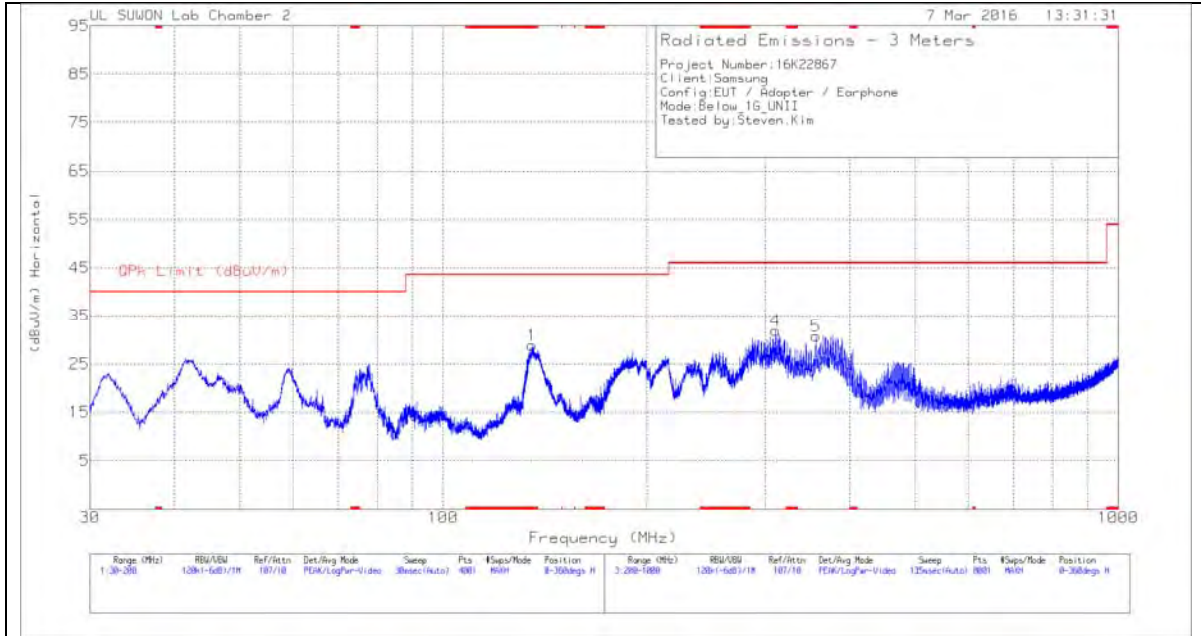

SPURIOUS EMISSIONS 30 TO 1000 MHz (WORST-CASE CONFIGURATION, VERTICAL)

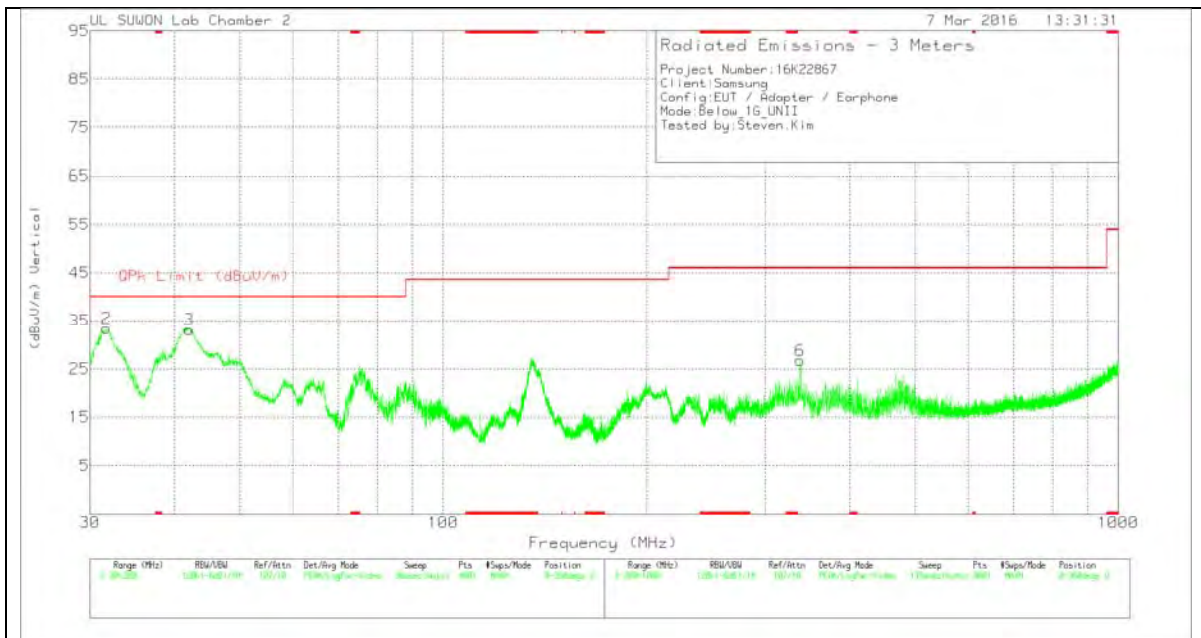

Below 1G Data

TRACE MARKERS

| Marker | Frequency (MHz) | Meter Reading (dBuV) | Det | VULB9163-749 | Below_1G | Corrected Reading (dBuV/m) | QPk Limit (dBuV/m) | Margin (dB) | Azimuth (Degs) | Height (cm) | Polarity | Marker |
|--------|-----------------|----------------------|-----|--------------|----------|----------------------------|--------------------|-------------|----------------|-------------|----------|--------|
| 1 | * 135.57 | 51.06 | Pk | 8.4 | -30.5 | 28.96 | 43.52 | -14.56 | 0-360 | 200 | H | 1 |
| 2 | 31.7425 | 53.81 | Pk | 10.4 | -30.8 | 33.41 | 40 | -6.59 | 0-360 | 100 | V | 2 |
| 3 | 42.0275 | 50.73 | Pk | 13.2 | -30.7 | 33.23 | 40 | -6.77 | 0-360 | 100 | V | 3 |
| 4 | 310.9 | 48.27 | Pk | 13.6 | -29.9 | 31.97 | 46.02 | -14.05 | 0-360 | 100 | H | 4 |
| 5 | 356.5 | 46.06 | Pk | 14.5 | -29.8 | 30.76 | 46.02 | -15.26 | 0-360 | 100 | H | 5 |
| 6 | 338.2 | 42.59 | Pk | 14.1 | -29.9 | 26.79 | 46.02 | -19.23 | 0-360 | 400 | V | 6 |

* - indicates frequency in CFR15.205/IC7.2.2 Restricted Band

Pk - Peak detector

13. AC POWER LINE CONDUCTED EMISSIONS

LIMITS

FCC §15.207 (a)

| Frequency of Emission (MHz) | Conducted Limit (dBuV) | |
|-----------------------------|------------------------|-----------|
| | Quasi-peak | Average |
| 0.15-0.5 | 66 to 56* | 56 to 46* |
| 0.5-5 | 56 | 46 |
| 5-30 | 60 | 50 |

*Decreases with the logarithm of the frequency.

TEST PROCEDURE

The EUT is placed on a non-conducting table 40 cm from the vertical ground plane and 80 cm above the horizontal ground plane. The EUT is configured in accordance with ANSI C63.10.

The receiver is set to a resolution bandwidth of 9 kHz. Peak detection is used unless otherwise noted as quasi-peak or average.

Line conducted data is recorded for both NEUTRAL and HOT lines.

RESULTS

6 WORST EMISSIONS

LINE 1 PLOT

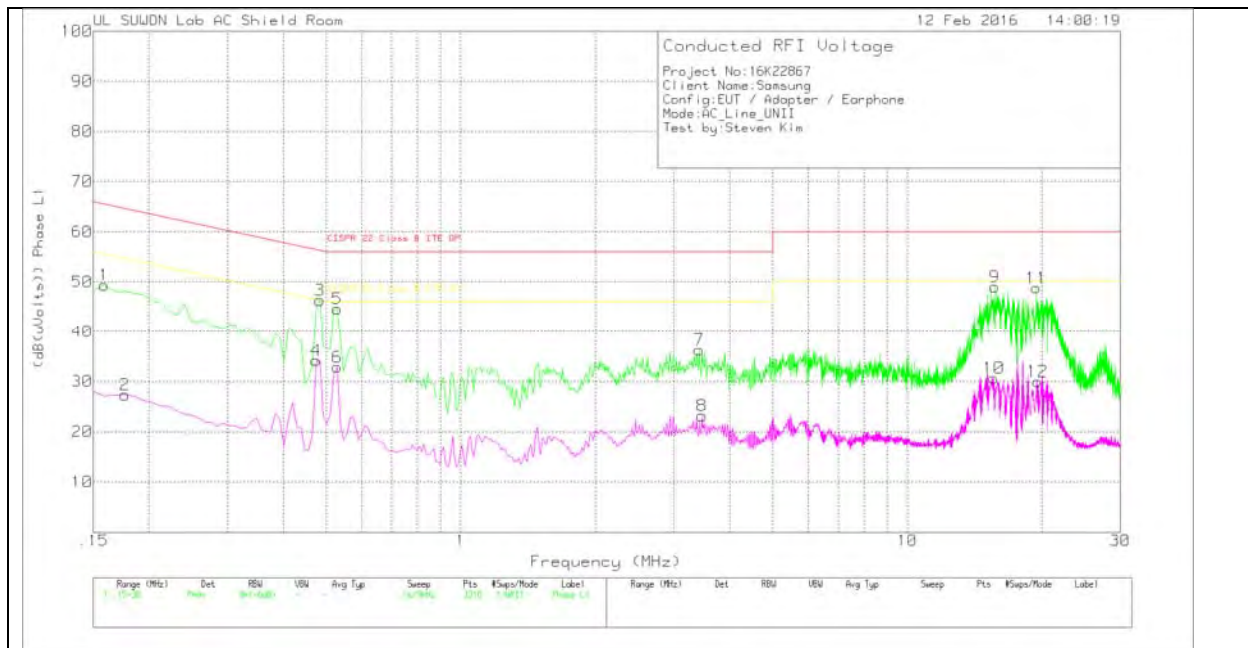

LINE 1 RESULTS

TRACE MARKERS

Phase L1 .15 - 30MHz

| Marker | Frequency (MHz) | Meter Reading (dBuV) | Det | 101837_w ith ex-cord_L1 | CE Shield Room | Corrected Reading (dB(uVolts)) | CISPR 22 Class B ITE QP | Margin (dB) | CISPR 22 Class B ITE AV | Margin (dB) |
|--------|-----------------|----------------------|-----|-------------------------|----------------|--------------------------------|-------------------------|-------------|-------------------------|-------------|
| 1 | .159 | 39.37 | Pk | 10 | 0 | 49.37 | 65.52 | -16.15 | - | - |
| 2 | .177 | 17.13 | Av | 10.2 | 0 | 27.33 | - | - | 54.63 | -27.3 |
| 3 | .483 | 36.13 | Pk | 10.2 | 0 | 46.33 | 56.29 | -9.96 | - | - |
| 4 | .474 | 24 | Av | 10.2 | 0 | 34.2 | - | - | 46.44 | -12.24 |
| 5 | .528 | 34.52 | Pk | 10.1 | 0 | 44.62 | 56 | -11.38 | - | - |
| 6 | .528 | 22.76 | Av | 10.1 | 0 | 32.86 | - | - | 46 | -13.14 |
| 7 | 3.417 | 26.41 | Pk | 9.8 | .1 | 36.31 | 56 | -19.69 | - | - |
| 8 | 3.471 | 13.3 | Av | 9.8 | .1 | 23.2 | - | - | 46 | -22.8 |
| 9 | 15.72 | 38.62 | Pk | 10.2 | .2 | 49.02 | 60 | -10.98 | - | - |
| 10 | 15.621 | 20.24 | Av | 10.2 | .2 | 30.64 | - | - | 50 | -19.36 |
| 11 | 19.473 | 38.18 | Pk | 10.4 | .2 | 48.78 | 60 | -11.22 | - | - |
| 12 | 19.59 | 19.37 | Av | 10.4 | .2 | 29.97 | - | - | 50 | -20.03 |

Pk - Peak detector

Av - Average detection

LINE 2 PLOT

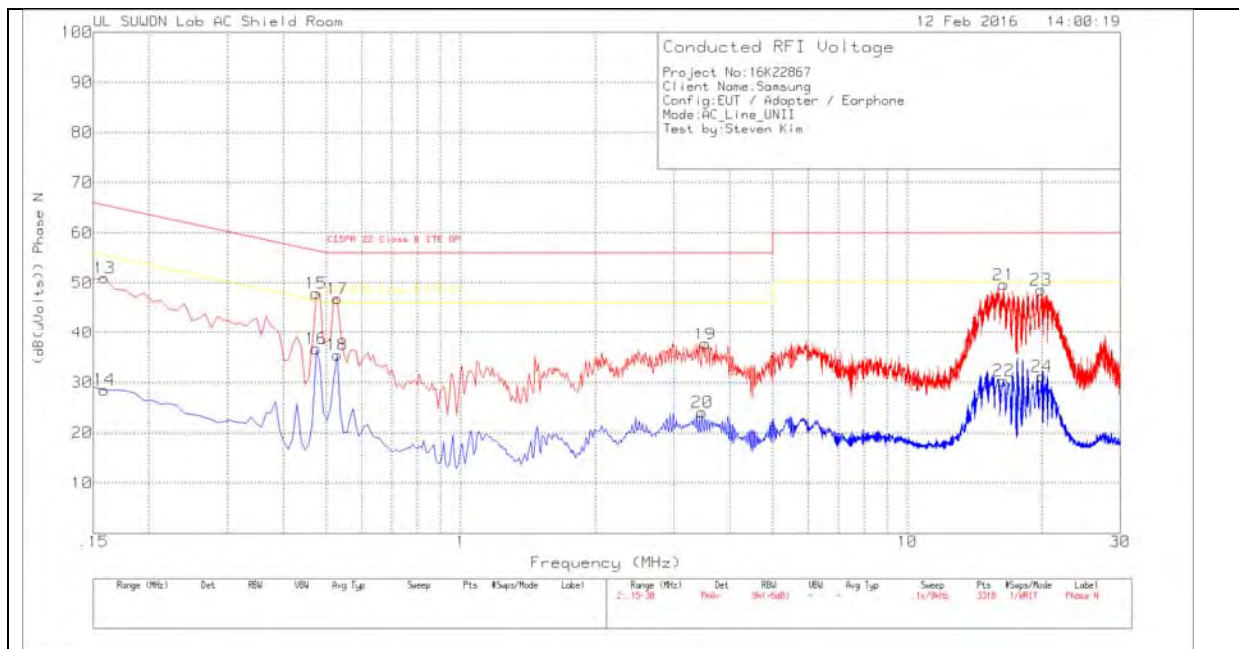

LINE 2 RESULTS

TRACE MARKERS

Phase N .15 - 30MHz

| Marker | Frequency (MHz) | Meter Reading (dBuV) | Det | 101837_wi th ex-cord_N | CE Shield Room | Corrected Reading (dB(uVolts)) | CISPR 22 Class B ITE QP | Margin (dB) | CISPR 22 Class B ITE AV | Margin (dB) |
|--------|-----------------|----------------------|-----|------------------------|----------------|--------------------------------|-------------------------|-------------|-------------------------|-------------|
| 13 | .159 | 41 | Pk | 10 | 0 | 51 | 65.52 | -14.52 | - | - |
| 14 | .159 | 18.52 | Av | 10 | 0 | 28.52 | - | - | 55.52 | -27 |
| 15 | .474 | 37.81 | Pk | 10.1 | 0 | 47.91 | 56.44 | -8.53 | - | - |
| 16 | .474 | 26.6 | Av | 10.1 | 0 | 36.7 | - | - | 46.44 | -9.74 |
| 17 | .528 | 36.74 | Pk | 10.1 | 0 | 46.84 | 56 | -9.16 | - | - |
| 18 | .528 | 25.37 | Av | 10.1 | 0 | 35.47 | - | - | 46 | -10.53 |
| 19 | 3.525 | 27.8 | Pk | 9.8 | .1 | 37.7 | 56 | -18.3 | - | - |
| 20 | 3.471 | 14.19 | Av | 9.8 | .1 | 24.09 | - | - | 46 | -21.91 |
| 21 | 16.44 | 39.07 | Pk | 10.4 | .2 | 49.67 | 60 | -10.33 | - | - |
| 22 | 16.44 | 19.74 | Av | 10.4 | .2 | 30.34 | - | - | 50 | -19.66 |
| 23 | 19.932 | 37.79 | Pk | 10.6 | .2 | 48.59 | 60 | -11.41 | - | - |
| 24 | 20.031 | 20.37 | Av | 10.6 | .2 | 31.17 | - | - | 50 | -18.83 |

Pk - Peak detector

Av - Average detection

Phase N .15 - 30MHz

| Frequency (MHz) | Meter Reading (dBuV) | Det | 101837_wi th ex-cord_N | CE Shield Room | Corrected Reading (dB(uVolts)) | CISPR 22 Class B ITE QP | Margin (dB) | CISPR 22 Class B ITE AV | Margin (dB) |
|-----------------|----------------------|-----|------------------------|----------------|--------------------------------|-------------------------|-------------|-------------------------|-------------|
| .4785 | 36.42 | Qp | 10.1 | 0 | 46.52 | 56.37 | -9.85 | - | - |
| .5244 | 34.09 | Qp | 10.1 | 0 | 44.19 | 56 | -11.81 | - | - |

Qp - Quasi-Peak detector

14. DYNAMIC FREQUENCY SELECTION

14.1. OVERVIEW

14.1.1. LIMITS

INDUSTRY CANADA

IC RSS-247 is closely harmonized with FCC Part 15 DFS rules. The deviations are as follows:

RSS-247 Issue §6.3

Note: For the band 5600–5650 MHz, no operation is permitted.

Until further notice, devices subject to this annex shall not be capable of transmitting in the band 5600–5650 MHz. This restriction is for the protection of Environment Canada weather radars operating in this band.

FCC

§15.407 (h), FCC KDB 905462 D02 “COMPLIANCE MEASUREMENT PROCEDURES FOR UNLICENSED-NATIONAL INFORMATION INFRASTRUCTURE DEVICES OPERATING IN THE 5250-5350 MHz AND 5470-5725 MHz BANDS INCORPORATING DYNAMIC FREQUENCY SELECTION” and KDB 905462 D03 “U-NII CLIENT DEVICES WITHOUT RADAR DETECTION CAPABILITY”.

Table 1: Applicability of DFS requirements prior to use of a channel

| Requirement | Operational Mode | | |
|---------------------------------|------------------|----------------------------------|-------------------------------|
| | Master | Client (without radar detection) | Client (with radar detection) |
| Non-Occupancy Period | Yes | Not required | Yes |
| DFS Detection Threshold | Yes | Not required | Yes |
| Channel Availability Check Time | Yes | Not required | Not required |
| U-NII Detection Bandwidth | Yes | Not required | Yes |

Table 2: Applicability of DFS requirements during normal operation

| Requirement | Operational Mode | | |
|-----------------------------------|------------------|----------------------|-------------------|
| | Master | Client (without DFS) | Client (with DFS) |
| DFS Detection Threshold | Yes | Not required | Yes |
| Channel Closing Transmission Time | Yes | Yes | Yes |
| Channel Move Time | Yes | Yes | Yes |
| U-NII Detection Bandwidth | Yes | Not required | Yes |

| | | |
|---|--|--|
| Additional requirements for devices with multiple bandwidth modes | Master Device or Client with Radar DFS | Client (without DFS) |
| U-NII Detection Bandwidth and Statistical Performance Check | All BW modes must be tested | Not required |
| Channel Move Time and Channel Closing Transmission Time | Test using widest BW mode available | Test using the widest BW mode available for the link |
| All other tests | Any single BW mode | Not required |

Note: Frequencies selected for statistical performance check (Section 7.8.4) should include several frequencies within the radar detection bandwidth and frequencies near the edge of the radar detection bandwidth. For 802.11 devices it is suggested to select frequencies in all 20 MHz channel blocks and a null frequency between the bonded 20 MHz channel blocks.

Table 3: Interference Threshold values, Master or Client incorporating In-Service Monitoring

| Maximum Transmit Power | Value (see notes) |
|---|----------------------|
| E.I.R.P. \geq 200 mill watt | -64 dBm |
| E.I.R.P. < 200 mill watt and power spectral density < 10 dBm/MHz | -62 dBm |
| E.I.R.P. < 200 mill watt that do not meet power spectral density requirement | -64 dBm |
| <p>Note 1: This is the level at the input of the receiver assuming a 0 dBi receive antenna Note 2: Throughout these test procedures an additional 1 dB has been added to the amplitude of the test transmission waveforms to account for variations in measurement equipment. This will ensure that the test signal is at or above the detection threshold level to trigger a DFS response. Note 3: E.I.R.P. is based on the highest antenna gain. For MIMO devices refer to KDB publication 662911 D01.</p> | |

Table 4: DFS Response requirement values

| Parameter | Value |
|--|--|
| <i>Non-occupancy period</i> | 30 minutes |
| <i>Channel Availability Check Time</i> | 60 seconds |
| <i>Channel Move Time</i> | 10 seconds (See Note 1) |
| <i>Channel Closing Transmission Time</i> | 200 milliseconds + approx. 60 milliseconds over remaining 10 second period. (See Notes 1 and 2) |
| <i>U-NII Detection Bandwidth</i> | Minimum 100% of the U-NII 99% transmission power bandwidth. (See Note 3) |
| <p>Note 1: <i>Channel Move Time</i> and the <i>Channel Closing Transmission Time</i> should be performed with Radar Type 0. The measurement timing begins at the end of the Radar Type 0 burst. Note 2: The <i>Channel Closing Transmission Time</i> is comprised of 200 milliseconds starting at the beginning of the <i>Channel Move Time</i> plus any additional intermittent control signals required to facilitate a <i>Channel</i> move (an aggregate of 60 milliseconds) during the remainder of the 10 second period. The aggregate duration of control signals will not count quiet periods in between transmissions. Note 3: During the <i>U-NII Detection Bandwidth</i> detection test, radar type 0 should be used. For each frequency step the minimum percentage of detection is 90 percent. Measurements are performed with no data traffic.</p> | |

Table 5 – Short Pulse Radar Test Waveforms

| Radar Type | Pulse Width (usec) | PRI (usec) | Pulses | Minimum Percentage of Successful Detection | Minimum Trials |
|---|--------------------|---|---|--|----------------|
| 0 | 1 | 1428 | 18 | See Note 1 | See Note 1 |
| 1 | 1 | Test A: 15 unique PRI values randomly selected from the list of 23 PRI values in table 5a | Roundup: $\{(1/360) \times (19 \times 10^6 \text{ PRI}_{\text{usec}})\}$ | 60% | 30 |
| | | Test B: 15 unique PRI values randomly selected within the range of 518-3066 usec. With a minimum increment of 1 usec, excluding PRI values selected in Test A | | | |
| 2 | 1-5 | 150-230 | 23-29 | 60% | 30 |
| 3 | 6-10 | 200-500 | 16-18 | 60% | 30 |
| 4 | 11-20 | 200-500 | 12-16 | 60% | 30 |
| Aggregate (Radar Types 1-4) | | | | 80% | 120 |
| Note 1: Short Pulse Radar Type 0 should be used for the <i>Detection Bandwidth</i> test, <i>Channel Move Time</i> , and <i>Channel Closing Time</i> tests. | | | | | |

Table 6 – Long Pulse Radar Test Signal

| Radar Waveform Type | Pulse Width (µsec) | Chirp Width (MHz) | PRI (µsec) | Pulses per Burst | Number of Bursts | Minimum Percentage of Successful Detection | Minimum Trials |
|---------------------|--------------------|-------------------|------------|------------------|------------------|--|----------------|
| 5 | 50-100 | 5-20 | 1000-2000 | 1-3 | 8-20 | 80% | 30 |

Table 7 – Frequency Hopping Radar Test Signal

| Radar Waveform Type | Pulse Width (µsec) | PRI (µsec) | Pulses per Hop | Hopping Rate (kHz) | Hopping Sequence Length (msec) | Minimum Percentage of Successful Detection | Minimum Trials |
|---------------------|--------------------|------------|----------------|--------------------|--------------------------------|--|----------------|
| 6 | 1 | 333 | 9 | 0.333 | 300 | 70% | 30 |

14.1.2. TEST AND MEASUREMENT SYSTEM

CONDUCTED METHOD SYSTEM BLOCK DIAGRAM

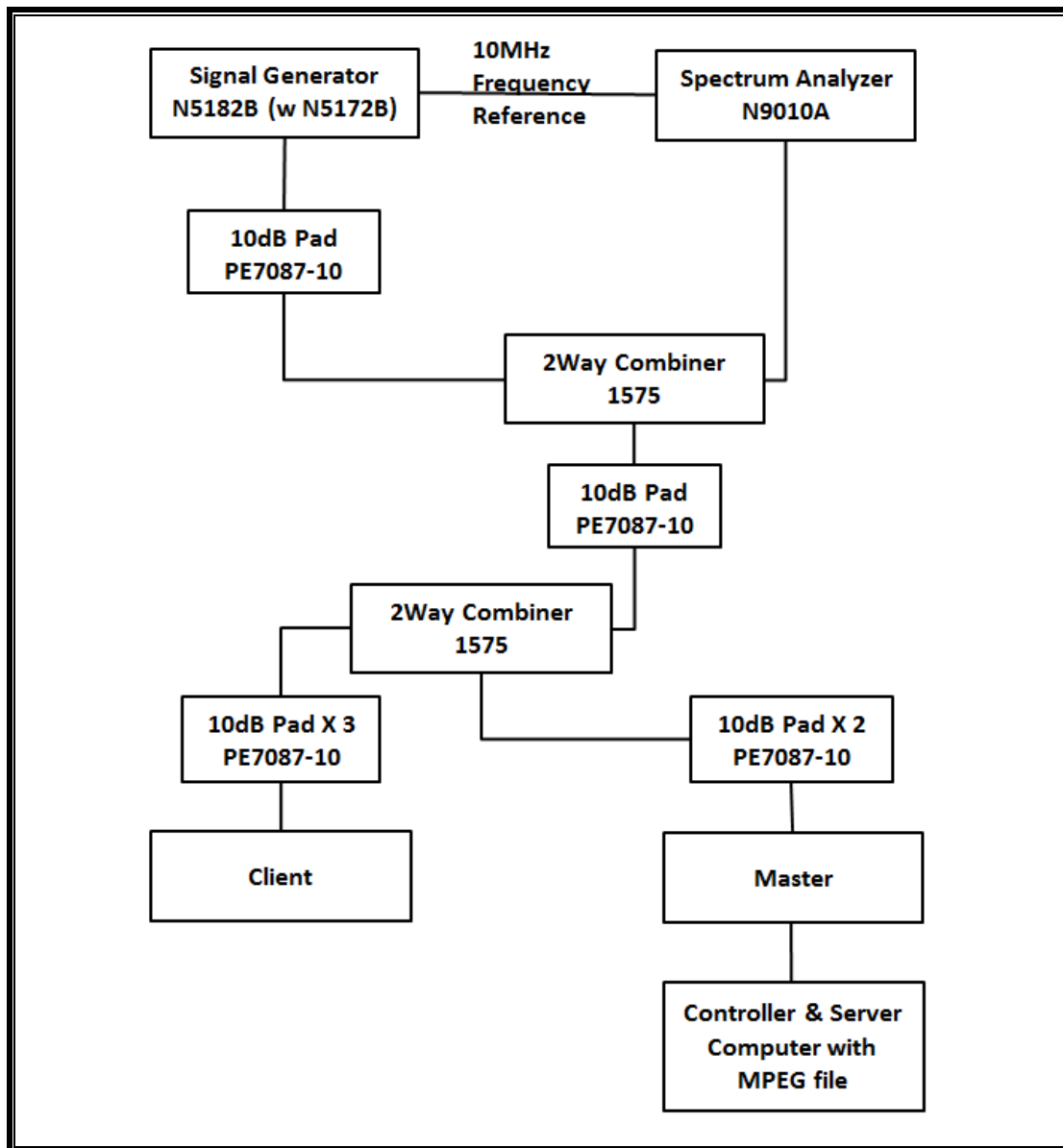

SYSTEM OVERVIEW

The short pulse and long pulse signal generating system utilizes the Keysite Signal Studio for Pulse Building as N5172B. The Vector Signal Generator has been validated by the NTIA. The hopping signal generating system utilizes the CCS simulated hopping method and system, which has been validated by the DoD, FCC and NTIA. The software selects waveform parameters from within the bounds of the signal type on a random basis using uniform distribution.

The short pulse types 1, 2, 3 and 4, and the long pulse type 5 parameters are randomized at run-time.

The hopping type 6 pulse parameters are fixed while the hopping sequence is based on the August 2005 NTIA Hopping Frequency List. The initial starting point randomized at run-time and each subsequent starting point is incremented by 475. Each frequency in the 100-length segment is compared to the boundaries of the EUT Detection Bandwidth and the software creates a hopping burst pattern in accordance with Section 7.4.1.3 Method #2 Simulated Frequency Hopping Radar Waveform Generating Subsystem of KDB 905462 D02. The frequency of the signal generator is incremented in 1 MHz steps from F_L to F_H for each successive trial. This incremental sequence is repeated as required to generate a minimum of 30 total trials and to maintain a uniform frequency distribution over the entire Detection Bandwidth.

The signal monitoring equipment consists of a spectrum analyzer. The aggregate ON time is calculated by multiplying the number of bins above a threshold during a particular observation period by the dwell time per bin, with the analyzer set to peak detection and max hold.

SYSTEM CALIBRATION

A 50-ohm load is connected in place of the spectrum analyzer, and the spectrum analyzer is connected to a horn antenna via a coaxial cable, with the reference level offset set to (horn antenna gain – coaxial cable loss). The signal generator is set to CW mode. The amplitude of the signal generator is adjusted to yield a level of –64 dBm as measured on the spectrum analyzer.

Without changing any of the instrument settings, the spectrum analyzer is reconnected to the Common port of the Spectrum Analyzer Combiner/Divider. The Reference Level Offset of the spectrum analyzer is adjusted so that the displayed amplitude of the signal is –64 dBm.

The spectrum analyzer displays the level of the signal generator as received at the antenna ports of the Master Device. The interference detection threshold may be varied from the calibrated value of –64 dBm and the spectrum analyzer will still indicate the level as received by the Master Device.

ADJUSTMENT OF DISPLAYED TRAFFIC LEVEL

A link is established between the Master and Slave and the distance between the units is adjusted as needed to provide a suitable received level at the Master and Slave devices. The video test file is streamed to generate WLAN traffic. The monitoring antenna is adjusted so that the WLAN traffic level, as displayed on the spectrum analyzer, is at lower amplitude than the radar detection threshold.

TEST AND MEASUREMENT EQUIPMENT

The following test and measurement equipment was utilized for the DFS tests documented in this report:

| TEST EQUIPMENT LIST | | | | |
|-------------------------------|--------------|--------|------------|----------|
| Description | Manufacturer | Model | S/N | Cal Due |
| Spectrum Analyzer, 7 GHz | Agilent / HP | N9010A | MY54200580 | 08-19-16 |
| Vector Signal Generator, 6GHz | Agilent / HP | N5182B | MY53051241 | 08-19-16 |

14.1.3. SETUP OF EUT

CONDUCTED METHOD EUT TEST SETUP

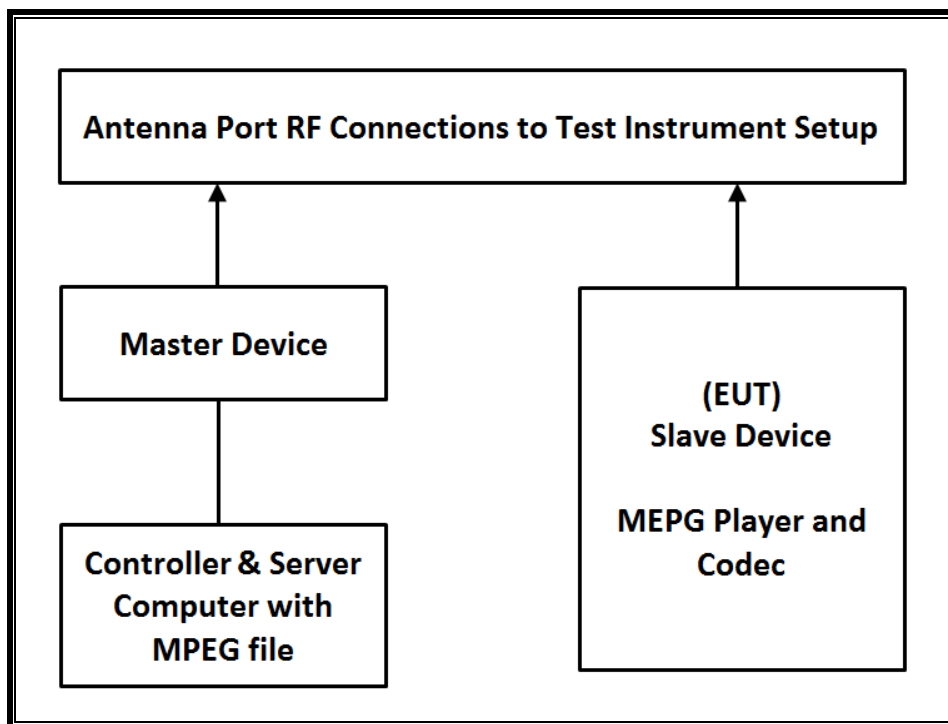

SUPPORT EQUIPMENT

The following support equipment was utilized for the DFS tests documented in this report:

| PERIPHERAL SUPPORT EQUIPMENT LIST | | | | |
|------------------------------------|--------------|-------------------------|---------------|-----------|
| Description | Manufacturer | Model | Serial Number | FCC ID |
| Wireless Access Point | Cisco | AIR-CAP3702E-A-K9 | FTX182276QX | LDK102087 |
| Notebook PC (Controller/Server) | HP | HP EliteDesk 800 G1 TWR | CZC4125J25 | DoC |

14.1.4. DESCRIPTION OF EUT

The EUT operates over the 5250-5350 MHz and 5470-5725 MHz ranges.

The EUT is a Slave Device without Radar Detection.

The highest power level within these bands is 14.31 dBm in the 5250-5350 MHz band and 14.36 dBm in the 5470-5725 MHz band.

The antenna assembly utilized two antenna with the EUT one is -3.08 dBi, and the other is -3.57 dBi.

The rated output power of the Master unit is > 23dBm (EIRP). Therefore the required interference threshold level is -64 dBm. After correction for procedural adjustments, the required conducted threshold at the antenna port is $-64 + 1 = -63$ dBm.

The calibrated radiated DFS Detection Threshold level is set to -64 dBm. The tested level is lower than the required level hence it provides a margin to the limit.

The EUT uses one transmitter/receiver chain connected to an antenna to perform radiated tests.

WLAN traffic that meets or exceeds the minimum required loading was generated by transferring a data stream from the controller/server PC to the EUT using iPerf version 2.0.5 software package.

TPC is not required since the maximum EIRP is less than 500 mW (27 dBm).

The EUT utilizes the 802.11ac architecture. Three nominal channel bandwidths are implemented: 20 MHz, 40 MHz and 80 MHz.

The software installed in the access point is 12.4(25d)JA1.

UNIFORM CHANNEL SPREADING

This requirement is not applicable to Slave radio devices.

OVERVIEW OF MASTER DEVICE WITH RESPECT TO §15.407 (h) REQUIREMENTS

The Master Device is a Cisco Access Point, FCC ID: LDK102087. The minimum antenna gain for the Master Device is 6 dBi.

The rated output power of the Master unit is > 23dBm (EIRP). Therefore the required interference threshold level is -64 dBm. After correction for procedural adjustments, the required radiated threshold at the antenna port is $-64 + 1 = -63$ dBm.

The calibrated radiated DFS Detection Threshold level is set to -64 dBm. The tested level is lower than the required level hence it provides a margin to the limit.

14.2. RESULTS FOR 20 MHz BANDWIDTH

14.2.1. TEST CHANNEL

All tests were performed at a channel center frequency of 5500 MHz.

14.2.2. RADAR WAVEFORM AND TRAFFIC

RADAR WAVEFORM

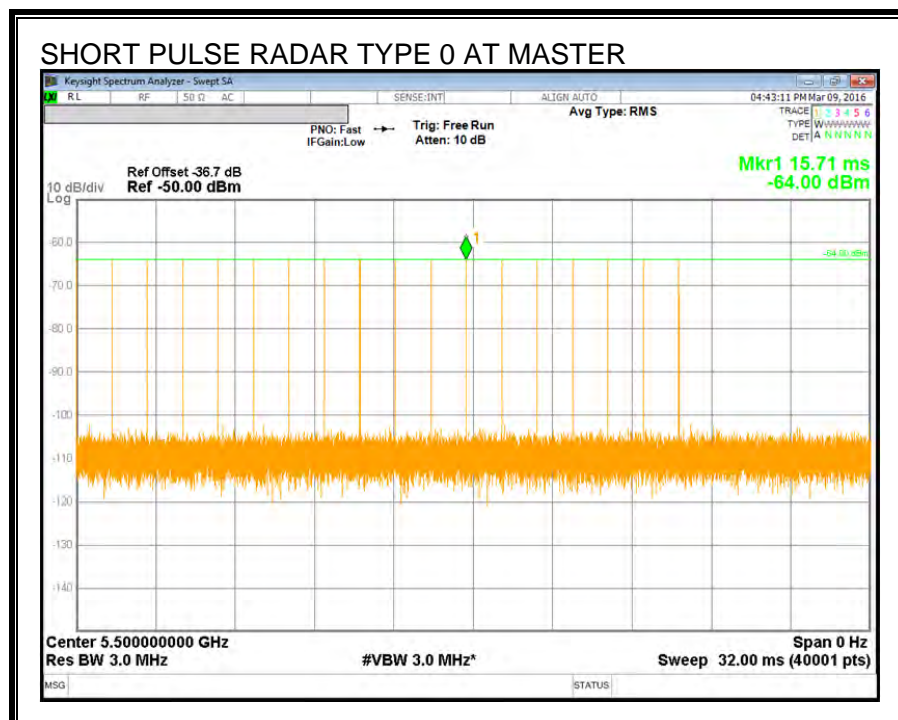

TRAFFIC

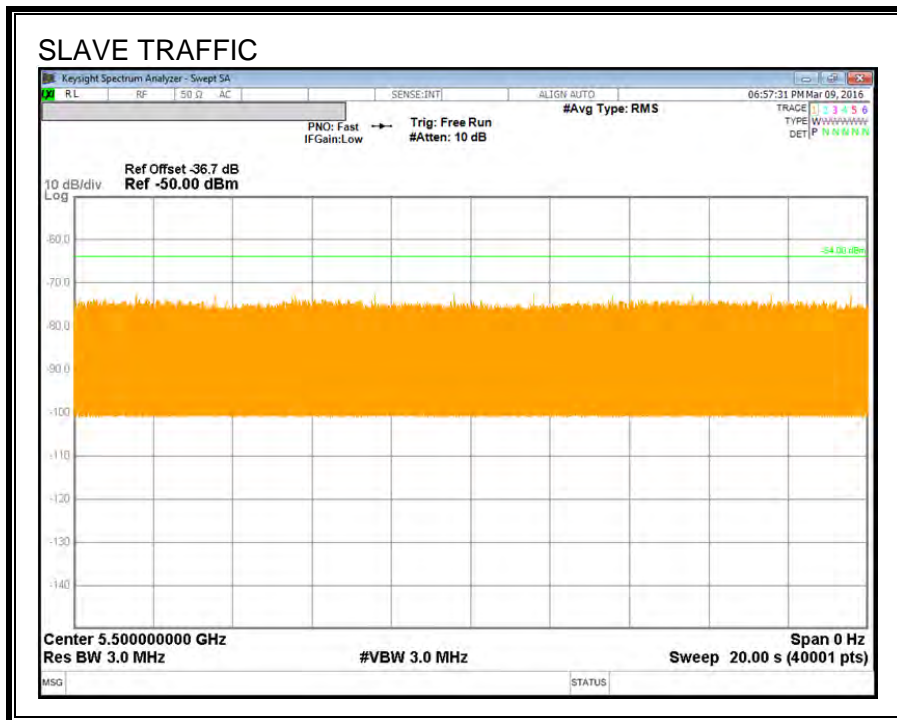

14.2.3. OVERLAPPING CHANNEL TESTS

RESULTS

These tests are not applicable.

14.2.4. MOVE AND CLOSING TIME

REPORTING NOTES

The reference marker is set at the end of last radar pulse.

The delta marker is set at the end of the last WLAN transmission following the radar pulse. This delta is the channel move time.

The aggregate channel closing transmission time is calculated as follows:

Aggregate Transmission Time =
(Number of analyzer bins showing transmission) * (dwell time per bin)

The observation period over which the aggregate time is calculated begins at (Reference Marker + 200 msec) and ends no earlier than (Reference Marker + 10 sec).

RESULTS

| Channel Move Time (sec) | Limit (sec) |
|------------------------------------|------------------------|
| 0.648 | 10 |

| Aggregate Channel Closing Transmission Time (msec) | Limit (msec) |
|---|-------------------------|
| 3.750 | 60 |

MOVE TIME & CHANNEL CLOSING TIME

AGGREGATE CHANNEL CLOSING TRANSMISSION TIME

No transmissions are observed during the aggregate monitoring period.

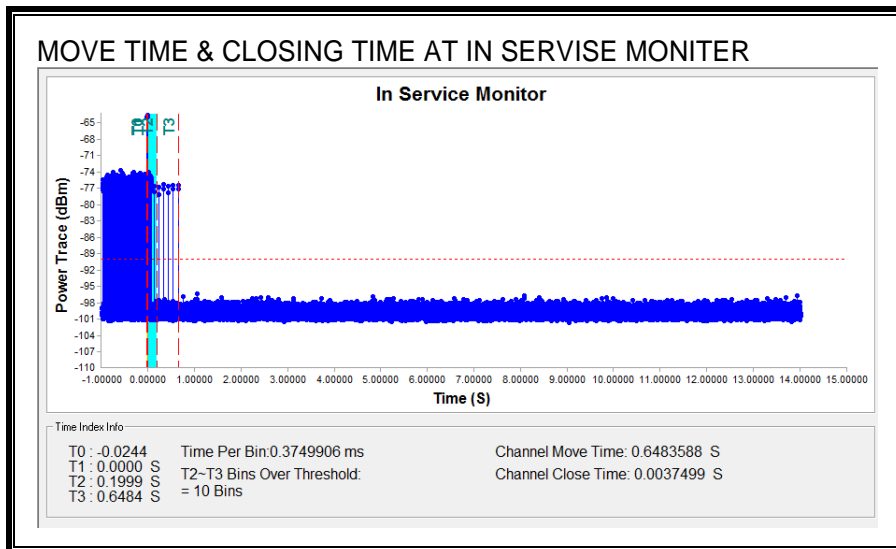
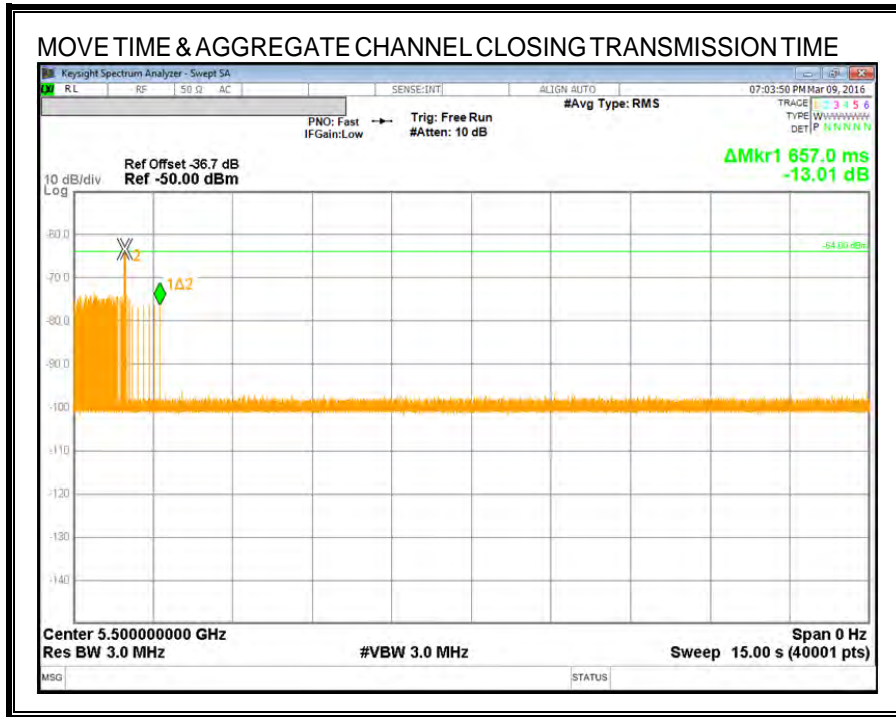

NON-OCCUPANCY PERIOD

RESULTS

No EUT transmissions were observed on the test channel during the 10-minute observation time.

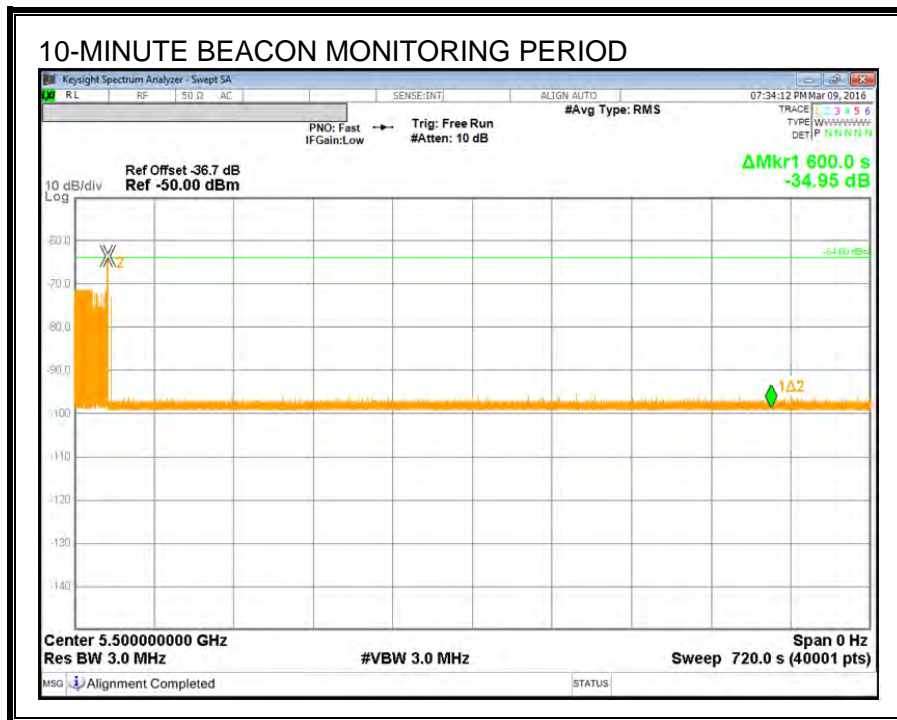

14.3. RESULTS FOR 40 MHz BANDWIDTH

14.3.1. TEST CHANNEL

All tests were performed at a channel center frequency of 5510 MHz.

14.3.2. RADAR WAVEFORM AND TRAFFIC

RADAR WAVEFORM

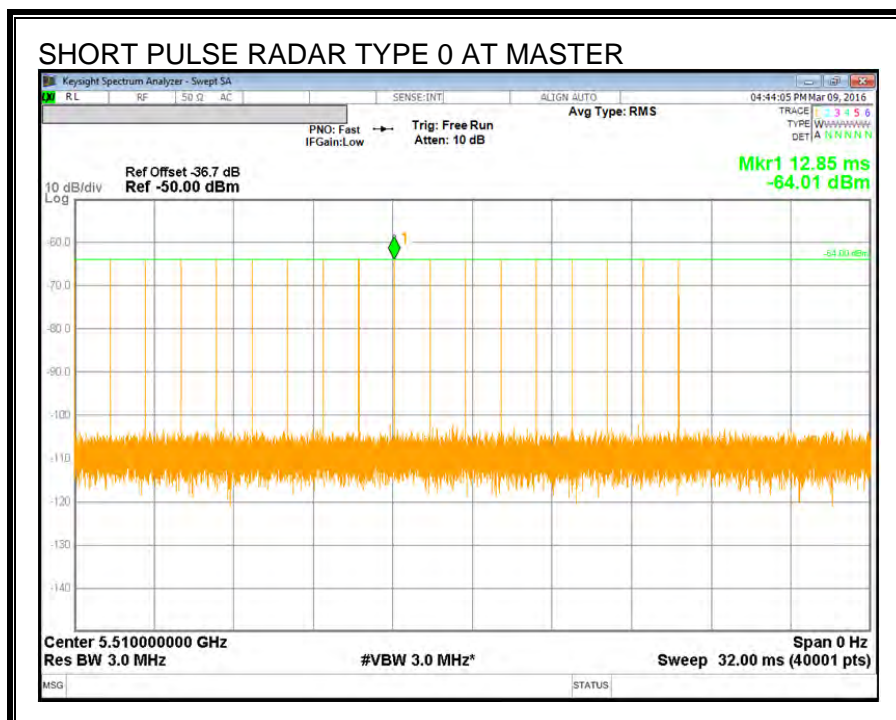

TRAFFIC

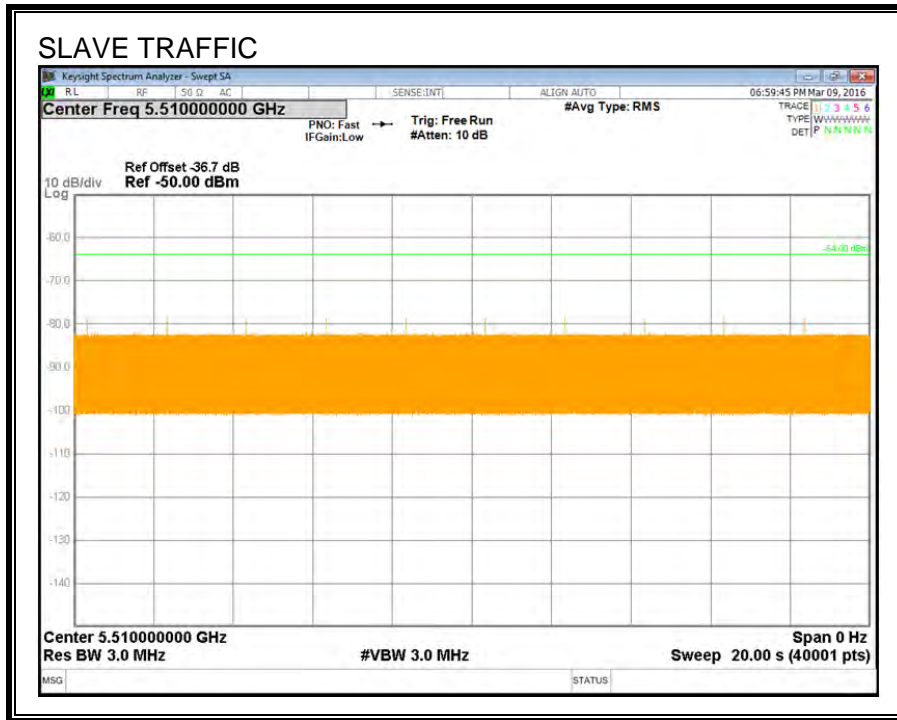

14.3.3. OVERLAPPING CHANNEL TESTS

RESULTS

These tests are not applicable.

14.3.4. MOVE AND CLOSING TIME

REPORTING NOTES

The reference marker is set at the end of last radar pulse.

The delta marker is set at the end of the last WLAN transmission following the radar pulse. This delta is the channel move time.

The aggregate channel closing transmission time is calculated as follows:

Aggregate Transmission Time =
(Number of analyzer bins showing transmission) * (dwell time per bin)

The observation period over which the aggregate time is calculated begins at (Reference Marker + 200 msec) and ends no earlier than (Reference Marker + 10 sec).

RESULTS

| Channel Move Time (sec) | Limit (sec) |
|------------------------------------|------------------------|
| 0.631 | 10 |

| Aggregate Channel Closing Transmission Time (msec) | Limit (msec) |
|---|-------------------------|
| 3.750 | 60 |

MOVE TIME & CHANNEL CLOSING TIME

AGGREGATE CHANNEL CLOSING TRANSMISSION TIME

No transmissions are observed during the aggregate monitoring period.

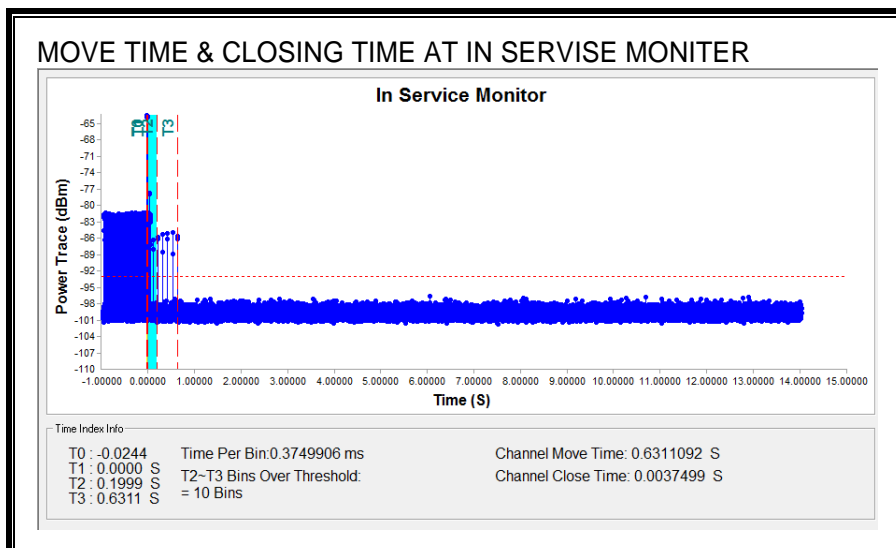
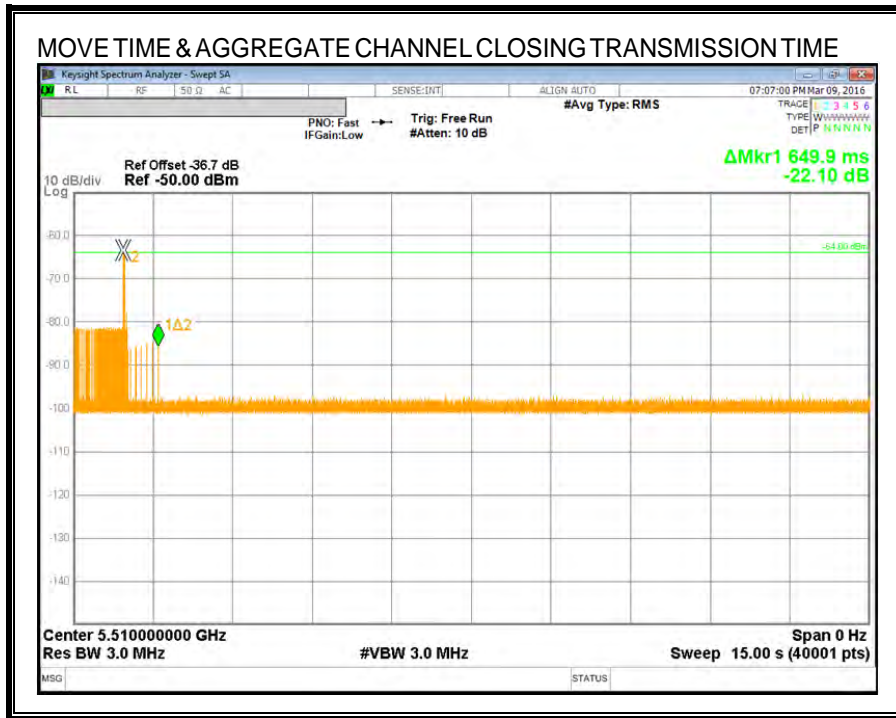

NON-OCCUPANCY PERIOD

RESULTS

No EUT transmissions were observed on the test channel during the 10-minute observation time.

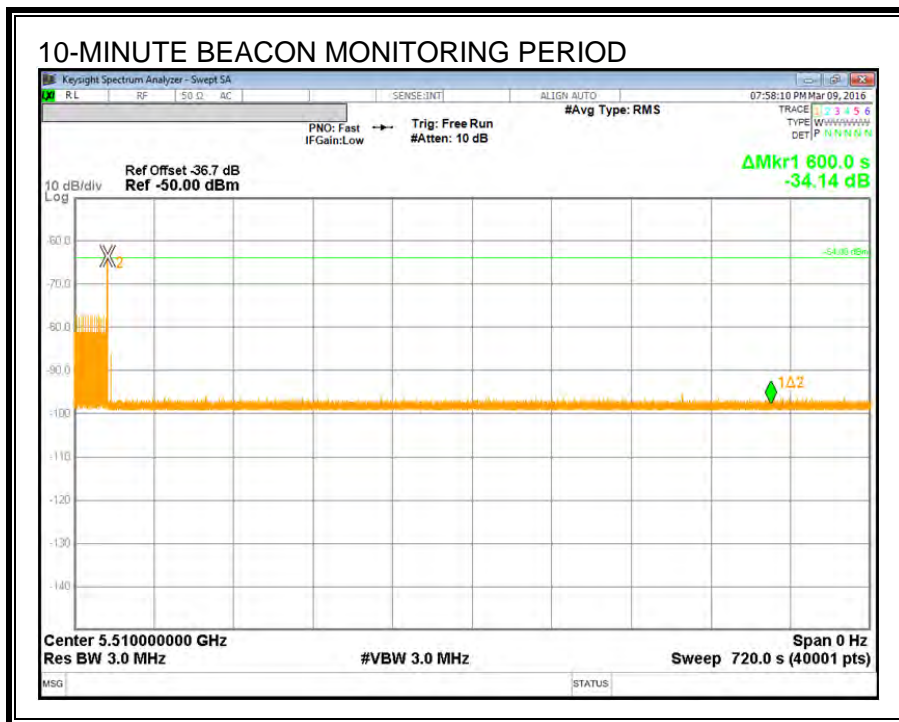

14.4. RESULTS FOR 80 MHz BANDWIDTH

14.4.1. TEST CHANNEL

All tests were performed at a channel center frequency of 5530 MHz.

14.4.2. RADAR WAVEFORM AND TRAFFIC

RADAR WAVEFORM

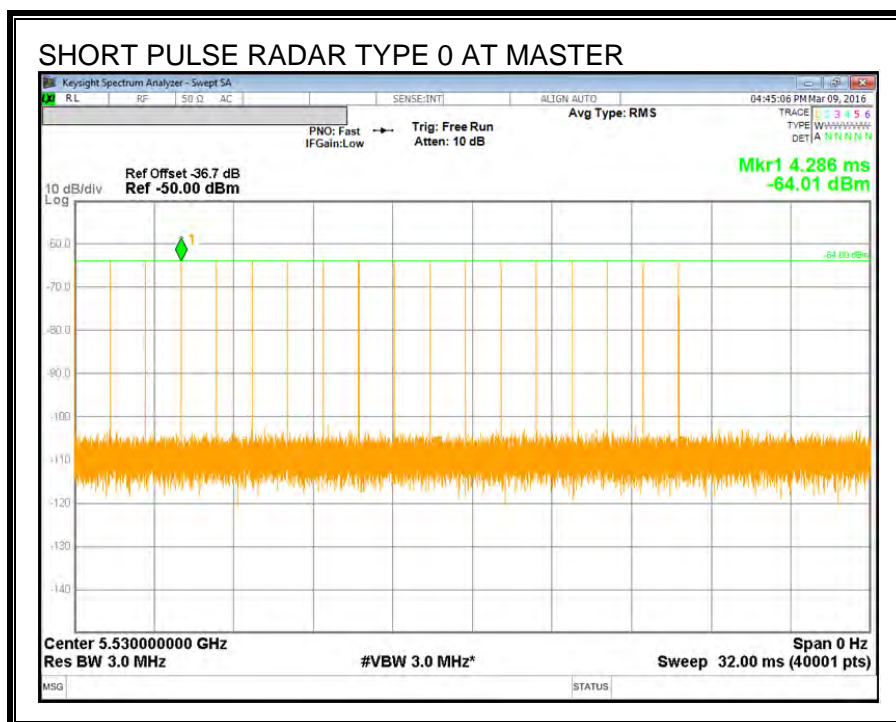

TRAFFIC

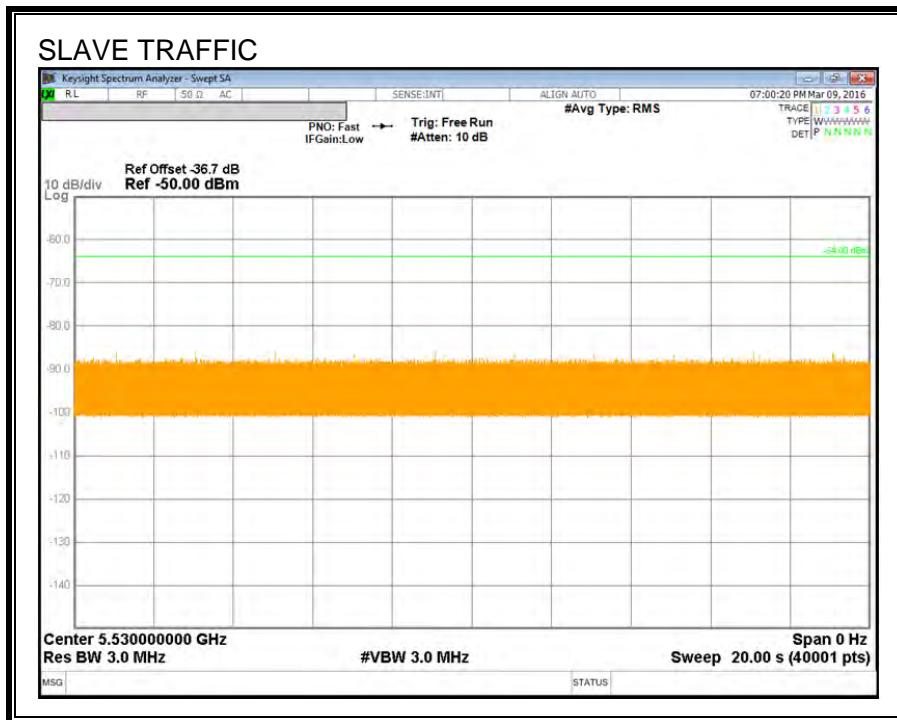

14.4.3. OVERLAPPING CHANNEL TESTS

RESULTS

These tests are not applicable.

14.4.4. MOVE AND CLOSING TIME

REPORTING NOTES

The reference marker is set at the end of last radar pulse.

The delta marker is set at the end of the last WLAN transmission following the radar pulse. This delta is the channel move time.

The aggregate channel closing transmission time is calculated as follows:

Aggregate Transmission Time =
(Number of analyzer bins showing transmission) * (dwell time per bin)

The observation period over which the aggregate time is calculated begins at (Reference Marker + 200 msec) and ends no earlier than (Reference Marker + 10 sec).

RESULTS

| Channel Move Time (sec) | Limit (sec) |
|------------------------------------|------------------------|
| 0.645 | 10 |

| Aggregate Channel Closing Transmission Time (msec) | Limit (msec) |
|---|-------------------------|
| 3.750 | 60 |

MOVE TIME & CHANNEL CLOSING TIME

AGGREGATE CHANNEL CLOSING TRANSMISSION TIME

No transmissions are observed during the aggregate monitoring period.

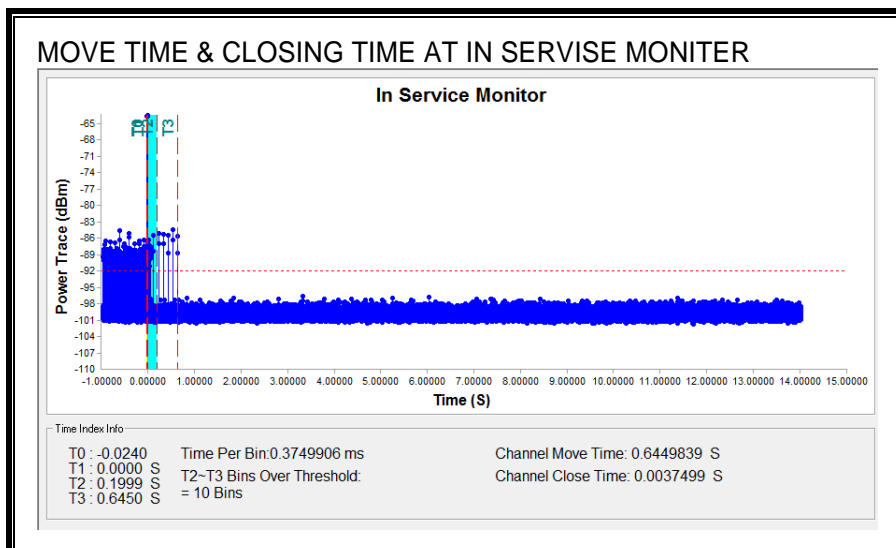
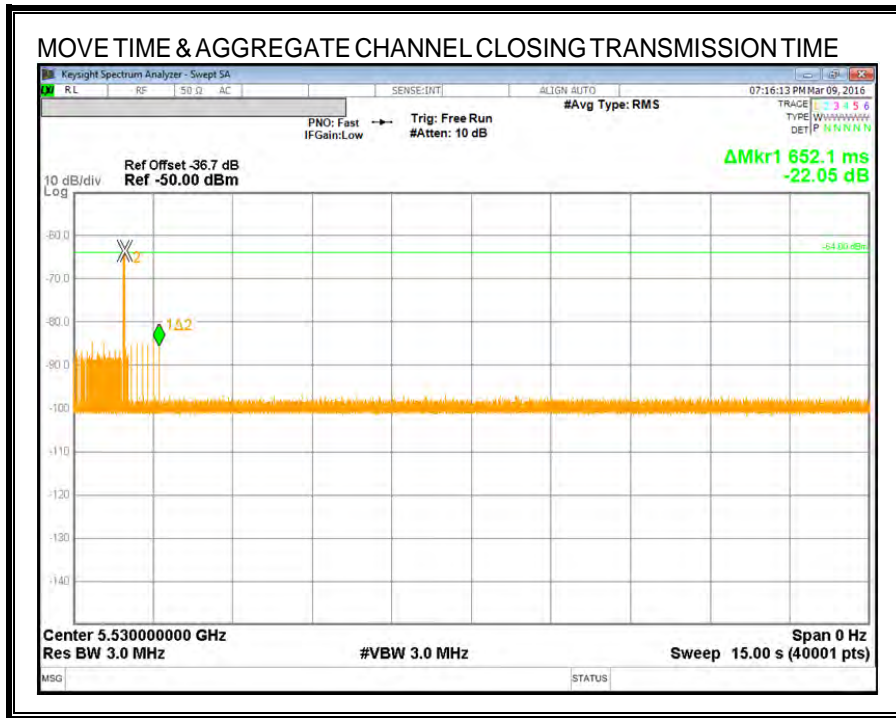

NON-OCCUPANCY PERIOD

RESULTS

No EUT transmissions were observed on the test channel during the 10-minute observation time.

