



FCC CFR47 PART 22 SUBPART H
FCC CFR47 PART 24 SUBPART E
FCC CFR47 PART 27 SUBPART H
FCC CFR47 PART 27 SUBPART L

WWAN

CERTIFICATION TEST REPORT

FOR

GSM/WCDMA/LTE Tablet + BT/BLE and DTS/UNII a/b/g/n/ac and ANT+

MODEL NUMBER : SM-T819Y

FCC ID: A3LSMT819Y

REPORT NUMBER: 16K23303-E6V1

ISSUE DATE: MAY 10, 2016

Prepared for
SAMSUNG ELECTRONICS CO., LTD.
129 SAMSUNG-RO, YEONGTONG-GU, SUWON-SI,
GYEONGGI-DO, 16677, KOREA

Prepared by
UL Korea, Ltd. Suwon Laboratory
218 Maeyeong-ro, Yeongtong-gu,
Suwon-si, Gyeonggi-do, 16675, Korea
TEL: (031) 337-9902
FAX: (031) 213-5433



Revision History

<u>Rev.</u>	<u>Issue Date</u>	<u>Revisions</u>	<u>Revised By</u>
V1	05/10/16	Initial issue	SungGil Park

TABLE OF CONTENTS

1. ATTESTATION OF TEST RESULTS	5
1.1. TEST DATA REUSE.....	6
1.2. SPOT CECK VERIFICATION DATA.....	6
1.3. REFERENCE DETAIL.....	6
2. TEST METHODOLOGY	7
3. FACILITIES AND ACCREDITATION	7
4. CALIBRATION AND UNCERTAINTY	7
4.1. MEASURING INSTRUMENT CALIBRATION.....	7
4.2. SAMPLE CALCULATION.....	7
4.3. MEASUREMENT UNCERTAINTY.....	7
5. EQUIPMENT UNDER TEST	8
5.1. DESCRIPTION OF EUT.....	8
5.2. MAXIMUM OUTPUT POWER (GSM).....	8
5.3. MAXIMUM OUTPUT POWER (WCDMA).....	8
5.4. MAXIMUM OUTPUT POWER (LTE).....	9
5.5. DESCRIPTION OF TEST SETUP.....	12
6. TEST AND MEASUREMENT EQUIPMENT	14
7. Summary Table	15
8. RF POWER OUTPUT VERIFICATION	16
8.1. GSM/GPRS/EDGE.....	16
8.1.1. GSM OUTPUT POWER RESULT.....	17
8.2. UMTS REL 99.....	19
8.2.1. WCDMA OUTPUT POWER RESULT.....	23
8.3. LTE OUTPUT VERIFICATION.....	26
8.3.1. LTE OUTPUT POWER RESULT.....	27
9. PEAK TO AVERAGE RATIO	33
9.1. CONDUCTED PEAK TO AVERAGE RESULT.....	33
9.2. CONDUCTED PEAK TO AVERAGE PLOTS.....	35
10. LIMITS AND CONDUCTED RESULTS	43
10.1. OCCUPIED BANDWIDTH.....	43
10.1.1. OCCUPIED BANDWIDTH RESULTS.....	43
10.1.2. OCCUPIED BANDWIDTH PLOTS.....	48

10.2.	<i>BAND EDGE EMISSIONS</i>	71
10.2.1.	<i>BAND EDGE PLOTS</i>	77
10.3.	<i>OUT OF BAND EMISSIONS</i>	100
10.3.1.	<i>OUT OF BAND EMISSIONS RESULT</i>	100
10.3.2.	<i>OUT OF BAND EMISSIONS PLOTS</i>	105
10.4.	<i>FREQUENCY STABILITY</i>	128
10.4.1.	<i>FREQUENCY STABILITY RESULTS</i>	129
11.	RADIATED TEST RESULTS	133
11.1.	<i>RADIATED POWER (ERP & EIRP)</i>	133
11.1.1.	<i>ERP/EIRP Results</i>	134
11.1.2.	<i>ERP/EIRP DATA</i>	139
11.2.	<i>FIELD STRENGTH OF SPURIOUS RADIATION</i>	162
11.2.1.	<i>SPURIOUS RADIATION PLOTS</i>	163
12.	SETUP PHOTOS	186

1. ATTESTATION OF TEST RESULTS

COMPANY NAME: SAMSUNG ELECTRONICS CO., LTD.
EUT DESCRIPTION: GSM/WCDMA/LTE Tablet + BT/BLE and DTS/UNII a/b/g/n/ac and ANT+
MODEL NUMBER: SM-T819Y
SERIAL NUMBER: R32H3009MNP (RADIATED); R32H3009N2E (CONDUCTED)
DATE TESTED: FEB 04, 2016 - MAY 05, 2016

APPLICABLE STANDARDS	
STANDARD	TEST RESULTS
FCC PART 22H, 24E, 27H and 27L	Pass

UL Korea, Ltd. tested the above equipment in accordance with the requirements set forth in the above standards. All indications of Pass/Fail in this report are opinions expressed by UL Korea, Ltd. based on interpretations and/or observations of test results. Measurement Uncertainties were not taken into account and are published for informational purposes only. The test results show that the equipment tested is capable of demonstrating compliance with the requirements as documented in this report.

Note: The results documented in this report apply only to the tested sample, under the conditions and modes of operation as described herein. This document may not be altered or revised in any way unless done so by UL Korea, Ltd. and all revisions are duly noted in the revisions section. Any alteration of this document not carried out by UL Korea, Ltd. will constitute fraud and shall nullify the document. This report must not be used by the client to claim product certification, approval, or endorsement by IAS, any agency of the Federal Government, or any agency of any government.

Approved & Released For
UL Korea, Ltd. By:



CY Choi
Suwon Lab Engineer
UL Korea, Ltd.

Tested By:

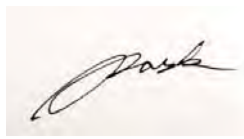

SungGil Park
Suwon Lab Engineer
UL Korea, Ltd.

1.1. TEST DATA REUSE

The FCC ID: A3LSMT819Y shares the same enclosure and circuit board as FCC ID: A3LSMT819. The re-used circuitry and layout are almost identical between these two units. And the re-used antennas and surrounding circuitry are same between these two units. The only differences between the A3LSMT819 and the A3LSMT819Y are that WCDMA B4, LTE B28 / B40 are added and LTE B20 is deleted.

After confirming through preliminary radiated emissions that the performance of the FCC ID: A3LSMT819 remains representative of FCC ID: A3LSMT819Y. The test data for FCC ID: A3LSMT819 is being submitted for this application to cover GSM850, WCDMA B5, LTE B2, LTE B4, LTE B5 and LTE B17 features.

1.2. SPOT CECK VERIFICATION DATA

Band	Test Item	Worst Mode	Worst Ch.	Worst Freq. (MHz)	Worst Bandwidth (MHz)	Test Limit (dBm)	Original Model SM-T819 (FCC ID : A3LSMT819)	Spot Check Model SM-T819Y (FCC ID : A3LSMT819Y)	Deviation	
							Measured Power (dBm)	Measured Power (dBm)		
GSM	850	ERP	GPRS	Low	824.2		38.5	29.85	30.56	0.71
		RSE	GPRS	High	848.8		-13.0	-30.90	-27.70	3.20
WCDMA	Band V	ERP	REL99	Low	826.4		38.5	19.09	19.30	0.21
		RSE	REL99	High	846.6		-13.0	-45.90	-50.00	-4.10
LTE	Band 2	EIRP	QPSK	High	1900.0	20	33.0	21.85	20.89	-0.96
		RSE	QPSK	High	1909.3	1.4	-13.0	-36.70	-40.40	-3.70
	Band 4	EIRP	QPSK	Low	1711.5	3	30.0	20.88	19.90	-0.98
		RSE	QPSK	Low	1710.7	1.4	-13.0	-35.80	-39.30	-3.50
	Band 5	ERP	QPSK	Low	829.0	10	38.5	20.48	18.85	-1.63
		RSE	QPSK	Mid	836.5	3	-13.0	-50.70	-53.20	-2.50
	Band 17	ERP	QPSK	Low	706.5	5	34.8	12.98	14.15	1.17
		RSE	QPSK	Low	706.5	5	-13.0	-48.80	-45.30	3.50

Comparison of two models, Deviation is within The EMC Lab Measurement Uncertainty range and all test results are under FCC Technical Limits.

1.3. REFERENCE DETAIL

Reference application that contains the reused reference data.

Equipment Class	Reference FCC ID	Report Title / Section
PCB	A3LSMT819	16K22867-E6V1 FCC Report WWAN / All sections for GSM850, WCDMA B5, LTE B2/B4/B5/B17

2. TEST METHODOLOGY

The tests documented in this report were performed in accordance with TIA-603-D, FCC CFR 47 Part 22, FCC CFR Part 24 and FCC CFR Part 27.

3. FACILITIES AND ACCREDITATION

The test sites and measurement facilities used to collect data are located at 218 Maeyeong-ro, Yeongtong-gu, Suwon-si, Gyeonggi-do, 16675, Korea. Line conducted emissions are measured only at the 218 address. The following table identifies which facilities were utilized for radiated emission measurements documented in this report. Specific facilities are also identified in the test results sections.

218 Maeyeong-ro	
<input checked="" type="checkbox"/>	Chamber 1
<input checked="" type="checkbox"/>	Chamber 2

UL Korea, Ltd. is accredited by IAS, Laboratory Code TL-637. The full scope of accreditation can be viewed at <http://www.iasonline.org/PDF/TL/TL-637.pdf>.

4. CALIBRATION AND UNCERTAINTY

4.1. MEASURING INSTRUMENT CALIBRATION

The measuring equipment utilized to perform the tests documented in this report has been calibrated in accordance with the manufacturer's recommendations, and is traceable to recognized national standards.

4.2. SAMPLE CALCULATION

Where relevant, the following sample calculation is provided:

EIRP = PSA reading with EUT worst orientation (dBm) + Path loss (dB) – cable loss(between the SG and substitution antenna) + Substitution Antenna Factor (dBi)

ERP = PSA reading with EUT worst orientation (dBm) + Path loss (dB) – cable loss(between the SG and substitution antenna)

(Path loss = Signal generator output – PSA reading with substitution antenna)

4.3. MEASUREMENT UNCERTAINTY

Where relevant, the following measurement uncertainty levels have been estimated for tests performed on the apparatus:

PARAMETER	UNCERTAINTY
Conducted Disturbance, 0.15 to 30 MHz	2.32 dB
Radiated Disturbance, Below 1GHz	4.14 dB
Radiated Disturbance, Above 1 GHz	5.97 dB

Uncertainty figures are valid to a confidence level of 95%.

5. EQUIPMENT UNDER TEST

5.1. DESCRIPTION OF EUT

The EUT is a GSM/WCDMA/LTE Tablet + BT/BLE and DTS/UNII a/b/g/n/ac and ANT+.

5.2. MAXIMUM OUTPUT POWER (GSM)

The transmitter has a maximum peak conducted and radiated ERP / EIRP output powers as follows:

FCC Part 22/24						
Band	Frequency Range	Modulation	Conducted		Radiated	
	[MHz]		Peak	Avg [dBm]	Avg [mW]	Avg [dBm]
GSM850	824~849	GMSK	32.31	1703.10		
		GPRS	32.31	1703.45	29.85	966.05
		EGPRS	27.70	588.87	26.23	419.76
GSM1900	1850~1910	GMSK	30.88	1224.92		
		GPRS	30.96	1246.55	31.75	1496.24
		EGPRS	26.89	488.86	27.99	629.51

5.3. MAXIMUM OUTPUT POWER (WCDMA)

The transmitter has a maximum peak conducted and radiated ERP / EIRP output powers as follows:

FCC Part 22/24						
Band	Frequency Range	Modulation	Conducted		Radiated	
	[MHz]		Peak	Avg [dBm]	Avg [mW]	Avg [dBm]
Band 5	824~849	REL99	22.49	177.28	19.09	81.10
		HSDPA	22.46	176.20	20.45	110.92
		HSUPA	21.43	139.10		
Band 4	1710~1755	REL99	22.24	167.43	24.42	276.69
		HSDPA	22.18	165.21	23.45	221.31
		HSUPA	22.22	166.67		
Band 2	1850~1910	REL99	23.68	233.50	25.35	342.77
		HSDPA	22.27	168.55	22.27	168.66
		HSUPA	22.08	161.55		

5.4. MAXIMUM OUTPUT POWER (LTE)

The transmitter has a maximum peak conducted and radiated ERP / EIRP output powers as follows:

LTE Band 17

FCC Part 27							
Band	Frequency Range [MHz]	BandWidth [MHz]	Modulation Peak	Conducted		Radiated	
				Avg [dBm]	Avg [mW]	Avg [dBm]	Avg [mW]
Band 17	704 ~ 716	10	QPSK	23.08	203.05	12.92	19.59
			16QAM	21.99	158.07	11.95	15.67
		5	QPSK	23.19	208.65	12.98	19.86
			16QAM	22.17	164.95	12.03	15.96

LTE Band 5

FCC Part 22							
Band	Frequency Range [MHz]	BandWidth [MHz]	Modulation Peak	Conducted		Radiated	
				Avg [dBm]	Avg [mW]	Avg [dBm]	Avg [mW]
Band 5	824 ~ 849	10	QPSK	23.31	214.29	20.48	111.69
			16QAM	22.39	173.34	19.52	89.54
		5	QPSK	23.25	211.44	20.27	106.41
			16QAM	22.33	171.08	19.33	85.70
		3	QPSK	23.14	206.01	20.18	104.23
			16QAM	22.10	162.10	19.12	81.66
		1.4	QPSK	23.07	202.72	20.20	104.71
			16QAM	22.32	170.72	19.13	81.85

LTE Band 4

FCC Part 27							
Band	Frequency Range [MHz]	BandWidth [MHz]	Modulation Peak	Conducted		Radiated	
				Avg [dBm]	Avg [mW]	Avg [dBm]	Avg [mW]
Band 4	1710 ~ 1755	20	QPSK	21.70	147.77	18.70	74.13
			16QAM	20.65	116.21	17.63	57.94
		15	QPSK	21.60	144.45	18.76	75.16
			16QAM	20.91	123.44	17.75	59.57
		10	QPSK	21.51	141.47	19.96	99.08
			16QAM	20.36	108.54	18.83	76.38
		5	QPSK	21.60	144.70	20.08	101.86
			16QAM	20.39	109.27	19.13	81.85
		3	QPSK	21.52	141.75	20.88	122.46
			16QAM	20.58	114.38	19.83	96.16
		1.4	QPSK	21.69	147.43	18.27	67.14
			16QAM	20.60	114.82	17.34	54.20

LTE Band 2

FCC Part 24							
Band	Frequency Range [MHz]	BandWidth [MHz]	Modulation Peak	Conducted		Radiated	
				Avg [dBm]	Avg [mW]	Avg [dBm]	Avg [mW]
Band 5	1850 ~ 1910	20	QPSK	23.00	199.53	21.85	153.11
			16QAM	21.53	142.25	21.00	125.89
		15	QPSK	22.83	191.66	20.75	118.85
			16QAM	22.00	158.49	19.83	96.16
		10	QPSK	23.00	199.53	21.34	136.14
			16QAM	21.81	151.55	20.33	107.89
		5	QPSK	22.79	190.18	21.04	127.06
			16QAM	21.81	151.68	20.05	101.16
		3	QPSK	22.94	196.94	21.21	132.13
			16QAM	21.94	156.41	20.17	103.99
		1.4	QPSK	22.81	190.80	20.23	105.44
			16QAM	22.00	158.49	18.78	75.51

DESCRIPTION OF AVAILABLE ANTENNAS

The radio utilizes a FPCB antenna for the [List the bands supported] with a maximum peak gain as follow:

Frequency (MHz)	Peak Gain (dBi)
GSM850 / WCDMA Band 5 / LTE Band 5 824 ~ 849 MHz	4.5
GSM1900 / WCDMA Band 2 / LTE Band 2 1850 ~ 1910 MHz	2.9
LTE Band 17 704 ~ 716 MHz	0.0
WCDMA Band 4 / LTE Band 4 1710 ~ 1755 MHz	1.0

5.5. DESCRIPTION OF TEST SETUP

SUPPORT EQUIPMENT

Support Equipment List				
Description	Manufacturer	Model	Serial Number	FCC ID
Charger	SAMSUNG	EP-TA20EWE	R37GBT1HN3DK3	N/A
Data Cable	SAMSUNG	EP-DG925UWE	N/A	N/A
Earphone	SAMSUNG	E0-EG900BW	N/A	N/A

I/O CABLES

I/O Cable List						
Cable No	Port	# of identical ports	Connector Type	Cable Type	Cable Length (m)	Remarks
1	DC Power	1	Mini-USB	Shielded	0.8m	N/A
2	Audio	1	Mini-Jack	Unshielded	1.0m	N/A

TEST SETUP

The EUT is continuously communicated to the call box during the tests.

SETUP DIAGRAM FOR TESTS (CONDUCTED TEST SETUP)

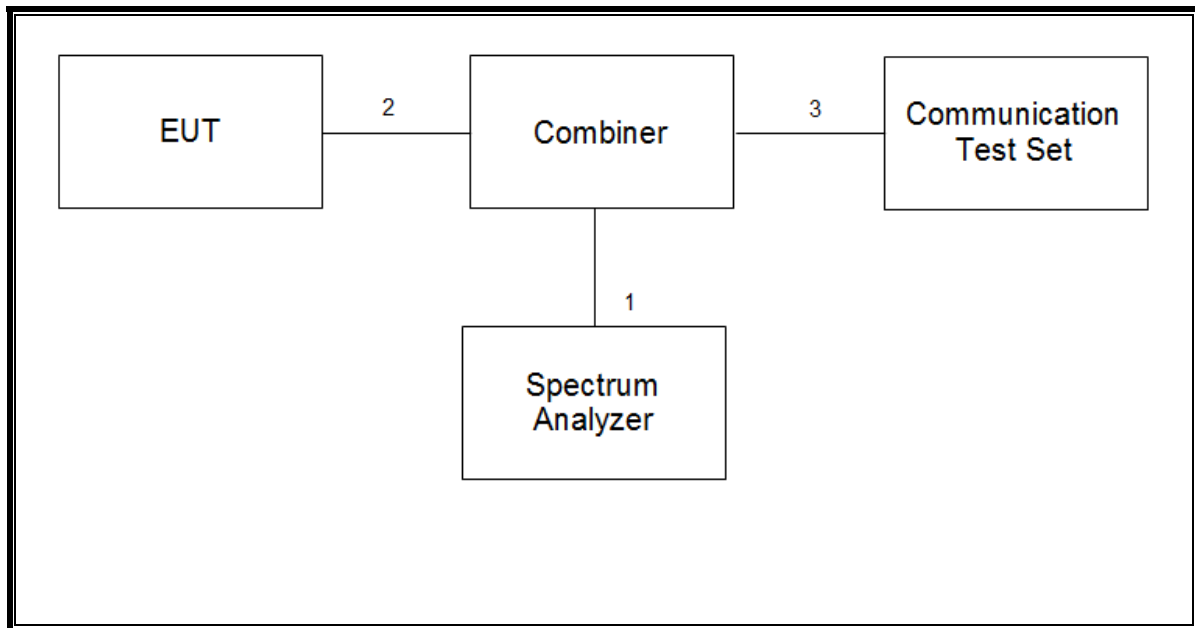

SETUP DIAGRAM FOR TESTS (RADIATED TEST SETUP)

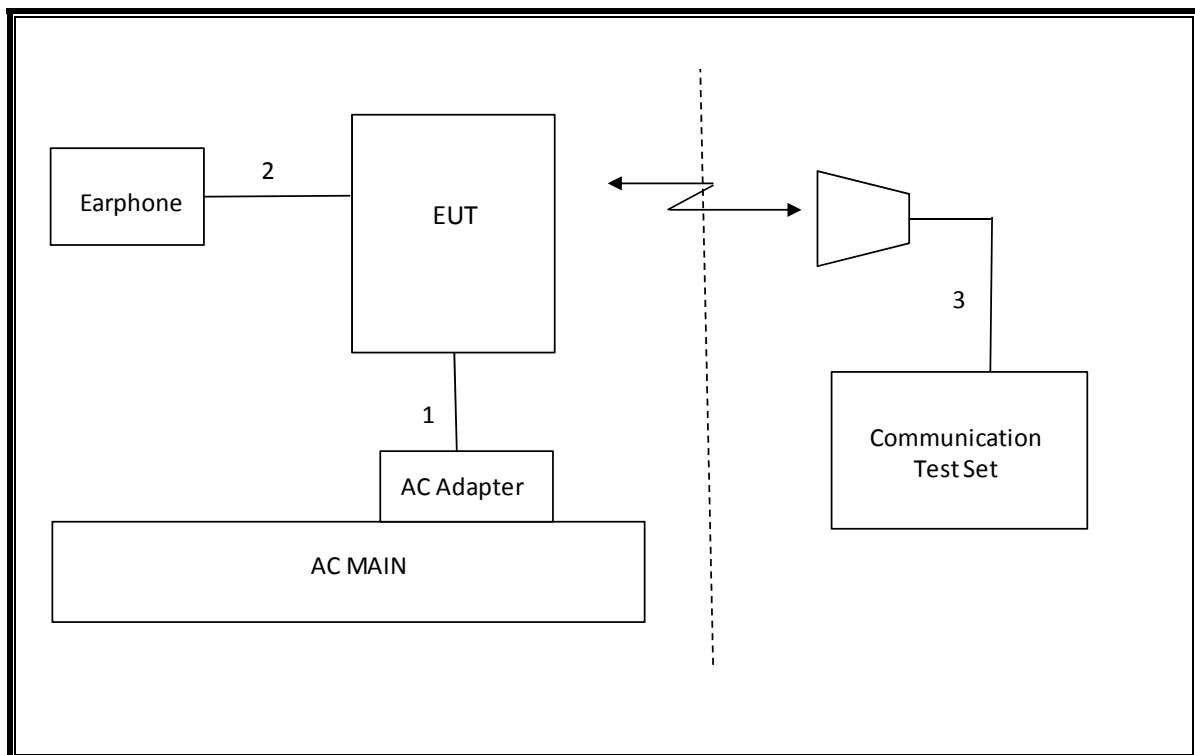

6. TEST AND MEASUREMENT EQUIPMENT

The following test and measurement equipment was utilized for the tests documented in this report:

Test Equipment List				
Description	Manufacturer	Model	S/N	Cal Due
Antenna, Tuned Dipole 400~1000 MHz	ETS	3121D DB4	00164753	07-28-16
Antenna, Horn, 40 GHz	ETS	3116C	00166155	09-23-16
Antenna, Horn, 40 GHz	ETS	3116C-PA	00168841	08-24-17
Antenna, Bilog, 30MHz-1GHz	SCHWARZBECK	VULB9163	750	11-17-16
Antenna, Bilog, 30MHz-1GHz	SCHWARZBECK	VULB9163	749	04-25-17
Antenna, Horn, 18 GHz	ETS	3115	00167211	09-26-16
Antenna, Horn, 18 GHz	ETS	3115	00161451	05-17-17
Antenna, Horn, 18 GHz	ETS	3117	00168724	06-17-17
Antenna, Horn, 18 GHz	ETS	3117	00168717	06-17-17
Combiner	WEINSCHTEL	1575	2151	08-20-16
Communications Test Set	R&S	CMW500	150312	08-18-16
Communications Test Set	R&S	CMW500	115331	08-18-16
Communications Test Set	R&S	CMW500	102271	08-18-16
DC Power Supply	Agilent / HP	E3640A	MY54226395	08-18-16
Preamplifier, 1000 MHz	Sonoma	310N	341282	08-18-16
Preamplifier, 1000 MHz	Sonoma	310N	351741	08-18-16
Preamplifier, 18 GHz	Miteq	AFS42-00101800-25-S-42	1876511	08-18-16
Preamplifier, 18 GHz	Miteq	AFS42-00101800-25-S-42	1896138	08-18-16
Spectrum Analyzer, 44 GHz	Agilent / HP	N9030A	MY54170614	08-19-16
Spectrum Analyzer, 44 GHz	Agilent / HP	N9030A	MY54490312	08-19-16
Bluetooth Tester	TESCOM	TC-3000C	3000C000546	08-18-16
Average Power Sensor	R&S	NRZ-Z91	102681	08-18-16
Average Power Sensor	Agilent / HP	U2000	MY54270007	08-18-16
EMI Test Receive, 40 GHz	R&S	ESU40	100439	08-19-16
EMI Test Receive, 40 GHz	R&S	ESU40	100457	08-19-16
EMI Test Receive, 3 GHz	R&S	ESR3	101832	08-19-16
Attenuator / Switch driver	HP	11713A	3748A04272	N/A
Low Pass Filter 3GHz	Micro-Tronics	LPS17541	009	08-18-16
Low Pass Filter 3GHz	Micro-Tronics	LPS17541	015	08-18-16
High Pass Filter 5GHz	Micro-Tronics	HPS17542	009	08-18-16
High Pass Filter 6GHz	Micro-Tronics	HPM17543	010	08-18-16
High Pass Filter 5GHz	Micro-Tronics	HPS17542	016	08-18-16
High Pass Filter 6GHz	Micro-Tronics	HPM17543	015	08-18-16
LISN	R&S	ENV-216	101836	08-19-16
LISN	R&S	ENV-216	101837	08-19-16

7. Summary Table

FCC Part Section	Test Description	Test Limit	Test Condition	Test Result	Note
2.1049	Occupied Band width (99%)	N/A	Conducted	Pass	17.867 MHz
22.917(a) 24.238(a) 27.53(g)	Band Edge / Conducted Spurious Emission	-13dBm		Pass	-15.04 dBm
2.1046	Conducted output power	N/A		Pass	32.31 dBm
22.355 24.235 27.54	Frequency Stability	2.5PPM		Pass	0.011PPM
22.913(a)(2)	Effective Radiated Power	38 dBm	Radiated	Pass	29.85 dBm
27.50(c)(10)		34.77 dBm		Pass	12.98
24.232(c)	Equivalent Isotropic Radiated Power	33dBm		Pass	31.75 dBm
27.50(d)(4)		30dBm		Pass	24.42dBm
22.917(a) 24.238(a) 27.53(g)	Radiated Spurious Emission	-13dBm		Pass	-30.9 dBm

FCC Rule Part	Frequency Range [MHz]	Output Power [W]	Frequency Tolerance	Emission Designator	Emission Bandwidth [MHz]	Communication Type
GSM						
22H	824.2 - 848.8	0.966	2.5 ppm	243KGXW		GSM850
22H	824.2 - 848.8	0.420	2.5 ppm	249KG7W		EDGE850
24E	1850.2 - 1909.8	1.496	2.5 ppm	246KGXW		GSM1900
24E	1850.2 - 1909.8	0.630	2.5 ppm	245KG7W		EDGE1900
WCDMA						
22H	826.4 - 846.6	0.111	2.5 ppm	4M15F9W		WCDMA
27L	1712.4 - 1752.6	0.277	2.5 ppm	4M12F9W		WCDMA
24E	1852.4 - 1907.6	0.343	2.5 ppm	4M13F9W		WCDMA
LTE Band 2						
24E	1860.0 - 1900.0	0.153	2.5 ppm	17M9G7W	20	QPSK
24E	1860.0 - 1900.0	0.126	2.5 ppm	17M8D7W	20	16QAM
LTE Band 4						
27L	1720.0 - 1745.0	0.074	2.5 ppm	17M8G7W	20	QPSK
27L	1720.0 - 1745.0	0.058	2.5 ppm	17M9D7W	20	16QAM
27L	1711.5 - 1753.5	0.122	2.5 ppm	2M69G7W	3	QPSK
27L	1711.5 - 1753.5	0.096	2.5 ppm	2M70D7W	3	16QAM
LTE Band 5						
22H	829.0 - 844.0	0.112	2.5 ppm	8M96G7W	10	QPSK
22H	829.0 - 844.0	0.090	2.5 ppm	8M95D7W	10	16QAM
LTE Band 17						
27H	709.0 - 711.0	0.020	2.5 ppm	8M95G7W	10	QPSK
27H	709.0 - 711.0	0.016	2.5 ppm	8M95D7W	10	16QAM
27H	706.5 - 713.5	0.020	2.5ppm	4M48G7W	5	QPSK
27H	706.5 - 713.5	0.016	2.5ppm	4M49D7W	5	16QAM

8. RF POWER OUTPUT VERIFICATION

8.1. GSM/GPRS/EDGE

Function: Menu select > GSM Mobile Station > GSM 850/900/1800/1900
Press Connection control to choose the different menus
Press RESET > choose all to reset all settings
Connection Press Signal Off to turn off the signal and change settings
Network Support > GSM+GPRS or GSM+EGPRS
Main Service > Packet Data
Service selection > Test Mode A – Auto Slot Config. off
MS Signal Press Slot Config bottom on the right twice to select and change the number of time slots and power setting
 > Slot configuration > Uplink/Gamma
 > 33 dBm for GPRS 850/900
 > 30 dBm for GPRS1800/1900
BS Signal Enter the same channel number for TCH channel (test channel) and BCCH channel
Frequency Offset > + 0 Hz
Mode > BCCH and TCH
BCCH Level > -85 dBm (May need to adjust if link is not stable)
BCCH Channel > choose desire test channel [Enter the same channel number for TCH channel (test channel) and BCCH channel]
Channel Type > Off
P0> 4 dB
Slot Config > Unchanged (if already set under MS Signal)
TCH > choose desired test channel
Hopping > Off
Main Timeslot > 3 (Default)
Network Coding Scheme > CS4 (GPRS) and MCS5 ~ MCS9 (EGPRS)
Bit Stream > 2E9-1PSR Bit Pattern
AF/RF Enter appropriate offsets for Ext. Att. Output and Ext. Att. Input
Connection Press Signal On to turn on the signal and change settings

8.1.1. GSM OUTPUT POWER RESULT

GSM850 Measured Results

Band	Mode	Coding Scheme	Time Slots	Ch No.	Freq. [MHz]	Max. Power	
						Burst Pw r [dBm]	Frame Pw r [dBm]
850	GSM (Voice)	CS1	1	128	824.2	32.31	23.28
				190	836.6	32.27	23.24
				251	848.8	32.31	23.27
	GPRS (GMSK)	CS1	1	128	824.2	32.31	23.28
				190	836.6	32.21	23.17
				251	848.8	32.21	23.18
			2	128	824.2	30.29	24.26
				190	836.6	30.32	24.30
				251	848.8	30.25	24.22
			3	128	824.2	28.18	23.92
				190	836.6	28.26	24.00
				251	848.8	28.16	23.90
			4	128	824.2	25.93	22.92
				190	836.6	26.00	22.99
				251	848.8	25.95	22.94
	EGPRS (8PSK)	MCS5	1	128	824.2	27.70	18.67
				190	836.6	27.54	18.50
				251	848.8	27.45	18.42
			2	128	824.2	25.41	19.39
				190	836.6	25.43	19.41
				251	848.8	25.32	19.30
			3	128	824.2	23.28	19.02
				190	836.6	23.29	19.03
				251	848.8	23.19	18.93
4			128	824.2	22.50	19.49	
			190	836.6	22.48	19.47	
			251	848.8	22.50	19.49	

GSM1900 Measured Results

Band	Mode	Coding Scheme	Time Slots	Ch No.	Freq. [MHz]	Max. Power	
						Burst Pwr [dBm]	Frame Pwr [dBm]
1900	GSM (Voice)	CS1	1	512	1850.2	30.82	21.79
				661	1880.0	30.73	21.70
				810	1909.8	30.88	21.85
	GPRS (GMSK)	CS1	1	512	1850.2	30.92	21.89
				661	1880.0	30.82	21.79
				810	1909.8	30.96	21.93
			2	512	1850.2	28.57	22.55
				661	1880.0	28.51	22.49
				810	1909.8	28.44	22.42
			3	512	1850.2	26.67	22.41
				661	1880.0	26.44	22.18
				810	1909.8	26.30	22.04
			4	512	1850.2	25.51	22.50
				661	1880.0	25.35	22.34
				810	1909.8	25.17	22.16
	EGPRS (8PSK)	MCS5	1	512	1850.2	26.89	17.86
				661	1880.0	26.67	17.64
				810	1909.8	26.57	17.54
			2	512	1850.2	26.27	20.25
				661	1880.0	26.03	20.01
				810	1909.8	25.89	19.87
			3	512	1850.2	24.22	19.96
				661	1880.0	23.98	19.72
				810	1909.8	23.81	19.55
4			512	1850.2	23.09	20.08	
			661	1880.0	22.84	19.83	
			810	1909.8	22.65	19.64	

8.2. UMTS REL 99

Release 99 Setup Procedures used to establish the test signals

The following tests were completed according to the test requirements outlined in section 5.2 of the 3GPP TS34.121-1 specification. The DUT supports power Class 3, which has a nominal maximum output power of 24 dBm (+1.7/-3.7).

Mode	Subtest	Rel99
WCDMA General Settings	Loopback Mode	Test Mode 2
	Rel99 RMC	12.2kbps RMC
	Power Control Algorithm	Algorithm2
	β_c/β_d	8/15

HSDPA Setup Procedures used to establish the test signals

The following 4 Sub-tests were completed according to Release 7 procedures in section 5.2 of 3GPP TS34.121. A summary of these settings are illustrated below:

Mode	Subtest	HSDPA	HSDPA	HSDPA	HSDPA
		1	2	3	4
W-CDMA General Settings	Loopback Mode	Test Mode 1			
	Rel99 RMC	12.2kbps RMC			
	HSDPA FRC	H-Set 1			
	Power Control Algorithm	Algorithm 2			
	β_c	2/15	11/15	15/15	15/15
	β_d	15/15	15/15	8/15	4/15
	Bd (SF)	64			
	β_c/β_d	2/15	12/15	15/8	15/4
	β_{hs}	4/15	24/15	30/15	30/15
	MPR (dB)	0	0	0.5	0.5
HSDPA Specific Settings	D_{ACK}	8			
	D_{NAK}	8			
	DCQI	8			
	Ack-Nack repetition factor	3			
	CQI Feedback (Table 5.2B.4)	4ms			
	CQI Repetition Factor (Table 5.2B.4)	2			
	$A_{hs}=\beta_{hs}/\beta_c$	30/15			

HSPA (HSDPA & HSUPA) Setup Procedures used to establish the test signals

The following 5 Sub-tests were completed according to Release 6 procedures in section 5.2 of 3GPP TS34.121. A summary of these settings are illustrated below:

	Mode	HSPA				
	Subtest	1	2	3	4	5
WCDMA General Settings	Loopback Mode	Test Mode 1				
	Rel99 RMC	12.2 kbps RMC				
	HSDPA FRC	H-Set 1				
	HSUPA Test	HSPA				
	Power Control Algorithm	Algorithm 2				Algorithm 1
	β_c	11/15	6/15	15/15	2/15	15/15
	β_d	15/15	15/15	9/15	15/15	0
	β_{ec}	209/225	12/15	30/15	2/15	5/15
	β_c/β_d	11/15	6/15	15/9	2/15	15/1
	β_{hs}	22/15	12/15	30/15	4/15	5/15
	β_{ed}	1309/225	94/75	47/15	56/75	47/15
	CM (dB)	1	3	2	3	1
MPR (dB)	0	2	1	2	0	
HSDPA Specific Settings	DACK	8				0
	DNAK	8				0
	DCQI	8				0
	Ack-Nack repetition factor	3				
	CQI Feedback (Table 5.2B.4)	4ms				
	CQI Repetition Factor (Table 5.2B.4)	2				
	$A_{hs} = \beta_{hs}/\beta_c$	30/15				
HSUPA Specific Settings	E-DPDCCH	6	8	8	5	7
	DHARQ	0	0	0	0	0
	AG Index	20	12	15	17	21
	ETFCI (from 34.121 Table C.11.1.3)	75	67	92	71	81
	Associated Max UL Data Rate kbps	242.1	174.9	482.8	205.8	308.9
	Reference E-TFCIs	5	5	2	5	1
	Reference E-TFCI	11	11	11	11	67
	Reference E-TFCI PO	4	4	4	4	18
	Reference E-TFCI	67	67	92	67	67
	Reference E-TFCI PO	18	18	18	18	18
	Reference E-TFCI	71	71	71	71	71
	Reference E-TFCI PO	23	23	23	23	23
	Reference E-TFCI	75	75	75	75	75
	Reference E-TFCI PO	26	26	26	26	26
	Reference E-TFCI	81	81	81	81	81
Reference E-TFCI PO	27	27	27	27	27	
Maximum Channelisation Codes	2xSF2				SF4	

DC-HSDPA Setup Procedures used to establish the test signals

The following tests were completed according to procedures in section 7.3.13 of 3GPP TS34.108 v9.5.0. A summary of these settings are illustrated below:

Downlink Physical Channels are set as per 3GPP TS34.121-1 v9.0.0 E.5.0

Table E.5.0: Levels for HSDPA connection setup

Parameter	Unit	Value
During Connection setup		
P-CPICH_Ec/Ior	dB	-10
P-CCPCH and SCH_Ec/Ior	dB	-12
PICH_Ec/Ior	dB	-15
HS-PDSCH	dB	off
HS-SCCH_1	dB	off
DPCH_Ec/Ior	dB	-5
OCNS_Ec/Ior	dB	-3.1

Call is set up as per 3GPP TS34.108 v9.5.0 sub clause 7.3.13

The configurations of the fixed reference channels for HSDPA RF tests are described in 3GPP TS 34.121, annex C for FDD and 3GPP TS 34.122.

Table C.8.1.12: Fixed Reference Channel H-Set 12

Parameter	Unit	Value
Nominal Avg. Inf. Bit Rate	kbps	60
Inter-TTI Distance	TTI's	1
Number of HARQ Processes	Processes	6
Information Bit Payload (N_{INF})	Bits	120
Number Code Blocks	Blocks	1
Binary Channel Bits Per TTI	Bits	960
Total Available SML's in UE	SML's	19200
Number of SML's per HARQ Proc.	SML's	3200
Coding Rate		0.15
Number of Physical Channel Codes	Codes	1
Modulation		QPSK
Note 1: The RMC is intended to be used for DC-HSDPA mode and both cells shall transmit with identical parameters as listed in the table. Note 2: Maximum number of transmission is limited to 1, i.e., retransmission is not allowed. The redundancy and constellation version 0 shall be used.		

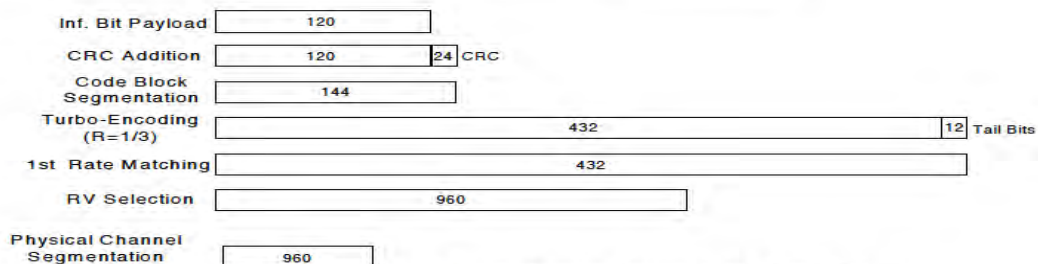

Figure C.8.19: Coding rate for Fixed reference Channel H-Set 12 (QPSK)

The following 4 Sub-tests for HSDPA were completed according to Release 8 procedures in section 5.2 of 3GPP TS34.121. A summary of subtest settings are illustrated below:

Mode	HSDPA	HSDPA	HSDPA	HSDPA
Subtest	1	2	3	4
WCDMA General Settings	Loopback Mode			
	Test Mode 1			
	Rel99 RMC			
	12.2kbps RMC			
	HSDPA FRC			
	H-Set 1			
	Power Control Algorithm			
	Algorithm2			
	β_c	2/15	11/15	15/15
β_d	15/15	15/15	8/15	4/15
β_d (SF)	64			
β_c/β_d	2/15	11/15	15/8	15/4
β_{hs}	4/15	24/15	30/15	30/15
MPR (dB)	0	0	0.5	0.5
HSDPA Specific Settings	DACK			
	8			
	DNAK			
	8			
	DCQI			
	8			
	Ack-Nack Repetition factor			
3				
CQI Feedback				
4ms				
CQI Repetition Factor				
2				
A _{hs} = β_{hs}/β_c				
30/15				

HSPA+

Since 16QAM is not used for uplink, the uplink Category and release is same as HSUPA, i.e., CAT 6 Rel 6. Therefore, the RF conducted power is not measured.

8.2.1. WCDMA OUTPUT POWER RESULT

WCDMA Band 5 Measured Results

Band	Mode		UL Ch No.	Freq. [MHz]	MPR [dB]	Avg Pwr [dBm]		
W-CDMA Band V	Rel 99	RMC, 12.2 kbps	4132	826.4	0	22.49		
			4183	836.6	0	22.35		
			4233	846.6	0	22.30		
	HSDPA	Subtest 1		4132	826.4	0	21.37	
				4183	836.6	0	21.27	
				4233	846.6	0	21.26	
		Subtest 2		4132	826.4	0	22.23	
				4183	836.6	0	22.04	
				4233	846.6	0	22.14	
		Subtest 3		4132	826.4	0.5	22.45	
				4183	836.6	0.5	22.34	
				4233	846.6	0.5	22.32	
		Subtest 4		4132	826.4	0.5	22.46	
				4183	836.6	0.5	22.31	
				4233	846.6	0.5	22.32	
		HSUPA	Subtest 1		4132	826.4	0	21.43
					4183	836.6	0	21.38
					4233	846.6	0	21.27
	Subtest 2			4132	826.4	2	18.49	
				4183	836.6	2	18.34	
				4233	846.6	2	18.24	
	Subtest 3			4132	826.4	1	19.49	
				4183	836.6	1	19.42	
				4233	846.6	1	19.38	
	Subtest 4			4132	826.4	2	18.42	
				4183	836.6	2	18.39	
				4233	846.6	2	18.23	
	Subtest 5			4132	826.4	0	21.43	
				4183	836.6	0	21.38	
				4233	846.6	0	21.27	

WCDMA Band 4 Measured Results

Band	Mode		UL Ch No.	Freq. [MHz]	MPR [dB]	Avg Pwr [dBm]	
W-CDMA Band IV	Rel 99	RMC, 12.2 kbps	1312	1712.4	0	22.24	
			1413	1732.6	0	22.23	
			1513	1752.6	0	22.05	
	HSDPA	Subtest 1	1312	1712.4	0	22.18	
			1413	1732.6	0	22.15	
			1513	1752.6	0	22.06	
		Subtest 2	1312	1712.4	0	20.86	
			1413	1732.6	0	20.90	
			1513	1752.6	0	20.84	
		Subtest 3	1312	1712.4	0.5	20.71	
			1413	1732.6	0.5	20.66	
			1513	1752.6	0.5	20.58	
		Subtest 4	1312	1712.4	0.5	20.70	
			1413	1732.6	0.5	20.66	
			1513	1752.6	0.5	20.59	
		HSUPA	Subtest 1	1312	1712.4	0	21.39
				1413	1732.6	0	21.34
				1513	1752.6	0	21.53
	Subtest 2		1312	1712.4	2	19.19	
			1413	1732.6	2	19.03	
			1513	1752.6	2	19.02	
	Subtest 3		1312	1712.4	1	20.19	
			1413	1732.6	1	20.07	
			1513	1752.6	1	20.09	
	Subtest 4		1312	1712.4	2	19.19	
			1413	1732.6	2	19.03	
			1513	1752.6	2	19.02	
	Subtest 5		1312	1712.4	0	22.22	
			1413	1732.6	0	22.10	
			1513	1752.6	0	22.14	

WCDMA Band 2 Measured Results

Band	Mode		UL Ch No.	Freq. [MHz]	MPR [dB]	Avg Pwr [dBm]	
W-CDMA Band II	Rel 99	RMC, 12.2 kbps	9262	1852.4	0	23.68	
			9400	1880.0	0	23.33	
			9538	1907.6	0	23.42	
	HSDPA	Subtest 1	9262	1852.4	0	22.27	
			9400	1880.0	0	21.85	
			9538	1907.6	0	21.83	
		Subtest 2	9262	1852.4	0	21.71	
			9400	1880.0	0	21.72	
			9538	1907.6	0	21.80	
		Subtest 3	9262	1852.4	0.5	21.60	
			9400	1880.0	0.5	21.29	
			9538	1907.6	0.5	21.27	
		Subtest 4	9262	1852.4	0.5	21.61	
			9400	1880.0	0.5	21.30	
			9538	1907.6	0.5	21.28	
		HSUPA	Subtest 1	9262	1852.4	0	22.08
				9400	1880.0	0	21.87
				9538	1907.6	0	21.84
	Subtest 2		9262	1852.4	2	20.65	
			9400	1880.0	2	20.31	
			9538	1907.6	2	20.15	
	Subtest 3		9262	1852.4	1	21.09	
			9400	1880.0	1	20.84	
			9538	1907.6	1	20.81	
	Subtest 4		9262	1852.4	2	20.70	
			9400	1880.0	2	20.37	
			9538	1907.6	2	20.22	
	Subtest 5		9262	1852.4	0	22.05	
			9400	1880.0	0	21.86	
			9538	1907.6	0	21.83	

8.3. LTE OUTPUT VERIFICATION

The following tests were conducted according to the test requirements outlined in section 6.2 of the 3GPP TS36.101 specification.

UE Power Class: 3 (23 +/- 2dBm). The allowed Maximum Power Reduction (MPR) for the maximum output power due to higher order modulation and transmit bandwidth configuration (resource blocks) is specified in Table 6.2.3-1 of the 3GPP TS36.101.

Table 6.2.3-1: Maximum Power Reduction (MPR) for Power Class 3

Modulation	Channel bandwidth / Transmission bandwidth (RB)						MPR (dB)
	1.4 MHz	3.0 MHz	5 MHz	10 MHz	15 MHz	20 MHz	
QPSK	> 5	> 4	> 8	> 12	> 16	> 18	≤ 1
16 QAM	≤ 5	≤ 4	≤ 8	≤ 12	≤ 16	≤ 18	≤ 1
16 QAM	> 5	> 4	> 8	> 12	> 16	> 18	≤ 2

The allowed A-MPR values specified below in Table 6.2.4.-1 of 3GPP TS36.101 are in addition to the allowed MPR requirements. All the measurements below were performed with A-MPR disabled, by using Network Signalling Value of "NS_01".

Table 6.2.4-1: Additional Maximum Power Reduction (A-MPR)

Network Signalling value	Requirements (sub-clause)	E-UTRA Band	Channel bandwidth (MHz)	Resources Blocks (N_{RB})	A-MPR (dB)
NS_01	6.6.2.1.1	Table 5.5-1	1.4, 3, 5, 10, 15, 20	Table 5.6-1	NA
NS_03	6.6.2.2.1	2, 4, 10, 23, 25, 35, 36	3	>5	≤ 1
			5	>6	≤ 1
			10	>6	≤ 1
			15	>8	≤ 1
			20	>10	≤ 1
NS_04	6.6.2.2.2	41	5	>6	≤ 1
			10, 15, 20	See Table 6.2.4-4	
NS_05	6.6.3.3.1	1	10, 15, 20	≥ 50	≤ 1
NS_06	6.6.2.2.3	12, 13, 14, 17	1.4, 3, 5, 10	Table 5.6-1	n/a
NS_07	6.6.2.2.3	13	10	Table 6.2.4-2	Table 6.2.4-2
	6.6.3.3.2				
NS_08	6.6.3.3.3	19	10, 15	> 44	≤ 3
NS_09	6.6.3.3.4	21	10, 15	> 40	≤ 1
				> 55	≤ 2
NS_10		20	15, 20	Table 6.2.4-3	Table 6.2.4-3
NS_11	6.6.2.2.1	23 ¹	1.4, 3, 5, 10	Table 6.2.4-5	Table 6.2.4-5
..					
NS_32	-	-	-	-	-

Note 1: Applies to the lower block of Band 23, i.e. a carrier placed in the 2000-2010 MHz region.

8.3.1. LTE OUTPUT POWER RESULT

LTE Band 17 Measured Results

BW (MHz)	Mode	RB Allocation	RB offset	Target MPR	Avg Pwr (dBm)	
					23790	710 MHz
10	QPSK	1	0	0	22.91	
		1	25	0	23.08	
		1	49	0	22.91	
		25	0	1	22.14	
		25	12	1	22.19	
		25	25	1	22.12	
		50	0	1	22.17	
	16QAM	1	0	1	21.94	
		1	25	1	21.99	
		1	49	1	21.28	
		25	0	2	21.16	
		25	12	2	21.13	
		25	25	2	21.21	
		50	0	2	21.10	
BW (MHz)	Mode	RB Allocation	RB offset	Target MPR	Avg Pwr (dBm)	
					23790	710 MHz
5	QPSK	1	0	0	23.12	
		1	12	0	23.19	
		1	24	0	22.98	
		12	0	1	22.15	
		12	7	1	22.16	
		12	13	1	22.11	
		25	0	1	22.03	
	16QAM	1	0	1	22.17	
		1	12	1	22.15	
		1	24	1	21.54	
		12	0	2	20.99	
		12	7	2	21.08	
		12	13	2	21.03	
		25	0	2	21.07	

LTE Band 5 Measured Results

Band	BW (MHz)	Mode	RB Allocation	RB offset	Target MPR	Avg Pwr [dBm]		
						Max. Power		
						829 MHz	836.5 MHz	844 MHz
LTE Band 5	10	QPSK	1	0	0	22.86	22.98	22.81
			1	25	0	23.13	23.31	22.84
			1	49	0	22.83	22.88	22.90
			25	0	1	21.93	21.97	21.88
			25	12	1	22.00	22.00	22.01
			25	25	1	21.86	21.86	21.87
		16QAM	50	0	1	21.88	22.00	21.92
			1	0	1	21.63	21.62	21.76
			1	25	1	22.39	21.81	22.01
			1	49	1	21.76	21.08	21.40
			25	0	2	20.95	21.11	20.88
			25	12	2	20.87	21.06	21.13
			25	25	2	20.96	21.11	20.93
			50	0	2	20.91	21.16	20.94
Band	BW (MHz)	Mode	RB Allocation	RB offset	Target MPR	Avg Pwr [dBm]		
						Max. Power		
						826.5 MHz	836.5 MHz	846.5 MHz
LTE Band 5	5	QPSK	1	0	0	22.76	22.74	22.90
			1	12	0	23.25	23.22	23.10
			1	24	0	22.85	22.63	23.03
			12	0	1	21.91	21.88	21.89
			12	7	1	21.93	22.02	21.90
			12	13	1	21.82	21.94	21.82
		16QAM	25	0	1	21.72	21.83	21.88
			1	0	1	21.45	21.87	21.66
			1	12	1	21.77	22.33	21.51
			1	24	1	21.05	21.67	21.23
			12	0	2	20.71	20.81	20.73
			12	7	2	20.93	20.80	20.73
			12	13	2	20.73	20.81	20.74
			25	0	2	20.98	21.08	20.82
Band	BW (MHz)	Mode	RB Allocation	RB offset	Target MPR	Avg Pwr [dBm]		
						Max. Power		
						825.5 MHz	836.5 MHz	847.5 MHz
LTE Band 5	3	QPSK	1	0	0	22.90	22.99	22.69
			1	8	0	23.09	23.14	22.88
			1	14	0	22.88	23.02	22.72
			8	0	1	21.94	21.93	21.82
			8	4	1	21.96	22.05	21.92
			8	7	1	21.87	21.97	21.86
		16QAM	15	0	1	21.88	21.87	21.92
			1	0	1	21.93	21.79	21.80
			1	8	1	21.96	22.10	21.93
			1	14	1	21.65	21.75	21.68
			8	0	2	21.16	20.63	20.86
			8	4	2	21.08	20.65	20.92
			8	7	2	20.91	20.67	20.91
			15	0	2	20.93	21.02	20.74
Band	BW (MHz)	Mode	RB Allocation	RB offset	Target MPR	Avg Pwr [dBm]		
						Max. Power		
						824.7 MHz	836.5 MHz	848.3 MHz
LTE Band 5	1.4	QPSK	1	0	0	23.03	22.82	22.83
			1	3	0	22.99	22.98	22.84
			1	5	0	23.03	22.89	22.81
			3	0	0	22.93	22.91	23.04
			3	1	0	23.07	23.01	23.06
			3	3	0	22.98	23.02	22.97
		16QAM	6	0	1	21.90	21.88	21.87
			1	0	1	22.14	21.72	21.92
			1	3	1	22.32	21.87	21.95
			1	5	1	22.16	21.72	21.99
			3	0	1	22.09	21.66	21.70
			3	1	1	22.13	21.96	21.62
			3	3	1	22.04	21.96	21.72
			6	0	2	20.81	20.71	21.02

LTE Band 4 Measured Results

Band	BW (MHz)	Mode	RB Allocation	RB offset	Target MPR	Avg Pwr (dBm)		
						20050	20175	20300
						1720 MHz	1732.5 MHz	1745 MHz
LTE Band 4	20	QPSK	1	0	0	21.50	21.29	21.18
			1	49	0	21.41	21.39	21.70
			1	99	0	21.15	21.28	21.49
			50	0	1	20.44	20.31	20.23
			50	24	1	20.28	20.18	20.45
			50	50	1	20.10	20.15	20.53
		16QAM	100	0	1	20.31	20.22	20.42
			1	0	1	20.65	20.60	20.01
			1	49	1	20.44	19.85	20.29
			1	99	1	19.92	19.66	20.48
			50	0	2	19.37	19.19	19.16
			50	24	2	19.18	19.17	19.32
			50	50	2	18.95	19.04	19.40
			100	0	2	19.25	19.14	19.31
Band	BW (MHz)	Mode	RB Allocation	RB offset	Target MPR	Avg Pwr (dBm)		
						20025	20175	20325
						1717.5 MHz	1732.5 MHz	1747.5 MHz
LTE Band 4	15	QPSK	1	0	0	21.53	21.21	21.22
			1	37	0	21.27	21.13	21.60
			1	74	0	21.12	21.01	21.41
			36	0	1	20.44	20.34	20.34
			36	20	1	20.35	20.07	20.59
			36	39	1	20.22	20.01	20.58
		16QAM	75	0	1	20.24	20.16	20.54
			1	0	1	20.00	19.84	20.63
			1	37	1	20.48	20.18	20.91
			1	74	1	20.04	19.85	20.85
			36	0	2	19.35	19.37	19.28
			36	20	2	19.20	19.16	19.43
			36	39	2	19.20	19.09	19.36
			75	0	2	19.43	19.12	19.51
Band	BW (MHz)	Mode	RB Allocation	RB offset	Target MPR	Avg Pwr (dBm)		
						20000	20175	20350
						1715 MHz	1732.5 MHz	1750 MHz
LTE Band 4	10	QPSK	1	0	0	21.51	21.07	21.32
			1	25	0	21.44	20.96	21.40
			1	49	0	21.23	21.01	21.31
			25	0	1	20.42	20.20	20.61
			25	12	1	20.44	20.05	20.55
			25	25	1	20.24	20.14	20.61
		16QAM	50	0	1	20.43	20.20	20.59
			1	0	1	19.92	20.01	20.27
			1	25	1	20.04	19.81	20.36
			1	49	1	19.84	19.49	20.27
			25	0	2	19.50	19.22	19.58
			25	12	2	19.42	18.96	19.52
			25	25	2	19.31	19.08	19.74
			50	0	2	19.36	19.22	19.51

LTE Band 4 Measured Results (continued)

Band	BW (MHz)	Mode	RB Allocation	RB offset	Target MPR	Avg Pwr (dBm)		
						19975	20175	20375
						1712.5 MHz	1732.5 MHz	1752.5 MHz
LTE Band 4	5	QPSK	1	0	0	21.27	20.93	21.39
			1	12	0	21.59	21.14	21.60
			1	24	0	21.60	21.00	21.42
			12	0	1	20.36	20.20	20.53
			12	7	1	20.53	20.13	20.52
			12	13	1	20.46	20.04	20.55
			25	0	1	20.47	20.10	20.54
		16QAM	1	0	1	20.39	20.06	20.14
			1	12	1	20.08	19.92	20.37
			1	24	1	20.16	19.61	20.02
			12	0	2	19.30	19.06	19.37
			12	7	2	19.40	19.06	19.42
			12	13	2	19.39	19.05	19.35
			25	0	2	19.53	19.24	19.40
Band	BW (MHz)	Mode	RB Allocation	RB offset	Target MPR	Avg Pwr (dBm)		
						19965	20175	20385
						1711.5 MHz	1732.5 MHz	1753.5 MHz
LTE Band 4	3	QPSK	1	0	0	21.32	21.10	21.46
			1	8	0	21.52	21.26	21.50
			1	14	0	21.46	21.13	21.42
			8	0	1	20.47	20.04	20.59
			8	4	1	20.45	20.05	20.58
			8	7	1	20.35	20.02	20.59
			15	0	1	20.48	20.04	20.53
		16QAM	1	0	1	20.57	20.04	20.42
			1	8	1	20.58	20.08	20.50
			1	14	1	20.24	19.88	20.58
			8	0	2	19.40	18.81	19.57
			8	4	2	19.36	18.79	19.59
			8	7	2	19.39	18.79	19.52
			15	0	2	19.37	19.04	19.30
Band	BW (MHz)	Mode	RB Allocation	RB offset	Target MPR	Avg Pwr (dBm)		
						19957	20175	20393
						1710.7 MHz	1732.5 MHz	1754.3 MHz
LTE Band 4	1.4	QPSK	1	0	0	21.52	20.81	21.42
			1	3	0	21.63	20.96	21.69
			1	5	0	21.41	20.88	21.46
			3	0	0	21.58	20.98	21.58
			3	1	0	21.47	21.07	21.62
			3	3	0	21.47	21.08	21.63
			6	0	1	20.47	20.14	20.69
		16QAM	1	0	1	20.37	19.86	20.42
			1	3	1	20.37	19.71	20.60
			1	5	1	20.22	19.52	20.56
			3	0	1	20.52	19.80	20.40
			3	1	1	20.37	19.83	20.37
			3	3	1	20.47	19.77	20.45
			6	0	2	19.56	18.82	19.74

LTE Band 2 Measured Results

Band	BW (MHz)	Mode	RB Allocation	RB offset	Target MPR	Avg Pwr [dBm]		
						Max. Power		
						1860 MHz	1880 MHz	1900 MHz
LTE Band 2	20	QPSK	1	0	0	22.66	22.90	22.82
			1	49	0	22.25	23.00	22.84
			1	99	0	22.40	22.96	22.39
			50	0	1	21.61	21.69	21.72
			50	24	1	21.73	21.74	21.59
			50	50	1	21.78	21.73	21.68
		16QAM	100	0	1	21.70	21.84	21.59
			1	0	1	21.43	21.45	21.46
			1	49	1	21.47	21.53	21.24
			1	99	1	21.48	21.28	20.81
			50	0	2	20.65	20.81	20.70
			50	24	2	20.79	20.80	20.74
			50	50	2	20.85	20.69	20.65
			100	0	2	20.75	20.79	20.67
Band	BW (MHz)	Mode	RB Allocation	RB offset	Target MPR	Avg Pwr [dBm]		
						Max. Power		
						1857.5 MHz	1880 MHz	1902.5 MHz
LTE Band 2	15	QPSK	1	0	0	22.78	22.64	22.83
			1	37	0	22.78	22.78	22.68
			1	74	0	22.73	22.81	22.52
			36	0	1	21.66	21.72	21.61
			36	20	1	21.66	21.74	21.62
			36	39	1	21.71	21.62	21.60
		16QAM	75	0	1	21.58	21.69	21.58
			1	0	1	21.71	21.16	22.00
			1	37	1	21.97	21.20	22.00
			1	74	1	22.00	21.42	22.00
			36	0	2	20.56	20.75	20.72
			36	20	2	20.68	20.75	20.74
			36	39	2	20.64	20.64	20.65
			75	0	2	20.69	20.78	20.64
Band	BW (MHz)	Mode	RB Allocation	RB offset	Target MPR	Avg Pwr [dBm]		
						Max. Power		
						1855 MHz	1880 MHz	1905 MHz
LTE Band 2	10	QPSK	1	0	0	22.87	22.68	22.61
			1	25	0	22.72	22.64	23.00
			1	49	0	22.51	22.54	22.70
			25	0	1	21.57	21.75	21.65
			25	12	1	21.68	21.69	21.66
			25	25	1	21.65	21.73	21.66
		16QAM	50	0	1	21.58	21.77	21.66
			1	0	1	21.75	21.50	21.63
			1	25	1	21.79	21.56	21.81
			1	49	1	21.32	21.40	21.39
			25	0	2	20.41	20.85	20.79
			25	12	2	20.44	20.86	20.81
			25	25	2	20.61	20.64	20.98
			50	0	2	20.63	20.76	20.77

LTE Band 2 Measured Results (continued)

Band	BW (MHz)	Mode	RB Allocation	RB offset	Target MPR	Avg Pwr [dBm]		
						Max. Power		
						1852.5 MHz	1880 MHz	1907.5 MHz
LTE Band 2	5	QPSK	1	0	0	22.52	22.57	22.74
			1	12	0	22.74	22.79	22.75
			1	24	0	22.44	22.62	22.58
			12	0	1	21.65	21.79	21.66
			12	7	1	21.70	21.78	21.65
			12	13	1	21.63	21.76	21.49
			25	0	1	21.67	21.75	21.57
		16QAM	1	0	1	21.19	21.69	21.12
			1	12	1	21.39	21.81	21.09
			1	24	1	21.06	21.02	21.10
			12	0	2	20.54	20.80	20.68
			12	7	2	20.50	20.80	20.70
			12	13	2	20.64	20.73	20.64
			25	0	2	20.83	20.82	20.59
			Band	BW (MHz)	Mode	RB Allocation	RB offset	Target MPR
Max. Power								
1851.5 MHz	1880 MHz	1908.5 MHz						
LTE Band 2	3	QPSK	1	0	0	22.47	22.66	22.73
			1	8	0	22.68	22.94	22.69
			1	14	0	22.42	22.93	22.58
			8	0	1	21.62	21.80	21.56
			8	4	1	21.72	21.79	21.65
			8	7	1	21.62	21.78	21.66
			15	0	1	21.65	21.70	21.64
		16QAM	1	0	1	21.94	21.45	21.79
			1	8	1	21.77	21.53	21.63
			1	14	1	21.38	21.56	21.43
			8	0	2	20.41	20.39	20.69
			8	4	2	20.43	20.47	20.74
			8	7	2	20.36	20.46	20.84
			15	0	2	20.62	20.70	20.77
			Band	BW (MHz)	Mode	RB Allocation	RB offset	Target MPR
18607	18900	19193						
1850.7 MHz	1880 MHz	1909.3 MHz						
LTE Band 2	1.4	QPSK	1	0	0	22.61	22.44	22.51
			1	3	0	22.53	22.51	22.81
			1	5	0	22.79	22.56	22.62
			3	0	0	22.45	22.62	22.76
			3	1	0	22.67	22.69	22.74
			3	3	0	22.48	22.75	22.79
			6	0	1	21.63	21.69	21.52
		16QAM	1	0	1	21.88	21.37	21.57
			1	3	1	22.00	21.41	21.67
			1	5	1	21.98	21.38	21.53
			3	0	1	21.90	21.35	21.73
			3	1	1	21.58	21.29	21.71
			3	3	1	21.36	21.37	21.52
			6	0	2	20.83	20.53	20.74

9. PEAK TO AVERAGE RATIO

Test Procedure

Per KDB 971168 D01 Power Meas License Digital Systems v02r02;

The transmitter output was connected to a CMW500 Test Set and configured to operate at maximum power. The PAR were measured on the Spectrum Analyzer.

Test Spec

In addition, when the transmitter power is measured in terms of average value, the peak-to-average ratio of the power shall not exceed 13 dB.

9.1. CONDUCTED PEAK TO AVERAGE RESULT

GSM

Band	Channel	f [MHz]	Mode	Ratio [dB]	Limit [dB]
GSM850	190	836.6	GPRS	2.73	13.00
			EGPRS	5.69	
GSM1900	661	1880.0	GPRS	2.72	
			EGPRS	5.53	

WCDMA

Band	Channel	f [MHz]	Mode	Ratio [dB]	Limit [dB]
Band 5	4183	836.6	REL99	2.82	13.00
			HSDPA	2.92	
Band 4	1413	1732.6	REL99	3.02	
			HSDPA	3.12	
Band 2	9400	1880.0	REL99	2.61	
			HSDPA	3.03	

LTE

Band	BW [MHz]	Channel	f [MHz]	Mode	Ratio [dB]	Limit [dB]
Band 17	10	23790	710	QPSK	4.08	13.00
				16QAM	4.76	
	5			QPSK	4.11	
				16QAM	4.88	
Band 5	10	20525	836.5	QPSK	4.23	
				16QAM	4.89	
	5			QPSK	4.27	
				16QAM	5.14	
	3			QPSK	4.21	
				16QAM	4.95	
	1.4			QPSK	4.22	
				16QAM	5.18	
Band 4	20	20174	1732.5	QPSK	4.28	
				16QAM	4.99	
	15			QPSK	4.28	
				16QAM	5.05	
	10			QPSK	4.3	
				16QAM	4.97	
	5			QPSK	4.3	
				16QAM	5.16	
	3			QPSK	4.31	
				16QAM	5.03	
1.4	QPSK	4.28				
	16QAM	5.02				
Band 2	20	18900	1880.0	QPSK	4.04	
				16QAM	4.77	
	15			QPSK	4.07	
				16QAM	4.79	
	10			QPSK	4.06	
				16QAM	4.84	
	5			QPSK	4.00	
				16QAM	4.83	
	3			QPSK	4.08	
				16QAM	4.62	
1.4	QPSK	3.98				
	16QAM	4.69				

9.2. CONDUCTED PEAK TO AVERAGE PLOTS

GSM

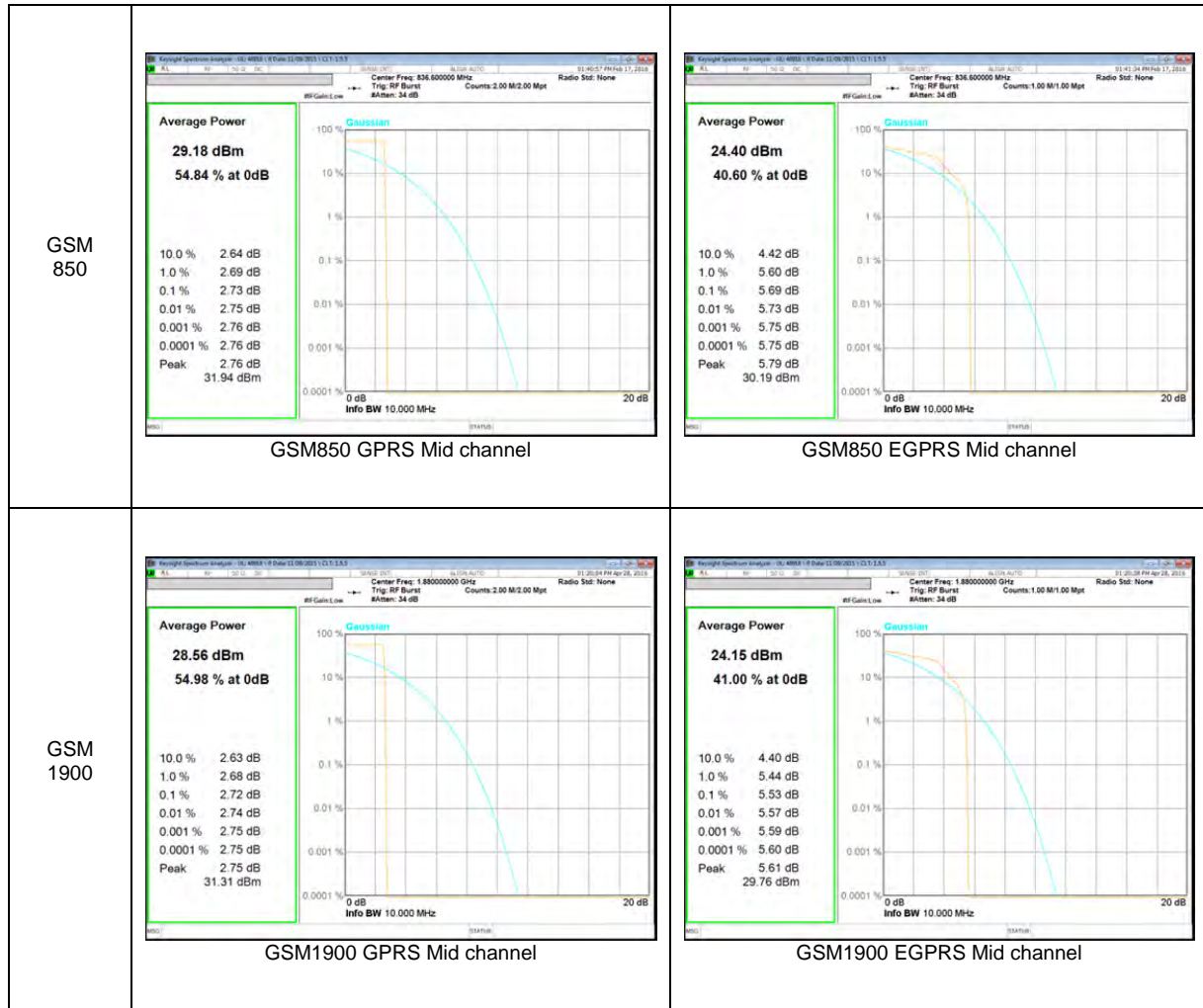

WCDMA

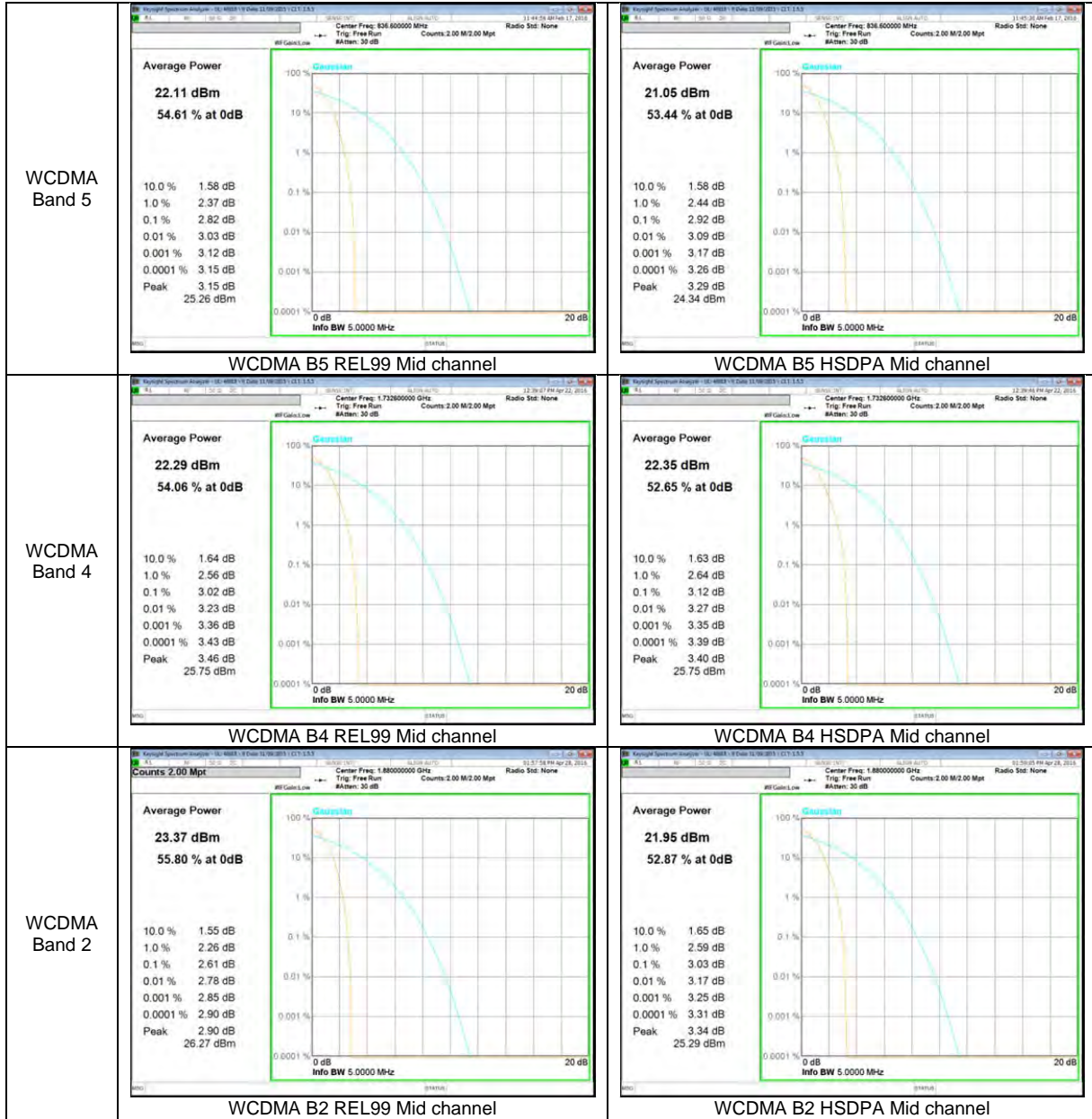

LTE Band 17

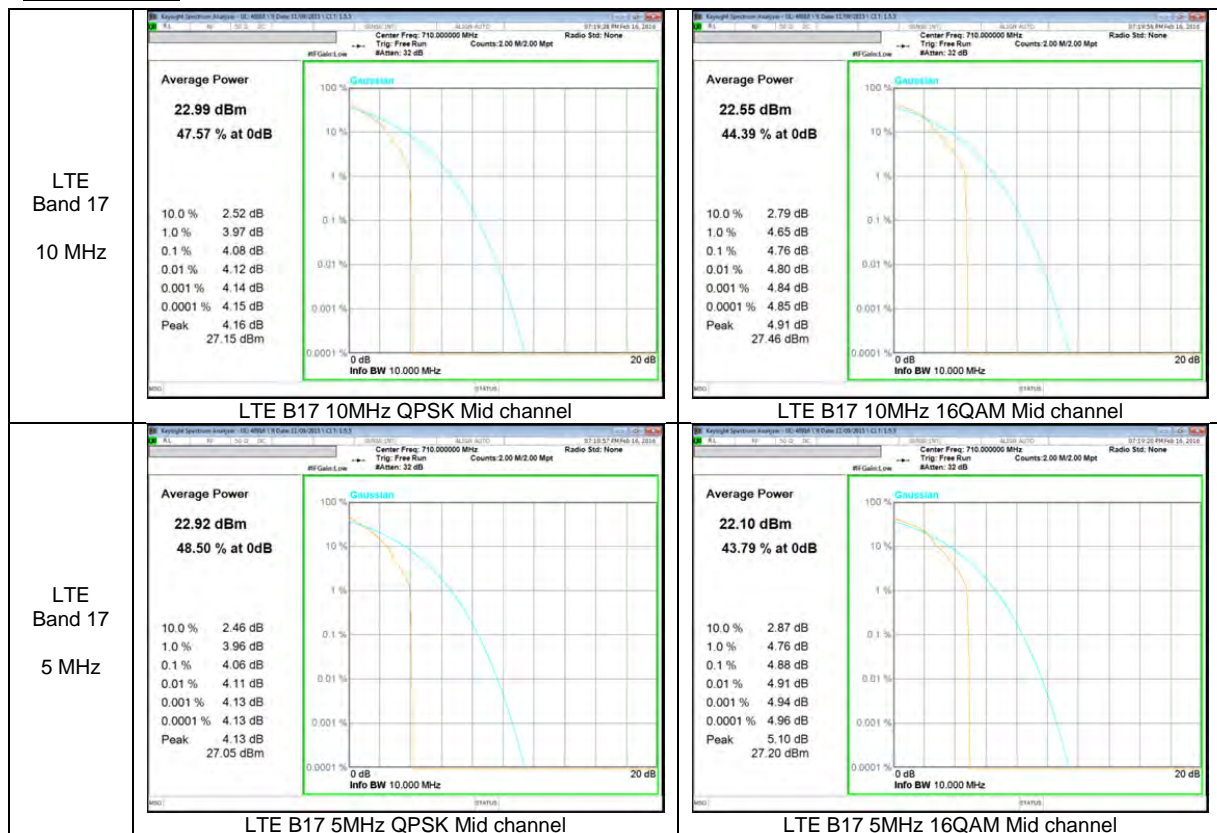

LTE Band 5

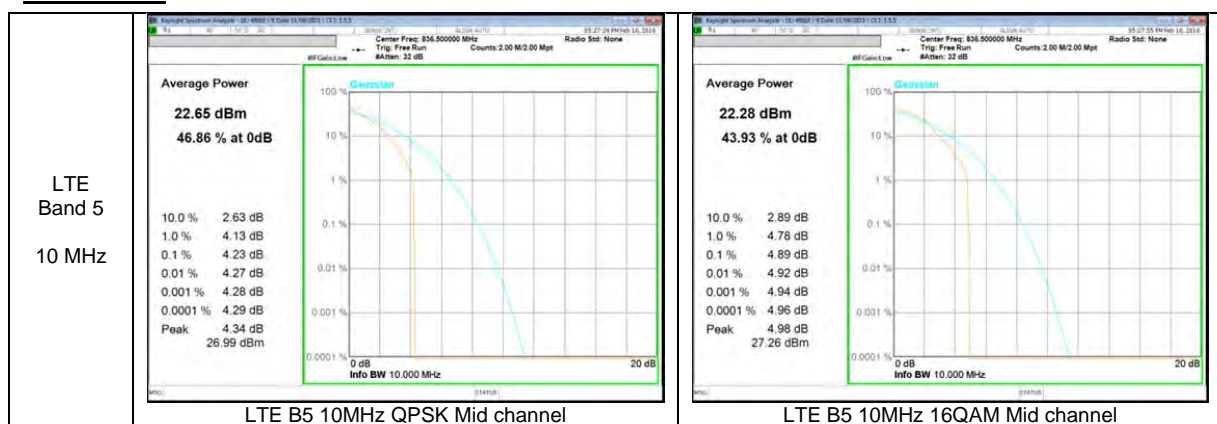

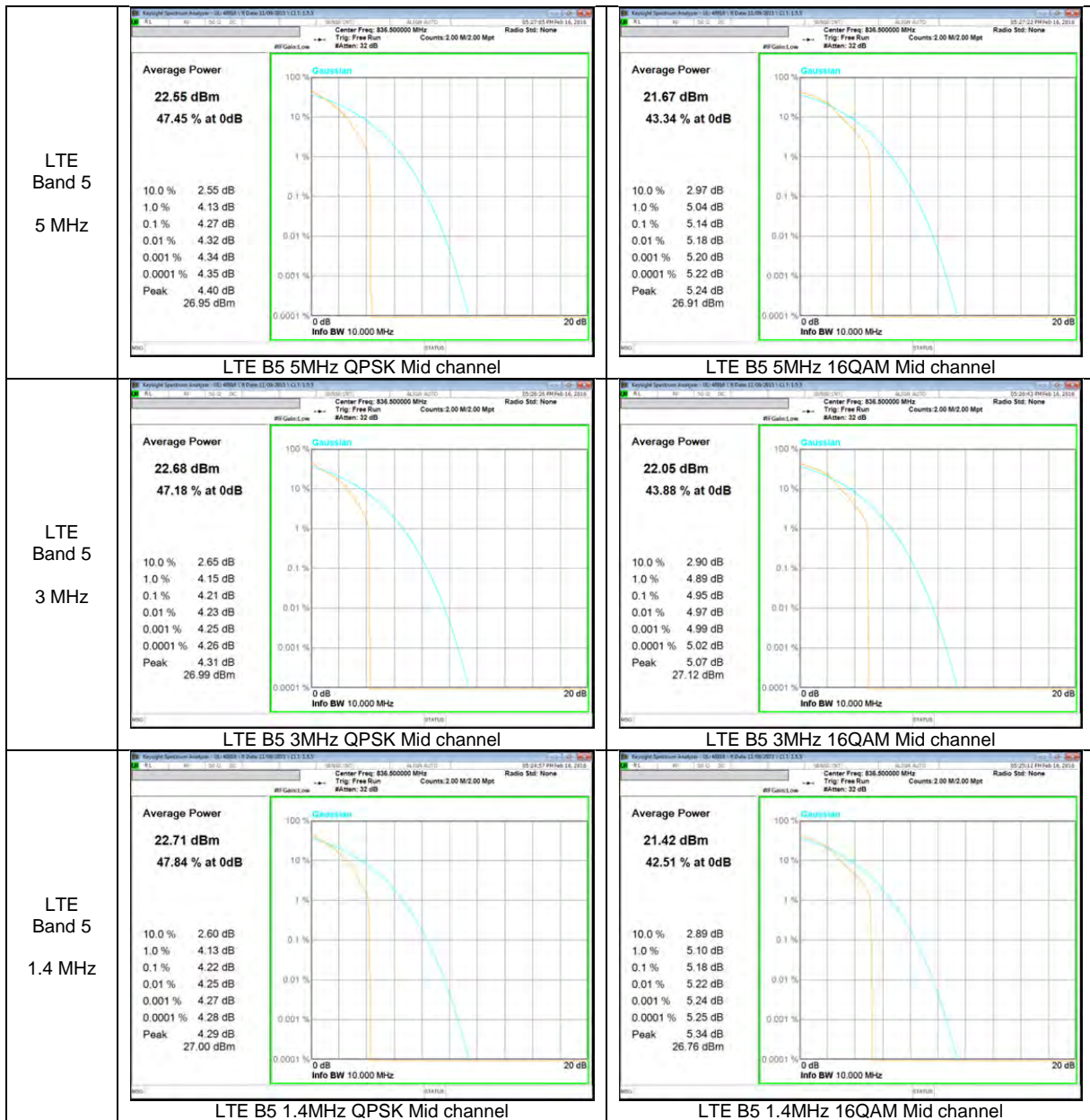

LTE Band 4

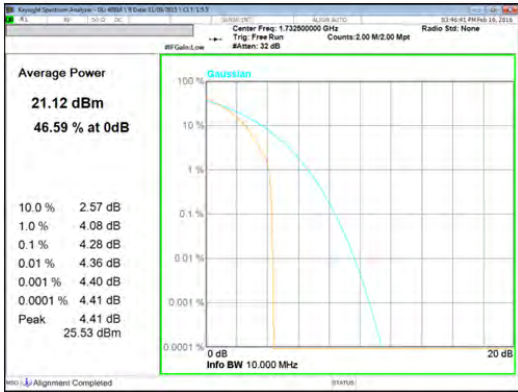
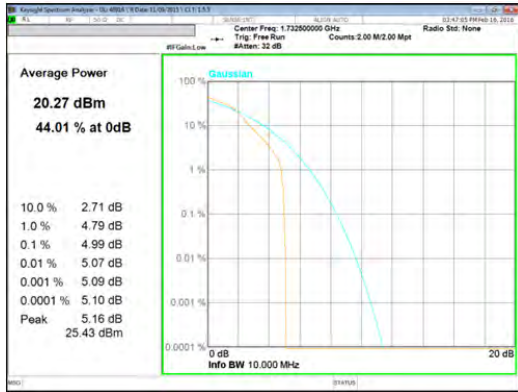
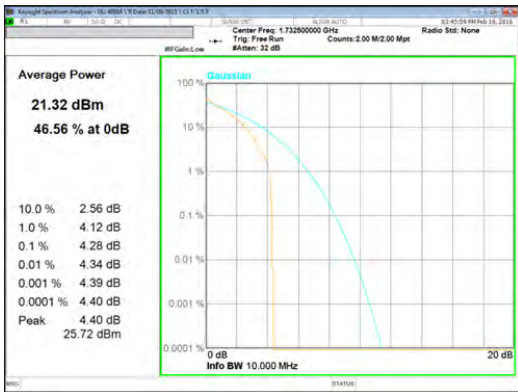
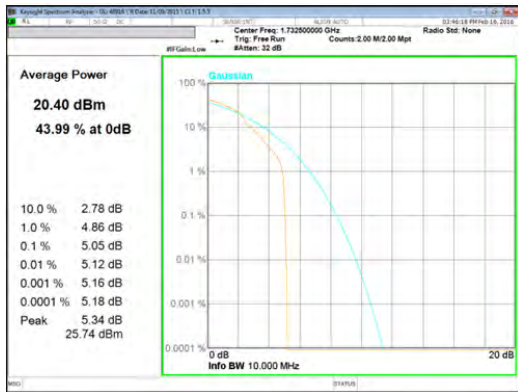
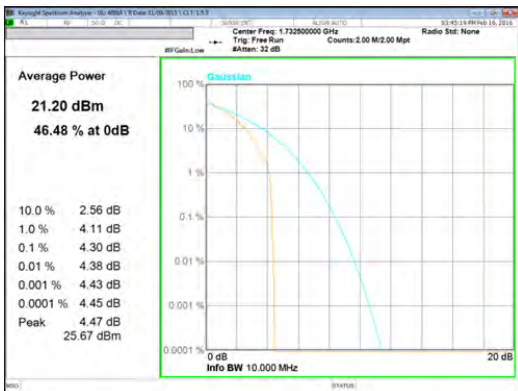
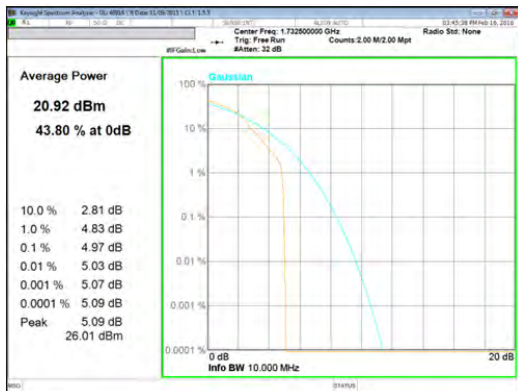
<p>LTE Band 4 20 MHz</p>	 <p>LTE B4 20MHz QPSK Mid channel</p>	 <p>LTE B4 20MHz 16QAM Mid channel</p>
<p>LTE Band 4 15 MHz</p>	 <p>LTE B4 15MHz QPSK Mid channel</p>	 <p>LTE B4 15MHz 16QAM Mid channel</p>
<p>LTE Band 4 10 MHz</p>	 <p>LTE B4 10MHz QPSK Mid channel</p>	 <p>LTE B4 10MHz 16QAM Mid channel</p>

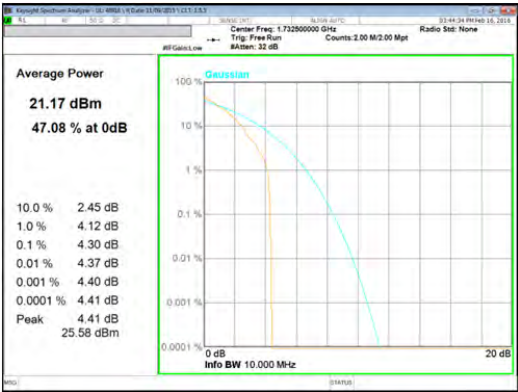
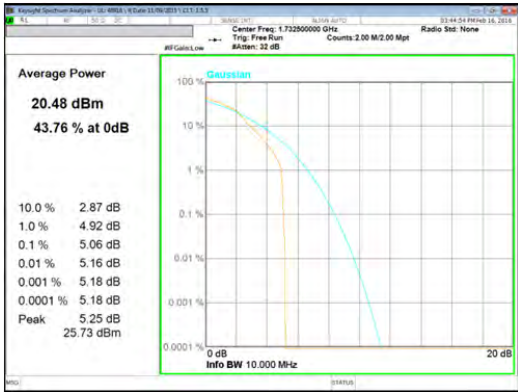
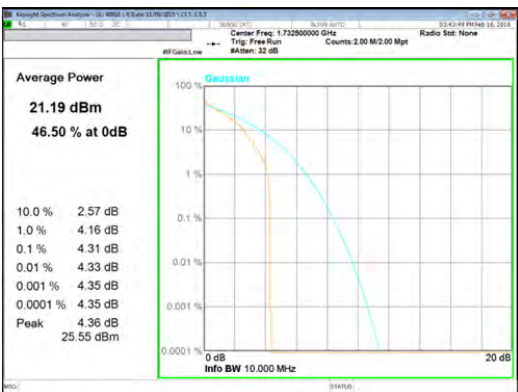
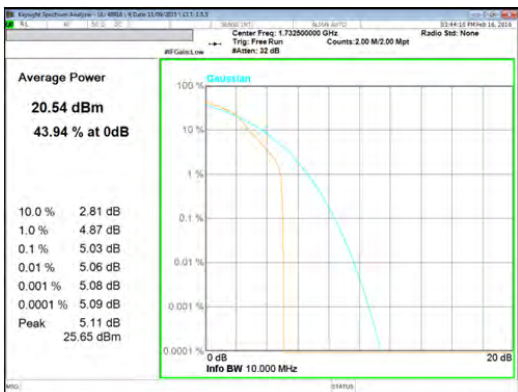
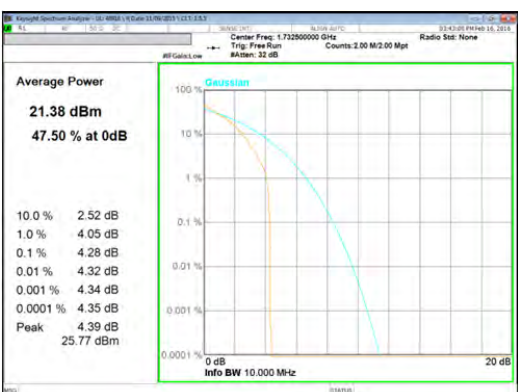
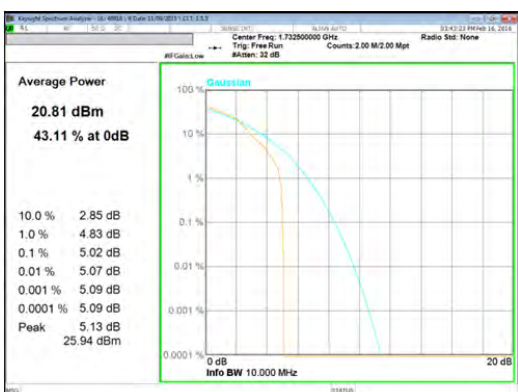
<p>LTE Band 4 5 MHz</p>	 <p>LTE B4 5MHz QPSK Mid channel</p>	 <p>LTE B4 5MHz 16QAM Mid channel</p>
<p>LTE Band 4 3 MHz</p>	 <p>LTE B4 3MHz QPSK Mid channel</p>	 <p>LTE B4 3MHz 16QAM Mid channel</p>
<p>LTE Band 4 1.4 MHz</p>	 <p>LTE B4 1.4MHz QPSK Mid channel</p>	 <p>LTE B4 1.4MHz 16QAM Mid channel</p>

LTE Band 2

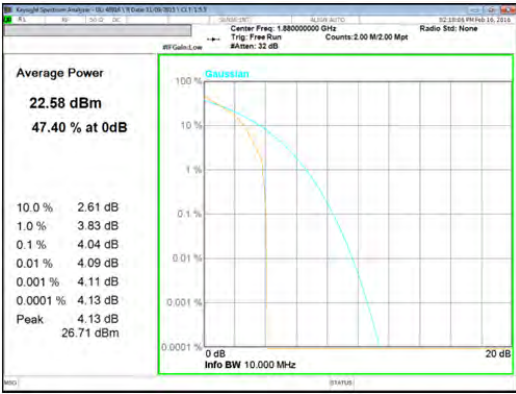
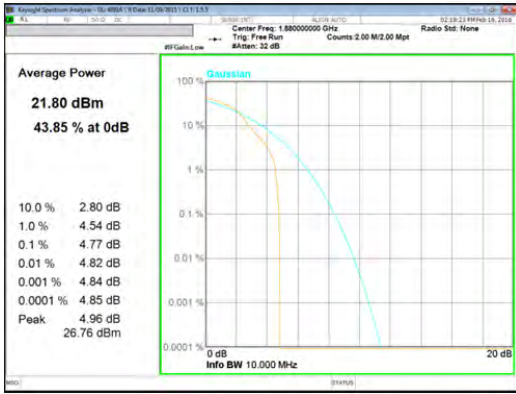
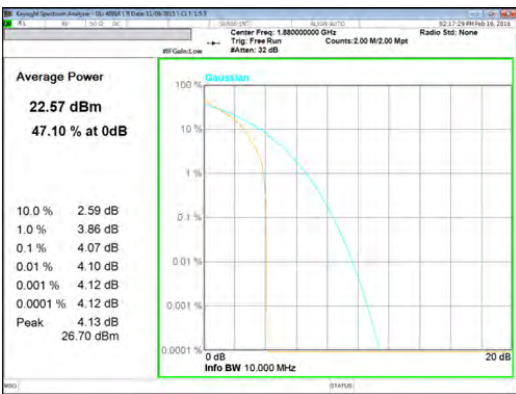
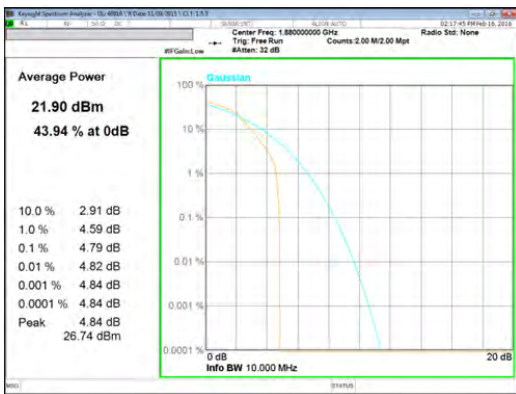
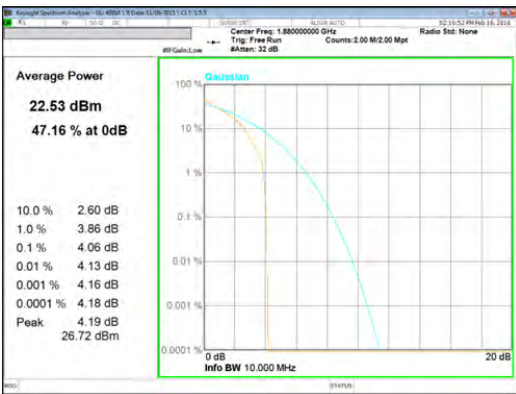
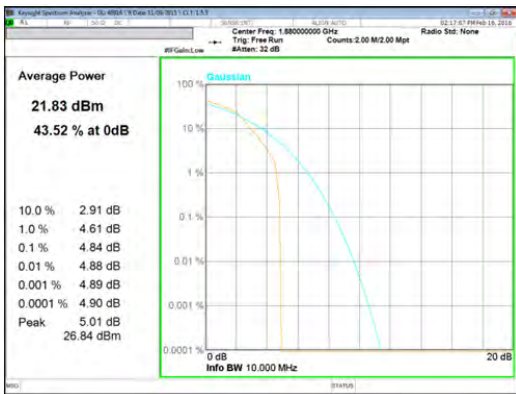
<p>LTE Band 2 20 MHz</p>	 <p>LTE B2 20MHz QPSK Mid channel</p>	 <p>LTE B2 20MHz 16QAM Mid channel</p>
<p>LTE Band 2 15 MHz</p>	 <p>LTE B2 15MHz QPSK Mid channel</p>	 <p>LTE B2 15MHz 16QAM Mid channel</p>
<p>LTE Band 2 10 MHz</p>	 <p>LTE B2 10MHz QPSK Mid channel</p>	 <p>LTE B2 10MHz 16QAM Mid channel</p>

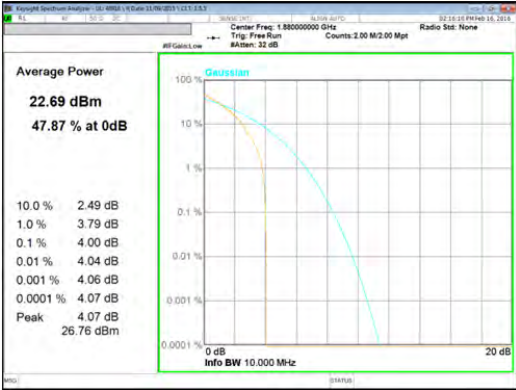
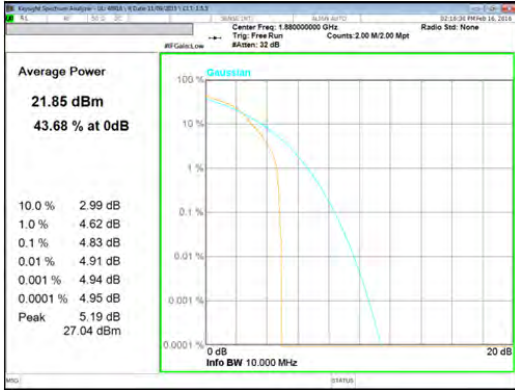
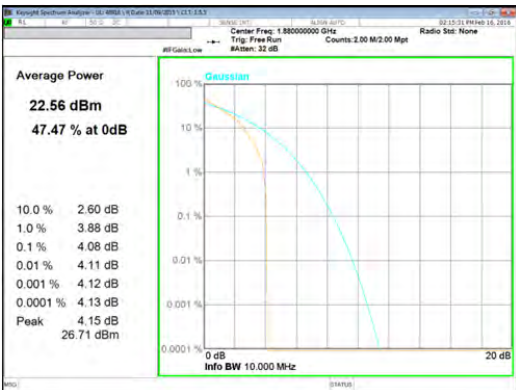
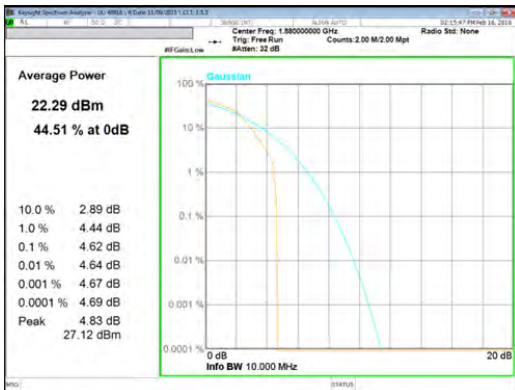
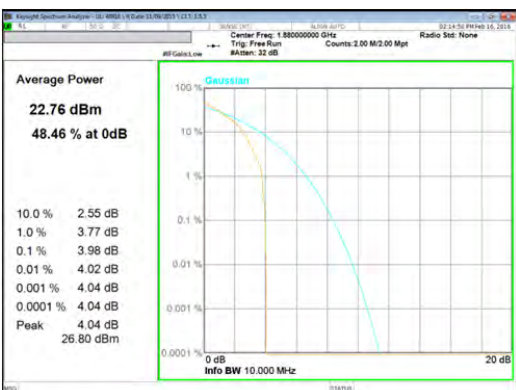
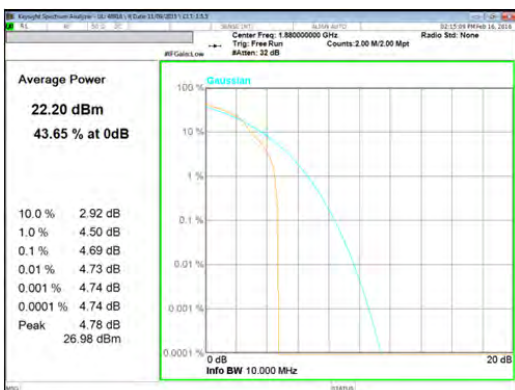
<p>LTE Band 2 5 MHz</p>	 <p>LTE B2 5MHz QPSK Mid channel</p>	 <p>LTE B2 5MHz 16QAM Mid channel</p>
<p>LTE Band 2 3 MHz</p>	 <p>LTE B2 3MHz QPSK Mid channel</p>	 <p>LTE B2 3MHz 16QAM Mid channel</p>
<p>LTE Band 2 1.4 MHz</p>	 <p>LTE B2 1.4MHz QPSK Mid channel</p>	 <p>LTE B2 1.4MHz 16QAM Mid channel</p>

10. LIMITS AND CONDUCTED RESULTS

10.1. OCCUPIED BANDWIDTH

RULE PART(S)

FCC: §2.1049

LIMITS

For reporting purposes only

TEST PROCEDURE

The transmitter output was connected to a calibrated coaxial cable and coupler, the other end of which was connected to a spectrum analyzer. The occupied bandwidth was measured with the spectrum analyzer at the low, middle and high channel in each band. The -26dB bandwidth was also measured and recorded.

(KDB 971168 D01 Power Meas License Digital Systems v02r02)

10.1.1. OCCUPIED BANDWIDTH RESULTS

GSM

Band	Mode	Channel	f [MHz]	99% BW [KHz]	26dB BW [KHz]
GSM850	GPRS	128	824.2	240.92	316.2
		190	836.6	237.09	313.3
		251	848.8	242.57	317.2
	EGPRS	128	824.2	249.10	322.5
		190	836.6	241.32	304.6
		251	848.8	247.61	301.8
GSM1900	GPRS	512	1850.2	241.66	318.7
		661	1880.0	249.87	324.4
		810	1909.8	244.49	309.2
	EGPRS	512	1850.2	242.12	305.3
		661	1880.0	240.08	304.9
		810	1909.8	242.99	303.8

WCDMA

Band	Mode	Channel	f [MHz]	99% BW [MHz]	26dB BW [MHz]
Band 5	REL99	4132	826.4	4.140	4.706
		4183	836.6	4.139	4.702
		4233	846.6	4.150	4.741
	HSDPA	4132	826.4	4.141	4.684
		4183	836.6	4.138	4.697
		4233	846.6	4.147	4.700
Band 4	REL99	1312	1712.4	4.118	4.674
		1413	1732.6	4.109	4.676
		1513	1752.6	4.118	4.680
	HSDPA	1312	1712.4	4.113	4.655
		1413	1732.6	4.118	4.645
		1513	1752.6	4.111	4.665
Band 2	REL99	9262	1852.4	4.127	4.696
		9400	1880.0	4.130	4.700
		9538	1907.6	4.130	4.729
	HSDPA	9262	1852.4	4.118	4.649
		9400	1880.0	4.111	4.652
		9538	1907.6	4.123	4.667

LTE Band 17

Band	BW [MHz]	Channel	f [MHz]	Mode	99% BW [MHz]	26dB BW [MHz]
Band 17	10	23780	709.0	QPSK	8.9362	9.748
				16QAM	8.9348	9.824
		23790	710.0	QPSK	8.9456	9.730
				16QAM	8.9334	9.758
		23799	711.0	QPSK	8.9271	9.774
				16QAM	8.9535	9.759
	5	23755	706.5	QPSK	4.4803	4.956
				16QAM	4.4861	4.964
		23790	710.0	QPSK	4.4733	4.937
				16QAM	4.4837	4.990
		23824	713.5	QPSK	4.4791	4.913
				16QAM	4.4807	4.494

LTE Band 5

Band	BW [MHz]	Channel	f [MHz]	Mode	99% BW [MHz]	26dB BW [MHz]
Band 5	10	20450	829.0	QPSK	8.9359	9.780
				16QAM	8.9308	9.790
		20524	836.5	QPSK	8.9582	9.741
				16QAM	8.9370	9.794
		20599	844.0	QPSK	8.9183	9.737
				16QAM	8.9523	9.751
	5	20425	826.5	QPSK	4.4774	4.950
				16QAM	4.4829	4.941
		20524	836.5	QPSK	4.4826	4.932
				16QAM	4.4845	4.949
		20624	846.5	QPSK	4.4735	4.936
				16QAM	4.4843	4.968
	3	20415	825.5	QPSK	2.6899	2.945
				16QAM	2.6962	2.967
		20524	836.5	QPSK	2.6929	2.976
				16QAM	2.6867	2.962
		20634	847.5	QPSK	2.6967	2.977
				16QAM	2.6905	2.971
	1.4	20407	824.7	QPSK	1.0859	1.259
				16QAM	1.0826	1.281
		20524	836.5	QPSK	1.0799	1.265
				16QAM	1.0839	1.272
		20624	848.3	QPSK	1.0844	1.284
				16QAM	1.0919	1.292

LTE Band 4

Band	BW [MHz]	Channel	f [MHz]	Mode	99% BW [MHz]	26dB BW [MHz]
Band 4	20	20050	1720.0	QPSK	17.8450	19.12
				16QAM	17.8670	19.22
		20174	1732.5	QPSK	17.8430	19.17
				16QAM	17.8330	19.19
		20299	1745.0	QPSK	17.8210	19.28
				16QAM	17.8410	19.32
	15	20025	1717.5	QPSK	13.3980	14.52
				16QAM	13.3850	14.52
		20174	1732.5	QPSK	13.3470	14.45
				16QAM	13.3730	14.50
		20324	1747.5	QPSK	13.3710	14.41
				16QAM	13.3730	14.50
	10	20000	1715.0	QPSK	8.9317	9.744
				16QAM	8.9267	9.809
		20174	1732.5	QPSK	8.9469	9.762
				16QAM	8.9353	9.781
		20349	1750.0	QPSK	8.9378	9.793
				16QAM	8.9574	9.736
	5	19975	1712.5	QPSK	4.4801	4.914
				16QAM	4.4843	4.958
		20174	1732.5	QPSK	4.4833	4.965
				16QAM	4.4882	4.937
		20374	1752.5	QPSK	4.4767	4.941
				16QAM	4.4891	4.984
	3	19965	1711.5	QPSK	2.6925	2.949
				16QAM	2.6951	2.983
		20174	1732.5	QPSK	2.6894	2.975
				16QAM	2.6913	2.979
		20384	1753.5	QPSK	2.6900	2.968
				16QAM	2.6874	2.980
	1.4	19957	1710.7	QPSK	1.0807	1.269
				16QAM	1.0844	1.287
20174		1732.5	QPSK	1.0856	1.278	
			16QAM	1.0922	1.298	
20392		1754.3	QPSK	1.0878	1.296	
			16QAM	1.0838	1.285	

LTE Band 2

Band	BW [MHz]	Channel	f [MHz]	Mode	99% BW [MHz]	26dB BW [MHz]
Band 2	20	18700	1860.0	QPSK	17.8270	19.39
				16QAM	17.8400	19.11
		18900	1880.0	QPSK	17.8540	19.12
				16QAM	17.8400	19.22
		19099	1900.0	QPSK	17.8440	19.20
				16QAM	17.8300	19.34
	15	18675	1857.5	QPSK	13.3730	14.60
				16QAM	13.3910	14.54
		18900	1880.0	QPSK	13.3770	14.46
				16QAM	13.3810	14.50
		19124	1902.5	QPSK	13.3630	14.56
				16QAM	13.3520	14.45
	10	18650	1955.0	QPSK	8.9367	9.805
				16QAM	8.9444	9.829
		18900	1880.0	QPSK	8.9541	9.710
				16QAM	8.9272	9.677
		19149	1905.0	QPSK	8.9299	9.696
				16QAM	8.9683	9.781
	5	18625	1852.5	QPSK	4.4800	4.930
				16QAM	4.4842	4.943
		18900	1880.0	QPSK	4.4840	4.974
				16QAM	4.4872	4.965
		18175	1907.5	QPSK	4.4766	4.938
				16QAM	4.4867	4.986
	3	18615	1815.5	QPSK	2.6867	2.965
				16QAM	2.6944	2.982
		18900	1880.0	QPSK	2.6849	2.987
				16QAM	2.6918	2.971
		19184	1908.5	QPSK	2.6939	2.976
				16QAM	2.6890	2.986
	1.4	18607	1850.7	QPSK	1.0844	1.291
				16QAM	1.0911	1.312
18900		1880.0	QPSK	1.0865	1.271	
			16QAM	1.0842	1.290	
19192		1909.3	QPSK	1.0811	1.280	
			16QAM	1.0865	1.322	

10.1.2. OCCUPIED BANDWIDTH PLOTS

GSM 850



GSM 1900

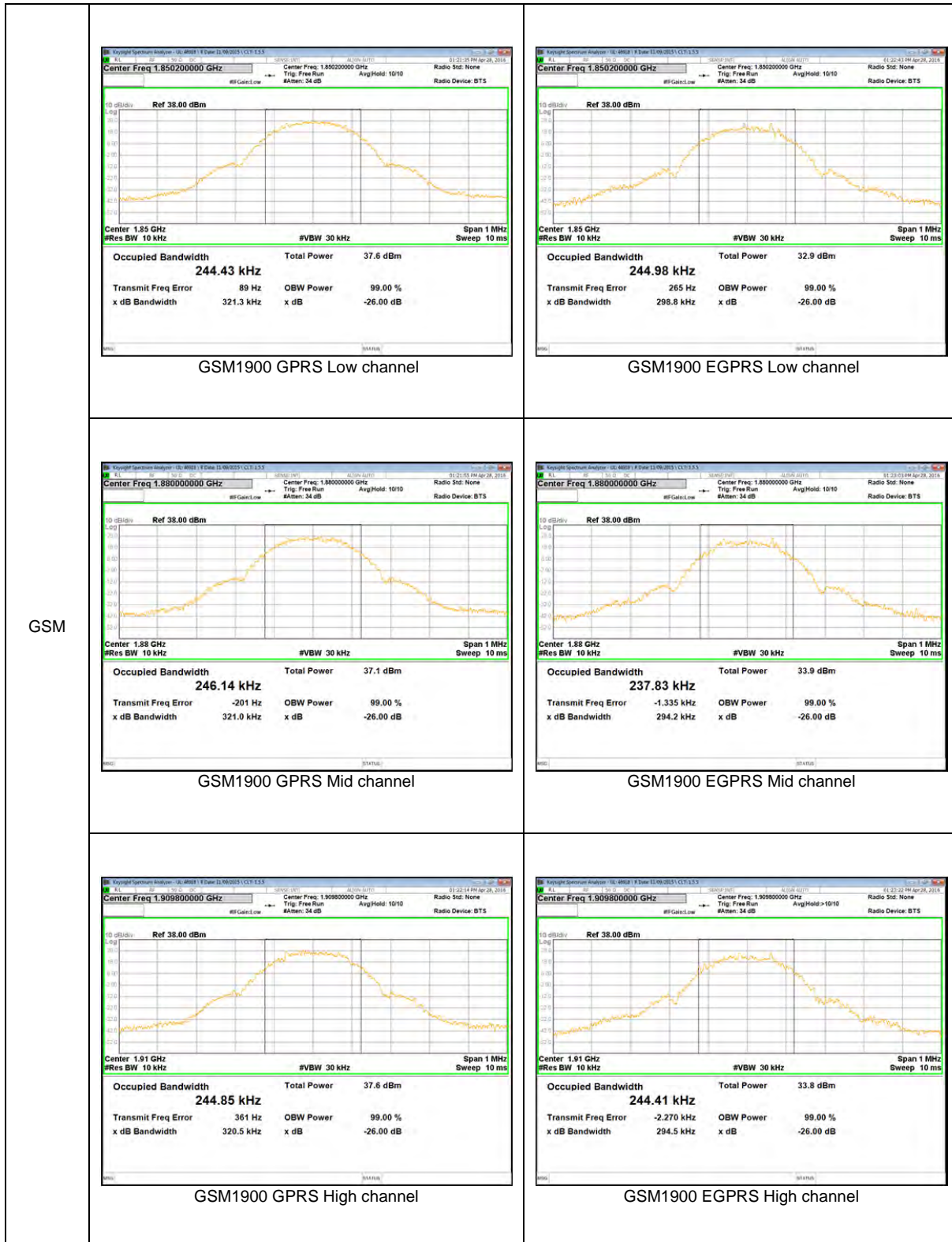

WCDMA Band 5

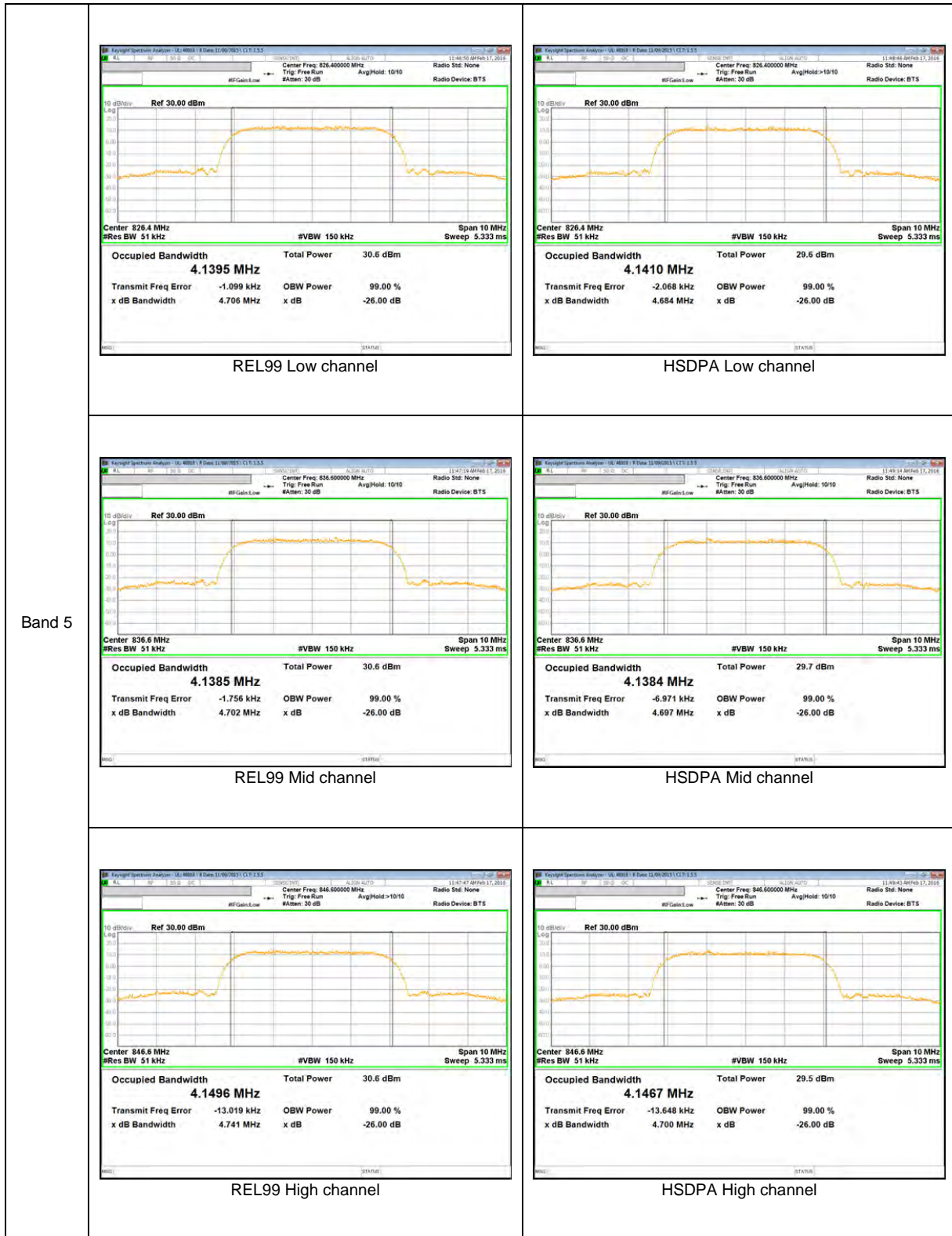

WCDMA Band 4



WCDMA Band 2

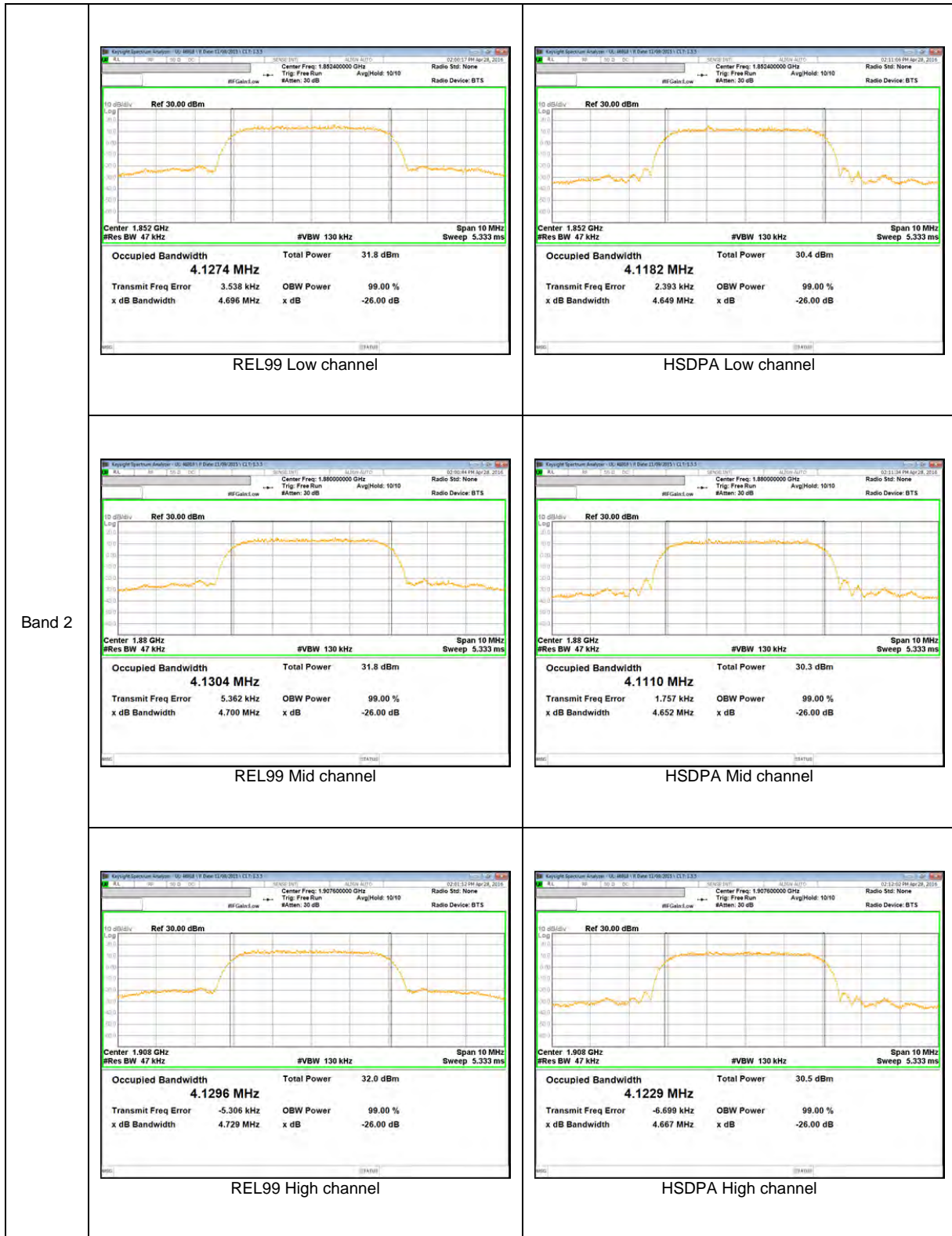

LTE Band 17

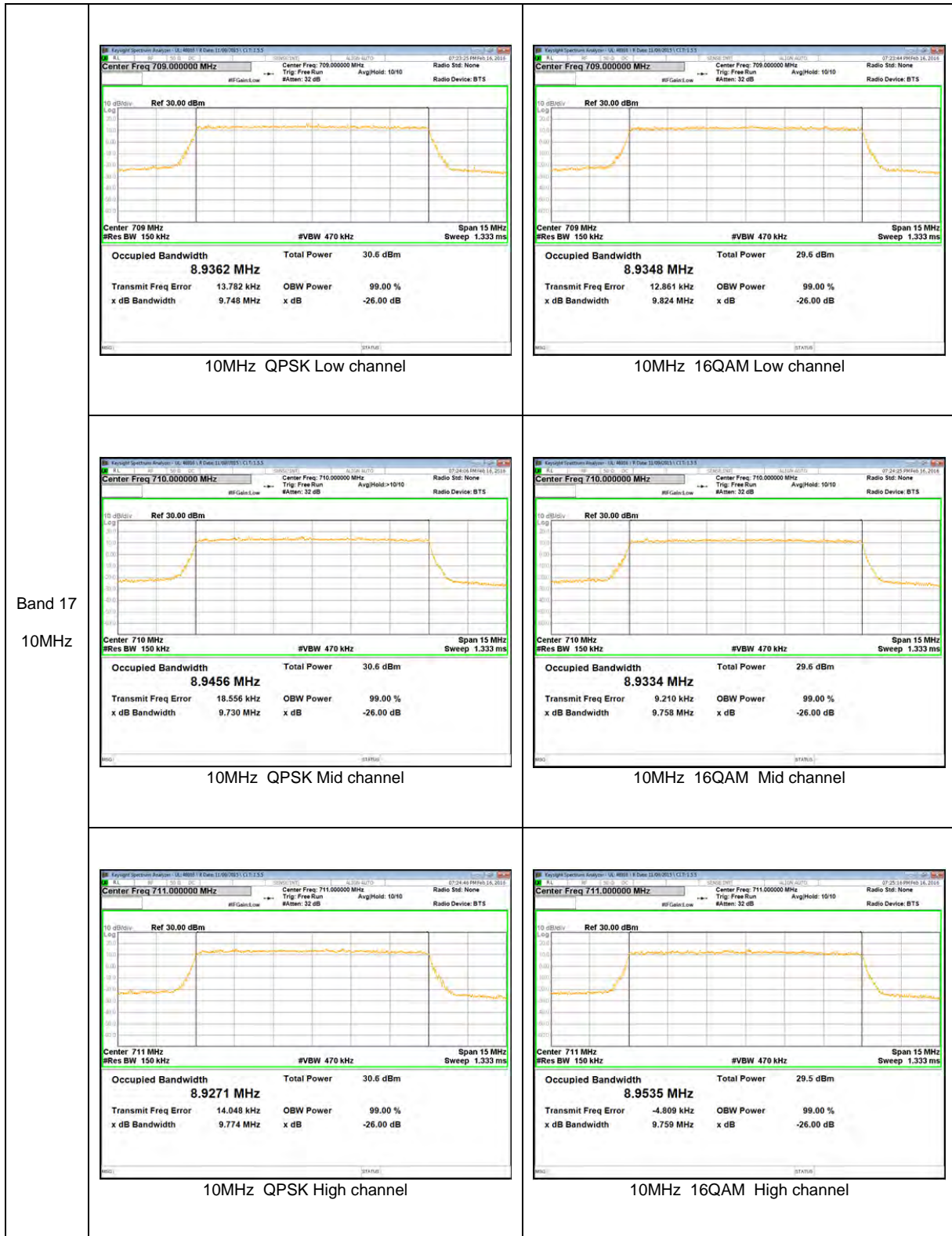



LTE Band 5

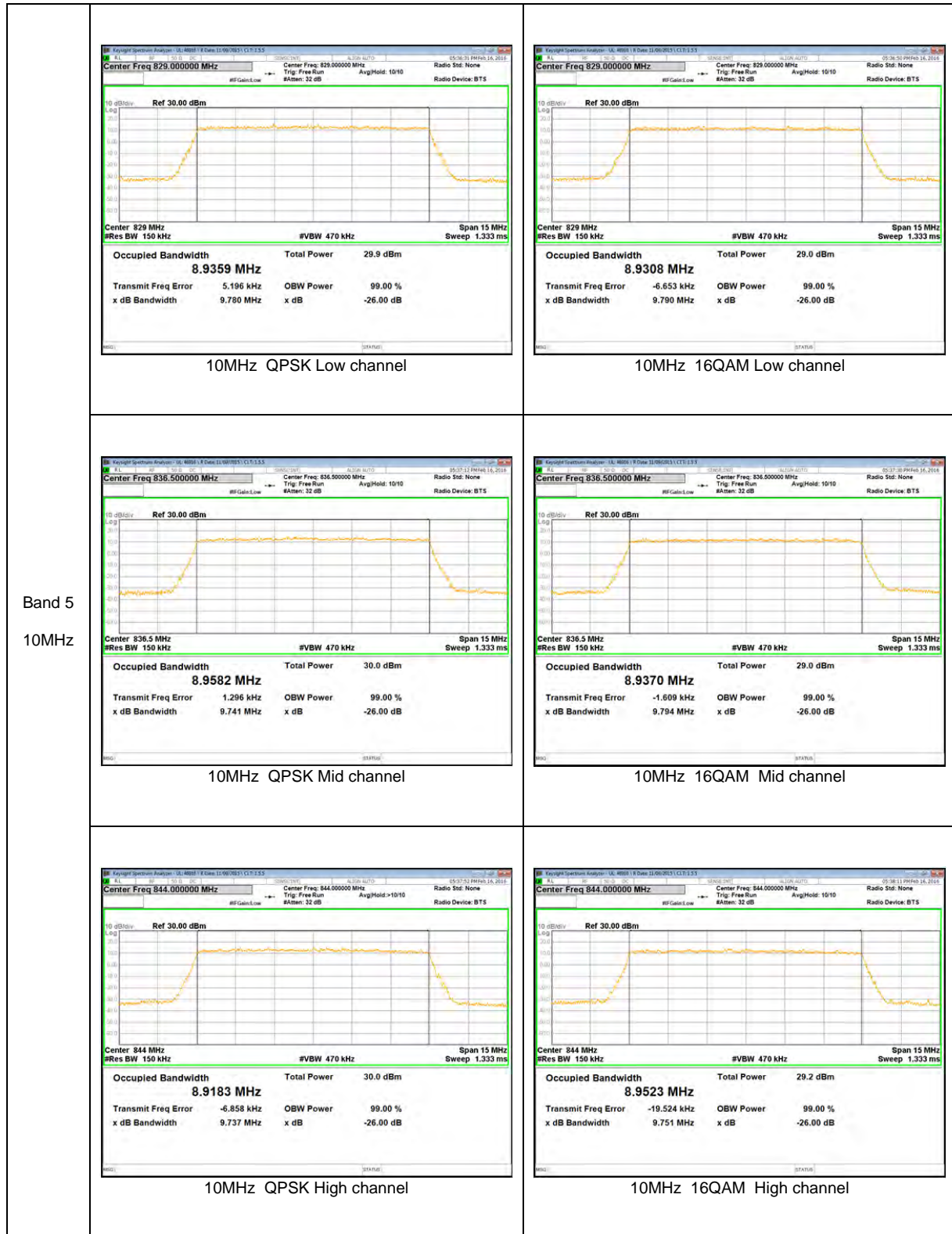

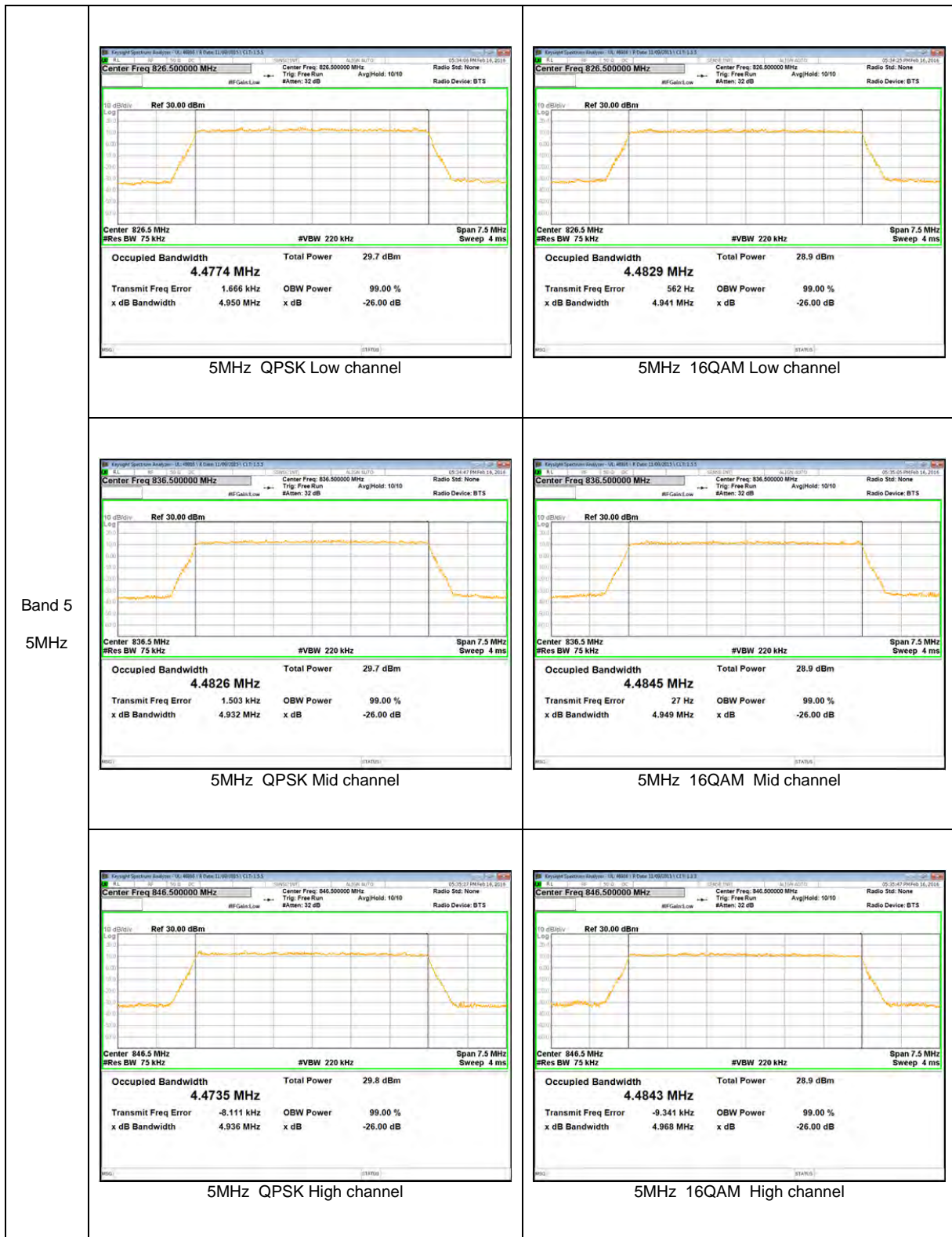

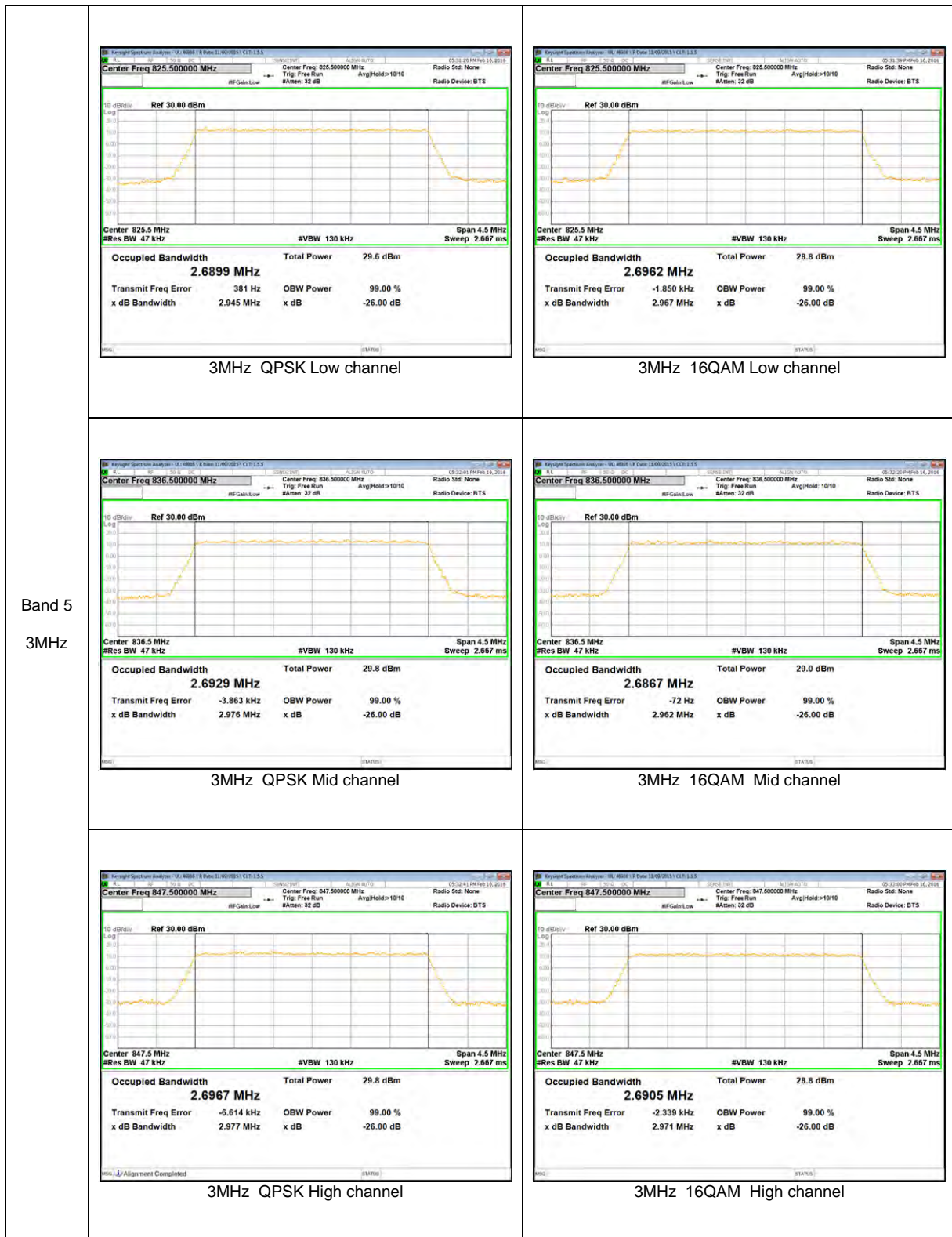

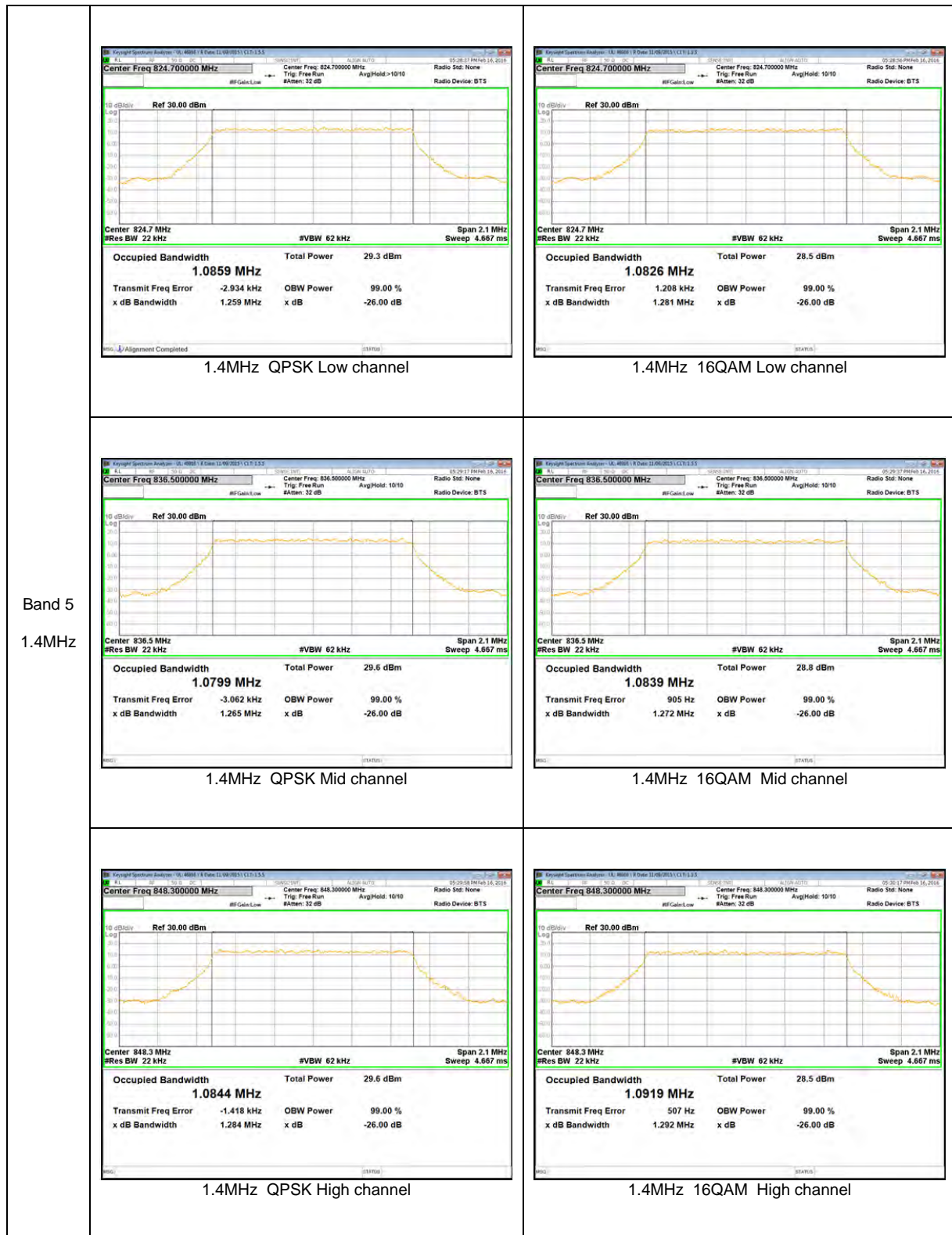

LTE Band 4

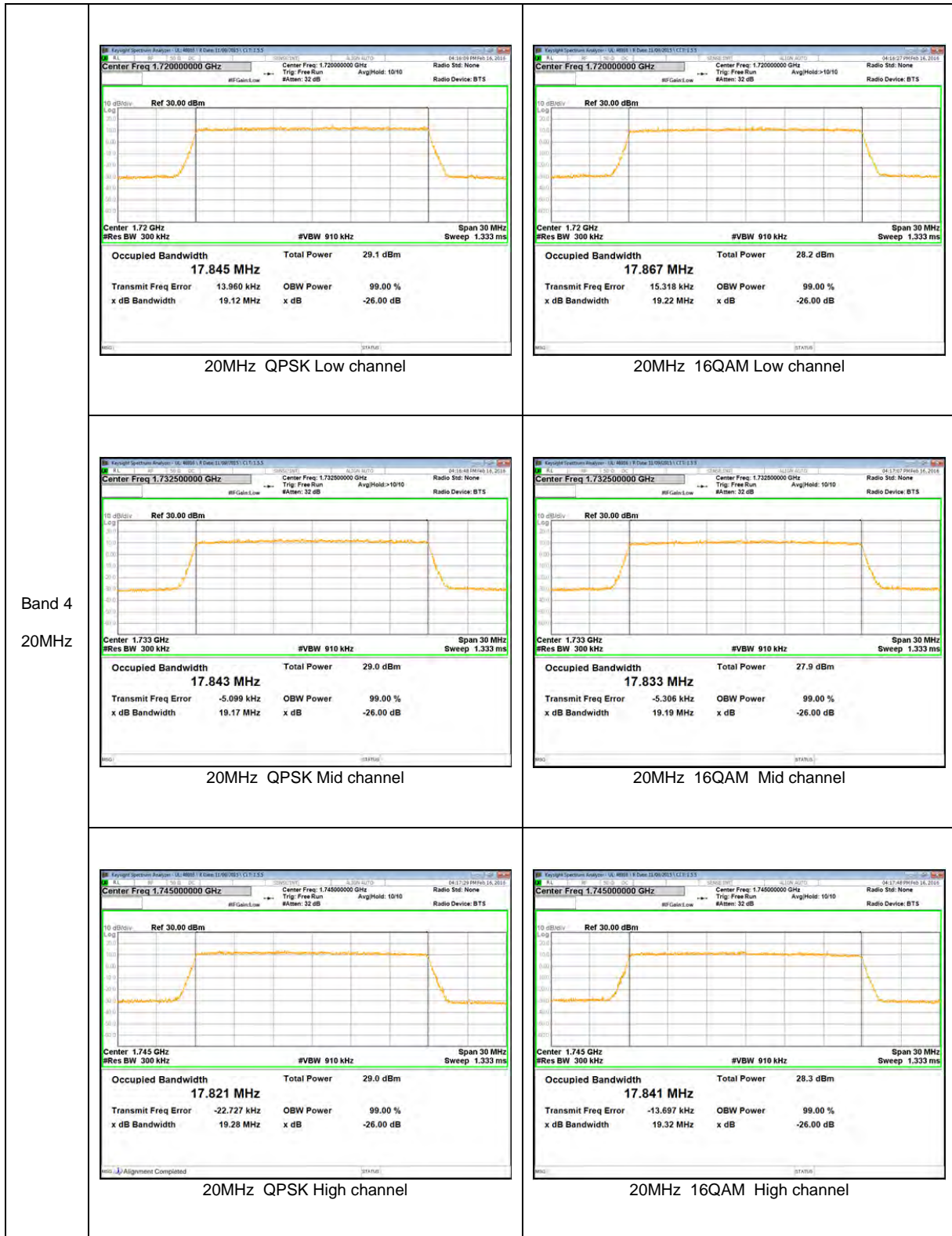

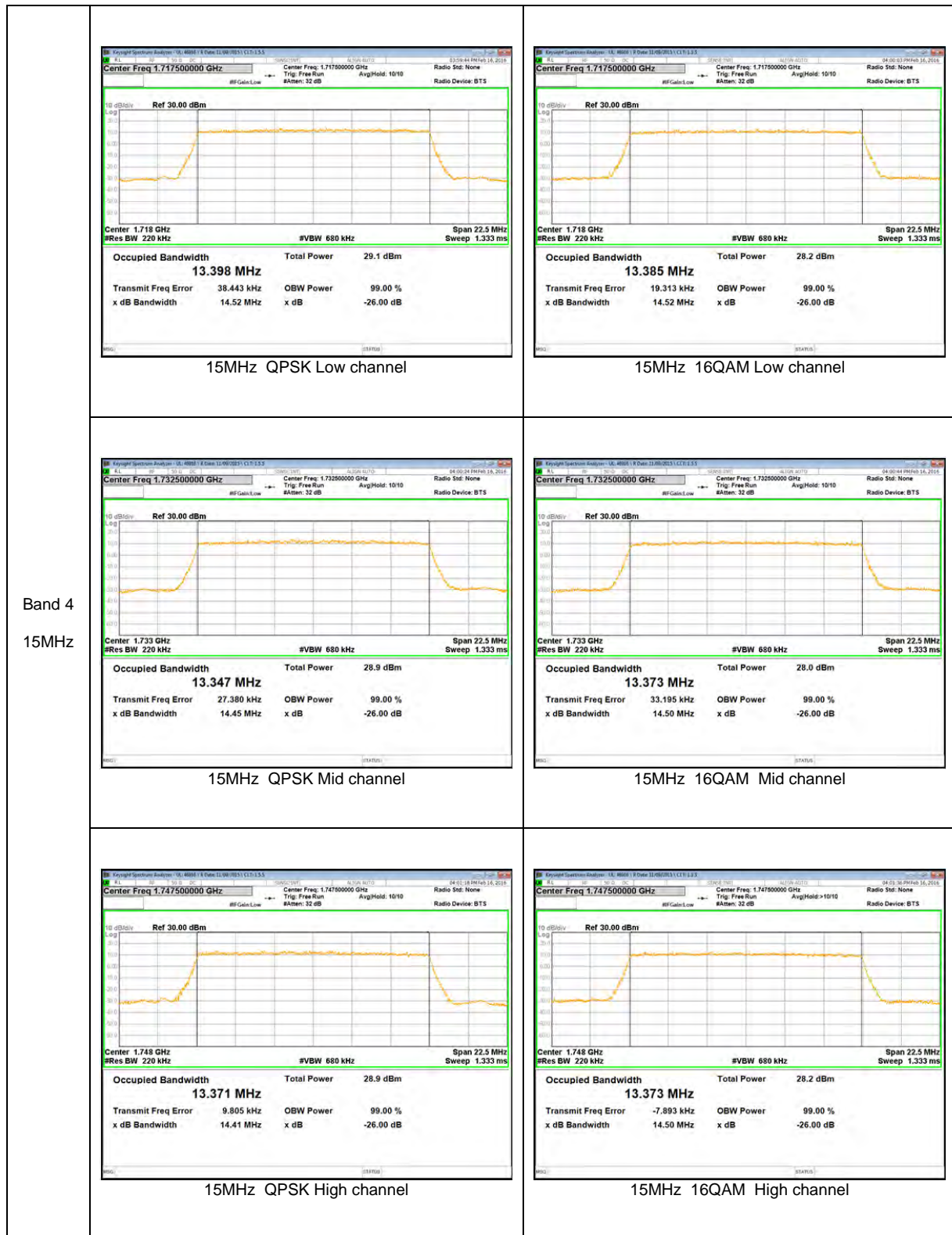

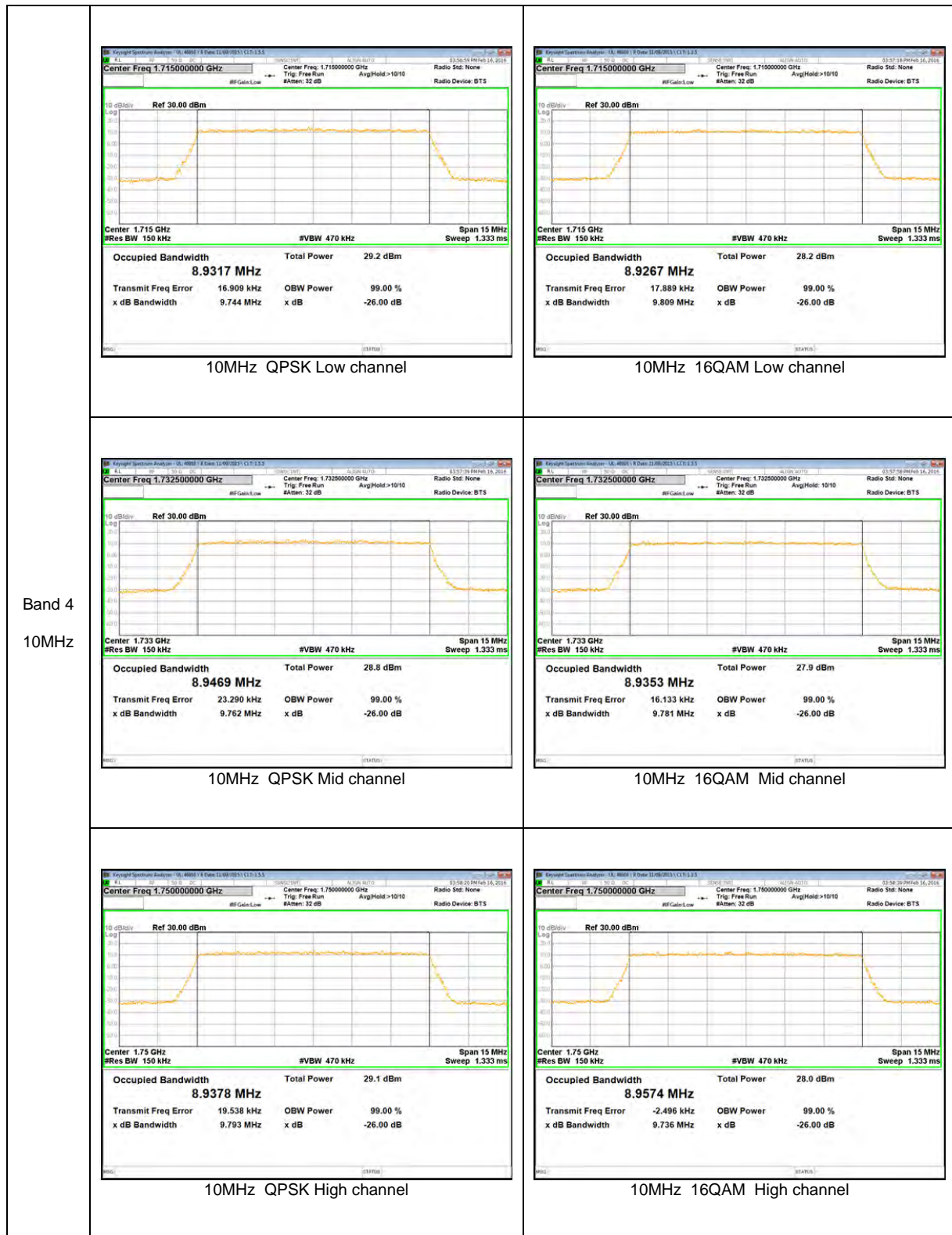

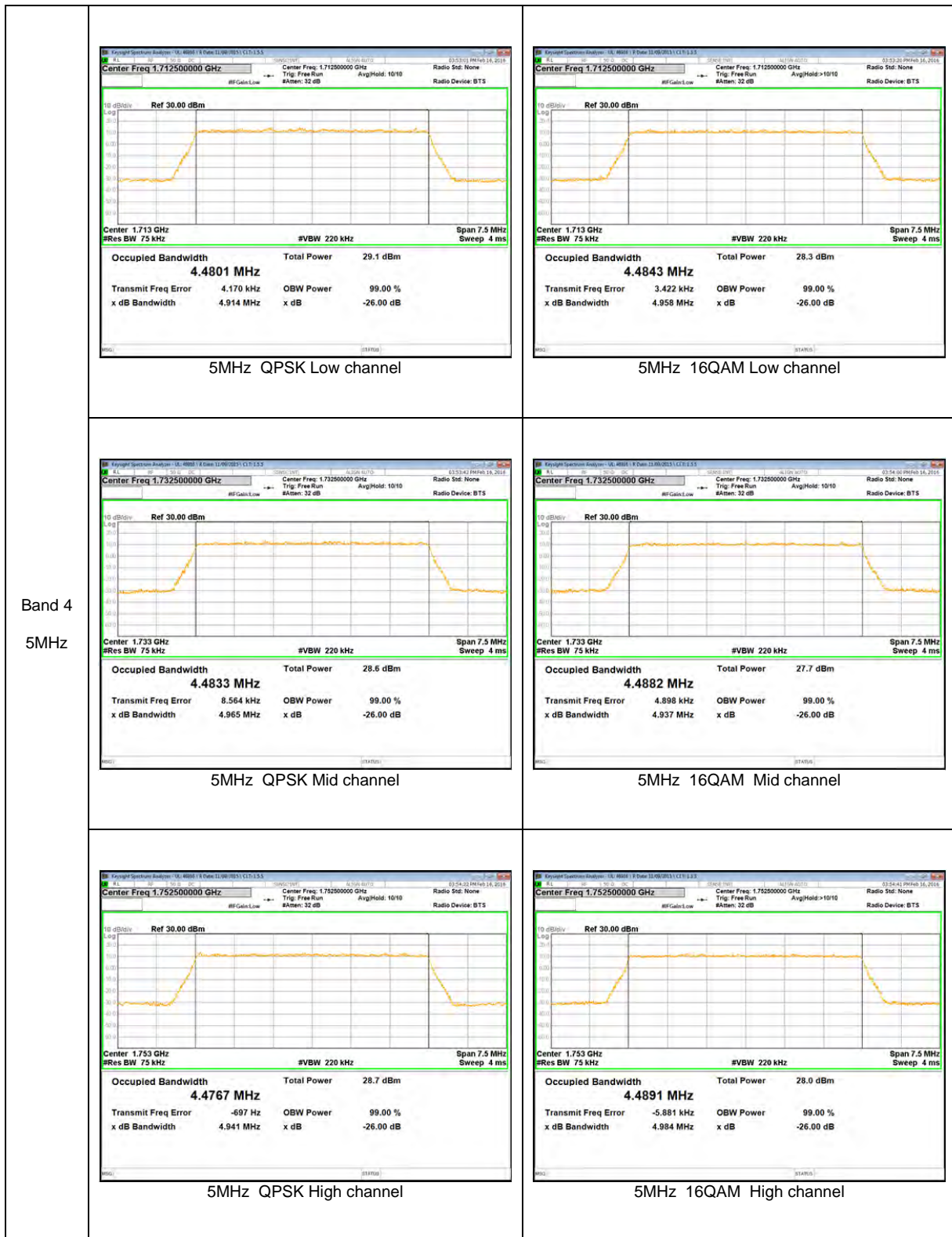

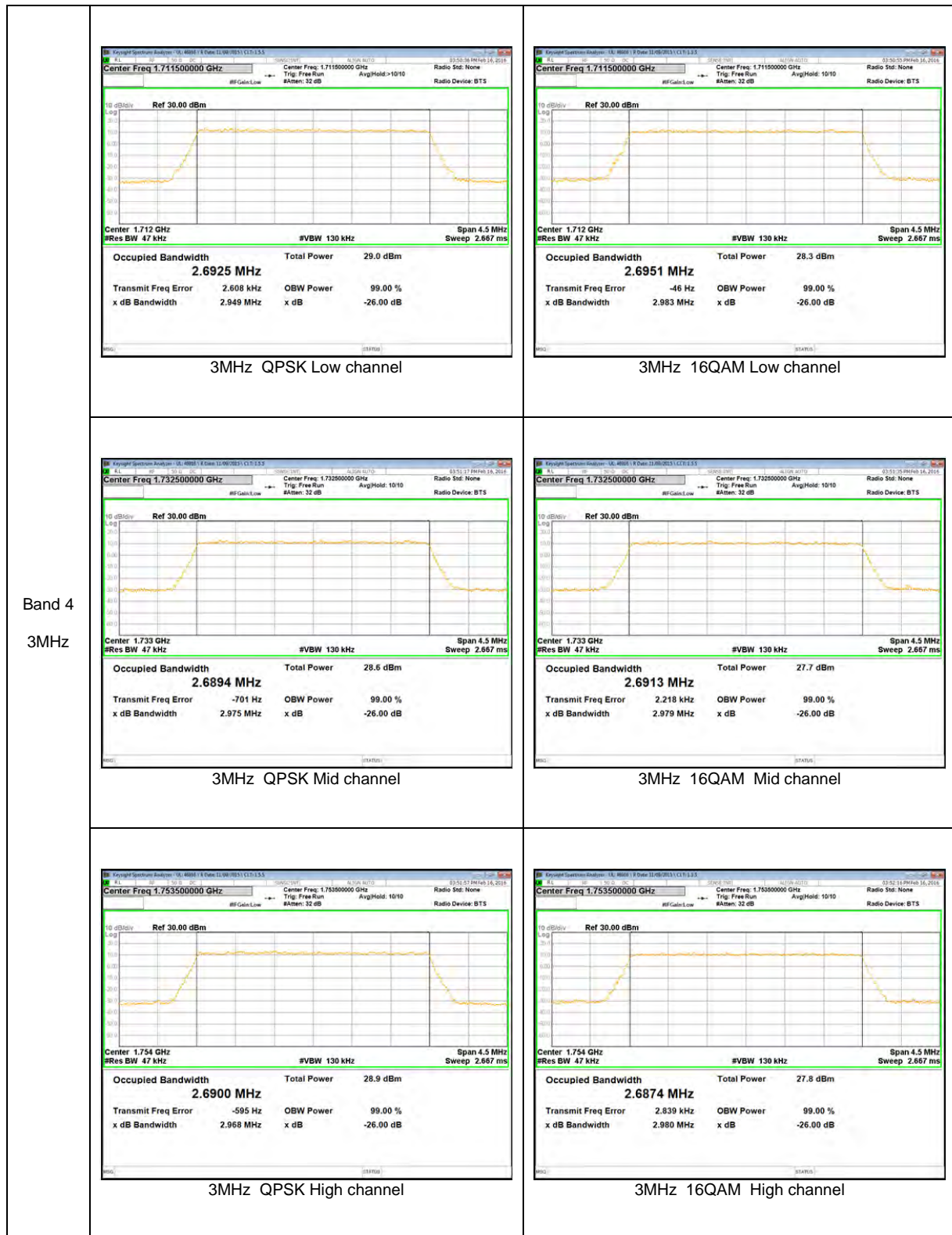

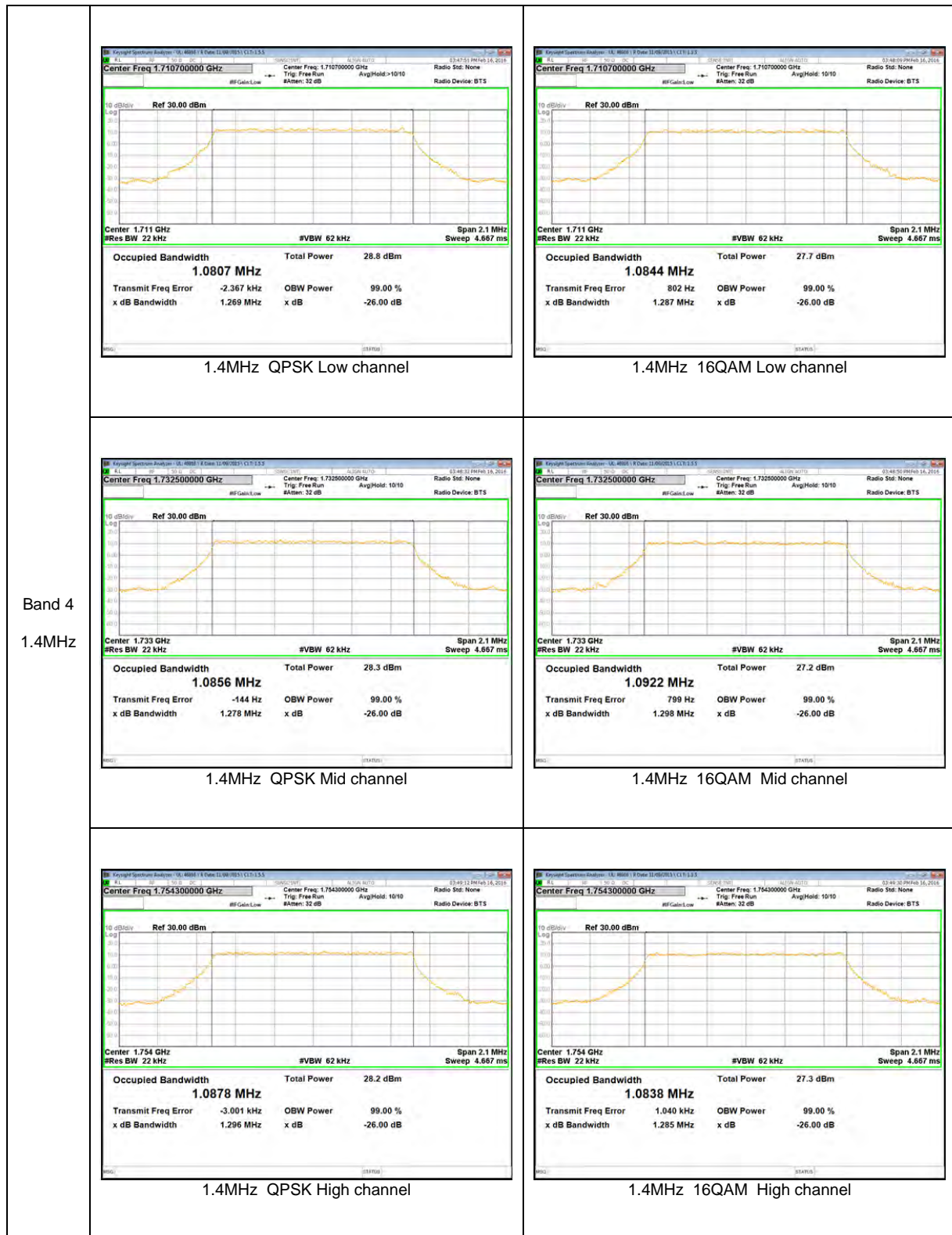

LTE Band 2

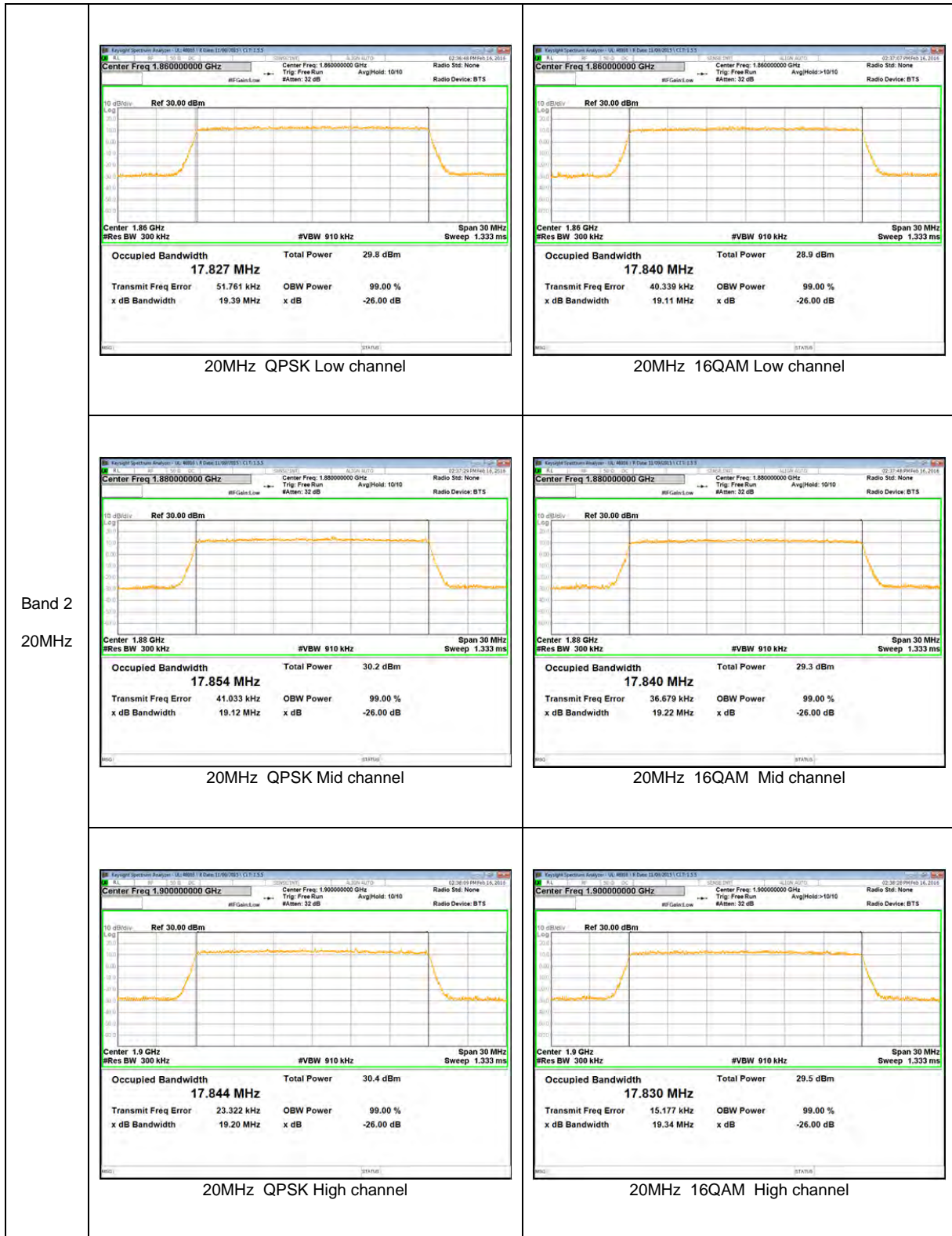



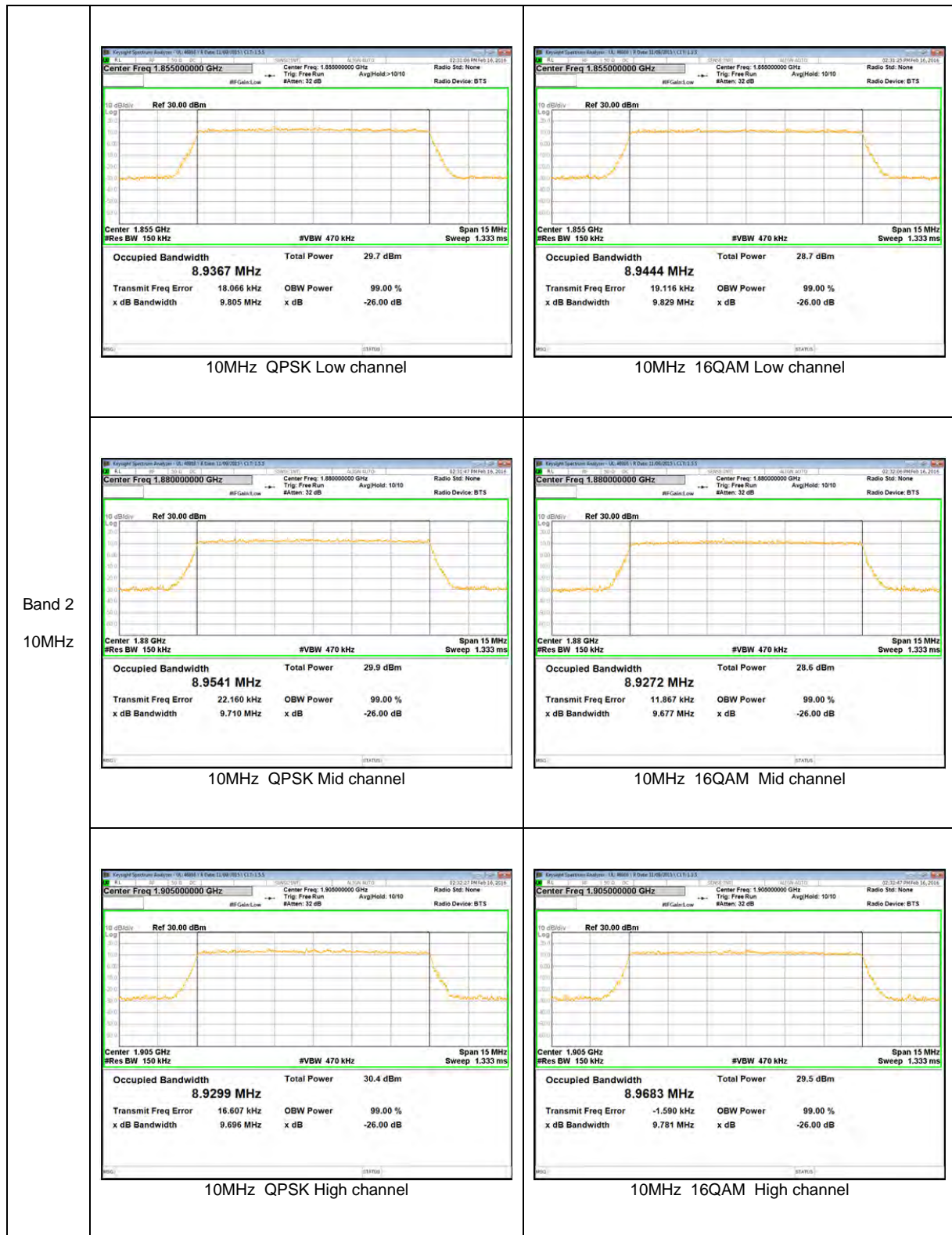

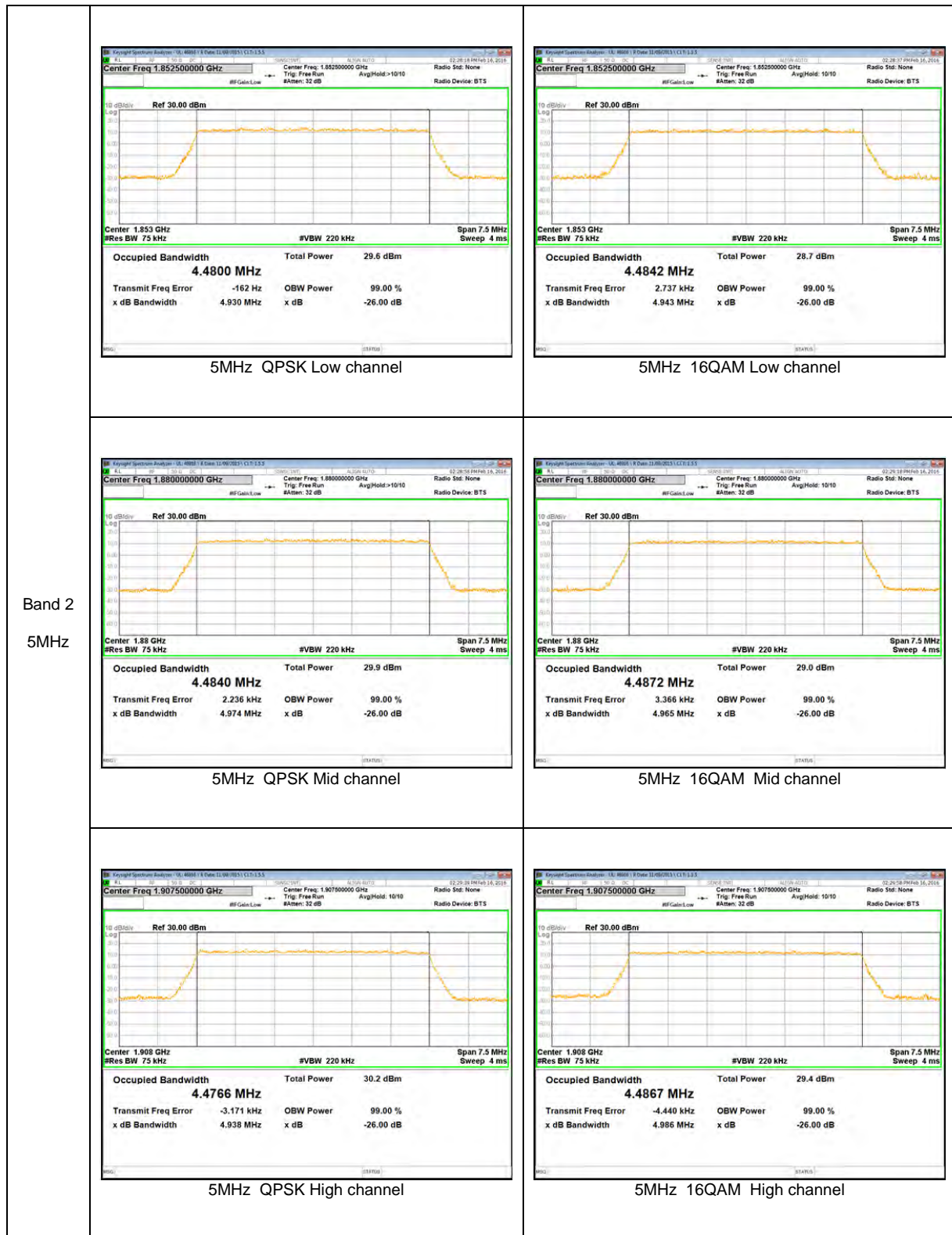

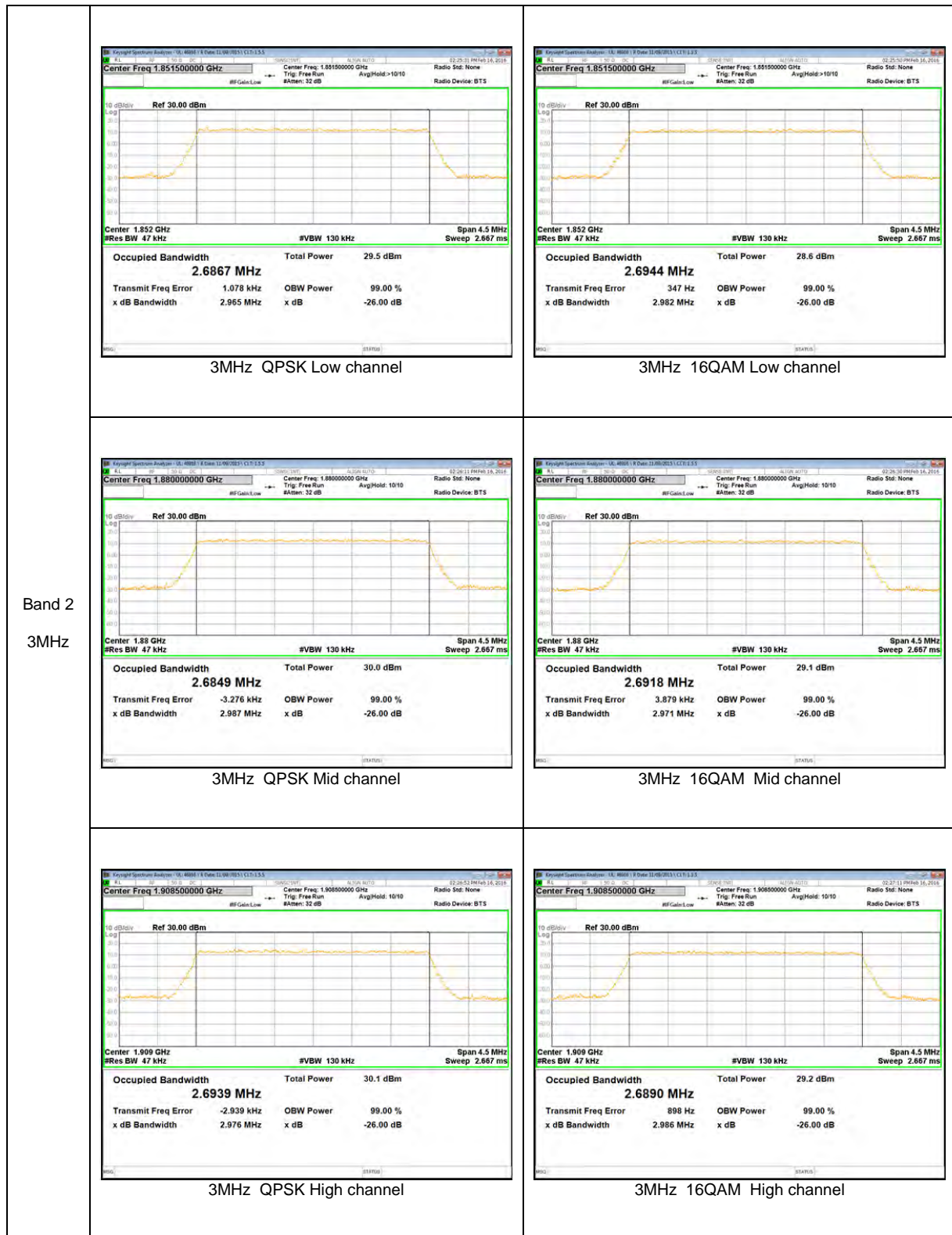

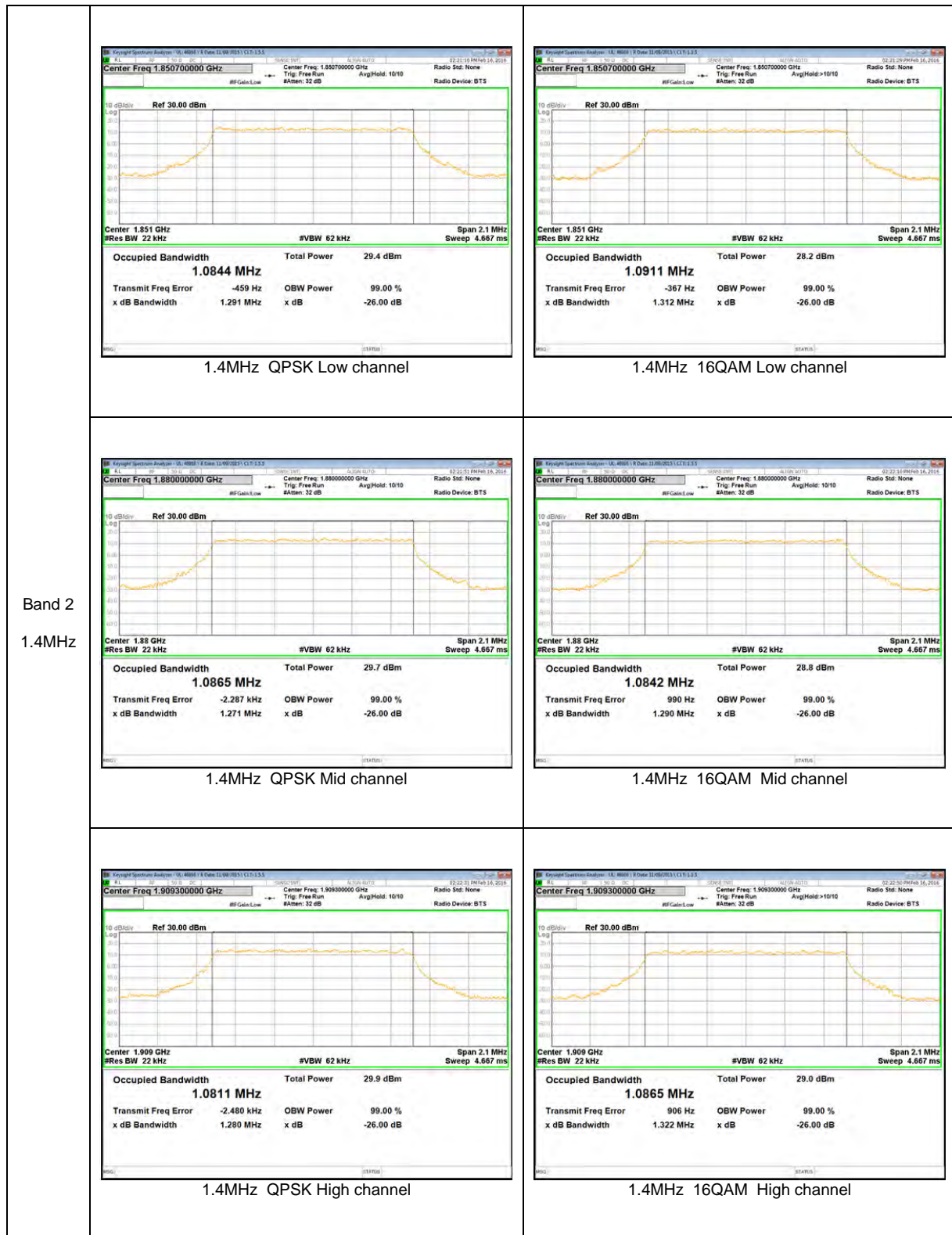

10.2. BAND EDGE EMISSIONS

RULE PART(S)

FCC: §22.359, §24.238 and §27. 53

LIMITS

The power of any emission outside of the authorized operating frequency ranges must be attenuated below the transmitting power (P) by a factor of at least $43 + 10 \log (P)$ dB.

TEST PROCEDURE

Per KDB 971168 D01 Power Meas License Digital Systems v02r02

The transmitter output was connected to a CMW500 Test Set and configured to operate at maximum power. The band edge emissions were measured at the required operating frequencies in each band on the Spectrum Analyzer.

RESULTS

GSM

Band	Mode	Side	f [MHz]	Level [dBm]	Limit [dBm]
GSM850	GPRS	Lower	823.982	-17.133	-13.00
		Upper	849.023	-16.969	
	EGPRS	Lower	823.987	-22.806	
		Upper	849.033	-24.127	
GSM1900	GPRS	Lower	1849.982	-16.860	
		Upper	1910.023	-16.855	
	EGPRS	Lower	1849.987	-22.659	
		Upper	1910.018	-23.060	

WCDMA

Band	Mode	Side	f [MHz]	Level [dBm]	Limit [dBm]
Band 5	REL99	Lower	824.000	-25.278	-13.00
		Upper	849.000	-24.925	
	HSDPA	Lower	824.000	-26.931	
		Upper	849.000	-26.346	
Band 4	REL99	Lower	1710.000	-28.658	
		Upper	1755.000	-30.432	
	HSDPA	Lower	1710.000	-28.798	
		Upper	1755.000	-30.456	
Band 2	REL99	Lower	1850.000	-22.140	
		Upper	1910.000	-22.961	
	HSDPA	Lower	1850.000	-28.900	
		Upper	1910.000	-29.602	

LTE 17

Bandwidth	Mode	Side	RB Status	f [MHz]	Level [dBm]	Limit [dBm]
10 MHz	QPSK	Lower	1RB	704.000	-29.216	-13.00
			FRB	704.000	-27.694	
		Upper	1RB	716.000	-26.563	
			FRB	716.000	-29.353	
	16QAM	Lower	1RB	704.000	-30.883	
			FRB	704.000	-28.962	
		Upper	1RB	716.000	-30.265	
			FRB	716.000	-31.465	
5 MHz	QPSK	Lower	1RB	704.000	-18.586	
			FRB	704.000	-26.930	
		Upper	1RB	716.000	-17.741	
			FRB	716.000	-26.690	
	16QAM	Lower	1RB	704.000	-20.268	
			FRB	704.000	-27.668	
		Upper	1RB	716.000	-19.703	
			FRB	716.000	-29.405	

LTE 5

Bandwidth	Mode	Side	RB Status	f [MHz]	Level [dBm]	Limit [dBm]
10 MHz	QPSK	Lower	1RB	824.000	-31.829	-13.00
			FRB	824.000	-31.145	
		Upper	1RB	849.000	-25.661	
			FRB	849.000	-31.176	
	16QAM	Lower	1RB	824.000	-32.946	
			FRB	824.000	-34.293	
		Upper	1RB	849.000	-27.344	
			FRB	849.000	-31.385	
5 MHz	QPSK	Lower	1RB	824.000	-18.983	-13.00
			FRB	824.000	-29.944	
		Upper	1RB	849.000	-18.933	
			FRB	849.000	-30.433	
	16QAM	Lower	1RB	824.000	-19.833	
			FRB	824.000	-30.664	
		Upper	1RB	849.000	-20.070	
			FRB	849.000	-30.682	
3 MHz	QPSK	Lower	1RB	824.000	-20.757	-13.00
			FRB	824.000	-29.823	
		Upper	1RB	849.000	-17.522	
			FRB	849.000	-28.586	
	16QAM	Lower	1RB	824.000	-19.105	
			FRB	824.000	-29.806	
		Upper	1RB	849.000	-20.392	
			FRB	849.000	-28.648	
1.4 MHz	QPSK	Lower	1RB	824.000	-23.840	-13.00
			FRB	824.000	-31.201	
		Upper	1RB	849.000	-21.851	
			FRB	849.000	-28.881	
	16QAM	Lower	1RB	824.000	-24.727	
			FRB	824.000	-32.448	
		Upper	1RB	849.000	-23.168	
			FRB	849.000	-30.505	

LTE 4

Bandwidth	Mode	Side	RB Status	f [MHz]	Level [dBm]	Limit [dBm]
20 MHz	QPSK	Lower	1RB	1710.000	-32.295	-13.00
			FRB	1710.000	-34.114	
		Upper	1RB	1755.000	-36.630	
			FRB	1755.000	-36.788	
	16QAM	Lower	1RB	1710.000	-34.786	
			FRB	1710.000	-35.574	
		Upper	1RB	1755.000	-37.450	
			FRB	1755.000	-35.389	
15 MHz	QPSK	Lower	1RB	1710.000	-24.786	-13.00
			FRB	1710.000	-34.251	
		Upper	1RB	1755.000	-26.855	
			FRB	1755.000	-33.841	
	16QAM	Lower	1RB	1710.000	-35.280	
			FRB	1710.000	-33.059	
		Upper	1RB	1755.000	-29.486	
			FRB	1755.000	-37.783	
10 MHz	QPSK	Lower	1RB	1710.000	-31.511	-13.00
			FRB	1710.000	-34.265	
		Upper	1RB	1755.000	-32.814	
			FRB	1755.000	-36.591	
	16QAM	Lower	1RB	1710.000	-30.715	
			FRB	1710.000	-32.980	
		Upper	1RB	1755.000	-31.158	
			FRB	1755.000	-33.929	
5 MHz	QPSK	Lower	1RB	1710.000	-17.657	-13.00
			FRB	1710.000	-28.138	
		Upper	1RB	1755.000	-18.382	
			FRB	1755.000	-29.727	
	16QAM	Lower	1RB	1710.000	-20.497	
			FRB	1710.000	-30.201	
		Upper	1RB	1755.000	-20.289	
			FRB	1755.000	-29.326	

Bandwidth	Mode	Side	RB Status	f [MHz]	Level [dBm]	Limit [dBm]
3 MHz	QPSK	Lower	1RB	1710.000	-18.866	-13.00
			FRB	1710.000	-26.292	
		Upper	1RB	1755.000	-18.416	
			FRB	1755.000	-26.181	
	16QAM	Lower	1RB	1710.000	-18.751	
			FRB	1710.000	-28.562	
		Upper	1RB	1755.000	-17.630	
			FRB	1755.000	-28.023	
1.4 MHz	QPSK	Lower	1RB	1710.000	-22.461	-13.00
			FRB	1710.000	-26.907	
		Upper	1RB	1755.000	-21.441	
			FRB	1755.000	-29.210	
	16QAM	Lower	1RB	1710.000	-22.829	
			FRB	1710.000	-30.027	
		Upper	1RB	1755.000	-22.941	
			FRB	1755.000	-29.517	

LTE 2

Bandwidth	Mode	Side	RB Status	f [MHz]	Level [dBm]	Limit [dBm]
20 MHz	QPSK	Lower	1RB	1850.000	-33.215	-13.00
			FRB	1850.000	-35.432	
		Upper	1RB	1910.000	-27.232	
			FRB	1910.000	-33.411	
	16QAM	Lower	1RB	1850.000	-34.720	
			FRB	1850.000	-34.729	
		Upper	1RB	1910.000	-25.387	
			FRB	1910.000	-35.048	
15 MHz	QPSK	Lower	1RB	1844.561	-27.492	-13.00
			FRB	1850.000	-30.717	
		Upper	1RB	1910.000	-31.517	
			FRB	1910.000	-31.368	
	16QAM	Lower	1RB	1844.558	-28.675	
			FRB	1850.000	-34.295	
		Upper	1RB	1915.427	-34.459	
			FRB	1910.000	-36.633	

Bandwidth	Mode	Side	RB Status	f [MHz]	Level [dBm]	Limit [dBm]
10 MHz	QPSK	Lower	1RB	1850.000	-28.589	-13.00
			FRB	1850.000	-31.889	
		Upper	1RB	1910.000	-28.321	
			FRB	1910.000	-31.517	
	16QAM	Lower	1RB	1850.000	-32.030	
			FRB	1850.000	-32.425	
		Upper	1RB	1910.000	-31.260	
			FRB	1910.000	-31.781	
5 MHz	QPSK	Lower	1RB	1850.000	-17.659	
			FRB	1850.000	-28.328	
		Upper	1RB	1910.000	-16.027	
			FRB	1910.000	-29.069	
	16QAM	Lower	1RB	1850.000	-19.598	
			FRB	1850.000	-27.213	
		Upper	1RB	1910.000	-16.462	
			FRB	1910.000	-28.528	
3 MHz	QPSK	Lower	1RB	1850.000	-16.455	
			FRB	1850.000	-25.615	
		Upper	1RB	1910.000	-15.036	
			FRB	1910.000	-25.825	
	16QAM	Lower	1RB	1850.000	-16.320	
			FRB	1850.000	-27.398	
		Upper	1RB	1910.000	-16.474	
			FRB	1910.000	-27.453	
1.4 MHz	QPSK	Lower	1RB	1850.000	-19.734	
			FRB	1850.000	-26.979	
		Upper	1RB	1910.000	-17.611	
			FRB	1910.000	-26.517	
	16QAM	Lower	1RB	1850.000	-21.735	
			FRB	1850.000	-28.329	
		Upper	1RB	1910.000	-19.974	
			FRB	1910.000	-27.627	

10.2.1. BAND EDGE PLOTS

GSM

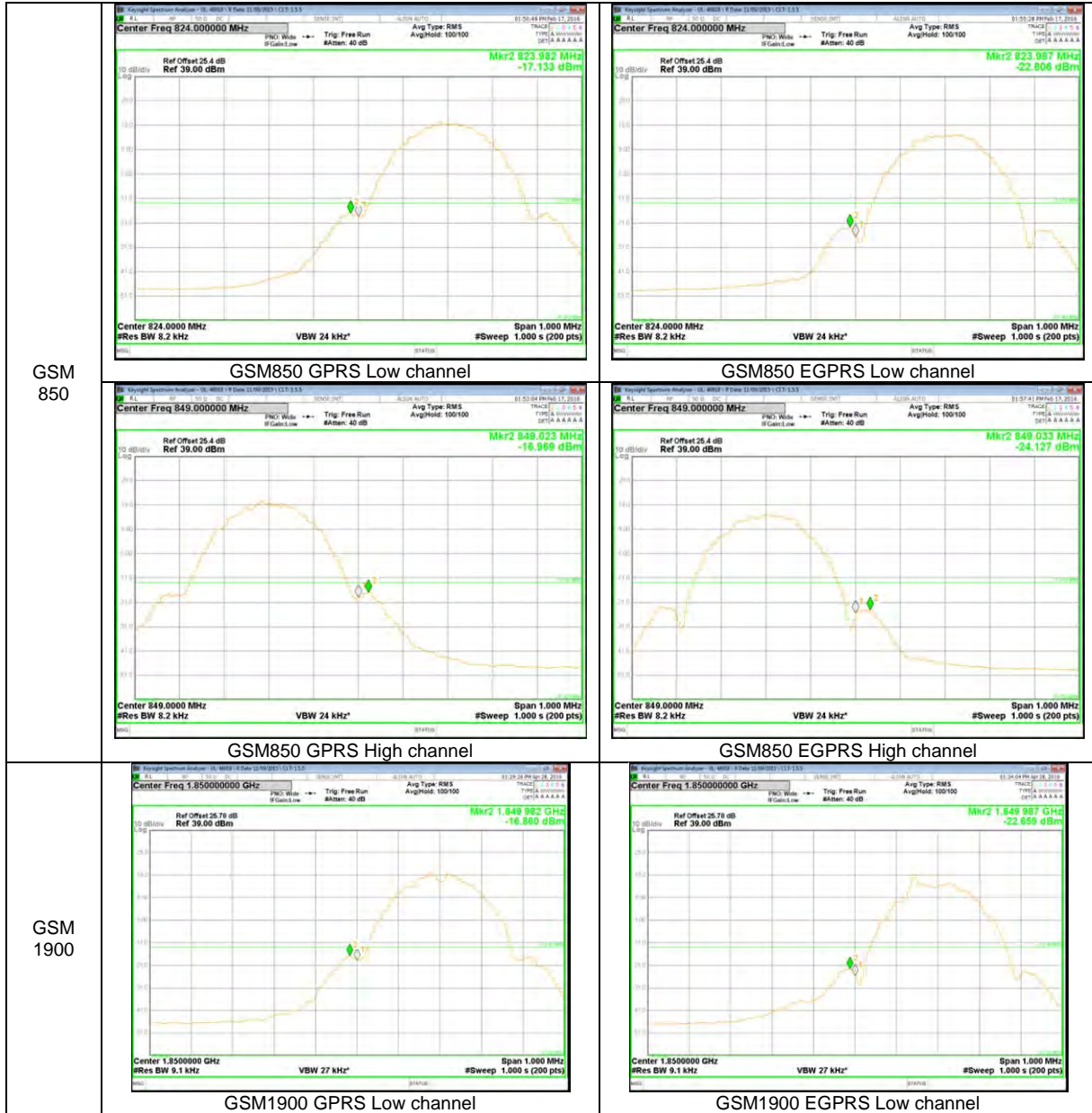

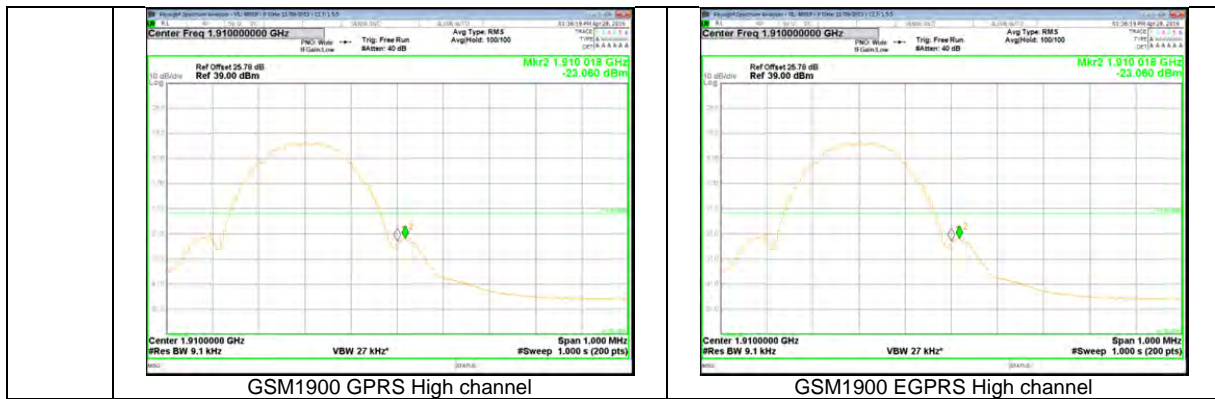

WCDMA

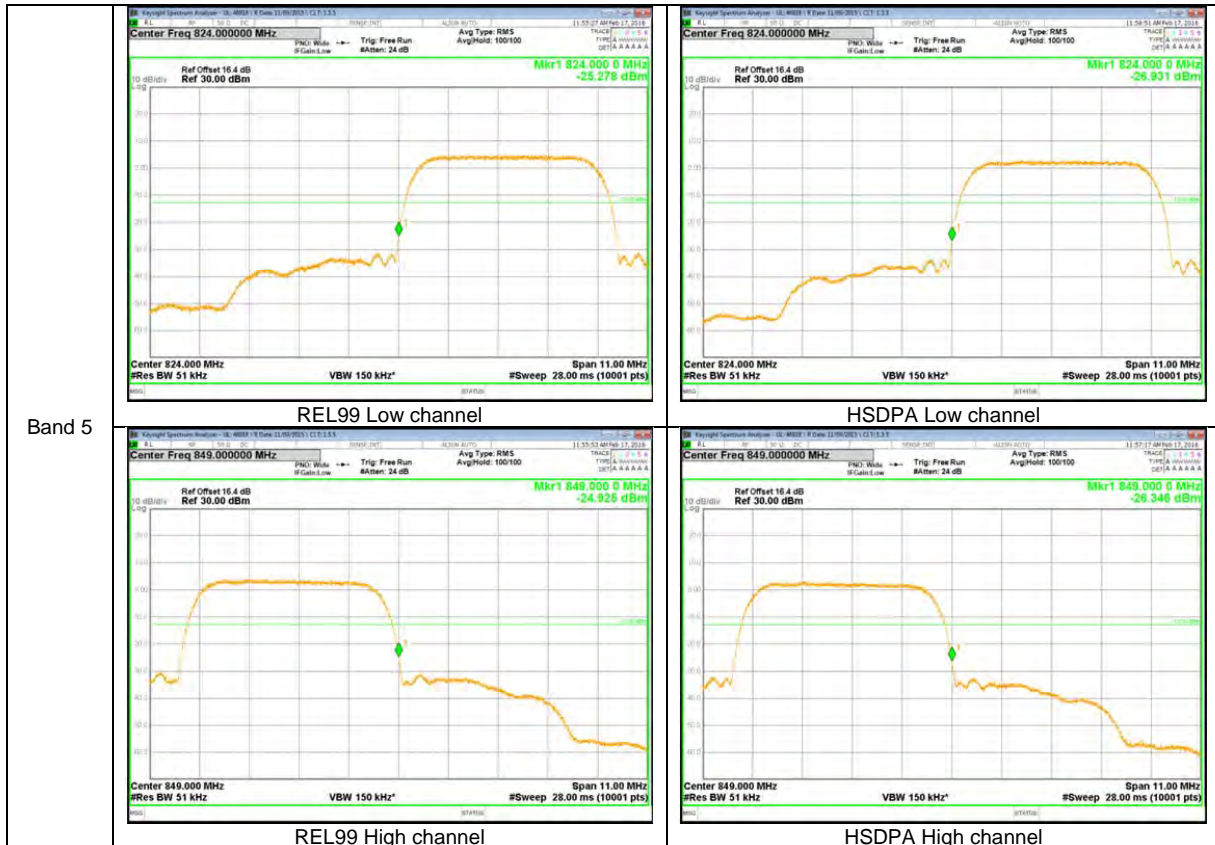

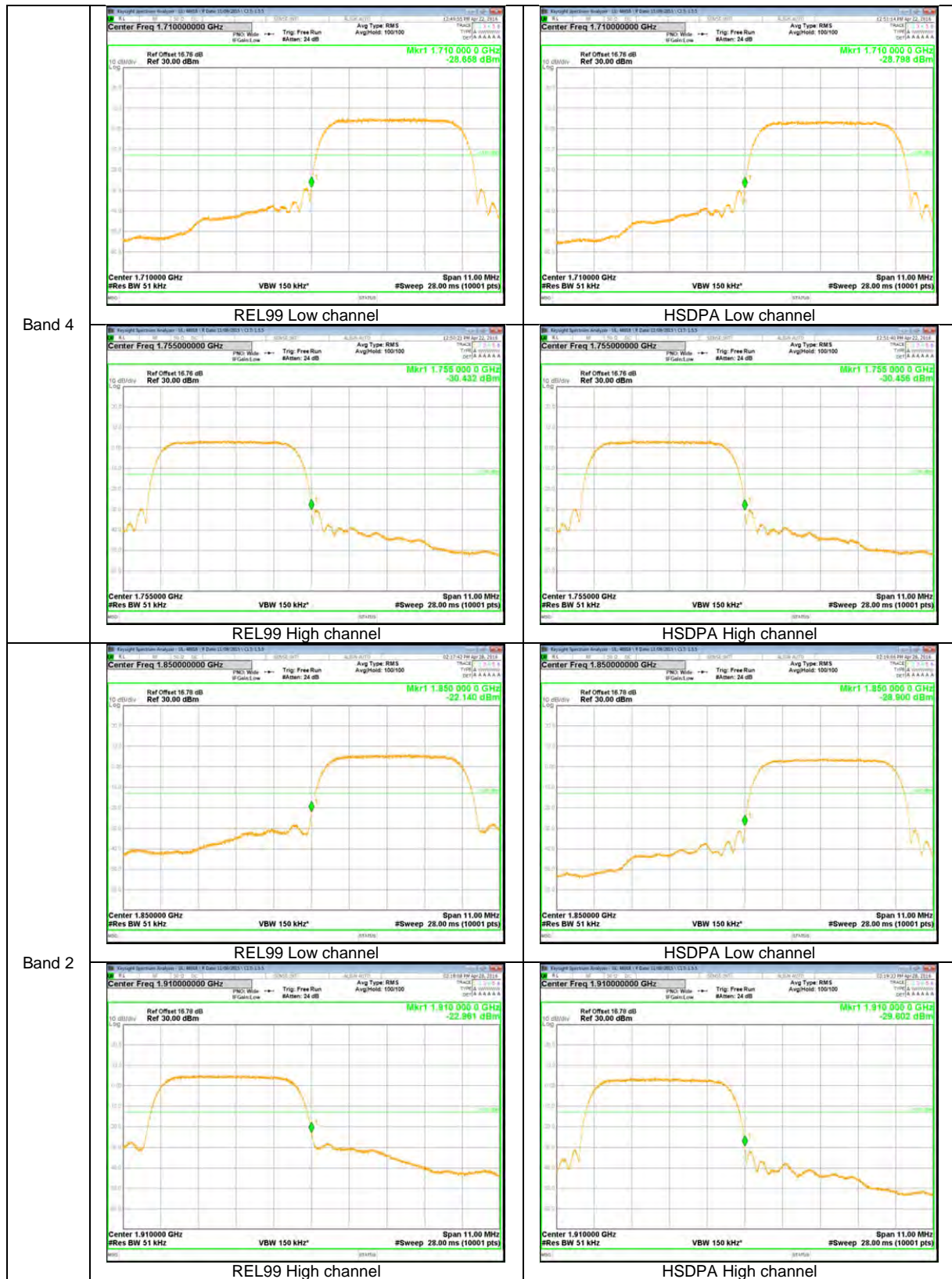

LTE Band 17

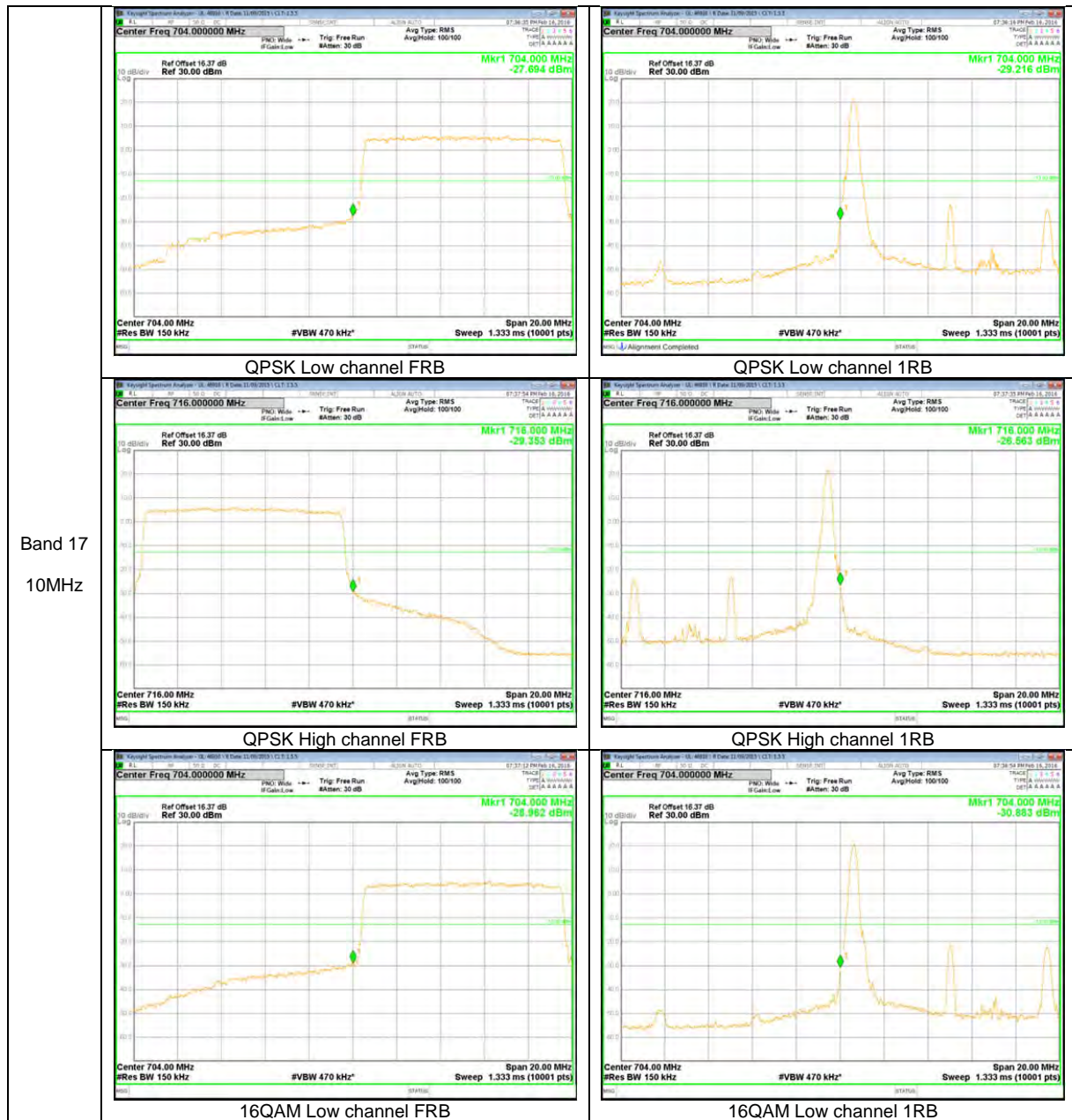

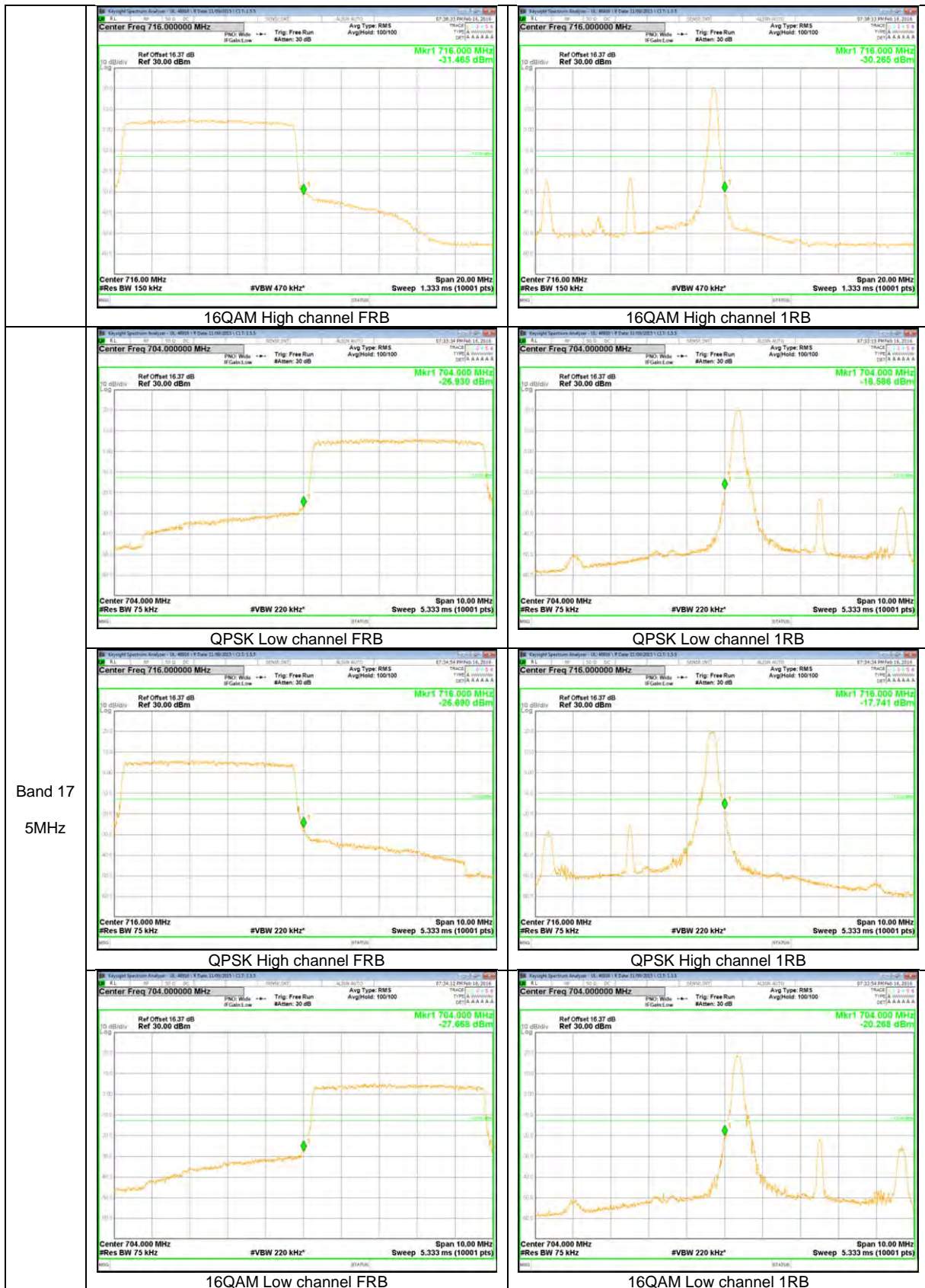

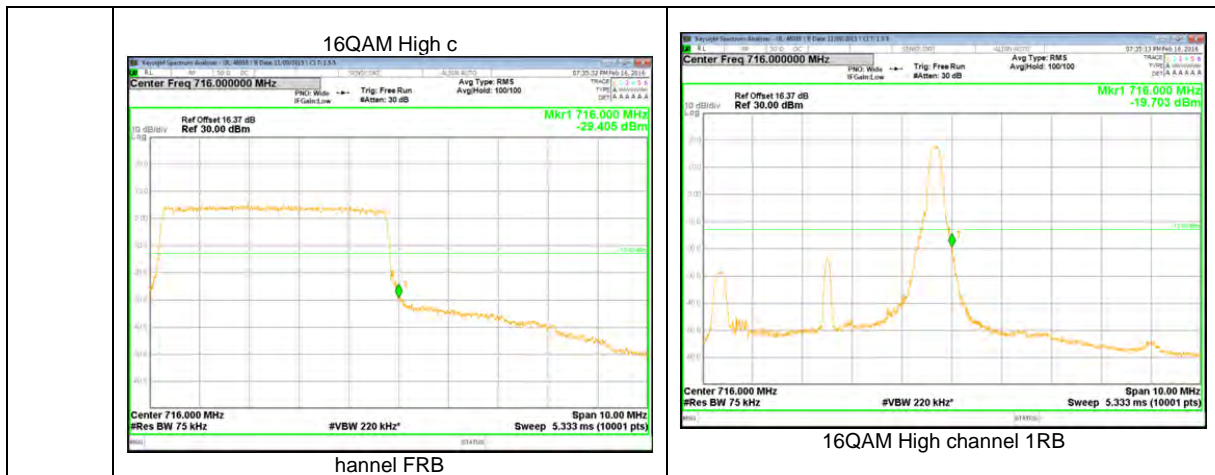

LTE Band 5

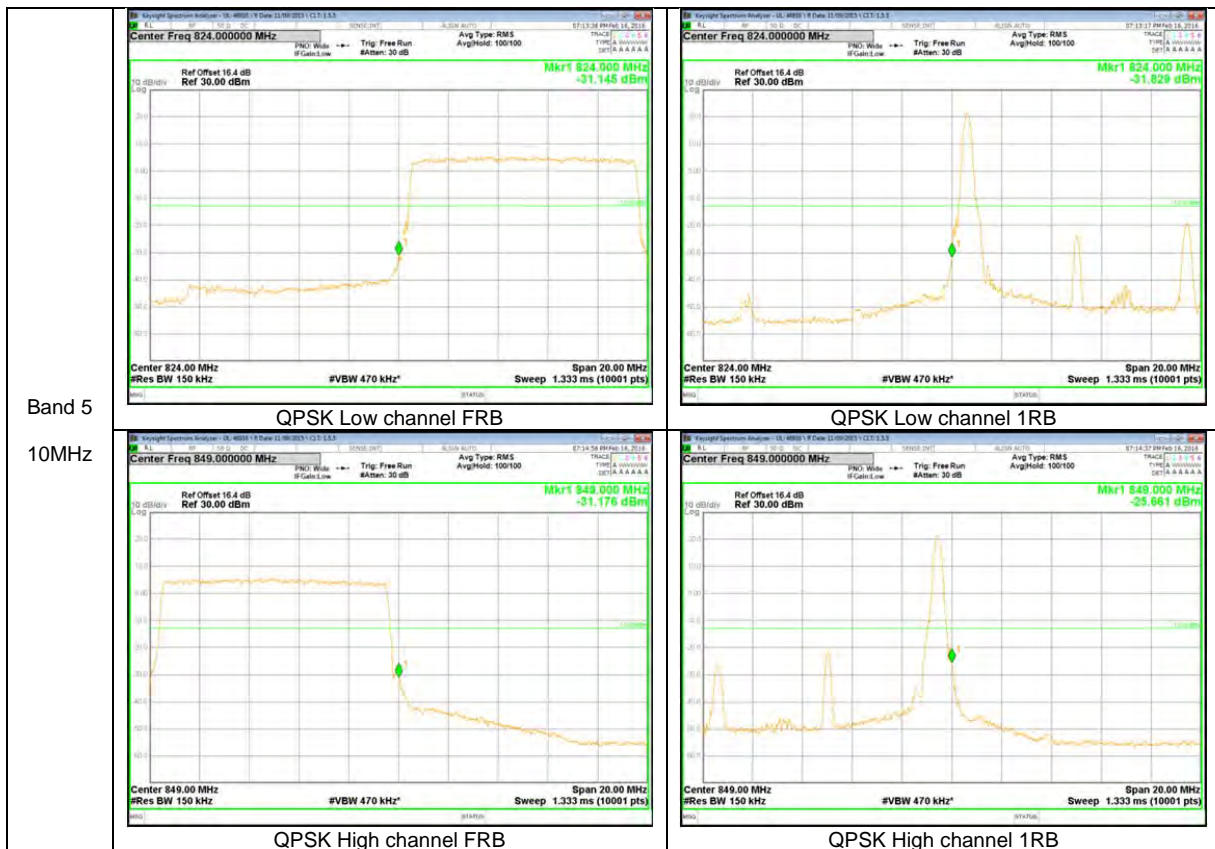

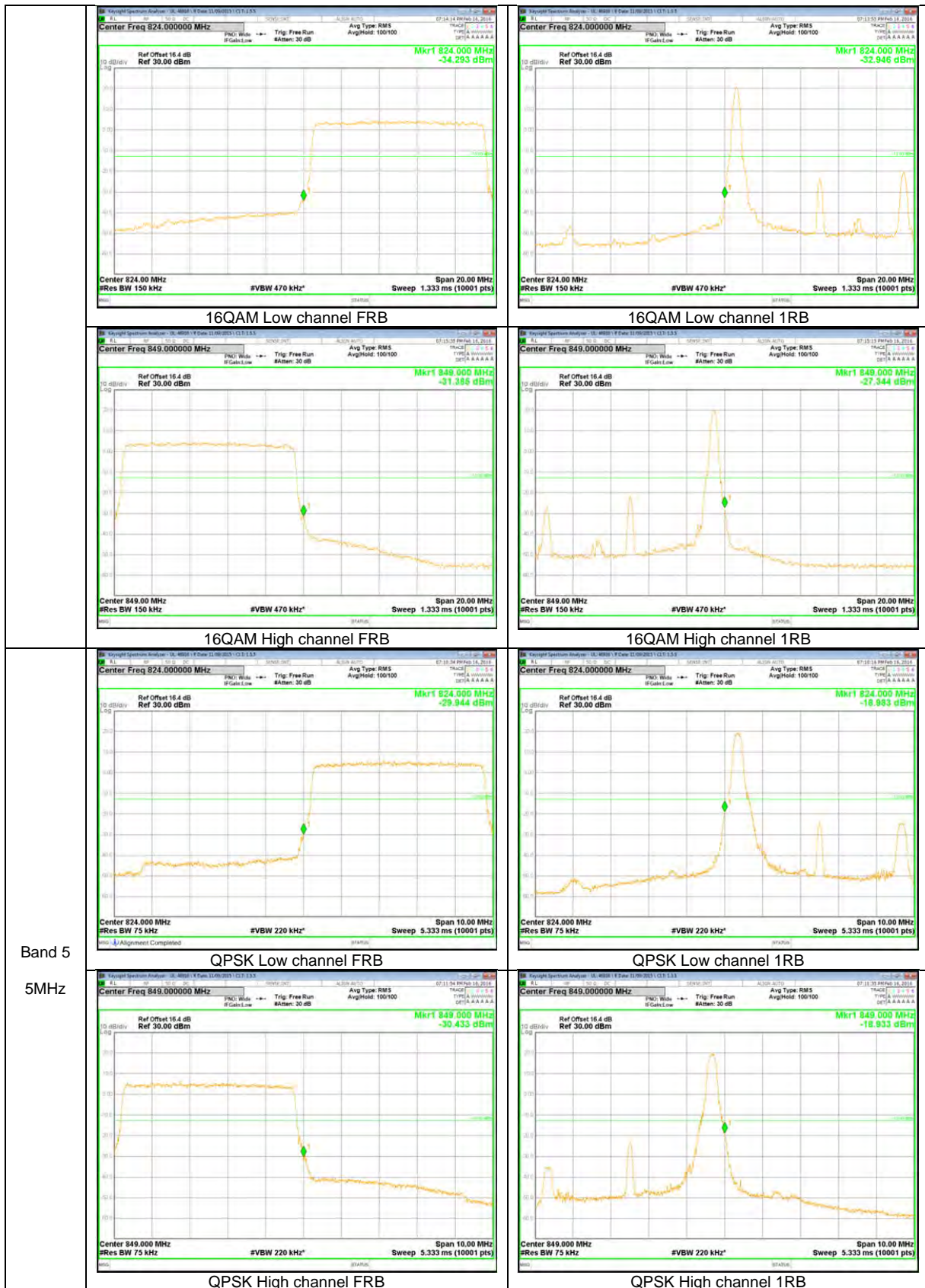

Band 5
5MHz

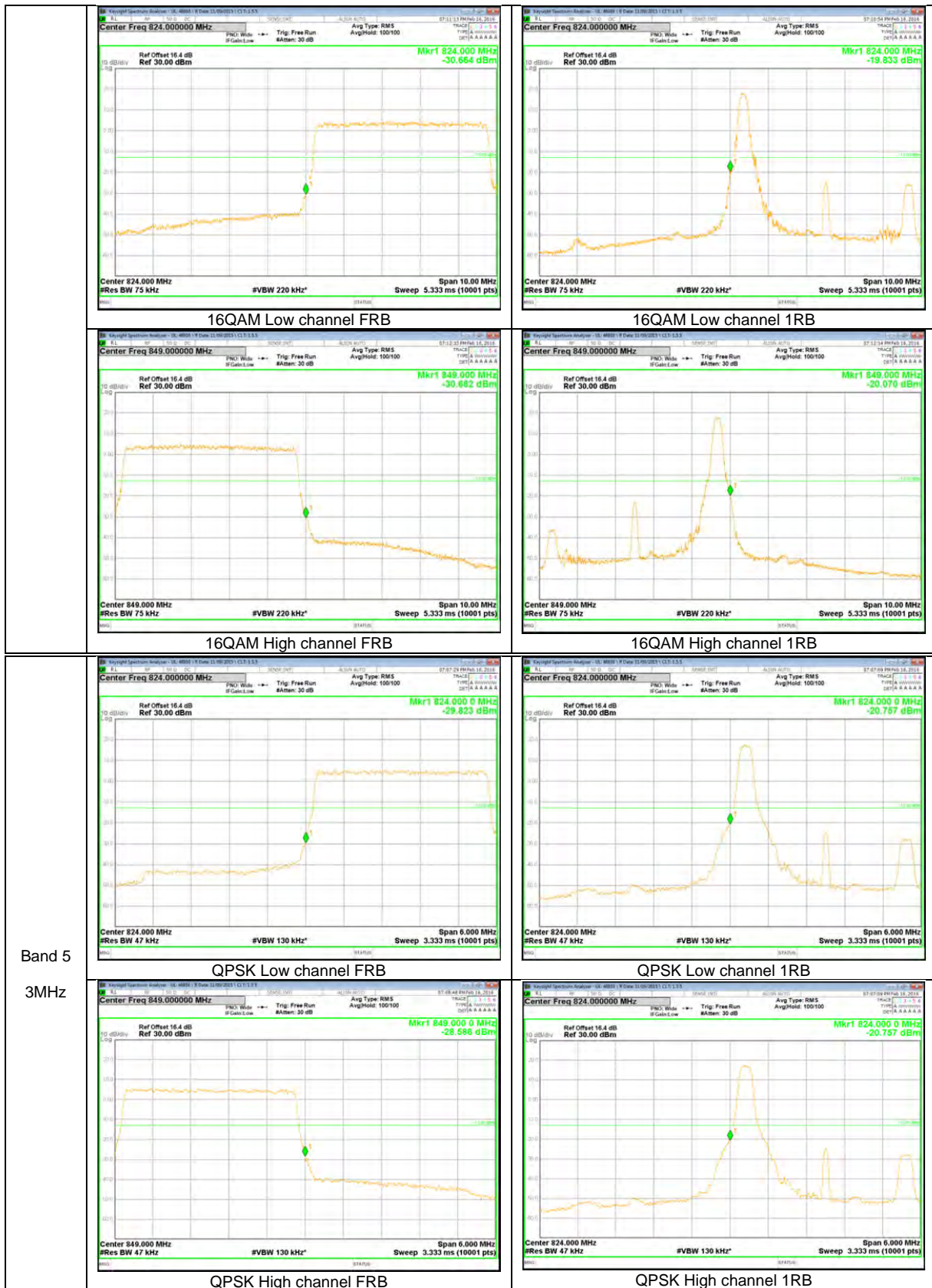

Band 5
3MHz

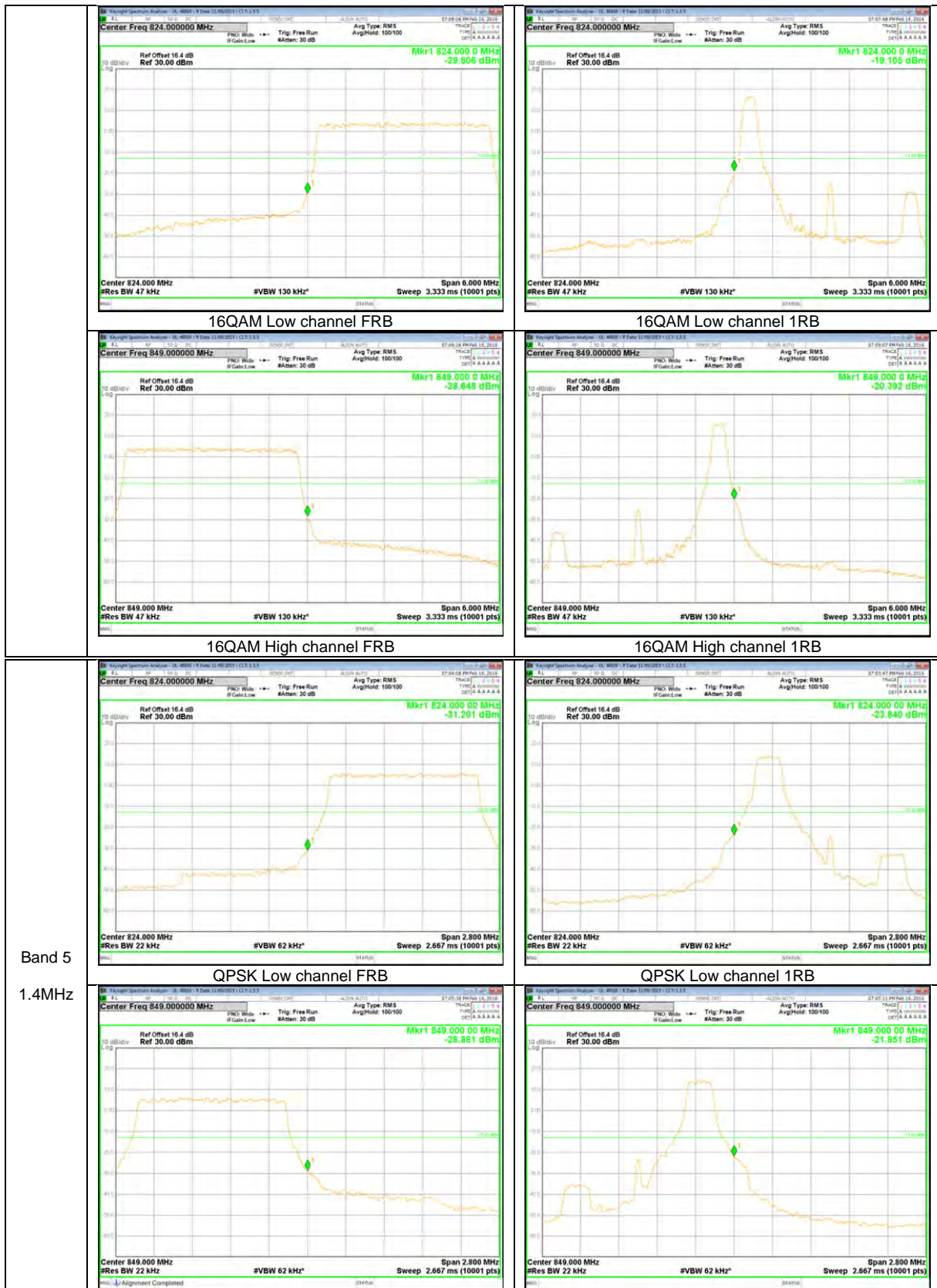

Band 5
1.4MHz

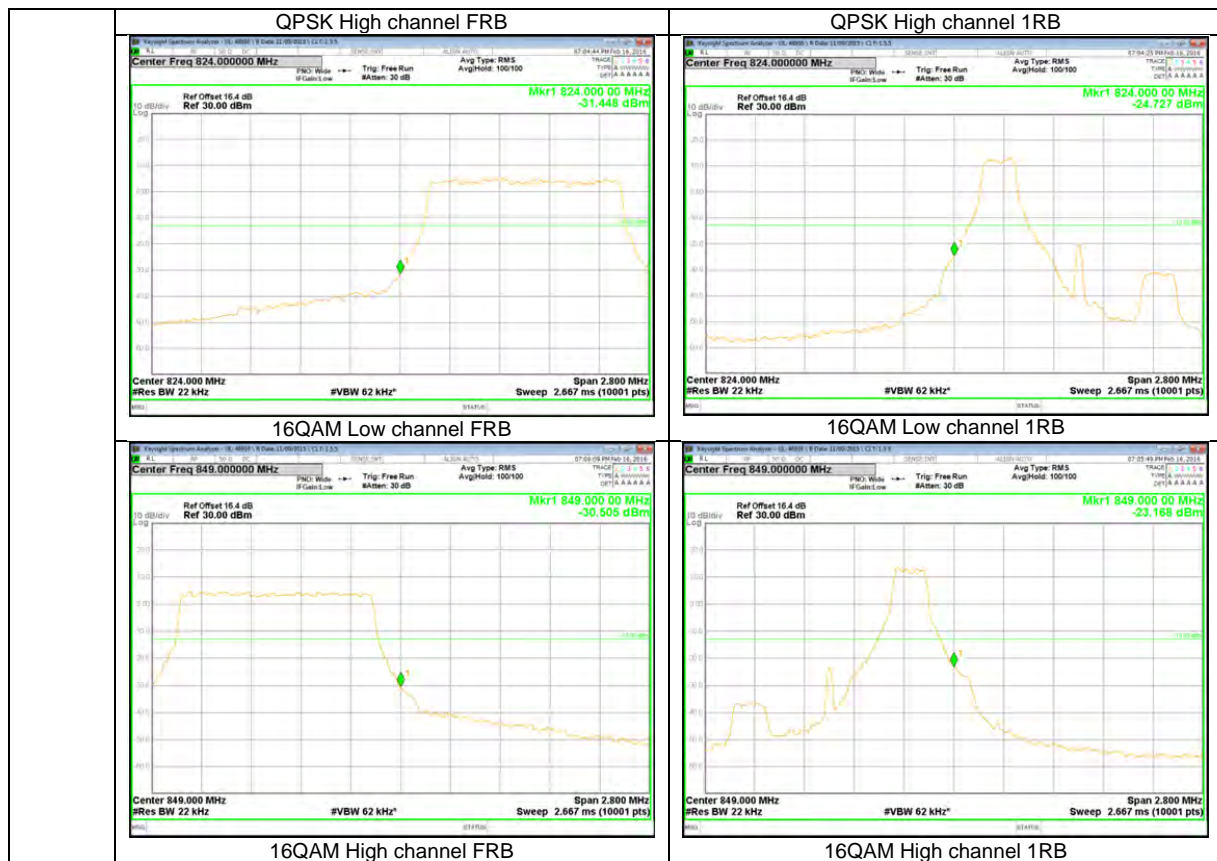

LTE Band 4

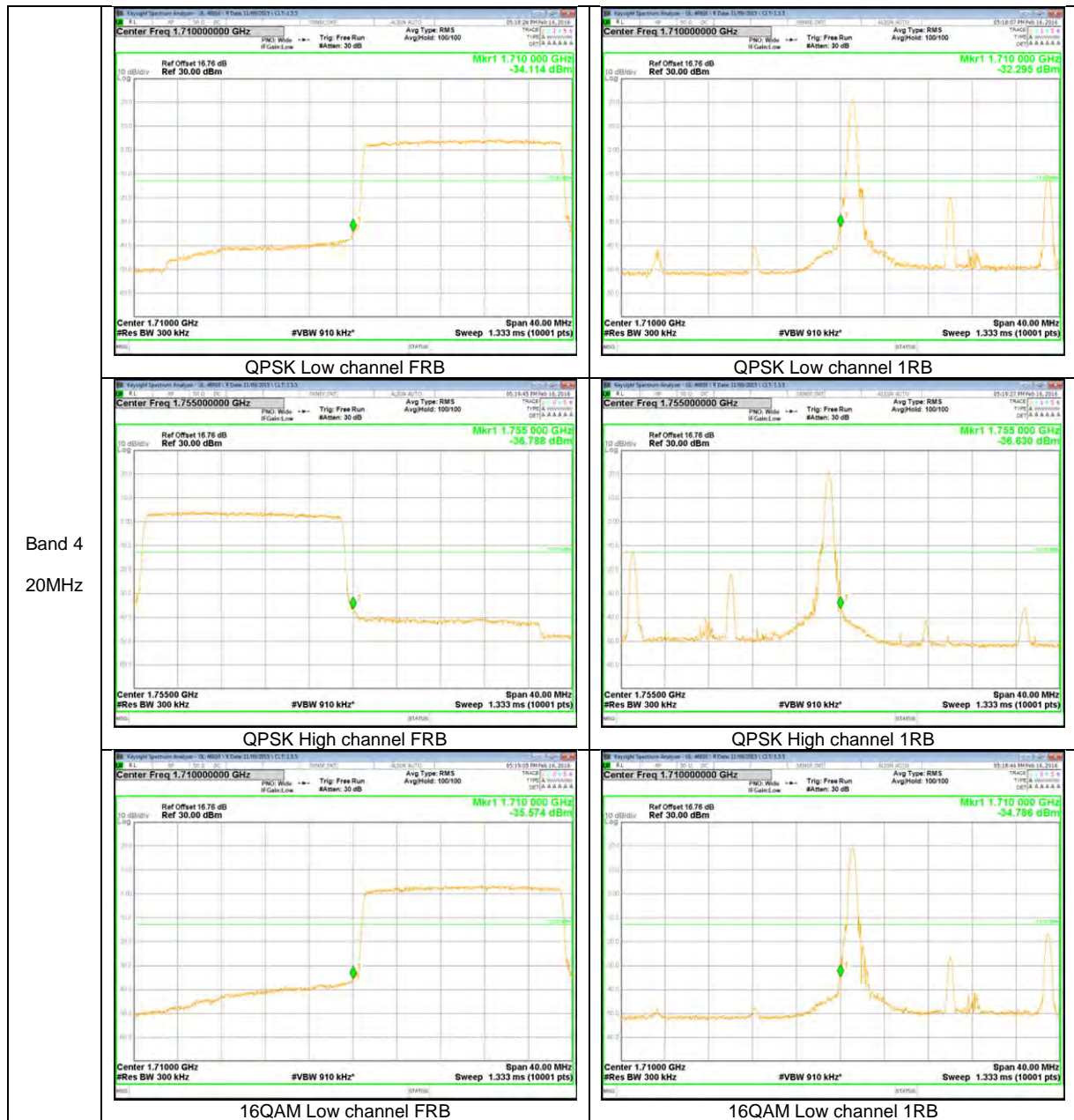

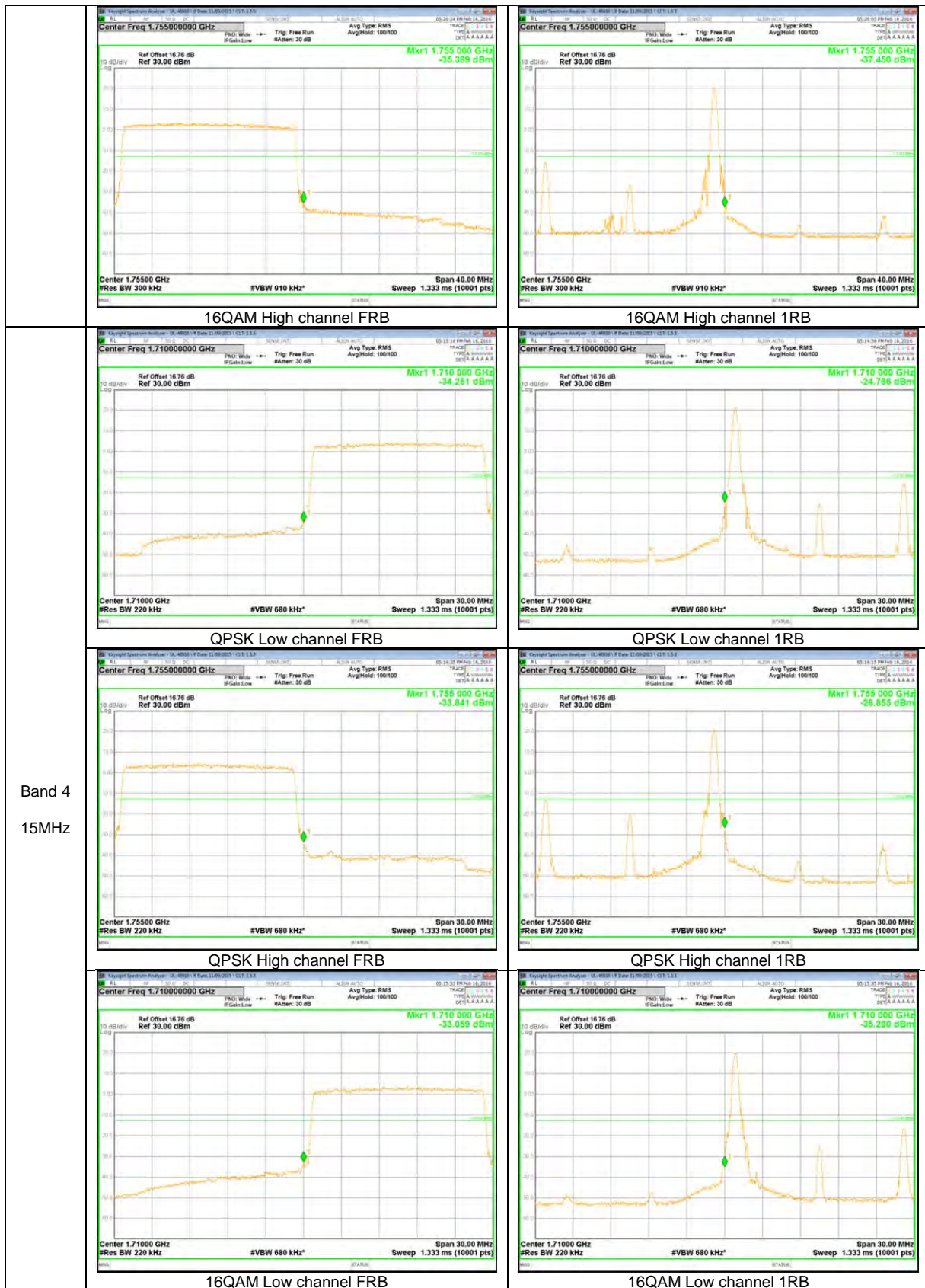

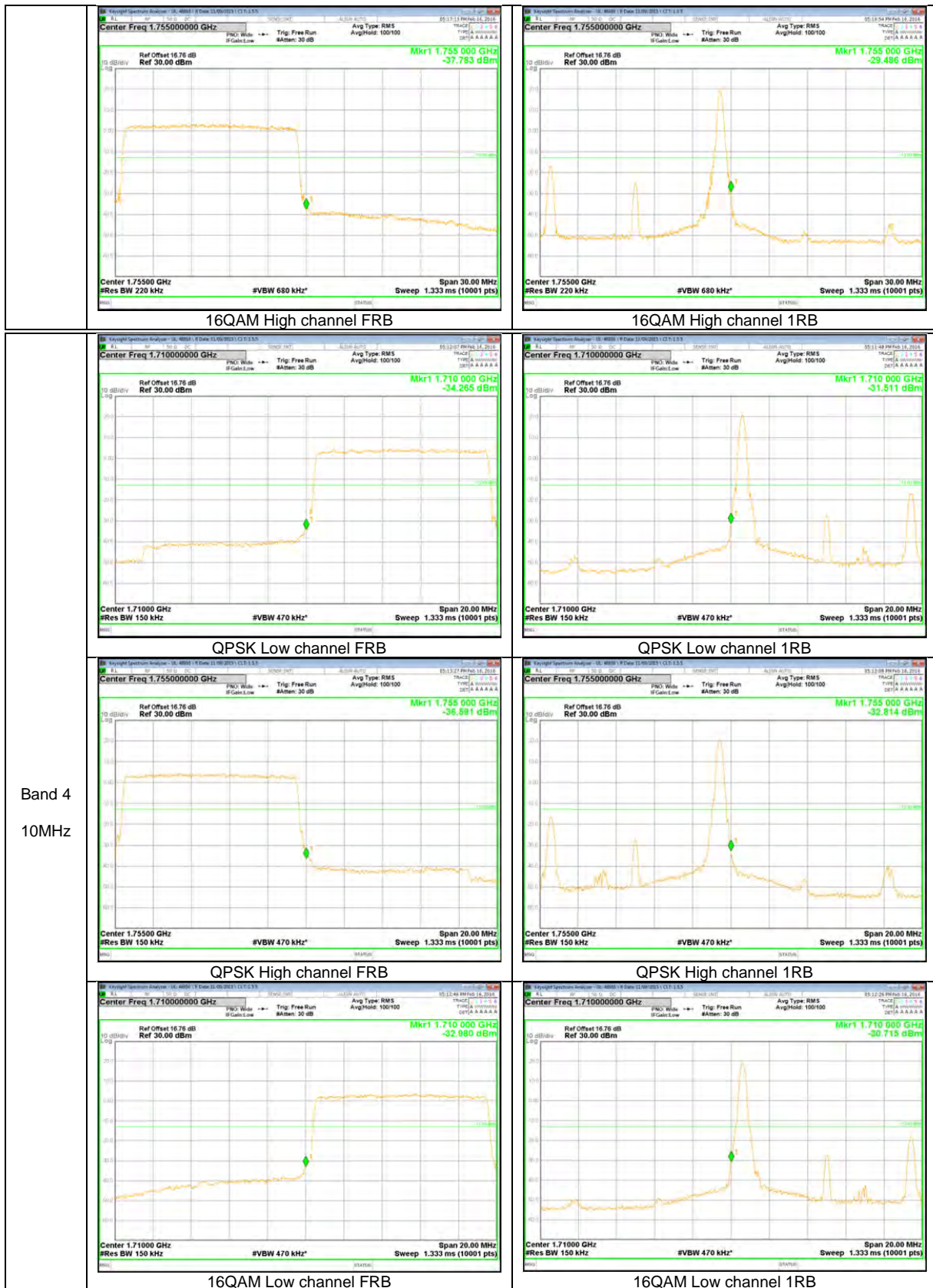

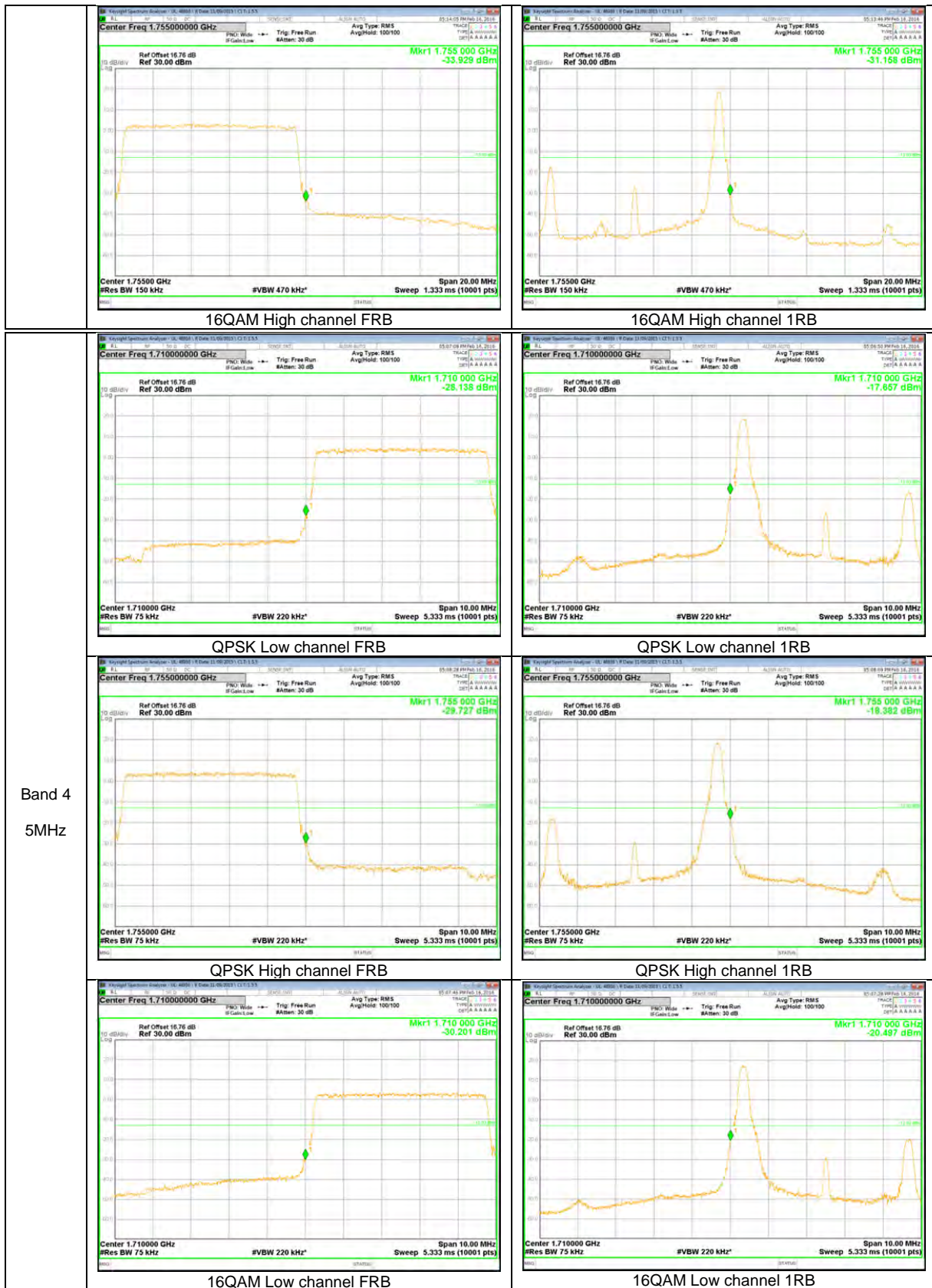

Band 4
5MHz

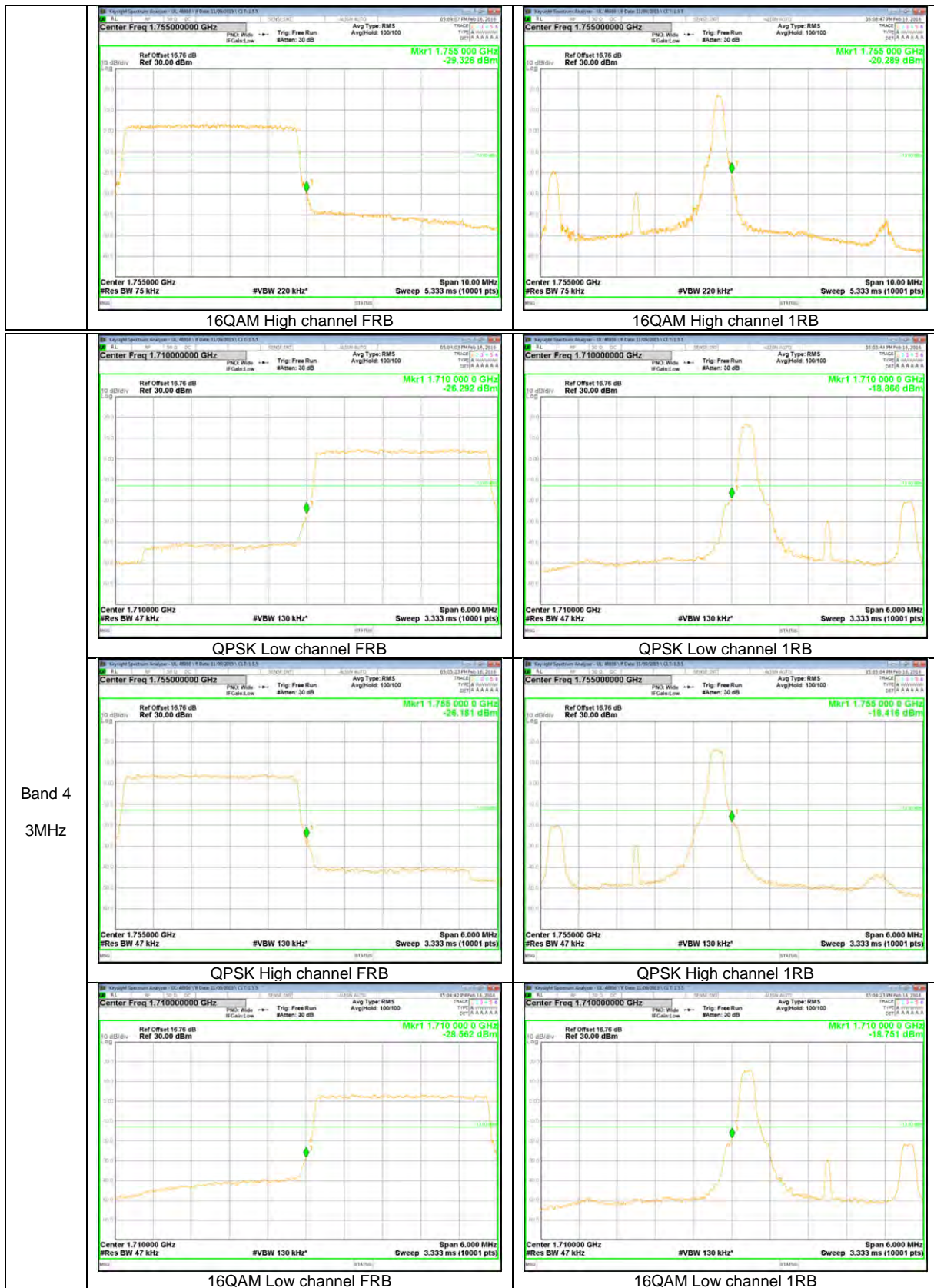

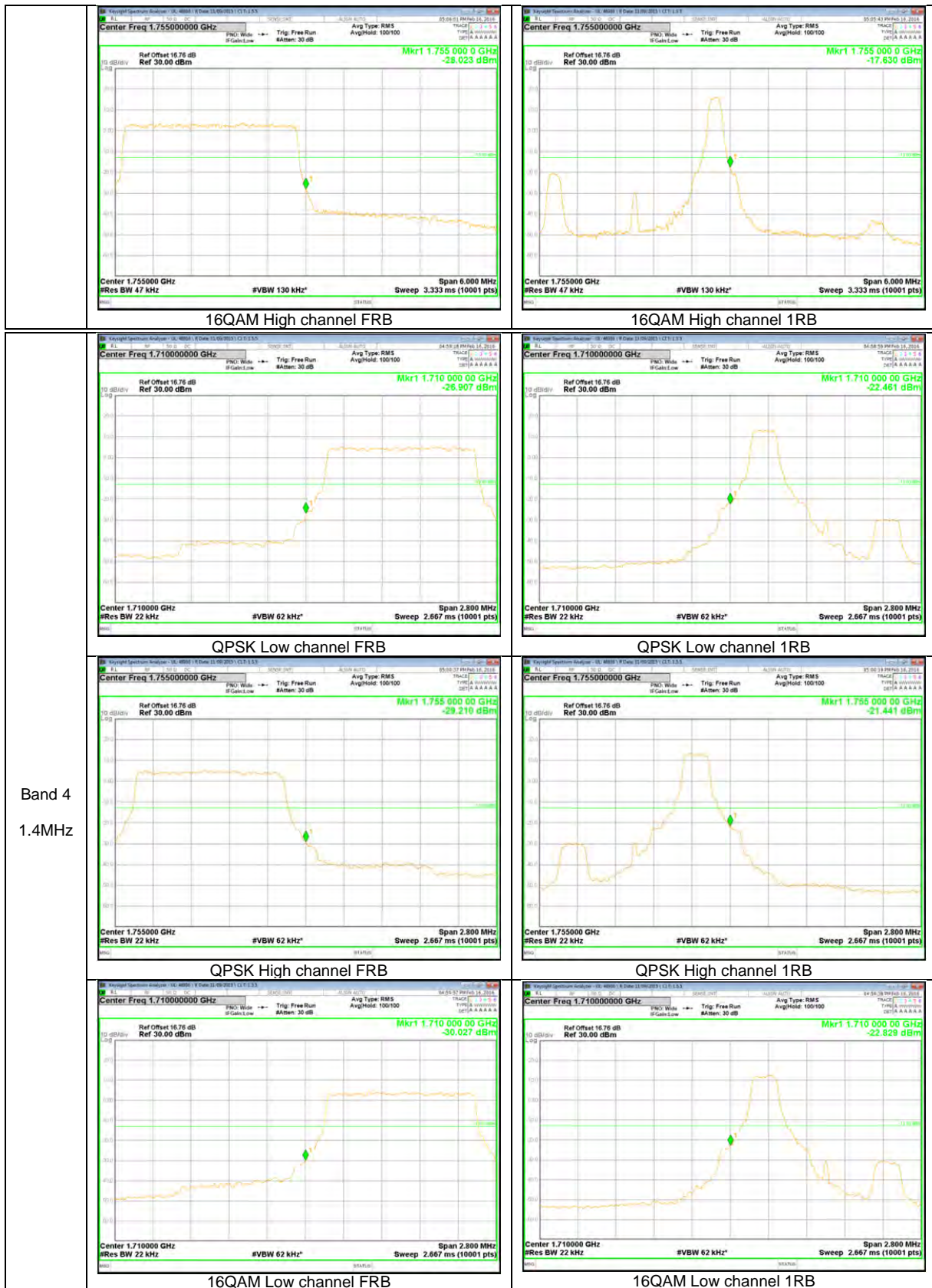

Band 4
 1.4MHz

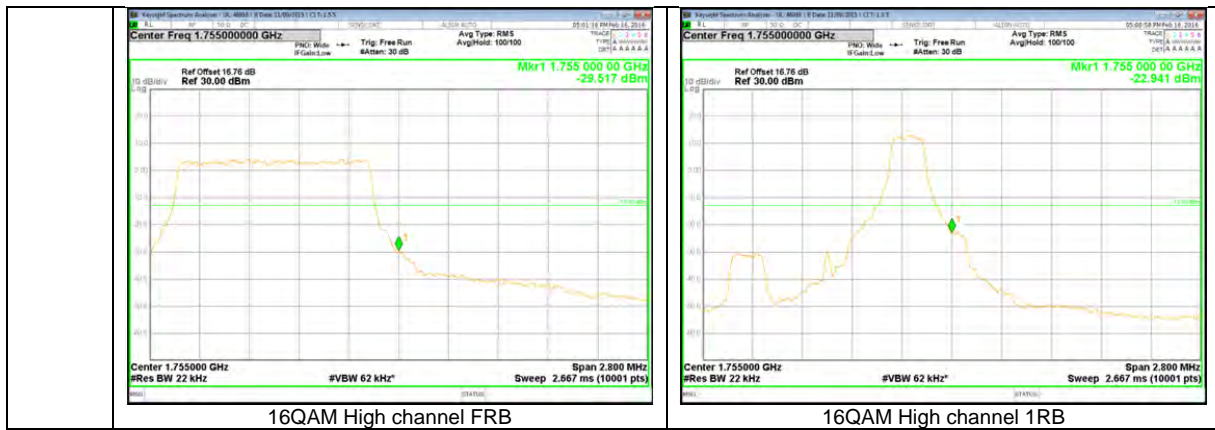

LTE Band 2

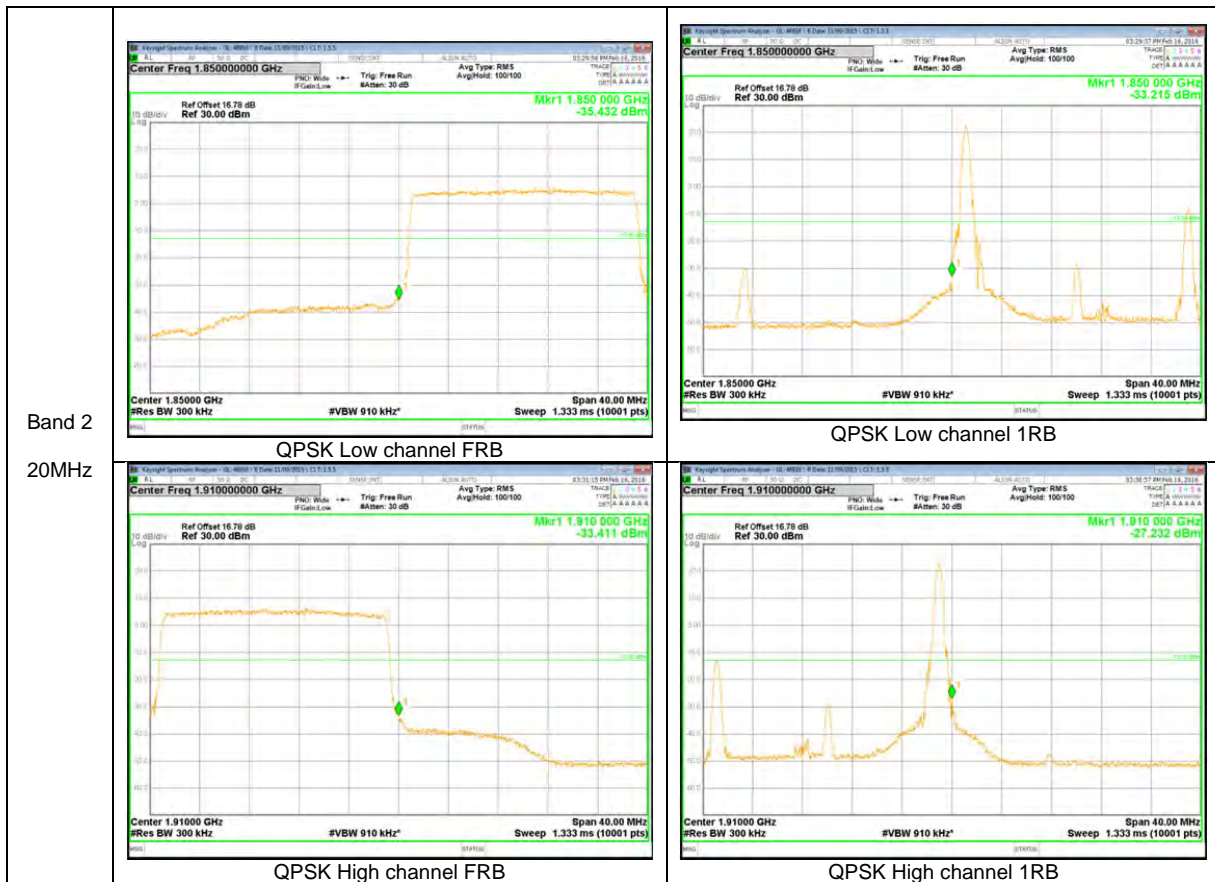

Band 2
 20MHz

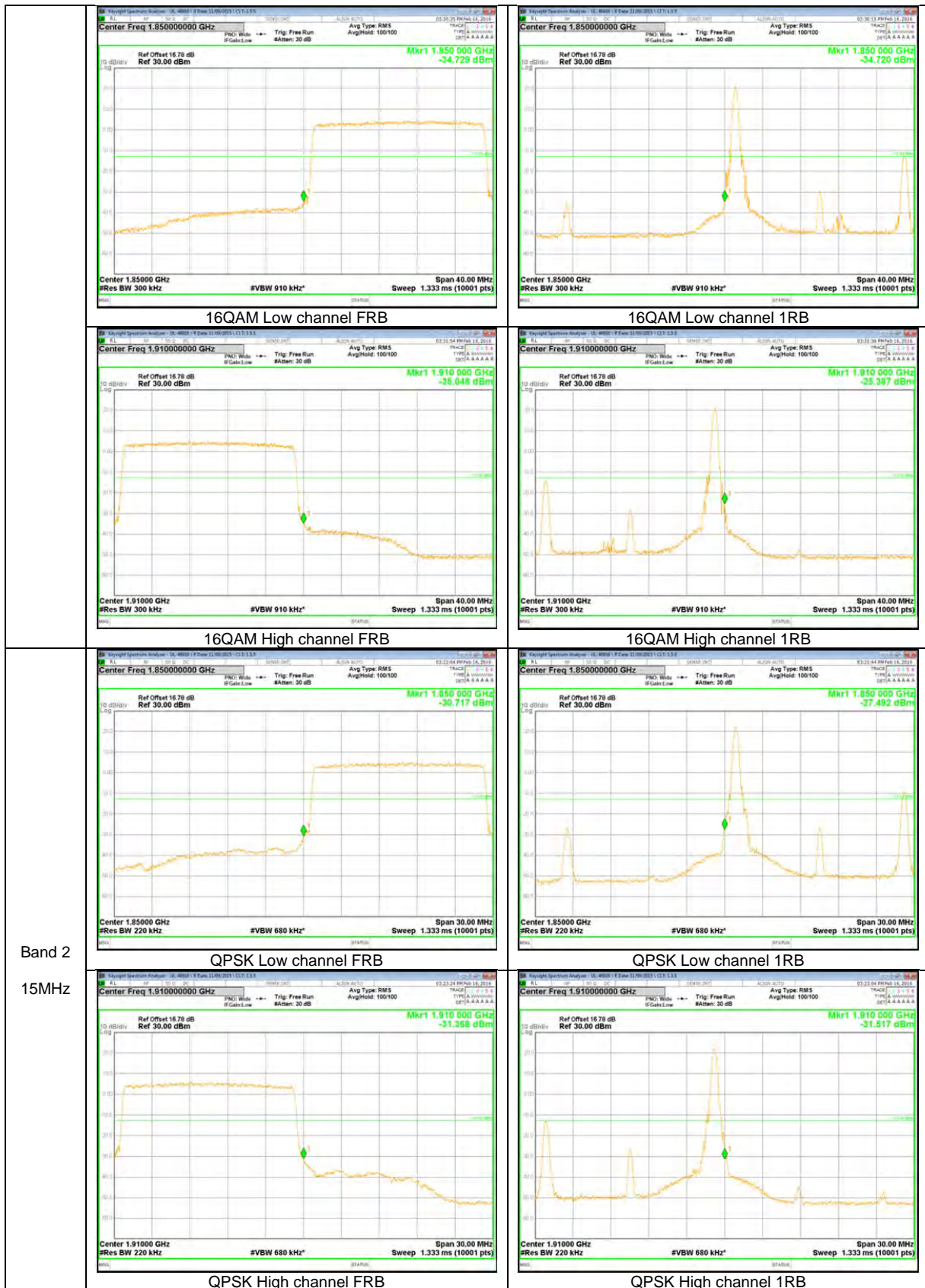

Band 2
 15MHz

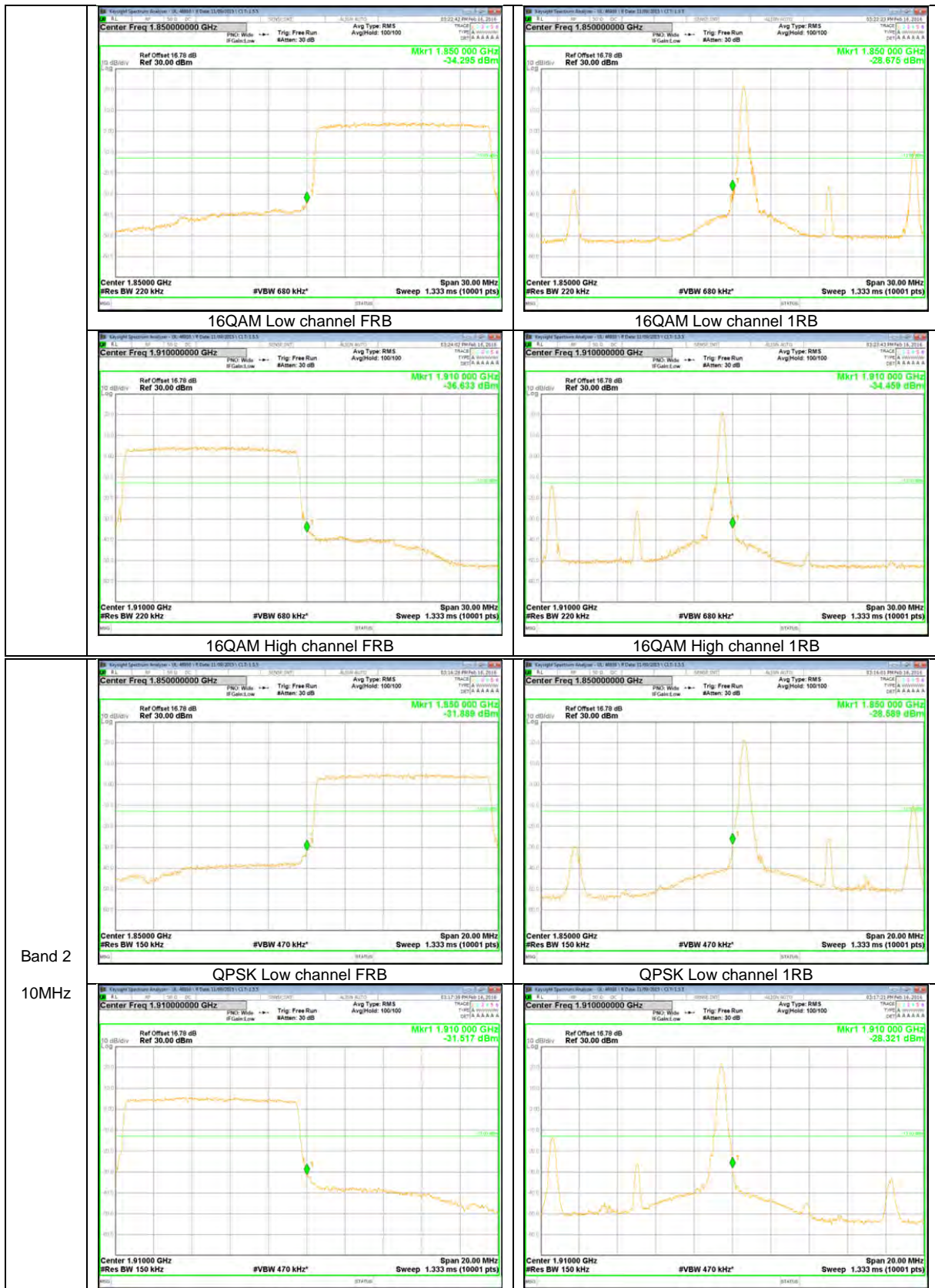

Band 2
10MHz

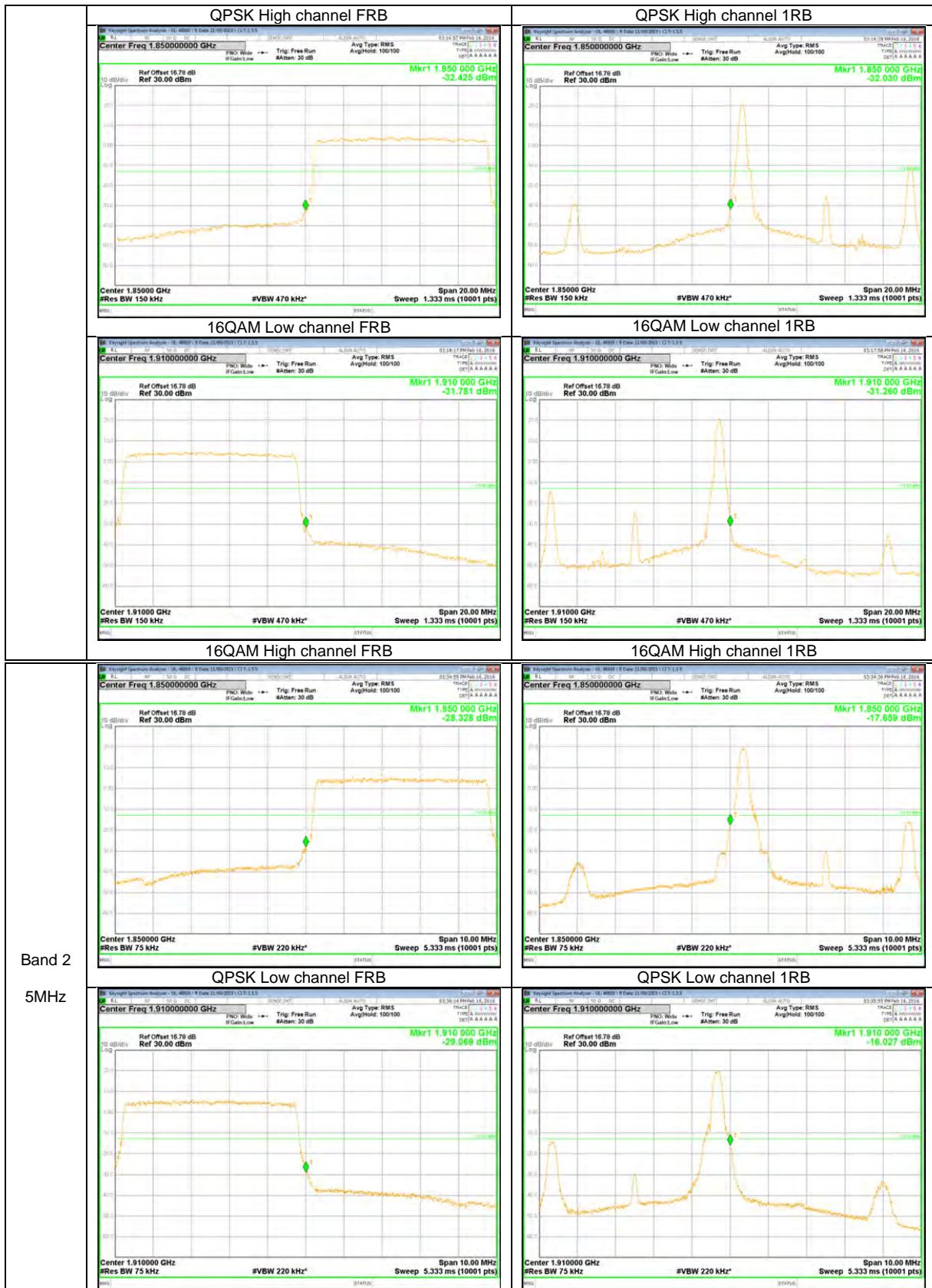

Band 2
5MHz

