



**FCC CFR47 PART 27 SUBPART D**

**LTE**

**CERTIFICATION TEST REPORT**

**FOR**

**WCDMA / LTE Tablet + Bluetooth/BLE, DTS/UNII a/b/g/n/ac and ANT+**

**MODEL NUMBER : SM-T677A**

**FCC ID: A3LSMT677A**

**REPORT NUMBER: 15K21698-E6**

**ISSUE DATE: SEP 23, 2015**

*Prepared for*  
**SAMSUNG ELECTRONICS CO., LTD.**  
**129 SAMSUNG-RO, YEONGTONG-GU, SUWON-SI,**  
**GYEONGGI-DO, 16677, KOREA**

*Prepared by*  
**UL Korea, Ltd. Suwon Laboratory**  
**218 Maeyeong-ro, Yeongtong-gu,**  
**Suwon-si, Gyeonggi-do, 16675, Korea**  
**TEL: (031) 337-9902**  
**FAX: (031) 213-5433**



---

Revision History

<u>Rev.</u>	<u>Issue Date</u>	<u>Revisions</u>	<u>Revised By</u>
--	09/23/15	Initial issue	Junwhan Lee

## TABLE OF CONTENTS

<b>1. ATTESTATION OF TEST RESULTS</b> .....	<b>5</b>
<b>2. TEST METHODOLOGY</b> .....	<b>6</b>
<b>3. FACILITIES AND ACCREDITATION</b> .....	<b>6</b>
<b>4. CALIBRATION AND UNCERTAINTY</b> .....	<b>6</b>
4.1. <i>MEASURING INSTRUMENT CALIBRATION</i> .....	6
4.2. <i>SAMPLE CALCULATION</i> .....	6
4.3. <i>MEASUREMENT UNCERTAINTY</i> .....	6
<b>5. EQUIPMENT UNDER TEST</b> .....	<b>7</b>
5.1. <i>DESCRIPTION OF EUT</i> .....	7
5.2. <i>MAXIMUM OUTPUT POWER (LTE)</i> .....	7
5.3. <i>DESCRIPTION OF TEST SETUP</i> .....	8
<b>6. TEST AND MEASUREMENT EQUIPMENT</b> .....	<b>10</b>
<b>7. Summary Table</b> .....	<b>11</b>
<b>8. RF POWER OUTPUT VERIFICATION</b> .....	<b>12</b>
8.1. <i>LTE OUTPUT VERIFICATION</i> .....	12
8.1.1. <i>LTE OUTPUT POWER RESULT</i> .....	13
<b>9. PEAK TO AVERAGE RATIO</b> .....	<b>14</b>
9.1. <i>CONDUCTED PEAK TO AVERAGE RESULT</i> .....	14
9.2. <i>CONDUCTED PEAK TO AVERAGE PLOTS</i> .....	15
<b>10. LIMITS AND CONDUCTED RESULTS</b> .....	<b>16</b>
10.1. <i>OCCUPIED BANDWIDTH</i> .....	16
10.1.1. <i>OCCUPIED BANDWIDTH RESULTS</i> .....	16
10.1.2. <i>OCCUPIED BANDWIDTH PLOTS</i> .....	17
10.2. <i>BAND EDGE EMISSIONS</i> .....	19
10.2.1. <i>EMISSION MASK PLOTS</i> .....	20
10.3. <i>OUT OF BAND EMISSIONS</i> .....	26
10.3.1. <i>OUT OF BAND EMISSIONS RESULT</i> .....	27
10.3.2. <i>OUT OF BAND EMISSIONS PLOTS</i> .....	28
10.4. <i>FREQUENCY STABILITY</i> .....	30
10.4.1. <i>FREQUENCY STABILITY RESULTS</i> .....	31
<b>11. RADIATED TEST RESULTS</b> .....	<b>32</b>
11.1. <i>RADIATED POWER (ERP &amp; EIRP)</i> .....	32
11.1.1. <i>ERP/EIRP Results</i> .....	33

---

11.1.2.	ERP/EIRP DATA.....	34
11.2.	<i>FIELD STRENGTH OF SPURIOUS RADIATION</i> .....	36
11.2.1.	SPURIOUS RADIATION PLOTS.....	37
12.	<b>SETUP PHOTOS</b> .....	<b>39</b>

# 1. ATTESTATION OF TEST RESULTS

**COMPANY NAME:** SAMSUNG ELECTRONICS CO., LTD.  
**EUT DESCRIPTION:** WCDMA / LTE Tablet + Bluetooth/BLE, DTS/UNII a/b/g/n/ac and ANT+.  
**MODEL NUMBER:** SM-T677A  
**SERIAL NUMBER:** R32G8007V7E (RADIATED); R32G8007NQL (CONDUCTED)  
**DATE TESTED:** SEP 10, 2015 - SEP 17, 2015

APPLICABLE STANDARDS	
STANDARD	TEST RESULTS
CFR 47 FCC PART 27D	Pass

UL Korea, Ltd. tested the above equipment in accordance with the requirements set forth in the above standards. All indications of Pass/Fail in this report are opinions expressed by UL Korea, Ltd. based on interpretations and/or observations of test results. Measurement Uncertainties were not taken into account and are published for informational purposes only. The test results show that the equipment tested is capable of demonstrating compliance with the requirements as documented in this report.

**Note:** The results documented in this report apply only to the tested sample, under the conditions and modes of operation as described herein. This document may not be altered or revised in any way unless done so by UL Korea, Ltd. and all revisions are duly noted in the revisions section. Any alteration of this document not carried out by UL Korea, Ltd. will constitute fraud and shall nullify the document. This report must not be used by the client to claim product certification, approval, or endorsement by IAS, any agency of the Federal Government, or any agency of any government.

Approved & Released For  
UL Korea, Ltd. By:



CY Choi  
Suwon Lab Engineer  
UL Korea, Ltd.

Tested By:



Junwhan Lee  
Suwon Lab Engineer  
UL Korea, Ltd.

## 2. TEST METHODOLOGY

The tests documented in this report were performed in accordance with TIA-603-D, FCC CFR 47 Part 27.

## 3. FACILITIES AND ACCREDITATION

The test sites and measurement facilities used to collect data are located at 218 Maeyeong-ro, Yeongtong-gu, Suwon-si, Gyeonggi-do, 16675, Korea. Line conducted emissions are measured only at the 218 address. The following table identifies which facilities were utilized for radiated emission measurements documented in this report. Specific facilities are also identified in the test results sections.

218 Maeyeong-ro	
<input type="checkbox"/>	Chamber 1
<input checked="" type="checkbox"/>	Chamber 2

UL Korea, Ltd. is accredited by IAS, Laboratory Code TL-637. The full scope of accreditation can be viewed at <http://www.iasonline.org/PDF/TL/TL-637.pdf>.

## 4. CALIBRATION AND UNCERTAINTY

### 4.1. MEASURING INSTRUMENT CALIBRATION

The measuring equipment utilized to perform the tests documented in this report has been calibrated in accordance with the manufacturer's recommendations, and is traceable to recognized national standards.

### 4.2. SAMPLE CALCULATION

Where relevant, the following sample calculation is provided:

EIRP = PSA reading with EUT worst orientation (dBm) + Path loss (dB) – cable loss( between the SG and substitution antenna) + Substitution Antenna Factor (dBi)

ERP = PSA reading with EUT worst orientation (dBm) + Path loss (dB) – cable loss( between the SG and substitution antenna)  
 (Path loss = Signal generator output – PSA reading with substitution antenna)

### 4.3. MEASUREMENT UNCERTAINTY

Where relevant, the following measurement uncertainty levels have been estimated for tests performed on the apparatus:

PARAMETER	UNCERTAINTY
Conducted Disturbance, 0.15 to 30 MHz	2.32 dB
Radiated Disturbance, Below 1GHz	4.14 dB
Radiated Disturbance, Above 1 GHz	5.97 dB

Uncertainty figures are valid to a confidence level of 95%.

## 5. EQUIPMENT UNDER TEST

### 5.1. DESCRIPTION OF EUT

The EUT is a WCDMA / LTE Tablet + Bluetooth/BLE, DTS/UNII a/b/g/n/ac and ANT+.

### 5.2. MAXIMUM OUTPUT POWER (LTE)

The transmitter has a maximum peak conducted and radiated ERP / EIRP output powers as follows:

Band	Frequency Range [MHz]	BandWidth [MHz]	Modulation Peak	Conducted		Radiated	
				Avg [dBm]	Avg [mW]	Avg [dBm]	Avg [mW]
LTE30	2307.5 ~ 2312.5	10	QPSK	23.00	199.53	15.80	38.02
			16QAM	22.00	158.49	14.86	30.62
		5	QPSK	23.00	199.53	16.32	42.85
			16QAM	22.00	158.49	15.34	34.20

### DESCRIPTION OF AVAILABLE ANTENNAS

The radio utilizes a FPCB antenna for the [List the bands supported] with a maximum peak gain as follow:

Frequency (MHz)	Peak Gain (dBi)
LTE Band 30 2307.5 ~ 2312.5 MHz	2.2

### 5.3. DESCRIPTION OF TEST SETUP

#### SUPPORT EQUIPMENT

Support Equipment List				
Description	Manufacturer	Model	Serial Number	FCC ID
Charger	SAMSUNG	KSAS0501900200HU	R37G819A01R0KT3	N/A
Data Cable	SAMSUNG	EP-DG925UWE	N/A	N/A
Earphone	SAMSUNG	GH59-13967A	N/A	N/A

#### I/O CABLES

I/O Cable List						
Cable No	Port	# of identical ports	Connector Type	Cable Type	Cable Length (m)	Remarks
1	DC Power	1	Mini-USB	Shielded	0.8m	N/A
2	Audio	1	Mini-Jack	Unshielded	1.0m	N/A

#### TEST SETUP

The EUT is continuously communicated to the call box during the tests.

**SETUP DIAGRAM FOR TESTS (CONDUCTED TEST SETUP)**

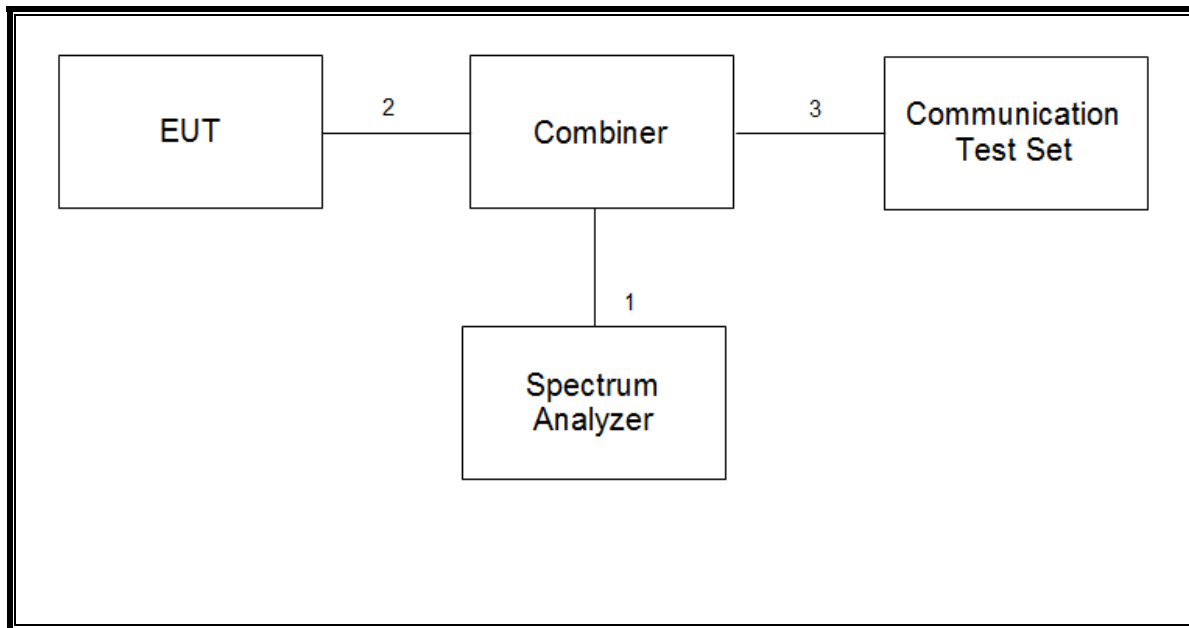

**SETUP DIAGRAM FOR TESTS (RADIATED TEST SETUP)**

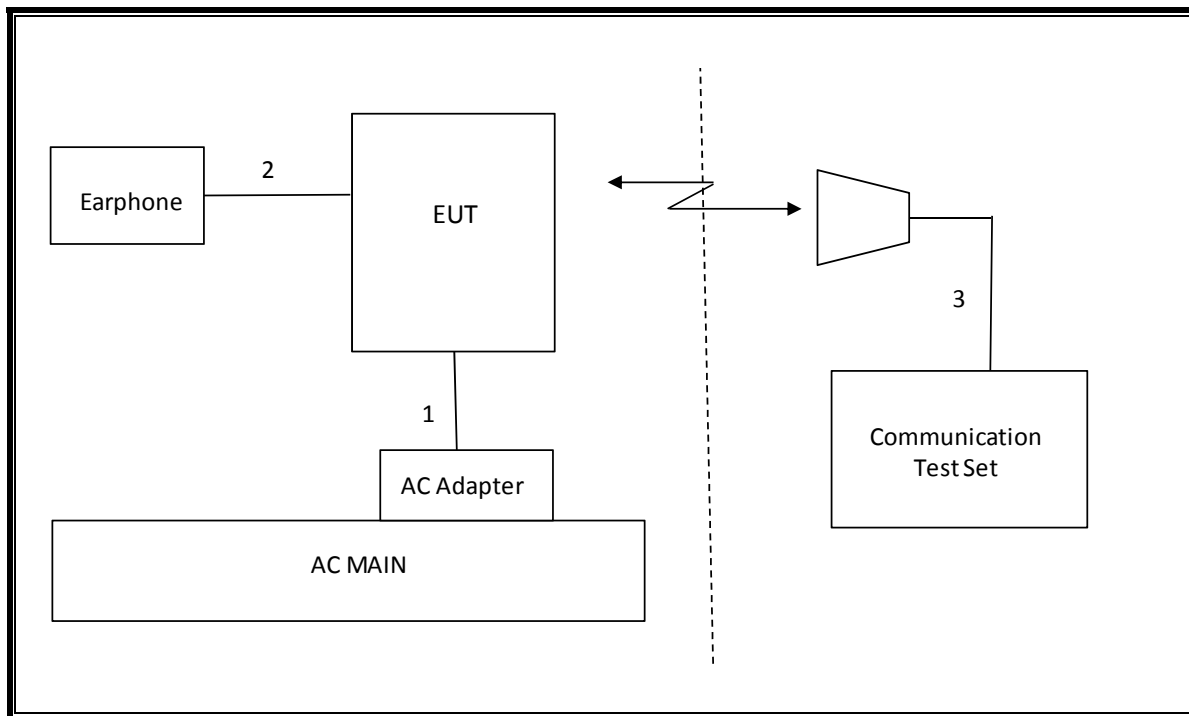

## 6. TEST AND MEASUREMENT EQUIPMENT

The following test and measurement equipment was utilized for the tests documented in this report:

Test Equipment List				
Description	Manufacturer	Model	S/N	Cal Due
Antenna, Tuned Dipole 400~1000 MHz	ETS	3121D DB4	00164753	07-28-16
Antenna, Bilog, 30MHz-1GHz	SCHWARZBECK	VULB9163	750	11-17-15
Antenna, Bilog, 30MHz-1GHz	SCHWARZBECK	VULB9163	749	04-25-16
Antenna, Horn, 18 GHz	ETS	3115	00161451	05-17-16
Antenna, Horn, 18 GHz	ETS	3117	00168724	06-17-16
Antenna, Horn, 18 GHz	ETS	3117	00168717	06-17-16
Antenna, Horn, 40 GHz	ETS	3116C	00166255	09-23-15
Antenna, Horn, 40 GHz	ETS	3116C-PA	00168841	09-29-15
Combiner	WEINSCHTEL	1575	2153	08-20-16
Communications Test Set	R&S	CMW500	150312	08-18-16
Communications Test Set	R&S	CMW500	115331	08-18-16
Communications Test Set	R&S	CMW500	102271	08-18-16
DC Power Supply	Agilent / HP	E3640A	MY54226395	08-18-16
Preamplifier, 1000 MHz	Sonoma	310N	341282	08-18-16
Preamplifier, 1000 MHz	Sonoma	310N	351741	08-18-16
Preamplifier, 18 GHz	Miteq	AFS42-00101800-25-S-42	1876511	08-18-16
Preamplifier, 18 GHz	Miteq	AFS42-00101800-25-S-42	1896138	08-18-16
Spectrum Analyzer, 44 GHz	Agilent / HP	N9030A	MY54170614	08-19-16
Spectrum Analyzer, 44 GHz	Agilent / HP	N9030A	MY54490312	08-19-16
Bluetooth Tester	TESCOM	TC-3000C	3000C000546	08-18-16
Average Power Sensor	R&S	NRZ-Z91	102681	08-18-16
Average Power Sensor	Agilent / HP	U2000	MY54270007	08-18-16
EMI Test Receive, 40 GHz	R&S	ESU40	100439	08-19-16
EMI Test Receive, 40 GHz	R&S	ESU40	100457	08-19-16
EMI Test Receive, 3 GHz	R&S	ESR3	101832	08-19-16
Attenuator / Switch driver	HP	11713A	3748A04272	N/A
Low Pass Filter 3GHz	Micro-Tronics	LPS17541	009	08-18-16
Low Pass Filter 3GHz	Micro-Tronics	LPS17541	015	08-18-16
High Pass Filter 5GHz	Micro-Tronics	HPS17542	009	08-18-16
High Pass Filter 6GHz	Micro-Tronics	HPM17543	010	08-18-16
High Pass Filter 5GHz	Micro-Tronics	HPS17542	016	08-18-16
High Pass Filter 6GHz	Micro-Tronics	HPM17543	015	08-18-16

## 7. Summary Table

FCC Part Section	Test Description	Test Limit	Test Condition	Test Result	Note
2.1049	Occupied Band width (99%)	N/A	Conducted	Pass	8.9491MHz
27.53(a)	Emission Mask	-		Pass	-
27.53(a)	Conducted Spurious Emission	-40dBm		Pass	-43.176dBm
2.1046	Conducted output power	N/A		Pass	23.00dBm
27.54	Frequency Stability	2.5PPM		Pass	0.006PPM
27.50(a)	Equivalent Isotropic Radiated Power	24dBm	Radiated	Pass	16.32dBm
27.53(a)	Radiated Spurious Emission	-40dBm		Pass	-46.5dBm

## 8. RF POWER OUTPUT VERIFICATION

### 8.1. LTE OUTPUT VERIFICATION

The following tests were conducted according to the test requirements outlined in section 6.2 of the 3GPP TS36.101 specification.

UE Power Class: 3 (23 +/- 2dBm). The allowed Maximum Power Reduction (MPR) for the maximum output power due to higher order modulation and transmit bandwidth configuration (resource blocks) is specified in Table 6.2.3-1 of the 3GPP TS36.101.

**Table 6.2.3-1: Maximum Power Reduction (MPR) for Power Class 3**

Modulation	Channel bandwidth / Transmission bandwidth (RB)						MPR (dB)
	1.4 MHz	3.0 MHz	5 MHz	10 MHz	15 MHz	20 MHz	
QPSK	> 5	> 4	> 8	> 12	> 16	> 18	≤ 1
16 QAM	≤ 5	≤ 4	≤ 8	≤ 12	≤ 16	≤ 18	≤ 1
16 QAM	> 5	> 4	> 8	> 12	> 16	> 18	≤ 2

The allowed A-MPR values specified below in Table 6.2.4.-1 of 3GPP TS36.101 are in addition to the allowed MPR requirements. All the measurements below were performed with A-MPR disabled, by using Network Signalling Value of “NS\_01”.

**Table 6.2.4-1: Additional Maximum Power Reduction (A-MPR)**

Network Signalling value	Requirements (sub-clause)	E-UTRA Band	Channel bandwidth (MHz)	Resources Blocks ( $N_{RB}$ )	A-MPR (dB)
NS_01	6.6.2.1.1	Table 5.5-1	1.4, 3, 5, 10, 15, 20	Table 5.6-1	NA
NS_03	6.6.2.2.1	2, 4, 10, 23, 25, 35, 36	3	>5	≤ 1
			5	>6	≤ 1
			10	>6	≤ 1
			15	>8	≤ 1
			20	>10	≤ 1
NS_04	6.6.2.2.2	41	5	>6	≤ 1
			10, 15, 20	See Table 6.2.4-4	
NS_05	6.6.3.3.1	1	10,15,20	≥ 50	≤ 1
NS_06	6.6.2.2.3	12, 13, 14, 17	1.4, 3, 5, 10	Table 5.6-1	n/a
NS_07	6.6.2.2.3	13	10	Table 6.2.4-2	Table 6.2.4-2
	6.6.3.3.2				
NS_08	6.6.3.3.3	19	10, 15	> 44	≤ 3
NS_09	6.6.3.3.4	21	10, 15	> 40	≤ 1
				> 55	≤ 2
NS_10		20	15, 20	Table 6.2.4-3	Table 6.2.4-3
NS_11	6.6.2.2.1	23 <sup>1</sup>	1.4, 3, 5, 10	Table 6.2.4-5	Table 6.2.4-5
..					
NS_32	-	-	-	-	-

Note 1: Applies to the lower block of Band 23, i.e. a carrier placed in the 2000-2010 MHz region.

### 8.1.1. LTE OUTPUT POWER RESULT

#### LTE Band 30 Measured Results

Mode	RB Allocation	RB offset	Target MPR	Avg Pwr (dBm)		
				27685 MHz	27710 MHz	27735 MHz
QPSK	1	0	0	22.80	22.62	22.87
	1	12	0	22.92	22.72	22.95
	1	24	0	23.00	22.90	23.00
	12	0	1	21.55	21.60	21.65
	12	7	1	21.72	21.68	21.65
	12	13	1	21.75	21.74	21.66
	25	0	1	21.62	21.63	21.66
16QAM	1	0	1	22.00	21.91	22.00
	1	12	1	22.00	21.95	22.00
	1	24	1	22.00	22.00	22.00
	12	0	2	20.63	20.59	20.61
	12	7	2	20.70	20.67	20.73
	12	13	2	20.74	20.72	20.72
	25	0	2	20.68	20.65	20.70

## 9. PEAK TO AVERAGE RATIO

### Test Procedure

Per KDB 971168 D01 Power Meas License Digital Systems v02r02;

The transmitter output was connected to a CMW500 Test Set and configured to operate at maximum power. The PAR were measured on the Spectrum Analyzer.

### Test Spec

In addition, when the transmitter power is measured in terms of average value, the peak-to-average ratio of the power shall not exceed 13 dB.

### 9.1. CONDUCTED PEAK TO AVERAGE RESULT

#### LTE

Band	BW [MHz]	Channel	f [MHz]	Mode	Ratio [dB]	Limit [dB]
Band 30	10	27710	2310	QPSK	4.36	13.00
				16QAM	5.61	
	5			QPSK	4.40	
				16QAM	5.39	

## 9.2. CONDUCTED PEAK TO AVERAGE PLOTS

### LTE30

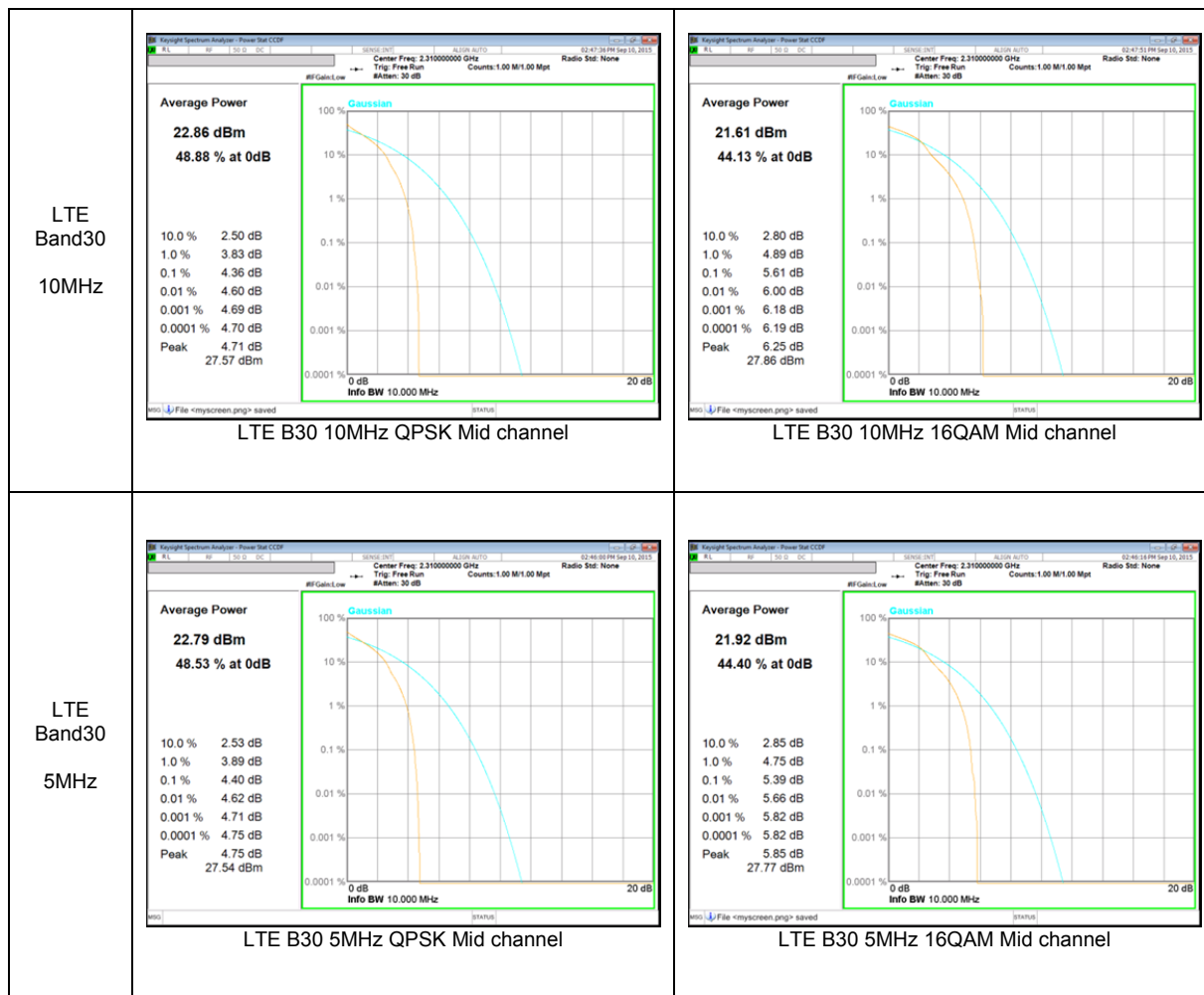

## 10. LIMITS AND CONDUCTED RESULTS

### 10.1. OCCUPIED BANDWIDTH

#### RULE PART(S)

FCC: §2.1049

#### LIMITS

For reporting purposes only

#### TEST PROCEDURE

The transmitter output was connected to a calibrated coaxial cable and coupler, the other end of which was connected to a spectrum analyzer. The occupied bandwidth was measured with the spectrum analyzer at the low, middle and high channel in each band. The -26dB bandwidth was also measured and recorded.

(KDB 971168 D01 Power Meas License Digital Systems v02r02)

#### 10.1.1. OCCUPIED BANDWIDTH RESULTS

##### LTE Band 5

Band	BW [MHz]	Channel	f [MHz]	Mode	99% BW [MHz]	26dB BW [MHz]
Band 5	10	27710	2310	QPSK	8.9491	10.17
				16QAM	8.9442	10.30
	5	27685	2307.5	QPSK	4.4994	5.255
				16QAM	4.5066	5.350
		27710	2310	QPSK	4.5015	5.196
				16QAM	4.5104	5.301
		27735	2312.5	QPSK	4.5028	5.217
				16QAM	4.5090	5.251

### 10.1.2. OCCUPIED BANDWIDTH PLOTS

#### LTE30

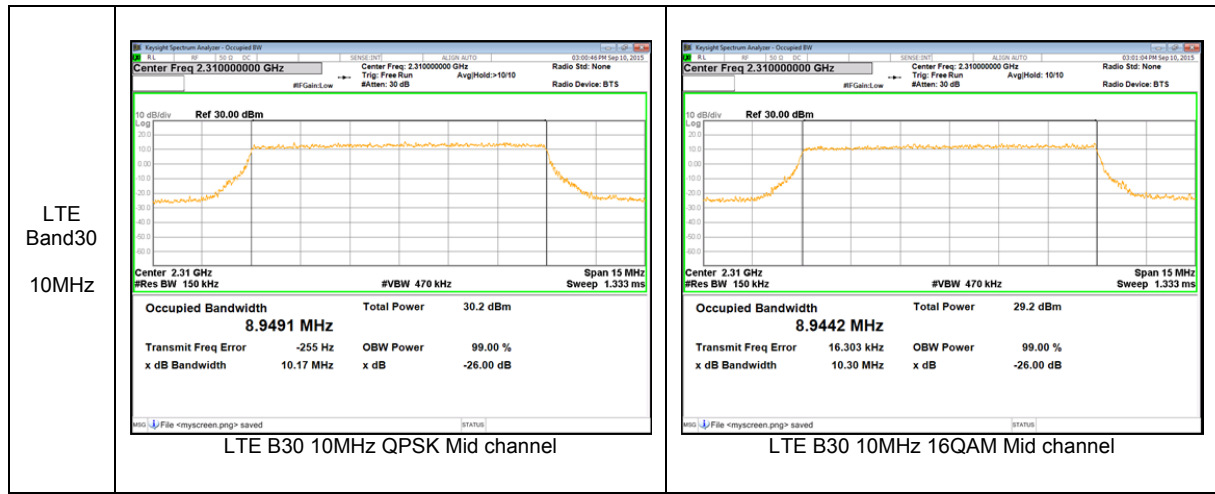

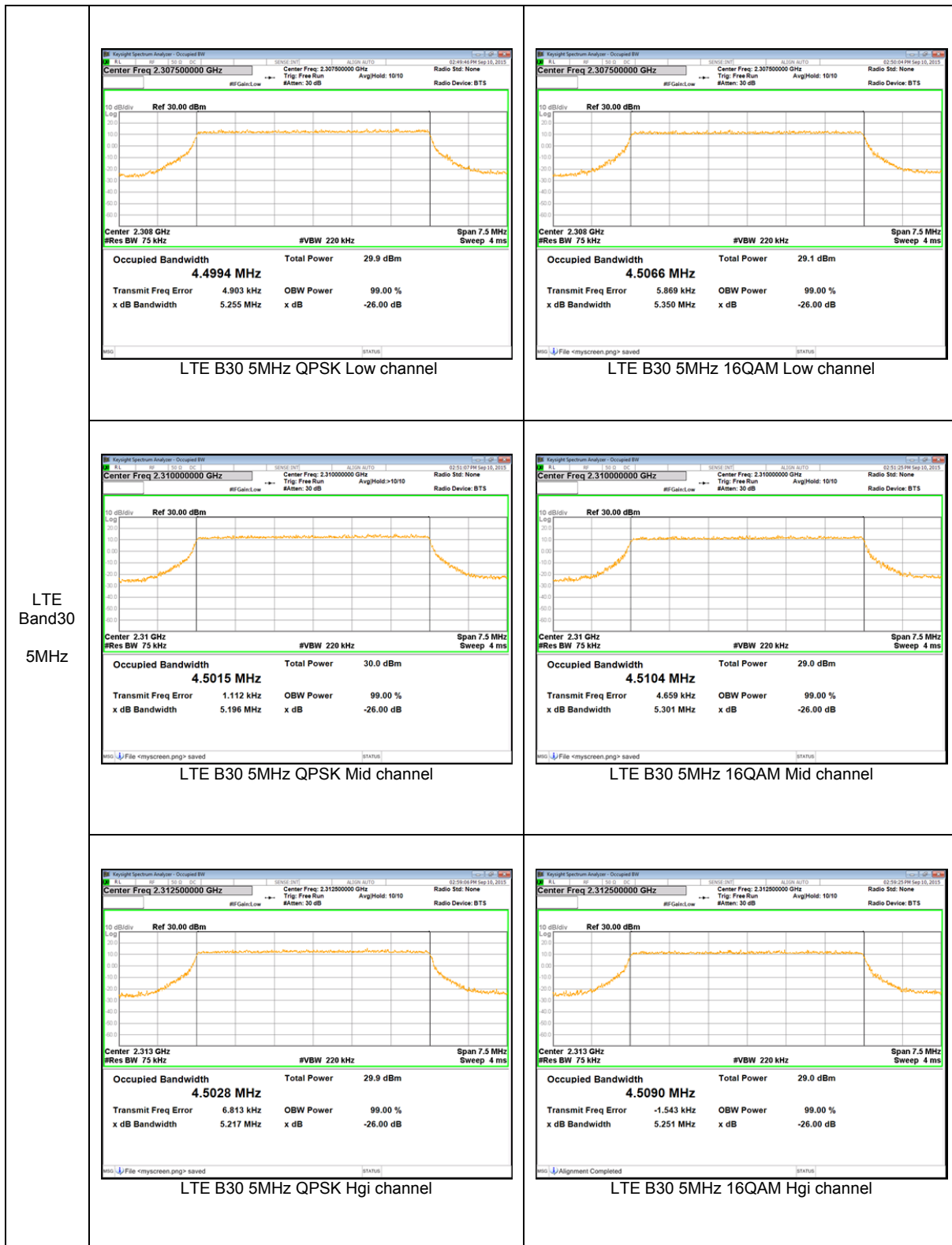

## 10.2. BAND EDGE EMISSIONS

### RULE PART(S)

FCC: §27.53

### LIMITS

§27.53(a)(4) - For mobile and portable stations operating in the 2305-2315 MHz and 2350-2360 MHz bands:

(i) By a factor of not less than:  $43 + 10 \log (P)$  dB on all frequencies between 2305 and 2320 MHz and on all frequencies between 2345 and 2360 MHz that are outside the licensed band(s) of operation, not less than  $55 + 10 \log (P)$  dB on all frequencies between 2320 and 2324 MHz and on all frequencies between 2341 and 2345 MHz, not less than  $61 + 10 \log (P)$  dB on all frequencies between 2324 and 2328 MHz and on all frequencies between 2337 and 2341 MHz, and not less than  $67 + 10 \log (P)$  dB on all frequencies between 2328 and 2337 MHz;

(ii) By a factor of not less than  $43 + 10 \log (P)$  dB on all frequencies between 2300 and 2305 MHz,  $55 + 10 \log (P)$  dB on all frequencies between 2296 and 2300 MHz,  $61 + 10 \log (P)$  dB on all frequencies between 2292 and 2296 MHz,  $67 + 10 \log (P)$  dB on all frequencies between 2288 and 2292 MHz, and  $70 + 10 \log (P)$  dB below 2288 MHz;

(iii) By a factor of not less than  $43 + 10 \log (P)$  dB on all frequencies between 2360 and 2365 MHz, and not less than  $70 + 10 \log (P)$  dB above 2365 MHz.

### TEST PROCEDURE

Per KDB 971168 D01 Power Meas License Digital Systems v02r02

The transmitter output was connected to a CMW500 Test Set and configured to operate at maximum power. The band edge emissions were measured at the required operating frequencies in each band on the Spectrum Analyzer.

### 10.2.1. EMISSION MASK PLOTS

#### LTE 30

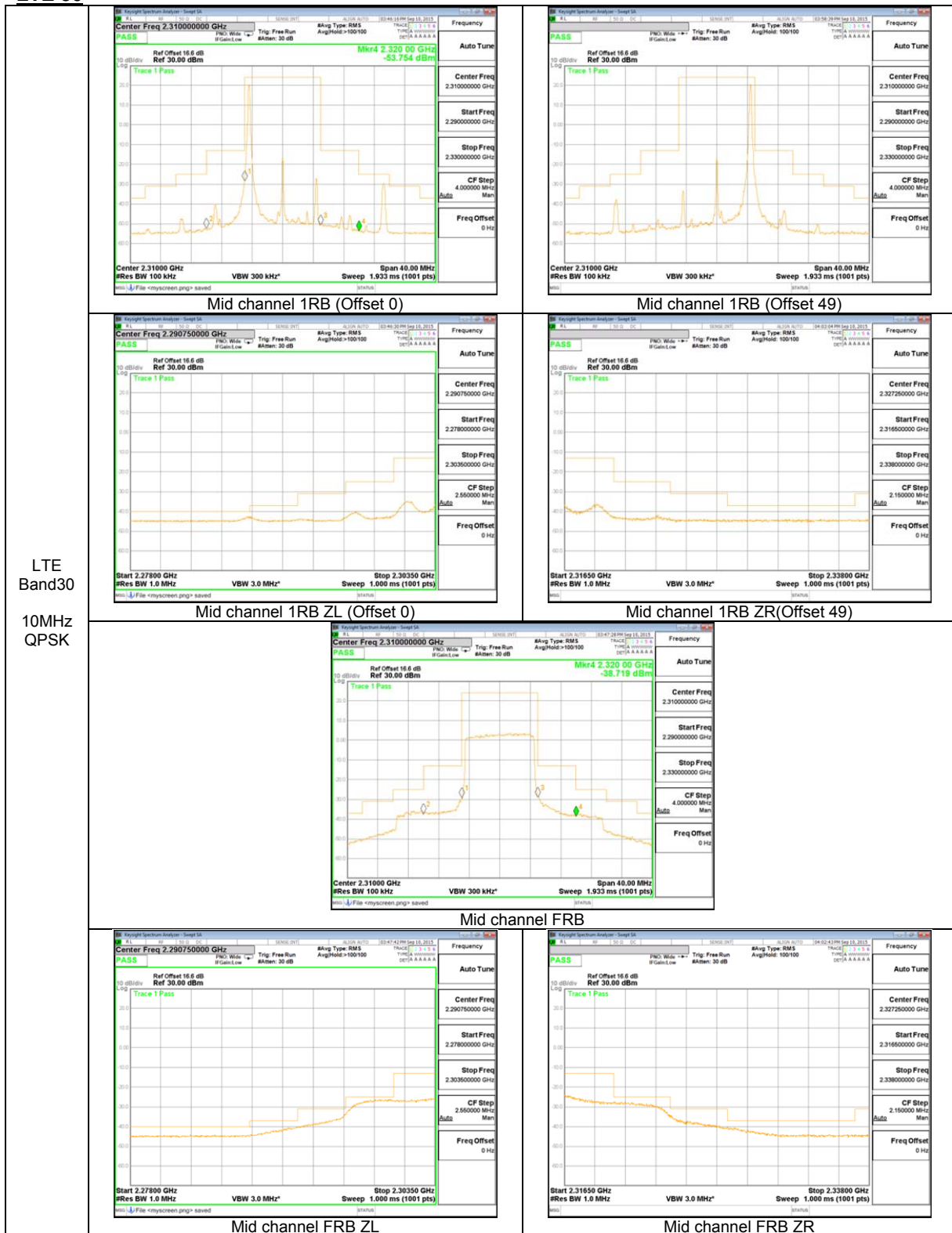

LTE Band30  
 10MHz QPSK

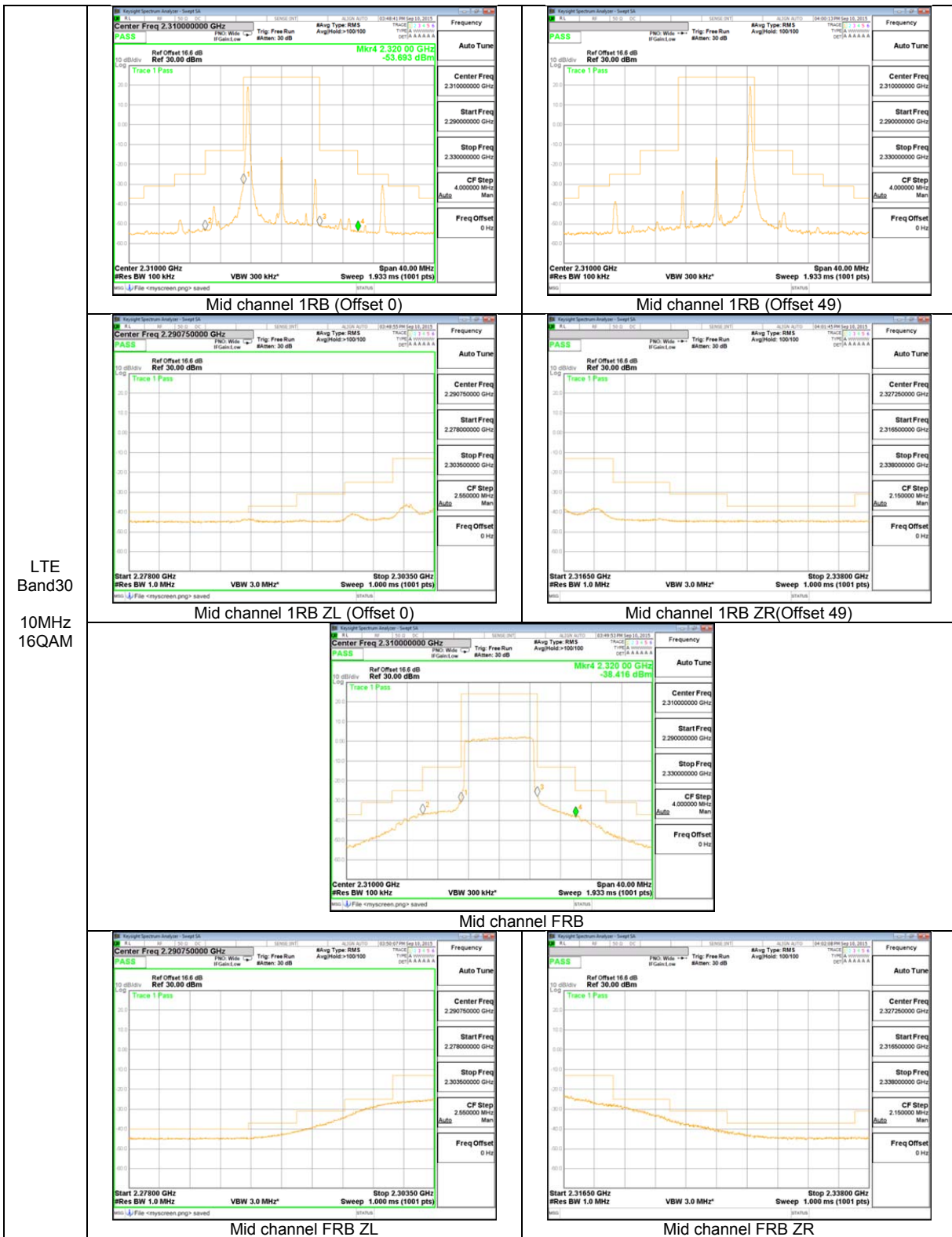

LTE  
 Band30  
 10MHz  
 16QAM



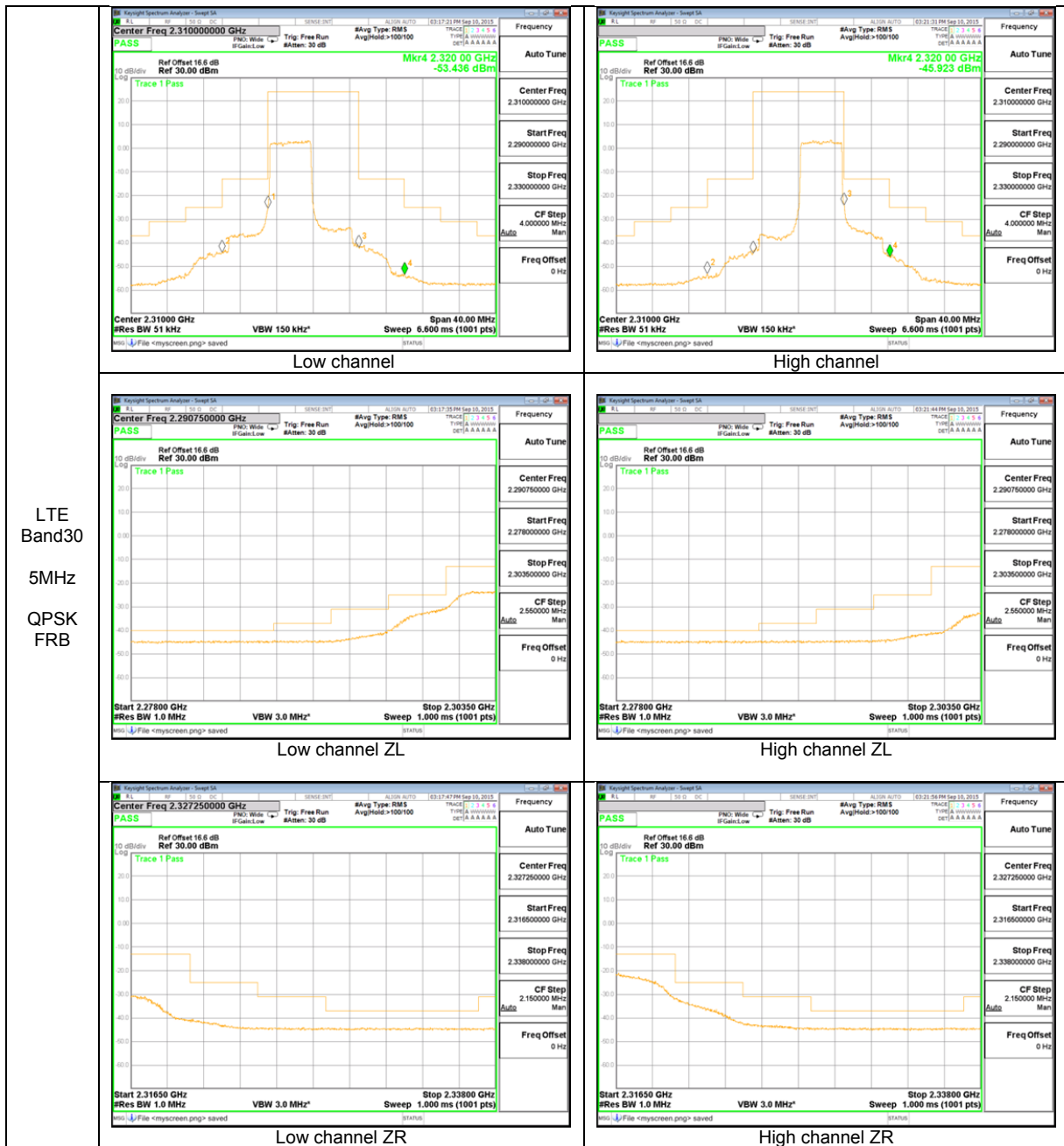

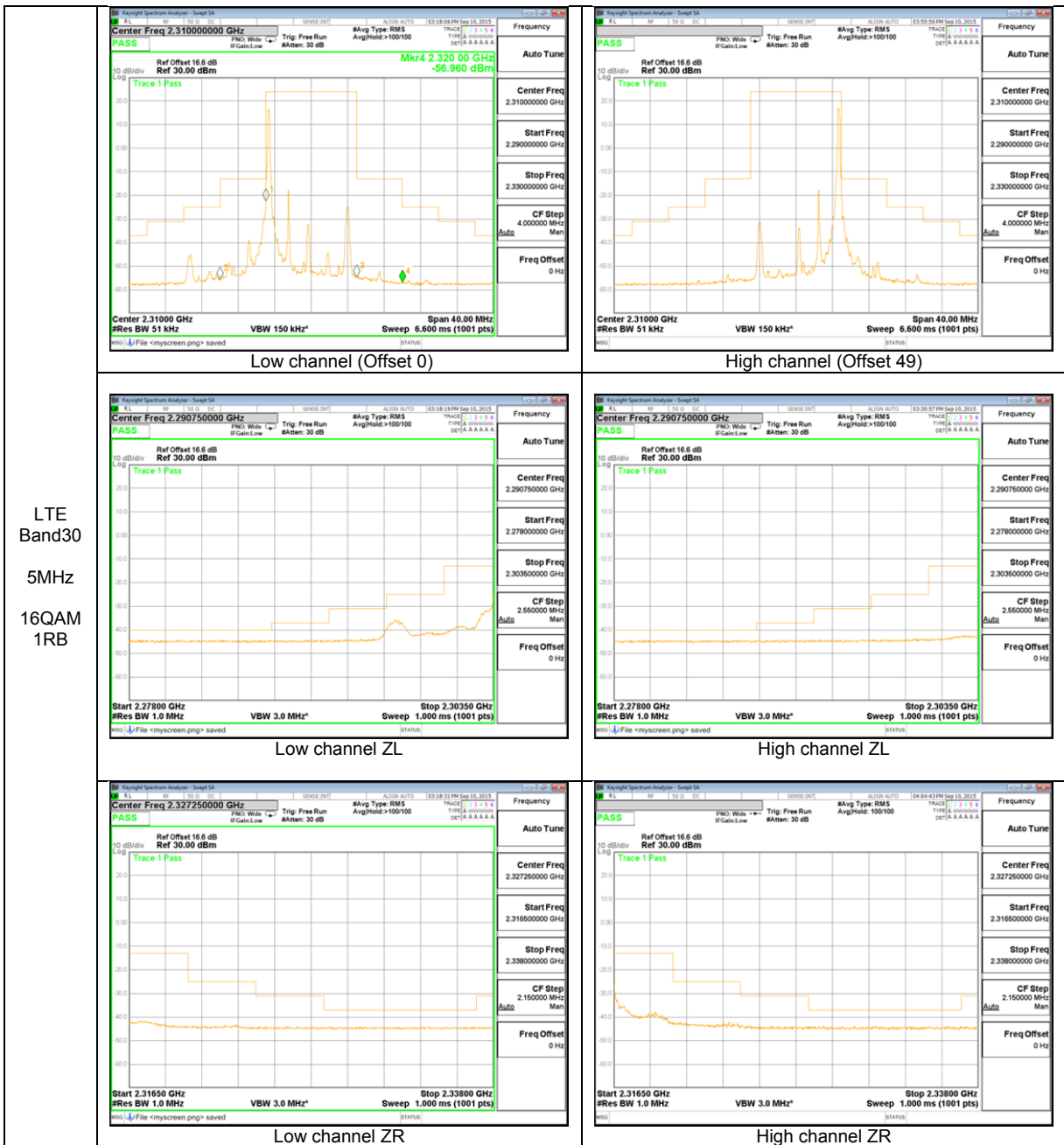

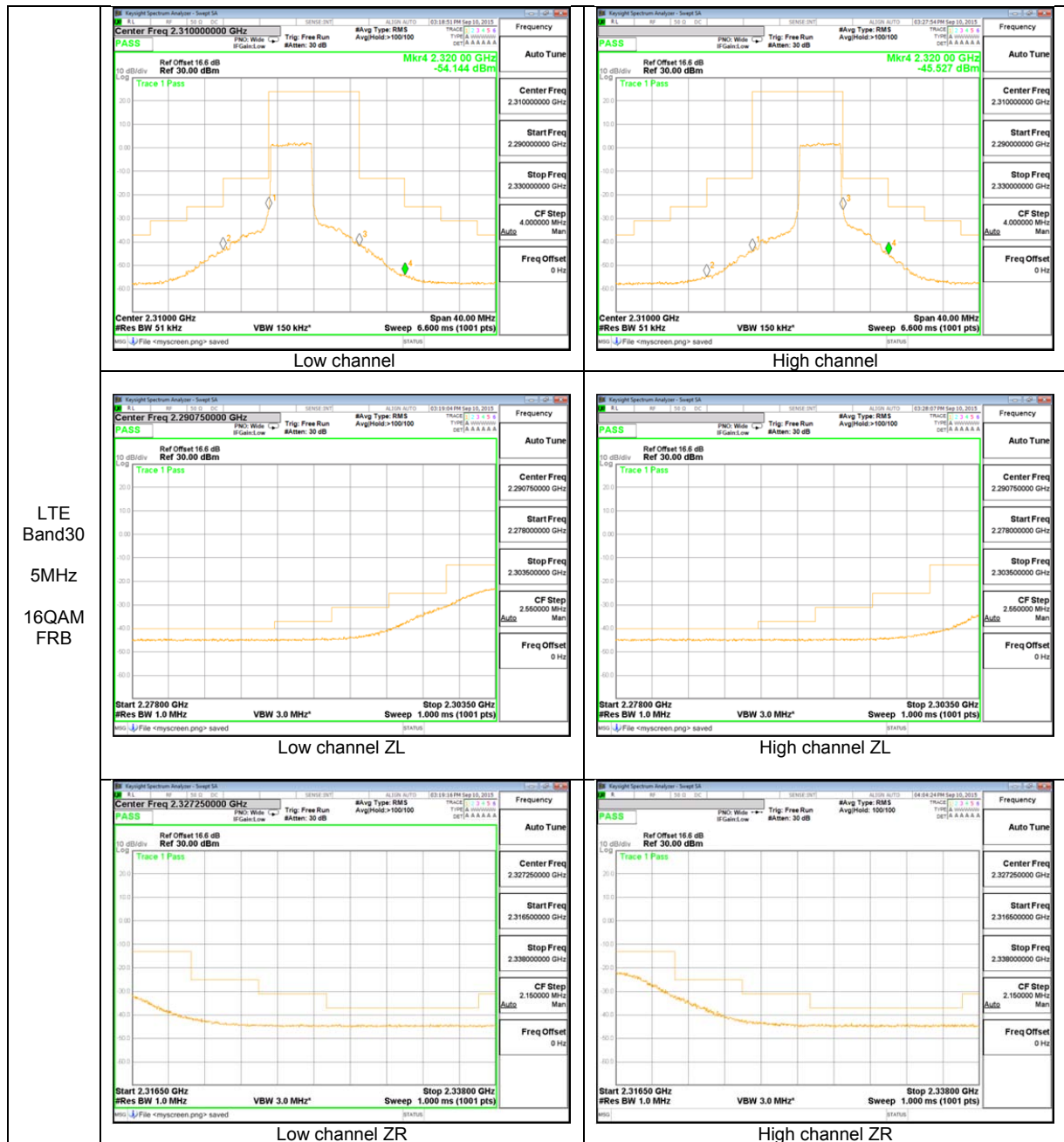

### **10.3. OUT OF BAND EMISSIONS**

#### **RULE PART(S)**

FCC: §2.1051, §27.53

#### **LIMITS**

§27.53(a)(4) - For mobile and portable stations operating in the 2305-2315 MHz and 2350-2360 MHz bands:

(i) By a factor of not less than:  $43 + 10 \log (P)$  dB on all frequencies between 2305 and 2320 MHz and on all frequencies between 2345 and 2360 MHz that are outside the licensed band(s) of operation, not less than  $55 + 10 \log (P)$  dB on all frequencies between 2320 and 2324 MHz and on all frequencies between 2341 and 2345 MHz, not less than  $61 + 10 \log (P)$  dB on all frequencies between 2324 and 2328 MHz and on all frequencies between 2337 and 2341 MHz, and not less than  $67 + 10 \log (P)$  dB on all frequencies between 2328 and 2337 MHz;

(ii) By a factor of not less than  $43 + 10 \log (P)$  dB on all frequencies between 2300 and 2305 MHz,  $55 + 10 \log (P)$  dB on all frequencies between 2296 and 2300 MHz,  $61 + 10 \log (P)$  dB on all frequencies between 2292 and 2296 MHz,  $67 + 10 \log (P)$  dB on all frequencies between 2288 and 2292 MHz, and  $70 + 10 \log (P)$  dB below 2288 MHz;

(iii) By a factor of not less than  $43 + 10 \log (P)$  dB on all frequencies between 2360 and 2365 MHz, and not less than  $70 + 10 \log (P)$  dB above 2365 MHz.

#### **TEST PROCEDURE**

Per KDB 971168 D01 Power Meas License Digital Systems v02r02

The RF output of the transmitter was connected to a spectrum analyzer through a calibrated coaxial cable. Sufficient scans were taken to show the out-of-band Emissions, if any, up to 10th harmonic. Multiple sweeps were recorded in maximum hold mode using a peak detector to ensure that the worst-case emissions were caught.

#### **RESULTS**

**10.3.1. OUT OF BAND EMISSIONS RESULT**

**LTE 30**

Bandwidth	Mode	f [MHz]	Spurious [dBm]	Limit [dBm]	Margin [dB]
10 MHz	QPSK	2310	-43.472	-40.00	3.472
	16QAM	2310	-43.748		3.748
5 MHz	QPSK	2307.5	-43.564		3.564
		2310	-46.870		6.870
		2312.5	-47.395		7.395
	16QAM	2307.5	-43.176		3.176
		2310	-46.437		6.437
		2312.5	-45.993		5.993

### 10.3.2. OUT OF BAND EMISSIONS PLOTS

#### LTE 30

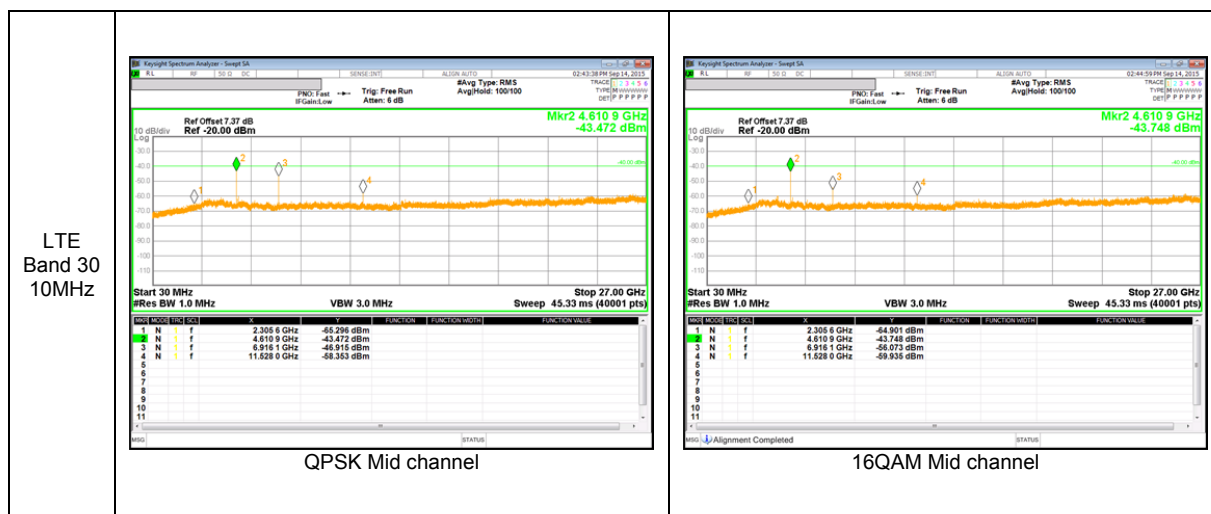

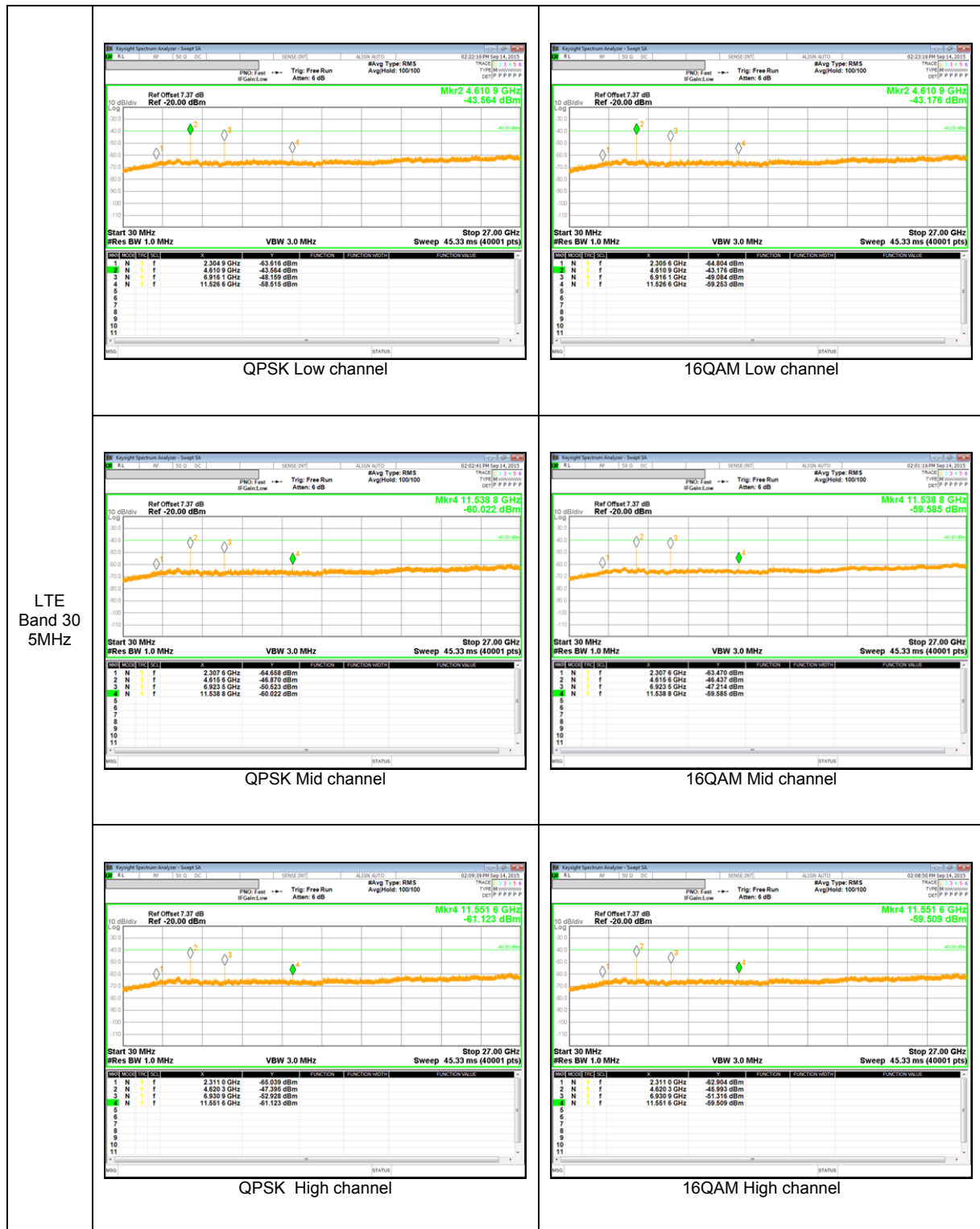

## **10.4. FREQUENCY STABILITY**

### **RULE PART(S)**

FCC: §2.1055, §27.54

### **LIMITS**

§27.54 - The frequency stability shall be sufficient to ensure that the fundamental emissions stay within the authorized bands of operation.

### **TEST PROCEDURE**

Per KDB 971168 D01 Power Meas License Digital Systems v02r02

### **RESULTS**

See the following pages.

**10.4.1. FREQUENCY STABILITY RESULTS**

**LTE Band 30, Channel 27710, Frequency 2310 MHz**

Reference Frequency: LTE Band30 Mid Channel 2310 MHz @ 20°C				
Limit: ± 2.5 ppm = 5775.000 Hz				
Power Supply (Vdc)	Environment Temperature (*C)	Frequency Deviation Measured with Time Elapse		
		(MHz)	Delta (ppm)	Limit (ppm)
11.34	50	2309.99997096	-0.001	2.5
11.34	40	2309.99996738	0.001	2.5
11.34	30	2309.99995621	0.006	2.5
<b>11.34</b>	<b>20</b>	<b>2309.99996940</b>	<b>0</b>	<b>2.5</b>
11.34	10	2309.99996899	0.000	2.5
11.34	0	2309.99996628	0.001	2.5
11.34	-10	2309.99997235	-0.001	2.5
11.34	-20	2309.99996315	0.003	2.5
11.34	-30	2309.99997553	-0.003	2.5

Reference Frequency: LTE Band30 Mid Channel 2310 MHz @ 20°C				
Limit: ± 2.5 ppm = 5775.000 Hz				
Power Supply (Vdc)	Environment Temperature (*C)	Frequency Deviation Measured with Time Elapse		
		(MHz)	Delta (ppm)	Limit (ppm)
<b>11.34</b>	<b>20</b>	<b>2309.99996112</b>	<b>0</b>	<b>2.5</b>
13.05	20	2309.99996479	-0.002	2.5
10.80	20	2309.99996271	-0.001	2.5

## 11. RADIATED TEST RESULTS

### 11.1. RADIATED POWER (ERP & EIRP)

#### RULE PART(S)

FCC: §2.1046, §27.50

#### LIMITS

§27.50(a) – (3) *Mobile and portable stations.* (i) For mobile and portable stations transmitting in the 2305-2315 MHz band or the 2350-2360 MHz band, the average EIRP must not exceed 50 milliwatts within any 1 megahertz of authorized bandwidth, *except that* for mobile and portable stations compliant with 3GPP LTE standards or another advanced mobile broadband protocol that avoids concentrating energy at the edge of the operating band the average EIRP must not exceed 250 milliwatts within any 5 megahertz of authorized bandwidth but may exceed 50 milliwatts within any 1 megahertz of authorized bandwidth.

In addition, when the transmitter power is measured in terms of average value, the peak-to-average ratio of the power shall not exceed 13dB.

#### TEST PROCEDURE

ANSI / TIA / EIA 603D Clause 2.2.17; MXA setting reference to 971168 D01 v02r02

For peak power measurement with a MXA:

a) Set the RBW  $\geq$  OBW; b) Set VBW  $\geq 3 \times$  RBW; c) Set span  $\geq 2 \times$  RBW; d) Sweep time = auto couple; e) Detector = peak; f) Ensure that the number of measurement points  $\geq$  span/RBW; g) Trace mode = max hold;

For average power measurement with a MXA:

a) Set span to at least 1.5 times the OBW; b) Set RBW = 1-5% of the OBW, not to exceed 1 MHz; c) Set VBW  $\geq 3 \times$  RBW; d) Set number of points in sweep  $\geq 2 \times$  span / RBW; e) Sweep time = auto-couple; f) Detector = RMS (power averaging); g) Use free run trigger If burst duty cycle  $\geq 98$ ; h) Use trigger to capture bursts If burst duty cycle  $< 98$ ; i) Trace average at least 100 traces in power averaging (*i.e.*, RMS) mode. j) Compute the power by integrating the spectrum across the OBW of the signal using the instrument's band power measurement function.

#### TEST RESULTS

**11.1.1. ERP/EIRP Results**

**LTE 30**

Band	BW [MHz]	Mode	RB/RB Size	f [MHz]	ERP / EIRP	
			Full RB		[dBm]	[mW]
Band 30	10	QPSK	50/0	2310	15.80	38.02
		16QAM	50/0	2310	14.86	30.62
	5	QPSK	25/0	2307.5	12.81	19.10
			25/0	2310	15.82	38.19
			25/0	2312.5	16.32	42.85
		16QAM	25/0	2307.5	11.91	15.52
			25/0	2310	14.81	30.27
	25/0	2312.5	15.34	34.20		

**11.1.2. ERP/EIRP DATA**

**LTE 30**

LTE Band 30  QPSK 10MHz	<b>High Frequency Substitution Measurement</b> <b>UL Korea, Ltd. Suwon Laboratory Chamber 2</b>																																				
	<b>Company:</b> Samsung <b>Project #:</b> 15K21698 <b>Date:</b> 09-12-15 <b>Test Engineer:</b> Steven.Kim <b>Configuration:</b> EUT / Y-Position <b>Mode:</b> LTE Band 30 QPSK, 10MHz																																				
	<b>Test Equipment:</b> <b>Receiving:</b> 3117[00168724] and Chamber 1 SMA Cables <b>Substitution:</b> 3115[00161451] Substitution, 3m SMA Cable Warehouse																																				
	<table border="1"> <thead> <tr> <th>f MHz</th> <th>SG reading (dBm)</th> <th>Ant. Pol. (H/V)</th> <th>Cable Loss (dB)</th> <th>Antenna Gain (dBi)</th> <th>EIRP (dBm)</th> <th>Limit (dBm)</th> <th>Margin (dB)</th> <th>Notes</th> </tr> </thead> <tbody> <tr> <td>Mid Ch</td> <td></td> <td></td> <td></td> <td></td> <td></td> <td></td> <td></td> <td></td> </tr> <tr> <td>2310.00</td> <td>7.31</td> <td>V</td> <td>1.9</td> <td>10.4</td> <td>15.80</td> <td>24.0</td> <td>-8.2</td> <td></td> </tr> <tr> <td>2310.00</td> <td>6.53</td> <td>H</td> <td>1.9</td> <td>10.4</td> <td>15.02</td> <td>24.0</td> <td>-9.0</td> <td></td> </tr> </tbody> </table>	f MHz	SG reading (dBm)	Ant. Pol. (H/V)	Cable Loss (dB)	Antenna Gain (dBi)	EIRP (dBm)	Limit (dBm)	Margin (dB)	Notes	Mid Ch									2310.00	7.31	V	1.9	10.4	15.80	24.0	-8.2		2310.00	6.53	H	1.9	10.4	15.02	24.0	-9.0	
f MHz	SG reading (dBm)	Ant. Pol. (H/V)	Cable Loss (dB)	Antenna Gain (dBi)	EIRP (dBm)	Limit (dBm)	Margin (dB)	Notes																													
Mid Ch																																					
2310.00	7.31	V	1.9	10.4	15.80	24.0	-8.2																														
2310.00	6.53	H	1.9	10.4	15.02	24.0	-9.0																														
	Rev. 3.17.11 Note: For Band 4 EIRP limit is 30dBm																																				
LTE Band 30  16QAM 10MHz	<b>High Frequency Substitution Measurement</b> <b>UL Korea, Ltd. Suwon Laboratory Chamber 2</b>																																				
	<b>Company:</b> Samsung <b>Project #:</b> 15K21698 <b>Date:</b> 09-12-15 <b>Test Engineer:</b> Steven.Kim <b>Configuration:</b> EUT / Y-Position <b>Mode:</b> LTE Band 30 16QAM, 10MHz																																				
	<b>Test Equipment:</b> <b>Receiving:</b> 3117[00168724] and Chamber 1 SMA Cables <b>Substitution:</b> 3115[00161451] Substitution, 3m SMA Cable Warehouse																																				
	<table border="1"> <thead> <tr> <th>f MHz</th> <th>SG reading (dBm)</th> <th>Ant. Pol. (H/V)</th> <th>Cable Loss (dB)</th> <th>Antenna Gain (dBi)</th> <th>EIRP (dBm)</th> <th>Limit (dBm)</th> <th>Margin (dB)</th> <th>Notes</th> </tr> </thead> <tbody> <tr> <td>Mid Ch</td> <td></td> <td></td> <td></td> <td></td> <td></td> <td></td> <td></td> <td></td> </tr> <tr> <td>2310.00</td> <td>6.37</td> <td>V</td> <td>1.9</td> <td>10.4</td> <td>14.86</td> <td>24.0</td> <td>-9.1</td> <td></td> </tr> <tr> <td>2310.00</td> <td>5.51</td> <td>H</td> <td>1.9</td> <td>10.4</td> <td>14.00</td> <td>24.0</td> <td>-10.0</td> <td></td> </tr> </tbody> </table>	f MHz	SG reading (dBm)	Ant. Pol. (H/V)	Cable Loss (dB)	Antenna Gain (dBi)	EIRP (dBm)	Limit (dBm)	Margin (dB)	Notes	Mid Ch									2310.00	6.37	V	1.9	10.4	14.86	24.0	-9.1		2310.00	5.51	H	1.9	10.4	14.00	24.0	-10.0	
f MHz	SG reading (dBm)	Ant. Pol. (H/V)	Cable Loss (dB)	Antenna Gain (dBi)	EIRP (dBm)	Limit (dBm)	Margin (dB)	Notes																													
Mid Ch																																					
2310.00	6.37	V	1.9	10.4	14.86	24.0	-9.1																														
2310.00	5.51	H	1.9	10.4	14.00	24.0	-10.0																														
	Rev. 3.17.11 Note: For Band 4 EIRP limit is 30dBm																																				

		High Frequency Substitution Measurement UL Korea, Ltd. Suwon Laboratory Chamber 2								
LTE Band 30  QPSK 5MHz	Company:		Samsung							
	Project #:		15K21698							
	Date:		09-10-15							
	Test Engineer:		Steven.Kim							
	Configuration:		EUT / Y-Position							
	Mode:		LTE Band 30 QPSK, 5MHz							
	<b>Test Equipment:</b>		Receiving: 3117[00168724] and Chamber 1 SMA Cables Substitution: 3115[00161451] Substitution, 3m SMA Cable Warehouse							
		<b>f</b>	<b>SG reading</b>	<b>Ant. Pol.</b>	<b>Cable Loss</b>	<b>Antenna Gain</b>	<b>EIRP</b>	<b>Limit</b>	<b>Margin</b>	<b>Notes</b>
		<b>MHz</b>	<b>(dBm)</b>	<b>(H/V)</b>	<b>(dB)</b>	<b>(dBi)</b>	<b>(dBm)</b>	<b>(dBm)</b>	<b>(dB)</b>	
		Low Ch								
		2307.50	5.55	V	1.9	9.1	12.81	24.0	-11.2	
		2307.50	5.47	H	1.9	9.1	12.73	24.0	-11.3	
		Mid Ch								
		2310.00	7.33	V	1.9	10.4	15.82	24.0	-8.2	
	2310.00	6.53	H	1.9	10.4	15.02	24.0	-9.0		
	High Ch									
	2312.50	7.88	V	1.9	10.3	16.32	24.0	-7.7		
	2312.50	7.03	H	1.9	10.3	15.47	24.0	-8.5		
		Rev. 3.17.11 Note: For Band 4 EIRP limit is 30dBm								
		High Frequency Substitution Measurement UL Korea, Ltd. Suwon Laboratory Chamber 2								
Company:		Samsung								
Project #:		15K21698								
Date:		09-10-15								
Test Engineer:		Steven.Kim								
Configuration:		EUT / Y-Position								
Mode:		LTE Band 30 16QAM, 5MHz								
<b>Test Equipment:</b>		Receiving: 3117[00168724] and Chamber 1 SMA Cables Substitution: 3115[00161451] Substitution, 3m SMA Cable Warehouse								
	<b>f</b>	<b>SG reading</b>	<b>Ant. Pol.</b>	<b>Cable Loss</b>	<b>Antenna Gain</b>	<b>EIRP</b>	<b>Limit</b>	<b>Margin</b>	<b>Notes</b>	
	<b>MHz</b>	<b>(dBm)</b>	<b>(H/V)</b>	<b>(dB)</b>	<b>(dBi)</b>	<b>(dBm)</b>	<b>(dBm)</b>	<b>(dB)</b>		
	Low Ch									
	2307.50	4.65	V	1.9	9.1	11.91	24.0	-12.1		
	2307.50	4.58	H	1.9	9.1	11.84	24.0	-12.2		
	Mid Ch									
	2310.00	6.32	V	1.9	10.4	14.81	24.0	-9.2		
	2310.00	5.49	H	1.9	10.4	13.98	24.0	-10.0		
	High Ch									
	2312.50	6.90	V	1.9	10.3	15.34	24.0	-8.7		
	2312.50	6.05	H	1.9	10.3	14.49	24.0	-9.5		
		Rev. 3.17.11 Note: For Band 4 EIRP limit is 30dBm								
LTE Band 30  16QAM 5MHz			High Frequency Substitution Measurement UL Korea, Ltd. Suwon Laboratory Chamber 2							

## 11.2. FIELD STRENGTH OF SPURIOUS RADIATION

### RULE PART(S)

FCC: §2.1053, §27.53

### LIMIT

§27.53(a)(4) - For mobile and portable stations operating in the 2305-2315 MHz and 2350-2360 MHz bands:

(ii) By a factor of not less than  $43 + 10 \log (P)$  dB on all frequencies between 2300 and 2305 MHz,  $55 + 10 \log (P)$  dB on all frequencies between 2296 and 2300 MHz,  $61 + 10 \log (P)$  dB on all frequencies between 2292 and 2296 MHz,  $67 + 10 \log (P)$  dB on all frequencies between 2288 and 2292 MHz, and  $70 + 10 \log (P)$  dB below 2288 MHz;

(iii) By a factor of not less than  $43 + 10 \log (P)$  dB on all frequencies between 2360 and 2365 MHz, and not less than  $70 + 10 \log (P)$  dB above 2365 MHz.

### TEST PROCEDURE

For Cellular equipment - Compliance with these rules is based on the use of measurement instrumentation employing a resolution bandwidth of 100 kHz or greater. In the 1 MHz bands immediately outside and adjacent to the frequency block a resolution bandwidth of at least one percent of the emission bandwidth of the fundamental emission of the transmitter may be employed. A narrower resolution bandwidth is permitted in all cases to improve measurement accuracy provided the measured power is integrated over the full required measurement bandwidth (i.e. 100 kHz or 1 percent of emission bandwidth, as specified). The emission bandwidth is defined as the width of the signal between two points, one below the carrier center frequency and one above the carrier center frequency, outside of which all emissions are attenuated at least 26 dB below the transmitter power.

For PCS equipment - Compliance with these rules is based on the use of measurement instrumentation employing a resolution bandwidth of 1 MHz or greater. However, in the 1 MHz bands immediately outside and adjacent to the frequency block a resolution bandwidth of at least one percent of the emission bandwidth of the fundamental emission of the transmitter may be employed. A narrower resolution bandwidth is permitted in all cases to improve measurement accuracy provided the measured power is integrated over the full required measurement bandwidth (i.e. 1 MHz or 1 percent of emission bandwidth, as specified). The emission bandwidth is defined as the width of the signal between two points, one below the carrier center frequency and one above the carrier center frequency, outside of which all emissions are attenuated at least 26 dB below the transmitter power.

### RESULTS

### 11.2.1. SPURIOUS RADIATION PLOTS

#### LTE 30

LTE Band 30  QPSK 10MHz	UL Korea, Ltd Suwon Laboratory Above 1GHz High Frequency Substitution Measurement																																																																																
	Company: Samsung Project #: 15K21698 Date: 09-12-15 Test Engineer: Steven.Kim Configuration: EUT / AC Adapter / Ear Phone / Y-Position Mode: TX, LTE BAND 30, 10MHz BW, QPSK																																																																																
	<table border="1" style="width: 100%; border-collapse: collapse;"> <tr> <td style="text-align: center; background-color: #e0f0ff;"><b>Chamber</b></td> <td style="text-align: center; background-color: #e0f0ff;"><b>Pre-amplifier</b></td> <td style="text-align: center; background-color: #e0f0ff;"><b>Filter</b></td> <td style="text-align: center; background-color: #e0f0ff;"><b>Limit</b></td> </tr> <tr> <td style="text-align: center;">Chamber 2</td> <td style="text-align: center;">AFS42</td> <td style="text-align: center;">Filter 1</td> <td style="text-align: center;">FCC Part 27</td> </tr> </table>	<b>Chamber</b>	<b>Pre-amplifier</b>	<b>Filter</b>	<b>Limit</b>	Chamber 2	AFS42	Filter 1	FCC Part 27																																																																								
<b>Chamber</b>	<b>Pre-amplifier</b>	<b>Filter</b>	<b>Limit</b>																																																																														
Chamber 2	AFS42	Filter 1	FCC Part 27																																																																														
	<table border="1" style="width: 100%; border-collapse: collapse;"> <thead> <tr> <th>f GHz</th> <th>SG reading (dBm)</th> <th>Ant. Pol. (H/V)</th> <th>Distance (m)</th> <th>Preamp (dB)</th> <th>Filter (dB)</th> <th>ERP (dBm)</th> <th>Limit (dBm)</th> <th>Delta (dB)</th> <th>Notes</th> </tr> </thead> <tbody> <tr> <td colspan="10">Mid Ch, (2310 MHz)</td> </tr> <tr> <td>4.6200</td> <td>-6.7</td> <td>V</td> <td>3.0</td> <td>40.9</td> <td>1.0</td> <td>-46.5</td> <td>-40.0</td> <td>-6.5</td> <td></td> </tr> <tr> <td>6.9300</td> <td>-8.9</td> <td>V</td> <td>3.0</td> <td>41.0</td> <td>1.0</td> <td>-48.9</td> <td>-40.0</td> <td>-8.9</td> <td></td> </tr> <tr> <td>9.2400</td> <td>-19.1</td> <td>V</td> <td>3.0</td> <td>39.6</td> <td>1.0</td> <td>-57.8</td> <td>-40.0</td> <td>-17.8</td> <td></td> </tr> <tr> <td>4.6200</td> <td>-6.7</td> <td>H</td> <td>3.0</td> <td>40.9</td> <td>1.0</td> <td>-46.6</td> <td>-40.0</td> <td>-6.6</td> <td></td> </tr> <tr> <td>6.9300</td> <td>-9.4</td> <td>H</td> <td>3.0</td> <td>41.0</td> <td>1.0</td> <td>-49.4</td> <td>-40.0</td> <td>-9.4</td> <td></td> </tr> <tr> <td>9.2400</td> <td>-19.3</td> <td>H</td> <td>3.0</td> <td>39.6</td> <td>1.0</td> <td>-57.9</td> <td>-40.0</td> <td>-17.9</td> <td></td> </tr> </tbody> </table> Rev. 03.03.09 Note: No other emissions were detected above the system noise floor.	f GHz	SG reading (dBm)	Ant. Pol. (H/V)	Distance (m)	Preamp (dB)	Filter (dB)	ERP (dBm)	Limit (dBm)	Delta (dB)	Notes	Mid Ch, (2310 MHz)										4.6200	-6.7	V	3.0	40.9	1.0	-46.5	-40.0	-6.5		6.9300	-8.9	V	3.0	41.0	1.0	-48.9	-40.0	-8.9		9.2400	-19.1	V	3.0	39.6	1.0	-57.8	-40.0	-17.8		4.6200	-6.7	H	3.0	40.9	1.0	-46.6	-40.0	-6.6		6.9300	-9.4	H	3.0	41.0	1.0	-49.4	-40.0	-9.4		9.2400	-19.3	H	3.0	39.6	1.0	-57.9	-40.0	-17.9	
f GHz	SG reading (dBm)	Ant. Pol. (H/V)	Distance (m)	Preamp (dB)	Filter (dB)	ERP (dBm)	Limit (dBm)	Delta (dB)	Notes																																																																								
Mid Ch, (2310 MHz)																																																																																	
4.6200	-6.7	V	3.0	40.9	1.0	-46.5	-40.0	-6.5																																																																									
6.9300	-8.9	V	3.0	41.0	1.0	-48.9	-40.0	-8.9																																																																									
9.2400	-19.1	V	3.0	39.6	1.0	-57.8	-40.0	-17.8																																																																									
4.6200	-6.7	H	3.0	40.9	1.0	-46.6	-40.0	-6.6																																																																									
6.9300	-9.4	H	3.0	41.0	1.0	-49.4	-40.0	-9.4																																																																									
9.2400	-19.3	H	3.0	39.6	1.0	-57.9	-40.0	-17.9																																																																									
LTE Band 30  16QAM 10MHz	UL Korea, Ltd Suwon Laboratory Above 1GHz High Frequency Substitution Measurement																																																																																
	Company: Samsung Project #: 15K21698 Date: 09-12-15 Test Engineer: Steven.Kim Configuration: EUT / AC Adapter / Ear Phone / Y-Position Mode: TX, LTE BAND 30, 10MHz BW, 16QAM																																																																																
	<table border="1" style="width: 100%; border-collapse: collapse;"> <tr> <td style="text-align: center; background-color: #e0f0ff;"><b>Chamber</b></td> <td style="text-align: center; background-color: #e0f0ff;"><b>Pre-amplifier</b></td> <td style="text-align: center; background-color: #e0f0ff;"><b>Filter</b></td> <td style="text-align: center; background-color: #e0f0ff;"><b>Limit</b></td> </tr> <tr> <td style="text-align: center;">Chamber 2</td> <td style="text-align: center;">AFS42</td> <td style="text-align: center;">Filter 1</td> <td style="text-align: center;">FCC Part 27</td> </tr> </table>	<b>Chamber</b>	<b>Pre-amplifier</b>	<b>Filter</b>	<b>Limit</b>	Chamber 2	AFS42	Filter 1	FCC Part 27																																																																								
<b>Chamber</b>	<b>Pre-amplifier</b>	<b>Filter</b>	<b>Limit</b>																																																																														
Chamber 2	AFS42	Filter 1	FCC Part 27																																																																														
	<table border="1" style="width: 100%; border-collapse: collapse;"> <thead> <tr> <th>f GHz</th> <th>SG reading (dBm)</th> <th>Ant. Pol. (H/V)</th> <th>Distance (m)</th> <th>Preamp (dB)</th> <th>Filter (dB)</th> <th>ERP (dBm)</th> <th>Limit (dBm)</th> <th>Delta (dB)</th> <th>Notes</th> </tr> </thead> <tbody> <tr> <td colspan="10">Mid Ch, (2310 MHz)</td> </tr> <tr> <td>4.6200</td> <td>-7.9</td> <td>V</td> <td>3.0</td> <td>40.9</td> <td>1.0</td> <td>-47.8</td> <td>-40.0</td> <td>-7.8</td> <td></td> </tr> <tr> <td>6.9300</td> <td>-10.5</td> <td>V</td> <td>3.0</td> <td>41.0</td> <td>1.0</td> <td>-50.5</td> <td>-40.0</td> <td>-10.5</td> <td></td> </tr> <tr> <td>9.2400</td> <td>-19.5</td> <td>V</td> <td>3.0</td> <td>39.6</td> <td>1.0</td> <td>-58.1</td> <td>-40.0</td> <td>-18.1</td> <td></td> </tr> <tr> <td>4.6200</td> <td>-8.0</td> <td>H</td> <td>3.0</td> <td>40.9</td> <td>1.0</td> <td>-47.9</td> <td>-40.0</td> <td>-7.9</td> <td></td> </tr> <tr> <td>6.9300</td> <td>-10.9</td> <td>H</td> <td>3.0</td> <td>41.0</td> <td>1.0</td> <td>-50.9</td> <td>-40.0</td> <td>-10.9</td> <td></td> </tr> <tr> <td>9.2400</td> <td>-19.7</td> <td>H</td> <td>3.0</td> <td>39.6</td> <td>1.0</td> <td>-58.4</td> <td>-40.0</td> <td>-18.4</td> <td></td> </tr> </tbody> </table> Rev. 03.03.09 Note: No other emissions were detected above the system noise floor.	f GHz	SG reading (dBm)	Ant. Pol. (H/V)	Distance (m)	Preamp (dB)	Filter (dB)	ERP (dBm)	Limit (dBm)	Delta (dB)	Notes	Mid Ch, (2310 MHz)										4.6200	-7.9	V	3.0	40.9	1.0	-47.8	-40.0	-7.8		6.9300	-10.5	V	3.0	41.0	1.0	-50.5	-40.0	-10.5		9.2400	-19.5	V	3.0	39.6	1.0	-58.1	-40.0	-18.1		4.6200	-8.0	H	3.0	40.9	1.0	-47.9	-40.0	-7.9		6.9300	-10.9	H	3.0	41.0	1.0	-50.9	-40.0	-10.9		9.2400	-19.7	H	3.0	39.6	1.0	-58.4	-40.0	-18.4	
f GHz	SG reading (dBm)	Ant. Pol. (H/V)	Distance (m)	Preamp (dB)	Filter (dB)	ERP (dBm)	Limit (dBm)	Delta (dB)	Notes																																																																								
Mid Ch, (2310 MHz)																																																																																	
4.6200	-7.9	V	3.0	40.9	1.0	-47.8	-40.0	-7.8																																																																									
6.9300	-10.5	V	3.0	41.0	1.0	-50.5	-40.0	-10.5																																																																									
9.2400	-19.5	V	3.0	39.6	1.0	-58.1	-40.0	-18.1																																																																									
4.6200	-8.0	H	3.0	40.9	1.0	-47.9	-40.0	-7.9																																																																									
6.9300	-10.9	H	3.0	41.0	1.0	-50.9	-40.0	-10.9																																																																									
9.2400	-19.7	H	3.0	39.6	1.0	-58.4	-40.0	-18.4																																																																									

UL Korea, Ltd Suwon Laboratory Above 1GHz High Frequency Substitution Measurement									
Company:		Samsung							
Project #:		15K21698							
Date:		09-10-15							
Test Engineer:		Steven.Kim							
Configuration:		EUT / AC Adapter / Ear Phone / Y-Position							
Mode:		TX, LTE BAND 30, 5MHz BW, QPSK							
Chamber		Pre-amplifier		Filter		Limit			
Chamber 2		AFS42		Filter 1		FCC Part 27			
f GHz	SG reading (dBm)	Ant. Pol. (HV)	Distance (m)	Preamp (dB)	Filter (dB)	ERP (dBm)	Limit (dBm)	Delta (dB)	Notes
Low Ch, (2307.5 MHz)									
4.6150	-9.7	V	3.0	40.9	1.0	-49.6	-40.0	-9.6	
6.9225	-7.2	V	3.0	41.0	1.0	-47.2	-40.0	-7.2	
9.2300	-19.6	V	3.0	39.6	1.0	-58.3	-40.0	-18.3	
4.6150	-6.7	H	3.0	40.9	1.0	-46.5	-40.0	-6.5	
6.9225	-7.1	H	3.0	41.0	1.0	-47.1	-40.0	-7.1	
9.2300	-21.2	H	3.0	39.6	1.0	-59.8	-40.0	-19.8	
Mid Ch, (2310 MHz)									
4.6200	-10.8	V	3.0	40.9	1.0	-50.7	-40.0	-10.7	
6.9300	-8.4	V	3.0	41.0	1.0	-48.4	-40.0	-8.4	
9.2400	-21.1	V	3.0	39.6	1.0	-59.8	-40.0	-19.8	
4.6200	-9.3	H	3.0	40.9	1.0	-49.2	-40.0	-9.2	
6.9300	-8.6	H	3.0	41.0	1.0	-48.6	-40.0	-8.6	
9.2400	-21.9	H	3.0	39.6	1.0	-60.5	-40.0	-20.5	
High Ch, (2312.5 MHz)									
4.6250	-14.5	V	3.0	40.9	1.0	-54.3	-40.0	-14.3	
6.9375	-11.4	V	3.0	41.0	1.0	-51.4	-40.0	-11.4	
9.2500	-22.3	V	3.0	39.6	1.0	-61.0	-40.0	-21.0	
4.6250	-7.8	H	3.0	40.9	1.0	-47.6	-40.0	-7.6	
6.9375	-12.9	H	3.0	41.0	1.0	-52.9	-40.0	-12.9	
9.2500	-20.9	H	3.0	39.6	1.0	-59.6	-40.0	-19.6	
Rev. 03.03.09 Note: No other emissions were detected above the system noise floor.									

LTE  
Band 30  
  
QPSK  
5MHz

UL Korea, Ltd Suwon Laboratory Above 1GHz High Frequency Substitution Measurement									
Company:		Samsung							
Project #:		15K21698							
Date:		09-10-15							
Test Engineer:		Steven.Kim							
Configuration:		EUT / AC Adapter / Ear Phone / Y-Position							
Mode:		TX, LTE BAND 30, 5MHz BW, 16QAM							
Chamber		Pre-amplifier		Filter		Limit			
Chamber 2		AFS42		Filter 1		FCC Part 27			
f GHz	SG reading (dBm)	Ant. Pol. (HV)	Distance (m)	Preamp (dB)	Filter (dB)	ERP (dBm)	Limit (dBm)	Delta (dB)	Notes
Low Ch, (2307.5 MHz)									
4.6150	-10.9	V	3.0	40.9	1.0	-50.7	-40.0	-10.7	
6.9225	-8.6	V	3.0	41.0	1.0	-48.6	-40.0	-8.6	
9.2300	-20.4	V	3.0	39.6	1.0	-59.0	-40.0	-19.0	
4.6150	-7.9	H	3.0	40.9	1.0	-47.8	-40.0	-7.8	
6.9225	-8.6	H	3.0	41.0	1.0	-48.6	-40.0	-8.6	
9.2300	-21.7	H	3.0	39.6	1.0	-60.4	-40.0	-20.4	
Mid Ch, (2310 MHz)									
4.6200	-12.0	V	3.0	40.9	1.0	-51.9	-40.0	-11.9	
6.9300	-10.0	V	3.0	41.0	1.0	-50.0	-40.0	-10.0	
9.2400	-21.7	V	3.0	39.6	1.0	-60.3	-40.0	-20.3	
4.6200	-10.5	H	3.0	40.9	1.0	-50.4	-40.0	-10.4	
6.9300	-10.1	H	3.0	41.0	1.0	-50.1	-40.0	-10.1	
9.2400	-22.4	H	3.0	39.6	1.0	-61.1	-40.0	-21.1	
High Ch, (2312.5 MHz)									
4.6250	-15.7	V	3.0	40.9	1.0	-55.6	-40.0	-15.6	
6.9375	-12.6	V	3.0	41.0	1.0	-52.6	-40.0	-12.6	
9.2500	-22.8	V	3.0	39.6	1.0	-61.5	-40.0	-21.5	
4.6250	-8.8	H	3.0	40.9	1.0	-48.7	-40.0	-8.7	
6.9375	-14.1	H	3.0	41.0	1.0	-54.1	-40.0	-14.1	
9.2500	-21.8	H	3.0	39.6	1.0	-60.4	-40.0	-20.4	
Rev. 03.03.09 Note: No other emissions were detected above the system noise floor.									

LTE  
Band 30  
  
QPSK  
5MHz