



Issue Date:

129 Samsung-ro,  
Yeongtong-gu, Suwon-Si,  
Gyeonggi-Do, 16677  
Korea  
Tel: 82-31-8062-4278  
Fax: 82-31-279-9985

# FCC TEST REPORT

**Manufacturer: SAMSUNG Electronics Co., Ltd.**

**Model: SM-T677A**

**FCC ID: A3LSMT677A**

**Application Type: Certification**

**EUT Type: Portable Tablet**

All measurements reported here are in accordance with FCC Rules,  
47CFR Part2 and Part27.

Prepared By ..... Date .....  
DH Ju  
Test Engineer

Checked and Authorized By ..... Date .....  
WT Jang  
Technical Manager



### Revision History

Rev. #	Issue Date	Revisions	Revised By
1		▪ Initial issue	DH Ju

– End of this page –



## Table of Contents

<b>§2.1033 General Information .....</b>	<b>4</b>
<b>1. INTRODUCTION .....</b>	<b>6</b>
1.1. General.....	6
<b>2. PRODUCT INFORMATION.....</b>	<b>6</b>
2.1. Equipment Description .....	6
2.2. Device Capabilities .....	6
<b>3. DESCRIPTION OF TESTS.....</b>	<b>7</b>
3.1. Evaluation Procedure.....	7
3.2. Measurement Procedure for Radiated Power and Radiated Spurious Emissions..	7
3.3. EMI Suppression Device(s)/Modifications .....	7
<b>4. TEST EQUIPMENT LIST .....</b>	<b>8</b>
<b>5. SAMPLE CALCULATIONS.....</b>	<b>10</b>
<b>6. TEST RESULTS.....</b>	<b>11</b>
6.1. Summary .....	11
6.2. Occupied Bandwidth .....	12
6.3. Spurious and Harmonic Emissions at Antenna Terminal.....	23
6.4. Band Edge Emissions at Antenna Terminal .....	49
6.5. Frequency Stability / Temperature Variation .....	70
6.6. Radiated Power (ERP/EIRP).....	73
6.7. Radiated Spurious Emissions Measurements .....	77
<b>7. CONCLUSION .....</b>	<b>82</b>

**§2.1033 General Information**

**APPLICANT:** Samsung Electronics Co., Ltd.

**APPLICANT ADDRESS:** 129 Samsung-ro,  
Yeongtong-gu, Suwon-si, Gyeonggi-do, 16677, Korea

**TEST SITE:** Samsung Electronics Co., Ltd.

**TEST SITE ADDRESS:** 129 Samsung-ro,  
Yeongtong-gu, Suwon-si, Gyeonggi-do, 16677, Korea

**FCC RULE PART(S):** §2, §27

**TEST PROCEDURE(S):** ANSI/TIA-603-D-2010, KDB971168 v02r02

**BASE MODEL:** SM-T677A

**FCC ID:** A3LSMT677A

**FCC CLASSIFICATION:** PCS Licensed Transmitter (PCB)

**MODE:** LTE

**EMISSION DESIGNATOR:** See Table 0-1

**TX FREQUENCY BLOCK** 699 – 716MHz (LTE Band 12)  
704 – 716MHz (LTE Band 17)  
1710 – 1755MHz (LTE Band 4)

**RX FREQUENCY BLOCK** 729 – 746MHz (LTE Band 12)  
734 – 746MHz (LTE Band 17)  
2110 – 2155MHz (LTE Band 4)

**MAX POWER RATING:** 0.029 W ERP LTE Band 12/17 (14.55 dBm)  
0.196 W EIRP LTE Band 4 (22.92 dBm)

**TEST DEVICE SERIAL NO.:** FCM-032-A & FCM-032-B

**DATE(S) OF TEST:** September 02 – 23, 2015



Issue Date:

Mode	Tx Frequency (MHz)	Emission Designator	Modulation	ERP/EIRP	
				Max. Power (Watt)	Max. Power (dBm)
LTE Band 12	699.7 – 715.3	1M09G7D	QPSK	0.028	14.40
LTE Band 12	699.7 – 715.3	1M10W7D	16QAM	0.023	13.55
LTE Band 12	700.5 – 714.5	2M69G7D	QPSK	0.028	14.43
LTE Band 12	700.5 – 714.5	2M69W7D	16QAM	0.022	13.49
LTE Band 12/17	701.5 – 713.5	4M50G7D	QPSK	0.029	14.55
LTE Band 12/17	701.5 – 713.5	4M49W7D	16QAM	0.022	13.39
LTE Band 12/17	704.0 – 711.0	8M95G7D	QPSK	0.027	14.34
LTE Band 12/17	704.0 – 711.0	8M93W7D	16QAM	0.021	13.12
LTE Band 4	1710.7 – 1754.3	1M10G7D	QPSK	0.176	22.45
LTE Band 4	1710.7 – 1754.3	1M10W7D	16QAM	0.158	21.99
LTE Band 4	1711.5 – 1753.5	2M69G7D	QPSK	0.175	22.44
LTE Band 4	1711.5 – 1753.5	2M69W7D	16QAM	0.149	21.73
LTE Band 4	1712.5 – 1752.5	4M50G7D	QPSK	0.167	22.22
LTE Band 4	1712.5 – 1752.5	4M50W7D	16QAM	0.153	21.84
LTE Band 4	1715.0 – 1750.0	8M95G7D	QPSK	0.196	22.92
LTE Band 4	1715.0 – 1750.0	8M93W7D	16QAM	0.146	21.65
LTE Band 4	1717.5 – 1747.5	13M5G7D	QPSK	0.160	22.05
LTE Band 4	1717.5 – 1747.5	13M5W7D	16QAM	0.124	20.94
LTE Band 4	1720.0 – 1745.0	17M9G7D	QPSK	0.151	21.79
LTE Band 4	1720.0 – 1745.0	17M9W7D	16QAM	0.137	21.36

Table 0-1. Emission Designator

– End of this page –



## 1. INTRODUCTION

### 1.1. General

These measurement tests were conducted at SAMSUNG ELECTRONICS CO., LTD. (SUWON). The site address is 129 Samsung-ro, Yeongtong-gu, Suwon-si, Gyeonggi-do, 16677, Korea.

## 2. PRODUCT INFORMATION

### 2.1. Equipment Description

The Equipment Under Test (EUT) is the Samsung Portable Tablet FCC ID: A3LSMT677A. The test data contained in this report pertains only to the emissions due to the EUT's LTE function.

### 2.2. Device Capabilities

This device contains the following capabilities:

850/1900 WCDMA/HSPA, Multi-band LTE, 802.11a/b/g/n/ac WLAN, Bluetooth (1x, EDR, LE), ANT+.



### 3. DESCRIPTION OF TESTS

#### 3.1. Evaluation Procedure

The measurement procedures described in the document titled "Land Mobile FM or PM - Communications Equipment- Measurements and Performance Standards" (ANSI/TIA-603-D-2010) and "Procedures for Compliance Measurement of the Fundamental Emission Power of Licensed Wideband (> 1MHz) Digital Transmission System" (KDB 971168) were used in the measurement of the Samsung Portable Tablet FCC ID: A3LSMT677A.

#### 3.2. Measurement Procedure for Radiated Power and Radiated Spurious Emissions

The radiated and spurious measurements were made at the semi-anechoic chamber. The equipment under test was placed on the Turn Table at the 80-centimeter height and a distance of 3-meters from the measuring antenna. For measurements above 1GHz absorbers are arranged on the floor between the turn table and the antenna mast in such way so as to maximize the reduction of reflections. For measurements below 1GHz, the absorbers are removed. A Maturo model PTT1.5x1.0x0.8-Rohacell turntable is used for radiated measurement. The table is fabricated from non-conducted material with a very low dielectric constant  $\epsilon_r$ .

The measuring antenna height is adjusted between 1 and 4 meter height, the turn table is rotated through 360 degrees, and the EUT is manipulated through all orthogonal planes representative of its typical use to achieve the highest reading on the receive spectrum analyzer. The measurement was made for each horizontal/vertical position in combination with horizontally and vertically polarized measuring antenna.

The substitution antenna will replace the EUT antenna at the same position. The frequency of the signal generator shall be set to the frequencies that were measured on the EUT. The output level of the signal generator shall be adjusted until an equal or a known related level that was measured from the EUT. This level was recorded. For emissions above 1 GHz, the above procedure is repeated by using horn antennas and dBi gain is taken into consideration.

The power of the emission is calculated using the following formula:

$$P_{d[\text{dBm}]} = P_{g[\text{dBm}]} - \text{cable loss}_{[\text{dB}]} + \text{antenna gain}_{[\text{dBd,dBi}]}$$

Where  $P_d$  is the dipole equivalent power,  $P_g$  is the generator output into the substitution antenna, and the antenna gain is the gain of the substitute antenna used relative to either a half-wave dipole(dBd) or an isotropic source(dBi). The cable connects the generator to the substitute antenna.

Radiated power levels and radiated spurious emissions levels are investigated per ANSI/TIA-603-D-2010.

#### 3.3. EMI Suppression Device(s)/Modifications

No EMI suppression device(s) were added and no modifications were made during testing.



#### 4. TEST EQUIPMENT LIST

The measuring equipment, which was utilized in performing the tests documented herein, has been calibrated in accordance with the manufacturer's recommendations for utilizing calibration equipment, which is traceable to recognized national standards.

Description	Model	Serial No.	Manufacturer	Cal. Date	Cal. Due
Wideband Radio Communication Tester	CMW500	140748	R&S	2014-10-28	2015-10-28
Wideband Radio Communication Tester	CMW500	100697	R&S	2014-11-03	2015-11-03
Signal & Spectrum Analyzer	FSW	103775	R&S	2014-12-17	2015-12-17
PXA Signal Analyzer	N9030A	MY52350977	Agilent	2014-10-24	2015-10-24
PSG Analog Signal Generator	E8257D	MY51501209	Agilent	2014-11-07	2015-11-07
EMI Test Receiver	ESU26	100521	R&S	2014-11-10	2015-11-10
EPM Series Power Meter	E4419B	GB41293846	Agilent	2014-09-22	2015-09-22
POWER SENSOR	E9300H	MY41495838	Agilent	2014-09-23	2015-09-23
DC Power Supply	E3642A	MY40022438	Agilent	2015-02-23	2016-02-23
Temperature Humidity Chamber	SH-641	92009178	Espec	2015-03-19	2016-03-19
Loop Antenna	HFH2-Z2	100276	R&S	2014-05-19	2016-05-19
DIPOLE ANTENNA	UHA 9105	9105-2413	Schwarzbeck	2015-09-08	2017-09-08
LOG-PERIODIC ANTENNA	VUSLP 9111	9111-311	Schwarzbeck	2015-08-28	2017-08-28
HORN Antenna	3115	156307	ETS LINDGREN	2015-05-07	2017-05-07
HORN Antenna	3115	143185	ETS LINDGREN	2015-09-01	2017-09-01
HORN Antenna & Pre-amplifier assembly	HAP18-26N	216250	Flann	2014-01-09	2016-01-09
HORN Antenna & Pre-amplifier assembly	HAP18-26N	216251	Flann	2015-04-30	2017-04-30
PRE-AMPLIFIER	8449B	3008A02672	Agilent	2014-11-25	2015-11-25
RF Power Amplifier	5S1G4	304866	AR	2015-02-09	2016-02-09
Hygrothermograph Data Logger	SK-L200TH2a	5077	SATO	2014-10-31	2015-10-31
Hygrothermograph Data Logger	SK-L200TH2a	5078	SATO	2014-10-31	2015-10-31
Hygrothermograph Data Logger	SK-L200TH2a	5095	SATO	2014-10-31	2015-10-31
Power Divider	11636B	58456	Agilent	2015-04-27	2016-04-27
Highpass Filter	WHVX1.0/15G-10SS	39	Wainwright	2015-01-07	2016-01-07
Highpass Filter	WHKX3.0/18G-10SS	206	Wainwright	2015-01-07	2016-01-07
Attenuator 10dB	8491B	MY39264180	Agilent	2015-06-23	2016-06-23
Attenuator 20dB	8493C	74158	Agilent	2015-08-20	2016-08-20

Table 4-1. Test Equipment



Note

1. EPM Series Power Meter was under calibration from 22-Sep-15 and POWER SENSOR was under calibration from 23-Sep-15, however, care was taken to ensure that this equipment was used before the calibration due date.

– End of this page –



## 5. SAMPLE CALCULATIONS

### 5.1. QPSK Modulation

Emission Designator = 8M62G7D

LTE BW = 8.62 MHz

G = Phase Modulation

7 = Quantized/Digital Info

D = Data transmission

### 5.2. 16QAM Modulation

Emission Designator = 8M45W7D

LTE BW = 8.45 MHz

W = Amplitude/Angle Modulation

7 = Quantized/Digital Info

D = Data transmission

### 5.3. Spurious Radiated Emission

Example: Spurious emission at 3700.40MHz

The receive spectrum analyzer reading at 3 meters with the EUT on the turn device was -81.0dBm. The gain of the substituted antenna is 8.1dBi. The signal generator connected to the substituted antenna terminals is adjusted to produce a reading of -81.0dBm on the spectrum analyzer. The loss of the cable between the signal generator and the terminals of the substituted antenna is 2.0dB at 3700.40MHz. So 6.1dB is added to the signal generator reading of -30.9dBm yielding -24.80dBm. The fundamental EIRP was 25.50dBm so this harmonic was  $25.50\text{dBm} - (-24.80) = 50.3\text{dBc}$ .

– End of this page –



## 6. TEST RESULTS

### 6.1. Summary

FCC Part Section(s)	Test Description	Test Limit	Test Condition	Test Result	Reference
TRANSMITTER MODE (TX)					
2.1049	Occupied Bandwidth	N/A	CONDUCTED	PASS	Section 6.2
2.1051 27.53(g) 27.53(h)	Conducted Band Edge / Spurious Emissions	> 43 +10 log <sub>10</sub> (P[Watts]) at Band Edge and for all out-of-band emissions		PASS	Sections 6.3, 6.4
2.1046	Transmitter Conducted Output Power	N/A		PASS	See SAR Report
2.1055 27.54	Frequency Stability	Fundamental emissions stay within authorized frequency block		PASS	Section 6.5
27.50(c)(10)	Effective Radiated Power	< 3 Watts max. ERP (Band 12/17)	RADIATED	PASS	Section 6.6
27.50(d)(4)	Equivalent Isotropic Radiated Power	< 1 Watts max. EIRP (Band 4)		PASS	Section 6.6
2.1053 27.53(g) 27.53(h)	Radiated Spurious Emissions	> 43 +10 log <sub>10</sub> (P[Watts]) at Band Edge and for all out-of-band emissions		PASS	Section 6.7

Table 6-1. Summary of Test Results

#### Notes:

1. All modes of operation and data rates were investigated. The test results shown in the following sections represent the worst case emissions.
2. The analyzer plots shown in this section were all taken with a correction table loaded into the analyzer. The correction table was used to account for the losses of the cables, couplers, and attenuators used as part of the system to connect the EUT to the analyzer at all frequencies of interest.
3. All antenna port conducted emissions testing was performed on a test bench with the antenna port of the EUT connected to the spectrum analyzer through calibrated cables and couplers.
4. The automated test software was used to measure emissions and capture the corresponding plots necessary to show compliance. The measurement software utilized is Rohde & Schwarz and SAMSUNG Electronics "CMWrun", Version 1.8.1.
5. This device supports LTE Band 12 and 17, however only Band 12 measurements are shown in this report since Band 12 overlaps the entire frequency range of Band 17 as well as modulation and antenna paths are identical.

## 6.2. Occupied Bandwidth §2.1049

### Test Overview

The Occupied bandwidth, that is the frequency bandwidth such that, below its lower and above its upper frequency limits, the mean powers radiated are each equal to 0.5 percent of the total mean power radiated by a given emission shall be measured. All modes of operation were investigated and the worst case configuration results are reported in this section.

### Test Procedure Used

KDB 971168 v02r02 – Section 4.2

### Test Settings

1. The signal analyzer's automatic bandwidth measurement capability was used to perform the 99% Occupied bandwidth. The bandwidth measurement was not influenced by any intermediate power nulls in the fundamental emission.
2. RBW = 1~5% of the expected OBW
3. VBW  $\geq 3 \times$  RBW
4. Detector = Peak
5. Trace mode = max hold
6. Sweep = auto couple
7. The trace was allowed to stabilize
8. If necessary, steps 2~7 were repeated after changing the RBW such that it would be within 1~5% of the 99% occupied bandwidth observed in Step 7

### Test Setup

The EUT and measurement equipment were set up as shown in the diagram below.

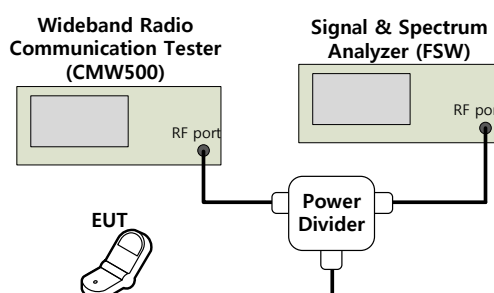
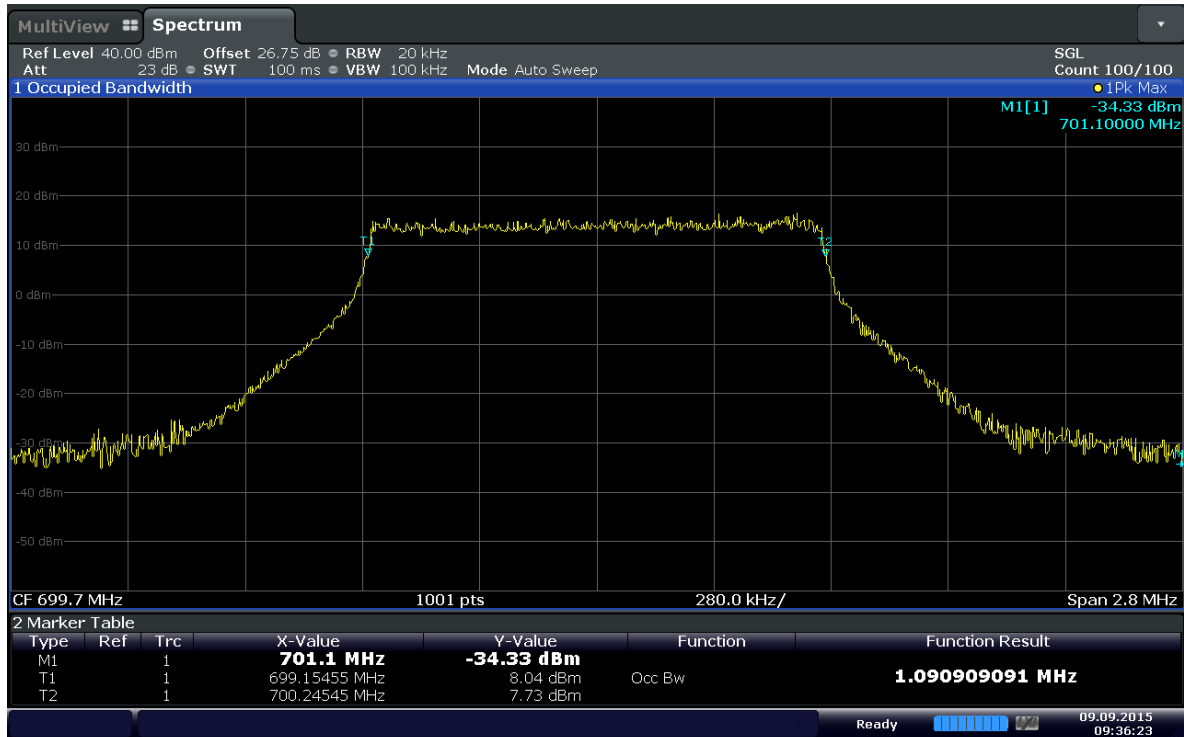

Figure 6-1. Test Instruments & Measurement Setup



Test Plots



Date: 9.SEP.2015 09:36:23

Plot 6-1. Occupied Bandwidth Plot (Band 12 – 1.4MHz QPSK - RB Size 6)

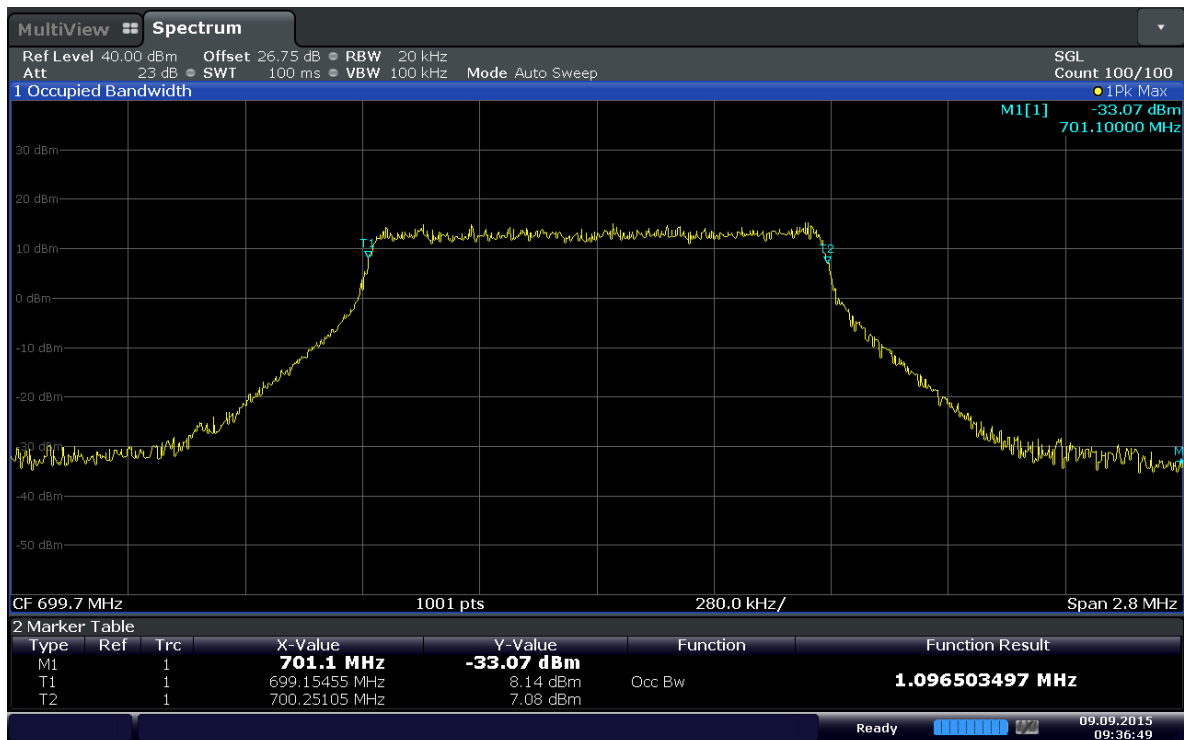

Date: 9.SEP.2015 09:36:49

Plot 6-2. Occupied Bandwidth Plot (Band 12 – 1.4MHz 16QAM - RB Size 6)

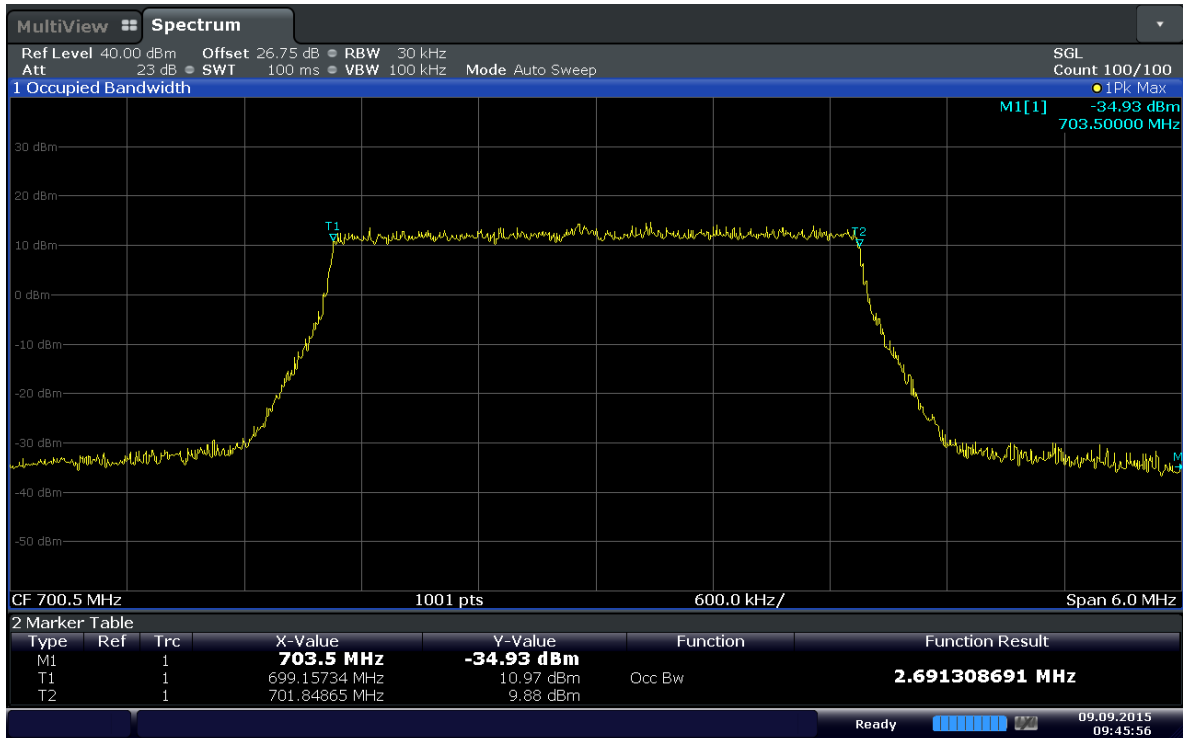

Date: 9.SEP.2015 09:45:57

Plot 6-3. Occupied Bandwidth Plot (Band 12 – 3MHz QPSK - RB Size 15)

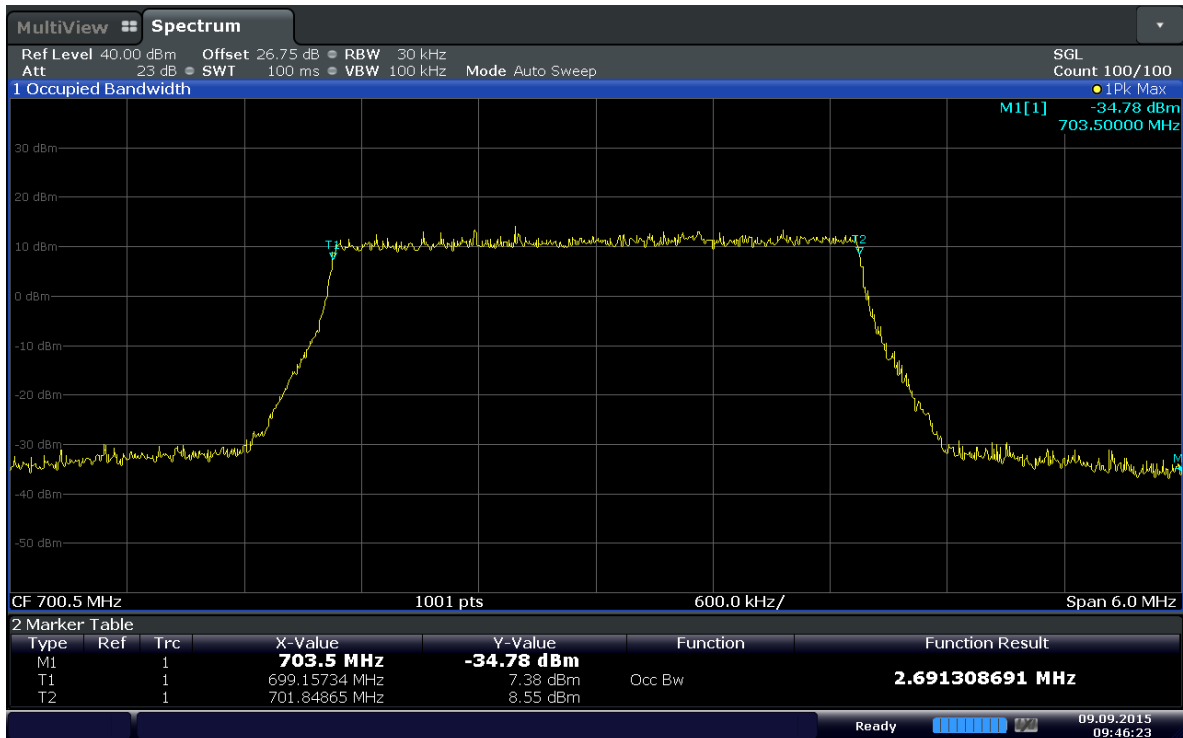

Date: 9.SEP.2015 09:46:23

Plot 6-4. Occupied Bandwidth Plot (Band 12 – 3MHz 16QAM - RB Size 15)

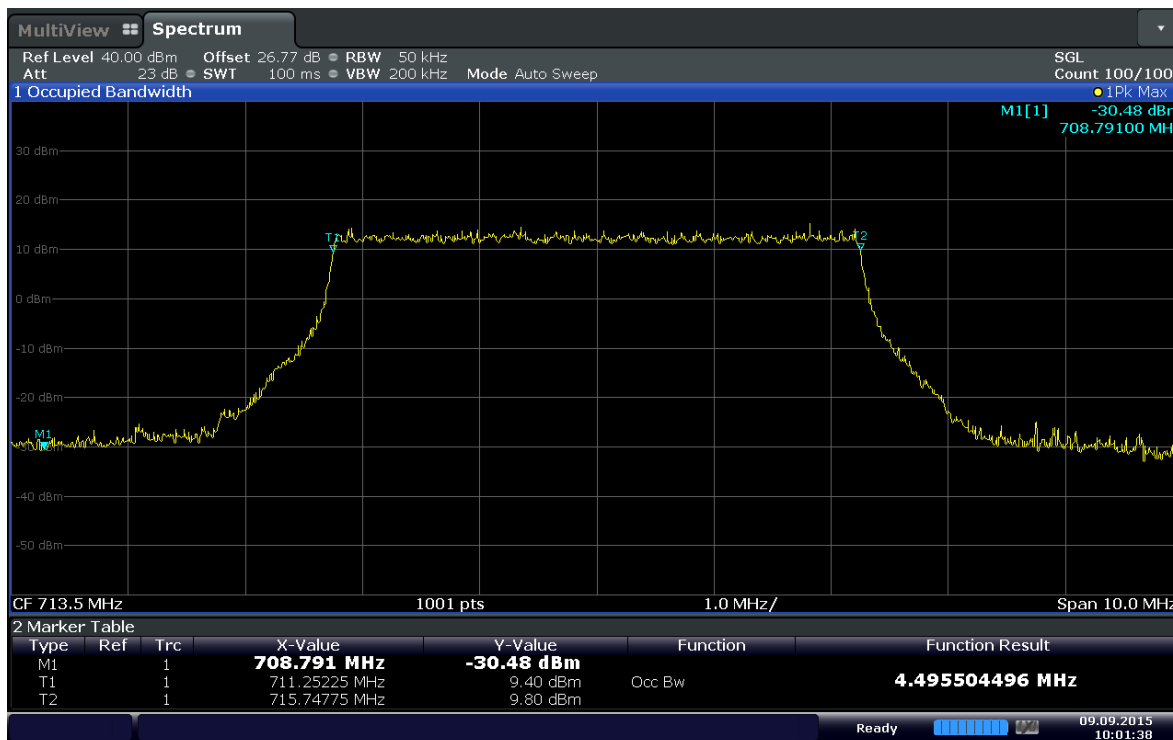

Date: 9.SEP.2015 10:01:39

Plot 6-5. Occupied Bandwidth Plot (Band 12 – 5MHz QPSK - RB Size 25)

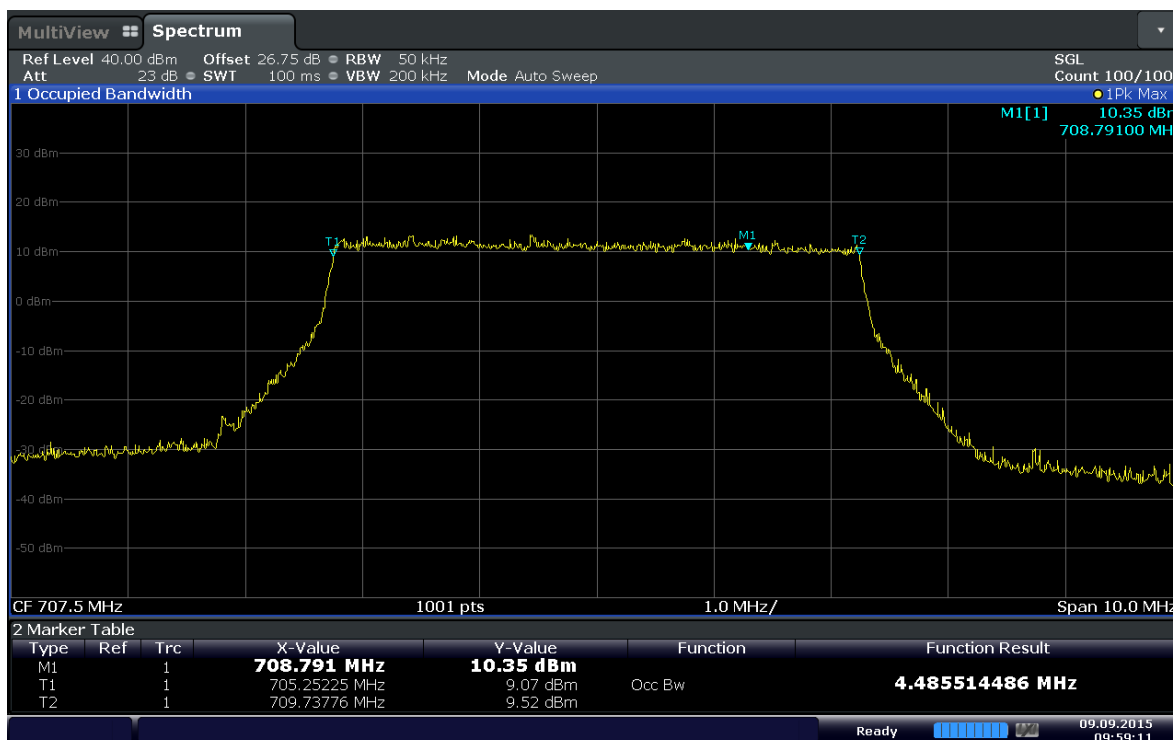

Date: 9.SEP.2015 09:59:12

Plot 6-6. Occupied Bandwidth Plot (Band 12 – 5MHz 16QAM - RB Size 25)

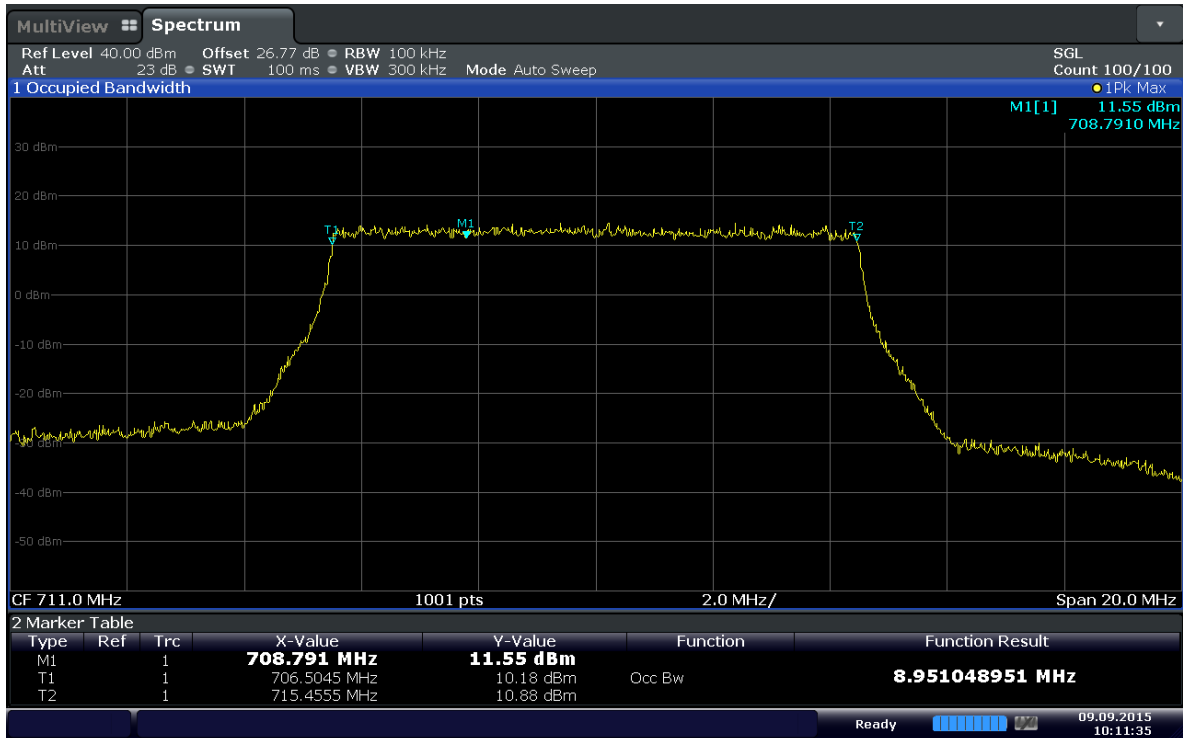

Date: 9.SEP.2015 10:11:35

Plot 6-7. Occupied Bandwidth Plot (Band 12 – 10MHz QPSK - RB Size 50)

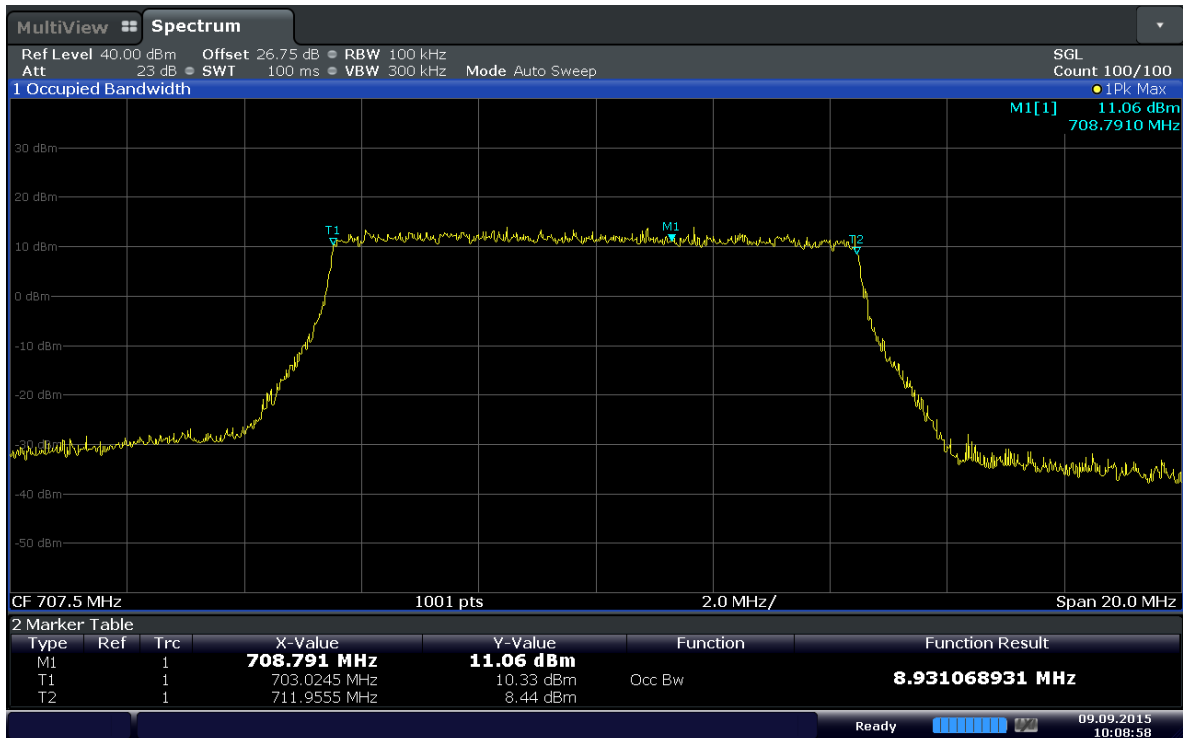

Date: 9.SEP.2015 10:08:59

Plot 6-8. Occupied Bandwidth Plot (Band 12 – 10MHz 16QAM - RB Size 50)

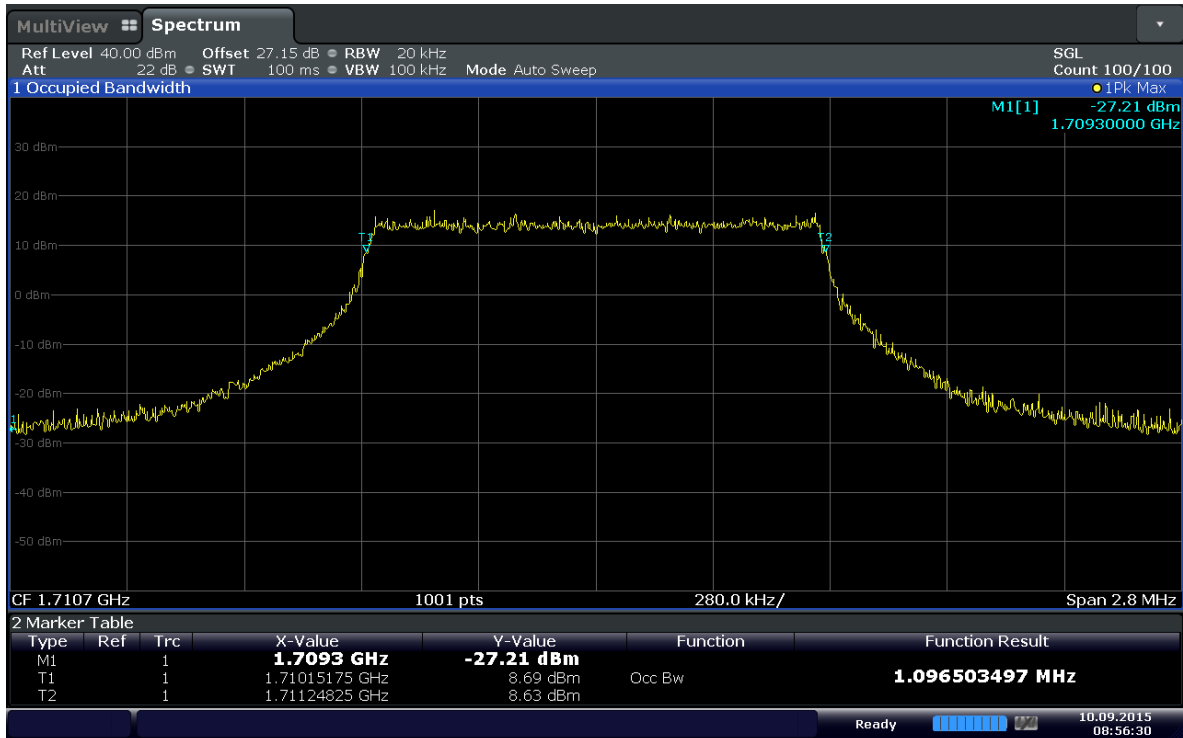

Date: 10.SEP.2015 08:56:30

Plot 6-9. Occupied Bandwidth Plot (Band 4 – 1.4MHz QPSK - RB Size 6)

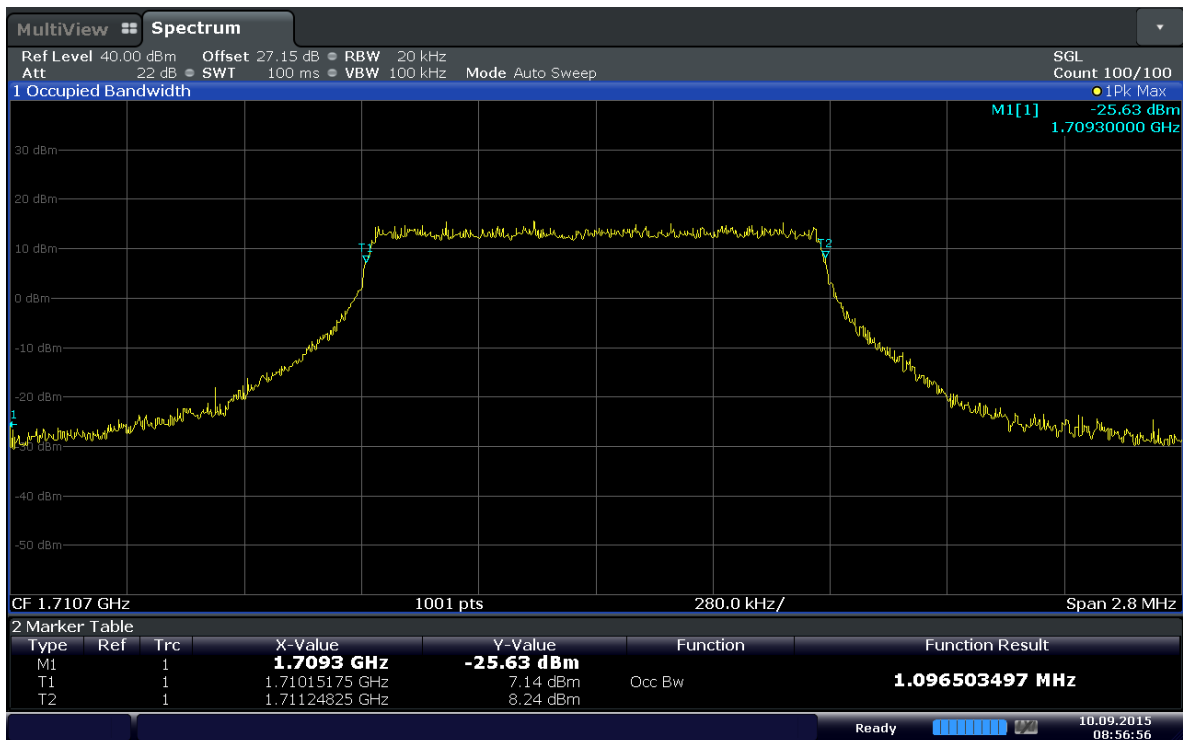

Date: 10.SEP.2015 08:56:57

Plot 6-10. Occupied Bandwidth Plot (Band 4 – 1.4MHz 16QAM - RB Size 6)



Issue Date:

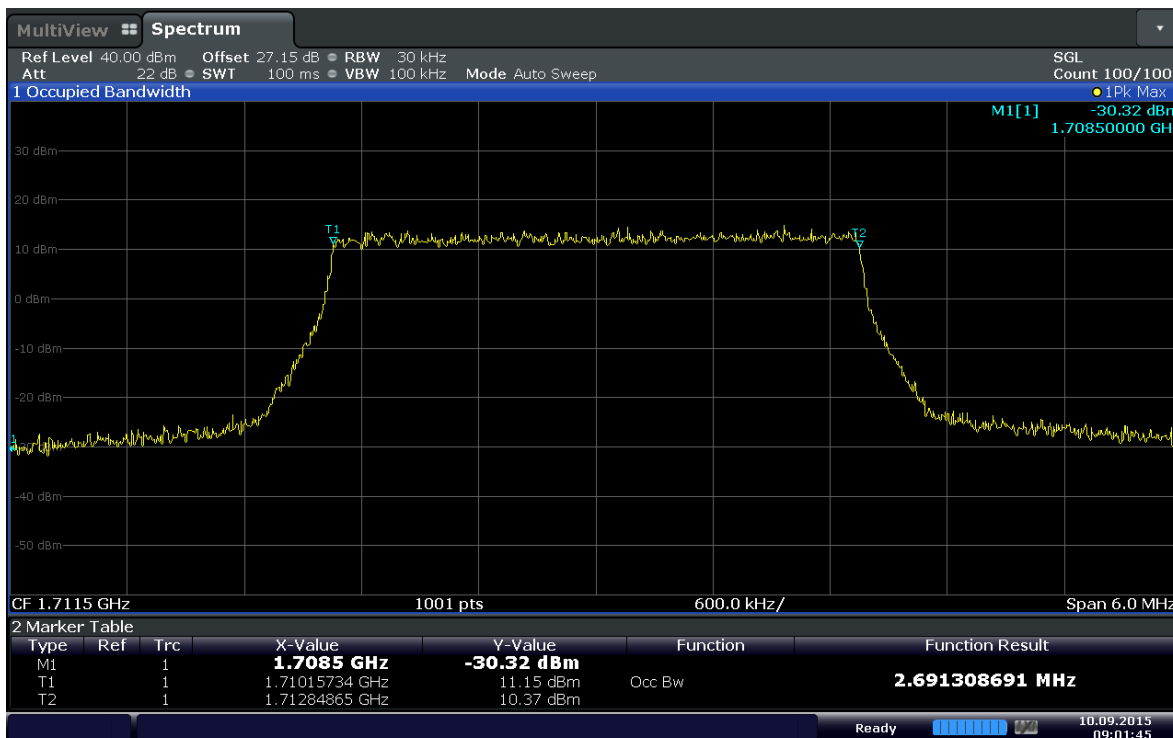

Date: 10.SEP.2015 09:01:46

Plot 6-11. Occupied Bandwidth Plot (Band 4 – 3MHz QPSK - RB Size 15)

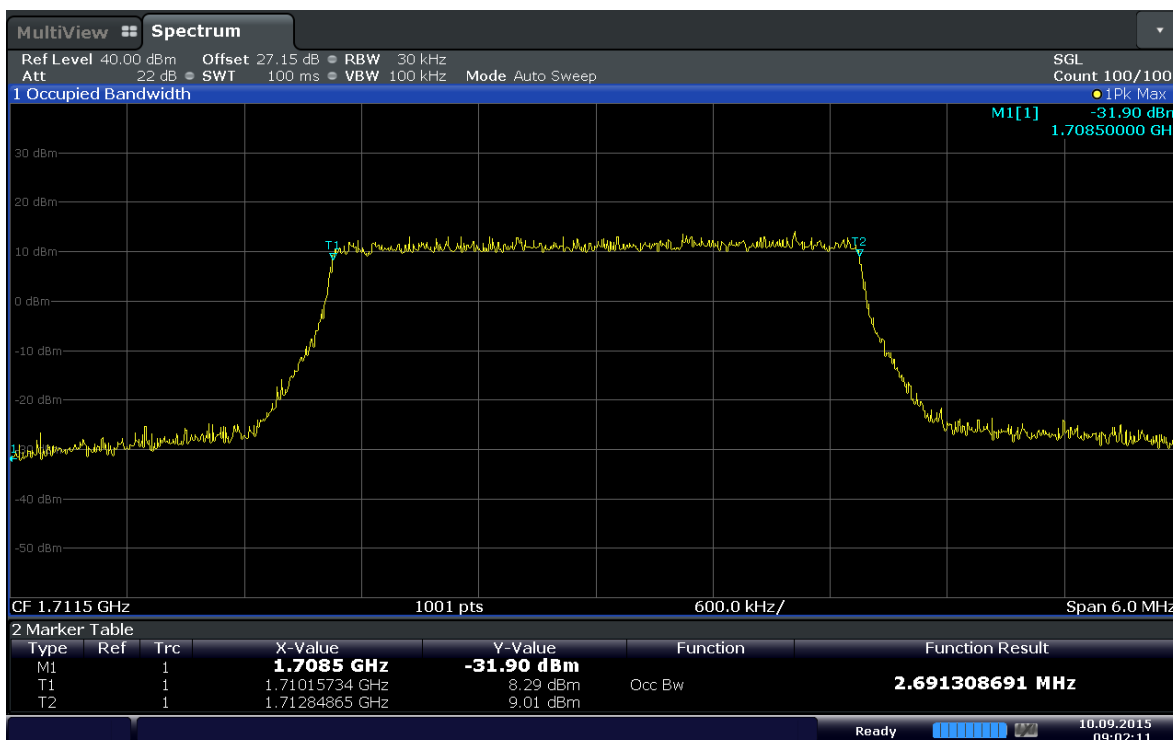

Date: 10.SEP.2015 09:02:12

Plot 6-12. Occupied Bandwidth Plot (Band 4 – 3MHz 16QAM - RB Size 15)

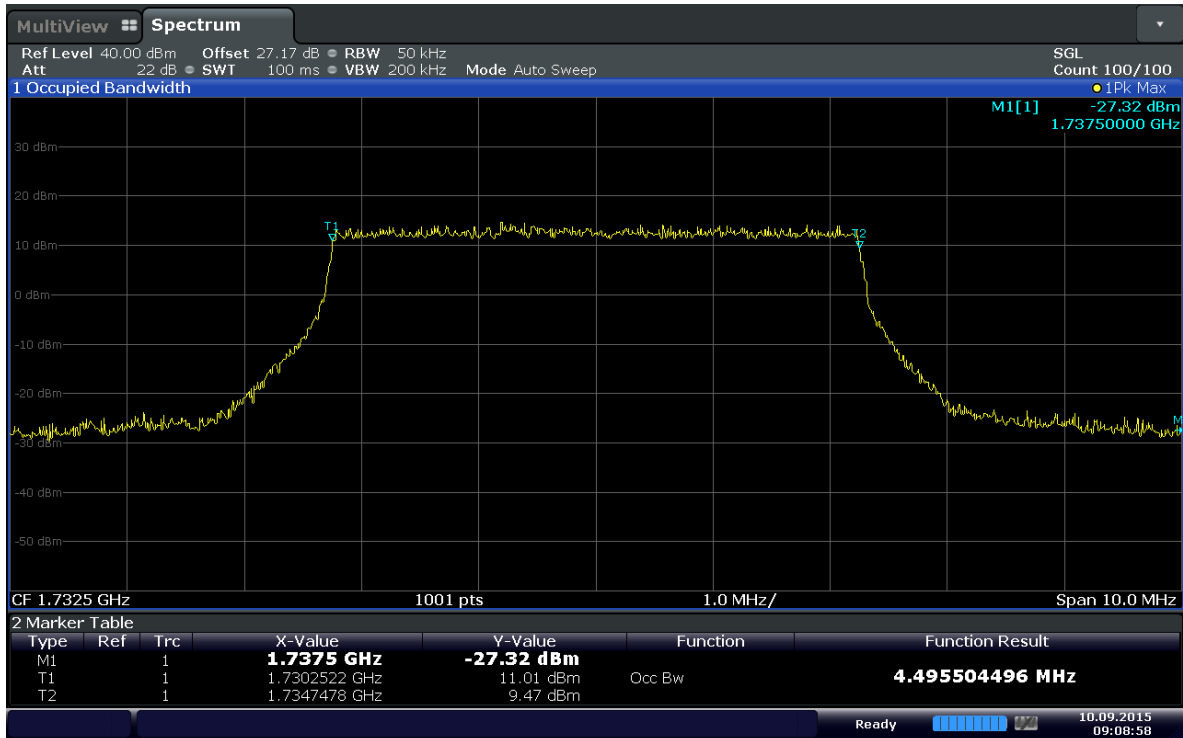

Date: 10.SEP.2015 09:08:58

Plot 6-13. Occupied Bandwidth Plot (Band 4 – 5MHz QPSK - RB Size 25)

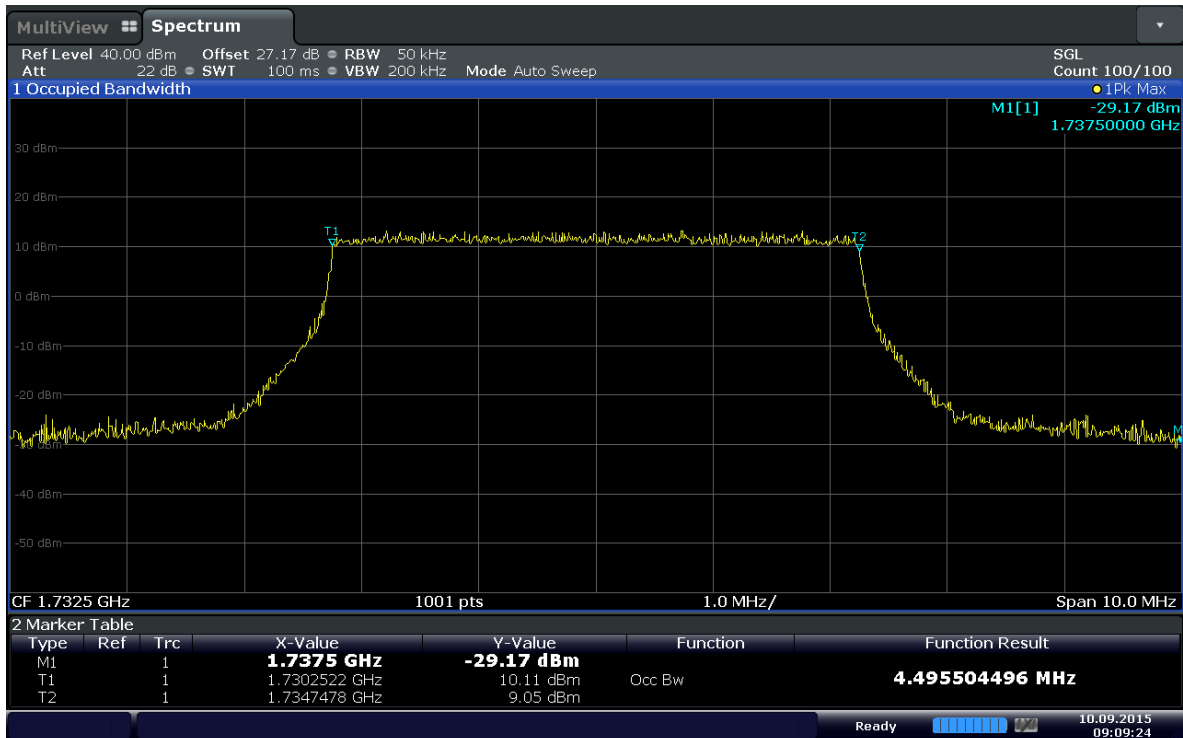

Date: 10.SEP.2015 09:09:25

Plot 6-14. Occupied Bandwidth Plot (Band 4 – 5MHz 16QAM - RB Size 25)

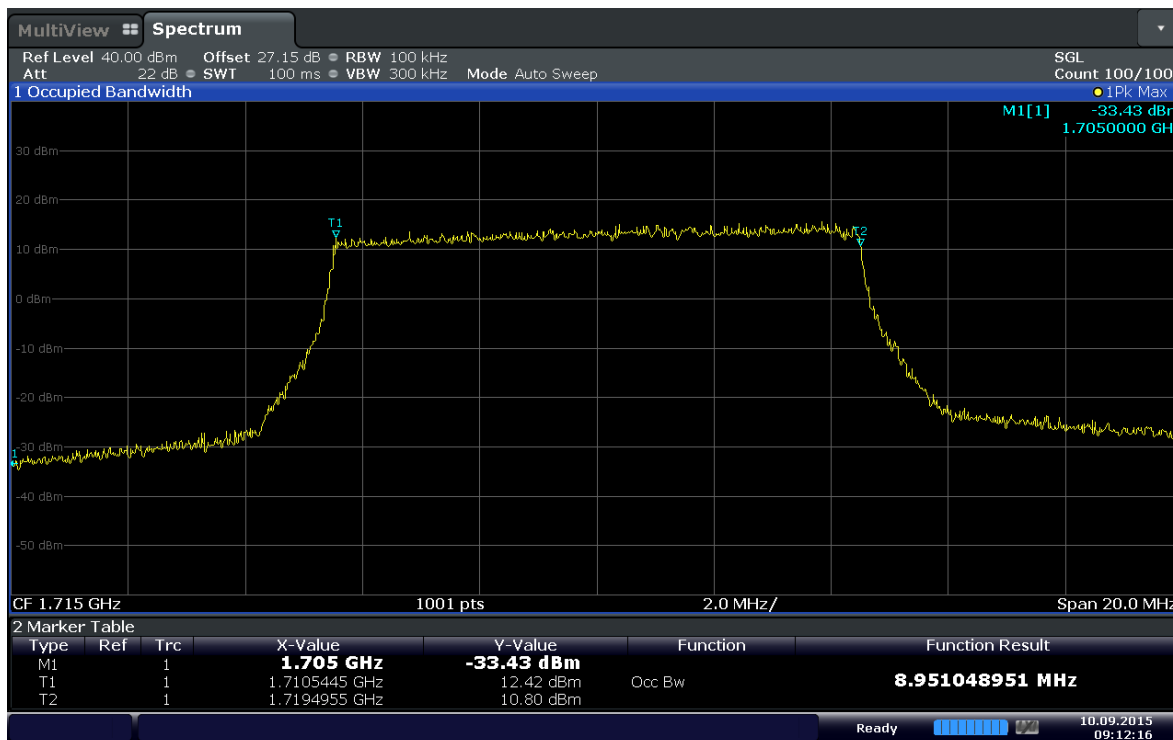

Date: 10.SEP.2015 09:12:16

Plot 6-15. Occupied Bandwidth Plot (Band 4 – 10MHz QPSK - RB Size 50)

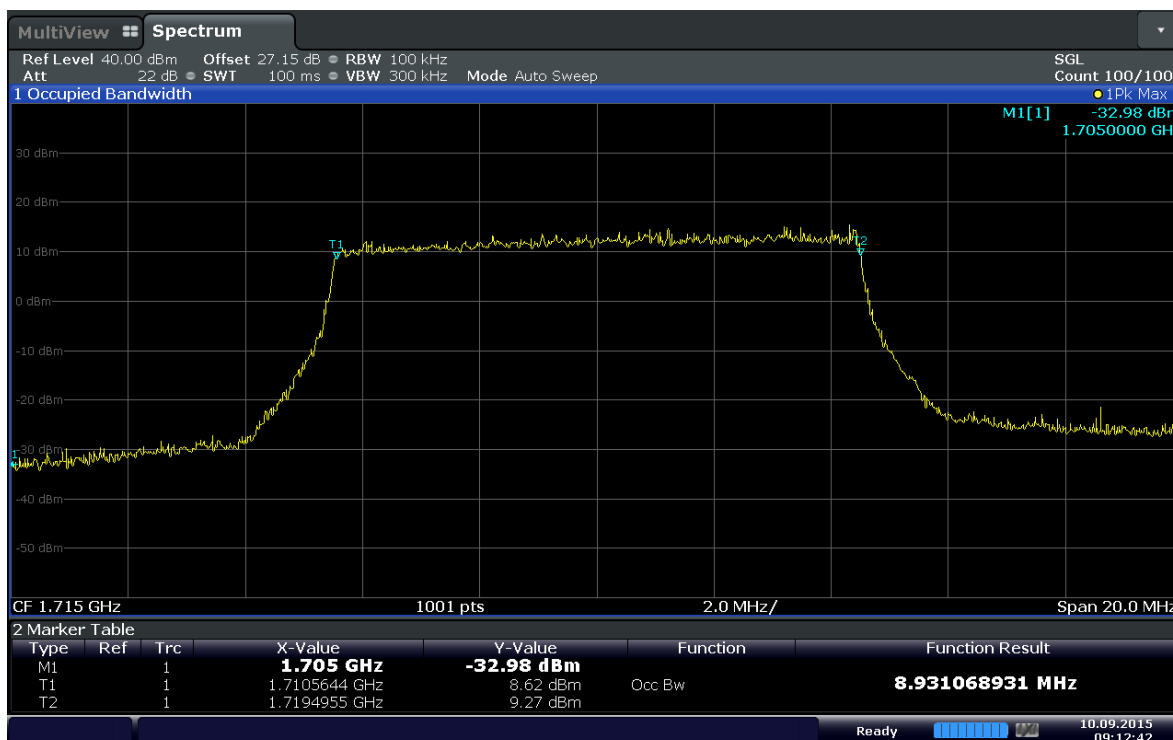

Date: 10.SEP.2015 09:12:43

Plot 6-16. Occupied Bandwidth Plot (Band 4 – 10MHz 16QAM - RB Size 50)

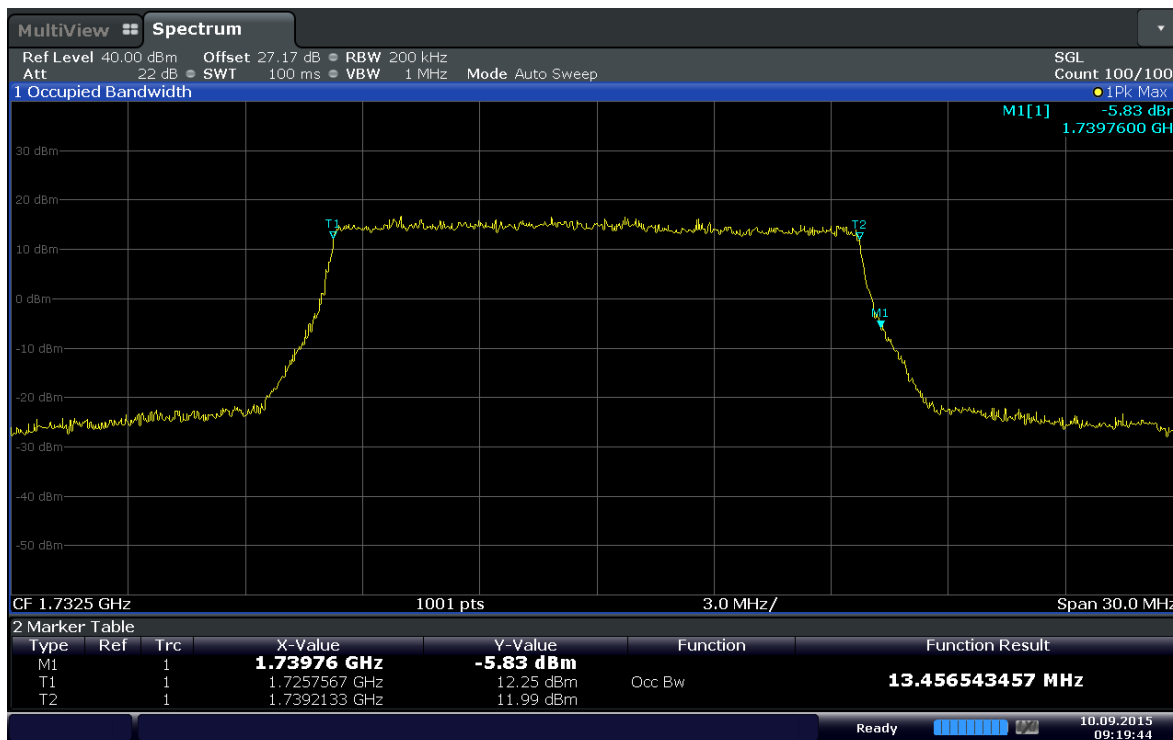

Date: 10.SEP.2015 09:19:45

Plot 6-17. Occupied Bandwidth Plot (Band 4 - 15MHz QPSK - RB Size 75)

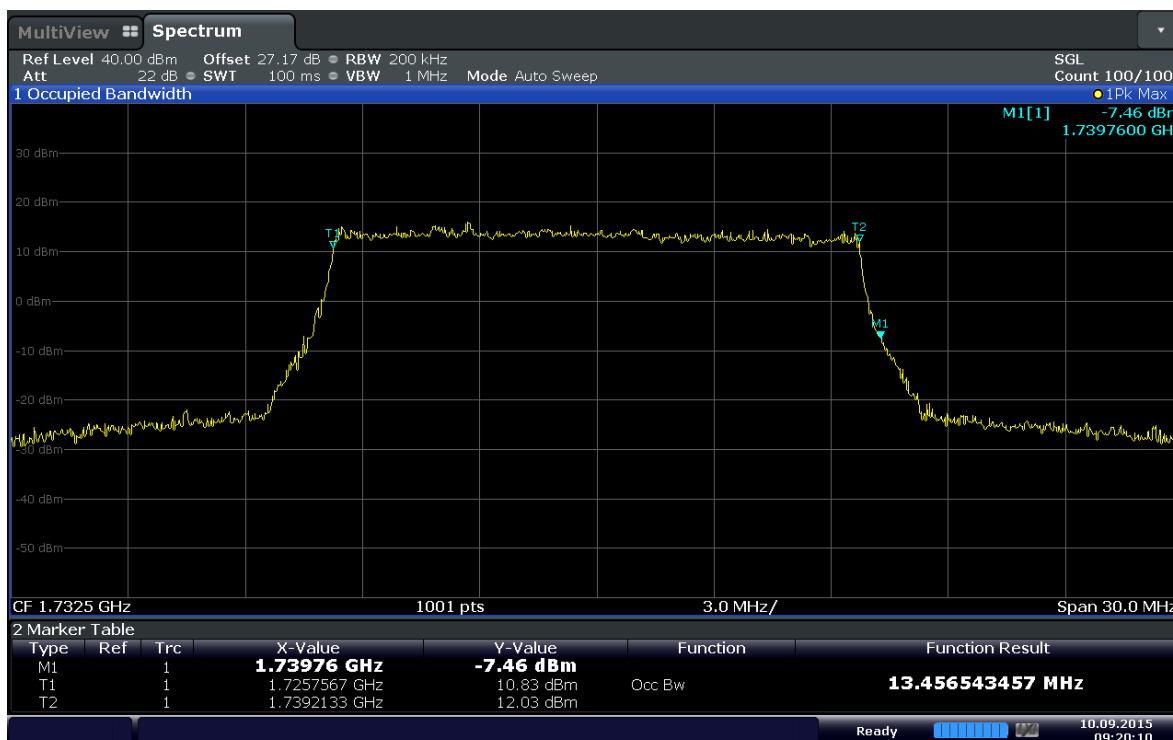

Date: 10.SEP.2015 09:20:11

Plot 6-18. Occupied Bandwidth Plot (Band 4 - 15MHz 16QAM - RB Size 75)

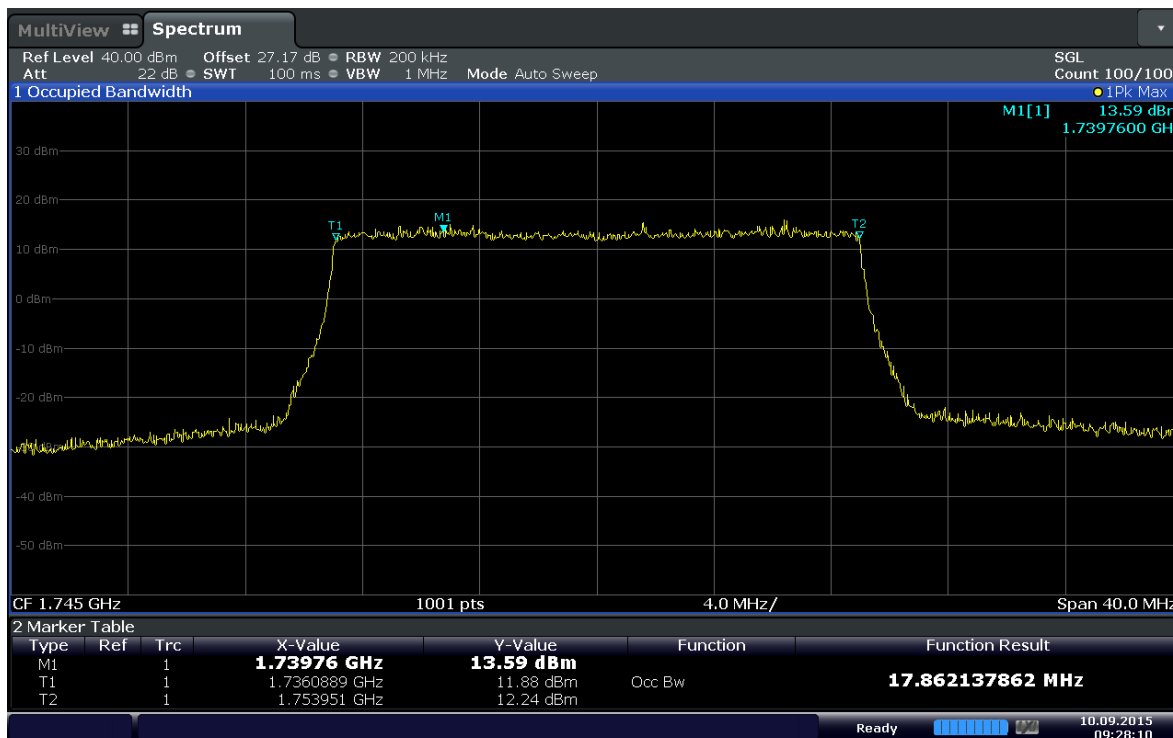

Date: 10.SEP.2015 09:28:10

Plot 6-19. Occupied Bandwidth Plot (Band 4 - 20MHz QPSK - RB Size 100)

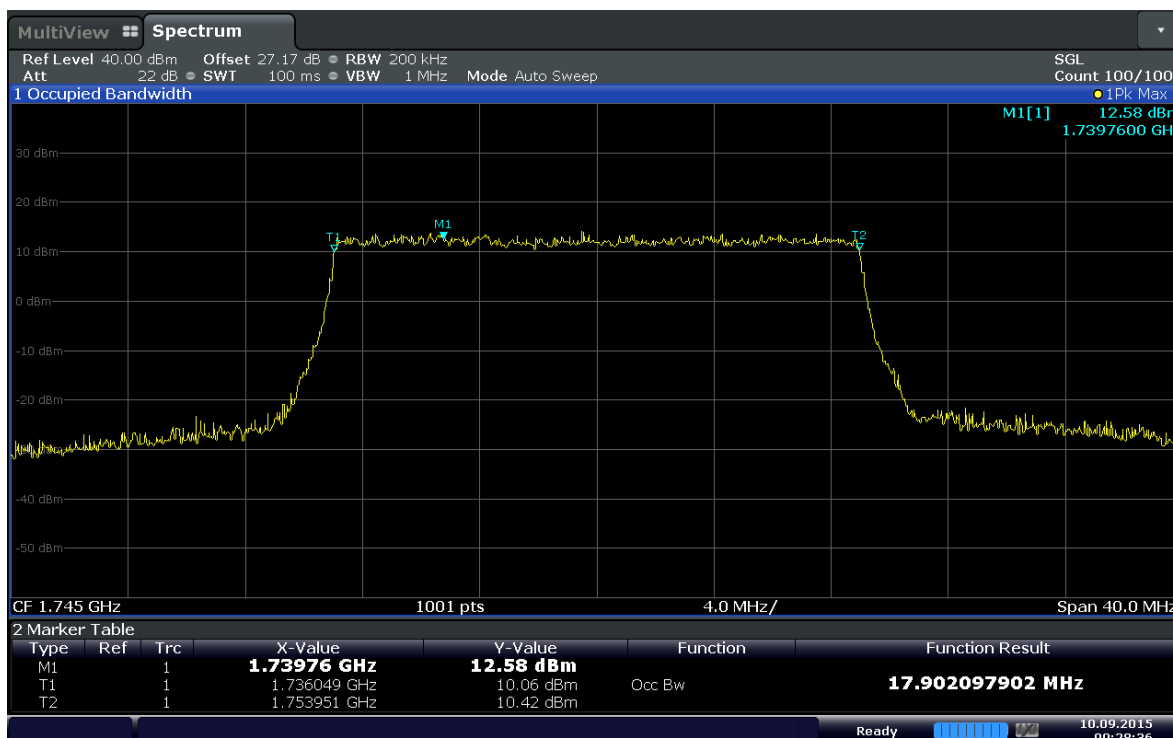

Date: 10.SEP.2015 09:28:36

Plot 6-20. Occupied Bandwidth Plot (Band 4 - 20MHz 16QAM - RB Size 100)



6.3. Spurious and Harmonic Emissions at Antenna Terminal  
§2.1051 §27.53(g) §27.53(h)

Test Overview

The level of the carrier and the various conducted spurious and harmonic frequencies is measured by means of a calibrated spectrum analyzer. The spectrum is scanned from the lowest frequency generated in the equipment up to a frequency including its 10th harmonic. All out of band emissions are measured with a spectrum analyzer connected to the antenna terminal of the EUT while the EUT is operating at maximum power, and at the appropriate frequencies. All data rates were investigated to determine the worst case configuration. All modes of operation were investigated and the worst case configuration results are reported in this section.

The minimum permissible attenuation level of any spurious emission is  $43 + 10 \log_{10}(P_{[\text{Watts}]})$ , where P is the transmitter power in Watts. Limit equivalent to -13dBm, calculation shown below.

$$\begin{aligned}43 + 10 \log_{10}(1.567\text{W}) &= 44.95 \text{ dB} \\1.567\text{W} &= 31.95 \text{ dBm} \\31.95 \text{ dBm} - 44.95 \text{ dB} &= -13 \text{ dBm}\end{aligned}$$

Test Procedure Used

KDB 971168 v02r02 – Section 6.0

Test Settings

1. Start frequency was set to 30MHz and stop frequency was set to at least 10<sup>th</sup> harmonic of the fundamental frequency (separated into two or more plots per channel if necessary)
2. RBW  $\geq$  1MHz
3. VBW  $\geq$  3 x RBW
4. Detector = RMS
5. Trace mode = max hold
6. Sweep time = auto couple
7. The trace was allowed to stabilize

### Test Setup

The EUT and measurement equipment were set up as shown in the diagram below.

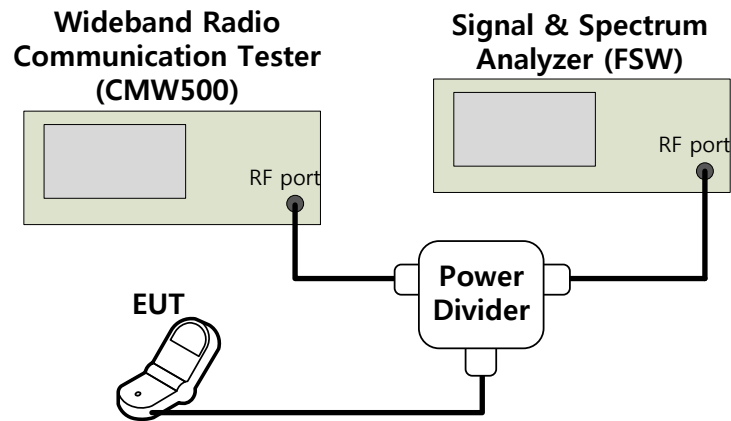

Figure 6-2. Test Instruments & Measurement Setup

### Test Note

1. Compliance with the applicable limits is based on the use of measurement instrumentation employing a resolution bandwidth of 100kHz or greater for cellular equipment whose frequencies are less than 1GHz. However, in the 1MHz bands immediately outside and adjacent to the frequency block a resolution bandwidth of at least one percent of the emission bandwidth of the fundamental emission of the transmitter may be employed. The emission bandwidth is defined as the width of the signal between two points, one below the carrier center frequency and one above the carrier center frequency, outside of which all emission are attenuated at least 26dB below the transmitter power.



Test Plots

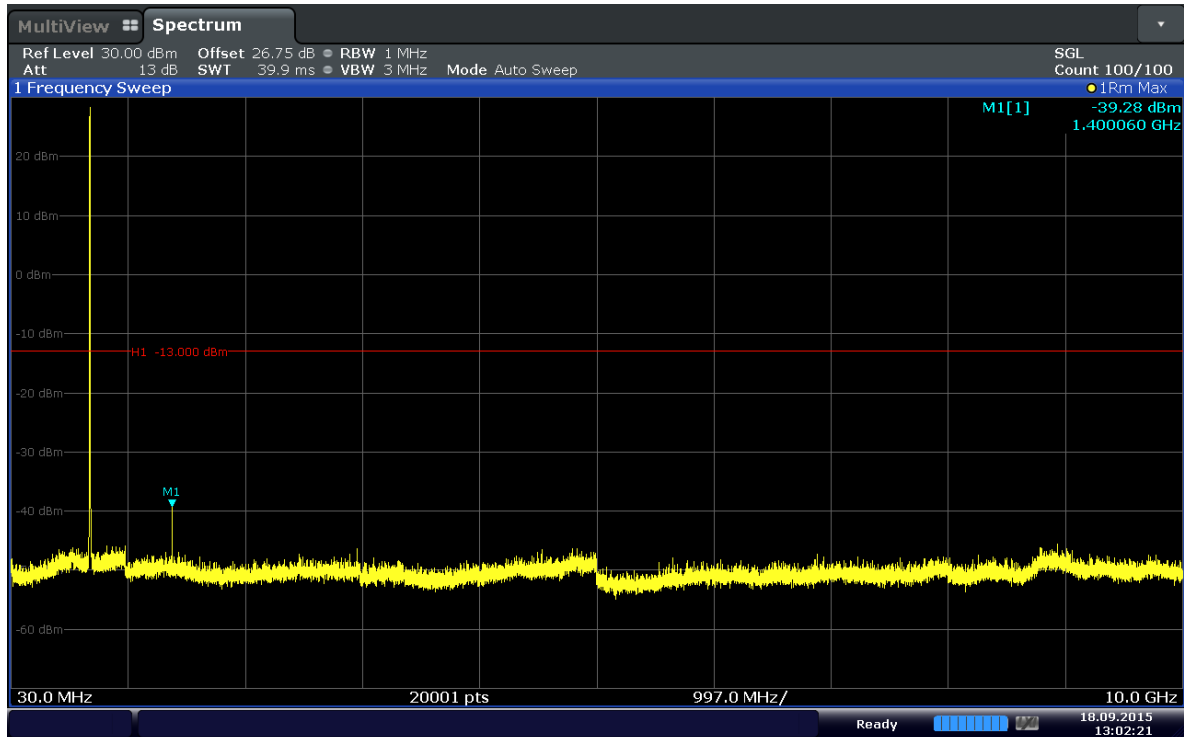

Date: 18.SEP.2015 13:02:22

Plot 6-21. Conducted Spurious Plot (Band 12-1.4MHz-QPSK-RB Size 1-RB Offset 5-Ch.23017)

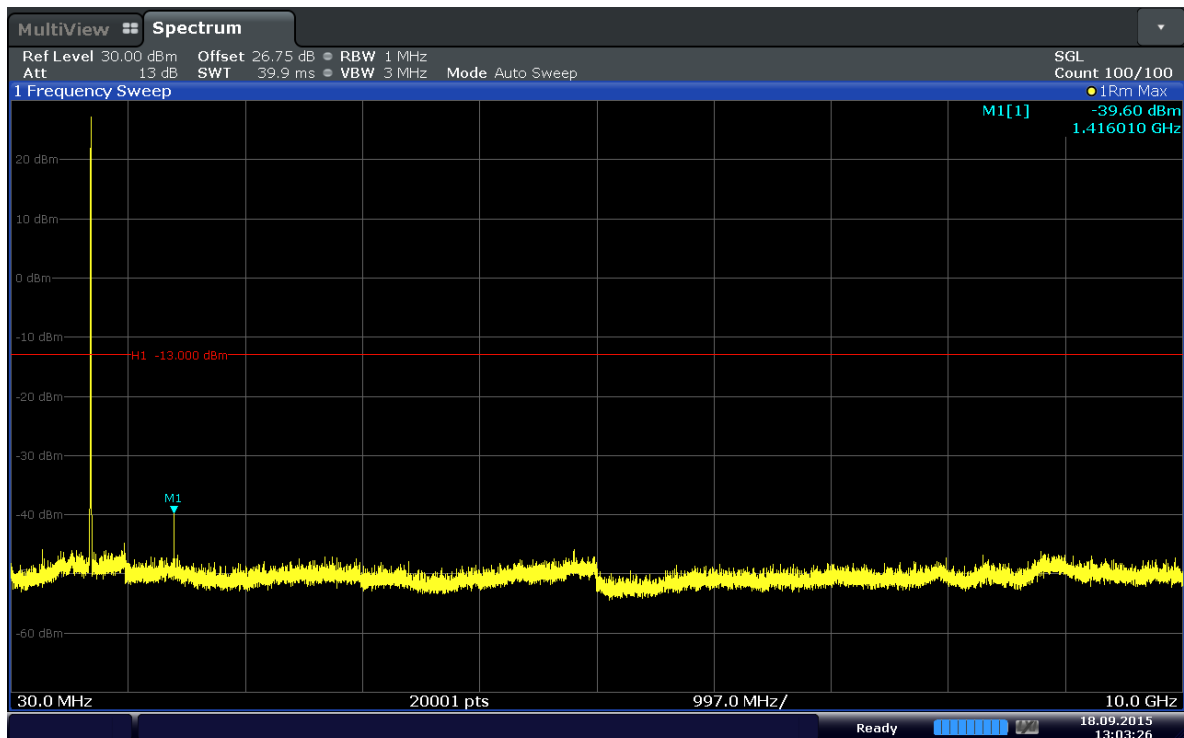

Date: 18.SEP.2015 13:03:26

Plot 6-22. Conducted Spurious Plot (Band 12-1.4MHz-QPSK-RB Size 1-RB Offset 5-Ch.23095)

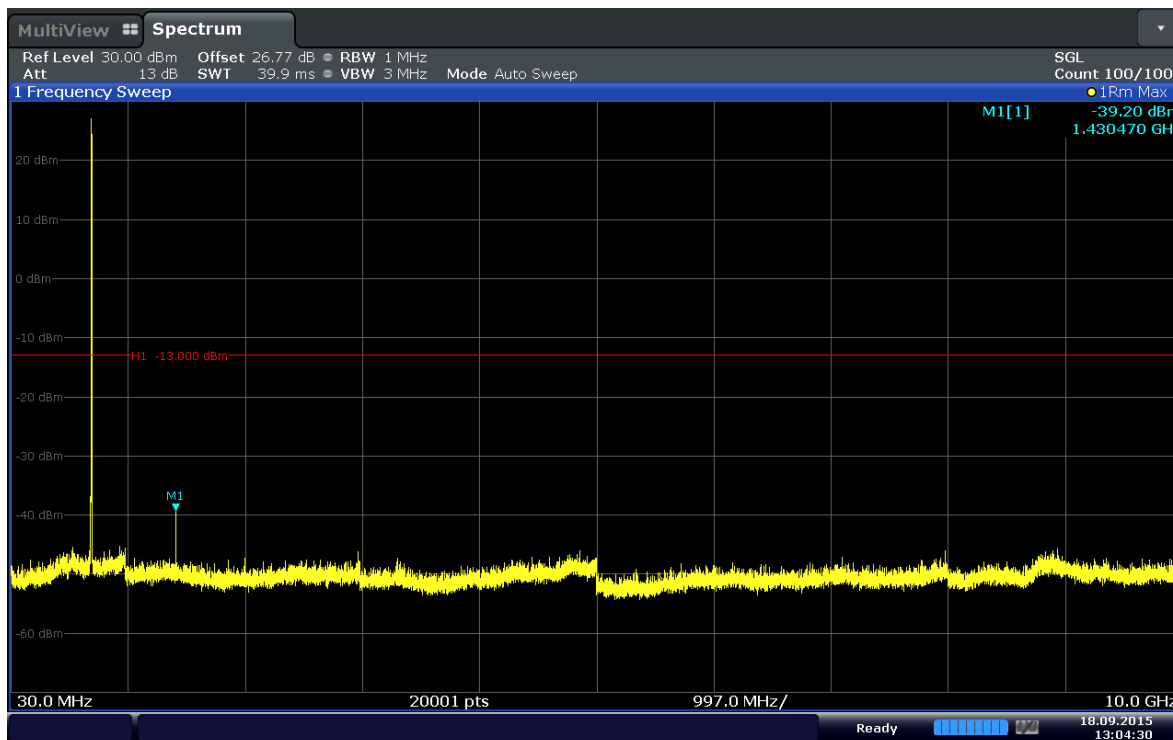

Date: 18.SEP.2015 13:04:31

Plot 6-23. Conducted Spurious Plot (Band 12-1.4MHz-QPSK-RB Size 1-RB Offset 2-Ch.23173)

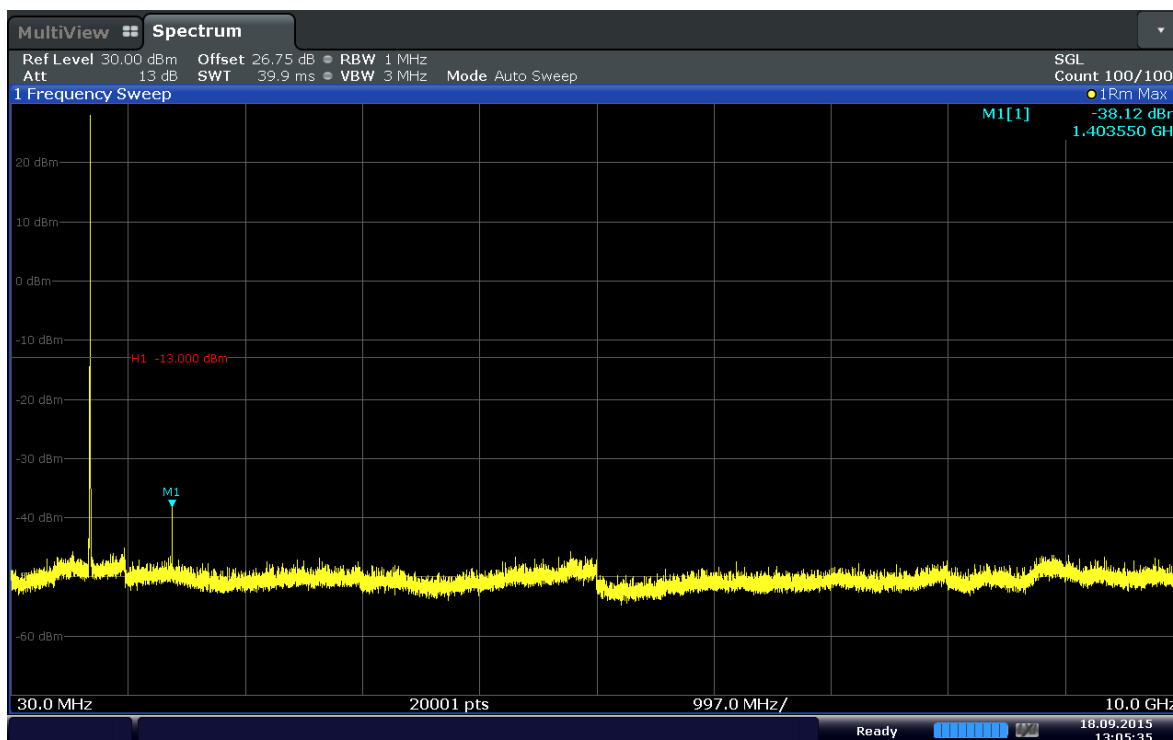

Date: 18.SEP.2015 13:05:35

Plot 6-24. Conducted Spurious Plot (Band 12-3MHz-QPSK-RB Size 1-RB Offset 14-Ch.23025)

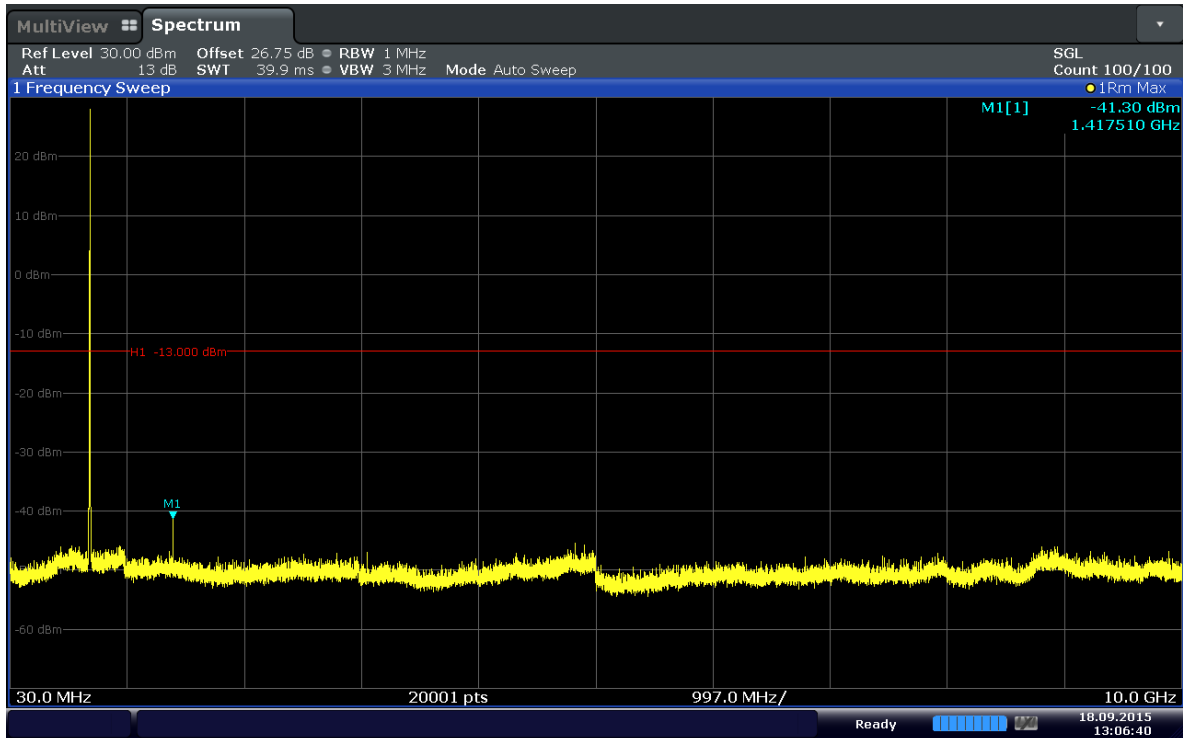

Date: 18.SEP.2015 13:06:40

Plot 6-25. Conducted Spurious Plot (Band 12-3MHz-QPSK-RB Size 1-RB Offset 14-Ch.23095)

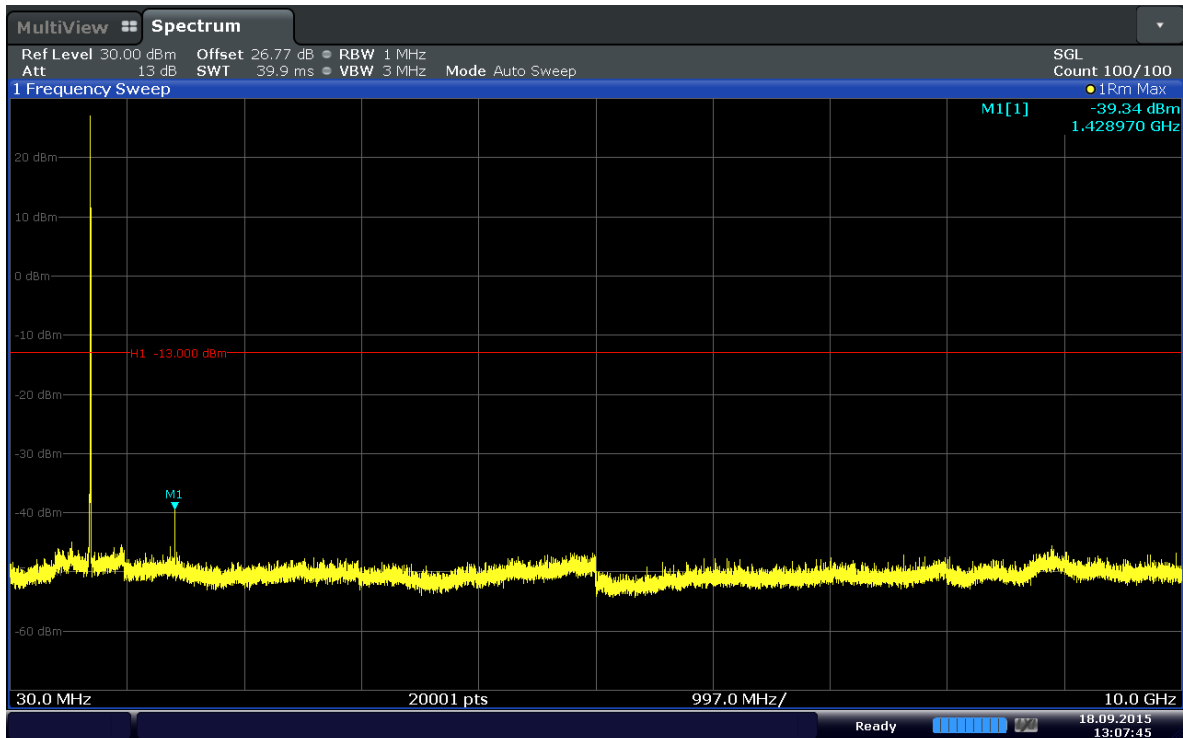

Date: 18.SEP.2015 13:07:44

Plot 6-26. Conducted Spurious Plot (Band 12-3MHz-QPSK-RB Size 1-RB Offset 7-Ch.23165)

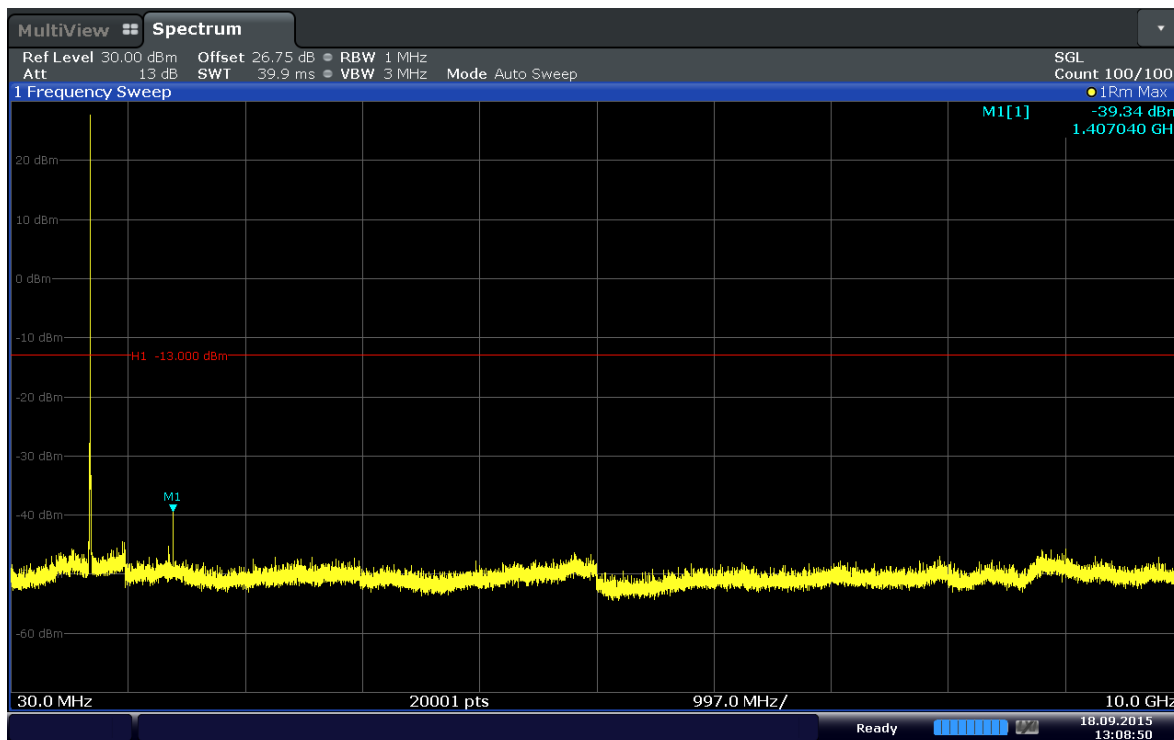

Date: 18.SEP.2015 13:08:49

Plot 6-27. Conducted Spurious Plot (Band 12-5MHz-QPSK-RB Size 1-RB Offset 24-Ch.23035)

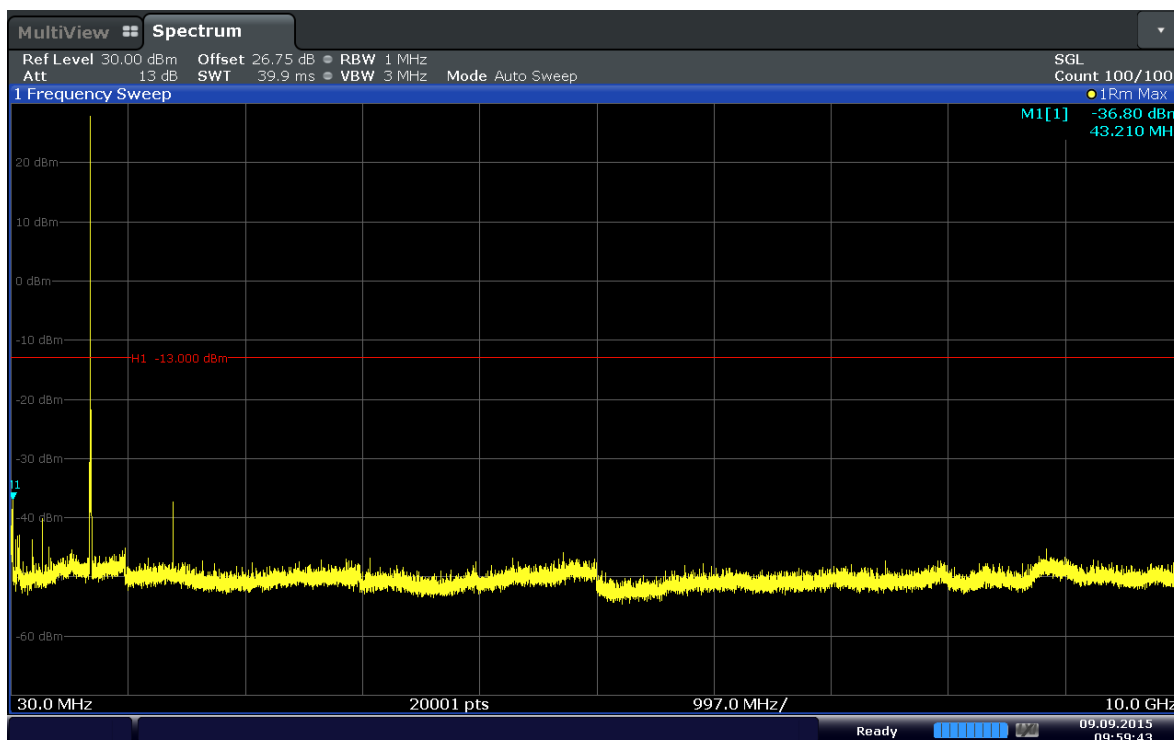

Date: 9.SEP.2015 09:59:43

Plot 6-28. Conducted Spurious Plot (Band 12-5MHz-QPSK-RB Size 1-RB Offset 24-Ch.23095)

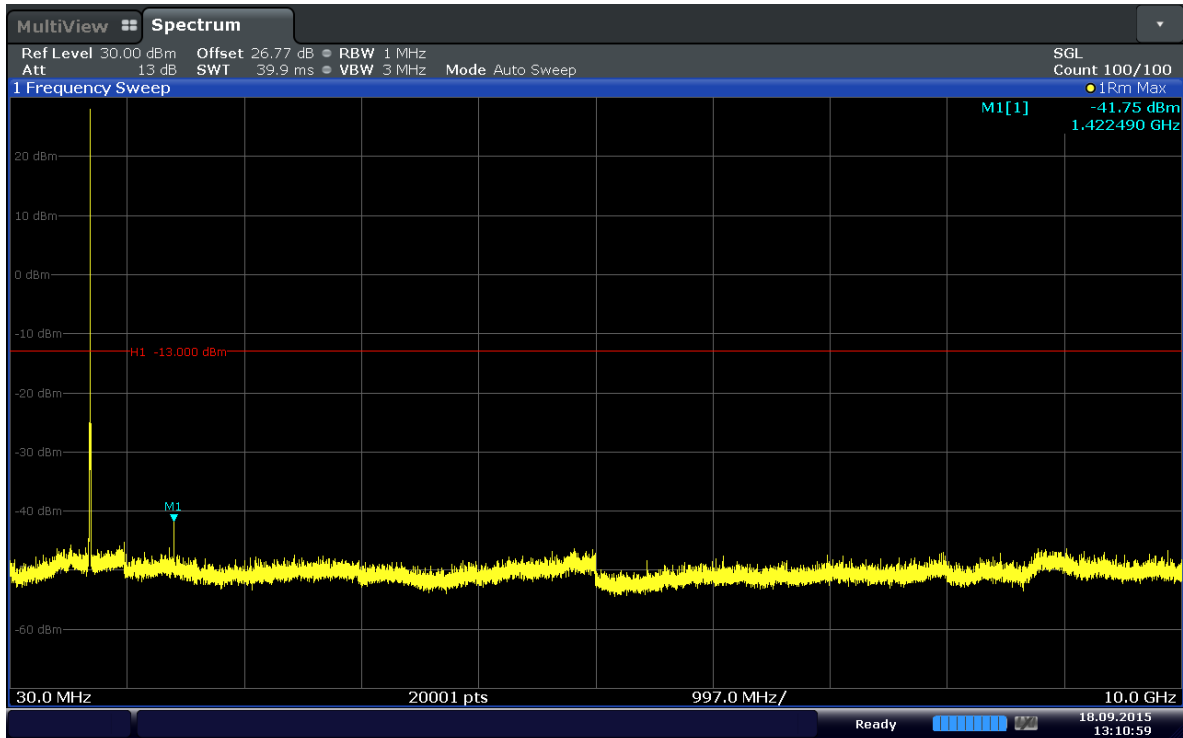

Date: 18.SEP.2015 13:10:59

Plot 6-29. Conducted Spurious Plot (Band 12–5MHz–QPSK–RB Size 1–RB Offset 0–Ch.23155)

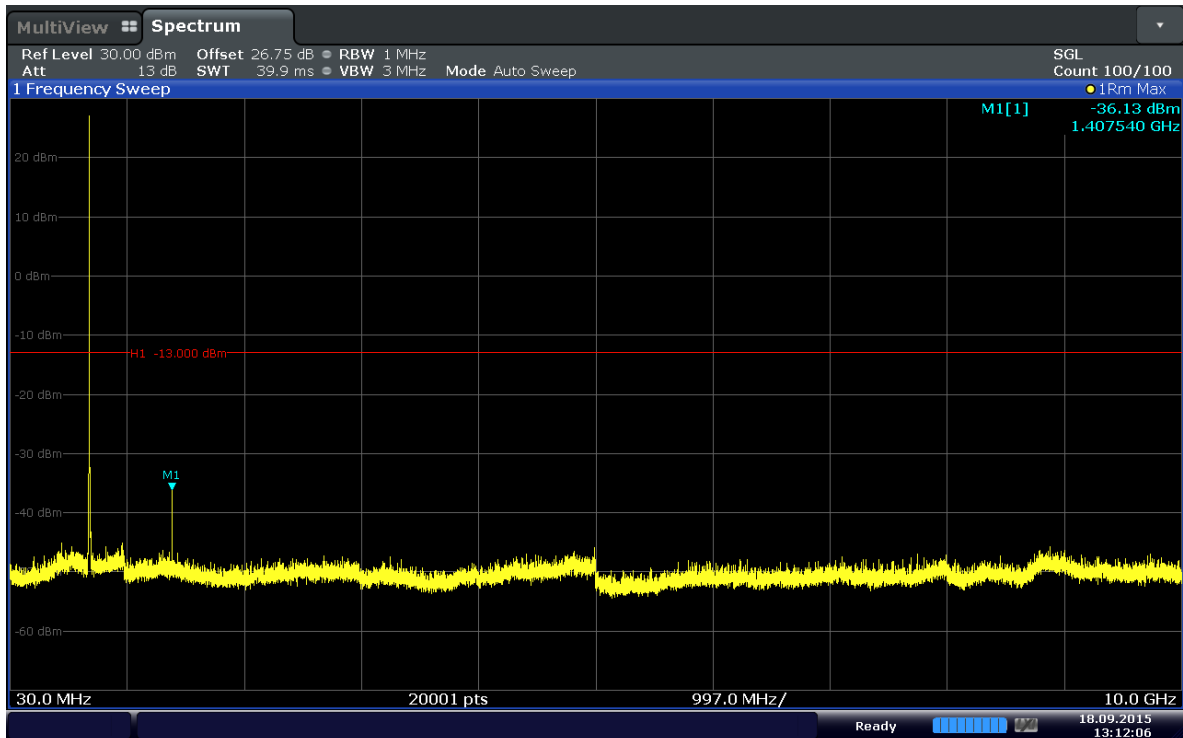

Date: 18.SEP.2015 13:12:07

Plot 6-30. Conducted Spurious Plot (Band 12–10MHz–QPSK–RB Size 1–RB Offset 24–Ch.23060)

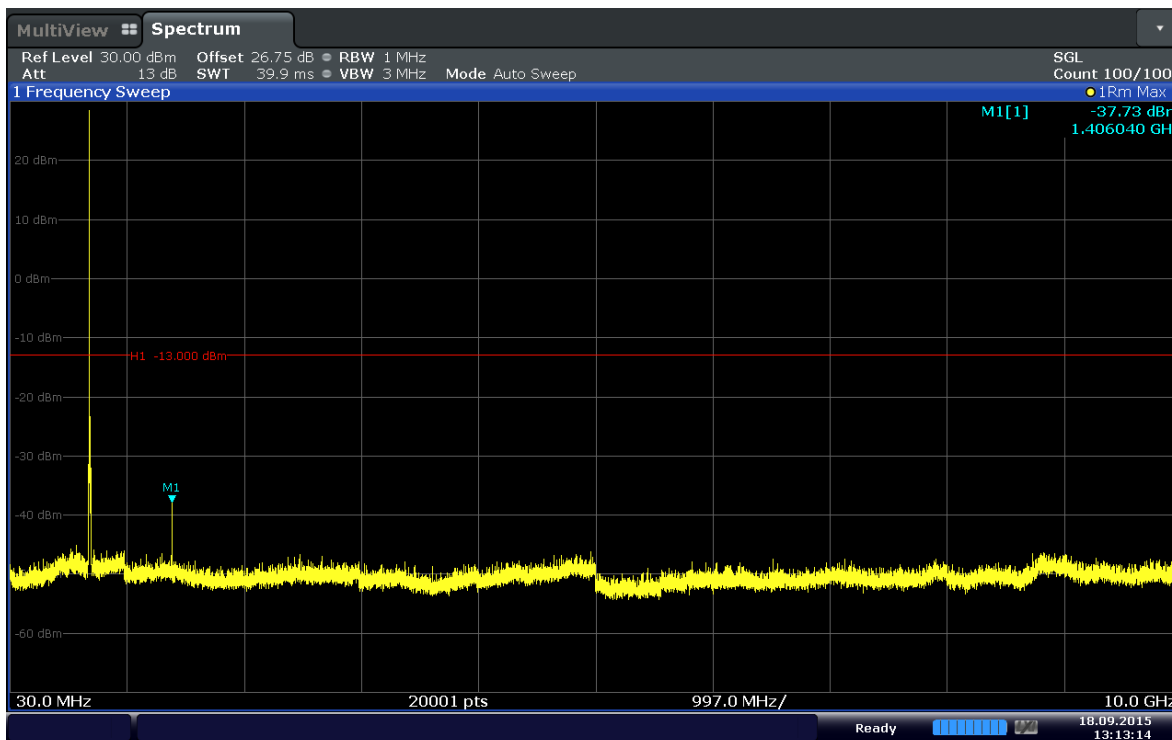

Date: 18.SEP.2015 13:13:14

Plot 6-31. Conducted Spurious Plot (Band 12-10MHz-QPSK-RB Size 1-RB Offset 0-Ch.23095)

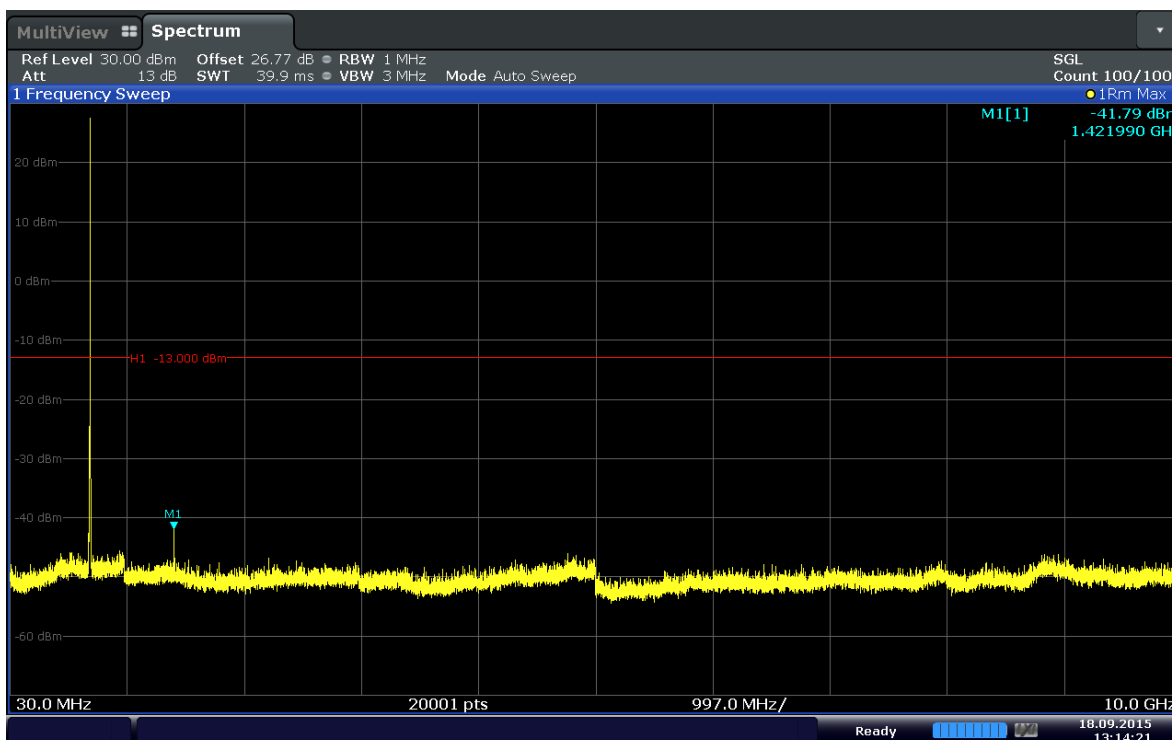

Date: 18.SEP.2015 13:14:21

Plot 6-32. Conducted Spurious Plot (Band 12-10MHz-QPSK-RB Size 1-RB Offset 24-Ch.23130)

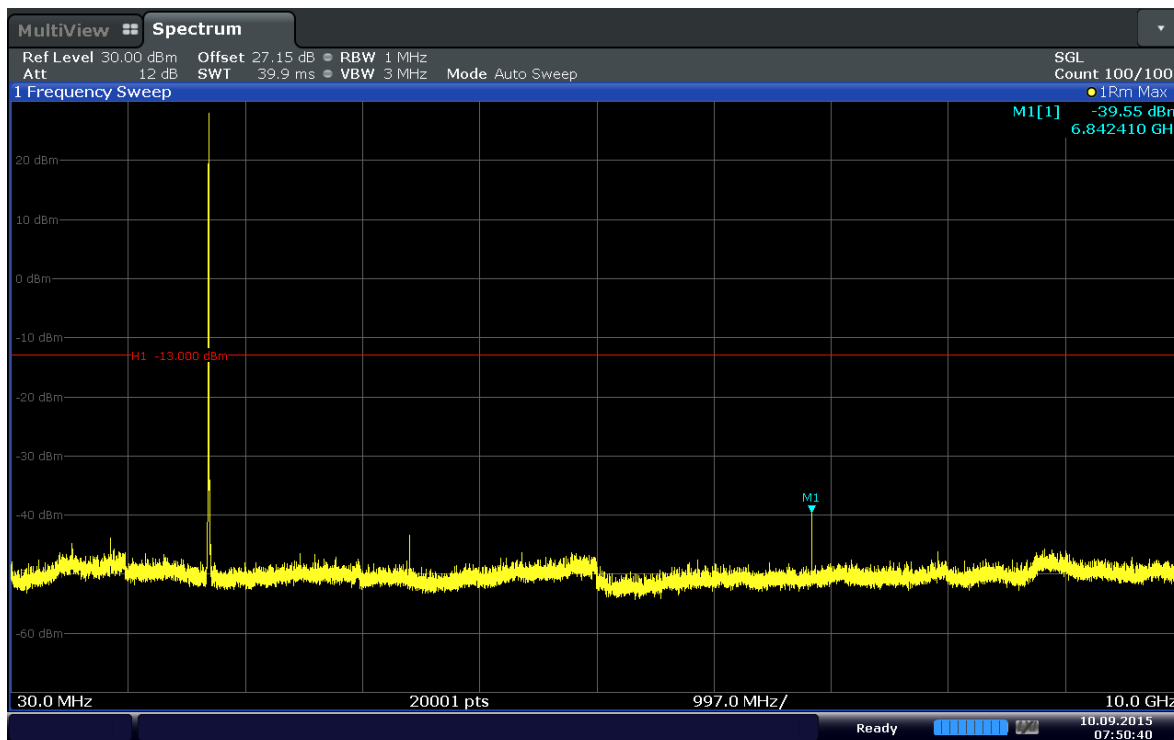

Date: 10.SEP.2015 07:50:41

Plot 6-33. Conducted Spurious Plot (Band 4–1.4MHz–QPSK–RB Size 1–RB Offset 2–Ch.19957)

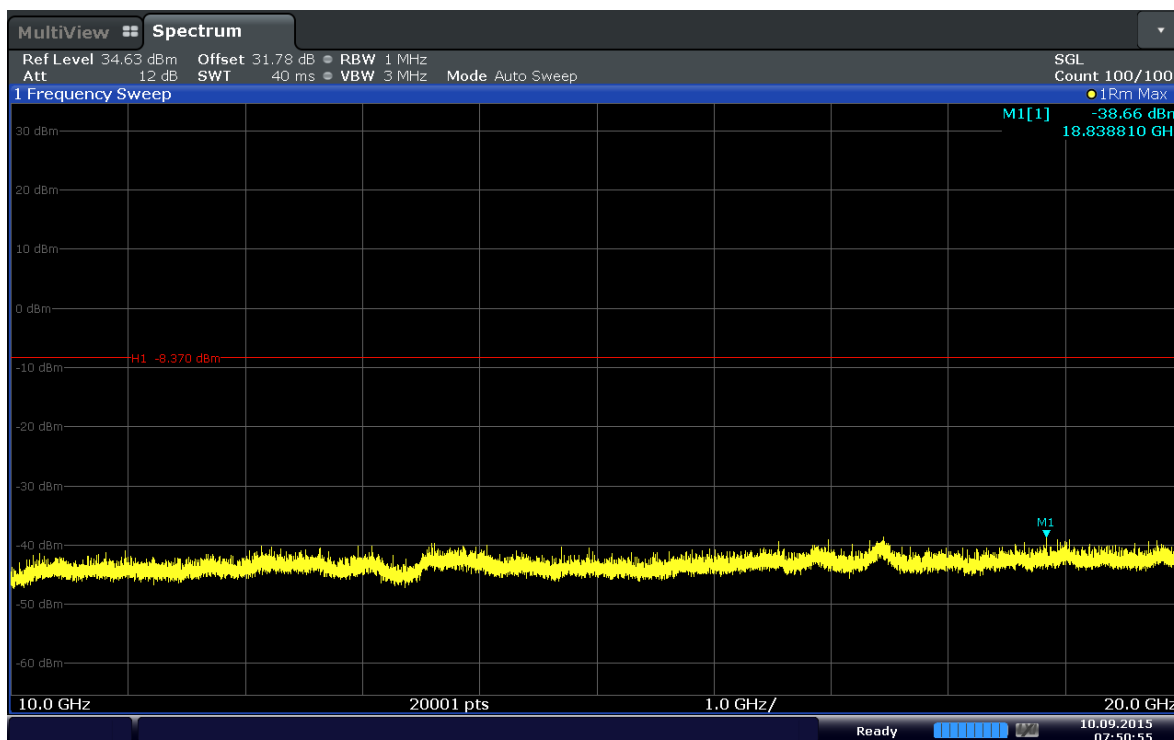

Date: 10.SEP.2015 07:50:55

Plot 6-34. Conducted Spurious Plot (Band 4–1.4MHz–QPSK–RB Size 1–RB Offset 2–Ch.19957)

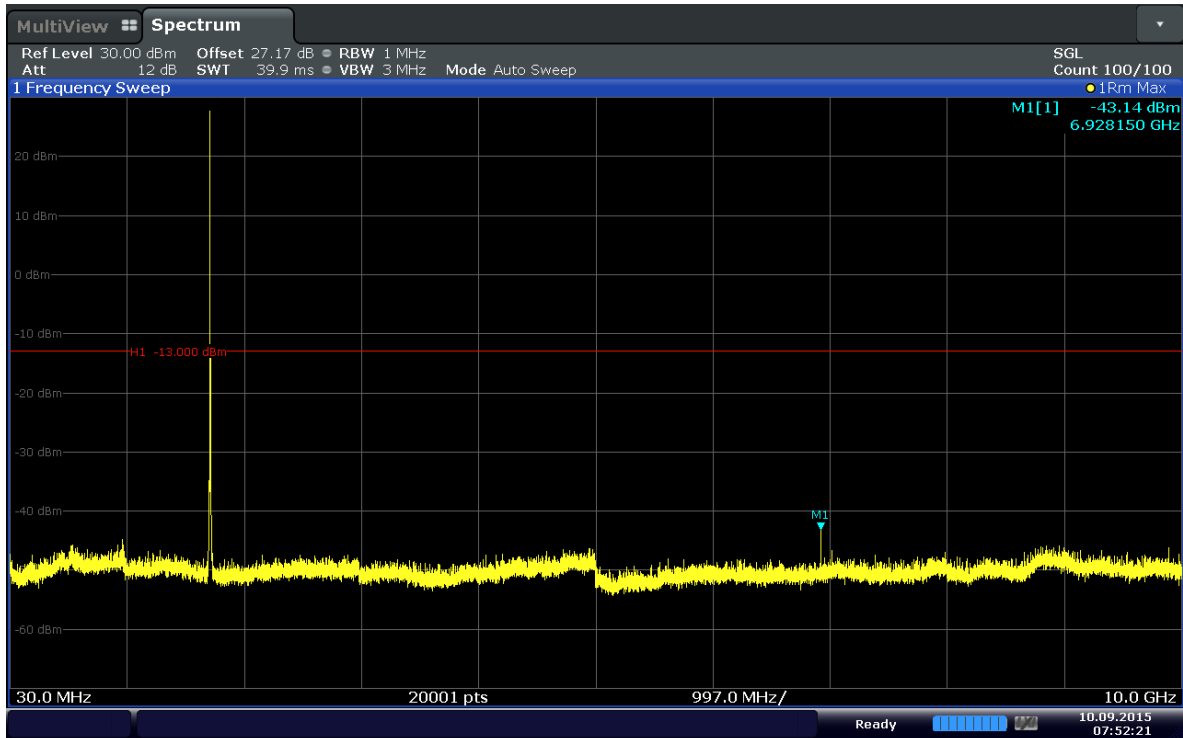

Date: 10.SEP.2015 07:52:21

Plot 6-35. Conducted Spurious Plot (Band 4-1.4MHz-QPSK-RB Size 1-RB Offset 0-Ch.20175)

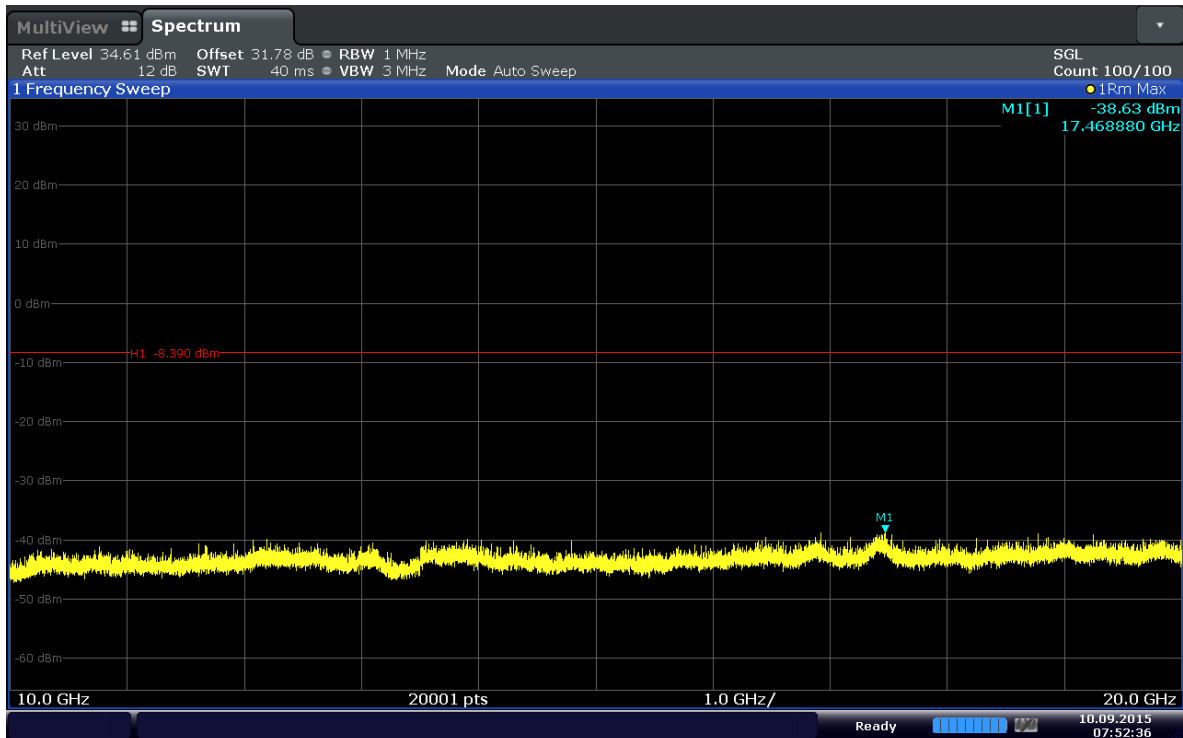

Date: 10.SEP.2015 07:52:36

Plot 6-36. Conducted Spurious Plot (Band 4-1.4MHz-QPSK-RB Size 1-RB Offset 0-Ch.20175)

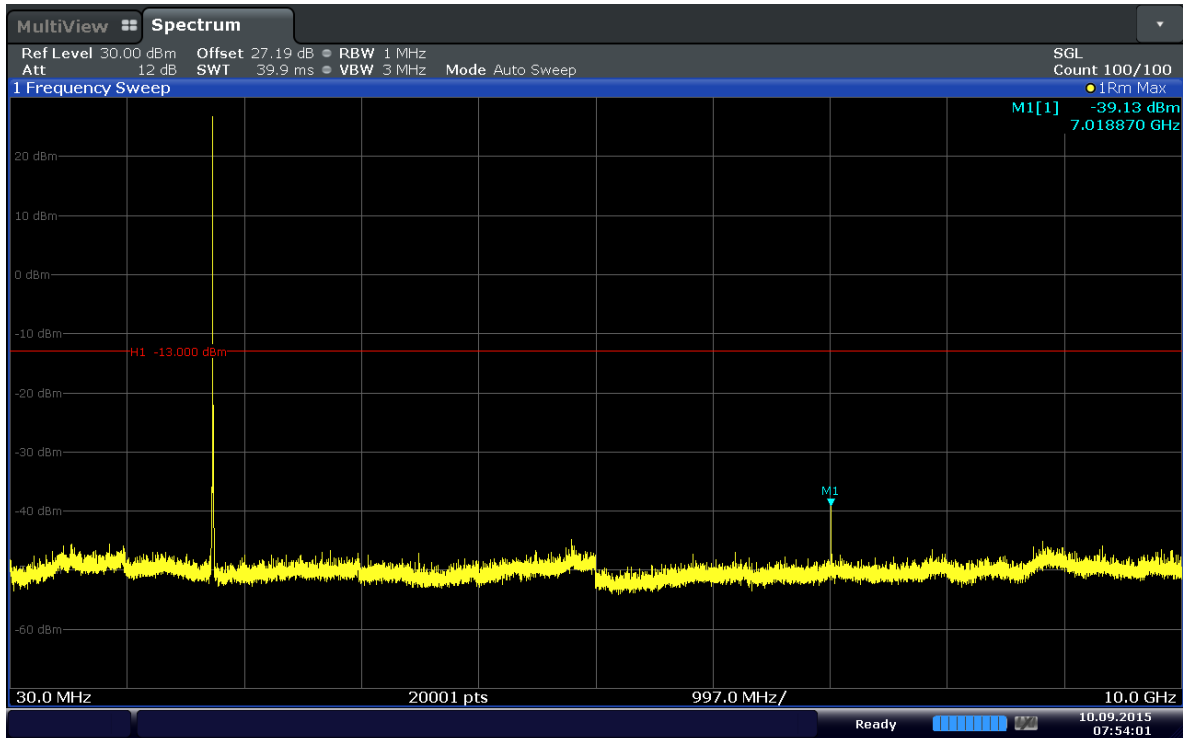

Date: 10.SEP.2015 07:54:01

Plot 6-37. Conducted Spurious Plot (Band 4-1.4MHz-QPSK-RB Size 1-RB Offset 5-Ch.20393)

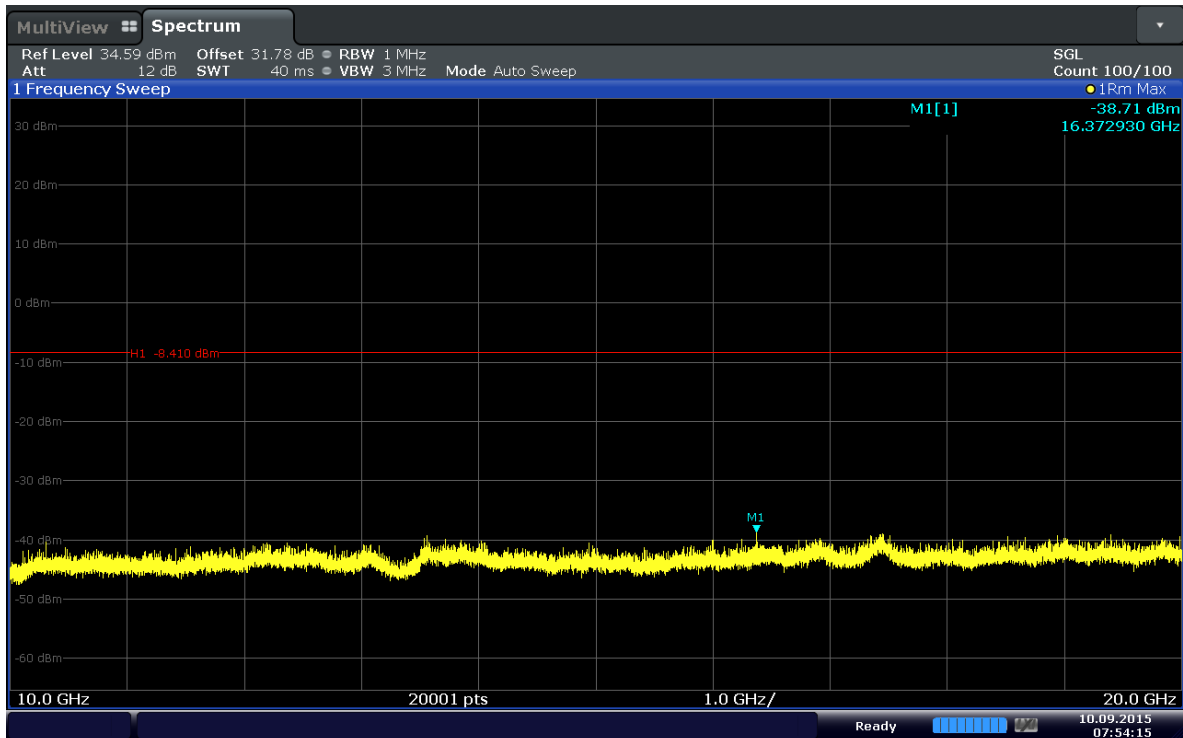

Date: 10.SEP.2015 07:54:16

Plot 6-38. Conducted Spurious Plot (Band 4-1.4MHz-QPSK-RB Size 1-RB Offset 5-Ch.20393)

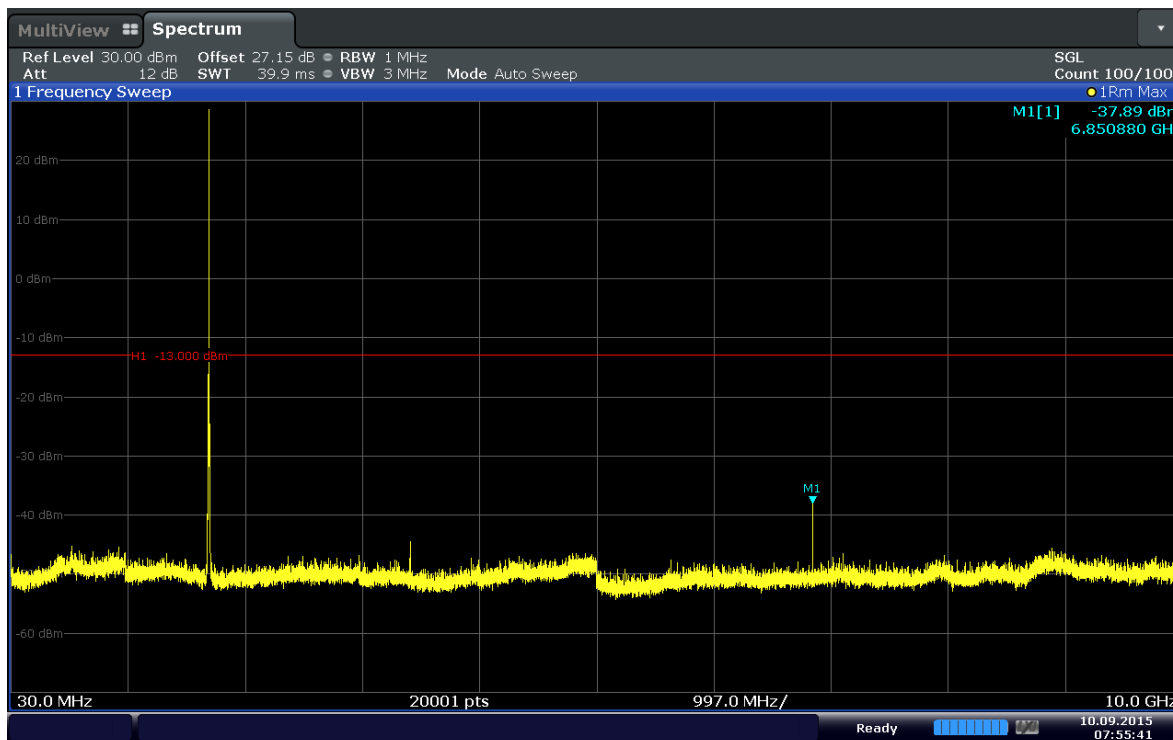

Date: 10.SEP.2015 07:55:41

Plot 6-39. Conducted Spurious Plot (Band 4-3MHz-QPSK-RB Size 1-RB Offset 14-Ch.19965)

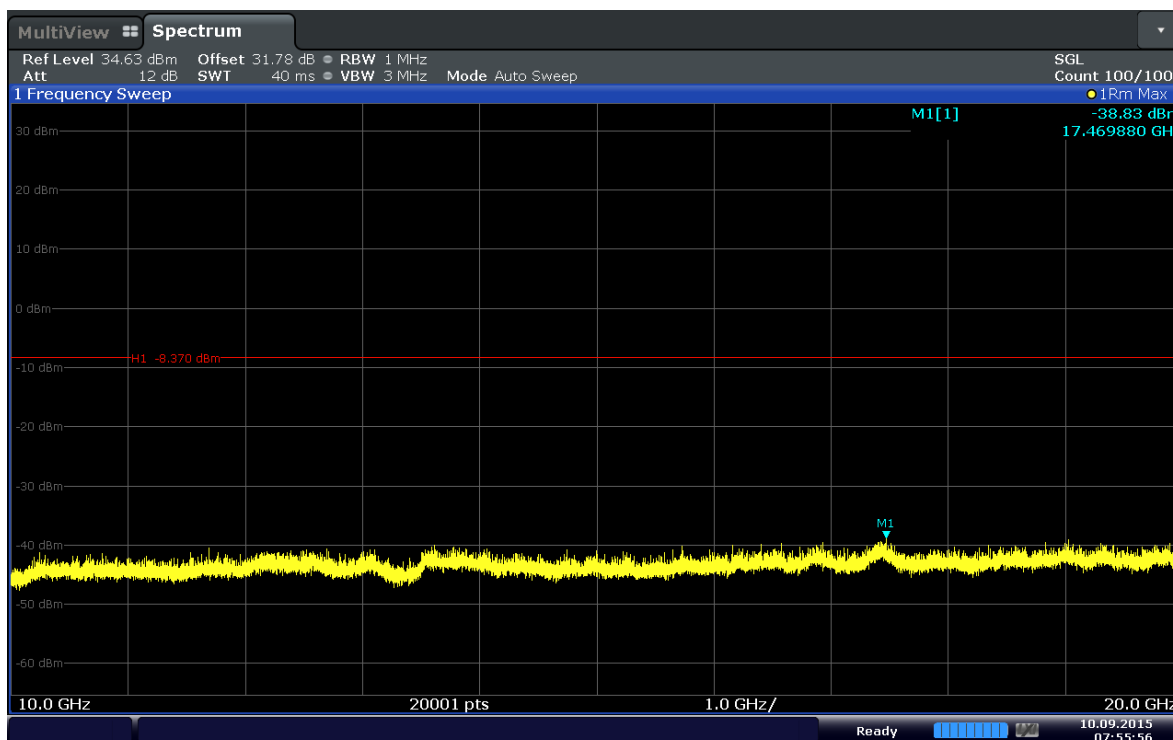

Date: 10.SEP.2015 07:55:56

Plot 6-40. Conducted Spurious Plot (Band 4-3MHz-QPSK-RB Size 1-RB Offset 14-Ch.19965)

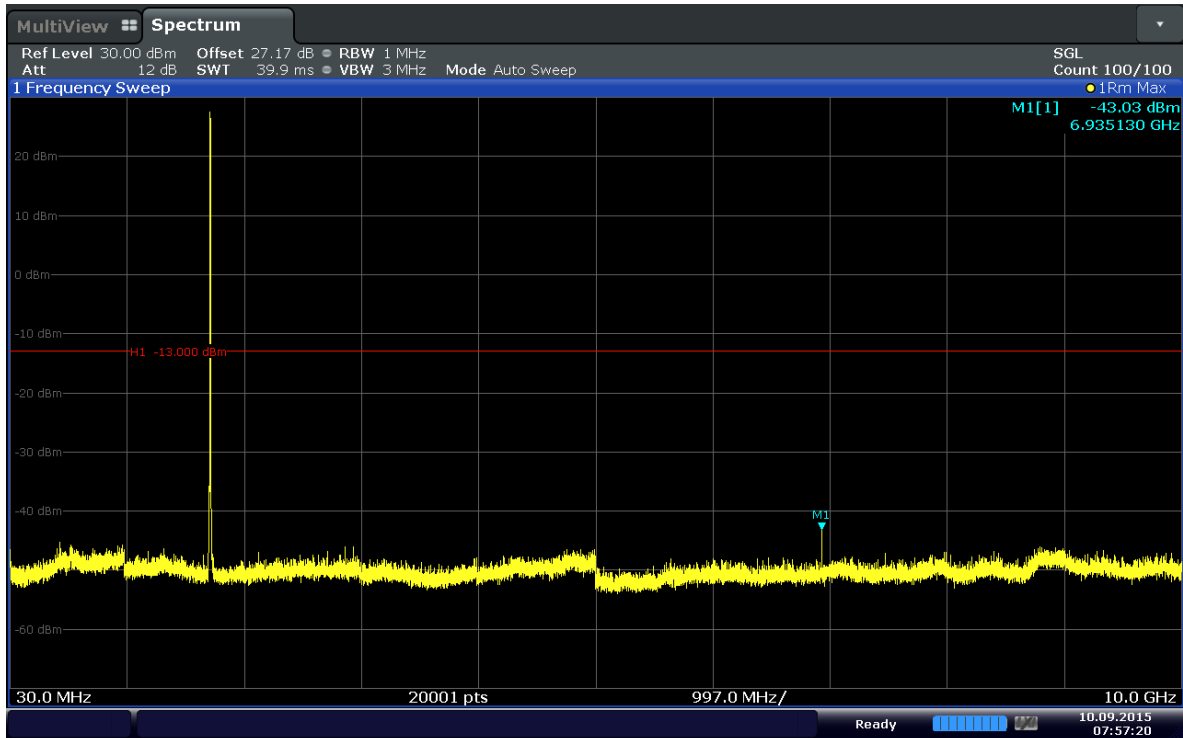

Date: 10.SEP.2015 07:57:20

Plot 6-41. Conducted Spurious Plot (Band 4-3MHz-QPSK-RB Size 1-RB Offset 14-Ch.20175)

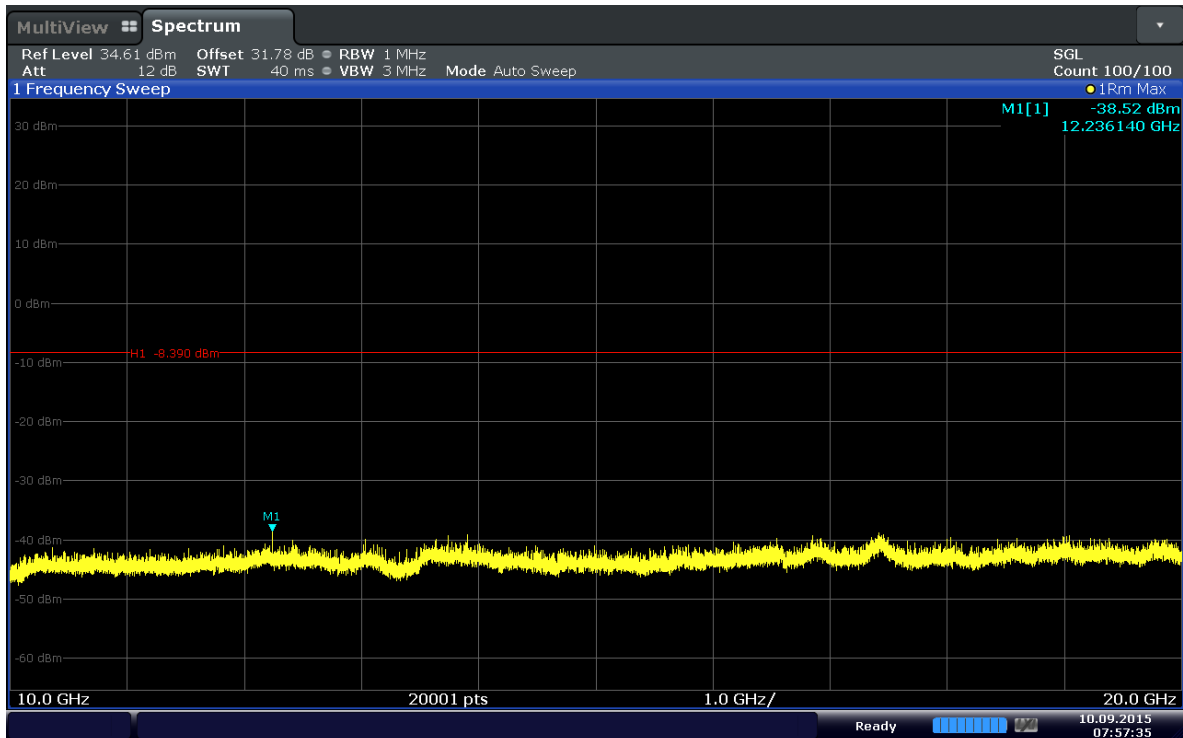

Date: 10.SEP.2015 07:57:35

Plot 6-42. Conducted Spurious Plot (Band 4-3MHz-QPSK-RB Size 1-RB Offset 14-Ch.20175)

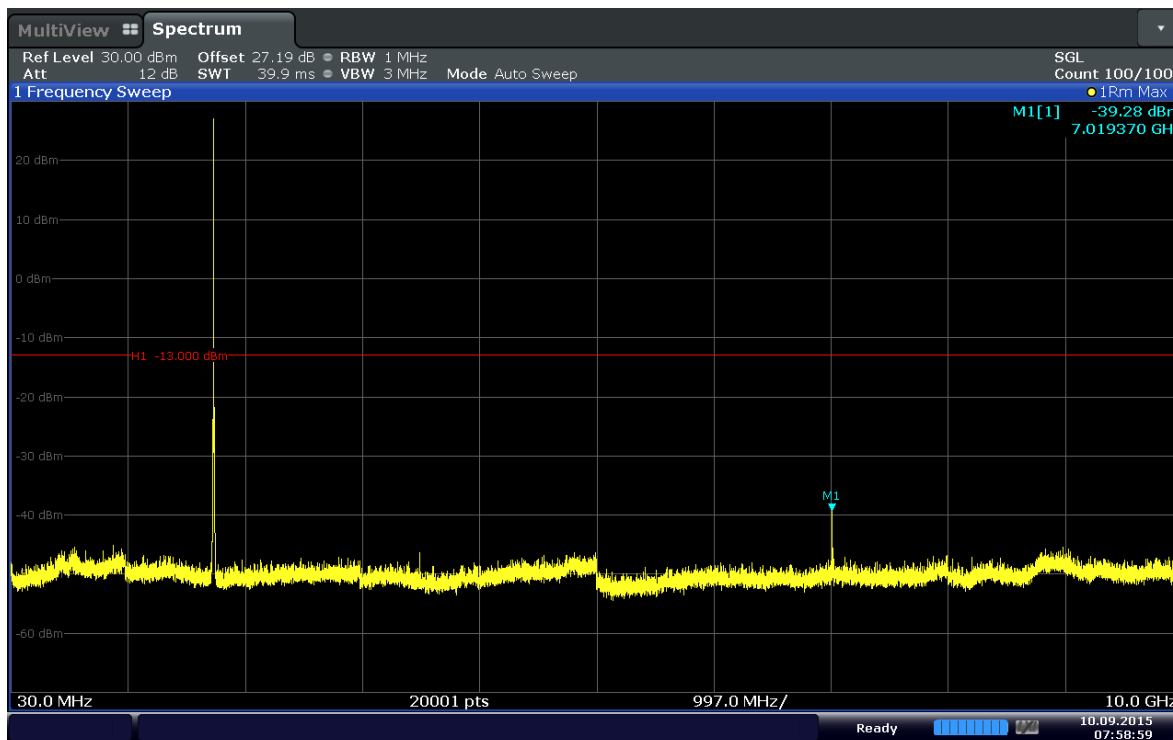

Date: 10.SEP.2015 07:58:59

Plot 6-43. Conducted Spurious Plot (Band 4-3MHz-QPSK-RB Size 1-RB Offset 14-Ch.20385)

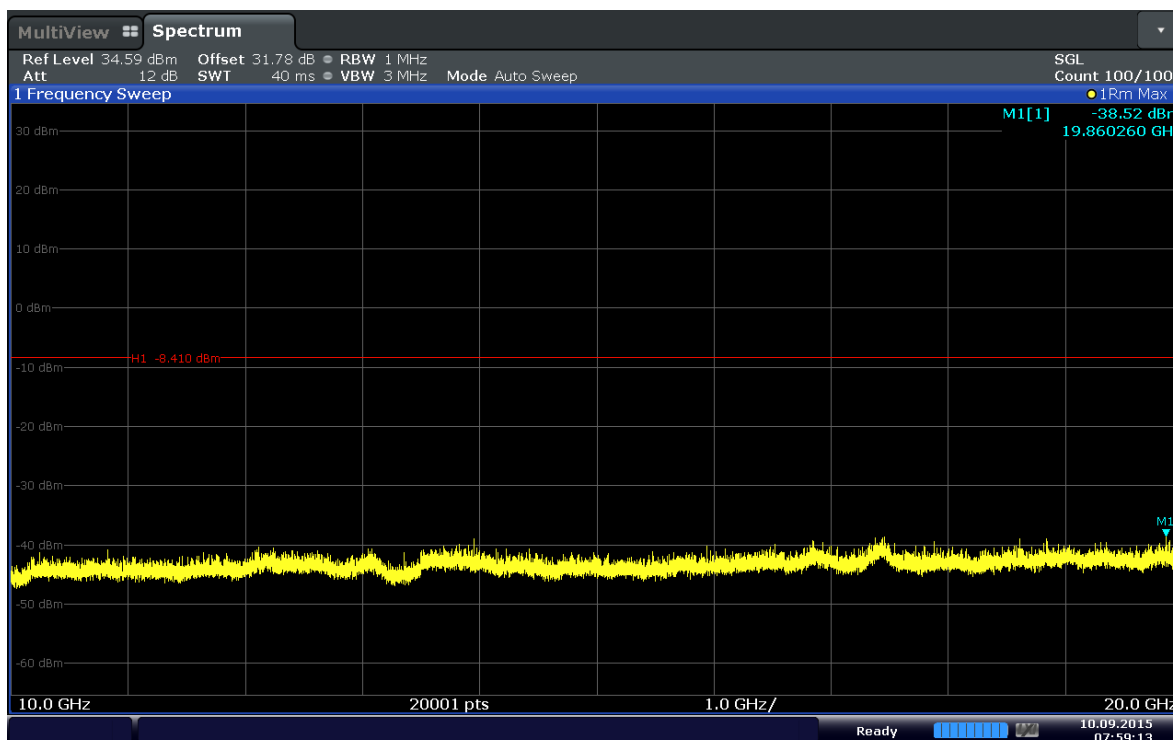

Date: 10.SEP.2015 07:59:14

Plot 6-44. Conducted Spurious Plot (Band 4-3MHz-QPSK-RB Size 1-RB Offset 14-Ch.20385)

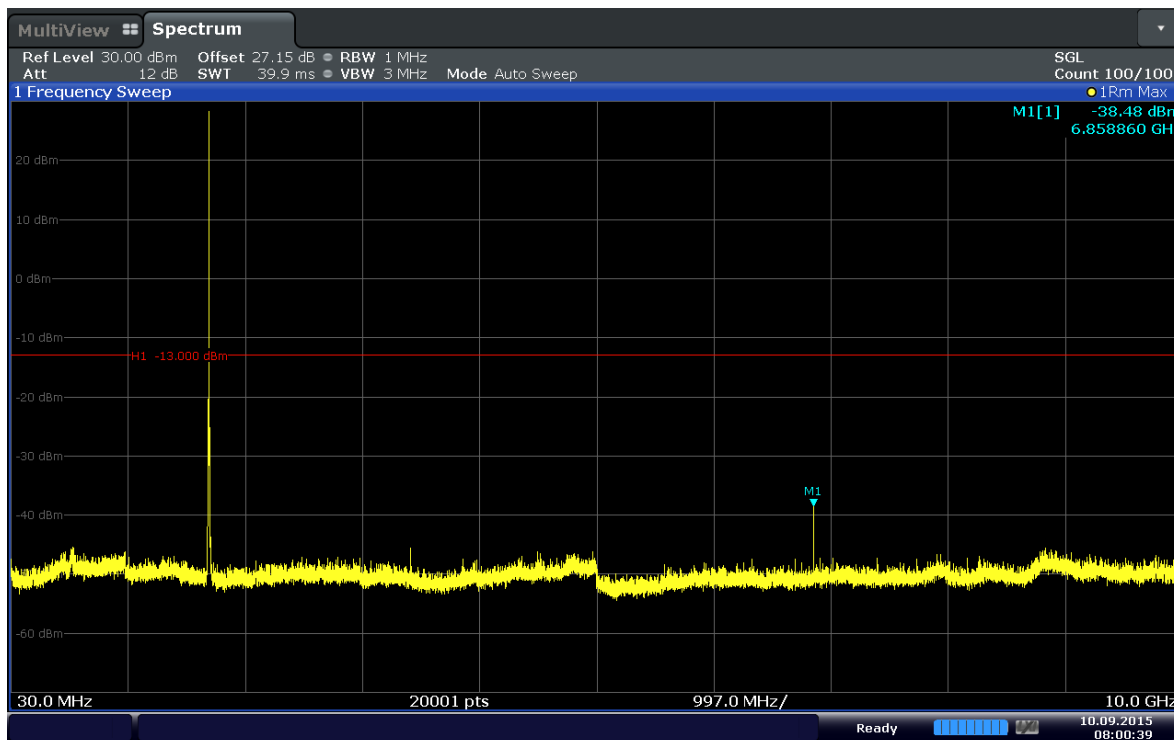

Date: 10.SEP.2015 08:00:38

Plot 6-45. Conducted Spurious Plot (Band 4–5MHz–QPSK–RB Size 1–RB Offset 24–Ch.19975)

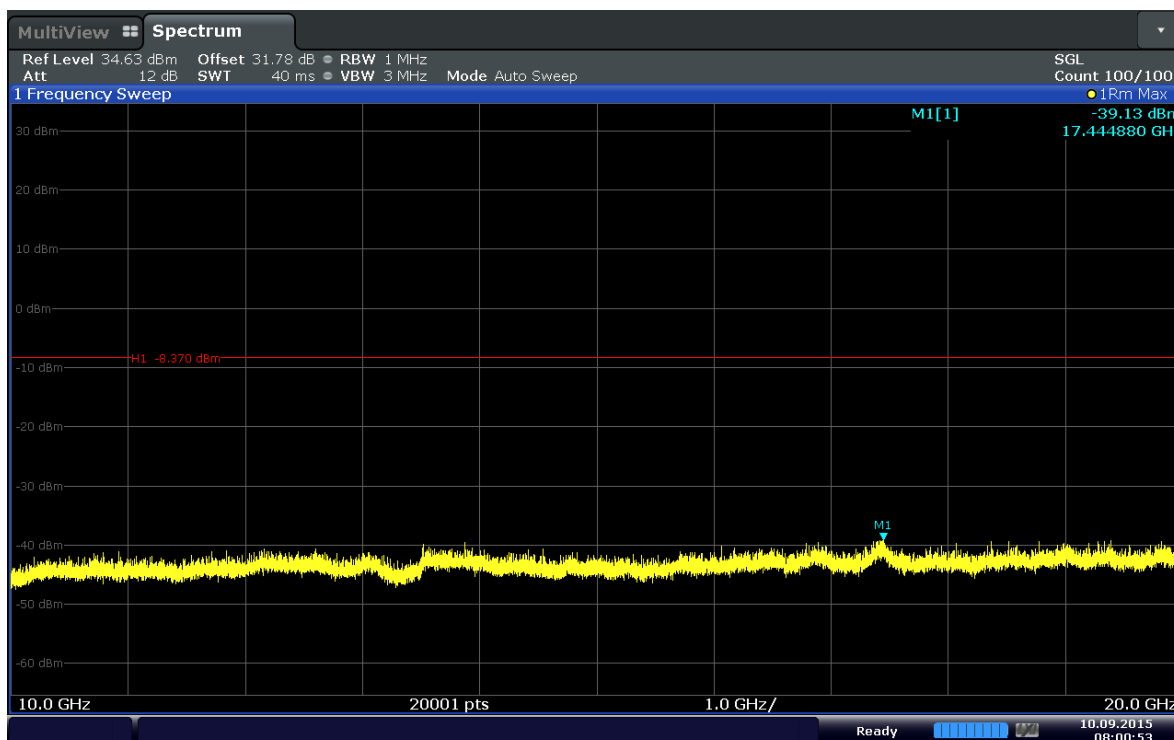

Date: 10.SEP.2015 08:00:53

Plot 6-46. Conducted Spurious Plot (Band 4–5MHz–QPSK–RB Size 1–RB Offset 24–Ch.19975)

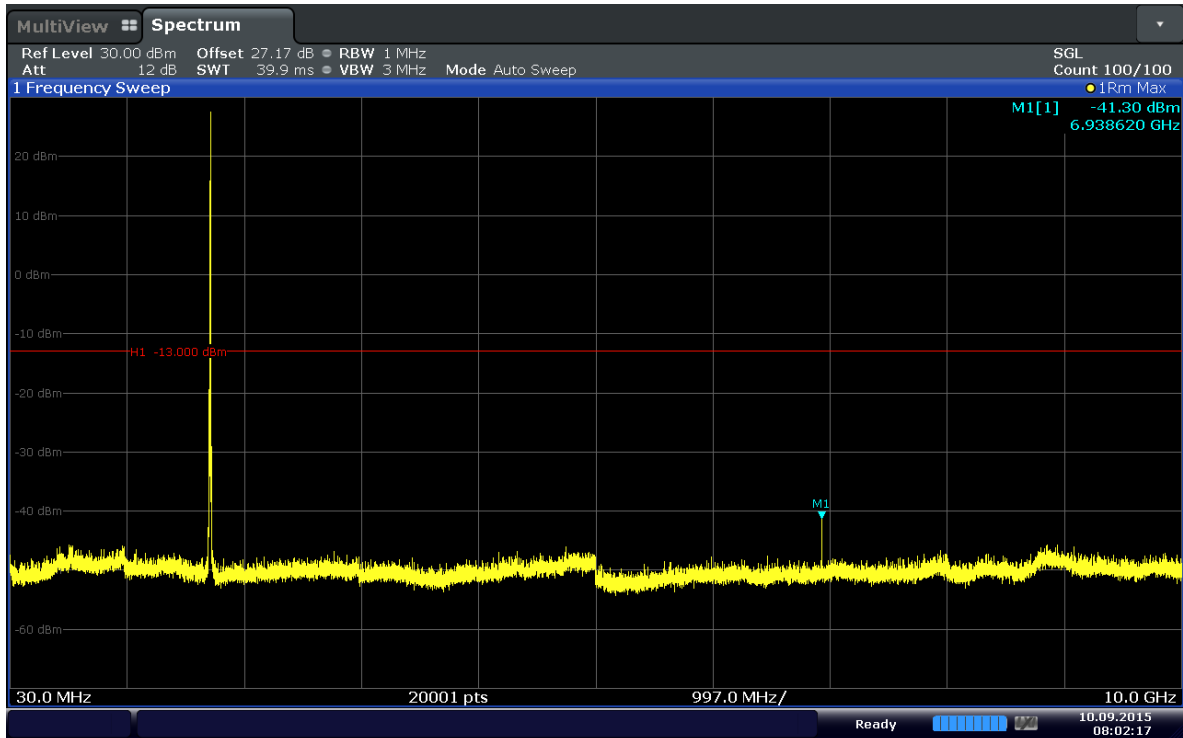

Date: 10.SEP.2015 08:02:17

Plot 6-47. Conducted Spurious Plot (Band 4–5MHz–QPSK–RB Size 1–RB Offset 24–Ch.20175)

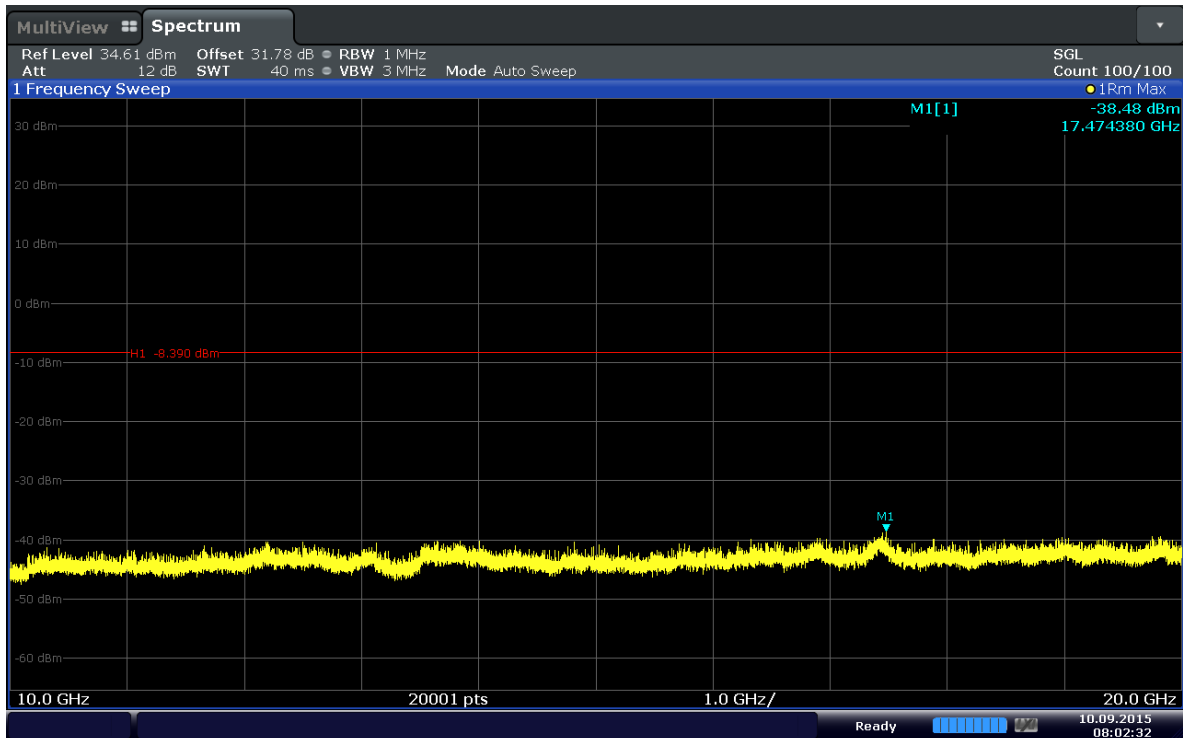

Date: 10.SEP.2015 08:02:32

Plot 6-48. Conducted Spurious Plot (Band 4–5MHz–QPSK–RB Size 1–RB Offset 24–Ch.20175)

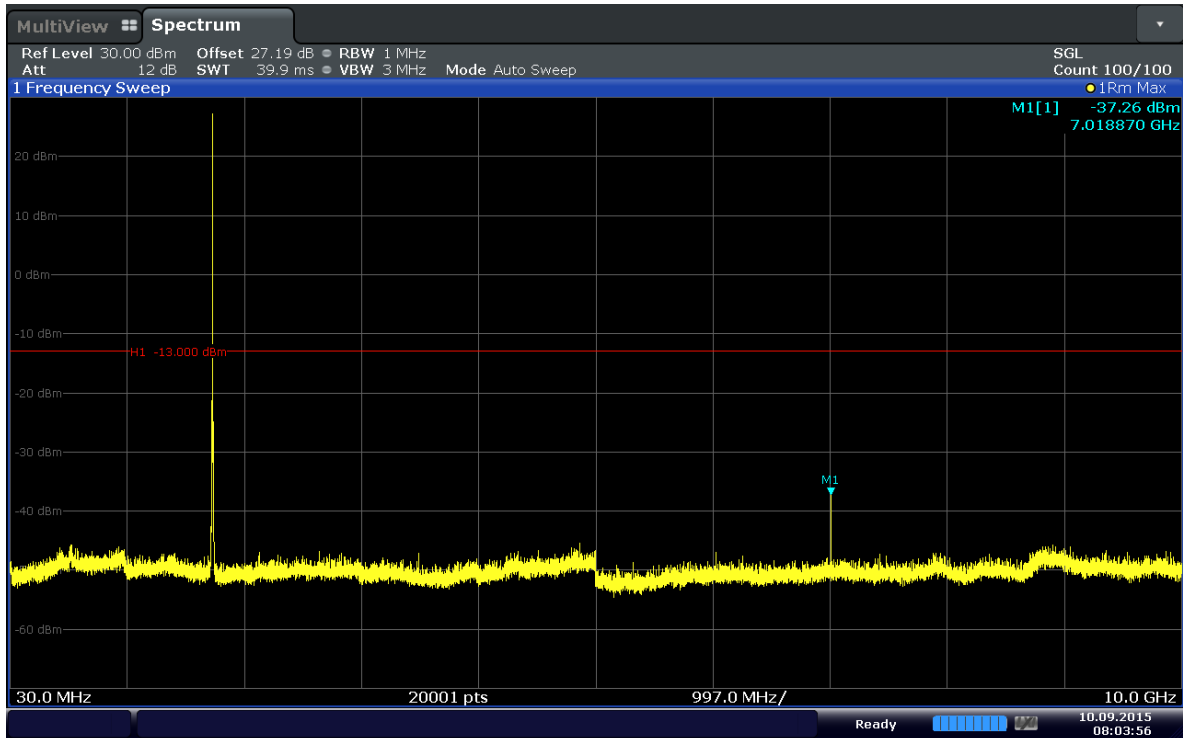

Date: 10.SEP.2015 08:03:56

Plot 6-49. Conducted Spurious Plot (Band 4–5MHz–QPSK–RB Size 1–RB Offset 24–Ch.20375)

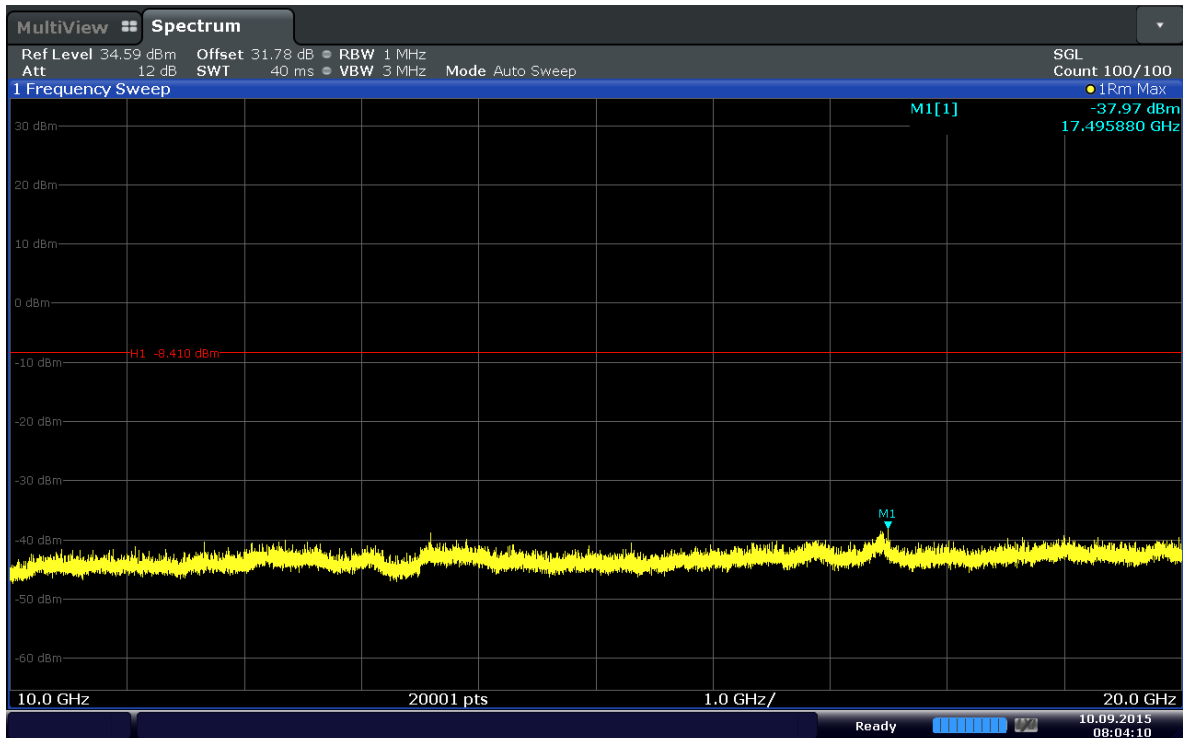

Date: 10.SEP.2015 08:04:11

Plot 6-50. Conducted Spurious Plot (Band 4–5MHz–QPSK–RB Size 1–RB Offset 24–Ch.20375)

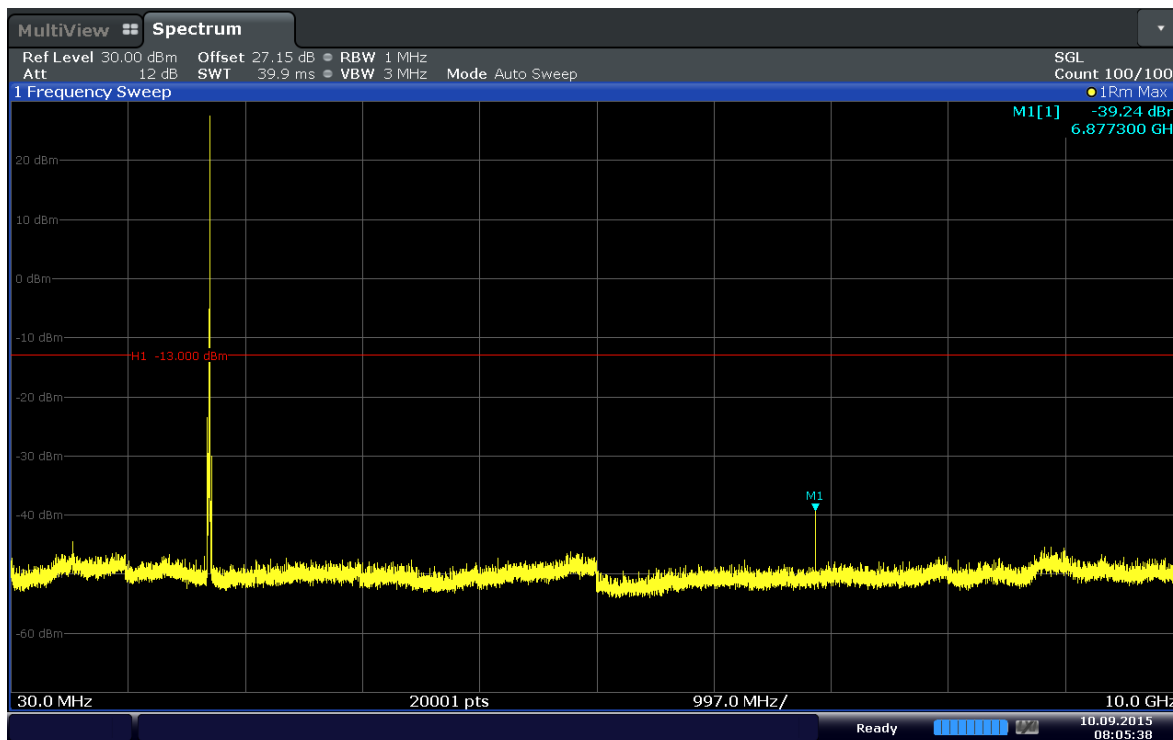

Date: 10.SEP.2015 08:05:38

Plot 6-51. Conducted Spurious Plot (Band 4-10MHz-QPSK-RB Size 1-RB Offset 49-Ch.20000)

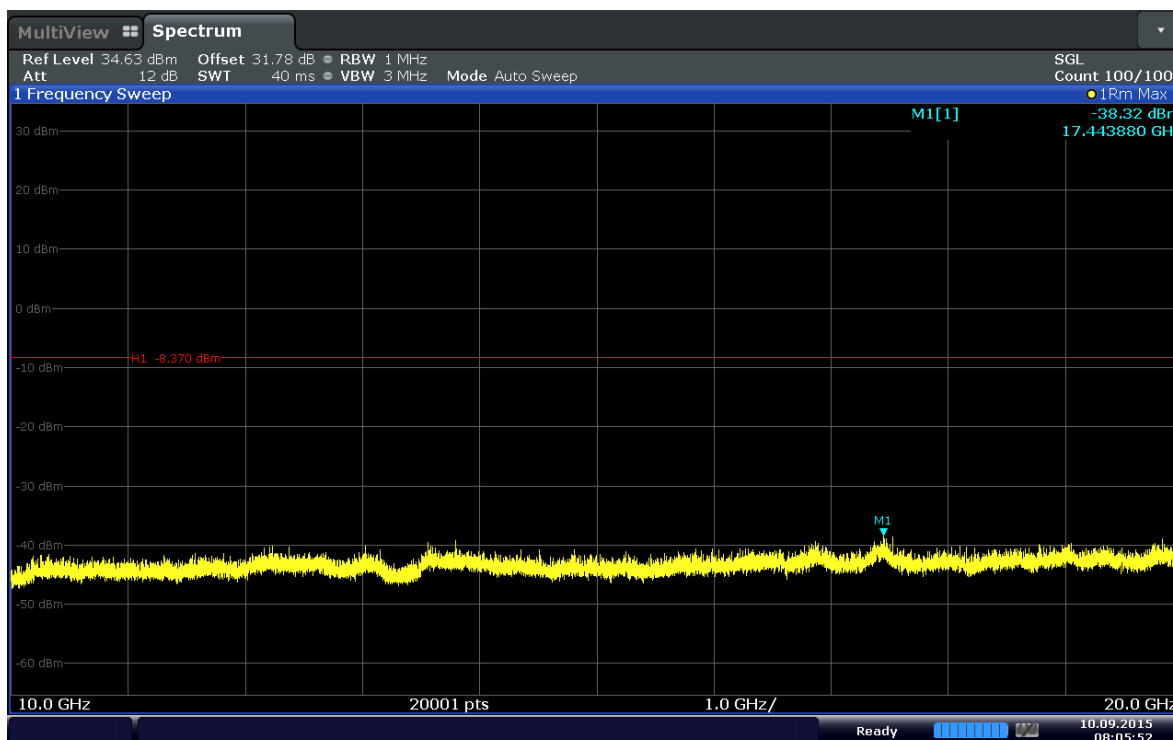

Date: 10.SEP.2015 08:05:52

Plot 6-52. Conducted Spurious Plot (Band 4-10MHz-QPSK-RB Size 1-RB Offset 49-Ch.20000)

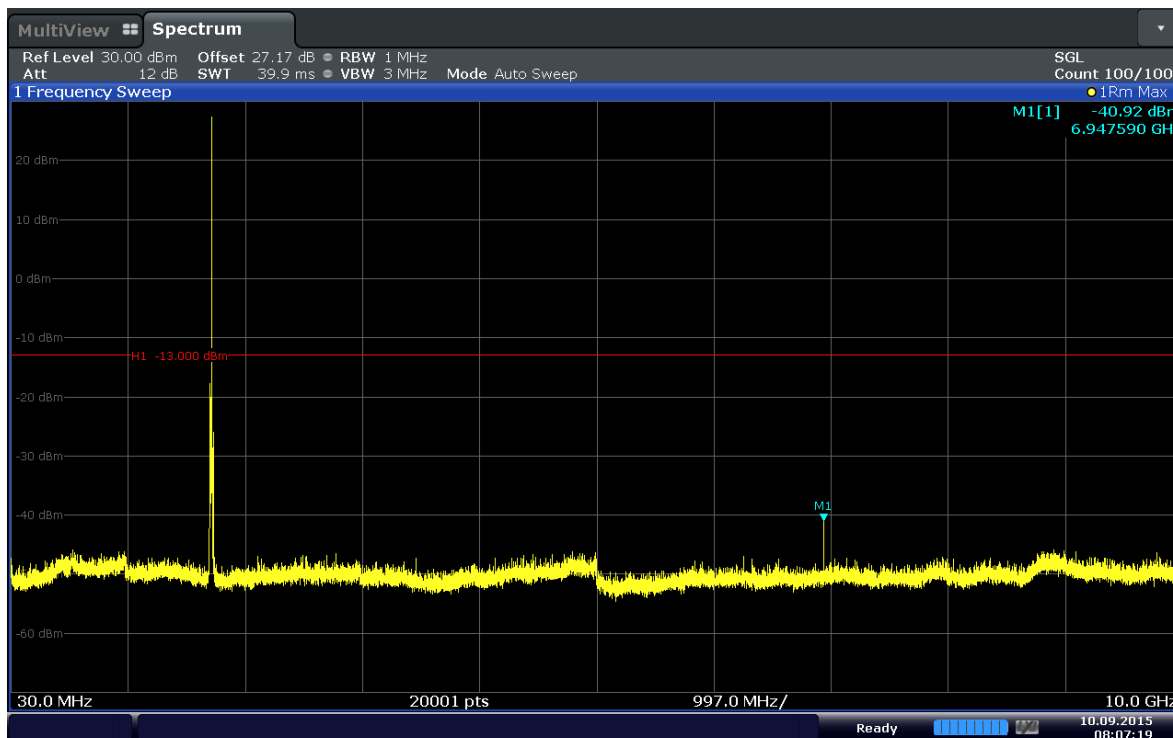

Date: 10.SEP.2015 08:07:19

Plot 6-53. Conducted Spurious Plot (Band 4-10MHz-QPSK-RB Size 1-RB Offset 49-Ch.20175)

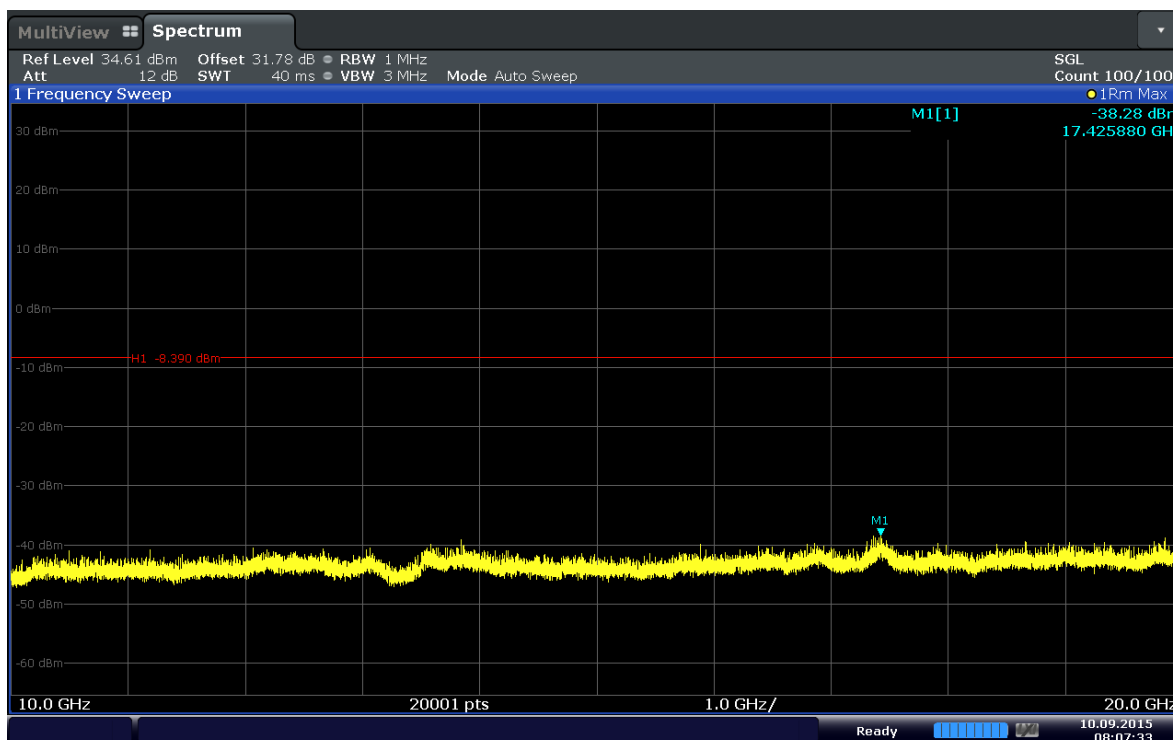

Date: 10.SEP.2015 08:07:34

Plot 6-54. Conducted Spurious Plot (Band 4-10MHz-QPSK-RB Size 1-RB Offset 49-Ch.20175)

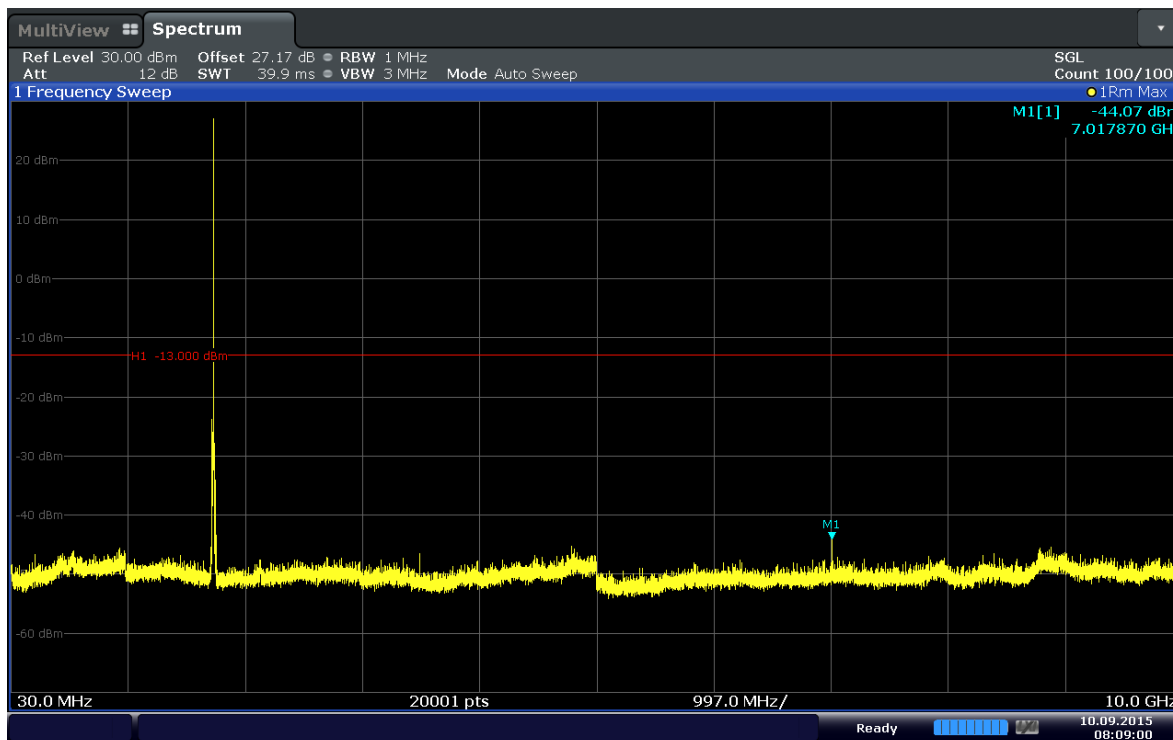

Date: 10.SEP.2015 08:09:00

Plot 6-55. Conducted Spurious Plot (Band 4-10MHz-QPSK-RB Size 1-RB Offset 49-Ch.20350)

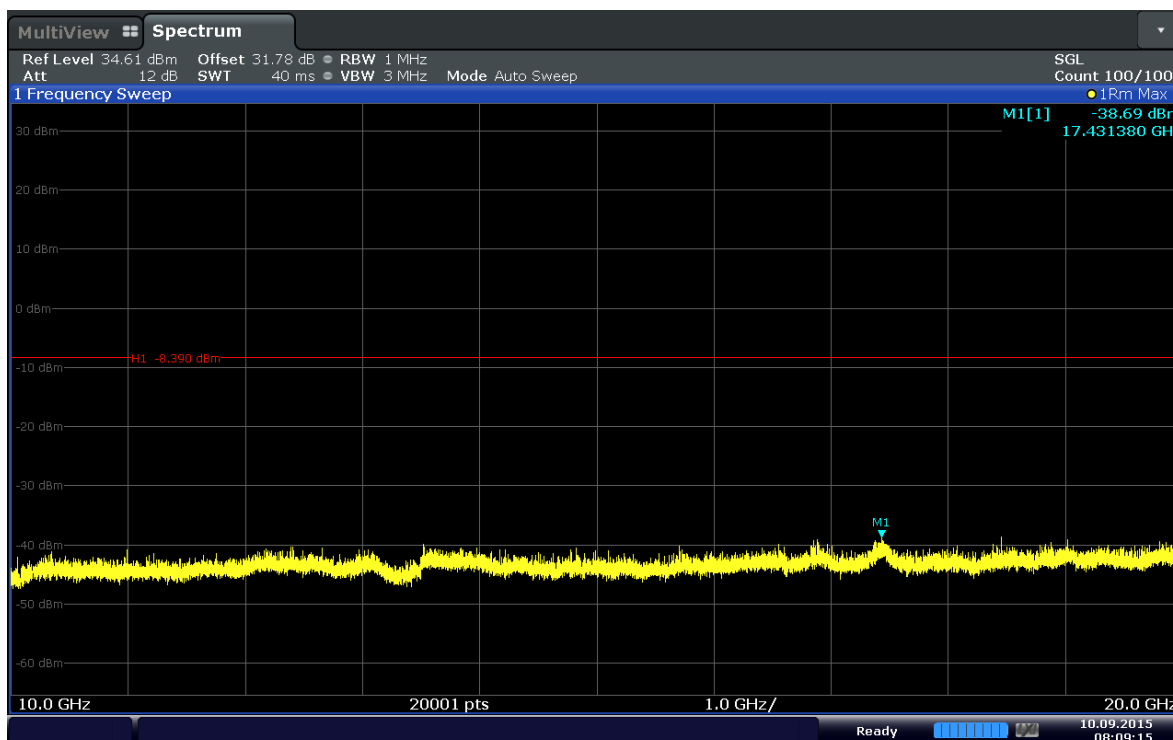

Date: 10.SEP.2015 08:09:15

Plot 6-56. Conducted Spurious Plot (Band 4-10MHz-QPSK-RB Size 1-RB Offset 49-Ch.20350)

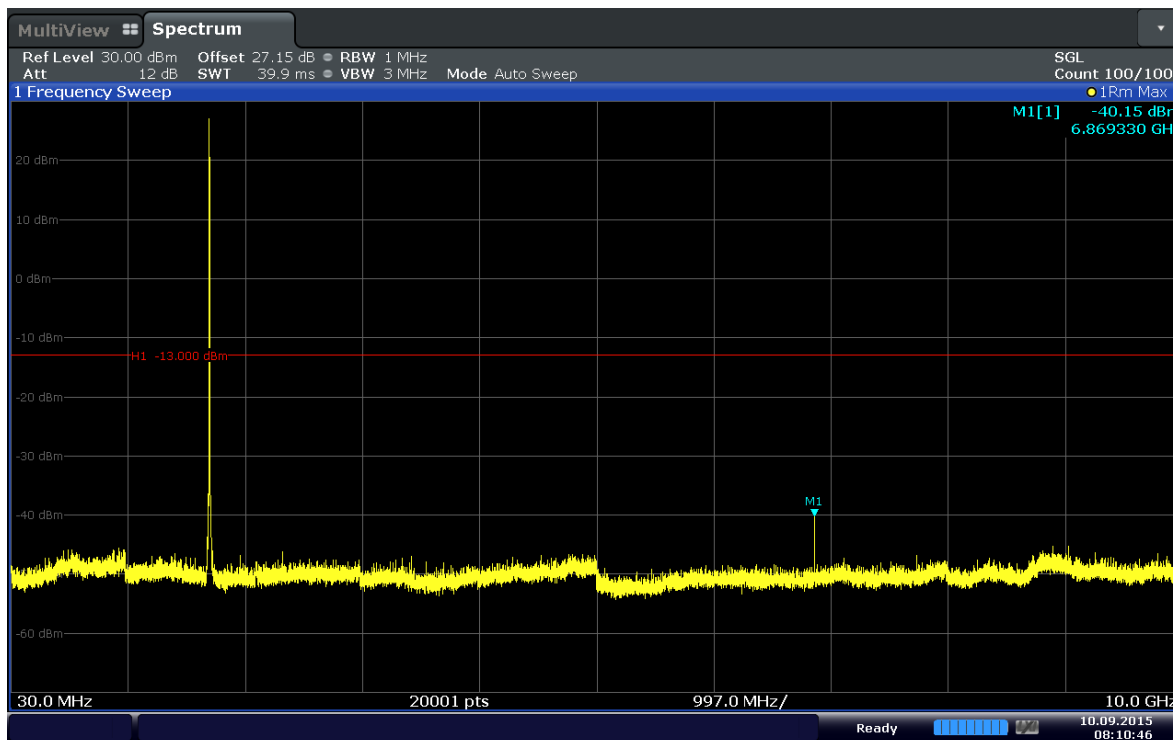

Date: 10.SEP.2015 08:10:46

Plot 6-57. Conducted Spurious Plot (Band 4–15MHz–QPSK–RB Size 1–RB Offset 36–Ch.20025)

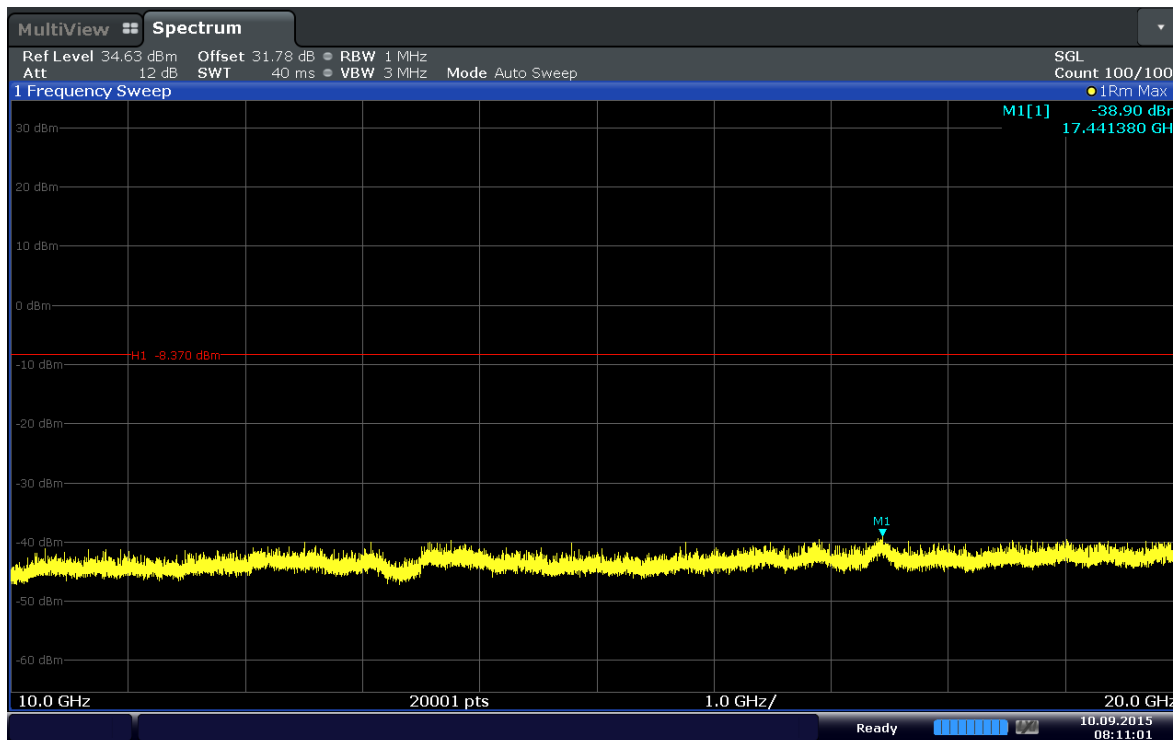

Date: 10.SEP.2015 08:11:01

Plot 6-58. Conducted Spurious Plot (Band 4–15MHz–QPSK–RB Size 1–RB Offset 36–Ch.20025)

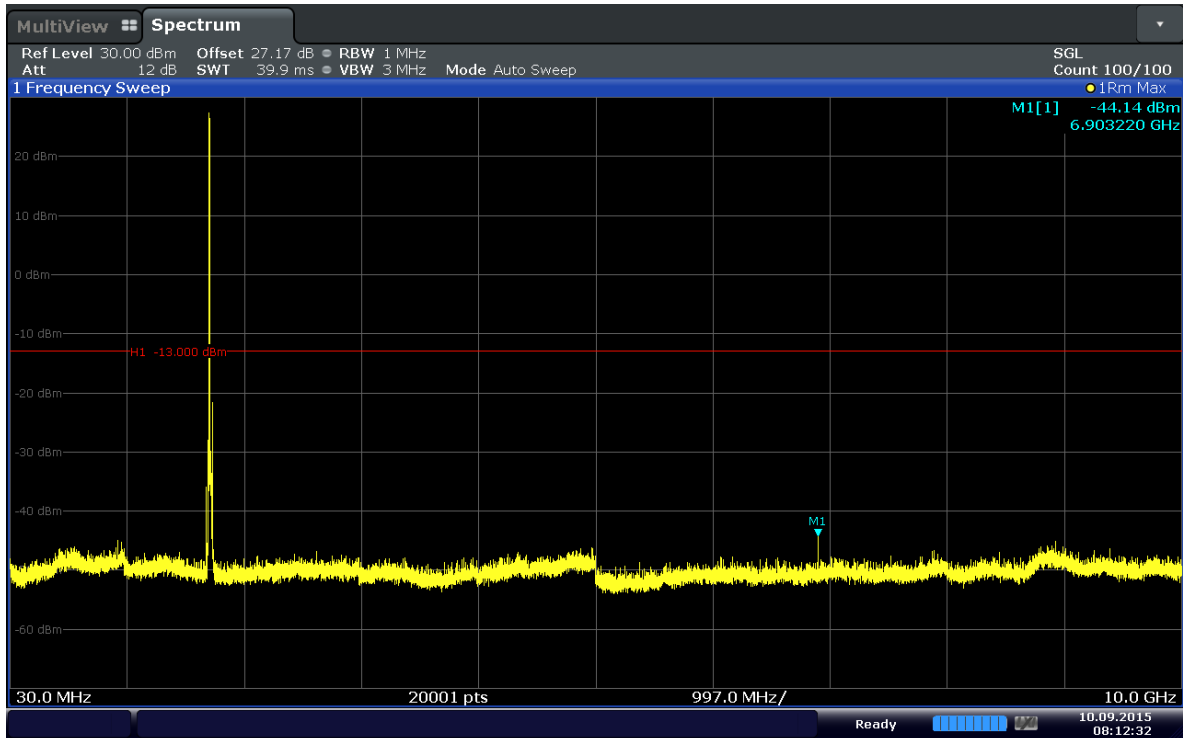

Date: 10.SEP.2015 08:12:33

Plot 6-59. Conducted Spurious Plot (Band 4–15MHz–QPSK–RB Size 1–RB Offset 0–Ch.20175)

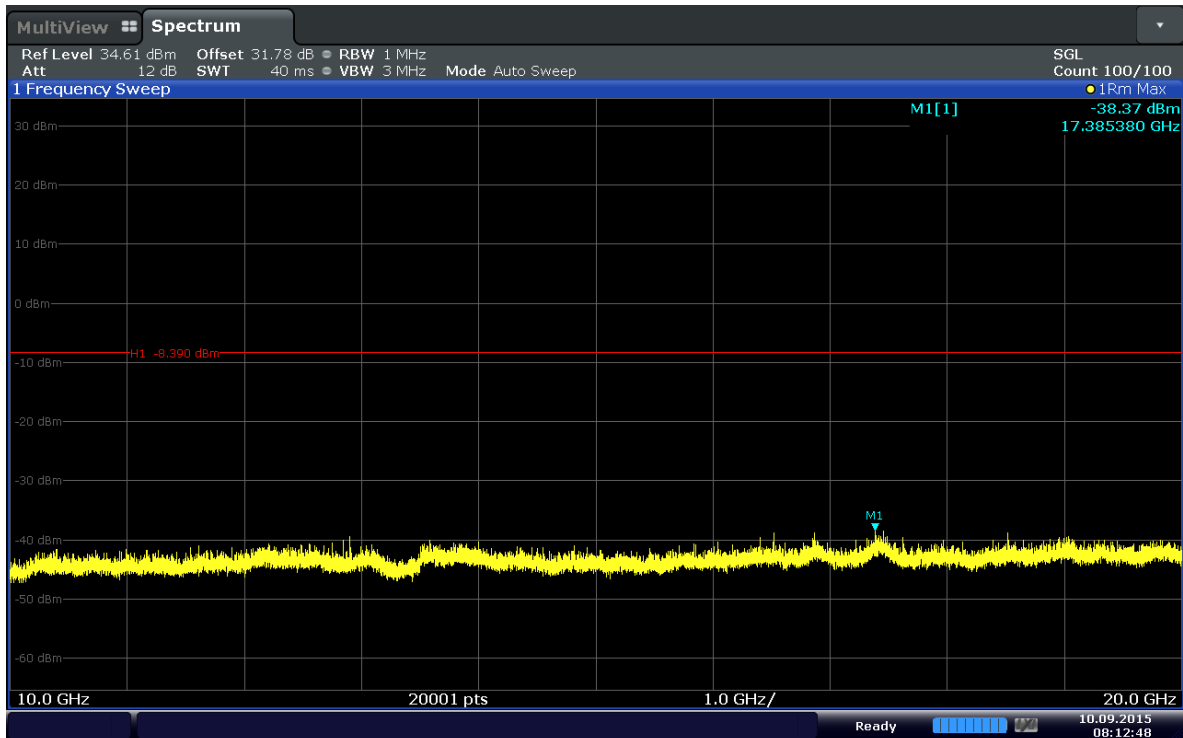

Date: 10.SEP.2015 08:12:47

Plot 6-60. Conducted Spurious Plot (Band 4–15MHz–QPSK–RB Size 1–RB Offset 0–Ch.20175)

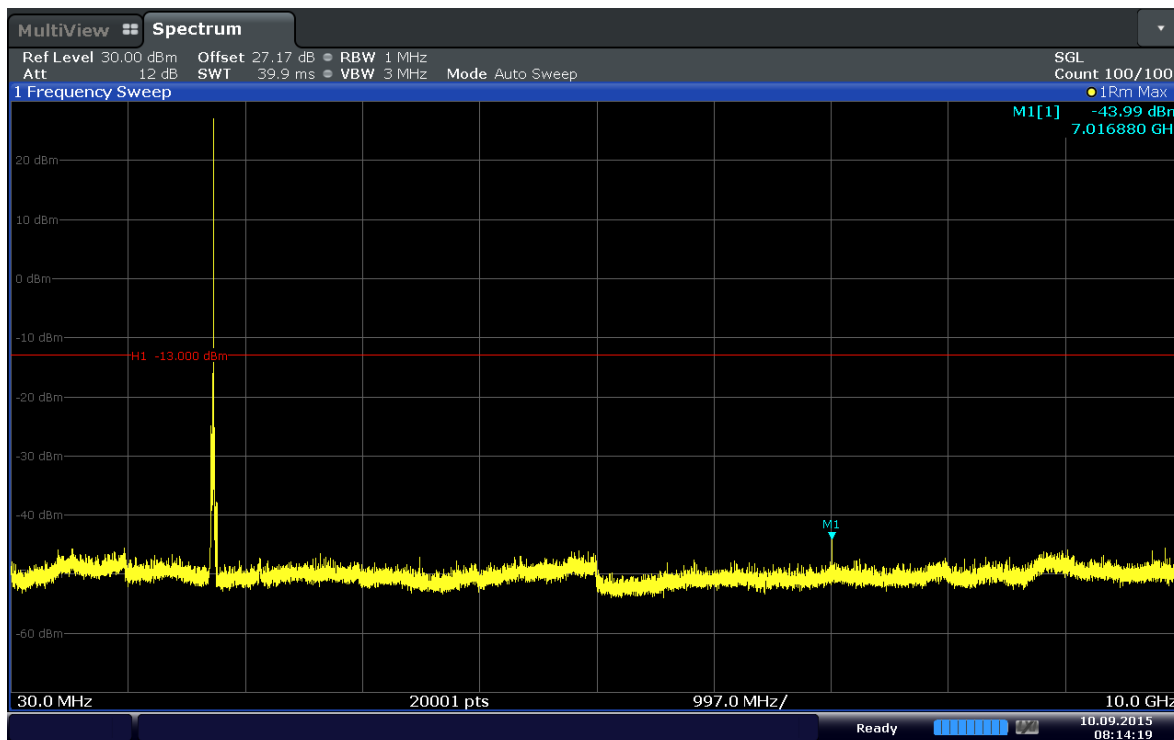

Date: 10.SEP.2015 08:14:19

Plot 6-61. Conducted Spurious Plot (Band 4-15MHz-QPSK-RB Size 1-RB Offset 74-Ch.20325)

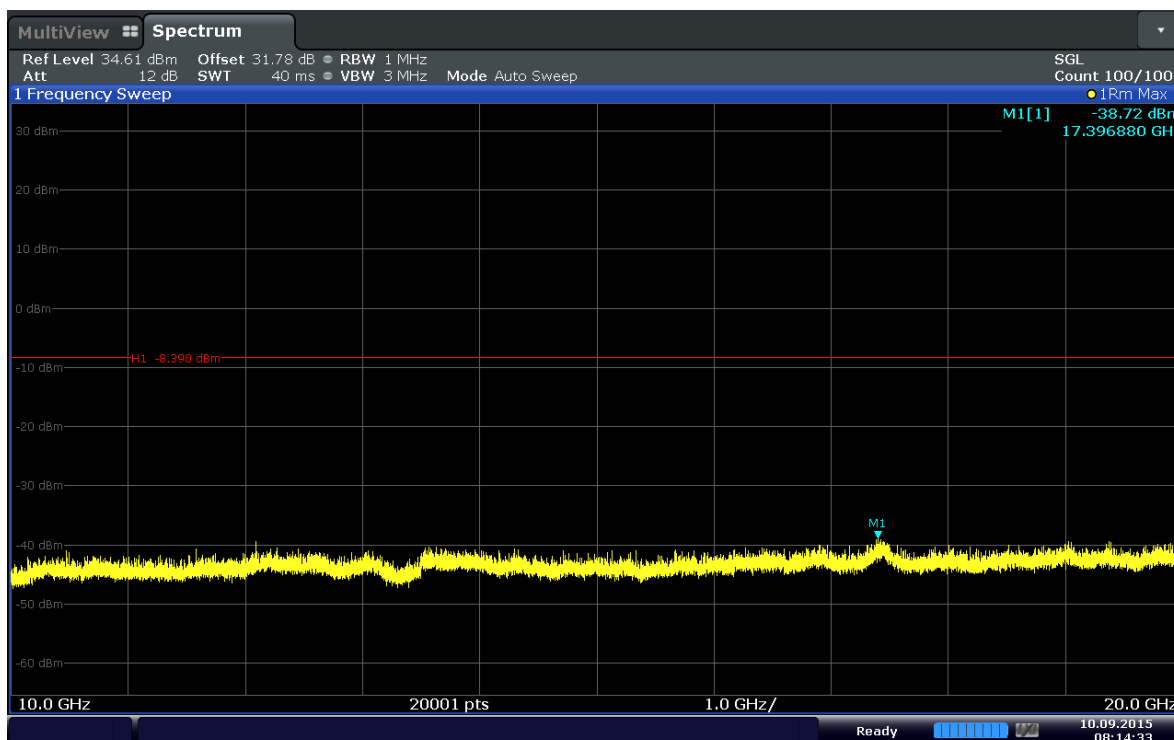

Date: 10.SEP.2015 08:14:33

Plot 6-62. Conducted Spurious Plot (Band 4-15MHz-QPSK-RB Size 1-RB Offset 74-Ch.20325)

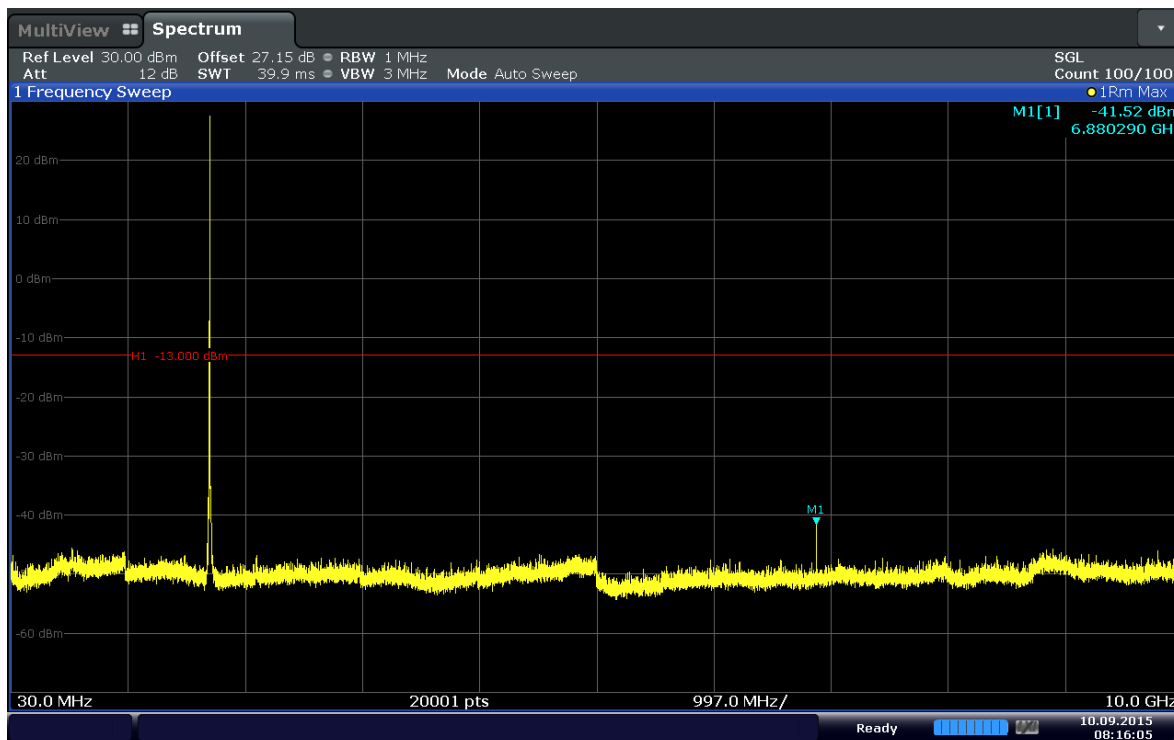

Date: 10.SEP.2015 08:16:06

Plot 6-63. Conducted Spurious Plot (Band 4–20MHz–QPSK–RB Size 1–RB Offset 50–Ch.20050)

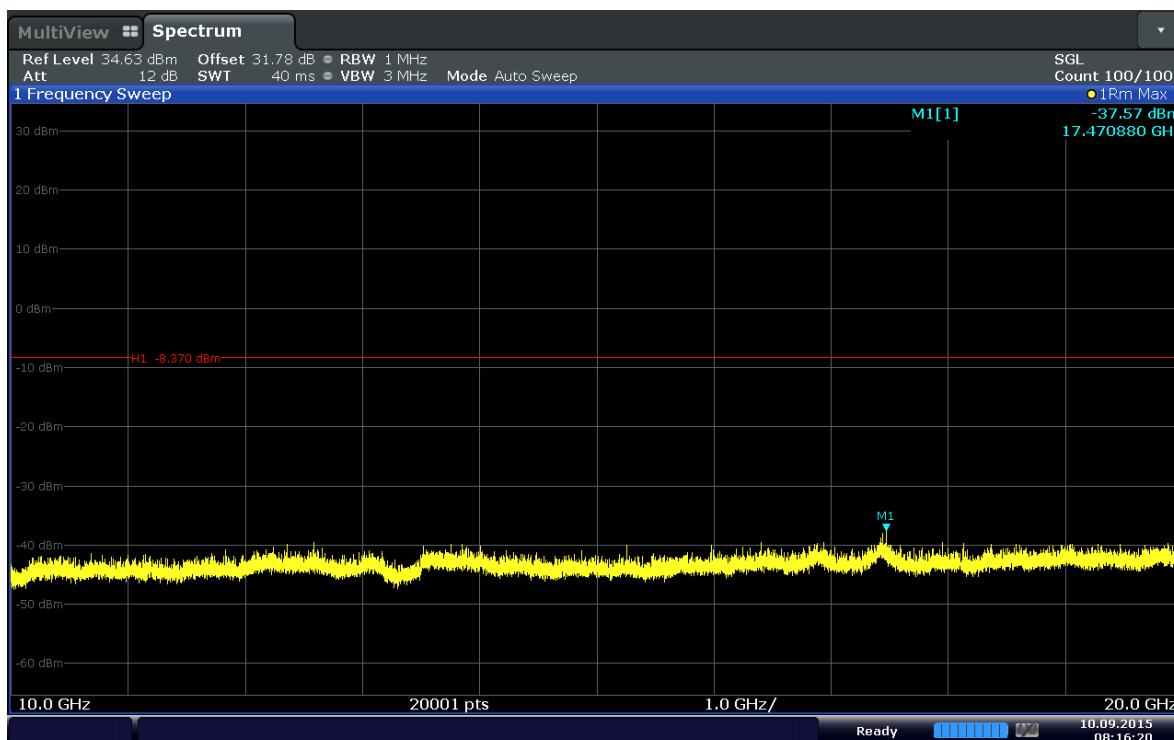

Date: 10.SEP.2015 08:16:20

Plot 6-64. Conducted Spurious Plot (Band 4–20MHz–QPSK–RB Size 1–RB Offset 50–Ch.20050)

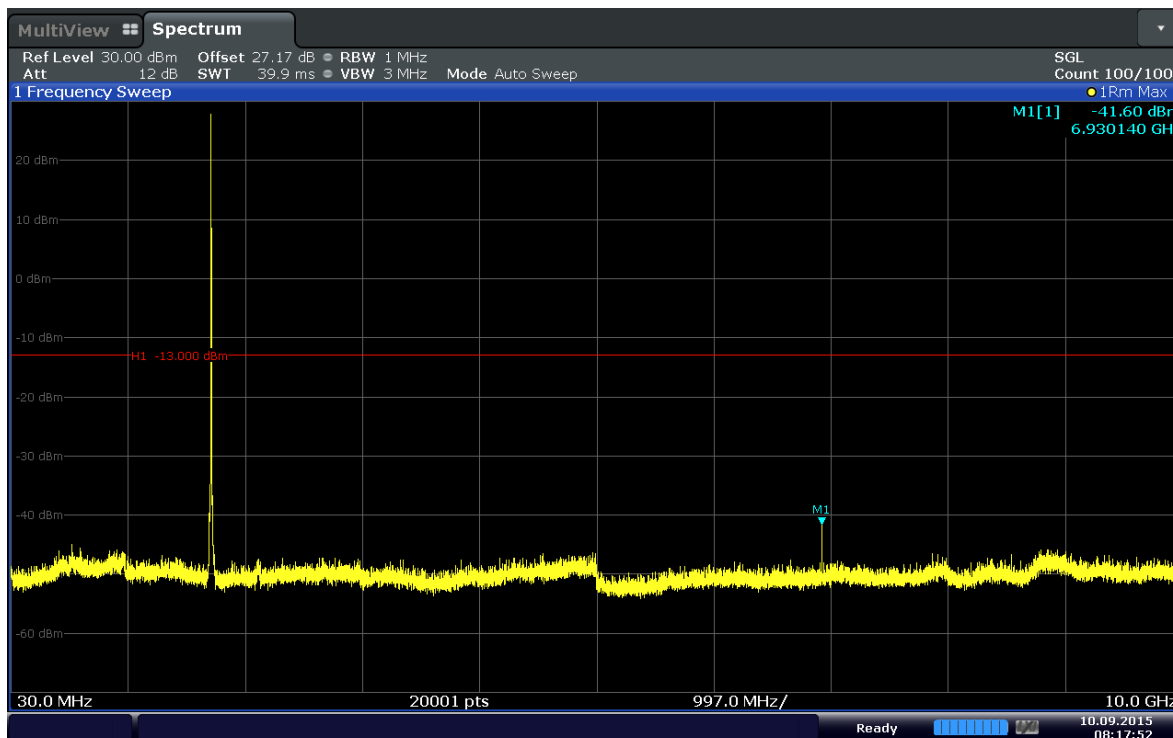

Date: 10.SEP.2015 08:17:52

Plot 6-65. Conducted Spurious Plot (Band 4–20MHz–QPSK–RB Size 1–RB Offset 50–Ch.20175)

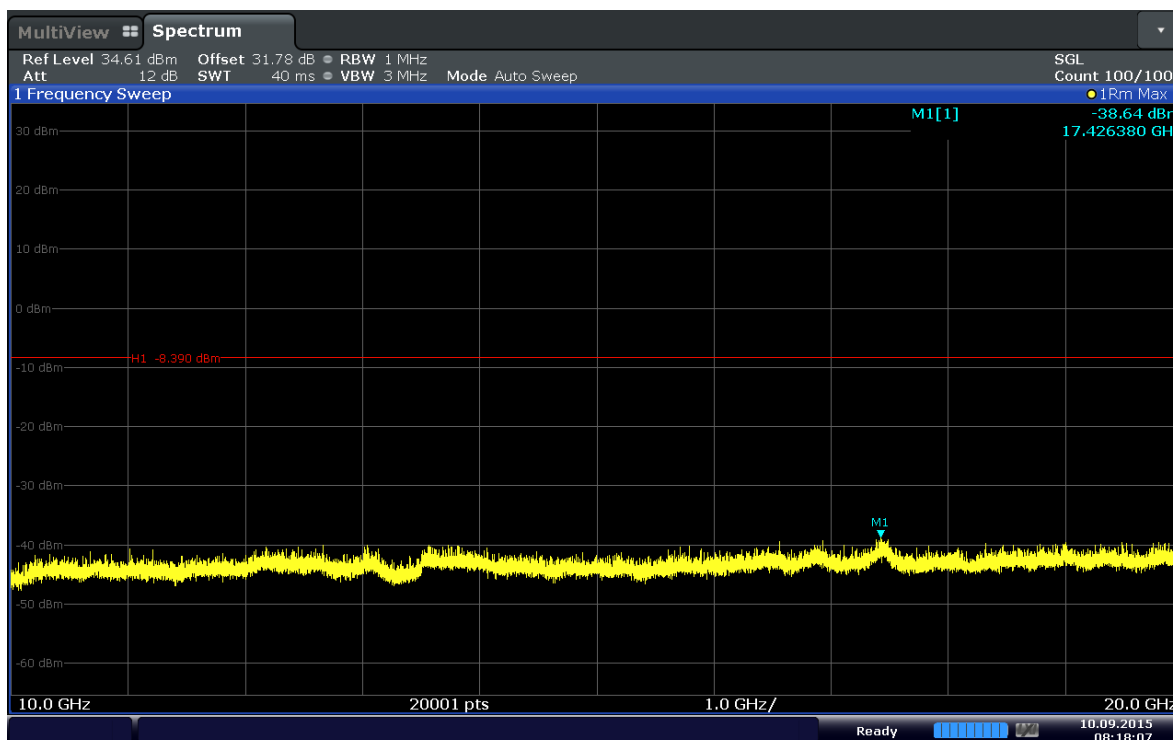

Date: 10.SEP.2015 08:18:07

Plot 6-66. Conducted Spurious Plot (Band 4–20MHz–QPSK–RB Size 1–RB Offset 50–Ch.20175)

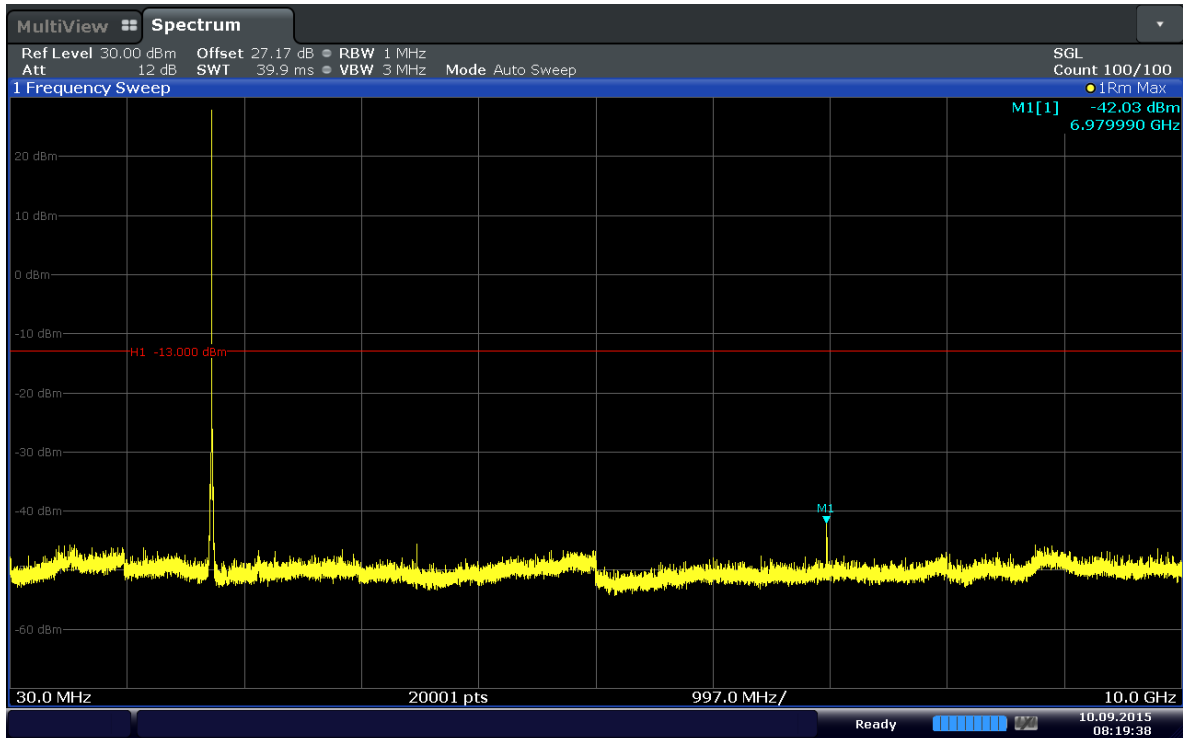

Date: 10.SEP.2015 08:19:39

Plot 6-67. Conducted Spurious Plot (Band 4–20MHz–QPSK–RB Size 1–RB Offset 50–Ch.20300)

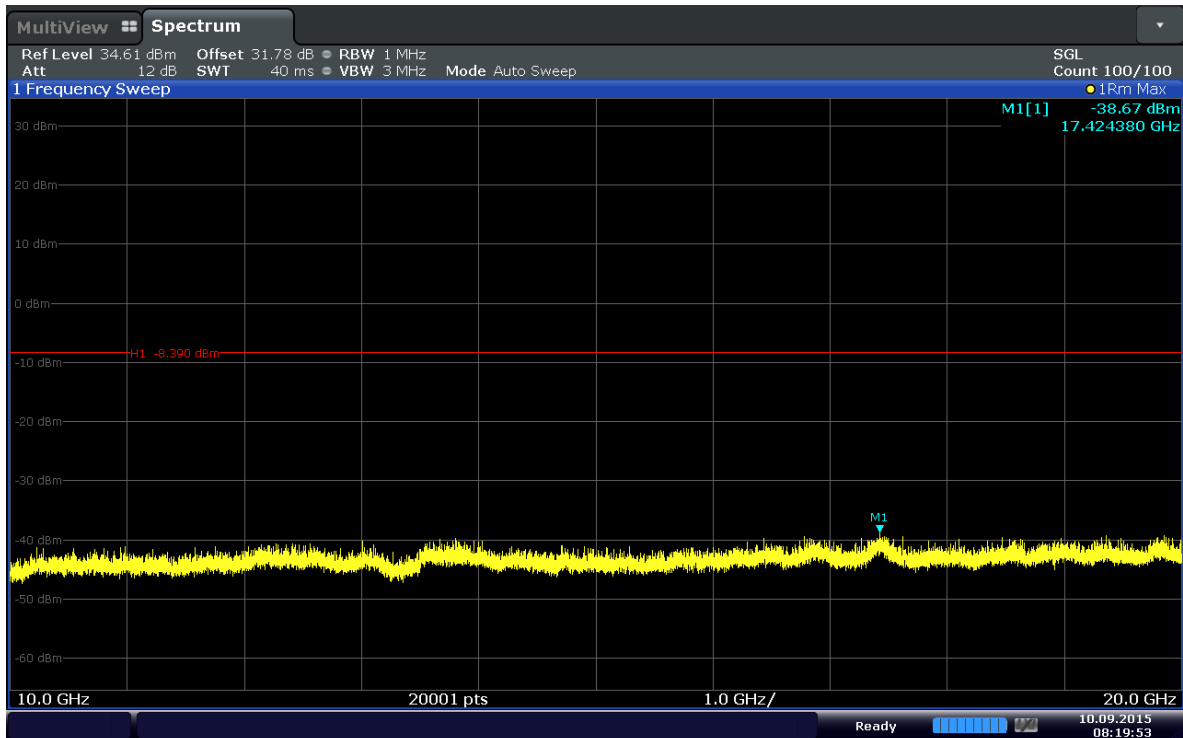

Date: 10.SEP.2015 08:19:54

Plot 6-68. Conducted Spurious Plot (Band 4–20MHz–QPSK–RB Size 1–RB Offset 50–Ch.20300)



#### 6.4. Band Edge Emissions at Antenna Terminal §2.1051 §27.53(g) §27.53(h)

##### Test Overview

All out of band emissions are measured with a spectrum analyzer connected to the antenna terminal of the EUT while the EUT is operating at its maximum duty cycle, at maximum power, and at the appropriate frequencies. All data rates were investigated to determine the worst case configuration. All modes of operation were investigated and the worst case configuration results are reported in this section.

The minimum permissible attenuation level of any spurious emission is  $43 + 10\log_{10}(P_{\text{[Watts]}})$ , where P is the transmitter power in Watts. Limit equivalent to -13dBm, calculation shown below.

$$43 + 10\log_{10}(1.567W) = 44.95 \text{ dB}$$

$$1.567W = 31.95 \text{ dBm}$$

$$31.95 \text{ dBm} - 44.95 \text{ dB} = -13 \text{ dBm}$$

##### Test Procedure Used

KDB 971168 v02r02 – Section 6.0

##### Test Settings

1. Start and stop frequency were set such that the band edge would be placed in the center of the plot.
2. Span was set large enough so as to capture all out of band emissions near the band edge
3. RBW  $\geq$  1% of the emission bandwidth
4. VBW  $\geq$  3 x RBW
5. Detector = RMS
6. Number of sweep points  $\geq$  2 x Span/RBW
7. Trace mode = average
8. Sweep time = auto couple
9. The trace was allowed to stabilize

### Test Setup

The EUT and measurement equipment were set up as shown in the diagram below.

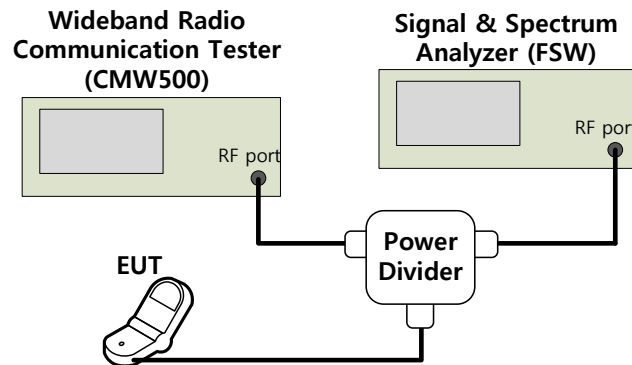

Figure 6-3. Test Instruments & Measurement Setup

### Test Notes

1. Per 27.53(a) 27.53(h), in the 1 MHz bands immediately outside and adjacent to the licensee's frequency or channel block, a resolution bandwidth of at least one percent of the emission bandwidth of the fundamental emission of the transmitter may be employed.
2. Per 27.53(g), in the 100 kilohertz bands immediately outside and adjacent to the licensee's frequency block, a resolution bandwidth of at least 30 kHz may be employed.



Test Plots

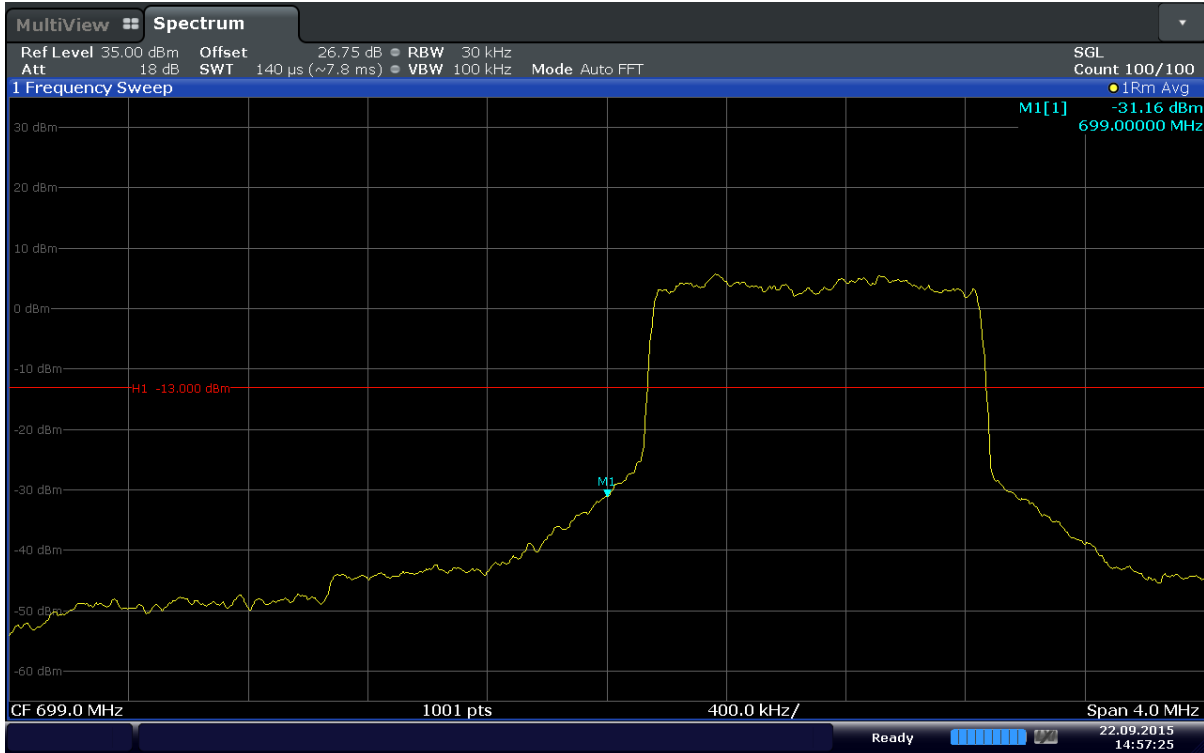

Date: 22.SEP.2015 14:57:26

Plot 6-69. Lower Band Edge Plot (Band 12 – 1.4MHz – QPSK – RB Size 6)

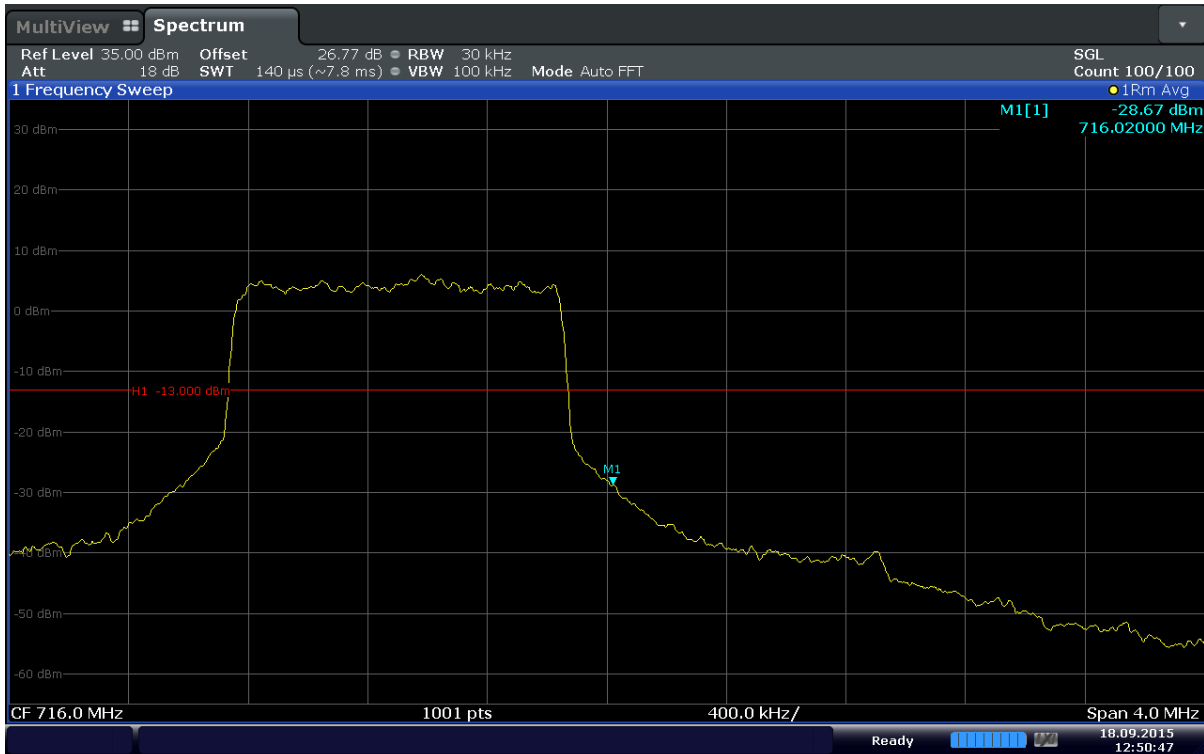

Date: 18.SEP.2015 12:50:47

Plot 6-70. Upper Band Edge Plot (Band 12 – 1.4MHz – QPSK – RB Size 6)



Date: 22.SEP.2015 14:59:04

Plot 6-71. Lower Band Edge Plot (Band 12 – 3MHz – QPSK – RB Size 15)

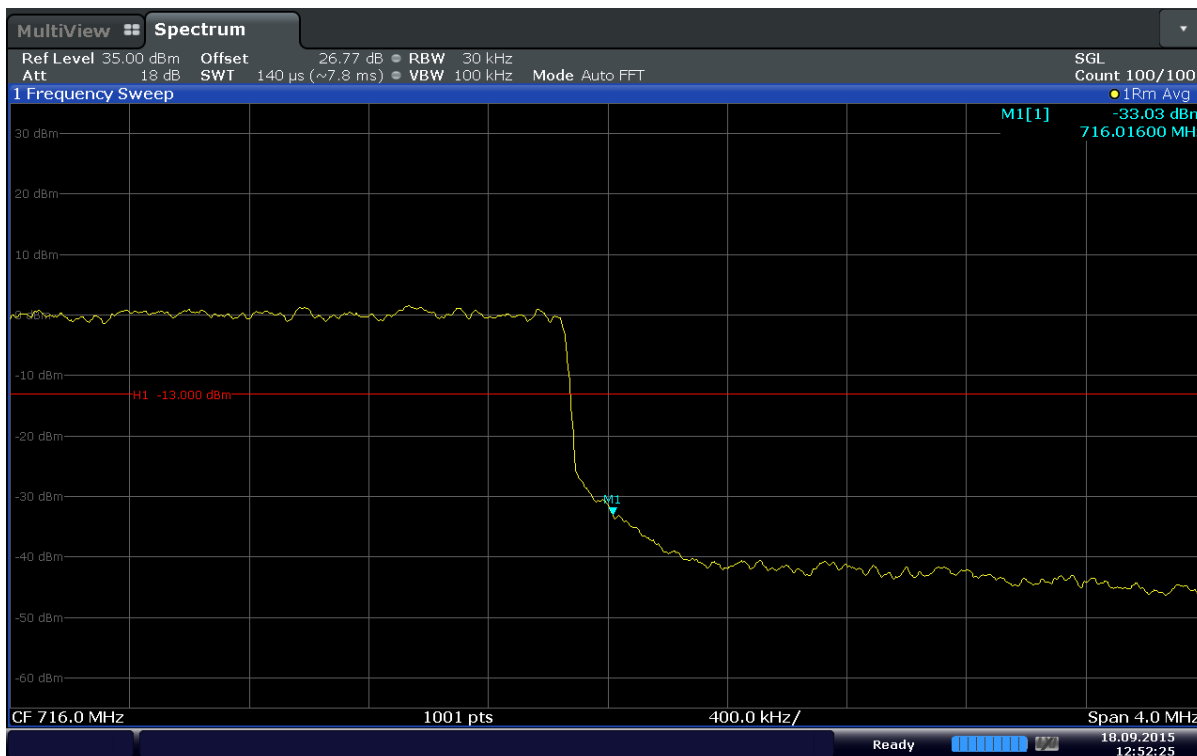

Date: 18.SEP.2015 12:52:25

Plot 6-72. Upper Band Edge Plot (Band 12 – 3MHz – QPSK – RB Size 15)



Date: 22.SEP.2015 15:00:42

Plot 6-73. Lower Band Edge Plot (Band 12 – 5MHz – QPSK – RB Size 25)



Date: 18.SEP.2015 12:54:03

Plot 6-74. Upper Band Edge Plot (Band 12 – 5MHz – QPSK – RB Size 25)

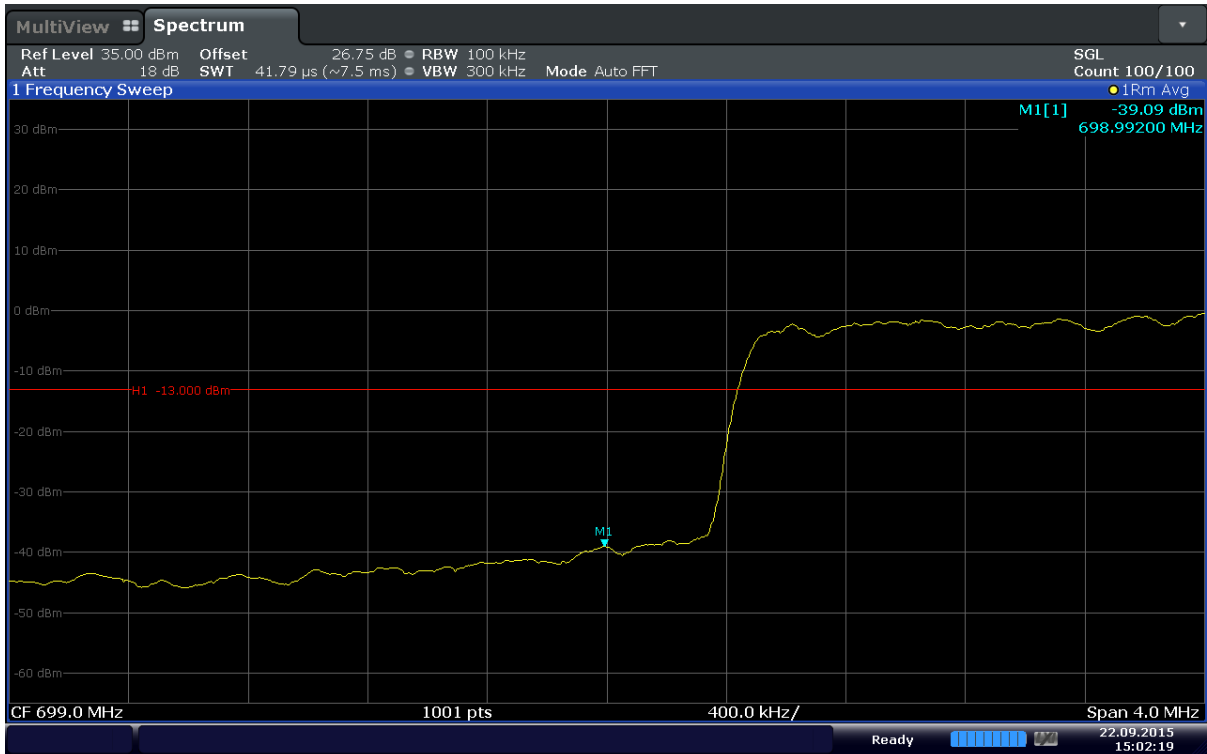

Date: 22.SEP.2015 15:02:20

Plot 6-75. Lower Band Edge Plot (Band 12 – 10MHz – QPSK – RB Size 50)

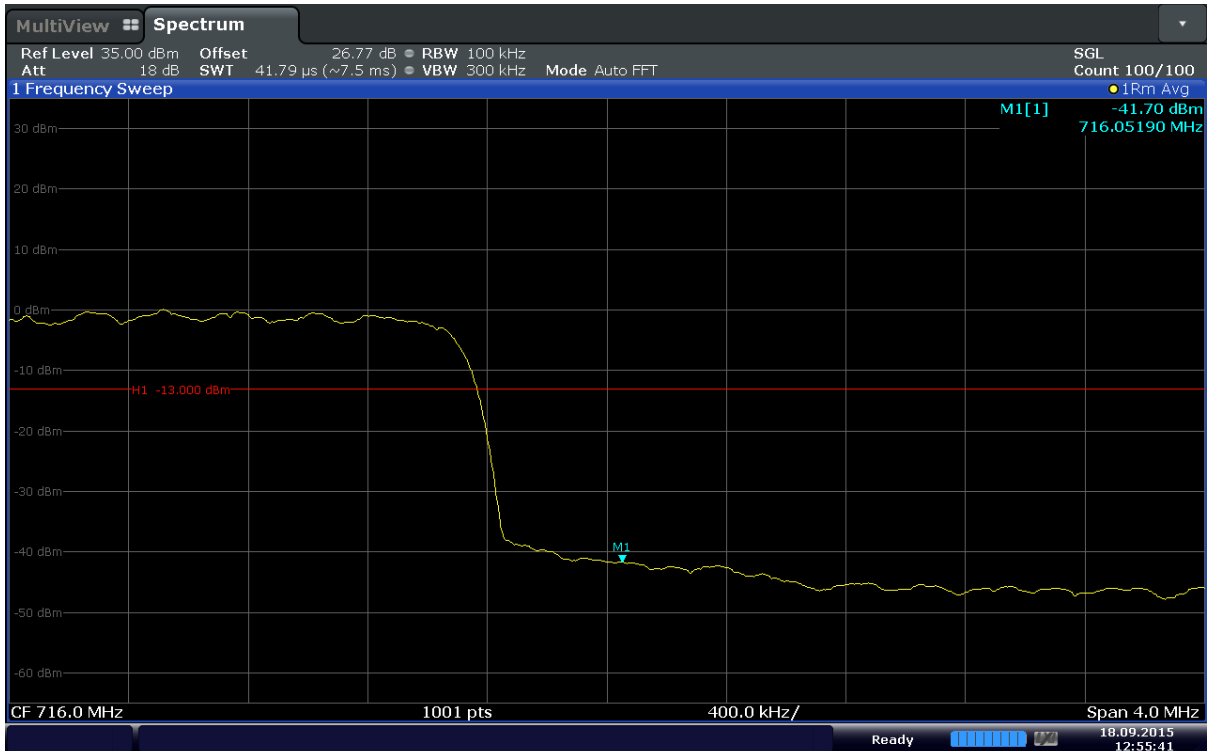

Date: 18.SEP.2015 12:55:41

Plot 6-76. Upper Band Edge Plot (Band 12 – 10MHz – QPSK – RB Size 50)

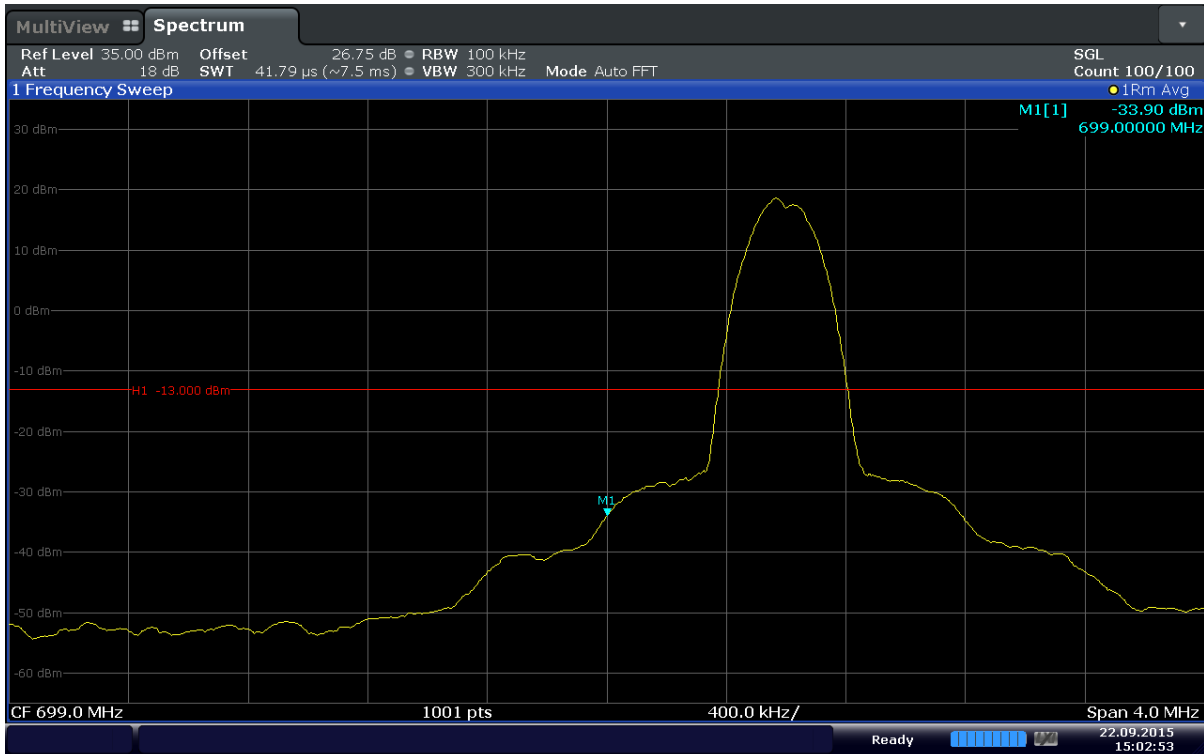

Date: 22.SEP.2015 15:02:53

Plot 6-77. Lower Band Edge Plot (Band 12 – 10MHz – QPSK – RB Size 1 – RB Offset 0)

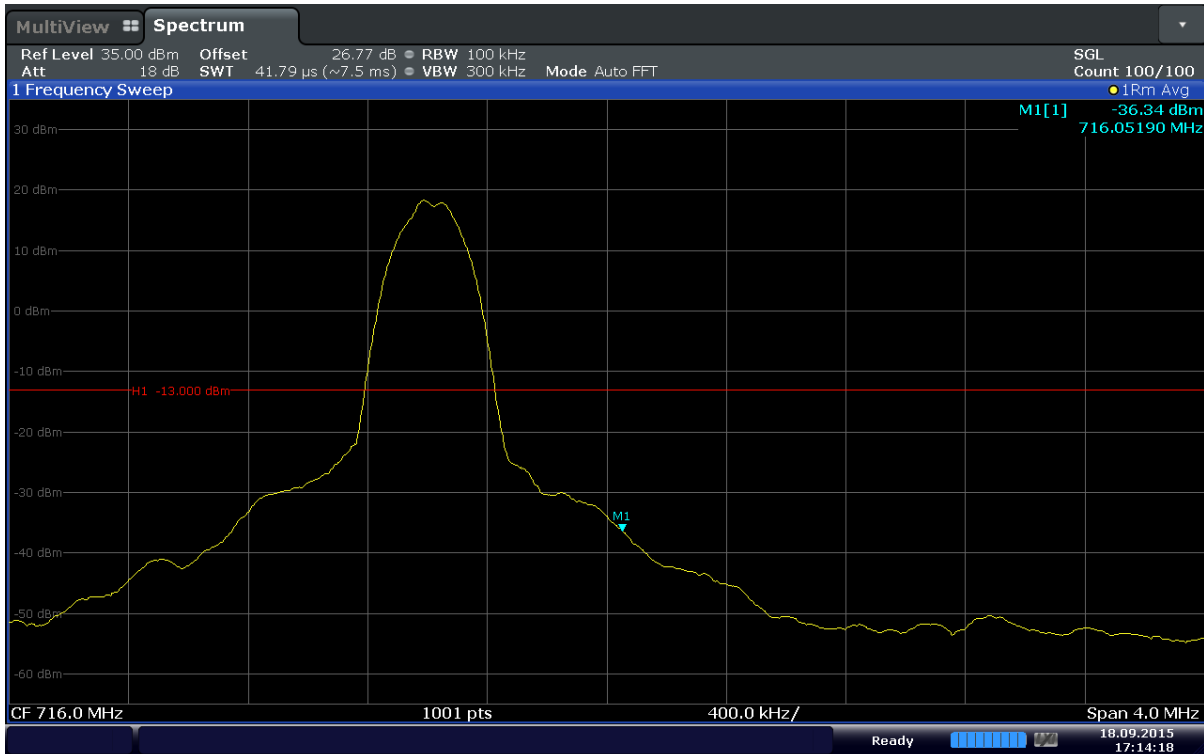

Date: 18.SEP.2015 17:14:18

Plot 6-78. Upper Band Edge Plot (Band 12 – 10MHz – QPSK – RB Size 1 – RB Offset 49)

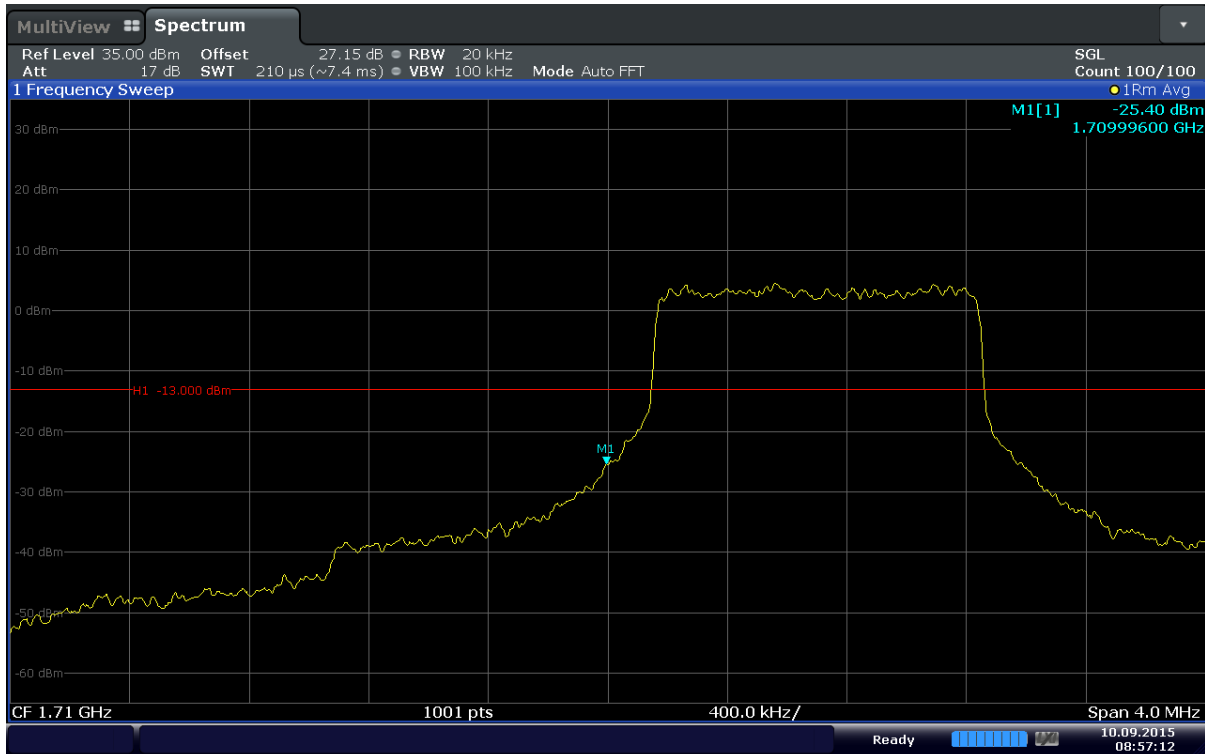

Date: 10.SEP.2015 08:57:12

Plot 6-79. Lower Band Edge Plot (Band 4 – 1.4MHz – QPSK – RB Size 6)

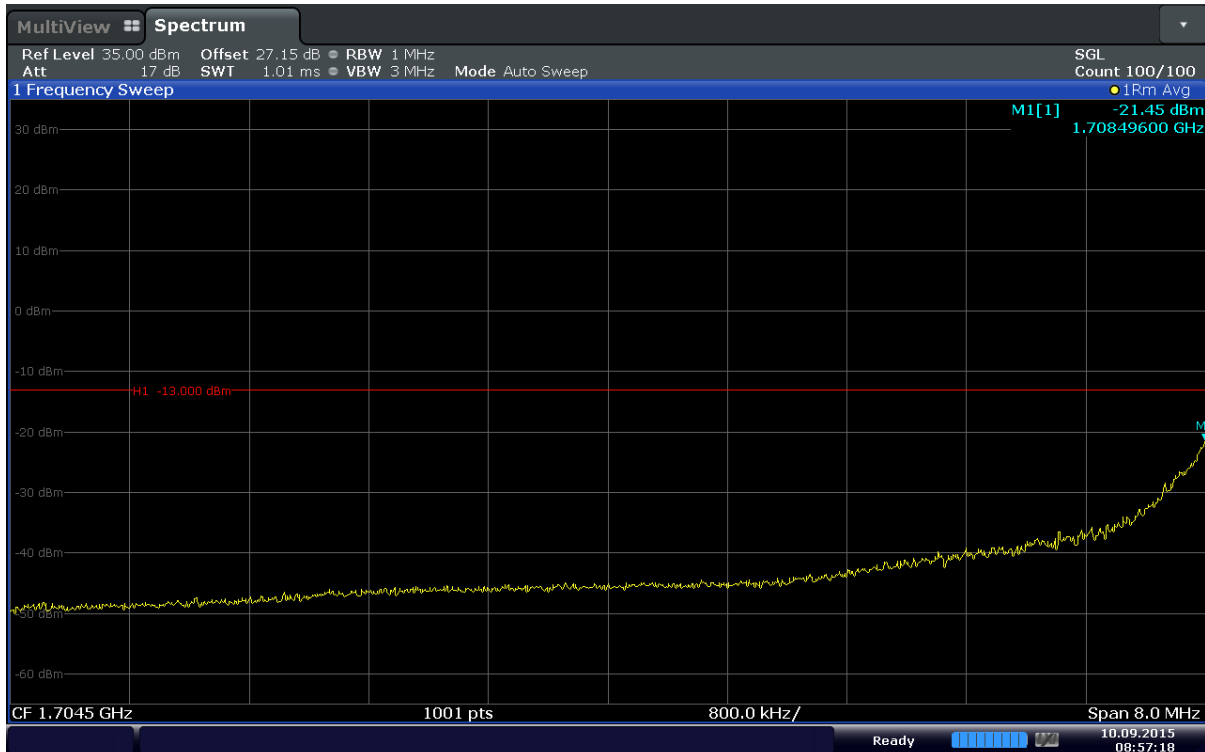

Date: 10.SEP.2015 08:57:19

Plot 6-80. Extended Lower Band Edge Plot (Band 4 – 1.4MHz – QPSK – RB Size 6)

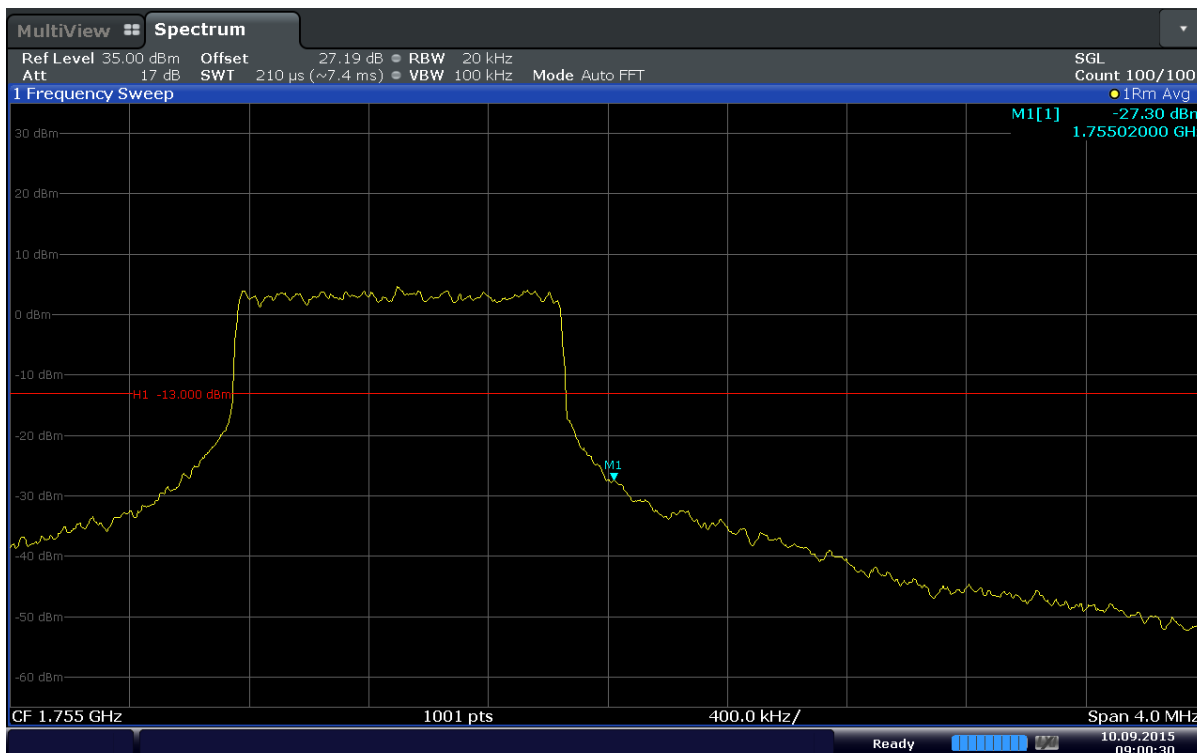

Date: 10.SEP.2015 09:00:31

Plot 6-81. Upper Band Edge Plot (Band 4 – 1.4MHz – QPSK – RB Size 6)

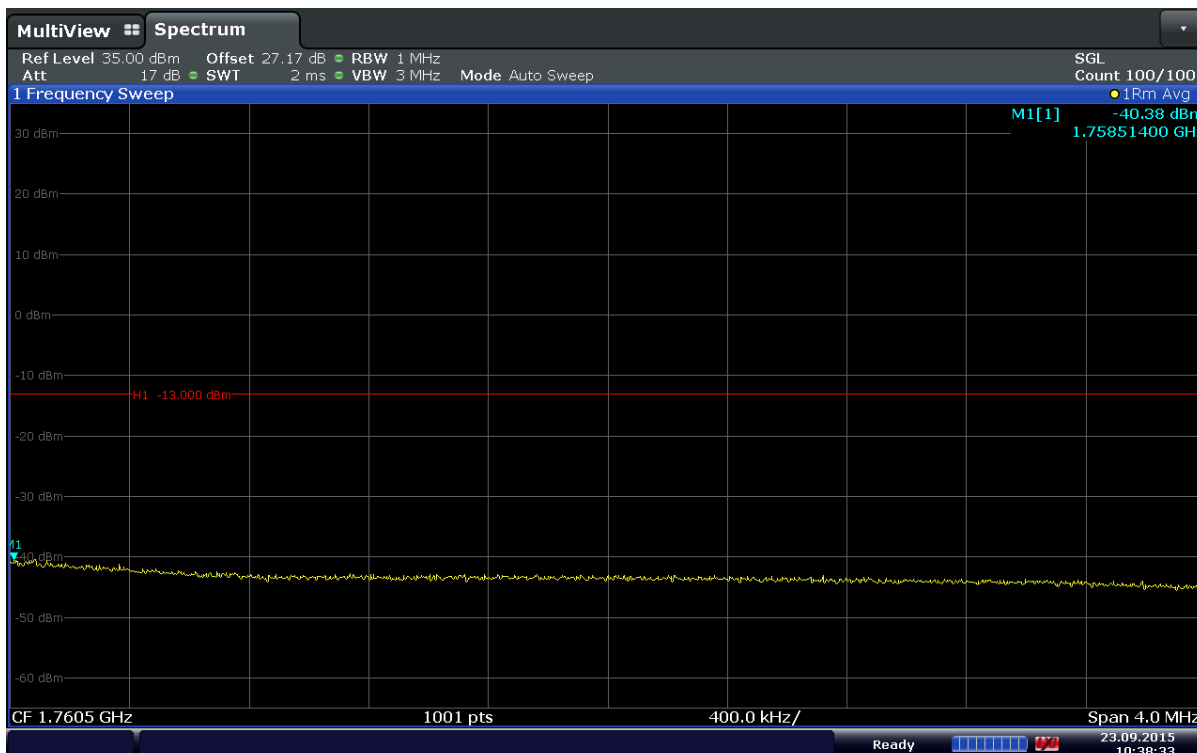

Date: 23.SEP.2015 10:38:33

Plot 6-82. Extended Upper Band Edge Plot (Band 4 – 1.4MHz – QPSK – RB Size 6)

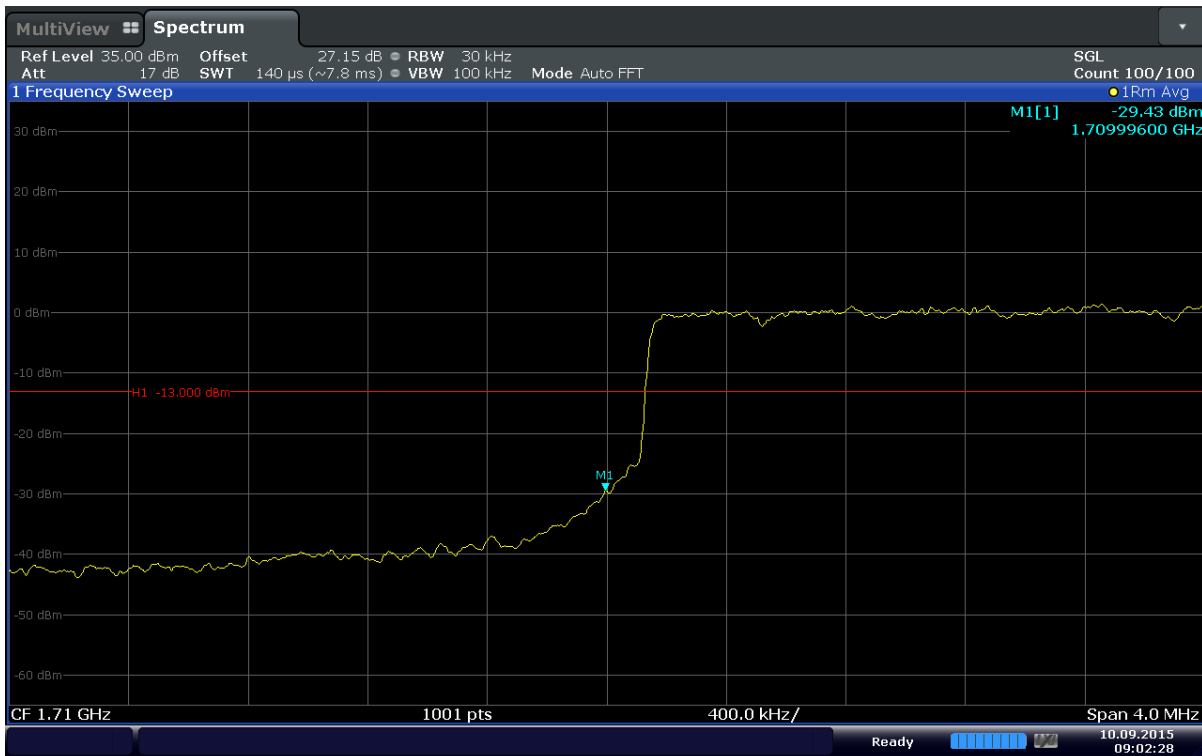

Date: 10.SEP.2015 09:02:28

Plot 6-83. Lower Band Edge Plot (Band 4 – 3MHz – QPSK – RB Size 15)

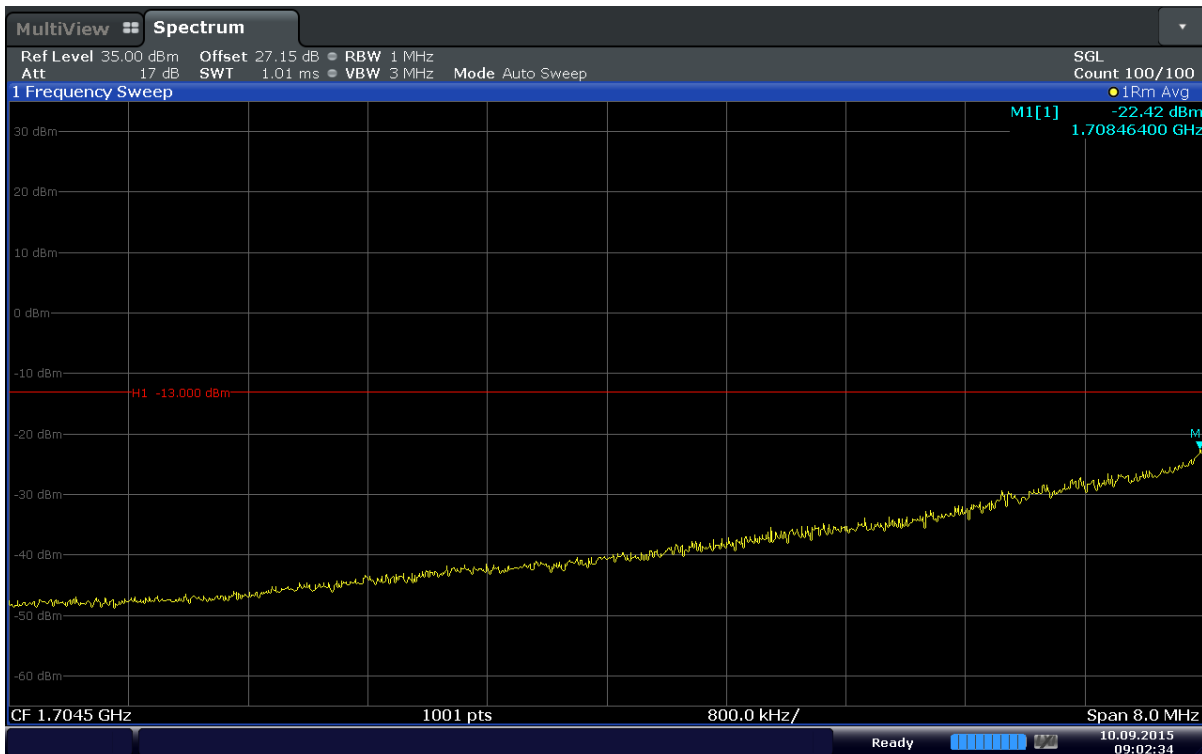

Date: 10.SEP.2015 09:02:34

Plot 6-84. Extended Lower Band Edge Plot (Band 4 – 3MHz – QPSK – RB Size 15)

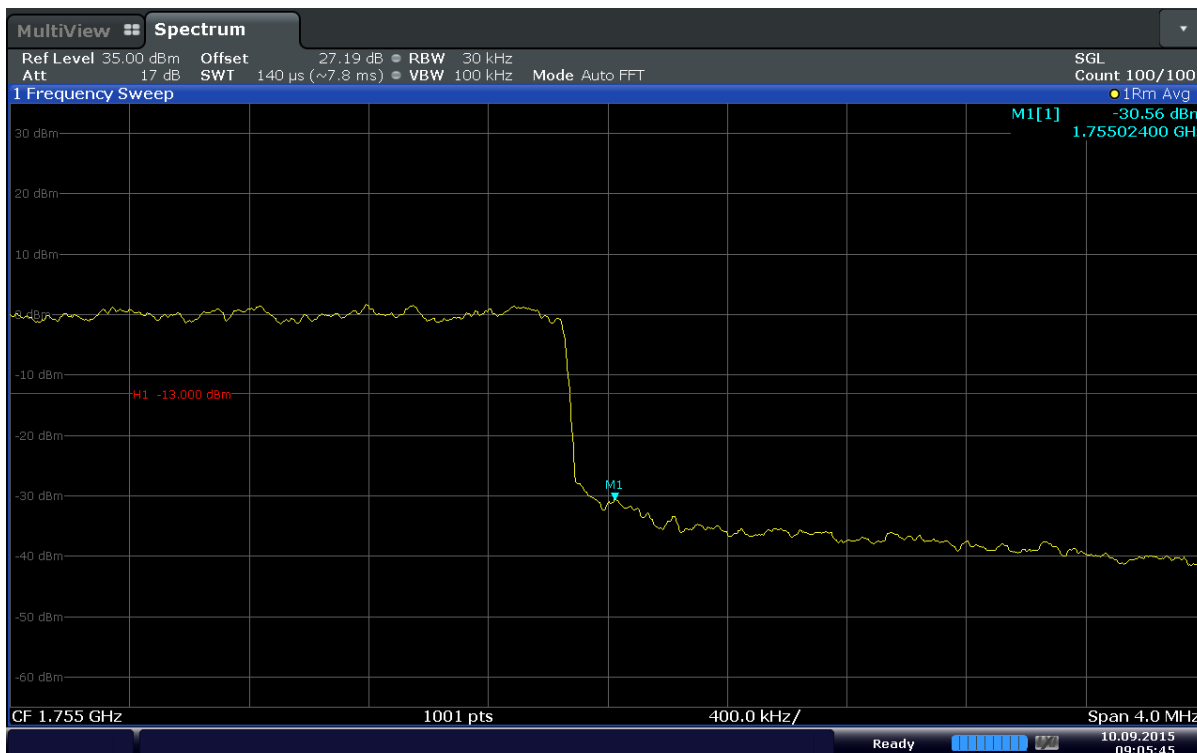

Date: 10.SEP.2015 09:05:46

Plot 6-85. Upper Band Edge Plot (Band 4 – 3MHz – QPSK – RB Size 15)

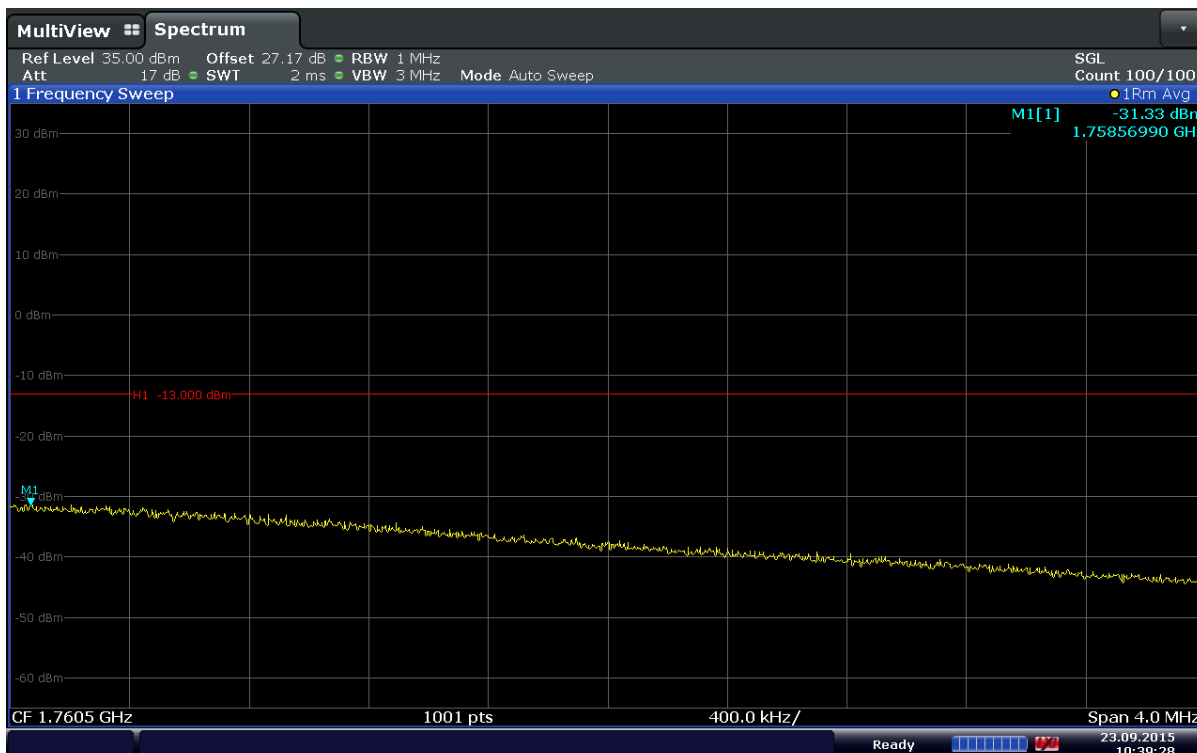

Date: 23.SEP.2015 10:39:28

Plot 6-86. Extended Upper Band Edge Plot (Band 4 – 3MHz – QPSK – RB Size 15)

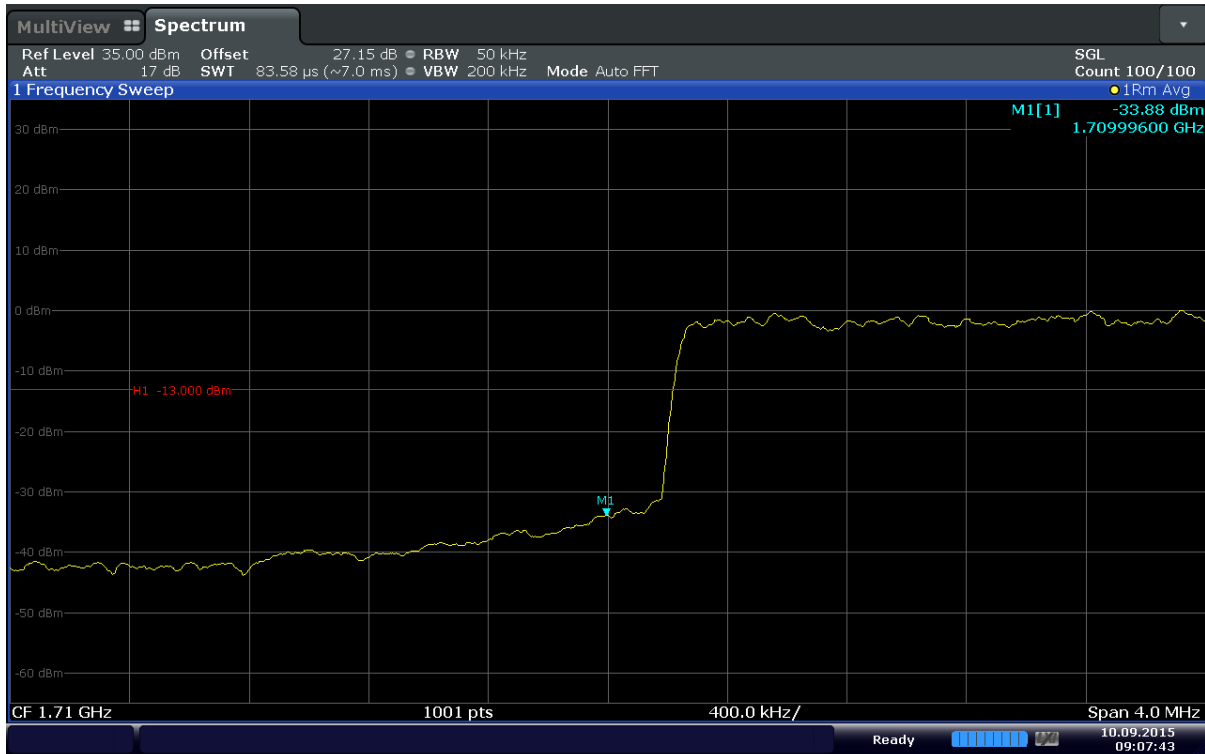

Date: 10.SEP.2015 09:07:43

Plot 6-87. Lower Band Edge Plot (Band 4 – 5MHz – QPSK – RB Size 25)

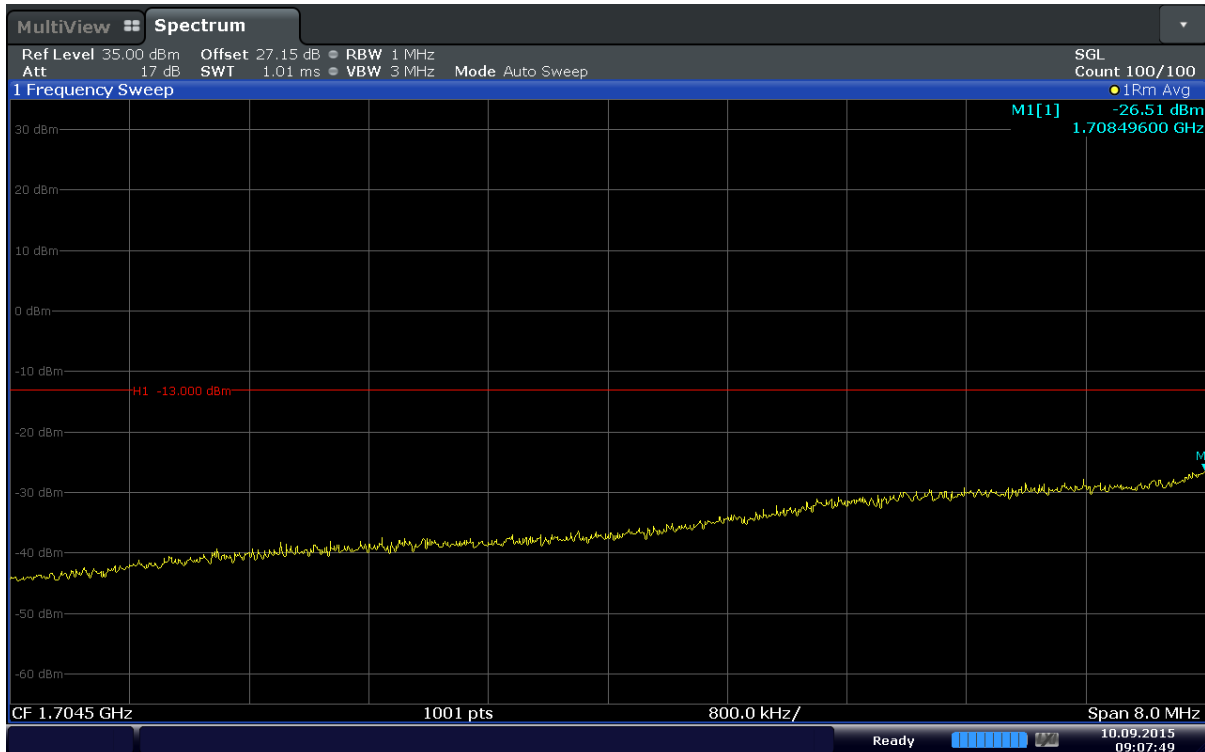

Date: 10.SEP.2015 09:07:49

Plot 6-88. Extended Lower Band Edge Plot (Band 4 – 5MHz – QPSK – RB Size 25)



Date: 10.SEP.2015 09:11:01

Plot 6-89. Upper Band Edge Plot (Band 4 – 5MHz – QPSK – RB Size 25)

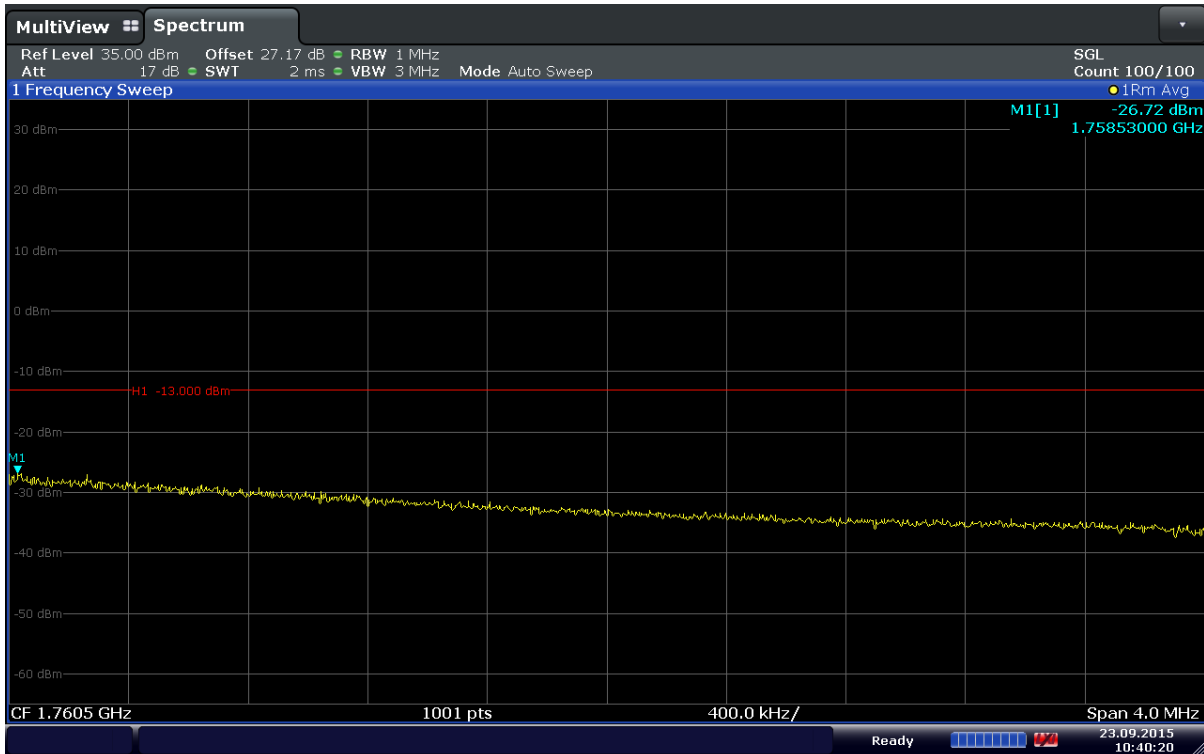

Date: 23.SEP.2015 10:40:20

Plot 6-90. Extended Upper Band Edge Plot (Band 4 – 5MHz – QPSK – RB Size 25)

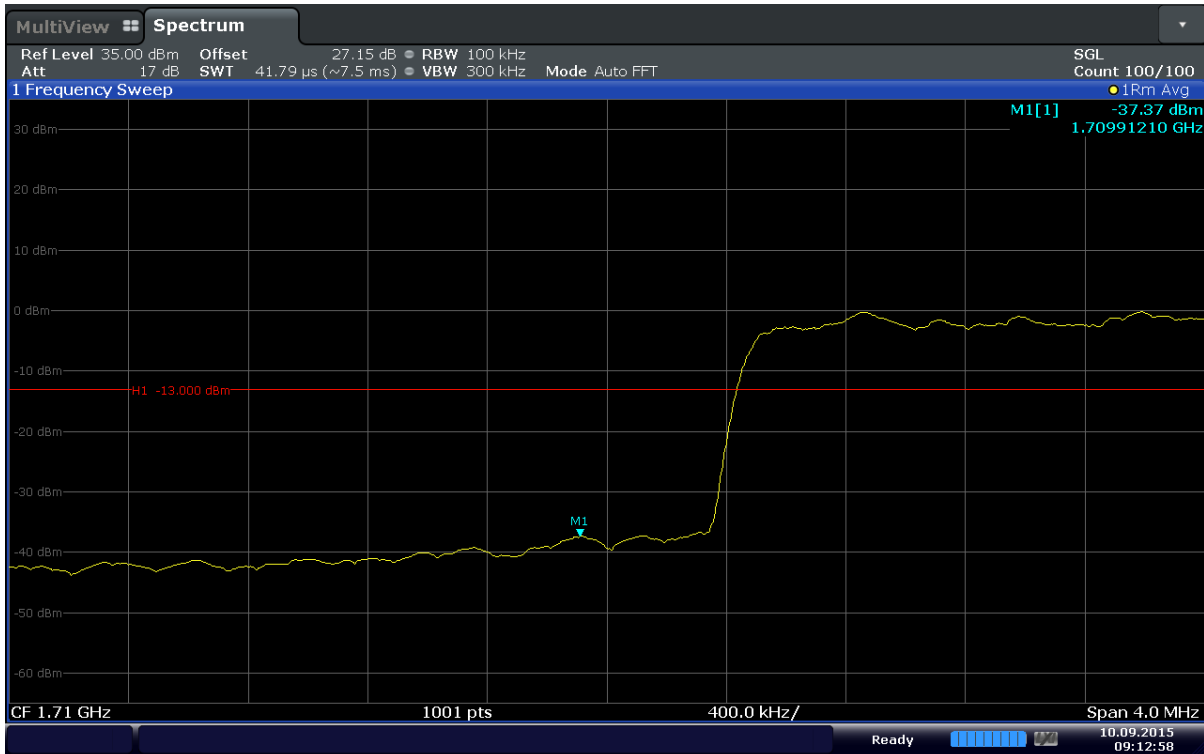

Date: 10.SEP.2015 09:12:58

Plot 6-91. Lower Band Edge Plot (Band 4 – 10MHz – QPSK – RB Size 50)

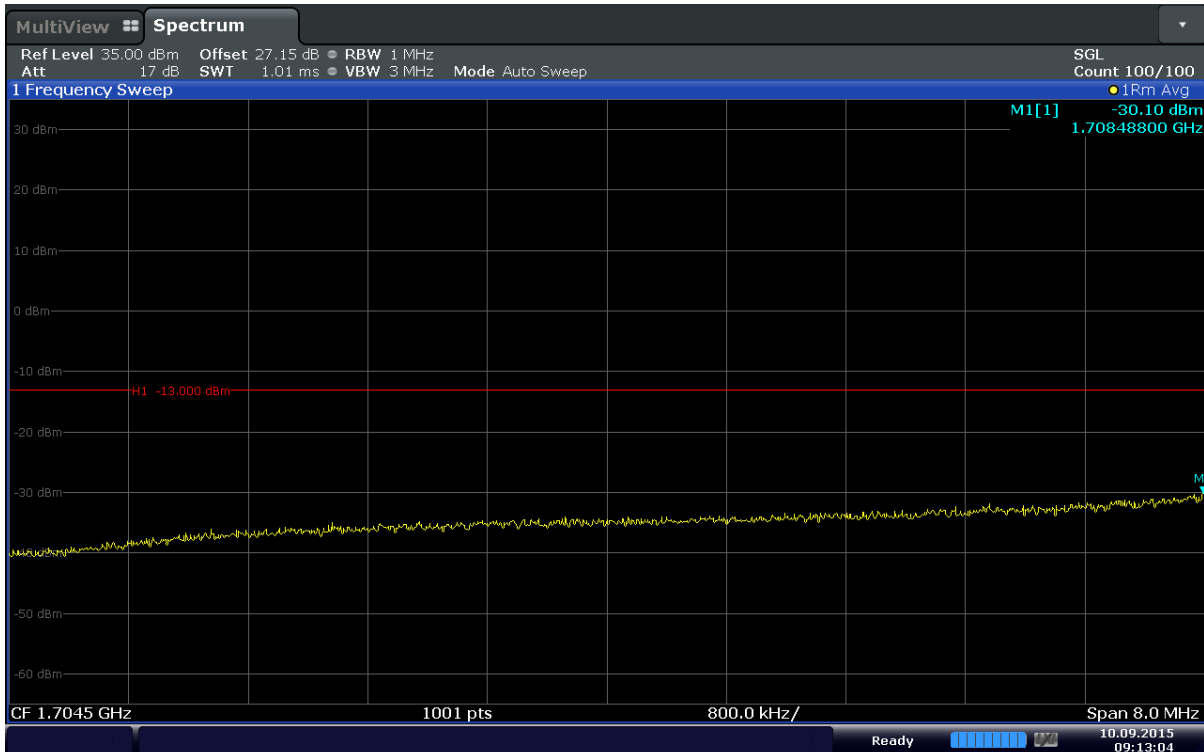

Date: 10.SEP.2015 09:13:05

Plot 6-92. Extended Lower Band Edge Plot (Band 4 – 10MHz – QPSK – RB Size 50)

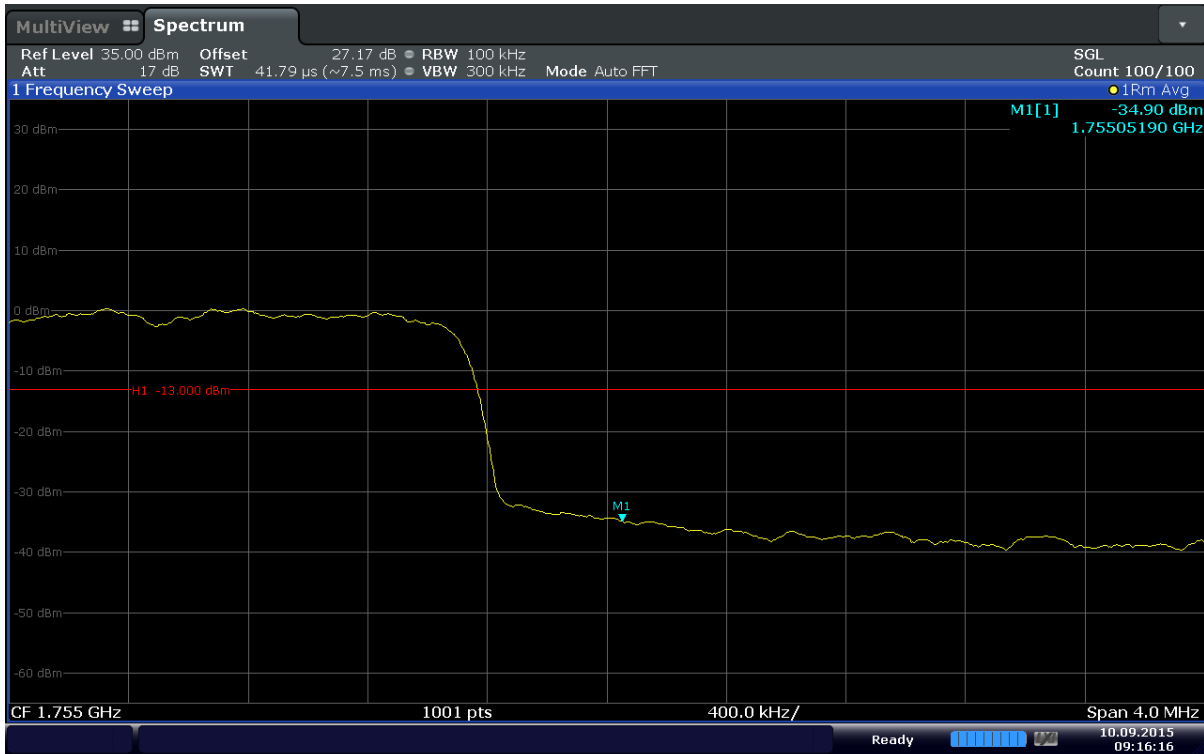

Date: 10.SEP.2015 09:16:17

Plot 6-93. Upper Band Edge Plot (Band 4 – 10MHz – QPSK – RB Size 50)

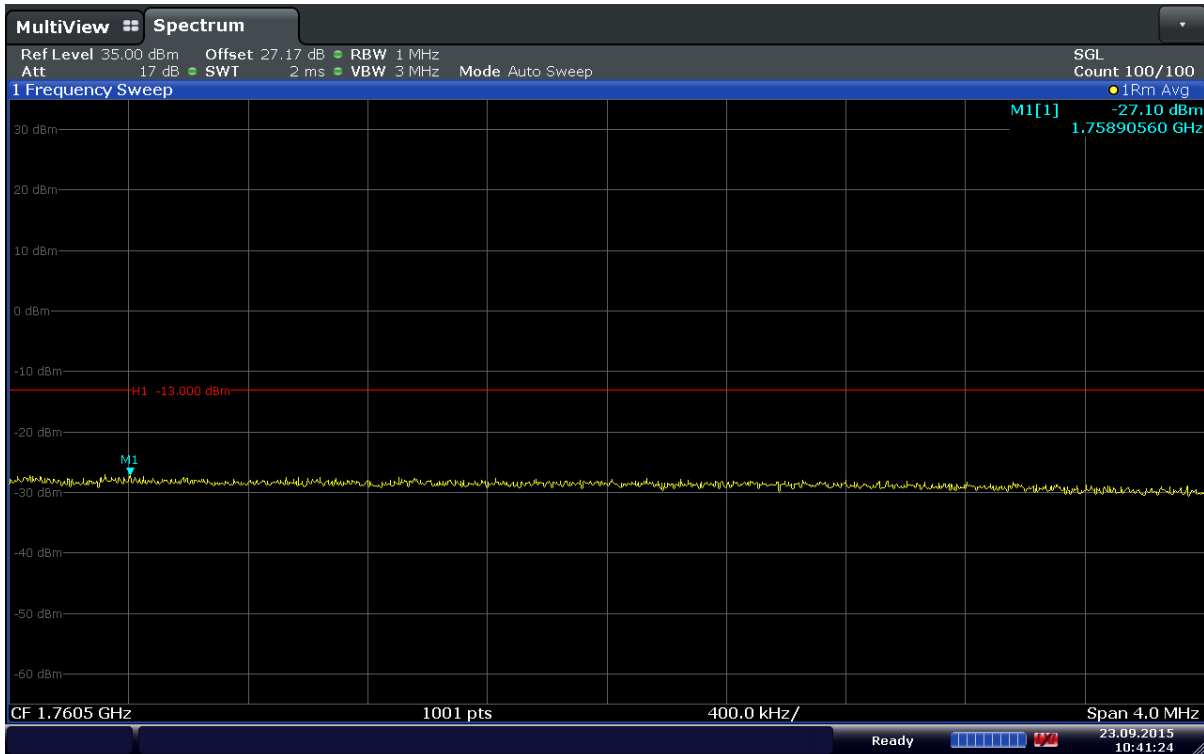

Date: 23.SEP.2015 10:41:23

Plot 6-94. Extended Upper Band Edge Plot (Band 4 – 10MHz – QPSK – RB Size 50)

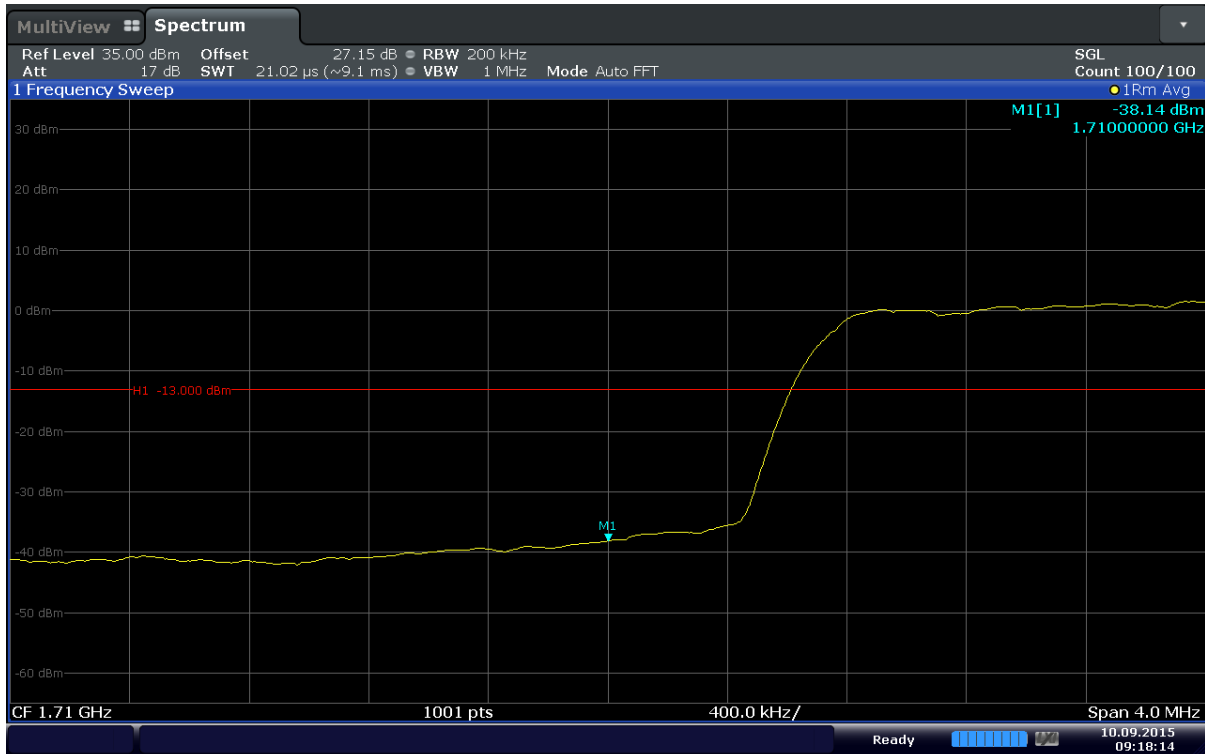

Date: 10.SEP.2015 09:18:14

Plot 6-95. Lower Band Edge Plot (Band 4 – 15MHz – QPSK – RB Size 75)

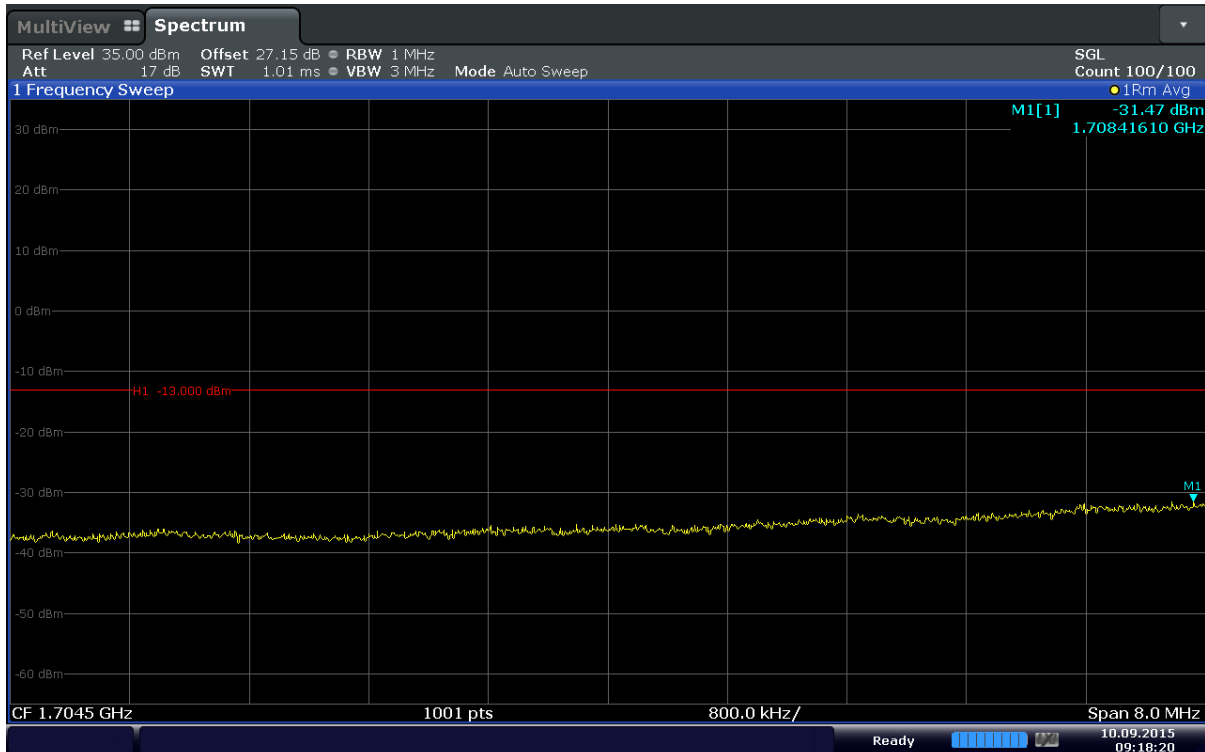

Date: 10.SEP.2015 09:18:20

Plot 6-96. Extended Lower Band Edge Plot (Band 4 – 15MHz – QPSK – RB Size 75)

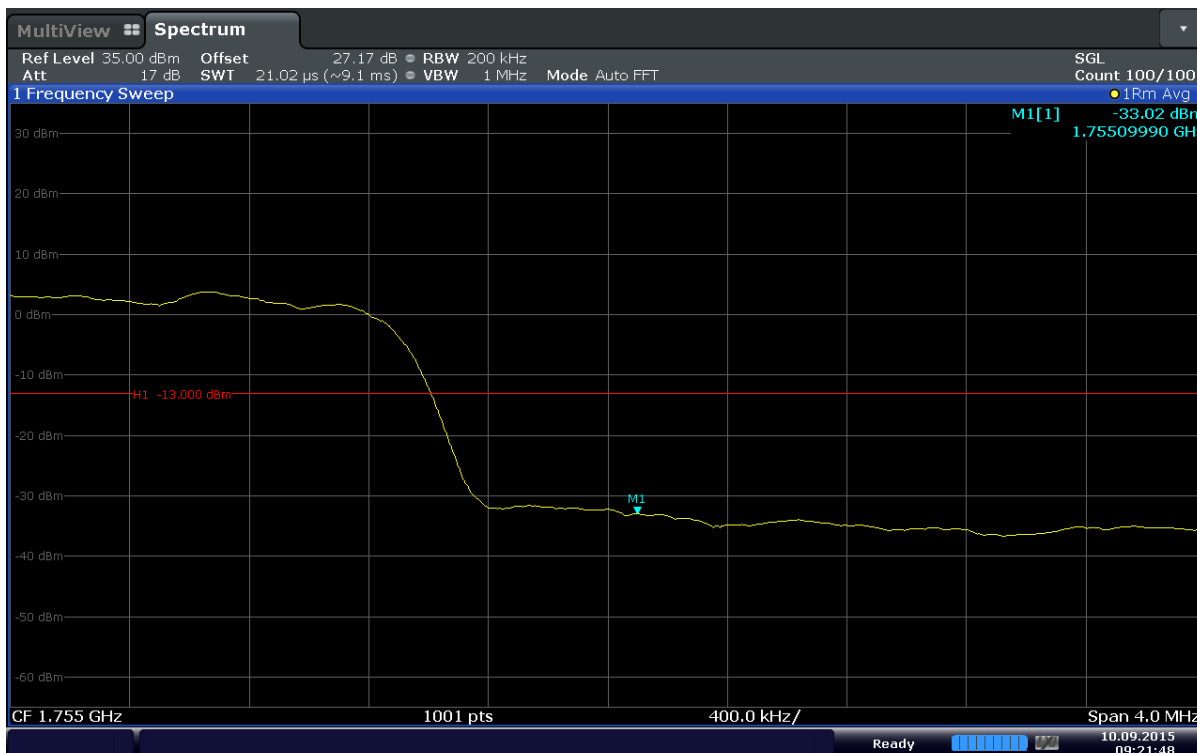

Date: 10.SEP.2015 09:21:48

Plot 6-97. Upper Band Edge Plot (Band 4 – 15MHz – QPSK – RB Size 75)

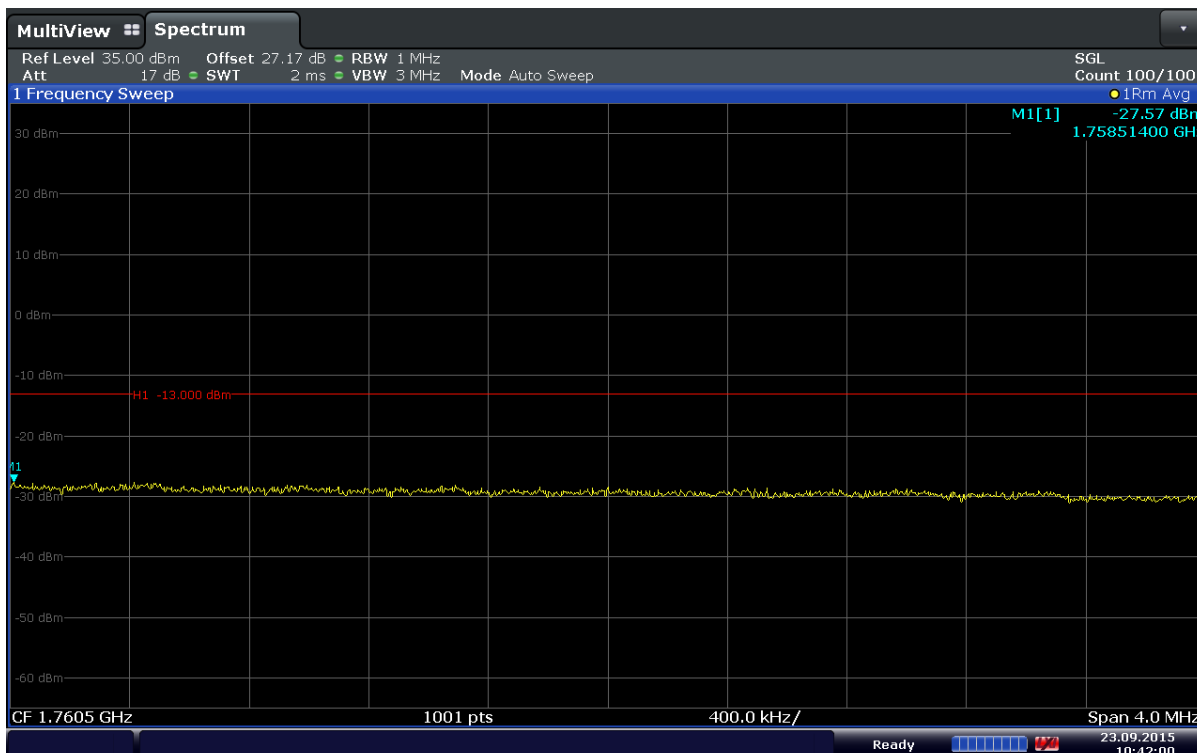

Date: 23.SEP.2015 10:42:01

Plot 6-98. Extended Upper Band Edge Plot (Band 4 – 15MHz – QPSK – RB Size 75)

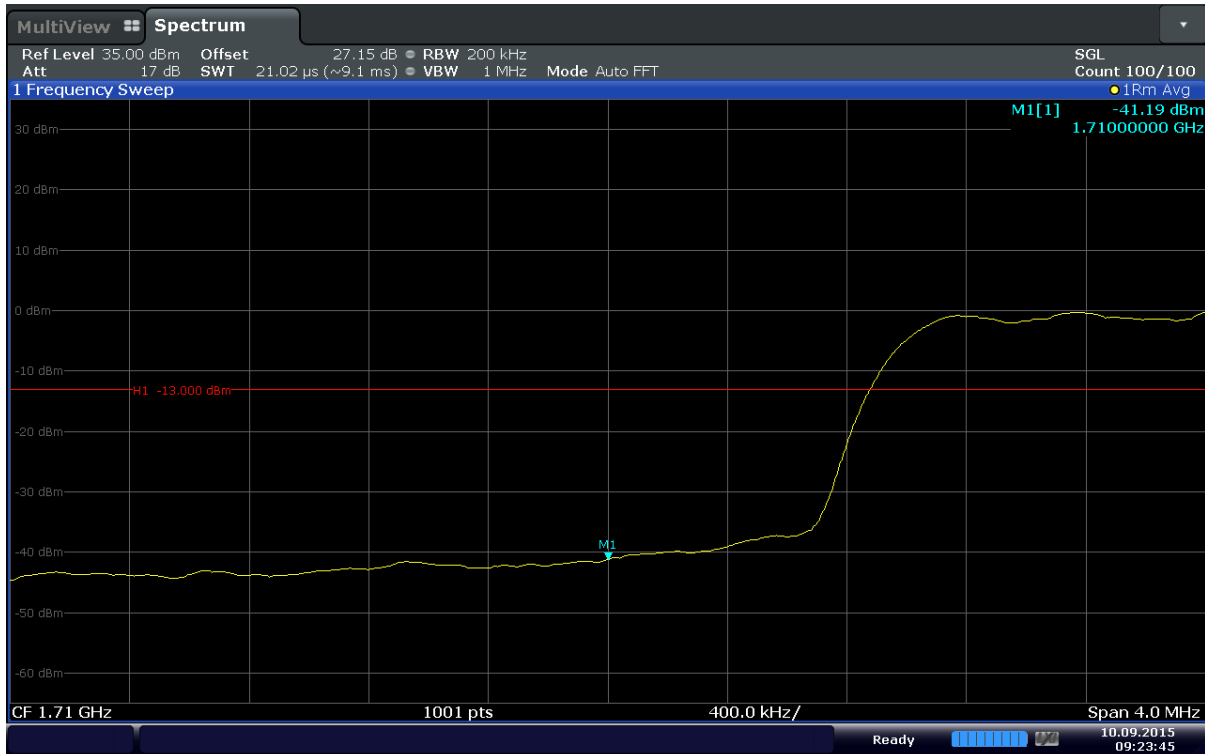

Date: 10.SEP.2015 09:23:45

Plot 6-99. Lower Band Edge Plot (Band 4 – 20MHz – QPSK – RB Size 100)

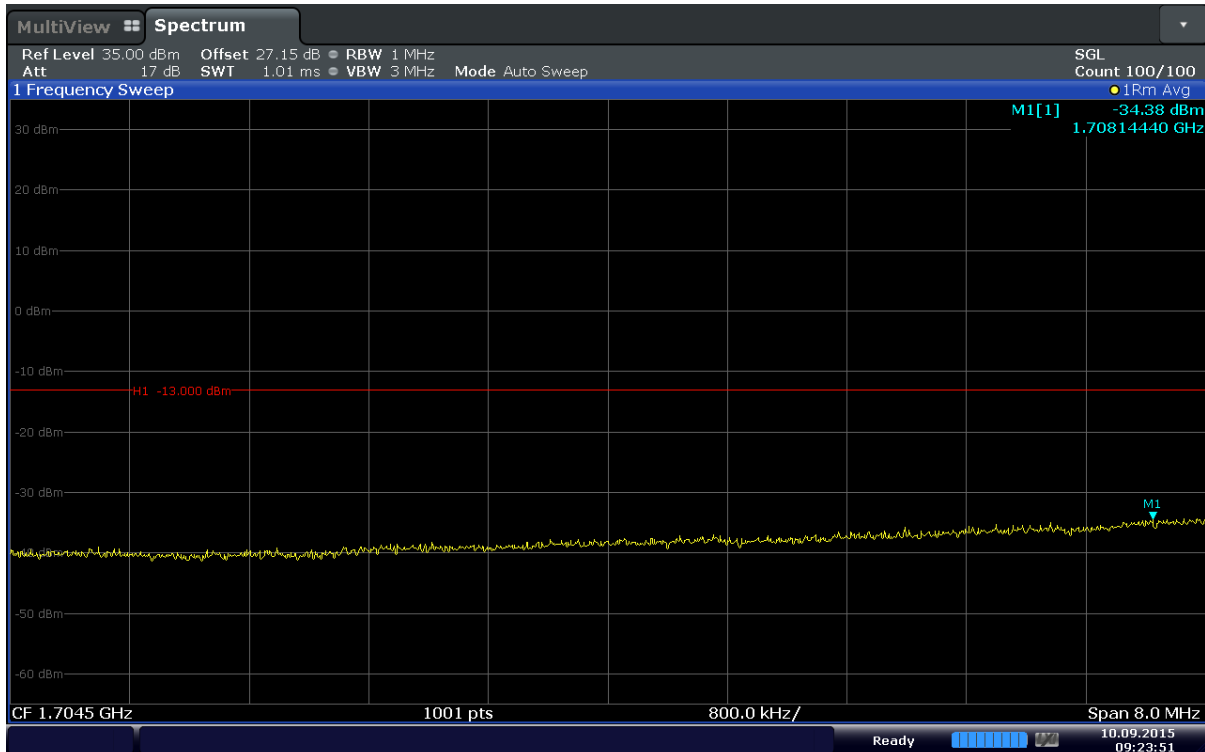

Date: 10.SEP.2015 09:23:51

Plot 6-100. Extended Lower Band Edge Plot (Band 4 – 20MHz – QPSK – RB Size 100)

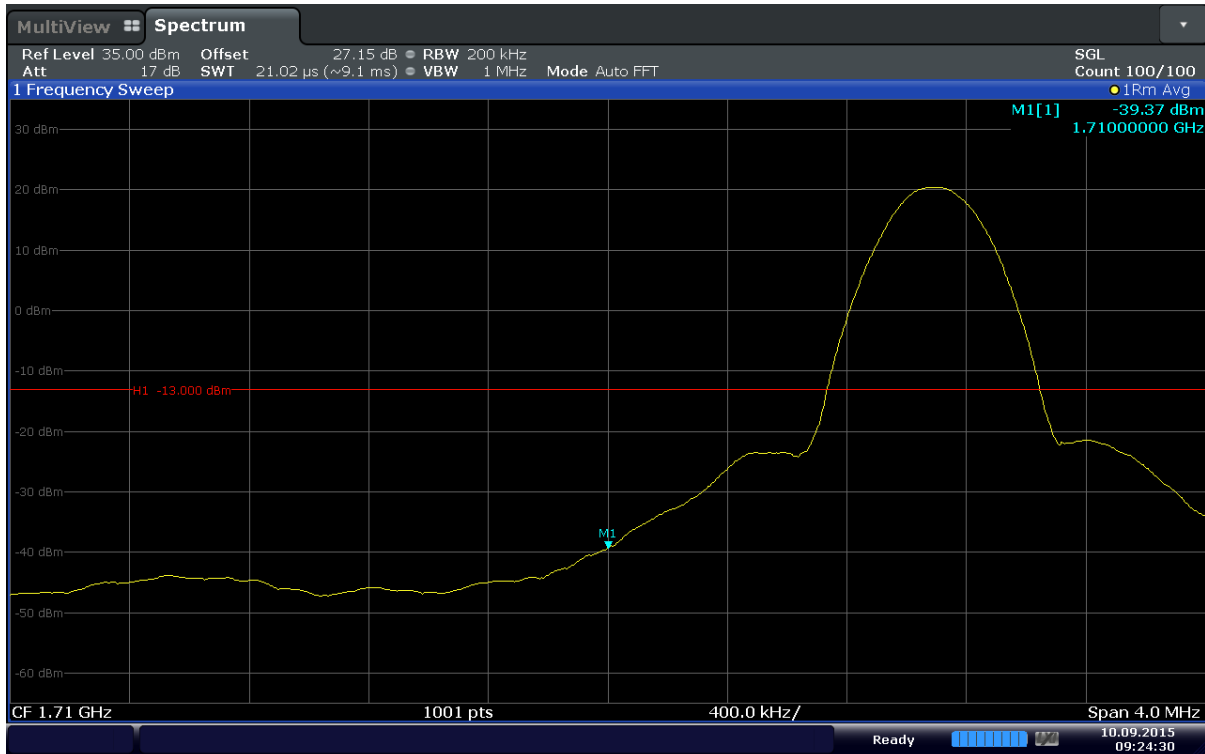

Date: 10.SEP.2015 09:24:30

Plot 6-101. Lower Band Edge Plot (Band 4 – 20MHz – QPSK – RB Size 1 – RB Offset 0)

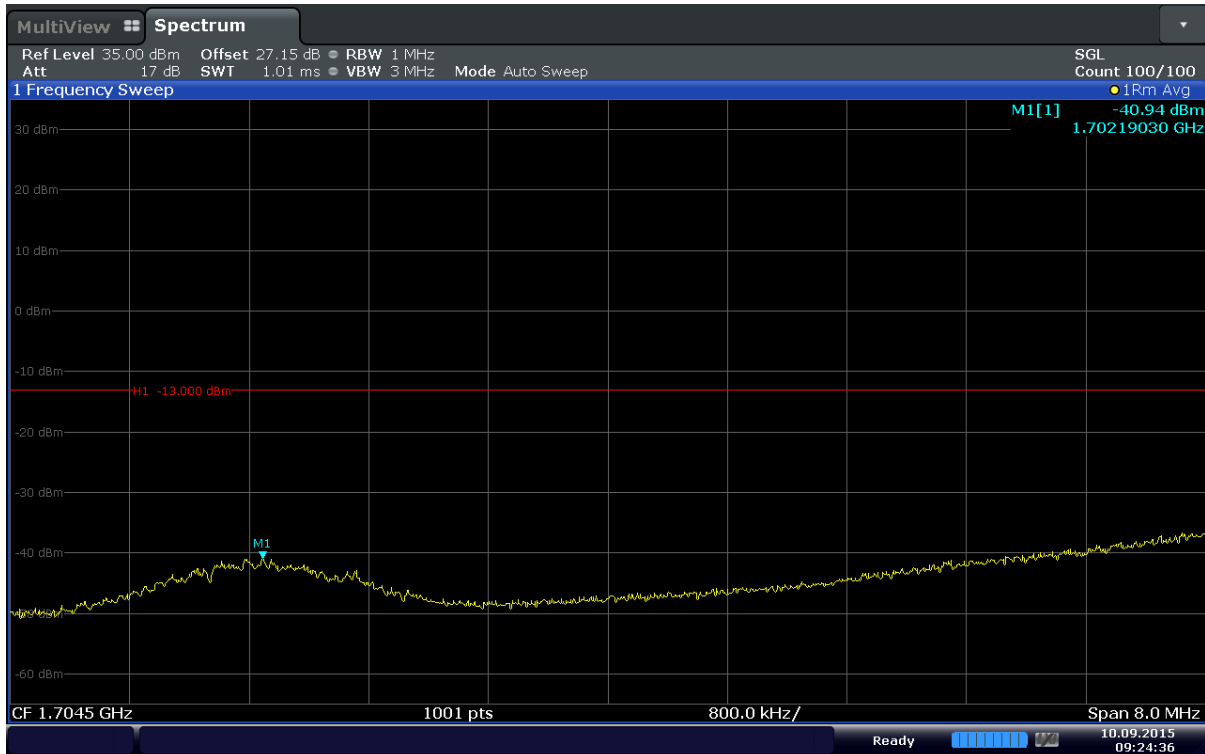

Date: 10.SEP.2015 09:24:37

Plot 6-102. Extended Lower Band Edge Plot (Band 4 – 20MHz – QPSK – RB Size 1 – RB Offset 0)

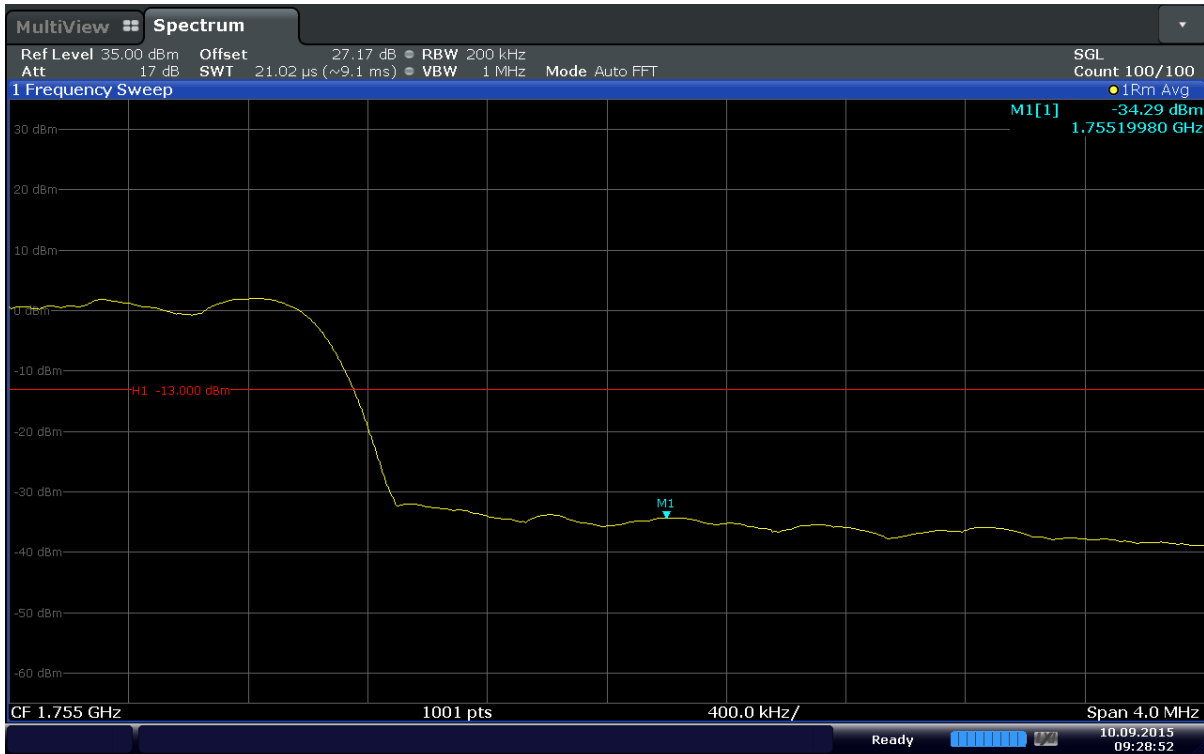

Date: 10.SEP.2015 09:28:52

Plot 6-103. Upper Band Edge Plot (Band 4 – 20MHz – QPSK – RB Size 100)

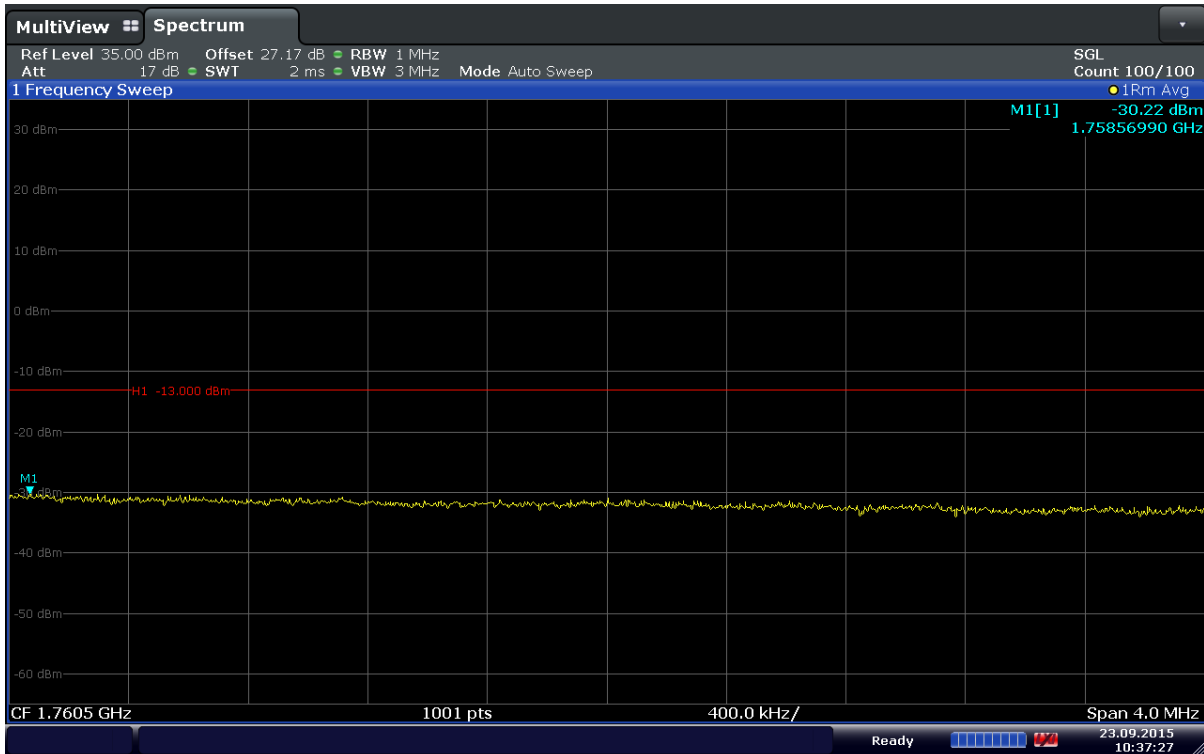

Date: 23.SEP.2015 10:37:27

Plot 6-104. Extended Upper Band Edge Plot (Band 4 – 20MHz – QPSK – RB Size 100)

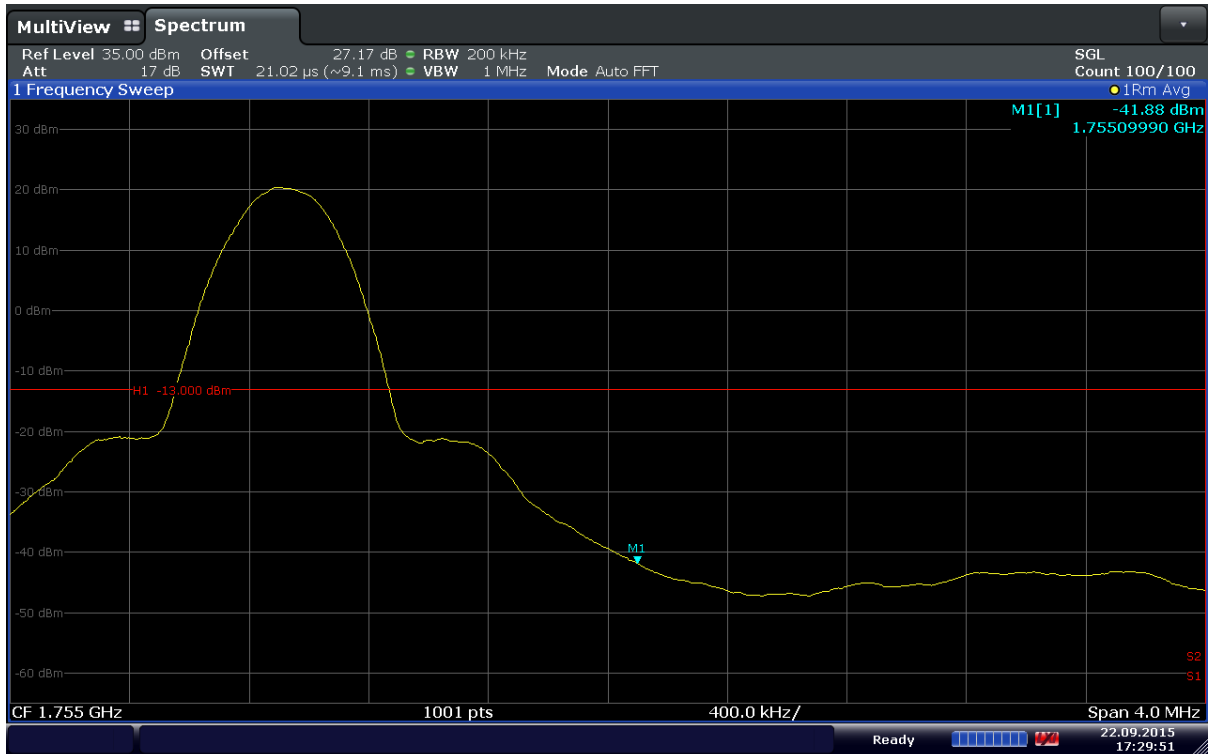

Date: 22.SEP.2015 17:29:51

Plot 6-105. Upper Band Edge Plot (Band 4 – 20MHz – QPSK – RB Size 1 – RB Offset 49)

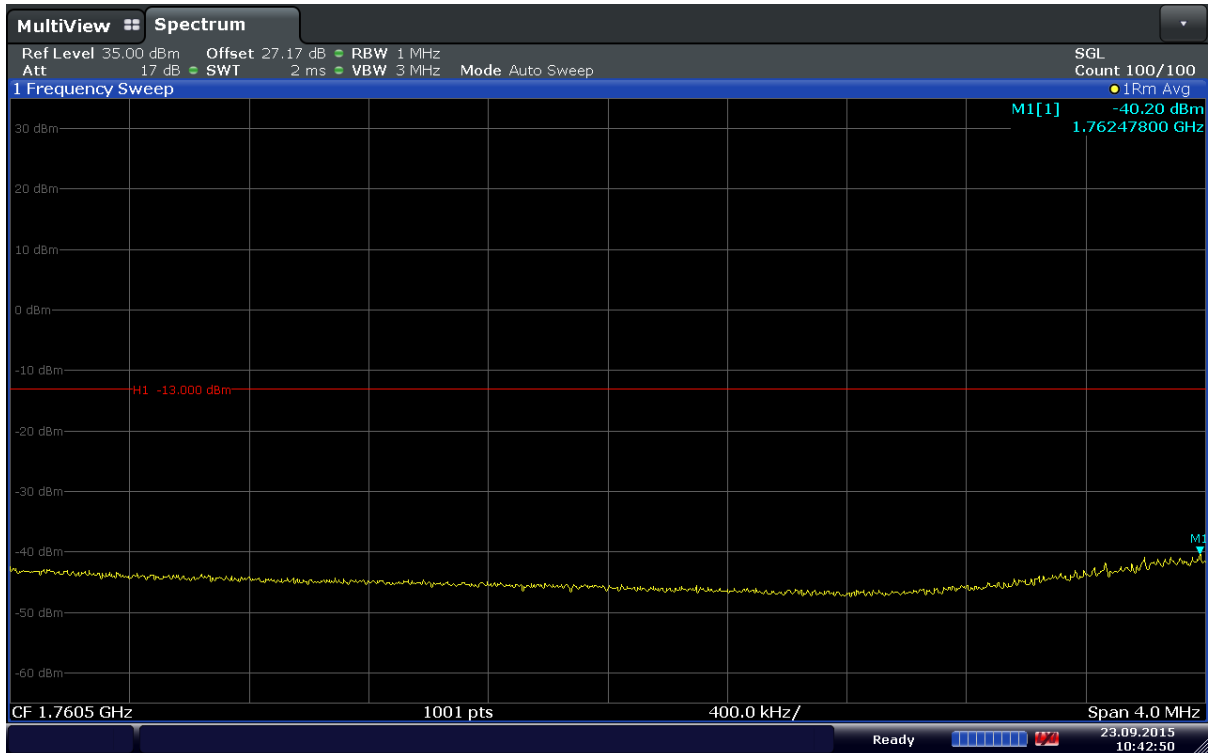

Date: 23.SEP.2015 10:42:50

Plot 6-106. Extended Upper Band Edge Plot (Band 4 – 20MHz – QPSK – RB Size 1 – RB Offset 49)



6.5. Frequency Stability / Temperature Variation  
§2.1055 §27.54

Test Overview and Limit

Frequency stability testing is performed in accordance with the guidelines of ANSI/TIA-603-D-2010. The frequency stability of the transmitter is measured by:

1. Temperature: The temperature is varied from -30°C to +50°C in 10°C increments using an environmental chamber.
2. Primary Supply Voltage: The primary supply voltage is varied from 85% to 115% of the nominal value for other than hand carried battery equipment. For hand-carried, battery-powered equipment, primary supply voltage is reduced to the battery operating end point(=Batt.End) which shall be specified by the manufacturer.

The frequency stability shall be sufficient to ensure that the fundamental emission stays within the authorized frequency block.

Test Procedure Used

ANSI/TIA-603-D-2010

Test Settings

1. The equipment is turned on in a "standby" condition for fifteen minutes before applying power to the transmitter. Measurement of the carrier frequency of the transmitter is made within one minute after applying power to the transmitter.
2. Frequency measurements are made at 10°C intervals ranging from -30°C to +50°C. A period of time sufficient to stabilize EUT at each temperature level shall be allowed prior to frequency measurement.

Test Setup

The EUT and measurement equipment were set up as shown in the diagram below.

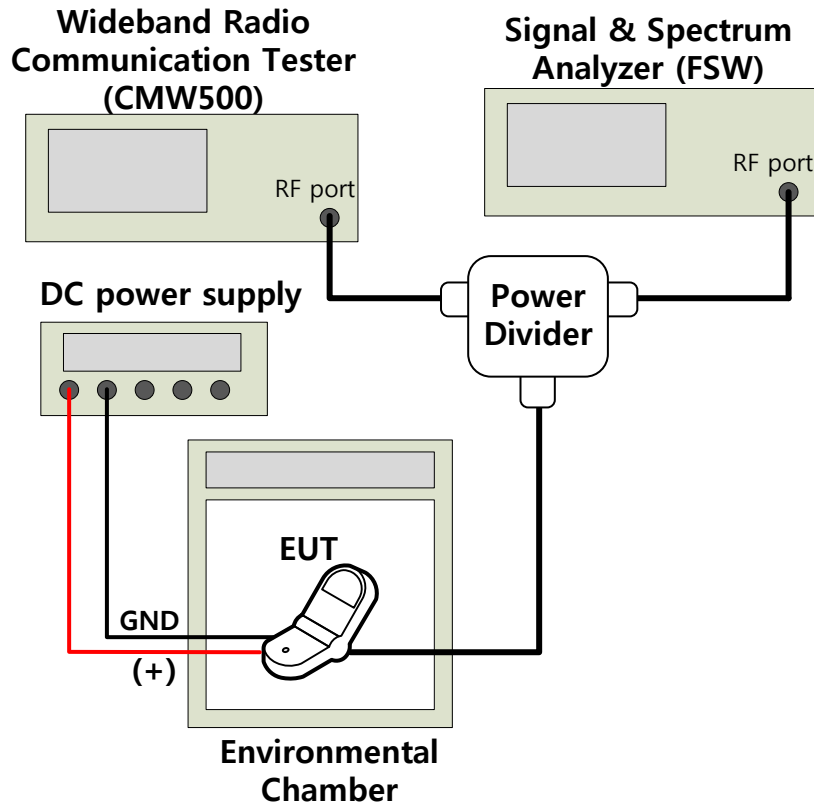

Figure 6-4. Test Instruments & Measurement Setup

Test Notes

1. MCF is the Measured Carrier Frequency  
ACF is the Assigned Carrier Frequency
2. Calculate the ppm frequency error by the following:

$$\text{ppm error} = \left( \frac{\text{MCF}_{[\text{MHz}]} - \text{ACF}_{[\text{MHz}]}}{\text{ACF}_{[\text{MHz}]}} \right) \times 10^6$$

3. Per §27.54, the fundamental emission should stay within the authorized frequency block. But, based on the results of the frequency stability test at the center channel, the frequency deviation results measured are very small. As such it is determined that the channels at the band edge would remain in-band when the maximum measured frequency deviation noted during the frequency stability tests is applied. Therefore the device is determined to remain operating in band over the temperature and voltage range as tested.



Issue Date:

Mode : LTE Band 12  
 Channel : 23017  
 Operating Frequency : 699.7 MHz  
 Reference Voltage : 11.34 VDC

Voltage [%]	Power [VDC]	Temp [°C]	ACF [MHz]	MCF [MHz]	Freq. Dev. [Hz]	ppm error
100 %	11.34	-30	699.7	699.699993	-7.38	-0.011
		-20	699.7	699.699992	-7.88	-0.011
		-10	699.7	699.699992	-8.17	-0.012
		0	699.7	699.699994	-5.81	-0.008
		+10	699.7	699.699992	-7.57	-0.011
		+20	699.7	699.699993	-6.61	-0.009
		+30	699.7	699.699994	-6.25	-0.009
		+40	699.7	699.699990	-10.07	-0.014
		+50	699.7	699.700006	5.94	0.008
115 %	13.05	+20	699.7	699.699993	-6.59	-0.009
Batt.End	10.80	+20	699.7	699.699993	-6.62	-0.009

Table 6-2. Frequency Stability Data (LTE Band 12)

Mode : LTE Band 4  
 Channel : 20393  
 Operating Frequency : 1754.3 MHz  
 Reference Voltage : 11.34 VDC

Voltage [%]	Power [VDC]	Temp [°C]	ACF [MHz]	MCF [MHz]	Freq. Dev. [Hz]	ppm error
100 %	11.34	-30	1754.3	1,754.299987	-12.56	-0.007
		-20	1754.3	1,754.299990	-10.24	-0.006
		-10	1754.3	1,754.299989	-10.69	-0.006
		0	1754.3	1,754.299987	-13.15	-0.007
		+10	1754.3	1,754.300015	15.18	0.009
		+20	1754.3	1,754.299983	-16.61	-0.009
		+30	1754.3	1,754.299985	-14.66	-0.008
		+40	1754.3	1,754.300014	14.19	0.008
		+50	1754.3	1,754.299982	-18.10	-0.010
115 %	13.05	+20	1754.3	1,754.299984	-15.66	-0.009
Batt.End	10.80	+20	1754.3	1,754.299989	-11.16	-0.006

Table 6-3. Frequency Stability Data (LTE Band 4)



6.6. Radiated Power (ERP/EIRP)  
§27.50(c)(10) §27.50(d)(4)

Test Overview

Effective Radiated Power (ERP) and Equivalent Isotropic Radiated Power (EIRP) measurements are performed using the substitution method described in ANSI/TIA-603-D-2010 with the EUT transmitting into an integral antenna. Measurements on signals operating below 1GHz are performed using dipole antennas. Measurements on signals operating above 1GHz are performed using broadband horn antennas. All measurements are performed as RMS average measurements while the EUT is operating at its maximum duty cycle, at maximum power, and at the appropriate frequencies.

Test Procedure Used

KDB 971168 v02r02 – Section 5.2.1

ANSI/TIA-603-D-2010 – Section 2.2.17

Test Settings

1. Radiated power measurements are performed using the signal analyzer's "channel power" measurement capability for signals with continuous operation.
2. RBW = 1 – 5% of the expected OBW, not to exceed 1MHz
3. VBW  $\geq 3 \times$  RBW
4. Span = 1.5 times the OBW
5. No. of sweep points  $\geq 2 \times$  span / RBW
6. Detector = RMS
7. Trigger is set to "free run" for signals with continuous operation with the sweep times set to "auto"
8. The integration bandwidth was roughly set equal to the measured OBW of the signal for signals with continuous operation.
9. Trace mode = trace averaging (RMS) over 100 sweeps
10. The trace was allowed to stabilize

Test Setup

The EUT and measurement equipment were set up as shown in the diagram below.

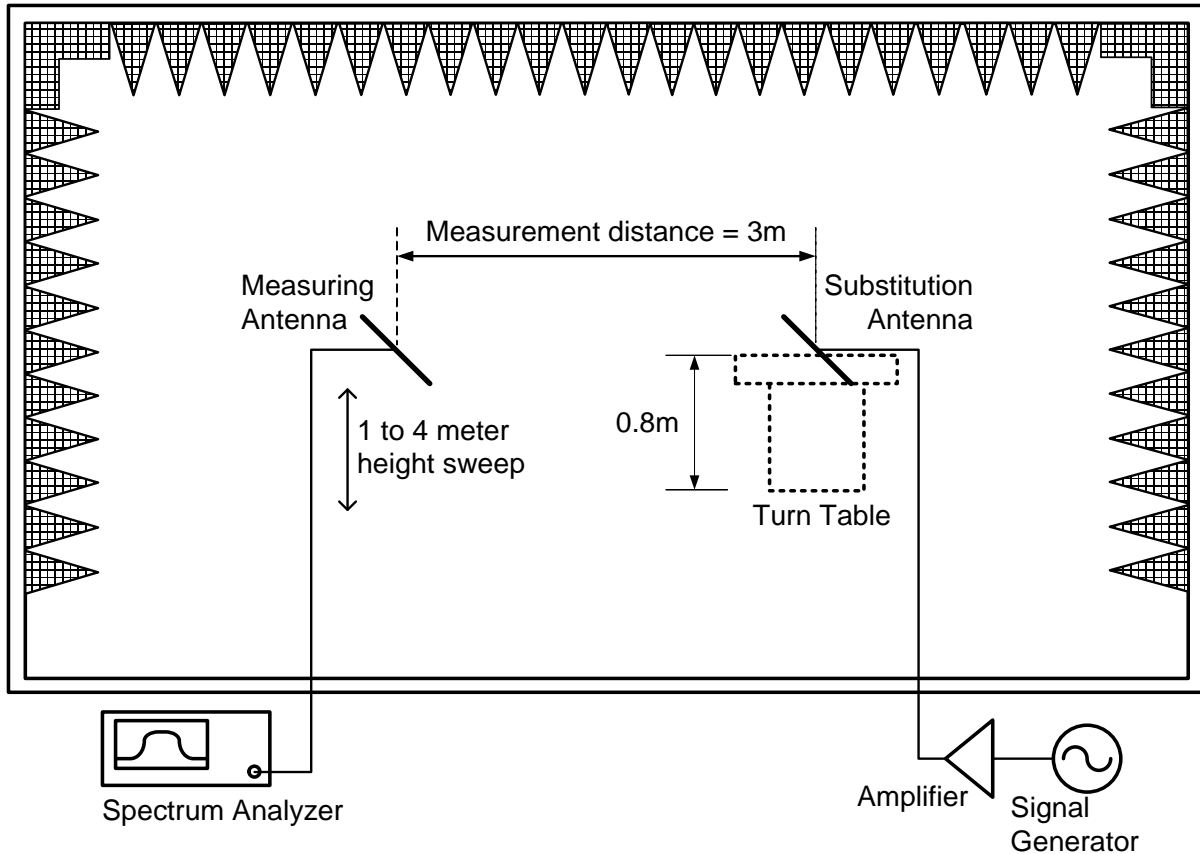

Figure 6-7. Test Instruments & Measurement Setup

Test Notes

1. The EUT was tested with Turn Device and the worst case emissions are reported with the EUT positioning, modulations, RB sizes and offsets, and channel bandwidth configurations shown in the tables below.
2. This unit was tested with its embedded battery.



Issue Date:

Test Results

Channel	Channel BW [MHz]	Mod.	RB Size /Offset	Ant Pol (H/V)	EUT Pol [X/Y/Z]	S/A Reading [dBm]	S/G Level [dBm]	Tx C/L [dB]	Ant. Gain [dBd]	ERP [dBm]	Margin [dB]
23017	1.4	QPSK	V	Y	1 / 5	-18.30	16.48	2.91	-0.72	12.85	21.92
23017	1.4	16QAM	V	Y	1 / 5	-18.90	15.88	2.91	-0.72	12.25	22.52
23095	1.4	QPSK	V	Y	1 / 5	-17.89	17.99	2.93	-0.76	14.30	20.47
23095	1.4	16QAM	V	Y	1 / 0	-18.98	16.90	2.93	-0.76	13.21	21.56
23173	1.4	QPSK	V	Y	1 / 2	-18.74	18.18	2.95	-0.84	14.40	20.37
23173	1.4	16QAM	V	Y	1 / 0	-19.59	17.33	2.95	-0.84	13.55	21.22
23025	3	QPSK	V	Y	1 / 14	-18.03	16.83	2.91	-0.72	13.20	21.57
23025	3	16QAM	V	Y	1 / 0	-19.36	15.50	2.91	-0.72	11.87	22.90
23095	3	QPSK	V	Y	1 / 14	-17.97	17.91	2.93	-0.76	14.22	20.55
23095	3	16QAM	V	Y	1 / 0	-19.24	16.64	2.93	-0.76	12.95	21.82
23165	3	QPSK	V	Y	1 / 7	-18.62	18.20	2.94	-0.83	14.43	20.34
23165	3	16QAM	V	Y	1 / 0	-19.56	17.26	2.94	-0.83	13.49	21.28
23035	5	QPSK	V	Y	1 / 24	-18.48	16.53	2.91	-0.73	12.89	21.88
23035	5	16QAM	V	Y	1 / 24	-19.73	15.28	2.91	-0.73	11.64	23.13
23095	5	QPSK	V	Y	1 / 24	-18.33	17.55	2.93	-0.76	13.86	20.91
23095	5	16QAM	V	Y	1 / 24	-19.44	16.44	2.93	-0.76	12.75	22.02
23155	5	QPSK	V	Y	1 / 0	-18.38	18.31	2.94	-0.82	14.55	20.22
23155	5	16QAM	V	Y	1 / 0	-19.54	17.15	2.94	-0.82	13.39	21.38
23060	10	QPSK	V	Y	1 / 24	-18.45	16.92	2.92	-0.74	13.26	21.51
23060	10	16QAM	V	Y	1 / 0	-19.89	15.48	2.92	-0.74	11.82	22.95
23095	10	QPSK	V	Y	1 / 0	-18.15	17.73	2.93	-0.76	14.04	20.73
23095	10	16QAM	V	Y	1 / 0	-19.07	16.81	2.93	-0.76	13.12	21.65
23130	10	QPSK	V	Y	1 / 24	-18.31	18.06	2.93	-0.79	14.34	20.43
23130	10	16QAM	V	Y	1 / 24	-19.61	16.76	2.93	-0.79	13.04	21.73

Table 6-4. ERP (LTE Band 12)

- End of this page -



Issue Date:

Channel	Channel BW [MHz]	Mod.	RB Size /Offset	Ant Pol (H/V)	EUT Pol [X/Y/Z]	S/A Reading [dBm]	S/G Level [dBm]	Tx C/L [dB]	Ant. Gain [dBi]	EIRP [dBm]	Margin [dB]
19957	1.4	QPSK	1 / 2	H	Z	-24.86	14.80	4.50	9.27	19.58	10.42
19957	1.4	16QAM	1 / 0	H	Z	-25.02	14.64	4.50	9.27	19.42	10.58
20175	1.4	QPSK	1 / 0	H	Z	-23.53	16.34	4.53	9.34	21.15	8.85
20175	1.4	16QAM	1 / 0	H	Z	-24.70	15.17	4.53	9.34	19.98	10.02
20393	1.4	QPSK	1 / 5	H	X	-22.47	17.60	4.56	9.41	22.45	7.55
20393	1.4	16QAM	1 / 5	V	Z	-23.37	17.14	4.56	9.41	21.99	8.01
19965	3	QPSK	1 / 14	H	Z	-24.70	14.97	4.50	9.28	19.75	10.25
19965	3	16QAM	1 / 0	H	Z	-25.53	14.14	4.50	9.28	18.92	11.08
20175	3	QPSK	1 / 14	H	Z	-23.25	16.62	4.53	9.34	21.43	8.57
20175	3	16QAM	1 / 0	H	Z	-24.66	15.21	4.53	9.34	20.02	9.98
20385	3	QPSK	1 / 14	H	X	-22.47	17.59	4.56	9.41	22.44	7.56
20385	3	16QAM	1 / 14	H	X	-23.18	16.88	4.56	9.41	21.73	8.27
19975	5	QPSK	1 / 24	H	Z	-25.03	14.65	4.50	9.28	19.43	10.57
19975	5	QPSK	1 / 24	H	Z	-25.64	14.04	4.50	9.28	18.82	11.18
20175	5	16QAM	1 / 24	H	Z	-23.59	16.28	4.53	9.34	21.09	8.91
20175	5	QPSK	1 / 0	H	Z	-24.57	15.30	4.53	9.34	20.11	9.89
20375	5	16QAM	1 / 24	H	X	-22.68	17.37	4.56	9.40	22.22	7.78
20375	5	QPSK	1 / 24	V	Z	-23.50	16.99	4.56	9.40	21.84	8.16
20000	10	16QAM	1 / 49	V	Z	-25.07	15.01	4.50	9.27	19.78	10.22
20000	10	QPSK	1 / 49	H	Z	-25.27	14.38	4.50	9.27	19.16	10.84
20175	10	16QAM	1 / 49	H	Z	-23.74	16.13	4.53	9.34	20.94	9.06
20175	10	QPSK	1 / 0	H	Z	-24.85	15.02	4.53	9.34	19.83	10.17
20350	10	16QAM	1 / 49	V	Z	-22.39	18.08	4.56	9.40	22.92	7.08
20350	10	QPSK	1 / 49	H	X	-23.22	16.81	4.56	9.40	21.65	8.35
20025	15	16QAM	1 / 36	H	Z	-24.98	14.74	4.51	9.29	19.53	10.47
20025	15	16QAM	1 / 74	H	Z	-25.05	14.67	4.51	9.29	19.46	10.54
20175	15	QPSK	1 / 0	H	Z	-24.06	15.81	4.53	9.34	20.62	9.38
20175	15	16QAM	1 / 0	H	Z	-24.45	15.42	4.53	9.34	20.23	9.77
20325	15	QPSK	1 / 74	H	X	-22.79	17.22	4.55	9.39	22.05	7.95
20325	15	16QAM	1 / 0	V	Z	-24.34	16.11	4.55	9.39	20.94	9.06
20050	20	QPSK	1 / 50	H	Z	-24.46	15.29	4.51	9.30	20.08	9.92
20050	20	16QAM	1 / 50	V	Z	-25.68	14.50	4.51	9.30	19.29	10.71
20175	20	QPSK	1 / 50	H	Z	-23.57	16.30	4.53	9.34	21.11	8.89
20175	20	16QAM	1 / 50	H	Z	-23.62	16.25	4.53	9.34	21.06	8.94
20300	20	QPSK	1 / 50	H	X	-23.03	16.95	4.55	9.38	21.79	8.21
20300	20	16QAM	1 / 99	H	X	-23.46	16.52	4.55	9.38	21.36	8.64

Table 6-5. EIRP (LTE Band 4)



6.7. Radiated Spurious Emissions Measurements  
§2.1053 §27.53(g) §27.53(h)

Test Overview

Radiated spurious emissions measurements are performed using the substitution method described in ANSI/TIA-603-D-2010 with the EUT transmitting into an integral antenna. Measurements on signals operating below 1GHz are performed using dipole antennas. Measurements on signals operating above 1GHz are performed using broadband horn antennas. All measurements are performed as peak measurements while the EUT is operating at its maximum duty cycle, at maximum power, and at the appropriate frequencies.

Test Procedure Used

KDB 971168 v02r02 – Section 5.8

ANSI/TIA-603-D-2010 – Section 2.2.12

Test Settings

1. RBW = 100kHz for emissions below 1GHz and 1MHz for emissions above 1GHz
2. VBW  $\geq 3 \times$  RBW
3. No. of sweep points  $\geq$  Span / RBW
4. Detector = Max Peak
5. Trace mode = max hold
6. The trace was allowed to stabilize

– End of this page –

Test Setup

The EUT and measurement equipment were set up as shown in the diagram below.

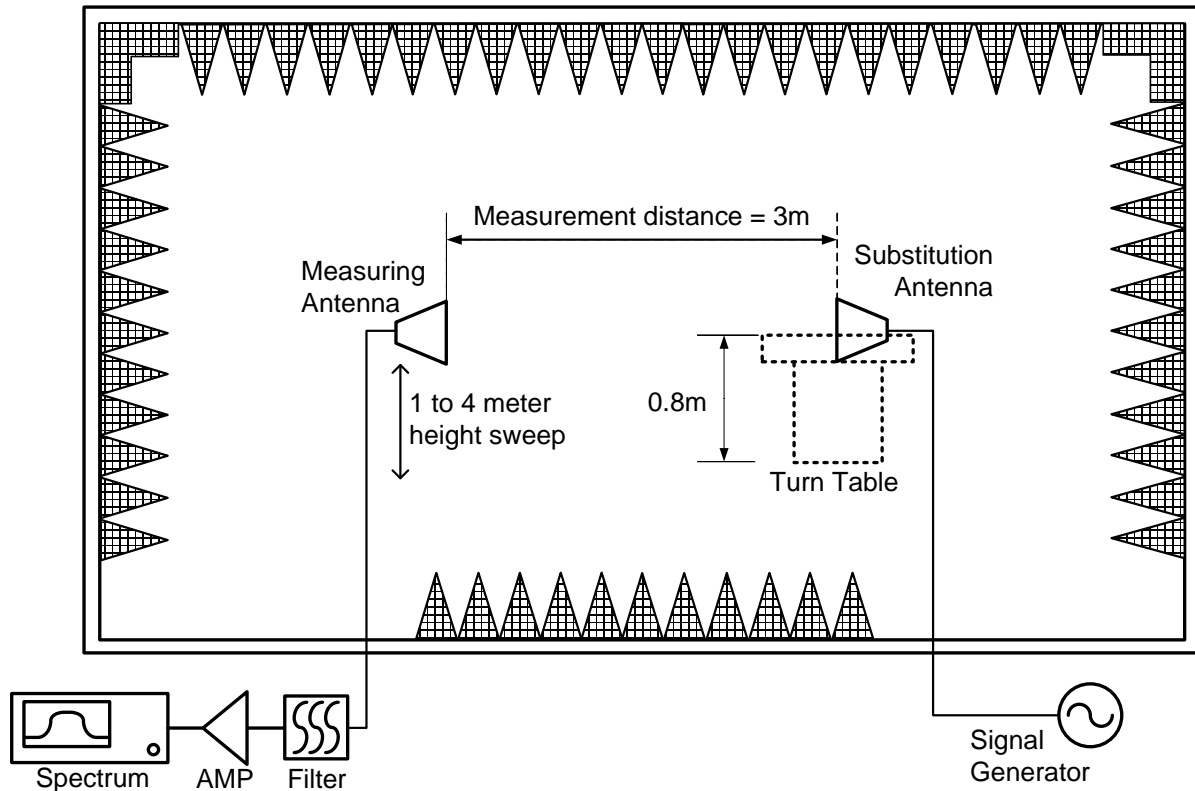

Figure 6-8. Test Instruments & Measurement Setup

Test Notes

1. The EUT was tested with Turn Device and the worst case emissions are reported with the EUT positioning, modulations, RB sizes and offsets, and channel bandwidth configurations shown in the tables below.
2. This unit was tested with its embedded battery.
3. The spectrum is measured from 9kHz to the 10<sup>th</sup> harmonic of the fundamental frequency of the transmitter. The worst-case emissions are reported.



Issue Date:

Test Results

Operating Frequency : 704.0 MHz  
 Channel : 23060  
 Measured Output Power : 13.26 dBm = 0.021 Watt  
 Modulation Signal : QPSK  
 Band Width : 10 MHz  
 RB Size / Offset : 1/24  
 Distance : 3 meters  
 Limit :  $43 + 10 \log_{10}(W)$  = 26.26 dBc  
 RSE Limit : -13 dBm

Freq. [MHz]	Ant Pol (H/V)	EUT Pol [X/Y/Z]	S/A reading [dBm]	S/G Lev. [dBm]	Tx C/L [dB]	Ant. Gain [dBd]	RSE Level [dBm]
1408.2	H	Z	-54.82	-51.15	4.08	5.39	-49.84
2112.5	H	X	-58.16	-48.94	4.99	5.00	-48.94
2816.2	H	X	-63.37	-54.38	5.82	7.41	-52.79
3520.0	Noise floor		-65.15	-53.23	6.52	7.72	-52.03

Table 6-6. Radiated Spurious Data (LTE Band 12 – Low Channel)

Operating Frequency : 707.5 MHz  
 Channel : 23095  
 Measured Output Power : 14.30 dBm = 0.027 Watt  
 Modulation Signal : QPSK  
 Band Width : 1.4 MHz  
 RB Size / Offset : 1/5  
 Distance : 3 meters  
 Limit :  $43 + 10 \log_{10}(W)$  = 27.30 dBc  
 RSE Limit : -13 dBm

Freq. [MHz]	Ant Pol (H/V)	EUT Pol [X/Y/Z]	S/A reading [dBm]	S/G Lev. [dBm]	Tx C/L [dB]	Ant. Gain [dBd]	RSE Level [dBm]
1415.9	V	Y	-60.37	-56.86	4.09	5.39	-55.55
2123.8	H	Y	-61.74	-52.73	5.01	5.14	-52.60
2831.3	H	X	-62.78	-53.82	5.83	7.50	-52.15

Table 6-7. Radiated Spurious Data (LTE Band 12 – Mid Channel)

– End of this page –



Issue Date:

Operating Frequency : 713.5 MHz  
 Channel : 23155  
 Measured Output Power : 14.55 dBm = 0.029 Watt  
 Modulation Signal : QPSK  
 Band Width : 5 MHz  
 RB Size / Offset : 1/0  
 Distance : 3 meters  
 Limit :  $43 + 10 \log_{10}(W)$  = 27.55 dBc  
 RSE Limit : -13 dBm

Freq. [MHz]	Ant Pol (H/V)	EUT Pol [X/Y/Z]	S/A reading [dBm]	S/G Lev. [dBm]	Tx C/L [dB]	Ant. Gain [dBd]	RSE Level [dBm]
1422.8	H	Z	-59.88	-56.08	4.11	5.40	-54.80
2134.0	V	Z	-58.90	-50.49	5.03	5.38	-50.14
2845.4	H	Y	-61.33	-52.42	5.85	7.67	-50.61

Table 6-8. Radiated Spurious Data (LTE Band 12 – High Channel)

Operating Frequency : 1720.0 MHz  
 Channel : 20050  
 Measured Output Power : 20.08 dBm = 0.102 Watt  
 Modulation Signal : QPSK  
 Band Width : 20 MHz  
 RB Size / Offset : 1/50  
 Distance : 3 Meters  
 Limit :  $43 + 10 \log_{10}(W)$  = 33.08 dBc  
 RSE Limit : -13 dBm

Freq. [MHz]	Ant Pol (H/V)	EUT Pol [X/Y/Z]	S/A reading [dBm]	S/G Lev. [dBm]	Tx C/L [dB]	Ant. Gain [dBd]	RSE Level [dBm]
3440.3	H	X	-57.02	-44.85	6.44	9.70	-41.59
5160.4	V	Z	-64.85	-49.43	7.96	11.44	-45.96
6880.3	H	Y	-56.95	-33.10	9.00	9.82	-32.28
8600.9	Noise floor		-67.14	-41.86	10.30	11.02	-41.14

Table 6-9. Radiated Spurious Data (LTE Band 4 – Low Channel)



Issue Date:

Operating Frequency : 1732.5 MHz  
 Channel : 20175  
 Measured Output Power : 21.43 dBm = 0.139 Watt  
 Modulation Signal : QPSK  
 Band Width : 3 MHz  
 RB Size / Offset : 1/14  
 Distance : 3 meters  
 Limit :  $43 + 10 \log_{10}(W)$  = 34.43 dBc  
 RSE Limit : -13 dBm

Freq. [MHz]	Ant Pol (H/V)	EUT Pol [X/Y/Z]	S/A reading [dBm]	S/G Lev. [dBm]	Tx C/L [dB]	Ant. Gain [dBd]	RSE Level [dBm]
3467.4	H	Z	-59.30	-47.12	6.47	9.76	-43.82
5201.3	V	Z	-60.64	-44.92	7.99	11.57	-41.34
6935.2	H	Y	-56.83	-32.66	9.04	9.74	-31.96

Table 6-10. Radiated Spurious Data (LTE Band 4 – Mid Channel)

Operating Frequency : 1750.0 MHz  
 Channel : 20350  
 Measured Output Power : 22.92 dBm = 0.196 Watt  
 Modulation Signal : QPSK  
 Band Width : 10 MHz  
 RB Size / Offset : 1/49  
 Distance : 3 meters  
 Limit :  $43 + 10 \log_{10}(W)$  = 35.92 dBc  
 RSE Limit : -13 dBm

Freq. [MHz]	Ant Pol (H/V)	EUT Pol [X/Y/Z]	S/A reading [dBm]	S/G Lev. [dBm]	Tx C/L [dB]	Ant. Gain [dBd]	RSE Level [dBm]
3508.7	H	Y	-61.14	-48.95	6.50	9.85	-45.60
5262.9	H	Y	-61.78	-45.33	8.06	11.62	-41.76
7017.6	H	Y	-54.43	-29.76	9.10	9.59	-29.27

Table 6-11. Radiated Spurious Data (LTE Band 4 – High Channel)

– End of this page –



## 7. CONCLUSION

The data collected relate only the item(s) tested and show that the Samsung Portable Tablet FCC ID: A3LSMT677A compliance with all the requirements of Parts 2, 27 of the FCC rules.

– End of this report –