



CERTIFICATION TEST REPORT

Report Number. : 4790430333-E7V1

Applicant : SAMSUNG ELECTRONICS CO., LTD.
129 SAMSUNG-RO, YEONGTONG-GU, SUWON-SI,
GYEONGGI-DO, 16677, KOREA

Model : SM-T638U

FCC ID : A3LSMT638U

IC : 649E-SMT638U

EUT Description : WCDMA/LTE/5G NR Tablet + BT/BLE, DTS/UNII a/b/g/n/ac/ax
and NFC

Test Standard(s) : FCC 47 CFR PART 15 SUBPART C
INDUSTRY CANADA RSS-210 Issue 10
INDUSTRY CANADA RSS-GEN Issue 5

Date Of Issue:

2022-08-11

Prepared by:

UL Korea, Ltd.

26th floor, 152, Teheran-ro, Gangnam-gu Seoul, 06236, Korea

Suwon Test Site: UL Korea, Ltd. Suwon Laboratory

218 Maeyeong-ro, Yeongtong-gu,
Suwon-si, Gyeonggi-do, 16675, Korea

TEL: (031) 337-9902

FAX: (031) 213-5433



Revision History

<u>Rev.</u>	<u>Issue Date</u>	<u>Revisions</u>	<u>Revised By</u>
V1	2022-08-11	Initial issue	Dexter(Hyunsik) Yun

TABLE OF CONTENTS

1. ATTESTATION OF TEST RESULTS	4
1.1. INTRODUCTION OF TEST DATA DEVIATION	5
1.2. DIFFERENCE	5
1.3. SPOT CHECK VERIFICATION DATA.....	5
1.4. REFERENCE DETAIL.....	5
2. TEST METHODOLOGY	6
3. FACILITIES AND ACCREDITATION	6
4. CALIBRATION AND UNCERTAINTY	7
4.1. MEASURING INSTRUMENT CALIBRATION.....	7
4.2. SAMPLE CALCULATION.....	7
4.3. MEASUREMENT UNCERTAINTY	7
4.4. DECISION RULE	7
5. EQUIPMENT UNDER TEST	8
5.1. DESCRIPTION OF EUT.....	8
5.2. MAXIMUM E-FIELD STRENGTH.....	8
5.3. WORST-CASE CONFIGURATION AND MODE	8
5.4. DESCRIPTION OF TEST SETUP	9
6. TEST AND MEASUREMENT EQUIPMENT	11
7. 20dB BANDWIDTH & 99% BANDWIDTH	12
8. RADIATED EMISSION TEST RESULTS	13
8.1. LIMITS AND PROCEDURE	13
8.1.1. FUNDAMENTAL AND SPURIOUS EMISSIONS (0.15 – 30 MHz)	15
8.1.2. SPURIOUS EMISSION 0.009 TO 30 MHz.....	16
8.1.3. TX SPURIOUS EMISSION 30 TO 1000 MHz	17
8.1.4. FUNDAMENTAL AND SPURIOUS EMISSIONS (0.15 – 30 MHz) [EUT with passive TAG mode]	18
8.1.5. SPURIOUS EMISSION 0.09 TO 30 MHz [EUT with passive TAG mode].....	19
8.1.6. TX SPURIOUS EMISSION 30 TO 1000 MHz [EUT with passive TAG mode]	20
9. AC MAINS LINE CONDUCTED EMISSIONS	21
9.1.1. AC Power Line (C to C)	22
9.1.2. AC Power Line (A to C).....	26
10. FREQUENCY STABILITY	30
11. SPOT-CHECK TEST RESULT	31

1. ATTESTATION OF TEST RESULTS

COMPANY NAME: SAMSUNG ELECTRONICS CO., LTD.

EUT DESCRIPTION: WCDMA/LTE/5G NR Tablet + BT/BLE, DTS/UNII a/b/g/n/ac/ax and NFC

MODEL NUMBER: SM-T638U

SERIAL NUMBER: R32T5002ZQH, R32T5004ZEX (RADIATED, Original);
R32T6001FZK, R32T6000DEB (RADIATED, Spot-check);

DATE TESTED: 2022-06-06 ~ 2022-07-26(Original);
2022-07-06 ~ 2022-08-05 (Spot-check);

APPLICABLE STANDARDS	
STANDARD	TEST RESULTS
CFR 47 Part 15 Subpart C	Complies
INDUSTRY CANADA RSS-210 Issue 10	Complies
INDUSTRY CANADA RSS-GEN Issue 5	Complies

UL Korea, Ltd. tested the above equipment in accordance with the requirements set forth in the above standards. All indications of Pass/Fail in this report are opinions expressed by UL Korea, Ltd. based on interpretations and/or observations of test results. Measurement Uncertainties were not taken into account and are published for informational purposes only. The test results show that the equipment tested is capable of demonstrating compliance with the requirements as documented in this report.

Note: The results documented in this report apply only to the tested sample, under the conditions and modes of operation as described herein. This document may not be altered or revised in any way unless done so by UL Korea, Ltd. and all revisions are duly noted in the revisions section. Any alteration of this document not carried out by UL Korea, Ltd. will constitute fraud and shall nullify the document. This report must not be used by the client to claim product certification, approval, or endorsement by IAS, any agency of the Federal Government, or any agency of any government.

Approved & Released For
UL Korea, Ltd. By:



Seokhwan Hong
Suwon Lab Engineer
UL Korea, Ltd.

Tested By:



Dexter(Hyunsik) Yun
Suwon Lab Engineer
UL Korea, Ltd.

1.1. INTRODUCTION OF TEST DATA DEVIATION

This report referenced from the FCC ID: A3LSMT636B DXX NFC(FCC CFR 47 Part 15C). And the applicant takes full responsibility that the test data as referenced in this report represent compliance for this FCC ID.

1.2. DIFFERENCE

The SM-T638U (IC: 649E-SMT638U) model shares the same enclosure and circuit board as SM-T636B. The NFC antennas and surrounding circuitry and layout are identical between these two units.

After confirming through preliminary radiated emissions that the performance of the SM-T638U (IC: 649E-SMT638U) remains representative of SM-T636B. The test data of SM-T636B being submitted for this application to cover NFC features.

1.3. SPOT CHECK VERIFICATION DATA

(Worst case of the radiated Fundamental and radiated spurious emissions)

Band	Test Item	Mode	Frequency	Test Limit	Original model	Spot check model	Deviation	Remark
					SM-T636B Results	SM-T638U Results		
					FCC ID : A3LSMT636B	FCC ID : A3LSMT638U		
NFC	NFC Fund	NFC_FUND_Y_Position	13.56 MHz	84.00 dBuV/m	23.10 dBuV/m	24.31 dBuV/m	1.21 dB	
	NFC RSE	NFC_RSE_Z_Position	11.26 MHz	29.50 dBuV/m	11.69 dBuV/m	11.24 dBuV/m	-0.45 dB	

Comparison of two models, upper deviation is within 3 dB range and all test results are under FCC Technical Limits.

1.4. REFERENCE DETAIL

Reference application that contains the reused reference data in the individual test reports:

Equipment Class	Reference FCC ID (Parent)	Application Type	Reference Test report number	Exhibit Type	Spot-Check Test Report Number
DTS	A3LSMT636B	Original Grant	4790406759-E3 (802.11b/g/n/ax)	Test Report	4790430333-E3 (802.11b/g/n/ax)
DTS	A3LSMT636B	Original Grant	4790406759-E4 (BLE)	Test Report	4790430333-E4 (BLE)
DSS	A3LSMT636B	Original Grant	4790406759-E5 (Bluetooth)	Test Report	4790430333-E5 (Bluetooth)
NII	A3LSMT636B	Original Grant	4790406759-E6 (802.11a/n/ac/ax)	Test Report	4790430333-E6 (802.11a/n/ac/ax)
DXX	A3LSMT636B	Original Grant	4790406759-E7 (NFC)	Test Report	4790430333-E7 (NFC)

2. TEST METHODOLOGY

The tests documented in this report were performed in accordance with following methods.

1. FCC CFR 47 Part 2.
2. FCC CFR 47 Part 15.
3. ANSI C63.10-2013.
4. KDB 414788 D01 Radiated Test Site v01r01
5. IC RSS-GEN Issue 5.
6. IC RSS-210 Issue 10.
7. KDB 484596 D01 Referencing Test Data v01

3. FACILITIES AND ACCREDITATION

The test sites and measurement facilities used to collect data are located at 218 Maeyeong-ro, Yeongtong-gu, Suwon-si, Gyeonggi-do, 16675, Korea. Line conducted emissions are measured only at the 218 address. The following table identifies which facilities were utilized for radiated emission measurements documented in this report. Specific facilities are also identified in the test results sections.

218 Maeyeong-ro	
<input checked="" type="checkbox"/>	Chamber 1(3m semi-anechoic chamber)
<input checked="" type="checkbox"/>	Chamber 2(3m semi-anechoic chamber)
<input type="checkbox"/>	Chamber 3(3m semi-anechoic chamber)
<input type="checkbox"/>	Chamber 4(3m Full-anechoic chamber)
<input type="checkbox"/>	Chamber 5(3m Full-anechoic chamber)

UL Korea, Ltd. is accredited by IAS, Laboratory Code TL-637. The full scope of accreditation can be viewed at <https://www.iasonline.org/wp-content/uploads/2017/05/TL-637-cert-New.pdf>.

Used ISED Test Site Reg.(company number) : 2324L
CAB Identifier: KR0161

4. CALIBRATION AND UNCERTAINTY

4.1. MEASURING INSTRUMENT CALIBRATION

The measuring equipment utilized to perform the tests documented in this report has been calibrated in accordance with the manufacturer's recommendations, and is traceable to recognized national standards.

4.2. SAMPLE CALCULATION

Where relevant, the following sample calculation is provided:

$$\begin{aligned} \text{Field Strength (dBuV/m)} &= \text{Measured Voltage (dBuV)} + \text{Antenna Factor (dB/m)} + \\ &\text{Cable Loss (dB)} - \text{Preamp Gain (dB)} \\ 36.5 \text{ dBuV} + 18.7 \text{ dB/m} + 0.6 \text{ dB} - 26.9 \text{ dB} &= 28.9 \text{ dBuV/m} \end{aligned}$$

4.3. MEASUREMENT UNCERTAINTY

Where relevant, the following measurement uncertainty levels have been estimated for tests performed on the apparatus:

PARAMETER	UNCERTAINTY
Conducted Disturbance, 0.15 to 30 MHz	3.02 dB
Radiated Disturbance, 9 kHz to 30 MHz	1.72 dB
Radiated Disturbance, 30 MHz to 1 GHz	4.05 dB

Uncertainty figures are valid to a confidence level of 95%.

4.4. DECISION RULE

Decision rule for statement(s) of conformity is based on Procedure 2, Clause 4.4.3 in IEC Guide 115:2021.

5. EQUIPMENT UNDER TEST

5.1. DESCRIPTION OF EUT

The EUT is a WCDMA/LTE/5G NR Phone + BT/BLE, DTS/UNII a/b/g/n/ac/ax and NFC.
This test report addresses the DXX (NFC) operational mode.

5.2. MAXIMUM E-FIELD STRENGTH

The testing was performed at 3 meter. The transmitter maximum E-field at 30m distance is 23.10 dBuV/m which convert from 3 meter data.

5.3. WORST-CASE CONFIGURATION AND MODE

The NFC function was tested at its' fundamental and only operational frequency of 13.56 MHz.

The NFC with tag mode's fundamental of the EUT was investigated in three orthogonal orientations X, Y and Z. It was determined that the Y orientation was the worst-case orientation; therefore all final radiated testing was performed with the EUT in the Y orientation while generating continuous emissions.

The NFC without tag mode's fundamental of the EUT was investigated in three orthogonal orientations X, Y and Z. It was determined that the Y orientation was the worst-case orientation; therefore all final radiated testing was performed with the EUT in the Y orientation while generating continuous emissions.

The fundamental level of the EUT was investigated each type and bitrate.
All test was performed worst case condition(type A and bit rate 106 kbps).

Radiated(fundamental level and spurious emissions) tests were performed both without reading a passive tag condition[test mode] and with reading a passive tag condition.

5.4. DESCRIPTION OF TEST SETUP

SUPPORT EQUIPMENT

Support Equipment List				
Description	Manufacturer	Model	Serial Number	FCC ID
Charger	SAMSUNG	EP-TA200	R37N6K421B2SE3	N/A
Data Cable	SAMSUNG	EP-DT725BWE	GH39-02020A	N/A
Charger	SAMSUNG	EP-TA800	R37N3MAH988DK3	N/A
Data Cable	SAMSUNG	EP-DN980	GH39-02115A	N/A
Earphone	SAMSUNG	GH59-15055A	EHS64AVFWE	N/A

I/O CABLE

I/O Cable List						
Cable No.	Port	# of identical ports	Connector Type	Cable Type	Cable Length (m)	Remarks
1	DC Power	1	A to C Type	Shielded	1.0 m	N/A
2	DC Power	1	C to C Type	Shielded	1.0 m	N/A
3	Audio	2	Mini-Jack	Unshielded	0.7 m	N/A

The EUT is a stand-alone device configured and tested in a worst-case setup.

Note: Worst case is using worst case orientation with AC charger attached to the EUT with NFC signal continuously transmitting.

SETUP DIAGRAM FOR TESTS (RADIATED TEST SETUP)

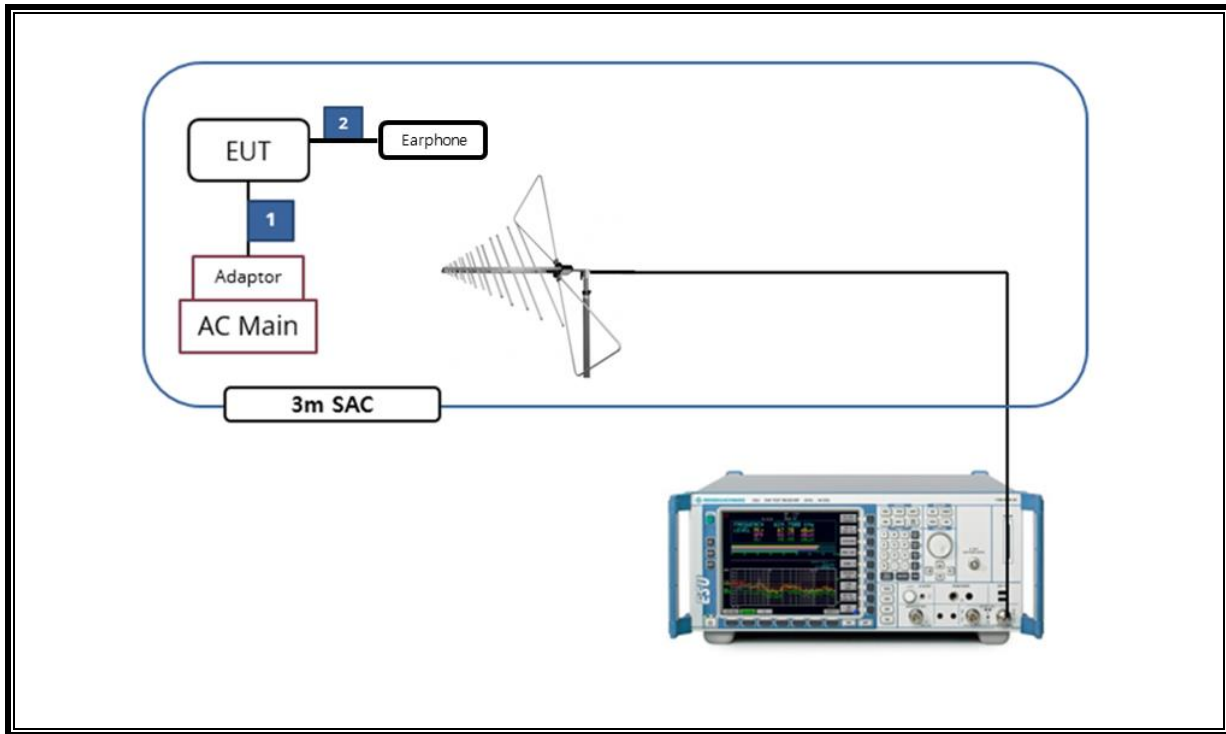

6. TEST AND MEASUREMENT EQUIPMENT

The following test and measurement equipment was utilized for the tests documented in this report:

Test Equipment List				
Description	Manufacturer	Model	S/N	Cal Due
Antenna, Bilog, 30MHz-1GHz	SCHWARZBECK	VULB9163	845	2022-08-13
Antenna, Bilog, 30MHz-1GHz	SCHWARZBECK	VULB9163	749	2022-08-13
Preamplifier, 1000 MHz	Sonoma	310N	341282	2022-08-02
Preamplifier, 1000 MHz	Sonoma	310N	351741	2022-08-02
Spectrum Analyzer, 7 GHz	Agilent / HP	N9010A	MY54200580	2022-08-02
EMI Test Receive, 3 GHz	R&S	ESR3	101832	2022-08-02
DC Power Supply	Agilent / HP	E3640A	MY54226395	2022-08-02
Temperature Chamber	ESPEC	SH-642	93001109	2022-08-02
LISN	R&S	ENV216	101837	2022-08-05
Antenna, Loop, 9kHz-30MHz	R&S	HFH2-Z2	100418	2023-10-06
UL Software				
Description	Manufacturer	Model	Version	
Radiated software	UL	UL EMC	Ver 9.5	
AC Line Conducted software	UL	UL EMC	Ver 9.5	

7. 20dB BANDWIDTH & 99% BANDWIDTH

LIMITS

§15.215

(c) Intentional radiators operating under the alternative provisions to the general emission limits, as contained in §§15.217 through 15.257 and in subpart E of this part, must be designed to ensure that the 20 dB bandwidth of the emission, or whatever bandwidth may otherwise be specified in the specific rule section under which the equipment operates, is contained within the frequency band designated in the rule section under which the equipment is operated

§15.225

Operation within the band 13.110 – 14.010MHz

TEST PROCEDURE

The spectrum analyzer connected receive antenna and the EUT placed on near the receive antenna. The RBW is set to 10kHz. The VBW is set to 3 times the RBW. The sweep time is coupled.

RESULTS

Frequency [MHz]	20 dB Bandwidth [kHz]	99 % BANDWIDTH [kHz]
13.56	437.00	621.77

20dB Bandwidth & 99% Bandwidth Plot

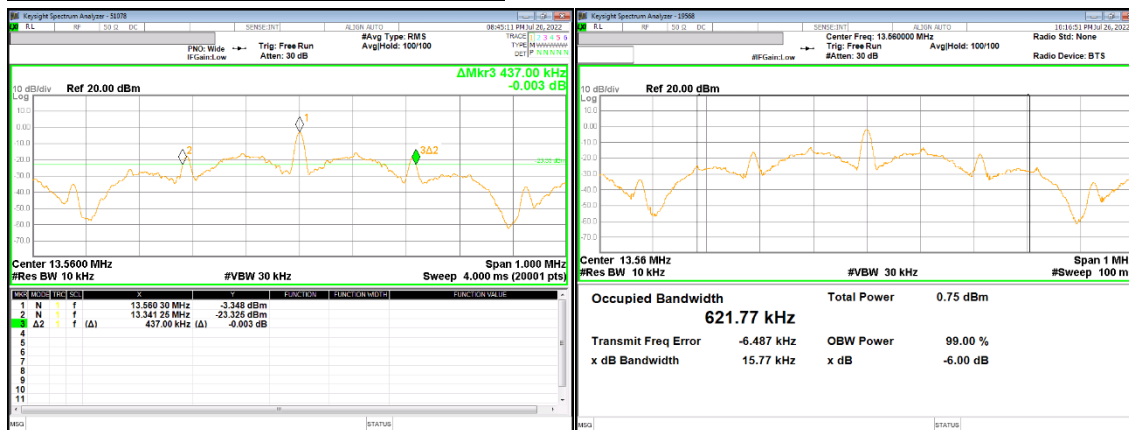

8. RADIATED EMISSION TEST RESULTS

8.1. LIMITS AND PROCEDURE

LIMIT

§15.225
 RSS-210 Issue 10

(a) The field strength of any emissions within the band 13.553–13.567 MHz shall not exceed 15,848 microvolts/ meter at 30 meters.

(b) Within the bands 13.410–13.553 MHz and 13.567–13.710 MHz, the field strength of any emissions shall not exceed 334 microvolts/meter at 30 meters.

(c) Within the bands 13.110–13.410 MHz and 13.710–14.010 MHz the field strength of any emissions shall not exceed 106 microvolts/meter at 30 meters.

(d) The field strength of any emissions appearing outside of the 13.110– 14.010 MHz and shall not exceed the general radiated emission limits in § 15.209 as follows:

§15.209 (a) Except as provided elsewhere in this subpart, the emissions from an intentional radiator shall not exceed the field strength levels specified in the following table:

Limits for radiated disturbance of an intentional radiator		
Frequency range (MHz)	Limits (µV/m)	Measurement Distance (m)
0.009 – 0.490	2400 / F (kHz)	300
0.490 – 1.705	24000 / F (kHz)	30
1.705 – 30.0	30	30
30 – 88	100**	3
88 - 216	150**	3
216 – 960	200**	3
Above 960	500	3

** Except as provided in paragraph (g), fundamental emissions from intentional radiators operating under this section shall not be located in the frequency bands 54-72 MHz, 76-88 MHz, 174-216 MHz or 470-806 MHz. However, operation within these frequency bands is permitted under other sections of this part, e.g. §§ 15.231 and 15.241.

§15.209 (b) In the emission table above, the tighter limit applies at the band edges.

Formula for converting the filed strength from uV/m to dBuV/m is:

Limit (dBuV/m) = 20 log limit (uV/m)

In addition:

§15.209 (d) The emission limits shown the above table are based on measurements employing a CISPR quasi-peak detector except for the frequency bands 9-90 kHz, 110-490 kHz and above 1000 MHz. Radiated emissions limits in these three bands are based on measurements employing an average detector.

§15.209 (d) The provisions in §§ 15.225, measuring emissions at distances other than the distances specified in the above table, determining the frequency range over which radiated emissions are to be measured, and limiting peak emissions apply to all devices operated under this part.

TEST PROCEDURE

ANSI C63.10-2013

The EUT is an intentional radiator that incorporates a digital device. The highest fundamental frequency generated or used in the device is 13.56 MHz. The frequency range was investigated from 0.15 MHz to the 10th harmonic of the highest fundamental frequency, or 1000 MHz, whichever is greater (1000MHz)

RESULTS

No non-compliance noted:

8.1.1. FUNDAMENTAL AND SPURIOUS EMISSIONS (0.15 – 30 MHz) [EUT without passive TAG mode]

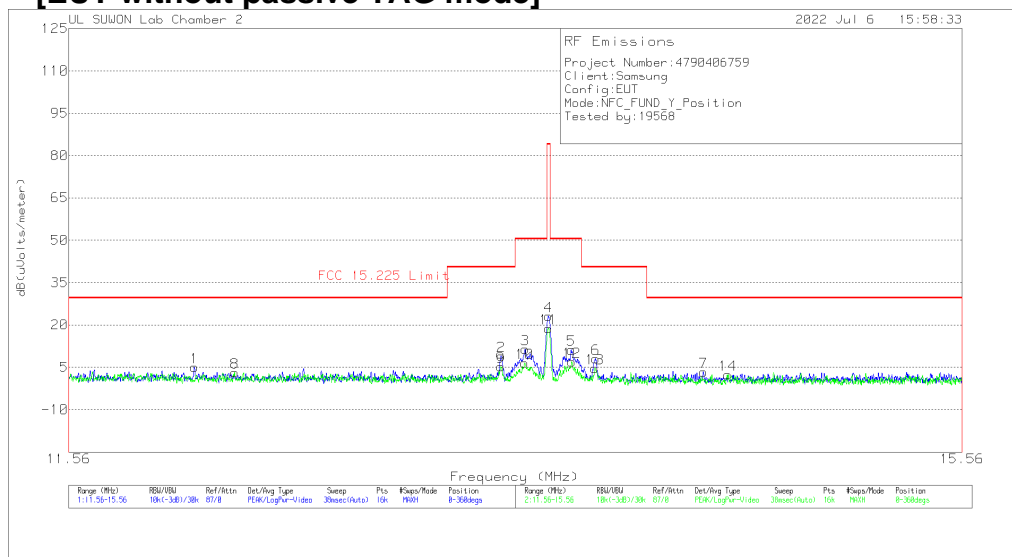

Trace Markers Face on

Marker	Frequency (MHz)	Meter Reading (dBuV)	Det	HFH2-Z2_Loop Antenna	Dist Corr 30m	Cable Loss	Corrected Reading dB(uVolts/meter)	FCC 15.225 Limit	Margin (dB)	Azimuth (Degs)
1	12.05325	24.53	Pk	20	-40	.5	5.03	29.54	-24.51	0-360
2	13.34838	28.58	Pk	20	-40	.5	9.08	40.51	-31.43	0-360
3	13.45513	30.97	Pk	20	-40	.5	11.47	50.5	-39.03	0-360
**4	13.55988	42.6	Pk	20	-40	.5	23.1	84	-60.9	0-360
5	13.66288	30.58	Pk	20	-40	.6	11.18	50.5	-39.32	0-360
6	13.77488	27.41	Pk	20	-40	.6	8.01	40.51	-32.5	0-360
7	14.27663	22.84	Pk	20	-40	.6	3.44	29.54	-26.1	0-360

Face off

Marker	Frequency (MHz)	Meter Reading (dBuV)	Det	HFH2-Z2_Loop Antenna	Dist Corr 30m	Cable Loss	Corrected Reading dB(uVolts/meter)	FCC 15.225 Limit	Margin (dB)	Azimuth (Degs)
8	12.21575	22.6	Pk	20	-40	.5	3.1	29.54	-26.44	0-360
9	13.34663	24.68	Pk	20	-40	.5	5.18	40.51	-35.33	0-360
10	13.45338	25.98	Pk	20	-40	.5	6.48	50.5	-44.02	0-360
**11	13.56025	38.39	Pk	20	-40	.5	18.89	84	-65.11	0-360
12	13.66563	26.34	Pk	20	-40	.6	6.94	50.5	-43.56	0-360
13	13.77138	24.09	Pk	20	-40	.6	4.69	40.51	-35.82	0-360
14	14.39538	21.84	Pk	20	-40	.6	2.44	29.54	-27.1	0-360

Pk - Peak detector
 **Fundamental

Note 1 : Although these tests were performed other than open filed test site, adequate comparison measurements were confirmed against 30 m open are test site.

Therefore sufficient tests were made to demonstrate that the alternative site produces results that correlate with the ones of tests made in an open field based on KDB 414788.

Note 2: Radiated test were investigated with three receiving antenna axes: Face-on, Face-off and horizontal (parallel to the ground plane) and the worse orientations of Face-on and Face-off were set for final test.

8.1.2. SPURIOUS EMISSION 0.009 TO 30 MHz

[EUT without passive TAG mode]

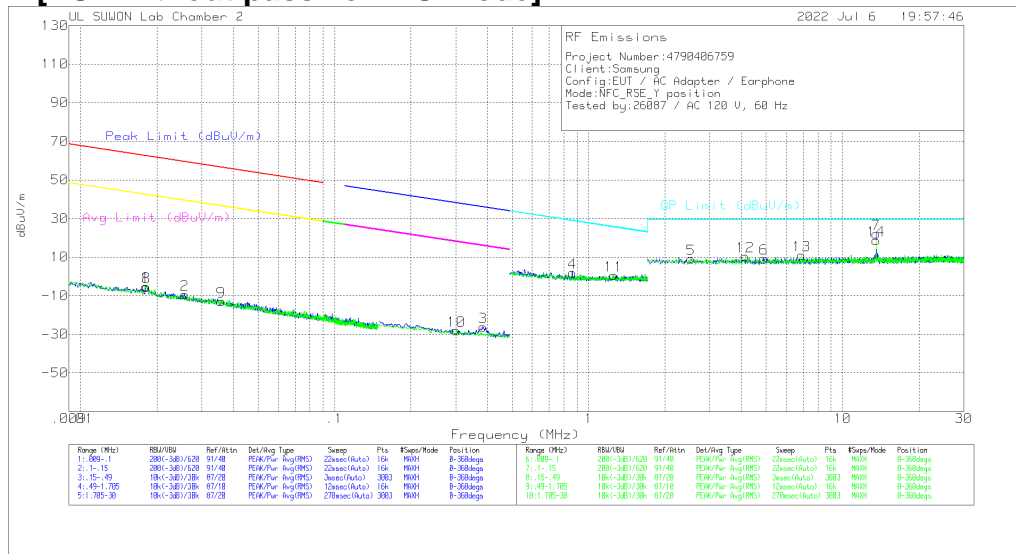

Trace Markers

Face on

Marker	Frequency (MHz)	Meter Reading (dBuV)	Det	HFH2-Z2_Loop Antenna	Cable Loss	Dist Corr 300m	Corrected Reading dBuV/m	Peak Limit (dBuV/m)	Margin (dB)	Avg Limit (dBuV/m)	Margin (dB)	Azimuth (Degs)
1	.01813	54.6	Pk	20.2	.1	-80	-5.1	62.42	-67.52	42.42	-47.52	0-360
2	.02567	50.45	Pk	20.1	.1	-80	-9.35	59.39	-68.74	39.39	-48.74	0-360
3	.38448	33.96	Pk	19.7	.1	-80	-26.24	35.91	-62.15	15.91	-42.15	0-360

Marker	Frequency (MHz)	Meter Reading (dBuV)	Det	HFH2-Z2_Loop Antenna	Cable Loss	Dist Corr 30m	Corrected Reading dBuV/m	QP Limit (dBuV/m)	Margin (dB)	Azimuth (Degs)
4	.86316	22.04	Pk	19.8	.2	-40	2.04	28.9	-26.86	0-360
5	2.5344	28.92	Pk	19.9	.3	-40	9.12	29.5	-20.38	0-360
6	4.90008	29.14	Pk	19.8	.3	-40	9.24	29.5	-20.26	0-360
**7	13.56165	41.53	Pk	20	.5	-40	22.03	29.5	-7.47	0-360

Face off

Marker	Frequency (MHz)	Meter Reading (dBuV)	Det	HFH2-Z2_Loop Antenna	Cable Loss	Dist Corr 300m	Corrected Reading dBuV/m	Peak Limit (dBuV/m)	Margin (dB)	Avg Limit (dBuV/m)	Margin (dB)	Azimuth (Degs)
8	.01814	54.32	Pk	20.2	.1	-80	-5.38	62.41	-67.79	42.41	-47.79	0-360
9	.03579	46.94	Pk	20	.1	-80	-12.96	56.51	-69.47	36.51	-49.47	0-360
10	.30244	32.18	Pk	19.7	.1	-80	-28.02	38	-66.02	18	-46.02	0-360

Marker	Frequency (MHz)	Meter Reading (dBuV)	Det	HFH2-Z2_Loop Antenna	Cable Loss	Dist Corr 30m	Corrected Reading dBuV/m	QP Limit (dBuV/m)	Margin (dB)	Azimuth (Degs)
11	1.25502	20.67	Pk	19.8	.2	-40	.67	25.65	-24.98	0-360
12	4.14608	30.35	Pk	19.8	.3	-40	10.45	29.5	-19.05	0-360
13	6.89818	30.83	Pk	19.9	.4	-40	11.13	29.5	-18.37	0-360
**14	13.56165	38.31	Pk	20	.5	-40	18.81	29.5	-10.69	0-360

Pk - Peak detector

**Fundamental

Note 1: The data for marker number 7 and 14 are the fundamental signal.

Please refer to section 8.1.1 about the fundamental level.

Frequency range 0.009MHz ~ 0.490MHz, only noise floor level and more than 20dB margin.

Note 2: Radiated test were investigated with three receiving antenna axes: Face-on, Face-off and horizontal (parallel to the ground plane) and the worse orientations of Face-on and Face-off were set for final test.

8.1.3. TX SPURIOUS EMISSION 30 TO 1000 MHz [EUT without passive TAG mode]

HORIZONTAL

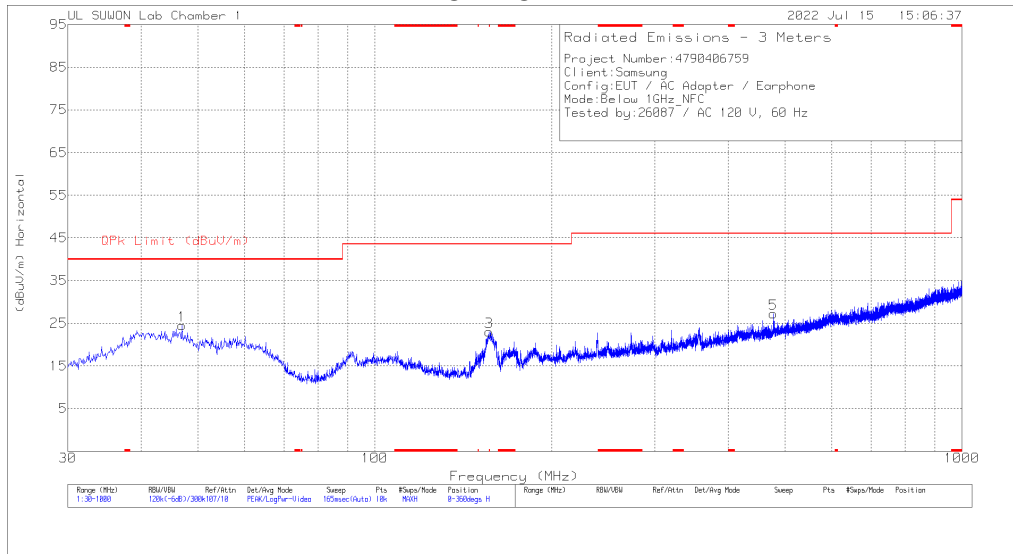

VERTICAL

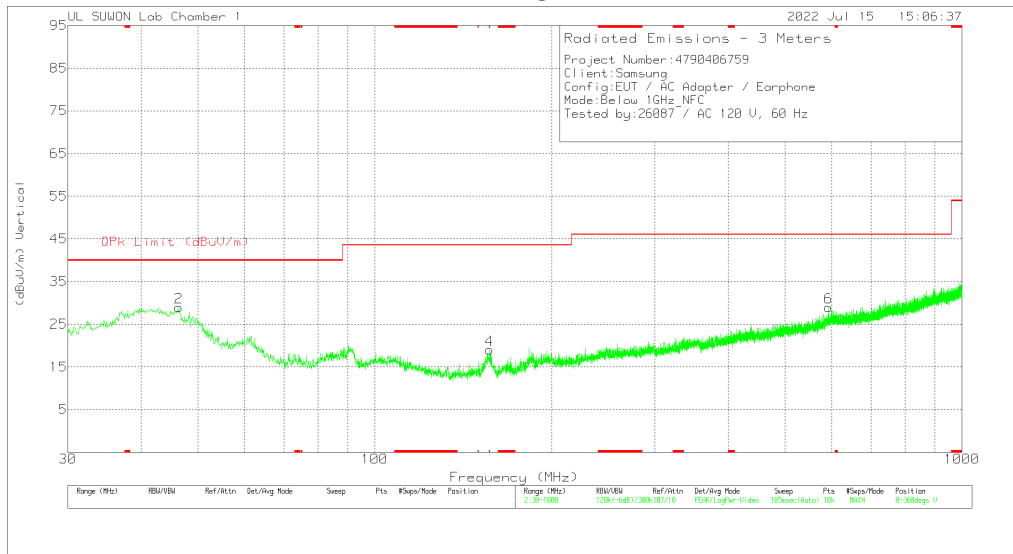

Trace Markers

Marker	Frequency (MHz)	Meter Reading (dBuV)	Det	VULB9163_750	Below_1G[dB]	Corrected Reading (dBuV/m)	QPk Limit (dBuV/m)	Margin (dB)	Azimuth (Degs)	Height (cm)	Polarity
1	46.975	35.44	Pk	19.9	-30.9	24.44	40	-15.56	0-360	300	H
3	156.488	38.58	Pk	14.1	-29.7	22.98	43.52	-20.54	0-360	100	H
5	477.073	32.28	Pk	22.6	-27.7	27.18	46.02	-18.84	0-360	100	H
2	46.393	40.12	Pk	19.9	-31	29.02	40	-10.98	0-360	200	V
4	* 156.876	34.38	Pk	14.2	-29.6	18.98	43.52	-24.54	0-360	200	V
6	592.988	31.05	Pk	25.2	-27.3	28.95	46.02	-17.07	0-360	300	V

* - indicates frequency in CFR47 Pt 15 / IC RSS-Restricted Band
 Pk - Peak detector

8.1.4. FUNDAMENTAL AND SPURIOUS EMISSIONS (0.15 – 30 MHz) [EUT with passive TAG mode]

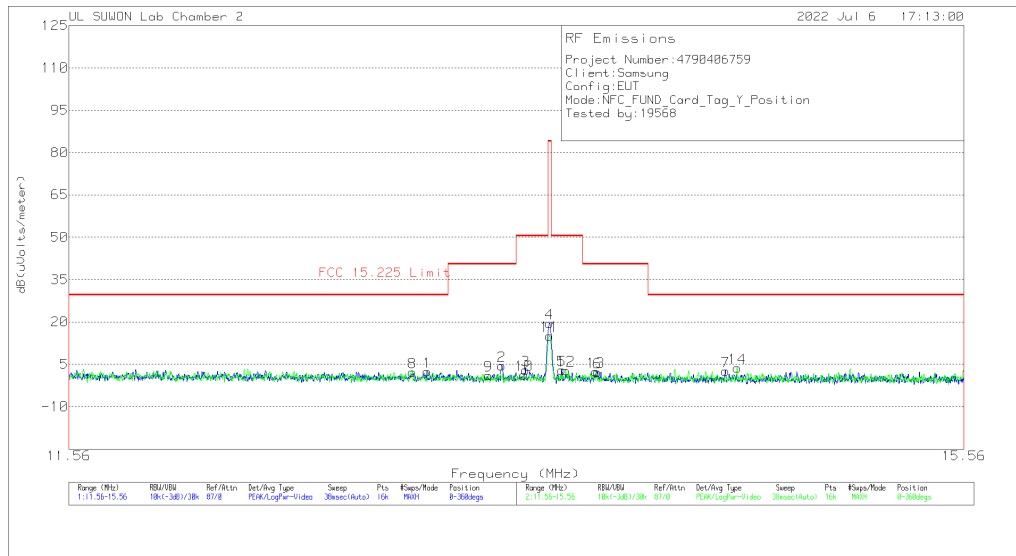

Trace Markers
 Face on

Marker	Frequency (MHz)	Meter Reading (dBuV)	Det	HFH2-Z2_Loop Antenna	Dist Corr 30m	Cable Loss	Corrected Reading dB(uVolts/meter)	FCC 15.225 Limit	Margin (dB)	Azimuth (Degs)
1	13.02125	21.96	Pk	20	-40	.5	2.46	29.54	-27.08	0-360
2	13.3475	23.99	Pk	20	-40	.5	4.49	40.51	-36.02	0-360
3	13.45325	22.55	Pk	20	-40	.5	3.05	50.5	-47.45	0-360
**4	13.5605	39.11	Pk	20	-40	.5	19.61	84	-64.39	0-360
5	13.61575	22.41	Pk	20	-40	.6	3.01	50.5	-47.49	0-360
6	13.77675	21.55	Pk	20	-40	.6	2.15	40.51	-38.36	0-360
7	14.37575	22	Pk	20	-40	.6	2.6	29.54	-26.94	0-360

Face off

Marker	Frequency (MHz)	Meter Reading (dBuV)	Det	HFH2-Z2_Loop Antenna	Dist Corr 30m	Cable Loss	Corrected Reading dB(uVolts/meter)	FCC 15.225 Limit	Margin (dB)	Azimuth (Degs)
8	12.95675	21.7	Pk	20	-40	.5	2.2	29.54	-27.34	0-360
9	13.28875	20.67	Pk	20	-40	.5	1.17	40.51	-39.34	0-360
10	13.44575	20.82	Pk	20	-40	.5	1.32	50.5	-49.18	0-360
**11	13.5605	34.63	Pk	20	-40	.5	15.13	84	-68.87	0-360
12	13.6345	22.28	Pk	20	-40	.6	2.88	50.5	-47.62	0-360
13	13.77	21.9	Pk	20	-40	.6	2.5	40.51	-38.01	0-360
14	14.43225	23.07	Pk	20	-40	.6	3.67	29.54	-25.87	0-360

Pk - Peak detector
 **Fundamental

Note 1: Although these tests were performed other than open filed test site, adequate comparison measurements were confirmed against 30 m open are test site. Therefore sufficient tests were made to demonstrate that the alternative site produces results that correlate with the ones of tests made in an open field based on KDB 414788.

Note 2: Radiated test were investigated with three receiving antenna axes: Face-on, Face-off and horizontal (parallel to the ground plane) and the worse orientations of Face-on and Face-off were set for final test.

8.1.5. SPURIOUS EMISSION 0.09 TO 30 MHz [EUT with passive TAG mode]

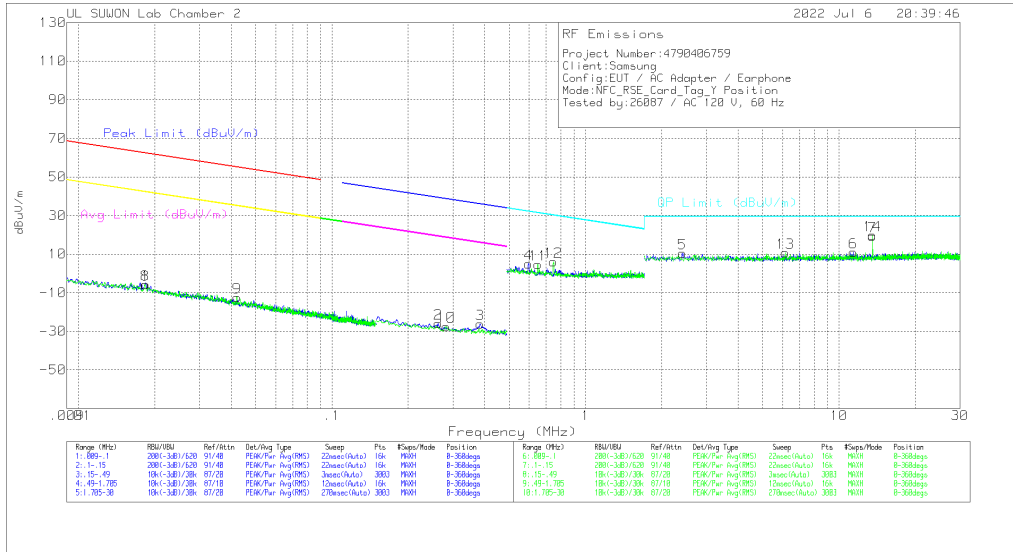

Trace Markers

Face on

Marker	Frequency (MHz)	Meter Reading (dBuV)	Det	HFH2-Z2_Loop Antenna	Cable Loss	Dist Corr 300m	Corrected Reading dBuV/m	Peak Limit (dBuV/m)	Margin (dB)	Avg Limit (dBuV/m)	Margin (dB)	Azimuth (Degs)
1	.01849	54.01	Pk	20.2	.1	-80	-5.69	62.25	-67.94	42.25	-47.94	0-360
2	.26272	34.23	Pk	19.7	.1	-80	-25.97	39.22	-65.19	19.22	-45.19	0-360
3	.38442	33.98	Pk	19.7	.1	-80	-26.22	35.91	-62.13	15.91	-42.13	0-360

Marker	Frequency (MHz)	Meter Reading (dBuV)	Det	HFH2-Z2_Loop Antenna	Cable Loss	Dist Corr 30m	Corrected Reading dBuV/m	QP Limit (dBuV/m)	Margin (dB)	Azimuth (Degs)
4	.59716	25.24	Pk	19.7	.1	-40	5.04	32.09	-27.05	0-360
5	2.41188	30.32	Pk	19.9	.2	-40	10.42	29.5	-19.08	0-360
6	11.37505	30.51	Pk	20	.5	-40	11.01	29.5	-18.49	0-360
**7	13.56165	38.83	Pk	20	.5	-40	19.33	29.5	-10.17	0-360

Face off

Marker	Frequency (MHz)	Meter Reading (dBuV)	Det	HFH2-Z2_Loop Antenna	Cable Loss	Dist Corr 300m	Corrected Reading dBuV/m	Peak Limit (dBuV/m)	Margin (dB)	Avg Limit (dBuV/m)	Margin (dB)	Azimuth (Degs)
8	.01833	54.02	Pk	20.2	.1	-80	-5.68	62.32	-68	42.32	-48	0-360
9	.04219	47.53	Pk	19.9	.1	-80	-12.47	55.08	-67.55	35.08	-47.55	0-360
10	.28227	32.78	Pk	19.7	.1	-80	-27.42	38.6	-66.02	18.6	-46.02	0-360

Marker	Frequency (MHz)	Meter Reading (dBuV)	Det	HFH2-Z2_Loop Antenna	Cable Loss	Dist Corr 30m	Corrected Reading dBuV/m	QP Limit (dBuV/m)	Margin (dB)	Azimuth (Degs)
11	.64884	24.91	Pk	19.7	.1	-40	4.71	31.37	-26.66	0-360
12	.74806	26.07	Pk	19.7	.2	-40	5.97	30.14	-24.17	0-360
13	6.13475	30.43	Pk	19.8	.4	-40	10.63	29.5	-18.87	0-360
**14	13.56165	39.32	Pk	20	.5	-40	19.82	29.5	-9.68	0-360

Pk - Peak detector

**Fundamental

Note 1: The data for marker number 7 and 14 are the fundamental signal.

Please refer to section 8.1.4 about the fundamental level.

Frequency range 0.009MHz ~ 0.490MHz, only noise floor level and more than 20dB margin.

Note 2: Radiated test were investigated with three receiving antenna axes: Face-on, Face-off and horizontal (parallel to the ground plane) and the worse orientations of Face-on and Face-off were set for final test.

8.1.6. TX SPURIOUS EMISSION 30 TO 1000 MHz [EUT with passive TAG mode]

HORIZONTAL

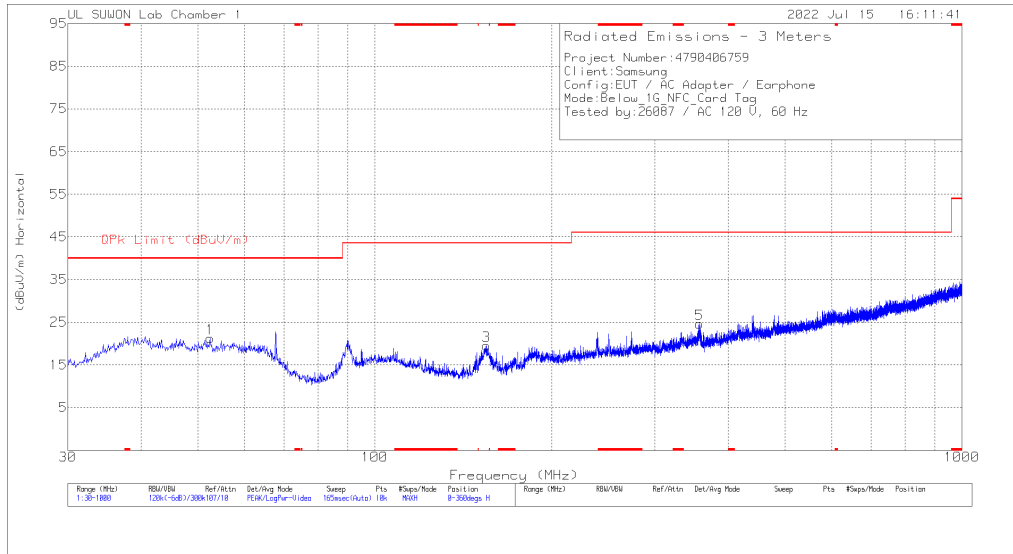

VERTICAL

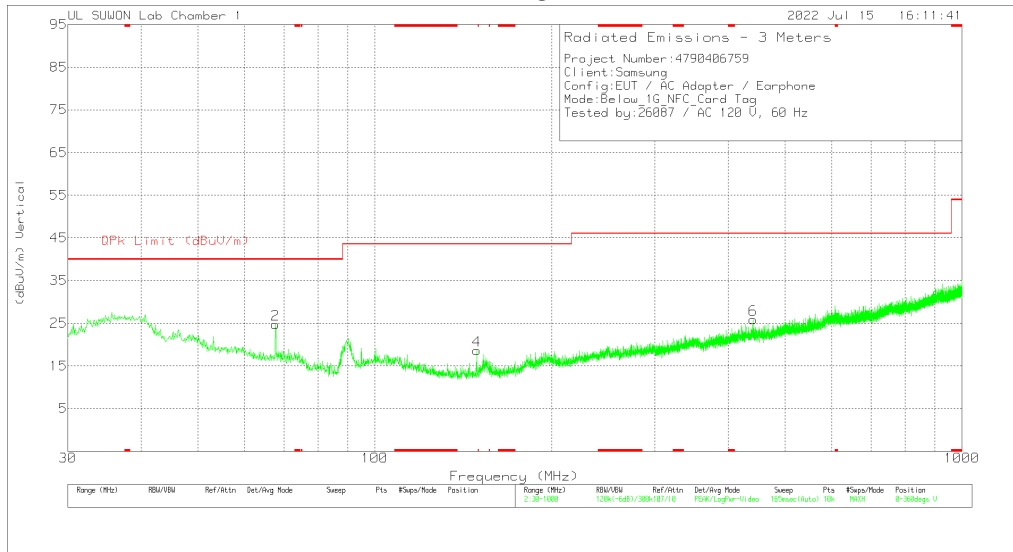

Trace Markers

Marker	Frequency (MHz)	Meter Reading (dBuV)	Det	VULB9163_750	Below_1G[dB]	Corrected Reading (dBuV/m)	QPk Limit (dBuV/m)	Margin (dB)	Azimuth (Degs)	Height (cm)	Polarity
1	52.407	32.48	Pk	19.7	-30.9	21.28	40	-18.72	0-360	200	H
3	154.839	35.13	Pk	14.1	-29.7	19.53	43.52	-23.99	0-360	100	H
5	357.569	32.56	Pk	20.4	-28.3	24.66	46.02	-21.36	0-360	100	H
2	67.733	39.14	Pk	16.3	-30.7	24.74	40	-15.26	0-360	300	V
4	149.116	34.59	Pk	13.9	-29.8	18.69	43.52	-24.83	0-360	200	V
6	440.698	31.71	Pk	22.1	-27.9	25.91	46.02	-20.11	0-360	200	V

Pk - Peak detector

9. AC MAINS LINE CONDUCTED EMISSIONS

LIMITS

§15.207

RSS-Gen 8.8

(a) Except as shown in paragraphs (b) and (c) of this section, for an intentional radiator that is designed to be connected to the public utility (AC) power line, the radio frequency voltage that is conducted back onto the AC power line on any frequency or frequencies, within the band 150 kHz to 30 MHz, shall not exceed the limits in the following table, as measured using a 50 μ H/50 ohms line impedance stabilization network (LISN). Compliance with the provisions of this paragraph shall be based on the measurement of the radio frequency voltage between each power line and ground at the power terminal. The lower limit applies at the band edges.

Frequency range (MHz)	Limits (dB μ V)	
	Quasi-peak	Average
0.15 to 0.50	66 to 56	56 to 46
0.50 to 5	56	46
5 to 30	60	50

Notes:
1. The lower limit shall apply at the transition frequencies
2. The limit decreases linearly with the logarithm of the frequency in the range 0.15 MHz to 0.50 MHz.

TEST PROCEDURE

The EUT is placed on a non-conducting table 40 cm from the vertical ground plane and 80 cm above the horizontal ground plane. The EUT is configured in accordance with ANSI C63.10.

The receiver is set to a resolution bandwidth of 9 kHz. Peak detection is used unless otherwise noted as quasi-peak or average.

Line conducted data is recorded for both NEUTRAL and HOT lines.

RESULTS

No non-compliance noted:

9.1.1. AC Power Line (C to C)

WORST EMISSIONS

LINE 1 PLOT

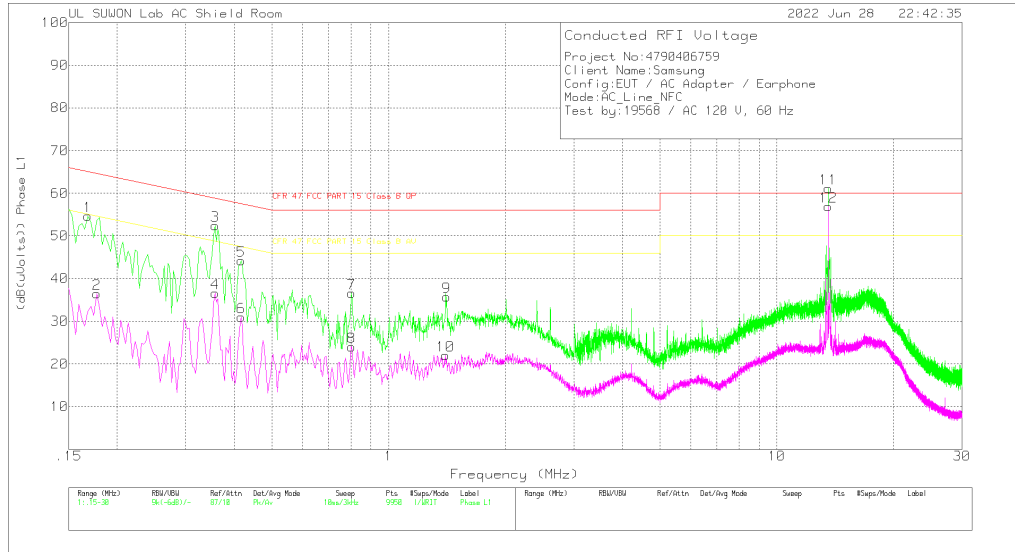

LINE 1 RESULTS

Trace Markers

Range 1: Phase L1 .15 - 30MHz

Marker	Frequency (MHz)	Meter Reading (dBuV)	Det	101836_With EX_L1[dB]	CABLELOS S(dB)	Corrected Reading (dB(uVolts))	CFR 47 FCC PART 15 Class B QP	Margin (dB)	CFR 47 FCC PART 15 Class B AV	Margin (dB)
1	.168	44.61	Pk	10	.1	54.71	65.06	-10.35	-	-
2	.177	26.39	Av	9.9	.2	36.49	-	-	54.63	-18.14
3	.357	42.42	Pk	9.8	.2	52.42	58.8	-6.38	-	-
4	.357	26.56	Av	9.8	.2	36.56	-	-	48.8	-12.24
5	.417	34.19	Pk	9.8	.2	44.19	57.51	-13.32	-	-
6	.417	21.04	Av	9.8	.2	31.04	-	-	47.51	-16.47
7	.804	26.57	Pk	9.8	.2	36.57	56	-19.43	-	-
8	.804	14.04	Av	9.8	.2	24.04	-	-	46	-21.96
9	1.41	25.78	Pk	9.7	.3	35.78	56	-20.22	-	-
10	1.401	11.96	Av	9.7	.3	21.96	-	-	46	-24.04
11	13.56	50.74	Pk	10	.4	61.14	60	1.14	-	-
12	13.56	46.56	Av	10	.4	56.96	-	-	50	6.96

Pk - Peak detector

Av - Average detection

Quasi-Peak Emissions

Range 1: Phase L1 .15 - 30MHz

Frequency (MHz)	Meter Reading (dBuV)	Det	101836_With EX_L1[dB]	CABLELOS S(dB)	Corrected Reading (dB(uVolts))	CFR 47 FCC PART 15 Class B QP	Margin (dB)	CFR 47 FCC PART 15 Class B AV	Margin (dB)
.35775	27.35	Qp	9.8	.2	37.35	58.78	-21.43	-	-
13.5602	51.59	Qp	10	.4	61.99	60	1.99	-	-

Qp - Quasi-Peak detector

LINE 2 PLOT

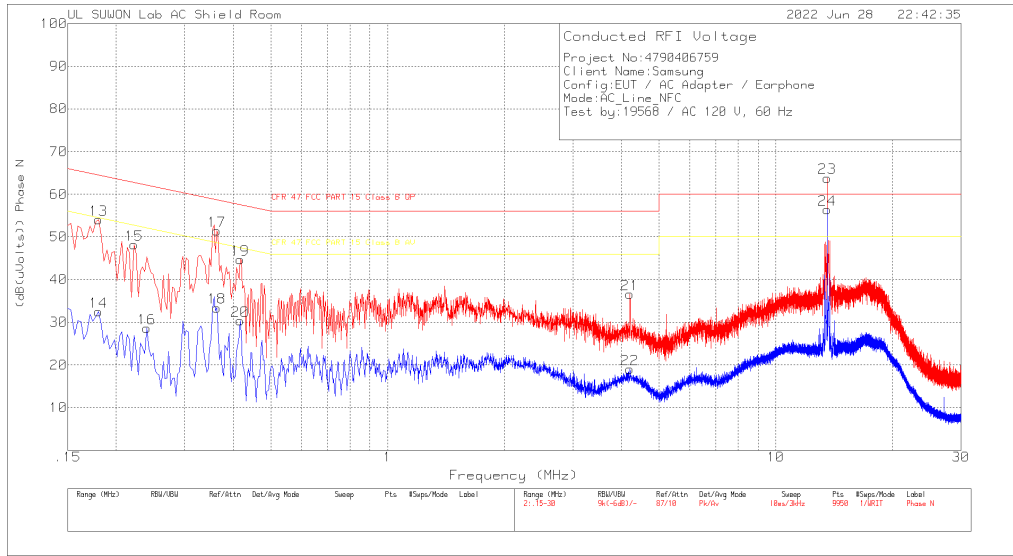

LINE 2 RESULTS

Trace Markers

Range 2: Phase N .15 - 30MHz

Marker	Frequency (MHz)	Meter Reading (dBuV)	Det	101836_With EX_N[dB]	CABLELOSS S(dB)	Corrected Reading (dB(uVolts))	CFR 47 FCC PART 15 Class B QP	Margin (dB)	CFR 47 FCC PART 15 Class B AV	Margin (dB)
13	.18	43.9	Pk	9.9	.2	54	64.49	-10.49	-	-
14	.18	22.34	Av	9.9	.2	32.44	-	-	54.49	-22.05
15	.222	38.27	Pk	9.7	.2	48.17	62.74	-14.57	-	-
16	.24	18.77	Av	9.7	.2	28.67	-	-	52.1	-23.43
17	.363	41.48	Pk	9.8	.2	51.48	58.66	-7.18	-	-
18	.363	23.42	Av	9.8	.2	33.42	-	-	48.66	-15.24
19	.417	34.72	Pk	9.8	.2	44.72	57.51	-12.79	-	-
20	.417	20.38	Av	9.8	.2	30.38	-	-	47.51	-17.13
21	4.212	26.61	Pk	9.7	.3	36.61	56	-19.39	-	-
22	4.212	9.04	Av	9.7	.3	19.04	-	-	46	-26.96
23	13.56	53.43	Pk	10	.4	63.83	60	3.83	-	-
24	13.56	46.07	Av	10	.4	56.47	-	-	50	6.47

Pk - Peak detector

Av - Average detection

Quasi-Peak Emissions

Range 2: Phase N .15 - 30MHz

Frequency (MHz)	Meter Reading (dBuV)	Det	101836_With EX_N[dB]	CABLELOSS (dB)	Corrected Reading (dB(uVolts))	CFR 47 FCC PART 15 Class B QP	Margin (dB)	CFR 47 FCC PART 15 Class B AV	Margin (dB)
.36375	37.44	Qp	9.8	.2	47.44	58.64	-11.2	-	-
13.5602	49.05	Qp	10	.4	59.45	60	-.55	-	-

Qp - Quasi-Peak detector

TERMINATED EMISSIONS

LINE 1 PLOT

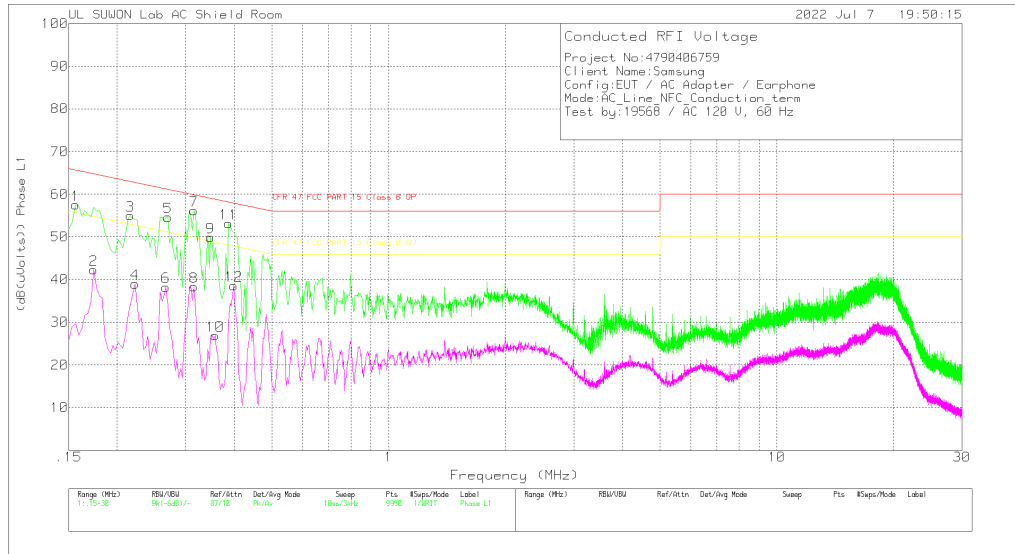

LINE 1 RESULTS

Trace Markers

Range 1: Phase L1 .15 - 30MHz

Marker	Frequency (MHz)	Meter Reading (dBuV)	Det	101836_With EX_L1[dB]	CABLELOS S(dB)	Corrected Reading (dB(uVolts))	CFR 47 FCC PART 15 Class B QP	Margin (dB)	CFR 47 FCC PART 15 Class B AV	Margin (dB)
1	.156	47.67	Pk	9.8	.1	57.57	65.67	-8.1	-	-
2	.174	32.15	Av	10	.2	42.35	-	-	54.77	-12.42
3	.216	45.04	Pk	9.8	.2	55.04	62.97	-7.93	-	-
4	.222	29.13	Av	9.7	.2	39.03	-	-	52.74	-13.71
5	.27	44.81	Pk	9.6	.2	54.61	61.12	-6.51	-	-
6	.267	28.48	Av	9.6	.2	38.28	-	-	51.21	-12.93
7	.315	46.25	Pk	9.7	.2	56.15	59.84	-3.69	-	-
8	.315	28.42	Av	9.7	.2	38.32	-	-	49.84	-11.52
9	.348	39.88	Pk	9.8	.2	49.88	59.01	-9.13	-	-
10	.357	16.83	Av	9.8	.2	26.83	-	-	48.8	-21.97
11	.387	43.16	Pk	9.8	.2	53.16	58.13	-4.97	-	-
12	.399	28.64	Av	9.8	.2	38.64	-	-	47.87	-9.23

Pk - Peak detector

Av - Average detection

Quasi-Peak Emissions

Range 1: Phase L1 .15 - 30MHz

Frequency (MHz)	Meter Reading (dBuV)	Det	101836_With EX_L1[dB]	CABLELOS S(dB)	Corrected Reading (dB(uVolts))	CFR 47 FCC PART 15 Class B QP	Margin (dB)	CFR 47 FCC PART 15 Class B AV	Margin (dB)
.15675	40.33	Qp	9.8	.1	50.23	65.63	-15.4	-	-
.21675	41.58	Qp	9.8	.2	51.58	62.94	-11.36	-	-
.26925	40.13	Qp	9.6	.2	49.93	61.14	-11.21	-	-
.31425	42.32	Qp	9.7	.2	52.22	59.86	-7.64	-	-
.34725	35.22	Qp	9.8	.2	45.22	59.03	-13.81	-	-
.38775	38.98	Qp	9.8	.2	48.98	58.11	-9.13	-	-

Qp - Quasi-Peak detector

LINE 2 PLOT

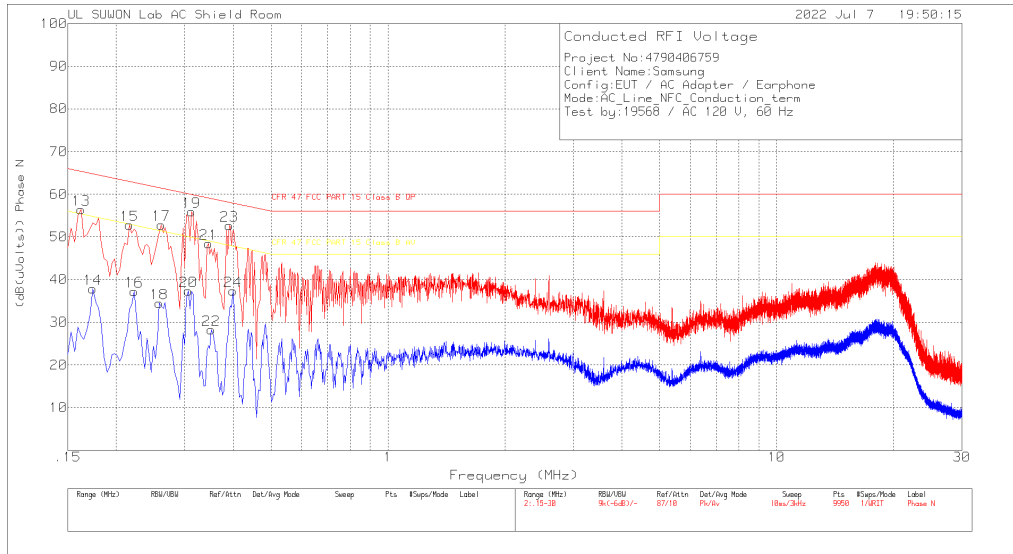

LINE 2 RESULTS

Trace Markers

Range 2: Phase N .15 - 30MHz

Marker	Frequency (MHz)	Meter Reading (dBuV)	Det	101836_With EX_N[dB]	CABLELOS S(dB)	Corrected Reading (dB(uVolts))	CFR 47 FCC PART 15 Class B QP	Margin (dB)	CFR 47 FCC PART 15 Class B AV	Margin (dB)
13	.162	46.46	Pk	9.9	.1	56.46	65.36	-8.9	-	-
14	.174	27.65	Av	10	.2	37.85	-	-	54.77	-16.92
15	.216	42.75	Pk	9.8	.2	52.75	62.97	-10.22	-	-
16	.222	27.38	Av	9.7	.2	37.28	-	-	52.74	-15.46
17	.261	43.06	Pk	9.6	.2	52.86	61.4	-8.54	-	-
18	.258	24.66	Av	9.6	.2	34.46	-	-	51.5	-17.04
19	.312	45.98	Pk	9.7	.2	55.88	59.92	-4.04	-	-
20	.306	27.5	Av	9.7	.2	37.4	-	-	50.08	-12.68
21	.345	38.38	Pk	9.8	.2	48.38	59.08	-10.7	-	-
22	.351	18.21	Av	9.8	.2	28.21	-	-	48.94	-20.73
23	.39	42.62	Pk	9.8	.2	52.62	58.06	-5.44	-	-
24	.399	27.31	Av	9.8	.2	37.31	-	-	47.87	-10.56

Pk - Peak detector

Av - Average detection

Quasi-Peak Emissions

Range 2: Phase N .15 - 30MHz

Frequency (MHz)	Meter Reading (dBuV)	Det	101836_With EX_N[dB]	CABLELOS S(dB)	Corrected Reading (dB(uVolts))	CFR 47 FCC PART 15 Class B QP	Margin (dB)	CFR 47 FCC PART 15 Class B AV	Margin (dB)
.16125	37.99	Qp	9.9	.1	47.99	65.4	-17.41	-	-
.26175	39.51	Qp	9.6	.2	49.31	61.38	-12.07	-	-
.31275	42.47	Qp	9.7	.2	52.37	59.9	-7.53	-	-
.38925	39.3	Qp	9.8	.2	49.3	58.08	-8.78	-	-

Qp - Quasi-Peak detector

9.1.2. AC Power Line (A to C)

WORST EMISSIONS

LINE 1 PLOT

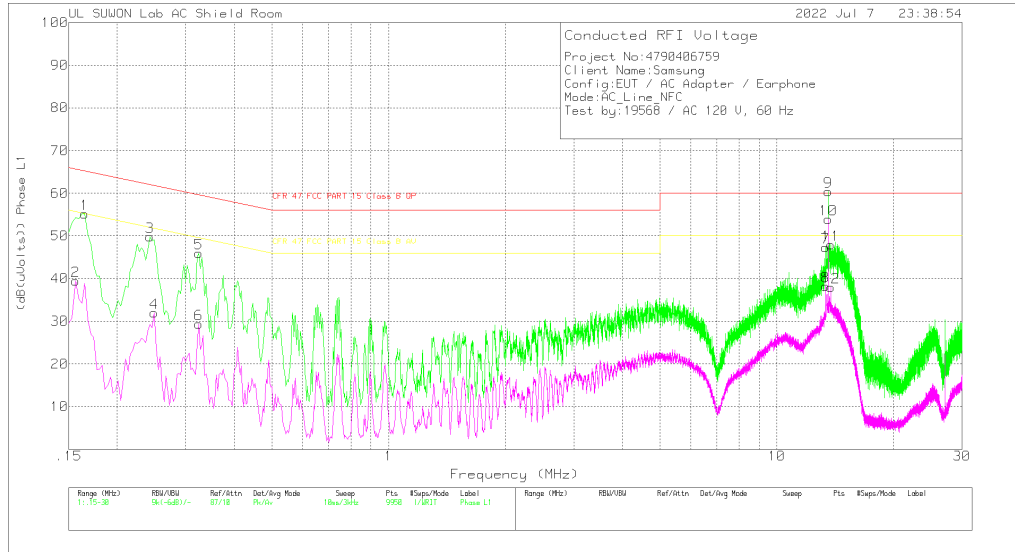

LINE 1 RESULTS

Trace Markers

Range 1: Phase L1 .15 - 30MHz

Marker	Frequency (MHz)	Meter Reading (dBuV)	Det	101836_With EX_L1[dB]	CABLELOSS S(dB)	Corrected Reading (dB(uVolts))	CFR 47 FCC PART 15 Class B QP	Margin (dB)	CFR 47 FCC PART 15 Class B AV	Margin (dB)
1	.165	45.2	Pk	9.9	.1	55.2	65.21	-10.01	-	-
2	.156	29.53	Av	9.8	.1	39.43	-	-	55.67	-16.24
3	.243	39.96	Pk	9.6	.2	49.76	61.99	-12.23	-	-
4	.249	22.18	Av	9.6	.2	31.98	-	-	51.79	-19.81
5	.324	36.03	Pk	9.7	.2	45.93	59.6	-13.67	-	-
6	.324	19.5	Av	9.7	.2	29.4	-	-	49.6	-20.2
7	13.347	36.87	Pk	10	.4	47.27	60	-12.73	-	-
8	13.347	27.84	Av	10	.4	38.24	-	-	50	-11.76
9	13.56	49.96	Pk	10	.4	60.36	60	.36	-	-
10	13.56	43.5	Av	10	.4	53.9	-	-	50	3.9
11	13.773	37.51	Pk	10	.4	47.91	60	-12.09	-	-
12	13.773	27.58	Av	10	.4	37.98	-	-	50	-12.02

Pk - Peak detector

Av - Average detection

Quasi-Peak Emissions

Range 1: Phase L1 .15 - 30MHz

Frequency (MHz)	Meter Reading (dBuV)	Det	101836_With EX_L1[dB]	CABLELOSS (dB)	Corrected Reading (dB(uVolts))	CFR 47 FCC PART 15 Class B QP	Margin (dB)	CFR 47 FCC PART 15 Class B AV	Margin (dB)
13.5602	47.43	Qp	10	.4	57.83	60	-2.17	-	-

Qp - Quasi-Peak detector

LINE 2 PLOT

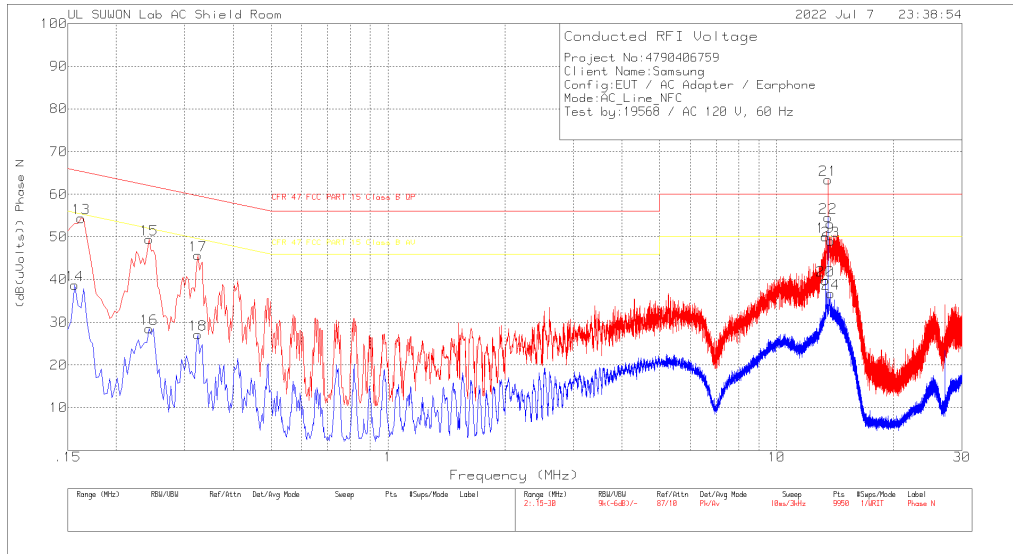

LINE 2 RESULTS

Trace Markers

Range 2: Phase N .15 - 30MHz

Marker	Frequency (MHz)	Meter Reading (dBuV)	Det	101836_With EX_N[dB]	CABLELOS S(dB)	Corrected Reading (dB(uVolts))	CFR 47 FCC PART 15 Class B QP	Margin (dB)	CFR 47 FCC PART 15 Class B AV	Margin (dB)
13	.162	44.36	Pk	9.9	.1	54.36	65.36	-11	-	-
14	.156	28.78	Av	9.8	.1	38.68	-	-	55.67	-16.99
15	.243	39.63	Pk	9.6	.2	49.43	61.99	-12.56	-	-
16	.243	18.71	Av	9.6	.2	28.51	-	-	51.99	-23.48
17	.324	35.83	Pk	9.7	.2	45.73	59.6	-13.87	-	-
18	.324	17.24	Av	9.7	.2	27.14	-	-	49.6	-22.46
19	13.35	39.62	Pk	10	.4	50.02	60	-9.98	-	-
20	13.35	29.43	Av	10	.4	39.83	-	-	50	-10.17
21	13.56	53	Pk	10	.4	63.4	60	3.4	-	-
22	13.56	44.18	Av	10	.4	54.58	-	-	50	4.58
23	13.791	38.71	Pk	10	.4	49.11	60	-10.89	-	-
24	13.77	26.29	Av	10	.4	36.69	-	-	50	-13.31

Pk - Peak detector

Av - Average detection

Quasi-Peak Emissions

Range 2: Phase N .15 - 30MHz

Frequency (MHz)	Meter Reading (dBuV)	Det	101836_With EX_N[dB]	CABLELOS S(dB)	Corrected Reading (dB(uVolts))	CFR 47 FCC PART 15 Class B QP	Margin (dB)	CFR 47 FCC PART 15 Class B AV	Margin (dB)
13.3493	35.41	Qp	10	.4	45.81	60	-14.19	-	-
13.5602	49.61	Qp	10	.4	60.01	60	.01	-	-

Qp - Quasi-Peak detector

TERMINATED EMISSIONS

LINE 1 PLOT

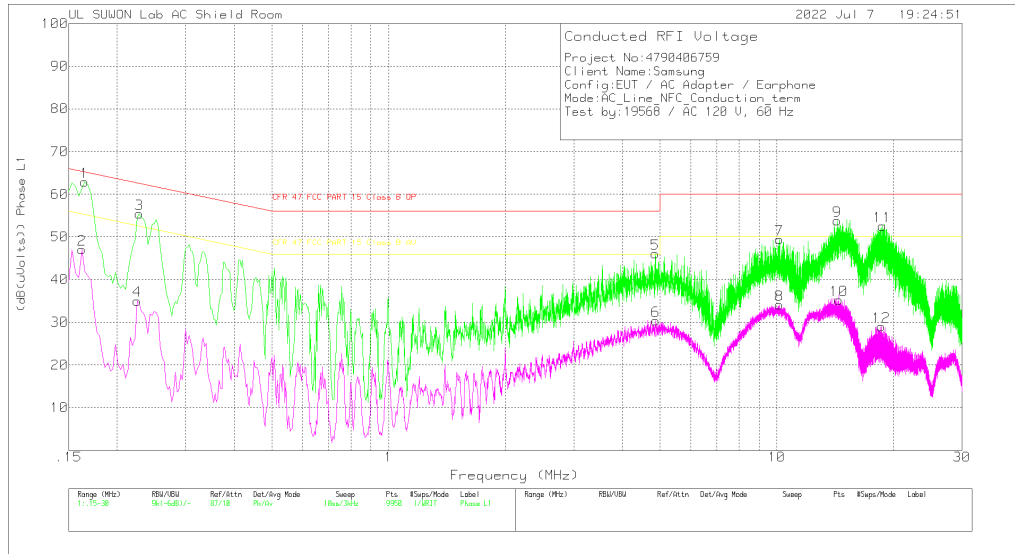

LINE 1 RESULTS

Trace Markers

Range 1: Phase L1 .15 - 30MHz

Marker	Frequency (MHz)	Meter Reading (dBuV)	Det	101836_With EX_L1[dB]	CABLELOS S(dB)	Corrected Reading (dB(uVolts))	CFR 47 FCC PART 15 Class B QP	Margin (dB)	CFR 47 FCC PART 15 Class B AV	Margin (dB)
1	.165	52.92	Pk	9.9	.1	62.92	65.21	-2.29	-	-
2	.162	37.1	Av	9.9	.1	47.1	-	-	55.36	-8.26
3	.228	45.54	Pk	9.7	.2	55.44	62.52	-7.08	-	-
4	.225	25.14	Av	9.7	.2	35.04	-	-	52.63	-17.59
5	4.869	36.05	Pk	9.7	.3	46.05	56	-9.95	-	-
6	4.881	20.42	Av	9.7	.3	30.42	-	-	46	-15.58
7	10.143	39.16	Pk	9.9	.4	49.46	60	-10.54	-	-
8	10.143	23.84	Av	9.9	.4	34.14	-	-	50	-15.86
9	14.298	43.42	Pk	10	.4	53.82	60	-6.18	-	-
10	14.466	24.81	Av	10	.4	35.21	-	-	50	-14.79
11	18.732	42.1	Pk	10.1	.4	52.6	60	-7.4	-	-
12	18.564	18.51	Av	10.1	.4	29.01	-	-	50	-20.99

Pk - Peak detector

Av - Average detection

Quasi-Peak Emissions

Range 1: Phase L1 .15 - 30MHz

Frequency (MHz)	Meter Reading (dBuV)	Det	101836_With EX_L1[dB]	CABLELOS S(dB)	Corrected Reading (dB(uVolts))	CFR 47 FCC PART 15 Class B QP	Margin (dB)	CFR 47 FCC PART 15 Class B AV	Margin (dB)
.16575	50.76	Qp	9.9	.1	60.76	65.17	-4.41	-	-
.22875	42.3	Qp	9.7	.2	52.2	62.49	-10.29	-	-
4.86915	26.81	Qp	9.7	.3	36.81	56	-19.19	-	-
14.2973	35.25	Qp	10	.4	45.65	60	-14.35	-	-
18.7313	33.75	Qp	10.1	.4	44.25	60	-15.75	-	-

Qp - Quasi-Peak detector

LINE 2 PLOT

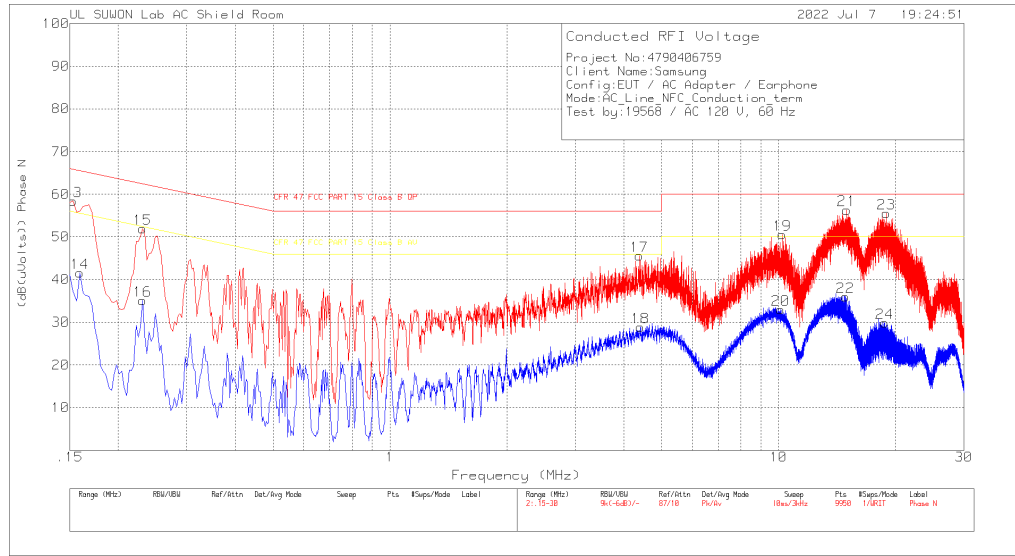

LINE 2 RESULTS

Trace Markers

Range 2: Phase N .15 - 30MHz

Marker	Frequency (MHz)	Meter Reading (dBuV)	Det	101836_With EX_N[dB]	CABLELOS S(dB)	Corrected Reading (dB(uVolts))	CFR 47 FCC PART 15 Class B QP	Margin (dB)	CFR 47 FCC PART 15 Class B AV	Margin (dB)
13	.153	48.52	Pk	9.8	.1	58.42	65.84	-7.42	-	-
14	.159	31.65	Av	9.8	.1	41.55	-	-	55.52	-13.97
15	.231	42.03	Pk	9.7	.2	51.93	62.41	-10.48	-	-
16	.231	25.17	Av	9.7	.2	35.07	-	-	52.41	-17.34
17	4.386	35.54	Pk	9.7	.3	45.54	56	-10.46	-	-
18	4.413	18.88	Av	9.7	.3	28.88	-	-	46	-17.12
19	10.23	40.23	Pk	9.9	.4	50.53	60	-9.47	-	-
20	10.134	22.7	Av	9.9	.4	33	-	-	50	-17
21	14.982	45.85	Pk	10.1	.4	56.35	60	-3.65	-	-
22	14.859	25.45	Av	10.1	.4	35.95	-	-	50	-14.05
23	18.927	44.92	Pk	10.2	.4	55.52	60	-4.48	-	-
24	18.783	19.29	Av	10.2	.4	29.89	-	-	50	-20.11

Pk - Peak detector

Av - Average detection

Quasi-Peak Emissions

Range 2: Phase N .15 - 30MHz

Frequency (MHz)	Meter Reading (dBuV)	Det	101836_With EX_N[dB]	CABLELOS S(dB)	Corrected Reading (dB(uVolts))	CFR 47 FCC PART 15 Class B QP	Margin (dB)	CFR 47 FCC PART 15 Class B AV	Margin (dB)
.15225	45.66	Qp	9.7	.1	55.46	65.88	-10.42	-	-
10.2302	29.8	Qp	9.9	.4	40.1	60	-19.9	-	-
14.9813	37.73	Qp	10.1	.4	48.23	60	-11.77	-	-
18.9278	35.91	Qp	10.2	.4	46.51	60	-13.49	-	-

Qp - Quasi-Peak detector

10. FREQUENCY STABILITY

LIMIT

§15.225 (e) The frequency tolerance of the carrier signal shall be maintained within $\pm 0.01\%$ of the operating frequency, over a temperature variation of -20 degrees to +50 degrees C at normal supply voltage, and for a variation in the primary supply voltage from 85% to 115% of the rated supply voltage at a temperature of 20 degrees C. For battery operated equipment, the equipment tests shall be performed using a new battery.

TEST PROCEDURE

ANSI C63.10 §6.8

RESULTS

Reference Frequency: EUT Channel 13.56 MHz @ 20°C Limit: ± 100 ppm = 1.356 kHz										
Power Supply (Vdc)	Envir. Temp (°C)	Frequency Deviation Measured with Time Elapse								
		Start up (MHz)	Delta (ppm)	@ 2mins (MHz)	Delta (ppm)	@ 5mins (MHz)	Delta (ppm)	@ 10 mins (MHz)	Delta (ppm)	Limit (ppm)
3.80	50	13.559970308	-7.401	13.559961661	-8.039	13.559959544	-8.195	13.559959378	-8.207	100
3.80	40	13.559999083	-5.279	13.559993015	-5.727	13.559985477	-6.282	13.559979262	-6.741	100
3.80	30	13.560028907	-3.080	13.560021260	-3.644	13.560016195	-4.017	13.56007499	-4.658	100
3.80	20	13.560070667	0	13.560040360	-2.235	13.560040335	-2.237	13.560040308	-2.239	100
3.80	10	13.560094218	1.737	13.560089650	1.400	13.560084414	1.014	13.560078643	0.588	100
3.80	0	13.560095704	1.846	13.560097471	1.977	13.560097067	1.947	13.560095525	1.833	100
3.80	-10	13.560081097	0.769	13.560087508	1.242	13.560091323	1.523	13.560093997	1.720	100
3.80	-20	13.560063147	-0.555	13.560067320	-0.247	13.560070328	-0.025	13.560072683	0.149	100
3.80	-30	13.560073013	0.173	13.560066942	-0.275	13.560066006	-0.344	13.560064603	-0.447	100

Reference Frequency: EUT Channel 13.56 MHz @ 20°C Limit: ± 100 ppm = 1.356 kHz										
Power Supply (Vdc)	Envir. Temp (°C)	Frequency Deviation Measured with Time Elapse								
		Start up (MHz)	Delta (ppm)	@ 2mins (MHz)	Delta (ppm)	@ 5mins (MHz)	Delta (ppm)	@ 10 mins (MHz)	Delta (ppm)	Limit (ppm)
3.80	20	13.559976862	0	13.559978900	0.150	13.559982003	0.379	13.559982032	0.381	100
3.40	20	13.559981526	0.344	13.559983054	0.457	13.559983247	0.471	13.559983244	0.471	100
4.30	20	13.559971567	-0.390	13.559977742	0.065	13.559980835	0.293	13.559981332	0.330	100

No non-compliance noted.

11. SPOT-CHECK TEST RESULT

BANDEDGE (WORST CASE: Without Card tag / Face on)

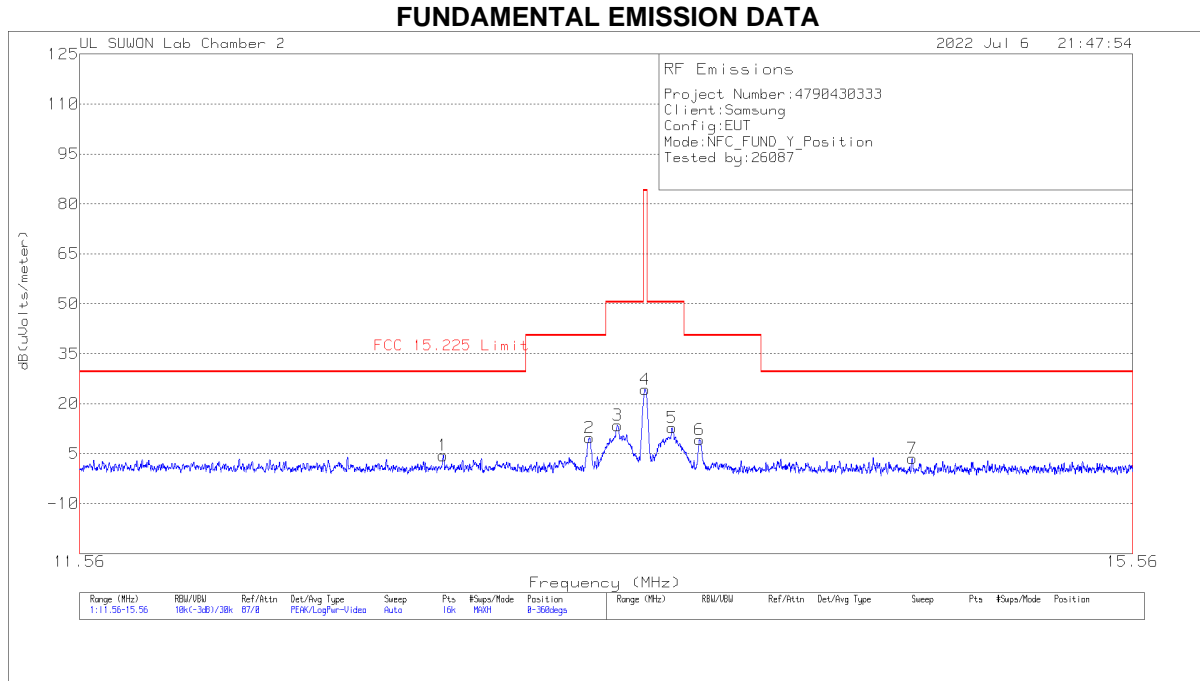

Trace Markers

Face on

Marker	Frequency (MHz)	Meter Reading (dBuV)	Det	HFH2-Z2_Loop Antenna	Dist Corr 30m	Cable Loss	Corrected Reading dB(uVolts/meter)	FCC 15.225 Limit	Margin (dB)	Azimuth (Degs)
1	12.80963	23.9	Pk	20	-40	.5	4.4	29.54	-25.14	0-360
2	13.34938	29.2	Pk	20	-40	.5	9.7	40.51	-30.81	0-360
3	13.45488	32.94	Pk	20	-40	.5	13.44	50.5	-37.06	0-360
**4	13.55988	43.81	Pk	20	-40	.5	24.31	84	-59.69	0-360
5	13.66363	32.23	Pk	20	-40	.6	12.83	50.5	-37.67	0-360
6	13.77038	28.54	Pk	20	-40	.6	9.14	40.51	-31.37	0-360
7	14.62163	22.96	Pk	20	-40	.6	3.56	29.54	-25.98	0-360

Pk - Peak detector

**Fundamental

HARMONICS AND SPURIOUS EMISSIONS(Without Card tag / Face off)

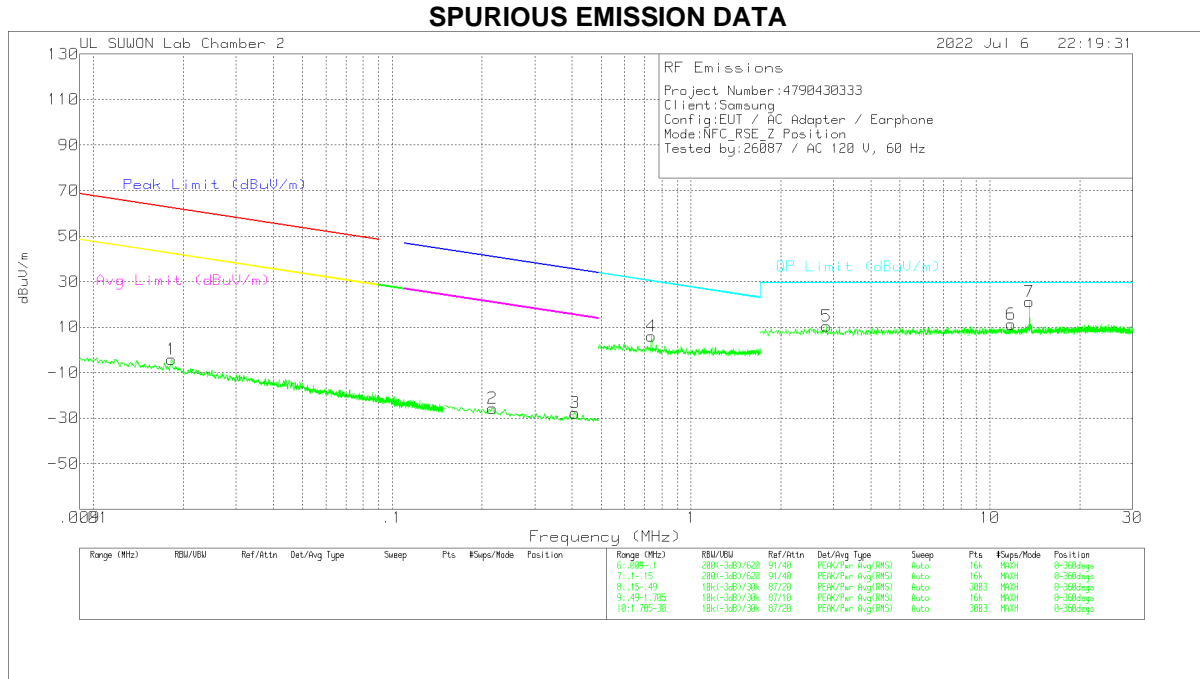

Note: Emission was scanned up to 40GHz; No emissions were detected above the noise floor which was at least 20dB below the specification limit.

Trace Markers
 Face off

Marker	Frequency (MHz)	Meter Reading (dBuV)	Det	HFH2-Z2_Loop Antenna	Cable Loss	Dist Corr 300m	Corrected Reading dBuV/m	Peak Limit (dBuV/m)	Margin (dB)	Avg Limit (dBuV/m)	Margin (dB)	Azimuth (Degs)
1	.01828	55.6	Pk	20.2	.1	-80	-4.1	62.35	-66.45	42.35	-46.45	0-360
2	.21701	34.68	Pk	19.7	.1	-80	-25.52	40.89	-66.41	20.89	-46.41	0-360
3	.40854	32.51	Pk	19.7	.1	-80	-27.69	35.38	-63.07	15.38	-43.07	0-360

Marker	Frequency (MHz)	Meter Reading (dBuV)	Det	HFH2-Z2_Loop Antenna	Cable Loss	Dist Corr 30m	Corrected Reading dBuV/m	QP Limit (dBuV/m)	Margin (dB)	Azimuth (Degs)
4	.7373	26.28	Pk	19.7	.1	-40	6.08	30.26	-24.18	0-360
5	2.836	30.31	Pk	19.9	.3	-40	10.51	29.5	-18.99	0-360
6	11.78033	30.74	Pk	20	.5	-40	11.24	29.5	-18.26	0-360
**7	13.56165	40.83	Pk	20	.5	-40	21.33	29.5	-8.17	0-360

Pk - Peak detector
 **Fundamental

END OF TEST REPORT