



**FCC CFR47 PART 15 SUBPART C
INDUSTRY CANADA RSS-247 ISSUE 2**

DTS Wireless LAN

CERTIFICATION TEST REPORT

FOR

BT/BLE, DTS/UNII a/b/g/n/ac and ANT+ Tablet

MODEL NUMBER : SM-T590

FCC ID: A3LSMT590

IC : 649E-SMT590

REPORT NUMBER: 4788494706-E1V2

ISSUE DATE: JUN 27, 2018

Prepared for
SAMSUNG ELECTRONICS CO., LTD.
129 SAMSUNG-RO, YEONGTONG-GU, SUWON-SI,
GYEONGGI-DO, 16677, KOREA

Prepared by
UL Korea, Ltd.
26th floor, 152, Teheran-ro, Gangnam-gu Seoul, 06236, Korea

Suwon Test Site: UL Korea, Ltd. Suwon Laboratory
218 Maeyeong-ro, Yeongtong-gu,
Suwon-si, Gyeonggi-do, 16675, Korea
TEL: (031) 337-9902
FAX: (031) 213-5433



ACCREDITED*

Testing
Laboratory

TL-637

Revision History

<u>Rev.</u>	<u>Issue Date</u>	<u>Revisions</u>	<u>Revised By</u>
V1	06/22/18	Initial issue	Hoonpyo Lee
V2	06/27/18	Updated to address TCB's question	Hoonpyo Lee

TABLE OF CONTENTS

1. ATTESTATION OF TEST RESULTS	5
1.1. INTRODUCTION OF TEST DATA REUSE.....	6
1.2. DIFFERENCE.....	6
1.3. SPOT CHECK VERIFICATION DATA	6
1.4. REFERENCE DETAIL	7
2. TEST METHODOLOGY	8
3. FACILITIES AND ACCREDITATION	8
4. CALIBRATION AND UNCERTAINTY	8
4.1. MEASURING INSTRUMENT CALIBRATION	8
4.2. SAMPLE CALCULATION	8
4.3. MEASUREMENT UNCERTAINTY.....	8
5. EQUIPMENT UNDER TEST	9
5.1. DESCRIPTION OF EUT	9
5.2. MAXIMUM OUTPUT POWER.....	9
5.3. DESCRIPTION OF AVAILABLE ANTENNAS	9
5.4. WORST-CASE CONFIGURATION AND MODE.....	9
5.5. DESCRIPTION OF TEST SETUP.....	10
6. TEST AND MEASUREMENT EQUIPMENT	12
7. REFERENCE MEASUREMENT RESULTS.....	13
7.1. ON TIME AND DUTY CYCLE RESULTS.....	13
7.1. 99% BANDWIDTH.....	14
7.1.1. 802.11b MODE IN THE 2.4 GHz BAND.....	14
7.1.2. 802.11g MODE IN THE 2.4 GHz BAND.....	14
7.1.3. 802.11n HT20 MODE IN THE 2.4 GHz BAND	14
7.1.4. 99% BANDWIDTH PLOTS	15
8. MEASUREMENT METHODS	21
9. SUMMARY TABLE	22
10. ANTENNA PORT TEST RESULTS	23
10.1. 6 dB BANDWIDTH	23
10.1.1. 802.11b MODE IN THE 2.4 GHz BAND	24
10.1.1.1. 802.11g MODE IN THE 2.4 GHz BAND	24
10.1.2. 802.11n HT20 MODE IN THE 2.4 GHz BAND.....	24
10.1.3. 6 dB BANDWIDTH PLOTS.....	25

10.2.	OUTPUT POWER.....	31
10.2.1.	802.11b MODE IN THE 2.4 GHz BAND	32
10.2.2.	802.11g MODE IN THE 2.4 GHz BAND	33
10.2.3.	802.11n HT20 MODE IN THE 2.4 GHz BAND.....	34
10.3.	PSD.....	35
10.3.1.	802.11b MODE IN THE 2.4 GHz BAND	36
10.3.2.	802.11g MODE IN THE 2.4 GHz BAND	36
10.3.3.	802.11n HT20 MODE IN THE 2.4 GHz BAND.....	36
10.3.4.	PSD PLOTS.....	37
10.4.	OUT-OF-BAND EMISSIONS.....	43
10.4.1.	802.11b MODE IN THE 2.4 GHz BAND	44
10.4.2.	802.11g MODE IN THE 2.4 GHz BAND	52
10.4.3.	802.11n HT20 MODE IN THE 2.4 GHz BAND.....	59
11.	RADIATED TEST RESULTS	66
11.1.	LIMITS AND PROCEDURE.....	66
11.2.	TRANSMITTER ABOVE 1 GHz.....	68
11.2.1.	TX ABOVE 1 GHz 802.11b MODE IN THE 2.4 GHz BAND.....	68
11.2.2.	TX ABOVE 1 GHz 802.11g MODE IN THE 2.4 GHz BAND.....	86
11.2.3.	TX ABOVE 1 GHz 802.11n HT20 MODE IN THE 2.4 GHz BAND	104
11.3.	WORST-CASE BELOW 1 GHz	122
12.	AC POWER LINE CONDUCTED EMISSIONS	124
13.	SETUP PHOTOS	129

1. ATTESTATION OF TEST RESULTS

COMPANY NAME: SAMSUNG ELECTRONICS CO., LTD.
EUT DESCRIPTION: BT/BLE, DTS/UNII a/b/g/n/ac and ANT+ Tablet
MODEL NUMBER: SM-T590
SERIAL NUMBER: R32K1000WAB (RADIATED, Original);
R32K400E4CK (CONDUCTED, Original)
R32K5005EDZ (RADIATED, Spot check)
DATE TESTED: MAY 23, 2018 - JUN 04, 2018 (Original)
JUN 16, 2018 (Spot check)

APPLICABLE STANDARDS	
STANDARD	TEST RESULTS
CFR 47 Part 15 Subpart C	Pass
INDUSTRY CANADA RSS-247 Issue 2	Pass
INDUSTRY CANADA RSS-GEN Issue 5	Pass

UL Korea, Ltd. tested the above equipment in accordance with the requirements set forth in the above standards. All indications of Pass/Fail in this report are opinions expressed by UL Korea, Ltd. based on interpretations and/or observations of test results. Measurement Uncertainties were not taken into account and are published for informational purposes only. The test results show that the equipment tested is capable of demonstrating compliance with the requirements as documented in this report.

Note: The results documented in this report apply only to the tested sample, under the conditions and modes of operation as described herein. This document may not be altered or revised in any way unless done so by UL Korea, Ltd. and all revisions are duly noted in the revisions section. Any alteration of this document not carried out by UL Korea, Ltd. will constitute fraud and shall nullify the document. This report must not be used by the client to claim product certification, approval, or endorsement by IAS, any agency of the Federal Government, or any agency of any government.

Approved & Released For
UL Korea, Ltd. By:

Tested By:



SungGil Park
Suwon Lab Engineer
UL Korea, Ltd.

Hoonpyo Lee
Suwon Lab Engineer
UL Korea, Ltd.

1.1. INTRODUCTION OF TEST DATA REUSE

This report referenced from the FCC ID: A3LSMT595 DTS WLAN(FCC CFR 47 Part 15C). And the applicant takes full responsibility that the test data as referenced in this report represent compliance for this FCC ID.

1.2. DIFFERENCE

The FCC ID: A3LSMT590(IC : 649E-SMT590, Model number : SM-T590), shares the same enclosure and circuit board as FCC ID: A3LSMT595 (Model number : SM-T595). The WLAN antennas and surrounding circuitry and layout are identical between these two units.

After confirming through preliminary radiated emissions that the performance of the FCC ID: A3LSMT595 (Model number : SM-T595) remains representative of FCC ID: A3LSMT590(IC : 649E-SMT590, Model number : SM-T590). The test data of FCC ID: A3LSMT595 (Model number : SM-T595) being submitted for this application to cover WLAN features.

Model number, SM-T595, is not certified for ISED certification.

1.3. SPOT CHECK VERIFICATION DATA

(Worst case of the radiated spurious and band edge emissions)

Band	Test Item	Mode	Frequency	Test Limit	Original model	Spot check model	Deviation	Remark
					SM-T595 Results	SM-T590 Results		
					FCC ID : A3LSMT595	FCC ID : A3LSMT590 IC : 649E-SMT590		
DTS WLAN (2.4GHz)	Band Edge	802.11b	2452 MHz	54 dBuV/m	42.95 dBuV/m	42.75 dBuV/m	-0.20 dB	
	RSE	802.11b	2422 MHz	54 dBuV/m	44.43 dBuV/m	43.86 dBuV/m	-0.57 dB	
	Band Edge	802.11g	2457 MHz	54 dBuV/m	49.59 dBuV/m	48.78 dBuV/m	-0.81 dB	
	RSE	802.11g	2412 MHz	74 dBuV/m	42.11 dBuV/m	43.06 dBuV/m	0.95 dB	Noise floor level
	Band Edge	802.11n	2462 MHz	54 dBuV/m	50.80 dBuV/m	49.64 dBuV/m	-1.16 dB	
	RSE	802.11n	2422 MHz	74 dBuV/m	41.21 dBuV/m	42.96 dBuV/m	1.75 dB	Noise floor level

Comparison of two models, upper deviation is within 3dB range and all test results are under FCC Technical Limits.

1.4. REFERENCE DETAIL

Reference application that contains the reused reference data.

Equipment Class	Reference FCC ID	Type Grant/Permissive Change	Reference Application	Folder Test/RF Exposure	Report Title / Section
DTS	A3LSMT595	Grant	4788452530-E1V2	Test	FCC Report DTS WLAN / All sections
			4788452530-E2V2	Test	FCC Report BLE All sections
DSS	A3LSMT595	Grant	4788452530-E3V2	Test	FCC Report BT / All sections
DXX	A3LSMT595	Grant	4788452530-E5V2	Test	FCC Report ANT+ / All sections
NII	A3LSMT595	Grant	4788452530-E4V2	Test	FCC Report UNII WLAN / All sections

2. TEST METHODOLOGY

The tests documented in this report were performed in accordance with following methods.

1. FCC CFR 47 Part 2.
2. FCC CFR 47 Part 15.
3. IC RSS-GEN Issue 5
4. IC RSS-247 Issue 2
5. KDB 558074 D01 DTS Meas Guidance v04.
6. ANSI C63.10-2013.

3. FACILITIES AND ACCREDITATION

The test sites and measurement facilities used to collect data are located at 218 Maeyeong-ro, Yeongtong-gu, Suwon-si, Gyeonggi-do, 16675, Korea. Line conducted emissions are measured only at the 218 address. The following table identifies which facilities were utilized for radiated emission measurements documented in this report. Specific facilities are also identified in the test results sections.

218 Maeyeong-ro	
<input type="checkbox"/>	Chamber 1
<input type="checkbox"/>	Chamber 2
<input checked="" type="checkbox"/>	Chamber 3

UL Korea, Ltd. is accredited by IAS, Laboratory Code TL-637. The full scope of accreditation can be viewed at <http://www.iasonline.org/PDF/TL/TL-637.pdf>.

4. CALIBRATION AND UNCERTAINTY

4.1. MEASURING INSTRUMENT CALIBRATION

The measuring equipment utilized to perform the tests documented in this report has been calibrated in accordance with the manufacturer's recommendations, and is traceable to recognized national standards.

4.2. SAMPLE CALCULATION

Where relevant, the following sample calculation is provided:

$$\begin{aligned} \text{Field Strength (dBuV/m)} &= \text{Measured Voltage (dBuV)} + \text{Antenna Factor (dB/m)} + \\ &\text{Cable Loss (dB)} - \text{Preamp Gain (dB)} \\ 36.5 \text{ dBuV} + 18.7 \text{ dB/m} + 0.6 \text{ dB} - 26.9 \text{ dB} &= 28.9 \text{ dBuV/m} \end{aligned}$$

4.3. MEASUREMENT UNCERTAINTY

Where relevant, the following measurement uncertainty levels have been estimated for tests performed on the apparatus:

PARAMETER	UNCERTAINTY
Conducted Disturbance, 0.15 to 30 MHz	2.32 dB
Radiated Disturbance, Below 1GHz	3.86 dB
Radiated Disturbance, Above 1 GHz	5.97 dB

Uncertainty figures are valid to a confidence level of 95%.

5. EQUIPMENT UNDER TEST

5.1. DESCRIPTION OF EUT

The EUT is a BT/BLE, DTS/UNII a/b/g/n/ac and ANT+ Tablet.
This test report addresses the DTS (WLAN) operational mode.

5.2. MAXIMUM OUTPUT POWER

The transmitter has a maximum total conducted average output power as follows:

Frequency Range [MHz]	Mode	Output Power [dBm]	Output Power [mW]
2412 - 2462	802.11b	17.03	50.47
	802.11g	15.95	39.36
	802.11n HT20	15.91	38.99

5.3. DESCRIPTION OF AVAILABLE ANTENNAS

The radio utilizes an internal antennas, with a antenna's maximum gain of 0.9 dBi.

5.4. WORST-CASE CONFIGURATION AND MODE

Radiated emission below 1GHz and power line conducted emission were performed with the EUT set to transmit at the channel with highest output power as worst-case scenario.

Radiated emission above 1GHz was performed with the EUT set to transmit 3/6/9 Channels.

The fundamental of the EUT was investigated in three orthogonal orientations X, Y and Z it was determined that Y orientation was worst-case orientation; therefore, all final radiated testing was performed with the EUT in Y orientation.

Based on the baseline scan, the worst-case data rates were:

802.11b mode: 1 Mbps
802.11g mode: 6 Mbps
802.11n HT20 mode: MCS0

Note : All radiated and power line conducted tests were performed connected with earphone and charger for evaluation of worst case mode.

5.5. DESCRIPTION OF TEST SETUP

SUPPORT EQUIPMENT

Support Equipment List				
Description	Manufacturer	Model	Serial Number	FCC ID
Charger	SAMSUNG	EP-TA20EWE	R37JCWL0FR5DK3	N/A
Data Cable	SAMSUNG	EP-DN930CWE	N/A	N/A
Earphone	SAMSUNG	EHS64AVFWE	N/A	N/A

I/O CABLES

I/O Cable List						
Cable No	Port	# of identical ports	Connector Type	Cable Type	Cable Length (m)	Remarks
1	DC Power	1	Mini-USB	Shielded	1.2m	N/A
2	Audio	2	Mini-Jack	Unshielded	1.2m	N/A

TEST SETUP

The EUT is a stand-alone unit during the tests.
 Test software in hidden menu exercised the EUT to enable DTS mode.

SETUP DIAGRAM FOR TESTS (CONDUCTED TEST SETUP)

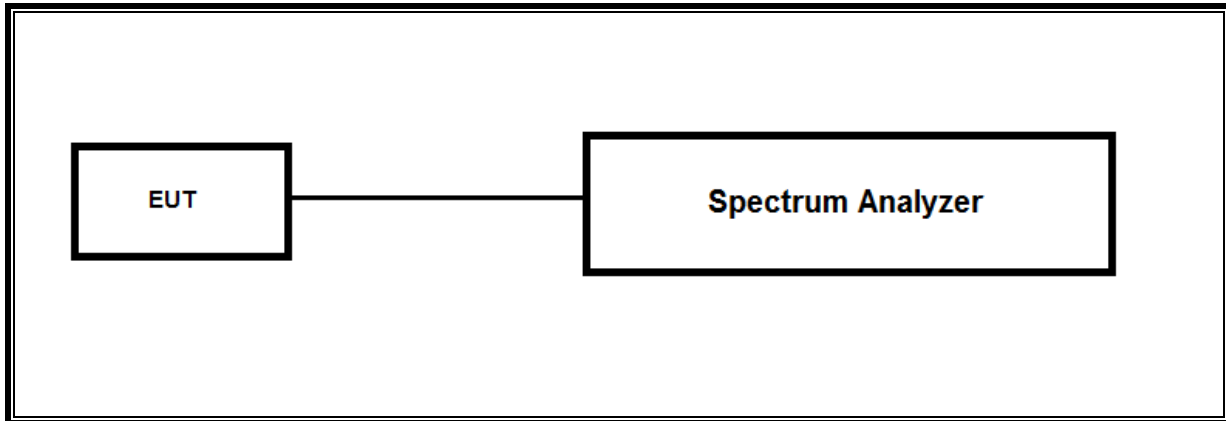

SETUP DIAGRAM FOR TESTS (RADIATED TEST SETUP)

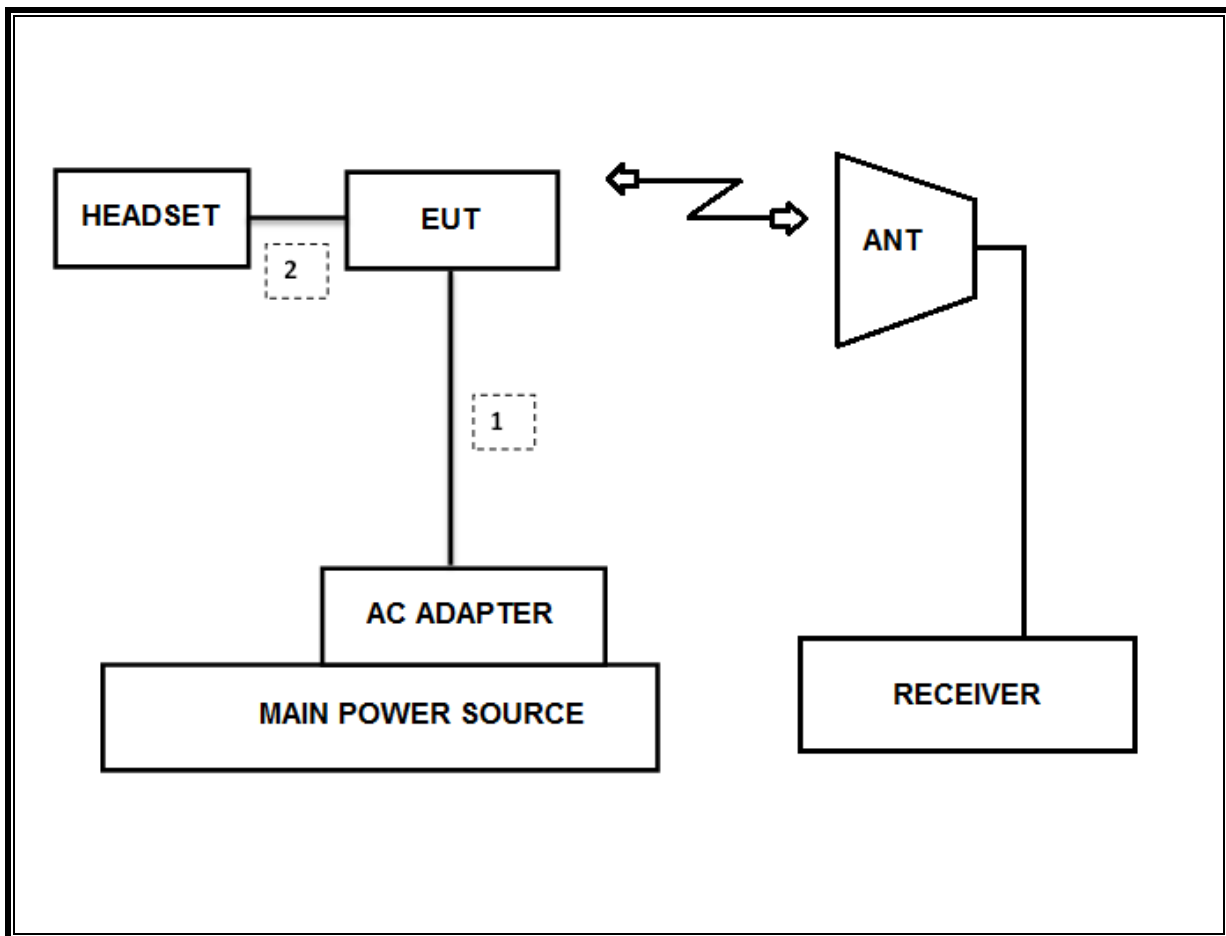

6. TEST AND MEASUREMENT EQUIPMENT

The following test and measurement equipment was utilized for the tests documented in this report:

Test Equipment List				
Description	Manufacturer	Model	S/N	Cal Due
Antenna, Bilog, 30MHz-1GHz	SCHWARZBECK	VULB9163	750	08-31-19
Antenna, Bilog, 30MHz-1GHz	SCHWARZBECK	VULB9163	749	09-14-19
Antenna, Bilog, 30MHz-1GHz	SCHWARZBECK	VULB9163	845	08-31-19
Antenna, Horn, 18 GHz	ETS	3115	00167211	10-14-18
Antenna, Horn, 18 GHz	ETS	3115	00161451	03-10-19
Antenna, Horn, 18 GHz	ETS	3117	00168724	05-31-19
Antenna, Horn, 18 GHz	ETS	3117	00168717	05-31-19
Antenna, Horn, 18 GHz	ETS	3117	00205959	11-29-18
Antenna, Horn, 40 GHz	ETS	3116C	00166155	12-04-19
Antenna, Horn, 40 GHz	ETS	3116C	00168645	12-04-19
Antenna, Horn, 40 GHz	ETS	3116C-PA	00168841	11-13-19
Preamplifier, 1000 MHz	Sonoma	310N	341282	08-09-18
Preamplifier, 1000 MHz	Sonoma	310N	351741	08-07-18
Preamplifier, 1000 MHz	Sonoma	310N	370599	08-10-18
Preamplifier, 18 GHz	Miteq	AFS42-00101800-25-S-42	1876511	08-08-18
Preamplifier, 18 GHz	Miteq	AFS42-00101800-25-S-42	1896138	08-08-18
Preamplifier, 18 GHz	Miteq	AFS42-00101800-25-S-42	2029169	08-11-18
Spectrum Analyzer, 44 GHz	Agilent / HP	N9030A	MY54170614	08-08-18
Spectrum Analyzer, 44 GHz	Agilent / HP	N9030A	MY54490312	08-08-18
Spectrum Analyzer, 43.5 GHz	R&S	FSW43	104089	08-11-18
Average Power Sensor	Agilent / HP	U2000	MY54270007	08-08-18
Attenuator	PASTERNAK	PE7087-10	A001	08-08-18
Attenuator	PASTERNAK	PE7087-10	A008	08-08-18
Attenuator	PASTERNAK	PE7087-10	2	08-10-18
Attenuator	PASTERNAK	PE7087-10	A009	08-08-18
EMI Test Receive, 40 GHz	R&S	ESU40	100439	08-08-18
EMI Test Receive, 40 GHz	R&S	ESU40	100457	08-08-18
EMI Test Receive, 44 GHz	R&S	ESW44	101590	08-09-18
EMI Test Receive, 3 GHz	R&S	ESR3	101832	08-07-18
Low Pass Filter 5GHz	Micro-Tronics	LPS17541	009	08-08-18
Low Pass Filter 5GHz	Micro-Tronics	LPS17541	015	08-08-18
Low Pass Filter 5GHz	Micro-Tronics	LPS17541	020	08-11-18
High Pass Filter 3GHz	Micro-Tronics	HPM17543	010	08-08-18
High Pass Filter 3GHz	Micro-Tronics	HPM17543	015	08-08-18
High Pass Filter 3GHz	Micro-Tronics	HPM17543	020	08-11-18
High Pass Filter 6GHz	Micro-Tronics	HPS17542	009	08-08-18
High Pass Filter 6GHz	Micro-Tronics	HPS17542	016	08-08-18
High Pass Filter 6GHz	Micro-Tronics	HPS17542	021	08-11-18
LISN	R&S	ENV-216	101837	08-09-18
UL Software				
Description	Manufacturer	Model	Version	
Radiated software	UL	UL EMC	Ver 9.5	

7. REFERENCE MEASUREMENT RESULTS

7.1. ON TIME AND DUTY CYCLE RESULTS

LIMITS

None; for reporting purposes only.

Mode	ON Time B [msec]	Period [msec]	Duty Cycle x [linear]	Duty Cycle [%]	Duty Cycle Correction Factor [dB]	1/T Minimum VBW [kHz]
2400MHz Bands						
802.11b	32.95	33.05	0.997	99.7%	0.00	0.010
802.11g	5.484	5.583	0.982	98.2%	0.00	0.010
802.11n HT20	5.068	5.166	0.981	98.1%	0.00	0.010

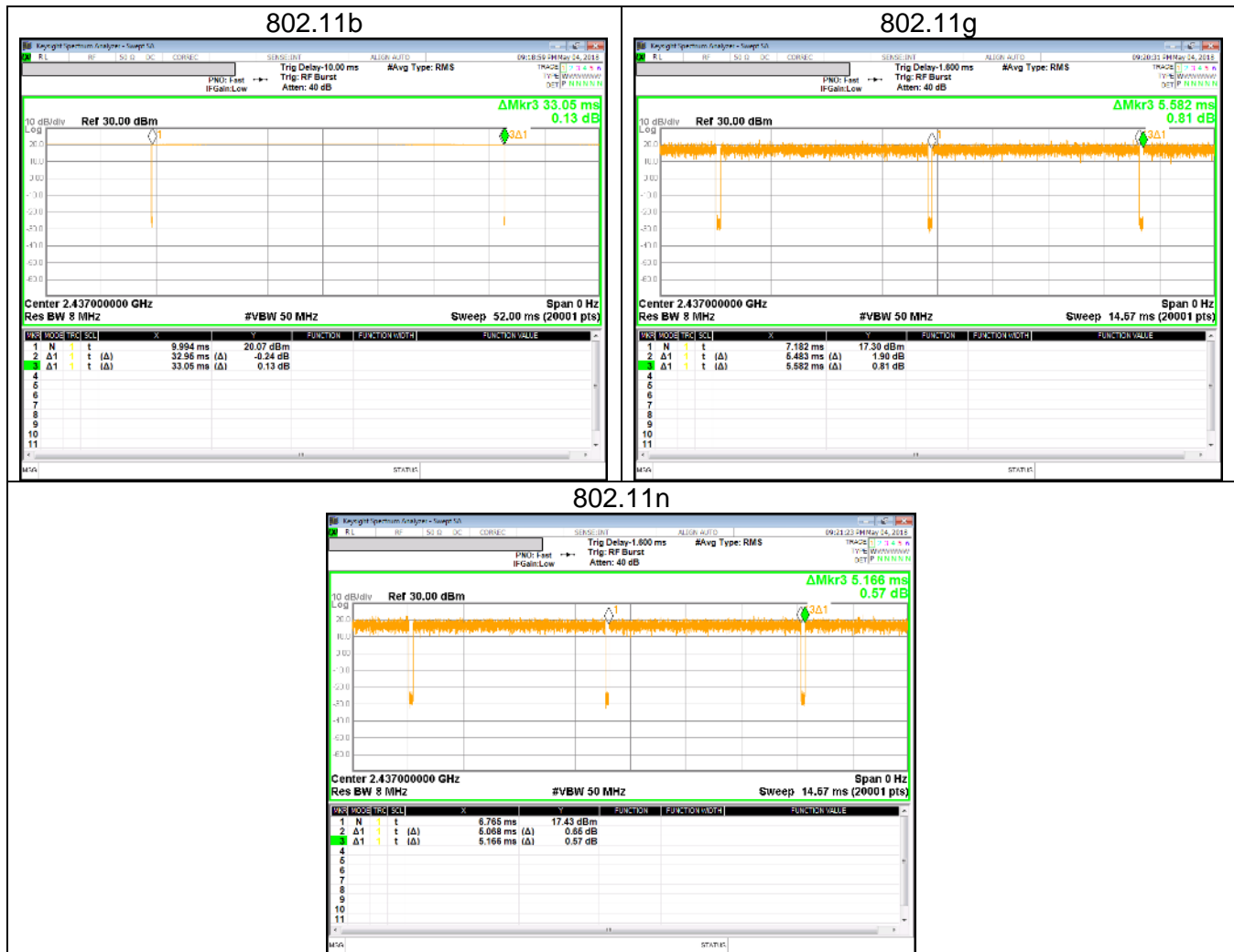

7.1. 99% BANDWIDTH

LIMITS

None; for reporting purposes only.

RESULTS

7.1.1. 802.11b MODE IN THE 2.4 GHz BAND

Channel	Frequency [MHz]	99% Bandwidth [MHz]
1	2412	12.937
2	2417	13.016
3	2422	13.208
6	2437	13.227
9	2452	13.194
10	2457	13.034
11	2462	12.851
Worst		13.227

7.1.2. 802.11g MODE IN THE 2.4 GHz BAND

Channel	Frequency [MHz]	99% Bandwidth [MHz]
1	2412	16.362
2	2417	16.417
3	2422	16.431
6	2437	16.420
9	2452	16.424
10	2457	16.383
11	2462	16.413
Worst		16.431

7.1.3. 802.11n HT20 MODE IN THE 2.4 GHz BAND

Channel	Frequency [MHz]	99% Bandwidth [MHz]
1	2412	17.547
2	2417	17.576
3	2422	17.595
6	2437	17.594
9	2452	17.608
10	2457	17.586
11	2462	17.561
Worst		17.608

7.1.4. 99% BANDWIDTH PLOTS

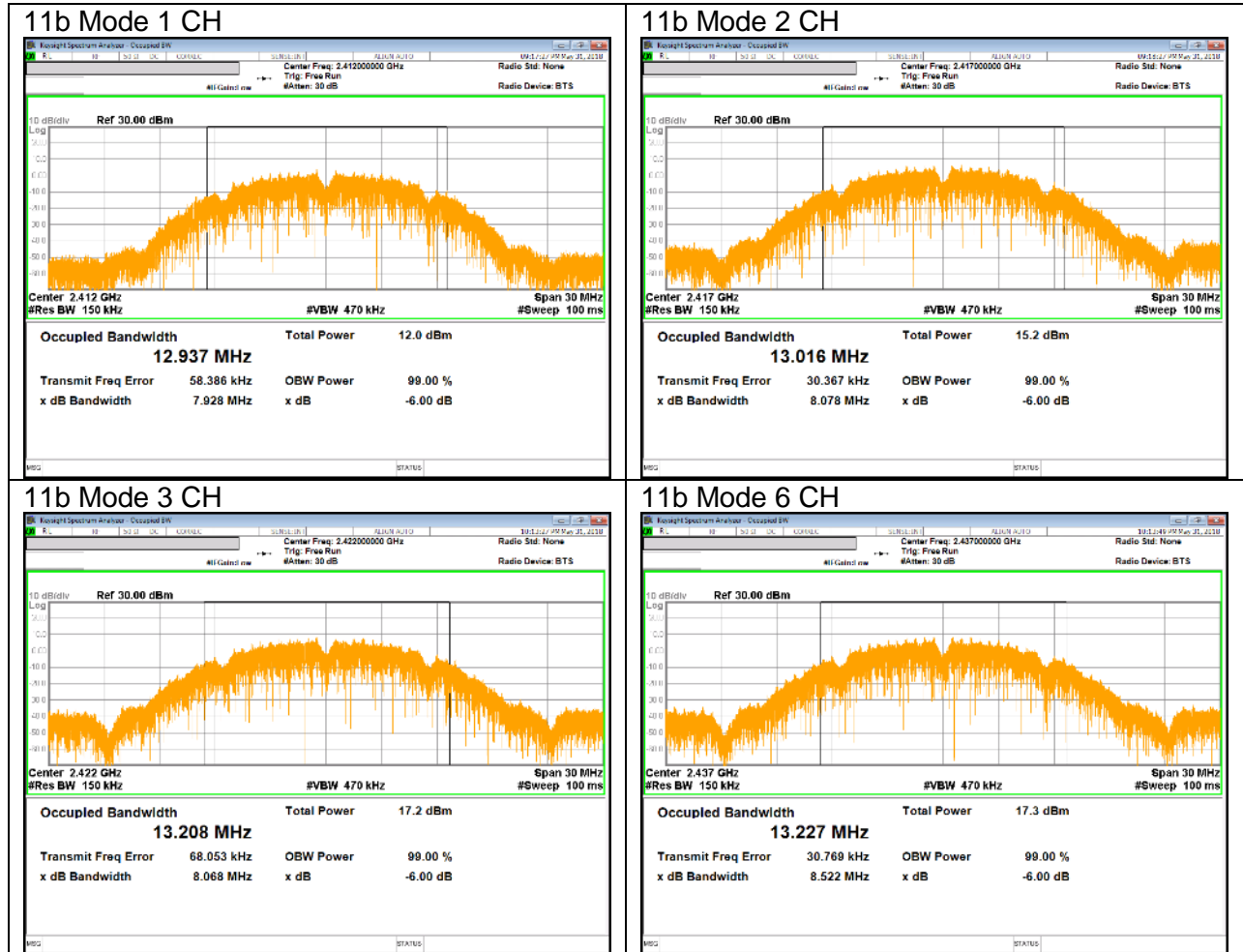

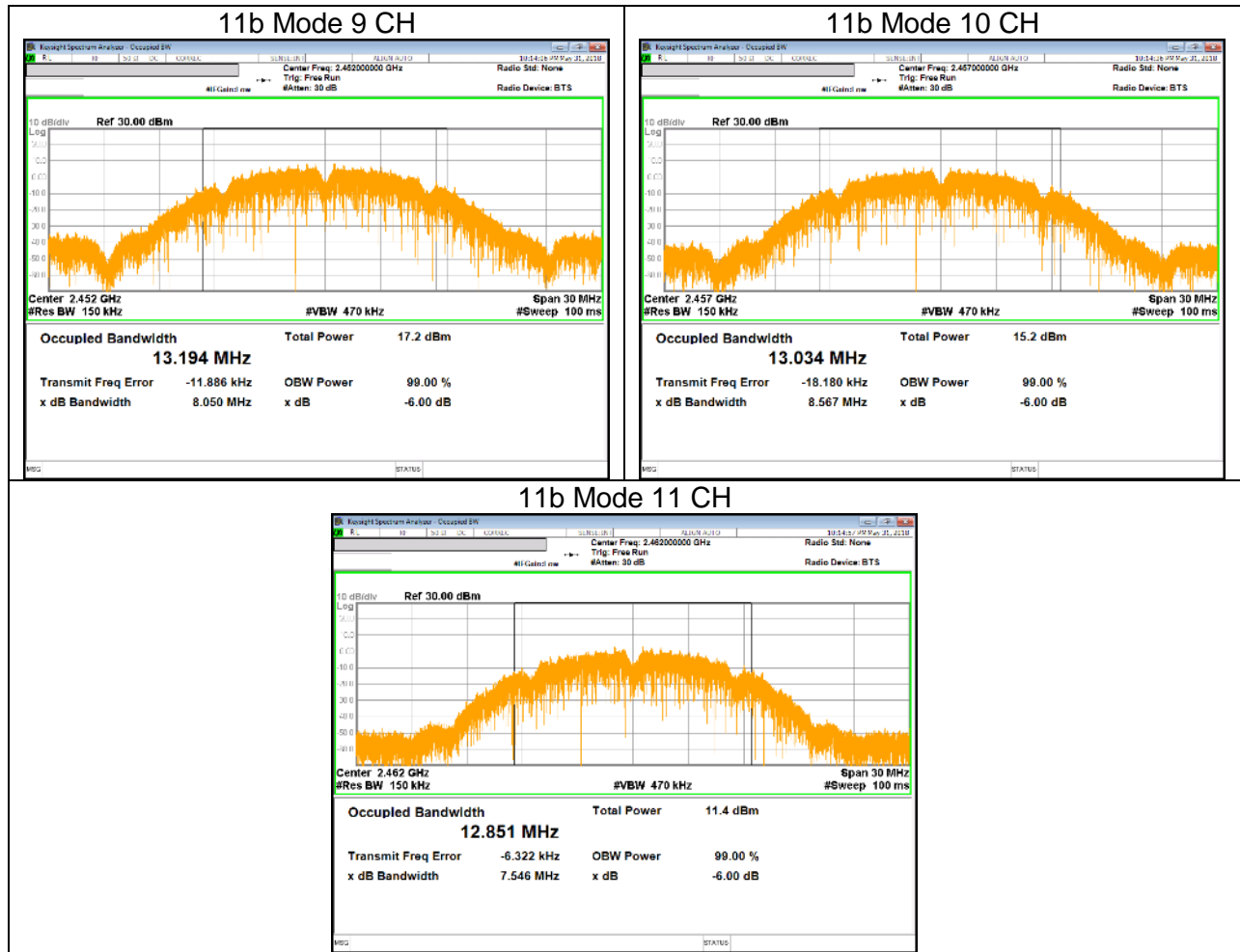

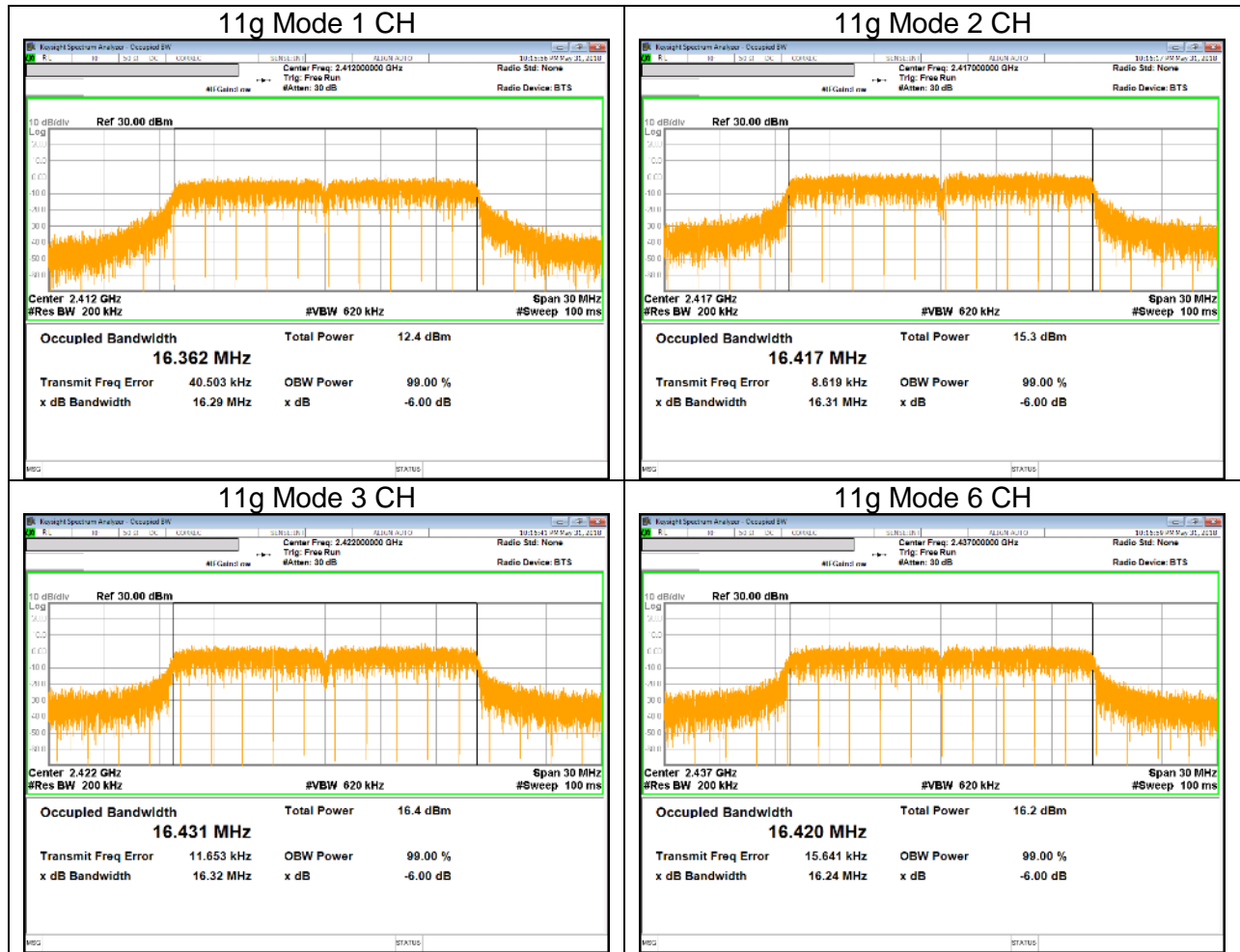

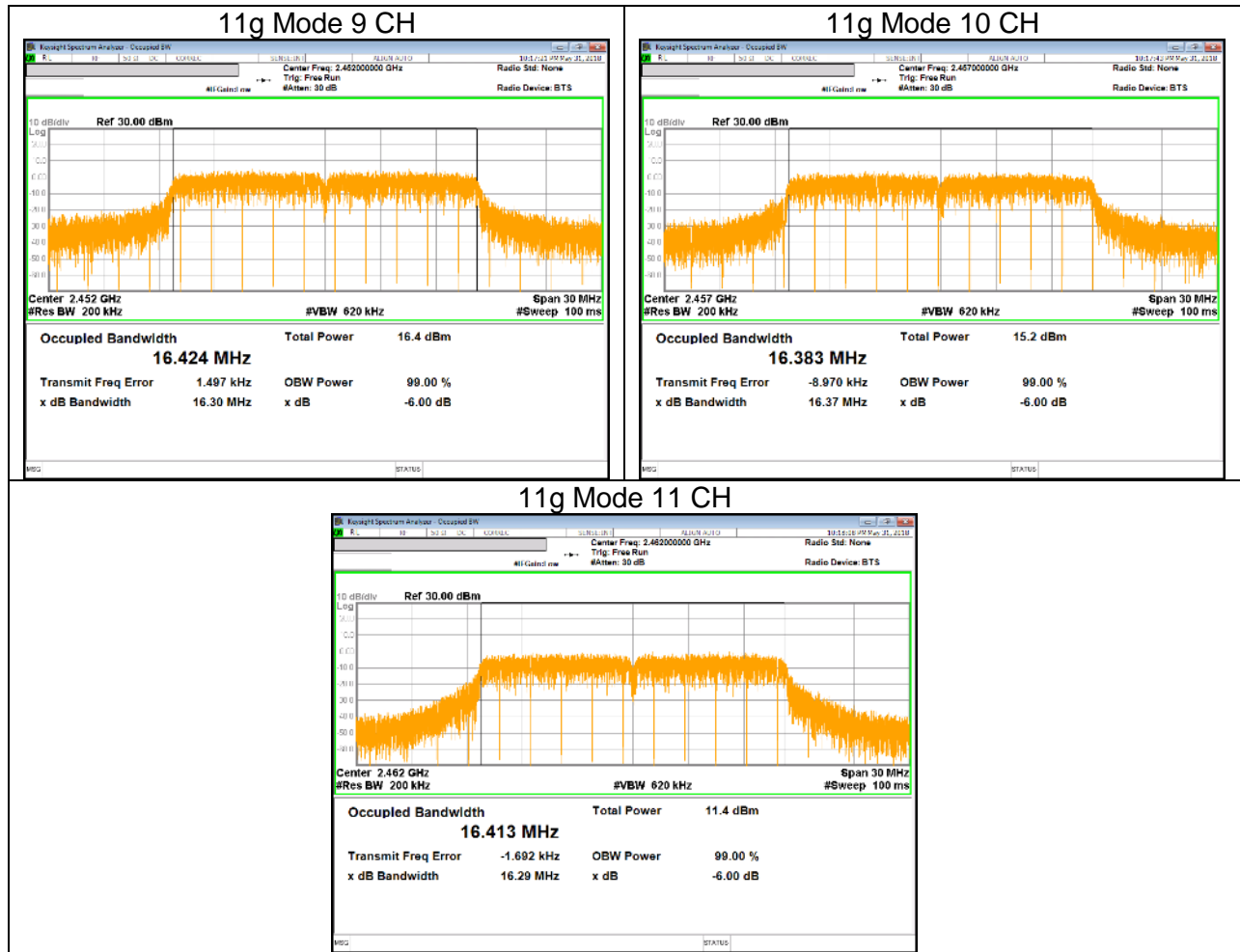

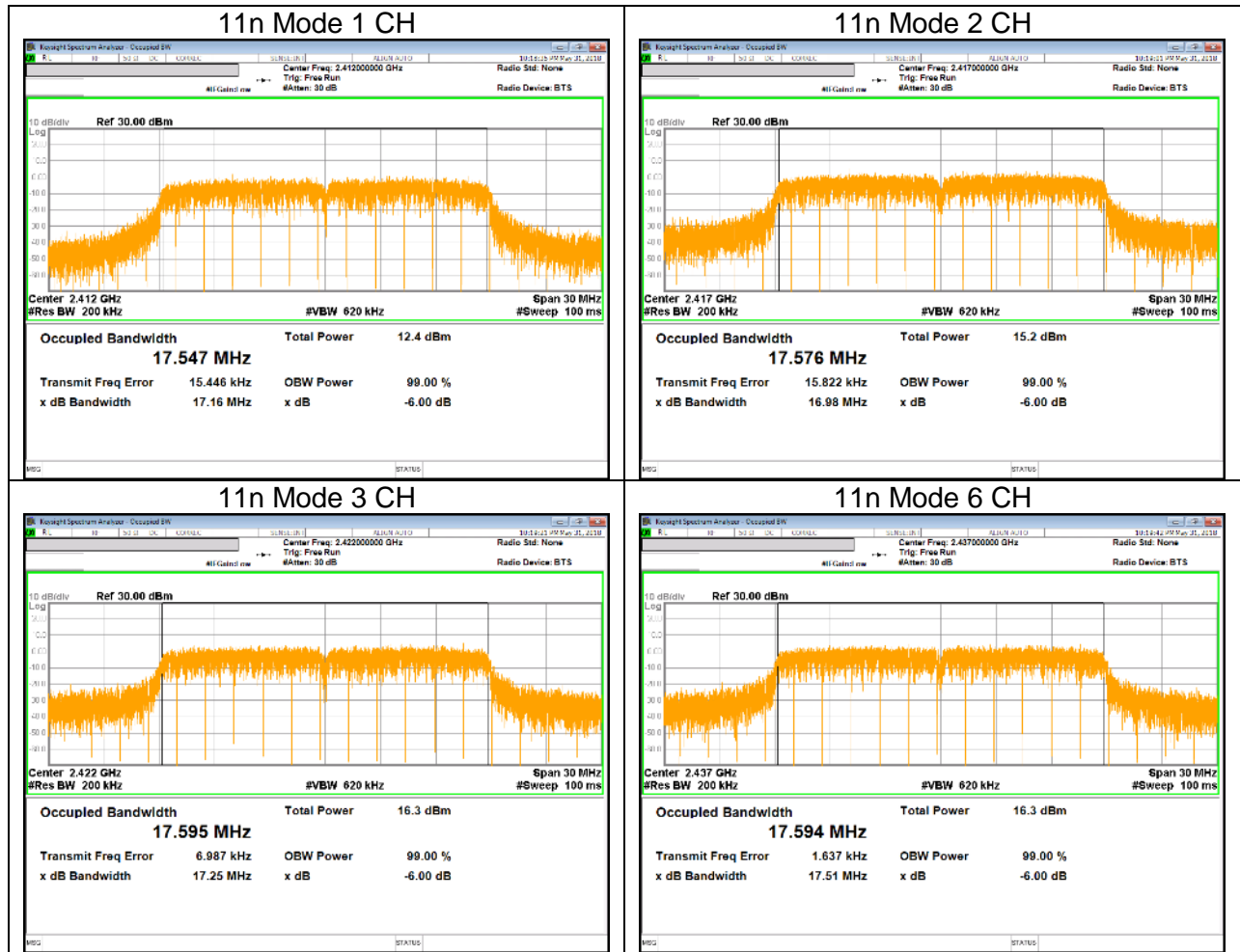



8. MEASUREMENT METHODS

6 dB BW : KDB 558074 D01 v04, Section 8.2.

OUTPUT POWER : KDB 558074 D01 v04, Section 9.2.3.1.

POWER SPECTRAL DENSITY : KDB 558074 D01 v04, Section 10.3./10.5.

Out-of-band EMISSIONS (Conducted) : KDB 558074 D01 v04, Section 11.1, 11.2.

Out-of-band EMISSIONS IN NON-RESTRICTED BANDS: KDB 558074 D01 v04, Section 11.0.

Out-of-band EMISSIONS IN RESTRICTED BANDS : KDB 558074 D01 v04, Section 12.1.

AC Power Line Conducted Emission : ANSI C63.10-2013, Section 6.2.

9. SUMMARY TABLE

FCC Part Section	IC Section	Test Description	Test Limit	Test Condition	Test Result
15.247 (a)(2)	RSS-247 5.2(a)	Occupied Band width (6dB)	>500KHz	Conducted	Pass
2.1051, 15.247 (d)	RSS-247 5.5	Band Edge / Conducted Spurious Emission	-30dBc		Pass
15.247 (b)(3)	RSS-247 5.4(d)	TX conducted output power	<30dBm		Pass
15.247 (e)	RSS-247 5.2(b)	PSD	<8dBm		Pass
15.207 (a)	RSS-GEN Clause 7 & 8.9	AC Power Line conducted emissions	Section 10	Power Line conducted	Pass
15.205, 15.209	RSS-GEN Clause 8.8	Radiated Spurious Emission	< 54dBuV/m	Radiated	Pass

10. ANTENNA PORT TEST RESULTS

10.1. 6 dB BANDWIDTH

LIMITS

FCC §15.247 (a) (2)
IC RSS-247 §5.2 (a)

The minimum 6 dB bandwidth shall be at least 500 kHz.

TEST PROCEDURE

Reference to KDB 558074 D01 DTS Meas Guidance v04: The transmitter output is connected to a spectrum analyzer with the RBW set to 100KHz, the VBW $\geq 3 \times$ RBW, peak detector and max hold.

RESULTS**10.1.1.802.11b MODE IN THE 2.4 GHz BAND**

Channel	Frequency [MHz]	6 dB Bandwidth [MHz]	Minimum Limit [MHz]
1	2412	8.541	0.5
2	2417	8.556	0.5
3	2422	9.017	0.5
6	2437	8.565	0.5
9	2452	8.052	0.5
10	2457	8.550	0.5
11	2462	8.044	0.5
Worst		8.044	0.5

10.1.1.1. 802.11g MODE IN THE 2.4 GHz BAND

Channel	Frequency [MHz]	6 dB Bandwidth [MHz]	Minimum Limit [MHz]
1	2412	15.920	0.5
2	2417	16.020	0.5
3	2422	16.290	0.5
6	2437	16.270	0.5
9	2452	16.300	0.5
10	2457	15.750	0.5
11	2462	16.300	0.5
Worst		15.750	0.5

10.1.2.802.11n HT20 MODE IN THE 2.4 GHz BAND

Channel	Frequency [MHz]	6 dB Bandwidth [MHz]	Minimum Limit [MHz]
1	2412	16.900	0.5
2	2417	16.900	0.5
3	2422	16.650	0.5
6	2437	16.540	0.5
9	2452	16.520	0.5
10	2457	16.780	0.5
11	2462	17.030	0.5
Worst		16.520	0.5

10.1.3. 6 dB BANDWIDTH PLOTS

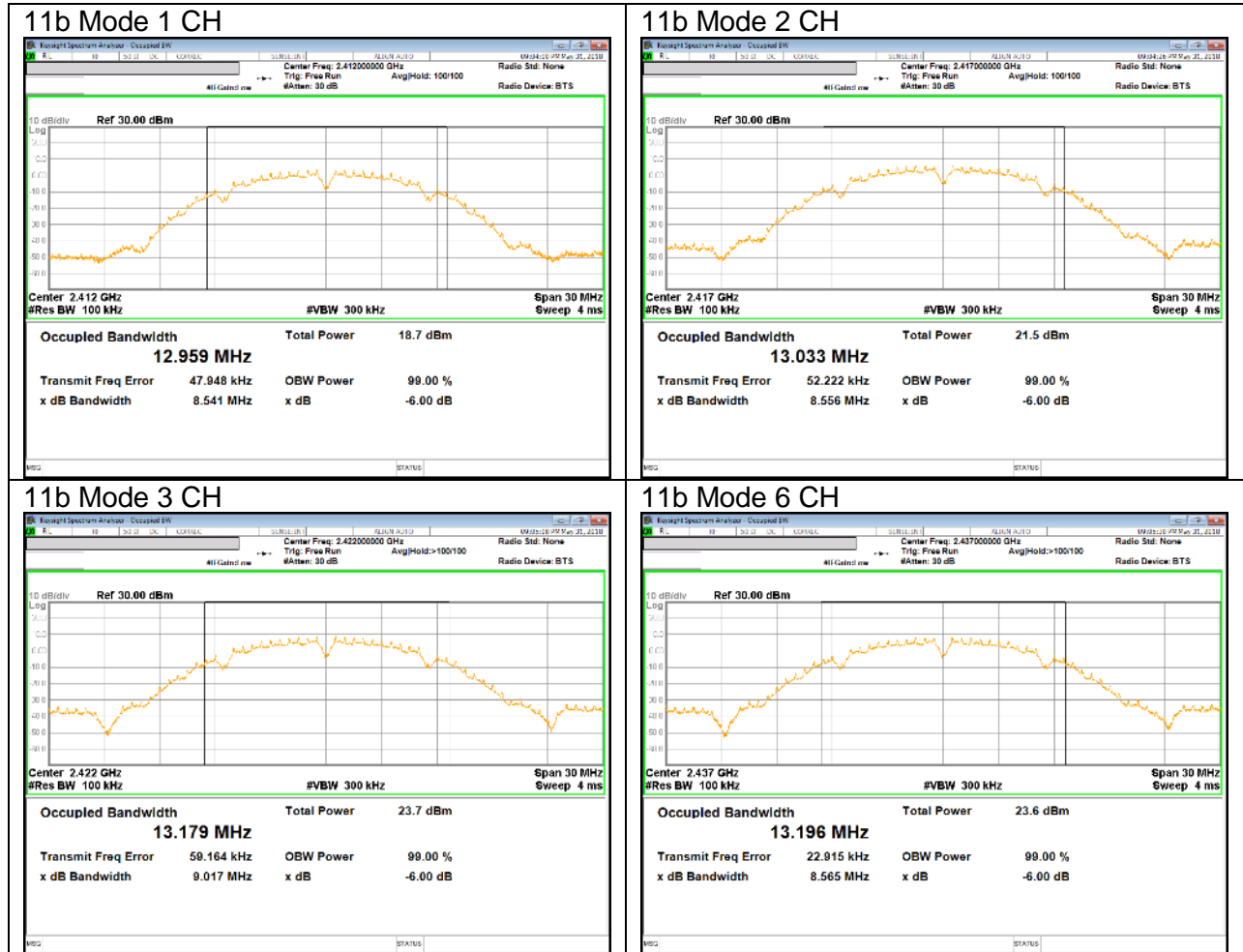

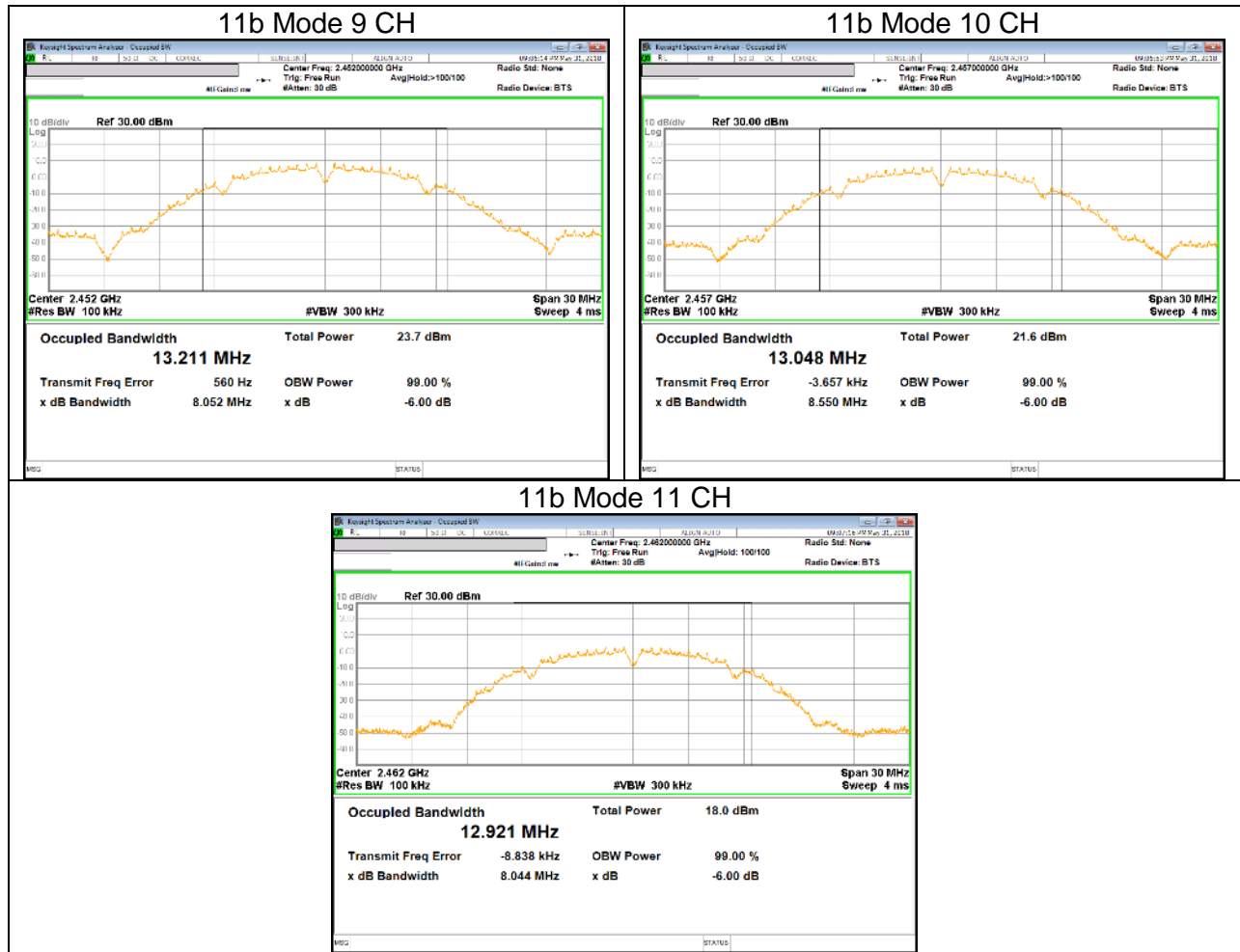

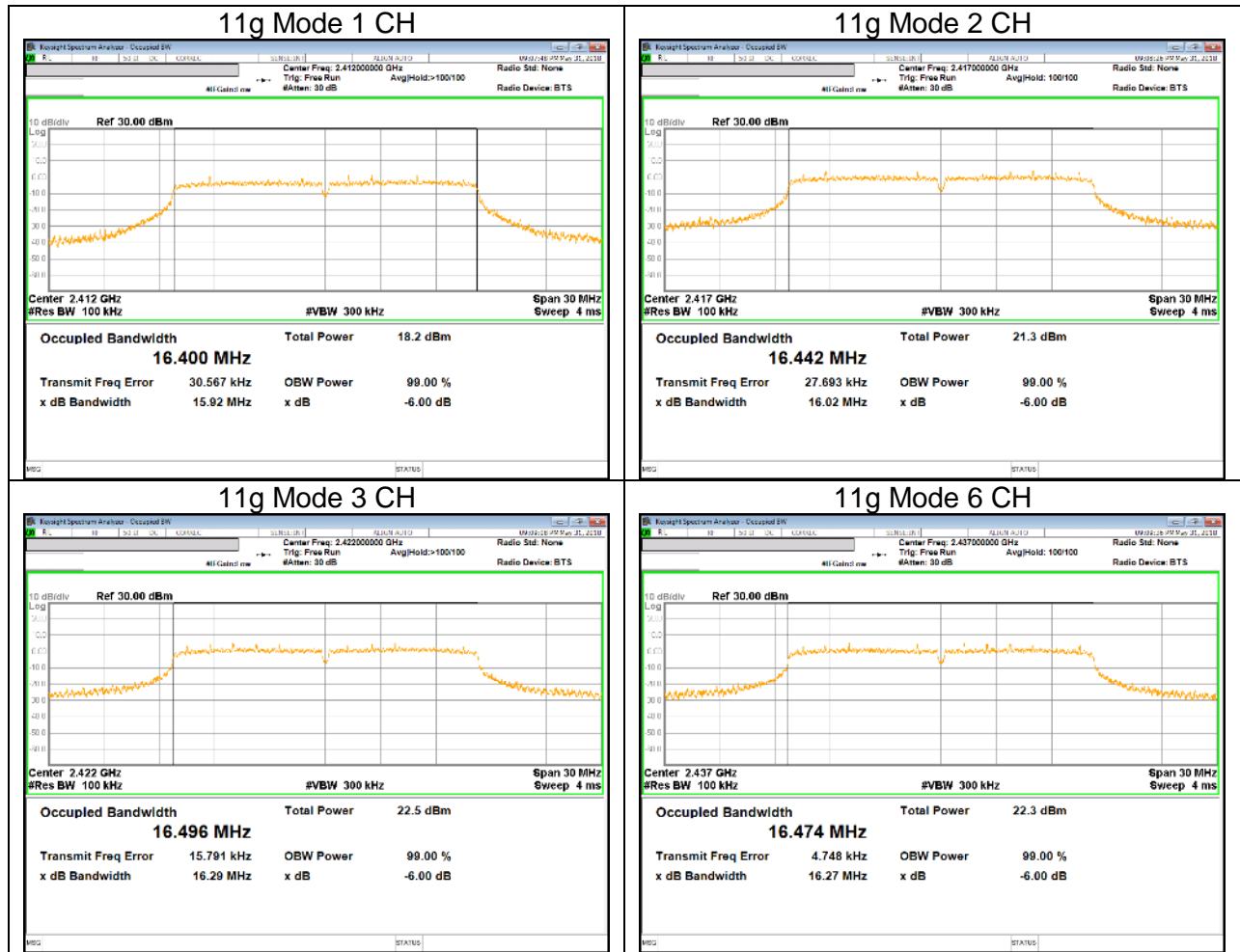

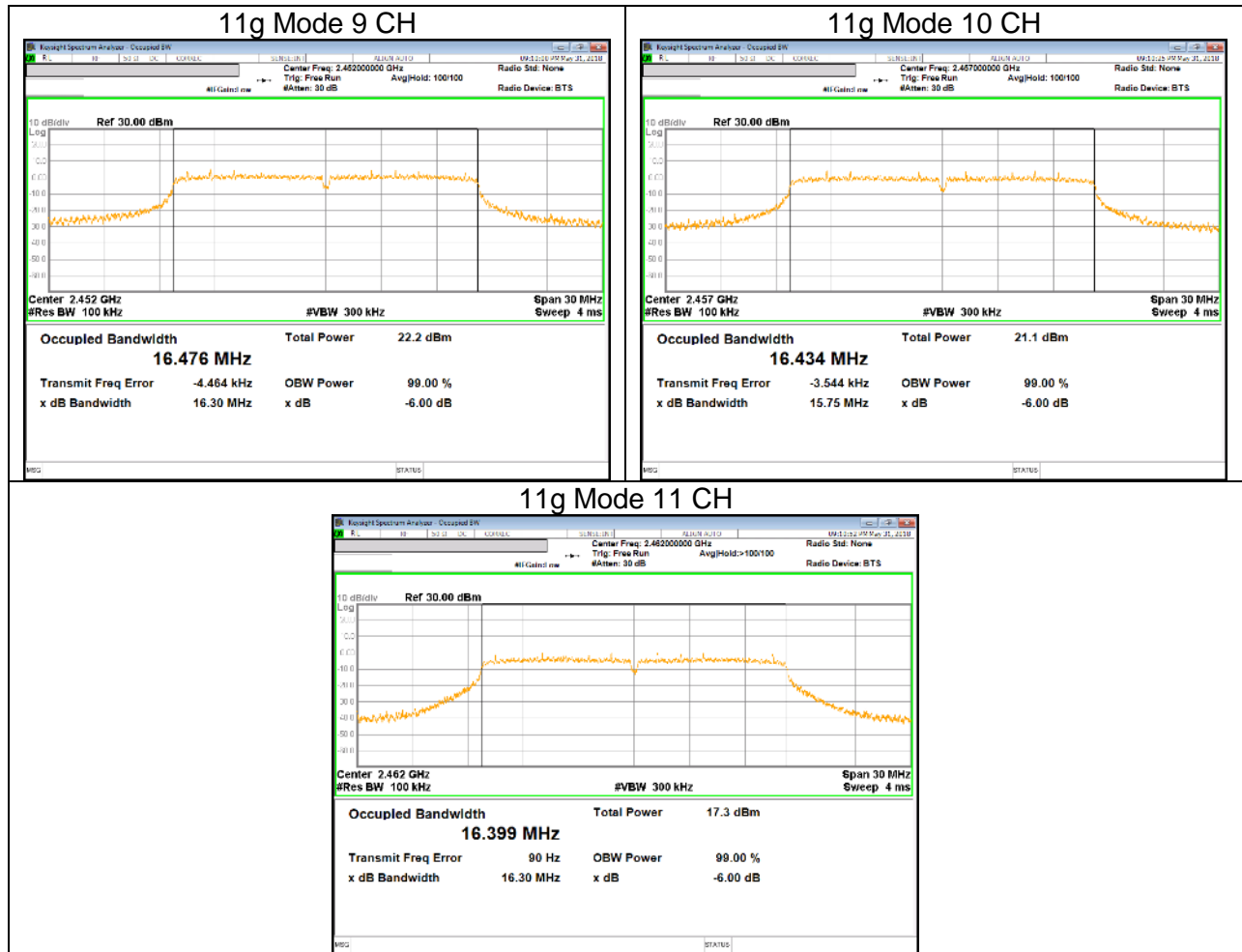

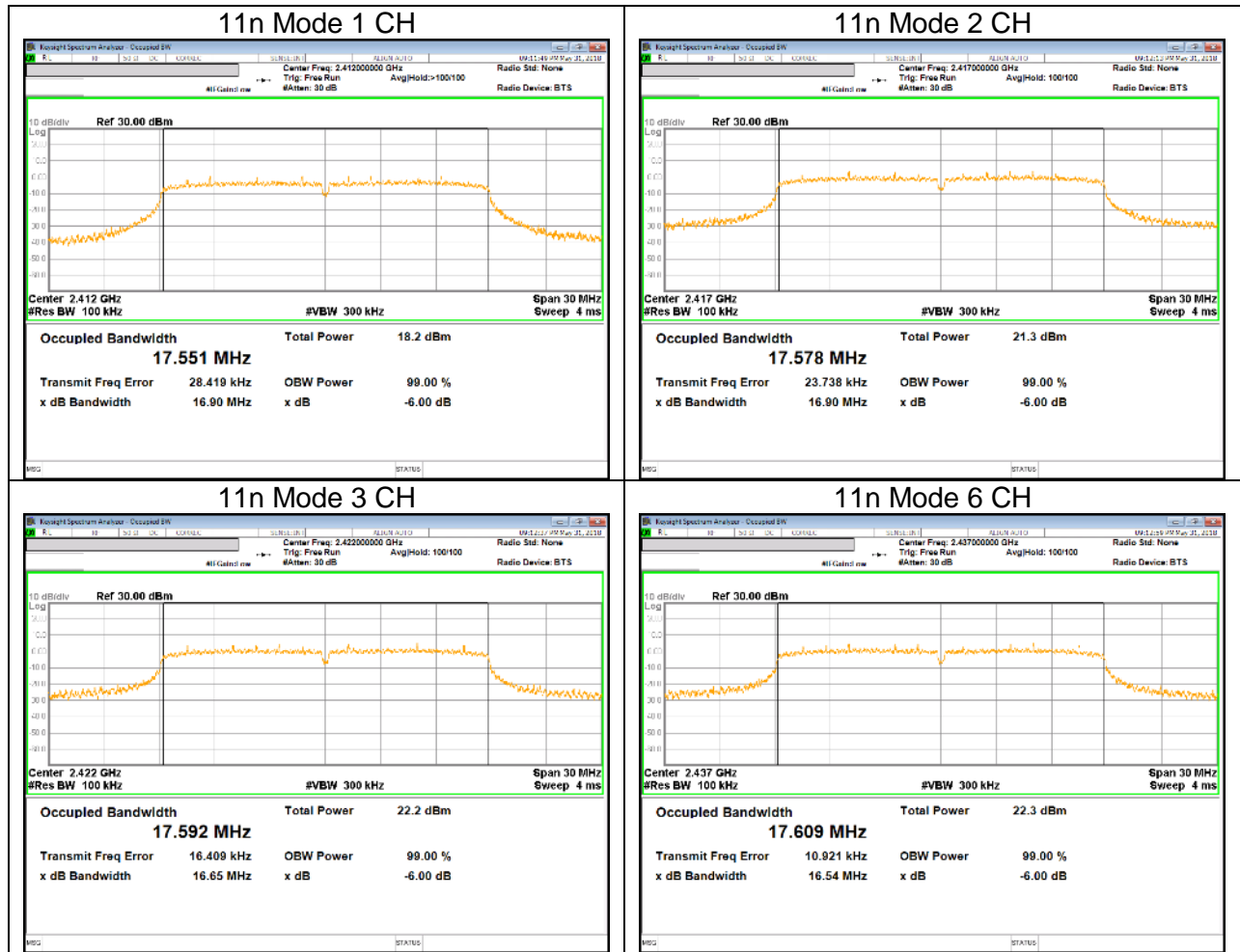

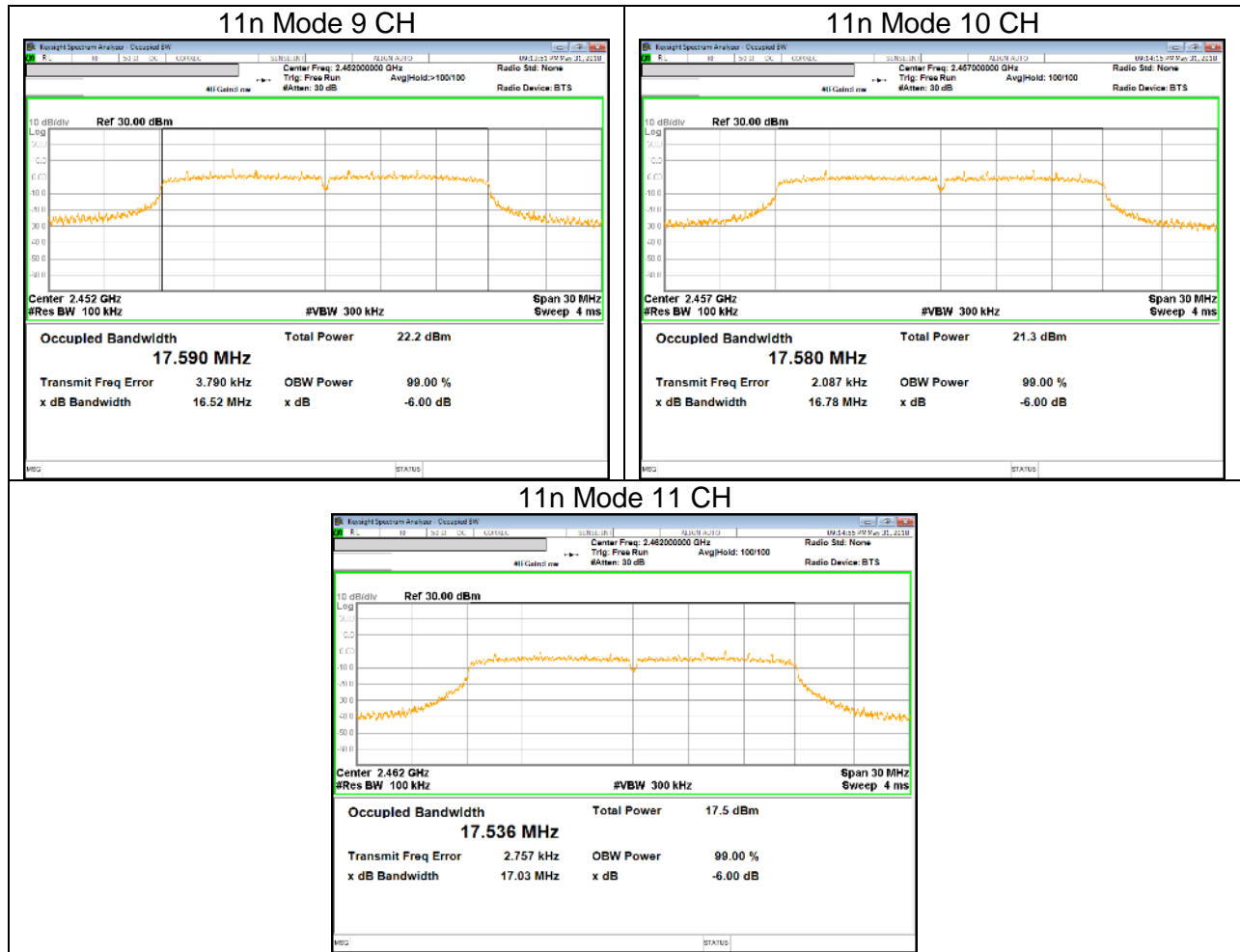

10.2. OUTPUT POWER

LIMITS

FCC §15.247
IC RSS-247 §5.4 (d)

For systems using digital modulation in the 902–928 MHz, 2400–2483.5 MHz, and 5725–5850 MHz bands: 1 Watt, based on the use of antennas with directional gains that do not exceed 6 dBi. If transmitting antennas of directional gain greater than 6 dBi are used, the conducted output power from the intentional radiator shall be reduced by the amount in dB that the directional gain of the antenna exceeds 6 dBi.

DIRECTIONAL ANTENNA GAIN

There is only one transmitter output therefore the directional gain is equal to the antenna gain.

TEST PROCEDURE

The transmitter output is connected to a power meter.

The cable assembly insertion loss was entered as an offset in the power meter to allow for direct reading of power.

Output power measurement was performed utilizing the “§9.2.3.1 AVGPM” under KDB558074 D01 DTS Meas Guidance v04.

Duty cycle correction factor is not added to the average output power results for duty cycle factor > 98%. (All mode)

10.2.1.802.11b MODE IN THE 2.4 GHz BAND**Limits**

Channel	Frequency [MHz]	Directional Gain Primary [dBi]	FCC Power Limit [dBm]	Max Power [dBm]
1	2412	0.90	30.00	30.00
2	2417	0.90	30.00	30.00
3	2422	0.90	30.00	30.00
6	2437	0.90	30.00	30.00
9	2452	0.90	30.00	30.00
10	2457	0.90	30.00	30.00
11	2462	0.90	30.00	30.00

Results

Channel	Frequency [MHz]	Meas Power [dBm]	Total Power [dBm]	Power Limit [dBm]	Margin [dB]
1	2412	12.16	12.16	30.00	-17.84
2	2417	14.98	14.98	30.00	-15.02
3	2422	17.03	17.03	30.00	-12.97
6	2437	17.01	17.01	30.00	-12.99
9	2452	17.03	17.03	30.00	-12.97
10	2457	15.01	15.01	30.00	-14.99
11	2462	10.99	10.99	30.00	-19.01
Worst			17.03	30.00	-12.97

10.2.2.802.11g MODE IN THE 2.4 GHz BAND

Limits

Channel	Frequency [MHz]	Directional Gain Primary [dBi]	FCC Power Limit [dBm]	Max Power [dBm]
1	2412	0.90	30.00	30.00
2	2417	0.90	30.00	30.00
3	2422	0.90	30.00	30.00
6	2437	0.90	30.00	30.00
9	2452	0.90	30.00	30.00
10	2457	0.90	30.00	30.00
11	2462	0.90	30.00	30.00

Results

Channel	Frequency [MHz]	Meas Power [dBm]	Total Power [dBm]	Power Limit [dBm]	Margin [dB]
1	2412	12.11	12.11	30.00	-17.89
2	2417	14.95	14.95	30.00	-15.05
3	2422	15.95	15.95	30.00	-14.05
6	2437	15.94	15.94	30.00	-14.06
9	2452	15.95	15.95	30.00	-14.05
10	2457	14.84	14.84	30.00	-15.16
11	2462	11.13	11.13	30.00	-18.87
Worst			15.95	30.00	-14.05

10.2.3.802.11n HT20 MODE IN THE 2.4 GHz BAND

Limits

Channel	Frequency [MHz]	Directional Gain Primary [dBi]	FCC Power Limit [dBm]	Max Power [dBm]
1	2412	0.90	30.00	30.00
2	2417	0.90	30.00	30.00
3	2422	0.90	30.00	30.00
6	2437	0.90	30.00	30.00
9	2452	0.90	30.00	30.00
10	2457	0.90	30.00	30.00
11	2462	0.90	30.00	30.00

Results

Channel	Frequency [MHz]	Meas Power [dBm]	Total Power [dBm]	Power Limit [dBm]	Margin [dB]
1	2412	12.03	12.03	30.00	-17.97
2	2417	15.00	15.00	30.00	-15.00
3	2422	15.88	15.88	30.00	-14.12
6	2437	15.90	15.90	30.00	-14.10
9	2452	15.91	15.91	30.00	-14.09
10	2457	14.88	14.88	30.00	-15.12
11	2462	11.12	11.12	30.00	-18.88
Worst			15.91	30.00	-14.09

10.3. PSD

LIMITS

FCC §15.247
IC RSS-247 §5.2 (b)

The power spectral density conducted from the transmitter to the antenna shall not be greater than 8 dBm in any 3 kHz band during any time interval of continuous transmission.

TEST PROCEDURE

Power Spectral Density was performed utilizing the "Method §10.3 AVGPS-1 (802.11 b/g/n mode) under KDB558074 D01 DTS Meas Guidance v04.

RESULTS

10.3.1.802.11b MODE IN THE 2.4 GHZ BAND

PSD Results

Channel	Frequency [MHz]	PSD Meas [dBm]	Duty Factor [dB]	Final PSD [dBm/3kHz]	Limit [dBm/3kHz]	Margin [dB]
1	2412	-19.287	0.00	-19.287	8.00	-27.287
2	2417	-16.131	0.00	-16.131	8.00	-24.131
3	2422	-14.319	0.00	-14.319	8.00	-22.319
6	2437	-14.397	0.00	-14.397	8.00	-22.397
9	2452	-14.221	0.00	-14.221	8.00	-22.221
10	2457	-16.206	0.00	-16.206	8.00	-24.206
11	2462	-20.209	0.00	-20.209	8.00	-28.209

10.3.2.802.11g MODE IN THE 2.4 GHZ BAND

PSD Results

Channel	Frequency [MHz]	PSD Meas [dBm]	Duty Factor [dB]	Final PSD [dBm/3kHz]	Limit [dBm/3kHz]	Margin [dB]
1	2412	-21.586	0.00	-21.586	8.00	-29.586
2	2417	18.924	0.00	18.924	8.00	10.924
3	2422	-17.897	0.00	-17.897	8.00	-25.897
6	2437	-18.036	0.00	-18.036	8.00	-26.036
9	2452	-18.133	0.00	-18.133	8.00	-26.133
10	2457	-19.292	0.00	-19.292	8.00	-27.292
11	2462	-22.978	0.00	-22.978	8.00	-30.978

10.3.3.802.11n HT20 MODE IN THE 2.4 GHZ BAND

PSD Results

Channel	Frequency [MHz]	PSD Meas [dBm]	Duty Factor [dB]	Final PSD [dBm/3kHz]	Limit [dBm/3kHz]	Margin [dB]
1	2412	-21.669	0.00	-21.669	8.00	-29.669
2	2417	-19.023	0.00	-19.023	8.00	-27.023
3	2422	-18.164	0.00	-18.164	8.00	-26.164
6	2437	-18.328	0.00	-18.328	8.00	-26.328
9	2452	-17.843	0.00	-17.843	8.00	-25.843
10	2457	-19.371	0.00	-19.371	8.00	-27.371
11	2462	-22.728	0.00	-22.728	8.00	-30.728

10.3.4.PSD PLOTS

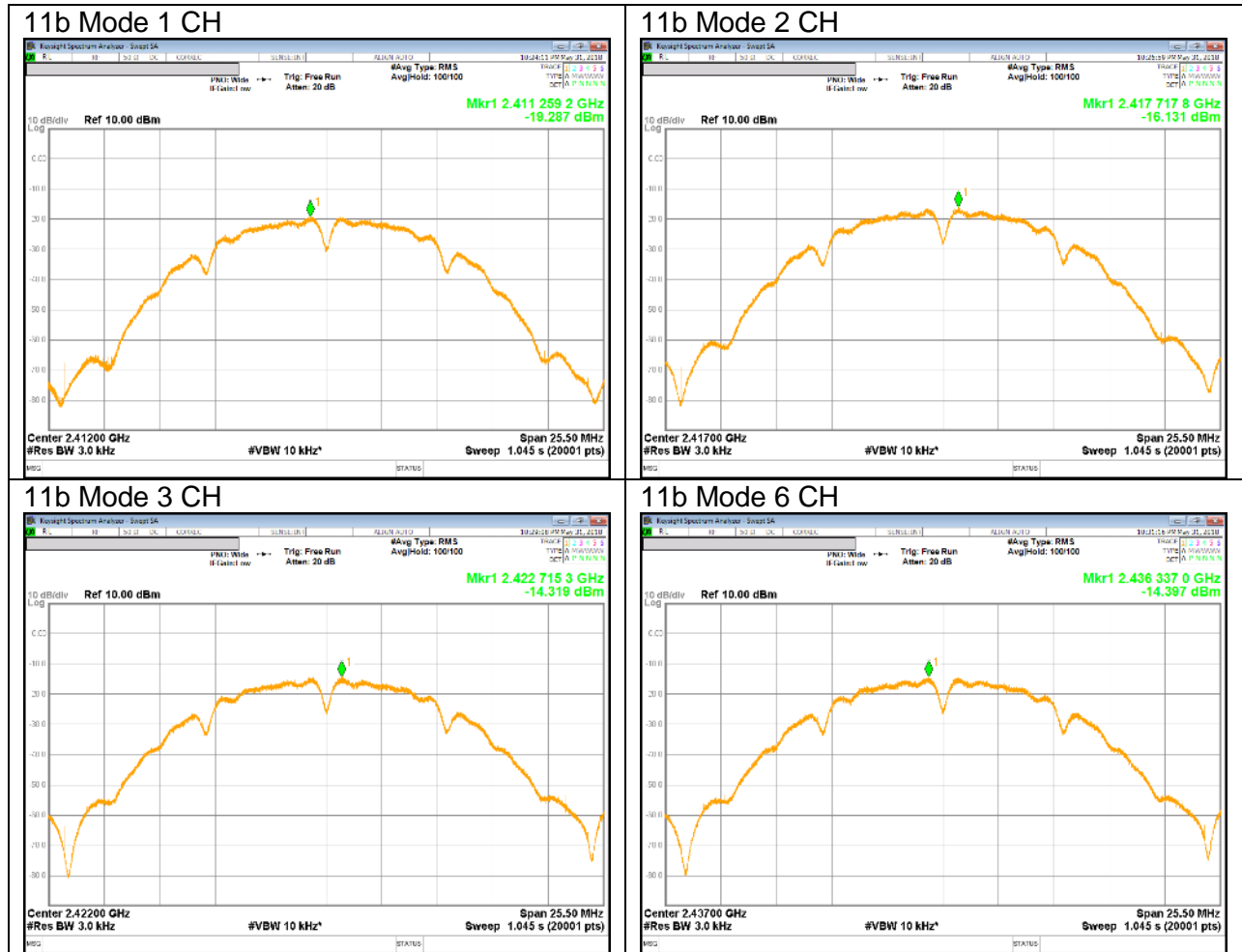

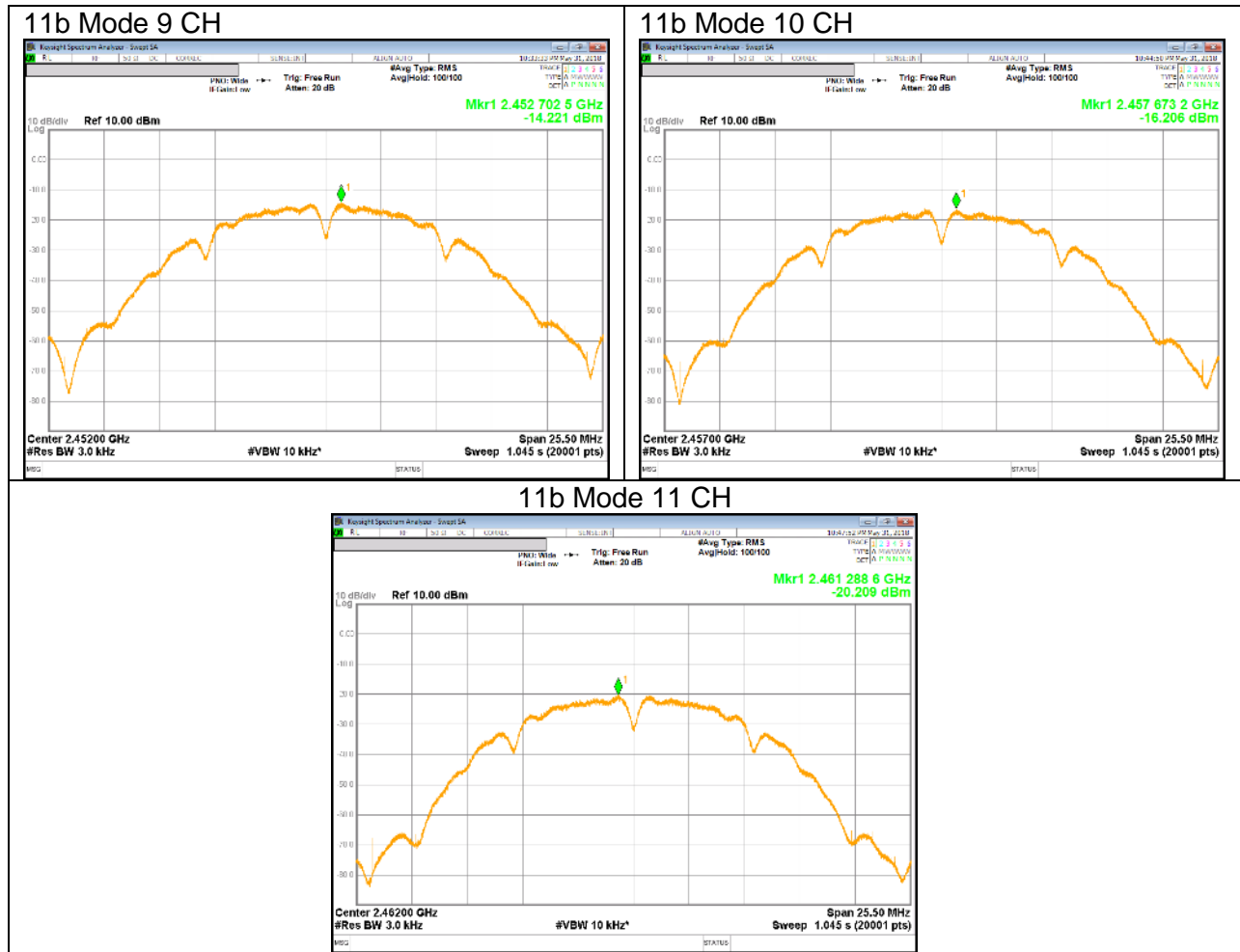

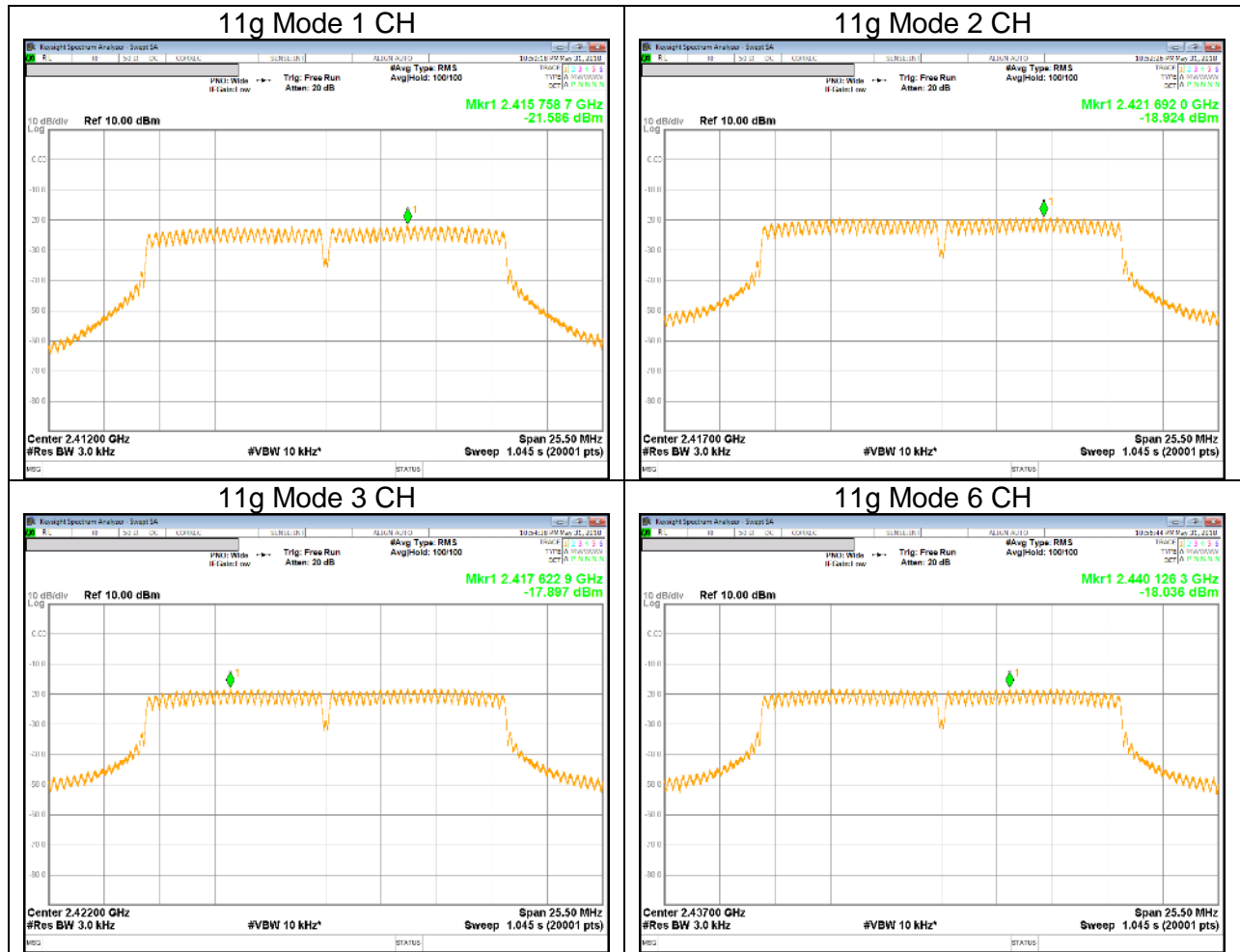

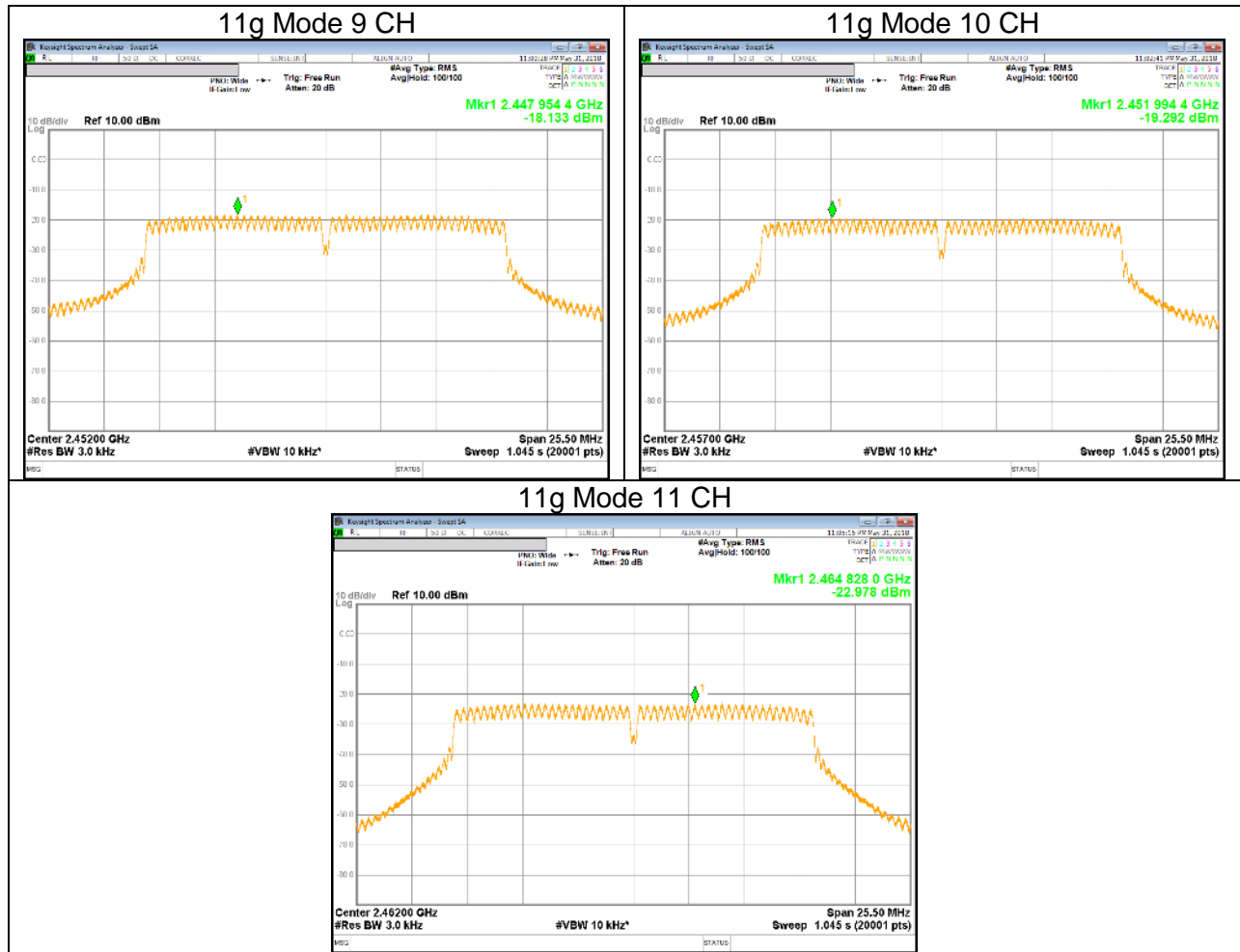

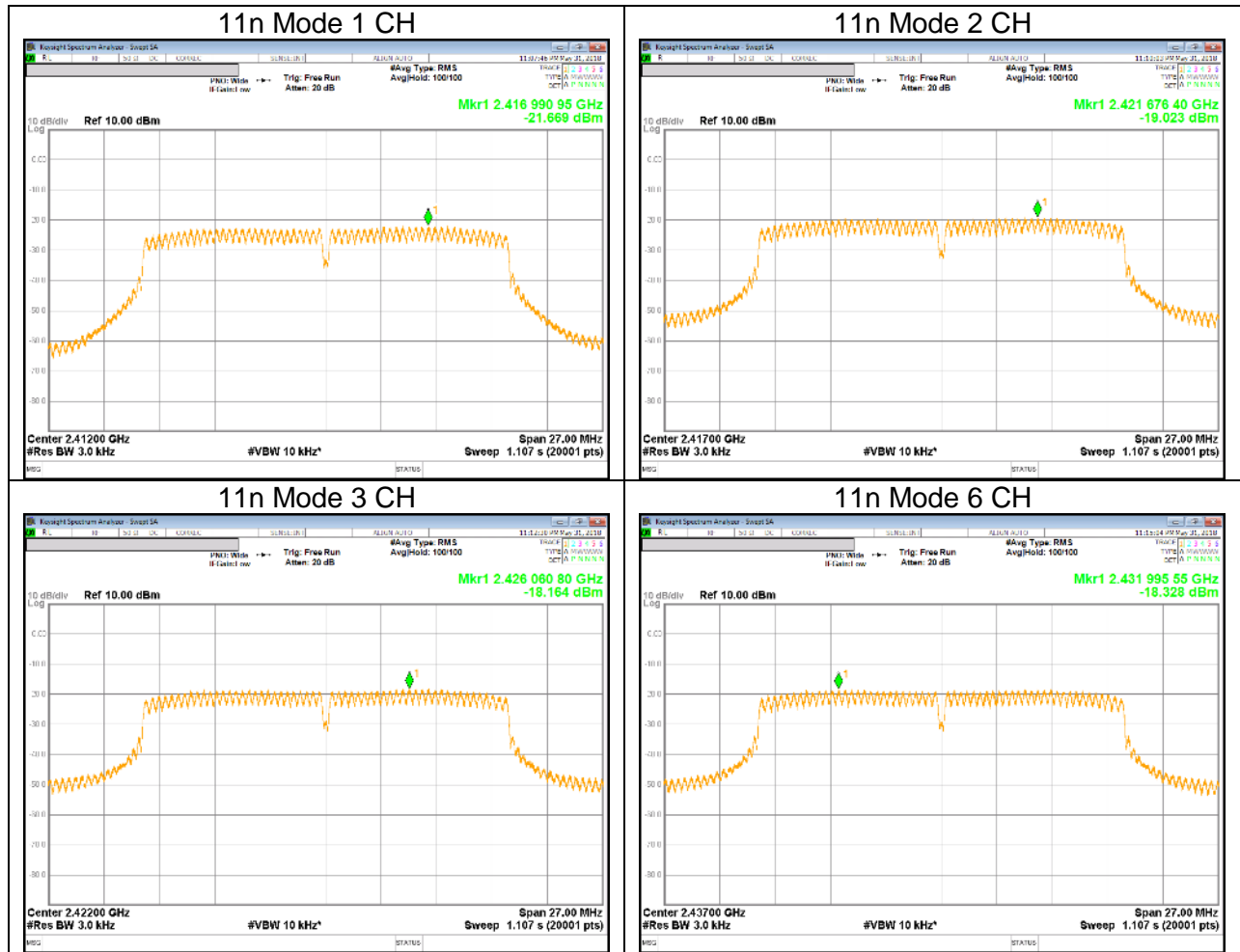

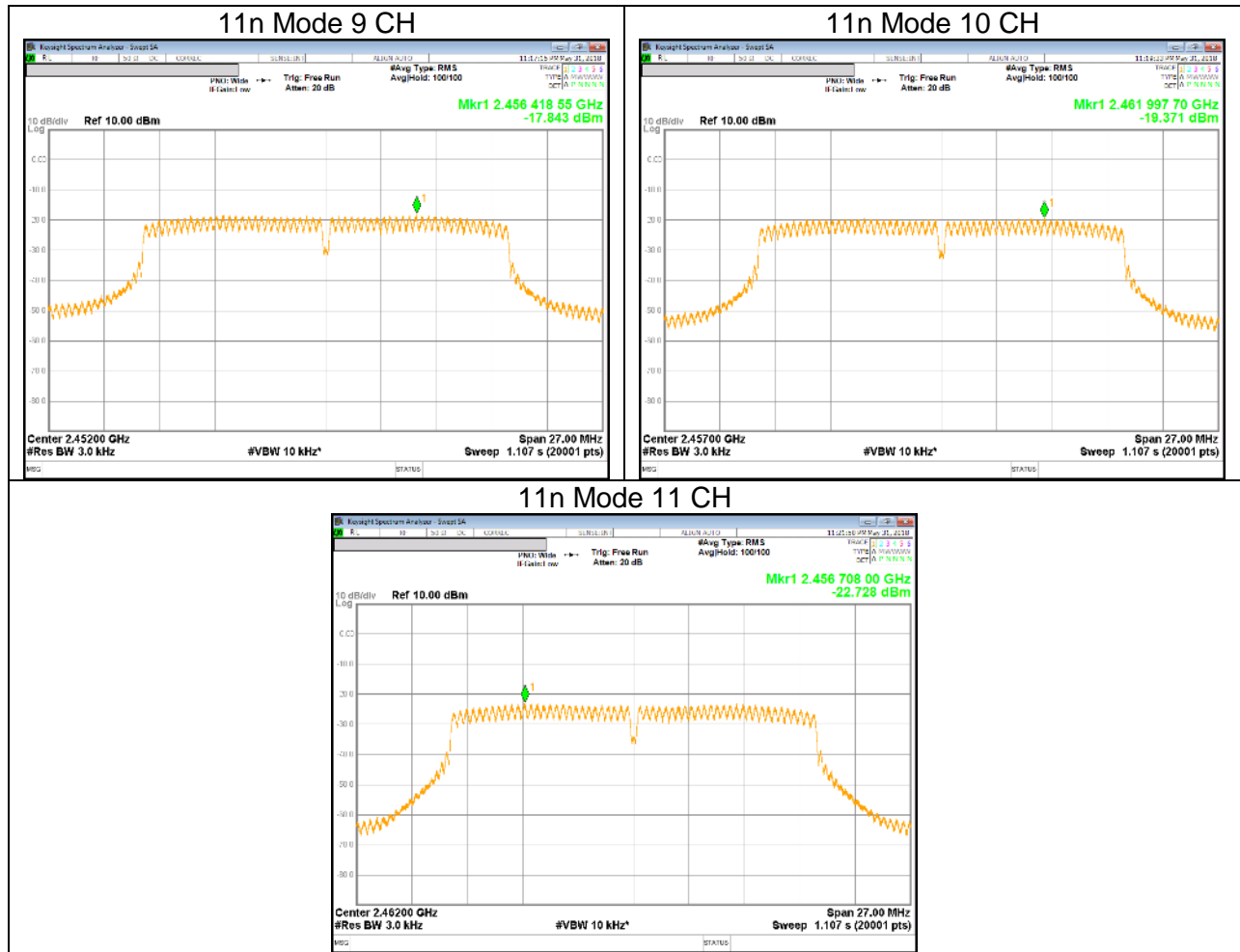

10.4. OUT-OF-BAND EMISSIONS

LIMITS

FCC §15.247 (d)
IC RSS-247 §5.5

In any 100 kHz bandwidth outside the frequency band in which the spread spectrum or digitally modulated intentional radiator is operating, the radio frequency power that is produced by the intentional radiator shall be at least 20 dB below that in the 100 kHz bandwidth within the band that contains the highest level of the desired power, based on either an RF conducted or a radiated measurement, provided the transmitter demonstrates compliance with the peak conducted power limits. If the transmitter complies with the conducted power limits based on the use of RMS averaging over a time interval, as permitted under paragraph (b)(3) of this section, the attenuation required under this paragraph shall be 30 dB instead of 20 dB. Attenuation below the general limits specified in §15.209(a) is not required.

TEST PROCEDURE

The transmitter output is connected to a spectrum analyzer with RBW = 100 kHz, VBW = 300 kHz, peak detector, and max hold. Measurements utilizing these settings are made of the in-band reference level, bandedge, out-of-band emissions (where measurements to the general radiated limits will not be made)

RESULTS

10.4.1.802.11b MODE IN THE 2.4 GHz BAND

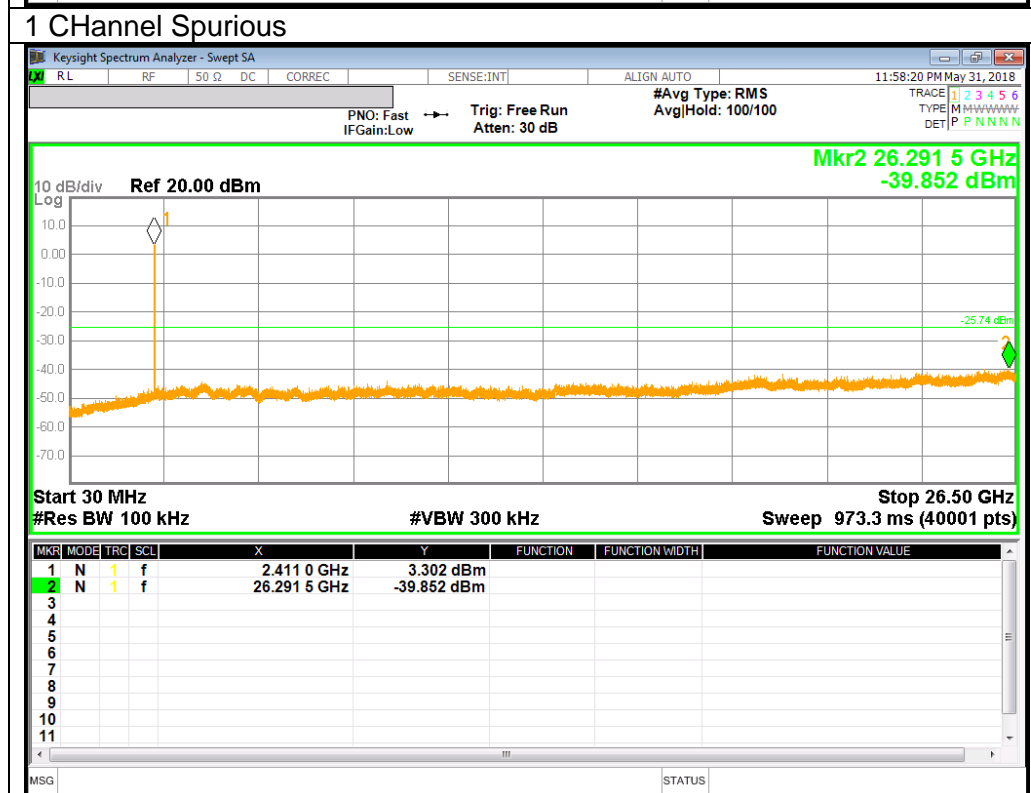
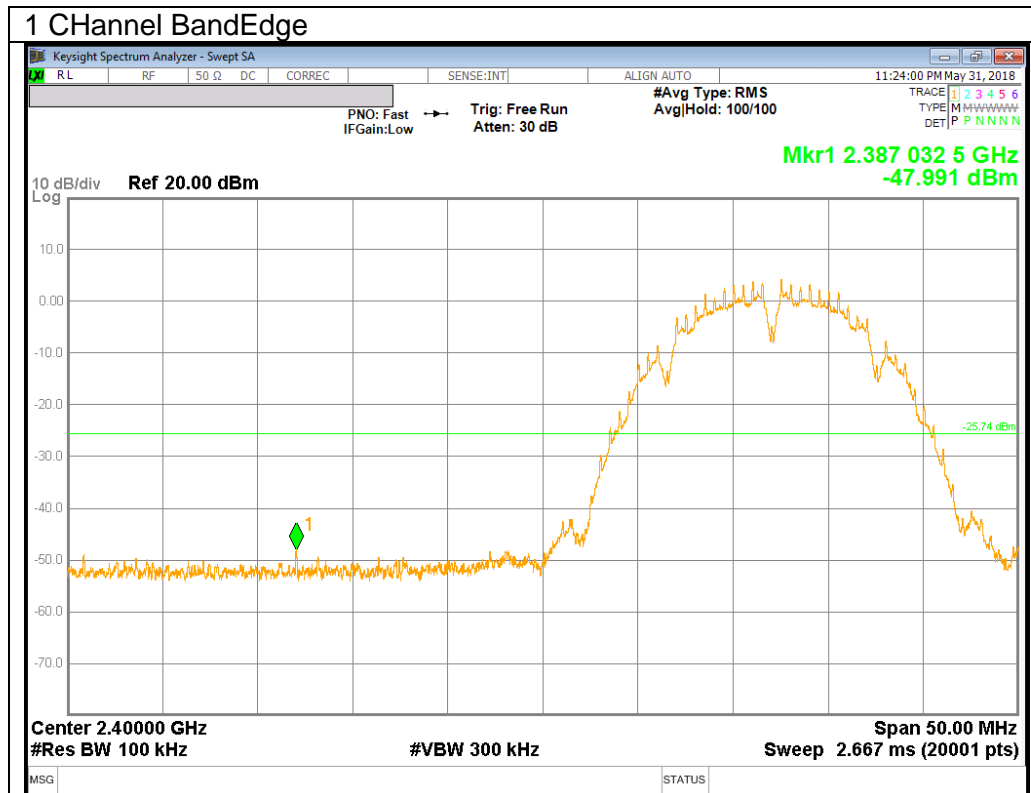

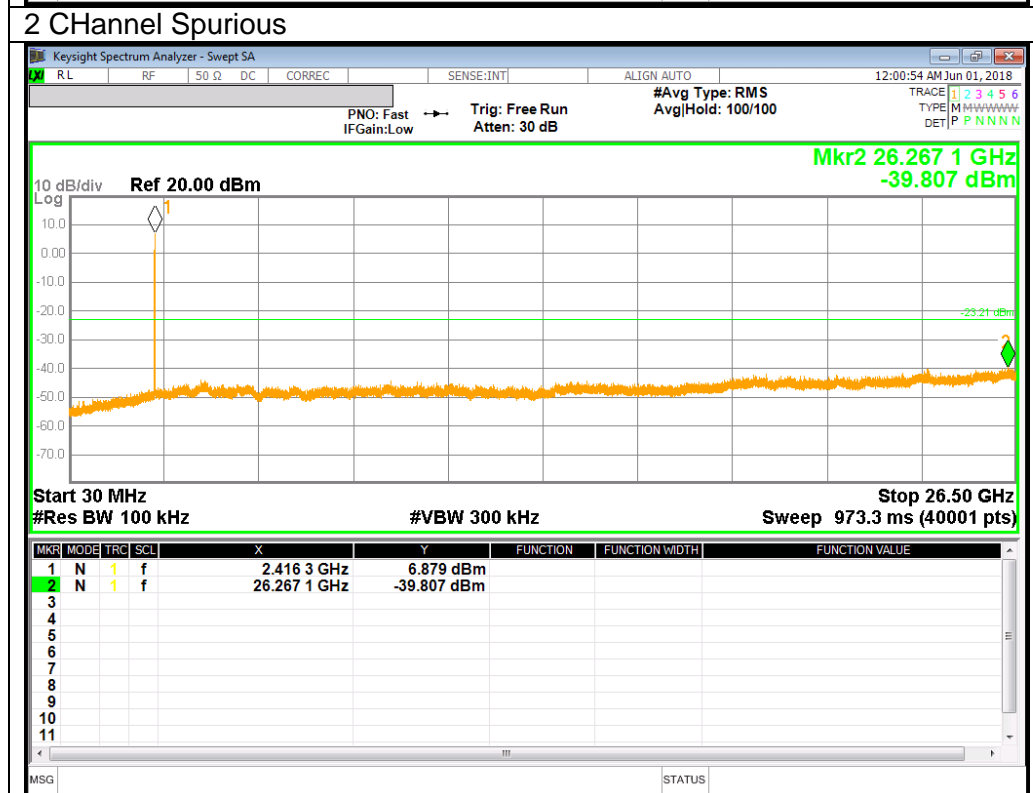
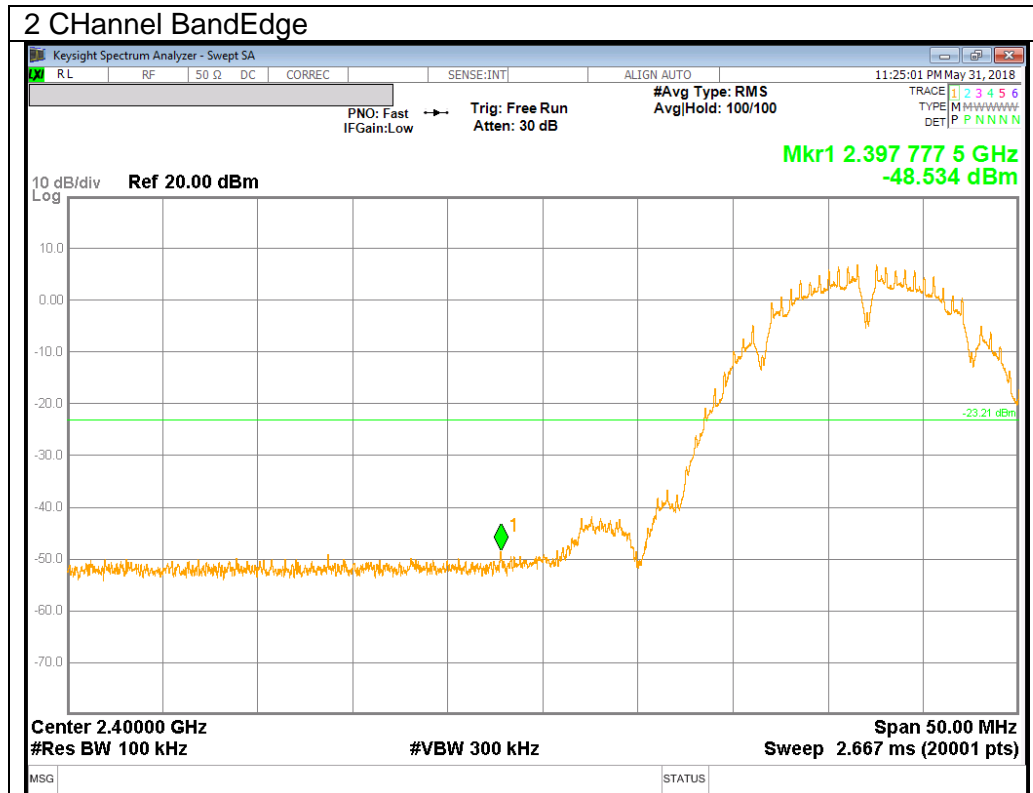

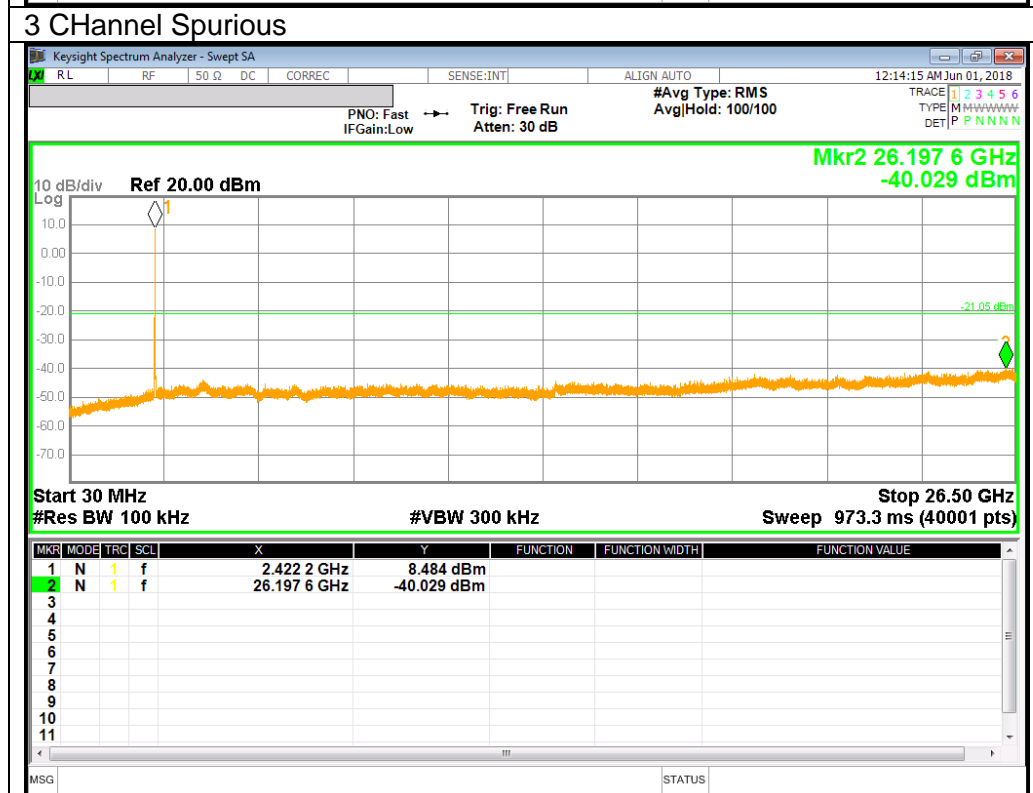
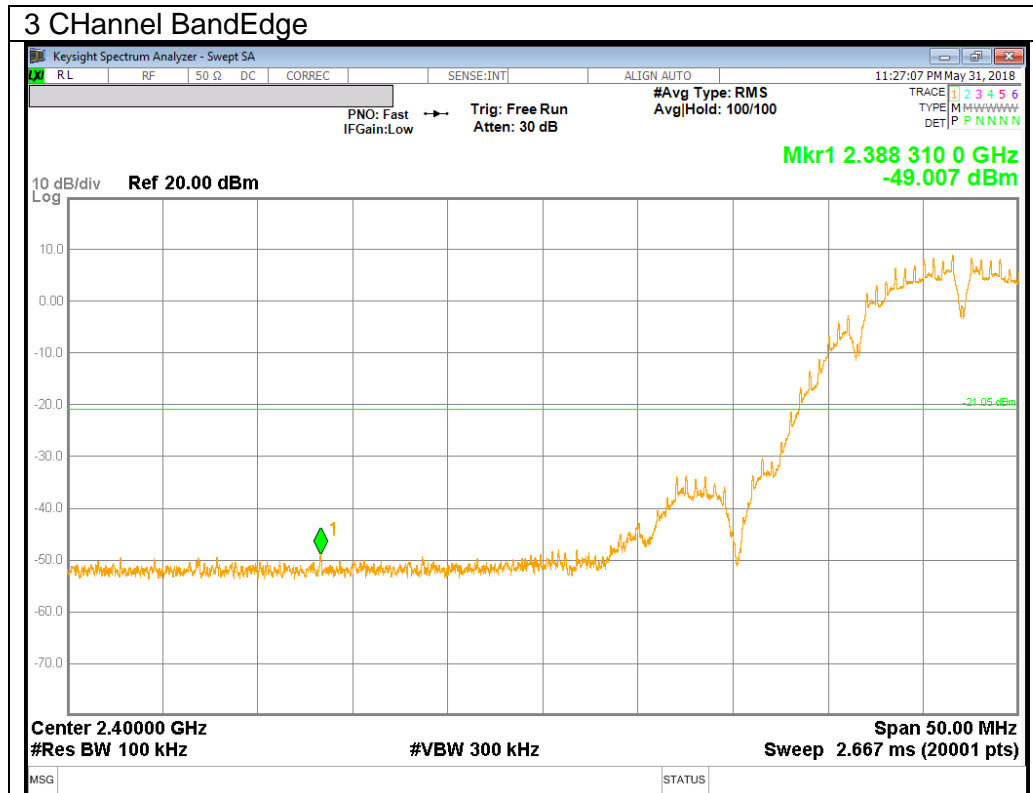

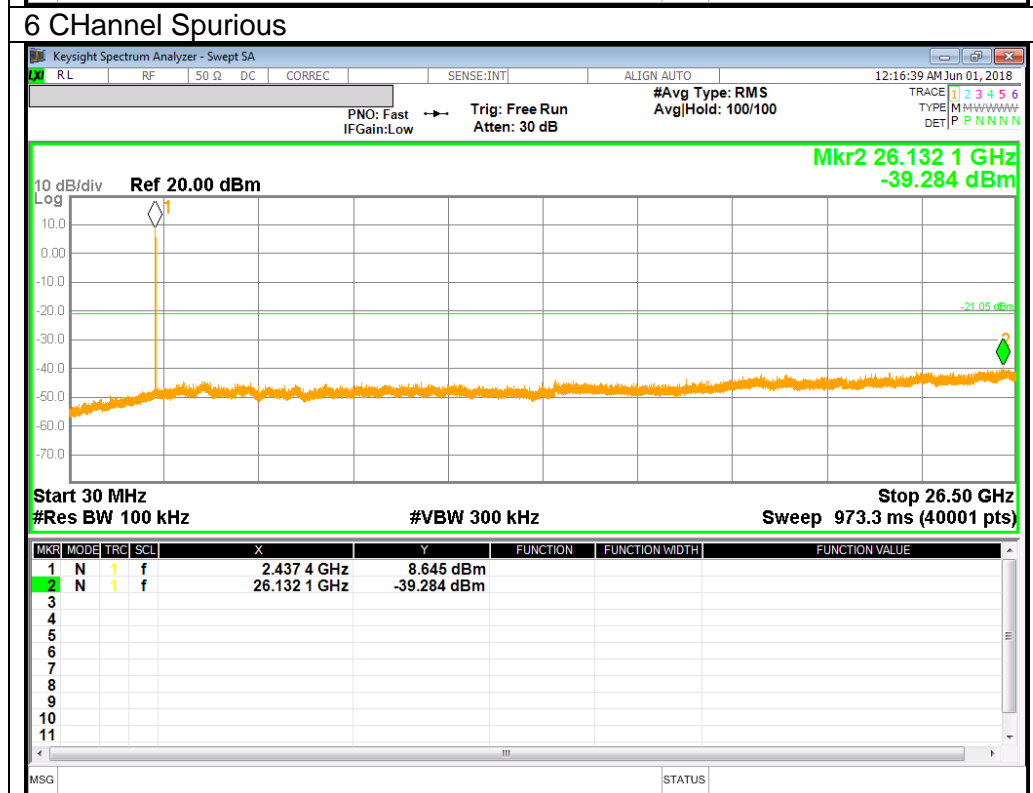
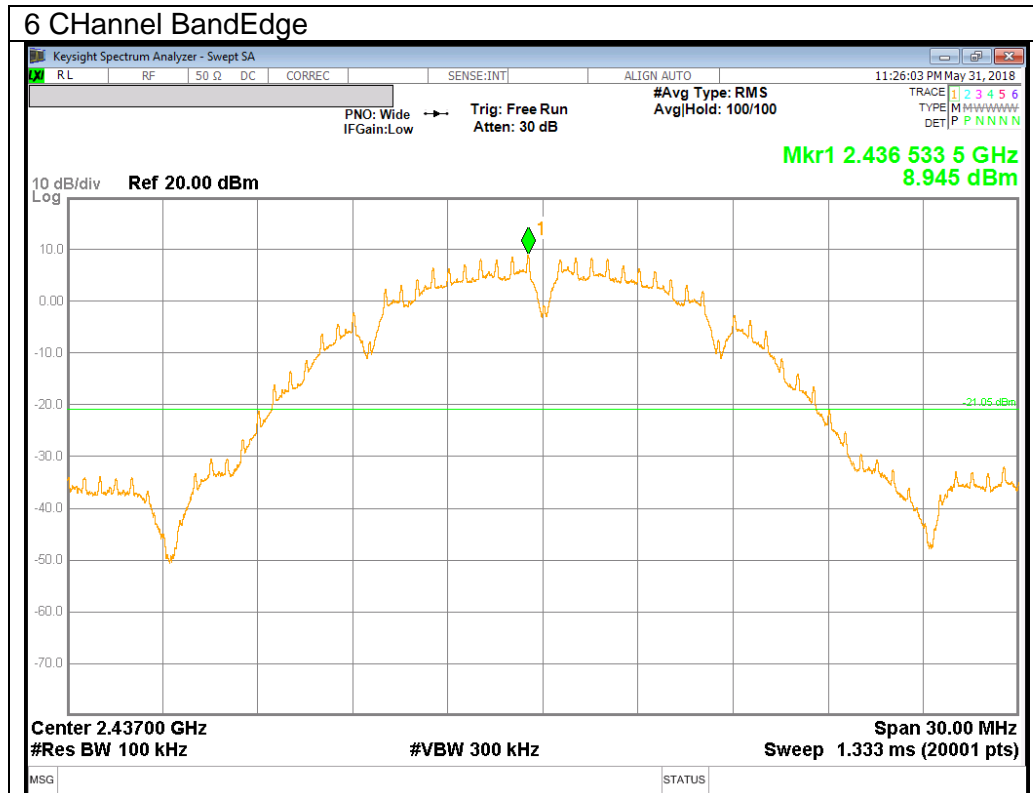

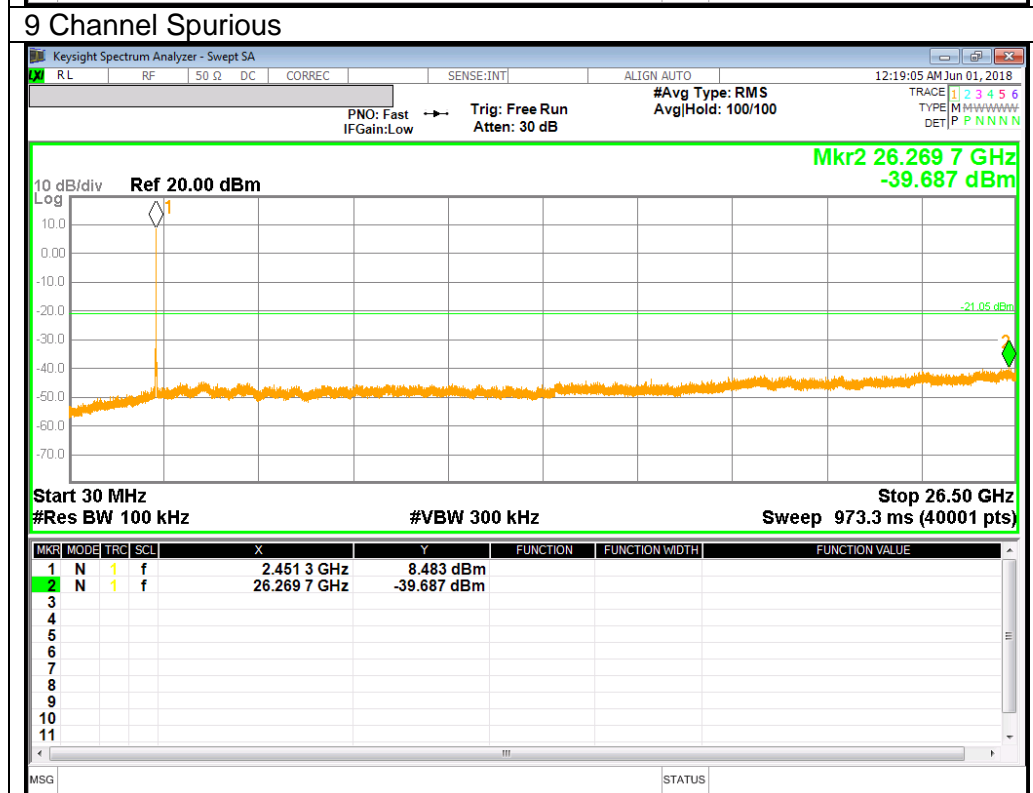
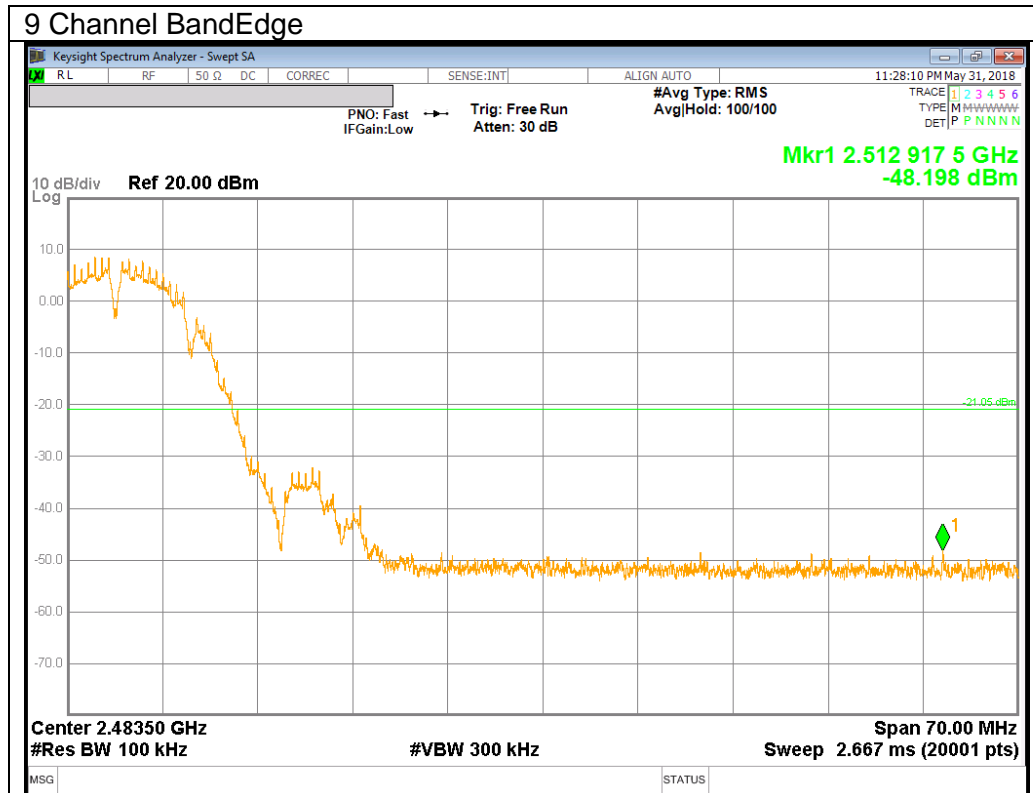

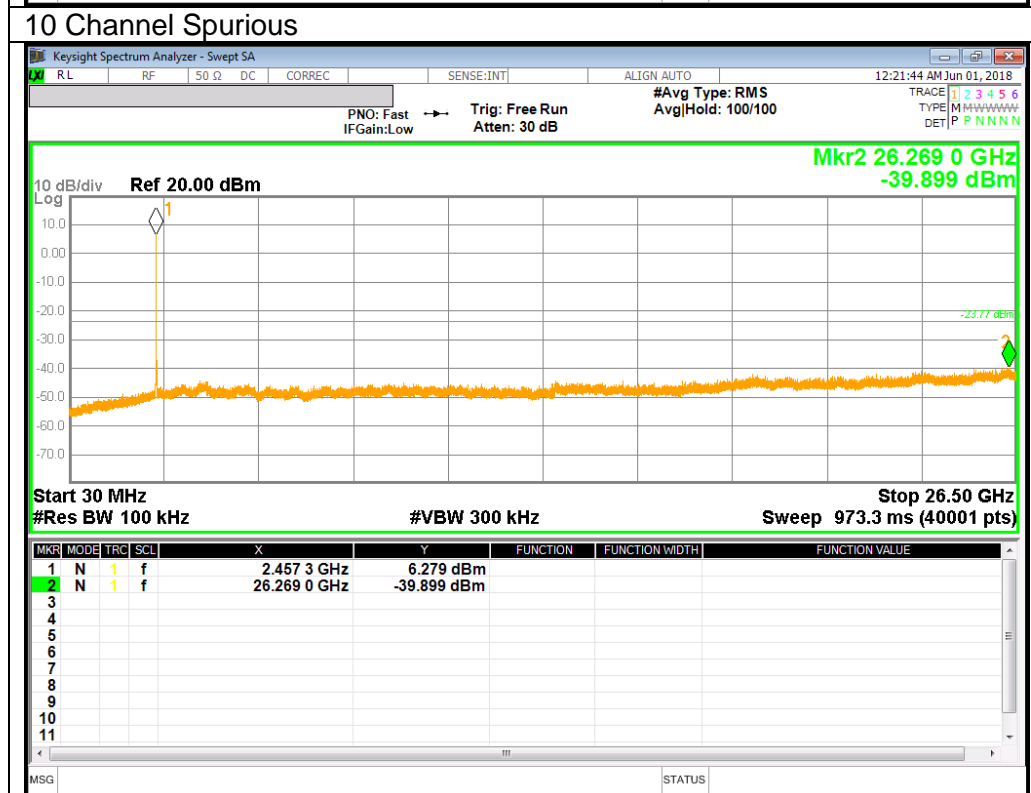
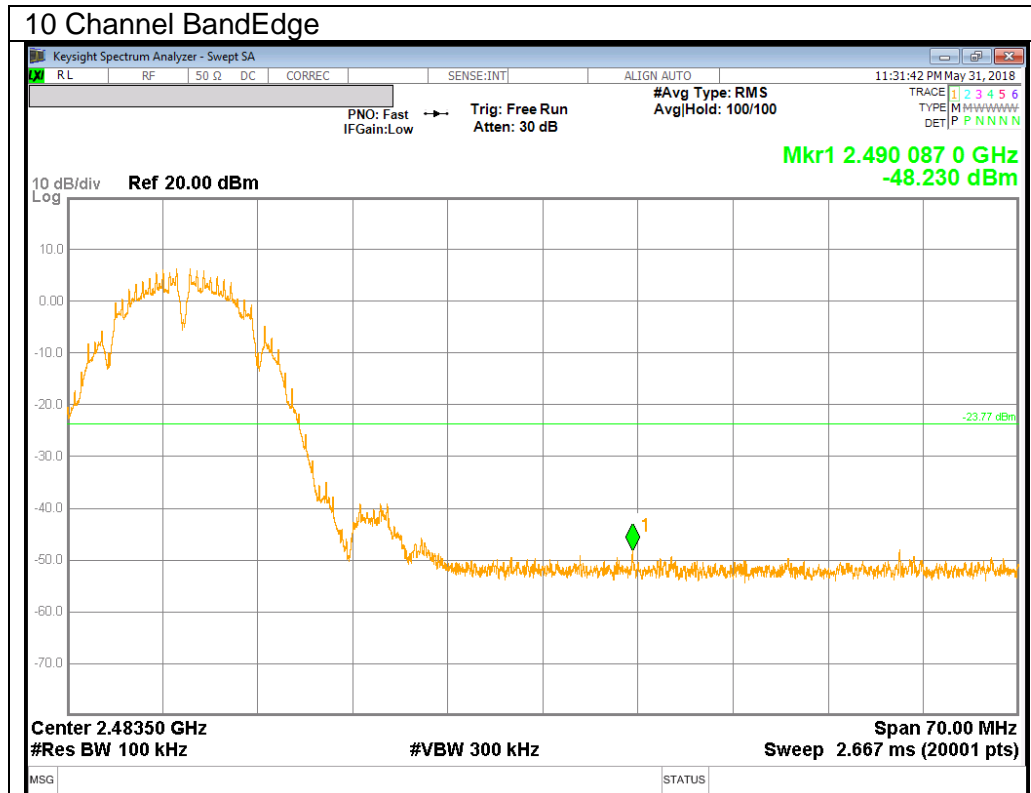

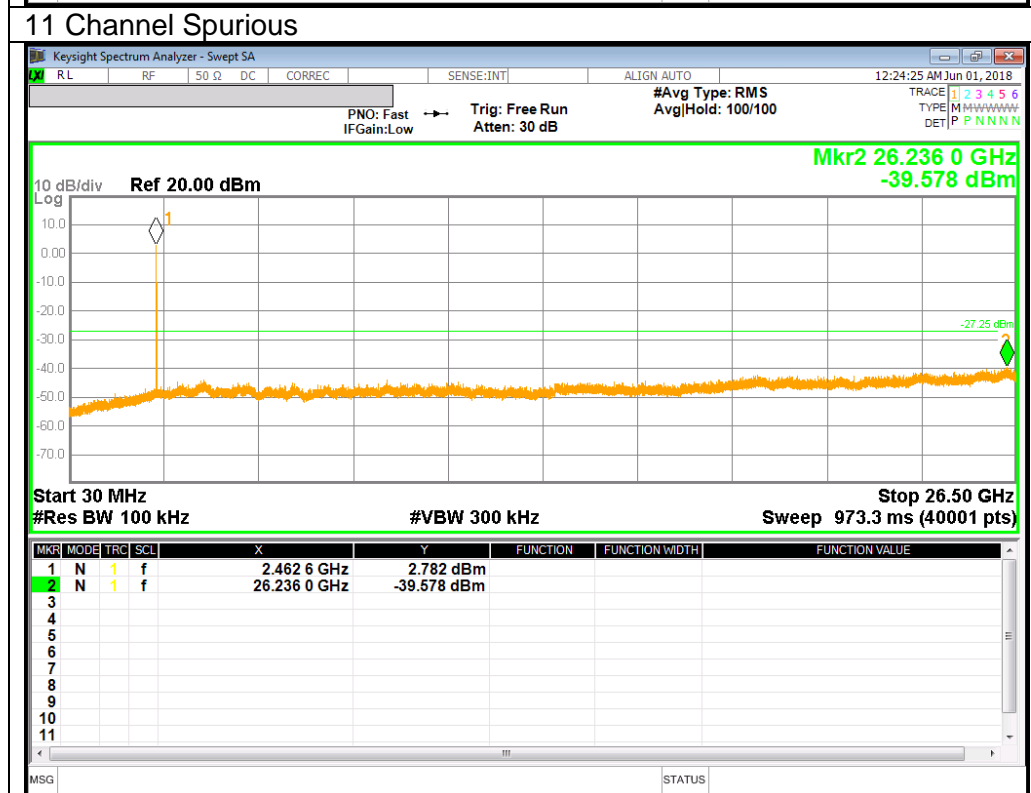
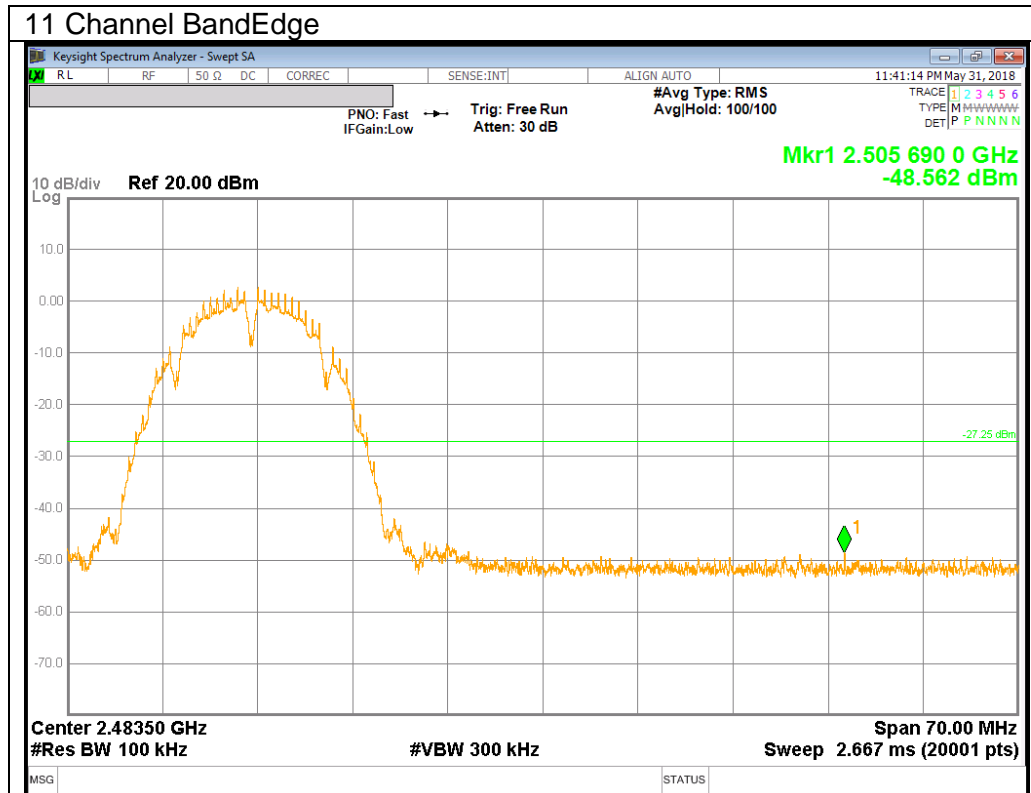

10.4.2.802.11g MODE IN THE 2.4 GHZ BAND

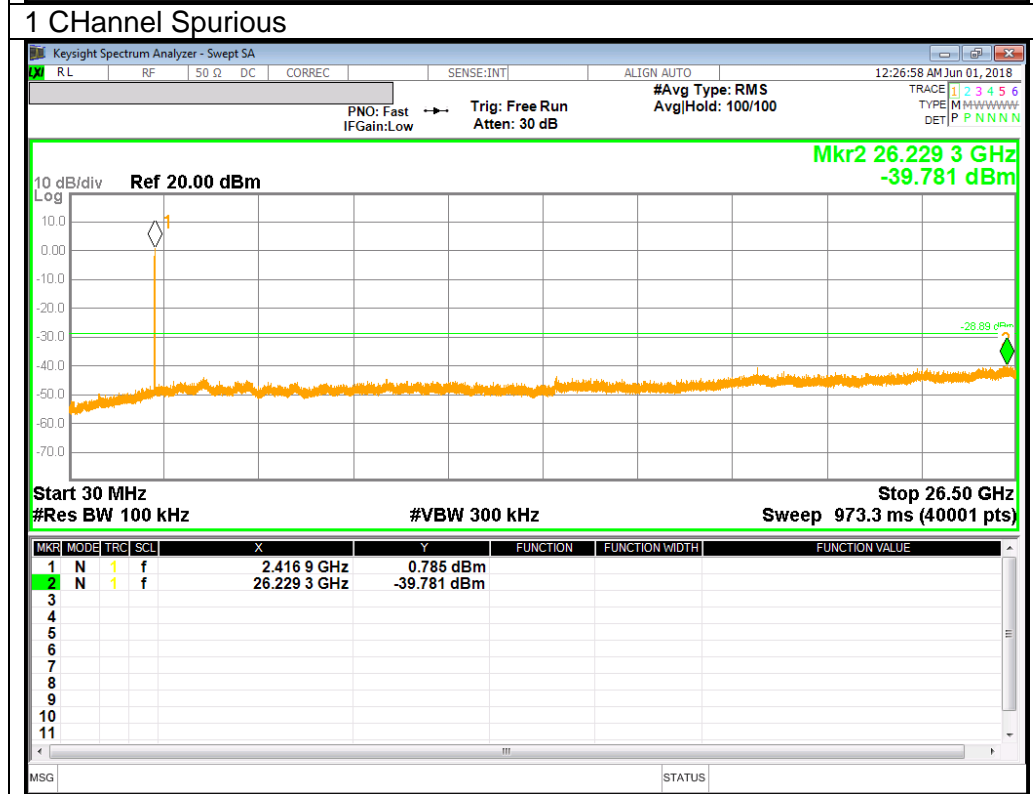
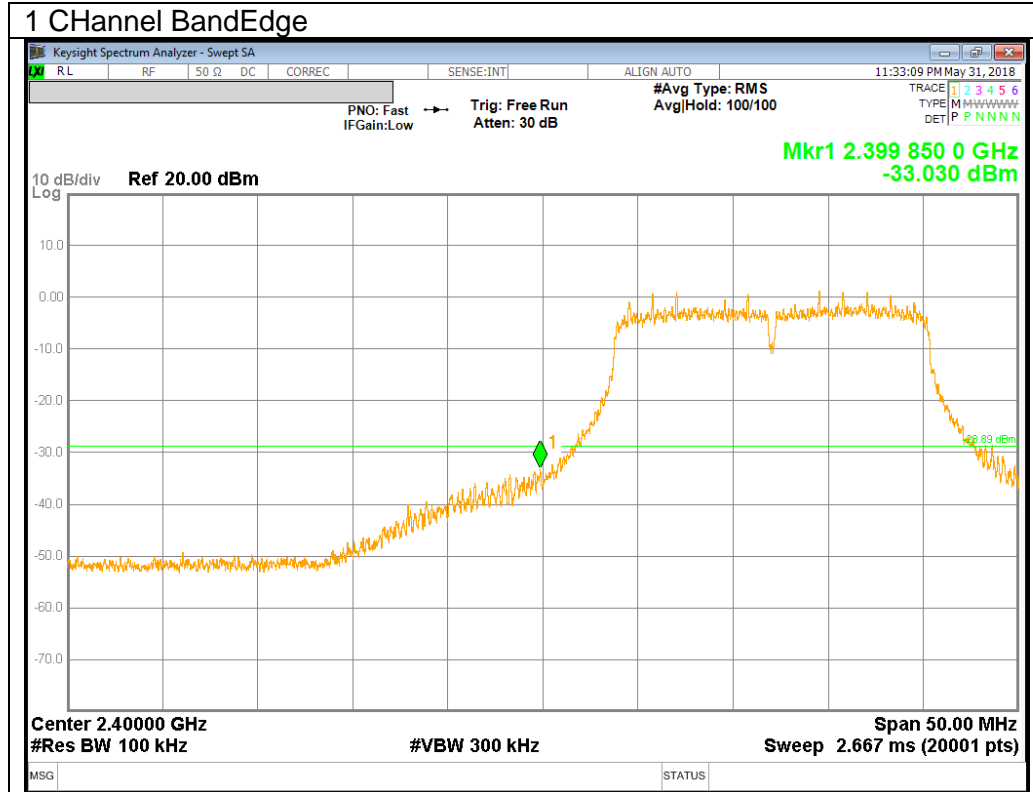

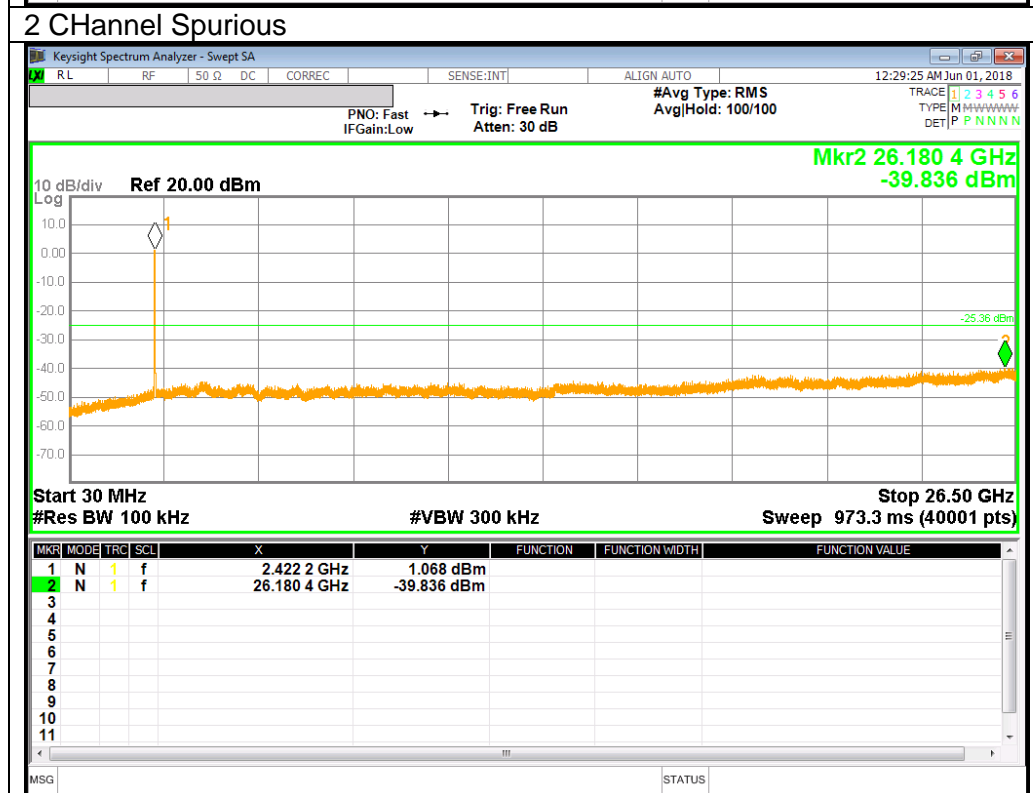
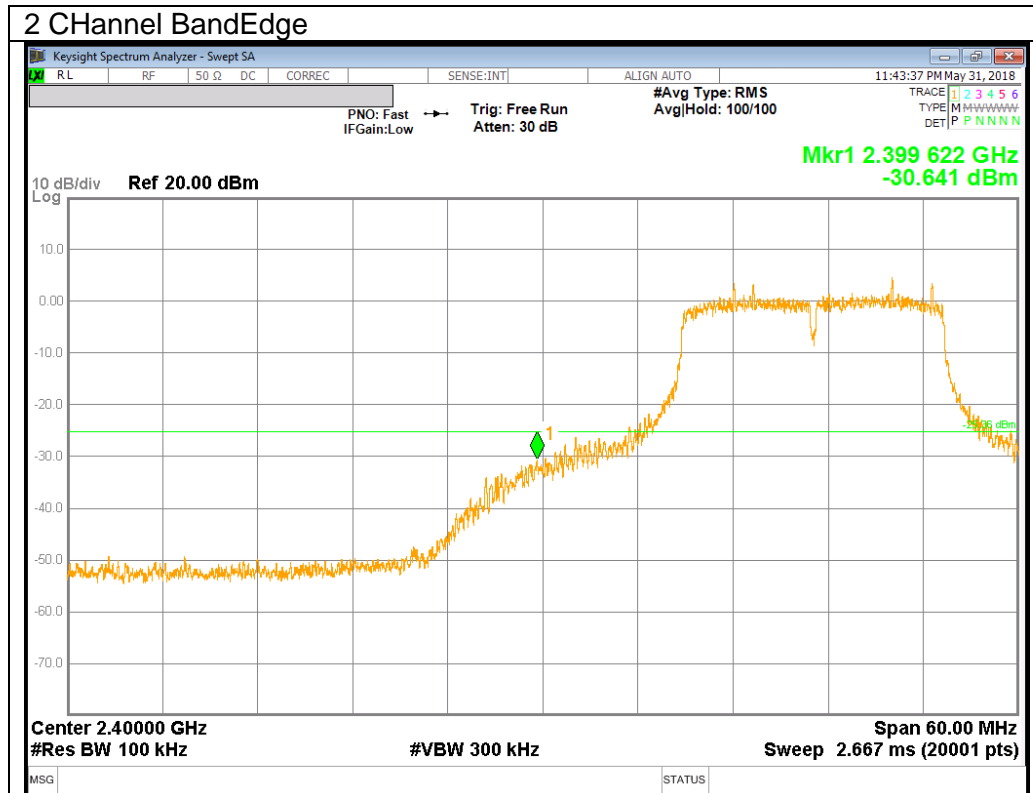

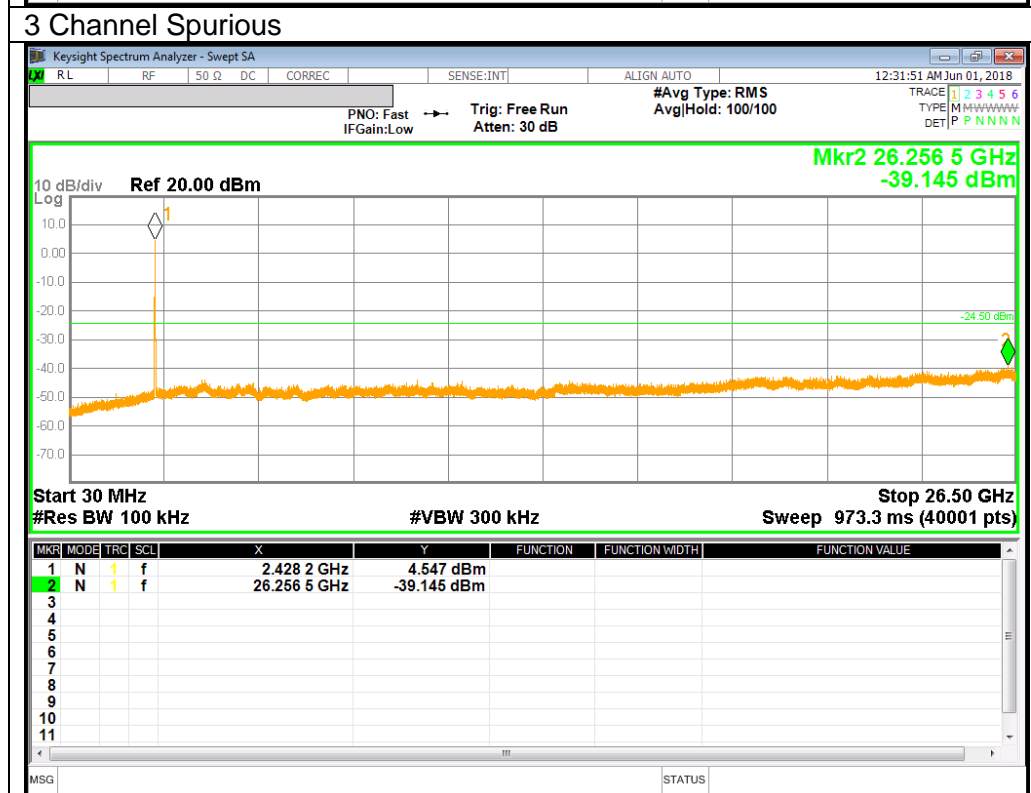
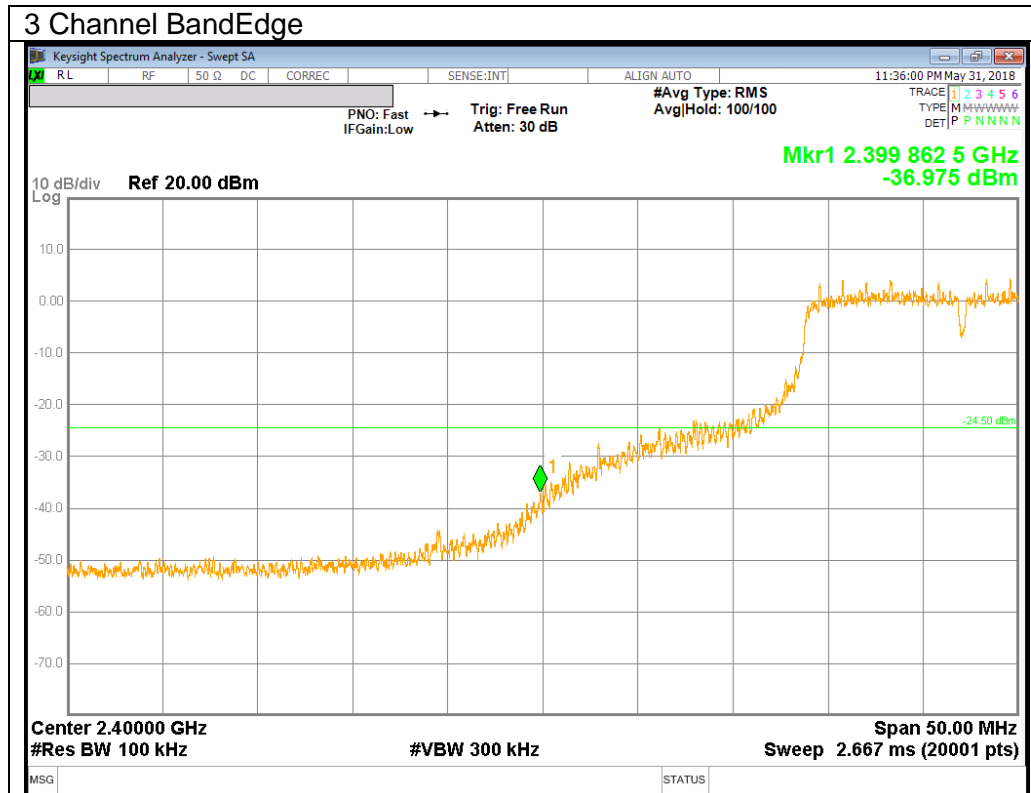

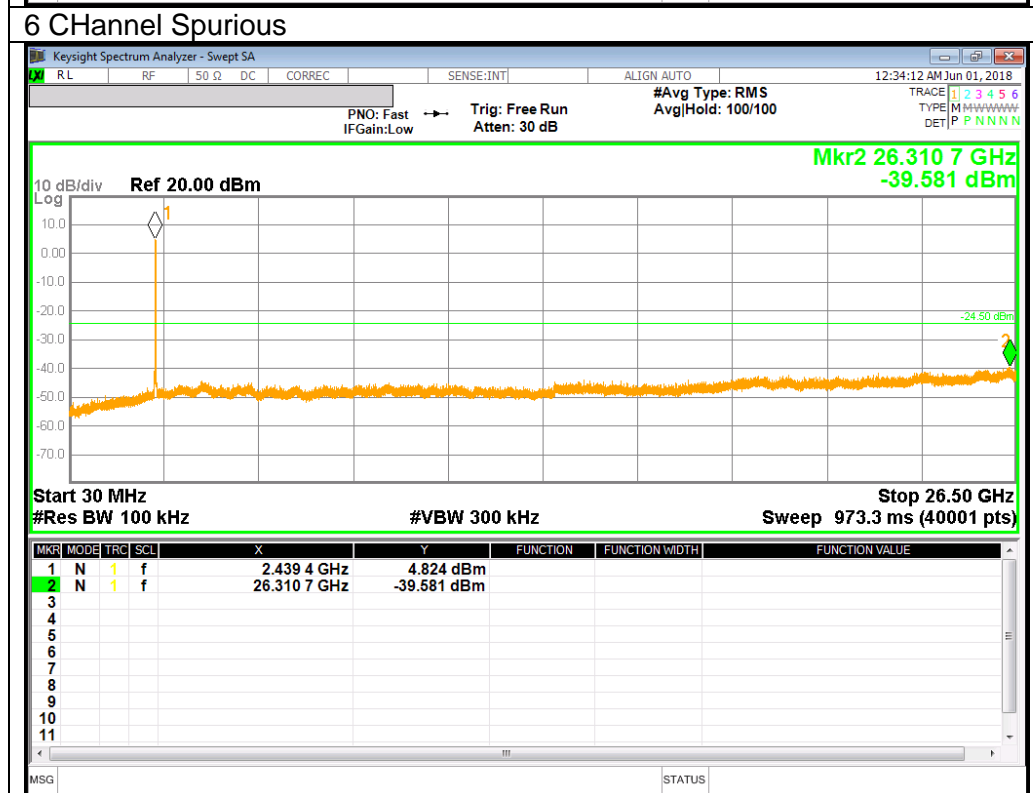
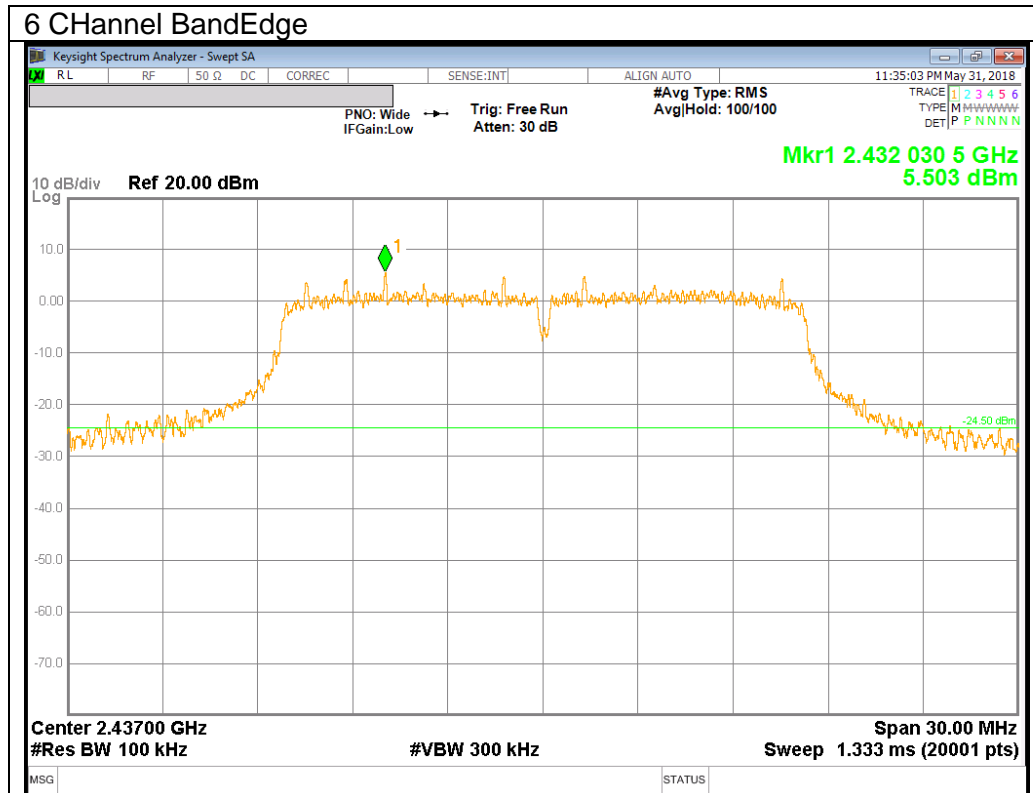

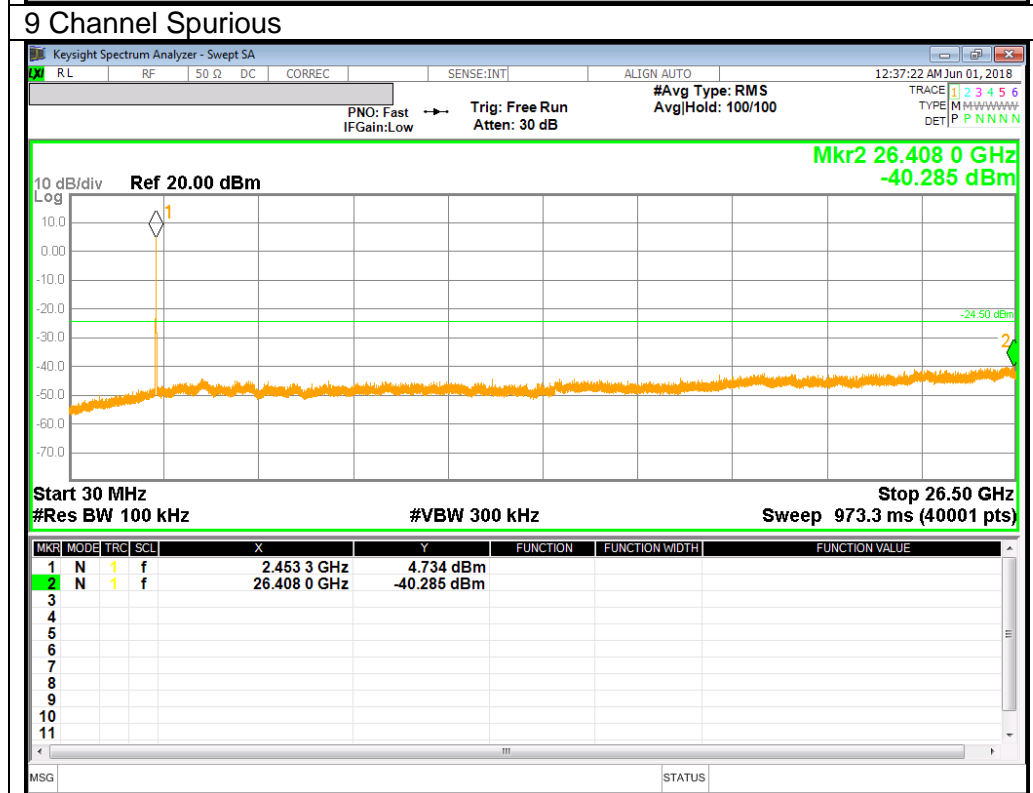
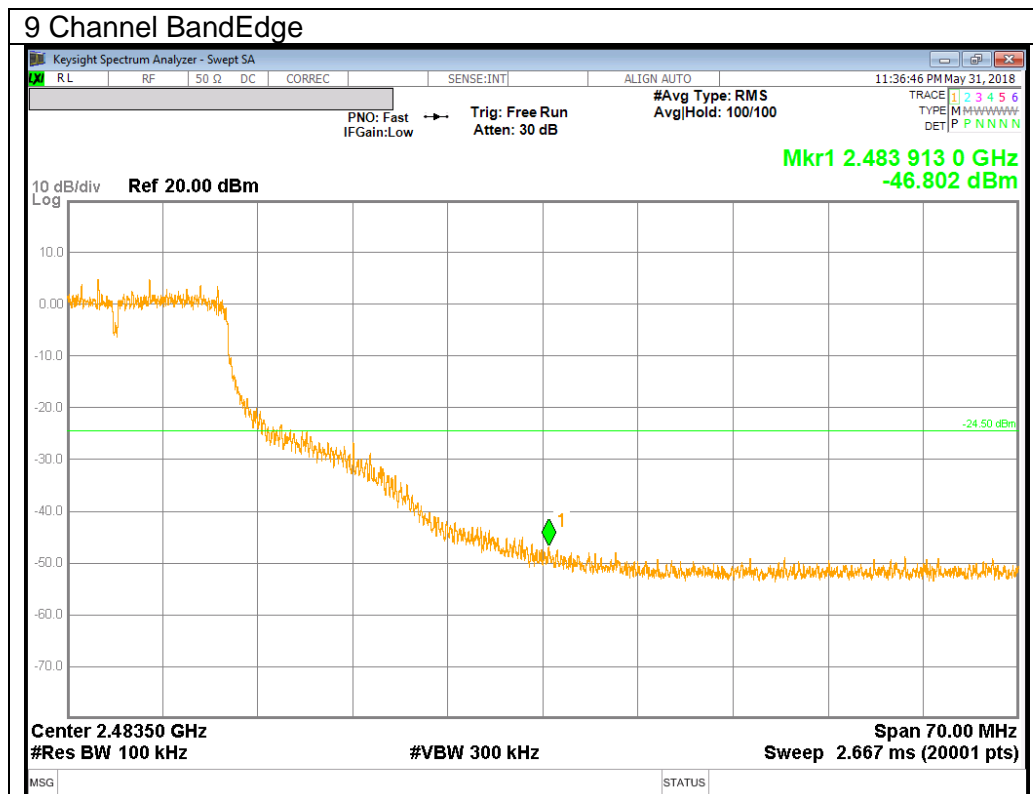

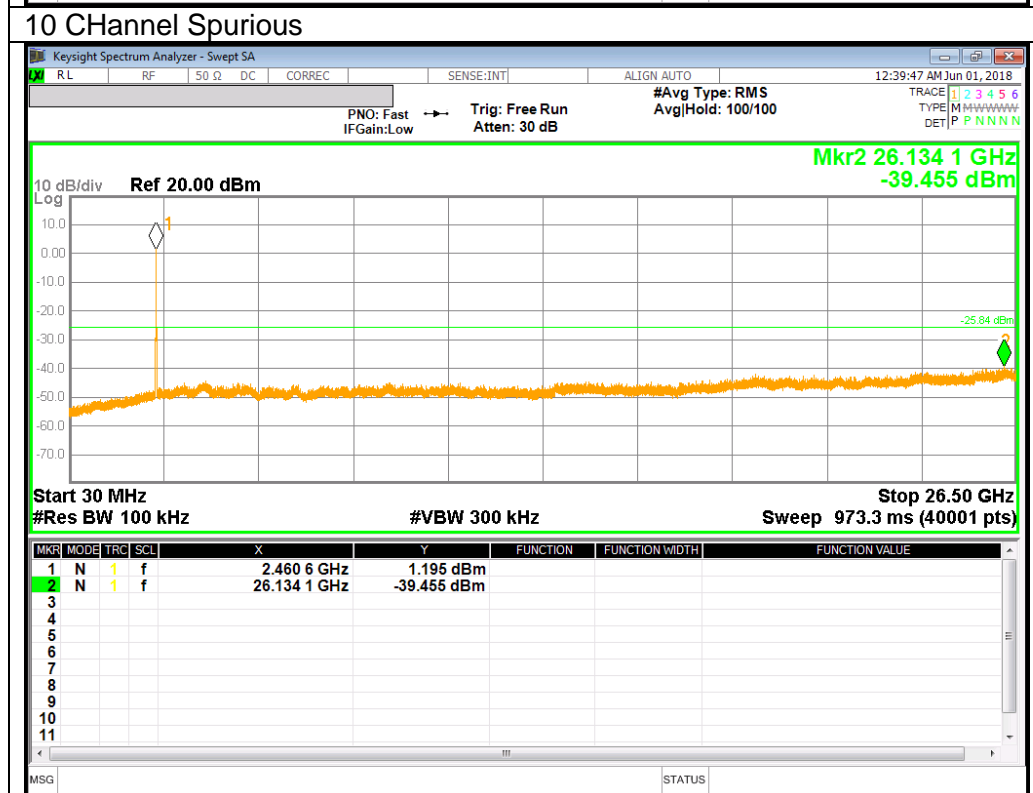
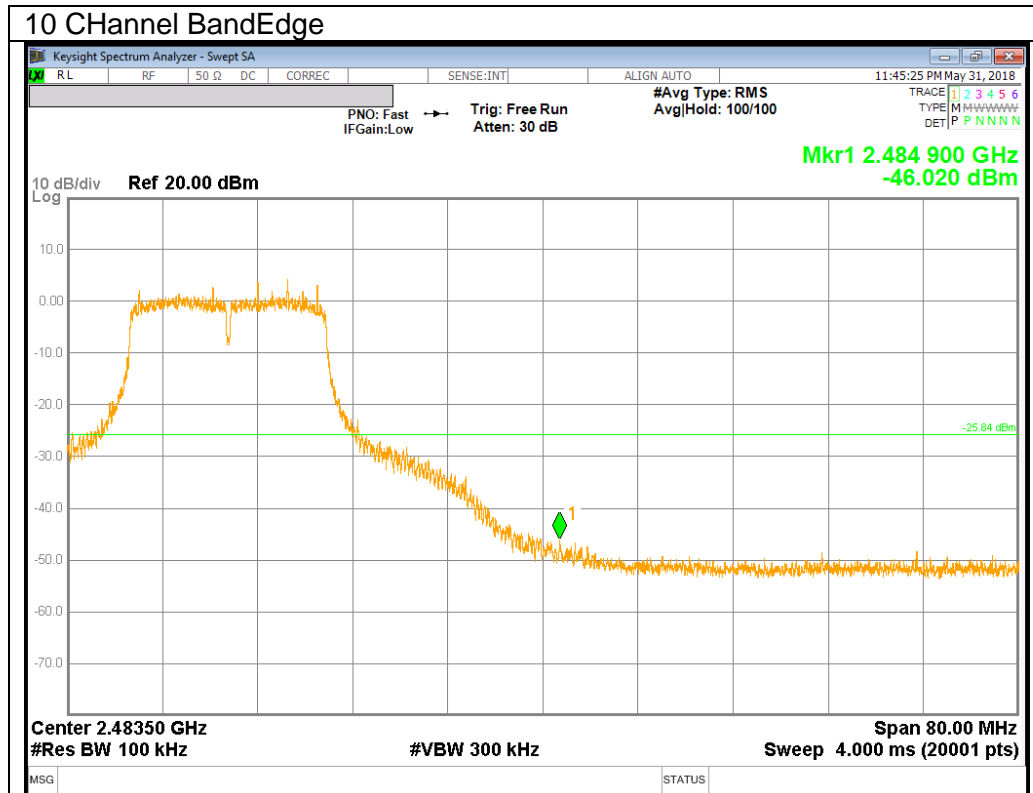

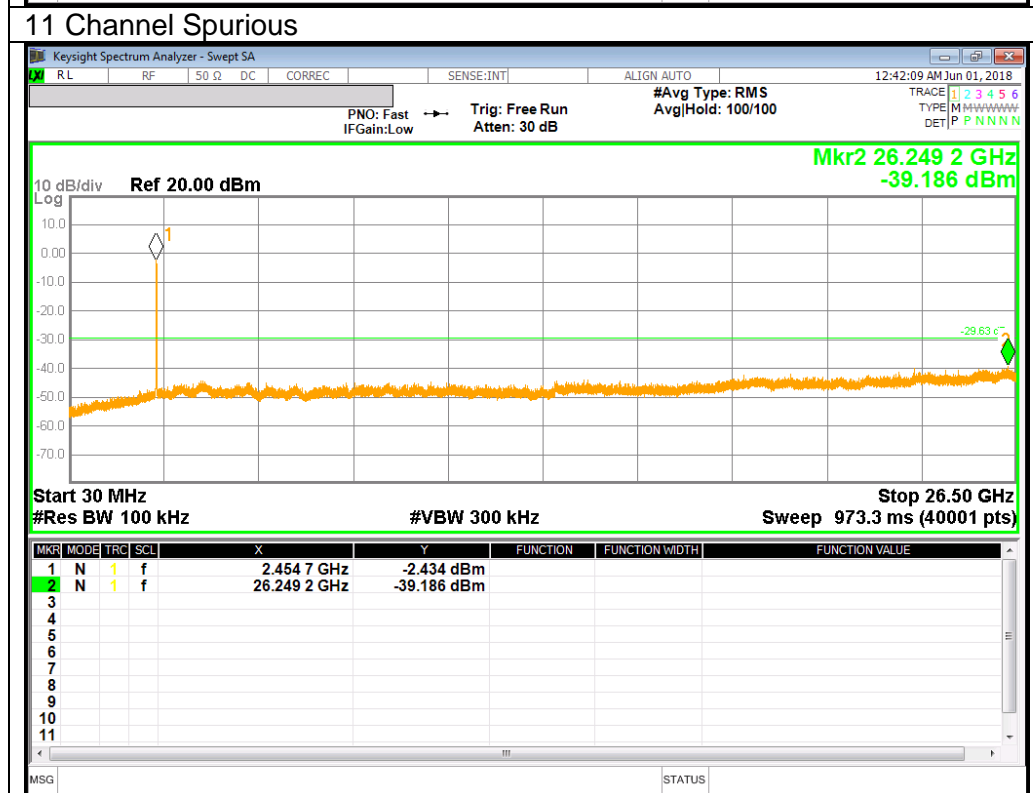
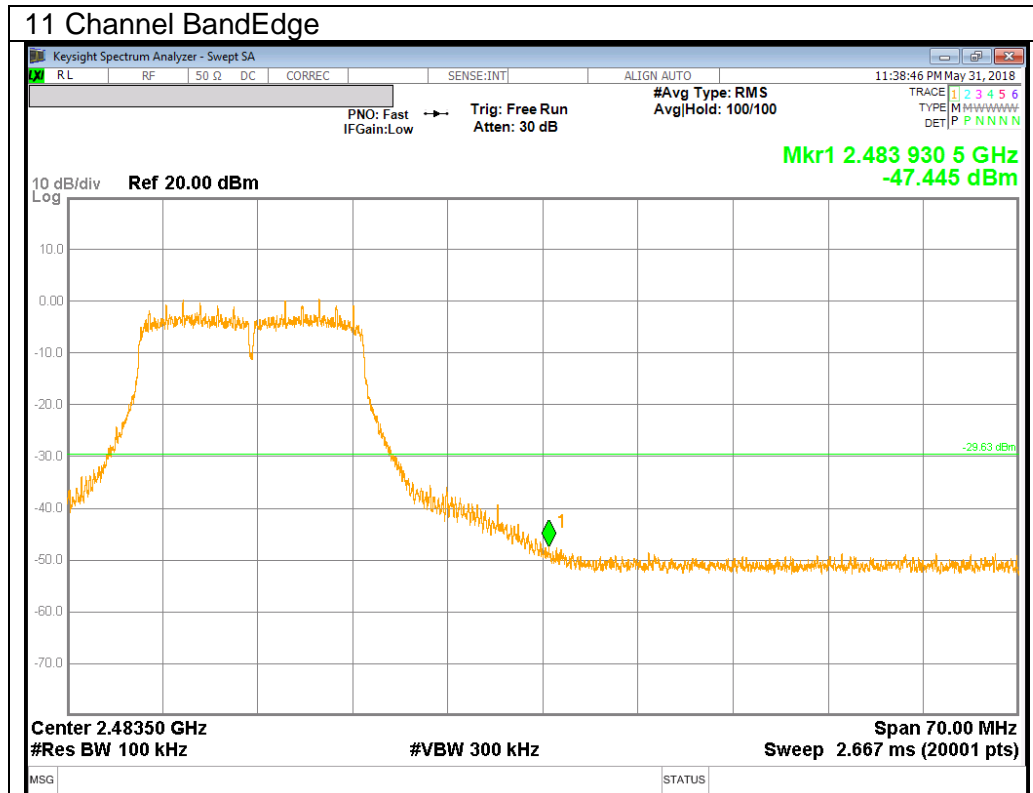

10.4.3.802.11n HT20 MODE IN THE 2.4 GHz BAND

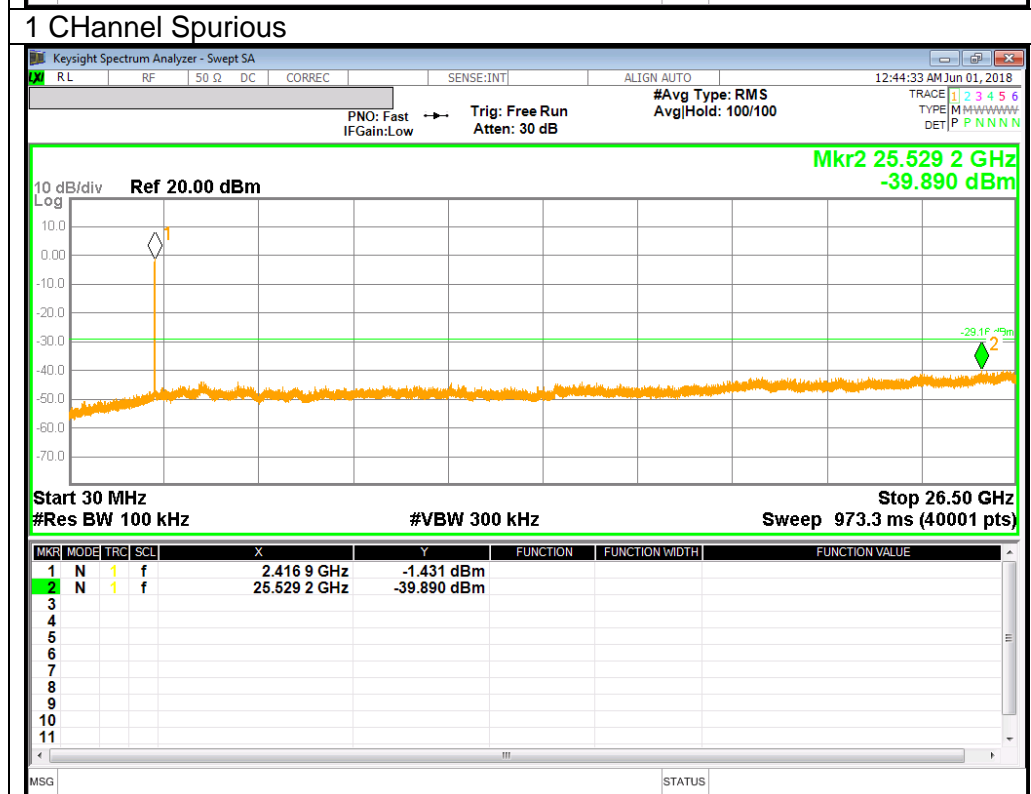
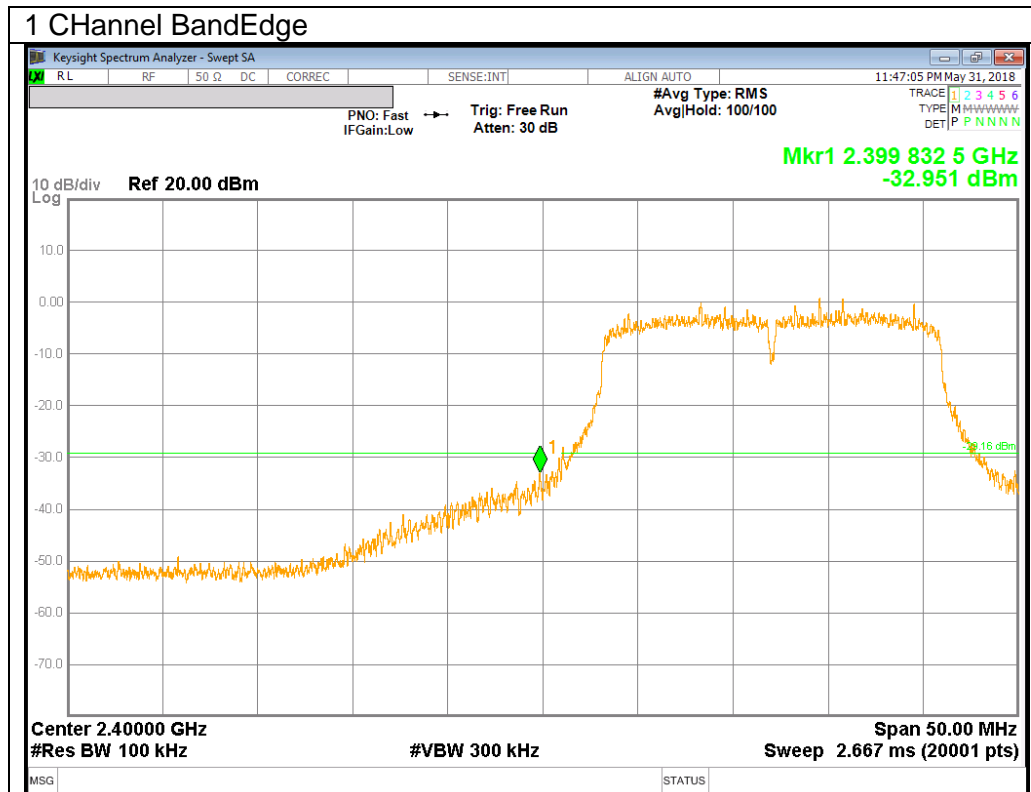

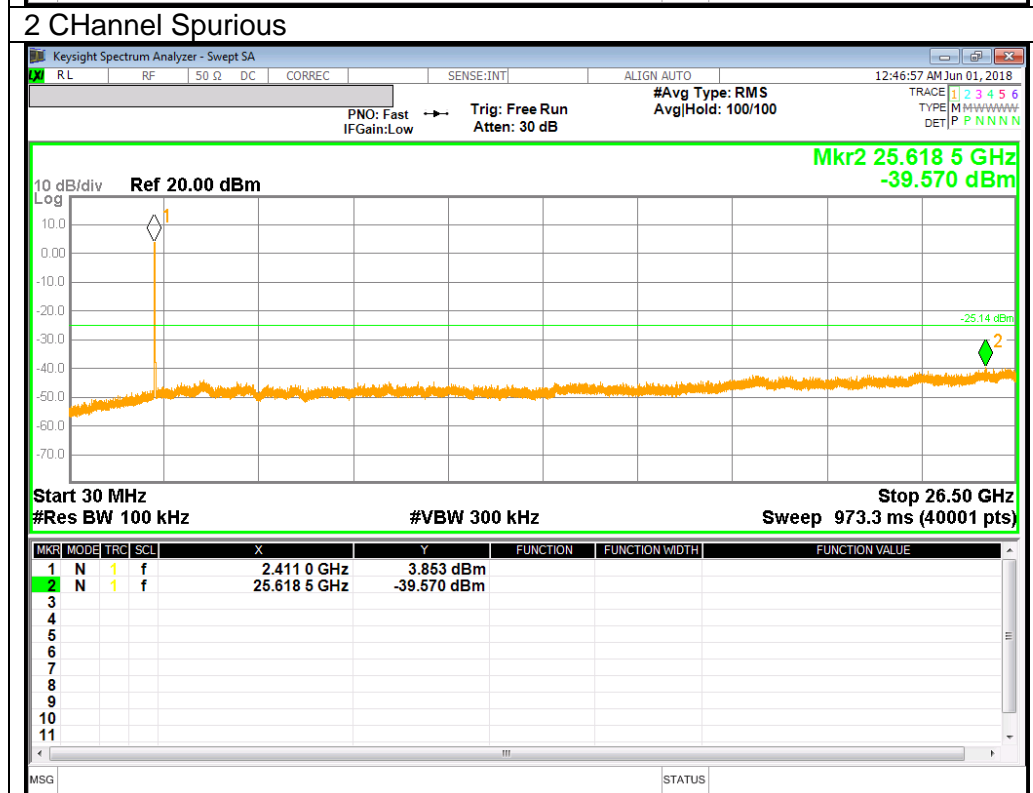
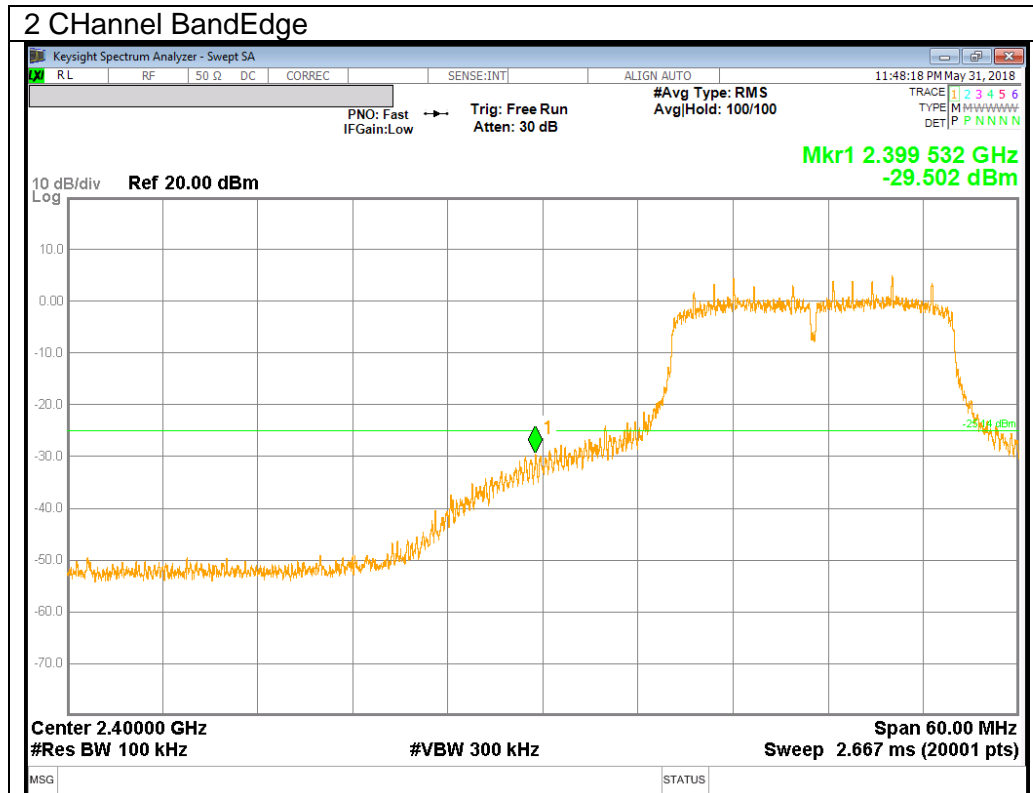

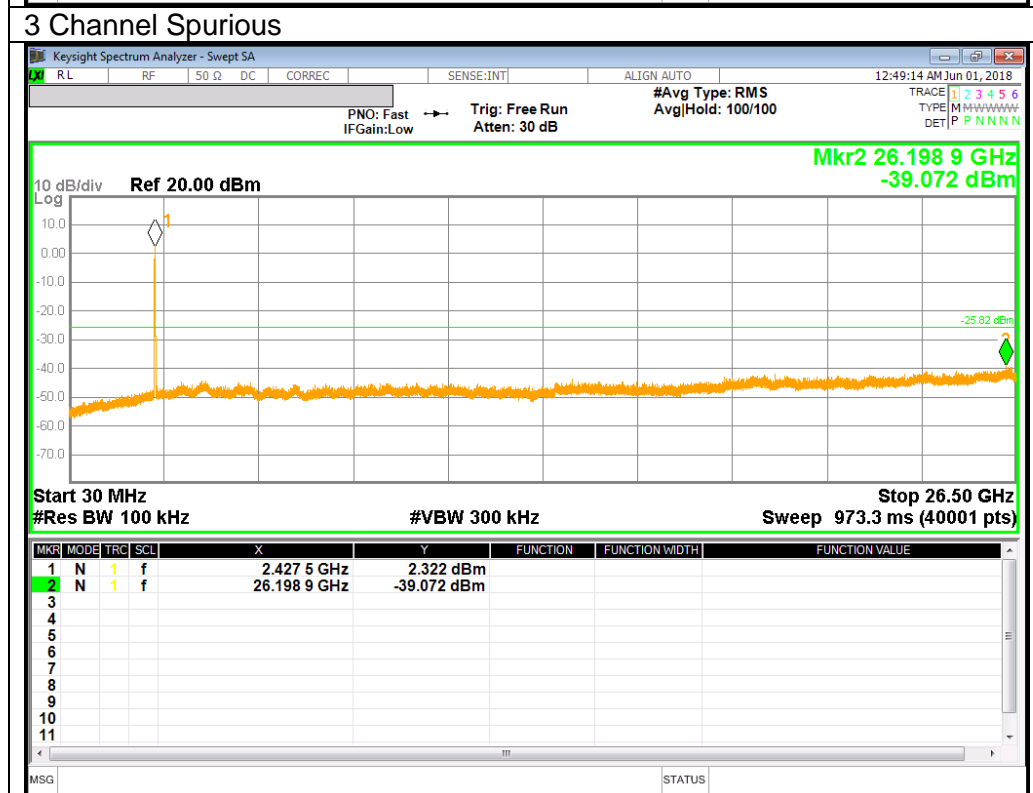
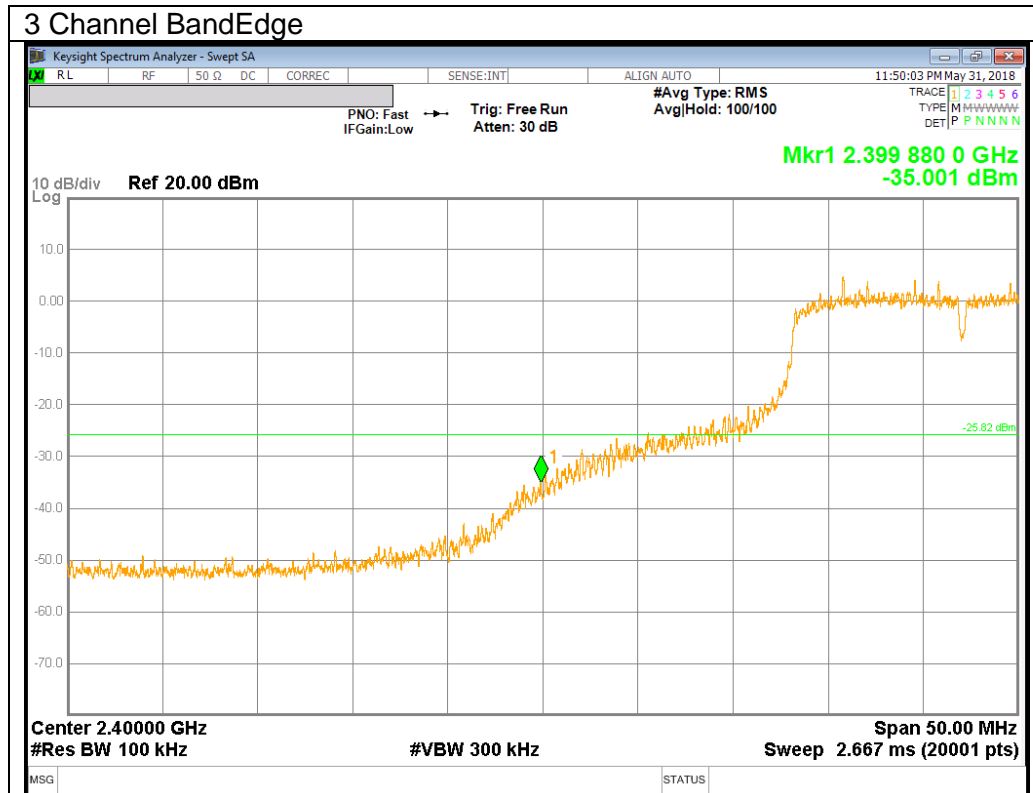

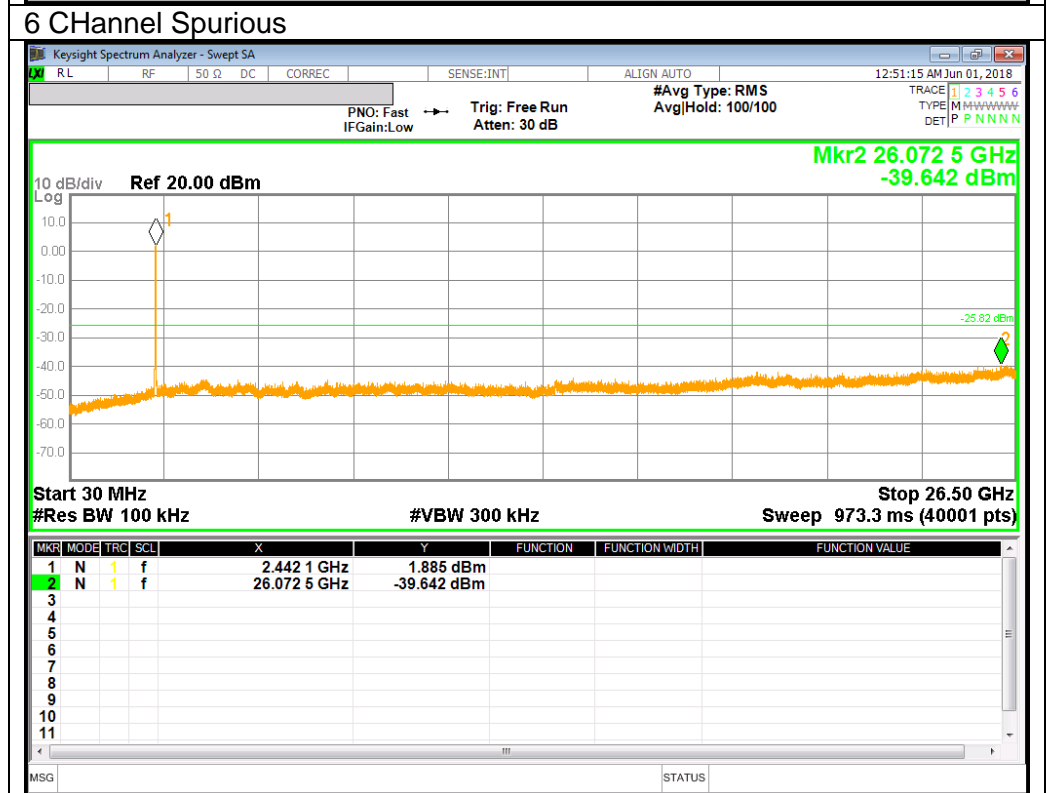
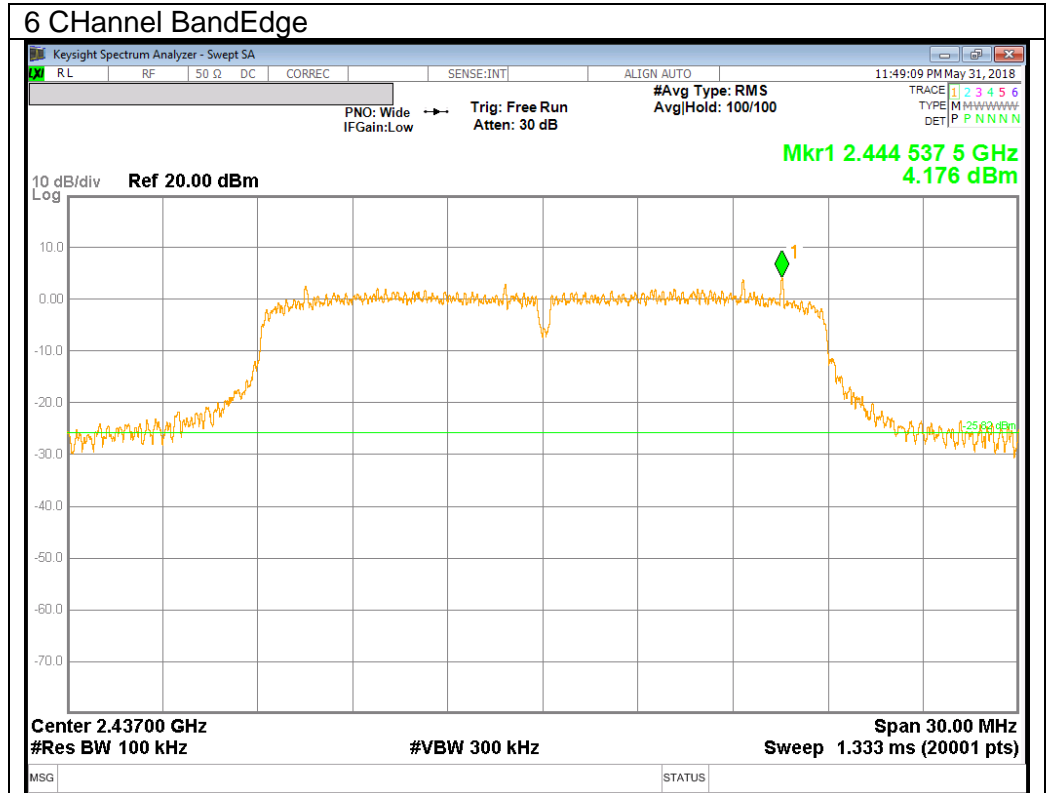

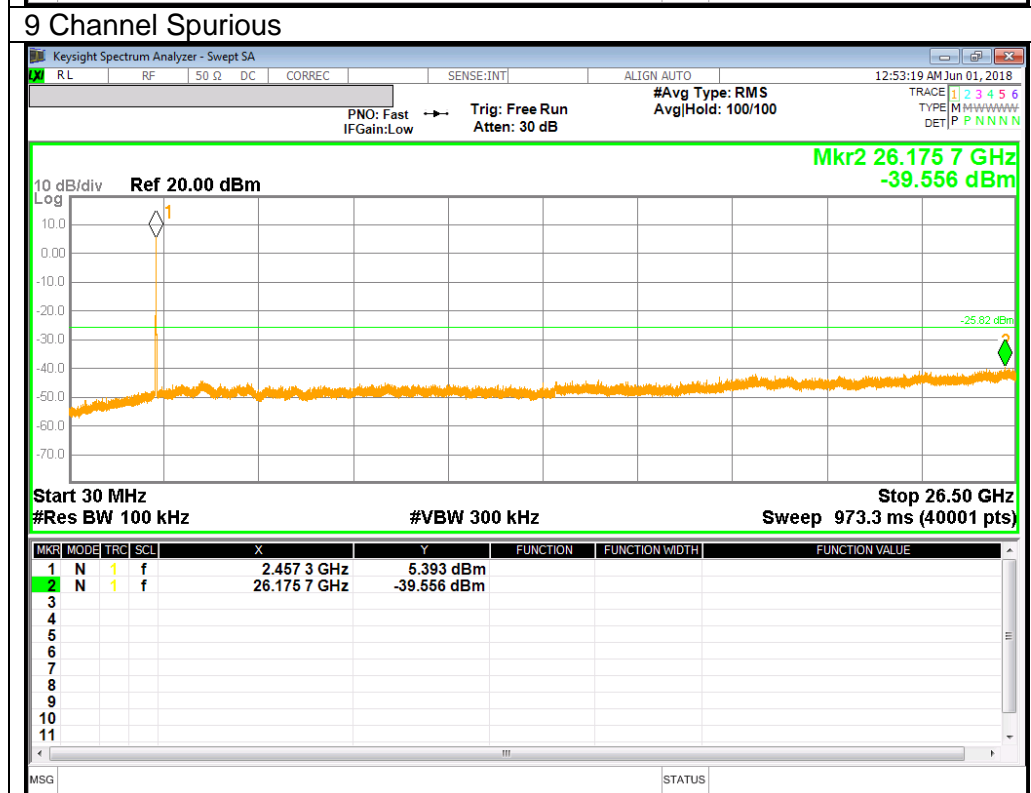
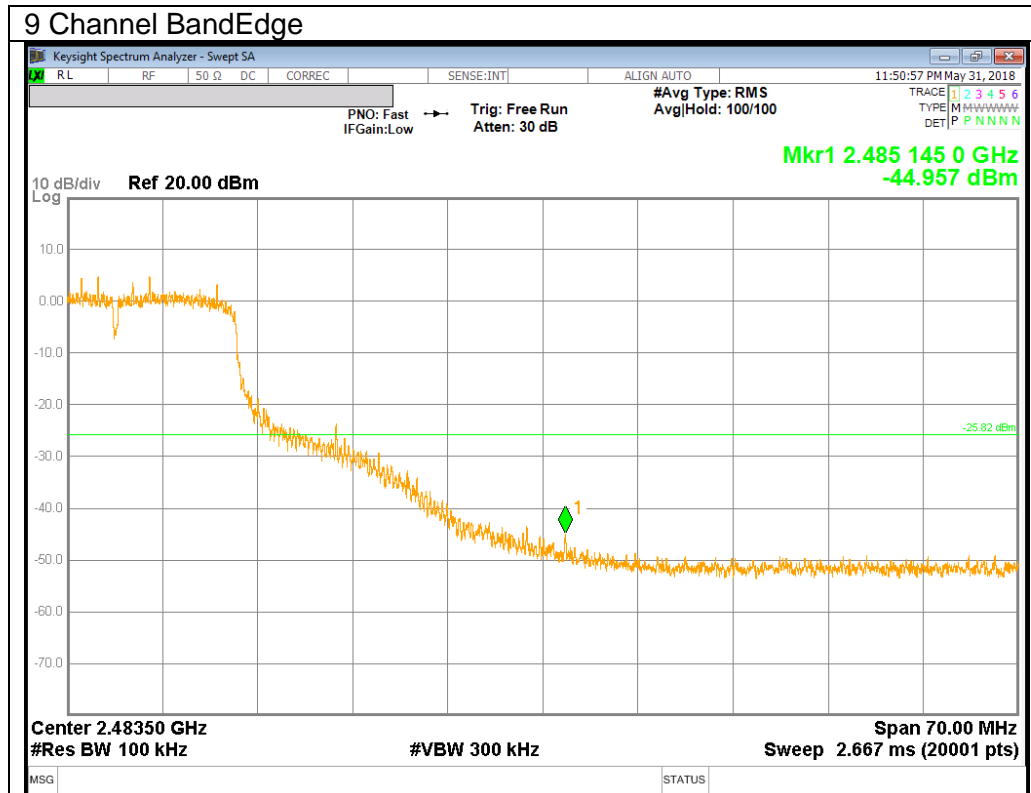

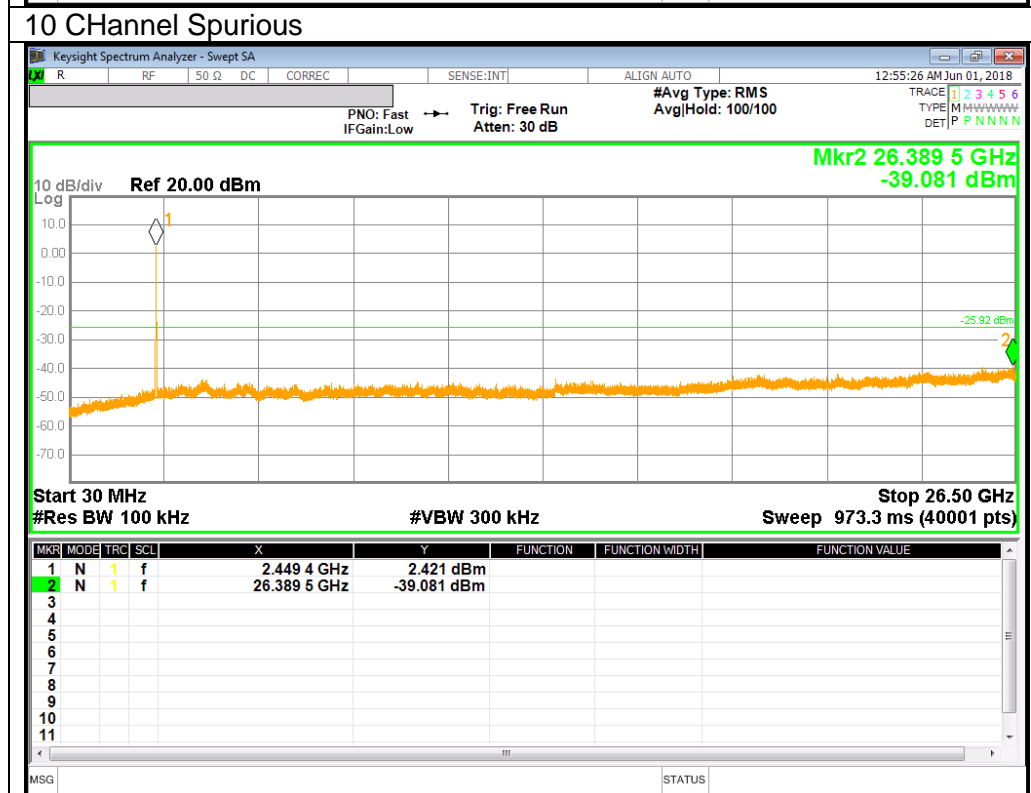
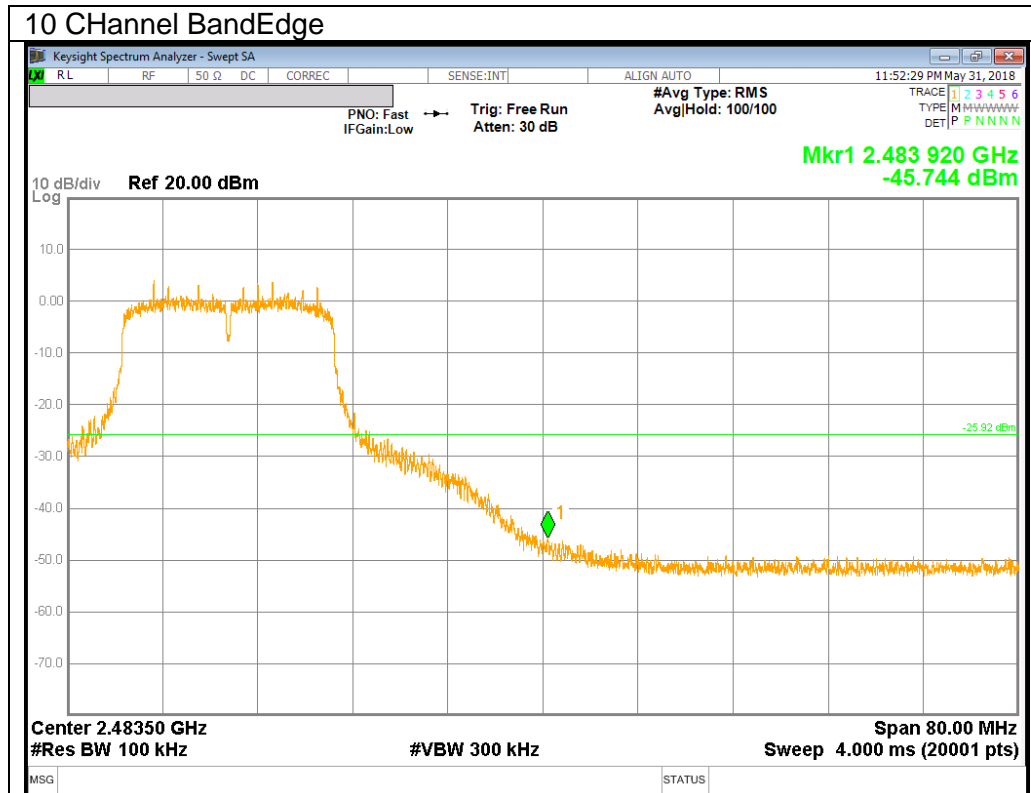

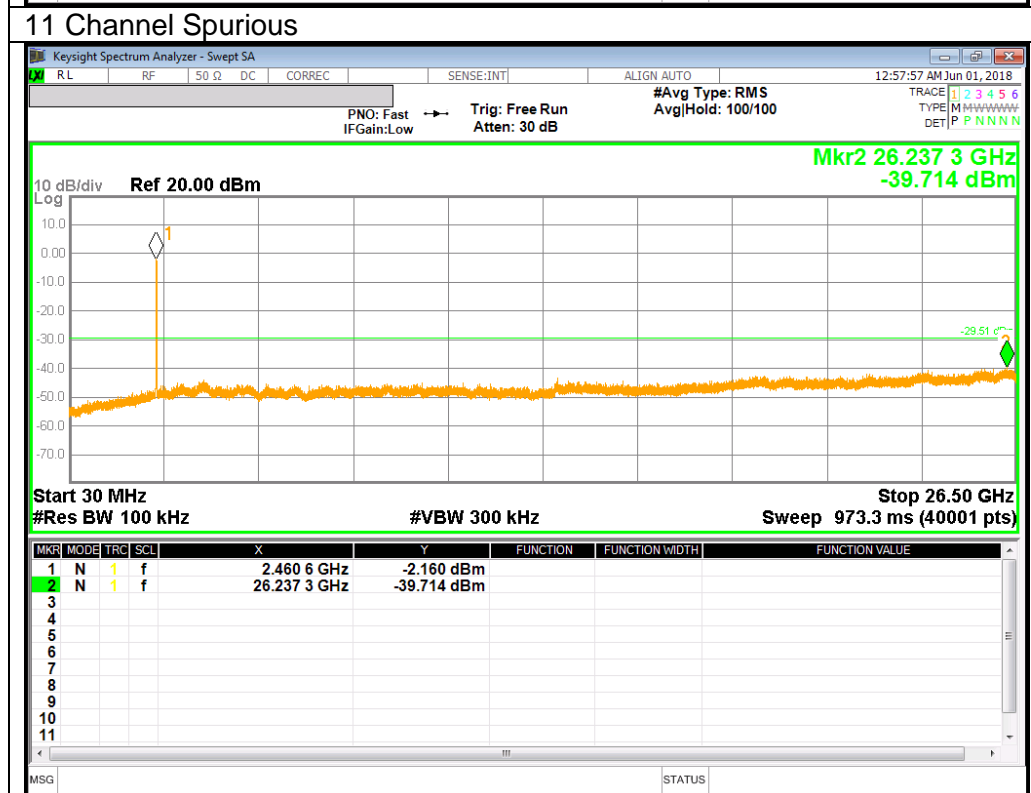
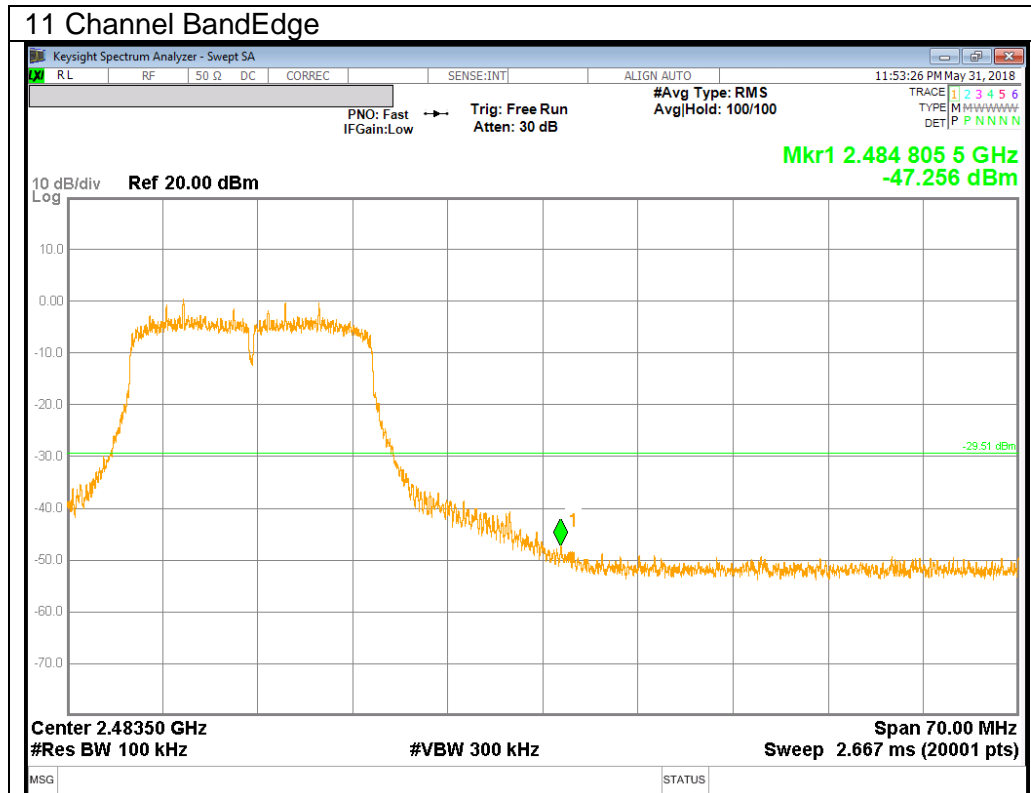

11. RADIATED TEST RESULTS

11.1. LIMITS AND PROCEDURE

LIMITS

FCC §15.205 and §15.209
IC RSS-GEN Clause 8.9 (Transmitter)
IC RSS-GEN Clause 7 (Receiver)

Limits for radiated disturbance of an intentional radiator		
Frequency range (MHz)	Limits (µV/m)	Measurement Distance (m)
0.009 – 0.490	2400 / F (kHz)	300
0.490 – 1.705	24000 / F (kHz)	30
1.705 – 30.0	30	30
30 – 88	100**	3
88 - 216	150**	3
216 – 960	200**	3
Above 960	500	3

** Except as provided in paragraph (g), fundamental emissions from intentional radiators operating under this section shall not be located in the frequency bands 54-72 MHz, 76-88 MHz, 174-216 MHz or 470-806 MHz. However, operation within these frequency bands is permitted under other sections of this part, e.g. §§ 15.231 and 15.241.

TEST PROCEDURE

The EUT is placed on a non-conducting table 80 cm above the ground plane for below 1GHz and 150 cm for above 1GHz. The antenna to EUT distance is 3 meters. The EUT is configured in accordance with ANSI C63.10. The EUT is set to transmit in a continuous mode.

For measurements below 1 GHz the resolution bandwidth is set to 100 kHz for peak detection measurements or 120 kHz for quasi-peak detection measurements. Peak detection is used unless otherwise noted as quasi-peak.

For measurements above 1 GHz the resolution bandwidth is set to 1 MHz; the video bandwidth is set to 3 MHz for peak measurements and add duty cycle factor for average measurements. (Restricted bandedge, Final detection of spurious harmonic emissions)
Duty cycle factor= $10\log(1/x)$ For this sample B mode = 0dB (duty cycle >98%); G mode = 0dB (duty cycle >98%); N mode = 0dB (duty cycle >98%).

Pre-scans to detect harmonic and spurious emissions, the resolution bandwidth is set to 1 MHz; the video bandwidth is set to 30 KHz for peak measurements.

The spectrum from 1 GHz to 26 GHz is investigated with the transmitter set to the lowest, middle, and highest channels in each applicable band.
(From 30MHz to 1GHz, test was performed with the EUT set to transmit at the channel with highest output power)

The frequency range of interest is monitored at a fixed antenna height and EUT azimuth. The EUT is rotated through 360 degrees to maximize emissions received. The antenna is scanned from 1 to 4 meters above the ground plane to further maximize the emission. Measurements are made with the antenna polarized in both the vertical and the horizontal positions.

11.2. TRANSMITTER ABOVE 1 GHz

11.2.1.TX ABOVE 1 GHz 802.11b MODE IN THE 2.4 GHz BAND

RESTRICTED BANDEDGE (1 CHANNEL)

HORIZONTAL PEAK AND AVERAGE PLOT

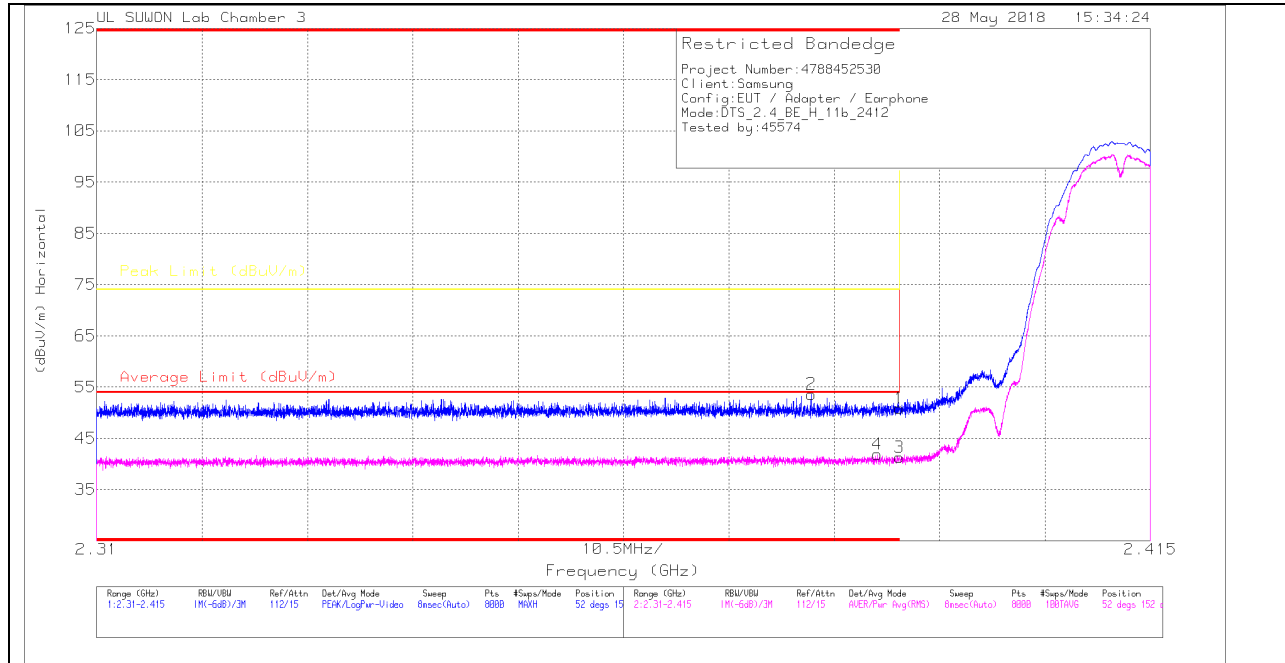

HORIZONTAL DATA

Trace Markers

Marker	Frequency (GHz)	Meter Reading (dBuV)	Det	3117(00205959)	10dB_ATT(dB)	DC Corr (dB)	Corrected Reading (dBuV/m)	Average Limit (dBuV/m)	Margin (dB)	Peak Limit (dBuV/m)	Pk Margin (dB)	Azimuth (Degs)	Height (cm)	Polarity
1	* 2.39	42.35	PK	31.8	-23.3	0	50.85	-	-	74	-23.15	52	152	H
2	* 2.381	45.11	PK	31.8	-23.3	0	53.61	-	-	74	-20.39	52	152	H
3	* 2.39	32.81	RMS	31.8	-23.3	0	41.31	54	-12.69	-	-	52	152	H
4	* 2.388	33.36	RMS	31.8	-23.3	0	41.86	54	-12.14	-	-	52	152	H

* - indicates frequency in CFR47 Pt 15 / IC RSS-Restricted Band

PK - Peak detector

RMS - RMS detection

VERTICAL PEAK AND AVERAGE PLOT

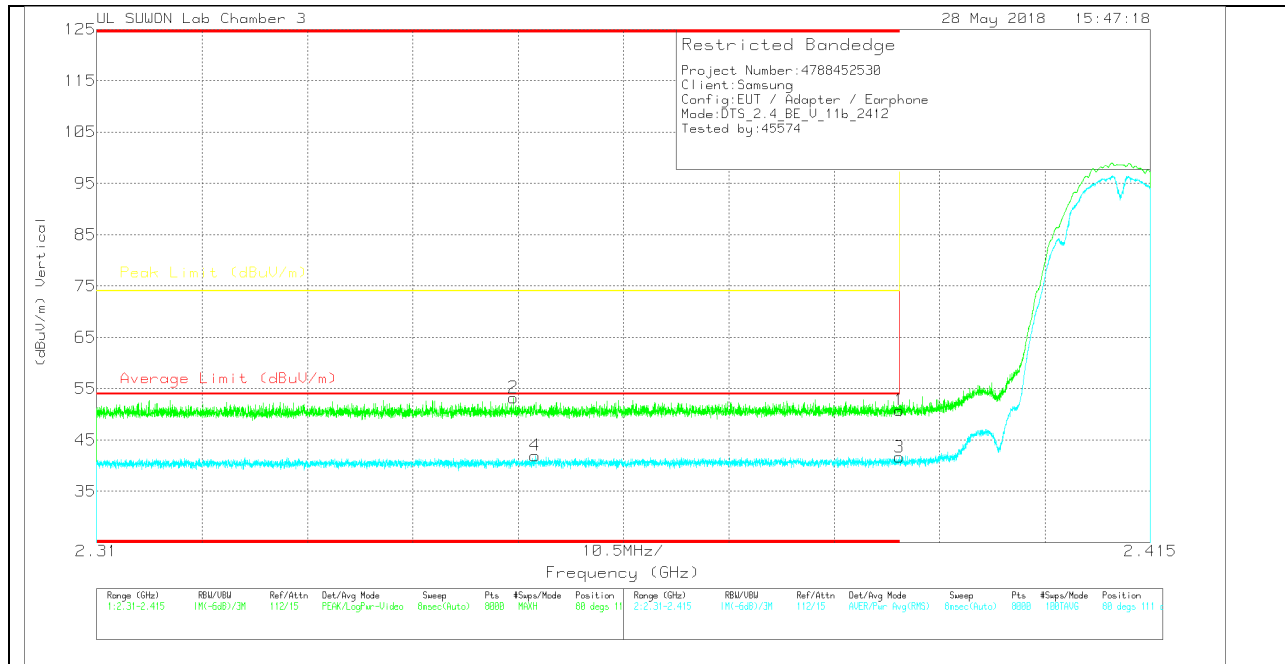

VERTICAL DATA

Trace Markers

Marker	Frequency (GHz)	Meter Reading (dBuV)	Det	3117(00205959)	10dB_ATT(dB)	DC Corr (dB)	Corrected Reading (dBuV/m)	Average Limit (dBuV/m)	Margin (dB)	Peak Limit (dBuV/m)	Pk Margin (dB)	Azimuth (Degs)	Height (cm)	Polarity
1	* 2.39	42.31	Pk	31.8	-23.3	0	50.81	-	-	74	-23.19	80	111	V
2	* 2.352	44.84	Pk	31.7	-23.3	0	53.24	-	-	74	-20.76	80	111	V
3	* 2.39	33.19	RMS	31.8	-23.3	0	41.69	54	-12.31	-	-	80	111	V
4	* 2.354	33.48	RMS	31.7	-23.2	0	41.98	54	-12.02	-	-	80	111	V

* - indicates frequency in CFR47 Pt 15 / IC RSS-Restricted Band

Pk - Peak detector

RMS - RMS detection

RESTRICTED BANDEDGE (2 CHANNEL)

HORIZONTAL PEAK AND AVERAGE PLOT

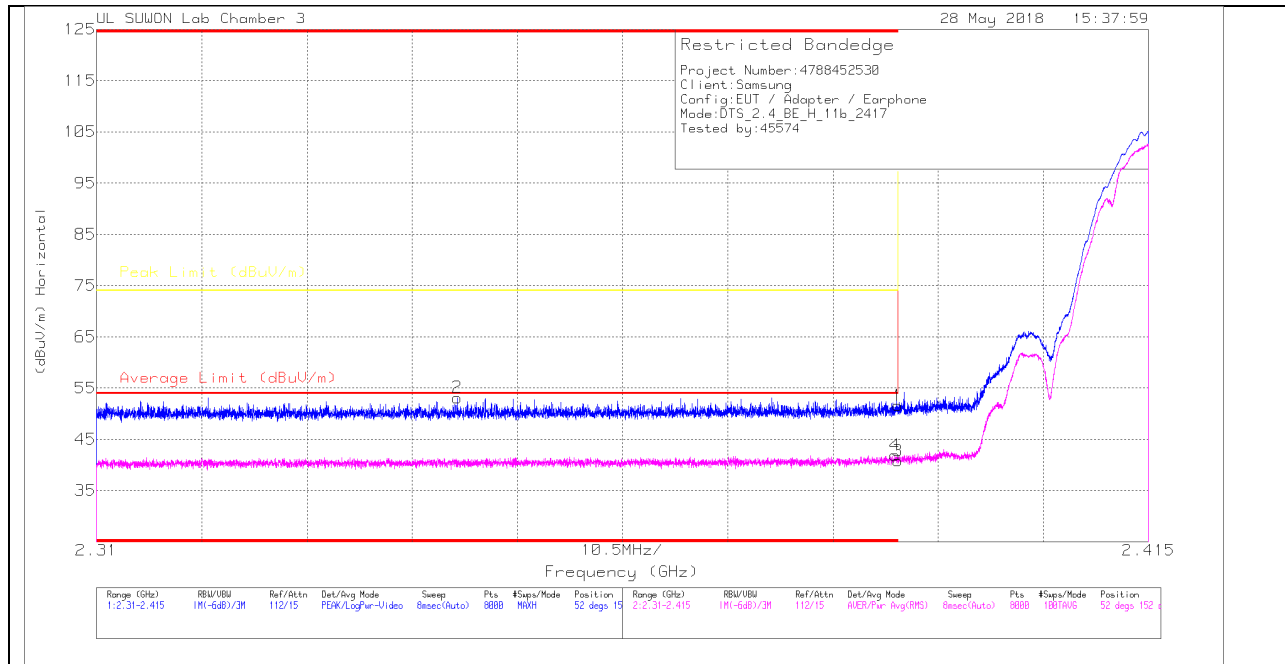

HORIZONTAL DATA

Trace Markers

Marker	Frequency (GHz)	Meter Reading (dBuV)	Det	311700205959	10dB_ATT[dB]	DC Corr (dB)	Corrected Reading (dBuV/m)	Average Limit (dBuV/m)	Margin (dB)	Peak Limit (dBuV/m)	PK Margin (dB)	Azimuth (Degs)	Height (cm)	Polarity
1	* 2.39	43.11	Pk		-23.3	0	51.61	-	-	74	-22.39	52	152	H
2	* 2.346	44.74	Pk		-23.3	0	53.14	-	-	74	-20.86	52	152	H
3	* 2.39	32.32	RMS		-23.3	0	40.82	54	-13.18	-	-	52	152	H
4	* 2.39	33.43	RMS		-23.3	0	41.93	54	-12.07	-	-	52	152	H

* - indicates frequency in CFR47 Pt 15 / IC RSS-Restricted Band

Pk - Peak detector

RMS - RMS detection

VERTICAL PEAK AND AVERAGE PLOT

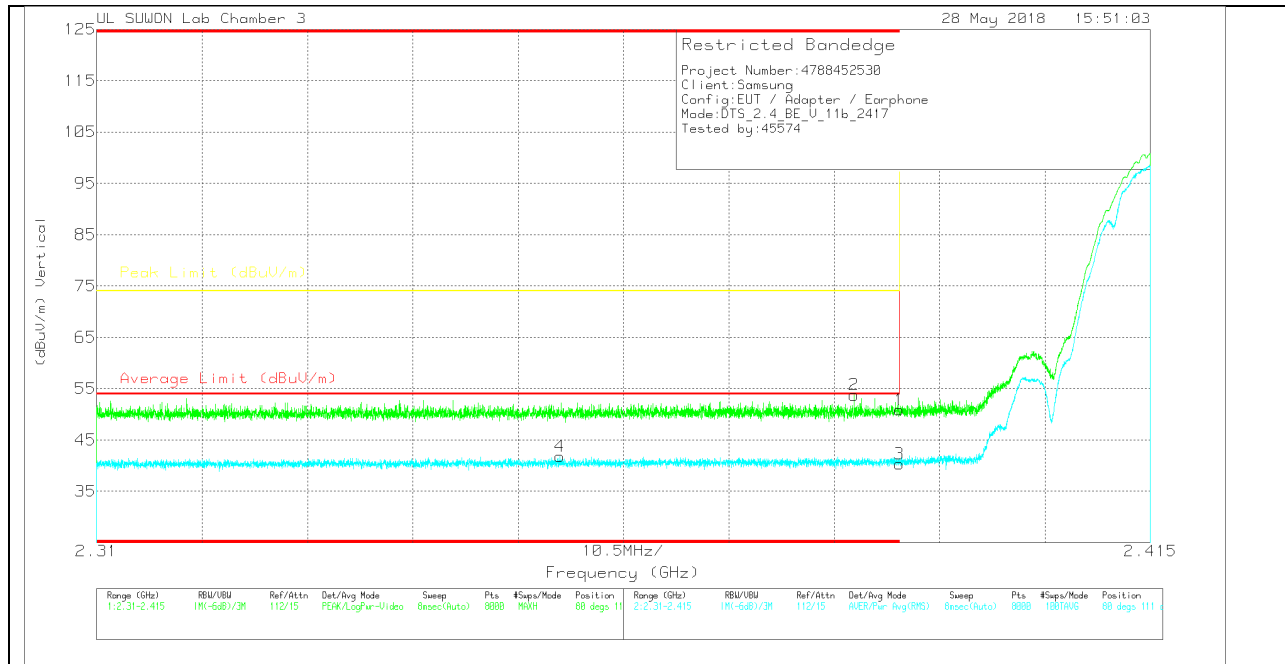

VERTICAL DATA

Trace Markers

Marker	Frequency (GHz)	Meter Reading (dBuV)	Det	3117(00205959)	10dB_ATT(dB)	DC Corr (dB)	Corrected Reading (dBuV/m)	Average Limit (dBuV/m)	Margin (dB)	Peak Limit (dBuV/m)	Pk Margin (dB)	Azimuth (Degs)	Height (cm)	Polarity
1	* 2.39	42.39	Pk	31.8	-23.3	0	50.89	-	-	74	-23.11	80	111	V
2	* 2.385	45.27	Pk	31.8	-23.3	0	53.77	-	-	74	-20.23	80	111	V
3	* 2.39	31.79	RMS	31.8	-23.3	0	40.29	54	-13.71	-	-	80	111	V
4	* 2.356	33.26	RMS	31.7	-23.2	0	41.76	54	-12.24	-	-	80	111	V

* - indicates frequency in CFR47 Pt 15 / IC RSS-Restricted Band

Pk - Peak detector

RMS - RMS detection

RESTRICTED BANDEDGE (3 CHANNEL)

HORIZONTAL PEAK AND AVERAGE PLOT

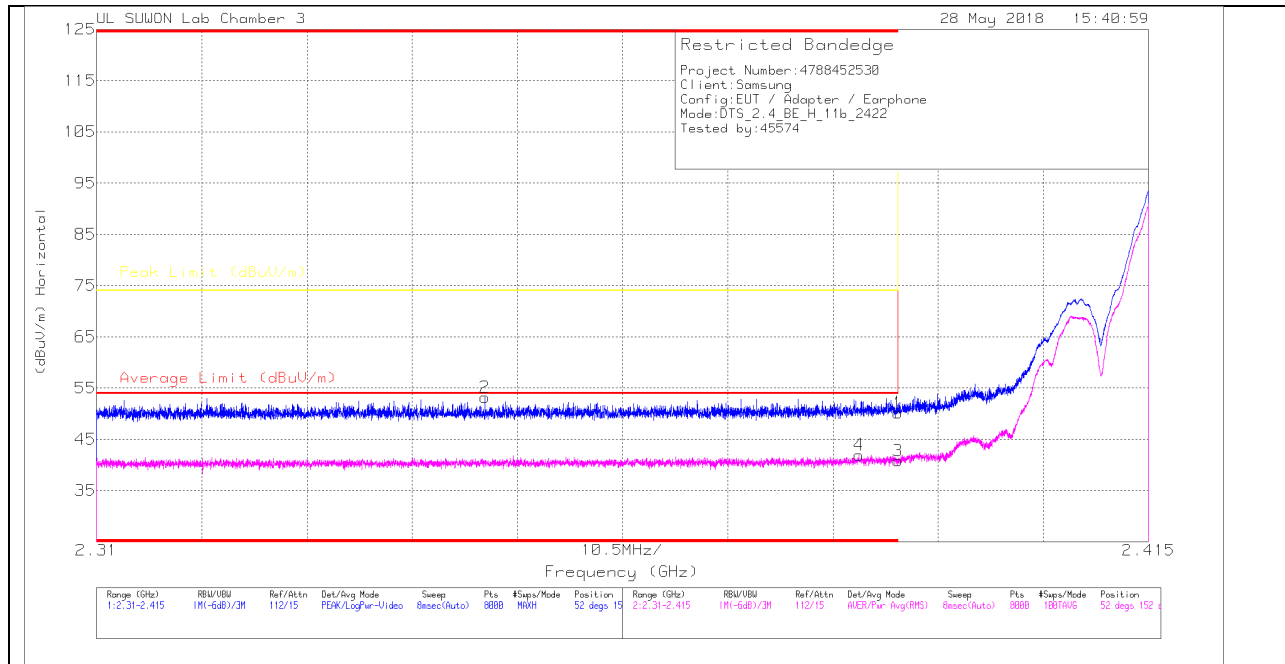

HORIZONTAL DATA

Trace Markers

Marker	Frequency (GHz)	Meter Reading (dBuV)	Det	3117000205959	10dB_ATT[dB]	DC Corr (dB)	Corrected Reading (dBuV/m)	Average Limit (dBuV/m)	Margin (dB)	Peak Limit (dBuV/m)	PK Margin (dB)	Azimuth (Degs)	Height (cm)	Polarity
1	* 2.39	41.66	Pk		-23.3	0	50.16	-	-	74	-23.84	52	152	H
2	* 2.349	44.77	Pk		-23.3	0	53.17	-	-	74	-20.83	52	152	H
3	* 2.39	32.28	RMS		-23.3	0	40.78	54	-13.22	-	-	52	152	H
4	* 2.386	33.44	RMS		-23.3	0	41.94	54	-12.06	-	-	52	152	H

* - indicates frequency in CFR47 Pt 15 / IC RSS-Restricted Band

Pk - Peak detector

RMS - RMS detection

VERTICAL PEAK AND AVERAGE PLOT

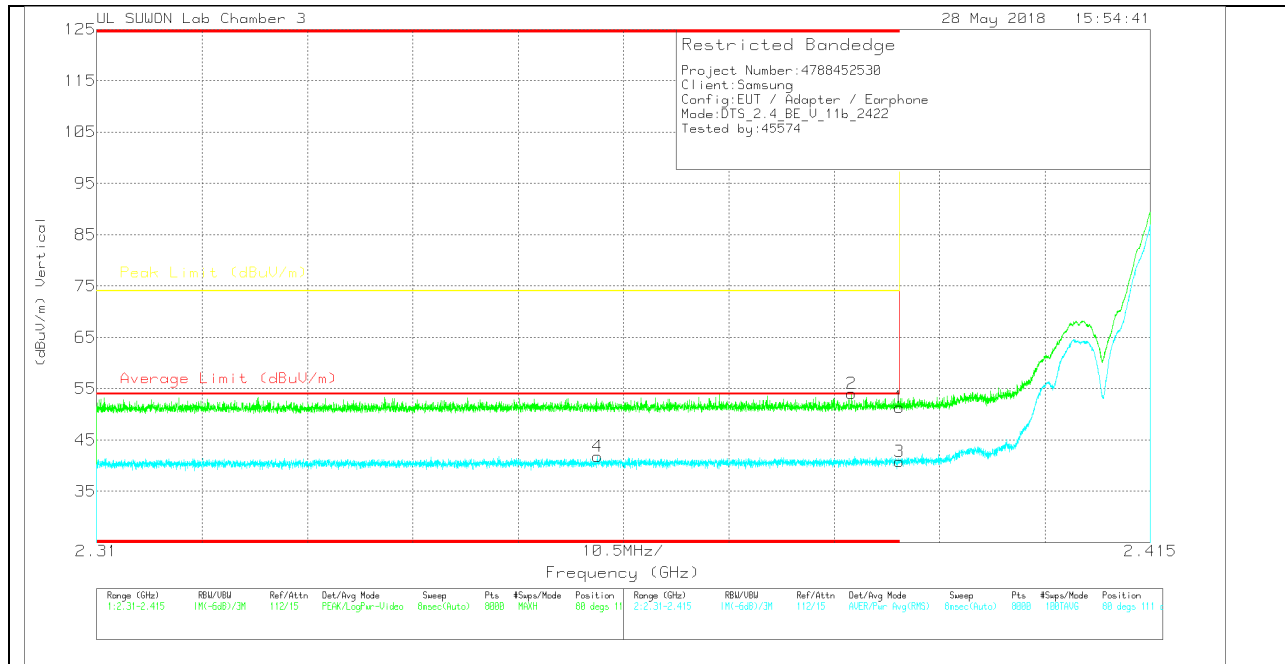

VERTICAL DATA

Trace Markers

Marker	Frequency (GHz)	Meter Reading (dBuV)	Det	3117(00205959)	10dB_ATT(dB)	DC Corr (dB)	Corrected Reading (dBuV/m)	Average Limit (dBuV/m)	Margin (dB)	Peak Limit (dBuV/m)	PK Margin (dB)	Azimuth (Degs)	Height (cm)	Polarity
1	* 2.39	42.91	Pk	31.8	-23.3	0	51.41	-	-	74	-22.59	80	111	V
2	* 2.385	45.42	Pk	31.8	-23.2	0	54.02	-	-	74	-19.98	80	111	V
3	* 2.39	32.3	RMS	31.8	-23.3	0	40.8	54	-13.2	-	-	80	111	V
4	* 2.36	33.41	RMS	31.7	-23.3	0	41.81	54	-12.19	-	-	80	111	V

* - indicates frequency in CFR47 Pt 15 / IC RSS-Restricted Band

Pk - Peak detector

RMS - RMS detection

AUTHORIZED BANDEDGE (9 CHANNEL)

HORIZONTAL PEAK AND AVERAGE PLOT

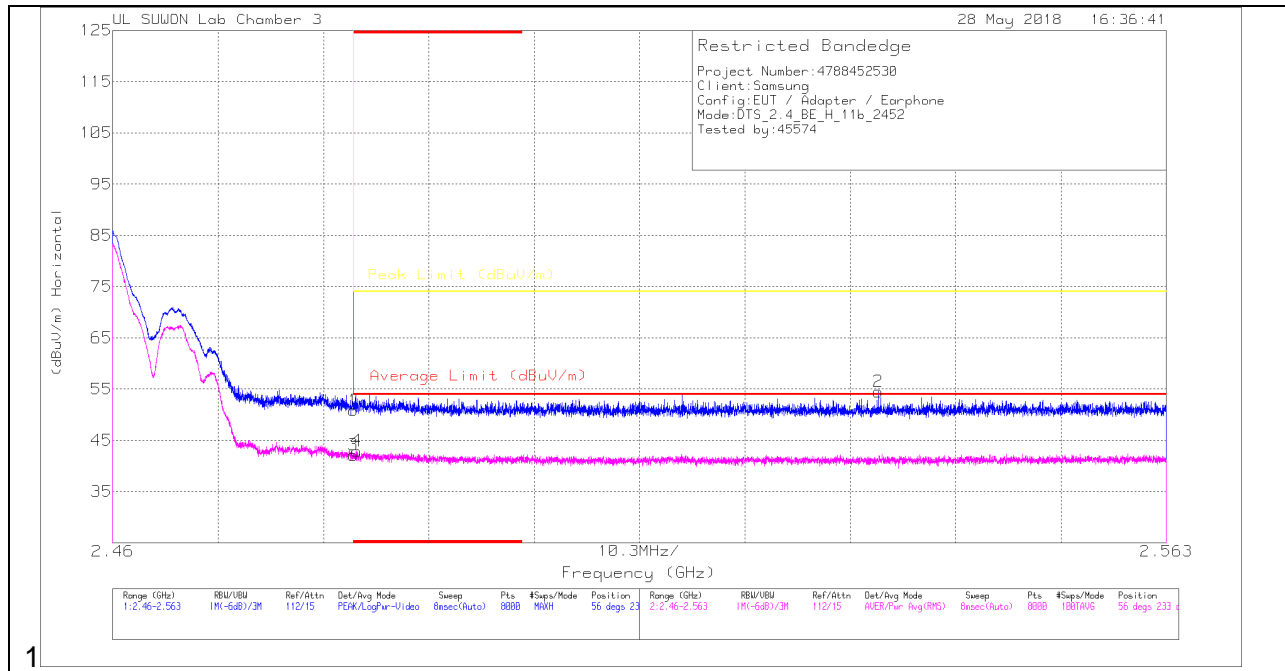

HORIZONTAL DATA

Trace Markers

Marker	Frequency (GHz)	Meter Reading (dBuV)	Det	3117(00205959)	10dB_ATT(dB)	DC Corr (dB)	Corrected Reading (dBuV/m)	Average Limit (dBuV/m)	Margin (dB)	Peak Limit (dBuV/m)	Pk Margin (dB)	Azimuth (Degs)	Height (cm)	Polarity
1	* 2.484	41.75	Pk	32.1	-23	0	50.85	-	-	74	-23.15	56	233	H
2	2.535	45.4	Pk	32.1	-23	0	54.5	-	-	74	-19.5	56	233	H
3	* 2.484	33.02	RMS	32.1	-23	0	42.12	54	-11.88	-	-	56	233	H
4	* 2.484	33.95	RMS	32.1	-23.1	0	42.95	54	-11.05	-	-	56	233	H

* - indicates frequency in CFR47 Pt 15 / IC RSS-Restricted Band

Pk - Peak detector

RMS - RMS detection

VERTICAL PEAK AND AVERAGE PLOT

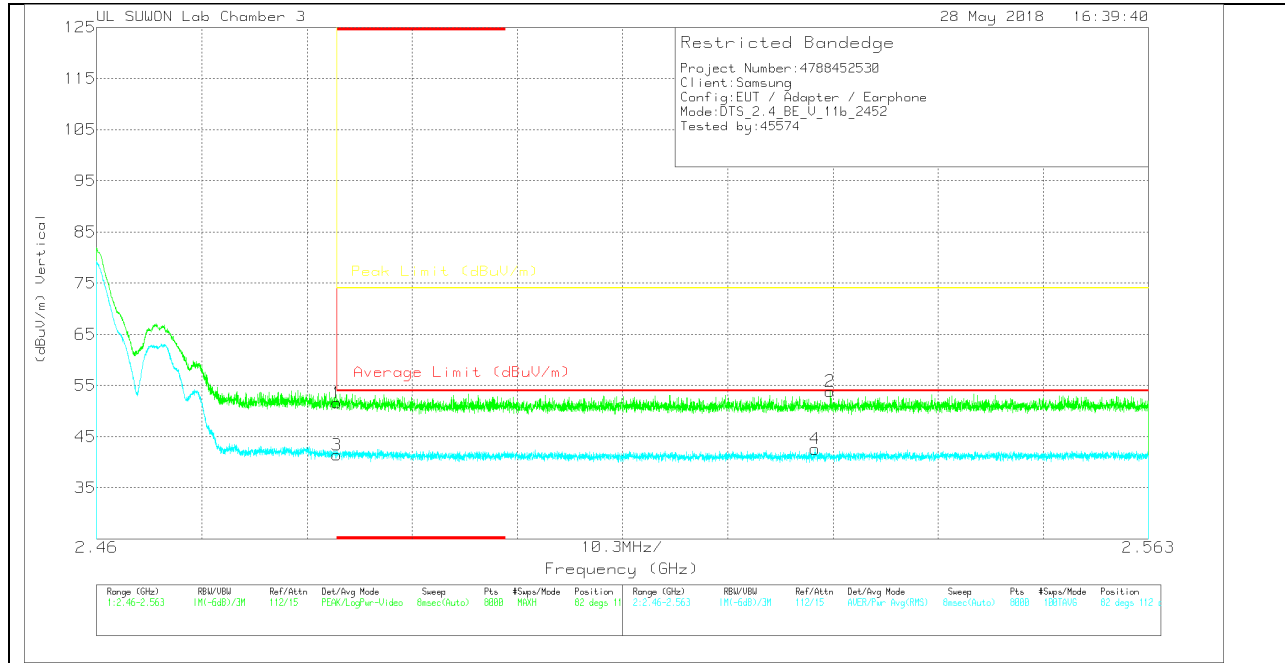

VERTICAL DATA

Trace Markers

Marker	Frequency (GHz)	Meter Reading (dBuV)	Det	3117(00205959)	10dB_ATT(dB)	DC Corr (dB)	Corrected Reading (dBuV/m)	Average Limit (dBuV/m)	Margin (dB)	Peak Limit (dBuV/m)	PK Margin (dB)	Azimuth (Degs)	Height (cm)	Polarity
1	* 2.484	42.49	Pk	32.1	-23	0	51.59	-	-	74	-22.41	82	112	V
2	2.532	44.84	Pk	32.1	-23.1	0	53.84	-	-	74	-20.16	82	112	V
3	* 2.484	32.33	RMS	32.1	-23	0	41.43	54	-12.57	-	-	82	112	V
4	2.53	33.5	RMS	32.1	-23	0	42.6	54	-11.4	-	-	82	112	V

* - indicates frequency in CFR47 Pt 15 / IC RSS-Restricted Band
 Pk - Peak detector
 RMS - RMS detection

AUTHORIZED BANDEDGE (10 CHANNEL)

HORIZONTAL PEAK AND AVERAGE PLOT

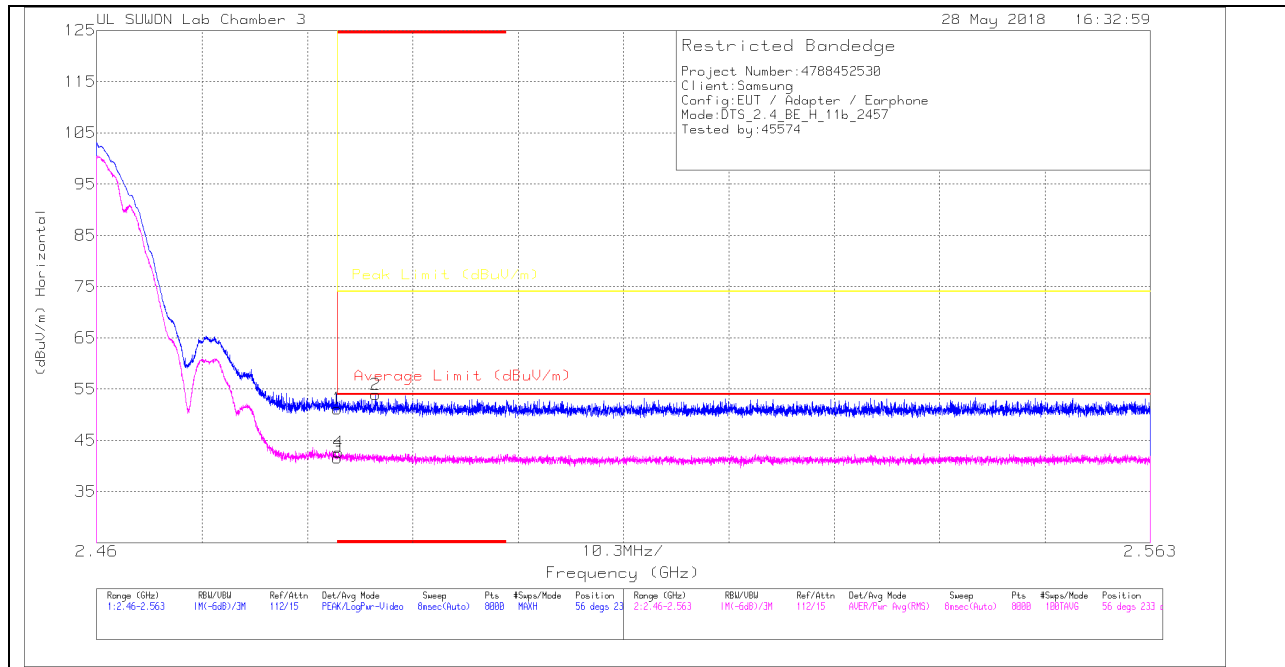

HORIZONTAL DATA

Trace Markers

Marker	Frequency (GHz)	Meter Reading (dBuV)	Det	3117000205959	10dB_ATT(dB)	DC Corr (dB)	Corrected Reading (dBuV/m)	Average Limit (dBuV/m)	Margin (dB)	Peak Limit (dBuV/m)	PK Margin (dB)	Azimuth (Degs)	Height (cm)	Polarity
1	* 2.484	42.07	Pk	32.1	-23	0	51.17	-	-	74	-22.83	56	233	H
2	* 2.487	44.93	Pk	32.1	-23.1	0	53.93	-	-	74	-20.07	56	233	H
3	* 2.484	32.51	RMS	32.1	-23	0	41.61	54	-12.39	-	-	56	233	H
4	* 2.484	33.55	RMS	32.1	-23	0	42.65	54	-11.35	-	-	56	233	H

* - indicates frequency in CFR47 Pt 15 / IC RSS-Restricted Band

Pk - Peak detector

RMS - RMS detection

VERTICAL PEAK AND AVERAGE PLOT

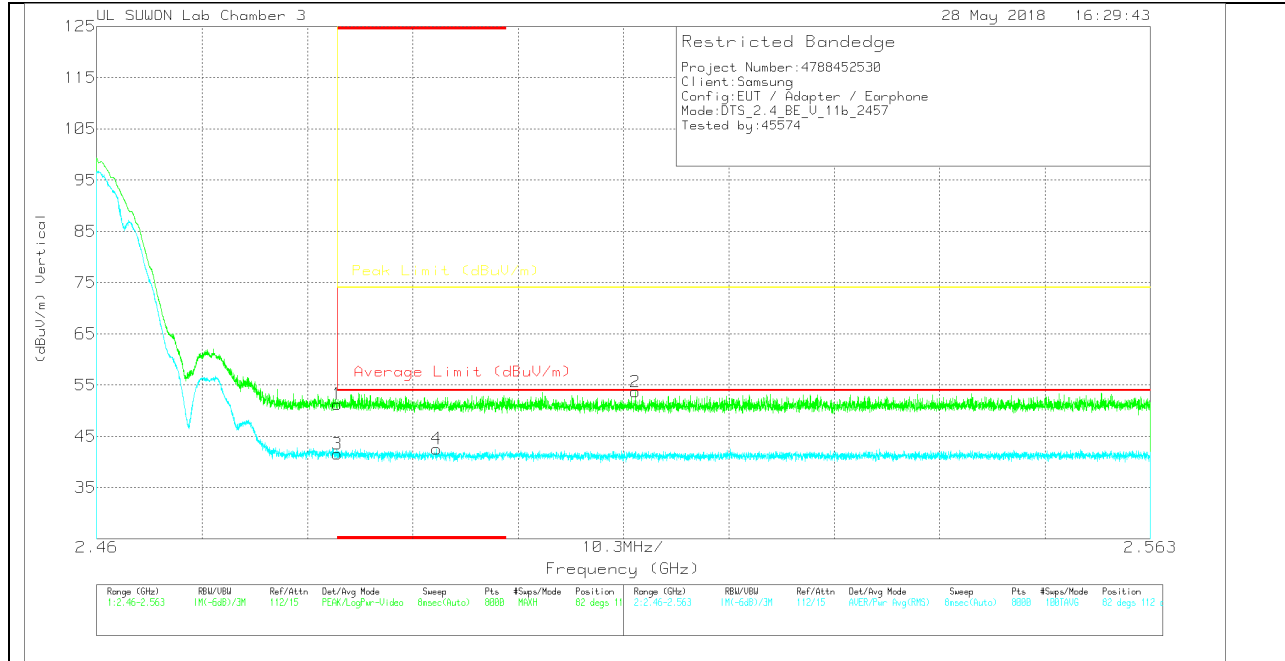

VERTICAL DATA

Trace Markers

Marker	Frequency (GHz)	Meter Reading (dBuV)	Det	3117(00205959)	10dB_ATT(dB)	DC Corr (dB)	Corrected Reading (dBuV/m)	Average Limit (dBuV/m)	Margin (dB)	Peak Limit (dBuV/m)	PK Margin (dB)	Azimuth (Degs)	Height (cm)	Polarity
1	* 2.484	42.18	Pk	32.1	-23	0	51.28	-	-	74	-22.72	82	112	V
2	2.513	44.59	Pk	32.1	-23	0	53.69	-	-	74	-20.31	82	112	V
3	* 2.484	32.42	RMS	32.1	-23	0	41.52	54	-12.48	-	-	82	112	V
4	* 2.493	33.58	RMS	32.1	-23.1	0	42.58	54	-11.42	-	-	82	112	V

* - indicates frequency in CFR47 Pt 15 / IC RSS-Restricted Band
 Pk - Peak detector
 RMS - RMS detection

AUTHORIZED BANDEDGE (11 CHANNEL)

HORIZONTAL PEAK AND AVERAGE PLOT

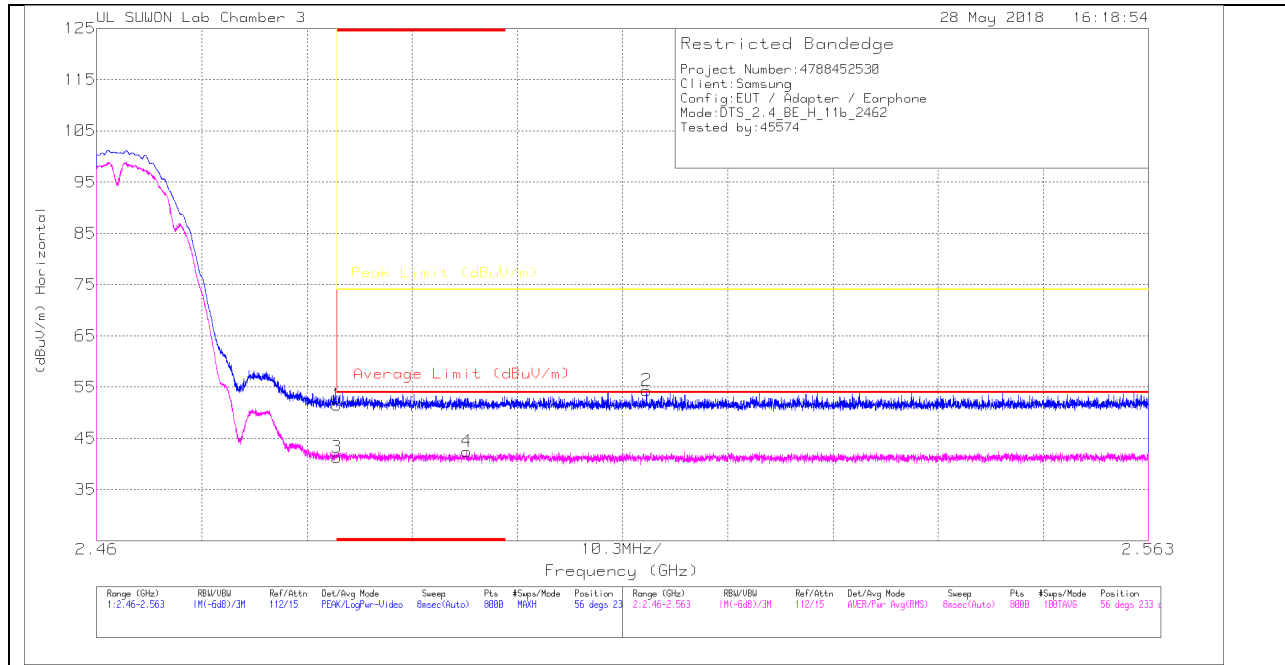

HORIZONTAL DATA

Trace Markers

Marker	Frequency (GHz)	Meter Reading (dBuV)	Det	3117(00205959)	100B_ATT1[0B]	DC Corr (dB)	Corrected Reading (dBuV/m)	Average Limit (dBuV/m)	Margin (dB)	Peak Limit (dBuV/m)	PK Margin (dB)	Azimuth (Degs)	Height (cm)	Polarity
1	* 2.484	42.45	PK	32.1	-23	0	51.55	-	-	74	-22.45	56	233	H
2	2.514	45.25	PK	32.1	-23	0	54.35	-	-	74	-19.65	56	233	H
3	* 2.484	32.25	RMS	32.1	-23	0	41.35	54	-12.65	-	-	56	233	H
4	* 2.496	33.36	RMS	32.1	-23	0	42.46	54	-11.54	-	-	56	233	H

* - indicates frequency in CFR47 Pt 15 / IC RSS-Restricted Band

PK - Peak detector

RMS - RMS detection

VERTICAL PEAK AND AVERAGE PLOT

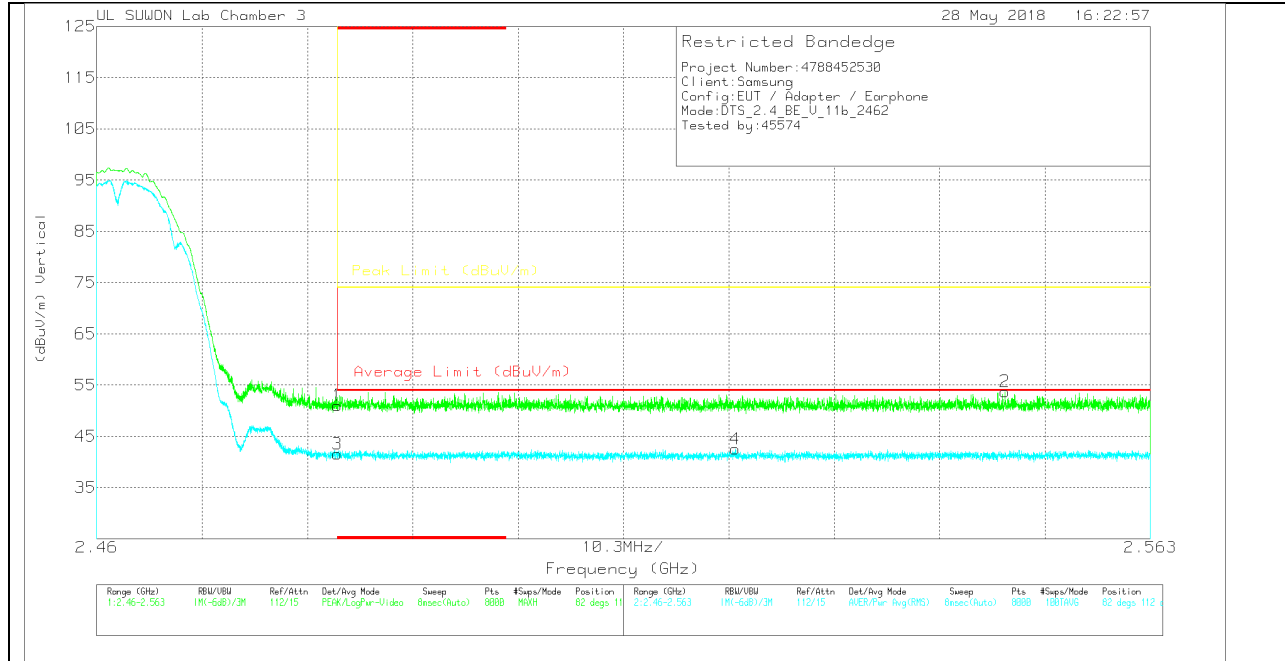

VERTICAL DATA

Trace Markers

Marker	Frequency (GHz)	Meter Reading (dBuV)	Det	3117(00205959)	10dB_ATT(dB)	DC Corr (dB)	Corrected Reading (dBuV/m)	Average Limit (dBuV/m)	Margin (dB)	Peak Limit (dBuV/m)	PK Margin (dB)	Azimuth (Degs)	Height (cm)	Polarity
1	* 2.484	41.93	Pk	32.1	-23	0	51.03	-	-	74	-22.97	82	112	V
2	2.549	44.62	Pk	32.1	-23	0	53.72	-	-	74	-20.28	82	112	V
3	* 2.484	32.41	RMS	32.1	-23	0	41.51	54	-12.49	-	-	82	112	V
4	2.522	33.35	RMS	32.1	-22.9	0	42.55	54	-11.45	-	-	82	112	V

* - indicates frequency in CFR47 Pt 15 / IC RSS-Restricted Band
 Pk - Peak detector
 RMS - RMS detection

HARMONICS AND SPURIOUS EMISSIONS

3 CHANNEL HORIZONTAL

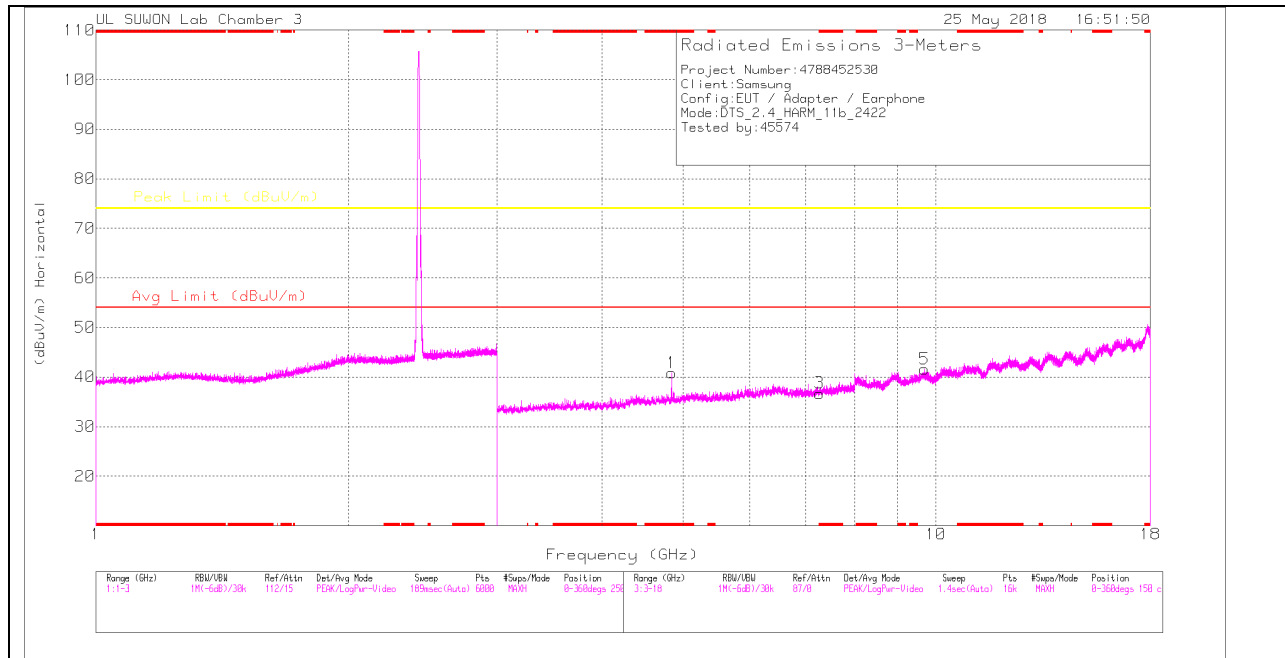

3 CHANNEL VERTICAL

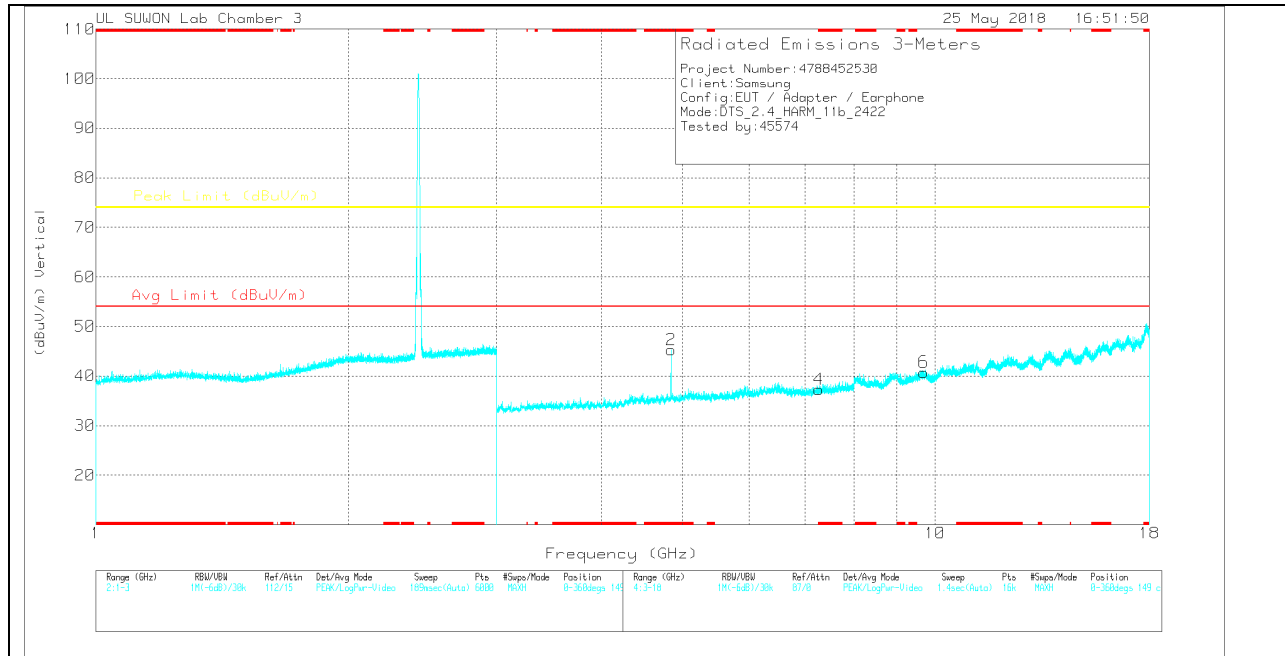

Note: Emission was scanned up to 26GHz; No emissions were detected above the noise floor which was at least 20dB below the specification limit.

3 CHANNEL DATA

Trace Markers

Marker	Frequency (GHz)	Meter Reading (dBuV)	Det	3117[00205959]	3GHz_HP[dB]	DC Corr (dB)	Corrected Reading (dBuV/m)	Avg Limit (dBuV/m)	Margin (dB)	Peak Limit (dBuV/m)	Margin (dB)	Azimuth (Degs)	Height (cm)	Polarity
1	* 4.843	35.45	PK	34	-28.6	0	40.85	-	-	74	-33.15	0-360	150	H
3	* 7.267	24.93	PK	35.6	-23.8	0	36.73	-	-	74	-37.27	0-360	150	H
5	9.689	24.33	PK	36.8	-19.5	0	41.63	-	-	74	-32.37	0-360	250	H
2	* 4.843	39.91	PK	34	-28.6	0	45.31	-	-	74	-28.69	0-360	250	V
4	* 7.266	25.53	PK	35.6	-23.8	0	37.33	-	-	74	-36.67	0-360	149	V
6	9.689	23.49	PK	36.8	-19.5	0	40.79	-	-	74	-33.21	0-360	149	V

* - indicates frequency in CFR47 Pt 15 / IC RSS-Restricted Band
 PK – Peak detector

Radiated Emissions

Frequency (GHz)	Meter Reading (dBuV)	Det	3117[00205959]	3GHz_HP[dB]	DC Corr (dB)	Corrected Reading (dBuV/m)	Avg Limit (dBuV/m)	Margin (dB)	Peak Limit (dBuV/m)	Margin (dB)	Azimuth (Degs)	Height (cm)	Polarity
* 4.844	42.55	PK2	34	-28.6	0	47.95	-	-	74	-26.05	346	101	H
* 4.844	36.52	MAv1	34	-28.6	0	41.92	54	-12.08	-	-	346	101	H
* 4.844	44.31	PK2	34	-28.6	0	49.71	-	-	74	-24.29	156	130	V
* 4.844	39.03	MAv1	34	-28.6	0	44.43	54	-9.57	-	-	156	130	V

* - indicates frequency in CFR47 Pt 15 / IC RSS-Restricted Band
 PK2 - KDB558074 Method: Maximum Peak
 MAv1 - KDB558074 Option 1 Maximum RMS Average

6 CHANNEL HORIZONTAL

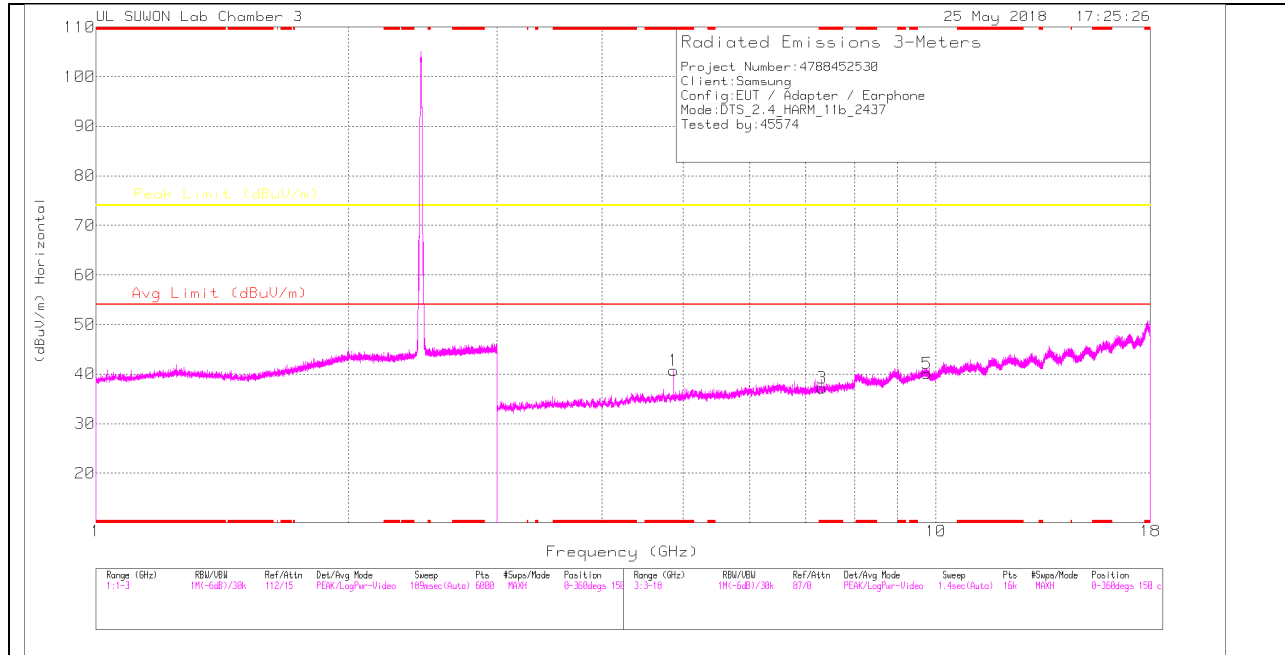

6 CHANNEL VERTICAL

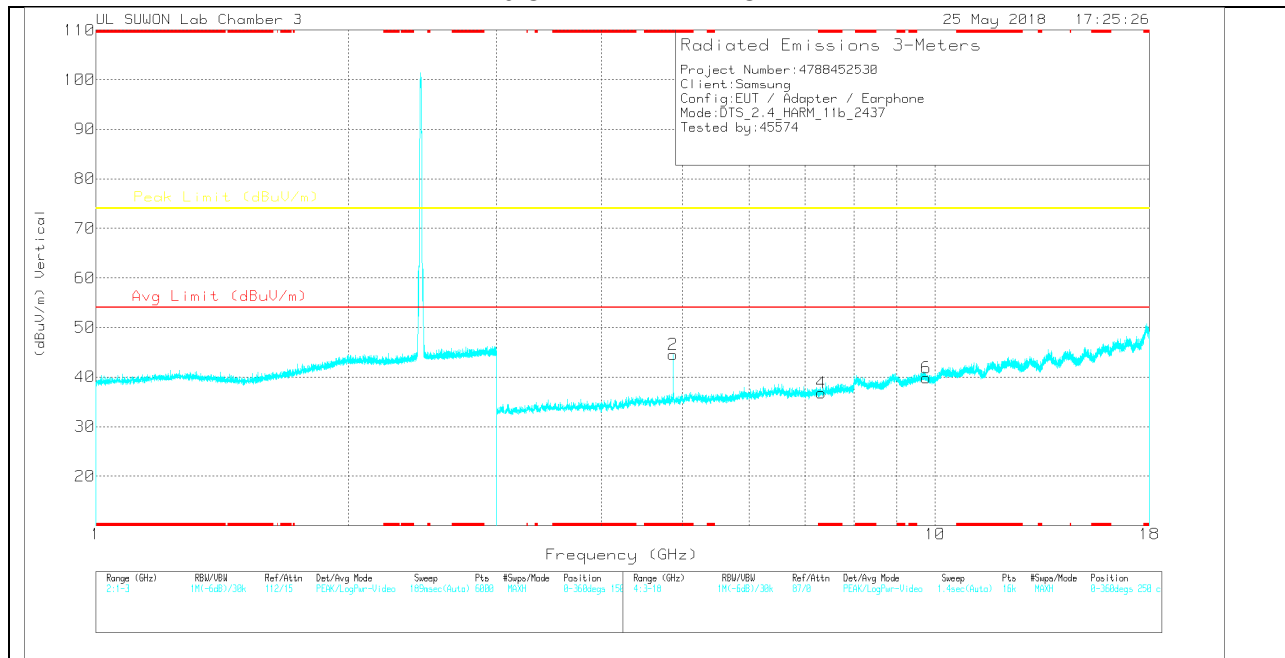

Note: Emission was scanned up to 26GHz; No emissions were detected above the noise floor which was at least 20dB below the specification limit.

6 CHANNEL DATA

Trace Markers

Marker	Frequency (GHz)	Meter Reading (dBuV)	Det	3117[00205959]	3GHz_HP[dB]	DC Corr (dB)	Corrected Reading (dBuV/m)	Avg Limit (dBuV/m)	Margin (dB)	Peak Limit (dBuV/m)	Margin (dB)	Azimuth (Degs)	Height (cm)	Polarity
1	* 4.873	35.57	PK	34	-28.8	0	40.77	-	-	74	-33.23	0-360	150	H
3	* 7.311	25.07	PK	35.6	-23.5	0	37.17	-	-	74	-36.83	0-360	150	H
5	9.749	22.76	PK	36.9	-19.6	0	40.06	-	-	74	-33.94	0-360	150	H
2	* 4.873	39.39	PK	34	-28.8	0	44.59	-	-	74	-29.41	0-360	250	V
4	* 7.311	24.7	PK	35.6	-23.5	0	36.8	-	-	74	-37.2	0-360	149	V
6	9.749	22.54	PK	36.9	-19.6	0	39.84	-	-	74	-34.16	0-360	149	V

* - indicates frequency in CFR47 Pt 15 / IC RSS-Restricted Band
 PK – Peak Detector

Radiated Emissions

Frequency (GHz)	Meter Reading (dBuV)	Det	3117[00205959]	3GHz_HP[dB]	DC Corr (dB)	Corrected Reading (dBuV/m)	Avg Limit (dBuV/m)	Margin (dB)	Peak Limit (dBuV/m)	Margin (dB)	Azimuth (Degs)	Height (cm)	Polarity
* 4.874	42.93	PK2	34	-28.9	0	48.03	-	-	74	-25.97	206	100	H
* 4.874	36.89	MAv1	34	-28.9	0	41.99	54	-12.01	-	-	206	100	H
* 4.874	44.33	PK2	34	-28.9	0	49.43	-	-	74	-24.57	151	303	V
* 4.874	38.56	MAv1	34	-28.9	0	43.66	54	-10.34	-	-	151	303	V

* - indicates frequency in CFR47 Pt 15 / IC RSS-Restricted Band
 PK2 - KDB558074 Method: Maximum Peak
 MAv1 - KDB558074 Option 1 Maximum RMS Average

9 CHANNEL HORIZONTAL

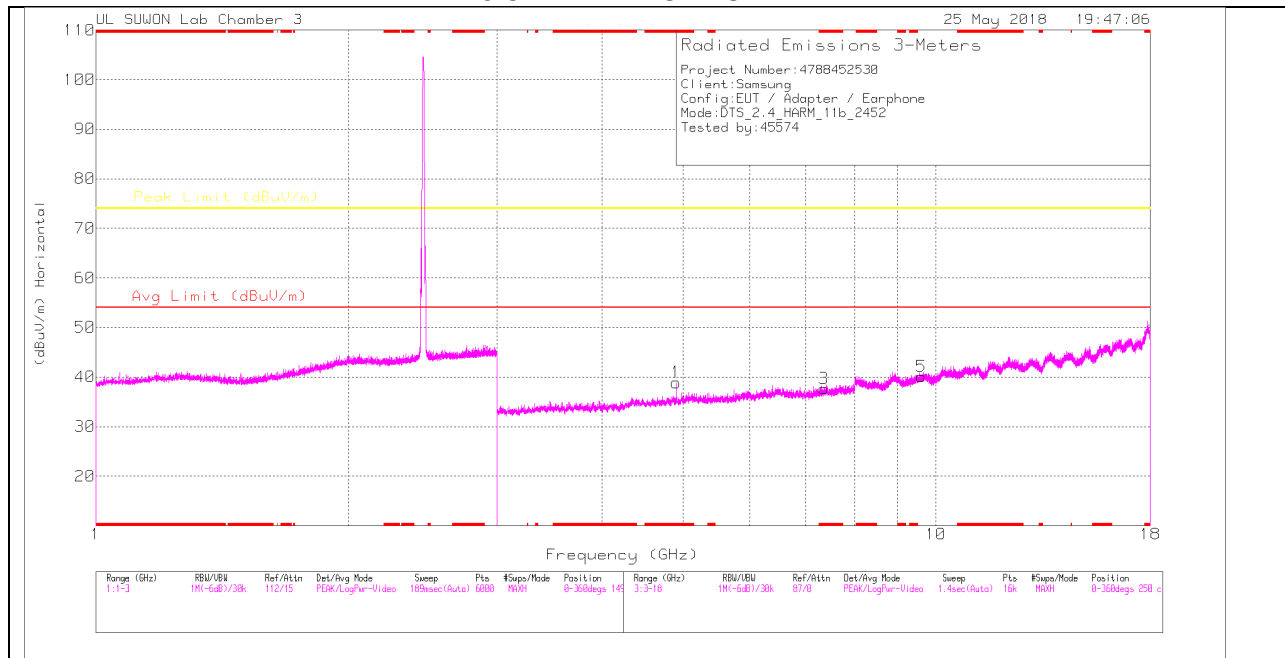

9 CHANNEL VERTICAL

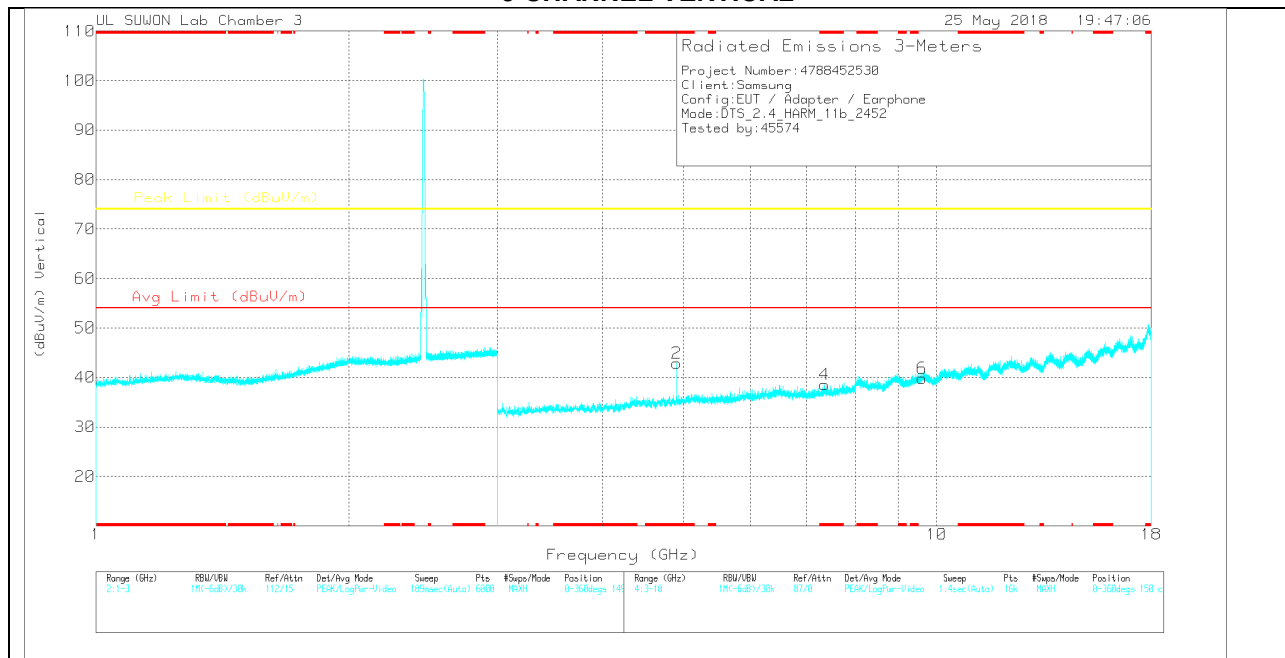

Note: Emission was scanned up to 26GHz; No emissions were detected above the noise floor which was at least 20dB below the specification limit.

9 CHANNEL DATA

Trace Markers

Marker	Frequency (GHz)	Meter Reading (dBuV)	Det	3117[00205959]	3GHz_HP[dB]	DC Corr (dB)	Corrected Reading (dBuV/m)	Avg Limit (dBuV/m)	Margin (dB)	Peak Limit (dBuV/m)	Margin (dB)	Azimuth (Degs)	Height (cm)	Polarity
1	* 4.903	33.89	PK	34	-29	0	38.89	-	-	74	-35.11	0-360	150	H
3	* 7.357	25.27	PK	35.6	-23.2	0	37.67	-	-	74	-36.33	0-360	150	H
5	9.608	23.3	PK	36.7	-19.9	0	40.1	-	-	74	-33.9	0-360	150	H
2	* 4.904	37.92	PK	34	-29	0	42.92	-	-	74	-31.08	0-360	250	V
4	* 7.357	26.2	PK	35.6	-23.2	0	38.6	-	-	74	-35.4	0-360	250	V
6	9.609	23.05	PK	36.7	-19.9	0	39.85	-	-	74	-34.15	0-360	250	V

* - indicates frequency in CFR47 Pt 15 / IC RSS-Restricted Band
 PK – Peak Detector

Radiated Emissions

Frequency (GHz)	Meter Reading (dBuV)	Det	3117[00205959]	3GHz_HP[dB]	DC Corr (dB)	Corrected Reading (dBuV/m)	Avg Limit (dBuV/m)	Margin (dB)	Peak Limit (dBuV/m)	Margin (dB)	Azimuth (Degs)	Height (cm)	Polarity
* 4.904	39.4	PK2	34	-29	0	44.4	-	-	74	-29.6	206	100	H
* 4.904	34.81	MAv1	34	-29	0	39.81	54	-14.19	-	-	206	100	H
* 4.904	41.29	PK2	34	-29	0	46.29	-	-	74	-27.71	151	303	V
* 4.904	37.22	MAv1	34	-29	0	42.22	54	-11.78	-	-	151	303	V

* - indicates frequency in CFR47 Pt 15 / IC RSS-Restricted Band
 PK2 - KDB558074 Method: Maximum Peak
 MAv1 - KDB558074 Option 1 Maximum RMS Average

11.2.2.TX ABOVE 1 GHz 802.11g MODE IN THE 2.4 GHz BAND

RESTRICTED BANDEDGE (1 CHANNEL)

HORIZONTAL PEAK AND AVERAGE PLOT

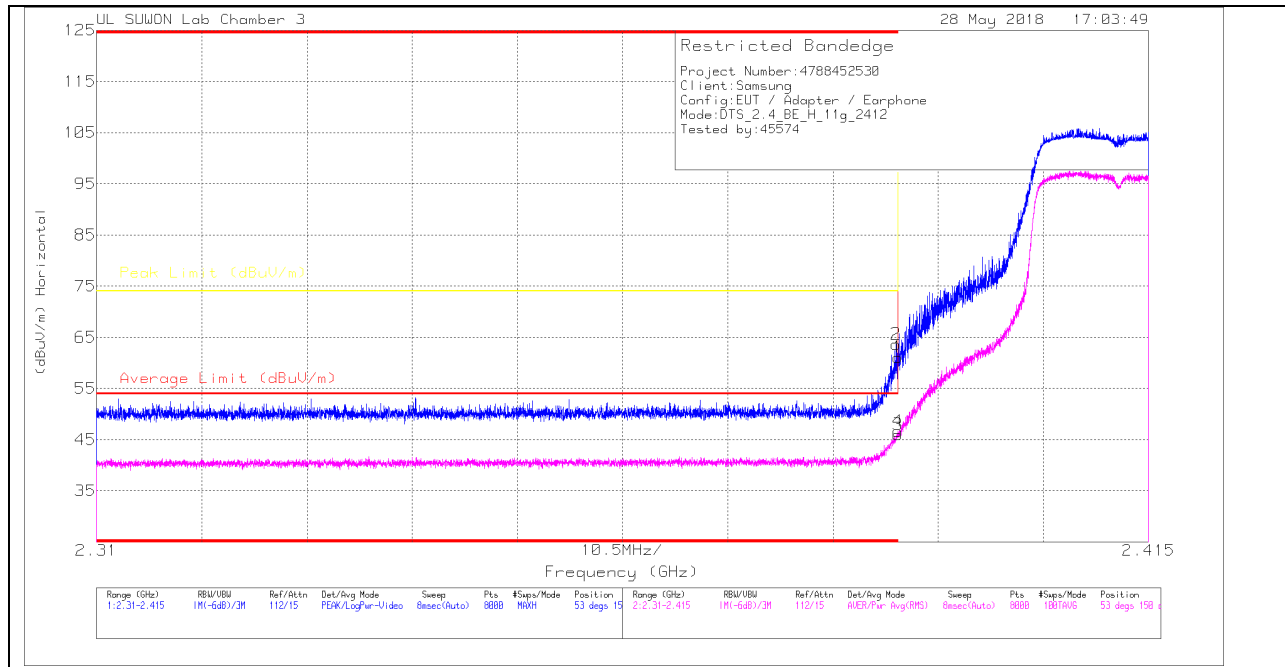

HORIZONTAL DATA

Trace Markers

Marker	Frequency (GHz)	Meter Reading (dBuV)	Det	311700205959	10dB_ATT[dB]	DC Corr (dB)	Corrected Reading (dBuV/m)	Average Limit (dBuV/m)	Margin (dB)	Peak Limit (dBuV/m)	PK Margin (dB)	Azimuth (Degs)	Height (cm)	Polarity
1	* 2.39	52.61	Pk	31.8	-23.3	0	61.11	-	-	74	-12.89	53	150	H
2	* 2.39	55.16	Pk	31.8	-23.3	0	63.66	-	-	74	-10.34	53	150	H
3	* 2.39	37.49	RMS	31.8	-23.3	0	45.99	54	-8.01	-	-	53	150	H
4	* 2.39	38.15	RMS	31.8	-23.3	0	46.65	54	-7.35	-	-	53	150	H

* - indicates frequency in CFR47 Pt 15 / IC RSS-Restricted Band

Pk - Peak detector

RMS - RMS detection

VERTICAL PEAK AND AVERAGE PLOT

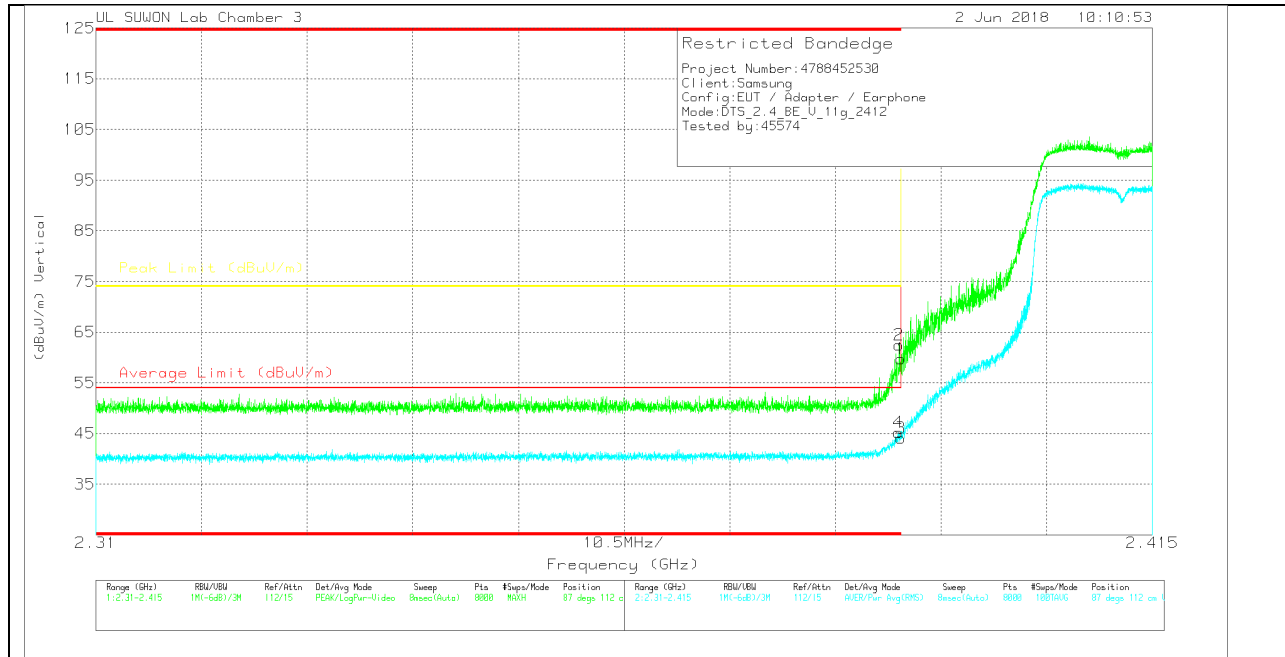

VERTICAL DATA

Trace Markers

Marker	Frequency (GHz)	Meter Reading (dBuV)	Det	3117(00205959)	10dB_ATT[dB]	DC Corr (dB)	Corrected Reading (dBuV/m)	Average Limit (dBuV/m)	Margin (dB)	Peak Limit (dBuV/m)	PK Margin (dB)	Asmuth (Degs)	Height (cm)	Polarity
1	* 2.39	51.19	Pk	31.8	-23.3	0	59.69	-	-	74	-14.31	87	112	V
2	* 2.39	53.94	Pk	31.8	-23.3	0	62.44	-	-	74	-11.56	87	112	V
3	* 2.39	35.62	RMS	31.8	-23.3	0	44.12	54	-9.88	-	-	87	112	V
4	* 2.39	36.72	RMS	31.8	-23.3	0	45.22	54	-8.78	-	-	87	112	V

* - indicates frequency in CFR47 Pt 15 / IC RSS-Restricted Band

Pk - Peak detector

RMS - RMS detection

RESTRICTED BANDEDGE (2 CHANNEL)

HORIZONTAL PEAK AND AVERAGE PLOT

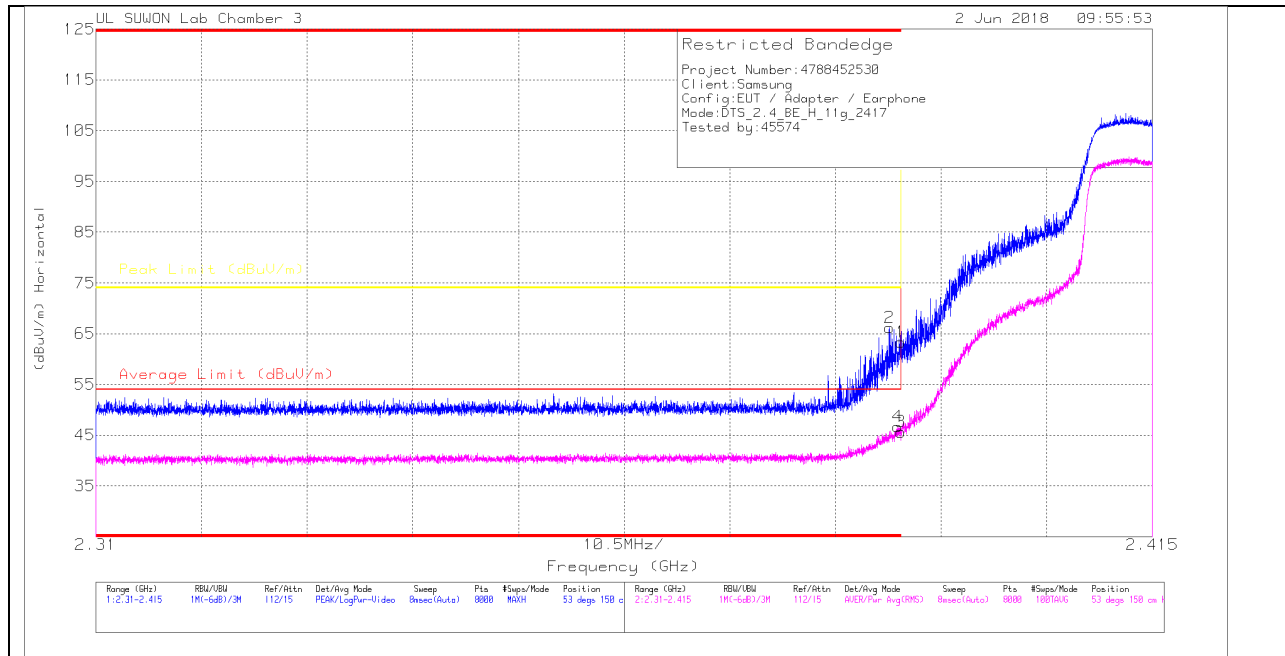

HORIZONTAL DATA

Trace Markers

Marker	Frequency (GHz)	Meter Reading (dBuV)	Det	3117(00205959)	10dB_ATT(dB)	DC Corr (dB)	Corrected Reading (dBuV/m)	Average Limit (dBuV/m)	Margin (dB)	Peak Limit (dBuV/m)	PK Margin (dB)	Azimuth (Degs)	Height (cm)	Polarity
1	* 2.39	54.84	PK	31.8	-23.3	0	63.34	-	-	74	-10.66	53	150	H
2	* 2.389	57.71	PK	31.8	-23.3	0	66.21	-	-	74	-7.79	53	150	H
3	* 2.39	37.14	RMS	31.8	-23.3	0	45.64	54	-8.36	-	-	53	150	H
4	* 2.39	38.17	RMS	31.8	-23.3	0	46.67	54	-7.33	-	-	53	150	H

* - indicates frequency in CFR47 Pt 15 / IC RSS-Restricted Band

PK - Peak detector

RMS - RMS detection

VERTICAL PEAK AND AVERAGE PLOT

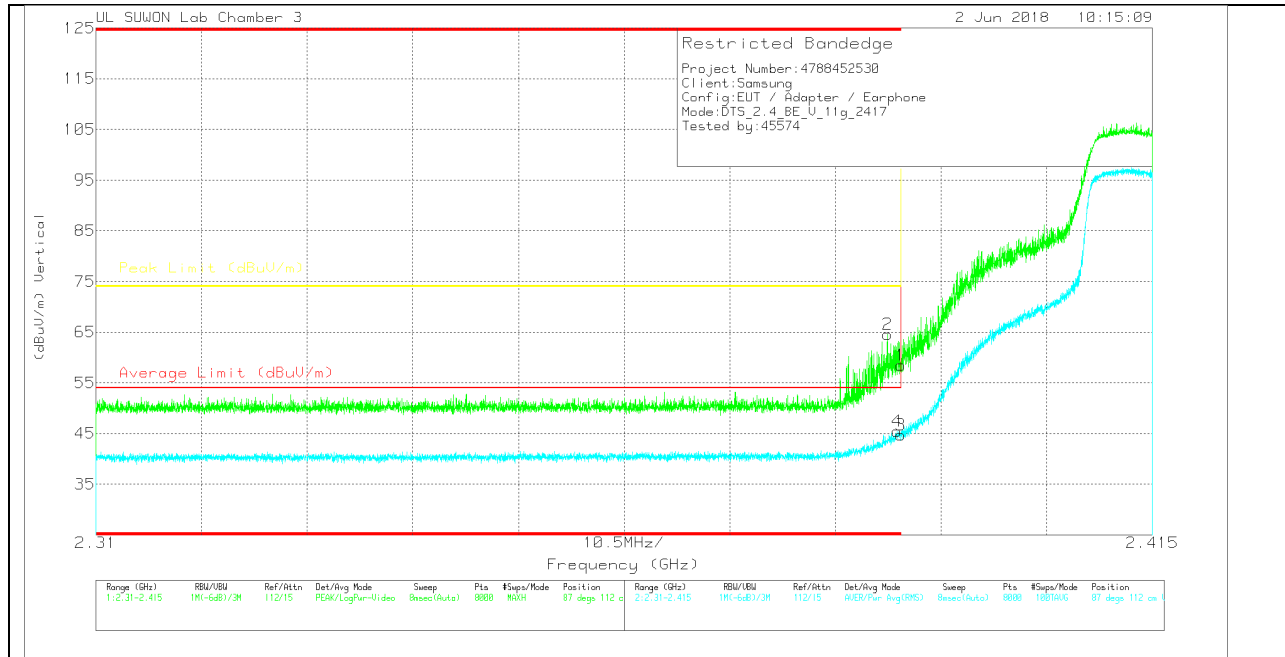

VERTICAL DATA

Trace Markers

Marker	Frequency (GHz)	Meter Reading (dBuV)	Det	3117(00205959)	10dB_ATT(dB)	DC Corr (dB)	Corrected Reading (dBuV/m)	Average Limit (dBuV/m)	Margin (dB)	Peak Limit (dBuV/m)	PK Margin (dB)	Azimuth (Degs)	Height (cm)	Polarity
1	* 2.39	49.98	Pk	31.8	-23.3	0	58.48	-	-	74	-15.52	87	112	V
2	* 2.389	56.03	Pk	31.8	-23.3	0	64.53	-	-	74	-9.47	87	112	V
3	* 2.39	36.23	RMS	31.8	-23.3	0	44.73	54	-9.27	-	-	87	112	V
4	* 2.39	36.97	RMS	31.8	-23.3	0	45.47	54	-8.53	-	-	87	112	V

* - indicates frequency in CFR47 Pt 15 / IC RSS-Restricted Band

Pk - Peak detector

RMS - RMS detection

RESTRICTED BANDEDGE (3 CHANNEL)

HORIZONTAL PEAK AND AVERAGE PLOT

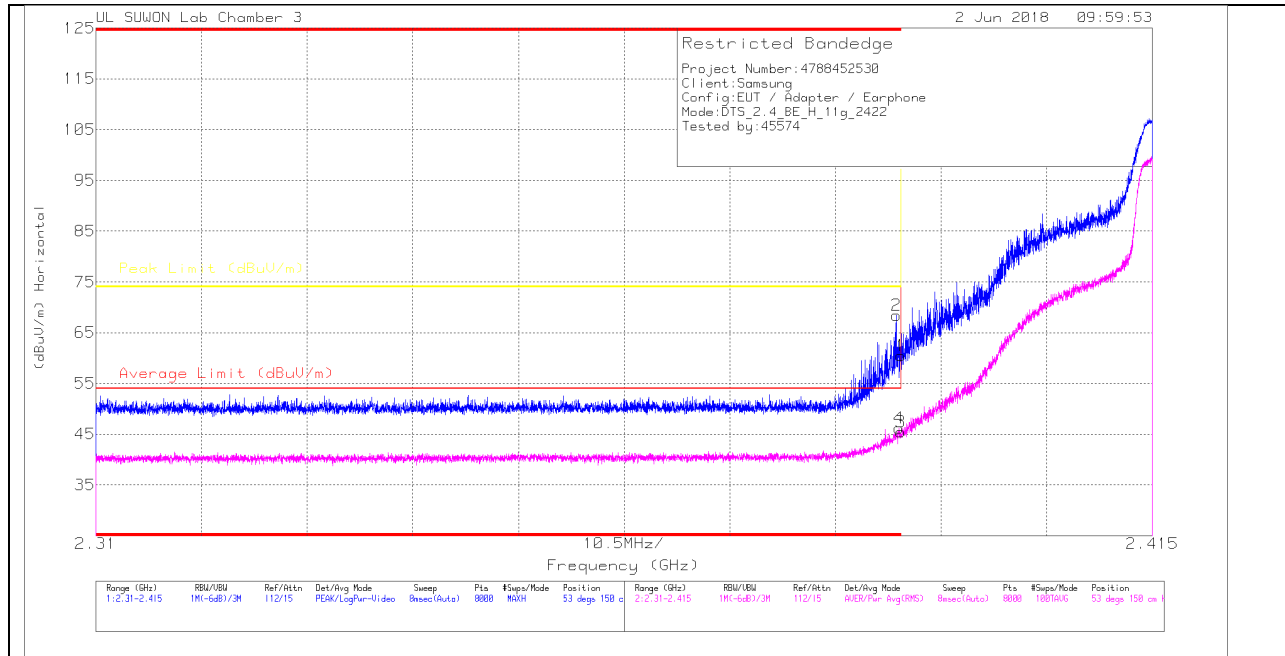

HORIZONTAL DATA

Trace Markers

Marker	Frequency (GHz)	Meter Reading (dBuV)	Det	3117(00205959)	10dB_ATT(dB)	DC Corr (dB)	Corrected Reading (dBuV/m)	Average Limit (dBuV/m)	Margin (dB)	Peak Limit (dBuV/m)	PK Margin (dB)	Azimuth (Degs)	Height (cm)	Polarity
1	* 2.39	51.94	Pk	31.8	-23.3	0	60.44	-	-	74	-13.56	53	150	H
2	* 2.39	59.94	Pk	31.8	-23.3	0	68.44	-	-	74	-5.56	53	150	H
3	* 2.39	36.99	RMS	31.8	-23.3	0	45.49	54	-8.51	-	-	53	150	H
4	* 2.39	37.66	RMS	31.8	-23.3	0	46.16	54	-7.84	-	-	53	150	H

* - indicates frequency in CFR47 Pt 15 / IC RSS-Restricted Band

Pk - Peak detector

RMS - RMS detection

VERTICAL PEAK AND AVERAGE PLOT

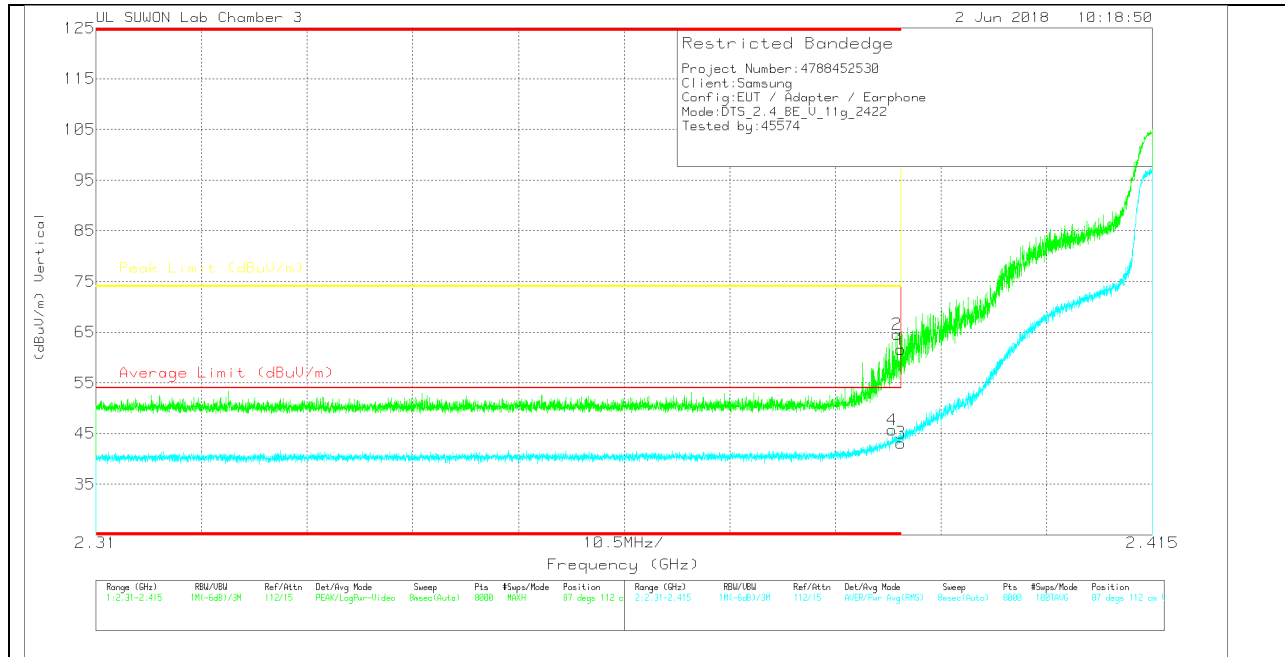

VERTICAL DATA

Trace Markers

Marker	Frequency (GHz)	Meter Reading (dBuV)	Det	3117(00205959)	10dB_ATT[dB]	DC Corr (dB)	Corrected Reading (dBuV/m)	Average Limit (dBuV/m)	Margin (dB)	Peak Limit (dBuV/m)	Pk Margin (dB)	Azimuth (Degs)	Height (cm)	Polarity
1	* 2.39	53.13	Pk	31.8	-23.3	0	61.63	-	-	74	-12.37	87	112	V
2	* 2.39	56.05	Pk	31.8	-23.3	0	64.55	-	-	74	-9.45	87	112	V
3	* 2.39	34.65	RMS	31.8	-23.3	0	43.15	54	-10.85	-	-	87	112	V
4	* 2.389	37.17	RMS	31.8	-23.3	0	45.67	54	-8.33	-	-	87	112	V

* - indicates frequency in CFR47 Pt 15 / IC RSS-Restricted Band

Pk - Peak detector

RMS - RMS detection

AUTHORIZED BANDEDGE (9 CHANNEL)

HORIZONTAL PEAK AND AVERAGE PLOT

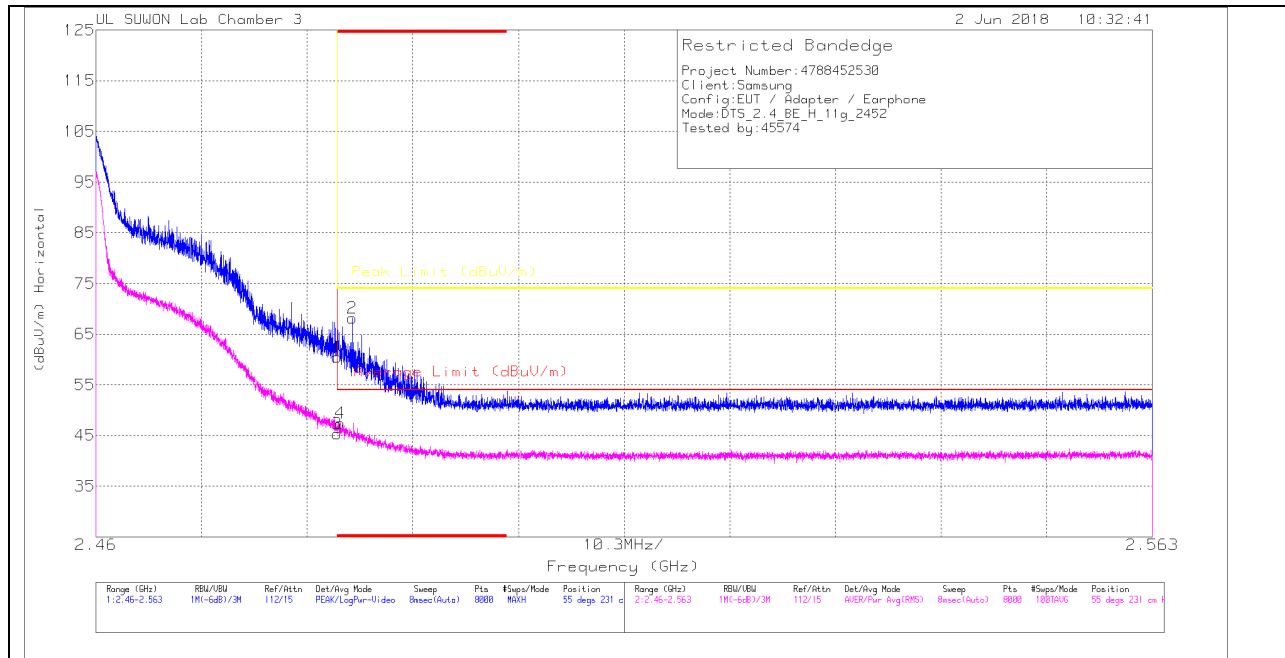

HORIZONTAL DATA

Trace Markers

Marker	Frequency (GHz)	Meter Reading (dBuV)	Det	3117(00205959)	10dB_ATT(dB)	DC Corr (dB)	Corrected Reading (dBuV/m)	Average Limit (dBuV/m)	Margin (dB)	Peak Limit (dBuV/m)	PK Margin (dB)	Azimuth (Degs)	Height (cm)	Polarity
1	* 2.484	51.35	Pk	32.1	-23	0	60.45	-	-	74	-13.55	55	231	H
2	* 2.485	59.14	Pk	32.1	-23.1	0	68.14	-	-	74	-5.86	55	231	H
3	* 2.484	36.2	RMS	32.1	-23	0	45.3	54	-8.7	-	-	55	231	H
4	* 2.484	38.44	RMS	32.1	-23.1	0	47.44	54	-6.56	-	-	55	231	H

* - indicates frequency in CFR47 Pt 15 / IC RSS-Restricted Band

Pk - Peak detector

RMS - RMS detection

VERTICAL PEAK AND AVERAGE PLOT

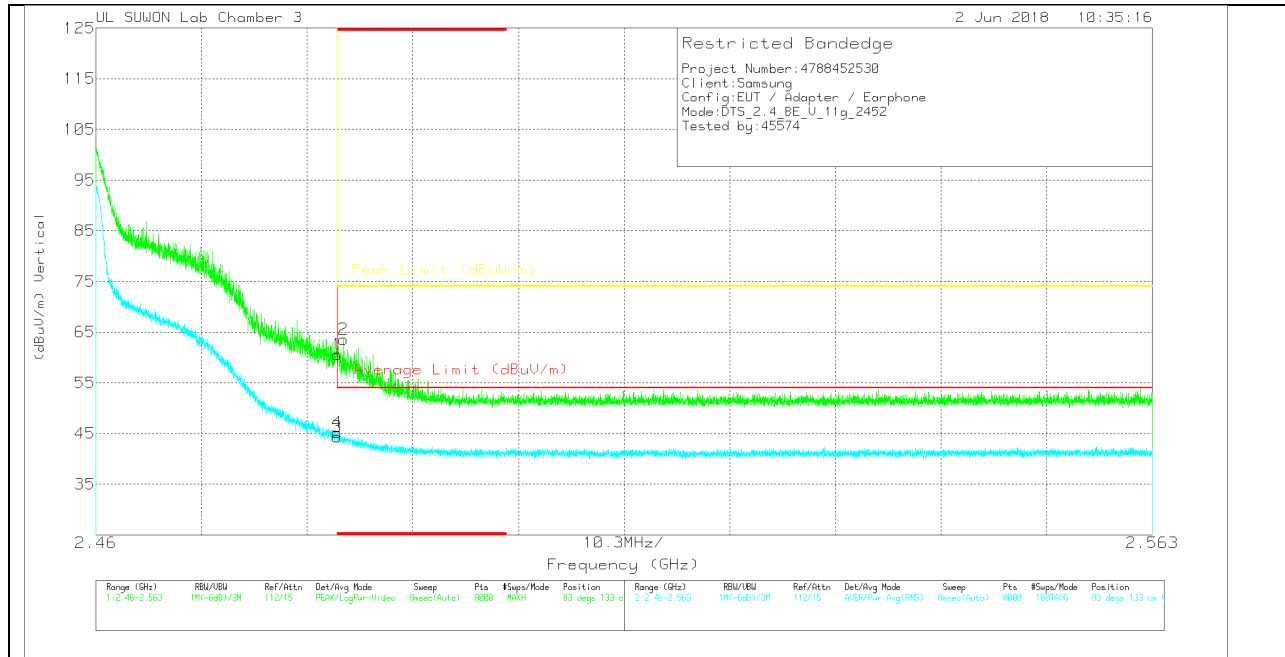

VERTICAL DATA

Trace Markers

Marker	Frequency (GHz)	Meter Reading (dBuV)	Det	3117(00205959)	10dB_ATT(dB)	DC Corr (dB)	Corrected Reading (dBuV/m)	Average Limit (dBuV/m)	Margin (dB)	Peak Limit (dBuV/m)	PK Margin (dB)	Azimuth (Degs)	Height (cm)	Polarity
1	* 2.484	51.44	Pk	32.1	-23	0	60.54	-	-	74	-13.46	83	133	V
2	* 2.484	54.55	Pk	32.1	-23.1	0	63.55	-	-	74	-10.45	83	133	V
3	* 2.484	35.2	RMS	32.1	-23	0	44.3	54	-9.7	-	-	83	133	V
4	* 2.484	36.15	RMS	32.1	-23	0	45.25	54	-8.75	-	-	83	133	V

* - indicates frequency in CFR47 Pt 15 / IC RSS-Restricted Band

Pk - Peak detector

RMS - RMS detection

AUTHORIZED BANDEDGE (10 CHANNEL)

HORIZONTAL PEAK AND AVERAGE PLOT

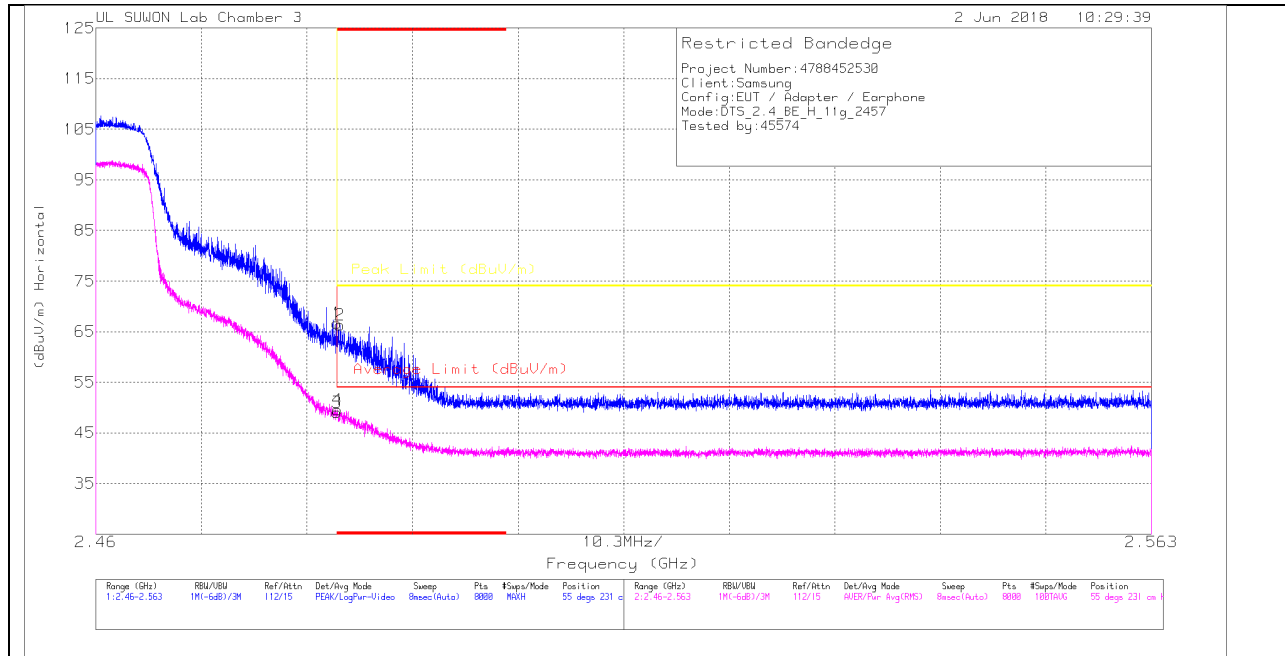

HORIZONTAL DATA

Trace Markers

Marker	Frequency (GHz)	Meter Reading (dBuV)	Det	3117(00205959)	10dB_ATT[dB]	DC Corr (dB)	Corrected Reading (dBuV/m)	Average Limit (dBuV/m)	Margin (dB)	Peak Limit (dBuV/m)	PK Margin (dB)	Azimuth (Degs)	Height (cm)	Polarity
1	* 2.484	57.54	Pk	32.1	-23	0	66.64	-	-	74	-7.36	55	231	H
2	* 2.484	57.29	Pk	32.1	-23.1	0	66.29	-	-	74	-7.71	55	231	H
3	* 2.484	39.98	RMS	32.1	-23	0	49.08	54	-4.92	-	-	55	231	H
4	* 2.484	40.49	RMS	32.1	-23	0	49.59	54	-4.41	-	-	55	231	H

* - indicates frequency in CFR47 Pt 15 / IC RSS-Restricted Band

Pk - Peak detector

RMS - RMS detection

VERTICAL PEAK AND AVERAGE PLOT

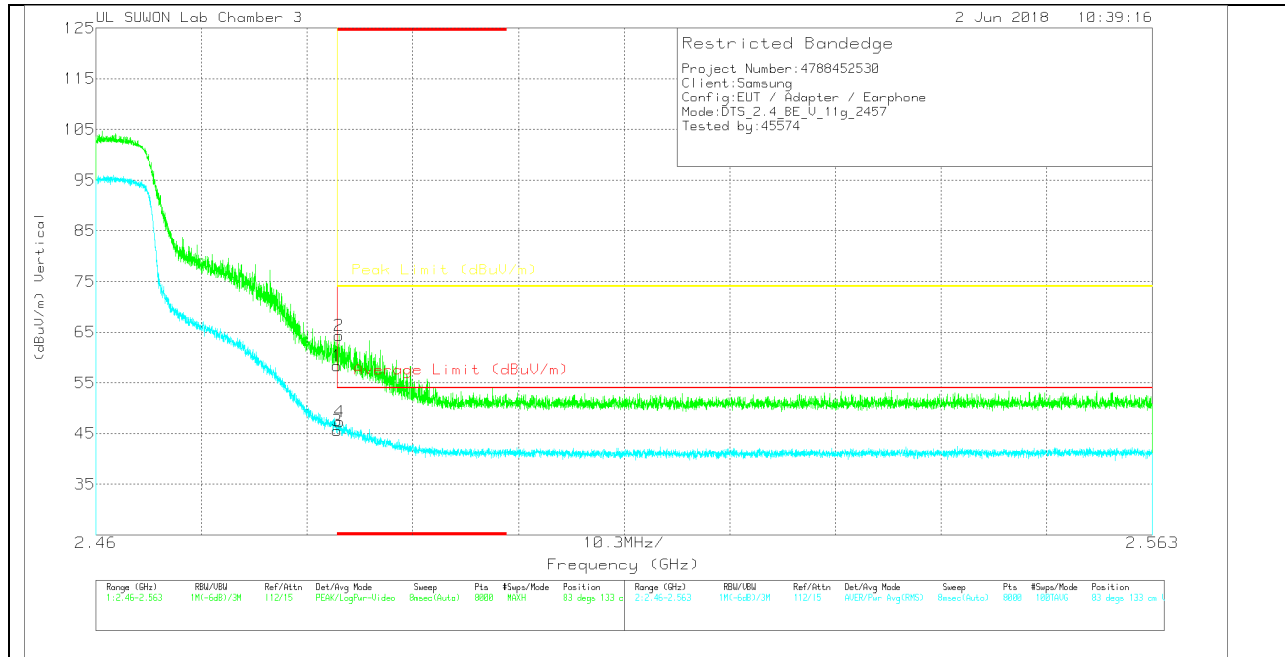

VERTICAL DATA

Trace Markers

Marker	Frequency (GHz)	Meter Reading (dBuV)	Det	3117(00205959)	10dB_ATT(dB)	DC Corr (dB)	Corrected Reading (dBuV/m)	Average Limit (dBuV/m)	Margin (dB)	Peak Limit (dBuV/m)	PK Margin (dB)	Azimuth (Degs)	Height (cm)	Polarity
1	* 2.484	49.3	Pk	32.1	-23	0	58.4	-	-	74	-15.6	83	133	V
2	* 2.484	55.27	Pk	32.1	-23	0	64.37	-	-	74	-9.63	83	133	V
3	* 2.484	36.46	RMS	32.1	-23	0	45.56	54	-8.44	-	-	83	133	V
4	* 2.484	38.33	RMS	32.1	-23.1	0	47.33	54	-6.67	-	-	83	133	V

* - indicates frequency in CFR47 Pt 15 / IC RSS-Restricted Band

Pk - Peak detector

RMS - RMS detection

AUTHORIZED BANDEDGE (11 CHANNEL)

HORIZONTAL PEAK AND AVERAGE PLOT

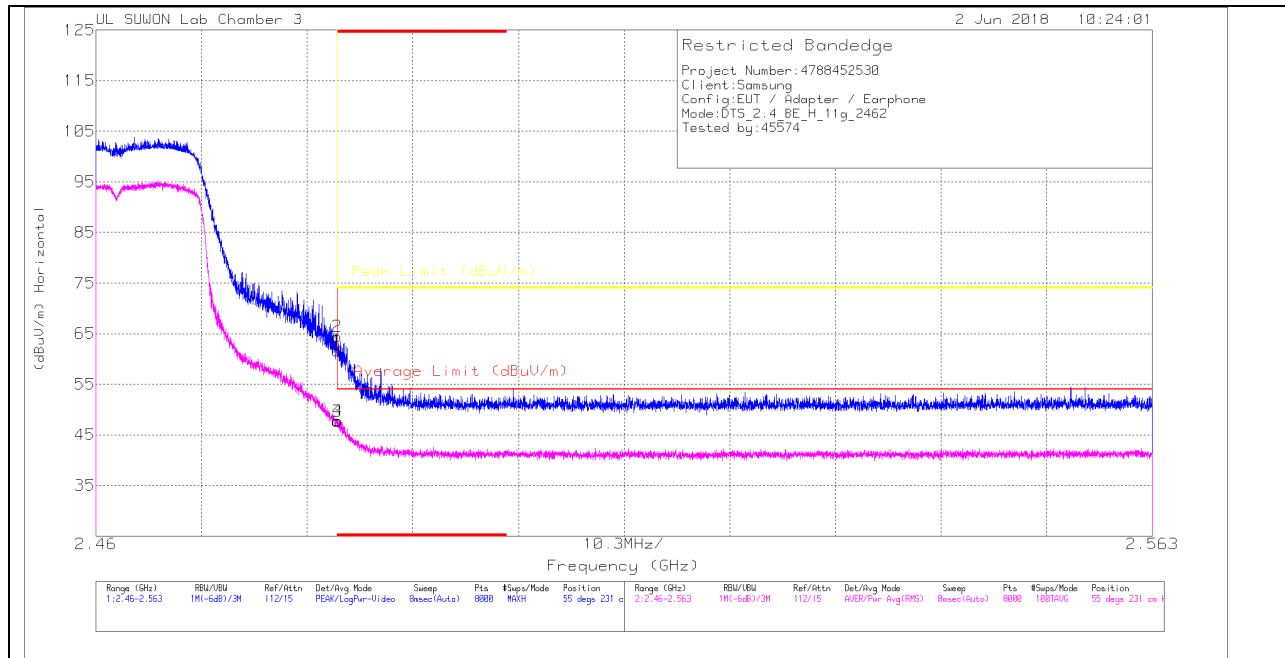

HORIZONTAL DATA

Trace Markers

Marker	Frequency (GHz)	Meter Reading (dBuV)	Det	3117(00205959)	10dB_ATT(dB)	DC Corr (dB)	Corrected Reading (dBuV/m)	Average Limit (dBuV/m)	Margin (dB)	Peak Limit (dBuV/m)	PK Margin (dB)	Azimuth (Degs)	Height (cm)	Polarity
1	* 2.484	52.46	PK	32.1	-23	0	61.56	-	-	74	-12.44	55	231	H
2	* 2.484	55.36	PK	32.1	-23	0	64.46	-	-	74	-9.54	55	231	H
3	* 2.484	38.62	RMS	32.1	-23	0	47.72	54	-6.28	-	-	55	231	H
4	* 2.484	38.76	RMS	32.1	-23	0	47.86	54	-6.14	-	-	55	231	H

* - indicates frequency in CFR47 Pt 15 / IC RSS-Restricted Band

PK - Peak detector

RMS - RMS detection

VERTICAL PEAK AND AVERAGE PLOT

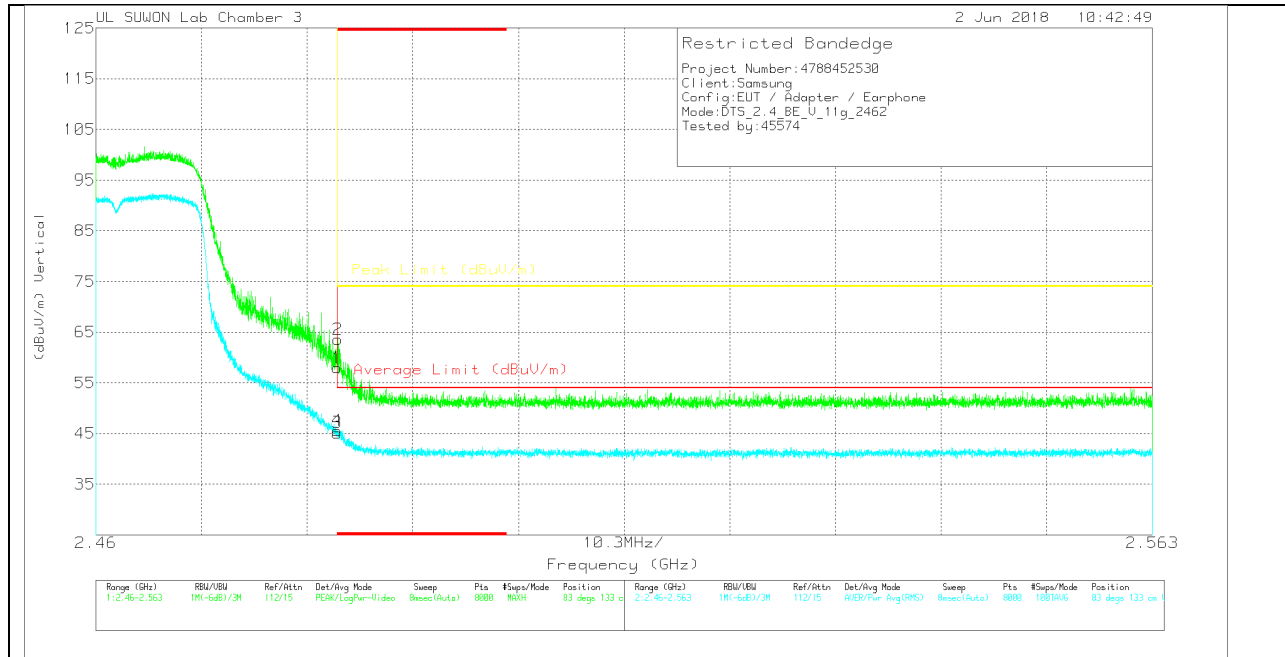

VERTICAL DATA

Trace Markers

Marker	Frequency (GHz)	Meter Reading (dBuV)	Det	3117(00205959)	10dB_ATT(dB)	DC Corr (dB)	Corrected Reading (dBuV/m)	Average Limit (dBuV/m)	Margin (dB)	Peak Limit (dBuV/m)	PK Margin (dB)	Azimuth (Degs)	Height (cm)	Polarity
1	* 2.484	48.92	Pk	32.1	-23	0	58.02	-	-	74	-15.98	83	133	V
2	* 2.484	54.46	Pk	32.1	-23	0	63.56	-	-	74	-10.44	83	133	V
3	* 2.484	36.04	RMS	32.1	-23	0	45.14	54	-8.86	-	-	83	133	V
4	* 2.484	36.51	RMS	32.1	-23	0	45.61	54	-8.39	-	-	83	133	V

* - indicates frequency in CFR47 Pt 15 / IC RSS-Restricted Band

Pk - Peak detector

RMS - RMS detection

HARMONICS AND SPURIOUS EMISSIONS

3 CHANNEL HORIZONTAL

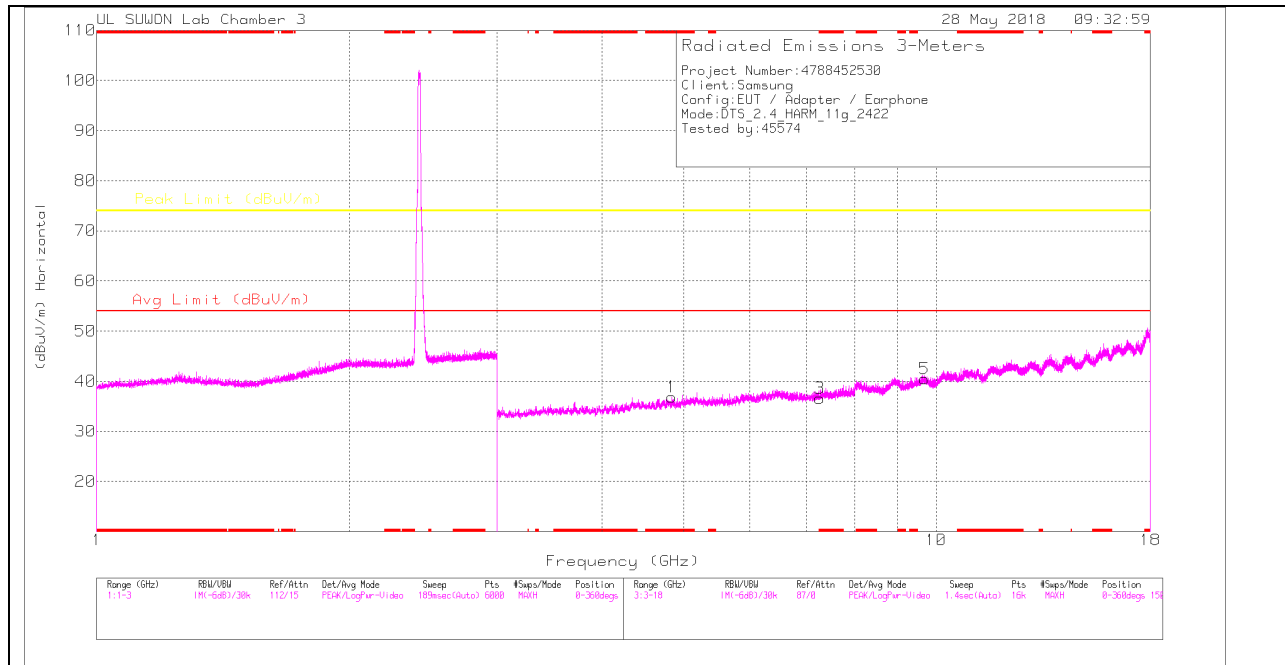

3 CHANNEL VERTICAL

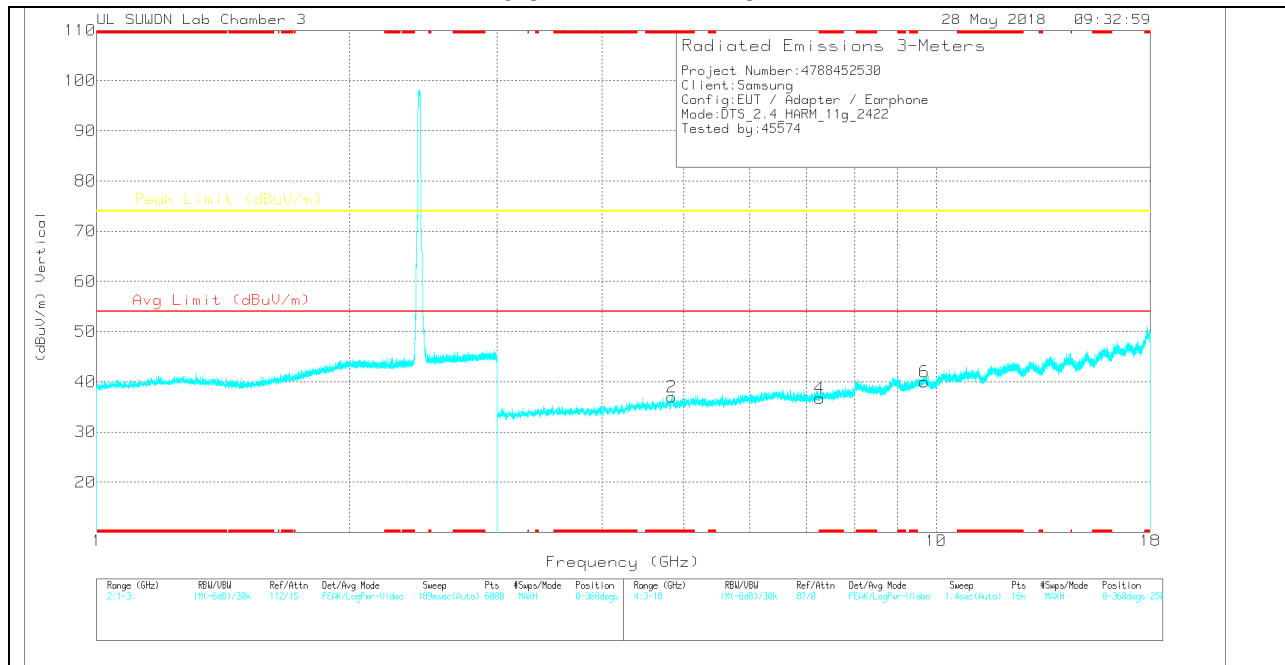

Note: Emission was scanned up to 26GHz; No emissions were detected above the noise floor which was at least 20dB below the specification limit.

3 CHANNEL DATA

Trace Markers

Marker	Frequency (GHz)	Meter Reading (dBuV)	Det	3117(00205959)	3GHz_HP[dB]	DC Corr (dB)	Corrected Reading (dBuV/m)	Ag Limit (dBuV/m)	Margin (dB)	Peak Limit (dBuV/m)	Margin (dB)	Asimuth (Degs)	Height (cm)	Polarity
1	* 4.843	31.45	PK	34	-28.6	0	36.85	-	-	74	-37.15	0-360	150	H
3	* 7.267	24.77	PK	35.6	-23.8	0	36.57	-	-	74	-37.43	0-360	250	H
5	9.689	23.17	PK	36.8	-19.5	0	40.47	-	-	74	-33.53	0-360	150	H
2	* 4.845	31.49	PK	34	-28.5	0	36.99	-	-	74	-37.01	0-360	250	V
4	* 7.267	24.91	PK	35.6	-23.8	0	36.71	-	-	74	-37.29	0-360	250	V
6	9.689	22.67	PK	36.8	-19.5	0	39.97	-	-	74	-34.03	0-360	250	V

* - indicates frequency in CFR47 Pt 15 / IC RSS-Restricted Band
 PK – Peak Detector

Note: Only peak measurement was performed. Because peak measurement result of unwanted emission is less than average limit (54dBuV/m).

6 CHANNEL HORIZONTAL

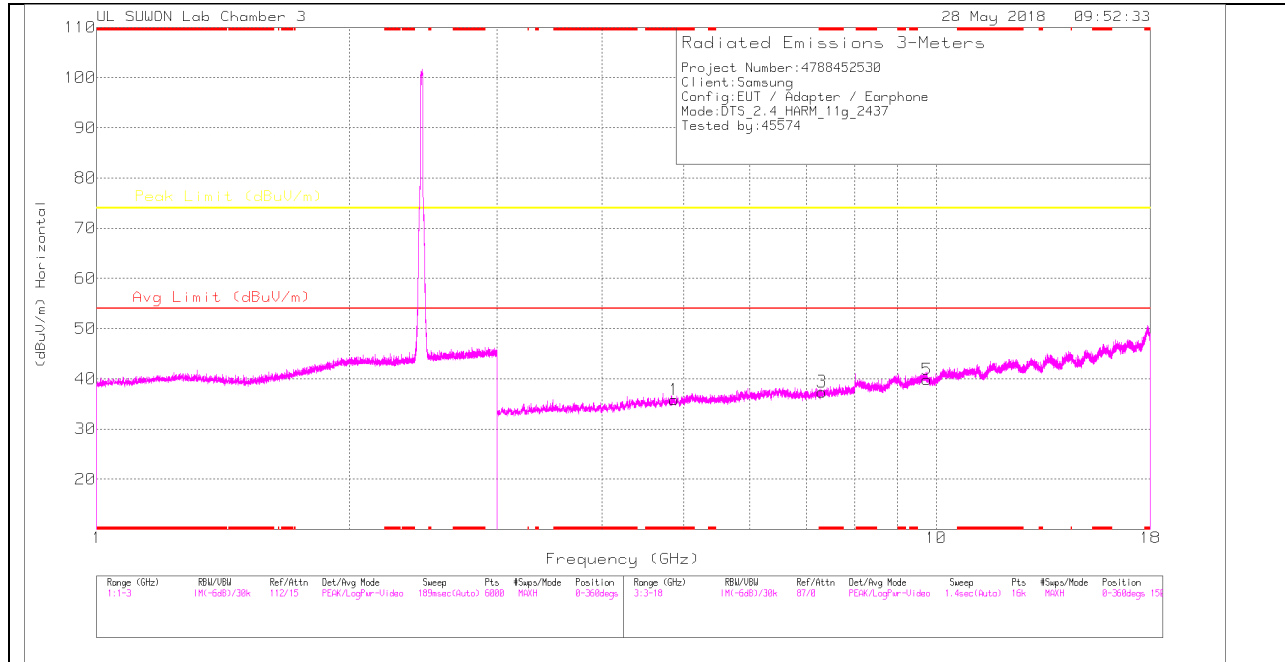

6 CHANNEL VERTICAL

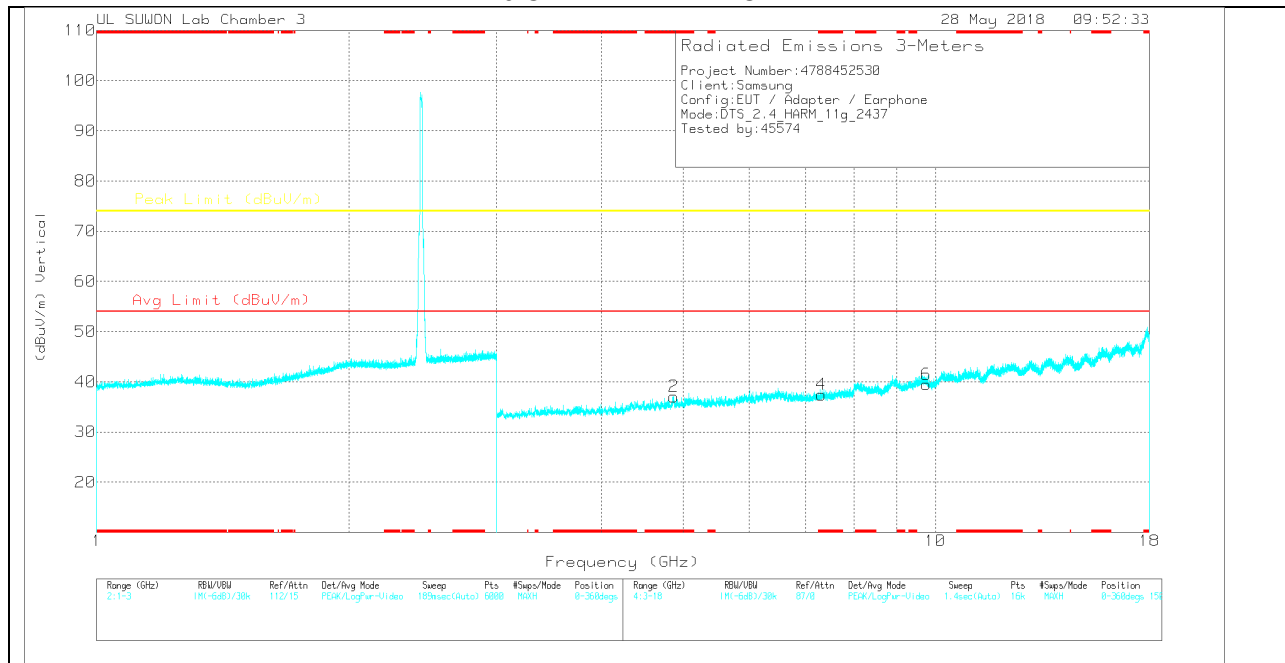

Note: Emission was scanned up to 26GHz; No emissions were detected above the noise floor which was at least 20dB below the specification limit.

6 CHANNEL DATA

Trace Markers

Marker	Frequency (GHz)	Meter Reading (dBuV)	Det	3117(00205959)	3GHz_HP[dB]	DC Corr (dB)	Corrected Reading (dBuV/m)	Avg Limit (dBuV/m)	Margin (dB)	Peak Limit (dBuV/m)	Margin (dB)	Azimuth (Degs)	Height (cm)	Polarity
1	* 4.874	30.75	PK	34	-28.9	0	35.85	-	-	74	-38.15	0-360	150	H
3	* 7.311	25.3	PK	35.6	-23.5	0	37.4	-	-	74	-36.6	0-360	250	H
5	9.749	22.57	PK	36.9	-19.6	0	39.87	-	-	74	-34.13	0-360	150	H
2	* 4.873	31.85	PK	34	-28.8	0	37.05	-	-	74	-36.95	0-360	150	V
4	* 7.311	25.33	PK	35.6	-23.5	0	37.43	-	-	74	-36.57	0-360	250	V
6	9.749	22.2	PK	36.9	-19.6	0	39.5	-	-	74	-34.5	0-360	150	V

* - indicates frequency in CFR47 Pt 15 / IC RSS-Restricted Band
 PK – Peak Detector

Note: Only peak measurement was performed. Because peak measurement result of unwanted emission is less than average limit (54dBuV/m).

9 CHANNEL HORIZONTAL

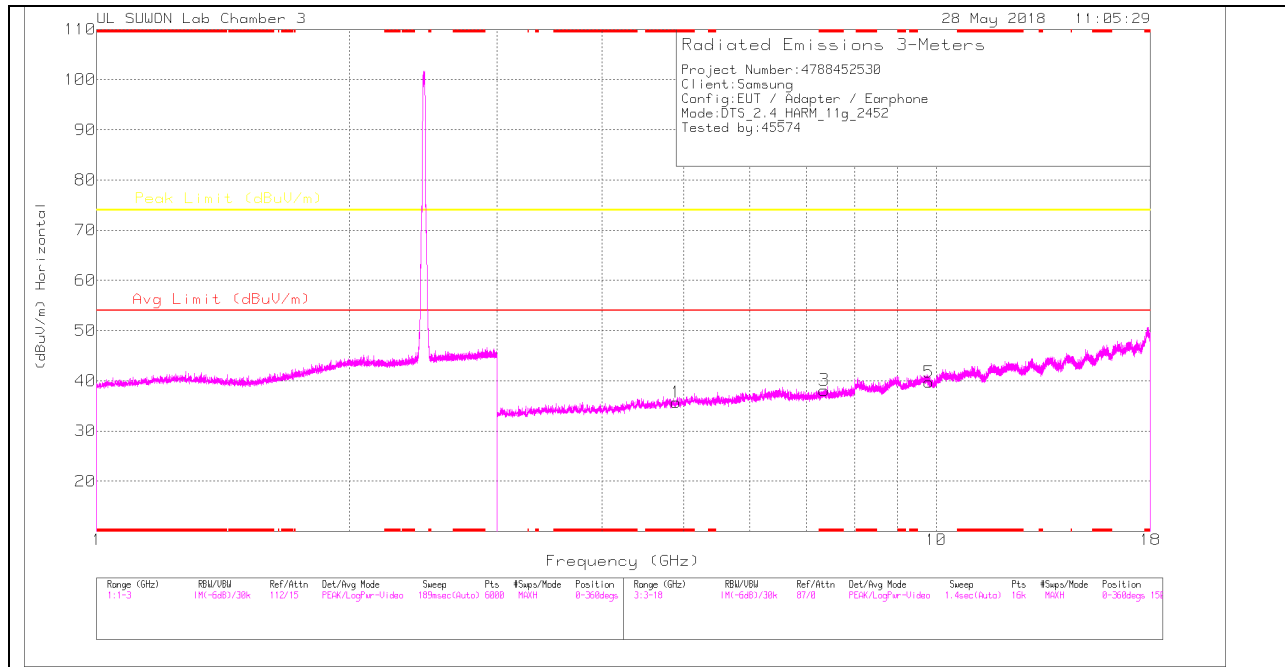

9 CHANNEL VERTICAL

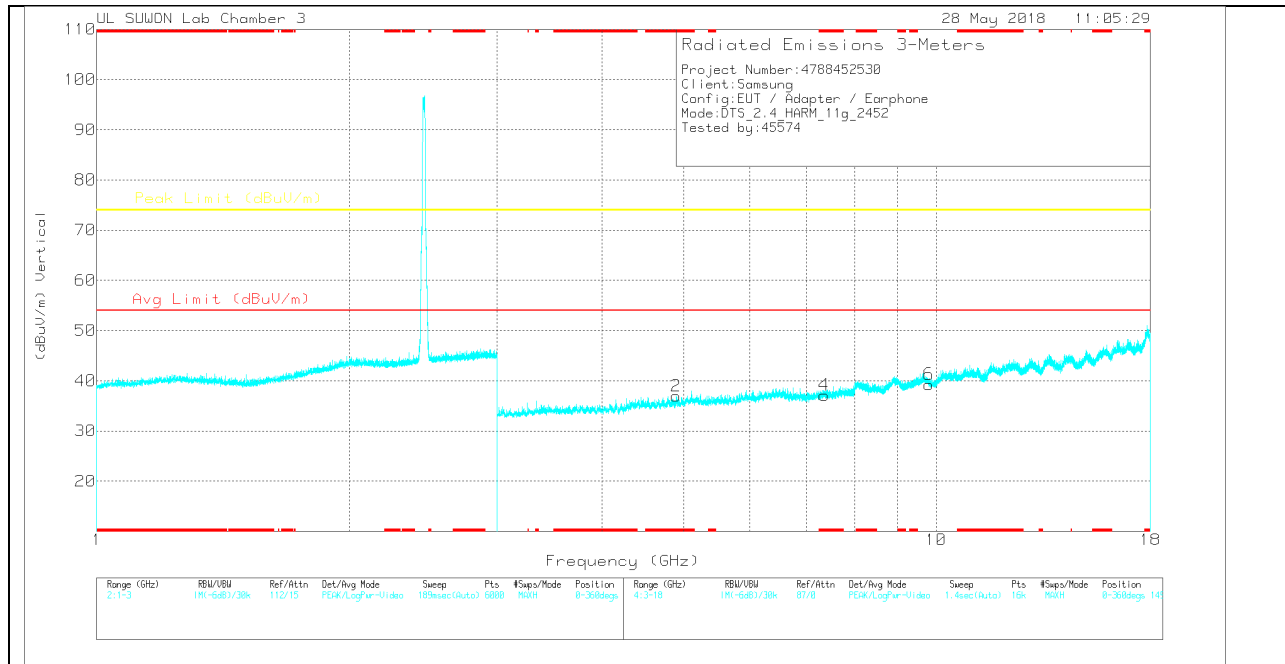

Note: Emission was scanned up to 26GHz; No emissions were detected above the noise floor which was at least 20dB below the specification limit.

9 CHANNEL DATA

Trace Markers

Marker	Frequency (GHz)	Meter Reading (dBuV)	Det	3117(00205959)	3GHz_HP[dB]	DC Corr (dB)	Corrected Reading (dBuV/m)	Avg Limit (dBuV/m)	Margin (dB)	Peak Limit (dBuV/m)	Margin (dB)	Azimuth (Degs)	Height (cm)	Polarity
1	* 4.902	30.69	PK	34	-29	0	35.69	-	-	74	-38.31	0-360	250	H
3	* 7.356	25.75	PK	35.6	-23.2	0	38.15	-	-	74	-35.85	0-360	250	H
5	9.809	22.42	PK	36.9	-19.6	0	39.72	-	-	74	-34.28	0-360	150	H
2	* 4.902	31.99	PK	34	-29	0	36.99	-	-	74	-37.01	0-360	149	V
4	* 7.357	24.74	PK	35.6	-23.2	0	37.14	-	-	74	-36.86	0-360	250	V
6	9.809	21.98	PK	36.9	-19.6	0	39.28	-	-	74	-34.72	0-360	250	V

* - indicates frequency in CFR47 Pt 15 / IC RSS-Restricted Band
 PK – Peak Detector

Note: Only peak measurement was performed. Because peak measurement result of unwanted emission is less than average limit (54dBuV/m).

11.2.3.TX ABOVE 1 GHz 802.11n HT20 MODE IN THE 2.4 GHz BAND

RESTRICTED BANDEDGE (1 CHANNEL)

HORIZONTAL PEAK AND AVERAGE PLOT

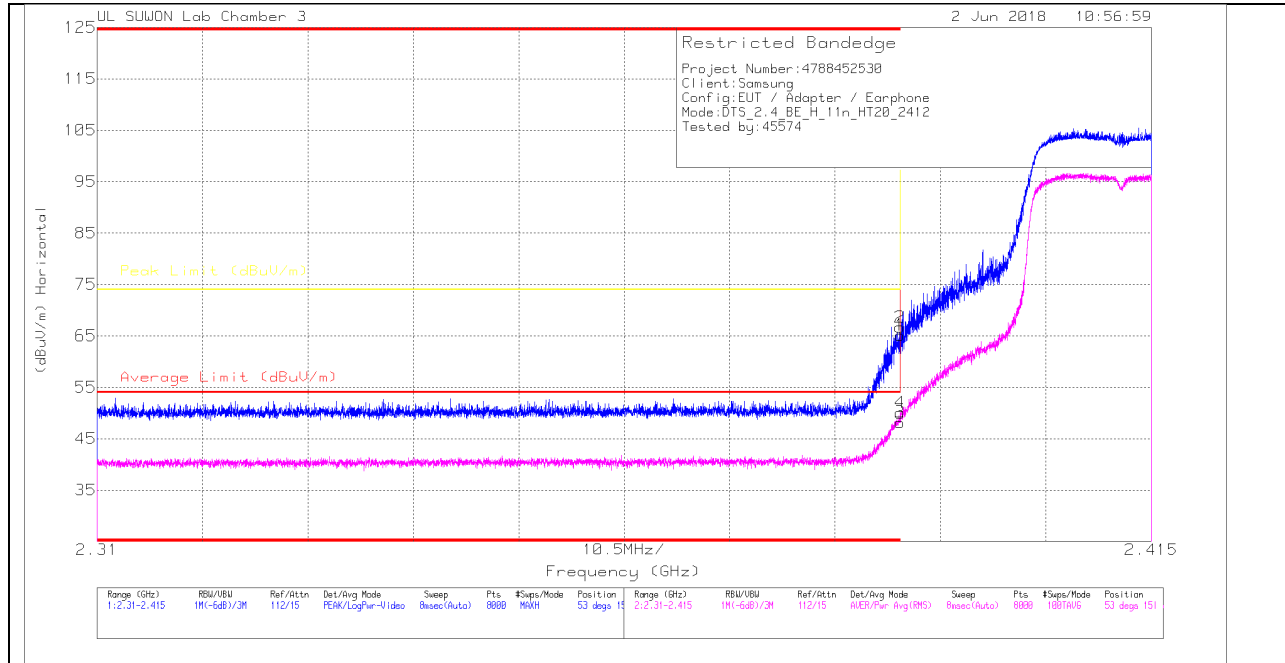

HORIZONTAL DATA

Trace Markers

Marker	Frequency (GHz)	Meter Reading (dBuV)	Det	311700205959	10dB_ATT[dB]	DC Corr (dB)	Corrected Reading (dBuV/m)	Average Limit (dBuV/m)	Margin (dB)	Peak Limit (dBuV/m)	PK Margin (dB)	Asmuth (Degs)	Height (cm)	Polarity
1	* 2.39	56.66	Pk		31.8	-23.3	0	65.16	-	74	-8.84	53	151	H
2	* 2.39	58.18	Pk		31.8	-23.3	0	66.68	-	74	-7.32	53	151	H
3	* 2.39	39.69	RMS		31.8	-23.3	0	48.19	54	-5.81	-	53	151	H
4	* 2.39	41.54	RMS		31.8	-23.3	0	50.04	54	-3.96	-	53	151	H

* - indicates frequency in CFR47 Pt 15 / IC RSS-Restricted Band

Pk - Peak detector

RMS - RMS detection

VERTICAL PEAK AND AVERAGE PLOT

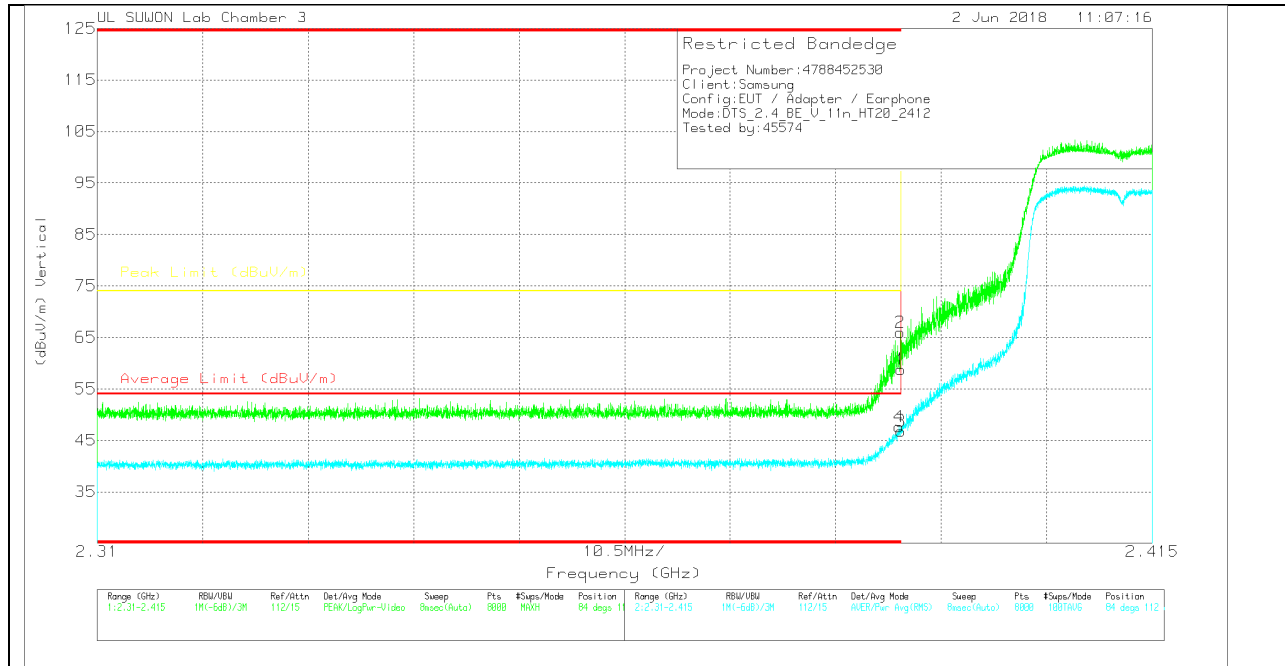

VERTICAL DATA

Trace Markers

Marker	Frequency (GHz)	Meter Reading (dBuV)	Det	3117(00205959)	10dB_ATT(dB)	DC Corr (dB)	Corrected Reading (dBuV/m)	Average Limit (dBuV/m)	Margin (dB)	Peak Limit (dBuV/m)	PK Margin (dB)	Azimuth (Degs)	Height (cm)	Polarity
1	* 2.39	50.27	PK	31.8	-23.3	0	58.77	-	-	74	-15.23	84	112	V
2	* 2.39	57.47	PK	31.8	-23.3	0	65.97	-	-	74	-8.03	84	112	V
3	* 2.39	38.3	RMS	31.8	-23.3	0	46.8	54	-7.2	-	-	84	112	V
4	* 2.39	39.13	RMS	31.8	-23.3	0	47.63	54	-6.37	-	-	84	112	V

* - indicates frequency in CFR47 Pt 15 / IC RSS-Restricted Band

PK - Peak detector

RMS - RMS detection