

**15M BW QPSK Low ch.**

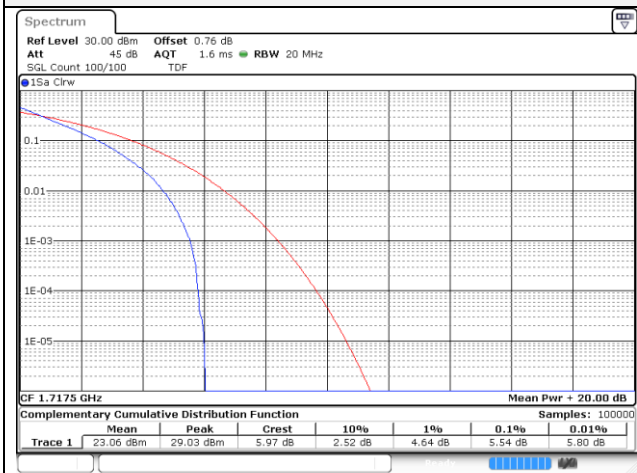

**15M BW 16QAM Low ch.**

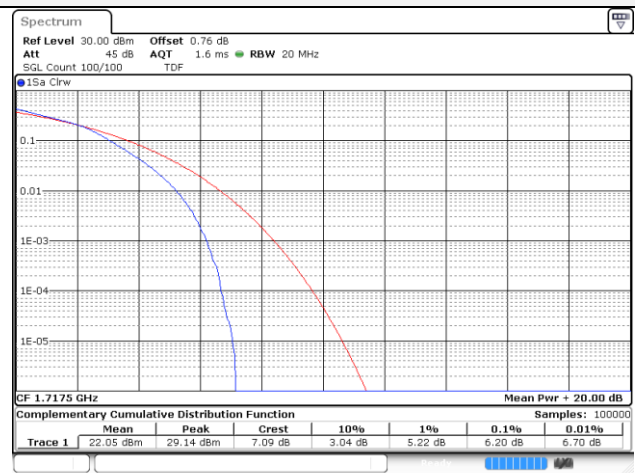

**15M BW QPSK Mid ch.**

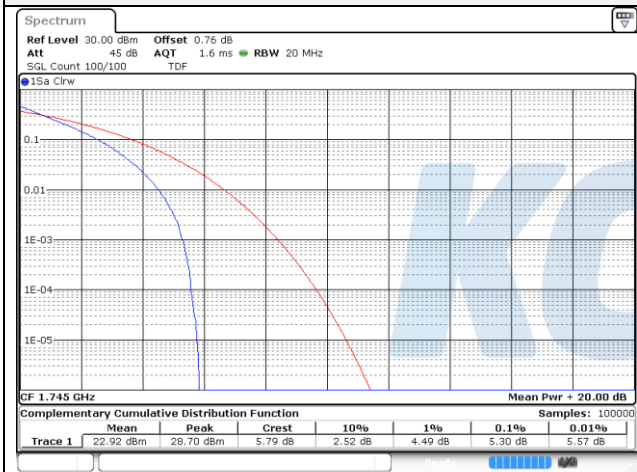

**15M BW 16QAM Mid ch.**

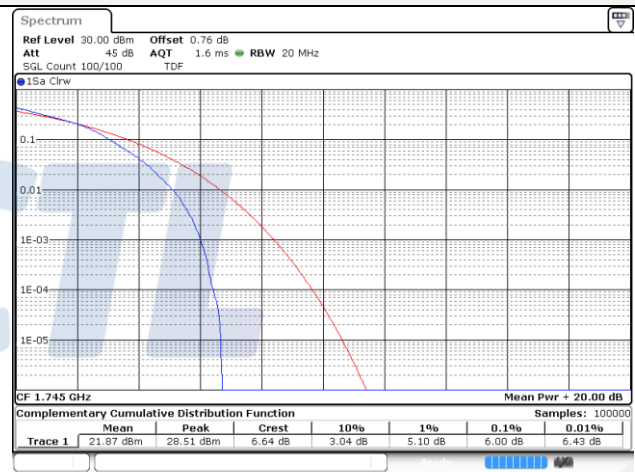

**15M BW QPSK High ch.**

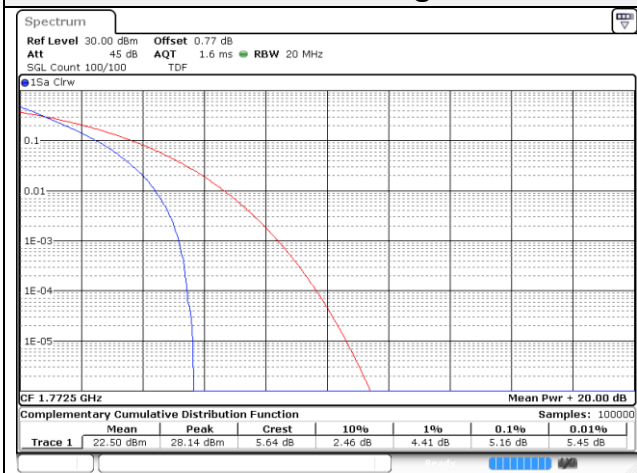

**15M BW 16QAM High ch.**

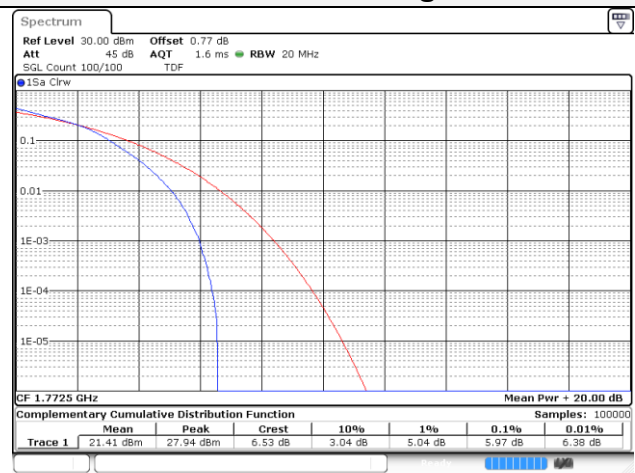

**20M BW QPSK Low ch.**

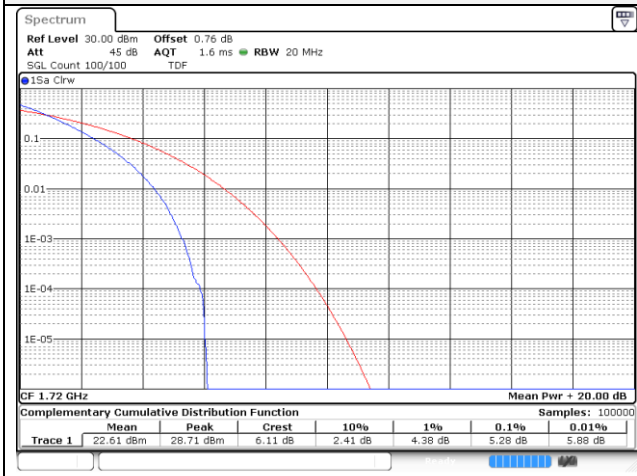

**20M BW 16QAM Low ch.**

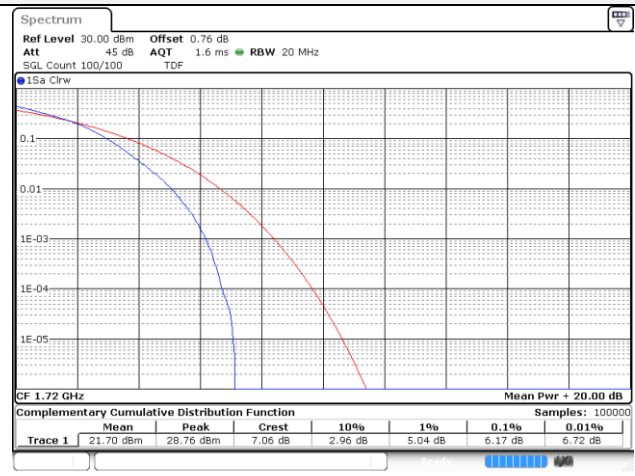

**20M BW QPSK Mid ch.**

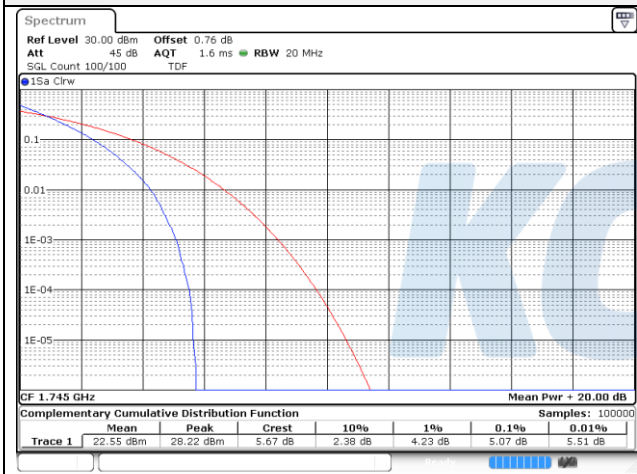

**20M BW 16QAM Mid ch.**

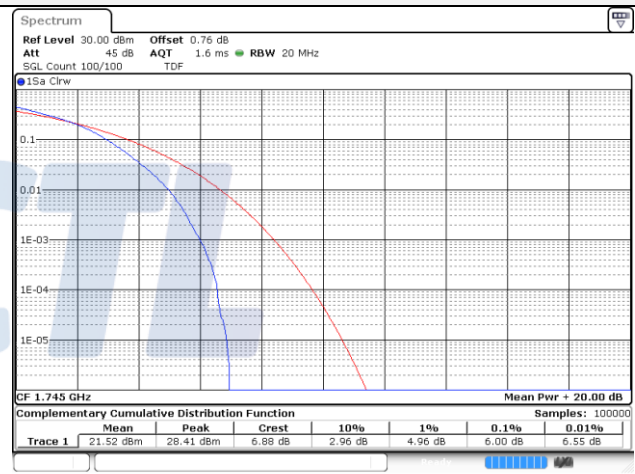

**20M BW QPSK High ch.**

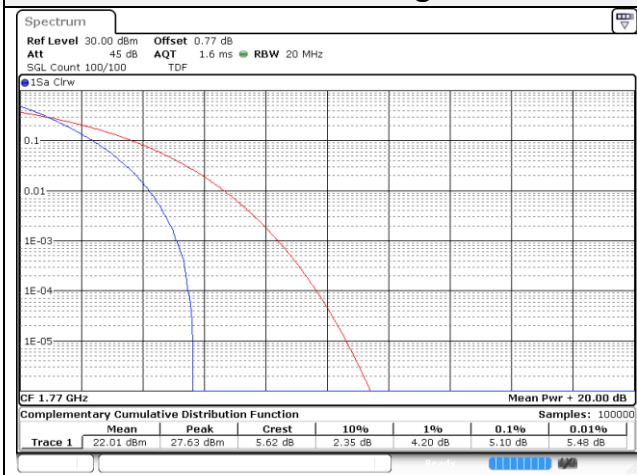

**20M BW 16QAM High ch.**

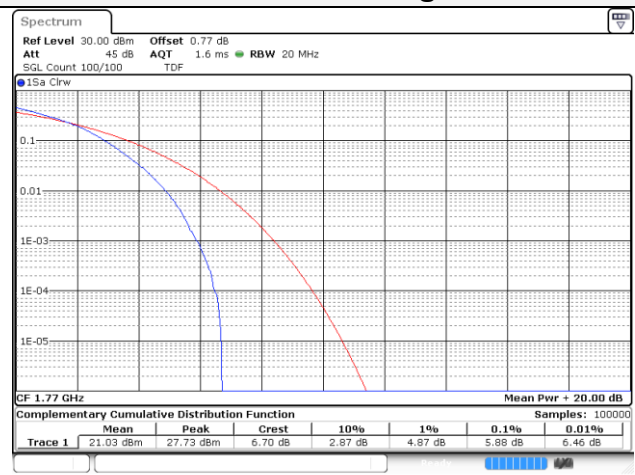

## 8.6. Frequency stability

### Test setup

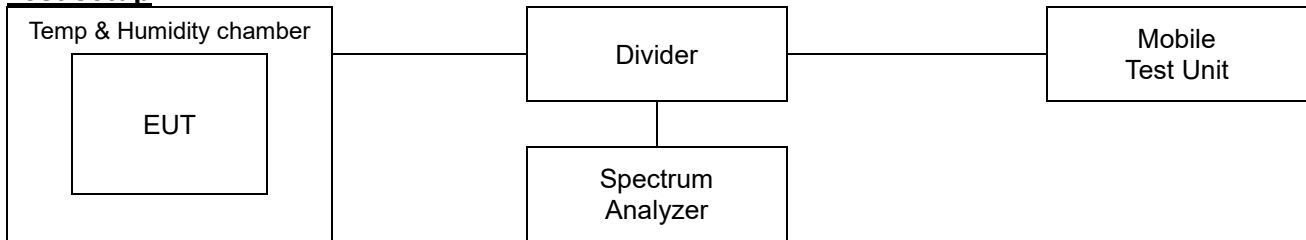

### Limit

#### According to §2.1055(a),

The frequency stability shall be measured with variation of ambient temperature as follows:

- 1) From  $-30^{\circ}$  to  $+50^{\circ}$  centigrade for all equipment except that specified in paragraphs (a) (2) and (3) of this section.
- 2) From  $-20^{\circ}$  to  $+50^{\circ}$  centigrade for equipment to be licensed for use in the maritime services under part 80 of this chapter, except for class A, B, and S emergency position indicating radiobeacons (EPIRBS), and equipment to be licensed for use above 952 MHz at operational fixed stations in all services, stations in the local television transmission service and point-to-point microwave radio service under part 21 of this chapter, equipment licensed for use aboard aircraft in the aviation services under part 87 of this chapter, and equipment authorized for use in the family radio service under part 95 of this chapter.
- 3) From  $0^{\circ}$  to  $+50^{\circ}$  centigrade for equipment to be licensed for use in the radio broadcast Services under part 73 of this chapter.

#### According to §2.1055(d),

The frequency stability shall be measured with variation of primary supply Voltage as follows:

- 1) Vary primary supply voltage from 85 to 115 percent of the nominal value for other than hand carried battery equipment.
- 2) For hand carried, battery powered equipment, reduce primary supply voltage to the battery operating and point which shall be specified by the manufacturer.
- 3) The supply voltage shall be measured at the input to the cable normally provided with the equipment, or at the power supply terminals if cables are not normally provided. Effects on frequency of transmitter keying (except for broadcast transmitters) and any heating element cycling at the nominal supply voltage and at each extreme also shall be shown.

#### According to §22.355 and RSS-132(5.3),

The carrier frequency of each transmitter in the public mobile services must be maintained within the tolerances given in Table of this section.

For mobile devices operating in the 824 to 849 MHz band at a power level than or equal to 3 Watts, the limit specified in Table C-1 is  $\pm 2.5$  ppm.

**According to §24.235 and RSS-133(6.3),**

The frequency stability shall be sufficient to ensure that the fundamental emission stays within the authorized frequency block.

The carrier frequency shall not depart from the reference frequency, in excess of  $\pm 2.5$  ppm for mobile stations and  $\pm 1.0$  ppm for base stations.

**According to §27.54 and RSS-130(4.5),**

The frequency stability shall be sufficient to ensure that the fundamental emission stays within the authorized frequency block.

**According to §27.54 and RSS-139(6.4), RSS-199(4.3)**

The frequency stability shall be sufficient to ensure that the fundamental emissions stay within the Authorized bands of operation.

**Test procedure**

ANSI 63.26-2015 – Section 5.6

**Test settings**

- 1) The carrier frequency of the transmitter is measured at room temperature.  
(20°C to provide a reference)
- 2) The equipment is turned on in a “standby” condition for one minute before applying power to the transmitter. Measurement of the carrier frequency of the transmitter is made within one minute after applying power to the transmitter.
- 3) Frequency measurements are made at 10°C intervals ranging from -30°C to +50°C.  
A period of at least one half-hour is provided to allow stabilization of the equipment at each Temperature level.

**Test results**

Test mode : LTE Band 5  
 Frequency (Hz) : 836 500 000  
 Channel : 20525  
 Deviation limit : ±0.00025% or 2.5ppm

Voltage (%)	Power (V)	Temp. (°C)	Frequency (Hz)	Frequency error (Hz)	Deviation	
					(ppm)	(%)
100%	3.85	+22(Ref)	836,499,996	-3.65	0.0	0.000 000
		-30	836,500,002	1.77	0.0	0.000 000
		-20	836,500,003	2.85	0.0	0.000 000
		-10	836,499,997	-2.63	0.0	0.000 000
		0	836,499,998	-1.54	0.0	0.000 000
		+10	836,500,004	3.88	0.0	0.000 000
		+20	836,499,998	-2.43	0.0	0.000 000
		+30	836,499,997	-3.19	0.0	0.000 000
		+40	836,500,002	2.41	0.0	0.000 000
		+50	836,500,004	3.77	0.0	0.000 000
115%	4.43	+22(Ref)	836,499,998	-2.02	0.0	0.000 000
End point	3.60	+22(Ref)	836,499,997	-2.53	0.0	0.000 000

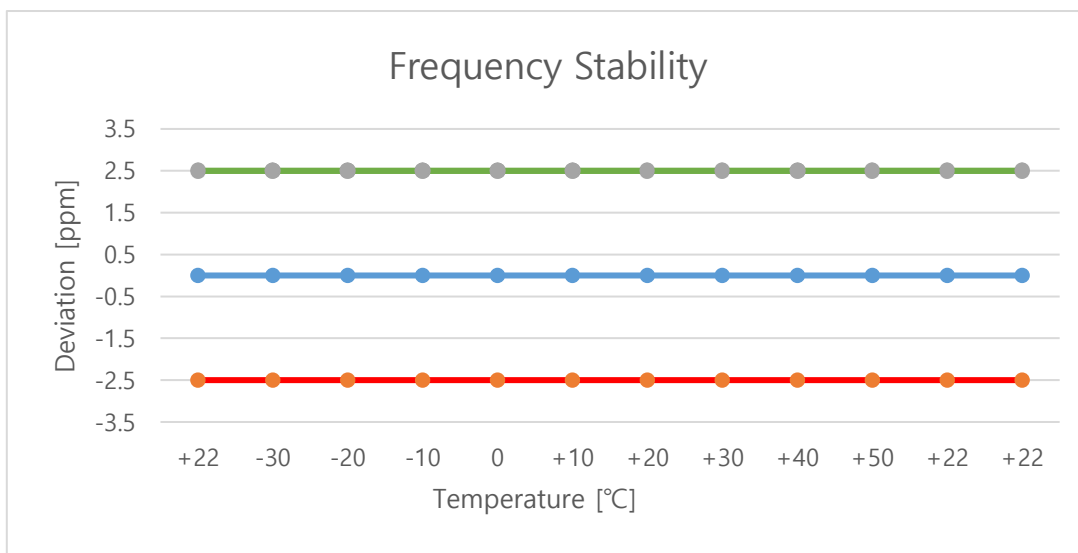

Test mode : LTE Band 7  
 Frequency (Hz) : 2 535 000 000  
 Channel : 21100  
 Deviation limit(FCC&IC) : The frequency stability shall be sufficient to ensure that the fundamental emission stays within the authorized bands of operation.

Voltage (%)	Power (V)	Temp. (°C)	Frequency (Hz)	Frequency error (Hz)	Deviation	
					(ppm)	(%)
100%	3.85	+22(Ref)	2,534,999,989	-10.83	0.0	0.000 000
		-30	2,534,999,986	-13.68	0.0	-0.000 001
		-20	2,534,999,988	-12.48	0.0	0.000 000
		-10	2,534,999,986	-13.56	0.0	-0.000 001
		0	2,534,999,989	-11.25	0.0	0.000 000
		+10	2,534,999,987	-12.96	0.0	-0.000 001
		+20	2,534,999,990	-10.29	0.0	0.000 000
		+30	2,534,999,990	-10.37	0.0	0.000 000
		+40	2,534,999,987	-12.63	0.0	0.000 000
		+50	2,534,999,986	-13.75	0.0	-0.000 001
115%	4.43	+22	2,534,999,988	-12.16	0.0	0.000 000
End point	3.60	+22	2,534,999,991	-9.5	0.0	0.000 000

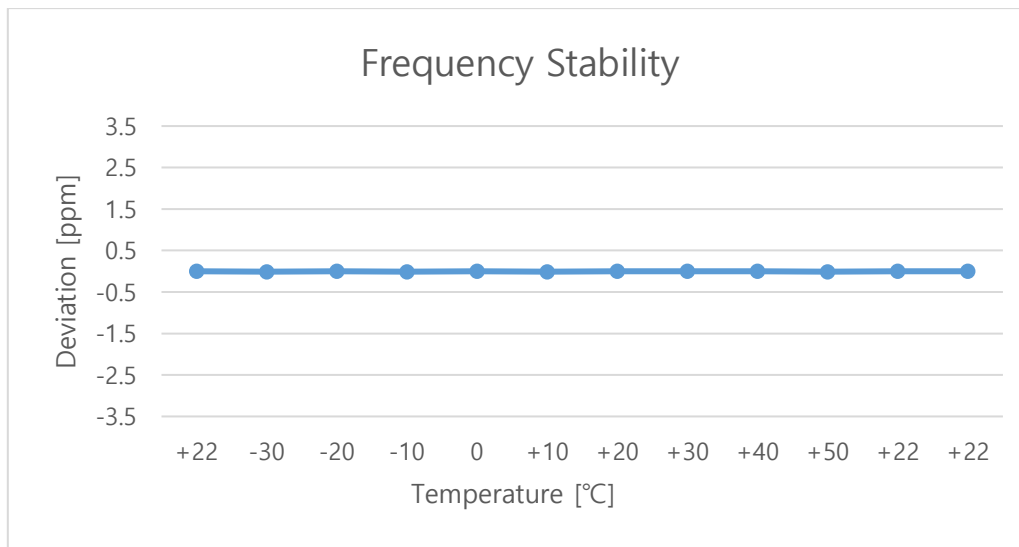

Test mode : LTE Band 12/17  
 Frequency (Hz) : 707 500 000  
 Channel : 23095  
 Deviation limit(FCC&IC) : The frequency stability shall be sufficient to ensure that the fundamental emission stays within the authorized bands of operation

Voltage (%)	Power (V)	Temp. (°C)	Frequency (Hz)	Frequency error (Hz)	Deviation	
					(ppm)	(%)
100%	3.85	+22(Ref)	707,499,998	-2.27	0.0	0.000 000
		-30	707,499,995	-4.78	0.0	-0.000 001
		-20	707,499,996	-3.51	0.0	0.000 000
		-10	707,499,997	-2.88	0.0	0.000 000
		0	707,500,003	2.93	0.0	0.000 000
		+10	707,500,003	3.15	0.0	0.000 000
		+20	707,499,997	-2.91	0.0	0.000 000
		+30	707,499,997	-3.14	0.0	0.000 000
		+40	707,499,995	-4.77	0.0	-0.000 001
		+50	707,499,995	-5.16	0.0	-0.000 001
115%	4.43	+22(Ref)	707,499,997	-3.29	0.0	0.000 000
End point	3.60	+22(Ref)	707,499,996	-3.78	0.0	-0.000 001

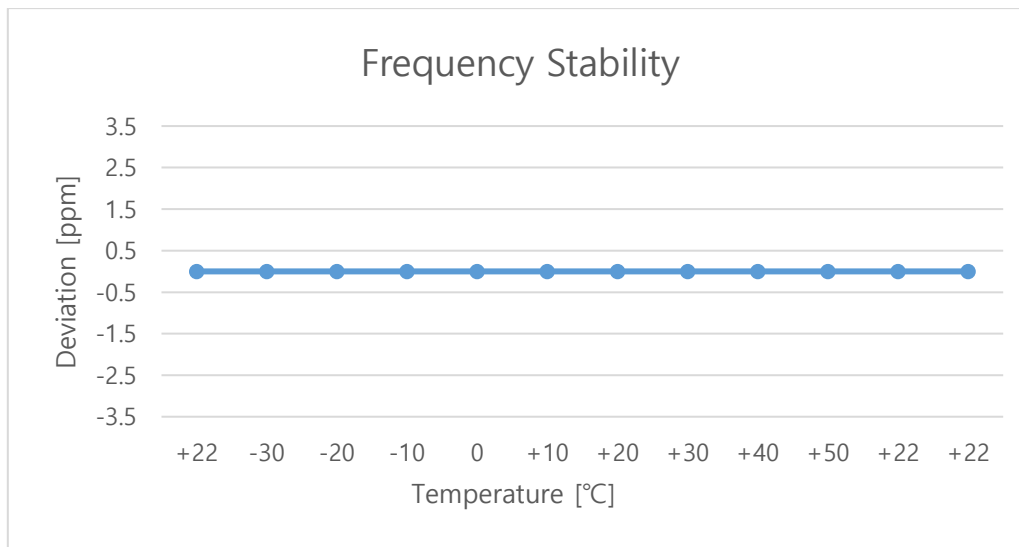



Test mode : LTE Band 13  
 Frequency (Hz) : 782 000 000  
 Channel : 23230  
 Deviation limit(FCC&IC) : The frequency stability shall be sufficient to ensure that the fundamental emission stays within the authorized bands of operation

Voltage (%)	Power (V)	Temp. (°C)	Frequency (Hz)	Frequency error (Hz)	Deviation	
					(ppm)	(%)
100%	3.85	+22(Ref)	781,999,997	-2.85	0.0	0.000 000
		-30	782,000,005	4.74	0.0	0.000 001
		-20	782,000,006	5.62	0.0	0.000 001
		-10	782,000,004	3.71	0.0	0.000 000
		0	782,000,003	2.88	0.0	0.000 000
		+10	782,000,002	1.69	0.0	0.000 000
		+20	781,999,998	-2.48	0.0	0.000 000
		+30	781,999,998	-2.22	0.0	0.000 000
		+40	781,999,996	-3.74	0.0	0.000 000
		+50	781,999,996	-4.11	0.0	-0.000 001
115%	4.43	+22(Ref)	781,999,997	-2.72	0.0	0.000 000
End point	3.60	+22(Ref)	781,999,997	-3.10	0.0	0.000 000

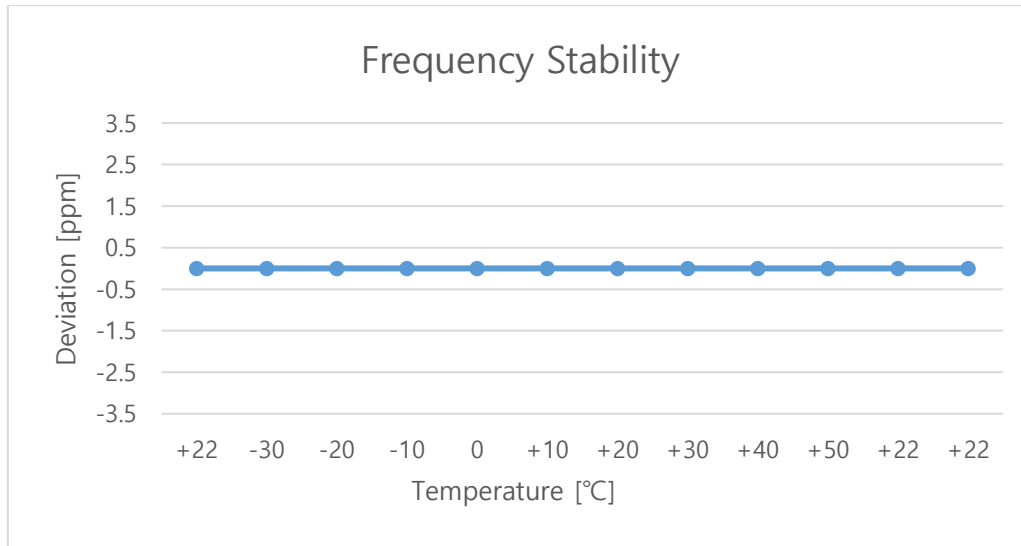



Test mode : LTE Band 25/2  
 Frequency (Hz) : 1 882 500 000  
 Channel : 26365  
 Deviation limit(FCC) : The frequency stability shall be sufficient to ensure that the fundamental emission stays within the authorized frequency block.  
 Deviation limit(IC) : ±0.00025% or 2.5ppm

Voltage (%)	Power (V)	Temp. (°C)	Frequency (Hz)	Frequency error (Hz)	Deviation	
					(ppm)	(%)
100%	3.85	+22(Ref)	1,882,499,991	-8.51	0.0	0.000 000
		-30	1,882,499,990	-10.37	0.0	-0.000 001
		-20	1,882,499,990	-9.54	0.0	-0.000 001
		-10	1,882,499,992	-8.31	0.0	0.000 000
		0	1,882,499,992	-7.99	0.0	0.000 000
		+10	1,882,499,992	-8.17	0.0	0.000 000
		+20	1,882,499,990	-9.66	0.0	-0.000 001
		+30	1,882,499,990	-9.72	0.0	-0.000 001
		+40	1,882,499,989	-10.81	0.0	-0.000 001
		+50	1,882,499,988	-11.87	0.0	-0.000 001
115%	4.43	+22(Ref)	1,882,499,990	-9.83	0.0	-0.000 001
End point	3.60	+22(Ref)	1,882,499,990	-9.53	0.0	-0.000 001

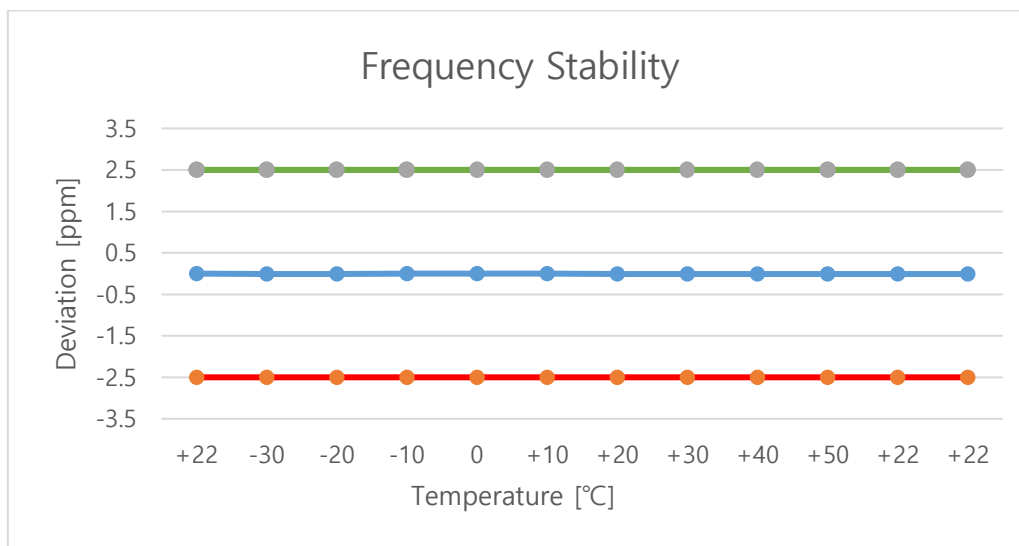

Test mode : LTE Band 26  
 Frequency (Hz) : 836 500 000  
 Channel : 26915  
 Deviation limit(FCC&IC) : ±0.00025% or 2.5ppm

Voltage (%)	Power (V)	Temp. (°C)	Frequency (Hz)	Frequency error (Hz)	Deviation	
					(ppm)	(%)
100%	3.85	+22(Ref)	836,499,994	-5.79	0.0	-0.000 001
		-30	836,499,993	-6.91	0.0	-0.000 001
		-20	836,499,993	-7.16	0.0	-0.000 001
		-10	836,499,994	-5.71	0.0	-0.000 001
		0	836,499,995	-4.93	0.0	-0.000 001
		+10	836,499,995	-4.81	0.0	-0.000 001
		+20	836,499,995	-5.37	0.0	-0.000 001
		+30	836,499,996	-4.21	0.0	-0.000 001
		+40	836,499,994	-5.76	0.0	-0.000 001
		+50	836,499,994	-6.17	0.0	-0.000 001
115%	4.43	+22(Ref)	836,499,996	-4.48	0.0	-0.000 001
End point	3.60	+22(Ref)	836,499,996	-4.29	0.0	-0.000 001

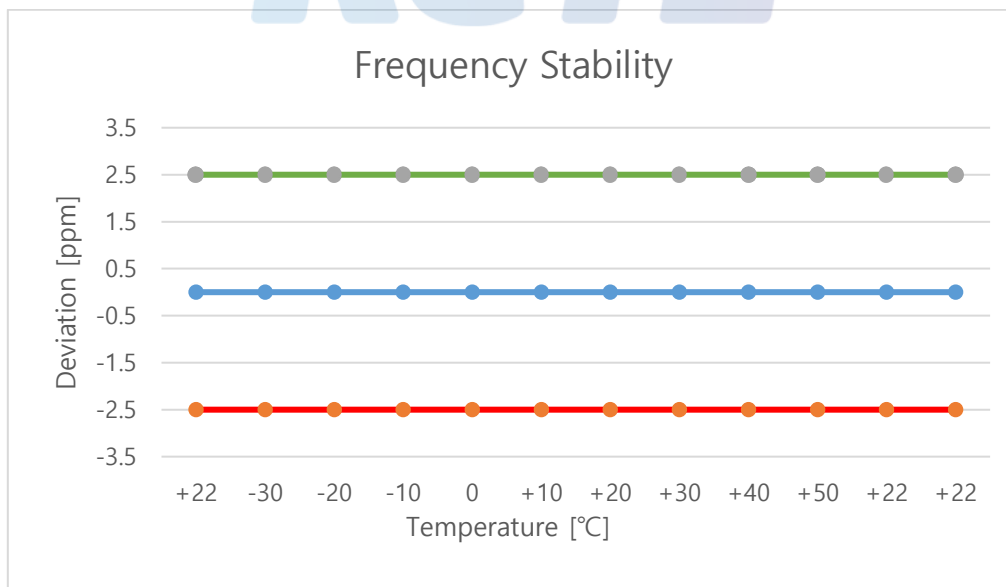

Test mode : LTE Band 41(PC2)  
 Frequency (Hz) : 2 593 000 000  
 Channel : 40620  
 Deviation limit(FCC&IC) : The frequency stability shall be sufficient to ensure that the fundamental emission stays within the authorized bands of operation.

Voltage (%)	Power (V)	Temp. (°C)	Frequency (Hz)	Frequency error (Hz)	Deviation	
					(ppm)	(%)
100%	3.85	+22(Ref)	2,592,999,985	-14.53	0.0	-0.000 001
		-30	2,592,999,986	-13.99	0.0	-0.000 001
		-20	2,592,999,983	-16.81	0.0	-0.000 001
		-10	2,592,999,986	-14.49	0.0	-0.000 001
		0	2,592,999,989	-11.27	0.0	0.000 000
		+10	2,592,999,987	-12.67	0.0	0.000 000
		+20	2,592,999,987	-13.21	0.0	-0.000 001
		+30	2,592,999,986	-14.29	0.0	-0.000 001
		+40	2,592,999,985	-14.83	0.0	-0.000 001
		+50	2,592,999,985	-15.25	0.0	-0.000 001
115%	4.43	+22	2,592,999,986	-13.99	0.0	-0.000 001
End point	3.60	+22	2,592,999,986	-14.06	0.0	-0.000 001

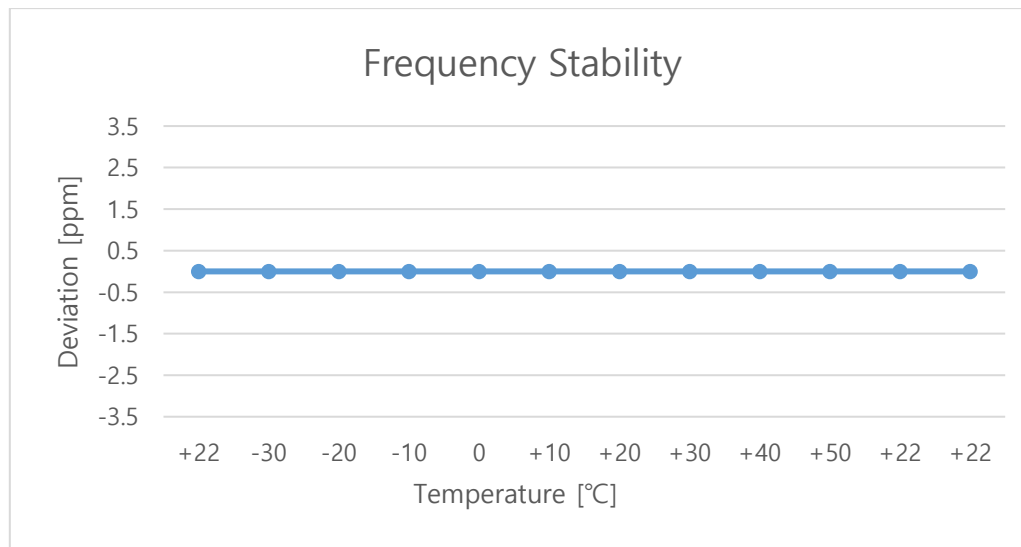

Test mode : LTE Band 41(PC3)  
 Frequency (Hz) : 2 593 000 000  
 Channel : 40620  
 Deviation limit(FCC&IC) : The frequency stability shall be sufficient to ensure that the fundamental emission stays within the authorized bands of operation.

Voltage (%)	Power (V)	Temp. (°C)	Frequency (Hz)	Frequency error (Hz)	Deviation	
					(ppm)	(%)
100%	3.85	+22(Ref)	2,592,999,992	-8.31	0.0	0.000 000
		-30	2,593,000,006	6.27	0.0	0.000 000
		-20	2,593,000,005	5.31	0.0	0.000 000
		-10	2,593,000,002	2.17	0.0	0.000 000
		0	2,592,999,996	-3.71	0.0	0.000 000
		+10	2,592,999,994	-5.83	0.0	0.000 000
		+20	2,592,999,993	-7.21	0.0	0.000 000
		+30	2,592,999,991	-8.62	0.0	0.000 000
		+40	2,592,999,992	-7.81	0.0	0.000 000
		+50	2,592,999,993	-7.24	0.0	0.000 000
115%	4.43	+22	2,592,999,991	-8.85	0.0	0.000 000
End point	3.60	+22	2,592,999,992	-8.15	0.0	0.000 000

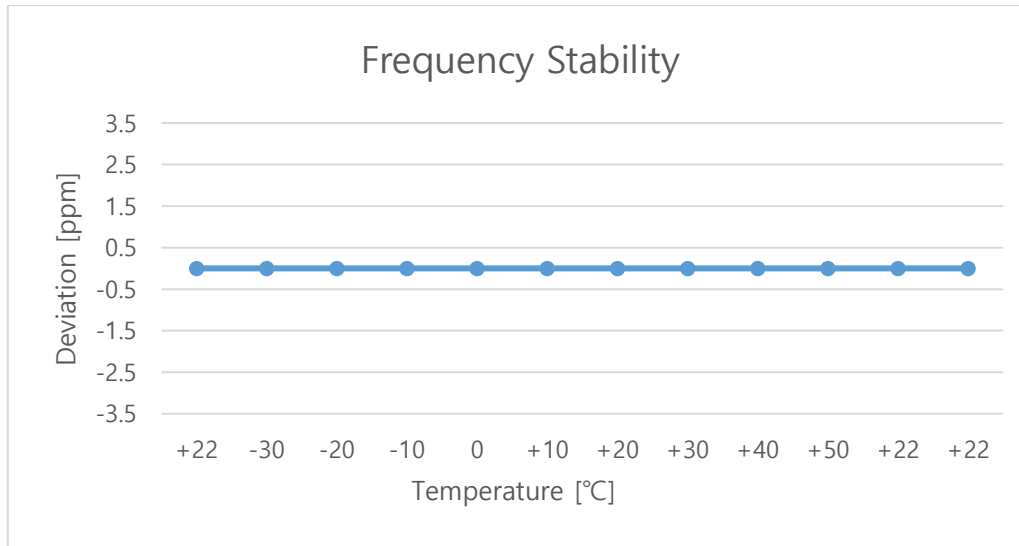

Test mode : LTE Band 66/4  
 Frequency (Hz) : 1 745 000 000  
 Channel : 132322  
 Deviation limit(FCC&IC) : The frequency stability shall be sufficient to ensure that the fundamental emission stays within the authorized bands of operation.

Voltage (%)	Power (V)	Temp. (°C)	Frequency (Hz)	Frequency error (Hz)	Deviation	
					(ppm)	(%)
100%	3.85	+22(Ref)	1,744,999,993	-6.88	0.0	0.000 000
		-30	1,745,000,004	3.52	0.0	0.000 000
		-20	1,745,000,003	2.78	0.0	0.000 000
		-10	1,745,000,003	3.17	0.0	0.000 000
		0	1,744,999,996	-3.52	0.0	0.000 000
		+10	1,744,999,995	-4.76	0.0	0.000 000
		+20	1,744,999,994	-5.84	0.0	0.000 000
		+30	1,744,999,993	-6.77	0.0	0.000 000
		+40	1,744,999,997	-3.22	0.0	0.000 000
		+50	1,744,999,995	-4.69	0.0	0.000 000
115%	4.43	+22(Ref)	1,744,999,993	-6.54	0.0	0.000 000
End point	3.60	+22(Ref)	1,744,999,993	-6.94	0.0	0.000 000

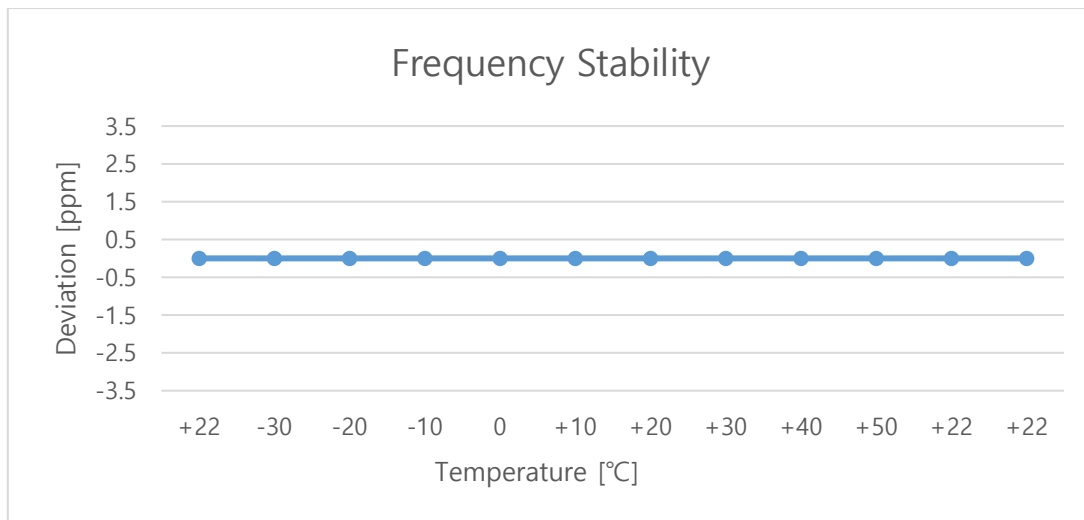

Test mode : LTE Band 71  
 Frequency (Hz) : 680 500 000  
 Channel : 133297  
 Deviation limit(FCC&IC) : The frequency stability shall be sufficient to ensure that the fundamental emission stays within the authorized bands of operation.

Voltage (%)	Power (V)	Temp. (°C)	Frequency (Hz)	Frequency error (Hz)	Deviation	
					(ppm)	(%)
100%	3.85	+22(Ref)	680,499,996	-3.84	0.0	-0.000 001
		-30	680,499,995	-4.93	0.0	-0.000 001
		-20	680,499,995	-5.13	0.0	-0.000 001
		-10	680,499,995	-4.66	0.0	-0.000 001
		0	680,499,997	-3.18	0.0	0.000 000
		+10	680,499,996	-3.55	0.0	-0.000 001
		+20	680,499,996	-4.23	0.0	-0.000 001
		+30	680,499,995	-5.37	0.0	-0.000 001
		+40	680,499,995	-4.51	0.0	-0.000 001
		+50	680,499,994	-5.68	0.0	-0.000 001
115%	4.43	+22	680,499,996	-4.11	0.0	-0.000 001
End point	3.60	+22	680,499,996	-3.91	0.0	-0.000 001

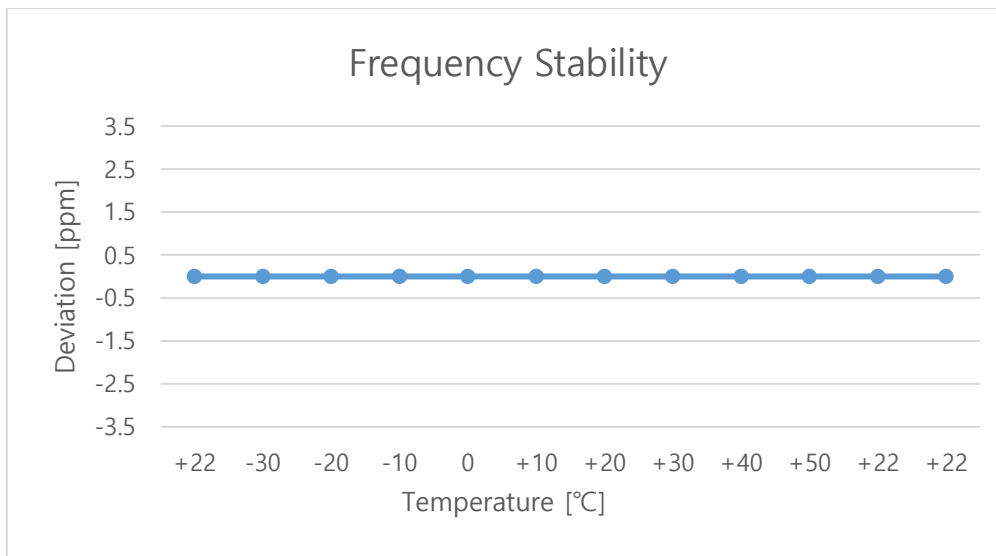

## 8.7. Radiated Power (ERP/EIRP)

### Test setup

The diagram below shows the test setup that is utilized to make the measurements for emission from 30 MHz to 1 GHz emissions.

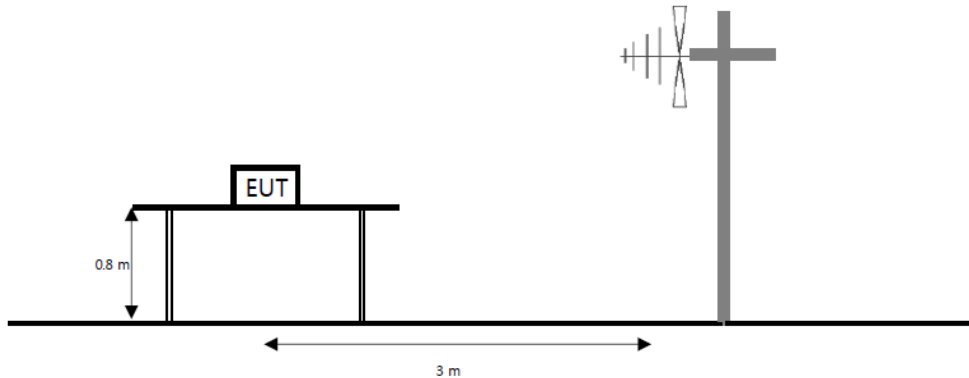

The diagram below shows the test setup that is utilized to make the measurements for emission from 1 GHz to the tenth harmonic of the highest fundamental frequency or to 40 GHz emissions, whichever is lower.

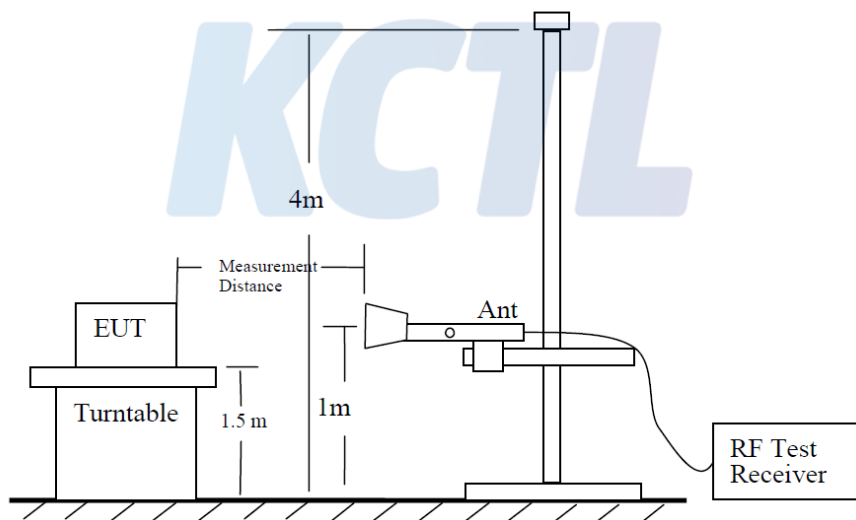

The diagram below shows the test setup for substituted method.

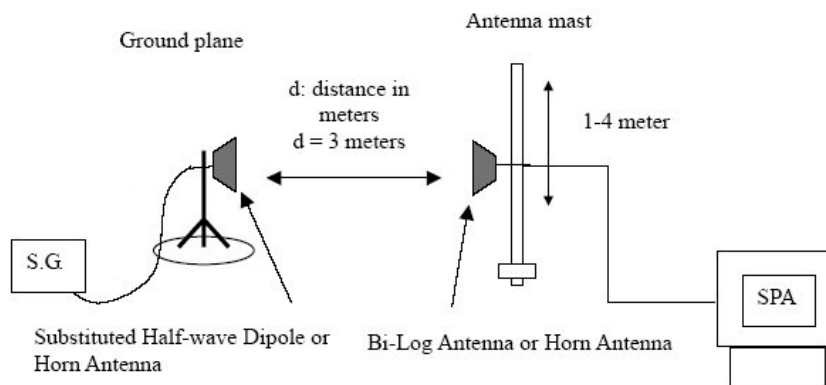



**Limit**

According to §22.913(a)(5), the ERP of transmitters in the cellular radiotelephone service must not exceed the limits in this section. The ERP of mobile transmitters and auxiliary test transmitters must not exceed 7 watts.

According to RSS-132(5.4), the equivalent isotropically radiated power (e.i.r.p) for mobile equipment shall not exceed 11.5 watts. Refer to SRSP-503 for base stations e.i.r.p limits.

According to §24.232(c) and RSS-133(6.4), RSS-199(4.4) Mobile and portable stations are limited to 2 watts EIRP and the equipment must employ a means for limiting power to the minimum necessary for successful communications.

According to §27.50(b)(10), 27.50(c)(10) and RSS-130(4.6), Portable stations (hand-held devices) in the 698 -746 MHz, 746-757 MHz, 776-788 MHz, and 805-806 MHz bands are limited 3 watts ERP.

According to §27.50(d)(4) and RSS-139(6.5), Fixed, mobile and portable (hand-held) stations operating in the 1710-1755 MHz and 1755-1780 MHz bands are limited to 1 watt EIRP.

**Test procedure**

971168 D01 v03r01 - Section 5.2 and 5.8, 412172 D01 v01r01

ANSI 63.26-2015 – Section 5.2

ANSI/TIA-603-E-2016 - Section 2.2.17

**Test settings**

- 1) RBW = 1 % to 5 % of the OBW.
- 2) VBW  $\geq 3 \times$  RBW.
- 3) SPAN = 2  $\times$  to 3  $\times$  the OBW.
- 4) Number of measurement points in sweep  $\geq 2 \times$  span / RBW.
- 5) Sweep time :
  - 1) Auto couple, or
  - 2)  $\geq [10 \times (\text{number of points in sweep}) \times (\text{transmission period})]$  for single sweep (automation-compatible) measurement. Transmission period is the on and off time of the transmitter.
- 6) Detector = RMS
- 7) If the EUT can be configured to transmit continuously, then set the trigger to free run.
- 8) If the EUT cannot be configured to transmit continuously, then use a sweep trigger with the level set to enable triggering only on full power bursts and configure the EUT to transmit at full power for the entire duration of each sweep. Verify that the sweep time is less than or equal to the transmission burst duration. Time gating can also be used under similar constraints (i.e., configured such that measurement data is collected only during active full-power transmissions).
- 9) Trace mode = trace averaging (RMS) over 100 sweeps.
- 10) Compute the power by integrating the spectrum across the OBW of the signal using the instrument's band or channel power measurement function, with the band/channel limits set equal to the OBW band edges. If the instrument does not have a band or channel power function, then sum the spectrum levels (in linear power units) at intervals equal to the RBW extending across the entire OBW of the spectrum.
- 11) Allow trace to fully stabilize.

**Notes:**

1. On a test site, the EUT shall be placed at 80 cm height on a turn table, and in the position close To normal use as declared by the applicant.
2. The test antenna shall be oriented initially for vertical polarization located 3 m from EUT to Correspond to the fundamental frequency of the transmitter.
3. The turntable is rotated through 360°, and the receiving antenna scans in order to determine the Level of the maximized emission.
4. The test antenna shall be raised and lowered again through the specified range of height until the maximum signal level is detected by the measuring receiver.
5. The maximum signal level detected by the measuring receiver shall be noted.
6. The EUT was replaced by half-wave dipole (1 GHz below) or horn antenna (1 GHz above) connected to a signal generator.  
The power is calculated by the following formula;  
$$Pd(\text{dBm}) = Pg(\text{dBm}) - \text{Cable loss (dB)} + \text{Antenna gain (dB)}$$
  
Note. Pd is the dipole equivalent power and Pg is the generator output power into the substitution antenna.
7. The test antenna shall be raised and lowered through the specified range of height to ensure that The maximum signal is received.
8. The input signal to the substitution antenna shall be adjusted to the level that produces a level Detected by the measuring corrected for the change of input attenuator setting of the measuring Receiver.
9. The input level to the substitution antenna shall be recorded as power level in dBm, corrected for Any change of input attenuator setting of the measuring receiver.
10. The measurement shall be repeated with the test antenna and the substitution antenna Orientated for horizontal polarization.

**Test results****Test mode: LTE Band 5**

Bandwidth	Modulation	Frequency	Pol.	Antenna Gain	C.L	Substitute Level	ERP	
		[MHz]	[V/H]	[dBi]	[dB]	[dBm]	[dBm]	[W]
1.4 M	QPSK	824.7	H	-0.20	3.69	25.75	21.86	0.153
		836.5	H	-0.20	3.72	25.32	21.40	0.138
		848.3	H	-0.60	3.74	25.64	21.30	0.135
	16QAM	824.7	H	-0.20	3.69	24.65	20.76	0.119
		836.5	H	-0.20	3.72	24.44	20.52	0.113
		848.3	H	-0.60	3.74	24.50	20.16	0.104
3 M	QPSK	825.5	H	-0.20	3.70	25.71	21.81	0.152
		836.5	H	-0.20	3.72	25.67	21.75	0.150
		847.5	H	-0.50	3.74	25.53	21.29	0.135
	16QAM	825.5	H	-0.20	3.70	25.07	21.17	0.131
		836.5	H	-0.20	3.72	24.73	20.81	0.121
		847.5	H	-0.50	3.74	24.62	20.38	0.109
5 M	QPSK	826.5	H	-0.20	3.71	26.14	22.23	0.167
		836.5	H	-0.20	3.72	25.59	21.67	0.147
		846.5	H	-0.50	3.73	25.69	21.46	0.140
	16QAM	826.5	H	-0.20	3.71	25.25	21.34	0.136
		836.5	H	-0.20	3.72	24.75	20.83	0.121
		846.5	H	-0.50	3.73	24.53	20.30	0.107
10 M	QPSK	829.0	H	0.70	3.71	25.67	<b>22.66</b>	<b>0.185</b>
		836.5	H	-0.20	3.72	25.57	21.65	0.146
		844.0	H	-0.50	3.73	25.61	21.38	0.137
	16QAM	829.0	H	0.70	3.71	24.76	21.75	0.150
		836.5	H	-0.20	3.72	25.02	21.10	0.129
		844.0	H	-0.50	3.73	24.69	20.46	0.111

Note.

1. E.R.P &amp; E.I.R.P(dBm) = Substitute Level(dB) + Antenna gain(dBi) - C.L(Cable loss) (dB)

**Test mode: LTE Band 7**

Bandwidth	Modulation	Frequency	Pol.	Antenna Gain	C.L	Substitute Level	ERP	
		[MHz]	[V/H]	[dBi]	[dB]	[dBm]	[dBm]	[W]
5 M	QPSK	2 502.5	H	5.41	6.48	24.90	23.83	0.242
		2 535.0	H	5.57	6.56	23.67	22.68	0.185
		2 567.5	H	5.72	6.63	22.63	21.72	0.149
	16QAM	2 502.5	H	5.41	6.48	24.04	22.97	0.198
		2 535.0	H	5.57	6.56	22.78	21.79	0.151
		2 567.5	H	5.72	6.63	21.52	20.61	0.115
10 M	QPSK	2 505.0	H	5.42	6.49	25.16	<b>24.09</b>	<b>0.256</b>
		2 535.0	H	5.57	6.56	23.67	22.68	0.185
		2 565.0	H	5.71	6.62	22.55	21.64	0.146
	16QAM	2 505.0	H	5.42	6.49	24.01	22.94	0.197
		2 535.0	H	5.57	6.56	22.55	21.56	0.143
		2 565.0	H	5.71	6.62	21.74	20.83	0.121
15 M	QPSK	2 507.5	H	5.44	6.50	25.04	23.98	0.250
		2 535.0	H	5.57	6.56	23.96	22.97	0.198
		2 562.5	H	5.70	6.61	22.63	21.72	0.149
	16QAM	2 507.5	H	5.44	6.50	24.10	23.04	0.201
		2 535.0	H	5.57	6.56	22.91	21.92	0.156
		2 562.5	H	5.70	6.61	21.74	20.83	0.121
20 M	QPSK	2 510.0	H	5.45	6.51	24.77	23.71	0.235
		2 535.0	H	5.57	6.56	23.95	22.96	0.198
		2 560.0	H	5.69	6.62	22.85	21.92	0.156
	16QAM	2 510.0	H	5.45	6.51	24.11	23.05	0.202
		2 535.0	H	5.57	6.56	23.17	22.18	0.165
		2 560.0	H	5.69	6.62	21.99	21.06	0.128

Note.

1. E.R.P &amp; E.I.R.P(dBm) = Substitute Level(dB) + Antenna gain(dBi) - C.L(Cable loss) (dB)

**Test mode: LTE Band 12/17**

Bandwidth	Modulation	Frequency	Pol.	Antenna Gain	C.L	Substitute Level	ERP	
		[MHz]	[V/H]	[dBi]	[dB]	[dBm]	[dBm]	[W]
1.4 M	QPSK	699.7	H	-0.70	3.40	25.16	21.06	0.128
		707.5	H	-0.60	3.42	25.99	21.97	0.157
		715.3	H	-0.80	3.44	26.36	22.12	0.163
	16QAM	699.7	H	-0.70	3.40	24.00	19.90	0.098
		707.5	H	-0.60	3.42	25.05	21.03	0.127
		715.3	H	-0.80	3.40	25.47	21.27	0.134
3 M	QPSK	700.5	H	-0.70	3.40	25.42	21.32	0.136
		707.5	H	-0.60	3.42	26.06	22.04	0.160
		714.5	H	-0.80	3.44	26.52	<b>22.28</b>	<b>0.169</b>
	16QAM	700.5	H	-0.70	3.40	24.25	20.15	0.104
		707.5	H	-0.60	3.42	25.04	21.02	0.126
		714.5	H	-0.80	3.44	25.62	21.38	0.137
5 M	QPSK	701.5	H	-0.70	3.40	25.42	21.32	0.136
		707.5	H	-0.60	3.42	26.12	22.10	0.162
		713.5	H	-0.80	3.44	26.45	22.21	0.166
	16QAM	701.5	H	-0.70	3.40	24.61	20.51	0.112
		707.5	H	-0.60	3.42	24.90	20.88	0.122
		713.5	H	-0.80	3.44	25.84	21.60	0.145
10 M	QPSK	704.0	H	-0.60	3.40	25.70	21.70	0.148
		707.5	H	-0.60	3.42	25.93	21.91	0.155
		711.0	H	-0.30	3.42	25.85	22.13	0.163
	16QAM	704.0	H	-0.60	3.40	24.54	20.54	0.113
		707.5	H	-0.60	3.42	25.01	20.99	0.126
		711.0	H	-0.30	3.42	25.05	21.33	0.136

**Test mode: LTE Band 13**

Bandwidth	Modulation	Frequency	Pol.	Antenna Gain	C.L	Substitute Level	ERP	
		[MHz]	[V/H]	[dBi]	[dB]	[dBm]	[dBm]	[W]
5 M	QPSK	779.5	H	0.60	3.59	23.49	20.50	0.112
		782.0	H	0.60	3.62	23.64	20.62	0.115
		784.5	H	0.10	3.62	24.07	20.55	0.114
	16QAM	779.5	H	0.60	3.59	22.35	19.36	0.086
		782.0	H	0.60	3.62	22.22	19.20	0.083
		784.5	H	0.10	3.62	22.99	19.47	0.089
10 M	QPSK	782.0	H	0.60	3.62	23.67	<b>20.65</b>	<b>0.116</b>
	16QAM	782.0	H	0.60	3.62	22.67	19.65	0.092

Note.

1. E.R.P &amp; E.I.R.P(dBm) = Substitute Level(dB) + Antenna gain(dBi) - C.L(Cable loss) (dB)

**Test mode: LTE Band 25/2**

Bandwidth	Modulation	Frequency	Pol.	Antenna Gain	C.L	Substitute Level	EIRP	
		[MHz]	[V/H]	[dBi]	[dB]	[dBm]	[dBm]	[W]
1.4 M	QPSK	1 850.7	H	5.55	5.64	24.37	24.28	0.268
		1 882.5	H	5.45	5.71	23.81	23.55	0.226
		1 914.3	H	5.36	5.75	23.84	23.45	0.221
	16QAM	1 850.7	H	5.55	5.64	23.39	23.30	0.214
		1 882.5	H	5.45	5.71	22.51	22.25	0.168
		1 914.3	H	5.36	5.75	22.68	22.29	0.169
3 M	QPSK	1 851.5	H	5.55	5.62	24.35	24.28	0.268
		1 882.5	H	5.45	5.71	23.60	23.34	0.216
		1 913.5	H	5.36	5.75	23.76	23.37	0.217
	16QAM	1 851.5	H	5.55	5.62	23.43	23.36	0.217
		1 882.5	H	5.45	5.71	22.86	22.60	0.182
		1 913.5	H	5.36	5.75	22.53	22.14	0.164
5 M	QPSK	1 852.5	H	5.54	5.63	24.41	<b>24.32</b>	<b>0.270</b>
		1 882.5	H	5.45	5.71	23.56	23.30	0.214
		1 912.5	H	5.36	5.75	23.70	23.31	0.214
	16QAM	1 852.5	H	5.54	5.63	23.49	23.40	0.219
		1 882.5	H	5.45	5.71	22.66	22.40	0.174
		1 912.5	H	5.36	5.75	22.51	22.12	0.163
10 M	QPSK	1 855.0	H	5.54	5.62	24.38	24.29	0.269
		1 882.5	H	5.45	5.71	23.68	23.42	0.220
		1 910.0	H	5.37	5.78	23.88	23.47	0.222
	16QAM	1 855.0	H	5.54	5.62	23.36	23.27	0.212
		1 882.5	H	5.45	5.71	22.57	22.31	0.170
		1 910.0	H	5.37	5.78	22.91	22.50	0.178
15 M	QPSK	1 857.5	H	5.53	5.64	24.37	24.26	0.267
		1 882.5	H	5.45	5.71	23.63	23.37	0.217
		1 907.5	H	5.38	5.79	23.80	23.39	0.218
	16QAM	1 857.5	H	5.53	5.64	23.43	23.32	0.215
		1 882.5	H	5.45	5.71	22.67	22.41	0.174
		1 907.5	H	5.38	5.79	22.64	22.23	0.167
20 M	QPSK	1 860.0	H	5.52	5.64	24.23	24.11	0.258
		1 882.5	H	5.45	5.71	23.80	23.54	0.226
		1 905.0	H	5.39	5.77	23.77	23.38	0.218
	16QAM	1 860.0	H	5.52	5.64	23.53	23.41	0.219
		1 882.5	H	5.45	5.71	22.80	22.54	0.179
		1 905.0	H	5.39	5.77	22.72	22.33	0.171

Note.

1. E.R.P &amp; E.I.R.P(dBm) = Substitute Level(dB) + Antenna gain(dBi) - C.L(Cable loss) (dB)

**Test mode: LTE Band 26**

Bandwidth	Modulation	Frequency	Pol.	Antenna Gain	C.L	Substitute Level	ERP		EIRP <sup>Note.1</sup>	
		[MHz]	[V/H]	[dBi]	[dB]	[dBm]	[dBm]	[W]	[dBm]	[W]
1.4 M	QPSK	824.7	H	-0.20	3.75	25.95	22.00	0.158	24.15	0.260
		836.5	H	-0.20	3.83	25.39	21.36	0.137	23.51	0.224
		848.3	H	-0.60	3.84	25.14	20.70	0.117	22.85	0.193
	16QAM	824.7	H	-0.20	3.75	24.86	20.91	0.123	23.06	0.202
		836.5	H	-0.20	3.83	24.50	20.47	0.111	22.62	0.183
		848.3	H	-0.60	3.84	24.10	19.66	0.092	21.81	0.152
3 M	QPSK	825.5	H	-0.20	3.75	25.99	22.04	0.160	24.19	0.262
		836.5	H	-0.20	3.83	25.50	21.47	0.140	23.62	0.230
		847.5	H	-0.50	3.85	24.70	20.35	0.108	22.50	0.178
	16QAM	825.5	H	-0.20	3.75	25.46	21.51	0.142	23.66	0.232
		836.5	H	-0.20	3.83	24.50	20.47	0.111	22.62	0.183
		847.5	H	-0.50	3.85	23.63	19.28	0.085	21.43	0.139
5 M	QPSK	826.5	H	-0.20	3.76	26.37	22.41	0.174	24.56	0.286
		836.5	H	-0.20	3.83	25.17	21.14	0.130	23.29	0.213
		846.5	H	-0.50	3.83	24.94	20.61	0.115	22.76	0.189
	16QAM	826.5	H	-0.20	3.76	25.24	21.28	0.134	23.43	0.220
		836.5	H	-0.20	3.83	24.65	20.62	0.115	22.77	0.189
		846.5	H	-0.50	3.83	24.08	19.75	0.094	21.90	0.155
10 M	QPSK	829.0	H	0.70	3.76	25.58	22.52	0.179	24.67	0.293
		836.5	H	-0.20	3.83	25.33	21.30	0.135	23.45	0.221
		844.0	H	-0.80	3.84	25.43	20.79	0.120	22.94	0.197
	16QAM	829.0	H	-0.70	3.76	26.02	21.56	0.143	23.71	0.235
		836.5	H	-0.20	3.83	24.29	20.26	0.106	22.41	0.174
		844.0	H	-0.80	3.84	24.56	19.92	0.098	22.07	0.161
15 M	QPSK	831.5	H	0.70	3.77	25.75	<b>22.68</b>	<b>0.185</b>	<b>24.83</b>	<b>0.304</b>
		836.5	H	-0.20	3.83	25.33	21.30	0.135	23.45	0.221
		841.5	H	-0.80	3.82	25.12	20.50	0.112	22.65	0.184
	16QAM	831.5	H	0.70	3.77	24.99	21.92	0.156	24.07	0.255
		836.5	H	-0.20	3.83	24.29	20.26	0.106	22.41	0.174
		841.5	H	-0.80	3.82	24.23	19.61	0.091	21.76	0.150

## Note.

1. The E.I.R.P conversion formula for IC : E.I.R.P result (dBm)

= E.R.P result (dBm) + 2.15 (dB)

2. E.R.P &amp; E.I.R.P(dBm) = Substitute Level(dB) + Antenna gain(dBi) - C.L(Cable loss) (dB)



**Test mode: LTE Band 41(PC2)**

Bandwidth	Modulation	Frequency	Pol.	Antenna Gain	C.L	Substitute Level	ERP	
		[MHz]	[V/H]	[dBi]	[dB]	[dBm]	[dBm]	[W]
5 M	QPSK	2 498.5	H	5.40	6.49	26.94	25.85	0.385
		2 593.0	H	5.85	6.61	25.21	24.45	0.279
		2 687.5	H	6.30	6.73	24.95	24.52	0.283
	16QAM	2 498.5	H	5.40	6.49	25.21	24.12	0.258
		2 693.0	H	5.85	6.61	23.33	22.57	0.181
		2 687.5	H	6.30	6.73	23.60	23.17	0.207
10 M	QPSK	2 501.0	H	5.40	6.49	28.49	<b>27.40</b>	<b>0.550</b>
		2 593.0	H	5.85	6.61	24.41	23.65	0.232
		2 685.0	H	6.29	6.73	24.16	23.72	0.236
	16QAM	2 501.0	H	5.40	6.49	25.31	24.22	0.264
		2 593.0	H	5.85	6.61	23.61	22.85	0.193
		2 685.0	H	6.29	6.73	24.46	24.02	0.252
15 M	QPSK	2 503.5	H	5.42	6.48	25.20	24.14	0.259
		2 593.0	H	5.85	6.61	25.23	24.47	0.280
		2 682.5	H	6.28	6.71	24.45	24.02	0.252
	16QAM	2 503.5	H	5.42	6.48	25.71	24.65	0.292
		2 593.0	H	5.85	6.61	25.14	24.38	0.274
		2 682.5	H	6.28	6.71	22.49	22.06	0.161
20 M	QPSK	2 506.0	H	5.43	6.49	26.16	25.10	0.324
		2 593.0	H	5.85	6.61	24.19	23.43	0.220
		2 680.0	H	6.26	6.72	23.17	22.71	0.187
	16QAM	2 506.0	H	5.43	6.49	25.01	23.95	0.248
		2 593.0	H	5.85	6.61	24.37	23.61	0.230
		2 680.0	H	6.26	6.72	22.61	22.15	0.164

Note.

1. E.R.P &amp; E.I.R.P(dBm) = Substitute Level(dB) + Antenna gain(dBi) - C.L(Cable loss) (dB)

**Test mode: LTE Band 41(PC3)**

Bandwidth	Modulation	Frequency	Pol.	Antenna Gain	C.L	Substitute Level	ERP	
		[MHz]	[V/H]	[dBi]	[dB]	[dBm]	[dBm]	[W]
5 M	QPSK	2 498.5	H	5.40	6.55	23.87	22.72	0.187
		2 502.5	H	5.41	6.48	24.91	23.84	0.242
		2 593.0	H	5.85	6.64	25.88	25.09	0.323
		2 687.5	H	6.30	6.74	20.66	20.22	0.105
	16QAM	2 498.5	H	5.40	6.55	22.49	21.34	0.136
		2 502.5	H	5.41	6.48	23.86	22.79	0.190
		2 693.0	H	5.85	6.64	22.46	21.67	0.147
		2 687.5	H	6.30	6.74	20.43	19.99	0.100
10 M	QPSK	2 501.0	H	5.40	6.53	23.16	22.03	0.160
		2 505.0	H	5.42	6.49	24.59	23.52	0.225
		2 593.0	H	5.85	6.64	24.99	24.20	0.263
		2 685.0	H	6.29	6.74	22.18	21.73	0.149
	16QAM	2 501.0	H	5.40	6.53	22.63	21.50	0.141
		2 505.0	H	5.42	6.49	24.06	22.99	0.199
		2 593.0	H	5.85	6.64	22.69	21.90	0.155
		2 685.0	H	6.29	6.74	21.08	20.63	0.116
15 M	QPSK	2 503.5	H	5.42	6.53	22.84	21.73	0.149
		2 507.5	H	5.44	6.50	24.72	23.66	0.232
		2 593.0	H	5.85	6.64	26.01	<b>25.22</b>	<b>0.333</b>
		2 682.5	H	6.28	6.74	22.34	21.88	0.154
	16QAM	2 503.5	H	5.42	6.53	22.39	21.28	0.134
		2 507.5	H	5.44	6.50	23.77	22.71	0.187
		2 593.0	H	5.85	6.64	24.93	24.14	0.259
		2 682.5	H	6.28	6.74	19.29	18.83	0.076
20 M	QPSK	2 506.0	H	5.43	6.54	23.64	22.53	0.179
		2 510.0	H	5.45	6.51	24.81	23.75	0.237
		2 593.0	H	5.85	6.64	24.49	23.70	0.234
		2 680.0	H	6.26	6.74	21.39	20.91	0.123
	16QAM	2 506.0	H	5.43	6.54	21.53	20.42	0.110
		2 510.0	H	5.45	6.51	23.67	22.61	0.182
		2 593.0	H	5.85	6.64	21.62	20.83	0.121
		2 680.0	H	6.26	6.74	21.98	21.50	0.141

Note.

1. E.R.P &amp; E.I.R.P(dBm) = Substitute Level(dB) + Antenna gain(dBi) - C.L(Cable loss) (dB)

**Test mode: LTE Band 66/4**

Bandwidth	Modulation	Frequency	Pol.	Antenna Gain	C.L	Substitute Level	EIRP	
		[MHz]	[V/H]	[dBi]	[dB]	[dBm]	[dBm]	[W]
1.4 M	QPSK	1 710.7	H	5.97	5.34	22.42	23.05	0.202
		1 745.0	H	5.87	5.39	23.41	23.88	0.244
		1 779.3	H	5.76	5.48	23.57	23.85	0.243
	16QAM	1 710.7	H	5.97	5.34	21.22	21.85	0.153
		1 745.0	H	5.87	5.39	22.50	22.97	0.198
		1 779.3	H	5.76	5.48	21.63	21.91	0.155
3 M	QPSK	1 711.5	H	5.97	5.35	22.24	22.86	0.193
		1 745.0	H	5.87	5.39	23.51	<b>23.98</b>	<b>0.250</b>
		1 778.5	H	5.76	5.48	22.35	22.63	0.183
	16QAM	1 711.5	H	5.97	5.35	20.96	21.58	0.144
		1 745.0	H	5.87	5.39	22.55	23.02	0.200
		1 778.5	H	5.76	5.48	21.36	21.64	0.146
5 M	QPSK	1 712.5	H	5.96	5.36	22.20	22.80	0.191
		1 745.0	H	5.87	5.39	23.45	23.92	0.247
		1 777.5	H	5.77	5.46	22.37	22.68	0.185
	16QAM	1 712.5	H	5.96	5.36	21.01	21.61	0.145
		1 745.0	H	5.87	5.39	22.47	22.94	0.197
		1 777.5	H	5.77	5.46	21.64	21.95	0.157
10 M	QPSK	1 715.0	H	5.96	5.36	22.28	22.87	0.194
		1 745.0	H	5.87	5.39	23.32	23.79	0.239
		1 775.0	H	5.78	5.45	22.50	22.82	0.191
	16QAM	1 715.0	H	5.96	5.36	21.37	21.96	0.157
		1 745.0	H	5.87	5.39	22.21	22.68	0.185
		1 775.0	H	5.78	5.45	21.80	22.12	0.163
15 M	QPSK	1 717.5	H	5.95	5.36	22.26	22.85	0.193
		1 745.0	H	5.87	5.39	23.30	23.77	0.238
		1 772.5	H	5.78	5.46	22.66	22.98	0.199
	16QAM	1 717.5	H	5.95	5.36	21.40	21.99	0.158
		1 745.0	H	5.87	5.39	22.55	23.02	0.200
		1 772.5	H	5.78	5.46	21.62	21.94	0.156
20 M	QPSK	1 720.0	H	5.94	5.37	22.39	22.96	0.198
		1 745.0	H	5.87	5.39	23.20	23.67	0.233
		1 770.0	H	5.79	5.45	23.00	23.34	0.216
	16QAM	1 720.0	H	5.94	5.37	21.26	21.83	0.152
		1 745.0	H	5.87	5.39	22.16	22.63	0.183
		1 770.0	H	5.79	5.45	21.96	22.30	0.170

Note.

1. E.R.P &amp; E.I.R.P(dBm) = Substitute Level(dB) + Antenna gain(dBi) - C.L(Cable loss) (dB)

**Test mode: LTE Band 71**

Bandwidth	Modulation	Frequency	Pol.	Antenna Gain	C.L	Substitute Level	ERP	
		[MHz]	[V/H]	[dBi]	[dB]	[dBm]	[dBm]	[W]
5 M	QPSK	665.50	H	-1.20	3.42	22.10	17.48	0.056
		680.50	H	-0.90	3.44	22.01	17.67	0.058
		695.50	H	-0.30	3.45	21.67	<b>17.92</b>	<b>0.062</b>
	16QAM	665.50	H	-1.20	3.42	20.94	16.32	0.043
		680.50	H	-0.90	3.44	20.89	16.55	0.045
		695.50	H	-0.30	3.45	20.55	16.80	0.048
10 M	QPSK	668.00	H	-1.20	3.42	22.10	17.48	0.056
		680.50	H	-0.90	3.44	21.97	17.63	0.058
		693.00	H	-0.70	3.45	21.95	17.80	0.060
	16QAM	668.00	H	-1.20	3.42	20.86	16.24	0.042
		680.50	H	-0.90	3.44	21.08	16.74	0.047
		693.00	H	-0.70	3.45	20.89	16.74	0.047
15 M	QPSK	670.50	H	-1.40	3.43	22.16	17.33	0.054
		680.50	H	-0.90	3.44	21.91	17.57	0.057
		690.50	H	-0.70	3.46	21.88	17.72	0.059
	16QAM	670.50	H	-1.40	3.43	21.31	16.48	0.044
		680.50	H	-0.90	3.44	21.14	16.80	0.048
		690.50	H	-0.70	3.46	20.85	16.69	0.047
20 M	QPSK	673.00	H	-1.40	3.43	22.43	17.60	0.058
		680.50	H	-0.90	3.44	21.82	17.48	0.056
		688.00	H	-1.20	3.45	22.26	17.61	0.058
	16QAM	673.00	H	-1.40	3.43	21.65	16.82	0.048
		680.50	H	-0.90	3.44	20.92	16.58	0.045
		688.00	H	-1.20	3.45	21.40	16.75	0.047

Note.

1. E.R.P &amp; E.I.R.P(dBm) = Substitute Level(dB) + Antenna gain(dBi) - C.L(Cable loss) (dB)

## 8.8. Radiated Spurious Emissions

### Test setup

The diagram below shows the test setup that is utilized to make the measurements for emission from 30 MHz to 1 GHz emissions.

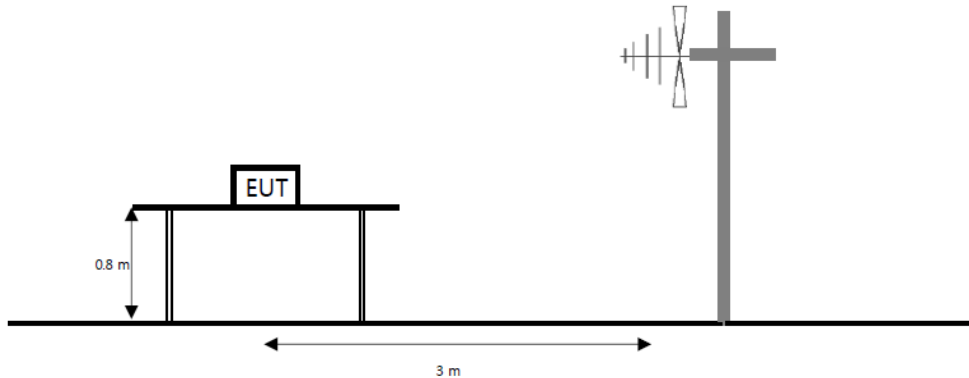

The diagram below shows the test setup that is utilized to make the measurements for emission from 1 GHz to the tenth harmonic of the highest fundamental frequency or to 40 GHz emissions, whichever is lower.

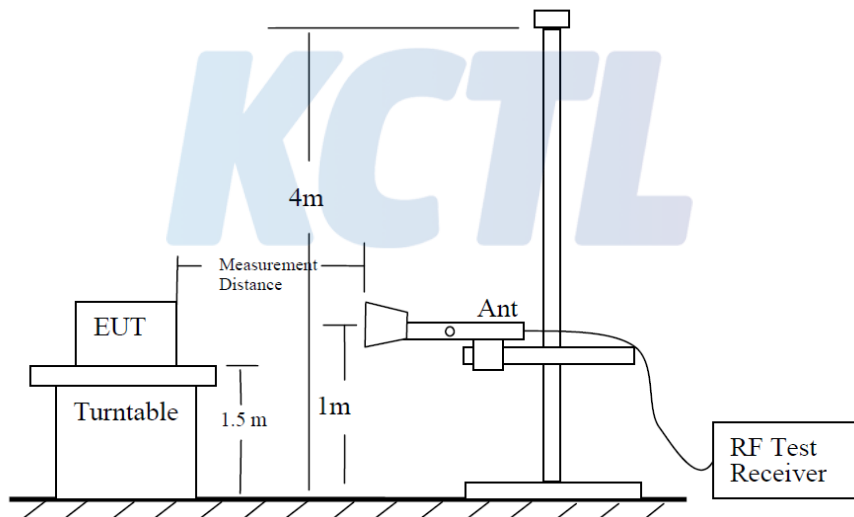

The diagram below shows the test setup for substituted method.

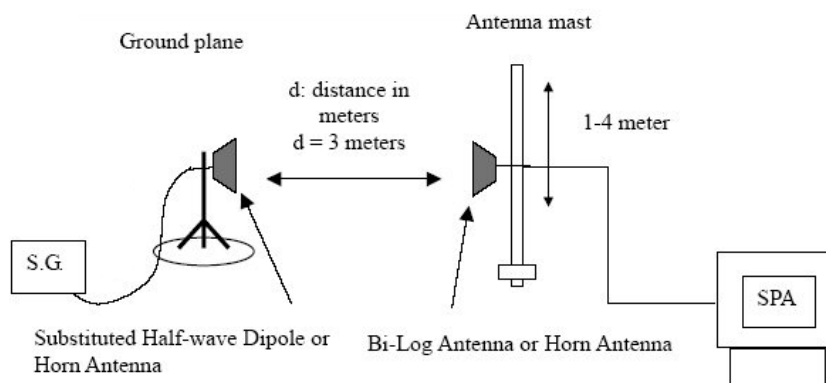

**Limit**

According to §22.917(a), §24.238(a) and RSS-132(5.5), RSS-133(6.5), the power of any emission outside of the authorized operating frequency ranges must be attenuated below the transmitting power (P) by a factor of at least  $43 + 10\log(P_{\text{[Watts]}})$  dB.

According to §27.53(c)(2) and RSS-130(4.7), on any frequency outside the 776-788 MHz band, the power of any emission shall be attenuated outside the band below the transmitter power (P) by at least  $43 + 10\log(P_{\text{[Watts]}})$  dB.

According to §27.53(f), for operations in the 746-758 MHz, 775-788 MHz, and 805-806 MHz bands, emissions in the band 1559-1610 MHz shall be limited to -70 dBW/MHz equivalent isotropically radiated power (EIRP) for wideband signals, and -80 dBW EIRP for discrete emissions of less than 700 Hz bandwidth. For the purpose of equipment authorization, a transmitter shall be tested with an antenna that is representative of the type that will be used with the equipment in normal operation.

According to §27.53(g) and RSS-130(4.7), for operations in the 600 MHz band and the 698-746 MHz band, the power of any emission outside a licensee's frequency band(s) of operation shall be attenuated below the transmitter power (P) within the licensed band(s) of operation, measured in watts, by at least  $43 + 10\log(P_{\text{[Watts]}})$  dB.

According to §27.53(h) and RSS-139(6.6), the power of any emission outside a licensee's frequency block shall be attenuated below the transmitter power (P) in watts by at least  $43 + 10\log(P_{\text{[Watts]}})$  dB.

According to §27.53(m)(4) and RSS-199(4.5) the minimum permissible attenuation level of any spurious emission is  $53 + 10\log(P_{\text{[Watts]}})$  dB.

**Test procedure**

971168 D01 v03r01 - Section 6.2

ANSI 63.26-2015 – Section 5.5

ANSI/TIA-603-E-2016 - Section 2.2.12

**Test settings**

- 1) RBW = 100 kHz for below 1 GHz and 1 MHz for above 1 GHz.
- 2) VBW  $\geq 3 \times$  RBW.
- 3) Detector = RMS
- 4) Trace mode = Max hold
- 5) Sweep time = Auto couple
- 6) Number of sweep points  $\geq 2 \times$  span / RBW
- 7) Allow trace to fully stabilize.

For the narrowband spurious settings:

- 1) RBW = 1 kHz
- 2) VBW = 3 kHz
- 3) Detector = RMS
- 4) Trace mode = Max hold
- 5) Sweep speed slow enough to maintain measurement calibration.

**Notes:**

1. On a test site, the EUT shall be placed at 80 cm height on a turn table, and in the position close to normal use as declared by the applicant.
2. The test antenna shall be oriented initially for vertical polarization located 3 m from EUT to correspond to the fundamental frequency of the transmitter.
3. The turntable is rotated through 360°, and the receiving antenna scans in order to determine the level of the maximized emission.
4. The test antenna shall be raised and lowered again through the specified range of height until the maximum signal level is detected by the measuring receiver.
5. The maximum signal level detected by the measuring receiver shall be noted.
6. The EUT was replaced by half-wave dipole (1 GHz below) or horn antenna (1 GHz above) connected to a signal generator.
7. The test antenna shall be raised and lowered through the specified range of height to ensure that the maximum signal is received.
8. The input signal to the substitution antenna shall be adjusted to the level that produces a level detected by the measuring corrected for the change of input attenuator setting of the measuring receiver.
9. The input level to the substitution antenna shall be recorded as power level in dBm, corrected for any change of input attenuator setting of the measuring receiver.
10. The measurement shall be repeated with the test antenna and the substitution antenna orientated for horizontal polarization.



**Test results (Above 1 000 MHz)**Test mode : LTE Band 5Frequency(MHz) : 829.0Channel : 20450Bandwidth(MHz) : 10

Mode	Frequency	Pol.	Antenna Gain	Cable loss	Substitute Level	Level	Limit	Margin
	[MHz]	[V/H]	[dBi]	[dB]	[dBm]	[dBm]	[dBm]	[dB]
QPSK	1 666.91	H	6.10	5.35	-55.75	-55.00	-13.00	42.00
	2 500.22	H	5.40	6.55	-48.85	-50.00	-13.00	37.00
	3 336.73	H	8.20	7.68	-59.02	-58.50	-13.00	45.50
	4 170.05	V	8.46	8.78	-59.38	-59.70	-13.00	46.70

Test mode : LTE Band 5Frequency(MHz) : 836.5Channel : 20525Bandwidth(MHz) : 10

Mode	Frequency	Pol.	Antenna Gain	Cable loss	Substitute Level	Level	Limit	Margin
	[MHz]	[V/H]	[dBi]	[dB]	[dBm]	[dBm]	[dBm]	[dB]
QPSK	1 672.67	H	6.08	5.35	-54.03	-53.30	-13.00	40.30
	2 509.82	H	5.45	6.56	-45.59	-46.70	-13.00	33.70
	3 346.65	H	8.22	7.69	-60.23	-59.70	-13.00	46.70
	4 182.21	H	8.45	8.80	-58.55	-58.90	-13.00	45.90

Test mode : LTE Band 5Frequency(MHz) : 844.0Channel : 20600Bandwidth(MHz) : 10

Mode	Frequency	Pol.	Antenna Gain	Cable loss	Substitute Level	Level	Limit	Margin
	[MHz]	[V/H]	[dBi]	[dB]	[dBm]	[dBm]	[dBm]	[dB]
QPSK	1 696.67	H	6.01	5.37	-55.04	-54.40	-13.00	41.40
	2 545.02	H	5.62	6.58	-50.44	-51.40	-13.00	38.40
	3 396.90	V	8.28	7.76	-57.82	-57.30	-13.00	44.30
	4 245.25	H	8.40	8.91	-56.99	-57.50	-13.00	44.50

Note.

1. ERP &amp; E.I.R.P(dB m)= Substitute Level(dB) + Antenna gain(dBi) – Cable Loss(dB)

Test mode : LTE Band 7Frequency(MHz) : 2 505.0Channel : 20800Bandwidth(MHz) : 10

Mode	Frequency	Pol.	Antenna Gain	Cable loss	Substitute Level	Level	Limit	Margin
	[MHz]	[V/H]	[dBi]	[dB]	[dBm]	[dBm]	[dBm]	[dB]
QPSK	5 010.08	H	10.21	10.85	-49.66	-50.30	-25.00	25.30
	7 515.18	V	12.12	13.98	-43.84	-45.70	-25.00	20.70
	10 020.88	V	13.00	15.19	-47.81	-50.00	-25.00	25.00
	12 525.38	V	13.21	17.04	-40.17	-44.00	-25.00	19.00

Test mode : LTE Band 7Frequency(MHz) : 2 535.0Channel : 21100Bandwidth(MHz) : 10

Mode	Frequency	Pol.	Antenna Gain	Cable loss	Substitute Level	Level	Limit	Margin
	[MHz]	[V/H]	[dBi]	[dB]	[dBm]	[dBm]	[dBm]	[dB]
QPSK	5 070.08	V	10.24	10.93	-51.01	-51.70	-25.00	26.70
	7 605.18	V	12.21	13.81	-47.30	-48.90	-25.00	23.90
	10 140.89	H	13.00	15.20	-47.70	-49.90	-25.00	24.90
	12 675.39	V	13.27	17.15	-46.82	-50.70	-25.00	25.70

Test mode : LTE Band 7Frequency(MHz) : 2 565.0Channel : 21400Bandwidth(MHz) : 10

Mode	Frequency	Pol.	Antenna Gain	Cable loss	Substitute Level	Level	Limit	Margin
	[MHz]	[V/H]	[dBi]	[dB]	[dBm]	[dBm]	[dBm]	[dB]
QPSK	5 140.89	V	10.28	11.33	-55.65	-56.70	-25.00	31.70
	7 710.79	V	12.31	13.84	-54.07	-55.60	-25.00	30.60
	10 280.69	H	13.00	15.53	-48.27	-50.80	-25.00	25.80
	12 850.59	V	13.34	17.64	-48.20	-52.50	-25.00	27.50

Note.

1. ERP &amp; E.I.R.P(dB m)= Substitute Level(dB) + Antenna gain(dBi) – Cable Loss(dB)

Test mode : LTE Band 12/17Frequency(MHz) : 700.5Channel : 23025Bandwidth(MHz) : 3

Mode	Frequency	Pol.	Antenna Gain	Cable loss	Substitute Level	Level	Limit	Margin
	[MHz]	[V/H]	[dBi]	[dB]	[dBm]	[dBm]	[dBm]	[dB]
QPSK	1 398.42	H	5.93	4.99	-58.94	-58.00	-13.00	45.00
	2 097.64	H	5.16	5.99	-49.57	-50.40	-13.00	37.40
	2 796.55	V	6.82	6.90	-59.12	-59.20	-13.00	46.20
	3 495.14	V	8.39	7.90	-59.99	-59.50	-13.00	46.50

Test mode : LTE Band 12/17Frequency(MHz) : 707.5Channel : 23095Bandwidth(MHz) : 3

Mode	Frequency	Pol.	Antenna Gain	Cable loss	Substitute Level	Level	Limit	Margin
	[MHz]	[V/H]	[dBi]	[dB]	[dBm]	[dBm]	[dBm]	[dB]
QPSK	1 415.06	H	6.04	5.03	-62.01	-61.00	-13.00	48.00
	2 122.93	H	5.17	6.02	-56.65	-57.50	-13.00	44.50
	2 830.47	V	6.99	6.95	-58.84	-58.80	-13.00	45.80
	3 537.38	V	8.41	7.97	-58.14	-57.70	-13.00	44.70

Test mode : LTE Band 12/17Frequency(MHz) : 714.5Channel : 23165Bandwidth(MHz) : 3

Mode	Frequency	Pol.	Antenna Gain	Cable loss	Substitute Level	Level	Limit	Margin
	[MHz]	[V/H]	[dBi]	[dB]	[dBm]	[dBm]	[dBm]	[dB]
QPSK	1 426.58	H	6.12	5.04	-56.98	-55.90	-13.00	42.90
	2 139.89	H	5.18	6.05	-51.03	-51.90	-13.00	38.90
	2 852.23	V	7.09	6.98	-59.21	-59.10	-13.00	46.10
	3 565.54	H	8.43	7.79	-57.94	-57.30	-13.00	44.30

Note.

1. ERP &amp; E.I.R.P(dB m)= Substitute Level(dB) + Antenna gain(dBi) – Cable Loss(dB)

Test mode : LTE Band 13Frequency(MHz) : 782.0Channel : 23230Bandwidth(MHz) : 10

Mode	Frequency	Pol.	Antenna Gain	Cable loss	Substitute Level	Level	Limit	Margin
	[MHz]	[V/H]	[dBi]	[dB]	[dBm]	[dBm]	[dBm]	[dB]
QPSK	1 572.82	H	6.38	5.29	-57.89	-56.80	-50.00	6.80
	2 361.01	H	5.32	6.35	-59.97	-61.00	-13.00	48.00
	3 148.25	V	7.98	7.40	-59.88	-59.30	-13.00	46.30
	3 935.48	V	8.57	8.49	-56.28	-56.20	-13.00	43.20

## Note.

1. Limit Calculation(dBm)= 43 + 10log(P<sub>[Watts]</sub>)

Limit Calculation of wide-band (dBm/MHz) = -70dBW/MHz (-40 dBm/MHz)

Limit Calculation of narrow-band (dBm) = -80dBW (-50dBm)

2. ERP &amp; E.I.R.P(dB m)= Substitute Level(dB) + Antenna gain(dBi) – Cable Loss(dB)

3. “\*” Narrow-band (1 559 – 1 610 MHz)

**KCTL**

Test mode : LTE Band 25/2Frequency(MHz) : 1 852.5Channel : 26065Bandwidth(MHz) : 5

Mode	Frequency	Pol.	Antenna Gain	Cable loss	Substitute Level	Level	Limit	Margin
	[MHz]	[V/H]	[dBi]	[dB]	[dBm]	[dBm]	[dBm]	[dB]
QPSK	3 700.83	H	8.48	9.44	-55.74	-56.70	-13.00	43.70
	5 550.70	H	10.51	11.90	-49.51	-50.90	-13.00	37.90
	7 400.58	H	11.94	13.96	-54.38	-56.40	-13.00	43.40
	9 250.45	H	13.20	14.74	-50.66	-52.20	-13.00	39.20

Test mode : LTE Band 25/2Frequency(MHz) : 1 882.5Channel : 26365Bandwidth(MHz) : 5

Mode	Frequency	Pol.	Antenna Gain	Cable loss	Substitute Level	Level	Limit	Margin
	[MHz]	[V/H]	[dBi]	[dB]	[dBm]	[dBm]	[dBm]	[dB]
QPSK	3 765.63	V	8.51	9.30	-56.91	-57.70	-13.00	44.70
	5 647.91	H	10.53	11.75	-49.58	-50.80	-13.00	37.80
	7 530.78	V	12.13	13.99	-54.24	-56.10	-13.00	43.10
	9 412.46	V	13.20	14.94	-51.46	-53.20	-13.00	40.20

Test mode : LTE Band 25/2Frequency(MHz) : 1 912.5Channel : 26665Bandwidth(MHz) : 5

Mode	Frequency	Pol.	Antenna Gain	Cable loss	Substitute Level	Level	Limit	Margin
	[MHz]	[V/H]	[dBi]	[dB]	[dBm]	[dBm]	[dBm]	[dB]
QPSK	3 830.43	V	8.53	9.38	-56.65	-57.50	-13.00	44.50
	5 745.71	V	10.55	12.25	-53.50	-55.20	-13.00	42.20
	7 660.99	H	12.26	13.85	-53.91	-55.50	-13.00	42.50
	9 575.06	H	13.17	15.13	-50.24	-52.20	-13.00	39.20

Note.

1. ERP &amp; E.I.R.P(dB m)= Substitute Level(dB) + Antenna gain(dBi) – Cable Loss(dB)

Test mode : LTE Band 26Frequency(MHz) : 831.5Channel : 26865Bandwidth(MHz) : 15

Mode	Frequency	Pol.	Antenna Gain	Cable loss	Substitute Level	Level	Limit	Margin
	[MHz]	[V/H]	[dBi]	[dB]	[dBm]	[dBm]	[dBm]	[dB]
QPSK	1 663.39	H	6.11	5.22	-53.29	-52.40	-13.00	39.40
	2 494.78	H	5.40	6.53	-51.47	-52.60	-13.00	39.60
	3 326.17	V	8.19	8.44	-56.45	-56.70	-13.00	43.70
	4 157.57	H	8.47	9.74	-56.03	-57.30	-13.00	44.30

Test mode : LTE Band 26Frequency(MHz) : 836.5Channel : 26915Bandwidth(MHz) : 15

Mode	Frequency	Pol.	Antenna Gain	Cable loss	Substitute Level	Level	Limit	Margin
	[MHz]	[V/H]	[dBi]	[dB]	[dBm]	[dBm]	[dBm]	[dB]
QPSK	1 673.63	H	6.08	5.25	-53.13	-52.30	-13.00	39.30
	2 510.14	H	5.45	6.51	-48.54	-49.60	-13.00	36.60
	3 346.65	H	8.22	8.49	-54.83	-55.10	-13.00	42.10
	4 182.85	H	8.45	9.77	-55.88	-57.20	-13.00	44.20

Test mode : LTE Band 26Frequency(MHz) : 841.5Channel : 26965Bandwidth(MHz) : 15

Mode	Frequency	Pol.	Antenna Gain	Cable loss	Substitute Level	Level	Limit	Margin
	[MHz]	[V/H]	[dBi]	[dB]	[dBm]	[dBm]	[dBm]	[dB]
QPSK	1 696.35	H	6.01	5.30	-52.81	-52.10	-13.00	39.10
	2 547.90	V	5.63	6.58	-56.55	-57.50	-13.00	44.50
	3 396.90	V	8.28	8.63	-56.35	-56.70	-13.00	43.70
	4 245.89	H	8.40	9.87	-57.33	-58.80	-13.00	45.80

Note.

1. ERP &amp; E.I.R.P(dB m)= Substitute Level(dB) + Antenna gain(dBi) – Cable Loss(dB)

Test mode : LTE Band 41(PC2)Frequency(MHz) : 2 501.0Channel : 39700Bandwidth(MHz) : 10

Mode	Frequency	Pol.	Antenna Gain	Cable loss	Substitute Level	Level	Limit	Margin
	[MHz]	[V/H]	[dBi]	[dB]	[dBm]	[dBm]	[dBm]	[dB]
QPSK	5 012.48	V	10.21	10.86	-55.55	-56.20	-25.00	31.20
	7 516.38	V	12.12	13.98	-47.84	-49.70	-25.00	24.70
	10 024.48	V	13.00	15.20	-49.20	-51.40	-25.00	26.40
	12 526.58	V	13.21	17.04	-41.17	-45.00	-25.00	20.00

Test mode : LTE Band 41(PC2)Frequency(MHz) : 2 593.0Channel : 40620Bandwidth(MHz) : 10

Mode	Frequency	Pol.	Antenna Gain	Cable loss	Substitute Level	Level	Limit	Margin
	[MHz]	[V/H]	[dBi]	[dB]	[dBm]	[dBm]	[dBm]	[dB]
QPSK	5 186.49	H	10.31	11.39	-52.92	-54.00	-25.00	29.00
	7 779.19	H	12.38	13.93	-48.55	-50.10	-25.00	25.10
	10 372.49	V	13.00	15.55	-49.45	-52.00	-25.00	27.00
	12 965.20	V	13.39	17.75	-48.44	-52.80	-25.00	27.80

Test mode : LTE Band 41(PC2)Frequency(MHz) : 2 685.0Channel : 41540Bandwidth(MHz) : 10

Mode	Frequency	Pol.	Antenna Gain	Cable loss	Substitute Level	Level	Limit	Margin
	[MHz]	[V/H]	[dBi]	[dB]	[dBm]	[dBm]	[dBm]	[dB]
QPSK	5 370.70	H	10.42	11.62	-55.60	-56.80	-25.00	31.80
	8 055.20	H	12.66	14.70	-46.96	-49.00	-25.00	24.00
	10 740.31	H	13.05	15.91	-47.54	-50.40	-25.00	25.40
	13 425.42	V	14.08	17.68	-46.00	-49.60	-25.00	24.60

Note.

1. ERP &amp; E.I.R.P(dB m)= Substitute Level(dB) + Antenna gain(dBi) – Cable Loss(dB)



Test mode : LTE Band 41(PC3)Frequency(MHz) : 2 503.5Channel : 39725Bandwidth(MHz) : 15

Mode	Frequency	Pol.	Antenna Gain	Cable loss	Substitute Level	Level	Limit	Margin
	[MHz]	[V/H]	[dBi]	[dB]	[dBm]	[dBm]	[dBm]	[dB]
QPSK	5 022.08	H	10.21	9.74	-58.97	-58.50	-25.00	33.50
	7 533.18	V	12.13	11.80	-56.23	-55.90	-25.00	30.90
	10 044.88	H	13.00	13.56	-51.04	-51.60	-25.00	26.60
	12 555.98	V	13.22	15.46	-50.36	-52.60	-25.00	27.60

Test mode : LTE Band 41(PC3)Frequency(MHz) : 2 593.0Channel : 40620Bandwidth(MHz) : 15

Mode	Frequency	Pol.	Antenna Gain	Cable loss	Substitute Level	Level	Limit	Margin
	[MHz]	[V/H]	[dBi]	[dB]	[dBm]	[dBm]	[dBm]	[dB]
QPSK	5 201.49	V	10.32	9.93	-59.19	-58.80	-25.00	33.80
	7 801.99	H	12.40	12.03	-55.17	-54.80	-25.00	29.80
	10 402.50	H	13.00	13.89	-50.71	-51.60	-25.00	26.60
	13 002.40	V	13.40	15.82	-49.08	-51.50	-25.00	26.50

Test mode : LTE Band 41(PC3)Frequency(MHz) : 2 682.5Channel : 41515Bandwidth(MHz) : 15

Mode	Frequency	Pol.	Antenna Gain	Cable loss	Substitute Level	Level	Limit	Margin
	[MHz]	[V/H]	[dBi]	[dB]	[dBm]	[dBm]	[dBm]	[dB]
QPSK	5 365.90	V	10.42	10.12	-57.70	-57.40	-25.00	32.40
	8 048.00	V	12.65	11.94	-47.51	-46.80	-25.00	21.80
	10 730.71	V	13.05	14.10	-48.95	-50.00	-25.00	25.00
	13 412.82	V	14.06	15.85	-50.01	-51.80	-25.00	26.80

Note.

1. ERP &amp; E.I.R.P(dB m)= Substitute Level(dB) + Antenna gain(dBi) – Cable Loss(dB)

Test mode : LTE Band 41(PC3) IC Low ch.

Frequency(MHz) : 2 502.5

Channel : 39715

Bandwidth(MHz) : 5

Mode	Frequency	Pol.	Antenna Gain	Cable loss	Substitute Level	Level	Limit	Margin
	[MHz]	[V/H]	[dBi]	[dB]	[dBm]	[dBm]	[dBm]	[dB]
QPSK	5 010.68	H	10.21	10.85	-56.16	-56.80	-25.00	31.80
	7 515.18	H	12.12	13.98	-52.74	-54.60	-25.00	29.60
	10 020.88	V	13.00	15.19	-50.61	-52.80	-25.00	27.80
	12 525.38	V	13.21	17.04	-47.47	-51.30	-25.00	26.30

Note.

1. ERP & E.I.R.P(dB m)= Substitute Level(dB) + Antenna gain(dBi) – Cable Loss(dB)

# KCTL

Test mode : LTE Band 66/4Frequency(MHz) : 1 711.5Channel : 131987Bandwidth(MHz) : 3

Mode	Frequency	Pol.	Antenna Gain	Cable loss	Substitute Level	Level	Limit	Margin
	[MHz]	[V/H]	[dBi]	[dB]	[dBm]	[dBm]	[dBm]	[dB]
QPSK	3 426.02	V	8.31	7.80	-55.91	-55.40	-13.00	42.40
	5 139.09	H	10.28	9.85	-56.43	-56.00	-13.00	43.00
	6 852.15	V	11.15	11.47	-54.98	-55.30	-13.00	42.30
	8 565.82	H	13.11	12.52	-55.89	-55.30	-13.00	42.30

Test mode : LTE Band 66/4Frequency(MHz) : 1 745.0Channel : 132322Bandwidth(MHz) : 3

Mode	Frequency	Pol.	Antenna Gain	Cable loss	Substitute Level	Level	Limit	Margin
	[MHz]	[V/H]	[dBi]	[dB]	[dBm]	[dBm]	[dBm]	[dB]
QPSK	3 490.22	V	8.39	7.90	-56.69	-56.20	-13.00	43.20
	5 235.69	H	10.34	9.97	-48.87	-48.50	-13.00	35.50
	6 980.56	V	11.28	11.50	-55.78	-56.00	-13.00	43.00
	8 725.43	H	13.15	12.63	-53.62	-53.10	-13.00	40.10

Test mode : LTE Band 66/4Frequency(MHz) : 1 778.5Channel : 132657Bandwidth(MHz) : 3

Mode	Frequency	Pol.	Antenna Gain	Cable loss	Substitute Level	Level	Limit	Margin
	[MHz]	[V/H]	[dBi]	[dB]	[dBm]	[dBm]	[dBm]	[dB]
QPSK	3 561.02	H	8.42	7.78	-59.34	-58.70	-13.00	45.70
	5 338.89	H	10.40	10.09	-51.11	-50.80	-13.00	37.80
	7 120.37	H	11.49	11.44	-52.55	-52.50	-13.00	39.50
	8 900.64	V	13.18	12.72	-54.86	-54.40	-13.00	41.40

Note.

1. ERP &amp; E.I.R.P(dB m)= Substitute Level(dB) + Antenna gain(dBi) – Cable Loss(dB)

Test mode : LTE Band 71Frequency(MHz) : 665.5Channel : 133147Bandwidth(MHz) : 5

Mode	Frequency	Pol.	Antenna Gain	Cable loss	Substitute Level	Level	Limit	Margin
	[MHz]	[V/H]	[dBi]	[dB]	[dBm]	[dBm]	[dBm]	[dB]
QPSK	1 331.85	V	5.49	4.71	-61.08	-60.30	-13.00	47.30
	1 996.84	H	5.11	5.86	-43.55	-44.30	-13.00	31.30
	2 662.79	H	6.18	6.79	-57.79	-58.40	-13.00	45.40
	3 327.13	V	8.19	8.44	-57.05	-57.30	-13.00	44.30

Test mode : LTE Band 71Frequency(MHz) : 680.5Channel : 133297Bandwidth(MHz) : 5

Mode	Frequency	Pol.	Antenna Gain	Cable loss	Substitute Level	Level	Limit	Margin
	[MHz]	[V/H]	[dBi]	[dB]	[dBm]	[dBm]	[dBm]	[dB]
QPSK	1 361.29	V	5.68	4.83	-62.25	-61.40	-13.00	48.40
	2 042.28	V	5.13	5.91	-52.62	-53.40	-13.00	40.40
	2 722.63	H	6.47	6.82	-57.65	-58.00	-13.00	45.00
	3 402.98	H	8.28	8.65	-56.53	-56.90	-13.00	43.90

Test mode : LTE Band 71Frequency(MHz) : 695.5Channel : 133447Bandwidth(MHz) : 5

Mode	Frequency	Pol.	Antenna Gain	Cable loss	Substitute Level	Level	Limit	Margin
	[MHz]	[V/H]	[dBi]	[dB]	[dBm]	[dBm]	[dBm]	[dB]
QPSK	1 391.38	V	5.88	4.88	-59.10	-58.10	-13.00	45.10
	2 087.08	H	5.15	5.97	-52.28	-53.10	-13.00	40.10
	2 782.79	V	6.76	6.99	-57.47	-57.70	-13.00	44.70
	3 477.22	H	8.37	8.84	-56.23	-56.70	-13.00	43.70

Note.

1. ERP &amp; E.I.R.P(dB m)= Substitute Level(dB) + Antenna gain(dBi) – Cable Loss(dB)

**9. Measurement equipment**

Equipment Name	Manufacturer	Model No.	Serial No.	Next Cal. Date
Biconical VHF-UHF Broadband Antenna	SCHWARZBECK	VUBA9117	275	22.04.09
Bilog Antenna	Teseq GmbH	CBL 6143A	35039	21.05.21
Horn Antenna	ETS.lindgren	3117	00227509	21.09.23*
Horn Antenna	ETS.lindgren	3117	161225	21.05.12
Horn Antenna	ETS.lindgren	3116	00086632	21.02.17
Horn Antenna	ETS.lindgren	3116	00086635	21.05.12
High pass Filter	Wainwright Instruments GmbH	WHKX3.0/18G-12SS	44	21.01.21
High pass Filter	Wainwright Instruments GmbH	WHKX1.0/15G-10SS	14	21.01.21
Attenuator	Weinschel ENGINEERING	10	AJ1239	21.05.15
Broadband Amplifier	SONOMA INSTRUMENT	310N	185799	21.01.21
Amplifier	L-3 Narda-MITEQ	AFS5-00101800-25-S-5	2054570	21.05.22
Amplifier	L-3 Narda-MITEQ	JS44-18004000-33-8P	2000997	21.07.29*
Spectrum Analyzer	AGILENT	N9040B	MY57010132	21.07.29*
Spectrum Analyzer	R&S	FSV40	100988	21.01.03
Power Divider	AGILENT	11636B	54456	21.01.06
Signal Generator	R&S	SMB100A	176206	21.01.21
Wideband Radio Communication Tester	R&S	CMW500	132423	21.03.12
Wideband Radio Communication Tester	R&S	CMW500	141780	21.04.16
Antenna Mast	MATURO	EAS 1.5	042/8941211	N/A
Antenna Mast	MATURO	EAS 1.5	043/8941211	N/A
Turn Table	MATURO	TT 0.8 PF	041/8941211	N/A
Biconical VHF-UHF Broadband Antenna	SCHWARZBECK	VUBA9117	275	22.04.09
Bilog Antenna	Teseq GmbH	CBL 6143A	35039	21.05.21
Amplifier	L-3 Narda-MITEQ	JS44-18004000-33-8P	2000997	21.07.29*
Antenna Mast	MATURO	EAS 1.5	042/8941211	N/A
Antenna Mast	MATURO	EAS 1.5	043/8941211	N/A
Turn Table	MATURO	TT 0.8 PF	041/8941211	N/A

\* Tests related to this equipment were progressed after the calibration was completed.

**End of test report**