

FCC SAR Test Report

APPLICANT : Samsung Electronics Co., Ltd.
EQUIPMENT : Tablet PC
BRAND NAME : SAMSUNG
MODEL NAME : SM-T555C
FCC ID : A3LSMT555C
STANDARD : FCC 47 CFR Part 2 (2.1093)
ANSI/IEEE C95.1-1992
IEEE 1528-2003

We, SPORTON INTERNATIONAL (SHENZHEN) INC., would like to declare that the tested sample has been evaluated in accordance with the procedures and had been in compliance with the applicable technical standards.

The test results in this report apply exclusively to the tested model / sample. Without written approval of SPORTON INTERNATIONAL (SHENZHEN) INC., the test report shall not be reproduced except in full.

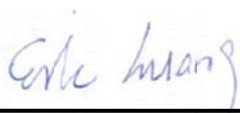

Reviewed by: Eric Huang / Deputy Manager

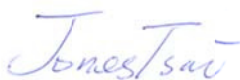

Approved by: Jones Tsai / Manager



SPORTON INTERNATIONAL (SHENZHEN) INC.
1F & 2F, Building A, Morning Business Center, No. 4003 ShiGu Rd., Xili Town,
Nanshan District, Shenzhen, Guangdong, P. R. China



Table of Contents

1. Statement of Compliance4

2. Administration Data5

3. Guidance Standard5

4. Equipment Under Test (EUT)6

 4.1 General Information6

 4.2 Maximum Tune-up Limit.....7

5. RF Exposure Limits8

 5.1 Uncontrolled Environment.....8

 5.2 Controlled Environment.....8

6. Specific Absorption Rate (SAR).....9

 6.1 Introduction9

 6.2 SAR Definition.....9

7. System Description and Setup10

8. Measurement Procedures11

 8.1 Spatial Peak SAR Evaluation.....11

 8.2 Power Reference Measurement.....12

 8.3 Area Scan12

 8.4 Zoom Scan.....13

 8.5 Volume Scan Procedures.....13

 8.6 Power Drift Monitoring.....13

9. Test Equipment List14

10. System Verification15

 10.1 Tissue Verification15

 10.2 System Performance Check Results.....16

11. RF Exposure Positions17

 11.1 SAR Testing for Body17

12. Conducted RF Output Power (Unit: dBm).....18

13. Antenna Location21

14. SAR Test Results23

 14.1 Body SAR24

 14.2 Repeated SAR Measurement25

15. Simultaneous Transmission Analysis.....26

 15.1 Body Exposure Conditions.....27

 15.2 SPLSR Evaluation and Analysis30

16. Uncertainty Assessment35

17. References38

Appendix A. Plots of System Performance Check

Appendix B. Plots of High SAR Measurement

Appendix C. DASy Calibration Certificate

Appendix D. SAR System Validation

Appendix E. Test Setup Photos

1. Statement of Compliance

The maximum results of Specific Absorption Rate (SAR) found during testing for **Samsung Electronics Co., Ltd., Tablet PC, SM-T555C**, are as follows.

Equipment Class	Frequency Band	Highest SAR Summary	
		Body 1g SAR (W/kg)	Highest Simultaneous Transmission Body 1g SAR (W/kg)
PCB	GSM850	0.52	1.56
	GSM1900	1.01	
	WCDMA Band V	0.88	
	WCDMA Band II	1.08	
	LTE Band 41	1.01	
DTS	WLAN 2.4GHz Band	0.83	1.39
DSS	Bluetooth	0.78	1.34
NII	WLAN 5.2GHz Band	1.09	1.56
	WLAN 5.3GHz Band	1.09	
	WLAN 5.8GHz Band	1.10	
Date of Testing		Apr. 08, 2015 ~ Apr. 11, 2015	

This device is in compliance with Specific Absorption Rate (SAR) for general population/uncontrolled exposure limits (1.6 W/kg) specified in FCC 47 CFR part 2 (2.1093) and ANSI/IEEE C95.1-1992, and had been tested in accordance with the measurement methods and procedures specified in IEEE 1528-2003.

Remark: SAR values for the WWAN operations are taken from test report FA531006 for FCC ID: A3LSMP555C. We did perform verification testing on FCC ID: SM-T555C to confirm that the SAR values reported for FCC ID: A3LSMP555C remain representative of FCC ID: SM-T555C demonstrates compliance for stand-alone SAR values for the WWAN operations.



2. Administration Data

Testing Laboratory	
Test Site	SPORTON INTERNATIONAL (SHENZHEN) INC.
Test Site Location	1F & 2F, Building A, Morning Business Center, No. 4003 ShiGu Rd., Xili Town, Nanshan District, Shenzhen, Guangdong, P. R. China TEL: +86-755-8637-9589 FAX: +86-755-8637-9595

Applicant	
Company Name	Samsung Electronics Co., Ltd.
Address	No.9 WeiWu Rd, Micro Electronic Industrial Park, Jingang Highway, Xiqing District, Tianjin, China

Manufacturer	
Company Name	Samsung Electronics Co., Ltd.
Address	No.9 WeiWu Rd, Micro Electronic Industrial Park, Jingang Highway, Xiqing District, Tianjin, China

3. Guidance Standard

The Specific Absorption Rate (SAR) testing specification, method, and procedure for this device is in accordance with the following standards:

- FCC 47 CFR Part 2 (2.1093)
- ANSI/IEEE C95.1-1992
- IEEE 1528-2003
- FCC KDB 865664 D01 SAR Measurement 100 MHz to 6 GHz v01r03
- FCC KDB 865664 D02 SAR Reporting v01r01
- FCC KDB 447498 D01 General RF Exposure Guidance v05r02
- FCC KDB 248227 D01 SAR meas for 802 11abg v01r02
- FCC KDB 616217 D04 SAR for laptop and tablets v01r01

4. Equipment Under Test (EUT)

4.1 General Information

Product Feature & Specification	
Equipment Name	Tablet PC
Brand Name	SAMSUNG
Model Name	SM-T555C
FCC ID	A3LSMT555C
IMEI Code	354377050006976
Wireless Technology and Frequency Range	GSM850: 824.2 MHz ~ 848.8 MHz GSM1900: 1850.2 MHz ~ 1909.8 MHz WCDMA Band V: 826.4 MHz ~ 846.6 MHz WCDMA Band II: 1852.4 MHz ~ 1907.6 MHz LTE Band 41: 2557.5 MHz ~ 2652.5 MHz WLAN 2.4GHz Band: 2412 MHz ~ 2462 MHz WLAN 5.2GHz Band: 5180 MHz ~ 5240 MHz WLAN 5.3GHz Band: 5260 MHz ~ 5320 MHz WLAN 5.8GHz Band: 5745 MHz ~ 5805 MHz Bluetooth: 2402 MHz ~ 2480 MHz ANT+: 2402 MHz ~ 2480 MHz
Mode	<ul style="list-style-type: none"> • GSM/GPRS/EGPRS • RMC/AMR 12.2Kbps • HSDPA • HSUPA • DC-HSDPA • LTE • WLAN 2.4GHz 802.11b/g/n HT20 • WLAN 5GHz 802.11a/n HT20/HT40 • Bluetooth v3.0 + EDR, Bluetooth v4.0 LE • ANT+: 2402 MHz ~ 2480 MHz
HW Version	REV1.0
SW Version	T555C.001
GSM / (E)GPRS Transfer mode	Class B – EUT cannot support Packet Switched and Circuit Switched Network simultaneously but can automatically switch between Packet and Circuit Switched Network.
EUT Stage	Identical Prototype
Remark:	
<ol style="list-style-type: none"> 1. 802.11n-HT40 is not supported in 2.4GHz WLAN. 2. This device 2.4GHz WLAN supports hotspot operation, 5.8GHz WLAN supports WiFi Direct (GC/GO), and 5.2GHz / 5.3GHz supports WiFi Direct (GC only). 3. The HSPA+ does not support 16QAM uplink. 4. This device supports GRPS/EGPRS mode up to multi-slot class33 and does not support DTM operation. 5. The voice is only limited to speakerphone mode and it does not supported near to the ear voice mode during normal using. 	



4.2 Maximum Tune-up Limit

Mode		Average Power (dBm)		
2.4GHz	802.11b	13.0		
	802.11g	12.5		
	802.11n-HT20	13.0		
5GHz	802.11a	5.2GHz	10.5	
		5.3GHz	9.0	
		5.8GHz	7.5	
	802.11n-HT20	5.2GHz	10.5	
		5.3GHz	9.0	
		5.8GHz	8.0	
	802.11n-HT40	5.2GHz	11.0	
		5.3GHz	9.5	
		5.8GHz	Channel 151	8.5
			Channel 159	8.0
Bluetooth v3.0 + EDR		11.5		
Bluetooth v4.0 LE		3.0		

5. RF Exposure Limits

5.1 Uncontrolled Environment

Uncontrolled Environments are defined as locations where there is the exposure of individuals who have no knowledge or control of their exposure. The general population/uncontrolled exposure limits are applicable to situations in which the general public may be exposed or in which persons who are exposed as a consequence of their employment may not be made fully aware of the potential for exposure or cannot exercise control over their exposure. Members of the general public would come under this category when exposure is not employment-related; for example, in the case of a wireless transmitter that exposes persons in its vicinity.

5.2 Controlled Environment

Controlled Environments are defined as locations where there is exposure that may be incurred by persons who are aware of the potential for exposure, (i.e. as a result of employment or occupation). In general, occupational/controlled exposure limits are applicable to situations in which persons are exposed as a consequence of their employment, who have been made fully aware of the potential for exposure and can exercise control over their exposure. The exposure category is also applicable when the exposure is of a transient nature due to incidental passage through a location where the exposure levels may be higher than the general population/uncontrolled limits, but the exposed person is fully aware of the potential for exposure and can exercise control over his or her exposure by leaving the area or by some other appropriate means.

Limits for Occupational/Controlled Exposure (W/kg)

Whole-Body	Partial-Body	Hands, Wrists, Feet and Ankles
0.4	8.0	20.0

Limits for General Population/Uncontrolled Exposure (W/kg)

Whole-Body	Partial-Body	Hands, Wrists, Feet and Ankles
0.08	1.6	4.0

Whole-Body SAR is averaged over the entire body, partial-body SAR is averaged over any 1gram of tissue defined as a tissue volume in the shape of a cube. SAR for hands, wrists, feet and ankles is averaged over any 10 grams of tissue defined as a tissue volume in the shape of a cube.

6. Specific Absorption Rate (SAR)

6.1 Introduction

SAR is related to the rate at which energy is absorbed per unit mass in an object exposed to a radio field. The SAR distribution in a biological body is complicated and is usually carried out by experimental techniques or numerical modeling. The standard recommends limits for two tiers of groups, occupational/controlled and general population/uncontrolled, based on a person's awareness and ability to exercise control over his or her exposure. In general, occupational/controlled exposure limits are higher than the limits for general population/uncontrolled.

6.2 SAR Definition

The SAR definition is the time derivative (rate) of the incremental energy (dW) absorbed by (dissipated in) an incremental mass (dm) contained in a volume element (dv) of a given density (ρ). The equation description is as below:

$$SAR = \frac{d}{dt} \left(\frac{dW}{dm} \right) = \frac{d}{dt} \left(\frac{dW}{\rho dv} \right)$$

SAR is expressed in units of Watts per kilogram (W/kg)

$$SAR = \frac{\sigma |E|^2}{\rho}$$

Where: σ is the conductivity of the tissue, ρ is the mass density of the tissue and E is the RMS electrical field strength.

7. System Description and Setup

The DASY system used for performing compliance tests consists of the following items:

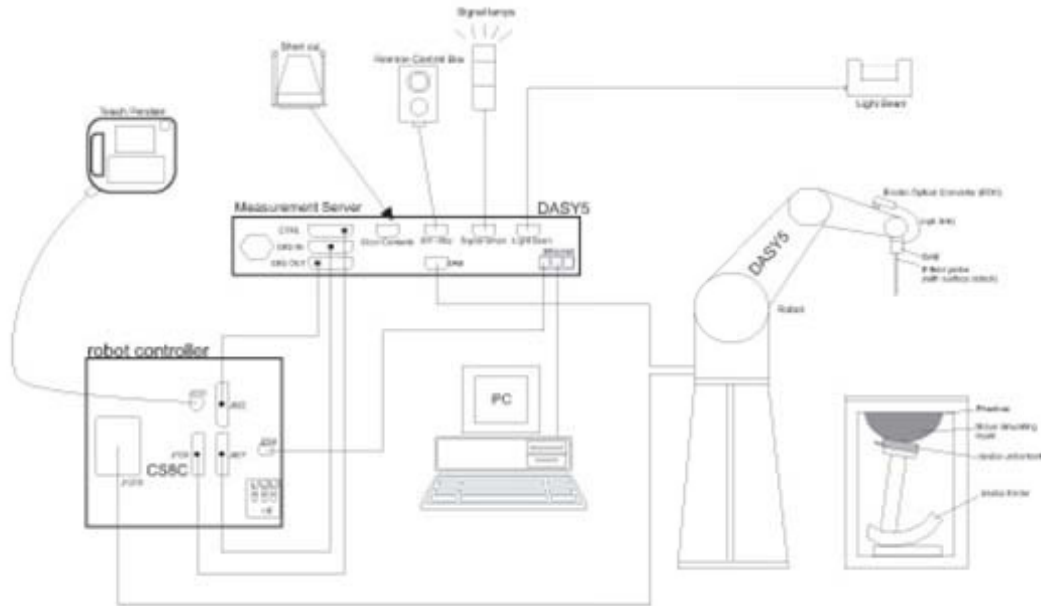

<SAM Twin Phantom>

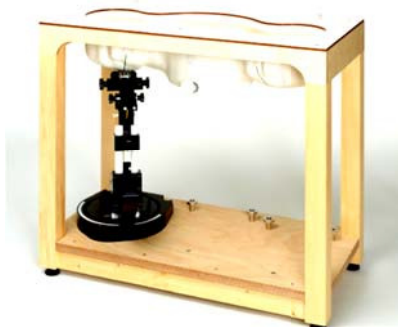
<p>Shell Thickness</p>	<p>2 ± 0.2 mm; Center ear point: 6 ± 0.2 mm</p>	 <p>Photo of SAM Phantom</p>
-------------------------------	---	--

- A standard high precision 6-axis robot with controller, teach pendant and software. An arm extension for accommodating the data acquisition electronics (DAE).
- An isotropic Field probe optimized and calibrated for the targeted measurement.
- A data acquisition electronics (DAE) which performs the signal amplification, signal multiplexing, AD-conversion, offset measurements, mechanical surface detection, collision detection, etc. The unit is battery powered with standard or rechargeable batteries. The signal is optically transmitted to the EOC.
- The Electro-optical converter (EOC) performs the conversion from optical to electrical signals for the digital communication to the DAE. To use optical surface detection, a special version of the EOC is required. The EOC signal is transmitted to the measurement server.
- The function of the measurement server is to perform the time critical tasks such as signal filtering, control of the robot operation and fast movement interrupts.
- The Light Beam used is for probe alignment. This improves the (absolute) accuracy of the probe positioning.
- A computer running WinXP or Win7 and the DASY5 software.
- Remote control and teach pendant as well as additional circuitry for robot safety such as warning lamps, etc.
- The phantom, the device holder and other accessories according to the targeted measurement.

8. Measurement Procedures

The measurement procedures are as follows:

<Conducted power measurement>

- (a) For WLAN/BT power measurement, use engineering software to configure EUT WLAN/BT continuously transmission, at maximum RF power in each supported wireless interface and frequency band
- (b) Connect EUT RF port through RF cable to the power meter, and measure WLAN/BT output power

<SAR measurement>

- (a) Engineering software to configure EUT WLAN/BT continuously transmission, at maximum RF power, in the highest power channel.
- (b) Place the EUT in the positions as Appendix D demonstrates.
- (c) Set scan area, grid size and other setting on the DASY software.
- (d) Measure SAR results for the highest power channel on each testing position.
- (e) Find out the largest SAR result on these testing positions of each band
- (f) Measure SAR results for other channels in worst SAR testing position if the reported SAR of highest power channel is larger than 0.8 W/kg

According to the test standard, the recommended procedure for assessing the peak spatial-average SAR value consists of the following steps:

- (a) Power reference measurement
- (b) Area scan
- (c) Zoom scan
- (d) Power drift measurement

8.1 Spatial Peak SAR Evaluation

The procedure for spatial peak SAR evaluation has been implemented according to the test standard. It can be conducted for 1g and 10g, as well as for user-specific masses. The DASY software includes all numerical procedures necessary to evaluate the spatial peak SAR value.

The base for the evaluation is a "cube" measurement. The measured volume must include the 1g and 10g cubes with the highest averaged SAR values. For that purpose, the center of the measured volume is aligned to the interpolated peak SAR value of a previously performed area scan.

The entire evaluation of the spatial peak values is performed within the post-processing engine (SEMCAD). The system always gives the maximum values for the 1g and 10g cubes. The algorithm to find the cube with highest averaged SAR is divided into the following stages:

- (a) Extraction of the measured data (grid and values) from the Zoom Scan
- (b) Calculation of the SAR value at every measurement point based on all stored data (A/D values and measurement parameters)
- (c) Generation of a high-resolution mesh within the measured volume
- (d) Interpolation of all measured values from the measurement grid to the high-resolution grid
- (e) Extrapolation of the entire 3-D field distribution to the phantom surface over the distance from sensor to surface
- (f) Calculation of the averaged SAR within masses of 1g and 10g

8.2 Power Reference Measurement

The Power Reference Measurement and Power Drift Measurements are for monitoring the power drift of the device under test in the batch process. The minimum distance of probe sensors to surface determines the closest measurement point to phantom surface. This distance cannot be smaller than the distance of sensor calibration points to probe tip as defined in the probe properties.

8.3 Area Scan

The area scan is used as a fast scan in two dimensions to find the area of high field values, before doing a fine measurement around the hot spot. The sophisticated interpolation routines implemented in DASY software can find the maximum found in the scanned area, within a range of the global maximum. The range (in dB) is specified in the standards for compliance testing. For example, a 2 dB range is required in IEEE standard 1528 and IEC 62209 standards, whereby 3 dB is a requirement when compliance is assessed in accordance with the ARIB standard (Japan), if only one zoom scan follows the area scan, then only the absolute maximum will be taken as reference. For cases where multiple maximums are detected, the number of zoom scans has to be increased accordingly.

Area scan parameters extracted from FCC KDB 865664 D01v01r03 SAR measurement 100 MHz to 6 GHz.

	≤ 3 GHz	> 3 GHz
Maximum distance from closest measurement point (geometric center of probe sensors) to phantom surface	5 ± 1 mm	$\frac{1}{2} \cdot \delta \cdot \ln(2) \pm 0.5$ mm
Maximum probe angle from probe axis to phantom surface normal at the measurement location	$30^\circ \pm 1^\circ$	$20^\circ \pm 1^\circ$
Maximum area scan spatial resolution: $\Delta x_{Area}, \Delta y_{Area}$	≤ 2 GHz: ≤ 15 mm $2 - 3$ GHz: ≤ 12 mm	$3 - 4$ GHz: ≤ 12 mm $4 - 6$ GHz: ≤ 10 mm
	When the x or y dimension of the test device, in the measurement plane orientation, is smaller than the above, the measurement resolution must be \leq the corresponding x or y dimension of the test device with at least one measurement point on the test device.	

8.4 Zoom Scan

Zoom scans are used assess the peak spatial SAR values within a cubic averaging volume containing 1 gram and 10 gram of simulated tissue. The zoom scan measures points (refer to table below) within a cube shoes base faces are centered on the maxima found in a preceding area scan job within the same procedure. When the measurement is done, the zoom scan evaluates the averaged SAR for 1 gram and 10 gram and displays these values next to the job's label.

Zoom scan parameters extracted from FCC KDB 865664 D01v01r03 SAR measurement 100 MHz to 6 GHz.

		≤ 3 GHz	> 3 GHz	
Maximum zoom scan spatial resolution: $\Delta x_{Zoom}, \Delta y_{Zoom}$		≤ 2 GHz: ≤ 8 mm 2 – 3 GHz: ≤ 5 mm*	3 – 4 GHz: ≤ 5 mm* 4 – 6 GHz: ≤ 4 mm*	
Maximum zoom scan spatial resolution, normal to phantom surface	uniform grid: $\Delta z_{Zoom}(n)$	≤ 5 mm	3 – 4 GHz: ≤ 4 mm 4 – 5 GHz: ≤ 3 mm 5 – 6 GHz: ≤ 2 mm	
	graded grid	$\Delta z_{Zoom}(1)$: between 1 st two points closest to phantom surface	≤ 4 mm	3 – 4 GHz: ≤ 3 mm 4 – 5 GHz: ≤ 2.5 mm 5 – 6 GHz: ≤ 2 mm
		$\Delta z_{Zoom}(n>1)$: between subsequent points	$\leq 1.5 \cdot \Delta z_{Zoom}(n-1)$	
Minimum zoom scan volume	x, y, z	≥ 30 mm	3 – 4 GHz: ≥ 28 mm 4 – 5 GHz: ≥ 25 mm 5 – 6 GHz: ≥ 22 mm	
Note: δ is the penetration depth of a plane-wave at normal incidence to the tissue medium; see draft standard IEEE P1528-2011 for details. * When zoom scan is required and the <i>reported</i> SAR from the <i>area scan based 1-g SAR estimation</i> procedures of KDB 447498 is ≤ 1.4 W/kg, ≤ 8 mm, ≤ 7 mm and ≤ 5 mm zoom scan resolution may be applied, respectively, for 2 GHz to 3 GHz, 3 GHz to 4 GHz and 4 GHz to 6 GHz.				

8.5 Volume Scan Procedures

The volume scan is used for assess overlapping SAR distributions for antennas transmitting in different frequency bands. It is equivalent to an oversized zoom scan used in standalone measurements. The measurement volume will be used to enclose all the simultaneous transmitting antennas. For antennas transmitting simultaneously in different frequency bands, the volume scan is measured separately in each frequency band. In order to sum correctly to compute the 1g aggregate SAR, the EUT remain in the same test position for all measurements and all volume scan use the same spatial resolution and grid spacing. When all volume scan were completed, the software, SEMCAD postprocessor can combine and subsequently superpose these measurement data to calculating the multiband SAR.

8.6 Power Drift Monitoring

All SAR testing is under the EUT install full charged battery and transmit maximum output power. In DASY measurement software, the power reference measurement and power drift measurement procedures are used for monitoring the power drift of EUT during SAR test. Both these procedures measure the field at a specified reference position before and after the SAR testing. The software will calculate the field difference in dB. If the power drifts more than 5%, the SAR will be retested.



9. Test Equipment List

Manufacturer	Name of Equipment	Type/Model	Serial Number	Calibration	
				Last Cal.	Due Date
SPEAG	2450MHz System Validation Kit	D2450V2	840	Nov. 19, 2014	Nov. 18, 2015
SPEAG	5000MHz System Validation Kit	D5GHzV2	1113	Nov. 24, 2014	Nov. 23, 2015
SPEAG	Data Acquisition Electronics	DAE4	1303	Dec. 11, 2014	Dec. 10, 2015
SPEAG	Dosimetric E-Field Probe	EX3DV4	3819	Nov. 13, 2014	Nov. 12, 2015
SPEAG	ELI4 Phantom	QD OVA 002 AA	TP-1149	NCR	NCR
SPEAG	Phone Positioner	N/A	N/A	NCR	NCR
Agilent	Wireless Communication Test Set	E5515C	MY50267224	Sep. 29, 2014	Sep. 28, 2015
R&S	Network Analyzer	ZVB8	100106	Sep. 29, 2014	Sep. 28, 2015
SPEAG	Dielectric Assessment KIT	DAK-3.5	1032	NCR	NCR
R&S	Signal Generator	SMBV100A	258305	Jan. 23, 2015	Jan. 22, 2016
mini-circuits	Amplifier	ZVE-3W-83+	162601250	NCR	NCR
Anritsu	Power Sensor	MA2411B	1207253	Jan. 28, 2015	Jan. 27, 2016
Anritsu	Power Meter	ML2495A	1218010	Jan. 28, 2015	Jan. 27, 2016
ARRA	Power Divider	A3200-2	N/A	NA	NA
R&S	CBT BLUETOOTH TESTER	CBT	100783	Aug. 11, 2014	Aug. 10, 2015
R&S	Spectrum Analyzer	FSP30	101362	Sep. 29, 2014	Sep. 28, 2015
Agilent	Dual Directional Coupler	778D	50422	Note1	
Woken	Attenuator 1	WK0602-XX	N/A	Note1	
PE	Attenuator 2	PE7005-10	N/A	Note1	
PE	Attenuator 3	PE7005- 3	N/A	Note1	
AR	Power Amplifier	5S1G4M2	0328767	Note1	
Mini-Circuits	Power Amplifier	ZVE-3W	162601250	Note1	
Mini-Circuits	Power Amplifier	ZHL-42W+	13440021344	Note1	

General Note:

1. Prior to system verification and validation, the path loss from the signal generator to the system check source and the power meter, which includes the amplifier, cable, attenuator and directional coupler, was measured by the network analyzer. The reading of the power meter was offset by the path loss difference between the path to the power meter and the path to the system check source to monitor the actual power level fed to the system check source.

10. System Verification

10.1 Tissue Verification

For the measurement of the field distribution inside the SAM phantom with DASY, the phantom must be filled with around 25 liters of homogeneous body tissue simulating liquid. For head SAR testing, the liquid height from the ear reference point (ERP) of the phantom to the liquid top surface is larger than 15 cm; For body SAR testing, the liquid height from the center of the flat phantom to the liquid top surface is larger than 15 cm, which are show as followings.



Photo of Liquid Height for Head SAR



Photo of Liquid Height for Body SAR

The following tissue formulations are provided for reference only as some of the parameters have not been thoroughly verified. The composition of ingredients may be modified accordingly to achieve the desired target tissue parameters required for routine SAR evaluation.

Frequency (MHz)	Water (%)	Sugar (%)	Cellulose (%)	Salt (%)	Preventol (%)	DGBE (%)	Conductivity (σ)	Permittivity (ϵ_r)
For Body								
2450	68.6	0	0	0	0	31.4	1.95	52.7

Simulating Liquid for 5GHz, Manufactured by SPEAG

Ingredients	(% by weight)
Water	64~78%
Mineral oil	11~18%
Emulsifiers	9~15%
Additives and Salt	2~3%

<Tissue Dielectric Parameter Check Results>

Frequency (MHz)	Tissue Type	Liquid Temp. (°C)	Conductivity (σ)	Permittivity (ϵ_r)	Conductivity Target (σ)	Permittivity Target (ϵ_r)	Delta (σ) (%)	Delta (ϵ_r) (%)	Limit (%)	Date
2450	Body	22.6	1.992	52.319	1.95	52.70	2.15	-0.72	±5	Apr. 08, 2015
2450	Body	22.8	1.991	52.291	1.95	52.70	2.10	-0.78	±5	Apr. 11, 2015
5200	Body	22.6	5.243	49.431	5.30	49.00	-1.08	0.88	±5	Apr. 11, 2015
5300	Body	22.7	5.382	49.270	5.42	48.90	-0.70	0.76	±5	Apr. 11, 2015
5800	Body	22.8	6.111	48.187	6.00	48.20	1.85	-0.03	±5	Apr. 11, 2015

10.2 System Performance Check Results

Comparing to the original SAR value provided by SPEAG, the verification data should be within its specification of 10 %. Below table shows the target SAR and measured SAR after normalized to 1W input power. The table below indicates the system performance check can meet the variation criterion and the plots can be referred to Appendix A of this report.

Date	Frequency (MHz)	Tissue Type	Input Power (mW)	Dipole S/N	Probe S/N	DAE S/N	Measured SAR (W/kg)	Targeted SAR (W/kg)	Normalized SAR (W/kg)	Deviation (%)
Apr. 08, 2015	2450	Body	250	D2450V2-840	3819	1303	12.70	51.00	50.8	-0.39
Apr. 11, 2015	2450	Body	250	D2450V2-840	3819	1303	12.90	51.00	51.6	1.18
Apr. 11, 2015	5200	Body	100	D5GHzV2-1113	3819	1303	8.08	74.90	80.8	7.88
Apr. 11, 2015	5300	Body	100	D5GHzV2-1113	3819	1303	8.35	77.80	83.5	7.33
Apr. 11, 2015	5800	Body	100	D5GHzV2-1113	3819	1303	7.79	75.40	77.9	3.32

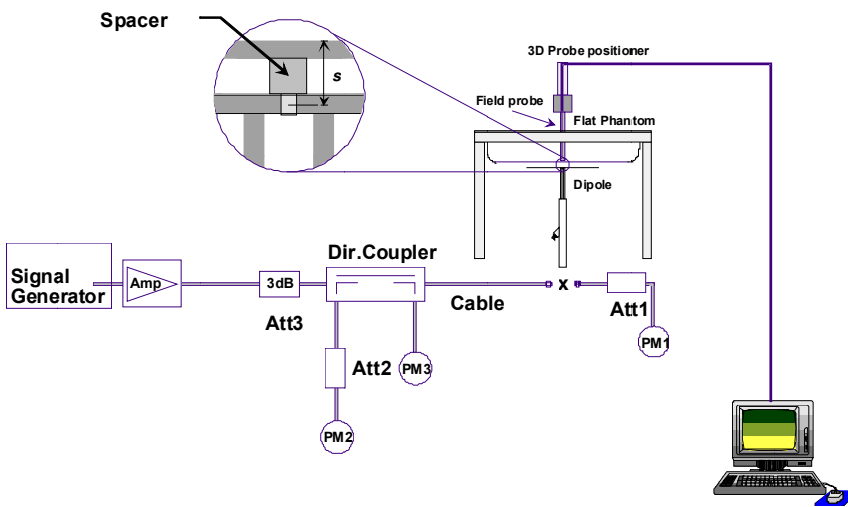

Fig 8.3.1 System Performance Check Setup



Fig 8.3.2 Setup Photo



11. RF Exposure Positions

11.1 SAR Testing for Body

This device can be used also in full sized tablet exposure conditions, due to its size. Per FCC KDB 616217, the back surface and edges of the tablet should be tested for SAR compliance with the tablet touching the phantom. The SAR exclusion threshold in KDB 447498 D01v05r02 can be applied to determine SAR test exclusion for adjacent edge configurations. The closest distance from the antenna to an adjacent tablet edge is used to determine if SAR testing is required for the adjacent edges, with the adjacent edge positioned against the phantom and the edge containing the antenna positioned perpendicular to the phantom.



12. Conducted RF Output Power (Unit: dBm)

<2.4GHz Bluetooth>

General Note:

- 1. Base on the same tune-up limit, for 2.4GHz Bluetooth SAR was selected v3.0 1Mbps to perform testing.
- 2. The duty factor is selected theoretical 83.3% perform Bluetooth SAR testing.

Bluetooth Burst Average Power (dBm)_DH5				
Channel	Frequency (MHz)	v3.0+EDR		
		1Mbps	2Mbps	3Mbps
CH 00	2402	10.84	9.11	9.10
CH 39	2441	10.99	9.36	9.37
CH 78	2480	10.08	8.40	8.43

Channel	Frequency (MHz)	Bluetooth Burst Average power (dBm)
		v4.0 LE
CH 00	2402	2.21
CH 19	2440	2.50
CH 39	2480	1.66

<WLAN Conducted Power>

General Note:

1. For 2.4GHz WLAN SAR testing, highest average RF output power channel for the lowest data rate for 802.11b were selected for SAR evaluation. 802.11g/n HT20 were not investigated since the average output powers over all channels and data rates were not more than 0.25 dB higher than the tested channel in the lowest data rate of 802.11b mode.
2. For 5 GHz WLAN SAR testing, highest average RF output power channel for the lowest data rate for 802.11a were selected for SAR evaluation. 802.11n HT20 mode was not investigated since the average output powers over all channels and data rates were not more than 0.25 dB higher than the tested channel in the lowest data rate of 802.11a mode.
3. For 5 GHz WLAN SAR testing, 802.11n HT40 average output power is higher than 1/4dB higher than 802.11a mode, these modes SAR will be verified at the highest RF exposure position found in 802.11a SAR testing.

<2.4GHz WLAN>

WLAN 2.4GHz 802.11b Average Power (dBm)						
Power vs. Channel			Power vs. Data Rate			
Channel	Frequency (MHz)	Data Rate 1Mbps	Channel	2Mbps	5.5Mbps	11Mbps
CH 01	2412	11.73	CH 11	12.75	12.77	12.75
CH 06	2437	12.17				
CH 11	2462	12.79				

WLAN 2.4GHz 802.11g Average Power (dBm)										
Power vs. Channel			Power vs. Data Rate							
Channel	Frequency (MHz)	Data Rate 6Mbps	Channel	9Mbps	12Mbps	18Mbps	24Mbps	36Mbps	48Mbps	54Mbps
CH 01	2412	11.98	CH 01	11.91	11.80	11.87	11.82	11.95	11.94	11.91
CH 06	2437	11.92								
CH 11	2462	11.86								

WLAN 2.4GHz 802.11n HT20 Average Power (dBm)										
Power vs. Channel			Power vs. MCS Index							
Channel	Frequency (MHz)	MCS Index MCS0	Channel	MCS1	MCS2	MCS3	MCS4	MCS5	MCS6	MCS7
CH 01	2412	12.15	CH 01	12.12	12.00	11.87	12.06	12.07	12.08	12.10
CH 06	2437	11.89								
CH 11	2462	11.78								



<5GHz WLAN>

WLAN 5GHz 802.11a Average Power (dBm)										
Power vs. Channel			Power vs. Data Rate							
Channel	Frequency (MHz)	Data Rate 6Mbps	Channel	9Mbps	12Mbps	18Mbps	24Mbps	36Mbps	48Mbps	54Mbps
CH 36	5180	9.66	CH 48	9.73	9.67	9.66	9.66	9.74	9.80	9.78
CH 40	5200	9.65								
CH 44	5220	9.78								
CH 48	5240	9.95								
CH 52	5260	8.00	CH 64	8.39	8.34	8.30	8.27	8.26	8.47	8.44
CH 56	5280	8.23								
CH 60	5300	8.49								
CH 64	5320	8.51								
CH 149	5745	7.17	CH 161	7.21	7.17	7.19	7.13	7.18	7.19	7.10
CH 153	5765	7.06								
CH 157	5785	7.12								
CH 161	5805	7.27								

WLAN 5GHz 802.11n HT20 Average Power (dBm)										
Power vs. Channel			Power vs. Data Rate							
Channel	Frequency (MHz)	Data Rate MCS0	Channel	MCS1	MCS2	MCS3	MCS4	MCS5	MCS6	MCS7
CH 36	5180	9.75	CH 48	9.96	10.01	10.01	9.95	9.94	10.03	9.94
CH 40	5200	9.78								
CH 44	5220	9.88								
CH 48	5240	10.05								
CH 52	5260	8.09	CH 64	8.51	8.55	8.53	8.52	8.50	8.56	8.53
CH 56	5280	8.32								
CH 60	5300	8.57								
CH 64	5320	8.59								
CH 149	5745	7.26	CH 161	7.33	7.31	7.29	7.32	7.26	7.23	7.20
CH 153	5765	7.18								
CH 157	5785	7.23								
CH 161	5805	7.34								

WLAN 5GHz 802.11n HT40 Average Power (dBm)										
Power vs. Channel			Power vs. Data Rate							
Channel	Frequency (MHz)	Data Rate MCS0	Channel	MCS1	MCS2	MCS3	MCS4	MCS5	MCS6	MCS7
CH 38	5190	10.23	CH 46	10.36	10.40	10.42	10.45	10.42	10.49	10.34
CH 46	5230	10.52								
CH 54	5270	8.70	CH 62	9.06	9.02	9.05	9.06	9.01	9.04	9.03
CH 62	5310	9.11								
CH 151	5755	8.00	CH 151	7.95	7.91	7.87	7.88	7.80	7.85	7.86
CH 159	5795	7.77								

13. Antenna Location

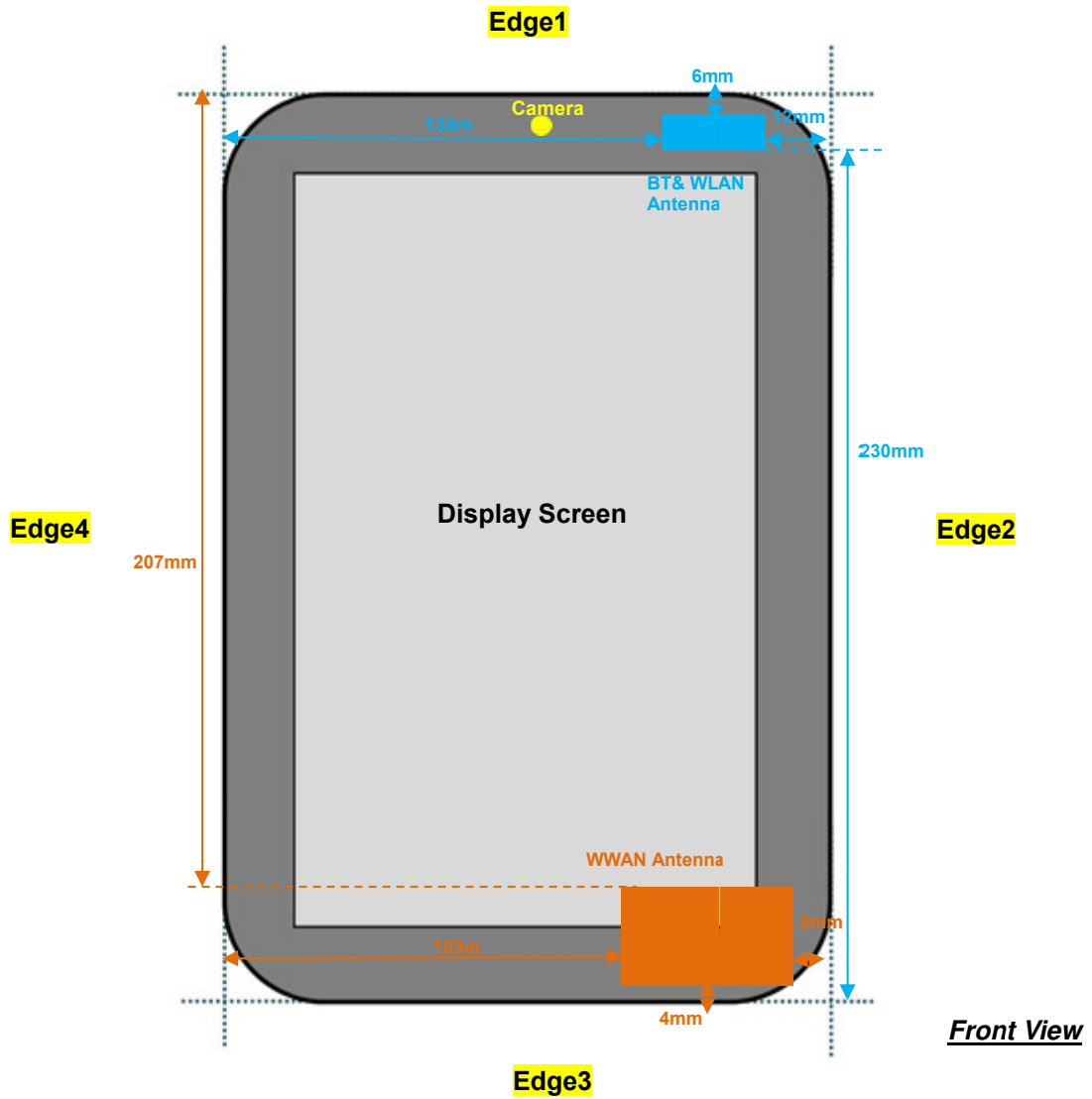

Diagonal Dimension: 286mm



General Note:

1. The below table, when the distance is < 50 mm exclusion threshold is "Ratio", when the distance is > 50 mm exclusion threshold is "mW"
2. Maximum power is the source-based time-average power and represents the maximum RF output power among production units
3. Per KDB 447498 D01v05r02, for larger devices, the test separation distance of adjacent edge configuration is determined by the closest separation between the antenna and the user.
4. Per KDB 447498 D01v05r02, standalone SAR test exclusion threshold is applied; If the test separation distance is < 5mm, 5mm is used to determine SAR exclusion threshold.
5. Per KDB 447498 D01v05r02, the 1-g and 10-g SAR test exclusion thresholds for 100 MHz to 6 GHz at *test separation distances* ≤ 50 mm are determined by:
 - [(max. power of channel, including tune-up tolerance, mW)/(min. test separation distance, mm)] · [√f(GHz)] ≤ 3.0 for 1-g SAR and ≤ 7.5 for 10-g extremity SAR
 - f(GHz) is the RF channel transmit frequency in GHz
 - Power and distance are rounded to the nearest mW and mm before calculation
 - The result is rounded to one decimal place for comparison
6. Per KDB 447498 D01v05r02, at 100 MHz to 6 GHz and for *test separation distances* > 50 mm, the SAR test exclusion threshold is determined according to the following
 - a) [Threshold at 50 mm in step 1) + (test separation distance - 50 mm) · (f(MHz)/150)] mW, at 100 MHz to 1500 MHz
 - b) [Threshold at 50 mm in step 1) + (test separation distance - 50 mm) · 10] mW at > 1500 MHz and ≤ 6 GHz

SAR test exclusion table distance is ≤ 50mm

Exposure Position	Wireless Interface	WLAN 2.4GHz 802.11b	BT 2.4GHz	WLAN 5.2GHz 802.11a
		Calculated Frequency (MHz)	2462	2480
	Tune-up Maximum power (dBm)	13.0	11.5	11.0
Bottom Face	Antenna to user (mm)	0		
	SAR exclusion threshold	6.3	4.4	6.3
	SAR testing required?	Yes	Yes	Yes
Edge 1	Antenna to user (mm)	6		
	SAR exclusion threshold	5.2	3.7	5.2
	SAR testing required?	Yes	Yes	Yes
Edge 2	Antenna to user (mm)	12		
	SAR exclusion threshold	2.6	1.8	2.6
	SAR testing required?	No	No	No

SAR test exclusion table distance is >50mm

Exposure Position	Wireless Interface	WLAN 2.4GHz 802.11b	BT 2.4GHz	WLAN 5.2GHz 802.11a
		Calculated Frequency (MHz)	2462	2480
	Tune-up Maximum power (dBm)	13.0	11.5	11.0
	Tune-up Maximum rated power (mW)	20	14	13
Edge 3	Antenna to user (mm)	230		
	SAR exclusion threshold	1896.0	1896.0	1862.0
	SAR testing required?	No	No	No
Edge 4	Antenna to user (mm)	138		
	SAR exclusion threshold	976.0	976.0	942.0
	SAR testing required?	No	No	No

14. SAR Test Results

General Note:

1. Per KDB 447498 D01v05r02, the reported SAR is the measured SAR value adjusted for maximum tune-up tolerance.
 - a. Tune-up scaling Factor = tune-up limit power (mW) / EUT RF power (mW), where tune-up limit is the maximum rated power among all production units.
 - b. Reported SAR(W/kg)= Measured SAR(W/kg)*Tune-up Scaling Factor
2. Per KDB 447498 D01v05r02, for each exposure position, testing of other required channels within the operating mode of a frequency band is not required when the *reported* 1-g or 10-g SAR for the mid-band or highest output power channel is:
 - ≤ 0.8 W/kg or 2.0 W/kg, for 1-g or 10-g respectively, when the transmission band is ≤ 100 MHz
 - ≤ 0.6 W/kg or 1.5 W/kg, for 1-g or 10-g respectively, when the transmission band is between 100 MHz and 200 MHz
 - ≤ 0.4 W/kg or 1.0 W/kg, for 1-g or 10-g respectively, when the transmission band is ≥ 200 MHz
3. This device 2.4GHz WLAN supports hotspot operation, and 5.8GHz WLAN supports WiFi Direct (Group Client / Group Owner), and 5.2GHz / 5.3GHz supports WiFi Direct (Group Client only).



14.1 Body SAR

<DTS WLAN SAR>

Plot No.	Band	Mode	Test Position	Gap (cm)	Ch.	Freq. (MHz)	Average Power (dBm)	Tune-Up Limit (dBm)	Tune-up Scaling Factor	Power Drift (dB)	Measured 1g SAR (W/kg)	Reported 1g SAR (W/kg)
01	WLAN 2.4GHz	802.11b 1Mbps	Bottom Face	0	11	2462	12.79	13.00	1.050	0.01	0.786	0.825
	WLAN 2.4GHz	802.11b 1Mbps	Edge 1	0	11	2462	12.79	13.00	1.050	0.03	0.092	0.097
	WLAN 2.4GHz	802.11b 1Mbps	Bottom Face	0	1	2412	11.73	13.00	1.340	-0.02	0.404	0.541
	WLAN 2.4GHz	802.11b 1Mbps	Bottom Face	0	6	2437	12.17	13.00	1.211	0.04	0.553	0.669

<DSS Bluetooth SAR>

Plot No.	Band	Mode	Test Position	Gap (cm)	Ch.	Freq. (MHz)	Average Power (dBm)	Tune-Up Limit (dBm)	Tune-up Scaling Factor	Power Drift (dB)	Measured 1g SAR (W/kg)	Reported 1g SAR (W/kg)
02	Bluetooth v3.0+EDR	1Mbps	Bottom Face	0	39	2441	10.99	11.50	1.124	-0.08	0.694	0.780
	Bluetooth v3.0+EDR	1Mbps	Edge 1	0	39	2441	10.99	11.50	1.124	-0.07	0.059	0.066

<NII WLAN SAR>

Plot No.	Band	Mode	Test Position	Gap (cm)	Ch.	Freq. (MHz)	Average Power (dBm)	Tune-Up Limit (dBm)	Tune-up Scaling Factor	Power Drift (dB)	Measured 1g SAR (W/kg)	Reported 1g SAR (W/kg)
	WLAN 5.2GHz	802.11a 6Mbps	Bottom Face	0	48	5240	9.95	10.50	1.135	-0.09	0.889	1.009
	WLAN 5.2GHz	802.11a 6Mbps	Edge 1	0	48	5240	9.95	10.50	1.135	0.04	0.411	0.466
03	WLAN 5.2GHz	802.11a 6Mbps	Bottom Face	0	36	5180	9.66	10.50	1.213	-0.04	0.902	1.094
	WLAN 5.2GHz	802.11n-HT40 MCS0	Bottom Face	0	46	5230	10.52	11.00	1.117	-0.02	0.971	1.084
	WLAN 5.2GHz	802.11n-HT40 MCS0	Bottom Face	0	38	5190	10.23	11.00	1.195	-0.07	0.892	1.066
	WLAN 5.3GHz	802.11a 6Mbps	Bottom Face	0	64	5320	8.51	9.00	1.119	-0.07	0.944	1.057
	WLAN 5.3GHz	802.11a 6Mbps	Edge 1	0	64	5320	8.51	9.00	1.119	0.06	0.382	0.428
	WLAN 5.3GHz	802.11a 6Mbps	Bottom Face	0	56	5280	8.23	9.00	1.194	-0.05	0.748	0.893
04	WLAN 5.3GHz	802.11n-HT40 MCS0	Bottom Face	0	62	5310	9.11	9.50	1.094	0.05	1.000	1.094
	WLAN 5.3GHz	802.11n-HT40 MCS0	Bottom Face	0	54	5270	8.70	9.50	1.204	-0.05	0.907	1.092
	WLAN 5.8GHz	802.11a 6Mbps	Bottom Face	0	161	5805	7.27	7.50	1.054	0.09	0.960	1.012
	WLAN 5.8GHz	802.11a 6Mbps	Edge 1	0	161	5805	7.27	7.50	1.054	-0.07	0.272	0.287
	WLAN 5.8GHz	802.11a 6Mbps	Bottom Face	0	149	5745	7.17	7.50	1.079	-0.01	1.01	1.090
	WLAN 5.8GHz	802.11n-HT40 MCS0	Bottom Face	0	151	5755	8.00	8.50	1.122	-0.05	0.948	1.064
05	WLAN 5.8GHz	802.11n-HT40 MCS0	Bottom Face	0	159	5795	7.77	8.00	1.054	0.02	1.040	1.097

14.2 Repeated SAR Measurement

No.	Band	Mode	Test Position	Gap	Ch.	Freq. (MHz)	Average Power (dBm)	Tune-Up Limit (dBm)	Scaling Factor	Power Drift (dB)	Measured 1g SAR (W/kg)	Ratio	Reported 1g SAR (W/kg)
1st	WLAN 5.2GHz	802.11n-HT40 MCS0	Bottom Face	0	46	5230	10.52	11.00	1.117	-0.02	0.971	1	1.084
2nd	WLAN 5.2GHz	802.11n-HT40 MCS0	Bottom Face	0	46	5230	10.52	11.00	1.117	-0.01	0.96	1.011	1.072
1st	WLAN 5.3GHz	802.11n-HT40 MCS0	Bottom Face	0	62	5310	9.11	9.50	1.094	0.05	1	1	1.094
2nd	WLAN 5.3GHz	802.11n-HT40 MCS0	Bottom Face	0	62	5310	9.11	9.50	1.094	0.02	0.965	1.036	1.056
1st	WLAN 5.8GHz	802.11n-HT40 MCS0	Bottom Face	0	159	5795	7.77	8.00	1.054	0.02	1.04	1	1.097
2nd	WLAN 5.8GHz	802.11n-HT40 MCS0	Bottom Face	0	159	5795	7.77	8.00	1.054	0.1	1.03	1.010	1.086

General Note:

1. Per KDB 865664 D01v01r03, for each frequency band, repeated SAR measurement is required only when the measured SAR is ≥ 0.8 W/kg
2. Per KDB 865664 D01v01r03, if the ratio among the repeated measurement is ≤ 1.2 and the measured SAR < 1.45 W/kg, only one repeated measurement is required.
3. The ratio is the difference in percentage between original and repeated *measured SAR*.
4. All measurement SAR result is scaled-up to account for tune-up tolerance and is compliant.

15. Simultaneous Transmission Analysis

NO.	Simultaneous Transmission Configurations	Body
1.	GPRS/EDGE(data) + WLAN 2.4GHz(data)	Yes
2.	WCDMA(data) + WLAN 2.4GHz(data)	Yes
3.	LTE(data) + WLAN2.4GHz(data)	Yes
4.	GPRS/EDGE(data) + Bluetooth(data)	Yes
5.	WCDMA(data) + Bluetooth(data)	Yes
6.	LTE(data) + Bluetooth(data)	Yes
7.	GPRS/EDGE(data) + WLAN 5GHz(data)	Yes
8.	WCDMA(data) + WLAN 5GHz(data)	Yes
9.	LTE(data) + WLAN5 GHz(data)	Yes

General Note:

1. EUT will choose each GSM, WCDMA and LTE according to the network signal condition; therefore, they will not operate simultaneously at any moment.
2. EUT will choose either WLAN 2.4GHz or WLAN 5GHz according to the network signal condition; therefore, 2.4GHz WLAN and 5GHz WLAN will not operate simultaneously at any moment.
3. WLAN and Bluetooth share the same antenna, and cannot transmit simultaneously.
4. This device 2.4GHz WLAN supports hotspot operation, 5.8GHz WLAN supports WiFi Direct (GC/GO), and 5.2GHz / 5.3GHz supports WiFi Direct (GC only).
5. The worst case 5 GHz WLAN reported SAR for each configuration was used for SAR summation, therefore, the following summations represent the absolute worst cases for simultaneous transmission with 5 GHz WLAN.
6. For simultaneous transmission analysis for exposure position of bottom face 1.5cm, WLAN/Bluetooth SAR tested at 0mm separation is worse and the test data is used for conservative SAR summation.
7. SAR values for the WWAN operations are taken from test report FA531006 for FCC ID: A3LSMP555C. We did perform verification testing on FCC ID: SM-T555C to confirm that the SAR values reported for FCC ID: A3LSMP555C remain representative of FCC ID: SM-T555C demonstrate compliance for stand-alone SAR values for the WWAN operations and can also be used in the evaluation for simultaneous transmission
8. The reported SAR summation is calculated based on the same configuration and test position.
9. Per KDB 447498 D01v05r02, simultaneous transmission SAR is compliant if,
 - i) Scalar SAR summation < 1.6W/kg.
 - ii) $SPLSR = (SAR_1 + SAR_2)^{1.5} / (min. \text{ separation distance, mm})$, and the peak separation distance is determined from the square root of $[(x_1-x_2)^2 + (y_1-y_2)^2 + (z_1-z_2)^2]$, where (x_1, y_1, z_1) and (x_2, y_2, z_2) are the coordinates of the extrapolated peak SAR locations in the zoom scan.
 - iii) If $SPLSR \leq 0.04$, simultaneously transmission SAR measurement is not necessary.
 - iv) Simultaneously transmission SAR measurement, and the reported multi-band SAR < 1.6W/kg.
 - v) The SPLSR calculated results please refer to section 15.2.

15.1 Body Exposure Conditions

<WWAN PCB + WLAN DTS>

WWAN Band		Exposure Position	WWAN PCB Max. WWAN SAR (W/kg)	WLAN DTS Max. WLAN SAR (W/kg)	Summed SAR (W/kg)	SPLSR	Case No
GSM	GSM850	Bottom Face at 1.5 cm	0.281	0.825	1.11		
		Edge 3 at 0.5 cm	0.284		0.28		
		Bottom Face at 0cm	0.424	0.825	1.25		
		Edge1 at 0cm		0.097	0.10		
		Edge2 at 0cm	0.515		0.52		
		Edge3 at 0cm	0.161		0.16		
	GSM1900	Bottom Face at 1.5 cm	0.421	0.825	1.25		
		Edge 3 at 0.5 cm	0.569		0.57		
		Bottom Face at 0cm	1.007	0.825	1.83	0.01	#1
		Edge1 at 0cm		0.097	0.10		
		Edge2 at 0cm	0.895		0.90		
		Edge3 at 0cm	0.219		0.22		
WCDMA	Band V	Bottom Face at 1.5 cm	0.238	0.825	1.06		
		Edge 3 at 0.5 cm	0.204		0.20		
		Bottom Face at 0cm	0.875	0.825	1.70	0.01	#2
		Edge1 at 0cm		0.097	0.10		
		Edge2 at 0cm	0.461		0.46		
		Edge3 at 0cm	0.240		0.24		
	Band II	Bottom Face at 1.5 cm	0.463	0.825	1.29		
		Edge 3 at 0.5 cm	0.588		0.59		
		Bottom Face at 0cm	0.564	0.825	1.39		
		Edge1 at 0cm		0.097	0.10		
		Edge2 at 0cm	1.081		1.08		
		Edge3 at 0cm	0.104		0.10		
LTE	Band 41	Bottom Face at 1.5 cm	0.417	0.825	1.24		
		Edge 3 at 0.5 cm	0.478		0.48		
		Bottom Face at 0cm	1.010	0.825	1.84	0.01	#3
		Edge1 at 0cm		0.097	0.10		
		Edge2 at 0cm	0.086		0.09		
		Edge3 at 0cm	0.266		0.27		



<WWAN PCB + Bluetooth DSS>

WWAN Band		Exposure Position	WWAN PCB	WLAN DSS	Summed SAR (W/kg)	SPLSR	Case No
			Max. WWAN SAR (W/kg)	Max. WLAN SAR (W/kg)			
GSM	GSM850	Bottom Face at 1.5 cm	0.281	0.780	1.06		
		Edge 3 at 0.5 cm	0.284		0.28		
		Bottom Face at 0cm	0.424	0.780	1.20		
		Edge1 at 0cm		0.066	0.07		
		Edge2 at 0cm	0.515		0.52		
		Edge3 at 0cm	0.161		0.16		
	GSM1900	Bottom Face at 1.5 cm	0.421	0.780	1.20		
		Edge 3 at 0.5 cm	0.569		0.57		
		Bottom Face at 0cm	1.007	0.780	1.79	0.01	#4
		Edge1 at 0cm		0.066	0.07		
		Edge2 at 0cm	0.895		0.90		
		Edge3 at 0cm	0.219		0.22		
WCDMA	Band V	Bottom Face at 1.5 cm	0.238	0.780	1.02		
		Edge 3 at 0.5 cm	0.204		0.20		
		Bottom Face at 0cm	0.875	0.780	1.66	0.01	#5
		Edge1 at 0cm		0.066	0.07		
		Edge2 at 0cm	0.461		0.46		
		Edge3 at 0cm	0.240		0.24		
	Band II	Bottom Face at 1.5 cm	0.463	0.780	1.24		
		Edge 3 at 0.5 cm	0.588		0.59		
		Bottom Face at 0cm	0.564	0.780	1.34		
		Edge1 at 0cm		0.066	0.07		
		Edge2 at 0cm	1.081		1.08		
		Edge3 at 0cm	0.104		0.10		
LTE	Band 41	Bottom Face at 1.5 cm	0.417	0.780	1.20		
		Edge 3 at 0.5 cm	0.478		0.48		
		Bottom Face at 0cm	1.010	0.780	1.79	0.01	#6
		Edge1 at 0cm		0.066	0.07		
		Edge2 at 0cm	0.086		0.09		
		Edge3 at 0cm	0.266		0.27		

<WWAN PCB + WLAN NII>

WWAN Band		Exposure Position	WWAN PCB	WLAN DTS	Summed SAR (W/kg)	SPLSR	Case No
			Max. WWAN SAR (W/kg)	Max. WLAN SAR (W/kg)			
GSM	GSM850	Bottom Face at 1.5 cm	0.281	1.097	1.38		
		Edge 3 at 0.5 cm	0.284		0.28		
		Bottom Face at 0cm	0.424	1.097	1.52		
		Edge1 at 0cm		0.466	0.47		
		Edge2 at 0cm	0.515		0.52		
		Edge3 at 0cm	0.161		0.16		
	GSM1900	Bottom Face at 1.5 cm	0.421	1.097	1.52		
		Edge 3 at 0.5 cm	0.569		0.57		
		Bottom Face at 0cm	1.007	1.097	2.10	0.01	#7
		Edge1 at 0cm		0.466	0.47		
		Edge2 at 0cm	0.895		0.90		
		Edge3 at 0cm	0.219		0.22		
WCDMA	Band V	Bottom Face at 1.5 cm	0.238	1.097	1.34		
		Edge 3 at 0.5 cm	0.204		0.20		
		Bottom Face at 0cm	0.875	1.097	1.97	0.01	#8
		Edge1 at 0cm		0.466	0.47		
		Edge2 at 0cm	0.461		0.46		
		Edge3 at 0cm	0.240		0.24		
	Band II	Bottom Face at 1.5 cm	0.463	1.097	1.56		
		Edge 3 at 0.5 cm	0.588		0.59		
		Bottom Face at 0cm	0.564	1.097	1.66	0.01	#9
		Edge1 at 0cm		0.466	0.47		
		Edge2 at 0cm	1.081		1.08		
		Edge3 at 0cm	0.104		0.10		
LTE	Band 41	Bottom Face at 1.5 cm	0.417	1.097	1.51		
		Edge 3 at 0.5 cm	0.478		0.48		
		Bottom Face at 0cm	1.010	1.097	2.11	0.01	#10
		Edge1 at 0cm		0.466	0.47		
		Edge2 at 0cm	0.086		0.09		
		Edge3 at 0cm	0.266		0.27		

15.2 SPLSR Evaluation and Analysis

General Note: $SPLSR = (SAR_1 + SAR_2)^{1.5} / (min. \text{ separation distance, mm})$. If $SPLSR \leq 0.04$, simultaneously transmission SAR measurement is not necessary.

Case No #1	Band	SAR (W/kg)	Gap (cm)	SAR peak location (m)			3D distance (mm)	Pair SAR sum (W/kg)	SPLSR	Simultaneous SAR
				X	Y	Z				
Bottom Face	GSM1900	1.007	0	-0.06	-0.109	-0.181	221.5	1.83	0.01	Not required
	WLAN2.4GHz	0.825	0	-0.0746	0.112	-0.181				

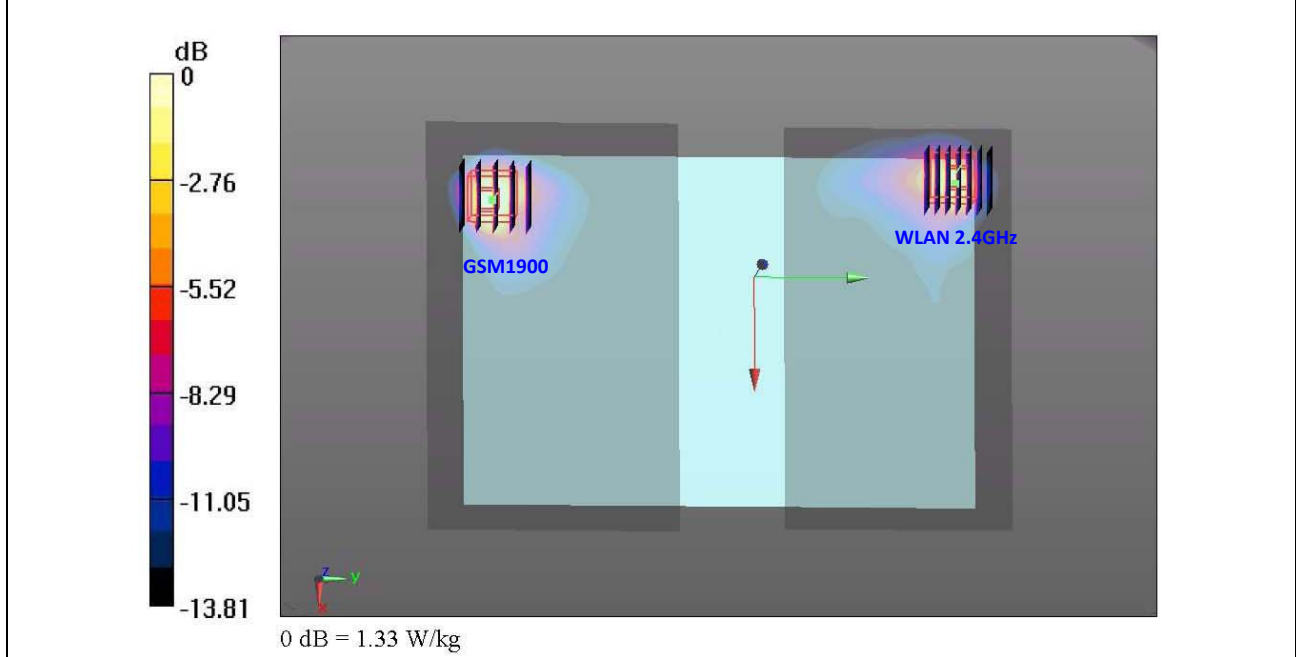

Case No #2	Band	SAR (W/kg)	Gap (cm)	SAR peak location (m)			3D distance (mm)	Pair SAR sum (W/kg)	SPLSR	Simultaneous SAR
				X	Y	Z				
Bottom Face	WCDMA Band V	0.875	0	-0.057	-0.106	-0.182	218.7	1.70	0.01	Not required
	WLAN 2.4GHz	0.825	0	-0.0746	0.112	-0.181				

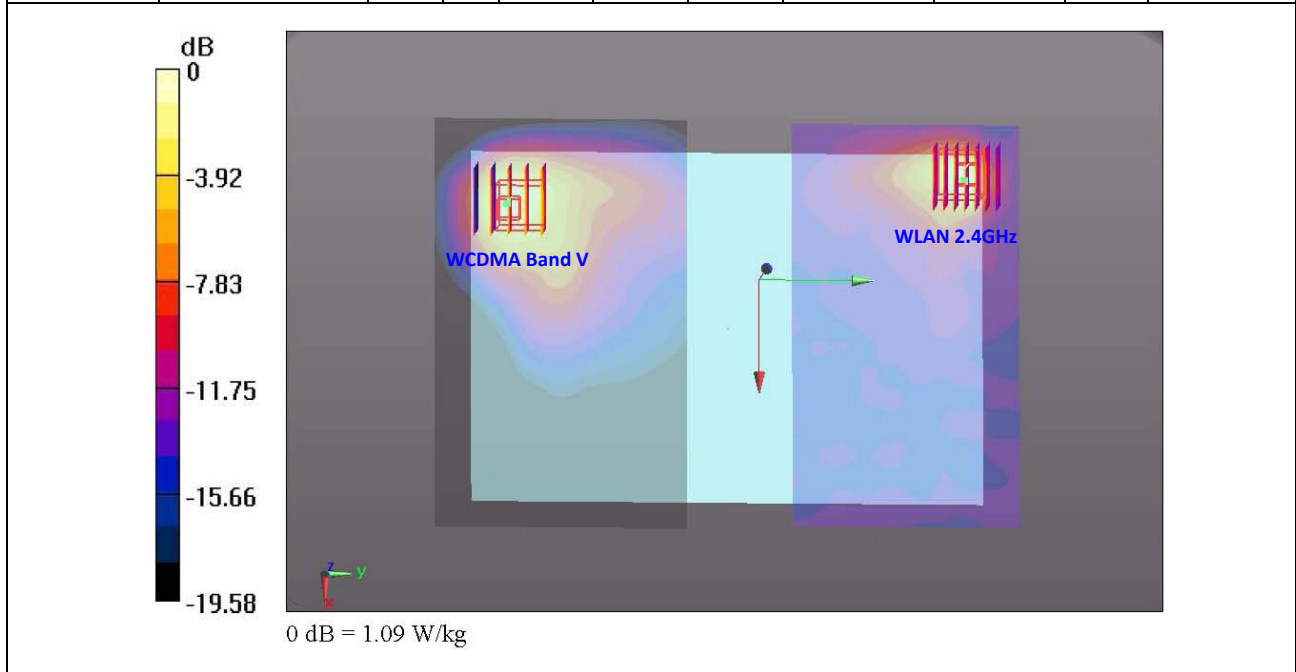

Case No #3	Band	SAR (W/kg)	Gap (cm)	SAR peak location (m)			3D distance (mm)	Pair SAR sum (W/kg)	SPLSR	Simultaneous SAR
				X	Y	Z				
Bottom Face	LTE Band 41	1.010	0	-0.0574	-0.113	-0.181	225.7	1.84	0.01	Not required
	WLAN2.4GHz	0.825	0	-0.0746	0.112	-0.181				

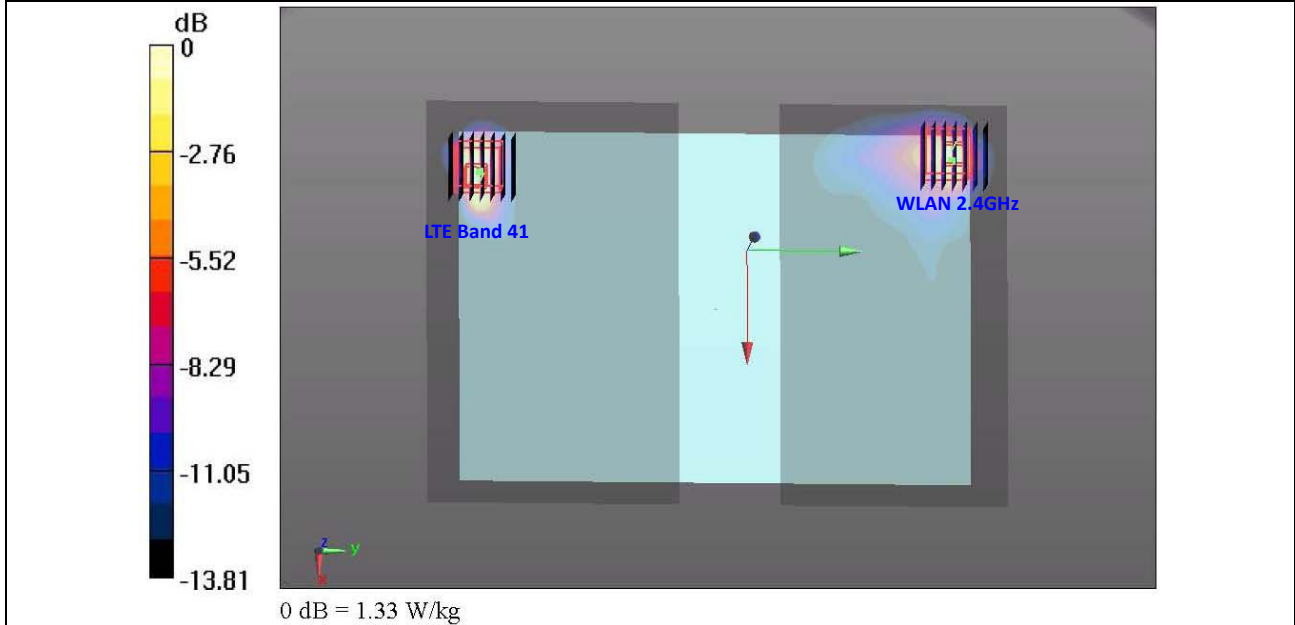

Case No #4	Band	SAR (W/kg)	Gap (cm)	SAR peak location (m)			3D distance (mm)	Pair SAR sum (W/kg)	SPLSR	Simultaneous SAR
				X	Y	Z				
Bottom Face	GSM1900	1.007	0	-0.06	-0.109	-0.181	218.3	1.79	0.01	Not required
	Bluetooth	0.780	0	-0.0722	0.109	-0.181				

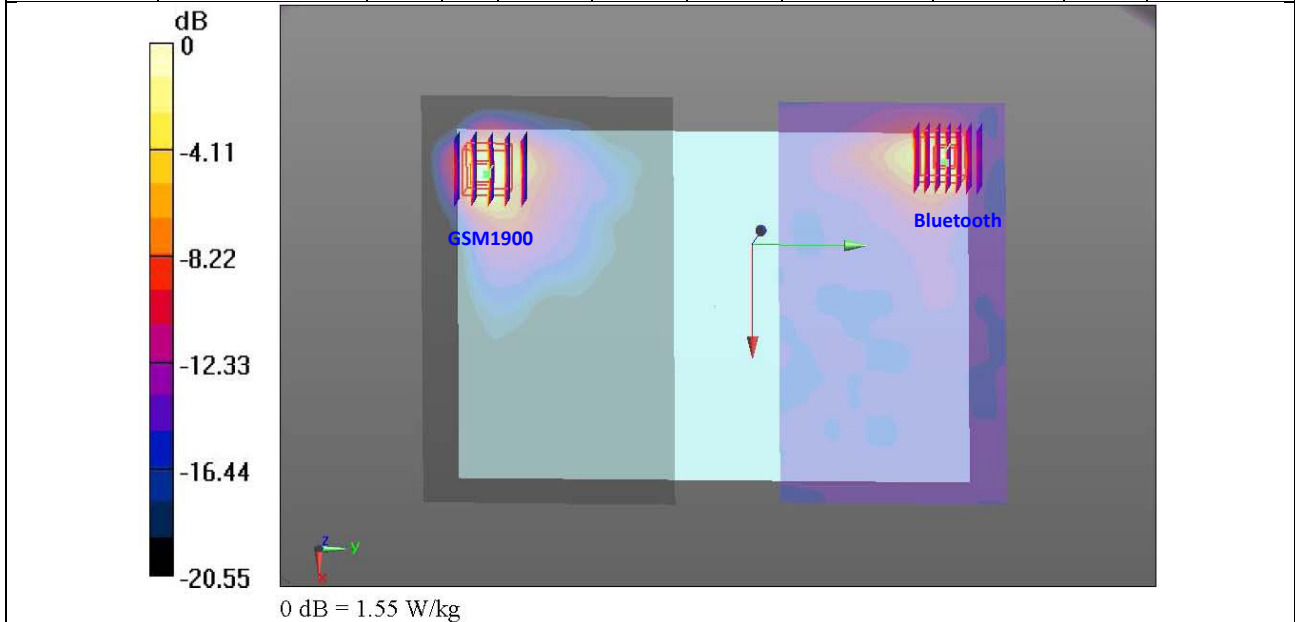

Case No #5	Band	SAR (W/kg)	Gap (cm)	SAR peak location (m)			3D distance (mm)	Pair SAR sum (W/kg)	SPLSR	Simultaneous SAR
				X	Y	Z				
Bottom Face	WCDMA Band V	0.875	0	-0.057	-0.106	-0.182	215.5	1.66	0.01	Not required
	Bluetooth	0.780	0	-0.0722	0.109	-0.181				

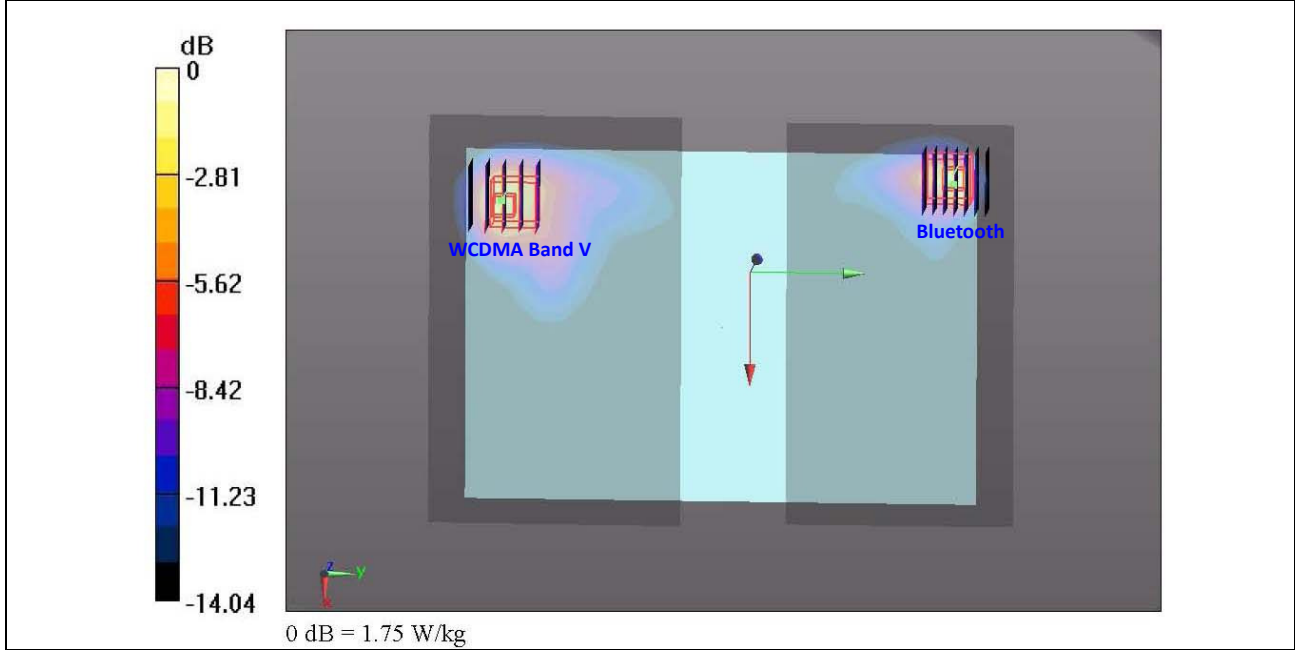

Case No #6	Band	SAR (W/kg)	Gap (cm)	SAR peak location (m)			3D distance (mm)	Pair SAR sum (W/kg)	SPLSR	Simultaneous SAR
				X	Y	Z				
Bottom Face	LTE Band 41	1.010	0	-0.0574	-0.113	-0.181	222.5	1.79	0.01	Not required
	Bluetooth	0.780	0	-0.0722	0.109	-0.181				

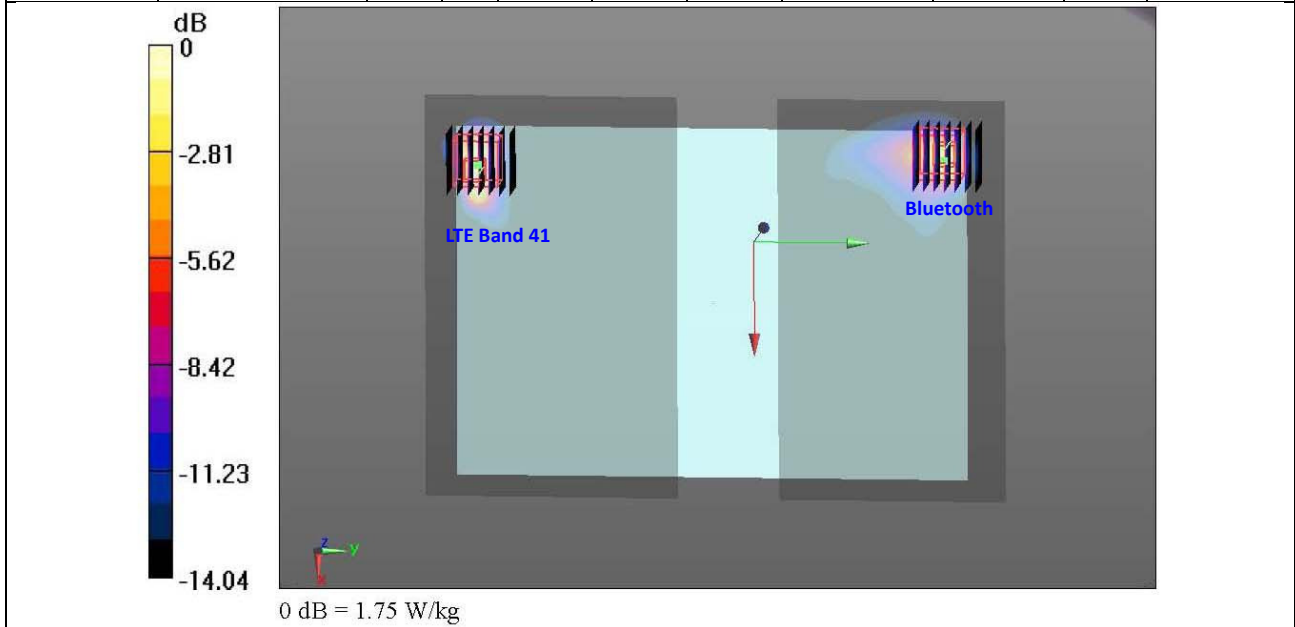

Case No #7	Band	SAR (W/kg)	Gap (cm)	SAR peak location (m)			3D distance (mm)	Pair SAR sum (W/kg)	SPLSR	Simultaneous SAR
				X	Y	Z				
Bottom Face	GSM1900	1.007	0	-0.06	-0.109	-0.181	220.1	2.10	0.01	Not required
	WLAN 5GHz	1.097	0	-0.068	0.111	-0.182				

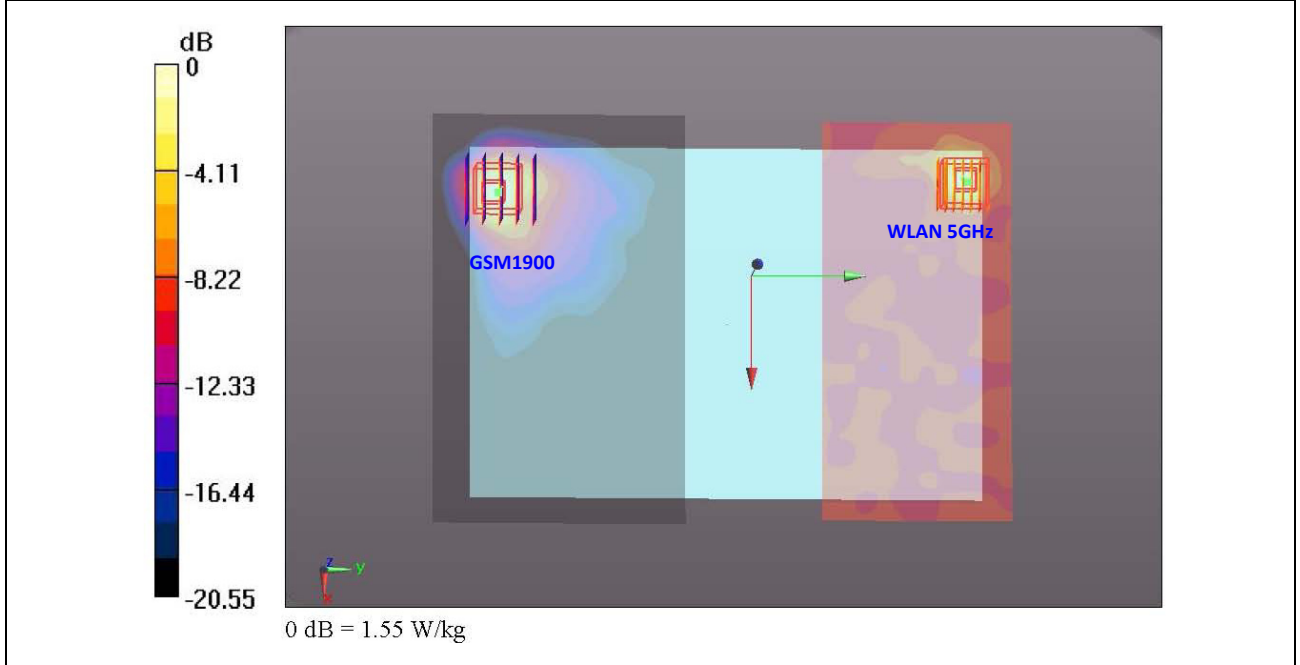

Case No #8	Band	SAR (W/kg)	Gap (cm)	SAR peak location (m)			3D distance (mm)	Pair SAR sum (W/kg)	SPLSR	Simultaneous SAR
				X	Y	Z				
Bottom Face	WCDMA Band V	0.875	0	-0.057	-0.106	-0.182	217.3	1.97	0.01	Not required
	WLAN 5GHz	1.097	0	-0.068	0.111	-0.182				

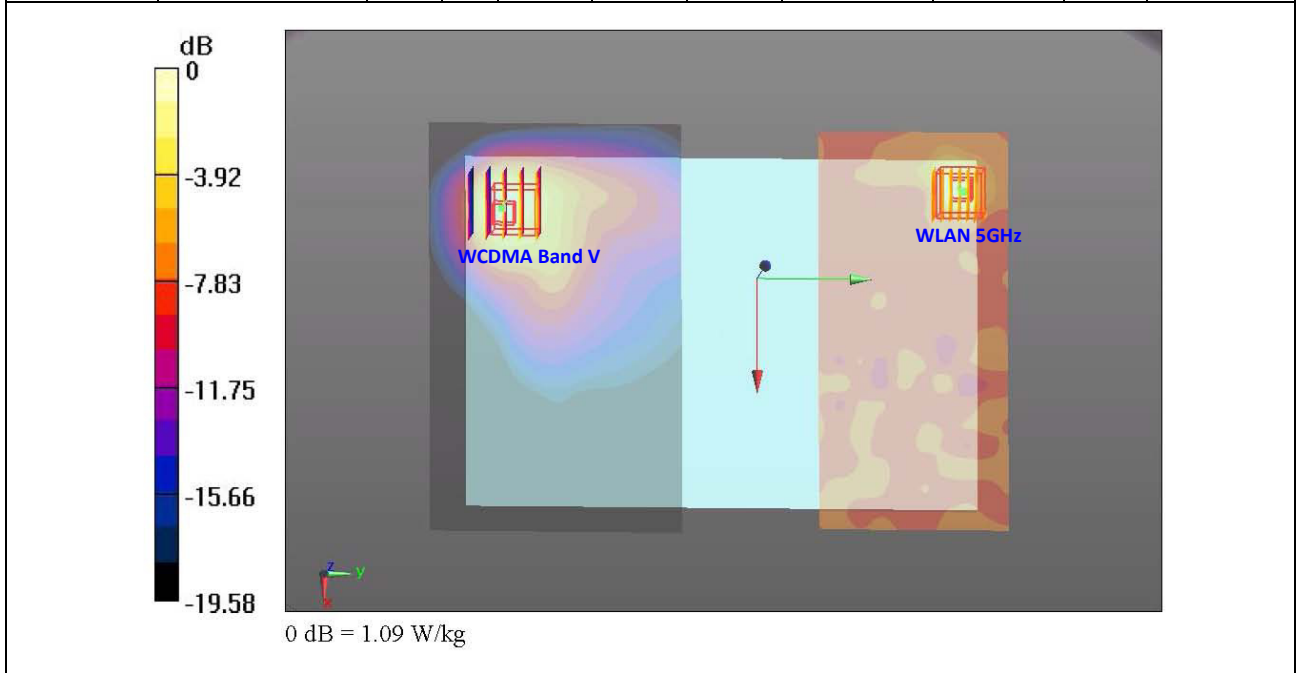

Case No #9	Band	SAR (W/kg)	Gap (cm)	SAR peak location (m)			3D distance (mm)	Pair SAR sum (W/kg)	SPLSR	Simultaneous SAR
				X	Y	Z				
Bottom Face	WCDMA Band II	0.564	0	-0.06	-0.117	-0.181	228.1	1.66	0.01	Not required
	WLAN 5GHz	1.097	0	-0.068	0.111	-0.182				

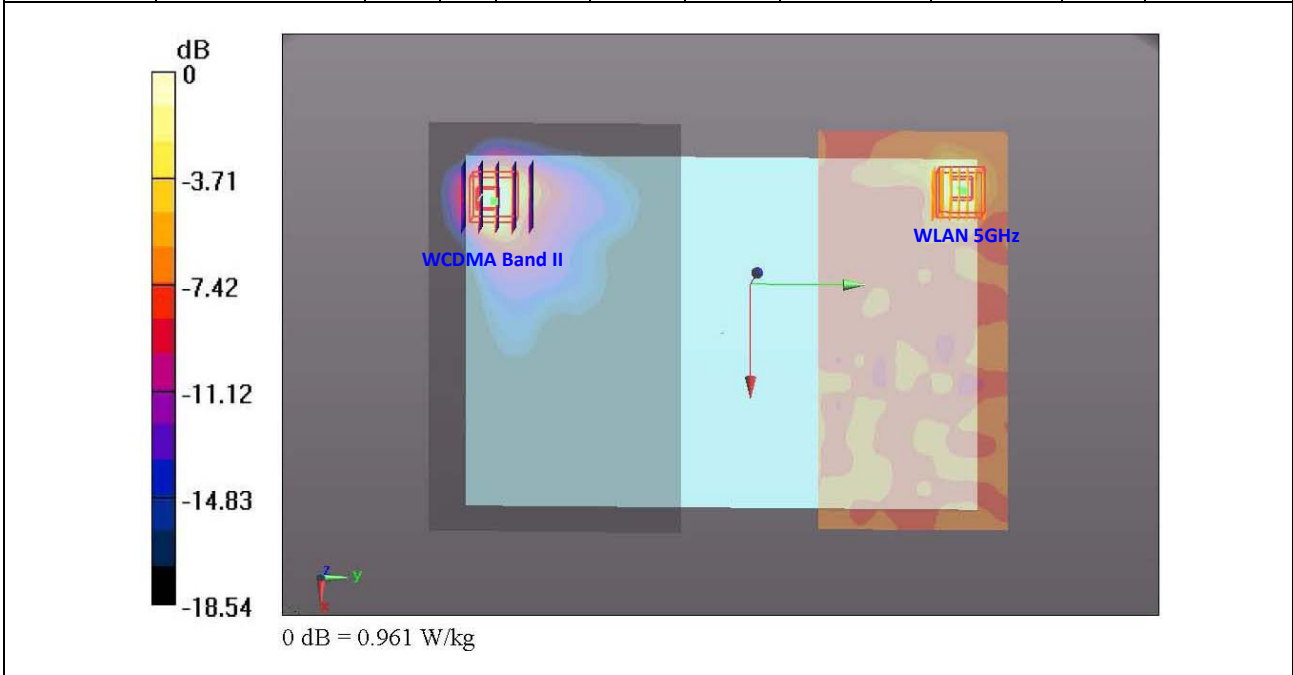

Case No #10	Band	SAR (W/kg)	Gap (cm)	SAR peak location (m)			3D distance (mm)	Pair SAR sum (W/kg)	SPLSR	Simultaneous SAR
				X	Y	Z				
Bottom Face	LTE Band 41	1.010	0	-0.0574	-0.113	-0.181	224.3	2.11	0.01	Not required
	WLAN 5GHz	1.097	0	-0.068	0.111	-0.182				

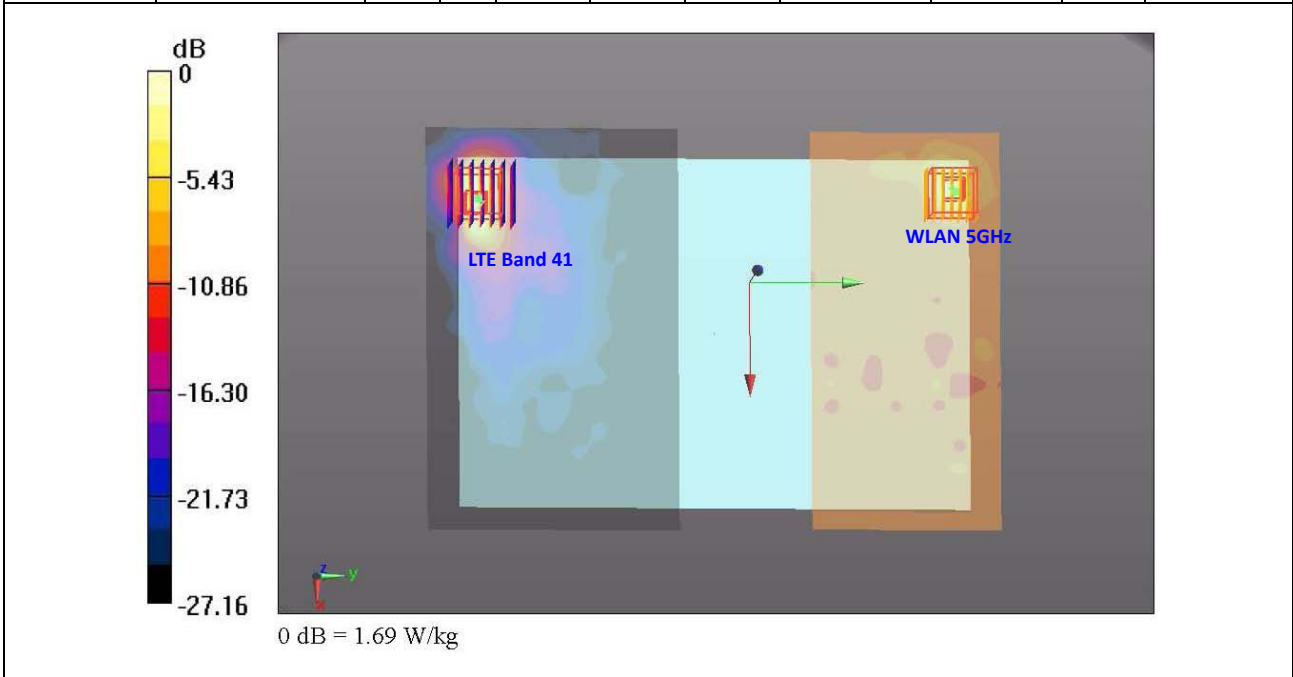

Test Engineer : Luke Lu

16. Uncertainty Assessment

The component of uncertainty may generally be categorized according to the methods used to evaluate them. The evaluation of uncertainty by the statistical analysis of a series of observations is termed a Type A evaluation of uncertainty. The evaluation of uncertainty by means other than the statistical analysis of a series of observation is termed a Type B evaluation of uncertainty. Each component of uncertainty, however evaluated, is represented by an estimated standard deviation, termed standard uncertainty, which is determined by the positive square root of the estimated variance.

A Type A evaluation of standard uncertainty may be based on any valid statistical method for treating data. This includes calculating the standard deviation of the mean of a series of independent observations; using the method of least squares to fit a curve to the data in order to estimate the parameter of the curve and their standard deviations; or carrying out an analysis of variance in order to identify and quantify random effects in certain kinds of measurement.

A type B evaluation of standard uncertainty is typically based on scientific judgment using all of the relevant information available. These may include previous measurement data, experience, and knowledge of the behavior and properties of relevant materials and instruments, manufacture’s specification, data provided in calibration reports and uncertainties assigned to reference data taken from handbooks. Broadly speaking, the uncertainty is either obtained from an outdoor source or obtained from an assumed distribution, such as the normal distribution, rectangular or triangular distributions indicated in table below.

Uncertainty Distributions	Normal	Rectangular	Triangular	U-Shape
Multi-plying Factor ^(a)	1/k ^(b)	1/√3	1/√6	1/√2

(a) standard uncertainty is determined as the product of the multiplying factor and the estimated range of variations in the measured quantity

(b) κ is the coverage factor

Table 17.1 Standard Uncertainty for Assumed Distribution

The combined standard uncertainty of the measurement result represents the estimated standard deviation of the result. It is obtained by combining the individual standard uncertainties of both Type A and Type B evaluation using the usual “root-sum-squares” (RSS) methods of combining standard deviations by taking the positive square root of the estimated variances.

Expanded uncertainty is a measure of uncertainty that defines an interval about the measurement result within which the measured value is confidently believed to lie. It is obtained by multiplying the combined standard uncertainty by a coverage factor. Typically, the coverage factor ranges from 2 to 3. Using a coverage factor allows the true value of a measured quantity to be specified with a defined probability within the specified uncertainty range. For purpose of this document, a coverage factor two is used, which corresponds to confidence interval of about 95 %. The DASY uncertainty Budget is shown in the following tables.

Error Description	Uncertainty Value (±%)	Probability Distribution	Divisor	Ci (1g)	Ci (10g)	Standard Uncertainty (1g)	Standard Uncertainty (10g)
Measurement System							
Probe Calibration	6.0	Normal	1	1	1	± 6.0 %	± 6.0 %
Axial Isotropy	4.7	Rectangular	√3	0.7	0.7	± 1.9 %	± 1.9 %
Hemispherical Isotropy	9.6	Rectangular	√3	0.7	0.7	± 3.9 %	± 3.9 %
Boundary Effects	1.0	Rectangular	√3	1	1	± 0.6 %	± 0.6 %
Linearity	4.7	Rectangular	√3	1	1	± 2.7 %	± 2.7 %
System Detection Limits	1.0	Rectangular	√3	1	1	± 0.6 %	± 0.6 %
Readout Electronics	0.3	Normal	1	1	1	± 0.3 %	± 0.3 %
Response Time	0.8	Rectangular	√3	1	1	± 0.5 %	± 0.5 %
Integration Time	2.6	Rectangular	√3	1	1	± 1.5 %	± 1.5 %
RF Ambient Noise	3.0	Rectangular	√3	1	1	± 1.7 %	± 1.7 %
RF Ambient Reflections	3.0	Rectangular	√3	1	1	± 1.7 %	± 1.7 %
Probe Positioner	0.4	Rectangular	√3	1	1	± 0.2 %	± 0.2 %
Probe Positioning	2.9	Rectangular	√3	1	1	± 1.7 %	± 1.7 %
Max. SAR Eval.	1.0	Rectangular	√3	1	1	± 0.6 %	± 0.6 %
Test Sample Related							
Device Positioning	2.9	Normal	1	1	1	± 2.9 %	± 2.9 %
Device Holder	3.6	Normal	1	1	1	± 3.6 %	± 3.6 %
Power Drift	5.0	Rectangular	√3	1	1	± 2.9 %	± 2.9 %
Phantom and Setup							
Phantom Uncertainty	4.0	Rectangular	√3	1	1	± 2.3 %	± 2.3 %
Liquid Conductivity (Target)	5.0	Rectangular	√3	0.64	0.43	± 1.8 %	± 1.2 %
Liquid Conductivity (Meas.)	2.5	Normal	1	0.64	0.43	± 1.6 %	± 1.1 %
Liquid Permittivity (Target)	5.0	Rectangular	√3	0.6	0.49	± 1.7 %	± 1.4 %
Liquid Permittivity (Meas.)	2.5	Normal	1	0.6	0.49	± 1.5 %	± 1.2 %
Combined Standard Uncertainty						± 11.0 %	± 10.8 %
Coverage Factor for 95 %						K=2	
Expanded Uncertainty						± 22.0 %	± 21.5 %

Table 17.2 Uncertainty Budget for frequency range 300 MHz to 3 GHz

Error Description	Uncertainty Value (±%)	Probability Distribution	Divisor	Ci (1g)	Ci (10g)	Standard Uncertainty (1g)	Standard Uncertainty (10g)
Measurement System							
Probe Calibration	6.55	Normal	1	1	1	± 6.55 %	± 6.55 %
Axial Isotropy	4.7	Rectangular	√3	0.7	0.7	± 1.9 %	± 1.9 %
Hemispherical Isotropy	9.6	Rectangular	√3	0.7	0.7	± 3.9 %	± 3.9 %
Boundary Effects	2.0	Rectangular	√3	1	1	± 1.2 %	± 1.2 %
Linearity	4.7	Rectangular	√3	1	1	± 2.7 %	± 2.7 %
System Detection Limits	1.0	Rectangular	√3	1	1	± 0.6 %	± 0.6 %
Readout Electronics	0.3	Normal	1	1	1	± 0.3 %	± 0.3 %
Response Time	0.8	Rectangular	√3	1	1	± 0.5 %	± 0.5 %
Integration Time	2.6	Rectangular	√3	1	1	± 1.5 %	± 1.5 %
RF Ambient Noise	3.0	Rectangular	√3	1	1	± 1.7 %	± 1.7 %
RF Ambient Reflections	3.0	Rectangular	√3	1	1	± 1.7 %	± 1.7 %
Probe Positioner	0.8	Rectangular	√3	1	1	± 0.5 %	± 0.5 %
Probe Positioning	9.9	Rectangular	√3	1	1	± 5.7 %	± 5.7 %
Max. SAR Eval.	4.0	Rectangular	√3	1	1	± 2.3 %	± 2.3 %
Test Sample Related							
Device Positioning	2.9	Normal	1	1	1	± 2.9 %	± 2.9 %
Device Holder	3.6	Normal	1	1	1	± 3.6 %	± 3.6 %
Power Drift	5.0	Rectangular	√3	1	1	± 2.9 %	± 2.9 %
Phantom and Setup							
Phantom Uncertainty	4.0	Rectangular	√3	1	1	± 2.3 %	± 2.3 %
Liquid Conductivity (Target)	5.0	Rectangular	√3	0.64	0.43	± 1.8 %	± 1.2 %
Liquid Conductivity (Meas.)	2.5	Normal	1	0.64	0.43	± 1.6 %	± 1.1 %
Liquid Permittivity (Target)	5.0	Rectangular	√3	0.6	0.49	± 1.7 %	± 1.4 %
Liquid Permittivity (Meas.)	2.5	Normal	1	0.6	0.49	± 1.5 %	± 1.2 %
Combined Standard Uncertainty						± 12.8 %	± 12.6 %
Coverage Factor for 95 %						K=2	
Expanded Uncertainty						± 25.6 %	± 25.2 %

Table 17.3 Uncertainty Budget for frequency range 3 GHz to 6 GHz



17. References

- [1] FCC 47 CFR Part 2 "Frequency Allocations and Radio Treaty Matters; General Rules and Regulations"
- [2] ANSI/IEEE Std. C95.1-1992, "IEEE Standard for Safety Levels with Respect to Human Exposure to Radio Frequency Electromagnetic Fields, 3 kHz to 300 GHz", September 1992
- [3] IEEE Std. 1528-2003, "Recommended Practice for Determining the Peak Spatial-Average Specific Absorption Rate (SAR) in the Human Head from Wireless Communications Devices: Measurement Techniques", December 2003
- [4] SPEAG DASY System Handbook
- [5] FCC KDB 865664 D01 v01r03, "SAR Measurement Requirements for 100 MHz to 6 GHz", Feb 2014
- [6] FCC KDB 865664 D02 v01r01, "RF Exposure Compliance Reporting and Documentation Considerations" May 2013
- [7] FCC KDB 447498 D01 v05r02, "Mobile and Portable Device RF Exposure Procedures and Equipment Authorization Policies", Feb 2014
- [8] FCC KDB 248227 D01 v01r02, "SAR Measurement Procedures for 802.11 a/b/g Transmitters", May 2007
- [9] FCC KDB 616217 D04 v01r01, "SAR Evaluation Considerations for Laptop, Notebook, Netbook and Tablet Computers", May 2013



Appendix A. Plots of System Performance Check

The plots are shown as follows.



Appendix B. Plots of SAR Measurement

The plots are shown as follows.



Appendix C. DASYS Calibration Certificate

The DASYS calibration certificates are shown as follows.