



**FCC CFR47 PART 22 SUBPART H
FCC CFR47 PART 24 SUBPART E
FCC CFR47 PART 27 SUBPART M**

WWAN

CERTIFICATION TEST REPORT

FOR

GSM/WCDMA/LTE Tablet + BT/BLE, DTS/UNII a/b/g/n/ac, ANT+ and NFC

MODEL NUMBER : SM-T395C

FCC ID: A3LSMT395C

REPORT NUMBER: 4788148881-E7V3

ISSUE DATE: OCT 19, 2017

Prepared for
**SAMSUNG ELECTRONICS CO., LTD.
129 SAMSUNG-RO, YEONGTONG-GU, SUWON-SI,
GYEONGGI-DO, 16677, KOREA**

Prepared by
**UL Korea, Ltd. Suwon Laboratory
218 Maeyeong-ro, Yeongtong-gu,
Suwon-si, Gyeonggi-do, 16675, Korea
TEL: (031) 337-9902
FAX: (031) 213-5433**



Revision History

<u>Rev.</u>	<u>Issue Date</u>	<u>Revisions</u>	<u>Revised By</u>
V1	10/13/17	Initial issue	Junwhan Lee
V2	10/18/17	Updated to address TCB's question	Junwhan Lee
V3	10/19/17	Updated to address TCB's question	Junwhan Lee

TABLE OF CONTENTS

1. ATTESTATION OF TEST RESULTS	5
2. TEST METHODOLOGY	6
3. FACILITIES AND ACCREDITATION	6
4. CALIBRATION AND UNCERTAINTY	6
4.1. <i>MEASURING INSTRUMENT CALIBRATION</i>	<i>6</i>
4.2. <i>SAMPLE CALCULATION</i>	<i>6</i>
4.3. <i>MEASUREMENT UNCERTAINTY.....</i>	<i>7</i>
5. EQUIPMENT UNDER TEST	8
5.1. <i>DESCRIPTION OF EUT</i>	<i>8</i>
5.2. <i>MAXIMUM OUTPUT POWER.....</i>	<i>8</i>
5.3. <i>DESCRIPTION OF AVAILABLE ANTENNAS</i>	<i>11</i>
5.4. <i>DESCRIPTION OF TEST SETUP.....</i>	<i>12</i>
6. TEST AND MEASUREMENT EQUIPMENT	14
7. Summary Table	15
8. PEAK TO AVERAGE RATIO	17
8.1. <i>CONDUCTED PEAK TO AVERAGE RESULT.....</i>	<i>17</i>
8.2. <i>CONDUCTED PEAK TO AVERAGE PLOTS.....</i>	<i>19</i>
9. LIMITS AND CONDUCTED RESULTS	24
9.1. <i>OCCUPIED BANDWIDTH</i>	<i>24</i>
9.1.1. <i>OCCUPIED BANDWIDTH RESULTS</i>	<i>24</i>
9.1.2. <i>OCCUPIED BANDWIDTH PLOTS.....</i>	<i>29</i>
9.2. <i>BAND EDGE EMISSIONS.....</i>	<i>46</i>
9.2.1. <i>BAND EDGE PLOTS.....</i>	<i>50</i>
9.2.2. <i>EMISSION MASK PLOTS.....</i>	<i>56</i>
10.3 <i>OUT OF BAND EMISSIONS.....</i>	<i>65</i>
9.3.1. <i>OUT OF BAND EMISSIONS PLOTS</i>	<i>70</i>
9.4. <i>FREQUENCY STABILITY.....</i>	<i>86</i>
9.4.1. <i>FREQUENCY STABILITY RESULTS</i>	<i>87</i>
10. RADIATED TEST RESULTS	94
10.1. <i>RADIATED POWER (ERP & EIRP).....</i>	<i>94</i>
10.1.1. <i>ERP/EIRP Results.....</i>	<i>95</i>
10.1.2. <i>ERP/EIRP DATA.....</i>	<i>100</i>

10.2.	<i>FIELD STRENGTH OF SPURIOUS RADIATION</i>	116
10.2.1.	SPURIOUS RADIATION PLOTS.....	117
11.	SETUP PHOTOS	145

1. ATTESTATION OF TEST RESULTS

COMPANY NAME: SAMSUNG ELECTRONICS CO., LTD.
EUT DESCRIPTION: GSM/WCDMA/LTE Tablet + BT/BLE, DTS/UNII a/b/g/n/ac, ANT+ and NFC
MODEL NUMBER: SM-T395C
SERIAL NUMBER: R22J800JR4W (RADIATED);
R22J800JT7A (CONDUCTED)
DATE TESTED: SEP 13, 2017 - OCT 12, 2017

APPLICABLE STANDARDS	
STANDARD	TEST RESULTS
FCC PART 22H, 24E and 27M	Pass

UL Korea, Ltd. tested the above equipment in accordance with the requirements set forth in the above standards. All indications of Pass/Fail in this report are opinions expressed by UL Korea, Ltd. based on interpretations and/or observations of test results. Measurement Uncertainties were not taken into account and are published for informational purposes only. The test results show that the equipment tested is capable of demonstrating compliance with the requirements as documented in this report.

Note: The results documented in this report apply only to the tested sample, under the conditions and modes of operation as described herein. This document may not be altered or revised in any way unless done so by UL Korea, Ltd. and all revisions are duly noted in the revisions section. Any alteration of this document not carried out by UL Korea, Ltd. will constitute fraud and shall nullify the document. This report must not be used by the client to claim product certification, approval, or endorsement by IAS, any agency of the Federal Government, or any agency of any government.

Approved & Released For
UL Korea, Ltd. By:



SungGil Park
Suwon Lab Engineer
UL Korea, Ltd.

Tested By:



Junwhan Lee
Suwon Lab Engineer
UL Korea, Ltd.

2. TEST METHODOLOGY

The tests documented in this report were performed in accordance with following methods.

1. FCC CFR 47 Part 2.
2. FCC CFR 47 Part 22.
3. FCC CFR 47 Part 24.
4. FCC CFR 47 Part 27.
5. ANSI TIA-603-E.
6. KDB 971168 D01 Power Meas License Digital Systems v02r02

3. FACILITIES AND ACCREDITATION

The test sites and measurement facilities used to collect data are located at 218 Maeyeong-ro, Yeongtong-gu, Suwon-si, Gyeonggi-do, 16675, Korea. Line conducted emissions are measured only at the 218 address. The following table identifies which facilities were utilized for radiated emission measurements documented in this report. Specific facilities are also identified in the test results sections.

218 Maeyeong-ro	
<input type="checkbox"/>	Chamber 1
<input checked="" type="checkbox"/>	Chamber 2

UL Korea, Ltd. is accredited by IAS, Laboratory Code TL-637. The full scope of accreditation can be viewed at <http://www.iasonline.org/PDF/TL/TL-637.pdf>.

4. CALIBRATION AND UNCERTAINTY

4.1. MEASURING INSTRUMENT CALIBRATION

The measuring equipment utilized to perform the tests documented in this report has been calibrated in accordance with the manufacturer's recommendations, and is traceable to recognized national standards.

4.2. SAMPLE CALCULATION

Where relevant, the following sample calculation is provided:

$EIRP = \text{PSA reading with EUT worst orientation (dBm)} + \text{Path loss (dB)} - \text{cable loss (between the SG and substitution antenna)} + \text{Substitution Antenna Factor (dBi)}$

$ERP = \text{PSA reading with EUT worst orientation (dBm)} + \text{Path loss (dB)} - \text{cable loss (between the SG and substitution antenna)}$

(Path loss = Signal generator output – PSA reading with substitution antenna)

4.3. MEASUREMENT UNCERTAINTY

Where relevant, the following measurement uncertainty levels have been estimated for tests performed on the apparatus:

PARAMETER	UNCERTAINTY
Conducted Disturbance, 0.15 to 30 MHz	2.32 dB
Radiated Disturbance, Below 1GHz	4.14 dB
Radiated Disturbance, Above 1 GHz	5.97 dB

Uncertainty figures are valid to a confidence level of 95%.

5. EQUIPMENT UNDER TEST

5.1. DESCRIPTION OF EUT

The EUT is a GSM/WCDMA/LTE Tablet + BT/BLE, DTS/UNII a/b/g/n/ac, ANT+ and NFC.

5.2. MAXIMUM OUTPUT POWER

The transmitter has a maximum conducted and radiated ERP / EIRP output powers as follows:

Note : Conducted output power results were excerpted from RF exposure test report.(4788148881-S1V1 FCC Report SAR)

GSM

FCC Part 22/24						
Band	Frequency Range	Modulation	Conducted		Radiated	
	[MHz]		Peak	Avg [dBm]	Avg [mW]	Avg [dBm]
GSM850	824~849	GMSK	32.7	1862.09		
		GPRS	32.7	1862.09	30.24	1056.82
		EGPRS	26.8	478.63	25.98	396.28
GSM1900	1850~1910	GMSK	28.7	741.31		
		GPRS	28.7	741.31	30.26	1061.70
		EGPRS	24.9	309.03	27.46	557.19

WCDMA

FCC Part 22/24						
Band	Frequency Range	Modulation	Conducted		Radiated	
	[MHz]		Peak	Avg [dBm]	Avg [mW]	Avg [dBm]
Band 5	824~849	REL99	22.9	194.98	20.45	110.92
		HSDPA	22.6	181.97	20.71	117.76
		HSUPA	21.3	134.90		
Band 2	1850~1910	REL99	22.6	181.97	24.00	251.19
		HSDPA	21.8	151.36	24.33	271.02
		HSUPA	20.8	120.23		

LTE Band 5

FCC Part 22							
Band	Frequency Range [MHz]	BandWidth [MHz]	Modulation	Conducted		Radiated	
				Peak	Avg [dBm]	Avg [mW]	Avg [dBm]
Band 5	824 ~ 849	10	QPSK	23.2	208.93	19.78	95.06
			16QAM	21.9	154.88	18.68	73.79
		5	QPSK	22.7	186.21	18.96	78.70
			16QAM	21.6	144.54	18.09	64.42
		3	QPSK	22.8	190.55	19.03	79.98
			16QAM	21.8	151.36	17.92	61.94
		1.4	QPSK	22.8	190.55	16.60	45.71
			16QAM	21.6	144.54	15.92	39.08

LTE Band 7

FCC Part 27							
Band	Frequency Range [MHz]	BandWidth [MHz]	Modulation Peak	Conducted		Radiated	
				Avg [dBm]	Avg [mW]	Avg [dBm]	Avg [mW]
Band 7	2500~2570	20	QPSK	23.0	199.53	19.03	79.98
			16QAM	21.9	154.88	18.07	64.12
		15	QPSK	23.1	204.17	17.91	61.80
			16QAM	22.0	158.49	16.90	48.98
		10	QPSK	23.0	199.53	19.13	81.85
			16QAM	22.2	165.96	18.19	65.92
		5	QPSK	22.6	181.97	18.37	68.71
			16QAM	21.8	151.36	17.41	55.08

LTE Band 41

FCC Part 27							
Band	Frequency Range [MHz]	BandWidth [MHz]	Modulation Peak	Conducted		Radiated	
				Avg [dBm]	Avg [mW]	Avg [dBm]	Avg [mW]
Band 41	2555~2655	20	QPSK	23.2	208.93	17.94	62.23
			16QAM	22.1	162.18	17.07	50.93
		15	QPSK	23.2	208.93	17.92	61.94
			16QAM	22.1	162.18	17.02	50.35
		10	QPSK	23.1	204.17	18.60	72.44
			16QAM	21.9	154.88	17.88	61.38
		5	QPSK	23.1	204.17	19.20	83.18
			16QAM	21.9	154.88	18.41	69.34

LTE Band 38

Due to frequency range and same output power setting, test was carried in LTE Band 41 to cover both LTE Band 41 and LTE Band 38.

5.3. DESCRIPTION OF AVAILABLE ANTENNAS

The radio utilizes a internal antenna for the [List the bands supported] with a maximum peak gain as follow:

Frequency (MHz)	Peak Gain (dBi)
GSM850 / WCDMA Band 5 / LTE Band 5 824 ~ 849 MHz	-2.7
GSM1900 / WCDMA Band 2 1850 ~ 1910 MHz	4.2
LTE Band 7 2500 ~ 2570 MHz	1.9
LTE Band 38/41 2555 ~ 2655 MHz	1.3

5.4. DESCRIPTION OF TEST SETUP

SUPPORT EQUIPMENT

Support Equipment List				
Description	Manufacturer	Model	Serial Number	FCC ID
Charger	SAMSUNG	EP-TA12CBC	DK2J606HS/B- E	N/A
Data Cable	SAMSUNG	EP-DN930CWE	N/A	N/A
Earphone	SAMSUNG	EO-EG920BW	N/A	N/A

I/O CABLES

I/O Cable List						
Cable No	Port	# of identical ports	Connector Type	Cable Type	Cable Length (m)	Remarks
1	DC Power	1	C-type	Shielded	1.2m	N/A
2	Audio	2	Mini-Jack	Unshielded	1.2m	N/A

NOTE : Protective cover (with S-pen) is in-box item. So additional ERP/EIRP and radiated spurious emission measurements were performed on worst case equipped with protective case. Test result for RSE of LTE band7/band41 were more worst than stand-alone condition. So test were performed on both condition(stan-alone and equipped with protective cover)for these test items.

TEST SETUP

The EUT is continuously communicated to the call box during the tests.

SETUP DIAGRAM FOR TESTS (CONDUCTED TEST SETUP)

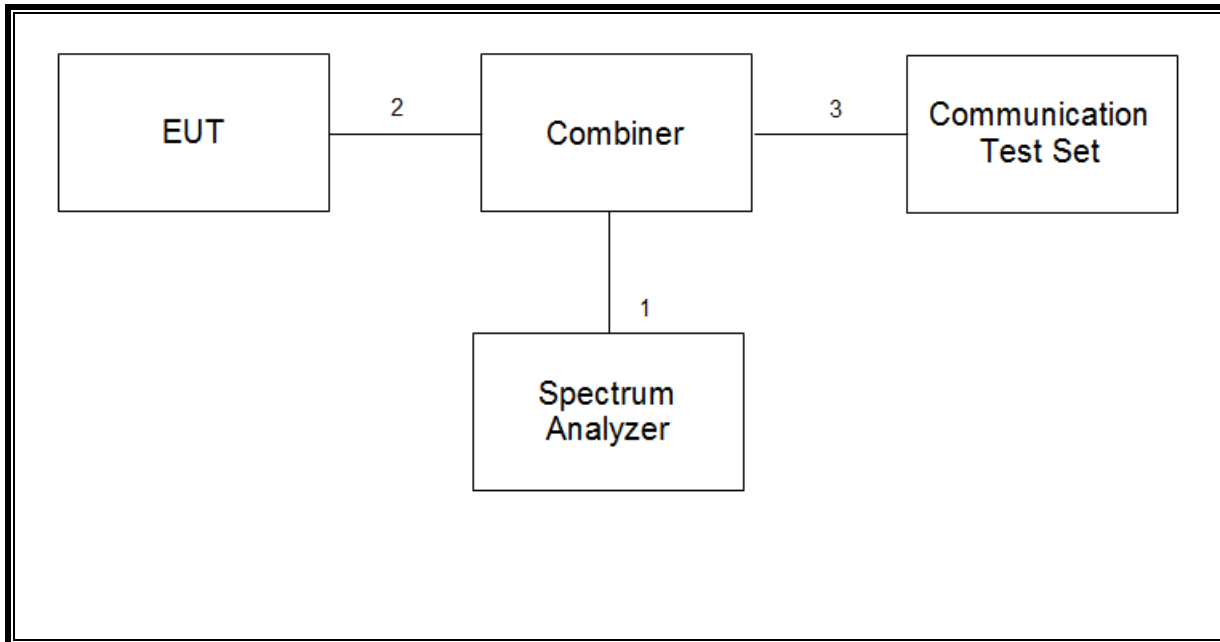

SETUP DIAGRAM FOR TESTS (RADIATED TEST SETUP)

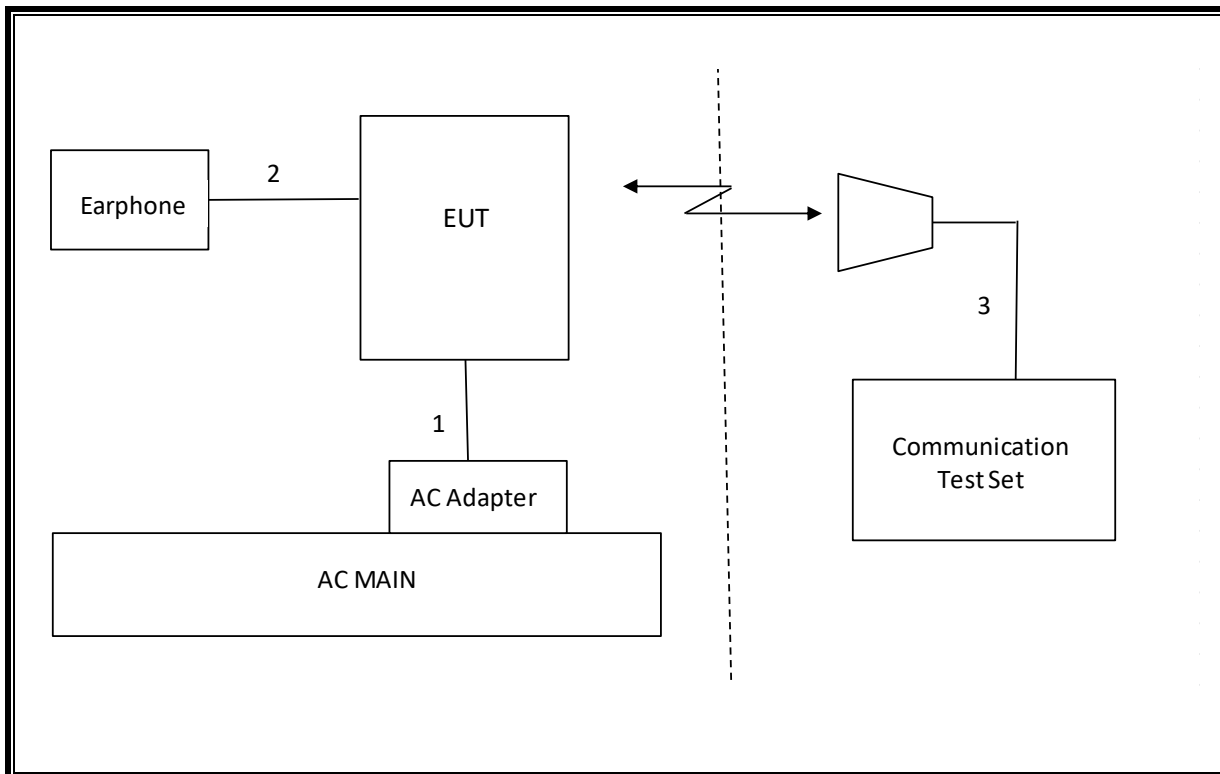

6. TEST AND MEASUREMENT EQUIPMENT

The following test and measurement equipment was utilized for the tests documented in this report:

Description	Manufacturer	Model	S/N	Cal Due
Antenna, Tuned Dipole 400~1000 MHz	ETS	3121D DB4	00164753	06-30-19
Antenna, Horn, 40 GHz	ETS	3116C	00166155	11-30-17
Antenna, Horn, 40 GHz	ETS	3116C-PA	00168841	12-15-17
Antenna, Bilog, 30MHz-1GHz	SCHWARZBECK	VULB9163	749	04-14-19
Antenna, Horn, 18 GHz	ETS	3115	00167211	10-14-18
Antenna, Horn, 18 GHz	ETS	3115	00161451	03-10-19
Antenna, Horn, 18 GHz	ETS	3117	00168724	05-31-19
Antenna, Horn, 18 GHz	ETS	3117	00168717	05-31-19
Combiner	WEINSCHTEL	1575	2152	08-08-18
Communications Test Set	R&S	CMW500	150312	08-07-18
Communications Test Set	R&S	CMW500	115331	08-07-18
DC Power Supply	Agilent / HP	E3640A	MY54226395	08-07-18
Preamplifier, 1000 MHz	Sonoma	310N	341282	08-09-18
Preamplifier, 1000 MHz	Sonoma	310N	351741	08-07-18
Preamplifier	ETS	3115-PA	00167475	08-09-18
Preamplifier, 18 GHz	Miteq	AFS42-00101800-25-S-42	1896138	08-08-18
Spectrum Analyzer, 44 GHz	Agilent / HP	N9030A	MY54490312	08-08-18
EMI Test Receive, 40 GHz	R&S	ESU40	100439	08-08-18
EMI Test Receive, 40 GHz	R&S	ESU40	100457	08-08-18
High Pass Filter 1.2GHz	Micro-Tronics	HPM50108-02	G005	08-09-18
High Pass Filter 1.2GHz	Micro-Tronics	HPM50108-02	G006	08-08-18
High Pass Filter 2.8GHz	Micro-Tronics	HPM50111-02	010	08-09-18
High Pass Filter 2.8GHz	Micro-Tronics	HPM50111-02	011	08-08-18
High Pass Filter 4GHz	Micro-Tronics	HPM50118-02	G001	08-09-18
High Pass Filter 4GHz	Micro-Tronics	HPM50118-02	G002	08-08-18
Attenuator	PASTERNAK	PE7087-10	A009	08-08-18
Temperature Chamber	ESPEC	SH-642	93001109	08-08-18
UL Software				
Description	Manufacturer	Model	Version	
Antenna port test software	UL	CLT	Ver 2.2	

7. Summary Table

FCC Part Section	Test Description	Test Limit	Test Condition	Test Result	Note
2.1049	Occupied Band width (99%)	N/A	Conducted	Pass	17.916 MHz
22.917(a) 24.238(a)	Band Edge / Conducted Spurious Emission	-13dBm		Pass	-13.918 dBm
27.53(m)	Conducted Spurious Emission	-25 dBm		Pass	-28.43 dBm
27.53(m)	Emission mask	Section 9.2.2		Pass	Pass
2.1046	Conducted output power	N/A		Pass	Refer to RF exposure test report
22.355 24.235 27.54	Frequency Stability	2.5PPM		Pass	-0.007 PPM
22.913(a)(2)	Effective Radiated Power	38.5 dBm		Radiated	Pass
24.232(c) 27.50(h)(2)	Equivalent Isotropic Radiated Power	33dBm	Pass		30.26 dBm
22.917(a) 24.238(a)	Radiated Spurious Emission	-13dBm	Pass		-35.8 dBm
27.53 (m)	Radiated Spurious Emission	-25dBm	Pass		-29.0 dBm

FCC Rule Part	Frequency Range [MHz]	Output Power [W]	Frequency Tolerance	Emission Designator	Emission Bandwidth [MHz]	Communication Type
GSM						
22H	824.2 - 848.8	1.057	2.5 ppm	241KGXW		GSM850
22H	824.2 - 848.8	0.396	2.5 ppm	238KG7W		EDGE850
24E	1850.2 - 1909.8	1.062	2.5 ppm	236KGXW		GSM1900
24E	1850.2 - 1909.8	0.557	2.5 ppm	239KG7W		EDGE1900
WCDMA						
22H	826.4 - 846.6	0.118	2.5 ppm	4M14F9W		WCDMA B5
24E	1852.4 - 1907.6	0.271	2.5 ppm	4M14F9W		WCDMA B2
LTE Band 5						
22H	829.0 - 844.0	0.095	2.5 ppm	8M98G7W	10	QPSK
22H	829.0 - 844.0	0.074	2.5 ppm	8M96D7W	10	16QAM
LTE Band 41						
27M	2565.0 - 2645.0	0.062	2.5 ppm	17M9G7W	20	QPSK
27M	2565.0 - 2645.0	0.051	2.5 ppm	17M9D7W	20	16QAM
27M	2557.5 - 2652.5	0.083	2.5 ppm	4M50G7W	5	QPSK
27M	2557.5 - 2652.5	0.069	2.5 ppm	4M51D7W	5	16QAM
LTE Band 7						
27M	2510.0 - 2560.0	0.080	2.5 ppm	17M9G7W	20	QPSK
27M	2510.0 - 2560.0	0.064	2.5 ppm	17M9D7W	20	16QAM
27M	2505.0 - 2565.0	0.082	2.5 ppm	8M96G7W	10	QPSK
27M	2505.0 - 2565.0	0.066	2.5 ppm	8M98D7W	10	16QAM

8. PEAK TO AVERAGE RATIO

Test Procedure

Per KDB 971168 D01 Power Meas License Digital Systems v02r02;

The transmitter output was connected to a CMW500 Test Set and configured to operate at maximum power. The PAR were measured on the Spectrum Analyzer.

Test Spec

In addition, when the transmitter power is measured in terms of average value, the peak-to-average ratio of the power shall not exceed 13 dB.

8.1. CONDUCTED PEAK TO AVERAGE RESULT

GSM

Band	Channel	f [MHz]	Mode	Ratio [dB]	Limit [dB]
GSM850	190	836.6	GPRS	0.45	13.00
			EGPRS	4.77	
GSM1900	661	1880.0	GPRS	0.38	
			EGPRS	3.51	

WCDMA

Band	Channel	f [MHz]	Mode	Ratio [dB]	Limit [dB]
Band 5	4183	836.6	REL99	2.69	13.00
			HSDPA	3.23	
Band 2	9400	1880.0	REL99	2.91	
			HSDPA	3.21	

LTE Band 5

Band	BW [MHz]	Channel	f [MHz]	Mode	Ratio [dB]	Limit [dB]
Band 5	10	20525	836.5	QPSK	4.37	13.00
				16QAM	5.60	
	5			QPSK	4.50	
				16QAM	5.60	
	3			QPSK	4.47	
				16QAM	5.66	
	1.4			QPSK	4.40	
				16QAM	5.34	

LTE Band 7

Band	BW [MHz]	Channel	f [MHz]	Mode	Ratio [dB]	Limit [dB]
Band 7	20	21100	2535	QPSK	4.98	13.00
				16QAM	6.17	
	15			QPSK	5.00	
				16QAM	6.27	
	10			QPSK	5.05	
				16QAM	6.31	
	5			QPSK	5.35	
				16QAM	6.35	

LTE Band 41

Band	BW [MHz]	Channel	f [MHz]	Mode	Ratio [dB]	Limit [dB]
Band 41	20	40740	2605.0	QPSK	4.72	13.00
				16QAM	5.84	
	15			QPSK	4.81	
				16QAM	5.80	
	10			QPSK	4.92	
				16QAM	5.69	
	5			QPSK	4.43	
				16QAM	5.77	

LTE Band 38

Due to frequency range and same output power setting, test was carried in LTE Band 41 to cover both LTE Band 41 and LTE Band 38.

8.2. CONDUCTED PEAK TO AVERAGE PLOTS

GSM

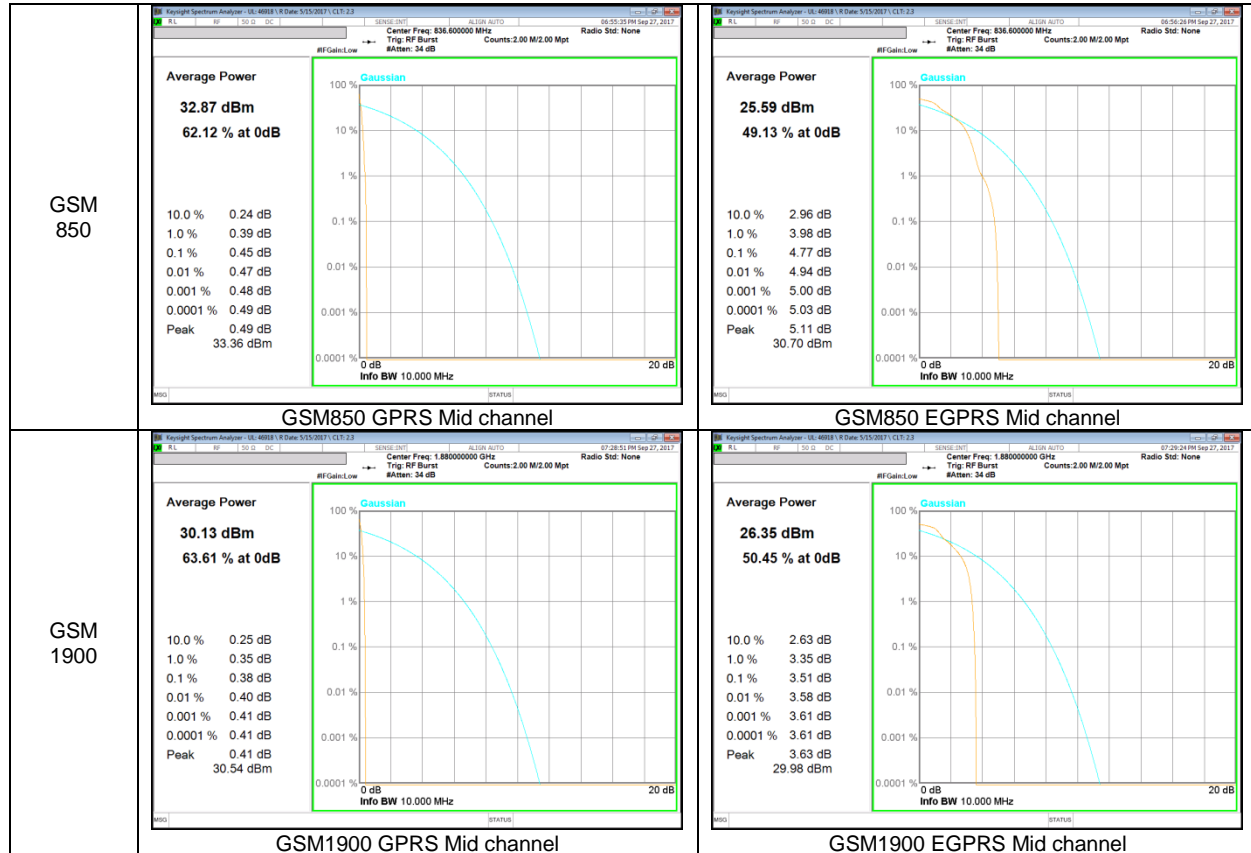

WCDMA

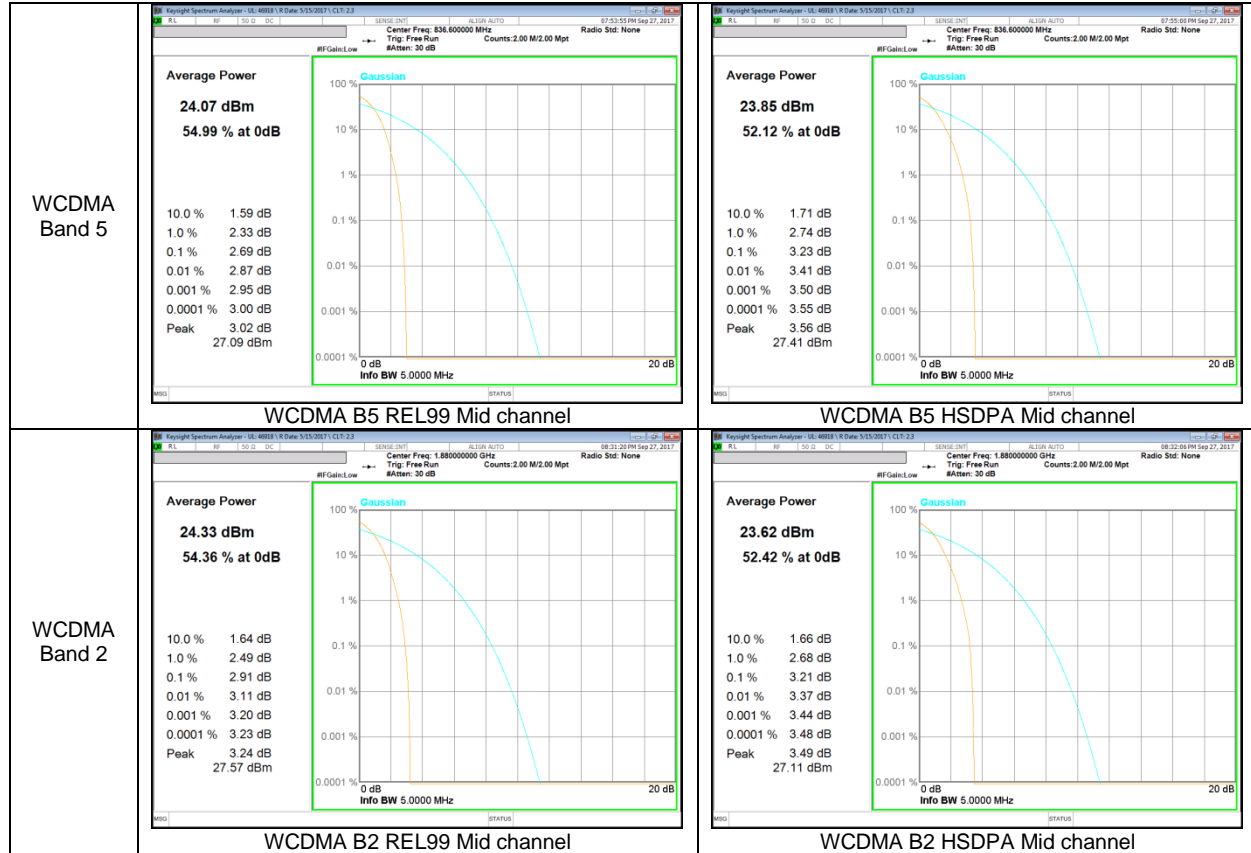

LTE Band 5

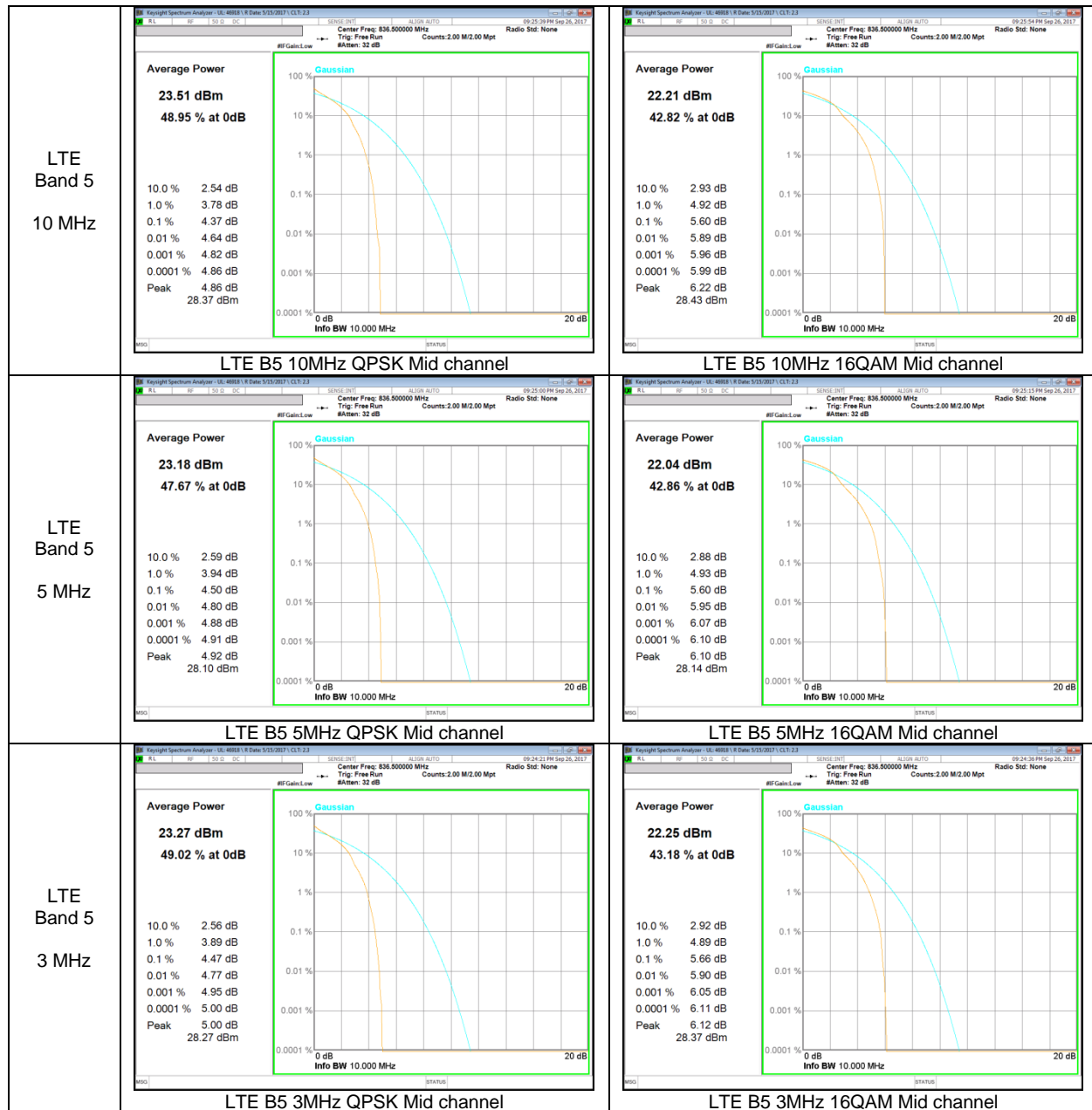

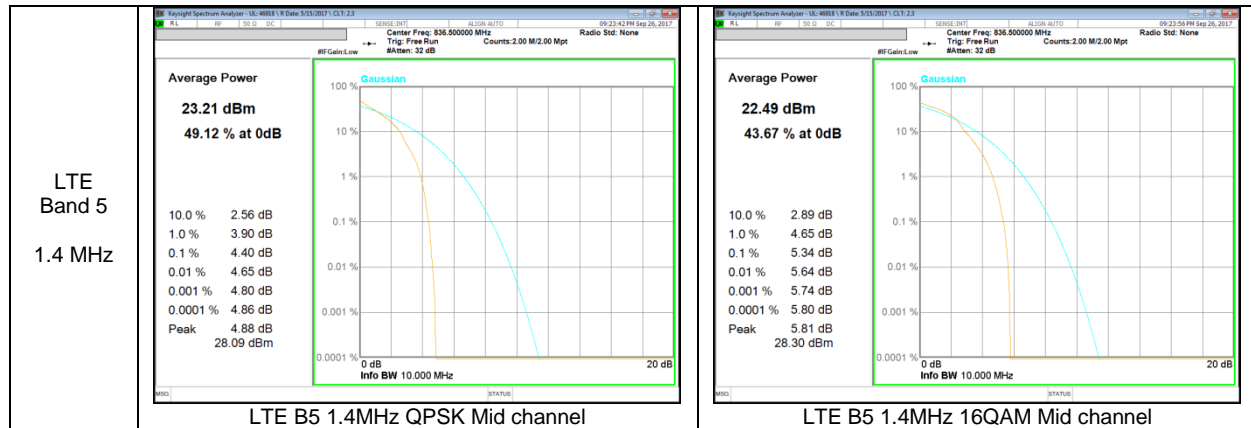

LTE Band 7

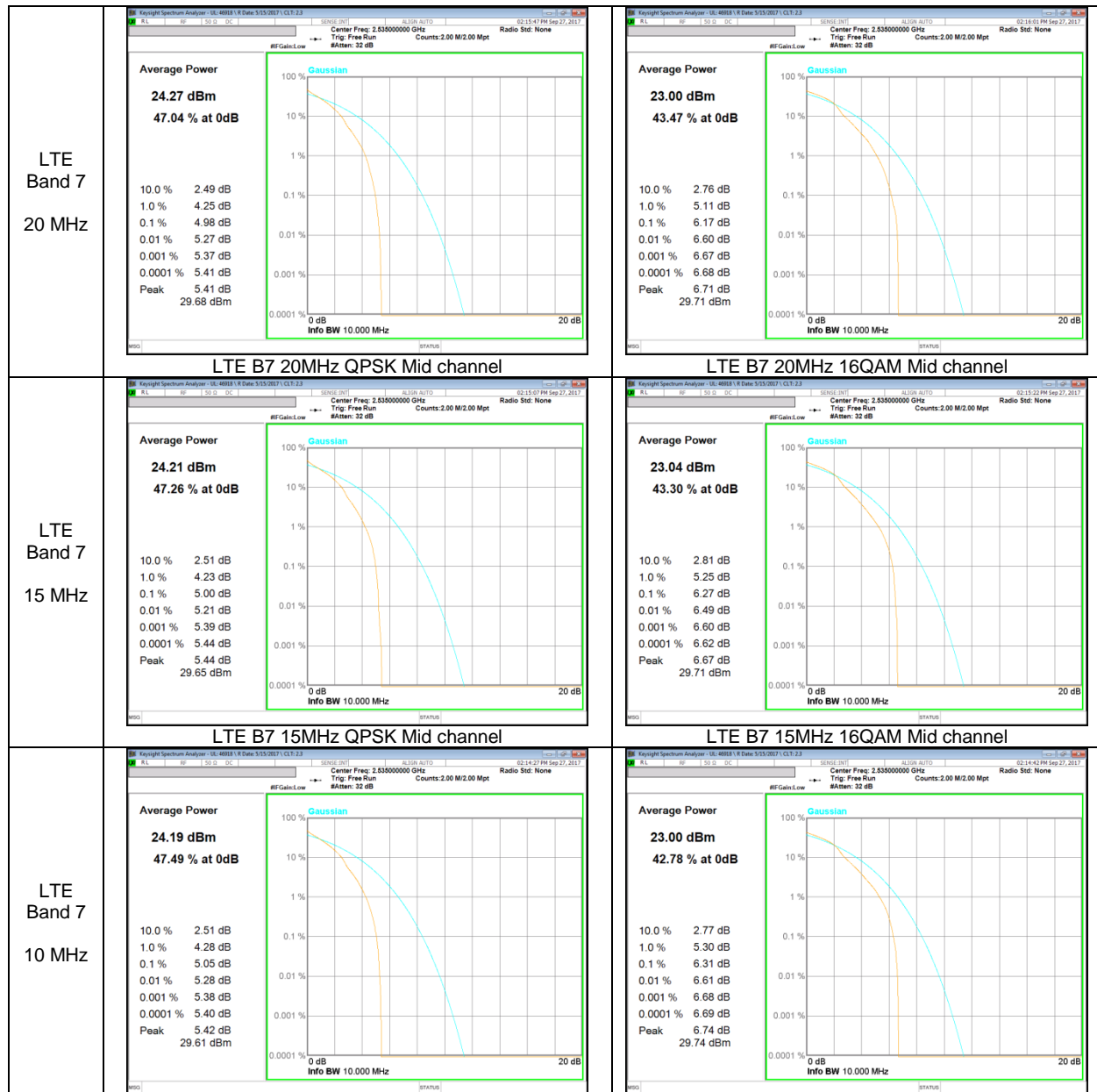

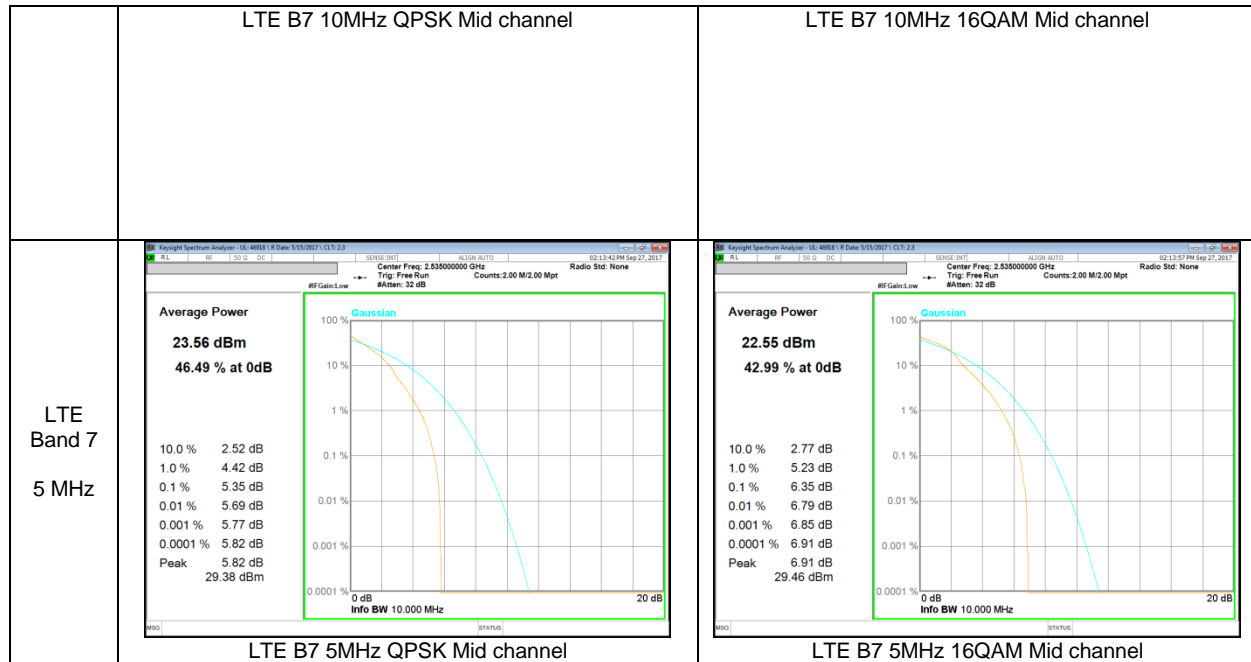

LTE Band 41

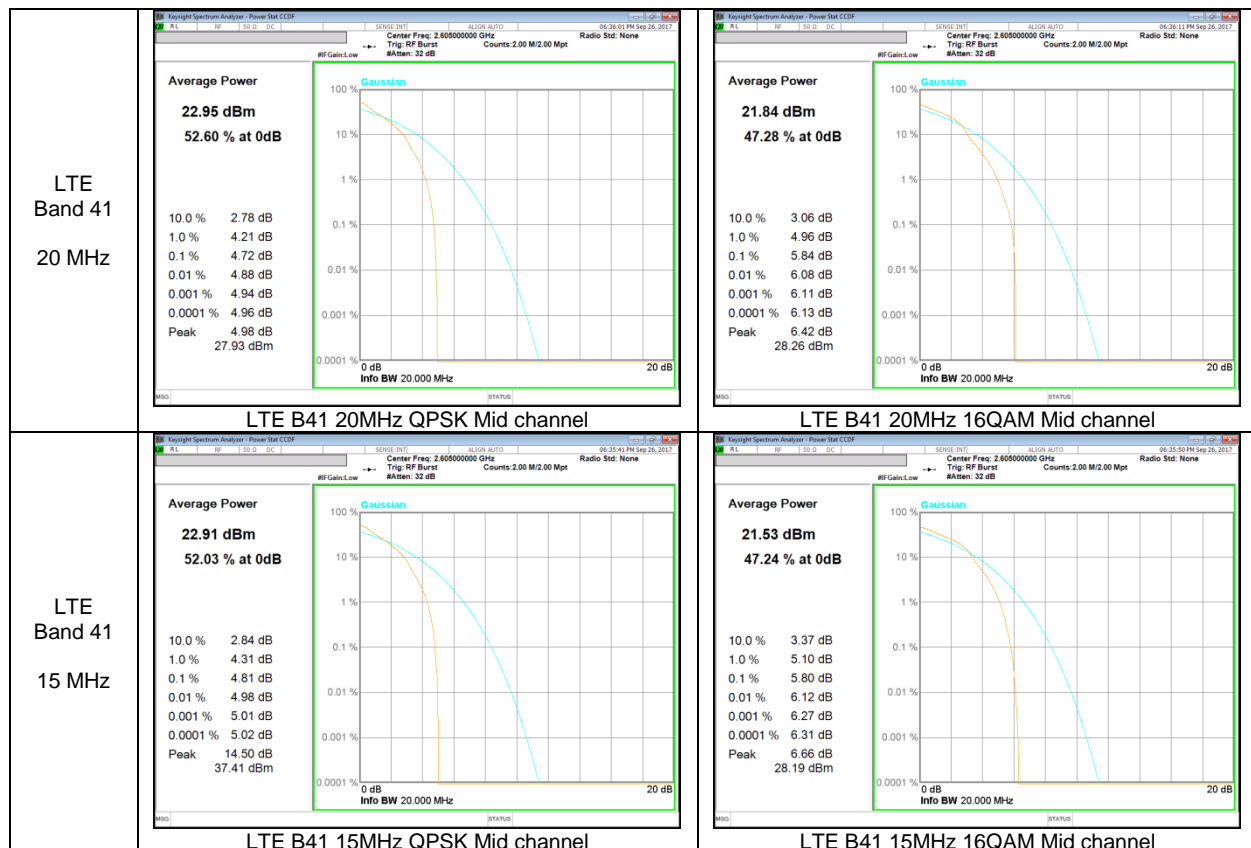

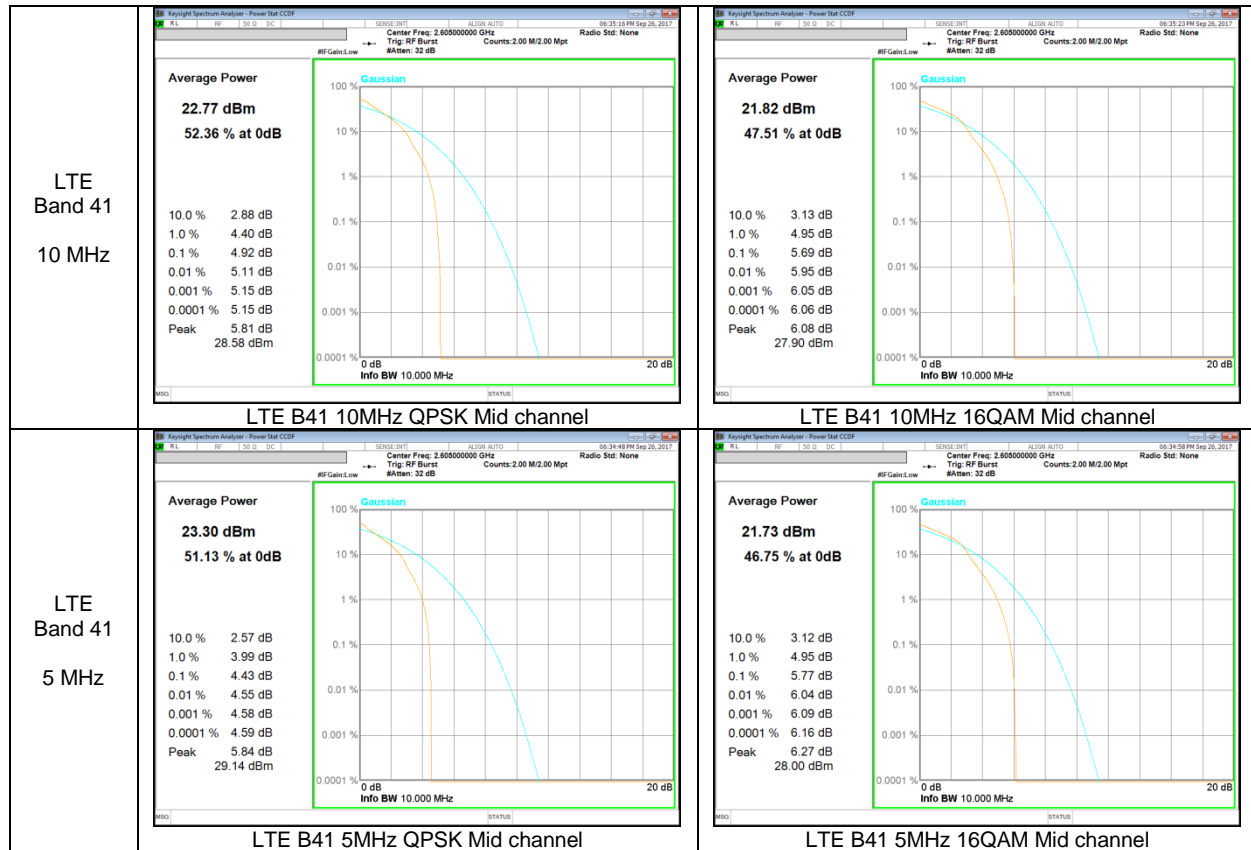

9. LIMITS AND CONDUCTED RESULTS

9.1. OCCUPIED BANDWIDTH

RULE PART(S)

FCC: §2.1049

LIMITS

For reporting purposes only

TEST PROCEDURE

The transmitter output was connected to a calibrated coaxial cable and coupler, the other end of which was connected to a spectrum analyzer. The occupied bandwidth was measured with the spectrum analyzer at the low, middle and high channel in each band. The -26dB bandwidth was also measured and recorded.

(KDB 971168 D01 Power Meas License Digital Systems v02r02)

9.1.1. OCCUPIED BANDWIDTH RESULTS

GSM

Band	Mode	Channel	f [MHz]	99% BW [KHz]	26dB BW [KHz]
GSM850	GPRS	128	824.2	237.07	305.0
		190	836.6	236.80	307.9
		251	848.8	240.57	313.8
	EGPRS	128	824.2	238.13	297.6
		190	836.6	237.05	309.1
		251	848.8	234.82	293.1
GSM1900	GPRS	512	1850.2	235.74	301.8
		661	1880.0	233.80	293.1
		810	1909.8	233.06	300.7
	EGPRS	512	1850.2	237.17	301.6
		661	1880.0	235.08	299.0
		810	1909.8	239.27	301.8

WCDMA

Band	Mode	Channel	f [MHz]	99% BW [MHz]	26dB BW [MHz]
Band 5	REL99	4132	826.4	4.1242	4.654
		4183	836.6	4.1216	4.697
		4233	846.6	4.1387	4.735
	HSDPA	4132	826.4	4.1299	4.636
		4183	836.6	4.1246	4.671
		4233	846.6	4.1374	4.687
Band 2	REL99	9262	1852.4	4.1365	4.712
		9400	1880.0	4.1383	4.698
		9538	1907.6	4.1385	4.733
	HSDPA	9262	1852.4	4.1328	4.690
		9400	1880.0	4.1356	4.659
		9538	1907.6	4.1314	4.664

LTE Band 5

Band	BW [MHz]	Channel	f [MHz]	Mode	99% BW [MHz]	26dB BW [MHz]
Band 5	10	20450	829.0	QPSK	8.9794	10.06
				16QAM	8.9609	10.18
		20524	836.5	QPSK	8.9454	10.25
				16QAM	8.9551	10.28
		20599	844.0	QPSK	8.9594	10.07
				16QAM	8.9641	10.28
	5	20425	826.5	QPSK	4.5097	5.310
				16QAM	4.5013	5.201
		20524	836.5	QPSK	4.5084	5.258
				16QAM	4.4943	5.200
		20624	846.5	QPSK	4.4980	5.259
				16QAM	4.5022	5.288
	3	20415	825.5	QPSK	2.6978	3.079
				16QAM	2.6991	3.106
		20524	836.5	QPSK	2.7008	3.063
				16QAM	2.6962	3.048

		20634	847.5	QPSK	2.6955	3.076
				16QAM	2.6947	3.077
	1.4	20407	824.7	QPSK	1.0904	1.357
				16QAM	1.0974	1.379
		20524	836.5	QPSK	1.0892	1.390
				16QAM	1.0910	1.366
		20624	848.3	QPSK	1.0900	1.378
				16QAM	1.0904	1.392

LTE Band 7

Band	BW [MHz]	Channel	f [MHz]	Mode	99% BW [MHz]	26dB BW [MHz]
Band 7	20	20850	2510	QPSK	17.834	19.60
				16QAM	17.872	19.68
		21100	2535	QPSK	17.894	19.68
				16QAM	17.910	19.72
		21350	2560	QPSK	17.873	19.73
				16QAM	17.890	19.78
	15	20825	2507.5	QPSK	13.426	15.09
				16QAM	13.416	14.92
		21100	2535	QPSK	13.437	14.95
				16QAM	13.447	15.09
		21375	2562.5	QPSK	13.441	15.03
				16QAM	13.424	14.97
	10	20800	2505	QPSK	8.9619	10.14
				16QAM	8.9600	10.02
		21100	2535	QPSK	8.9619	10.08

		21400	2565	16QAM	8.9749	10.23
				QPSK	8.9627	10.20
				16QAM	8.9753	10.17
	5	20775	2502.5	QPSK	4.4982	5.357
				16QAM	4.5044	5.364
		21100	2535	QPSK	4.5052	5.328
				16QAM	4.5028	5.324
		21425	2567.5	QPSK	4.5087	5.485
				16QAM	4.5052	5.317

LTE Band 41

Band	BW [MHz]	Channel	f [MHz]	Mode	99% BW [MHz]	26dB BW [MHz]
Band 41	20	40340	2565.0	QPSK	17.916	22.39
				16QAM	17.886	19.56
		40740	2605.0	QPSK	17.909	23.23
				16QAM	17.880	24.34
		41140	2645.0	QPSK	17.897	19.63
				16QAM	17.905	19.57
	15	40315	2562.5	QPSK	13.459	15.18
				16QAM	13.450	14.98
		40740	2605.0	QPSK	13.448	17.76
				16QAM	13.446	14.91
		41165	2647.5	QPSK	13.418	15.11
				16QAM	13.456	15.68
	10	40290	2560.0	QPSK	8.9557	10.11
				16QAM	8.9781	11.05

	5	40740	2605.0	QPSK	8.9691	10.09
				16QAM	8.9531	10.05
		41190	2650.0	QPSK	8.9699	10.23
				16QAM	8.9536	11.07
		40265	2557.5	QPSK	4.4927	5.266
				16QAM	4.5073	5.377
	40740		2605.0	QPSK	4.5048	5.439
				16QAM	4.4995	5.375
	41215	2652.5	QPSK	4.5032	5.408	
			16QAM	4.4973	5.249	

LTE Band 38

Due to frequency range and same output power setting, test was carried in LTE Band 41 to cover both LTE Band 41 and LTE Band 38.

9.1.2. OCCUPIED BANDWIDTH PLOTS

GSM 850

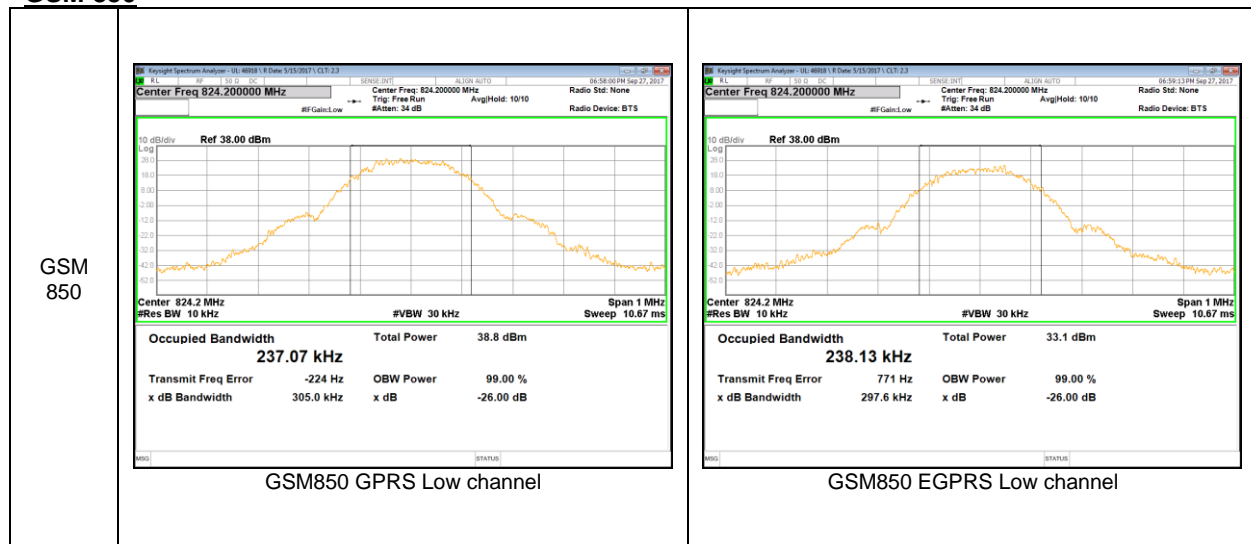



GSM 1900

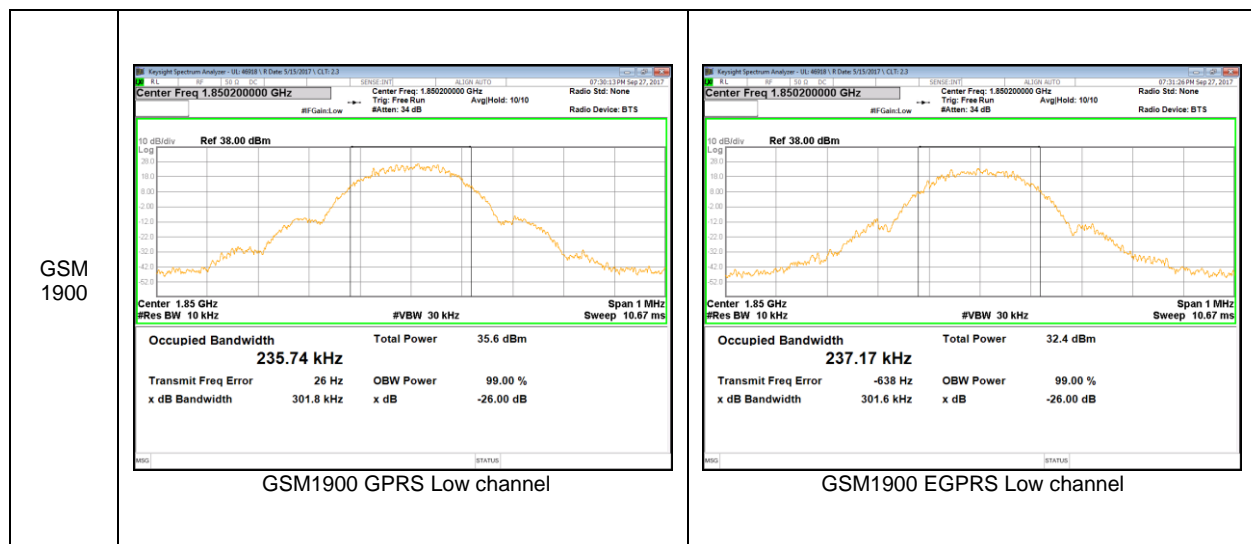

GSM 1900



WCDMA Band 5

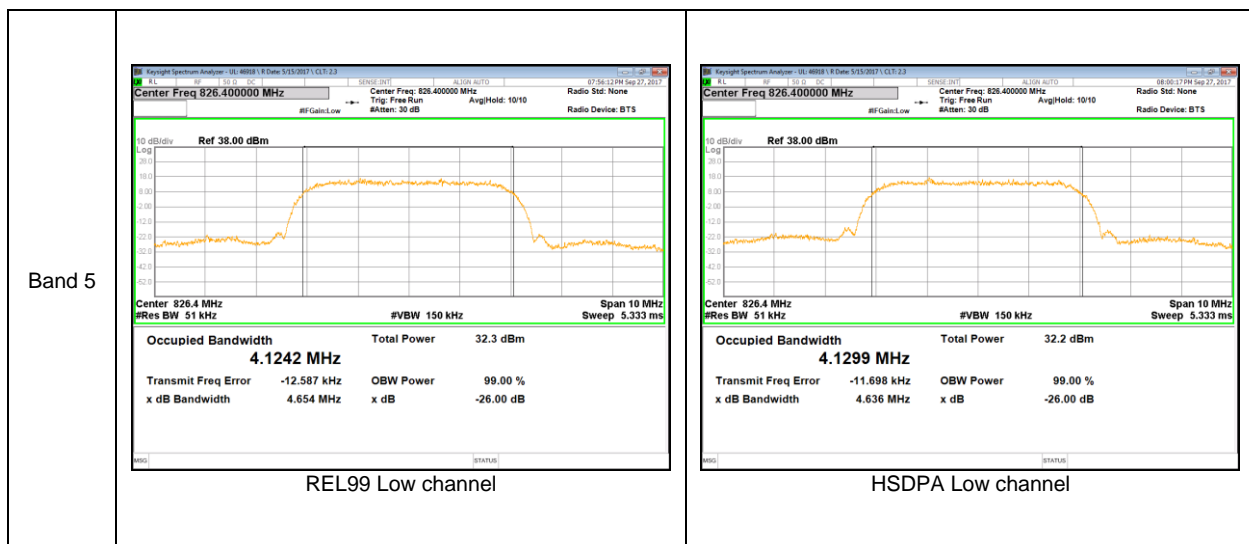

Band 5



WCDMA Band 2

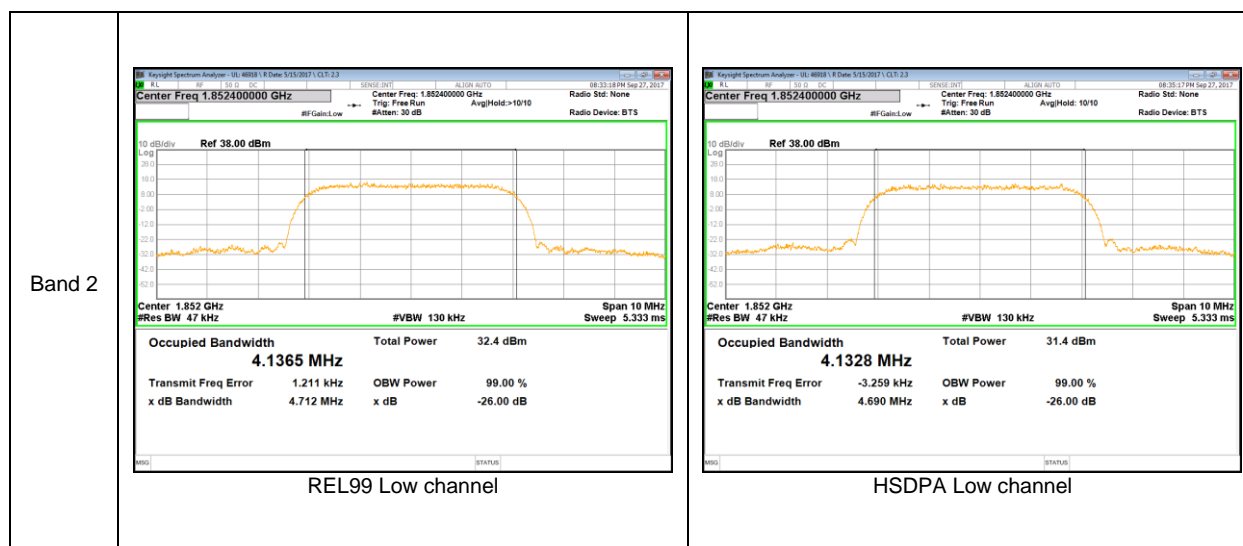



LTE Band 5

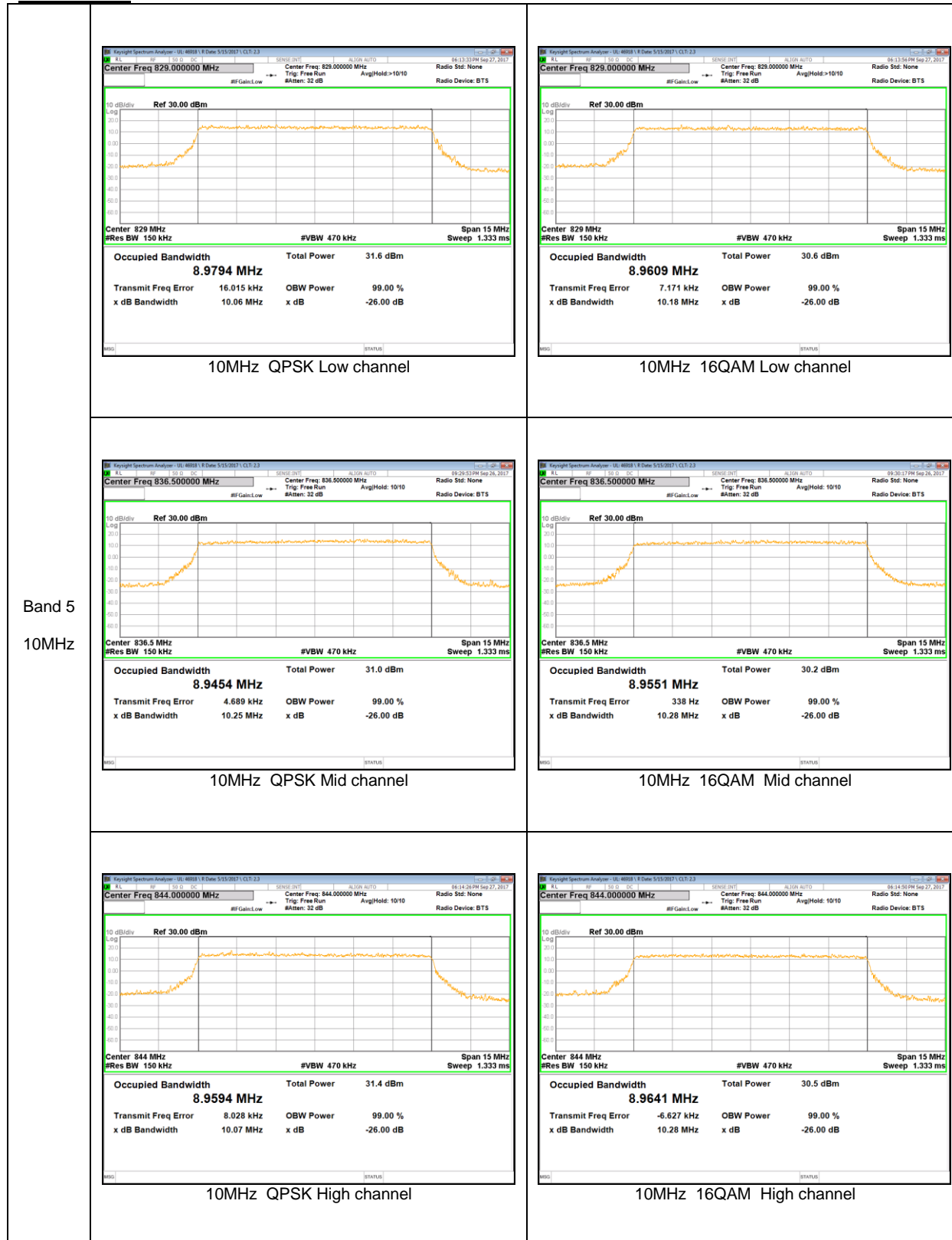

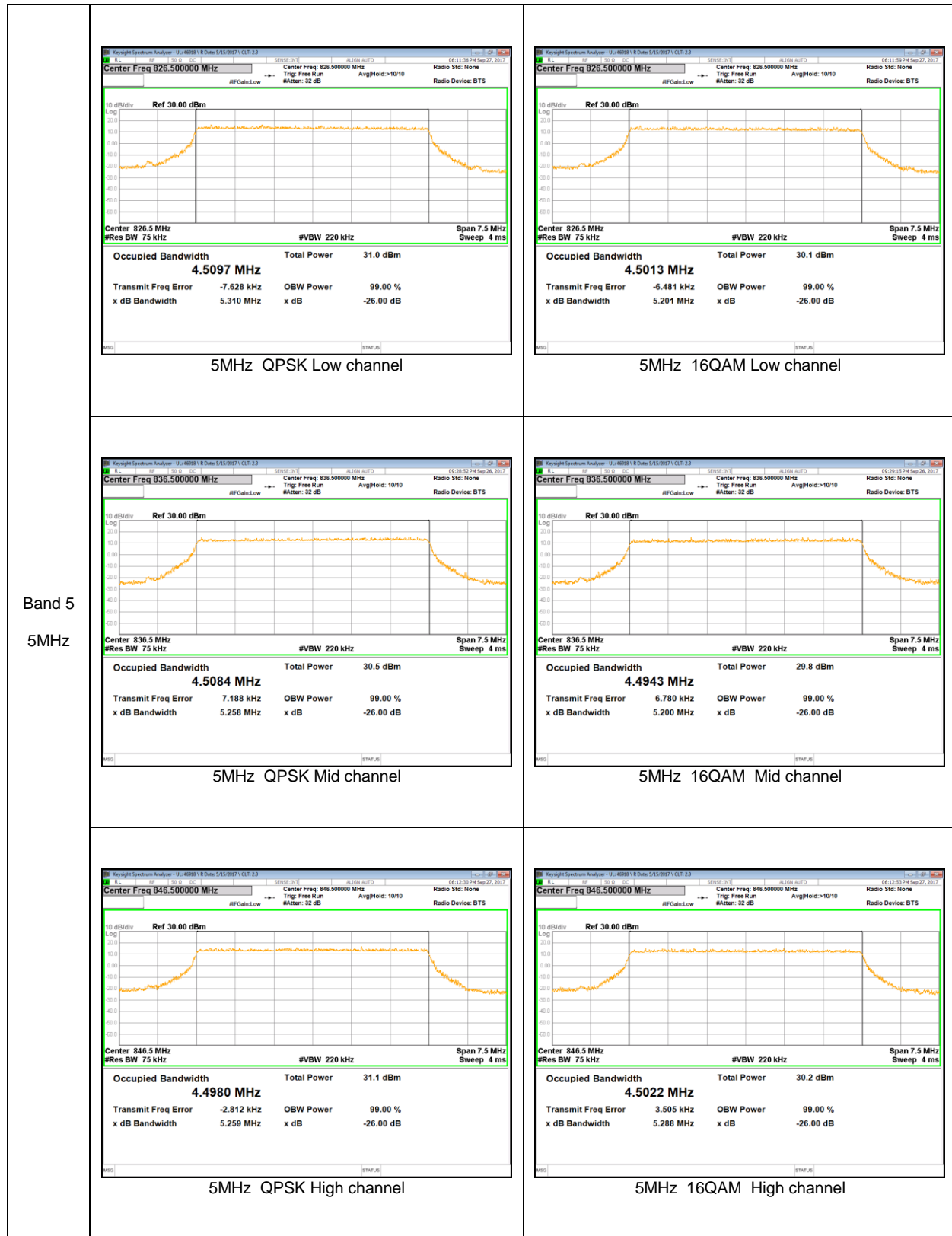

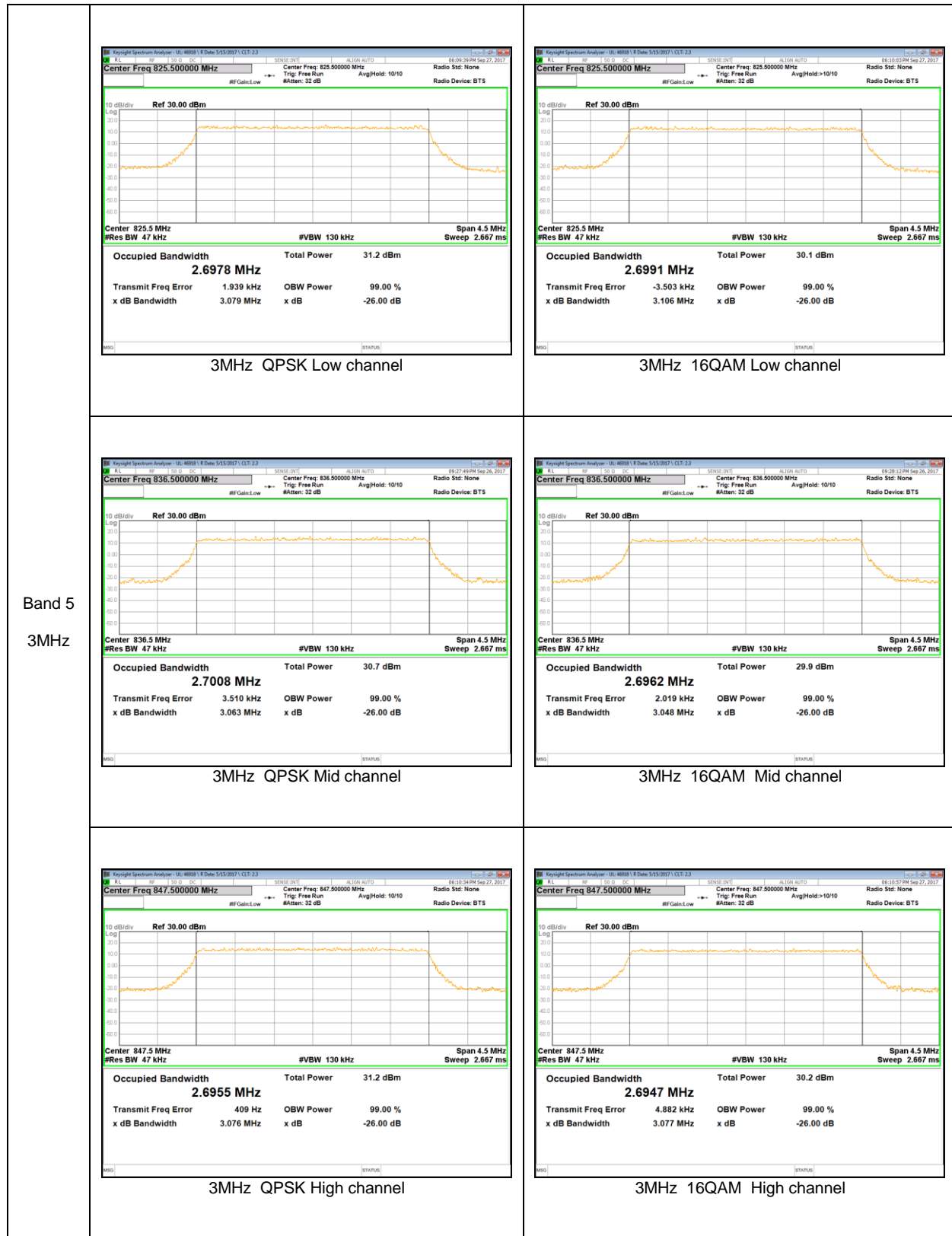

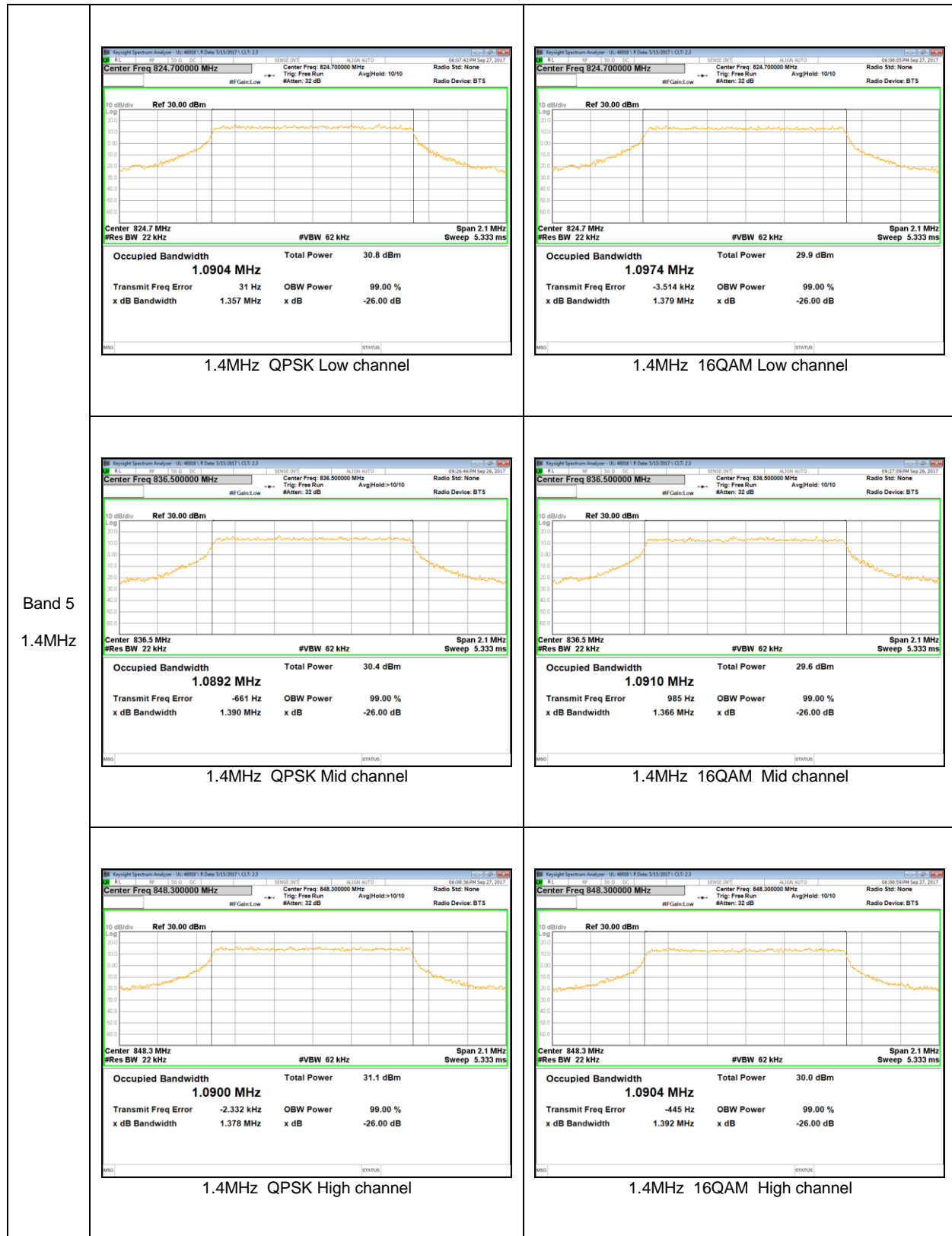

LTE Band 7

