

STRADDLE CHANNEL HORIZONTAL

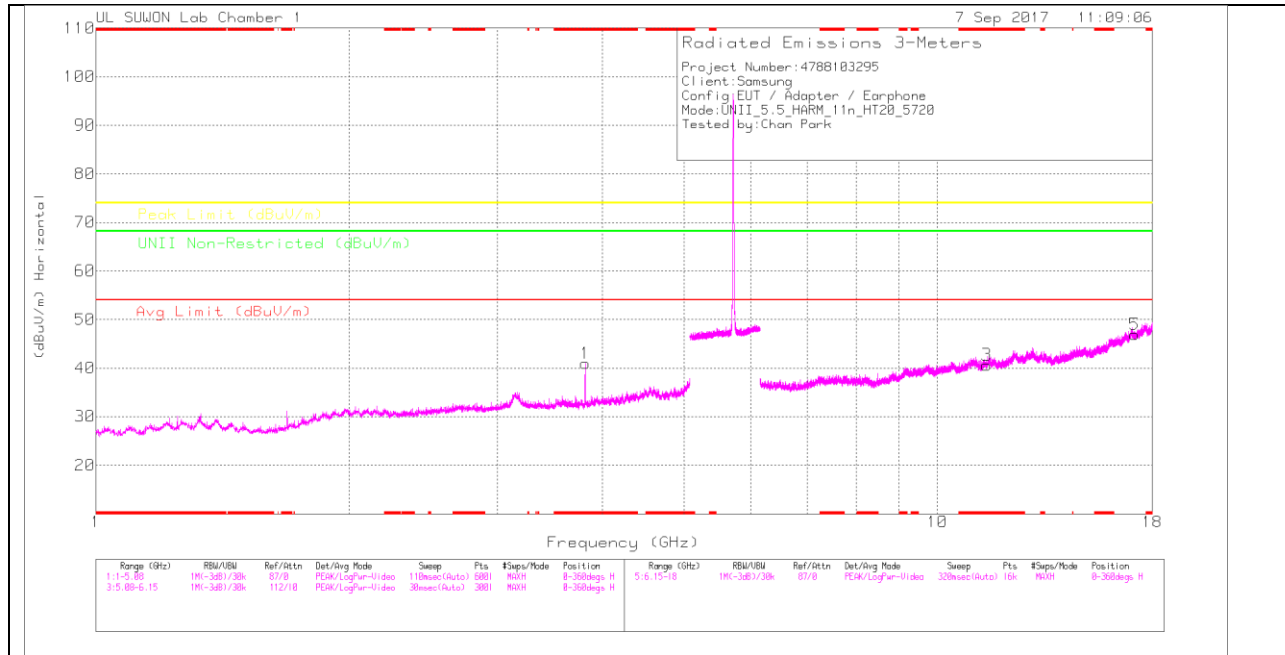

STRADDLE CHANNEL VERTICAL

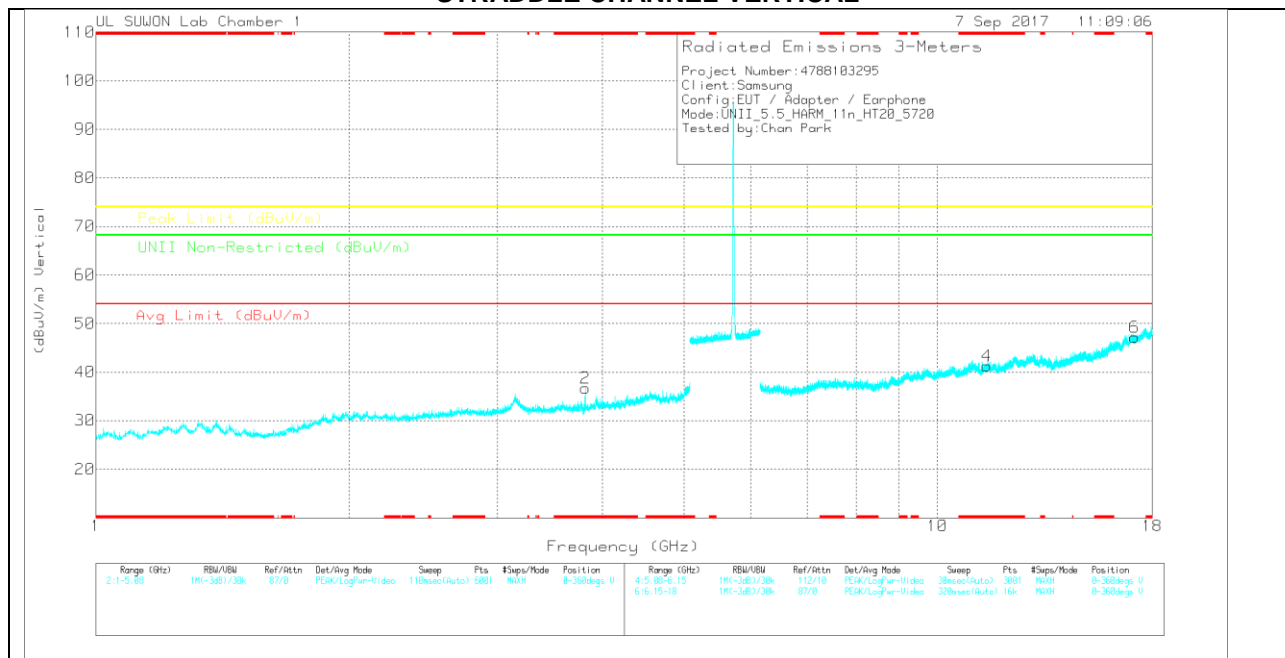

Note: Emission was scanned up to 40GHz; No emissions were detected above the noise floor which was at least 20dB below the specification limit.

STRADDLE CHANNEL DATA

Trace Markers

Marker	Frequency (GHz)	Meter Reading (dBuV)	Det	20170531_3117_0016 8717	5GHz_LP(dB)_170809	DC Corr (dB)	Corrected Reading (dBuV/m)	Avg Limit (dBuV/m)	Margin (dB)	Peak Limit (dBuV/m)	Margin (dB)	UNII Non-Restricted (dBuV/m)	Margin (dB)	Azimuth (Degs)	Height (cm)	Polarity
1	* 3.813	40.97	PK	33	-33	0	40.97	-	-	74	-33.03	-	-	0-360	150	H
2	* 3.813	36.66	PK	33	-33	0	36.66	-	-	74	-37.34	-	-	0-360	250	V
3	* 11.439	25.35	PK	38.1	-22.8	0	40.65	-	-	74	-33.35	-	-	0-360	250	H
5	17.16	23.85	PK	41.4	-18.3	0	46.95	-	-	-	-	68.2	-21.25	0-360	150	H
4	* 11.442	25.92	PK	38.1	-22.8	0	41.22	-	-	74	-32.78	-	-	0-360	250	V
6	17.157	24.1	PK	41.4	-18.3	0	47.2	-	-	-	-	68.2	-21	0-360	250	V

* - indicates frequency in CFR15.205/IC7.2.2 Restricted Band

PK – Peak detector

Radiated Emissions

Frequency (GHz)	Meter Reading (dBuV)	Det	20170531_3117_00168717	5GHz_LP(dB)_170809	DC Corr (dB)	Corrected Reading (dBuV/m)	Avg Limit (dBuV/m)	Margin (dB)	Peak Limit (dBuV/m)	Margin (dB)	UNII Non-Restricted (dBuV/m)	Margin (dB)	Azimuth (Degs)	Height (cm)	Polarity
* 3.813	48.14	PK-U	33	-33	0	48.14	-	-	74	-25.86	-	-	357	117	H
* 3.813	41.21	ADR	33	-33	.16	41.37	54	-12.63	-	-	-	-	357	117	H
* 3.813	45.04	PK-U	33	-33	0	45.04	-	-	74	-28.96	-	-	72	227	V
* 3.813	35.26	ADR	33	-33	.16	35.42	54	-18.58	-	-	-	-	72	227	V

* - indicates frequency in CFR15.205/IC7.2.2 Restricted Band

PK-U - U-NII: Maximum Peak

ADR - U-NII AD primary method, RMS average

10.3.3. TX ABOVE 1GHz 802.11n HT40 MODE IN THE 5.5GHz BAND RESTRICTED BANDEDGE (LOW CHANNEL)

HORIZONTAL PEAK AND AVERAGE PLOT

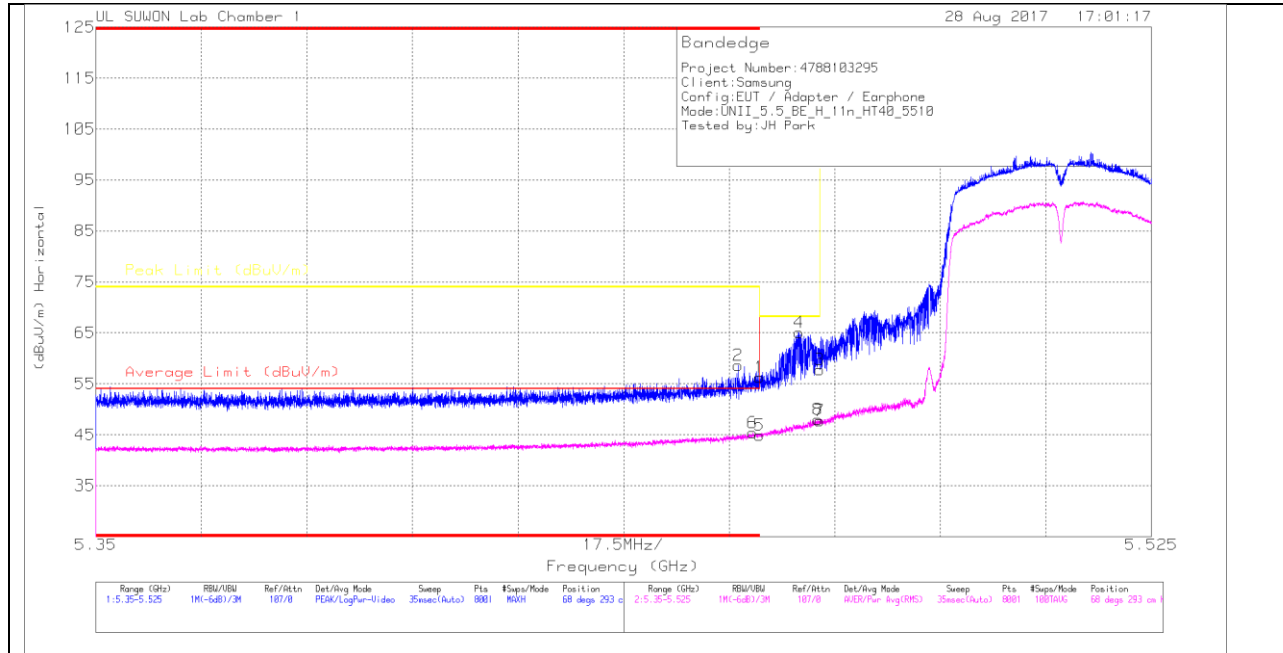

HORIZONTAL DATA

Trace Markers

Marker	Frequency (GHz)	Meter Reading (dBuV)	Det	20170531_31 17_00168717	10dB_ATT(dB) _170809	DC Corr (dB)	Corrected Reading (dBuV/m)	Average Limit (dBuV/m)	Margin (dB)	Peak Limit (dBuV/m)	PK Margin (dB)	Azimuth (Degs)	Height (cm)	Polarity
1	* 5.46	43.48	PK	34.3	-21.5	0	56.28	-	-	74	-17.72	68	293	H
2	* 5.456	45.9	PK	34.3	-21.6	0	58.6	-	-	74	-15.4	68	293	H
3	5.47	44.93	PK	34.3	-21.5	0	57.73	-	-	68.2	-10.47	68	293	H
4	5.467	52.39	PK	34.3	-21.6	0	65.09	-	-	68.2	-3.11	68	293	H
5	* 5.46	31.74	RMS	34.3	-21.5	.38	44.92	54	-9.08	-	-	68	293	H
6	* 5.459	32.27	RMS	34.3	-21.6	.38	45.35	54	-8.65	-	-	68	293	H

* - indicates frequency in CFR15.205/IC7.2.2 Restricted Band

PK - Peak detector

RMS - RMS detection

VERTICAL PEAK AND AVERAGE PLOT

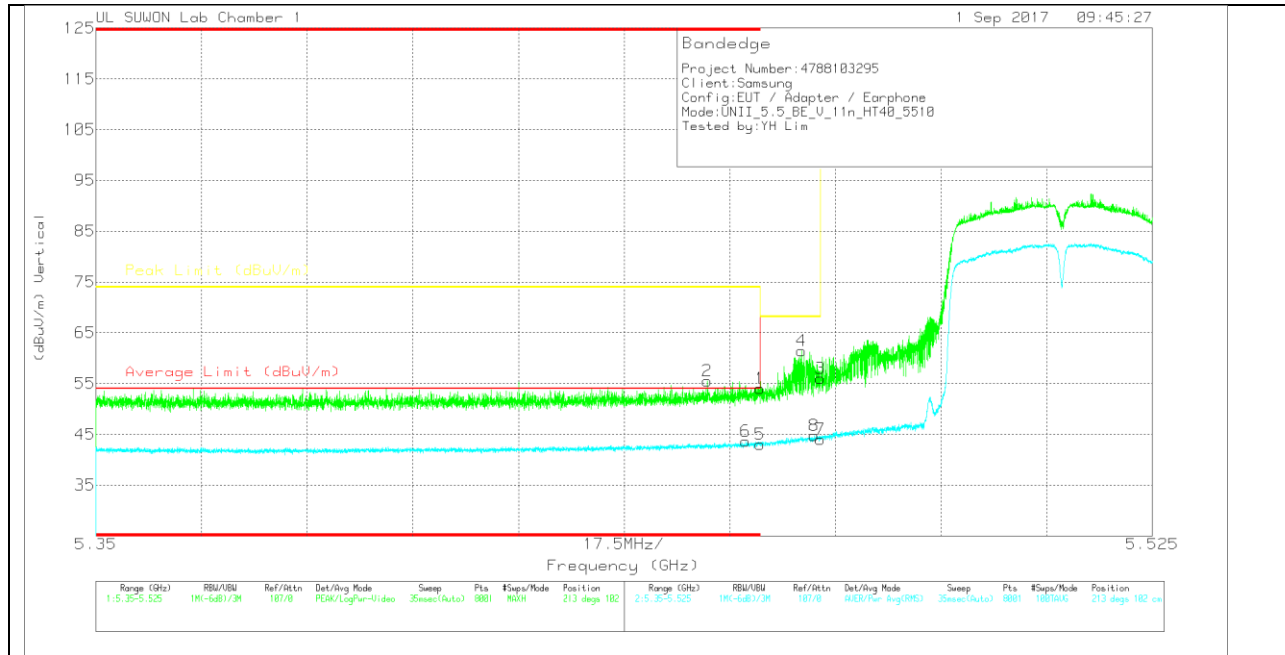

VERTICAL DATA

Trace Markers

Marker	Frequency (GHz)	Meter Reading (dBuV)	Det	20170531_3 117_001687 17	10dB_ATT(dB)_170809	DC Corr (dB)	Corrected Reading (dBuV/m)	Average Limit (dBuV/m)	Margin (dB)	Peak Limit (dBuV/m)	PK Margin (dB)	Azimuth (Degs)	Height (cm)	Polarity
1	* 5.46	41.19	PK	34.3	-21.5	0	53.99	-	-	74	-20.01	213	102	V
2	* 5.451	42.87	PK	34.3	-21.6	0	55.57	-	-	74	-18.43	213	102	V
3	5.47	43.2	PK	34.3	-21.5	0	56	-	-	68.2	-12.2	213	102	V
4	5.467	48.79	PK	34.3	-21.6	0	61.49	-	-	68.2	-6.71	213	102	V
5	* 5.46	29.8	RMS	34.3	-21.5	.38	42.98	54	-11.02	-	-	213	102	V
6	* 5.458	30.53	RMS	34.3	-21.6	.38	43.61	54	-10.39	-	-	213	102	V

* - indicates frequency in CFR15.205/IC7.2.2 Restricted Band

PK - Peak detector

RMS - RMS detection

AUTHORIZED BANDEDGE (HIGH CHANNEL)

HORIZONTAL PEAK AND AVERAGE PLOT

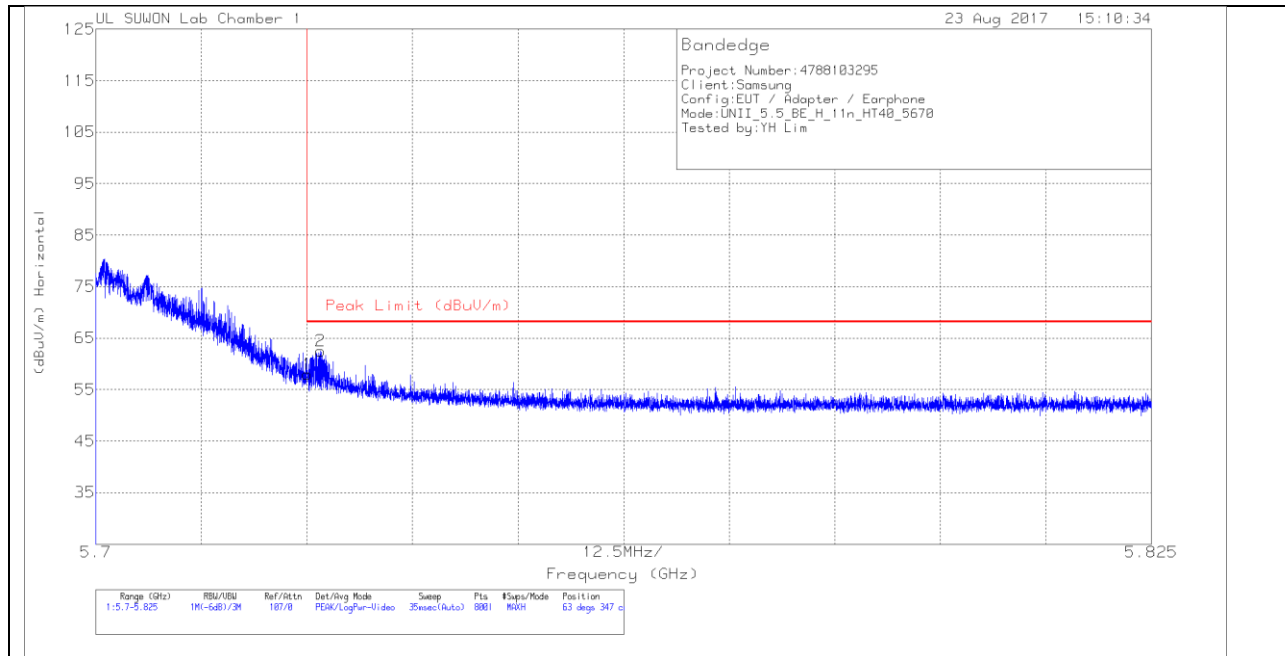

HORIZONTAL DATA

Trace Markers

Marker	Frequency (GHz)	Meter Reading (dBuV)	Det	20170531_3117_0016 8717	10dB_ATT(dB)_17080 9	DC Corr (dB)	Corrected Reading (dBuV/m)	Peak Limit (dBuV/m)	PK Margin (dB)	Azimuth (Degs)	Height (cm)	Polarity
1	5.725	44.83	Pk	34.4	-21.2	0	58.03	68.2	-10.17	63	347	H
2	5.727	49.32	Pk	34.4	-21.2	0	62.52	68.2	-5.68	63	347	H

Pk - Peak detector

VERTICAL PEAK AND AVERAGE PLOT

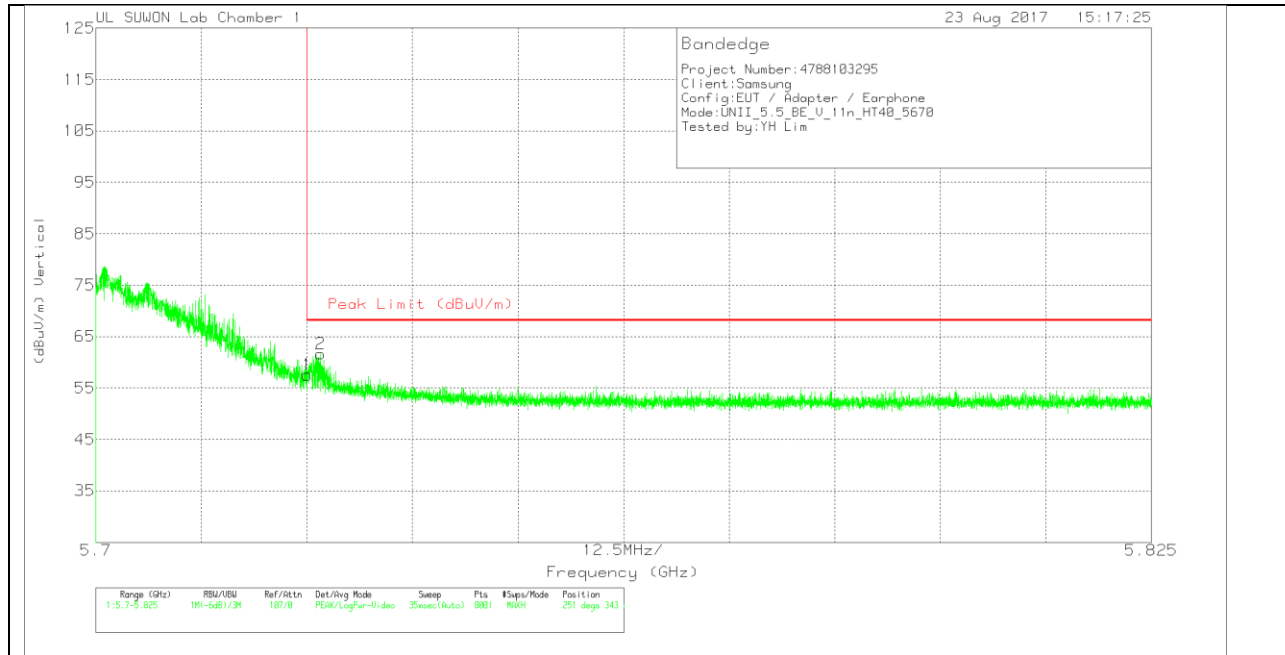

VERTICAL DATA

Trace Markers

Marker	Frequency (GHz)	Meter Reading (dBuV)	Det	20170531_3117_00168717	10dB_ATT(dB)_170809	DC Corr (dB)	Corrected Reading (dBuV/m)	Peak Limit (dBuV/m)	PK Margin (dB)	Azimuth (Degs)	Height (cm)	Polarity
1	5.725	44.36	Pk	34.4	-21.2	0	57.56	68.2	-10.64	251	343	V
2	5.727	48.47	Pk	34.4	-21.2	0	61.67	68.2	-6.53	251	343	V

Pk - Peak detector

HARMONICS AND SPURIOUS EMISSIONS

LOW CHANNEL HORIZONTAL

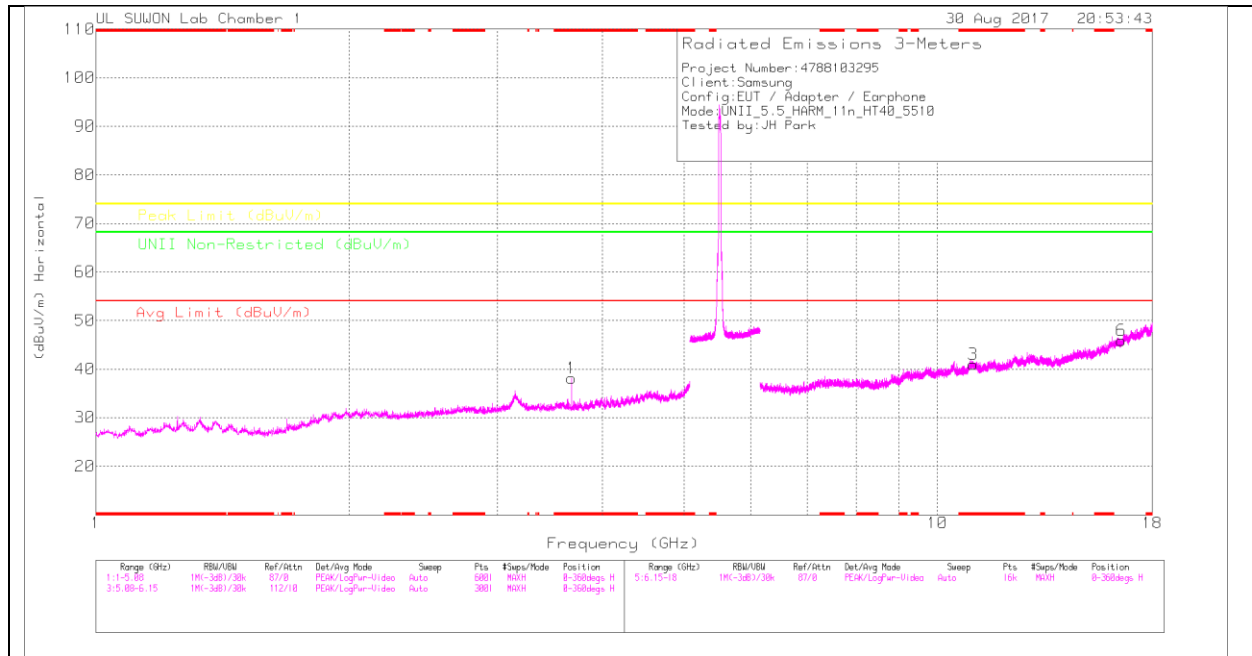

LOW CHANNEL VERTICAL

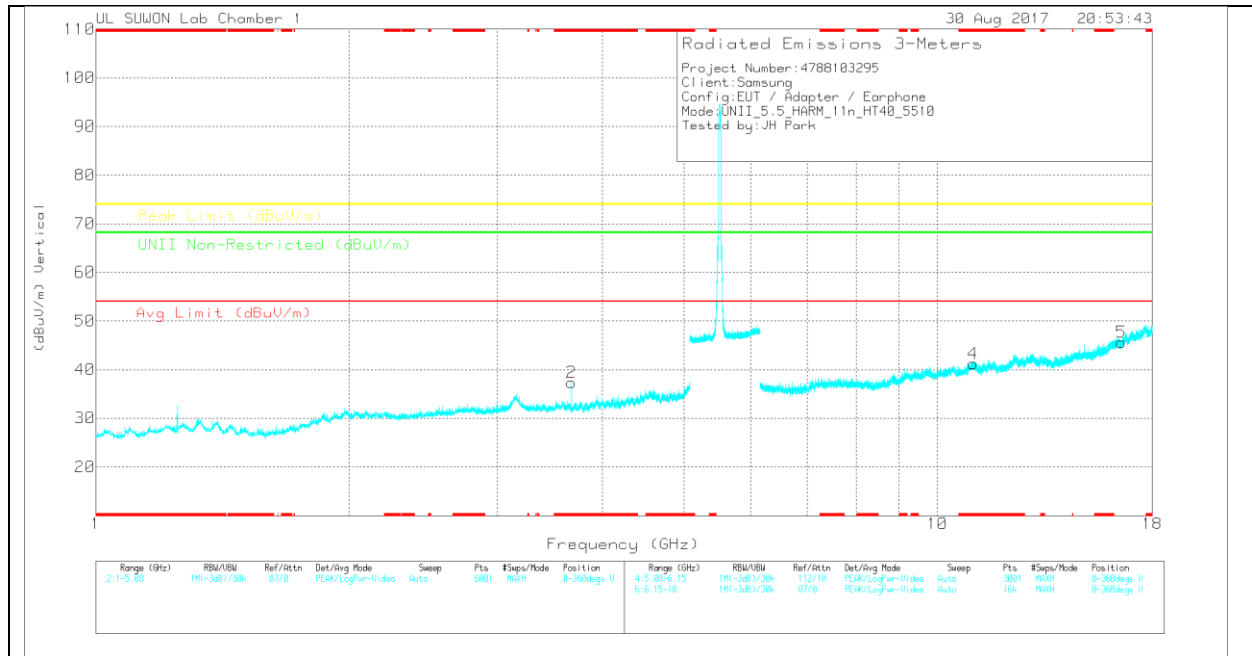

Note: Emission was scanned up to 40GHz; No emissions were detected above the noise floor which was at least 20dB below the specification limit.

LOW CHANNEL DATA

Trace Markers

Marker	Frequency (GHz)	Meter Reading (dBuV)	Det	20170531_3117_0016 8717	5GHz_LP(dB)_170809	DC Corr (dB)	Corrected Reading (dBuV/m)	Avg Limit (dBuV/m)	Margin (dB)	Peak Limit (dBuV/m)	Margin (dB)	UNII Non-Restricted (dBuV/m)	Margin (dB)	Azimuth (Degs)	Height (cm)	Polarity
1	* 3.674	37.73	PK	32.7	-32.3	0	38.13	-	-	74	-35.87	-	-	0-360	150	H
2	* 3.674	36.96	PK	32.7	-32.3	0	37.36	-	-	74	-36.64	-	-	0-360	250	V
3	* 11.02	24.98	PK	38	-22	0	40.98	-	-	74	-33.02	-	-	0-360	150	H
6	16.528	25.09	PK	40.7	-19.9	0	45.89	-	-	-	-	68.2	-22.31	0-360	150	H
4	* 11.024	25.24	PK	38	-22	0	41.24	-	-	74	-32.76	-	-	0-360	250	V
5	16.53	24.86	PK	40.7	-19.9	0	45.66	-	-	-	-	68.2	-22.54	0-360	150	V

* - indicates frequency in CFR15.205/IC7.2.2 Restricted Band

PK – Peak Detector

Radiated Emissions

Frequency (GHz)	Meter Reading (dBuV)	Det	20170531_3117_00168717	5GHz_LP(dB)_170809	DC Corr (dB)	Corrected Reading (dBuV/m)	Avg Limit (dBuV/m)	Margin (dB)	Peak Limit (dBuV/m)	Margin (dB)	UNII Non-Restricted (dBuV/m)	Margin (dB)	Azimuth (Degs)	Height (cm)	Polarity
* 3.673	46.03	PK-U	32.7	-32.3	0	46.43	-	-	74	-27.57	-	-	334	389	H
* 3.673	38.98	ADR	32.7	-32.3	.38	39.76	54	-14.24	-	-	-	-	334	389	H
* 3.673	45.57	PK-U	32.7	-32.3	0	45.97	-	-	74	-28.03	-	-	127	276	V
* 3.673	37.37	ADR	32.7	-32.3	.38	38.15	54	-15.85	-	-	-	-	127	276	V

* - indicates frequency in CFR15.205/IC7.2.2 Restricted Band

PK-U - U-NII: Maximum Peak

ADR - U-NII AD primary method, RMS average

MID CHANNEL HORIZONTAL

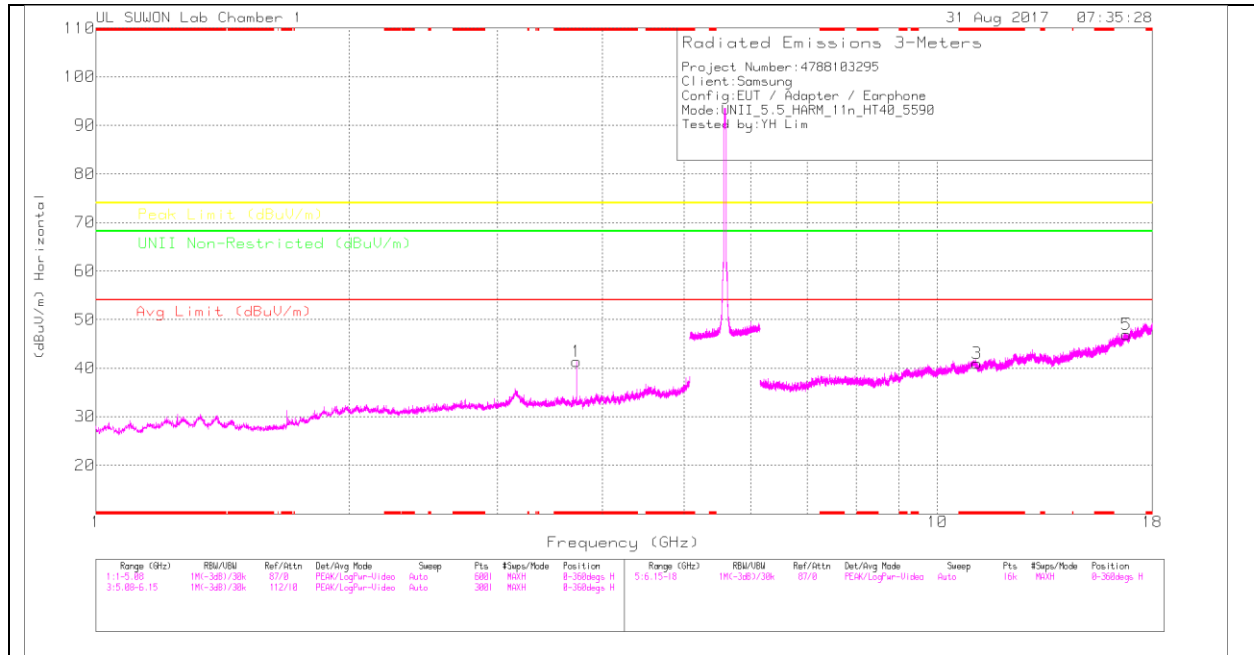

MID CHANNEL VERTICAL

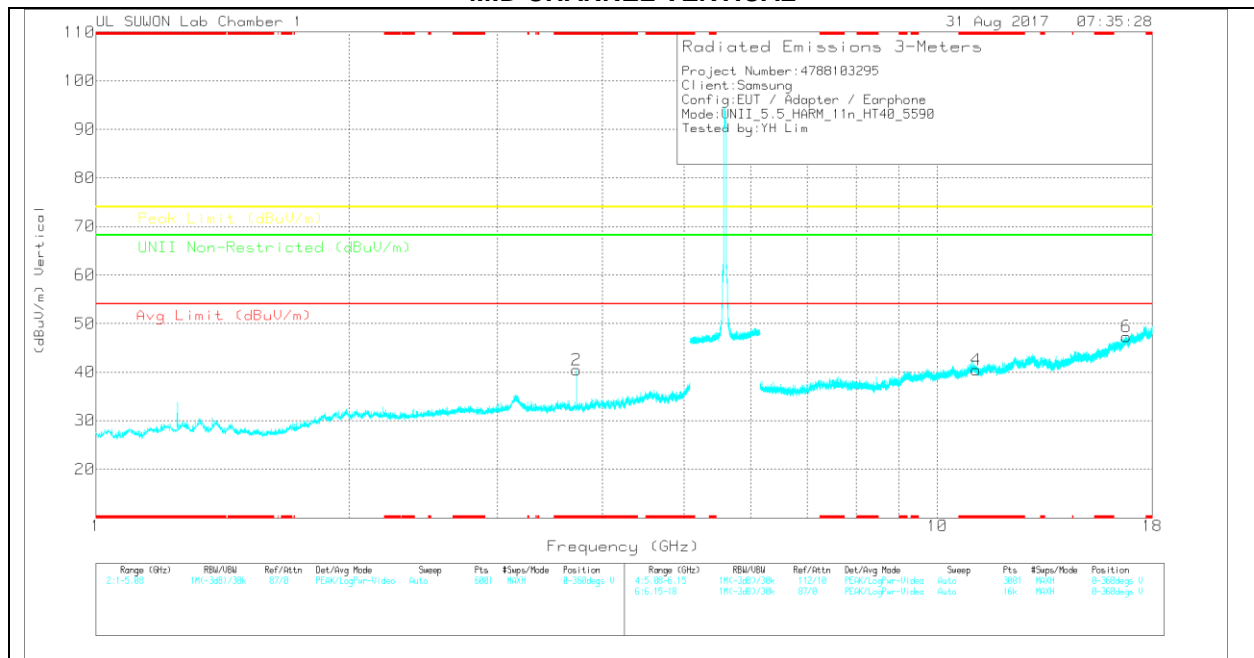

Note: Emission was scanned up to 40GHz; No emissions were detected above the noise floor which was at least 20dB below the specification limit.

MID CHANNEL DATA

Trace Markers

Marker	Frequency (GHz)	Meter Reading (dBuV)	Det	20170531_3117_00168717	5GHz_LP(dB)_170809	DC Corr (dB)	Corrected Reading (dBuV/m)	Avg Limit (dBuV/m)	Margin (dB)	Peak Limit (dBuV/m)	Margin (dB)	UNII Non-Restricted (dBuV/m)	Margin (dB)	Azimuth (Degs)	Height (cm)	Polarity
1	* 3.727	41.11	PK	32.8	-32.6	0	41.31	-	-	74	-32.69	-	-	0-360	150	H
2	* 3.727	40.24	PK	32.8	-32.6	0	40.44	-	-	74	-33.56	-	-	0-360	250	V
3	* 11.133	25.82	PK	37.9	-22.7	0	41.02	-	-	74	-32.98	-	-	0-360	250	H
5	16.762	24.19	PK	40.9	-18.2	0	46.89	-	-	-	-	68.2	-21.31	0-360	250	H
4	* 11.127	25.41	PK	37.9	-22.8	0	40.51	-	-	74	-33.49	-	-	0-360	250	V
6	16.768	24.66	PK	40.9	-18.2	0	47.36	-	-	-	-	68.2	-20.84	0-360	250	V

* - indicates frequency in CFR15.205/IC7.2.2 Restricted Band

PK – Peak Detector

Radiated Emissions

Frequency (GHz)	Meter Reading (dBuV)	Det	20170531_3117_00168717	5GHz_LP(dB)_170809	DC Corr (dB)	Corrected Reading (dBuV/m)	Avg Limit (dBuV/m)	Margin (dB)	Peak Limit (dBuV/m)	Margin (dB)	UNII Non-Restricted (dBuV/m)	Margin (dB)	Azimuth (Degs)	Height (cm)	Polarity
* 3.727	47.03	PK-U	32.8	-32.6	0	47.23	-	-	74	-26.77	-	-	352	318	H
* 3.727	40.85	ADR	32.8	-32.6	.38	41.43	54	-12.57	-	-	-	-	352	318	H
* 3.727	47.1	PK-U	32.8	-32.6	0	47.3	-	-	74	-26.7	-	-	124	313	V
* 3.727	40.15	ADR	32.8	-32.6	.38	40.73	54	-13.27	-	-	-	-	124	313	V

* - indicates frequency in CFR15.205/IC7.2.2 Restricted Band

PK-U - U-NII: Maximum Peak

ADR - U-NII AD primary method, RMS average

HIGH CHANNEL HORIZONTAL

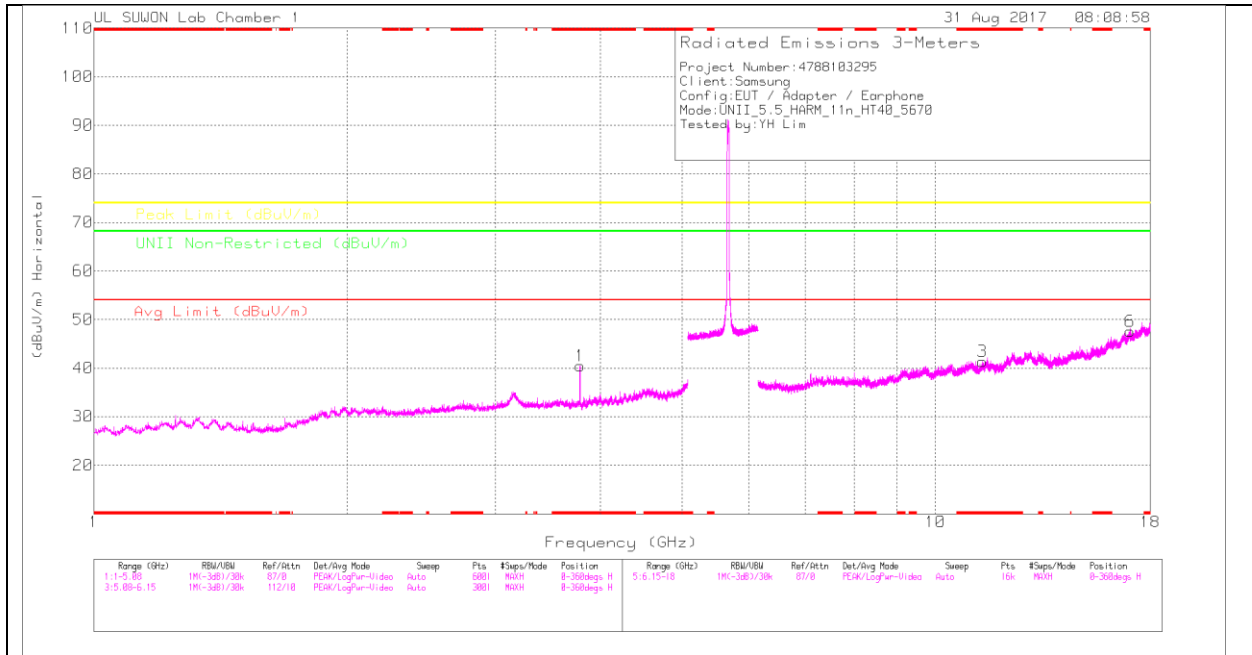

HIGH CHANNEL VERTICAL

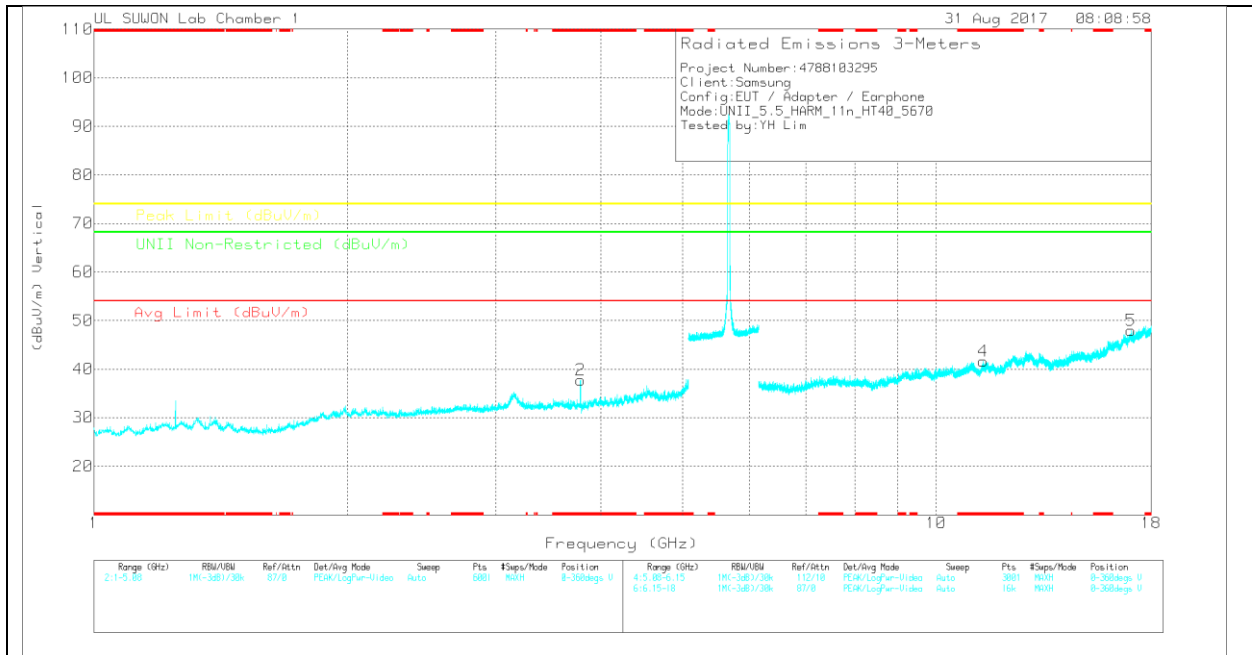

Note: Emission was scanned up to 40GHz; No emissions were detected above the noise floor which was at least 20dB below the specification limit.

HIGH CHANNEL DATA

Trace Markers

Marker	Frequency (GHz)	Meter Reading (dBuV)	Det	20170531_3117_0016 8717	5GHz_LP(dB)_170809	DC Corr (dB)	Corrected Reading (dBuV/m)	Avg Limit (dBuV/m)	Margin (dB)	Peak Limit (dBuV/m)	Margin (dB)	UNII Non-Restricted (dBuV/m)	Margin (dB)	Azimuth (Degs)	Height (cm)	Polarity
1	* 3.781	40.35	PK	33	-32.9	0	40.45	-	-	74	-33.55	-	-	0-360	150	H
2	* 3.781	37.61	PK	33	-32.9	0	37.71	-	-	74	-36.29	-	-	0-360	250	V
3	* 11.375	26.12	PK	38	-22.7	0	41.42	-	-	74	-32.58	-	-	0-360	150	H
6	17.034	24.19	PK	41.1	-17.7	0	47.59	-	-	-	-	68.2	-20.61	0-360	250	H
4	* 11.364	26.28	PK	38	-22.7	0	41.58	-	-	74	-32.42	-	-	0-360	250	V
5	17.044	24.58	PK	41.1	-17.7	0	47.98	-	-	-	-	68.2	-20.22	0-360	250	V

* - indicates frequency in CFR15.205/IC7.2.2 Restricted Band

PK – Peak Detector

Radiated Emissions

Frequency (GHz)	Meter Reading (dBuV)	Det	20170531_3117_00168717	5GHz_LP(dB)_170809	DC Corr (dB)	Corrected Reading (dBuV/m)	Avg Limit (dBuV/m)	Margin (dB)	Peak Limit (dBuV/m)	Margin (dB)	UNII Non-Restricted (dBuV/m)	Margin (dB)	Azimuth (Degs)	Height (cm)	Polarity
* 3.78	47.7	PK-U	33	-32.9	0	47.8	-	-	74	-26.2	-	-	346	190	H
* 3.78	40.57	ADR	33	-32.9	.38	41.05	54	-12.95	-	-	-	-	346	190	H
* 3.78	46.57	PK-U	33	-32.9	0	46.67	-	-	74	-27.33	-	-	114	380	V
* 3.78	38.91	ADR	33	-32.9	.38	39.39	54	-14.61	-	-	-	-	114	380	V

* - indicates frequency in CFR15.205/IC7.2.2 Restricted Band

PK-U - U-NII: Maximum Peak

ADR - U-NII AD primary method, RMS average

STRADDLE CHANNEL HORIZONTAL

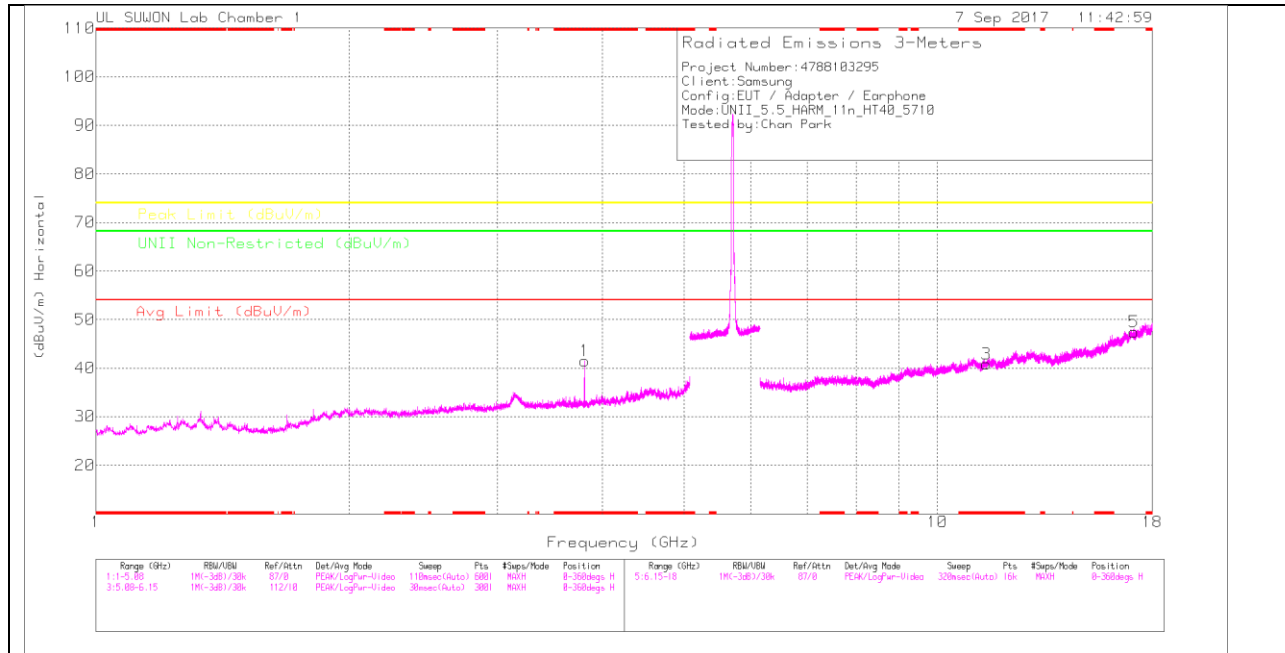

STRADDLE CHANNEL VERTICAL

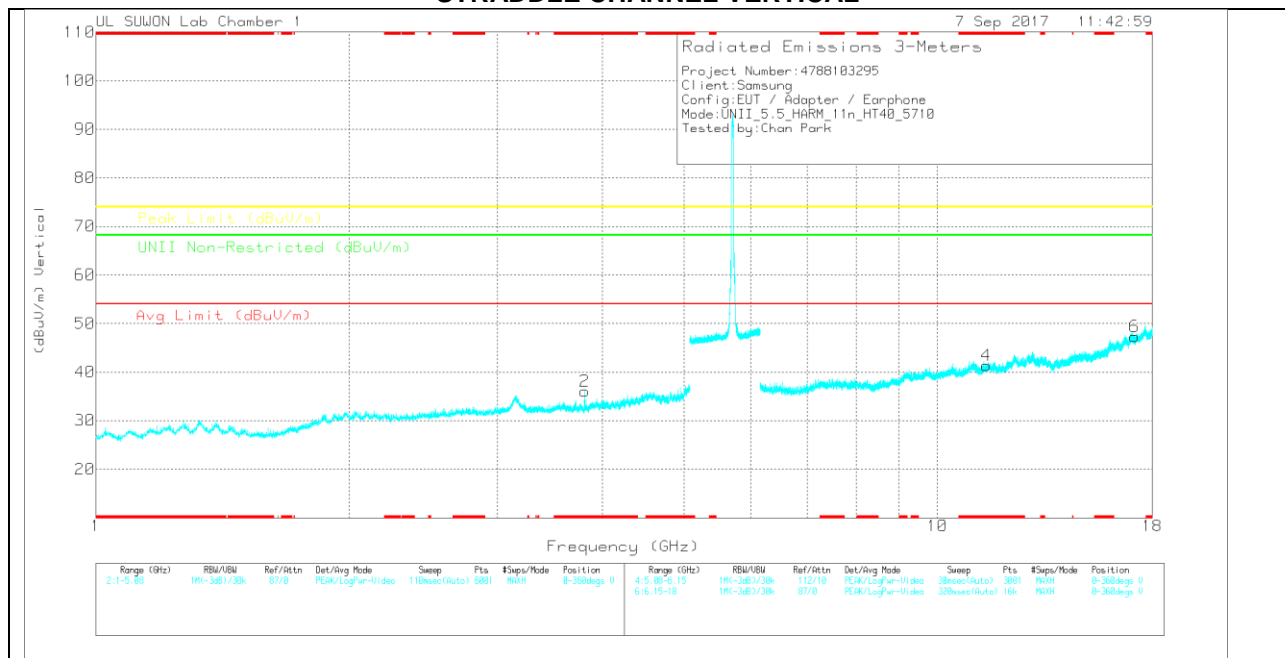

Note: Emission was scanned up to 40GHz; No emissions were detected above the noise floor which was at least 20dB below the specification limit.

STRADDLE CHANNEL DATA

Trace Markers

Marker	Frequency (GHz)	Meter Reading (dBuV)	Det	20170531_3117_0016 8717	5GHz_LP(dB)_170809	DC Corr (dB)	Corrected Reading (dBuV/m)	Avg Limit (dBuV/m)	Margin (dB)	Peak Limit (dBuV/m)	Margin (dB)	UNII Non-Restricted (dBuV/m)	Margin (dB)	Azimuth (Degs)	Height (cm)	Polarity
1	* 3.807	41.53	PK	33	-33	0	41.53	-	-	74	-32.47	-	-	0-360	250	H
2	* 3.806	36.01	PK	33	-33	0	36.01	-	-	74	-37.99	-	-	0-360	250	V
3	* 11.421	25.47	PK	38.1	-22.7	0	40.87	-	-	74	-33.13	-	-	0-360	250	H
5	17.132	24.3	PK	41.4	-18.3	0	47.4	-	-	-	-	68.2	-20.8	0-360	250	H
4	* 11.42	25.94	PK	38.1	-22.7	0	41.34	-	-	74	-32.66	-	-	0-360	250	V
6	17.136	24.16	PK	41.4	-18.3	0	47.26	-	-	-	-	68.2	-20.94	0-360	250	V

* - indicates frequency in CFR15.205/IC7.2.2 Restricted Band

PK – Peak detector

Radiated Emissions

Frequency (GHz)	Meter Reading (dBuV)	Det	20170531_3117_00168717	5GHz_LP(dB)_170809	DC Corr (dB)	Corrected Reading (dBuV/m)	Avg Limit (dBuV/m)	Margin (dB)	Peak Limit (dBuV/m)	Margin (dB)	UNII Non-Restricted (dBuV/m)	Margin (dB)	Azimuth (Degs)	Height (cm)	Polarity
* 3.806	47.29	PK-U	33	-33	0	47.29	-	-	74	-26.71	-	-	348	117	H
* 3.807	40.82	ADR	33	-33	.38	41.2	54	-12.8	-	-	-	-	348	117	H
* 3.807	45.56	PK-U	33	-33	0	45.56	-	-	74	-28.44	-	-	47	382	V
* 3.807	36.3	ADR	33	-33	.38	36.68	54	-17.32	-	-	-	-	47	382	V

* - indicates frequency in CFR15.205/IC7.2.2 Restricted Band

PK-U - U-NII: Maximum Peak

ADR - U-NII AD primary method, RMS average

10.4. 5.8 GHz

10.4.1. TX ABOVE 1GHz 802.11a MODE IN THE 5.8GHz BAND BANDEDGE (LOW CHANNEL)

HORIZONTAL PEAK PLOT

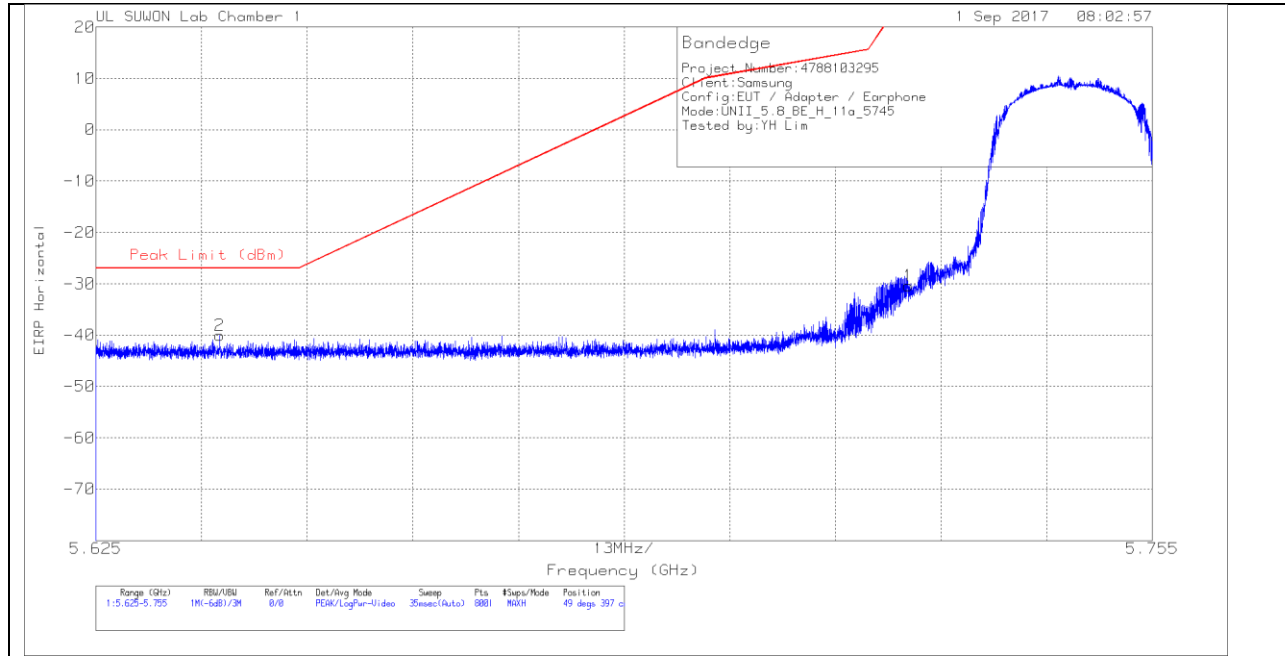

HORIZONTAL DATA

Trace Markers

Marker	Frequency (GHz)	Meter Reading (dBm)	Det	20170531_3117_001_68717	10dB_ATT(dB)_17080_9	Conversion Factor (dB)	DC Corr (dB)	Corrected Reading EIRP	Peak Limit (dBm)	PK Margin (dB)	Azimuth (Degs)	Height (cm)	Polarity
1	5.725	-55.52	Pk	34.5	-21.2	11.8	0	-30.42	26.97	-57.39	49	397	H
2	5.64	-65.01	Pk	34.4	-21.2	11.8	0	-40.01	-27	-13.01	49	397	H

Pk - Peak detector

VERTICAL PEAK PLOT

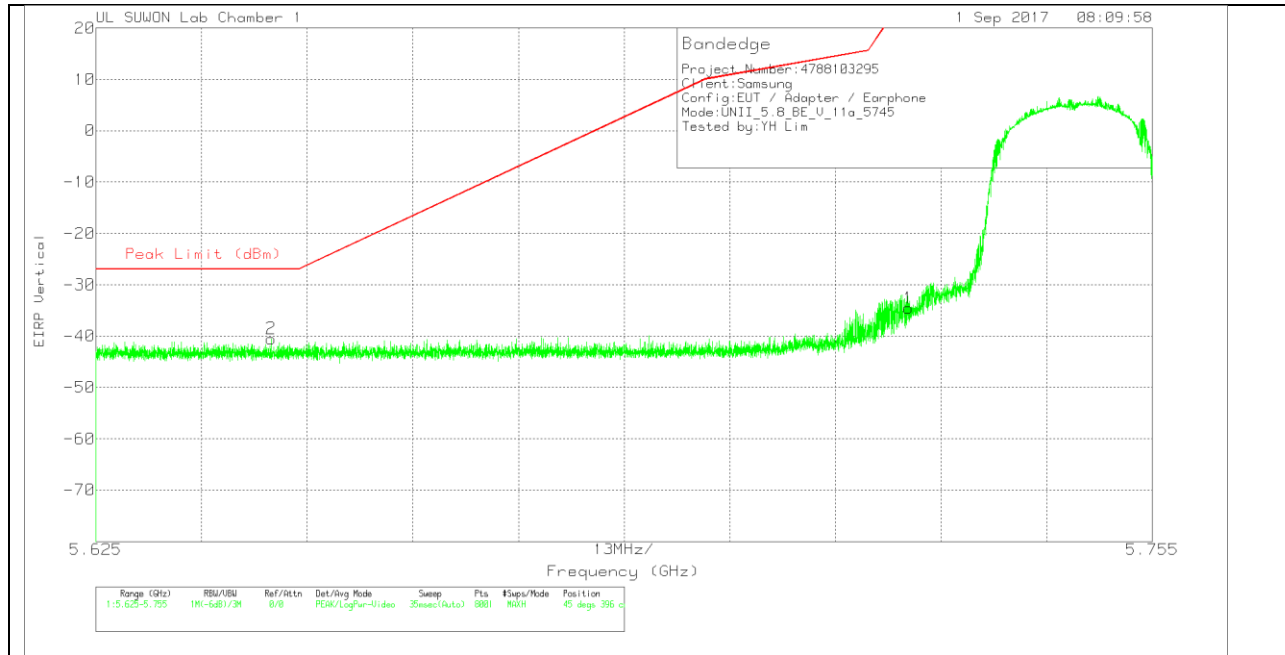

VERTICAL DATA

Trace Markers

Marker	Frequency (GHz)	Meter Reading (dBm)	Det	20170531_3117_001_68717	10dB_ATT(dB)_17080_9	Conversion Factor (dB)	DC Corr (dB)	Corrected Reading EIRP	Peak Limit (dBm)	PK Margin (dB)	Azimuth (Degs)	Height (cm)	Polarity
1	5.725	-59.66	Pk	34.5	-21.2	11.8	0	-34.56	26.97	-61.53	45	396	V
2	5.647	-65.37	Pk	34.4	-21.3	11.8	0	-40.47	-27	-13.47	45	396	V

Pk - Peak detector

BANDEDGE (HIGH CHANNEL)

HORIZONTAL PEAK PLOT

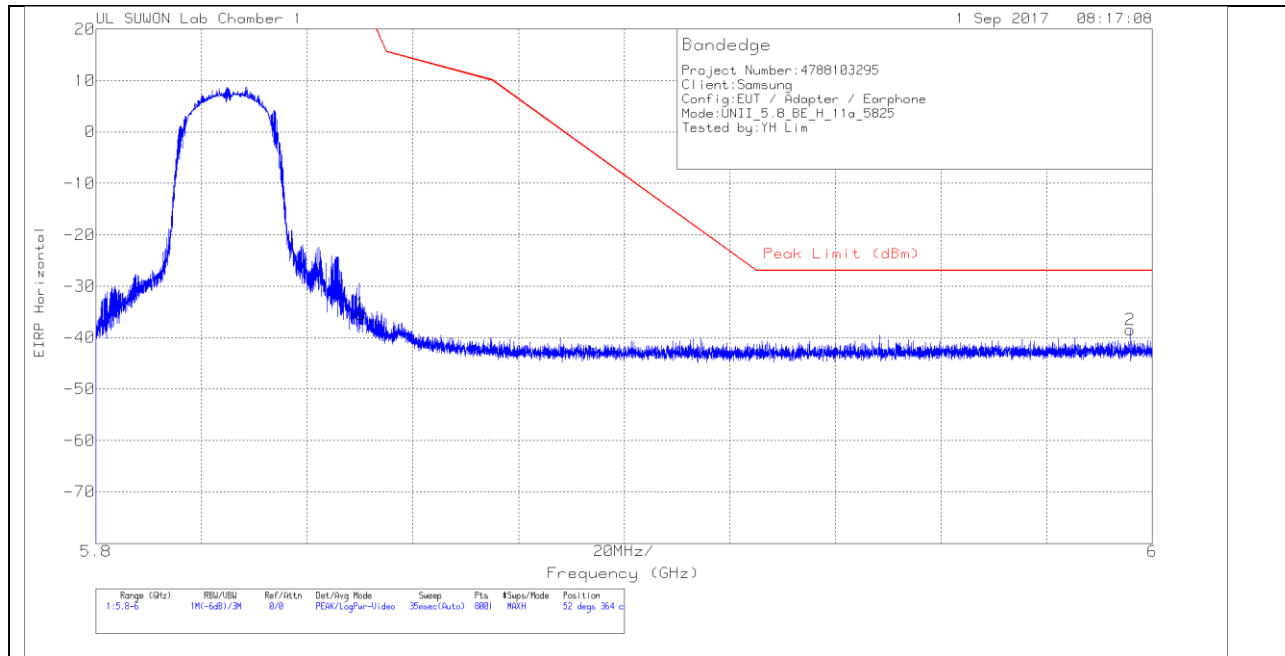

HORIZONTAL DATA

Trace Markers

Marker	Frequency (GHz)	Meter Reading (dBm)	Det	20170531_3117_001_68717	10dB_ATT(dB)_17080_9	Conversion Factor (dB)	DC Corr (dB)	Corrected Reading EIRP	Peak Limit (dBm)	PK Margin (dB)	Azimuth (Degs)	Height (cm)	Polarity
1	5.85	-60.65	Pk	34.5	-21.1	11.8	0	-35.45	26.94	-62.39	52	364	H
2	5.996	-64.23	Pk	34.8	-20.8	11.8	0	-38.43	-27	-11.43	52	364	H

Pk - Peak detector

VERTICAL PEAK PLOT

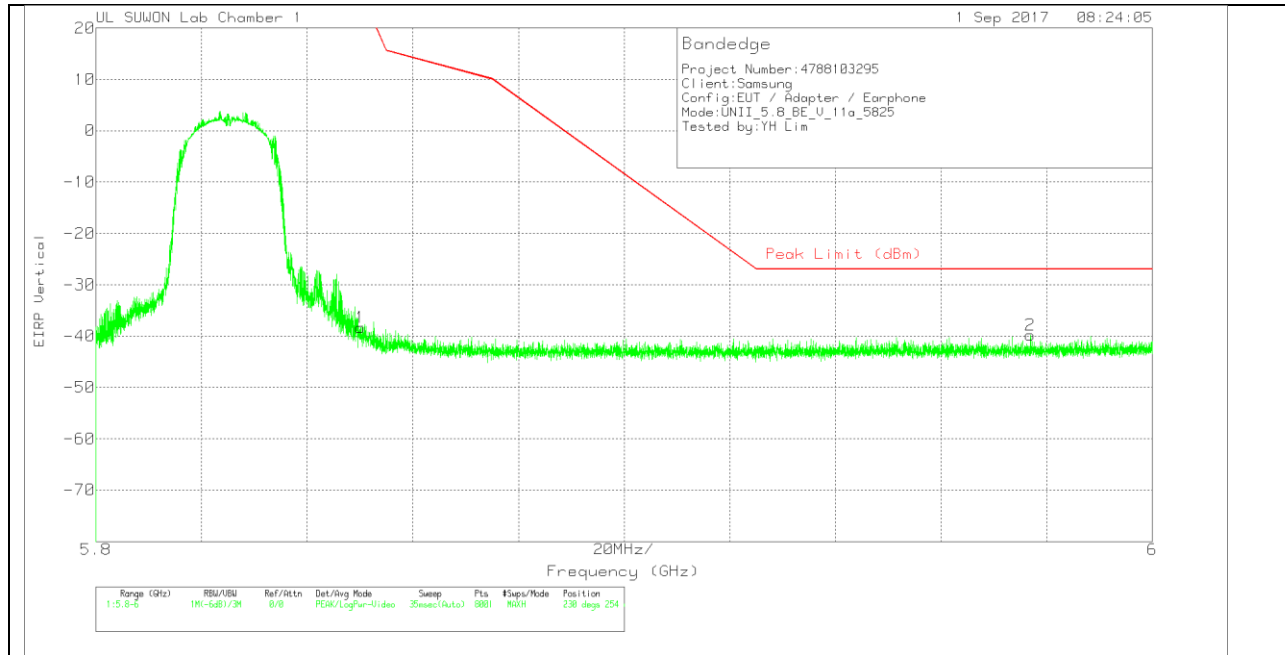

VERTICAL DATA

Trace Markers

Marker	Frequency (GHz)	Meter Reading (dBm)	Det	20170531_3117_001_68717	10dB_ATT(dB)_17080_9	Conversion Factor (dB)	DC Corr (dB)	Corrected Reading EIRP	Peak Limit (dBm)	PK Margin (dB)	Azimuth (Degs)	Height (cm)	Polarity
1	5.85	-63.55	Pk	34.5	-21.1	11.8	0	-38.35	26.94	-65.29	230	254	V
2	5.977	-65.39	Pk	34.7	-20.9	11.8	0	-39.79	-27	-12.79	230	254	V

Pk - Peak detector

LOW CHANNEL HORIZONTAL

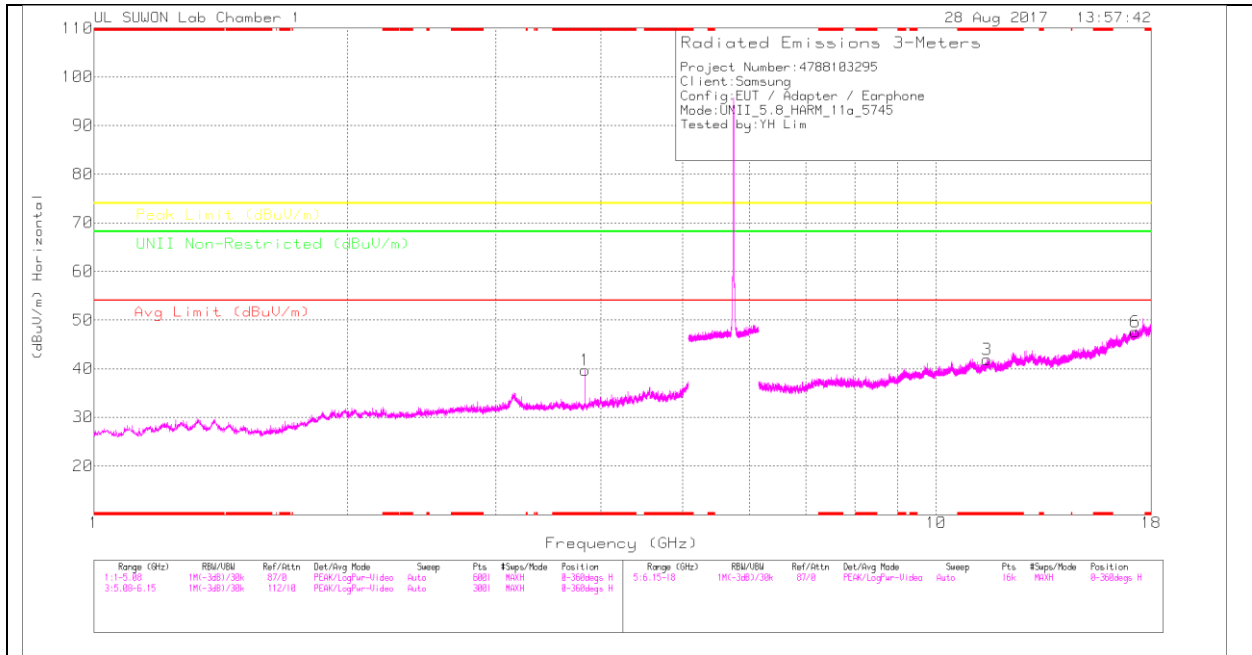

LOW CHANNEL VERTICAL

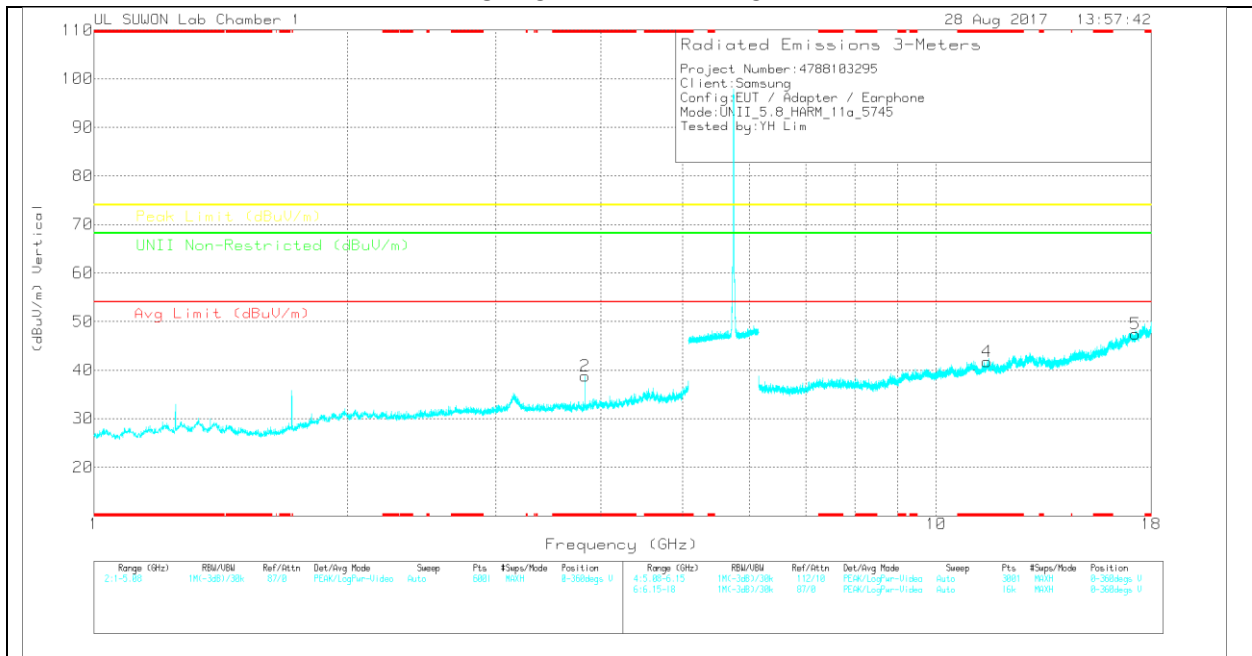

Note: Emission was scanned up to 40GHz; No emissions were detected above the noise floor which was at least 20dB below the specification limit.

LOW CHANNEL DATA

Trace Markers

Marker	Frequency (GHz)	Meter Reading (dBuV)	Det	20170531_3117_0016 8717	5GHz_LP(dB)_170809	DC Corr (dB)	Corrected Reading (dBuV/m)	Avg Limit (dBuV/m)	Margin (dB)	Peak Limit (dBuV/m)	Margin (dB)	UNII Non-Restricted (dBuV/m)	Margin (dB)	Azimuth (Degs)	Height (cm)	Polarity
1	* 3.83	39.57	PK	33.1	-33	0	39.67	-	-	74	-34.33	-	-	0-360	150	H
2	* 3.83	38.67	PK	33.1	-33	0	38.77	-	-	74	-35.23	-	-	0-360	250	V
3	* 11.493	26.47	PK	38.2	-22.8	0	41.87	-	-	74	-32.13	-	-	0-360	150	H
6	17.235	24.05	PK	41.6	-18.1	0	47.55	-	-	-	-	68.2	-20.65	0-360	250	H
4	* 11.494	26.36	PK	38.2	-22.8	0	41.76	-	-	74	-32.24	-	-	0-360	250	V
5	17.234	23.9	PK	41.6	-18.1	0	47.4	-	-	-	-	68.2	-20.8	0-360	150	V

* - indicates frequency in CFR15.205/IC7.2.2 Restricted Band

PK – Peak Detector

Radiated Emissions

Frequency (GHz)	Meter Reading (dBuV)	Det	20170531_3117_00168717	5GHz_LP(dB)_170809	DC Corr (dB)	Corrected Reading (dBuV/m)	Avg Limit (dBuV/m)	Margin (dB)	Peak Limit (dBuV/m)	Margin (dB)	UNII Non-Restricted (dBuV/m)	Margin (dB)	Azimuth (Degs)	Height (cm)	Polarity
* 3.83	47.25	PK-U	33.1	-33	0	47.35	-	-	74	-26.65	-	-	3	126	H
* 3.83	39.44	ADR	33.1	-33	.18	39.72	54	-14.28	-	-	-	-	3	126	H
* 3.83	46.04	PK-U	33.1	-33	0	46.14	-	-	74	-27.86	-	-	356	254	V
* 3.83	38.1	ADR	33.1	-33	.18	38.38	54	-15.62	-	-	-	-	356	254	V

* - indicates frequency in CFR15.205/IC7.2.2 Restricted Band

PK-U - U-NII: Maximum Peak

ADR - U-NII AD primary method, RMS average

MID CHANNEL HORIZONTAL

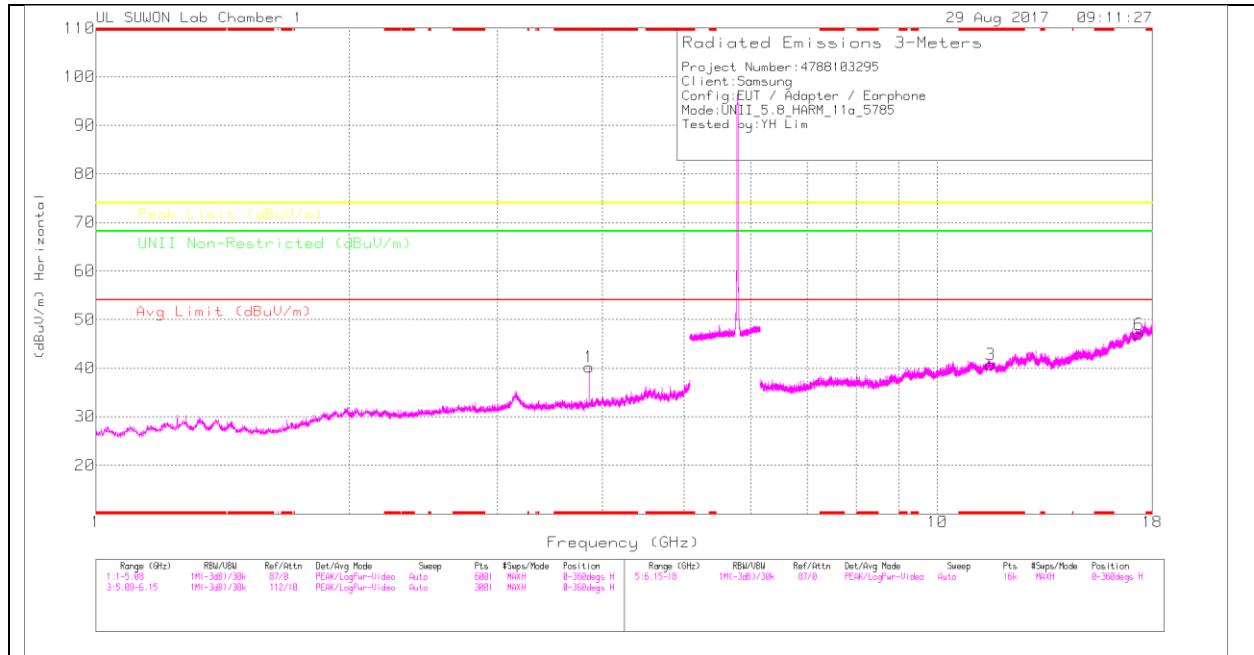

MID CHANNEL VERTICAL

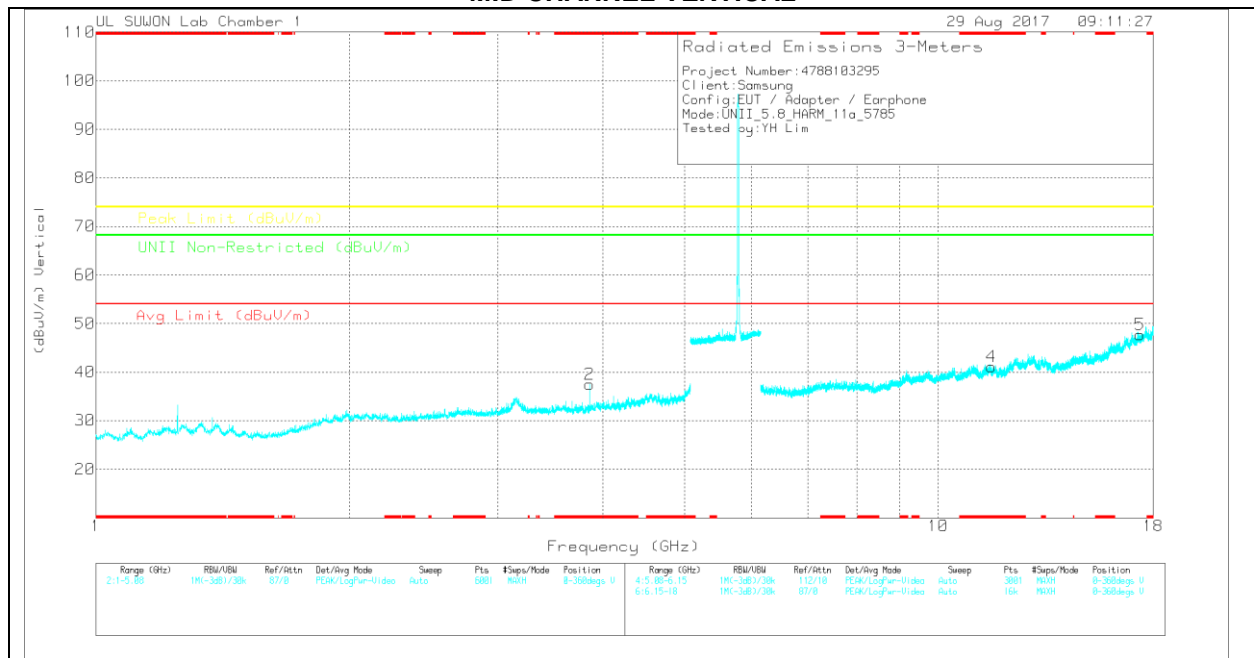

Note: Emission was scanned up to 40GHz; No emissions were detected above the noise floor which was at least 20dB below the specification limit.

MID CHANNEL DATA

Trace Markers

Marker	Frequency (GHz)	Meter Reading (dBuV)	Det	20170531_3117_00168717	5GHz_LP(dB)_170809	DC Corr (dB)	Corrected Reading (dBuV/m)	Avg Limit (dBuV/m)	Margin (dB)	Peak Limit (dBuV/m)	Margin (dB)	UNII Non-Restricted (dBuV/m)	Margin (dB)	Azimuth (Degs)	Height (cm)	Polarity
1	* 3.857	39.97	PK	33.1	-32.9	0	40.17	-	-	74	-33.83	-	-	0-360	250	H
2	* 3.857	37.24	PK	33.1	-32.9	0	37.44	-	-	74	-36.56	-	-	0-360	250	V
3	* 11.567	25.46	PK	38.2	-22.9	0	40.76	-	-	74	-33.24	-	-	0-360	250	H
6	17.347	23.45	PK	41.4	-17.9	0	46.95	-	-	-	-	68.2	-21.25	0-360	250	H
4	* 11.57	25.83	PK	38.2	-22.9	0	41.13	-	-	74	-32.87	-	-	0-360	250	V
5	17.345	24.25	PK	41.4	-17.9	0	47.75	-	-	-	-	68.2	-20.45	0-360	250	V

* - indicates frequency in CFR15.205/IC7.2.2 Restricted Band

PK – Peak Detector

Radiated Emissions

Frequency (GHz)	Meter Reading (dBuV)	Det	20170531_3117_00168717	5GHz_LP(dB)_170809	DC Corr (dB)	Corrected Reading (dBuV/m)	Avg Limit (dBuV/m)	Margin (dB)	Peak Limit (dBuV/m)	Margin (dB)	UNII Non-Restricted (dBuV/m)	Margin (dB)	Azimuth (Degs)	Height (cm)	Polarity
* 3.856	46.39	PK-U	33.1	-32.9	0	46.59	-	-	74	-27.41	-	-	344	146	H
* 3.857	39.69	ADR	33.1	-32.9	.18	40.07	54	-13.93	-	-	-	-	344	146	H
* 3.857	44.49	PK-U	33.1	-32.9	0	44.69	-	-	74	-29.31	-	-	205	264	V
* 3.857	34.13	ADR	33.1	-32.9	.18	34.51	54	-19.49	-	-	-	-	205	264	V

* - indicates frequency in CFR15.205/IC7.2.2 Restricted Band

PK-U - U-NII: Maximum Peak

ADR - U-NII AD primary method, RMS average

HIGH CHANNEL HORIZONTAL

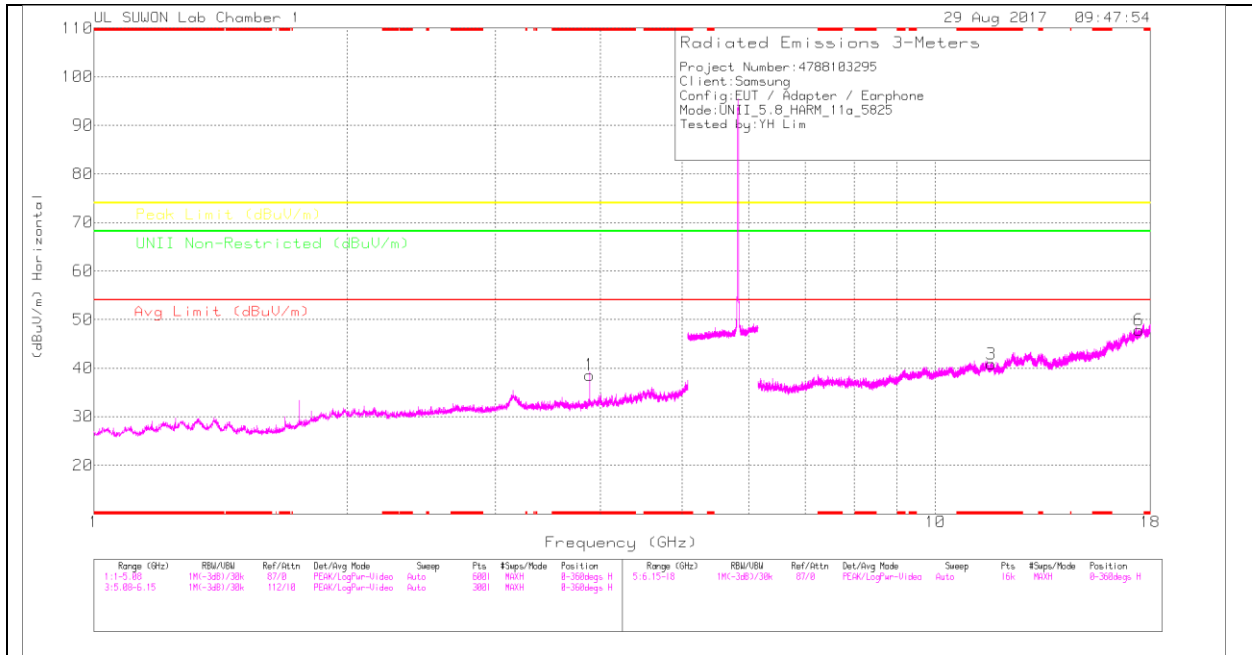

HIGH CHANNEL VERTICAL

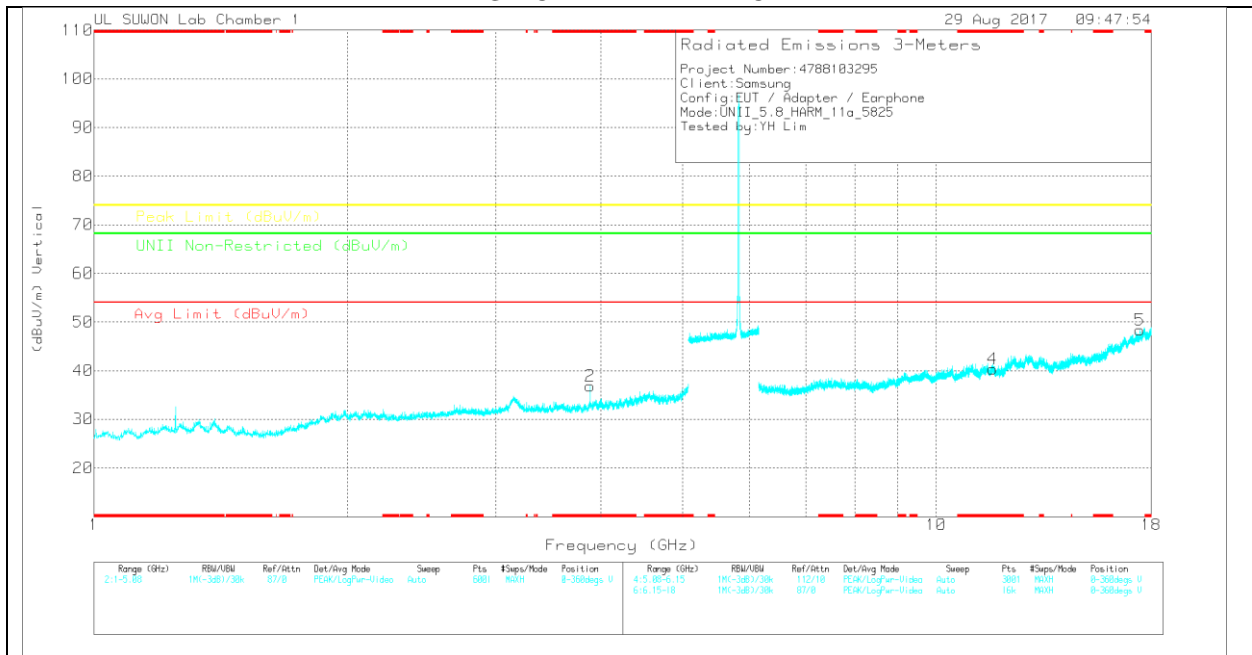

Note: Emission was scanned up to 40GHz; No emissions were detected above the noise floor which was at least 20dB below the specification limit.

HIGH CHANNEL DATA

Trace Markers

Marker	Frequency (GHz)	Meter Reading (dBuV)	Det	20170531_3117_0016 8717	5GHz_LP(dB)_170809	DC Corr (dB)	Corrected Reading (dBuV/m)	Avg Limit (dBuV/m)	Margin (dB)	Peak Limit (dBuV/m)	Margin (dB)	UNII Non-Restricted (dBuV/m)	Margin (dB)	Azimuth (Degs)	Height (cm)	Polarity
1	* 3.884	38.28	PK	33.1	-32.8	0	38.58	-	-	74	-35.42	-	-	0-360	250	H
2	* 3.883	36.46	PK	33.1	-32.7	0	36.86	-	-	74	-37.14	-	-	0-360	250	V
3	* 11.652	24.9	PK	38.1	-22.1	0	40.9	-	-	74	-33.1	-	-	0-360	150	H
6	17.446	24.17	PK	41.3	-17.7	0	47.77	-	-	-	-	68.2	-20.43	0-360	250	H
4	* 11.661	24.37	PK	38.1	-22.1	0	40.37	-	-	74	-33.63	-	-	0-360	150	V
5	17.448	24.75	PK	41.3	-17.7	0	48.35	-	-	-	-	68.2	-19.85	0-360	250	V

* - indicates frequency in CFR15.205/IC7.2.2 Restricted Band

PK – Peak Detector

Radiated Emissions

Frequency (GHz)	Meter Reading (dBuV)	Det	20170531_3117_00168717	5GHz_LP(dB)_170809	DC Corr (dB)	Corrected Reading (dBuV/m)	Avg Limit (dBuV/m)	Margin (dB)	Peak Limit (dBuV/m)	Margin (dB)	UNII Non-Restricted (dBuV/m)	Margin (dB)	Azimuth (Degs)	Height (cm)	Polarity
* 3.883	46.61	PK-U	33.1	-32.8	0	46.91	-	-	74	-27.09	-	-	349	286	H
* 3.883	39.03	ADR	33.1	-32.8	.18	39.51	54	-14.49	-	-	-	-	349	286	H
* 3.883	44.59	PK-U	33.1	-32.7	0	44.99	-	-	74	-29.01	-	-	127	337	V
* 3.883	34.37	ADR	33.1	-32.8	.18	34.85	54	-19.15	-	-	-	-	127	337	V

* - indicates frequency in CFR15.205/IC7.2.2 Restricted Band

PK-U - U-NII: Maximum Peak

ADR - U-NII AD primary method, RMS average

10.4.2. TX ABOVE 1GHz 802.11n HT20 MODE IN THE 5.8GHz BAND BANDEDGE (LOW CHANNEL)

HORIZONTAL PEAK PLOT

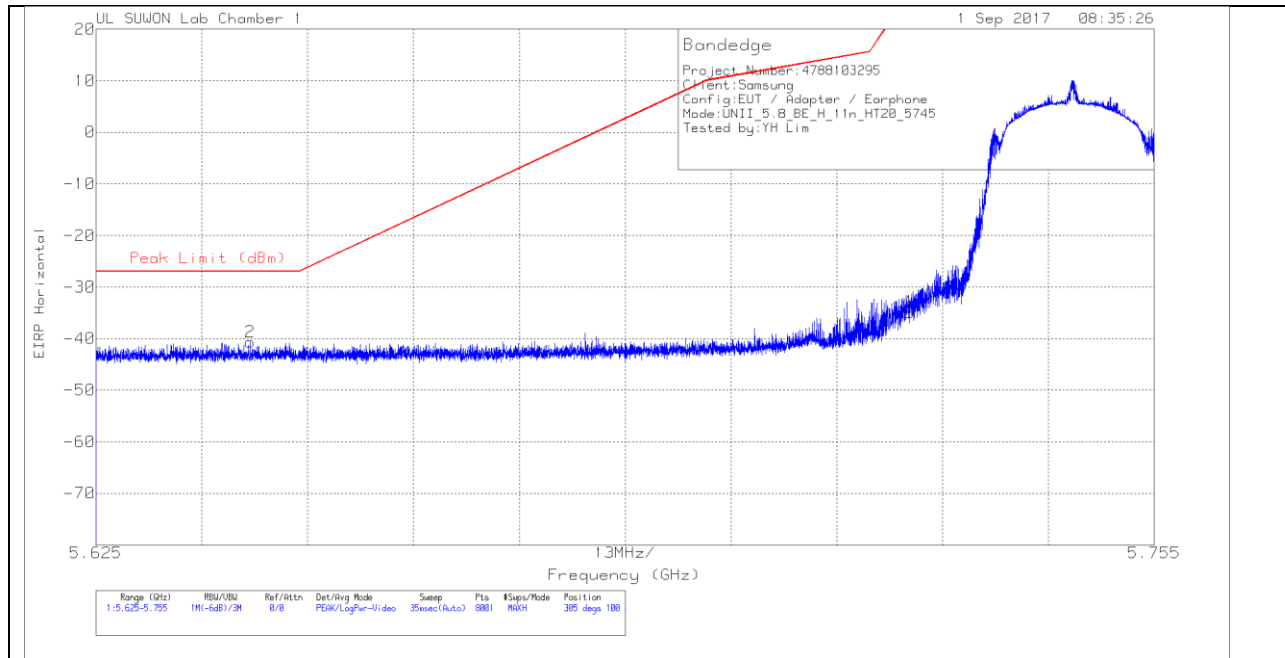

HORIZONTAL DATA

Trace Markers

Marker	Frequency (GHz)	Meter Reading (dBm)	Det	20170531_3117_001_68717	10dB_ATT(dB)_17080_9	Conversion Factor (dB)	DC Corr (dB)	Corrected Reading EIRP	Peak Limit (dBm)	PK Margin (dB)	Azimuth (Degs)	Height (cm)	Polarity
1	5.725	-59.94	Pk	34.5	-21.2	11.8	0	-34.84	26.97	-61.81	305	100	H
2	5.644	-65.5	Pk	34.4	-21.3	11.8	0	-40.6	-27	-13.6	305	100	H

Pk - Peak detector

VERTICAL PEAK PLOT

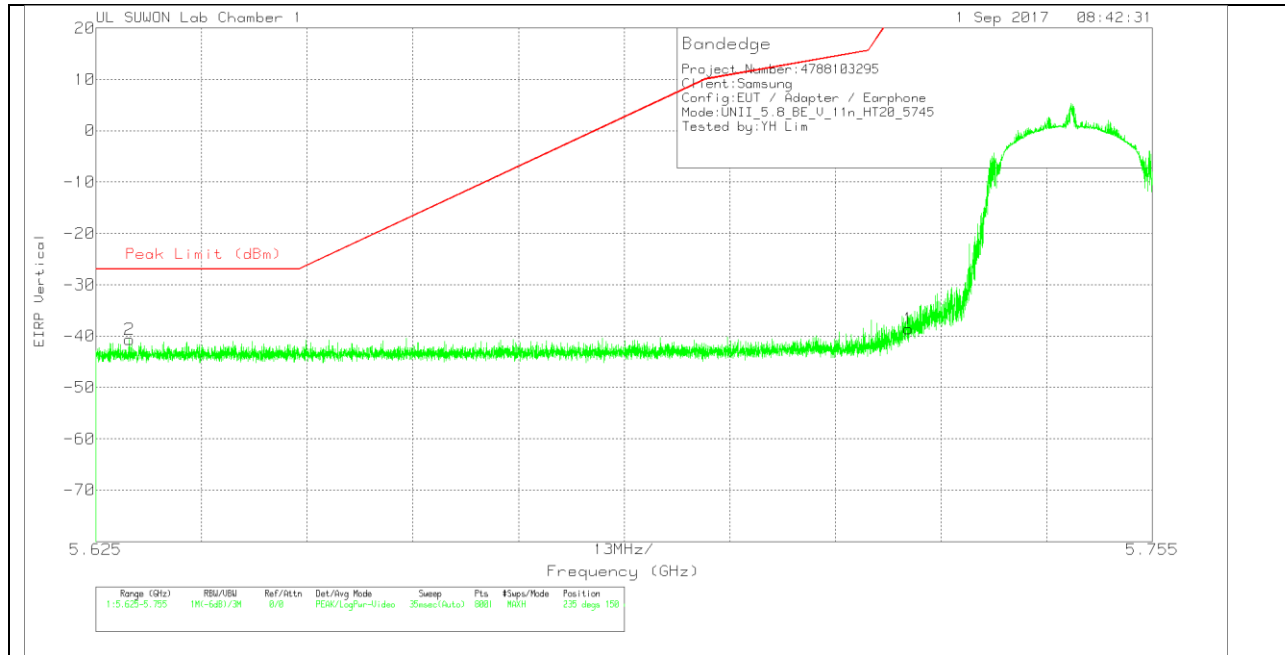

VERTICAL DATA

Trace Markers

Marker	Frequency (GHz)	Meter Reading (dBm)	Det	20170531_3117_001_68717	10dB_ATT(dB)_17080_9	Conversion Factor (dB)	DC Corr (dB)	Corrected Reading EIRP	Peak Limit (dBm)	PK Margin (dB)	Azimuth (Degs)	Height (cm)	Polarity
1	5.725	-63.62	Pk	34.5	-21.2	11.8	0	-38.52	26.97	-65.49	235	150	V
2	5.629	-65.58	Pk	34.4	-21.3	11.8	0	-40.68	-27	-13.68	235	150	V

Pk - Peak detector

BANDEDGE (HIGH CHANNEL)

HORIZONTAL PEAK AND AVERAGE PLOT

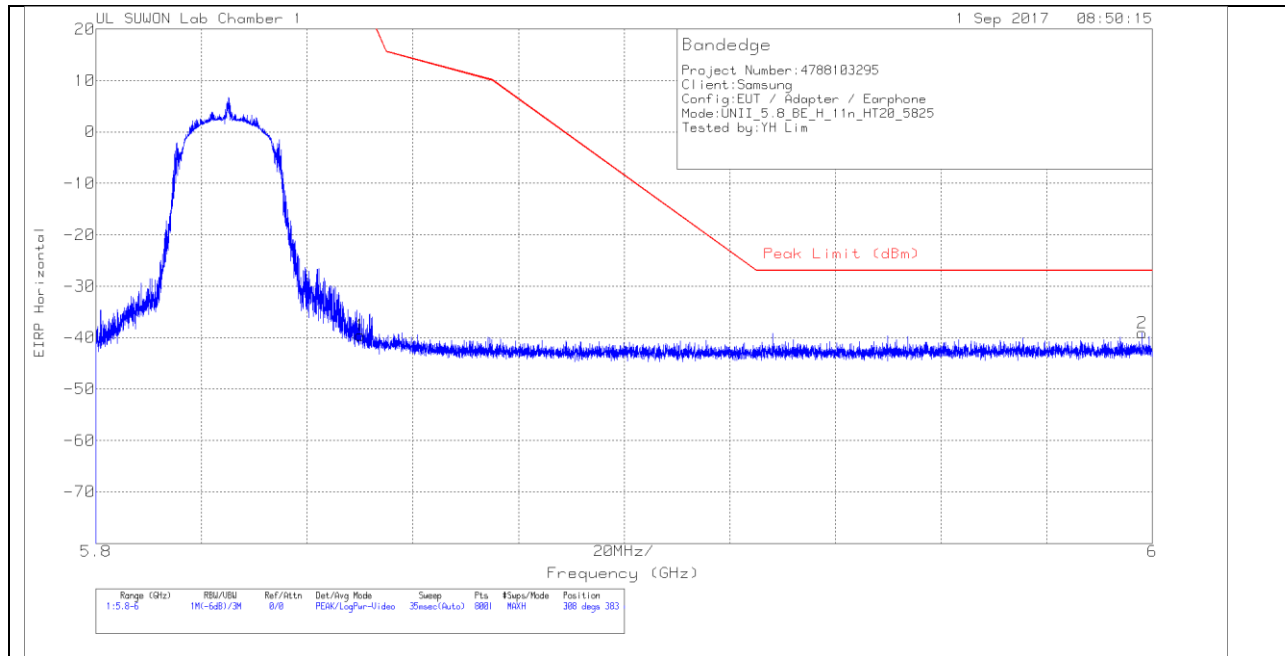

HORIZONTAL DATA

Trace Markers

Marker	Frequency (GHz)	Meter Reading (dBm)	Det	20170531_3117_001_68717	10dB_ATT(dB)_17080_9	Conversion Factor (dB)	DC Corr (dB)	Corrected Reading EIRP	Peak Limit (dBm)	PK Margin (dB)	Azimuth (Degs)	Height (cm)	Polarity
1	5.85	-64.7	Pk	34.5	-21.1	11.8	0	-39.5	26.94	-66.44	308	383	H
2	5.998	-64.84	Pk	34.8	-20.8	11.8	0	-39.04	-27	-12.04	308	383	H

Pk - Peak detector

VERTICAL PEAK PLOT

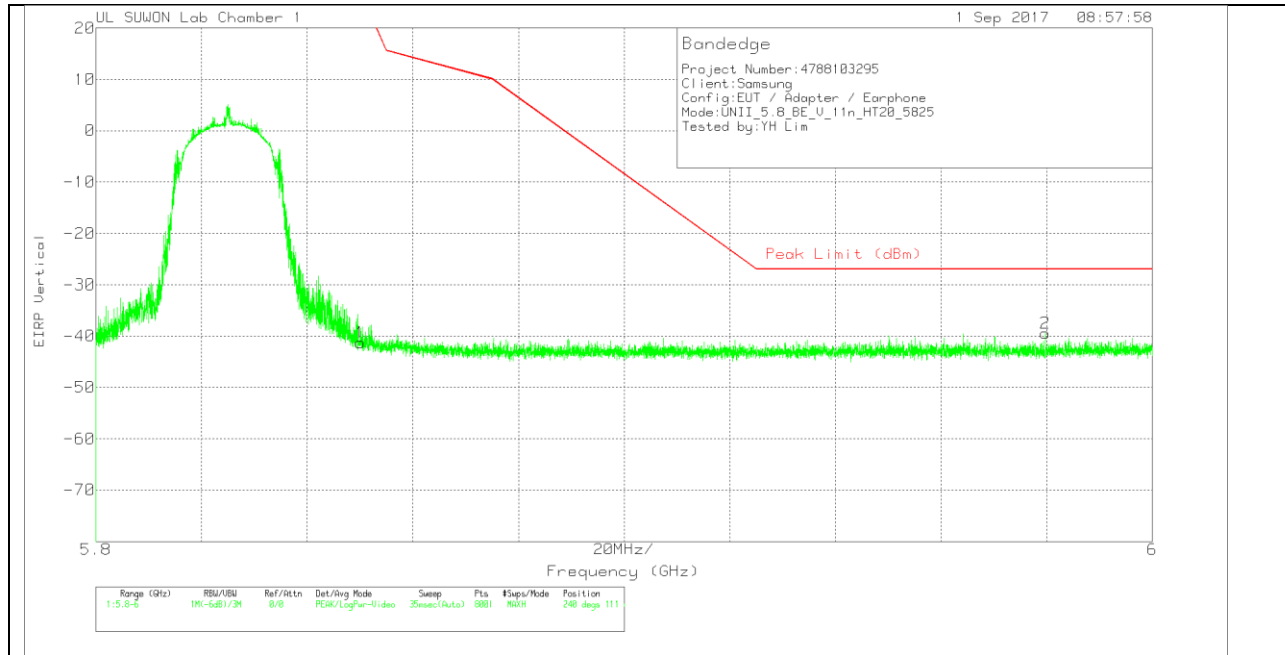

VERTICAL DATA

Trace Markers

Marker	Frequency (GHz)	Meter Reading (dBm)	Det	20170531_3117_001_68717	10dB_ATT(dB)_17080_9	Conversion Factor (dB)	DC Corr (dB)	Corrected Reading EIRP	Peak Limit (dBm)	PK Margin (dB)	Azimuth (Degs)	Height (cm)	Polarity
1	5.85	-66.51	Pk	34.5	-21.1	11.8	0	-41.31	26.94	-68.25	240	111	V
2	5.98	-65.06	Pk	34.7	-20.9	11.8	0	-39.46	-27	-12.46	240	111	V

Pk - Peak detector

LOW CHANNEL HORIZONTAL

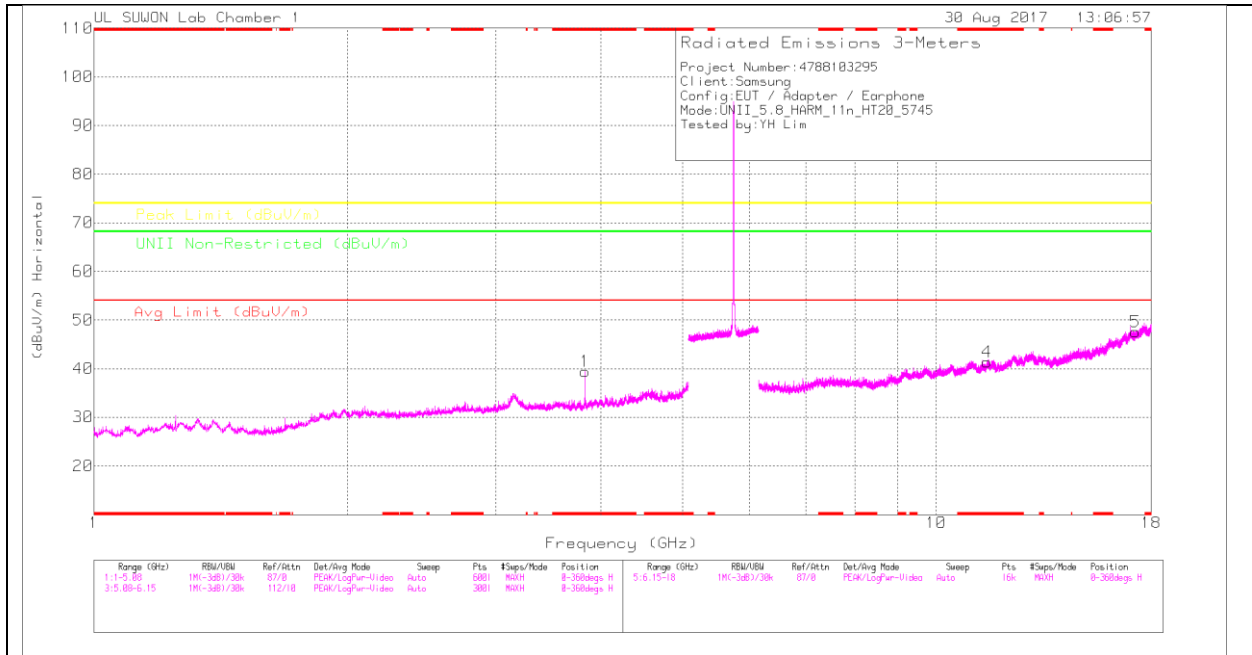

LOW CHANNEL VERTICAL

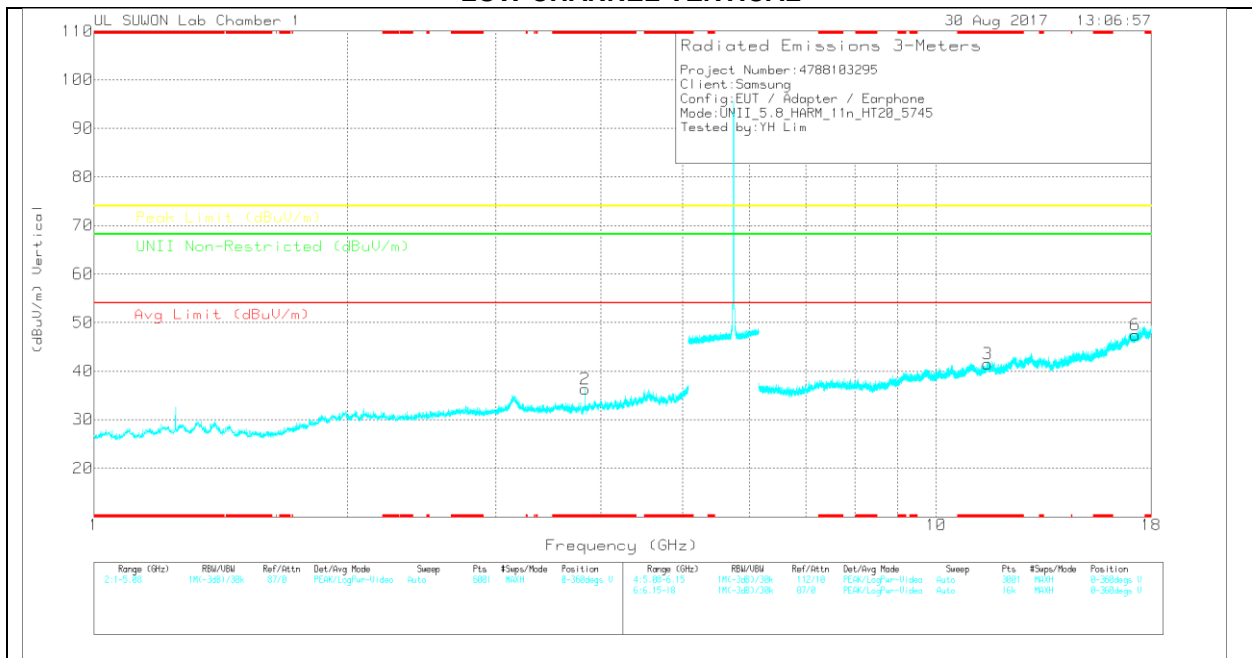

Note: Emission was scanned up to 40GHz; No emissions were detected above the noise floor which was at least 20dB below the specification limit.

LOW CHANNEL DATA

Trace Markers

Marker	Frequency (GHz)	Meter Reading (dBuV)	Det	20170531_3117_0016 8717	5GHz_LP(dB)_170809	DC Corr (dB)	Corrected Reading (dBuV/m)	Avg Limit (dBuV/m)	Margin (dB)	Peak Limit (dBuV/m)	Margin (dB)	UNII Non-Restricted (dBuV/m)	Margin (dB)	Azimuth (Degs)	Height (cm)	Polarity
1	* 3.83	39.31	PK	33.1	-33	0	39.41	-	-	74	-34.59	-	-	0-360	150	H
2	* 3.829	36.17	PK	33.1	-33	0	36.27	-	-	74	-37.73	-	-	0-360	250	V
4	* 11.498	25.91	PK	38.2	-22.8	0	41.31	-	-	74	-32.69	-	-	0-360	250	H
5	17.251	23.92	PK	41.6	-17.9	0	47.62	-	-	-	-	68.2	-20.58	0-360	250	H
3	* 11.499	26.09	PK	38.2	-22.8	0	41.49	-	-	74	-32.51	-	-	0-360	150	V
6	17.248	23.88	PK	41.6	-18	0	47.48	-	-	-	-	68.2	-20.72	0-360	250	V

* - indicates frequency in CFR15.205/IC7.2.2 Restricted Band

PK – Peak Detector

Radiated Emissions

Frequency (GHz)	Meter Reading (dBuV)	Det	20170531_3117_00168717	5GHz_LP(dB)_170809	DC Corr (dB)	Corrected Reading (dBuV/m)	Avg Limit (dBuV/m)	Margin (dB)	Peak Limit (dBuV/m)	Margin (dB)	UNII Non-Restricted (dBuV/m)	Margin (dB)	Azimuth (Degs)	Height (cm)	Polarity
* 3.83	48.01	PK-U	33.1	-33	0	48.11	-	-	74	-25.89	-	-	357	181	H
* 3.83	38.5	ADR	33.1	-33	.16	38.76	54	-15.24	-	-	-	-	357	181	H
* 3.83	44.53	PK-U	33.1	-33	0	44.63	-	-	74	-29.37	-	-	52	224	V
* 3.83	34.18	ADR	33.1	-33	.16	34.44	54	-19.56	-	-	-	-	52	224	V

* - indicates frequency in CFR15.205/IC7.2.2 Restricted Band

PK-U - U-NII: Maximum Peak

ADR - U-NII AD primary method, RMS average

MID CHANNEL HORIZONTAL

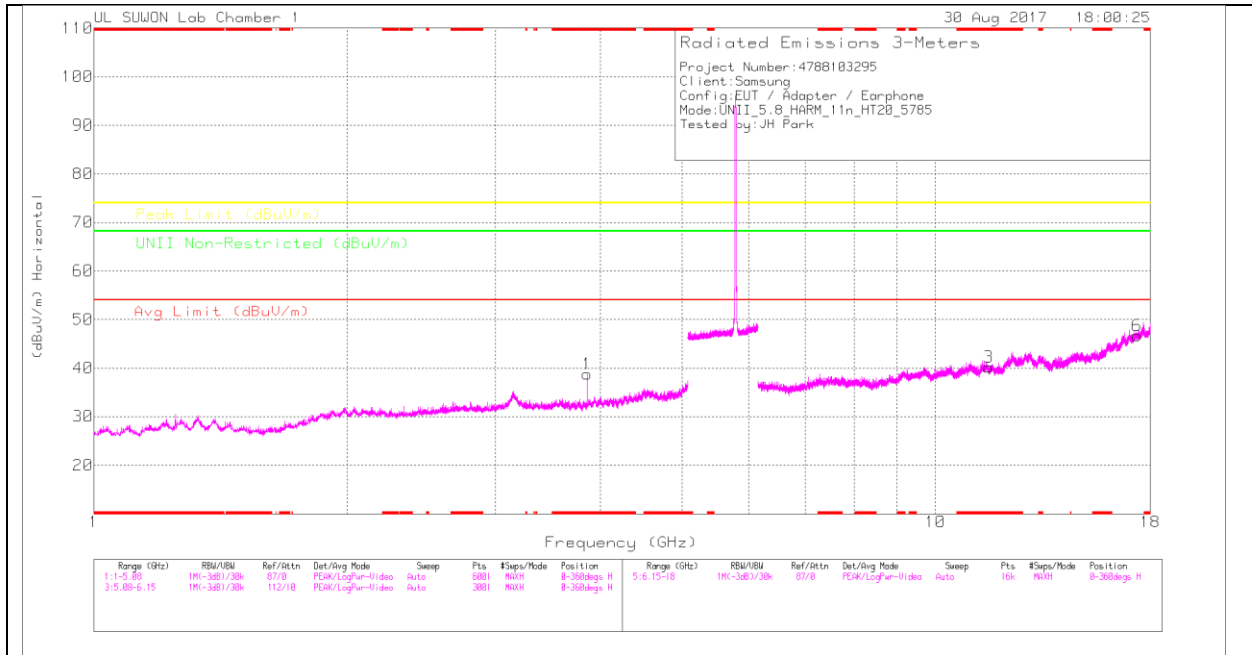

MID CHANNEL VERTICAL

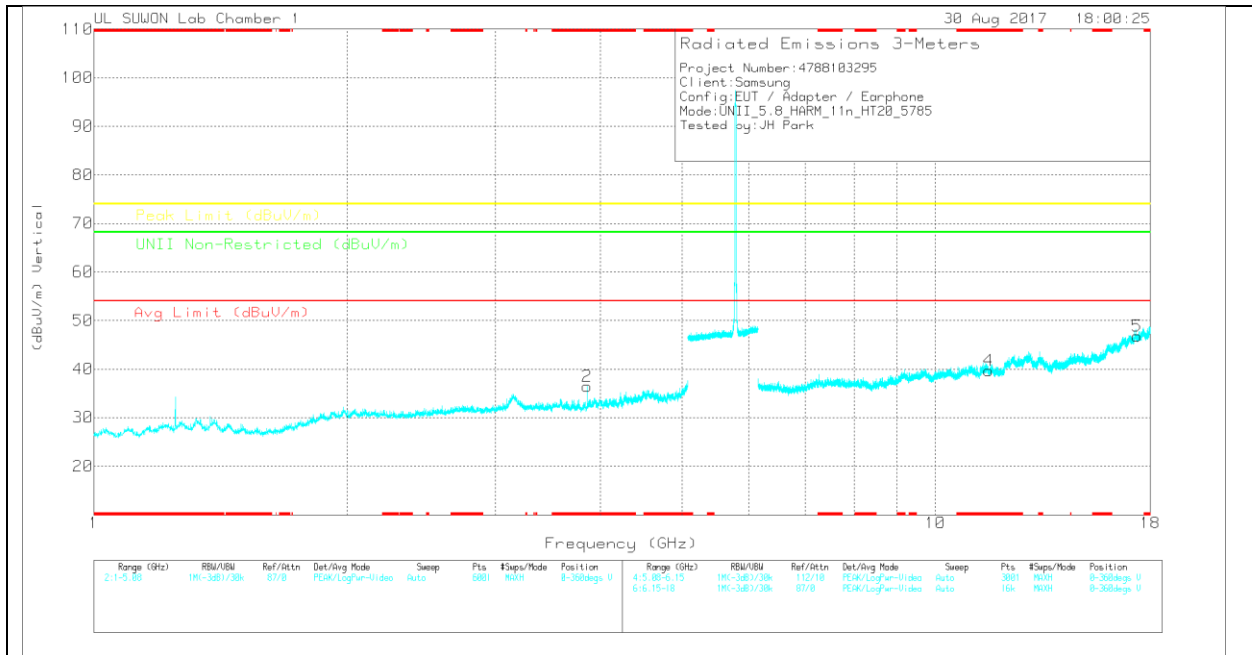

Note: Emission was scanned up to 40GHz; No emissions were detected above the noise floor which was at least 20dB below the specification limit.

MID CHANNEL DATA

Trace Markers

Marker	Frequency (GHz)	Meter Reading (dBuV)	Det	20170531_3117_00168717	5GHz_LP(dB)_170809	DC Corr (dB)	Corrected Reading (dBuV/m)	Avg Limit (dBuV/m)	Margin (dB)	Peak Limit (dBuV/m)	Margin (dB)	UNII Non-Restricted (dBuV/m)	Margin (dB)	Azimuth (Degs)	Height (cm)	Polarity
1	* 3.857	38.54	PK	33.1	-32.9	0	38.74	-	-	74	-35.26	-	-	0-360	150	H
2	* 3.857	36.28	PK	33.1	-32.9	0	36.48	-	-	74	-37.52	-	-	0-360	250	V
3	* 11.57	24.94	PK	38.2	-22.9	0	40.24	-	-	74	-33.76	-	-	0-360	150	H
6	17.351	23.28	PK	41.4	-18	0	46.68	-	-	-	-	68.2	-21.52	0-360	150	H
4	* 11.575	24.27	PK	38.2	-22.8	0	39.67	-	-	74	-34.33	-	-	0-360	150	V
5	17.356	23.38	PK	41.4	-18	0	46.78	-	-	-	-	68.2	-21.42	0-360	250	V

* - indicates frequency in CFR15.205/IC7.2.2 Restricted Band

PK – Peak Detector

Radiated Emissions

Frequency (GHz)	Meter Reading (dBuV)	Det	20170531_3117_00168717	5GHz_LP(dB)_170809	DC Corr (dB)	Corrected Reading (dBuV/m)	Avg Limit (dBuV/m)	Margin (dB)	Peak Limit (dBuV/m)	Margin (dB)	UNII Non-Restricted (dBuV/m)	Margin (dB)	Azimuth (Degs)	Height (cm)	Polarity
* 3.857	45.85	PK-U	33.1	-32.9	0	46.05	-	-	74	-27.95	-	-	0	106	H
* 3.857	37.24	ADR	33.1	-32.9	.16	37.6	54	-16.4	-	-	-	-	0	106	H
* 3.857	44.52	PK-U	33.1	-32.9	0	44.72	-	-	74	-29.28	-	-	1	340	V
* 3.857	32.52	ADR	33.1	-32.9	.16	32.88	54	-21.12	-	-	-	-	1	340	V

* - indicates frequency in CFR15.205/IC7.2.2 Restricted Band

PK-U - U-NII: Maximum Peak

ADR - U-NII AD primary method, RMS average

HIGH CHANNEL HORIZONTAL

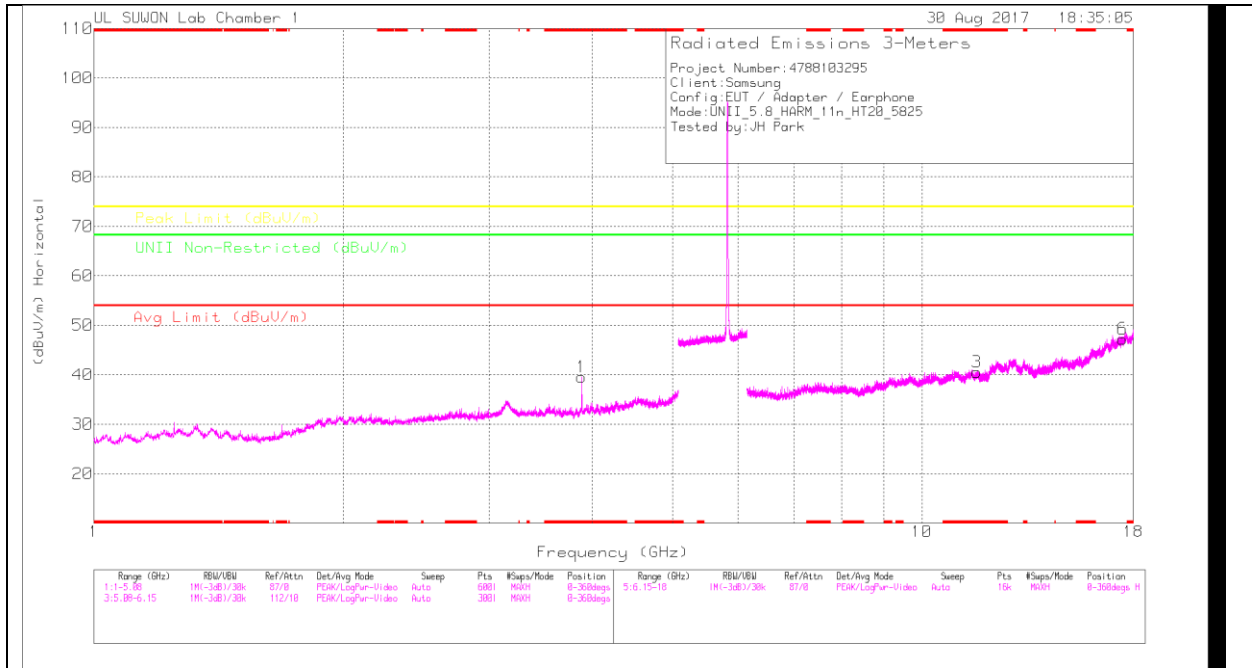

HIGH CHANNEL VERTICAL

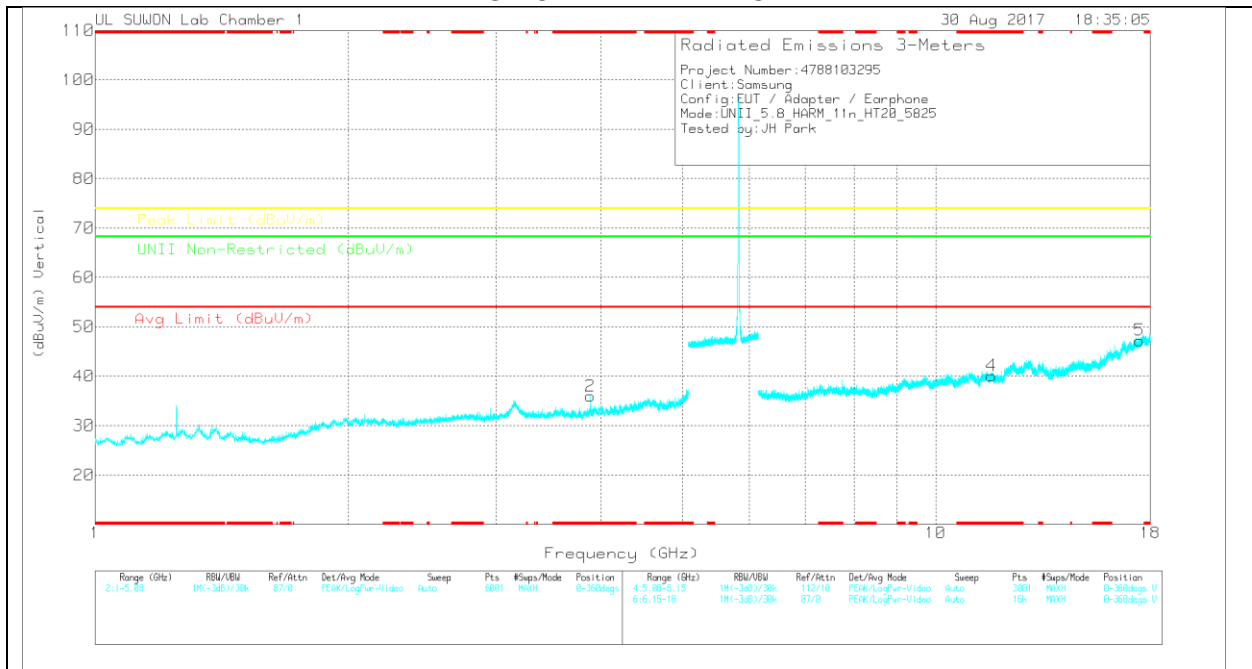

Note: Emission was scanned up to 40GHz; No emissions were detected above the noise floor which was at least 20dB below the specification limit.

HIGH CHANNEL DATA

Trace Markers

Marker	Frequency (GHz)	Meter Reading (dBuV)	Det	20170531_3117_0016 8717	5GHz_LP(d B)_170809	DC Corr (dB)	Corrected Reading (dBuV/m)	Avg Limit (dBuV/m)	Margin (dB)	Peak Limit (dBuV/m)	Margin (dB)	UNII Non-Restricted (dBuV/m)	Margin (dB)	Azimuth (Degs)	Height (cm)	Polarity
1	* 3.883	39.12	PK	33.1	-32.7	0	39.52	-	-	74	-34.48	-	-	0-360	150	H
2	* 3.883	35.56	PK	33.1	-32.7	0	35.96	-	-	74	-38.04	-	-	0-360	250	V
3	* 11.648	24.62	PK	38.1	-22.2	0	40.52	-	-	74	-33.48	-	-	0-360	150	H
6	17.476	23.72	PK	41.2	-17.7	0	47.22	-	-	-	-	68.2	-20.98	0-360	150	H
4	* 11.653	24.07	PK	38.1	-22.1	0	40.07	-	-	74	-33.93	-	-	0-360	250	V
5	17.475	23.64	PK	41.3	-17.7	0	47.24	-	-	-	-	68.2	-20.96	0-360	150	V

* - indicates frequency in CFR15.205/IC7.2.2 Restricted Band

PK – Peak Detector

Radiated Emissions

Frequency (GHz)	Meter Reading (dBuV)	Det	20170531_3117_00168717	5GHz_LP(dB)_170809	DC Corr (dB)	Corrected Reading (dBuV/m)	Avg Limit (dBuV/m)	Margin (dB)	Peak Limit (dBuV/m)	Margin (dB)	UNII Non-Restricted (dBuV/m)	Margin (dB)	Azimuth (Degs)	Height (cm)	Polarity
* 3.883	46.43	PK-U	33.1	-32.7	0	46.83	-	-	74	-27.17	-	-	357	149	H
* 3.883	38.51	ADR	33.1	-32.8	.16	38.97	54	-15.03	-	-	-	-	357	149	H
* 3.883	45.55	PK-U	33.1	-32.7	0	45.95	-	-	74	-28.05	-	-	6	366	V
* 3.883	34.49	ADR	33.1	-32.8	.16	34.95	54	-19.05	-	-	-	-	6	366	V

* - indicates frequency in CFR15.205/IC7.2.2 Restricted Band

PK-U - U-NII: Maximum Peak

ADR - U-NII AD primary method, RMS average

10.4.3. TX ABOVE 1GHz 802.11n HT40 MODE IN THE 5.8GHz BAND BANDEDGE (LOW CHANNEL)

HORIZONTAL PEAK PLOT

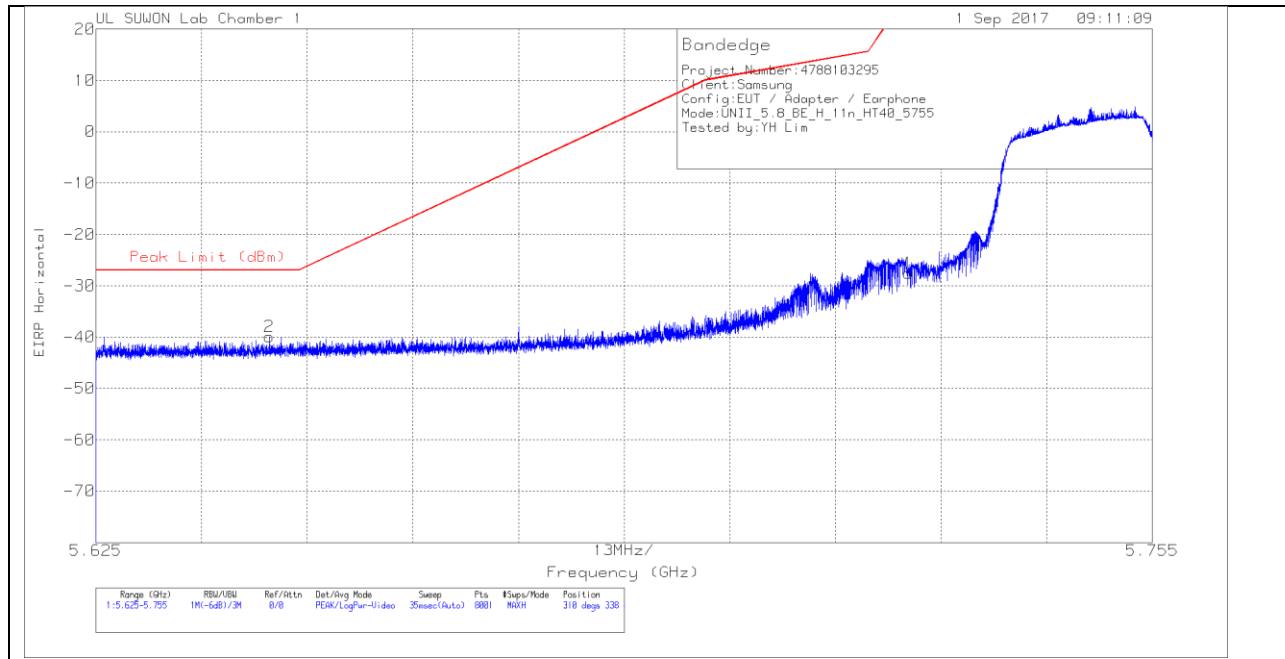

HORIZONTAL DATA

Trace Markers

Marker	Frequency (GHz)	Meter Reading (dBm)	Det	20170531 _3117_001 68717	10dB_ATT(dB)_17080 9	Conversion Factor (dB)	DC Corr (dB)	Corrected Reading EIRP	Peak Limit (dBm)	PK Margin (dB)	Azimuth (Degs)	Height (cm)	Polarity
1	5.725	-52.69	Pk	34.5	-21.2	11.8	0	-27.59	26.97	-54.56	310	338	H
2	5.646	-64.84	Pk	34.4	-21.3	11.8	0	-39.94	-27	-12.94	310	338	H

Pk - Peak detector

VERTICAL PEAK PLOT

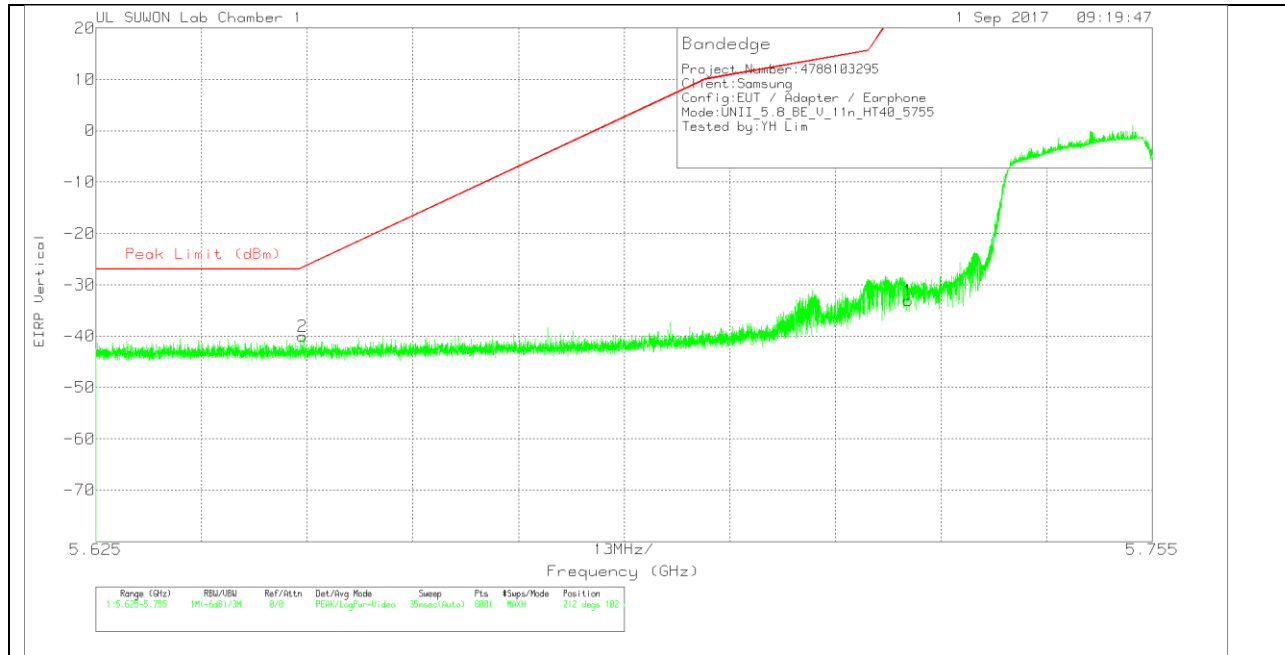

VERTICAL DATA

Trace Markers

Marker	Frequency (GHz)	Meter Reading (dBm)	Det	20170531_3117_001_68717	10dB_ATT(dB)_17080_9	Conversion Factor (dB)	DC Corr (dB)	Corrected Reading EIRP	Peak Limit (dBm)	PK Margin (dB)	Azimuth (Degs)	Height (cm)	Polarity
1	5.725	-58.15	Pk	34.5	-21.2	11.8	0	-33.05	26.97	-60.02	212	102	V
2	5.65	-64.98	Pk	34.4	-21.3	11.8	0	-40.08	-26.68	-13.4	212	102	V

Pk - Peak detector

BANDEDGE (HIGH CHANNEL)

HORIZONTAL PEAK PLOT

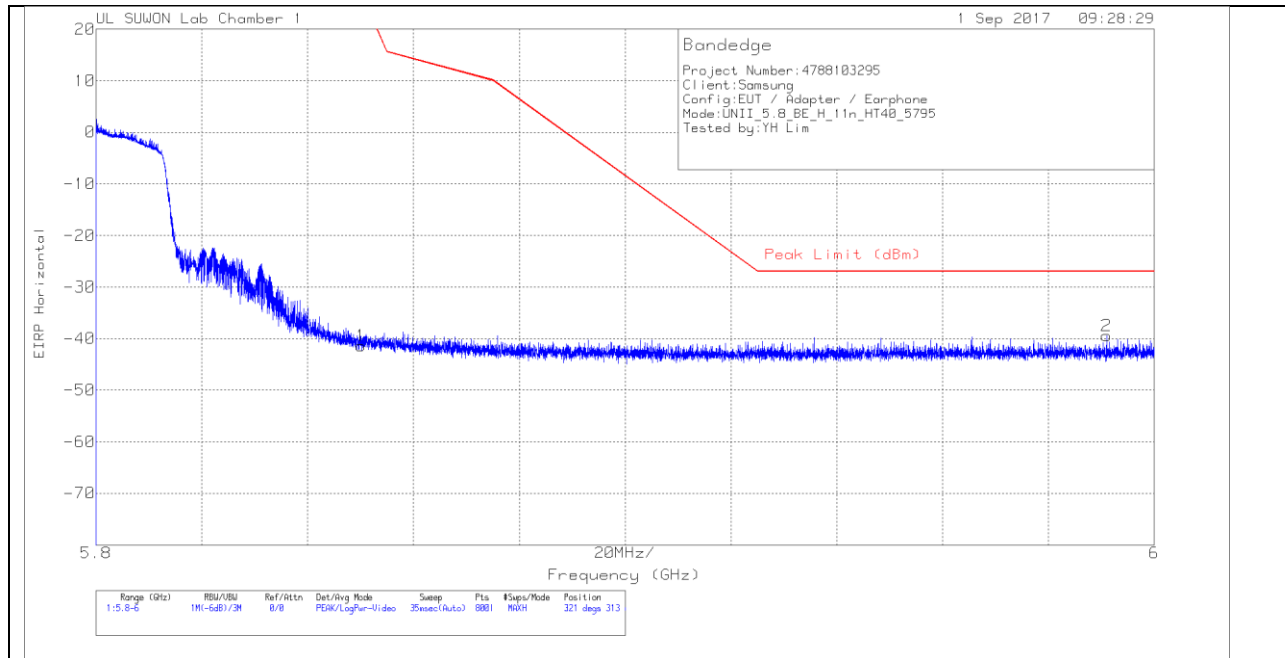

HORIZONTAL DATA

Trace Markers

Marker	Frequency (GHz)	Meter Reading (dBm)	Det	20170531_3117_001_68717	10dB_ATT(dB)_17080_9	Conversion Factor (dB)	DC Corr (dB)	Corrected Reading EIRP	Peak Limit (dBm)	PK Margin (dB)	Azimuth (Degs)	Height (cm)	Polarity
1	5.85	-66.56	Pk	34.5	-21.1	11.8	0	-41.36	26.94	-68.3	321	313	H
2	5.991	-65.26	Pk	34.8	-20.8	11.8	0	-39.46	-27	-12.46	321	313	H

Pk - Peak detector

VERTICAL PEAK PLOT

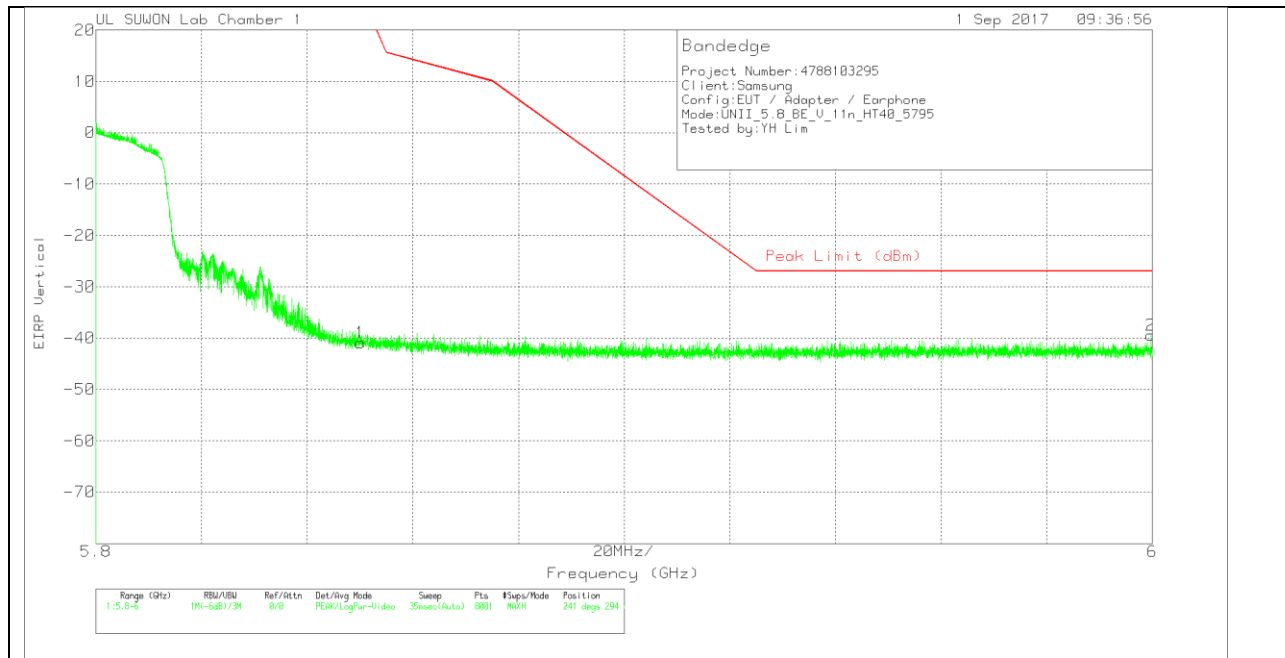

VERTICAL DATA

Trace Markers

Marker	Frequency (GHz)	Meter Reading (dBm)	Det	20170531_3117_001_68717	10dB_ATT(dB)_17080_9	Conversion Factor (dB)	DC Corr (dB)	Corrected Reading EIRP	Peak Limit (dBm)	PK Margin (dB)	Azimuth (Degs)	Height (cm)	Polarity
1	5.85	-66.06	Pk	34.5	-21.1	11.8	0	-40.86	26.94	-67.8	241	294	V
2	6	-65.21	Pk	34.8	-20.8	11.8	0	-39.41	-27	-12.41	241	294	V

Pk - Peak detector

LOW CHANNEL HORIZONTAL

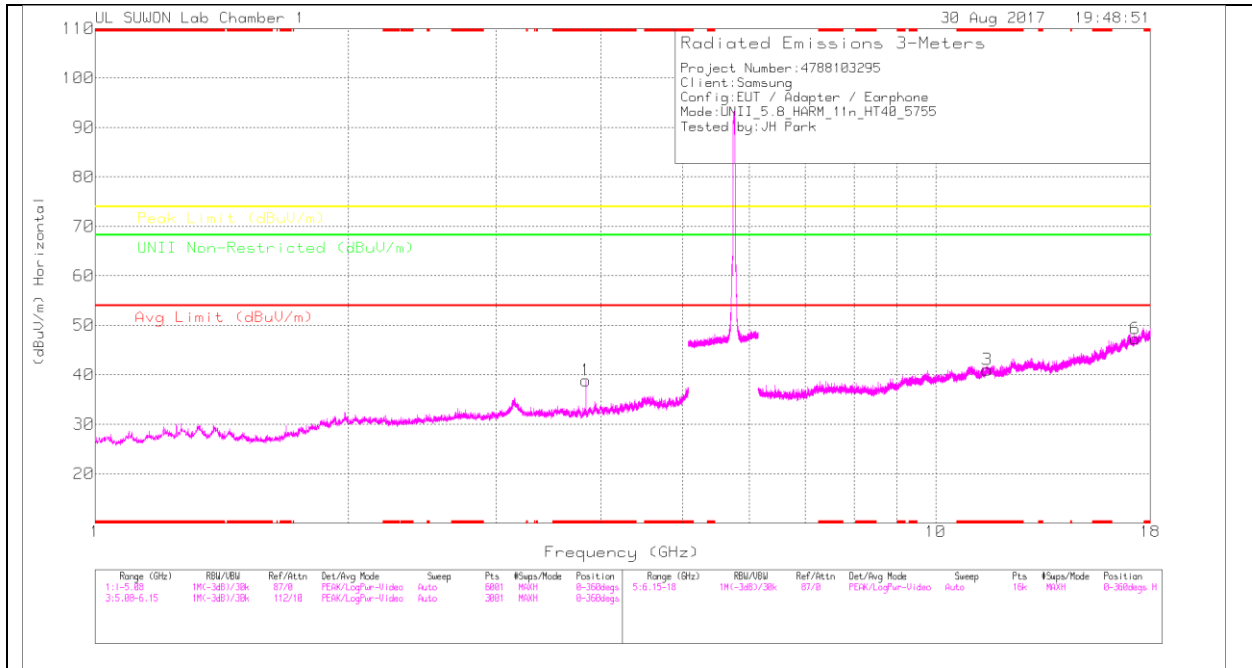

LOW CHANNEL VERTICAL

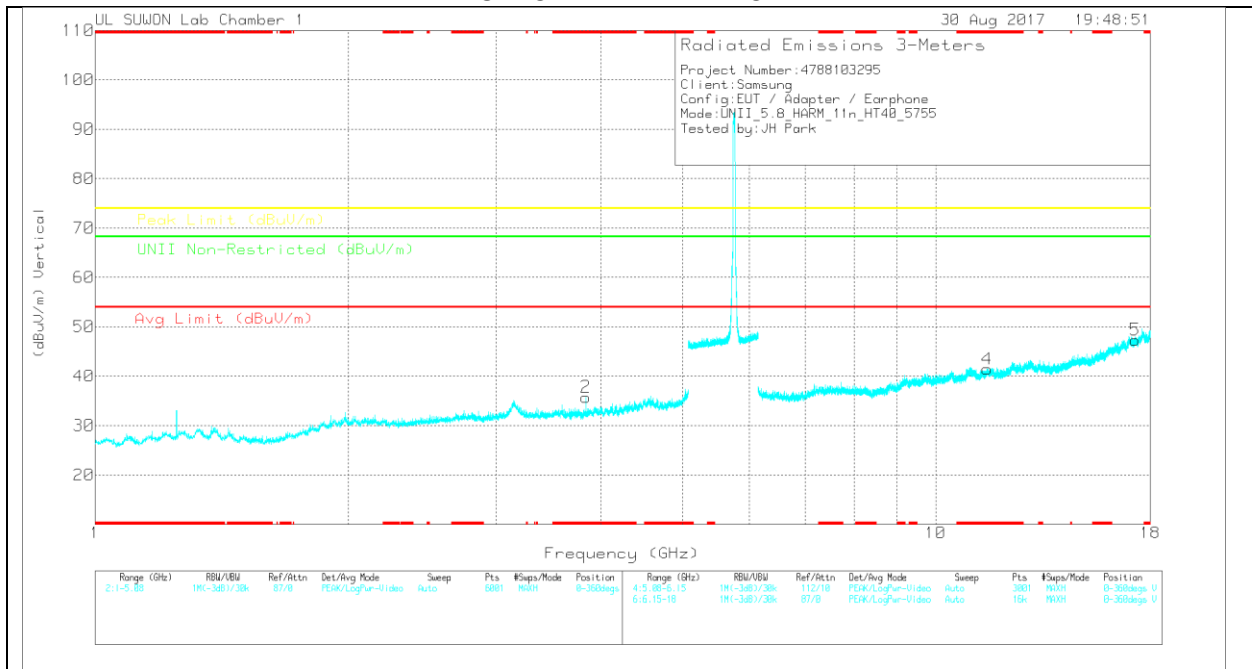

Note: Emission was scanned up to 40GHz; No emissions were detected above the noise floor which was at least 20dB below the specification limit.

LOW CHANNEL DATA

Trace Markers

Marker	Frequency (GHz)	Meter Reading (dBuV)	Det	20170531_3117_0016 8717	5GHz_LP(dB)_170809	DC Corr (dB)	Corrected Reading (dBuV/m)	Avg Limit (dBuV/m)	Margin (dB)	Peak Limit (dBuV/m)	Margin (dB)	UNII Non-Restricted (dBuV/m)	Margin (dB)	Azimuth (Degs)	Height (cm)	Polarity
1	* 3.837	38.76	PK	33.1	-33	0	38.86	-	-	74	-35.14	-	-	0-360	150	H
2	* 3.837	35.66	PK	33.1	-33	0	35.76	-	-	74	-38.24	-	-	0-360	250	V
3	* 11.513	25.62	PK	38.2	-22.8	0	41.02	-	-	74	-32.98	-	-	0-360	150	H
6	17.263	23.59	PK	41.5	-17.8	0	47.29	-	-	-	-	68.2	-20.91	0-360	150	H
4	* 11.514	26.05	PK	38.2	-22.8	0	41.45	-	-	74	-32.55	-	-	0-360	250	V
5	17.264	23.64	PK	41.5	-17.8	0	47.34	-	-	-	-	68.2	-20.86	0-360	250	V

* - indicates frequency in CFR15.205/IC7.2.2 Restricted Band

PK – Peak Detector

Radiated Emissions

Frequency (GHz)	Meter Reading (dBuV)	Det	20170531_3117_00168717	5GHz_LP(dB)_170809	DC Corr (dB)	Corrected Reading (dBuV/m)	Avg Limit (dBuV/m)	Margin (dB)	Peak Limit (dBuV/m)	Margin (dB)	UNII Non-Restricted (dBuV/m)	Margin (dB)	Azimuth (Degs)	Height (cm)	Polarity
* 3.837	47.04	PK-U	33.1	-33	0	47.14	-	-	74	-26.86	-	-	353	124	H
* 3.837	39.52	ADR	33.1	-33	.38	40	54	-14	-	-	-	-	353	124	H
* 3.837	45.05	PK-U	33.1	-33	0	45.15	-	-	74	-28.85	-	-	3	347	V
* 3.837	35.47	ADR	33.1	-33	.38	35.95	54	-18.05	-	-	-	-	3	347	V

* - indicates frequency in CFR15.205/IC7.2.2 Restricted Band

PK-U - U-NII: Maximum Peak

ADR - U-NII AD primary method, RMS average

HIGH CHANNEL HORIZONTAL

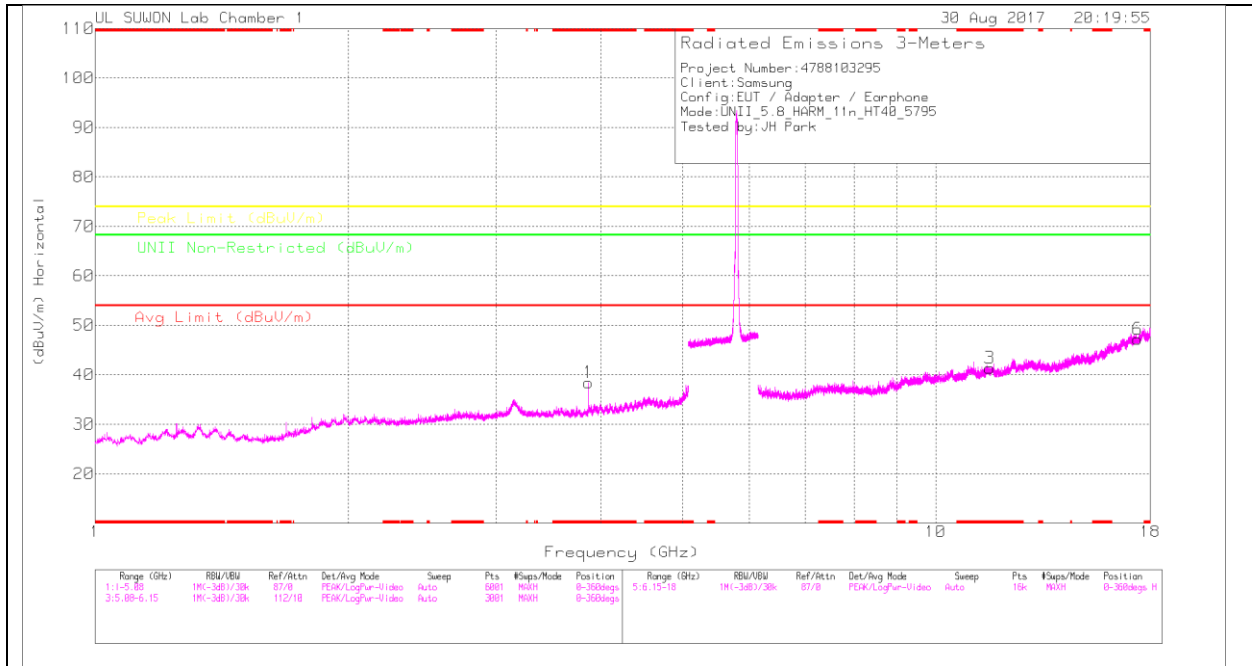

HIGH CHANNEL VERTICAL

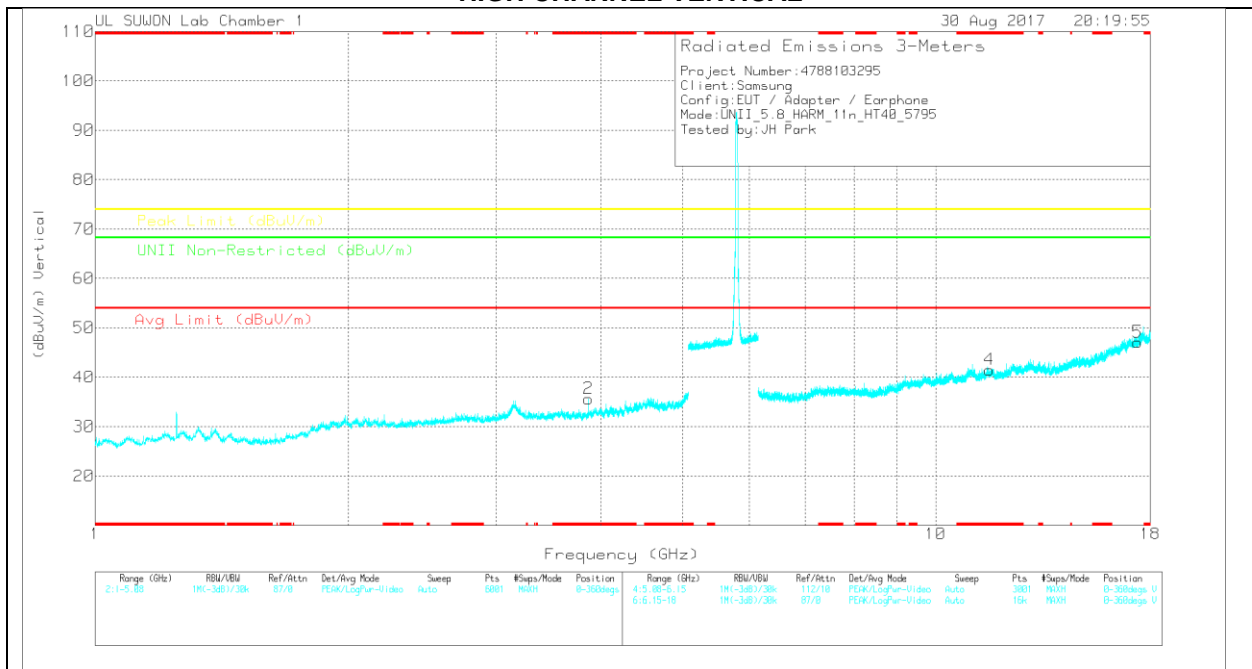

Note: Emission was scanned up to 40GHz; No emissions were detected above the noise floor which was at least 20dB below the specification limit.

HIGH CHANNEL DATA

Trace Markers

Marker	Frequency (GHz)	Meter Reading (dBuV)	Det	20170531_3117_0016 8717	5GHz_LP(dB)_170809	DC Corr (dB)	Corrected Reading (dBuV/m)	Avg Limit (dBuV/m)	Margin (dB)	Peak Limit (dBuV/m)	Margin (dB)	UNII Non-Restricted (dBuV/m)	Margin (dB)	Azimuth (Degs)	Height (cm)	Polarity
1	* 3.863	38.23	PK	33.1	-32.9	0	38.43	-	-	74	-35.57	-	-	0-360	150	H
2	* 3.863	35.46	PK	33.1	-32.9	0	35.66	-	-	74	-38.34	-	-	0-360	250	V
3	* 11.593	25.97	PK	38.2	-22.8	0	41.37	-	-	74	-32.63	-	-	0-360	250	H
6	17.387	23.9	PK	41.3	-18	0	47.2	-	-	-	-	68.2	-21	0-360	250	H
4	* 11.589	26.11	PK	38.2	-22.8	0	41.51	-	-	74	-32.49	-	-	0-360	150	V
5	17.387	23.78	PK	41.3	-18	0	47.08	-	-	-	-	68.2	-21.12	0-360	150	V

* - indicates frequency in CFR15.205/IC7.2.2 Restricted Band

PK – Peak Detector

Radiated Emissions

Frequency (GHz)	Meter Reading (dBuV)	Det	20170531_3117_00168717	5GHz_LP(dB)_170809	DC Corr (dB)	Corrected Reading (dBuV/m)	Avg Limit (dBuV/m)	Margin (dB)	Peak Limit (dBuV/m)	Margin (dB)	UNII Non-Restricted (dBuV/m)	Margin (dB)	Azimuth (Degs)	Height (cm)	Polarity
* 3.863	45.96	PK-U	33.1	-32.9	0	46.16	-	-	74	-27.84	-	-	357	395	H
* 3.863	37.47	ADR	33.1	-32.9	.38	38.05	54	-15.95	-	-	-	-	357	395	H
* 3.863	44.45	PK-U	33.1	-32.9	0	44.65	-	-	74	-29.35	-	-	75	376	V
* 3.863	34.26	ADR	33.1	-32.9	.38	34.84	54	-19.16	-	-	-	-	75	376	V

* - indicates frequency in CFR15.205/IC7.2.2 Restricted Band

PK-U - U-NII: Maximum Peak

ADR - U-NII AD primary method, RMS average

11. WORST-CASE BELOW 1 GHz (in the 5.3 GHz Band)

SPURIOUS EMISSIONS 30 TO 1000 MHz (WORST-CASE CONFIGURATION, HORIZONTAL)

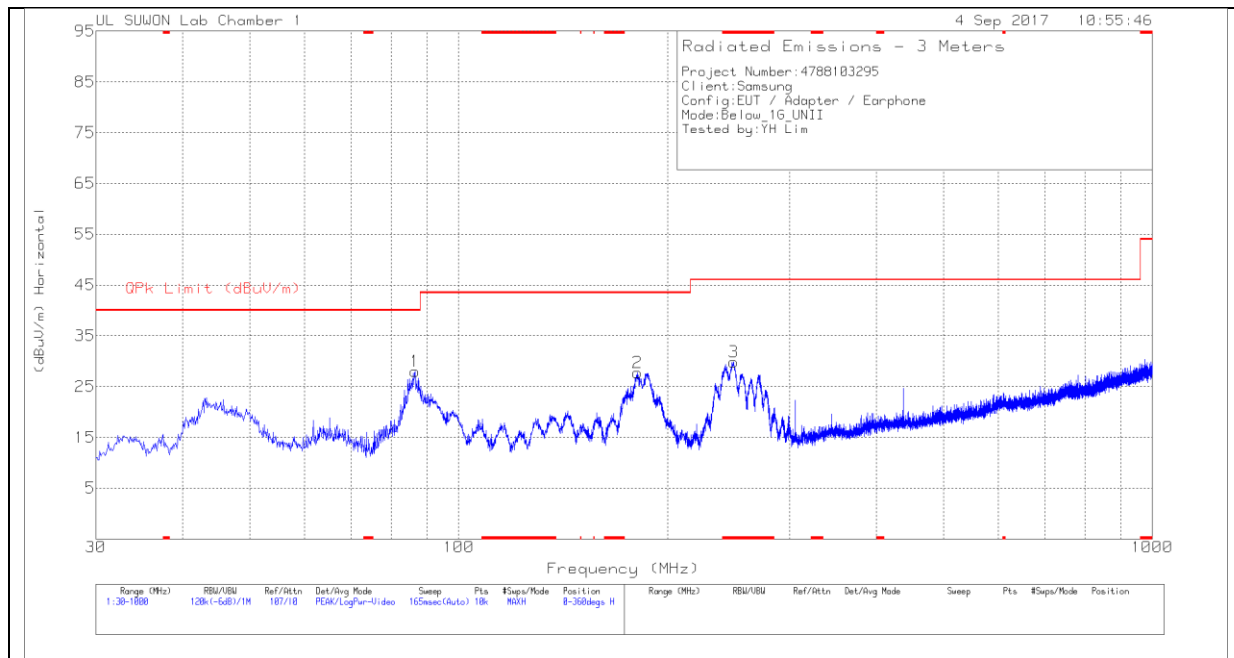

SPURIOUS EMISSIONS 30 TO 1000 MHz (WORST-CASE CONFIGURATION, VERTICAL)

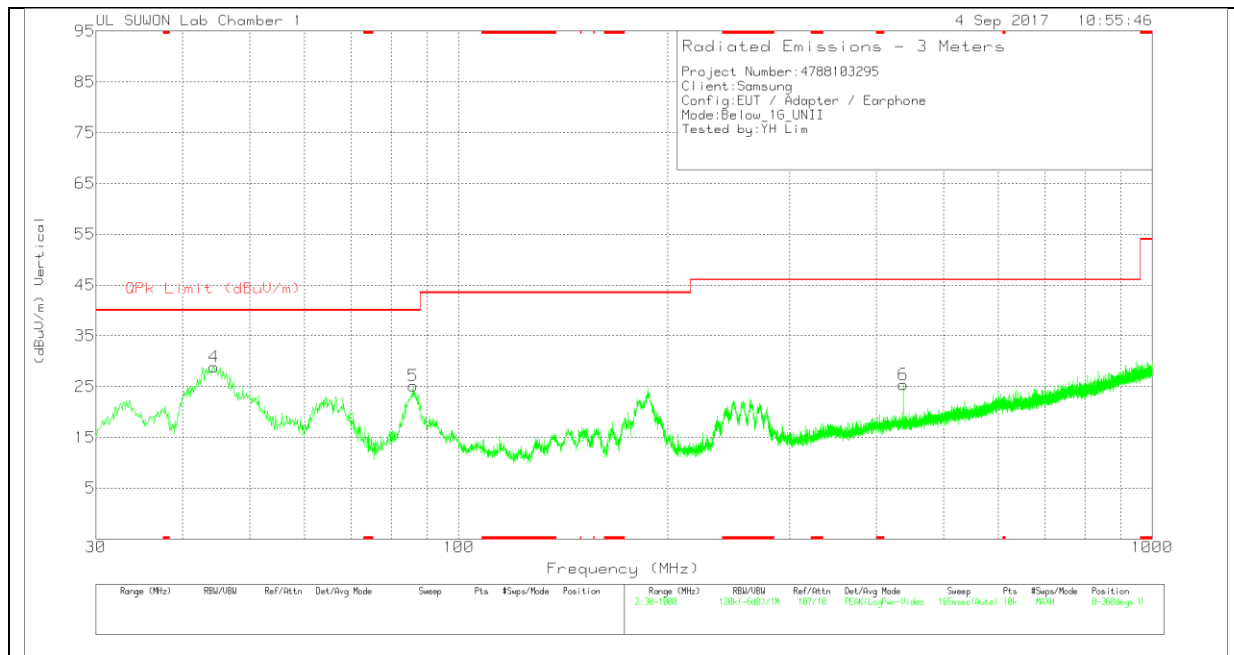

Below 1G Data

Trace Markers

Marker	Frequency (MHz)	Meter Reading (dBuV)	Det	VULB9163_75 0(dB)	30-1000MHz[dB]	Corrected Reading (dBuV/m)	QPk Limit (dBuV/m)	Margin (dB)	Azimuth (Degs)	Height (cm)	Polarity
1	86.551	48.16	Pk	8.6	-28.8	27.96	40	-12.04	0-360	300	H
2	180.932	45.89	Pk	9.5	-27.6	27.79	43.52	-15.73	0-360	100	H
3	* 249.414	45.02	Pk	12.2	-27.4	29.82	46.02	-16.2	0-360	100	H
4	44.356	44.82	Pk	13.5	-29.5	28.82	40	-11.18	0-360	100	V
5	86.066	45.44	Pk	8.5	-28.8	25.14	40	-14.86	0-360	100	V
6	437.497	35.54	Pk	15.9	-26	25.44	46.02	-20.58	0-360	200	V

* - indicates frequency in CFR15.205/IC7.2.2 Restricted Band

Pk - Peak detector

12. AC POWER LINE CONDUCTED EMISSIONS

LIMITS

FCC §15.207 (a)

Frequency of Emission (MHz)	Conducted Limit (dBuV)	
	Quasi-peak	Average
0.15-0.5	66 to 56	56 to 46
0.5-5	56	46
5-30	60	50

*Decreases with the logarithm of the frequency.

TEST PROCEDURE

The EUT is placed on a non-conducting table 40 cm from the vertical ground plane and 80 cm above the horizontal ground plane. The EUT is configured in accordance with ANSI C63.10.

The receiver is set to a resolution bandwidth of 9 kHz. Peak detection is used unless otherwise noted as quasi-peak or average.

Line conducted data is recorded for both NEUTRAL and HOT lines.

RESULTS

6 WORST EMISSIONS

LINE 1 PLOT

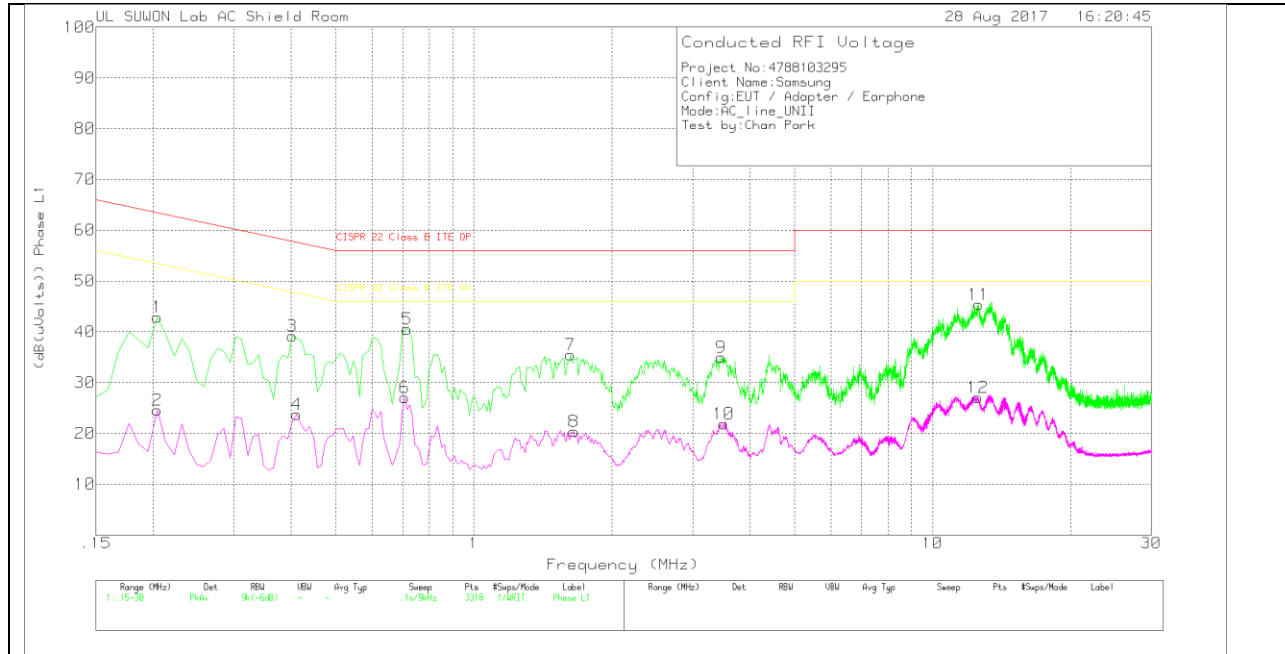

LINE 1 RESULTS

Trace Markers

Phase L1 .15 - 30MHz

Marker	Frequency (MHz)	Meter Reading (dBuV)	Det	101837_L 1_with extension	CABLELOS S(dB)	Corrected Reading (dB(uVolts))	CISPR 22 Class B ITE QP	Margin (dB)	CISPR 22 Class B ITE AV	Margin (dB)
1	.204	32.87	Pk	9.8	.2	42.87	63.45	-20.58	-	-
2	.204	14.56	Av	9.8	.2	24.56	-	-	53.45	-28.89
3	.402	29.21	Pk	9.8	.2	39.21	57.81	-18.6	-	-
4	.411	13.71	Av	9.8	.2	23.71	-	-	47.63	-23.92
5	.717	30.66	Pk	9.7	.2	40.56	56	-15.44	-	-
6	.708	17.16	Av	9.7	.2	27.06	-	-	46	-18.94
7	1.626	25.26	Pk	9.9	.3	35.46	56	-20.54	-	-
8	1.653	10.13	Av	9.9	.3	20.33	-	-	46	-25.67
9	3.462	24.92	Pk	9.8	.3	35.02	56	-20.98	-	-
10	3.507	11.82	Av	9.8	.3	21.92	-	-	46	-24.08
11	12.615	35.22	Pk	9.8	.3	45.32	60	-14.68	-	-
12	12.552	17	Av	9.8	.3	27.1	-	-	50	-22.9

Pk - Peak detector

Av - Average detection

LINE 2 PLOT

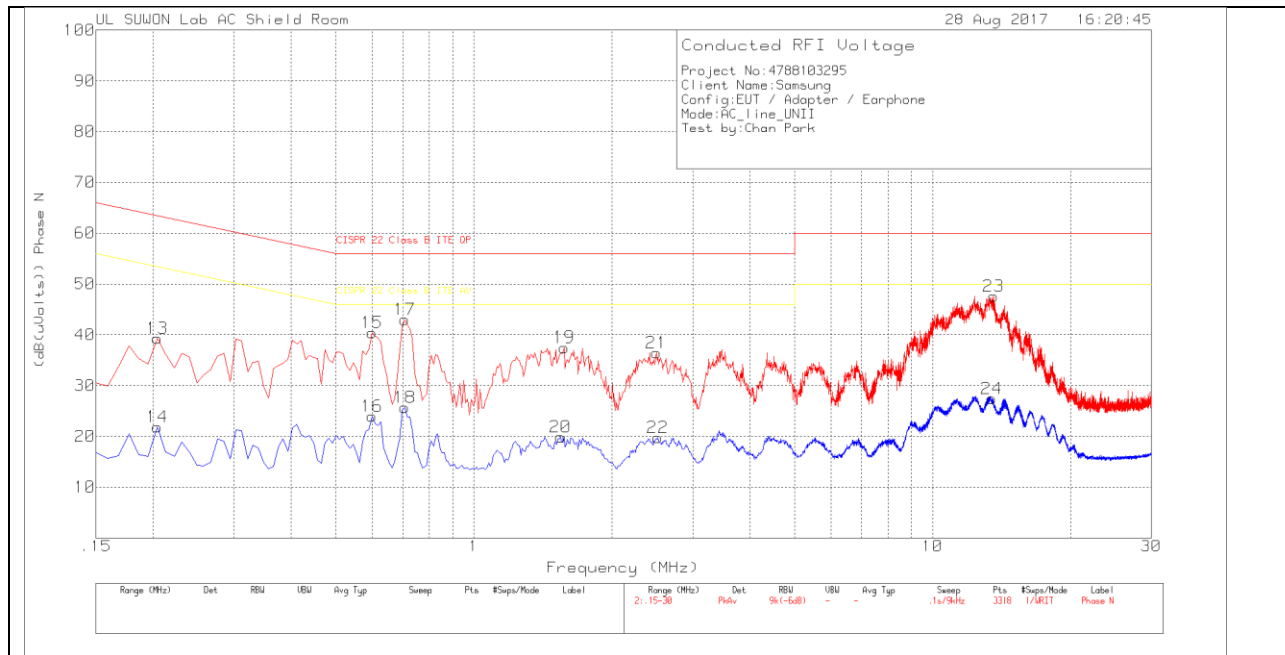

LINE 2 RESULTS

Trace Markers

Phase N .15 - 30MHz

Marker	Frequency (MHz)	Meter Reading (dBuV)	Det	101837_N _with extension	CABLELOS S(dB)	Corrected Reading (dB(uVolts))	CISPR 22 Class B ITE QP	Margin (dB)	CISPR 22 Class B ITE AV	Margin (dB)
13	.204	29.33	Pk	9.8	.2	39.33	63.45	-24.12	-	-
14	.204	11.83	Av	9.8	.2	21.83	-	-	53.45	-31.62
15	.6	30.57	Pk	9.7	.2	40.47	56	-15.53	-	-
16	.6	14.08	Av	9.7	.2	23.98	-	-	46	-22.02
17	.708	33.04	Pk	9.8	.2	43.04	56	-12.96	-	-
18	.708	15.69	Av	9.8	.2	25.69	-	-	46	-20.31
19	1.572	27.31	Pk	9.9	.3	37.51	56	-18.49	-	-
20	1.545	9.69	Av	9.9	.3	19.89	-	-	46	-26.11
21	2.499	26.28	Pk	9.9	.3	36.48	56	-19.52	-	-
22	2.517	9.53	Av	9.9	.3	19.73	-	-	46	-26.27
23	13.578	37.39	Pk	9.8	.4	47.59	60	-12.41	-	-
24	13.479	17.22	Av	9.8	.4	27.42	-	-	50	-22.58

Pk - Peak detector

Av - Average detection

13. DYNAMIC FREQUENCY SELECTION

13.1. OVERVIEW

13.1.1. LIMITS

FCC

§15.407 (h), FCC KDB 905462 D02 "COMPLIANCE MEASUREMENT PROCEDURES FOR UNLICENSED-NATIONAL INFORMATION INFRASTRUCTURE DEVICES OPERATING IN THE 5250-5350 MHz AND 5470-5725 MHz BANDS INCORPORATING DYNAMIC FREQUENCY SELECTION" and KDB 905462 D03 "U-NII CLIENT DEVICES WITHOUT RADAR DETECTION CAPABILITY".

Table 1: Applicability of DFS requirements prior to use of a channel

Requirement	Operational Mode		
	Master	Client (without radar detection)	Client (with radar detection)
Non-Occupancy Period	Yes	Not required	Yes
DFS Detection Threshold	Yes	Not required	Yes
Channel Availability Check Time	Yes	Not required	Not required
U-NII Detection Bandwidth	Yes	Not required	Yes

Table 2: Applicability of DFS requirements during normal operation

Requirement	Operational Mode		
	Master	Client (without DFS)	Client (with DFS)
DFS Detection Threshold	Yes	Not required	Yes
Channel Closing Transmission Time	Yes	Yes	Yes
Channel Move Time	Yes	Yes	Yes
U-NII Detection Bandwidth	Yes	Not required	Yes

Additional requirements for devices with multiple bandwidth modes	Master Device or Client with Radar DFS	Client (without DFS)
U-NII Detection Bandwidth and Statistical Performance Check	All BW modes must be tested	Not required
Channel Move Time and Channel Closing Transmission Time	Test using widest BW mode available	Test using the widest BW mode available for the link
All other tests	Any single BW mode	Not required
Note: Frequencies selected for statistical performance check (Section 7.8.4) should include several frequencies within the radar detection bandwidth and frequencies near the edge of the radar detection bandwidth. For 802.11 devices it is suggested to select frequencies in all 20 MHz channel blocks and a null frequency between the bonded 20 MHz channel blocks.		

Table 3: Interference Threshold values, Master or Client incorporating In-Service Monitoring

Maximum Transmit Power	Value (see notes)
E.I.R.P. \geq 200 mill watt	-64 dBm
E.I.R.P. < 200 mill watt and power spectral density < 10 dBm/MHz	-62 dBm
E.I.R.P. < 200 mill watt that do not meet power spectral density requirement	-64 dBm
<p>Note 1: This is the level at the input of the receiver assuming a 0 dBi receive antenna</p> <p>Note 2: Throughout these test procedures an additional 1 dB has been added to the amplitude of the test transmission waveforms to account for variations in measurement equipment. This will ensure that the test signal is at or above the detection threshold level to trigger a DFS response.</p> <p>Note 3: E.I.R.P. is based on the highest antenna gain. For MIMO devices refer to KDB publication 662911 D01.</p>	

Table 4: DFS Response requirement values

Parameter	Value
<i>Non-occupancy period</i>	30 minutes
<i>Channel Availability Check Time</i>	60 seconds
<i>Channel Move Time</i>	10 seconds (See Note 1)
<i>Channel Closing Transmission Time</i>	200 milliseconds + approx. 60 milliseconds over remaining 10 second period. (See Notes 1 and 2)
<i>U-NII Detection Bandwidth</i>	Minimum 100% of the U-NII 99% transmission power bandwidth. (See Note 3)
<p>Note 1: <i>Channel Move Time</i> and the <i>Channel Closing Transmission Time</i> should be performed with Radar Type 0. The measurement timing begins at the end of the Radar Type 0 burst.</p> <p>Note 2: The <i>Channel Closing Transmission Time</i> is comprised of 200 milliseconds starting at the beginning of the <i>Channel Move Time</i> plus any additional intermittent control signals required to facilitate a <i>Channel</i> move (an aggregate of 60 milliseconds) during the remainder of the 10 second period. The aggregate duration of control signals will not count quiet periods in between transmissions.</p> <p>Note 3: During the <i>U-NII Detection Bandwidth</i> detection test, radar type 0 should be used. For each frequency step the minimum percentage of detection is 90 percent. Measurements are performed with no data traffic.</p>	

Table 5 – Short Pulse Radar Test Waveforms

Radar Type	Pulse Width (usec)	PRI (usec)	Pulses	Minimum Percentage of Successful Detection	Minimum Trials
0	1	1428	18	See Note 1	See Note 1
1	1	Test A: 15 unique PRI values randomly selected from the list of 23 PRI values in table 5a	Roundup: $\{(1/360) \times (19 \times 10^6 \text{ PRI}_{\text{usec}})\}$	60%	30
		Test B: 15 unique PRI values randomly selected within the range of 518-3066 usec. With a minimum increment of 1 usec, excluding PRI values selected in Test A			
2	1-5	150-230	23-29	60%	30
3	6-10	200-500	16-18	60%	30
4	11-20	200-500	12-16	60%	30
Aggregate (Radar Types 1-4)				80%	120
Note 1: Short Pulse Radar Type 0 should be used for the <i>Detection Bandwidth</i> test, <i>Channel Move Time</i> , and <i>Channel Closing Time</i> tests.					

Table 6 – Long Pulse Radar Test Signal

Radar Waveform Type	Pulse Width (µsec)	Chirp Width (MHz)	PRI (µsec)	Pulses per Burst	Number of Bursts	Minimum Percentage of Successful Detection	Minimum Trials
5	50-100	5-20	1000-2000	1-3	8-20	80%	30

Table 7 – Frequency Hopping Radar Test Signal

Radar Waveform Type	Pulse Width (µsec)	PRI (µsec)	Pulses per Hop	Hopping Rate (kHz)	Hopping Sequence Length (msec)	Minimum Percentage of Successful Detection	Minimum Trials
6	1	333	9	0.333	300	70%	30

13.1.1. TEST AND MEASUREMENT SYSTEM

CONDUCTED METHOD SYSTEM BLOCK DIAGRAM

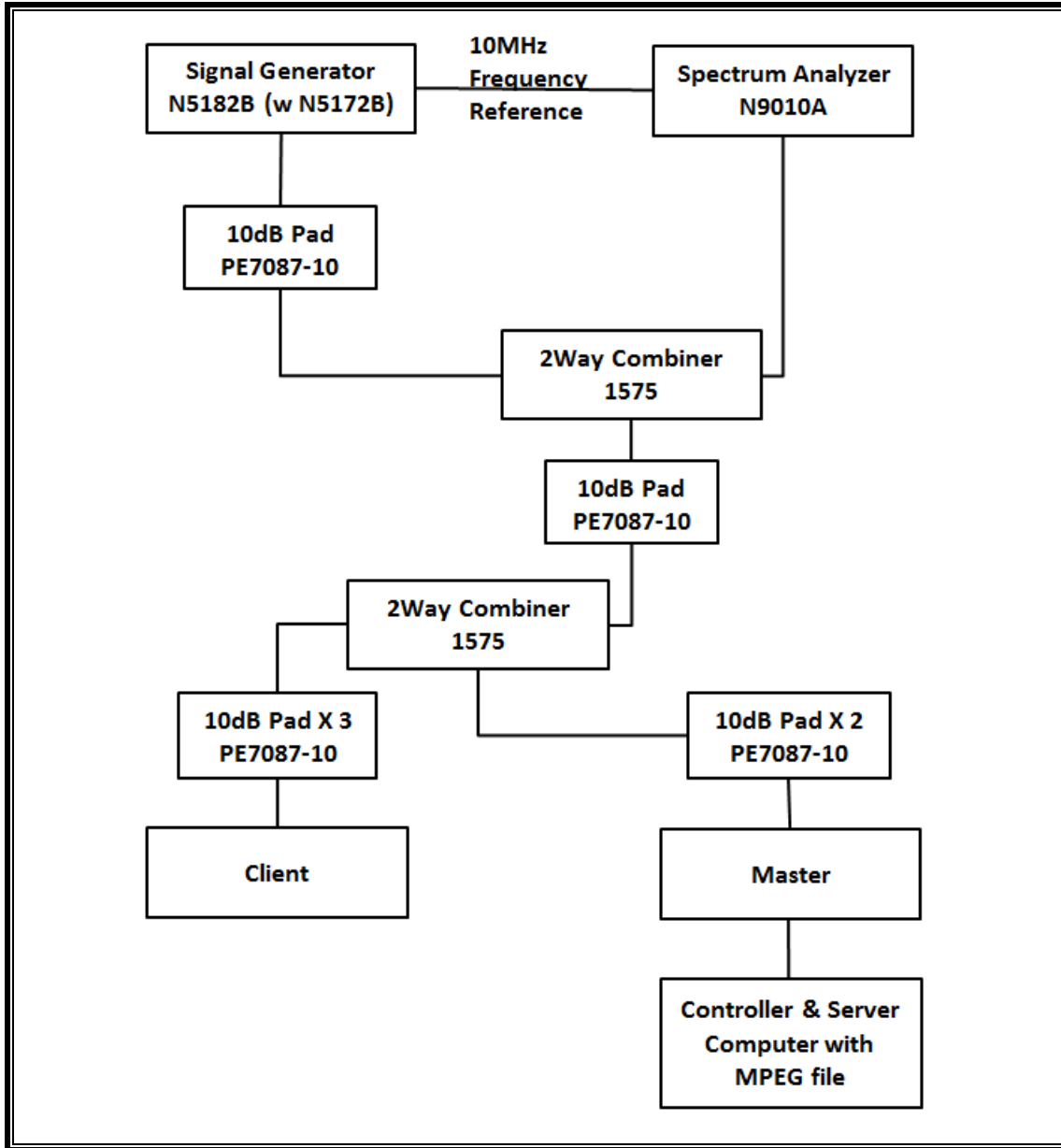

SYSTEM OVERVIEW

The short pulse and long pulse signal generating system utilizes the Keysite Signal Studio for Pulse Building as N5172B. The Vector Signal Generator has been validated by the NTIA. The hopping signal generating system utilizes the CCS simulated hopping method and system, which has been validated by the DoD, FCC and NTIA. The software selects waveform parameters from within the bounds of the signal type on a random basis using uniform distribution.

The short pulse types 1, 2, 3 and 4, and the long pulse type 5 parameters are randomized at run-time.

The hopping type 6 pulse parameters are fixed while the hopping sequence is based on the August 2005 NTIA Hopping Frequency List. The initial starting point randomized at run-time and each subsequent starting point is incremented by 475. Each frequency in the 100-length segment is compared to the boundaries of the EUT Detection Bandwidth and the software creates a hopping burst pattern in accordance with Section 7.4.1.3 Method #2 Simulated Frequency Hopping Radar Waveform Generating Subsystem of KDB 905462 D02. The frequency of the signal generator is incremented in 1 MHz steps from F_L to F_H for each successive trial. This incremental sequence is repeated as required to generate a minimum of 30 total trials and to maintain a uniform frequency distribution over the entire Detection Bandwidth.

The signal monitoring equipment consists of a spectrum analyzer. The aggregate ON time is calculated by multiplying the number of bins above a threshold during a particular observation period by the dwell time per bin, with the analyzer set to peak detection and max hold.

SYSTEM CALIBRATION

A 50-ohm load is connected in place of the spectrum analyzer, and the spectrum analyzer is connected to a horn antenna via a coaxial cable, with the reference level offset set to (horn antenna gain – coaxial cable loss). The signal generator is set to CW mode. The amplitude of the signal generator is adjusted to yield a level of –64 dBm as measured on the spectrum analyzer.

Without changing any of the instrument settings, the spectrum analyzer is reconnected to the Common port of the Spectrum Analyzer Combiner/Divider. The Reference Level Offset of the spectrum analyzer is adjusted so that the displayed amplitude of the signal is –64 dBm.

The spectrum analyzer displays the level of the signal generator as received at the antenna ports of the Master Device. The interference detection threshold may be varied from the calibrated value of –64 dBm and the spectrum analyzer will still indicate the level as received by the Master Device.

ADJUSTMENT OF DISPLAYED TRAFFIC LEVEL

A link is established between the Master and Slave and the distance between the units is adjusted as needed to provide a suitable received level at the Master and Slave devices. The video test file is streamed to generate WLAN traffic. The monitoring antenna is adjusted so that the WLAN traffic level, as displayed on the spectrum analyzer, is at lower amplitude than the radar detection threshold.

TEST AND MEASUREMENT EQUIPMENT

The following test and measurement equipment was utilized for the DFS tests documented in this report:

TEST EQUIPMENT LIST				
Description	Manufacturer	Model	S/N	Cal Due
Spectrum Analyzer, 7 GHz	Agilent / HP	N9010A	MY54200580	08-07-18
Vector Signal Generator, 6GHz	Agilent / HP	N5182B	MY53051241	08-07-18

13.1.2. SETUP OF EUT

CONDUCTED METHOD EUT TEST SETUP

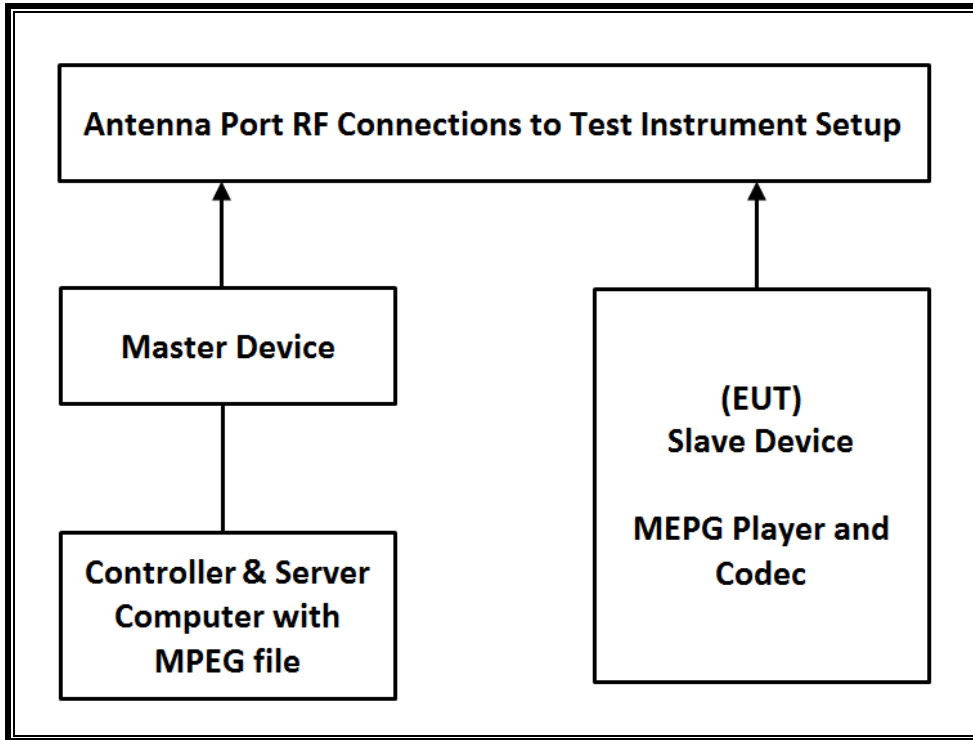

SUPPORT EQUIPMENT

The following support equipment was utilized for the DFS tests documented in this report:

PERIPHERAL SUPPORT EQUIPMENT LIST				
Description	Manufacturer	Model	Serial Number	FCC ID
Wireless Access Point	Cisco	AIR-CAP3702E-A-K9	FTX182276QX	LDK102087
PC (Controller/Server)	HP	HP EliteDesk 800 G1 TWR	CZC4125J25	DoC

13.1.3. DESCRIPTION OF EUT

The EUT operates over the 5250-5350 MHz and 5470-5725 MHz ranges.

The EUT is a Slave Device without Radar Detection.

The highest power level within these bands is 12.408 dBm in the 5250-5350 MHz band and 12.425 dBm in the 5470-5725 MHz band.

The antenna gain assembly utilized with the EUT are -0.29 dBi in the 5250-5350 MHz band and 0.62 dBi in the 5470-5725 MHz band.

The rated output power of the Master unit is > 23dBm (EIRP). Therefore the required interference threshold level is -64 dBm. After correction for procedural adjustments, the required conducted threshold at the antenna port is $-64 + 1 = -63$ dBm.

The calibrated radiated DFS Detection Threshold level is set to -64 dBm. The tested level is lower than the required level hence it provides a margin to the limit.

The EUT uses one transmitter/receiver chain connected to an antenna to perform radiated tests.

WLAN traffic that meets or exceeds the minimum required loading was generated by transferring a data stream from the controller/server PC to the EUT using iPerf version 2.0.5 software package.

TPC is not required since the maximum EIRP is less than 500 mW (27 dBm).

The EUT utilizes the 802.11a/n architecture. Two nominal channel bandwidths are implemented: 20 MHz and 40 MHz.

The software installed in the access point is 12.4(25d)JA1.

UNIFORM CHANNEL SPREADING

This requirement is not applicable to Slave radio devices.

OVERVIEW OF MASTER DEVICE WITH RESPECT TO §15.407 (h) REQUIREMENTS

The Master Device is a Cisco Access Point, FCC ID: LDK102087. The minimum antenna gain for the Master Device is 6 dBi.

The rated output power of the Master unit is > 23dBm (EIRP). Therefore the required interference threshold level is -64 dBm. After correction for procedural adjustments, the required radiated threshold at the antenna port is $-64 + 1 = -63$ dBm.

The calibrated radiated DFS Detection Threshold level is set to -64 dBm. The tested level is lower than the required level hence it provides a margin to the limit.

13.1. RESULTS FOR 20 MHz BANDWIDTH

13.1.1. TEST CHANNEL

All tests were performed at a channel center frequency of 5500 MHz.

13.1.2. RADAR WAVEFORM AND TRAFFIC

RADAR WAVEFORM

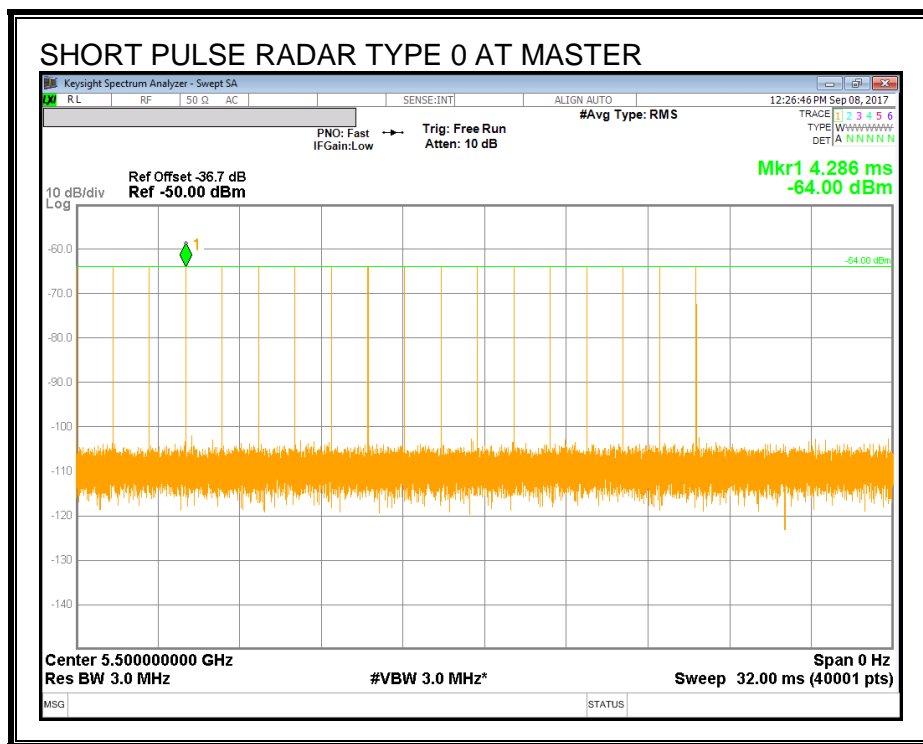

TRAFFIC

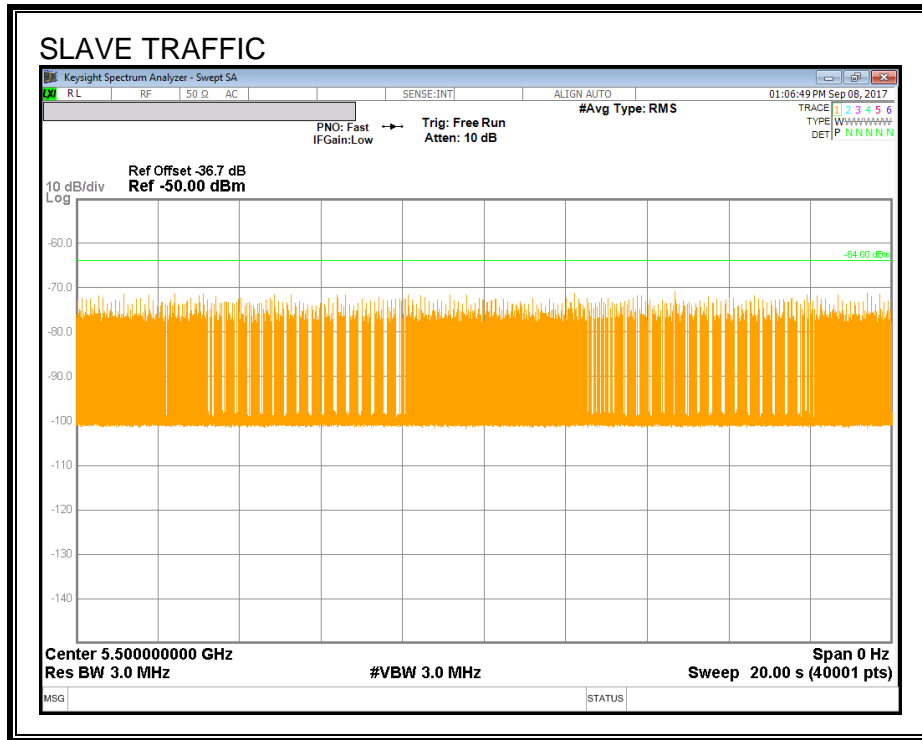

13.1.3.OVERLAPPING CHANNEL TESTS

RESULTS

These tests are not applicable.

13.1.4.MOVE AND CLOSING TIME

REPORTING NOTES

The reference marker is set at the end of last radar pulse.

The delta marker is set at the end of the last WLAN transmission following the radar pulse. This delta is the channel move time.

The aggregate channel closing transmission time is calculated as follows:

Aggregate Transmission Time =
(Number of analyzer bins showing transmission) * (dwell time per bin)

The observation period over which the aggregate time is calculated begins at (Reference Marker + 200 msec) and ends no earlier than (Reference Marker + 10 sec).

RESULTS

Channel Move Time (sec)	Limit (sec)
0.779	10

Aggregate Channel Closing Transmission Time (msec)	Limit (msec)
4.500	60

MOVE TIME & CHANNEL CLOSING TIME

AGGREGATE CHANNEL CLOSING TRANSMISSION TIME

No transmissions are observed during the aggregate monitoring period.

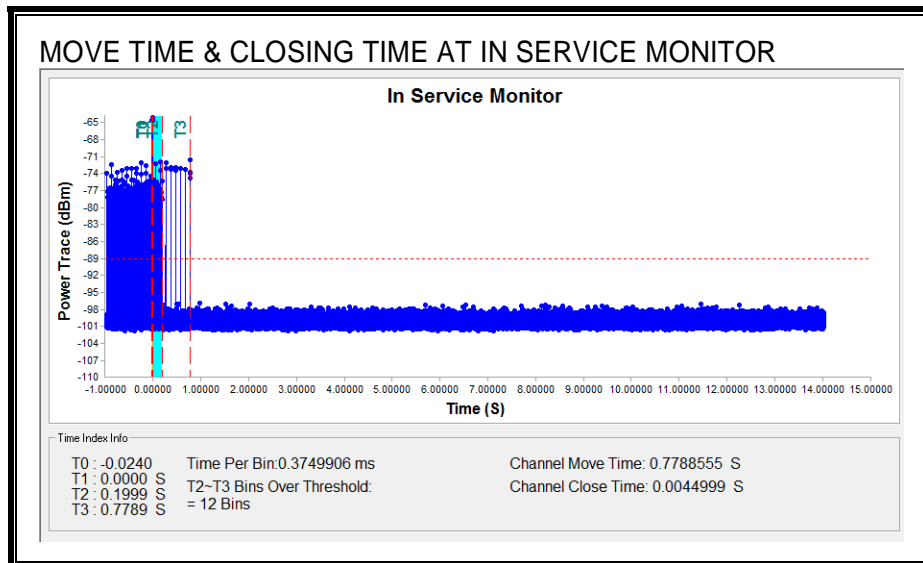
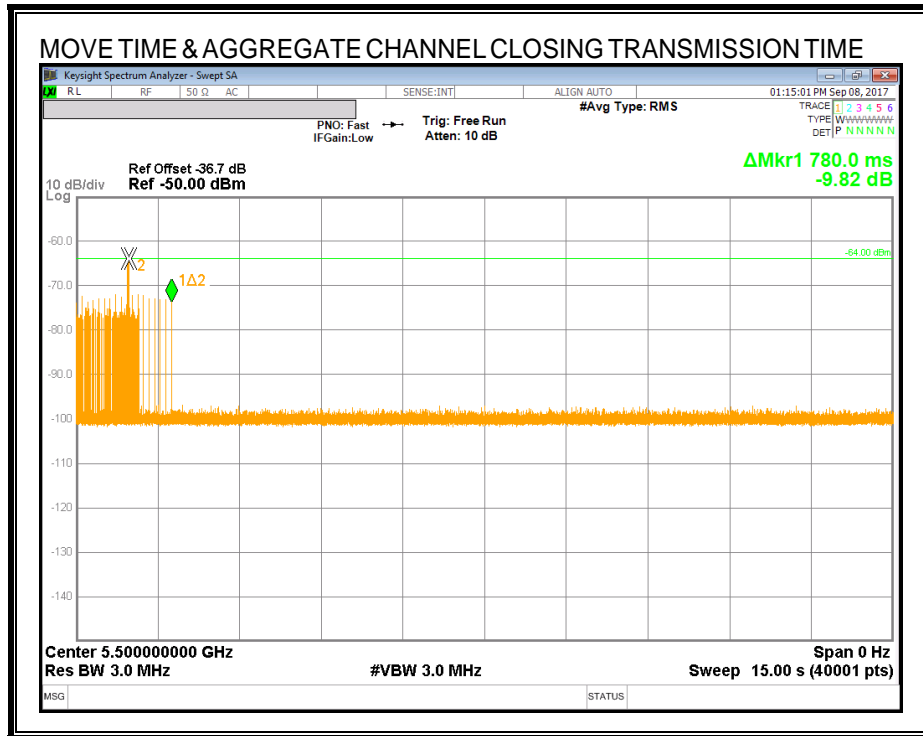

NON-OCCUPANCY PERIOD

RESULTS

No EUT transmissions were observed on the test channel during the 10-minute observation time.

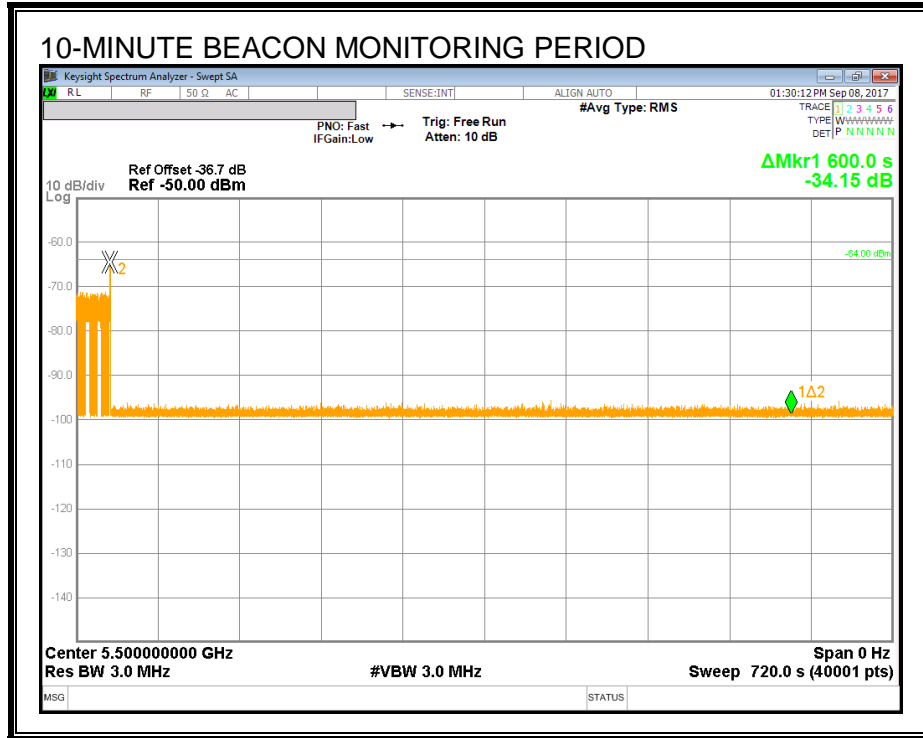

13.2. RESULTS FOR 40 MHz BANDWIDTH

13.2.1. TEST CHANNEL

All tests were performed at a channel center frequency of 5510 MHz.

13.2.2. RADAR WAVEFORM AND TRAFFIC

RADAR WAVEFORM

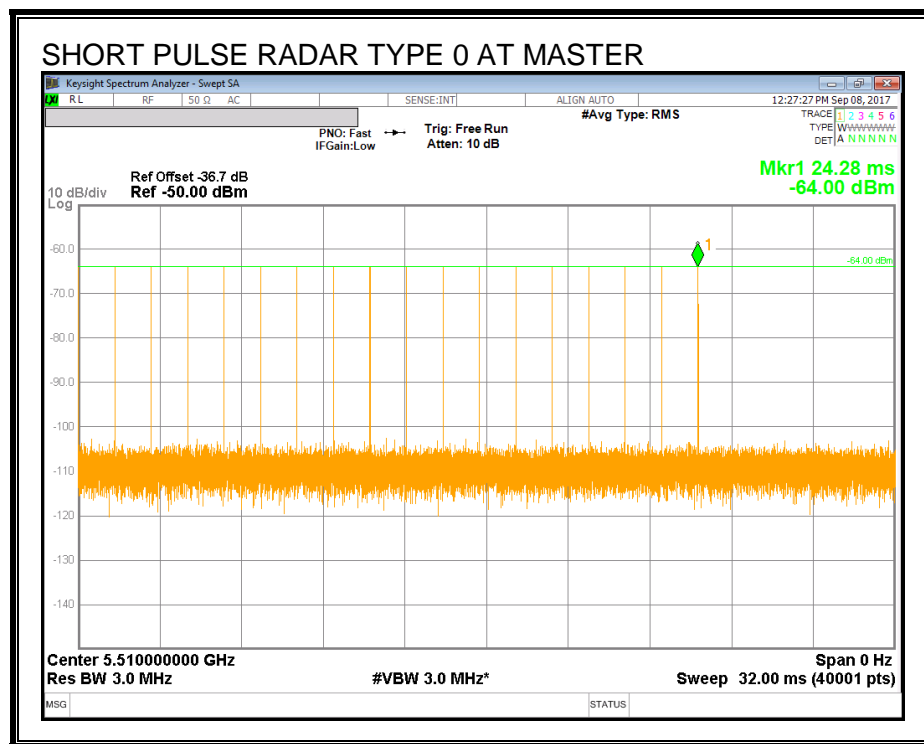

TRAFFIC

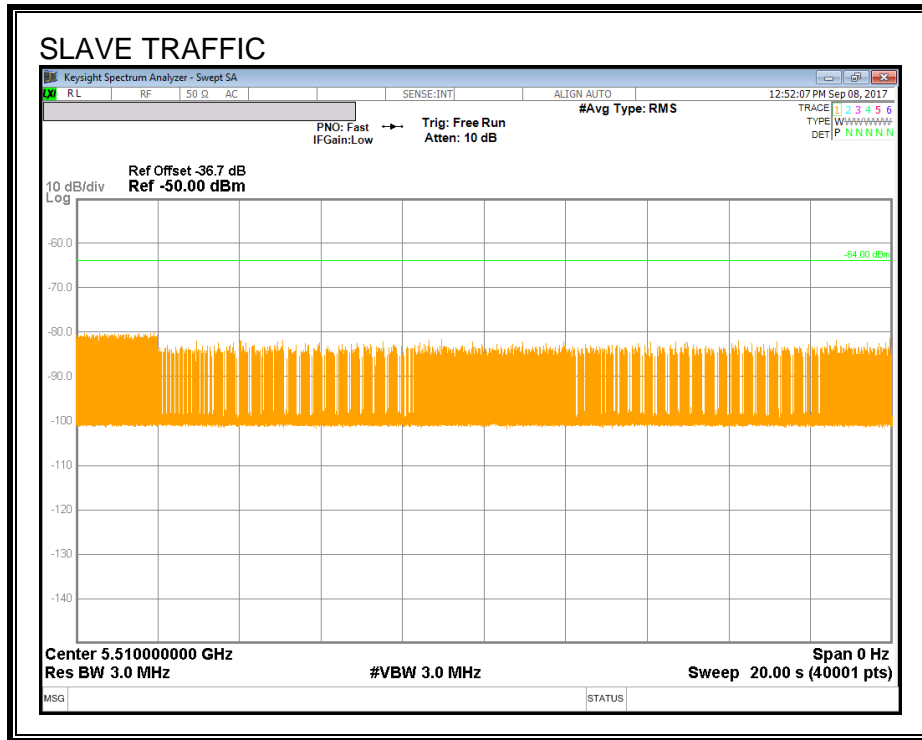

13.2.3.OVERLAPPING CHANNEL TESTS

RESULTS

These tests are not applicable.

13.2.4.MOVE AND CLOSING TIME

REPORTING NOTES

The reference marker is set at the end of last radar pulse.

The delta marker is set at the end of the last WLAN transmission following the radar pulse. This delta is the channel move time.

The aggregate channel closing transmission time is calculated as follows:

Aggregate Transmission Time =
(Number of analyzer bins showing transmission) * (dwell time per bin)

The observation period over which the aggregate time is calculated begins at (Reference Marker + 200 msec) and ends no earlier than (Reference Marker + 10 sec).

RESULTS

Channel Move Time (sec)	Limit (sec)
0.778	10

Aggregate Channel Closing Transmission Time (msec)	Limit (msec)
6.000	60

MOVE TIME & CHANNEL CLOSING TIME

AGGREGATE CHANNEL CLOSING TRANSMISSION TIME

No transmissions are observed during the aggregate monitoring period.

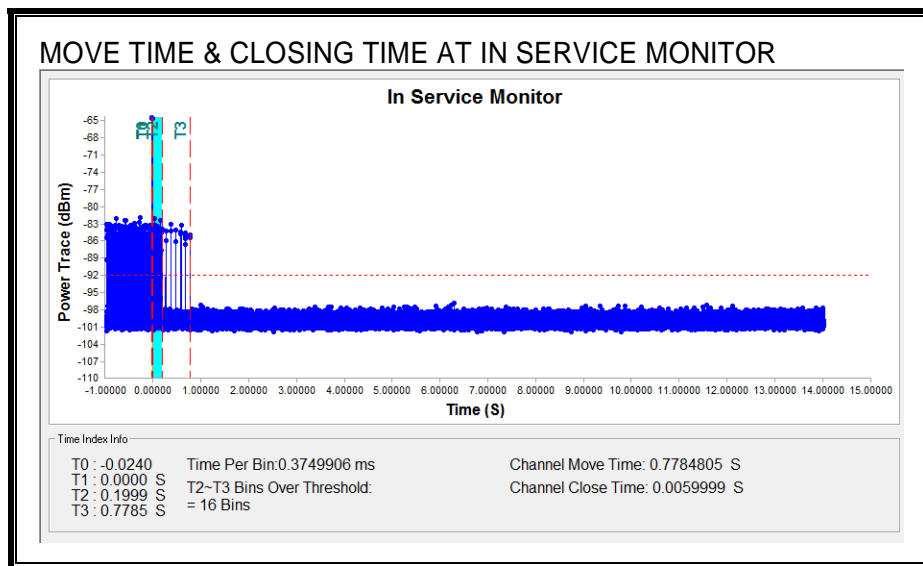
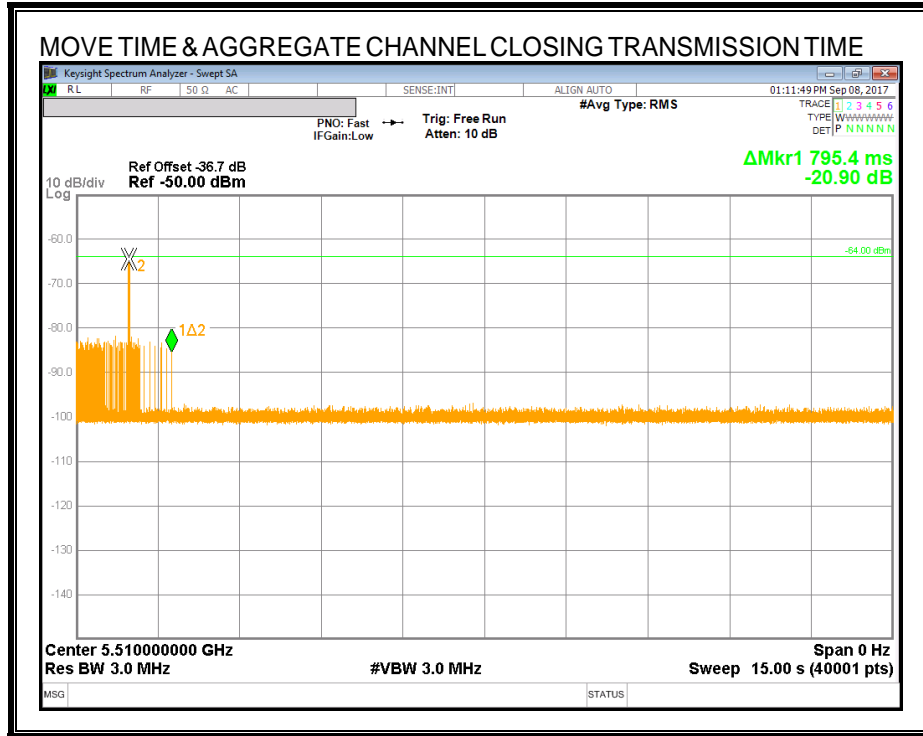

NON-OCCUPANCY PERIOD

RESULTS

No EUT transmissions were observed on the test channel during the 10-minute observation time.

