



FCC CFR47 PART 22 SUBPART H
FCC CFR47 PART 24 SUBPART E
FCC CFR47 PART 27 SUBPART F
FCC CFR47 PART 27 SUBPART L
FCC CFR47 PART 27 SUBPART M

WWAN

CERTIFICATION TEST REPORT

FOR

WCDMA/LTE Tablet + BT/BLE and DTS/UNII a/b/g/n

MODEL NUMBER : SM-T378V

FCC ID: A3LSMT378V

REPORT NUMBER: 4788103295-E5V2

ISSUE DATE: SEP 21, 2017

Prepared for
SAMSUNG ELECTRONICS CO., LTD.
129 SAMSUNG-RO, YEONGTONG-GU, SUWON-SI,
GYEONGGI-DO, 16677, KOREA

Prepared by
UL Korea, Ltd. Suwon Laboratory
218 Maeyeong-ro, Yeongtong-gu,
Suwon-si, Gyeonggi-do, 16675, Korea
TEL: (031) 337-9902
FAX: (031) 213-5433



Revision History

<u>Rev.</u>	<u>Issue Date</u>	<u>Revisions</u>	<u>Revised By</u>
V1	09/14/17	Initial issue	Junwhan Lee
V2	09/21/17	Updated report to address TCB's questions	Junwhan Lee

TABLE OF CONTENTS

1. ATTESTATION OF TEST RESULTS	5
2. TEST METHODOLOGY	6
3. FACILITIES AND ACCREDITATION	6
4. CALIBRATION AND UNCERTAINTY	6
4.1. <i>MEASURING INSTRUMENT CALIBRATION</i>	<i>6</i>
4.2. <i>SAMPLE CALCULATION</i>	<i>6</i>
4.3. <i>MEASUREMENT UNCERTAINTY.....</i>	<i>7</i>
5. EQUIPMENT UNDER TEST	8
5.1. <i>DESCRIPTION OF EUT</i>	<i>8</i>
5.2. <i>MAXIMUM OUTPUT POWER.....</i>	<i>8</i>
5.3. <i>DESCRIPTION OF AVAILABLE ANTENNAS</i>	<i>11</i>
5.4. <i>DESCRIPTION OF TEST SETUP.....</i>	<i>12</i>
6. TEST AND MEASUREMENT EQUIPMENT	14
7. Summary Table	15
8. PEAK TO AVERAGE RATIO	17
8.1. <i>CONDUCTED PEAK TO AVERAGE RESULT.....</i>	<i>17</i>
8.2. <i>CONDUCTED PEAK TO AVERAGE PLOTS.....</i>	<i>20</i>
9. LIMITS AND CONDUCTED RESULTS	28
9.1. <i>OCCUPIED BANDWIDTH</i>	<i>28</i>
9.1.1. <i>OCCUPIED BANDWIDTH RESULTS</i>	<i>28</i>
9.1.2. <i>OCCUPIED BANDWIDTH PLOTS.....</i>	<i>34</i>
9.2. <i>BAND EDGE EMISSIONS.....</i>	<i>58</i>
WCDMA/LTE.....	59
9.2.1. <i>BAND EDGE PLOTS.....</i>	<i>66</i>
9.2.2. <i>EMISSION MASK PLOTS.....</i>	<i>87</i>
10.3 <i>OUT OF BAND EMISSIONS.....</i>	<i>91</i>
9.3.1. <i>OUT OF BAND EMISSIONS PLOTS</i>	<i>98</i>
9.4. <i>FREQUENCY STABILITY.....</i>	<i>122</i>
9.4.1. <i>FREQUENCY STABILITY RESULTS</i>	<i>123</i>
10. RADIATED TEST RESULTS	130
10.1. <i>RADIATED POWER (ERP & EIRP).....</i>	<i>130</i>

10.1.1.	ERP/EIRP Results.....	131
10.1.2.	ERP/EIRP DATA.....	137
10.2.	<i>FIELD STRENGTH OF SPURIOUS RADIATION</i>	161
10.2.1.	SPURIOUS RADIATION PLOTS.....	162
11.	SETUP PHOTOS	190

1. ATTESTATION OF TEST RESULTS

COMPANY NAME: SAMSUNG ELECTRONICS CO., LTD.
EUT DESCRIPTION: WCDMA/LTE Tablet + BT/BLE and DTS/UNII a/b/g/n
MODEL NUMBER: SM-T378V
SERIAL NUMBER: R32J7008GAP, R32J7008DTM (RADIATED);
R32J7008GGF (CONDUCTED)
DATE TESTED: AUG 16, 2017 - SEP 07, 2017

APPLICABLE STANDARDS	
STANDARD	TEST RESULTS
FCC PART 22H, 24E, 27F, 27L and 27M	Pass

UL Korea, Ltd. tested the above equipment in accordance with the requirements set forth in the above standards. All indications of Pass/Fail in this report are opinions expressed by UL Korea, Ltd. based on interpretations and/or observations of test results. Measurement Uncertainties were not taken into account and are published for informational purposes only. The test results show that the equipment tested is capable of demonstrating compliance with the requirements as documented in this report.

Note: The results documented in this report apply only to the tested sample, under the conditions and modes of operation as described herein. This document may not be altered or revised in any way unless done so by UL Korea, Ltd. and all revisions are duly noted in the revisions section. Any alteration of this document not carried out by UL Korea, Ltd. will constitute fraud and shall nullify the document. This report must not be used by the client to claim product certification, approval, or endorsement by IAS, any agency of the Federal Government, or any agency of any government.

Approved & Released For
UL Korea, Ltd. By:



SungGil Park
Suwon Lab Engineer
UL Korea, Ltd.

Tested By:



Junwhan Lee
Suwon Lab Engineer
UL Korea, Ltd.

2. TEST METHODOLOGY

The tests documented in this report were performed in accordance with following methods.

1. FCC CFR 47 Part 2.
2. FCC CFR 47 Part 22.
3. FCC CFR 47 Part 24.
4. FCC CFR 47 Part 27.
5. ANSI TIA-603-E, 2016
6. KDB 971168 D01 Power Meas License Digital Systems v02r02

3. FACILITIES AND ACCREDITATION

The test sites and measurement facilities used to collect data are located at 218 Maeyeong-ro, Yeongtong-gu, Suwon-si, Gyeonggi-do, 16675, Korea. Line conducted emissions are measured only at the 218 address. The following table identifies which facilities were utilized for radiated emission measurements documented in this report. Specific facilities are also identified in the test results sections.

218 Maeyeong-ro	
<input type="checkbox"/>	Chamber 1
<input checked="" type="checkbox"/>	Chamber 2

UL Korea, Ltd. is accredited by IAS, Laboratory Code TL-637. The full scope of accreditation can be viewed at <http://www.iasonline.org/PDF/TL/TL-637.pdf>.

4. CALIBRATION AND UNCERTAINTY

4.1. MEASURING INSTRUMENT CALIBRATION

The measuring equipment utilized to perform the tests documented in this report has been calibrated in accordance with the manufacturer's recommendations, and is traceable to recognized national standards.

4.2. SAMPLE CALCULATION

Where relevant, the following sample calculation is provided:

$EIRP = \text{PSA reading with EUT worst orientation (dBm)} + \text{Path loss (dB)} - \text{cable loss (between the SG and substitution antenna)} + \text{Substitution Antenna Factor (dBi)}$

$ERP = \text{PSA reading with EUT worst orientation (dBm)} + \text{Path loss (dB)} - \text{cable loss (between the SG and substitution antenna)}$

(Path loss = Signal generator output – PSA reading with substitution antenna)

4.3. MEASUREMENT UNCERTAINTY

Where relevant, the following measurement uncertainty levels have been estimated for tests performed on the apparatus:

PARAMETER	UNCERTAINTY
Conducted Disturbance, 0.15 to 30 MHz	2.32 dB
Radiated Disturbance, Below 1GHz	4.14 dB
Radiated Disturbance, Above 1 GHz	5.97 dB

Uncertainty figures are valid to a confidence level of 95%.

5. EQUIPMENT UNDER TEST

5.1. DESCRIPTION OF EUT

The EUT is a WCDMA/LTE Tablet + BT/BLE and DTS/UNII a/b/g/n.

5.2. MAXIMUM OUTPUT POWER

The transmitter has a maximum conducted and radiated ERP / EIRP output powers as follows:

Note : Conducted output power results were excerpted from RF exposure test report.(4788103295-S1V2 FCC Report SAR)

WCDMA

FCC Part 22/24						
Band	Frequency Range	Modulation	Conducted		Radiated	
	[MHz]		Peak	Avg [dBm]	Avg [mW]	Avg [dBm]
Band 5	824~849	REL99	22.95	197.24	21.63	145.55
		HSDPA	22.71	186.64	21.56	143.22
		HSUPA	21.61	144.88		
Band 2	1850~1910	REL99	22.61	182.39	23.75	237.14
		HSDPA	22.50	177.83	24.13	258.82
		HSUPA	22.26	168.27		

LTE Band 5

FCC Part 22							
Band	Frequency Range [MHz]	BandWidth [MHz]	Modulation	Conducted		Radiated	
				Peak	Avg [dBm]	Avg [mW]	Avg [dBm]
Band 5	824 ~ 849	10	QPSK	23.90	245.47	20.82	120.78
			16QAM	23.03	200.91	19.86	96.83
		5	QPSK	23.94	247.74	20.66	116.41
			16QAM	22.93	196.34	19.75	94.41
		3	QPSK	23.97	249.46	20.59	114.55
			16QAM	23.09	203.70	19.61	91.41
		1.4	QPSK	23.89	244.91	18.51	70.96
			16QAM	23.00	199.53	17.60	57.54

LTE Band 4

FCC Part 27							
Band	Frequency Range [MHz]	BandWidth [MHz]	Modulation Peak	Conducted		Radiated	
				Avg [dBm]	Avg [mW]	Avg [dBm]	Avg [mW]
Band 4	1710 ~ 1755	20	QPSK	23.44	220.80	23.84	242.10
			16QAM	22.60	181.97	22.85	192.75
		15	QPSK	23.61	229.61	23.93	247.17
			16QAM	22.74	187.93	22.92	195.88
		10	QPSK	23.65	231.74	24.56	285.76
			16QAM	22.83	191.87	23.58	228.03
		5	QPSK	23.60	229.09	25.23	333.43
			16QAM	22.59	181.55	24.25	266.07
		3	QPSK	23.69	233.88	21.01	126.18
			16QAM	22.59	181.55	19.90	97.72
		1.4	QPSK	23.72	235.50	19.52	89.54
			16QAM	22.75	188.36	18.34	68.23

LTE Band 2

FCC Part 24							
Band	Frequency Range [MHz]	BandWidth [MHz]	Modulation Peak	Conducted		Radiated	
				Avg [dBm]	Avg [mW]	Avg [dBm]	Avg [mW]
Band 2	1850 ~ 1910	20	QPSK	23.14	206.06	23.98	250.03
			16QAM	22.26	168.27	23.00	199.53
		15	QPSK	23.29	213.30	24.43	277.33
			16QAM	22.27	168.66	23.45	221.31
		10	QPSK	23.30	213.80	23.29	213.30
			16QAM	22.29	169.43	23.27	212.32
		5	QPSK	23.34	215.77	23.17	207.49
			16QAM	22.38	172.98	22.21	166.34
		3	QPSK	23.41	219.28	23.88	244.34
			16QAM	22.36	172.19	22.86	193.20
		1.4	QPSK	23.33	215.28	21.78	150.66
			16QAM	22.45	175.79	20.81	120.50

LTE Band 7

FCC Part 27							
Band	Frequency Range [MHz]	BandWidth h [MHz]	Modulation Peak	Conducted		Radiated	
				Avg [dBm]	Avg [mW]	Avg [dBm]	Avg [mW]
Band 7	2500~2570	20	QPSK	22.61	182.39	19.19	82.99
			16QAM	21.65	146.22	18.22	66.37
		15	QPSK	22.59	181.55	18.28	67.30
			16QAM	21.75	149.62	17.26	53.21
		10	QPSK	22.61	182.39	18.85	76.74
			16QAM	21.69	147.57	17.88	61.38
		5	QPSK	22.57	180.72	19.51	89.33
			16QAM	21.72	148.59	18.03	63.53

LTE Band 13

FCC Part 27							
Band	Frequency Range [MHz]	BandWidth [MHz]	Modulation Peak	Conducted		Radiated	
				Avg [dBm]	Avg [mW]	Avg [dBm]	Avg [mW]
Band 13	777 ~ 787	10	QPSK	23.69	233.88	18.65	73.28
			16QAM	22.67	184.93	17.71	59.02
		5	QPSK	23.59	228.56	18.50	70.79
			16QAM	22.68	185.35	18.05	63.83

5.3. DESCRIPTION OF AVAILABLE ANTENNAS

The radio utilizes a internal antenna for the [List the bands supported] with a maximum peak gain as follow:

Frequency (MHz)	Peak Gain (dBi)
WCDMA Band 5 / LTE Band 5 824 ~ 849 MHz	0.2
WCDMA Band 2 / LTE Band 2 1850 ~ 1910 MHz	1.7
LTE Band 4 1710 ~ 1755 MHz	2.5
LTE Band 7 2500 ~ 2570 MHz	2.6
LTE Band 13 777 ~ 787 MHz	-2.3

5.4. DESCRIPTION OF TEST SETUP

SUPPORT EQUIPMENT

Support Equipment List				
Description	Manufacturer	Model	Serial Number	FCC ID
Charger	SAMSUNG	EP-TA12JWE	RT4J221eS/B- E	N/A
Data Cable	SAMSUNG	EP-DG915UWZ	N/A	N/A
Earphone	SAMSUNG	EHS64AVFWE	N/A	N/A

I/O CABLES

I/O Cable List						
Cable No	Port	# of identical ports	Connector Type	Cable Type	Cable Length (m)	Remarks
1	DC Power	1	Mini-USB	Shielded	1.1m	N/A
2	Audio	2	Mini-Jack	Unshielded	1.1m	N/A

TEST SETUP

The EUT is continuously communicated to the call box during the tests.

SETUP DIAGRAM FOR TESTS (CONDUCTED TEST SETUP)

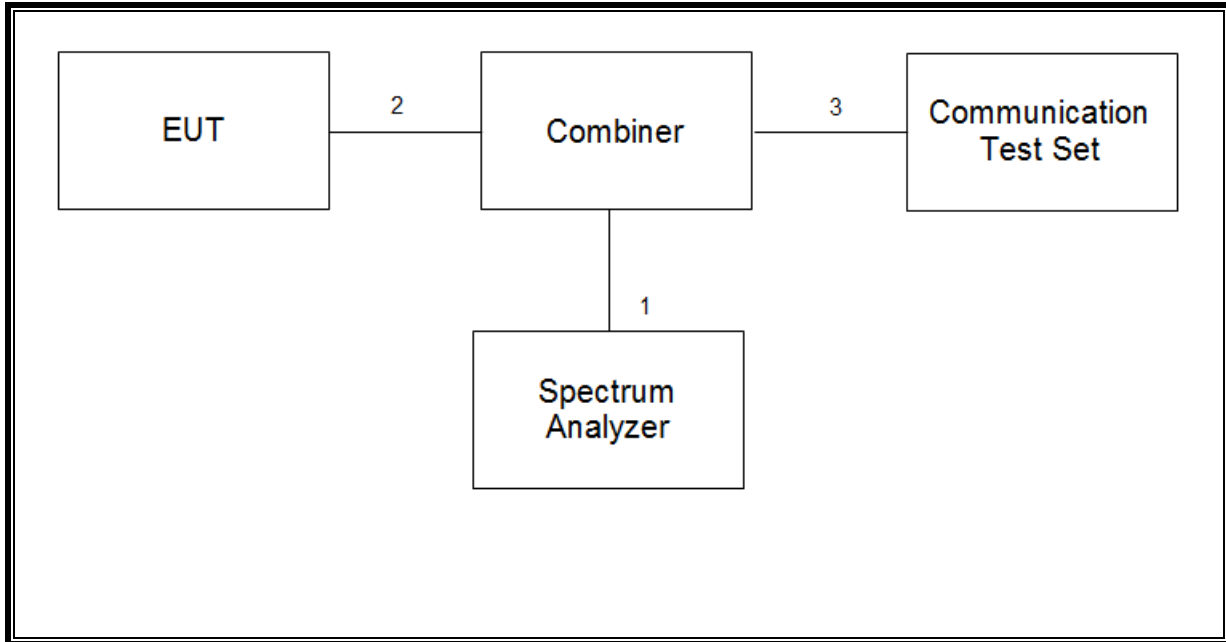

SETUP DIAGRAM FOR TESTS (RADIATED TEST SETUP)

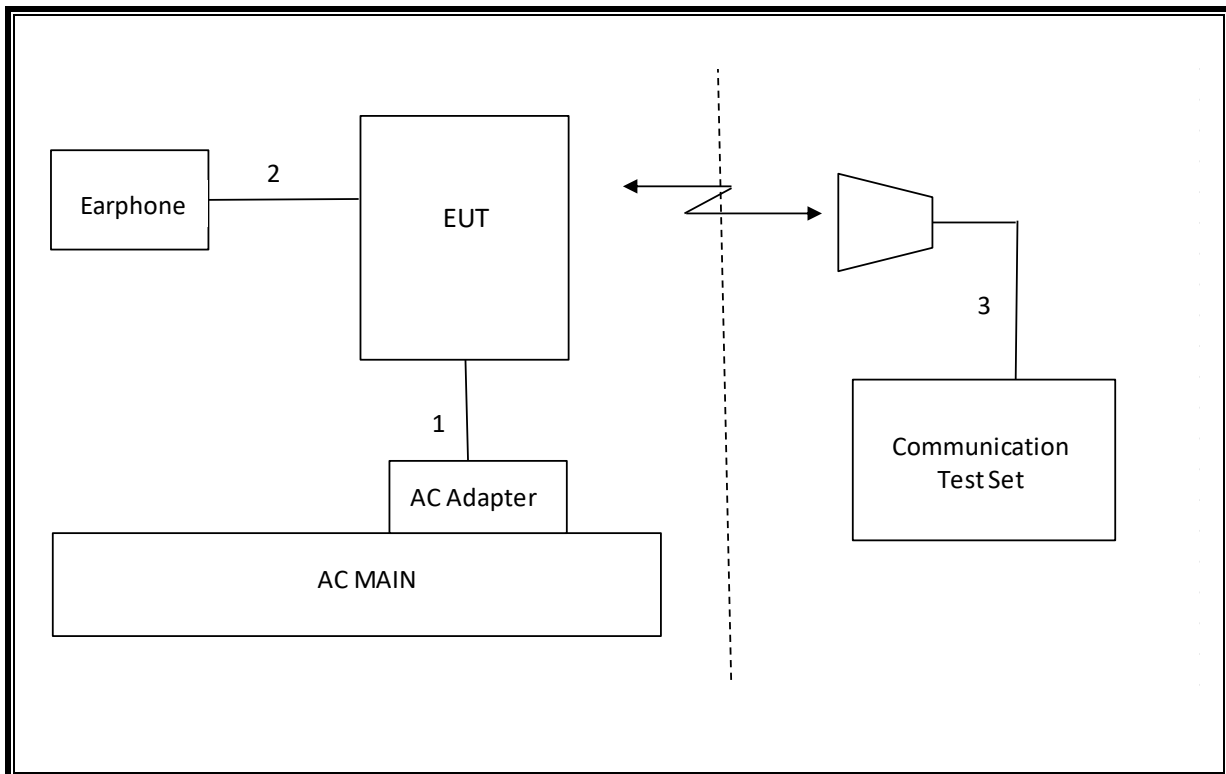

6. TEST AND MEASUREMENT EQUIPMENT

The following test and measurement equipment was utilized for the tests documented in this report:

Description	Manufacturer	Model	S/N	Cal Due
Antenna, Tuned Dipole 400~1000 MHz	ETS	3121D DB4	00164753	06-30-19
Antenna, Horn, 40 GHz	ETS	3116C	00166155	11-30-17
Antenna, Horn, 40 GHz	ETS	3116C-PA	00168841	12-15-17
Antenna, Bilog, 30MHz-1GHz	SCHWARZBECK	VULB9163	750	10-14-18
Antenna, Bilog, 30MHz-1GHz	SCHWARZBECK	VULB9163	749	04-14-19
Antenna, Horn, 18 GHz	ETS	3115	00167211	10-14-18
Antenna, Horn, 18 GHz	ETS	3115	00161451	03-10-19
Antenna, Horn, 18 GHz	ETS	3117	00168724	05-31-19
Antenna, Horn, 18 GHz	ETS	3117	00168717	05-31-19
Combiner	WEINSCHTEL	1575	2152	08-08-18
Communications Test Set	R&S	CMW500	150312	08-07-18
Communications Test Set	R&S	CMW500	115331	08-07-18
DC Power Supply	Agilent / HP	E3640A	MY54226395	08-07-18
Preamplifier, 1000 MHz	Sonoma	310N	341282	08-09-18
Preamplifier, 1000 MHz	Sonoma	310N	351741	08-07-18
Preamplifier	ETS	3115-PA	00167475	08-09-18
Preamplifier, 18 GHz	Miteq	AFS42-00101800-25-S-42	1896138	08-08-18
Spectrum Analyzer, 44 GHz	Agilent / HP	N9030A	MY54490312	08-08-18
EMI Test Receive, 40 GHz	R&S	ESU40	100439	08-08-18
EMI Test Receive, 40 GHz	R&S	ESU40	100457	08-08-18
High Pass Filter 1.2GHz	Micro-Tronics	HPM50108-02	G005	08-09-18
High Pass Filter 1.2GHz	Micro-Tronics	HPM50108-02	G006	08-08-18
High Pass Filter 2.8GHz	Micro-Tronics	HPM50111-02	010	08-09-18
High Pass Filter 2.8GHz	Micro-Tronics	HPM50111-02	011	08-08-18
High Pass Filter 4GHz	Micro-Tronics	HPM50118-02	G001	08-09-18
High Pass Filter 4GHz	Micro-Tronics	HPM50118-02	G002	08-08-18
Attenuator	PASTERNAK	PE7087-10	A009	08-08-18
Temperature Chamber	ESPEC	SH-642	93001109	08-08-18
UL Software				
Description	Manufacturer	Model	Version	
Antenna port test software	UL	CLT	Ver 2.2	

7. Summary Table

FCC Part Section	Test Description	Test Limit	Test Condition	Test Result	Note
2.1049	Occupied Band width (99%)	N/A	Conducted	Pass	17.9152 MHz
22.917(a) 24.238(a) 27.53(g)	Band Edge / Conducted Spurious Emission	-13dBm		Pass	-14.73 dBm
27.53(m)	Conducted Spurious Emission	-25 dBm		Pass	-30.17 dBm
27.53(m)	Emission mask	Section 9.2.2		Pass	Pass
2.1046	Conducted output power	N/A		Pass	Refer to RF exposure test report
22.355 24.235 27.54	Frequency Stability	2.5PPM		Pass	-0.003 PPM
22.913(a)(2)	Effective Radiated Power	38.5 dBm		Radiated	Pass
27.50(b)(10)		34.77 dBm	Pass		18.65 dBm
24.232(c) 27.50(h)(2)	Equivalent Isotropic Radiated Power	33dBm	Pass		24.43 dBm
27.50(d)(4)		30dBm	Pass		25.23 dBm
22.917(a) 24.238(a) 27.53(h)	Radiated Spurious Emission	-13dBm	Pass		-32.0 dBm
27.53 (m)	Radiated Spurious Emission	-25dBm	Pass		-39.8 dBm

FCC Rule Part	Frequency Range [MHz]	Output Power [W]	Frequency Tolerance	Emission Designator	Emission Bandwidth [MHz]	Communication Type
WCDMA						
22H	826.4 - 846.6	0.146	2.5 ppm	4M14F9W		WCDMA B5
24E	1852.4 - 1907.6	0.259	2.5 ppm	4M15F9W		WCDMA B2
LTE Band 2						
24E	1860.0 - 1900.0	0.250	2.5 ppm	17M9G7W	20	QPSK
24E	1860.0 - 1900.0	0.200	2.5 ppm	17M9D7W	20	16QAM
24E	1857.5 - 1902.5	0.277	2.5 ppm	13M5G7W	15	QPSK
24E	1857.5 - 1902.5	0.221	2.5 ppm	13M4D7W	15	16QAM
LTE Band 4						
27L	1720.0 - 1745.0	0.242	2.5 ppm	17M9G7W	20	QPSK
27L	1720.0 - 1745.0	0.193	2.5 ppm	17M9D7W	20	16QAM
27L	1712.5 - 1752.5	0.333	2.5 ppm	4M50G7W	5	QPSK
27L	1712.5 - 1752.5	0.266	2.5 ppm	4M50D7W	5	16QAM
LTE Band 5						
22H	829.0 - 844.0	0.121	2.5 ppm	8M98G7W	10	QPSK
22H	829.0 - 844.0	0.097	2.5 ppm	8M99D7W	10	16QAM
LTE Band 13						
27F	782	0.073	2.5 ppm	8M96G7W	10	QPSK
27F	782	0.059	2.5 ppm	8M95D7W	10	16QAM
27F	779.5 - 784.5	0.064	2.5 ppm	4M50D7W	5	16QAM
LTE Band 7						
27M	2510.0 - 2560.0	0.083	2.5 ppm	17M9G7W	20	QPSK
27M	2510.0 - 2560.0	0.066	2.5 ppm	17M9D7W	20	16QAM
27M	2502.5 - 2567.5	0.089	2.5 ppm	4M50G7W	5	QPSK

8. PEAK TO AVERAGE RATIO

Test Procedure

Per KDB 971168 D01 Power Meas License Digital Systems v02r02;

The transmitter output was connected to a CMW500 Test Set and configured to operate at maximum power. The PAR were measured on the Spectrum Analyzer.

Test Spec

In addition, when the transmitter power is measured in terms of average value, the peak-to-average ratio of the power shall not exceed 13 dB.

8.1. CONDUCTED PEAK TO AVERAGE RESULT

WCDMA

Band	Channel	f [MHz]	Mode	Ratio [dB]	Limit [dB]
Band 5	4183	836.6	REL99	2.87	13.00
			HSDPA	3.13	
Band 2	9400	1880.0	REL99	2.81	
			HSDPA	3.05	

LTE Band 5/4/2

Band	BW [MHz]	Channel	f [MHz]	Mode	Ratio [dB]	Limit [dB]
Band 5	10	20525	836.5	QPSK	3.82	13.00
				16QAM	5.23	
	5			QPSK	3.80	
				16QAM	5.22	
	3			QPSK	3.87	
				16QAM	5.13	
	1.4			QPSK	3.78	
				16QAM	4.85	
Band 4	20	20174	1732.5	QPSK	4.53	
				16QAM	5.68	
	15			QPSK	4.55	
				16QAM	5.76	
	10			QPSK	4.51	
				16QAM	5.67	
	5			QPSK	4.45	
				16QAM	5.77	
	3			QPSK	4.53	
				16QAM	5.72	
	1.4			QPSK	4.51	
				16QAM	5.71	
Band 2	20	18900	1880.0	QPSK	4.57	
				16QAM	5.86	
	15			QPSK	4.63	
				16QAM	5.76	
	10			QPSK	4.62	
				16QAM	5.78	
	5			QPSK	4.57	
				16QAM	5.83	
	3			QPSK	4.41	
				16QAM	5.83	
	1.4			QPSK	4.52	
				16QAM	5.73	

LTE Band 7

Band	BW [MHz]	Channel	f [MHz]	Mode	Ratio [dB]	Limit [dB]
Band 7	20	21100	2535	QPSK	4.09	13.00
				16QAM	5.34	
	15			QPSK	4.07	
				16QAM	5.42	
	10			QPSK	4.06	
				16QAM	5.38	
	5			QPSK	4.04	
				16QAM	5.30	

LTE Band 13

Band	BW [MHz]	Channel	f [MHz]	Mode	Ratio [dB]	Limit [dB]
Band 13	10	23230	782	QPSK	4.03	13.00
				16QAM	5.35	
	5			QPSK	4.02	
				16QAM	5.31	

8.2. CONDUCTED PEAK TO AVERAGE PLOTS

WCDMA

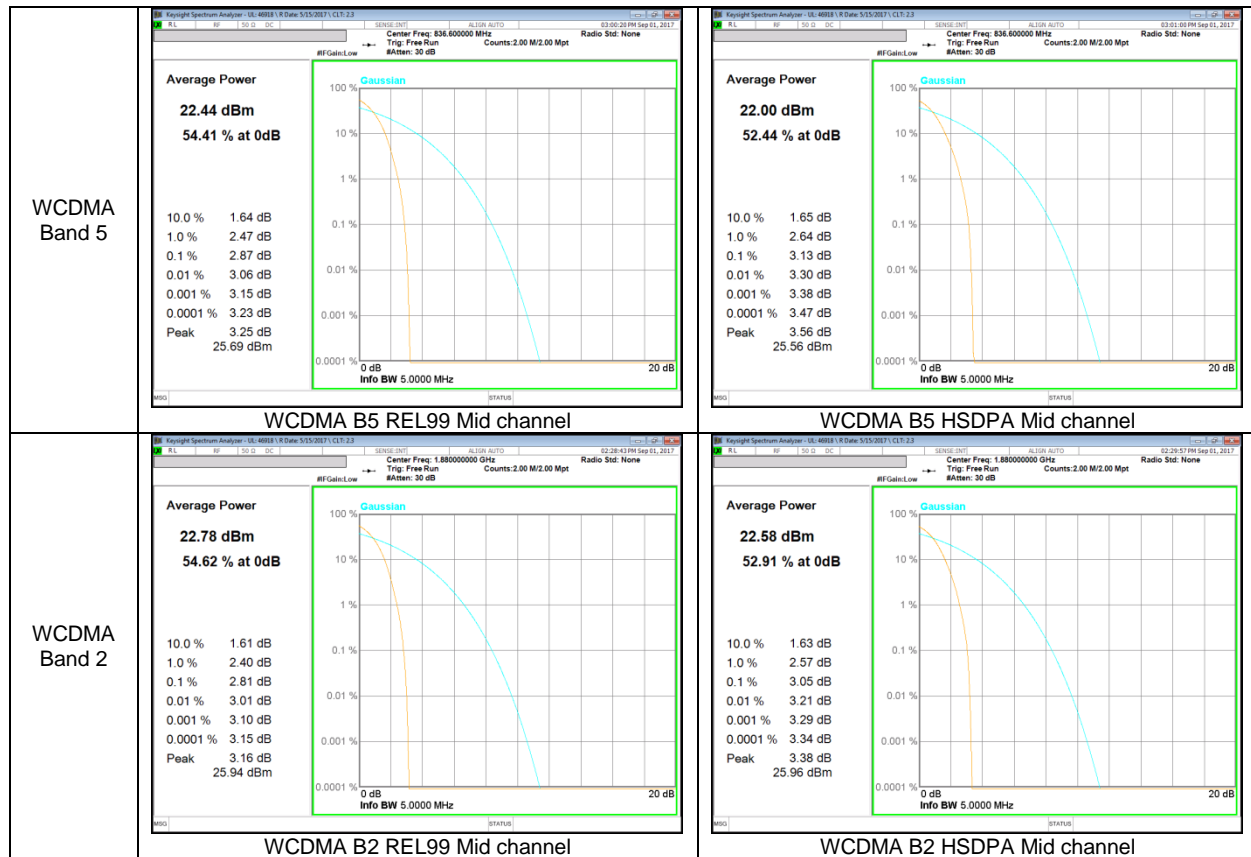

LTE Band 5

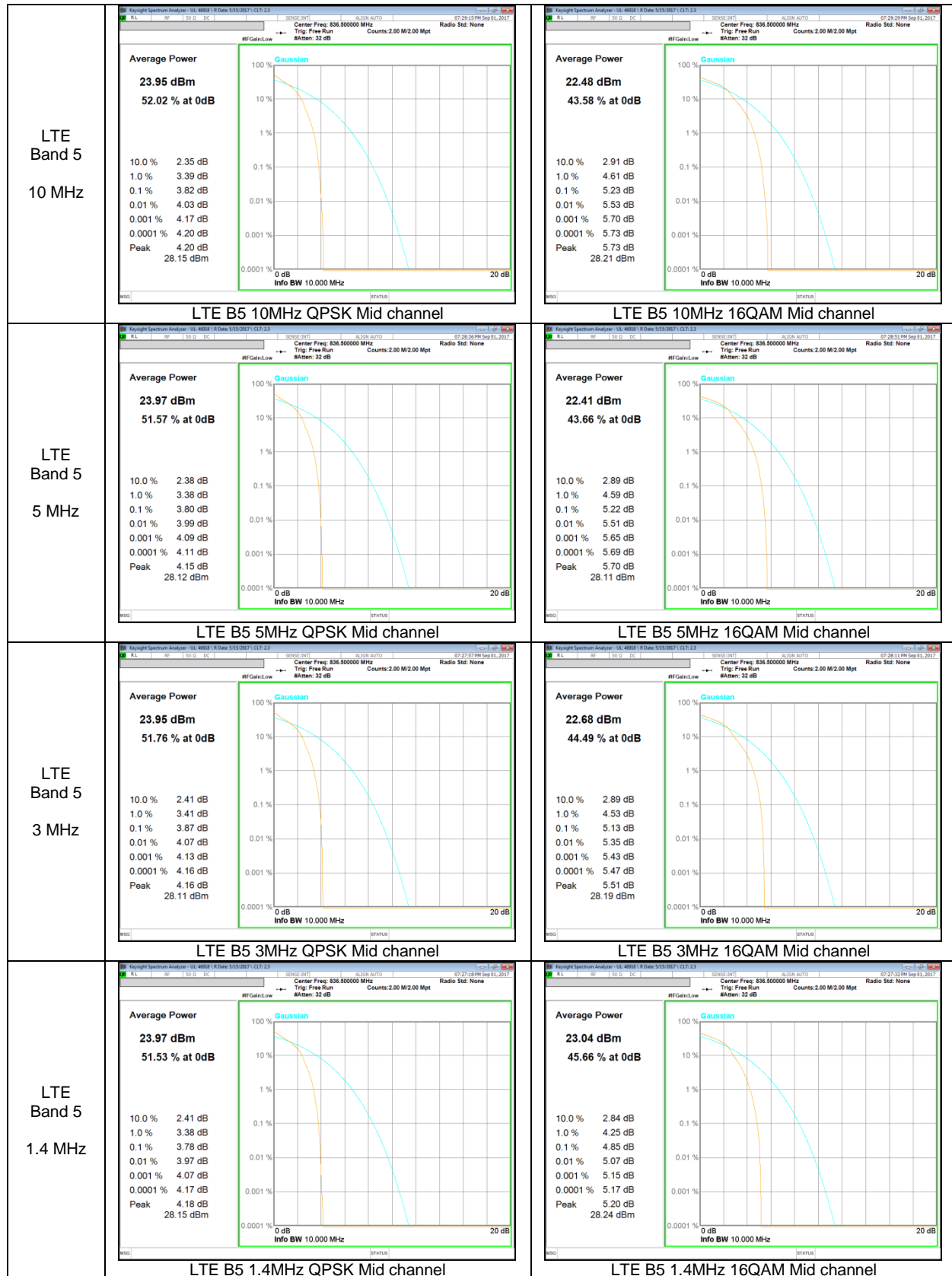

LTE Band 4

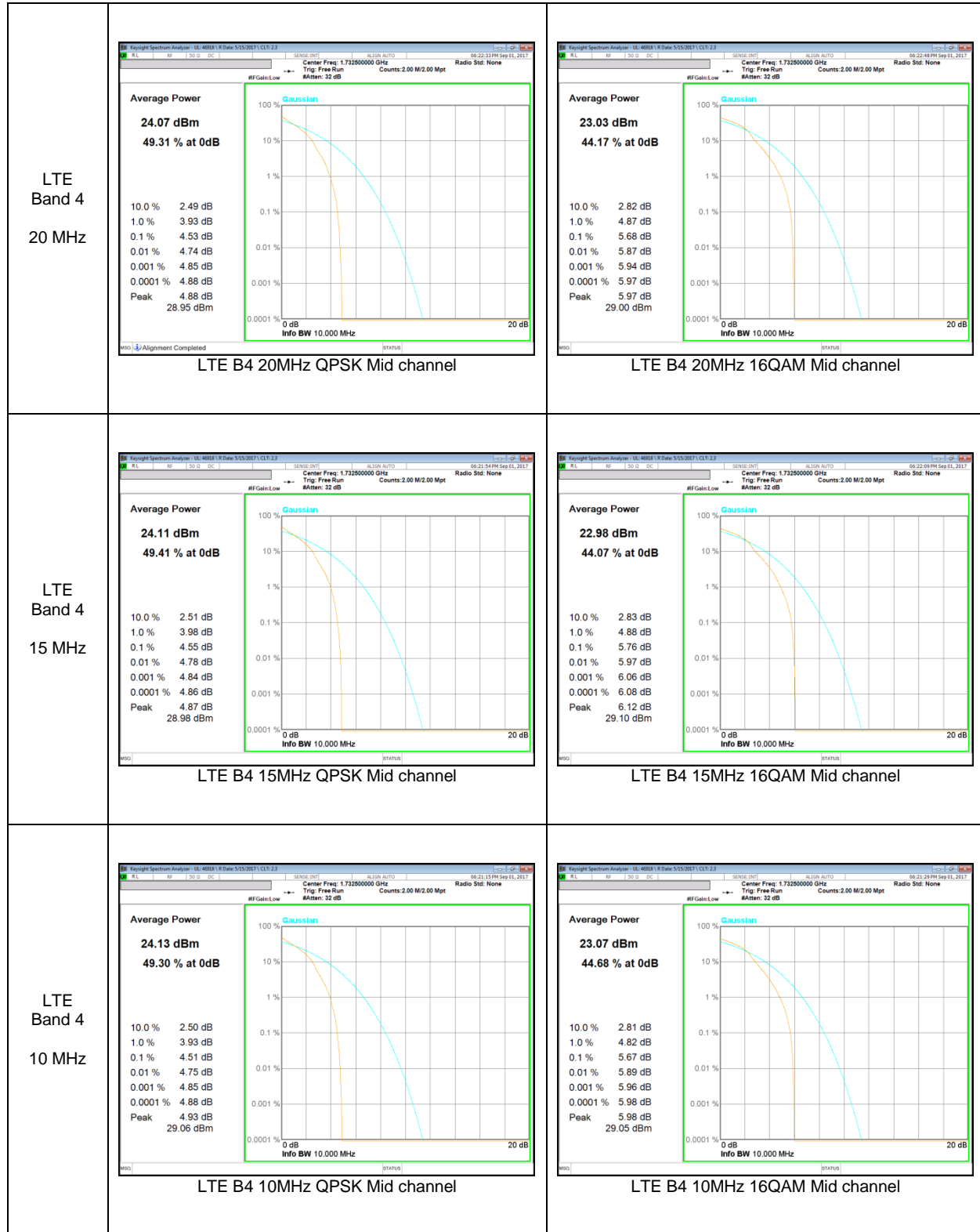

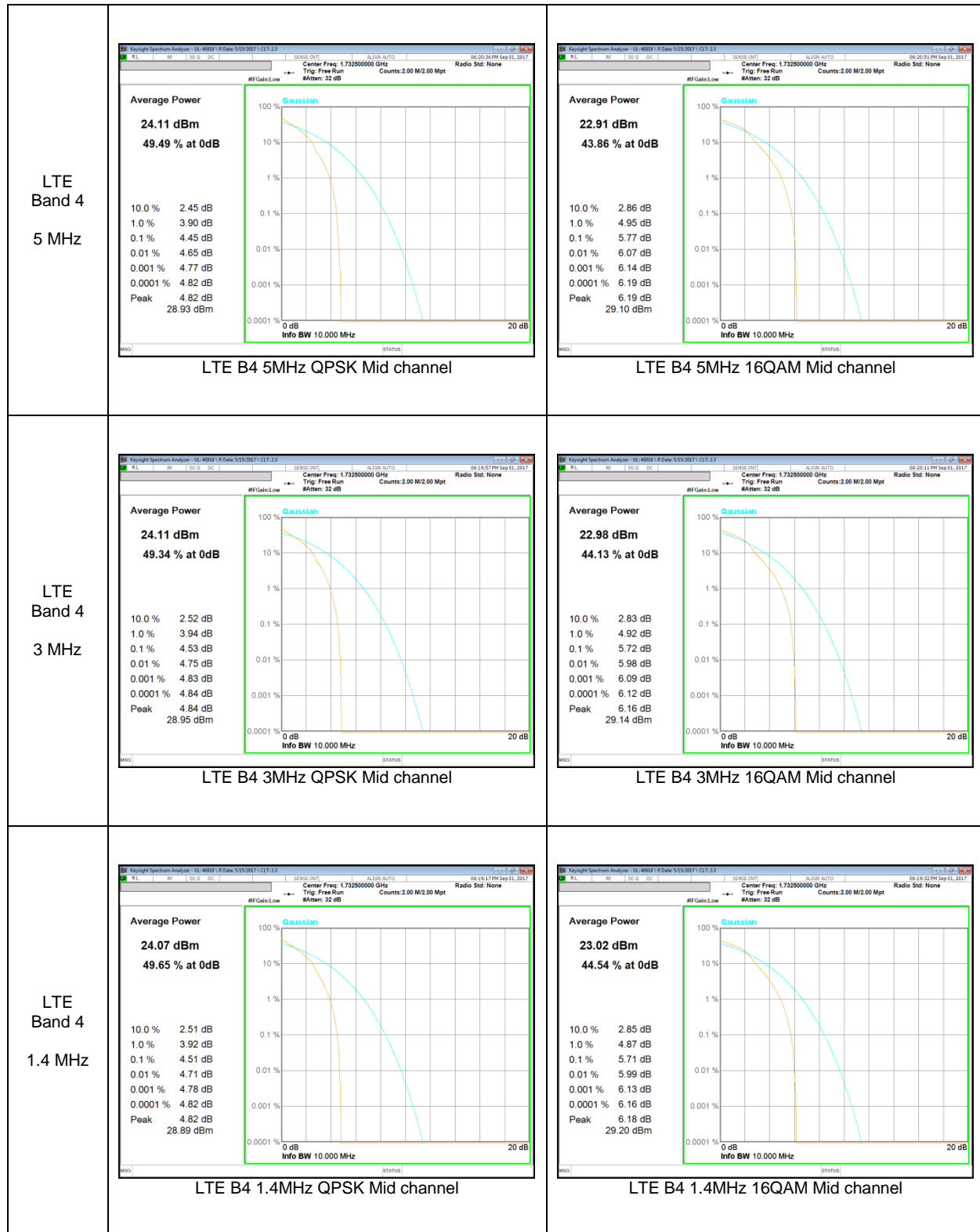

LTE Band 2

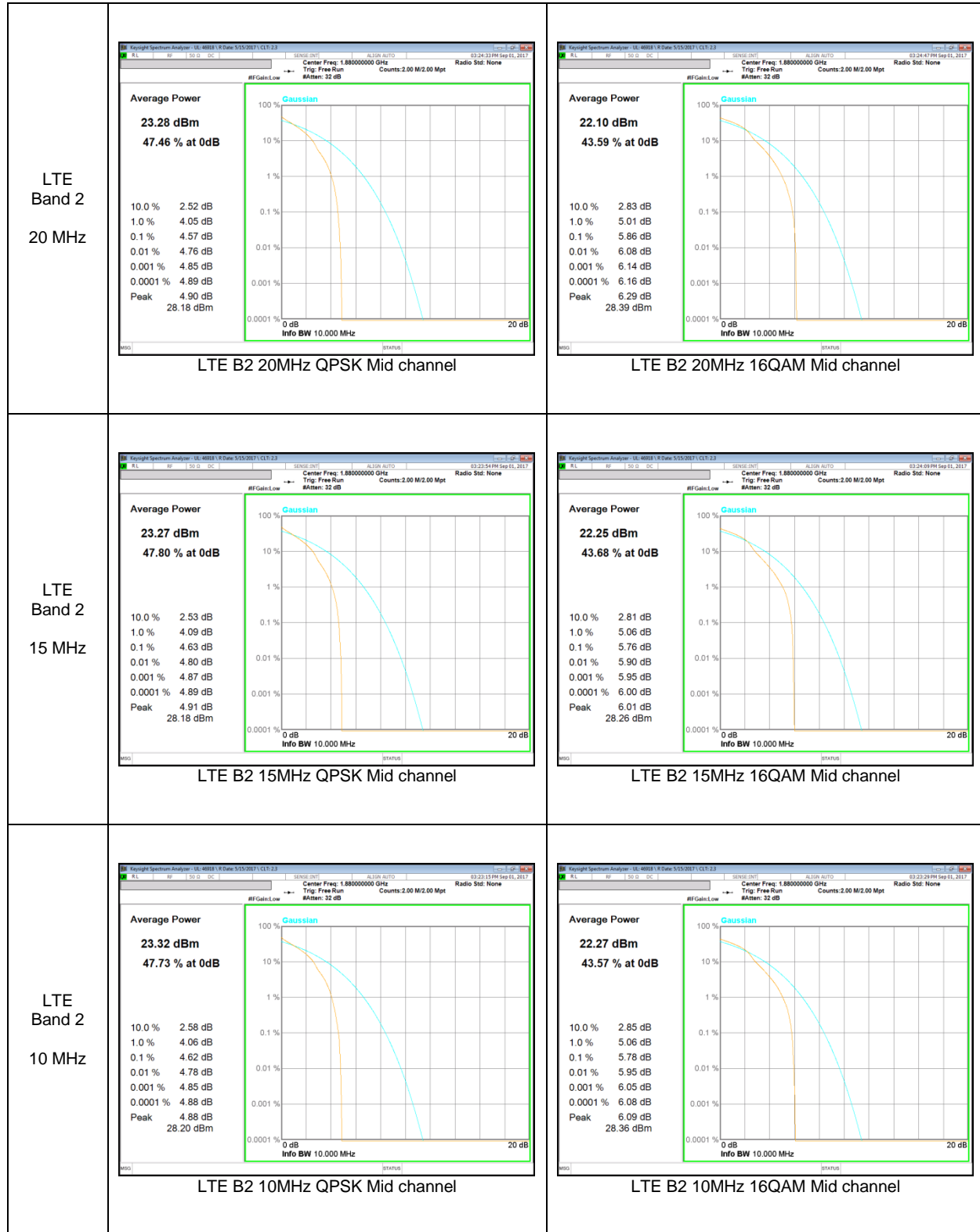

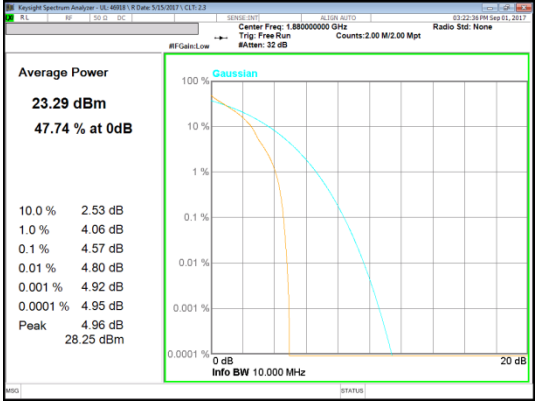
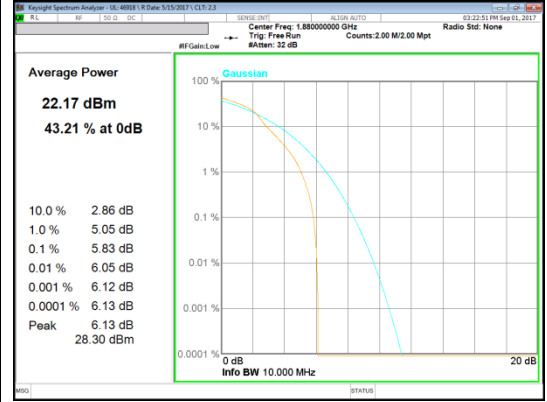
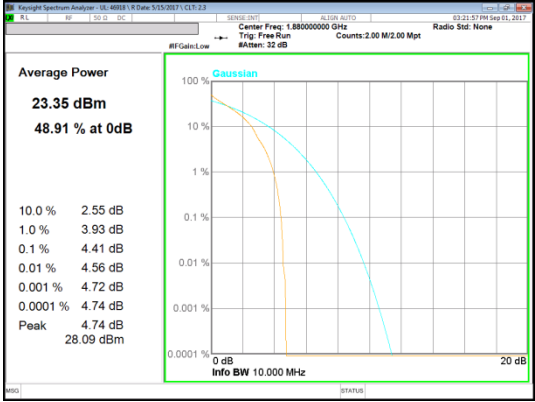
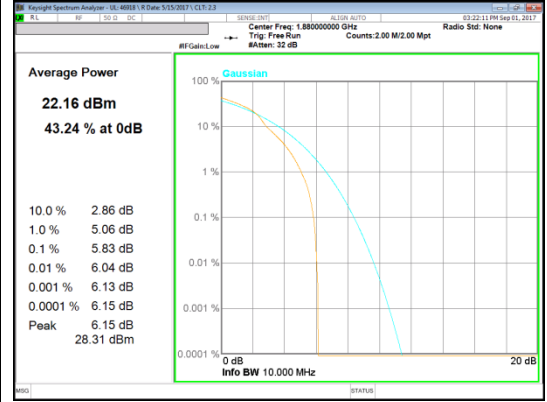
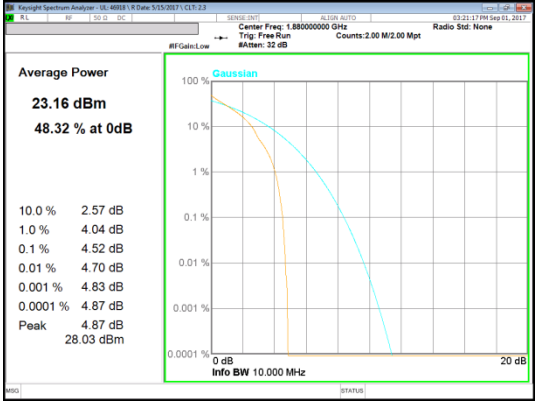
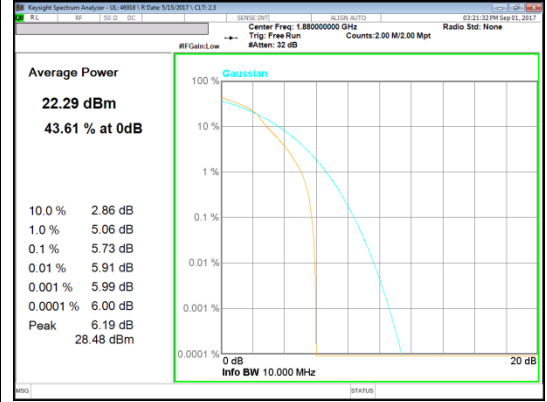
<p>LTE Band 2 5 MHz</p>	 <p>LTE B2 5MHz QPSK Mid channel</p>	 <p>LTE B2 5MHz 16QAM Mid channel</p>
<p>LTE Band 2 3 MHz</p>	 <p>LTE B2 3MHz QPSK Mid channel</p>	 <p>LTE B2 3MHz 16QAM Mid channel</p>
<p>LTE Band 2 1.4 MHz</p>	 <p>LTE B2 1.4MHz QPSK Mid channel</p>	 <p>LTE B2 1.4MHz 16QAM Mid channel</p>

LTE Band 13

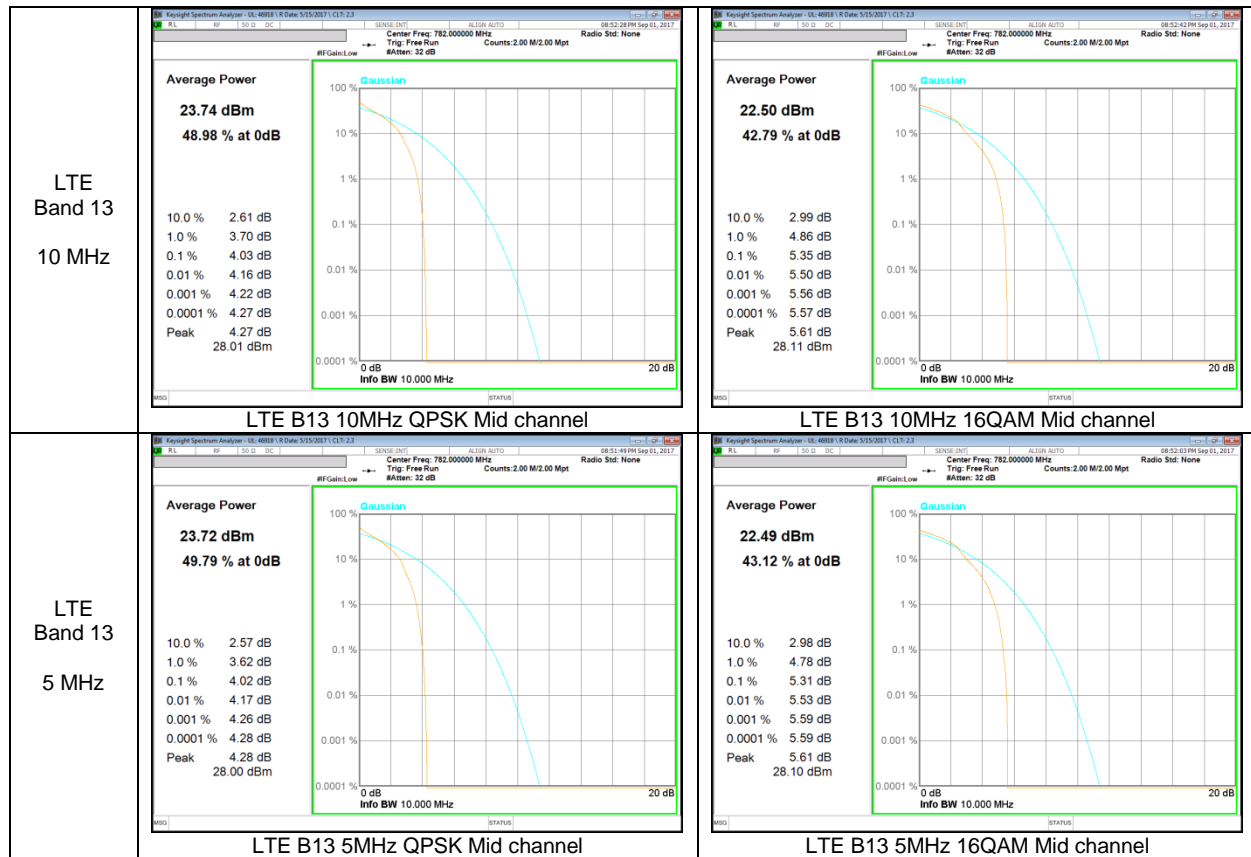

LTE Band 7

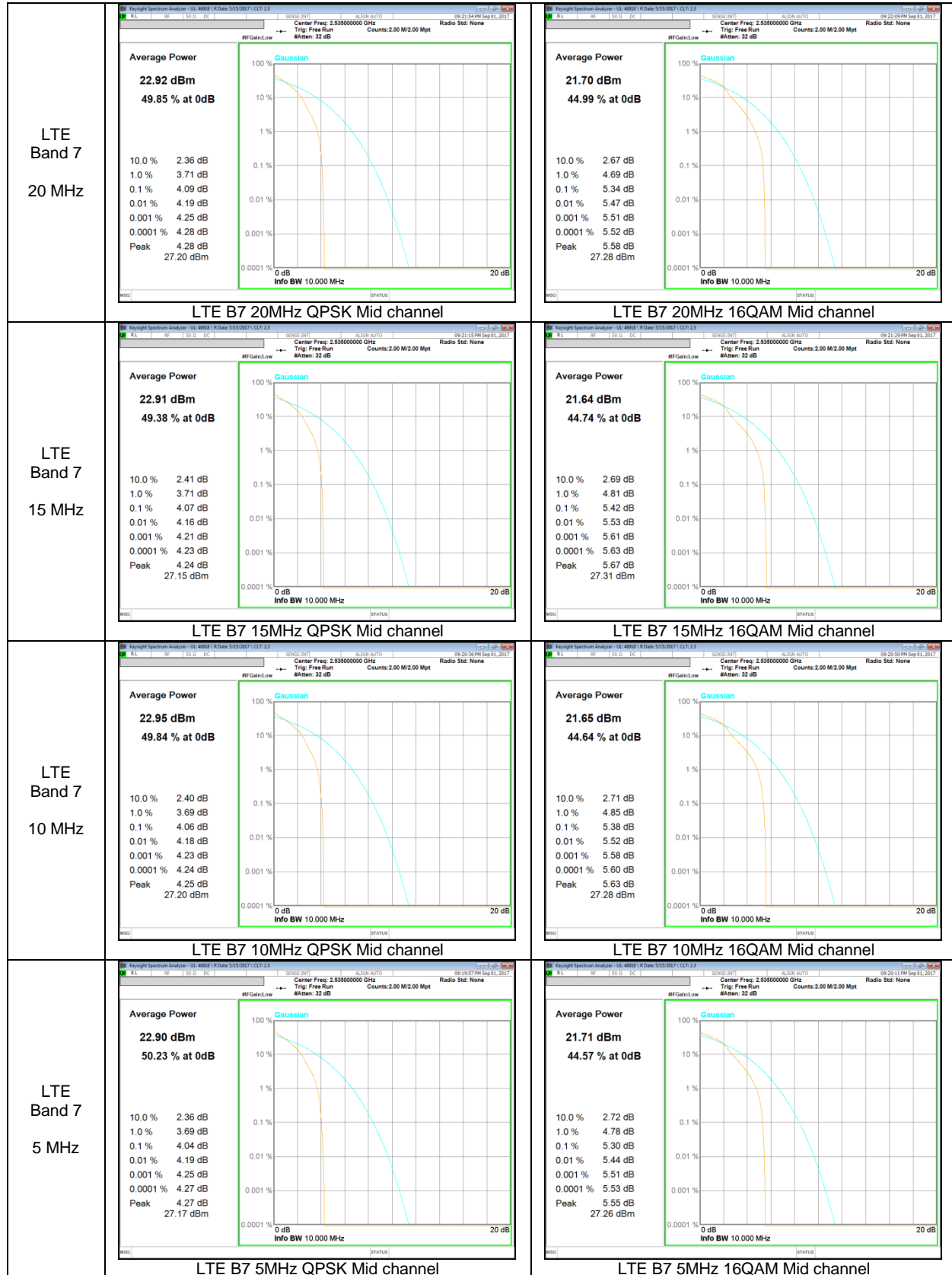

9. LIMITS AND CONDUCTED RESULTS

9.1. OCCUPIED BANDWIDTH

RULE PART(S)

FCC: §2.1049

LIMITS

For reporting purposes only

TEST PROCEDURE

The transmitter output was connected to a calibrated coaxial cable and coupler, the other end of which was connected to a spectrum analyzer. The occupied bandwidth was measured with the spectrum analyzer at the low, middle and high channel in each band. The -26dB bandwidth was also measured and recorded.

(KDB 971168 D01 Power Meas License Digital Systems v02r02)

9.1.1. OCCUPIED BANDWIDTH RESULTS

WCDMA

Band	Mode	Channel	f [MHz]	99% BW [MHz]	26dB BW [MHz]
Band 5	REL99	4132	826.4	4.1354	4.676
		4183	836.6	4.1323	4.703
		4233	846.6	4.1313	4.708
	HSDPA	4132	826.4	4.1441	4.670
		4183	836.6	4.1274	4.680
		4233	846.6	4.1416	4.676
Band 2	REL99	9262	1852.4	4.1486	4.728
		9400	1880.0	4.1403	4.717
		9538	1907.6	4.1397	4.699
	HSDPA	9262	1852.4	4.1393	4.697
		9400	1880.0	4.1424	4.677
		9538	1907.6	4.1398	4.698

LTE Band 5

Band	BW [MHz]	Channel	f [MHz]	Mode	99% BW [MHz]	26dB BW [MHz]
Band 5	10	20450	829.0	QPSK	8.9556	10.36
				16QAM	8.9601	10.00
		20524	836.5	QPSK	8.9654	10.40
				16QAM	8.9477	10.19
		20599	844.0	QPSK	8.9837	10.32
				16QAM	8.9858	10.24
	5	20425	826.5	QPSK	4.5075	5.364
				16QAM	4.5033	5.210
		20524	836.5	QPSK	4.4914	5.264
				16QAM	4.4989	5.211
		20624	846.5	QPSK	4.5017	5.300
				16QAM	4.5017	5.291
	3	20415	825.5	QPSK	2.6975	3.085
				16QAM	2.6970	3.098
		20524	836.5	QPSK	2.7105	3.099
				16QAM	2.7059	3.090
		20634	847.5	QPSK	2.6991	3.103
				16QAM	2.6929	3.070
	1.4	20407	824.7	QPSK	1.0935	1.368
				16QAM	1.0945	1.392
		20524	836.5	QPSK	1.0899	1.358
				16QAM	1.0906	1.385
		20624	848.3	QPSK	1.0912	1.407
				16QAM	1.0897	1.376

LTE Band 4

Band	BW [MHz]	Channel	f [MHz]	Mode	99% BW [MHz]	26dB BW [MHz]
Band 4	20	20050	1720.0	QPSK	17.878	19.57
				16QAM	17.865	19.53
		20174	1732.5	QPSK	17.903	19.82
				16QAM	17.892	19.69
		20299	1745.0	QPSK	17.915	19.53
				16QAM	17.897	19.60
	15	20025	1717.5	QPSK	13.418	15.15
				16QAM	13.413	15.08
		20174	1732.5	QPSK	13.446	15.10
				16QAM	13.431	15.25
		20324	1747.5	QPSK	13.462	15.15
				16QAM	13.446	15.00
	10	20000	1715.0	QPSK	8.9749	10.16
				16QAM	8.9527	10.16
		20174	1732.5	QPSK	8.9685	10.11
				16QAM	8.9606	10.20
		20349	1750.0	QPSK	8.9667	10.15
				16QAM	8.9688	10.24
	5	19975	1712.5	QPSK	4.4975	5.303
				16QAM	4.5022	5.253
		20174	1732.5	QPSK	4.4970	5.262
				16QAM	4.5003	5.244
		20374	1752.5	QPSK	4.4992	5.323
				16QAM	4.5057	5.193
	3	19965	1711.5	QPSK	2.6981	3.114
				16QAM	2.7057	3.108
		20174	1732.5	QPSK	2.7035	3.123
				16QAM	2.6991	3.049
		20384	1753.5	QPSK	2.6998	3.064
				16QAM	2.6937	3.065
	1.4	19957	1710.7	QPSK	1.0924	1.412
				16QAM	1.0963	1.433
20174		1732.5	QPSK	1.0903	1.365	
			16QAM	1.0953	1.379	
20392		1754.3	QPSK	1.0899	1.393	
			16QAM	1.0916	1.342	

LTE Band 2

Band	BW [MHz]	Channel	f [MHz]	Mode	99% BW [MHz]	26dB BW [MHz]
Band 2	20	18700	1860.0	QPSK	17.898	19.88
				16QAM	17.896	19.46
		18900	1880.0	QPSK	17.846	19.48
				16QAM	17.855	19.44
		19099	1900.0	QPSK	17.832	19.75
				16QAM	17.843	19.53
	15	18675	1857.5	QPSK	13.425	15.11
				16QAM	13.418	15.20
		18900	1880.0	QPSK	13.453	14.95
				16QAM	13.420	14.95
		19124	1902.5	QPSK	13.405	15.07
				16QAM	13.380	14.85
	10	18650	1855.0	QPSK	8.9530	10.12
				16QAM	8.9484	10.11
		18900	1880.0	QPSK	8.9534	10.12
				16QAM	8.9628	10.48
		19149	1905.0	QPSK	8.9288	10.07
				16QAM	8.9454	9.989
	5	18625	1852.5	QPSK	4.5027	5.236
				16QAM	4.4977	5.294
		18900	1880.0	QPSK	4.5049	5.270
				16QAM	4.4984	5.205
		18175	1907.5	QPSK	4.5029	5.237
				16QAM	4.5028	5.240
	3	18615	1851.5	QPSK	2.7019	3.122
				16QAM	2.7008	3.062
		18900	1880.0	QPSK	2.6975	3.126
				16QAM	2.6980	3.096
		19184	1908.5	QPSK	2.6990	3.092
				16QAM	2.6919	3.046
1.4	18607	1850.7	QPSK	1.0945	1.382	
			16QAM	1.0981	1.405	
	18900	1880.0	QPSK	1.0877	1.349	
			16QAM	1.0961	1.450	
	19192	1909.3	QPSK	1.0904	1.376	
			16QAM	1.0940	1.379	

LTE Band 7

Band	BW [MHz]	Channel	f [MHz]	Mode	99% BW [MHz]	26dB BW [MHz]
Band 7	20	20850	2510	QPSK	17.888	19.78
				16QAM	17.903	19.73
		21100	2535	QPSK	17.916	19.79
				16QAM	17.881	19.62
		21350	2560	QPSK	17.888	19.78
				16QAM	17.904	19.52
	15	20825	2507.5	QPSK	13.447	15.22
				16QAM	13.437	15.22
		21100	2535	QPSK	13.459	15.13
				16QAM	13.461	15.10
		21375	2562.5	QPSK	13.458	15.16
				16QAM	13.426	14.98
	10	20800	2505	QPSK	8.9651	10.41
				16QAM	8.9624	10.39
		21100	2535	QPSK	8.9617	10.20
				16QAM	8.9658	10.21
		21400	2565	QPSK	8.9677	10.13
				16QAM	8.9746	10.17
	5	20775	2502.5	QPSK	4.5023	5.303
				16QAM	4.4951	5.284
		21100	2535	QPSK	4.4956	5.271
				16QAM	4.5050	5.273
		21425	2567.5	QPSK	4.5004	5.306
				16QAM	4.5027	5.251

LTE Band 13

Band	BW [MHz]	Channel	f [MHz]	Mode	99% BW [MHz]	26dB BW [MHz]
Band 13	10	23230	782.0	QPSK	8.9624	10.13
				16QAM	8.9532	10.24
	5	23207	779.5	QPSK	4.4813	5.197
				16QAM	4.4890	5.285
		23230	782.0	QPSK	4.5007	5.204
				16QAM	4.5016	5.224
		23255	784.5	QPSK	4.5052	5.309
				16QAM	4.5029	5.286

9.1.2. OCCUPIED BANDWIDTH PLOTS

WCDMA Band 5

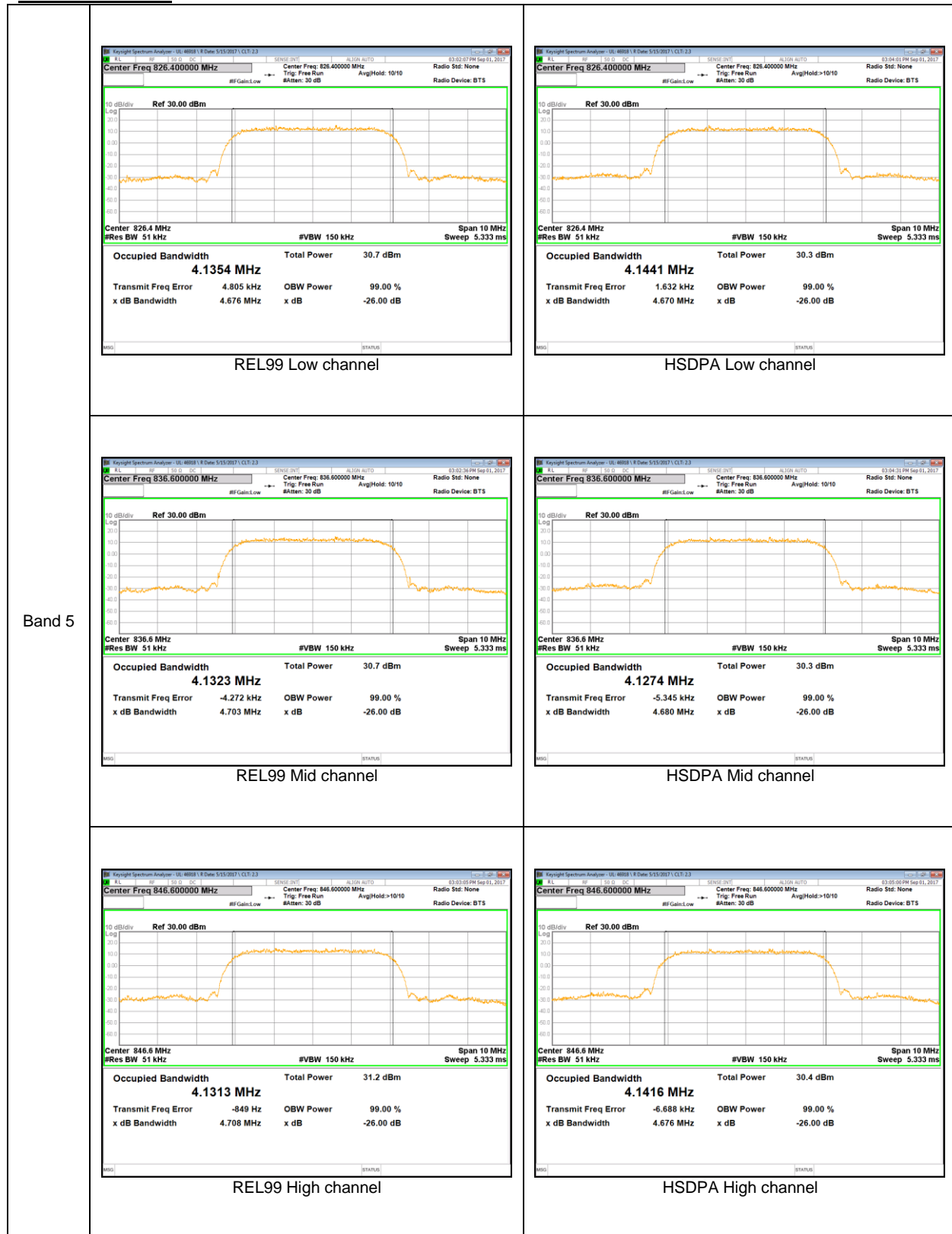

WCDMA Band 2

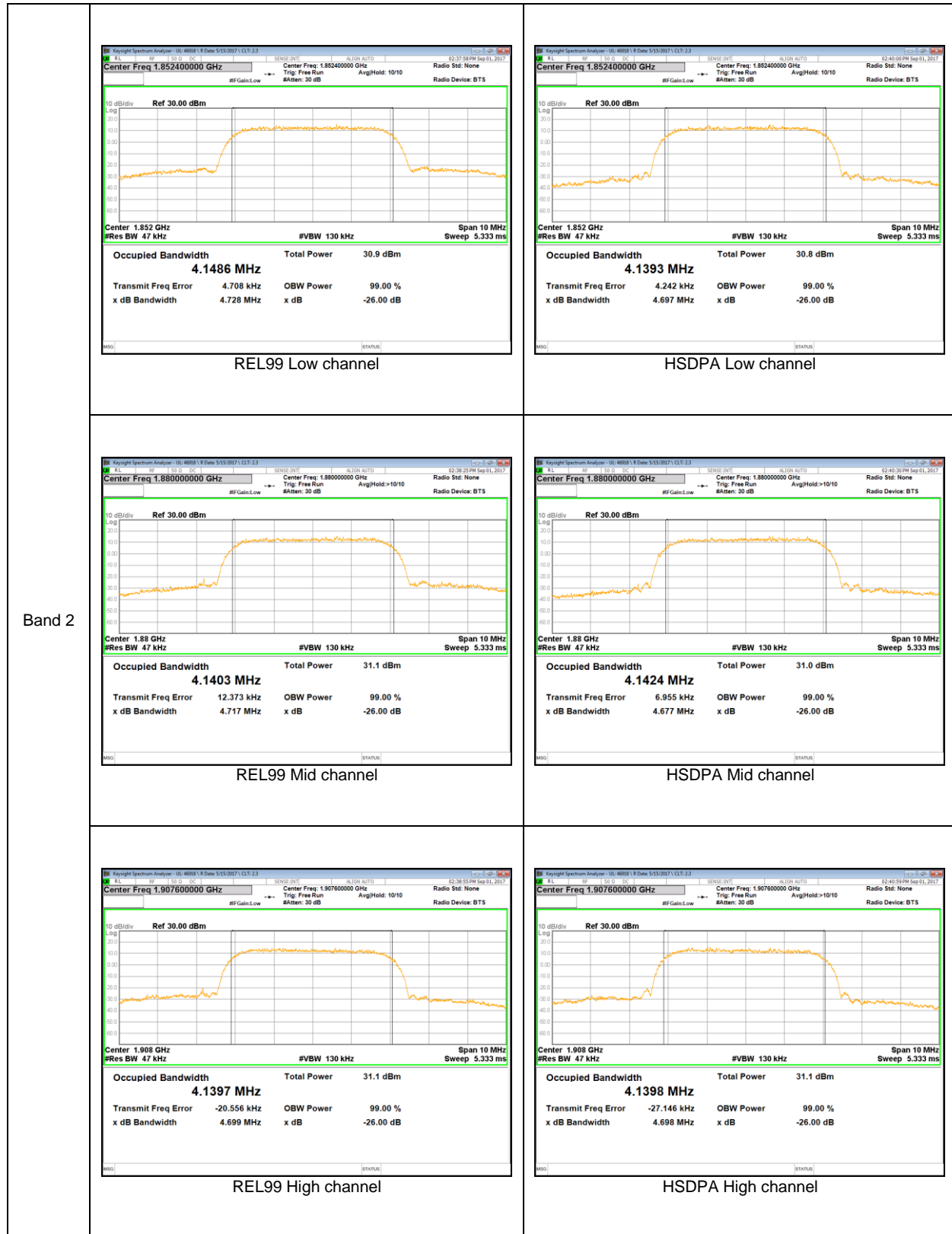

LTE Band 5

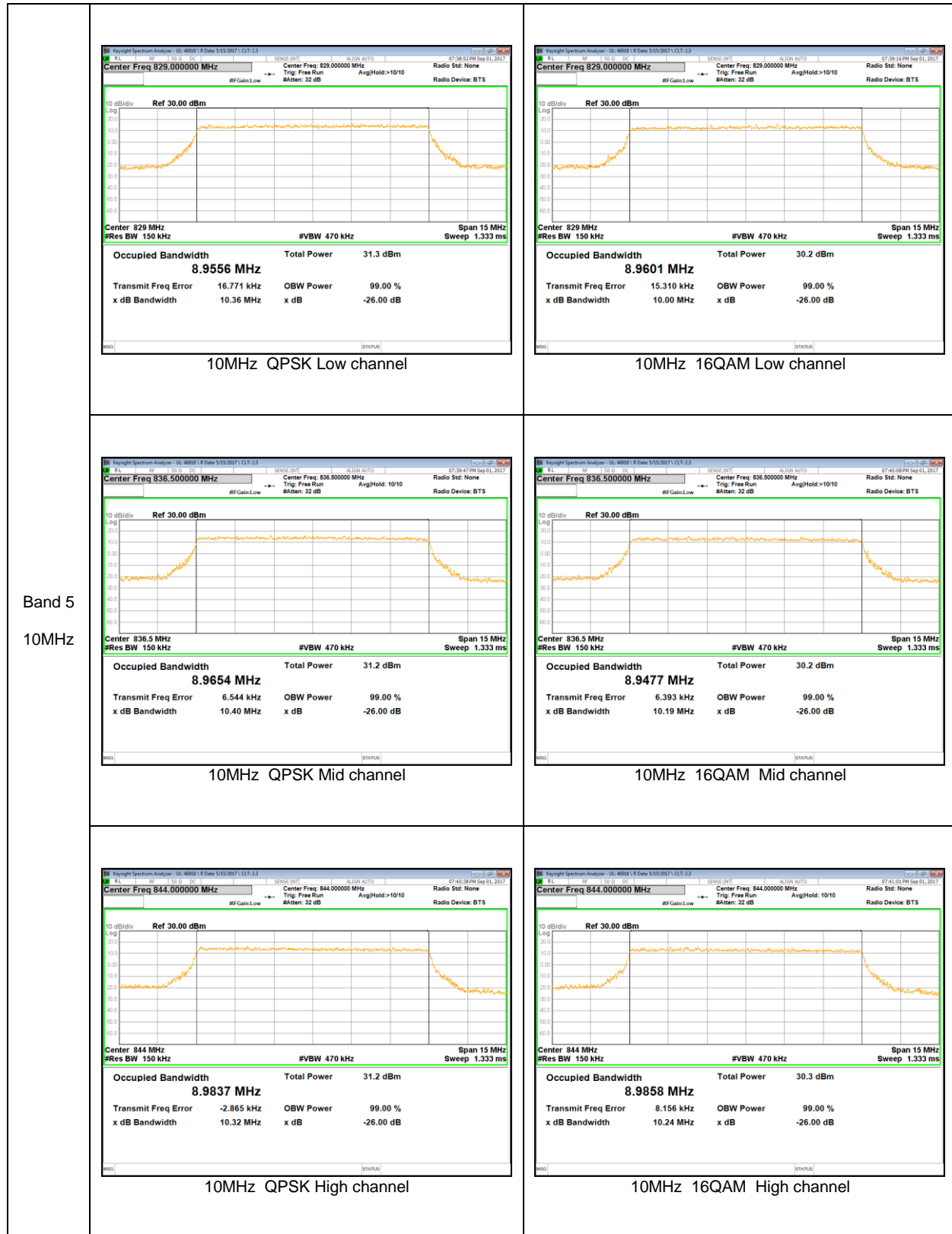

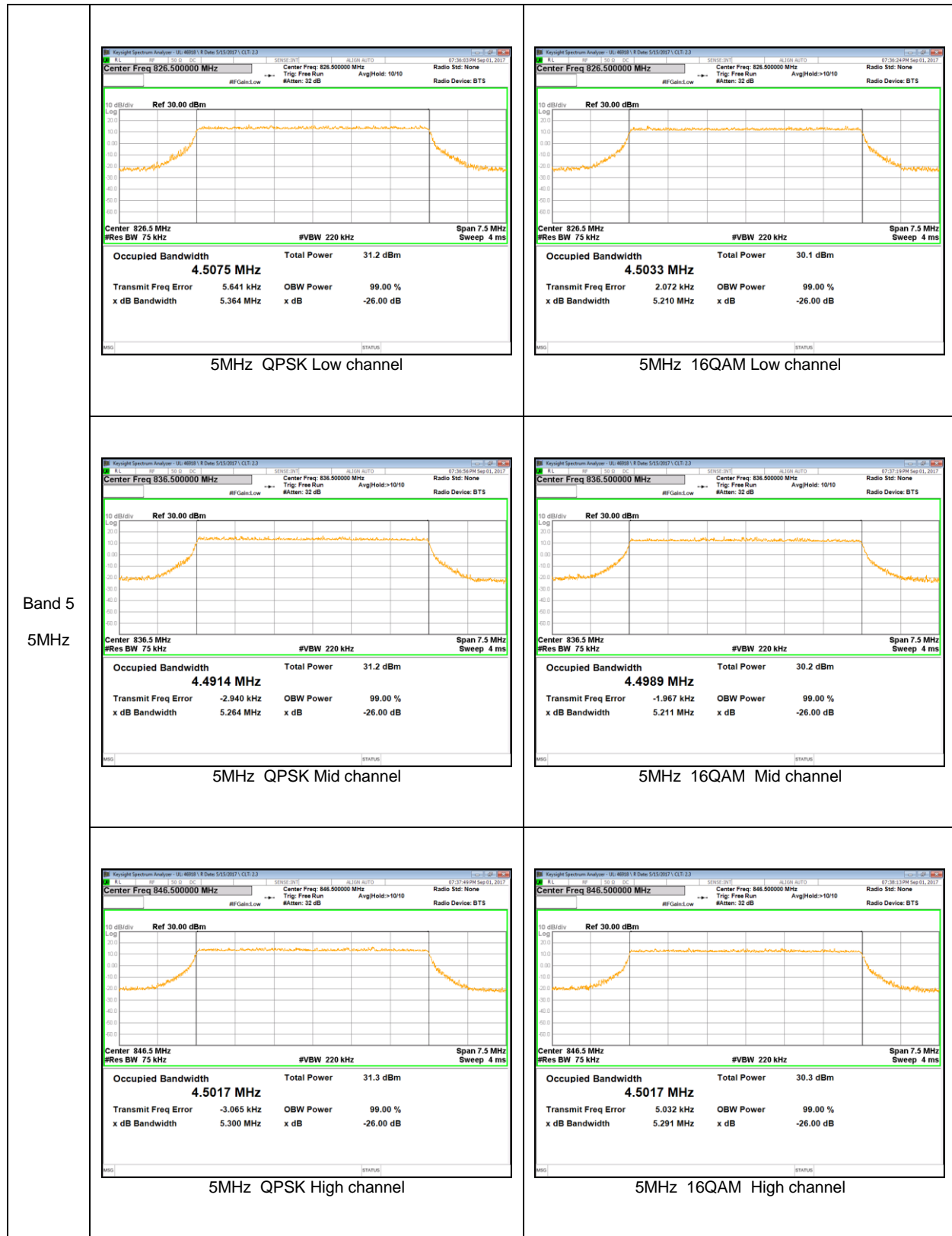

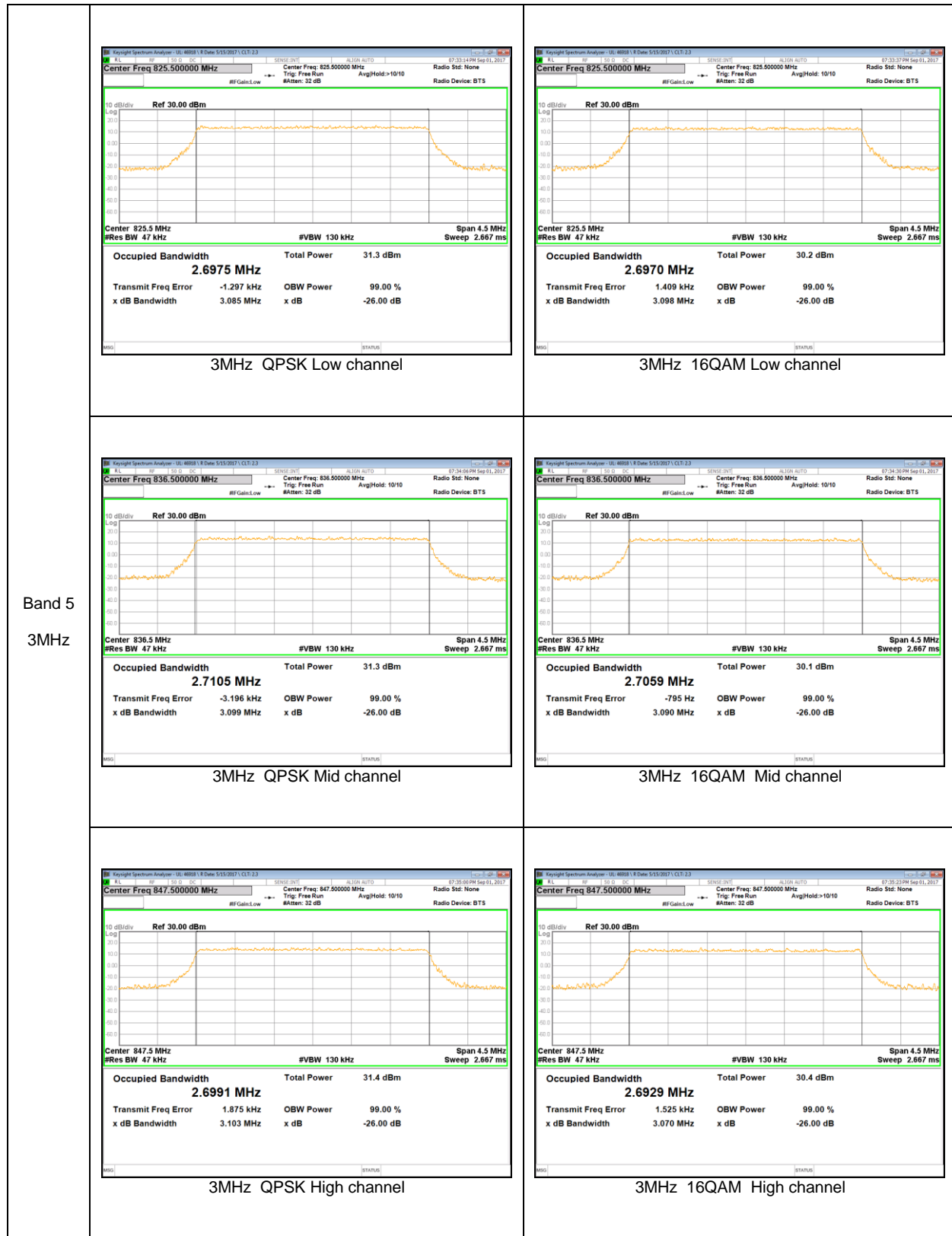

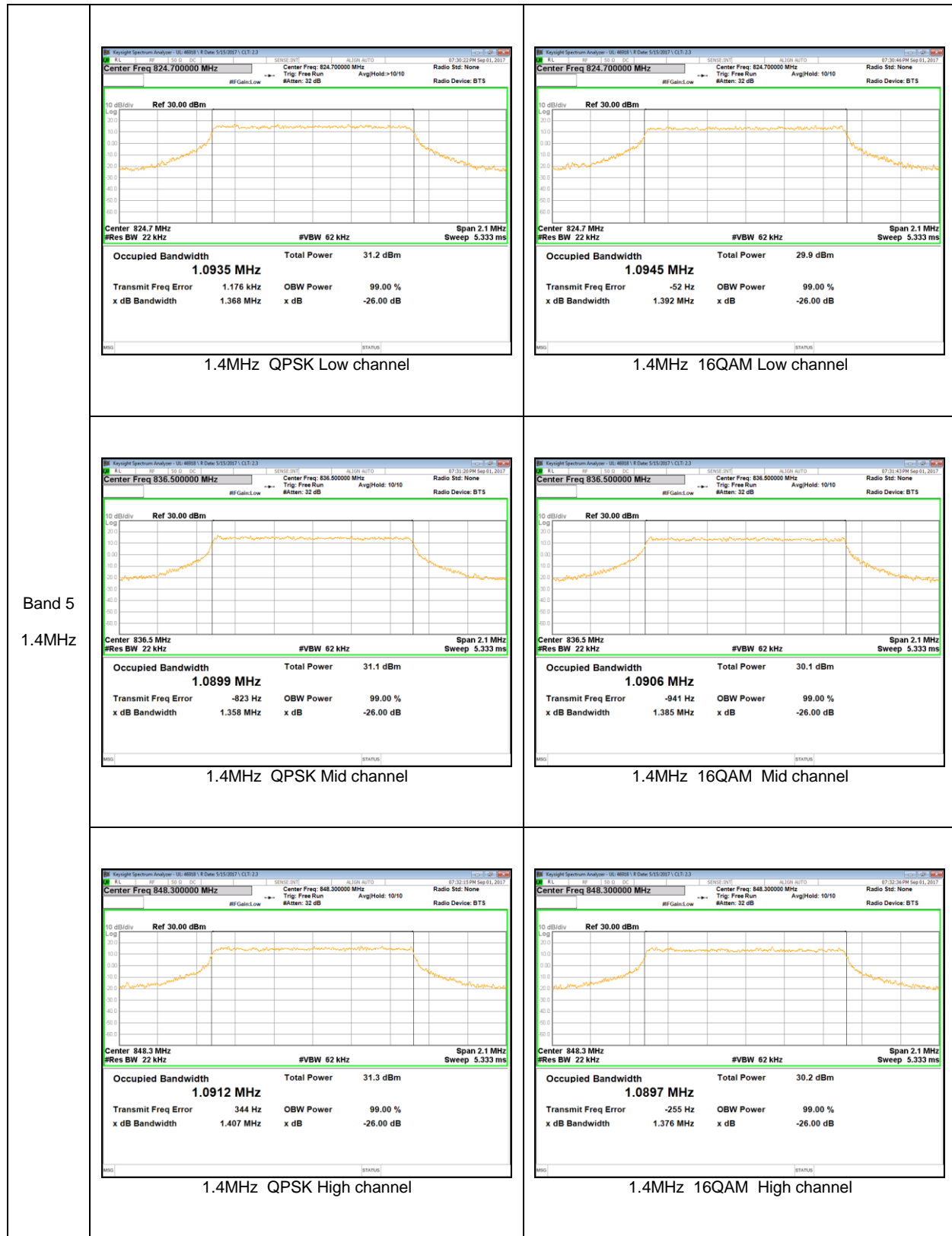

LTE Band 4

