

HEARING AID COMPATIBILITY

Applicant Name:
Samsung Electronics Co., Ltd.
129, Samsung-ro, Maetan dong,
Yeongtong-gu, Suwon-si
Gyeonggi-do 16677, Korea

Date of Testing:
10/09/2023 - 10/22/2023
Test Site/Location:
Element Washington DC LLC,
Columbia, MD, USA
Test Report Serial No.:
1M2308210092-27-R1.A3L
Date of Issue:
11/1/2023

FCC ID: A3LSMS928U

APPLICANT: SAMSUNG ELECTRONICS CO., LTD.

Scope of Test: Audio Band Magnetic Testing (T-Coil)
Application Type: Certification
FCC Rule Part(s): CFR §20.19(b)
HAC Standard: ANSI C63.19-2019
285076 D01 HAC Guidance v06r02
285076 D02 T-Coil testing for CMRS IP v04
DUT Type: Portable Handset
Model: SM-S928U
Additional Model(s): SM-S928U1
Test Device Serial No.: Pre-Production Sample [S/N: 0855M]

C63.19-2019 HAC Verdict: PASS

Note: This revised Test Report (S/N: 1M2308210092-27-R1.A3L) supersedes and replaces the previously issued test report on the same subject device for the same type of testing as indicated. Please discard or destroy the previously issued test report(s) and dispose of it accordingly.

This wireless portable device has been shown to be hearing-aid compatible as specified in ANSI/IEEE Std. C63.19-2019 and has been tested in accordance with the specified measurement procedures. Test results reported herein relate only to the item(s) tested. Hearing-Aid Compatibility is based on the assumption that all production units will be designed electrically identical to the device tested in this report. North American Bands only.

I attest to the accuracy of data. All measurements reported herein were performed by me or were made under my supervision and are correct to the best of my knowledge and belief. I assume full responsibility for the completeness of these measurements and vouch for the qualifications of all persons taking them.



RJ Ortanez
Executive Vice President



FCC ID: A3LSMS928U		HAC (T-COIL) TEST REPORT	Approved by: Managing Director
Filename: 1M2308210092-27-R1.A3L	Test Dates: 10/09/2023 - 10/22/2023	DUT Type: Portable Handset	Page 1 of 72

T A B L E O F C O N T E N T S

1.	INTRODUCTION	3
2.	DUT DESCRIPTION.....	4
3.	ANSI C63.19-2019 Compliance requirements	6
4.	METHOD OF MEASUREMENT	8
5.	VOLTE TEST SYSTEM SETUP AND DUT CONFIGURATION	16
6.	VONR TEST SYSTEM SETUP AND DUT CONFIGURATION.....	21
7.	VOWIFI TEST SYSTEM SETUP AND DUT CONFIGURATION	24
8.	OTT VOIP TEST SYSTEM AND DUT CONFIGURATION	27
9.	FCC 3G MEASUREMENTS	31
10.	T-COIL TEST SUMMARY	32
11.	MEASUREMENT UNCERTAINTY	47
12.	EQUIPMENT LIST.....	48
13.	TEST DATA(Single Point Measurement)	49
14.	TEST DATA(sCan Measurement).....	59
15.	CALIBRATION CERTIFICATES.....	63
16.	CONCLUSION.....	67
17.	REFERENCES	68
18.	TEST SETUP PHOTOGRAPHS	70

FCC ID: A3LSMS928U		HAC (T-COIL) TEST REPORT	Approved by: Managing Director
Filename: 1M2308210092-27-R1.A3L	Test Dates: 10/09/2023 - 10/22/2023	DUT Type: Portable Handset	Page 2 of 72

1. INTRODUCTION

On July 10, 2003, the Federal Communications Commission (FCC) adopted new rules requiring wireless manufacturers and service providers to provide digital wireless phones that are compatible with hearing aids. The FCC has modified the exemption for wireless phones under the Hearing Aid Compatibility Act of 1998 (HAC Act) in WT Docket 01-309 RM-8658¹ to extend the benefits of wireless telecommunications to individuals with hearing disabilities. These benefits encompass business, social and emergency communications, which increase the value of the wireless network for everyone. An estimated more than 10% of the population in the United States show signs of hearing impairment and of that fraction, almost 80% use hearing aids. Approximately 500 million people worldwide and 30 million people in the United States suffer from hearing loss.

Compatibility Tests Involved:

The standard calls for wireless communications devices to be measured for:

- RF Electric-field emissions
- T-coil mode, magnetic-signal strength in the audio band
- T-coil mode, magnetic-signal frequency response through the audio band
- T-coil mode, magnetic-signal and noise articulation index
- T-coil mode, acoustic-signal conversational gain in the audio band
- T-coil mode, acoustic-signal frequency response through the audio band
- T-coil mode, acoustic-signal distortion through audio band
- Volume Control, receive volume control performance
- Volume Control, receive distortion and noise performance
- Volume Control, receive acoustic frequency response performance

The hearing aid may be measured for:

- RF immunity in microphone mode
- RF immunity in T-coil mode

In the following tests and results, this report includes the evaluation for a wireless communications device.



Figure 1-1 Hearing Aid *in-vitu*

¹ FCC Rule & Order, WT Docket 01-309 RM-8658

FCC ID: A3LSMS928U	 element	HAC (T-COIL) TEST REPORT	Approved by: Managing Director
Filename: 1M2308210092-27-R1.A3L	Test Dates: 10/09/2023 - 10/22/2023	DUT Type: Portable Handset	Page 3 of 72

2. DUT DESCRIPTION

FCC ID: A3LSMS928U
Applicant: Samsung Electronics Co., Ltd.
129, Samsung-ro, Maetan dong,
Yeongtong-gu, Suwon-si
Gyeonggi-do 16677, Korea
Model: SM-S928U
Additional Model(s): SM-S928U1
Serial Number: 0855M
HW Version: REV1.0
SW Version: S928U.001
Antenna: Internal Antenna
DUT Type: Portable Handset

I. LTE Band Selection

This device supports LTE capabilities with overlapping transmission frequency ranges. When the supported frequency range of an LTE band falls completely within an LTE band with a larger transmission frequency range, both LTE bands have the same target power (or the band with the larger transmission frequency range has a higher target power), and both LTE bands share the same transmission path and signal characteristics, hearing-aid compatibility compliance was only assessed for the band with the larger transmission frequency range. However, overlapped LTE bands which are anchor bands for dual connectivity (EN-DC) scenarios between LTE and NR were evaluated as independent LTE bands.

II. NR Band Selection

This device supports NR capabilities with overlapping transmission frequency ranges. When the supported frequency range of an NR band falls completely within an NR band with a larger transmission frequency range, both NR bands have the same target power (or the band with the larger transmission frequency range has a higher target power), and both NR bands share the same transmission path and signal characteristics, hearing-aid compatibility compliance was only assessed for the band with the larger transmission frequency range.

FCC ID: A3LSMS928U	 element	HAC (T-COIL) TEST REPORT	Approved by: Managing Director
Filename: 1M2308210092-27-R1.A3L	Test Dates: 10/09/2023 - 10/22/2023	DUT Type: Portable Handset	Page 4 of 72

**Table 2-1
A3LSMS928U HAC Air Interfaces**

Air-Interface	Band (MHz)	Type Transport	HAC Tested	Simultaneous But Not Tested	Name of Voice Service	Audio Codec Evaluated
GSM	850	VO	Yes	Yes: WIFI or BT	CMRS Voice ¹	EFR
	1900					
	GPRS/EDGE	VD	Yes	Yes: WIFI or BT	Google Meet ¹	OPUS
UMTS	850	VD	Yes	Yes: WIFI or BT	CMRS Voice ¹	NB AMR, WB AMR
	1700					
	1900					
LTE (FDD)	HSPA	VD	Yes	Yes: NR, WIFI or BT	VoLTE ¹ , Google Meet ¹	VoLTE: NB AMR, WB AMR, EVS Google Meet: OPUS
	680 (B71)					
	700 (B12)					
	780 (B13)					
	790 (B14)					
	850 (B5)					
	850 (B26)					
	1700 (B4)					
	1700 (B66)					
	1900 (B2)					
	1900 (B25)					
	2300 (B30)					
	2500 (B7)					
	2600 (B41)					
LTE (TDD)	2600 (B38)	VD	Yes	Yes: NR, WIFI or BT	VoLTE ¹ , Google Meet ¹	VoLTE: NB AMR, WB AMR, EVS Google Meet: OPUS
	3600 (B48)					
NR (FDD)	680 (n71)	VD	Yes	Yes: LTE, WIFI or BT	VoNR ¹ , Google Meet ¹	VoNR: NB AMR, WB AMR, EVS Google Meet: OPUS
	700 (n12)					
	850 (n26)					
	850 (n5)					
	1700 (n70)					
	1700 (n66)					
	1900 (n2)					
	1900 (n25)					
NR (TDD)	2300 (n30)	VD	Yes	Yes: LTE, WIFI or BT	VoNR ¹ , Google Meet ¹	VoNR: NB AMR, WB AMR, EVS Google Meet: OPUS
	2600 (n41)					
	2600 (n38)					
	3500 (n77, DoD)					
	3500 (n78, DoD)					
	3600 (n48)					
	3750 (n78)					
	3800 (n77)					
	24500 (n258)					
	28000 (n261)					
WIFI	39000 (n260)	DT	No ²	Yes: GSM, UMTS, LTE, or NR	VoWIFI ¹ , Google Meet ¹	VoWIFI: NB AMR, WB AMR, EVS Google Meet: OPUS
	2450					
	5200 (U-NII 1)					
	5300 (U-NII 2A)					
	5500 (U-NII 2C)					
	5800 (U-NII 3)					
	5900 (U-NII 4)					
	6175 (U-NII 5)					
	6475 (U-NII 6)					
	6700 (U-NII 7)					
7000 (U-NII 8)						
BT	2450	DT	No	Yes: GSM, UMTS, LTE, or NR	N/A	N/A
Type Transport VO = Voice Only DT = Digital Data - Not intended for Voice Services VD = CMRS and/or IP Voice over Data Transport			Notes: 1. Reference level in accordance with 6.4.3.2 of ANSI C63.19-2019 2. n258, n260, and n261 are currently outside the scope of ANSI C63.19 and FCC HAC regulations therefore they were not evaluated. 3. WIFI U-NII band 5 was evaluated for operations which are entirely below 6 GHz. Operations partially or entirely above 6 GHz were not evaluated due to equipment limitations and being outside the scope of ANSI C63.19 and FCC HAC regulations. 4. WIFI U-NII bands 6 through 8 were not evaluated due to equipment limitations and being outside the scope of ANSI C63.19 and FCC HAC regulations.			

FCC ID: A3LSMS928U		HAC (T-COIL) TEST REPORT	Approved by: Managing Director
Filename: 1M2308210092-27-R1.A3L	Test Dates: 10/09/2023 - 10/22/2023	DUT Type: Portable Handset	Page 5 of 72

3. ANSI C63.19-2019 COMPLIANCE REQUIREMENTS

The ANSI Standard provides guidance on measuring the baseband (audio frequency) magnetic T-Coil signal from a wireless device (WD) when coupled with a hearing aid's telecoil. This report will cover the measurement and evaluation of the field strength of the desired signal at the center of the audio band (desired ABM signal), the frequency response of the desired signal measured across the audio band and the field strength of the undesired audio band magnetic field.

I. MAGNETIC COUPLING

Qualifying Field Strengths

Per C63.19-2019 §6.6.2, there are two groups of qualifying measurement points:

Primary group: A qualifying measurement point shall have magnetic field strength (desired ABM signal, ≥ -18 dB(A/m) at 1 kHz, in a 1/3 octave band filter. Additionally, the qualifying measurement point shall have weighted magnetic noise, undesired ABM field, ≤ -38 dB(A/m)).

Secondary group: A qualifying measurement point shall have weighted magnetic noise ≤ -38 dB(A/m). This group inherently includes all the members of the primary group.

Desired ABM Signal, undesired ABM field Qualification Requirements

The below requirements ensure an adequate area where desired ABM signal is sufficiently strong to be heard and a larger area where undesired ABM field is sufficiently low as to avoid undue annoyance.

Non-2G GSM Operating Modes

Both the primary and secondary group requirements shall be met:

- The primary group shall include at least 75 measurement points.
- The secondary group shall include at least 300 contiguous measurement points.

Additionally, the secondary group shall include at least one longitudinal column of at least 10 contiguous qualifying points and at least one transverse row containing at least 15 contiguous qualifying points.

2G GSM Operating Modes Requirements

Both the primary and secondary group requirements shall be met:

- The primary group shall include at least 25 measurement points.
- The secondary group shall include at least 125 contiguous measurement points.

FCC ID: A3LSMS928U	 element	HAC (T-COIL) TEST REPORT	Approved by: Managing Director
Filename: 1M2308210092-27-R1.A3L	Test Dates: 10/09/2023 - 10/22/2023	DUT Type: Portable Handset	Page 6 of 72

Frequency Response

The frequency response of the magnetic field shall follow the response curve specified in EIA RS-504-1983, over the frequency range 300 Hz – 3000 Hz per §6.6.3.

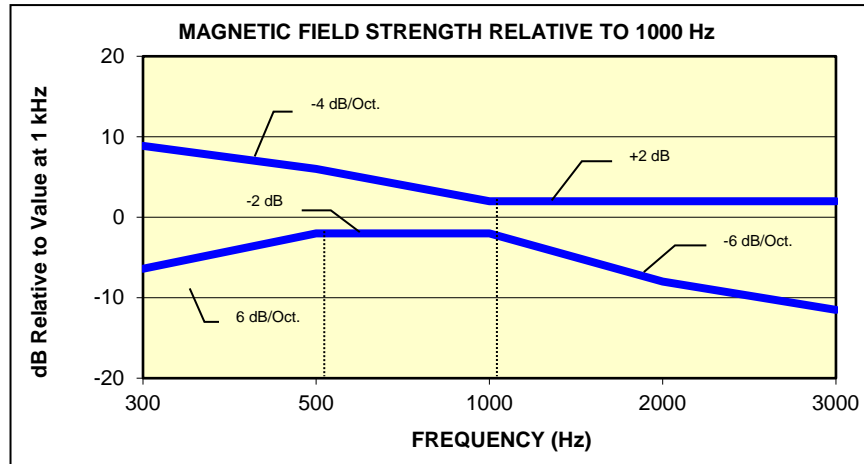

Figure 3-1
Magnetic field frequency response for Wireless Devices with a maximum field strength ≤ 15 dB(A/m) at 1 kHz

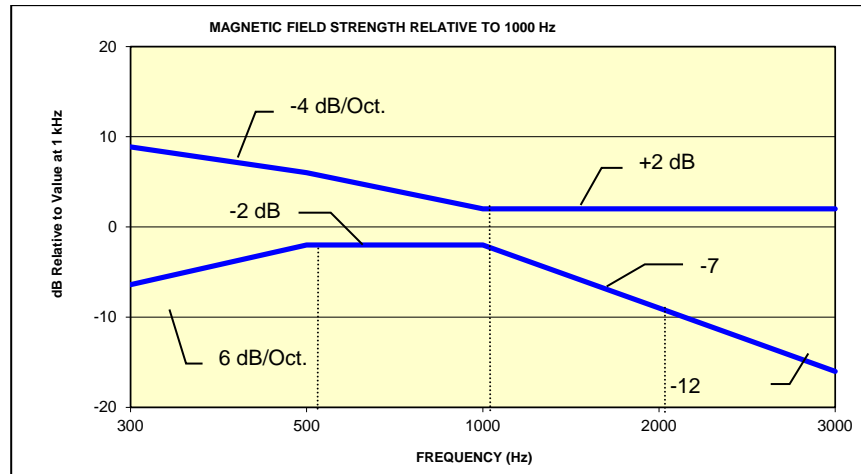



Figure 3-2
Magnetic Field frequency response for wireless devices with a maximum field strength that exceeds -15 dB(A/m) at 1 kHz

FCC ID: A3LSMS928U		HAC (T-COIL) TEST REPORT	Approved by: Managing Director
Filename: 1M2308210092-27-R1.A3L	Test Dates: 10/09/2023 - 10/22/2023	DUT Type: Portable Handset	Page 7 of 72

4. METHOD OF MEASUREMENT

I. Test Setup

The equipment was connected as shown in an RF-shielded chamber:

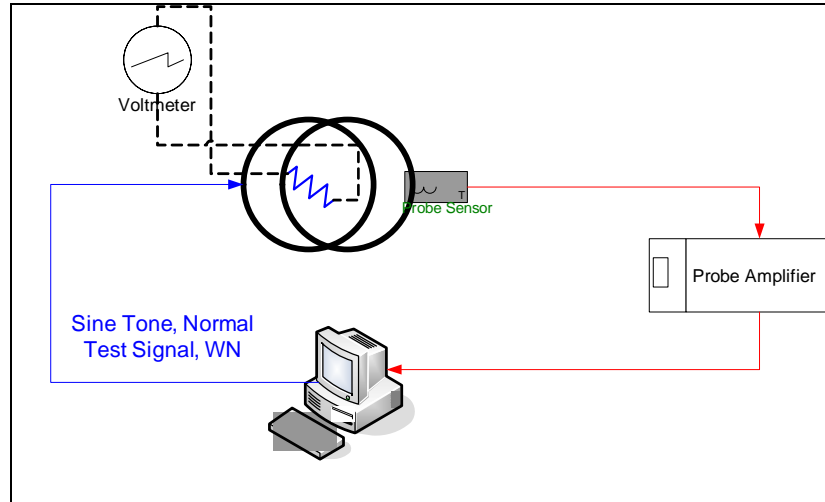

Figure 4-1
Validation Setup with Helmholtz Coil

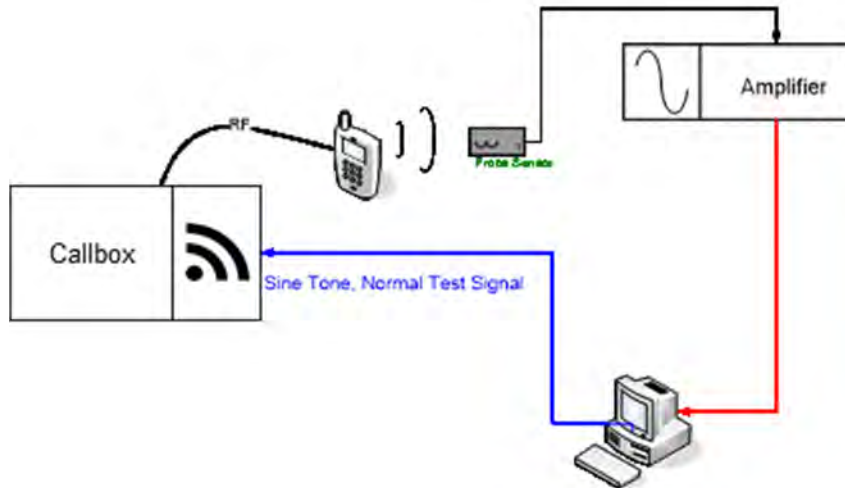



Figure 4-2
T-Coil Test Setup

FCC ID: A3LSMS928U	 element	HAC (T-COIL) TEST REPORT	Approved by: Managing Director
Filename: 1M2308210092-27-R1.A3L	Test Dates: 10/09/2023 - 10/22/2023	DUT Type: Portable Handset	Page 8 of 72

II. Scanning Mechanism

Manufacturer:	TEM
Accuracy:	± 0.83 cm/meter
Minimum Step Size:	0.1 mm
Maximum speed	6.1 cm/sec
Line Voltage:	115 VAC
Line Frequency:	60 Hz
Material Composite:	Delrin (Acetal)
Data Control:	Parallel Port
Dynamic Range (X-Y-Z):	45 x 31.75 x 47 cm
Dimensions:	36" x 25" x 38"
Operating Area:	36" x 49" x 55"
Reflections:	< -20 dB (in anechoic chamber)

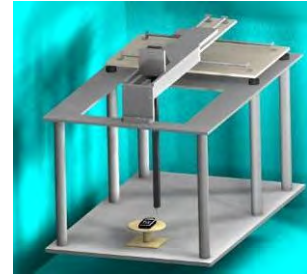

Figure 4-3
RF Near-Field Scanner

III. 3GPP2 Normal Test Signal (Speech)

Manufacturer:	3GPP2 (TIA 1042 §3.3.1)
Stimulus Type:	Modified-IRS weighted, multi-talker speech signal, 4 Male and 4 Female speakers (alternating)
Single Sample Duration:	51.62 seconds
Activity Level:	77.4%

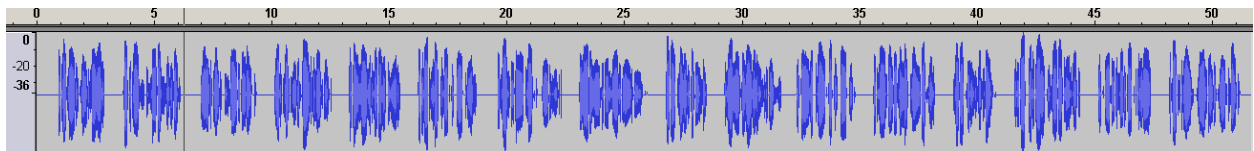



Figure 4-4
Temporal Characteristic of Normal Test Signal

FCC ID: A3LSMS928U	 element	HAC (T-COIL) TEST REPORT	Approved by: Managing Director
Filename: 1M2308210092-27-R1.A3L	Test Dates: 10/09/2023 - 10/22/2023	DUT Type: Portable Handset	Page 9 of 72

IV. Test Procedure

1. Ambient Noise Check per C63.19-2019 §6.3.2
 - a. Ambient interference was monitored using a Real-Time Analyzer between 100-10,000 Hz with 1/3 octave filtering.
 - b. Spectral/temporal weighting per C63.19-2019 Annex D.4 to D.6 was applied.
 - c. Since this measurement was measured using the same method as undesired ABM field measurements, this level was verified to be more than 10 dB below the lowest measurement signal (which is the highest undesired ABM field measurement for a compliant WD). Therefore the maximum noise level for a compliant WD is:

$$-38 - 10 = -48 \text{ dB (A/m)}$$

2. Measurement System Validation (See Figure 4-1)
 - a. The measurement system including the probe, pre-amplifier and acquisition system were validated as an entire system to ensure the reliability of test measurements.
 - b. Desired ABM Signal Validation
 The magnetic field at the center of the Helmholtz coil is given by the equation (per C63.19-2019 Annex D.10.1):

$$H_c = \frac{NI}{r\sqrt{1.25^3}} = \frac{N\left(\frac{V}{R}\right)}{r\sqrt{1.25^3}}$$

Where H_c = magnetic field strength in amperes per meter
 N = number of turns per coil

Therefore, a pure tone of 1kHz was applied into the coils such that was observed across the resistor. The voltmeter used for measurement was verified to be capable of measurements in the audio band range. This theoretically generates an expected field of -10 dB(A/m) in the center of the Helmholtz coil which was used to validate the probe measurement at -10dB(A/m). This was verified to be within ± 0.5 dB of the -10dB(A/m) value (see Page 45).

- c. Frequency Response Validation
 The frequency response through the Helmholtz Coil was verified to be within 0.5 dB relative to 1kHz, between 300 – 3000 Hz using the Normal signal as shown below:
 - d. Undesired ABM Field Strength Measurement Validation
 WD noise measurements are filtered with spectral/temporal weighting over a frequency range of 100Hz – 10kHz to process undesired ABM field strength measurements.
3. Point Measurement Test Setup
 - a. Fine scan above the WD (TEM)
 - i. A multitone signal was applied to the handset such that the phone acoustic output was stable within 1dB over the probe settling time and with the acoustic output level at the C63.19 specified levels (below). The measurement step size was in 2 mm increments at a distance of 10 mm between the surface of the wireless device as shown below (note that in Figure 4-6, the grid is not to scale but merely a graphical representation of the coordinate system in use):

FCC ID: A3LSMS928U		HAC (T-COIL) TEST REPORT	Approved by: Managing Director
Filename: 1M2308210092-27-R1.A3L	Test Dates: 10/09/2023 - 10/22/2023	DUT Type: Portable Handset	Page 10 of 72

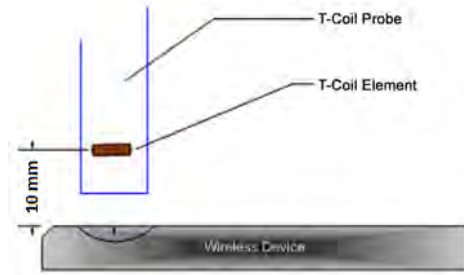

**Figure 4-5
Measurement Distance**

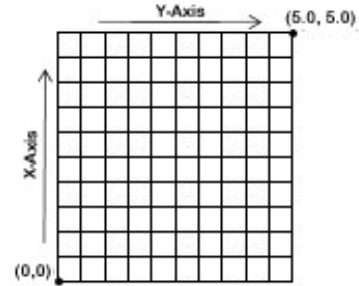

**Figure 4-6
Measurement Grid**

- ii. After scanning, the planar field maximum point was determined. The position of the probe was moved to this location to setup the test using the SoundCheck system.
- b. Speech Signal Setup to Base Station Simulator
 - i. C63.19 Table 6-1 states audio reference input levels for various technologies:

Standard	Technology	Input Level (dBm0)
TIA2000	CDMA	-18
J-STD-007	GSM (217)	-16
T1/T1P1/3GPP	UMTS (WCDMA)	-16
iDEN™	TDMA (22 and 11 Hz)	-18
VoIP	Voice over Internet Protocol	-16

- ii. See Section 5 and 7 for more information regarding CMW500 audio level settings for Voice Over LTE (VoLTE) and Voice Over WIFI (VoWIFI) testing.
- iii. See Section 6 for more information regarding CMW500 and CMX500 audio level settings for Voice Over NR (VoNR) testing.
- iv. See Section 8 for more information regarding audio level settings for Over-The-Top (OTT) Voice Over IP (VoIP) Testing.
- c. Real-Time Analyzer (RTA)
 - i. The Real-Time Analyzer was configured to analyze measurements using 1/3 Octave band weighted filtering.
- d. WD Radio Configuration Selection
 - i. The device was chosen to be tested in the condition resulting in the worst-case undesired ABM field (See Section 8 and 9 for more information regarding worst-case configurations for GSM and UMTS. LTE configuration information can be found in Section 5 and 8. NR configuration information can be found in Section 6 and 8. WIFI configuration information can be found in Section 7 and 8.)
- 4. Signal Quality Data Analysis
 - a. Narrow-band Magnetic Intensity
 - i. The standard specifies a 1kHz 1/3 octave band minimum field intensity for a sine tone. The desired ABM signal measurements were evaluated at 1kHz with 1/3 octave band filtering over an averaged period of 10 seconds.
 - b. Frequency Response
 - i. The appropriate frequency response curve was measured to curves in Figure 3-1 or Figure 3-2 between 300 – 3000 Hz using digital linear averaging (limit lines chosen according to measurement found in step 4a). A linear average over 3x the length of the artificial voice signal (3x sampling) was performed. A 10 second delay was configured in the measurement process of the stimulus to ensure handset

FCC ID: A3LSMS928U	element	HAC (T-COIL) TEST REPORT	Approved by: Managing Director
Filename: 1M2308210092-27-R1.A3L	Test Dates: 10/09/2023 - 10/22/2023	DUT Type: Portable Handset	Page 11 of 72

- vocoder latency effects and echo cancellation devices (if any) were appropriately stabilized during measurements.
 - ii. The appropriate post-processing was applied according to the system processing chain described in C63.19-2019. All R10 frequencies were plotted with respect to 0dB at 1kHz value and aligned with respect to the EIA-504 mask.
 - c. Signal Quality Index
 - i. Ensuring the WD was at maximum RF power, maximum volume, backlight off, display on, maximum contrast setting, keypad lights on (when possible) with no audio signal through the vocoder, the WD was measured over at least 100 Hz – 10,000 Hz, maximized over 5 seconds with a 50ms sample time for the undesired ABM field measurement (5 second time period is used in noise measurements under standards such as IEEE 269, etc.).
 - ii. Measure the broadband undesired T-Coil noise at the locations where desired ABM signal strength was just measured. The measurement shall be made using the specified spectral and temporal weighted filter, applied to the half-band integrated probe coil signal (T-Coil response), as described in C63.19-2019 Annex D.9.2. Any additional bandwidth-limiting filtering that might be applied shall not affect frequencies within the range of at least 100 Hz to 10 kHz. Set the measurement system averaging interval duration to be long enough so as to enable an accurate steady state reading. The resulting reading represents the “1 kHz equivalent” value of the broadband weighted T-Coil response magnetic noise (undesired ABM field) for each measurement position. All results should be reported in dB(A/m).
 - iii. This result was subtracted from the desired ABM signal result in step a, to obtain the Signal Quality.
- 5. Signal Compliance Analysis
 - a. Fine scan above the WD (TEM)
 - i. The worst-case signal quality index configuration for each wireless communication technology was used to evaluate the respective qualifying measurement points over a 52 mm square measurement area. The measurement step size was in 4 mm increments at 10 mm from the surface of the wireless device.
 - ii. At each step, a multitone signal was applied to the handset such that the phone acoustic output was stable within 1 dB over the probe settling time and with the acoustic output level at the C63.19 specified level. The desired ABM signal was measured, and the multitone signal was subsequently disabled before measuring the weighted magnitude of the undesired ABM field.
 - iii. The above steps were repeated for all supported wireless communication technologies.

FCC ID: A3LSMS928U	 element	HAC (T-COIL) TEST REPORT	Approved by: Managing Director
Filename: 1M2308210092-27-R1.A3L	Test Dates: 10/09/2023 - 10/22/2023	DUT Type: Portable Handset	Page 12 of 72

V. Test Setup

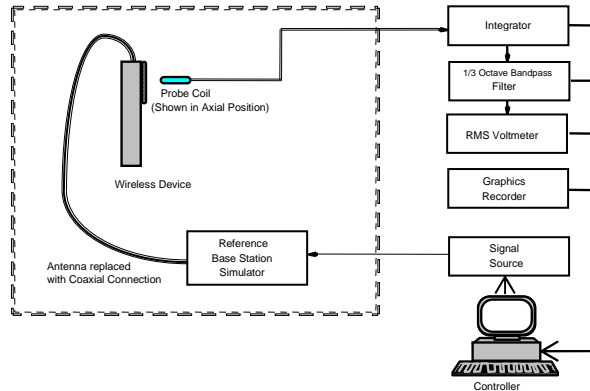

Figure 4-7
Audio Magnetic Field Test Setup

Environmental conditions such as temperature and relative humidity are monitored to ensure there are no impacts on system specifications. Proper voltage and power line frequency conditions are maintained with three phase power sources. Environmental noise and reflections are monitored through system checks.

VI. Deviation from C63.19 Test Procedure

Non-conducted RF connection due to inaccessible RF ports.

VII. Air Interface Technologies Tested

All air interfaces which support voice capabilities over a managed CMRS or pre-installed OTT VoIP applications were tested for T-coil unless otherwise noted. See Table 2-1 for more details regarding which modes were tested.

FCC ID: A3LSMS928U		HAC (T-COIL) TEST REPORT	Approved by: Managing Director
Filename: 1M2308210092-27-R1.A3L	Test Dates: 10/09/2023 - 10/22/2023	DUT Type: Portable Handset	Page 13 of 72

VIII. Wireless Device Channels and Frequencies

1. 2G/3G Modes

The frequencies listed in the table below are those that lie in the center of the bands used for cellular telephony. Low, middle and high channels were tested in each band for FCC compliance evaluation to ensure the maximum emission is captured across the entire band. Only middle channels were evaluated for data modes.

**Table 4-1
Center Channels and Frequencies**

Test frequencies & associated channels	
Channel	Frequency (MHz)
Cellular 850	
190 (GSM)	836.60
4183 (UMTS)	836.60
AWS 1750	
1412 (UMTS)	1730.40
PCS 1900	
661 (GSM)	1880
9400 (UMTS)	1880

2. 4G (LTE) Modes

The middle channel for every band and maximum bandwidth combination was tested at the planar field maximum point. The middle channels and supported bandwidths from the worst-case band according to Tables 8-6 and 8-7 were additionally evaluated with OTT VoIP. See Tables 10-6 to 10-17 as well as 10-40 for LTE bandwidths and channels. The scan result is available in Table 10-18.

3. 5G (NR) Modes

The middle channel for every band and maximum bandwidth combination was tested at the planar field maximum point. The middle channel and supported bandwidths from the worst-case NR band according to Tables 8-10 and 8-11 was evaluated with OTT VoIP. See Tables 10-19 to 10-30 as well as Table 10-41 for NR bandwidths and channels. The scan results are available in Tables 10-31 and 10-58.

4. WIFI

The middle channel for each IEEE 802.11 standard was tested at the planar field maximum point. 2.4GHz IEEE 802.11 standard from each probe orientation resulting in the worst-case SNNR was additionally tested using low and high channels. The 5GHz IEEE 802.11 standard from each probe orientation resulting in the worst-case SNNR was additionally tested on higher U-NII bands as well as applicable low and high channels. See Tables 10-32 to 10-36 as well as 10-42 to 10-46 for WIFI standards and channels. The scan result is available in Table 10-37.

FCC ID: A3LSMS928U	 element	HAC (T-COIL) TEST REPORT	Approved by: Managing Director
Filename: 1M2308210092-27-R1.A3L	Test Dates: 10/09/2023 - 10/22/2023	DUT Type: Portable Handset	Page 14 of 72

IX. Test Flow

The flow diagram below was followed (From C63.19)

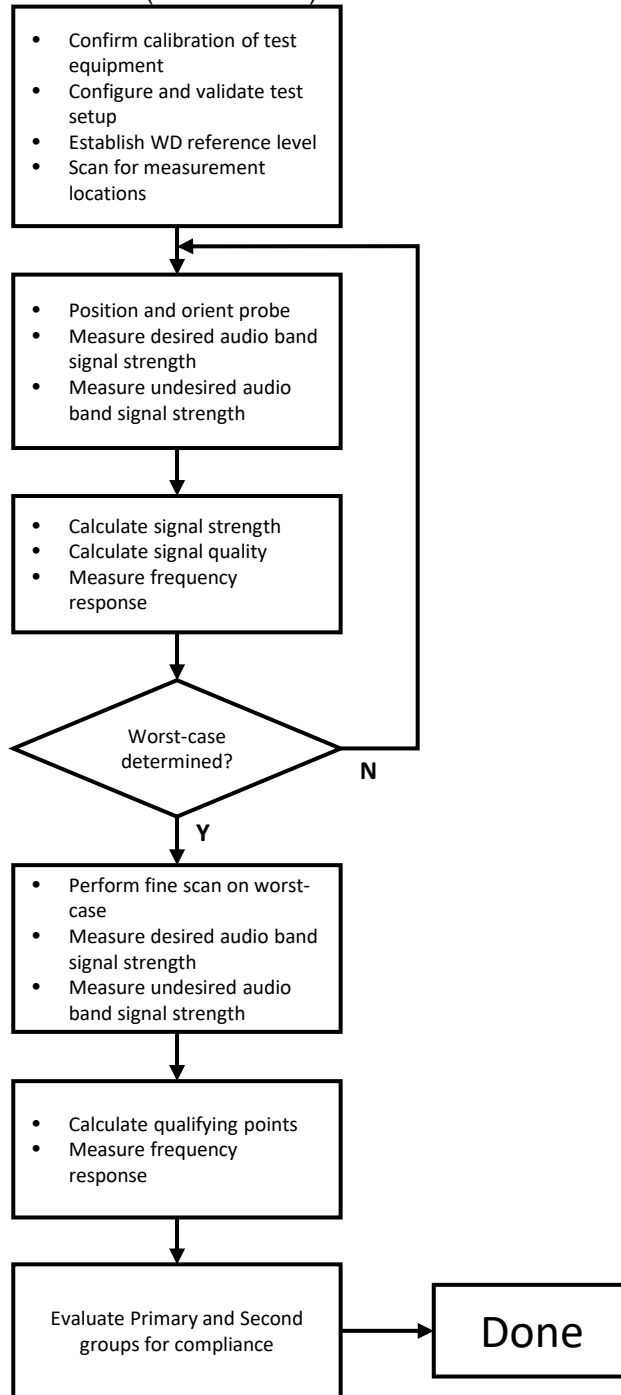



Figure 4-8
C63.19 T-Coil Signal Test Process

FCC ID: A3LSMS928U	 element	HAC (T-COIL) TEST REPORT	Approved by: Managing Director
Filename: 1M2308210092-27-R1.A3L	Test Dates: 10/09/2023 - 10/22/2023	DUT Type: Portable Handset	Page 15 of 72

5. VOLTE TEST SYSTEM SETUP AND DUT CONFIGURATION

I. Test System Setup for VoLTE over IMS T-coil Testing

1. Equipment Setup

The general test setup used for VoLTE over IMS is shown below. The callbox used when performing VoLTE over IMS T-coil measurements is a CMW500. The Data Application Unit (DAU) of the CMW500 was used to simulate the IP Multimedia Subsystem (IMS) server.

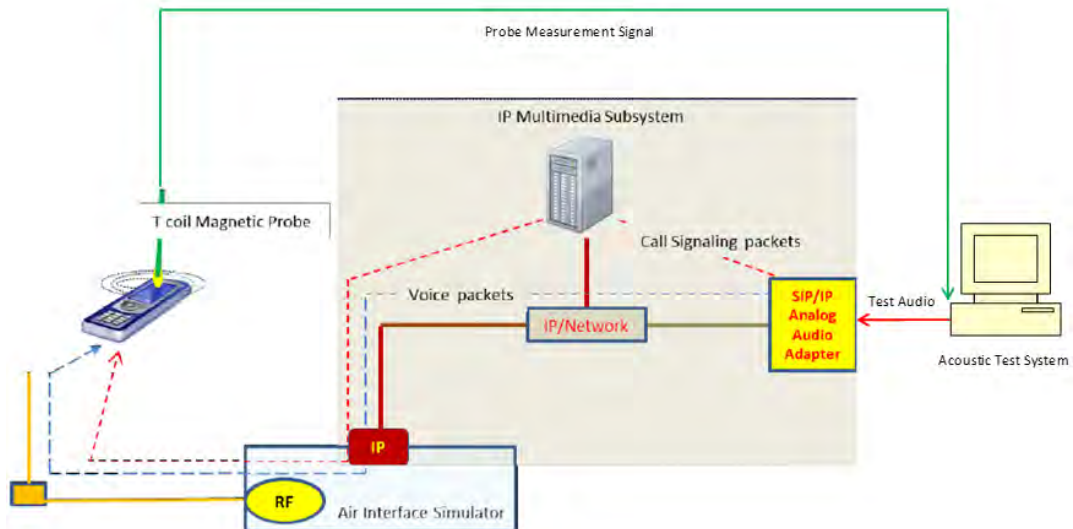



Figure 5-1
Test Setup for VoLTE over IMS T-Coil Measurements

2. Audio Level Settings

Per C63.19 Table 6-1, -16dBm0 shall be used as the normal speech input level for VoLTE over IMS T-coil testing. The CMW500 base station simulator was manually configured to ensure that the settings for speech input and full scale levels resulted in the -16dBm0 speech input level to the DUT for the VoLTE over IMS connection.

FCC ID: A3LSMS928U	 element	HAC (T-COIL) TEST REPORT	Approved by: Managing Director
Filename: 1M2308210092-27-R1.A3L	Test Dates: 10/09/2023 - 10/22/2023	DUT Type: Portable Handset	Page 16 of 72

II. DUT Configuration for VoLTE over IMS T-coil Testing

1. Radio Configuration

An investigation was performed to determine the modulation and RB configuration to be used for testing. The effects of modulation and RB configuration were found to be independent of band and bandwidth; therefore, only one band and bandwidth were used for this investigation. 16QAM, 1RB, 0RB offset was used for the testing as the worst-case configuration for the handset. See below table for SNNR comparison between different radio configurations:

**Table 5-1
VoLTE over IMS SNNR by Radio Configuration**

Band	Frequency [MHz]	Channel	Bandwidth [MHz]	Modulation	RB Size	RB Offset	Desired ABM [dB(A/m)]	Undesired ABM [dB(A/m)]	SNNR [dB]
66	1745.0	132322	20	QPSK	1	0	0.48	-50.71	51.19
66	1745.0	132322	20	16QAM	1	0	0.30	-49.98	50.28
66	1745.0	132322	20	64QAM	1	0	0.49	-51.36	51.85
66	1745.0	132322	20	256QAM	1	0	0.11	-50.87	50.98
66	1745.0	132322	20	16QAM	1	50	0.09	-50.59	50.68
66	1745.0	132322	20	16QAM	1	99	0.27	-50.53	50.80
66	1745.0	132322	20	16QAM	50	0	0.22	-52.44	52.66
66	1745.0	132322	20	16QAM	50	25	0.79	-52.32	53.11
66	1745.0	132322	20	16QAM	50	50	0.36	-50.59	50.95
66	1745.0	132322	20	16QAM	100	0	0.44	-52.53	52.97

2. Codec Configuration

An investigation was performed to determine the audio codec configuration to be used for testing. The effects of codec configuration were found to be independent of radio configuration; therefore, only one radio configuration was used for this investigation. The WB AMR 6.60kbps setting was used for the audio codec on the CMW500 for VoLTE over IMS T-coil testing. See below table for comparisons between different codecs and codec data rates:

**Table 5-2
AMR Codec Investigation – VoLTE over IMS**

Codec Setting:	WB AMR 23.85kbps	WB AMR 6.60kbps	NB AMR 12.2kbps	NB AMR 4.75kbps	Orientation	Band / BW	Channel
Desired (dBA/m)	1.42	0.09	2.02	1.82	Radial	LTE Band 66 20MHz	132322
Undesired (dBA/m)	-50.02	-49.57	-49.46	-49.59			
Frequency Response	Pass	Pass	Pass	Pass			
S+N/N (dB)	51.44	49.66	51.48	51.41			

FCC ID: A3LSMS928U	 element	HAC (T-COIL) TEST REPORT	Approved by: Managing Director
Filename: 1M2308210092-27-R1.A3L	Test Dates: 10/09/2023 - 10/22/2023	DUT Type: Portable Handset	Page 17 of 72

**Table 5-3
EVS Codec Investigation - VoLTE over IMS**

Codec Setting:	EVS Primary SWB 128kbps	EVS Primary SWB 9.6kbps	EVS Primary WB 128kbps	EVS Primary WB 5.9kbps	EVS Primary NB 24.4kbps	EVS Primary NB 5.9kbps	Orientation	Band / BW	Channel
Desired (dBA/m)	1.60	1.05	1.55	1.08	1.72	1.67	Radial	LTE Band 66 20MHz	132322
Undesired (dBA/m)	-50.11	-50.29	-50.04	-49.68	-50.32	-49.78			
Frequency Response	Pass	Pass	Pass	Pass	Pass	Pass			
S+N/N (dB)	51.71	51.34	51.59	50.76	52.04	51.45			

- Mute on; Backlight off; Max Volume; Max Contrast
- TPC = "Max Power"

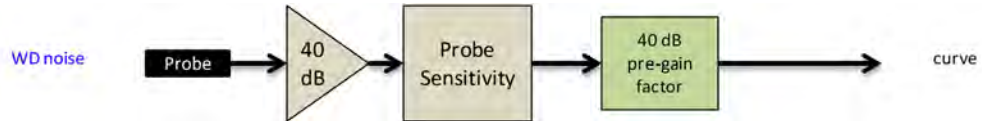

**Figure 5-2
Audio Band Magnetic Curve Measurement Block Diagram**

FCC ID: A3LSMS928U		HAC (T-COIL) TEST REPORT	Approved by: Managing Director
Filename: 1M2308210092-27-R1.A3L	Test Dates: 10/09/2023 - 10/22/2023	DUT Type: Portable Handset	Page 18 of 72

3. LTE TDD Uplink-Downlink Configuration Investigation for VoLTE over IMS

An investigation was performed to determine the worst-case Uplink-Downlink configuration for VoLTE over IMS T-Coil testing.

Per 3GPP TS 36.211, the total frame length for each TDD radio frame of length $T_f = 307200 \cdot T_s = 10$ ms, where T_s is a number of time units equal to $1/(15000 \times 2048)$ seconds. Additionally, each radio frame consists of 10 subframes, each of length $30720 \cdot T_s = 1$ ms, and subframes can be designated as uplink (U), downlink (D), or special subframe (S), depending on the Uplink-Downlink configuration as indicated in Table 4.2-2 of 3GPP TS 36.211. In the transmission duty factor calculation, the special subframe configuration with the shortest UpPTS duration within the special subframe is used and will be applied for measurement. From 3GPP TS 36.211 Table 4.2-1, the shortest UpPTS is $2192 \cdot T_s$ which occurs in the normal cyclic prefix and special subframe configuration 4.

See table below outlining the calculated transmission duty cycles for each Uplink-Downlink configuration:

**Table 5-4
Uplink-Downlink Configurations for Type 2 Frame Structures**

Uplink-downlink configuration	Downlink-to-Uplink Switch-point periodicity	Subframe number										Calculated Transmission Duty Cycle (%)
		0	1	2	3	4	5	6	7	8	9	
0	5 ms	D	S	U	U	U	D	S	U	U	U	61.4%
1	5 ms	D	S	U	U	D	D	S	U	U	D	41.4%
2	5 ms	D	S	U	D	D	D	S	U	D	D	21.4%
3	10 ms	D	S	U	U	U	D	D	D	D	D	30.7%
4	10 ms	D	S	U	U	D	D	D	D	D	D	20.7%
5	10 ms	D	S	U	D	D	D	D	D	D	D	10.7%
6	5 ms	D	S	U	U	U	D	S	U	U	D	51.4%

a. Power Class 3 Uplink-Downlink Configuration Investigation

Power Class 3 was evaluated with the following radio configuration: channel 40620, 20MHz BW, 16QAM, 1RB, 0RB offset. For Power Class 3, all configurations (0-6) are supported. The configuration which resulted in the worst SNNR was used for full testing. Uplink-Downlink configuration 0 was used as the worst-case configuration for Power Class 3 VoLTE over IMS T-Coil testing. See table below for the SNNR comparison between each Uplink-Downlink configuration:

**Table 5-5
Power Class 3 VoLTE over IMS SNNR by UL-DL Configuration**

Frequency [MHz]	Channel	Bandwidth [MHz]	Modulation	RB Size	RB Offset	UL-DL Configuration	Desired ABM [dB(A/m)]	Undesired ABM [dB(A/m)]	SNNR [dB]
2593.0	40620	20	16QAM	1	0	0	0.50	-33.02	33.52
2593.0	40620	20	16QAM	1	0	1	0.71	-33.15	33.86
2593.0	40620	20	16QAM	1	0	2	0.73	-33.03	33.76
2593.0	40620	20	16QAM	1	0	3	0.61	-36.16	36.77
2593.0	40620	20	16QAM	1	0	4	0.48	-36.13	36.61
2593.0	40620	20	16QAM	1	0	5	0.28	-35.85	36.13
2593.0	40620	20	16QAM	1	0	6	0.44	-33.33	33.77

FCC ID: A3LSMS928U	 element	HAC (T-COIL) TEST REPORT		Approved by: Managing Director
Filename: 1M2308210092-27-R1.A3L	Test Dates: 10/09/2023 - 10/22/2023	DUT Type: Portable Handset		Page 19 of 72

b. Power Class 2 Uplink-Downlink Configuration Investigation

Power Class 2 was evaluated with the following radio configuration: channel 40620, 20MHz BW, 16QAM, 1RB, 0RB offset. For Power Class 2, configurations 1-5 are supported. The configuration which resulted in the worst SNNR was used for full testing. Uplink-Downlink configuration 1 was used as the worst-case configuration for Power Class 2 VoLTE over IMS T-Coil testing. See table below for the SNNR comparison between each Uplink-Downlink configuration:

**Table 5-6
Power Class 2 VoLTE over IMS SNNR by UL-DL Configuration**

Frequency [MHz]	Channel	Bandwidth [MHz]	Modulation	RB Size	RB Offset	UL-DL Configuration	Desired ABM [dB(A/m)]	Undesired ABM [dB(A/m)]	SNNR [dB]
2593.0	40620	20	16QAM	1	0	1	0.32	-31.35	31.67
2593.0	40620	20	16QAM	1	0	2	0.52	-31.22	31.74
2593.0	40620	20	16QAM	1	0	3	0.47	-34.49	34.96
2593.0	40620	20	16QAM	1	0	4	0.20	-34.46	34.66
2593.0	40620	20	16QAM	1	0	5	0.37	-34.26	34.63

Note: LTE TDD B41 Power Class 2 only supports UL-DL configurations 1-5, not 0 or 6.

c. Conclusion

Per the investigations above, UL-DL Configuration 0 was used to evaluate Power Class 3 VoLTE over IMS. UL-DL Configuration 1 was used to evaluate Power Class 2 VoLTE over IMS.

FCC ID: A3LSMS928U	 element	HAC (T-COIL) TEST REPORT	Approved by: Managing Director
Filename: 1M2308210092-27-R1.A3L	Test Dates: 10/09/2023 - 10/22/2023	DUT Type: Portable Handset	Page 20 of 72

6. VONR TEST SYSTEM SETUP AND DUT CONFIGURATION

I. Test System Setup for VoNR over IMS T-coil Testing

1. Equipment Setup

The general test setup used for VoNR over IMS is shown below. The callboxes used when performing VoNR over IMS T-coil measurements are CMW500 and CMX500. The Data Application Unit (DAU) of the CMW500 was used to simulate the IP Multimedia Subsystem (IMS) server. The CMX500 provided the baseband signal to perform NR signaling. An external USB audio interface is used to perform the A/D conversion and ensure proper speech input level to the DUT.

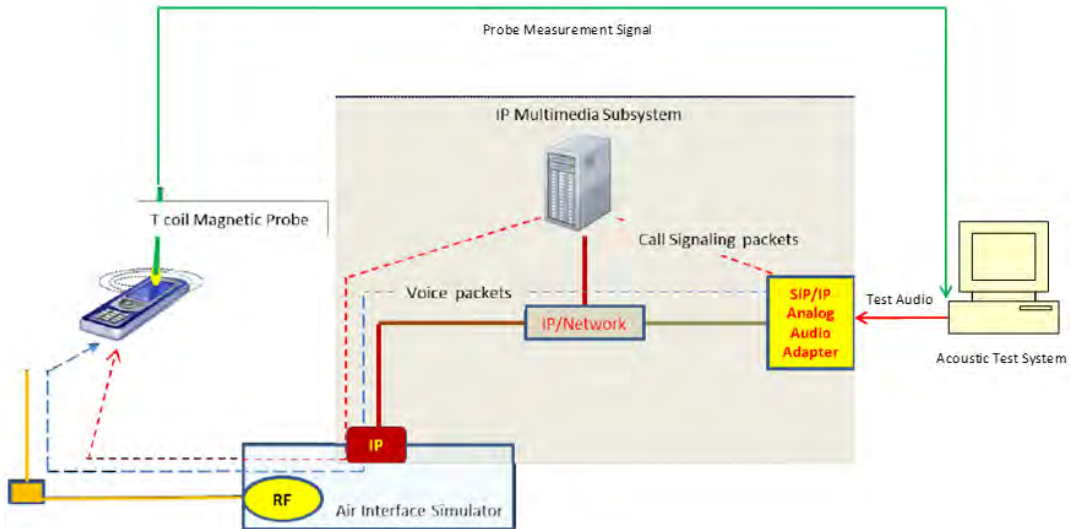



Figure 6-1
Test Setup for VoNR over IMS T-Coil Measurements

2. Audio Level Settings

Per C63.19 Table 6-1, -16dBm0 was used as the normal speech input level for VoNR over IMS T-coil testing. The acoustic test system was manually configured to ensure that the settings for speech input and full scale levels resulted in the -16dBm0 speech input level to the DUT for the VoNR over IMS connection.

FCC ID: A3LSMS928U		HAC (T-COIL) TEST REPORT	Approved by: Managing Director
Filename: 1M2308210092-27-R1.A3L	Test Dates: 10/09/2023 - 10/22/2023	DUT Type: Portable Handset	Page 21 of 72

II. DUT Configuration for VoNR over IMS T-coil Testing

1. Radio Configuration

An investigation was performed to determine the waveform, modulation, and RB configuration to be used for testing. The effects of waveform, modulation, and RB configuration were found to be independent of band and bandwidth; therefore, only one band and bandwidth were used for this investigation. DFT-s-OFDM, 16QAM, 1RB, 99%RB offset was used for the testing as the worst-case configuration for the handset. See below table for SNNR comparison between different radio configurations:

**Table 6-1
VoNR over IMS SNNR by Radio Configuration (CP-OFDM)**

Band	Frequency [MHz]	Channel	Bandwidth [MHz]	Waveform	Modulation	RB Size	RB Offset	Desired ABM [dB(A/m)]	Undesired ABM [dB(A/m)]	SNNR [dB]
n66	1745.0	349000	40	CP-OFDM	QPSK	1	1	0.71	-39.99	40.70
n66	1745.0	349000	40	CP-OFDM	16QAM	1	1	0.98	-40.06	41.04
n66	1745.0	349000	40	CP-OFDM	64QAM	1	1	0.91	-39.80	40.71
n66	1745.0	349000	40	CP-OFDM	256QAM	1	1	0.95	-40.84	41.79

**Table 6-2
VoNR over IMS SNNR by Radio Configuration (DFT-s-OFDM)**

Band	Frequency [MHz]	Channel	Bandwidth [MHz]	Waveform	Modulation	RB Size	RB Offset	Desired ABM [dB(A/m)]	Undesired ABM [dB(A/m)]	SNNR [dB]
n66	1745.0	349000	40	DFT-s-OFDM	$\pi/2$ -BPSK	1	1	0.96	-40.09	41.05
n66	1745.0	349000	40	DFT-s-OFDM	QPSK	1	1	0.89	-39.71	40.60
n66	1745.0	349000	40	DFT-s-OFDM	16QAM	1	1	0.94	-39.29	40.23
n66	1745.0	349000	40	DFT-s-OFDM	16QAM	1	137	0.76	-38.74	39.50
n66	1745.0	349000	40	DFT-s-OFDM	16QAM	1	271	0.89	-37.16	38.05
n66	1745.0	349000	40	DFT-s-OFDM	16QAM	135	0	0.98	-38.30	39.28
n66	1745.0	349000	40	DFT-s-OFDM	16QAM	135	69	0.86	-38.41	39.27
n66	1745.0	349000	40	DFT-s-OFDM	16QAM	135	138	0.74	-39.23	39.97
n66	1745.0	349000	40	DFT-s-OFDM	16QAM	270	0	0.84	-37.92	38.76
n66	1745.0	349000	40	DFT-s-OFDM	64QAM	1	1	0.94	-39.93	40.87
n66	1745.0	349000	40	DFT-s-OFDM	256QAM	1	1	0.80	-40.78	41.58

FCC ID: A3LSMS928U	 element	HAC (T-COIL) TEST REPORT	Approved by: Managing Director
Filename: 1M2308210092-27-R1.A3L	Test Dates: 10/09/2023 - 10/22/2023	DUT Type: Portable Handset	Page 22 of 72

2. Codec Configuration

An investigation was performed to determine the audio codec configuration to be used for testing. The effects of codec configuration were found to be independent of radio configuration; therefore, only one radio configuration was used for this investigation. The WB AMR 6.60kbps setting was used for the audio codec on the CMX500/CMW500 for VoNR over IMS T-coil testing. See below table for comparisons between different codecs and codec data rates:

Codec Setting:	WB AMR 23.85kbps	WB AMR 6.60kbps	NB AMR 12.2kbps	NB AMR 4.75kbps	Orientation	Band / BW	Channel
Desired (dBA/m)	1.44	0.59	1.92	1.64	Radial	NR n41 100MHz	518598
Undesired (dBA/m)	-32.47	-32.33	-32.53	-32.38			
Frequency Response	Pass	Pass	Pass	Pass			
S+N/N (dB)	33.91	32.92	34.45	34.02			

**Table 6-3
AMR Codec Investigation – VoNR over IMS**

Codec Setting:	EVS Primary SWB 128kbps	EVS Primary SWB 9.6kbps	EVS Primary WB 128kbps	EVS Primary WB 5.9kbps	EVS Primary NB 24.4kbps	EVS Primary NB 5.9kbps	Orientation	Band / BW	Channel
Desired (dBA/m)	1.61	1.10	1.56	1.16	1.68	1.67	Radial	NR n41 100MHz	518598
Undesired (dBA/m)	-32.37	-32.50	-32.41	-32.23	-32.26	-32.34			
Frequency Response	Pass	Pass	Pass	Pass	Pass	Pass			
S+N/N (dB)	33.98	33.60	33.97	33.39	33.94	34.01			

**Table 6-4
EVS Codec Investigation - VoNR over IMS**

- Mute on; Backlight off; Max Volume; Max Contrast
- TPC = “Max Power”

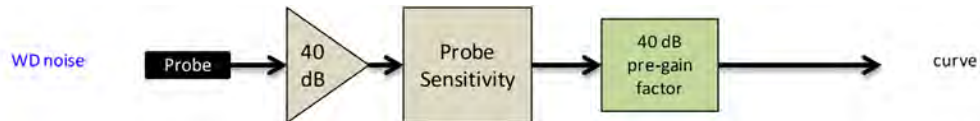

**Figure 6-2
Audio Band Magnetic Curve Measurement Block Diagram**

FCC ID: A3LSMS928U	element	HAC (T-COIL) TEST REPORT	Approved by: Managing Director
Filename: 1M2308210092-27-R1.A3L	Test Dates: 10/09/2023 - 10/22/2023	DUT Type: Portable Handset	Page 23 of 72

7. VOWIFI TEST SYSTEM SETUP AND DUT CONFIGURATION

I. Test System Setup for VoWiFi over IMS T-coil Testing

1. Equipment Setup

The general test setup used for VoWiFi over IMS, or CMRS WiFi Calling, is shown below. The callbox used when performing VoWiFi over IMS T-coil measurements is a CMW500. The Data Application Unit (DAU) of the CMW500 was used to simulate the IP Multimedia Subsystem (IMS) server.

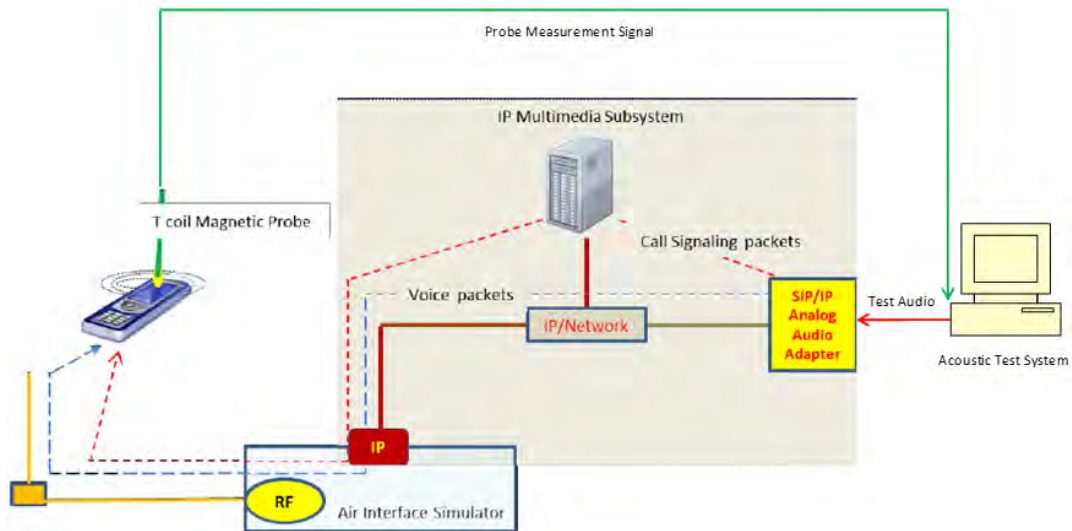



Figure 7-1
Test Setup for VoWiFi over IMS T-Coil Measurements

2. Audio Level Settings

Per C63.19 Table 6-1, -16dBm0 shall be used as the normal speech input level for VoWiFi over IMS T-coil testing. The CMW500 base station simulator was manually configured to ensure that the settings for speech input and full scale levels resulted in the -20dBm0 speech input level to the DUT for the VoWiFi over IMS connection.

FCC ID: A3LSMS928U	 element	HAC (T-COIL) TEST REPORT	Approved by: Managing Director
Filename: 1M2308210092-27-R1.A3L	Test Dates: 10/09/2023 - 10/22/2023	DUT Type: Portable Handset	Page 24 of 72

II. DUT Configuration for VoWiFi over IMS T-coil Testing

1. Radio Configuration

An investigation was performed on all applicable data rates and modulations to determine the radio configuration to be used for testing. See tables below for SNNR comparison between radio configurations in each IEEE 802.11 standard:

Table 7-1
IEEE 802.11b SNNR by Radio Configuration

Mode	Channel	Modulation	Data Rate [Mbps]	Desired ABM [dB(A/m)]	Undesired ABM [dB(A/m)]	SNNR [dB]
IEEE 802.11b	6	DSSS	1	0.81	-43.04	43.85
IEEE 802.11b	6	CCK	11	1.10	-42.39	43.49

Table 7-2
IEEE 802.11g/a SNNR by Radio Configuration

Mode	Channel	Modulation	Data Rate [Mbps]	Desired ABM [dB(A/m)]	Undesired ABM [dB(A/m)]	SNNR [dB]
IEEE 802.11g	6	BPSK	6	0.88	-42.36	43.24
IEEE 802.11g	6	64QAM	54	1.07	-43.03	44.10

Table 7-3
IEEE 802.11n/ac 20MHz BW SNNR by Radio Configuration

Mode	Bandwidth [MHz]	Channel	Modulation	MCS Index	Desired ABM [dB(A/m)]	Undesired ABM [dB(A/m)]	SNNR [dB]
IEEE 802.11n	20	40	BPSK	0	1.14	-43.37	44.51
IEEE 802.11n	20	40	64QAM	7	1.12	-44.40	45.52
IEEE 802.11ac	20	40	256QAM	8	0.79	-44.05	44.84

Table 7-4
IEEE 802.11ax SU 20MHz BW SNNR by Radio Configuration

Mode	Bandwidth [MHz]	Channel	Modulation	MCS Index	Desired ABM [dB(A/m)]	Undesired ABM [dB(A/m)]	SNNR [dB]
IEEE 802.11ax SU	20	40	BPSK	0	1.18	-44.40	45.58
IEEE 802.11ax SU	20	40	1024QAM	11	1.01	-45.62	46.63

Table 7-5
IEEE 802.11ax RU 20MHz BW SNNR by Radio Configuration

Mode	Bandwidth [MHz]	Channel	Modulation	MCS Index	RU Index	Desired ABM [dB(A/m)]	Undesired ABM [dB(A/m)]	SNNR [dB]
IEEE 802.11ax RU	20	40	BPSK	0	0	1.00	-43.30	44.30
IEEE 802.11ax RU	20	40	BPSK	0	61	0.90	-43.50	44.40

Table 7-6
IEEE 802.11n/ac 40MHz BW SNNR by Radio Configuration

Mode	Bandwidth [MHz]	Channel	Modulation	MCS Index	Desired ABM [dB(A/m)]	Undesired ABM [dB(A/m)]	SNNR [dB]
IEEE 802.11n	40	38	BPSK	0	1.09	-43.17	44.26
IEEE 802.11n	40	38	64QAM	7	1.42	-44.46	45.88
IEEE 802.11ac	40	38	256QAM	9	1.13	-43.82	44.95

FCC ID: A3LSMS928U	 element	HAC (T-COIL) TEST REPORT		Approved by: Managing Director
Filename: 1M2308210092-27-R1.A3L	Test Dates: 10/09/2023 - 10/22/2023	DUT Type: Portable Handset		Page 25 of 72

Table 7-7
IEEE 802.11ax SU 40MHz BW SNNR by Radio Configuration

Mode	Bandwidth [MHz]	Channel	Modulation	MCS Index	Desired ABM [dB(A/m)]	Undesired ABM [dB(A/m)]	SNNR [dB]
IEEE 802.11ax SU	40	38	BPSK	0	1.24	-42.90	44.14
IEEE 802.11ax SU	40	38	1024QAM	11	0.91	-44.24	45.15

Table 7-8
IEEE 802.11ax RU 40MHz BW SNNR by Radio Configuration

Mode	Bandwidth [MHz]	Channel	Modulation	MCS Index	RU Index	Desired ABM [dB(A/m)]	Undesired ABM [dB(A/m)]	SNNR [dB]
IEEE 802.11ax RU	40	38	BPSK	0	0	1.08	-43.25	44.33
IEEE 802.11ax RU	40	38	BPSK	0	65	1.08	-42.34	43.42

2. Codec Configuration

An investigation was performed to determine the audio codec configuration to be used for testing. The effects of codec configuration were found to be independent of radio configuration; therefore, only one radio configuration was used for this investigation. The WB AMR 6.60kbps setting was used for the audio codec on the CMW500 for VoWiFi over IMS T-coil testing. See below table for comparisons between different codecs and codec data rates:

Table 7-9
AMR Codec Investigation – VoWiFi over IMS

Codec Setting:	WB AMR 23.85kbps	WB AMR 6.60kbps	NB AMR 12.2kbps	NB AMR 4.75kbps	Orientation	Band	Standard	Channel
Desired (dBA/m)	2.44	0.89	3.00	2.02	Radial	2.4GHz	IEEE 802.11b	6
Undesired (dBA/m)	-42.60	-42.42	-42.27	-42.43				
Frequency Response	Pass	Pass	Pass	Pass				
S+N/N (dB)	45.04	43.31	45.27	44.45				

Table 7-10
EVS Codec Investigation – VoWiFi over IMS

Codec Setting:	EVS Primary SWB 128kbps	EVS Primary SWB 9.6kbps	EVS Primary WB 128kbps	EVS Primary WB 5.9kbps	EVS Primary NB 24.4kbps	EVS Primary NB 5.9kbps	Orientation	Band	Standard	Channel
Desired (dBA/m)	2.84	2.10	2.69	1.51	2.68	1.20	Radial	2.4GHz	IEEE 802.11b	6
Undesired (dBA/m)	-42.39	-42.22	-42.58	-42.83	-42.59	-42.31				
Frequency Response	Pass	Pass	Pass	Pass	Pass	Pass				
S+N/N (dB)	45.23	44.32	45.27	44.34	45.27	43.51				

- Mute on; Backlight off; Max Volume; Max Contrast

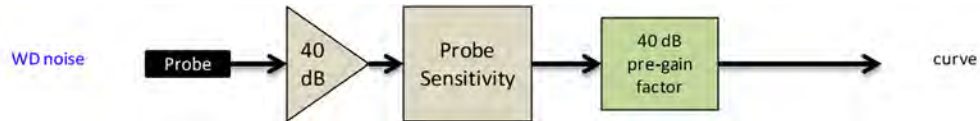

Figure 7-2
Audio Band Magnetic Curve Measurement Block Diagram

FCC ID: A3LSMS928U		HAC (T-COIL) TEST REPORT	Approved by: Managing Director
Filename: 1M2308210092-27-R1.A3L	Test Dates: 10/09/2023 - 10/22/2023	DUT Type: Portable Handset	Page 26 of 72

8. OTT VOIP TEST SYSTEM AND DUT CONFIGURATION

I. Test System Setup for OTT VoIP T-Coil Testing

1. OTT VoIP Application

Google Meet is a pre-installed application on the DUT which allows for VoIP calls in a held-to-ear scenario. Meet uses the OPUS audio codec and supports a bitrate range of 6kb/s to 75kb/s. All air interfaces capable of a data connection were evaluated with Google Meet.

2. Equipment Setup

A CMW500 callbox was used to perform OTT VoIP T-coil measurements. The Data Application Unit (DAU) of the CMW500 was connected to the internet and allowed for an IP data connection on the DUT. An auxiliary VoIP unit was used to initiate an OTT VoIP call to the DUT. The auxiliary VoIP unit allowed for the configuration and monitoring of the OTT VoIP codec bitrate during a call. Both high and low bitrate settings were evaluated in to determine the worst-case configuration.

3. Audio Level Settings

Per C63.19 Table 6-1, an average speech level of -16dBm0 shall be used for VoIP testing. The auxiliary VoIP unit allowed for monitoring the signal input level to ensure that the settings for speech input and full scale levels resulted in the -16dBm0 speech input level to the DUT for the OTT VoIP call.

II. DUT Configuration for OTT VoIP T-Coil Testing

1. Codec Configuration

An investigation was performed for each applicable data mode to determine the audio codec configuration to be used for testing. The effects of codec configuration were found to be independent of radio configuration; therefore, only one radio configuration for each applicable data mode was used for these investigations. The 6kbps codec setting was used for the audio codec on the auxiliary VoIP unit for OTT VoIP T-Coil testing. See below tables for comparisons between codec data rates on all applicable data modes:

Table 8-1
Codec Investigation – OTT VoIP (EDGE)

Codec Setting:	75kbps	6kbps	Orientation	Channel
Desired (dBA/m)	0.12	-0.25	Radial	190
Undesired (dBA/m)	-35.02	-35.35		
Frequency Response	Pass	Pass		
S+N/N (dB)	35.14	35.10		

FCC ID: A3LSMS928U	 element	HAC (T-COIL) TEST REPORT	Approved by: Managing Director
Filename: 1M2308210092-27-R1.A3L	Test Dates: 10/09/2023 - 10/22/2023	DUT Type: Portable Handset	Page 27 of 72

Table 8-2
Codec Investigation – OTT VoIP (HSPA)

Codec Setting:	75kbps	6kbps	Orientation	Channel
Desired (dBA/m)	0.00	-0.29	Radial	9400
Undesired (dBA/m)	-51.16	-50.33		
Frequency Response	Pass	Pass		
S+N/N (dB)	51.16	50.04		

Table 8-3
Codec Investigation – OTT VoIP (LTE)

Codec Setting:	75kbps	6kbps	Orientation	Band / BW	Channel
Desired (dBA/m)	-0.04	-0.10	Radial	LTE Band 66 20MHz	132322
Undesired (dBA/m)	-47.44	-47.24			
Frequency Response	Pass	Pass			
S+N/N (dB)	47.40	47.14			

Table 8-4
Codec Investigation – OTT VoIP (NR)

Codec Setting:	75kbps	6kbps	Orientation	Band / BW	Channel
Desired (dBA/m)	-0.14	-0.35	Radial	NR n66 40MHz	349000
Undesired (dBA/m)	-46.98	-46.87			
Frequency Response	Pass	Pass			
S+N/N (dB)	46.84	46.52			

Table 8-5
Codec Investigation – OTT VoIP (WIFI)

Codec Setting:	75kbps	6kbps	Orientation	Band	Standard	Channel
Desired (dBA/m)	-0.21	-0.41	Radial	2.4GHz	IEEE 802.11b	6
Undesired (dBA/m)	-41.71	-41.67				
Frequency Response	Pass	Pass				
S+N/N (dB)	41.50	41.26				

- Mute on; Backlight off; Max Volume; Max Contrast
- Radio Configurations can be found in Section 10.II.G

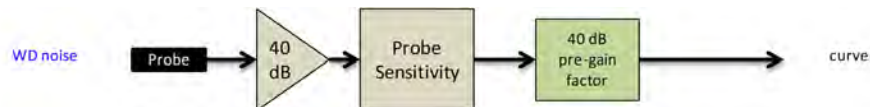

Figure 8-1
Audio Band Magnetic Curve Measurement Block Diagram

FCC ID: A3LSMS928U	element	HAC (T-COIL) TEST REPORT	Approved by: Managing Director
Filename: 1M2308210092-27-R1.A3L	Test Dates: 10/09/2023 - 10/22/2023	DUT Type: Portable Handset	Page 28 of 72

2. Radio Configuration for OTT VoIP (LTE)

An investigation was performed to determine the worst-case LTE FDD band to be used for OTT VoIP testing. LTE TDD Band 41 (PC2) was used for the testing as the worst-case configuration for the handset. See below table for SNNR comparison between different LTE FDD bands:

Table 8-6
OTT VoIP (LTE FDD) SNNR by LTE Band

Band	ANT Config.	Frequency [MHz]	Channel	Bandwidth [MHz]	Modulation	RB Size	RB Offset	Desired ABM [dB(A/m)]	Undesired ABM [dB(A/m)]	SNNR [dB]
71	A	680.5	133297	20	16QAM	1	0	-0.01	-47.93	47.92
71	E	680.5	133297	20	16QAM	1	0	-0.61	-47.21	46.60
12	A	707.5	23095	10	16QAM	1	0	-0.48	-48.68	48.20
12	E	707.5	23095	10	16QAM	1	0	-0.13	-50.54	50.41
13	A	782.0	23230	10	16QAM	1	0	-0.40	-45.54	45.14
13	E	782.0	23230	10	16QAM	1	0	0.25	-44.32	44.57
14	A	793.0	23330	10	16QAM	1	0	-0.38	-48.06	47.68
14	E	793.0	23330	10	16QAM	1	0	-0.11	-48.10	47.99
26	A	831.5	26865	15	16QAM	1	0	0.17	-49.04	49.21
26	E	831.5	26865	15	16QAM	1	0	-0.35	-48.78	48.43
66	A	1745.0	132322	20	16QAM	1	0	-0.30	-47.78	47.48
66	F	1745.0	132322	20	16QAM	1	0	-0.03	-48.62	48.59
25	A	1882.5	26365	20	16QAM	1	0	-0.03	-47.84	47.81
25	F	1882.5	26365	20	16QAM	1	0	-0.61	-49.86	49.25
30	A	2310.0	27710	10	16QAM	1	0	-0.28	-49.75	49.47
30	F	2310.0	27710	10	16QAM	1	0	-0.22	-46.65	46.43
7	B	2535.0	21100	20	16QAM	1	0	-0.26	-48.14	47.88
7	F	2535.0	21100	20	16QAM	1	0	-0.49	-51.01	50.52

Table 8-7
OTT VoIP (LTE TDD) SNNR by LTE Band

Band	ANT Config.	Frequency [MHz]	Channel	Bandwidth [MHz]	Modulation	RB Size	RB Offset	Desired ABM [dB(A/m)]	Undesired ABM [dB(A/m)]	SNNR [dB]
41 (PC3)	B	2593.0	40620	20	16QAM	1	0	-0.24	-35.23	34.99
41 (PC2)	B	2593.0	40620	20	16QAM	1	0	-0.21	-33.41	33.20
41 (PC3)	F	2593.0	40620	20	16QAM	1	0	-0.34	-44.36	44.02
41 (PC2)	F	2593.0	40620	20	16QAM	1	0	-0.36	-43.88	43.52
48	F	3625.0	55990	20	16QAM	1	0	-0.19	-39.15	38.96

3. LTE FDD Uplink Carrier Aggregation for OTT VoIP

LTE FDD ULCA was evaluated to ensure LTE FDD standalone was the worst-case scenario. The configurations in Table 8-8 were determined from Table 8-6 and satisfy the configuration requirements as defined in 3GPP 36.101.

Table 8-8
LTE FDD SNNR for OTT VoIP Uplink Carrier Aggregation

Combination	ANT Config.	PCC							SCC							Desired ABM [dB(A/m)]	Undesired ABM [dB(A/m)]	SNNR [dB]
		PCC Band	PCC Bandwidth [MHz]	PCC (UL) Channel	PCC (UL) Frequency [MHz]	Modulation	PCC UL# RB	PCC UL RB Offset	SCC Band	SCC Bandwidth [MHz]	SCC (UL) Channel	SCC (UL) Frequency [MHz]	Modulation	SCC UL# RB	SCC UL RB Offset			
CA_66B	A	LTE B66	10	132322	1745.0	16QAM	1	0	LTE B66	10	132223	1735.1	16QAM	1	49	-0.59	-48.34	47.75
CA_66B	F	LTE B66	10	132322	1745.0	16QAM	1	0	LTE B66	10	132223	1735.1	16QAM	1	49	-0.02	-48.85	48.83
CA_66C	A	LTE B66	20	132322	1745.0	16QAM	1	0	LTE B66	20	132124	1725.5	16QAM	1	99	-0.46	-46.07	45.61
CA_66C	F	LTE B66	20	132322	1745.0	16QAM	1	0	LTE B66	20	132124	1725.5	16QAM	1	99	-0.40	-48.77	48.37

FCC ID: A3LSMS928U		HAC (T-COIL) TEST REPORT	Approved by: Managing Director
Filename: 1M2308210092-27-R1.A3L	Test Dates: 10/09/2023 - 10/22/2023	DUT Type: Portable Handset	Page 29 of 72

4. LTE TDD Uplink Carrier Aggregation for OTT VoIP

LTE TDD ULCA was evaluated to ensure LTE TDD standalone was the worst-case scenario. The configurations in Table 8-9 were determined from Table 8-7 and satisfy the configuration requirements as defined in 3GPP 36.101.

Table 8-9
LTE TDD SNNR for OTT VoIP Uplink Carrier Aggregation

Combination	ANT Config.	PCC						SCC						Desired ABM [dB(A/m)]	Undesired ABM [dB(A/m)]	SNNR [dB]		
		PCC Band	PCC Bandwidth [MHz]	PCC (UL/DL) Channel	PCC (UL/DL) Frequency [MHz]	Modulation	PCC UL# RB	PCC UL RB Offset	SCC Band	SCC Bandwidth [MHz]	SCC (UL/DL) Channel	SCC (UL/DL) Frequency [MHz]	Modulation				SCC UL# RB	SCC UL RB Offset
CA_41C (PC3)	B	LTE B41	20	40620	2593.0	16QAM	1	0	LTE B41	20	40422	2573.2	16QAM	1	99	-0.66	-35.20	34.54
CA_41C (PC3)	F	LTE B41	20	40620	2593.0	16QAM	1	0	LTE B41	20	40422	2573.2	16QAM	1	99	-0.02	-42.79	42.77
CA_41C (PC2)	B	LTE B41	20	40620	2593.0	16QAM	1	0	LTE B41	20	40422	2573.2	16QAM	1	99	-0.71	-33.73	33.02
CA_41C (PC2)	F	LTE B41	20	40620	2593.0	16QAM	1	0	LTE B41	20	40422	2573.2	16QAM	1	99	-0.27	-41.54	41.27
CA_48C	F	LTE B48	20	55990	3625.0	16QAM	1	0	LTE B48	20	55792	3605.2	16QAM	1	99	-0.33	-40.31	39.98

5. Radio Configuration for OTT VoIP (NR)

An investigation was performed to determine the worst-case NR band to be used for OTT VoIP testing. NR TDD n41 (PC2) ANT F was used for testing as the worst-case configuration for the handset. See below table for SNNR comparison between different NR bands:

Table 8-10
OTT VoIP (NR FDD) SNNR by NR Band

Band	ANT Config	Frequency [MHz]	Channel	Bandwidth [MHz]	Waveform	Modulation	RB Size	RB Offset	Desired ABM [dB(A/m)]	Undesired ABM [dB(A/m)]	SNNR [dB]
n71	A	680.5	136100	20	DFT-s-OFDM	16QAM	1	104	-0.61	-48.50	47.89
n71	E	680.5	136100	20	DFT-s-OFDM	16QAM	1	104	-0.05	-46.81	46.76
n12	A	707.5	141500	15	DFT-s-OFDM	16QAM	1	77	-0.52	-49.56	49.04
n12	E	707.5	141500	15	DFT-s-OFDM	16QAM	1	77	-0.36	-47.42	47.06
n26	A	831.5	166300	20	DFT-s-OFDM	16QAM	1	104	-0.57	-49.40	48.83
n26	E	831.5	166300	20	DFT-s-OFDM	16QAM	1	104	-0.54	-47.87	47.33
n70	A	1702.5	340500	15	DFT-s-OFDM	16QAM	1	77	-0.83	-47.35	46.52
n70	F	1702.5	340500	15	DFT-s-OFDM	16QAM	1	77	-0.41	-49.75	49.34
n66	A	1745.0	349000	40	DFT-s-OFDM	16QAM	1	214	-0.15	-46.99	46.84
n66	F	1745.0	349000	40	DFT-s-OFDM	16QAM	1	214	-0.07	-49.73	49.66
n25	A	1882.5	376500	40	DFT-s-OFDM	16QAM	1	214	-0.31	-46.48	46.17
n25	F	1882.5	376500	40	DFT-s-OFDM	16QAM	1	214	-0.19	-47.83	47.64
n30	A	2310.0	462000	10	DFT-s-OFDM	16QAM	1	50	-0.31	-47.95	47.64
n30	F	2310.0	462000	10	DFT-s-OFDM	16QAM	1	50	-0.51	-46.79	46.28
n7	B	2535.0	507000	40	DFT-s-OFDM	16QAM	1	214	-0.69	-47.50	46.81
n7	F	2535.0	507000	40	DFT-s-OFDM	16QAM	1	214	-0.51	-48.72	48.21

Table 8-11
OTT VoIP (NR TDD) SNNR by NR Band

Band	ANT Config	Frequency [MHz]	Channel	Bandwidth [MHz]	Waveform	Modulation	RB Size	RB Offset	Desired ABM [dB(A/m)]	Undesired ABM [dB(A/m)]	SNNR [dB]
n41 (PC2)	B	2592.99	518598	100	DFT-s-OFDM	16QAM	1	271	-0.33	-38.65	38.32
n41 (PC2)	F	2592.99	518598	100	DFT-s-OFDM	16QAM	1	271	-0.29	-32.49	32.20
n77 (DoD, PC2)	F	3500.0	633334	100	DFT-s-OFDM	16QAM	1	271	-0.47	-36.31	35.84
n48	F	3625.0	641666	100	DFT-s-OFDM	16QAM	1	271	-0.25	-36.39	36.14
n77 (PC2)	F	3840.00	656000	100	DFT-s-OFDM	16QAM	1	271	-0.09	-38.36	38.27

FCC ID: A3LSMS928U		HAC (T-COIL) TEST REPORT	Approved by: Managing Director
Filename: 1M2308210092-27-R1.A3L	Test Dates: 10/09/2023 - 10/22/2023	DUT Type: Portable Handset	Page 30 of 72

9. FCC 3G MEASUREMENTS

I. GSM Test Configurations

FR V1 Was used for the testing as the worst-case configuration for the handset.

Table 9-1
Codec Investigation - GSM

Configuration:	FR V1	FR V2	HR V1	Orientation	Channel
Desired (dBA/m)	1.67	1.74	2.01	Radial	190
Undesired (dBA/m)	-33.74	-33.74	-36.20		
Frequency Response	Pass	Pass	Pass		
S+N/N (dB)	35.41	35.48	38.21		

- Mute on; Backlight off; Max Volume; Max Contrast
- GSM850: PCL=0,

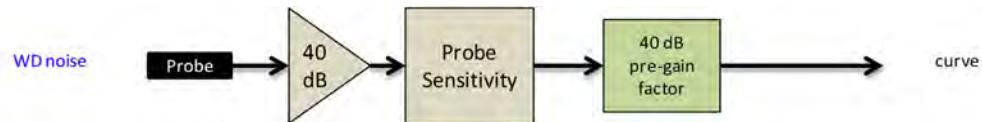

Figure 9-1

Audio Band Magnetic Curve Measurement Block Diagram

II. UMTS Test Configurations

WB AMR 6.60kbps, 13.6kbps SRB was used for the testing as the worst-case configuration for the handset.

Table 9-2
Codec Investigation - UMTS

Codec Setting:	WB AMR 23.85kbps	WB AMR 6.60kbps	NB AMR 12.2kbps	NB AMR 4.75kbps	Orientation	Channel
Desired (dBA/m)	1.10	0.28	1.59	1.40	Radial	9400
Undesired (dBA/m)	-53.05	-53.38	-53.04	-53.36		
Frequency Response	Pass	Pass	Pass	Pass		
S+N/N (dB)	54.15	53.66	54.63	54.76		

- Mute on; Backlight off; Max Volume; Max Contrast
- TPC="All 1s"

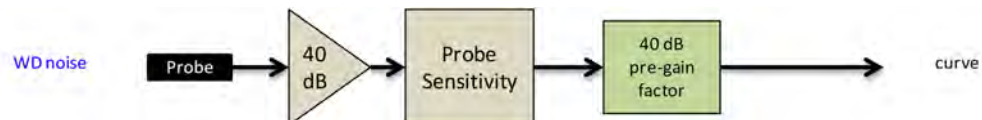

Figure 9-2

Audio Band Magnetic Curve Measurement Block Diagram

FCC ID: A3LSMS928U	element	HAC (T-COIL) TEST REPORT	Approved by: Managing Director
Filename: 1M2308210092-27-R1.A3L	Test Dates: 10/09/2023 - 10/22/2023	DUT Type: Portable Handset	Page 31 of 72

10. T-COIL TEST SUMMARY

Table 10-1
Consolidated Tabled Results

	Primary Pts	Secondary Pts	Contiguous Longitudinal	Contiguous Transverse	Freq. Response Margin	C63.19 Verdict
GSM	PASS	PASS	PASS	PASS	PASS	Compliant
UMTS	PASS	PASS	PASS	PASS	PASS	Compliant
LTE	PASS	PASS	PASS	PASS	PASS	Compliant
NR	PASS	PASS	PASS	PASS	PASS	Compliant
WLAN	PASS	PASS	PASS	PASS	PASS	Compliant
OTT VoIP	PASS	PASS	PASS	PASS	PASS	Compliant

I. Raw Handset Data

Table 10-2
Raw Data Results for GSM

Mode	Orientation	Channel	ANT Config.	Desired ABM [dB(A/m)]	Undesired ABM [dB(A/m)]	Ambient Noise [dB(A/m)]	Frequency Response Margin (dB)	S+N/N (dB)	Test Coordinates
GSM850	Radial	128	A	2.15	-29.65	-61.59	2.00	31.80	1.6, 2.0
		190	A	2.01	-29.15		2.00	31.16	
		190	E	1.90	-33.58		2.00	35.48	
		251	A	2.08	-28.21		2.00	30.29	
GSM1900	Radial	512	A	2.01	-34.72	-61.59	2.00	36.73	1.6, 2.0
		661	A	1.93	-33.94		2.00	35.87	
		810	A	2.11	-32.69		2.00	34.80	

Table 10-3
Worst-Case Scan Results for GSM

Mode	Orientation	Channel	ANT Config.	Primary Pts	Secondary Pts	Contiguous Longitudinal	Contiguous Transverse	Frequency Response Margin (dB)	Verdict	Frequency Response Coordinates
C63.19-2019 T-Coil Scan										
GSM850	Radial	251	A	65	233	22	26	2.00	PASS	1.6, 2.0

FCC ID: A3LSMS928U		HAC (T-COIL) TEST REPORT	Approved by: Managing Director
Filename: 1M2308210092-27-R1.A3L	Test Dates: 10/09/2023 - 10/22/2023	DUT Type: Portable Handset	Page 32 of 72

Table 10-4
Raw Data Results for UMTS

Mode	Orientation	Channel	ANT Config.	Desired ABM [dB(A/m)]	Undesired ABM [dB(A/m)]	Ambient Noise [dB(A/m)]	Frequency Response Margin (dB)	S+N/N (dB)	Test Coordinates
UMTS V	Radial	4132	A	0.03	-52.91	-61.59	1.95	52.94	1.6, 2.0
		4183	A	0.07	-52.95		2.00	53.02	
		4183	E	0.21	-53.29		2.00	53.50	
		4233	A	0.33	-53.04		2.00	53.37	
UMTS IV	Radial	1312	A	0.30	-52.81	-61.59	2.00	53.11	1.6, 2.0
		1412	A	0.10	-52.96		2.00	53.06	
		1513	A	0.00	-53.04		2.00	53.04	
UMTS II	Radial	9262	A	0.14	-53.42	-61.59	1.89	53.56	1.6, 2.0
		9400	A	0.00	-53.07		1.91	53.07	
		9538	A	0.28	-53.02		2.00	53.30	

Table 10-5
Worst-Case Scan Results for UMTS

Mode	Orientation	Channel	ANT Config.	Primary Pts	Secondary Pts	Contiguous Longitudinal	Contiguous Transverse	Frequency Response Margin (dB)	Verdict	Frequency Response Coordinates
C63.19-2019 T-Coil Scan										
UMTS V	Radial	4132	A	397	672	26	26	2.00	PASS	1.6, 2.0

Table 10-6
Raw Data Results for LTE B71

Mode	Orientation	Bandwidth	Channel	ANT Config.	Desired ABM [dB(A/m)]	Undesired ABM [dB(A/m)]	Ambient Noise [dB(A/m)]	Frequency Response Margin (dB)	S+N/N (dB)	Test Coordinates
LTE Band 71	Radial	20MHz	133297	A	0.61	-48.36	-61.59	1.98	48.97	1.6, 2.0
		20MHz	133297	E	0.71	-49.52		2.00	50.23	

Table 10-7
Raw Data Results for LTE B12

Mode	Orientation	Bandwidth	Channel	ANT Config.	Desired ABM [dB(A/m)]	Undesired ABM [dB(A/m)]	Ambient Noise [dB(A/m)]	Frequency Response Margin (dB)	S+N/N (dB)	Test Coordinates
LTE Band 12	Radial	10MHz	23095	A	0.29	-49.05	-61.59	2.00	49.34	1.6, 2.0
		10MHz	23095	E	0.45	-50.00		2.00	50.45	

Table 10-8
Raw Data Results for LTE B13

Mode	Orientation	Bandwidth	Channel	ANT Config.	Desired ABM [dB(A/m)]	Undesired ABM [dB(A/m)]	Ambient Noise [dB(A/m)]	Frequency Response Margin (dB)	S+N/N (dB)	Test Coordinates
LTE Band 13	Radial	10MHz	23230	A	0.32	-46.72	-61.59	2.00	47.04	1.6, 2.0
		10MHz	23230	E	0.13	-50.45		2.00	50.58	

Table 10-9
Raw Data Results for LTE B14

Mode	Orientation	Bandwidth	Channel	ANT Config.	Desired ABM [dB(A/m)]	Undesired ABM [dB(A/m)]	Ambient Noise [dB(A/m)]	Frequency Response Margin (dB)	S+N/N (dB)	Test Coordinates
LTE Band 14	Radial	10MHz	23330	A	0.61	-47.84	-61.59	2.00	48.45	1.6, 2.0
		10MHz	23330	E	0.47	-48.15		2.00	48.62	

FCC ID: A3LSMS928U		HAC (T-COIL) TEST REPORT	Approved by: Managing Director
Filename: 1M2308210092-27-R1.A3L	Test Dates: 10/09/2023 - 10/22/2023	DUT Type: Portable Handset	Page 33 of 72

Table 10-10
Raw Data Results for LTE B26

Mode	Orientation	Bandwidth	Channel	ANT Config.	Desired ABM [dB(A/m)]	Undesired ABM [dB(A/m)]	Ambient Noise [dB(A/m)]	Frequency Response Margin (dB)	S+N/N (dB)	Test Coordinates
LTE Band 26	Radial	15MHz	26865	A	0.14	-49.09	-61.59	1.98	49.23	1.6, 2.0
		15MHz	26865	E	0.39	-49.78		2.00	50.17	

Table 10-11
Raw Data Results for LTE B66

Mode	Orientation	Bandwidth	Channel	ANT Config.	Desired ABM [dB(A/m)]	Undesired ABM [dB(A/m)]	Ambient Noise [dB(A/m)]	Frequency Response Margin (dB)	S+N/N (dB)	Test Coordinates
LTE Band 66	Radial	20MHz	132322	A	0.51	-48.52	-61.59	2.00	49.03	1.6, 2.0
		20MHz	132322	F	0.63	-50.89		2.00	51.52	

Table 10-12
Raw Data Results for LTE B25

Mode	Orientation	Bandwidth	Channel	ANT Config.	Desired ABM [dB(A/m)]	Undesired ABM [dB(A/m)]	Ambient Noise [dB(A/m)]	Frequency Response Margin (dB)	S+N/N (dB)	Test Coordinates
LTE Band 25	Radial	20MHz	26365	A	0.32	-47.46	-61.59	2.00	47.78	1.6, 2.0
		20MHz	26365	F	0.72	-49.67		2.00	50.39	

Table 10-13
Raw Data Results for LTE B30

Mode	Orientation	Bandwidth	Channel	ANT Config.	Desired ABM [dB(A/m)]	Undesired ABM [dB(A/m)]	Ambient Noise [dB(A/m)]	Frequency Response Margin (dB)	S+N/N (dB)	Test Coordinates
LTE Band 30	Radial	10MHz	27710	A	0.28	-49.21	-61.59	2.00	49.49	1.6, 2.0
		10MHz	27710	F	0.31	-46.04		2.00	46.35	

Table 10-14
Raw Data Results for LTE B7

Mode	Orientation	Bandwidth	Channel	ANT Config.	Desired ABM [dB(A/m)]	Undesired ABM [dB(A/m)]	Ambient Noise [dB(A/m)]	Frequency Response Margin (dB)	S+N/N (dB)	Test Coordinates
LTE Band 7	Radial	20MHz	21100	B	0.45	-48.11	-61.59	2.00	48.56	1.6, 2.0
		20MHz	21100	F	0.73	-50.72		2.00	51.45	

Table 10-15
Raw Data Results for LTE B41 Power Class 3

Mode	Orientation	Bandwidth	Channel	ANT Config.	Desired ABM [dB(A/m)]	Undesired ABM [dB(A/m)]	Ambient Noise [dB(A/m)]	Frequency Response Margin (dB)	S+N/N (dB)	Test Coordinates
LTE Band 41 (PC3)	Radial	20MHz	40620	B	0.30	-32.90	-61.59	2.00	33.20	1.6, 2.0
		20MHz	40620	F	0.40	-41.90		2.00	42.30	

Table 10-16
Raw Data Results for LTE B41 Power Class 2

Mode	Orientation	Bandwidth	Channel	ANT Config.	Desired ABM [dB(A/m)]	Undesired ABM [dB(A/m)]	Ambient Noise [dB(A/m)]	Frequency Response Margin (dB)	S+N/N (dB)	Test Coordinates
LTE Band 41 (PC2)	Radial	20MHz	40620	B	0.32	-31.43	-61.59	2.00	31.75	1.6, 2.0
		20MHz	40620	F	0.36	-41.39		2.00	41.75	
		15MHz	41490	B	0.65	-33.14		2.00	33.79	
		15MHz	41055	B	0.53	-32.45		2.00	32.98	
		15MHz	40620	B	0.60	-30.63		1.88	31.23	
		15MHz	40185	B	0.32	-32.73		2.00	33.05	
		15MHz	39750	B	0.39	-31.97		2.00	32.36	
		10MHz	40620	B	0.48	-31.27		1.90	31.75	
		5MHz	40620	B	0.30	-31.64		2.00	31.94	

FCC ID: A3LSMS928U		HAC (T-COIL) TEST REPORT	Approved by: Managing Director
Filename: 1M2308210092-27-R1.A3L	Test Dates: 10/09/2023 - 10/22/2023	DUT Type: Portable Handset	Page 34 of 72

Table 10-17
Raw Data Results for LTE B48

Mode	Orientation	Bandwidth	Channel	Desired ABM [dB(A/m)]	Undesired ABM [dB(A/m)]	Ambient Noise [dB(A/m)]	Frequency Response Margin (dB)	S+N/N (dB)	Test Coordinates
LTE Band 48	Radial	20MHz	55990	0.36	-41.76	-61.59	2.00	42.12	1.6, 2.0

Table 10-18
Worst-Case Scan Results for LTE

Mode	Orientation	Bandwidth	Channel	ANT Config.	Primary Pts	Secondary Pts	Contiguous Longitudinal	Contiguous Transverse	Frequency Response Margin (dB)	Verdict	Frequency Response Coordinates
C63.19-2019 T-Coil Scan											
LTE Band 41 (PC2)	Radial	15MHz	40620	B	86	324	24	26	2.00	Pass	1.6, 2.0

Table 10-19
Raw Data Results for NR n71

Mode	Orientation	Bandwidth	Channel	ANT Config.	Desired ABM [dB(A/m)]	Undesired ABM [dB(A/m)]	Ambient Noise [dB(A/m)]	Frequency Response Margin (dB)	S+N/N (dB)	Test Coordinates
NR n71	Radial	20MHz	136100	A	0.52	-51.89	-63.53	2.00	52.41	1.6, 2.0
		20MHz	136100	E	0.67	-49.22		2.00	49.89	

Table 10-20
Raw Data Results for NR n12

Mode	Orientation	Bandwidth	Channel	ANT Config.	Desired ABM [dB(A/m)]	Undesired ABM [dB(A/m)]	Ambient Noise [dB(A/m)]	Frequency Response Margin (dB)	S+N/N (dB)	Test Coordinates
NR n12	Radial	15MHz	141500	A	0.41	-49.06	-63.53	2.00	49.47	1.6, 2.0
		15MHz	141500	E	0.64	-51.09		2.00	51.73	

Table 10-21
Raw Data Results for NR n26

Mode	Orientation	Bandwidth	Channel	ANT Config.	Desired ABM [dB(A/m)]	Undesired ABM [dB(A/m)]	Ambient Noise [dB(A/m)]	Frequency Response Margin (dB)	S+N/N (dB)	Test Coordinates
NR n26	Radial	20MHz	166300	A	0.74	-49.45	-63.53	2.00	50.19	1.6, 2.0
		20MHz	166300	E	0.49	-51.50		2.00	51.99	

Table 10-22
Raw Data Results for NR n70

Mode	Orientation	Bandwidth	Channel	ANT Config.	Desired ABM [dB(A/m)]	Undesired ABM [dB(A/m)]	Ambient Noise [dB(A/m)]	Frequency Response Margin (dB)	S+N/N (dB)	Test Coordinates
NR n26	Radial	20MHz	166300	A	0.74	-49.45	-63.53	2.00	50.19	1.6, 2.0
		20MHz	166300	E	0.49	-51.50		2.00	51.99	

Table 10-23
Raw Data Results for NR n66

Mode	Orientation	Bandwidth	Channel	ANT Config.	Desired ABM [dB(A/m)]	Undesired ABM [dB(A/m)]	Ambient Noise [dB(A/m)]	Frequency Response Margin (dB)	S+N/N (dB)	Test Coordinates
NR n66	Radial	40MHz	349000	A	0.47	-49.14	-63.53	2.00	49.61	1.6, 2.0
		40MHz	349000	F	0.51	-49.73		2.00	50.24	

FCC ID: A3LSMS928U		HAC (T-COIL) TEST REPORT	Approved by: Managing Director
Filename: 1M2308210092-27-R1.A3L	Test Dates: 10/09/2023 - 10/22/2023	DUT Type: Portable Handset	Page 35 of 72

Table 10-24
Raw Data Results for NR n25

Mode	Orientation	Bandwidth	Channel	ANT Config.	Desired ABM [dB(A/m)]	Undesired ABM [dB(A/m)]	Ambient Noise [dB(A/m)]	Frequency Response Margin (dB)	S+N/N (dB)	Test Coordinates
NR n25	Radial	40MHz	376500	A	0.55	-50.04	-63.53	2.00	50.59	1.6, 2.0
		40MHz	376500	F	0.59	-47.96		2.00	48.55	

Table 10-25
Raw Data Results for NR n30

Mode	Orientation	Bandwidth	Channel	ANT Config.	Desired ABM [dB(A/m)]	Undesired ABM [dB(A/m)]	Ambient Noise [dB(A/m)]	Frequency Response Margin (dB)	S+N/N (dB)	Test Coordinates
NR n30	Radial	10MHz	462000	A	0.79	-48.26	-63.53	2.00	49.05	1.6, 2.0
		10MHz	462000	F	0.63	-47.64		2.00	48.27	

Table 10-26
Raw Data Results for NR n7

Mode	Orientation	Bandwidth	Channel	ANT Config.	Desired ABM [dB(A/m)]	Undesired ABM [dB(A/m)]	Ambient Noise [dB(A/m)]	Frequency Response Margin (dB)	S+N/N (dB)	Test Coordinates
NR n7	Radial	40MHz	507000	B	0.64	-50.59	-63.53	2.00	51.23	1.6, 2.0
		40MHz	507000	F	0.60	-49.45		2.00	50.05	

Table 10-27
Raw Data Results for NR n41 (PC2)

Mode	Orientation	Bandwidth	Channel	ANT Config.	Desired ABM [dB(A/m)]	Undesired ABM [dB(A/m)]	Ambient Noise [dB(A/m)]	Frequency Response Margin (dB)	S+N/N _{NR} (dB)	Test Coordinates
NR n41 (PC2)	Radial	100MHz	518598	B	0.68	-37.12	-63.53	2.00	37.80	1.6, 2.0
		100MHz	518598	F	0.66	-32.17		2.00	32.83	
		90MHz	518598	F	0.92	-31.61		2.00	32.53	
		90MHz	508200	F	0.76	-32.53		2.00	33.29	
		80MHz	529998	F	0.79	-31.85		2.00	32.64	
		80MHz	518598	F	0.90	-31.54		2.00	32.44	
		80MHz	512898	F	0.70	-31.86		2.00	32.56	
		80MHz	507204	F	0.85	-32.43		2.00	33.28	
		70MHz	518598	F	0.91	-33.09		2.00	34.00	
		60MHz	518598	F	0.84	-32.83		2.00	33.67	
		50MHz	518598	F	0.84	-32.02		2.00	32.86	
		40MHz	518598	F	0.82	-33.06		2.00	33.88	
		30MHz	518598	F	0.75	-32.34		2.00	33.09	
		25MHz	518598	F	0.86	-33.32		2.00	34.18	
		20MHz	518598	F	0.84	-33.46		2.00	34.30	
15MHz	518598	F	0.91	-33.40	2.00	34.31				
10MHz	518598	F	0.76	-33.40	2.00	34.16				

Table 10-28
Raw Data Results for NR n77 (DoD, PC2)

Mode	Orientation	Bandwidth	Channel	ANT Config.	Desired ABM [dB(A/m)]	Undesired ABM [dB(A/m)]	Ambient Noise [dB(A/m)]	Frequency Response Margin (dB)	S+N/N (dB)	Test Coordinates
NR n77 (DoD, PC2)	Radial	100MHz	633334	F	0.68	-38.54	-63.53	2.00	39.22	1.6, 2.0

Table 10-29
Raw Data Results for NR n48

Mode	Orientation	Bandwidth	Channel	ANT Config.	Desired ABM [dB(A/m)]	Undesired ABM [dB(A/m)]	Ambient Noise [dB(A/m)]	Frequency Response Margin (dB)	S+N/N (dB)	Test Coordinates
NR n48	Radial	40MHz	643500	F	0.56	-40.67	-63.53	1.98	41.23	1.6, 2.0

FCC ID: A3LSMS928U		HAC (T-COIL) TEST REPORT	Approved by: Managing Director
Filename: 1M2308210092-27-R1.A3L	Test Dates: 10/09/2023 - 10/22/2023	DUT Type: Portable Handset	Page 36 of 72

**Table 10-30
Raw Data Results for NR n77 (PC2)**

Mode	Orientation	Bandwidth	Channel	ANT Config.	Desired ABM [dB(A/m)]	Undesired ABM [dB(A/m)]	Ambient Noise [dB(A/m)]	Frequency Response Margin (dB)	S+N/N (dB)	Test Coordinates
NR n77 (PC2)	Radial	100MHz	656000	F	0.54	-40.18	-63.53	2.00	40.72	1.6, 2.0

**Table 10-31
Worst-Case Scan Results for NR TDD**

Mode	Orientation	Bandwidth	Channel	Device SN	Primary Pts	Secondary Pts	Contiguous Longitudinal	Contiguous Transverse	Frequency Response Margin (dB)	Verdict	Frequency Response Coordinates
C63.19-2019 T-Coil Scan											
NR n41 (PC2)	Radial	80MHz	518598	0855M	76	312	24	26	2.00	PASS	1.6, 2.0

**Table 10-32
Raw Data Results for 2.4GHz WIFI**

Mode	Orientation	Channel	Desired ABM [dB(A/m)]	Undesired ABM [dB(A/m)]	Ambient Noise [dB(A/m)]	Frequency Response Margin (dB)	S+N/N (dB)	Test Coordinates
IEEE 802.11b	Radial	1	1.13	-42.53	-61.59	2.00	43.66	1.6, 2.0
		6	1.09	-42.68		2.00	43.77	
		11	1.11	-42.99		2.00	44.10	
IEEE 802.11g	Radial	6	1.19	-42.70	-61.59	2.00	43.89	1.6, 2.0
IEEE 802.11n	Radial	6	1.03	-44.07	-61.59	2.00	45.10	1.6, 2.0
IEEE 802.11ac	Radial	6	0.90	-44.97	-61.59	2.00	45.87	1.6, 2.0
IEEE 802.11ax SU	Radial	6	1.11	-43.94	-61.59	2.00	45.05	1.6, 2.0
IEEE 802.11ax RU	Radial	6	1.06	-44.26	-61.59	2.00	45.32	1.6, 2.0

**Table 10-33
Raw Data Results for 5GHz WIFI IEEE 802.11a**

Mode	Orientation	Bandwidth	U-NII	Channel	Desired ABM [dB(A/m)]	Undesired ABM [dB(A/m)]	Ambient Noise [dB(A/m)]	Frequency Response Margin (dB)	S+N/N (dB)	Test Coordinates
IEEE 802.11a	Radial	20MHz	1	40	1.38	-44.31	-61.59	2.00	45.69	1.6, 2.0

**Table 10-34
Raw Data Results for 5GHz WIFI IEEE 802.11n**

Mode	Orientation	Bandwidth	U-NII	Channel	Desired ABM [dB(A/m)]	Undesired ABM [dB(A/m)]	Ambient Noise [dB(A/m)]	Frequency Response Margin (dB)	S+N/N (dB)	Test Coordinates
IEEE 802.11n	Radial	40MHz	1	38	1.02	-44.10	-61.59	2.00	45.12	1.6, 2.0
		20MHz	1	40	0.99	-44.66		2.00	45.65	

FCC ID: A3LSMS928U		HAC (T-COIL) TEST REPORT	Approved by: Managing Director
Filename: 1M2308210092-27-R1.A3L	Test Dates: 10/09/2023 - 10/22/2023	DUT Type: Portable Handset	Page 37 of 72

Table 10-35
Raw Data Results for 5GHz WIFI IEEE 802.11ac

Mode	Orientation	Bandwidth	U-NII	Channel	Desired ABM [dB(A/m)]	Undesired ABM [dB(A/m)]	Ambient Noise [dB(A/m)]	Frequency Response Margin (dB)	S+N/N (dB)	Test Coordinates
IEEE 802.11ac	Radial	40MHz	1	38	1.17	-43.66	-61.59	2.00	44.83	1.6, 2.0
		20MHz	1	40	1.03	-44.31		2.00	45.34	

Table 10-36
Raw Data Results for 5GHz WIFI IEEE 802.11ax

Mode	Orientation	Bandwidth	U-NII	Channel	Desired ABM [dB(A/m)]	Undesired ABM [dB(A/m)]	Ambient Noise [dB(A/m)]	Frequency Response Margin (dB)	S+N/N (dB)	Test Coordinates
IEEE 802.11ax SU	Radial	40MHz	1	38	1.02	-43.11	-61.59	2.00	44.13	1.6, 2.0
		20MHz	1	40	1.13	-44.42		2.00	45.55	
IEEE 802.11ax RU	Radial	40MHz	1	38	1.38	-42.24	-61.59	2.00	43.62	1.6, 2.0
		40MHz	1	46	1.21	-42.97		2.00	44.18	
		20MHz	1	40	1.14	-43.78		2.00	44.92	
		40MHz	2A	54	0.94	-43.40		2.00	44.34	
		20MHz	2A	56	1.07	-44.21		2.00	45.28	
		40MHz	2C	118	1.08	-43.75		2.00	44.83	
		20MHz	2C	120	1.10	-43.65		2.00	44.75	
		40MHz	3	151	1.05	-42.62		2.00	43.67	
		20MHz	3	157	1.12	-42.82		2.00	43.94	
		40MHz	4	175	1.11	-43.36		2.00	44.47	
		20MHz	4	173	1.09	-43.40		2.00	44.49	
		40MHz	5	7	0.97	-45.44		2.00	46.41	
		20MHz	5	5	0.92	-45.29		2.00	46.21	

Table 10-37
Worst-Case Scan Results for WIFI

Mode	Orientation	Bandwidth	U-NII	Channel	Primary Pts	Secondary Pts	Contiguous Longitudinal	Contiguous Transverse	Frequency Response Margin (dB)	Verdict	Frequency Response Coordinates
C63.19-2019 T-Coil Scan											
IEEE 802.11ax RU	Radial	40MHz	1	38	295	557	26	26	2.00	PASS	1.6, 2.0

Table 10-38
Raw Data Results for EDGE (OTT VoIP)

Mode	Orientation	Channel	ANT Config.	Desired ABM [dB(A/m)]	Undesired ABM [dB(A/m)]	Ambient Noise [dB(A/m)]	Frequency Response Margin (dB)	S+N/N (dB)	Test Coordinates
EDGE850	Radial	190	A	-0.47	-31.47	-61.59	1.97	31.00	1.6, 2.0
		190	E	-0.24	-35.64		1.70	35.40	
EDGE1900	Radial	661	A	-0.22	-36.87	-61.59	2.00	36.65	1.6, 2.0

Table 10-39
Raw Data Results for HSPA (OTT VoIP)

Mode	Orientation	Channel	ANT Config.	Desired ABM [dB(A/m)]	Undesired ABM [dB(A/m)]	Ambient Noise [dB(A/m)]	Frequency Response Margin (dB)	S+N/N (dB)	Test Coordinates
HSPA V	Radial	4183	A	0.38	-50.83	-61.59	2.00	51.21	1.6, 2.0
		4183	E	-0.21	-51.72		1.96	51.51	
HSPA IV	Radial	1412	A	-0.41	-50.67	-61.59	2.00	50.26	1.6, 2.0
HSPA II	Radial	9400	A	-0.06	-50.40	-61.59	1.92	50.34	1.6, 2.0

FCC ID: A3LSMS928U		HAC (T-COIL) TEST REPORT	Approved by: Managing Director
Filename: 1M2308210092-27-R1.A3L	Test Dates: 10/09/2023 - 10/22/2023	DUT Type: Portable Handset	Page 38 of 72

Table 10-40
Raw Data Results for LTE TDD B41 (PC2) (OTT VoIP)

Mode	Orientation	Bandwidth	Channel	Desired ABM [dB(A/m)]	Undesired ABM [dB(A/m)]	Ambient Noise [dB(A/m)]	Frequency Response Margin (dB)	S+N/N (dB)	Test Coordinates
LTE Band 41 (PC2)	Radial	20MHz	41490	-0.24	-35.07	-61.59	1.78	34.83	1.6, 2.0
		20MHz	41055	-0.13	-33.79		2.00	33.66	
		20MHz	40620	-0.22	-33.39		1.92	33.17	
		20MHz	40185	-0.27	-34.22		2.00	33.95	
		20MHz	39750	-0.26	-33.66		2.00	33.40	
		15MHz	40620	-0.30	-33.74		2.00	33.44	
		10MHz	40620	-0.32	-33.73		1.90	33.41	
		5MHz	40620	-0.23	-33.70		2.00	33.47	

Table 10-41
Raw Data Results for NR TDD n41 (PC2) (OTT VoIP)

Mode	Orientation	Bandwidth	Channel	Desired ABM [dB(A/m)]	Undesired ABM [dB(A/m)]	Ambient Noise [dB(A/m)]	Frequency Response Margin (dB)	S+N/N (dB)	Test Coordinates
NR n41 (PC2)	Radial	100MHz	528000	-0.18	-33.19	-61.59	1.72	33.01	1.6, 2.0
		100MHz	523302	0.04	-33.51		2.00	33.55	
		100MHz	518598	-0.22	-32.74		1.99	32.52	
		100MHz	513900	-0.17	-33.11		2.00	32.94	
		100MHz	509202	0.00	-34.12		1.89	34.12	
		90MHz	518598	0.01	-32.88		2.00	32.89	
		80MHz	518598	0.00	-33.07		2.00	33.07	
		70MHz	518598	-0.03	-34.48		1.89	34.45	
		60MHz	518598	-0.13	-34.92		1.70	34.79	
		50MHz	518598	-0.02	-34.93		2.00	34.91	
		40MHz	518598	-0.35	-33.74		2.00	33.39	
		30MHz	518598	0.11	-34.64		1.85	34.75	
		25MHz	518598	0.00	-34.57		2.00	34.57	
		20MHz	518598	0.09	-33.29		1.78	33.38	
		15MHz	518598	0.11	-34.77		2.00	34.88	
		10MHz	518598	-0.10	-34.69		1.97	34.59	

FCC ID: A3LSMS928U		HAC (T-COIL) TEST REPORT	Approved by: Managing Director
Filename: 1M2308210092-27-R1.A3L	Test Dates: 10/09/2023 - 10/22/2023	DUT Type: Portable Handset	Page 39 of 72

Table 10-42
Raw Data Results for 2.4GHz WIFI (OTT VoIP)

Mode	Orientation	Channel	Desired ABM [dB(A/m)]	Undesired ABM [dB(A/m)]	Ambient Noise [dB(A/m)]	Frequency Response Margin (dB)	S+N/N (dB)	Test Coordinates
IEEE 802.11b	Radial	1	-0.29	-41.56	-61.59	1.53	41.27	1.6, 2.0
		6	-0.36	-41.61		1.18	41.25	
		11	-0.14	-41.33		1.43	41.19	
IEEE 802.11g	Radial	6	-0.32	-41.80	-61.59	1.34	41.48	1.6, 2.0
IEEE 802.11n	Radial	6	-0.27	-44.41	-61.59	1.31	44.14	1.6, 2.0
IEEE 802.11ac	Radial	6	-0.41	-44.61	-61.59	1.35	44.20	1.6, 2.0
IEEE 802.11ax SU	Radial	6	-0.35	-44.67	-61.59	1.38	44.32	1.6, 2.0
IEEE 802.11ax RU	Radial	6	-0.27	-44.07	-61.59	1.47	43.80	1.6, 2.0

Table 10-43
Raw Data Results for 5GHz WIFI IEEE 802.11a (OTT VoIP)

Mode	Orientation	Bandwidth	U-NII	Channel	Desired ABM [dB(A/m)]	Undesired ABM [dB(A/m)]	Ambient Noise [dB(A/m)]	Frequency Response Margin (dB)	S+N/N (dB)	Test Coordinates
IEEE 802.11a	Radial	20MHz	1	40	-0.24	-42.82	-61.59	1.44	42.58	1.6, 2.0

Table 10-44
Raw Data Results for 5GHz WIFI IEEE 802.11n (OTT VoIP)

Mode	Orientation	Bandwidth	U-NII	Channel	Desired ABM [dB(A/m)]	Undesired ABM [dB(A/m)]	Ambient Noise [dB(A/m)]	Frequency Response Margin (dB)	S+N/N (dB)	Test Coordinates
IEEE 802.11n	Radial	40MHz	1	38	-0.25	-42.30	-61.59	1.34	42.05	1.6, 2.0
		20MHz	1	40	-0.39	-44.13		1.18	43.74	

Table 10-45
Raw Data Results for 5GHz WIFI IEEE 802.11ac (OTT VoIP)

Mode	Orientation	Bandwidth	U-NII	Channel	Desired ABM [dB(A/m)]	Undesired ABM [dB(A/m)]	Ambient Noise [dB(A/m)]	Frequency Response Margin (dB)	S+N/N (dB)	Test Coordinates
IEEE 802.11ac	Radial	40MHz	1	38	-0.32	-42.12	-61.59	1.40	41.80	1.6, 2.0
		20MHz	1	40	-0.22	-42.44		1.28	42.22	

FCC ID: A3LSMS928U		HAC (T-COIL) TEST REPORT	Approved by: Managing Director
Filename: 1M2308210092-27-R1.A3L	Test Dates: 10/09/2023 - 10/22/2023	DUT Type: Portable Handset	Page 40 of 72

Table 10-46
Raw Data Results for 5GHz WIFI IEEE 802.11ax (OTT VoIP)

Mode	Orientation	Bandwidth	U-NII	Channel	Desired ABM [dB(A/m)]	Undesired ABM [dB(A/m)]	Ambient Noise [dB(A/m)]	Frequency Response Margin (dB)	S+N/N (dB)	Test Coordinates
IEEE 802.11ax SU	Radial	40MHz	1	38	-0.50	-42.44	-61.59	1.22	41.94	1.6, 2.0
		20MHz	1	40	-0.67	-42.69		1.31	42.02	
IEEE 802.11ax RU	Radial	40MHz	1	38	-0.47	-42.11	-61.59	1.28	41.64	1.6, 2.0
		20MHz	1	40	-0.68	-42.80		1.26	42.12	
		40MHz	2A	54	-0.33	-41.86		1.45	41.53	
		20MHz	2A	56	-0.56	-42.54		1.23	41.98	
		40MHz	2C	118	-0.52	-43.14		1.50	42.62	
		20MHz	2C	120	-0.54	-43.36		1.39	42.82	
		40MHz	3	151	-0.36	-41.97		1.44	41.61	
		40MHz	3	159	-0.59	-42.81		1.41	42.22	
		20MHz	3	157	-0.52	-43.09		1.31	42.57	
		40MHz	4	175	-0.39	-43.27		1.35	42.88	
		20MHz	4	173	-0.50	-43.44		1.51	42.94	
		40MHz	5	7	-0.59	-44.64		1.57	44.05	
		20MHz	5	5	-0.53	-44.51		1.27	43.98	

Table 10-47
Worst-Case Scan Results for EDGE (OTT VoIP)

Mode	Orientation	Channel	ANT Config.	Primary Pts	Secondary Pts	Contiguous Longitudinal	Contiguous Transverse	Frequency Response Margin (dB)	Verdict	Frequency Response Coordinates
C63.19-2019 T-Coil Scan										
EDGE850	Radial	190	A	107	255	22	26	1.71	PASS	1.6, 2.0

Table 10-48
Worst-Case Scan Results for NR TDD n41 (OTT VoIP)

Mode	Orientation	Bandwidth	Channel	Primary Pts	Secondary Pts	Contiguous Longitudinal	Contiguous Transverse	Frequency Response Margin (dB)	Verdict	Frequency Response Coordinates
C63.19-2019 T-Coil Scan										
NR n41 (PC2)	Radial	100MHz	518598	171	373	25	26	2	PASS	1.6, 2.0

II. Test Notes

A. General

1. Phone Condition: Mute on; Backlight off; Max Volume; Max Contrast
2. 'Radial' orientation refers to radial transverse.
3. Hearing Aid Mode (Phone → Call settings → Other call settings → Hearing aid compatibility) was set to ON for HAC compliance
4. Speech Signal: 3GPP2 Normal Test Signal
5. Bluetooth and WIFI were disabled while testing 2G/3G/4G/5G modes.
6. Licensed data modes and Bluetooth were disabled while testing WIFI modes.
7. The number of passing points and frequency response value shown in the scan result table satisfy the limit for compliance.

B. GSM

1. Power Configuration: GSM850: PCL=0, GSM1900: PCL=0;
2. Vocoder Configuration: EFR (GSM);

FCC ID: A3LSMS928U	 element	HAC (T-COIL) TEST REPORT	Approved by: Managing Director
Filename: 1M2308210092-27-R1.A3L	Test Dates: 10/09/2023 - 10/22/2023	DUT Type: Portable Handset	Page 41 of 72

C. UMTS

1. Power Configuration: TPC= "All 1s";
2. Vocoder Configuration: WB AMR 6.60kbps (UMTS);

D. LTE

1. Power Configuration: TPC = "Max Power"
2. Radio Configuration: 16QAM, 1RB, 0RB offset
3. Power Class 3 Uplink-Downlink configuration: 0
4. Power Class 2 Uplink-Downlink configuration: 1
5. Vocoder Configuration: WB AMR 6.60kbps
LTE Band 41 (Power Class 2) at 15MHz is the worst-case LTE configuration.

E. NR

1. Power Configuration: TPC = "Max Power"
2. Radio Configuration: DFT-s-OFDM, 16QAM, 1RB, 99%RB offset
3. Vocoder Configuration: WB AMR 6.60kbps
4. NR n41 (Power Class 2) at 80MHz is the worst-case NR TDD configuration.

F. WIFI

1. Radio Configuration
 - a. IEEE 802.11b: CCK, 11Mbps
 - b. IEEE 802.11g/a: BPSK, 6Mbps
 - c. IEEE 802.11n/ac 20MHz: BPSK, MCS 0
 - d. IEEE 802.11ax SU 20MHz: BPSK, MCS 0
 - e. IEEE 802.11n/ac 40MHz: BPSK, MCS 0
 - f. IEEE 802.11ax SU 40MHz: BPSK, MCS 0
2. RU Index
 - a. IEEE 802.11ax RU 20MHz: RU Index 0
 - b. IEEE 802.11ax RU 40MHz: RU Index 65
3. Vocoder Configuration: WB AMR 6.60kbps
4. The worst-case standard for 2.4GHz WIFI is additionally tested on the low and high channels. IEEE 802.11b is the worst-case 2.4GHz WIFI standard.
5. The worst-case standard for 5GHz WIFI in each probe orientation is additionally tested on higher U-NII bands as well as applicable low and high channels. IEEE 802.11ax RU (U-NII 1) is the worst-case 5GHz WIFI standard.

G. OTT VoIP

1. Vocoder Configuration: 6kbps
2. EDGE Configuration
 - a. MCS Index: 7
 - b. Number of TX slots: 2
3. HSPA Configuration:
 - a. Release: 6
 - b. 3GPP 34.121 Subtest 1
4. LTE Configuration:
 - a. Power Configuration: TPC = "Max Power"
 - b. Radio Configuration: 16QAM, 1RB, 0RB offset
 - c. Power Class 3 Uplink-Downlink configuration: 0

FCC ID: A3LSMS928U	 element	HAC (T-COIL) TEST REPORT	Approved by: Managing Director
Filename: 1M2308210092-27-R1.A3L	Test Dates: 10/09/2023 - 10/22/2023	DUT Type: Portable Handset	Page 42 of 72

- d. Power Class 2 Uplink-Downlink configuration: 1
 - e. LTE Band 41 (PC3) was the worst-case band from Table 8-7.
 - f. The worst-case band and bandwidth combination is additionally investigated on the low, low-mid, high-mid, and high channels for those combinations. LTE Band 41 (Power Class 2) at 20MHz is the worst-case LTE TDD configuration.
5. NR TDD Configuration
- a. Power Configuration: TxAGC is set such that the DUT operates at max power.
 - b. Radio Configuration: DFT-s-OFDM, 16QAM, 1RB, 99%RB offset
 - c. NR n41 (PC2) was the worst-case band from Table 8-11.
 - d. The worst-case band and bandwidth combination is additionally investigated on the low and high channels for those combinations. NR n41 (PC2) at 100MHz is the worst-case NR TDD configuration.
6. WIFI Configuration:
- a. Radio Configuration
 - i. IEEE 802.11b: CCK, 11Mbps
 - ii. IEEE 802.11g/a: BPSK, 6Mbps
 - iii. IEEE 802.11n/ac 20MHz: BPSK, MCS 0
 - iv. IEEE 802.11ax SU 20MHz: BPSK, MCS 0
 - v. IEEE 802.11n/ac 40MHz: BPSK, MCS 0
 - vi. IEEE 802.11ax SU 40MHz: BPSK, MCS 0
 - b. RU Index
 - i. IEEE 802.11ax RU 20MHz: RU Index 0
 - ii. IEEE 802.11ax RU 40MHz: RU Index 65
 - c. The worst-case standard for 2.4GHz WIFI is additionally investigated on the low and high channels. IEEE 802.11b is the worst-case 2.4GHz WIFI standard.
 - d. The worst-case standard for 5GHz WIFI is additionally investigated on higher U-NII bands as well as applicable low and high channels. IEEE 802.11ax RU (U-NII 3) is the worst-case 5GHz WIFI standard.

FCC ID: A3LSMS928U	 element	HAC (T-COIL) TEST REPORT	Approved by: Managing Director
Filename: 1M2308210092-27-R1.A3L	Test Dates: 10/09/2023 - 10/22/2023	DUT Type: Portable Handset	Page 43 of 72

III. 1 kHz Vocoder Application Check

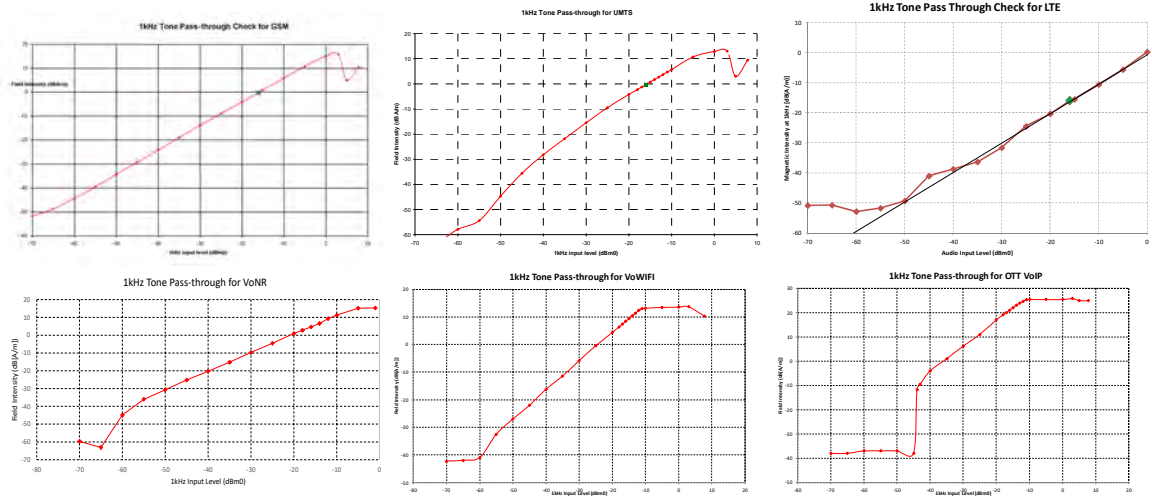

This model was verified to be within the linear region for desired ABM measurements at -16 dBm₀ for GSM, UMTS, VoLTE over IMS, and VoNR over IMS. This model was verified to be within the linear region for desired ABM measurements at -16 dBm₀ for VoWiFi over IMS, and OTT VoIP. This measurement was taken in the Radial configuration above the maximum location.

FCC ID: A3LSMS928U		HAC (T-COIL) TEST REPORT	Approved by: Managing Director
Filename: 1M2308210092-27-R1.A3L	Test Dates: 10/09/2023 - 10/22/2023	DUT Type: Portable Handset	Page 44 of 72

IV. T-Coil Validation Test Results

**Table 10-49
Helmholtz Coil Verification Table of Results**

Date	Orientation	Item	Target	Result	Verdict
10/09/23	Radial	Magnetic Intensity, -10 dBA/m	$-10 \pm 0.5 \text{ dB}$	-9.971	PASS
		Environmental Noise	< -48 dBA/m	-63.53	PASS
		Frequency Response, from limits	> 0 dB	0.70	PASS
10/16/23	Radial	Magnetic Intensity, -10 dBA/m	$-10 \pm 0.5 \text{ dB}$	-10.250	PASS
		Environmental Noise	< -48 dBA/m	-61.59	PASS
		Frequency Response, from limits	> 0 dB	0.60	PASS

FCC ID: A3LSMS928U	 element	HAC (T-COIL) TEST REPORT	Approved by: Managing Director
Filename: 1M2308210092-27-R1.A3L	Test Dates: 10/09/2023 - 10/22/2023	DUT Type: Portable Handset	Page 45 of 72

V. Desired ABM Magnetic Field Distribution Scan Overlays

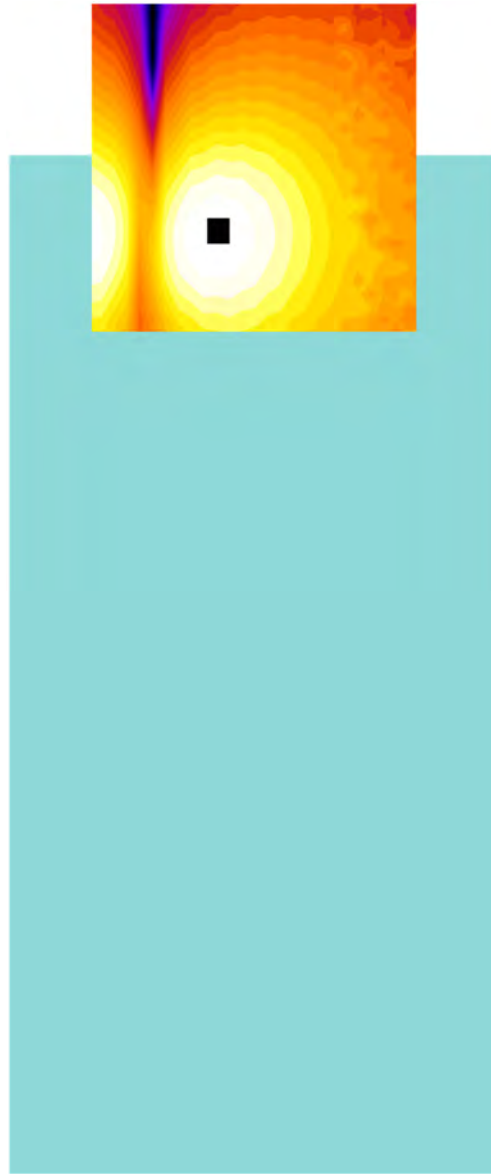

Radial (Transverse)

Figure 10-1
T-Coil Scan Overlay Magnetic Field Distributions

Notes:

1. Final measurement locations are indicated by a cursor on the contour plots.
2. See Test Setup Photographs for actual WD overlay.

FCC ID: A3LSMS928U	 element	HAC (T-COIL) TEST REPORT	Approved by: Managing Director
Filename: 1M2308210092-27-R1.A3L	Test Dates: 10/09/2023 - 10/22/2023	DUT Type: Portable Handset	Page 46 of 72

11. MEASUREMENT UNCERTAINTY

**Table 11-1
Uncertainty Estimation Table**

Contribution	Data +/- %	Data +/- dB	Data Type	Probability distribution	Divisor	Standard uncertainty	Standard Uncertainty (dB)
ABM Noise	7.0%	0.29	Std. Dev.	Normal k=1	1.00	7.0%	
RF Reflections	4.7%	0.20	Specification	Rectangular	1.73	2.7%	
Reference Signal Level	12.2%	0.50	Specification	Rectangular	1.73	7.0%	
Positioning Accuracy	10.0%	0.41	Uncertainty	Rectangular	1.73	5.8%	
Probe Coil Sensitivity	12.2%	0.50	Specification	Rectangular	1.73	7.0%	
Probe Linearity	2.4%	0.10	Std. Dev.	Normal k=1	1.00	2.4%	
Cable Loss	2.8%	0.12	Specification	Rectangular	1.73	1.6%	
Frequency Analyzer	5.0%	0.21	Specification	Rectangular	1.73	2.9%	
System Repeatability	5.0%	0.21	Std. Dev.	Normal k=1	1.00	5.0%	
WD Repeatability	9.0%	0.37	Std. Dev.	Normal k=1	1.00	9.0%	
Positioner Accuracy	1.0%	0.04	Specification	Rectangular	1.73	0.6%	
Combined standard uncertainty, u_c (k=1)						17.7%	0.71
Expanded uncertainty (k=2), 95% confidence level						35.3%	1.31

Notes:

1. Test equipments are calibrated according to techniques outlined in NIS81, NIS3003 and NIST Tech Note 1297.
2. All equipments have traceability according to NIST. Measurement Uncertainties are defined in further detail in NIS 81 and NIST Tech Note 1297 and UKAS M3003.

Measurement uncertainty reflects the quality and accuracy of a measured result as compared to the true value. Such statements are generally required when stating results of measurements so that it is clear to the intended audience that the results may differ when reproduced by different facilities. Measurement results vary due to the measurement uncertainty of the instrumentation, measurement technique, and test engineer. Most uncertainties are calculated using the tolerances of the instrumentation used in the measurement, the measurement setup variability, and the technique used in performing the test. While not generally included, the variability of the equipment under test also figures into the overall measurement uncertainty. Another component of the overall uncertainty is based on the variability of repeated measurements (so-called Type A uncertainty). This may mean that the Hearing Aid compatibility tests may have to be repeated by taking down the test setup and resetting it up so that there are a statistically significant number of repeat measurements to identify the measurement uncertainty. By combining the repeat measurement results with that of the instrumentation chain using the technique contained in NIS 81 and NIS 3003, the overall measurement uncertainty was estimated.

FCC ID: A3LSMS928U	 element	HAC (T-COIL) TEST REPORT	Approved by: Managing Director
Filename: 1M2308210092-27-R1.A3L	Test Dates: 10/09/2023 - 10/22/2023	DUT Type: Portable Handset	Page 47 of 72

12. EQUIPMENT LIST

**Table 12-1
Equipment List**

Manufacturer	Model	Description	Cal Date	Cal Interval	Cal Due	Serial Number
Listen	SoundConnect	Microphone Power Supply	8/10/2022	Biennial	8/10/2024	PS2612
RME	Fireface UC	Soundcheck Acoustic Analyzer External Audio Interface	8/23/2022	Biennial	8/23/2024	23528889
Rohde & Schwarz	CMW500	Wideband Radio Communication Tester	8/9/2023	Annual	8/9/2024	162125
Rohde & Schwarz	CMW500	Radio Communication Tester	8/10/2023	Annual	8/10/2024	140144
Rohde & Schwarz	CMX500	Radio Communication Tester	N/A		N/A	100298
Seekonk	NC-100	Torque Wrench (8" lb)	11/28/2022	Biennial	11/28/2024	80790
TEM	Radial T-Coil Probe	Radial T-Coil Probe	8/10/2022	Biennial	8/10/2024	TEM-1128
TEM		HAC Positioner	N/A		N/A	N/A
TEM		HAC System Controller with Software	N/A		N/A	N/A
TEM	Helmholtz Coil	Helmholtz Coil	9/15/2022	Biennial	9/15/2024	SBI 1052
YellowTec	YT4211	USB Audio Interface	N/A		N/A	20000365
Netgear	XS708E	Ethernet Switch	N/A		N/A	4FU3875C001A8

FCC ID: A3LSMS928U	 element	HAC (T-COIL) TEST REPORT	Approved by: Managing Director
Filename: 1M2308210092-27-R1.A3L	Test Dates: 10/09/2023 - 10/22/2023	DUT Type: Portable Handset	Page 48 of 72

13. TEST DATA(SINGLE POINT MEASUREMENT)

FCC ID: A3LSMS928U	 element	HAC (T-COIL) TEST REPORT	Approved by: Managing Director
Filename: 1M2308210092-27-R1.A3L	Test Dates: 10/09/2023 - 10/22/2023	DUT Type: Portable Handset	Page 49 of 72



Element Hearing-Aid Compatibility Facility

DUT: HH Coil – SN: SBI 1052

Type: HH Coil
Serial: SBI 1052

Measurement Standard: ANSI C63.19

Equipment:

- Probe: Radial T-Coil Probe – SN: TEM-1128; Calibrated: 8/10/2022
- Helmholtz Coil – SN: SBI 1052; Calibrated: 9/15/2022

Noise Spectrum

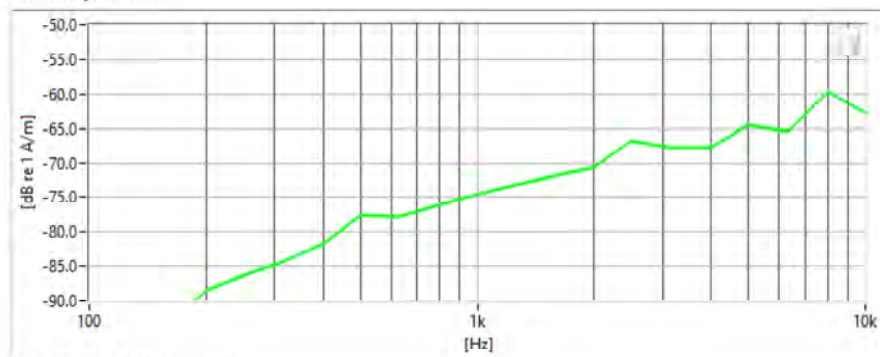

Frequency Response

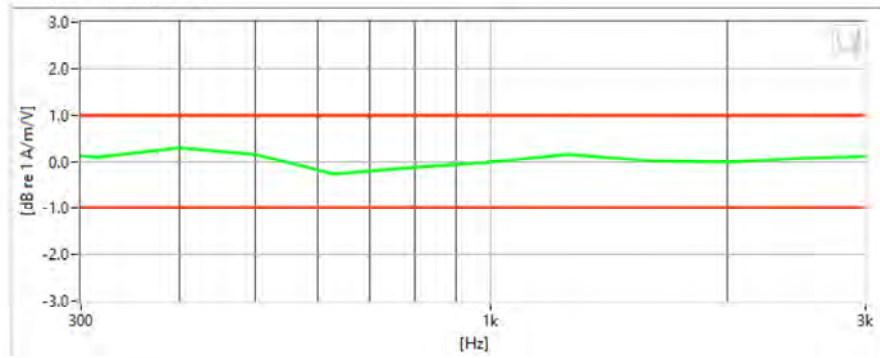

Results

Verification 1kHz Intensity	-9.971 dB	✓	Max/Min	-9.5/-10.5
Verification ABM2	-63.53 dB	✓	Maximum	-58.0
Frequency Response Margin	700m dB	✓	Tolerance curves	Aligned Data

FCC ID: A3LSMS928U		HAC (T-COIL) TEST REPORT	Approved by: Managing Director
Filename: 1M2308210092-27-R1.A3L	Test Dates: 10/09/2023 - 10/22/2023	DUT Type: Portable Handset	Page 50 of 72



Element Hearing-Aid Compatibility Facility

DUT: HH Coil – SN: SBI 1052

Type: HH Coil
Serial: SBI 1052

Measurement Standard: ANSI C63.19

Equipment:

- Probe: Radial T-Coil Probe – SN: TEM-1128; Calibrated: 8/10/2022
- Helmholtz Coil – SN: SBI 1052; Calibrated: 9/15/2022

Noise Spectrum

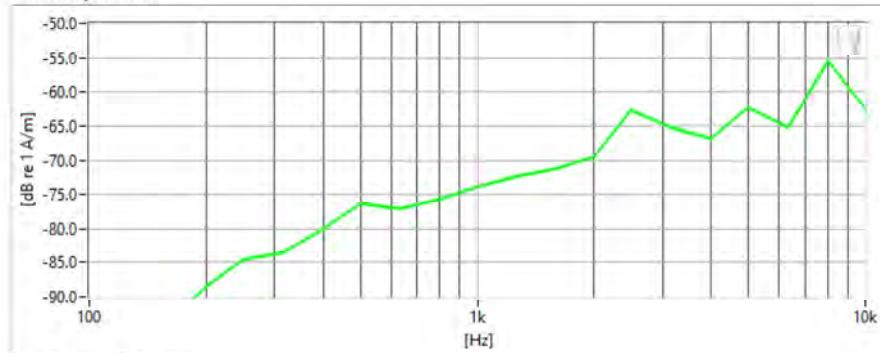

Frequency Response

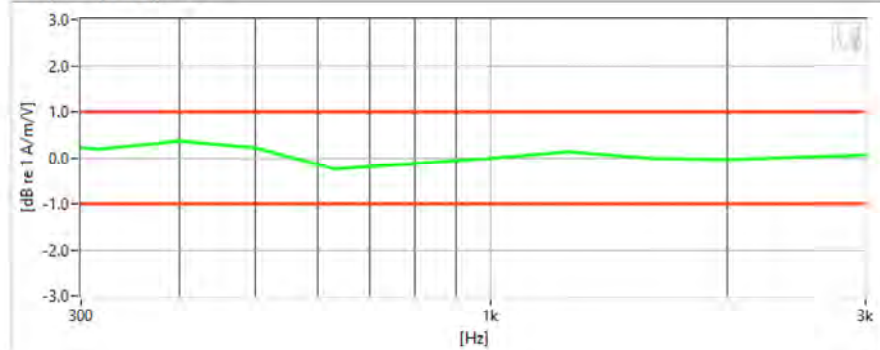

Results

Verification 1kHz Intensity	-10.25 dB	✓	Max/Min	-9.5/-10.5
Verification ABM2	-61.59 dB	✓	Maximum	-58.0
Frequency Response Margin	600m dB	✓	Tolerance curves	Aligned Data

FCC ID: A3LSMS928U		HAC (T-COIL) TEST REPORT		Approved by: Managing Director
Filename: 1M2308210092-27-R1.A3L	Test Dates: 10/09/2023 - 10/22/2023	DUT Type: Portable Handset		Page 51 of 72



Element Hearing-Aid Compatibility Facility

DUT: A3LSMS928U

Type: Portable Handset
Serial: 0855M

Measurement Standard: ANSI C63.19-2011

Equipment:

- Probe: Radial T-Coil Probe – SN: TEM-1128; Calibrated: 8/10/2022

Test Configuration:

- Mode: GSM850
- Channel: 251
- Speech Signal: 3GPP2 Normal Test Signal
- ANT Configuration: A

Noise Spectrum

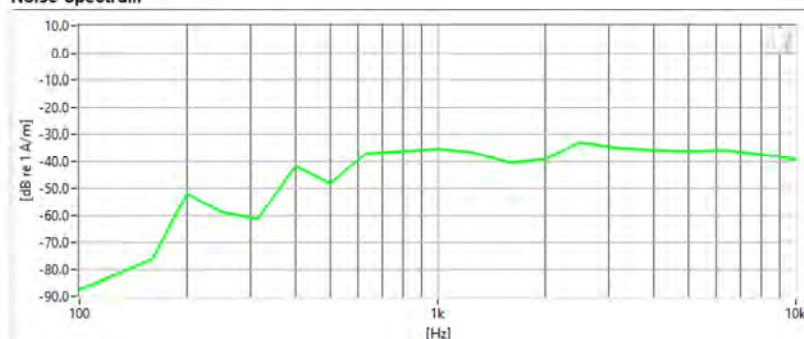

Frequency Response

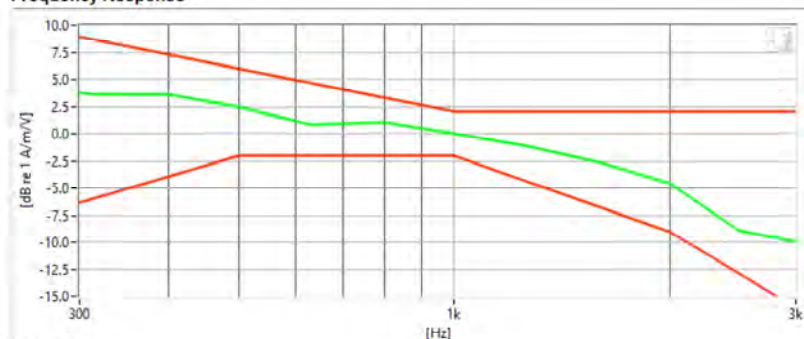

Results

Desired ABM	2.08 dB	✓	Minimum	-18.0
Undesired ABM	-28.21 dB	✓	Maximum	0.0
SNNR	30.29 dB	✓	Minimum	20.0
Aligned Response - Normal	2 dB	✓	Tolerance curves	Aligned Data

FCC ID: A3LSMS928U		HAC (T-COIL) TEST REPORT	Approved by: Managing Director
Filename: 1M2308210092-27-R1.A3L	Test Dates: 10/09/2023 - 10/22/2023	DUT Type: Portable Handset	Page 52 of 72



Element Hearing-Aid Compatibility Facility

DUT: A3LSMS928U

Type: Portable Handset
Serial: 0855M

Measurement Standard: ANSI C63.19-2011

Equipment:

- Probe: Radial T-Coil Probe – SN: TEM-1128; Calibrated: 8/10/2022

Test Configuration:

- Mode: UMTS V
- Channel: 4132
- Speech Signal: 3GPP2 Normal Test Signal
- ANT Configuration: A

Noise Spectrum

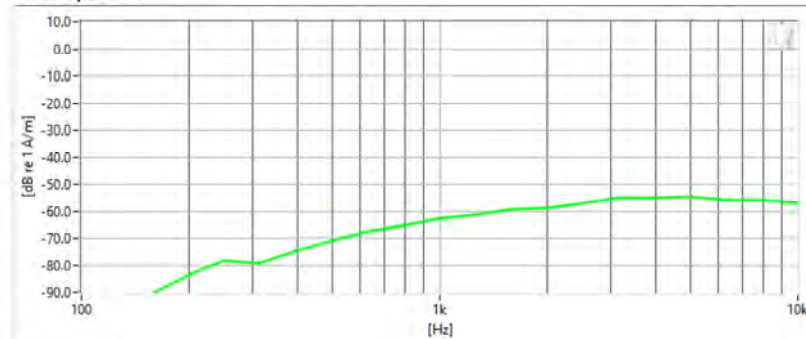

Frequency Response

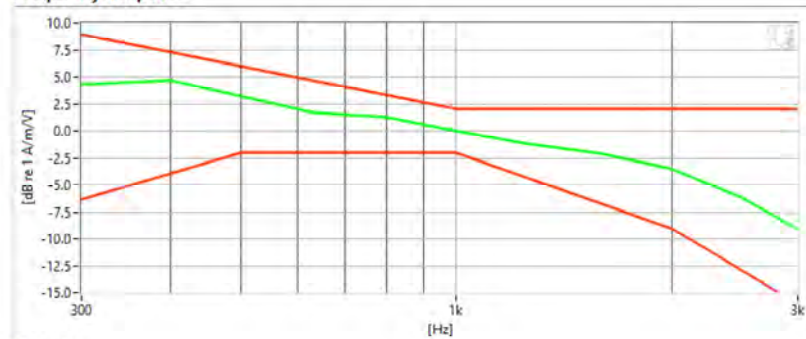

Results

Desired ABM	30m dB	✓	Minimum	-18.0
Undesired ABM	-52.91 dB	✓	Maximum	0.0
SNNR	52.94 dB	✓	Minimum	20.0
Aligned Response - Normal	1.95 dB	✓	Tolerance curves	Aligned Data

FCC ID: A3LSMS928U		HAC (T-COIL) TEST REPORT	Approved by: Managing Director
Filename: 1M2308210092-27-R1.A3L	Test Dates: 10/09/2023 - 10/22/2023	DUT Type: Portable Handset	Page 53 of 72



Element Hearing-Aid Compatibility Facility

DUT: A3LSMS928U

Type: Portable Handset
Serial: (no DUT SN found)

Measurement Standard: ANSI C63.19-2011

Equipment:

- Probe: Radial T-Coil Probe – SN: TEM-1128; Calibrated: 8/10/2022

Test Configuration:

- Mode: LTE TDD Band 41 (PC2)
- Bandwidth: 15MHz
- Channel: 40620
- Speech Signal: 3GPP2 Normal Test Signal
- ANT Configuration: B

Noise Spectrum

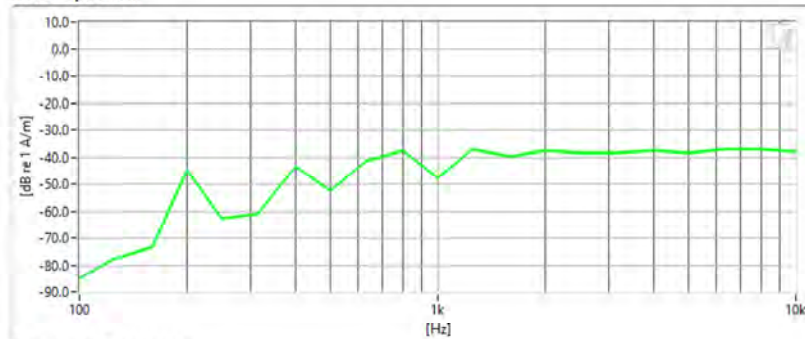

Frequency Response

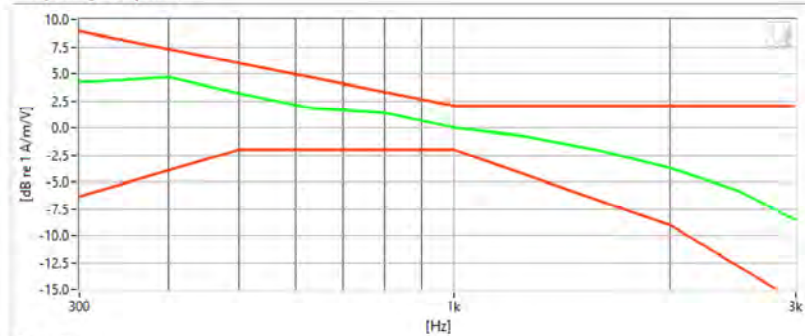

Results

Desired ABM	600m dB	✓	Minimum	-18.0
Undesired ABM	-30.64 dB	✓	Maximum	0.0
SNNR	31.23 dB	✓	Minimum	20.0
Aligned Response - Normal	1.88 dB	✓	Tolerance curves	Aligned Data

FCC ID: A3LSMS928U		HAC (T-COIL) TEST REPORT	Approved by: Managing Director
Filename: 1M2308210092-27-R1.A3L	Test Dates: 10/09/2023 - 10/22/2023	DUT Type: Portable Handset	Page 54 of 72



Element Hearing-Aid Compatibility Facility

DUT: A3LSMS928U

Type: Portable Handset
Serial: 0855M

Measurement Standard: ANSI C63.19-2011

Equipment:

- Probe: Radial T-Coil Probe – SN: TEM-1128; Calibrated: 8/10/2022

Test Configuration:

- Mode: NR TDD Band 41 (PC2)
- Bandwidth: 80MHz
- Channel: 518598
- Speech Signal: 3GPP2 Normal Test Signal
- ANT Configuration: F

Noise Spectrum

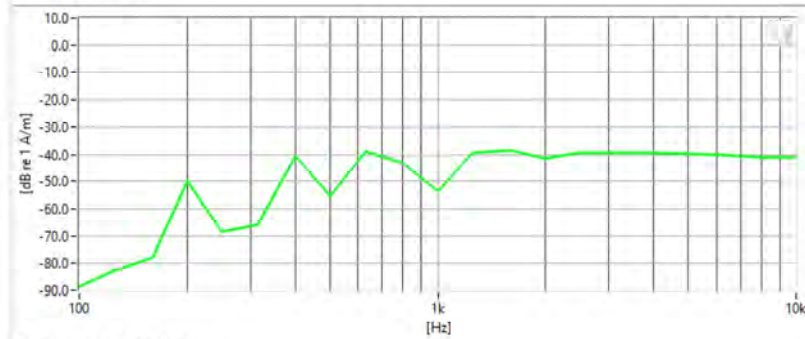

Frequency Response

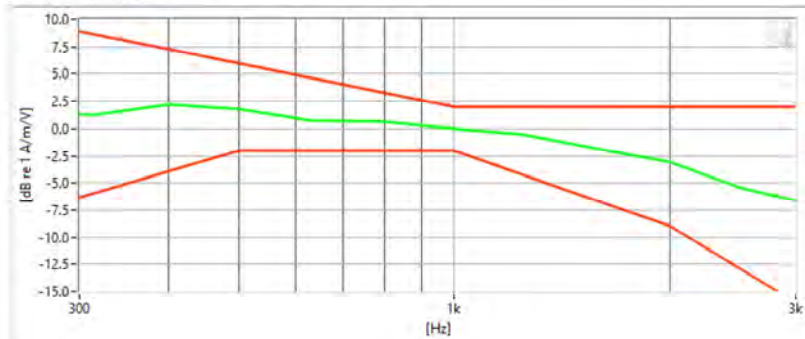

Results

Desired ABM	900m dB	✓	Minimum	-18.0
Undesired ABM	-31.54 dB	✓	Maximum	0.0
SNNR	32.44 dB	✓	Minimum	20.0
Aligned Response - Normal	2 dB	✓	Tolerance curves	Aligned Data

FCC ID: A3LSMS928U		HAC (T-COIL) TEST REPORT	Approved by: Managing Director
Filename: 1M2308210092-27-R1.A3L	Test Dates: 10/09/2023 - 10/22/2023	DUT Type: Portable Handset	Page 55 of 72



Element Hearing-Aid Compatibility Facility

DUT: A3LSMS928U

Type: Portable Handset
Serial: (no DUT SN found)

Measurement Standard: ANSI C63.19-2011

Equipment:

- Probe: Radial T-Coil Probe – SN: TEM-1128; Calibrated: 8/10/2022

Test Configuration:

- Mode: 5GHz WLAN
- Standard: IEEE 802.11ax (RU)
- Bandwidth: 40MHz
- Channel: 38
- Speech Signal: 3GPP2 Normal Test Signal

Noise Spectrum

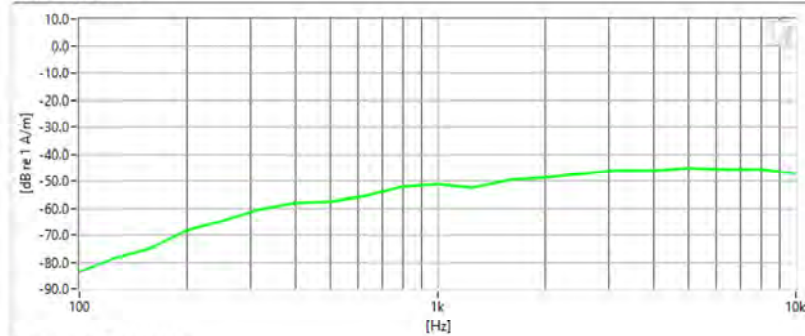

Frequency Response

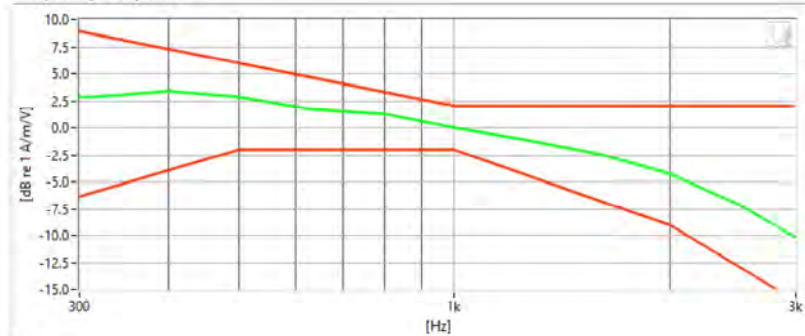

Results

Desired ABM	1.38 dB	✓	Minimum	-18.0
Undesired ABM	-42.23 dB	✓	Maximum	0.0
SNNR	43.62 dB	✓	Minimum	20.0
Aligned Response - Normal	2 dB	✓	Tolerance curves	Aligned Data

FCC ID: A3LSMS928U		HAC (T-COIL) TEST REPORT	Approved by: Managing Director
Filename: 1M2308210092-27-R1.A3L	Test Dates: 10/09/2023 - 10/22/2023	DUT Type: Portable Handset	Page 56 of 72



Element Hearing-Aid Compatibility Facility

DUT: A3LSMS928U

Type: Portable Handset
Serial: 0855M

Measurement Standard: ANSI C63.19-2011

Equipment:

- Probe: Radial T-Coil Probe – SN: TEM-1128; Calibrated: 8/10/2022

Test Configuration:

- VoIP Application: Google Meet
- Mode: EDGE850
- Channel: 190
- Speech Signal: 3GPP2 Normal Test Signal
- ANT Configuration: A

Noise Spectrum

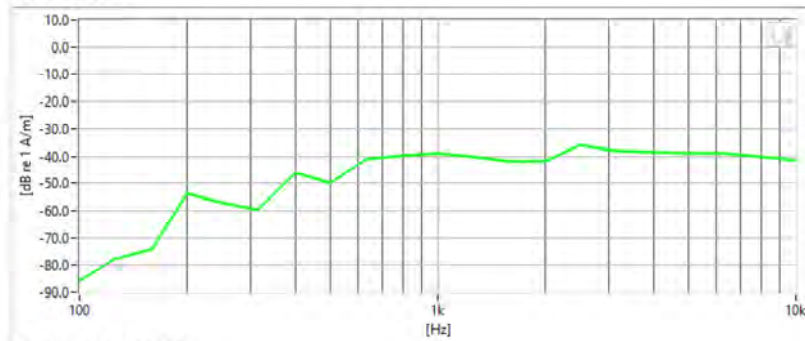

Frequency Response

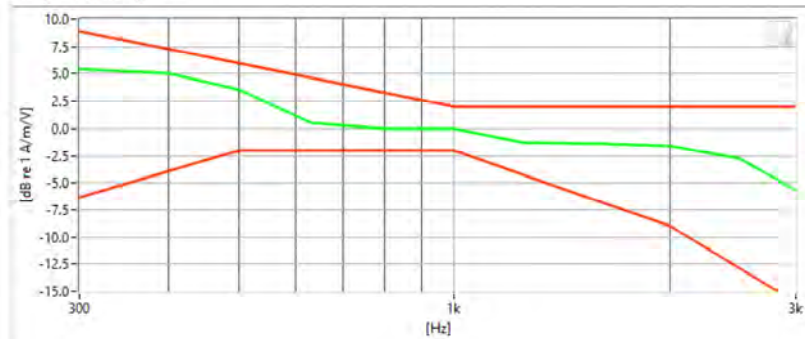

Results

Desired ABM	-470m dB	✓	Minimum	-18.0
Undesired ABM	-31.47 dB	✓	Maximum	0.0
SNNR	31 dB	✓	Minimum	20.0
Aligned Response - Normal	1.97 dB	✓	Tolerance curves	Aligned Data

FCC ID: A3LSMS928U		HAC (T-COIL) TEST REPORT	Approved by: Managing Director
Filename: 1M2308210092-27-R1.A3L	Test Dates: 10/09/2023 - 10/22/2023	DUT Type: Portable Handset	Page 57 of 72



Element Hearing-Aid Compatibility Facility

DUT: A3LSMS928U

Type: Portable Handset
Serial: 0855M

Measurement Standard: ANSI C63.19-2011

Equipment:

- Probe: Radial T-Coil Probe – SN: TEM-1128; Calibrated: 8/10/2022

Test Configuration:

- VoIP Application: Google Duo
- Mode: NR TDD Band 41 (PC2)
- Bandwidth: 100MHz
- Channel: 518598Speech Signal: 3GPP2 Normal Test Signal
- ANT Configuration: F

Noise Spectrum

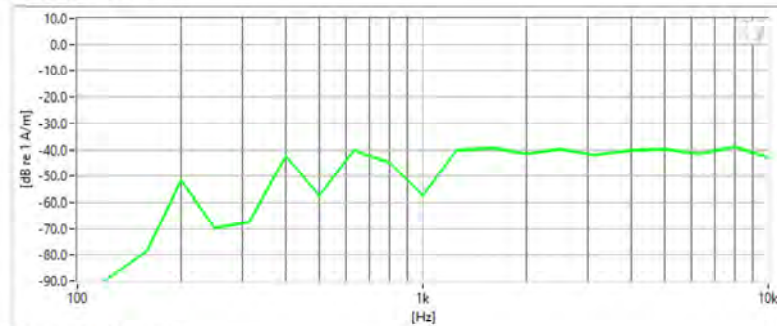

Frequency Response

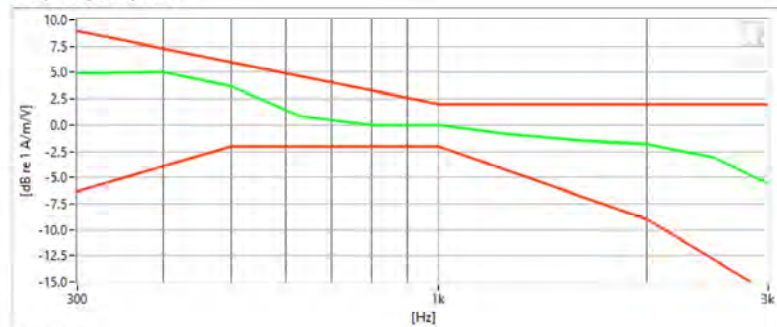

Results

Desired ABM	-220m dB	✓	Minimum	-18.0
Undesired ABM	-32.74 dB	✓	Maximum	0.0
SNNR	32.52 dB	✓	Minimum	20.0
Aligned Response - Normal	1.99 dB	✓	Tolerance curves	Aligned Data

FCC ID: A3LSMS928U		HAC (T-COIL) TEST REPORT	Approved by: Managing Director
Filename: 1M2308210092-27-R1.A3L	Test Dates: 10/09/2023 - 10/22/2023	DUT Type: Portable Handset	Page 58 of 72

14. TEST DATA(SCAN MEASUREMENT)

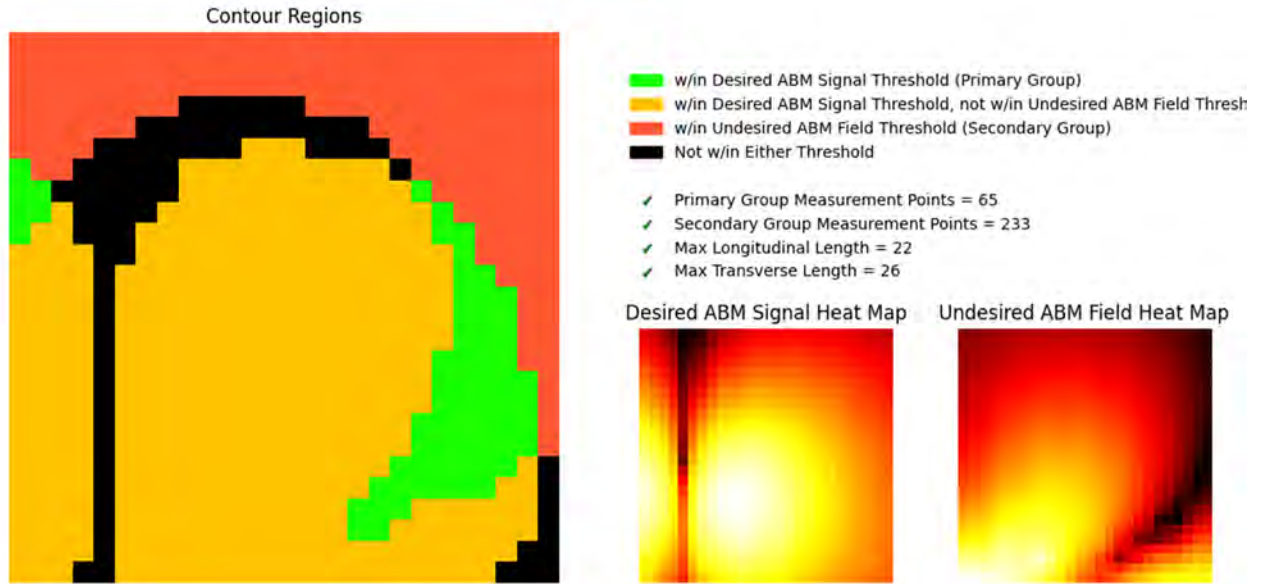

Table 14-1
Worst-Case Scan Results for GSM
GSM 850 CH.251, EFR: FR V1

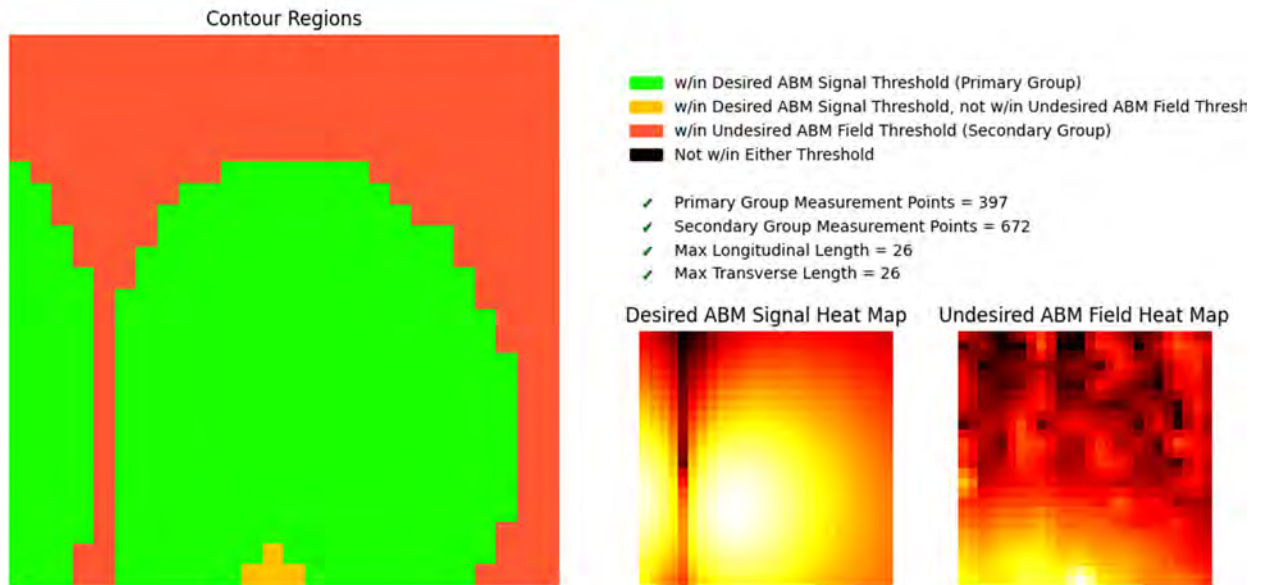

Table 14-2
Worst-Case Scan Results for UMTS
UMTS Band 5 CH.4132, WB AMR 6.60KBPS

FCC ID: A3LSMS928U		HAC (T-COIL) TEST REPORT	Approved by: Managing Director
Filename: 1M2308210092-27-R1.A3L	Test Dates: 10/09/2023 - 10/22/2023	DUT Type: Portable Handset	Page 59 of 72

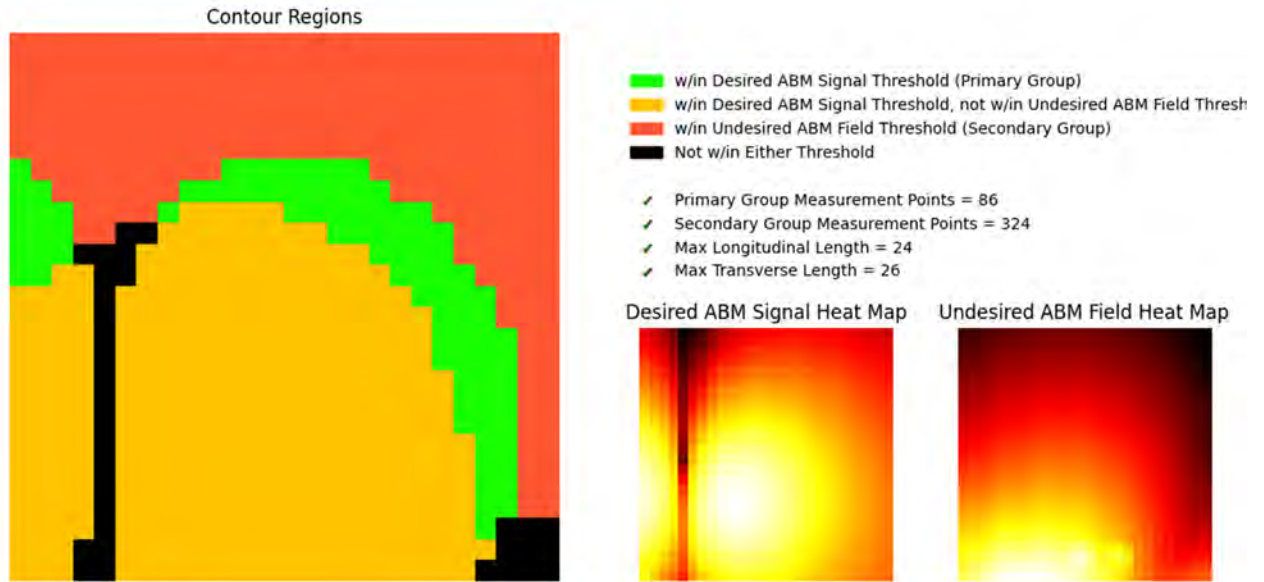

Table 14-2
Worst-Case Scan Results for LTE
LTE TDD Band 41 (PC2) 15MHz CH.40620, WB AMR 6.60KBPS

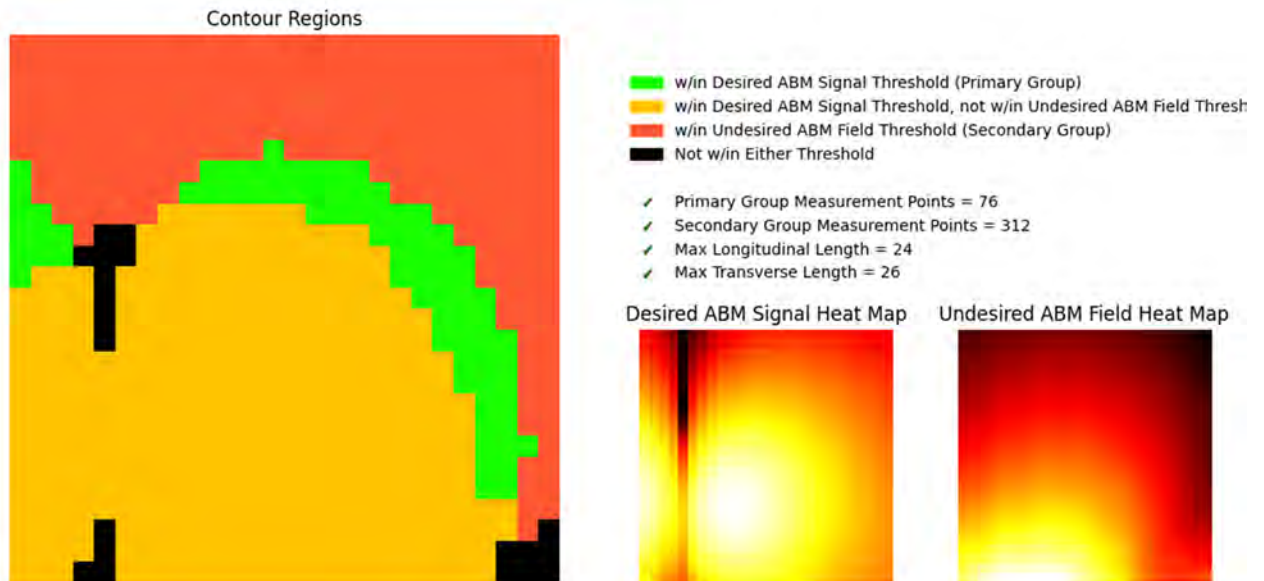

Table 14-2
Worst-Case Scan Results for NR
NR TDD n41 (PC2) 80MHz CH.518598, WB AMR 6.60KBPS

FCC ID: A3LSMS928U	element	HAC (T-COIL) TEST REPORT	Approved by: Managing Director
Filename: 1M2308210092-27-R1.A3L	Test Dates: 10/09/2023 - 10/22/2023	DUT Type: Portable Handset	Page 60 of 72

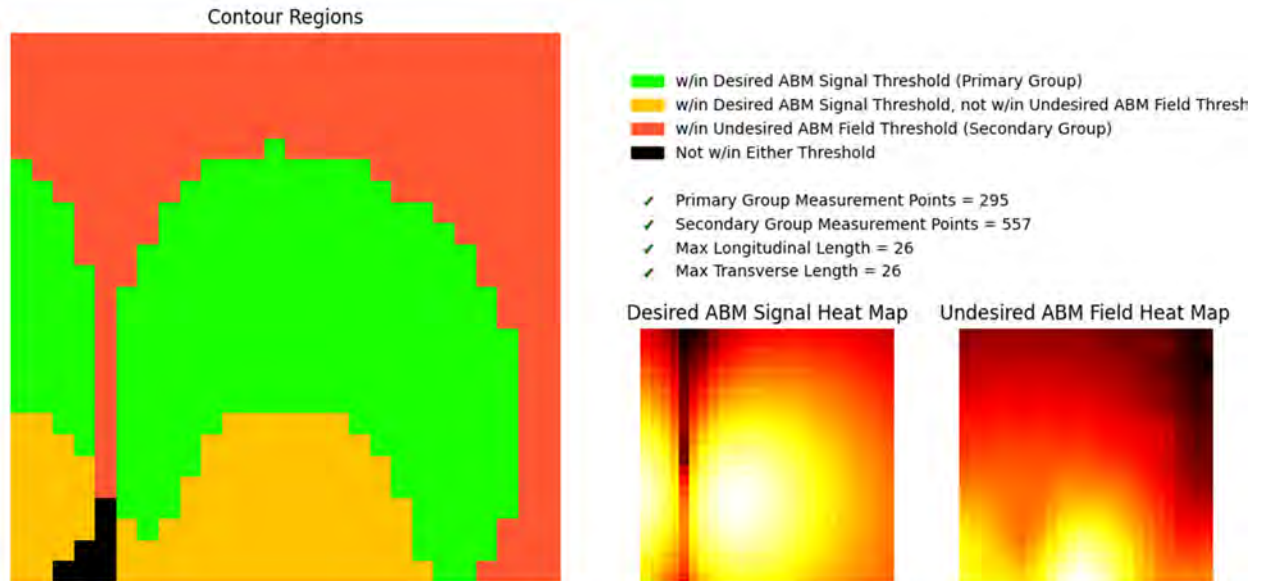

Table 14-2
Worst-Case Scan Results for WIFI
5GHz WIFI IEEE 802.11ax RU 40MHz CH.38, WB AMR 6.60KBPS

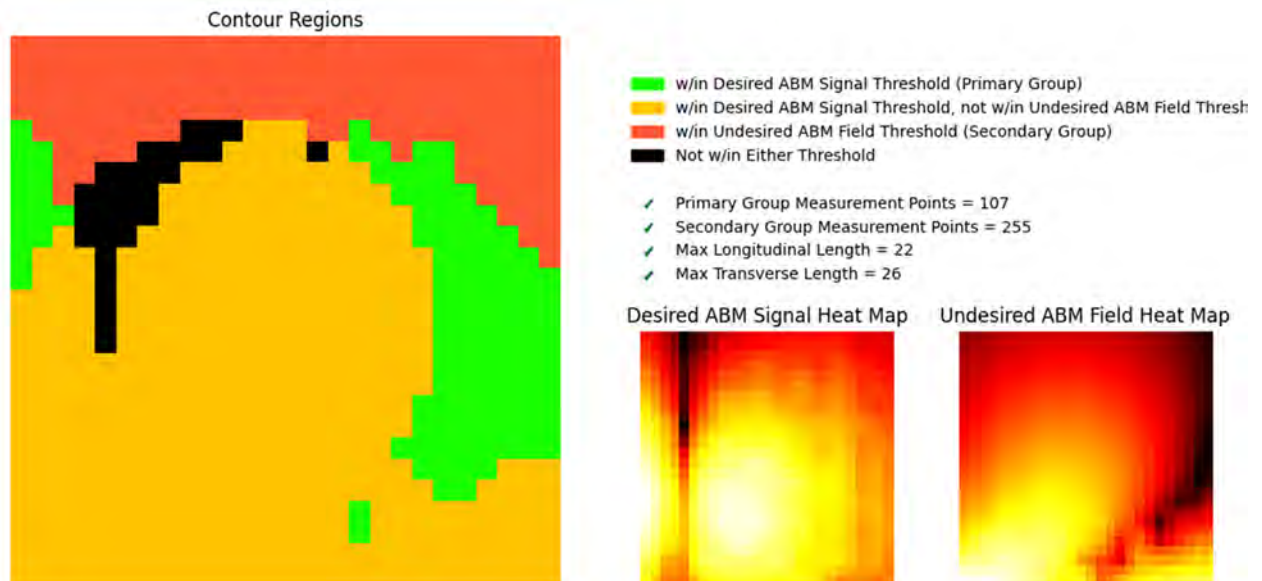

Table 14-2
Worst-Case Scan Results for EDGE (OTT VoIP)
EDGE 850 CH.190, OPUS 6KBPS

FCC ID: A3LSMS928U		HAC (T-COIL) TEST REPORT	Approved by: Managing Director
Filename: 1M2308210092-27-R1.A3L	Test Dates: 10/09/2023 - 10/22/2023	DUT Type: Portable Handset	Page 61 of 72

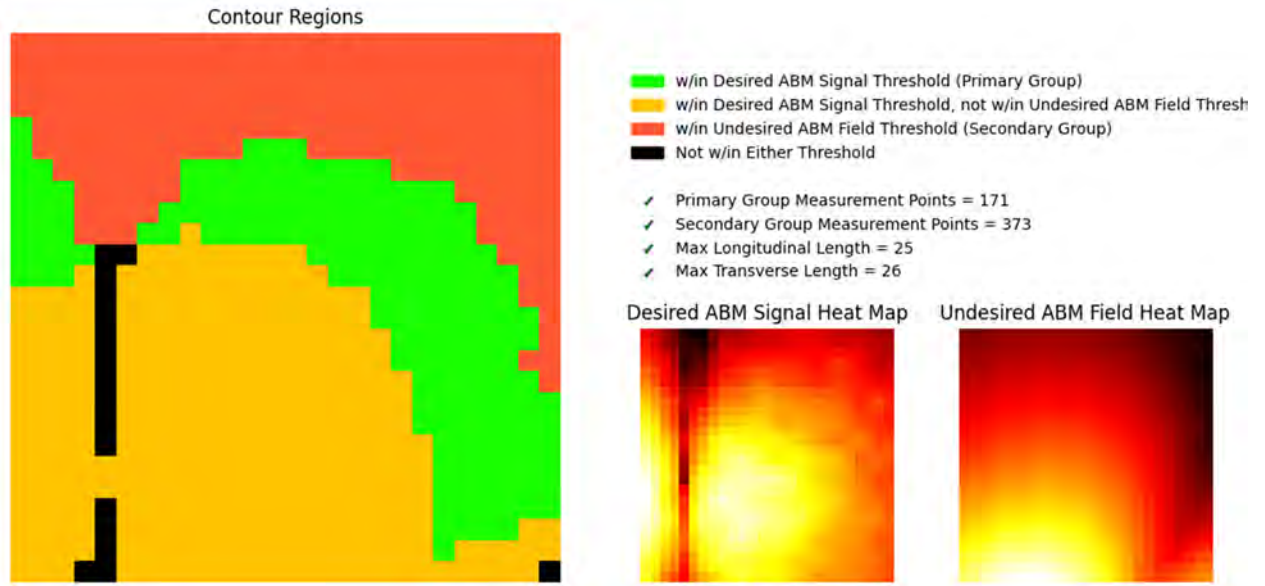



Table 14-2
Worst-Case Scan Results for NR (OTT VoIP)
NR TDD n41 (PC2) 100MHz CH.518598, OPUS 6KBPS

FCC ID: A3LSMS928U	element	HAC (T-COIL) TEST REPORT	Approved by: Managing Director
Filename: 1M2308210092-27-R1.A3L	Test Dates: 10/09/2023 - 10/22/2023	DUT Type: Portable Handset	Page 62 of 72

15. CALIBRATION CERTIFICATES

FCC ID: A3LSMS928U	 element	HAC (T-COIL) TEST REPORT	Approved by: Managing Director
Filename: 1M2308210092-27-R1.A3L	Test Dates: 10/09/2023 - 10/22/2023	DUT Type: Portable Handset	Page 63 of 72

Unless otherwise specified, no part of this report may be reproduced or utilized in any part, form or by any means, electronic or mechanical, including photocopying and microfilm, without permission in writing from Element. If you have any questions about this or have an enquiry about obtaining additional rights to this report or assembly of contents thereof, please contact CT.INFO@ELEMENT.COM.

West Caldwell Calibration Laboratories Inc.
Certificate of Calibration

for

Radial T Coil Probe

Manufactured by: LISTEN INC.
 Model No: RADIAL T COIL PROBE
 Serial No: TEM-1128
 Calibration Recall No: 33271

Submitted By:

Customer: Tae Kim
 Company: Element Materials Technology Washington DC LLC
 Address: 7185 Oakland Mills Road
 Columbia MD 21046

The subject instrument was calibrated to the indicated specification using standards traceable to the SI through the National Institute of Standards and Technology or to accepted values of natural physical constants. This document certifies that the instrument met the following specification upon its return to the submitter.

West Caldwell Calibration Laboratories Procedure No. RADIAL T LISTE

Upon receipt for Calibration, the instrument was found to be:

Within (X)

✓ TK
9/2/2022

tolerance of the indicated specification. See attached Report of Calibration.

The information supplied certifies that the item listed above meets acceptance criteria under the decision rule: $A=L-(U95)$, where A is the acceptance criteria, L is manufacturer specifications, and U95 is confidence level of 95% at $k=2$. The decision rule has been communicated and approved by customer during contract review. Measurements marked with (*) are not covered by the scope of current A2LA accreditation.

West Caldwell Calibration Laboratories' calibration control system meets the following requirements: ANSI/NCSL Z540-1, ISO 9001, and ISO 17025.

Note: With this Certificate, Report of Calibration is included.

Approved by:



James Zhu

Quality Manager

Calibration Date: 10-Aug-22
 Certificate Issue Date: 01-Sep-22 Rev 2.0
 Certificate No: 33271 - 2

QA Doc. #1051 Rev. 3.0 5/29/20

Certificate Page 1 of 1

ISO/IEC 17025

West Caldwell Calibration Laboratories, Inc.
 uncompromised calibration
 1575 State Route 96, Victor, NY 14564, U.S.A.



Calibration Lab. Cert. # 1533.01

FCC ID: A3LSMS928U		HAC (T-COIL) TEST REPORT	Approved by: Managing Director
Filename: 1M2308210092-27-R1.A3L	Test Dates: 10/09/2023 - 10/22/2023	DUT Type: Portable Handset	Page 64 of 72



REPORT OF CALIBRATION

for

TEM Consulting LP Radial T Coil Probe Model No.: Radial T Coil Probe Serial No.: TEM-1128
 Company: Element Materials Technology Washington D.C. LLC. I. D. No.: XXXX

Calibration results:			
Probe Sensitivity measured with Helmholtz Coil			
<i>Helmholtz Coil;</i>			
the number of turns on each coil;	10	No.	Before & after data same: ...X...
the radius of each coil, in meters;	0.204	m	
the current in the coils, in amperes.;	0.09	A	
<i>Helmholtz Coil Constant;</i>			
	7.09	A/m/V	Laboratory Environment:
<i>Helmholtz Coil magnetic field;</i>			
	5.96	A/m	Ambient Temperature: 20.5 °C
			Ambient Humidity: 43.5 % RH
			Ambient Pressure: 99.709 kPa
			Calibration Date: 10-Aug-2022
Probe Sensitivity at	1000	Hz.	Re-calibration Due:
was	-60.02	dBV/A/m	Report Number: 33271 -2
	0.997	mV/A/m	Control Number: 33271
Probe resistance	902	Ohms	

The above listed instrument meets or exceeds the tested manufacturer's specifications.

This Calibration is traceable through NIST test numbers: ,682636

The expanded uncertainty of calibration: 0.30dB at 95% confidence level with a coverage factor of k=2.

Graph represents Probes Frequency Response.

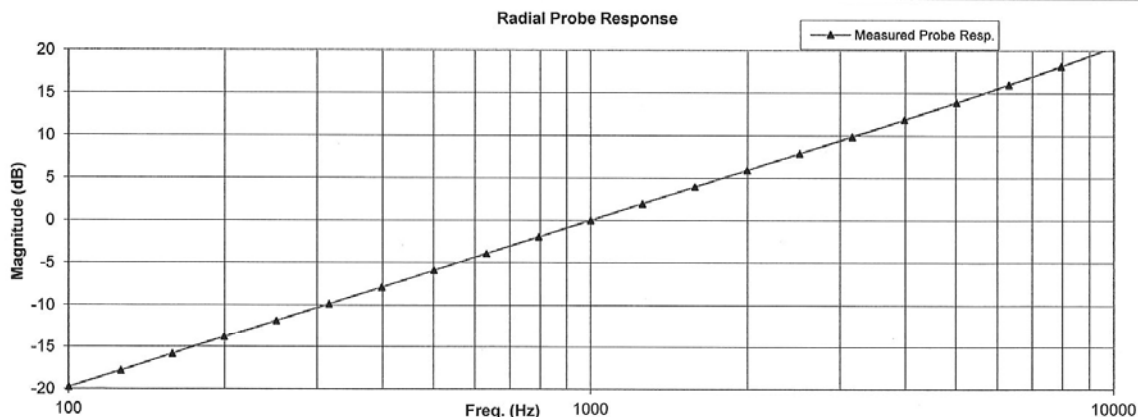

The above listed instrument was checked using calibration procedure documented in West Caldwell Calibration Laboratories Inc. procedure : Rev. 7.0 Jan. 24, 2014 Doc. # 1038 HCRTEMC
 Calibration was performed by West Caldwell Calibration Laboratories Inc. under Operating Procedures intended to implement the requirements of ANSI/NCSL Z540-1, ISO 9001, and ISO 17025.

Cal. Date: 10-Aug-2022
 Calibrated on WCCL system type 9700

Measurements performed by:
James Zhu

This document shall not be reproduced, except in full, without the written approval from West Caldwell Cal. Labs. Inc.

Rev. 7.0 Jan. 24, 2014 Doc. # 1038 HCRTEMC

FCC ID: A3LSMS928U		HAC (T-COIL) TEST REPORT	Approved by: Managing Director
Filename: 1M2308210092-27-R1.A3L	Test Dates: 10/09/2023 - 10/22/2023	DUT Type: Portable Handset	Page 65 of 72

HCRTEMC_TEM-1128_Aug-10-2022

West Caldwell Calibration Laboratories Inc.

1575 State Route 96, Victor NY 14564
Tel. (585) 586-3900 FAX (585) 586-4327

Calibration Data Record

TEM Consulting LP Radial T Coil Probe for Model No.: Radial T Coil Probe Serial No.: TEM-1128
Company: Element Materials Technology Washington D.C. LLC.

Test	Function	Tolerance		Measured values		
				Before	Out	Remarks
1.0	Probe Sensitivity at	1000 Hz.	dBV/A/m	-60.02		
2.0	Probe Level Linearity	Ref. (0 dB)	dB			
			6	6.03		
			0	0.00		
			-6	-6.03		
			-12	-12.05		
3.0	Probe Frequency Response	Ref. (0 dB)	Hz			
			100	-19.8		
			126	-17.8		
			158	-15.8		
			200	-13.8		
			251	-11.9		
			316	-9.9		
			398	-7.9		
			501	-5.9		
			631	-3.9		
			794	-2.0		
			1000	0.0		
			1259	2.0		
			1585	4.0		
			1995	5.9		
			2512	7.9		
			3162	9.9		
3981	11.9					
5012	13.9					
6310	16.0					
7943	18.2					
10000	20.5					

Instruments used for calibration:			Date of Cal.	Traceability No.	Due Date
HP	34401A	S/N US360641	24-Jun-2022	.682636	24-Jun-2023
HP	34401A	S/N US361024	24-Jun-2022	.682636	24-Jun-2023
HP	33120A	S/N US360437	24-Jun-2022	.682636	24-Jun-2023
B&K	2133	S/N 1583254	5-Jul-2022	.682636	5-Jul-2023

Cal. Date: 10-Aug-2022

Tested by: James Zhu

Calibrated on WCCL system type 9700

This document shall not be reproduced, except in full, without the written approval from West Caldwell Cal. Labs. Inc.

Rev. 7.0 Jan. 24, 2014 Doc. # 1038 HCRTEMC

FCC ID: A3LSMS928U		HAC (T-COIL) TEST REPORT	Approved by: Managing Director
Filename: 1M2308210092-27-R1.A3L	Test Dates: 10/09/2023 - 10/22/2023	DUT Type: Portable Handset	Page 66 of 72

16. CONCLUSION

The measurements indicate that the wireless communications device complies with the HAC limits specified in accordance with the ANSI C63.19 Standard and FCC WT Docket No. 01-309 RM-8658. Precise laboratory measures were taken to assure repeatability of the tests. The tested device complies with the requirements in respect to all parameters specific to the test. The test results and statements relate only to the item(s) tested.

The measurement system and techniques presented in this evaluation are proposed in the ANSI standard as a means of best approximating wireless device compatibility with a hearing-aid. The literature is under continual re-construction.

FCC ID: A3LSMS928U	 element	HAC (T-COIL) TEST REPORT	Approved by: Managing Director
Filename: 1M2308210092-27-R1.A3L	Test Dates: 10/09/2023 - 10/22/2023	DUT Type: Portable Handset	Page 67 of 72

17. REFERENCES

1. ANSI C63.19-2019, American National Standard for Methods of Measurement of Compatibility between Wireless communication devices and Hearing Aids.”, New York, NY, IEEE, August 2019
2. FCC Office of Engineering and Technology KDB, “285076 D01 HAC Guidance v06r02,” September 19, 2022
3. FCC Office of Engineering and Technology KDB, “285076 D02 T-Coil Testing for CMRS IP v04,” February 23, 2022
4. FCC Public Notice DA 06-1215, *Wireless Telecommunications Bureau and Office of Engineering and Technology Clarify Use of Revised Wireless Phone Hearing Aid Compatibility Standard*, June 6, 2006
5. FCC 3G Review Guidance, Laboratory Division OET FCC, May/June 2006
6. Berger, H. S., “Compatibility Between Hearing Aids and Wireless Devices,” Electronic Industries Forum, Boston, MA, May, 1997
7. Berger, H. S., “Hearing Aid and Cellular Phone Compatibility: Working Toward Solutions,” Wireless Telephones and Hearing Aids: New Challenges for Audiology, Gallaudet University, Washington, D.C., May, 1997 (To be reprinted in the American Journal of Audiology).
8. Berger, H. S., “Hearing Aid Compatibility with Wireless Communications Devices,” IEEE International Symposium on Electromagnetic Compatibility, Austin, TX, August, 1997.
9. Bronaugh, E. L., “Simplifying EMI Immunity (Susceptibility) Tests in TEM Cells,” in the 1990 IEEE International Symposium on Electromagnetic Compatibility Symposium Record, Washington, D.C., August 1990, pp. 488-491
10. Byrne, D. and Dillon, H., The National Acoustics Laboratory (NAL) New Procedure for Selecting the Gain and Frequency Response of a Hearing Aid, Ear and Hearing 7:257-265, 1986.
11. Crawford, M. L., “Measurement of Electromagnetic Radiation from Electronic Equipment using TEM Transmission Cells,” U.S. Department of Commerce, National Bureau of Standards, NBSIR 73-306, Feb. 1973.
12. Crawford, M. L., and Workman, J. L., “Using a TEM Cell for EMC Measurements of Electronic Equipment,” U.S. Department of Commerce, National Bureau of Standards. Technical Note 1013, July 1981.
13. EHIMA GSM Project, Development phase, Project Report (1st part) Revision A. Technical-Audiological Laboratory and Telecom Denmark, October 1993.
14. EHIMA GSM Project, Development phase, Part II Project Report. Technical-Audiological Laboratory and Telecom Denmark, June 1994.
15. EHIMA GSM Project Final Report, Hearing Aids and GSM Mobile Telephones: Interference Problems, Methods of Measurement and Levels of Immunity. Technical-Audiological Laboratory and Telecom Denmark, 1995.

FCC ID: A3LSMS928U	 element	HAC (T-COIL) TEST REPORT	Approved by: Managing Director
Filename: 1M2308210092-27-R1.A3L	Test Dates: 10/09/2023 - 10/22/2023	DUT Type: Portable Handset	Page 68 of 72

16. HAMPIS Report, Comparison of Mobile phone electromagnetic near field with an upscaled electromagnetic far field, using hearing aid as reference, 21 October 1999.
17. Hearing Aids/GSM, Report from OTWIDAM, Technical-Audiological Laboratory and Telecom Denmark, April 1993.
18. IEEE 100, The Authoritative Dictionary of IEEE Standards Terms, Seventh Edition.
19. Joyner, K. H., et. al., Interference to Hearing Aids by the New Digital Mobile Telephone System, Global System for Mobile (GSM) Communication Standard, National Acoustic Laboratory, Australian Hearing Series, Sydney 1993.
20. Joyner, K. H., et. al., Interference to Hearing Aids by the Digital Mobile Telephone System, Global System for Mobile Communications (GSM), NAL Report #131, National Acoustic Laboratory, Australian Hearing Series, Sydney, 1995.
21. Kecker, W. T., Crawford, M. L., and Wilson, W. A., "Construction of a Transverse Electromagnetic Cell", U.S. Department of Commerce, National Bureau of Standards, Technical Note 1011, Nov. 1978.
22. Konigstein, D., and Hansen, D., "A New Family of TEM Cells with enlarged bandwidth and Optimized working Volume," in the Proceedings of the 7th International Symposium on EMC, Zurich, Switzerland, March 1987; 50:9, pp. 127-132.
23. Kuk, F., and Hjorstgaard, N. K., "Factors affecting interference from digital cellular telephones," Hearing Journal, 1997; 50:9, pp 32-34.
24. Ma, M. A., and Kanda, M., "Electromagnetic Compatibility and Interference Metrology," U.S. Department of Commerce, National Bureau of Standards, Technical Note 1099, July 1986, pp. 17-43.
25. Ma, M. A., Sreenivashiah, I. , and Chang, D. C., "A Method of Determining the Emission and Susceptibility Levels of Electrically Small Objects Using a TEM Cell," U.S. Department of Commerce, National Bureau of Standards, Technical Note 1040, July 1981.
26. McCandless, G. A., and Lyregaard, P. E., Prescription of Gain/Output (POGO) for Hearing Aids, Hearing Instruments 1:16-21, 1983
27. Skopec, M., "Hearing Aid Electromagnetic Interference from Digital Wireless Telephones, "IEEE Transactions on Rehabilitation Engineering, vol. 6, no. 2, pp. 235-239, June 1998.
28. Technical Report, GSM 05.90, GSM EMC Considerations, European Telecommunications Standards Institute, January 1993.
29. Victorian, T. A., "Digital Cellular Telephone Interference and Hearing Aid Compatibility—an Update," Hearing Journal 1998; 51:10, pp. 53-60
30. Wong, G. S. K., and Embleton, T. F. W., eds., AIP Handbook of Condenser Microphones: Theory, Calibration and Measurements, AIP Press.

FCC ID: A3LSMS928U	 element	HAC (T-COIL) TEST REPORT	Approved by: Managing Director
Filename: 1M2308210092-27-R1.A3L	Test Dates: 10/09/2023 - 10/22/2023	DUT Type: Portable Handset	Page 69 of 72