

# APPENDIX I: LTE DOWNLINK ONLY CARRIER AGGREGATION TEST REDUCTION METHODOLOGY

SAR test exclusion for LTE downlink Carrier Aggregation is determined by power measurements according to the number of component carriers (CCs) supported by the product implementation. Per April 2018 TCBC Workshop Notes, the following test reduction methodology was applied to determine the combinations required for conducted power measurements.

## LTE DLCA Test Reduction Methodology:

- The supported combinations were arranged by the number of component carriers in columns.
- Any limitations on the PCC or SCC for each combination were identified alongside the combination (e.g. CA\_2A-2A-4A-12A, but B12 can only be configured as a SCC).
- Power measurements were performed for "supersets" (LTE CA combinations with multiple components carriers) and any "subsets" (LTE CA combinations with fewer component carriers) that were not completely covered by the supersets.
- Only subsets that have the exact same components as a superset were excluded for measurement.
- When there were certain restrictions on component carriers that existed in the superset that were not applied for the subset, the subset configuration was additionally evaluated.
- Both inter-band and intra-band downlink carrier aggregation scenarios were considered.
- Downlink CA combinations for SISO and 4x4 Downlink MIMO operations were measured independently, per May 2017 TCBC Workshop notes.

Table I-1 – Example of Exclusion Table for SISO Configurations

Index	CC	Supported Channel Bandwidth (MHz)				Restriction	Completely Covered by Measurement Superset	Index	CC	Supported Channel Bandwidth (MHz)				Restriction	Completely Covered by Measurement Superset	Index	CC	Supported Channel Bandwidth (MHz)				Restriction	Completely Covered by Measurement Superset
		CC1	CC2	CC3	CC4					CC1	CC2	CC3	CC4					CC1	CC2	CC3	CC4		
DEC-001	CA	5, 10, 15, 20	5, 10, 15, 20			No	DEC-001	CA	5, 10, 15, 20	5, 10, 15, 20	5, 10, 15, 20		No	DEC-001	CA	5, 10, 15, 20	5, 10, 15, 20	5, 10, 15, 20		No			
DEC-002	CA	5, 10, 15, 20	5, 10, 15, 20			No	DEC-002	CA	5, 10, 15, 20	5, 10, 15, 20	5, 10, 15, 20		No	DEC-002	CA	5, 10, 15, 20	5, 10, 15, 20	5, 10, 15, 20		No			
DEC-003	CA	5, 10, 15, 20	5, 10, 15, 20			No	DEC-003	CA	5, 10, 15, 20	5, 10, 15, 20	5, 10, 15, 20		No	DEC-003	CA	5, 10, 15, 20	5, 10, 15, 20	5, 10, 15, 20		No			
DEC-004	CA	5, 10, 15, 20	5, 10, 15, 20			No	DEC-004	CA	5, 10, 15, 20	5, 10, 15, 20	5, 10, 15, 20		No	DEC-004	CA	5, 10, 15, 20	5, 10, 15, 20	5, 10, 15, 20		No			
DEC-005	CA	5, 10, 15, 20	5, 10, 15, 20			No	DEC-005	CA	5, 10, 15, 20	5, 10, 15, 20	5, 10, 15, 20		No	DEC-005	CA	5, 10, 15, 20	5, 10, 15, 20	5, 10, 15, 20		No			
DEC-006	CA	5, 10, 15, 20	5, 10, 15, 20			No	DEC-006	CA	5, 10, 15, 20	5, 10, 15, 20	5, 10, 15, 20		No	DEC-006	CA	5, 10, 15, 20	5, 10, 15, 20	5, 10, 15, 20		No			
DEC-007	CA	5, 10, 15, 20	5, 10, 15, 20			No	DEC-007	CA	5, 10, 15, 20	5, 10, 15, 20	5, 10, 15, 20		No	DEC-007	CA	5, 10, 15, 20	5, 10, 15, 20	5, 10, 15, 20		No			
DEC-008	CA	5, 10, 15, 20	5, 10, 15, 20			No	DEC-008	CA	5, 10, 15, 20	5, 10, 15, 20	5, 10, 15, 20		No	DEC-008	CA	5, 10, 15, 20	5, 10, 15, 20	5, 10, 15, 20		No			
DEC-009	CA	5, 10, 15, 20	5, 10, 15, 20			No	DEC-009	CA	5, 10, 15, 20	5, 10, 15, 20	5, 10, 15, 20		No	DEC-009	CA	5, 10, 15, 20	5, 10, 15, 20	5, 10, 15, 20		No			
DEC-010	CA	5, 10, 15, 20	5, 10, 15, 20			No	DEC-010	CA	5, 10, 15, 20	5, 10, 15, 20	5, 10, 15, 20		No	DEC-010	CA	5, 10, 15, 20	5, 10, 15, 20	5, 10, 15, 20		No			
DEC-011	CA	5, 10, 15, 20	5, 10, 15, 20			No	DEC-011	CA	5, 10, 15, 20	5, 10, 15, 20	5, 10, 15, 20		No	DEC-011	CA	5, 10, 15, 20	5, 10, 15, 20	5, 10, 15, 20		No			
DEC-012	CA	5, 10, 15, 20	5, 10, 15, 20			No	DEC-012	CA	5, 10, 15, 20	5, 10, 15, 20	5, 10, 15, 20		No	DEC-012	CA	5, 10, 15, 20	5, 10, 15, 20	5, 10, 15, 20		No			
DEC-013	CA	5, 10, 15, 20	5, 10, 15, 20			No	DEC-013	CA	5, 10, 15, 20	5, 10, 15, 20	5, 10, 15, 20		No	DEC-013	CA	5, 10, 15, 20	5, 10, 15, 20	5, 10, 15, 20		No			
DEC-014	CA	5, 10, 15, 20	5, 10, 15, 20			No	DEC-014	CA	5, 10, 15, 20	5, 10, 15, 20	5, 10, 15, 20		No	DEC-014	CA	5, 10, 15, 20	5, 10, 15, 20	5, 10, 15, 20		No			
DEC-015	CA	5, 10, 15, 20	5, 10, 15, 20			No	DEC-015	CA	5, 10, 15, 20	5, 10, 15, 20	5, 10, 15, 20		No	DEC-015	CA	5, 10, 15, 20	5, 10, 15, 20	5, 10, 15, 20		No			
DEC-016	CA	5, 10, 15, 20	5, 10, 15, 20			No	DEC-016	CA	5, 10, 15, 20	5, 10, 15, 20	5, 10, 15, 20		No	DEC-016	CA	5, 10, 15, 20	5, 10, 15, 20	5, 10, 15, 20		No			
DEC-017	CA	5, 10, 15, 20	5, 10, 15, 20			No	DEC-017	CA	5, 10, 15, 20	5, 10, 15, 20	5, 10, 15, 20		No	DEC-017	CA	5, 10, 15, 20	5, 10, 15, 20	5, 10, 15, 20		No			
DEC-018	CA	5, 10, 15, 20	5, 10, 15, 20			No	DEC-018	CA	5, 10, 15, 20	5, 10, 15, 20	5, 10, 15, 20		No	DEC-018	CA	5, 10, 15, 20	5, 10, 15, 20	5, 10, 15, 20		No			
DEC-019	CA	5, 10, 15, 20	5, 10, 15, 20			No	DEC-019	CA	5, 10, 15, 20	5, 10, 15, 20	5, 10, 15, 20		No	DEC-019	CA	5, 10, 15, 20	5, 10, 15, 20	5, 10, 15, 20		No			
DEC-020	CA	5, 10, 15, 20	5, 10, 15, 20			No	DEC-020	CA	5, 10, 15, 20	5, 10, 15, 20	5, 10, 15, 20		No	DEC-020	CA	5, 10, 15, 20	5, 10, 15, 20	5, 10, 15, 20		No			
DEC-021	CA	5, 10, 15, 20	5, 10, 15, 20			No	DEC-021	CA	5, 10, 15, 20	5, 10, 15, 20	5, 10, 15, 20		No	DEC-021	CA	5, 10, 15, 20	5, 10, 15, 20	5, 10, 15, 20		No			
DEC-022	CA	5, 10, 15, 20	5, 10, 15, 20			No	DEC-022	CA	5, 10, 15, 20	5, 10, 15, 20	5, 10, 15, 20		No	DEC-022	CA	5, 10, 15, 20	5, 10, 15, 20	5, 10, 15, 20		No			
DEC-023	CA	5, 10, 15, 20	5, 10, 15, 20			No	DEC-023	CA	5, 10, 15, 20	5, 10, 15, 20	5, 10, 15, 20		No	DEC-023	CA	5, 10, 15, 20	5, 10, 15, 20	5, 10, 15, 20		No			

Table I-2 – Example of Exclusion Table for 4x4 Downlink MIMO Configurations

Index	CC	Supported Channel Bandwidth (MHz)			Restriction	Completely Covered by Measurement Superset	Index	CC	Supported Channel Bandwidth (MHz)			Restriction	Completely Covered by Measurement Superset	Index	CC	Supported Channel Bandwidth (MHz)				Restriction	Completely Covered by Measurement Superset
		CC1	CC2	CC3					CC1	CC2	CC3					CC4					
DEC-001	CA	5, 10, 15, 20	5, 10, 15, 20			No	DEC-001	CA	5, 10, 15, 20	5, 10, 15, 20	5, 10, 15, 20		No	DEC-001	CA	5, 10, 15, 20	5, 10, 15, 20	5, 10, 15, 20		No	
DEC-002	CA	5, 10, 15, 20	5, 10, 15, 20			No	DEC-002	CA	5, 10, 15, 20	5, 10, 15, 20	5, 10, 15, 20		No	DEC-002	CA	5, 10, 15, 20	5, 10, 15, 20	5, 10, 15, 20		No	
DEC-003	CA	5, 10, 15, 20	5, 10, 15, 20			No	DEC-003	CA	5, 10, 15, 20	5, 10, 15, 20	5, 10, 15, 20		No	DEC-003	CA	5, 10, 15, 20	5, 10, 15, 20	5, 10, 15, 20		No	
DEC-004	CA	5, 10, 15, 20	5, 10, 15, 20			No	DEC-004	CA	5, 10, 15, 20	5, 10, 15, 20	5, 10, 15, 20		No	DEC-004	CA	5, 10, 15, 20	5, 10, 15, 20	5, 10, 15, 20		No	
DEC-005	CA	5, 10, 15, 20	5, 10, 15, 20			No	DEC-005	CA	5, 10, 15, 20	5, 10, 15, 20	5, 10, 15, 20		No	DEC-005	CA	5, 10, 15, 20	5, 10, 15, 20	5, 10, 15, 20		No	
DEC-006	CA	5, 10, 15, 20	5, 10, 15, 20			No	DEC-006	CA	5, 10, 15, 20	5, 10, 15, 20	5, 10, 15, 20		No	DEC-006	CA	5, 10, 15, 20	5, 10, 15, 20	5, 10, 15, 20		No	
DEC-007	CA	5, 10, 15, 20	5, 10, 15, 20			No	DEC-007	CA	5, 10, 15, 20	5, 10, 15, 20	5, 10, 15, 20		No	DEC-007	CA	5, 10, 15, 20	5, 10, 15, 20	5, 10, 15, 20		No	
DEC-008	CA	5, 10, 15, 20	5, 10, 15, 20			No	DEC-008	CA	5, 10, 15, 20	5, 10, 15, 20	5, 10, 15, 20		No	DEC-008	CA	5, 10, 15, 20	5, 10, 15, 20	5, 10, 15, 20		No	
DEC-009	CA	5, 10, 15, 20	5, 10, 15, 20			No	DEC-009	CA	5, 10, 15, 20	5, 10, 15, 20	5, 10, 15, 20		No	DEC-009	CA	5, 10, 15, 20	5, 10, 15, 20	5, 10, 15, 20		No	
DEC-010	CA	5, 10, 15, 20	5, 10, 15, 20			No	DEC-010	CA	5, 10, 15, 20	5, 10, 15, 20	5, 10, 15, 20		No	DEC-010	CA	5, 10, 15, 20	5, 10, 15, 20	5, 10, 15, 20		No	
DEC-011	CA	5, 10, 15, 20	5, 10, 15, 20			No	DEC-011	CA	5, 10, 15, 20	5, 10, 15, 20	5, 10, 15, 20		No	DEC-011	CA	5, 10, 15, 20	5, 10, 15, 20	5, 10, 15, 20		No	
DEC-012	CA	5, 10, 15, 20	5, 10, 15, 20			No	DEC-012	CA	5, 10, 15, 20	5, 10, 15, 20	5, 10, 15, 20		No	DEC-012	CA	5, 10, 15, 20	5, 10, 15, 20	5, 10, 15, 20		No	
DEC-013	CA	5, 10, 15, 20	5, 10, 15, 20			No	DEC-013	CA	5, 10, 15, 20	5, 10, 15, 20	5, 10, 15, 20		No	DEC-013	CA	5, 10, 15, 20	5, 10, 15, 20	5, 10, 15, 20		No	
DEC-014	CA	5, 10, 15, 20	5, 10, 15, 20			No	DEC-014	CA	5, 10, 15, 20	5, 10, 15, 20	5, 10, 15, 20		No	DEC-014	CA	5, 10, 15, 20	5, 10, 15, 20	5, 10, 15, 20		No	
DEC-015	CA	5, 10, 15, 20	5, 10, 15, 20			No	DEC-015	CA	5, 10, 15, 20	5, 10, 15, 20	5, 10, 15, 20		No	DEC-015	CA	5, 10, 15, 20	5, 10, 15, 20	5, 10, 15, 20		No	
DEC-016	CA	5, 10, 15, 20	5, 10, 15, 20			No	DEC-016	CA	5, 10, 15, 20	5, 10, 15, 20	5, 10, 15, 20		No	DEC-016	CA	5, 10, 15, 20	5, 10, 15, 20	5, 10, 15, 20		No	
DEC-017	CA	5, 10, 15, 20	5, 10, 15, 20			No	DEC-017	CA	5, 10, 15, 20	5, 10, 15, 20	5, 10, 15, 20		No	DEC-017	CA	5, 10, 15, 20	5, 10, 15, 20	5, 10, 15, 20		No	
DEC-018	CA	5, 10, 15, 20	5, 10, 15, 20			No	DEC-018	CA	5, 10, 15, 20	5, 10, 15, 20	5, 10, 15, 20		No	DEC-018	CA	5, 10, 15, 20	5, 10, 15, 20	5, 10, 15, 20		No	
DEC-019	CA	5, 10, 15, 20	5, 10, 15, 20			No	DEC-019	CA	5, 10, 15, 20	5, 10, 15, 20	5, 10, 15, 20		No	DEC-019	CA	5, 10, 15, 20	5, 10, 15, 20	5, 10, 15, 20		No	
DEC-020	CA	5, 10, 15, 20	5, 10, 15, 20			No	DEC-020	CA	5, 10, 15, 20	5, 10, 15, 20	5, 10, 15, 20		No	DEC-020	CA	5, 10, 15, 20	5, 10, 15, 20	5, 10, 15, 20		No	
DEC-021	CA	5, 10, 15, 20	5, 10, 15, 20			No	DEC-021	CA	5, 10, 15, 20	5, 10, 15, 20	5, 10, 15, 20		No	DEC-021	CA	5, 10, 15, 20	5, 10, 15, 20	5, 10, 15, 20		No	
DEC-022	CA	5, 10, 15, 20	5, 10, 15, 20			No	DEC-022	CA													

only) active are made in accordance to KDB Publication 941225 D05Av01r02. The RRC connection is only handled by one cell, the primary component carrier (PCC) for downlink and uplink communications. After making a data connection to the PCC, the UE device adds secondary component carrier(s) (SCC) on the downlink only. All uplink communications and acknowledgements remain identical to specifications when downlink carrier aggregation is inactive on the PCC. Additional conducted output powers are measured with the downlink carrier aggregation active for the configuration with highest measured maximum conducted power with downlink carrier aggregation active measured among the channel bandwidth, modulation, and RB combinations in each frequency band.

Per FCC KDB Publication 941225 D05Av01r02, no SAR measurements are required for carrier aggregation configurations when the maximum average output power with downlink only carrier aggregation active is not more than 0.25 dB higher than the average output power with downlink only carrier aggregation inactive. All bands required for SAR testing per FCC KDB procedures were considered. Based on the measured maximum powers below, no additional SAR tests were required for DLCA SAR configurations.

General PCC and SCC configuration selection procedure

- PCC uplink channel, channel bandwidth, modulation and RB configurations were selected based on section C)3)b)ii) of KDB 941225 D05 V01r02. All LTE bandwidth conducted powers needed for PCC uplink configuration selection can be found in the RF Conducted Powers Section and LTE/NR Lower Bandwidth RF Conducted Power Appendix. The downlink PCC channel was paired with the selected PCC uplink channel according to normal configurations without carrier aggregation.
- To maximize aggregated bandwidth, highest channel bandwidth available for that CA combination was selected for SCC. For inter-band CA, the SCC downlink channels were selected near the middle of their transmission bands. For contiguous intra-band CA, the downlink channel spacing between the component carriers was set to multiple of 300 kHz less than the nominal channel spacing defined in section 5.4.1A of 3GPP TS 36.521. For non-contiguous intra-band CA, the downlink channel spacing between the component carriers was set to be larger than the nominal channel spacing and provided maximum separation between the component carriers.
- All selected PCC and SCC(s) remained fully within the uplink/downlink transmission band of the respective component carrier.

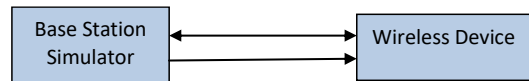

**Figure I-1**  
**DL CA Power Measurement Setup**

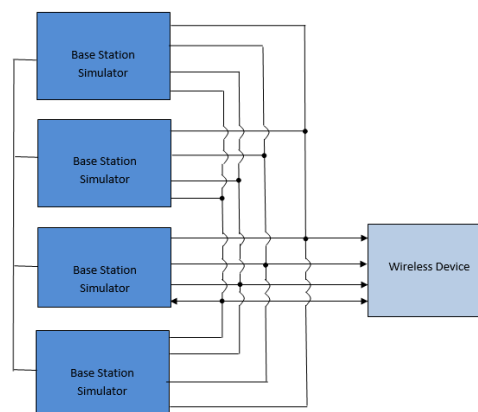

**Figure I-2**  
**DL CA with DL 4x4 MIMO Power Measurement Setup**

FCC ID: A3LSMS928B	SAR EVALUATION REPORT	Approved by: Technical Manager
DUT Type: Portable Handset		APPENDIX I: Page 2 of 5

## I.2 Downlink Carrier Aggregation RF Conducted Powers

### I.2.1 LTE Band 12 as PCC

Table I-3  
Maximum Output Powers

Combination	PCC								SCC 1				SCC 2				Power		
	PCC Band	PCC BW [MHz]	PCC (UL) Ch.	PCC (UL) Freq. [MHz]	Mod.	PCC UL# RB	PCC UL RB Offset	PCC (DL) Channel	PCC (DL) Freq. [MHz]	SCC Band	SCC BW [MHz]	SCC (DL) Channel	SCC (DL) Freq. [MHz]	SCC Band	SCC BW [MHz]	SCC (DL) Channel	SCC (DL) Freq. [MHz]	LTE Tx.Power with DL CA Enabled (dBm)	LTE Single Carrier Tx Power (dBm)
CA 2A-12A (1)	LTE B12	5	23095	707.5	QPSK	1	0	5095	737.5	LTE B2	20	900	1960	-	-	-	-	24.01	23.98
CA 4A-12A (1)	LTE B12	5	23095	707.5	QPSK	1	0	5095	737.5	LTE B4	20	2175	2132.5	-	-	-	-	24.02	23.98
CA 4A-12A (2)	LTE B12	5	23095	707.5	QPSK	1	0	5095	737.5	LTE B4	20	2175	2132.5	-	-	-	-	24.02	23.98
CA 12A-25A	LTE B12	5	23095	707.5	QPSK	1	0	5095	737.5	LTE B25	20	8365	1962.5	-	-	-	-	23.92	23.98
CA 12A-66A (1)	LTE B12	5	23095	707.5	QPSK	1	0	5095	737.5	LTE B66	20	66786	2145	-	-	-	-	24.03	23.98
CA 12A-66A (2)	LTE B12	5	23095	707.5	QPSK	1	0	5095	737.5	LTE B66	20	66786	2145	-	-	-	-	24.03	23.98
CA 4A-4A-12A	LTE B12	5	23095	707.5	QPSK	1	0	5095	737.5	LTE B4	20	2175	2132.5	LTE B4	10	2350	2150	23.95	23.98
CA 12A-66A-66A	LTE B12	5	23095	707.5	QPSK	1	0	5095	737.5	LTE B66	20	66786	2145	LTE B66	20	67236	2190	23.77	23.98

### I.2.2 LTE Band 13 as PCC

Table I-4  
Maximum Output Powers

Combination	PCC								SCC 1				SCC 2				Power		
	PCC Band	PCC BW [MHz]	PCC (UL) Ch.	PCC (UL) Freq. [MHz]	Mod.	PCC UL# RB	PCC UL RB Offset	PCC (DL) Channel	PCC (DL) Freq. [MHz]	SCC Band	SCC BW [MHz]	SCC (DL) Channel	SCC (DL) Freq. [MHz]	SCC Band	SCC BW [MHz]	SCC (DL) Channel	SCC (DL) Freq. [MHz]	LTE Tx.Power with DL CA Enabled (dBm)	LTE Single Carrier Tx Power (dBm)
CA 2A-13A (2)	LTE B13	5	23230	782	QPSK	1	0	5230	751	LTE B2	20	900	1960	-	-	-	-	24.20	24.23
CA 2A-4A-13A	LTE B13	10	23230	782	QPSK	1	0	5230	751	LTE B2	20	900	1960	LTE B4	20	2175	2132.5	24.15	24.22

### I.2.3 LTE Band 26 as PCC

Table I-5  
Maximum Output Powers

Combination	PCC								SCC 1				SCC 2				Power		
	PCC Band	PCC BW [MHz]	PCC (UL) Ch.	PCC (UL) Freq. [MHz]	Mod.	PCC UL# RB	PCC UL RB Offset	PCC (DL) Channel	PCC (DL) Freq. [MHz]	SCC Band	SCC BW [MHz]	SCC (DL) Channel	SCC (DL) Freq. [MHz]	SCC Band	SCC BW [MHz]	SCC (DL) Channel	SCC (DL) Freq. [MHz]	LTE Tx.Power with DL CA Enabled (dBm)	LTE Single Carrier Tx Power (dBm)
CA 2A-26A	LTE B26	15	26865	831.5	QPSK	1	0	8865	876.5	LTE B2	20	900	1960	-	-	-	-	23.91	23.92
CA 26A-41A	LTE B26	15	26865	831.5	QPSK	1	0	8865	876.5	LTE B41	20	40620	2593	-	-	-	-	23.75	23.92
CA 26A-41C	LTE B26	15	26865	831.5	QPSK	1	0	8865	876.5	LTE B41	20	40620	2593	LTE B41	20	40422	2573.2	23.95	23.92

### I.2.4 LTE Band 66 as PCC

Table I-6  
Maximum Output Powers

Combination	PCC								SCC 1				SCC 2				Power		
	PCC Band	PCC BW [MHz]	PCC (UL) Ch.	PCC (UL) Freq. [MHz]	Mod.	PCC UL# RB	PCC UL RB Offset	PCC (DL) Channel	PCC (DL) Freq. [MHz]	SCC Band	SCC BW [MHz]	SCC (DL) Channel	SCC (DL) Freq. [MHz]	SCC Band	SCC BW [MHz]	SCC (DL) Channel	SCC (DL) Freq. [MHz]	LTE Tx.Power with DL CA Enabled (dBm)	LTE Single Carrier Tx Power (dBm)
CA 2A-66A	LTE B66	10	132022	1715	QPSK	1	49	66486	2115	LTE B2	20	900	1960	-	-	-	-	23.42	23.36
CA 12A-66A (1)	LTE B66	10	132022	1715	QPSK	1	49	66486	2115	LTE B12	10	5095	737.5	-	-	-	-	23.43	23.36
CA 12A-66A (2)	LTE B66	10	132022	1715	QPSK	1	49	66486	2115	LTE B12	10	5095	737.5	-	-	-	-	23.43	23.36
CA 66B	LTE B66	10	132022	1715	QPSK	1	49	66486	2115	LTE B66	10	66585	2124.9	-	-	-	-	23.38	23.36
CA 2A-5A-66A	LTE B66	10	132022	1715	QPSK	1	49	66486	2115	LTE B2	20	900	1960	LTE B5	10	2525	881.5	23.43	23.36
CA 2A-66A-66A	LTE B66	10	132022	1715	QPSK	1	49	66486	2115	LTE B66	20	67236	2190	LTE B2	20	900	1960	23.37	23.36
CA 5A-66A-66A	LTE B66	10	132022	1715	QPSK	1	49	66486	2115	LTE B66	20	67236	2190	LTE B5	10	2525	881.5	23.42	23.36
CA 5A-66C	LTE B66	10	132022	1715	QPSK	1	49	66486	2115	LTE B66	20	66630	2129.4	LTE B5	10	2525	881.5	23.40	23.36
CA 12A-66A-66A	LTE B66	10	132022	1715	QPSK	1	49	66486	2115	LTE B66	20	67236	2190	LTE B12	10	5095	737.5	23.41	23.36

### I.2.5 LTE Band 25 as PCC

Table I-7  
Maximum Output Powers

Combination	PCC								SCC 1				Power		
	PCC Band	PCC BW [MHz]	PCC (UL) Ch.	PCC (UL) Freq. [MHz]	Mod.	PCC UL# RB	PCC UL RB Offset	PCC (DL) Channel	PCC (DL) Freq. [MHz]	SCC Band	SCC BW [MHz]	SCC (DL) Channel	SCC (DL) Freq. [MHz]	LTE Tx.Power with DL CA Enabled (dBm)	LTE Single Carrier Tx Power (dBm)
CA 12A-25A	LTE B25	10	26365	1882.5	QPSK	1	49	8365	1962.5	LTE B12	10	5095	737.5	23.57	23.61

FCC ID: A3LSMS928B	SAR EVALUATION REPORT	Approved by: Technical Manager
DUT Type: Portable Handset		APPENDIX I: Page 3 of 5

## I.2.6 LTE Band 41 as PCC

Table I-8  
Maximum Output Powers

Combination	PCC Band	PCC BW [MHz]	PCC										SCC 1				SCC 2				SCC 3				SCC 4				Power	
			PCC (UL) Ch.	PCC (UL) Freq. [MHz]	Mod.	PCC UL# RB	PCC UL RB Offset	PCC (DL) Channel	PCC (DL) Freq. [MHz]	SCC Band	SCC BW [MHz]	SCC (DL) Channel	SCC (DL) Freq. [MHz]	SCC Band	SCC BW [MHz]	SCC (DL) Channel	SCC (DL) Freq. [MHz]	SCC Band	SCC BW [MHz]	SCC (DL) Channel	SCC (DL) Freq. [MHz]	SCC Band	SCC BW [MHz]	SCC (DL) Channel	SCC (DL) Freq. [MHz]	LTE Tx Power with DL CA Enabled (dBm)	LTE Single Carrier Tx Power (dBm)			
CA 41A-41A (1)	LTE B41	10	41055	2636.5	QPSK	1	25	41055	2636.5	LTE B41	20	39750	2506	-	-	-	-	-	-	-	-	-	-	-	-	-	-	24.65	24.73	
CA 41A-41C	LTE B41	10	41055	2636.5	QPSK	1	25	41055	2636.5	LTE B41	20	39948	2525.8	LTE B41	20	39750	2506	-	-	-	-	-	-	-	-	-	-	-	24.65	24.73
CA 41C-41A	LTE B41	10	41055	2636.5	QPSK	1	25	41055	2636.5	LTE B41	20	40911	2622.1	LTE B41	20	39750	2506	-	-	-	-	-	-	-	-	-	-	-	24.73	24.73
CA 41A-41D	LTE B41	10	41055	2636.5	QPSK	1	25	41055	2636.5	LTE B41	20	40146	2545.6	LTE B41	20	39948	2525.8	LTE B41	20	39750	2506	-	-	-	-	-	-	-	24.73	24.73
CA 41D-41A	LTE B41	10	41055	2636.5	QPSK	1	25	41055	2636.5	LTE B41	20	40911	2622.1	LTE B41	20	40713	2602.3	LTE B41	20	39750	2506	-	-	-	-	-	-	-	24.65	24.73
CA 41C-41C	LTE B41	10	41055	2636.5	QPSK	1	25	41055	2636.5	LTE B41	20	40911	2622.1	LTE B41	20	39948	2525.8	LTE B41	20	39750	2506	-	-	-	-	-	-	-	24.67	24.73
CA 41E	LTE B41	20	41055	2636.5	QPSK	1	50	41055	2636.5	LTE B41	20	40887	2616.7	LTE B41	20	40659	2596.9	LTE B41	20	40481	2577.1	-	-	-	-	-	-	-	24.65	24.65
CA 41C-41D	LTE B41	10	41055	2636.5	QPSK	1	25	41055	2636.5	LTE B41	20	40911	2622.1	LTE B41	20	40146	2545.6	LTE B41	20	39948	2525.8	LTE B41	20	39750	2506	-	-	-	24.73	24.73
CA 41D-41C	LTE B41	10	41055	2636.5	QPSK	1	25	41055	2636.5	LTE B41	20	40911	2622.1	LTE B41	20	40713	2602.3	LTE B41	20	39948	2525.8	LTE B41	20	39750	2506	-	-	-	24.74	24.73

## I.3 DL CA with DL 4x4 MIMO RF Conduction Powers

This device supports downlink 4x4 MIMO operations for some LTE bands. Uplink transmission is limited to a single output stream. When carrier aggregation was applicable, the general test selection and setup procedures described in Section I.1 were applied.

Per May 2017 TCB Workshop Notes, SAR for 4x4 DL MIMO was not needed since the maximum average output power in 4x4 DL MIMO mode was not more than 0.25 dB higher than the maximum output power with 4x4 DL MIMO inactive. Additionally, SAR for 4x4 MIMO Downlink Carrier Aggregation was not needed since the maximum average output power in 4x4 MIMO Downlink Carrier Aggregation mode was not more than 0.25 dB higher than the maximum output power with 4x4 MIMO Downlink and downlink carrier aggregation inactive.

### I.3.1 LTE 4x4 MIMO DL Standalone Powers

Table I-9  
Maximum Output Powers

LTE Band	Bandwidth [MHz]	Channel	Frequency [MHz]	Modulation	RB Size	RB Offset	4x4 DL MIMO Tx. Power [dBm]	Single Antenna Tx. Power [dBm]	Target Power [dBm]
66	10	132022	1715	QPSK	1	49	23.26	23.36	23.0
41	10	41055	2636.5	QPSK	1	25	24.65	24.73	24.0

### I.3.2 LTE Band 12 as PCC

Table I-10  
Maximum Output Powers

Combination	PCC Band	PCC BW [MHz]	PCC										SCC 1				SCC 2				Power						
			PCC (UL) Ch.	PCC (UL) Freq. [MHz]	Mod.	PCC UL# RB	PCC UL RB Offset	PCC (DL) Ch.	PCC (DL) Freq. [MHz]	DL Ant. Config.	SCC Band	SCC BW [MHz]	SCC (DL) Ch.	SCC (DL) Freq. [MHz]	DL Ant. Config.	SCC Band	SCC BW [MHz]	SCC (DL) Ch.	SCC (DL) Freq. [MHz]	DL Ant. Config.	LTE Tx Power with DL CA Enabled (dBm)	LTE Single Carrier Tx Power (dBm)					
CA [4A]-[12A] (1)	LTE B12	5	23095	707.5	QPSK	1	0	5095	737.5	2x2	LTE B4	20	2175	2132.5	4x4	-	-	-	-	-	-	-	-	24.00	23.98		
CA [4A]-[12A] (2)	LTE B12	5	23095	707.5	QPSK	1	0	5095	737.5	2x2	LTE B4	20	2175	2132.5	4x4	-	-	-	-	-	-	-	-	-	24.00	23.98	
CA [12A]-[66A] (1)	LTE B12	5	23095	707.5	QPSK	1	0	5095	737.5	2x2	LTE B66	20	66786	2145	4x4	-	-	-	-	-	-	-	-	-	24.01	23.98	
CA [12A]-[66A] (2)	LTE B12	5	23095	707.5	QPSK	1	0	5095	737.5	2x2	LTE B66	20	66786	2145	4x4	-	-	-	-	-	-	-	-	-	24.01	23.98	
CA [4A]-[4A]-[12A]	LTE B12	5	23095	707.5	QPSK	1	0	5095	737.5	2x2	LTE B4	20	2175	2132.5	4x4	LTE B4	10	2350	2150	2x2	-	-	-	-	-	23.94	23.98
CA [4A]-[4A]-[12A]	LTE B12	5	23095	707.5	QPSK	1	0	5095	737.5	2x2	LTE B4	20	2175	2132.5	4x4	LTE B4	10	2350	2150	4x4	-	-	-	-	-	24.05	23.98
CA [12A]-[66A]-[66A]	LTE B12	5	23095	707.5	QPSK	1	0	5095	737.5	2x2	LTE B66	20	66786	2145	4x4	LTE B66	20	67236	2190	2x2	-	-	-	-	-	23.94	23.98
CA [12A]-[66A]-[66A]	LTE B12	5	23095	707.5	QPSK	1	0	5095	737.5	2x2	LTE B66	20	66786	2145	4x4	LTE B66	20	67236	2190	4x4	-	-	-	-	-	23.90	23.98

### I.3.3 LTE Band 13 as PCC

Table I-11  
Maximum Output Powers

FCC ID: A3LSMS928B	SAR EVALUATION REPORT	Approved by: Technical Manager
DUT Type: Portable Handset		APPENDIX I: Page 4 of 5

Combination	PCC Band	PCC										SCC 1				SCC 2				Power		
		PCC BW [MHz]	PCC [UL] Ch.	PCC [UL] Freq. [MHz]	Mod.	PCC UL/RB	PCC UL RB Offset	PCC [DL] Ch.	PCC [DL] Freq. [MHz]	DL Ant. Config.	SCC Band	SCC BW [MHz]	SCC [DL] Ch.	SCC [DL] Freq. [MHz]	DL Ant. Config.	SCC Band	SCC BW [MHz]	SCC [DL] Ch.	SCC [DL] Freq. [MHz]	DL Ant. Config.	LTE Tx Power with DL CA Enabled (dBm)	LTE Single Carrier Tx Power (dBm)
CA_2A-14A-13A	LTE B13	10	23230	782	QPSK	1	0	5230	751	2x2	LTE B2	20	900	1960	2x2	LTE B4	20	2175	2132.5	4x4	24.13	24.22

### I.3.4 LTE Band 26 as PCC

Table I-12  
Maximum Output Powers

Combination	PCC Band	PCC										SCC 1				SCC 2				Power		
		PCC BW [MHz]	PCC [UL] Ch.	PCC [UL] Freq. [MHz]	Mod.	PCC UL/RB	PCC UL RB Offset	PCC [DL] Ch.	PCC [DL] Freq. [MHz]	DL Ant. Config.	SCC Band	SCC BW [MHz]	SCC [DL] Ch.	SCC [DL] Freq. [MHz]	DL Ant. Config.	SCC Band	SCC BW [MHz]	SCC [DL] Ch.	SCC [DL] Freq. [MHz]	DL Ant. Config.	LTE Tx Power with DL CA Enabled (dBm)	LTE Single Carrier Tx Power (dBm)
CA_26A-14A	LTE B26	15	26865	831.5	QPSK	1	0	8865	876.5	2x2	LTE B41	20	40620	2593	4x4	-	-	-	-	-	23.88	23.92
CA_26A-14C	LTE B26	15	26865	831.5	QPSK	1	0	8865	876.5	2x2	LTE B41	20	40620	2593	4x4	LTE B41	20	40422	2573.2	4x4	23.96	23.92

### I.3.5 LTE Band 66 as PCC

Table I-13  
Maximum Output Powers

Combination	PCC Band	PCC										SCC 1				SCC 2				Power		
		PCC BW [MHz]	PCC [UL] Ch.	PCC [UL] Freq. [MHz]	Mod.	PCC UL/RB	PCC UL RB Offset	PCC [DL] Ch.	PCC [DL] Freq. [MHz]	DL Ant. Config.	SCC Band	SCC BW [MHz]	SCC [DL] Ch.	SCC [DL] Freq. [MHz]	DL Ant. Config.	SCC Band	SCC BW [MHz]	SCC [DL] Ch.	SCC [DL] Freq. [MHz]	DL Ant. Config.	LTE Tx Power with DL CA Enabled (dBm)	LTE Single Carrier Tx Power (dBm)
CA_2A-66A	LTE B66	10	132022	1715	QPSK	1	49	66486	2115	4x4	LTE B2	20	900	1960	2x2	-	-	-	-	-	23.29	23.36
CA_12A-66A (1)	LTE B66	10	132022	1715	QPSK	1	49	66486	2115	4x4	LTE B12	10	5095	737.5	2x2	-	-	-	-	-	23.32	23.36
CA_12A-66A (2)	LTE B66	10	132022	1715	QPSK	1	49	66486	2115	4x4	LTE B12	10	5095	737.5	2x2	-	-	-	-	-	23.32	23.36
CA_66B	LTE B66	10	132022	1715	QPSK	1	49	66486	2115	4x4	LTE B66	10	66585	2124.9	4x4	-	-	-	-	-	23.35	23.36
CA_2A-5A-66A	LTE B66	10	132022	1715	QPSK	1	49	66486	2115	4x4	LTE B2	20	900	1960	2x2	LTE B5	10	2525	881.5	2x2	23.30	23.36
CA_2A-66A-66A	LTE B66	10	132022	1715	QPSK	1	49	66486	2115	4x4	LTE B66	20	67236	2190	2x2	LTE B2	20	900	1960	2x2	23.37	23.36
CA_2A-66A-66A	LTE B66	10	132022	1715	QPSK	1	49	66486	2115	4x4	LTE B66	20	67236	2190	2x2	LTE B2	20	900	1960	2x2	23.32	23.36
CA_2A-66A-66A	LTE B66	10	132022	1715	QPSK	1	49	66486	2115	4x4	LTE B66	20	67236	2190	4x4	LTE B2	20	900	1960	2x2	23.30	23.36
CA_5A-66A-66A	LTE B66	10	132022	1715	QPSK	1	49	66486	2115	4x4	LTE B66	20	67236	2190	2x2	LTE B5	10	2525	881.5	2x2	23.38	23.36
CA_5A-66A-66A	LTE B66	10	132022	1715	QPSK	1	49	66486	2115	4x4	LTE B66	20	67236	2190	4x4	LTE B5	10	2525	881.5	2x2	23.36	23.36
CA_5A-66A-66A	LTE B66	10	132022	1715	QPSK	1	49	66486	2115	4x4	LTE B66	20	67236	2190	4x4	LTE B5	10	2525	881.5	2x2	23.37	23.36
CA_5A-66C	LTE B66	10	132022	1715	QPSK	1	49	66486	2115	4x4	LTE B66	20	66630	2129.4	4x4	LTE B5	10	2525	881.5	2x2	23.35	23.36
CA_12A-66A-66A	LTE B66	10	132022	1715	QPSK	1	49	66486	2115	4x4	LTE B66	20	67236	2190	2x2	LTE B12	10	5095	737.5	2x2	23.37	23.36
CA_12A-66A-66A	LTE B66	10	132022	1715	QPSK	1	49	66486	2115	2x2	LTE B66	20	67236	2190	4x4	LTE B12	10	5095	737.5	2x2	23.39	23.36
CA_12A-66A-66A	LTE B66	10	132022	1715	QPSK	1	49	66486	2115	4x4	LTE B66	20	67236	2190	4x4	LTE B12	10	5095	737.5	2x2	23.28	23.36

### I.3.6 LTE Band 41 as PCC

Table I-14  
Maximum Output Powers

Combination	PCC Band	PCC										SCC 1				SCC 2				SCC 3				SCC 4				Power							
		PCC BW [MHz]	PCC [UL] Ch.	PCC [UL] Freq. [MHz]	Mod.	PCC UL/RB	PCC UL RB Offset	PCC [DL] Ch.	PCC [DL] Freq. [MHz]	DL Ant. Config.	SCC Band	SCC BW [MHz]	SCC [DL] Ch.	SCC [DL] Freq. [MHz]	DL Ant. Config.	SCC Band	SCC BW [MHz]	SCC [DL] Ch.	SCC [DL] Freq. [MHz]	DL Ant. Config.	SCC Band	SCC BW [MHz]	SCC [DL] Ch.	SCC [DL] Freq. [MHz]	DL Ant. Config.	SCC Band	SCC BW [MHz]	SCC [DL] Ch.	SCC [DL] Freq. [MHz]	DL Ant. Config.	LTE Tx Power with DL CA Enabled (dBm)	LTE Single Carrier Tx Power (dBm)			
CA_41A-41A (1)	LTE B41	10	41055	2636.5	QPSK	1	25	41055	2636.5	4x4	LTE B41	20	39750	2506	2x2	-	-	-	-	-	-	-	-	-	-	-	-	-	-	-	-	-	24.66	24.73	
CA_41A-41A (1)	LTE B41	10	41055	2636.5	QPSK	1	25	41055	2636.5	2x2	LTE B41	20	39750	2506	4x4	-	-	-	-	-	-	-	-	-	-	-	-	-	-	-	-	-	24.66	24.73	
CA_41A-41A (1)	LTE B41	10	41055	2636.5	QPSK	1	25	41055	2636.5	4x4	LTE B41	20	39750	2506	4x4	-	-	-	-	-	-	-	-	-	-	-	-	-	-	-	-	-	24.66	24.73	
CA_41A-41C	LTE B41	10	41055	2636.5	QPSK	1	25	41055	2636.5	4x4	LTE B41	20	39948	2526.8	2x2	LTE B41	20	39750	2506	2x2	-	-	-	-	-	-	-	-	-	-	-	-	-	24.65	24.73
CA_41C-41A	LTE B41	10	41055	2636.5	QPSK	1	25	41055	2636.5	2x2	LTE B41	20	40911	2622.1	2x2	LTE B41	20	39750	2506	4x4	-	-	-	-	-	-	-	-	-	-	-	-	-	24.64	24.73
CA_41C-41C	LTE B41	10	41055	2636.5	QPSK	1	25	41055	2636.5	4x4	LTE B41	20	40911	2622.1	4x4	LTE B41	20	39750	2506	2x2	-	-	-	-	-	-	-	-	-	-	-	-	-	24.65	24.73
CA_41A-41C	LTE B41	10	41055	2636.5	QPSK	1	25	41055	2636.5	4x4	LTE B41	20	39948	2526.8	4x4	LTE B41	20	39750	2506	4x4	-	-	-	-	-	-	-	-	-	-	-	-	-	24.66	24.73
CA_41C-41A	LTE B41	10	41055	2636.5	QPSK	1	25	41055	2636.5	4x4	LTE B41	20	40911	2622.1	4x4	LTE B41	20	39750	2506	4x4	-	-	-	-	-	-	-	-	-	-	-	-	-	24.66	24.73
CA_41C-41C	LTE B41	10	41055	2636.5	QPSK	1	25	41055	2636.5	4x4	LTE B41	20	40911	2622.1	4x4	LTE B41	20	39948	2526.8	4x4	LTE B41	20	39750	2506	4x4	-	-	-	-	-	-	-	-	24.68	24.73
CA_41A-41C	LTE B41	10	41055	2636.5	QPSK	1	25	41055	2636.5	4x4	LTE B41	20	40911	2622.1	4x4	LTE B41	20	39948	2526.8	4x4	LTE B41	20	39750	2506	4x4	-	-	-	-	-	-	-	-	24.68	24.73
CA_41C-41A	LTE B41	10	41055	2636.5	QPSK	1	25	41055	2636.5	4x4	LTE B41	20	40911	2622.1	4x4	LTE B41	20	39948	2526.8	4x4	LTE B41	20	39750	2506	4x4	-	-	-	-	-	-	-	-	24.68	24.73
CA_41C-41C	LTE B41	10	41055	2636.5	QPSK	1	25	41055	2636.5	4x4	LTE B41	20	40911	2622.1	4x4	LTE B41	20	40146	2646.6	4x4	LTE B41	20	39948	2526.8	4x4	-	-	-	-	-	-	-	-	24.64	24.73
CA_41A-41C	LTE B41	10	41055	2636.5	QPSK	1	25	41055	2636.5	4x4	LTE B41	20	40911	2622.1	4x4	LTE B41	20	40146	2646.6	4x4	LTE B41	20	39948	2526.8	4x4	-	-	-	-	-	-	-	-	24.68	24.73
CA_41C-41A	LTE B41	10	41055	2636.5	QPSK	1	25	41055	2636.5	4x4	LTE B41	20	40911	2622.1	4x4	LTE B41	20	40146	2646.6	4x4	LTE B41	20	39948	2526.8	4x4	-	-	-	-	-	-	-	-	24.68	24.73
CA_41C-41C	LTE B41	10	41055	2636.5	QPSK	1	25	41055	2636.5	4x4	LTE B41	20	40911	2622.1	4x4	LTE B41	20	40146	2646.6	4x4	LTE B41	20	39948	2526.8	4x4	-	-	-	-	-	-	-	-	24.68	24.73

FCC ID: A3LSMS928B  
DUT Type:  
Portable Handset

SAR EVALUATION REPORT

Approved by:  
Technical Manager  
APPENDIX I:  
Page 5 of 5