

- SP

802.11 ax HE160 / UNII-7 / CH143 6665 MHz



- LP

802.11 ax HE160 / UNII-7 / CH143 6665 MHz

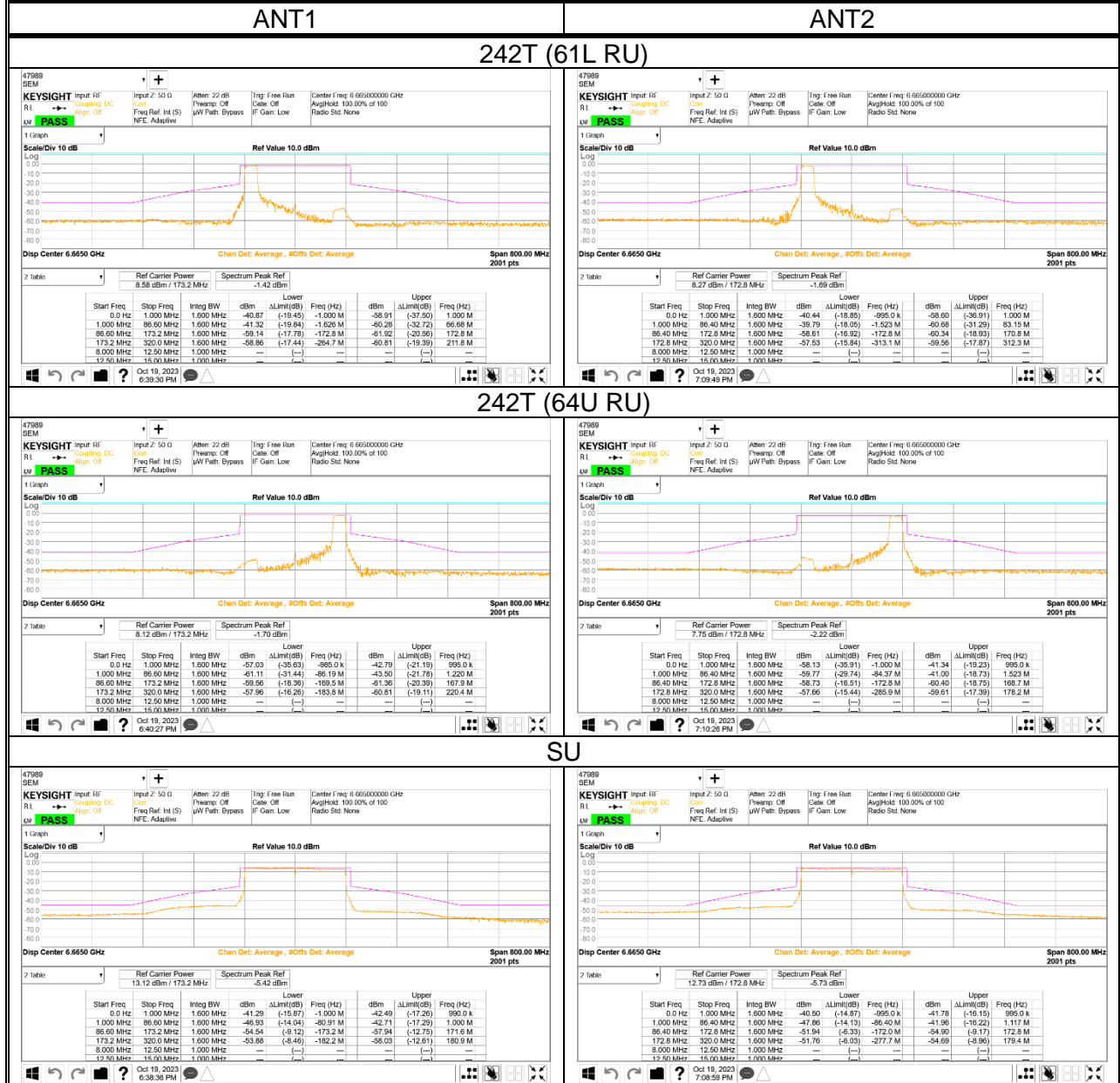

- LP

802.11 ax HE160 / UNII-7 / CH175 6825 MHz

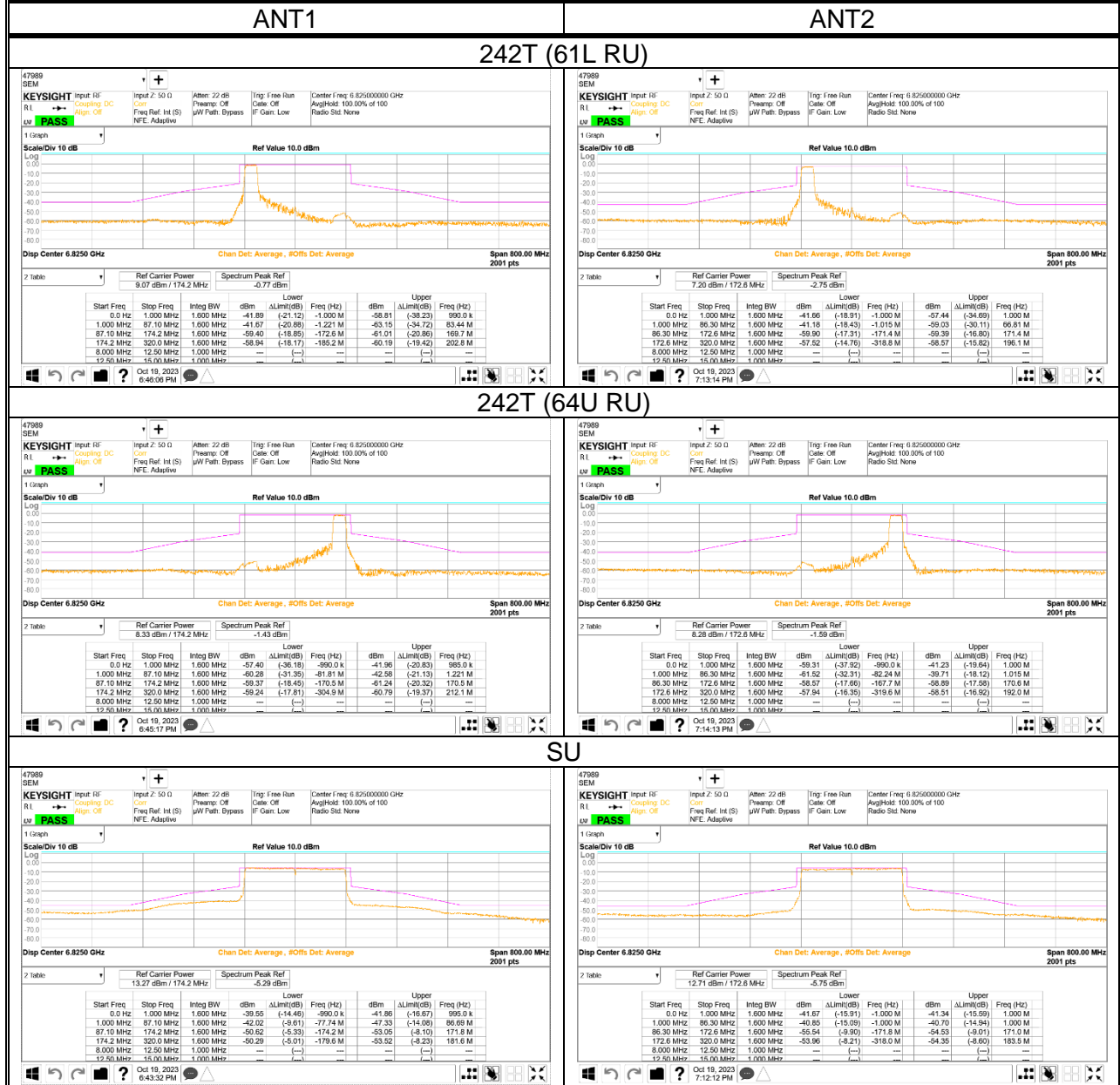

- LP

802.11 ax HE160 / UNII-8 / CH207 6985 MHz

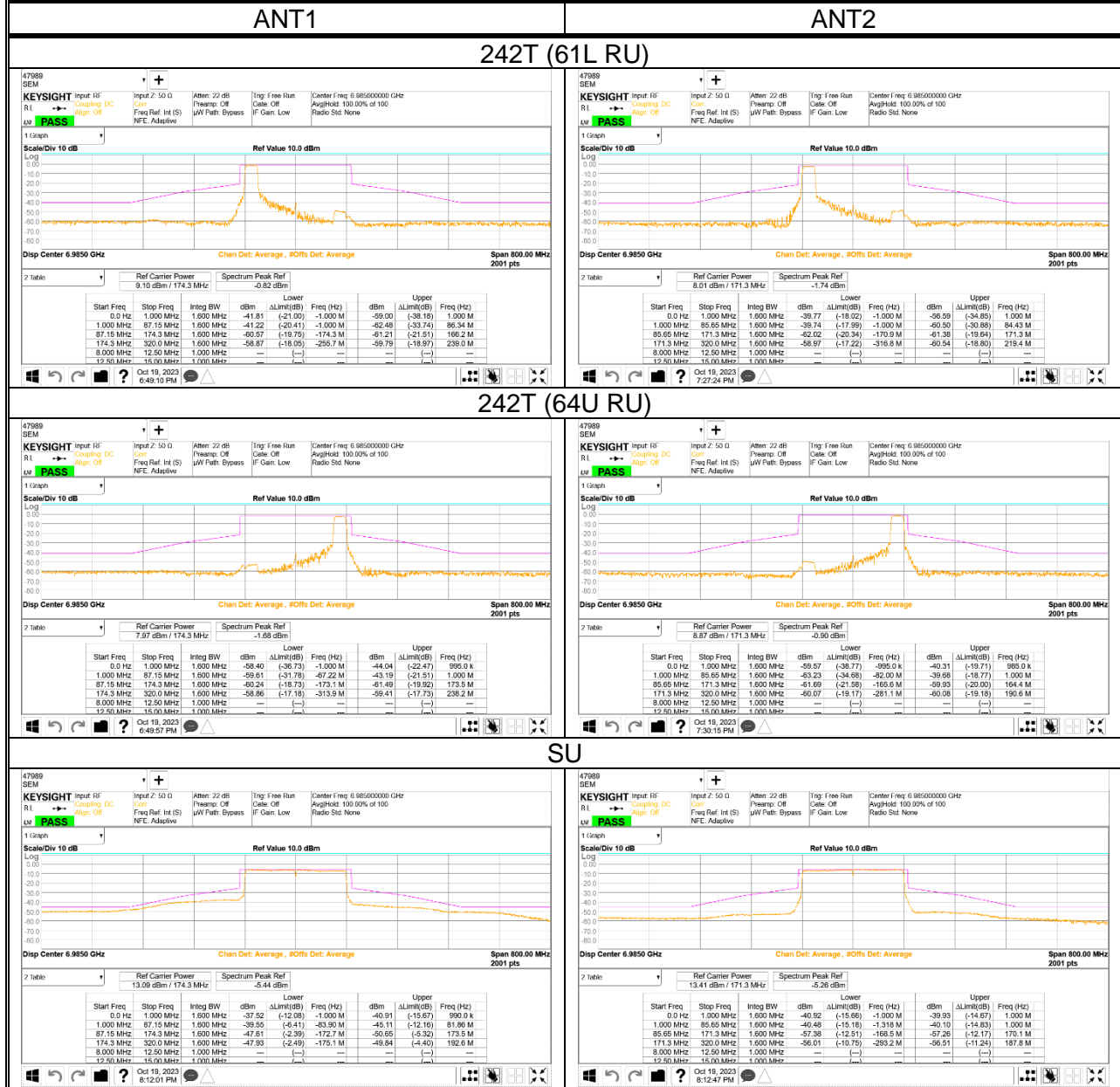

11. TRANSMITTER ABOVE 1 GHz

LIMITS

FCC §15.205 and §15.209

Limits for radiated disturbance of an intentional radiator		
Frequency range (MHz)	Limits (µV/m)	Measurement Distance (m)
0.009 – 0.490	2400 / F (kHz)	300
0.490 – 1.705	24000 / F (kHz)	30
1.705 – 30.0	30	30
30 – 88	100**	3
88 - 216	150**	3
216 – 960	200**	3
Above 960	500	3

** Except as provided in paragraph (g), fundamental emissions from intentional radiators operating under this section shall not be located in the frequency bands 54-72 MHz, 76-88 MHz, 174-216 MHz or 470-806 MHz. However, operation within these frequency bands is permitted under other sections of this part, e.g. §§ 15.231 and 15.241.

FCC Part 15.205 (a) : Only spurious emissions are permitted in any of the frequency bands listed below :

MHz	MHz	MHz	MHz	GHz	GHz
0.009 ~ 0.110	8.41425 ~ 8.41475	108 ~ 121.94	1300 ~ 1427	4.5 ~ 5.15	14.47 ~ 14.5
0.495 ~ 0.505	12.29 ~ 12.293	123 ~ 138	1435 ~ 1626.5	5.35 ~ 5.46	15.35 ~ 16.2
2.1735 ~ 2.1905	12.51975 ~ 12.52025	149.9 ~ 150.05	1645.5 ~ 1646.5	7.25 ~ 7.75	17.7 ~ 21.4
4.125 ~ 4.128	12.57675 ~ 12.57725	156.52475 ~ 156.52525	1660 ~ 1710	8.025 ~ 8.5	22.01 ~ 23.12
4.17725 ~ 4.17775	13.36 ~ 13.41	156.7 ~ 156.9	1718.8 ~ 1722.2	9.0 ~ 9.2	23.6 ~ 24.0
4.20725 ~ 4.20775	16.42 ~ 16.423	162.0125 ~ 167.17	2200 ~ 2300	9.3 ~ 9.5	31.2 ~ 31.8
6.215 ~ 6.218	16.69475 ~ 16.69525	167.72 ~ 173.2	2310 ~ 2390	10.6 ~ 12.7	36.43 ~ 36.5
6.26775 ~ 6.26825	16.80425 ~ 16.80475	240 ~ 285	2483.5 ~ 2500	13.25 ~ 13.4	Above 38.6
6.31175 ~ 6.31225	25.5 ~ 25.67	322 ~ 335.4	2655 ~ 2900		
8.291 ~ 8.294	37.5 ~ 38.25	399.90 ~ 410	3260 ~ 3267		
8.362 ~ 8.366	73 ~ 74.6	608 ~ 614	3332 ~ 3339		
8.37625 ~ 8.38675	74.8 ~ 75.2	960 ~ 1240	3345.8 ~ 3358 3600 ~ 4400		

▪ FCC Part 15.205(b) : The field strength of emissions appearing within these frequency bands shall not exceed the limits shown in §15.209. At frequencies equal to or less than 1000 MHz, compliance with the limits in §15.209 shall be demonstrated using measurement instrumentation employing a CISPR quasi-peak detector. Above 1000 MHz, compliance with the emission limits in §15.209 shall be demonstrated based on the average value of the measured emissions. The provisions in §15.35 apply to these measurements.

FCC §15.407 (b)

(6) For transmitters operating within the 5.925-7.125 GHz band: Any emissions outside of the 5.925-7.125 GHz band must not exceed an e.i.r.p. of -27 dBm/MHz.

(8) The emission measurements shall be performed using a minimum resolution bandwidth of 1 MHz. A lower resolution bandwidth may be employed near the band edge, when necessary, provided the measured energy is integrated to show the total power over 1 MHz.

(9) Unwanted emissions below 1 GHz must comply with the general field strength limits set forth in §15.209. Further, any U-NII devices using an AC power line are required to comply also with the conducted limits set forth in §15.207.

(10) The provisions of §15.205 apply to intentional radiators operating under this section.

(11) When measuring the emission limits, the nominal carrier frequency shall be adjusted as close to the upper and lower frequency band edges as the design of the equipment permits.

Note

- Limit translation to field strength level (FCC §15.407)

$$E[\text{dBuV/m}] = \text{EIRP}[\text{dBm}] + 95.2 = -27\text{dBm} + 95.2 = 68.2\text{dBuV/m}$$

TEST PROCEDURE

The EUT is placed on a non-conducting table 80 cm above the ground plane for below 1GHz and 100 cm for above 1GHz. EUT is set 3 meters away from the receiving antenna and scan from 1m to 4m to find out the highest emission.

The EUT is configured in accordance with ANSI C63.10. The EUT is set to transmit in a continuous mode.

For measurements below 1 GHz the resolution bandwidth is set to 100 kHz for peak detection measurements or 120 kHz for quasi-peak detection measurements. Peak detection is used unless otherwise noted as quasi-peak.

Reference to KDB 789033 D02 v02r01 UNII part G) 6) c) Method AD:

For measurements above 1 GHz the resolution bandwidth is set to 1 MHz; the video bandwidth is set to 3 MHz for peak measurements and add duty cycle factor to the reading offset for average measurements.

Pre-scans to detect harmonic and spurious emissions, the resolution bandwidth is set to 1 MHz; the video bandwidth is set to 30 kHz for peak measurements.

Radiated harmonics spurious 1~18 GHz Low/Mid/High channels,18-40GHz were performed with the EUT set at the 2TX MIMO mode.

(From 30MHz to 1GHz, test was performed with the EUT set to transmit at the channel with highest output power)

The frequency range of interest is monitored at a fixed antenna height and EUT azimuth. The EUT is rotated through 360 degrees to maximize emissions received. The antenna is scanned from 1 to 4 meters above the ground plane to further maximize the emission. Measurements are made with the antenna polarized in both the vertical and the horizontal positions.

Note : Emission was pre-scanned from 9kHz to 30MHz; No emissions were detected which was at least 20dB below the specification limit (consider distance correction factor).

Per FCC part 15.31(o), test results were not reported.

Although these tests were performed other than open field test site, adequate comparison measurements were confirmed against 30 m open are test site.

Therefore sufficient tests were made to demonstrate that the alternative site produces results that correlate with the one of tests made in an open field based on KDB 414788.

11.1. TX ABOVE 1GHz 2Tx MODE IN U-NII-5 BAND

BANDEDGE (WORST CASE: 802.11ax HE80 / 5985 MHz / SU)

HORIZONTAL PEAK AND AVERAGE DATA

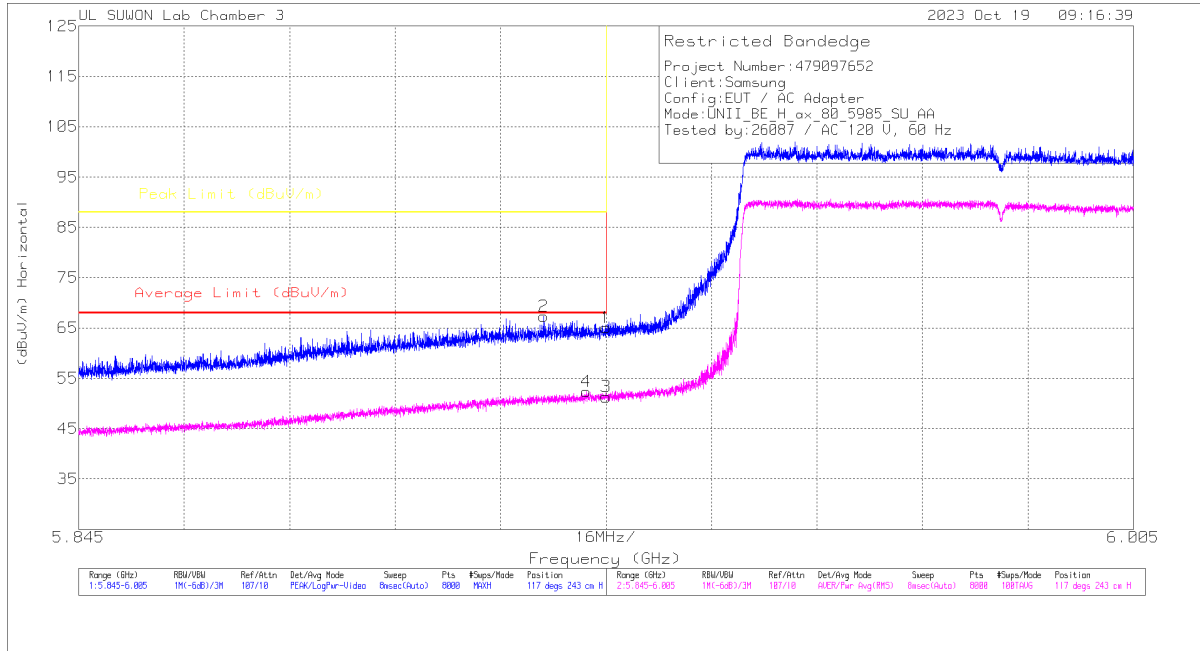

Trace Markers

Marker	Frequency (GHz)	Meter Reading (dBuV)	Det	3117_00218957	10dB_ATT(dB)	DC Corr (dB)	Corrected Reading (dBuV/m)	Average Limit (dBuV/m)	Margin (dB)	Peak Limit (dBuV/m)	PK Margin (dB)	Altitude (Degs)	Height (cm)	Polarity
1	5.92499	48.96	PK	35.5	-19.4	0	65.06	-	-	88	-22.94	117	243	H
2	5.91549	51.26	PK	35.5	-19.4	0	67.36	-	-	88	-20.64	117	243	H
3	5.92499	35.22	RMS	35.5	-19.4	0	51.32	68	-16.68	-	-	117	243	H
4	5.92201	36.15	RMS	35.5	-19.3	0	52.35	68	-15.65	-	-	117	243	H

PK - Peak detector
 RMS - RMS detection

BANDEDGE TEST DATA

Mode	Freq. [MHz]	Antenna	Frequency [GHz]	Reading [dBuV]	Detector Mode	ANT Factor [dB(1/m)]	Loss [dB]	DC Corr [dB]	Result [dBuV/m]	AV Limit [dBuV/m]	AV Margin [dB]	PK Limit [dBuV/m]	PK Margin [dB]	Azimuth [Degs]	Height [cm]	Polarity
802.11a	5955	MIMO	5.92499	37.15	Pk	35.50	-19.40	0.00	53.25	-	-	88.00	-34.75	117	242	H
			5.92475	39.84	Pk	35.50	-19.40	0.00	55.94	-	-	88.00	-32.06	117	242	H
			5.92499	26.38	RMS	35.50	-19.40	0.15	42.63	68.00	-25.37	-	-	117	242	H
			5.91893	27.77	RMS	35.50	-19.40	0.15	44.02	68.00	-23.98	-	-	117	242	H
			5.92499	37.27	Pk	35.50	-19.40	0.00	53.37	-	-	88.00	-34.63	92	115	V
			5.91427	39.68	Pk	35.50	-19.40	0.00	55.78	-	-	88.00	-32.22	92	115	V
			5.92499	26.86	RMS	35.50	-19.40	0.15	43.11	68.00	-24.89	-	-	92	115	V
802.11ax (HE20) SU	5955	MIMO	5.91253	27.84	RMS	35.50	-19.40	0.15	44.09	68.00	-23.91	-	-	92	115	V
			5.92499	38.23	Pk	35.50	-19.40	0.00	54.33	-	-	88.00	-33.67	115	232	H
			5.92157	40.19	Pk	35.50	-19.30	0.00	56.39	-	-	88.00	-31.61	115	232	H
			5.92499	29.20	RMS	35.50	-19.40	0.00	45.30	68.00	-22.70	-	-	115	232	H
			5.92195	29.18	RMS	35.50	-19.30	0.00	45.38	68.00	-22.62	-	-	115	232	H
			5.92499	39.18	Pk	35.50	-19.40	0.00	55.28	-	-	88.00	-32.72	94	101	V
			5.92427	40.27	Pk	35.50	-19.40	0.00	56.37	-	-	88.00	-31.63	94	101	V
802.11ax (HE40) SU mode	5965	MIMO	5.92499	28.23	RMS	35.50	-19.40	0.00	44.33	68.00	-23.67	-	-	94	100	V
			5.92459	28.95	RMS	35.50	-19.40	0.00	45.05	68.00	-22.95	-	-	94	100	V
			5.92499	41.68	Pk	35.50	-19.40	0.00	57.78	-	-	88.00	-30.22	117	242	H
			5.92389	44.64	Pk	35.50	-19.40	0.00	60.74	-	-	88.00	-27.26	117	242	H
			5.92499	31.32	RMS	35.50	-19.40	0.00	47.42	68.00	-20.58	-	-	117	242	H
			5.92455	32.36	RMS	35.50	-19.40	0.00	48.46	68.00	-19.54	-	-	117	242	H
			5.92499	42.11	Pk	35.50	-19.40	0.00	58.21	-	-	88.00	-29.79	93	103	V
802.11ax (HE80) SU mode	5985	MIMO	5.92157	44.36	Pk	35.50	-19.30	0.00	60.56	-	-	88.00	-27.44	93	103	V
			5.92499	30.69	RMS	35.50	-19.40	0.00	46.79	68.00	-21.21	-	-	93	103	V
			5.92447	31.92	RMS	35.50	-19.40	0.00	48.02	68.00	-19.98	-	-	93	103	V
			5.92499	48.96	Pk	35.50	-19.40	0.00	65.06	-	-	88.00	-22.94	117	243	H
			5.91549	51.26	Pk	35.50	-19.40	0.00	67.36	-	-	88.00	-20.64	117	243	H
			5.92499	35.22	RMS	35.50	-19.40	0.00	51.32	68.00	-16.68	-	-	117	243	H
			5.92201	36.15	RMS	35.50	-19.30	0.00	52.35	68.00	-15.65	-	-	117	243	H
802.11ax (HE160) SU mode	6025	MIMO	5.92499	46.46	Pk	35.50	-19.40	0.00	62.56	-	-	88.00	-25.44	92	114	V
			5.92397	49.97	Pk	35.50	-19.40	0.00	66.07	-	-	88.00	-21.93	92	114	V
			5.92499	35.45	RMS	35.50	-19.40	0.00	51.55	68.00	-16.45	-	-	92	114	V
			5.92335	36.24	RMS	35.50	-19.40	0.00	52.34	68.00	-15.66	-	-	92	114	V
			5.92499	46.62	Pk	35.50	-19.40	0.00	62.72	-	-	88.00	-25.28	117	243	H
			5.92347	48.56	Pk	35.50	-19.40	0.00	64.66	-	-	88.00	-23.34	117	243	H
			5.92499	32.49	RMS	35.50	-19.40	0.00	48.59	68.00	-19.41	-	-	117	243	H
802.11ax (HE160) SU mode	6025	MIMO	5.91401	33.30	RMS	35.50	-19.40	0.00	49.40	68.00	-18.60	-	-	117	243	H
			5.92499	44.27	Pk	35.50	-19.40	0.00	60.37	-	-	88.00	-27.63	96	103	V
			5.92027	47.45	Pk	35.50	-19.40	0.00	63.55	-	-	88.00	-24.45	96	103	V
			5.92499	30.99	RMS	35.50	-19.40	0.00	47.09	68.00	-20.91	-	-	96	103	V
			5.92397	33.02	RMS	35.50	-19.40	0.00	49.12	68.00	-18.88	-	-	96	103	V

Note1. Pk - Peak detector, RMS - RMS detector
 Note2. * - indicates frequency in CFR47 Pt 15 / IC RSS-Restricted Band

HARMONICS AND SPURIOUS EMISSIONS(WORST CASE: 802.11ax HE20 6415 MHz / 52T / 37RU)

HORIZONTAL

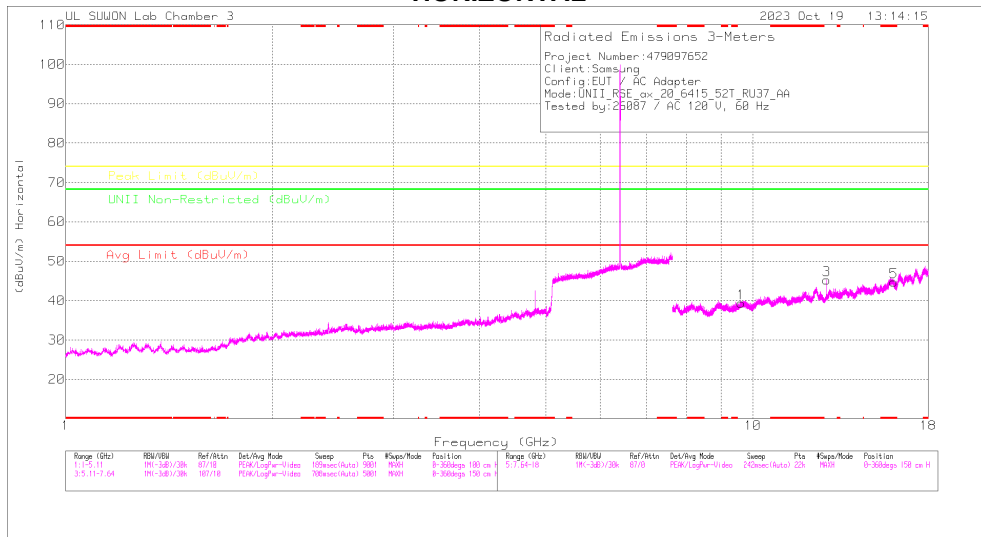

VERTICAL

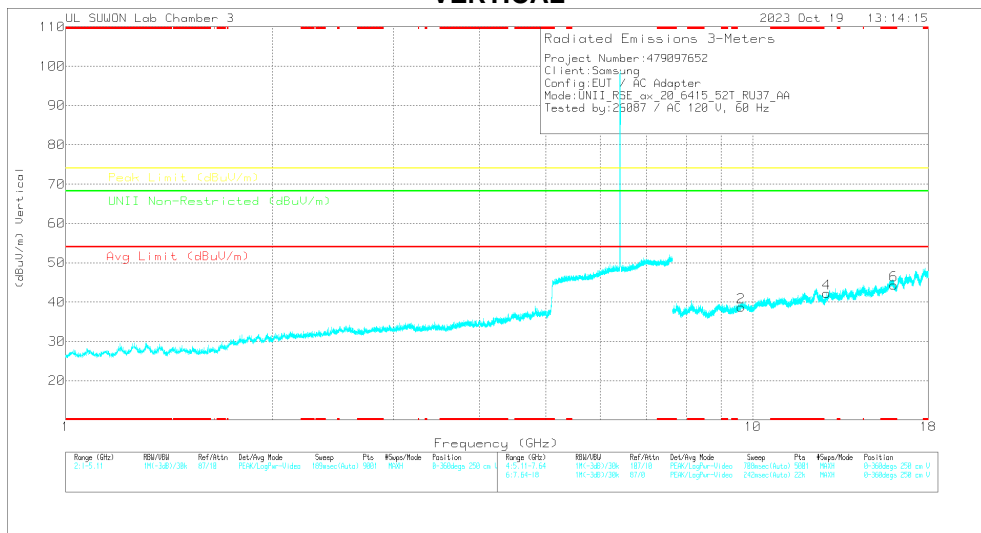

Note: Emission was scanned up to 40GHz; No emissions were detected above the noise floor which was at least 20dB below the specification limit.

Radiated Emissions

Frequency (GHz)	Meter Reading (dBuV)	Dir	3117_00218957	ICHz_HF(MHz)	DC Corr (dB)	Corrected Reading (dBuV/m)	Avg Limit (dBuV/m)	Margin (dB)	Peak Limit (dBuV/m)	Margin (dB)	UNII Non-Restricted (dBuV/m)	Margin (dB)	Azimuth (Deg)	Height (m)	Polarity
9.62371	34.27	PK-U	36.7	-21.7	0	49.27	-	-	-	-	68.2	-18.93	0	100	H
9.62128	34.13	PK-U	36.7	-21.7	0	49.13	-	-	-	-	68.2	-19.07	0	100	V
12.81815	40.93	PK-U	39.3	-22.7	0	57.53	-	-	-	-	68.2	-10.67	228	185	H
12.81898	35.35	PK-U	39.3	-22.7	0	51.95	-	-	-	-	68.2	-16.25	0	100	V
*16.03676	33.4	PK-U	41.1	-19.9	0	54.6	-	-	74	-19.4	-	-	0	100	H
*16.03694	33.45	PK-U	41.1	-19.9	0	54.65	-	-	74	-19.35	-	-	0	100	V
*16.03676	21.02	ADR	41.1	-19.9	0	42.22	54	-11.78	-	-	-	-	0	100	H
*16.03694	21.42	ADR	41.1	-19.9	0	42.62	54	-11.38	-	-	-	-	0	100	V

* - indicates frequency in CFR47 Pt 15 / IC RSS-Restricted Band
 PK-U - U-NII: Maximum Peak
 ADR - U-NII AD primary method, RMS average

HARMONICS AND SPOURIOUS EMISSIONS TEST DATA

Mode	Freq. [MHz]	Antenna	Frequency [GHz]	Reading [dBuV]	Detector Mode	ANT Factor [dB(1/m)]	Loss [dB]	DC Corr [dB]	Result [dBuV/m]	AV Limit [dBuV/m]	AV Margin [dB]	PK Limit [dBuV/m]	PK Margin [dB]	Non-Restricted [dBuV/m]	Margin [dB]	Azimuth [Degs]	Height [cm]	Polarity		
802.11a	5955	MIMO	8.93275	34.97	PK-U	36.20	-22.50	0.00	48.67	-	-	-	-	68.20	-19.53	0	100	H		
			8.93281	35.44	PK-U	36.20	-22.50	0.00	49.14	-	-	-	-	68.20	-19.06	0	100	V		
			*11.91059	35.19	PK-U	38.60	-22.00	0.00	51.79	-	-	74.00	-22.21	-	-	-	0	100	H	
			*11.91048	34.87	PK-U	38.60	-22.00	0.00	51.47	-	-	74.00	-22.53	-	-	-	0	100	V	
			14.88743	35.76	PK-U	39.80	-22.10	0.00	53.46	-	-	-	-	-	-	68.20	-14.74	0	100	H
			14.88752	35.37	PK-U	39.80	-22.10	0.00	53.07	-	-	-	-	-	-	68.20	-15.13	0	100	V
	6175	MIMO	9.26291	33.85	PK-U	36.50	-22.00	0.00	48.35	-	-	-	-	-	68.20	-19.85	1	100	H	
			9.26259	33.41	PK-U	36.50	-22.00	0.00	47.91	-	-	-	-	-	68.20	-20.29	1	100	V	
			*12.35049	35.31	PK-U	39.20	-21.70	0.00	52.81	-	-	74.00	-21.19	-	-	-	1	100	H	
			*12.35021	34.75	PK-U	39.20	-21.70	0.00	52.25	-	-	74.00	-21.75	-	-	-	1	100	V	
			*15.43788	34.45	PK-U	40.00	-21.50	0.00	52.95	-	-	74.00	-21.05	-	-	-	1	100	H	
			*15.43801	34.89	PK-U	40.00	-21.50	0.00	53.39	-	-	74.00	-20.61	-	-	-	1	100	V	
	6415	MIMO	9.62264	34.69	PK-U	36.70	-21.70	0.00	49.69	-	-	-	-	-	68.20	-18.51	0	100	H	
			9.62248	34.19	PK-U	36.70	-21.70	0.00	49.19	-	-	-	-	-	68.20	-19.01	0	100	V	
			12.83049	35.16	PK-U	39.30	-22.60	0.00	51.86	-	-	-	-	-	68.20	-16.34	0	100	H	
			12.83079	35.19	PK-U	39.30	-22.70	0.00	51.79	-	-	-	-	-	68.20	-16.41	0	100	V	
			*16.03724	33.79	PK-U	41.10	-19.80	0.00	55.09	-	-	74.00	-18.91	-	-	-	0	100	H	
			*16.03716	33.92	PK-U	41.10	-19.80	0.00	55.22	-	-	74.00	-18.78	-	-	-	0	100	V	
	802.11ax (HE20) RU mode 52Tone offset 37 Spot-Check	6415	MIMO	*16.03724	21.70	ADR	41.10	-19.80	0.15	43.15	54.00	-10.85	-	-	-	-	0	100	H	
				*16.03716	21.55	ADR	41.10	-19.80	0.15	43.00	54.00	-11.00	-	-	-	-	0	100	V	
				9.62371	34.27	PK-U	36.70	-21.70	0.00	49.27	-	-	-	-	-	68.20	-18.93	0	100	H
				9.62128	34.13	PK-U	36.70	-21.70	0.00	49.13	-	-	-	-	-	68.20	-19.07	0	100	V
				12.81615	40.93	PK-U	39.30	-22.70	0.00	57.53	-	-	-	-	-	68.20	-10.67	226	185	H
				12.81698	35.35	PK-U	39.30	-22.70	0.00	51.95	-	-	-	-	-	68.20	-16.25	0	100	V
6405		MIMO	*16.03676	33.40	PK-U	41.10	-19.90	0.00	54.80	-	-	74.00	-19.40	-	-	0	100	H		
			*16.03694	33.45	PK-U	41.10	-19.90	0.00	54.65	-	-	74.00	-19.35	-	-	0	100	V		
			*16.03676	21.02	ADR	41.10	-19.90	0.00	42.22	54.00	-11.78	-	-	-	-	0	100	H		
			*16.03694	21.42	ADR	41.10	-19.90	0.00	42.62	54.00	-11.38	-	-	-	-	0	100	V		
			9.60776	34.34	PK-U	36.70	-21.80	0.00	49.24	-	-	-	-	-	68.20	-18.96	0	100	H	
			9.60775	34.49	PK-U	36.70	-21.80	0.00	49.39	-	-	-	-	-	68.20	-18.81	0	100	V	
6385		MIMO	12.81052	34.86	PK-U	39.30	-22.70	0.00	51.46	-	-	-	-	-	68.20	-16.74	0	100	H	
			12.81041	35.07	PK-U	39.30	-22.70	0.00	51.67	-	-	-	-	-	68.20	-16.53	0	100	V	
			*16.01261	33.96	PK-U	41.00	-19.90	0.00	55.06	-	-	74.00	-18.94	-	-	0	100	H		
			*16.01258	34.22	PK-U	41.00	-19.90	0.00	55.32	-	-	74.00	-18.68	-	-	0	100	V		
			*16.01261	21.88	ADR	41.00	-19.90	0.00	42.98	54.00	-11.02	-	-	-	-	0	100	H		
			*16.01258	21.92	ADR	41.00	-19.90	0.00	43.02	54.00	-10.98	-	-	-	-	0	100	V		
802.11ax (HE80) RU mode 52Tone offset 37 Spot-Check		6345	MIMO	9.57785	34.16	PK-U	36.70	-21.70	0.00	49.16	-	-	-	-	68.20	-19.04	0	100	H	
				9.57773	34.01	PK-U	36.70	-21.70	0.00	49.01	-	-	-	-	-	68.20	-19.19	0	100	V
				12.77098	34.14	PK-U	39.20	-22.70	0.00	50.64	-	-	-	-	-	68.20	-17.56	0	100	H
				12.77061	34.61	PK-U	39.20	-22.70	0.00	51.11	-	-	-	-	-	68.20	-17.09	0	100	V
				*15.96252	34.29	PK-U	40.90	-19.90	0.00	55.29	-	-	74.00	-18.71	-	-	0	100	H	
				*15.96234	34.92	PK-U	40.90	-19.90	0.00	55.32	-	-	74.00	-18.08	-	-	0	100	V	
802.11ax (HE160) RU mode 52Tone offset 37 Spot-Check	6345	MIMO	*15.96252	22.15	ADR	40.90	-19.90	0.00	43.15	54.00	-10.85	-	-	-	-	0	100	H		
			*15.96234	22.11	ADR	40.90	-19.90	0.00	43.11	54.00	-10.89	-	-	-	-	0	100	V		
			9.51757	33.98	PK-U	36.70	-21.80	0.00	48.88	-	-	-	-	-	68.20	-19.32	0	100	H	
			9.51755	33.96	PK-U	36.70	-21.80	0.00	48.86	-	-	-	-	-	68.20	-19.34	0	100	V	
			*12.69041	34.46	PK-U	39.20	-22.70	0.00	50.96	-	-	74.00	-23.04	-	-	0	100	H		
			*12.69022	34.52	PK-U	39.20	-22.70	0.00	51.02	-	-	74.00	-22.98	-	-	0	100	V		
6345	MIMO	*15.86261	34.77	PK-U	40.70	-20.60	0.00	54.87	-	-	74.00	-19.13	-	-	0	100	H			
		*15.86279	34.57	PK-U	40.70	-20.60	0.00	54.67	-	-	74.00	-19.33	-	-	0	100	V			
		*15.86261	22.32	ADR	40.70	-20.60	0.00	42.42	54.00	-11.58	-	-	-	-	0	100	H			
		*15.86279	22.30	ADR	40.70	-20.60	0.00	42.40	54.00	-11.60	-	-	-	-	0	100	V			

Note1. PK-U - U-NII: Maximum Peak, ADR - U-NII AD primary method, RMS average
 Note2. * - indicates frequency in CFR47 Pt 15 / IC RSS-Restricted Band

11.2. TX ABOVE 1GHz 2Tx MODE IN U-NII-6 BAND

HARMONICS AND SPURIOUS EMISSIONS(WORST CASE: 802.11a / 6435 MHz)

HORIZONTAL

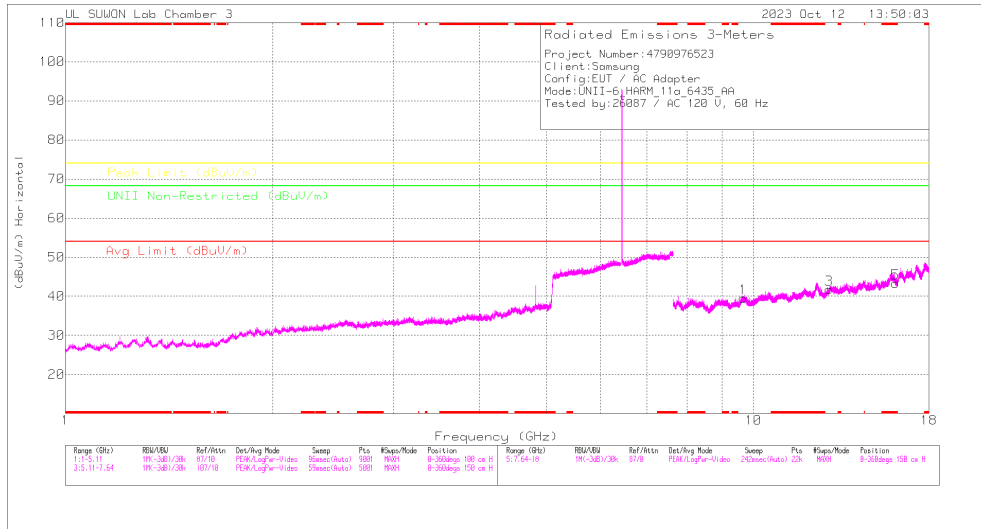

VERTICAL

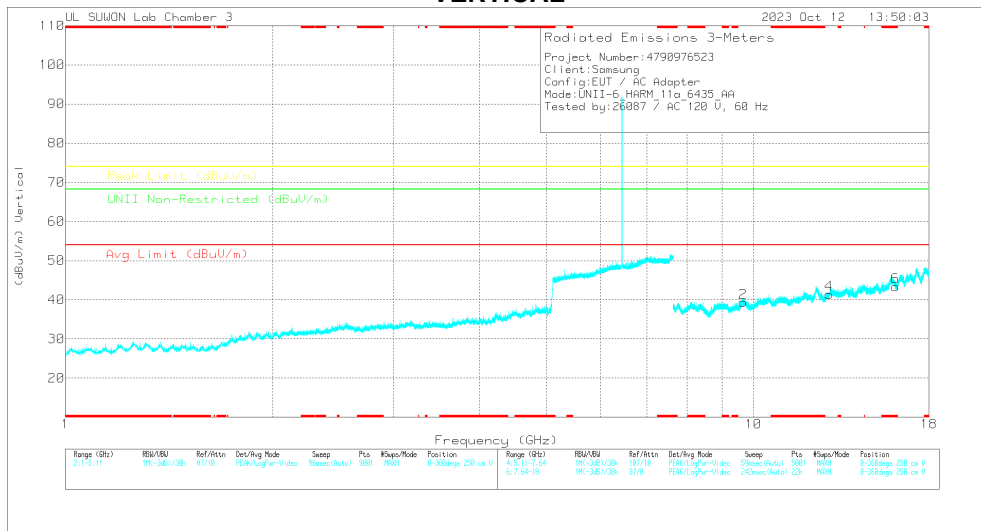

Note: Emission was scanned up to 40GHz; No emissions were detected above the noise floor which was at least 20dB below the specification limit.

Radiated Emissions

Frequency (GHz)	Meas Reading (dBuV/m)	Det	3177_30219857	ISGz(H/98)	DC Corr (dB)	Conducted Reading (dBuV/m)	Avg Limit (dBuV/m)	Margin (dB)	Peak Limit (dBuV/m)	Margin (dB)	UNII Non-Restricted (dBuV/m)	Margin (dB)	Altitude (Degs)	Height (cm)	Polarity
9.6525	34.56	PK-U	36.8	-21.7	0	49.66	-	-	-	-	68.2	-18.54	0	100	H
9.6543	34.41	PK-U	36.8	-21.7	0	49.51	-	-	-	-	68.2	-18.69	0	100	V
12.87078	35.69	PK-U	39.3	-22.5	0	52.49	-	-	-	-	68.2	-15.71	0	100	H
12.87082	34.86	PK-U	39.3	-22.5	0	51.66	-	-	-	-	68.2	-16.54	0	100	V
*16.08778	33.38	PK-U	41.1	-19.9	0	54.58	-	-	74	-19.42	-	-	0	100	H
**16.0876	33.52	PK-U	41.1	-19.9	0	54.72	-	-	74	-19.28	-	-	0	100	V
*16.08778	21.02	ADR	41.1	-19.9	15	42.37	54	-11.63	-	-	-	-	0	100	H
*16.0876	22.14	ADR	41.1	-19.9	15	43.49	54	-10.51	-	-	-	-	0	100	V

* - indicates frequency in CFR47 Pt 15 / IC RSS-Restricted Band
 PK-U - U-NII: Maximum Peak
 ADR - U-NII AD primary method, RMS average

HARMONICS AND SPURIOUS EMISSIONS TEST DATA

Mode	Freq. [MHz]	Antenna	Frequency [GHz]	Reading [dBuV]	Detector Mode	ANT Factor [dB(1/m)]	Loss [dB]	DC Corr [dB]	Result [dBuV/m]	AV Limit [dBuV/m]	AV Margin [dB]	PK Limit [dBuV/m]	PK Margin [dB]	Non-Restricted [dBuV/m]	Margin [dB]	Azimuth [Degs]	Height [cm]	Polarity			
802.11a	6435	MIMO	9.65250	34.56	PK-U	36.80	-21.70	0.00	49.66	-	-	-	-	-	68.20	-18.54	0	100	H		
			9.65243	34.41	PK-U	36.80	-21.70	0.00	49.51	-	-	-	-	-	-	68.20	-18.69	0	100	V	
			12.87078	35.69	PK-U	39.30	-22.50	0.00	52.49	-	-	-	-	-	-	68.20	-15.71	0	100	H	
			12.87082	34.86	PK-U	39.30	-22.50	0.00	51.66	-	-	-	-	-	-	68.20	-16.54	0	100	V	
			* 16.08778	33.38	PK-U	41.10	-19.90	0.00	54.58	-	-	74.00	-19.42	-	-	-	-	0	100	H	
			* 16.0876	33.52	PK-U	41.10	-19.90	0.00	54.72	-	-	74.00	-19.28	-	-	-	-	0	100	V	
			* 16.08778	21.02	ADR	41.10	-19.90	0.15	42.37	54.00	-11.63	-	-	-	-	-	-	0	100	H	
			* 16.0876	22.14	ADR	41.10	-19.90	0.15	43.49	54.00	-10.51	-	-	-	-	-	-	0	100	V	
			9.71297	33.92	PK-U	36.90	-21.50	0.00	49.32	-	-	-	-	-	-	-	68.20	-18.88	0	100	H
			9.71288	34.44	PK-U	36.90	-21.50	0.00	49.84	-	-	-	-	-	-	-	68.20	-18.36	0	100	V
	12.95007	35.14	PK-U	39.30	-22.10	0.00	52.34	-	-	-	-	-	-	-	68.20	-15.86	0	100	H		
	12.95040	35.44	PK-U	39.30	-22.10	0.00	52.64	-	-	-	-	-	-	-	68.20	-15.56	0	100	V		
	* 16.18729	32.67	PK-U	41.20	-19.90	0.00	53.97	-	-	74.00	-20.03	-	-	-	-	0	100	H			
	* 16.18721	32.82	PK-U	41.20	-19.90	0.00	54.12	-	-	74.00	-19.88	-	-	-	-	0	100	V			
	* 16.18729	20.31	ADR	41.20	-19.90	0.15	41.76	54.00	-12.24	-	-	-	-	-	-	0	100	H			
	* 16.18721	20.22	ADR	41.20	-19.90	0.15	41.67	54.00	-12.33	-	-	-	-	-	-	0	100	V			
	9.77259	34.04	PK-U	36.90	-21.60	0.00	49.34	-	-	-	-	-	-	-	68.20	-18.86	0	100	H		
	9.77254	33.80	PK-U	36.90	-21.60	0.00	49.10	-	-	-	-	-	-	-	68.20	-19.10	0	100	V		
	13.02433	37.10	PK-U	39.20	-22.30	0.00	54.00	-	-	-	-	-	-	-	68.20	-14.20	226	193	H		
	13.02986	35.55	PK-U	39.20	-22.30	0.00	52.45	-	-	-	-	-	-	-	68.20	-15.75	0	100	V		
	16.28719	33.64	PK-U	41.30	-19.40	0.00	55.54	-	-	-	-	-	-	-	68.20	-12.66	0	100	H		
	16.28730	34.22	PK-U	41.30	-19.40	0.00	56.12	-	-	-	-	-	-	-	68.20	-12.08	0	100	V		
	802.11ax (HE20) RU mode 106Tone offset 53 Spot-Check	6475	MIMO	9.71386	34.29	PK-U	36.90	-21.50	0.00	49.69	-	-	-	-	-	68.20	-18.51	0	100	H	
	9.71376			33.57	PK-U	36.90	-21.50	0.00	48.97	-	-	-	-	-	-	68.20	-19.23	0	100	V	
	12.94957			37.07	PK-U	39.30	-22.10	0.00	54.27	-	-	-	-	-	-	68.20	-13.93	217	196	H	
	12.94957			35.38	PK-U	39.30	-22.10	0.00	52.58	-	-	-	-	-	-	68.20	-15.62	181	320	V	
	* 16.18676			32.32	PK-U	41.20	-19.90	0.00	53.62	-	-	74.00	-20.38	-	-	-	-	0	100	H	
	* 16.18507			32.51	PK-U	41.20	-20.00	0.00	53.71	-	-	74.00	-20.29	-	-	-	-	0	100	V	

Note1. PK-U - U-NII: Maximum Peak / ADR - U-NII AD primary method, RMS average

Note2. * - indicates frequency in CFR47 Pt 15 / IC RSS-Restricted Band

11.3. TX ABOVE 1GHz 2Tx MODE IN U-NII-7 BAND

HARMONICS AND SPURIOUS EMISSIONS(WORST CASE: 802.11a / 6695 MHz)

HORIZONTAL

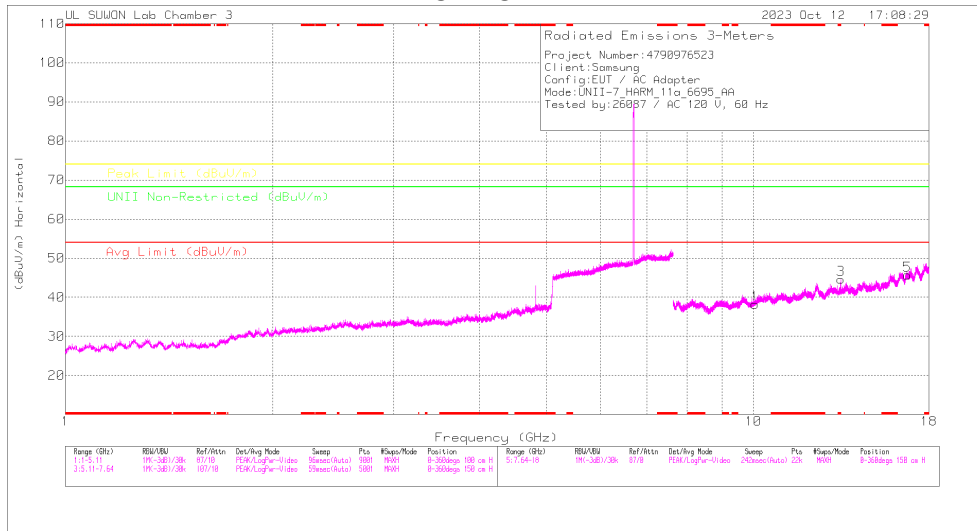

VERTICAL

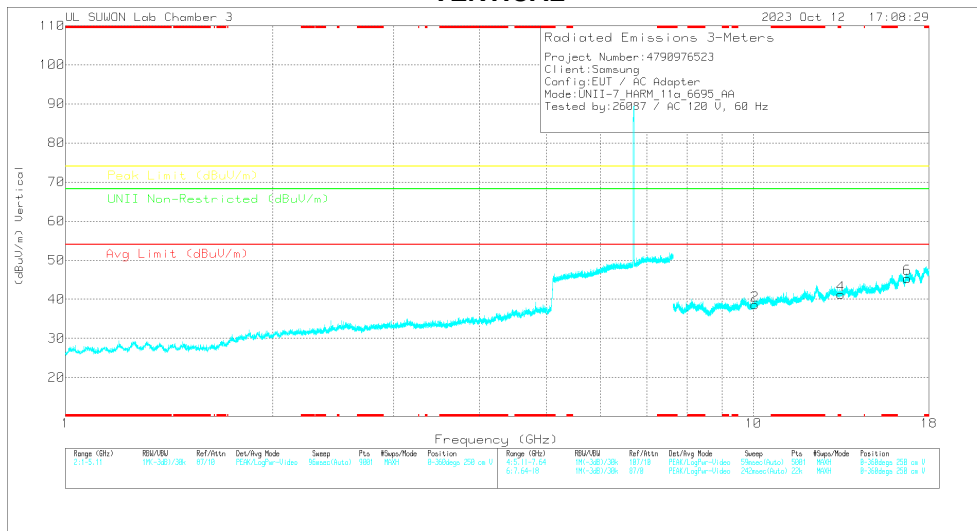

Note. Emission was scanned up to 40GHz; No emissions were detected above the noise floor which was at least 20dB below the specification limit.

Radiated Emissions

Frequency (GHz)	Meas Reading (dBuV)	Det	3117_00218657	#Hz_H(P)(dB)	DC Corr (dB)	Corrected Reading (dBuV/m)	Avg Limit (dBuV/m)	Margin (dB)	Peak Limit (dBuV/m)	Margin (dB)	UNII Non-Restricted (dBuV/m)	Margin (dB)	Altitude (Degs)	Height (cm)	Polarity
10.04223	32.75	PK-U	37.3	-21.4	0	48.65	-	-	-	-	68.2	-19.55	0	100	H
10.04251	32.96	PK-U	37.3	-21.3	0	48.96	-	-	-	-	68.2	-19.24	0	100	V
*13.39041	36.33	PK-U	39.1	-21.9	0	53.53	-	-	74	-20.47	-	-	146	199	H
*13.39033	24.49	ADR	39.1	-21.9	15	41.84	54	-12.16	-	-	-	-	146	199	H
*13.39032	34.22	PK-U	39.1	-21.9	0	51.42	-	-	74	-22.58	-	-	0	100	V
16.73714	32.83	PK-U	41.8	-18.3	0	56.33	-	-	-	-	68.2	-11.87	0	100	H
16.73704	32.29	PK-U	41.8	-18.3	0	55.79	-	-	-	-	68.2	-12.41	0	100	V

PK-U - U-NII: Maximum Peak

HARMONICS AND SPURIOUS EMISSIONS TEST DATA

Mode	Freq. [MHz]	Antenna	Frequency [GHz]	Reading [dBuV]	Detector Mode	ANT Factor [dB(1/m)]	Loss [dB]	DC Corr [dB]	Result [dBuV/m]	AV Limit [dBuV/m]	AV Margin [dB]	PK Limit [dBuV/m]	PK Margin [dB]	Non-Restricted [dBuV/m]	Margin [dB]	Azimuth [Degs]	Height [cm]	Polarity		
802.11a	6535	MIMO	9.80245	33.81	PK-U	37.00	-21.60	0.00	49.21	-	-	-	-	68.20	-18.99	0	100	H		
			9.80220	33.65	PK-U	37.00	-21.60	0.00	49.05	-	-	-	-	68.20	-19.15	0	100	V		
			13.07048	35.05	PK-U	39.20	-22.40	0.00	51.85	-	-	-	-	68.20	-16.35	0	100	H		
			13.07025	35.56	PK-U	39.20	-22.40	0.00	52.36	-	-	-	-	68.20	-15.84	0	100	V		
			16.33781	33.67	PK-U	41.30	-19.10	0.00	55.87	-	-	-	-	68.20	-12.33	0	100	H		
			16.33789	34.03	PK-U	41.30	-19.10	0.00	56.23	-	-	-	-	68.20	-11.97	0	100	V		
	6695	MIMO	10.04223	32.75	PK-U	37.30	-21.40	0.00	48.65	-	-	-	-	68.20	-19.55	0	100	H		
			10.04251	32.96	PK-U	37.30	-21.30	0.00	48.96	-	-	-	-	68.20	-19.24	0	100	V		
			*13.39041	36.33	PK-U	39.10	-21.90	0.00	53.53	-	-	74.00	-20.47	-	-	146	199	H		
			*13.39033	24.49	ADR	39.10	-21.90	0.15	41.84	54.00	-12.16	-	-	-	-	-	146	199	H	
			*13.39032	34.22	PK-U	39.10	-21.90	0.00	51.42	-	-	74.00	-22.58	-	-	-	0	100	V	
			16.73714	32.83	PK-U	41.80	-18.30	0.00	56.33	-	-	-	-	-	-	68.20	-11.87	0	100	H
	6855	MIMO	10.28262	34.02	PK-U	37.50	-21.20	0.00	50.32	-	-	-	-	68.20	-17.88	0	100	H		
			10.28275	33.74	PK-U	37.50	-21.20	0.00	50.04	-	-	-	-	68.20	-18.16	0	100	V		
			13.71088	36.87	PK-U	38.70	-23.10	0.00	52.47	-	-	-	-	68.20	-15.73	0	100	H		
			13.71054	36.90	PK-U	38.70	-23.10	0.00	52.50	-	-	-	-	68.20	-15.70	0	100	V		
			*15.76672	34.49	PK-U	40.50	-20.60	0.00	54.39	-	-	74.00	-19.61	-	-	-	0	100	H	
			*15.76677	35.28	PK-U	40.50	-20.60	0.00	55.18	-	-	74.00	-18.82	-	-	-	0	100	V	
	802.11ax (HE-40) RU mode s2Tone offset 37 Spot-Check	6695	MIMO	*15.76672	21.86	ADR	40.50	-20.60	0.15	41.91	54.00	-12.09	-	-	-	-	0	100	H	
				*15.76677	21.92	ADR	40.50	-20.60	0.15	41.97	54.00	-12.03	-	-	-	-	-	0	100	V
				10.04458	32.88	PK-U	37.30	-21.30	0.00	48.88	-	-	-	-	68.20	-19.32	0	100	H	
				10.03879	32.90	PK-U	37.30	-21.40	0.00	48.80	-	-	-	-	68.20	-19.40	0	100	V	
				*13.39326	33.77	PK-U	39.10	-21.90	0.00	50.97	-	-	74.00	-23.03	-	-	-	0	100	H
				*13.39405	33.57	PK-U	39.10	-22.00	0.00	50.67	-	-	74.00	-23.33	-	-	-	0	100	V
16.73276	32.58	PK-U	41.80	-18.30	0.00	56.08	-	-	-	-	-	-	68.20	-12.12	0	100	H			
16.73266	32.18	PK-U	41.80	-18.30	0.00	55.68	-	-	-	-	-	-	68.20	-12.52	0	100	V			

Note1. PK-U - U-NII: Maximum Peak / ADR - U-NII AD primary method, RMS average
 Note2. * - indicates frequency in CFR47 Pt 15 / IC RSS-Restricted Band

11.4. TX ABOVE 1GHz 2Tx MODE IN U-NII-8 BAND

BANDEDGE (WORST CASE: 802.11a / 7115 MHz)

HORIZONTAL PEAK DATA

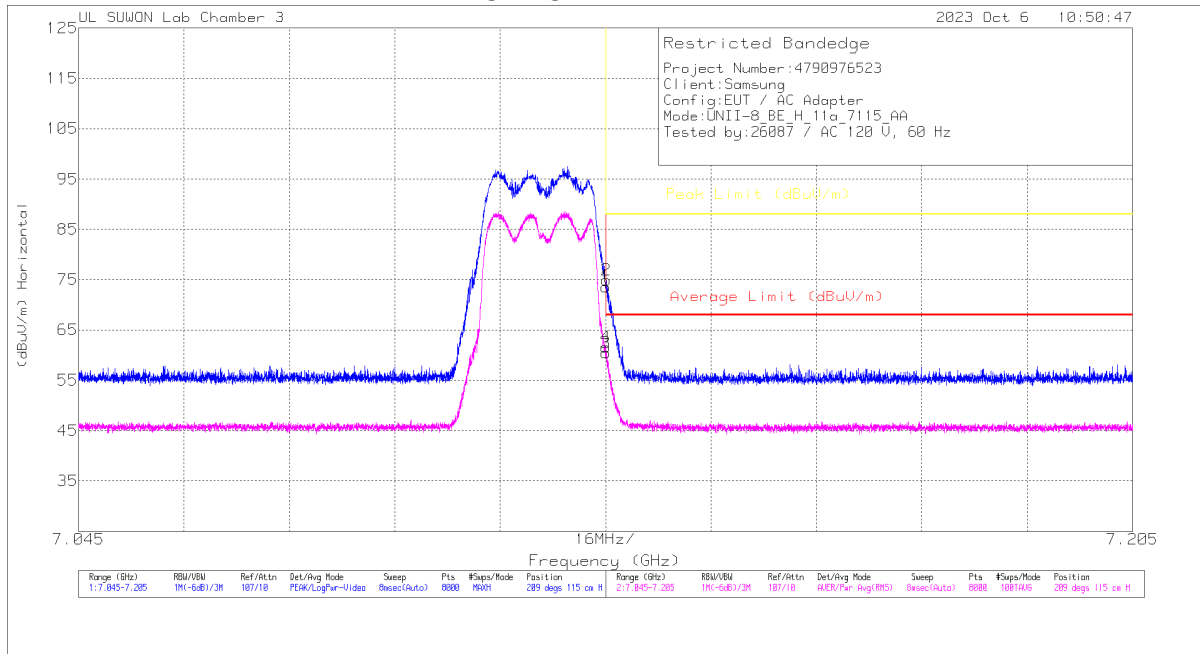

Trace Markers

Marker	Frequency (GHz)	Meter Reading (dBuV)	Det	3117_00218967	10dB_ATT(dB)	DC Corr (dB)	Corrected Reading (dBuV/m)	Average Limit (dBuV/m)	Margin (dB)	Peak Limit (dBuV/m)	PK Margin (dB)	Azimuth (Degs)	Height (cm)	Polarity
1	7.12501	54.27	PK	35.9	-16.6	0	73.57	-	-	88	-14.43	209	115	H
2	7.12509	55.67	PK	35.9	-16.6	0	74.97	-	-	88	-13.03	209	115	H
3	7.12501	40.99	RMS	35.9	-16.6	.15	60.44	68	-7.56	-	-	209	115	H
4	7.12507	42.15	RMS	35.9	-16.6	.15	61.6	68	-6.4	-	-	209	115	H

PK - Peak detector
 RMS - RMS detection

BANDEDGE TEST DATA

Mode	Freq. [MHz]	Antenna	Frequency [GHz]	Reading [dBuV]	Detector Mode	ANT Factor [dB(1/m)]	Loss [dB]	DC Corr [dB]	Result [dBuV/m]	AV Limit [dBuV/m]	AV Margin [dB]	PK Limit [dBuV/m]	PK Margin [dB]	Azimuth [Degs]	Height [cm]	Polarity
802.11a	7115	MIMO	7.12501	54.27	Pk	35.90	-16.60	0.00	73.57	-	-	88.00	-14.43	209	115	H
			7.12509	55.67	Pk	35.90	-16.60	0.00	74.97	-	-	88.00	-13.03	209	115	H
			7.12501	40.99	RMS	35.90	-16.60	0.15	60.44	68.00	-7.56	-	-	209	115	H
			7.12507	42.15	RMS	35.90	-16.60	0.15	61.60	68.00	-6.40	-	-	209	115	H
			7.12501	48.78	Pk	35.90	-16.60	0.00	68.08	-	-	88.00	-19.92	130	398	V
			7.12509	49.70	Pk	35.90	-16.60	0.00	69.00	-	-	88.00	-19.00	130	398	V
			7.12501	35.35	RMS	35.90	-16.60	0.15	54.80	68.00	-13.20	-	-	130	398	V
			7.12503	35.49	RMS	35.90	-16.60	0.15	54.94	68.00	-13.06	-	-	130	398	V
802.11ax (HE20) SU mode	7115	MIMO	7.12551	59.53	Pk	35.90	-16.70	0.00	78.73	-	-	88.00	-9.27	64	100	H
			7.12559	58.21	Pk	35.90	-16.70	0.00	77.41	-	-	88.00	-10.59	64	100	H
			7.12551	40.26	RMS	35.90	-16.70	0.00	59.46	68.00	-8.54	-	-	64	100	H
			7.12559	38.76	RMS	35.90	-16.70	0.00	57.96	68.00	-10.04	-	-	64	100	H
			7.12551	54.66	Pk	35.90	-16.70	0.00	73.86	-	-	88.00	-14.14	90	103	V
			7.12575	53.16	Pk	35.90	-16.70	0.00	72.36	-	-	88.00	-15.64	90	103	V
			7.12551	36.16	RMS	35.90	-16.70	0.00	55.36	68.00	-12.64	-	-	90	103	V
			7.12559	35.04	RMS	35.90	-16.70	0.00	54.24	68.00	-13.76	-	-	90	103	V
802.11ax (HE40) SU mode	7085	MIMO	7.12501	36.38	Pk	35.90	-16.60	0.00	55.68	-	-	88.00	-32.32	207	211	H
			7.13231	39.24	Pk	35.90	-16.60	0.00	58.54	-	-	88.00	-29.46	207	211	H
			7.12501	25.98	RMS	35.90	-16.60	0.00	45.28	68.00	-22.72	-	-	207	211	H
			7.12513	27.36	RMS	35.90	-16.60	0.00	46.66	68.00	-21.34	-	-	207	211	H
			7.12501	36.46	Pk	35.90	-16.60	0.00	55.76	-	-	88.00	-32.24	91	106	V
			7.15864	38.75	Pk	35.90	-16.60	0.00	58.05	-	-	88.00	-29.95	91	106	V
			7.12501	26.32	RMS	35.90	-16.60	0.00	45.62	68.00	-22.38	-	-	91	106	V
			7.13125	27.40	RMS	35.90	-16.60	0.00	46.70	68.00	-21.30	-	-	91	106	V
802.11ax (HE80) SU mode	7025	MIMO	7.12501	36.40	Pk	35.90	-16.60	0.00	55.70	-	-	88.00	-32.30	218	100	H
			7.17026	38.46	Pk	35.90	-16.60	0.00	57.76	-	-	88.00	-30.24	218	100	H
			7.12501	25.95	RMS	35.90	-16.60	0.00	45.25	68.00	-22.75	-	-	218	100	H
			7.17474	27.43	RMS	35.90	-16.50	0.00	46.83	68.00	-21.17	-	-	218	100	H
			7.12501	36.60	Pk	35.90	-16.60	0.00	55.90	-	-	88.00	-32.10	143	107	V
			7.16186	39.21	Pk	35.90	-16.60	0.00	58.51	-	-	88.00	-29.49	143	107	V
			7.12501	26.49	RMS	35.90	-16.60	0.00	45.79	68.00	-22.21	-	-	143	107	V
			7.12933	27.81	RMS	35.90	-16.60	0.00	47.11	68.00	-20.89	-	-	143	107	V
802.11ax (HE160) SU mode	6985	MIMO	7.12501	39.61	Pk	35.90	-16.60	0.00	58.91	-	-	88.00	-29.09	217	103	H
			7.14019	40.88	Pk	35.90	-16.60	0.00	60.18	-	-	88.00	-27.82	217	103	H
			7.12501	27.91	RMS	35.90	-16.60	0.00	47.21	68.00	-20.79	-	-	217	103	H
			7.14161	29.15	RMS	35.90	-16.60	0.00	48.45	68.00	-19.55	-	-	217	103	H
			7.12501	39.98	Pk	35.90	-16.60	0.00	59.28	-	-	88.00	-28.72	96	107	V
			7.13837	43.11	Pk	35.90	-16.70	0.00	62.31	-	-	88.00	-25.69	96	107	V
			7.12501	30.79	RMS	35.90	-16.60	0.00	50.09	68.00	-17.91	-	-	96	107	V
			7.18764	31.40	RMS	35.80	-16.60	0.00	50.60	68.00	-17.40	-	-	96	107	V

Note1. PK-U - U-NII: Maximum Peak / ADR - U-NII AD primary method, RMS average

HARMONICS AND SPURIOUS EMISSIONS(WORST CASE: 802.11a / 7115 MHz)

HORIZONTAL

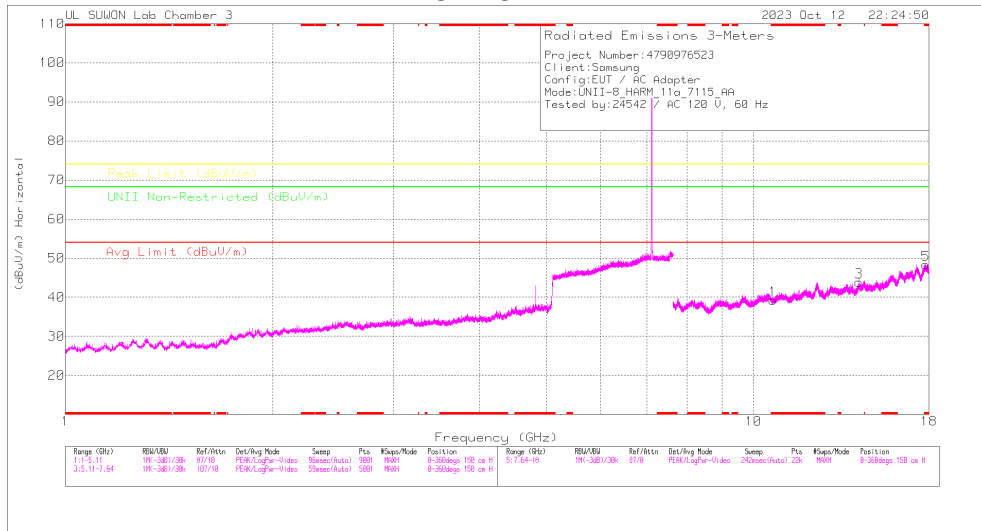

VERTICAL

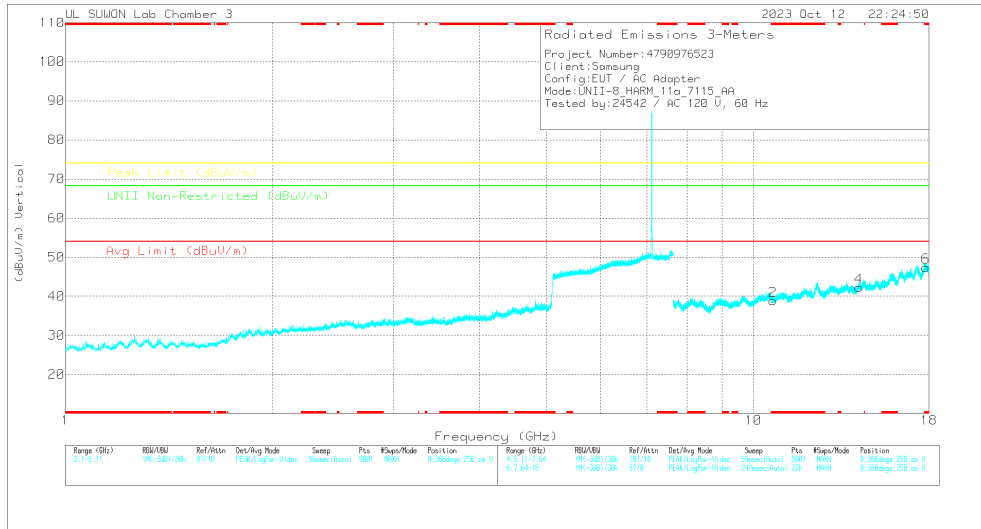

Note: Emission was scanned up to 40GHz; No emissions were detected above the noise floor which was at least 20dB below the specification limit.

Radiated Emissions

Frequency (GHz)	Meas Reading (dBuV)	Dist	3117_00218657	8GHz_HPa(dB)	DC Corr (dB)	Corrected Reading (dBuV/m)	Avg Limit (dBuV/m)	Margin (dB)	Peak Limit (dBuV/m)	Margin (dB)	UNII Non-Restricted (dBuV/m)	Margin (dB)	Azimuth (Deg)	Height (cm)	Polarity
* 10.6695	33.24	PK-U	37.7	-21.2	0	49.74	-	-	74	-24.26	-	-	0	100	H
* 10.67662	32.9	PK-U	37.8	-21.2	0	49.5	-	-	74	-24.5	-	-	0	100	V
* 14.22767	35.54	PK-U	39.3	-22.3	0	52.54	-	-	-	-	68.2	-15.66	0	100	H
* 14.22993	35.2	PK-U	39.3	-22.4	0	53.1	-	-	-	-	68.2	-15.1	0	100	V
* 17.78662	32.72	PK-U	41.4	-15.8	0	58.32	-	-	74	-15.68	-	-	0	100	H
* 17.78679	32.25	PK-U	41.4	-15.8	0	57.85	-	-	74	-16.15	-	-	0	100	V
* 17.78662	20.05	ADR	41.4	-15.8	-15	45.8	54	-8.2	-	-	-	-	0	100	H
* 17.78679	19.89	ADR	41.4	-15.8	-15	45.64	54	-8.36	-	-	-	-	0	100	V

PK-U - U-NII: Maximum Peak

HARMONICS AND SPURIOUS EMISSIONS TEST DATA

Mode	Freq. [MHz]	Antenna	Frequency [GHz]	Reading [dBuV]	Detector Mode	ANT Factor [dB(1/m)]	Loss [dB]	DC Corr [dB]	Result [dBuV/m]	AV Limit [dBuV/m]	AV Margin [dB]	PK Limit [dBuV/m]	PK Margin [dB]	Non-Restricted [dBuV/m]	Margin [dB]	Azimuth [Degs]	Height [cm]	Polarity		
802.11a	6895	MIMO	10.34059	33.61	PK-U	37.50	-21.20	0.00	49.91	-	-	-	-	68.20	-18.29	0	100	H		
			10.34645	33.46	PK-U	37.50	-21.20	0.00	49.76	-	-	-	-	-	68.20	-18.44	0	100	V	
			13.79080	40.67	PK-U	38.70	-23.40	0.00	55.97	-	-	-	-	-	68.20	-12.23	222	185	H	
			13.78681	36.30	PK-U	38.70	-23.40	0.00	51.60	-	-	-	-	-	68.20	-16.60	210	257	V	
			17.23715	32.42	PK-U	41.10	-16.70	0.00	56.82	-	-	-	-	-	68.20	-11.38	0	100	H	
			17.24030	32.23	PK-U	41.10	-16.70	0.00	56.63	-	-	-	-	-	68.20	-11.57	0	100	V	
	6995	MIMO	10.48931	33.66	PK-U	37.60	-21.00	0.00	50.26	-	-	-	-	-	68.20	-17.94	0	100	H	
			10.49370	34.00	PK-U	37.60	-21.00	0.00	50.60	-	-	-	-	-	68.20	-17.60	0	100	V	
			13.98787	35.78	PK-U	38.80	-23.50	0.00	51.08	-	-	-	-	-	68.20	-17.12	0	100	H	
			13.99215	36.07	PK-U	38.80	-23.40	0.00	51.47	-	-	-	-	-	68.20	-16.73	0	100	V	
			17.48891	31.12	PK-U	41.20	-16.70	0.00	55.62	-	-	-	-	-	68.20	-12.58	0	100	H	
			17.48694	31.19	PK-U	41.20	-16.70	0.00	55.69	-	-	-	-	-	68.20	-12.51	0	100	V	
	7115	MIMO	* 10.6695	33.24	PK-U	37.70	-21.20	0.00	49.74	-	-	74.00	-24.26	-	-	-	0	100	H	
			* 10.67662	32.90	PK-U	37.80	-21.20	0.00	49.50	-	-	74.00	-24.50	-	-	-	0	100	V	
			14.22767	35.54	PK-U	39.30	-22.30	0.00	52.54	-	-	-	-	-	68.20	-15.66	0	100	H	
			14.22993	36.20	PK-U	39.30	-22.40	0.00	53.10	-	-	-	-	-	68.20	-15.10	0	100	V	
			* 17.78662	32.72	PK-U	41.40	-15.80	0.00	58.32	-	-	74.00	-15.68	-	-	-	0	100	H	
			* 17.78679	32.25	PK-U	41.40	-15.80	0.00	57.85	-	-	74.00	-16.15	-	-	-	0	100	V	
	802.11ax (HE20) RU mode 106 Tone offset 54 Spot-check	6895	MIMO	* 17.78662	20.05	ADR	41.40	-15.80	0.15	45.80	54.00	-8.20	-	-	-	-	0	100	H	
				* 17.78679	19.89	ADR	41.40	-15.80	0.15	45.64	54.00	-8.36	-	-	-	-	-	0	100	V
				10.33842	34.24	PK-U	37.50	-21.20	0.00	50.54	-	-	-	-	-	68.20	-17.66	0	100	H
			10.33986	33.37	PK-U	37.50	-21.20	0.00	49.67	-	-	-	-	68.20	-18.53	0	100	V		
			13.79257	36.45	PK-U	38.70	-23.40	0.00	51.75	-	-	-	-	68.20	-16.45	0	100	H		
			13.78669	36.05	PK-U	38.70	-23.40	0.00	51.35	-	-	-	-	68.20	-16.85	0	100	V		
			17.23877	33.46	PK-U	41.10	-16.70	0.00	57.86	-	-	-	-	68.20	-10.34	0	100	H		
			17.23651	32.53	PK-U	41.10	-16.70	0.00	56.93	-	-	-	-	68.20	-11.27	0	100	V		

Note1. PK-U - U-NII: Maximum Peak / ADR - U-NII AD primary method, RMS average
 Note2. * - indicates frequency in CFR47 Pt 15 / IC RSS-Restricted Band

12. WORST-CASE BELOW 1 GHz

SPURIOUS EMISSIONS 30 TO 1000 MHz (WORST-CASE CONFIGURATION, HORIZONTAL)

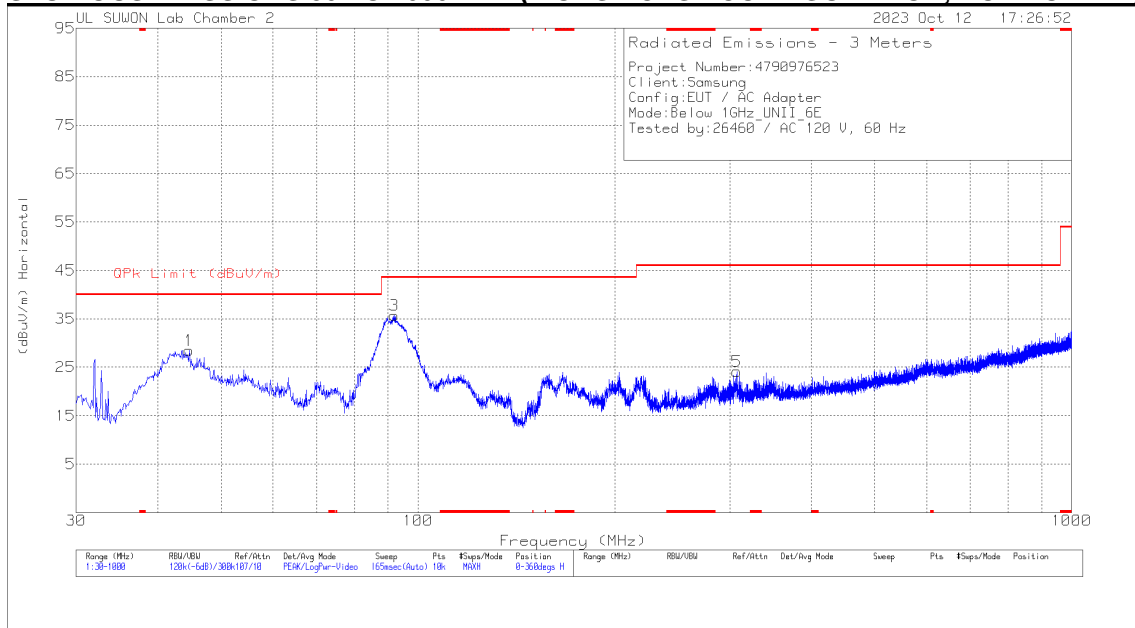

SPURIOUS EMISSIONS 30 TO 1000 MHz (WORST-CASE CONFIGURATION, VERTICAL)



Trace Markers

Marker	Frequency (MHz)	Meter Reading (dBuV)	Det	Antenna Correction Factor[dB(1/m)]	Path Loss(dB)	Corrected Reading (dBuV/m)	QPK Limit (dBuV/m)	Margin (dB)	Azimuth (Degs)	Height (cm)	Polarity
1	63.174	34.09	Pk	17.8	-31.5	20.39	40	-19.61	0-360	300	H
3	97.9	44.73	Pk	17.2	-31.3	30.63	43.52	-12.89	0-360	200	H
5	287.632	35.73	Pk	19	-30.2	24.53	46.02	-21.49	0-360	100	H
2	32.134	42.25	Pk	15.5	-31.9	25.85	40	-14.15	0-360	100	V
4	94.214	43.1	Pk	16.4	-31.2	28.3	43.52	-15.22	0-360	100	V
6	734.511	32.48	Pk	25.9	-28.8	29.58	46.02	-16.44	0-360	100	V

* - indicates frequency in CFR47 Pt 15 / IC RSS-Restricted Band
 Pk - Peak detector

13. AC POWER LINE CONDUCTED EMISSIONS

LIMITS

FCC §15.207 (a)
IC RSS-GEN Clause 8.8

Frequency of Emission (MHz)	Conducted Limit (dBuV)	
	Quasi-peak	Average
0.15-0.5	66 to 56	56 to 46
0.5-5	56	46
5-30	60	50

Decreases with the logarithm of the frequency.

TEST PROCEDURE

The EUT is placed on a non-conducting table 40 cm from the vertical ground plane and 80 cm above the horizontal ground plane. The EUT is configured in accordance with ANSI C63.10.

The receiver is set to a resolution bandwidth of 9 kHz. Peak detection is used unless otherwise noted as quasi-peak or average.

Line conducted data is recorded for both NEUTRAL and HOT lines.

RESULTS

WORST EMISSIONS

LINE 1 DATA

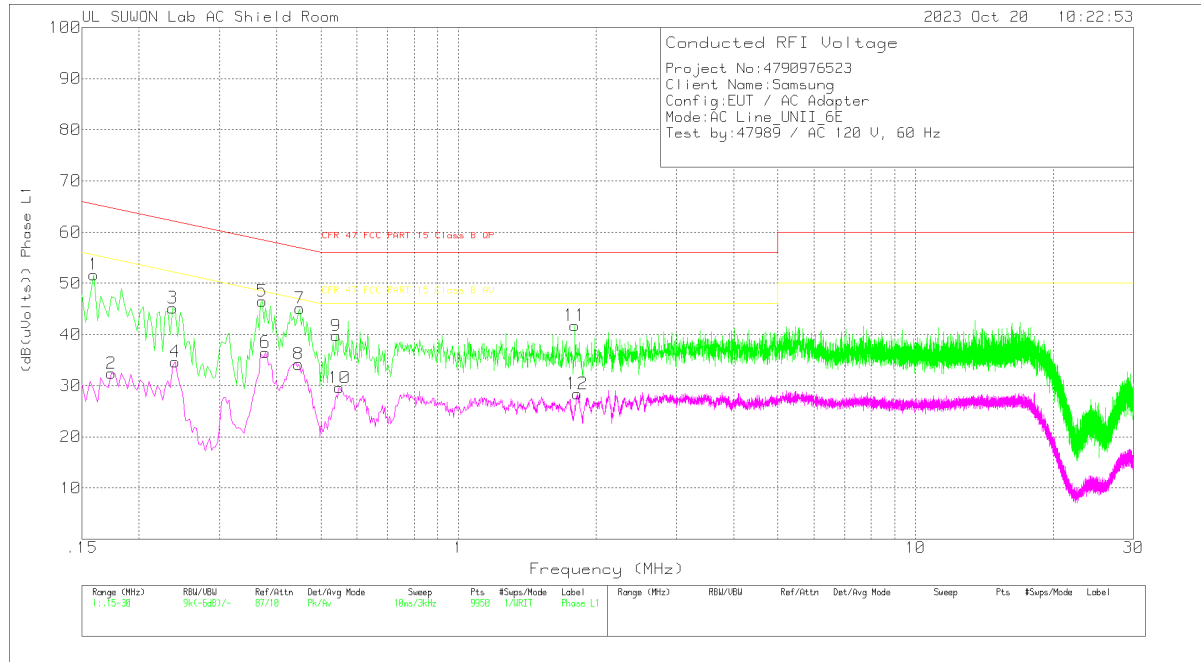

Trace Markers

Range 1: Phase L1 .15 - 30MHz

Marker	Frequency (MHz)	Meter Reading (dBuV)	Det	101836_AU TO_With EX_L1[dB]	CABLELOS S[dB]	Corrected Reading (dB(uVolts))	CFR 47 FCC PART 15 Class B QP (dB(uVolts))	Margin (dB)	CFR 47 FCC PART 15 Class B AV (dB(uVolts))	Margin (dB)
1	.159	42.1	Pk	9.5	.1	51.7	65.52	-13.82	-	-
2	.174	22.71	Av	9.5	.2	32.41	-	-	54.77	-22.36
3	.237	35.49	Pk	9.5	.2	45.19	62.2	-17.01	-	-
4	.24	24.98	Av	9.5	.2	34.68	-	-	52.1	-17.42
5	.372	36.83	Pk	9.5	.2	46.53	58.46	-11.93	-	-
6	.378	26.8	Av	9.5	.2	36.5	-	-	48.32	-11.82
7	.45	35.4	Pk	9.5	.2	45.1	56.88	-11.78	-	-
8	.447	24.51	Av	9.5	.2	34.21	-	-	46.93	-12.72
9	.54	29.96	Pk	9.6	.2	39.76	56	-16.24	-	-
10	.549	19.81	Av	9.6	.2	29.61	-	-	46	-16.39
11	1.797	31.87	Pk	9.6	.3	41.77	56	-14.23	-	-
12	1.818	18.53	Av	9.6	.3	28.43	-	-	46	-17.57

Pk - Peak detector

Av - Average detection

LINE 2 DATA

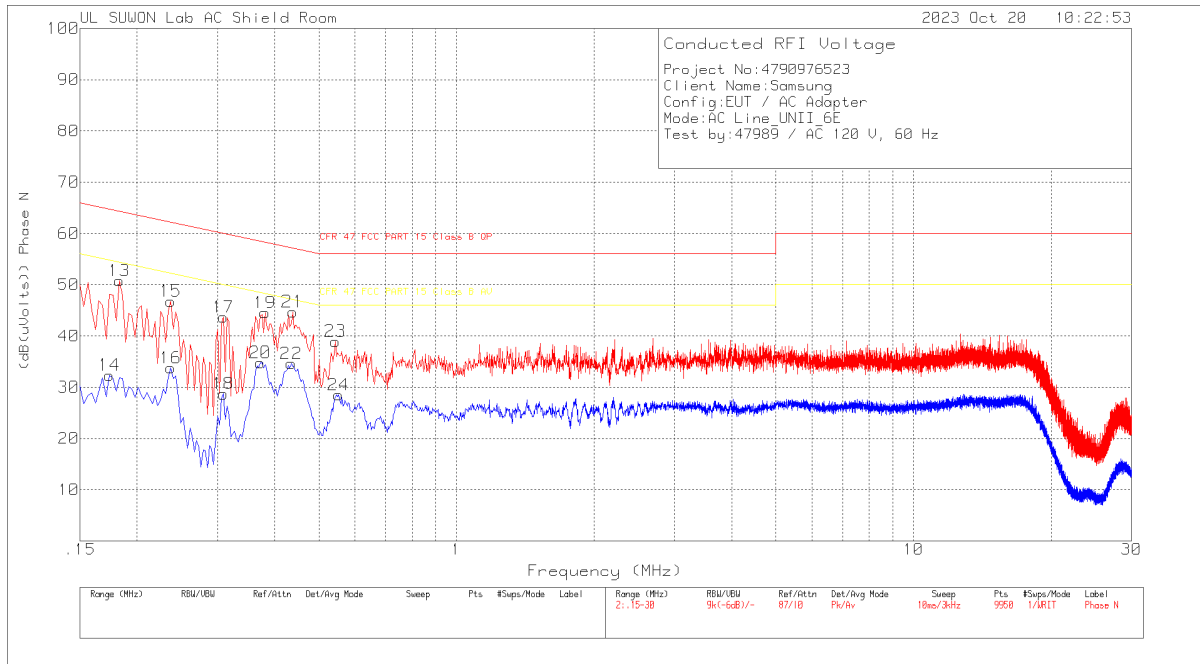

Trace Markers

Range 2: Phase N .15 - 30MHz

Marker	Frequency (MHz)	Meter Reading (dBuV)	Det	101836_AU TO_With EX_N[dB]	CABLELOS S[dB]	Corrected Reading (dB(uVolts))	CFR 47 FCC PART 15 Class B QP (dB(uVolts))	Margin (dB)	CFR 47 FCC PART 15 Class B AV (dB(uVolts))	Margin (dB)
13	.183	41.06	Pk	9.5	.2	50.76	64.35	-13.59	-	-
14	.174	22.63	Av	9.5	.2	32.33	-	-	54.77	-22.44
15	.237	37.07	Pk	9.5	.2	46.77	62.2	-15.43	-	-
16	.237	24.07	Av	9.5	.2	33.77	-	-	52.2	-18.43
17	.309	33.98	Pk	9.5	.2	43.68	60	-16.32	-	-
18	.309	19.02	Av	9.5	.2	28.72	-	-	50	-21.28
19	.381	34.83	Pk	9.5	.2	44.53	58.26	-13.73	-	-
20	.372	25.06	Av	9.5	.2	34.76	-	-	48.46	-13.7
21	.438	34.99	Pk	9.5	.2	44.69	57.1	-12.41	-	-
22	.435	24.91	Av	9.5	.2	34.61	-	-	47.16	-12.55
23	.543	29.14	Pk	9.6	.2	38.94	56	-17.06	-	-
24	.552	18.71	Av	9.6	.2	28.51	-	-	46	-17.49

Pk - Peak detector
 Av - Average detection

14. Contention Based Protocol

14.1. OVERVIEW

14.1.1. LIMITS

FCC

§15.407 (d) (6)
KDB 987594 D02

Indoor access points, subordinate devices and client devices operating in the 5.925-7.125 GHz band (herein referred to as unlicensed devices) are required to use technologies that include a contention-based protocol to avoid co-channel interference with incumbent devices sharing the band. To ensure incumbent co-channel operations are detected in a technology-agnostic manner, unlicensed devices are required to detect co-channel radio frequency energy (energy detect) and avoid simultaneous transmission.

Unlicensed low-power indoor devices must detect co-channel radio frequency power that is at least -62 dBm or lower. Upon detection of energy in the band, unlicensed low power indoor devices must vacate the channel (in which incumbent signal is transmitted) and stay off the incumbent channel as long as detected radio frequency power is equal to or greater than the threshold (-62 dBm)¹. The -62 dBm (or lower) threshold is referenced to a 0 dBi antenna gain.

To ensure incumbent operations are reliably detected in the band, low power indoor devices must detect RF energy throughout their intended operating channel. For example, an 802.11 device that plans to transmit a 40 MHz- wide signal (on a primary 20 MHz channel and a secondary 20 MHz channel) must detect energy throughout the entire 40 MHz channel. Additionally, low-power indoor devices must detect co-channel energy with 90% or greater certainty.

Note. This device does not support channel puncturing / bandwidth reduction functions.

14.1.2. TEST AND MEASUREMENT SYSTEM

CONDUCTED METHOD SYSTEM BLOCK DIAGRAM

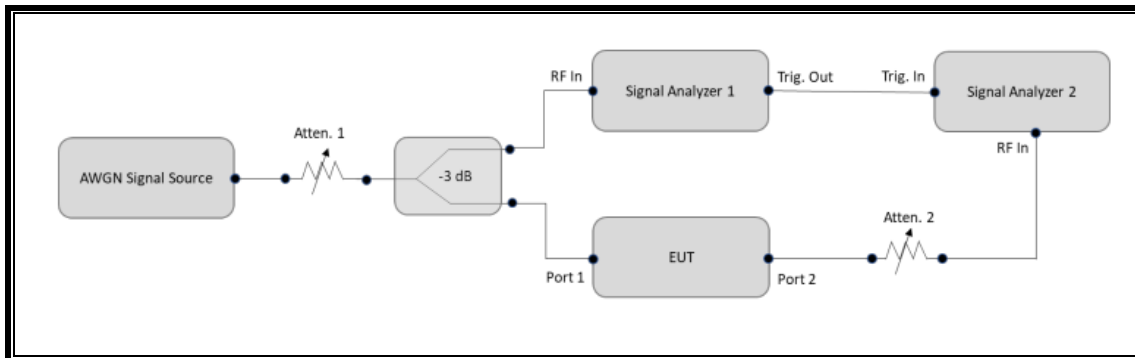

TEST SETTING

- 1) Configure the EUT to transmit with a constant duty cycle.
- 2) Set the operating parameters of the EUT including power level, operating frequency, modulation and bandwidth.
- 3) Set the signal analyzer center frequency to the nominal EUT channel center frequency. The span range of the signal analyzer shall be between two times and five times the OBW of the EUT. Connect the output port of the EUT to the signal analyzer 2, as shown in Figure 2. Ensure that the attenuator 2 provides enough attenuation to not overload the signal analyzer 2 receiver.
- 4) Monitoring the signal analyzer 2, verify the EUT is operating and transmitting with the parameters set at step two.
- 5) Using an AWGN signal source, generate (but do not transmit, i.e., RF OFF) a 10 MHz-wide AWGN signal. Use Table 1 to determine the center frequency of the 10 MHz AWGN signal relative to the EUT's channel bandwidth and center frequency.
- 6) Set the AWGN signal power to an extremely low level (more than 20 dB below the -62 dBm threshold). Connect the AWGN signal source, via a 3-dB splitter, to the signal analyzer 1 and the EUT as shown in Figure 2.
- 7) Transmit the AWGN signal (RF ON) and verify its characteristics on the signal analyzer 1.
- 8) Monitor the signal analyzer 2 to verify if the AWGN signal has been detected and the EUT has ceased transmission. If the EUT continues to transmit, then incrementally increase the AWGN signal power level until the EUT stops transmitting.
- 9) (Including all losses in the RF paths) Determine and record the AWGN signal power level (at the EUT's antenna port) at which the EUT ceased transmission. Repeat the procedure at least 10 times to verify the EUT can detect an AWGN signal with 90% (or better) level of certainty.
- 10) Refer to Table 1 to determine number of times the detection threshold testing needs to be repeated. If testing is required more than once, then go back to step 5, choose a different center frequency for the AWGN signal and repeat the process.

TEST AND MEASUREMENT EQUIPMENT

The following test and measurement equipment was utilized for the tests documented in this report:

TEST EQUIPMENT LIST				
Description	Manufacturer	Model	S/N	Next Cal Due
Spectrum Analyzer	Keysight	N9030B	MY60070693	2024-01-09
Spectrum Analyzer	Agilent	N9030A	MY54170614	2024-07-24
Vector Signal Generator	R&S	SMW200A	110251	2024-07-27
Combiner	WEINSCHTEL	WA1534	UL001	2024-01-13
Combiner	WEINSCHTEL	WA1534	UL003	2024-01-09
Combiner	WEINSCHTEL	WA1534	UL004	2024-01-09
Attenuator	WEINSCHTEL	WA76-30-21	A015	2024-07-24
Attenuator	PASTERNAK	PE7087-10	A001	2024-07-23
Attenuator	PASTERNAK	PE7087-10	A008	2024-07-27

SUPPORT EQUIPMENT

The following support equipment was utilized for the CBP tests documented in this report:

PERIPHERAL SUPPORT EQUIPMENT LIST				
Description	Manufacturer	Model	Serial Number	FCC ID
Wireless Access Point	ASUS	GT-AXE11000	M3IAJF200742	MSQ-RTAXJF00
Notebook PC (Controller/Server)	HP	HP EliteDesk 800 G1 TWR	CZC4125J25	DoC

14.2. TEST RESULTS

14.2.1. AWGN Sample signal

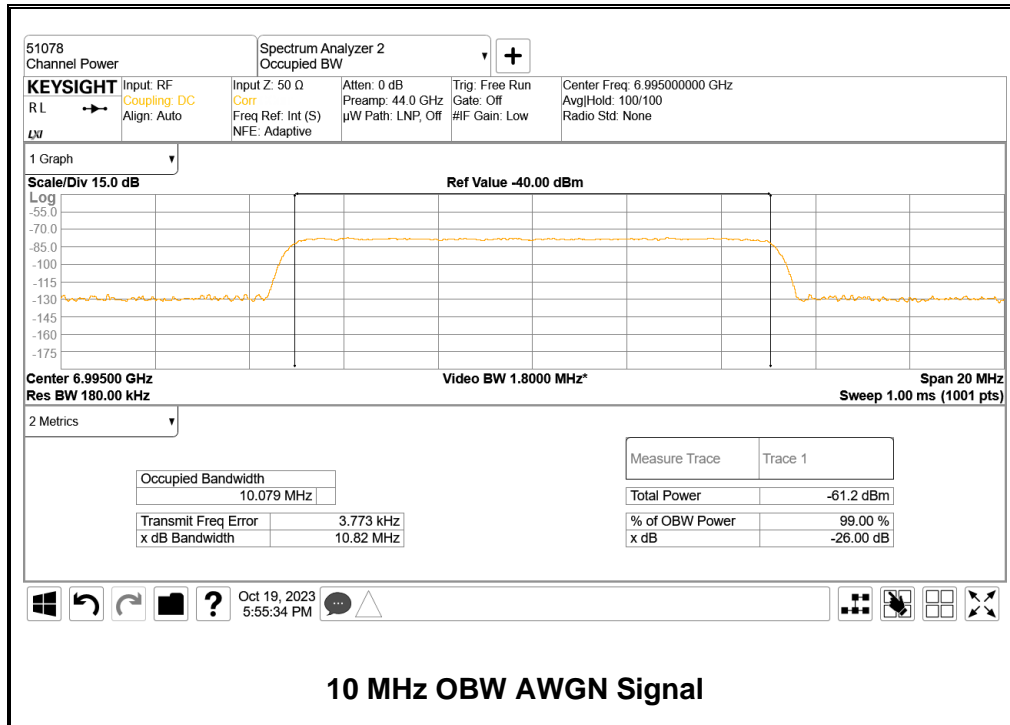

14.2.2. Contention Based Protocol Timing Plot(Measurement Criteria)

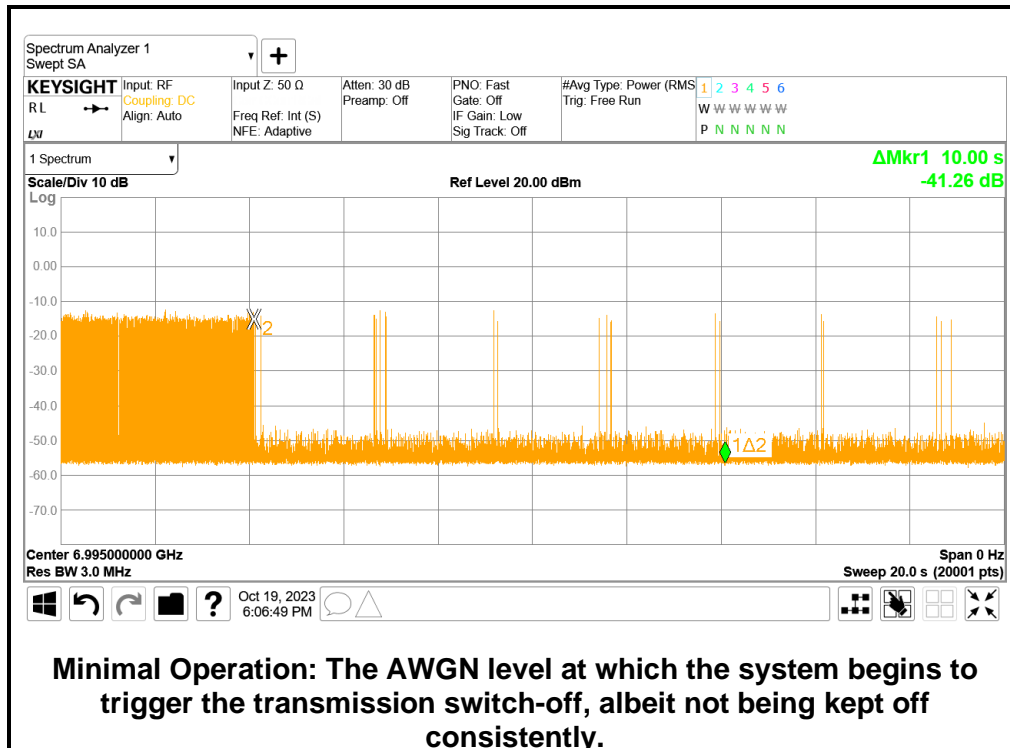
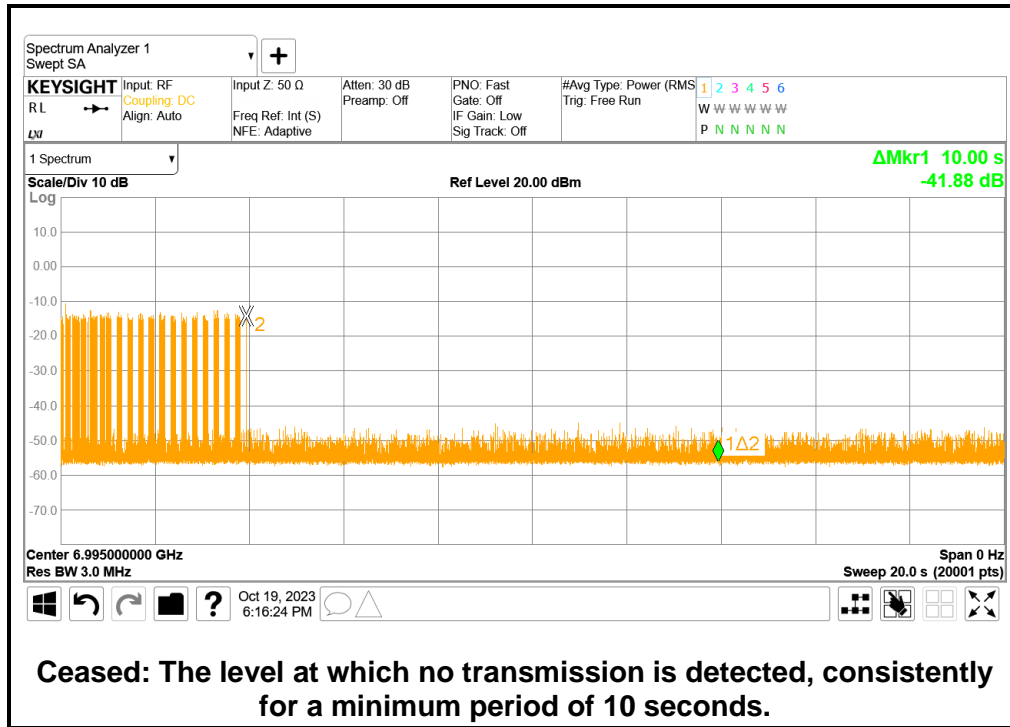

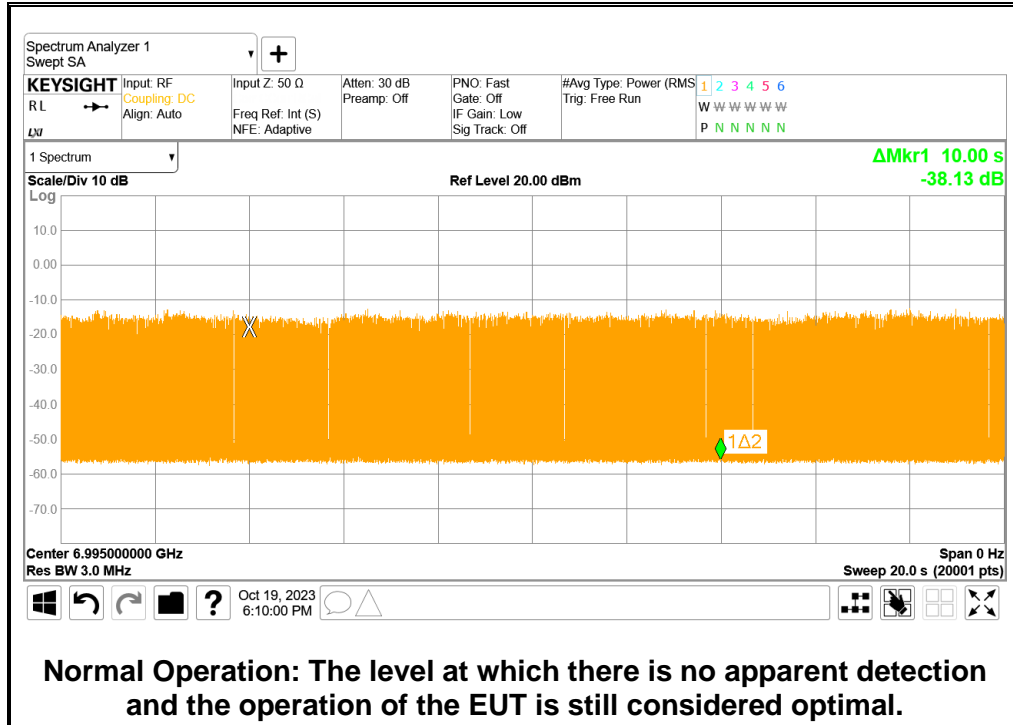

14.2.3. Contention Based Protocol – Incumbent Detection & Trial Results

Band	Channel	Freq	BW	Inc. Freq	Detection power level (Prior)	Detection limit	Gain	Detection limit (include Gain)	Margin	Condition
5	45	6175	20	6175	-77.79	-62.00	-8.59	-70.59	-7.20	Ceased
					-80.71	-62.00	-8.59	-70.59	-10.12	Minimal
					-83.76	-62.00	-8.59	-70.59	-13.17	Normal
	47	6185	160	6110	-74.77	-62.00	-8.59	-70.59	-4.18	Ceased
					-76.81	-62.00	-8.59	-70.59	-6.22	Minimal
					-79.65	-62.00	-8.59	-70.59	-9.06	Normal
				6185	-74.74	-62.00	-8.59	-70.59	-4.15	Ceased
					-76.77	-62.00	-8.59	-70.59	-6.18	Minimal
					-78.80	-62.00	-8.59	-70.59	-8.21	Normal
				6260	-75.79	-62.00	-8.59	-70.59	-5.20	Ceased
					-77.72	-62.00	-8.59	-70.59	-7.13	Minimal
					-79.66	-62.00	-8.59	-70.59	-9.07	Normal
6	105	6475	20	6475	-77.77	-62.00	-8.44	-70.44	-7.33	Ceased
					-82.71	-62.00	-8.44	-70.44	-12.27	Minimal
					-86.37	-62.00	-8.44	-70.44	-15.93	Normal
	111	6505	160	6435	-76.61	-62.00	-8.44	-70.44	-6.17	Ceased
					-79.74	-62.00	-8.44	-70.44	-9.30	Minimal
					-81.62	-62.00	-8.44	-70.44	-11.18	Normal
				6505	-75.70	-62.00	-8.44	-70.44	-5.26	Ceased
					-77.64	-62.00	-8.44	-70.44	-7.20	Minimal
					-79.63	-62.00	-8.44	-70.44	-9.19	Normal
				6575	-74.57	-62.00	-8.44	-70.44	-4.13	Ceased
					-77.50	-62.00	-8.44	-70.44	-7.06	Minimal
					-80.45	-62.00	-8.44	-70.44	-10.01	Normal
7	149	6695	20	6695	-76.54	-62.00	-8.74	-70.74	-5.80	Ceased
					-82.45	-62.00	-8.74	-70.74	-11.71	Minimal
					-87.23	-62.00	-8.74	-70.74	-16.49	Normal
	143	6665	160	6595	-73.42	-62.00	-8.74	-70.74	-2.68	Ceased
					-78.29	-62.00	-8.74	-70.74	-7.55	Minimal
					-80.43	-62.00	-8.74	-70.74	-9.69	Normal
				6665	-72.31	-62.00	-8.74	-70.74	-1.57	Ceased
					-74.47	-62.00	-8.74	-70.74	-3.73	Minimal
					-76.41	-62.00	-8.74	-70.74	-5.67	Normal
				6735	-71.50	-62.00	-8.74	-70.74	-0.76	Ceased
					-74.31	-62.00	-8.74	-70.74	-3.57	Minimal
					-80.29	-62.00	-8.74	-70.74	-9.55	Normal
8	209	6995	20	6995	-78.48	-62.00	-8.80	-70.80	-7.68	Ceased
					-84.20	-62.00	-8.80	-70.80	-13.40	Minimal
					-87.10	-62.00	-8.80	-70.80	-16.30	Normal
	207	6985	160	6915	-75.48	-62.00	-8.80	-70.80	-4.68	Ceased
					-82.54	-62.00	-8.80	-70.80	-11.74	Minimal
					-84.49	-62.00	-8.80	-70.80	-13.69	Normal
				6985	-73.56	-62.00	-8.80	-70.80	-2.76	Ceased
					-76.54	-62.00	-8.80	-70.80	-5.74	Minimal
					-81.54	-62.00	-8.80	-70.80	-10.74	Normal
				7055	-74.40	-62.00	-8.80	-70.80	-3.60	Ceased
					-77.52	-62.00	-8.80	-70.80	-6.72	Minimal
					-82.45	-62.00	-8.80	-70.80	-11.65	Normal

Band	Channel	Freq	BW	Inc. Freq	1	2	3	4	5	6	7	8	9	10	Detection Rate (%)
5	45	6175	20	6175	○	○	○	○	○	○	○	○	○	○	100
				6110	○	X	○	○	○	○	○	○	○	○	○
	47	6185	160	6185	○	○	○	○	○	○	○	○	○	○	100
				6260	○	○	○	○	○	○	○	○	○	X	○
6	105	6475	20	6475	○	○	○	○	○	○	○	○	○	○	100
				6435	○	○	○	○	○	○	○	○	○	○	○
	111	6505	160	6495	○	○	○	○	○	○	○	○	○	○	100
				6575	○	○	○	○	○	○	○	○	○	○	○
7	149	6695	20	6695	○	○	○	○	○	○	○	○	○	○	100
				6595	○	○	○	○	○	○	○	○	○	○	○
	143	6665	160	6655	○	○	○	○	○	○	○	○	○	○	100
				6735	○	○	○	○	○	○	○	○	○	○	○
8	209	6995	20	6995	○	X	○	○	○	○	○	○	○	○	100
				6915	○	○	○	○	○	○	○	○	○	○	○
	207	6985	160	6975	○	○	○	○	○	○	○	○	○	○	100
				7055	○	○	○	○	○	○	○	○	○	○	○

15. SPOT-CHECK TEST RESULT

2TX Antenna 1 + Antenna 2

BANDEDGE (WORST CASE: 802.11a / 5955 MHz)

5955 MHz VERTICAL

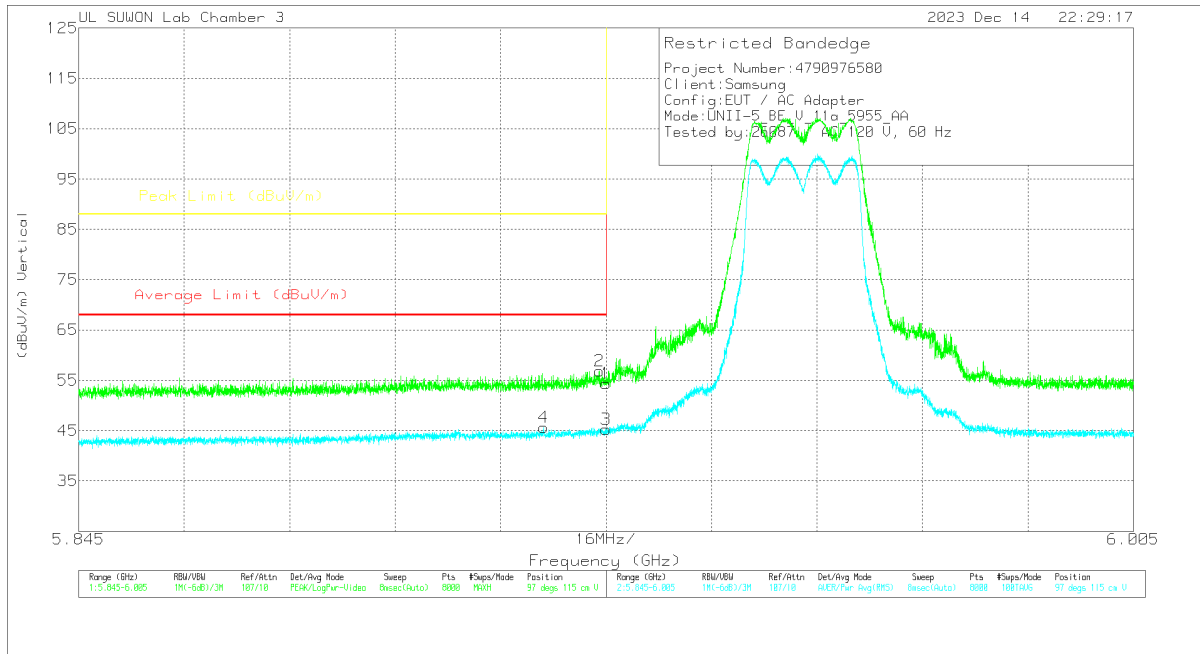

Trace Markers

Marker	Frequency (GHz)	Meter Reading (dBu)	Det	Antenna Correction Factor (dBm)	Path loss (dB)	DC Corr (dB)	Corrected Reading (dBu/m)	Average Limit (dBu/m)	Margin (dB)	Peak Limit (dBu/m)	PK Margin (dB)	Azimuth (Deg)	Height (cm)	Polarity
1	5.92499	38.3	Pk	35.5	-19.4	0	54.4	-	-	88	-33.6	97	115	V
2	5.92395	40.77	Pk	35.5	-19.4	0	56.87	-	-	88	-31.13	97	115	V
3	5.92499	28.97	RMS	35.5	-19.4	-15	45.22	68	-22.78	-	-	97	115	V
4	5.91549	29.4	RMS	35.5	-19.4	-15	45.65	68	-22.35	-	-	97	115	V

Pk - Peak detector
 RMS - RMS detection

HARMONICS AND SPURIOUS EMISSIONS(WORST CASE: 802.11a / 5955 MHz)

5955 MHz HORIZONTAL

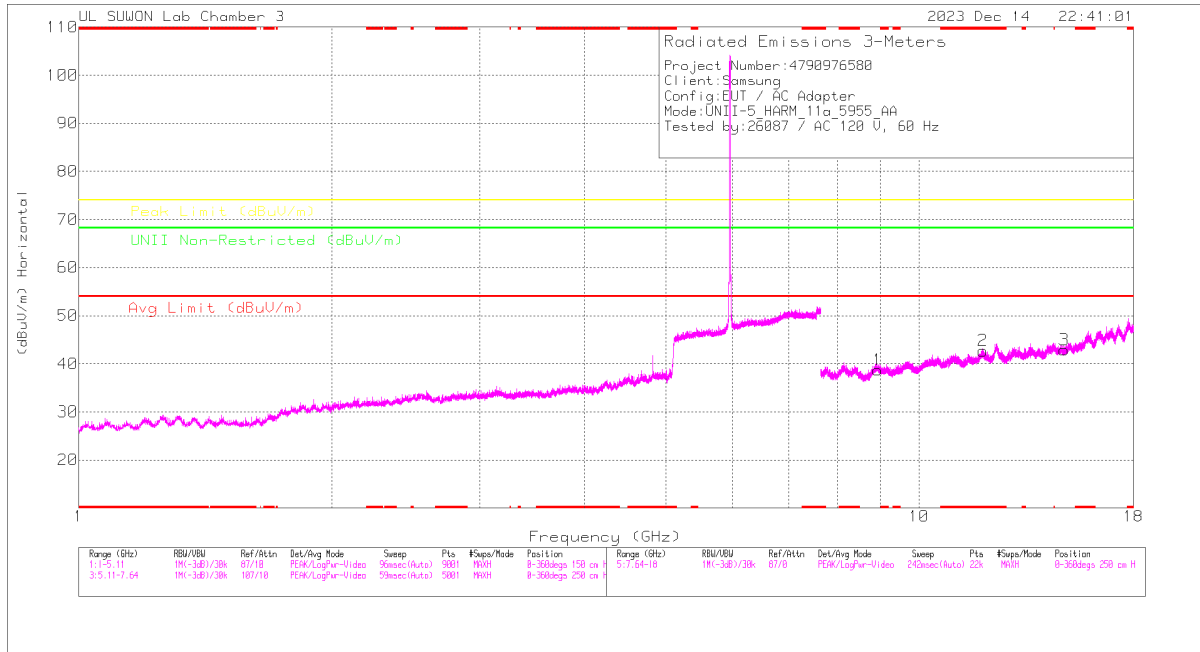

Note: Emission was scanned up to 40GHz; No emissions were detected above the noise floor which was at least 20dB below the specification limit.

Radiated Emissions

Frequency (GHz)	Meas Reading (dBuV)	Det	Antenna Correction Factor(dBm)	Path loss(dB)	DC Corr (dB)	Corrected Reading (dBuV/m)	Avg Limit (dBuV/m)	Margin (dB)	Peak Limit (dBuV/m)	Margin (dB)	UNII Non-Restricted (dBuV/m)	Margin (dB)	Altitude (Height) (m)	Height (m)	Polarity
14.88731	35.68	PK-U	39.8	-22.1	0	53.38	-	-	-	-	65.2	-14.82	0	100	H

* - indicates frequency in CFR47 Pt 15 / IC RSS-Restricted Band
 PK-U - U-NII: Maximum Peak

2TX Antenna 1 + Antenna 2

HARMONICS AND SPURIOUS EMISSIONS(WORST CASE: 802.11a / 6515 MHz)

6515 MHz HORIZONTAL

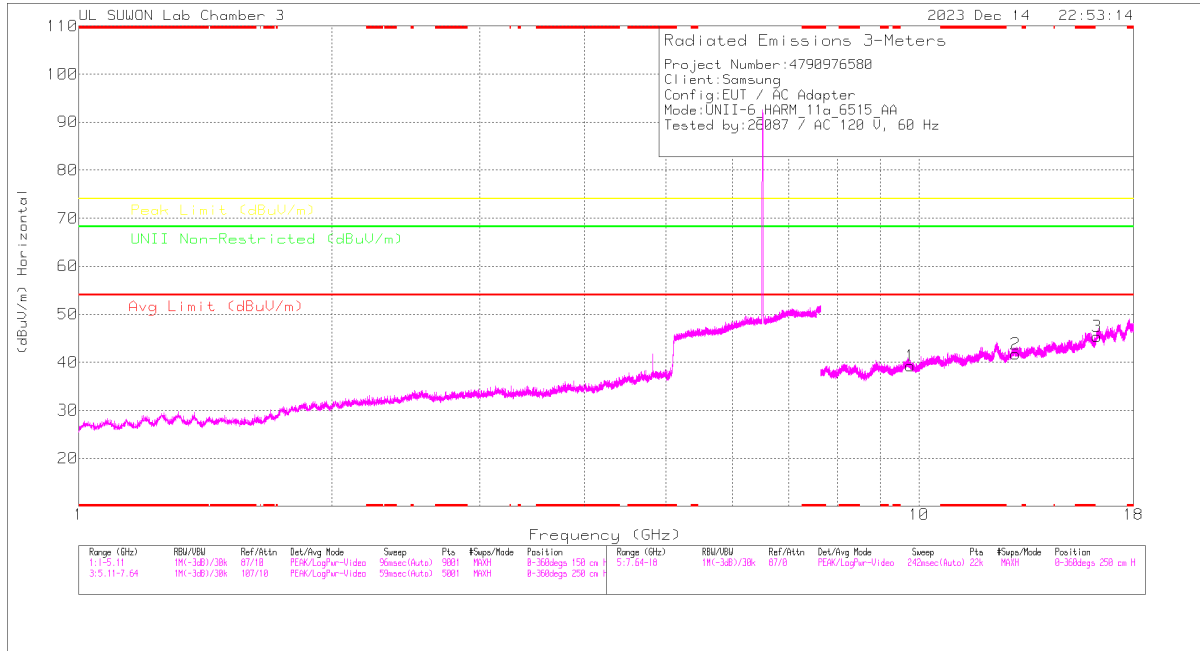

Note: Emission was scanned up to 40GHz; No emissions were detected above the noise floor which was at least 20dB below the specification limit.

Radiated Emissions

Frequency (GHz)	Meas Reading (dBuV)	Dist	Antenna Correction Factor(dBm)	Path loss(dB)	DC Corr (dB)	Corrected Reading (dBuV/m)	Avg Limit (dBuV/m)	Margin (dB)	Peak Limit (dBuV/m)	Margin (dB)	UNII Non-Restricted (dBuV/m)	Margin (dB)	Azimuth (Degs)	Height (cm)	Polarity
13.03058	35.66	PK-U	39.2	-22.3	0	52.56	-	-	-	-	68.2	-15.64	0	100	H

PK-U - U-NII: Maximum Peak

2TX Antenna 1 + Antenna 2

HARMONICS AND SPURIOUS EMISSIONS(WORST CASE: 802.11a / 6695 MHz)

6695 MHz HORIZONTAL

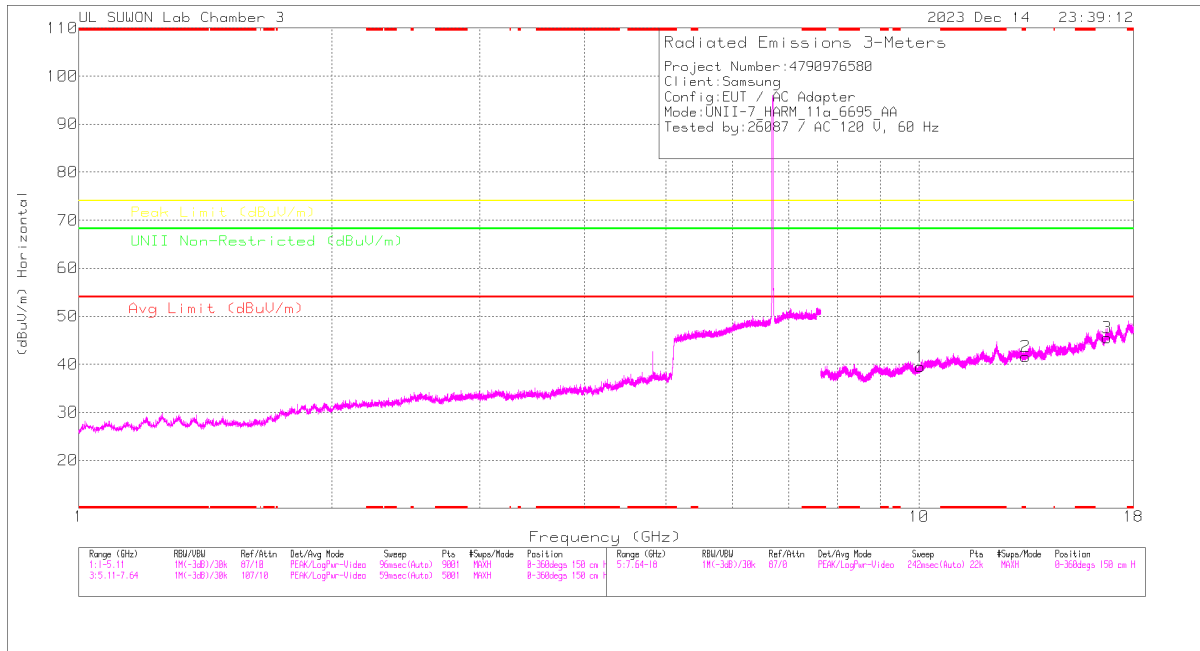

Note: Emission was scanned up to 40GHz; No emissions were detected above the noise floor which was at least 20dB below the specification limit.

Radiated Emissions

Frequency (GHz)	Meas Reading (dBuV)	Det	Antenna Correction Factor(dBm)	Path loss(dB)	DC Corr (dB)	Corrected Reading (dBuV)	Avg Limit (dBuV/m)	Margin (dB)	Peak Limit (dBuV/m)	Margin (dB)	UNII Non-Restricted (dBuV/m)	Margin (dB)	Azimuth (degs)	Height (cm)	Polarity
* 13.38971	33.94	PK-U	39.1	-21.9	0	51.14	-	-	74	-22.86	-	-	0	100	H
* 13.39017	22.49	ADR	39.1	-21.9	15	39.84	54	-14.16	-	-	-	-	0	100	H

* - indicates frequency in CFR47 Pt 15 / IC RSS-Restricted Band
 PK-U - U-NII: Maximum Peak
 ADR - U-NII AD primary method, RMS average

2TX Antenna 1 + Antenna 2

BANDEDGE (WORST CASE: 802.11a / 7115 MHz)

7115 MHz HORIZONTAL

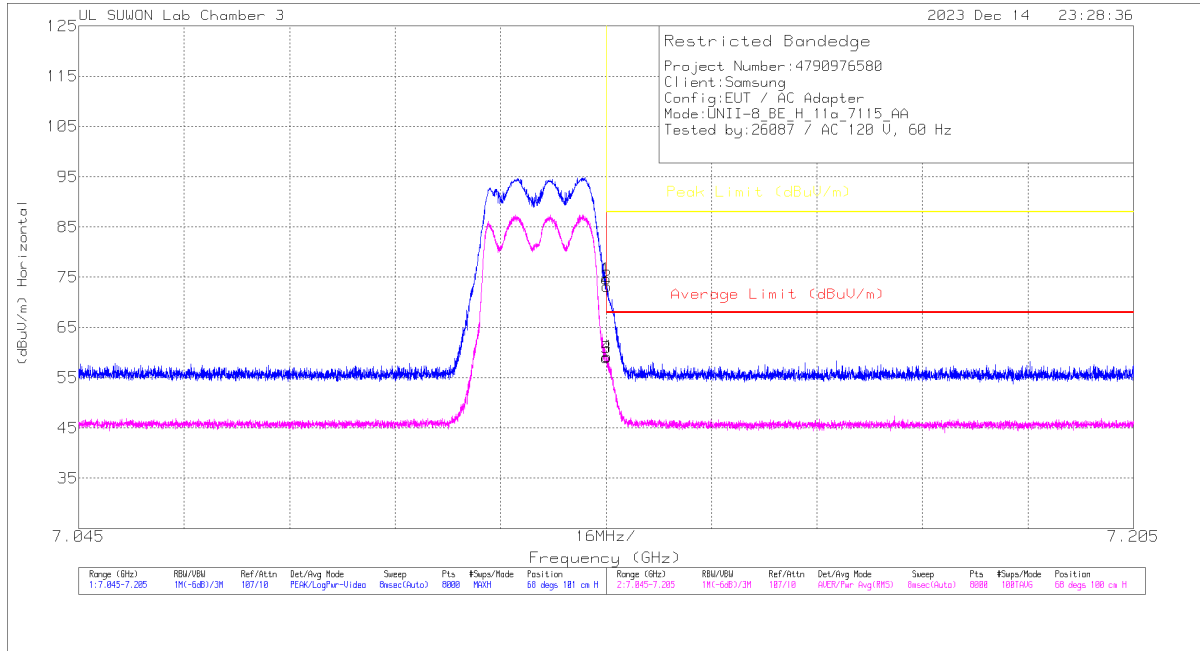

Trace Markers

Marker	Frequency (GHz)	Meter Reading (dBuV)	Det	Antenna Correction Factor (dBm)	Path loss (dB)	DC Corr (dB)	Corrected Reading (dBuV/m)	Average Limit (dBuV/m)	Margin (dB)	Peak Limit (dBuV/m)	PK Margin (dB)	Azimuth (Degs)	Height (cm)	Polarity
1	7.12501	55.4	Pk	35.9	-16.6	0	74.7	-	-	88	-13.3	68	101	H
2	7.12513	53.84	Pk	35.9	-16.6	0	73.14	-	-	88	-14.86	68	101	H
3	7.12501	39.54	RMS	35.9	-16.6	.15	58.99	68	-9.01	-	-	68	100	H
4	7.12517	39.78	RMS	35.9	-16.6	.15	59.23	68	-8.77	-	-	68	100	H

Pk - Peak detector
 RMS - RMS detection

HARMONICS AND SPURIOUS EMISSIONS(WORST CASE: 802.11a / 6895 MHz)

6895 MHz HORIZONTAL

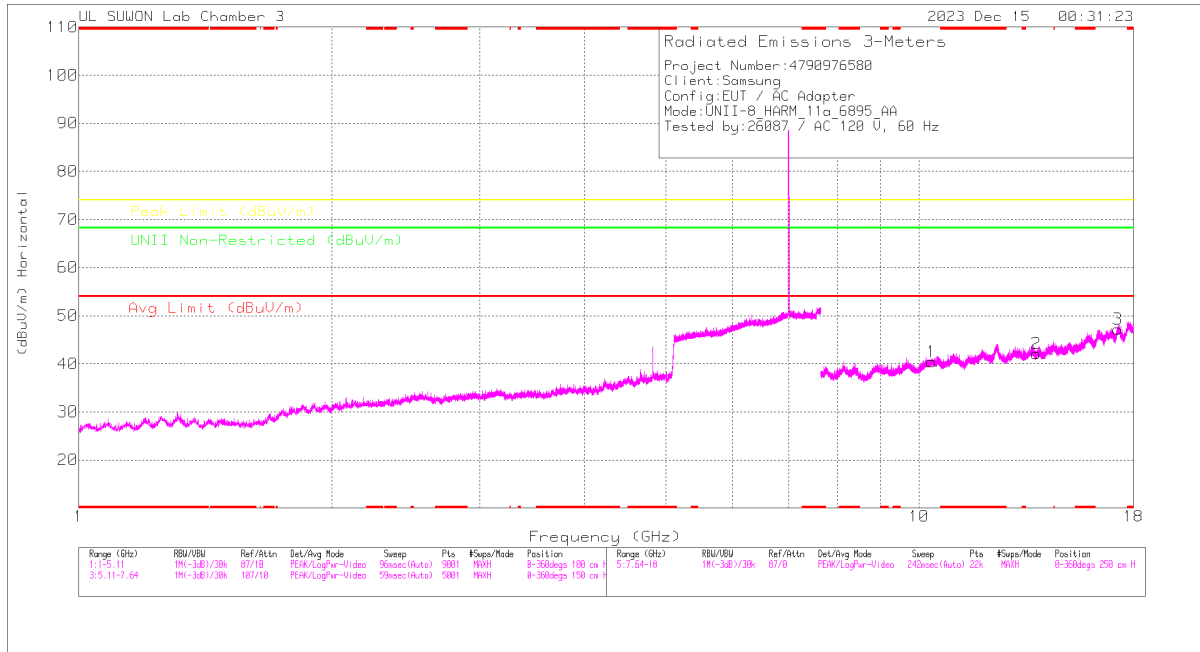

Note: Emission was scanned up to 40GHz; No emissions were detected above the noise floor which was at least 20dB below the specification limit.

Radiated Emissions

Frequency (GHz)	Meas Reading (dBuV)	Det	Antenna Correction Factor(dBm)	Path loss(dB)	DC Corr (dB)	Corrected Reading (dBuV/m)	Avg Limit (dBuV/m)	Margin (dB)	Peak Limit (dBuV/m)	Margin (dB)	UNII Non-Restricted (dBuV/m)	Margin (dB)	Altitude (Height) (m)	Height (cm)	Polarity
13.79206	36.45	PK-U	38.7	-23.4	0	51.75	-	-	-	-	68.2	-16.45	0	100	H

PK-U - U-NII: Maximum Peak

BANDEDGE (WORST CASE: 802.11ax HE80 / 5985 MHz)

5985 MHz HORIZONTAL

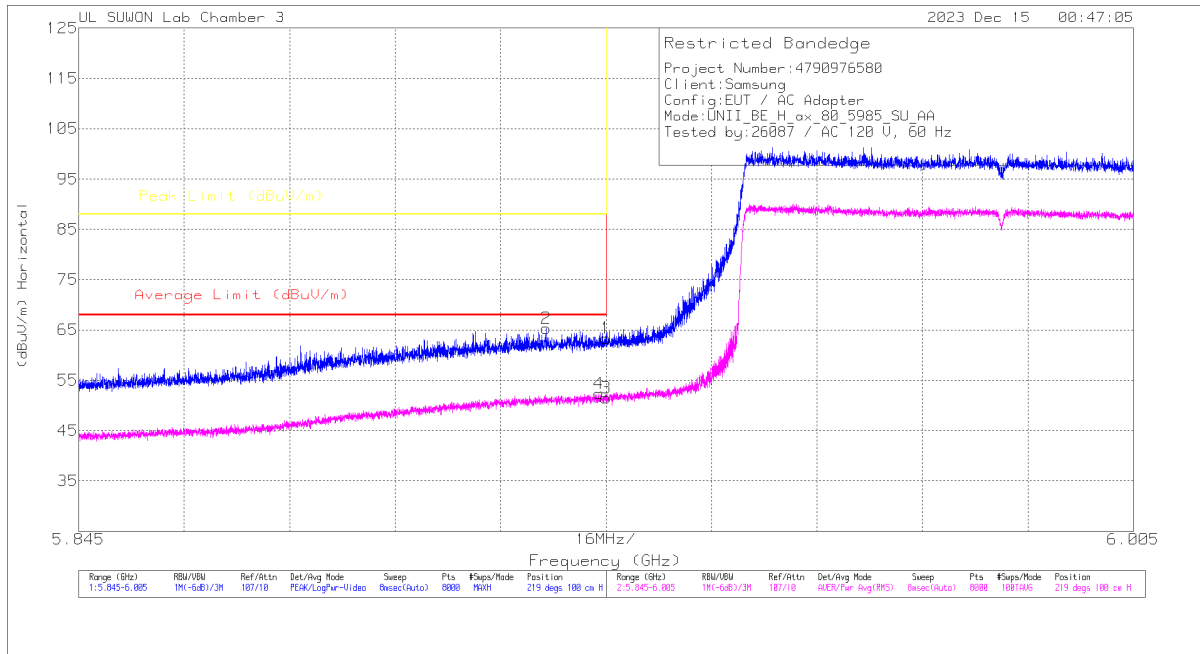

Trace Markers

Marker	Frequency (GHz)	Mask Reading (dBuV)	Det	Antenna Correction Factor (dBm)	Path loss (dB)	DC Corr (dB)	Corrected Reading (dBuV/m)	Average Limit (dBuV/m)	Margin (dB)	Peak Limit (dBuV/m)	PK Margin (dB)	Azimuth (Degs)	Height (cm)	Polarity
1	5.92499	47.3	PK	35.5	-19.4	0	63.4	-	-	88	-24.6	219	100	H
2	5.91587	49.16	PK	35.5	-19.4	0	65.28	-	-	88	-22.72	219	100	H
3	5.92499	35.45	RMS	35.5	-19.4	0	51.55	68	-16.45	-	-	219	100	H
4	5.92391	36.23	RMS	35.5	-19.4	0	52.33	68	-15.67	-	-	219	100	H

PK - Peak detector
RMS - RMS detection

HARMONICS AND SPURIOUS EMISSIONS(WORST CASE: 802.11ax HE20 52T 37RU / 6415 MHz)

6415 MHz HORIZONTAL

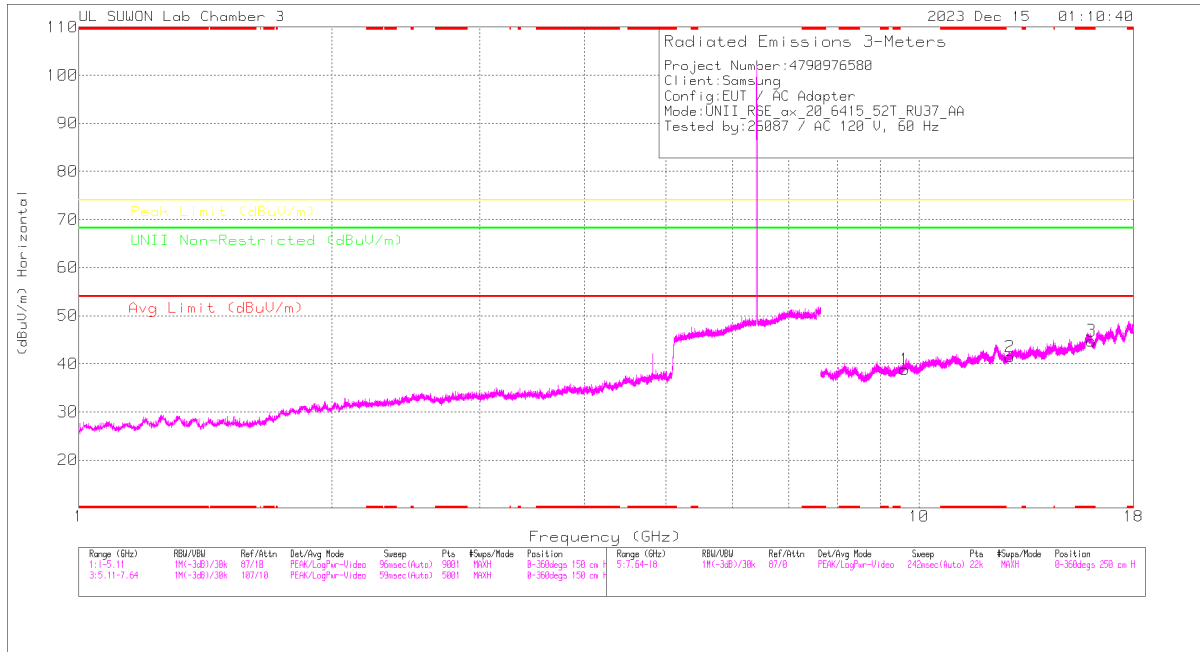

Note: Emission was scanned up to 40GHz; No emissions were detected above the noise floor which was at least 20dB below the specification limit.

Radiated Emissions

Frequency (GHz)	Meas. Reading (dBuV)	Det	Antenna Correction Factor (dBm)	Path loss (dB)	DC Corr (dB)	Corrected Reading (dBuV/m)	Avg Limit (dBuV/m)	Margin (dB)	Peak Limit (dBuV/m)	Margin (dB)	UNII Non-Restricted (dBuV/m)	Margin (dB)	Altitude (Height) (m)	Height (m)	Polarity
12.83038	35.57	PK-U	39.3	-22.6	0	52.27	-	-	-	-	68.2	-15.93	0	100	H

* - indicates frequency in CFR47 Pt 15 / IC RSS-Restricted Band
 PK-U - U-NII: Maximum Peak

2TX Antenna 1 + Antenna 2

HARMONICS AND SPURIOUS EMISSIONS(WORST CASE: 802.11ax HE20 106T 106T 53RU / 6475 MHz)

6475 MHz HORIZONTAL

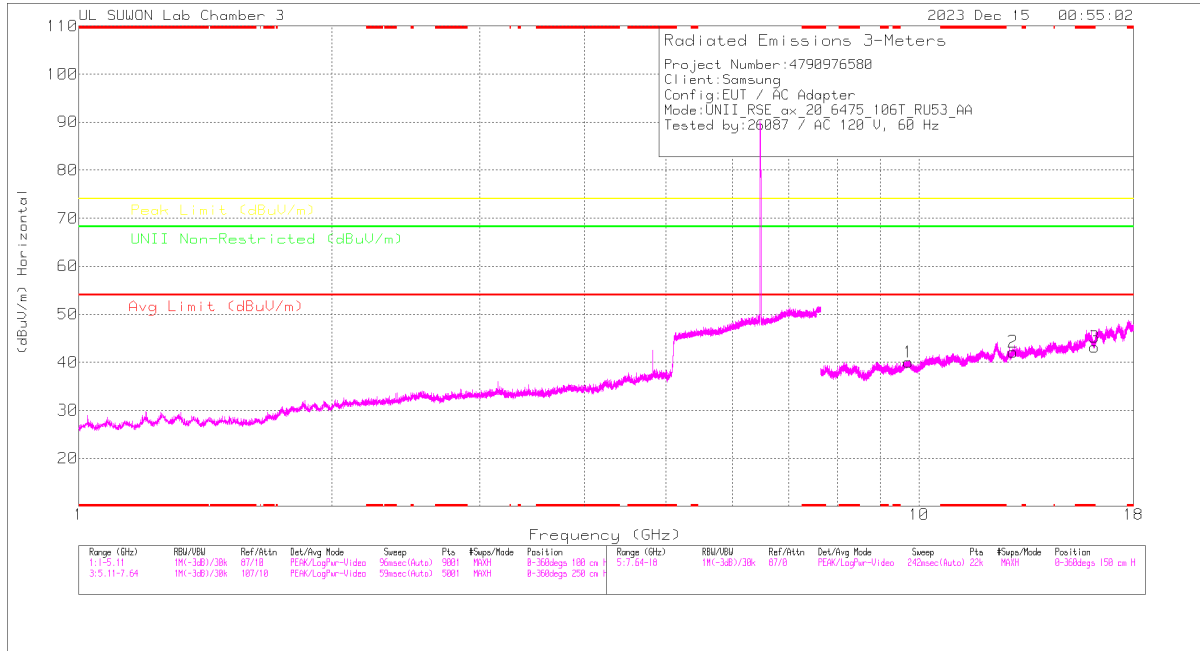

Note: Emission was scanned up to 40GHz; No emissions were detected above the noise floor which was at least 20dB below the specification limit.

Radiated Emissions

Frequency (GHz)	Meas Reading (dBuV)	Dist	Antenna Correction Factor(dBm)	Path loss(dB)	DC Corr (dB)	Corrected Reading (dBuV/m)	Avg Limit (dBV/m)	Margin (dB)	Peak Limit (dBV/m)	Margin (dB)	UNII Non-Restricted (dBV/m)	Margin (dB)	Azimuth (Degs)	Height (cm)	Polarity
12.94923	34.69	PK-U	39.3	-22.1	0	51.89	-	-	-	-	68.2	-16.31	0	100	H

* - indicates frequency in CFR47 Pt 15 / IC RSS-Restricted Band
 PK-U - U-NII: Maximum Peak

2TX Antenna 1 + Antenna 2

HARMONICS AND SPURIOUS EMISSIONS(WORST CASE: 802.11ax HE20 52T 37RU / 6695 MHz)

6695 MHz HORIZONTAL

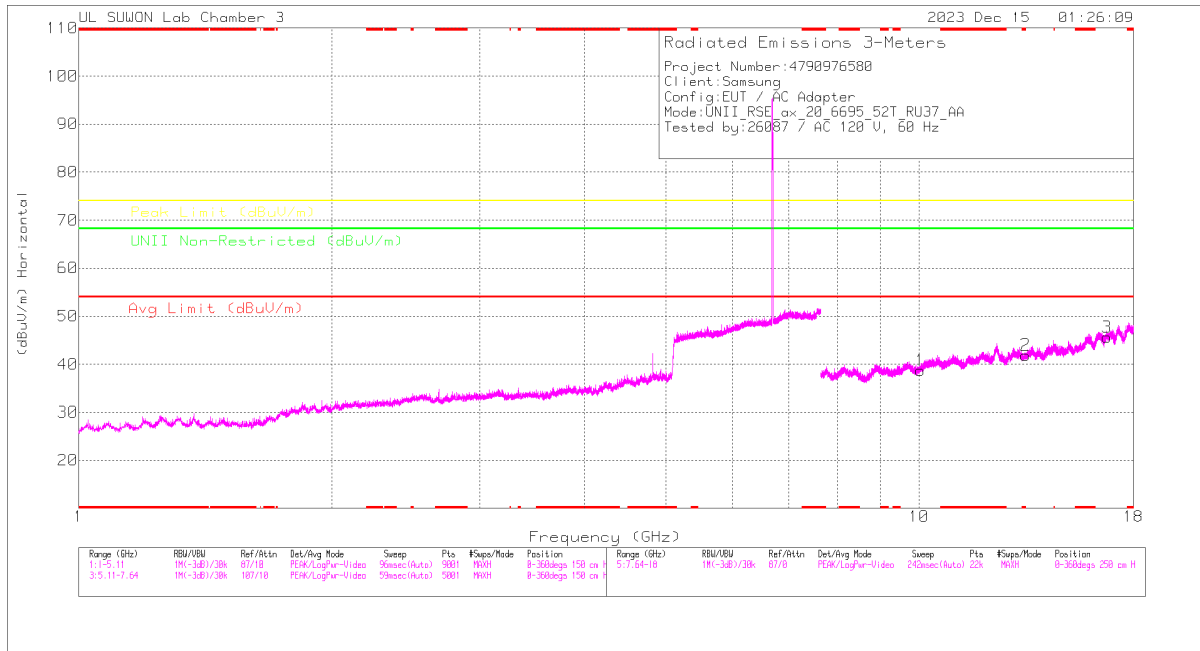

Note: Emission was scanned up to 40GHz; No emissions were detected above the noise floor which was at least 20dB below the specification limit.

Radiated Emissions

Frequency (GHz)	Meas. Reading (dBuV)	Dist	Antenna Correction Factor(dBm)	Path loss(dB)	DC Corr (dB)	Corrected Reading (dBuV/m)	Avg Limit (dBV/m)	Margin (dB)	Peak Limit (dBV/m)	Margin (dB)	UNII Non-Restricted (dBV/m)	Margin (dB)	Azimuth (Degs)	Height (cm)	Polarity
16.73582	33.06	PK-U	41.8	-18.3	0	56.56	-	-	-	-	68.2	-11.64	0	100	H

* - indicates frequency in CFR47 Pt 15 / IC RSS-Restricted Band
 PK-U - U-NII: Maximum Peak

2TX Antenna 1 + Antenna 2

BANDEDGE (WORST CASE: 802.11ax HE20 SU / 7115 MHz)

7115 MHz HORIZONTAL

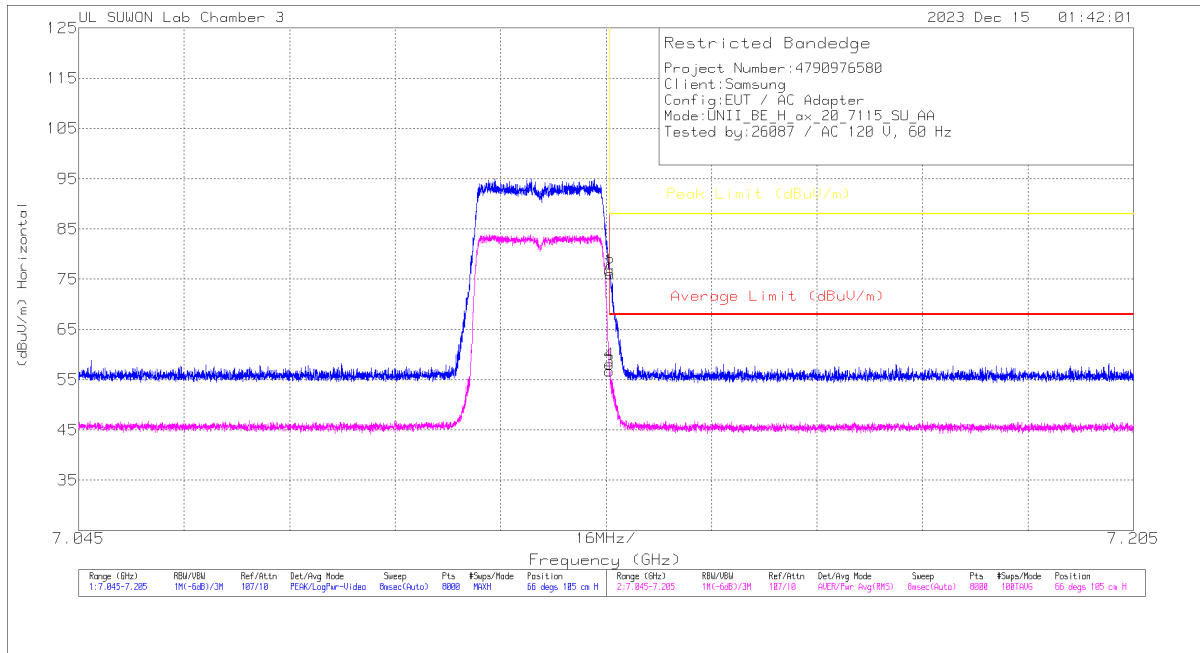

Trace Markers

Marker	Frequency (GHz)	Meter Reading (dBuV)	Det	Antenna Correction Factor(dBm)	Path loss(dB)	DC Corr (dB)	Corrected Reading (dBuV/m)	Average Limit (dBuV/m)	Margin (dB)	Peak Limit (dBuV/m)	PK Margin (dB)	Azimuth (Degs)	Height (cm)	Polarity
1	7.12551	57.58	Pk	35.9	-16.7	0	76.78	-	-	88	-11.22	66	105	H
2	7.12557	56.9	Pk	35.9	-16.7	0	76.1	-	-	88	-11.9	66	105	H
3	7.12551	37.59	RMS	35.9	-16.7	0	56.79	68	-11.21	-	-	66	105	H
4	7.12553	38.93	RMS	35.9	-16.7	0	58.13	68	-9.87	-	-	66	105	H

Pk - Peak detector
 RMS - RMS detection

HARMONICS AND SPURIOUS EMISSIONS(WORST CASE: 802.11ax HE20 106T 4RU / 6895 MHz)

6895 MHz HORIZONTAL

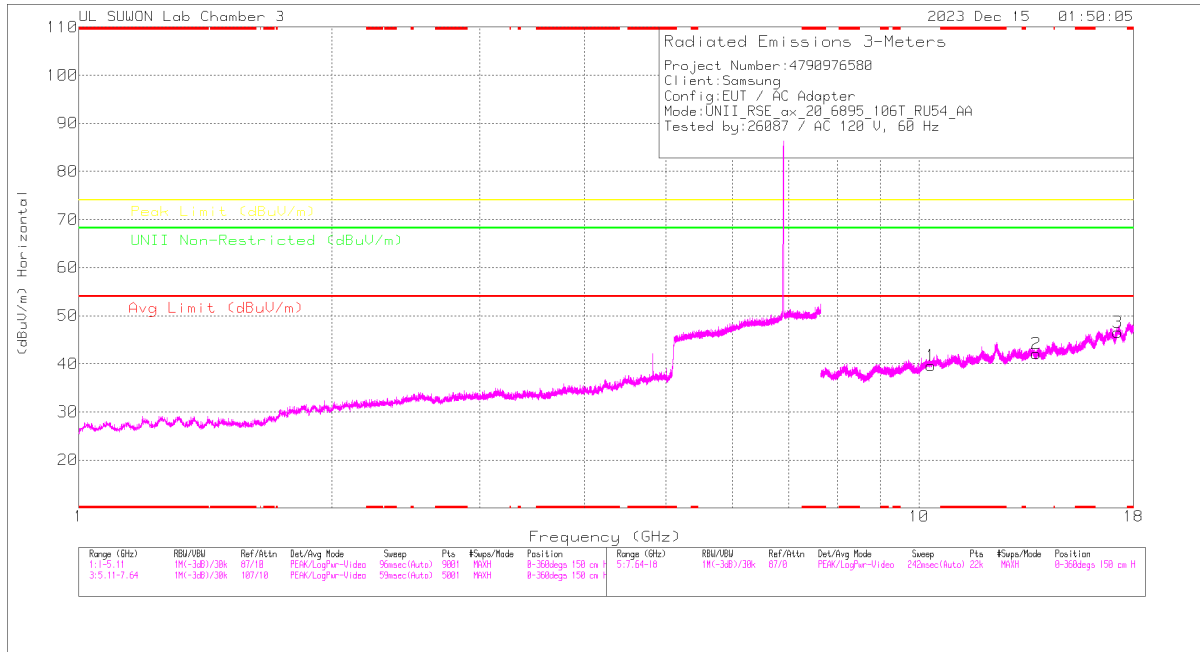

Note: Emission was scanned up to 40GHz; No emissions were detected above the noise floor which was at least 20dB below the specification limit.

Radiated Emissions

Frequency (GHz)	Meas Reading (dBuV)	Det	Antenna Correction Factor(dBm)	Path loss(dB)	DC Corr (dB)	Corrected Reading (dBuV/m)	Avg Limit (dBuV/m)	Margin (dB)	Peak Limit (dBuV/m)	Margin (dB)	UNII Non-Restricted (dBuV/m)	Margin (dB)	Altitude (Height) (cm)	Height (cm)	Polarity
17.23731	33.04	PK-U	41.1	-16.7	0	57.44	-	-	-	-	68.2	-10.76	0	100	H

PK-U - U-NII: Maximum Peak

END OF TEST REPORT