

BANDEDGE TEST DATA

Mode	Freq. [MHz]	Antenna	Frequency [GHz]	Reading [dBm]	Detector Mode	ANT Factor	Loss [dB]	Conv. F [dB]	DC Corr [dB]	Result [dBm]	PK Limit [dBm]	PK Margin [dB]	Azimuth [Degs]	Height [cm]	Polarity
802.11a	5745	MIMO	5.72500	-53.91	Pk	35.60	-19.50	11.80	0.00	-26.01	27.00	-53.01	106	114	H
			5.64835	-63.44	Pk	35.50	-19.80	11.80	0.00	-35.94	-27.00	-8.94	106	114	H
			5.72500	-52.91	Pk	35.60	-19.50	11.80	0.00	-25.01	27.00	-52.01	88	103	V
			5.63836	-63.47	Pk	35.50	-19.80	11.80	0.00	-35.97	-27.00	-8.97	88	103	V
802.11n (HT20)	5745	MIMO	5.72500	-50.93	Pk	35.60	-19.50	11.80	0.00	-23.03	27.00	-50.03	110	264	H
			5.63857	-62.29	Pk	35.50	-19.80	11.80	0.00	-34.79	-27.00	-7.79	110	264	H
			5.72500	-51.98	Pk	35.60	-19.50	11.80	0.00	-24.08	27.00	-51.08	97	113	V
			5.64879	-63.48	Pk	35.50	-19.80	11.80	0.00	-35.98	-27.00	-8.98	97	113	V
802.11n (HT40)	5755	MIMO	5.72500	-49.28	Pk	35.60	-19.50	11.80	0.00	-21.38	27.00	-48.38	113	183	H
			5.63534	-62.16	Pk	35.50	-19.80	11.80	0.00	-34.66	-27.00	-7.66	113	183	H
			5.72500	-50.89	Pk	35.60	-19.50	11.80	0.00	-22.99	27.00	-49.99	96	103	V
			5.64320	-61.66	Pk	35.50	-19.80	11.80	0.00	-34.16	-27.00	-7.16	96	103	V
802.11ac (VHT80)	5775	MIMO	5.72500	-62.66	Pk	35.60	-19.50	11.80	0.00	-34.76	27.00	-61.76	117	238	H
			5.62962	-63.07	Pk	35.50	-19.90	11.80	0.00	-35.67	-27.00	-8.67	117	238	H
			5.72500	-63.79	Pk	35.60	-19.50	11.80	0.00	-35.89	27.00	-62.89	94	103	V
			5.64067	-63.45	Pk	35.50	-19.80	11.80	0.00	-35.95	-27.00	-8.95	94	103	V
802.11ac (VHT160)	5815 Lower	MIMO	5.72500	-62.66	Pk	35.60	-19.50	11.80	0.00	-34.76	27.00	-61.76	114	248	H
			5.64967	-62.94	Pk	35.50	-19.80	11.80	0.00	-35.44	-27.00	-8.44	114	248	H
			5.72500	-63.29	Pk	35.60	-19.50	11.80	0.00	-35.39	27.00	-62.39	97	103	V
			5.64928	-63.06	Pk	35.50	-19.80	11.80	0.00	-35.56	-27.00	-8.56	97	103	V
802.11ax (HE20)	5745	MIMO	5.72500	-45.24	Pk	35.60	-19.50	11.80	0.00	-17.34	27.00	-44.34	114	248	H
			5.63862	-63.67	Pk	35.50	-19.80	11.80	0.00	-36.17	-27.00	-9.17	114	248	H
			5.72500	-43.70	Pk	35.60	-19.50	11.80	0.00	-15.80	27.00	-42.80	89	103	V
			5.62984	-62.92	Pk	35.50	-19.90	11.80	0.00	-35.52	-27.00	-8.52	89	103	V
802.11ax (HE40)	5755	MIMO	5.72500	-49.45	Pk	35.60	-19.50	11.80	0.00	-21.55	27.00	-48.55	111	272	H
			5.63719	-59.99	Pk	35.50	-19.80	11.80	0.00	-32.49	-27.00	-5.49	111	272	H
			5.72500	-49.44	Pk	35.60	-19.50	11.80	0.00	-21.54	27.00	-48.54	89	103	V
			5.64753	-59.29	Pk	35.50	-19.80	11.80	0.00	-31.79	-27.00	-4.79	89	103	V
802.11ax (HE80)	5775	MIMO	5.72500	-54.76	Pk	35.60	-19.50	11.80	0.00	-26.86	27.00	-53.86	112	274	H
			5.64863	-57.78	Pk	35.50	-19.80	11.80	0.00	-30.28	-27.00	-3.28	112	274	H
			5.72500	-55.84	Pk	35.60	-19.50	11.80	0.00	-27.94	27.00	-54.94	87	106	V
			5.64297	-57.23	Pk	35.50	-19.80	11.80	0.00	-29.73	-27.00	-2.73	87	106	V
802.11ax (HE160)	5815 Lower	MIMO	5.72500	-64.38	Pk	35.60	-19.50	11.80	0.00	-36.48	27.00	-63.48	119	274	H
			5.64185	-62.43	Pk	35.50	-19.80	11.80	0.00	-34.93	-27.00	-7.93	119	274	H
			5.72500	-65.32	Pk	35.60	-19.50	11.80	0.00	-37.42	27.00	-64.42	88	121	V
			5.64795	-63.22	Pk	35.50	-19.80	11.80	0.00	-35.72	-27.00	-8.72	88	121	V

Note. Pk - Peak detector

HARMONICS AND SPURIOUS EMISSIONS(WORST CASE: 802.11a / 5745 MHz)
5745 MHz HORIZONTAL

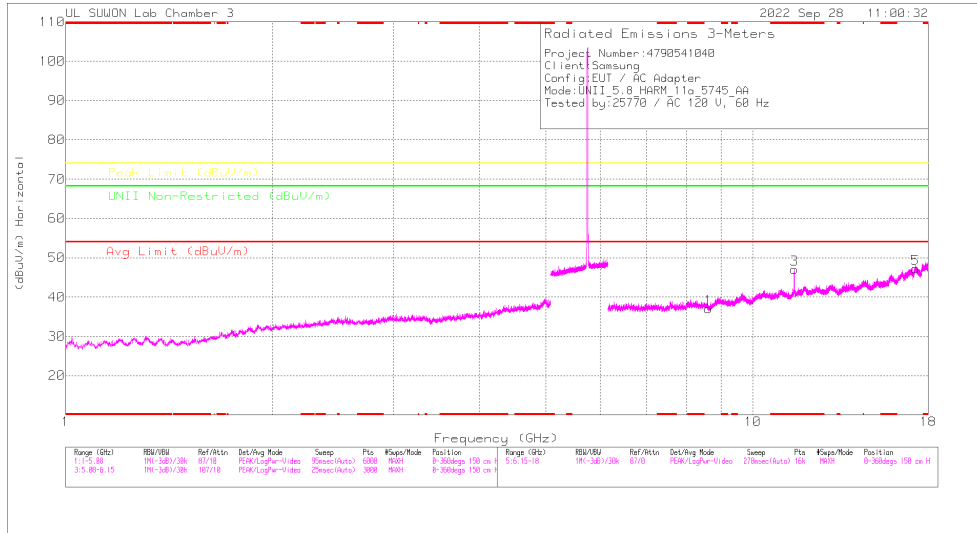

5745 MHz VERTICAL

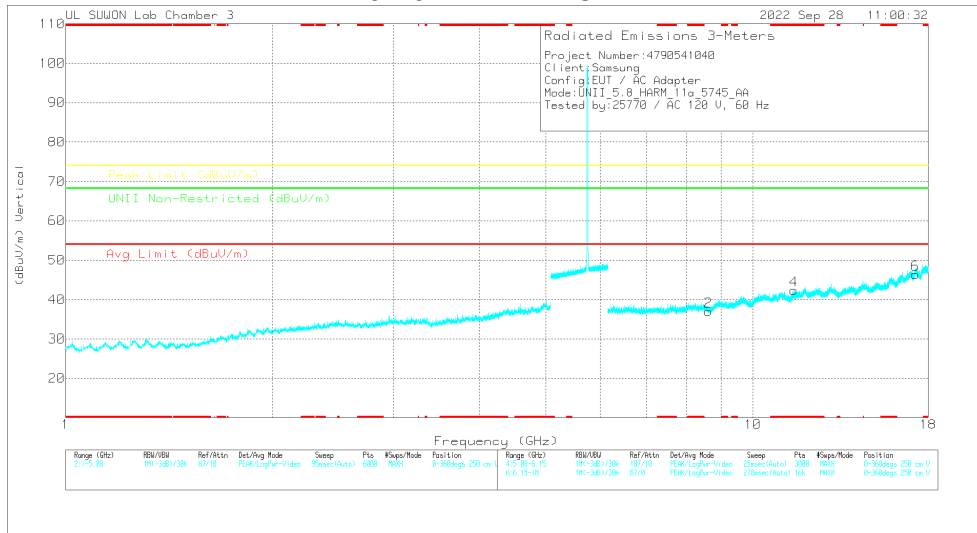

Note: Emission was scanned up to 40GHz; No emissions were detected above the noise floor which was at least 20dB below the specification limit.

5745 MHz DATA

Radiated Emissions

Frequency (GHz)	Max Reading (dBuV)	Det	317_0021867	6GHz_HPSDR	DC Corr (dB)	Corrected Reading (dBuV/m)	Avg Limit (dBuV/m)	Margin (dB)	Peak Limit (dBuV/m)	Margin (dB)	UNII Non-Restricted (dBuV/m)	Margin (dB)	Altitude (m)	Height (m)	Polarity
8.62371	34.83	PK-U	36.5	-23.1	0	48.23	-	-	-	-	68.2	-19.97	0	100	H
8.61443	33.71	PK-U	36.5	-23.1	0	47.11	-	-	-	-	68.2	-21.09	0	100	V
* 11.49225	41.07	PK-U	38.7	-21.4	0	58.37	-	-	74	-15.63	-	-	187	181	H
* 11.49254	28.64	ADR	38.7	-21.4	-17	46.11	54	-7.89	-	-	-	-	187	191	H
* 11.48707	35.71	PK-U	38.7	-21.4	0	53.01	-	-	74	-20.99	-	-	139	105	V
* 11.49222	23.58	ADR	38.7	-21.4	-17	41.05	54	-12.95	-	-	-	-	139	105	V
17.23355	32.29	PK-U	42.1	-17.1	0	57.29	-	-	-	-	68.2	-10.81	0	100	H
17.24144	31.9	PK-U	42.1	-17.1	0	56.9	-	-	-	-	68.2	-11.3	0	100	V

* - indicates frequency in CFR47 Pt 15 / IC RSS-Restricted Band
 PK-U - U-NII: Maximum Peak
 ADR - U-NII AD primary method, RMS average

HARMONICS AND SPOURIOUS EMISSIONS TEST DATA

Mode	Freq. [MHz]	Antenna	Frequency [GHz]	Reading [dBuV]	Detector Mode	ANT Factor	Loss [dB]	DC Corr [dB]	Result [dBuV/m]	AV Limit [dBuV/m]	AV Margin [dB]	PK Limit [dBuV/m]	PK Margin [dB]	Non-Restricted [dBuV/m]	Margin [dB]	Azimuth [Degs]	Height [cm]	Polarity		
802.11a	5745	MIMO	8.624	34.83	PK-U	36.50	-23.10	0.00	48.23	-	-	-	-	68.20	-19.97	0	100	H		
			8.614	33.71	PK-U	36.50	-23.10	0.00	47.11	-	-	-	-	68.20	-21.09	0	100	V		
			* 11.4925	41.07	PK-U	38.70	-21.40	0.00	58.37	-	-	-	74.00	-15.63	-	-	187	191	H	
			* 11.49254	28.64	ADR	38.70	-21.40	0.17	46.11	54.00	-7.89	-	-	-	-	-	-	187	191	H
			* 11.48707	35.71	PK-U	38.70	-21.40	0.00	53.01	-	-	-	74.00	-20.99	-	-	-	139	105	V
			* 11.49222	23.58	ADR	38.70	-21.40	0.17	41.05	54.00	-12.95	-	-	-	-	-	-	139	105	V
			17.234	32.29	PK-U	42.10	-17.10	0.00	57.29	-	-	-	-	-	-	68.20	-10.91	0	100	H
			17.241	31.90	PK-U	42.10	-17.10	0.00	56.90	-	-	-	-	-	-	68.20	-11.30	0	100	V
			8.674	34.27	PK-U	36.50	-23.00	0.00	47.77	-	-	-	-	-	-	68.20	-20.43	0	100	H
	8.673	33.95	PK-U	36.50	-23.00	0.00	47.45	-	-	-	-	-	-	68.20	-20.75	0	100	V		
	* 11.57216	40.22	PK-U	38.80	-21.60	0.00	57.42	-	-	-	74.00	-16.58	-	-	-	189	189	H		
	* 11.56815	28.46	ADR	38.80	-21.50	0.17	45.93	54.00	-8.07	-	-	-	-	-	-	189	189	H		
	* 11.57517	34.09	PK-U	38.80	-21.60	0.00	51.29	-	-	-	74.00	-22.71	-	-	-	0	100	V		
	17.364	31.53	PK-U	42.00	-17.30	0.00	56.23	-	-	-	-	-	-	68.20	-11.97	0	100	H		
	17.355	31.67	PK-U	42.00	-17.20	0.00	56.47	-	-	-	-	-	-	68.20	-11.73	0	100	V		
	7.767	42.29	PK-U	36.30	-24.60	0.00	53.99	-	-	-	-	-	-	68.20	-14.21	65	249	H		
	7.767	42.00	PK-U	36.30	-24.60	0.00	53.70	-	-	-	-	-	-	68.20	-14.50	149	109	V		
	* 11.65124	38.63	PK-U	38.90	-21.50	0.00	56.03	-	-	-	74.00	-17.97	-	-	-	210	100	H		
	* 11.6514	26.71	ADR	38.90	-21.50	0.17	44.28	54.00	-9.72	-	-	-	-	-	-	210	100	H		
	* 11.65377	34.37	PK-U	38.90	-21.50	0.00	51.77	-	-	-	74.00	-22.23	-	-	-	0	100	V		
	17.471	31.19	PK-U	42.00	-16.80	0.00	56.39	-	-	-	-	-	-	68.20	-11.81	360	100	H		
	17.469	30.90	PK-U	42.00	-16.80	0.00	56.10	-	-	-	-	-	-	68.20	-12.10	0	100	V		
	802.11ax (HE20) 8RU Spot-check	5825	MIMO	7.767	42.05	PK-U	36.30	-24.60	0.00	53.75	-	-	-	-	68.20	-14.45	69	248	H	
				7.767	42.21	PK-U	36.30	-24.60	0.00	53.91	-	-	-	-	68.20	-14.29	148	100	V	
* 11.65297				34.24	PK-U	38.90	-21.50	0.00	51.64	-	-	74.00	-22.36	-	-	-	0	100	H	
* 11.64433				34.39	PK-U	38.80	-21.50	0.00	51.69	-	-	74.00	-22.31	-	-	-	0	100	V	
17.485				30.89	PK-U	42.00	-16.80	0.00	56.09	-	-	-	-	-	-	68.20	-12.11	0	100	H
17.476				31.39	PK-U	42.00	-16.80	0.00	56.59	-	-	-	-	-	-	68.20	-11.61	0	100	V

Note1. PK-U - U-NII: Maximum Peak / ADR - U-NII AD primary method, RMS average
 Note2. * - indicates frequency in CFR47 Pt 15 / IC RSS-Restricted Band

11.5. TX ABOVE 1GHz 2Tx MODE IN THE 5.9 GHz BAND

BANDEDGE (WORST CASE: 802.11ax HE20 / 5885 MHz)

HORIZONTAL PEAK DATA

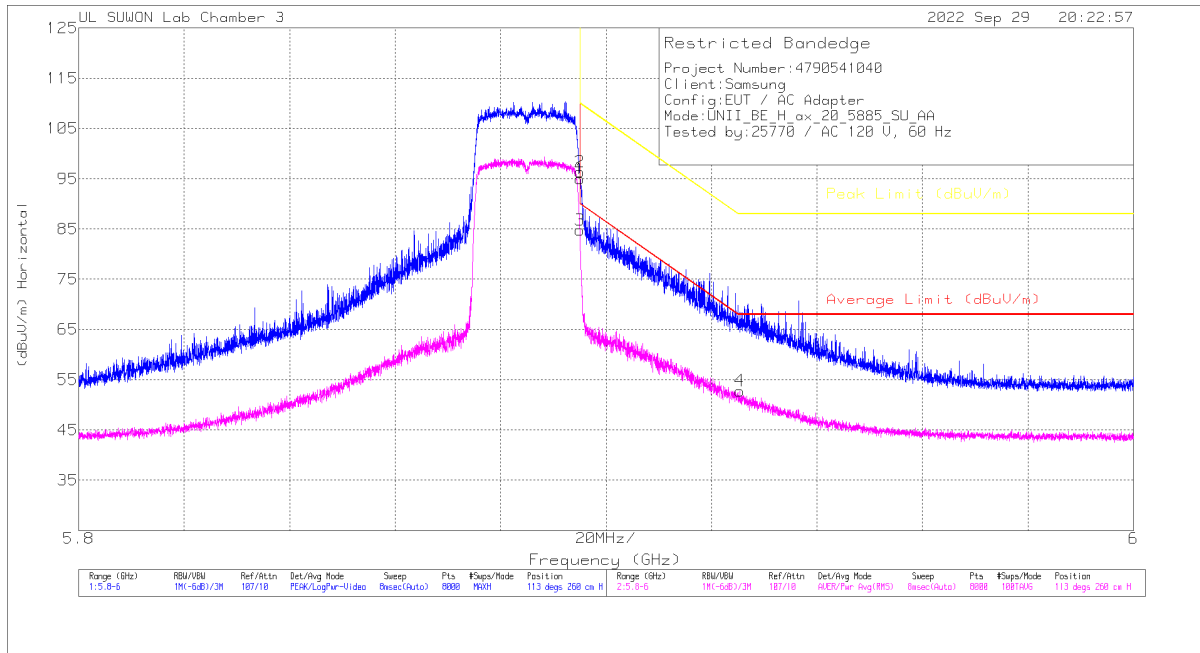

Trace Markers

Marker	Frequency (GHz)	Meter Reading (dBm)	Det	3117_00218957	10dB_ATT[dB]	DC Corr (dB)	Corrected Reading (dBm)	Average Limit (dBm)	Margin (dB)	Peak Limit (dBm)	PK Margin (dB)	Azimuth (Degs)	Height (cm)	Polarity
1	5.89501	73.33	PK	36	-19.3	0	95.03	-	-	109.99	-14.96	113	260	H
2	5.89509	79.66	PK	36	-19.3	0	96.36	-	-	109.94	-13.58	113	260	H
3	5.89501	68.04	RMS	36	-19.3	0	84.74	89.99	-5.25	-	-	113	260	H
4	5.92534	36.11	RMS	36	-19.3	0	52.81	68	-15.19	-	-	113	260	H

RMS - RMS detection

HARMONICS AND SPURIOUS EMISSIONS(WORST CASE: 802.11a / 5885 MHz)
5885 MHz HORIZONTAL

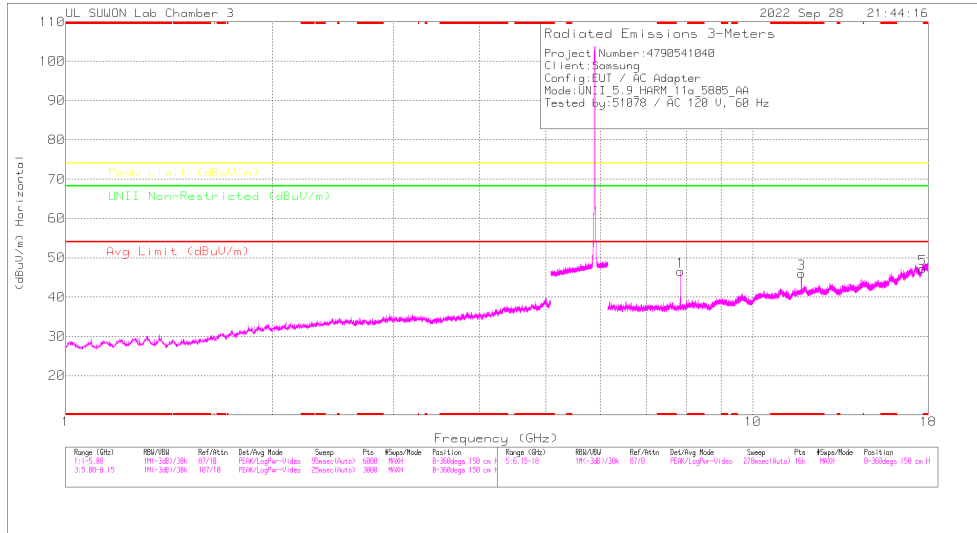

5885 MHz VERTICAL

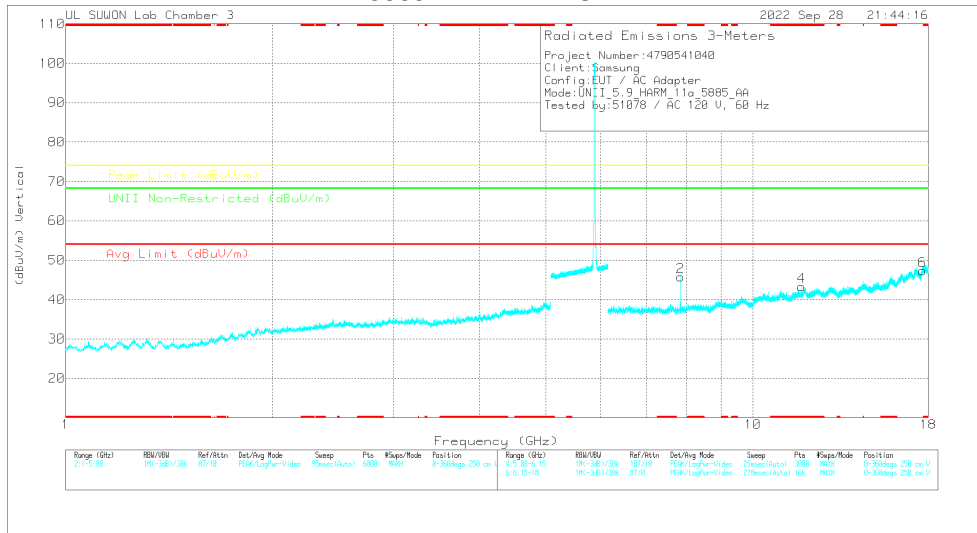

Note: Emission was scanned up to 40GHz; No emissions were detected above the noise floor which was at least 20dB below the specification limit.

5885 MHz DATA

Radiated Emissions

Frequency (GHz)	Max Reading (dBuV)	Det	317_00218657	6GHz_HPSDR	DC Corr (dB)	Corrected Reading (dBuV/m)	Avg Limit (dBuV/m)	Margin (dB)	Peak Limit (dBuV/m)	Margin (dB)	UNII Non-Restricted (dBuV/m)	Margin (dB)	Altitude (m)	Height (m)	Polarity
7.84647	40.24	PK-U	36.3	-24.2	0	52.34	-	-	-	-	68.2	-15.86	67	252	H
7.84641	40.45	PK-U	36.3	-24.2	0	52.55	-	-	-	-	68.2	-15.65	141	102	V
*11.76988	42.6	PK-U	39	-21.5	0	60.1	-	-	74	-13.9	-	-	128	101	H
*11.77008	27.81	ADR	39	-21.5	-17	45.69	54	-8.52	-	-	-	-	128	101	H
*11.77216	38.38	PK-U	39	-21.5	0	55.88	-	-	74	-18.12	-	-	221	101	V
*11.77231	25.1	ADR	39	-21.5	-17	42.77	54	-11.23	-	-	-	-	221	101	V
17.85269	31.11	PK-U	41.9	-15.7	0	57.31	-	-	-	-	68.2	-10.89	0	100	H
17.85715	31.29	PK-U	41.9	-15.6	0	57.69	-	-	-	-	68.2	-10.61	0	100	V

* - indicates frequency in CFR47 Pt 15 / IC RSS-Restricted Band
 PK-U - U-NII: Maximum Peak
 ADR - U-NII AD primary method, RMS average

HARMONICS AND SPURIOUS EMISSIONS TEST DATA

Mode	Freq. [MHz]	Antenna	Frequency [GHz]	Reading [dBuV]	Detector Mode	ANT Factor	Loss [dB]	DC Corr [dB]	Result [dBuV/m]	AV Limit [dBuV/m]	AV Margin [dB]	PK Limit [dBuV/m]	PK Margin [dB]	Non-Restricted [dBuV/m]	Margin [dB]	Azimuth [Degs]	Height [cm]	Polarity		
802.11a	5845	MIMO	7.793	41.15	PK-U	36.30	-24.50	0.00	52.95	-	-	-	-	68.20	-15.25	63	104	H		
			7.793	41.48	PK-U	36.30	-24.50	0.00	53.28	-	-	-	-	68.20	-14.92	145	101	V		
			* 11.69286	39.08	PK-U	38.90	-21.50	0.00	56.48	-	-	74.00	-17.52	-	-	-	195	272	H	
			* 11.68821	26.90	ADR	38.90	-21.50	0.17	44.47	54.00	-9.53	-	-	-	-	-	-	195	272	H
			* 11.69031	36.02	PK-U	38.90	-21.50	0.00	53.42	-	-	74.00	-20.58	-	-	-	-	213	111	V
			* 11.69029	24.11	ADR	38.90	-21.50	0.17	41.68	54.00	-12.32	-	-	-	-	-	-	213	111	V
			17.530	31.28	PK-U	42.00	-17.00	0.00	56.28	-	-	-	-	-	-	68.20	-11.92	0	100	H
			17.538	31.17	PK-U	42.00	-17.00	0.00	56.17	-	-	-	-	-	-	68.20	-12.03	0	100	V
			7.820	40.73	PK-U	36.30	-24.30	0.00	52.73	-	-	-	-	-	-	68.20	-15.47	67	244	H
	7.820	41.80	PK-U	36.30	-24.30	0.00	53.80	-	-	-	-	-	-	68.20	-14.40	140	100	V		
	* 11.73205	38.72	PK-U	38.90	-21.60	0.00	56.02	-	-	74.00	-17.98	-	-	-	-	212	100	H		
	* 11.73121	26.40	ADR	38.90	-21.60	0.17	43.87	54.00	-10.13	-	-	-	-	-	-	212	100	H		
	* 11.73215	38.07	PK-U	38.90	-21.60	0.00	55.37	-	-	74.00	-18.63	-	-	-	-	225	100	V		
	* 11.73181	24.87	ADR	38.90	-21.60	0.17	42.34	54.00	-11.66	-	-	-	-	-	-	225	100	V		
	17.603	31.21	PK-U	42.00	-16.50	0.00	56.71	-	-	-	-	-	-	68.20	-11.49	0	100	H		
	17.601	31.41	PK-U	42.00	-16.60	0.00	56.81	-	-	-	-	-	-	68.20	-11.39	0	100	V		
	5885	MIMO	7.846	40.24	PK-U	36.30	-24.20	0.00	52.34	-	-	-	-	-	68.20	-15.86	67	252	H	
			7.846	40.45	PK-U	36.30	-24.20	0.00	52.55	-	-	-	-	-	68.20	-15.65	141	102	V	
* 11.76588			42.60	PK-U	39.00	-21.50	0.00	60.10	-	-	74.00	-13.90	-	-	-	128	101	H		
* 11.77008			27.81	ADR	39.00	-21.50	0.17	45.48	54.00	-8.52	-	-	-	-	-	128	101	H		
* 11.77216			38.38	PK-U	39.00	-21.50	0.00	55.88	-	-	74.00	-18.12	-	-	-	221	101	V		
* 11.77231			25.10	ADR	39.00	-21.50	0.17	42.77	54.00	-11.23	-	-	-	-	-	221	101	V		
17.653			31.11	PK-U	41.90	-15.70	0.00	57.31	-	-	-	-	-	-	68.20	-10.89	0	100	H	
17.657			31.29	PK-U	41.90	-15.60	0.00	57.59	-	-	-	-	-	-	68.20	-10.61	0	100	V	
802.11ax (HE20) 8RU Spot-check			5845	MIMO	7.793	41.42	PK-U	36.30	-24.50	0.00	53.22	-	-	-	-	68.20	-14.98	65	237	H
	7.793	41.76			PK-U	36.30	-24.50	0.00	53.56	-	-	-	-	-	68.20	-14.64	149	103	V	
	* 11.68164	34.58			PK-U	38.90	-21.50	0.00	51.98	-	-	74.00	-22.02	-	-	-	0	100	H	
	* 11.69306	34.69			PK-U	38.90	-21.50	0.00	52.09	-	-	74.00	-21.91	-	-	-	0	100	V	
	17.545	31.25			PK-U	42.00	-17.00	0.00	56.25	-	-	-	-	-	-	68.20	-11.95	0	100	H
	17.540	31.43			PK-U	42.00	-17.00	0.00	56.43	-	-	-	-	-	-	68.20	-11.77	0	100	V

Note1. PK-U - U-NII: Maximum Peak / ADR - U-NII AD primary method, RMS average
 Note2. * - indicates frequency in CFR47 Pt 15 / IC RSS-Restricted Band

11.6. Spurious Emissions for Simultaneous Transmission

11.6.1. Worst test case RSDB condition

Case 1	2.4 GHz WLAN ANT1 + ANT2	5GHz WLAN ANT1 + ANT2
Mode	802.11b	802.11ax HE20
Channel	1	116
Frequency[MHz]	2412	5580
Tone	-	26T
RU	-	8RU
Data Rate	1 Mbps	MCS 0
Axis (Worst)		Y

NOTE

The lowest margin condition among the channels and modes were selected for test. Low, mid, and high channels of 2.4GH WLAN were tested, and the worst case configuration & data were listed in the test report.

11.6.2. Test Results

Spurious emission for Simultaneous Transmission Case1. – Y axis

HORIZONTAL

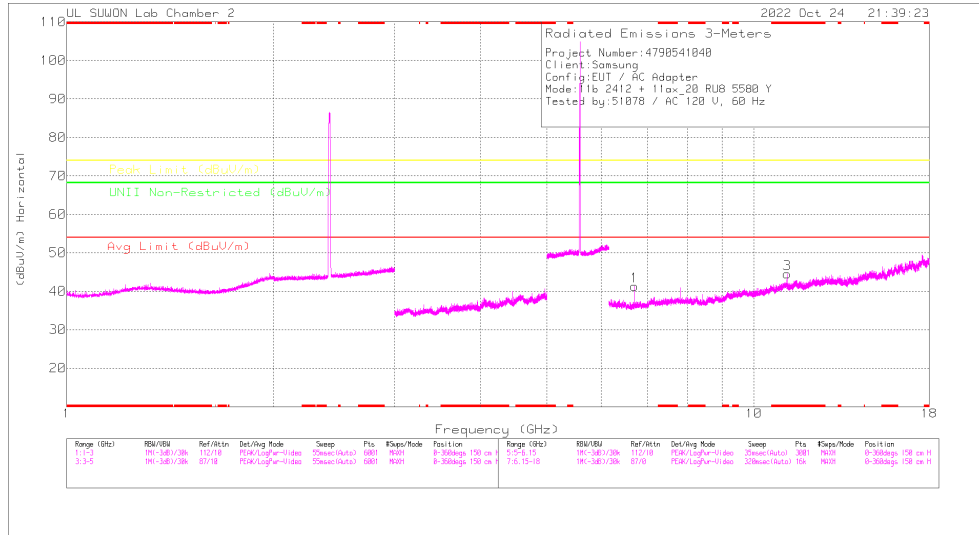

VERTICAL

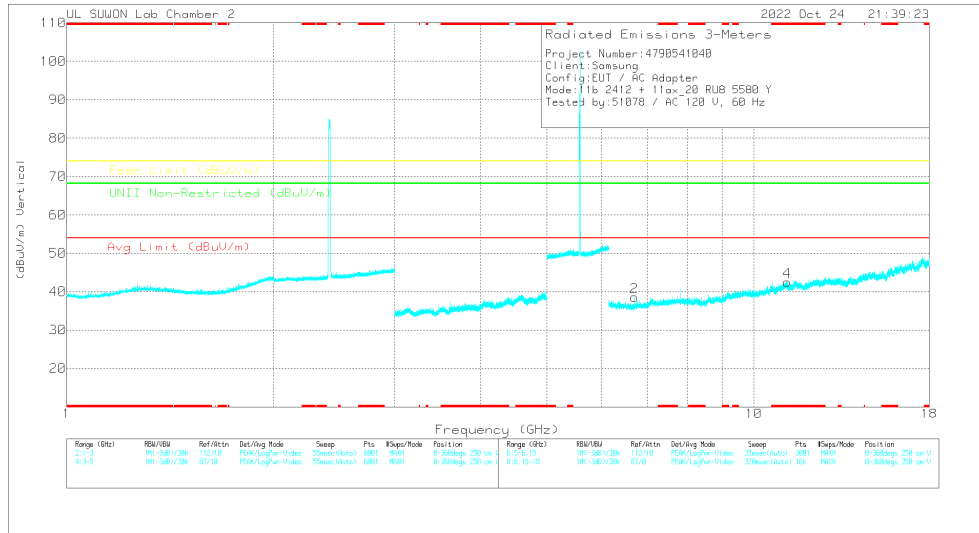

Radiated Emissions

Frequency (GHz)	Meas. Reading (dBuV)	Det	317.00168724	6GHz_HPSDR	DC Corr (dB)	Corrected Reading (dBuV/m)	Avg Limit (dBuV/m)	Margin (dB)	Peak Limit (dBuV/m)	Margin (dB)	UNII Non-Restricted (dBuV/m)	Margin (dB)	Altitude (Degs)	Height (cm)	Polarity
6.70337	38.77	PK-U	35.4	-25.6	0	48.57	-	-	-	-	68.2	-19.63	324	107	H
6.70441	41.58	PK-U	35.4	-25.6	0	51.38	-	-	-	-	68.2	-16.82	84	148	V
* 11.17665	45.77	PK-U	38	-19.6	0	64.87	-	-	74	-8.83	-	-	156	183	H
* 11.17638	27.6	ADR	38	-19.6	0	46	54	-8	-	-	-	-	182	183	H
* 11.17668	39.37	PK-U	38	-19.6	0	57.77	-	-	74	-16.23	-	-	182	100	V
* 11.17678	23.35	ADR	38	-19.6	0	41.75	54	-12.25	-	-	-	-	182	100	V

* - indicates frequency in CFR47 Pt 15 / IC RSS-Restricted Band
 PK-U - U-NII: Maximum Peak
 ADR - U-NII AD primary method, RMS average

12. WORST-CASE BELOW 1 GHz SPURIOUS EMISSIONS 30 TO 1000 MHz (WORST-CASE CONFIGURATION, HORIZONTAL)

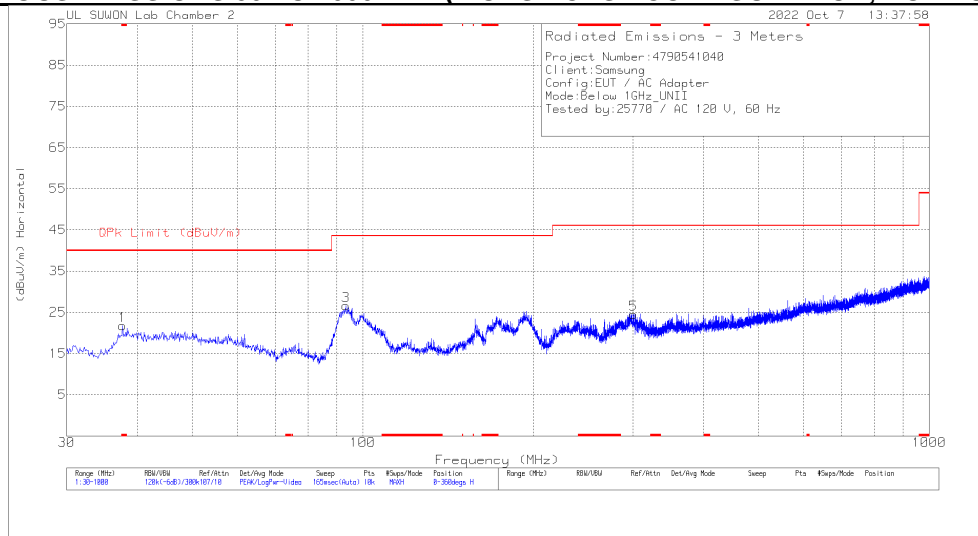

SPURIOUS EMISSIONS 30 TO 1000 MHz (WORST-CASE CONFIGURATION, VERTICAL)

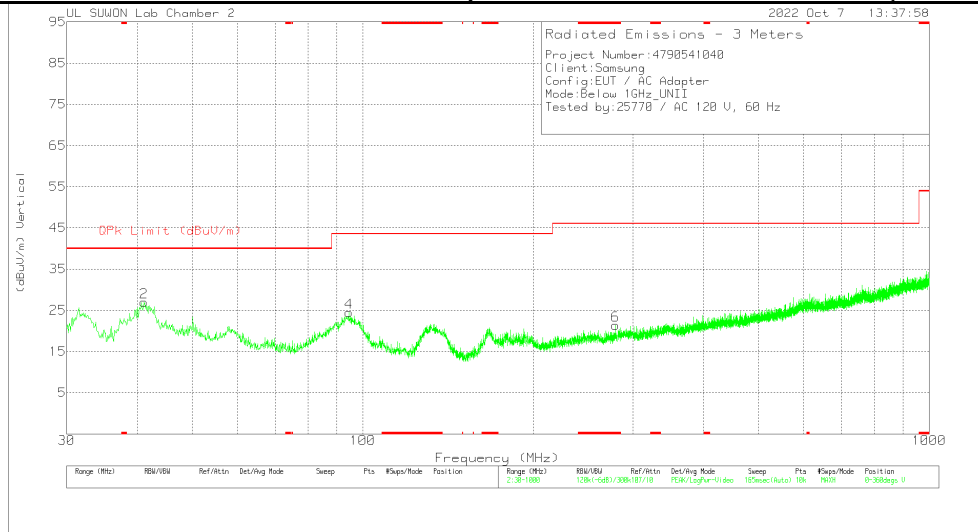

Trace Markers

Marker	Frequency (MHz)	Meter Reading (dBuV)	Det	VULB9163_749	Below 1G[dB]	DC Corr (dB)	Corrected Reading (dBuV/m)	QPK Limit (dBuV/m)	Margin (dB)	Azimuth (Degs)	Height (cm)	Polarity
1	* 37.663	35.12	Pk	17.9	-31.3	0	21.72	40	-18.28	0-360	300	H
2	41.058	39.28	Pk	19	-31.3	0	26.98	40	-13.02	0-360	100	V
3	93.341	40.95	Pk	16.3	-30.6	0	26.65	43.52	-16.87	0-360	100	H
4	94.505	38.65	Pk	16.5	-30.7	0	24.45	43.52	-19.07	0-360	100	V
5	300.533	34.44	Pk	19.1	-29	0	24.54	46.02	-21.48	0-360	100	H
6	* 279.193	31.88	Pk	18.7	-29.2	0	21.38	46.02	-24.64	0-360	300	V

* - indicates frequency in CFR47 Pt 15 / IC RSS-Restricted Band
 Pk - Peak detector

13. AC POWER LINE CONDUCTED EMISSIONS

LIMITS

FCC §15.207 (a)

Frequency of Emission (MHz)	Conducted Limit (dBuV)	
	Quasi-peak	Average
0.15-0.5	66 to 56	56 to 46
0.5-5	56	46
5-30	60	50

*Decreases with the logarithm of the frequency.

TEST PROCEDURE

The EUT is placed on a non-conducting table 40 cm from the vertical ground plane and 80 cm above the horizontal ground plane. The EUT is configured in accordance with ANSI C63.10.

The receiver is set to a resolution bandwidth of 9 kHz. Peak detection is used unless otherwise noted as quasi-peak or average.

Line conducted data is recorded for both NEUTRAL and HOT lines.

RESULTS

WORST EMISSIONS

LINE 1 DATA

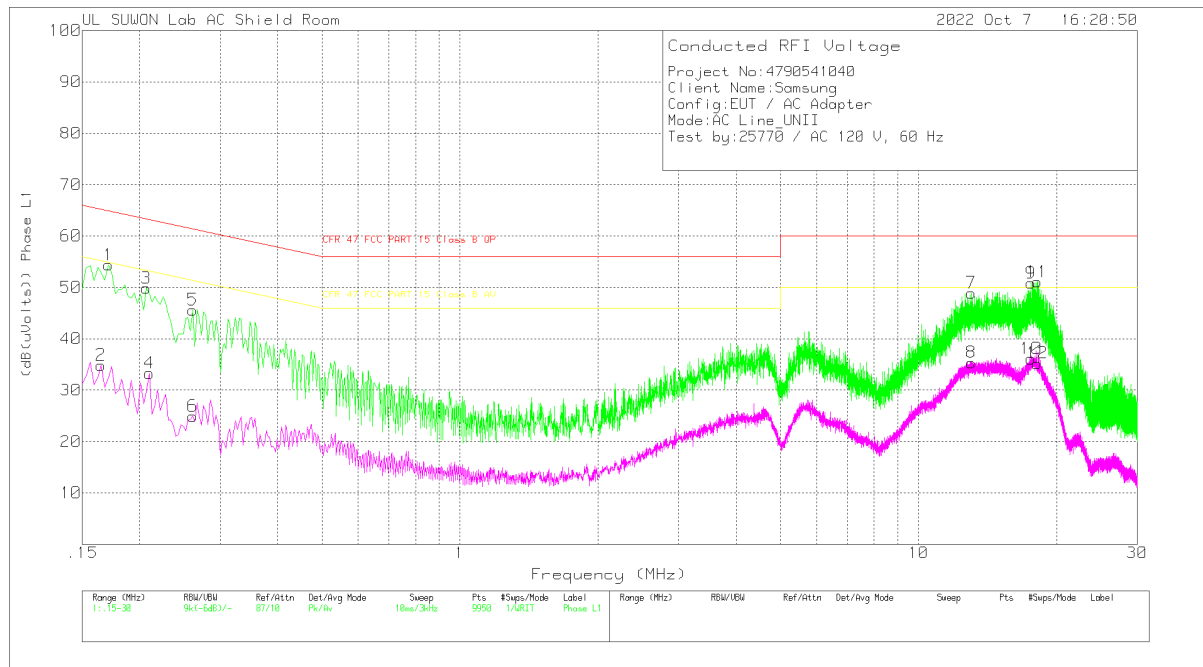

Trace Markers

Range 1: Phase L1 .15 - 30MHz

Marker	Frequency (MHz)	Meter Reading (dBuV)	Det	101836_Wit h EX_L1[dB]	CABLELOS S(dB)	Corrected Reading (dB(uVolts))	CFR 47 FCC PART 15 Class B QP	Margin (dB)	CFR 47 FCC PART 15 Class B AV	Margin (dB)
1	.171	44.17	Pk	10	.2	54.37	64.91	-10.54	-	-
2	.165	24.85	Av	9.9	.1	34.85	-	-	55.21	-20.36
3	.207	39.84	Pk	9.8	.2	49.84	63.32	-13.48	-	-
4	.21	23.3	Av	9.8	.2	33.3	-	-	53.21	-19.91
5	.261	35.82	Pk	9.6	.2	45.62	61.4	-15.78	-	-
6	.261	15.16	Av	9.6	.2	24.96	-	-	51.4	-26.44
7	13.041	38.6	Pk	9.9	.4	48.9	60	-11.1	-	-
8	13.032	25.07	Av	9.9	.4	35.37	-	-	50	-14.63
9	17.607	40.31	Pk	10.1	.4	50.81	60	-9.19	-	-
10	17.61	25.63	Av	10.1	.4	36.13	-	-	50	-13.87
11	18.168	40.57	Pk	10.1	.4	51.07	60	-8.93	-	-
12	18.159	24.74	Av	10.1	.4	35.24	-	-	50	-14.76

Pk - Peak detector

Av - Average detection

Quasi-Peak Emissions

Range 1: Phase L1 .15 - 30MHz

Frequency (MHz)	Meter Reading (dBuV)	Det	101836_Wit h EX_L1[dB]	CABLELOS S(dB)	Corrected Reading (dB(uVolts))	CFR 47 FCC PART 15 Class B QP	Margin (dB)	CFR 47 FCC PART 15 Class B AV	Margin (dB)
17.6078	23.95	Qp	10.1	.4	34.45	60	-25.55	-	-
18.1673	29.63	Qp	10.1	.4	40.13	60	-19.87	-	-

Qp - Quasi-Peak detector

LINE 2 DATA

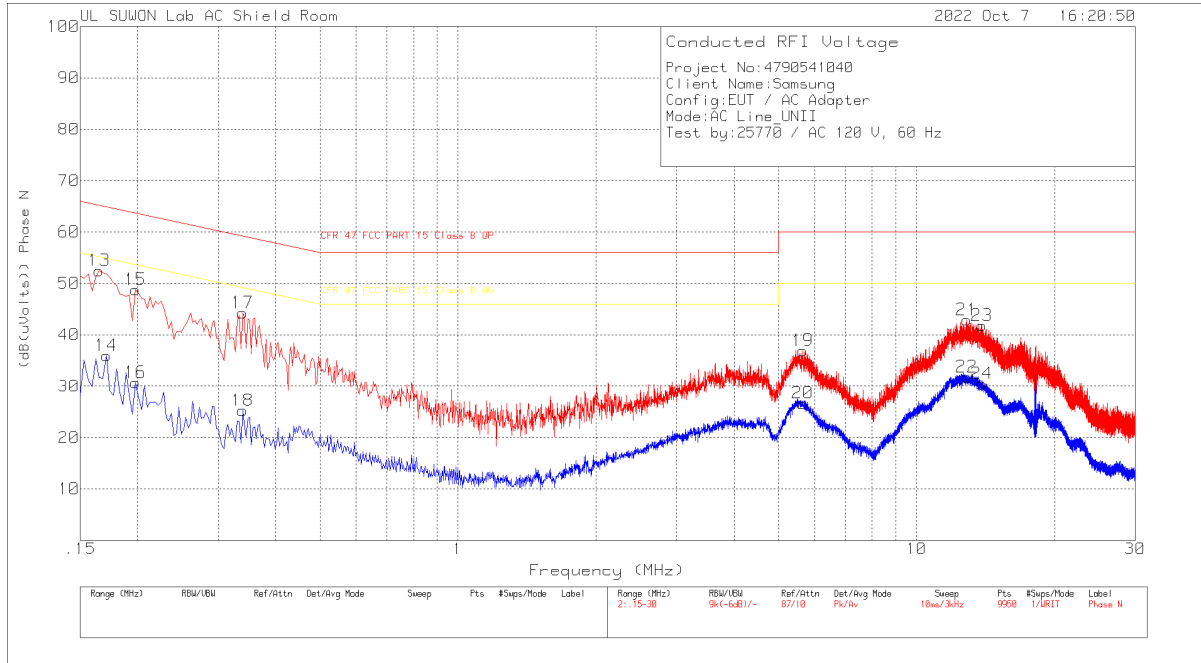

Trace Markers

Range 2: Phase N .15 - 30MHz

Marker	Frequency (MHz)	Meter Reading (dBuV)	Det	101836_Wit h EX_N[dB]	CABLELOS S(dB)	Corrected Reading (dB(uVolts))	CFR 47 FCC PART 15 Class B QP	Margin (dB)	CFR 47 FCC PART 15 Class B AV	Margin (dB)
13	.165	42.48	Pk	9.9	.1	52.48	65.21	-12.73	-	-
14	.171	25.75	Av	10	.2	35.95	-	-	54.91	-18.96
15	.198	38.77	Pk	9.8	.2	48.77	63.69	-14.92	-	-
16	.198	20.69	Av	9.8	.2	30.69	-	-	53.69	-23
17	.339	34.27	Pk	9.8	.2	44.27	59.23	-14.96	-	-
18	.339	15.28	Av	9.8	.2	25.28	-	-	49.23	-23.95
19	5.652	26.91	Pk	9.7	.3	36.91	60	-23.09	-	-
20	5.652	16.68	Av	9.7	.3	26.68	-	-	50	-23.32
21	12.879	32.5	Pk	10	.4	42.9	60	-17.1	-	-
22	12.879	21.4	Av	10	.4	31.8	-	-	50	-18.2
23	13.893	31.4	Pk	10	.4	41.8	60	-18.2	-	-
24	13.893	20.1	Av	10	.4	30.5	-	-	50	-19.5

Pk - Peak detector

Av - Average detection

14. DYNAMIC FREQUENCY SELECTION

14.1. OVERVIEW

14.1.1. LIMITS

FCC

§15.407 (h), FCC KDB 905462 D02 “COMPLIANCE MEASUREMENT PROCEDURES FOR UNLICENSED-NATIONAL INFORMATION INFRASTRUCTURE DEVICES OPERATING IN THE 5250-5350 MHz AND 5470-5725 MHz BANDS INCORPORATING DYNAMIC FREQUENCY SELECTION” and KDB 905462 D03 “U-NII CLIENT DEVICES WITHOUT RADAR DETECTION CAPABILITY”.

Table 1: Applicability of DFS requirements prior to use of a channel

Requirement	Operational Mode		
	Master	Client (without radar detection)	Client (with radar detection)
Non-Occupancy Period	Yes	Not required	Yes
DFS Detection Threshold	Yes	Not required	Yes
Channel Availability Check Time	Yes	Not required	Not required
U-NII Detection Bandwidth	Yes	Not required	Yes

Table 2: Applicability of DFS requirements during normal operation

Requirement	Operational Mode		
	Master	Client (without DFS)	Client (with DFS)
DFS Detection Threshold	Yes	Not required	Yes
Channel Closing Transmission Time	Yes	Yes	Yes
Channel Move Time	Yes	Yes	Yes
U-NII Detection Bandwidth	Yes	Not required	Yes

Additional requirements for devices with multiple bandwidth modes	Master Device or Client with Radar DFS	Client (without DFS)
U-NII Detection Bandwidth and Statistical Performance Check	All BW modes must be tested	Not required
Channel Move Time and Channel Closing Transmission Time	Test using widest BW mode available	Test using the widest BW mode available for the link
All other tests	Any single BW mode	Not required

Note: Frequencies selected for statistical performance check (Section 7.8.4) should include several frequencies within the radar detection bandwidth and frequencies near the edge of the radar detection bandwidth. For 802.11 devices it is suggested to select frequencies in all 20 MHz channel blocks and a null frequency between the bonded 20 MHz channel blocks.

Table 3: Interference Threshold values, Master or Client incorporating In-Service Monitoring

Maximum Transmit Power	Value (see notes)
E.I.R.P. \geq 200 mill watt	-64 dBm
E.I.R.P. < 200 mill watt and power spectral density < 10 dBm/MHz	-62 dBm
E.I.R.P. < 200 mill watt that do not meet power spectral density requirement	-64 dBm
<p>Note 1: This is the level at the input of the receiver assuming a 0 dBi receive antenna Note 2: Throughout these test procedures an additional 1 dB has been added to the amplitude of the test transmission waveforms to account for variations in measurement equipment. This will ensure that the test signal is at or above the detection threshold level to trigger a DFS response. Note 3: E.I.R.P. is based on the highest antenna gain. For MIMO devices refer to KDB publication 662911 D01.</p>	

Table 4: DFS Response requirement values

Parameter	Value
<i>Non-occupancy period</i>	30 minutes
<i>Channel Availability Check Time</i>	60 seconds
<i>Channel Move Time</i>	10 seconds (See Note 1)
<i>Channel Closing Transmission Time</i>	200 milliseconds + approx. 60 milliseconds over remaining 10 second period. (See Notes 1 and 2)
<i>U-NII Detection Bandwidth</i>	Minimum 100% of the U- NII 99% transmission power bandwidth. (See Note 3)
<p>Note 1: <i>Channel Move Time</i> and the <i>Channel Closing Transmission Time</i> should be performed with Radar Type 0. The measurement timing begins at the end of the Radar Type 0 burst. Note 2: The <i>Channel Closing Transmission Time</i> is comprised of 200 milliseconds starting at the beginning of the <i>Channel Move Time</i> plus any additional intermittent control signals required to facilitate a <i>Channel</i> move (an aggregate of 60 milliseconds) during the remainder of the 10 second period. The aggregate duration of control signals will not count quiet periods in between transmissions. Note 3: During the <i>U-NII Detection Bandwidth</i> detection test, radar type 0 should be used. For each frequency step the minimum percentage of detection is 90 percent. Measurements are performed with no data traffic.</p>	

Table 5 – Short Pulse Radar Test Waveforms

Radar Type	Pulse Width (usec)	PRI (usec)	Pulses	Minimum Percentage of Successful Detection	Minimum Trials
0	1	1428	18	See Note 1	See Note 1
1	1	Test A: 15 unique PRI values randomly selected from the list of 23 PRI values in table 5a	Roundup: $\{(1/360) \times (19 \times 10^6 \text{ PRI}_{\text{usec}})\}$	60%	30
		Test B: 15 unique PRI values randomly selected within the range of 518-3066 usec. With a minimum increment of 1 usec, excluding PRI values selected in Test A			
2	1-5	150-230	23-29	60%	30
3	6-10	200-500	16-18	60%	30
4	11-20	200-500	12-16	60%	30
Aggregate (Radar Types 1-4)				80%	120
Note 1: Short Pulse Radar Type 0 should be used for the <i>Detection Bandwidth</i> test, <i>Channel Move Time</i> , and <i>Channel Closing Time</i> tests.					

Table 6 – Long Pulse Radar Test Signal

Radar Waveform Type	Pulse Width (μsec)	Chirp Width (MHz)	PRI (μsec)	Pulses per Burst	Number of Bursts	Minimum Percentage of Successful Detection	Minimum Trials
5	50-100	5-20	1000-2000	1-3	8-20	80%	30

Table 7 – Frequency Hopping Radar Test Signal

Radar Waveform Type	Pulse Width (μsec)	PRI (μsec)	Pulses per Hop	Hopping Rate (kHz)	Hopping Sequence Length (msec)	Minimum Percentage of Successful Detection	Minimum Trials
6	1	333	9	0.333	300	70%	30

14.1.2. TEST AND MEASUREMENT SYSTEM

CONDUCTED METHOD SYSTEM BLOCK DIAGRAM

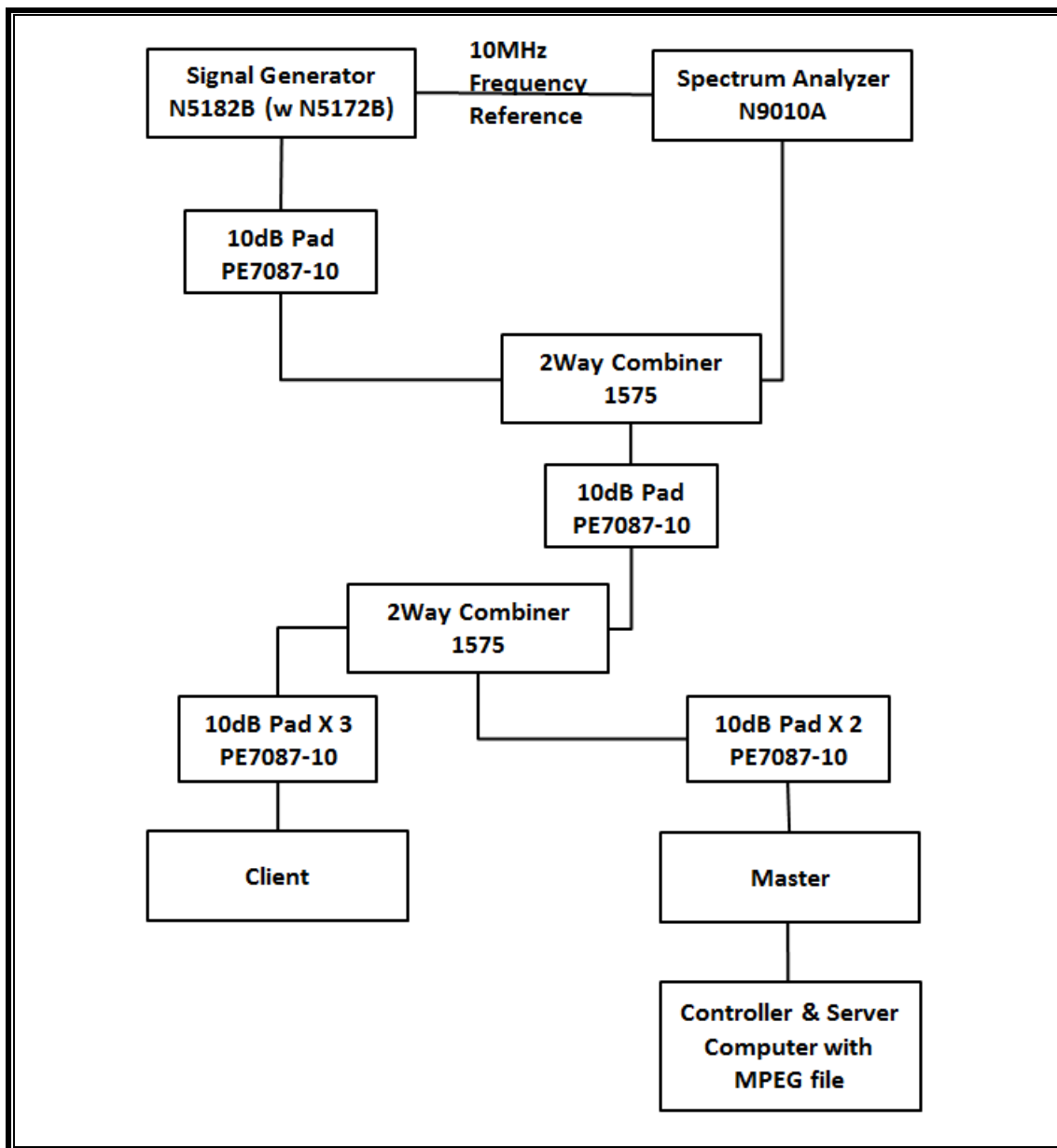

SYSTEM OVERVIEW

The short pulse and long pulse signal generating system utilizes the Keysite Signal Studio for Pulse Building as N5172B. The Vector Signal Generator has been validated by the NTIA. The hopping signal generating system utilizes the CCS simulated hopping method and system, which has been validated by the DoD, FCC and NTIA. The software selects waveform parameters from within the bounds of the signal type on a random basis using uniform distribution.

The short pulse types 1, 2, 3 and 4, and the long pulse type 5 parameters are randomized at run-time.

The hopping type 6 pulse parameters are fixed while the hopping sequence is based on the August 2005 NTIA Hopping Frequency List. The initial starting point randomized at run-time and each subsequent starting point is incremented by 475. Each frequency in the 100-length segment is compared to the boundaries of the EUT Detection Bandwidth and the software creates a hopping burst pattern in accordance with Section 7.4.1.3 Method #2 Simulated Frequency Hopping Radar Waveform Generating Subsystem of KDB 905462 D02. The frequency of the signal generator is incremented in 1 MHz steps from F_L to F_H for each successive trial. This incremental sequence is repeated as required to generate a minimum of 30 total trials and to maintain a uniform frequency distribution over the entire Detection Bandwidth.

The signal monitoring equipment consists of a spectrum analyzer. The aggregate ON time is calculated by multiplying the number of bins above a threshold during a particular observation period by the dwell time per bin, with the analyzer set to peak detection and max hold.

SYSTEM CALIBRATION

A 50-ohm load is connected in place of the spectrum analyzer, and the spectrum analyzer is connected to a horn antenna via a coaxial cable, with the reference level offset set to (horn antenna gain – coaxial cable loss). The signal generator is set to CW mode. The amplitude of the signal generator is adjusted to yield a level of –64 dBm as measured on the spectrum analyzer.

Without changing any of the instrument settings, the spectrum analyzer is reconnected to the Common port of the Spectrum Analyzer Combiner/Divider. The Reference Level Offset of the spectrum analyzer is adjusted so that the displayed amplitude of the signal is –64 dBm.

The spectrum analyzer displays the level of the signal generator as received at the antenna ports of the Master Device. The interference detection threshold may be varied from the calibrated value of –64 dBm and the spectrum analyzer will still indicate the level as received by the Master Device.

ADJUSTMENT OF DISPLAYED TRAFFIC LEVEL

A link is established between the Master and Slave and the distance between the units is adjusted as needed to provide a suitable received level at the Master and Slave devices. The video test file is streamed to generate WLAN traffic. The monitoring antenna is adjusted so that the WLAN traffic level, as displayed on the spectrum analyzer, is at lower amplitude than the radar detection threshold.

TEST AND MEASUREMENT EQUIPMENT

The following test and measurement equipment was utilized for the DFS tests documented in this report:

TEST EQUIPMENT LIST				
Description	Manufacturer	Model	S/N	Next Cal Due
Spectrum Analyzer, 7 GHz	Agilent / HP	N9010A	MY54200580	08-01-23
Vector Signal Generator, 6GHz	Agilent / HP	N5182B	MY53051241	08-01-23
Combiner	WEINSCHTEL	WA1534	UL001	01-20-23
Combiner	WEINSCHTEL	WA1534	UL003	01-11-23

14.1.3. SETUP OF EUT

CONDUCTED METHOD EUT TEST SETUP

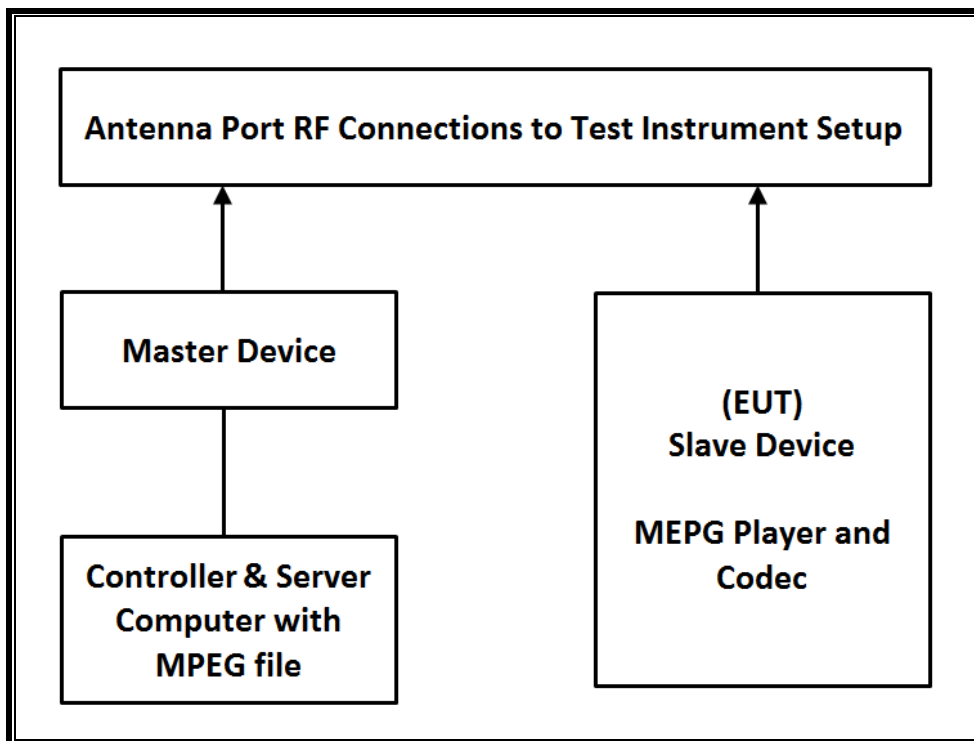

SUPPORT EQUIPMENT

The following support equipment was utilized for the DFS tests documented in this report:

PERIPHERAL SUPPORT EQUIPMENT LIST				
Description	Manufacturer	Model	Serial Number	FCC ID
Wireless Access Point	Cisco	AIR-CAP3702E-A-K9	FTX182276QX	LDK102087
Notebook PC (Controller/Server)	HP	HP EliteDesk 800 G1 TWR	CZC4125J25	DoC

14.1.4. DESCRIPTION OF EUT

The EUT operates over the 5250-5350 MHz and 5470-5725 MHz ranges.

The EUT is a Slave Device without Radar Detection.

The highest power level of the widest bandwidth (802.11ac VHT80) within these bands is 14.34 dBm in the 5250-5350 MHz band and 14.61 dBm in the 5470-5725 MHz band.

The antenna assembly utilized two antenna.

Gain of ANT1 : -2.10 dBi for UNII 2A and -3.07 dBi for UNII 2C.

Gain of ANT2 : -2.40 dBi for UNII 2A and -2.46 dBi for UNII 2C.

The rated output power of the Master unit is > 23dBm (EIRP). Therefore the required interference threshold level is -64 dBm. After correction for procedural adjustments, the required conducted threshold at the antenna port is $-64 + 1 = -63$ dBm.

The calibrated radiated DFS Detection Threshold level is set to -64 dBm. The tested level is lower than the required level hence it provides a margin to the limit.

The EUT uses one transmitter/receiver chain connected to an antenna to perform radiated tests. WLAN traffic that meets or exceeds the minimum required loading was generated by transferring a data stream from the controller/server PC to the EUT using iPerf version 2.0.5 software package.

TPC is not required since the maximum EIRP is less than 500 mW (27 dBm).

The EUT utilizes the 802.11 architecture. Three nominal channel bandwidths are implemented: 20 MHz, 40 MHz and 80 MHz.

The software installed in the access point is 12.4(25d)JA1.

UNIFORM CHANNEL SPREADING

This requirement is not applicable to Slave radio devices.

CHANNEL PUNCTURING(802.11ax)

This EUT does not support channel puncturing.

OVERVIEW OF MASTER DEVICE WITH RESPECT TO §15.407 (h) REQUIREMENTS

The Master Device is a Cisco Access Point, FCC ID: LDK102087. The minimum antenna gain for the Master Device is 6 dBi.

The rated output power of the Master unit is > 23dBm (EIRP). Therefore the required interference threshold level is -64 dBm. After correction for procedural adjustments, the required radiated threshold at the antenna port is $-64 + 1 = -63$ dBm.

The calibrated radiated DFS Detection Threshold level is set to -64 dBm. The tested level is lower than the required level hence it provides a margin to the limit.

14.2. RESULTS FOR 80 MHz BANDWIDTH (UNII-2A BAND)

14.2.1. TEST CHANNEL

All tests were performed at a channel center frequency of 5290 MHz.

14.2.2. RADAR WAVEFORM AND TRAFFIC

RADAR WAVEFORM



14.2.3. OVERLAPPING CHANNEL TESTS

RESULTS

These tests are not applicable.

14.2.4. MOVE AND CLOSING TIME

REPORTING NOTES

The reference marker is set at the end of last radar pulse.

The delta marker is set at the end of the last WLAN transmission following the radar pulse. This delta is the channel move time.

The aggregate channel closing transmission time is calculated as follows:

Aggregate Transmission Time =
(Number of analyzer bins showing transmission) * (dwell time per bin)

The observation period over which the aggregate time is calculated begins at (Reference Marker + 200 msec) and ends no earlier than (Reference Marker + 10 sec).

RESULTS

Channel Move Time (sec)	Limit (sec)
0.741	10

Aggregate Channel Closing Transmission Time (msec)	Limit (msec)
1.125	60

MOVE TIME & CHANNEL CLOSING TIME

AGGREGATE CHANNEL CLOSING TRANSMISSION TIME

No transmissions are observed during the aggregate monitoring period.

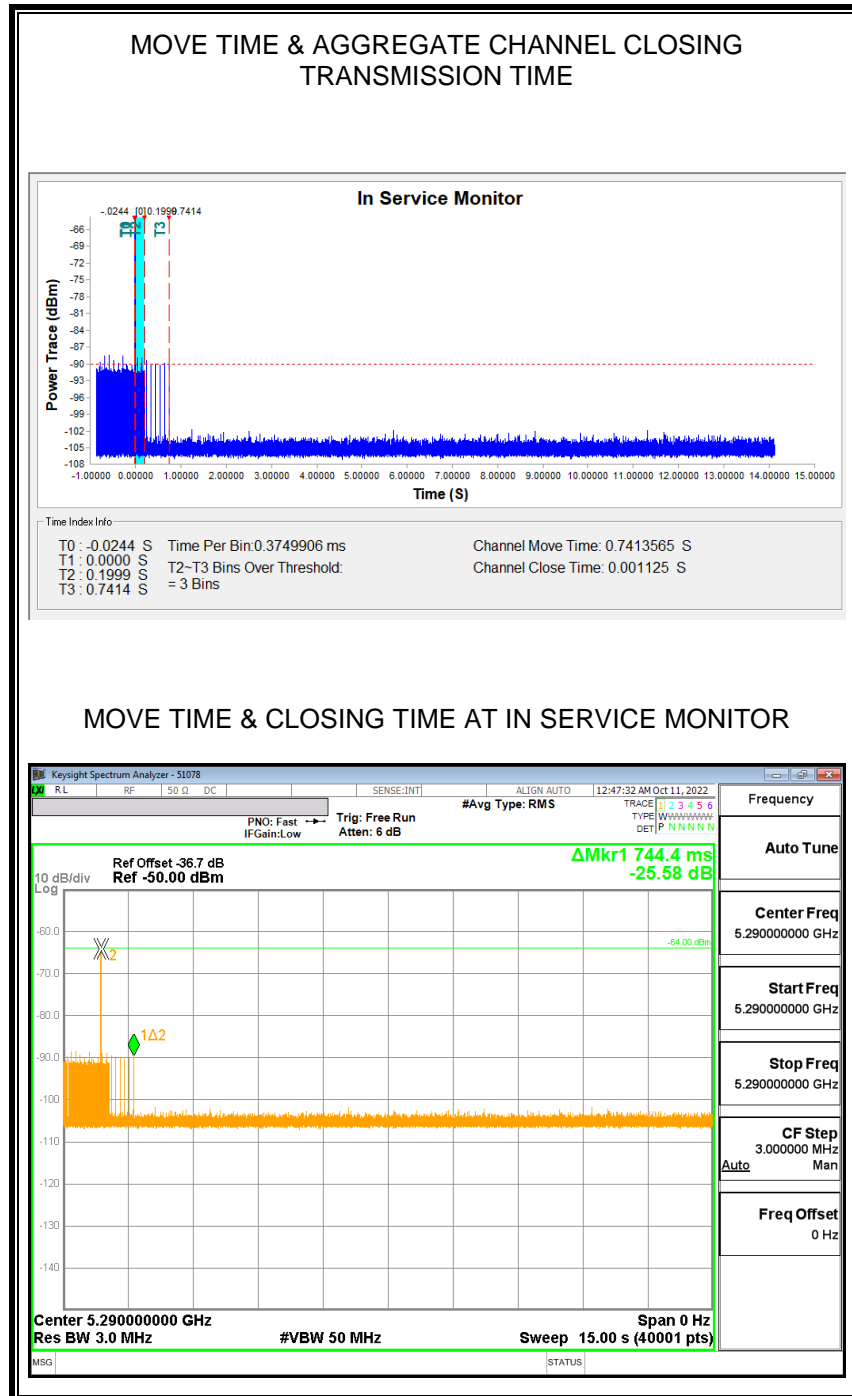

NON-OCCUPANCY PERIOD

RESULTS

No EUT transmissions were observed on the test channel during the 10-minute observation time.

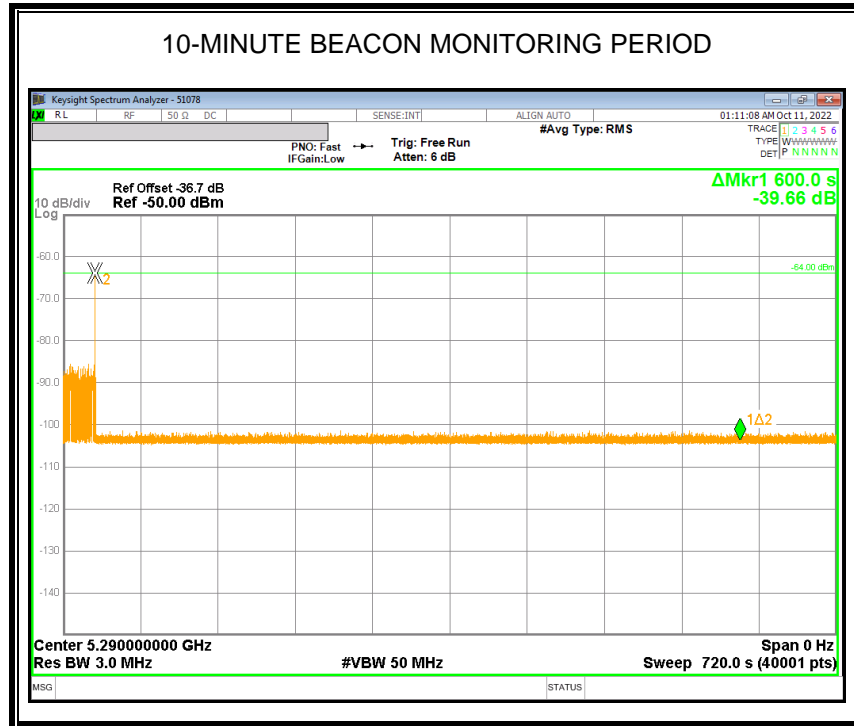

14.3. RESULTS FOR 80 MHz BANDWIDTH (UNII-2C BAND)

14.3.1. TEST CHANNEL

All tests were performed at a channel center frequency of 5530 MHz.

14.3.2. RADAR WAVEFORM AND TRAFFIC

RADAR WAVEFORM

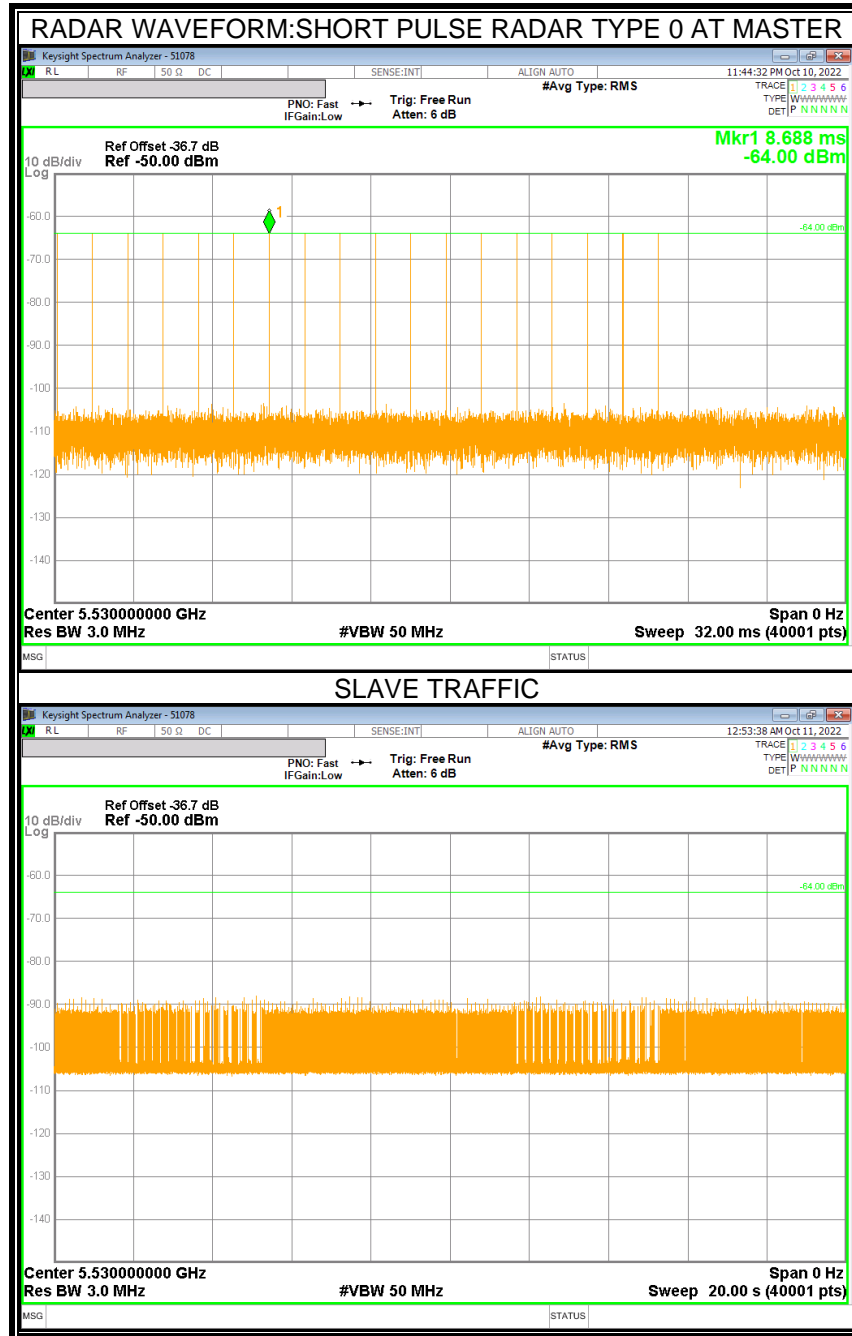

14.3.3. OVERLAPPING CHANNEL TESTS

RESULTS

These tests are not applicable.

14.3.4. MOVE AND CLOSING TIME

REPORTING NOTES

The reference marker is set at the end of last radar pulse.

The delta marker is set at the end of the last WLAN transmission following the radar pulse. This delta is the channel move time.

The aggregate channel closing transmission time is calculated as follows:

Aggregate Transmission Time =
(Number of analyzer bins showing transmission) * (dwell time per bin)

The observation period over which the aggregate time is calculated begins at (Reference Marker + 200 msec) and ends no earlier than (Reference Marker + 10 sec).

RESULTS

Channel Move Time (sec)	Limit (sec)
0.748	10

Aggregate Channel Closing Transmission Time (msec)	Limit (msec)
1.500	60

MOVE TIME & CHANNEL CLOSING TIME

AGGREGATE CHANNEL CLOSING TRANSMISSION TIME

No transmissions are observed during the aggregate monitoring period.

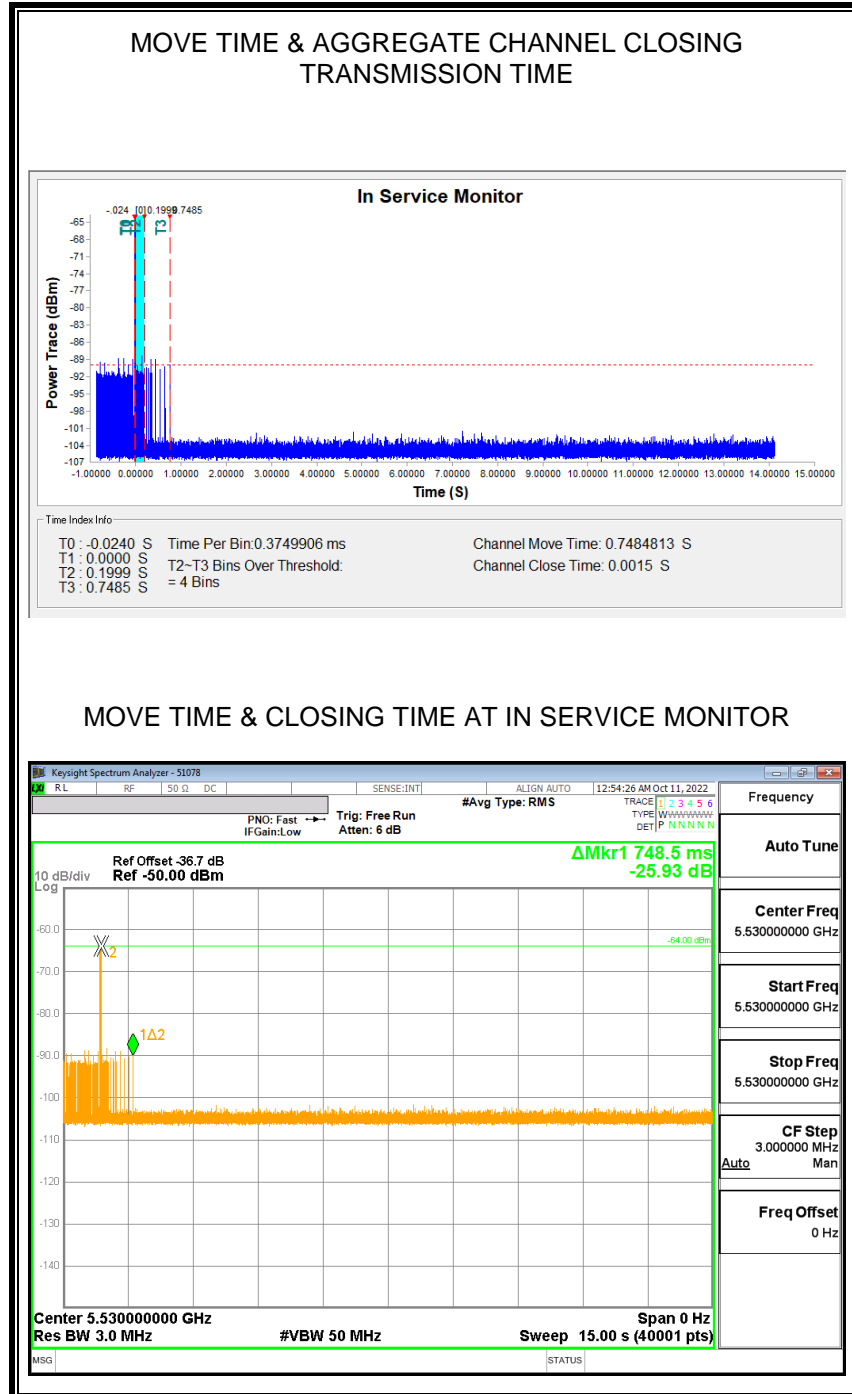

NON-OCCUPANCY PERIOD

RESULTS

No EUT transmissions were observed on the test channel during the 10-minute observation time.

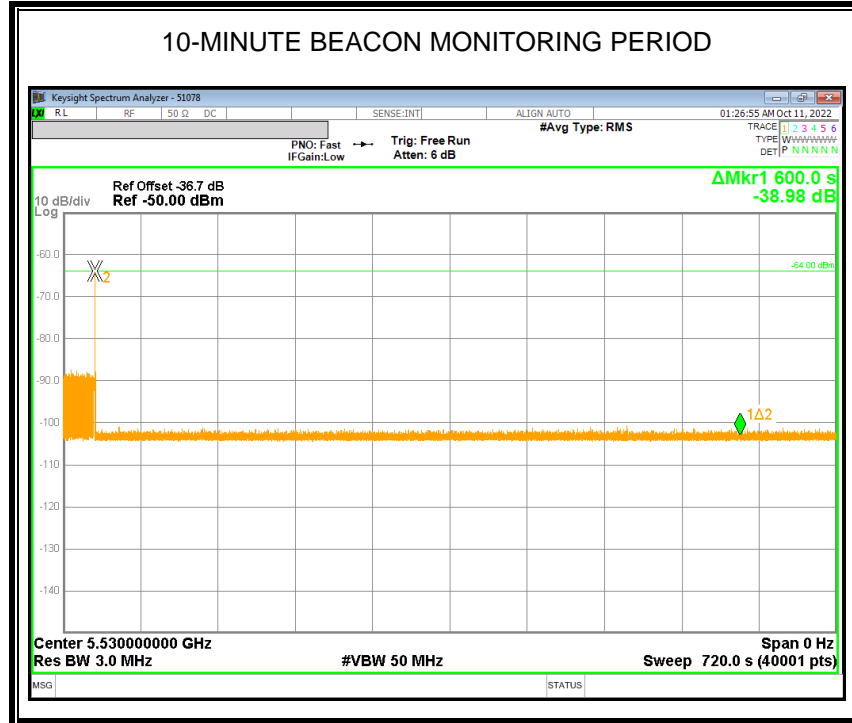

END OF TEST REPORT