

# APPENDIX I: LTE DOWNLINK ONLY CARRIER AGGREGATION TEST REDUCTION METHODOLOGY

SAR test exclusion for LTE downlink Carrier Aggregation is determined by power measurements according to the number of component carriers (CCs) supported by the product implementation. Per April 2018 TCBC Workshop Notes, the following test reduction methodology was applied to determine the combinations required for conducted power measurements.

### LTE DLCA Test Reduction Methodology:

- The supported combinations were arranged by the number of component carriers in columns.
- Any limitations on the PCC or SCC for each combination were identified alongside the combination (e.g. CA\_2A-2A-4A-12A, but B12 can only be configured as a SCC).
- Power measurements were performed for "supersets" (LTE CA combinations with multiple components carriers) and any "subsets" (LTE CA combinations with fewer component carriers) that were not completely covered by the supersets.
- Only subsets that have the exact same components as a superset were excluded for measurement.
- When there were certain restrictions on component carriers that existed in the superset that were not applied for the subset, the subset configuration was additionally evaluated.
- Both inter-band and intra-band downlink carrier aggregation scenarios were considered.
- Downlink CA combinations for SISO and 4x4 Downlink MIMO operations were measured independently, per May 2017 TCBC Workshop notes.

**Table I-1 – Example of Exclusion Table for SISO Configurations**

Index	BCC	Supported Channel Bandwidth (MHz)				Restriction	Completely Covered by Measurement Superset
		CC1	CC2	CC3	CC4		
CC#1	CA_2A	5, 10, 15, 20	5, 10, 15, 20			No	
CC#2	CA_2A-2A	5, 10, 15, 20	5, 10, 15, 20			No	
CC#3	CA_2A-2A-2A	5, 10, 15, 20	5, 10, 15, 20			No	
CC#4	CA_2A-2A-4A	5, 10, 15, 20	5, 10, 15, 20			No	
CC#5	CA_2A-2A-4A-12A	5, 10, 15, 20	5, 10, 15, 20			No	
CC#6	CA_2A-2A-4A-12A	5, 10, 15, 20	5, 10, 15, 20			No	
CC#7	CA_2A-2A-4A-12A	5, 10, 15, 20	5, 10, 15, 20			No	
CC#8	CA_2A-2A-4A-12A	5, 10, 15, 20	5, 10, 15, 20			No	
CC#9	CA_2A-2A-4A-12A	5, 10, 15, 20	5, 10, 15, 20			No	
CC#10	CA_2A-2A-4A-12A	5, 10, 15, 20	5, 10, 15, 20			No	
CC#11	CA_2A-2A-4A-12A	5, 10, 15, 20	5, 10, 15, 20			No	
CC#12	CA_2A-2A-4A-12A	5, 10, 15, 20	5, 10, 15, 20			No	
CC#13	CA_2A-2A-4A-12A	5, 10, 15, 20	5, 10, 15, 20			No	
CC#14	CA_2A-2A-4A-12A	5, 10, 15, 20	5, 10, 15, 20			No	
CC#15	CA_2A-2A-4A-12A	5, 10, 15, 20	5, 10, 15, 20			No	
CC#16	CA_2A-2A-4A-12A	5, 10, 15, 20	5, 10, 15, 20			No	
CC#17	CA_2A-2A-4A-12A	5, 10, 15, 20	5, 10, 15, 20			No	
CC#18	CA_2A-2A-4A-12A	5, 10, 15, 20	5, 10, 15, 20			No	
CC#19	CA_2A-2A-4A-12A	5, 10, 15, 20	5, 10, 15, 20			No	
CC#20	CA_2A-2A-4A-12A	5, 10, 15, 20	5, 10, 15, 20			No	



**Table I-2 – Example of Exclusion Table for 4x4 Downlink MIMO Configurations**

Index	BCC	Supported Channel Bandwidth (MHz)				Restriction	Completely Covered by Measurement Superset
		CC1	CC2	CC3	CC4		
CC#M1	CA_2A	5, 10, 15, 20	5, 10, 15, 20			No	
CC#M2	CA_2A-2A	5, 10, 15, 20	5, 10, 15, 20			No	
CC#M3	CA_2A-2A-2A	5, 10, 15, 20	5, 10, 15, 20			No	
CC#M4	CA_2A-2A-4A	5, 10, 15, 20	5, 10, 15, 20			No	
CC#M5	CA_2A-2A-4A-12A	5, 10, 15, 20	5, 10, 15, 20			No	
CC#M6	CA_2A-2A-4A-12A	5, 10, 15, 20	5, 10, 15, 20			No	
CC#M7	CA_2A-2A-4A-12A	5, 10, 15, 20	5, 10, 15, 20			No	
CC#M8	CA_2A-2A-4A-12A	5, 10, 15, 20	5, 10, 15, 20			No	
CC#M9	CA_2A-2A-4A-12A	5, 10, 15, 20	5, 10, 15, 20			No	
CC#M10	CA_2A-2A-4A-12A	5, 10, 15, 20	5, 10, 15, 20			No	
CC#M11	CA_2A-2A-4A-12A	5, 10, 15, 20	5, 10, 15, 20			No	
CC#M12	CA_2A-2A-4A-12A	5, 10, 15, 20	5, 10, 15, 20			No	
CC#M13	CA_2A-2A-4A-12A	5, 10, 15, 20	5, 10, 15, 20			No	
CC#M14	CA_2A-2A-4A-12A	5, 10, 15, 20	5, 10, 15, 20			No	
CC#M15	CA_2A-2A-4A-12A	5, 10, 15, 20	5, 10, 15, 20			No	
CC#M16	CA_2A-2A-4A-12A	5, 10, 15, 20	5, 10, 15, 20			No	
CC#M17	CA_2A-2A-4A-12A	5, 10, 15, 20	5, 10, 15, 20			No	
CC#M18	CA_2A-2A-4A-12A	5, 10, 15, 20	5, 10, 15, 20			No	
CC#M19	CA_2A-2A-4A-12A	5, 10, 15, 20	5, 10, 15, 20			No	
CC#M20	CA_2A-2A-4A-12A	5, 10, 15, 20	5, 10, 15, 20			No	
CC#M21	CA_2A-2A-4A-12A	5, 10, 15, 20	5, 10, 15, 20			No	
CC#M22	CA_2A-2A-4A-12A	5, 10, 15, 20	5, 10, 15, 20			No	
CC#M23	CA_2A-2A-4A-12A	5, 10, 15, 20	5, 10, 15, 20			No	
CC#M24	CA_2A-2A-4A-12A	5, 10, 15, 20	5, 10, 15, 20			No	
CC#M25	CA_2A-2A-4A-12A	5, 10, 15, 20	5, 10, 15, 20			No	
CC#M26	CA_2A-2A-4A-12A	5, 10, 15, 20	5, 10, 15, 20			No	
CC#M27	CA_2A-2A-4A-12A	5, 10, 15, 20	5, 10, 15, 20			No	
CC#M28	CA_2A-2A-4A-12A	5, 10, 15, 20	5, 10, 15, 20			No	
CC#M29	CA_2A-2A-4A-12A	5, 10, 15, 20	5, 10, 15, 20			No	
CC#M30	CA_2A-2A-4A-12A	5, 10, 15, 20	5, 10, 15, 20			No	
CC#M31	CA_2A-2A-4A-12A	5, 10, 15, 20	5, 10, 15, 20			No	
CC#M32	CA_2A-2A-4A-12A	5, 10, 15, 20	5, 10, 15, 20			No	
CC#M33	CA_2A-2A-4A-12A	5, 10, 15, 20	5, 10, 15, 20			No	
CC#M34	CA_2A-2A-4A-12A	5, 10, 15, 20	5, 10, 15, 20			No	
CC#M35	CA_2A-2A-4A-12A	5, 10, 15, 20	5, 10, 15, 20			No	
CC#M36	CA_2A-2A-4A-12A	5, 10, 15, 20	5, 10, 15, 20			No	
CC#M37	CA_2A-2A-4A-12A	5, 10, 15, 20	5, 10, 15, 20			No	
CC#M38	CA_2A-2A-4A-12A	5, 10, 15, 20	5, 10, 15, 20			No	
CC#M39	CA_2A-2A-4A-12A	5, 10, 15, 20	5, 10, 15, 20			No	
CC#M40	CA_2A-2A-4A-12A	5, 10, 15, 20	5, 10, 15, 20			No	
CC#M41	CA_2A-2A-4A-12A	5, 10, 15, 20	5, 10, 15, 20			No	
CC#M42	CA_2A-2A-4A-12A	5, 10, 15, 20	5, 10, 15, 20			No	
CC#M43	CA_2A-2A-4A-12A	5, 10, 15, 20	5, 10, 15, 20			No	
CC#M44	CA_2A-2A-4A-12A	5, 10, 15, 20	5, 10, 15, 20			No	
CC#M45	CA_2A-2A-4A-12A	5, 10, 15, 20	5, 10, 15, 20			No	
CC#M46	CA_2A-2A-4A-12A	5, 10, 15, 20	5, 10, 15, 20			No	
CC#M47	CA_2A-2A-4A-12A	5, 10, 15, 20	5, 10, 15, 20			No	
CC#M48	CA_2A-2A-4A-12A	5, 10, 15, 20	5, 10, 15, 20			No	
CC#M49	CA_2A-2A-4A-12A	5, 10, 15, 20	5, 10, 15, 20			No	
CC#M50	CA_2A-2A-4A-12A	5, 10, 15, 20	5, 10, 15, 20			No	

Note: [CC] indicates component carrier with 4x4 DL MIMO antenna configuration

## I.1 LTE Downlink Only Carrier Aggregation Test Selection and Setup

SAR test exclusion for LTE downlink Carrier Aggregation is determined by power measurements according to the number component carriers (CCs) supported by the product implementation. For those configurations required by April 2018 TCBC Workshop Notes, conducted power measurements with LTE Carrier Aggregation (CA) (downlink

<b>FCC ID</b> A3LSMS901JPN	 <b>SAR EVALUATION REPORT</b>		<b>Approved by:</b> Quality Manager
<b>Test Dates:</b> 12/20/21 - 02/02/22	<b>DUT Type:</b> Portable Handset	<b>APPENDIX I:</b> Page 1 of 4	

only) active are made in accordance to KDB Publication 941225 D05Av01r02. The RRC connection is only handled by one cell, the primary component carrier (PCC) for downlink and uplink communications. After making a data connection to the PCC, the UE device adds secondary component carrier(s) (SCC) on the downlink only. All uplink communications and acknowledgements remain identical to specifications when downlink carrier aggregation is inactive on the PCC. Additional conducted output powers are measured with the downlink carrier aggregation active for the configuration with highest measured maximum conducted power with downlink carrier aggregation active measured among the channel bandwidth, modulation, and RB combinations in each frequency band.

Per FCC KDB Publication 941225 D05Av01r02, no SAR measurements are required for carrier aggregation configurations when the maximum average output power with downlink only carrier aggregation active is not more than 0.25 dB higher than the average output power with downlink only carrier aggregation inactive. All bands required for SAR testing per FCC KDB procedures were considered. Based on the measured maximum powers below, no additional SAR tests were required for DLCA SAR configurations.

General PCC and SCC configuration selection procedure

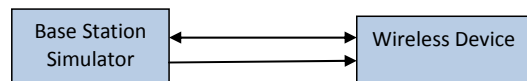

- PCC uplink channel, channel bandwidth, modulation and RB configurations were selected based on section C)3)b)ii) of KDB 941225 D05 V01r02. All LTE bandwidth conducted powers needed for PCC uplink configuration selection can be found in Section 9.3 and appendix F. The downlink PCC channel was paired with the selected PCC uplink channel according to normal configurations without carrier aggregation.
- To maximize aggregated bandwidth, highest channel bandwidth available for that CA combination was selected for SCC. For inter-band CA, the SCC downlink channels were selected near the middle of their transmission bands. For contiguous intra-band CA, the downlink channel spacing between the component carriers was set to multiple of 300 kHz less than the nominal channel spacing defined in section 5.4.1A of 3GPP TS 36.521. For non-contiguous intra-band CA, the downlink channel spacing between the component carriers was set to be larger than the nominal channel spacing and provided maximum separation between the component carriers.
- All selected PCC and SCC(s) remained fully within the uplink/downlink transmission band of the respective component carrier.

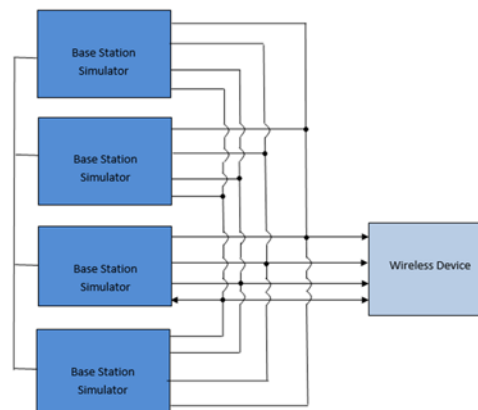

**Figure I-1**  
**DL CA Power Measurement Setup**



**Figure I-2**  
**DL CA with DL 4x4 MIMO Power Measurement Setup**

FCC ID A3LSMS901JPN	 PCTEST <small>Provided to be part of Samsung</small>	SAR EVALUATION REPORT		Approved by: Quality Manager
Test Dates: 12/20/21 - 02/02/22	DUT Type: Portable Handset			APPENDIX I: Page 2 of 4

## I.2 Downlink Carrier Aggregation RF Conducted Powers

### I.2.1 LTE Band 41 as PCC

Table I-3  
Maximum Output Powers

Combination	PCC									SCC				Power	
	PCC Band	PCC BW [MHz]	PCC (UL) Channel	PCC (UL) Freq. [MHz]	Modulation	PCC UL# RB	PCC UL RB Offset	PCC (DL) Ch.	PCC (DL) Freq. [MHz]	SCC Band	SCC BW [MHz]	SCC (DL) Ch.	SCC (DL) Freq. [MHz]	LTE Tx.Power with DL CA Enabled (dBm)	LTE Single Carrier Tx Power (dBm)
CA_41C (1)	LTE B41	5	41490	2680	QPSK	1	12	41490	2680	LTE B41	20	41373	2668.3	24.75	24.77

## I.3 DL CA with DL 4x4 MIMO RF Conduction Powers

This device supports downlink 4x4 MIMO operations for some LTE bands. Uplink transmission is limited to a single output stream. When carrier aggregation was applicable, the general test selection and setup procedures described in Section I.1 were applied.

Per May 2017 TCB Workshop Notes, SAR for 4x4 DL MIMO was not needed since the maximum average output power in 4x4 DL MIMO mode was not more than 0.25 dB higher than the maximum output power with 4x4 DL MIMO inactive. Additionally, SAR for 4x4 MIMO Downlink Carrier Aggregation was not needed since the maximum average output power in 4x4 MIMO Downlink Carrier Aggregation mode was not more than 0.25 dB higher than the maximum output power with 4x4 MIMO Downlink and downlink carrier aggregation inactive.

### I.3.1 LTE 4x4 MIMO DL Standalone Powers



Table I-4  
Maximum Output Powers

LTE Band	Bandwidth [MHz]	Channel	Frequency [MHz]	Modulation	RB Size	RB Offset	4x4 DL MIMO Tx. Power [dBm]	Single Antenna Tx. Power [dBm]
41	5	41490	2680	QPSK	1	12	24.83	24.77

### I.3.2 LTE Band 41 as PCC

Table I-5  
Maximum Output Powers

Combination	PCC										SCC				Power		
	PCC Band	PCC Bandwidth [MHz]	PCC (UL) Channel	PCC (UL) Frequency [MHz]	Modulation	PCC UL# RB	PCC UL RB Offset	PCC (DL) Channel	PCC (DL) Frequency [MHz]	DL Ant. Config.	SCC Band	SCC Bandwidth [MHz]	SCC (DL) Channel	SCC (DL) Frequency [MHz]	DL Ant. Config.	LTE Tx.Power with DL CA Enabled (dBm)	LTE Single Carrier Tx Power (dBm)
CA_41C (1)	LTE B41	5	41490	2680	QPSK	1	12	41490	2680	4x4	LTE B41	20	41373	2668.3	4x4	24.82	24.77

FCC ID A3LSMS901JPN	 PCTEST Proud to be part of 	SAR EVALUATION REPORT		Approved by: Quality Manager
Test Dates: 12/20/21 - 02/02/22	DUT Type: Portable Handset	APPENDIX I: Page 3 of 4		

## I.4 CA\_41C Uplink Carrier Aggregation with Additional Downlink Carriers

This device supports uplink carrier aggregation (ULCA) with additional Carrier Aggregation configurations active in the downlink. Power measurements were performed with ULCA active and additional CA configurations active in the downlink for the configuration per Fall 2017 TCB Workshop Notes.



Per FCC Guidance, additional SAR measurements for these configurations were not required since their maximum output power was not more than 0.25 dB higher than the maximum output power for with only ULCA active.

### I.4.1 UL Carrier Aggregation with DL 4x4 MIMO RF Conducted Powers

Note: 4x4 DL MIMO is only operating in the downlink. Uplink transmission is limited to a single output stream for each component carrier of ULCA.

**Table I-6**  
**Maximum Output Powers**

Combination	PCC										SCC 1							Power				
	PCC Band	PCC BW [MHz]	PCC (UL) Ch.	PCC (UL) Freq. [MHz]	Mod.	PCC UL# RB	PCC UL RB Offset	PCC (DL) Ch.	PCC (DL) Freq. [MHz]	DL Ant. Config.	SCC Band	SCC BW [MHz]	SCC (UL) Ch.	SCC (UL) Freq. [MHz]	Mod.	SCC UL# RB	SCC UL RB Offset	SCC (DL) Ch.	SCC (DL) Freq. [MHz]	DL Ant. Config.	ULCA Tx Power with add'l CA config.	ULCA Tx Power (dBm)
CA_41C	LTE B41	20	41490	2680	QPSK	1	0	41490	2680	4x4	LTE B41	20	41292	2660.2	QPSK	1	99	41292	2660.2	4x4	24.67	24.72

FCC ID A3LSMS901JPN	 PCTEST <small>Provided to the part of Samsung</small>	SAR EVALUATION REPORT		Approved by: Quality Manager
Test Dates: 12/20/21 - 02/02/22	DUT Type: Portable Handset			APPENDIX I: Page 4 of 4