



only) active are made in accordance to KDB Publication 941225 D05Av01r02. The RRC connection is only handled by one cell, the primary component carrier (PCC) for downlink and uplink communications. After making a data connection to the PCC, the UE device adds secondary component carrier(s) (SCC) on the downlink only. All uplink communications and acknowledgements remain identical to specifications when downlink carrier aggregation is inactive on the PCC. Additional conducted output powers are measured with the downlink carrier aggregation active for the configuration with highest measured maximum conducted power with downlink carrier aggregation active measured among the channel bandwidth, modulation, and RB combinations in each frequency band.

Per FCC KDB Publication 941225 D05Av01r02, no SAR measurements are required for carrier aggregation configurations when the maximum average output power with downlink only carrier aggregation active is not more than 0.25 dB higher than the average output power with downlink only carrier aggregation inactive. All bands required for SAR testing per FCC KDB procedures were considered. Based on the measured maximum powers below, no additional SAR tests were required for DLCA SAR configurations.

General PCC and SCC configuration selection procedure

- PCC uplink channel, channel bandwidth, modulation and RB configurations were selected based on section C)3)b)ii) of KDB 941225 D05 V01r02. All LTE bandwidth conducted powers needed for PCC uplink configuration selection can be found in the RF Conducted Powers Section and LTE/NR Lower Bandwidth RF Conducted Power Appendix. The downlink PCC channel was paired with the selected PCC uplink channel according to normal configurations without carrier aggregation.
- To maximize aggregated bandwidth, highest channel bandwidth available for that CA combination was selected for SCC. For inter-band CA, the SCC downlink channels were selected near the middle of their transmission bands. For contiguous intra-band CA, the downlink channel spacing between the component carriers was set to multiple of 300 kHz less than the nominal channel spacing defined in section 5.4.1A of 3GPP TS 36.521. For non-contiguous intra-band CA, the downlink channel spacing between the component carriers was set to be larger than the nominal channel spacing and provided maximum separation between the component carriers.
- All selected PCC and SCC(s) remained fully within the uplink/downlink transmission band of the respective component carrier.

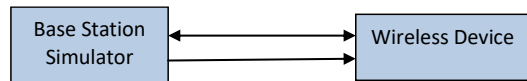

**Figure I-1**  
**DL CA Power Measurement Setup**

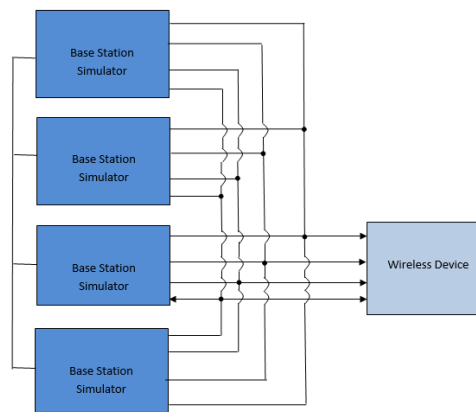

**Figure I-2**  
**DL CA with DL 4x4 MIMO Power Measurement Setup**

FCC ID: A3LSMS711B	SAR EVALUATION REPORT	Approved by: Technical Manager
DUT Type: Portable Handset		APPENDIX I: Page 2 of 6

## I.2 Downlink Carrier Aggregation RF Conducted Powers

### I.2.1 LTE Band 12 as PCC

**Table I-3**  
Maximum Output Powers

Combination	PCC								SCC 1				SCC 2				Power		
	PCC Band	PCC BW [MHz]	PCC (UL) Ch.	PCC (UL) Freq. [MHz]	Mod.	PCC UL# RB	PCC UL RB Offset	PCC (DL) Channel	PCC (DL) Freq. [MHz]	SCC Band	SCC BW [MHz]	SCC (DL) Channel	SCC (DL) Freq. [MHz]	SCC Band	SCC BW [MHz]	SCC (DL) Channel	SCC (DL) Freq. [MHz]	LTE Tx.Power with DL CA Enabled (dBm)	LTE Single Carrier Tx Power (dBm)
CA_2A-12A (1)	LTE B12	5	23155	713.5	QPSK	1	24	5155	743.5	LTE B2	20	900	1960	-	-	-	-	23.93	23.84
CA_4A-12A (1)	LTE B12	5	23155	713.5	QPSK	1	24	5155	743.5	LTE B4	20	2175	2132.5	-	-	-	-	23.92	23.84
CA_4A-12A (2)	LTE B12	5	23155	713.5	QPSK	1	24	5155	743.5	LTE B4	20	2175	2132.5	-	-	-	-	23.92	23.84
CA_12A-66A (1)	LTE B12	5	23155	713.5	QPSK	1	24	5155	743.5	LTE B66	20	66786	2145	-	-	-	-	23.93	23.84
CA_12A-66A (2)	LTE B12	5	23155	713.5	QPSK	1	24	5155	743.5	LTE B66	20	66786	2145	-	-	-	-	23.93	23.84
CA_4A-4A-12A	LTE B12	5	23155	713.5	QPSK	1	24	5155	743.5	LTE B4	20	2175	2132.5	LTE B4	10	2350	2150	24.09	23.84
CA_12A-66A-66A	LTE B12	5	23155	713.5	QPSK	1	24	5155	743.5	LTE B66	20	66786	2145	LTE B66	20	67236	2190	24.02	23.84

### I.2.2 LTE Band 13 as PCC

**Table I-4**  
Maximum Output Powers

Combination	PCC								SCC 1				SCC 2				Power		
	PCC Band	PCC BW [MHz]	PCC (UL) Ch.	PCC (UL) Freq. [MHz]	Mod.	PCC UL# RB	PCC UL RB Offset	PCC (DL) Channel	PCC (DL) Freq. [MHz]	SCC Band	SCC BW [MHz]	SCC (DL) Channel	SCC (DL) Freq. [MHz]	SCC Band	SCC BW [MHz]	SCC (DL) Channel	SCC (DL) Freq. [MHz]	LTE Tx.Power with DL CA Enabled (dBm)	LTE Single Carrier Tx Power (dBm)
CA_2A-13A (2)	LTE B13	10	23230	782	QPSK	1	25	5230	751	LTE B2	20	900	1960	-	-	-	-	24.13	23.98
CA_2A-4A-13A	LTE B13	10	23230	782	QPSK	1	25	5230	751	LTE B2	20	900	1960	LTE B4	20	2175	2132.5	24.15	23.98

### I.2.3 LTE Band 5 as PCC

**Table I-5**  
Maximum Output Powers

Combination	PCC								SCC 1				SCC 2				Power		
	PCC Band	PCC BW [MHz]	PCC (UL) Ch.	PCC (UL) Freq. [MHz]	Mod.	PCC UL# RB	PCC UL RB Offset	PCC (DL) Channel	PCC (DL) Freq. [MHz]	SCC Band	SCC BW [MHz]	SCC (DL) Channel	SCC (DL) Freq. [MHz]	SCC Band	SCC BW [MHz]	SCC (DL) Channel	SCC (DL) Freq. [MHz]	LTE Tx.Power with DL CA Enabled (dBm)	LTE Single Carrier Tx Power (dBm)
CA_5A-41A	LTE B5	5	20425	826.5	QPSK	1	0	2425	871.5	LTE B41	20	40620	2593	-	-	-	-	24.13	24.18
CA_2A-4A-5A	LTE B5	5	20425	826.5	QPSK	1	0	2425	871.5	LTE B2	20	900	1960	LTE B4	20	2175	2132.5	24.26	24.18
CA_2A-5A-66A	LTE B5	5	20425	826.5	QPSK	1	0	2425	871.5	LTE B2	20	900	1960	LTE B66	20	66786	2145	24.25	24.18
CA_5A-66A-66A	LTE B5	5	20425	826.5	QPSK	1	0	2425	871.5	LTE B66	20	66786	2145	LTE B66	20	67236	2190	24.26	24.18
CA_5A-66C	LTE B5	5	20425	826.5	QPSK	1	0	2425	871.5	LTE B66	20	66786	2145	LTE B66	20	66984	2164.8	24.26	24.18

### I.2.4 LTE Band 26 as PCC

**Table I-6**  
Maximum Output Powers

Combination	PCC								SCC 1				SCC 2				Power		
	PCC Band	PCC BW [MHz]	PCC (UL) Ch.	PCC (UL) Freq. [MHz]	Mod.	PCC UL# RB	PCC UL RB Offset	PCC (DL) Channel	PCC (DL) Freq. [MHz]	SCC Band	SCC BW [MHz]	SCC (DL) Channel	SCC (DL) Freq. [MHz]	SCC Band	SCC BW [MHz]	SCC (DL) Channel	SCC (DL) Freq. [MHz]	LTE Tx.Power with DL CA Enabled (dBm)	LTE Single Carrier Tx Power (dBm)
CA_26A-41A	LTE B26	15	26865	831.5	QPSK	1	0	8865	876.5	LTE B41	20	40620	2593	-	-	-	-	24.19	24.14
CA_26A-41C	LTE B26	15	26865	831.5	QPSK	1	0	8865	876.5	LTE B41	20	40620	2593	LTE B41	20	40422	2573.2	24.73	24.14

### I.2.5 LTE Band 66 as PCC

**Table I-7**  
Maximum Output Powers

Combination	PCC								SCC 1				SCC 2				Power		
	PCC Band	PCC BW [MHz]	PCC (UL) Ch.	PCC (UL) Freq. [MHz]	Mod.	PCC UL# RB	PCC UL RB Offset	PCC (DL) Channel	PCC (DL) Freq. [MHz]	SCC Band	SCC BW [MHz]	SCC (DL) Channel	SCC (DL) Freq. [MHz]	SCC Band	SCC BW [MHz]	SCC (DL) Channel	SCC (DL) Freq. [MHz]	LTE Tx.Power with DL CA Enabled (dBm)	LTE Single Carrier Tx Power (dBm)
CA_2A-66A	LTE B66	20	132322	1745	QPSK	1	50	66786	2145	LTE B2	20	900	1960	-	-	-	-	23.81	23.77
CA_12A-66A (1)	LTE B66	20	132322	1745	QPSK	1	50	66786	2145	LTE B12	10	5095	737.5	-	-	-	-	23.78	23.77
CA_12A-66A (2)	LTE B66	20	132322	1745	QPSK	1	50	66786	2145	LTE B12	10	5095	737.5	-	-	-	-	23.78	23.77
CA_66B	LTE B66	5	132322	1745	QPSK	1	12	66786	2145	LTE B66	15	66693	2135.7	-	-	-	-	23.63	23.54
CA_2A-5A-66A	LTE B66	20	132322	1745	QPSK	1	50	66786	2145	LTE B2	20	900	1960	LTE B5	10	2525	881.5	23.85	23.77
CA_2A-66A-66A	LTE B66	20	132322	1745	QPSK	1	50	66786	2145	LTE B66	20	67236	2190	LTE B2	20	900	1960	23.92	23.77
CA_5A-66A-66A	LTE B66	20	132322	1745	QPSK	1	50	66786	2145	LTE B66	20	67236	2190	LTE B5	10	2525	881.5	23.92	23.77
CA_5A-66C	LTE B66	20	132322	1745	QPSK	1	50	66786	2145	LTE B66	20	66588	2125.2	LTE B5	10	2525	881.5	23.94	23.77
CA_12A-66A-66A	LTE B66	20	132322	1745	QPSK	1	50	66786	2145	LTE B66	20	67236	2190	LTE B12	10	5095	737.5	23.95	23.77

FCC ID: A3LSMS711B	SAR EVALUATION REPORT	Approved by: Technical Manager
DUT Type: Portable Handset		APPENDIX I: Page 3 of 6

## I.2.6 LTE Band 2 as PCC

**Table I-8  
Maximum Output Powers**

Combination	PCC								SCC 1				SCC 2				Power		
	PCC Band	PCC BW [MHz]	PCC (UL) Ch.	PCC (UL) Freq. [MHz]	Mod.	PCC UL# RB	PCC UL RB Offset	PCC (DL) Channel	PCC (DL) Freq. [MHz]	SCC Band	SCC BW [MHz]	SCC (DL) Channel	SCC (DL) Freq. [MHz]	SCC Band	SCC BW [MHz]	SCC (DL) Channel	SCC (DL) Freq. [MHz]	LTE Tx Power with DL CA Enabled [dBm]	LTE Single Carrier Tx Power [dBm]
CA_2A-2A	LTE B2	20	19100	1900	QPSK	1	0	1100	1980	LTE B2	20	700	1940	-	-	-	-	23.58	23.67
CA_2C	LTE B2	20	19100	1900	QPSK	1	0	1100	1980	LTE B2	20	902	1960.2	-	-	-	-	23.60	23.67
CA_2A-4A	LTE B2	20	19100	1900	QPSK	1	0	1100	1980	LTE B4	20	2175	2132.5	-	-	-	-	23.61	23.67
CA_2A-12A (1)	LTE B2	20	19100	1900	QPSK	1	0	1100	1980	LTE B12	10	5095	737.5	-	-	-	-	23.63	23.67
CA_2A-13A (2)	LTE B2	20	19100	1900	QPSK	1	0	1100	1980	LTE B13	10	5230	751	-	-	-	-	23.60	23.67
CA_2A-66A	LTE B2	20	19100	1900	QPSK	1	0	1100	1980	LTE B66	20	66786	2145	-	-	-	-	23.62	23.67
CA_2A-4A-5A	LTE B2	20	19100	1900	QPSK	1	0	1100	1980	LTE B4	20	2175	2132.5	LTE B5	10	2525	881.5	23.63	23.67
CA_2A-4A-13A	LTE B2	20	19100	1900	QPSK	1	0	1100	1980	LTE B4	20	2175	2132.5	LTE B13	10	5230	751	23.64	23.67
CA_2A-5A-66A	LTE B2	20	19100	1900	QPSK	1	0	1100	1980	LTE B5	10	2525	881.5	LTE B66	20	66786	2145	23.59	23.67
CA_2A-66A-66A	LTE B2	20	19100	1900	QPSK	1	0	1100	1980	LTE B66	20	66786	2145	LTE B66	20	67236	2190	23.58	23.67

## I.2.7 LTE Band 41 as PCC

**Table I-9  
Maximum Output Powers**

Combination	PCC								SCC 1				SCC 2				SCC 3				SCC 4				Power					
	PCC Band	PCC BW [MHz]	PCC (UL) Ch.	PCC (UL) Freq. [MHz]	Mod.	PCC UL# RB	PCC UL RB Offset	PCC (DL) Channel	PCC (DL) Freq. [MHz]	SCC Band	SCC BW [MHz]	SCC (DL) Channel	SCC (DL) Freq. [MHz]	SCC Band	SCC BW [MHz]	SCC (DL) Channel	SCC (DL) Freq. [MHz]	SCC Band	SCC BW [MHz]	SCC (DL) Channel	SCC (DL) Freq. [MHz]	SCC Band	SCC BW [MHz]	SCC (DL) Channel	SCC (DL) Freq. [MHz]	LTE Tx Power with DL CA Enabled [dBm]	LTE Single Carrier Tx Power [dBm]			
CA_41A-41A (1)	LTE B41	5	40185	2549.5	QPSK	1	12	40185	2549.5	LTE B41	20	41490	2680	-	-	-	-	-	-	-	-	-	-	-	-	-	-	24.79	24.99	
CA_41A-41C	LTE B41	5	40185	2549.5	QPSK	1	12	40185	2549.5	LTE B41	20	41292	2660.2	LTE B41	20	41490	2680	-	-	-	-	-	-	-	-	-	-	-	24.97	24.99
CA_41C-41A	LTE B41	5	40185	2549.5	QPSK	1	12	40185	2549.5	LTE B41	20	40302	2561.2	LTE B41	20	41490	2680	-	-	-	-	-	-	-	-	-	-	-	24.99	24.99
CA_41C-41C	LTE B41	10	40185	2549.5	QPSK	1	49	40185	2549.5	LTE B41	20	40302	2563.9	LTE B41	20	41292	2660.2	LTE B41	20	41490	2680	-	-	-	-	-	-	-	24.98	24.97
CA_41E	LTE B41	15	40185	2549.5	QPSK	1	74	40185	2549.5	LTE B41	20	40096	2569.6	LTE B41	20	40094	2568.4	LTE B41	20	40792	2608.2	-	-	-	-	-	-	-	24.91	24.97
CA_41C-41D	LTE B41	10	40185	2549.5	QPSK	1	49	40185	2549.5	LTE B41	20	40302	2563.9	LTE B41	20	41294	2640.4	LTE B41	20	41292	2660.2	LTE B41	20	41490	2680	-	-	24.96	24.97	
CA_41D-41C	LTE B41	10	40185	2549.5	QPSK	1	49	40185	2549.5	LTE B41	20	40302	2563.9	LTE B41	20	40027	2583.7	LTE B41	20	41292	2660.2	LTE B41	20	41490	2680	-	-	24.94	24.97	

## I.3 DL CA with DL 4x4 MIMO RF Conduction Powers

This device supports downlink 4x4 MIMO operations for some LTE bands. Uplink transmission is limited to a single output stream. When carrier aggregation was applicable, the general test selection and setup procedures described in Section I.1 were applied.

Per May 2017 TCB Workshop Notes, SAR for 4x4 DL MIMO was not needed since the maximum average output power in 4x4 DL MIMO mode was not more than 0.25 dB higher than the maximum output power with 4x4 DL MIMO inactive. Additionally, SAR for 4x4 MIMO Downlink Carrier Aggregation was not needed since the maximum average output power in 4x4 MIMO Downlink Carrier Aggregation mode was not more than 0.25 dB higher than the maximum output power with 4x4 MIMO Downlink and downlink carrier aggregation inactive.

### I.3.1 LTE 4x4 MIMO DL Standalone Powers

**Table I-10  
Maximum Output Powers**

LTE Band	Bandwidth [MHz]	Channel	Frequency [MHz]	Modulation	RB Size	RB Offset	4x4 DL MIMO Tx. Power [dBm]	Single Antenna Tx. Power [dBm]	Target Power [dBm]
66	20	132322	1745	QPSK	1	50	23.69	23.77	23.5
41	5	40185	2549.5	QPSK	1	12	24.96	24.99	24.0

FCC ID: A3LSMS711B	SAR EVALUATION REPORT	Approved by: Technical Manager
DUT Type: Portable Handset		APPENDIX I: Page 4 of 6

### I.3.2 LTE Band 12 as PCC

Table I-11  
Maximum Output Powers

Combination	PCC										SCC 1				SCC 2				Power			
	PCC Band	PCC BW [MHz]	PCC (UL) Ch.	PCC (UL) Freq. [MHz]	Mod.	PCC UL# RB	PCC UL RB Offset	PCC (DL) Ch.	PCC (DL) Freq. [MHz]	DL Ant. Config.	SCC Band	SCC BW [MHz]	SCC (DL) Ch.	SCC (DL) Freq. [MHz]	DL Ant. Config.	SCC Band	SCC BW [MHz]	SCC (DL) Ch.	SCC (DL) Freq. [MHz]	DL Ant. Config.	LTE Tx.Power with DL CA Enabled	LTE Single Carrier Tx Power (dBm)
CA_4A-12A (1)	LTE B12	5	23155	713.5	QPSK	1	24	5155	743.5	2x2	LTE B4	20	2175	2132.5	4x4	-	-	-	-	-	23.81	23.84
CA_4A-12A (2)	LTE B12	5	23155	713.5	QPSK	1	24	5155	743.5	2x2	LTE B4	20	2175	2132.5	4x4	-	-	-	-	-	23.81	23.84
CA_12A-66A (1)	LTE B12	5	23155	713.5	QPSK	1	24	5155	743.5	2x2	LTE B66	20	66786	2145	4x4	-	-	-	-	-	23.78	23.84
CA_12A-66A (2)	LTE B12	5	23155	713.5	QPSK	1	24	5155	743.5	2x2	LTE B66	20	66786	2145	4x4	-	-	-	-	-	23.78	23.84
CA_4A-4A-12A	LTE B12	5	23155	713.5	QPSK	1	24	5155	743.5	2x2	LTE B4	20	2175	2132.5	4x4	LTE B4	10	2350	2150	2x2	23.82	23.84
CA_4A-4A-12A	LTE B12	5	23155	713.5	QPSK	1	24	5155	743.5	2x2	LTE B4	20	2175	2132.5	4x4	LTE B4	10	2350	2150	4x4	23.81	23.84
CA_12A-66A-66A	LTE B12	5	23155	713.5	QPSK	1	24	5155	743.5	2x2	LTE B66	20	66786	2145	4x4	LTE B66	20	67236	2190	2x2	23.83	23.84
CA_12A-66A-66A	LTE B12	5	23155	713.5	QPSK	1	24	5155	743.5	2x2	LTE B66	20	66786	2145	4x4	LTE B66	20	67236	2190	4x4	23.80	23.84

### I.3.3 LTE Band 13 as PCC

Table I-12  
Maximum Output Powers

Combination	PCC										SCC 1				SCC 2				Power			
	PCC Band	PCC BW [MHz]	PCC (UL) Ch.	PCC (UL) Freq. [MHz]	Mod.	PCC UL# RB	PCC UL RB Offset	PCC (DL) Ch.	PCC (DL) Freq. [MHz]	DL Ant. Config.	SCC Band	SCC BW [MHz]	SCC (DL) Ch.	SCC (DL) Freq. [MHz]	DL Ant. Config.	SCC Band	SCC BW [MHz]	SCC (DL) Ch.	SCC (DL) Freq. [MHz]	DL Ant. Config.	LTE Tx.Power with DL CA Enabled	LTE Single Carrier Tx Power (dBm)
CA_2A-4A-13A	LTE B13	10	23230	782	QPSK	1	25	5230	751	2x2	LTE B2	20	900	1960	2x2	LTE B4	20	2175	2132.5	4x4	24.03	23.98

### I.3.4 LTE Band 5 as PCC

Table I-13  
Maximum Output Powers

Combination	PCC										SCC 1				SCC 2				Power			
	PCC Band	PCC BW [MHz]	PCC (UL) Ch.	PCC (UL) Freq. [MHz]	Mod.	PCC UL# RB	PCC UL RB Offset	PCC (DL) Ch.	PCC (DL) Freq. [MHz]	DL Ant. Config.	SCC Band	SCC BW [MHz]	SCC (DL) Ch.	SCC (DL) Freq. [MHz]	DL Ant. Config.	SCC Band	SCC BW [MHz]	SCC (DL) Ch.	SCC (DL) Freq. [MHz]	DL Ant. Config.	LTE Tx.Power with DL CA Enabled	LTE Single Carrier Tx Power (dBm)
CA_5A-41A	LTE B5	5	20425	826.5	QPSK	1	0	2425	871.5	2x2	LTE B41	20	40620	2593	4x4	-	-	-	-	-	24.13	24.18
CA_2A-4A-5A	LTE B5	5	20425	826.5	QPSK	1	0	2425	871.5	2x2	LTE B2	20	900	1960	2x2	LTE B4	20	2175	2132.5	4x4	24.10	24.18
CA_2A-5A-66A	LTE B5	5	20425	826.5	QPSK	1	0	2425	871.5	2x2	LTE B2	20	900	1960	2x2	LTE B66	20	66786	2145	4x4	24.12	24.18
CA_5A-66A-66A	LTE B5	5	20425	826.5	QPSK	1	0	2425	871.5	2x2	LTE B66	20	66786	2145	4x4	LTE B66	20	67236	2190	2x2	24.11	24.18
CA_5A-66A-66A	LTE B5	5	20425	826.5	QPSK	1	0	2425	871.5	2x2	LTE B66	20	66786	2145	4x4	LTE B66	20	67236	2190	4x4	24.18	24.18
CA_5A-66C	LTE B5	5	20425	826.5	QPSK	1	0	2425	871.5	2x2	LTE B66	20	66786	2145	4x4	LTE B66	20	66984	2164.8	4x4	24.17	24.18

### I.3.5 LTE Band 26 as PCC

Table I-14  
Maximum Output Powers

Combination	PCC										SCC 1				SCC 2				Power			
	PCC Band	PCC BW [MHz]	PCC (UL) Ch.	PCC (UL) Freq. [MHz]	Mod.	PCC UL# RB	PCC UL RB Offset	PCC (DL) Ch.	PCC (DL) Freq. [MHz]	DL Ant. Config.	SCC Band	SCC BW [MHz]	SCC (DL) Ch.	SCC (DL) Freq. [MHz]	DL Ant. Config.	SCC Band	SCC BW [MHz]	SCC (DL) Ch.	SCC (DL) Freq. [MHz]	DL Ant. Config.	LTE Tx.Power with DL CA Enabled	LTE Single Carrier Tx Power (dBm)
CA_26A-41A	LTE B26	15	26865	831.5	QPSK	1	0	8865	876.5	2x2	LTE B41	20	40620	2593	4x4	-	-	-	-	-	24.13	24.14
CA_26A-41C	LTE B26	15	26865	831.5	QPSK	1	0	8865	876.5	2x2	LTE B41	20	40620	2593	4x4	LTE B41	20	40422	2573.2	4x4	24.15	24.14

### I.3.6 LTE Band 66 as PCC

Table I-15  
Maximum Output Powers

Combination	PCC										SCC 1				SCC 2				Power			
	PCC Band	PCC BW [MHz]	PCC (UL) Ch.	PCC (UL) Freq. [MHz]	Mod.	PCC UL# RB	PCC UL RB Offset	PCC (DL) Ch.	PCC (DL) Freq. [MHz]	DL Ant. Config.	SCC Band	SCC BW [MHz]	SCC (DL) Ch.	SCC (DL) Freq. [MHz]	DL Ant. Config.	SCC Band	SCC BW [MHz]	SCC (DL) Ch.	SCC (DL) Freq. [MHz]	DL Ant. Config.	LTE Tx.Power with DL CA Enabled	LTE Single Carrier Tx Power (dBm)
CA_2A-66A	LTE B66	20	132322	1745	QPSK	1	50	66786	2145	4x4	LTE B2	20	900	1960	2x2	-	-	-	-	-	23.66	23.77
CA_12A-66A (1)	LTE B66	20	132322	1745	QPSK	1	50	66786	2145	4x4	LTE B12	10	5095	737.5	2x2	-	-	-	-	-	23.68	23.77
CA_12A-66A (2)	LTE B66	20	132322	1745	QPSK	1	50	66786	2145	4x4	LTE B12	10	5095	737.5	2x2	-	-	-	-	-	23.68	23.77
CA_66B	LTE B66	5	132322	1745	QPSK	1	12	66786	2145	4x4	LTE B66	15	66693	2135.7	4x4	-	-	-	-	-	23.57	23.54
CA_2A-5A-66A	LTE B66	20	132322	1745	QPSK	1	50	66786	2145	4x4	LTE B2	20	900	1960	2x2	LTE B5	10	2525	881.5	2x2	23.79	23.77
CA_2A-66A-66A	LTE B66	20	132322	1745	QPSK	1	50	66786	2145	4x4	LTE B66	20	67236	2190	2x2	LTE B2	20	900	1960	2x2	23.75	23.77
CA_2A-66A-66A	LTE B66	20	132322	1745	QPSK	1	50	66786	2145	2x2	LTE B66	20	67236	2190	4x4	LTE B2	20	900	1960	2x2	23.78	23.77
CA_2A-66A-66A	LTE B66	20	132322	1745	QPSK	1	50	66786	2145	4x4	LTE B66	20	67236	2190	4x4	LTE B2	20	900	1960	2x2	23.76	23.77
CA_5A-66A-66A	LTE B66	20	132322	1745	QPSK	1	50	66786	2145	4x4	LTE B66	20	67236	2190	2x2	LTE B5	10	2525	881.5	2x2	23.77	23.77
CA_5A-66A-66A	LTE B66	20	132322	1745	QPSK	1	50	66786	2145	2x2	LTE B66	20	67236	2190	4x4	LTE B5	10	2525	881.5	2x2	23.75	23.77
CA_5A-66A-66A	LTE B66	20	132322	1745	QPSK	1	50	66786	2145	4x4	LTE B66	20	67236	2190	4x4	LTE B5	10	2525	881.5	2x2	23.77	23.77
CA_5A-66C	LTE B66	20	132322	1745	QPSK	1	50	66786	2145	4x4	LTE B66	20	66588	2125.2	4x4	LTE B5	10	2525	881.5	2x2	23.66	23.77
CA_12A-66A-66A	LTE B66	20	132322	1745	QPSK	1	50	66786	2145	4x4	LTE B66	20	67236	2190	2x2	LTE B12	10	5095	737.5	2x2	23.69	23.77
CA_12A-66A-66A	LTE B66	20	132322	1745	QPSK	1	50	66786	2145	2x2	LTE B66	20	67236	2190	4x4	LTE B12	10	5095	737.5	2x2	23.72	23.77
CA_12A-66A-66A	LTE B66	20	132322	1745	QPSK	1	50	66786	2145	4x4	LTE B66	20	67236	2190	4x4	LTE B12	10	5095	737.5	2x2	23.73	23.77

FCC ID: A3LSMS711B	SAR EVALUATION REPORT	Approved by: Technical Manager
DUT Type: Portable Handset		APPENDIX I: Page 5 of 6

