

Test mode: LTE Band 25/2

1.4M BW QPSK Mid ch.

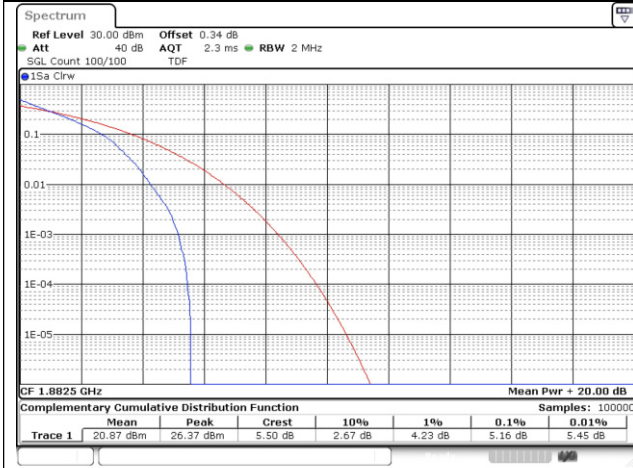

1.4M BW 16QAM Mid ch.

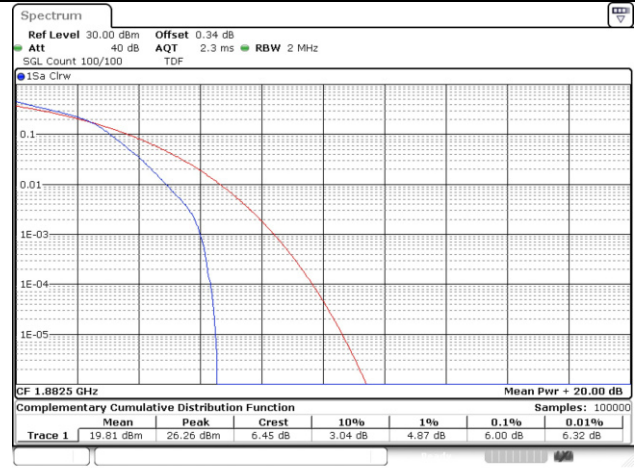

3M BW QPSK Mid ch.

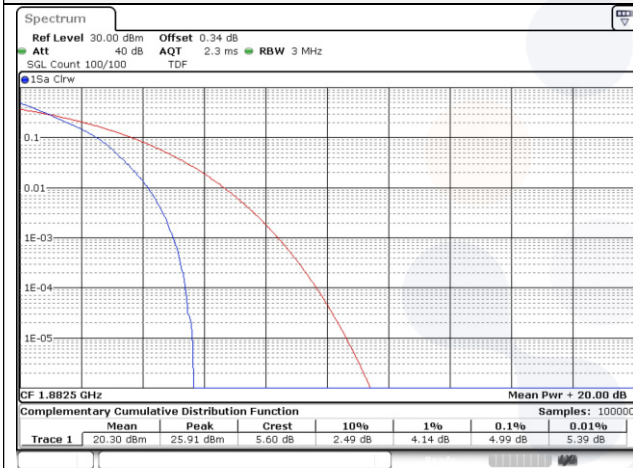

3M BW 16QAM Mid ch.

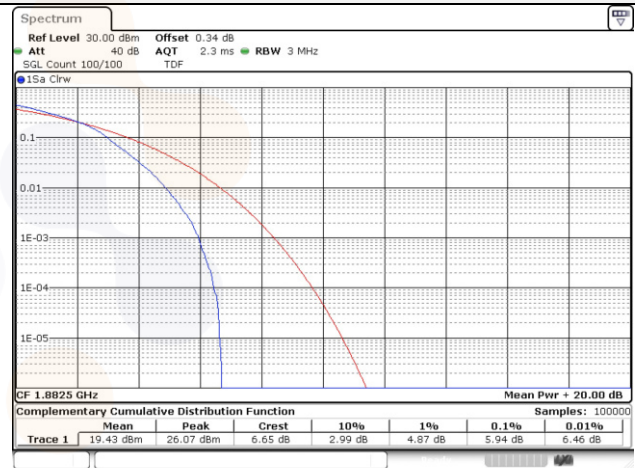

5M BW QPSK Mid ch.

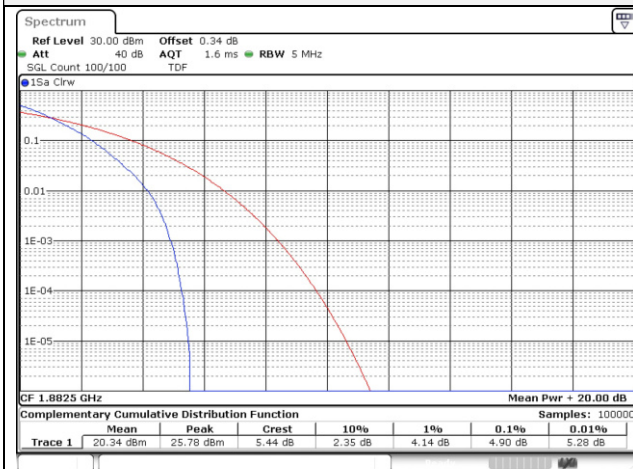

5M BW 16QAM Mid ch.

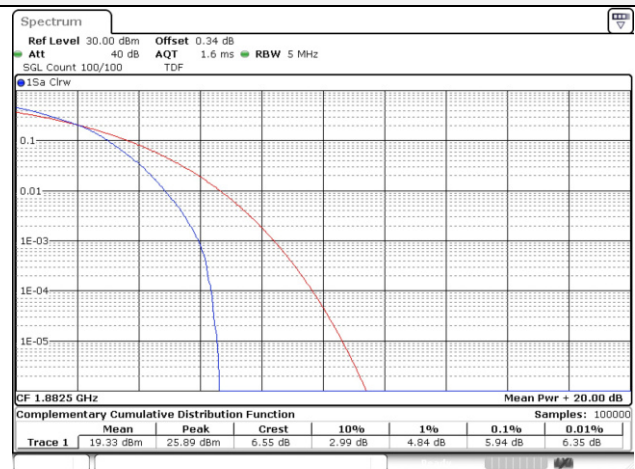

10M BW QPSK Mid ch.

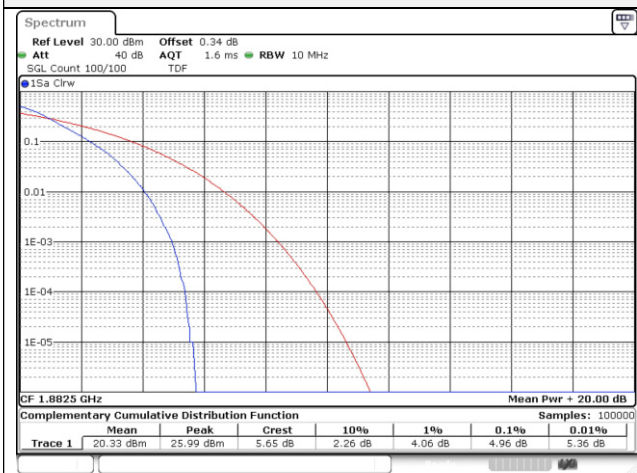

10M BW 16QAM Mid ch.

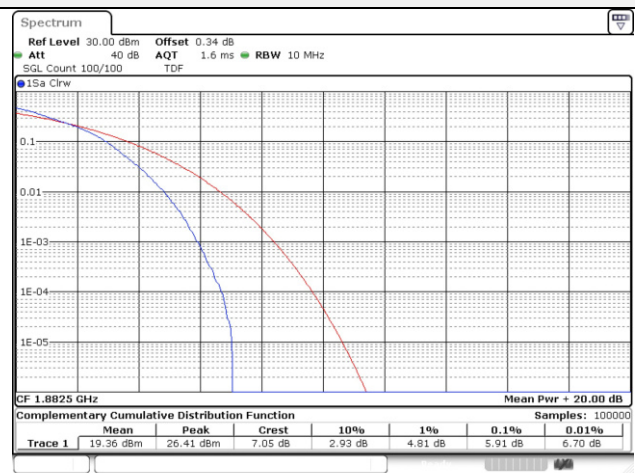

15M BW QPSK Mid ch.

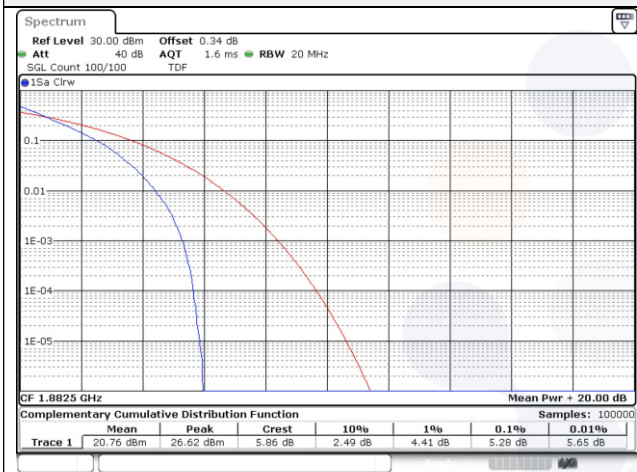

15M BW 16QAM Mid ch.

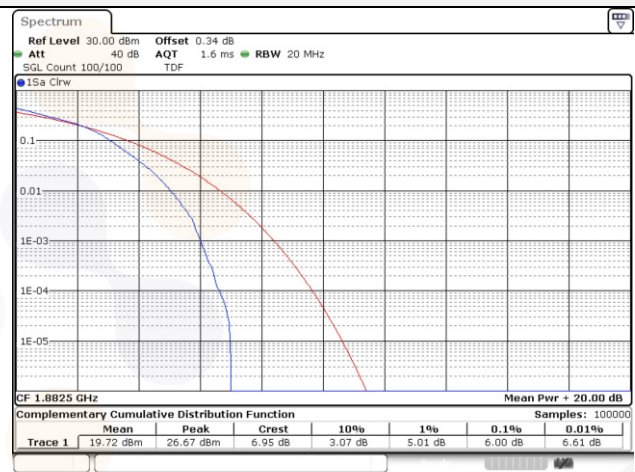

20M BW QPSK Mid ch.

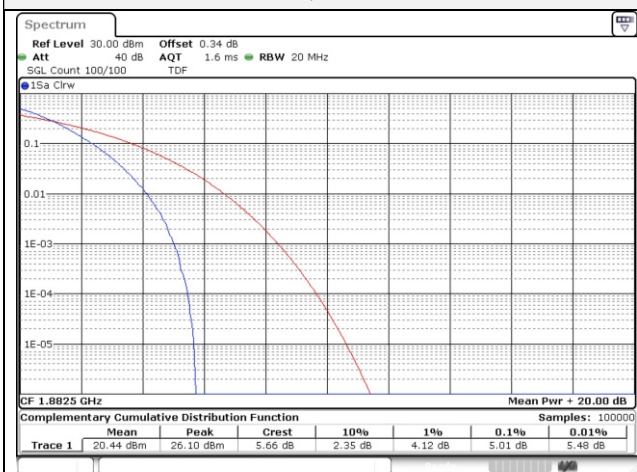

20M BW 16QAM Mid ch.

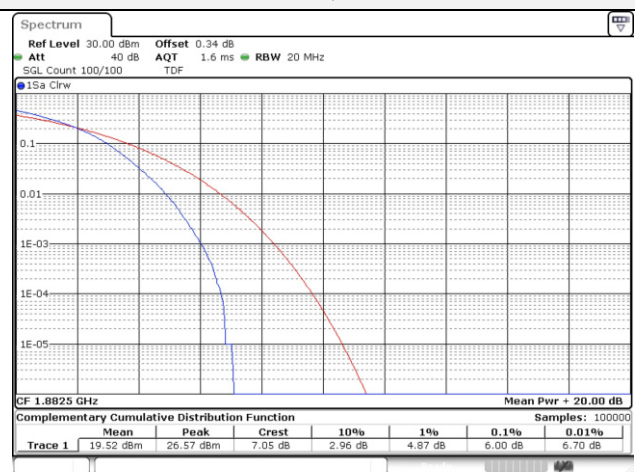

Test mode: LTE Band 26

1.4M BW QPSK Mid ch.

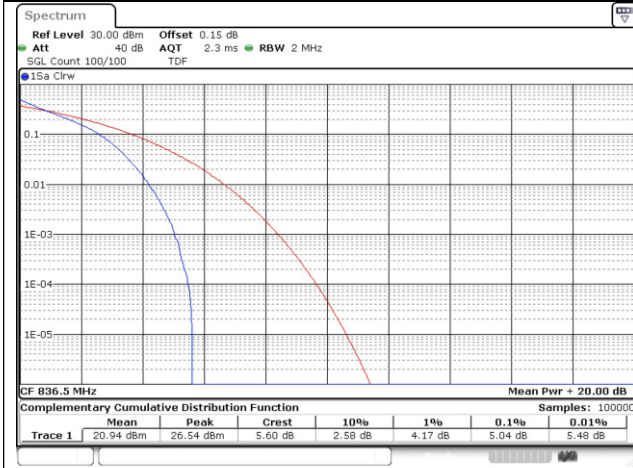

1.4M BW 16QAM Mid ch.

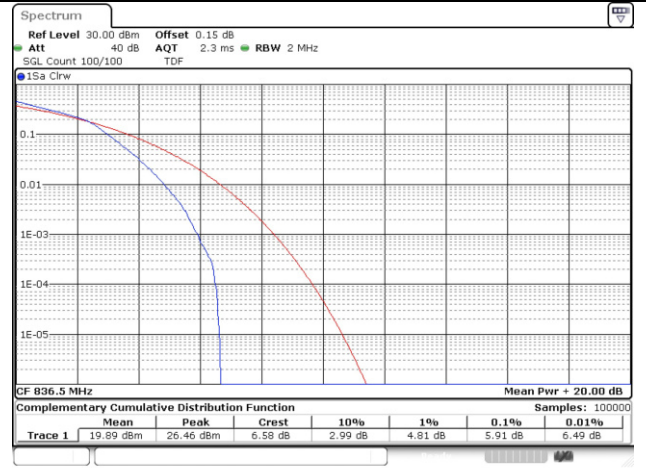

3M BW QPSK Mid ch.

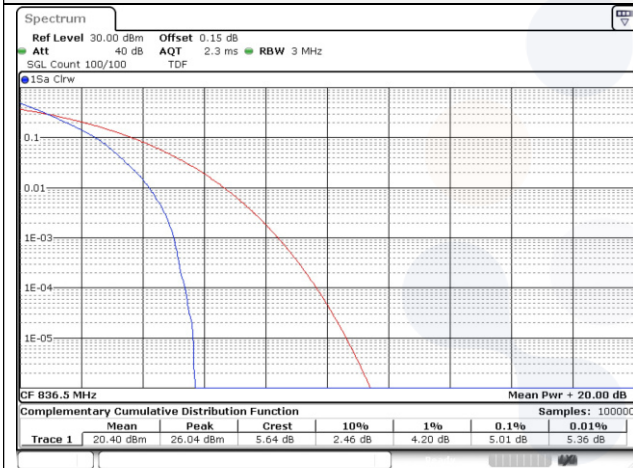

3M BW 16QAM Mid ch.

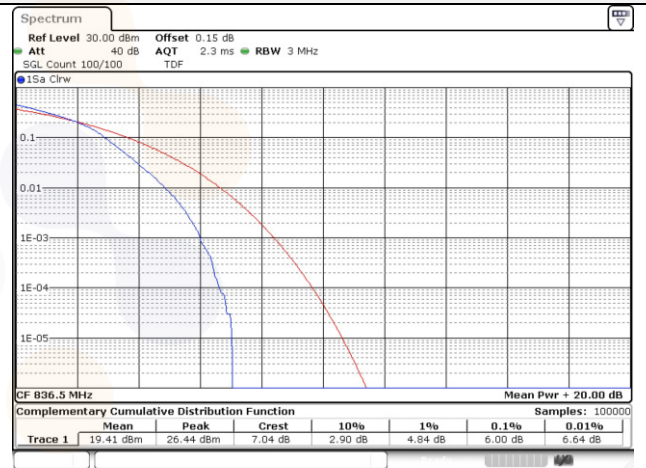

5M BW QPSK Mid ch.

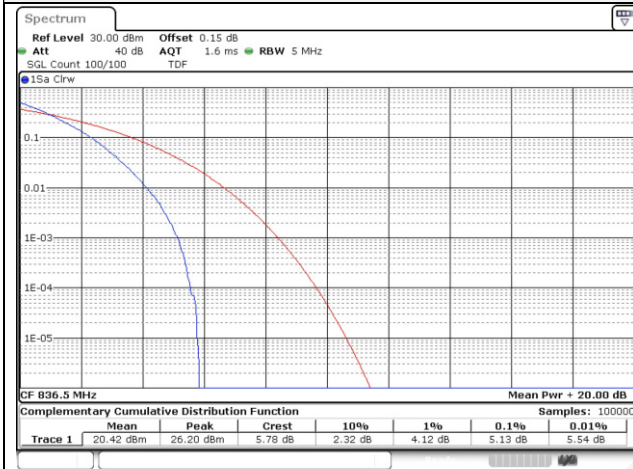

5M BW 16QAM Mid ch.

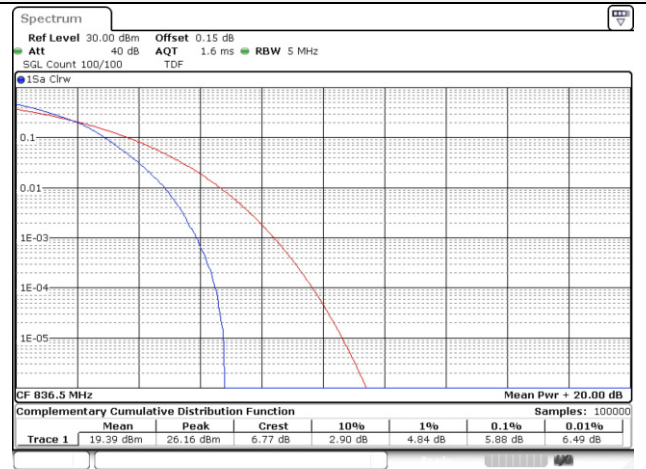

10M BW QPSK Mid ch.

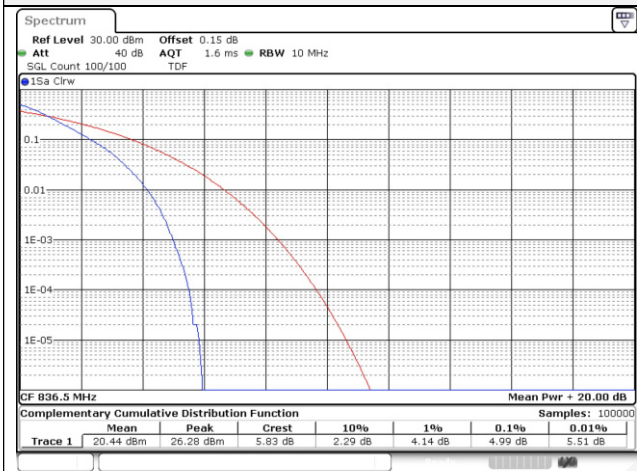

10M BW 16QAM Mid ch.

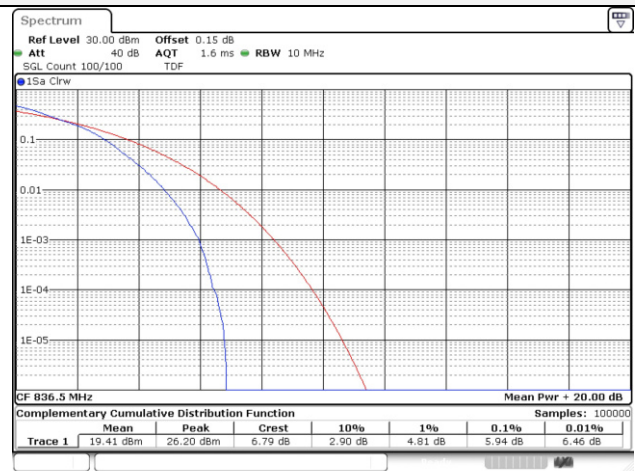

15M BW QPSK Mid ch.

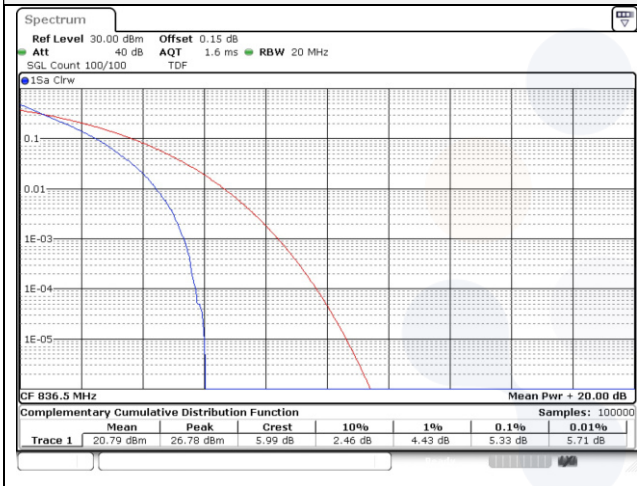

15M BW 16QAM Mid ch.

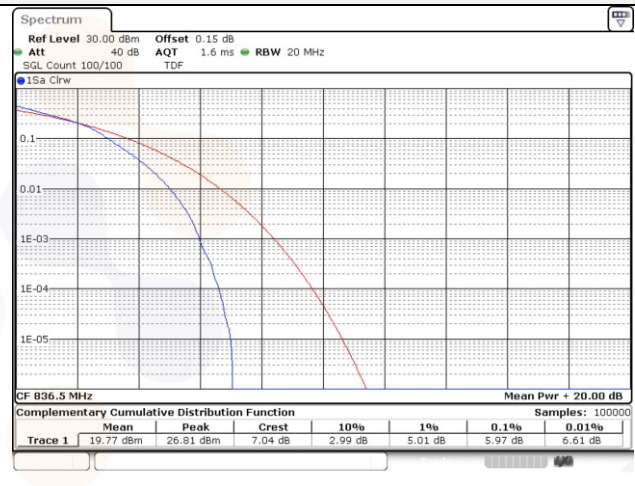

Test mode: LTE Band 66/4

1.4M BW QPSK Mid ch.

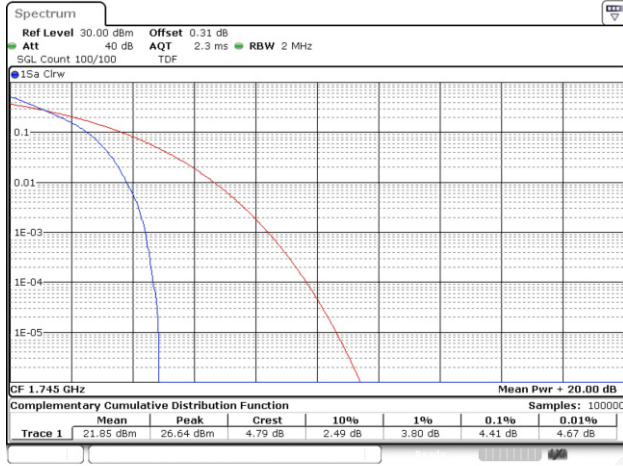

1.4M BW 16QAM Mid ch.

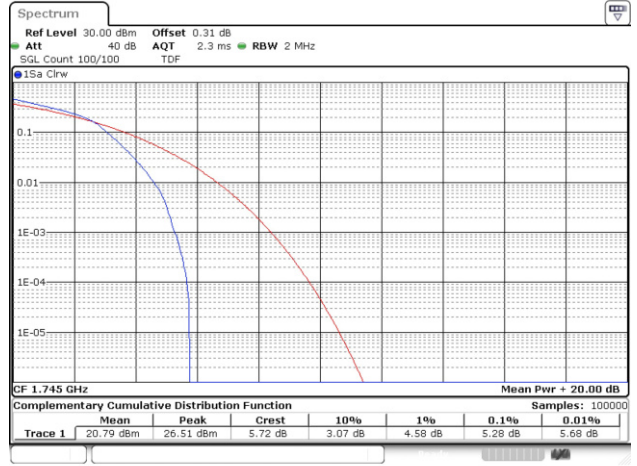

3M BW QPSK Mid ch.

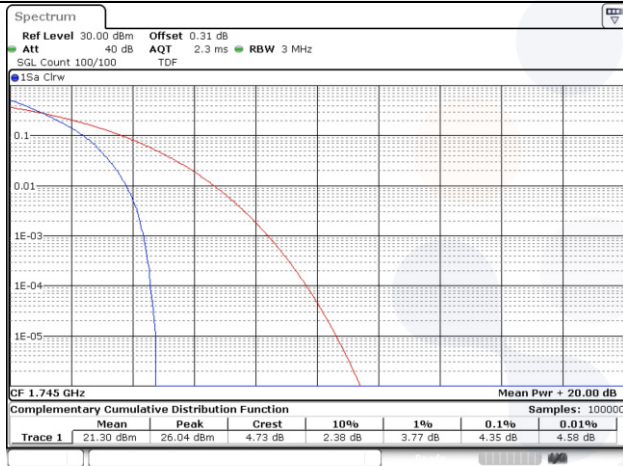

3M BW 16QAM Mid ch.

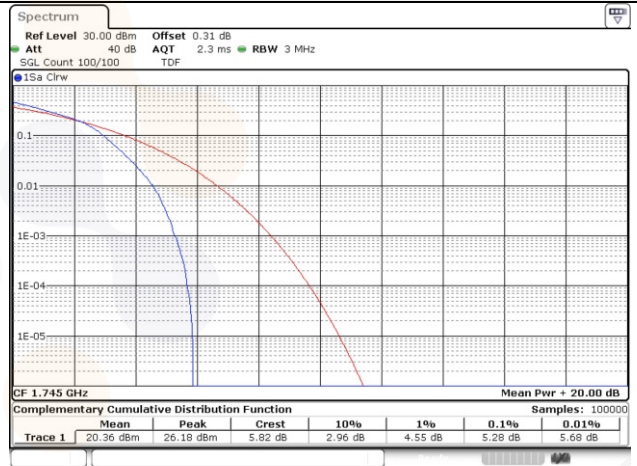

5M BW QPSK Mid ch.

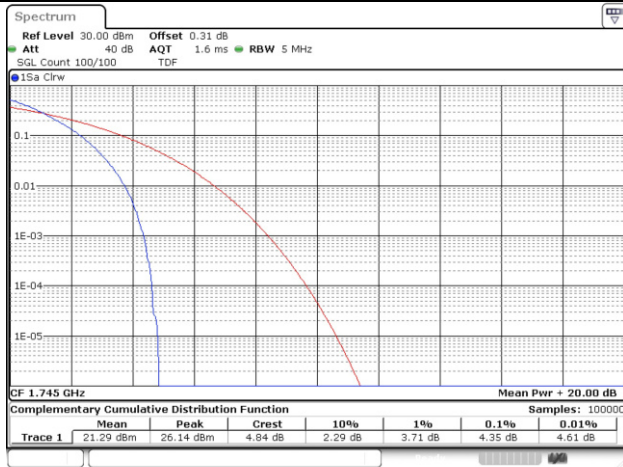

5M BW 16QAM Mid ch.

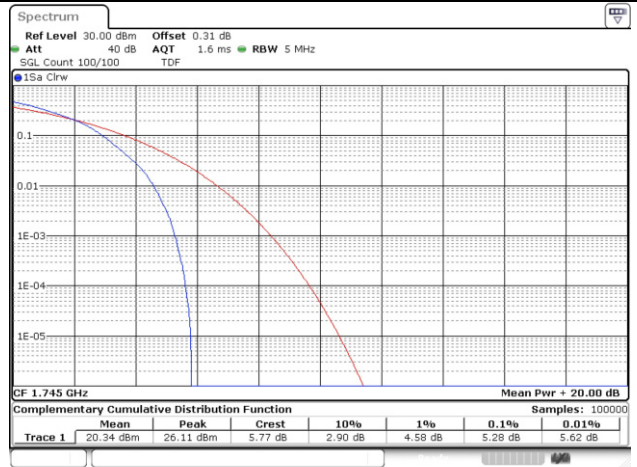

10M BW QPSK Mid ch.

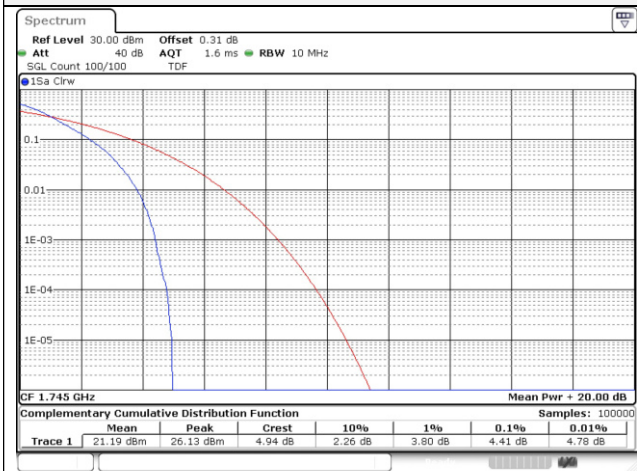

10M BW 16QAM Mid ch.

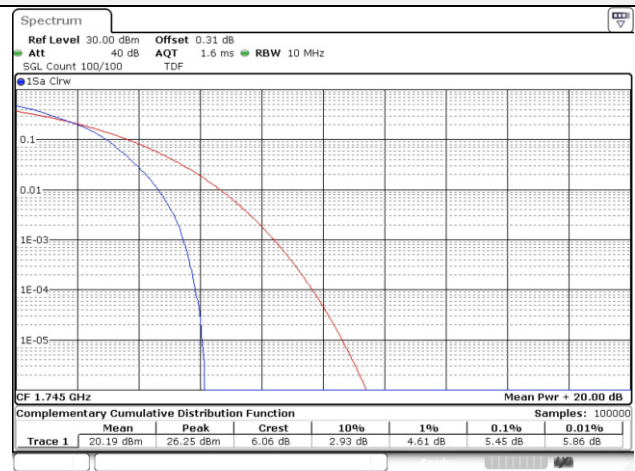

15M BW QPSK Mid ch.

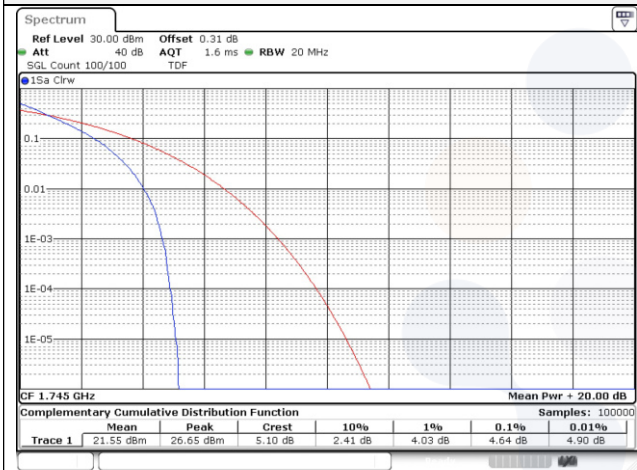

15M BW 16QAM Mid ch.

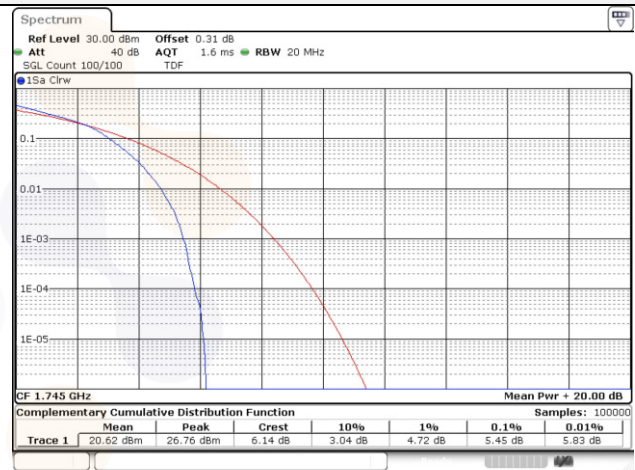

20M BW QPSK Mid ch.

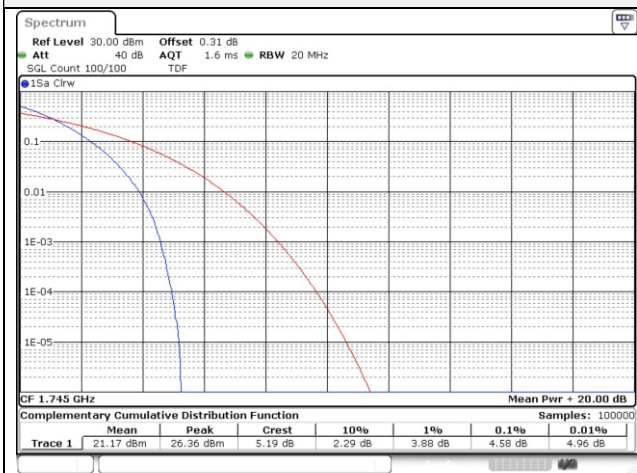

20M BW 16QAM Mid ch.

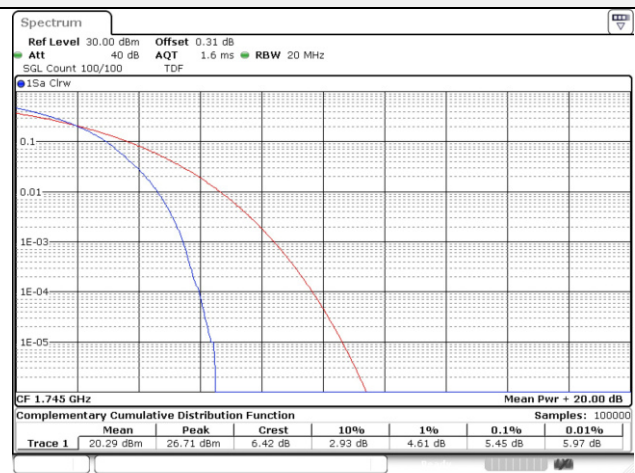

7.6. Frequency stability

Test setup

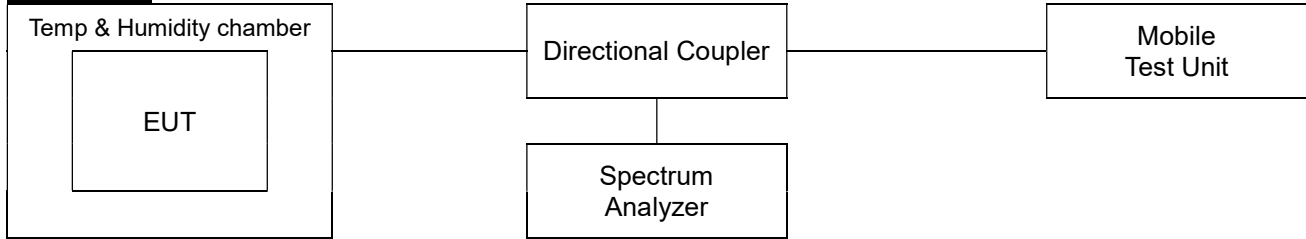

Limit

According to §2.1055(a),

The frequency stability shall be measured with variation of ambient temperature as follows:

- 1) From -30° to $+50^{\circ}$ centigrade for all equipment except that specified in paragraphs (a) (2) and (3) of this section.
- 2) From -20° to $+50^{\circ}$ centigrade for equipment to be licensed for use in the maritime services under part 80 of this chapter, except for class A, B, and S emergency position indicating radio beacons (EPIRBS), and equipment to be licensed for use above 952 MHz at operational fixed stations in all services, stations in the local television transmission service and point-to-point microwave radio service under part 21 of this chapter, equipment licensed for use aboard aircraft in the aviation services under part 87 of this chapter, and equipment authorized for use in the family radio service under part 95 of this chapter.
- 3) From 0° to $+50^{\circ}$ centigrade for equipment to be licensed for use in the radio broadcast Services under part 73 of this chapter.

According to §2.1055(d),



The frequency stability shall be measured with variation of primary supply Voltage as follows:

- 1) Vary primary supply voltage from 85 to 115 percent of the nominal value for other than hand carried battery equipment.
- 2) For hand carried, battery powered equipment, reduce primary supply voltage to the battery operating and point which shall be specified by the manufacturer.
- 3) The supply voltage shall be measured at the input to the cable normally provided with the equipment, or at the power supply terminals if cables are not normally provided. Effects on frequency of transmitter keying (except for broadcast transmitters) and any heating element cycling at the nominal supply voltage and at each extreme also shall be shown.

According to §22.355 and RSS-132(5.3)

For FCC, the carrier frequency of each transmitter in the public mobile services must be maintained within the tolerances given in Table of this section. For mobile devices operating in the 824 to 849 MHz band at a power level than or equal to 3 Watts, the limit specified in Table C-1 is ± 2.5 ppm.

For ISED, the frequency stability shall be sufficient to ensure that the occupied bandwidth stays within each of the sub-bands when tested at the temperature and supply voltage variations specified in RSS-Gen

<p>Eurofins KCTL Co.,Ltd. 65, Sinwon-ro, Yeongtong-gu, Suwon-si, Gyeonggi-do, 16677, Korea TEL: 82-70-5008-1021 FAX: 82-505-299-8311 www.kctl.co.kr</p>	<p>Report No.: KR23-SRF0161 Page (137) of (167)</p>	 
--	---	--

According to §24.235 and RSS-133(6.3),

For FCC, the frequency stability shall be sufficient to ensure that the fundamental emission stays within the authorized frequency block.

For ISED, the carrier frequency shall not depart from the reference frequency, in excess of ± 2.5 ppm for mobile stations and ± 1.0 ppm for base stations.

According to §27.54 and RSS-130(4.5), RSS-199(4.3)

For FCC&ISED, the frequency stability shall be sufficient to ensure that the fundamental emissions stay within the authorized bands of operation.

According to §27.54 and RSS-139(5.4),

For FCC, the frequency stability shall be sufficient to ensure that the fundamental emissions stay within the authorized bands of operation.

For ISED, the frequency stability shall be sufficient to ensure that the occupied bandwidth stay within the operating frequency block or frequency block group when tested to the temperature and supply voltage variations specified in RSS-Gen.

Test procedure

ANSI 63.26-2015 – Section 5.6

Test settings

- 1) The carrier frequency of the transmitter is measured at room temperature.
(20°C to provide a reference)
- 2) The equipment is turned on in a “standby” condition for one minute before applying power to the transmitter. Measurement of the carrier frequency of the transmitter is made within one minute after applying power to the transmitter.
- 3) Frequency measurements are made at 10°C intervals ranging from -30°C to +50°C.
A period of at least one half-hour is provided to allow stabilization of the equipment at each Temperature level.

Test results

Test mode : LTE Band 5
 Frequency (Hz) : 836 500 000
 Channel : 20525
 Deviation limit(FCC) : ±0.00025% or 2.5ppm
 Deviation limit(IC) : The frequency stability shall be sufficient to ensure that the occupied bandwidth stays within each of the sub-bands when tested at the temperature and supply voltage

Voltage (%)	Power (V)	Temp. (°C)	Frequency (Hz)	Frequency error (Hz)	Deviation	
					(ppm)	(%)
100%	3.88	+21.5(Ref)	836,499,995	5.18	0.0	-0.000001
		-30	836,500,004	-3.87	0.0	0.000000
		-20	836,500,004	-4.33	0.0	0.000001
		-10	836,499,999	1.09	0.0	0.000000
		0	836,499,995	5.08	0.0	-0.000001
		+10	836,499,996	4.44	0.0	-0.000001
		+20	836,499,993	6.88	0.0	-0.000001
		+30	836,499,992	8.49	0.0	-0.000001
		+40	836,499,990	10.34	0.0	-0.000001
		+50	836,499,990	9.87	0.0	-0.000001
115%	4.46	+21.5(Ref)	836,499,995	5.45	0.0	-0.000001
End point	3.40	+21.5(Ref)	836,499,995	4.61	0.0	-0.000001

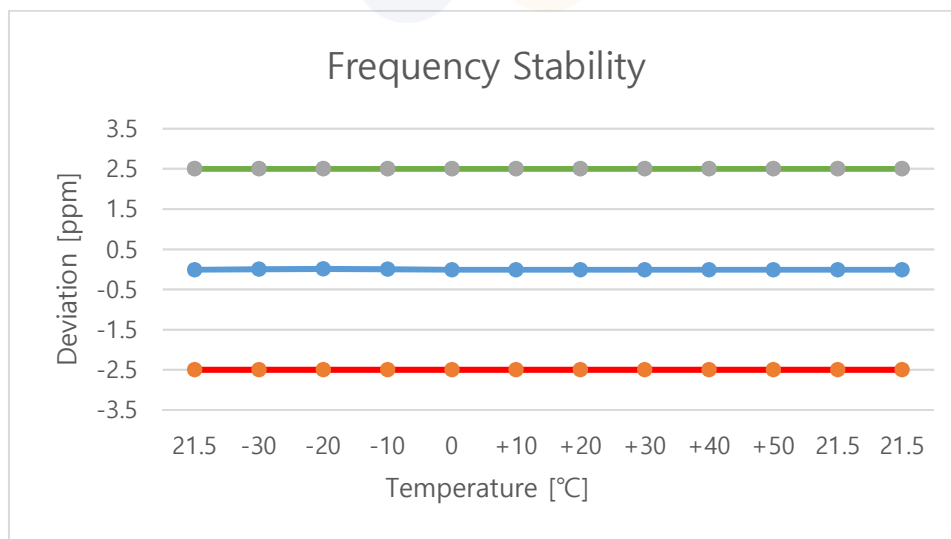

Test mode : LTE Band 7
 Frequency (Hz) : 2 535 000 000
 Channel : 21100
 Deviation limit(FCC&IC) : The frequency stability shall be sufficient to ensure that the fundamental emission stay within the authorized bands of operation

Voltage (%)	Power (V)	Temp. (°C)	Frequency (Hz)	Frequency error (Hz)	Deviation	
					(ppm)	(%)
100%	3.88	+21.5(Ref)	2,534,999,983	17.14	0.0	-0.000001
		-30	2,534,999,987	13.29	0.0	-0.000001
		-20	2,534,999,985	15.31	0.0	-0.000001
		-10	2,534,999,992	8.29	0.0	0.000000
		0	2,534,999,993	7.19	0.0	0.000000
		+10	2,534,999,990	10.11	0.0	0.000000
		+20	2,534,999,982	17.55	0.0	-0.000001
		+30	2,534,999,985	15.31	0.0	-0.000001
		+40	2,534,999,987	13.10	0.0	-0.000001
		+50	2,534,999,996	4.38	0.0	0.000000
115%	4.46	+21.5(Ref)	2,534,999,982	18.28	0.0	-0.000001
End point	3.40	+21.5(Ref)	2,534,999,981	18.60	0.0	-0.000001

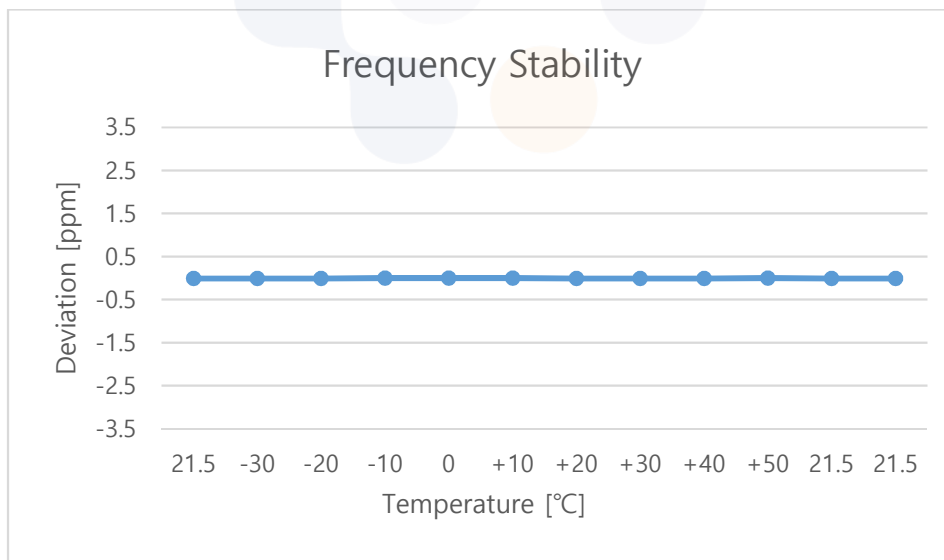

Test mode : LTE Band 12
 Frequency (Hz) : 707 500 000
 Channel : 23095
 Deviation limit(FCC&IC) : The frequency stability shall be sufficient to ensure that the fundamental emission stay within the authorized bands of operation

Voltage (%)	Power (V)	Temp. (°C)	Frequency (Hz)	Frequency error (Hz)	Deviation	
					(ppm)	(%)
100%	3.88	+21.5(Ref)	707,500,004	3.96	0.0	0.000001
		-30	707,499,995	-5.23	0.0	-0.000001
		-20	707,499,995	-5.10	0.0	-0.000001
		-10	707,499,997	-3.47	0.0	0.000000
		0	707,500,001	1.09	0.0	0.000000
		+10	707,500,005	4.66	0.0	0.000001
		+20	707,500,004	3.55	0.0	0.000001
		+30	707,500,006	6.48	0.0	0.000001
		+40	707,500,005	5.11	0.0	0.000001
		+50	707,500,002	2.08	0.0	0.000000
115%	4.46	+21.5(Ref)	707,500,003	3.06	0.0	0.000000
End point	3.40	+21.5(Ref)	707,500,003	3.06	0.0	0.000000

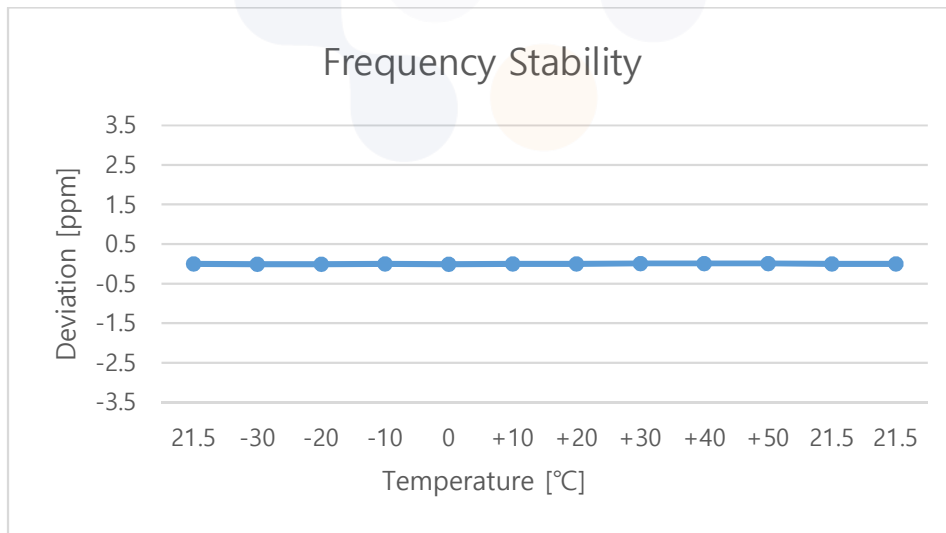

Test mode : LTE Band 13
 Frequency (Hz) : 782 000 000
 Channel : 23230
 Deviation limit(FCC&IC) : The frequency stability shall be sufficient to ensure that the fundamental emission stay within the authorized bands of operation

Voltage (%)	Power (V)	Temp. (°C)	Frequency (Hz)	Frequency error (Hz)	Deviation	
					(ppm)	(%)
100%	3.88	+21.5(Ref)	782,000,002	2.37	0.0	0.000000
		-30	781,999,993	-6.66	0.0	-0.000001
		-20	781,999,993	-7.19	0.0	-0.000001
		-10	781,999,997	-3.09	0.0	0.000000
		0	781,999,994	-5.94	0.0	-0.000001
		+10	781,999,997	-2.58	0.0	0.000000
		+20	782,000,003	3.16	0.0	0.000000
		+30	782,000,004	4.42	0.0	0.000001
		+40	782,000,005	4.66	0.0	0.000001
		+50	782,000,008	8.09	0.0	0.000001
115%	4.46	+21.5(Ref)	782,000,004	3.50	0.0	0.000000
End point	3.40	+21.5(Ref)	782,000,003	2.85	0.0	0.000000

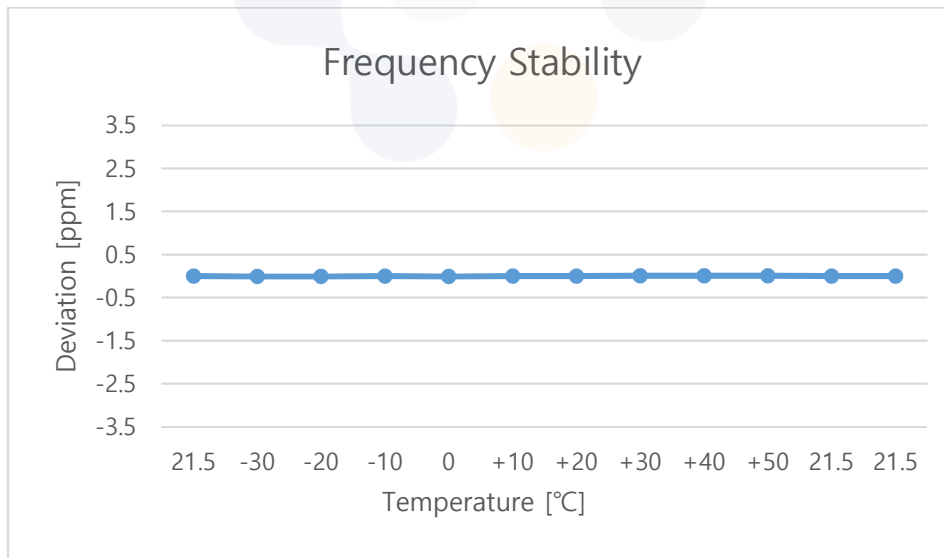

Test mode : LTE Band 25/2
 Frequency (Hz) : 1 882 500 000
 Channel : 26365
 Deviation limit(FCC) : The frequency stability shall be sufficient to ensure that the fundamental emission stays within the authorized frequency block.
 Deviation limit(IC) : ±0.00025% or 2.5ppm

Voltage (%)	Power (V)	Temp. (°C)	Frequency (Hz)	Frequency error (Hz)	Deviation	
					(ppm)	(%)
100%	3.88	+21.5(Ref)	1,882,500,008	8.18	0.0	0.000000
		-30	1,882,500,013	13.34	0.0	0.000001
		-20	1,882,500,010	10.09	0.0	0.000001
		-10	1,882,500,007	6.85	0.0	0.000000
		0	1,882,500,003	3.39	0.0	0.000000
		+10	1,882,500,005	5.43	0.0	0.000000
		+20	1,882,500,007	7.09	0.0	0.000000
		+30	1,882,500,004	4.19	0.0	0.000000
		+40	1,882,500,002	2.22	0.0	0.000000
		+50	1,882,500,002	1.64	0.0	0.000000
115%	4.46	+21.5(Ref)	1,882,500,008	8.18	0.0	0.000000
End point	3.40	+21.5(Ref)	1,882,500,009	9.08	0.0	0.000000

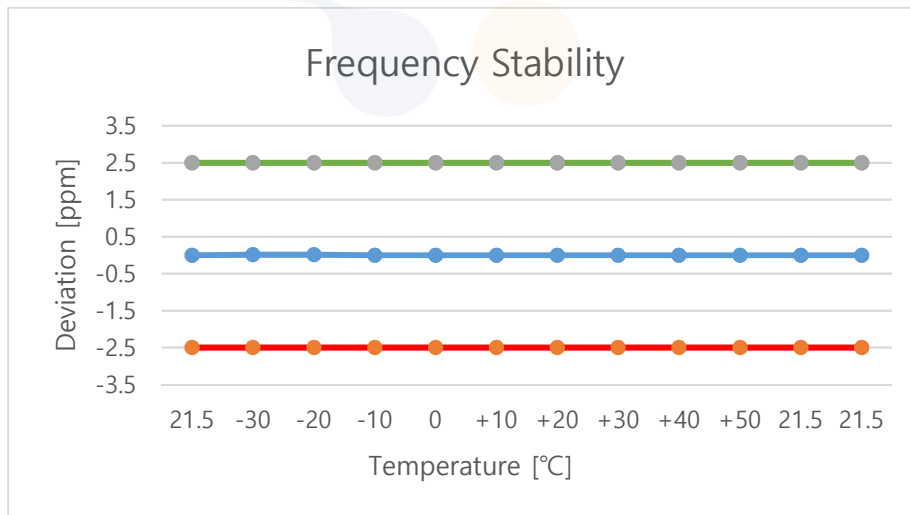

Test mode : LTE Band 26
 Frequency (Hz) : 836 500 000
 Channel : 26915
 Deviation limit(FCC) : ±0.00025% or 2.5ppm
 Deviation limit(IC) : The frequency stability shall be sufficient to ensure that the occupied bandwidth stays within each of the sub-bands when tested at the temperature and supply voltage

Voltage (%)	Power (V)	Temp. (°C)	Frequency (Hz)	Frequency error (Hz)	Deviation	
					(ppm)	(%)
100%	3.88	+21.5(Ref)	836,500,004	3.59	0.0	0.000000
		-30	836,499,995	-5.13	0.0	-0.000001
		-20	836,499,995	-5.09	0.0	-0.000001
		-10	836,499,996	-4.46	0.0	-0.000001
		0	836,499,997	-2.88	0.0	0.000000
		+10	836,500,001	1.16	0.0	0.000000
		+20	836,500,003	3.27	0.0	0.000000
		+30	836,500,006	5.55	0.0	0.000001
		+40	836,500,006	6.09	0.0	0.000001
		+50	836,500,008	8.31	0.0	0.000001
115%	4.46	+21.5(Ref)	836,500,003	3.10	0.0	0.000000
End point	3.40	+21.5(Ref)	836,500,003	3.33	0.0	0.000000

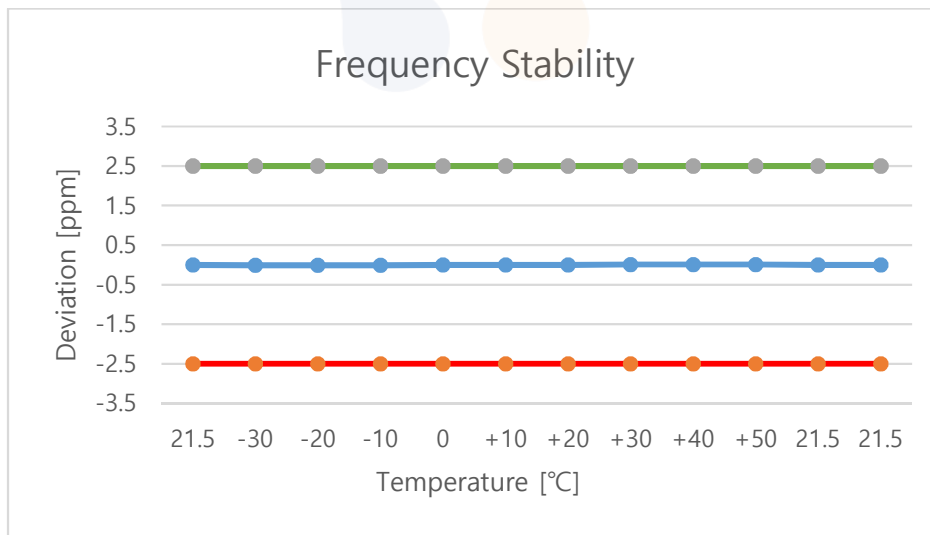

Test mode : LTE Band 66/4
 Frequency (Hz) : 1 745 000 000
 Channel : 132322
 Deviation limit(FCC) : The frequency stability shall be sufficient to ensure that the fundamental emission stay within the authorized bands of operation.
 Deviation limit(IC) : The frequency stability shall be sufficient to ensure that the occupied bandwidth stays within each of the sub-bands when tested at the temperature and supply voltage

Voltage (%)	Power (V)	Temp. (°C)	Frequency (Hz)	Frequency error (Hz)	Deviation	
					(ppm)	(%)
100%	3.88	+21.5(Ref)	1,745,000,007	7.38	0.0	0.000000
		-30	1,744,999,997	-3.45	0.0	0.000000
		-20	1,744,999,995	-5.31	0.0	0.000000
		-10	1,745,000,002	2.49	0.0	0.000000
		0	1,745,000,005	5.09	0.0	0.000000
		+10	1,745,000,006	5.55	0.0	0.000000
		+20	1,745,000,006	6.09	0.0	0.000000
		+30	1,745,000,004	4.11	0.0	0.000000
		+40	1,745,000,002	2.09	0.0	0.000000
		+50	1,745,000,000	0.19	0.0	0.000000
115%	4.46	+21.5(Ref)	1,745,000,007	6.71	0.0	0.000000
End point	3.40	+21.5(Ref)	1,745,000,008	7.94	0.0	0.000000

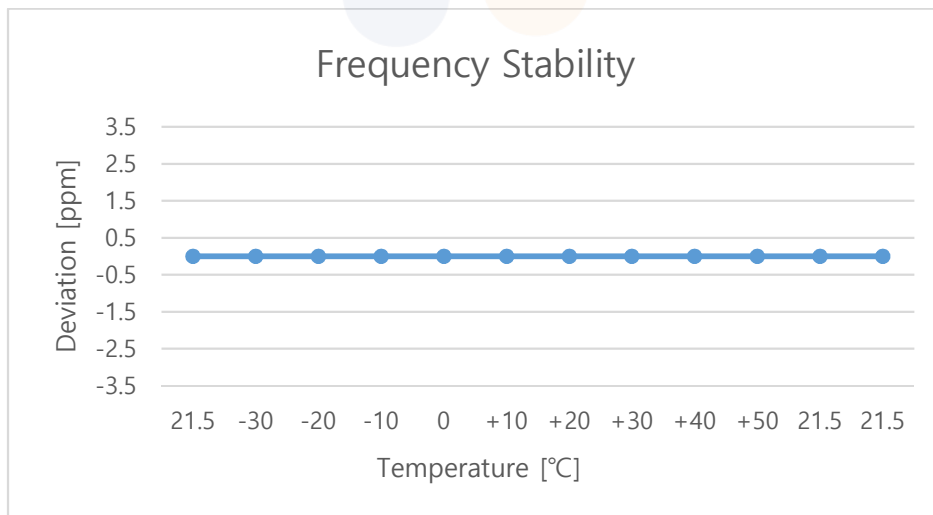

Test mode : LTE Band 71
 Frequency (Hz) : 680 500 000
 Channel : 133297
 Deviation limit(FCC) : The frequency stability shall be sufficient to ensure that the fundamental emission stay within the authorized bands of operation.

Voltage (%)	Power (V)	Temp. (°C)	Frequency (Hz)	Frequency error (Hz)	Deviation	
					(ppm)	(%)
100%	3.88	+21.5(Ref)	680,500,003	2.63	0.0	0.000000
		-30	680,499,996	-4.21	0.0	-0.000001
		-20	680,499,992	-7.61	0.0	-0.000001
		-10	680,499,994	-5.55	0.0	-0.000001
		0	680,499,997	-3.31	0.0	0.000000
		+10	680,499,998	-2.09	0.0	0.000000
		+20	680,500,002	1.99	0.0	0.000000
		+30	680,500,004	4.18	0.0	0.000001
		+40	680,500,006	6.08	0.0	0.000001
		+50	680,500,005	5.10	0.0	0.000001
115%	4.46	+21.5(Ref)	680,500,003	3.38	0.0	0.000000
End point	3.40	+21.5(Ref)	680,500,003	2.55	0.0	0.000000

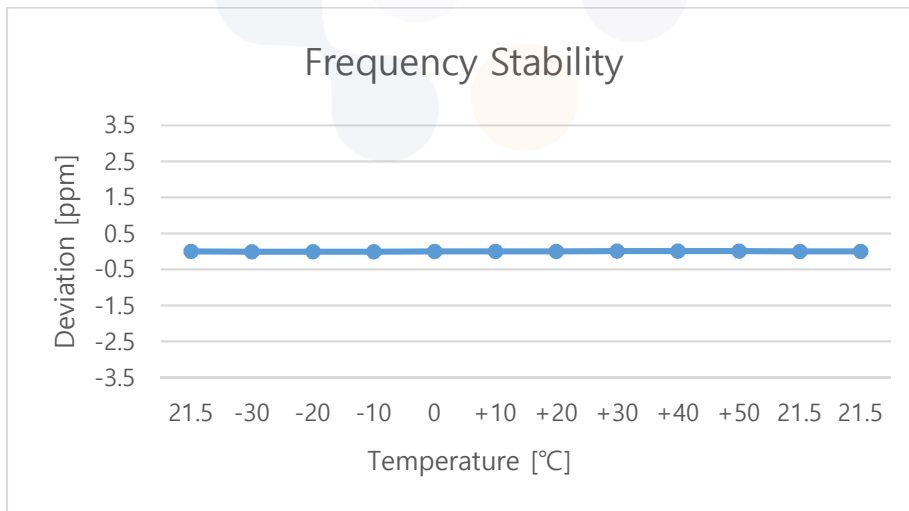

7.7. Radiated Power (ERP/EIRP)

Test setup

The diagram below shows the test setup that is utilized to make the measurements for emission from 30 MHz to 1 GHz emissions.

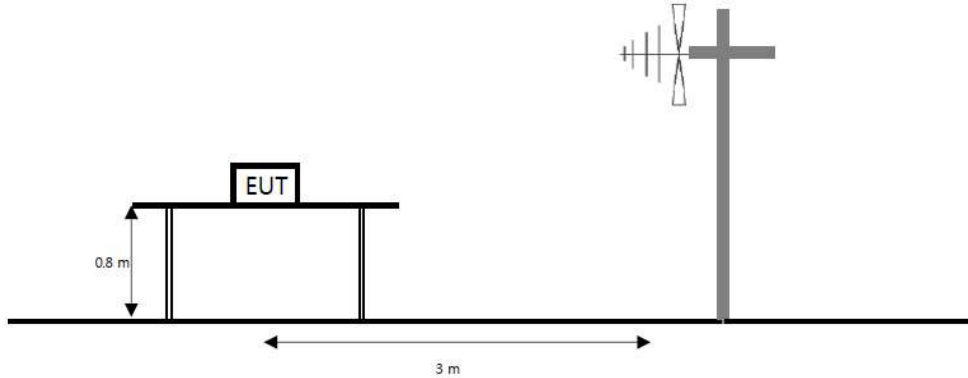

The diagram below shows the test setup that is utilized to make the measurements for emission from 1 GHz to the tenth harmonic of the highest fundamental frequency or to 40 GHz emissions, whichever is lower.

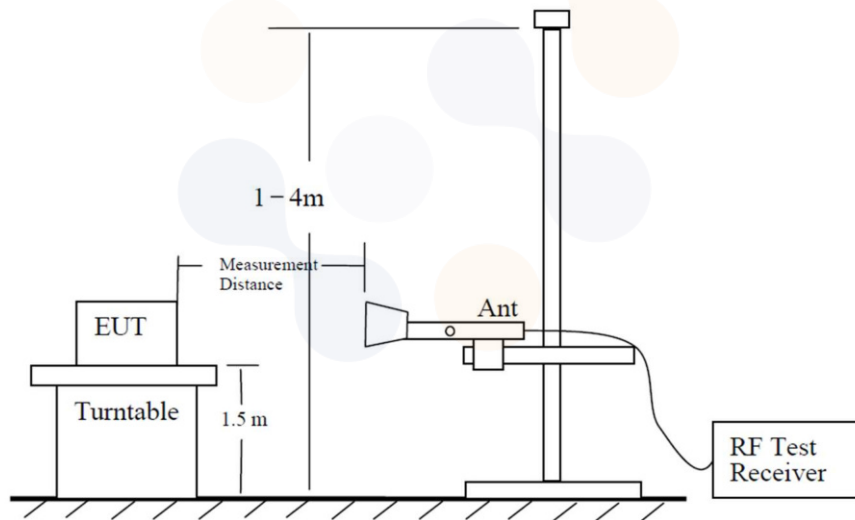

The diagram below shows the test setup for substituted method.

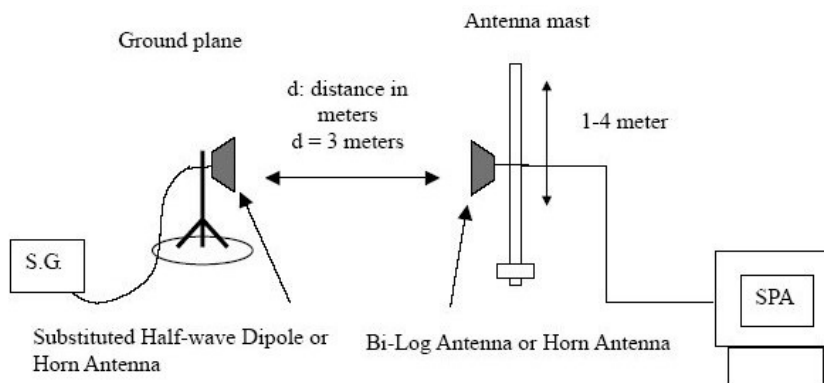

Limit

According to §22.913(a)(5), the ERP of transmitters in the cellular radiotelephone service must not exceed the limits in this section. The ERP of mobile transmitters and auxiliary test transmitters must not exceed 7 watts.

According to RSS-132(5.4), the equivalent radiated power (e.r.p.) shall not exceed 7 watts for mobile equipment and 3 watts for portable equipment.

According to §24.232(c) and RSS-133(6.4), Mobile and portable stations are limited to 2 watts EIRP and the equipment must employ a means for limiting power to the minimum necessary for successful communications.

According to §27.50(b)(10), 27.50(c)(10) and RSS-130(4.6), Portable stations (hand-held devices) in the 698 -746 MHz, 746-757 MHz, 776-788 MHz, and 805-806 MHz bands are limited 3 watts ERP.

According to §27.50(d)(4), Fixed, mobile and portable (hand-held) stations operating in the 1710-1755 MHz and 1755-1780 MHz bands are limited to 1 watt EIRP.

According to RSS-139(5.5), the equivalent isotropically radiated power (e.i.r.p.) for mobile and portable transmitters shall not exceed one watt. The e.i.r.p. for fixed and base stations in the band 1710-1780 MHz shall not exceed one watt(30 dBm e.i.r.p./channel bandwidth).

According to §27.57(h), mobile stations are limited to 2.0 watts EIRP. All user stations are limited to 2.0 watts transmitter output power.



According to RSS-199(4.4), for mobile subscriber equipment, the e.i.r.p. shall not exceed 2 W.

Test procedure

971168 D01 v03r01 - Section 5.2 and 5.8, 412172 D01 v01r01
ANSI 63.26-2015 – Section 5.2
ANSI/TIA-603-E-2016 - Section 2.2.17

Test settings

- 1) RBW = 1 % to 5 % of the OBW.
- 2) VBW $\geq 3 \times$ RBW.
- 3) SPAN = 2 \times to 3 \times the OBW.
- 4) Number of measurement points in sweep $\geq 2 \times$ span / RBW.
- 5) Sweep time :
 - 1) Auto couple, or
 - 2) $\geq [10 \times (\text{number of points in sweep}) \times (\text{transmission period})]$ for single sweep (automation-compatible) measurement. Transmission period is the on and off time of the transmitter.
- 6) Detector = RMS
- 7) If the EUT can be configured to transmit continuously, then set the trigger to free run.
- 8) If the EUT cannot be configured to transmit continuously, then use a sweep trigger with the level set to enable triggering only on full power bursts and configure the EUT to transmit at full power for the entire duration of each sweep. Verify that the sweep time is less than or equal to the transmission burst duration. Time gating can also be used under similar constraints (i.e., configured such that measurement data is collected only during active full-power transmissions).
- 9) Trace mode = trace averaging (RMS) over 100 sweeps.
- 10) Compute the power by integrating the spectrum across the OBW of the signal using the instrument's band or channel power measurement function, with the band/channel limits

<p>Eurofins KCTL Co.,Ltd. 65, Sinwon-ro, Yeongtong-gu, Suwon-si, Gyeonggi-do, 16677, Korea TEL: 82-70-5008-1021 FAX: 82-505-299-8311 www.kctl.co.kr</p>	<p>Report No.: KR23-SRF0161 Page (148) of (167)</p>	 
--	---	---

set equal to the OBW band edges. If the instrument does not have a band or channel power function, then sum the spectrum levels (in linear power units) at intervals equal to the RBW extending across the entire OBW of the spectrum.

- 11) Allow trace to fully stabilize.

Notes:

1. On a test site, the EUT shall be placed at 80 cm or 1.5 m height on a turn table, and in the position close to normal use as declared by the applicant.
2. The test antenna shall be oriented initially for vertical polarization located 3 m from EUT to correspond to the fundamental frequency of the transmitter.
3. The turntable is rotated through 360°, and the receiving antenna scans in order to determine the Level of the maximized emission.
4. The test antenna shall be raised and lowered again through the specified range of height until the maximum signal level is detected by the measuring receiver.
5. The maximum signal level detected by the measuring receiver shall be noted.
6. The EUT was replaced by half-wave dipole (1 GHz below) or horn antenna (1 GHz above) connected to a signal generator.
The power is calculated by the following formula;

$$Pd(\text{dBm}) = Pg(\text{dBm}) - \text{Cable loss (dB)} + \text{Antenna gain (dB)}$$
Note. Pd is the dipole equivalent power and Pg is the generator output power into the substitution antenna.
7. The test antenna shall be raised and lowered through the specified range of height to ensure that The maximum signal is received.
8. The input signal to the substitution antenna shall be adjusted to the level that produces a level Detected by the measuring corrected for the change of input attenuator setting of the measuring Receiver.
9. The input level to the substitution antenna shall be recorded as power level in dBm, corrected for Any change of input attenuator setting of the measuring receiver.
10. The measurement shall be repeated with the test antenna and the substitution antenna Orientated for horizontal polarization.

Test results

Test mode: LTE Band 5

Bandwidth	Modulation	Frequency	Pol.	Antenna Gain	C.L	Substitute Level	ERP	
		[MHz]	[V/H]	[dBd]	[dB]	[dBm]	[dBm]	[W]
1.4 M	QPSK	824.7	H	5.24	2.66	11.78	14.36	0.027
		836.5	H	5.40	2.58	10.74	13.56	0.023
		848.3	H	5.48	2.39	11.01	14.10	0.026
	16QAM	824.7	H	5.24	2.66	10.83	13.41	0.022
		836.5	H	5.40	2.58	9.80	12.62	0.018
		848.3	H	5.48	2.39	10.22	13.31	0.021
3 M	QPSK	825.5	H	5.27	2.67	11.37	13.96	0.025
		836.5	H	5.40	2.58	10.87	13.69	0.023
		847.5	H	5.48	2.58	11.17	14.06	0.025
	16QAM	825.5	H	5.27	2.67	10.13	12.72	0.019
		836.5	H	5.40	2.58	9.75	12.57	0.018
		847.5	H	5.48	2.58	10.07	12.96	0.020
5 M	QPSK	826.5	H	5.30	2.78	11.21	13.72	0.024
		836.5	H	5.40	2.58	10.86	13.68	0.023
		846.5	H	5.47	2.16	11.23	14.53	0.028
	16QAM	826.5	H	5.30	2.78	10.30	12.81	0.019
		836.5	H	5.40	2.58	9.98	12.80	0.019
		846.5	H	5.47	2.16	10.08	13.38	0.022
10 M	QPSK	829.0	H	5.37	2.57	11.38	14.18	0.026
		836.5	H	5.40	2.58	11.19	14.01	0.025
		844.0	H	5.44	2.78	11.31	13.97	0.025
	16QAM	829.0	H	5.37	2.57	10.21	13.01	0.020
		836.5	H	5.40	2.58	10.27	13.09	0.020
		844.0	H	5.44	2.78	10.14	12.80	0.019

Note.

1. E.R.P & E.I.R.P(dBm) = Substitute Level(dB) + Antenna gain(dBi&dBd) - C.L(Cable loss) (dB)

Test mode: LTE Band 7

Bandwidth	Modulation	Frequency	Pol.	Antenna Gain	C.L	Substitute Level	EIRP	
		[MHz]	[V/H]	[dBi]	[dB]	[dBm]	[dBm]	[W]
5 M	QPSK	2 502.5	V	6.20	5.91	13.31	13.60	0.023
		2 535.0	V	6.24	5.98	12.39	12.64	0.018
		2 567.5	V	6.27	6.20	10.75	10.82	0.012
	16QAM	2 502.5	V	6.20	5.91	12.20	12.49	0.018
		2 535.0	V	6.24	5.98	11.15	11.40	0.014
		2 567.5	V	6.27	6.20	9.62	9.69	0.009
10 M	QPSK	2 505.0	V	6.21	5.95	13.21	13.46	0.022
		2 535.0	V	6.24	5.98	12.13	12.38	0.017
		2 565.0	V	6.27	6.19	10.83	10.90	0.012
	16QAM	2 505.0	V	6.21	5.95	12.27	12.52	0.018
		2 535.0	V	6.24	5.98	11.27	11.52	0.014
		2 565.0	V	6.27	6.19	9.66	9.73	0.009
15 M	QPSK	2 507.5	V	6.21	5.97	12.92	13.16	0.021
		2 535.0	V	6.24	5.98	12.24	12.49	0.018
		2 562.5	V	6.26	6.19	10.66	10.73	0.012
	16QAM	2 507.5	V	6.21	5.97	12.15	12.39	0.017
		2 535.0	V	6.24	5.98	11.22	11.47	0.014
		2 562.5	V	6.26	6.19	9.73	9.80	0.010
20 M	QPSK	2 510.0	V	6.21	5.98	12.63	12.86	0.019
		2 535.0	V	6.24	5.98	12.25	12.50	0.018
		2 560.0	V	6.26	6.19	10.37	10.44	0.011
	16QAM	2 510.0	V	6.21	5.98	11.82	12.05	0.016
		2 535.0	V	6.24	5.98	11.21	11.46	0.014
		2 560.0	V	6.26	6.19	9.67	9.74	0.009

Note.

1. E.R.P & E.I.R.P(dBm) = Substitute Level(dB) + Antenna gain(dBi&dBd) - C.L(Cable loss) (dB)

Test mode: LTE Band 12

Bandwidth	Modulation	Frequency	Pol.	Antenna Gain	C.L	Substitute Level	ERP	
		[MHz]	[V/H]	[dBd]	[dB]	[dBm]	[dBm]	[W]
1.4 M	QPSK	699.7	H	4.50	2.45	11.84	13.89	0.024
		707.5	H	4.65	2.29	11.88	14.24	0.027
		715.3	H	4.65	2.37	11.98	14.26	0.027
	16QAM	699.7	H	4.50	2.45	10.61	12.66	0.018
		707.5	H	4.65	2.29	10.89	13.25	0.021
		715.3	H	4.65	2.37	10.92	13.20	0.021
3 M	QPSK	700.5	H	4.51	2.69	12.14	13.96	0.025
		707.5	H	4.65	2.29	12.00	14.36	0.027
		714.5	H	4.66	2.42	12.16	14.39	0.027
	16QAM	700.5	H	4.51	2.69	10.78	12.60	0.018
		707.5	H	4.65	2.29	10.99	13.35	0.022
		714.5	H	4.66	2.42	11.10	13.33	0.022
5 M	QPSK	701.5	H	4.53	2.50	12.14	14.17	0.026
		707.5	H	4.65	2.29	11.94	14.30	0.027
		713.5	H	4.67	2.15	12.11	14.62	0.029
	16QAM	701.5	H	4.53	2.50	11.21	13.24	0.021
		707.5	H	4.65	2.29	10.99	13.35	0.022
		713.5	H	4.67	2.15	10.94	13.45	0.022
10 M	QPSK	704.0	H	4.58	2.73	12.48	14.33	0.027
		707.5	H	4.65	2.29	12.19	14.55	0.029
		711.0	H	4.69	2.46	12.18	14.41	0.028
	16QAM	704.0	H	4.58	2.73	11.10	12.95	0.020
		707.5	H	4.65	2.29	11.13	13.49	0.022
		711.0	H	4.69	2.46	11.39	13.62	0.023

Test mode: LTE Band 13

Bandwidth	Modulation	Frequency	Pol.	Antenna Gain	C.L	Substitute Level	ERP	
		[MHz]	[V/H]	[dBd]	[dB]	[dBm]	[dBm]	[W]
5 M	QPSK	779.5	H	5.30	2.78	12.07	14.59	0.029
		782.0	H	5.30	2.64	11.95	14.61	0.029
		784.5	H	5.30	2.63	11.52	14.19	0.026
	16QAM	779.5	H	5.30	2.78	10.75	13.27	0.021
		782.0	H	5.30	2.64	11.13	13.79	0.024
		784.5	H	5.30	2.63	10.56	13.23	0.021
10 M	QPSK	782.0	H	5.30	2.64	12.31	14.97	0.031
	16QAM	782.0	H	5.30	2.64	11.36	14.02	0.025

Note.

1. E.R.P & E.I.R.P(dBm) = Substitute Level(dB) + Antenna gain(dBi&dBd) - C.L(Cable loss) (dB)

Test mode: LTE Band 25/2

Bandwidth	Modulation	Frequency	Pol.	Antenna Gain	C.L	Substitute Level	EIRP	
		[MHz]	[V/H]	[dBi]	[dB]	[dBm]	[dBm]	[W]
1.4 M	QPSK	1 850.7	V	5.60	5.17	15.53	15.96	0.039
		1 882.5	V	5.54	5.08	15.53	15.98	0.040
		1 914.3	V	5.47	5.29	13.61	13.79	0.024
	16QAM	1 850.7	V	5.60	5.17	14.51	14.94	0.031
		1 882.5	V	5.54	5.08	14.52	14.97	0.031
		1 914.3	V	5.47	5.29	12.47	12.65	0.018
3 M	QPSK	1 851.5	V	5.60	5.18	15.60	16.02	0.040
		1 882.5	V	5.54	5.08	15.82	16.27	0.042
		1 913.5	V	5.47	5.29	13.57	13.75	0.024
	16QAM	1 851.5	V	5.60	5.18	14.62	15.04	0.032
		1 882.5	V	5.54	5.08	14.74	15.19	0.033
		1 913.5	V	5.47	5.29	12.41	12.59	0.018
5 M	QPSK	1 852.5	V	5.60	5.18	15.40	15.81	0.038
		1 882.5	V	5.54	5.08	15.94	16.39	0.044
		1 912.5	V	5.48	5.21	13.63	13.89	0.024
	16QAM	1 852.5	V	5.60	5.18	14.53	14.94	0.031
		1 882.5	V	5.54	5.08	15.14	15.59	0.036
		1 912.5	V	5.48	5.21	12.16	12.42	0.017
10 M	QPSK	1 855.0	V	5.59	5.19	15.38	15.78	0.038
		1 882.5	V	5.54	5.08	16.36	16.81	0.048
		1 910.0	V	5.48	5.24	14.41	14.65	0.029
	16QAM	1 855.0	V	5.59	5.19	14.38	14.78	0.030
		1 882.5	V	5.54	5.08	15.04	15.49	0.035
		1 910.0	V	5.48	5.24	13.28	13.52	0.022
15 M	QPSK	1 857.5	V	5.59	5.21	15.32	15.69	0.037
		1 882.5	V	5.54	5.08	16.49	16.94	0.049
		1 907.5	V	5.49	5.31	14.10	14.27	0.027
	16QAM	1 857.5	V	5.59	5.21	14.30	14.67	0.029
		1 882.5	V	5.54	5.08	15.28	15.73	0.037
		1 907.5	V	5.49	5.31	13.14	13.31	0.021
20 M	QPSK	1 860.0	V	5.58	5.17	15.54	15.95	0.039
		1 882.5	V	5.54	5.08	16.13	16.58	0.045
		1 905.0	V	5.49	5.26	14.21	14.44	0.028
	16QAM	1 860.0	V	5.58	5.17	14.50	14.91	0.031
		1 882.5	V	5.54	5.08	15.00	15.45	0.035
		1 905.0	V	5.49	5.26	13.18	13.41	0.022

Note.

1. E.R.P & E.I.R.P(dBm) = Substitute Level(dB) + Antenna gain(dBi&dBd) - C.L(Cable loss) (dB)

Test mode: LTE Band 26

Bandwidth	Modulation	Frequency	Pol.	Antenna Gain	C.L	Substitute Level	ERP	
		[MHz]	[V/H]	[dBd]	[dB]	[dBm]	[dBm]	[W]
1.4 M	QPSK	824.7	H	5.24	2.66	10.23	12.81	0.019
		836.5	H	5.40	2.58	9.92	12.74	0.019
		848.3	H	5.48	2.39	10.00	13.09	0.020
	16QAM	824.7	H	5.24	2.66	9.05	11.63	0.015
		836.5	H	5.40	2.58	8.96	11.78	0.015
		848.3	H	5.48	2.39	8.76	11.85	0.015
3 M	QPSK	825.5	H	5.27	2.67	10.50	13.09	0.020
		836.5	H	5.40	2.58	10.15	12.97	0.020
		847.5	H	5.48	2.58	10.30	13.19	0.021
	16QAM	825.5	H	5.27	2.67	9.40	11.99	0.016
		836.5	H	5.40	2.58	9.08	11.90	0.015
		847.5	H	5.48	2.58	9.18	12.07	0.016
5 M	QPSK	826.5	H	5.30	2.78	10.40	12.91	0.020
		836.5	H	5.40	2.58	10.20	13.02	0.020
		846.5	H	5.47	2.16	10.07	13.37	0.022
	16QAM	826.5	H	5.30	2.78	9.54	12.05	0.016
		836.5	H	5.40	2.58	9.00	11.82	0.015
		846.5	H	5.47	2.16	8.98	12.28	0.017
10 M	QPSK	829.0	H	5.37	2.57	10.37	13.17	0.021
		836.5	H	5.40	2.58	10.19	13.01	0.020
		844.0	H	5.44	2.78	9.88	12.54	0.018
	16QAM	829.0	H	5.37	2.57	9.38	12.18	0.017
		836.5	H	5.40	2.58	9.50	12.32	0.017
		844.0	H	5.44	2.78	8.90	11.56	0.014
15 M	QPSK	831.5	H	5.40	2.52	10.62	13.50	0.022
		836.5	H	5.40	2.58	10.57	13.39	0.022
		841.5	H	5.42	2.75	10.20	12.86	0.019
	16QAM	831.5	H	5.40	2.52	9.57	12.45	0.018
		836.5	H	5.40	2.58	9.52	12.34	0.017
		841.5	H	5.42	2.75	9.22	11.88	0.015

Note.

1. E.R.P & E.I.R.P(dBm) = Substitute Level(dB) + Antenna gain(dBi&dBd) - C.L(Cable loss) (dB)

Test mode: LTE Band 66/4

Bandwidth	Modulation	Frequency	Pol.	Antenna Gain	C.L	Substitute Level	EIRP	
		[MHz]	[V/H]	[dBi]	[dB]	[dBm]	[dBm]	[W]
1.4 M	QPSK	1 710.7	V	5.88	5.20	15.53	16.21	0.042
		1 745.0	V	5.81	5.21	15.91	16.51	0.045
		1 779.3	V	5.74	5.26	14.96	15.44	0.035
	16QAM	1 710.7	V	5.88	5.20	14.60	15.28	0.034
		1 745.0	V	5.81	5.21	14.92	15.52	0.036
		1 779.3	V	5.74	5.26	13.89	14.37	0.027
3 M	QPSK	1 711.5	V	5.88	5.19	15.50	16.19	0.042
		1 745.0	V	5.81	5.21	15.76	16.36	0.043
		1 778.5	V	5.74	5.26	15.18	15.66	0.037
	16QAM	1 711.5	V	5.88	5.19	14.55	15.24	0.033
		1 745.0	V	5.81	5.21	15.06	15.66	0.037
		1 778.5	V	5.74	5.26	13.88	14.36	0.027
5 M	QPSK	1 712.5	V	5.88	5.16	16.11	16.82	0.048
		1 745.0	V	5.81	5.21	15.98	16.58	0.045
		1 777.5	V	5.75	5.28	15.41	15.87	0.039
	16QAM	1 712.5	V	5.88	5.16	15.12	15.83	0.038
		1 745.0	V	5.81	5.21	15.21	15.81	0.038
		1 777.5	V	5.75	5.28	14.47	14.93	0.031
10 M	QPSK	1 715.0	V	5.87	5.08	16.37	17.16	0.052
		1 745.0	V	5.81	5.21	16.07	16.67	0.046
		1 775.0	V	5.75	5.23	16.52	17.04	0.051
	16QAM	1 715.0	V	5.87	5.08	15.46	16.25	0.042
		1 745.0	V	5.81	5.21	15.15	15.75	0.038
		1 775.0	V	5.75	5.23	15.38	15.90	0.039
15 M	QPSK	1 717.5	V	5.87	5.17	16.67	17.36	0.054
		1 745.0	V	5.81	5.21	16.11	16.71	0.047
		1 772.5	V	5.76	5.26	17.03	17.52	0.056
	16QAM	1 717.5	V	5.87	5.17	15.78	16.47	0.044
		1 745.0	V	5.81	5.21	15.45	16.05	0.040
		1 772.5	V	5.76	5.26	15.73	16.22	0.042
20 M	QPSK	1 720.0	V	5.86	5.19	17.11	17.78	0.060
		1 745.0	V	5.81	5.21	15.81	16.41	0.044
		1 770.0	V	5.76	5.29	16.77	17.24	0.053
	16QAM	1 720.0	V	5.86	5.19	16.12	16.79	0.048
		1 745.0	V	5.81	5.21	15.07	15.67	0.037
		1 770.0	V	5.76	5.29	16.07	16.54	0.045

Note.

1. E.R.P & E.I.R.P(dBm) = Substitute Level(dB) + Antenna gain(dBi&dBd) - C.L(Cable loss) (dB)

Test mode: LTE Band 71

Bandwidth	Modulation	Frequency	Pol.	Antenna Gain	C.L	Substitute Level	ERP	
		[MHz]	[V/H]	[dBd]	[dB]	[dBm]	[dBm]	[W]
5 M	QPSK	665.5	H	4.84	2.48	9.09	11.44	0.014
		680.5	H	4.51	2.43	10.89	12.96	0.020
		695.5	H	4.55	2.67	10.89	12.76	0.019
	16QAM	665.5	H	4.84	2.48	8.30	10.65	0.012
		680.5	H	4.51	2.43	9.51	11.58	0.014
		695.5	H	4.55	2.67	9.62	11.49	0.014
10 M	QPSK	668.0	H	4.76	2.52	9.82	12.06	0.016
		680.5	H	4.51	2.43	10.94	13.01	0.020
		693.0	H	4.57	2.51	10.82	12.88	0.019
	16QAM	668.0	H	4.76	2.52	8.83	11.07	0.013
		680.5	H	4.51	2.43	9.72	11.79	0.015
		693.0	H	4.57	2.51	9.52	11.58	0.014
15 M	QPSK	670.5	H	4.69	2.42	10.63	12.90	0.019
		680.5	H	4.51	2.43	10.86	12.93	0.020
		690.5	H	4.60	2.58	10.83	12.84	0.019
	16QAM	670.5	H	4.69	2.42	9.41	11.68	0.015
		680.5	H	4.51	2.43	9.66	11.73	0.015
		690.5	H	4.60	2.58	9.93	11.94	0.016
20 M	QPSK	673.0	H	4.64	2.58	10.70	12.76	0.019
		680.5	H	4.51	2.43	10.79	12.86	0.019
		688.0	H	4.58	2.58	10.83	12.83	0.019
	16QAM	673.0	H	4.64	2.58	9.61	11.67	0.015
		680.5	H	4.51	2.43	9.56	11.63	0.015
		688.0	H	4.58	2.58	9.65	11.65	0.015

Note.

1. E.R.P & E.I.R.P(dBm) = Substitute Level(dB) + Antenna gain(dBi&dBd) - C.L(Cable loss) (dB)

7.8. Radiated Spurious Emissions

Test setup

The diagram below shows the test setup that is utilized to make the measurements for emission from 30 MHz to 1 GHz emissions.

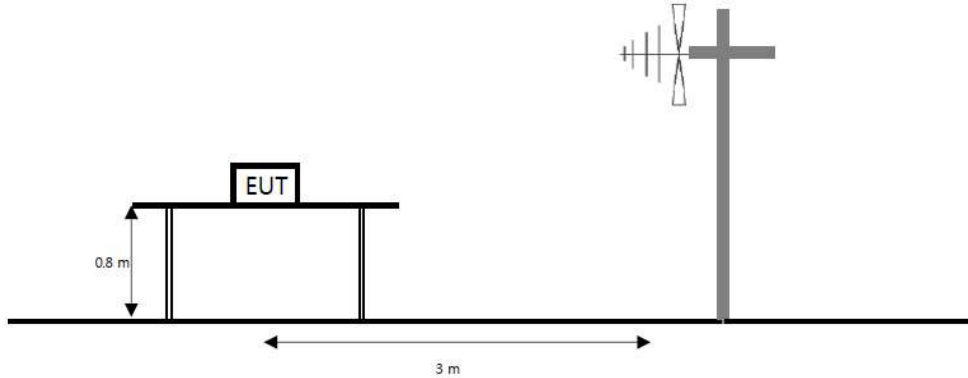

The diagram below shows the test setup that is utilized to make the measurements for emission from 1 GHz to the tenth harmonic of the highest fundamental frequency or to 40 GHz emissions, whichever is lower.

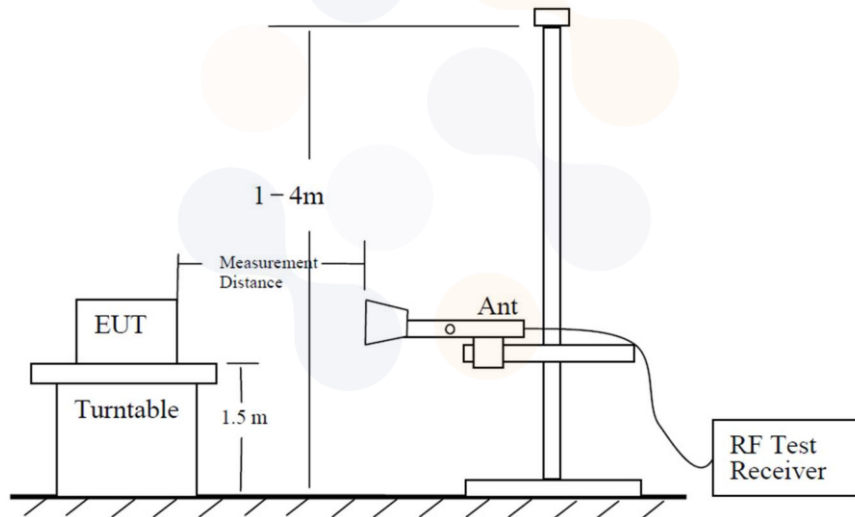

The diagram below shows the test setup for substituted method.

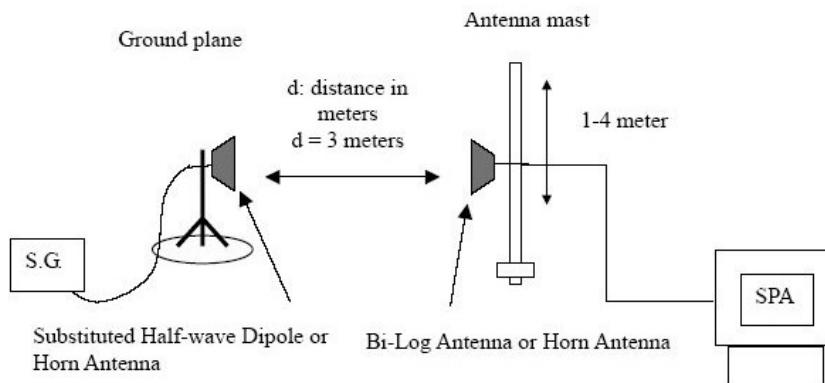

Limit

According to §22.917(a), §24.238(a) and RSS-132(5.5), RSS-133(6.5), the power of any emission outside of the authorized operating frequency ranges must be attenuated below the transmitting power (P) by a factor of at least $43 + 10\log(P_{\text{[Watts]}})$ dB.

According to §27.53(c)(2) and RSS-130(4.7), on any frequency outside the 776-788 MHz band, the power of any emission shall be attenuated outside the band below the transmitter power (P) by at least $43 + 10\log(P_{\text{[Watts]}})$ dB.

According to §27.53(f) and RSS-130(4.7), for operations in the 746-758 MHz, 775-788 MHz, and 805-806 MHz bands, emissions in the band 1559-1610 MHz shall be limited to -70 dBW/MHz equivalent isotropically radiated power (EIRP) for wideband signals, and -80 dBW EIRP for discrete emissions of less than 700 Hz bandwidth. For the purpose of equipment authorization, a transmitter shall be tested with an antenna that is representative of the type that will be used with the equipment in normal operation.

According to §27.53(g) and RSS-130(4.7), for operations in the 600 MHz band and the 698-746 MHz band, the power of any emission outside a licensee's frequency band(s) of operation shall be attenuated below the transmitter power (P) within the licensed band(s) of operation, measured in watts, by at least $43 + 10\log(P_{\text{[Watts]}})$ dB.

According to §27.53(h) and RSS-139(5.6), the power of any emission outside a licensee's frequency block shall be attenuated below the transmitter power (P) in watts by at least $43 + 10\log(P_{\text{[Watts]}})$ dB.



According to §27.53(m) and RSS-199(4.5), the minimum permissible attenuation level of any spurious emission is $55 + 10\log(P_{\text{[Watts]}})$ dB.

Test procedure

971168 D01 v03r01 - Section 6.2
ANSI 63.26-2015 – Section 5.5
ANSI/TIA-603-E-2016 - Section 2.2.12

Test settings

- 1) RBW = 100 kHz for below 1 GHz and 1 MHz for above 1 GHz.
- 2) VBW $\geq 3 \times$ RBW.
- 3) Detector = RMS
- 4) Trace mode = Max hold
- 5) Sweep time = Auto couple
- 6) Number of sweep points $\geq 2 \times$ span / RBW
- 7) Allow trace to fully stabilize.

<p>Eurofins KCTL Co.,Ltd. 65, Sinwon-ro, Yeongtong-gu, Suwon-si, Gyeonggi-do, 16677, Korea TEL: 82-70-5008-1021 FAX: 82-505-299-8311 www.kctl.co.kr</p>	<p>Report No.: KR23-SRF0161 Page (158) of (167)</p>	<p> </p>
--	---	--

Notes:

1. On a test site, the EUT shall be placed at 80 cm or 1.5 m height on a turn table, and in the position close to normal use as declared by the applicant.
2. The test antenna shall be oriented initially for vertical polarization located 3 m from EUT to correspond to the fundamental frequency of the transmitter.
3. The turntable is rotated through 360°, and the receiving antenna scans in order to determine the level of the maximized emission.
4. The test antenna shall be raised and lowered again through the specified range of height until the maximum signal level is detected by the measuring receiver.
5. The maximum signal level detected by the measuring receiver shall be noted.
6. The EUT was replaced by half-wave dipole (1 GHz below) or horn antenna (1 GHz above) connected to a signal generator.
7. The test antenna shall be raised and lowered through the specified range of height to ensure that the maximum signal is received.
8. The input signal to the substitution antenna shall be adjusted to the level that produces a level detected by the measuring corrected for the change of input attenuator setting of the measuring receiver.
9. The input level to the substitution antenna shall be recorded as power level in dBm, corrected for any change of input attenuator setting of the measuring receiver.
10. The measurement shall be repeated with the test antenna and the substitution antenna orientated for horizontal polarization.

Test results (Above 1 000 MHz)

Test mode : LTE Band 5

Frequency(MHz) : 826.5

Channel : 20425

Bandwidth(MHz) : 5

Mode	Frequency	Pol.	Antenna Gain	Cable loss	Substitute Level	Level	Limit	Margin
	[MHz]	[V/H]	[dBi]	[dB]	[dBm]	[dBm]	[dBm]	[dB]
QPSK	1 648.80	H	6.00	5.02	-57.18	-56.20	-13.00	43.20
	2 473.20	H	6.15	6.01	-57.44	-57.30	-13.00	44.30
	3 296.40	H	7.65	6.75	-57.00	-56.10	-13.00	43.10
	4 118.00	H	8.99	7.38	-56.91	-55.30	-13.00	42.30

Test mode : LTE Band 5

Frequency(MHz) : 836.5

Channel : 20525

Bandwidth(MHz) : 5

Mode	Frequency	Pol.	Antenna Gain	Cable loss	Substitute Level	Level	Limit	Margin
	[MHz]	[V/H]	[dBi]	[dB]	[dBm]	[dBm]	[dBm]	[dB]
QPSK	1 677.20	H	5.95	5.14	-53.11	-52.30	-13.00	39.30
	2 516.40	H	6.22	5.99	-55.43	-55.20	-13.00	42.20
	3 353.20	H	7.83	6.80	-56.23	-55.20	-13.00	42.20
	4 195.20	H	9.06	7.32	-57.04	-55.30	-13.00	42.30

Test mode : LTE Band 5

Frequency(MHz) : 846.5

Channel : 20625

Bandwidth(MHz) : 5

Mode	Frequency	Pol.	Antenna Gain	Cable loss	Substitute Level	Level	Limit	Margin
	[MHz]	[V/H]	[dBi]	[dB]	[dBm]	[dBm]	[dBm]	[dB]
QPSK	1 693.60	H	5.91	5.17	-56.04	-55.30	-13.00	42.30
	2 540.00	H	6.24	5.98	-54.56	-54.30	-13.00	41.30
	3 386.40	H	7.94	6.84	-58.00	-56.90	-13.00	43.90
	4 230.40	H	9.08	7.27	-56.41	-54.60	-13.00	41.60

Note.

1. E.R.P & E.I.R.P(dB m) = Substitute Level(dB) + Antenna gain(dB i&dB d) - C.L(Cable loss) (dB)

Test mode : LTE Band 7

Frequency(MHz) : 2 502.5

Channel : 20775

Bandwidth(MHz) : 5

Mode	Frequency	Pol.	Antenna Gain	Cable loss	Substitute Level	Level	Limit	Margin
	[MHz]	[V/H]	[dBi]	[dB]	[dBm]	[dBm]	[dBm]	[dB]
QPSK	5 000.25	H	10.20	8.32	-56.28	-54.40	-25.00	29.40
	7 500.00	H	12.10	9.45	-54.05	-51.40	-25.00	26.40
	10 002.75	V	13.10	10.56	-49.54	-47.00	-25.00	22.00
	12 501.75	H	13.20	11.35	-49.85	-48.00	-25.00	23.00

Test mode : LTE Band 7

Frequency(MHz) : 2 535.0

Channel : 21100

Bandwidth(MHz) : 5

Mode	Frequency	Pol.	Antenna Gain	Cable loss	Substitute Level	Level	Limit	Margin
	[MHz]	[V/H]	[dBi]	[dB]	[dBm]	[dBm]	[dBm]	[dB]
QPSK	5076.75	H	10.25	8.39	-54.56	-52.70	-25.00	27.70
	7 612.50	H	12.19	9.64	-54.55	-52.00	-25.00	27.00
	10 150.50	V	13.13	10.48	-48.75	-46.10	-25.00	21.10
	12 685.50	V	13.31	10.82	-48.39	-45.90	-25.00	20.90

Test mode : LTE Band 7

Frequency(MHz) : 2 567.5

Channel : 21425

Bandwidth(MHz) : 5

Mode	Frequency	Pol.	Antenna Gain	Cable loss	Substitute Level	Level	Limit	Margin
	[MHz]	[V/H]	[dBi]	[dB]	[dBm]	[dBm]	[dBm]	[dB]
QPSK	5 140.50	H	10.28	8.40	-55.88	-54.00	-25.00	29.00
	7 710.00	H	12.27	9.94	-51.13	-48.80	-25.00	23.80
	10 278.75	V	13.16	10.47	-49.79	-47.10	-25.00	22.10
	12 848.25	H	13.41	11.87	-46.34	-44.80	-25.00	19.80

Note.

1. E.R.P & E.I.R.P(dB m) = Substitute Level(dB) + Antenna gain(dB i&dB d) - C.L(Cable loss) (dB)

Test mode : LTE Band 12

Frequency(MHz) : 701.5

Channel : 23035

Bandwidth(MHz) : 5

Mode	Frequency	Pol.	Antenna Gain	Cable loss	Substitute Level	Level	Limit	Margin
	[MHz]	[V/H]	[dBi]	[dB]	[dBm]	[dBm]	[dBm]	[dB]
QPSK	1 403.20	H	5.58	4.44	-58.14	-57.00	-13.00	44.00
	2 105.20	H	5.49	5.35	-57.04	-56.90	-13.00	43.90
	2 804.00	H	6.50	6.31	-56.09	-55.90	-13.00	42.90
	3 506.00	H	8.31	6.94	-57.57	-56.20	-13.00	43.20

Test mode : LTE Band 12

Frequency(MHz) : 707.5

Channel : 23095

Bandwidth(MHz) : 5

Mode	Frequency	Pol.	Antenna Gain	Cable loss	Substitute Level	Level	Limit	Margin
	[MHz]	[V/H]	[dBi]	[dB]	[dBm]	[dBm]	[dBm]	[dB]
QPSK	1 419.60	V	5.71	4.48	-56.73	-55.50	-13.00	42.50
	2 129.20	H	5.53	5.39	-58.44	-58.30	-13.00	45.30
	2 841.60	H	6.54	6.34	-57.20	-57.00	-13.00	44.00
	3 548.40	V	8.36	6.98	-55.18	-53.80	-13.00	40.80

Test mode : LTE Band 12

Frequency(MHz) : 713.5

Channel : 23155

Bandwidth(MHz) : 5

Mode	Frequency	Pol.	Antenna Gain	Cable loss	Substitute Level	Level	Limit	Margin
	[MHz]	[V/H]	[dBi]	[dB]	[dBm]	[dBm]	[dBm]	[dB]
QPSK	1 427.60	V	5.76	4.49	-56.07	-54.80	-13.00	41.80
	2 139.60	V	5.55	5.40	-59.55	-59.40	-13.00	46.40
	2 853.20	H	6.55	6.35	-56.60	-56.40	-13.00	43.40
	3 565.60	H	8.38	7.10	-57.28	-56.00	-13.00	43.00

Note.

1. E.R.P & E.I.R.P(dB m) = Substitute Level(dB) + Antenna gain(dB i&dB d) - C.L(Cable loss) (dB)

Test mode : LTE Band 13

Frequency(MHz) : 782.0

Channel : 23230

Bandwidth(MHz) : 10

Mode	Frequency	Pol.	Antenna Gain	Cable loss	Substitute Level	Level	Limit	Margin
	[MHz]	[V/H]	[dBi]	[dB]	[dBm]	[dBm]	[dBm]	[dB]
QPSK	1 555.20	H	6.19	4.88	-56.81	-55.50	-13.00	42.50
	2 332.00	H	5.90	5.71	-55.99	-55.80	-13.00	42.80
	3 110.00	V	7.05	6.58	-54.67	-54.20	-13.00	41.20
	3 885.20	H	8.76	7.26	-56.20	-54.70	-13.00	41.70

Test mode : LTE Band 13

Frequency(MHz) : 782.0 (1 559 – 1 610 MHz)

Channel : 23230

Bandwidth(MHz) : 10

Mode	Frequency	Pol.	Antenna Gain	Cable loss	Substitute Level	Level	Limit	Margin
	[MHz]	[V/H]	[dBi]	[dB]	[dBm]	[dBm]	[dBm]	[dB]
QPSK	1 572.80	H	6.15	4.91	-58.74	-57.50	-40.00	17.50

Note.

1. Limit Calculation(dBm)= 43 + 10log(P_[Watts])

Limit Calculation of wide-band (dBm/MHz) = -70dBW/MHz (-40 dBm/MHz)

Limit Calculation of narrow-band (dBm) = -80dBW (-50dBm)

2. E.R.P & E.I.R.P(dB m) = Substitute Level(dB) + Antenna gain(dB i&dB d) - C.L(Cable loss) (dB)

Test mode : LTE Band 25/2

Frequency(MHz) : 1 857.5

Channel : 26115

Bandwidth(MHz) : 15

Mode	Frequency	Pol.	Antenna Gain	Cable loss	Substitute Level	Level	Limit	Margin
	[MHz]	[V/H]	[dBi]	[dB]	[dBm]	[dBm]	[dBm]	[dB]
QPSK	3 714.75	H	8.56	7.12	-55.34	-53.90	-13.00	40.90
	5 571.75	H	10.53	8.65	-55.08	-53.20	-13.00	40.20
	7 430.25	V	12.02	9.31	-53.81	-51.10	-13.00	38.10
	9 287.25	V	13.30	9.85	-51.95	-48.50	-13.00	35.50

Test mode : LTE Band 25/2

Frequency(MHz) : 1 882.5

Channel : 26365

Bandwidth(MHz) : 15

Mode	Frequency	Pol.	Antenna Gain	Cable loss	Substitute Level	Level	Limit	Margin
	[MHz]	[V/H]	[dBi]	[dB]	[dBm]	[dBm]	[dBm]	[dB]
QPSK	3 780.00	V	8.64	6.98	-56.46	-54.80	-13.00	41.80
	5 673.75	H	10.57	8.70	-52.57	-50.70	-13.00	37.70
	7 564.50	V	12.15	9.44	-56.01	-53.30	-13.00	40.30
	9 455.25	H	13.30	10.29	-51.31	-48.30	-13.00	35.30

Test mode : LTE Band 25/2

Frequency(MHz) : 1 907.5

Channel : 26615

Bandwidth(MHz) : 15

Mode	Frequency	Pol.	Antenna Gain	Cable loss	Substitute Level	Level	Limit	Margin
	[MHz]	[V/H]	[dBi]	[dB]	[dBm]	[dBm]	[dBm]	[dB]
QPSK	3 804.00	H	8.66	7.01	-55.45	-53.80	-13.00	40.80
	5 703.00	V	10.58	8.62	-51.86	-49.90	-13.00	36.90
	7 598.25	V	12.18	9.44	-52.54	-49.80	-13.00	36.80
	9 501.75	V	13.30	10.68	-49.32	-46.70	-13.00	33.70

Note.

1. E.R.P & E.I.R.P(dB m) = Substitute Level(dB) + Antenna gain(dB i&dB d) - C.L(Cable loss) (dB)

Test mode : LTE Band 26

Frequency(MHz) : 831.5

Channel : 26865

Bandwidth(MHz) : 15

Mode	Frequency	Pol.	Antenna Gain	Cable loss	Substitute Level	Level	Limit	Margin
	[MHz]	[V/H]	[dBi]	[dB]	[dBm]	[dBm]	[dBm]	[dB]
QPSK	1 649.60	H	6.00	5.02	-56.78	-55.80	-13.00	42.80
	2 472.40	H	6.15	6.01	-55.64	-55.50	-13.00	42.50
	3 296.00	V	7.65	6.75	-57.40	-56.50	-13.00	43.50
	4 121.60	H	9.00	7.38	-56.02	-54.40	-13.00	41.40

Test mode : LTE Band 26

Frequency(MHz) : 836.5

Channel : 26915

Bandwidth(MHz) : 15

Mode	Frequency	Pol.	Antenna Gain	Cable loss	Substitute Level	Level	Limit	Margin
	[MHz]	[V/H]	[dBi]	[dB]	[dBm]	[dBm]	[dBm]	[dB]
QPSK	1 660.00	H	5.98	5.10	-58.18	-57.30	-13.00	44.30
	2 486.00	H	6.17	6.03	-57.34	-57.20	-13.00	44.20
	3 315.60	V	7.71	6.77	-57.34	-56.40	-13.00	43.40
	4 144.00	H	9.02	7.40	-56.42	-54.80	-13.00	41.80

Test mode : LTE Band 26

Frequency(MHz) : 841.5

Channel : 26965

Bandwidth(MHz) : 15

Mode	Frequency	Pol.	Antenna Gain	Cable loss	Substitute Level	Level	Limit	Margin
	[MHz]	[V/H]	[dBi]	[dB]	[dBm]	[dBm]	[dBm]	[dB]
QPSK	1 669.60	H	5.96	5.12	-56.84	-56.00	-13.00	43.00
	2 502.40	H	6.20	5.92	-55.08	-54.80	-13.00	41.80
	3 335.20	H	7.77	6.79	-57.08	-56.10	-13.00	43.10
	4 170.00	V	9.04	7.29	-55.55	-53.80	-13.00	40.80

Note.

1. E.R.P & E.I.R.P(dB m) = Substitute Level(dB) + Antenna gain(dB i&dB d) - C.L(Cable loss) (dB)

Test mode : LTE Band 66/4

Frequency(MHz) : 1 720.0

Channel : 132072

Bandwidth(MHz) : 20

Mode	Frequency	Pol.	Antenna Gain	Cable loss	Substitute Level	Level	Limit	Margin
	[MHz]	[V/H]	[dBi]	[dB]	[dBm]	[dBm]	[dBm]	[dB]
QPSK	3 439.50	H	8.11	6.88	-55.93	-54.70	-13.00	41.70
	5 158.50	V	10.30	8.42	-54.28	-52.40	-13.00	39.40
	6 882.00	V	11.36	10.34	-52.32	-51.30	-13.00	38.30
	8 601.75	H	13.14	9.62	-51.62	-48.10	-13.00	35.10

Test mode : LTE Band 66/4

Frequency(MHz) : 1 745.0

Channel : 132322

Bandwidth(MHz) : 20

Mode	Frequency	Pol.	Antenna Gain	Cable loss	Substitute Level	Level	Limit	Margin
	[MHz]	[V/H]	[dBi]	[dB]	[dBm]	[dBm]	[dBm]	[dB]
QPSK	3 510.00	H	8.31	6.95	-59.16	-57.80	-13.00	44.80
	5 267.25	H	10.36	8.55	-55.01	-53.20	-13.00	40.20
	7 020.75	H	11.52	9.36	-50.96	-48.80	-13.00	35.80
	8 778.00	H	13.21	10.12	-51.39	-48.30	-13.00	35.30

Test mode : LTE Band 66/4

Frequency(MHz) : 1 770.0

Channel : 132572

Bandwidth(MHz) : 20

Mode	Frequency	Pol.	Antenna Gain	Cable loss	Substitute Level	Level	Limit	Margin
	[MHz]	[V/H]	[dBi]	[dB]	[dBm]	[dBm]	[dBm]	[dB]
QPSK	3 522.00	H	8.33	6.96	-53.87	-52.50	-13.00	39.50
	5 278.50	H	10.37	8.57	-55.60	-53.80	-13.00	40.80
	7 041.75	H	11.55	9.36	-51.79	-49.60	-13.00	36.60
	8 802.00	H	13.22	10.03	-50.99	-47.80	-13.00	34.80

Note.

1. E.R.P & E.I.R.P(dB m) = Substitute Level(dB) + Antenna gain(dB i&dB d) - C.L(Cable loss) (dB)

Test mode : LTE Band 71

Frequency(MHz) : 668.0

Channel : 133172

Bandwidth(MHz) : 10

Mode	Frequency	Pol.	Antenna Gain	Cable loss	Substitute Level	Level	Limit	Margin
	[MHz]	[V/H]	[dBi]	[dB]	[dBm]	[dBm]	[dBm]	[dB]
QPSK	1 344.80	V	5.15	4.46	-51.39	-50.70	-13.00	37.70
	2 020.00	V	5.34	5.22	-61.22	-61.10	-13.00	48.10
	2 693.60	H	6.39	6.21	-56.08	-55.90	-13.00	42.90
	3 366.00	H	7.87	6.82	-55.15	-54.10	-13.00	41.10

Test mode : LTE Band 71

Frequency(MHz) : 680.5

Channel : 133297

Bandwidth(MHz) : 10

Mode	Frequency	Pol.	Antenna Gain	Cable loss	Substitute Level	Level	Limit	Margin
	[MHz]	[V/H]	[dBi]	[dB]	[dBm]	[dBm]	[dBm]	[dB]
QPSK	1 361.20	V	5.27	4.42	-51.75	-50.90	-13.00	37.90
	2 041.60	H	5.37	5.25	-60.42	-60.30	-13.00	47.30
	2 720.80	H	6.42	6.23	-55.39	-55.20	-13.00	42.20
	3 402.00	H	7.99	6.85	-56.04	-54.90	-13.00	41.90

Test mode : LTE Band 71

Frequency(MHz) : 693.0

Channel : 133422

Bandwidth(MHz) : 10

Mode	Frequency	Pol.	Antenna Gain	Cable loss	Substitute Level	Level	Limit	Margin
	[MHz]	[V/H]	[dBi]	[dB]	[dBm]	[dBm]	[dBm]	[dB]
QPSK	1 377.20	V	5.39	4.46	-55.23	-54.30	-13.00	41.30
	2 064.00	V	5.42	5.29	-59.13	-59.00	-13.00	46.00
	2 753.20	H	6.45	6.26	-55.59	-55.40	-13.00	42.40
	3 442.00	V	8.11	6.89	-57.22	-56.00	-13.00	43.00

Note.

1. E.R.P & E.I.R.P(dB m) = Substitute Level(dB) + Antenna gain(dB i&dB d) - C.L(Cable loss) (dB)

8. Measurement equipment

Equipment Name	Manufacturer	Model No.	Serial No.	Next Cal. Date
Spectrum Analyzer	R&S	FSV30	100810	23.07.12
Spectrum Analyzer	AGILENT	N9040B	MY57010132	23.10.14
Signal Generator	R&S	SMB100A	176206	24.01.19
DC Power Supply	AGILENT	E3632A	KR73001026	24.01.19
Directional Coupler	AAMCS	AAMCS-UDC-0.5G-18G-10dB-SF	399	24.01.19
Directional Coupler	Marki Microwave, Inc.	CBR17-0026	0001	23.08.10
Wideband Radio Communication Tester	R&S	CMW500	106840	24.01.19
Wideband Radio Communication Tester	R&S	CMW500	168683	24.02.09
Wideband Radio Communication Tester	R&S	CMW500	141780	24.01.19
Temp & Humid Chamber	Daejin Engineering	DJ-THR11000	10041	24.01.19
Bi-log Antenna	Teseq GmbH	CBL 6112D	62027	24.11.17
Bi-log Antenna	ETS.LINDGREN	3143B	228420	23.09.28
Horn Antenna	ETS-LINDGREN	3117	251528	24.02.02
Horn Antenna	ETS.LINDGREN	3117	227509	23.09.20
Horn Antenna	ETS-Lindgren	3116	00086632	24.01.25
Horn Antenna	ETS-LINDGREN	3116C	251516	24.02.02
Amplifier	SONOMA INSTRUMENT	310N	421822	23.12.14
Amplifier	C&K Technologies, Inc.	BZRT-00504000-481055-382525	26299-27735	23.09.19
Amplifier	C&K Technologies, Inc.	BZR-00504000-551028-252525	27736	23.09.19
High Pass Filter	Wainwright Instruments GmbH	WHKX10-900-1000-15000-40SS	11	23.08.10
High Pass Filter	Wainwright Instruments GmbH	WHKX12-2805-3000-18000-40SS	32	23.08.10
Antenna Mast	innco systems GmbH	MA4640-XP-ET	N/A	-
Controller	Innco Systems	CO3000	1175/4585031 9/P	-

End of test report