



FCC CFR47 PART 15 SUBPART C

DTS Wireless LAN

CERTIFICATION TEST REPORT

FOR

LTE Watch + BT/BLE and DTS b/g/n

MODEL NUMBER : SM-R775V

FCC ID: A3LSMR775V

REPORT NUMBER: 4787852390-E1V1

ISSUE DATE: MAR 03, 2017

Prepared for
SAMSUNG ELECTRONICS CO., LTD.
129 SAMSUNG-RO, YEONGTONG-GU, SUWON-SI,
GYEONGGI-DO, 16677, KOREA

Prepared by
UL Korea, Ltd. Suwon Laboratory
218 Maeyeong-ro, Yeongtong-gu,
Suwon-si, Gyeonggi-do, 16675, Korea
TEL: (031) 337-9902
FAX: (031) 213-5433



Revision History

<u>Rev.</u>	<u>Issue Date</u>	<u>Revisions</u>	<u>Revised By</u>
V1	03/03/17	Initial issue	Junwhan Lee

TABLE OF CONTENTS

1. ATTESTATION OF TEST RESULTS	5
2. TEST METHODOLOGY	6
3. FACILITIES AND ACCREDITATION	6
4. CALIBRATION AND UNCERTAINTY	6
4.1. MEASURING INSTRUMENT CALIBRATION	6
4.2. SAMPLE CALCULATION	6
4.3. MEASUREMENT UNCERTAINTY	7
5. EQUIPMENT UNDER TEST	8
5.1. DESCRIPTION OF EUT	8
5.2. MAXIMUM OUTPUT POWER	8
5.3. DESCRIPTION OF AVAILABLE ANTENNAS	8
5.4. WORST-CASE CONFIGURATION AND MODE	8
5.5. DESCRIPTION OF TEST SETUP	9
6. TEST AND MEASUREMENT EQUIPMENT	11
7. REFERENCE MEASUREMENT RESULTS	12
7.1. ON TIME AND DUTY CYCLE RESULTS	12
7.2. 99% BANDWIDTH	14
7.2.1. 802.11b MODE IN THE 2.4 GHz BAND	14
7.2.2. 802.11g MODE IN THE 2.4 GHz BAND	14
7.2.3. 802.11n HT20 MODE IN THE 2.4 GHz BAND	14
7.2.4. 99% BANDWIDTH PLOTS	15
7.3. Verification of geo-location functioning for Wi-Fi Ch. 12& 13	18
7.3.1. Setup Configuration	18
7.3.2. Test Results	18
8. SUMMARY TABLE	19
9. ANTENNA PORT TEST RESULTS	20
9.1. 6 dB BANDWIDTH	20
9.1.1. 802.11b MODE IN THE 2.4 GHz BAND	20
9.1.2. 802.11g MODE IN THE 2.4 GHz BAND	20
9.1.3. 802.11n HT20 MODE IN THE 2.4 GHz BAND	20
9.1.4. 6 dB BANDWIDTH PLOTS	21
9.2. OUTPUT POWER	24
9.2.1. 802.11b MODE IN THE 2.4 GHz BAND	25
9.2.2. 802.11g MODE IN THE 2.4 GHz BAND	26
9.2.3. 802.11n HT20 MODE IN THE 2.4 GHz BAND	27

9.3.	<i>PSD</i>	28
9.3.1.	802.11b MODE IN THE 2.4 GHz BAND	29
9.3.2.	802.11g MODE IN THE 2.4 GHz BAND	29
9.3.3.	802.11n HT20 MODE IN THE 2.4 GHz BAND	29
9.3.4.	PSD PLOTS	30
9.4.	<i>OUT-OF-BAND EMISSIONS</i>	33
9.4.1.	802.11b MODE IN THE 2.4 GHz BAND	34
9.4.2.	802.11g MODE IN THE 2.4 GHz BAND	37
9.4.3.	802.11n HT20 MODE IN THE 2.4 GHz BAND	40
10.	RADIATED TEST RESULTS	43
10.1.	<i>LIMITS AND PROCEDURE</i>	43
10.2.	<i>TRANSMITTER ABOVE 1 GHz</i>	45
10.2.1.	TX ABOVE 1 GHz 802.11b MODE IN THE 2.4 GHz BAND	45
10.2.2.	TX ABOVE 1 GHz 802.11g MODE IN THE 2.4 GHz BAND	55
10.2.3.	TX ABOVE 1 GHz 802.11n HT20 MODE IN THE 2.4 GHz BAND	65
10.3.	<i>WORST-CASE BELOW 1 GHz</i>	75
11.	AC POWER LINE CONDUCTED EMISSIONS	77
12.	SETUP PHOTOS	82

1. ATTESTATION OF TEST RESULTS

COMPANY NAME: SAMSUNG ELECTRONICS CO., LTD.
EUT DESCRIPTION: LTE Watch + BT/BLE and DTS b/g/n
MODEL NUMBER: SM-R775V
SERIAL NUMBER: R3AJ20007YJ, R3AJ2000AND, R3AJ20006PF (RADIATED);
R3AJ200069J (CONDUCTED)
DATE TESTED: FEB 06, 2017 - FEB 27, 2017

APPLICABLE STANDARDS	
STANDARD	TEST RESULTS
CFR 47 Part 15 Subpart C	Pass

UL Korea, Ltd. tested the above equipment in accordance with the requirements set forth in the above standards. All indications of Pass/Fail in this report are opinions expressed by UL Korea, Ltd. based on interpretations and/or observations of test results. Measurement Uncertainties were not taken into account and are published for informational purposes only. The test results show that the equipment tested is capable of demonstrating compliance with the requirements as documented in this report.

Note: The results documented in this report apply only to the tested sample, under the conditions and modes of operation as described herein. This document may not be altered or revised in any way unless done so by UL Korea, Ltd. and all revisions are duly noted in the revisions section. Any alteration of this document not carried out by UL Korea, Ltd. will constitute fraud and shall nullify the document. This report must not be used by the client to claim product certification, approval, or endorsement by IAS, any agency of the Federal Government, or any agency of any government.

Approved & Released For
UL Korea, Ltd. By:



SungGil Park
Suwon Lab Engineer
UL Korea, Ltd.

Tested By:



Junwhan Lee
Suwon Lab Engineer
UL Korea, Ltd.

2. TEST METHODOLOGY

The tests documented in this report were performed in accordance with following methods.

1. FCC CFR 47 Part 2.
2. FCC CFR 47 Part 15.
3. KDB 558074 D01 DTS Meas Guidance v03r05.
4. KDB 594280 D01 Software configuration control v02r01.
5. ANSI C63.10-2013.

3. FACILITIES AND ACCREDITATION

The test sites and measurement facilities used to collect data are located at 218 Maeyeong-ro, Yeongtong-gu, Suwon-si, Gyeonggi-do, 16675, Korea. Line conducted emissions are measured only at the 218 address. The following table identifies which facilities were utilized for radiated emission measurements documented in this report. Specific facilities are also identified in the test results sections.

218 Maeyeong-ro
<input checked="" type="checkbox"/> Chamber 1
<input checked="" type="checkbox"/> Chamber 2

UL Korea, Ltd. is accredited by IAS, Laboratory Code TL-637. The full scope of accreditation can be viewed at <http://www.iasonline.org/PDF/TL/TL-637.pdf>.

4. CALIBRATION AND UNCERTAINTY

4.1. MEASURING INSTRUMENT CALIBRATION

The measuring equipment utilized to perform the tests documented in this report has been calibrated in accordance with the manufacturer's recommendations, and is traceable to recognized national standards.

4.2. SAMPLE CALCULATION

Where relevant, the following sample calculation is provided:

$$\begin{aligned} \text{Field Strength (dBuV/m)} &= \text{Measured Voltage (dBuV)} + \text{Antenna Factor (dB/m)} + \\ &\text{Cable Loss (dB)} - \text{Preamp Gain (dB)} \\ 36.5 \text{ dBuV} + 18.7 \text{ dB/m} + 0.6 \text{ dB} - 26.9 \text{ dB} &= 28.9 \text{ dBuV/m} \end{aligned}$$

4.3. MEASUREMENT UNCERTAINTY

Where relevant, the following measurement uncertainty levels have been estimated for tests performed on the apparatus:

PARAMETER	UNCERTAINTY
Conducted Disturbance, 0.15 to 30 MHz	2.32 dB
Radiated Disturbance, Below 1GHz	4.14 dB
Radiated Disturbance, Above 1 GHz	5.97 dB

Uncertainty figures are valid to a confidence level of 95%.

5. EQUIPMENT UNDER TEST

5.1. DESCRIPTION OF EUT

The EUT is a LTE Watch + BT/BLE and DTS b/g/n.
This test report addresses the DTS (WLAN) operational mode.

5.2. MAXIMUM OUTPUT POWER

The transmitter has a maximum total conducted average output power as follows:

Frequency Range [MHz]	Mode	Output Power [dBm]	Output Power [mW]
2412 - 2462	802.11b	17.48	55.98
	802.11g	15.38	34.51
	802.11n HT20	14.17	26.12

5.3. DESCRIPTION OF AVAILABLE ANTENNAS

The radio utilizes an internal antennas, with a antenna's maximum gain of -4.5 dBi.

5.4. WORST-CASE CONFIGURATION AND MODE

Radiated emission below 1GHz and power line conducted emission were performed with the EUT set to transmit at the channel with highest output power as worst-case scenario.

Radiated emission above 1GHz was performed with the EUT set to transmit low/mid/high channels.

The fundamental of the EUT was investigated in three orthogonal orientations X, Y and Z it was determined that Y orientation was worst-case orientation; therefore, all final radiated testing was performed with the EUT in Y orientation.

Based on the baseline scan, the worst-case data rates were:

802.11b mode: 1 Mbps
802.11g mode: 6 Mbps
802.11n HT20 mode: MCS0

5.5. DESCRIPTION OF TEST SETUP

SUPPORT EQUIPMENT

Support Equipment List				
Description	Manufacturer	Model	Serial Number	FCC ID
Adapter	SAMSUNG	ETA0U60JBE	DK2H202VS/7 -E	N/A
Data Cable	SAMSUNG	ECB-DU2EBE	N/A	N/A
Wireless Charger	SAMSUNG	EP-YO760	RF7HC1KGZSVCIS	A3LEPYO760

I/O CABLES

I/O Cable List						
Cable No	Port	# of identical ports	Connector Type	Cable Type	Cable Length (m)	Remarks
1	DC Power	1	Mini-USB	Shielded	0.8m	N/A

TEST SETUP

The EUT is a stand-alone unit during the tests.
Test software in hidden menu exercised the EUT to enable DTS mode.

SETUP DIAGRAM FOR TESTS

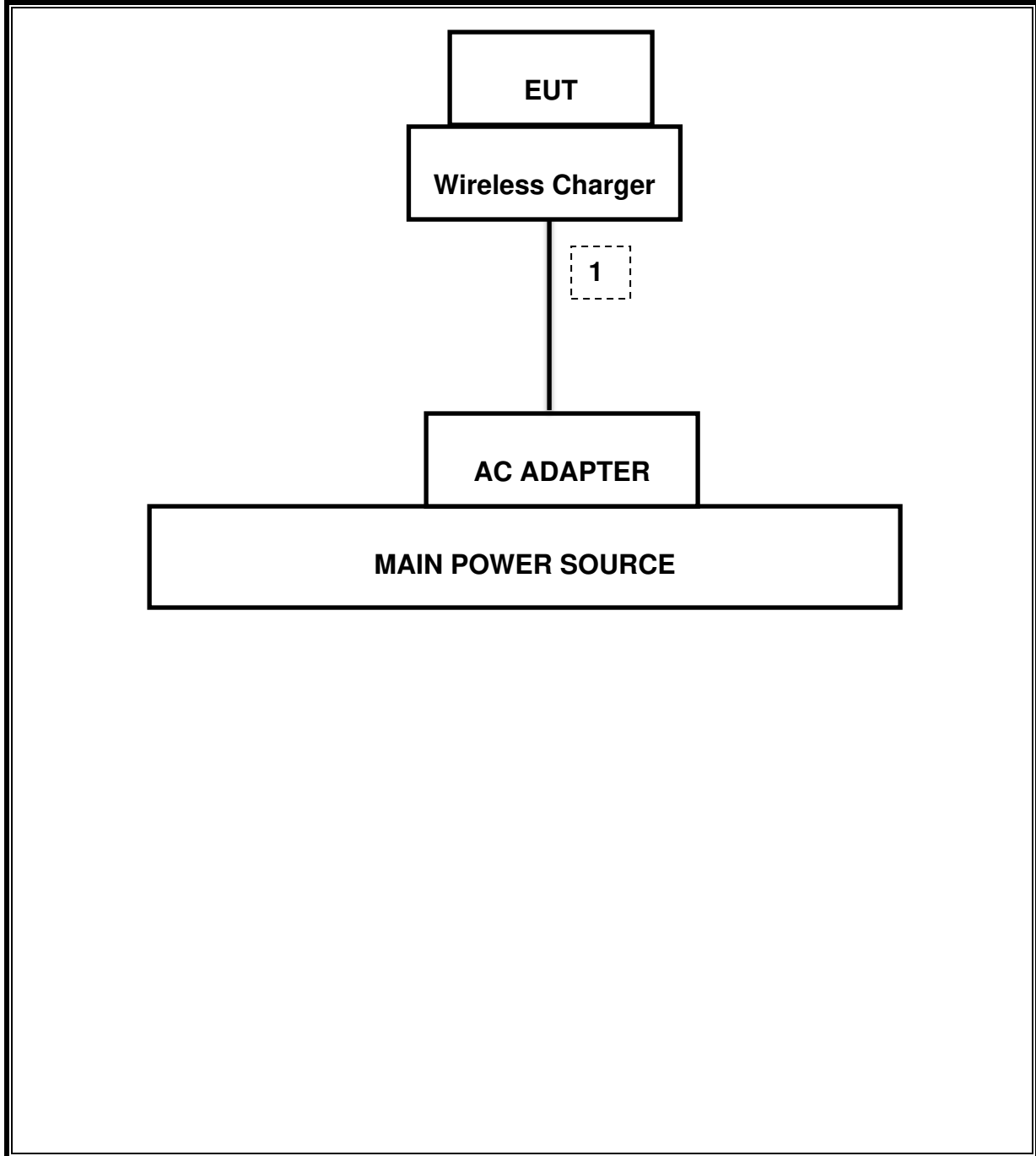

6. TEST AND MEASUREMENT EQUIPMENT

The following test and measurement equipment was utilized for the tests documented in this report:

Test Equipment List				
Description	Manufacturer	Model	S/N	Cal Due
Antenna, Bilog, 30MHz-1GHz	SCHWARZBECK	VULB9163	750	10-14-18
Antenna, Bilog, 30MHz-1GHz	SCHWARZBECK	VULB9163	749	04-25-17
Antenna, Horn, 18 GHz	ETS	3115	00167211	10-14-18
Antenna, Horn, 18 GHz	ETS	3117	00168724	06-17-17
Antenna, Horn, 18 GHz	ETS	3117	00168717	06-17-17
Antenna, Horn, 40 GHz	ETS	3116C	00166155	11-30-17
Antenna, Horn, 40 GHz	ETS	3116C-PA	00168841	12-15-17
Preamplifier, 1000 MHz	Sonoma	310N	341282	08-17-17
Preamplifier, 1000 MHz	Sonoma	310N	351741	08-16-17
Preamplifier	ETS	3115-PA	00167475	08-17-17
Preamplifier, 18 GHz	Miteq	AFS42-00101800-25-S-42	1896138	08-16-17
Spectrum Analyzer, 44 GHz	Agilent / HP	N9030A	MY54170614	08-17-17
Spectrum Analyzer, 7 GHz	Agilent / HP	N9010A	MY54200580	08-17-17
Antenna, Loop, 9kHz-30MHz	R&S	HFH2-Z2	100418	11-25-17
Average Power Sensor	R&S	NRP-Z91	102681	08-16-17
Average Power Sensor	Agilent / HP	U2000	MY54270007	08-17-17
EMI Test Receive, 40 GHz	R&S	ESU40	100439	08-17-17
EMI Test Receive, 40 GHz	R&S	ESU40	100457	08-16-17
EMI Test Receive, 3 GHz	R&S	ESR3	101832	08-16-17
Low Pass Filter 5GHz	Micro-Tronics	LPS17541	009	08-17-17
Low Pass Filter 5GHz	Micro-Tronics	LPS17541	015	08-16-17
High Pass Filter 3GHz	Micro-Tronics	HPM17543	010	08-17-17
High Pass Filter 3GHz	Micro-Tronics	HPM17543	015	08-16-17
High Pass Filter 6GHz	Micro-Tronics	HPM17542	009	08-17-17
High Pass Filter 6GHz	Micro-Tronics	HPM17542	016	08-16-17
LISN	R&S	ENV-216	101836	08-16-17
LISN	R&S	ENV-216	101837	08-16-17
Attenuator	PASTERNAK	PE7087-10	A007	08-17-17
UL Software				
Description	Manufacturer	Model	Version	
Radiated software	UL	UL EMC	Ver 9.5	
AC Line Conducted software	UL	UL EMC	Ver 9.5	

7. REFERENCE MEASUREMENT RESULTS

7.1. ON TIME AND DUTY CYCLE RESULTS

LIMITS

None; for reporting purposes only.

Mode	ON Time B [msec]	Period [msec]	Duty Cycle x [linear]	Duty Cycle [%]	Duty Cycle Correction Factor [dB]	1/T Minimum VBW [kHz]
2400MHz Bands						
802.11b	8.606	8.71	0.988	98.8%	0.00	0.010
802.11g	1.427	1.536	0.929	92.9%	0.32	0.701
802.11n HT20	1.335	1.444	0.925	92.5%	0.34	0.749

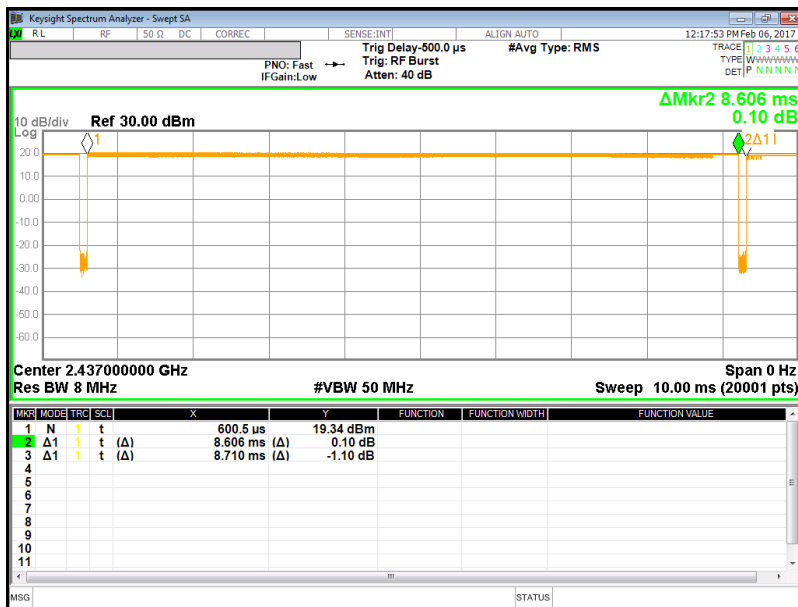

[802.11b]

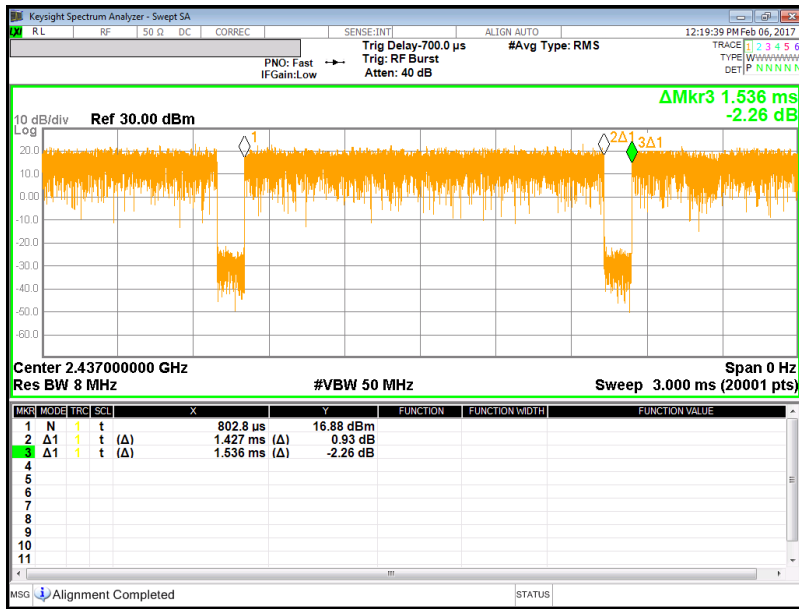

[802.11g]

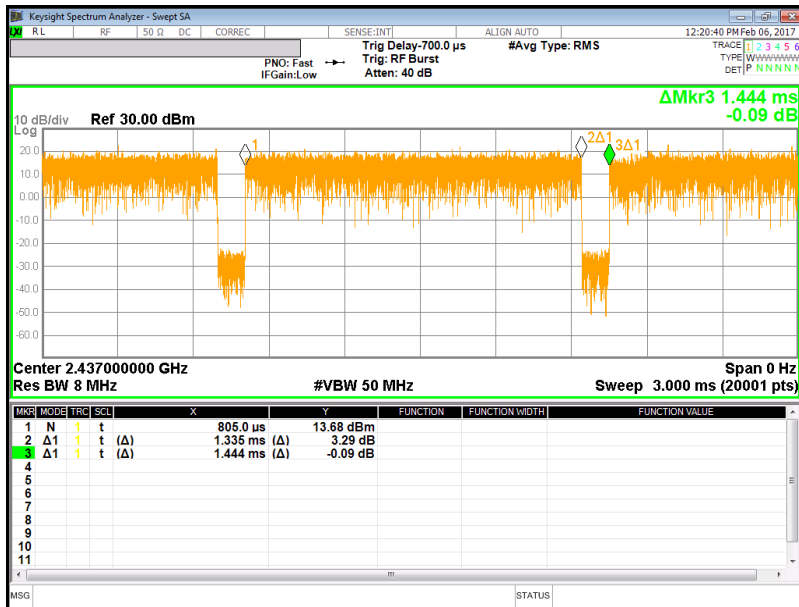

[802.11n]

7.2. 99% BANDWIDTH

LIMITS

None; for reporting purposes only.

RESULTS

7.2.1. 802.11b MODE IN THE 2.4 GHz BAND

Channel	Frequency [MHz]	99% Bandwidth [MHz]
Low	2412	11.684
Mid	2437	12.311
High	2462	11.705
Worst		12.311

7.2.2. 802.11g MODE IN THE 2.4 GHz BAND

Channel	Frequency [MHz]	99% Bandwidth [MHz]
Low	2412	16.351
Mid	2437	16.404
High	2462	16.344
Worst		16.404

7.2.3. 802.11n HT20 MODE IN THE 2.4 GHz BAND

Channel	Frequency [MHz]	99% Bandwidth [MHz]
Low	2412	17.558
Mid	2437	17.547
High	2462	17.571
Worst		17.571

7.2.4. 99% BANDWIDTH PLOTS

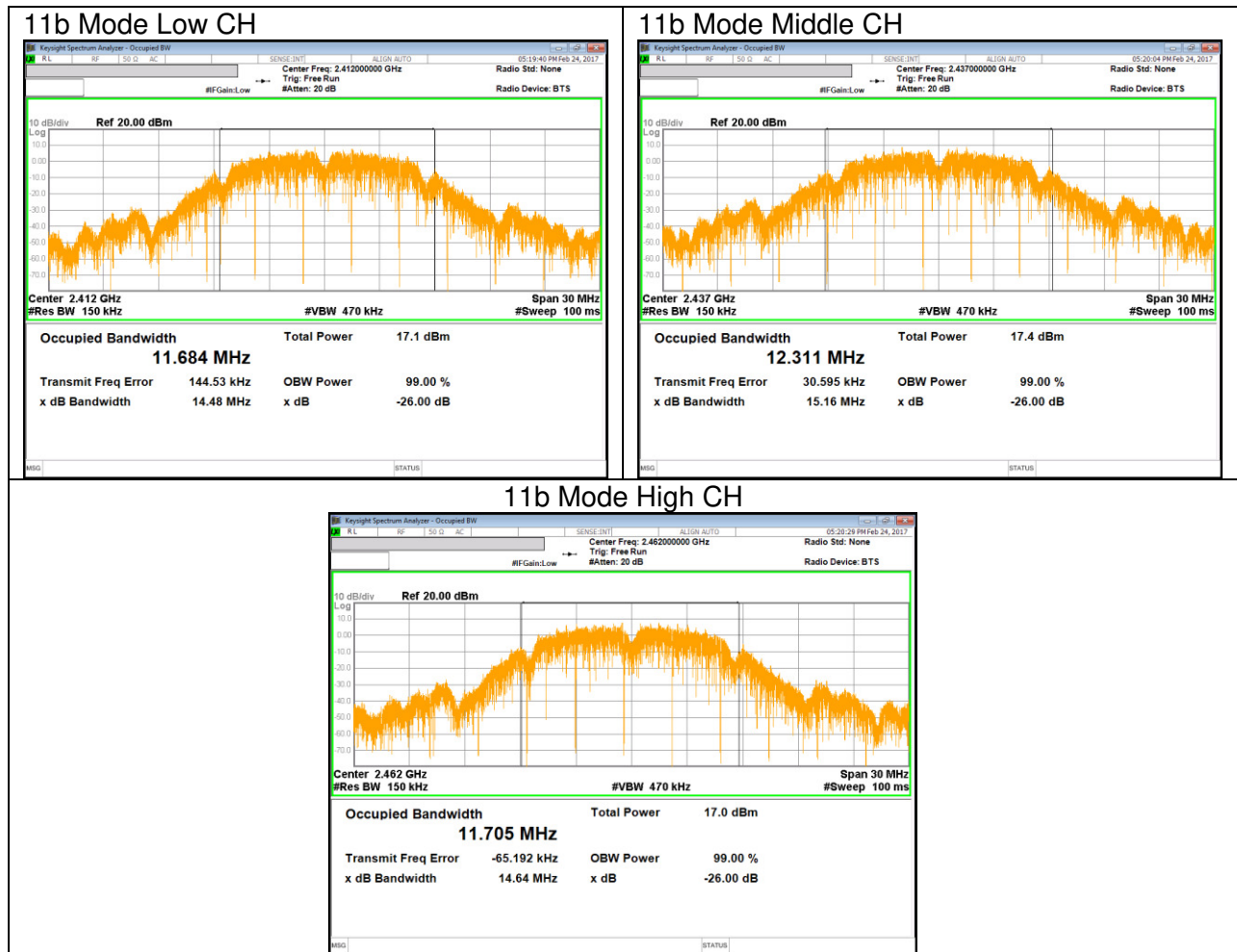

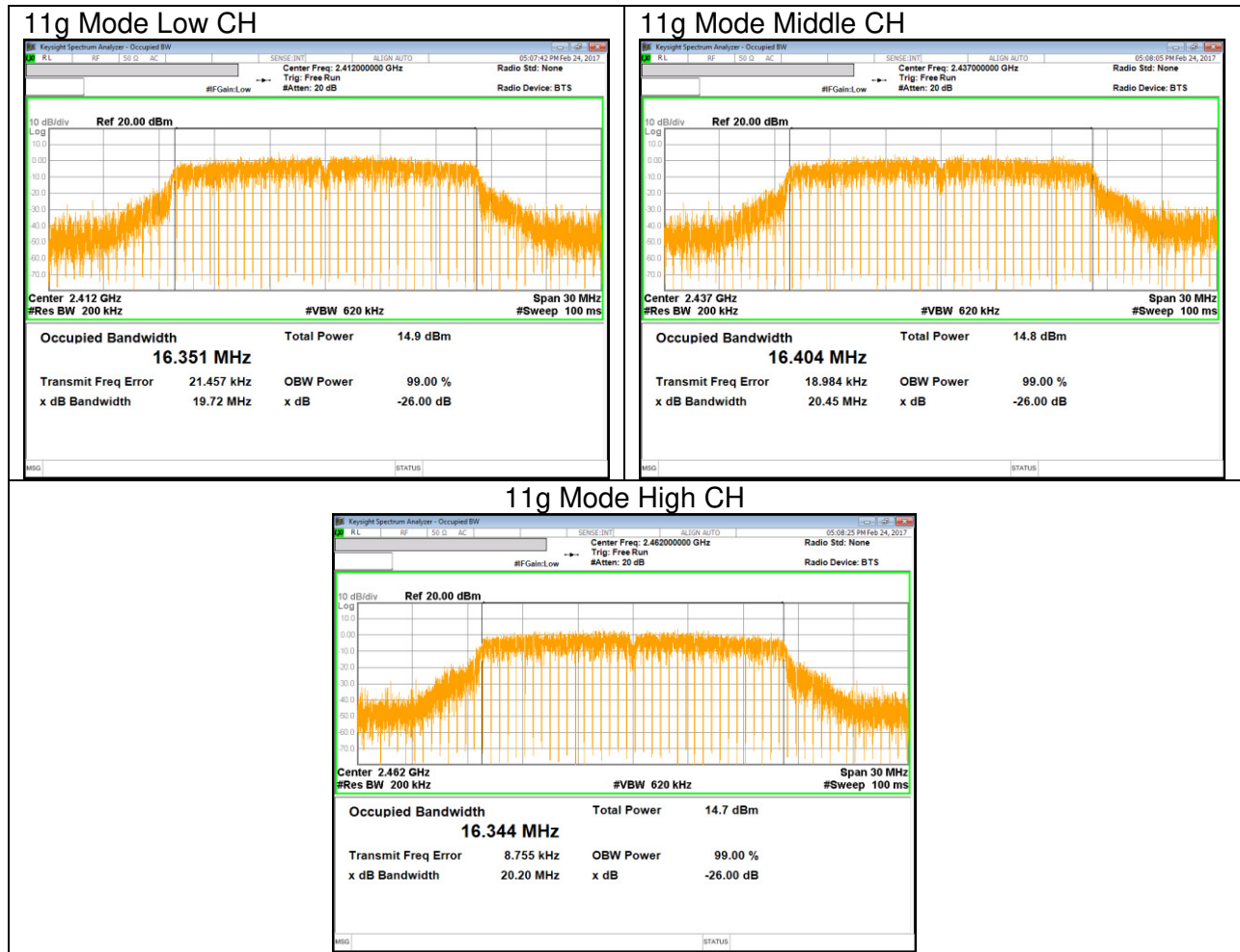

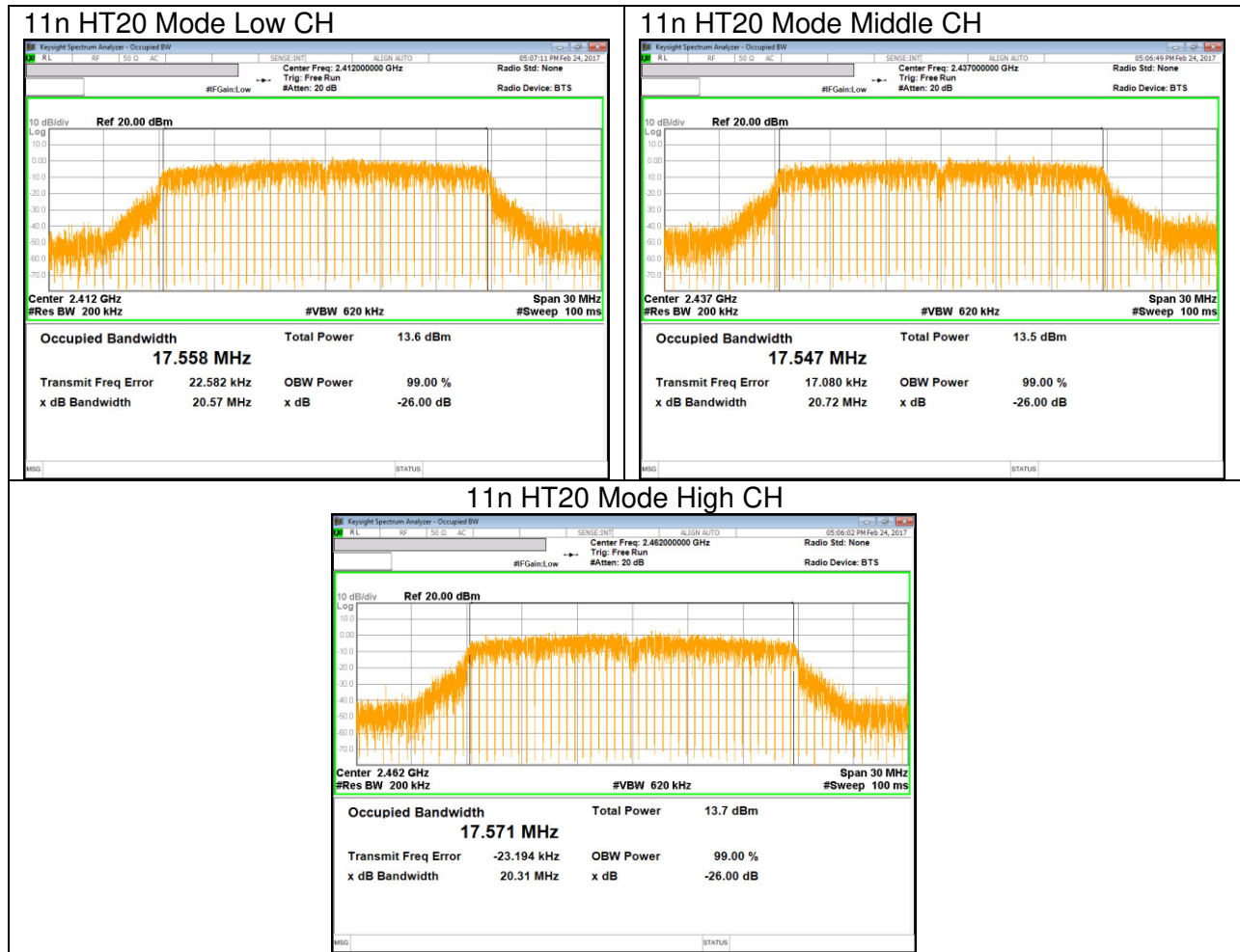

7.3. Verification of geo-location functioning for Wi-Fi Ch. 12& 13

7.3.1. Setup Configuration

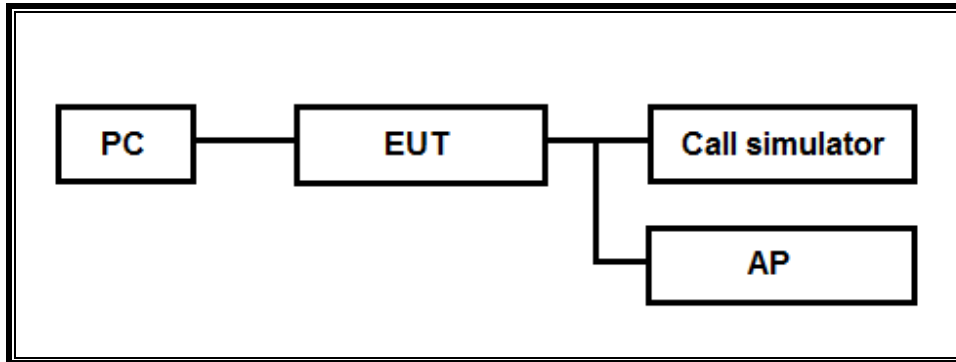

7.3.2. Test Results

MCC	US	Non-US (KR)	Airplane
Country	United States	Korea	Default mode (US)
Channel 1	Connected	Connected	Connected
Channel 2	Connected	Connected	Connected
Channel 3	Connected	Connected	Connected
Channel 4	Connected	Connected	Connected
Channel 5	Connected	Connected	Connected
Channel 6	Connected	Connected	Connected
Channel 7	Connected	Connected	Connected
Channel 8	Connected	Connected	Connected
Channel 9	Connected	Connected	Connected
Channel 10	Connected	Connected	Connected
Channel 11	Connected	Connected	Connected
Channel 12	Not Connected	Connected	Not Connected
Channel 13	Not Connected	Connected	Not Connected

Note : Test scripts used are fully described in the operational description

8. SUMMARY TABLE

FCC Part Section	Test Description	Test Limit	Test Condition	Test Result	Worst Case
15.247 (a)(2)	Occupied Band width (6dB)	>500KHz	Conducted	Pass	8.569 MHz
2.1051, 15.247 (d)	Band Edge / Conducted Spurious Emission	-30dBc		Pass	-27.028 dBm
15.247	TX conducted output power	<30dBm		Pass	17.48 dBm
15.247	PSD	<8dBm		Pass	-13.914 dBm
15.207 (a)	AC Power Line conducted emissions	Section 10	Power Line conducted	Pass	40.68 dBuV (Pk)
15.205, 15.209	Radiated Spurious Emission	< 54dBuV/m	Radiated	Pass	48.77 dBuV/m (Av)

9. ANTENNA PORT TEST RESULTS

9.1. 6 dB BANDWIDTH

LIMITS

FCC §15.247 (a) (2)

The minimum 6 dB bandwidth shall be at least 500 kHz.

TEST PROCEDURE

Reference to KDB 558074 D01 DTS Meas Guidance v03r05: The transmitter output is connected to a spectrum analyzer with the RBW set to 100KHz, the VBW $\geq 3 \times$ RBW, peak detector and max hold.

RESULTS

9.1.1. 802.11b MODE IN THE 2.4 GHz BAND

Channel	Frequency [MHz]	6 dB Bandwidth [MHz]	Minimum Limit [MHz]
Low	2412	8.569	0.5
Mid	2437	9.038	0.5
High	2462	8.569	0.5
Worst		8.569	0.5

9.1.2. 802.11g MODE IN THE 2.4 GHz BAND

Channel	Frequency [MHz]	6 dB Bandwidth [MHz]	Minimum Limit [MHz]
Low	2412	15.109	0.5
Mid	2437	15.479	0.5
High	2462	15.417	0.5
Worst		15.109	0.5

9.1.3. 802.11n HT20 MODE IN THE 2.4 GHz BAND

Channel	Frequency [MHz]	6 dB Bandwidth [MHz]	Minimum Limit [MHz]
Low	2412	15.268	0.5
Mid	2437	15.943	0.5
High	2462	15.982	0.5
Worst		15.268	0.5

9.1.4. 6 dB BANDWIDTH PLOTS

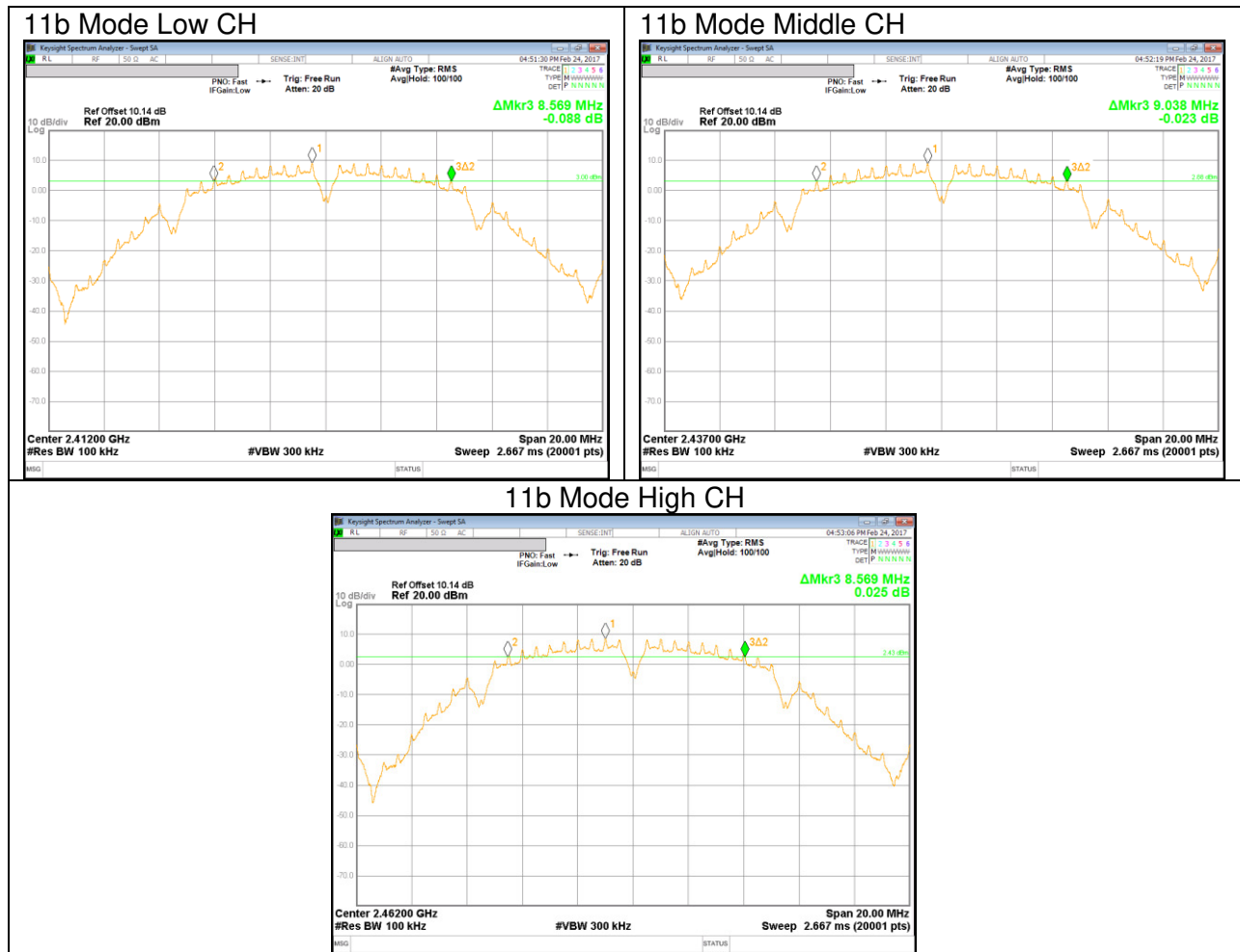

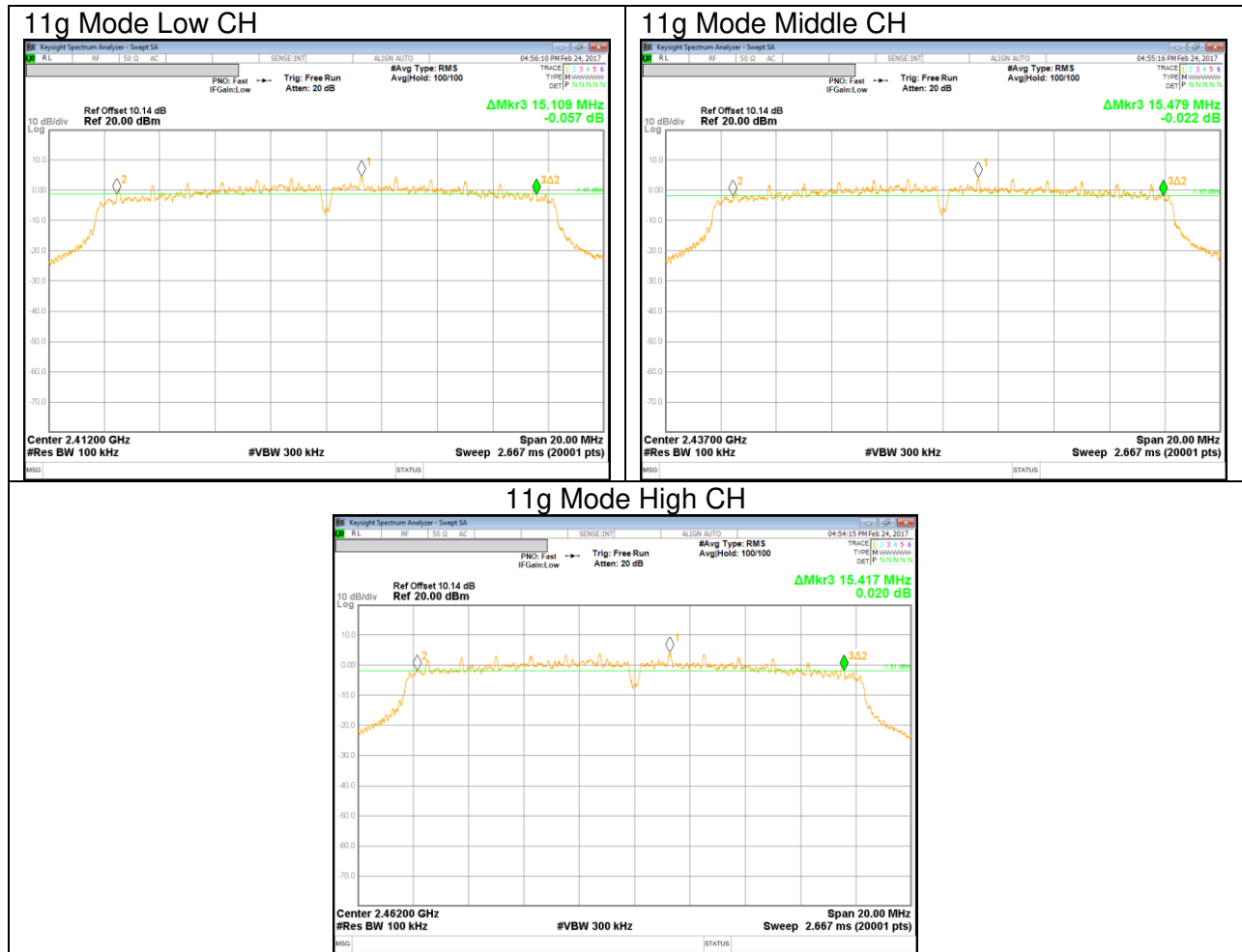

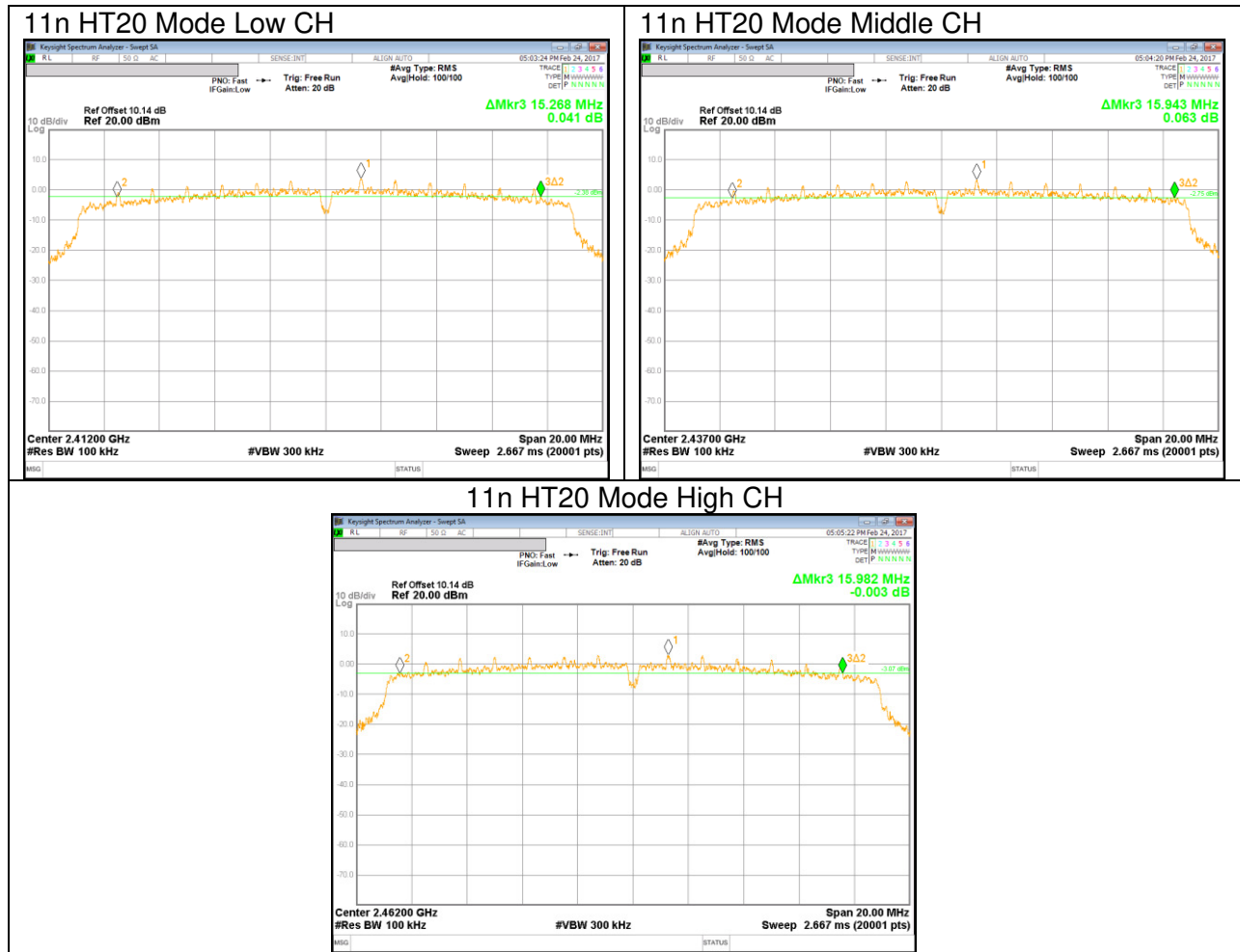

9.2. OUTPUT POWER

LIMITS

FCC §15.247

For systems using digital modulation in the 902–928 MHz, 2400–2483.5 MHz, and 5725–5850 MHz bands: 1 Watt, based on the use of antennas with directional gains that do not exceed 6 dBi. If transmitting antennas of directional gain greater than 6 dBi are used, the conducted output power from the intentional radiator shall be reduced by the amount in dB that the directional gain of the antenna exceeds 6 dBi.

DIRECTIONAL ANTENNA GAIN

There is only one transmitter output therefore the directional gain is equal to the antenna gain.

TEST PROCEDURE

The transmitter output is connected to a power meter.

The cable assembly insertion loss of 10.1 dB (including 10 dB pad and 0.1 dB cable) was entered as an offset in the power meter to allow for direct reading of power.

Output power measurement was performed utilizing the “§9.2.3.1 AVGPM” under KDB558074 D01 DTS Meas Guidance v03r05.

Duty cycle correction factor is already added to the average output power results for duty cycle factor < 98%. (802.11g, 802.11n mode)

RESULTS

9.2.1. 802.11b MODE IN THE 2.4 GHz BAND

Limits

Channel	Frequency [MHz]	Directional Gain Primary [dBi]	FCC Power Limit [dBm]	Max Power [dBm]
Low	2412	-4.50	30.00	30.00
Mid	2437	-4.50	30.00	30.00
High	2462	-4.50	30.00	30.00

Results

Channel	Frequency [MHz]	Meas Power [dBm]	Total Power [dBm]	Power Limit [dBm]	Margin [dB]
Low	2412	17.48	17.48	30.00	-12.52
Mid	2437	17.47	17.47	30.00	-12.53
High	2462	17.12	17.12	30.00	-12.88
Worst			17.48	30.00	-12.52

9.2.2. 802.11g MODE IN THE 2.4 GHz BAND

Limits

Channel	Frequency [MHz]	Directional Gain Primary [dBi]	FCC Power Limit [dBm]	Max Power [dBm]
Low	2412	-4.50	30.00	30.00
Mid	2437	-4.50	30.00	30.00
High	2462	-4.50	30.00	30.00

Results

Channel	Frequency [MHz]	Meas Power [dBm]	Total Power [dBm]	Power Limit [dBm]	Margin [dB]
Low	2412	15.38	15.38	30.00	-14.62
Mid	2437	15.33	15.33	30.00	-14.67
High	2462	15.23	15.23	30.00	-14.77
Worst			15.38	30.00	-14.62

9.2.3. 802.11n HT20 MODE IN THE 2.4 GHz BAND

Limits

Channel	Frequency [MHz]	Directional Gain Primary [dBi]	FCC Power Limit [dBm]	Max Power [dBm]
Low	2412	-4.50	30.00	30.00
Mid	2437	-4.50	30.00	30.00
High	2462	-4.50	30.00	30.00

Results

Channel	Frequency [MHz]	Meas Power [dBm]	Total Power [dBm]	Power Limit [dBm]	Margin [dB]
Low	2412	14.17	14.17	30.00	-15.83
Mid	2437	14.09	14.09	30.00	-15.91
High	2462	14.07	14.07	30.00	-15.93
Worst			14.17	30.00	-15.83

9.3. PSD

LIMITS

FCC §15.247

The power spectral density conducted from the transmitter to the antenna shall not be greater than 8 dBm in any 3 kHz band during any time interval of continuous transmission.

TEST PROCEDURE

Power Spectral Density was performed utilizing the “Method §10.3 AVGPSD-1 (802.11 b mode) and §10.5 AVGPSD-2(802.11 g/n mode)” under KDB558074 D01 DTS Meas Guidance v03r05.

RESULTS

9.3.1. 802.11b MODE IN THE 2.4 GHz BAND

PSD Results

Channel	Frequency [MHz]	PSD Meas [dBm]	Duty Factor [dB]	Final PSD [dBm]	Limit [dBm]	Margin [dB]
Low	2412	-14.046	0.00	-14.046	8.00	-22.046
Mid	2437	-13.914	0.00	-13.914	8.00	-21.914
High	2462	-14.037	0.00	-14.037	8.00	-22.037

9.3.2. 802.11g MODE IN THE 2.4 GHz BAND

PSD Results

Channel	Frequency [MHz]	PSD Meas [dBm]	Duty Factor [dB]	Final PSD [dBm]	Limit [dBm]	Margin [dB]
Low	2412	-15.447	0.32	-15.127	8.00	-23.447
Mid	2437	-15.515	0.32	-15.195	8.00	-23.515
High	2462	-15.064	0.32	-14.744	8.00	-23.064

9.3.3. 802.11n HT20 MODE IN THE 2.4 GHz BAND

PSD Results

Channel	Frequency [MHz]	PSD Meas [dBm]	Duty Factor [dB]	Final PSD [dBm]	Limit [dBm]	Margin [dB]
Low	2412	-18.89	0.34	-18.550	8.00	-26.890
Mid	2437	-19.630	0.34	-19.290	8.00	-27.630
High	2462	-19.294	0.34	-18.954	8.00	-27.294

9.3.4. PSD PLOTS

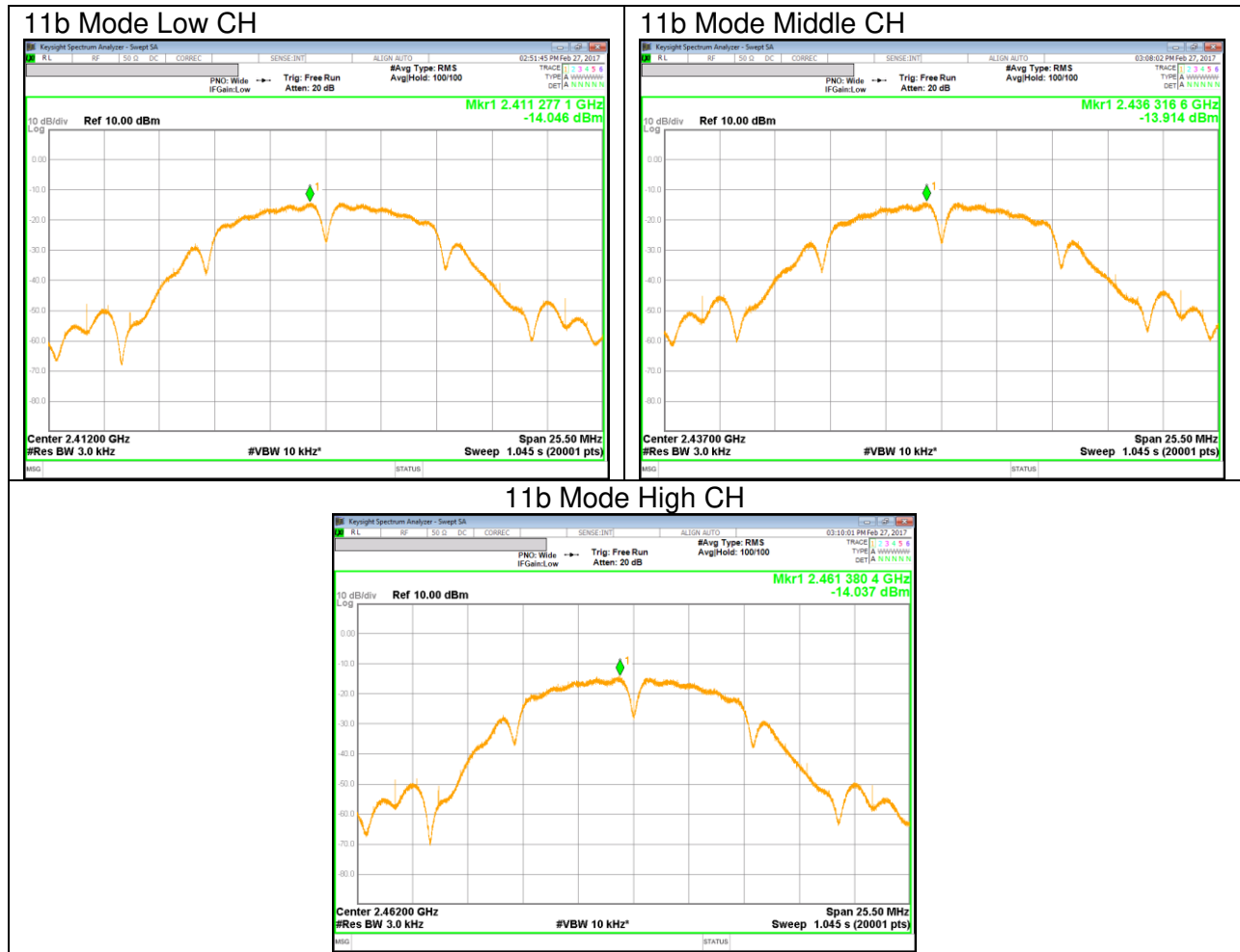

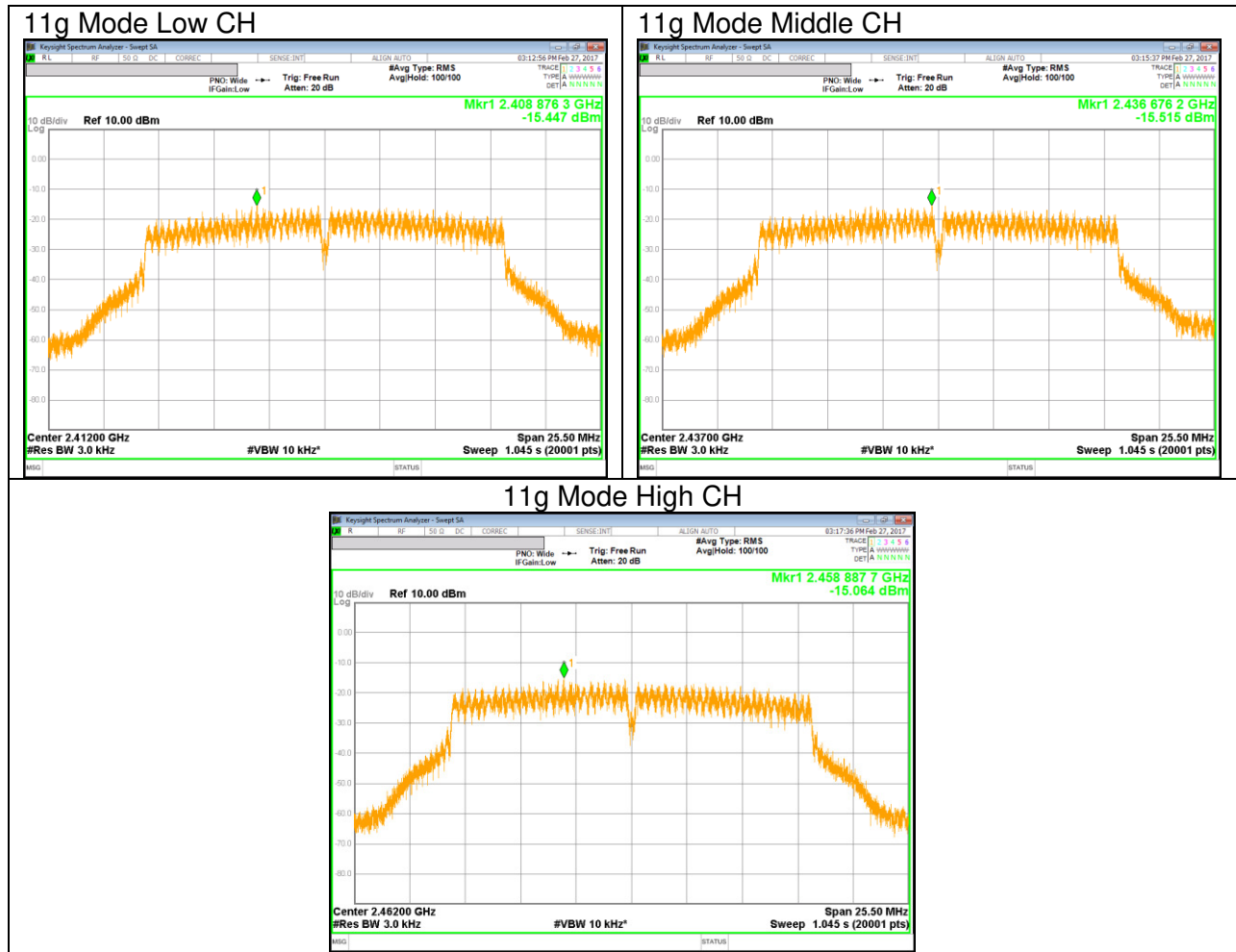

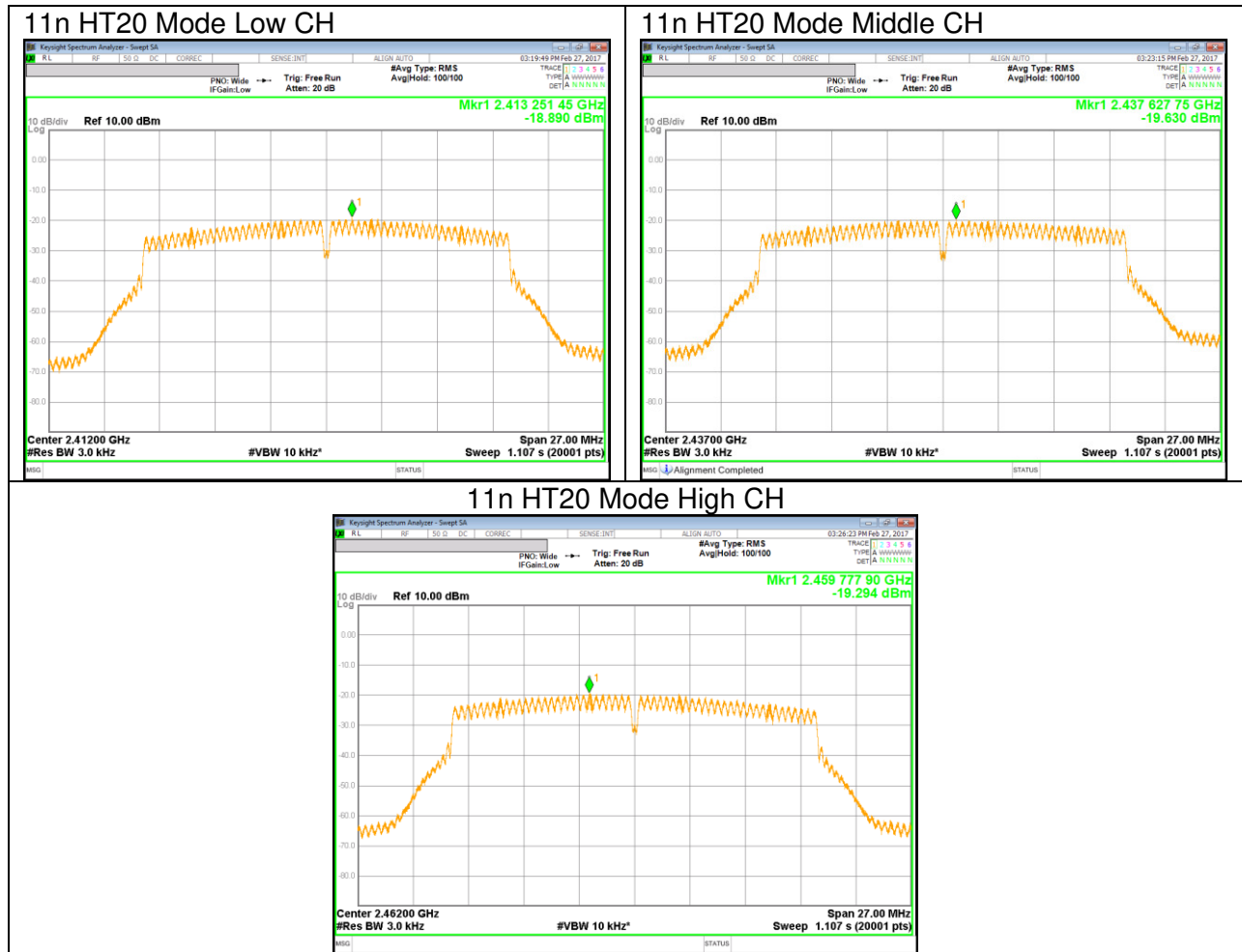

9.4. OUT-OF-BAND EMISSIONS

LIMITS

FCC §15.247 (d)

In any 100 kHz bandwidth outside the frequency band in which the spread spectrum or digitally modulated intentional radiator is operating, the radio frequency power that is produced by the intentional radiator shall be at least 20 dB below that in the 100 kHz bandwidth within the band that contains the highest level of the desired power, based on either an RF conducted or a radiated measurement, provided the transmitter demonstrates compliance with the peak conducted power limits. If the transmitter complies with the conducted power limits based on the use of RMS averaging over a time interval, as permitted under paragraph (b)(3) of this section, the attenuation required under this paragraph shall be 30 dB instead of 20 dB. Attenuation below the general limits specified in §15.209(a) is not required.

TEST PROCEDURE

The transmitter output is connected to a spectrum analyzer with RBW = 100 kHz, VBW = 300 kHz, peak detector, and max hold. Measurements utilizing these settings are made of the in-band reference level, bandedge (where measurements to the general radiated limits will not be made) and out-of-band emissions.

RESULTS

9.4.1. 802.11b MODE IN THE 2.4 GHz BAND

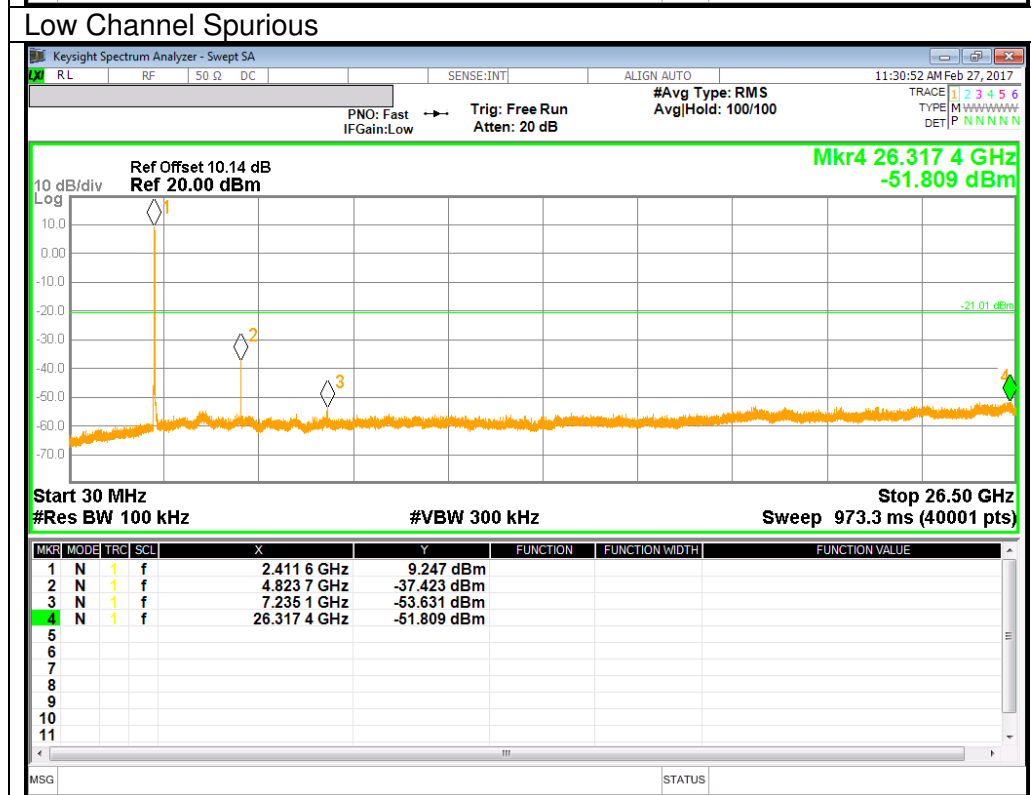
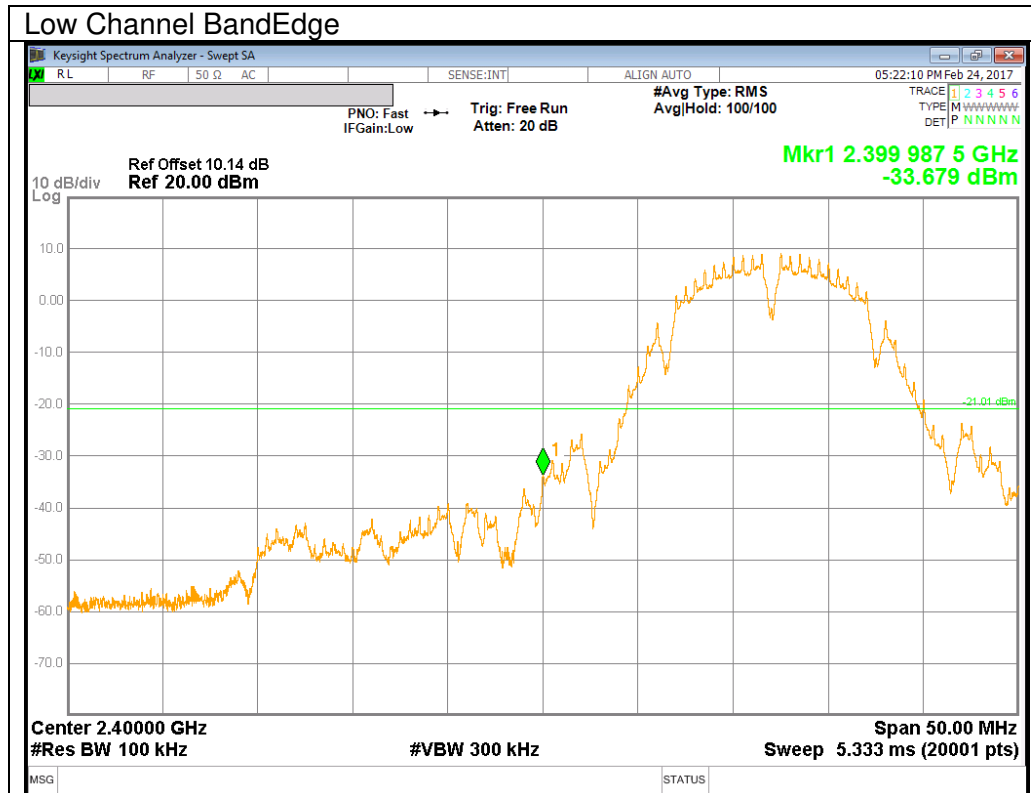

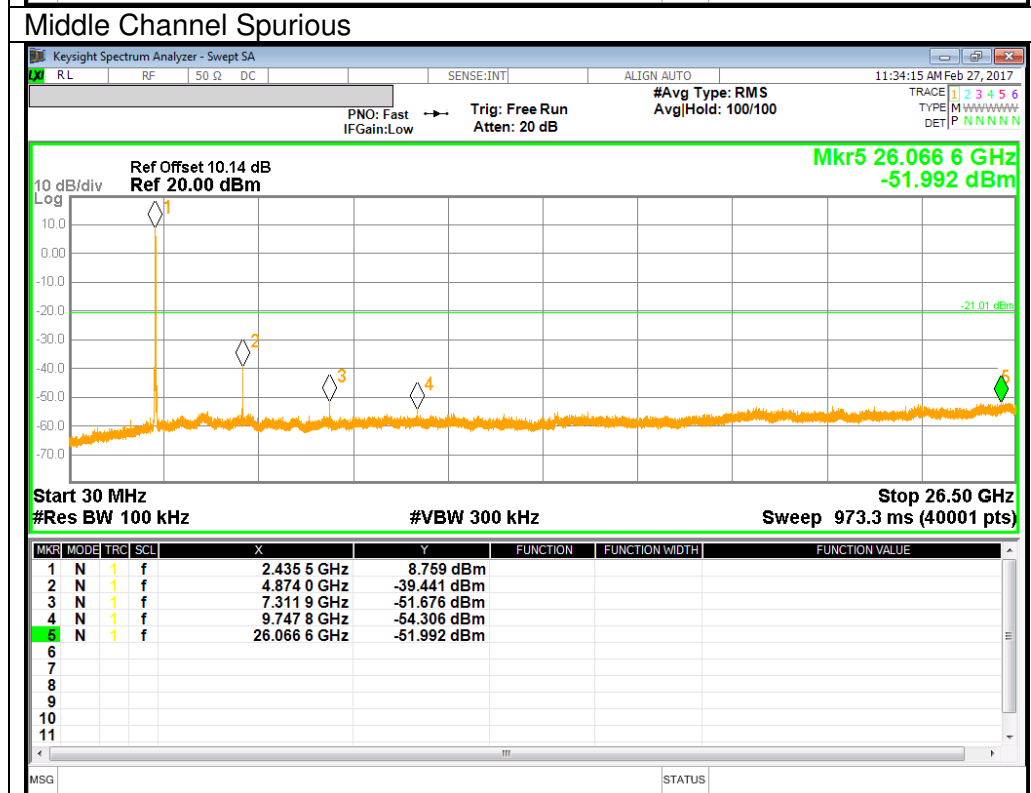
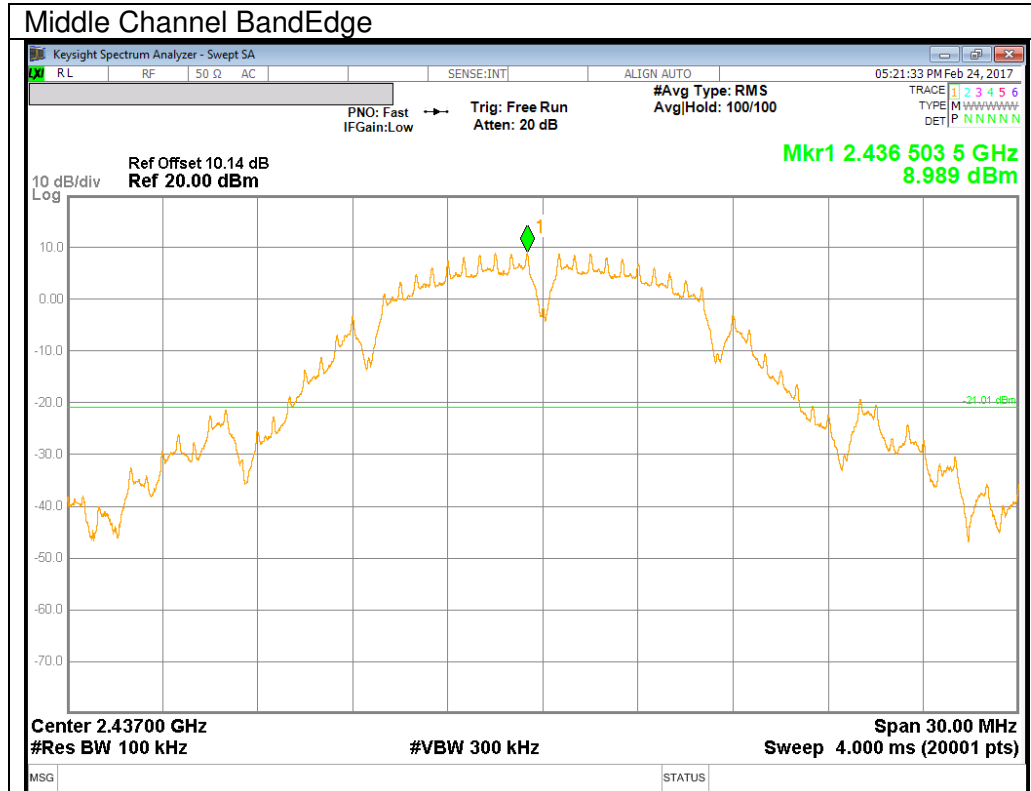

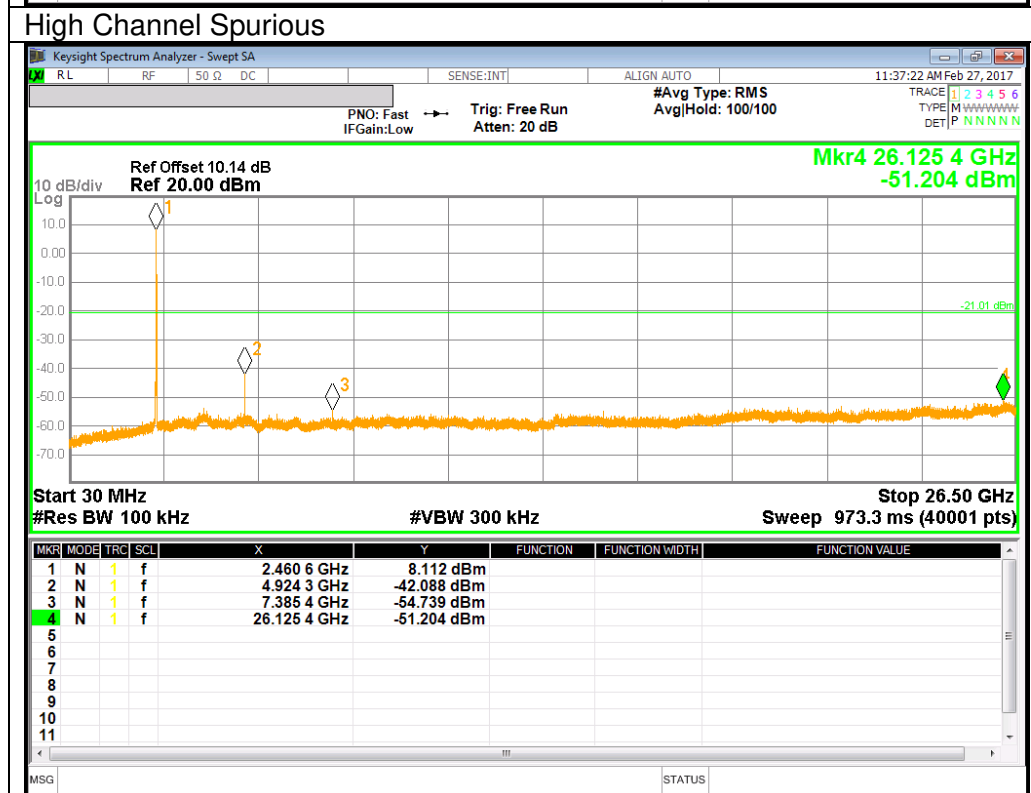
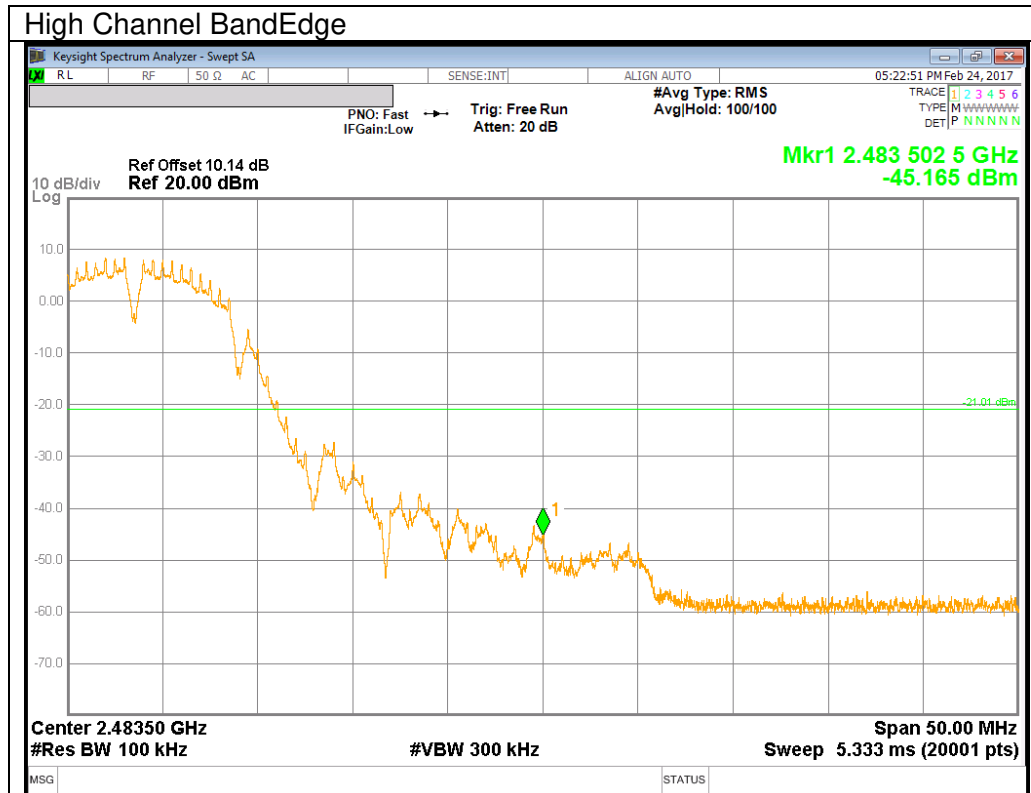

9.4.2. 802.11g MODE IN THE 2.4 GHz BAND

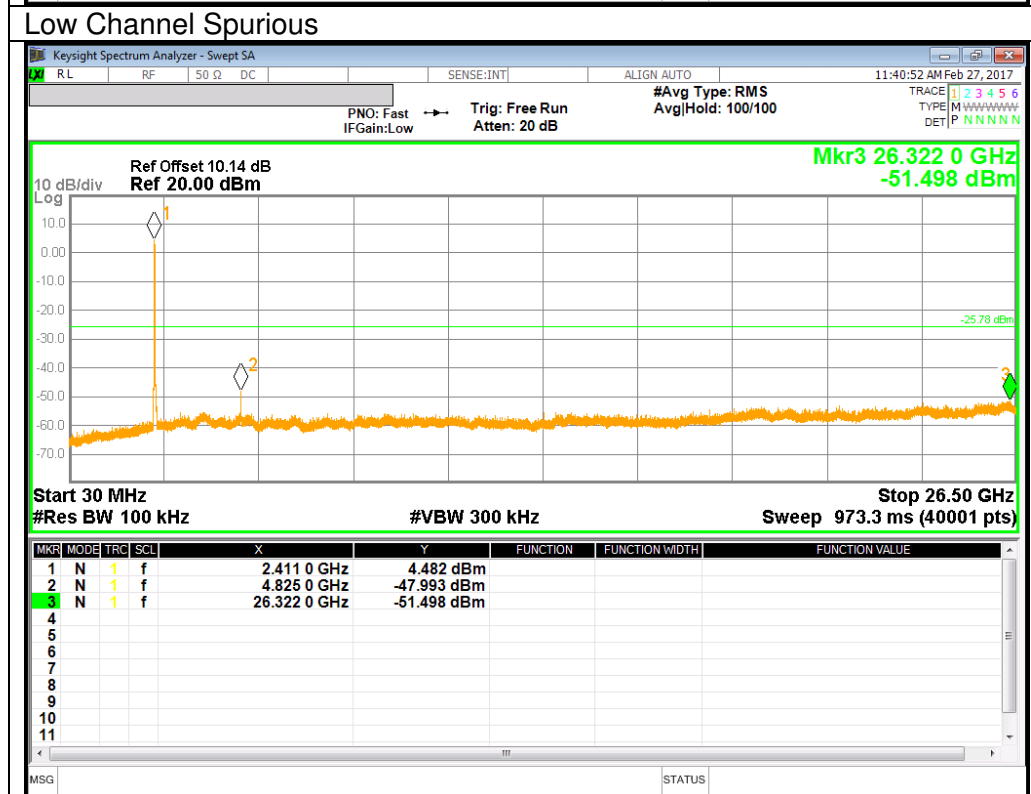
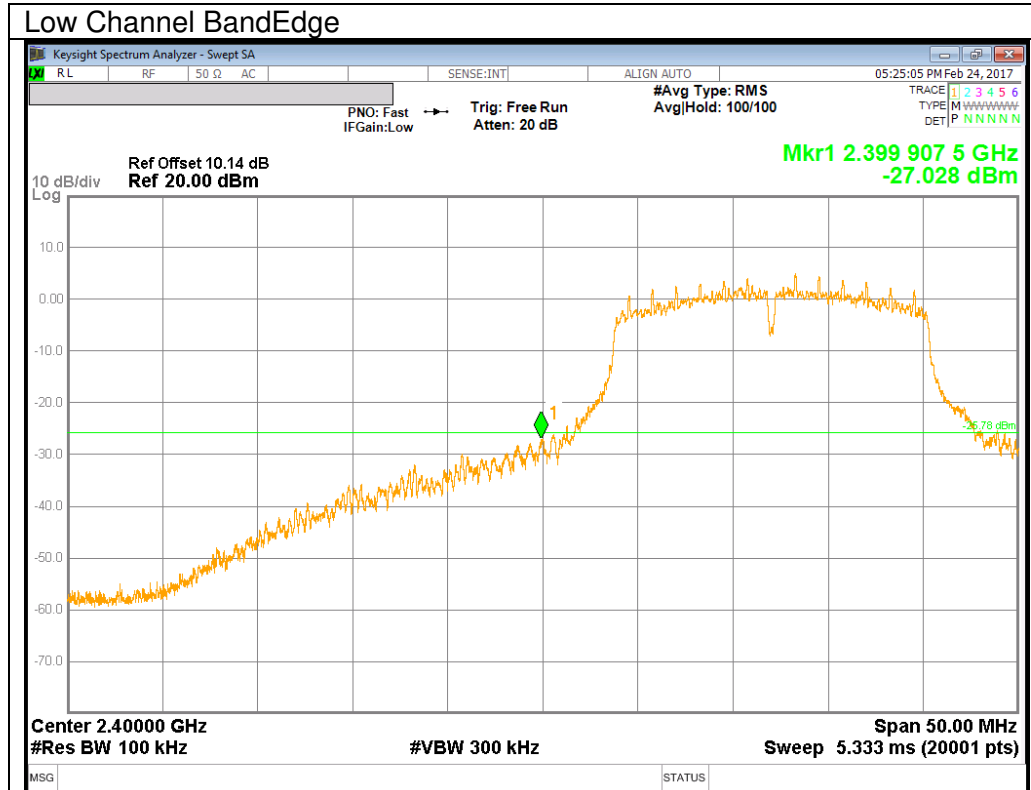

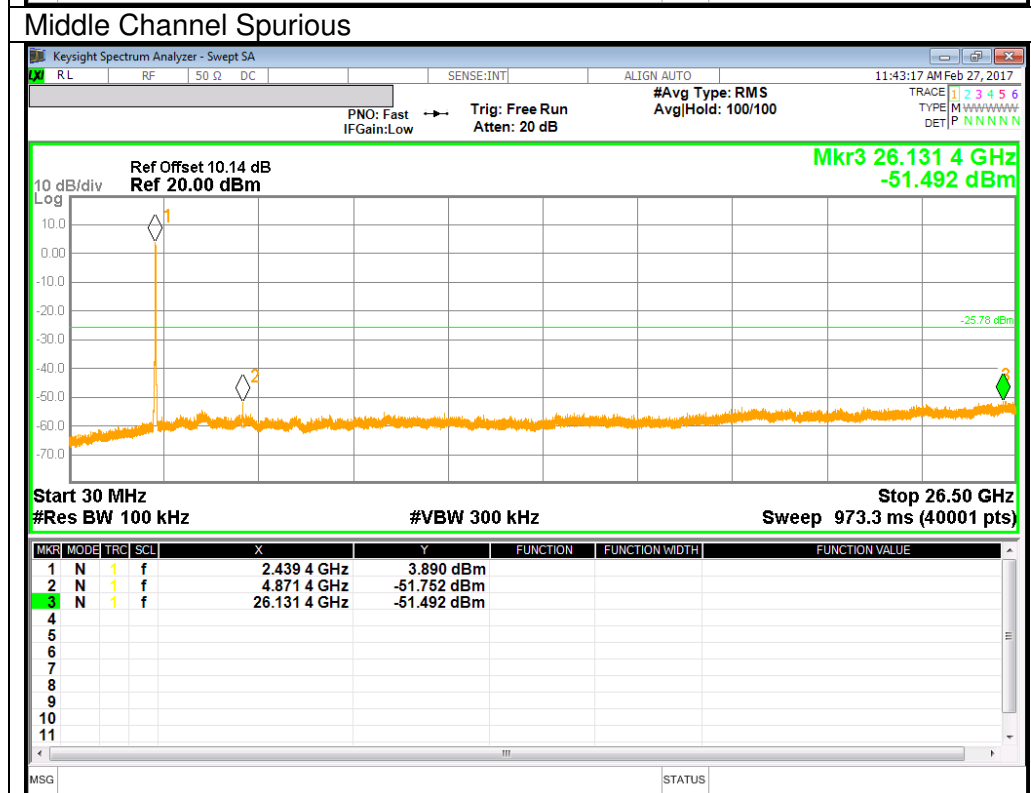
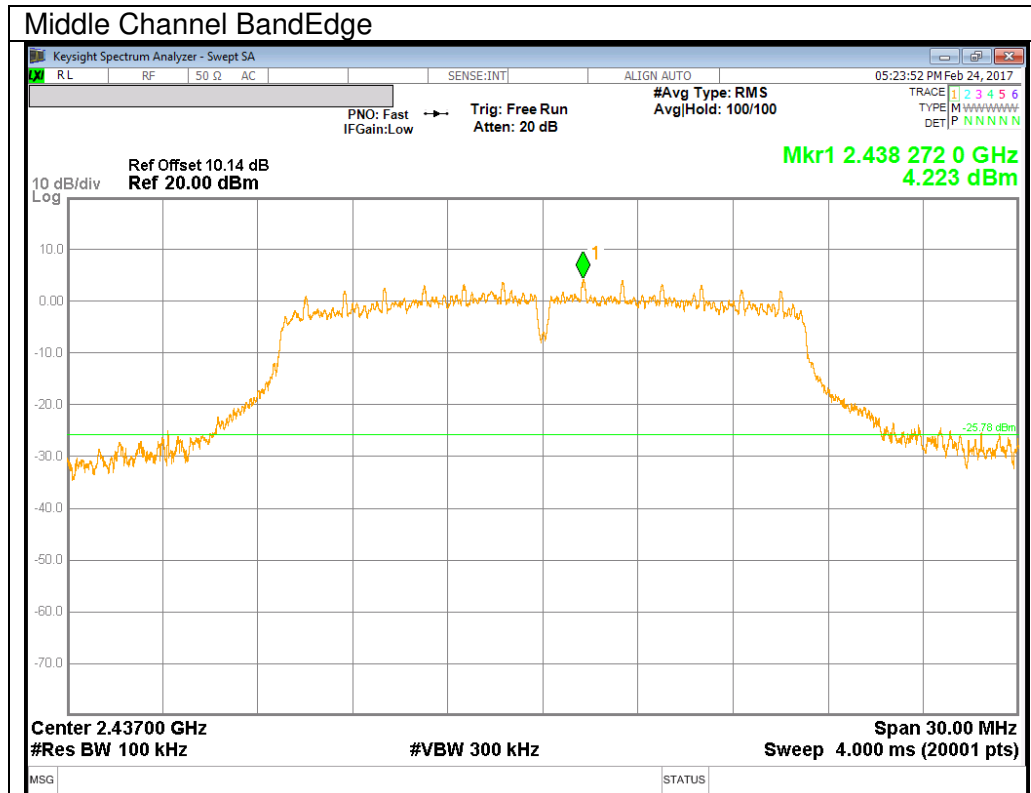

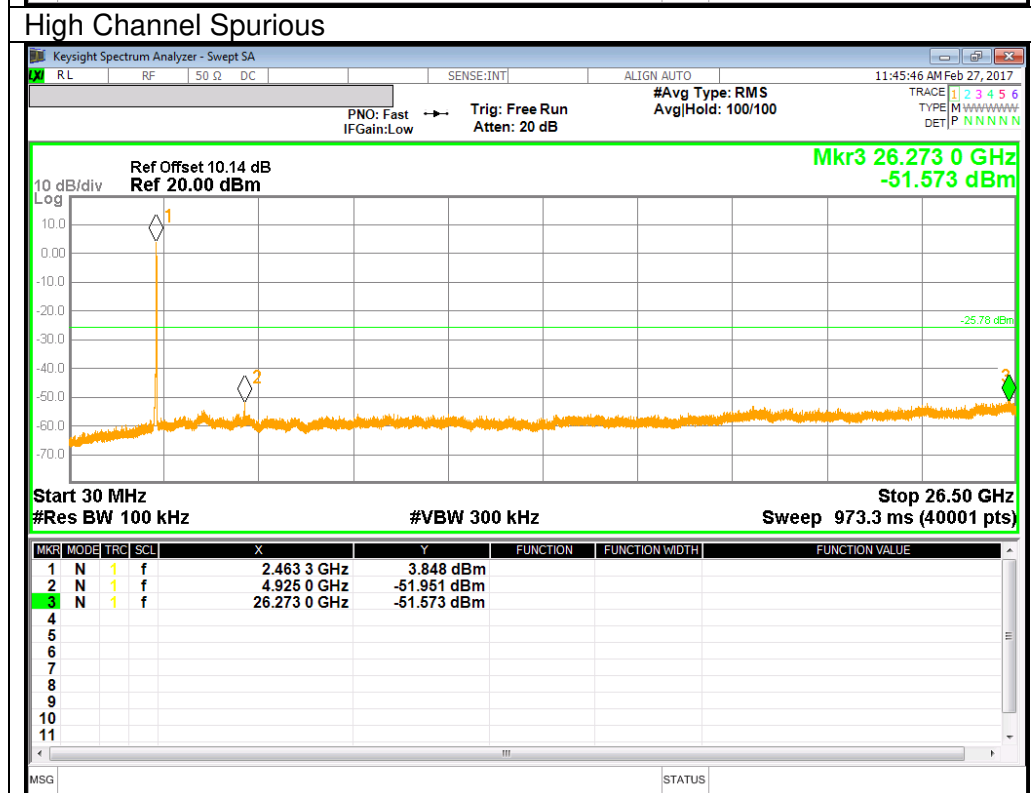
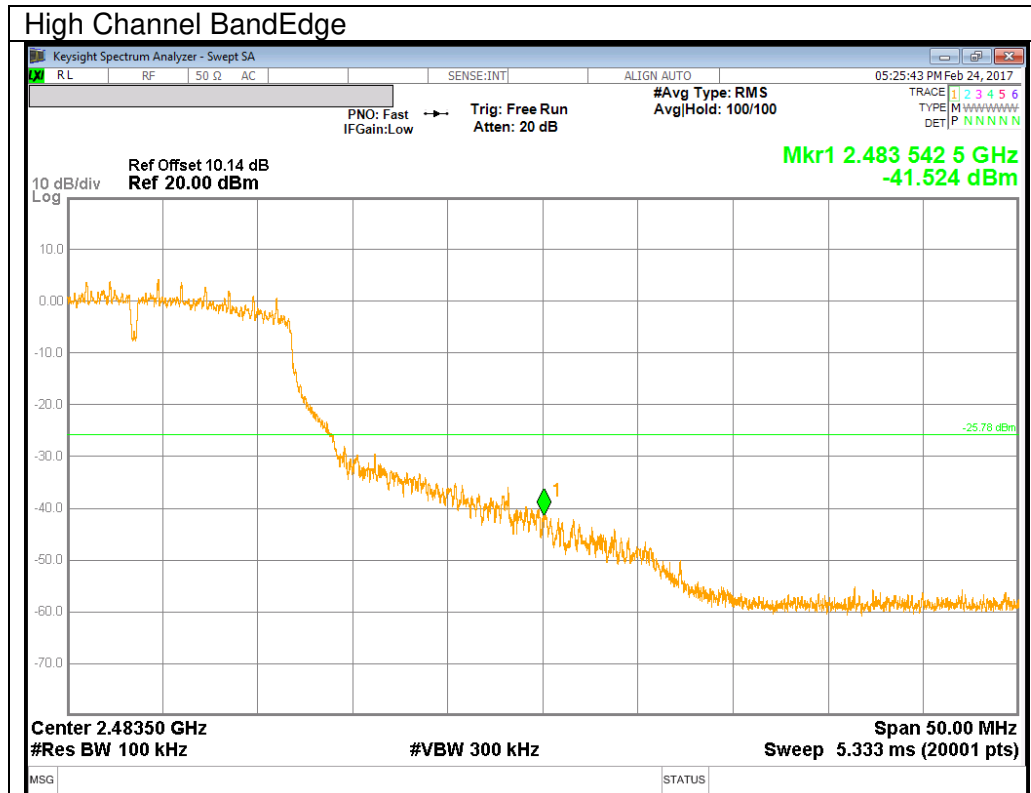

9.4.3. 802.11n HT20 MODE IN THE 2.4 GHz BAND

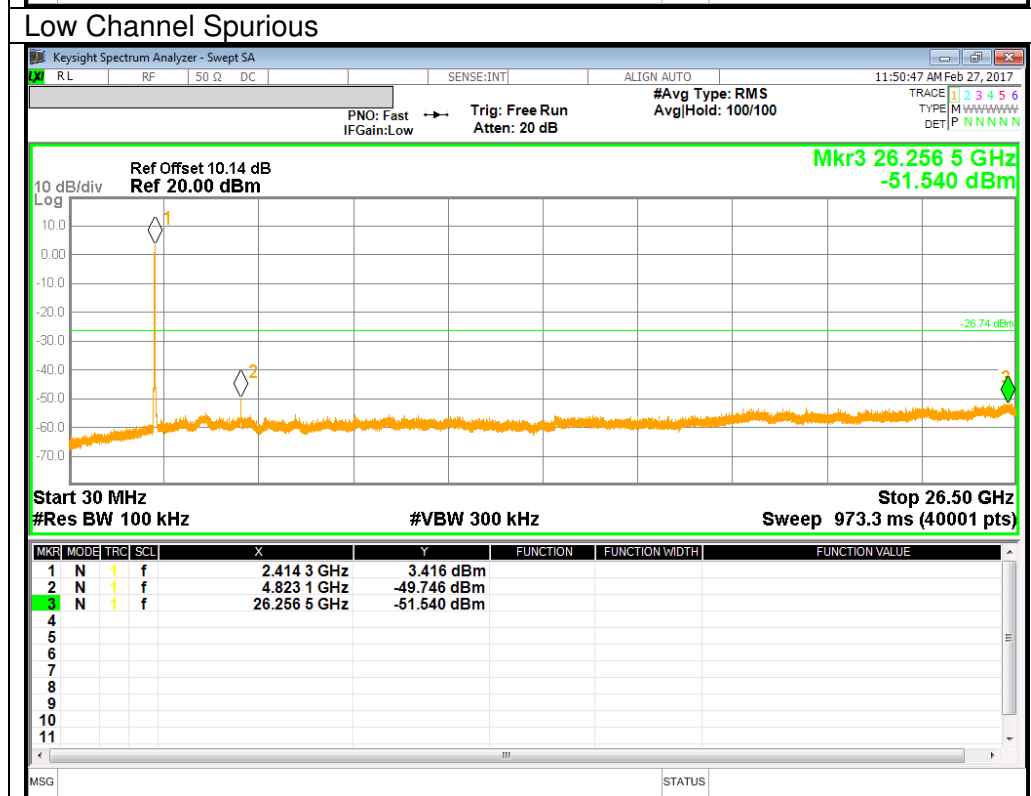
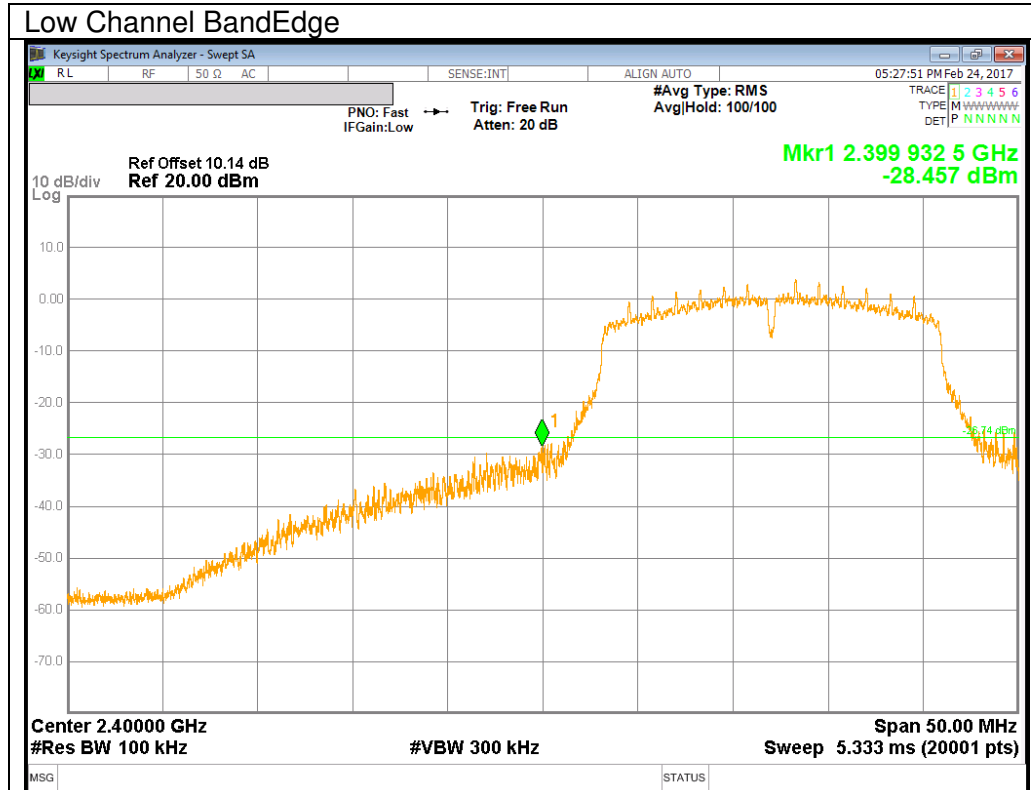

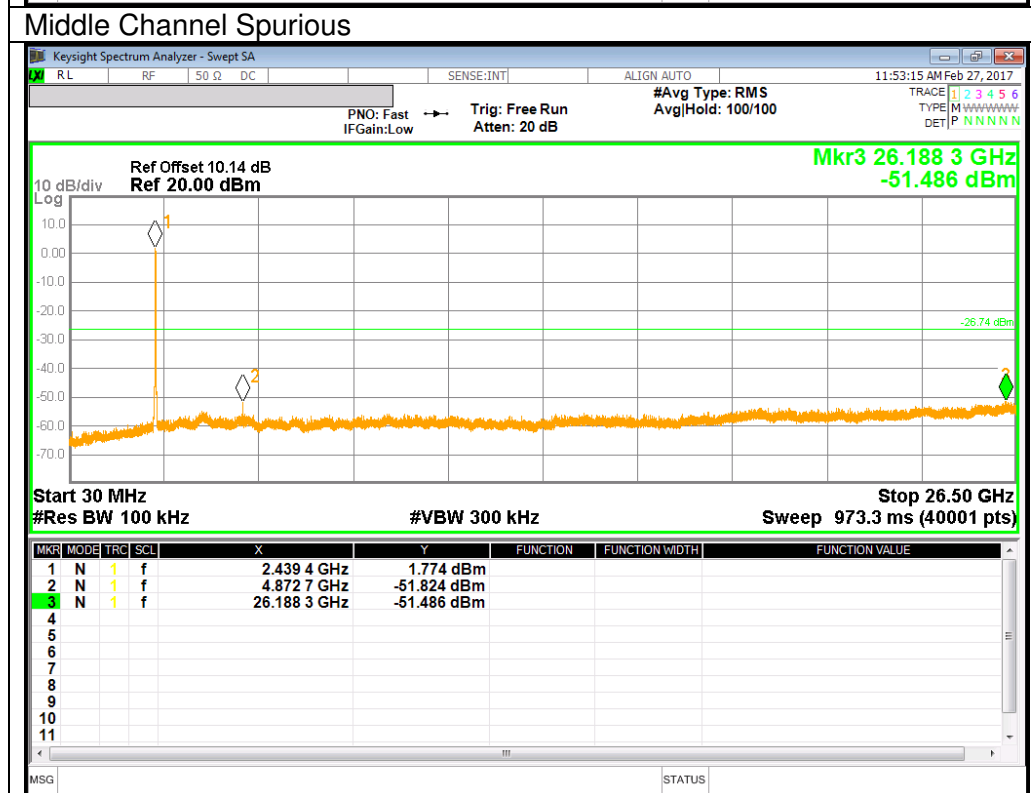
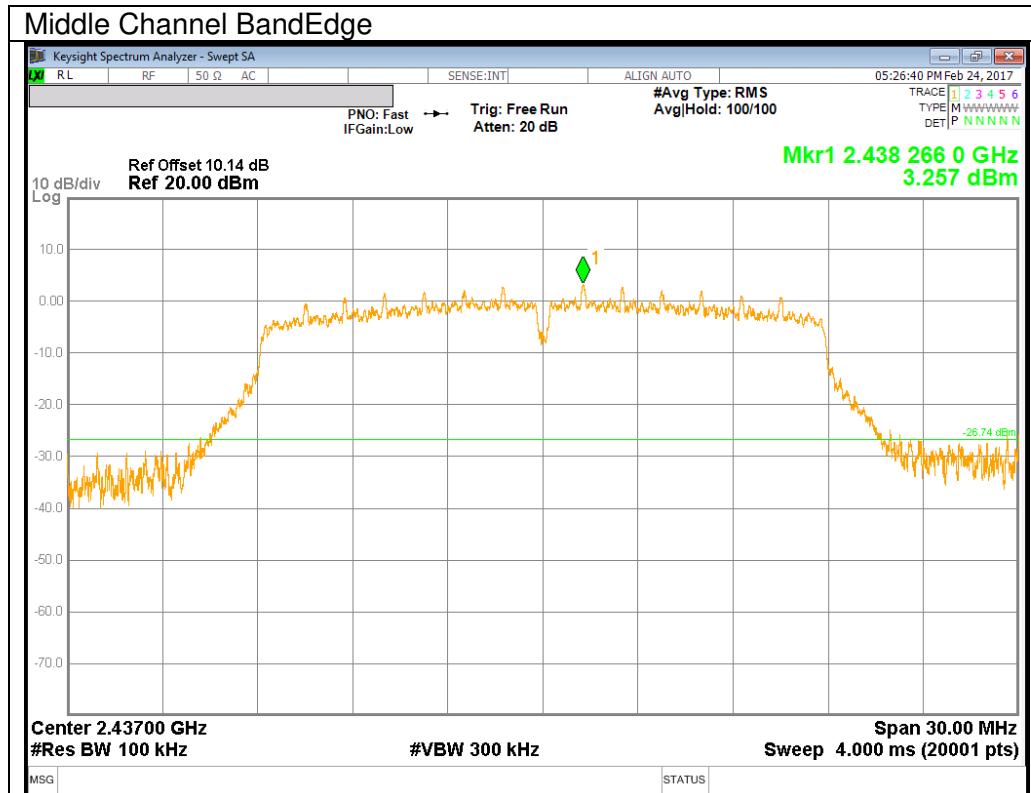

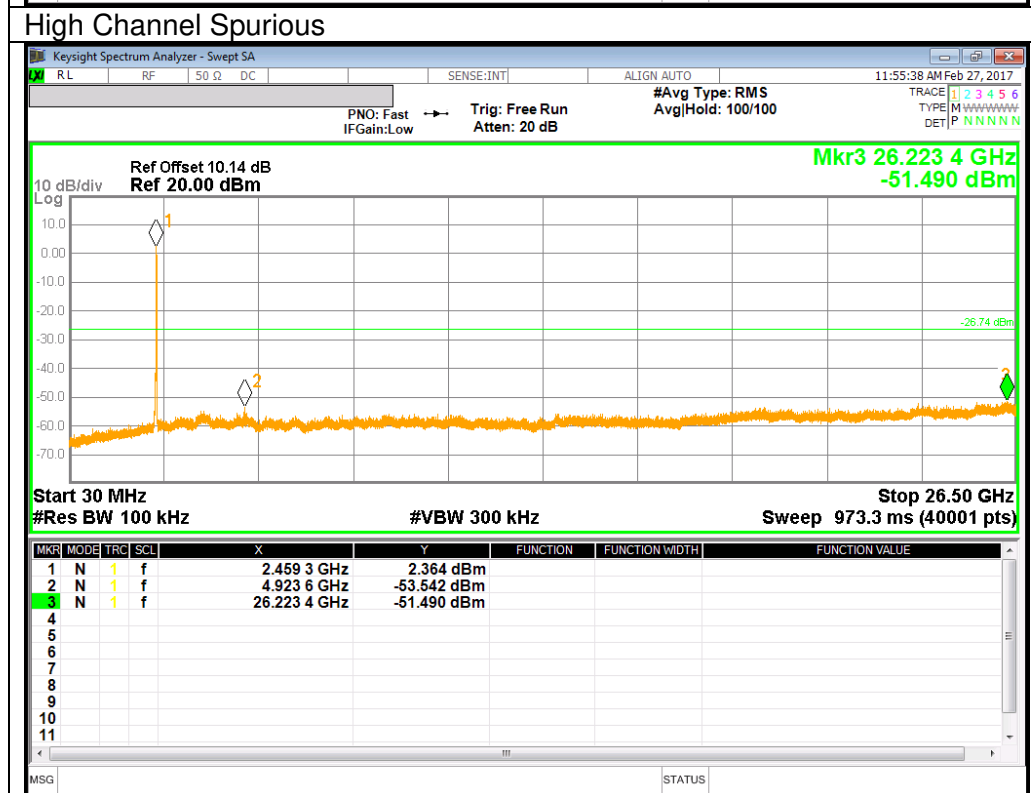
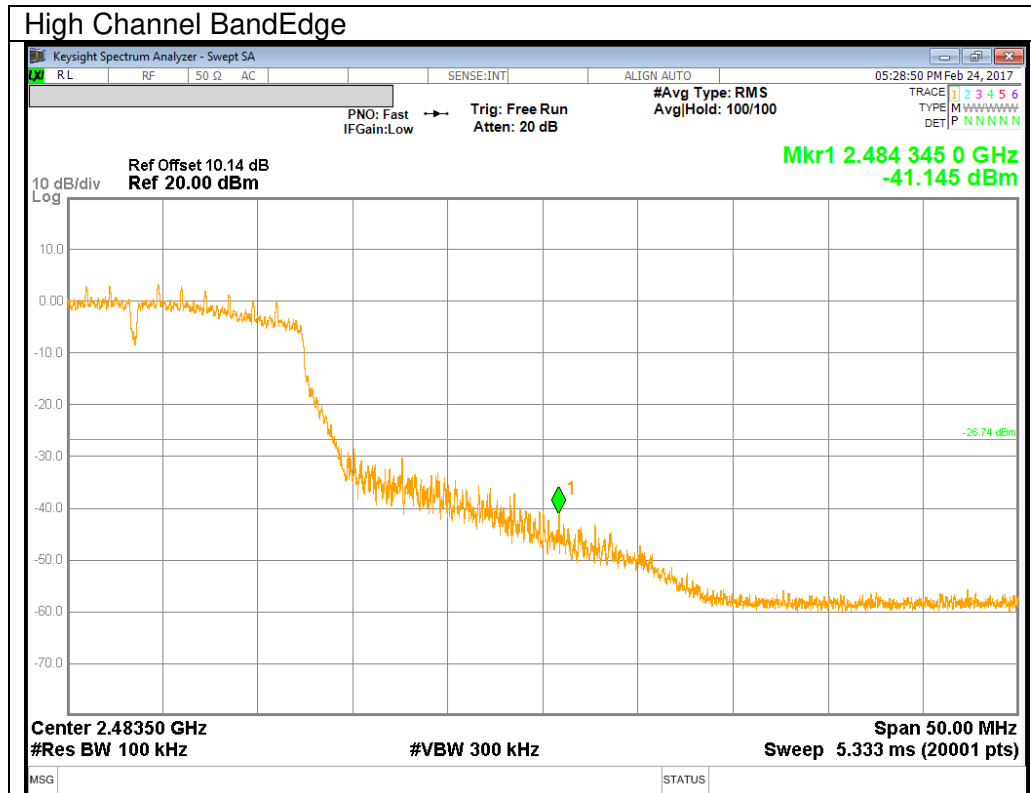

10. RADIATED TEST RESULTS

10.1. LIMITS AND PROCEDURE

LIMITS

FCC §15.205 and §15.209

Limits for radiated disturbance of an intentional radiator		
Frequency range (MHz)	Limits (µV/m)	Measurement Distance (m)
0.009 – 0.490	2400 / F (kHz)	300
0.490 – 1.705	24000 / F (kHz)	30
1.705 – 30.0	30	30
30 – 88	100**	3
88 - 216	150**	3
216 – 960	200**	3
Above 960	500	3

** Except as provided in paragraph (g), fundamental emissions from intentional radiators operating under this section shall not be located in the frequency bands 54-72 MHz, 76-88 MHz, 174-216 MHz or 470-806 MHz. However, operation within these frequency bands is permitted under other sections of this part, e.g. §§ 15.231 and 15.241.

TEST PROCEDURE

The EUT is placed on a non-conducting table 80 cm above the ground plane for below 1GHz and 150 cm for above 1GHz. The antenna to EUT distance is 3 meters. The EUT is configured in accordance with ANSI C63.10. The EUT is set to transmit in a continuous mode.

For measurements below 1 GHz the resolution bandwidth is set to 100 kHz for peak detection measurements or 120 kHz for quasi-peak detection measurements. Peak detection is used unless otherwise noted as quasi-peak.

For measurements above 1 GHz the resolution bandwidth is set to 1 MHz; the video bandwidth is set to 3 MHz for peak measurements and add duty cycle factor for average measurements. (Restricted bandedge, Final detection of spurious harmonic emissions)
Duty cycle factor= $10\log(1/x)$ For this sample B mode = 0dB (duty cycle >98%); G mode = 0.32dB; N mode = 0.34dB.

Pre-scans to detect harmonic and spurious emissions, the resolution bandwidth is set to 1 MHz; the video bandwidth is set to 30 KHz for peak measurements.

The spectrum from 1 GHz to 26 GHz is investigated with the transmitter set to the lowest, middle, and highest channels in each applicable band.
(From 30MHz to 1GHz, test was performed with the EUT set to transmit at the channel with highest output power)

The frequency range of interest is monitored at a fixed antenna height and EUT azimuth. The EUT is rotated through 360 degrees to maximize emissions received. The antenna is scanned from 1 to 4 meters above the ground plane to further maximize the emission. Measurements are made with the antenna polarized in both the vertical and the horizontal positions.

Unwanted emissions within Restricted Bands are measured using traditional radiated procedures.

Band edge emissions within Restricted Bands are measured using RMS with duty cycle factor offset method.

Note : Emission was pre-scanned from 9KHz to 30MHz; No emissions were detected which was at least 20dB below the specification limit (consider distance correction factor).
Per FCC part 15.31(o), test results were not reported.

Formula for converting the filed strength from uV/m to dBuV/m is:
Limit (dBuV/m) = $20 \log \text{limit (uV/m)}$

Although these tests were performed other than open area test site, adequate comparison measurements were confirmed against 30 m open are test site.
Therefore sufficient tests were made to demonstrate that the alternative site produces results that correlate with the one of tests made in an open field based on KDB 937606.

10.2. TRANSMITTER ABOVE 1 GHz

10.2.1. TX ABOVE 1 GHz 802.11b MODE IN THE 2.4 GHz BAND

RESTRICTED BANDEDGE (LOW CHANNEL)

HORIZONTAL PEAK AND AVERAGE PLOT

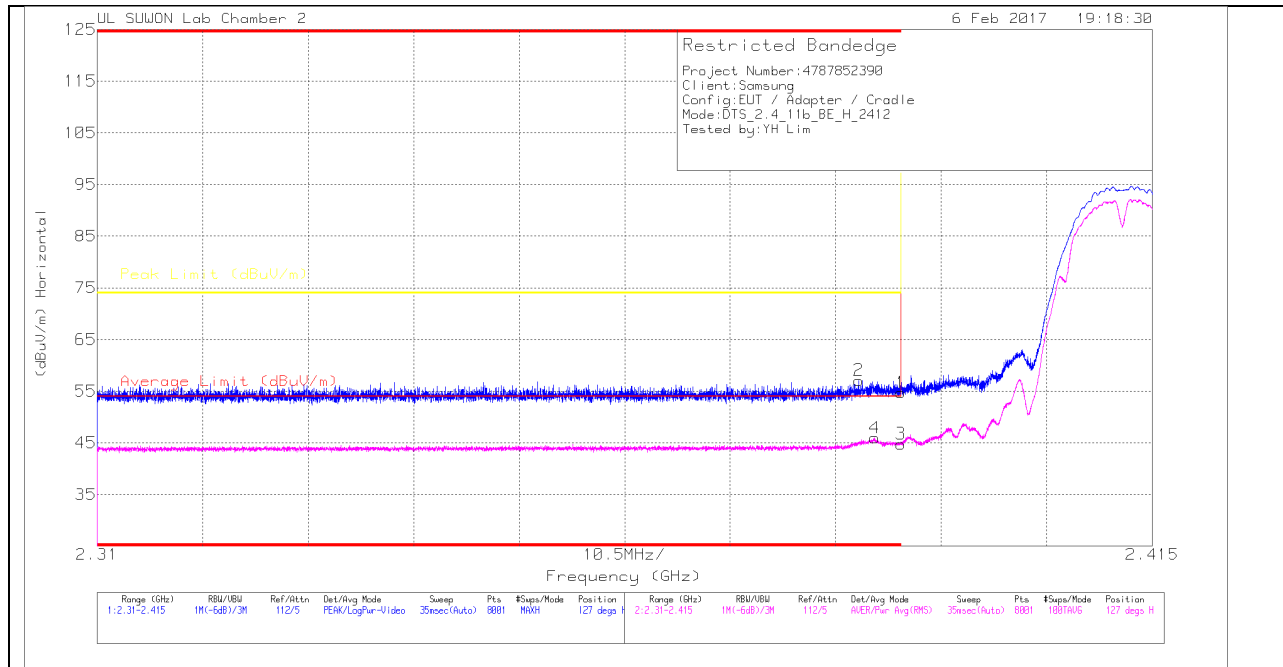

HORIZONTAL DATA

Trace Markers

Marker	Frequency (GHz)	Meter Reading (dBuV)	Det	3117(001687 24)_150619	10dB(dB)	DC Corr (dB)	Corrected Reading (dBuV/m)	Average Limit (dBuV/m)	Margin (dB)	Peak Limit (dBuV/m)	PK Margin (dB)	Azimuth (Degs)	Height (cm)	Polarity
1	* 2.39	41.21	Pk	31.7	-18.2	0	54.71	-	-	74	-19.29	127	140	H
2	* 2.386	43.6	Pk	31.7	-18.2	0	57.1	-	-	74	-16.9	127	140	H
3	* 2.39	31.31	RMS	31.7	-18.2	0	44.81	54	-9.19	-	-	127	140	H
4	* 2.387	32.47	RMS	31.7	-18.2	0	45.97	54	-8.03	-	-	127	140	H

* - indicates frequency in CFR15.205/IC7.2.2 Restricted Band

Pk - Peak detector

RMS - RMS detection

VERTICAL PEAK AND AVERAGE PLOT

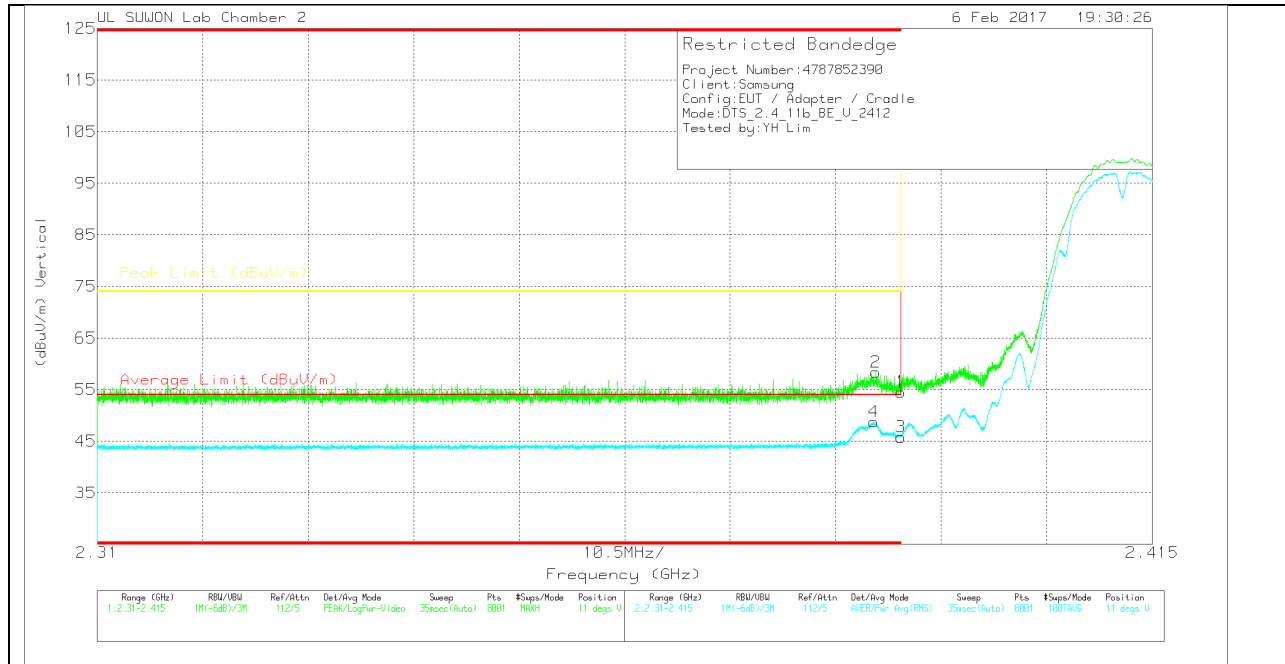

VERTICAL DATA

Trace Markers

Marker	Frequency (GHz)	Meter Reading (dBuV)	Det	3117/001687 24_150619	10dB(dB)	DC Corr (dB)	Corrected Reading (dBuV/m)	Average Limit (dBuV/m)	Margin (dB)	Peak Limit (dBuV/m)	PK Margin (dB)	Azimuth (Degs)	Height (cm)	Polarity
1	* 2.39	41.05	Pk		-18.2	0	54.55	-	-	74	-19.45	11	295	V
2	* 2.388	44.87	Pk		-18.2	0	58.37	-	-	74	-15.63	11	295	V
3	* 2.39	32.31	RMS		-18.2	0	45.81	54	-8.19	-	-	11	295	V
4	* 2.387	35.27	RMS		-18.2	0	48.77	54	-5.23	-	-	11	295	V

* - indicates frequency in CFR15.205/IC7.2.2 Restricted Band

Pk - Peak detector

RMS - RMS detection

AUTHORIZED BANDEDGE (HIGH CHANNEL)

HORIZONTAL PEAK AND AVERAGE PLOT

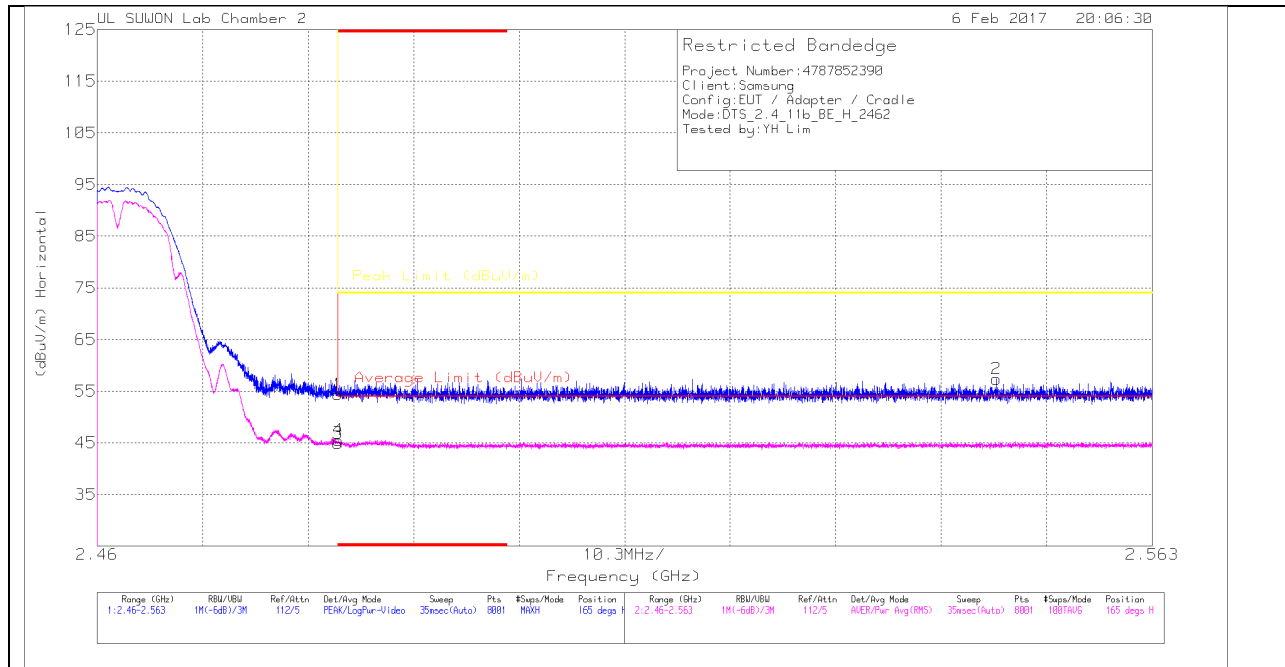

HORIZONTAL DATA

Trace Markers

Marker	Frequency (GHz)	Meter Reading (dBuV)	Det	3117(001687 24)_150619	10dB(dB)	DC Corr (dB)	Corrected Reading (dBuV/m)	Average Limit (dBuV/m)	Margin (dB)	Peak Limit (dBuV/m)	PK Margin (dB)	Azimuth (Degs)	Height (cm)	Polarity
1	* 2.484	40.59	Pk		-18	0	54.39	-	-	74	-19.61	165	157	H
2	2.548	43.48	Pk		-18	0	57.38	-	-	74	-16.62	165	157	H
3	* 2.484	31.13	RMS		-18	0	44.93	54	-9.07	-	-	165	157	H
4	* 2.484	31.75	RMS		-18	0	45.55	54	-8.45	-	-	165	157	H

* - indicates frequency in CFR15.205/IC7.2.2 Restricted Band

Pk - Peak detector

RMS - RMS detection

VERTICAL PEAK AND AVERAGE PLOT

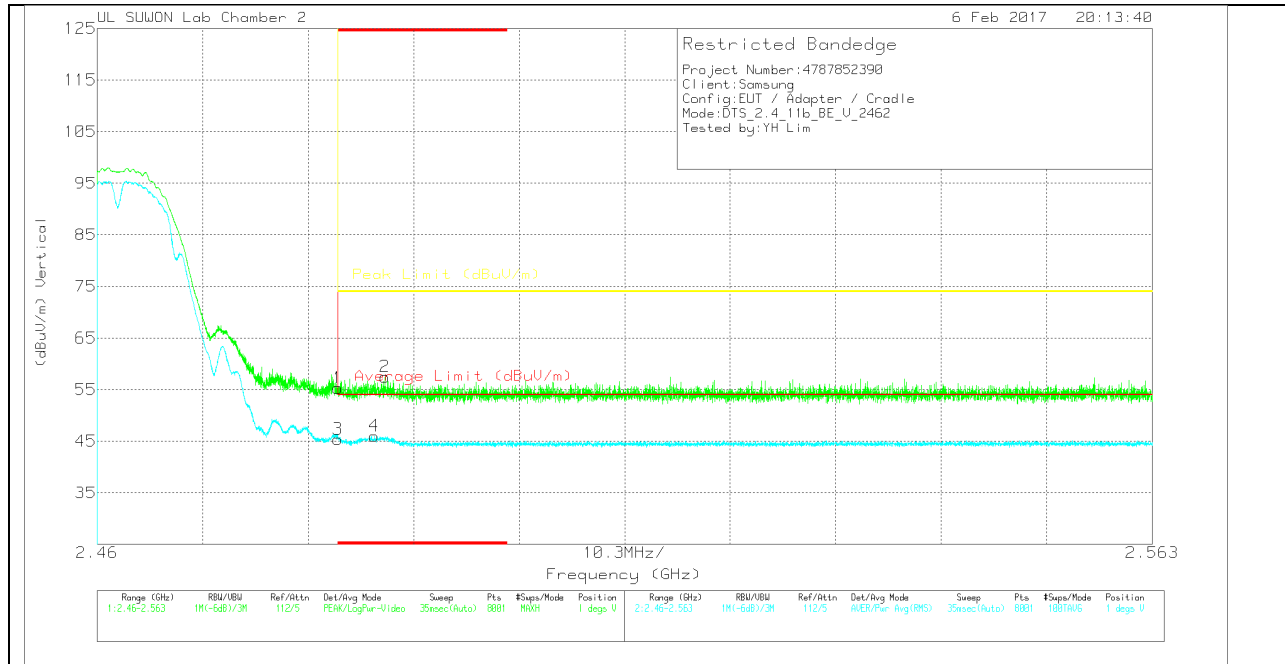

VERTICAL DATA

Trace Markers

Marker	Frequency (GHz)	Meter Reading (dBuV)	Det	3117/001687 24_150619	10dB(dB)	DC Corr (dB)	Corrected Reading (dBuV/m)	Average Limit (dBuV/m)	Margin (dB)	Peak Limit (dBuV/m)	PK Margin (dB)	Azimuth (Degs)	Height (cm)	Polarity
1	* 2.484	41.5	Pk	31.8	-18	0	55.3	-	-	74	-18.7	1	227	V
2	* 2.488	43.69	Pk	31.8	-18	0	57.49	-	-	74	-16.51	1	227	V
3	* 2.484	31.61	RMS	31.8	-18	0	45.41	54	-8.59	-	-	1	227	V
4	* 2.487	32.22	RMS	31.8	-18	0	46.02	54	-7.98	-	-	1	227	V

* - indicates frequency in CFR15.205/IC7.2.2 Restricted Band

Pk - Peak detector

RMS - RMS detection

HARMONICS AND SPURIOUS EMISSIONS

LOW CHANNEL HORIZONTAL

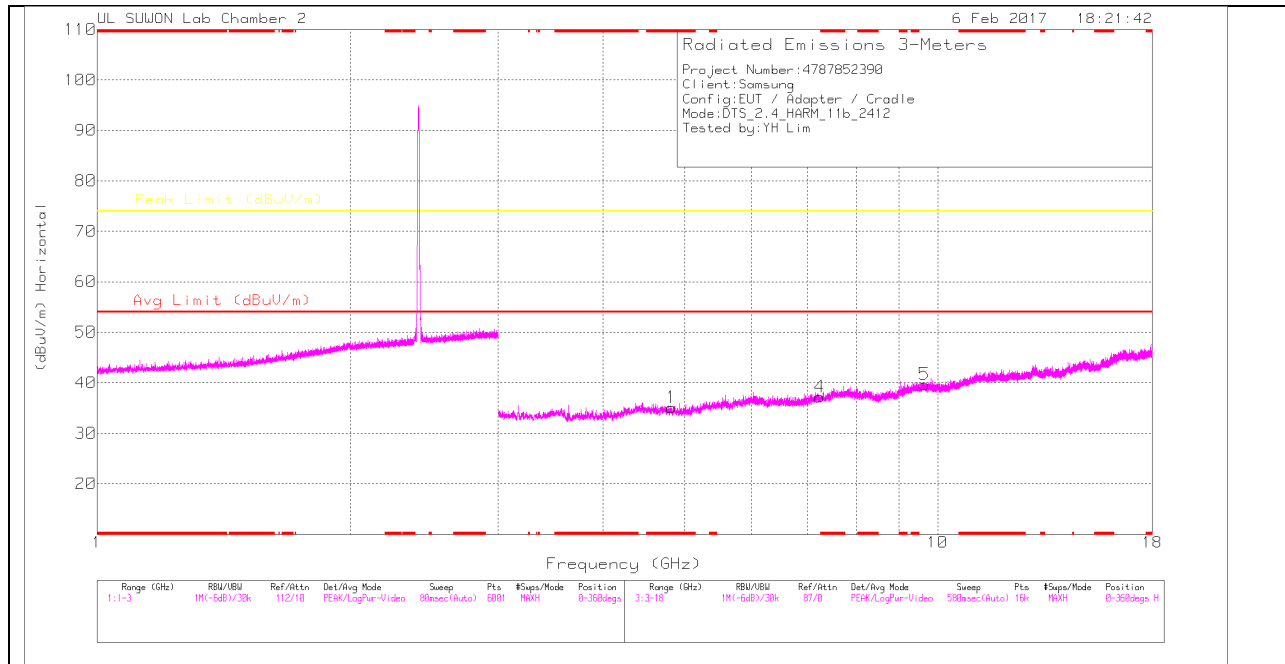

LOW CHANNEL VERTICAL

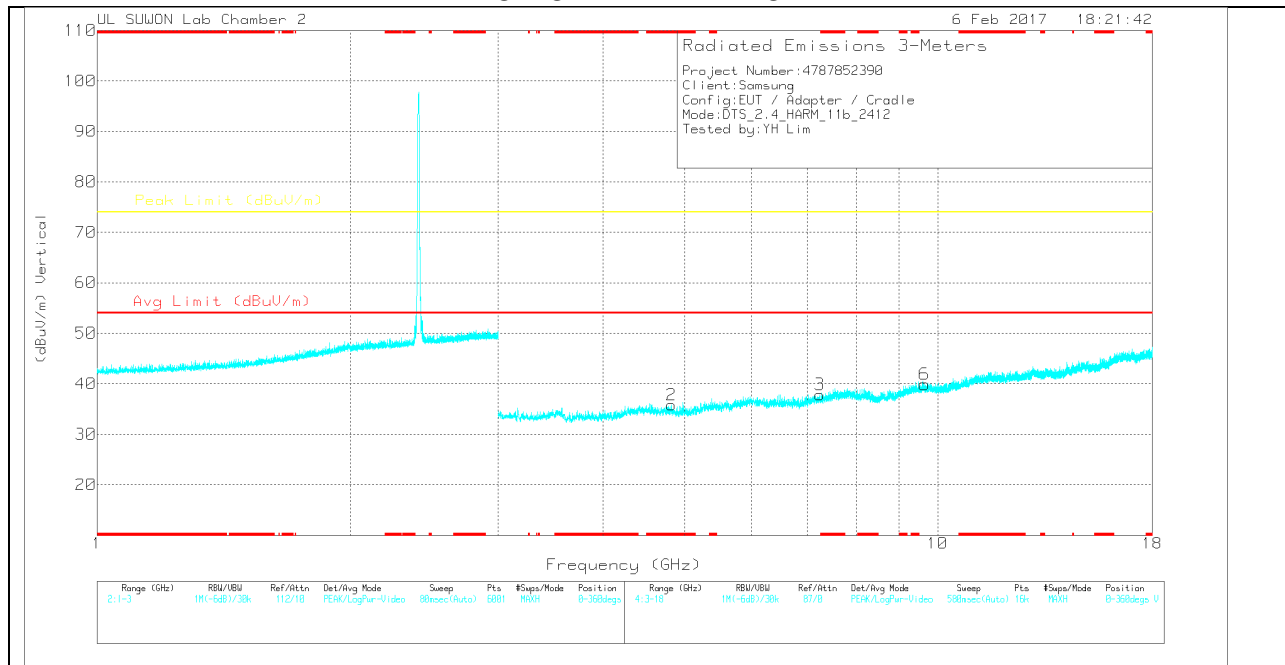

Note: Emission was scanned up to 26GHz; No emissions were detected above the noise floor which was at least 20dB below the specification limit.

LOW CHANNEL DATA

Trace Markers

Marker	Frequency (GHz)	Meter Reading (dBuV)	Det	3117(001687 24_150619)	3GHz_HP[dB]	DC Corr (dB)	Corrected Reading (dBuV/m)	Avg Limit (dBuV/m)	Margin (dB)	Peak Limit (dBuV/m)	Margin (dB)	Azimuth (Degs)	Height (cm)	Polarity
1	* 4.822	25.52	Pk	33.9	-24.3	0	35.12	-	-	74	-38.88	0-360	250	H
4	7.236	23.41	Pk	35.8	-22	0	37.21	-	-	74	-36.79	0-360	250	H
5	9.643	21.1	Pk	36.9	-18.3	0	39.7	-	-	74	-34.3	0-360	250	H
2	* 4.825	26.19	Pk	33.9	-24.3	0	35.79	-	-	74	-38.21	0-360	250	V
3	7.236	24.05	Pk	35.8	-22	0	37.85	-	-	74	-36.15	0-360	150	V
6	9.644	21.28	Pk	36.9	-18.3	0	39.88	-	-	74	-34.12	0-360	150	V

* - indicates frequency in CFR15.205/IC7.2.2 Restricted Band

Pk – Peak detector

Note: Only peak measurement was performed. Because peak measurement result of unwanted emission is less than average limit (54dBuV/m).

MID CHANNEL HORIZONTAL

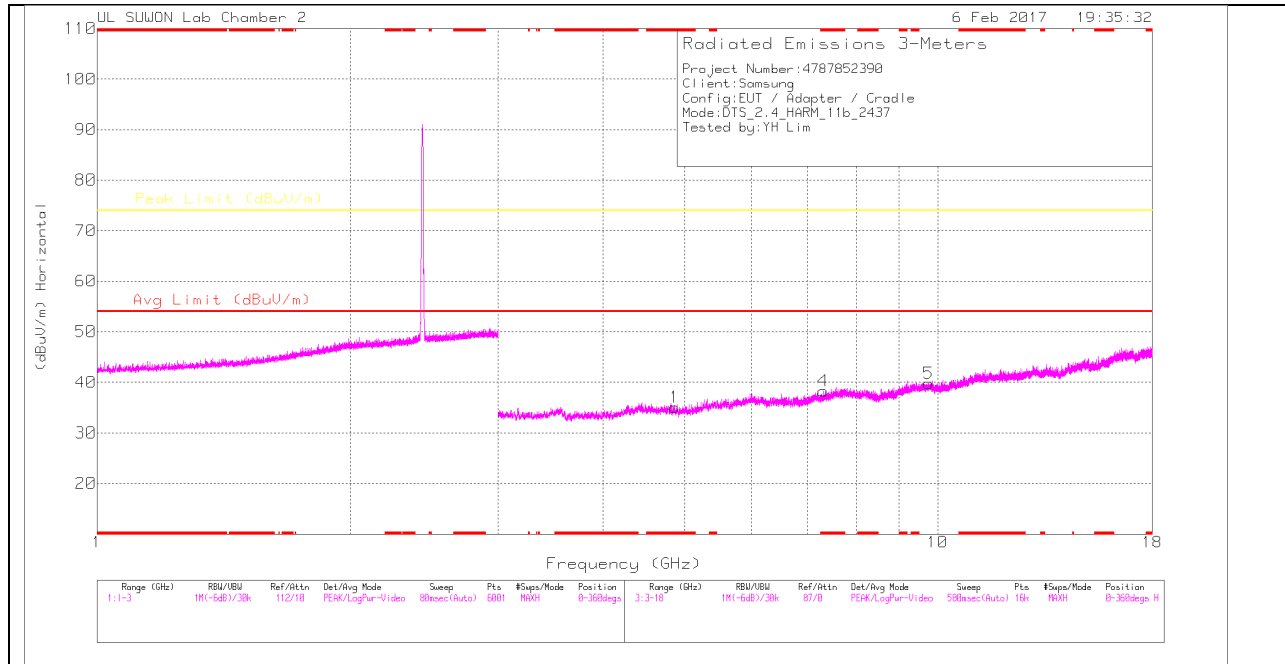

MID CHANNEL VERTICAL

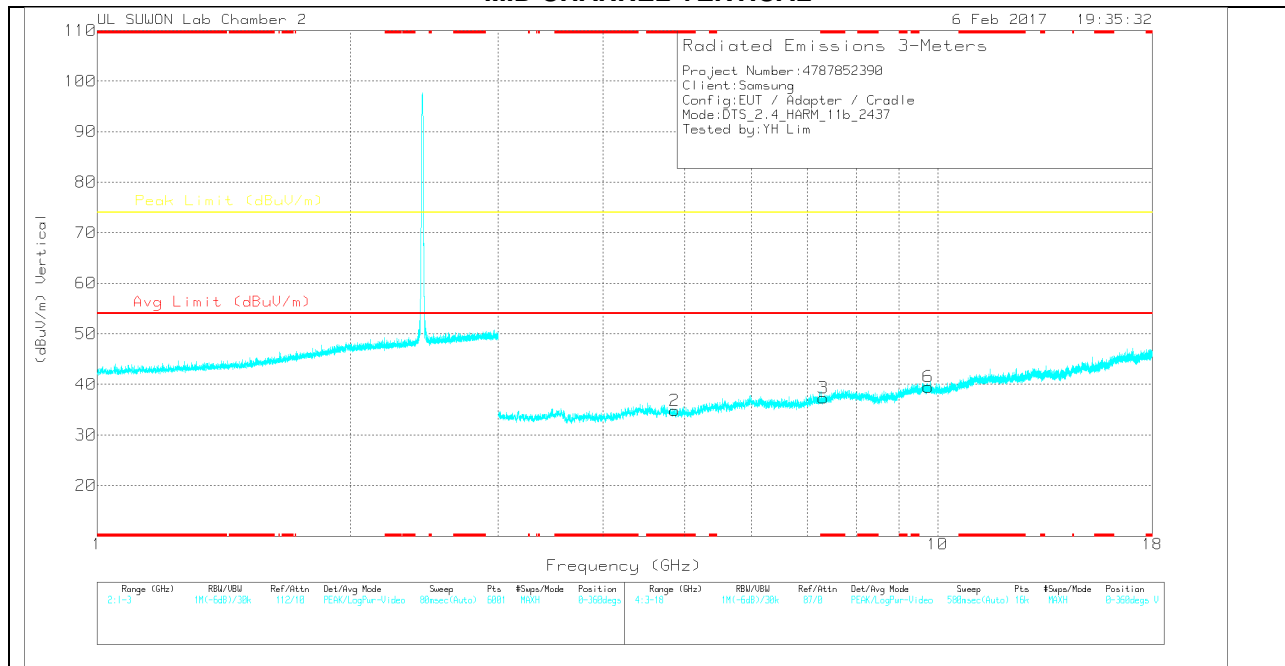

Note: Emission was scanned up to 26GHz; No emissions were detected above the noise floor which was at least 20dB below the specification limit.

MID CHANNEL DATA

Trace Markers

Marker	Frequency (GHz)	Meter Reading (dBuV)	Det	3117(001687 24_150619)	3GHz_HP[dB]	DC Corr (dB)	Corrected Reading (dBuV/m)	Avg Limit (dBuV/m)	Margin (dB)	Peak Limit (dBuV/m)	Margin (dB)	Azimuth (Degs)	Height (cm)	Polarity
1	* 4.865	25.57	Pk	33.9	-24.4	0	35.07	-	-	74	-38.93	0-360	250	H
4	* 7.31	24.4	Pk	35.9	-22	0	38.3	-	-	74	-35.7	0-360	150	H
5	9.755	20.78	Pk	37	-18	0	39.78	-	-	74	-34.22	0-360	250	H
2	* 4.864	25.29	Pk	33.9	-24.4	0	34.79	-	-	74	-39.21	0-360	250	V
3	* 7.308	23.41	Pk	35.9	-22	0	37.31	-	-	74	-36.69	0-360	250	V
6	9.745	20.6	Pk	37	-18.1	0	39.5	-	-	74	-34.5	0-360	150	V

* - indicates frequency in CFR15.205/IC7.2.2 Restricted Band

Pk – Peak detector

Note: Only peak measurement was performed. Because peak measurement result of unwanted emission is less than average limit (54dBuV/m).

HIGH CHANNEL HORIZONTAL

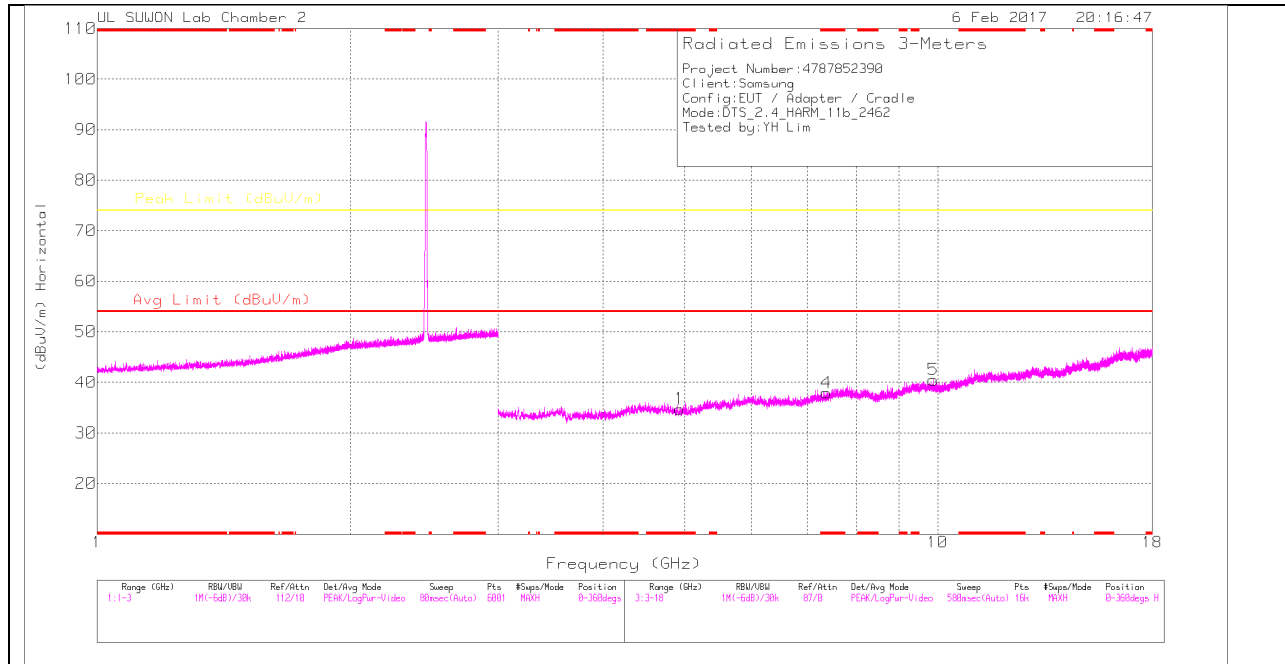

HIGH CHANNEL VERTICAL

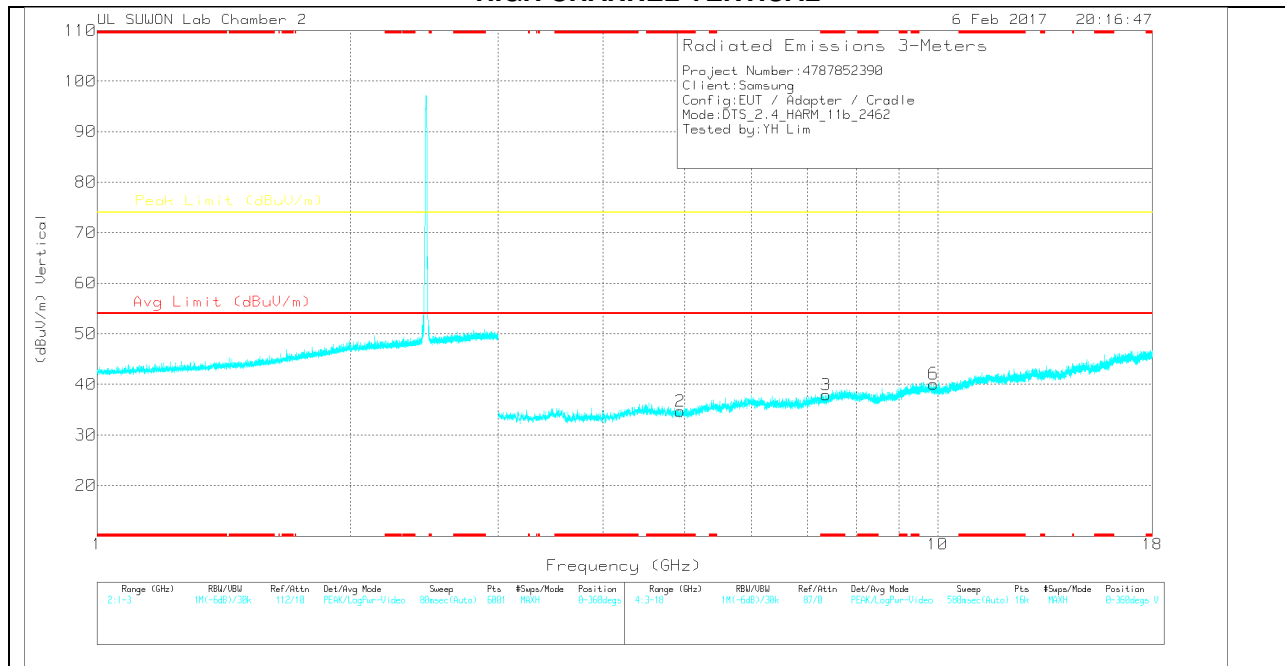

Note: Emission was scanned up to 26GHz; No emissions were detected above the noise floor which was at least 20dB below the specification limit.

HIGH CHANNEL DATA

Trace Markers

Marker	Frequency (GHz)	Meter Reading (dBuV)	Det	3117(001687 24_150619)	3GHz_HP[dB]	DC Corr (dB)	Corrected Reading (dBuV/m)	Avg Limit (dBuV/m)	Margin (dB)	Peak Limit (dBuV/m)	Margin (dB)	Azimuth (Degs)	Height (cm)	Polarity
1	* 4.934	25.52	Pk	33.9	-24.7	0	34.72	-	-	74	-39.28	0-360	150	H
4	* 7.372	23.6	Pk	35.9	-21.6	0	37.9	-	-	74	-36.1	0-360	150	H
5	9.88	21.4	Pk	37.1	-18	0	40.5	-	-	74	-33.5	0-360	150	H
2	* 4.94	25.59	Pk	33.9	-24.8	0	34.69	-	-	74	-39.31	0-360	150	V
3	* 7.366	23.63	Pk	35.9	-21.6	0	37.93	-	-	74	-36.07	0-360	150	V
6	9.893	20.99	Pk	37.1	-18	0	40.09	-	-	74	-33.91	0-360	150	V

* - indicates frequency in CFR15.205/IC7.2.2 Restricted Band

Pk – Peak detector

Note: Only peak measurement was performed. Because peak measurement result of unwanted emission is less than average limit (54dBuV/m).

10.2.2. TX ABOVE 1 GHz 802.11g MODE IN THE 2.4 GHz BAND RESTRICTED BANDEDGE (LOW CHANNEL)

HORIZONTAL PEAK AND AVERAGE PLOT

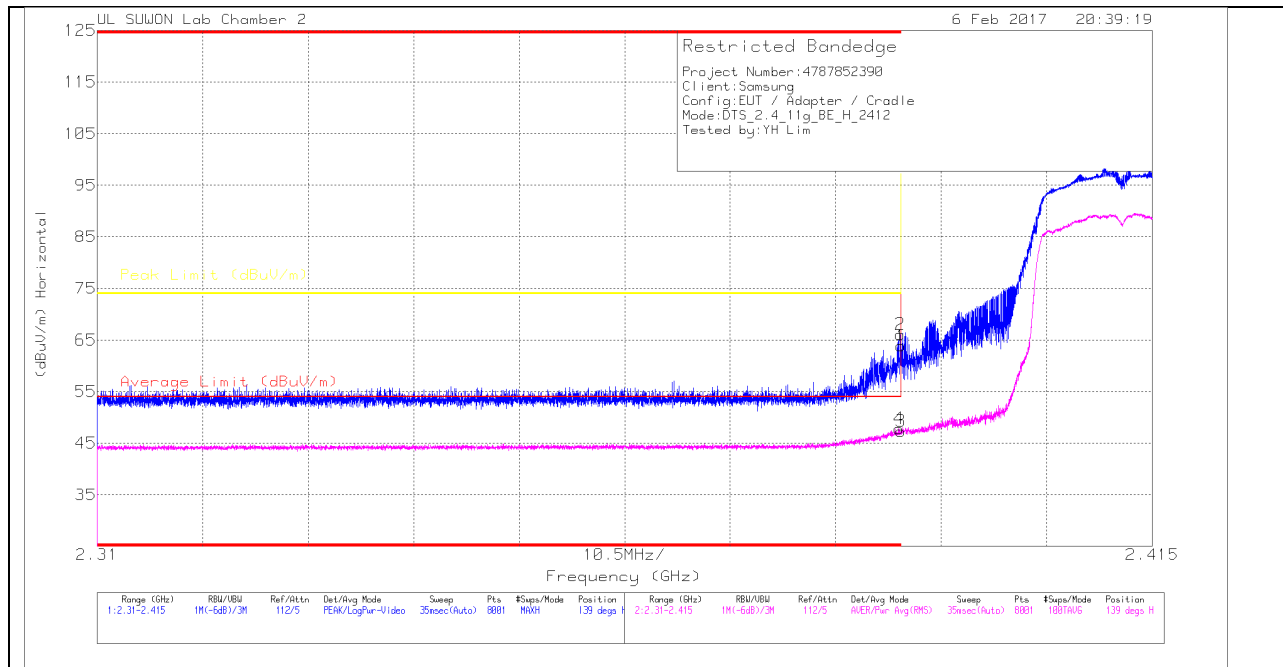

HORIZONTAL DATA

Trace Markers

Marker	Frequency (GHz)	Meter Reading (dBuV)	Det	3117(001687 24)_150619	10dB(dB)	DC Corr (dB)	Corrected Reading (dBuV/m)	Average Limit (dBuV/m)	Margin (dB)	Peak Limit (dBuV/m)	PK Margin (dB)	Azimuth (Degs)	Height (cm)	Polarity
1	* 2.39	50.38	Pk	31.7	-18.2	0	63.88	-	-	74	-10.12	139	140	H
2	* 2.39	52.59	Pk	31.7	-18.2	0	66.09	-	-	74	-7.91	139	140	H
3	* 2.39	33.54	RMS	31.7	-18.2	.32	47.36	54	-6.64	-	-	139	140	H
4	* 2.39	34.01	RMS	31.7	-18.2	.32	47.83	54	-6.17	-	-	139	140	H

* - indicates frequency in CFR15.205/IC7.2.2 Restricted Band

Pk - Peak detector

RMS - RMS detection

VERTICAL PEAK AND AVERAGE PLOT

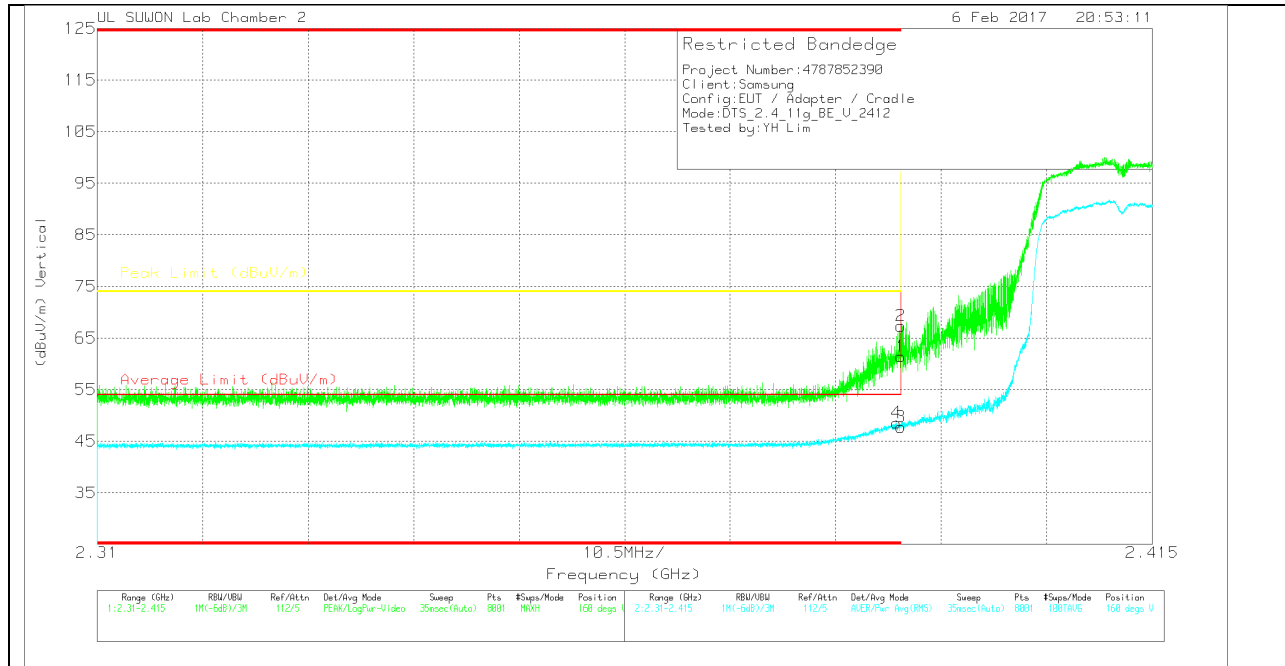

VERTICAL DATA

Trace Markers

Marker	Frequency (GHz)	Meter Reading (dBuV)	Det	3117(001687 24)_150619	10dB(dB)	DC Corr (dB)	Corrected Reading (dBuV/m)	Average Limit (dBuV/m)	Margin (dB)	Peak Limit (dBuV/m)	PK Margin (dB)	Azimuth (Degs)	Height (cm)	Polarity
1	* 2.39	47.92	Pk	31.7	-18.2	0	61.42	-	-	74	-12.58	160	153	V
2	* 2.39	53.86	Pk	31.7	-18.2	0	67.36	-	-	74	-6.64	160	153	V
3	* 2.39	33.95	RMS	31.7	-18.2	.32	47.77	54	-6.23	-	-	160	153	V
4	* 2.39	34.73	RMS	31.7	-18.2	.32	48.55	54	-5.45	-	-	160	153	V

* - indicates frequency in CFR15.205/IC7.2.2 Restricted Band

Pk - Peak detector

RMS - RMS detection

AUTHORIZED BANDEDGE (HIGH CHANNEL)

HORIZONTAL PEAK AND AVERAGE PLOT

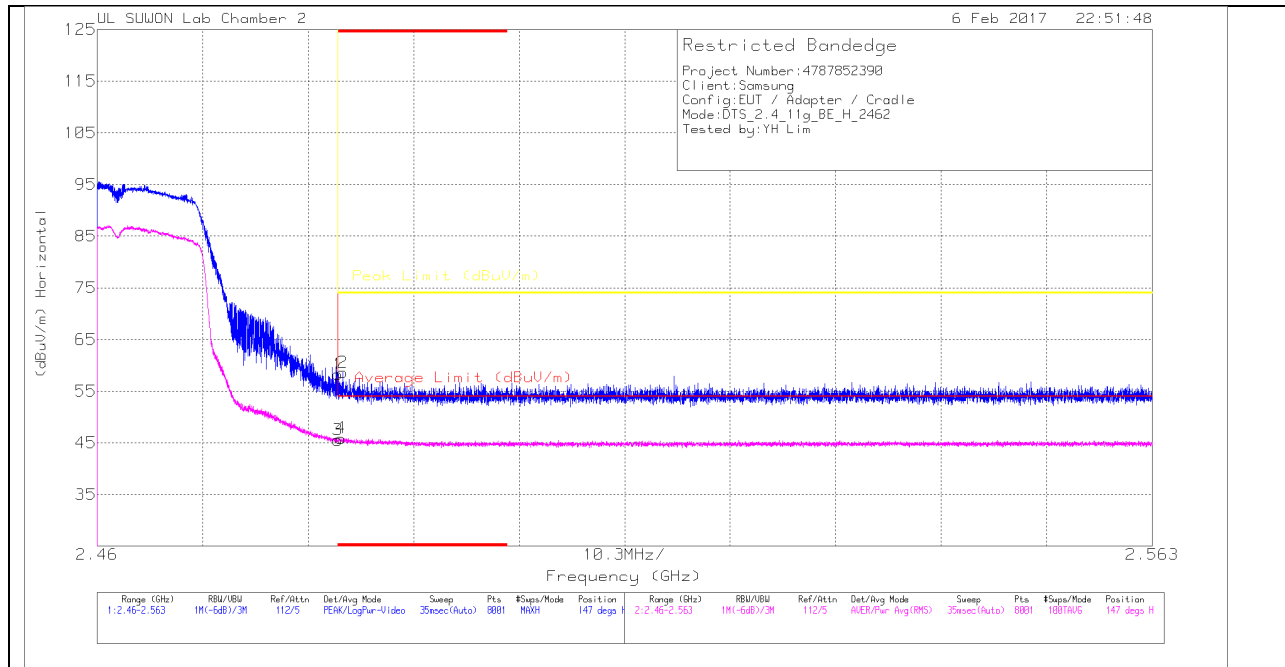

HORIZONTAL DATA

Trace Markers

Marker	Frequency (GHz)	Meter Reading (dBuV)	Det	3117(001687 24)_150619	10dB(dB)	DC Corr (dB)	Corrected Reading (dBuV/m)	Average Limit (dBuV/m)	Margin (dB)	Peak Limit (dBuV/m)	PK Margin (dB)	Azimuth (Degs)	Height (cm)	Polarity
1	* 2.484	44.44	Pk		-18	0	58.24	-	-	74	-15.76	147	107	H
2	* 2.484	44.82	Pk		-18	0	58.62	-	-	74	-15.38	147	107	H
3	* 2.484	31.44	RMS		-18	.32	45.56	54	-8.44	-	-	147	107	H
4	* 2.484	31.79	RMS		-18	.32	45.91	54	-8.09	-	-	147	107	H

* - indicates frequency in CFR15.205/IC7.2.2 Restricted Band

Pk - Peak detector

RMS - RMS detection

VERTICAL PEAK AND AVERAGE PLOT

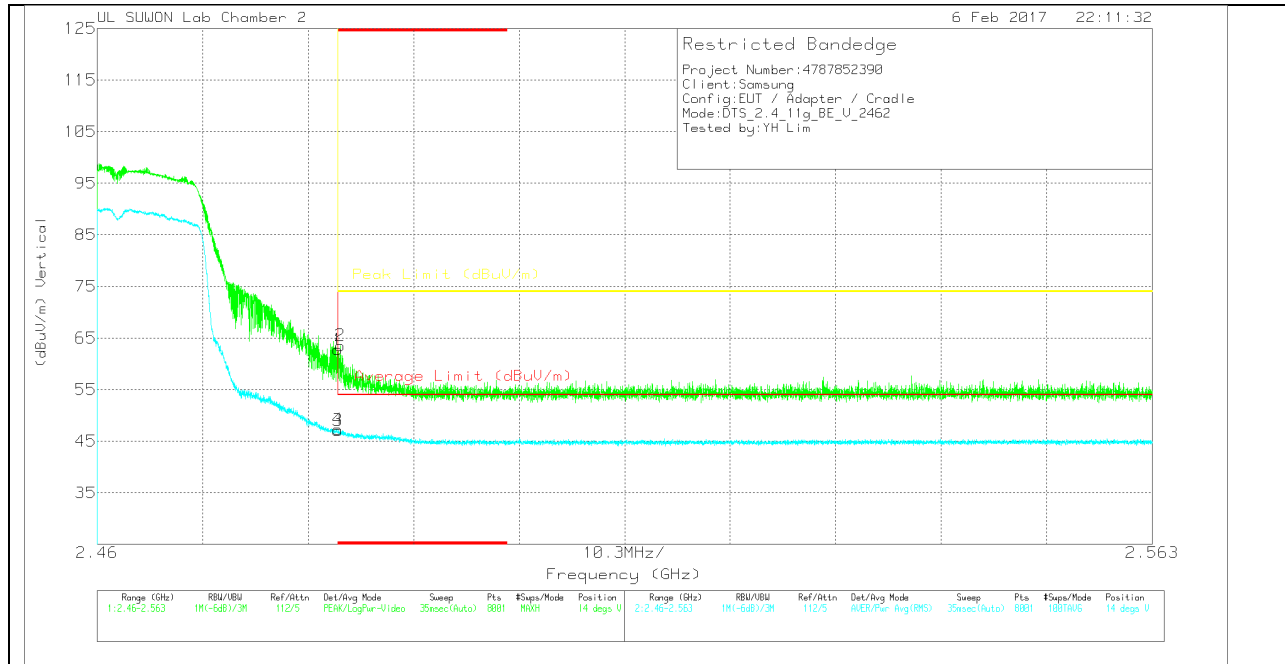

VERTICAL DATA

Trace Markers

Marker	Frequency (GHz)	Meter Reading (dBuV)	Det	3117(001687 24)_150619	10dB(dB)	DC Corr (dB)	Corrected Reading (dBuV/m)	Average Limit (dBuV/m)	Margin (dB)	Peak Limit (dBuV/m)	PK Margin (dB)	Azimuth (Degs)	Height (cm)	Polarity
1	* 2.484	48.98	Pk	31.8	-18	0	62.78	-	-	74	-11.22	14	216	V
2	* 2.484	49.74	Pk	31.8	-18	0	63.54	-	-	74	-10.46	14	216	V
3	* 2.484	32.99	RMS	31.8	-18	.32	47.11	54	-6.89	-	-	14	216	V
4	* 2.484	33.17	RMS	31.8	-18	.32	47.29	54	-6.71	-	-	14	216	V

* - indicates frequency in CFR15.205/IC7.2.2 Restricted Band

Pk - Peak detector

RMS - RMS detection

HARMONICS AND SPURIOUS EMISSIONS

LOW CHANNEL HORIZONTAL

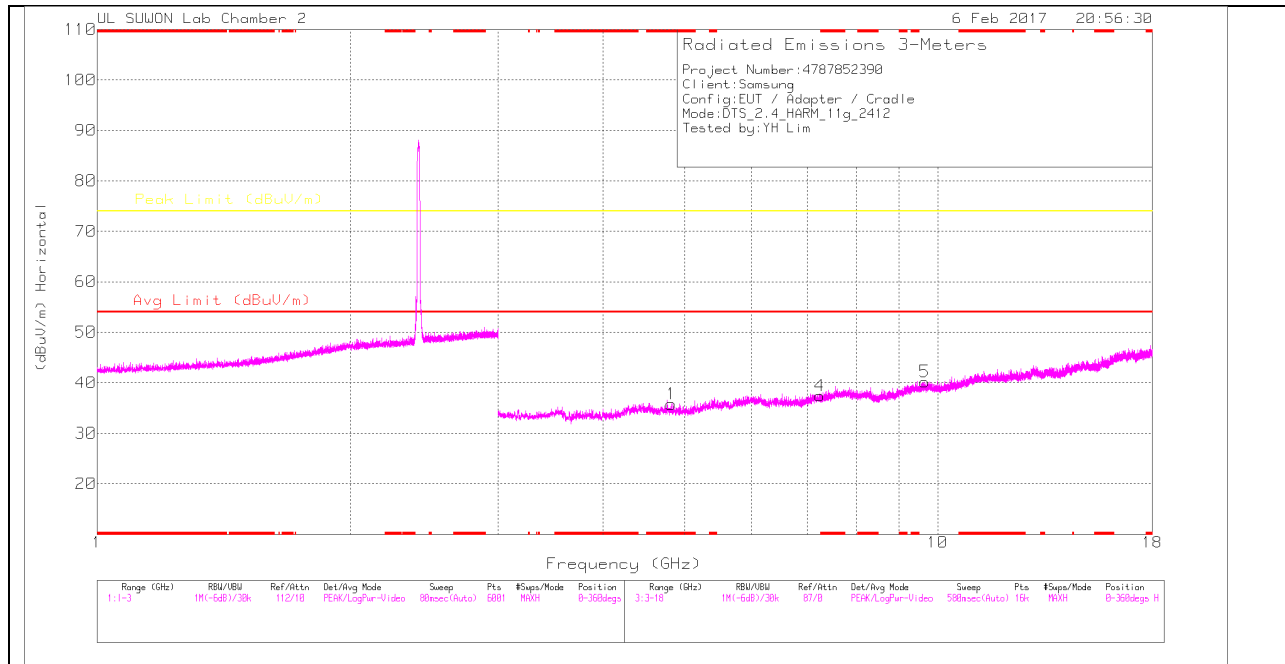

LOW CHANNEL VERTICAL

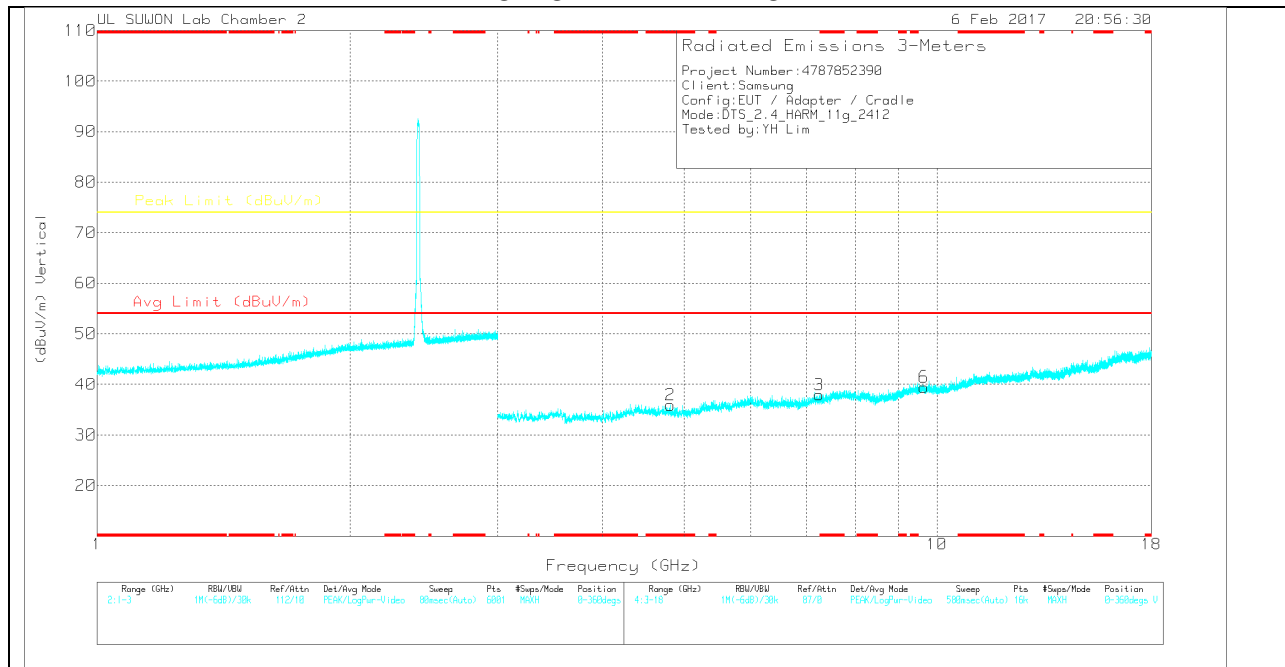

Note: Emission was scanned up to 26GHz; No emissions were detected above the noise floor which was at least 20dB below the specification limit.

LOW CHANNEL DATA

Trace Markers

Marker	Frequency (GHz)	Meter Reading (dBuV)	Det	3117(001687 24)_150619	3GHz_HP[dB]	DC Corr (dB)	Corrected Reading (dBuV/m)	Avg Limit (dBuV/m)	Margin (dB)	Peak Limit (dBuV/m)	Margin (dB)	Azimuth (Degs)	Height (cm)	Polarity
1	* 4.82	26.17	Pk	33.9	-24.3	0	35.77	-	-	74	-38.23	0-360	250	H
4	7.244	23.63	Pk	35.8	-22	0	37.43	-	-	74	-36.57	0-360	150	H
5	9.654	21.59	Pk	36.9	-18.3	0	40.19	-	-	74	-33.81	0-360	250	H
2	* 4.814	26.3	Pk	33.9	-24.3	0	35.9	-	-	74	-38.1	0-360	250	V
3	7.241	24.11	Pk	35.8	-22	0	37.91	-	-	74	-36.09	0-360	250	V
6	9.651	20.84	Pk	36.9	-18.3	0	39.44	-	-	74	-34.56	0-360	150	V

* - indicates frequency in CFR15.205/IC7.2.2 Restricted Band

Pk - Peak detector

Note: Only peak measurement was performed. Because peak measurement result of unwanted emission is less than average limit (54dBuV/m).

MID CHANNEL HORIZONTAL

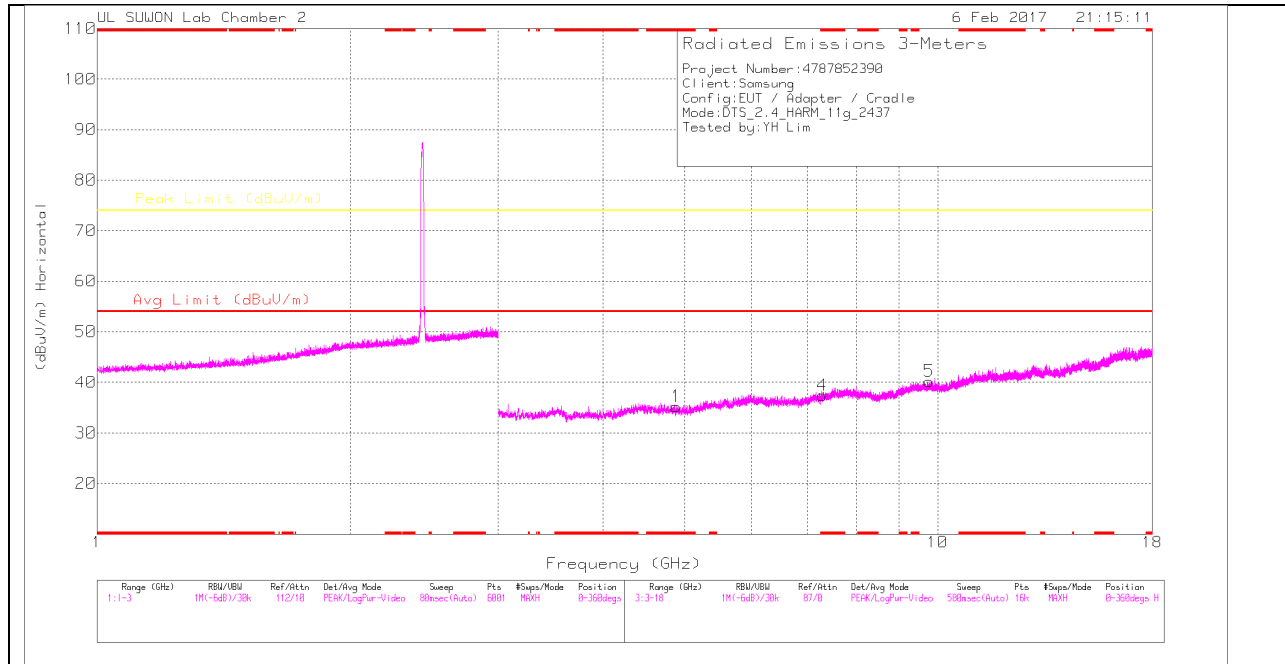

MID CHANNEL VERTICAL

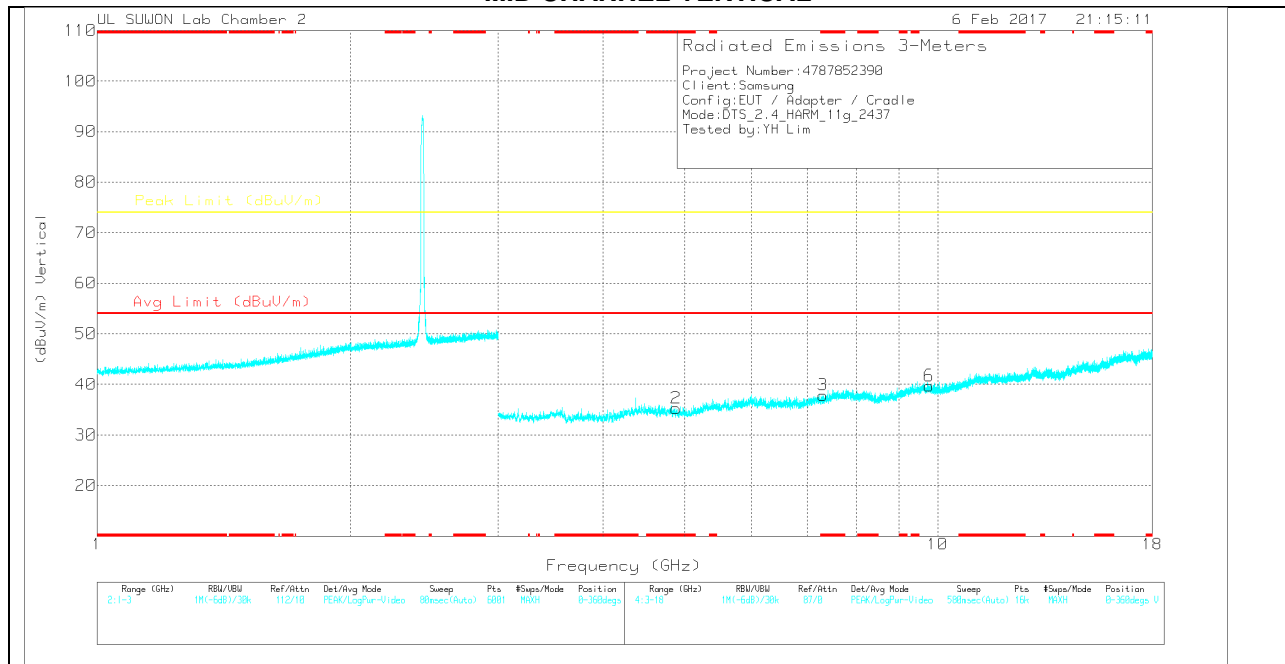

Note: Emission was scanned up to 26GHz; No emissions were detected above the noise floor which was at least 20dB below the specification limit.

MID CHANNEL DATA

Trace Markers

Marker	Frequency (GHz)	Meter Reading (dBuV)	Det	3117(001687 24_150619)	3GHz_HP[dB]	DC Corr (dB)	Corrected Reading (dBuV/m)	Avg Limit (dBuV/m)	Margin (dB)	Peak Limit (dBuV/m)	Margin (dB)	Azimuth (Degs)	Height (cm)	Polarity
1	* 4.886	25.91	Pk	33.9	-24.6	0	35.21	-	-	74	-38.79	0-360	150	H
4	* 7.294	23.63	Pk	35.8	-22	0	37.43	-	-	74	-36.57	0-360	250	H
5	9.772	21.21	Pk	37	-18	0	40.21	-	-	74	-33.79	0-360	250	H
2	* 4.885	25.96	Pk	33.9	-24.6	0	35.26	-	-	74	-38.74	0-360	250	V
3	* 7.3	23.96	Pk	35.9	-22	0	37.86	-	-	74	-36.14	0-360	250	V
6	9.774	20.69	Pk	37	-18	0	39.69	-	-	74	-34.31	0-360	250	V

* - indicates frequency in CFR15.205/IC7.2.2 Restricted Band

Pk – Peak detector

Note: Only peak measurement was performed. Because peak measurement result of unwanted emission is less than average limit (54dBuV/m).

HIGH CHANNEL HORIZONTAL

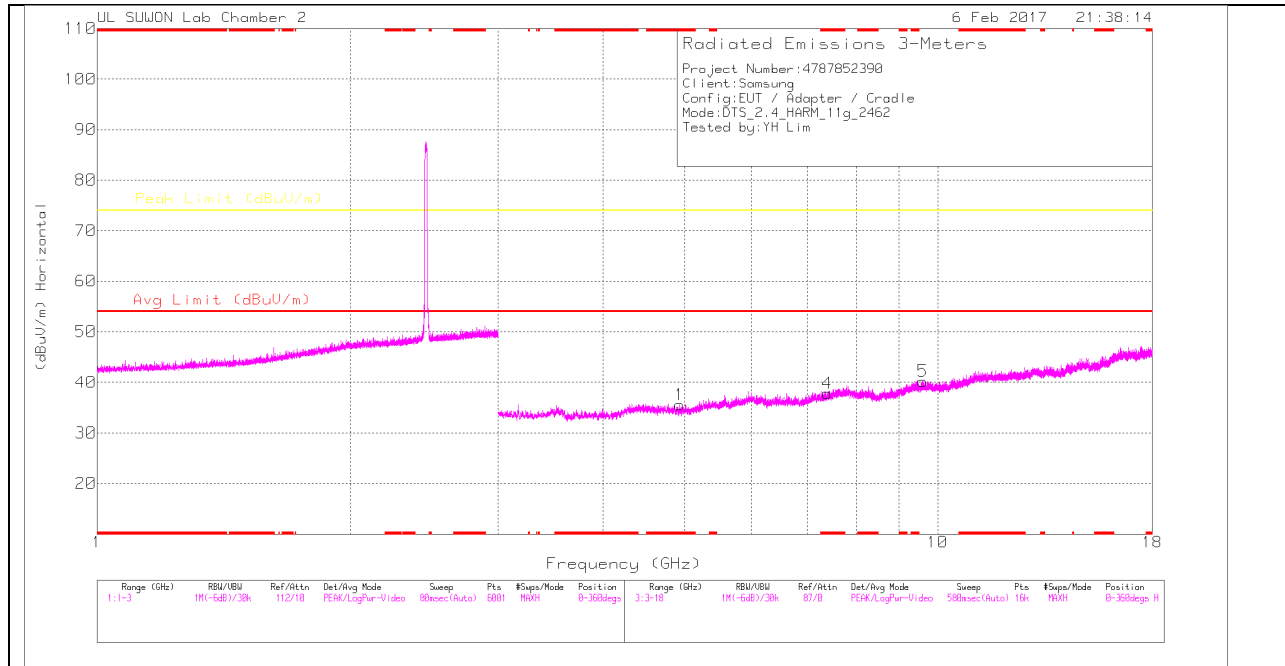

HIGH CHANNEL VERTICAL

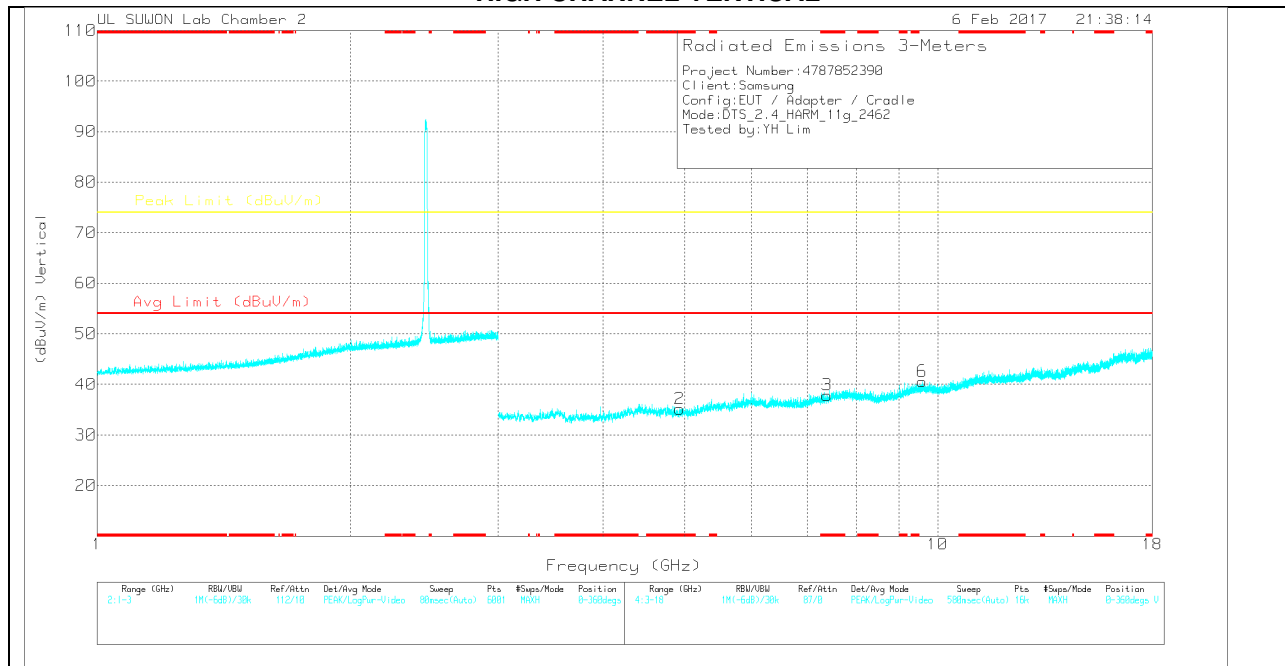

Note: Emission was scanned up to 26GHz; No emissions were detected above the noise floor which was at least 20dB below the specification limit.

HIGH CHANNEL DATA

Trace Markers

Marker	Frequency (GHz)	Meter Reading (dBuV)	Det	3117(001687 24_150619)	3GHz_HP[dB]	DC Corr (dB)	Corrected Reading (dBuV/m)	Avg Limit (dBuV/m)	Margin (dB)	Peak Limit (dBuV/m)	Margin (dB)	Azimuth (Degs)	Height (cm)	Polarity
1	* 4.932	26.37	Pk	33.9	-24.7	0	35.57	-	-	74	-38.43	0-360	250	H
4	* 7.39	23.17	Pk	35.9	-21.3	0	37.77	-	-	74	-36.23	0-360	150	H
5	9.604	21.7	Pk	36.9	-18.4	0	40.2	-	-	74	-33.8	0-360	250	H
2	* 4.935	25.95	Pk	33.9	-24.7	0	35.15	-	-	74	-38.85	0-360	150	V
3	* 7.384	23.37	Pk	35.9	-21.4	0	37.87	-	-	74	-36.13	0-360	150	V
6	9.591	22.07	Pk	36.9	-18.4	0	40.57	-	-	74	-33.43	0-360	250	V

* - indicates frequency in CFR15.205/IC7.2.2 Restricted Band

Pk - Peak detector

Note: Only peak measurement was performed. Because peak measurement result of unwanted emission is less than average limit (54dBuV/m).

10.2.3. TX ABOVE 1 GHz 802.11n HT20 MODE IN THE 2.4 GHz BAND RESTRICTED BANDEDGE (LOW CHANNEL)

HORIZONTAL PEAK AND AVERAGE PLOT

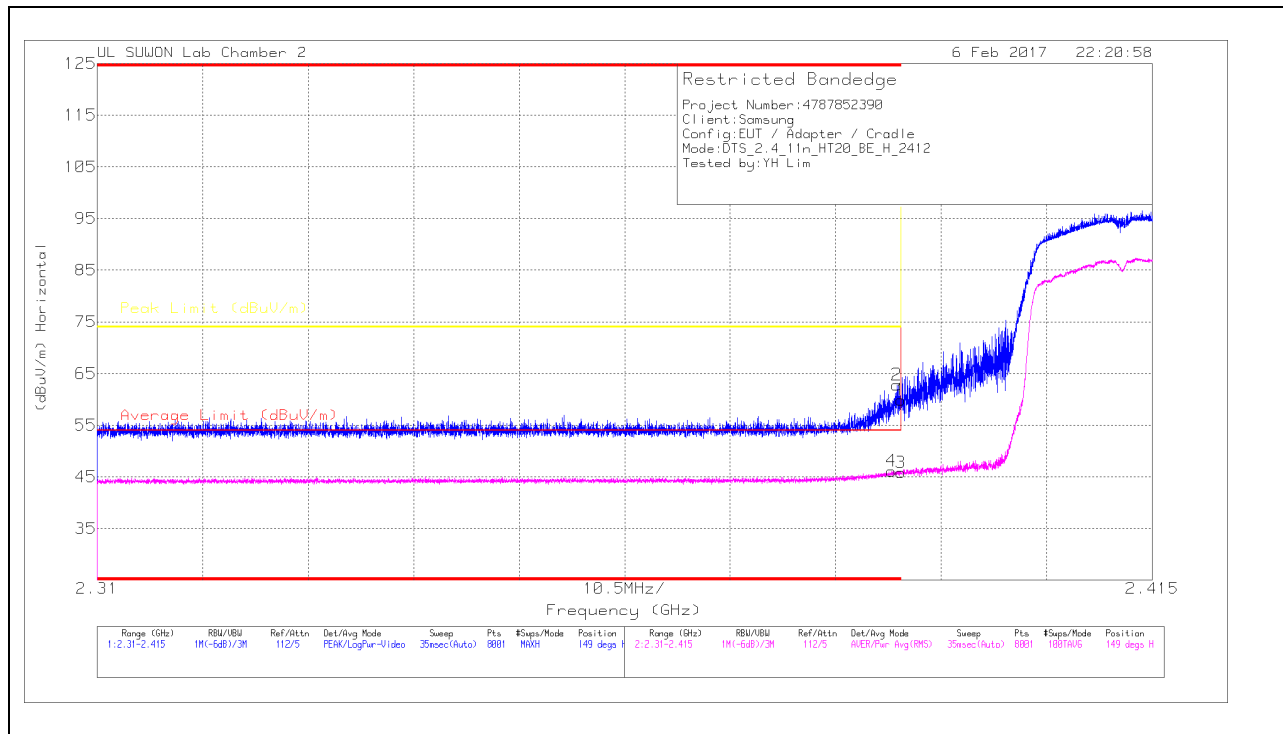

HORIZONTAL DATA

Trace Markers

Marker	Frequency (GHz)	Meter Reading (dBuV)	Det	3117(001687 24)_150619	10dB(dB)	DC Corr (dB)	Corrected Reading (dBuV/m)	Average Limit (dBuV/m)	Margin (dB)	Peak Limit (dBuV/m)	PK Margin (dB)	Azimuth (Degs)	Height (cm)	Polarity
1	* 2.39	46.42	Pk	31.7	-18.2	0	59.92	-	-	74	-14.08	149	116	H
2	* 2.39	49.3	Pk	31.7	-18.2	0	62.8	-	-	74	-11.2	149	116	H
3	* 2.39	32.03	RMS	31.7	-18.2	.34	45.87	54	-8.13	-	-	149	116	H
4	* 2.389	32.31	RMS	31.7	-18.2	.34	46.15	54	-7.85	-	-	149	116	H

* - indicates frequency in CFR15.205/IC7.2.2 Restricted Band

Pk - Peak detector

RMS - RMS detection

VERTICAL PEAK AND AVERAGE PLOT

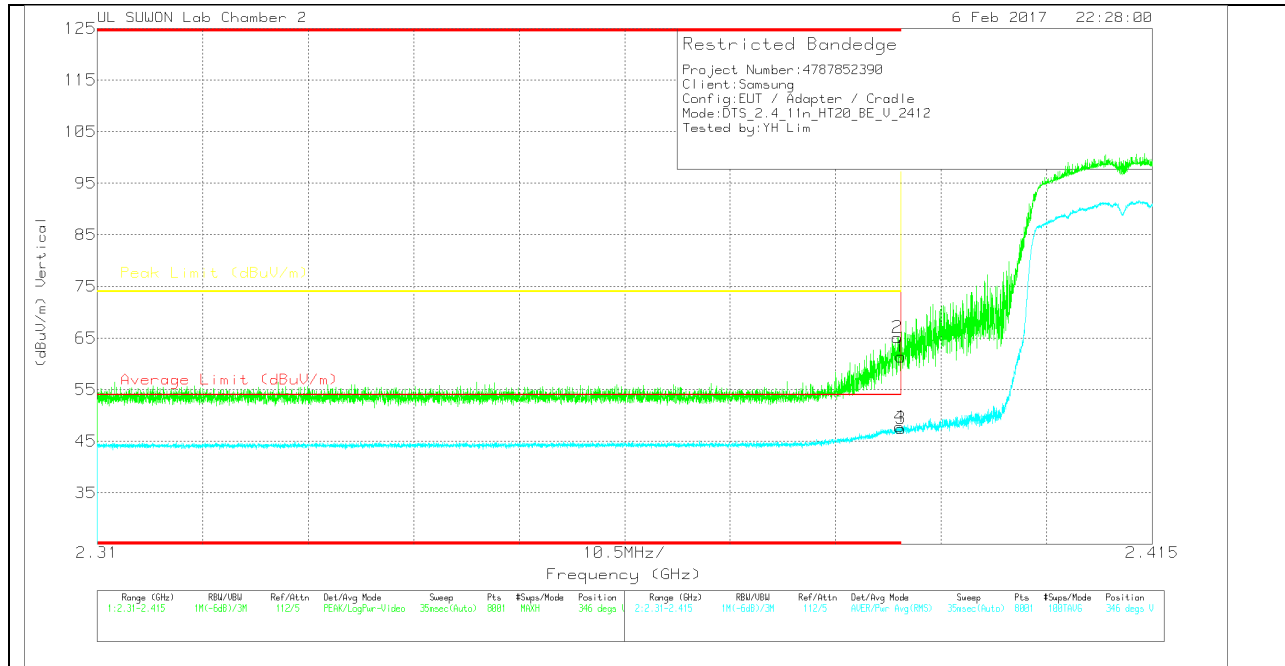

VERTICAL DATA

Trace Markers

Marker	Frequency (GHz)	Meter Reading (dBuV)	Det	3117(001687 24)_150619	10dB(dB)	DC Corr (dB)	Corrected Reading (dBuV/m)	Average Limit (dBuV/m)	Margin (dB)	Peak Limit (dBuV/m)	PK Margin (dB)	Azimuth (Degs)	Height (cm)	Polarity
1	* 2.39	47.9	Pk	31.7	-18.2	0	61.4	-	-	74	-12.6	346	207	V
2	* 2.39	51.64	PK	31.7	-18.2	0	65.14	-	-	74	-8.86	346	207	V
3	* 2.39	33.65	RMS	31.7	-18.2	.34	47.49	54	-6.51	-	-	346	207	V
4	* 2.39	33.96	RMS	31.7	-18.2	.34	47.8	54	-6.2	-	-	346	207	V

* - indicates frequency in CFR15.205/IC7.2.2 Restricted Band

Pk - Peak detector

RMS - RMS detection

AUTHORIZED BANDEDGE (HIGH CHANNEL)

HORIZONTAL PEAK AND AVERAGE PLOT

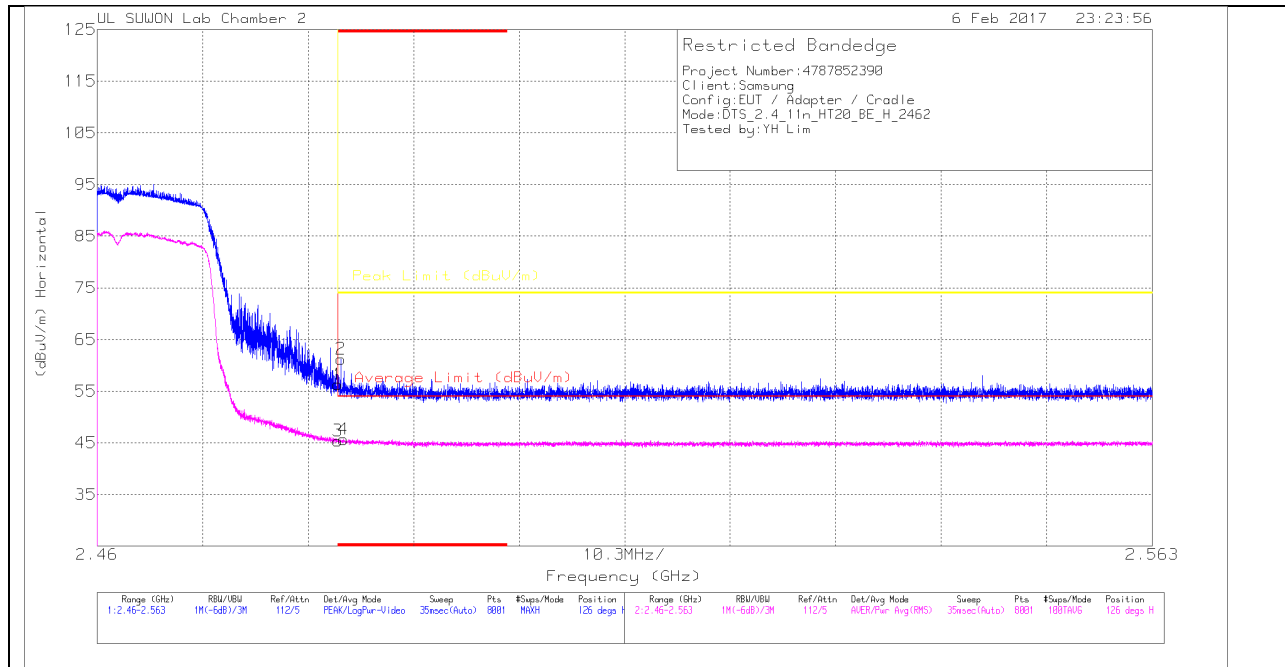

HORIZONTAL DATA

Trace Markers

Marker	Frequency (GHz)	Meter Reading (dBuV)	Det	3117(001687 24)_150619	10dB(dB)	DC Corr (dB)	Corrected Reading (dBuV/m)	Average Limit (dBuV/m)	Margin (dB)	Peak Limit (dBuV/m)	PK Margin (dB)	Azimuth (Degs)	Height (cm)	Polarity
1	* 2.484	42.51	Pk	31.8	-18	0	56.31	-	-	74	-17.69	126	147	H
2	* 2.484	47.44	Pk	31.8	-18	0	61.24	-	-	74	-12.76	126	147	H
3	* 2.484	31.27	RMS	31.8	-18	.34	45.41	54	-8.59	-	-	126	147	H
4	* 2.484	31.55	RMS	31.8	-18	.34	45.69	54	-8.31	-	-	126	147	H

* - indicates frequency in CFR15.205/IC7.2.2 Restricted Band

Pk - Peak detector

RMS - RMS detection

VERTICAL PEAK AND AVERAGE PLOT

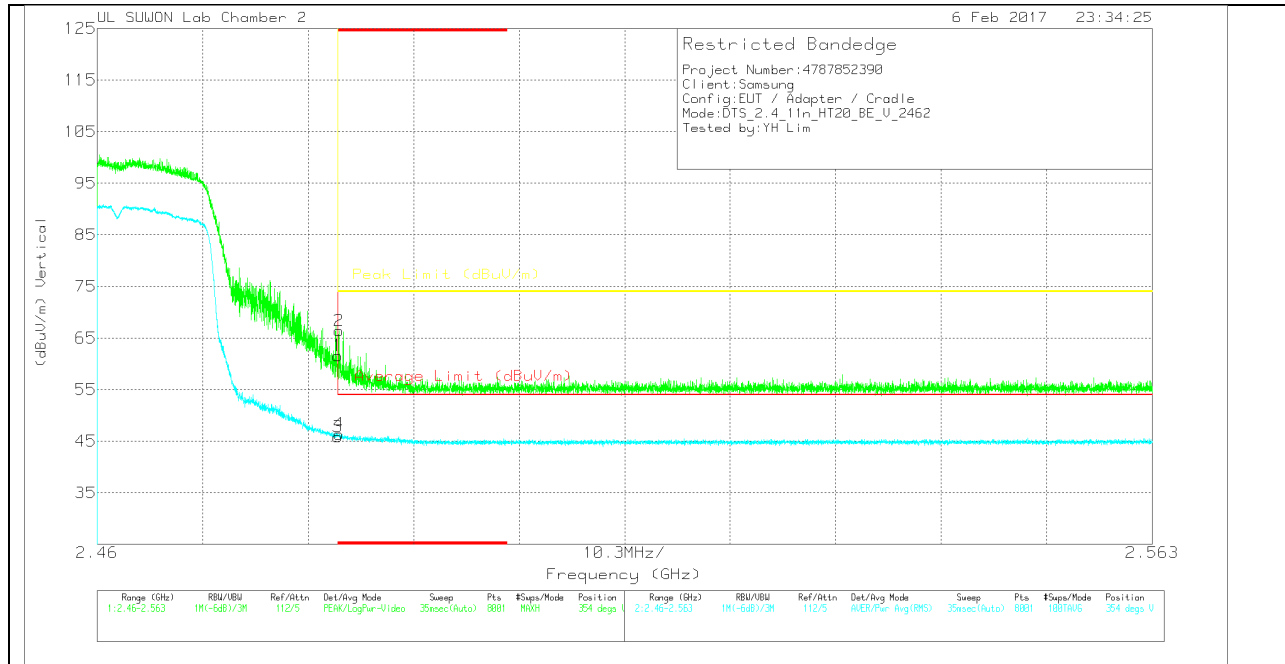

VERTICAL DATA

Trace Markers

Marker	Frequency (GHz)	Meter Reading (dBuV)	Det	3117(001687 24)_150619	10dB[dB]	DC Corr (dB)	Corrected Reading (dBuV/m)	Average Limit (dBuV/m)	Margin (dB)	Peak Limit (dBuV/m)	PK Margin (dB)	Azimuth (Degs)	Height (cm)	Polarity
1	* 2.484	47.81	Pk	31.8	-18	0	61.61	-	-	74	-12.39	354	172	V
2	* 2.484	52.61	Pk	31.8	-18	0	66.41	-	-	74	-7.59	354	172	V
3	* 2.484	31.69	RMS	31.8	-18	.34	45.83	54	-8.17	-	-	354	172	V
4	* 2.484	32.26	RMS	31.8	-18	.34	46.4	54	-7.6	-	-	354	172	V

* - indicates frequency in CFR15.205/IC7.2.2 Restricted Band

Pk - Peak detector

RMS - RMS detection

HARMONICS AND SPURIOUS EMISSIONS

LOW CHANNEL HORIZONTAL

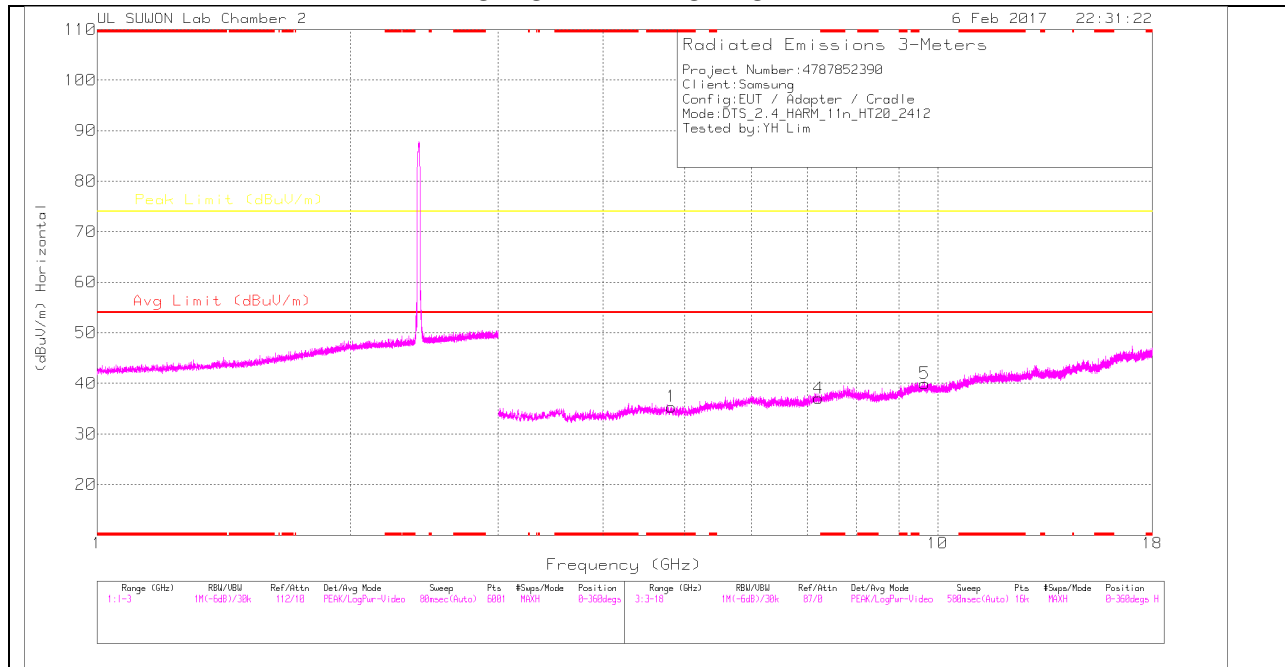

LOW CHANNEL VERTICAL

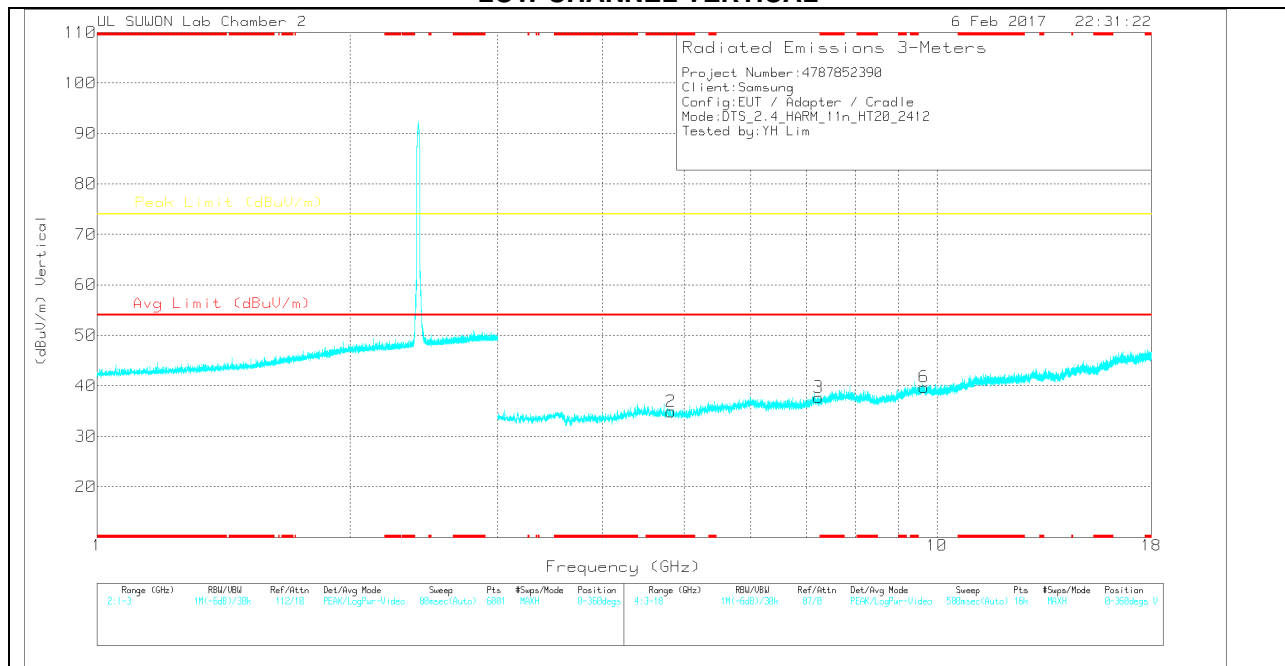

Note: Emission was scanned up to 26GHz; No emissions were detected above the noise floor which was at least 20dB below the specification limit.

LOW CHANNEL DATA

Trace Markers

Marker	Frequency (GHz)	Meter Reading (dBuV)	Det	3117(001687 24_150619)	3GHz_HP[dB]	DC Corr (dB)	Corrected Reading (dBuV/m)	Avg Limit (dBuV/m)	Margin (dB)	Peak Limit (dBuV/m)	Margin (dB)	Azimuth (Degs)	Height (cm)	Polarity
1	* 4.826	25.78	Pk	33.9	-24.3	0	35.38	-	-	74	-38.62	0-360	150	H
4	7.218	23.04	Pk	35.8	-21.8	0	37.04	-	-	74	-36.96	0-360	150	H
5	9.65	21.35	Pk	36.9	-18.3	0	39.95	-	-	74	-34.05	0-360	250	H
2	* 4.826	25.3	Pk	33.9	-24.3	0	34.9	-	-	74	-39.1	0-360	250	V
3	7.224	23.81	Pk	35.8	-21.9	0	37.71	-	-	74	-36.29	0-360	150	V
6	9.655	21.13	Pk	36.9	-18.3	0	39.73	-	-	74	-34.27	0-360	250	V

* - indicates frequency in CFR15.205/IC7.2.2 Restricted Band

Pk - Peak detector

Note: Only peak measurement was performed. Because peak measurement result of unwanted emission is less than average limit (54dBuV/m).

MID CHANNEL HORIZONTAL

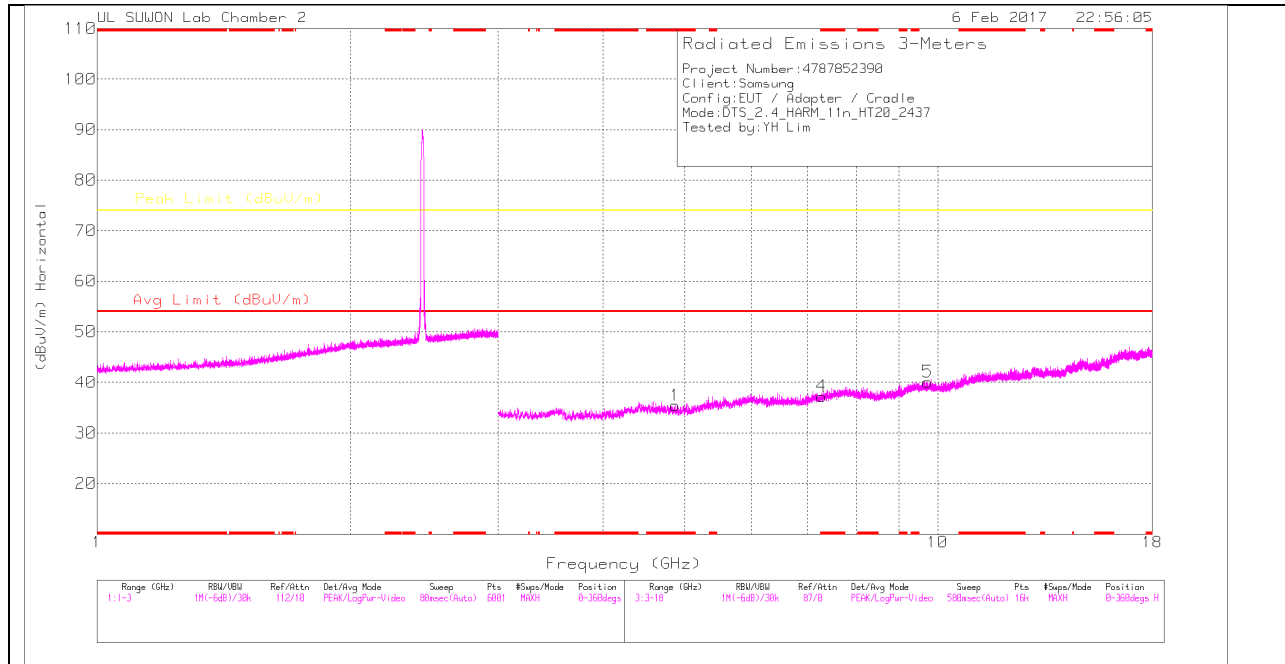

MID CHANNEL VERTICAL

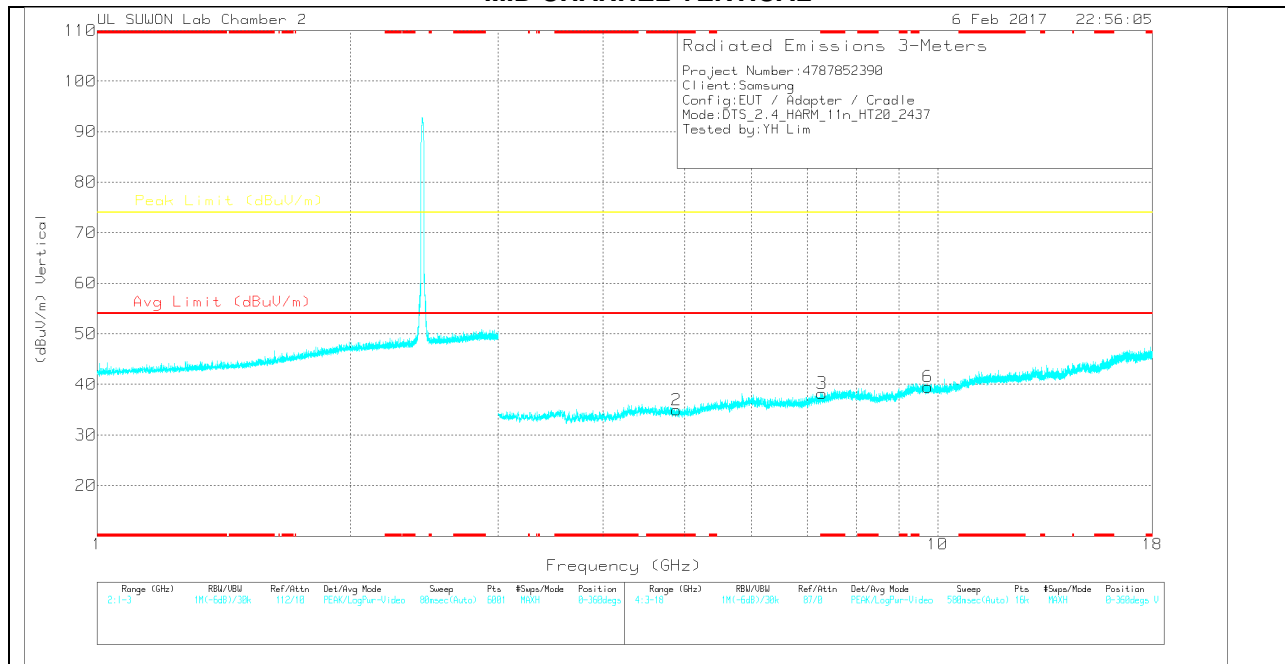

Note: Emission was scanned up to 26GHz; No emissions were detected above the noise floor which was at least 20dB below the specification limit.

MID CHANNEL DATA

Trace Markers

Marker	Frequency (GHz)	Meter Reading (dBuV)	Det	3117(001687 24_150619)	3GHz_HP[dB]	DC Corr (dB)	Corrected Reading (dBuV/m)	Avg Limit (dBuV/m)	Margin (dB)	Peak Limit (dBuV/m)	Margin (dB)	Azimuth (Degs)	Height (cm)	Polarity
1	* 4.874	26.05	Pk	33.9	-24.5	0	35.45	-	-	74	-38.55	0-360	250	H
4	* 7.282	23.53	Pk	35.8	-22.1	0	37.23	-	-	74	-36.77	0-360	150	H
5	9.728	21.19	Pk	37	-18.1	0	40.09	-	-	74	-33.91	0-360	150	H
2	* 4.888	25.64	Pk	33.9	-24.6	0	34.94	-	-	74	-39.06	0-360	150	V
3	* 7.284	24.51	Pk	35.8	-22.1	0	38.21	-	-	74	-35.79	0-360	150	V
6	9.732	20.6	Pk	37	-18.1	0	39.5	-	-	74	-34.5	0-360	250	V

* - indicates frequency in CFR15.205/IC7.2.2 Restricted Band

Pk – Peak detector

Note: Only peak measurement was performed. Because peak measurement result of unwanted emission is less than average limit (54dBuV/m).

HIGH CHANNEL HORIZONTAL

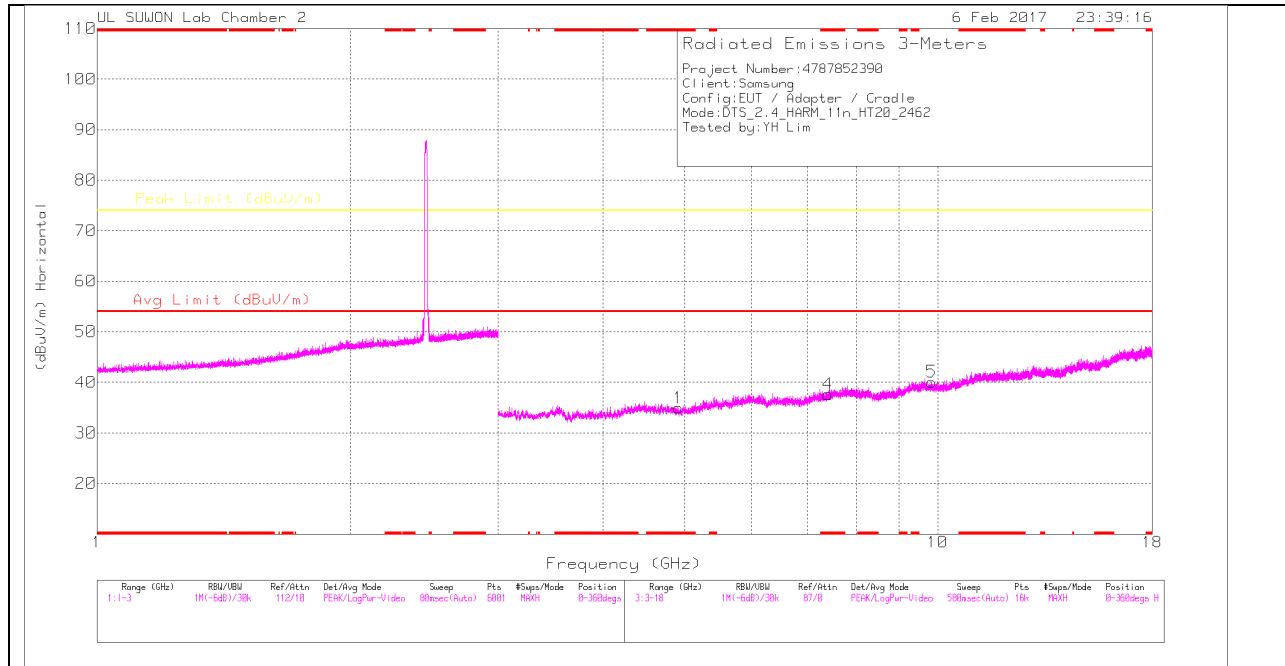

HIGH CHANNEL VERTICAL

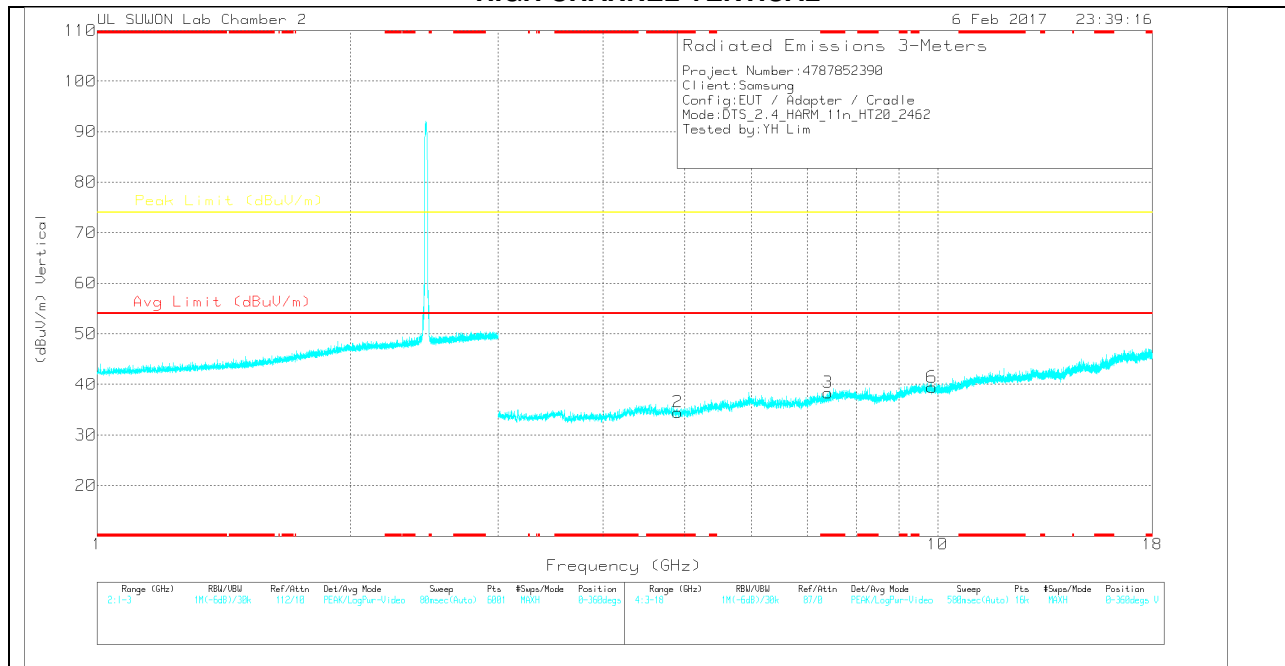

Note: Emission was scanned up to 26GHz; No emissions were detected above the noise floor which was at least 20dB below the specification limit.

HIGH CHANNEL DATA

Trace Markers

Marker	Frequency (GHz)	Meter Reading (dBuV)	Det	3117(001687 24_150619)	3GHz_HP[dB]	DC Corr (dB)	Corrected Reading (dBuV/m)	Avg Limit (dBuV/m)	Margin (dB)	Peak Limit (dBuV/m)	Margin (dB)	Azimuth (Degs)	Height (cm)	Polarity
1	* 4.912	25.61	Pk	33.9	-24.6	0	34.91	-	-	74	-39.09	0-360	250	H
4	* 7.402	22.93	Pk	36	-21.3	0	37.63	-	-	74	-36.37	0-360	150	H
5	9.84	20.89	Pk	37.1	-17.9	0	40.09	-	-	74	-33.91	0-360	150	H
2	* 4.91	25.2	Pk	33.9	-24.6	0	34.5	-	-	74	-39.5	0-360	150	V
3	* 7.407	23.66	Pk	36	-21.3	0	38.36	-	-	74	-35.64	0-360	150	V
6	9.846	20.25	Pk	37.1	-17.9	0	39.45	-	-	74	-34.55	0-360	150	V

* - indicates frequency in CFR15.205/IC7.2.2 Restricted Band

Pk – Peak detector

Note: Only peak measurement was performed. Because peak measurement result of unwanted emission is less than average limit (54dBuV/m).

10.3. WORST-CASE BELOW 1 GHz

SPURIOUS EMISSIONS 30 TO 1000 MHz (WORST-CASE CONFIGURATION, HORIZONTAL)

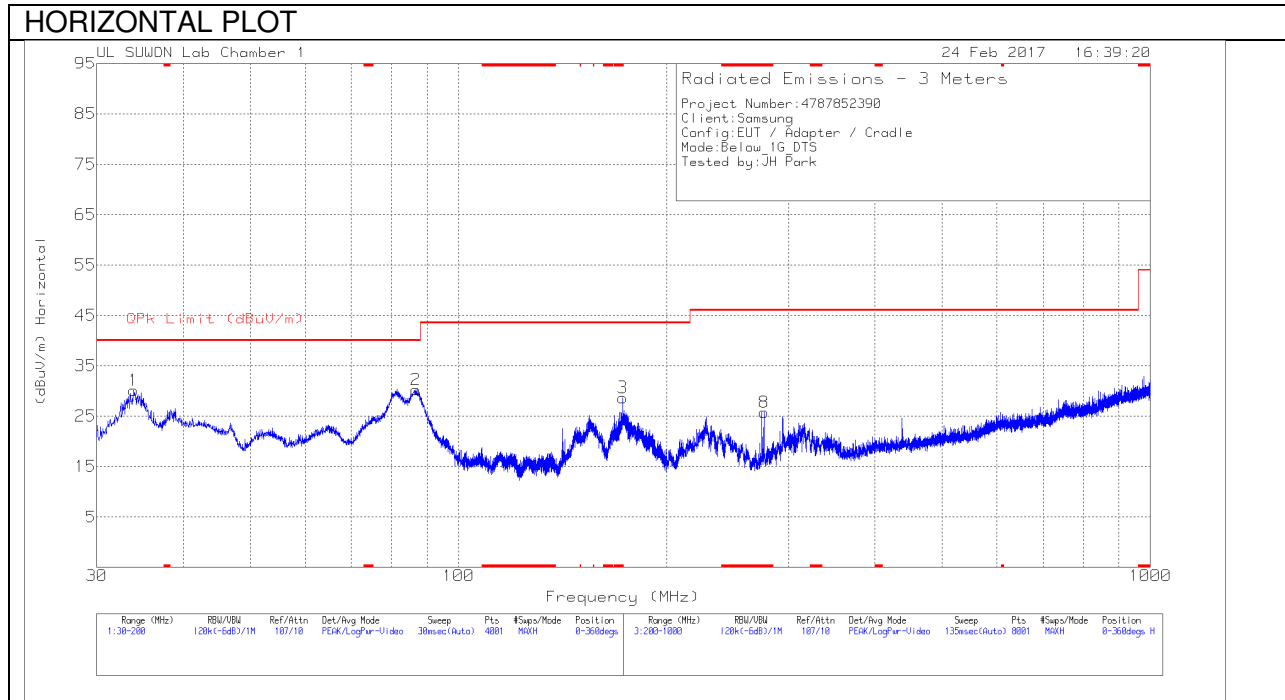

SPURIOUS EMISSIONS 30 TO 1000 MHz (WORST-CASE CONFIGURATION, VERTICAL)

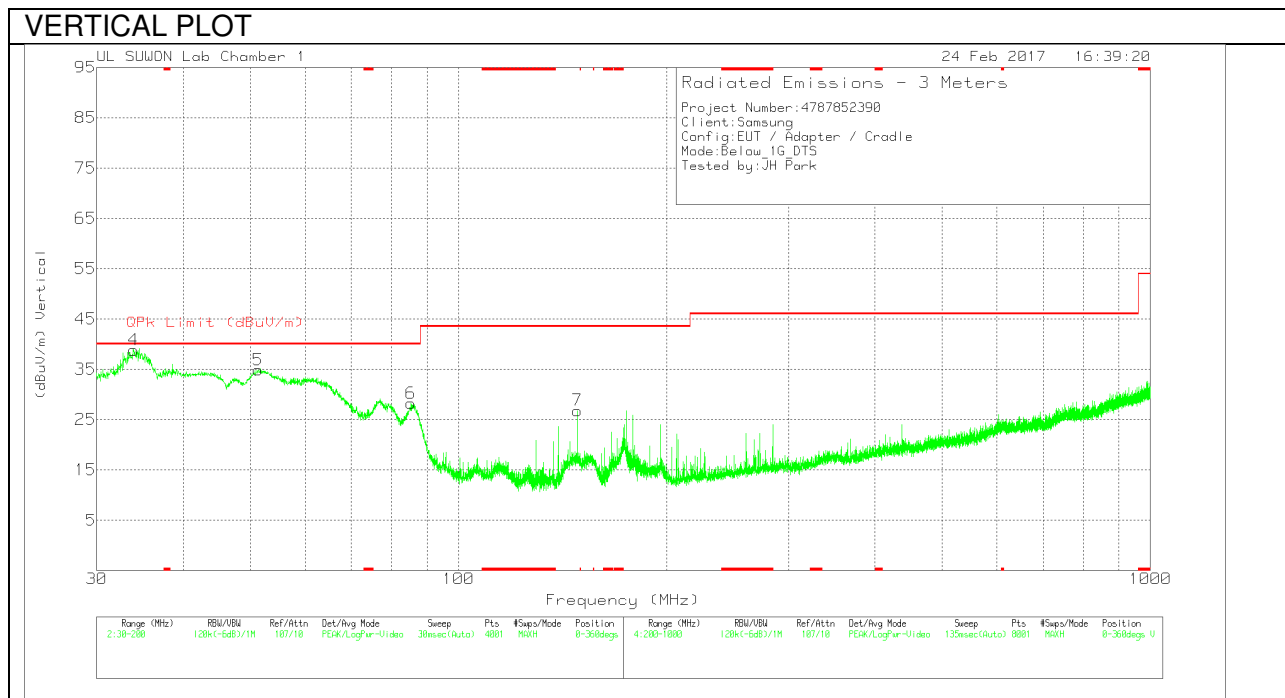

Below 1G Data

Trace Markers

Marker	Frequency (MHz)	Meter Reading (dBuV)	Det	VULB9163_750(dB)	30-1000MHz(dB)	Corrected Reading (dBuV/m)	QPk Limit (dBuV/m)	Margin (dB)	Azimuth (Degs)	Height (cm)	Polarity
1	33.91	47.81	Pk	10.6	-28.3	30.11	40	-9.89	0-360	300	H
2	86.695	49.25	Pk	8.7	-27.7	30.25	40	-9.75	0-360	400	H
3	* 172.7575	46.15	Pk	9	-26.5	28.65	43.52	-14.87	0-360	300	H
4	33.91	56.52	Pk	10.6	-28.3	38.82	40	-1.18	0-360	100	V
5	51.335	48.88	Pk	13.8	-27.8	34.88	40	-5.12	0-360	100	V
6	85.3775	47.73	Pk	8.3	-27.8	28.23	40	-11.77	0-360	100	V
7	148.575	46.01	Pk	7.8	-27	26.81	43.52	-16.71	0-360	100	V
8	* 276.7	39.01	Pk	12.8	-26.1	25.71	46.02	-20.31	0-360	100	H

* - indicates frequency in CFR15.205/IC7.2.2 Restricted Band

Pk - Peak detector

Radiated Emissions

Frequency (MHz)	Meter Reading (dBuV)	Det	VULB9163_750(dB)	30-1000MHz(dB)	Corrected Reading (dBuV/m)	QPk Limit (dBuV/m)	Margin (dB)	Azimuth (Degs)	Height (cm)	Polarity
34.0702	49.46	Qp	10.6	-28.4	31.66	40	-8.34	305	115	V

* - indicates frequency in CFR15.205/IC7.2.2 Restricted Band

Qp - Quasi-Peak detector

11. AC POWER LINE CONDUCTED EMISSIONS

LIMITS

FCC §15.207 (a)

Frequency of Emission (MHz)	Conducted Limit (dBuV)	
	Quasi-peak	Average
0.15-0.5	66 to 56*	56 to 46*
0.5-5	56	46
5-30	60	50

*Decreases with the logarithm of the frequency.

TEST PROCEDURE

The EUT is placed on a non-conducting table 40 cm from the vertical ground plane and 80 cm above the horizontal ground plane. The EUT is configured in accordance with ANSI C63.10.

The receiver is set to a resolution bandwidth of 9 kHz. Peak detection is used unless otherwise noted as quasi-peak or average.

Line conducted data is recorded for both NEUTRAL and HOT lines.

RESULTS

WORST EMISSIONS

LINE 1 PLOT

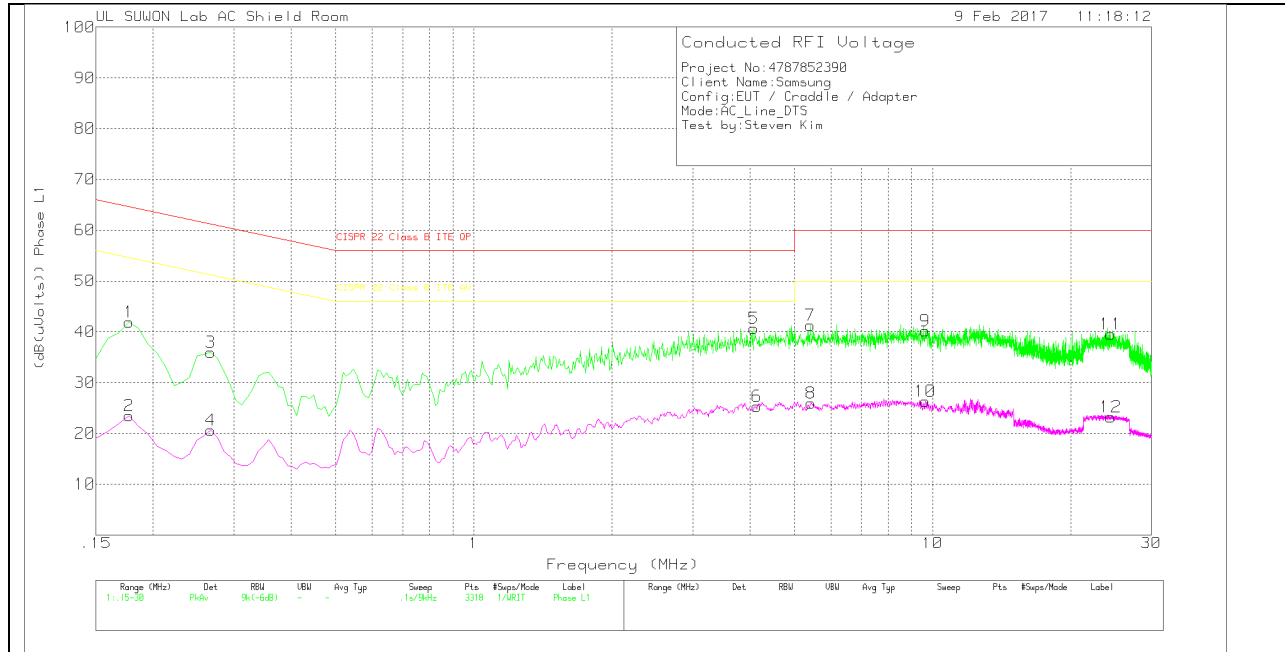

LINE 1 RESULTS

Trace Markers

Phase L1 .15 - 30MHz

Marker	Frequency (MHz)	Meter Reading (dBuV)	Det	101837_w ith ex-cord_L1	CE Shield Room	Corrected Reading (dB(uVolts))	CISPR 22 Class B ITE QP	Margin (dB)	CISPR 22 Class B ITE AV	Margin (dB)
1	.177	31.86	Pk	10	0	41.86	64.63	-22.77	-	-
2	.177	13.51	Av	10	0	23.51	-	-	54.63	-31.12
3	.267	26.22	Pk	9.7	0	35.92	61.21	-25.29	-	-
4	.267	10.94	Av	9.7	0	20.64	-	-	51.21	-30.57
5	4.074	30.78	Pk	9.8	.1	40.68	56	-15.32	-	-
6	4.146	15.38	Av	9.8	.1	25.28	-	-	46	-20.72
7	5.415	31.42	Pk	9.8	.1	41.32	60	-18.68	-	-
8	5.433	16.08	Av	9.8	.1	25.98	-	-	50	-24.02
9	9.645	29.96	Pk	10	.2	40.16	60	-19.84	-	-
10	9.645	16.1	Av	10	.2	26.3	-	-	50	-23.7
11	24.468	28.89	Pk	10.5	.2	39.59	60	-20.41	-	-
12	24.468	12.53	Av	10.5	.2	23.23	-	-	50	-26.77

Pk - Peak detector

Av – Average detection

LINE 2 PLOT

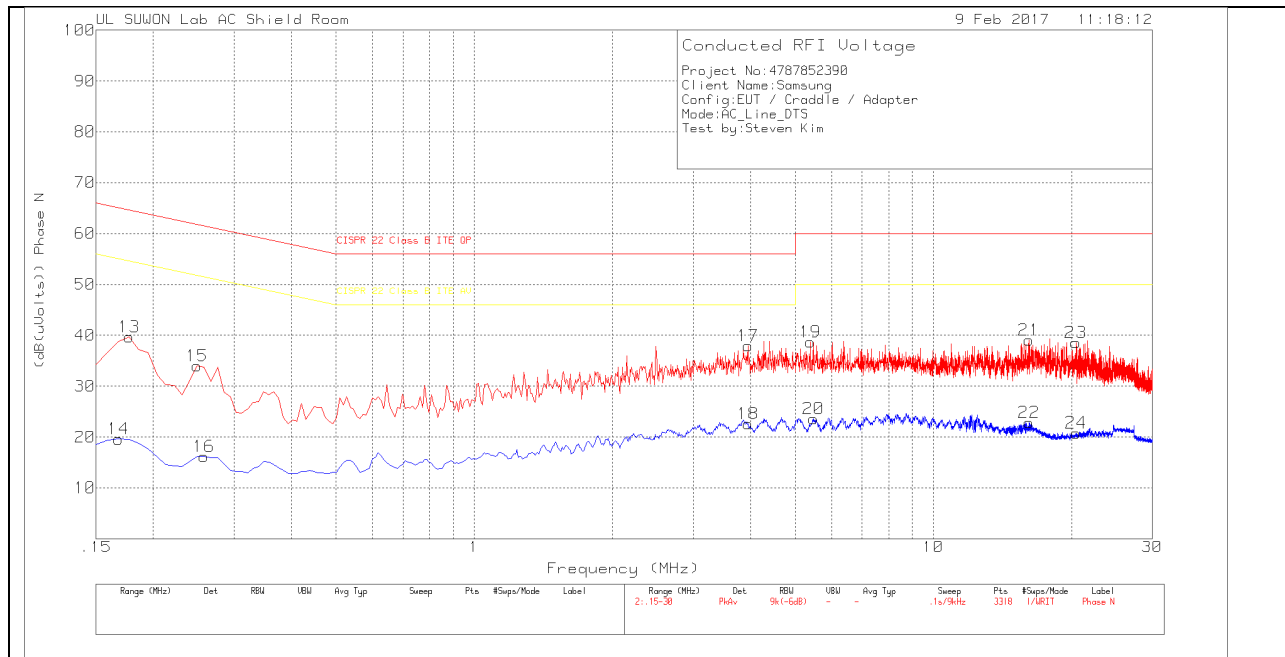

LINE 2 RESULTS

Trace Markers

Phase N .15 - 30MHz

Marker	Frequency (MHz)	Meter Reading (dBuV)	Det	101837_w ith ex-cord_N	CE Shield Room	Corrected Reading (dB(uVolts))	CISPR 22 Class B ITE QP	Margin (dB)	CISPR 22 Class B ITE AV	Margin (dB)
13	.177	29.69	Pk	10	0	39.69	64.63	-24.94	-	-
14	.168	9.58	Av	10	0	19.58	-	-	55.06	-35.48
15	.249	24.26	Pk	9.7	0	33.96	61.79	-27.83	-	-
16	.258	6.51	Av	9.7	0	16.21	-	-	51.5	-35.29
17	3.948	28.07	Pk	9.8	.1	37.97	56	-18.03	-	-
18	3.948	12.66	Av	9.8	.1	22.56	-	-	46	-23.44
19	5.397	28.8	Pk	9.8	.1	38.7	60	-21.3	-	-
20	5.478	13.56	Av	9.9	.1	23.56	-	-	50	-26.44
21	16.179	28.49	Pk	10.4	.2	39.09	60	-20.91	-	-
22	16.179	12.2	Av	10.4	.2	22.8	-	-	50	-27.2
23	20.445	27.61	Pk	10.7	.2	38.51	60	-21.49	-	-
24	20.49	9.91	Av	10.7	.2	20.81	-	-	50	-29.19

Pk - Peak detector

Av - Average detection