



**FCC CFR47 PART 27 SUBPART F
FCC CFR47 PART 27 SUBPART L**

WWAN

CERTIFICATION TEST REPORT

FOR

LTE Watch + BT/BLE and DTS b/g/n

MODEL NUMBER : SM-R775V

FCC ID: A3LSMR775V

REPORT NUMBER: 4787852390-E4V1

ISSUE DATE: MAR 03, 2017

Prepared for
**SAMSUNG ELECTRONICS CO., LTD.
129 SAMSUNG-RO, YEONGTONG-GU, SUWON-SI,
GYEONGGI-DO, 16677, KOREA**

Prepared by
**UL Korea, Ltd. Suwon Laboratory
218 Maeyeong-ro, Yeongtong-gu,
Suwon-si, Gyeonggi-do, 16675, Korea
TEL: (031) 337-9902
FAX: (031) 213-5433**



Revision History

<u>Rev.</u>	<u>Issue Date</u>	<u>Revisions</u>	<u>Revised By</u>
V1	03/03/17	Initial issue	Junwhan Lee

TABLE OF CONTENTS

1. ATTESTATION OF TEST RESULTS	5
2. TEST METHODOLOGY	6
3. FACILITIES AND ACCREDITATION	6
4. CALIBRATION AND UNCERTAINTY	6
4.1. MEASURING INSTRUMENT CALIBRATION	6
4.2. SAMPLE CALCULATION	6
4.3. MEASUREMENT UNCERTAINTY	7
5. EQUIPMENT UNDER TEST	8
5.1. DESCRIPTION OF EUT	8
5.2. MAXIMUM OUTPUT POWER (LTE)	8
5.3. DESCRIPTION OF TEST SETUP	10
6. TEST AND MEASUREMENT EQUIPMENT	12
7. Summary Table	13
8. RF POWER OUTPUT VERIFICATION	14
8.1. LTE OUTPUT VERIFICATION	14
8.1.1. LTE OUTPUT POWER RESULT	15
9. PEAK TO AVERAGE RATIO	18
9.1. CONDUCTED PEAK TO AVERAGE RESULT	18
9.2. CONDUCTED PEAK TO AVERAGE PLOTS	19
10. LIMITS AND CONDUCTED RESULTS	22
10.1. OCCUPIED BANDWIDTH	22
10.1.1. OCCUPIED BANDWIDTH PLOTS	25
10.2. BAND EDGE EMISSIONS	33
10.2.1. BAND EDGE PLOTS	36
10.3. OUT OF BAND EMISSIONS	46
10.3.1. OUT OF BAND EMISSIONS RESULT	47
10.3.2. OUT OF BAND EMISSIONS PLOTS	49
10.4. FREQUENCY STABILITY	57
10.4.1. FREQUENCY STABILITY RESULTS	58
11. RADIATED TEST RESULTS	60
11.1. RADIATED POWER (ERP & EIRP)	60
11.1.1. ERP/EIRP Results	61
11.1.2. ERP/EIRP DATA	61

11.2.	FIELD STRENGTH OF SPURIOUS RADIATION.....	69
11.2.1.	SPURIOUS RADIATION PLOTS.....	70
12.	SETUP PHOTOS.....	78

1. ATTESTATION OF TEST RESULTS

COMPANY NAME: SAMSUNG ELECTRONICS CO., LTD.
EUT DESCRIPTION: LTE Watch + BT/BLE and DTS b/g/n
MODEL NUMBER: SM-R775V
SERIAL NUMBER: R3AJ2000AND, R3AJ20006PF (RADIATED);
R3AJ2000F5Z (CONDUCTED)
DATE TESTED: FEB 07, 2017 - MAR 03, 2017

APPLICABLE STANDARDS	
STANDARD	TEST RESULTS
FCC PART 27F and 27L	Pass

UL Korea, Ltd. tested the above equipment in accordance with the requirements set forth in the above standards. All indications of Pass/Fail in this report are opinions expressed by UL Korea, Ltd. based on interpretations and/or observations of test results. Measurement Uncertainties were not taken into account and are published for informational purposes only. The test results show that the equipment tested is capable of demonstrating compliance with the requirements as documented in this report.

Note: The results documented in this report apply only to the tested sample, under the conditions and modes of operation as described herein. This document may not be altered or revised in any way unless done so by UL Korea, Ltd. and all revisions are duly noted in the revisions section. Any alteration of this document not carried out by UL Korea, Ltd. will constitute fraud and shall nullify the document. This report must not be used by the client to claim product certification, approval, or endorsement by IAS, any agency of the Federal Government, or any agency of any government.

Approved & Released For
UL Korea, Ltd. By:

Tested By:



SungGil Park
Suwon Lab Engineer
UL Korea, Ltd.

Junwhan Lee
Suwon Lab Engineer
UL Korea, Ltd.

2. TEST METHODOLOGY

The tests documented in this report were performed in accordance with following methods.

1. FCC CFR 47 Part 2
2. FCC CFR 47 Part 27
3. ANSI TIA-603-D
4. KDB 971168 D01 Power Meas License Digital Systems v02r02

3. FACILITIES AND ACCREDITATION

The test sites and measurement facilities used to collect data are located at 218 Maeyeong-ro, Yeongtong-gu, Suwon-si, Gyeonggi-do, 16675, Korea. Line conducted emissions are measured only at the 218 address. The following table identifies which facilities were utilized for radiated emission measurements documented in this report. Specific facilities are also identified in the test results sections.

218 Maeyeong-ro	
<input checked="" type="checkbox"/>	Chamber 1
<input checked="" type="checkbox"/>	Chamber 2

UL Korea, Ltd. is accredited by IAS, Laboratory Code TL-637. The full scope of accreditation can be viewed at <http://www.iasonline.org/PDF/TL/TL-637.pdf>.

4. CALIBRATION AND UNCERTAINTY

4.1. MEASURING INSTRUMENT CALIBRATION

The measuring equipment utilized to perform the tests documented in this report has been calibrated in accordance with the manufacturer's recommendations, and is traceable to recognized national standards.

4.2. SAMPLE CALCULATION

Where relevant, the following sample calculation is provided:

$EIRP = \text{PSA reading with EUT worst orientation (dBm)} + \text{Path loss (dB)} - \text{cable loss (between the SG and substitution antenna)} + \text{Substitution Antenna Factor (dBi)}$

$ERP = \text{PSA reading with EUT worst orientation (dBm)} + \text{Path loss (dB)} - \text{cable loss (between the SG and substitution antenna)}$

(Path loss = Signal generator output – PSA reading with substitution antenna)

4.3. MEASUREMENT UNCERTAINTY

Where relevant, the following measurement uncertainty levels have been estimated for tests performed on the apparatus:

PARAMETER	UNCERTAINTY
Conducted Disturbance, 0.15 to 30 MHz	2.32 dB
Radiated Disturbance, Below 1GHz	4.14 dB
Radiated Disturbance, Above 1 GHz	5.97 dB

Uncertainty figures are valid to a confidence level of 95%.

5. EQUIPMENT UNDER TEST

5.1. DESCRIPTION OF EUT

The EUT is a LTE Watch + Bluetooth/BLE and DTS b/g/n.

5.2. MAXIMUM OUTPUT POWER (LTE)

The transmitter has a maximum peak conducted and radiated ERP / EIRP output powers as follows:

LTE Band 4

FCC Part 27							
Band	Frequency Range [MHz]	BandWidth [MHz]	Modulation Peak	Conducted		Radiated	
				Avg [dBm]	Avg [mW]	Avg [dBm]	Avg [mW]
Band 4	1710 ~ 1755	20	QPSK	23.00	199.53	16.94	49.43
			16QAM	22.00	158.49	16.01	39.90
		15	QPSK	22.95	197.24	17.00	50.12
			16QAM	22.00	158.49	16.03	40.09
		10	QPSK	22.83	191.87	18.74	74.82
			16QAM	22.00	158.49	17.79	60.12
		5	QPSK	22.93	196.34	18.48	70.47
			16QAM	21.89	154.53	17.45	55.59
		3	QPSK	23.00	199.53	14.84	30.48
			16QAM	22.00	158.49	15.85	38.46
		1.4	QPSK	22.95	197.24	16.19	41.59
			16QAM	21.99	158.12	15.25	33.50

LTE Band 13

FCC Part 27							
Band	Frequency Range [MHz]	BandWidth [MHz]	Modulation Peak	Conducted		Radiated	
				Avg [dBm]	Avg [mW]	Avg [dBm]	Avg [mW]
Band 13	777 ~ 787	10	QPSK	22.93	196.34	-0.83	0.83
			16QAM	21.96	157.04	-1.89	0.65
		5	QPSK	22.88	194.09	-2.31	0.59
			16QAM	21.89	154.53	-3.30	0.47

DESCRIPTION OF AVAILABLE ANTENNAS

The radio utilizes an internal antenna for the [List the bands supported with a maximum peak gain as follow:

Frequency (MHz)	Peak Gain (dBi)
LTE Band 4 1710 ~ 1755 MHz	-2.6
LTE Band 13 777 ~ 787 MHz	-14.8

5.3. DESCRIPTION OF TEST SETUP

SUPPORT EQUIPMENT

Support Equipment List				
Description	Manufacturer	Model	Serial Number	FCC ID
Adapter	SAMSUNG	ETA0U60JBE	DK2H202VS/7 -E	N/A
Data Cable	SAMSUNG	ECB-DU2EBE	N/A	N/A
Wireless Charger	SAMSUNG	EP-YO760	RF7HC1KGZSVCIS	A3LEPYO760

I/O CABLES

I/O Cable List						
Cable No	Port	# of identical ports	Connector Type	Cable Type	Cable Length (m)	Remarks
1	DC Power	1	Mini-USB	Shielded	0.8m	N/A

TEST SETUP

The EUT is continuously communicated to the call box during the tests.

SETUP DIAGRAM FOR TESTS (CONDUCTED TEST SETUP)

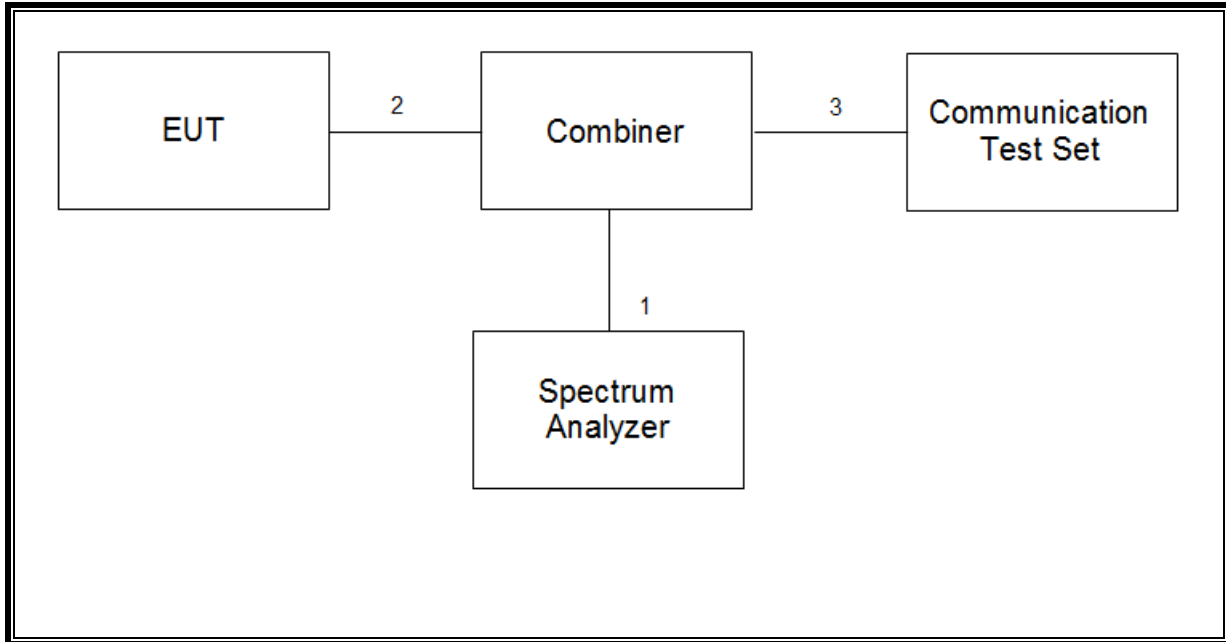

SETUP DIAGRAM FOR TESTS (RADIATED TEST SETUP)

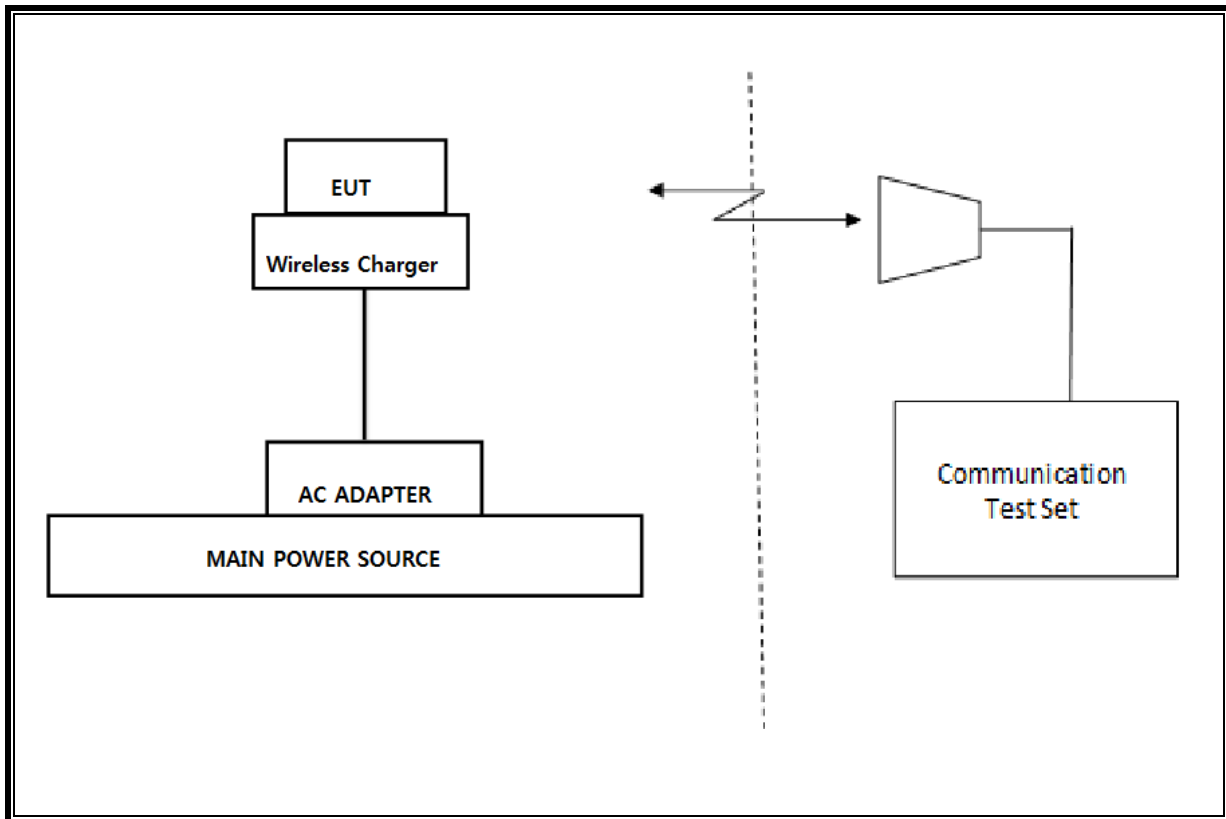

6. TEST AND MEASUREMENT EQUIPMENT

The following test and measurement equipment was utilized for the tests documented in this report:

Test Equipment List				
Description	Manufacturer	Model	S/N	Cal Due
Antenna, Tuned Dipole 400~1000 MHz	ETS	3121D DB4	00164753	07-28-17
Antenna, Horn, 40 GHz	ETS	3116C	00166155	11-30-17
Antenna, Horn, 40 GHz	ETS	3116C-PA	00168841	12-15-17
Antenna, Bilog, 30MHz-1GHz	SCHWARZBECK	VULB9163	750	10-14-18
Antenna, Bilog, 30MHz-1GHz	SCHWARZBECK	VULB9163	749	04-25-17
Antenna, Horn, 18 GHz	ETS	3115	00167211	10-14-18
Antenna, Horn, 18 GHz	ETS	3117	00168724	06-17-17
Antenna, Horn, 18 GHz	ETS	3117	00168717	06-17-17
Combiner	WEINSCHEL	1575	2152	08-16-17
Communications Test Set	R&S	CMW500	150312	08-17-17
Communications Test Set	R&S	CMW500	115331	08-17-17
DC Power Supply	Agilent / HP	E3640A	MY54226395	08-16-17
Preamplifier, 1000 MHz	Sonoma	310N	341282	08-17-17
Preamplifier, 1000 MHz	Sonoma	310N	351741	08-16-17
Preamplifier	ETS	3115-PA	00167475	08-17-17
Preamplifier, 18 GHz	Miteq	AFS42-00101800-25-S-42	1896138	08-16-17
Spectrum Analyzer, 44 GHz	Agilent / HP	N9030A	MY54170614	08-17-17
Average Power Sensor	R&S	NRZ-Z91	102681	08-16-17
Average Power Sensor	Agilent / HP	U2000	MY54270007	08-17-17
EMI Test Receive, 40 GHz	R&S	ESU40	100439	08-17-17
EMI Test Receive, 40 GHz	R&S	ESU40	100457	08-16-17
EMI Test Receive, 3 GHz	R&S	ESR3	101832	08-16-17
High Pass Filter 1.2GHz	Micro-Tronics	HPM50108-02	G005	08-17-17
High Pass Filter 1.2GHz	Micro-Tronics	HPM50108-02	G006	08-17-17
High Pass Filter 2.8GHz	Micro-Tronics	HPM50111-02	010	08-17-17
High Pass Filter 2.8GHz	Micro-Tronics	HPM50111-02	011	08-17-17
High Pass Filter 4GHz	Micro-Tronics	HPM50118-02	G001	08-17-17
High Pass Filter 4GHz	Micro-Tronics	HPM50118-02	G002	08-17-17
Attenuator	PASTERNAK	PE7087-10	A009	08-16-17
Temperature Chamber	ESPEC	SH-642	93001109	08-17-17
UL Software				
Description	Manufacturer	Model	Version	
Antenna port test software	UL	CLT	Ver 1.6 / 1.7	

7. Summary Table

FCC Part Section	Test Description	Test Limit	Test Condition	Test Result	Note
2.1049	Occupied Band width (99%)	N/A	Conducted	Pass	17.936 MHz
27.53	Band Edge / Conducted Spurious Emission	-13dBm		Pass	-14.409dBm
2.1046	Conducted output power	N/A		Pass	23.00 dBm
27.54	Frequency Stability	2.5PPM		Pass	-0.003PPM
27.50(d)	Equivalent Isotropic Radiated Power	30 dBm	Radiated	Pass	18.74 dBm
27.50(b)	Effective Radiated Power	34.77 dBm		Pass	-0.83 dBm
27.53(c),(h)	Radiated Spurious Emission	-13dBm		Pass	-35.8 dBm
27.53(f)		-40dBm		Pass	-45.2 dBm

FCC Rule Part	Frequency Range [MHz]	Output Power [W]	Frequency Tolerance	Emission Designator	Emission Bandwidth	Communication Type
LTE Band 4						
27L	1720.0 - 1745.0	0.04943	2.5 ppm	17M9G7W	20	QPSK
27L	1720.0 - 1745.0	0.03990	2.5 ppm	17M9D7W	20	16QAM
27L	1715.0 - 1750.0	0.07482	2.5 ppm	8M97G7W	10	QPSK
27L	1715.0 - 1750.0	0.06012	2.5 ppm	8M96D7W	10	16QAM
LTE Band 13						
27F	782	0.00083	2.5 ppm	8M95G7W	10	QPSK
27F	782	0.00065	2.5 ppm	8M96D7W	10	16QAM

8. RF POWER OUTPUT VERIFICATION

8.1. LTE OUTPUT VERIFICATION

The following tests were conducted according to the test requirements outlined in section 6.2 of the 3GPP TS36.101 specification.

UE Power Class: 3 (23 +/- 2dBm). The allowed Maximum Power Reduction (MPR) for the maximum output power due to higher order modulation and transmit bandwidth configuration (resource blocks) is specified in Table 6.2.3-1 of the 3GPP TS36.101.

Table 6.2.3-1: Maximum Power Reduction (MPR) for Power Class 3

Modulation	Channel bandwidth / Transmission bandwidth (RB)						MPR (dB)
	1.4 MHz	3.0 MHz	5 MHz	10 MHz	15 MHz	20 MHz	
QPSK	> 5	> 4	> 8	> 12	> 16	> 18	≤ 1
16 QAM	≤ 5	≤ 4	≤ 8	≤ 12	≤ 16	≤ 18	≤ 1
16 QAM	> 5	> 4	> 8	> 12	> 16	> 18	≤ 2

The allowed A-MPR values specified below in Table 6.2.4.-1 of 3GPP TS36.101 are in addition to the allowed MPR requirements. All the measurements below were performed with A-MPR disabled, by using Network Signalling Value of "NS_01".

Table 6.2.4-1: Additional Maximum Power Reduction (A-MPR)

Network Signalling value	Requirements (sub-clause)	E-UTRA Band	Channel bandwidth (MHz)	Resources Blocks (N_{RB})	A-MPR (dB)
NS_01	6.6.2.1.1	Table 5.5-1	1.4, 3, 5, 10, 15, 20	Table 5.6-1	NA
NS_03	6.6.2.2.1	2, 4, 10, 23, 25, 35, 36	3	>5	≤ 1
			5	>6	≤ 1
			10	>6	≤ 1
			15	>8	≤ 1
			20	>10	≤ 1
NS_04	6.6.2.2.2	41	5	>6	≤ 1
			10, 15, 20	See Table 6.2.4-4	
NS_05	6.6.3.3.1	1	10,15,20	≥ 50	≤ 1
NS_06	6.6.2.2.3	12, 13, 14, 17	1.4, 3, 5, 10	Table 5.6-1	n/a
NS_07	6.6.2.2.3	13	10	Table 6.2.4-2	Table 6.2.4-2
	6.6.3.3.2				
NS_08	6.6.3.3.3	19	10, 15	> 44	≤ 3
				> 40	≤ 1
				> 55	≤ 2
NS_10		20	15, 20	Table 6.2.4-3	Table 6.2.4-3
NS_11	6.6.2.2.1	23 ¹	1.4, 3, 5, 10	Table 6.2.4-5	Table 6.2.4-5
..					
NS_32	-	-	-	-	-

Note 1: Applies to the lower block of Band 23, i.e. a carrier placed in the 2000-2010 MHz region.

8.1.1. LTE OUTPUT POWER RESULT

LTE Band 4 Measured Results

Band	BW (MHz)	Mode	RB Allocation	RB offset	Target MPR	Avg Pwr (dBm)		
						20050	20175	20300
						1720 MHz	1732.5 MHz	1745 MHz
LTE Band 4	20	QPSK	1	0	0	22.77	22.91	22.87
			1	49	0	22.74	22.87	22.89
			1	99	0	22.71	22.75	23.00
			50	0	1	21.77	21.74	21.65
			50	24	1	21.69	21.72	21.70
			50	50	1	21.64	21.70	21.76
		16QAM	100	0	1	21.70	21.72	21.70
			1	0	1	21.69	21.58	21.80
			1	49	1	21.56	21.54	21.82
			1	99	1	21.53	21.44	22.00
			50	0	2	20.74	20.74	20.60
			50	24	2	20.68	20.71	20.66
			50	50	2	20.62	20.69	20.72
			100	0	2	20.68	20.72	20.69
Band	BW (MHz)	Mode	RB Allocation	RB offset	Target MPR	Avg Pwr (dBm)		
						20025	20175	20325
						1717.5 MHz	1732.5 MHz	1747.5 MHz
LTE Band 4	15	QPSK	1	0	0	22.74	22.92	22.57
			1	37	0	22.43	22.77	22.71
			1	74	0	22.51	22.95	22.54
			36	0	1	21.66	21.83	21.72
			36	20	1	21.63	21.79	21.78
			36	39	1	21.58	21.79	21.83
		16QAM	75	0	1	21.61	21.81	21.76
			1	0	1	21.62	22.00	21.45
			1	37	1	21.32	21.93	21.66
			1	74	1	21.42	22.00	21.47
			36	0	2	20.61	20.84	20.64
			36	20	2	20.57	20.77	20.69
			36	39	2	20.52	20.78	20.74
			75	0	2	20.56	20.79	20.69
Band	BW (MHz)	Mode	RB Allocation	RB offset	Target MPR	Avg Pwr (dBm)		
						20000	20175	20350
						1715 MHz	1732.5 MHz	1750 MHz
LTE Band 4	10	QPSK	1	0	0	22.75	22.83	22.68
			1	25	0	22.62	22.71	22.70
			1	49	0	22.73	22.65	22.67
			25	0	1	21.58	21.73	21.78
			25	12	1	21.62	21.71	21.77
			25	25	1	21.61	21.72	21.84
		16QAM	50	0	1	21.60	21.72	21.80
			1	0	1	21.65	22.00	21.73
			1	25	1	21.53	21.88	21.71
			1	49	1	21.61	21.74	21.67
			25	0	2	20.58	20.74	20.81
			25	12	2	20.60	20.72	20.79
			25	25	2	20.60	20.73	20.86
			50	0	2	20.60	20.69	20.78

LTE Band 4 Measured Results (continued)

Band	BW (MHz)	Mode	RB Allocation	RB offset	Target MPR	Avg Pwr (dBm)		
						19975	20175	20375
						1712.5 MHz	1732.5 MHz	1752.5 MHz
LTE Band 4	5	QPSK	1	0	0	22.79	22.89	22.55
			1	12	0	22.71	22.55	22.85
			1	24	0	22.60	22.93	22.68
			12	0	1	21.63	21.80	21.67
			12	7	1	21.67	21.65	21.81
			12	13	1	21.58	21.64	21.83
			25	0	1	21.61	21.72	21.69
		16QAM	1	0	1	21.81	21.77	21.81
			1	12	1	21.81	21.58	21.89
			1	24	1	21.73	21.86	21.54
			12	0	2	20.57	20.78	20.47
			12	7	2	20.59	20.63	20.67
			12	13	2	20.53	20.63	20.80
			25	0	2	20.65	20.65	20.64
Band	BW (MHz)	Mode	RB Allocation	RB offset	Target MPR	Avg Pwr (dBm)		
						19965	20175	20385
						1711.5 MHz	1732.5 MHz	1753.5 MHz
LTE Band 4	3	QPSK	1	0	0	22.80	22.94	22.94
			1	8	0	22.65	22.77	23.00
			1	14	0	22.81	22.76	22.72
			8	0	1	21.71	21.83	21.90
			8	4	1	21.63	21.77	21.93
			8	7	1	21.59	21.70	21.93
			15	0	1	21.64	21.70	21.80
		16QAM	1	0	1	21.56	21.99	22.00
			1	8	1	21.37	21.85	22.00
			1	14	1	21.56	21.73	21.77
			8	0	2	20.61	20.58	20.84
			8	4	2	20.51	20.54	20.88
			8	7	2	20.47	20.49	20.90
			15	0	2	20.56	20.71	20.75
Band	BW (MHz)	Mode	RB Allocation	RB offset	Target MPR	Avg Pwr (dBm)		
						19957	20175	20393
						1710.7 MHz	1732.5 MHz	1754.3 MHz
LTE Band 4	1.4	QPSK	1	0	0	22.59	22.82	22.95
			1	3	0	22.68	22.80	22.91
			1	5	0	22.73	22.78	22.64
			3	0	0	22.63	22.84	22.88
			3	1	0	22.69	22.81	22.90
			3	3	0	22.69	22.79	22.84
			6	0	1	21.71	21.83	21.91
		16QAM	1	0	1	21.61	21.92	21.99
			1	3	1	21.66	21.89	21.96
			1	5	1	21.68	21.85	21.71
			3	0	1	21.62	21.87	21.85
			3	1	1	21.65	21.79	21.83
			3	3	1	21.65	21.79	21.86
			6	0	2	20.72	20.77	20.88

LTE Band 13 Measured Results

Band	BW (MHz)	Mode	RB Allocation	RB offset	Target MPR	Avg Pwr (dBm)
						23230
						782 MHz
LTE Band 13	10	QPSK	1	0	0	22.93
			1	25	0	22.81
			1	49	0	22.89
			25	0	1	21.93
			25	12	1	21.88
			25	25	1	21.87
		16QAM	1	0	1	21.96
			1	25	1	21.82
			1	49	1	21.90
			25	0	2	20.86
			25	12	2	20.84
			25	25	2	20.87
			50	0	2	20.88
			50	0	2	20.88
Band	BW (MHz)	Mode	RB Allocation	RB offset	Target MPR	Avg Pwr (dBm)
						23230
						782 MHz
LTE Band 13	5	QPSK	1	0	0	22.88
			1	12	0	22.82
			1	24	0	22.84
			12	0	1	21.90
			12	7	1	21.90
			12	13	1	21.89
			25	0	1	21.87
		16QAM	1	0	1	21.87
			1	12	1	21.81
			1	24	1	21.89
			12	0	2	20.84
			12	7	2	20.82
			12	13	2	20.83
			25	0	2	20.87

9. PEAK TO AVERAGE RATIO

Test Procedure

Per KDB 971168 D01 Power Meas License Digital Systems v02r02;

The transmitter output was connected to a CMW500 Test Set and configured to operate at maximum power. The PAR were measured on the Spectrum Analyzer.

Test Spec

In addition, when the transmitter power is measured in terms of average value, the peak-to-average ratio of the power shall not exceed 13 dB.

9.1. CONDUCTED PEAK TO AVERAGE RESULT

LTE B4

Band	BW [MHz]	Channel	f [MHz]	Mode	Ratio [dB]	Limit [dB]
Band 4	20	20174	1732.5	QPSK	4.13	13.00
				16QAM	5.24	
	15			QPSK	4.15	
				16QAM	5.29	
	10			QPSK	4.21	
				16QAM	5.27	
	5			QPSK	4.22	
				16QAM	5.47	
	3			QPSK	4.26	
				16QAM	5.38	
	1.4			QPSK	4.23	
				16QAM	5.31	

LTE B13

Band	BW [MHz]	Channel	f [MHz]	Mode	Ratio [dB]	Limit [dB]
Band 13	10	23230	782	QPSK	5.52	13.00
				16QAM	6.74	
	5			QPSK	5.60	
				16QAM	6.74	

9.2. CONDUCTED PEAK TO AVERAGE PLOTS

LTE Band 4

<p>LTE Band 4 20 MHz</p>	<p>Average Power 23.56 dBm 52.04 % at 0dB</p> <p>10.0 % 2.33 dB 1.0 % 3.65 dB 0.1 % 4.13 dB 0.01 % 4.30 dB 0.001 % 4.42 dB 0.0001 % 4.46 dB Peak 4.47 dB 28.03 dBm</p> <p>LTE B4 20MHz QPSK Mid channel</p>	<p>Average Power 22.35 dBm 45.36 % at 0dB</p> <p>10.0 % 2.76 dB 1.0 % 4.56 dB 0.1 % 5.24 dB 0.01 % 5.55 dB 0.001 % 5.66 dB 0.0001 % 5.70 dB Peak 5.71 dB 28.06 dBm</p> <p>LTE B4 20MHz 16QAM Mid channel</p>
<p>LTE Band 4 15 MHz</p>	<p>Average Power 23.51 dBm 51.80 % at 0dB</p> <p>10.0 % 2.33 dB 1.0 % 3.65 dB 0.1 % 4.15 dB 0.01 % 4.35 dB 0.001 % 4.42 dB 0.0001 % 4.47 dB Peak 4.49 dB 28.00 dBm</p> <p>LTE B4 15MHz QPSK Mid channel</p>	<p>Average Power 22.40 dBm 45.76 % at 0dB</p> <p>10.0 % 2.73 dB 1.0 % 4.62 dB 0.1 % 5.29 dB 0.01 % 5.52 dB 0.001 % 5.65 dB 0.0001 % 5.70 dB Peak 5.73 dB 28.13 dBm</p> <p>LTE B4 15MHz 16QAM Mid channel</p>
<p>LTE Band 4 10 MHz</p>	<p>Average Power 23.48 dBm 51.64 % at 0dB</p> <p>10.0 % 2.37 dB 1.0 % 3.70 dB 0.1 % 4.21 dB 0.01 % 4.42 dB 0.001 % 4.49 dB 0.0001 % 4.54 dB Peak 4.54 dB 28.02 dBm</p> <p>LTE B4 10MHz QPSK Mid channel</p>	<p>Average Power 22.45 dBm 45.74 % at 0dB</p> <p>10.0 % 2.73 dB 1.0 % 4.59 dB 0.1 % 5.27 dB 0.01 % 5.48 dB 0.001 % 5.56 dB 0.0001 % 5.60 dB Peak 5.64 dB 28.09 dBm</p> <p>LTE B4 10MHz 16QAM Mid channel</p>

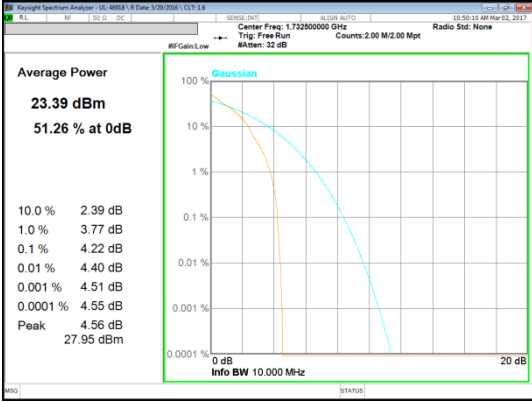
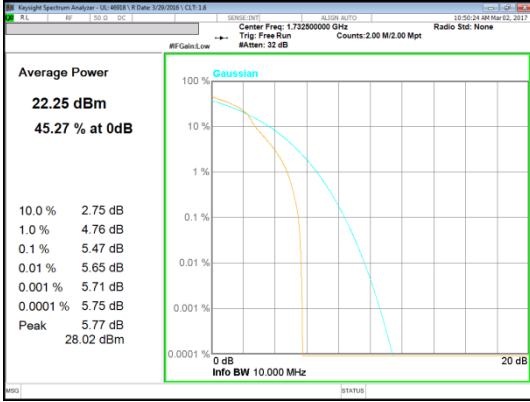
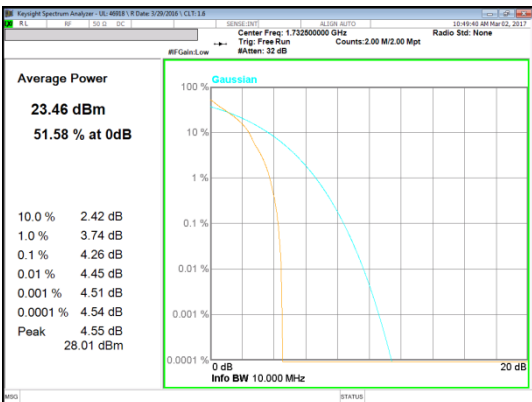
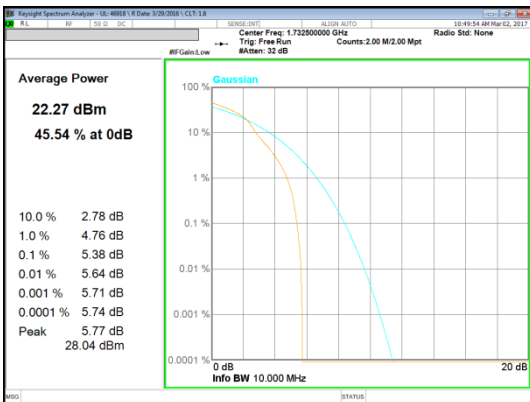
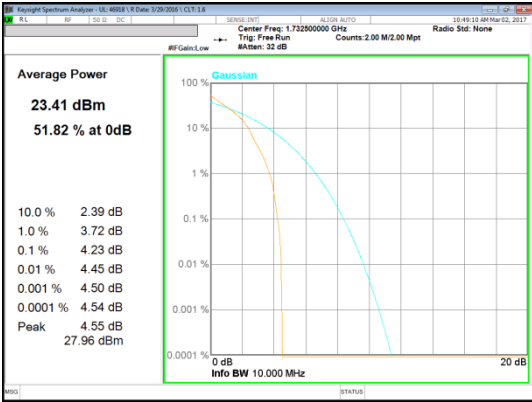
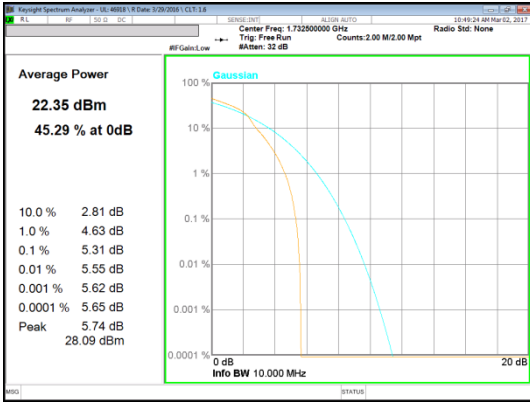
<p>LTE Band 4 5 MHz</p>	 <p>LTE B4 5MHz QPSK Mid channel</p>	 <p>LTE B4 5MHz 16QAM Mid channel</p>
<p>LTE Band 4 3 MHz</p>	 <p>LTE B4 3MHz QPSK Mid channel</p>	 <p>LTE B4 3MHz 16QAM Mid channel</p>
<p>LTE Band 4 1.4 MHz</p>	 <p>LTE B4 1.4MHz QPSK Mid channel</p>	 <p>LTE B4 1.4MHz 16QAM Mid channel</p>

LTE Band 13

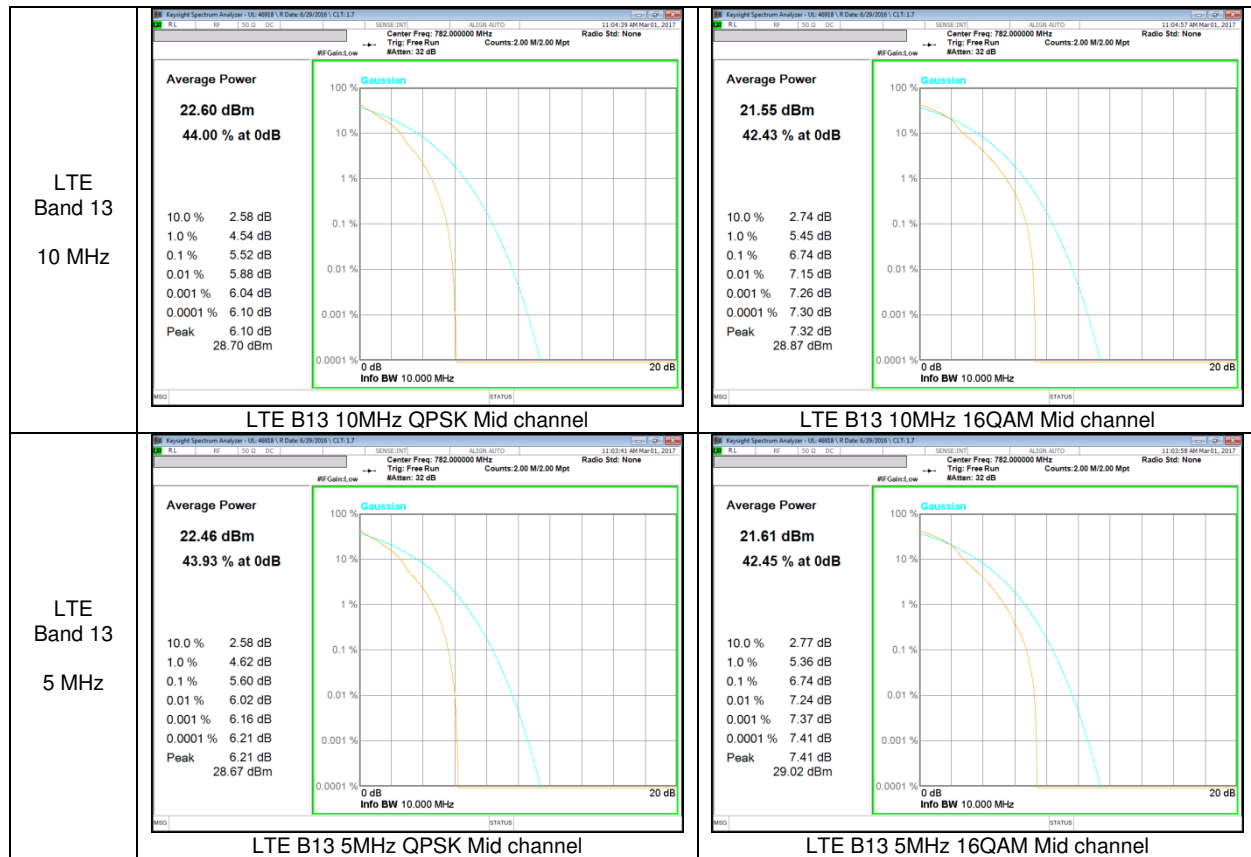

10. LIMITS AND CONDUCTED RESULTS

10.1. OCCUPIED BANDWIDTH

RULE PART(S)

FCC: §2.1049

LIMITS

For reporting purposes only

TEST PROCEDURE

The transmitter output was connected to a calibrated coaxial cable and coupler, the other end of which was connected to a spectrum analyzer. The occupied bandwidth was measured with the spectrum analyzer at the low, middle and high channel in each band. The -26dB bandwidth was also measured and recorded.

(KDB 971168 D01 Power Meas License Digital Systems v02r02)

LTE Band 4

Band	BW [MHz]	Channel	f [MHz]	Mode	99% BW [MHz]	26dB BW [MHz]
Band 4	20	20050	1720.0	QPSK	17.871	19.61
				16QAM	17.873	19.79
		20174	1732.5	QPSK	17.828	19.60
				16QAM	17.866	19.54
		20299	1745.0	QPSK	17.905	19.74
				16QAM	17.936	19.48
	15	20025	1717.5	QPSK	13.437	15.27
				16QAM	13.417	15.18
		20174	1732.5	QPSK	13.405	14.88
				16QAM	13.427	15.11
		20324	1747.5	QPSK	13.457	15.17
				16QAM	13.463	15.28
	10	20000	1715.0	QPSK	8.9714	10.23
				16QAM	8.9532	10.11
		20174	1732.5	QPSK	8.9653	10.02
				16QAM	8.9645	10.20
		20349	1750.0	QPSK	8.9662	10.22
				16QAM	8.9552	10.25
	5	19975	1712.5	QPSK	4.4974	5.223
				16QAM	4.4936	5.246
		20174	1732.5	QPSK	4.4976	5.326
				16QAM	4.5121	5.195
		20374	1752.5	QPSK	4.5123	5.463
				16QAM	4.4990	5.286
	3	19965	1711.5	QPSK	2.6922	3.063
				16QAM	2.7044	3.112
		20174	1732.5	QPSK	2.7014	3.100
				16QAM	2.6911	3.096
		20384	1753.5	QPSK	2.6993	3.097
				16QAM	2.6940	3.070
1.4	19957	1710.7	QPSK	1.0976	1.430	
			16QAM	1.0882	1.365	
	20174	1732.5	QPSK	1.0913	1.385	
			16QAM	1.0905	1.396	
	20392	1754.3	QPSK	1.0952	1.398	
			16QAM	1.0967	1.407	

LTE Band 13

Band	BW [MHz]	Channel	f [MHz]	Mode	99% BW [MHz]	26dB BW [MHz]
Band 13	10	23230	782.0	QPSK	8.9491	10.28
				16QAM	8.9616	10.15
	5	23207	779.5	QPSK	4.4994	5.232
				16QAM	4.4971	5.146
		23230	782.0	QPSK	4.4848	5.227
				16QAM	4.4839	5.106
		23255	784.5	QPSK	4.5111	5.206
				16QAM	4.5046	5.286

10.1.1. OCCUPIED BANDWIDTH PLOTS
LTE Band 4

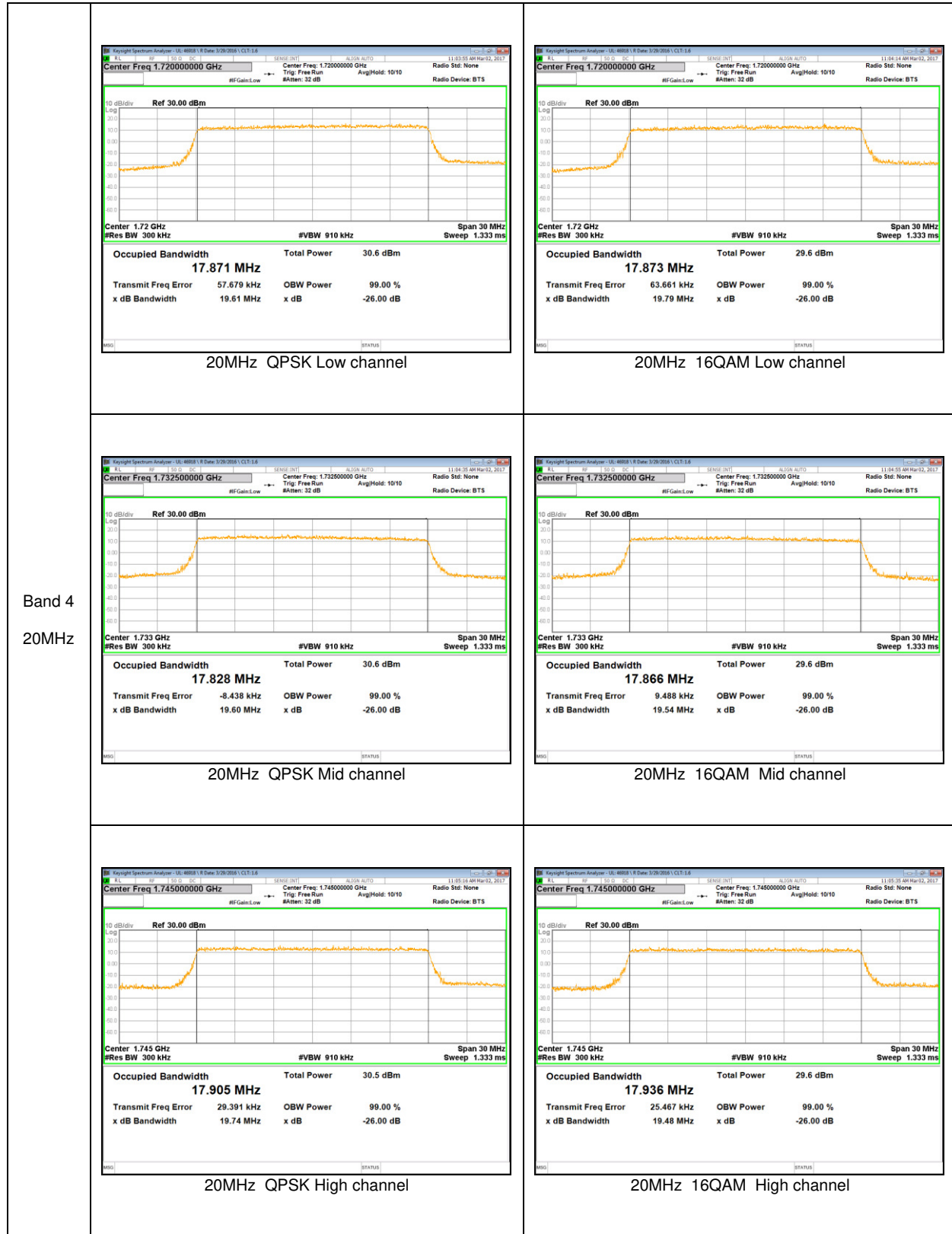

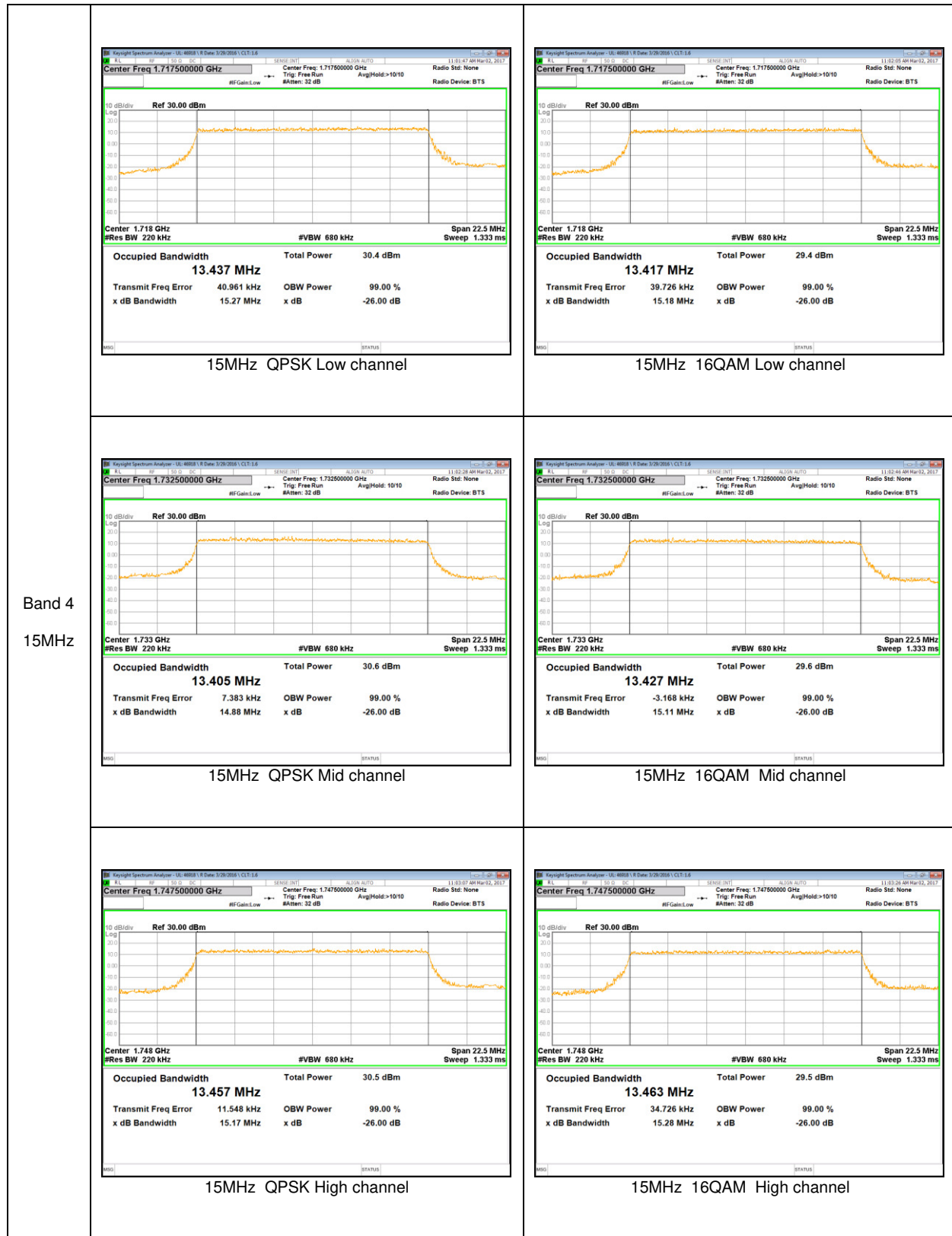

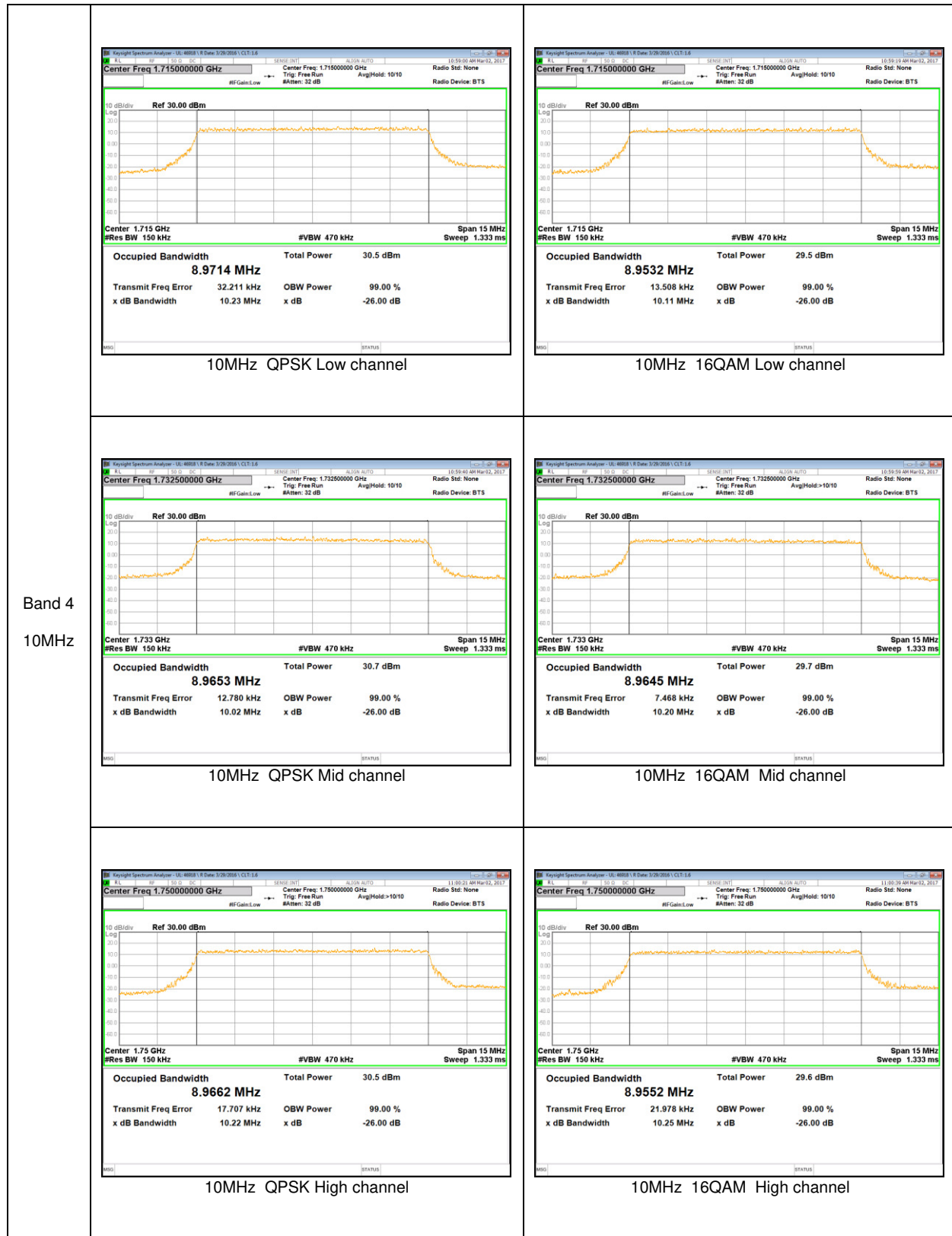

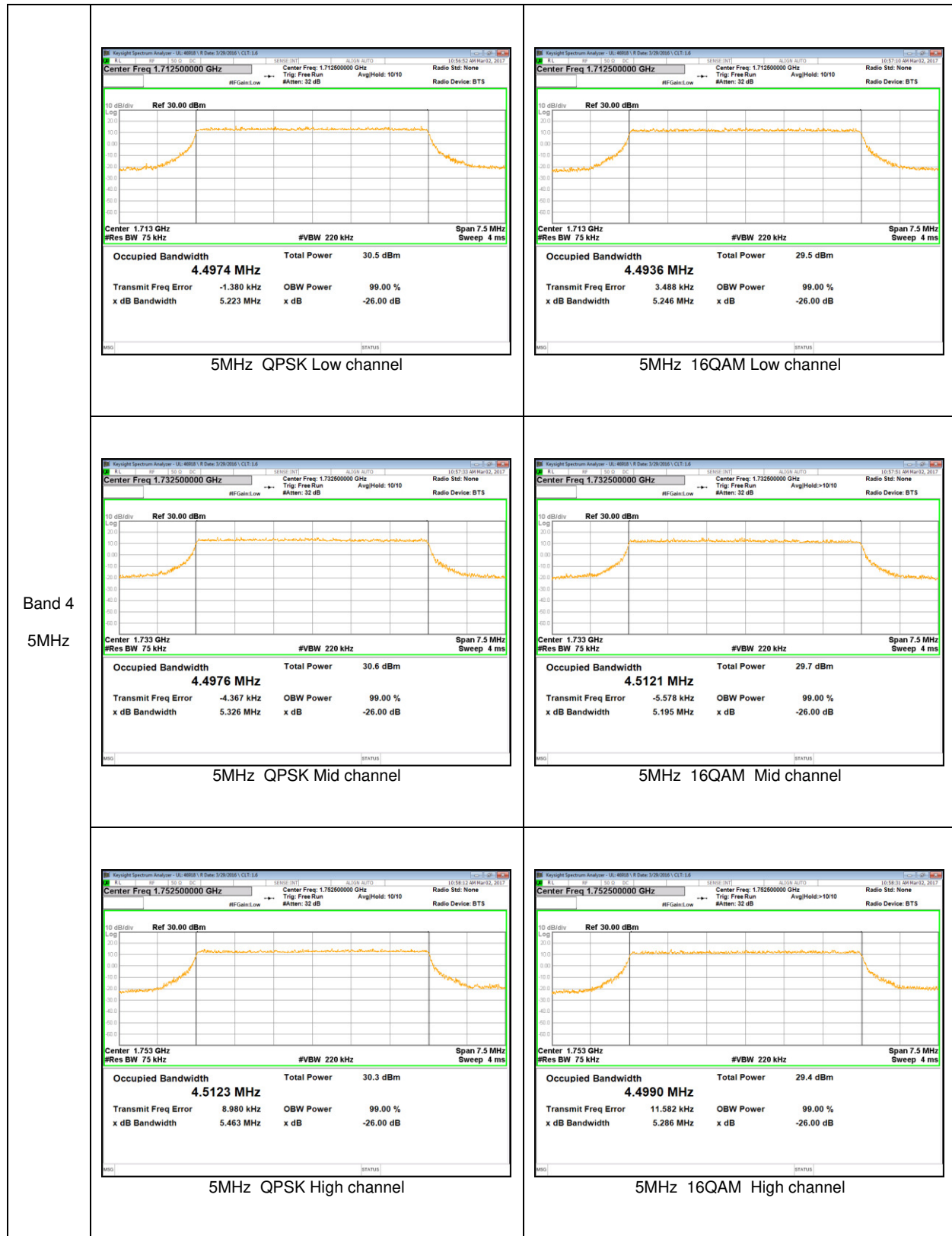

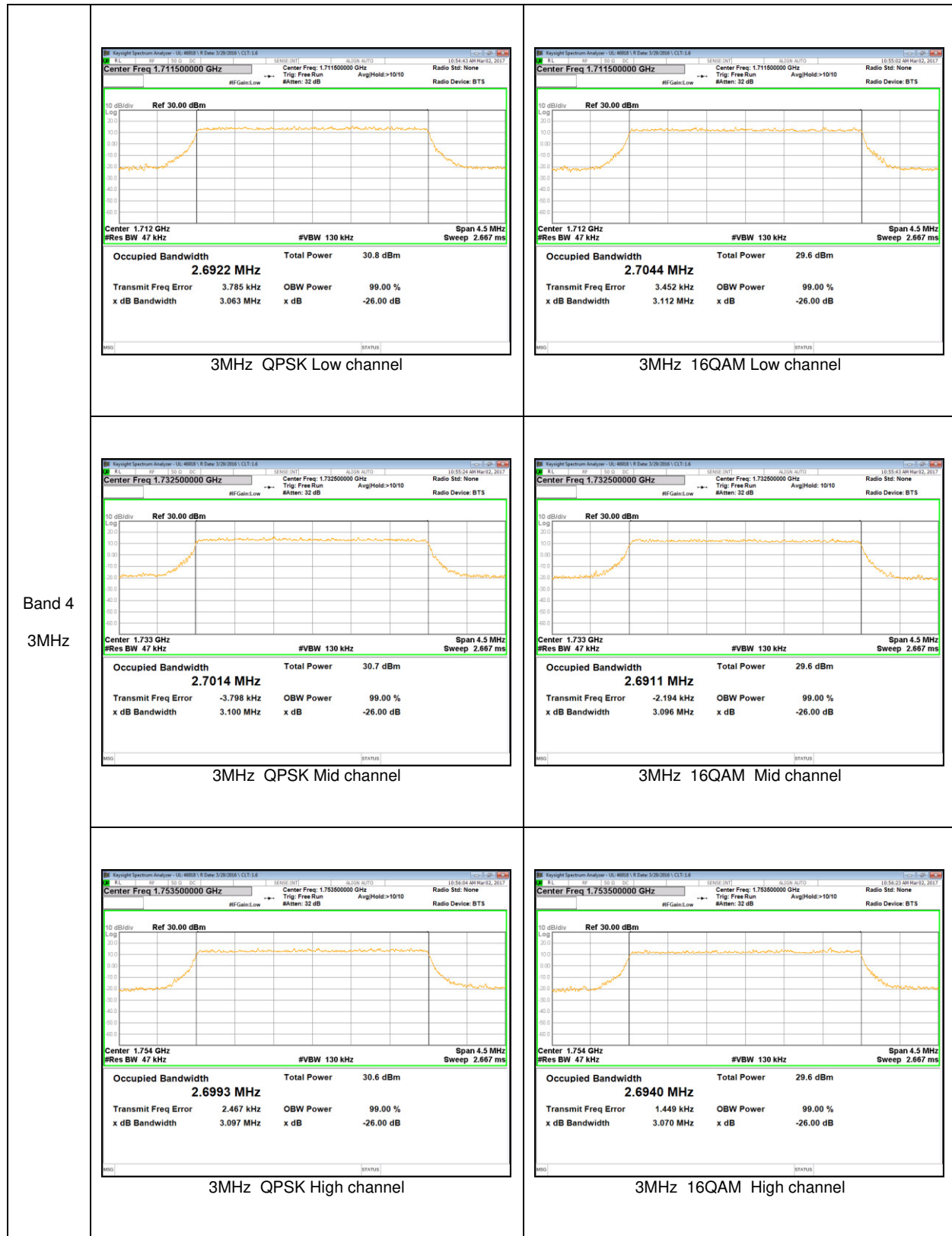

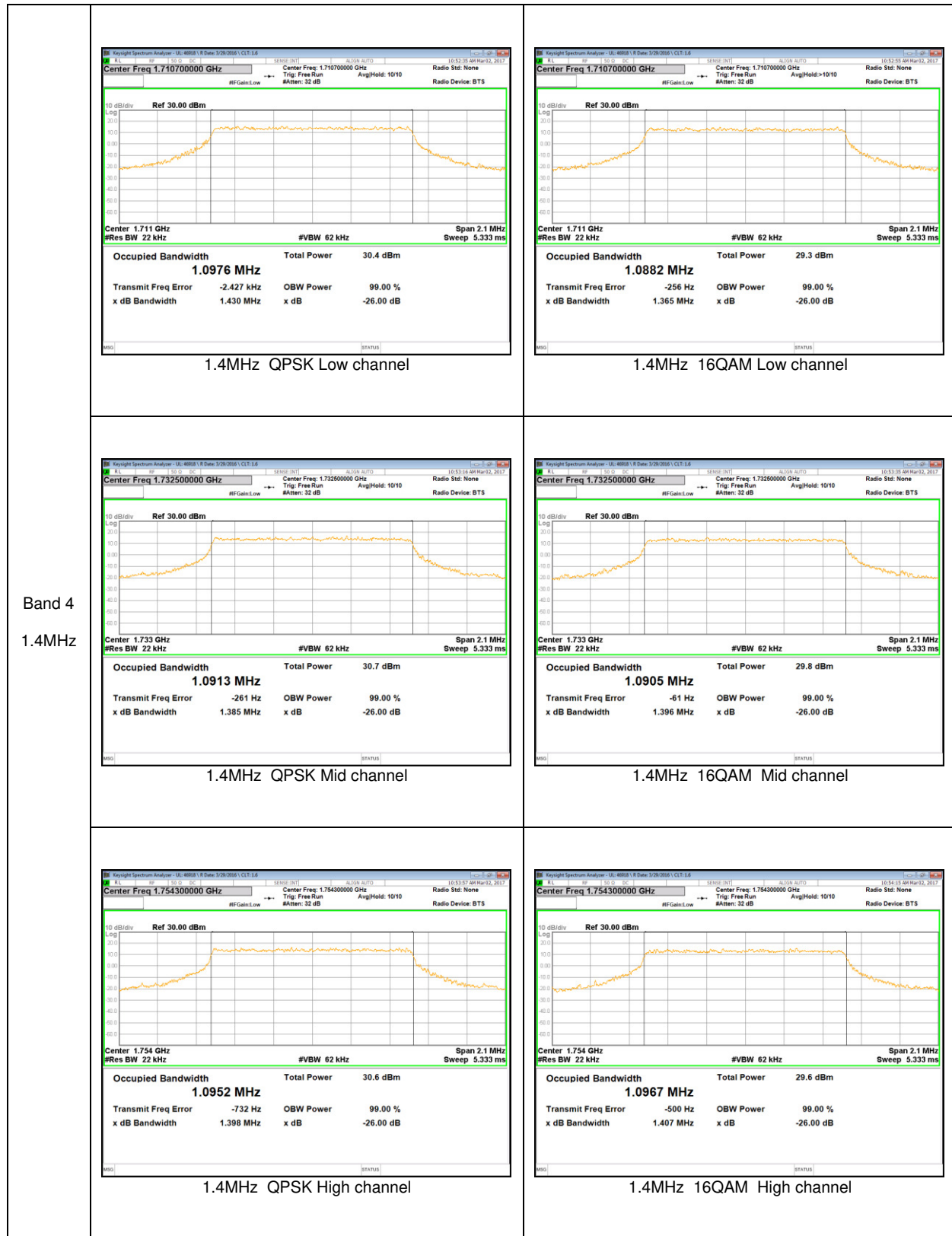

LTE Band 13

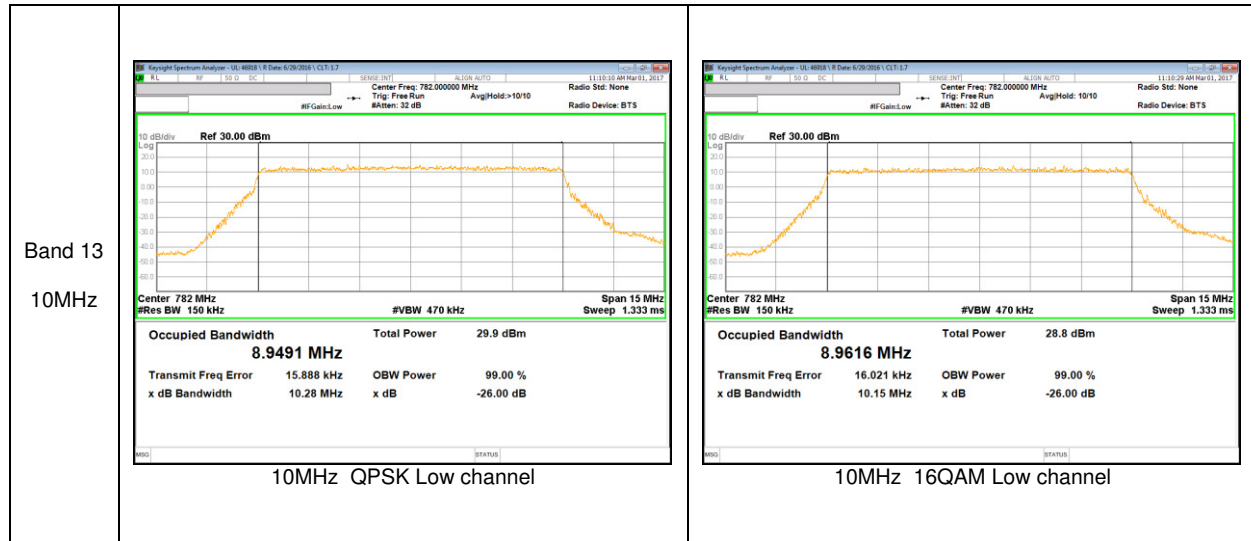

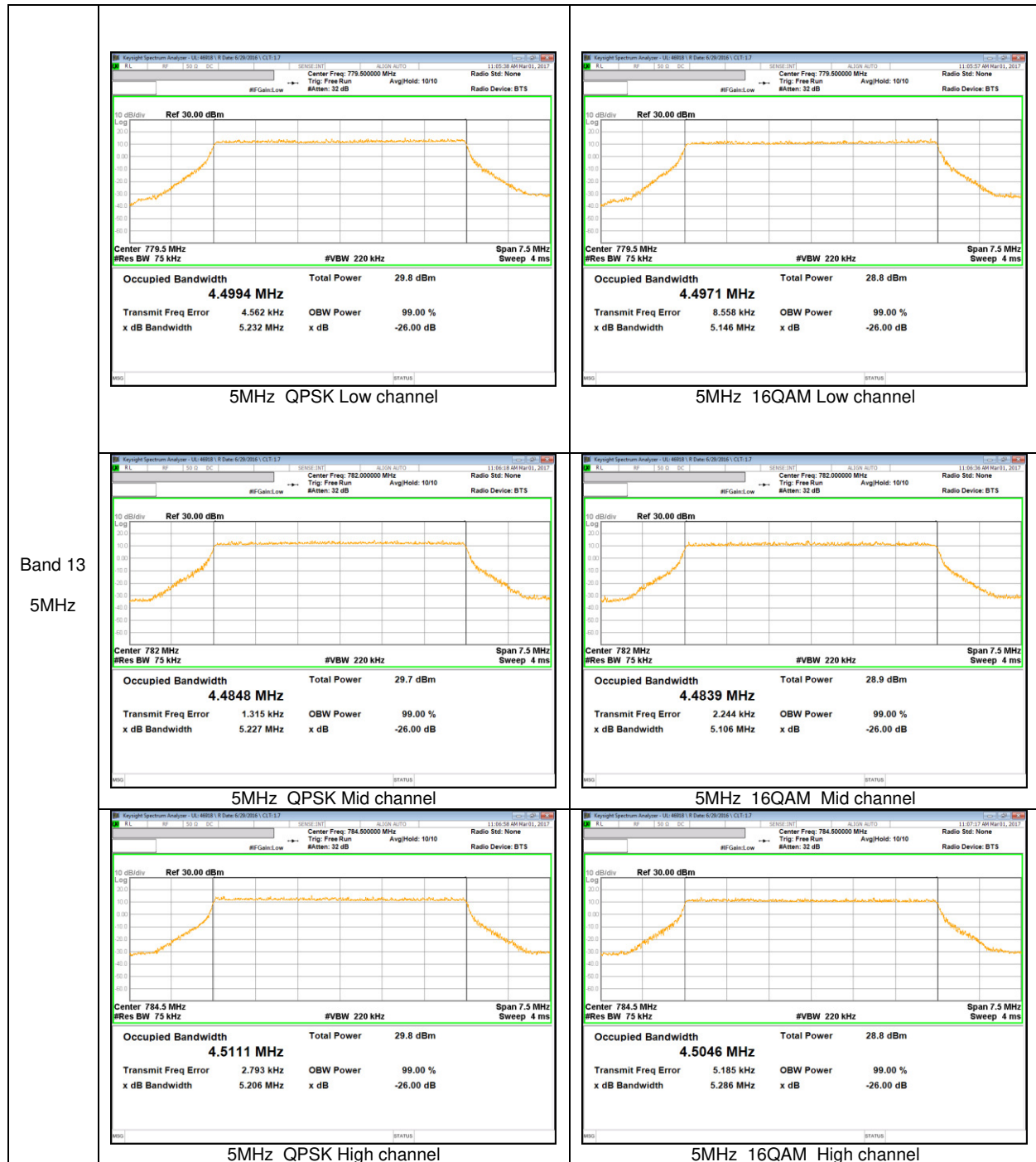

10.2. BAND EDGE EMISSIONS

RULE PART(S)

FCC: §27.53(c) (2), (4), (h)

LIMITS

(c) For operations in the 746-758 MHz band and the 776-788 MHz band, the power of any emission outside the licensee's frequency band(s) of operation shall be attenuated below the transmitter power (P) within the licensed band(s) of operation, measured in watts, in accordance with the following:

(2) On any frequency outside the 776-788 MHz band, the power of any emission shall be attenuated outside the band below the transmitter power (P) by at least $43 + 10 \log (P)$ dB;

(4) On all frequencies between 763-775 MHz and 793-805 MHz, by a factor not less than $65 + 10 \log (P)$ dB in a 6.25 kHz band segment, for mobile and portable stations;

(h) The power of any emission outside a licensee's frequency block shall be attenuated below the transmitter power (P) in watts by at least $43 + 10 \log_{10} (P)$ dB.

TEST PROCEDURE

Per KDB 971168 D01 Power Meas License Digital Systems v02r02

The transmitter output was connected to a CMW500 Test Set and configured to operate at maximum power. The band edge emissions were measured at the required operating frequencies in each band on the Spectrum Analyzer.

LTE

- a) Set the RBW = 1 ~ 1.5 % of OBW(Typically limited to a minimum RBW of 1% of the OBW)
- b) Set VBW $\geq 3 \times$ RBW;
- c) Set span ≥ 1.5 times the OBW;
- d) Sweep time = Auto ;
- e) Detector = RMS;
- f) Ensure that the number of measurement points $\geq 2 \times$ Span/RBW;
- g) Trace mode = Average(100);

Note: For frequency range of 763-775 MHz and 793-805 MHz,

- a) Set the RBW = 6.2kHz
- b) Set VBW $\geq 3 \times$ RBW;
- c) Sweep time = 1 second ;
- d) Detector = RMS;
- e) Ensure that the number of measurement points $\geq 2 \times$ Span/RBW;
- f) Trace mode = Maxhold;

RESULTS

LTE 4

Bandwidth	Mode	Side	RB Status	f [MHz]	Level [dBm]	Limit [dBm]
20 MHz	QPSK	Lower	1RB	1710.000	-31.154	-13.00
			FRB	1710.000	-26.276	
		Upper	1RB	1755.000	-28.572	
			FRB	1755.000	-24.113	
	16QAM	Lower	1RB	1710.000	-26.064	
			FRB	1710.000	-28.867	
		Upper	1RB	1755.000	-31.488	
			FRB	1755.000	-26.493	
15 MHz	QPSK	Lower	1RB	1710.000	-22.978	
			FRB	1710.000	-26.389	
		Upper	1RB	1755.000	-20.070	
			FRB	1755.000	-22.668	
	16QAM	Lower	1RB	1710.000	-21.259	
			FRB	1710.000	-28.695	
		Upper	1RB	1755.000	-20.800	
			FRB	1755.000	-26.964	
10 MHz	QPSK	Lower	1RB	1710.000	-30.874	
			FRB	1710.000	-25.587	
		Upper	1RB	1755.000	-25.472	
			FRB	1755.000	-21.402	
	16QAM	Lower	1RB	1710.000	-32.870	
			FRB	1710.000	-27.783	
		Upper	1RB	1755.000	-26.655	
			FRB	1755.000	-22.108	
5 MHz	QPSK	Lower	1RB	1710.000	-21.110	
			FRB	1710.000	-25.021	
		Upper	1RB	1755.000	-19.980	
			FRB	1755.000	-21.588	
	16QAM	Lower	1RB	1710.000	-21.455	
			FRB	1710.000	-25.015	
		Upper	1RB	1755.000	-21.095	
			FRB	1755.000	-21.879	

Bandwidth	Mode	Side	RB Status	f [MHz]	Level [dBm]	Limit [dBm]
3 MHz	QPSK	Lower	1RB	1710.000	-15.991	-13.00
			FRB	1710.000	-20.389	
		Upper	1RB	1755.000	-14.409	
			FRB	1755.000	-21.289	
	16QAM	Lower	1RB	1710.000	-18.010	
			FRB	1710.000	-23.651	
		Upper	1RB	1755.000	-17.200	
			FRB	1755.000	-22.759	
1.4 MHz	QPSK	Lower	1RB	1710.000	-20.790	-13.00
			FRB	1710.000	-20.230	
		Upper	1RB	1755.000	-17.569	
			FRB	1755.000	-17.921	
	16QAM	Lower	1RB	1710.000	-23.442	
			FRB	1710.000	-21.621	
		Upper	1RB	1755.000	-18.674	
			FRB	1755.000	-19.802	

LTE 13

Bandwidth	Mode	Side	RB Status	f [MHz]	Level [dBm]	Limit [dBm]
10 MHz	QPSK	Lower	1RB	777.000	-30.663	-13.00
			FRB	777.000	-30.376	
		Upper	1RB	787.000	-26.382	
			FRB	787.000	-26.487	
	16QAM	Lower	1RB	777.000	-34.138	
			FRB	777.000	-29.841	
		Upper	1RB	787.000	-32.202	
			FRB	787.000	-28.908	
5 MHz	QPSK	Lower	1RB	777.000	-20.973	-13.00
			FRB	777.000	-24.129	
		Upper	1RB	787.000	-20.883	
			FRB	787.000	-25.307	
	16QAM	Lower	1RB	777.000	-22.002	
			FRB	777.000	-25.107	
		Upper	1RB	787.000	-22.761	
			FRB	787.000	-22.099	

10.2.1. BAND EDGE PLOTS

LTE Band 4

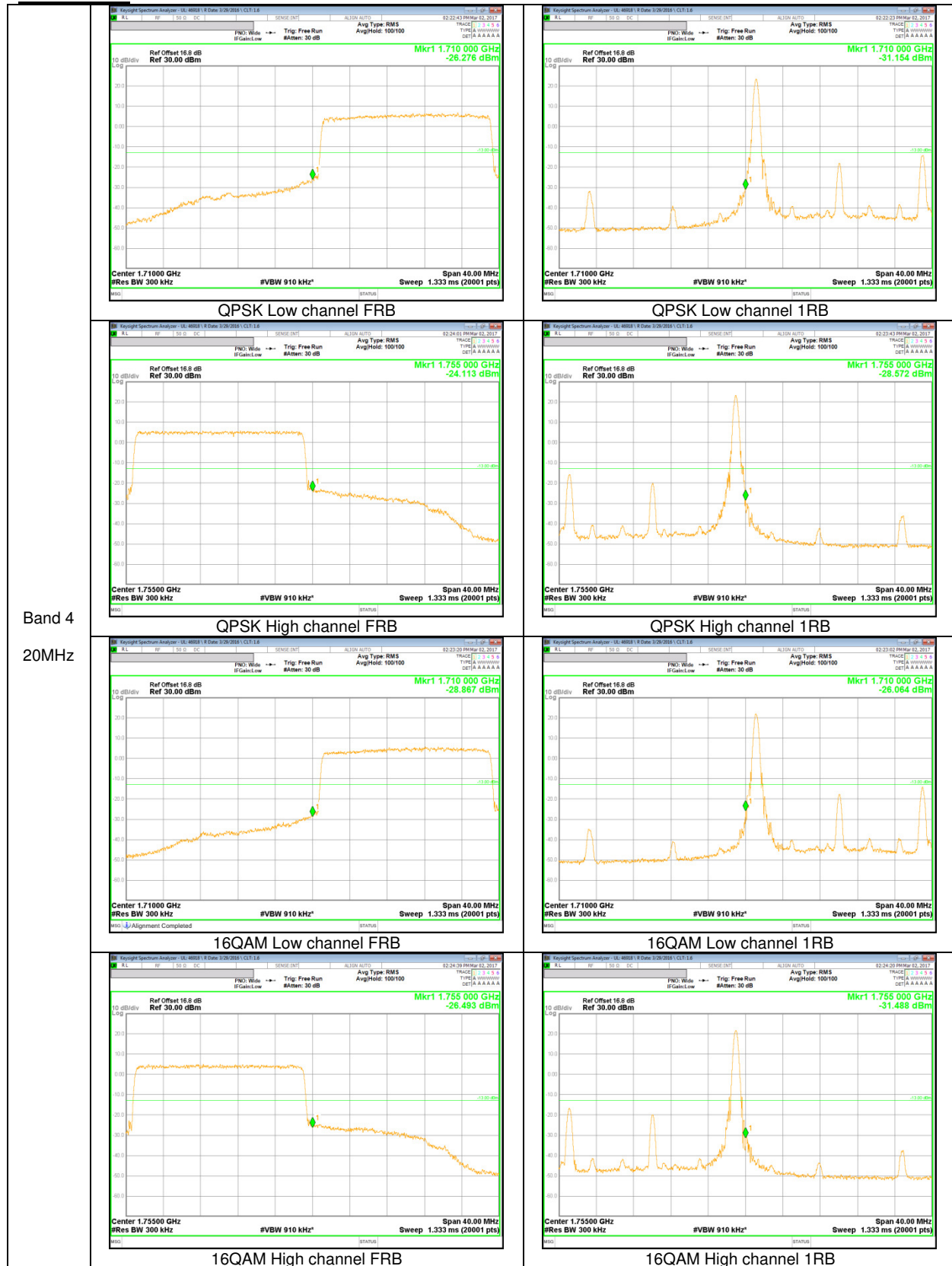

Band 4
20MHz

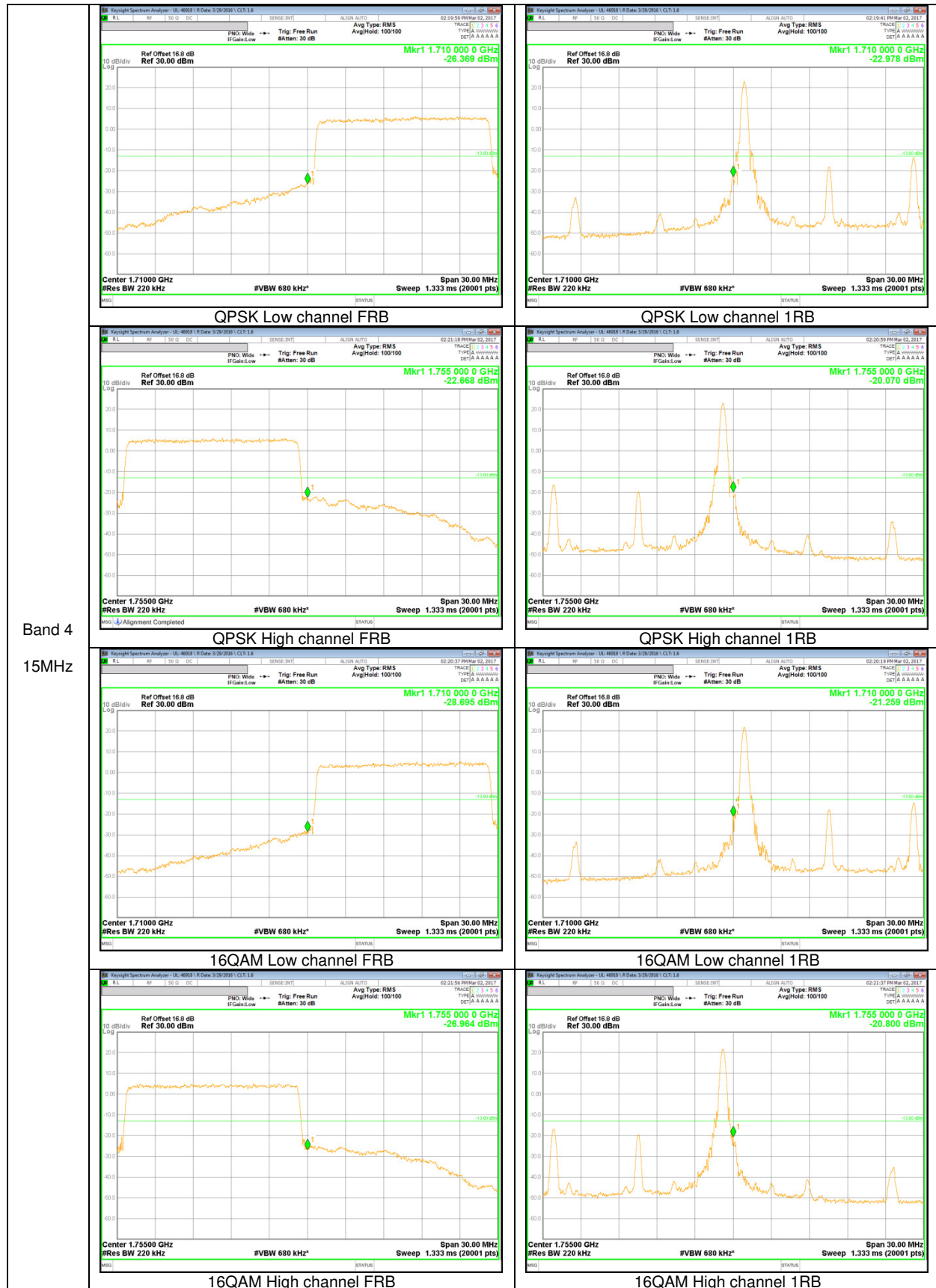

Band 4
 15MHz

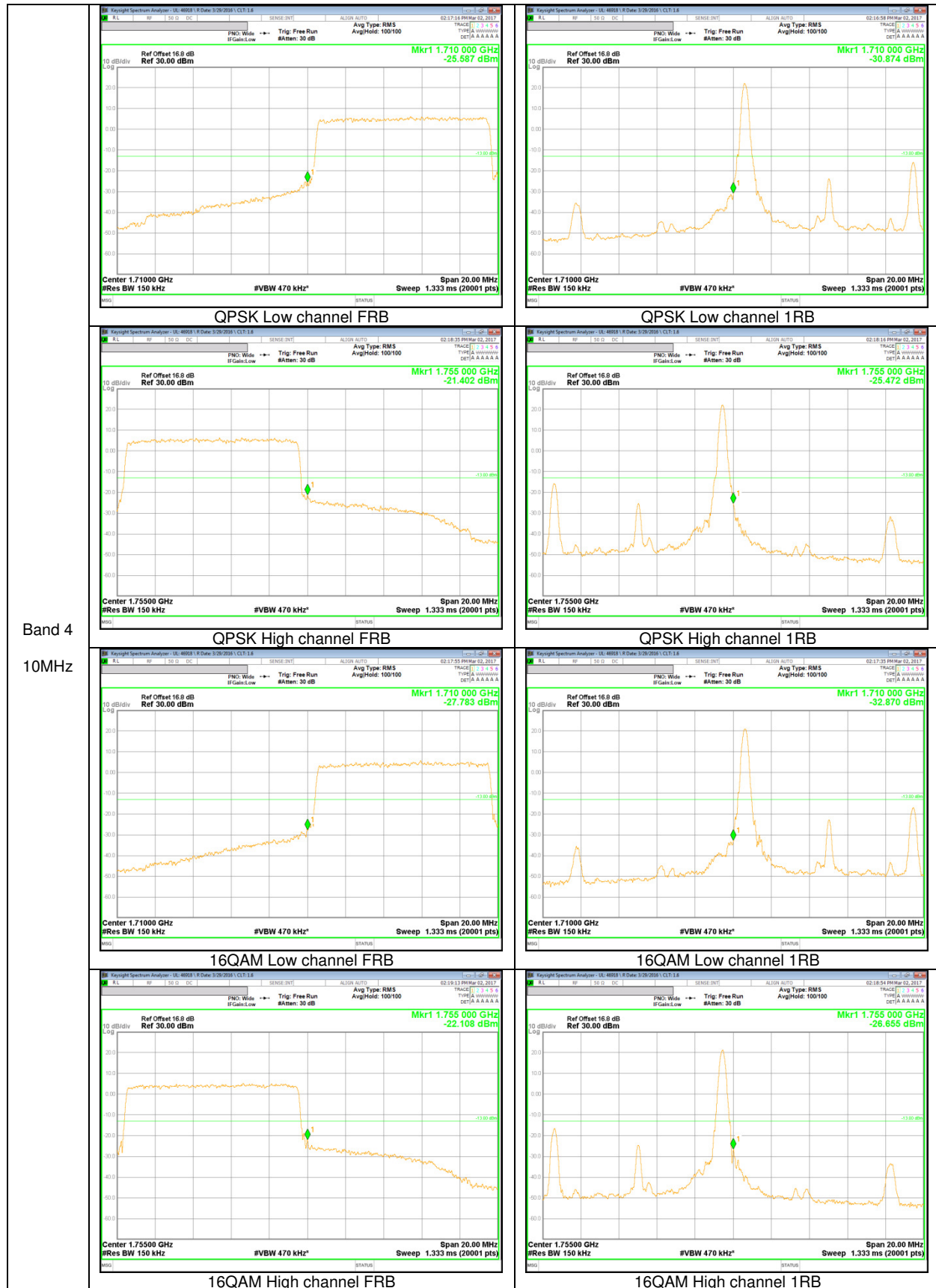

Band 4
10MHz