



**FCC CFR47 PART 22 SUBPART H
FCC CFR47 PART 24 SUBPART E
FCC CFR47 PART 27 SUBPART L**

WWAN

CERTIFICATION TEST REPORT

FOR

WCDMA/LTE Watch + Bluetooth/BLE and DTS b/g/n

MODEL NUMBER : SM-R765T, SM-R765A

FCC ID: A3LSMR765U

REPORT NUMBER: 16K23793-E4V2

ISSUE DATE: SEP 02, 2016

Prepared for
**SAMSUNG ELECTRONICS CO., LTD.
129 SAMSUNG-RO, YEONGTONG-GU, SUWON-SI,
GYEONGGI-DO, 16677, KOREA**

Prepared by
**UL Korea, Ltd. Suwon Laboratory
218 Maeyeong-ro, Yeongtong-gu,
Suwon-si, Gyeonggi-do, 16675, Korea
TEL: (031) 337-9902
FAX: (031) 213-5433**



Revision History

<u>Rev.</u>	<u>Issue Date</u>	<u>Revisions</u>	<u>Revised By</u>
V1	08/29/16	Initial issue	Junwhan Lee
V2	09/02/16	Revised section 2, 8.1	Junwhan Lee

TABLE OF CONTENTS

1. ATTESTATION OF TEST RESULTS	5
2. TEST METHODOLOGY	6
3. FACILITIES AND ACCREDITATION	6
4. CALIBRATION AND UNCERTAINTY	6
4.1. <i>MEASURING INSTRUMENT CALIBRATION</i>	6
4.2. <i>SAMPLE CALCULATION</i>	6
4.3. <i>MEASUREMENT UNCERTAINTY</i>	6
5. EQUIPMENT UNDER TEST	7
5.1. <i>DESCRIPTION OF EUT</i>	7
5.2. <i>MAXIMUM OUTPUT POWER (WCDMA)</i>	7
5.3. <i>MAXIMUM OUTPUT POWER (LTE)</i>	8
5.4. <i>DESCRIPTION OF AVAILABLE ANTENNAS</i>	10
5.5. <i>DESCRIPTION OF TEST SETUP</i>	11
6. TEST AND MEASUREMENT EQUIPMENT	13
7. Summary Table	14
8. RF POWER OUTPUT VERIFICATION	16
8.1. <i>W-CDMA</i>	16
8.1.1. <i>WCDMA OUTPUT POWER RESULT</i>	18
8.2. <i>LTE OUTPUT VERIFICATION</i>	21
8.2.1. <i>LTE OUTPUT POWER RESULT</i>	22
9. PEAK TO AVERAGE RATIO	27
9.1. <i>CONDUCTED PEAK TO AVERAGE RESULT</i>	27
9.2. <i>CONDUCTED PEAK TO AVERAGE PLOTS</i>	29
10. LIMITS AND CONDUCTED RESULTS	35
10.1. <i>OCCUPIED BANDWIDTH</i>	35
10.1.1. <i>OCCUPIED BANDWIDTH RESULTS</i>	35
10.1.2. <i>OCCUPIED BANDWIDTH PLOTS</i>	39
10.2. <i>BAND EDGE EMISSIONS</i>	58
10.2.1. <i>BAND EDGE PLOTS</i>	63
10.3. <i>OUT OF BAND EMISSIONS</i>	81
10.3.1. <i>OUT OF BAND EMISSIONS RESULT</i>	81
10.3.2. <i>OUT OF BAND EMISSIONS PLOTS</i>	85

10.4.	<i>FREQUENCY STABILITY</i>	104
10.4.1.	FREQUENCY STABILITY RESULTS.....	105
11.	RADIATED TEST RESULTS	111
11.1.	<i>RADIATED POWER (ERP & EIRP)</i>	111
11.1.1.	ERP/EIRP Results	112
11.1.2.	ERP/EIRP DATA	116
11.2.	<i>FIELD STRENGTH OF SPURIOUS RADIATION</i>	135
11.2.1.	SPURIOUS RADIATION PLOTS.....	136
12.	SETUP PHOTOS	155

1. ATTESTATION OF TEST RESULTS

COMPANY NAME: SAMSUNG ELECTRONICS CO., LTD.
EUT DESCRIPTION: WCDMA/LTE Watch + Bluetooth/BLE and DTS b/g/n
MODEL NUMBER: SM-R765T, SM-R765A
SERIAL NUMBER: R3AH700KECL, R3AH700KEDZ, R3AH700KEED
R3AH700KEFF, R3AH700KEGM, R3AH700KEHT
R3AH700KEJY, R3AH700KEZZ, R3AH700KEYL (RADIATED);
R3AH700KEAE, R3AH700KELR (CONDUCTED)
DATE TESTED: AUG 11, 2016 - AUG 29, 2016

APPLICABLE STANDARDS	
STANDARD	TEST RESULTS
FCC PART 22H, 24E and 27L	Pass

UL Korea, Ltd. tested the above equipment in accordance with the requirements set forth in the above standards. All indications of Pass/Fail in this report are opinions expressed by UL Korea, Ltd. based on interpretations and/or observations of test results. Measurement Uncertainties were not taken into account and are published for informational purposes only. The test results show that the equipment tested is capable of demonstrating compliance with the requirements as documented in this report.

Note: The results documented in this report apply only to the tested sample, under the conditions and modes of operation as described herein. This document may not be altered or revised in any way unless done so by UL Korea, Ltd. and all revisions are duly noted in the revisions section. Any alteration of this document not carried out by UL Korea, Ltd. will constitute fraud and shall nullify the document. This report must not be used by the client to claim product certification, approval, or endorsement by IAS, any agency of the Federal Government, or any agency of any government.

Approved & Released For
UL Korea, Ltd. By:



CY Choi
Suwon Lab Engineer
UL Korea, Ltd.

Tested By:



Junwhan Lee
Suwon Lab Engineer
UL Korea, Ltd.

2. TEST METHODOLOGY

The tests documented in this report were performed in accordance with TIA-603-D, FCC CFR 47 Part 2, FCC CFR 47 Part 22, FCC CFR Part 24 and FCC CFR Part 27.

3. FACILITIES AND ACCREDITATION

The test sites and measurement facilities used to collect data are located at 218 Maeyeong-ro, Yeongtong-gu, Suwon-si, Gyeonggi-do, 16675, Korea. Line conducted emissions are measured only at the 218 address. The following table identifies which facilities were utilized for radiated emission measurements documented in this report. Specific facilities are also identified in the test results sections.

218 Maeyeong-ro	
<input type="checkbox"/>	Chamber 1
<input checked="" type="checkbox"/>	Chamber 2

UL Korea, Ltd. is accredited by IAS, Laboratory Code TL-637. The full scope of accreditation can be viewed at <http://www.iasonline.org/PDF/TL/TL-637.pdf>.

4. CALIBRATION AND UNCERTAINTY

4.1. MEASURING INSTRUMENT CALIBRATION

The measuring equipment utilized to perform the tests documented in this report has been calibrated in accordance with the manufacturer's recommendations, and is traceable to recognized national standards.

4.2. SAMPLE CALCULATION

Where relevant, the following sample calculation is provided:

$EIRP = PSA \text{ reading with EUT worst orientation (dBm)} + \text{Path loss (dB)} - \text{cable loss (between the SG and substitution antenna)} + \text{Substitution Antenna Factor (dBi)}$

$ERP = PSA \text{ reading with EUT worst orientation (dBm)} + \text{Path loss (dB)} - \text{cable loss (between the SG and substitution antenna)}$

(Path loss = Signal generator output – PSA reading with substitution antenna)

4.3. MEASUREMENT UNCERTAINTY

Where relevant, the following measurement uncertainty levels have been estimated for tests performed on the apparatus:

PARAMETER	UNCERTAINTY
Conducted Disturbance, 0.15 to 30 MHz	2.32 dB
Radiated Disturbance, Below 1GHz	4.14 dB
Radiated Disturbance, Above 1 GHz	5.97 dB

Uncertainty figures are valid to a confidence level of 95%.

5. EQUIPMENT UNDER TEST

5.1. DESCRIPTION OF EUT

The EUT is a WCDMA/LTE Watch + Bluetooth/BLE and DTS b/g/n

SM-R765T and SM-R765A are same H/W and only difference is supported band.
 Band 4 (LTE and WCDMA) of SM-R765A are disabled by S/W.
 SM-R765T was used for the test.

5.2. MAXIMUM OUTPUT POWER (WCDMA)

The transmitter has a maximum peak conducted and radiated ERP / EIRP output powers as follows:

FCC Part 22/24						
Band	Frequency Range	Modulation	Conducted		Radiated	
	[MHz]		Peak	Avg [dBm]	Avg [mW]	Avg [dBm]
Band 5	824~849	REL99	23.33	215.28	2.41	1.74
		HSDPA	22.10	162.18	2.23	1.67
		HSUPA	21.43	139.00		
Band 4	1710~1755	REL99	22.31	170.22	15.96	39.45
		HSDPA	22.16	164.44	16.13	41.02
		HSUPA	21.49	140.93		
Band 2	1850~1910	REL99	22.27	168.66	17.74	59.43
		HSDPA	22.07	161.06	17.49	56.10
		HSUPA	21.41	138.36		

5.3. MAXIMUM OUTPUT POWER (LTE)

The transmitter has a maximum peak conducted and radiated ERP / EIRP output powers as follows:

LTE Band 5

FCC Part 22							
Band	Frequency Range [MHz]	BandWidth [MHz]	Modulation Peak	Conducted		Radiated	
				Avg [dBm]	Avg [mW]	Avg [dBm]	Avg [mW]
Band 5	824 ~ 849	10	QPSK	22.84	192.31	-1.87	0.65
			16QAM	21.90	154.88	-2.87	0.52
		5	QPSK	22.77	189.23	-0.50	0.89
			16QAM	21.77	150.31	-1.45	0.72
		3	QPSK	22.70	186.21	-1.45	0.72
			16QAM	21.81	151.71	-2.18	0.61
		1.4	QPSK	22.72	187.07	-3.33	0.46
			16QAM	21.68	147.23	-4.26	0.37

LTE Band 4

FCC Part 27							
Band	Frequency Range [MHz]	BandWidth [MHz]	Modulation Peak	Conducted		Radiated	
				Avg [dBm]	Avg [mW]	Avg [dBm]	Avg [mW]
Band 4	1710 ~ 1755	20	QPSK	22.89	194.54	15.51	35.56
			16QAM	21.99	158.12	15.05	31.99
		15	QPSK	22.80	190.55	14.86	30.62
			16QAM	21.76	149.97	13.87	24.38
		10	QPSK	22.88	194.09	15.94	39.26
			16QAM	21.84	152.76	14.98	31.48
		5	QPSK	22.78	189.67	15.89	38.82
			16QAM	21.90	154.88	14.85	30.55
		3	QPSK	22.82	191.43	14.62	28.97
			16QAM	21.59	144.21	13.40	21.88
		1.4	QPSK	22.83	191.87	13.24	21.09
			16QAM	21.79	151.01	12.28	16.90

LTE Band 2

FCC Part 24							
Band	Frequency Range [MHz]	BandWidth [MHz]	Modulation Peak	Conducted		Radiated	
				Avg [dBm]	Avg [mW]	Avg [dBm]	Avg [mW]
Band 2	1850 ~ 1910	20	QPSK	22.86	193.20	15.88	38.73
			16QAM	22.00	158.49	14.87	30.69
		15	QPSK	23.00	199.53	15.96	39.45
			16QAM	22.00	158.49	14.98	31.48
		10	QPSK	22.88	194.09	16.08	40.55
			16QAM	21.96	157.04	15.11	32.43
		5	QPSK	22.95	197.24	15.32	34.04
			16QAM	22.00	158.49	14.35	27.23
		3	QPSK	22.90	194.98	14.66	29.24
			16QAM	21.92	155.60	13.63	23.07
		1.4	QPSK	22.74	187.93	16.38	43.45
			16QAM	21.71	148.25	15.43	34.91

5.4. DESCRIPTION OF AVAILABLE ANTENNAS

The radio utilizes a FPCB antenna for the [List the bands supported] with a maximum peak gain as follow:

Frequency (MHz)	Peak Gain (dBi)
WCDMA Band 5 / LTE Band 5 824 ~ 849 MHz	-14.5
WCDMA Band 2 / LTE Band 2 1850 ~ 1910 MHz	-2.8
WCDMA Band 4 / LTE Band 4 1710 ~ 1755 MHz	-2.6

5.5. DESCRIPTION OF TEST SETUP

SUPPORT EQUIPMENT

Support Equipment List				
Description	Manufacturer	Model	Serial Number	FCC ID
Adapter	SAMSUNG	ETA0U60JBE	DK1G826HS17-E	N/A
Data Cable	SAMSUNG	ECB-DU2EBE	N/A	N/A
Wireless Charger	SAMSUNG	EP-YO760	N/A	A3LEPYO760

I/O CABLES

I/O Cable List						
Cable No	Port	# of identical ports	Connector Type	Cable Type	Cable Length (m)	Remarks
1	DC Power	1	Mini-USB	Shielded	0.8m	N/A

TEST SETUP

The EUT is continuously communicated to the call box during the tests.

SETUP DIAGRAM FOR TESTS (CONDUCTED TEST SETUP)

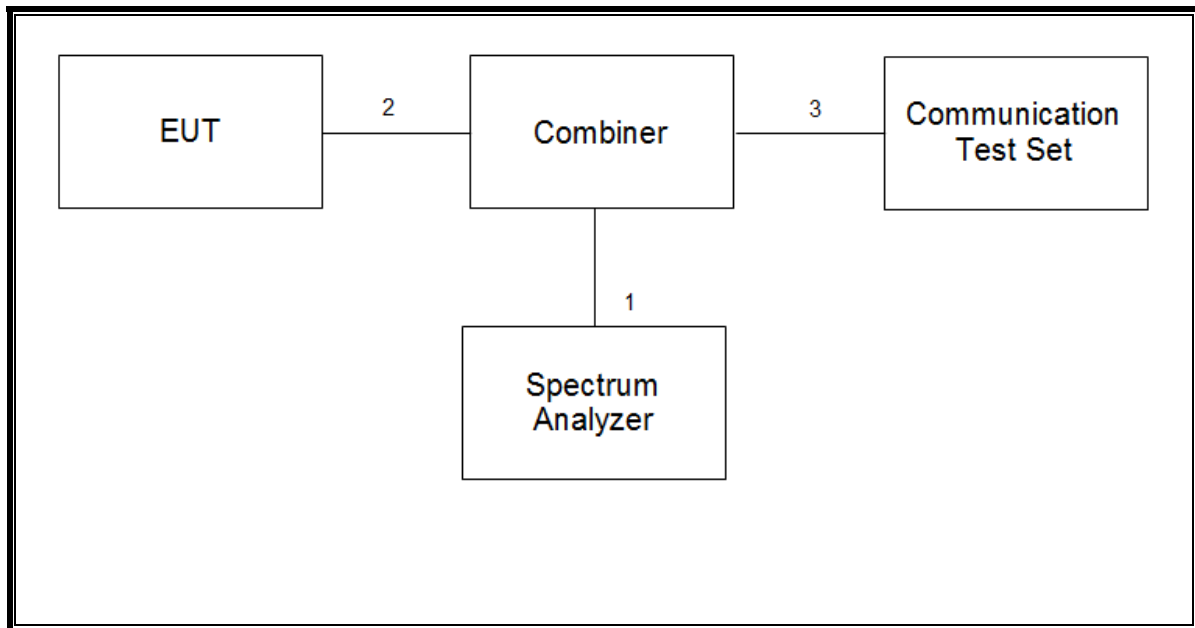

SETUP DIAGRAM FOR TESTS (RADIATED TEST SETUP)

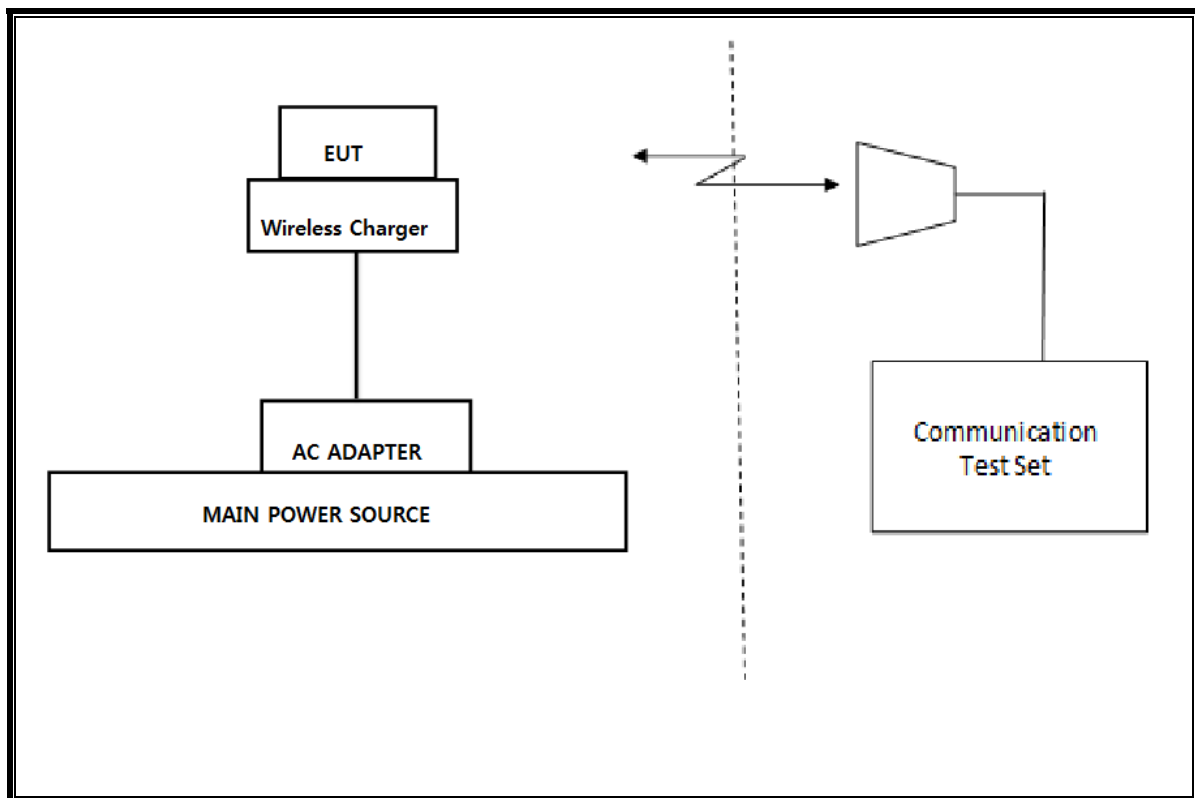

6. TEST AND MEASUREMENT EQUIPMENT

The following test and measurement equipment was utilized for the tests documented in this report:

Test Equipment List				
Description	Manufacturer	Model	S/N	Cal Due
Antenna, Tuned Dipole 400~1000 MHz	ETS	3121D DB4	00164753	07-28-17
Antenna, Horn, 40 GHz	ETS	3116C	00166155	11-30-17
Antenna, Horn, 40 GHz	ETS	3116C-PA	00168841	12-15-17
Antenna, Bilog, 30MHz-1GHz	SCHWARZBECK	VULB9163	750	11-17-16
Antenna, Bilog, 30MHz-1GHz	SCHWARZBECK	VULB9163	749	04-25-17
Antenna, Horn, 18 GHz	ETS	3115	00167211	09-20-16
Antenna, Horn, 18 GHz	ETS	3115	00161451	05-17-17
Antenna, Horn, 18 GHz	ETS	3117	00168724	06-17-17
Antenna, Horn, 18 GHz	ETS	3117	00168717	06-17-17
Combiner	WEINSCHTEL	1575	2152	08-16-17
Communications Test Set	R&S	CMW500	150312	08-17-17
Communications Test Set	R&S	CMW500	115331	08-17-17
DC Power Supply	Agilent / HP	E3640A	MY54226395	08-16-17
Preamplifier, 1000 MHz	Sonoma	310N	341282	08-17-17
Preamplifier, 1000 MHz	Sonoma	310N	351741	08-16-17
Preamplifier	ETS	3115-PA	00167475	08-17-17
Preamplifier, 18 GHz	Miteq	AFS42-00101800-25-S-42	1896138	08-16-17
Spectrum Analyzer, 44 GHz	Agilent / HP	N9030A	MY54170614	08-17-17
Spectrum Analyzer, 44 GHz	Agilent / HP	N9030A	MY54490312	08-16-17
Bluetooth Tester	TESCOM	TC-3000C	3000C000546	08-18-17
Average Power Sensor	R&S	NRZ-Z91	102681	08-16-17
Average Power Sensor	Agilent / HP	U2000	MY54270007	08-17-17
EMI Test Receive, 40 GHz	R&S	ESU40	100439	08-17-17
EMI Test Receive, 40 GHz	R&S	ESU40	100457	08-16-17
EMI Test Receive, 3 GHz	R&S	ESR3	101832	08-16-17
Attenuator / Switch driver	HP	11713A	3748A04272	N/A
High Pass Filter 1.2GHz	Micro-Tronics	HPM50108-02	G005	08-17-17
High Pass Filter 1.2GHz	Micro-Tronics	HPM50108-02	G006	08-17-17
High Pass Filter 2.8GHz	Micro-Tronics	HPM50111-02	010	08-17-17
High Pass Filter 2.8GHz	Micro-Tronics	HPM50111-02	011	08-17-17
High Pass Filter 4GHz	Micro-Tronics	HPM50118-02	G001	08-17-17
High Pass Filter 4GHz	Micro-Tronics	HPM50118-02	G002	08-17-17
LISN	R&S	ENV-216	101836	08-16-17
LISN	R&S	ENV-216	101837	08-16-17
Attenuator	PASTERNAK	PE7087-10	A009	08-16-17

7. Summary Table

FCC Part Section	Test Description	Test Limit	Test Condition	Test Result	Note
2.1049	Occupied Band width (99%)	N/A	Conducted	Pass	17.908 MHz
22.917(a) 24.238(a) 27.53(g)	Band Edge / Conducted Spurious Emission	-13dBm		Pass	-15.366dBm
2.1046	Conducted output power	N/A		Pass	23.33 dBm
22.355 24.235 27.54	Frequency Stability	2.5PPM		Pass	0.003 ppm
22.913(a)(2)	Effective Radiated Power	38 dBm	Radiated	Pass	2.41 dBm
24.232(c)	Equivalent Isotropic Radiated Power	33dBm		Pass	17.74 dBm
27.50(d)(4)		30dBm		Pass	16.13 dBm
22.917(a) 24.238(a) 27.53(g)	Radiated Spurious Emission	-13dBm		Pass	-30.7 dBm

FCC Rule Part	Frequency Range [MHz]	Output Power [W]	Frequency Tolerance	Emission Designator	Emission Bandwidth [MHz]	Communication Type
WCDMA						
22H	826.4 - 846.6	0.00174	2.5 ppm	4M15F9W		WCDMA B5
27L	1712.4 - 1752.6	0.041	2.5 ppm	4M16F9W		WCDMA B4
24E	1852.4 - 1907.6	0.059	2.5 ppm	4M14F9W		WCDMA B2
LTE Band 2						
24E	1860.0 - 1900.0	0.039	2.5 ppm	17M9G7W	20	QPSK
24E	1860.0 - 1900.0	0.031	2.5 ppm	17M9D7W	20	16QAM
24E	1850.7 - 1909.3	0.043	2.5 ppm	1M09G7W	1.4	QPSK
24E	1850.7 - 1909.3	0.035	2.5 ppm	1M10D7W	1.4	16QAM
LTE Band 4						
27L	1720.0 - 1745.0	0.036	2.5 ppm	17M9G7W	20	QPSK
27L	1720.0 - 1745.0	0.032	2.5 ppm	17M9D7W	20	16QAM
27L	1715.0 - 1750.0	0.039	2.5 ppm	8M97G7W	10	QPSK
LTE Band 5						
22H	829.0 - 844.0	0.00065	2.5 ppm	8M96G7W	10	QPSK
22H	829.0 - 844.0	0.00052	2.5 ppm	8M98D7W	10	16QAM
22H	826.5 - 846.5	0.00089	2.5 ppm	4M51G7W	5	QPSK
22H	826.5 - 846.5	0.00072	2.5 ppm	4M51D7W	5	16QAM

8. RF POWER OUTPUT VERIFICATION

8.1. W-CDMA

Release 99 Setup Procedures used to establish the test signals

The following tests were completed according to the test requirements outlined in section 5.2 of the 3GPP TS34.121-1 specification. The DUT supports power Class 3, which has a nominal maximum output power of 24 dBm (+1.7/-3.7).

Mode	Subtest	Rel99
WCDMA General Settings	Loopback Mode	Test Mode 2
	Rel99 RMC	12.2kbps RMC
	Power Control Algorithm	Algorithm2
	β_c/β_d	8/15

HSDPA Setup Procedures used to establish the test signals

The following 4 Sub-tests were completed according to Release 5 procedures in section 5.2 of 3GPP TS34.121. A summary of these settings are illustrated below:

Mode	HSDPA	HSDPA	HSDPA	HSDPA	
Subtest	1	2	3	4	
W-CDMA General Settings	Loopback Mode				Test Mode 1
	Rel99 RMC				12.2kbps RMC
	HSDPA FRC				H-Set 1
	Power Control Algorithm				Algorithm 2
	β_c	2/15	11/15	15/15	15/15
	β_d	15/15	15/15	8/15	4/15
	Bd (SF)	64			
	β_c/β_d	2/15	11/15	15/8	15/4
	β_{hs}	4/15	24/15	30/15	30/15
MPR (dB)	0	0	0.5	0.5	
HSDPA Specific Settings	D_{ACK}				8
	D_{NAK}				8
	DCQI				8
	Ack-Nack repetition factor				3
	CQI Feedback (Table 5.2B.4)				4ms
	CQI Repetition Factor (Table 5.2B.4)				2
	$A_{hs}=\beta_{hs}/\beta_c$				30/15

HSPA (HSDPA & HSUPA) Setup Procedures used to establish the test signals

The following 5 Sub-tests were completed according to Release 6 procedures in section 5.2 of 3GPP TS34.121. A summary of these settings are illustrated below:

	Mode	HSPA				
	Subtest	1	2	3	4	5
WCDMA General Settings	Loopback Mode	Test Mode 1				
	Rel99 RMC	12.2 kbps RMC				
	HSDPA FRC	H-Set 1				
	HSUPA Test	HSPA				
	Power Control Algorithm	Algorithm 2				Algorithm 1
	β_c	11/15	6/15	15/15	2/15	15/15
	β_d	15/15	15/15	9/15	15/15	0
	β_{ec}	209/225	12/15	30/15	2/15	5/15
	β_c/β_d	11/15	6/15	15/9	2/15	15/1
	β_{hs}	22/15	12/15	30/15	4/15	5/15
	β_{ed}	1309/225	94/75	47/15	56/75	47/15
	CM (dB)	1	3	2	3	1
MPR (dB)	0	2	1	2	0	
HSDPA Specific Settings	DACK	8				0
	DNAK	8				0
	DCQI	8				0
	Ack-Nack repetition factor	3				
	CQI Feedback (Table 5.2B.4)	4ms				
	CQI Repetition Factor (Table 5.2B.4)	2				
	$A_{hs} = \beta_{hs}/\beta_c$	30/15				
HSUPA Specific Settings	E-DPDCCH	6	8	8	5	7
	DHARQ	0	0	0	0	0
	AG Index	20	12	15	17	21
	ETFCI (from 34.121 Table C.11.1.3)	75	67	92	71	81
	Associated Max UL Data Rate kbps	242.1	174.9	482.8	205.8	308.9
	Reference E-TFCIs	5	5	2	5	1
	Reference E-TFCI	11	11	11	11	67
	Reference E-TFCI PO	4	4	4	4	18
	Reference E-TFCI	67	67	92	67	67
	Reference E-TFCI PO	18	18	18	18	18
	Reference E-TFCI	71	71	71	71	71
	Reference E-TFCI PO	23	23	23	23	23
	Reference E-TFCI	75	75	75	75	75
	Reference E-TFCI PO	26	26	26	26	26
	Reference E-TFCI	81	81	81	81	81
Reference E-TFCI PO	27	27	27	27	27	
Maximum Channelization Codes	2xSF2				SF4	

HSPA+

Since 16QAM is not used for uplink, the uplink Category and release is same as HSUPA, i.e., Rel. 7. Therefore, the RF conducted power is not measured.

8.1.1. WCDMA OUTPUT POWER RESULT

WCDMA Band 5 Measured Results

Band	Mode		UL Ch No.	Freq. [MHz]	MPR [dB]	Avg Pwr [dBm]	
W-CDMA Band V	Rel 99	RMC, 12.2 kbps	4132	826.4	0	23.32	
			4183	836.6	0	23.25	
			4233	846.6	0	23.33	
	HSDPA	Subtest 1	4132	826.4	0	21.25	
			4183	836.6	0	21.22	
			4233	846.6	0	21.30	
		Subtest 2	4132	826.4	0	22.10	
			4183	836.6	0	21.96	
			4233	846.6	0	22.06	
		Subtest 3	4132	826.4	0.5	21.35	
			4183	836.6	0.5	21.29	
			4233	846.6	0.5	21.35	
		Subtest 4	4132	826.4	0.5	20.41	
			4183	836.6	0.5	20.32	
			4233	846.6	0.5	20.40	
		HSUPA	Subtest 1	4132	826.4	0	19.53
				4183	836.6	0	19.59
				4233	846.6	0	19.66
	Subtest 2		4132	826.4	2	18.03	
			4183	836.6	2	18.05	
			4233	846.6	2	18.16	
	Subtest 3		4132	826.4	1	19.12	
			4183	836.6	1	19.15	
			4233	846.6	1	19.23	
	Subtest 4		4132	826.4	2	18.06	
			4183	836.6	2	18.05	
			4233	846.6	2	18.18	
	Subtest 5		4132	826.4	0	21.36	
			4183	836.6	0	21.32	
			4233	846.6	0	21.43	

WCDMA Band 4 Measured Results

Band	Mode		UL Ch No.	Freq. [MHz]	MPR [dB]	Avg Pwr [dBm]	
W-CDMA Band IV	Rel 99	RMC, 12.2 kbps	1312	1712.4	0	22.23	
			1413	1732.6	0	22.08	
			1513	1752.6	0	22.31	
	HSDPA	Subtest 1	1312	1712.4	0	21.15	
			1413	1732.6	0	21.02	
			1513	1752.6	0	21.22	
		Subtest 2	1312	1712.4	0	22.09	
			1413	1732.6	0	21.90	
			1513	1752.6	0	22.16	
		Subtest 3	1312	1712.4	0.5	21.29	
			1413	1732.6	0.5	21.13	
			1513	1752.6	0.5	21.38	
		Subtest 4	1312	1712.4	0.5	20.26	
			1413	1732.6	0.5	20.14	
			1513	1752.6	0.5	20.37	
		HSUPA	Subtest 1	1312	1712.4	0	19.56
				1413	1732.6	0	19.52
				1513	1752.6	0	19.72
	Subtest 2		1312	1712.4	2	18.24	
			1413	1732.6	2	18.22	
			1513	1752.6	2	18.33	
	Subtest 3		1312	1712.4	1	19.19	
			1413	1732.6	1	19.17	
			1513	1752.6	1	19.38	
	Subtest 4		1312	1712.4	2	18.19	
			1413	1732.6	2	18.25	
			1513	1752.6	2	18.33	
	Subtest 5	1312	1712.4	0	21.49		
		1413	1732.6	0	21.43		
		1513	1752.6	0	21.01		

WCDMA Band 2 Measured Results

Band	Mode		UL Ch No.	Freq. [MHz]	MPR [dB]	Avg Pwr [dBm]	
W-CDMA Band II	Rel 99	RMC, 12.2 kbps	9262	1852.4	0	22.23	
			9400	1880.0	0	22.27	
			9538	1907.6	0	22.26	
	HSDPA	Subtest 1	9262	1852.4	0	21.21	
			9400	1880.0	0	21.23	
			9538	1907.6	0	21.18	
		Subtest 2	9262	1852.4	0	21.96	
			9400	1880.0	0	22.07	
			9538	1907.6	0	22.03	
		Subtest 3	9262	1852.4	0.5	21.29	
			9400	1880.0	0.5	21.29	
			9538	1907.6	0.5	21.24	
		Subtest 4	9262	1852.4	0.5	20.28	
			9400	1880.0	0.5	20.34	
			9538	1907.6	0.5	20.29	
		HSUPA	Subtest 1	9262	1852.4	0	19.62
				9400	1880.0	0	19.72
				9538	1907.6	0	19.71
	Subtest 2		9262	1852.4	2	18.06	
			9400	1880.0	2	18.11	
			9538	1907.6	2	18.13	
	Subtest 3		9262	1852.4	1	19.22	
			9400	1880.0	1	19.24	
			9538	1907.6	1	19.23	
	Subtest 4		9262	1852.4	2	18.02	
			9400	1880.0	2	18.09	
			9538	1907.6	2	18.10	
	Subtest 5		9262	1852.4	0	21.19	
			9400	1880.0	0	21.28	
			9538	1907.6	0	21.41	

8.2. LTE OUTPUT VERIFICATION

The following tests were conducted according to the test requirements outlined in section 6.2 of the 3GPP TS36.101 specification.

UE Power Class: 3 (23 +/- 2dBm). The allowed Maximum Power Reduction (MPR) for the maximum output power due to higher order modulation and transmit bandwidth configuration (resource blocks) is specified in Table 6.2.3-1 of the 3GPP TS36.101.

Table 6.2.3-1: Maximum Power Reduction (MPR) for Power Class 3

Modulation	Channel bandwidth / Transmission bandwidth (RB)						MPR (dB)
	1.4 MHz	3.0 MHz	5 MHz	10 MHz	15 MHz	20 MHz	
QPSK	> 5	> 4	> 8	> 12	> 16	> 18	≤ 1
16 QAM	≤ 5	≤ 4	≤ 8	≤ 12	≤ 16	≤ 18	≤ 1
16 QAM	> 5	> 4	> 8	> 12	> 16	> 18	≤ 2

The allowed A-MPR values specified below in Table 6.2.4.-1 of 3GPP TS36.101 are in addition to the allowed MPR requirements. All the measurements below were performed with A-MPR disabled, by using Network Signalling Value of "NS_01".

Table 6.2.4-1: Additional Maximum Power Reduction (A-MPR)

Network Signalling value	Requirements (sub-clause)	E-UTRA Band	Channel bandwidth (MHz)	Resources Blocks (N_{RB})	A-MPR (dB)
NS_01	6.6.2.1.1	Table 5.5-1	1.4, 3, 5, 10, 15, 20	Table 5.6-1	NA
NS_03	6.6.2.2.1	2, 4, 10, 23, 25, 35, 36	3	>5	≤ 1
			5	>6	≤ 1
			10	>6	≤ 1
			15	>8	≤ 1
			20	>10	≤ 1
NS_04	6.6.2.2.2	41	5	>6	≤ 1
			10, 15, 20	See Table 6.2.4-4	
NS_05	6.6.3.3.1	1	10, 15, 20	≥ 50	≤ 1
NS_06	6.6.2.2.3	12, 13, 14, 17	1.4, 3, 5, 10	Table 5.6-1	n/a
NS_07	6.6.2.2.3	13	10	Table 6.2.4-2	Table 6.2.4-2
	6.6.3.3.2				
NS_08	6.6.3.3.3	19	10, 15	> 44	≤ 3
NS_09	6.6.3.3.4	21	10, 15	> 40	≤ 1
				> 55	≤ 2
NS_10		20	15, 20	Table 6.2.4-3	Table 6.2.4-3
NS_11	6.6.2.2.1	23 ¹	1.4, 3, 5, 10	Table 6.2.4-5	Table 6.2.4-5
..					
NS_32	-	-	-	-	-

Note 1: Applies to the lower block of Band 23, i.e. a carrier placed in the 2000-2010 MHz region.

8.2.1. LTE OUTPUT POWER RESULT

LTE Band 5

Band	BW (MHz)	Mode	RB Allocation	RB offset	Target MPR	Avg Pwr [dBm]		
						Max. Power		
						829 MHz	836.5 MHz	844 MHz
LTE Band 5	10	QPSK	1	0	0	22.74	22.84	22.74
			1	25	0	22.67	22.78	22.70
			1	49	0	22.62	22.77	22.70
			25	0	1	21.65	21.65	21.63
			25	12	1	21.61	21.64	21.61
			25	25	1	21.58	21.64	21.60
			50	0	1	21.60	21.66	21.63
		16QAM	1	0	1	21.44	21.90	21.73
			1	25	1	21.35	21.84	21.71
			1	49	1	21.33	21.85	21.72
			25	0	2	20.65	20.73	20.67
			25	12	2	20.61	20.70	20.67
			25	25	2	20.59	20.68	20.67
			50	0	2	20.61	20.60	20.64
Band	BW (MHz)	Mode	RB Allocation	RB offset	Target MPR	Avg Pwr [dBm]		
						Max. Power		
						826.5 MHz	836.5 MHz	846.5 MHz
LTE Band 5	5	QPSK	1	0	0	22.70	22.77	22.70
			1	12	0	22.65	22.74	22.69
			1	24	0	22.65	22.74	22.72
			12	0	1	21.59	21.63	21.61
			12	7	1	21.59	21.63	21.61
			12	13	1	21.56	21.62	21.60
			25	0	1	21.57	21.62	21.60
		16QAM	1	0	1	21.68	21.77	21.44
			1	12	1	21.63	21.73	21.42
			1	24	1	21.61	21.75	21.44
			12	0	2	20.58	20.60	20.55
			12	7	2	20.56	20.57	20.55
			12	13	2	20.57	20.57	20.55
			25	0	2	20.65	20.63	20.61
Band	BW (MHz)	Mode	RB Allocation	RB offset	Target MPR	Avg Pwr [dBm]		
						Max. Power		
						825.5 MHz	836.5 MHz	847.5 MHz
LTE Band 5	3	QPSK	1	0	0	22.63	22.70	22.67
			1	8	0	22.63	22.68	22.66
			1	14	0	22.58	22.69	22.65
			8	0	1	21.57	21.64	21.60
			8	4	1	21.55	21.62	21.60
			8	7	1	21.53	21.60	21.61
			15	0	1	21.52	21.58	21.60
		16QAM	1	0	1	21.42	21.80	21.42
			1	8	1	21.37	21.79	21.38
			1	14	1	21.37	21.81	21.37
			8	0	2	20.56	20.49	20.65
			8	4	2	20.54	20.50	20.65
			8	7	2	20.52	20.48	20.65
			15	0	2	20.55	20.56	20.57
Band	BW (MHz)	Mode	RB Allocation	RB offset	Target MPR	Avg Pwr [dBm]		
						Max. Power		
						824.7 MHz	836.5 MHz	848.3 MHz
LTE Band 5	1.4	QPSK	1	0	0	22.67	22.58	22.69
			1	3	0	22.66	22.57	22.69
			1	5	0	22.67	22.58	22.72
			3	0	0	22.56	22.54	22.56
			3	1	0	22.57	22.56	22.61
			3	3	0	22.57	22.53	22.62
			6	0	1	21.53	21.58	21.58
		16QAM	1	0	1	21.48	21.66	21.58
			1	3	1	21.47	21.68	21.56
			1	5	1	21.47	21.66	21.64
			3	0	1	21.50	21.58	21.58
			3	1	1	21.47	21.57	21.56
			3	3	1	21.53	21.64	21.57
			6	0	2	20.54	20.53	20.60

LTE Band 4 Measured Results

Band	BW (MHz)	Mode	RB Allocation	RB offset	Target MPR	Avg Pwr (dBm)		
						20050	20175	20300
						1720 MHz	1732.5 MHz	1745 MHz
LTE Band 4	20	QPSK	1	0	0	22.61	22.71	22.50
			1	49	0	22.55	22.63	22.76
			1	99	0	22.45	22.89	22.88
			50	0	1	21.48	21.46	21.55
			50	24	1	21.42	21.46	21.63
			50	50	1	21.41	21.52	21.67
			100	0	1	21.45	21.50	21.61
		16QAM	1	0	1	21.52	21.51	21.65
			1	49	1	21.41	21.43	21.91
			1	99	1	21.26	21.69	21.99
			50	0	2	20.43	20.40	20.50
			50	24	2	20.38	20.43	20.57
			50	50	2	20.35	20.47	20.63
			100	0	2	20.48	20.48	20.62
Band	BW (MHz)	Mode	RB Allocation	RB offset	Target MPR	Avg Pwr (dBm)		
						20025	20175	20325
						1717.5 MHz	1732.5 MHz	1747.5 MHz
LTE Band 4	15	QPSK	1	0	0	22.76	22.63	22.73
			1	37	0	22.66	22.63	22.74
			1	74	0	22.65	22.70	22.80
			36	0	1	21.63	21.58	21.61
			36	20	1	21.58	21.59	21.65
			36	39	1	21.56	21.61	21.69
			75	0	1	21.59	21.59	21.66
		16QAM	1	0	1	21.45	21.68	21.63
			1	37	1	21.37	21.71	21.68
			1	74	1	21.37	21.76	21.70
			36	0	2	20.57	20.56	20.56
			36	20	2	20.52	20.57	20.57
			36	39	2	20.50	20.57	20.64
			75	0	2	20.54	20.56	20.61
Band	BW (MHz)	Mode	RB Allocation	RB offset	Target MPR	Avg Pwr (dBm)		
						20000	20175	20350
						1715 MHz	1732.5 MHz	1750 MHz
LTE Band 4	10	QPSK	1	0	0	22.67	22.57	22.76
			1	25	0	22.63	22.55	22.83
			1	49	0	21.53	22.60	22.88
			25	0	1	21.56	21.47	21.61
			25	12	1	21.55	21.49	21.65
			25	25	1	21.52	21.50	21.69
			50	0	1	21.54	21.52	21.67
		16QAM	1	0	1	21.70	21.39	21.78
			1	25	1	21.67	21.34	21.82
			1	49	1	21.61	21.38	21.84
			25	0	2	20.57	20.49	20.64
			25	12	2	20.56	20.49	20.68
			25	25	2	20.51	20.50	20.71
			50	0	2	20.53	20.47	20.59

LTE Band 4 Measured Results (continued)

Band	BW (MHz)	Mode	RB Allocation	RB offset	Target MPR	Avg Pwr (dBm)		
						19975	20175	20375
						1712.5 MHz	1732.5 MHz	1752.5 MHz
LTE Band 4	5	QPSK	1	0	0	22.68	22.67	22.69
			1	12	0	22.60	22.59	22.70
			1	24	0	22.65	22.78	22.70
			12	0	1	21.58	21.50	21.68
			12	7	1	21.56	21.47	21.67
			12	13	1	21.54	21.49	21.68
		16QAM	25	0	1	21.57	21.49	21.65
			1	0	1	21.41	21.80	21.55
			1	12	1	21.39	21.73	21.52
			1	24	1	21.41	21.90	21.54
			12	0	2	20.51	20.49	20.62
			12	7	2	20.49	20.45	20.60
			12	13	2	20.50	20.46	20.60
			25	0	2	20.61	20.43	20.61
Band	BW (MHz)	Mode	RB Allocation	RB offset	Target MPR	Avg Pwr (dBm)		
						19965	20175	20385
						1711.5 MHz	1732.5 MHz	1753.5 MHz
LTE Band 4	3	QPSK	1	0	0	22.64	22.56	22.82
			1	8	0	22.62	22.52	22.68
			1	14	0	22.60	22.54	22.78
			8	0	1	21.51	21.53	21.72
			8	4	1	21.50	21.51	21.65
			8	7	1	21.52	21.46	21.62
		16QAM	15	0	1	21.51	21.47	21.66
			1	0	1	21.31	21.51	21.59
			1	8	1	21.32	21.50	21.44
			1	14	1	21.34	21.52	21.52
			8	0	2	20.54	20.37	20.64
			8	4	2	20.53	20.37	20.56
			8	7	2	20.56	20.32	20.54
			15	0	2	20.45	20.42	20.57
Band	BW (MHz)	Mode	RB Allocation	RB offset	Target MPR	Avg Pwr (dBm)		
						19957	20175	20393
						1710.7 MHz	1732.5 MHz	1754.3 MHz
LTE Band 4	1.4	QPSK	1	0	0	22.50	22.49	22.82
			1	3	0	22.54	22.41	22.83
			1	5	0	22.55	22.47	22.76
			3	0	0	22.50	22.37	22.71
			3	1	0	22.51	22.35	22.71
			3	3	0	22.55	22.34	22.69
		16QAM	6	0	1	21.53	21.42	21.72
			1	0	1	21.25	21.55	21.55
			1	3	1	21.33	21.49	21.58
			1	5	1	21.38	21.50	21.53
			3	0	1	21.38	21.45	21.75
			3	1	1	21.49	21.47	21.78
			3	3	1	21.51	21.43	21.79
			6	0	2	20.52	20.27	20.71

LTE Band 2

Band	BW (MHz)	Mode	RB Allocation	RB offset	Target MPR	Avg Pwr [dBm]		
						Max. Power		
						1860 MHz	1880 MHz	1900 MHz
LTE Band 2	20	QPSK	1	0	0	22.67	22.57	22.83
			1	49	0	22.70	22.64	22.85
			1	99	0	22.80	22.86	22.71
			50	0	1	21.55	21.71	21.90
			50	24	1	21.55	21.78	21.86
			50	50	1	21.61	21.87	21.79
		16QAM	100	0	1	21.57	21.80	21.81
			1	0	1	21.44	21.56	22.00
			1	49	1	21.47	21.67	22.00
			1	99	1	21.58	21.79	21.70
			50	0	2	20.58	20.76	20.92
			50	24	2	20.59	20.83	20.89
			50	50	2	20.63	20.90	20.82
			100	0	2	20.65	20.85	20.92
Band	BW (MHz)	Mode	RB Allocation	RB offset	Target MPR	Avg Pwr [dBm]		
						Max. Power		
						1857.5 MHz	1880 MHz	1902.5 MHz
LTE Band 2	15	QPSK	1	0	0	22.71	22.74	22.93
			1	37	0	22.76	22.88	22.85
			1	74	0	22.76	23.00	22.59
			36	0	1	21.61	21.75	21.88
			36	20	1	21.62	21.80	21.82
			36	39	1	21.67	21.83	21.75
		16QAM	75	0	1	21.66	21.80	21.81
			1	0	1	21.52	21.85	21.87
			1	37	1	21.57	22.00	21.80
			1	74	1	21.58	22.00	21.53
			36	0	2	20.60	20.83	20.89
			36	20	2	20.63	20.87	20.84
			36	39	2	20.67	20.92	20.77
			75	0	2	20.68	20.81	20.86
Band	BW (MHz)	Mode	RB Allocation	RB offset	Target MPR	Avg Pwr [dBm]		
						Max. Power		
						1855 MHz	1880 MHz	1905 MHz
LTE Band 2	10	QPSK	1	0	0	22.67	22.74	22.88
			1	25	0	22.63	22.77	22.71
			1	49	0	22.71	22.83	22.58
			25	0	1	21.56	21.65	21.72
			25	12	1	21.53	21.67	21.66
			25	25	1	21.57	21.73	21.60
		16QAM	50	0	1	21.58	21.69	21.68
			1	0	1	21.43	21.86	21.85
			1	25	1	21.39	21.90	21.72
			1	49	1	21.46	21.96	21.62
			25	0	2	20.58	20.73	20.81
			25	12	2	20.57	20.76	20.73
			25	25	2	20.61	20.81	20.67
			50	0	2	20.56	20.72	20.71

LTE Band 2 Measured Results (continued)

Band	BW (MHz)	Mode	RB Allocation	RB offset	Target MPR	Avg Pwr [dBm]		
						Max. Power		
						1852.5 MHz	1880 MHz	1907.5 MHz
LTE Band 2	5	QPSK	1	0	0	22.75	22.88	22.84
			1	12	0	22.74	22.94	22.83
			1	24	0	22.78	22.95	22.66
			12	0	1	21.64	21.72	21.74
			12	7	1	21.62	21.77	21.73
			12	13	1	21.62	21.79	21.66
			25	0	1	21.63	21.76	21.66
		16QAM	1	0	1	21.51	22.00	21.62
			1	12	1	21.52	22.00	21.62
			1	24	1	21.55	21.59	21.44
			12	0	2	20.63	20.76	20.72
			12	7	2	20.62	20.78	20.70
			12	13	2	20.61	20.81	20.62
			25	0	2	20.70	20.74	20.72
			LTE Band 2	3	QPSK	1	0	0
1	8	0				22.70	22.83	22.73
1	14	0				22.71	22.90	22.59
8	0	1				21.65	21.74	21.71
8	4	1				21.66	21.76	21.69
8	7	1				21.67	21.79	21.65
15	0	1				21.66	21.73	21.64
16QAM	1	0			1	21.52	21.81	21.59
	1	8			1	21.52	21.84	21.56
	1	14			1	21.54	21.92	21.46
	8	0			2	20.67	20.64	20.70
	8	4			2	20.69	20.69	20.67
	8	7			2	20.70	20.69	20.66
	15	0			2	20.63	20.79	20.71
	LTE Band 2	1.4			QPSK	1	0	0
1			3	0		22.71	22.62	22.63
1			5	0		22.73	22.69	22.62
3			0	0		22.59	22.62	22.55
3			1	0		22.60	22.64	22.57
3			3	0		22.60	22.66	22.56
6			0	1		21.61	21.68	21.58
16QAM			1	0	1	21.52	21.68	21.44
			1	3	1	21.52	21.68	21.39
			1	5	1	21.52	21.71	21.38
			3	0	1	21.49	21.67	21.51
			3	1	1	21.53	21.66	21.52
			3	3	1	21.53	21.68	21.48
			6	0	2	20.67	20.63	20.67

9. PEAK TO AVERAGE RATIO

Test Procedure

Per KDB 971168 D01 Power Meas License Digital Systems v02r02;

The transmitter output was connected to a CMW500 Test Set and configured to operate at maximum power. The PAR were measured on the Spectrum Analyzer.

Test Spec

In addition, when the transmitter power is measured in terms of average value, the peak-to-average ratio of the power shall not exceed 13 dB.

9.1. CONDUCTED PEAK TO AVERAGE RESULT

WCDMA

Band	Channel	f [MHz]	Mode	Ratio [dB]	Limit [dB]
Band 5	4183	836.6	REL99	2.67	13.00
			HSDPA	3.10	
Band 4	1413	1732.6	REL99	3.00	
			HSDPA	3.16	
Band 2	9400	1880.0	REL99	2.67	
			HSDPA	3.10	

LTE

Band	BW [MHz]	Channel	f [MHz]	Mode	Ratio [dB]	Limit [dB]
Band 5	10	20525	836.5	QPSK	3.88	13.00
				16QAM	4.97	
	5			QPSK	3.95	
				16QAM	4.95	
	3			QPSK	3.89	
				16QAM	4.97	
1.4	QPSK	3.93				
	16QAM	5.07				
Band 4	20	20174	1732.5	QPSK	4.44	
				16QAM	5.57	
	15			QPSK	4.43	
				16QAM	5.62	
	10			QPSK	4.48	
				16QAM	5.82	
	5			QPSK	4.48	
				16QAM	5.61	
	3			QPSK	4.47	
				16QAM	5.69	
1.4	QPSK	4.46				
	16QAM	5.69				
Band 2	20	18900	1880.0	QPSK	4.29	
				16QAM	5.52	
	15			QPSK	4.58	
				16QAM	5.61	
	10			QPSK	4.47	
				16QAM	5.65	
	5			QPSK	4.68	
				16QAM	5.60	
	3			QPSK	4.37	
				16QAM	5.50	
1.4	QPSK	4.44				
	16QAM	5.52				

9.2. CONDUCTED PEAK TO AVERAGE PLOTS

WCDMA

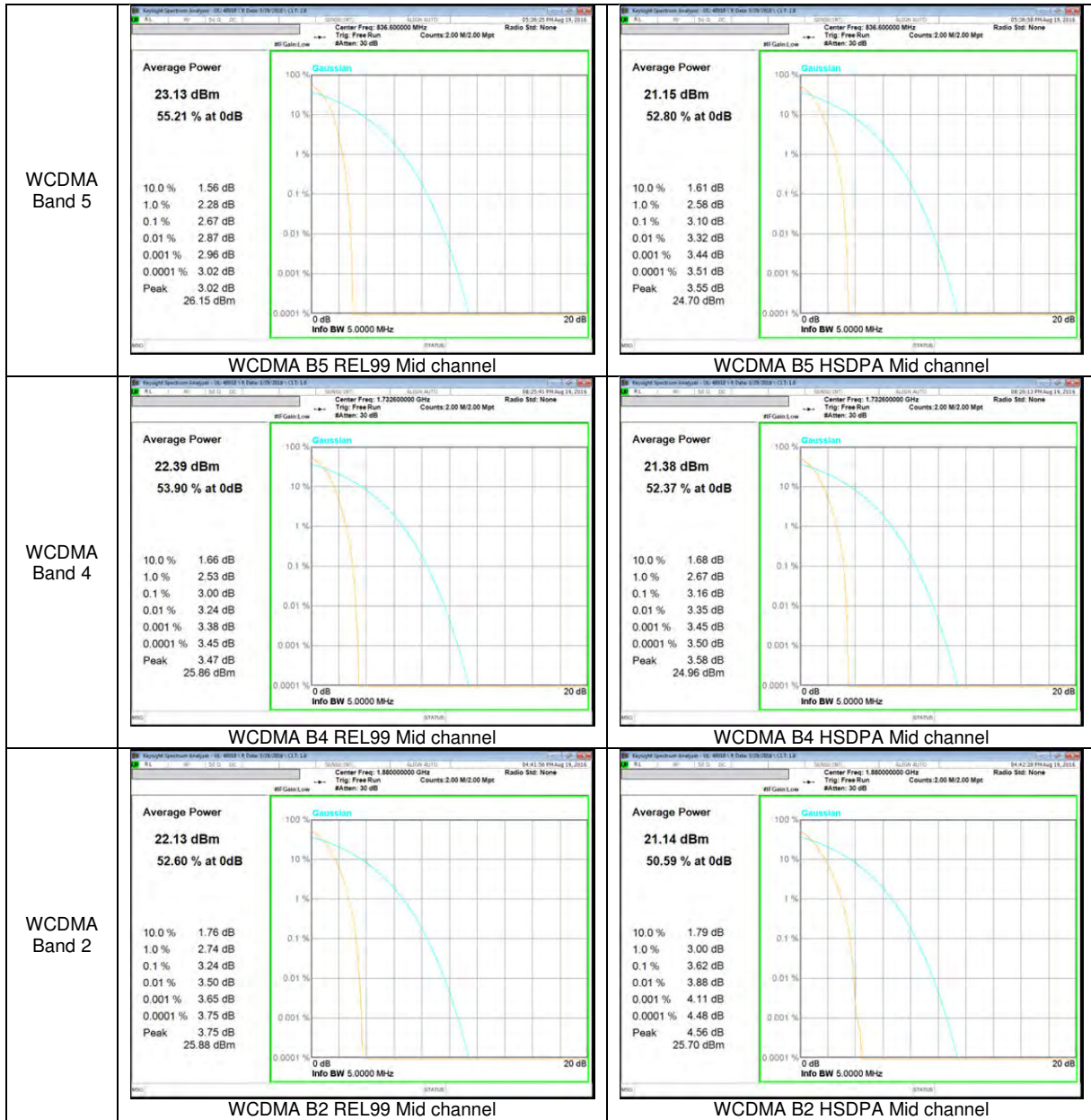

LTE Band 5

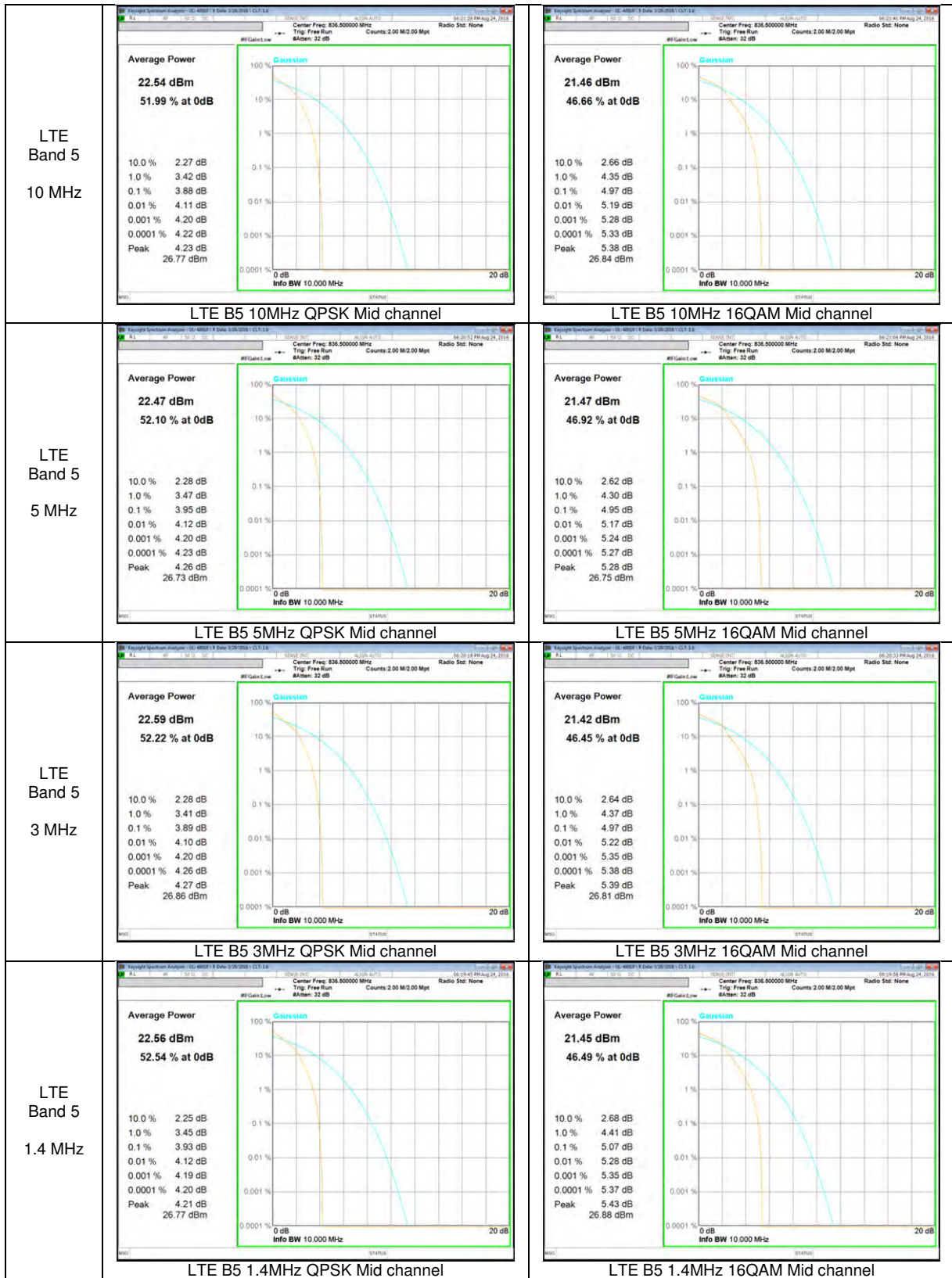

LTE Band 4

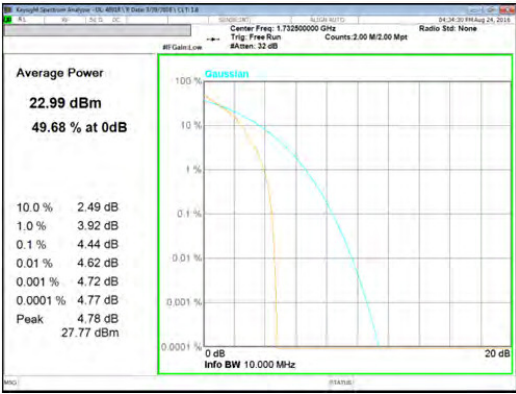
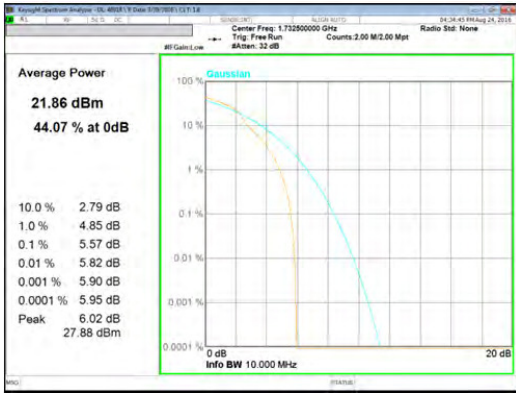
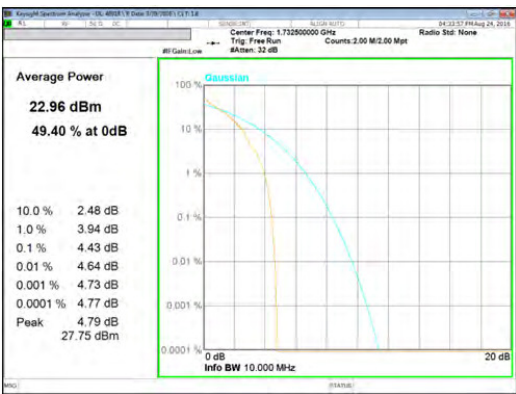
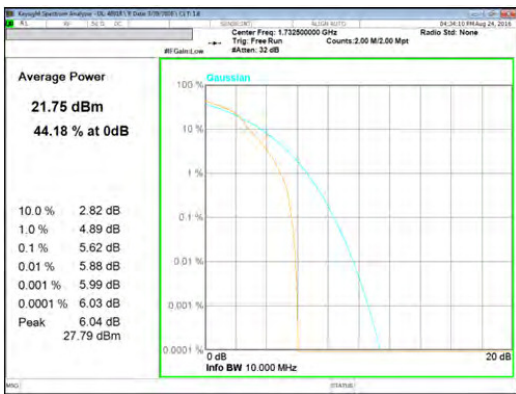
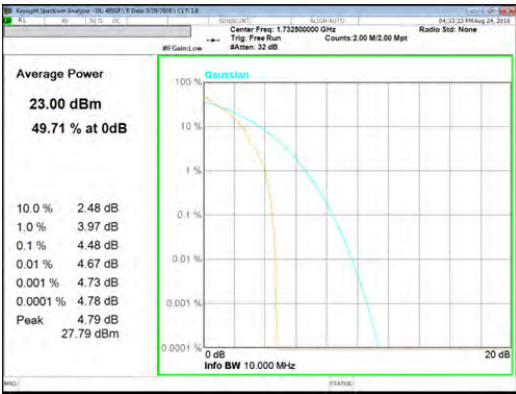
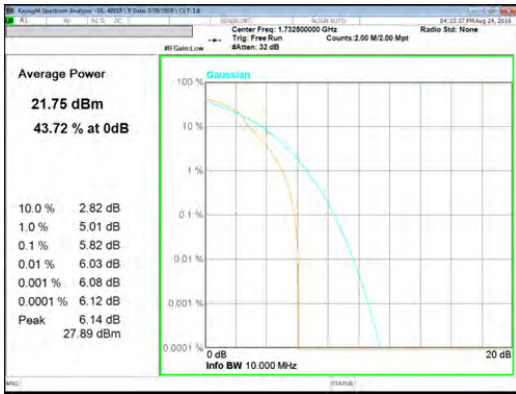
<p>LTE Band 4 20 MHz</p>	 <p>LTE B4 20MHz QPSK Mid channel</p>	 <p>LTE B4 20MHz 16QAM Mid channel</p>
<p>LTE Band 4 15 MHz</p>	 <p>LTE B4 15MHz QPSK Mid channel</p>	 <p>LTE B4 15MHz 16QAM Mid channel</p>
<p>LTE Band 4 10 MHz</p>	 <p>LTE B4 10MHz QPSK Mid channel</p>	 <p>LTE B4 10MHz 16QAM Mid channel</p>

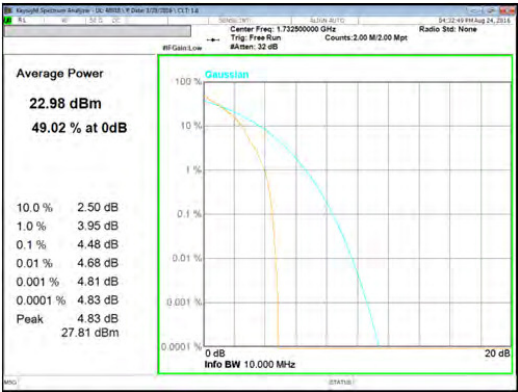
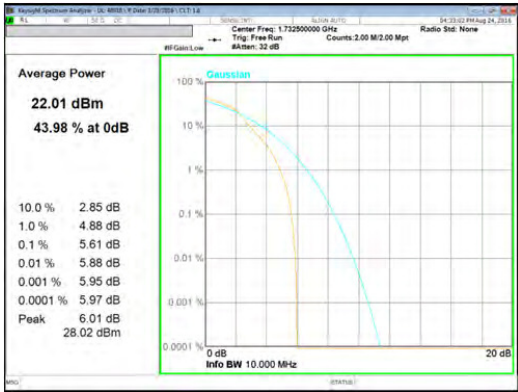
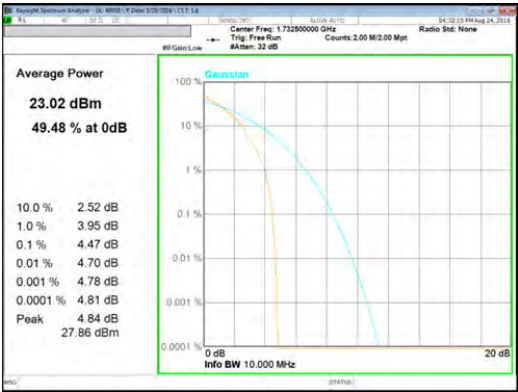
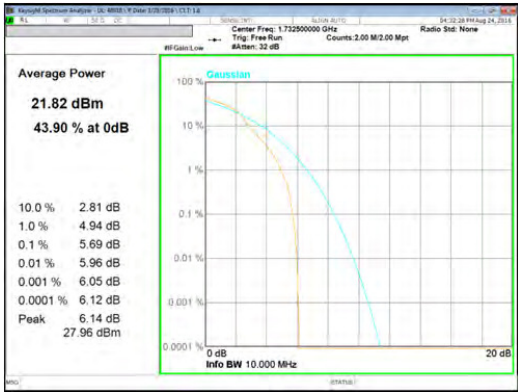
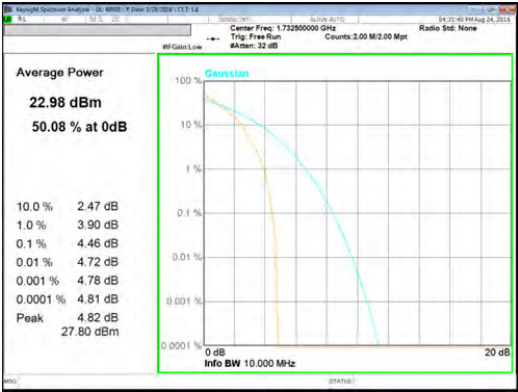
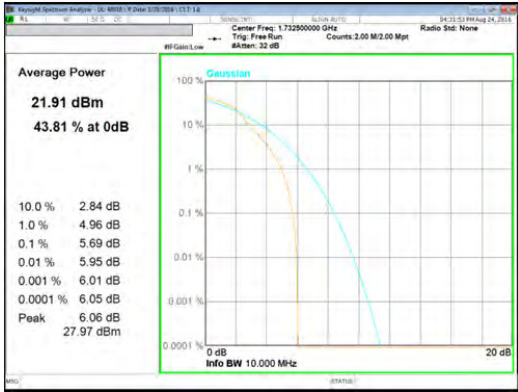
<p>LTE Band 4 5 MHz</p>	 <p>LTE B4 5MHz QPSK Mid channel</p>	 <p>LTE B4 5MHz 16QAM Mid channel</p>
<p>LTE Band 4 3 MHz</p>	 <p>LTE B4 3MHz QPSK Mid channel</p>	 <p>LTE B4 3MHz 16QAM Mid channel</p>
<p>LTE Band 4 1.4 MHz</p>	 <p>LTE B4 1.4MHz QPSK Mid channel</p>	 <p>LTE B4 1.4MHz 16QAM Mid channel</p>

LTE Band 2

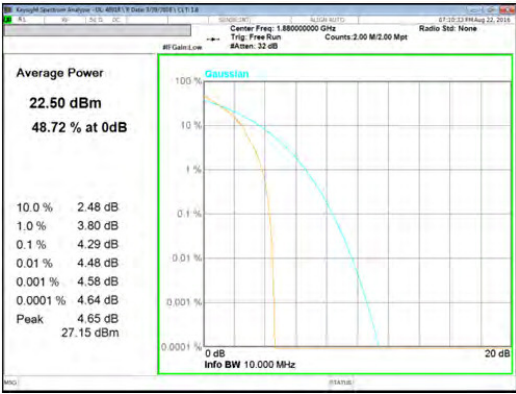
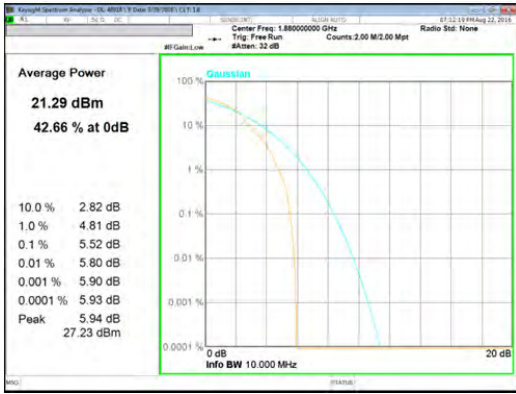
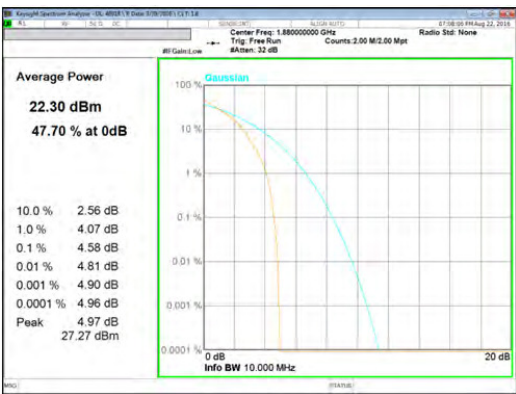
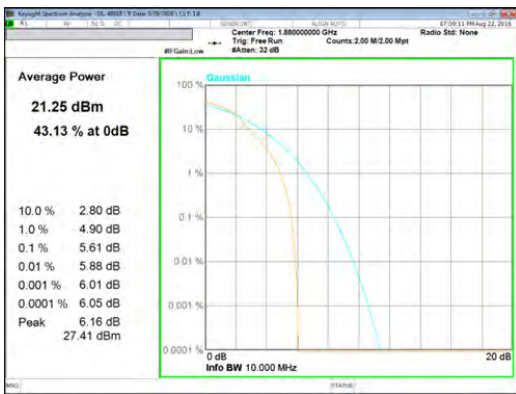
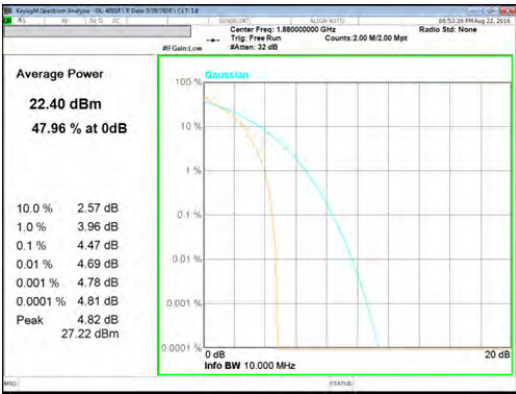
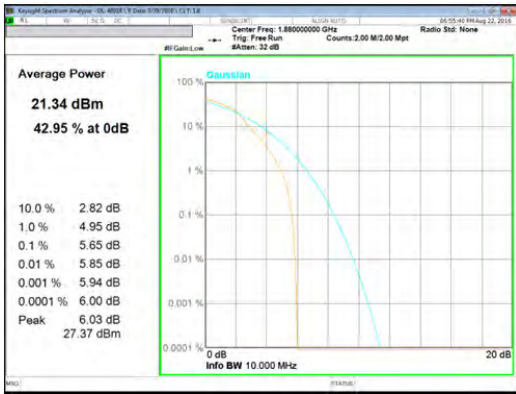
<p>LTE Band 2 20 MHz</p>	 <p>Average Power 22.50 dBm 48.72 % at 0dB</p> <p>10.0 % 2.48 dB 1.0 % 3.80 dB 0.1 % 4.29 dB 0.01 % 4.48 dB 0.001 % 4.58 dB 0.0001 % 4.64 dB Peak 4.65 dBm 27.15 dBm</p> <p>LTE B2 20MHz QPSK Mid channel</p>	 <p>Average Power 21.29 dBm 42.66 % at 0dB</p> <p>10.0 % 2.82 dB 1.0 % 4.81 dB 0.1 % 5.52 dB 0.01 % 5.80 dB 0.001 % 5.90 dB 0.0001 % 5.93 dB Peak 5.94 dBm 27.23 dBm</p> <p>LTE B2 20MHz 16QAM Mid channel</p>
<p>LTE Band 2 15 MHz</p>	 <p>Average Power 22.30 dBm 47.70 % at 0dB</p> <p>10.0 % 2.56 dB 1.0 % 4.07 dB 0.1 % 4.58 dB 0.01 % 4.81 dB 0.001 % 4.90 dB 0.0001 % 4.96 dB Peak 4.97 dBm 27.27 dBm</p> <p>LTE B2 15MHz QPSK Mid channel</p>	 <p>Average Power 21.25 dBm 43.13 % at 0dB</p> <p>10.0 % 2.80 dB 1.0 % 4.90 dB 0.1 % 5.61 dB 0.01 % 5.88 dB 0.001 % 6.01 dB 0.0001 % 6.05 dB Peak 6.16 dBm 27.41 dBm</p> <p>LTE B2 15MHz 16QAM Mid channel</p>
<p>LTE Band 2 10 MHz</p>	 <p>Average Power 22.40 dBm 47.96 % at 0dB</p> <p>10.0 % 2.57 dB 1.0 % 3.96 dB 0.1 % 4.47 dB 0.01 % 4.69 dB 0.001 % 4.78 dB 0.0001 % 4.81 dB Peak 4.82 dBm 27.22 dBm</p> <p>LTE B2 10MHz QPSK Mid channel</p>	 <p>Average Power 21.34 dBm 42.95 % at 0dB</p> <p>10.0 % 2.82 dB 1.0 % 4.95 dB 0.1 % 5.65 dB 0.01 % 5.85 dB 0.001 % 5.94 dB 0.0001 % 6.00 dB Peak 6.03 dBm 27.37 dBm</p> <p>LTE B2 10MHz 16QAM Mid channel</p>

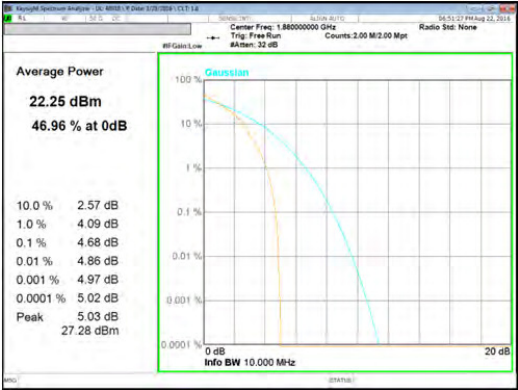
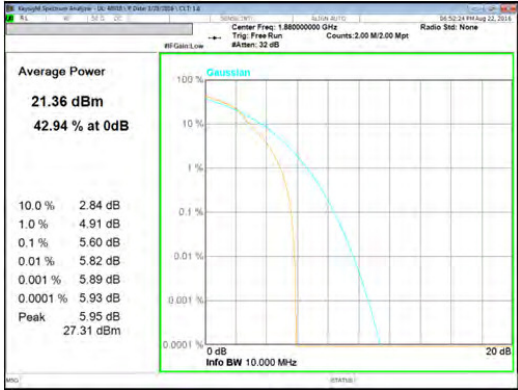
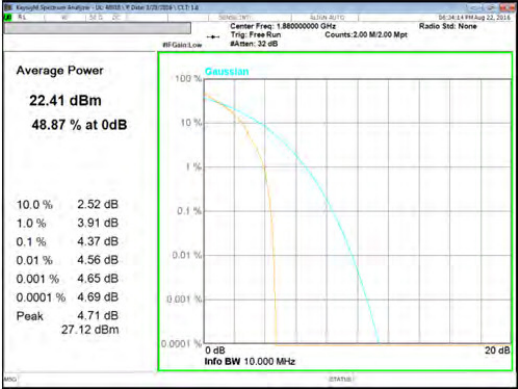
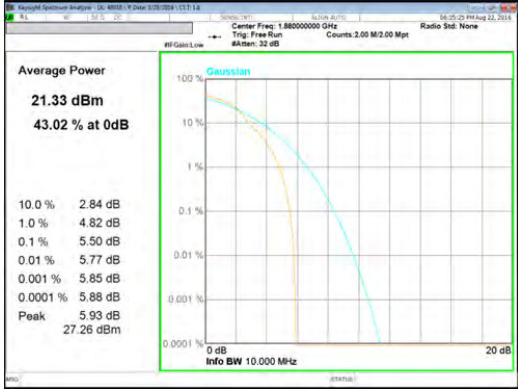
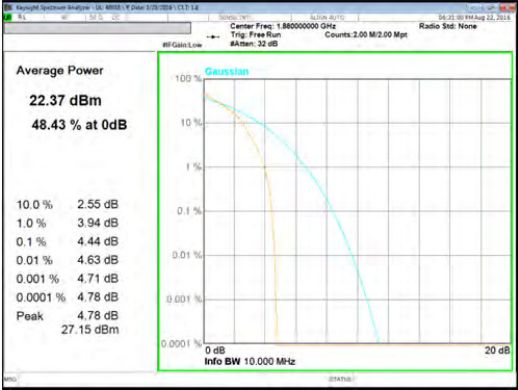
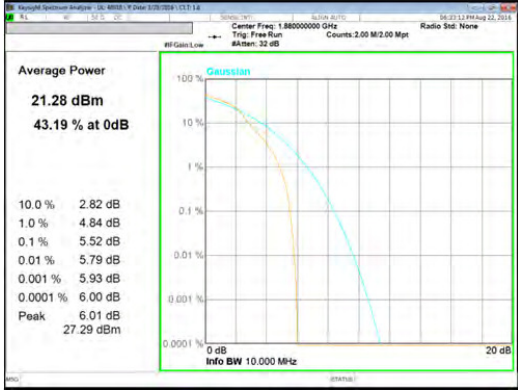
<p>LTE Band 2 5 MHz</p>	 <p>LTE B2 5MHz QPSK Mid channel</p>	 <p>LTE B2 5MHz 16QAM Mid channel</p>
<p>LTE Band 2 3 MHz</p>	 <p>LTE B2 3MHz QPSK Mid channel</p>	 <p>LTE B2 3MHz 16QAM Mid channel</p>
<p>LTE Band 2 1.4 MHz</p>	 <p>LTE B2 1.4MHz QPSK Mid channel</p>	 <p>LTE B2 1.4MHz 16QAM Mid channel</p>

10. LIMITS AND CONDUCTED RESULTS

10.1. OCCUPIED BANDWIDTH

RULE PART(S)

FCC: §2.1049

LIMITS

For reporting purposes only

TEST PROCEDURE

The transmitter output was connected to a calibrated coaxial cable and coupler, the other end of which was connected to a spectrum analyzer. The occupied bandwidth was measured with the spectrum analyzer at the low, middle and high channel in each band. The -26dB bandwidth was also measured and recorded.

(KDB 971168 D01 Power Meas License Digital Systems v02r02)

10.1.1. OCCUPIED BANDWIDTH RESULTS

WCDMA

Band	Mode	Channel	f [MHz]	99% BW [MHz]	26dB BW [MHz]
Band 5	REL99	4132	826.4	4.1322	4.674
		4183	836.6	4.1524	4.730
		4233	846.6	4.1281	4.703
	HSDPA	4132	826.4	4.1452	4.690
		4183	836.6	4.1328	4.698
		4233	846.6	4.1364	4.708
Band 4	REL99	1312	1712.4	4.1372	4.695
		1413	1732.6	4.1407	4.712
		1513	1752.6	4.1348	4.703
	HSDPA	1312	1712.4	4.1584	4.688
		1413	1732.6	4.1411	4.701
		1513	1752.6	4.1495	4.709
Band 2	REL99	9262	1852.4	4.1412	4.672
		9400	1880.0	4.1371	4.665
		9538	1907.6	4.1447	4.689
	HSDPA	9262	1852.4	4.1412	4.648
		9400	1880.0	4.1337	4.653
		9538	1907.6	4.1271	4.646

LTE Band 5

Band	BW [MHz]	Channel	f [MHz]	Mode	99% BW [MHz]	26dB BW [MHz]
Band 5	10	20450	829.0	QPSK	8.9439	10.19
				16QAM	8.9378	10.20
		20524	836.5	QPSK	8.9405	10.26
				16QAM	8.9739	10.18
		20599	844.0	QPSK	8.9549	10.18
				16QAM	8.9801	10.18
	5	20425	826.5	QPSK	4.4957	5.224
				16QAM	4.4996	5.231
		20524	836.5	QPSK	4.5012	5.261
				16QAM	4.5040	5.299
		20624	846.5	QPSK	4.5050	5.215
				16QAM	4.4966	5.412
	3	20415	825.5	QPSK	2.7025	3.057
				16QAM	2.6979	3.042
		20524	836.5	QPSK	2.7075	3.130
				16QAM	2.7019	3.074
		20634	847.5	QPSK	2.6996	3.083
				16QAM	2.6957	3.088
	1.4	20407	824.7	QPSK	1.0921	1.367
				16QAM	1.0899	1.351
		20524	836.5	QPSK	1.0911	1.372
				16QAM	1.0957	1.454
		20624	848.3	QPSK	1.0906	1.368
				16QAM	1.0928	1.408

LTE Band 4

Band	BW [MHz]	Channel	f [MHz]	Mode	99% BW [MHz]	26dB BW [MHz]
Band 4	20	20050	1720.0	QPSK	17.843	19.72
				16QAM	17.857	19.60
		20174	1732.5	QPSK	17.908	20.02
				16QAM	17.852	19.62
		20299	1745.0	QPSK	17.893	20.04
				16QAM	17.891	19.61
	15	20025	1717.5	QPSK	13.421	15.19
				16QAM	13.411	15.07
		20174	1732.5	QPSK	13.440	14.86
				16QAM	13.455	15.39
		20324	1747.5	QPSK	13.417	15.08
				16QAM	13.428	15.01
	10	20000	1715.0	QPSK	8.9596	10.42
				16QAM	8.9567	10.31
		20174	1732.5	QPSK	8.9461	10.10
				16QAM	8.9814	10.27
		20349	1750.0	QPSK	8.9674	10.19
				16QAM	8.9711	10.17
	5	19975	1712.5	QPSK	4.5018	5.391
				16QAM	4.5103	5.341
		20174	1732.5	QPSK	4.5037	5.213
				16QAM	4.5093	5.347
		20374	1752.5	QPSK	4.4957	5.139
				16QAM	4.5030	5.377
	3	19965	1711.5	QPSK	2.6964	3.092
				16QAM	2.6966	3.102
		20174	1732.5	QPSK	2.7003	3.109
				16QAM	2.6964	3.103
		20384	1753.5	QPSK	2.7063	3.125
				16QAM	2.7000	3.130
	1.4	19957	1710.7	QPSK	1.0971	1.392
				16QAM	1.0923	1.410
20174		1732.5	QPSK	1.0934	1.403	
			16QAM	1.0888	1.387	
20392		1754.3	QPSK	1.0952	1.425	
			16QAM	1.0933	1.439	

LTE Band 2

Band	BW [MHz]	Channel	f [MHz]	Mode	99% BW [MHz]	26dB BW [MHz]
Band 2	20	18700	1860.0	QPSK	17.884	19.64
				16QAM	17.857	19.67
		18900	1880.0	QPSK	17.870	19.46
				16QAM	17.873	19.64
		19099	1900.0	QPSK	17.787	19.13
				16QAM	17.852	19.49
	15	18675	1857.5	QPSK	13.424	15.20
				16QAM	13.436	15.30
		18900	1880.0	QPSK	13.460	15.07
				16QAM	13.413	14.78
		19124	1902.5	QPSK	13.412	14.96
				16QAM	13.423	14.78
	10	18650	1955.0	QPSK	8.9751	10.20
				16QAM	8.9833	10.07
		18900	1880.0	QPSK	8.9777	10.18
				16QAM	8.9823	10.29
		19149	1905.0	QPSK	8.9582	10.11
				16QAM	8.9455	9.974
	5	18625	1852.5	QPSK	4.5092	5.212
				16QAM	4.5072	5.317
		18900	1880.0	QPSK	4.4924	5.166
				16QAM	4.5147	5.311
		18175	1907.5	QPSK	4.5066	5.181
				16QAM	4.5024	5.344
	3	18615	1815.5	QPSK	2.7037	3.087
				16QAM	2.6924	3.054
		18900	1880.0	QPSK	2.7026	3.084
				16QAM	2.7003	3.082
		19184	1908.5	QPSK	2.7055	3.109
				16QAM	2.6948	3.045
	1.4	18607	1850.7	QPSK	1.0927	1.374
				16QAM	1.0999	1.411
18900		1880.0	QPSK	1.0931	1.410	
			16QAM	1.0922	1.408	
19192		1909.3	QPSK	1.0924	1.389	
			16QAM	1.0943	1.486	

10.1.2. OCCUPIED BANDWIDTH PLOTS

WCDMA Band 5



WCDMA Band 4

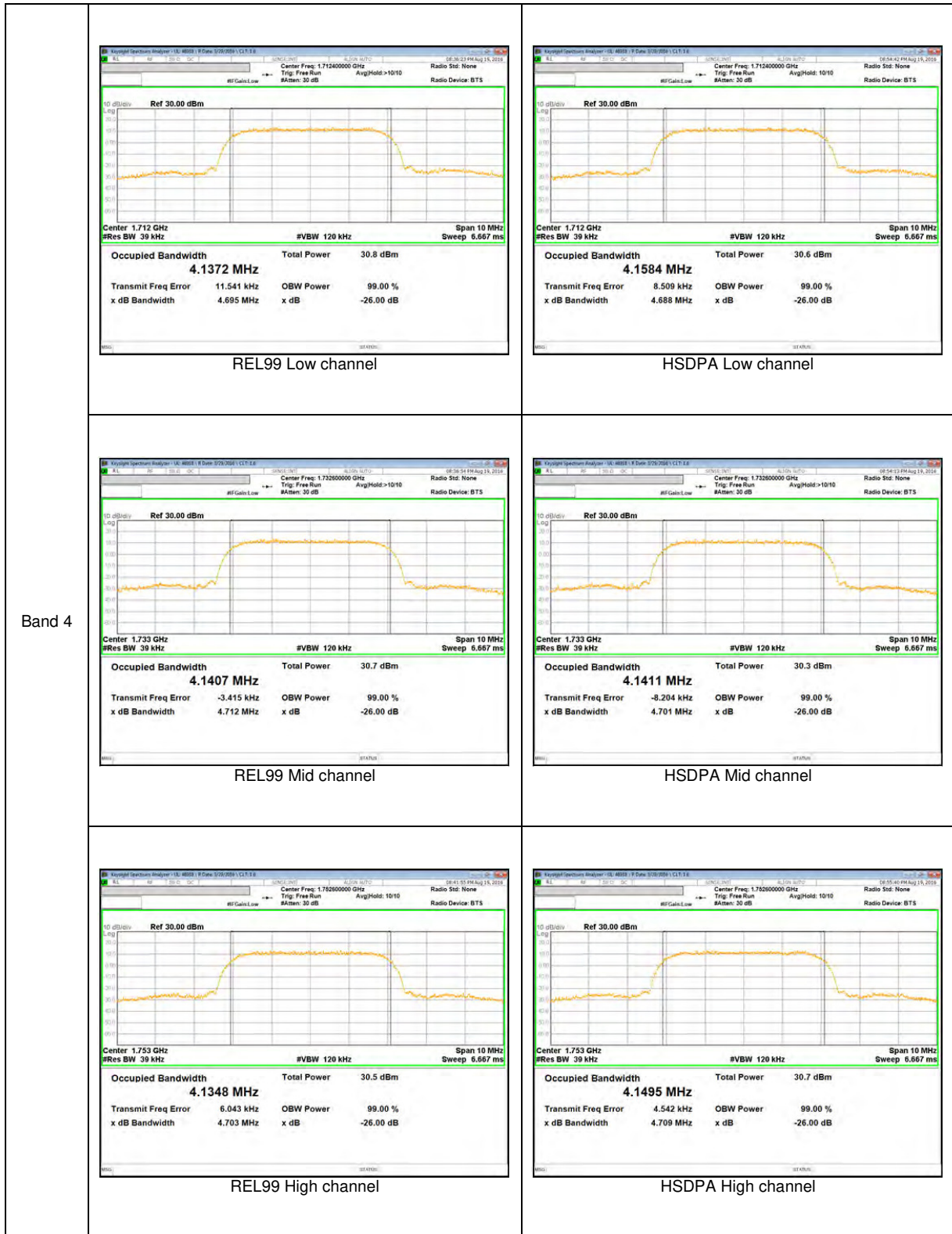

WCDMA Band 2

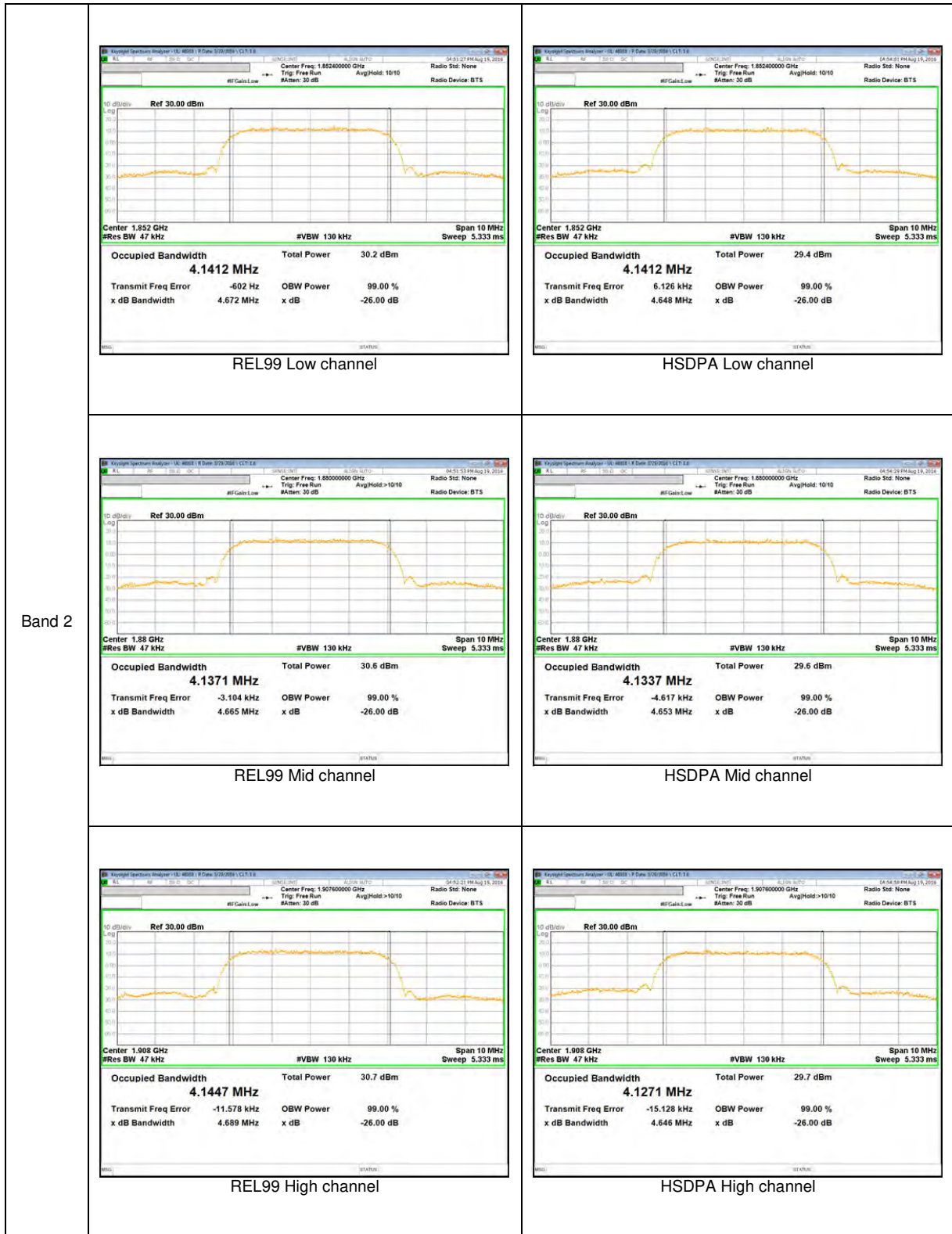

LTE Band 5

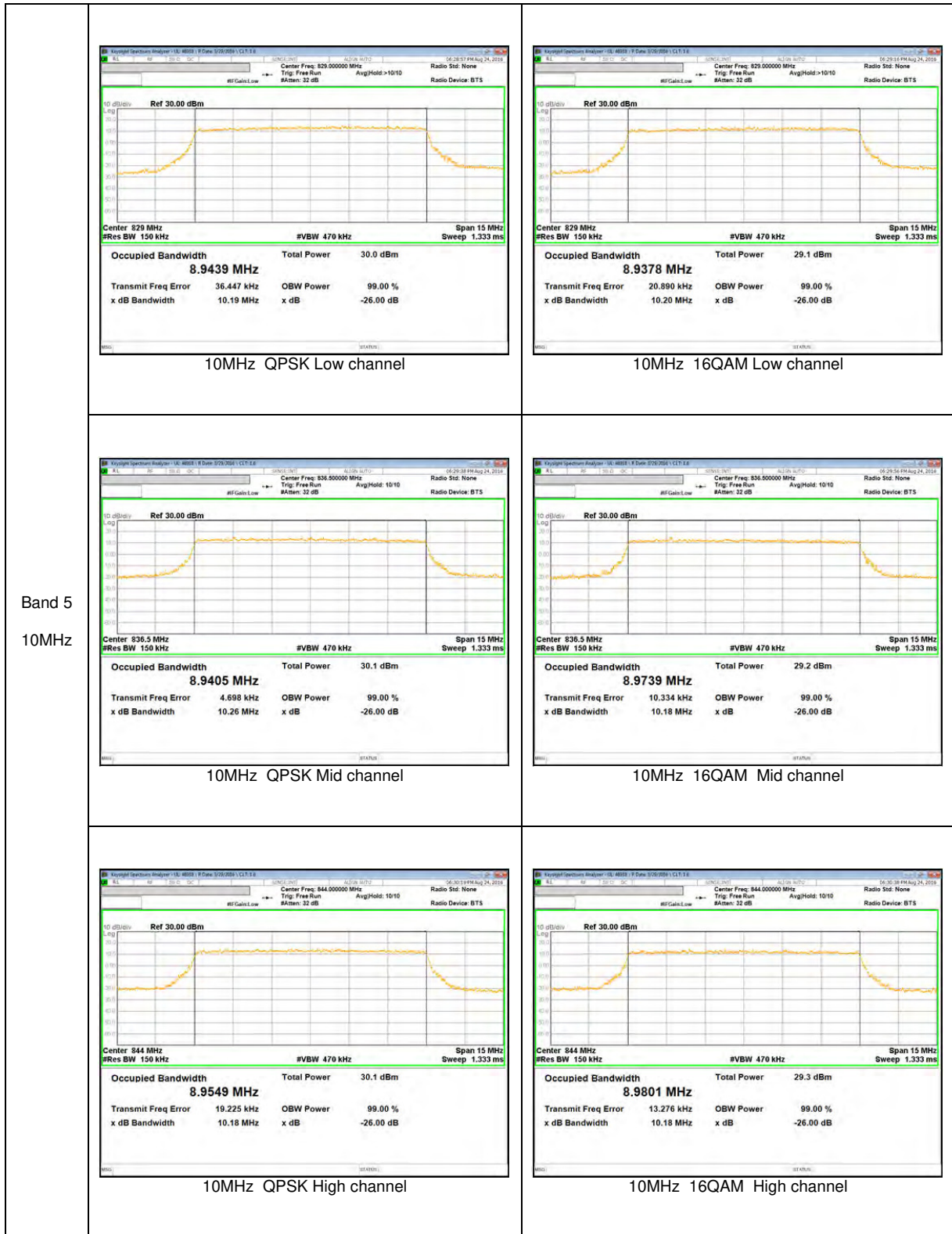

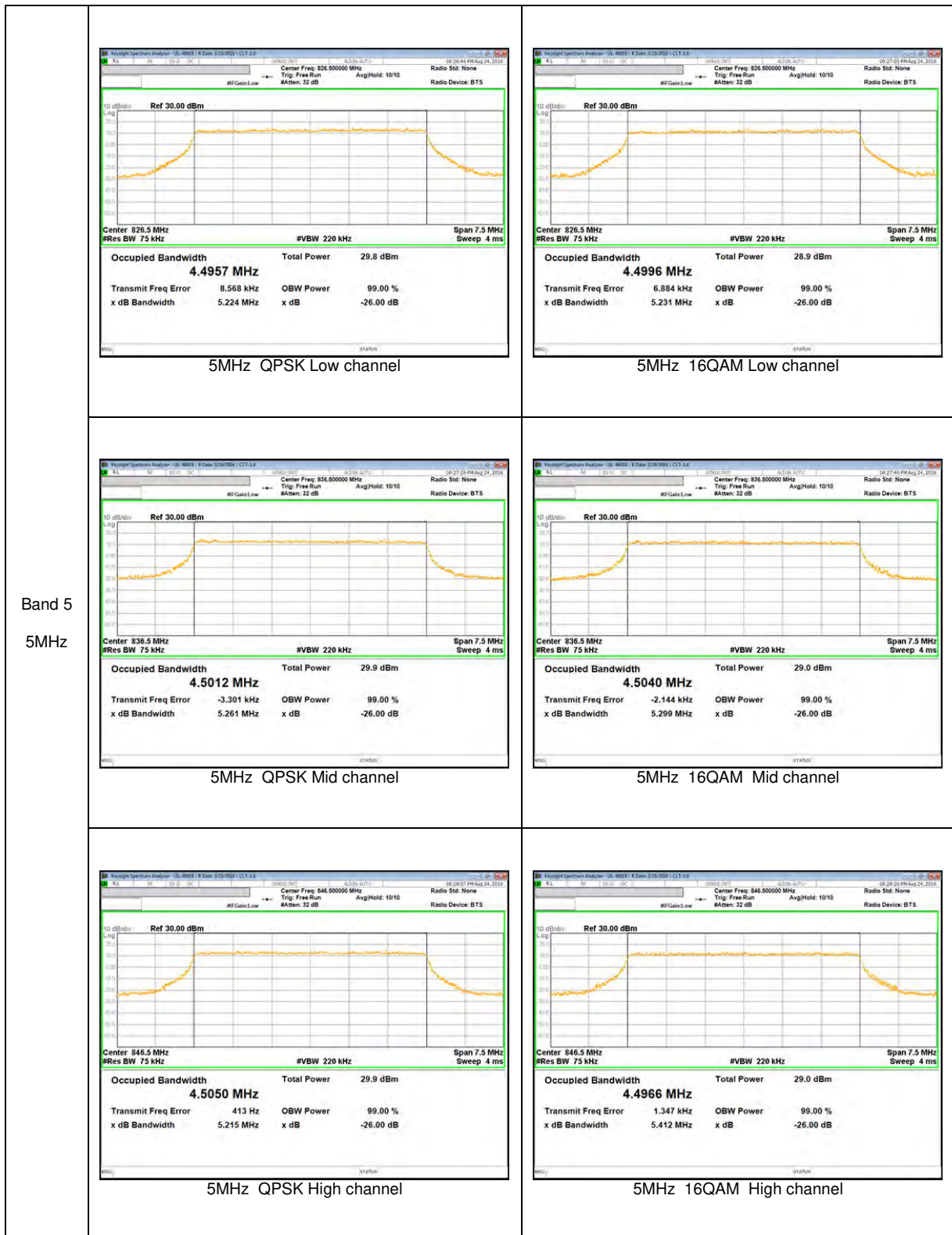

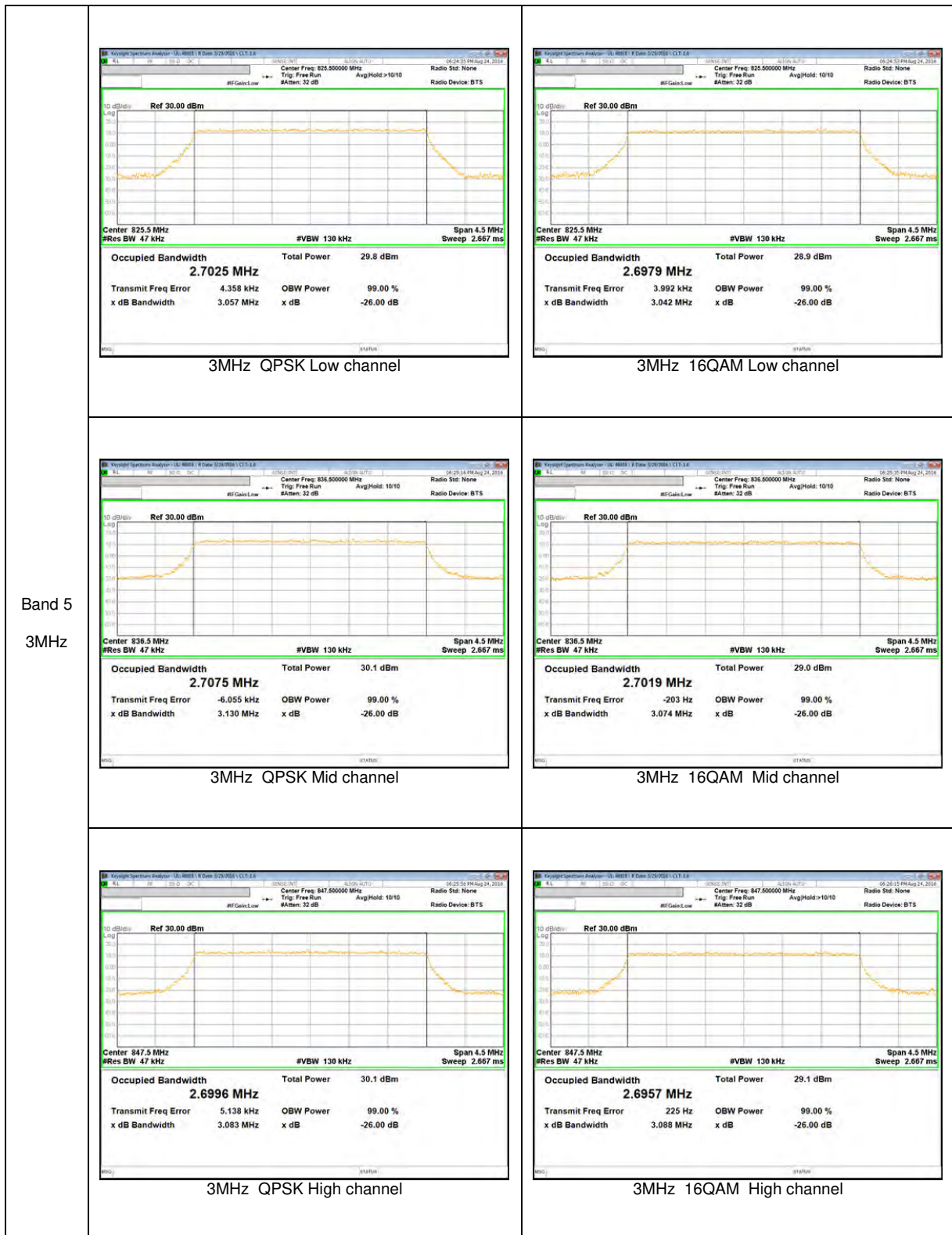

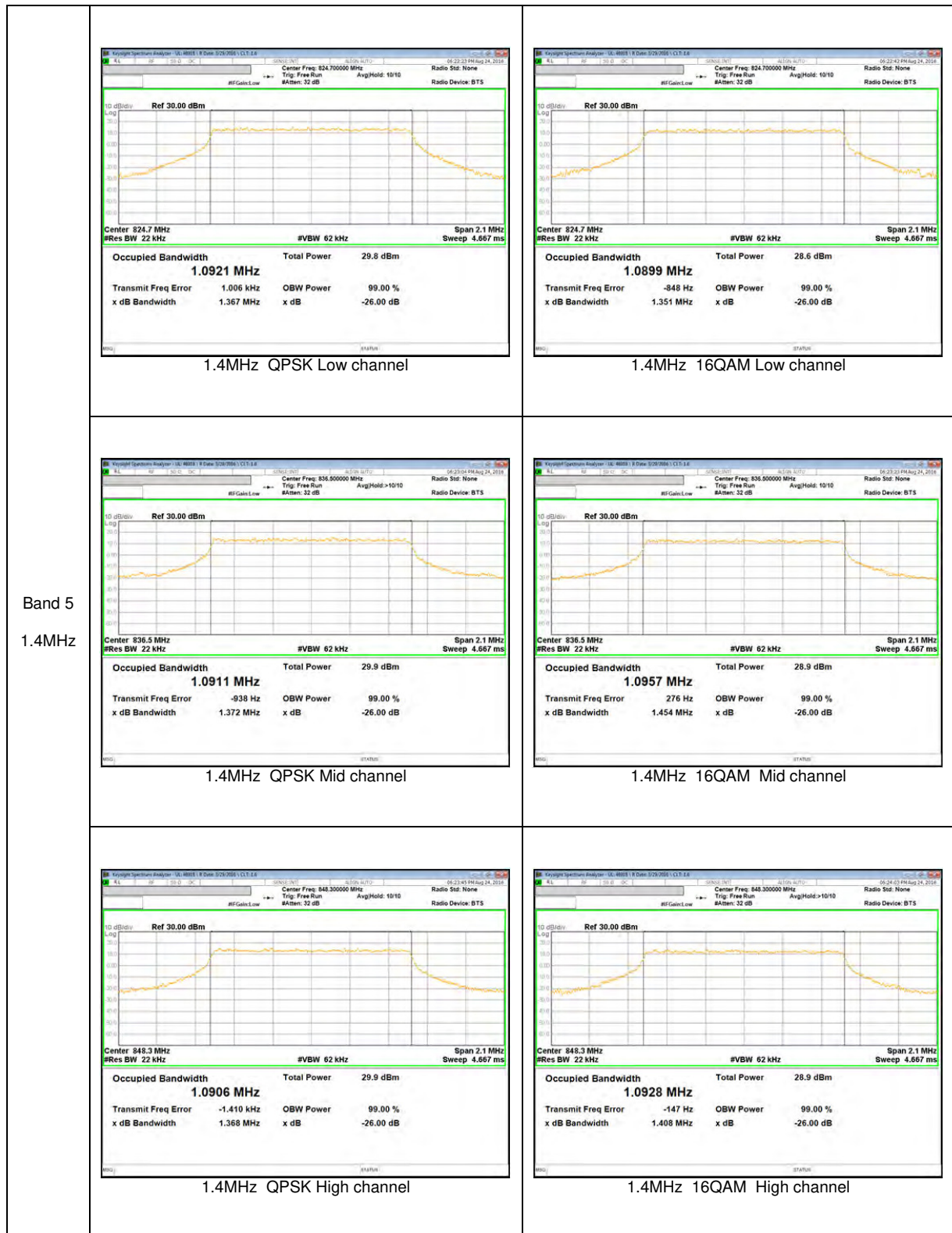

LTE Band 4

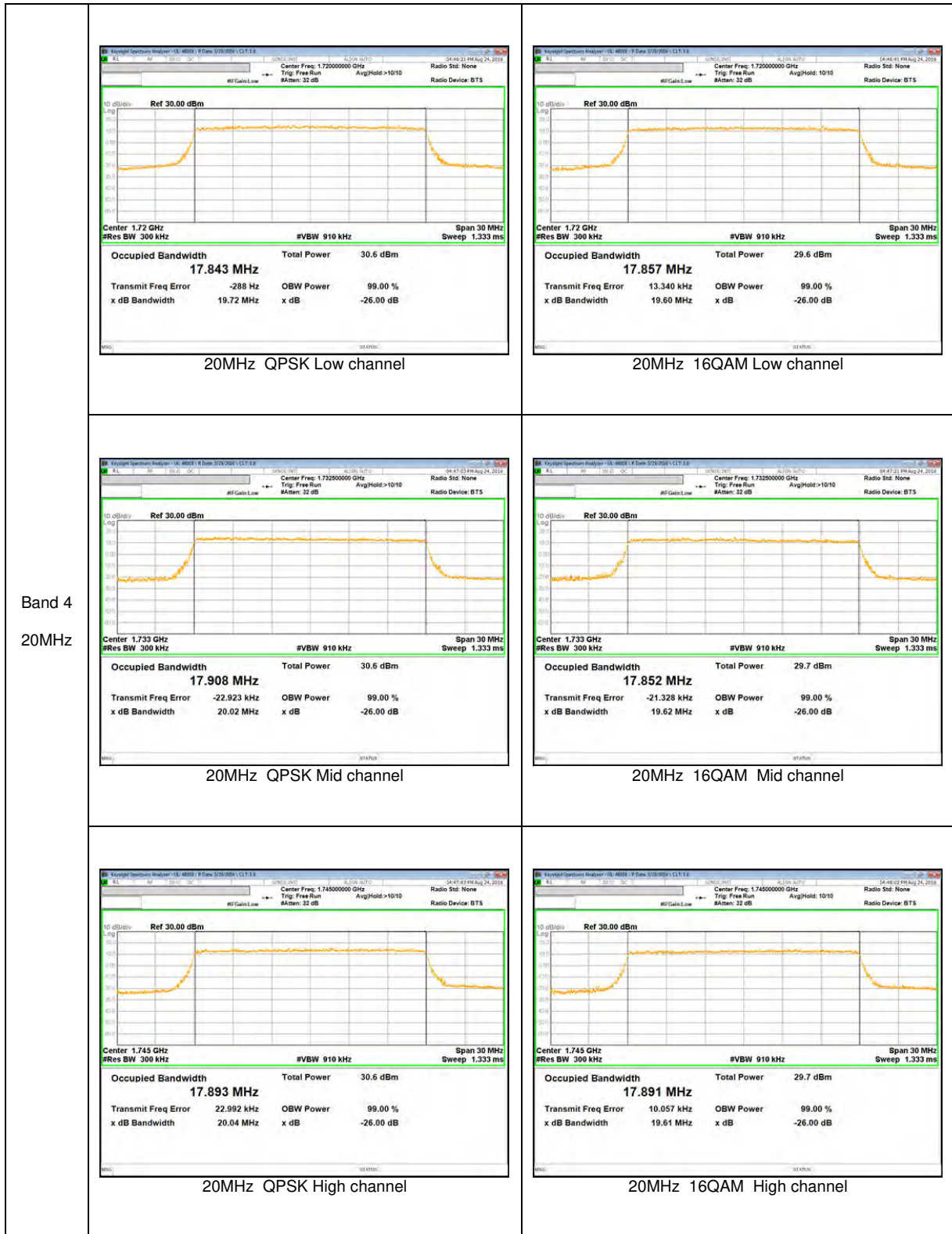

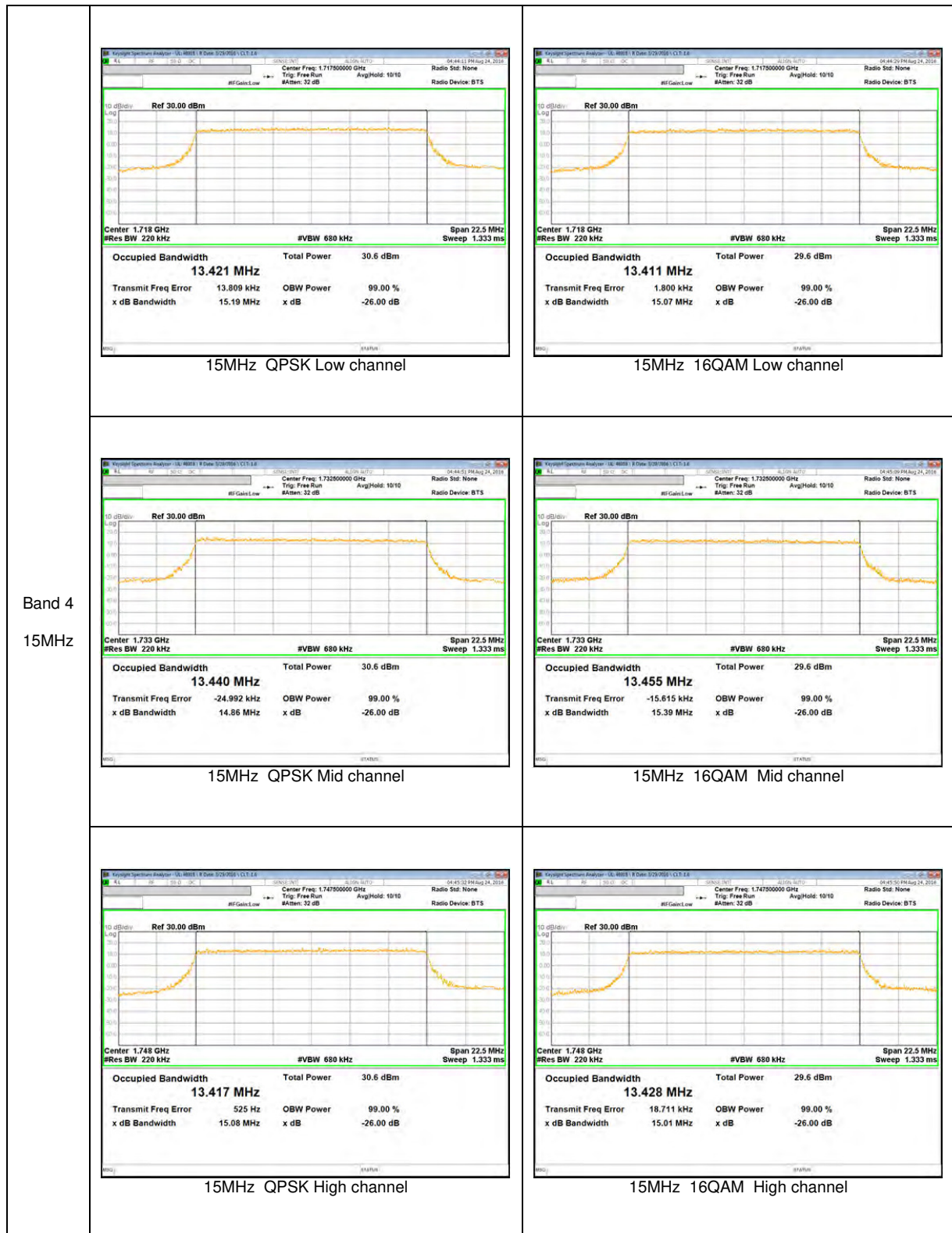

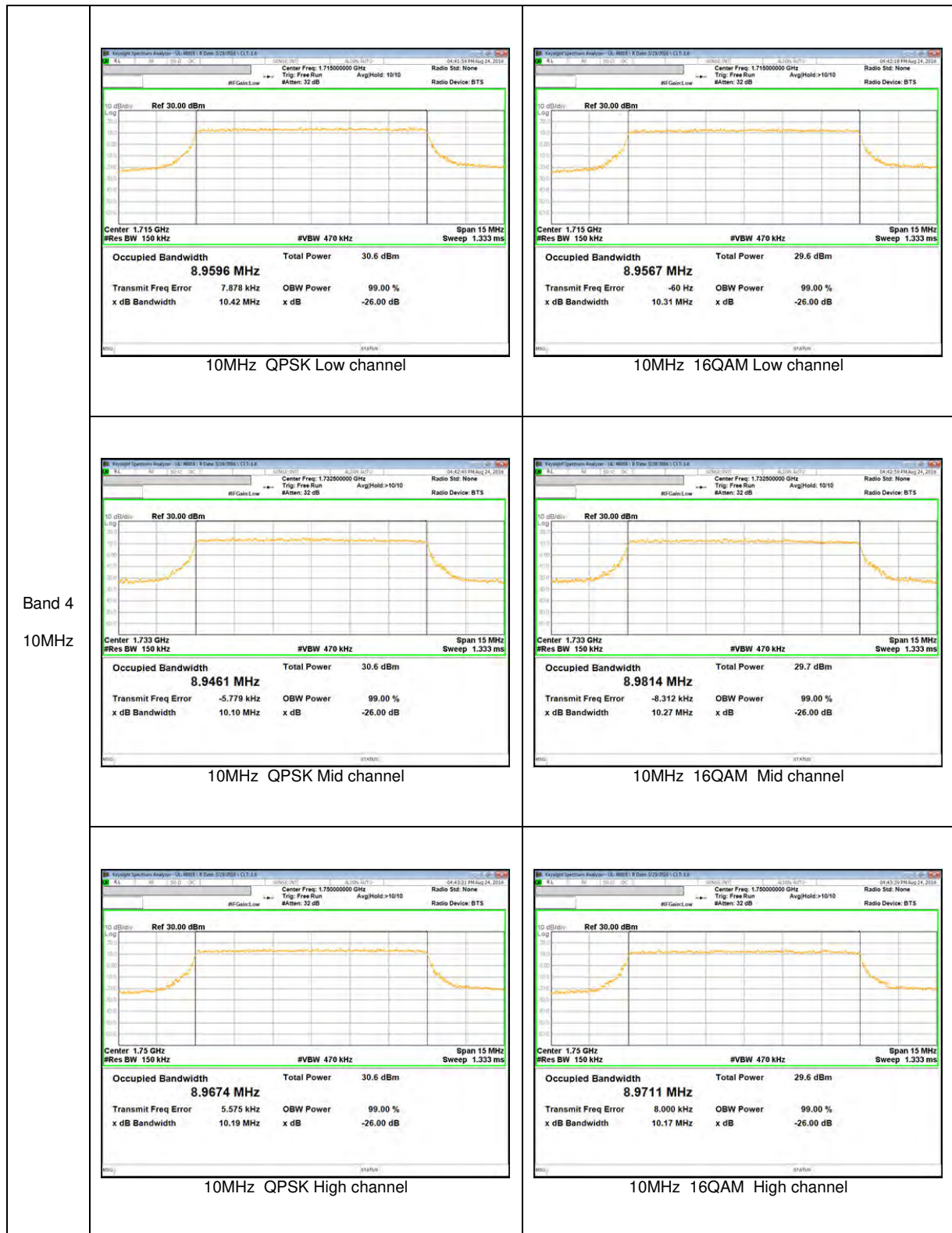

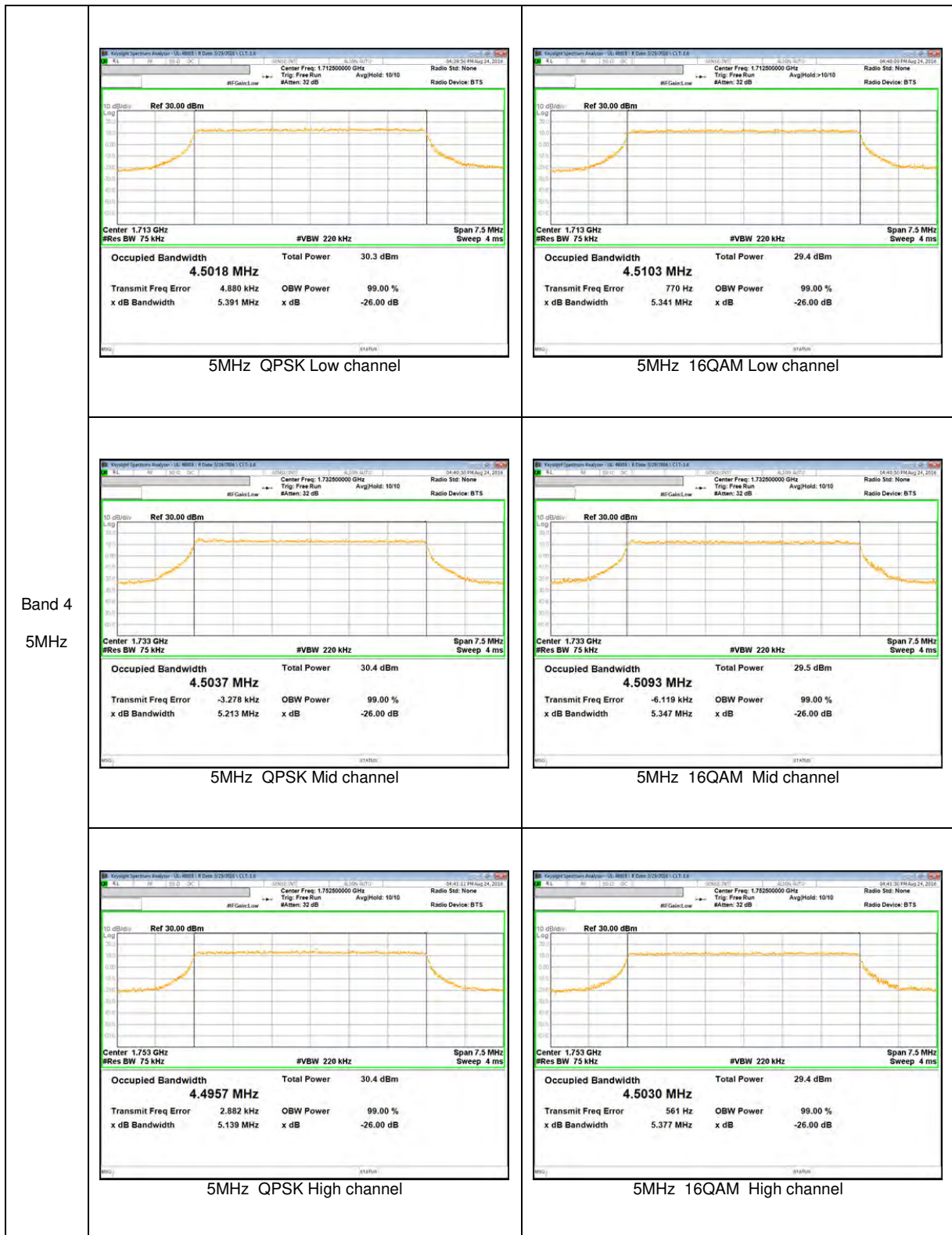

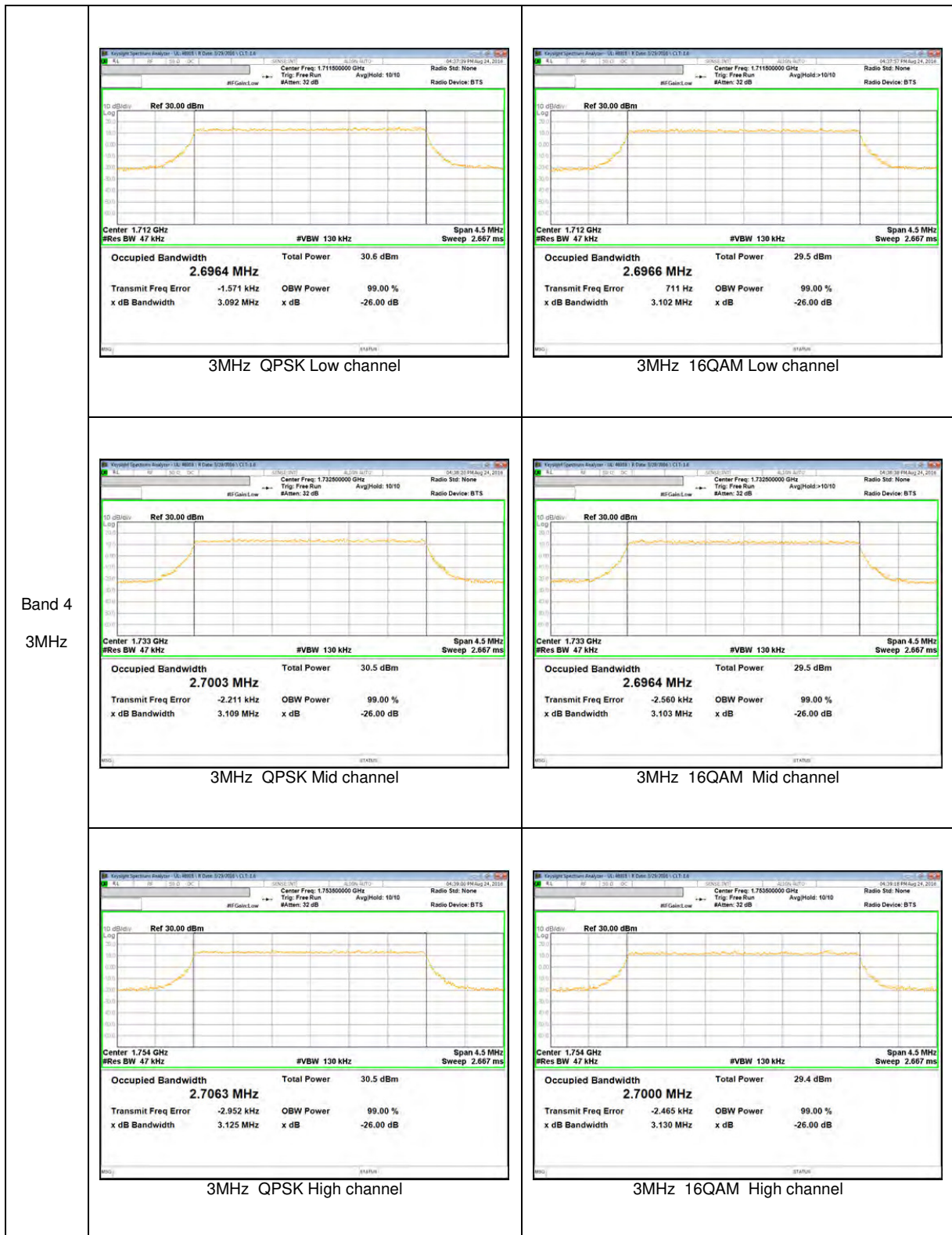

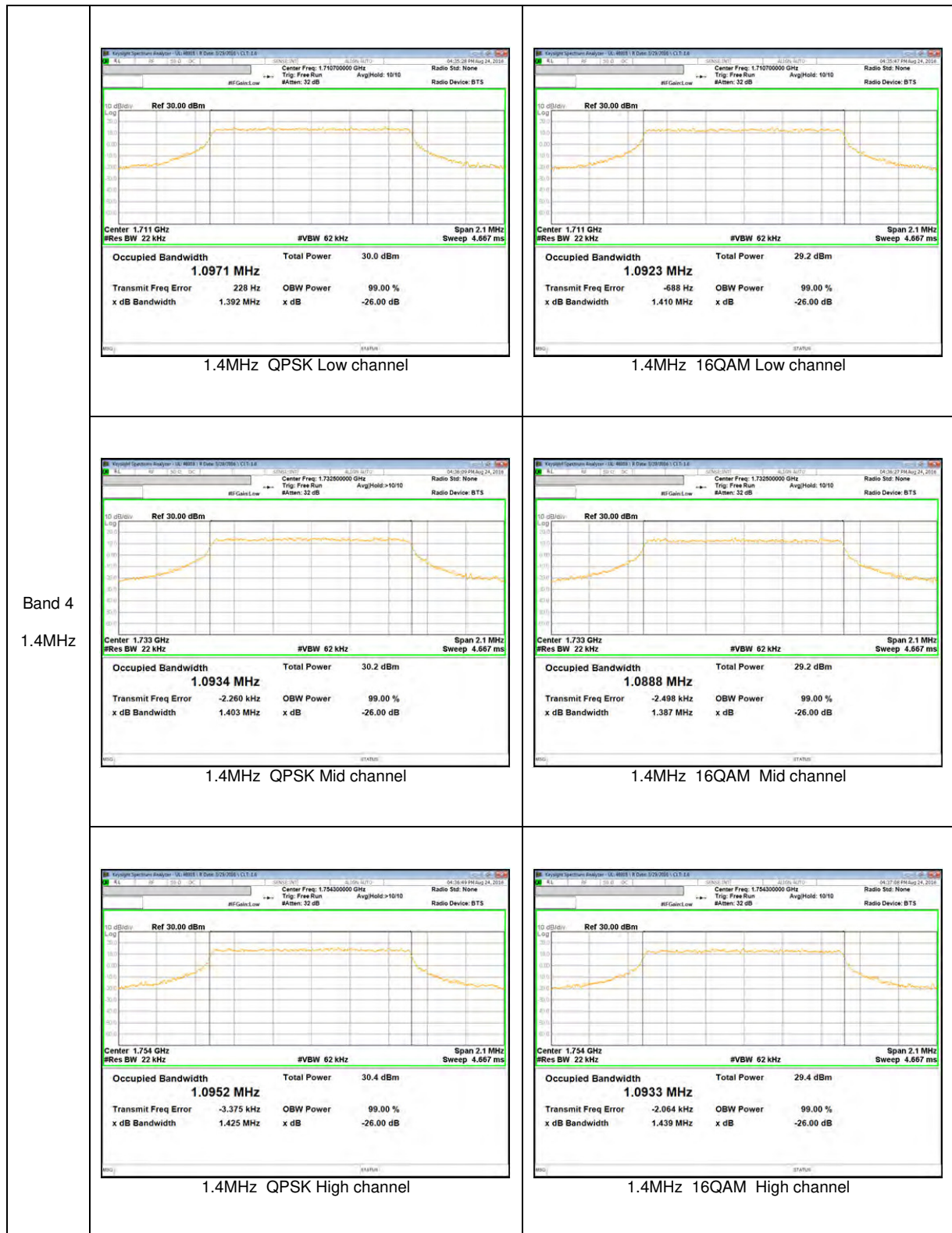

LTE Band 2

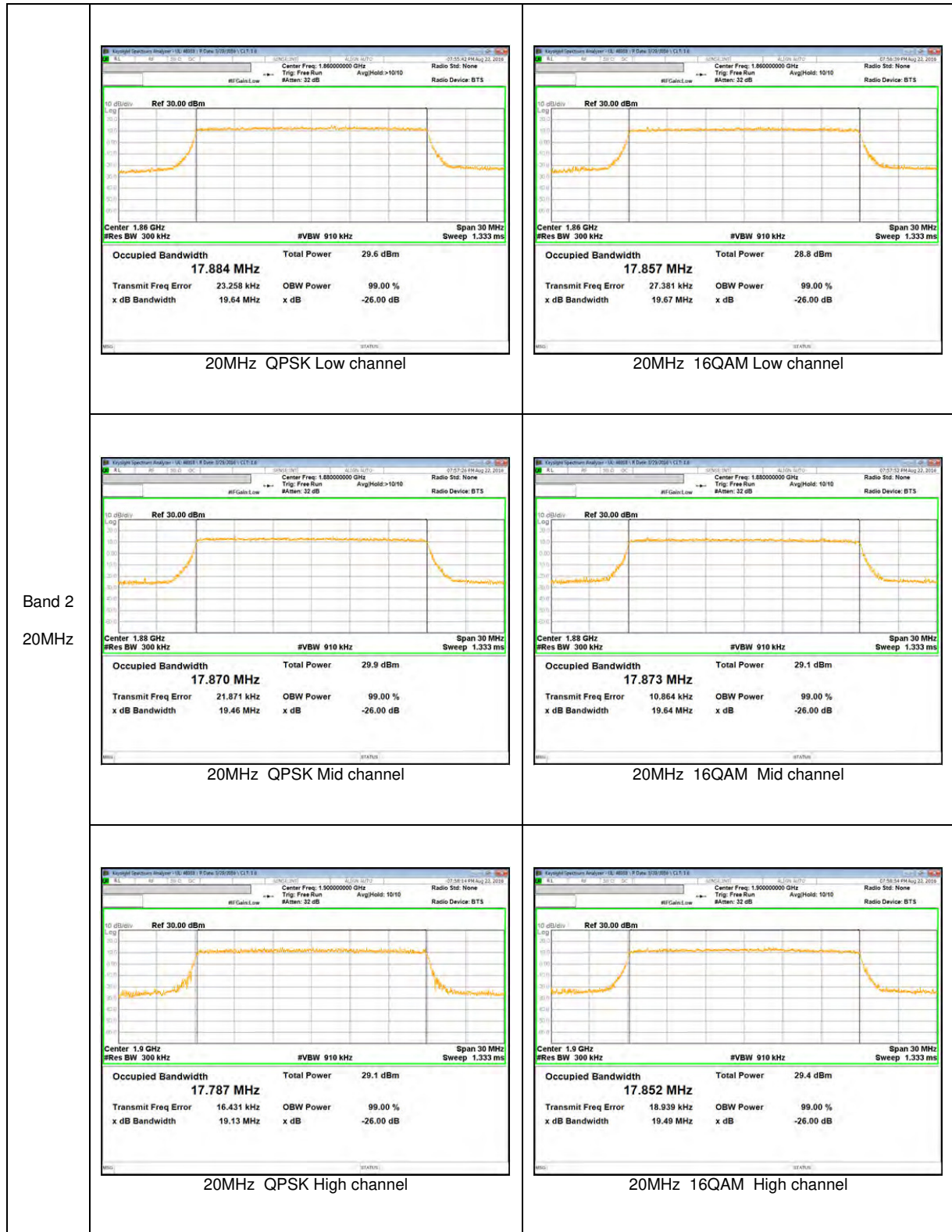

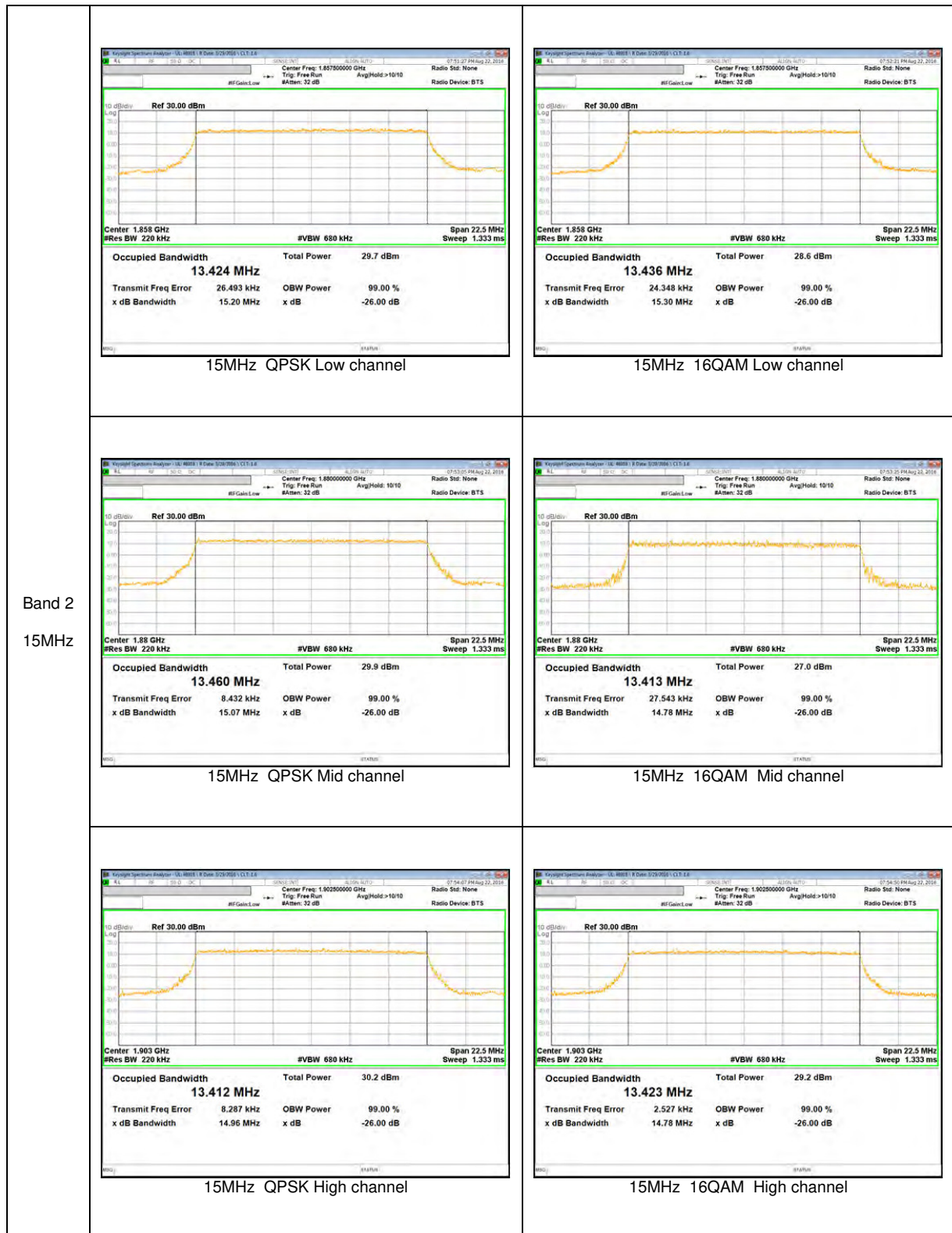

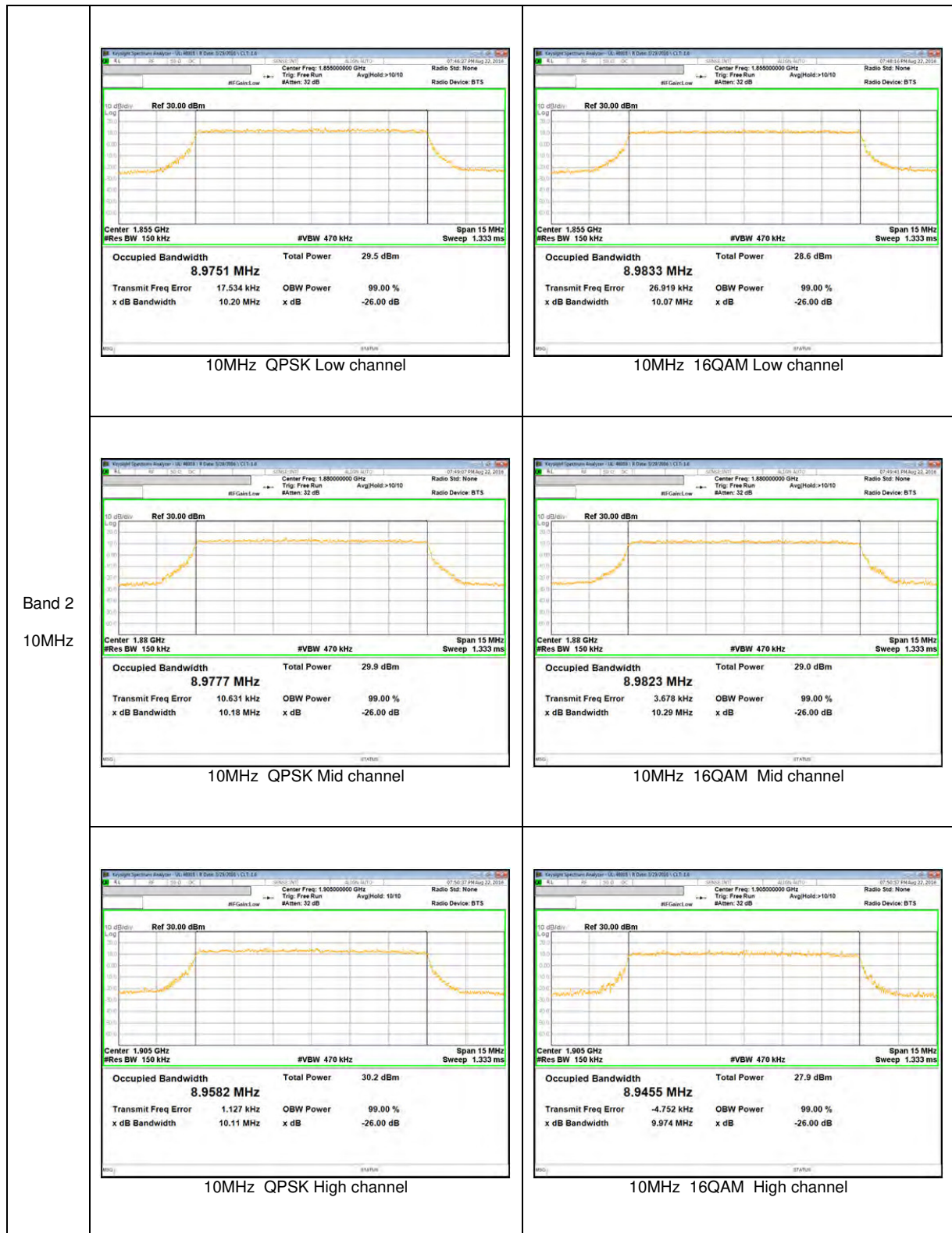

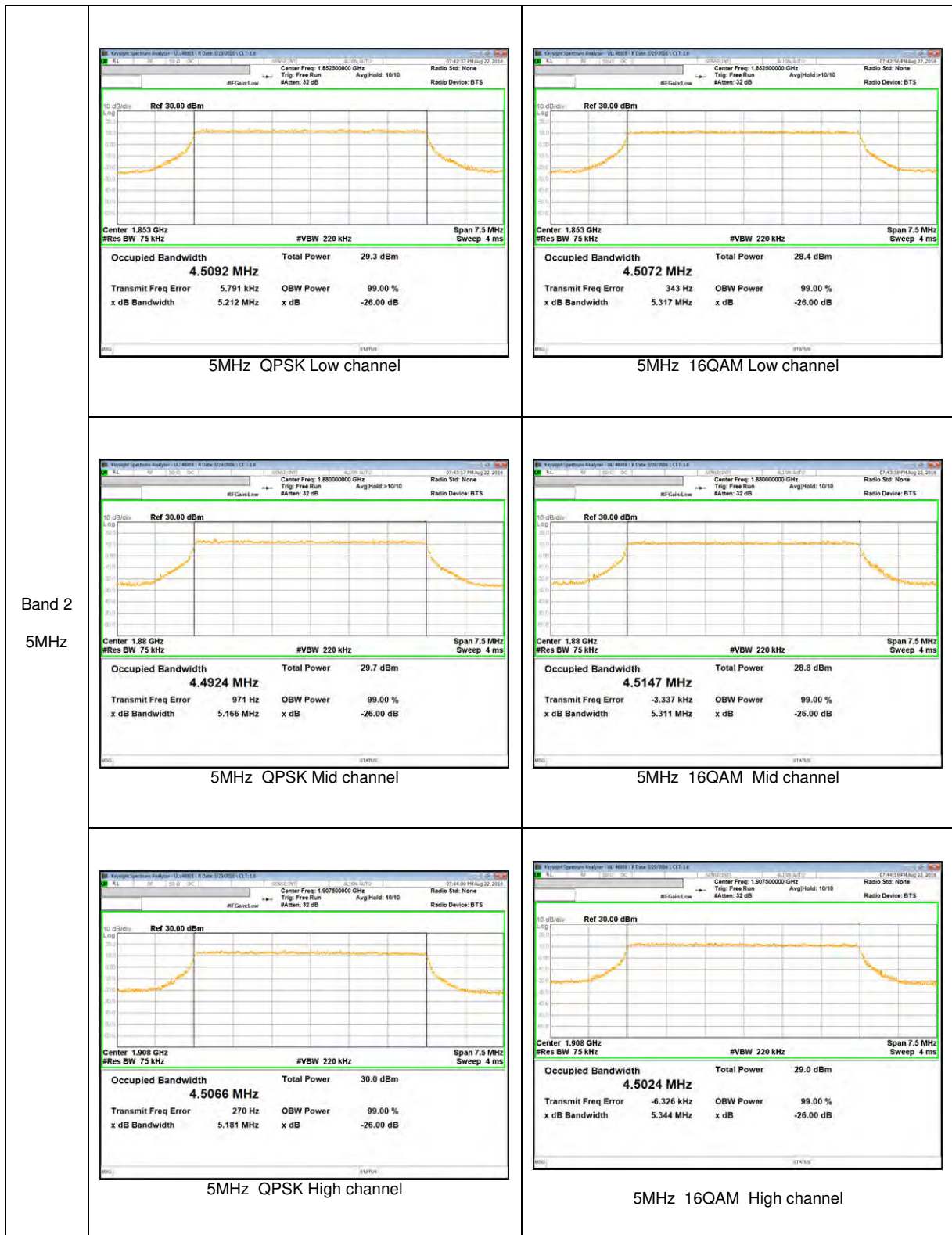

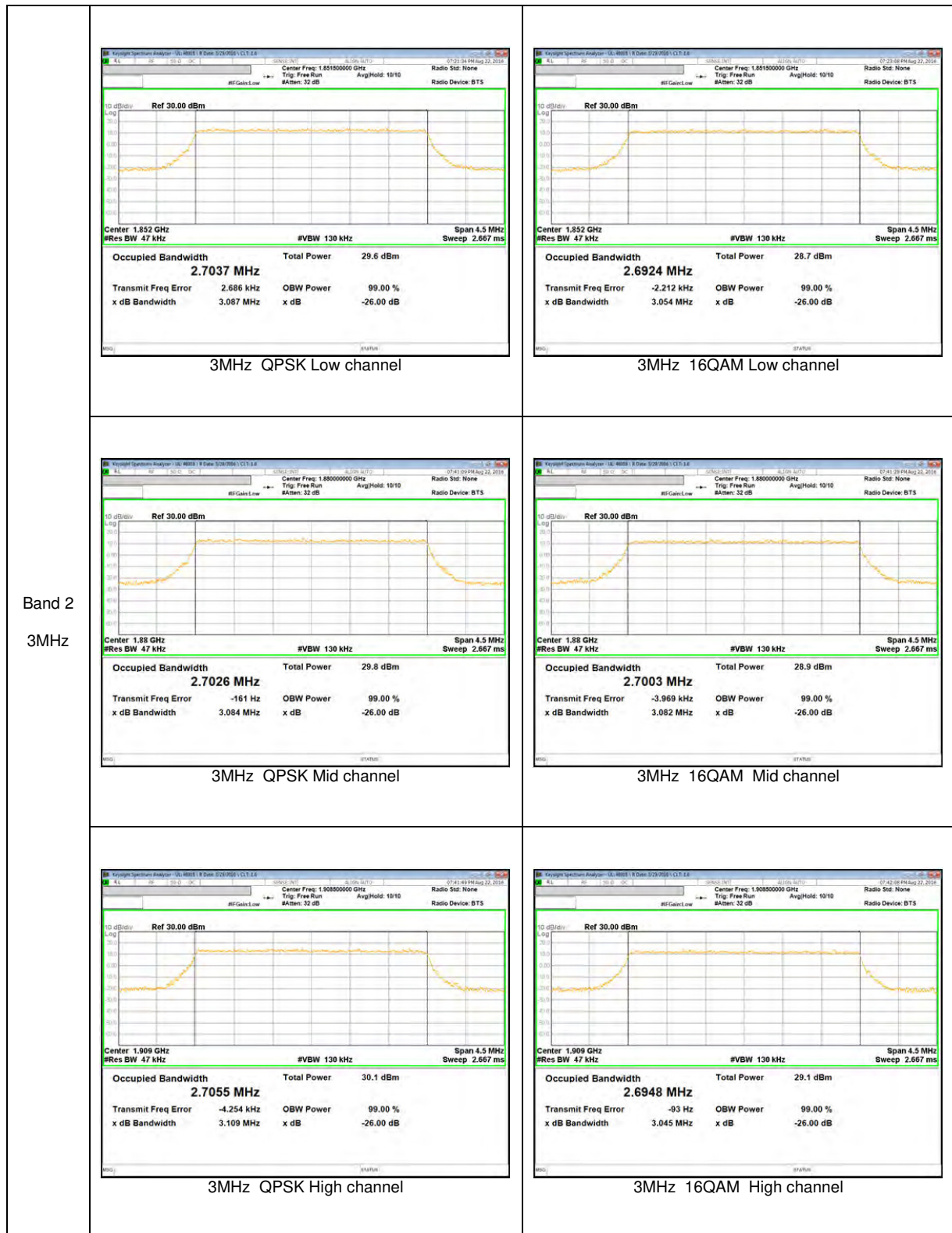

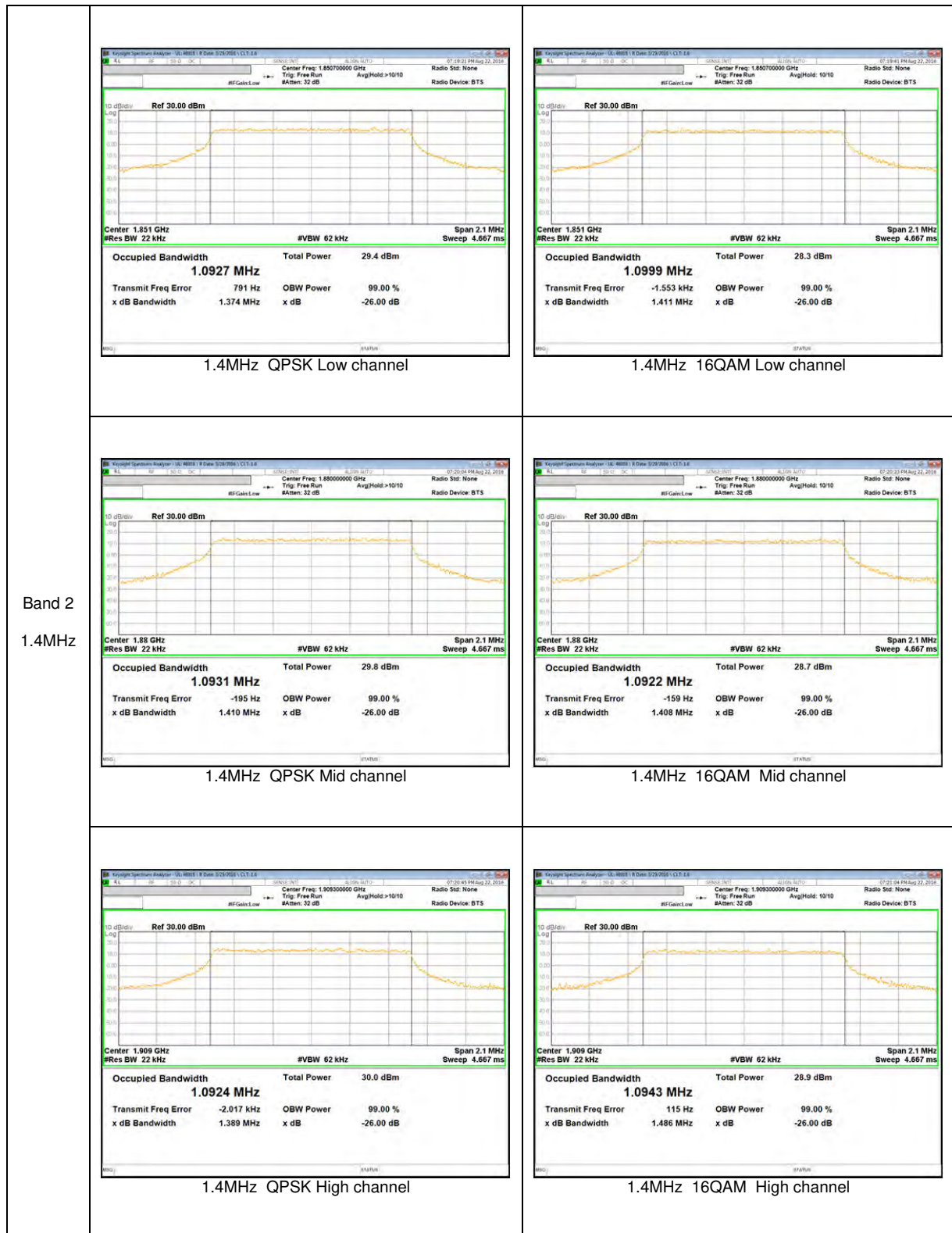

10.2. BAND EDGE EMISSIONS

RULE PART(S)

FCC: §22.359, §24.238 and §27. 53

LIMITS

The power of any emission outside of the authorized operating frequency ranges must be attenuated below the transmitting power (P) by a factor of at least $43 + 10 \log (P)$ dB.

TEST PROCEDURE

Per KDB 971168 D01 Power Meas License Digital Systems v02r02

The transmitter output was connected to a CMW500 Test Set and configured to operate at maximum power. The band edge emissions were measured at the required operating frequencies in each band on the Spectrum Analyzer.

RESULTS

WCDMA

Band	Mode	Side	f [MHz]	Level [dBm]	Limit [dBm]
Band 5	REL99	Lower	824.000	-26.620	-13.00
		Upper	849.000	-25.017	
	HSDPA	Lower	824.000	-27.962	
		Upper	849.000	-28.444	
Band 4	REL99	Lower	1710.000	-25.499	
		Upper	1755.000	-26.113	
	HSDPA	Lower	1710.000	-29.524	
		Upper	1755.000	-27.603	
Band 2	REL99	Lower	1850.000	-28.578	
		Upper	1910.000	-28.791	
	HSDPA	Lower	1850.000	-22.873	
		Upper	1910.000	-25.108	

LTE 5

Bandwidth	Mode	Side	RB Status	f [MHz]	Level [dBm]	Limit [dBm]
10 MHz	QPSK	Lower	1RB	824.000	-28.447	-13.00
			FRB	824.000	-31.423	
		Upper	1RB	849.000	-29.828	
			FRB	849.000	-24.478	
	16QAM	Lower	1RB	824.000	-32.684	
			FRB	824.000	-31.902	
		Upper	1RB	849.000	-29.441	
			FRB	849.000	-25.344	
5 MHz	QPSK	Lower	1RB	824.000	-19.646	-13.00
			FRB	824.000	-22.335	
		Upper	1RB	849.000	-20.240	
			FRB	849.000	-23.928	
	16QAM	Lower	1RB	824.000	-22.513	
			FRB	824.000	-27.929	
		Upper	1RB	849.000	-18.677	
			FRB	849.000	-25.625	
3 MHz	QPSK	Lower	1RB	824.000	-20.059	-13.00
			FRB	824.000	-23.756	
		Upper	1RB	849.000	-16.364	
			FRB	849.000	-23.701	
	16QAM	Lower	1RB	824.000	-19.263	
			FRB	824.000	-25.473	
		Upper	1RB	849.000	-18.675	
			FRB	849.000	-23.176	
1.4 MHz	QPSK	Lower	1RB	824.000	-25.195	-13.00
			FRB	824.000	-25.486	
		Upper	1RB	849.000	-23.944	
			FRB	849.000	-23.739	
	16QAM	Lower	1RB	824.000	-26.563	
			FRB	824.000	-25.008	
		Upper	1RB	849.000	-24.454	
			FRB	849.000	-25.165	

LTE 4

Bandwidth	Mode	Side	RB Status	f [MHz]	Level [dBm]	Limit [dBm]
20 MHz	QPSK	Lower	1RB	1710.000	-30.482	-13.00
			FRB	1710.000	-25.614	
		Upper	1RB	1755.000	-27.689	
			FRB	1755.000	-24.295	
	16QAM	Lower	1RB	1710.000	-31.386	
			FRB	1710.000	-27.581	
		Upper	1RB	1755.000	-24.189	
			FRB	1755.000	-26.558	
15 MHz	QPSK	Lower	1RB	1710.000	-22.644	-13.00
			FRB	1710.000	-25.390	
		Upper	1RB	1755.000	-22.097	
			FRB	1755.000	-26.285	
	16QAM	Lower	1RB	1710.000	-29.588	
			FRB	1710.000	-26.628	
		Upper	1RB	1755.000	-19.560	
			FRB	1755.000	-25.160	
10 MHz	QPSK	Lower	1RB	1710.000	-29.775	-13.00
			FRB	1710.000	-25.290	
		Upper	1RB	1755.000	-24.760	
			FRB	1755.000	-23.191	
	16QAM	Lower	1RB	1710.000	-32.754	
			FRB	1710.000	-27.428	
		Upper	1RB	1755.000	-29.025	
			FRB	1755.000	-26.012	
5 MHz	QPSK	Lower	1RB	1710.000	-19.855	-13.00
			FRB	1710.000	-23.843	
		Upper	1RB	1755.000	-16.837	
			FRB	1755.000	-23.609	
	16QAM	Lower	1RB	1710.000	-20.802	
			FRB	1710.000	-23.659	
		Upper	1RB	1755.000	-21.148	
			FRB	1755.000	-22.685	

Bandwidth	Mode	Side	RB Status	f [MHz]	Level [dBm]	Limit [dBm]
3 MHz	QPSK	Lower	1RB	1710.000	-18.580	-13.00
			FRB	1710.000	-22.451	
		Upper	1RB	1755.000	-15.366	
			FRB	1755.000	-21.058	
	16QAM	Lower	1RB	1710.000	-18.056	
			FRB	1710.000	-22.262	
		Upper	1RB	1755.000	-17.153	
			FRB	1755.000	-22.724	
1.4 MHz	QPSK	Lower	1RB	1710.000	-22.616	-13.00
			FRB	1710.000	-21.322	
		Upper	1RB	1755.000	-21.427	
			FRB	1755.000	-21.475	
	16QAM	Lower	1RB	1710.000	-23.643	
			FRB	1710.000	-20.846	
		Upper	1RB	1755.000	-22.439	
			FRB	1755.000	-23.174	

LTE 2

Bandwidth	Mode	Side	RB Status	f [MHz]	Level [dBm]	Limit [dBm]
20 MHz	QPSK	Lower	1RB	1850.000	-36.194	-13.00
			FRB	1850.000	-28.820	
		Upper	1RB	1910.000	-33.954	
			FRB	1910.000	-29.626	
	16QAM	Lower	1RB	1850.000	-30.153	
			FRB	1850.000	-29.315	
		Upper	1RB	1910.000	-30.150	
			FRB	1910.000	-31.084	
15 MHz	QPSK	Lower	1RB	1850.000	-19.120	-13.00
			FRB	1850.000	-26.990	
		Upper	1RB	1910.000	-23.997	
			FRB	1910.000	-27.919	
	16QAM	Lower	1RB	1850.000	-22.981	
			FRB	1850.000	-30.232	
		Upper	1RB	1910.000	-22.995	
			FRB	1910.000	-31.146	

Bandwidth	Mode	Side	RB Status	f [MHz]	Level [dBm]	Limit [dBm]
10 MHz	QPSK	Lower	1RB	1850.000	-28.486	-13.00
			FRB	1850.000	-30.153	
		Upper	1RB	1910.000	-26.501	
			FRB	1910.000	-29.065	
	16QAM	Lower	1RB	1850.000	-29.980	
			FRB	1850.000	-26.634	
		Upper	1RB	1910.000	-29.250	
			FRB	1910.000	-27.964	
5 MHz	QPSK	Lower	1RB	1850.000	-21.010	
			FRB	1850.000	-22.627	
		Upper	1RB	1910.000	-19.081	
			FRB	1910.000	-23.616	
	16QAM	Lower	1RB	1850.000	-21.449	
			FRB	1850.000	-23.666	
		Upper	1RB	1910.000	-19.379	
			FRB	1910.000	-24.944	
3 MHz	QPSK	Lower	1RB	1850.000	-17.838	
			FRB	1850.000	-21.976	
		Upper	1RB	1910.000	-15.743	
			FRB	1910.000	-22.981	
	16QAM	Lower	1RB	1850.000	-17.975	
			FRB	1850.000	-22.999	
		Upper	1RB	1910.000	-18.290	
			FRB	1910.000	-26.872	
1.4 MHz	QPSK	Lower	1RB	1850.000	-23.385	
			FRB	1850.000	-20.822	
		Upper	1RB	1910.000	-20.972	
			FRB	1910.000	-22.030	
	16QAM	Lower	1RB	1850.000	-23.359	
			FRB	1850.000	-22.325	
		Upper	1RB	1910.000	-23.470	
			FRB	1910.000	-23.199	

10.2.1. BAND EDGE PLOTS

WCDMA

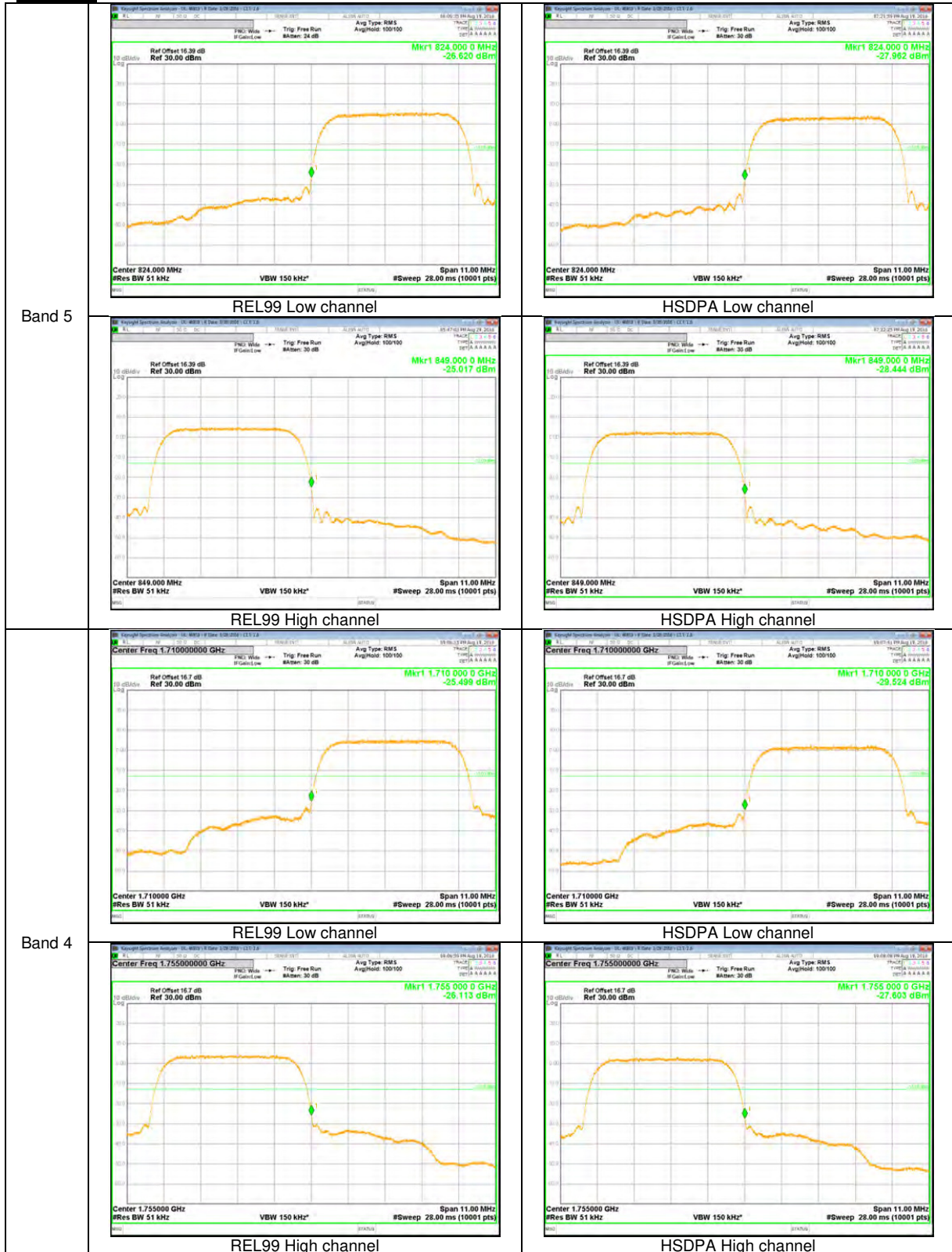

WCDMA

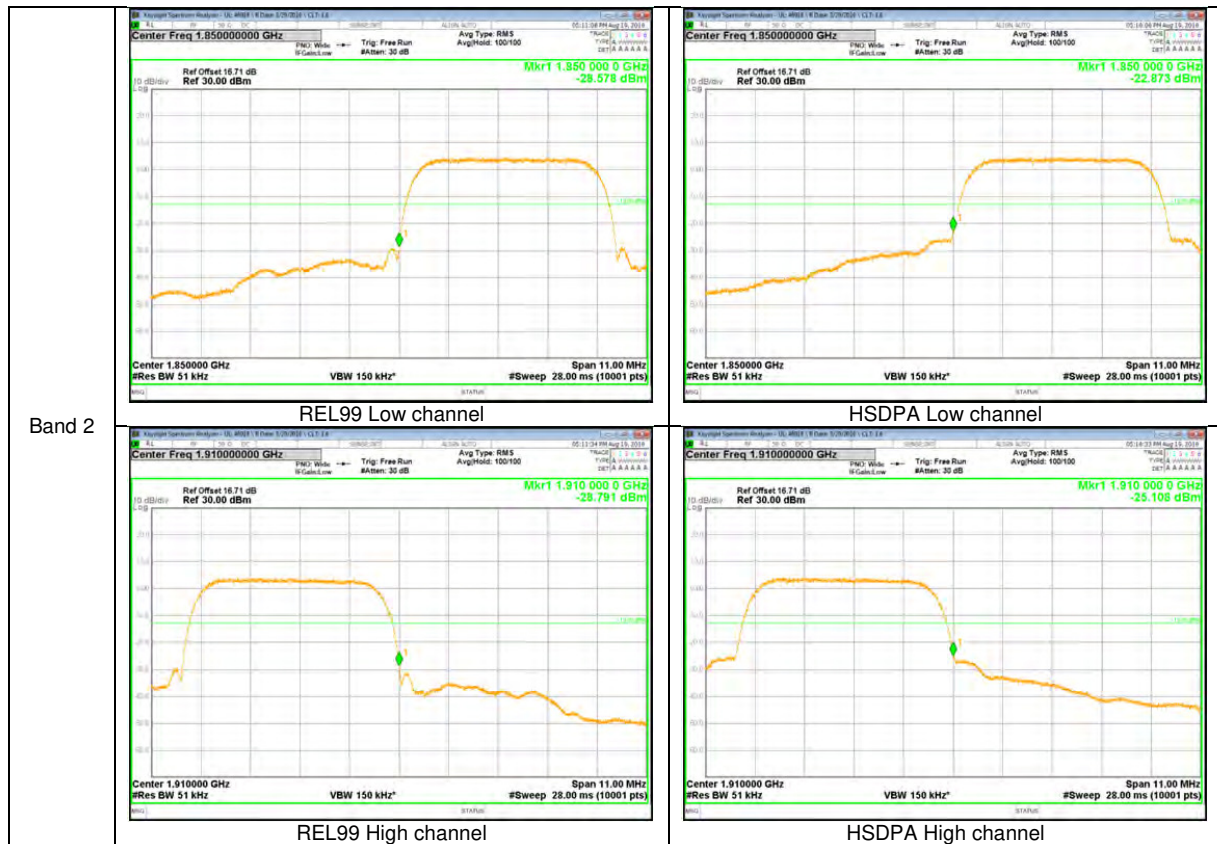

LTE Band 5

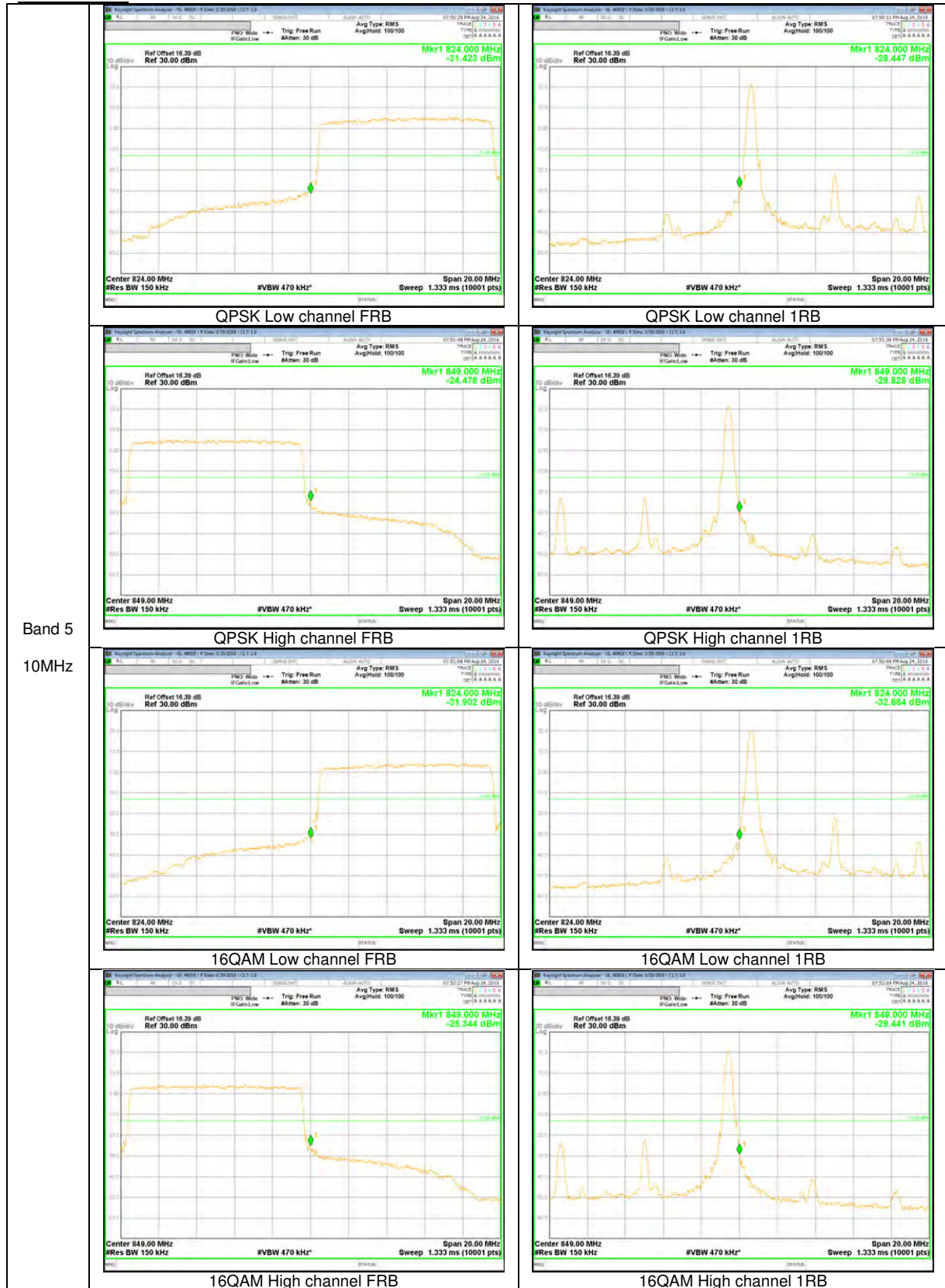

Band 5
 10MHz

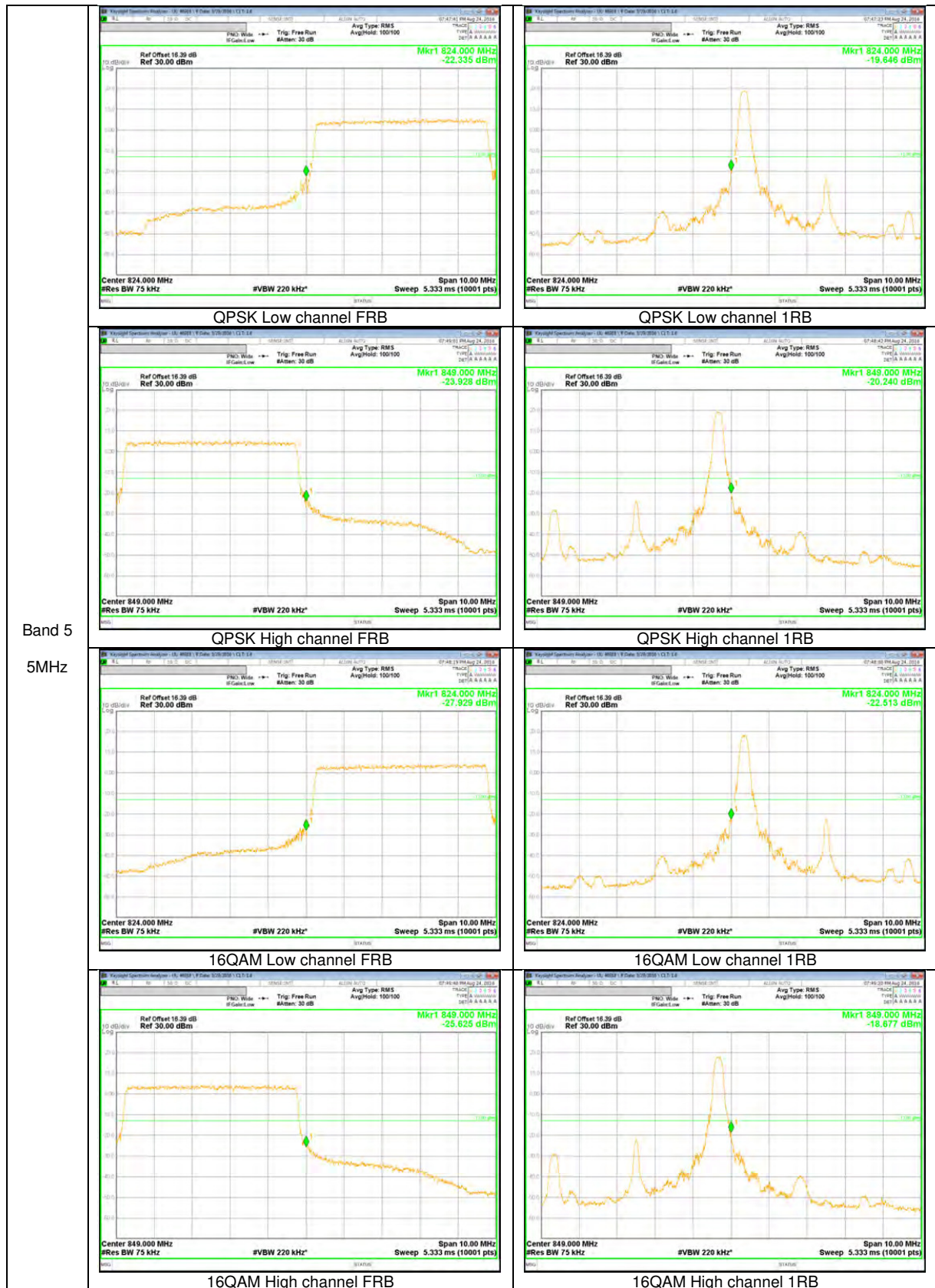

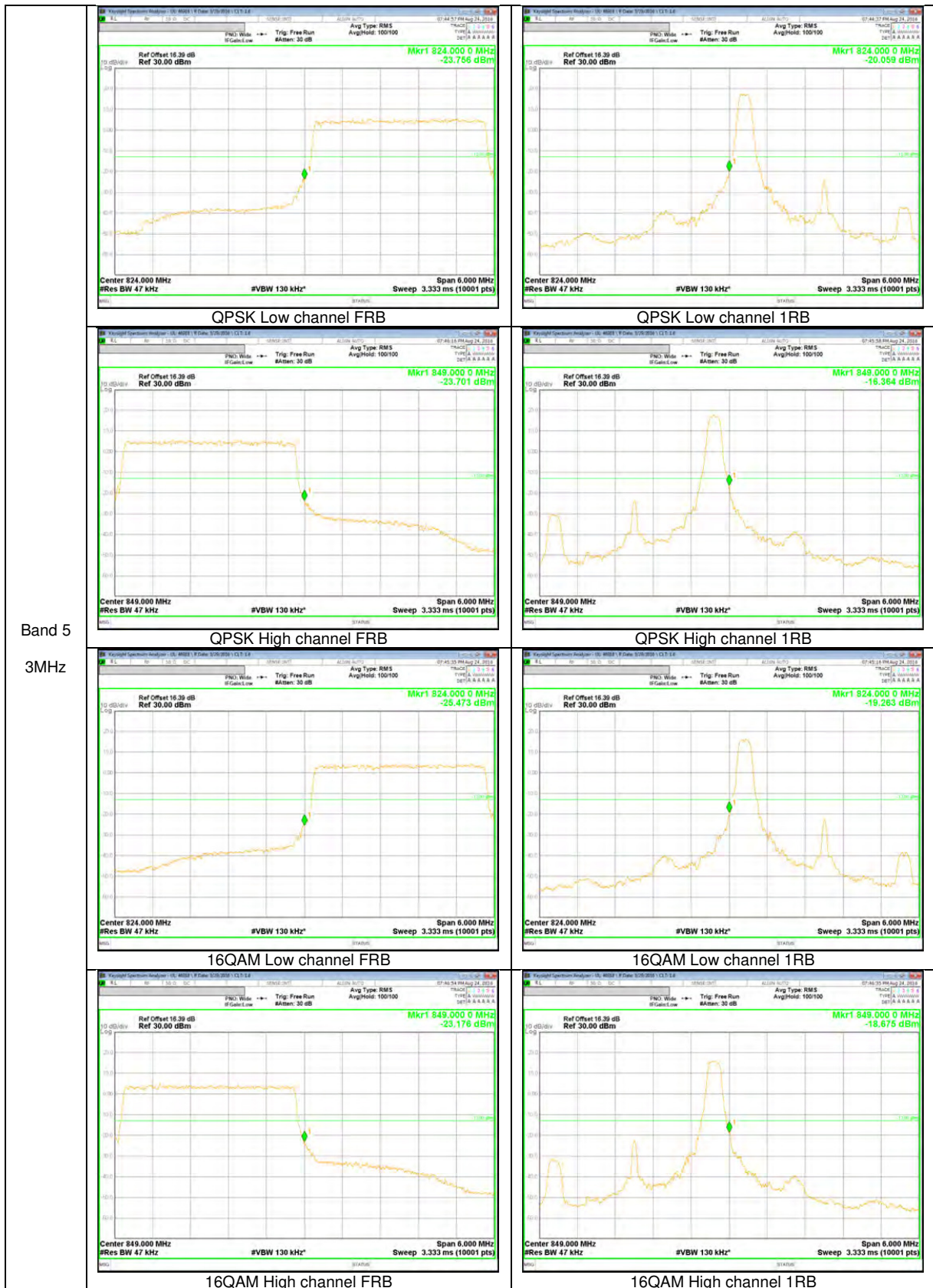

Band 5
3MHz

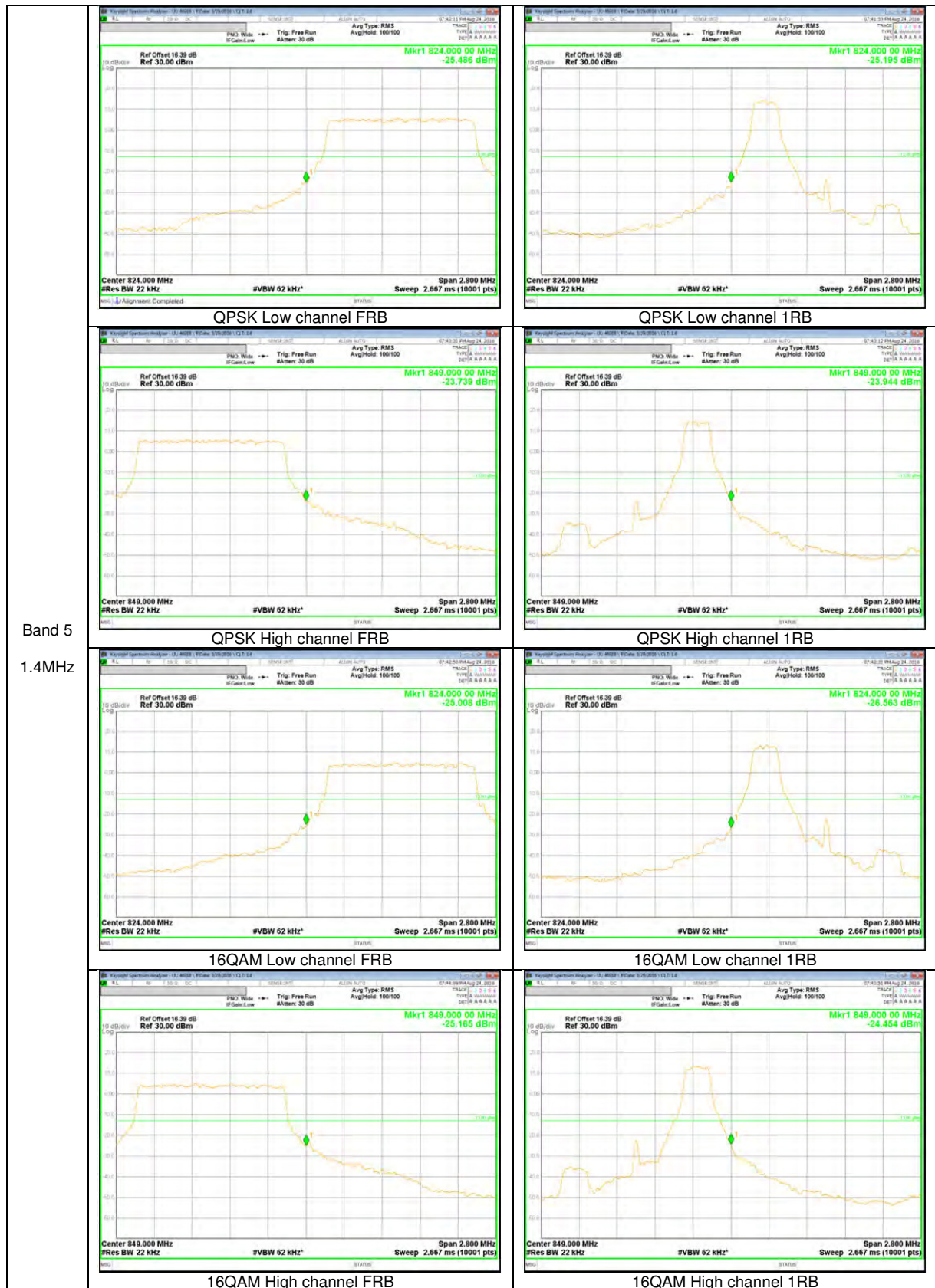

LTE Band 4

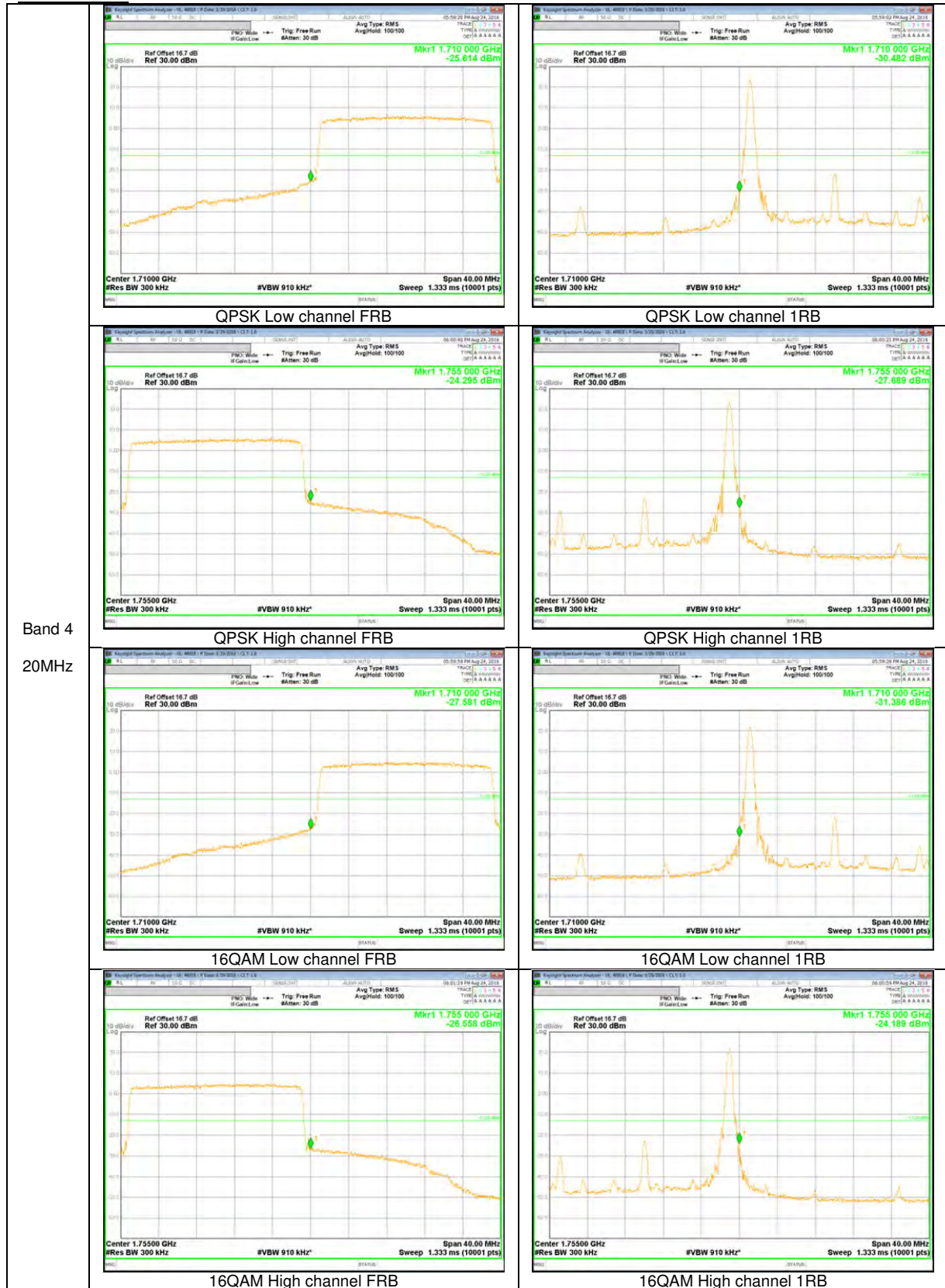

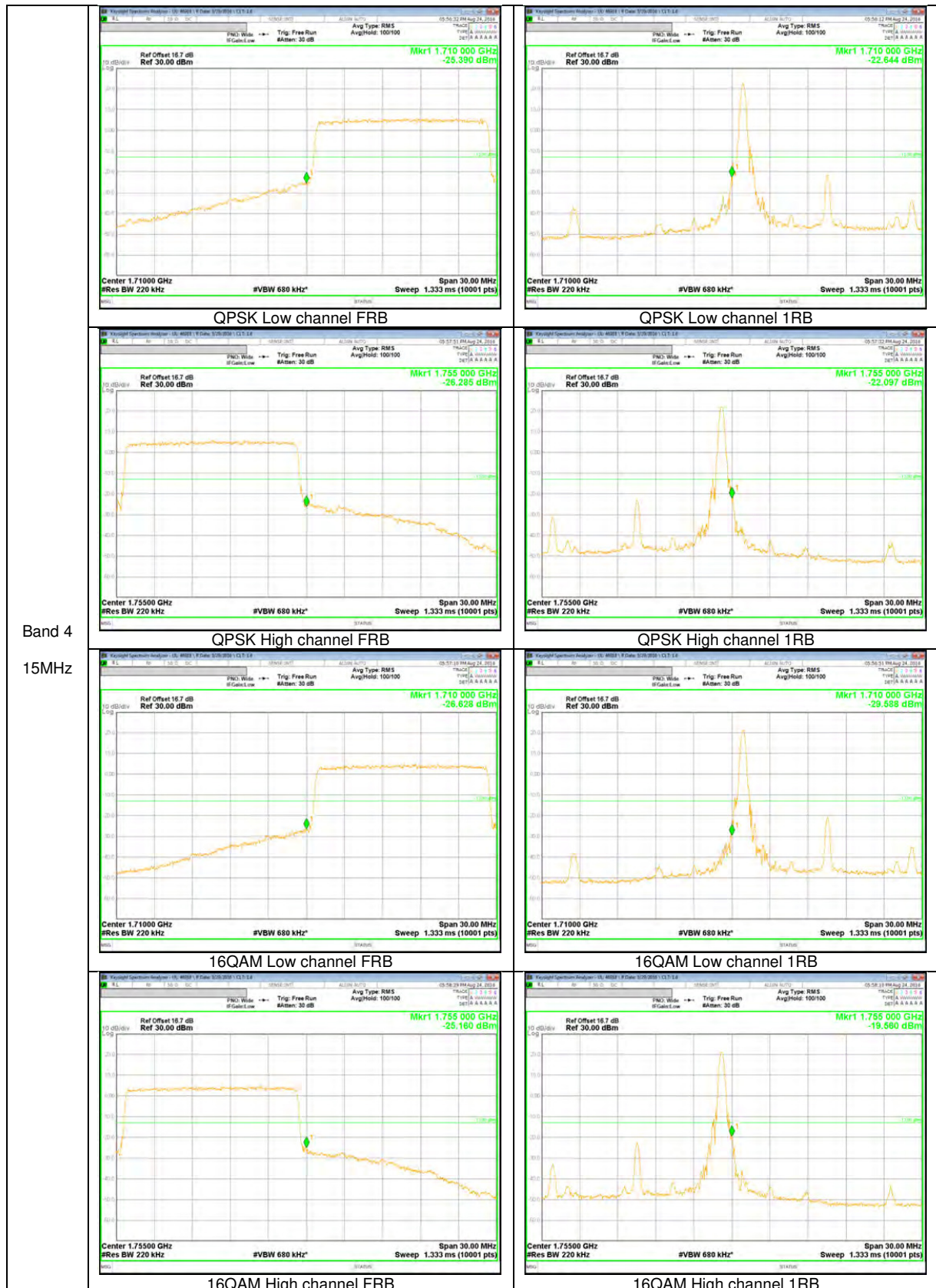

Band 4
 15MHz

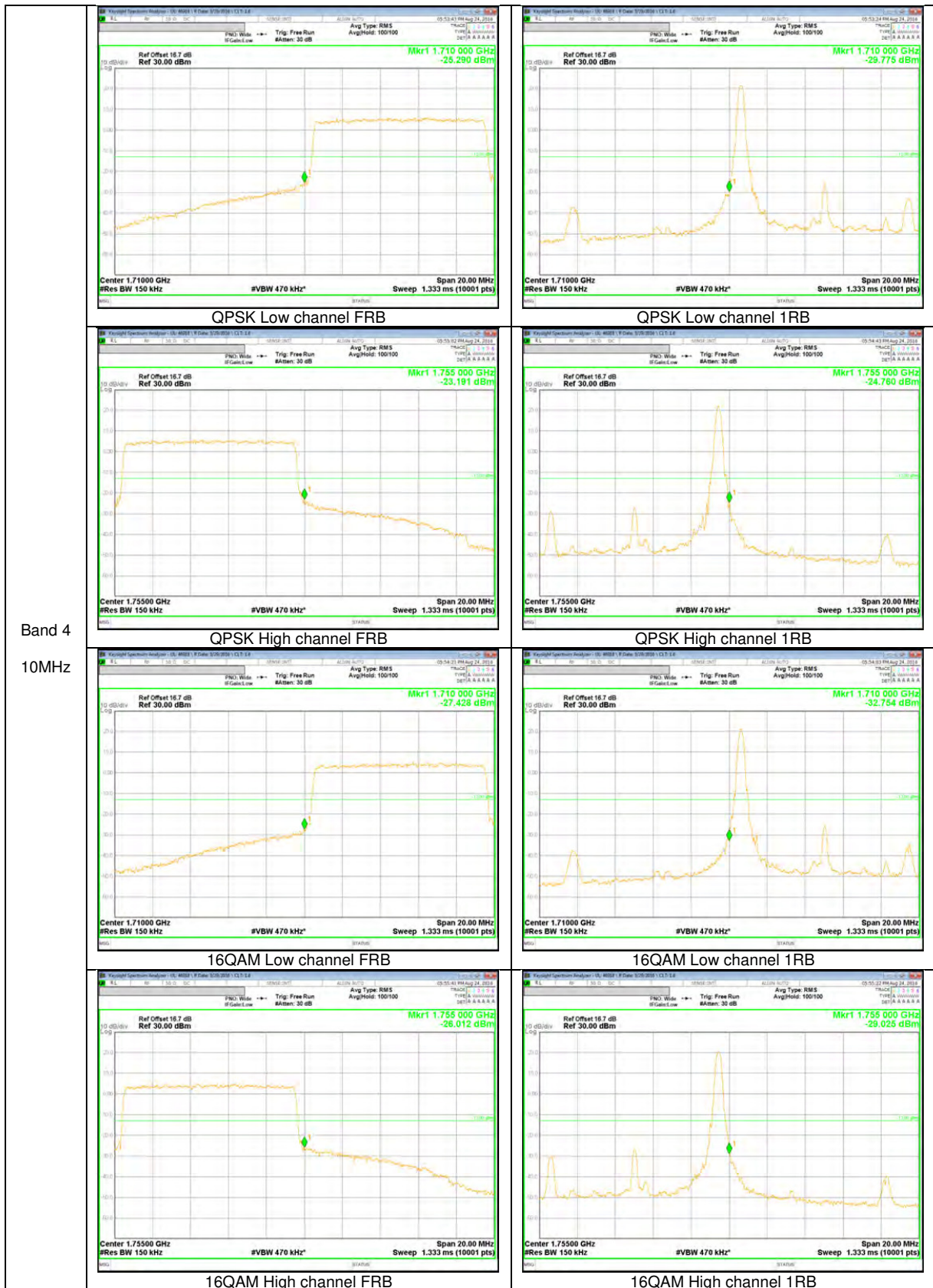

Band 4
 10MHz

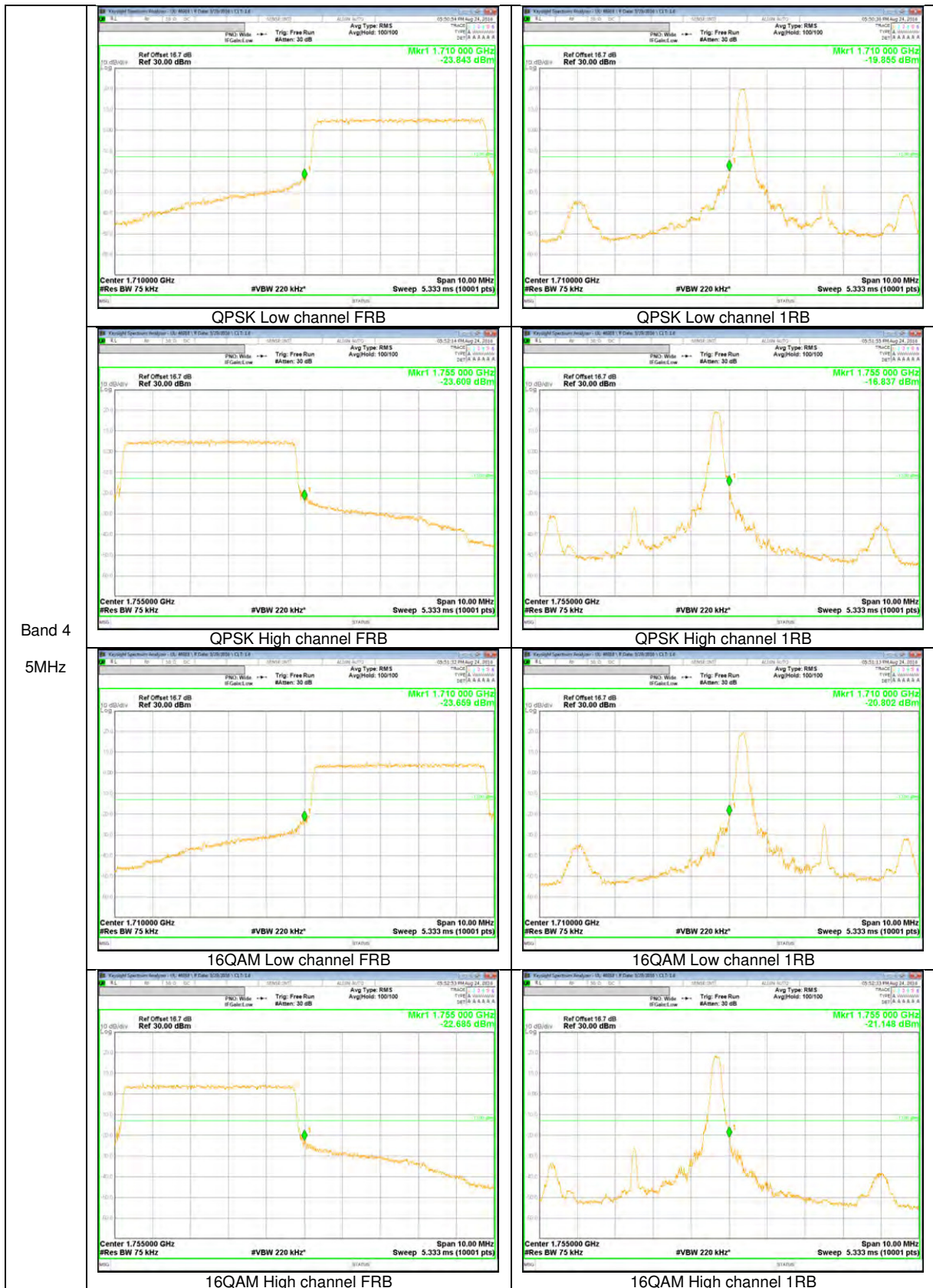

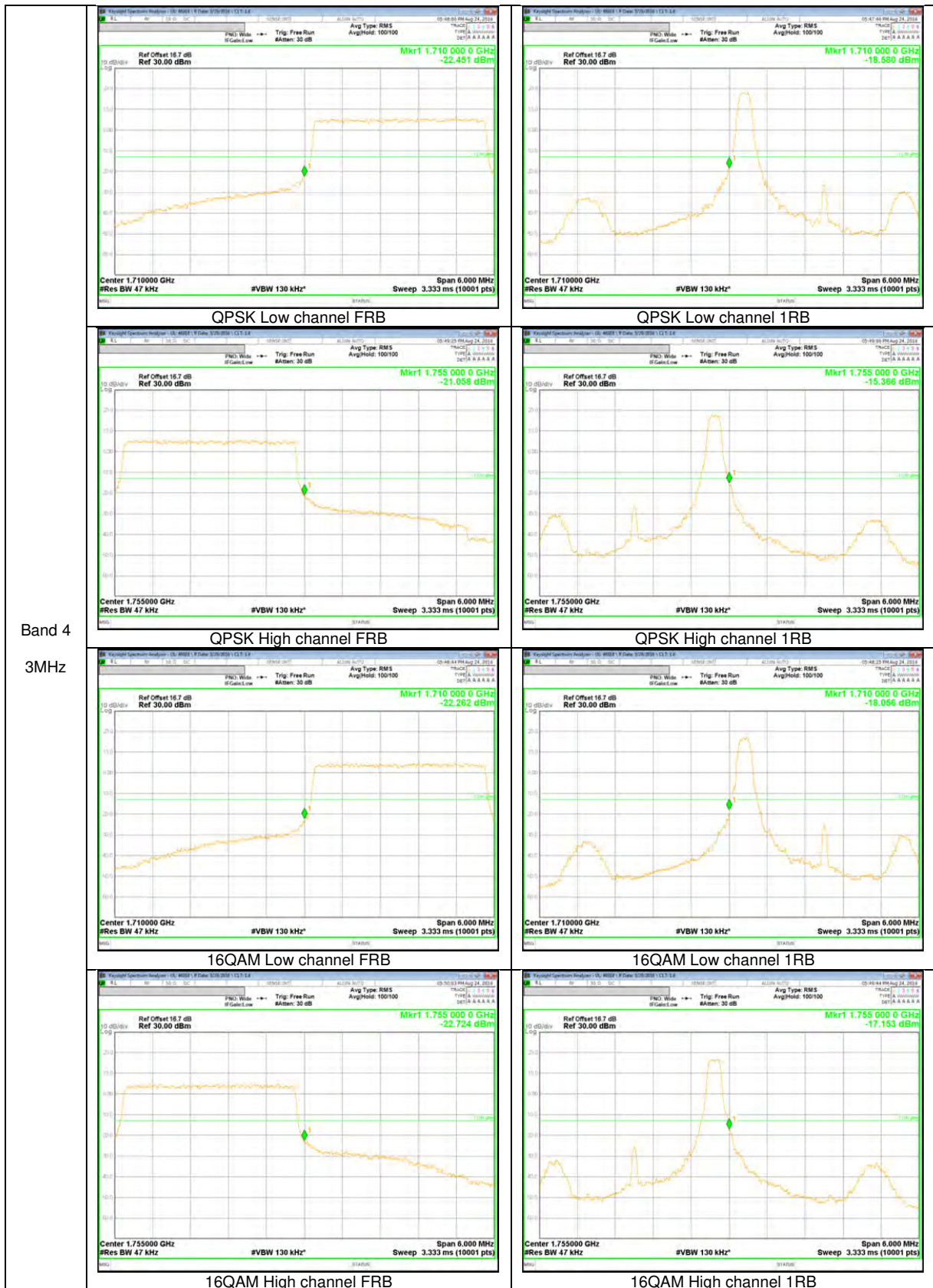

Band 4
 3MHz

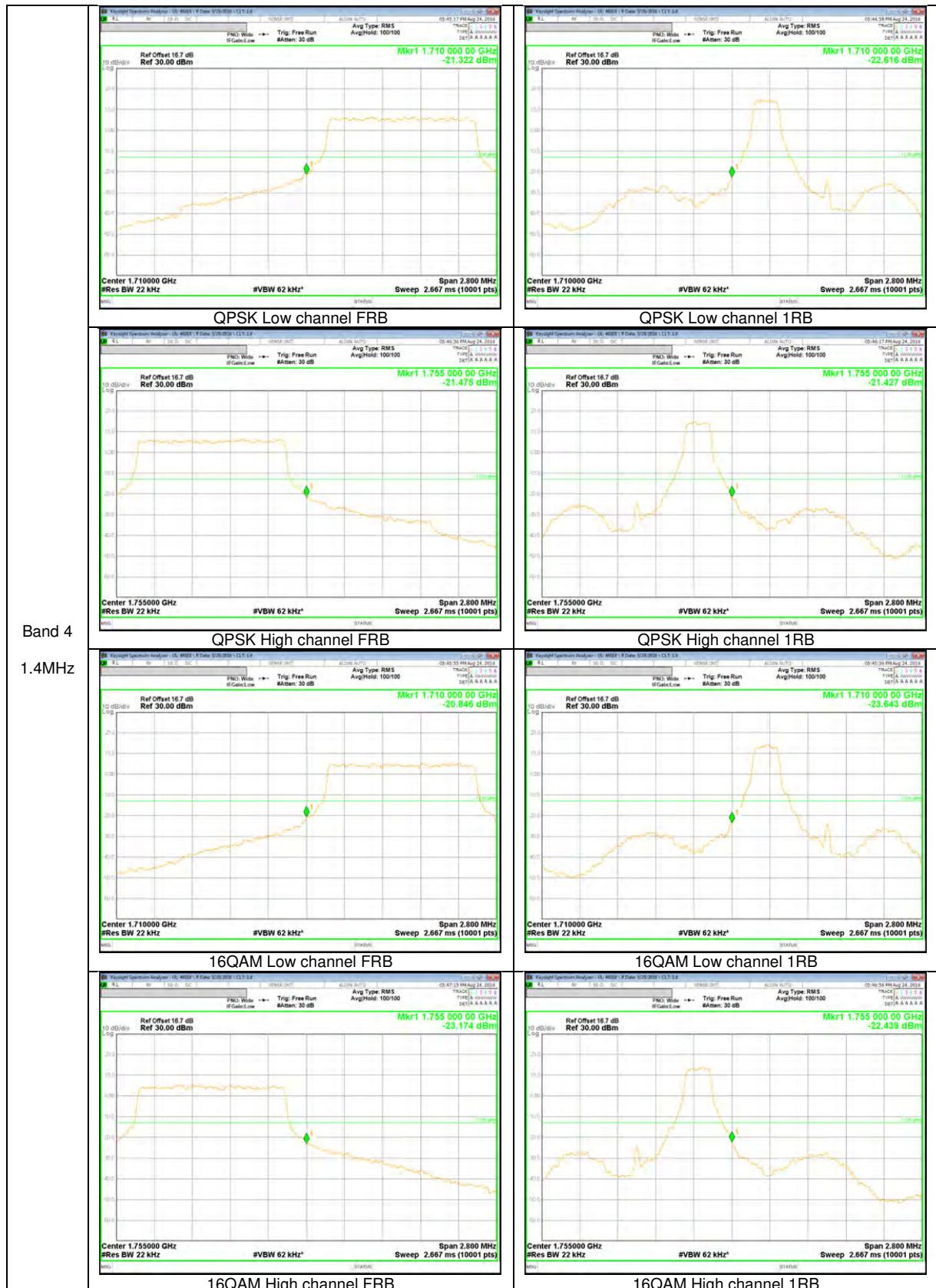

Band 4
 1.4MHz

LTE Band 2

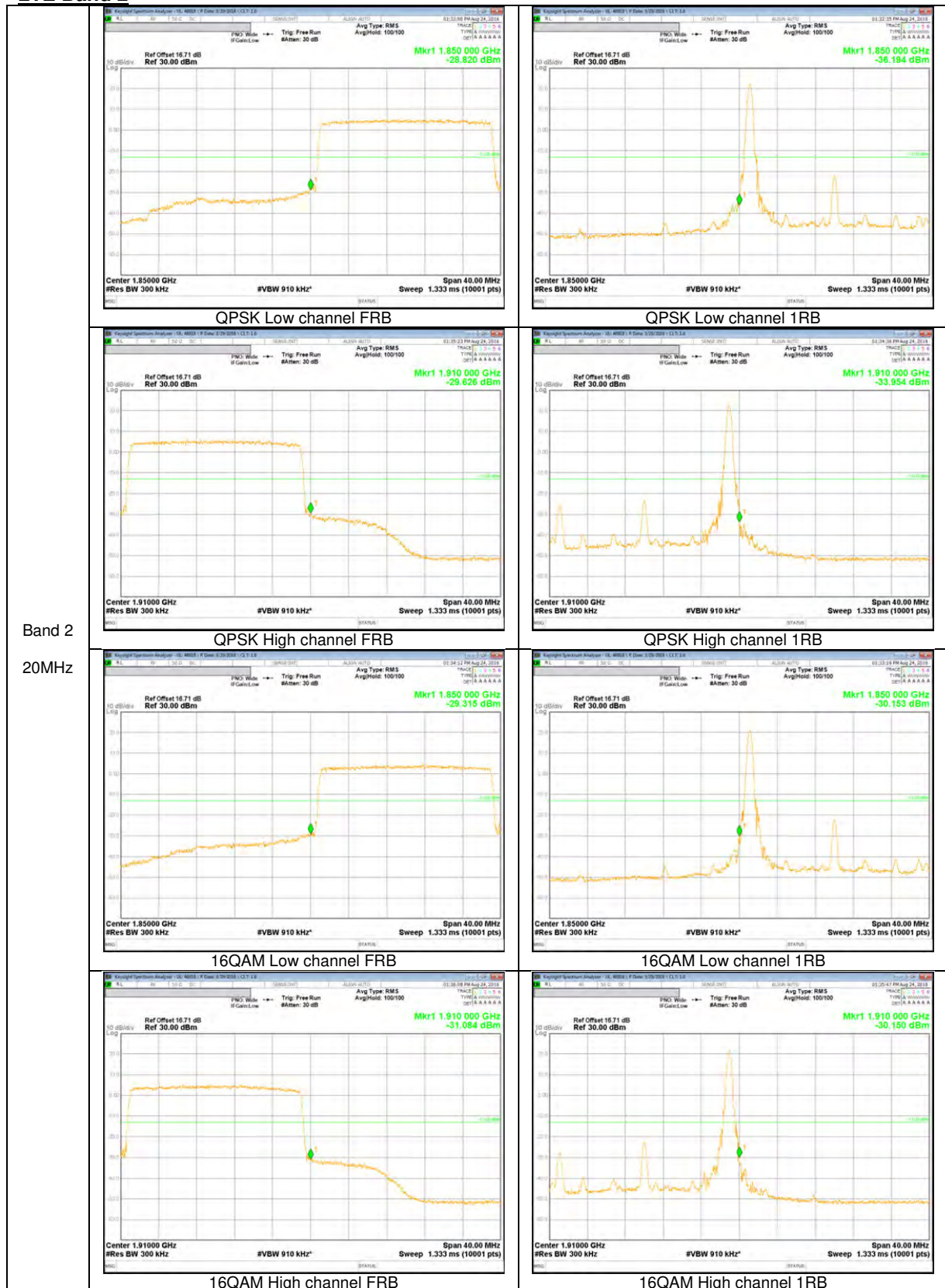

Band 2
20MHz

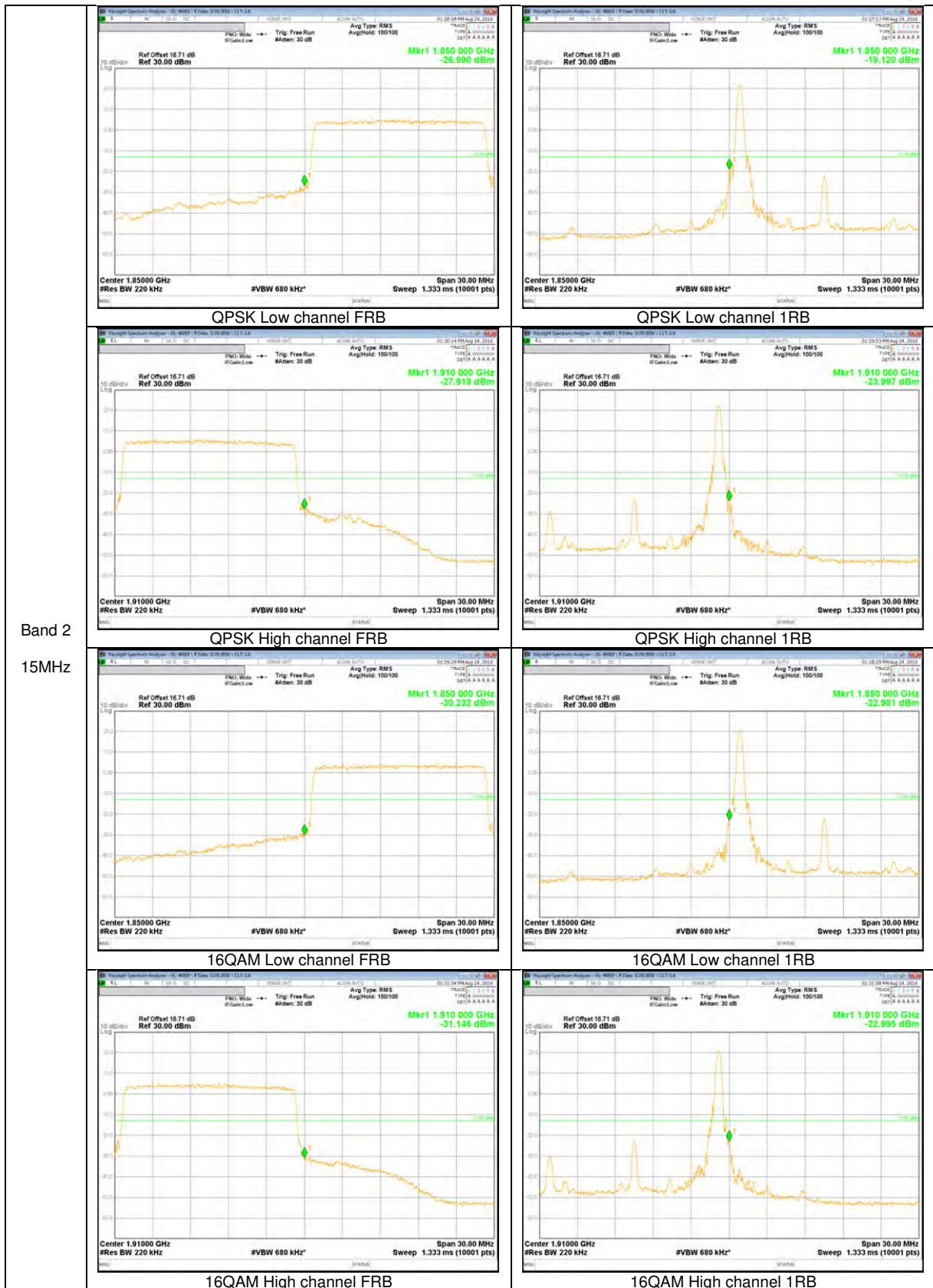

Band 2
15MHz

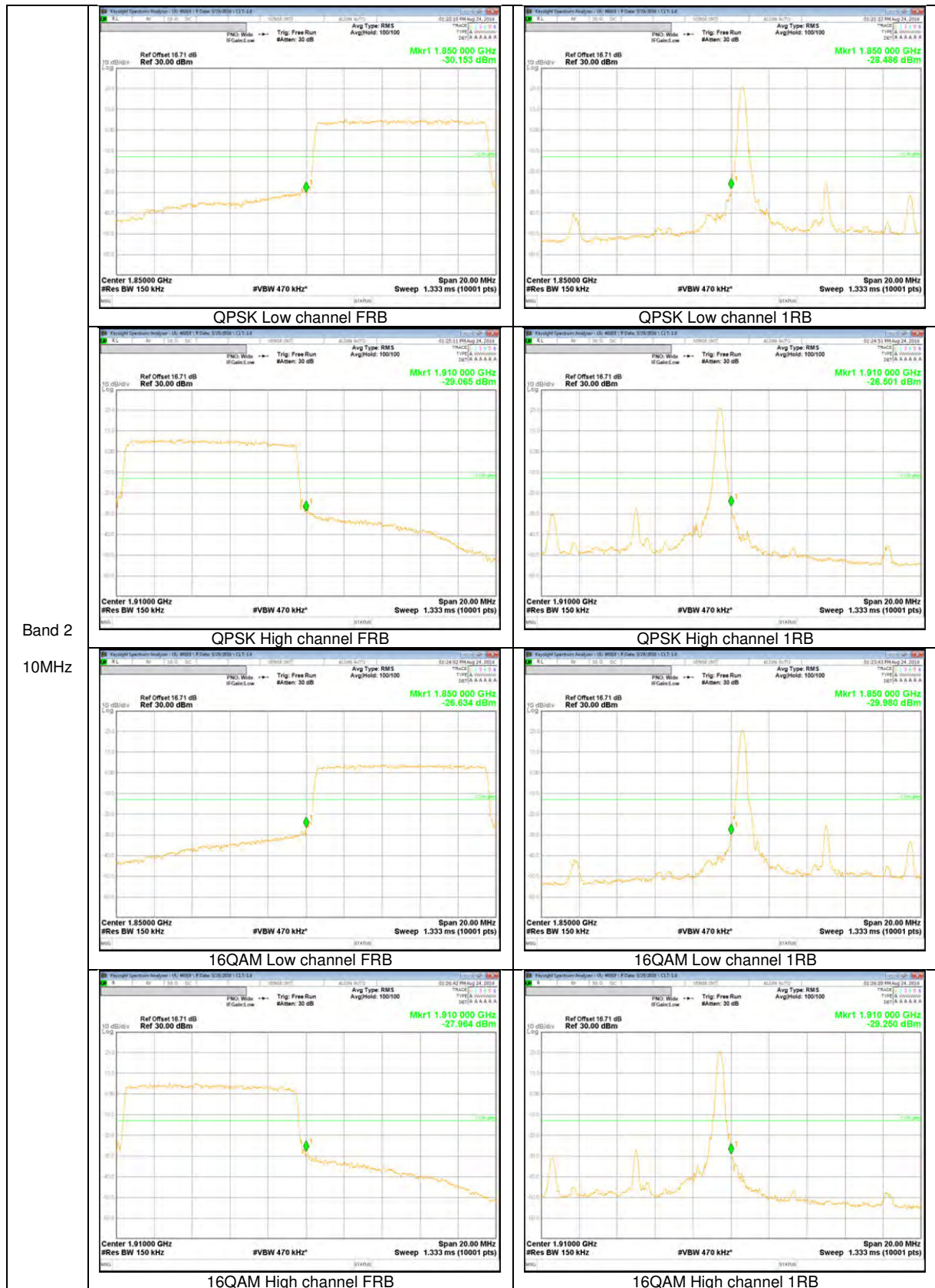

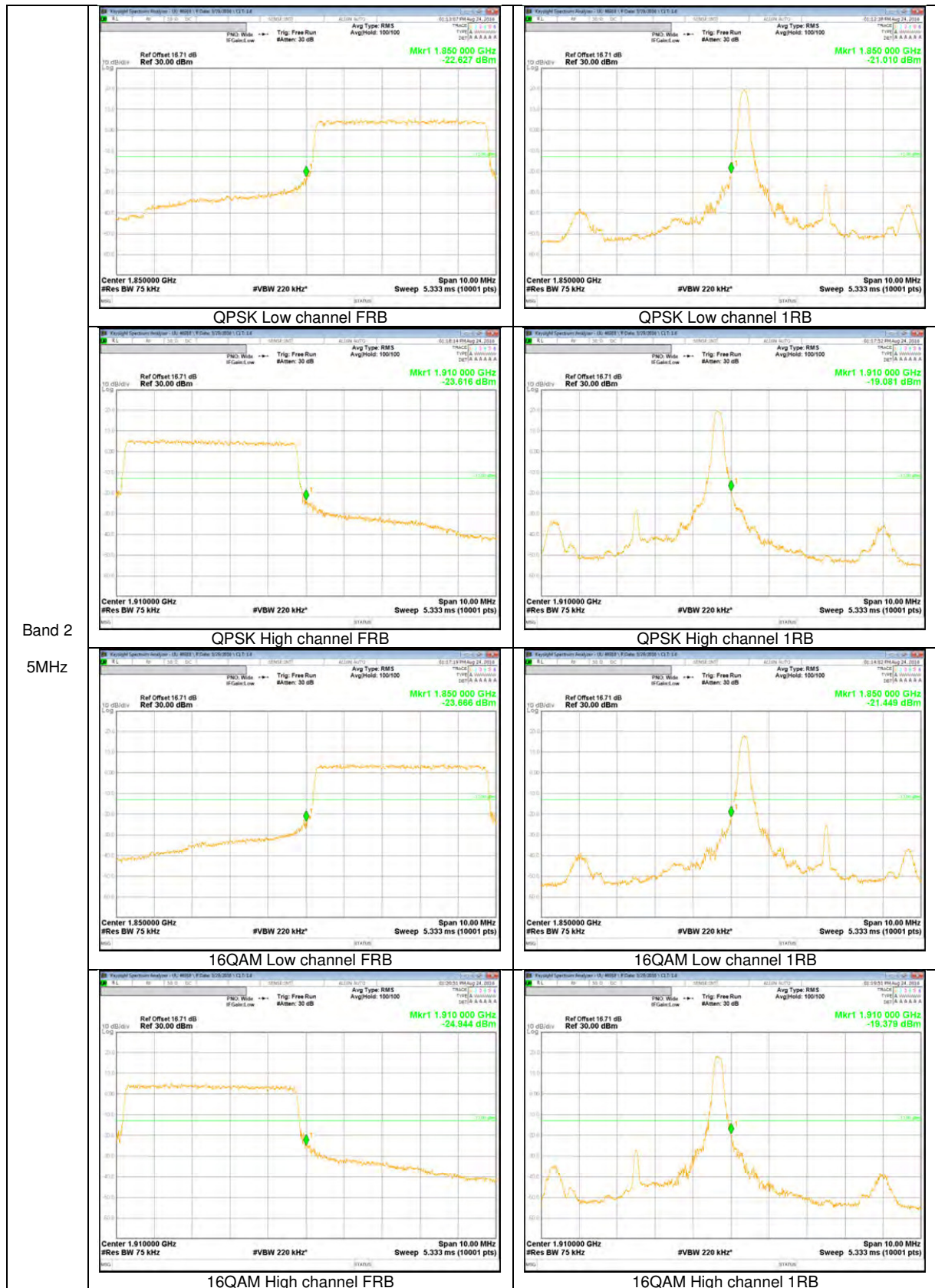

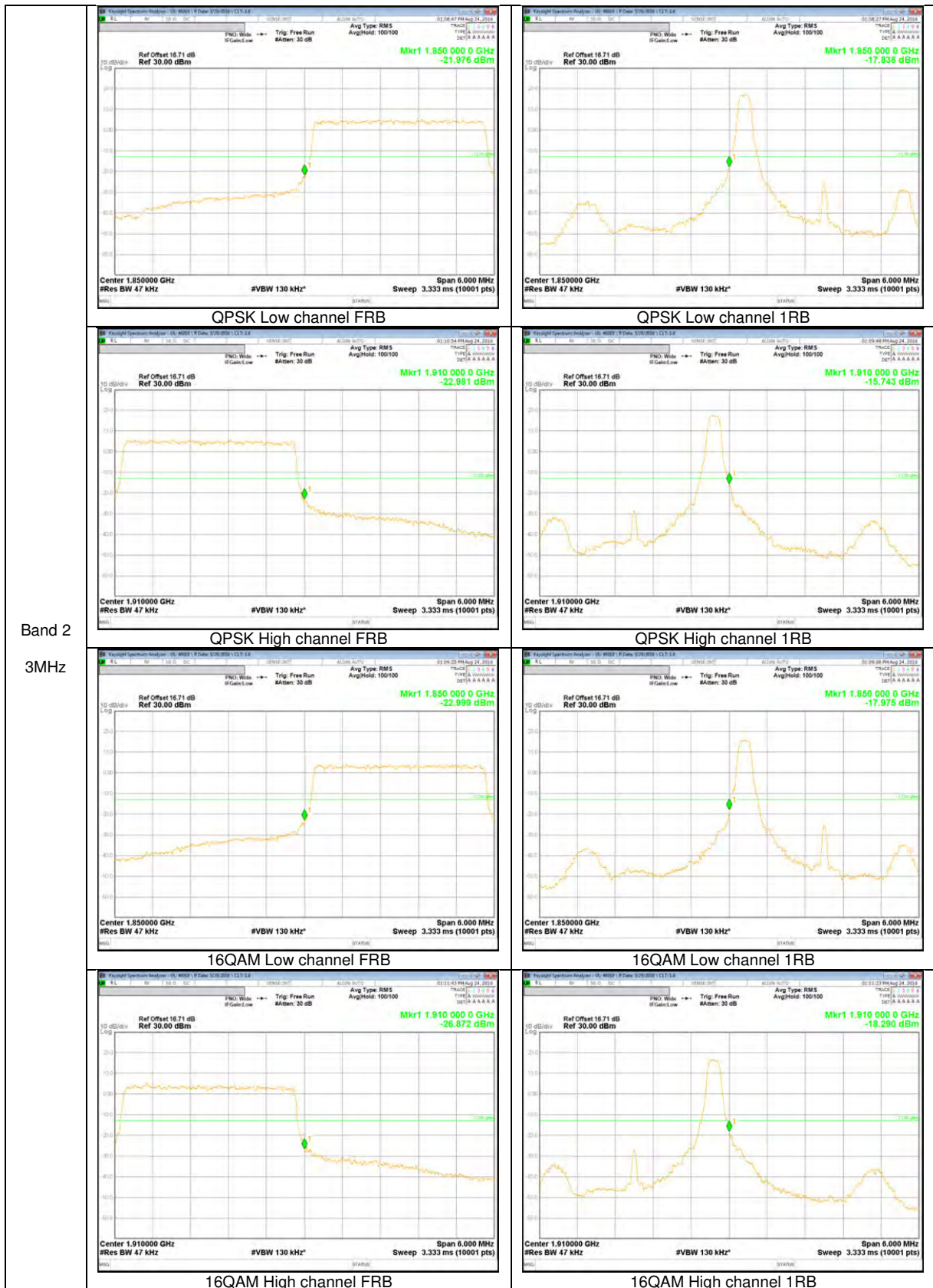

Band 2
 3MHz

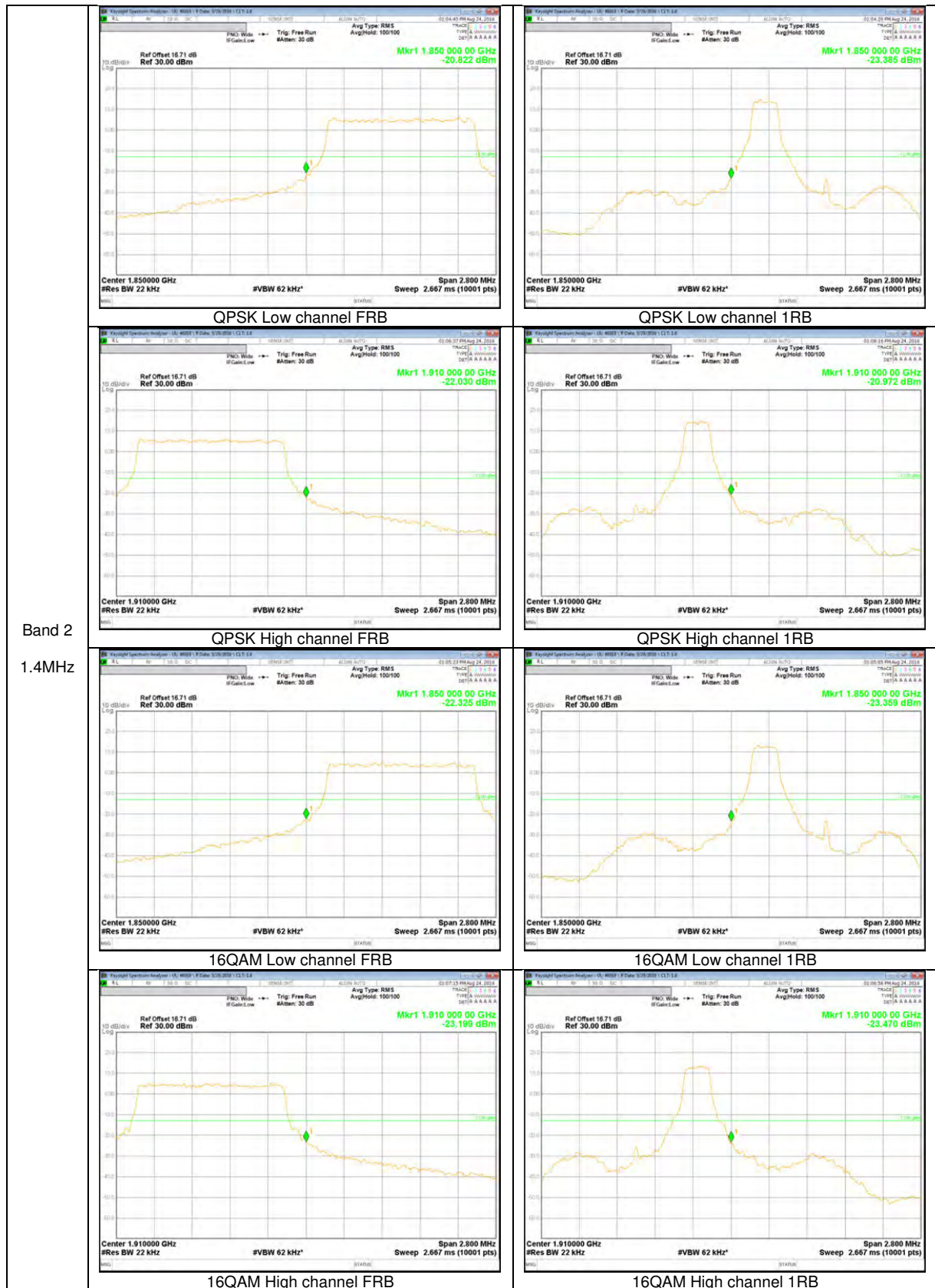

10.3 OUT OF BAND EMISSIONS

RULE PART(S)

FCC: §2.1051, §22.901, §22.917, §24.238 and §27. 53

LIMITS

The power of any emission outside of the authorized operating frequency ranges must be attenuated below the transmitting power (P) by a factor of at least 43 + 10 log (P) dB.

TEST PROCEDURE

Per KDB 971168 D01 Power Meas License Digital Systems v02r02

The RF output of the transmitter was connected to a spectrum analyzer through a calibrated coaxial cable. Sufficient scans were taken to show the out-of-band Emissions, if any, up to 10th harmonic. Multiple sweeps were recorded in maximum hold mode using a peak detector to ensure that the worst-case emissions were caught.

RESULTS

10.3.1. OUT OF BAND EMISSIONS RESULT

WCDMA

Band	Mode	f [MHz]	Spurious [dBm]	Limit [dBm]
Band 5	REL99	826.4	-32.49	-13.00
		836.6	-33.07	
		846.6	-32.13	
	HSDPA	826.4	-33.46	
		836.6	-33.21	
		846.6	-32.72	
Band 4	REL99	1712.4	-32.73	
		1732.6	-32.45	
		1752.6	-33.65	
	HSDPA	1712.4	-32.81	
		1732.6	-33.24	
		1752.6	-32.55	
Band 2	REL99	1852.4	-32.92	
		1880.0	-32.60	
		1907.6	-32.47	
	HSDPA	1852.4	-33.05	
		1880.0	-32.67	
		1907.6	-32.77	

LTE 5

Bandwidth	Mode	f [MHz]	Spurious [dBm]	Limit [dBm]
10 MHz	QPSK	829.0	-27.36	-13.00
		836.5	-26.85	
		844.0	-28.06	
	16QAM	829.0	-26.69	
		836.5	-25.88	
		844.0	-27.56	
5 MHz	QPSK	826.5	-27.84	
		836.5	-25.87	
		846.5	-27.11	
	16QAM	826.5	-27.66	
		836.5	-27.01	
		846.5	-27.36	
3 MHz	QPSK	825.5	-26.79	
		836.5	-27.66	
		847.5	-27.79	
	16QAM	825.5	-27.37	
		836.5	-26.67	
		847.5	-27.12	
1.4 MHz	QPSK	824.7	-27.62	
		836.5	-26.77	
		848.3	-27.29	
	16QAM	824.7	-27.60	
		836.5	-27.12	
		848.3	-27.10	

LTE 4

Bandwidth	Mode	f [MHz]	Spurious [dBm]	Limit [dBm]
20 MHz	QPSK	1720.0	-27.47	-13.00
		1732.5	-26.45	
		1745.0	-26.05	
	16QAM	1720.0	-26.85	
		1732.5	-26.95	
		1745.0	-26.42	
15 MHz	QPSK	1717.5	-26.63	
		1732.5	-26.19	
		1747.5	-27.08	
	16QAM	1717.5	-27.00	
		1732.5	-26.27	
		1747.5	-26.72	
10 MHz	QPSK	1715.0	-27.07	
		1732.5	-27.29	
		1750.0	-26.66	
	16QAM	1715.0	-26.34	
		1732.5	-27.11	
		1750.0	-27.10	
5 MHz	QPSK	1712.5	-26.92	
		1732.5	-27.21	
		1752.5	-26.84	
	16QAM	1712.5	-26.34	
		1732.5	-26.77	
		1752.5	-26.27	
3 MHz	QPSK	1711.5	-27.59	
		1732.5	-27.37	
		1753.5	-26.15	
	16QAM	1711.5	-26.62	
		1732.5	-27.09	
		1753.5	-27.54	
1.4 MHz	QPSK	1710.7	-26.85	
		1732.5	-27.12	
		1754.3	-26.43	
	16QAM	1710.7	-26.56	
		1732.5	-25.75	
		1754.3	-26.50	

LTE 2

Bandwidth	Mode	f [MHz]	Spurious [dBm]	Limit [dBm]
20 MHz	QPSK	1860.0	-27.46	-13.00
		1880.0	-26.69	
		1900.0	-25.92	
	16QAM	1860.0	-26.54	
		1880.0	-27.10	
		1900.0	-27.00	
15 MHz	QPSK	1857.5	-27.24	
		1880.0	-27.49	
		1902.5	-26.72	
	16QAM	1857.5	-27.14	
		1880.0	-26.82	
		1902.5	-26.41	
10 MHz	QPSK	1855.0	-25.54	
		1880.0	-26.30	
		1905.0	-26.18	
	16QAM	1855.0	-26.25	
		1880.0	-26.34	
		1905.0	-26.38	
5 MHz	QPSK	1852.5	-26.69	
		1880.0	-26.94	
		1907.5	-26.78	
	16QAM	1852.5	-25.84	
		1880.0	-26.93	
		1907.5	-26.31	
3 MHz	QPSK	1851.5	-26.36	
		1880.0	-27.53	
		1908.5	-26.86	
	16QAM	1851.5	-27.24	
		1880.0	-26.60	
		1908.5	-26.16	
1.4 MHz	QPSK	1850.7	-25.99	
		1880.0	-26.83	
		1909.3	-26.79	
	16QAM	1850.7	-26.51	
		1880.0	-27.00	
		1909.3	-27.30	

10.3.2. OUT OF BAND EMISSIONS PLOTS

WCDMA Band 5

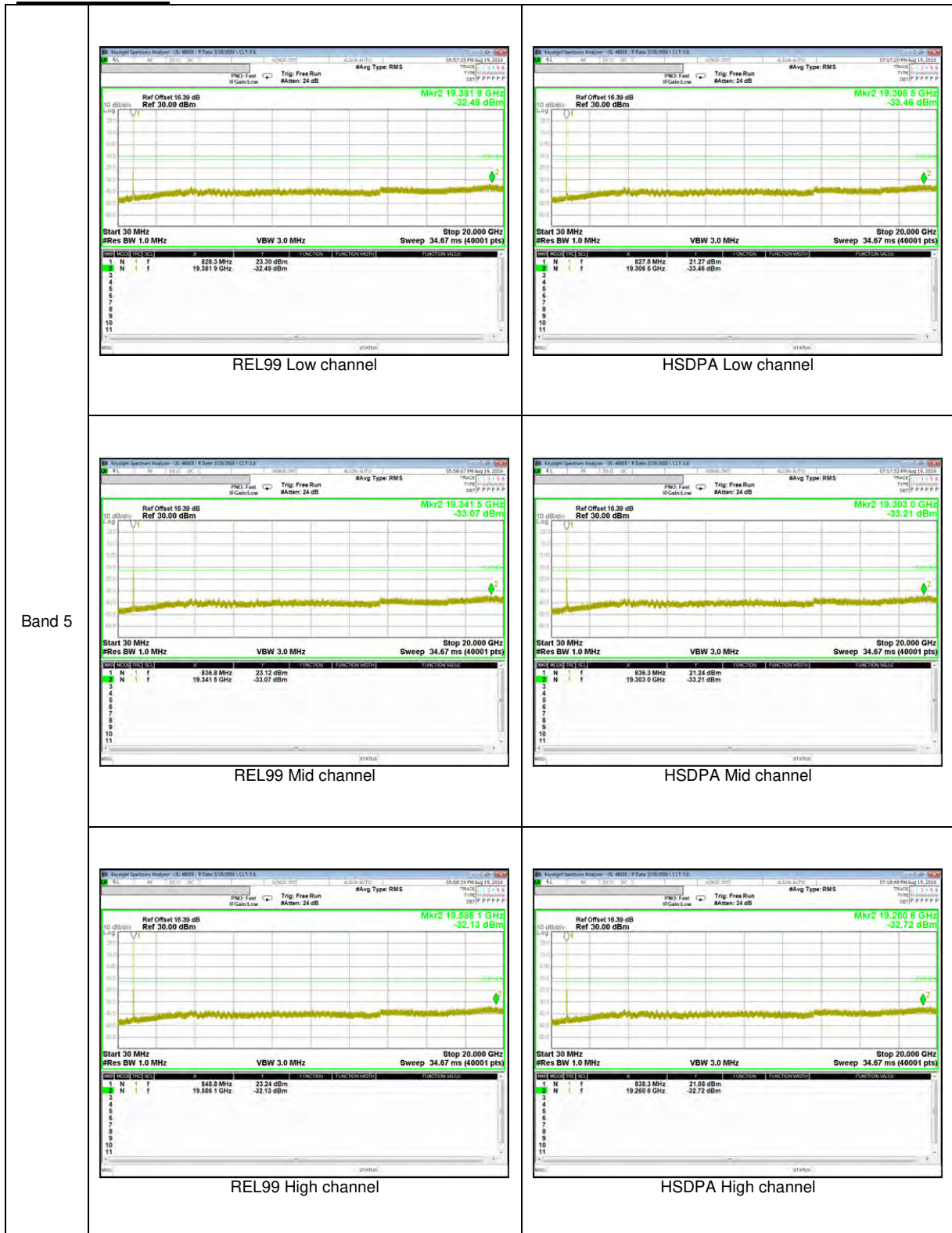

WCDMA Band 4

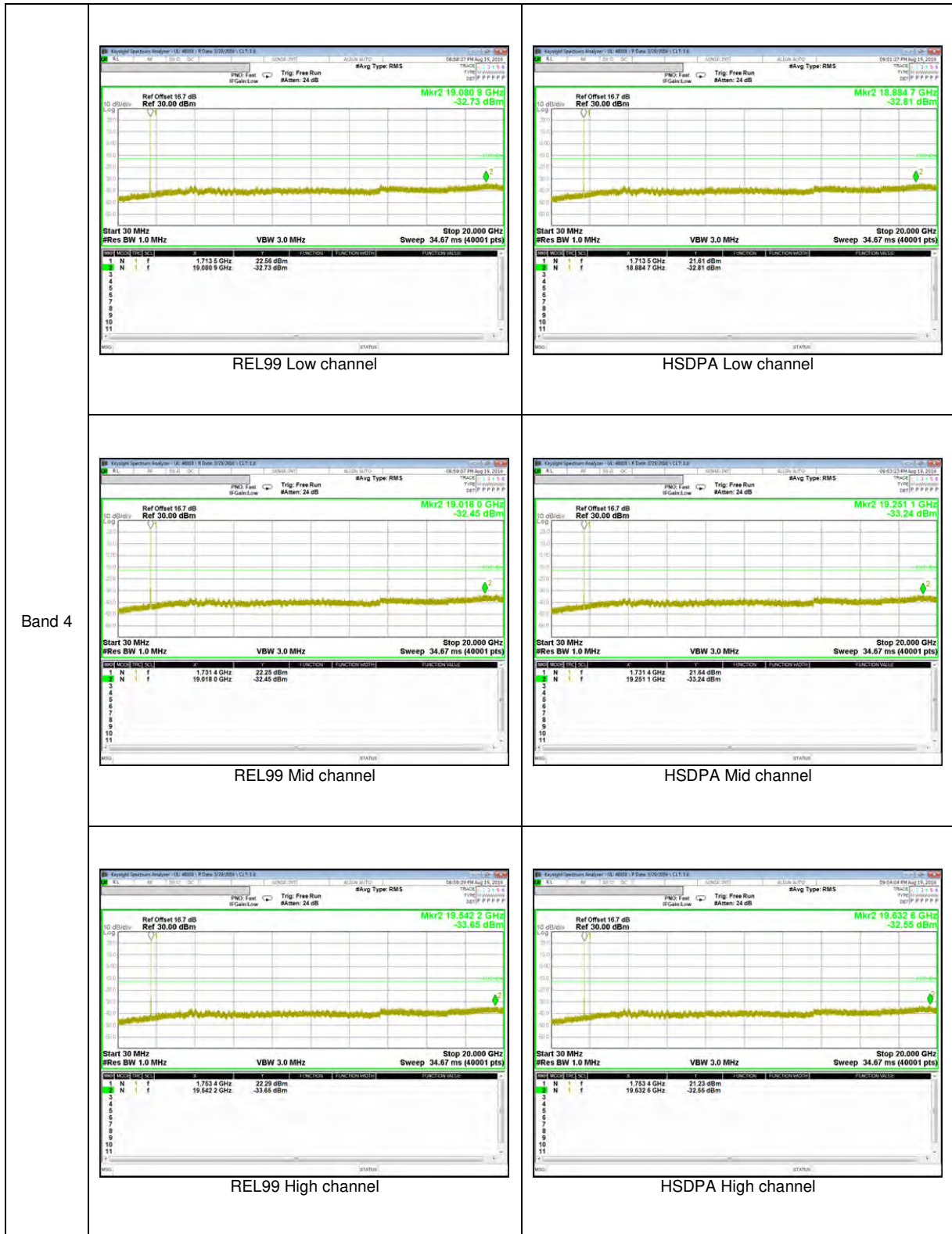

WCDMA Band 2

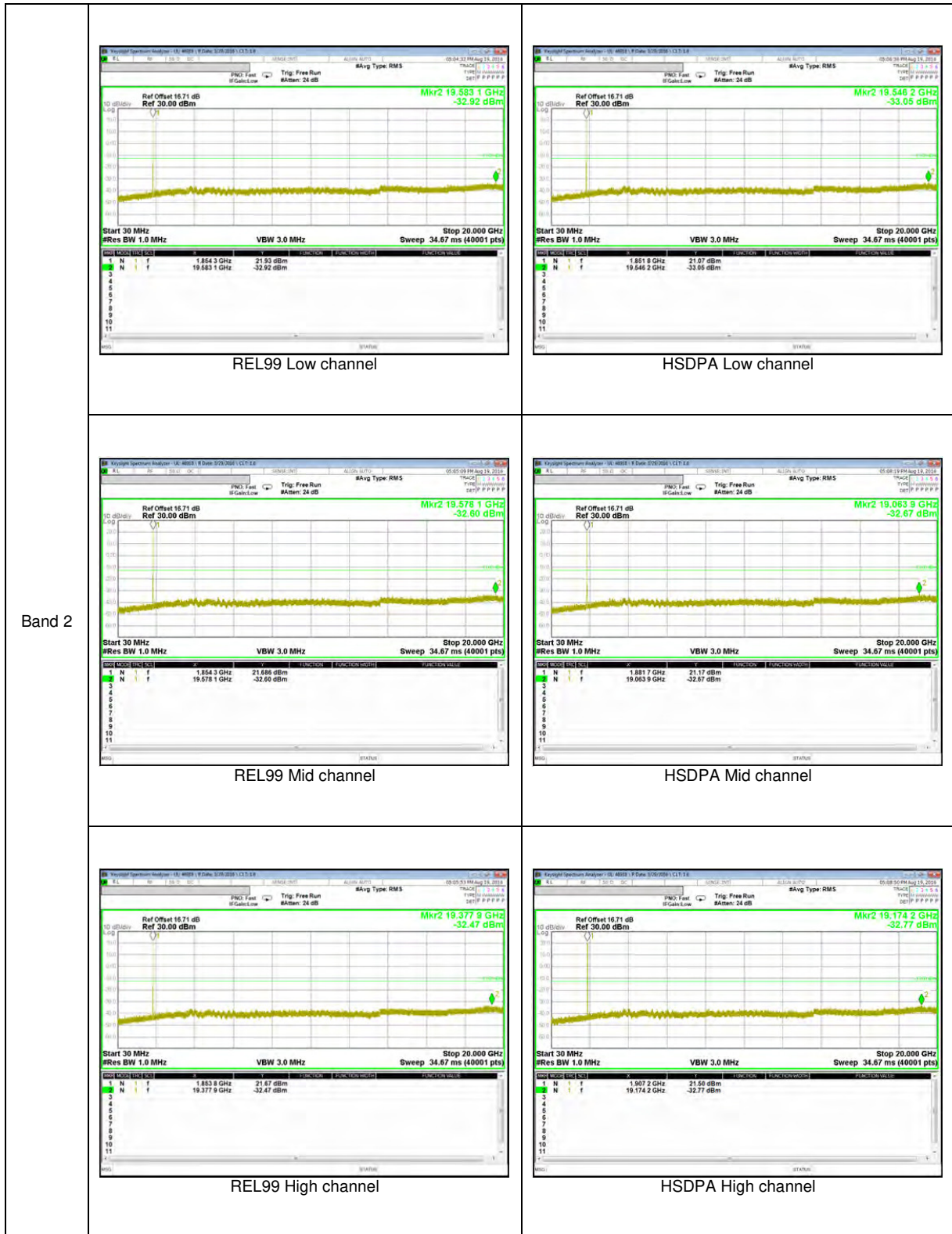

LTE Band 5

