

7.3. Spurious Emissions at Antenna Terminal

Test setup

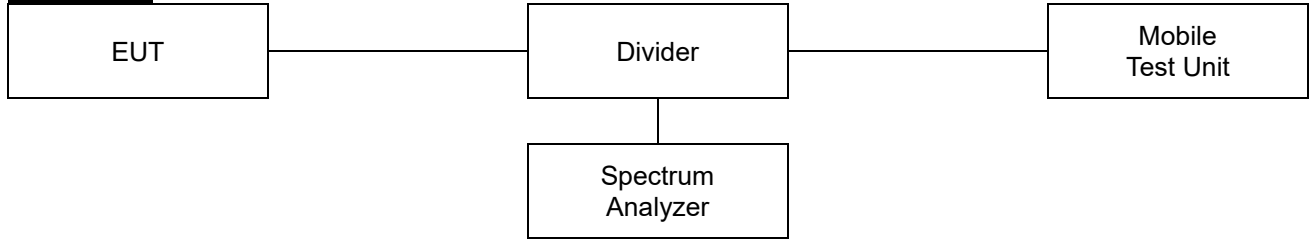

Limit

According to §22.917(a), §24.238(a), the power of any emission outside of the authorized operating frequency ranges must be attenuated below the transmitting power (P) by a factor of at least $43 + 10\log(P)$ dB.

According to §27.53(h), the power of any emission outside a licensee's frequency block shall be attenuated below the transmitter power (P) in watts by at least $43 + 10\log(P_{\text{[Watts]}})$ dB.

Test procedure

971168 D01 v03r01 - Section 6
ANSI 63.26-2015 – Section 5.7

Test settings

- 1) Start frequency was set to 30 MHz and stop frequency was set to at least 10th the fundamental frequency.
- 2) Detector = RMS
- 3) Sweep time = auto couple.
- 4) Trace mode = trace average
- 5) Allow trace to fully stabilize.
- 6) Please see test notes below RBW and VBW settings.

Notes:

1. Per 22.917(b), 24.238(b), 27.53(h)(3), compliance with these provisions is based on the use of measurement instrumentation employing a resolution bandwidth of 100 kHz or greater for frequencies less than 1 GHz and 1 MHz or greater for frequencies greater than 1 GHz.
The emission bandwidth is defined as the width of the signal between two points, one below the carrier center frequency and one above the carrier center frequency, outside of which all emissions are attenuated at least 26 dB below the transmitter power.

KCTL Inc.

65, Sinwon-ro, Yeongtong-gu,
Suwon-si, Gyeonggi-do, 16677, Korea
TEL: 82-31-285-0894 FAX: 82-505-299-8311
www.kctl.co.kr

Report No.:
KR22-SRF0054-A
Page (28) of (63)



Test results

Test mode: GSM 850

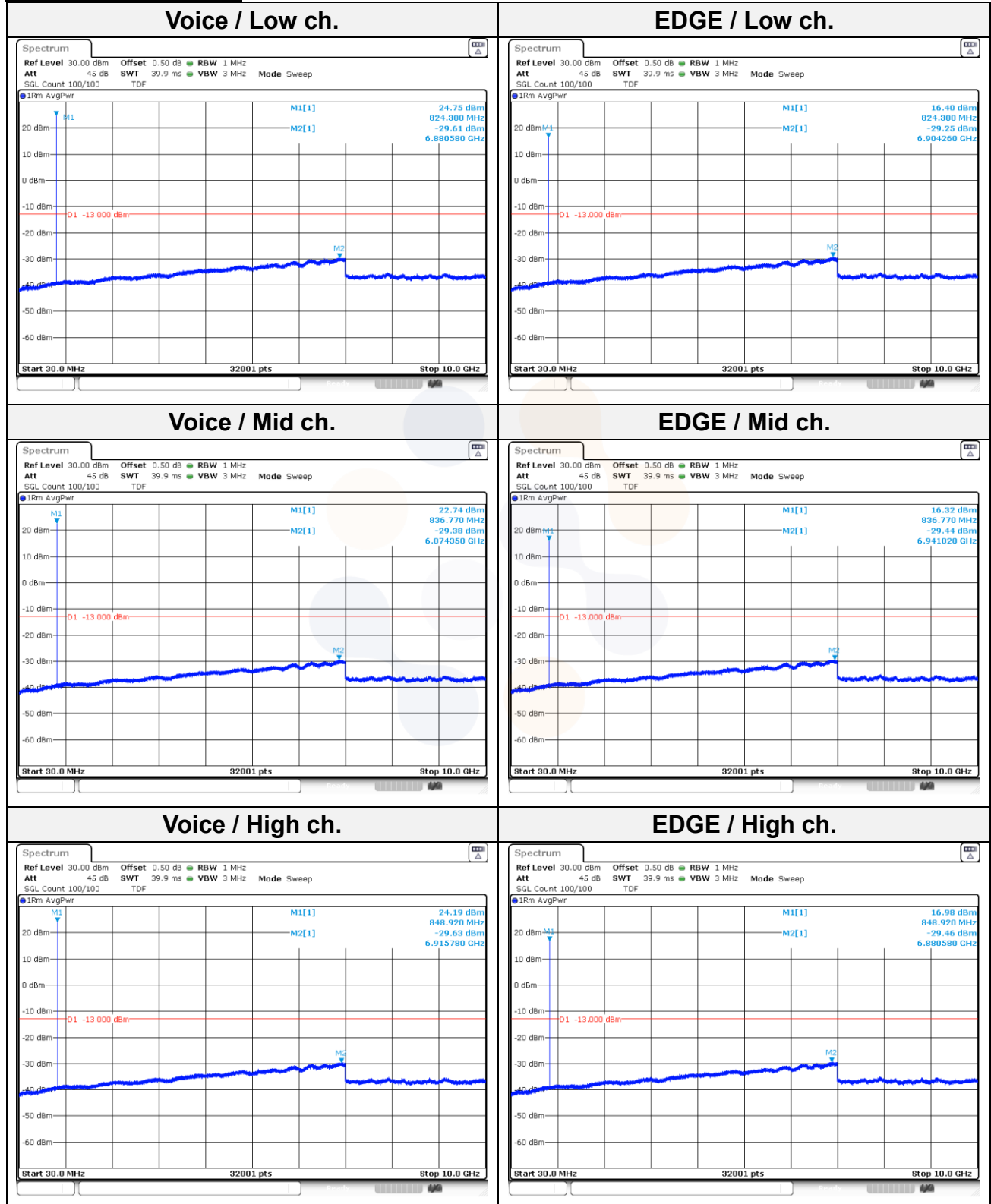

KCTL Inc.

65, Sinwon-ro, Yeongtong-gu,
Suwon-si, Gyeonggi-do, 16677, Korea
TEL: 82-31-285-0894 FAX: 82-505-299-8311
www.kctl.co.kr

Report No.:
KR22-SRF0054-A
Page (29) of (63)



Test mode: GSM 1900

Voice / Low ch.

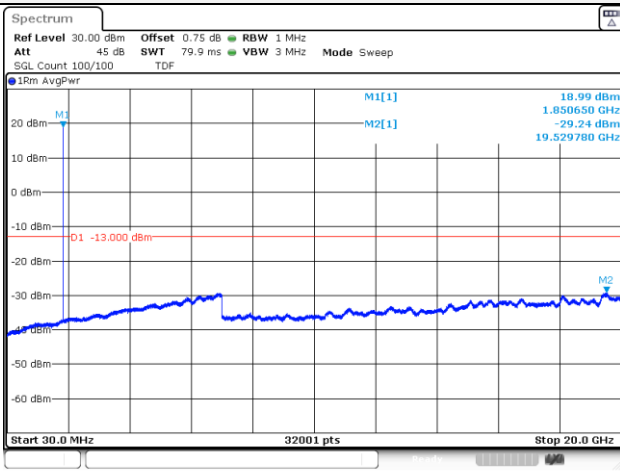

EDGE / Low ch.

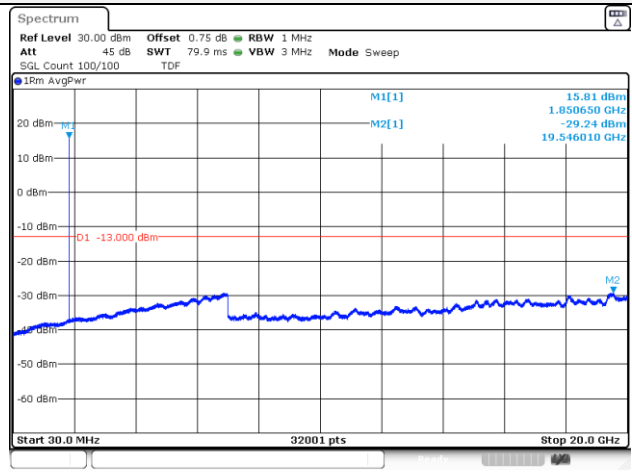

Voice / Mid ch.



EDGE / Mid ch.

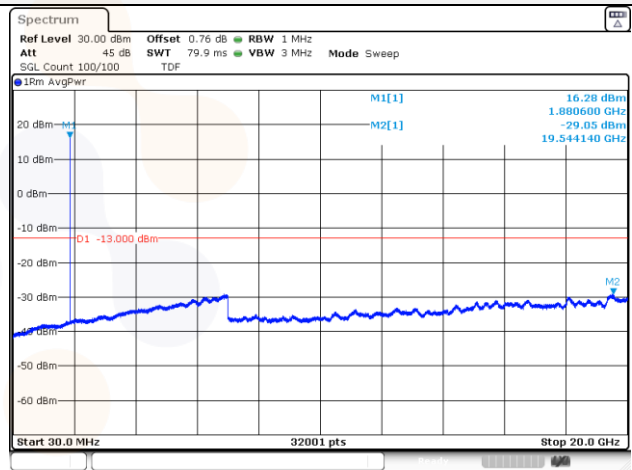

Voice / High ch.

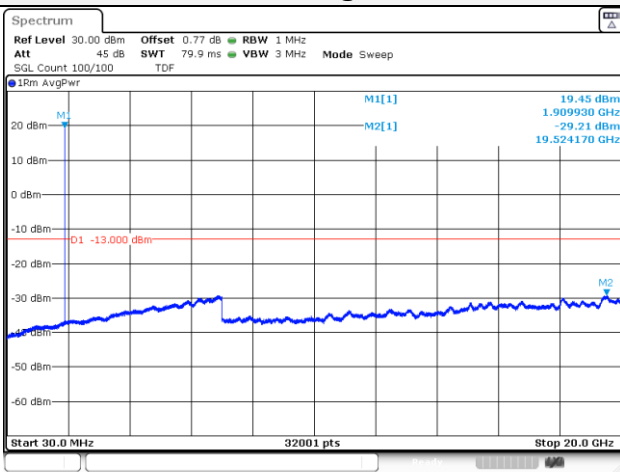

EDGE / High ch.

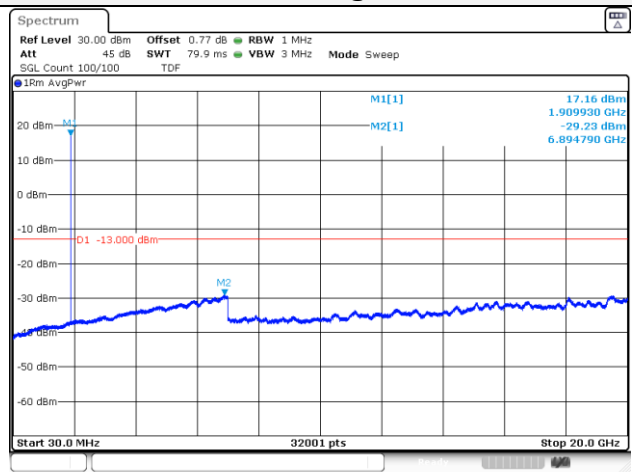

KCTL Inc.

65, Sinwon-ro, Yeongtong-gu,
Suwon-si, Gyeonggi-do, 16677, Korea
TEL: 82-31-285-0894 FAX: 82-505-299-8311
www.kctl.co.kr

Report No.:
KR22-SRF0054-A
Page (30) of (63)



Test mode: WCDMA 850

RMC / Low ch.

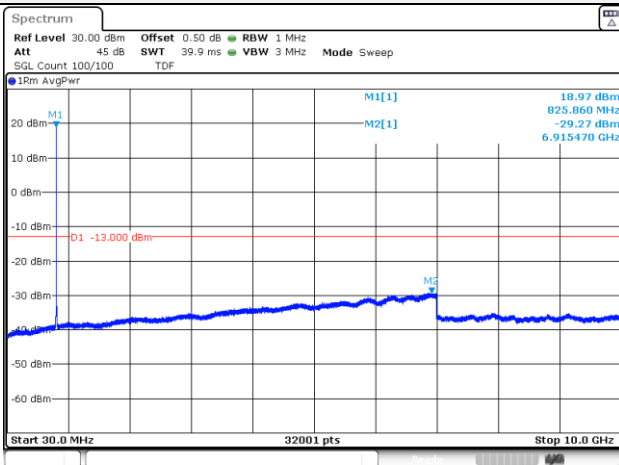

RMC / Mid ch.

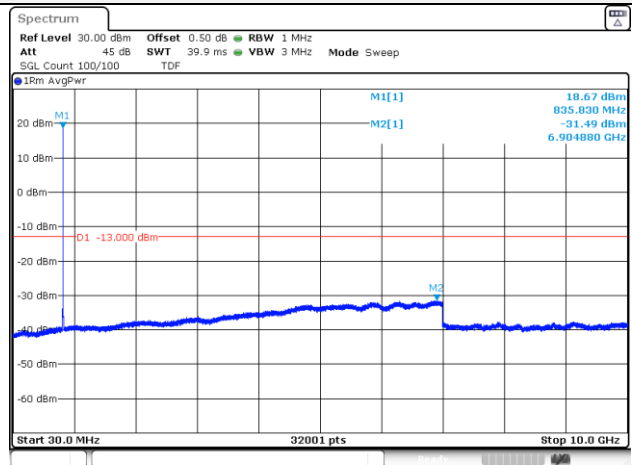

RMC / High ch.

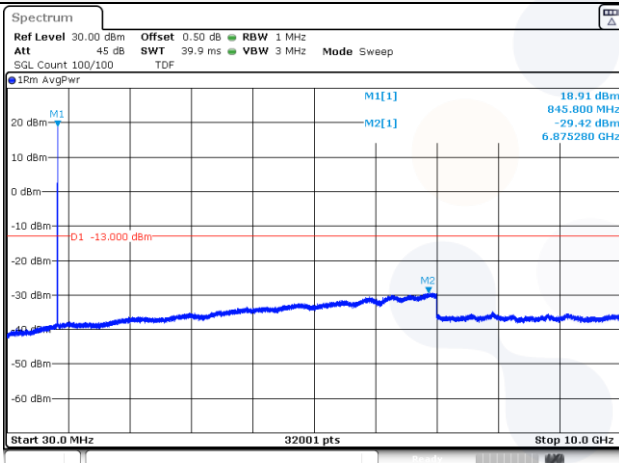

Blank

KCTL Inc.

65, Sinwon-ro, Yeongtong-gu,
Suwon-si, Gyeonggi-do, 16677, Korea
TEL: 82-31-285-0894 FAX: 82-505-299-8311
www.kctl.co.kr

Report No.:
KR22-SRF0054-A
Page (31) of (63)



Test mode: WCDMA 1700

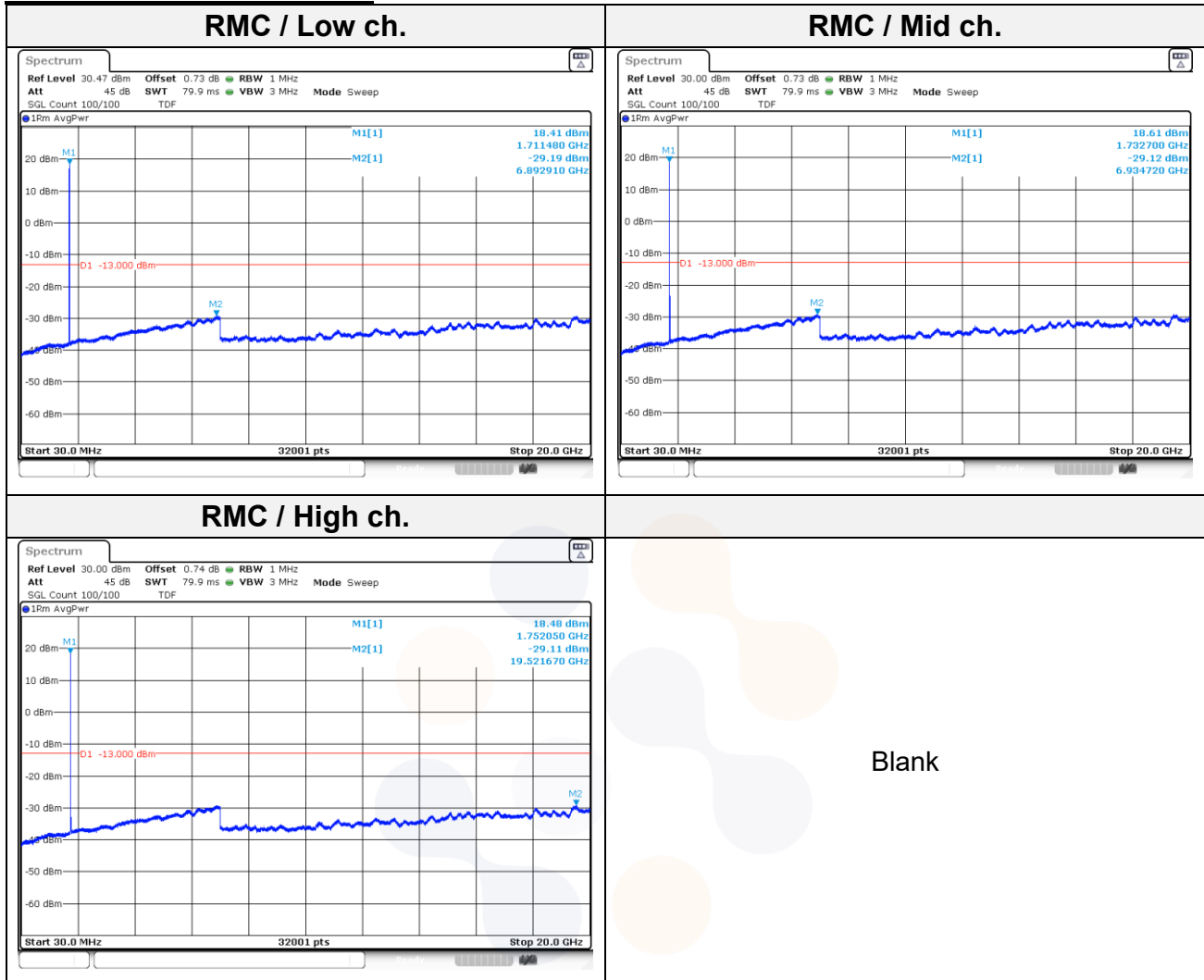

KCTL Inc.

65, Sinwon-ro, Yeongtong-gu,
Suwon-si, Gyeonggi-do, 16677, Korea
TEL: 82-31-285-0894 FAX: 82-505-299-8311
www.kctl.co.kr

Report No.:
KR22-SRF0054-A
Page (32) of (63)



Test mode: WCDMA 1900

RMC / Low ch.

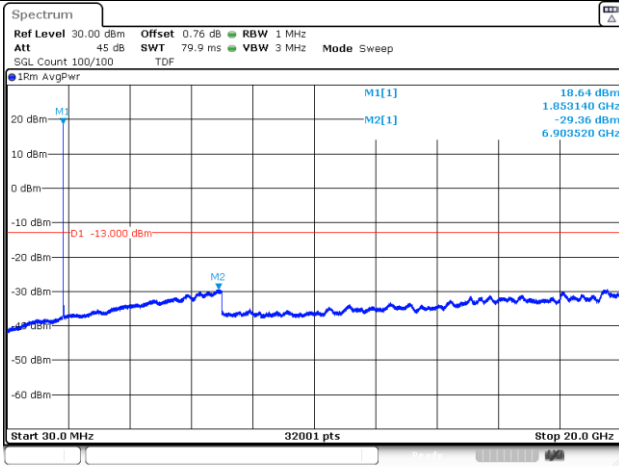

RMC / Mid ch.

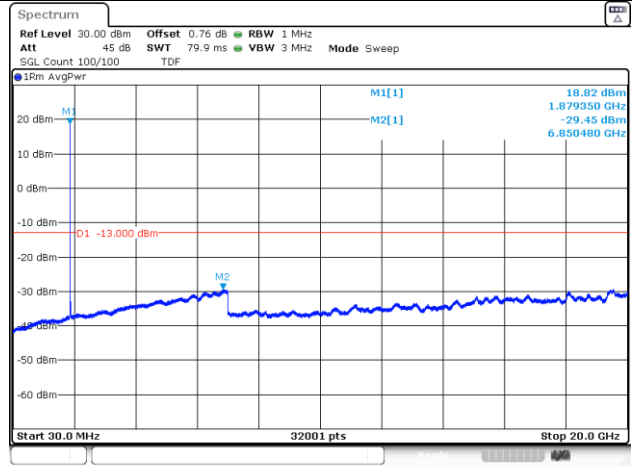

RMC / High ch.

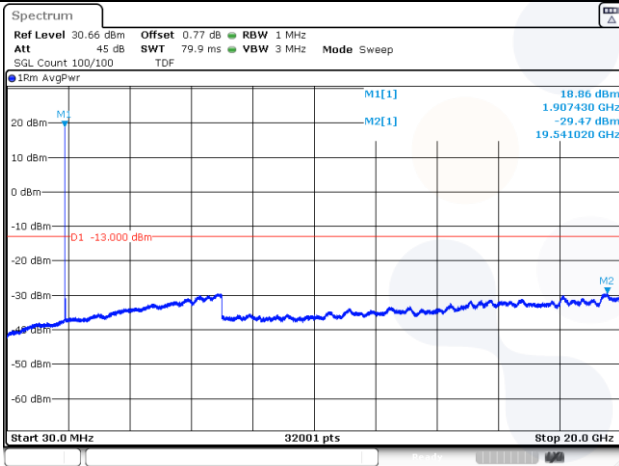

Blank

7.4. Band Edge Emissions at Antenna Terminal

Test setup

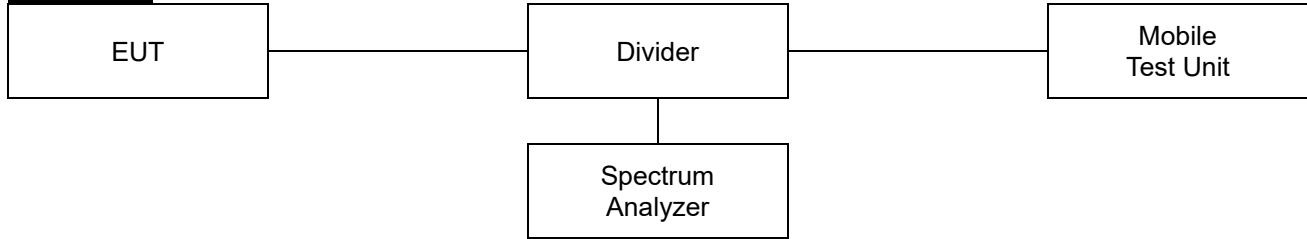

Limit

According to §22.917(a), §24.238(a), the power of any emission outside of the authorized operating frequency ranges must be attenuated below the transmitting power (P) by a factor of at least $43 + 10\log(P)$ dB.

According to §27.53(h), the power of any emission outside a licensee's frequency block shall be attenuated below the transmitter power (P) in watts by at least $43 + 10\log(P_{\text{[Watts]}})$ dB.

Test procedure

971168 D01 v03r01 - Section 6

ANSI C63.26-2015 – Section 5.7

Test settings

- 1) Start frequency was set to 30 MHz and stop frequency was set to at least 10th the fundamental frequency.
- 2) Span was set large enough so as to capture all out of band emissions near the band edge.
- 3) Set the RBW > 1% of the emission bandwidth.
- 4) Set the VBW $\geq 3 \times$ RBW.
- 5) Set the number of sweep points $\geq 2 \times$ Span/RBW
- 6) Detector = RMS
- 7) Trace mode = trace average
- 8) Sweep time should be auto for peak detection. For RMS detection the sweep time should be set as follows:
 - a) If the device can be configured to transmit continuously (duty cycle $\geq 98\%$), set the (sweep time) > (number of points in sweep) \times (symbol period) (e.g., by a factor of 10 \times symbol period \times number of points) Increasing the sweep time (i.e., slowing the sweep speed) will allow for averaging over multiple symbols.
 - b) If the device cannot transmit continuously (duty cycle < 98%), a gated sweep shall be used when possible (i.e., gate triggered such that the analyzer only sweeps when the device is transmitting at full power), set the sweep time > (number of points in sweep) \times (symbol period) but the sweep time shall always be maintained at a value that is less than or equal to the minimum transmission time
 - c) If the device cannot be configured to transmit continuously (duty cycle > 98%), and a free-running sweep must be used, set the sweep time so that the averaging is performed over multiple on/off cycles by setting the sweep time > (number of points in sweep) \times (transmitter period) (i.e., the transmit on-time + the off-time). The spectrum analyzer readings shall subsequently be corrected by

[10 log (1/duty cycle)]. This assumes that the transmission period and duty cycle is relatively constant (duty cycle variation $\leq \pm 2\%$).

- d) If the device cannot be configured to transmit continuously and a free-running sweep must be used, and if the transmissions exhibit a non-constant duty cycle (duty cycle variations $> \pm 2\%$), set the sweep time so that the averaging is performed over the on-period by setting the sweep time $>$ (symbol period) \times (number of points), while also maintaining the sweep time $<$ (transmitter on-time). The trace mode shall be set to max hold, since not every display point will be averaged only over just the on-time. Thus, multiple sweeps (e.g., 100) in maximum hold are necessary to ensure that the maximum power is measured.
- 9) Allow trace to fully stabilize.

Notes:

1. Per 22.917(b), 24.238(b), 24.53(h)(3), compliance with these rules is based on the use of measurement instrumentation employing a resolution bandwidth of 1 MHz or greater. However in the 1 MHz bands immediately outside and adjacent to the frequency block a resolution bandwidth of at least one percent of the emission bandwidth of the fundamental emission of the transmitter may be employed. The emission bandwidth is defined as the width of the signal between two points, one below the carrier center frequency and one above the carrier center frequency, outside of which all emissions are attenuated at least 26 dB below the transmitter power.

KCTL Inc.

65, Sinwon-ro, Yeongtong-gu,
Suwon-si, Gyeonggi-do, 16677, Korea
TEL: 82-31-285-0894 FAX: 82-505-299-8311
www.kctl.co.kr

Report No.:
KR22-SRF0054-A
Page (35) of (63)



Test results

Test mode: GSM 850

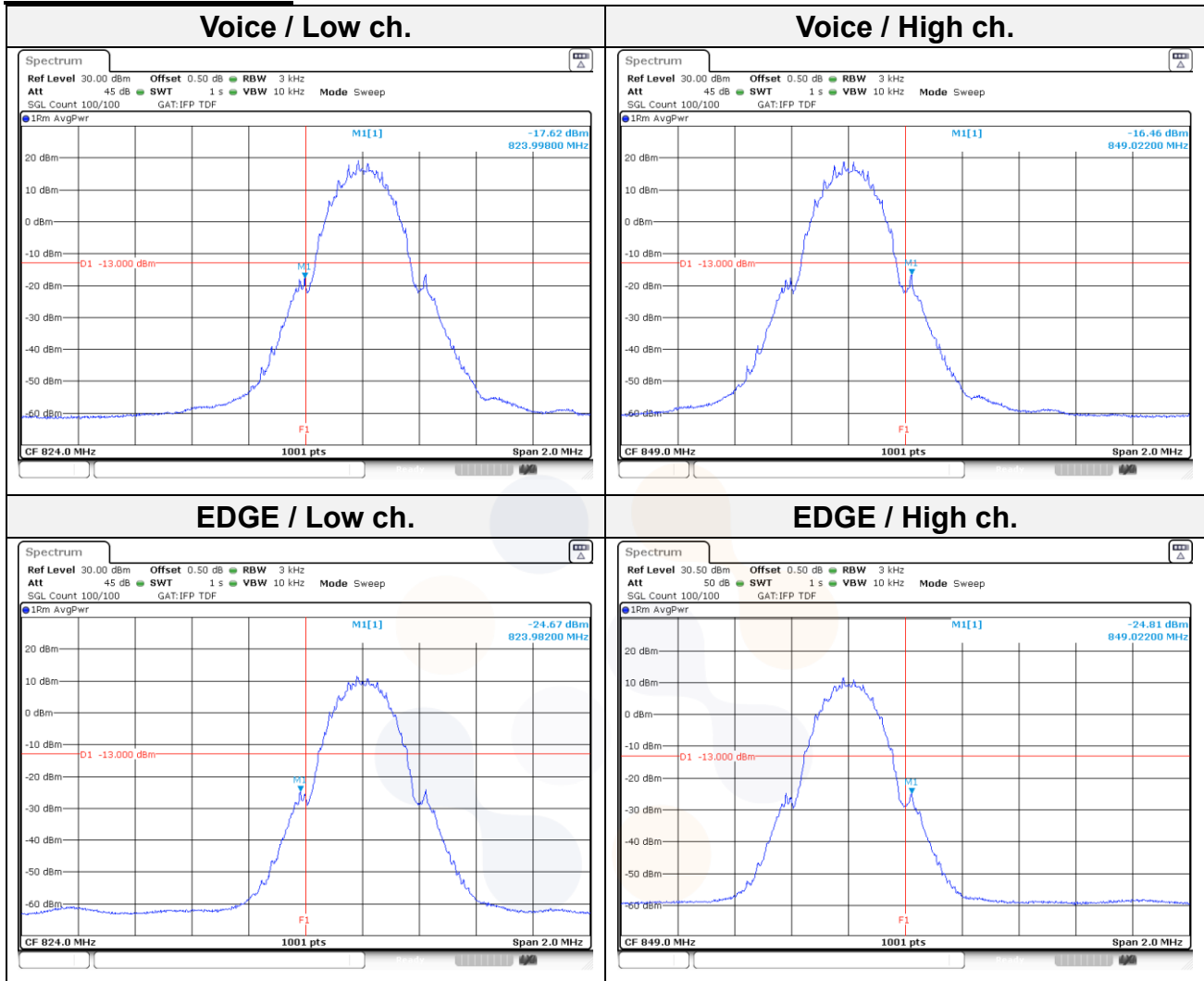

KCTL Inc.

65, Sinwon-ro, Yeongtong-gu,
Suwon-si, Gyeonggi-do, 16677, Korea
TEL: 82-31-285-0894 FAX: 82-505-299-8311
www.kctl.co.kr

Report No.:
KR22-SRF0054-A
Page (36) of (63)



Test mode: GSM 1900

Voice / Low ch.

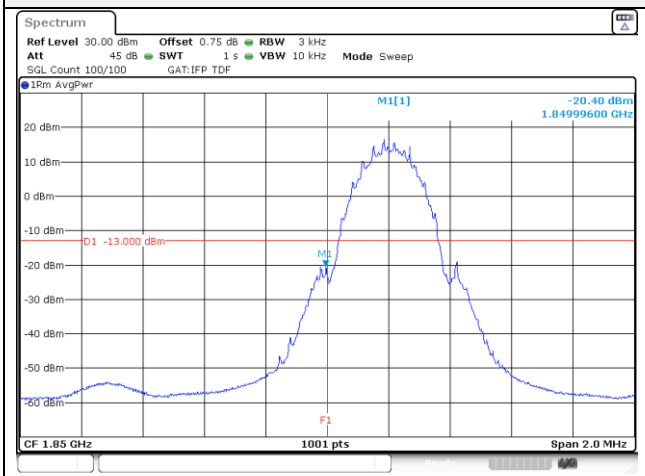

Voice / High ch.

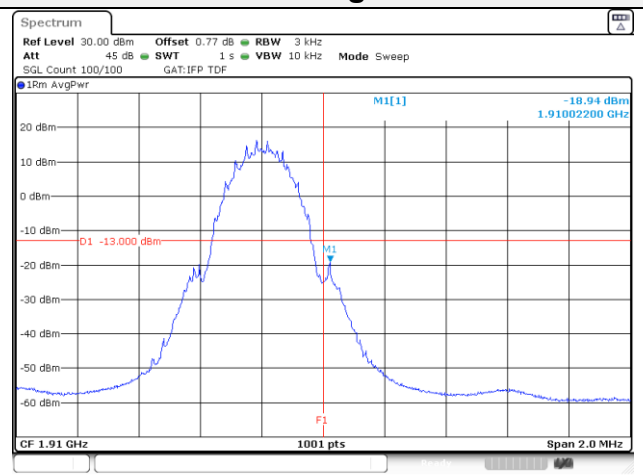

EDGE / Low ch.



EDGE / High ch.

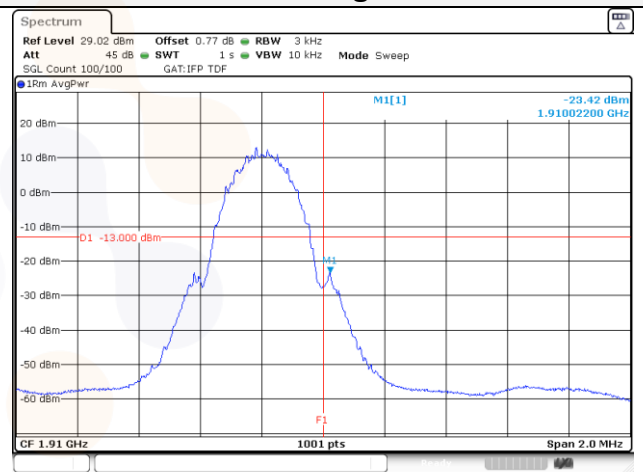

KCTL Inc.

65, Sinwon-ro, Yeongtong-gu,
Suwon-si, Gyeonggi-do, 16677, Korea
TEL: 82-31-285-0894 FAX: 82-505-299-8311
www.kctl.co.kr

Report No.:
KR22-SRF0054-A
Page (37) of (63)



Test mode: WCDMA 850

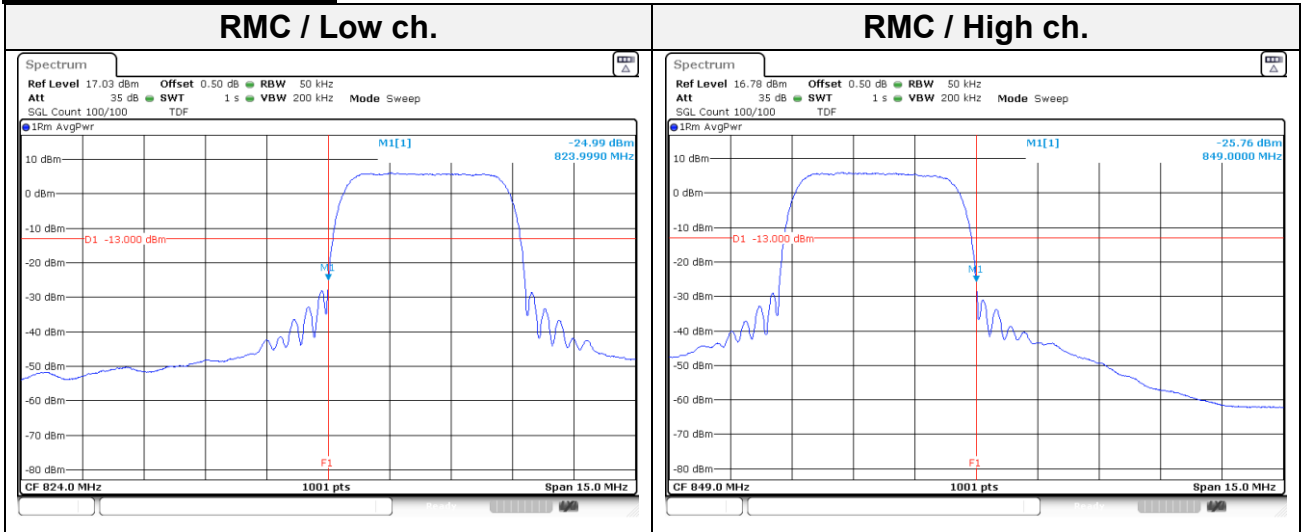

Test mode: WCDMA 1700

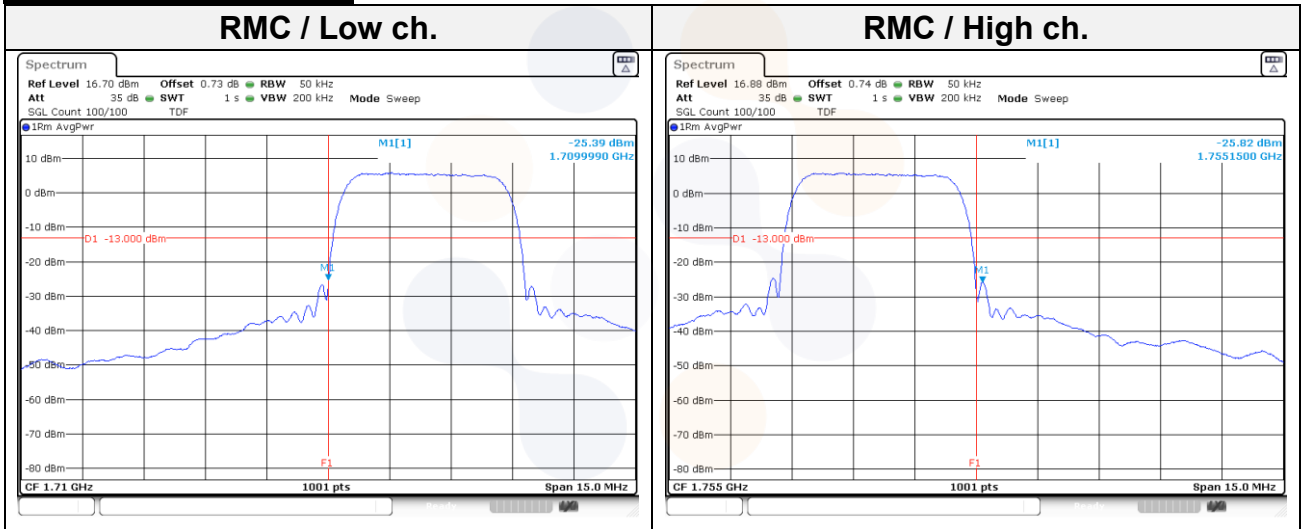

Test mode: WCDMA 1900

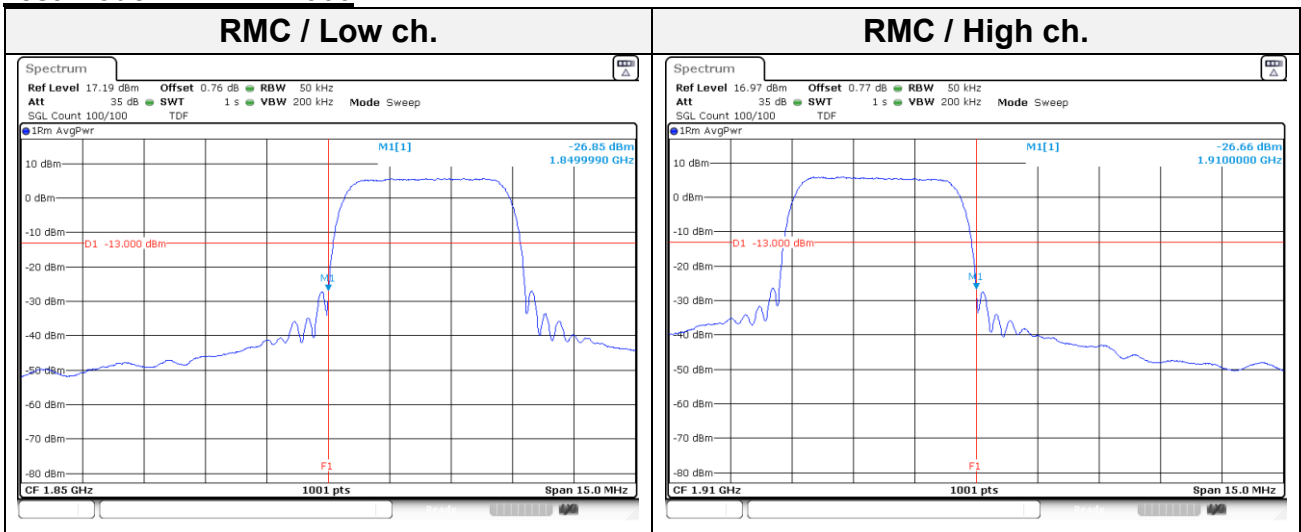

7.5. Peak to Average Power Ratio (PAPR)

Test setup

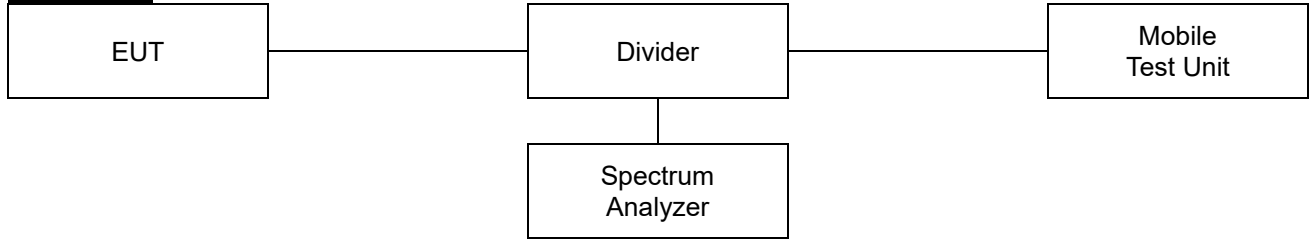

Limit

According to §24.232(d), §27.50(d)(5), the peak-to-average ratio(PAR) of the transmission must not exceed 13 dB.

Test procedure

971168 D01 v03r01 - Section 5.7.2 or 5.7.3

971168 D02 v02r01 – Section VII

ANSI 63.26-2015 – Section 5.2.3.4 or 5.2.6

Test settings

5.2.3.4 Measurement of peak power in a broadband noise-like signal using CCDF

- 1) Set resolution/measurement bandwidth \geq OBW or specified reference bandwidth
- 2) Set the number of counts to a value that stabilizes the measured CCDF curve.
- 3) Set the measurement interval as follows:
 - a) For continuous transmissions, set to the greater of $[10 \times (\text{number of points in sweep}) \times (\text{transmission symbol period})]$ or 1 ms.
 - b) For burst transmissions, employ an external trigger that is synchronized with the EUT burst timing sequence, or use the internal burst trigger with a trigger level that allows the burst to stabilize. Set the measurement interval to a time that is less than or equal to the burst duration.
 - c) If there are several carriers in a single antenna port, the peak power shall be determined for each individual carrier (by disabling the other carriers while measuring the required carrier) and the total peak power calculated from the sum of the individual carrier peak powers.
- 4) Record the maximum PAPR level associated with a probability of 0.1%

5.2.6 Peak-to-average power ratio

Use one of the procedures presented in 5.2(ANSI C63.26-2015) to measure the total peak power and record as P_{PK} .

Use one of the applicable procedure presented 5.2(ANSI C63.26-2015) to measure the total average power and record as P_{AG} . Determine the P.A.P.R from:

$$\text{PAPR(dB)} = P_{PK}(\text{dBm or dBW}) - P_{AG}(\text{dBm or dBW})$$

KCTL Inc.

65, Sinwon-ro, Yeongtong-gu,
Suwon-si, Gyeonggi-do, 16677, Korea
TEL: 82-31-285-0894 FAX: 82-505-299-8311
www.kctl.co.kr

Report No.:
KR22-SRF0054-A
Page (39) of (63)



Test results

Test mode: GSM 850

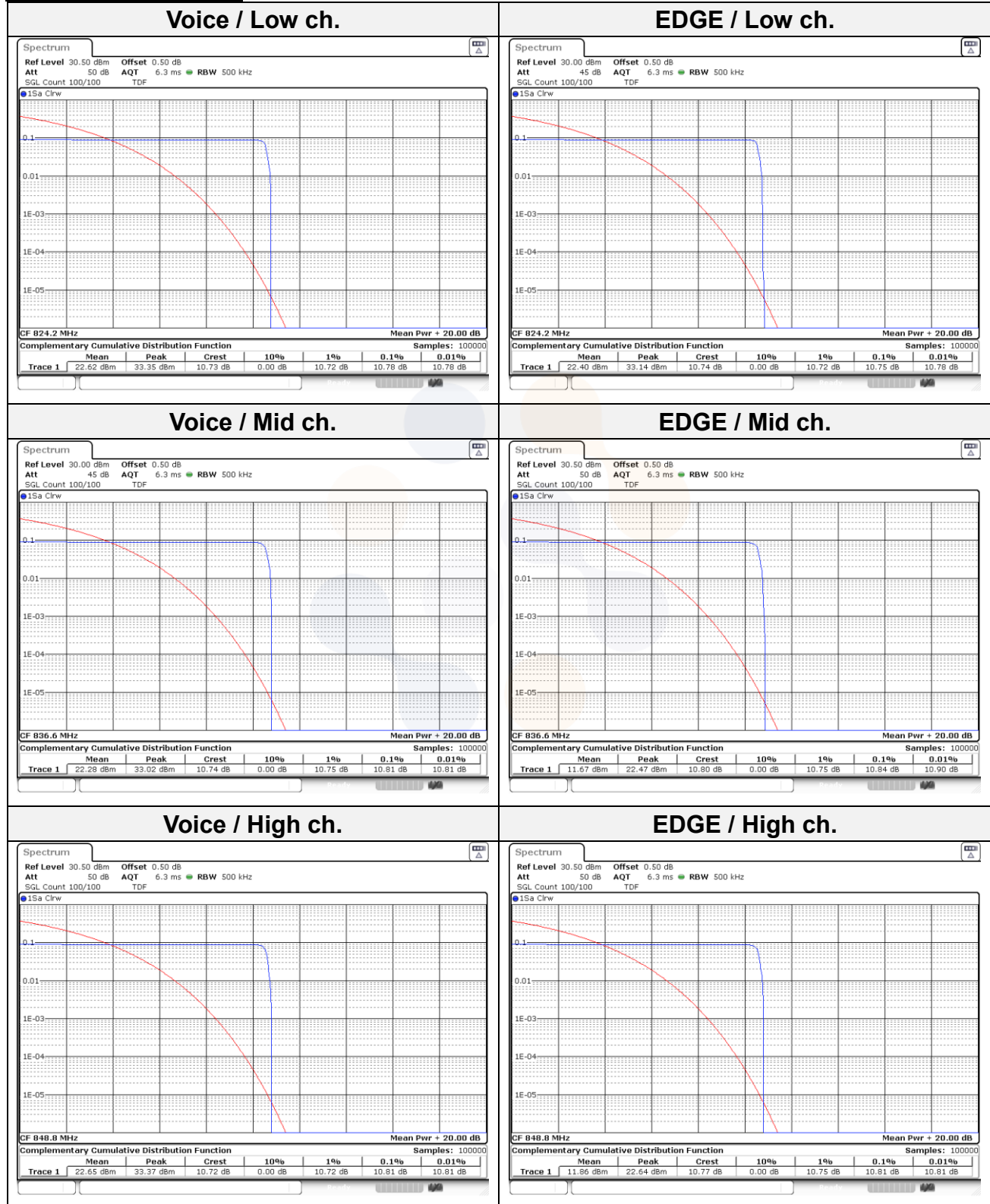

KCTL Inc.

65, Sinwon-ro, Yeongtong-gu,
Suwon-si, Gyeonggi-do, 16677, Korea
TEL: 82-31-285-0894 FAX: 82-505-299-8311
www.kctl.co.kr

Report No.:
KR22-SRF0054-A
Page (40) of (63)



Test mode: GSM 1900

Voice / Low ch.

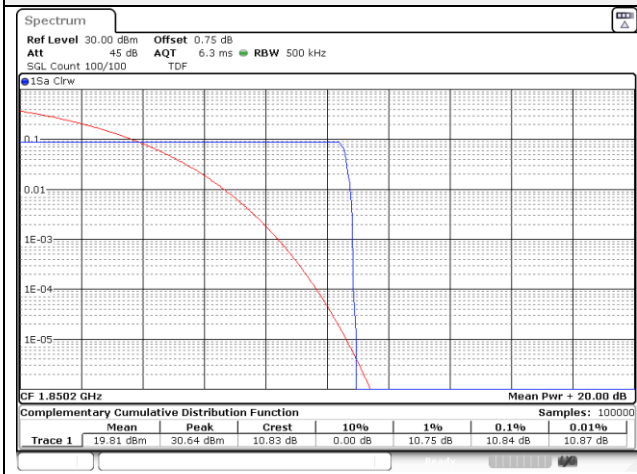

EDGE / Low ch.

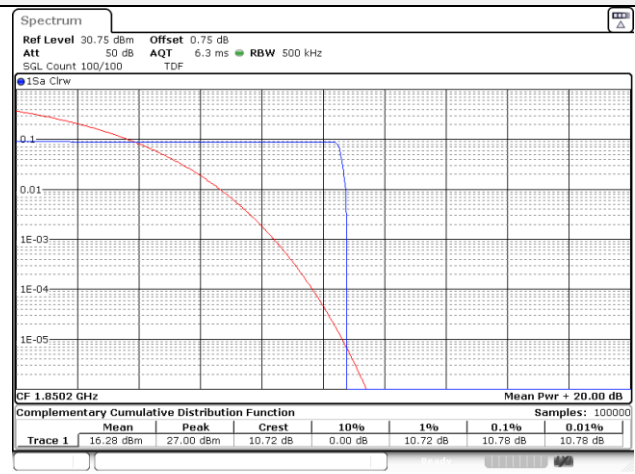

Voice / Mid ch.

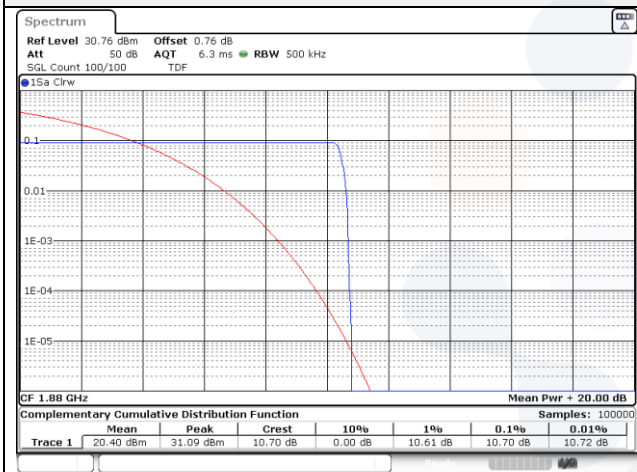

EDGE / Mid ch.

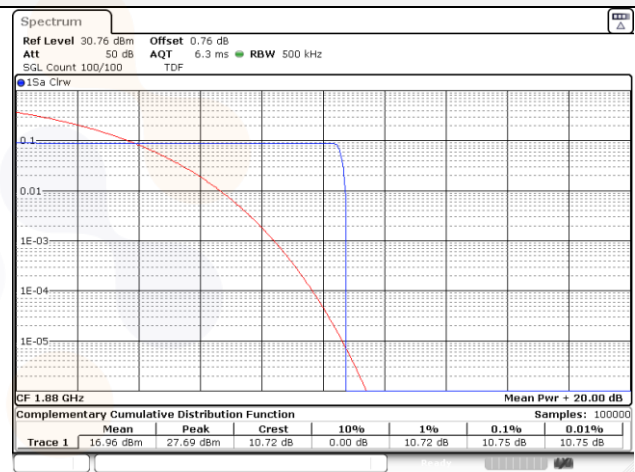

Voice / High ch.

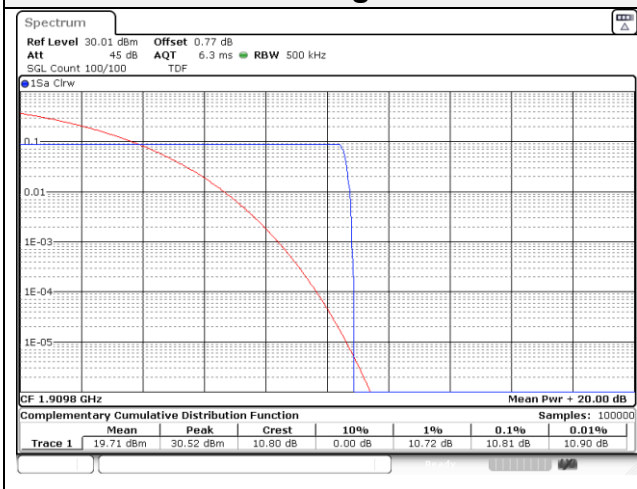

EDGE / High ch.

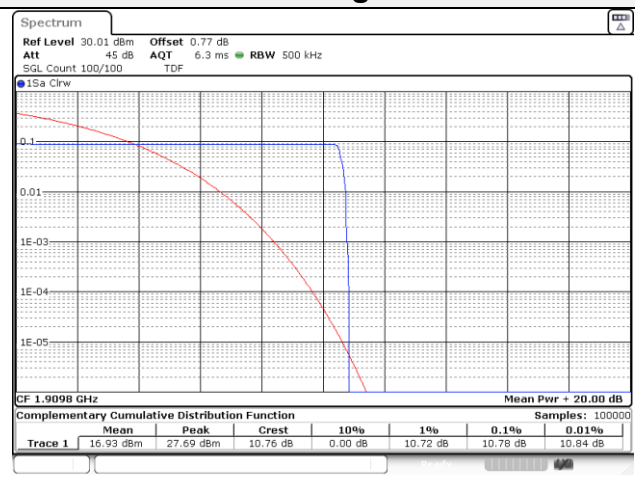

KCTL Inc.

65, Sinwon-ro, Yeongtong-gu,
Suwon-si, Gyeonggi-do, 16677, Korea
TEL: 82-31-285-0894 FAX: 82-505-299-8311
www.kctl.co.kr

Report No.:
KR22-SRF0054-A
Page (41) of (63)



Test mode: WCDMA 850

RMC / Low ch.

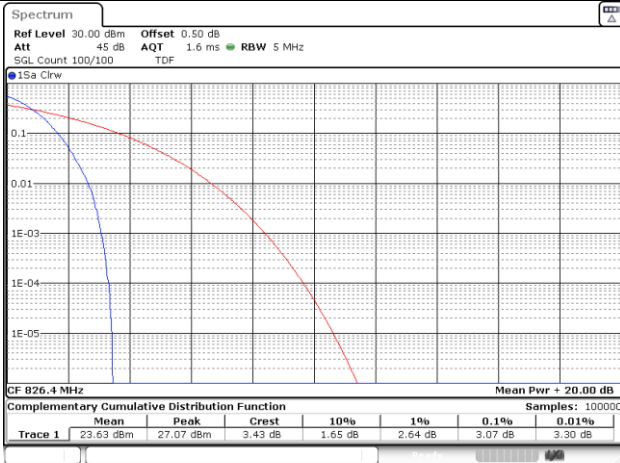

RMC / Mid ch.

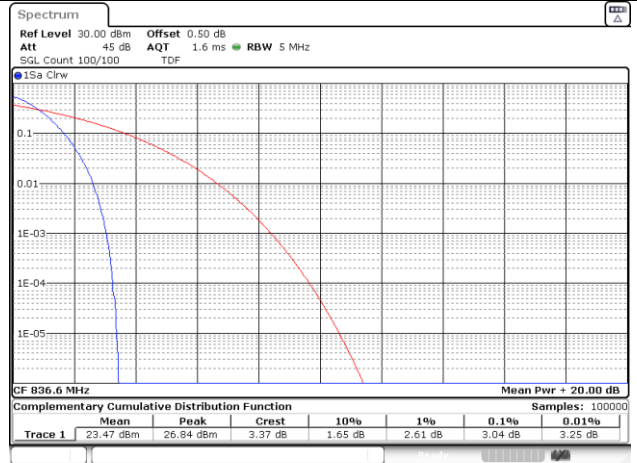

RMC / High ch.

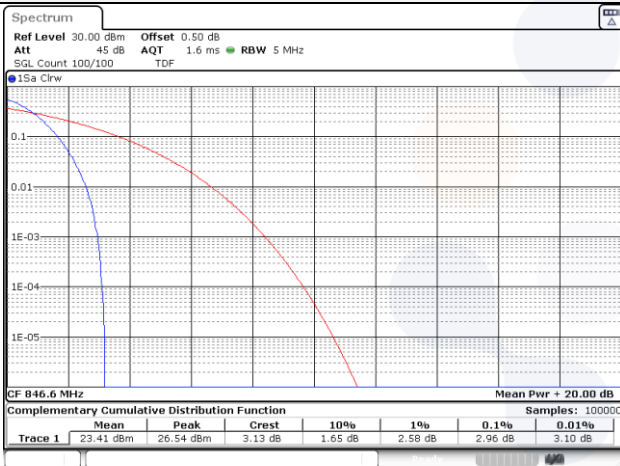

Blank

KCTL Inc.

65, Sinwon-ro, Yeongtong-gu,
Suwon-si, Gyeonggi-do, 16677, Korea
TEL: 82-31-285-0894 FAX: 82-505-299-8311
www.kctl.co.kr

Report No.:
KR22-SRF0054-A
Page (42) of (63)



Test mode: WCDMA 1700

RMC / Low ch.

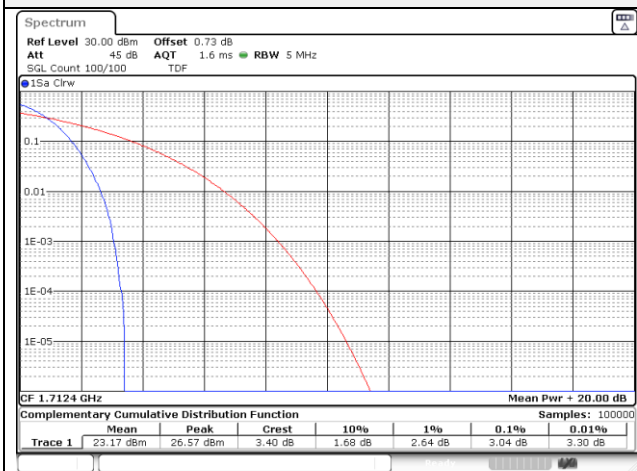

RMC / Mid ch.

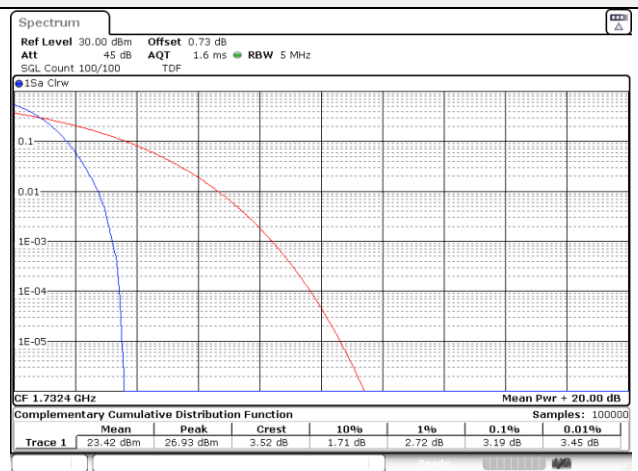

RMC / High ch.

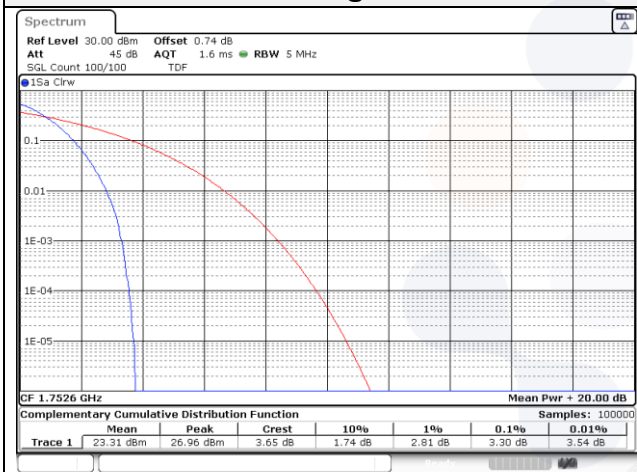

Blank

KCTL Inc.

65, Sinwon-ro, Yeongtong-gu,
Suwon-si, Gyeonggi-do, 16677, Korea
TEL: 82-31-285-0894 FAX: 82-505-299-8311
www.kctl.co.kr

Report No.:
KR22-SRF0054-A
Page (43) of (63)



Test mode: WCDMA 1900

RMC / Low ch.

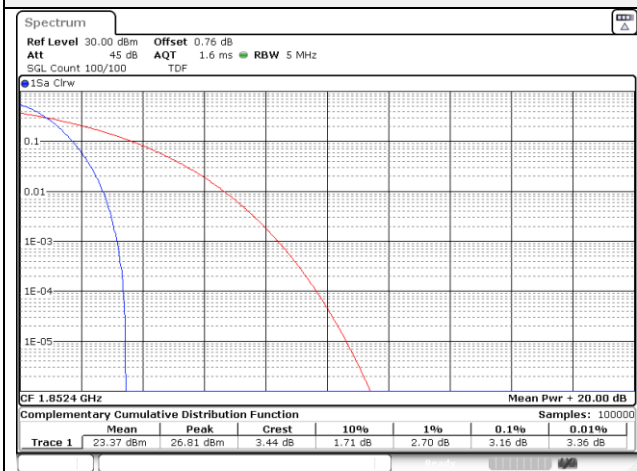

RMC / Mid ch.

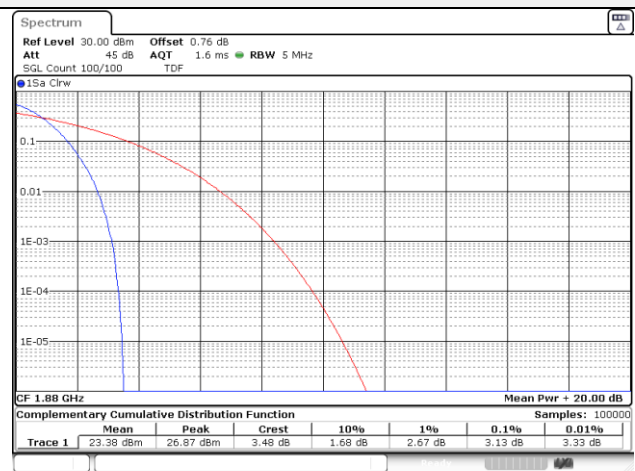

RMC / High ch.

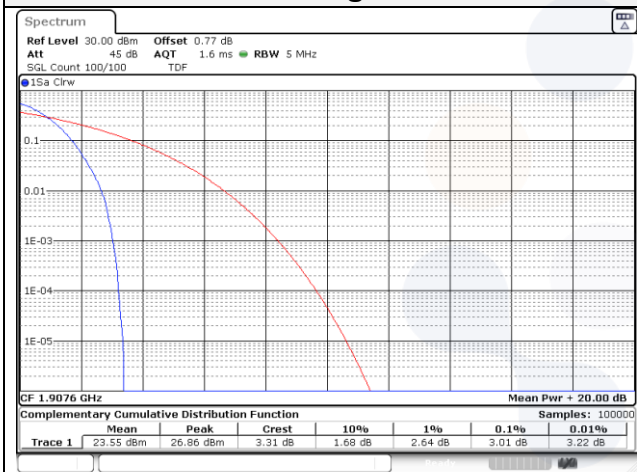

Blank

7.6. Frequency stability

Test setup

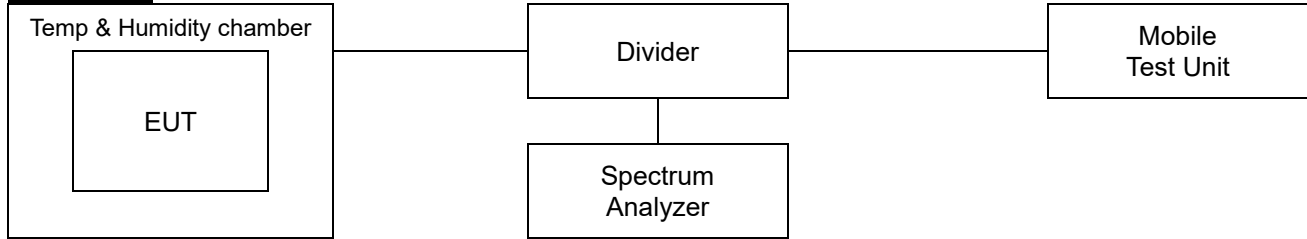

Limit

According to §2.1055(a),

The frequency stability shall be measured with variation of ambient temperature as follows:

- 1) From -30° to $+50^{\circ}$ centigrade for all equipment except that specified in paragraphs (a) (2) and (3) of this section.
- 2) From -20° to $+50^{\circ}$ centigrade for equipment to be licensed for use in the maritime services under part 80 of this chapter, except for class A, B, and S emergency position indicating radiobeacons (EPIRBS), and equipment to be licensed for use above 952 MHz at operational fixed stations in all services, stations in the local television transmission service and point-to-point microwave radio service under part 21 of this chapter, equipment licensed for use aboard aircraft in the aviation services under part 87 of this chapter, and equipment authorized for use in the family radio service under part 95 of this chapter.
- 3) From 0° to $+50^{\circ}$ centigrade for equipment to be licensed for use in the radio broadcast Services under part 73 of this chapter.

According to §2.1055(d),

The frequency stability shall be measured with variation of primary supply Voltage as follows:

- 1) Vary primary supply voltage from 85 to 115 percent of the nominal value for other than hand carried battery equipment.
- 2) For hand carried, battery powered equipment, reduce primary supply voltage to the battery operating and point which shall be specified by the manufacturer.
- 3) The supply voltage shall be measured at the input to the cable normally provided with the equipment, or at the power supply terminals if cables are not normally provided. Effects on frequency of transmitter keying (except for broadcast transmitters) and any heating element cycling at the nominal supply voltage and at each extreme also shall be shown.

According to §22.355,

The carrier frequency of each transmitter in the public mobile services must be maintained within the tolerances given in Table of this section.

For mobile devices operating in the 824 to 849 MHz band at a power level than or equal to 3 Watts, the limit specified in Table C-1 is ± 2.5 ppm.

According to §24.235,

The frequency stability shall be sufficient to ensure that the fundamental emission stays within the authorized frequency block.

The carrier frequency shall not depart from the reference frequency, in excess of ± 2.5 ppm for mobile stations and ± 1.0 ppm for base stations.

KCTL Inc.

65, Sinwon-ro, Yeongtong-gu,
Suwon-si, Gyeonggi-do, 16677, Korea
TEL: 82-31-285-0894 FAX: 82-505-299-8311
www.kctl.co.kr

Report No.:
KR22-SRF0054-A
Page (45) of (63)



According to §27.54,

The frequency stability shall be sufficient to ensure that the fundamental emissions stay within the Authorized bands of operation.

Test procedure

ANSI 63.26-2015 – Section 5.6

Test settings

- 1) The carrier frequency of the transmitter is measured at room temperature.
(20°C to provide a reference)
- 2) The equipment is turned on in a “standby” condition for one minute before applying power to the transmitter. Measurement of the carrier frequency of the transmitter is made within one minute after applying power to the transmitter.
- 3) Frequency measurements are made at 10°C intervals ranging from -30°C to +50°C.
A period of at least one half-hour is provided to allow stabilization of the equipment at each Temperature level.



KCTL Inc.

65, Sinwon-ro, Yeongtong-gu,
Suwon-si, Gyeonggi-do, 16677, Korea
TEL: 82-31-285-0894 FAX: 82-505-299-8311
www.kctl.co.kr

Report No.:
KR22-SRF0054-A
Page (46) of (63)



Test results

Test mode : GSM 850
Frequency (Hz) : 836 600 000
Channel : 190
Deviation limit : ±0.00025% or 2.5ppm

Voltage (%)	Power (V)	Temp. (°C)	Frequency (Hz)	Frequency error (Hz)	Deviation	
					(ppm)	(%)
100%	3.85	+22(Ref)	836,600,003	3.36	0.0	0.000000
		-30	836,599,996	-4.42	0.0	-0.000001
		-20	836,599,996	-3.71	0.0	0.000000
		-10	836,599,997	-2.86	0.0	0.000000
		0	836,599,999	-1.39	0.0	0.000000
		+10	836,599,999	-0.61	0.0	0.000000
		+20	836,600,001	1.01	0.0	0.000000
		+30	836,600,004	3.55	0.0	0.000000
		+40	836,600,006	5.91	0.0	0.000001
		+50	836,600,010	9.94	0.0	0.000001
115%	4.43	+22	836,600,003	2.71	0.0	0.000000
End point	3.65	+22	836,600,003	3.03	0.0	0.000000

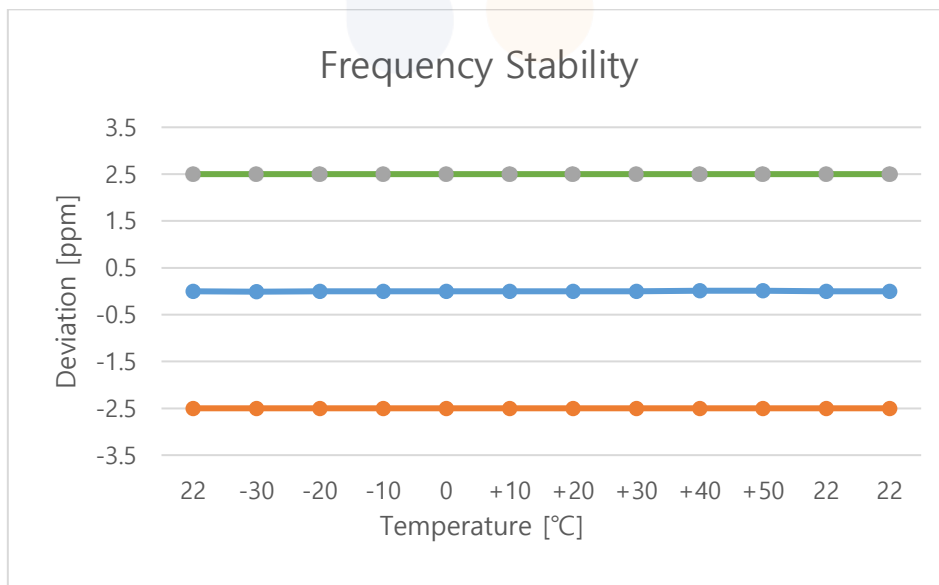

KCTL Inc.

65, Sinwon-ro, Yeongtong-gu,
Suwon-si, Gyeonggi-do, 16677, Korea
TEL: 82-31-285-0894 FAX: 82-505-299-8311
www.kctl.co.kr

Report No.:
KR22-SRF0054-A
Page (47) of (63)



Test mode : GSM 1900
 Frequency (Hz) : 1 880 000 000
 Channel : 661
 Deviation limit : The frequency stability shall be sufficient to ensure that the fundamental emission stays within the authorized frequency block.

Voltage (%)	Power (V)	Temp. (°C)	Frequency (Hz)	Frequency error (Hz)	Deviation	
					(ppm)	(%)
100%	3.85	+22(Ref)	1,879,999,997	2.87	0.0	0.000000
		-30	1,880,000,008	-7.70	0.0	0.000000
		-20	1,880,000,005	-5.18	0.0	0.000000
		-10	1,880,000,002	-2.13	0.0	0.000000
		0	1,880,000,002	-2.16	0.0	0.000000
		+10	1,880,000,001	-1.35	0.0	0.000000
		+20	1,880,000,001	-0.78	0.0	0.000000
		+30	1,880,000,009	-8.78	0.0	0.000000
		+40	1,880,000,006	-6.13	0.0	0.000000
		+50	1,880,000,012	-12.37	0.0	0.000001
115%	4.43	+22	1,879,999,997	3.07	0.0	0.000000
End point	3.65	+22	1,879,999,998	2.36	0.0	0.000000

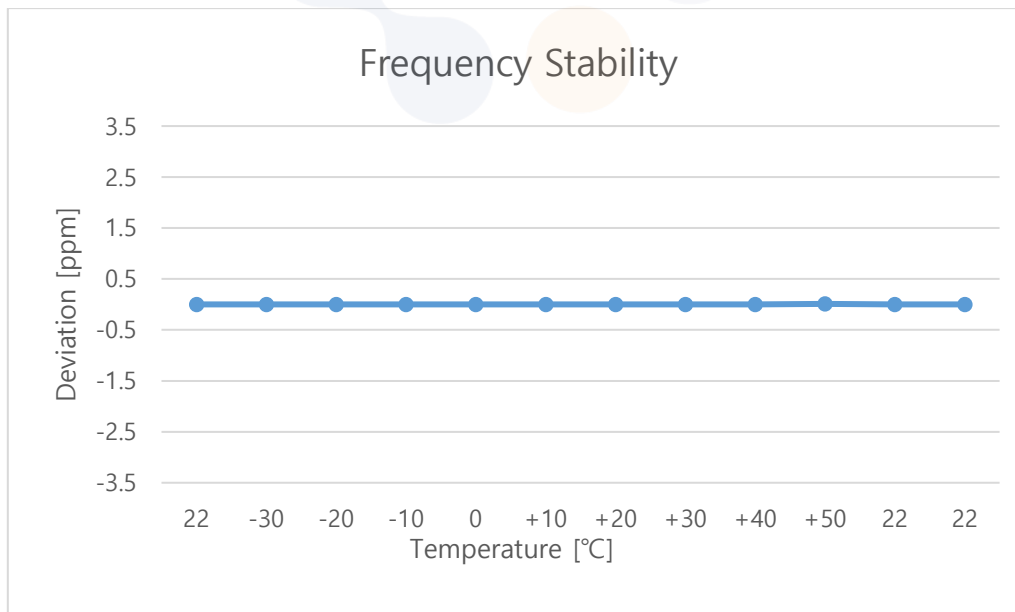

KCTL Inc.

65, Sinwon-ro, Yeongtong-gu,
Suwon-si, Gyeonggi-do, 16677, Korea
TEL: 82-31-285-0894 FAX: 82-505-299-8311
www.kctl.co.kr

Report No.:
KR22-SRF0054-A
Page (48) of (63)



Test mode : WCDMA 850
Frequency (Hz) : 836 600 000
Channel : 4183
Deviation limit : ±0.00025% or 2.5 ppm

Voltage (%)	Power (V)	Temp. (°C)	Frequency (Hz)	Frequency error (Hz)	Deviation	
					(ppm)	(%)
100%	3.85	+22(Ref)	836,600,000	0.23	0.0	0.000000
		-30	836,599,990	10.29	0.0	-0.000001
		-20	836,599,992	7.62	0.0	-0.000001
		-10	836,599,992	8.37	0.0	-0.000001
		0	836,599,996	4.25	0.0	-0.000001
		+10	836,599,996	3.81	0.0	0.000000
		+20	836,600,001	-0.93	0.0	0.000000
		+30	836,600,007	-6.90	0.0	0.000001
		+40	836,600,008	-8.41	0.0	0.000001
		+50	836,600,006	-6.12	0.0	0.000001
115%	4.43	+22(Ref)	836,599,999	0.54	0.0	0.000000
End point	3.65	+22(Ref)	836,600,000	0.34	0.0	0.000000

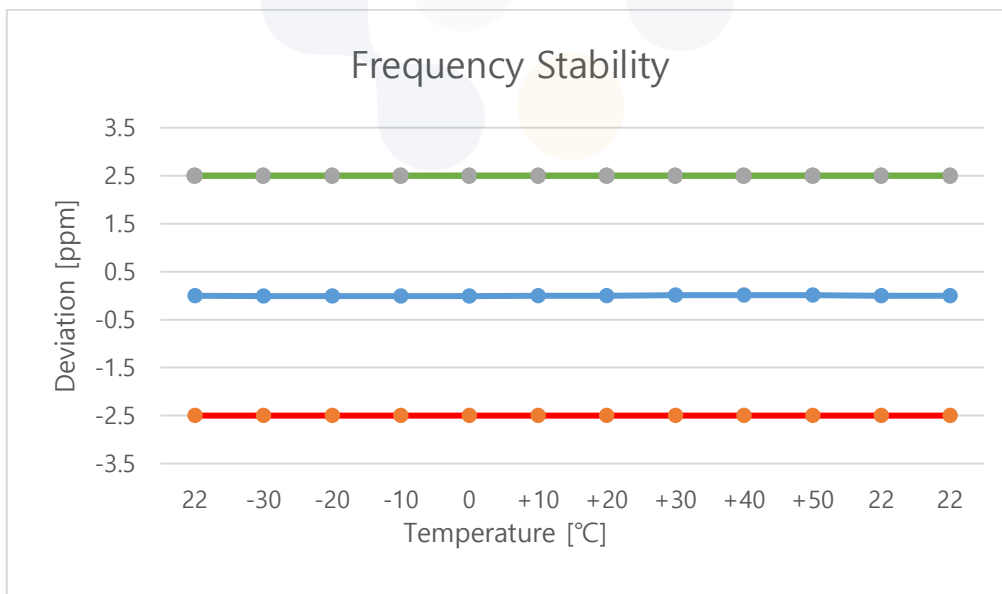

KCTL Inc.

65, Sinwon-ro, Yeongtong-gu,
Suwon-si, Gyeonggi-do, 16677, Korea
TEL: 82-31-285-0894 FAX: 82-505-299-8311
www.kctl.co.kr

Report No.:
KR22-SRF0054-A
Page (49) of (63)



Test mode : WCDMA 1700
 Frequency (Hz) : 1 732 400 000
 Channel : 1412
 Deviation limit : The frequency stability shall be sufficient to ensure that the fundamental emission stays within the authorized bands of operation.

Voltage (%)	Power (V)	Temp. (°C)	Frequency (Hz)	Frequency error (Hz)	Deviation	
					(ppm)	(%)
100%	3.85	+22(Ref)	1,732,399,997	3.00	0.0	0.000000
			1,732,399,994	5.67	0.0	0.000000
		-20	1,732,399,994	6.05	0.0	0.000000
		-10	1,732,399,997	3.32	0.0	0.000000
		0	1,732,399,995	4.96	0.0	0.000000
		+10	1,732,399,995	4.56	0.0	0.000000
		+20	1,732,399,996	4.29	0.0	0.000000
		+30	1,732,400,003	-2.95	0.0	0.000000
		+40	1,732,400,004	-3.81	0.0	0.000000
		+50	1,732,400,003	-2.95	0.0	0.000000
115%	4.43	+22(Ref)	1,732,399,995	5.19	0.0	0.000000
End point	3.65	+22(Ref)	1,732,399,996	4.23	0.0	0.000000

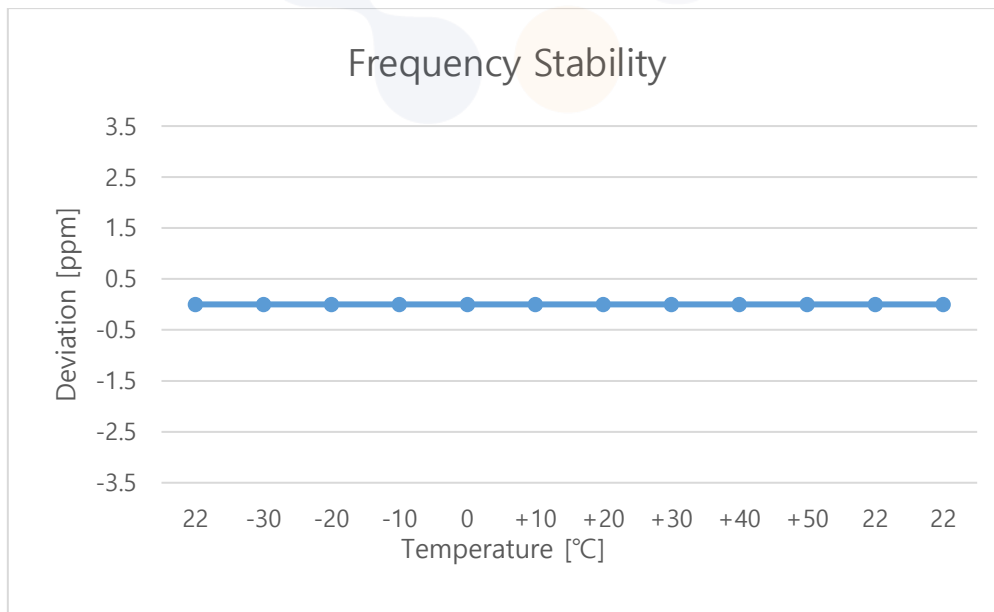

KCTL Inc.

65, Sinwon-ro, Yeongtong-gu,
Suwon-si, Gyeonggi-do, 16677, Korea
TEL: 82-31-285-0894 FAX: 82-505-299-8311
www.kctl.co.kr

Report No.:
KR22-SRF0054-A
Page (50) of (63)



Test mode : WCDMA 1900
 Frequency (Hz) : 1 880 000 000
 Channel : 9400
 Deviation limit : The frequency stability shall be sufficient to ensure that the fundamental emission stays within the authorized frequency block.

Voltage (%)	Power (V)	Temp. (°C)	Frequency (Hz)	Frequency error (Hz)	Deviation	
					(ppm)	(%)
100%	3.85	+22(Ref)	1,879,999,989	10.96	0.0	-0.000001
			1,879,999,987	13.36	0.0	-0.000001
		-20	1,879,999,986	13.53	0.0	-0.000001
		-10	1,879,999,989	10.55	0.0	-0.000001
		0	1,879,999,994	5.76	0.0	0.000000
		+10	1,879,999,994	6.49	0.0	0.000000
		+20	1,879,999,991	9.17	0.0	0.000000
		+30	1,879,999,995	4.62	0.0	0.000000
		+40	1,880,000,003	-2.78	0.0	0.000000
		+50	1,880,000,003	-3.15	0.0	0.000000
115%	4.43	+22(Ref)	1,879,999,989	11.30	0.0	-0.000001
End point	3.65	+22(Ref)	1,879,999,990	10.22	0.0	-0.000001

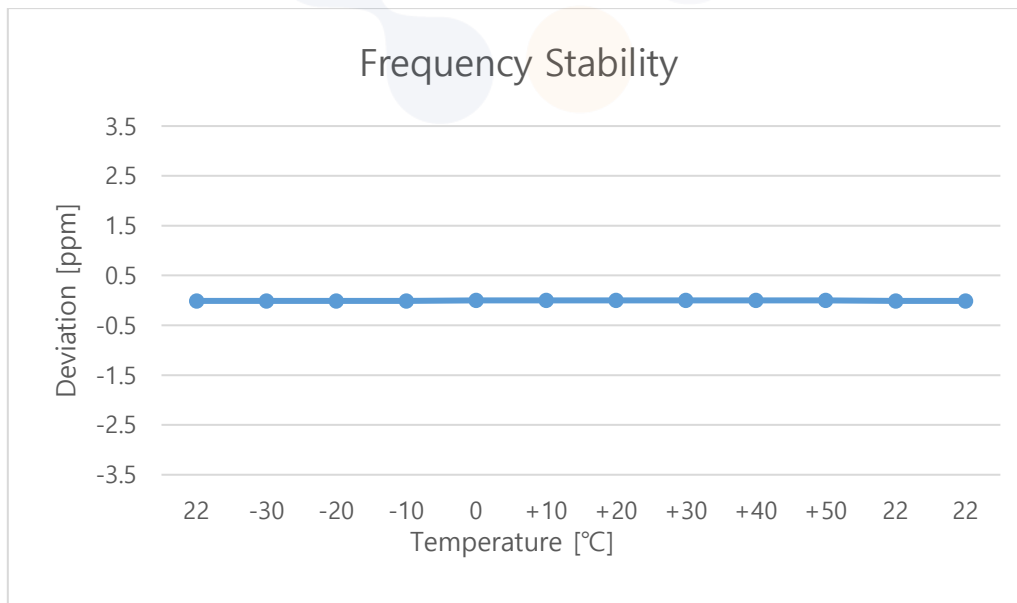

7.7. Radiated Power (ERP/EIRP)

Test setup

The diagram below shows the test setup that is utilized to make the measurements for emission from 30 MHz to 1 GHz emissions.

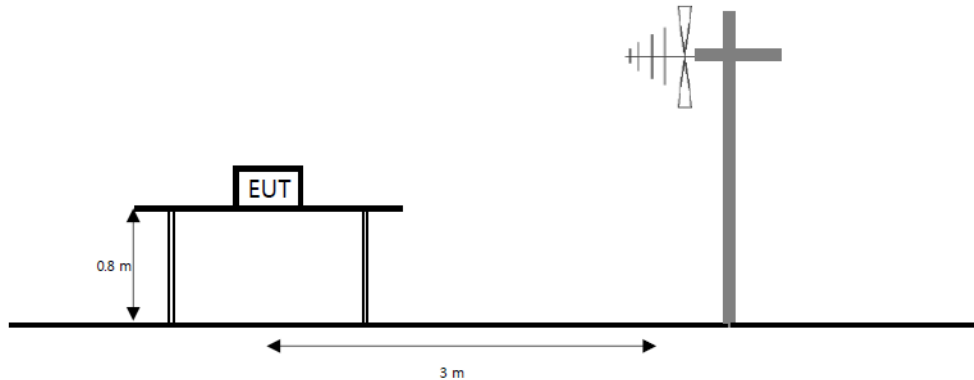

The diagram below shows the test setup that is utilized to make the measurements for emission from 1 GHz to the tenth harmonic of the highest fundamental frequency or to 40 GHz emissions, whichever is lower.

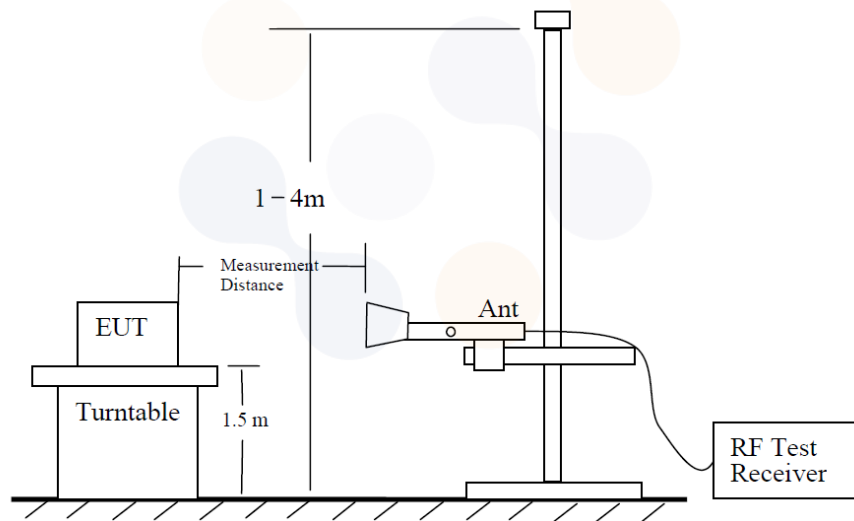

The diagram below shows the test setup for substituted method.

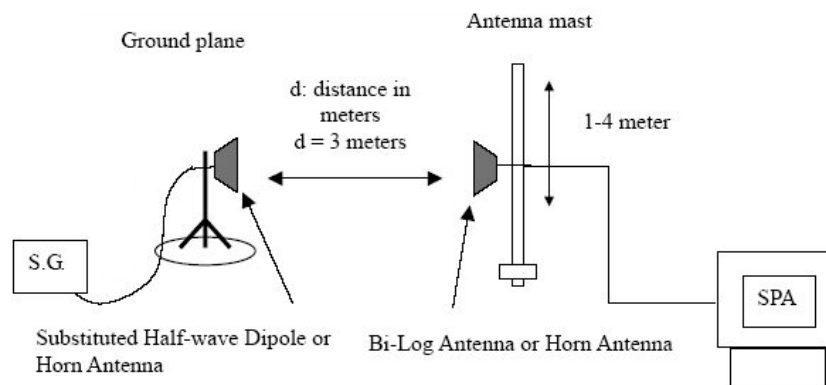

Limit

According to §22.913(a)(5), the ERP of transmitters in the cellular radiotelephone service must not exceed the limits in this section. The ERP of mobile transmitters and auxiliary test transmitters must not exceed 7 watts.

According to §24.232(c), mobile and portable stations are limited to 2 watts EIRP and the equipment must employ a means for limiting power to the minimum necessary for successful communications.

According to §27.50(d)(4), fixed, mobile, and portable (hand-held) stations operating in the 1710~1755 MHz band and mobile and portable stations operating in the 1695~1710 MHz and 1755~1780 MHz bands are 1 watt EIRP.

Test procedure

971168 D01 v03r01 - Section 5.2.2
ANSI 63.26-2015 – Section 5.2.4.4.1
ANSI/TIA-603-E-2016 - Section 2.2.17

Test settings

- 1) RBW = 1 % to 5 % of the OBW.
- 2) VBW $\geq 3 \times$ RBW.
- 3) SPAN = 2 \times to 3 \times the OBW.
- 4) Number of measurement points in sweep $\geq 2 \times$ span / RBW.
- 5) Sweep time :
 - 1) Auto couple, or
 - 2) $\geq [10 \times (\text{number of points in sweep}) \times (\text{transmission period})]$ for single sweep (automation-compatible) measurement. Transmission period is the on and off time of the transmitter.
- 6) Detector = RMS
- 7) If the EUT can be configured to transmit continuously, then set the trigger to free run.
- 8) If the EUT cannot be configured to transmit continuously, then use a sweep trigger with the level set to enable triggering only on full power bursts and configure the EUT to transmit at full power for the entire duration of each sweep. Verify that the sweep time is less than or equal to the transmission burst duration. Time gating can also be used under similar constraints (i.e., configured such that measurement data is collected only during active full-power transmissions).
- 9) Trace mode = trace averaging (RMS) over 100 sweeps.
- 10) Compute the power by integrating the spectrum across the OBW of the signal using the instrument's band or channel power measurement function, with the band/channel limits set equal to the OBW band edges. If the instrument does not have a band or channel power function, then sum the spectrum levels (in linear power units) at intervals equal to the RBW extending across the entire OBW of the spectrum.
- 11) Allow trace to fully stabilize.

KCTL Inc.

65, Sinwon-ro, Yeongtong-gu,
Suwon-si, Gyeonggi-do, 16677, Korea
TEL: 82-31-285-0894 FAX: 82-505-299-8311
www.kctl.co.kr

Report No.:
KR22-SRF0054-A
Page (53) of (63)



Notes:

1. On a test site, the EUT shall be placed at 80 cm or 1.5 m height on a turn table, and in the position close to normal use as declared by the applicant.
2. The test antenna shall be oriented initially for vertical polarization located 3 m from EUT to correspond to the fundamental frequency of the transmitter.
3. The turntable is rotated through 360°, and the receiving antenna scans in order to determine the Level of the maximized emission.
4. The test antenna shall be raised and lowered again through the specified range of height until the maximum signal level is detected by the measuring receiver.
5. The maximum signal level detected by the measuring receiver shall be noted.
6. The EUT was replaced by half-wave dipole (1 GHz below) or horn antenna (1 GHz above) connected to a signal generator.
The power is calculated by the following formula;
$$P_d(\text{dBm}) = P_g(\text{dBm}) - \text{Cable loss (dB)} + \text{Antenna gain (dB)}$$

Note. P_d is the dipole equivalent power and P_g is the generator output power into the substitution antenna.
7. The test antenna shall be raised and lowered through the specified range of height to ensure that The maximum signal is received.
8. The input signal to the substitution antenna shall be adjusted to the level that produces a level Detected by the measuring corrected for the change of input attenuator setting of the measuring Receiver.
9. The input level to the substitution antenna shall be recorded as power level in dBm, corrected for Any change of input attenuator setting of the measuring receiver.
10. The measurement shall be repeated with the test antenna and the substitution antenna Orientated for horizontal polarization.

KCTL Inc.

65, Sinwon-ro, Yeongtong-gu,
Suwon-si, Gyeonggi-do, 16677, Korea
TEL: 82-31-285-0894 FAX: 82-505-299-8311
www.kctl.co.kr

Report No.:
KR22-SRF0054-A
Page (54) of (63)

**Test results****Test mode: GSM 850**

Mode	Channel	Frequency	Pol.	Antenna Gain	C.L	Substitute Level	ERP	
		[MHz]	[V/H]	[dBd]	[dB]	[dB m]	[dB m]	[W]
Voice	128	824.2	H	-2.03	5.02	36.96	29.91	0.979
	190	836.6	H	-2.44	5.13	36.49	28.92	0.780
	251	848.8	H	-2.77	5.18	35.66	27.71	0.590
EDGE	128	824.2	H	-2.03	5.02	30.73	23.68	0.233
	190	836.6	H	-2.44	5.13	30.36	22.79	0.190
	251	848.8	H	-2.77	5.18	29.84	21.89	0.155

Test mode: GSM 1900

Mode	Channel	Frequency	Pol.	Antenna Gain	C.L	Substitute Level	EIRP	
		[MHz]	[V/H]	[dBi]	[dB]	[dB m]	[dB m]	[W]
GPRS	512	1 850.2	H	5.46	7.66	34.55	32.35	1.718
	661	1 880.0	H	5.39	7.76	33.36	30.99	1.256
	810	1 909.8	H	5.32	7.83	32.08	29.57	0.906
EDGE	512	1 850.2	H	5.46	7.66	29.83	27.63	0.579
	661	1 880.0	H	5.39	7.76	31.81	29.44	0.879
	810	1 909.8	H	5.32	7.83	30.49	27.98	0.628

Note.

1. E.R.P & E.I.R.P(dBm) = Substitute Level(dB) + Antenna gain(dBd&dBi) - C.L(Cable loss) (dB)

KCTL Inc.

65, Sinwon-ro, Yeongtong-gu,
Suwon-si, Gyeonggi-do, 16677, Korea
TEL: 82-31-285-0894 FAX: 82-505-299-8311
www.kctl.co.kr

Report No.:
KR22-SRF0054-A
Page (55) of (63)

**Test mode: WCDMA 850**

Mode	Channel	Frequency	Pol.	Antenna Gain	C.L	Substitute Level	ERP	
		[MHz]	[V/H]	[dBd]	[dB]	[dB m]	[dB m]	[W]
RMC	4132	826.40	H	-1.81	5.05	27.89	21.03	0.127
	4183	836.60	H	-2.44	5.13	28.37	20.80	0.120
	4233	846.60	H	-2.82	5.17	28.80	20.81	0.121

Test mode: WCDMA 1700

Mode	Channel	Frequency	Pol.	Antenna Gain	C.L	Substitute Level	EIRP	
		[MHz]	[V/H]	[dBi]	[dB]	[dB m]	[dB m]	[W]
RMC	1312	1 712.4	V	5.79	7.38	23.71	22.12	0.163
	1412	1 732.4	V	5.74	7.43	23.05	21.36	0.137
	1513	1 752.6	V	5.69	7.45	22.66	20.90	0.123

Test mode: WCDMA 1900

Mode	Channel	Frequency	Pol.	Antenna Gain	C.L	Substitute Level	EIRP	
		[MHz]	[V/H]	[dBi]	[dB]	[dB m]	[dB m]	[W]
RMC	9262	1 852.4	H	5.45	7.66	26.81	24.60	0.288
	9400	1 880.0	H	5.39	7.76	28.00	25.63	0.366
	9538	1 907.6	H	5.32	7.84	26.62	24.10	0.257

Note.

1. E.R.P & E.I.R.P(dBm) = Substitute Level(dB) + Antenna gain(dBd&dBi) - C.L(Cable loss) (dB)

7.8. Radiated Spurious Emissions

Test setup

The diagram below shows the test setup that is utilized to make the measurements for emission from 30 MHz to 1 GHz emissions.

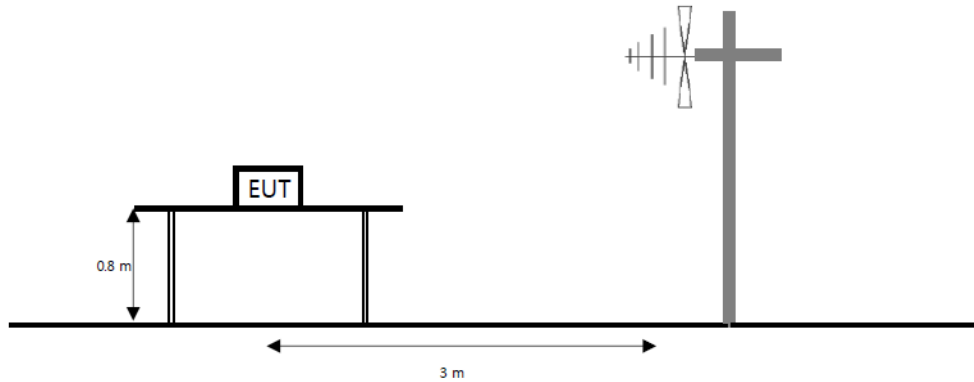

The diagram below shows the test setup that is utilized to make the measurements for emission from 1 GHz to the tenth harmonic of the highest fundamental frequency or to 40 GHz emissions, whichever is lower.

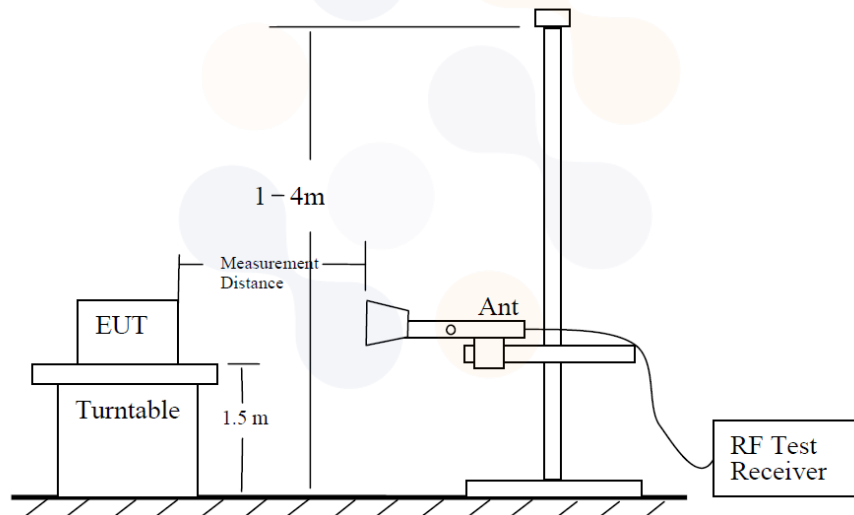

The diagram below shows the test setup for substituted method.

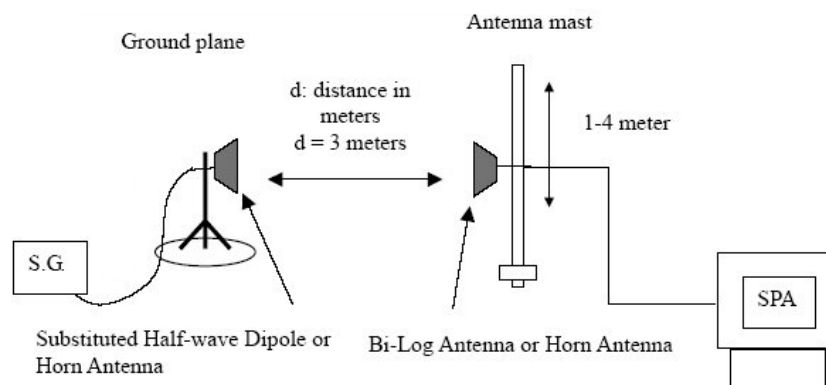

KCTL Inc.

65, Sinwon-ro, Yeongtong-gu,
Suwon-si, Gyeonggi-do, 16677, Korea
TEL: 82-31-285-0894 FAX: 82-505-299-8311
www.kctl.co.kr

Report No.:
KR22-SRF0054-A
Page (57) of (63)



Limit

According to §22.917(a), §24.238(a), the power of any emission outside of the authorized operating frequency ranges must be attenuated below the transmitting power (P) by a factor of at least $43 + 10\log(P)$ dB.

According to §27.53(h), the power of any emission outside a licensee's frequency block shall be attenuated below the transmitter power (P) in watts by at least $43 + 10\log(P_{\text{[Watts]}})$ dB.

Test procedure

971168 D01 v03r01 - Section 5.8
ANSI 63.26-2015 – Section 5.5
ANSI/TIA-603-E-2016 - Section 2.2.12

Test settings

- 1) RBW = 1 kHz for below 1 GHz and 1 MHz for above 1 GHz.
- 2) VBW $\geq 3 \times$ RBW.
- 3) Detector = RMS
- 4) Trace mode = Max hold
- 5) Sweep time = Auto couple
- 6) Number of sweep points $\geq 2 \times$ span / RBW
- 7) Allow trace to fully stabilize.

Notes:

1. On a test site, the EUT shall be placed at 80 cm or 1.5 m height on a turn table, and in the position close to normal use as declared by the applicant.
2. The test antenna shall be oriented initially for vertical polarization located 3 m from EUT to correspond to the fundamental frequency of the transmitter.
3. The turntable is rotated through 360° , and the receiving antenna scans in order to determine the Level of the maximized emission.
4. The test antenna shall be raised and lowered again through the specified range of height until the maximum signal level is detected by the measuring receiver.
5. The maximum signal level detected by the measuring receiver shall be noted.
6. The EUT was replaced by half-wave dipole (1 GHz below) or horn antenna (1 GHz above) connected to a signal generator.
7. The test antenna shall be raised and lowered through the specified range of height to ensure that The maximum signal is received.
8. The input signal to the substitution antenna shall be adjusted to the level that produces a level Detected by the measuring corrected for the change of input attenuator setting of the measuring Receiver.
9. The input level to the substitution antenna shall be recorded as power level in dBm, corrected for Any change of input attenuator setting of the measuring receiver.
10. The measurement shall be repeated with the test antenna and the substitution antenna Orientated for horizontal polarization.

KCTL Inc.

65, Sinwon-ro, Yeongtong-gu,
Suwon-si, Gyeonggi-do, 16677, Korea
TEL: 82-31-285-0894 FAX: 82-505-299-8311
www.kctl.co.kr

Report No.:
KR22-SRF0054-A
Page (58) of (63)

**Test results (Above 1 000 MHz)**

Test mode : GSM 850

Frequency(MHz) : 824.2

Channel : 128

Mode	Frequency	Pol.	Antenna Gain	Cable loss	Substitute Level	Level	Limit	Margin
	[MHz]	[V/H]	[dBi]	[dB]	[dBm]	[dBm]	[dBm]	[dB]
Voice	1 650.29	H	5.94	7.18	-58.96	-60.20	-13.00	47.20
	2 472.49	V	6.14	8.89	-56.25	-59.00	-13.00	46.00
	3 295.50	H	7.73	10.55	-54.68	-57.50	-13.00	44.50
	4 118.52	H	8.83	11.93	-54.60	-57.70	-13.00	44.70

Test mode : GSM 850

Frequency(MHz) : 836.6

Channel : 190

Mode	Frequency	Pol.	Antenna Gain	Cable loss	Substitute Level	Level	Limit	Margin
	[MHz]	[V/H]	[dBi]	[dB]	[dBm]	[dBm]	[dBm]	[dB]
Voice	1 672.03	H	5.89	7.24	-59.75	-61.10	-13.00	48.10
	2 507.36	V	6.21	8.92	-54.79	-57.50	-13.00	44.50
	3 346.79	V	7.87	10.65	-53.32	-56.10	-13.00	43.10
	4 182.52	V	8.79	11.77	-53.22	-56.20	-13.00	43.20

Test mode : GSM 850

Frequency(MHz) : 848.8

Channel : 251

Mode	Frequency	Pol.	Antenna Gain	Cable loss	Substitute Level	Level	Limit	Margin
	[MHz]	[V/H]	[dBi]	[dB]	[dBm]	[dBm]	[dBm]	[dB]
Voice	1 699.52	V	5.82	7.31	-60.61	-62.10	-13.00	49.10
	2 546.34	H	6.26	9.01	-55.55	-58.30	-13.00	45.30
	3 395.61	V	8.01	10.75	-52.26	-55.00	-13.00	42.00
	4 242.01	V	8.75	11.88	-53.67	-56.80	-13.00	43.80

Note.

1. Limit Calculation(dBm)= 43 + 10log(P_[Watts])

2. E.R.P & E.I.R.P(dBm) = Substitute Level(dB) + Antenna gain(dBd&dBi) - C.L(Cable loss) (dB)

KCTL Inc.

65, Sinwon-ro, Yeongtong-gu,
Suwon-si, Gyeonggi-do, 16677, Korea
TEL: 82-31-285-0894 FAX: 82-505-299-8311
www.kctl.co.kr

Report No.:
KR22-SRF0054-A
Page (59) of (63)



Test mode : GSM 1900

Frequency(MHz) : 1 850.2

Channel : 512

Mode	Frequency	Pol.	Antenna Gain	Cable loss	Substitute Level	Level	Limit	Margin
	[MHz]	[V/H]	[dBi]	[dB]	[dBm]	[dBm]	[dBm]	[dB]
GPRS	3 701.52	V	8.54	11.36	-54.48	-57.30	-13.00	44.30
	5 548.19	H	10.51	13.87	-53.04	-56.40	-13.00	43.40
	7 399.97	H	11.96	16.10	-49.66	-53.80	-13.00	40.80
	9 251.12	V	13.20	17.90	-47.90	-52.60	-13.00	39.60

Test mode : GSM 1900

Frequency(MHz) : 1 880.0

Channel : 661

Mode	Frequency	Pol.	Antenna Gain	Cable loss	Substitute Level	Level	Limit	Margin
	[MHz]	[V/H]	[dBi]	[dB]	[dBm]	[dBm]	[dBm]	[dB]
GPRS	3 758.33	V	8.61	11.25	-54.86	-57.50	-13.00	44.50
	5 639.47	V	10.53	13.84	-53.79	-57.10	-13.00	44.10
	7 521.26	H	12.12	16.18	-49.54	-53.60	-13.00	40.60
	9 397.93	V	13.20	18.35	-48.25	-53.40	-13.00	40.40

Test mode : GSM 1900

Frequency(MHz) : 1 909.8

Channel : 810

Mode	Frequency	Pol.	Antenna Gain	Cable loss	Substitute Level	Level	Limit	Margin
	[MHz]	[V/H]	[dBi]	[dB]	[dBm]	[dBm]	[dBm]	[dB]
GPRS	3 819.61	H	8.68	11.64	-53.54	-56.50	-13.00	43.50
	5 732.03	V	10.55	13.94	-52.61	-56.00	-13.00	43.00
	7 641.26	H	12.21	16.41	-49.60	-53.80	-13.00	40.80
	9 547.94	V	13.19	18.36	-47.93	-53.10	-13.00	40.10

Note.

1. Limit Calculation(dBm)= 43 + 10log(P_{Watts})

2. E.R.P & E.I.R.P(dB m) = Substitute Level(dB) + Antenna gain(dB d&dB i) - C.L(Cable loss) (dB)

KCTL Inc.

65, Sinwon-ro, Yeongtong-gu,
Suwon-si, Gyeonggi-do, 16677, Korea
TEL: 82-31-285-0894 FAX: 82-505-299-8311
www.kctl.co.kr

Report No.:
KR22-SRF0054-A
Page (60) of (63)



Test mode : WCDMA 850

Frequency(MHz) : 826.4

Channel : 4132

Mode	Frequency	Pol.	Antenna Gain	Cable loss	Substitute Level	Level	Limit	Margin
	[MHz]	[V/H]	[dBi]	[dB]	[dBm]	[dBm]	[dBm]	[dB]
RMC	1 655.21	H	5.93	7.19	-58.44	-59.70	-13.00	46.70
	2 479.87	V	6.16	8.91	-55.35	-58.10	-13.00	45.10
	3 304.94	V	7.75	10.56	-53.89	-56.70	-13.00	43.70
	4 131.65	V	8.82	11.95	-52.87	-56.00	-13.00	43.00

Test mode : WCDMA 850

Frequency(MHz) : 836.6

Channel : 4183

Mode	Frequency	Pol.	Antenna Gain	Cable loss	Substitute Level	Level	Limit	Margin
	[MHz]	[V/H]	[dBi]	[dB]	[dBm]	[dBm]	[dBm]	[dB]
RMC	1 673.68	V	5.88	7.24	-59.14	-60.50	-13.00	47.50
	2 509.82	V	6.21	8.94	-55.97	-58.70	-13.00	45.70
	3 348.84	V	7.88	10.65	-53.23	-56.00	-13.00	43.00
	4 184.98	V	8.79	11.77	-53.82	-56.80	-13.00	43.80

Test mode : WCDMA 850

Frequency(MHz) : 846.6

Channel : 4233

Mode	Frequency	Pol.	Antenna Gain	Cable loss	Substitute Level	Level	Limit	Margin
	[MHz]	[V/H]	[dBi]	[dB]	[dBm]	[dBm]	[dBm]	[dB]
RMC	1 695.01	V	5.83	7.30	-59.33	-60.80	-13.00	47.80
	2 539.77	V	6.26	9.00	-54.96	-57.70	-13.00	44.70
	3 384.53	V	7.98	10.72	-54.96	-57.70	-13.00	44.70
	4 230.94	V	8.76	11.85	-53.41	-56.50	-13.00	43.50

Note.

1. Limit Calculation(dBm)= 43 + 10log(P_{Watts})

2. E.R.P & E.I.R.P(dB m) = Substitute Level(dB) + Antenna gain(dB d&dB i) - C.L(Cable loss) (dB)

KCTL Inc.

65, Sinwon-ro, Yeongtong-gu,
Suwon-si, Gyeonggi-do, 16677, Korea
TEL: 82-31-285-0894 FAX: 82-505-299-8311
www.kctl.co.kr

Report No.:
KR22-SRF0054-A
Page (61) of (63)



Test mode : WCDMA 1700

Frequency(MHz) : 1 712.4

Channel : 1312

Mode	Frequency	Pol.	Antenna Gain	Cable loss	Substitute Level	Level	Limit	Margin
	[MHz]	[V/H]	[dBi]	[dB]	[dBm]	[dBm]	[dBm]	[dB]
RMC	3 424.64	V	8.09	10.81	-56.98	-59.70	-13.00	46.70
	5 136.26	V	10.21	13.49	-53.92	-57.20	-13.00	44.20
	6 846.35	V	11.22	15.52	-51.10	-55.40	-13.00	42.40
	8 560.28	V	13.02	17.40	-49.82	-54.20	-13.00	41.20

Test mode : WCDMA 1700

Frequency(MHz) : 1 732.4

Channel : 1412

Mode	Frequency	Pol.	Antenna Gain	Cable loss	Substitute Level	Level	Limit	Margin
	[MHz]	[V/H]	[dBi]	[dB]	[dBm]	[dBm]	[dBm]	[dB]
RMC	3 464.64	V	8.20	10.89	-56.01	-58.70	-13.00	45.70
	5 198.57	V	10.26	13.56	-52.40	-55.70	-13.00	42.70
	6 929.43	H	11.32	15.58	-50.94	-55.20	-13.00	42.20
	8 661.83	V	13.06	17.31	-50.95	-55.20	-13.00	42.20

Test mode : WCDMA 1700

Frequency(MHz) : 1 752.6

Channel : 1513

Mode	Frequency	Pol.	Antenna Gain	Cable loss	Substitute Level	Level	Limit	Margin
	[MHz]	[V/H]	[dBi]	[dB]	[dBm]	[dBm]	[dBm]	[dB]
RMC	3 506.95	V	8.31	10.97	-56.04	-58.70	-13.00	45.70
	5 255.50	V	10.30	13.42	-53.28	-56.40	-13.00	43.40
	7 010.98	V	11.42	15.68	-49.84	-54.10	-13.00	41.10
	8 765.68	H	13.11	17.77	-50.04	-54.70	-13.00	41.70

Note.

1. Limit Calculation(dBm)= 43 + 10log(P_[Watts])

2. E.R.P & E.I.R.P(dB m) = Substitute Level(dB) + Antenna gain(dB d&dB i) - C.L(Cable loss) (dB)

KCTL Inc.

65, Sinwon-ro, Yeongtong-gu,
Suwon-si, Gyeonggi-do, 16677, Korea
TEL: 82-31-285-0894 FAX: 82-505-299-8311
www.kctl.co.kr

Report No.:
KR22-SRF0054-A
Page (62) of (63)



Test mode : WCDMA 1900

Frequency(MHz) : 1 852.4

Channel : 9262

Mode	Frequency	Pol.	Antenna Gain	Cable loss	Substitute Level	Level	Limit	Margin
	[MHz]	[V/H]	[dBi]	[dB]	[dBm]	[dBm]	[dBm]	[dB]
RMC	3 702.34	V	8.54	11.36	-53.88	-56.70	-13.00	43.70
	5 557.05	H	10.51	13.88	-52.83	-56.20	-13.00	43.20
	7 407.92	H	11.97	16.01	-49.76	-53.80	-13.00	40.80
	9 264.17	V	13.20	17.92	-49.38	-54.10	-13.00	41.10

Test mode : WCDMA 1900

Frequency(MHz) : 1 880.0

Channel : 9400

Mode	Frequency	Pol.	Antenna Gain	Cable loss	Substitute Level	Level	Limit	Margin
	[MHz]	[V/H]	[dBi]	[dB]	[dBm]	[dBm]	[dBm]	[dB]
RMC	3 760.81	V	8.61	11.26	-54.55	-57.20	-13.00	44.20
	5 641.67	H	10.53	13.84	-51.89	-55.20	-13.00	42.20
	7 519.46	V	12.12	16.17	-50.75	-54.80	-13.00	41.80
	9 399.56	H	13.20	18.35	-48.25	-53.40	-13.00	40.40

Test mode : WCDMA 1900

Frequency(MHz) : 1 907.6



Channel : 9538

Mode	Frequency	Pol.	Antenna Gain	Cable loss	Substitute Level	Level	Limit	Margin
	[MHz]	[V/H]	[dBi]	[dB]	[dBm]	[dBm]	[dBm]	[dB]
RMC	3 815.43	H	8.68	11.63	-55.35	-58.30	-13.00	45.30
	5 723.99	V	10.54	13.92	-52.42	-55.80	-13.00	42.80
	7 631.78	H	12.21	16.40	-51.21	-55.40	-13.00	42.40
	9 540.34	V	13.19	18.36	-48.13	-53.30	-13.00	40.30

Note.

1. Limit Calculation(dBm)= 43 + 10log(P_[Watts])

2. E.R.P & E.I.R.P(dBm) = Substitute Level(dB) + Antenna gain(dB&dBi) - C.L(Cable loss) (dB)

KCTL Inc. 65, Sinwon-ro, Yeongtong-gu, Suwon-si, Gyeonggi-do, 16677, Korea TEL: 82-31-285-0894 FAX: 82-505-299-8311 www.kctl.co.kr	Report No.: KR22-SRF0054-A Page (63) of (63)	 
---	---	---

8. Measurement equipment

Equipment Name	Manufacturer	Model No.	Serial No.	Next Cal. Date
Spectrum Analyzer	R&S	FSV40-N	101462	23.01.06
Power Divider	Aeroflex/ Weinschel, Inc	1580-1	NX380	22.07.29
Vector Signal Generator	R&S	SMBV100A	257566	22.07.09
Signal Generator	R&S	SMB100A	176206	23.01.19
DC Power Supply	AGILENT	E3632A	MY40007371	22.05.10
Temp & Humid Chamber	Myeongseong R&P	CTHC-50P-DT	20150824-1	22.12.21
Wideband Radio Communication Tester	R&S	CMW500	168683	23.03.10
Biconical VHF-UHF Broadband Antenna	SCHWARZBECK	VUBA9117	275	24.03.30*
Bilog Antenna	ETS.LINDGREN	3143B	00228420	23.09.28
Horn Antenna	ETS.LINDGREN	3117	161225	22.05.11
Horn Antenna	ETS.LINDGREN	3117	00227509	22.09.27
Horn Antenna	ETS.lindgren	3116	00086632	23.01.25
Horn Antenna	ETS.lindgren	3116	00086635	22.05.17
High Pass Filter	Wainwright Instruments GmbH	WHKX10-900-1000-15000-40SS	11	22.08.20
High Pass Filter	Wainwright Instruments GmbH	WHKX12-2805-3000-18000-40SS	32	22.08.20
Broadband Amplifier	SONOMA INSTRUMENT	315	300314	23.01.19
Amplifier	LTC MICROWAVE	LLA01185522Q-B	139	22.07.19
Amplifier	L-3 Narda-MITEQ	JS44-18004000-33-8P	2000996	23.01.19
Spectrum Analyzer	AGILENT	N9040B	MY57010132	22.12.31
Wideband Radio Communication Tester	R&S	CMW500	141780	23.03.28*
Antenna Stand	innco systems GmbH	AS1500-EP-10kg	N/A	N/A
Antenna Stand	innco systems GmbH	AS1500-EP-10kg	N/A	N/A
Compact Table	innco systems GmbH	CT1000	N/A	N/A

* Tests related to this equipment were progressed before the calibration was completed.

End of test report