

**UNII Straddle Ch. IEEE 802.11n HT40 mode Output Power and PSD**

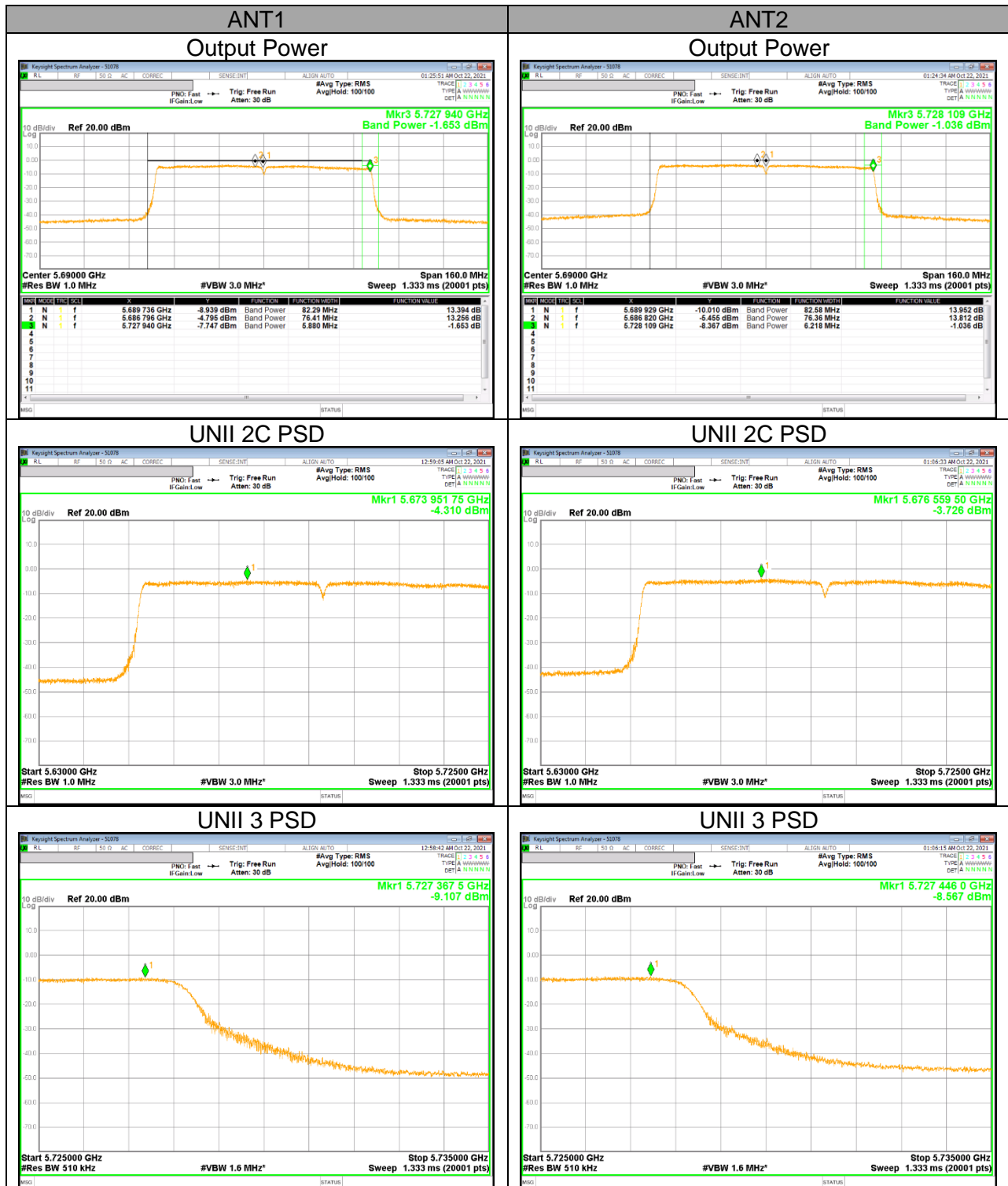

**UNII Straddle Ch. IEEE 802.11ac VHT80 mode Output Power and PSD**



**UNII Straddle Ch. IEEE 802.11ax HE20(SU) mode Output Power and PSD**

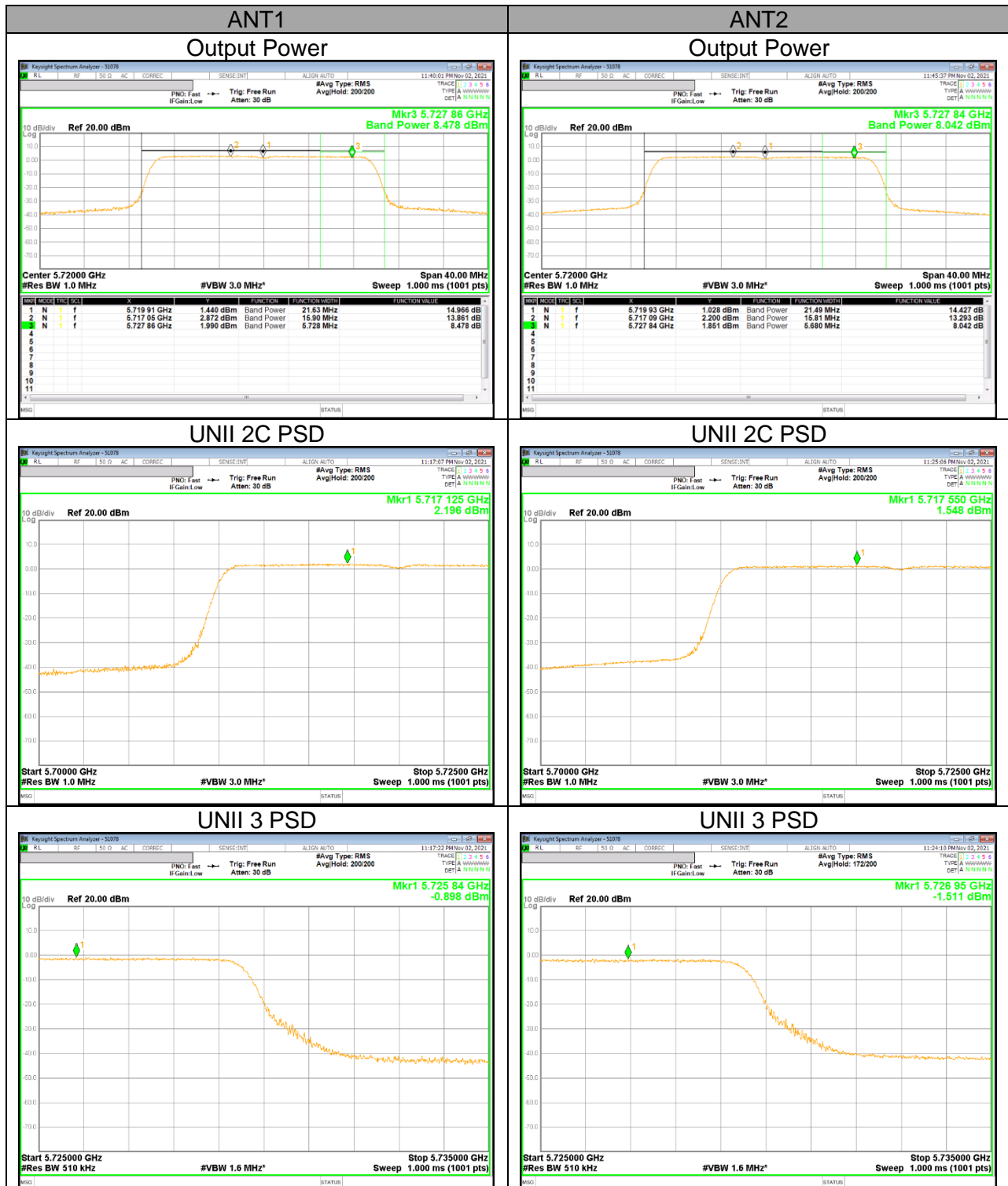

**UNII Straddle Ch. IEEE 802.11ax HE40(SU) mode Output Power and PSD**

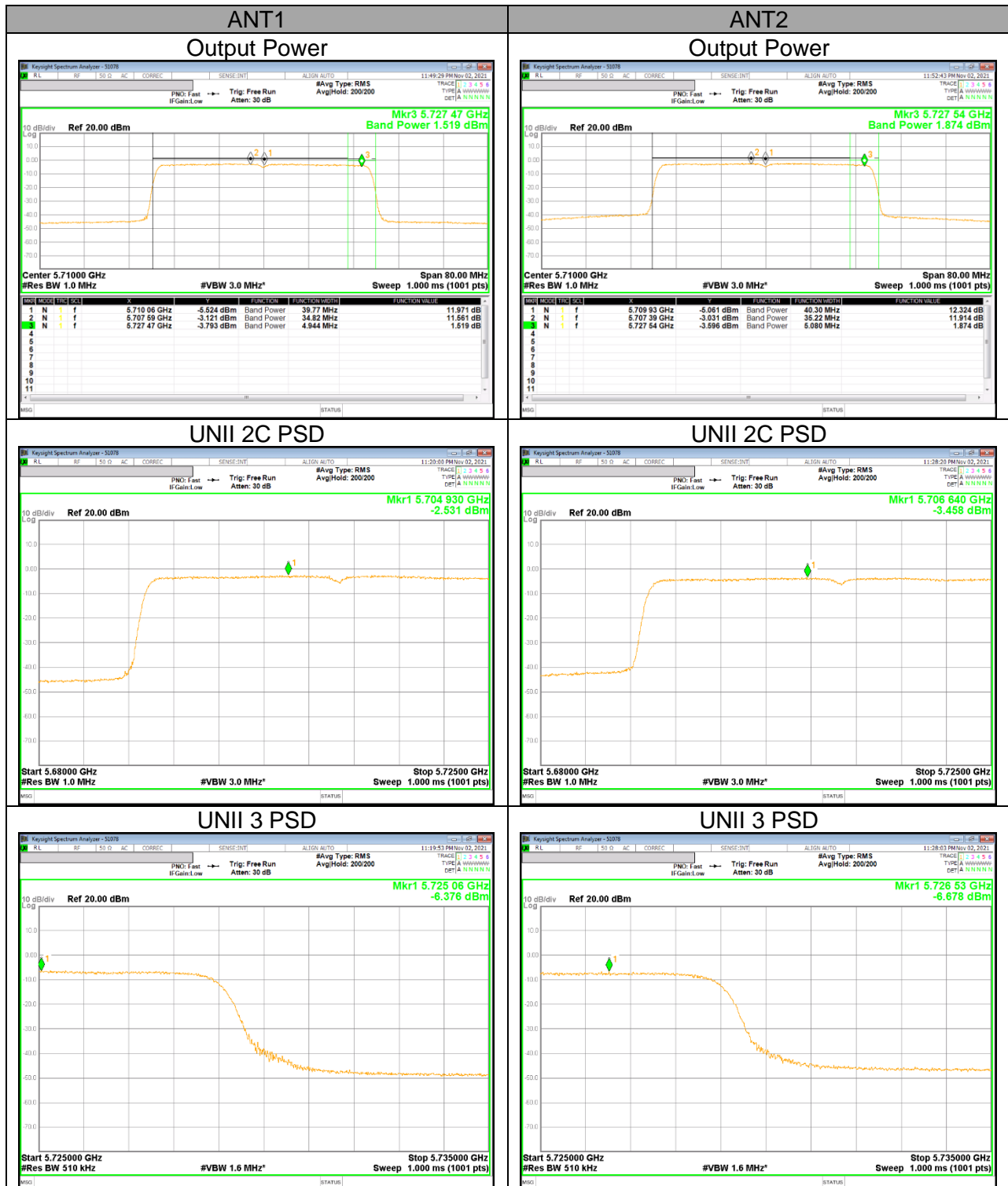

**UNII Straddle Ch. IEEE 802.11ax HE80(SU) mode Output Power and PSD**

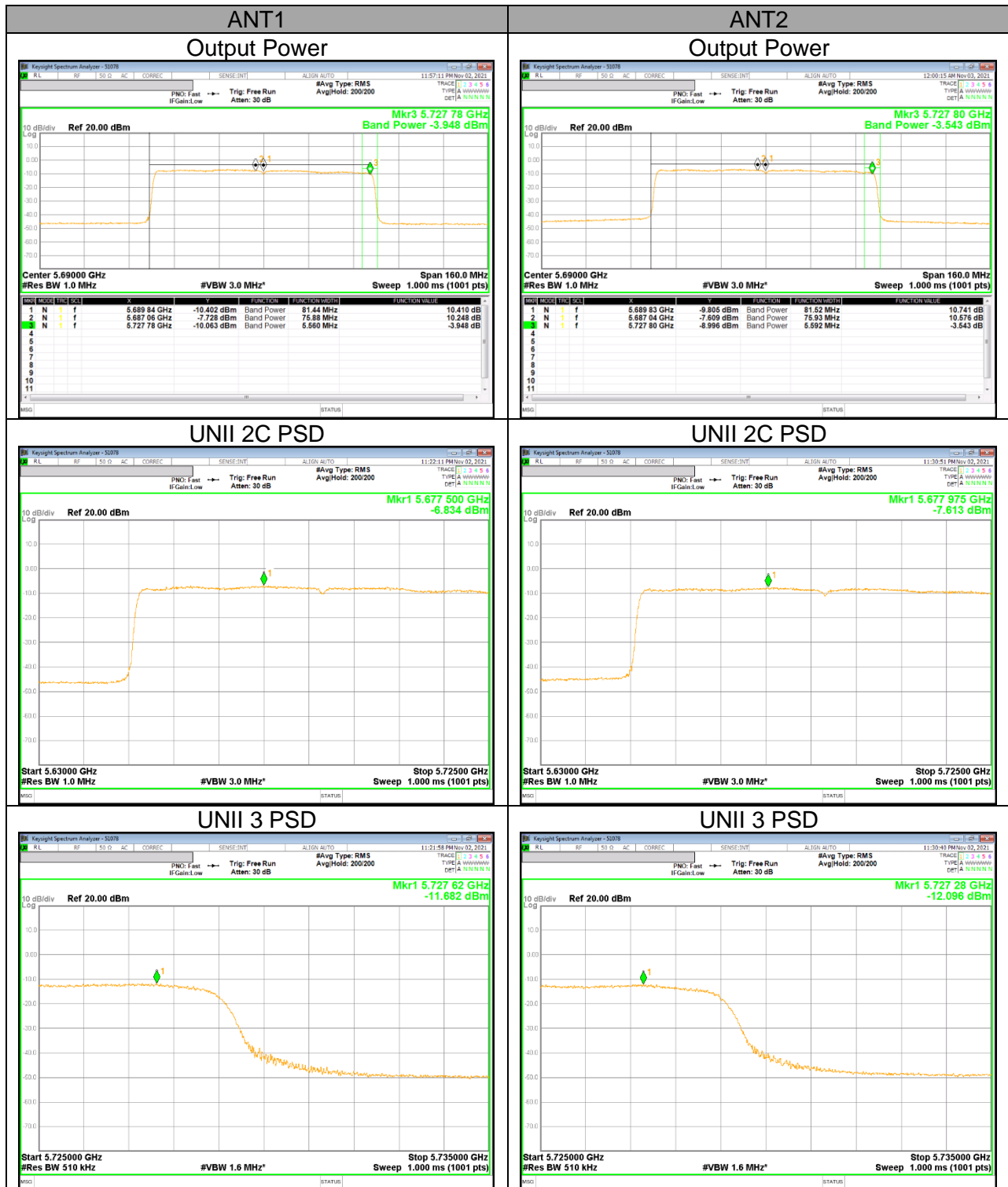

**UNII Straddle Ch. IEEE 802.11ax HE20(6RU) mode Output Power and PSD**

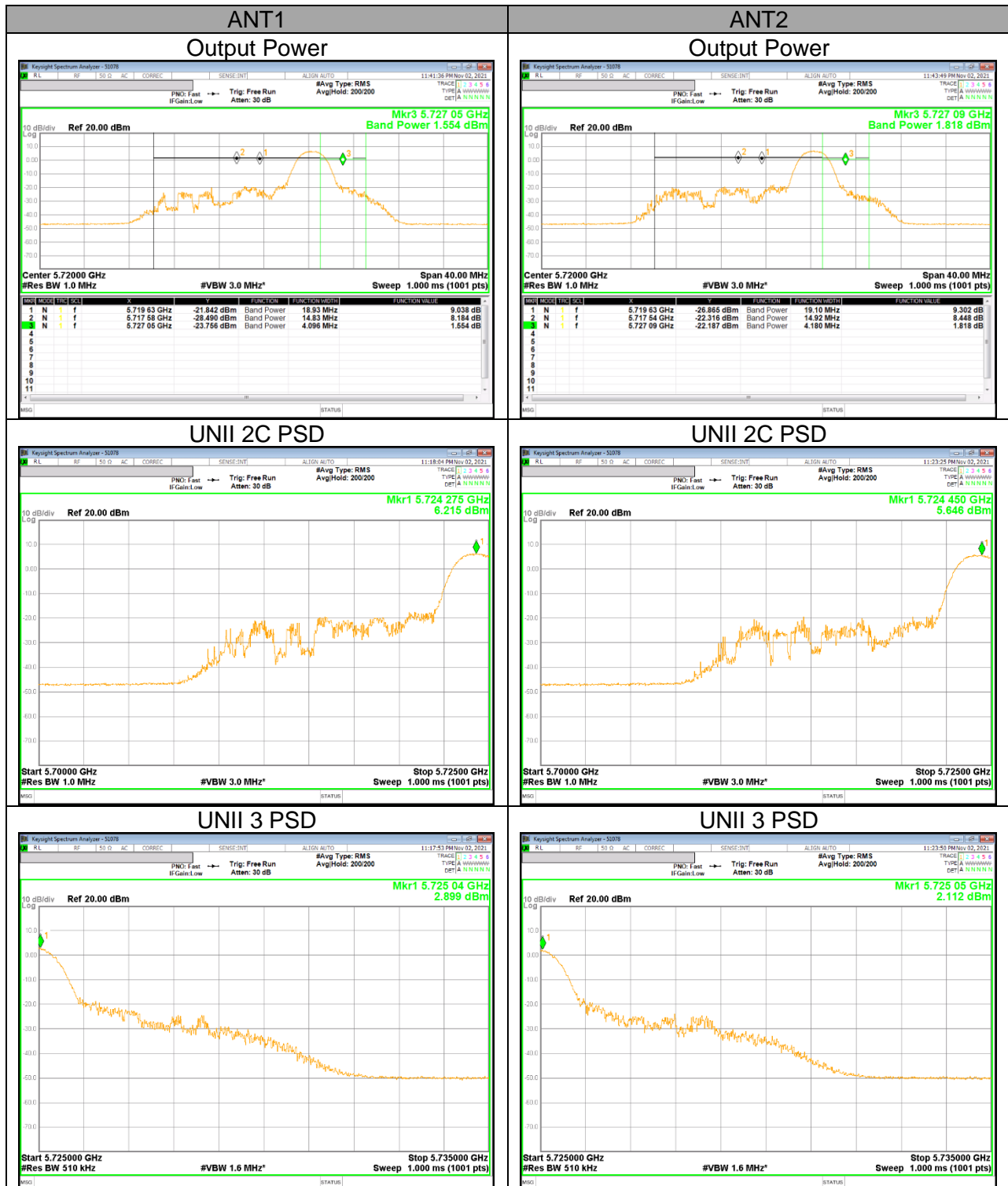

**UNII Straddle Ch. IEEE 802.11ax HE40(15RU) mode Output Power and PSD**





**UNII Straddle Ch. IEEE 802.11ax HE80(34RU) mode Output Power and PSD**





## 11. TRANSMITTER ABOVE 1 GHz

### LIMITS

FCC §15.205 and §15.209

Limits for radiated disturbance of an intentional radiator		
Frequency range (MHz)	Limits (µV/m)	Measurement Distance (m)
0.009 – 0.490	2400 / F (kHz)	300
0.490 – 1.705	24000 / F (kHz)	30
1.705 – 30.0	30	30
30 – 88	100**	3
88 - 216	150**	3
216 – 960	200**	3
Above 960	500	3

\*\* Except as provided in paragraph (g), fundamental emissions from intentional radiators operating under this section shall not be located in the frequency bands 54-72 MHz, 76-88 MHz, 174-216 MHz or 470-806 MHz. However, operation within these frequency bands is permitted under other sections of this part, e.g. §§ 15.231 and 15.241.

FCC Part 15.205 (a) : Only spurious emissions are permitted in any of the frequency bands listed below :

MHz	MHz	MHz	MHz	GHz	GHz
0.009 ~ 0.110	8.41425 ~ 8.41475	108 ~ 121.94	1300 ~ 1427	4.5 ~ 5.15	14.47 ~ 14.5
0.495 ~ 0.505	12.29 ~ 12.293	123 ~ 138	1435 ~ 1626.5	5.35 ~ 5.46	15.35 ~ 16.2
2.1735 ~ 2.1905	12.51975 ~ 12.52025	149.9 ~ 150.05	1645.5 ~ 1646.5	7.25 ~ 7.75	17.7 ~ 21.4
4.125 ~ 4.128	12.57675 ~ 12.57725	156.52475 ~ 156.52525	1660 ~ 1710	8.025 ~ 8.5	22.01 ~ 23.12
4.17725 ~ 4.17775	13.36 ~ 13.41	156.7 ~ 156.9	1718.8 ~ 1722.2	9.0 ~ 9.2	23.6 ~ 24.0
4.20725 ~ 4.20775	16.42 ~ 16.423	162.0125 ~ 167.17	2200 ~ 2300	9.3 ~ 9.5	31.2 ~ 31.8
6.215 ~ 6.218	16.69475 ~ 16.69525	167.72 ~ 173.2	2310 ~ 2390	10.6 ~ 12.7	36.43 ~ 36.5
6.26775 ~ 6.26825	16.80425 ~ 16.80475	240 ~ 285	2483.5 ~ 2500	13.25 ~ 13.4	Above 38.6
6.31175 ~ 6.31225	25.5 ~ 25.67	322 ~ 335.4	2655 ~ 2900		
8.291 ~ 8.294	37.5 ~ 38.25	399.90 ~ 410	3260 ~ 3267		
8.362 ~ 8.366	73 ~ 74.6	608 ~ 614	3332 ~ 3339		
8.37625 ~ 8.38675	74.8 ~ 75.2	960 ~ 1240	3345.8 ~ 3358 3600 ~ 4400		

▪ FCC Part 15.205(b) : The field strength of emissions appearing within these frequency bands shall not exceed the limits shown in §15.209. At frequencies equal to or less than 1000 MHz, compliance with the limits in §15.209 shall be demonstrated using measurement instrumentation employing a CISPR quasi-peak detector. Above 1000 MHz, compliance with the emission limits in §15.209 shall be demonstrated based on the average value of the measured emissions. The provisions in §15.35 apply to these measurements.

**FCC §15.407 (b)**

(b) Undesirable emission limits. Except as shown in paragraph (b)(7) of this section, the maximum emissions outside of the frequency bands of operation shall be attenuated in accordance with the following limits:

- (1) For transmitters operating in the 5.15-5.25 GHz band: All emissions outside of the 5.15-5.35 GHz band shall not exceed an e.i.r.p. of -27 dBm/MHz.
- (2) For transmitters operating in the 5.25-5.35 GHz band: All emissions outside of the 5.15-5.35 GHz band shall not exceed an e.i.r.p. of -27 dBm/MHz.
- (3) For transmitters operating in the 5.47-5.725 GHz band: All emissions outside of the 5.47-5.725 GHz band shall not exceed an e.i.r.p. of -27 dBm/MHz.
- (4) For transmitters operating solely in the 5.850-5.895 GHz band or operating on a channel that spans across 5.725-5.895 GHz:

(iii) For a client device or indoor access point or subordinate device, all emissions below 5.725 GHz shall not exceed an e.i.r.p. of -27 dBm/MHz at 5.65 GHz increasing linearly to 10 dBm/MHz at 5.7 GHz, and from 5.7 GHz increasing linearly to a level of 15.6 dBm/MHz at 5.72 GHz, and from 5.72 GHz increasing linearly to a level of 27 dBm/MHz at 5.725 GHz

- (5) The emission measurements shall be performed using a minimum resolution bandwidth of 1 MHz. A lower resolution bandwidth may be employed near the band edge, when necessary,  
provided the measured energy is integrated to show the total power over 1 MHz.
- (6) Unwanted emissions below 1 GHz must comply with the general field strength limits set forth in §15.209. Further, any U-NII devices using an AC power line are required to comply also with the conducted limits set forth in §15.207.
- (7) The provisions of §15.205 apply to intentional radiators operating under this section.
- (8) When measuring the emission limits, the nominal carrier frequency shall be adjusted as close to the upper and lower frequency band edges as the design of the equipment permits.

**Note**

- Limit translation to field strength level (FCC §15.407)

$$E[\text{dBuV/m}] = \text{EIRP}[\text{dBm}] + 95.2 = -27\text{dBm} + 95.2 = 68.2\text{dBuV/m}$$

$$E[\text{dBuV/m}] = \text{EIRP}[\text{dBm}] + 95.2 = -17\text{dBm} + 95.2 = 78.2\text{dBuV/m}$$

## **TEST PROCEDURE**

The EUT is placed on a non-conducting table 80 cm above the ground plane for below 1GHz and 100 cm for above 1GHz. The antenna to EUT distance is 3 meters. The EUT is configured in accordance with ANSI C63.10. The EUT is set to transmit in a continuous mode.

For measurements below 1 GHz the resolution bandwidth is set to 100 kHz for peak detection measurements or 120 kHz for quasi-peak detection measurements. Peak detection is used unless otherwise noted as quasi-peak.

Reference to KDB 789033 D02 v02r01 UNII part G) 6) c) Method AD:

For measurements above 1 GHz the resolution bandwidth is set to 1 MHz; the video bandwidth is set to 3 MHz for peak measurements and add duty cycle factor to the reading offset for average measurements.

Pre-scans to detect harmonic and spurious emissions, the resolution bandwidth is set to 1 MHz; the video bandwidth is set to 30 kHz for peak measurements.

The spectrum from 1GHz to 40 GHz is investigated with the transmitter set to the lowest, middle, and highest channels in each applicable band.  
(From 30MHz to 1GHz, test was performed with the EUT set to transmit at the channel with highest output power)

The frequency range of interest is monitored at a fixed antenna height and EUT azimuth. The EUT is rotated through 360 degrees to maximize emissions received. The antenna is scanned from 1 to 4 meters above the ground plane to further maximize the emission. Measurements are made with the antenna polarized in both the vertical and the horizontal positions.

Note : Emission was pre-scanned from 9kHz to 30MHz; No emissions were detected which was at least 20dB below the specification limit (consider distance correction factor).  
Per FCC part 15.31(o), test results were not reported.

Although these tests were performed other than open field test site, adequate comparison measurements were confirmed against 30 m open are test site.  
Therefore sufficient tests were made to demonstrate that the alternative site produces results that correlate with the one of tests made in an open field based on KDB 414788.

### 11.1. TX ABOVE 1GHz 2Tx MODE IN THE 5.2GHz BAND

**BANDEDGE (WORST CASE: 802.11n HT40 / 5190 MHz)**

**HORIZONTAL PEAK AND AVERAGE DATA**

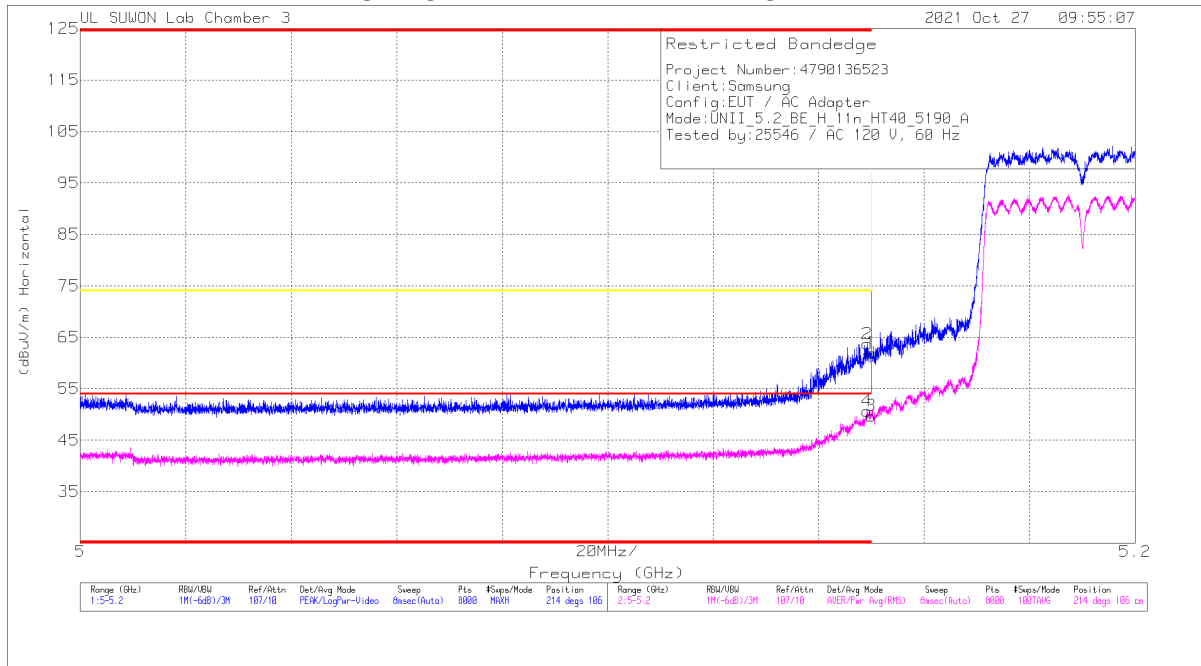

**Trace Markers**

Marker	Frequency (GHz)	Meter Reading (dBuV)	Det	3117_00218957	10dB_ATT[dB]	DC Corr (dB)	Corrected Reading (dBuV/m)	Average Limit (dBuV/m)	Margin (dB)	Peak Limit (dBuV/m)	PK Margin (dB)	Acimuth (Degs)	Height (cm)	Polarity
1	* 5.14999	48.32	Pk		-21.2	0	61.92	-	-	74	-12.08	214	106	H
2	* 5.14919	50.01	Pk		-21.1	0	63.71	-	-	74	-10.29	214	106	H
3	* 5.14999	36.01	RMS		-21.2	-12	49.73	54	-4.27	-	-	214	106	H
4	* 5.14912	36.8	RMS		-21.1	-12	50.62	54	-3.38	-	-	214	106	H

\* - indicates frequency in CFR47 Pt 15 / IC RSS-Restricted Band

Pk - Peak detector

RMS - RMS detection

**BANDEDGE TEST DATA**

Mode	Freq. [MHz]	Antenna	Frequency [GHz]	Reading [dBuV]	Detector Mode	ANT Factor	Loss [dB]	DC Corr [dB]	Result [dBuV/m]	AV Limit [dBuV/m]	AV Margin [dB]	PK Limit [dBuV/m]	PK Margin [dB]	Azimuth [Degs]	Height [cm]	Polarity		
802.11a	5180	MIMO	* 5.14999	40.60	Pk	34.80	-21.20	0.00	54.20	-	-	74.00	-19.80	213	212	H		
			* 5.11764	40.95	Pk	34.80	-21.10	0.00	54.65	-	-	74.00	-19.35	213	212	H		
			* 5.14999	29.38	RMS	34.80	-21.20	0.15	43.13	54.00	-10.87	-	-	74.00	-19.35	213	212	H
			* 5.14574	29.81	RMS	34.80	-21.10	0.15	43.66	54.00	-10.34	-	-	74.00	-19.35	213	212	H
			* 5.14999	37.76	Pk	34.80	-21.20	0.00	51.36	-	-	-	-	74.00	-22.64	208	101	V
			* 5.00538	41.30	Pk	34.70	-21.20	0.00	54.80	-	-	-	-	74.00	-19.20	208	101	V
			* 5.14999	27.90	RMS	34.80	-21.20	0.15	41.65	54.00	-12.35	-	-	74.00	-19.20	208	100	V
* 5.0007	29.41	RMS	34.70	-21.20	0.15	43.06	54.00	-10.94	-	-	74.00	-19.20	208	100	V			
802.11n (HT20)	5180	MIMO	* 5.14999	41.93	Pk	34.80	-21.20	0.00	55.53	-	-	74.00	-18.47	214	106	H		
			* 5.14994	44.00	Pk	34.80	-21.20	0.00	57.60	-	-	74.00	-16.40	214	106	H		
			* 5.14999	29.62	RMS	34.80	-21.20	0.00	43.22	54.00	-10.78	-	-	74.00	-16.40	214	106	H
			* 5.14954	30.19	RMS	34.80	-21.20	0.00	43.79	54.00	-10.21	-	-	74.00	-16.40	214	106	H
			* 5.14999	37.71	Pk	34.80	-21.20	0.00	51.31	-	-	-	-	74.00	-22.69	85	100	V
			* 5.00245	40.68	Pk	34.70	-21.20	0.00	54.18	-	-	-	-	74.00	-19.82	85	100	V
			* 5.14999	27.63	RMS	34.80	-21.20	0.00	41.23	54.00	-12.77	-	-	74.00	-19.82	85	100	V
* 5.14834	29.02	RMS	34.80	-21.10	0.00	42.72	54.00	-11.28	-	-	74.00	-19.82	85	100	V			
802.11n (HT40)	5190	MIMO	* 5.14999	48.32	Pk	34.80	-21.20	0.00	61.92	-	-	74.00	-12.08	214	106	H		
			* 5.14919	50.01	Pk	34.80	-21.10	0.00	63.71	-	-	74.00	-10.29	214	106	H		
			* 5.14999	36.01	RMS	34.80	-21.20	0.12	49.73	54.00	-4.27	-	-	74.00	-10.29	214	106	H
			* 5.14912	36.80	RMS	34.80	-21.10	0.12	50.62	54.00	-3.38	-	-	74.00	-10.29	214	106	H
			* 5.14999	40.98	Pk	34.80	-21.20	0.00	54.58	-	-	-	-	74.00	-19.42	204	359	V
			* 5.14937	44.00	Pk	34.80	-21.20	0.00	57.60	-	-	-	-	74.00	-16.40	204	359	V
			* 5.14999	30.63	RMS	34.80	-21.20	0.12	44.35	54.00	-9.65	-	-	74.00	-16.40	204	359	V
* 5.14947	31.67	RMS	34.80	-21.20	0.12	45.39	54.00	-8.61	-	-	74.00	-16.40	204	359	V			
802.11ac (VHT80)	5210	MIMO	* 5.14999	45.97	Pk	34.80	-21.20	0.00	59.57	-	-	74.00	-14.43	249	106	H		
			* 5.14504	48.03	Pk	34.80	-21.20	0.00	61.63	-	-	74.00	-12.37	249	106	H		
			* 5.14999	35.03	RMS	34.80	-21.20	0.20	48.83	54.00	-5.17	-	-	74.00	-12.37	249	106	H
			* 5.14637	36.04	RMS	34.80	-21.10	0.20	49.94	54.00	-4.06	-	-	74.00	-12.37	249	106	H
			* 5.14999	41.83	Pk	34.80	-21.20	0.00	55.43	-	-	-	-	74.00	-16.57	88	101	V
			* 5.14977	43.79	Pk	34.80	-21.20	0.00	57.39	-	-	-	-	74.00	-16.61	88	101	V
			* 5.14999	30.99	RMS	34.80	-21.20	0.20	44.79	54.00	-9.21	-	-	74.00	-16.61	88	100	V
* 5.14734	31.75	RMS	34.80	-21.10	0.20	45.65	54.00	-8.35	-	-	74.00	-16.61	88	100	V			
802.11ax (HE20)	5180	MIMO	* 5.14999	36.74	Pk	34.80	-21.20	0.00	50.34	-	-	74.00	-23.66	250	111	H		
			* 5.13014	40.32	Pk	34.80	-21.00	0.00	54.12	-	-	74.00	-19.88	250	111	H		
			* 5.14999	28.32	RMS	34.80	-21.20	0.40	42.32	54.00	-11.68	-	-	74.00	-19.88	250	111	H
			* 5.14544	29.34	RMS	34.80	-21.20	0.40	43.34	54.00	-10.66	-	-	74.00	-19.88	250	111	H
			* 5.14999	38.71	Pk	34.80	-21.20	0.00	52.31	-	-	-	-	74.00	-21.69	210	102	V
			* 5.00365	40.81	Pk	34.70	-21.20	0.00	54.31	-	-	-	-	74.00	-19.69	210	102	V
			* 5.14999	28.02	RMS	34.80	-21.20	0.40	42.02	54.00	-11.98	-	-	74.00	-19.69	210	102	V
* 5.009	29.28	RMS	34.70	-21.20	0.40	43.18	54.00	-10.82	-	-	74.00	-19.69	210	102	V			
802.11ax (HE40)	5190	MIMO	* 5.14999	36.96	Pk	34.80	-21.20	0.00	50.56	-	-	74.00	-23.44	213	236	H		
			* 5.13987	40.14	Pk	34.80	-21.10	0.00	53.84	-	-	74.00	-20.16	213	236	H		
			* 5.14999	29.08	RMS	34.80	-21.20	0.72	43.40	54.00	-10.60	-	-	74.00	-20.16	213	236	H
			* 5.00765	29.33	RMS	34.70	-21.20	0.72	43.55	54.00	-10.45	-	-	74.00	-20.16	213	236	H
			* 5.14999	38.96	Pk	34.80	-21.20	0.00	52.56	-	-	-	-	74.00	-21.44	77	107	V
			* 5.00363	41.07	Pk	34.70	-21.20	0.00	54.57	-	-	-	-	74.00	-19.43	77	107	V
			* 5.14999	27.53	RMS	34.80	-21.20	0.40	41.53	54.00	-12.47	-	-	74.00	-19.43	77	107	V
* 5.00233	29.17	RMS	34.70	-21.20	0.40	43.07	54.00	-10.93	-	-	74.00	-19.43	77	107	V			
802.11ax (HE80)	5210	MIMO	* 5.14999	39.07	Pk	34.80	-21.20	0.00	52.67	-	-	74.00	-21.33	194	211	H		
			* 5.13197	40.93	Pk	34.80	-21.10	0.00	54.63	-	-	74.00	-19.37	194	211	H		
			* 5.14999	28.94	RMS	34.80	-21.20	1.26	43.80	54.00	-10.20	-	-	74.00	-19.37	194	211	H
			* 5.14142	29.32	RMS	34.80	-21.10	1.26	44.28	54.00	-9.72	-	-	74.00	-19.37	194	211	H
			* 5.14999	37.95	Pk	34.80	-21.20	0.00	51.55	-	-	-	-	74.00	-22.45	198	108	V
			* 5.00095	40.62	Pk	34.70	-21.20	0.00	54.12	-	-	-	-	74.00	-19.88	198	108	V
			* 5.14999	27.94	RMS	34.80	-21.20	1.26	42.80	54.00	-11.20	-	-	74.00	-19.88	198	108	V
* 5.00238	29.24	RMS	34.70	-21.20	1.26	44.00	54.00	-10.00	-	-	74.00	-19.88	198	108	V			
802.11ax (HE20) ORU Spot-check	5180	ANT1	* 5.15	37.25	Pk	34.40	-18.00	0.00	53.65	-	-	74.00	-20.35	106	256	H		
			* 5.06923	39.50	Pk	34.30	-18.00	0.00	55.80	-	-	74.00	-18.20	106	256	H		
			* 5.15	26.76	RMS	34.40	-18.00	0.00	43.16	54.00	-10.84	-	-	74.00	-18.20	106	256	H
			* 5.0454	27.71	RMS	34.20	-18.00	0.00	43.91	54.00	-10.09	-	-	74.00	-18.20	106	256	H
			* 5.15	35.14	Pk	34.40	-18.00	0.00	51.54	-	-	-	-	74.00	-22.46	72	132	V
			* 5.11918	39.07	Pk	34.30	-18.00	0.00	55.37	-	-	-	-	74.00	-18.63	72	132	V
			* 5.15	26.24	RMS	34.40	-18.00	0.00	42.64	54.00	-11.36	-	-	74.00	-18.63	72	132	V
* 5.083	27.40	RMS	34.30	-18.00	0.00	43.70	54.00	-10.30	-	-	74.00	-18.63	72	132	V			

Note1. Pk - Peak detector, RMS - RMS detector  
 Note2. \* - indicates frequency in CFR47 Pt 15 / IC RSS-Restricted Band

**HARMONICS AND SPURIOUS EMISSIONS(WORST CASE: 802.11a / 5240 MHz)**  
**5240 MHz HORIZONTAL**

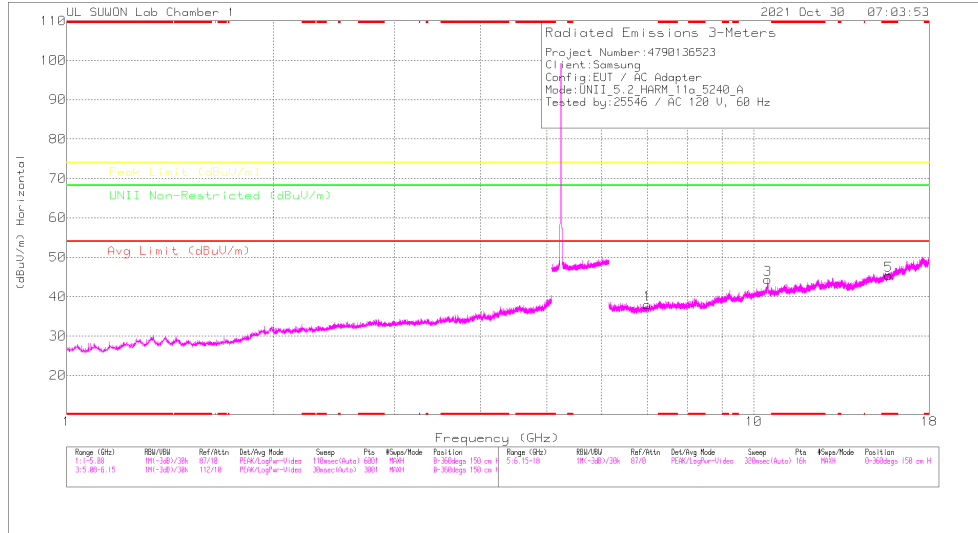

**5240 MHz VERTICAL**

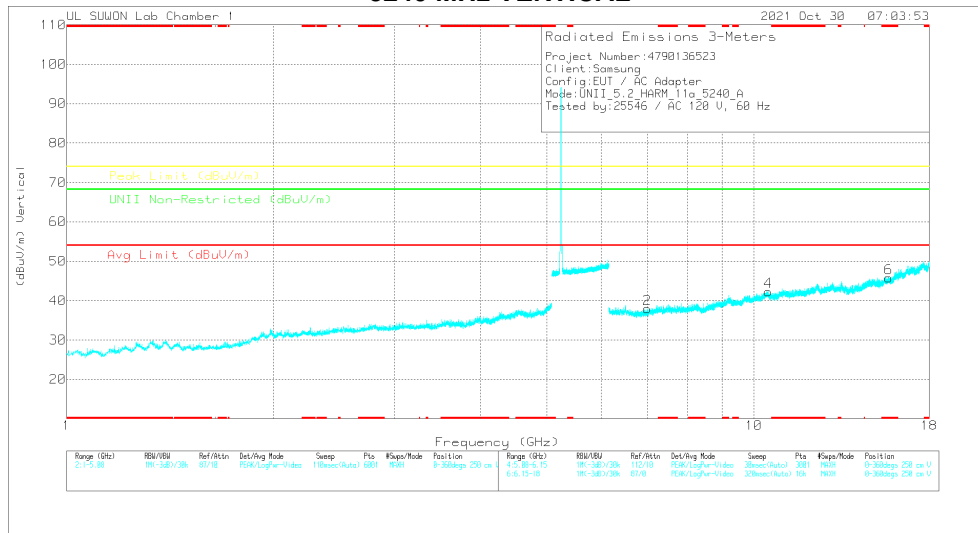

Note: Emission was scanned up to 40GHz; No emissions were detected above the noise floor which was at least 20dB below the specification limit.

**5240 MHz DATA**

**Radiated Emissions**

Frequency (GHz)	Meas Reading (dBuV)	Det	317_00168717	60Hz HF[dB]	DC Corr (dB)	Corrected Reading (dBuV/m)	Avg Limit (dBuV/m)	Margin (dB)	Peak Limit (dBuV/m)	Margin (dB)	UNII Non-Restricted (dBuV/m)	Margin (dB)	Altitude (Degs)	Height (m)	Polarity
6.99596	39.33	PK-U	35.7	-27.4	0	47.63	-	-	-	-	68.2	-20.57	0	100	H
6.99843	38.77	PK-U	35.7	-27.4	0	48.07	-	-	-	-	68.2	-20.13	0	100	V
10.47828	40.89	PK-U	37.9	-22.1	0	56.69	-	-	-	-	68.2	-11.51	240	219	H
10.49052	35.93	PK-U	37.9	-22.2	0	51.63	-	-	-	-	68.2	-16.57	0	100	V
* 15.71994	36.88	PK-U	40.1	-20.6	0	56.38	-	-	74	-17.82	-	-	0	100	H
* 15.71778	36.88	PK-U	40.1	-20.6	0	56.18	-	-	74	-17.82	-	-	0	100	V

\* - indicates frequency in CFR47 Pt 15 / IC RSS-Restricted Band  
 PK-U - U-NII: Maximum Peak  
 ADR - U-NII AD primary method, RMS average

**HARMONICS AND SPURIOUS EMISSIONS TEST DATA**

Freq. [MHz]	Antenna	Frequency [GHz]	Reading [dBuV]	Detector Mode	ANT Factor	Loss [dB]	DC Corr [dB]	Result [dBuV/m]	AV Limit [dBuV/m]	AV Margin [dB]	PK Limit [dBuV/m]	PK Margin [dB]	Non-Restricted [dBuV/m]	Margin [dB]	Azimuth [Degs]	Height [cm]	Polarity	
5180	MIMO	7.776	36.71	PK-U	36.30	-24.90	0.00	48.11	-	-	-	-	68.20	-20.09	0	100	H	
		7.764	36.66	PK-U	36.30	-25.00	0.00	47.96	-	-	-	-	68.20	-20.24	0	100	V	
		10.362	39.55	PK-U	38.10	-21.30	0.00	56.35	-	-	-	-	68.20	-11.85	208	100	H	
		10.355	34.88	PK-U	38.10	-21.30	0.00	51.68	-	-	-	-	68.20	-16.52	211	100	V	
		*15.53634	34.60	PK-U	40.20	-22.00	0.00	52.80	-	-	74.00	-21.20	-	-	-	0	100	H
		*15.5453	34.45	PK-U	40.20	-21.90	0.00	52.75	-	-	74.00	-21.25	-	-	-	0	100	V
5200	MIMO	6.930	40.39	PK-U	35.70	-28.00	0.00	48.09	-	-	-	-	68.20	-20.11	0	150	H	
		6.925	39.67	PK-U	35.60	-28.00	0.00	47.27	-	-	-	-	68.20	-20.93	102	250	V	
		10.398	39.44	PK-U	37.80	-21.40	0.00	55.84	-	-	-	-	68.20	-12.36	102	169	V	
		10.403	35.61	PK-U	37.80	-21.40	0.00	52.01	-	-	-	-	68.20	-16.19	102	250	V	
		*15.6077	36.81	PK-U	40.10	-21.10	0.00	55.81	-	-	74.00	-18.19	-	-	-	0	100	H
		*15.60635	24.56	ADR	40.10	-21.10	0.15	43.71	54.00	-10.29	-	-	-	-	-	0	100	H
		*15.60075	36.34	PK-U	40.10	-21.10	0.00	55.34	-	-	74.00	-18.66	-	-	-	0	100	V
		*15.60689	24.64	ADR	40.10	-21.10	0.15	43.79	54.00	-10.21	-	-	-	-	-	0	100	V
5240	MIMO	6.996	39.33	PK-U	35.70	-27.40	0.00	47.63	-	-	-	-	68.20	-20.57	0	150	H	
		6.998	39.77	PK-U	35.70	-27.40	0.00	48.07	-	-	-	-	68.20	-20.13	240	250	V	
		10.478	40.89	PK-U	37.90	-22.10	0.00	56.69	-	-	-	-	68.20	-11.51	240	219	H	
		10.491	35.93	PK-U	37.90	-22.20	0.00	51.63	-	-	-	-	68.20	-16.57	240	250	V	
		*15.71994	36.88	PK-U	40.10	-20.60	0.00	56.38	-	-	74.00	-17.62	-	-	-	0	100	H
		*15.72254	24.78	ADR	40.10	-20.60	0.15	44.43	54.00	-9.57	-	-	-	-	-	0	100	H
		*15.71778	36.68	PK-U	40.10	-20.60	0.00	56.18	-	-	74.00	-17.82	-	-	-	0	100	V
		*15.71795	24.94	ADR	40.10	-20.60	0.15	44.59	54.00	-9.41	-	-	-	-	-	0	100	V
5240	MIMO	7.860	35.80	PK-U	36.30	-24.30	0.00	47.80	-	-	-	-	68.20	-20.40	1	100	H	
		7.862	36.16	PK-U	36.30	-24.20	0.00	48.25	-	-	-	-	68.20	-19.94	1	100	V	
		10.480	33.61	PK-U	38.20	-21.50	0.00	50.31	-	-	-	-	68.20	-17.89	1	100	H	
		10.480	33.87	PK-U	38.20	-21.50	0.00	50.57	-	-	-	-	68.20	-17.63	1	100	V	
		*15.73131	34.12	PK-U	40.50	-21.50	0.00	53.12	-	-	74.00	-20.88	-	-	-	1	100	H
*15.72748	34.53	PK-U	40.50	-21.50	0.00	53.53	-	-	74.00	-20.47	-	-	-	1	100	V		

Note1. PK-U - U-NII: Maximum Peak

Note2. \* - indicates frequency in CFR47 Pt 15 / IC RSS-Restricted Band



## 11.2. TX ABOVE 1GHz 2Tx MODE IN THE 5.3GHz BAND

### BANDEDGE (WORST CASE: 802.11ac VHT80 / 5290 MHz)

#### HORIZONTAL PEAK AND AVERAGE DATA

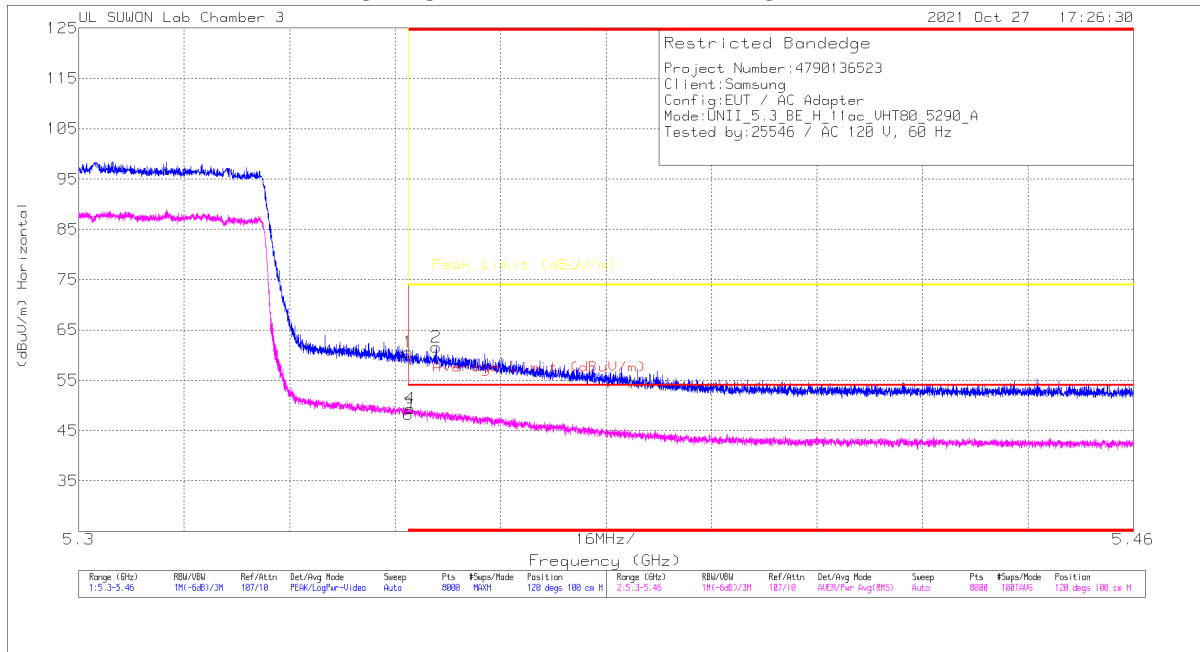

#### Trace Markers

Marker	Frequency (GHz)	Meter Reading (dBuV)	Det	3117_00218957	10dB_ATT[dB]	DC Cor (dB)	Corrected Reading (dBuV/m)	Average Limit (dBuV/m)	Margin (dB)	Peak Limit (dBuV/m)	PK Margin (dB)	Azimuth (Degs)	Height (cm)	Polarity
1	* 5.35001	46.18	Pk	35.1	-20.7	0	60.58	-	-	74	-13.42	120	100	H
2	* 5.35423	47.17	Pk	35.1	-20.7	0	61.57	-	-	74	-12.43	120	100	H
3	* 5.35001	33.62	RMS	35.1	-20.7	-2	48.22	54	-5.78	-	-	120	100	H
4	* 5.35027	34.73	RMS	35.1	-20.7	-2	49.33	54	-4.67	-	-	120	100	H

\* - indicates frequency in CFR47 Pt 15 / IC RSS-Restricted Band

Pk - Peak detector

RMS - RMS detection

**BANDEDGE TEST DATA**

Mode	Freq. [MHz]	Antenna	Frequency [GHz]	Reading [dBuV]	Detector Mode	ANT Factor	Loss [dB]	DC Corr [dB]	Result [dBuV/m]	AV Limit [dBuV/m]	AV Margin [dB]	PK Limit [dBuV/m]	PK Margin [dB]	Azimuth [Degs]	Height [cm]	Polarity		
802.11a	5320	MIMO	* 5.35001	38.59	Pk	35.10	-20.70	0.00	52.99	-	-	74.00	-21.01	119	100	H		
			* 5.35019	42.27	Pk	35.10	-20.70	0.00	56.67	-	-	74.00	-17.33	119	100	H		
			* 5.35001	29.09	RMS	35.10	-20.70	0.15	43.64	54.00	-10.36	-	-	-	119	100	H	
			* 5.35169	30.32	RMS	35.10	-20.80	0.15	44.77	54.00	-9.23	-	-	-	119	100	H	
			* 5.35001	38.78	Pk	35.10	-20.70	0.00	53.18	-	-	-	-	74.00	-20.82	210	109	V
			* 5.36333	40.61	Pk	35.10	-20.80	0.00	54.91	-	-	-	-	74.00	-19.09	210	109	V
			* 5.35001	28.77	RMS	35.10	-20.70	0.15	43.32	54.00	-10.68	-	-	-	-	210	109	V
			* 5.35891	29.05	RMS	35.10	-20.70	0.15	43.60	54.00	-10.40	-	-	-	-	210	109	V
802.11n (HT20)	5320	MIMO	* 5.35001	39.30	Pk	35.10	-20.70	0.00	53.70	-	-	74.00	-20.30	120	103	H		
			* 5.35037	42.81	Pk	35.10	-20.70	0.00	57.21	-	-	74.00	-16.79	120	103	H		
			* 5.35001	29.19	RMS	35.10	-20.70	0.00	43.59	54.00	-10.41	-	-	-	120	103	H	
			* 5.35153	30.52	RMS	35.10	-20.80	0.00	44.82	54.00	-9.18	-	-	-	120	103	H	
			* 5.35001	38.84	Pk	35.10	-20.70	0.00	53.24	-	-	-	-	74.00	-20.76	209	108	V
			* 5.35041	40.96	Pk	35.10	-20.70	0.00	55.36	-	-	-	-	74.00	-18.64	209	108	V
			* 5.35001	27.95	RMS	35.10	-20.70	0.00	42.35	54.00	-11.65	-	-	-	-	209	108	V
			* 5.35415	28.97	RMS	35.10	-20.70	0.00	43.37	54.00	-10.63	-	-	-	-	209	108	V
802.11n (HT40)	5310	MIMO	* 5.35001	46.00	Pk	35.10	-20.70	0.00	60.40	-	-	74.00	-13.60	245	100	H		
			* 5.35071	50.77	Pk	35.10	-20.70	0.00	65.17	-	-	74.00	-8.83	245	100	H		
			* 5.35001	33.44	RMS	35.10	-20.70	0.12	47.96	54.00	-6.04	-	-	-	245	100	H	
			* 5.35003	34.53	RMS	35.10	-20.70	0.12	49.05	54.00	-4.95	-	-	-	245	100	H	
			* 5.35001	46.26	Pk	35.10	-20.70	0.00	60.66	-	-	-	-	74.00	-13.34	210	103	V
			* 5.35131	48.05	Pk	35.10	-20.80	0.00	62.35	-	-	-	-	74.00	-11.65	210	103	V
			* 5.35001	31.49	RMS	35.10	-20.70	0.12	46.01	54.00	-7.99	-	-	-	-	210	103	V
			* 5.35213	33.10	RMS	35.10	-20.80	0.12	47.52	54.00	-6.48	-	-	-	-	210	103	V
802.11ac (VHT80)	5290	MIMO	* 5.35001	46.18	Pk	35.10	-20.70	0.00	60.58	-	-	74.00	-13.42	120	100	H		
			* 5.35423	47.17	Pk	35.10	-20.70	0.00	61.57	-	-	74.00	-12.43	120	100	H		
			* 5.35001	33.62	RMS	35.10	-20.70	0.20	48.22	54.00	-5.78	-	-	-	120	100	H	
			* 5.35027	34.73	RMS	35.10	-20.70	0.20	49.33	54.00	-4.67	-	-	-	120	100	H	
			* 5.35001	40.55	Pk	35.10	-20.70	0.00	54.95	-	-	-	-	74.00	-19.05	211	106	V
			* 5.37059	44.82	Pk	35.10	-20.70	0.00	59.22	-	-	-	-	74.00	-14.78	211	106	V
			* 5.35001	30.77	RMS	35.10	-20.70	0.20	45.37	54.00	-8.63	-	-	-	-	211	106	V
			* 5.35115	32.06	RMS	35.10	-20.80	0.20	46.56	54.00	-7.44	-	-	-	-	211	106	V
802.11ax (HE20) 8RU Spot-check	5320	ANT1	* 5.35002	38.52	Pk	34.50	-18.00	0.00	55.02	-	-	74.00	-18.98	112	258	H		
			* 5.43214	40.11	Pk	34.60	-18.10	0.00	56.61	-	-	74.00	-17.39	112	258	H		
			* 5.35002	27.99	RMS	34.50	-18.00	0.00	43.89	54.00	-10.11	-	-	-	112	258	H	
			* 5.43252	28.07	RMS	34.60	-18.10	0.00	44.57	54.00	-9.43	-	-	-	112	258	H	
			* 5.35002	37.12	Pk	34.50	-18.00	0.00	53.62	-	-	-	-	74.00	-20.38	90	156	V
			* 5.406	40.52	Pk	34.60	-18.00	0.00	57.12	-	-	-	-	74.00	-16.88	90	156	V
			* 5.35002	27.07	RMS	34.50	-18.00	0.00	43.57	54.00	-10.43	-	-	-	-	90	156	V
			* 5.42798	27.58	RMS	34.60	-18.00	0.00	44.18	54.00	-9.82	-	-	-	-	90	156	V

Note1. Pk - Peak detector, RMS - RMS detector  
 Note2. \* - indicates frequency in CFR47 Pt 15 / IC RSS-Restricted Band

**HARMONICS AND SPURIOUS EMISSIONS(WORST CASE: 802.11a / 5300 MHz)**  
**5300 MHz HORIZONTAL**

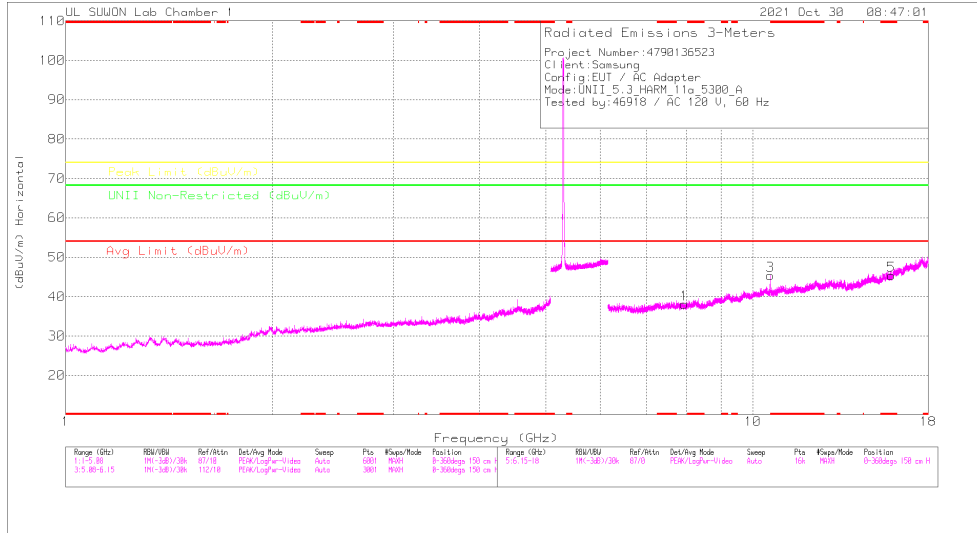

**5300 MHz VERTICAL**

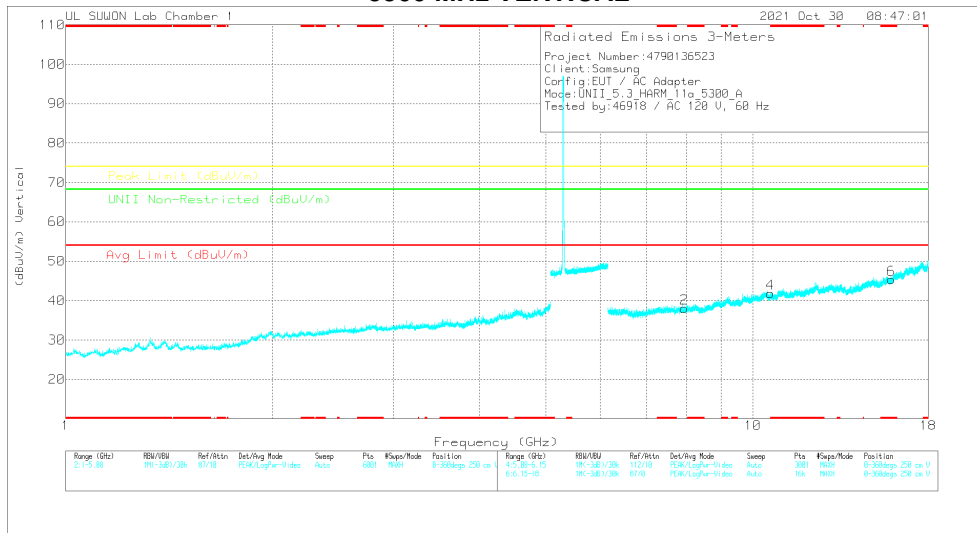

Note: Emission was scanned up to 40GHz; No emissions were detected above the noise floor which was at least 20dB below the specification limit.

**5300 MHz DATA**

**Radiated Emissions**

Frequency (GHz)	Max. Reading (dBuV)	Det	317_00168717	60Hz_HPS(B)	DC Corr (dB)	Consolidated Reading (dBuV/m)	Avg Limit (dBuV/m)	Margin (dB)	Peak Limit (dBuV/m)	Margin (dB)	UNII Non-Restricted (dBuV/m)	Margin (dB)	Azimuth (Deg)	Height (m)	Polarity
7.95046	38.12	PK-U	36	-25.9	0	48.22	-	-	-	-	68.2	-19.98	0	150	H
7.94915	38.64	PK-U	36	-25.9	0	48.74	-	-	-	-	68.2	-19.46	0	250	V
*10.60174	39.95	PK-U	38	-22.3	0	55.65	-	-	74	-18.35	-	-	103	127	H
*10.60227	27.23	ADR	38	-22.3	-15	43.08	54	-10.92	-	-	-	-	103	127	H
*10.60285	36.68	PK-U	38	-22.3	0	52.38	-	-	74	-21.62	-	-	215	248	V
*10.60205	24.47	ADR	38	-22.3	-15	40.32	54	-13.68	-	-	-	-	215	248	V
*15.9015	36.56	PK-U	40.3	-20.8	0	56.06	-	-	74	-17.94	-	-	360	150	H
*15.89973	36.99	PK-U	40.3	-20.8	0	56.49	-	-	74	-17.51	-	-	360	100	V

\* - indicates frequency in CFR47 Pt 15 / IC RSS-Restricted Band  
 PK-U - U-NII: Maximum Peak  
 ADR - U-NII AD primary method, RMS average

**HARMONICS AND SPURIOUS EMISSIONS TEST DATA**

Mode	Freq. [MHz]	Antenna	Frequency [GHz]	Reading [dBuV]	Detector Mode	ANT Factor	Loss [dB]	DC Corr [dB]	Result [dBuV/m]	AV Limit [dBuV/m]	AV Margin [dB]	PK Limit [dBuV/m]	PK Margin [dB]	Non-Restricted [dBuV/m]	Margin [dB]	Azimuth [Degs]	Height [cm]	Polarity		
802.11a	5260	MIMO	7.231	39.74	PK-U	35.90	-27.00	0.00	48.64	-	-	-	-	68.20	-19.56	360	100	H		
			7.227	39.29	PK-U	35.90	-27.10	0.00	48.09	-	-	-	-	68.20	-20.11	360	100	V		
			10.523	40.10	PK-U	37.90	-22.50	0.00	55.50	-	-	-	-	68.20	-12.70	194	190	H		
			10.520	36.13	PK-U	37.90	-22.40	0.00	51.63	-	-	-	-	68.20	-16.57	0	100	V		
			*15.77986	36.62	PK-U	40.20	-20.60	0.00	56.22	-	-	-	74.00	-17.78	-	-	0	100	H	
			*15.77892	24.62	ADR	40.20	-20.60	0.15	44.37	54.00	-9.63	-	-	-	-	-	0	100	H	
			*15.77859	37.85	PK-U	40.20	-20.60	0.00	57.45	-	-	-	74.00	-16.55	-	-	0	100	V	
			*15.77804	24.80	ADR	40.20	-20.60	0.15	44.55	54.00	-9.45	-	-	-	-	-	0	100	V	
	5300	MIMO	7.950	38.12	PK-U	36.00	-25.90	0.00	48.22	-	-	-	-	68.20	-19.98	0	150	H		
			7.949	38.64	PK-U	36.00	-25.90	0.00	48.74	-	-	-	-	68.20	-19.46	0	250	V		
			*10.60174	39.95	PK-U	38.00	-22.30	0.00	55.65	-	-	-	74.00	-18.35	-	-	103	127	H	
			*10.60227	27.23	ADR	38.00	-22.30	0.15	43.08	54.00	-10.92	-	-	-	-	-	103	127	H	
			*10.60285	36.68	PK-U	38.00	-22.30	0.00	52.38	-	-	-	74.00	-21.62	-	-	215	248	V	
			*10.60205	24.47	ADR	38.00	-22.30	0.15	40.32	54.00	-13.68	-	-	-	-	-	215	248	V	
			*15.9015	36.56	PK-U	40.30	-20.80	0.00	56.06	-	-	-	74.00	-17.94	-	-	360	150	H	
			*15.90272	24.24	ADR	40.30	-20.80	0.15	43.89	54.00	-10.11	-	-	-	-	-	360	150	H	
			*15.89973	36.99	PK-U	40.30	-20.80	0.00	56.49	-	-	-	74.00	-17.51	-	-	360	100	V	
			*15.89894	24.28	ADR	40.30	-20.80	0.15	43.93	54.00	-10.07	-	-	-	-	-	360	100	V	
			5320	MIMO	7.987	36.00	PK-U	36.30	-24.60	0.00	47.70	-	-	-	-	68.20	-20.50	0	100	H
					*7.979	35.69	PK-U	36.30	-24.60	0.00	47.39	-	-	-	-	68.20	-20.81	0	100	V
	*10.6387	37.03			PK-U	38.30	-21.60	0.00	53.73	-	-	-	74.00	-20.27	-	-	186	208	H	
	*10.6421	24.64			ADR	38.30	-21.50	0.15	41.59	54.00	-12.41	-	-	-	-	186	208	H		
	*10.63251	34.57			PK-U	38.30	-21.60	0.00	51.27	-	-	-	74.00	-22.73	-	-	94	101	V	
	*10.64202	23.22			ADR	38.30	-21.50	0.15	40.17	54.00	-13.83	-	-	-	-	94	101	V		
*15.96739	34.82	PK-U			40.90	-20.90	0.00	54.82	-	-	-	74.00	-19.18	-	-	0	100	H		
*15.96684	22.12	ADR			40.90	-20.90	0.15	42.27	54.00	-11.73	-	-	-	-	0	100	H			
802.11ax (HE20) 8RU Spot-Check	5320	MIMO	7.984	35.79	PK-U	36.30	-24.60	0.00	47.49	-	-	-	-	68.20	-20.71	0	100	H		
			7.987	35.74	PK-U	36.30	-24.70	0.00	47.34	-	-	-	-	68.20	-20.86	0	100	V		
			*10.63497	33.56	PK-U	38.30	-21.50	0.00	50.36	-	-	-	74.00	-23.64	-	-	0	100	H	
			*15.95867	34.16	PK-U	40.90	-20.90	0.00	54.16	-	-	-	74.00	-19.84	-	-	0	100	H	
			*15.95798	21.82	ADR	40.90	-20.90	0.00	41.82	54.00	-12.18	-	-	-	-	0	100	H		
			*10.64123	33.80	PK-U	38.30	-21.50	0.00	50.60	-	-	-	74.00	-23.40	-	-	0	100	V	
			*15.96455	34.85	PK-U	40.90	-20.90	0.00	54.85	-	-	-	74.00	-19.15	-	-	0	100	V	
			*15.96382	22.64	ADR	40.90	-20.90	0.00	42.64	54.00	-11.36	-	-	-	-	0	100	V		

Note1. PK-U - U-NII: Maximum Peak / ADR - U-NII AD primary method, RMS average

Note2. \* - indicates frequency in CFR47 Pt 15 / IC RSS-Restricted Band

### 11.3. TX ABOVE 1GHz 2Tx MODE IN THE 5.5 GHz BAND

**BANDEDGE (WORST CASE: 802.11a / 5700 MHz)**

**HORIZONTAL PEAK AND AVERAGE DATA**

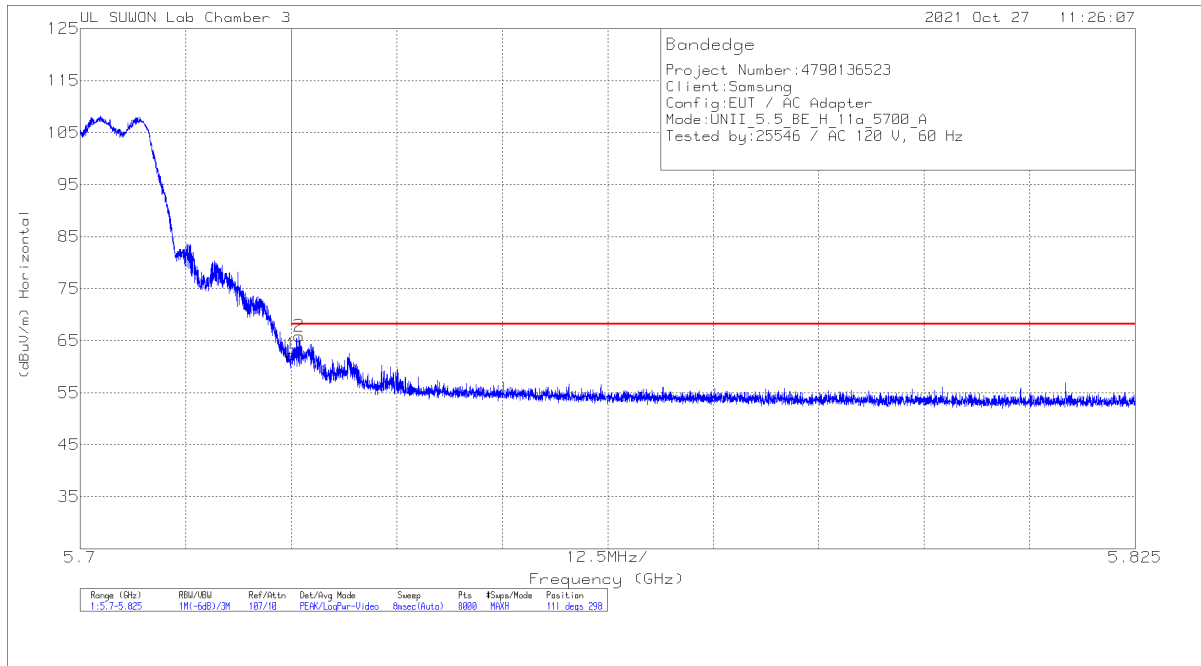

**Trace Markers**

Marker	Frequency (GHz)	Meter Reading (dBuV)	Det	3117_00218957	10dB_ATT[dB]	DC Corr (dB)	Corrected Reading (dBuV/m)	Peak Limit (dBuV/m)	PK Margin (dB)	Azimuth (Degs)	Height (cm)	Polarity
1	5.725	46.7	Pk	35.7	-20	0	62.4	68.2	-5.8	111	298	H
2	5.72593	50.18	Pk	35.7	-20	0	65.88	68.2	-2.32	111	298	H

\* - indicates frequency in CFR47 Pt 15 / IC RSS-Restricted Band  
 Pk - Peak detector  
 RMS - RMS detection

**BANDEDGE TEST DATA**

Mode	Freq. [MHz]	Antenna	Frequency [GHz]	Reading [dBuV]	Detector Mode	ANT Factor	Loss [dB]	DC Corr [dB]	Result [dBuV/m]	AV Limit [dBuV/m]	AV Margin [dB]	PK Limit [dBuV/m]	PK Margin [dB]	Azimuth [Degs]	Height [cm]	Polarity	
802.11a	5500	MIMO	* 5.45998	40.02	Pk	35.30	-20.60	0.00	54.72	-	-	74.00	-19.28	106	337	H	
			* 5.43736	41.36	Pk	35.30	-20.70	0.00	55.96	-	-	74.00	-18.04	106	337	H	
			5.46998	41.14	Pk	35.30	-20.60	0.00	55.84	-	-	68.20	-12.36	106	337	H	
			5.46963	43.79	Pk	35.30	-20.60	0.00	58.49	-	-	68.20	-9.71	106	337	H	
			* 5.45998	29.31	RMS	35.30	-20.60	0.15	44.16	54.00	-9.84	-	-	106	337	H	
			* 5.45628	30.05	RMS	35.30	-20.60	0.15	44.90	54.00	-9.10	-	-	106	337	H	
			5.46998	30.46	RMS	35.30	-20.60	0.15	45.31	-	-	-	-	106	337	H	
			5.46864	30.99	RMS	35.30	-20.60	0.15	45.84	-	-	-	-	106	337	H	
			* 5.45998	37.98	Pk	35.30	-20.60	0.00	52.68	-	-	74.00	-21.32	176	258	V	
			* 5.43635	40.51	Pk	35.30	-20.70	0.00	55.11	-	-	74.00	-18.89	176	258	V	
			5.46998	40.23	Pk	35.30	-20.60	0.00	54.93	-	-	68.20	-13.27	176	258	V	
			5.46845	44.40	Pk	35.30	-20.60	0.00	59.10	-	-	68.20	-9.10	176	258	V	
	* 5.45998	27.79	RMS	35.30	-20.60	0.15	42.64	54.00	-11.36	-	-	176	258	V			
	* 5.45197	29.54	RMS	35.30	-20.60	0.15	44.39	54.00	-9.61	-	-	176	258	V			
	5.46998	29.43	RMS	35.30	-20.60	0.15	44.28	-	-	-	-	176	258	V			
	5.46893	30.55	RMS	35.30	-20.60	0.15	45.40	-	-	-	-	176	258	V			
	* 5.72500	46.70	Pk	35.70	-20.00	0.00	62.40	-	-	68.20	-5.80	111	298	H			
	5.72593	50.18	Pk	35.70	-20.00	0.00	65.88	-	-	68.20	-2.32	111	298	H			
	5.72500	46.01	Pk	35.70	-20.00	0.00	61.71	-	-	68.20	-6.49	157	132	V			
	5.72502	48.04	Pk	35.70	-20.00	0.00	63.74	-	-	68.20	-4.46	157	132	V			
	802.11n (HT20)	5500	MIMO	* 5.45998	39.13	Pk	35.30	-20.60	0.00	53.83	-	-	74.00	-20.17	109	288	H
				* 5.45178	42.05	Pk	35.30	-20.60	0.00	56.75	-	-	74.00	-17.25	109	288	H
				5.46998	43.11	Pk	35.30	-20.60	0.00	57.81	-	-	68.20	-10.39	109	288	H
				5.46867	48.17	Pk	35.30	-20.60	0.00	62.87	-	-	68.20	-5.33	109	288	H
* 5.45998				29.02	RMS	35.30	-20.60	0.00	43.72	54.00	-10.28	-	-	109	288	H	
* 5.45637				30.52	RMS	35.30	-20.60	0.00	45.22	54.00	-8.78	-	-	109	288	H	
5.46998				31.34	RMS	35.30	-20.60	0.00	46.04	-	-	-	-	109	288	H	
5.46858				32.60	RMS	35.30	-20.60	0.00	47.30	-	-	-	-	109	288	H	
* 5.45998				39.28	Pk	35.30	-20.60	0.00	53.98	-	-	74.00	-20.02	154	374	V	
* 5.38691				40.69	Pk	35.20	-20.70	0.00	55.19	-	-	74.00	-18.81	154	374	V	
5.46998				41.66	Pk	35.30	-20.60	0.00	56.36	-	-	68.20	-11.84	154	374	V	
5.46661				44.18	Pk	35.30	-20.60	0.00	58.88	-	-	68.20	-9.32	154	374	V	
* 5.45998		28.68	RMS	35.30	-20.60	0.00	43.38	54.00	-10.62	-	-	154	374	V			
* 5.41019		29.19	RMS	35.20	-20.60	0.00	43.79	54.00	-10.21	-	-	154	374	V			
5.46998		28.78	RMS	35.30	-20.60	0.00	43.48	-	-	-	-	154	374	V			
5.46875		30.34	RMS	35.30	-20.60	0.00	45.04	-	-	-	-	154	374	V			
* 5.72500		44.58	Pk	35.70	-20.00	0.00	60.28	-	-	68.20	-7.92	107	269	H			
5.72524		47.96	Pk	35.70	-20.00	0.00	63.66	-	-	68.20	-4.54	107	269	H			
* 5.72500		45.01	Pk	35.70	-20.00	0.00	60.71	-	-	68.20	-7.49	158	134	V			
5.72505		47.98	Pk	35.70	-20.00	0.00	63.68	-	-	68.20	-4.52	158	134	V			
802.11n (HT40)		5510	MIMO	* 5.45998	40.14	Pk	35.30	-20.60	0.00	54.84	-	-	74.00	-19.16	112	337	H
				* 5.45961	43.65	Pk	35.30	-20.60	0.00	58.35	-	-	74.00	-15.65	112	337	H
				5.46998	45.08	Pk	35.30	-20.60	0.00	59.78	-	-	68.20	-8.42	112	337	H
				5.46950	48.67	Pk	35.30	-20.60	0.00	63.37	-	-	68.20	-4.83	112	337	H
	* 5.45998			29.46	RMS	35.30	-20.60	0.12	44.28	54.00	-9.72	-	-	112	337	H	
	* 5.45919			30.17	RMS	35.30	-20.50	0.12	45.09	54.00	-8.91	-	-	112	337	H	
	5.46998			30.90	RMS	35.30	-20.60	0.12	45.72	-	-	-	-	112	337	H	
	5.46882			33.29	RMS	35.30	-20.60	0.12	48.11	-	-	-	-	112	337	H	
	* 5.45998			38.46	Pk	35.30	-20.60	0.00	53.16	-	-	74.00	-20.84	204	100	V	
	* 5.45902			41.94	Pk	35.30	-20.50	0.00	56.74	-	-	74.00	-17.26	204	100	V	
	5.46998			41.90	Pk	35.30	-20.60	0.00	56.60	-	-	68.20	-11.60	204	100	V	
	5.46961			45.13	Pk	35.30	-20.60	0.00	59.83	-	-	68.20	-8.37	204	100	V	
	* 5.45998	28.45	RMS	35.30	-20.60	0.12	43.27	54.00	-10.73	-	-	204	100	V			
	* 5.45908	29.31	RMS	35.30	-20.50	0.12	44.23	54.00	-9.77	-	-	204	100	V			
	5.46998	31.39	RMS	35.30	-20.60	0.12	46.21	-	-	-	-	204	100	V			
	5.46937	32.30	RMS	35.30	-20.60	0.12	47.12	-	-	-	-	204	100	V			
	* 5.72500	40.96	Pk	35.70	-20.00	0.00	56.66	-	-	68.20	-11.54	112	270	H			
	5.72538	43.28	Pk	35.70	-20.00	0.00	58.98	-	-	68.20	-9.22	112	270	H			
	5.72500	40.14	Pk	35.70	-20.00	0.00	55.84	-	-	68.20	-12.36	157	127	V			
	5.72743	43.38	Pk	35.70	-20.00	0.00	59.08	-	-	68.20	-9.12	157	127	V			
	802.11ac (VHT80)	5530	MIMO	* 5.45998	45.19	Pk	35.30	-20.60	0.00	59.89	-	-	74.00	-14.11	112	236	H
				* 5.45797	48.90	Pk	35.30	-20.60	0.00	63.60	-	-	74.00	-10.40	112	236	H
				5.46998	47.52	Pk	35.30	-20.60	0.00	62.22	-	-	68.20	-5.98	112	236	H
				5.46037	50.32	Pk	35.30	-20.60	0.00	65.02	-	-	68.20	-3.18	112	236	H
* 5.45998				33.12	RMS	35.30	-20.60	0.20	48.02	54.00	-5.98	-	-	112	236	H	
* 5.45943				34.37	RMS	35.30	-20.60	0.20	49.27	54.00	-4.73	-	-	112	236	H	
5.46998				34.27	RMS	35.30	-20.60	0.20	49.17	-	-	-	-	112	236	H	
5.46746				35.35	RMS	35.30	-20.60	0.20	50.25	-	-	-	-	112	236	H	
* 5.45998				43.06	Pk	35.30	-20.60	0.00	57.76	-	-	74.00	-16.24	195	100	V	
* 5.45974				44.50	Pk	35.30	-20.60	0.00	59.20	-	-	74.00	-14.80	195	100	V	
5.46998				43.01	Pk	35.30	-20.60	0.00	57.71	-	-	68.20	-10.49	195	100	V	
5.46915				45.91	Pk	35.30	-20.60	0.00	60.61	-	-	68.20	-7.59	195	100	V	
* 5.45998		31.75	RMS	35.30	-20.60	0.20	46.65	54.00	-7.35	-	-	195	100	V			
* 5.45854		31.90	RMS	35.30	-20.60	0.20	46.80	54.00	-7.20	-	-	195	100	V			
5.46998		32.17	RMS	35.30	-20.60	0.20	47.07	-	-	-	-	195	100	V			
5.46996		32.96	RMS	35.30	-20.60	0.20	47.86	-	-	-	-	195	100	V			
* 5.72501		37.47	Pk	35.70	-20.00	0.00	53.17	-	-	68.20	-15.03	109	262	H			
5.72644		40.04	Pk	35.70	-20.00	0.00	55.74	-	-	68.20	-12.46	109	262	H			
5.72501		38.36	Pk	35.70	-20.00	0.00	54.06	-	-	68.20	-14.14	162	125	V			
5.80154		40.04	Pk	35.80	-19.80	0.00	56.04	-	-	68.20	-12.16	162	125	V			

Mode	Freq. [MHz]	Antenna	Frequency [GHz]	Reading [dBuV]	Detector Mode	ANT Factor	Loss [dB]	DC Corr [dB]	Result [dBuV/m]	AV Limit [dBuV/m]	AV Margin [dB]	PK Limit [dBuV/m]	PK Margin [dB]	Azimuth [Degs]	Height [cm]	Polarity		
802.11ax (HE20) Spot-check	5500 ORU	ANT1	* 5.45999	36.74	Pk	34.60	-18.00	0.00	53.34	-	-	74.00	-20.66	113	267	H		
			* 5.44015	40.07	Pk	34.60	-18.10	0.00	56.57	-	-	74.00	-17.43	113	267	H		
			5.46998	37.08	Pk	34.60	-18.00	0.00	53.68	-	-	68.20	-14.52	113	267	H		
			5.46152	39.50	Pk	34.60	-18.10	0.00	56.00	-	-	68.20	-12.20	113	267	H		
			* 5.45999	27.40	RMS	34.60	-18.00	0.00	44.00	54.00	-10.00	-	-	-	-	113	267	H
			* 5.41114	28.03	RMS	34.60	-18.10	0.00	44.53	54.00	-9.47	-	-	-	-	113	267	H
			5.46998	27.45	RMS	34.60	-18.00	0.00	44.05	-	-	-	-	-	-	113	267	H
			5.46911	28.23	RMS	34.60	-18.00	0.00	44.83	-	-	-	-	-	-	113	267	H
			* 5.45999	37.23	Pk	34.60	-18.00	0.00	53.83	-	-	74.00	-20.17	148	336	V		
			* 5.42788	39.57	Pk	34.60	-18.00	0.00	56.17	-	-	74.00	-17.83	148	336	V		
			5.46998	35.86	Pk	34.60	-18.00	0.00	52.46	-	-	68.20	-15.74	148	336	V		
			5.46843	39.30	Pk	34.60	-18.00	0.00	55.90	-	-	68.20	-12.30	148	336	V		
	* 5.45999	26.69	RMS	34.60	-18.00	0.00	43.29	54.00	-10.71	-	-	-	-	148	336	V		
	* 5.45738	27.69	RMS	34.60	-18.00	0.00	44.29	54.00	-9.71	-	-	-	-	148	336	V		
	5.46998	27.62	RMS	34.60	-18.00	0.00	44.22	-	-	-	-	-	-	148	336	V		
	5.46113	27.51	RMS	34.60	-18.10	0.00	44.01	-	-	-	-	-	-	148	336	V		
	5700 8RU	ANT1	5.72502	39.13	Pk	34.70	-17.40	0.00	56.43	-	-	68.20	-11.77	102	278	H		
			5.81591	40.44	Pk	34.90	-17.30	0.00	58.04	-	-	68.20	-10.16	102	278	H		
			5.72502	35.71	Pk	34.70	-17.40	0.00	53.01	-	-	68.20	-15.19	139	118	V		
			5.76784	40.39	Pk	34.80	-17.40	0.00	57.79	-	-	68.20	-10.41	139	118	V		
			* 5.45999	38.84	Pk	34.60	-18.00	0.00	55.44	-	-	74.00	-18.56	107	283	H		
			* 5.45979	43.57	Pk	34.60	-18.00	0.00	60.17	-	-	74.00	-13.83	107	283	H		
	802.11n (HT40)	5510	ANT1	5.46998	42.71	Pk	34.60	-18.00	0.00	59.31	-	-	68.20	-8.89	107	283	H	
				5.46823	48.68	Pk	34.60	-18.00	0.00	65.28	-	-	68.20	-2.92	107	283	H	
* 5.45999				29.39	RMS	34.60	-18.00	0.12	46.11	54.00	-7.89	-	-	-	107	283	H	
* 5.45835				30.05	RMS	34.60	-18.10	0.12	46.67	54.00	-7.33	-	-	-	107	283	H	
5.46998				31.77	RMS	34.60	-18.00	0.12	48.49	-	-	-	-	-	-	107	283	H
5.46955				31.87	RMS	34.60	-18.00	0.12	48.59	-	-	-	-	-	-	107	283	H
* 5.45999				39.17	Pk	34.60	-18.00	0.00	55.77	-	-	74.00	-18.23	136	291	V		
* 5.4585				40.76	Pk	34.60	-18.10	0.00	57.26	-	-	74.00	-16.74	136	291	V		
5.46998				41.08	Pk	34.60	-18.00	0.00	57.68	-	-	68.20	-10.52	136	291	V		
5.46953				46.15	Pk	34.60	-18.00	0.00	62.75	-	-	68.20	-5.45	136	291	V		
* 5.45999				27.60	RMS	34.60	-18.00	0.12	44.32	54.00	-9.68	-	-	-	-	136	291	V
* 5.45887				28.65	RMS	34.60	-18.10	0.12	45.27	54.00	-8.73	-	-	-	-	136	291	V
5.46998				29.07	RMS	34.60	-18.00	0.12	45.79	-	-	-	-	-	-	136	291	V
5.46950				29.61	RMS	34.60	-18.00	0.12	46.33	-	-	-	-	-	-	136	291	V
* 5.45999				37.61	Pk	34.60	-18.00	0.00	54.21	-	-	74.00	-19.79	137	148	H		
* 5.45938				39.86	Pk	34.60	-18.10	0.00	56.36	-	-	74.00	-17.64	137	148	H		
5.46998				41.18	Pk	34.60	-18.00	0.00	57.78	-	-	68.20	-10.42	137	148	H		
5.46992				43.88	Pk	34.60	-18.00	0.00	60.48	-	-	68.20	-7.72	137	148	H		
* 5.45999	27.91	RMS	34.60	-18.00	0.12	44.63	54.00	-9.37	-	-	-	-	137	148	H			
* 5.4599	28.42	RMS	34.60	-18.00	0.12	45.14	54.00	-8.86	-	-	-	-	137	148	H			
5.46998	30.90	RMS	34.60	-18.00	0.12	47.62	-	-	-	-	-	-	137	148	H			
5.46985	31.43	RMS	34.60	-18.00	0.12	48.15	-	-	-	-	-	-	137	148	H			
* 5.45999	40.16	Pk	34.60	-18.00	0.00	56.76	-	-	74.00	-17.24	146	107	V					
* 5.45686	41.30	Pk	34.60	-18.10	0.00	57.80	-	-	74.00	-15.20	146	107	V					
5.46998	42.17	Pk	34.60	-18.00	0.00	58.77	-	-	68.20	-9.43	146	107	V					
5.46909	45.23	Pk	34.60	-18.00	0.00	61.83	-	-	68.20	-6.37	146	107	V					
* 5.45999	28.52	RMS	34.60	-18.00	0.12	45.24	54.00	-8.76	-	-	-	-	146	107	V			
* 5.45973	29.25	RMS	34.60	-18.10	0.12	45.87	54.00	-8.13	-	-	-	-	146	107	V			
5.46998	32.46	RMS	34.60	-18.00	0.12	49.18	-	-	-	-	-	-	146	107	V			
5.46950	32.12	RMS	34.60	-18.00	0.12	48.84	-	-	-	-	-	-	146	107	V			

Note1. Pk - Peak detector, RMS - RMS detector  
 Note2. \* - indicates frequency in CFR47 Pt 15 / IC RSS-Restricted Band



**HARMONICS AND SPURIOUS EMISSIONS(WORST CASE: 802.11a / 5580 MHz)**  
**5580 MHz HORIZONTAL**

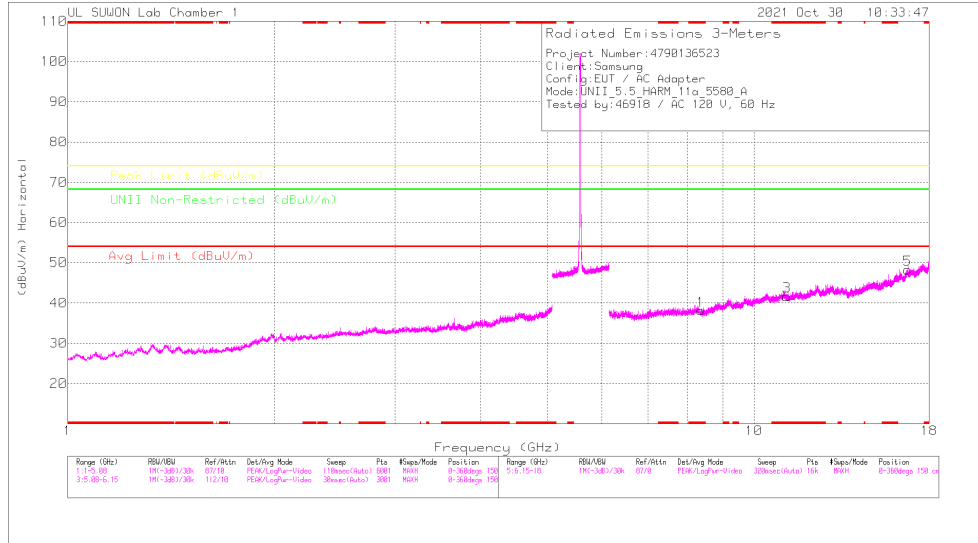

**5580 MHz VERTICAL**

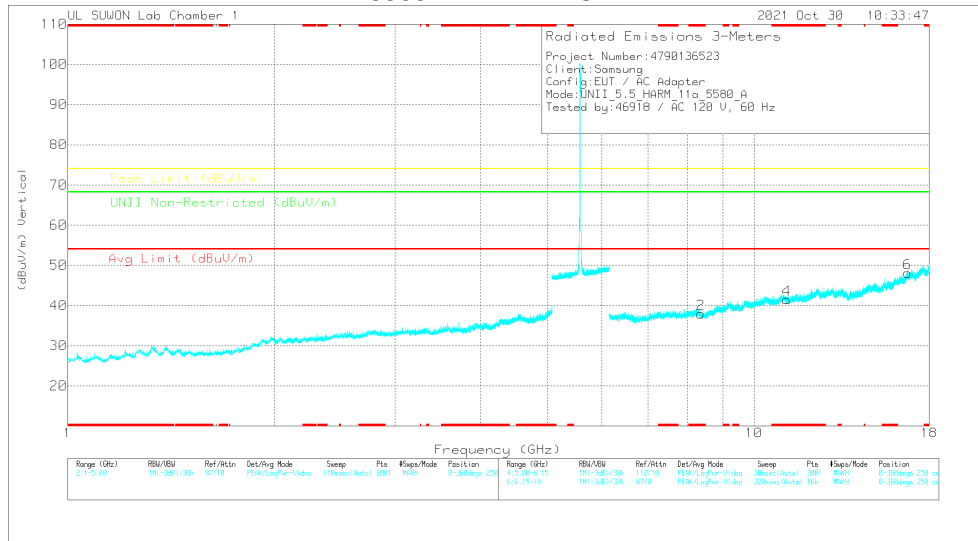

Note. Emission was scanned up to 40GHz; No emissions were detected above the noise floor which was at least 20dB below the specification limit.

**5580 MHz DATA**

**Radiated Emissions**

Frequency (GHz)	Max Reading (dBuV)	Det	3117_50148717	5GHz_HF(dB)	DC Corr (dB)	Corrected Reading (dBuV/m)	Avg Limit (dBuV/m)	Margin (dB)	Peak Limit (dBuV/m)	Margin (dB)	UNII Non-Restricted (dBuV/m)	Margin (dB)	Altitude (Degs)	Height (cm)	Polarity	
* 8.36934	37.68	PK-U	36.3	-25.3	0	48.68	-	-	74	-25.32	-	-	-	360	100	H
* 8.37146	37.93	PK-U	36.3	-25.4	0	48.63	-	-	74	-25.17	-	-	-	360	100	V
* 11.16006	36.34	PK-U	38.4	-22.3	0	52.44	-	-	74	-21.56	-	-	-	360	100	H
* 11.15984	36.76	PK-U	38.4	-22.3	0	52.86	-	-	74	-21.14	-	-	-	360	100	V
16.73818	34.45	PK-U	41.5	-17.4	0	58.55	-	-	-	-	68.2	-9.65	360	100	H	
16.73869	34.25	PK-U	41.5	-17.4	0	58.35	-	-	-	-	68.2	-9.85	360	100	V	

\* - indicates frequency in CFR47 Pt 15 / IC RSS-Restricted Band  
 PK-U - U-NII: Maximum Peak

**HARMONICS AND SPURIOUS EMISSIONS TEST DATA**

Mode	Freq. [MHz]	Antenna	Frequency [GHz]	Reading [dBuV]	Detector Mode	ANT Factor	Loss [dB]	DC Corr [dB]	Result [dBuV/m]	AV Limit [dBuV/m]	AV Margin [dB]	PK Limit [dBuV/m]	PK Margin [dB]	Non-Restricted [dBuV/m]	Margin [dB]	Azimuth [Degs]	Height [cm]	Polarity		
802.11a	5500	MIMO	* 8.25547	37.81	PK-U	36.30	-25.00	0.00	49.11	-	-	74.00	-24.89	-	-	360	100	H		
			* 8.25138	37.55	PK-U	36.30	-25.00	0.00	48.85	-	-	74.00	-25.15	-	-	-	360	100	V	
			* 10.99855	35.53	PK-U	38.20	-21.60	0.00	52.13	-	-	74.00	-21.87	-	-	-	360	100	H	
			* 10.99926	35.48	PK-U	38.20	-21.70	0.00	51.98	-	-	74.00	-22.02	-	-	-	360	100	V	
			16.502	36.55	PK-U	41.10	-19.40	0.00	58.25	-	-	-	-	-	-	68.20	-9.95	360	100	H
			16.501	35.56	PK-U	41.10	-19.40	0.00	57.26	-	-	-	-	-	-	68.20	-10.94	360	100	V
	5580	MIMO	* 8.36934	37.68	PK-U	36.30	-25.30	0.00	48.68	-	-	74.00	-25.32	-	-	-	360	100	H	
			* 8.37146	37.93	PK-U	36.30	-25.40	0.00	48.83	-	-	74.00	-25.17	-	-	-	360	100	V	
			* 11.16006	36.34	PK-U	38.40	-22.30	0.00	52.44	-	-	74.00	-21.56	-	-	-	360	100	H	
			* 11.15984	36.76	PK-U	38.40	-22.30	0.00	52.86	-	-	74.00	-21.14	-	-	-	360	100	V	
			16.738	34.45	PK-U	41.50	-17.40	0.00	58.55	-	-	-	-	-	-	68.20	-9.65	360	100	H
			16.740	34.25	PK-U	41.50	-17.40	0.00	58.35	-	-	-	-	-	-	68.20	-9.85	360	100	V
	5700	MIMO	8.552	37.61	PK-U	36.20	-24.40	0.00	49.41	-	-	-	-	-	68.20	-18.79	360	100	H	
			8.551	37.53	PK-U	36.20	-24.40	0.00	49.33	-	-	-	-	-	68.20	-18.87	360	100	V	
			* 11.39831	35.53	PK-U	38.40	-21.90	0.00	52.03	-	-	74.00	-21.97	-	-	-	360	100	H	
			* 11.39724	35.56	PK-U	38.40	-21.90	0.00	52.06	-	-	74.00	-21.94	-	-	-	360	100	V	
			17.102	34.36	PK-U	41.50	-17.40	0.00	58.46	-	-	-	-	-	-	68.20	-9.74	360	100	H
			17.101	34.14	PK-U	41.50	-17.40	0.00	58.24	-	-	-	-	-	-	68.20	-9.96	360	100	V
	5720	MIMO	8.578	36.52	PK-U	36.30	-24.20	0.00	48.62	-	-	-	-	-	68.20	-19.58	360	100	H	
			8.581	36.99	PK-U	36.30	-24.20	0.00	49.09	-	-	-	-	-	68.20	-19.11	360	100	V	
			* 11.44038	35.60	PK-U	38.40	-21.80	0.00	52.20	-	-	74.00	-21.80	-	-	-	360	100	H	
			* 11.43893	35.68	PK-U	38.40	-21.90	0.00	52.18	-	-	74.00	-21.82	-	-	-	360	100	V	
			17.158	34.01	PK-U	41.40	-17.80	0.00	57.61	-	-	-	-	-	-	68.20	-10.59	360	100	H
			17.162	34.45	PK-U	41.40	-17.80	0.00	58.05	-	-	-	-	-	-	68.20	-10.15	360	100	V
802.11ax (HE20) 4RU Spot-Check	5580	MIMO	* 8.36541	36.21	PK-U	36.20	-23.90	0.00	48.51	-	-	74.00	-25.49	-	-	0	100	H		
			* 11.60593	34.77	PK-U	38.80	-21.80	0.00	51.77	-	-	74.00	-22.23	-	-	0	100	H		
			* 11.60536	35.40	PK-U	38.80	-21.80	0.00	52.40	-	-	74.00	-21.60	-	-	0	100	V		
			16.741	32.16	PK-U	42.30	-19.10	0.00	55.36	-	-	-	-	-	-	68.20	-12.84	0	100	H
			16.741	32.29	PK-U	42.30	-19.10	0.00	55.49	-	-	-	-	-	-	68.20	-12.71	0	100	V
			* 8.36683	35.79	PK-U	36.20	-23.90	0.00	48.09	-	-	74.00	-25.91	-	-	-	0	100	V	

Note1. PK-U - U-NII: Maximum Peak / ADR - U-NII AD primary method, RMS average  
 Note2. \* - indicates frequency in CFR47 Pt 15 / IC RSS-Restricted Band

### 11.4. TX ABOVE 1GHz 2Tx MODE IN THE 5.8 GHz BAND

**BANDEDGE (WORST CASE: 802.11ac VHT80 UPPER SIDE / 5775 MHz)**

#### HORIZONTAL PEAK DATA

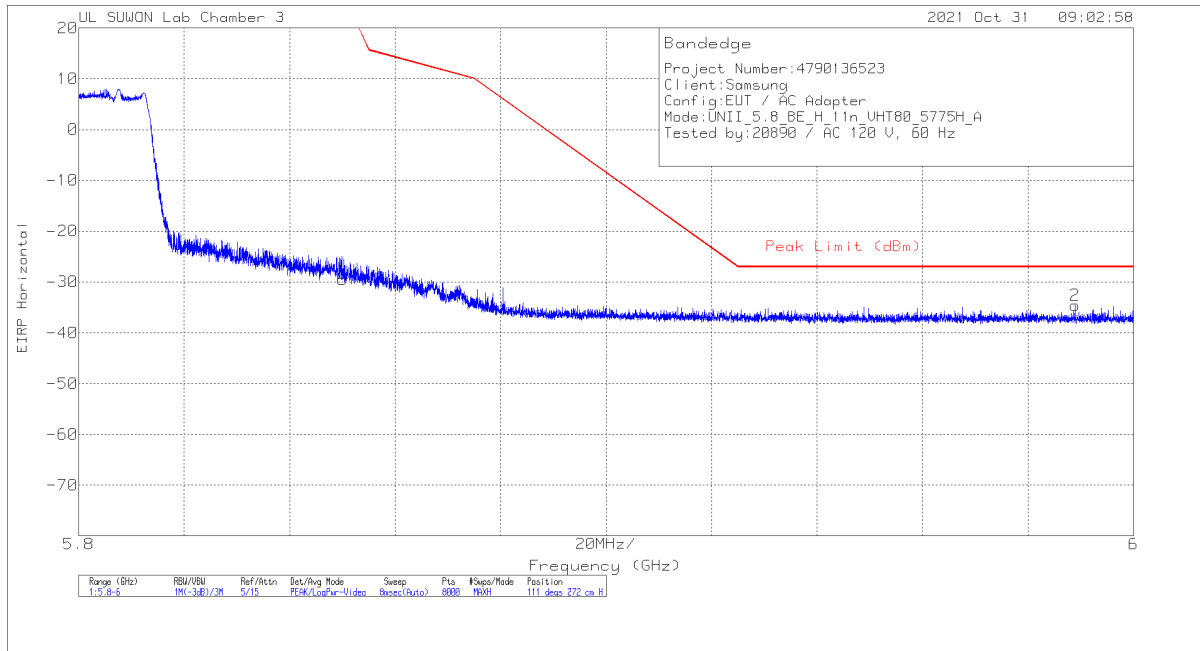

#### Trace Markers

Marker	Frequency(GHz)	Meter Reading (dBm)	Det	3117_00218957	10dB_ATT[dB]	Conversion Factor (dB)	Corrected Reading EIRP	Peak Limit (dBm)	PK Margin (dB)	Azimuth (Degs)	Height (cm)	Polarity
1	5.85001	-57.46	Pk	35.9	-19.8	11.8	-29.56	26.99	-56.55	111	272	H
2	5.98897	-62.66	Pk	36	-19.7	11.8	-34.56	-27	-7.56	111	272	H

Pk - Peak detector

**BANDEDGE TEST DATA**

Mode	Freq. [MHz]	Antenna	Frequency [GHz]	Reading [dBm]	Detector Mode	ANT Factor	Loss [dB]	Conv. F [dB]	DC Corr [dB]	Result [dBm]	PK Limit [dBm]	PK Margin [dB]	Azimuth [Degs]	Height [cm]	Polarity
802.11a	5745	MIMO	5.72500	-45.23	Pk	35.60	-20.00	11.80	0.00	-17.83	27.00	-44.83	111	296	H
			5.62580	-62.31	Pk	35.50	-20.30	11.80	0.00	-35.31	-27.00	-8.31	111	296	H
			5.72500	-41.64	Pk	35.60	-20.00	11.80	0.00	-14.24	27.00	-41.24	158	106	V
			5.64878	-61.56	Pk	35.50	-20.30	11.80	0.00	-34.56	-27.00	-7.56	158	106	V
			5.85001	-56.41	Pk	35.90	-19.80	11.80	0.00	-28.51	26.99	-55.50	105	103	H
	5825	MIMO	5.94079	-63.33	Pk	36.00	-19.80	11.80	0.00	-35.33	-27.00	-8.33	105	103	H
			5.85001	-53.47	Pk	35.90	-19.80	11.80	0.00	-25.57	26.99	-52.56	196	103	V
			5.92802	-62.59	Pk	36.00	-19.80	11.80	0.00	-34.59	-27.00	-7.59	196	103	V
			5.72500	-45.23	Pk	35.60	-20.00	11.80	0.00	-17.83	27.00	-44.83	111	296	H
			5.62580	-62.31	Pk	35.50	-20.30	11.80	0.00	-35.31	-27.00	-8.31	111	296	H
802.11n (HT20)	5745	MIMO	5.72500	-41.88	Pk	35.60	-20.00	11.80	0.00	-14.48	27.00	-41.48	147	135	V
			5.63417	-62.37	Pk	35.50	-20.30	11.80	0.00	-35.37	-27.00	-8.37	147	135	V
			5.85001	-53.11	Pk	35.90	-19.80	11.80	0.00	-25.21	26.99	-52.20	104	217	H
			5.95727	-63.12	Pk	36.00	-19.70	11.80	0.00	-35.02	-27.00	-8.02	104	217	H
			5.85001	-48.62	Pk	35.90	-19.80	11.80	0.00	-20.72	26.99	-47.71	180	113	V
	5825	MIMO	5.94104	-62.72	Pk	36.00	-19.80	11.80	0.00	-34.72	-27.00	-7.72	180	113	V
			5.72500	-52.67	Pk	35.60	-20.00	11.80	0.00	-25.27	27.00	-52.27	118	103	H
			5.63907	-62.88	Pk	35.50	-20.30	11.80	0.00	-35.88	-27.00	-8.88	118	103	H
			5.72500	-47.64	Pk	35.60	-20.00	11.80	0.00	-20.24	27.00	-47.24	194	101	V
			5.63139	-62.71	Pk	35.50	-20.30	11.80	0.00	-35.71	-27.00	-8.71	194	101	V
802.11n (HT40)	5755	MIMO	5.85001	-53.11	Pk	35.90	-19.80	11.80	0.00	-25.21	26.99	-52.20	104	217	H
			5.95727	-63.12	Pk	36.00	-19.70	11.80	0.00	-35.02	-27.00	-8.02	104	217	H
			5.85001	-60.91	Pk	35.90	-19.80	11.80	0.00	-33.01	26.99	-60.00	195	100	V
			5.93004	-62.57	Pk	36.00	-19.80	11.80	0.00	-34.57	-27.00	-7.57	195	100	V
			5.72500	-52.27	Pk	35.60	-20.00	11.80	0.00	-24.87	27.00	-51.87	124	104	H
	5795	MIMO	5.64117	-62.25	Pk	35.50	-20.40	11.80	0.00	-35.35	-27.00	-8.35	124	104	H
			5.72500	-53.10	Pk	35.60	-20.00	11.80	0.00	-25.70	27.00	-52.70	194	111	V
			5.64814	-62.16	Pk	35.50	-20.30	11.80	0.00	-35.16	-27.00	-8.16	194	111	V
			5.85001	-57.46	Pk	35.90	-19.80	11.80	0.00	-29.56	26.99	-56.55	111	272	H
			5.98897	-62.66	Pk	36.00	-19.70	11.80	0.00	-34.56	-27.00	-7.56	111	272	H
802.11ac (VHT80)	5775 (Lower Side)	MIMO	5.85001	-55.06	Pk	35.90	-19.80	11.80	0.00	-27.16	26.99	-54.15	187	114	V
			5.93789	-62.76	Pk	36.00	-19.80	11.80	0.00	-34.76	-27.00	-7.76	187	114	V
			5.72500	-52.27	Pk	35.60	-20.00	11.80	0.00	-24.87	27.00	-51.87	124	104	H
			5.64117	-62.25	Pk	35.50	-20.40	11.80	0.00	-35.35	-27.00	-8.35	124	104	H
			5.72500	-53.10	Pk	35.60	-20.00	11.80	0.00	-25.70	27.00	-52.70	194	111	V

Note. Pk - Peak detector

**HARMONICS AND SPURIOUS EMISSIONS(WORST CASE: 802.11a / 5825 MHz)**  
**5825 MHz HORIZONTAL**

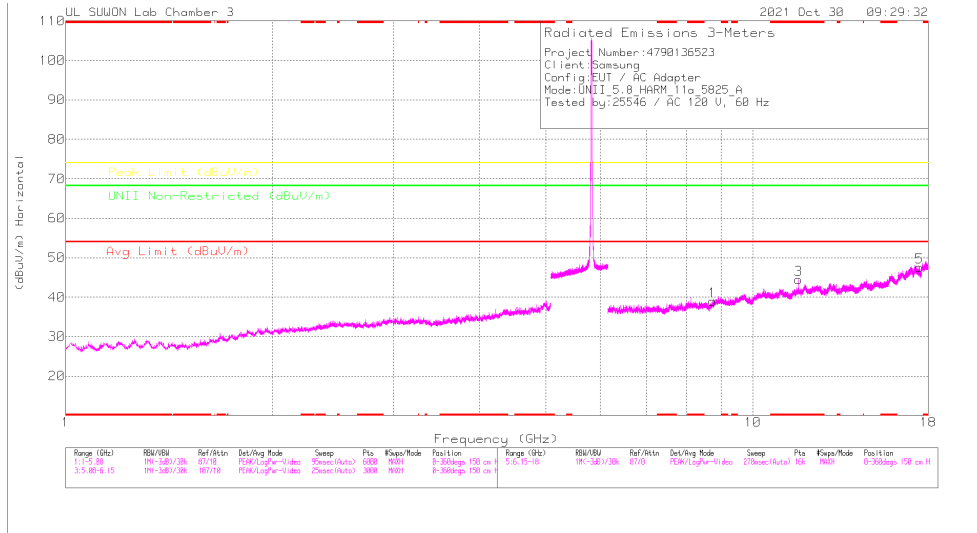

**5825 MHz VERTICAL**

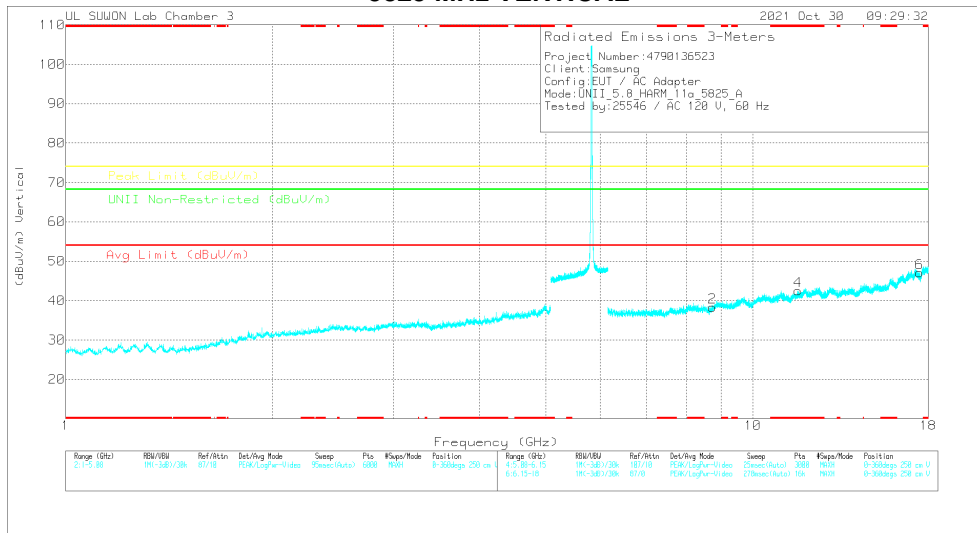

Note: Emission was scanned up to 40GHz; No emissions were detected above the noise floor which was at least 20dB below the specification limit.

**5825 MHz DATA**

**Radiated Emissions**

Frequency (GHz)	Missed Reading (dBm)	Det	317_00218967	60Hz_HPSDR	DC Corr (dB)	Consolidated Reading (dBm)	Avg Limit (dBuV/m)	Margin (dB)	Peak Limit (dBuV/m)	Margin (dB)	UNII Non-Restricted (dBuV/m)	Margin (dB)	Altitude (Height) (m)	Height (m)	Polarity
8.73993	34.68	PK-U	36.5	-23	0	48.18	-	-	-	-	68.2	-20.02	0	100	H
8.74542	34.65	PK-U	36.5	-23	0	48.15	-	-	-	-	68.2	-20.05	0	100	V
*11.64812	36.78	PK-U	38.8	-21.7	0	53.88	-	74	-	-20.12	-	-	257	223	H
*11.64817	24.92	ADR	38.8	-21.7	-15	42.17	54	-11.83	-	-	-	-	257	223	H
*11.64899	38.5	PK-U	38.8	-21.7	0	55.6	-	74	-	-18.4	-	-	185	311	V
*11.65298	26.09	ADR	38.8	-21.7	-15	43.44	54	-10.56	-	-	-	-	185	311	V
17.4809	31.65	PK-U	42	-17.4	0	56.25	-	-	-	-	68.2	-11.95	0	100	H
17.4806	31.54	PK-U	42	-17.4	0	56.14	-	-	-	-	68.2	-12.06	0	100	V

\* - indicates frequency in CFR47 Pt 15 / IC RSS-Restricted Band  
 PK-U - U-NII: Maximum Peak  
 ADR - U-NII AD primary method, RMS average

**HARMONICS AND SPURIOUS EMISSIONS TEST DATA**

Mode	Freq. [MHz]	Antenna	Frequency [GHz]	Reading [dBuV]	Detector Mode	ANT Factor	Loss [dB]	DC Corr [dB]	Result [dBuV/m]	AV Limit [dBuV/m]	AV Margin [dB]	PK Limit [dBuV/m]	PK Margin [dB]	Non-Restricted [dBuV/m]	Margin [dB]	Azimuth [Degs]	Height [cm]	Polarity		
802.11a	5745	MIMO	* 7.66188	36.23	PK-U	36.20	-25.20	0.00	47.23	-	-	74.00	-26.77	-	-	360	100	H		
			** 7.66181	36.13	PK-U	36.20	-25.20	0.00	47.13	-	-	74.00	-26.87	-	-	230	250	V		
			** 11.48785	33.50	PK-U	38.70	-21.70	0.00	50.50	-	-	74.00	-23.50	-	-	360	100	H		
			* 11.48307	34.71	PK-U	38.70	-21.60	0.00	51.81	-	-	74.00	-22.19	-	-	360	100	V		
			** 17.234	35.38	PK-U	42.10	-17.70	0.00	59.78	-	-	-	-	-	-	68.20	-8.42	360	100	H
			** 17.238	34.36	PK-U	42.10	-17.60	0.00	58.86	-	-	-	-	-	-	68.20	-9.34	360	100	V
	5785	MIMO	8.681	35.15	PK-U	36.50	-23.30	0.00	48.35	-	-	-	-	-	68.20	-19.85	360	100	H	
			8.679	34.40	PK-U	36.50	-23.30	0.00	47.60	-	-	-	-	-	68.20	-20.60	360	100	V	
			* 11.57294	34.26	PK-U	38.80	-21.90	0.00	51.16	-	-	74.00	-22.84	-	-	360	100	H		
			* 11.57336	35.12	PK-U	38.80	-21.90	0.00	52.02	-	-	74.00	-21.98	-	-	360	100	V		
			** 17.358	36.82	PK-U	42.00	-17.80	0.00	61.02	-	-	-	-	-	-	68.20	-7.18	225	100	H
			** 17.359	33.08	PK-U	42.00	-17.80	0.00	57.28	-	-	-	-	-	-	68.20	-10.92	132	256	V
	5825	MIMO	8.740	34.68	PK-U	36.50	-23.00	0.00	48.18	-	-	-	-	-	68.20	-20.02	0	100	H	
			8.745	34.65	PK-U	36.50	-23.00	0.00	48.15	-	-	-	-	-	68.20	-20.05	0	100	V	
			* 11.64812	36.78	PK-U	38.80	-21.70	0.00	53.88	-	-	74.00	-20.12	-	-	257	223	H		
			* 11.64817	24.92	ADR	38.80	-21.70	0.15	42.17	54.00	-11.83	-	-	-	-	257	223	H		
			* 11.64899	38.50	PK-U	38.80	-21.70	0.00	55.60	-	-	74.00	-18.40	-	-	185	311	V		
			* 11.65298	26.09	ADR	38.90	-21.70	0.15	43.44	54.00	-10.56	-	-	-	-	185	311	V		
	802.11n (HT20) Spot-Check	5785	MIMO	** 17.481	31.65	PK-U	42.00	-17.40	0.00	56.25	-	-	-	-	-	68.20	-11.95	0	100	H
				** 17.481	31.54	PK-U	42.00	-17.40	0.00	56.14	-	-	-	-	-	68.20	-12.06	0	100	V
				8.676	36.91	PK-U	36.30	-24.90	0.00	48.31	-	-	-	-	-	68.20	-19.89	360	100	H
				8.677	38.64	PK-U	36.30	-24.90	0.00	50.04	-	-	-	-	-	68.20	-18.16	360	100	V
				* 11.57342	36.09	PK-U	38.30	-22.00	0.00	52.39	-	-	74.00	-21.61	-	-	360	100	H	
				* 11.57293	36.15	PK-U	38.30	-22.10	0.00	52.35	-	-	74.00	-21.65	-	-	360	100	V	
5755		MIMO	** 17.345	34.83	PK-U	41.20	-17.10	0.00	58.93	-	-	-	-	-	68.20	-9.27	49	394	H	
			** 17.357	34.62	PK-U	41.20	-17.10	0.00	58.72	-	-	-	-	-	68.20	-9.48	249	186	V	
			8.631	37.07	PK-U	36.30	-24.50	0.00	48.87	-	-	-	-	-	68.20	-19.33	360	100	H	
			8.632	36.80	PK-U	36.30	-24.50	0.00	48.60	-	-	-	-	-	68.20	-19.60	360	100	V	
			* 11.51039	36.05	PK-U	38.30	-22.20	0.00	52.15	-	-	74.00	-21.85	-	-	360	100	H		
			* 11.51095	35.96	PK-U	38.30	-22.20	0.00	52.06	-	-	74.00	-21.94	-	-	360	100	V		
802.11ac (VHT80) Spot-Check	5775	MIMO	** 17.265	34.30	PK-U	41.20	-17.10	0.00	58.40	-	-	-	-	-	68.20	-9.80	360	100	H	
			** 17.265	34.36	PK-U	41.20	-17.10	0.00	58.46	-	-	-	-	-	68.20	-9.74	360	100	V	
			8.639	37.22	PK-U	36.30	-24.50	0.00	49.02	-	-	-	-	-	68.20	-19.18	360	100	H	
			8.634	37.62	PK-U	36.30	-24.50	0.00	49.42	-	-	-	-	-	68.20	-18.78	360	100	V	
			* 11.51186	36.16	PK-U	38.30	-22.20	0.00	52.26	-	-	74.00	-21.74	-	-	360	100	H		
			* 11.5104	35.89	PK-U	38.30	-22.20	0.00	51.99	-	-	74.00	-22.01	-	-	360	100	V		
802.11ax (HE20) 4RU Spot-check	5785	MIMO	** 17.270	34.38	PK-U	41.20	-17.10	0.00	58.48	-	-	-	-	-	68.20	-9.72	360	100	H	
			** 17.269	34.56	PK-U	41.20	-17.10	0.00	58.66	-	-	-	-	-	68.20	-9.54	360	100	V	
			8.683	34.47	PK-U	36.50	-23.30	0.00	47.67	-	-	-	-	-	68.20	-20.53	0	100	H	
			* 11.56678	34.41	PK-U	38.80	-21.90	0.00	51.31	-	-	74.00	-22.69	-	-	0	100	H		
			** 17.363	31.87	PK-U	42.00	-17.70	0.00	56.17	-	-	-	-	-	-	68.20	-12.03	0	100	H
			8.676	34.94	PK-U	36.50	-23.30	0.00	48.14	-	-	-	-	-	-	68.20	-20.06	0	100	V
			* 11.56787	34.22	PK-U	38.80	-21.90	0.00	51.12	-	-	74.00	-22.88	-	-	0	100	V		
			** 17.362	33.09	PK-U	42.00	-17.80	0.00	57.29	-	-	-	-	68.20	-10.91	0	100	V		

Note1. PK-U - U-NII: Maximum Peak / ADR - U-NII AD primary method, RMS average

Note2. \* - indicates frequency in CFR47 Pt 15 / IC RSS-Restricted Band

## 11.5. Spurious Emissions for Simultaneous Transmission

### 11.5.1. Worst test case RSDB condition

Case 1	2.4 GHz WLAN ANT2	5GHz WLAN ANT1 + ANT2
Mode	802.11b	802.11a
Channel	11	60
Frequency[MHz]	2462	5300
Tone	-	-
RU	-	-
Data Rate	1 Mbps	MCS 0
Axis (Worst)	Y & Z	

Case 2	2.4 GHz WLAN ANT1 + ANT2	5GHz WLAN ANT1 + ANT2
Mode	802.11g	802.11a
Channel	11	60
Frequency[MHz]	2462	5300
Tone	-	-
RU	-	-
Data Rate	6 Mbps	MCS 0
Axis (Worst)	Y	

#### **NOTE**

The lowest margin condition among the channels and modes were selected for test. Low, mid, and high channels of 2.4GH WLAN were tested, and the worst case configuration & data were listed in the test report.



### 11.5.1. Test Results

#### Spurious emission for Simultaneous Transmission Case1. - Y axis

#### HORIZONTAL

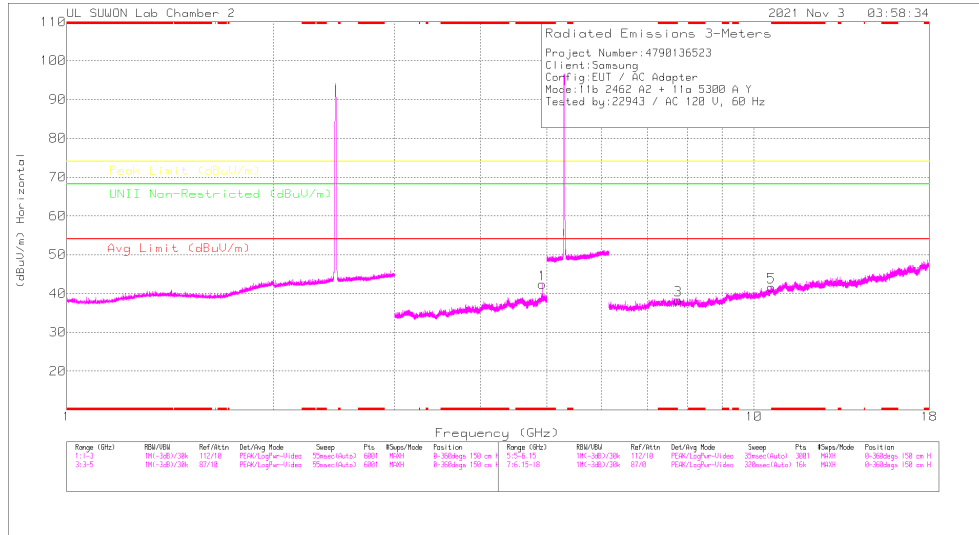

#### VERTICAL

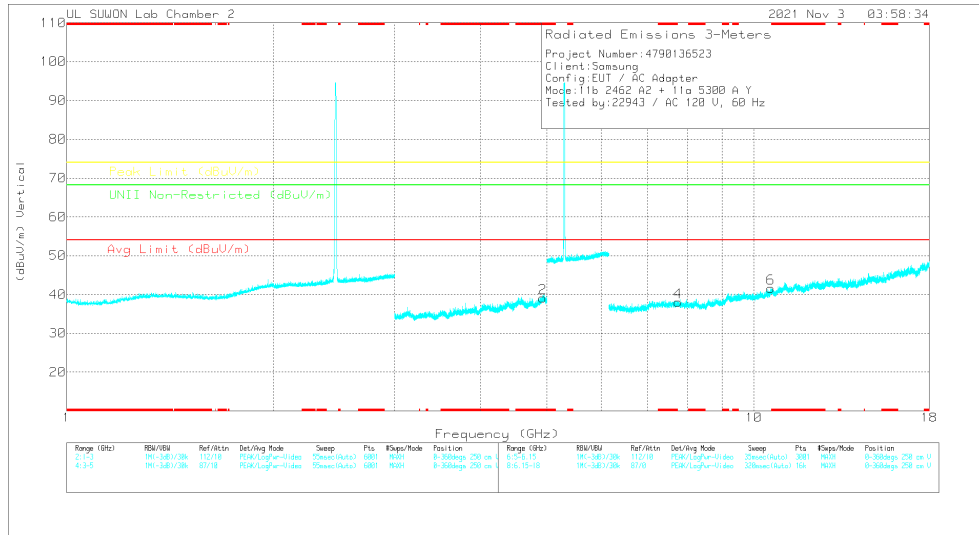

#### Radiated Emissions

Frequency (GHz)	Meas Reading (dBuV)	Det	3117_00168724	SGHz_LF(dB)	DTS Noise(dB)	DC Cor (dB)	Corrected Reading (dBuV/m)	Avg Limit (dBuV/m)	Margin (dB)	Peak Limit (dBuV/m)	Margin (dB)	UNII Non-Restricted (dBuV/m)	Margin (dB)	Azimuth (Degs)	Height (cm)	Polarity
* 4.92412	43.24	PK2	34.1	-26.2	.5	0	51.54	-	-	74	-22.36	-	-	159	152	H
* 4.92406	33.55	MAV1	34.1	-26.2	.5	-15	42.1	54	-11.9	-	-	-	-	159	152	H
* 4.92462	41.78	PK2	34.1	-26.2	.5	0	50.18	-	-	74	-23.62	-	-	210	373	V
* 4.924	31.05	MAV1	34.1	-26.2	.5	-15	39.51	54	-14.33	-	-	-	-	210	373	V

  

Frequency (GHz)	Meas Reading (dBuV)	Det	3117_00168724	SGHz_LF(dB)	DC Cor (dB)	Corrected Reading (dBuV/m)	Avg Limit (dBuV/m)	Margin (dB)	Peak Limit (dBuV/m)	Margin (dB)	UNII Non-Restricted (dBuV/m)	Margin (dB)	Azimuth (Degs)	Height (cm)	Polarity
7.78019	35.55	PK-U	36	-23.5	0	48.35	-	-	-	-	65.2	-18.85	360	100	H
7.78219	35.49	PK-U	36	-23.5	0	47.69	-	-	-	-	65.2	-20.51	360	100	V
* 10.60264	33.08	PK-U	37.9	-19.5	0	51.48	-	-	-	74	-22.52	-	360	100	H
* 10.6045	33.31	PK-U	37.9	-19.5	0	51.71	-	-	-	74	-22.29	-	360	100	V

\* - indicates frequency in CFR47 Pt 15 / IC RSS-Restricted Band  
 PK2 - KDB558074 Method: Maximum Peak  
 MAV1 - KDB558074 Option 1 Maximum RMS Average  
 PK-U - U-NII: Maximum Peak

**Case1. - Z axis**

**HORIZONTAL**

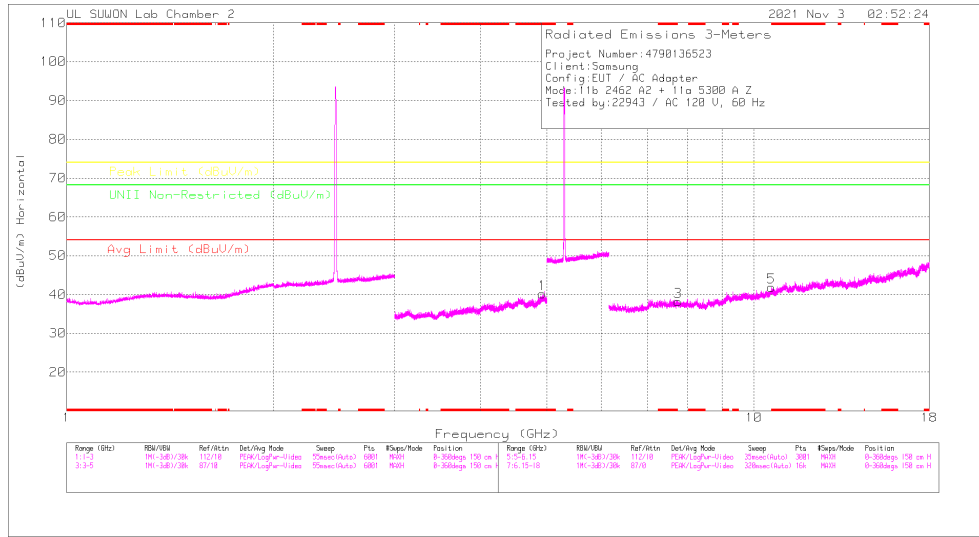

**VERTICAL**

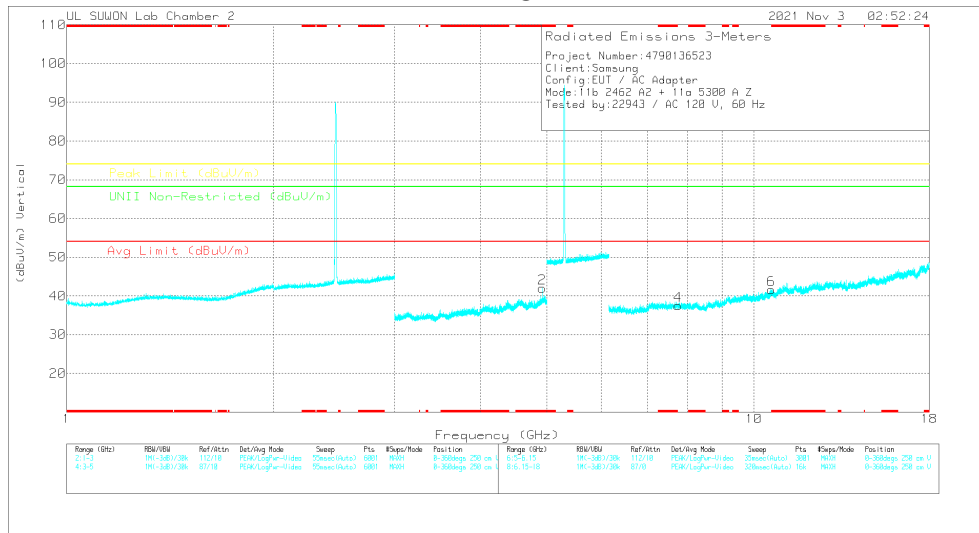

**Radiated Emissions**

Frequency (GHz)	Max Reading (dBuV)	Det	317_00168724	5GHz_HP15B	DTS (neq)(dB)	DC Cor (dB)	Corrected Reading (dBuV/m)	Avg Limit (dBuV/m)	Margin (dB)	Peak Limit (dBuV/m)	Margin (dB)	UNII Non-Restricted (dBuV/m)	Margin (dB)	Altitude (Degs)	Height (cm)	Polarity
* 4.92424	41.89	PK2	34.1	-26.2	.5	0	50.39	-	-	74	-23.61	-	-	233	158	H
* 4.92409	31.77	MAV1	34.1	-26.2	.5	-15	40.32	54	-13.68	-	-	-	-	233	158	H
* 4.92424	43.89	PK2	34.1	-26.2	.5	0	52.29	-	-	74	-21.71	-	-	184	104	V
* 4.924	35.46	MAV1	34.1	-26.2	.5	-15	44.01	54	-9.99	-	-	-	-	184	104	V

Frequency (GHz)	Max Reading (dBuV)	Det	317_00168724	6GHz_HP15B	DC Cor (dB)	Corrected Reading (dBuV/m)	Avg Limit (dBuV/m)	Margin (dB)	Peak Limit (dBuV/m)	Margin (dB)	UNII Non-Restricted (dBuV/m)	Margin (dB)	Altitude (Degs)	Height (cm)	Polarity
7.76121	36.3	PK-U	36	-23.5	0	48.8	-	-	-	-	68.2	-19.4	1	100	H
7.76133	36.01	PK-U	36	-23.5	0	48.51	-	-	-	-	68.2	-19.69	0	100	V
* 10.60402	33.19	PK-U	37.9	-19.5	0	51.59	-	-	74	-22.41	-	-	1	100	H
* 10.60262	33.63	PK-U	37.9	-19.5	0	52.03	-	-	74	-21.97	-	-	0	100	V

\* - indicates frequency in CFR47 Pt 15 / IC RSS-Restricted Band  
 PK2 - KDB558074 Method: Maximum Peak  
 MAV1 - KDB558074 Option 1 Maximum RMS Average  
 PK-U - U-NII: Maximum Peak

**Case2. - Y axis**

**HORIZONTAL**

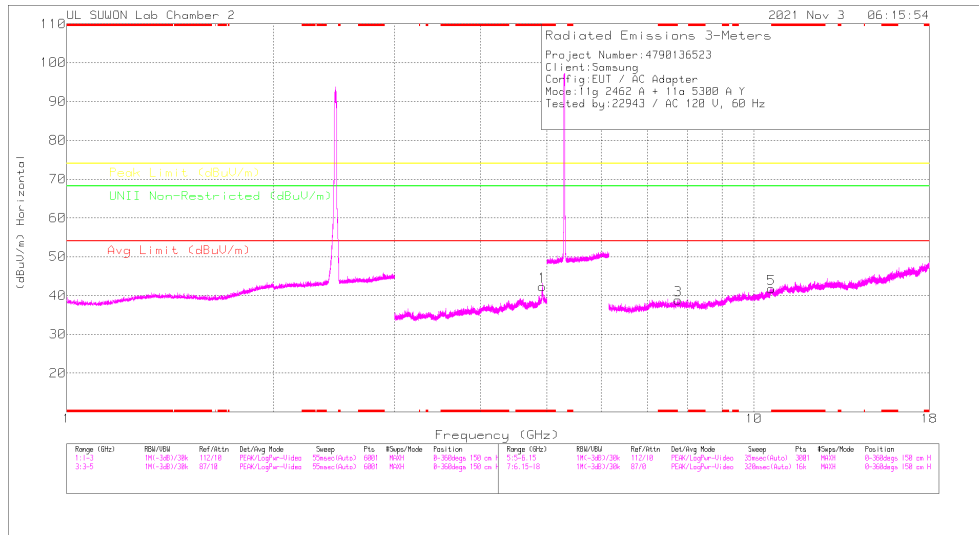

**VERTICAL**

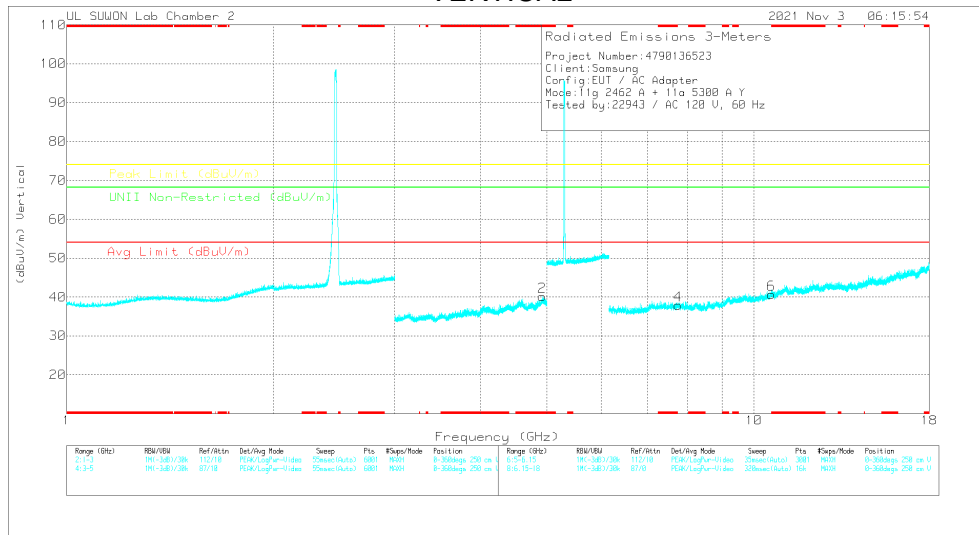

**Radiated Emissions**

Frequency (GHz)	Max Reading (dBuV)	Det	317_00168724	5GHz_LF(dB)	DTS Noise(dB)	DC Corr (dB)	Corrected Reading (dBuV/m)	Avg Limit (dBuV/m)	Margin (dB)	Peak Limit (dBuV/m)	Margin (dB)	UNII Non-Restricted (dBuV/m)	Margin (dB)	Azimuth (Degs)	Height (cm)	Polarity
* 4.92493	46.16	PK2	34.1	-26.2	.5	0	54.56	-	-	74	-19.44	-	-	162	106	H
* 4.92481	34.42	MAV1	34.1	-26.2	.5	-15	42.97	54	-11.03	-	-	-	-	162	106	H
* 4.92418	42.62	PK2	34.1	-26.2	.5	0	51.02	-	-	74	-22.98	-	-	214	370	V
* 4.92472	30.84	MAV1	34.1	-26.2	.5	-15	39.39	54	-14.61	-	-	-	-	214	370	V

Frequency (GHz)	Max Reading (dBuV)	Det	317_00168724	5GHz_HF(dB)	DC Corr (dB)	Corrected Reading (dBuV/m)	Avg Limit (dBuV/m)	Margin (dB)	Peak Limit (dBuV/m)	Margin (dB)	UNII Non-Restricted (dBuV/m)	Margin (dB)	Azimuth (Degs)	Height (cm)	Polarity
7.76347	36.01	PK-U	36	-23.6	0	49.41	-	-	-	-	68.2	-19.79	0	100	H
7.76202	36.61	PK-U	36	-23.5	0	49.11	-	-	-	-	68.2	-19.09	0	100	V
* 10.60264	32.8	PK-U	37.9	-19.5	0	51.2	-	-	74	-22.8	-	-	0	100	H
* 10.60214	33.39	PK-U	37.9	-19.5	0	51.79	-	-	74	-22.21	-	-	0	100	V

\* - indicates frequency in CFR47 Pt 15 / IC RSS-Restricted Band  
 PK2 - KDB558074 Method: Maximum Peak  
 MAV1 - KDB558074 Option 1 Maximum RMS Average  
 PK-U - U-NII: Maximum Peak

## 12. WORST-CASE BELOW 1 GHz SPURIOUS EMISSIONS 30 TO 1000 MHz (WORST-CASE CONFIGURATION, HORIZONTAL)

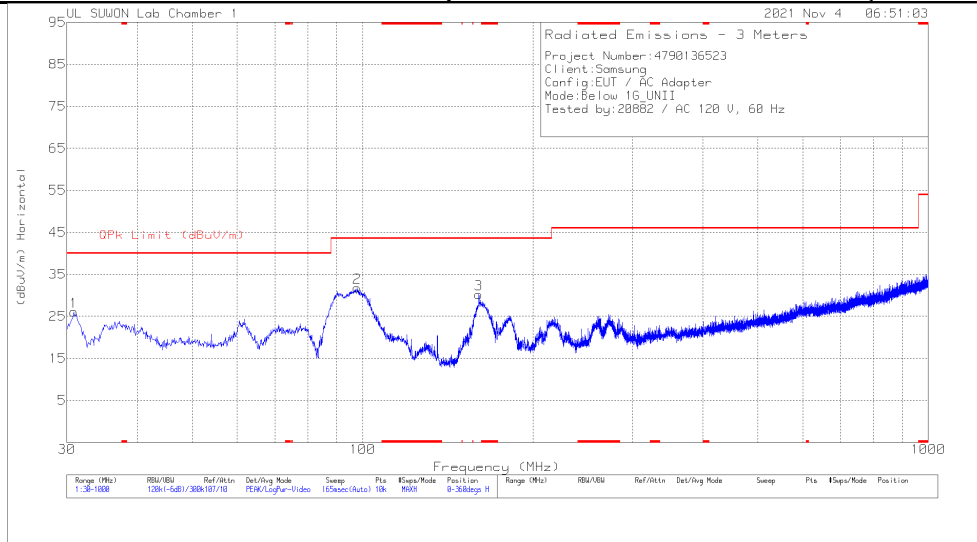

## SPURIOUS EMISSIONS 30 TO 1000 MHz (WORST-CASE CONFIGURATION, VERTICAL)

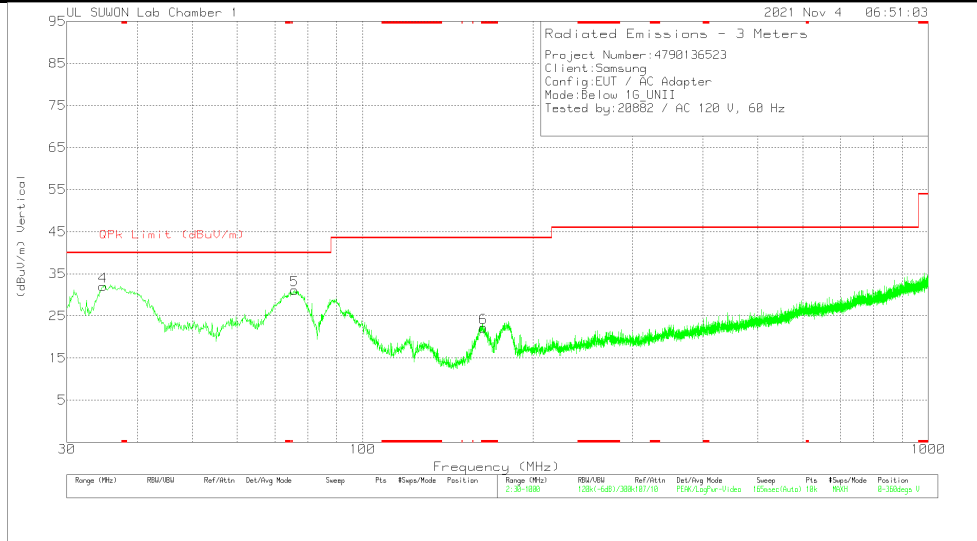

### Trace Markers

Marker	Frequency (MHz)	Meter Reading (dBuV)	Det	VULB9163_750	Below_1G[dB]	Corrected Reading (dBuV/m)	QPk Limit (dBuV/m)	Margin (dB)	Azimuth (Degs)	Height (cm)	Polarity
1	30.873	41.7	Pk	15.7	-31.3	26.1	40	-13.9	0-360	200	H
2	97.803	44.64	Pk	17.3	-30.1	31.84	43.52	-11.68	0-360	200	H
3	160.465	45.64	Pk	14.3	-29.7	30.24	43.52	-13.28	0-360	100	H
4	34.753	46.79	Pk	16.5	-31.3	31.99	40	-8.01	0-360	200	V
5	75.784	48.41	Pk	13.2	-30.5	31.11	40	-8.89	0-360	200	V
6	* 163.472	37.3	Pk	14.4	-29.5	22.2	43.52	-21.32	0-360	300	V

\* - indicates frequency in CFR47 Pt 15 / IC RSS-Restricted Band  
 Pk - Peak detector

### 13. AC POWER LINE CONDUCTED EMISSIONS

#### LIMITS

FCC §15.207 (a)  
IC RSS-GEN Clause 8.8

Frequency of Emission (MHz)	Conducted Limit (dBuV)	
	Quasi-peak	Average
0.15-0.5	66 to 56 <sup>*</sup>	56 to 46 <sup>*</sup>
0.5-5	56	46
5-30	60	50

<sup>\*</sup>Decreases with the logarithm of the frequency.

#### TEST PROCEDURE

The EUT is placed on a non-conducting table 40 cm from the vertical ground plane and 80 cm above the horizontal ground plane. The EUT is configured in accordance with ANSI C63.10.

The receiver is set to a resolution bandwidth of 9 kHz. Peak detection is used unless otherwise noted as quasi-peak or average.

Line conducted data is recorded for both NEUTRAL and HOT lines.

#### RESULTS

**WORST EMISSIONS**

**LINE 1 DATA**

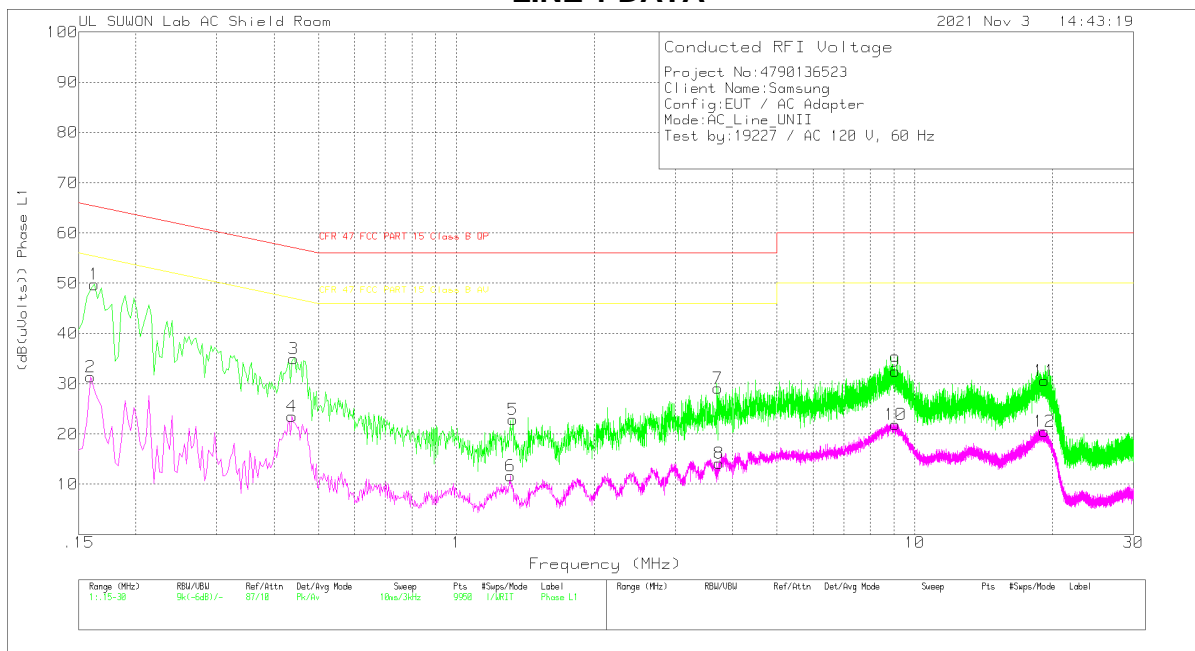

**Trace Markers**

Range 1: Phase L1 .15 - 30MHz

Marker	Frequency (MHz)	Meter Reading (dBuV)	Det	101836_Wit h EX_L1[dB]	CABLELOS S(dB)	Corrected Reading (dB(uVolts))	CFR 47 FCC PART 15 Class B QP	Margin (dB)	CFR 47 FCC PART 15 Class B AV	Margin (dB)
1	.162	39.75	Pk	9.9	.1	49.75	65.36	-15.61	-	-
2	.159	21.42	Av	9.8	.1	31.32	-	-	55.52	-24.2
3	.441	25.01	Pk	9.8	.2	35.01	57.04	-22.03	-	-
4	.438	13.47	Av	9.8	.2	23.47	-	-	47.1	-23.63
5	1.329	12.88	Pk	9.7	.3	22.88	56	-33.12	-	-
6	1.314	1.72	Av	9.7	.3	11.72	-	-	46	-34.28
7	3.723	19.17	Pk	9.7	.3	29.17	56	-26.83	-	-
8	3.744	4.22	Av	9.7	.3	14.22	-	-	46	-31.78
9	9.06	22.33	Pk	9.8	.4	32.53	60	-27.47	-	-
10	9.081	11.71	Av	9.8	.4	21.91	-	-	50	-28.09
11	19.188	20.14	Pk	10.1	.4	30.64	60	-29.36	-	-
12	19.191	10.01	Av	10.1	.4	20.51	-	-	50	-29.49

Pk - Peak detector  
 Av - Average detection

**LINE 2 DATA**

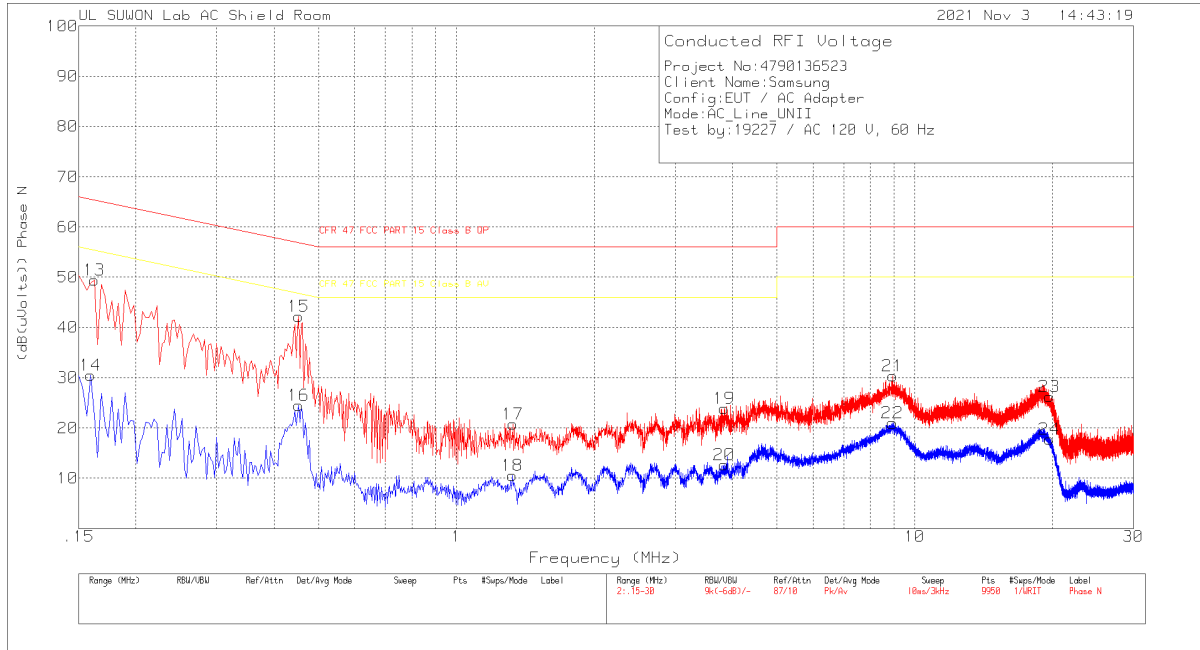

**Trace Markers**

Range 2: Phase N .15 - 30MHz

Marker	Frequency (MHz)	Meter Reading (dBuV)	Det	101836_Wit h EX_N[dB]	CABLELOS S(dB)	Corrected Reading (dB(uVolts))	CFR 47 FCC PART 15 Class B QP	Margin (dB)	CFR 47 FCC PART 15 Class B AV	Margin (dB)
13	.162	39.39	Pk	9.9	.1	49.39	65.36	-15.97	-	-
14	.159	20.61	Av	9.8	.1	30.51	-	-	55.52	-25.01
15	.453	32.08	Pk	9.9	.2	42.18	56.82	-14.64	-	-
16	.453	14.42	Av	9.9	.2	24.52	-	-	46.82	-22.3
17	1.329	10.77	Pk	9.7	.3	20.77	56	-35.23	-	-
18	1.326	.54	Av	9.7	.3	10.54	-	-	46	-35.46
19	3.843	13.94	Pk	9.7	.3	23.94	56	-32.06	-	-
20	3.843	2.7	Av	9.7	.3	12.7	-	-	46	-33.3
21	8.943	20.19	Pk	9.8	.4	30.39	60	-29.61	-	-
22	8.94	10.76	Av	9.8	.4	20.96	-	-	50	-29.04
23	19.686	15.71	Pk	10.2	.4	26.31	60	-33.69	-	-
24	19.662	7.22	Av	10.2	.4	17.82	-	-	50	-32.18

Pk - Peak detector  
 Av - Average detection



## 14. DYNAMIC FREQUENCY SELECTION

### 14.1. OVERVIEW

#### 14.1.1. LIMITS

#### FCC

§15.407 (h), FCC KDB 905462 D02 “COMPLIANCE MEASUREMENT PROCEDURES FOR UNLICENSED-NATIONAL INFORMATION INFRASTRUCTURE DEVICES OPERATING IN THE 5250-5350 MHz AND 5470-5725 MHz BANDS INCORPORATING DYNAMIC FREQUENCY SELECTION” and KDB 905462 D03 “U-NII CLIENT DEVICES WITHOUT RADAR DETECTION CAPABILITY”.

**Table 1: Applicability of DFS requirements prior to use of a channel**

Requirement	Operational Mode		
	Master	Client (without radar detection)	Client (with radar detection)
Non-Occupancy Period	Yes	Not required	Yes
DFS Detection Threshold	Yes	Not required	Yes
Channel Availability Check Time	Yes	Not required	Not required
U-NII Detection Bandwidth	Yes	Not required	Yes

**Table 2: Applicability of DFS requirements during normal operation**

Requirement	Operational Mode		
	Master	Client (without DFS)	Client (with DFS)
DFS Detection Threshold	Yes	Not required	Yes
Channel Closing Transmission Time	Yes	Yes	Yes
Channel Move Time	Yes	Yes	Yes
U-NII Detection Bandwidth	Yes	Not required	Yes

Additional requirements for devices with multiple bandwidth modes	Master Device or Client with Radar DFS	Client (without DFS)
U-NII Detection Bandwidth and Statistical Performance Check	All BW modes must be tested	Not required
Channel Move Time and Channel Closing Transmission Time	Test using widest BW mode available	Test using the widest BW mode available for the link
All other tests	Any single BW mode	Not required

**Note:** Frequencies selected for statistical performance check (Section 7.8.4) should include several frequencies within the radar detection bandwidth and frequencies near the edge of the radar detection bandwidth. For 802.11 devices it is suggested to select frequencies in all 20 MHz channel blocks and a null frequency between the bonded 20 MHz channel blocks.

**Table 3: Interference Threshold values, Master or Client incorporating In-Service Monitoring**

Maximum Transmit Power	Value (see notes)
E.I.R.P. $\geq$ 200 mill watt	-64 dBm
E.I.R.P. < 200 mill watt and power spectral density < 10 dBm/MHz	-62 dBm
E.I.R.P. < 200 mill watt that do not meet power spectral density requirement	-64 dBm
<p><b>Note 1:</b> This is the level at the input of the receiver assuming a 0 dBi receive antenna  <b>Note 2:</b> Throughout these test procedures an additional 1 dB has been added to the amplitude of the test transmission waveforms to account for variations in measurement equipment. This will ensure that the test signal is at or above the detection threshold level to trigger a DFS response.  <b>Note 3:</b> E.I.R.P. is based on the highest antenna gain. For MIMO devices refer to KDB publication 662911 D01.</p>	

**Table 4: DFS Response requirement values**

Parameter	Value
<i>Non-occupancy period</i>	30 minutes
<i>Channel Availability Check Time</i>	60 seconds
<i>Channel Move Time</i>	10 seconds (See Note 1)
<i>Channel Closing Transmission Time</i>	200 milliseconds + approx. 60 milliseconds over remaining 10 second period. (See Notes 1 and 2)
<i>U-NII Detection Bandwidth</i>	Minimum 100% of the U- NII 99% transmission power bandwidth. (See Note 3)
<p><b>Note 1:</b> <i>Channel Move Time</i> and the <i>Channel Closing Transmission Time</i> should be performed with Radar Type 0. The measurement timing begins at the end of the Radar Type 0 burst.  <b>Note 2:</b> The <i>Channel Closing Transmission Time</i> is comprised of 200 milliseconds starting at the beginning of the <i>Channel Move Time</i> plus any additional intermittent control signals required to facilitate a <i>Channel</i> move (an aggregate of 60 milliseconds) during the remainder of the 10 second period. The aggregate duration of control signals will not count quiet periods in between transmissions.  <b>Note 3:</b> During the <i>U-NII Detection Bandwidth</i> detection test, radar type 0 should be used. For each frequency step the minimum percentage of detection is 90 percent. Measurements are performed with no data traffic.</p>	

**Table 5 – Short Pulse Radar Test Waveforms**

Radar Type	Pulse Width (usec)	PRI (usec)	Pulses	Minimum Percentage of Successful Detection	Minimum Trials
0	1	1428	18	See Note 1	See Note 1
1	1	Test A: 15 unique PRI values randomly selected from the list of 23 PRI values in table 5a	Roundup: $\{(1/360) \times (19 \times 10^6 \text{ PRI}_{\text{usec}})\}$	60%	30
		Test B: 15 unique PRI values randomly selected within the range of 518-3066 usec. With a minimum increment of 1 usec, excluding PRI values selected in Test A			
2	1-5	150-230	23-29	60%	30
3	6-10	200-500	16-18	60%	30
4	11-20	200-500	12-16	60%	30
Aggregate (Radar Types 1-4)				80%	120
<b>Note 1:</b> Short Pulse Radar Type 0 should be used for the <i>Detection Bandwidth</i> test, <i>Channel Move Time</i> , and <i>Channel Closing Time</i> tests.					

**Table 6 – Long Pulse Radar Test Signal**

Radar Waveform Type	Pulse Width (μsec)	Chirp Width (MHz)	PRI (μsec)	Pulses per Burst	Number of Bursts	Minimum Percentage of Successful Detection	Minimum Trials
5	50-100	5-20	1000-2000	1-3	8-20	80%	30

**Table 7 – Frequency Hopping Radar Test Signal**

Radar Waveform Type	Pulse Width (μsec)	PRI (μsec)	Pulses per Hop	Hopping Rate (kHz)	Hopping Sequence Length (msec)	Minimum Percentage of Successful Detection	Minimum Trials
6	1	333	9	0.333	300	70%	30

### 14.1.2. TEST AND MEASUREMENT SYSTEM

#### CONDUCTED METHOD SYSTEM BLOCK DIAGRAM

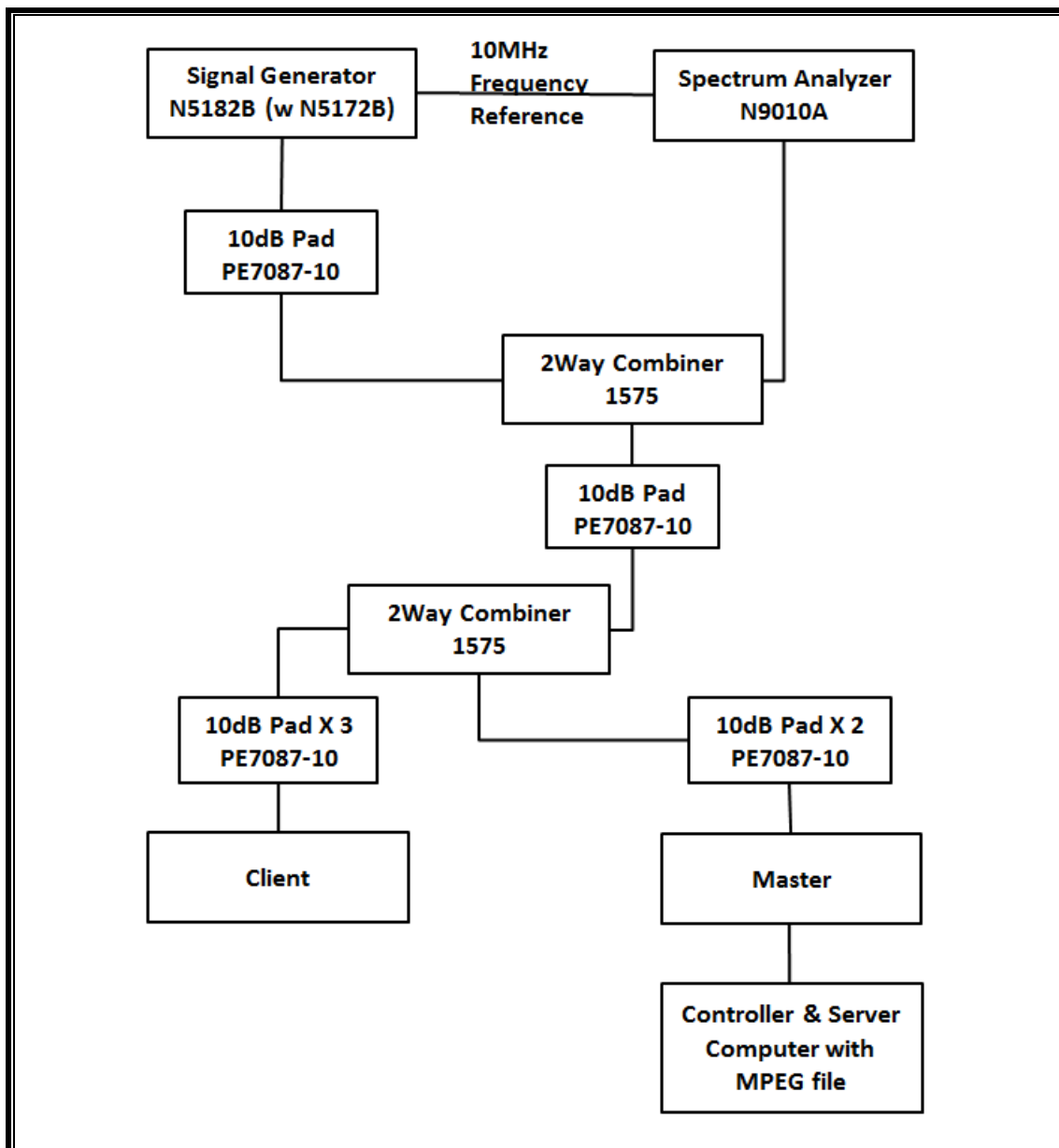

## **SYSTEM OVERVIEW**

The short pulse and long pulse signal generating system utilizes the Keysite Signal Studio for Pulse Building as N5172B. The Vector Signal Generator has been validated by the NTIA. The hopping signal generating system utilizes the CCS simulated hopping method and system, which has been validated by the DoD, FCC and NTIA. The software selects waveform parameters from within the bounds of the signal type on a random basis using uniform distribution.

The short pulse types 1, 2, 3 and 4, and the long pulse type 5 parameters are randomized at run-time.

The hopping type 6 pulse parameters are fixed while the hopping sequence is based on the August 2005 NTIA Hopping Frequency List. The initial starting point randomized at run-time and each subsequent starting point is incremented by 475. Each frequency in the 100-length segment is compared to the boundaries of the EUT Detection Bandwidth and the software creates a hopping burst pattern in accordance with Section 7.4.1.3 Method #2 Simulated Frequency Hopping Radar Waveform Generating Subsystem of KDB 905462 D02. The frequency of the signal generator is incremented in 1 MHz steps from  $F_L$  to  $F_H$  for each successive trial. This incremental sequence is repeated as required to generate a minimum of 30 total trials and to maintain a uniform frequency distribution over the entire Detection Bandwidth.

The signal monitoring equipment consists of a spectrum analyzer. The aggregate ON time is calculated by multiplying the number of bins above a threshold during a particular observation period by the dwell time per bin, with the analyzer set to peak detection and max hold.

## **SYSTEM CALIBRATION**

A 50-ohm load is connected in place of the spectrum analyzer, and the spectrum analyzer is connected to a horn antenna via a coaxial cable, with the reference level offset set to (horn antenna gain – coaxial cable loss). The signal generator is set to CW mode. The amplitude of the signal generator is adjusted to yield a level of –64 dBm as measured on the spectrum analyzer.

Without changing any of the instrument settings, the spectrum analyzer is reconnected to the Common port of the Spectrum Analyzer Combiner/Divider. The Reference Level Offset of the spectrum analyzer is adjusted so that the displayed amplitude of the signal is –64 dBm.

The spectrum analyzer displays the level of the signal generator as received at the antenna ports of the Master Device. The interference detection threshold may be varied from the calibrated value of –64 dBm and the spectrum analyzer will still indicate the level as received by the Master Device.

**ADJUSTMENT OF DISPLAYED TRAFFIC LEVEL**

A link is established between the Master and Slave and the distance between the units is adjusted as needed to provide a suitable received level at the Master and Slave devices. The video test file is streamed to generate WLAN traffic. The monitoring antenna is adjusted so that the WLAN traffic level, as displayed on the spectrum analyzer, is at lower amplitude than the radar detection threshold.

**TEST AND MEASUREMENT EQUIPMENT**

The following test and measurement equipment was utilized for the DFS tests documented in this report:

TEST EQUIPMENT LIST				
Description	Manufacturer	Model	S/N	Next Cal Due
Spectrum Analyzer, 7 GHz	Agilent / HP	N9010A	MY54200580	08-02-22
Vector Signal Generator, 6GHz	Agilent / HP	N5182B	MY53051241	08-02-22
Combiner	WEINSCHTEL	WA1534	UL001	01-27-22
Combiner	WEINSCHTEL	WA1535	UL002	01-27-22

### 14.1.3. SETUP OF EUT

#### CONDUCTED METHOD EUT TEST SETUP

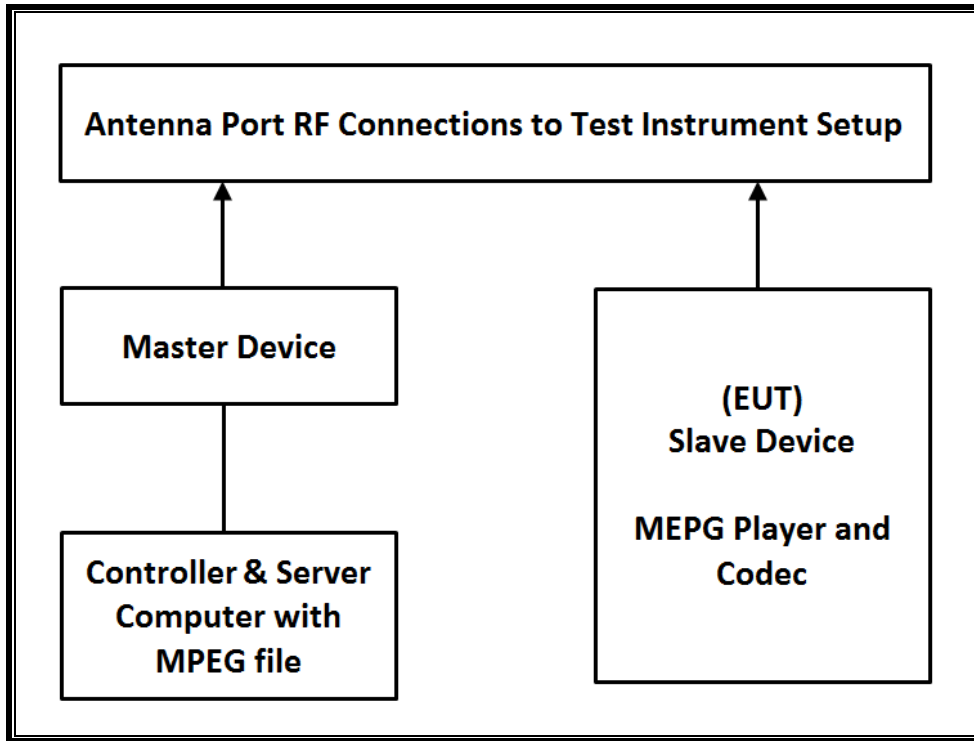

#### SUPPORT EQUIPMENT

The following support equipment was utilized for the DFS tests documented in this report:

PERIPHERAL SUPPORT EQUIPMENT LIST				
Description	Manufacturer	Model	Serial Number	FCC ID
Wireless Access Point	Cisco	AIR-CAP3702E-A-K9	FTX182276QX	LDK102087
Notebook PC (Controller/Server)	HP	HP EliteDesk 800 G1 TWR	CZC4125J25	DoC

#### **14.1.4. DESCRIPTION OF EUT**

The EUT operates over the 5250-5350 MHz and 5470-5725 MHz ranges.

The EUT is a Slave Device without Radar Detection.

The highest power level of the widest bandwidth (802.11ac VHT80) within these bands is 14.15 dBm in the 5250-5350 MHz band and 14.25 dBm in the 5470-5725 MHz band.

The antenna assembly utilized two antenna.

Gain of ANT1 : -5.01 dBi for UNII 2A and -5.85 dBi for UNII 2C.

Gain of ANT2 : -5.31 dBi for UNII 2A and -5.62 dBi for UNII 2C.

The rated output power of the Master unit is > 23dBm (EIRP). Therefore the required interference threshold level is -64 dBm. After correction for procedural adjustments, the required conducted threshold at the antenna port is  $-64 + 1 = -63$  dBm.

The calibrated radiated DFS Detection Threshold level is set to -64 dBm. The tested level is lower than the required level hence it provides a margin to the limit.

The EUT uses one transmitter/receiver chain connected to an antenna to perform radiated tests. WLAN traffic that meets or exceeds the minimum required loading was generated by transferring a data stream from the controller/server PC to the EUT using iPerf version 2.0.5 software package.

TPC is not required since the maximum EIRP is less than 500 mW (27 dBm).

The EUT utilizes the 802.11 architecture. Three nominal channel bandwidths are implemented: 20 MHz, 40 MHz and 80 MHz.

The software installed in the access point is 12.4(25d)JA1.

#### **UNIFORM CHANNEL SPREADING**

This requirement is not applicable to Slave radio devices.

#### **CHANNEL PUNCTURING(802.11ax)**

This EUT does not support channel puncturing.

#### **OVERVIEW OF MASTER DEVICE WITH RESPECT TO §15.407 (h) REQUIREMENTS**

The Master Device is a Cisco Access Point, FCC ID: LDK102087. The minimum antenna gain for the Master Device is 6 dBi.

The rated output power of the Master unit is > 23dBm (EIRP). Therefore the required interference threshold level is -64 dBm. After correction for procedural adjustments, the required radiated threshold at the antenna port is  $-64 + 1 = -63$  dBm.

The calibrated radiated DFS Detection Threshold level is set to -64 dBm. The tested level is lower than the required level hence it provides a margin to the limit.



## 14.2. RESULTS FOR 80 MHz BANDWIDTH (UNII-2A BAND)

### 14.2.1. TEST CHANNEL

All tests were performed at a channel center frequency of 5290 MHz.

### 14.2.2. RADAR WAVEFORM AND TRAFFIC

#### RADAR WAVEFORM



### 14.2.3. OVERLAPPING CHANNEL TESTS

#### RESULTS

These tests are not applicable.

### 14.2.4. MOVE AND CLOSING TIME

#### REPORTING NOTES

The reference marker is set at the end of last radar pulse.

The delta marker is set at the end of the last WLAN transmission following the radar pulse. This delta is the channel move time.

The aggregate channel closing transmission time is calculated as follows:

Aggregate Transmission Time =  
(Number of analyzer bins showing transmission) \* (dwell time per bin)

The observation period over which the aggregate time is calculated begins at (Reference Marker + 200 msec) and ends no earlier than (Reference Marker + 10 sec).

#### RESULTS

Channel Move Time (sec)	Limit (sec)
0.807	10

Aggregate Channel Closing Transmission Time (msec)	Limit (msec)
4.875	60

**MOVE TIME & CHANNEL CLOSING TIME**

**AGGREGATE CHANNEL CLOSING TRANSMISSION TIME**

No transmissions are observed during the aggregate monitoring period.

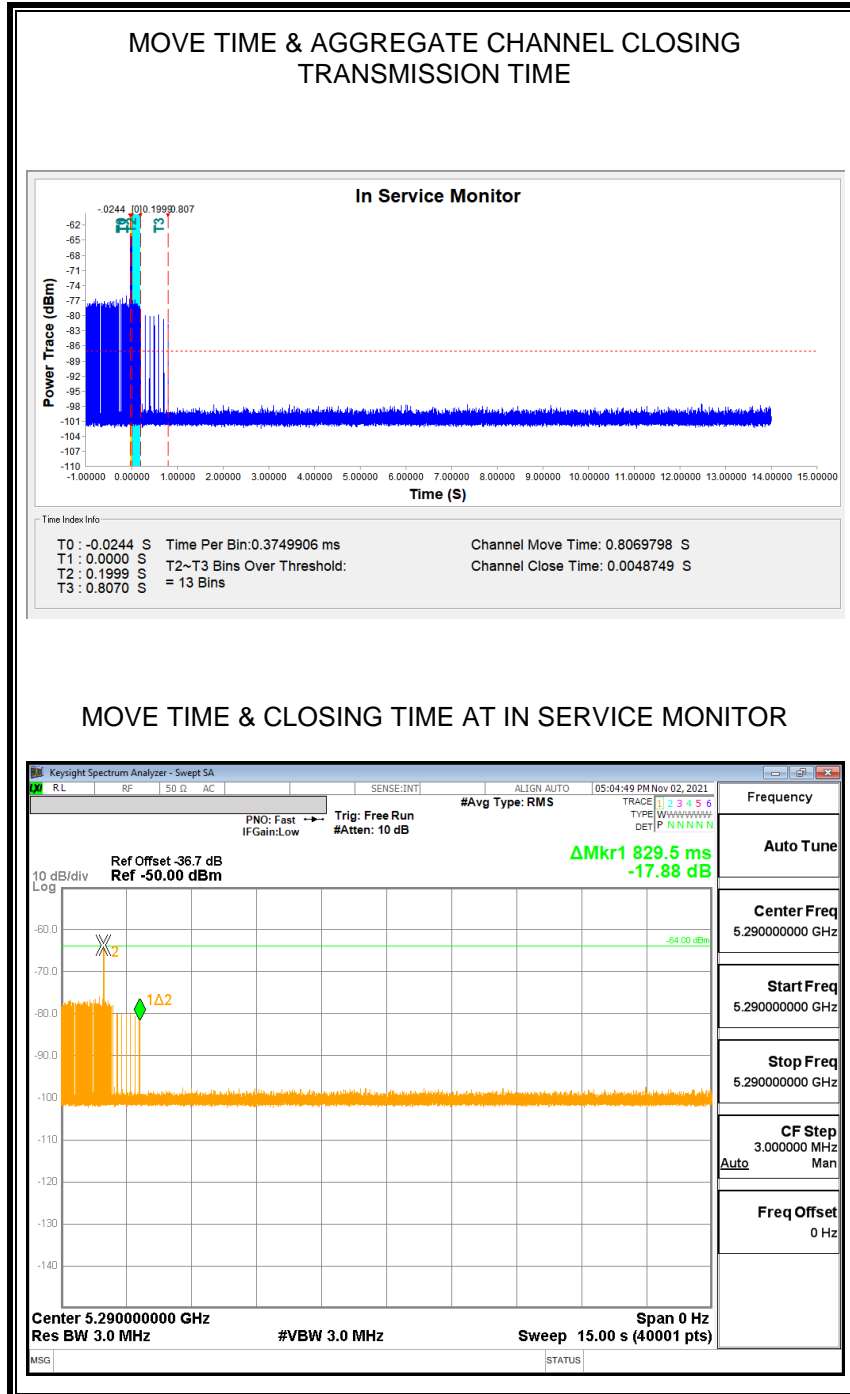

**NON-OCCUPANCY PERIOD**

**RESULTS**

No EUT transmissions were observed on the test channel during the 10-minute observation time.

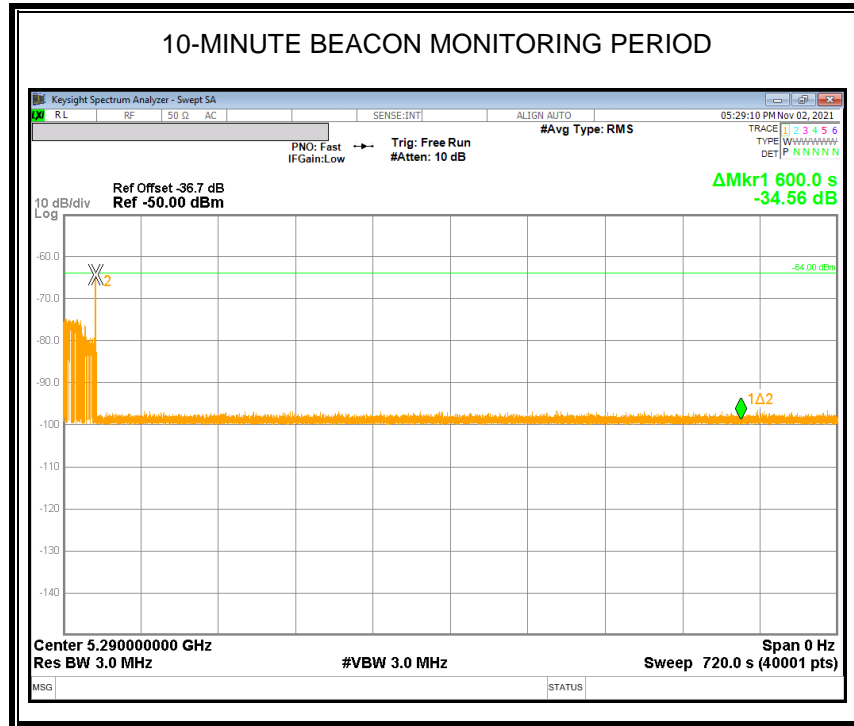

### 14.3. RESULTS FOR 80 MHz BANDWIDTH (UNII-2C BAND)

#### 14.3.1. TEST CHANNEL

All tests were performed at a channel center frequency of 5530 MHz.

#### 14.3.2. RADAR WAVEFORM AND TRAFFIC

##### RADAR WAVEFORM



### 14.3.3. OVERLAPPING CHANNEL TESTS

#### RESULTS

These tests are not applicable.

### 14.3.4. MOVE AND CLOSING TIME

#### REPORTING NOTES

The reference marker is set at the end of last radar pulse.

The delta marker is set at the end of the last WLAN transmission following the radar pulse. This delta is the channel move time.

The aggregate channel closing transmission time is calculated as follows:

Aggregate Transmission Time =  
(Number of analyzer bins showing transmission) \* (dwell time per bin)

The observation period over which the aggregate time is calculated begins at (Reference Marker + 200 msec) and ends no earlier than (Reference Marker + 10 sec).

#### RESULTS

Channel Move Time (sec)	Limit (sec)
0.728	10

Aggregate Channel Closing Transmission Time (msec)	Limit (msec)
5.625	60

**MOVE TIME & CHANNEL CLOSING TIME**

**AGGREGATE CHANNEL CLOSING TRANSMISSION TIME**

No transmissions are observed during the aggregate monitoring period.

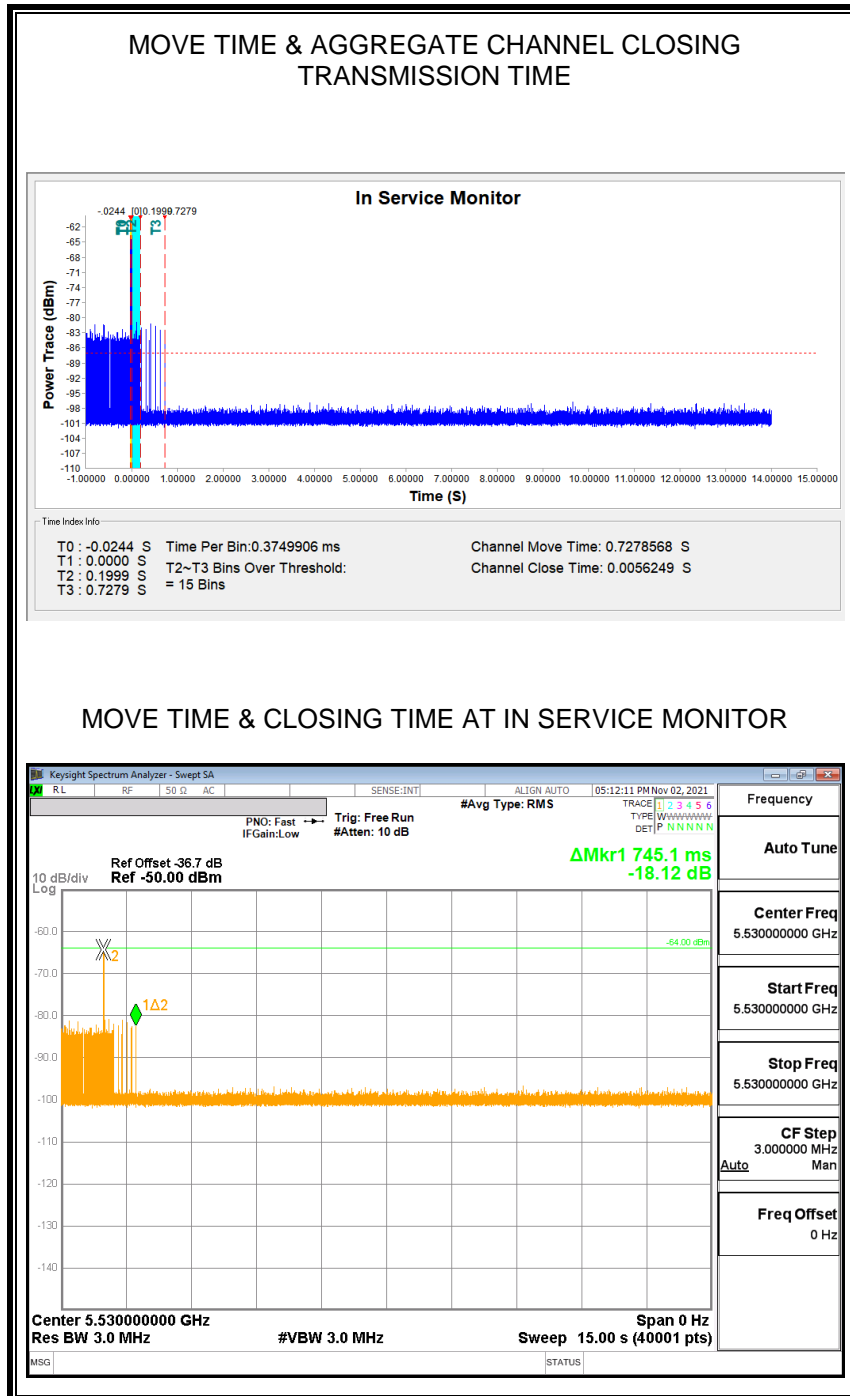

**NON-OCCUPANCY PERIOD**

**RESULTS**

No EUT transmissions were observed on the test channel during the 10-minute observation time.

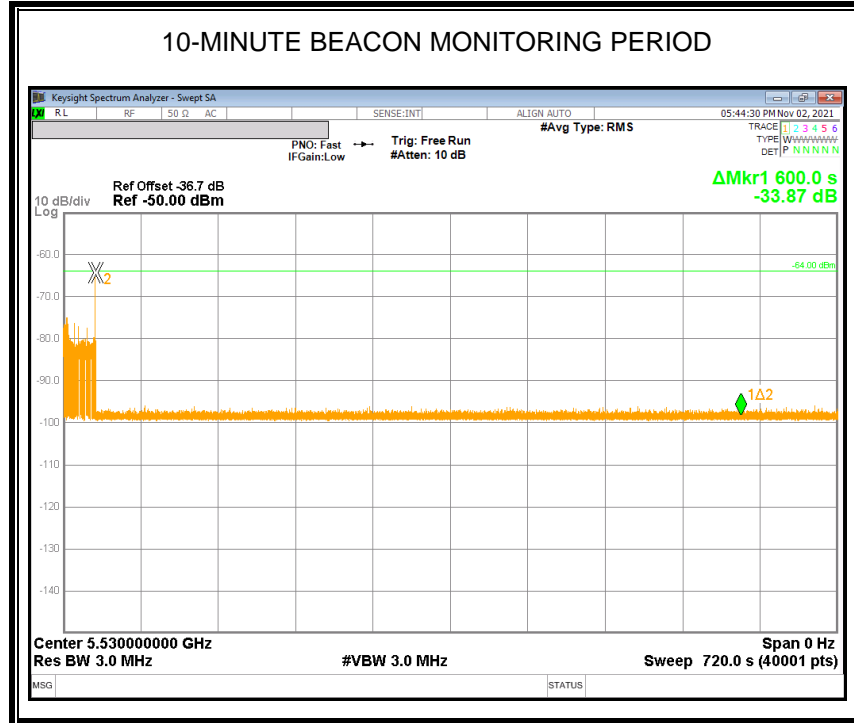

**END OF TEST REPORT**