



**HAC T-COIL SIGNAL TEST REPORT**

**FCC 47 CFR § 20.19  
ANSI C63.19-2011**

*For*

**GSM/WCDMA/LTE Phone + BT/BLE,DTS/UNII a/b/g/n/ac/ax, UWB, WPT and NFC**

**MODEL NUMBER : SM-N986B1/DS, SM-N986B1**

**FCC ID: A3LSMN986B1**

**REPORT NUMBER: 4790136523-S3V2**

**ISSUE DATE: 11/15/2021**

*Prepared for*

**SAMSUNG ELECTRONICS CO., LTD.  
129 SAMSUNG-RO, YEONGTONG-GU, SUWON-SI,  
GYEONGGI-DO, 16677, KOREA**

*Prepared by*

**UL Korea, Ltd.**

**26th floor, 152, Teheran-ro, Gangnam-gu Seoul, 06236, Korea**

**Suwon Test Site: UL Korea, Ltd. Suwon Laboratory  
218 Maeyeong-ro, Yeongtong-gu,  
Suwon-si, Gyeonggi-do, 16675, Korea  
TEL: (031) 337-9902  
FAX: (031) 213-5433**



**Testing Laboratory**

**TL-637**

**Revision History**

Rev.	Date	Revisions	Revised By
V1	11/2/2021	Initial Issue	
V2	11/15/2021	Section 5.2, 5.3, 6.4 and 8.1 removed PAG reuse item Section 9.7 corrected typo	Eunji Choi

## Table of Contents

<b>1. Attestation of Test Results</b> .....	<b>4</b>
<b>2. Test Methodology</b> .....	<b>5</b>
<b>3. Facilities and Accreditation</b> .....	<b>5</b>
<b>4. Calibration and Uncertainty</b> .....	<b>5</b>
4.1. <i>Measuring Instrument Calibration</i> .....	5
4.2. <i>Measurement Uncertainty</i> .....	6
4.3. <i>Decision Rule</i> .....	6
<b>5. Test Procedures for all Technologies</b> .....	<b>7</b>
5.1. <i>General Procedures C63.19-2011, Section 7</i> .....	7
5.2. <i>VoWiFi</i> .....	8
5.3. <i>Over the Top (OTT)</i> .....	9
<b>6. Audio Level and Gain Measurements</b> .....	<b>11</b>
6.1. <i>GSM / W-CDMA</i> .....	11
6.2. <i>VoLTE</i> .....	11
6.3. <i>VoWi-Fi</i> .....	12
6.4. <i>Over the Top (OTT)</i> .....	12
<b>7. T-coil Measurement Criteria</b> .....	<b>13</b>
7.1. <i>Frequency Response</i> .....	13
7.2. <i>Signal to Noise</i> .....	14
<b>8. Device Under Test</b> .....	<b>15</b>
8.1. <i>Air Interfaces and Operating Mode</i> .....	15
<b>9. HAC (T-coil) Test Results</b> .....	<b>16</b>
9.1. <i>Antenna Investigation</i> .....	16
9.2. <i>GSM/WCDMA/VoLTE Codec Investigation</i> .....	16
9.3. <i>GSM/WCDMA/VoLTE Air Interface Investigation</i> .....	18
9.4. <i>VoWi-Fi Codec Investigation</i> .....	21
9.5. <i>VoWi-Fi Air Interface Investigation</i> .....	21
9.6. <i>OTT Codec Investigation</i> .....	24
9.7. <i>OTT Air Interface Investigation</i> .....	25
9.8. <i>HAC (T-coil) Test Results</i> .....	26
9.9. <i>Worst Case T-Coil Test Plot</i> .....	28
<b>Appendix</b> .....	<b>29</b>
4790136523-S3_T-coil App A: <i>Setup Photo</i> .....	29
4790136523-S3_T-coil App B: <i>Test Plots</i> .....	29
4790136523-S3_T-coil App C: <i>Probe Certificates</i> .....	29

# 1. Attestation of Test Results

Applicant Name	SAMSUNG ELECTRONICS CO.,LTD.
FCC ID	A3LSMN986B1
Model Name	SM-N986B1/DS, SM-N986B1
Applicable Standards	FCC 47 CFR § 20.19 ANSI C63.19-2011
HAC Rating	T4
Date Tested	10/20/2021 to 11/2/2021
Test Results	Pass

UL Korea, Ltd. tested the above equipment in accordance with the requirements set forth in the above standards. All indications of Pass/Fail in this report are opinions expressed by UL Korea, Ltd. based on interpretations and/or observations of test results. Measurement Uncertainties were not taken into account and are published for informational purposes only. The test results show that the equipment tested is capable of demonstrating compliance with the requirements as documented in this report.

**Note:** The results documented in this report apply only to the tested sample, under the conditions and modes of operation as described herein. This document may not be altered or revised in any way unless done so by UL Korea, Ltd. and all revisions are duly noted in the revisions section. Any alteration of this document not carried out by UL Korea, Ltd. will constitute fraud and shall nullify the document. This report must not be used by the client to claim product certification, approval, or endorsement by IAS, any agency of the Federal Government, or any agency of any government.

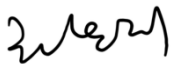
Approved & Released By: 	Prepared By: 
Justin Park Operations Leader UL Korea, Ltd. Suwon Laboratory	Eunji Choi Test Engineer UL Korea, Ltd. Suwon Laboratory

## 2. Test Methodology

The tests documented in this report were performed in accordance with ANSI C63.19-2011 Methods of Measurement of Compatibility between Wireless Communications Devices and Hearing Aids and FCC published procedure

KDB 285076 D01 HAC Guidance v05r01  
 KDB 285076 D02 T-Coil testing for CMRS IP v03r01  
 KDB 285076 D03 HAC FAQ v01r04  
 TCB workshop updates

## 3. Facilities and Accreditation

The test sites and measurement facilities used to collect data are located at

Suwon
SAR 2 Room (HAC)

UL Korea, Ltd. is accredited by IAS, Laboratory Code TL-637.

The full scope of accreditation can be viewed at <https://www.iasonline.org/wp-content/uploads/2017/05/TL-637-cert-New.pdf>

## 4. Calibration and Uncertainty

### 4.1. Measuring Instrument Calibration

The measuring equipment used to perform the tests documented in this report has been calibrated in accordance with the manufacturers' recommendations and is traceable to recognized national standards.

Name of Equipment	Manufacturer	Type/Model	Serial No.	Cal. Due Date
ABM Probe	SPEAG	AM1DV3	3137	07-26-2022
Data Acquisition Electronics	SPEAG	DAE4	1447	03-23-2022
Radio Communication Tester	R & S	CMW 500	150314	08-04-2022
Support Device	Samsung	SM-G770U1	R38MC0CE4ZN	N/A
DAC	Sound Devices	USBPre 2	HB1218172005	N/A

## 4.2. Measurement Uncertainty

### Measurement Uncertainty for Audio Band Magnetic Measurement

#### Measurement Uncertainty for Audio Band Magnetic Measurement

Error Description	Explanation	Uncertainty value (±%)	Probe Dist.	Divisor	(Ci) ABM1	(Ci) ABM2	Std. Unc.(±%)	
							ABM1	ABM2
<b>Probe Sensitivity</b>								
Reference Level	B.1	3.0	Normal	1	1	1	3.0	3.0
AMCC Geometry	B.2	0.4	Rectangular	1.732	1	1	0.2	0.2
AMCC Current	B.3	1.0	Rectangular	1.732	1	1	0.6	0.6
Probe Positioning during Calibration	B.4	0.1	Rectangular	1.732	1	1	0.1	0.1
Noise Contribution	B.5	0.7	Rectangular	1.732	0.0143	1	0.0	0.4
Frequency Slope	B.6	5.9	Rectangular	1.732	0.1	1	0.3	3.41
<b>Probe System</b>								
Repeatability / Drift	B.7	1.0	Rectangular	1.732	1	1	0.6	0.6
Linearity / Dynamic Range	B.8	0.6	Rectangular	1.732	1	1	0.3	0.3
Acoustic Noise	B.9	1.0	Rectangular	1.732	0.1	1	0.1	0.6
Probe Angle	B.10	2.3	Rectangular	1.732	1	1	1.3	1.3
Spectral Processing	B.11	0.9	Rectangular	1.732	1	1	0.5	0.5
Integration Time	B.12	0.6	Normal	1	1	5	0.6	3.0
Field Disturbation	B.13	0.2	Rectangular	1.732	1	1	0.1	0.1
<b>Test Signal</b>								
Ref. Signal Spectral Response	B.14	0.6	Rectangular	1.732	0	1	0.0	0.3
<b>Positioning</b>								
Probe Positioning	B.15	1.9	Rectangular	1.732	1	1	1.1	1.1
Phantom Thickness	B.16	0.9	Rectangular	1.732	1	1	0.5	0.5
DUT Positioning	B.17	1.9	Rectangular	1.732	1	1	1.1	1.1
<b>External Contributions</b>								
RF interference	B.18	0.0	Rectangular	1.732	1	0.3	0.0	0.0
Test Signal Variation	B.19	2.0	Rectangular	1.732	1	1	1.2	1.2
<b>Combined Std. Uncertainty (ABM Field)</b>							<b>4.0</b>	<b>6.1</b>
<b>Expanded Std. Uncertainty</b>							<b>8.1</b>	<b>12.2</b>
Notes for table								
1. Ci - is te sensitivity coefficient								
2. Expanded Std. Uncertainty, Coverage Factor = 2, > 95% Confidence								

## 4.3. Decision Rule

Decision rule for statement(s) of conformity is based on Procedure 1, Clause 4.4.2 in IEC Guide 115:2007.

## 5. Test Procedures for all Technologies

### 5.1. General Procedures C63.19-2011, Section 7

This document describes the procedures used to measure the ABM (T-Coil) performance of the WD. In addition to measuring the absolute signal levels, the A-weighted magnitude of the unintended signal shall also be determined. In order to assure that the required signal quality is measured, the measurement of the intended signal and the measurement of the unintended signal must be made at the same location for all measurement positions. In addition, the RF field strength at each measurement location must be at or below that required for the assigned category.

Measurements shall not include undesired properties from the WD's RF field; therefore, use of a coaxial connection to a base station simulator or non-radiating load may be necessary. However, even then with a coaxial connection to a base station simulator or non-radiating load there may still be RF leakage from the WD, which may interfere with the desired measurement. Pre-measurement checks should be made to avoid this possibility. All measurements shall be done with the WD operating on battery power with an appropriate normal speech audio signal input level given in Table 7.1. If the device display can be turned off during a phone call then that may be done during the measurement as well.

Measurements shall be performed at two locations specified in A.3, with the correct probe orientation for a particular location, in a multistage sequence by first measuring the field intensity of the desired T-Coil signal (ABM1) that is useful to a hearing aid T-Coil. The undesired magnetic components (ABM2) must be measured at the same location as the desired ABM or T-Coil signal (ABM1), and the ratio of desired to undesired ABM signals must be calculated. For the perpendicular field location, only the ABM1 frequency response shall be determined in a third measurement stage. The flow chart in Figure 7.3 illustrates this three-stage, two orientation process.

The following steps summarize the basic test flow for determining ABM1<sup>1</sup> and ABM2<sup>2</sup>. These steps assume that a sine wave or narrowband 1/3 octave signal can be used for the measurement of ABM1.

- a. A validation of the test setup and instrumentation may be performed using a TMFS or Helmholtz coil. Measure the emissions and confirm that they are within the specified tolerance.
- b. Position the WD in the test setup and connect the WD RF connector to a base station simulator or a non-radiating load as shown in Figure 7.1 or Figure 7.2. Confirm that equipment that requires calibration has been calibrated, and that the noise level meets the requirements given in 7.3.1.
- c. The drive level to the WD is set such that the reference input level specified in Table 7.1 is input to the base station simulator (or manufacturer's test mode equivalent) in the 1 kHz, 1/3 octave band. This drive level shall be used for the T-Coil signal test (ABM1) at  $f = 1$  kHz. Either a sine wave at 1025 Hz or a voice-like signal, band-limited to the 1 kHz 1/3 octave, as defined in 7.4.2, shall be used for the reference audio signal. If interference is found at 1025 Hz an alternative nearby reference audio signal frequency may be used.<sup>46</sup> The same drive level will be used for the ABM1 frequency response measurements at each 1/3 octave band center frequency. The WD volume control may be set at any level up to maximum, provided that a signal at any frequency at maximum modulation would not result in clipping or signal overload.
- d. Determine the magnetic measurement locations for the WD device (A.3), if not already specified by the manufacturer, as described in 7.4.4.1.1 and 7.4.4.2.
- e. At each measurement location, measure and record the desired T-Coil magnetic signals (ABM1 at  $f_i$ ) as described in 7.4.4.2 in each individual ISO 266-1975 R10 standard 1/3 octave band. The desired audio band input frequency ( $f_i$ ) shall be centered in each 1/3 octave band maintaining the same drive level as determined in item c) and the reading taken for that band.

Equivalent methods of determining the frequency response may also be employed, such as fast Fourier transform (FFT) analysis using noise excitation or input-output comparison using simulated speech. The full-band integrated or half-band integrated probe output, as specified in D.9, may be used, as long as the appropriate calibration curve is applied to the measured result, so as to yield an accurate measurement of the field magnitude. (The resulting measurement shall be an accurate measurement in dB A/m.)

---

<sup>1</sup> **Audio Band Magnetic signal - desired (ABM1):** Measured quantity of the desired magnetic signal

<sup>2</sup> **Audio Band Magnetic signal - undesired (ABM2):** Measured quantity of the undesired magnetic signal, such as interference from battery current and similar non-signal elements.

All measurements of the desired signal shall be shown to be of the desired signal and not of an undesired signal. This may be shown by turning the desired signal ON and OFF with the probe measuring the same location. If the scanning method is used the scans shall show that all measurement points selected for the ABM1 measurement meet the ambient and test system noise criteria in 7.3.1.

- f. At the measurement location for each orientation, measure and record the undesired broadband audio magnetic signal (ABM2) as specified in 7.4.4.4 with no audio signal applied (or digital zero applied, if appropriate) using A-weighting and the half-band integrator. Calculate the ratio of the desired to undesired signal strength (i.e., signal quality).
- g. Obtain the data from the postprocessor, SEMCAD, and determine the category that properly classifies the signal quality based on Table 8.5.

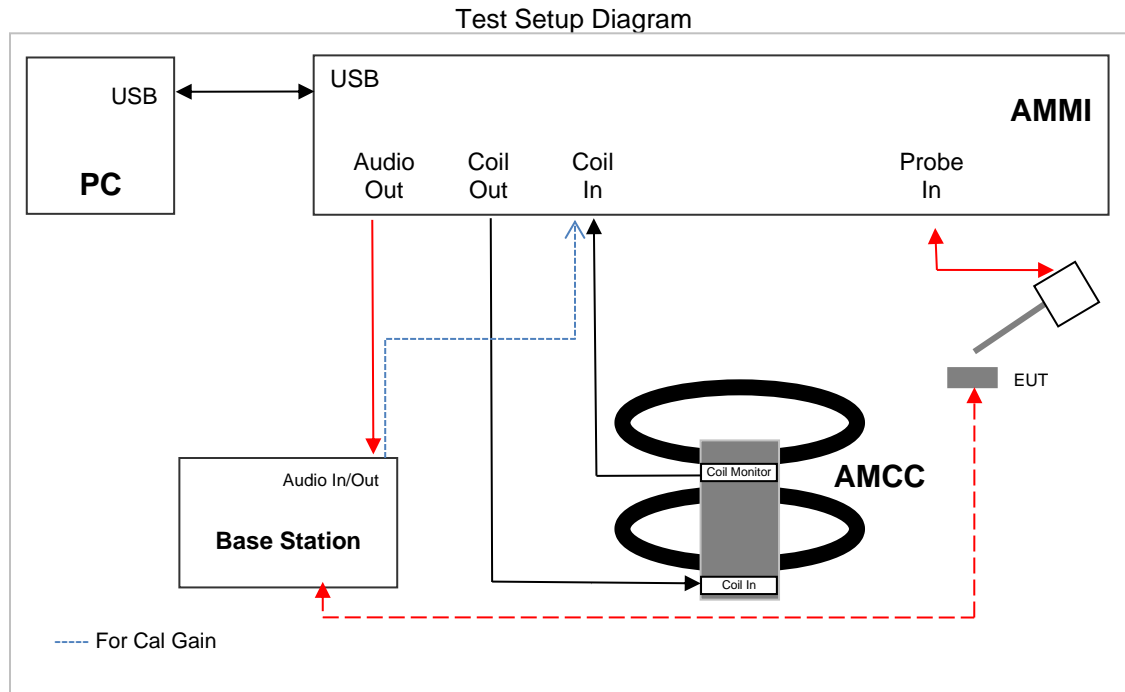

## 5.2. VoWiFi

This device supports Wi-Fi calling (aka Voice over Wi-Fi or VoWiFi) which is an extended feature of the carriers CMRS service to offload VoLTE calls onto local area networks over WI-FI via the internet and subject to HAC assessment for phones with a HAC rating.

The set up for VoWiFi uses the Base station as described in section 5.15.1 with the exception that the reference audio level is set at -20dBm0. The reference level is calibrated using the standard call box calibration procedures with the exception of the -20dBm0 reference level being used (refer to section 6.3).

An investigation was performed to determine worst case codec, bit rate and air interface configuration (refer to section 9).



### 5.3. Over the Top (OTT)

This device supports VoIP via a preinstalled application that uses the Google Duo service and related codec “OPUS”. VoIP capabilities require HAC assessment when voice calls are supported over the cellular data connection via pre-installed applications.

The equipment is set up as shown below with a support device used to originate the call using the IP transport. This support device includes test software that allows the codec bit rate for the IP call to be selected. The support device connects to the cloud-based Google Duo service via a Wi-Fi access point and router. The DUT connects to the VoIP service via a cellular air interface to the call box and an ethernet connection from call box to internet. The various codec bit rate and air interface configurations are evaluated to determine the worst-case configuration (refer to section 9).

Test Setup configuration for OTT Calls

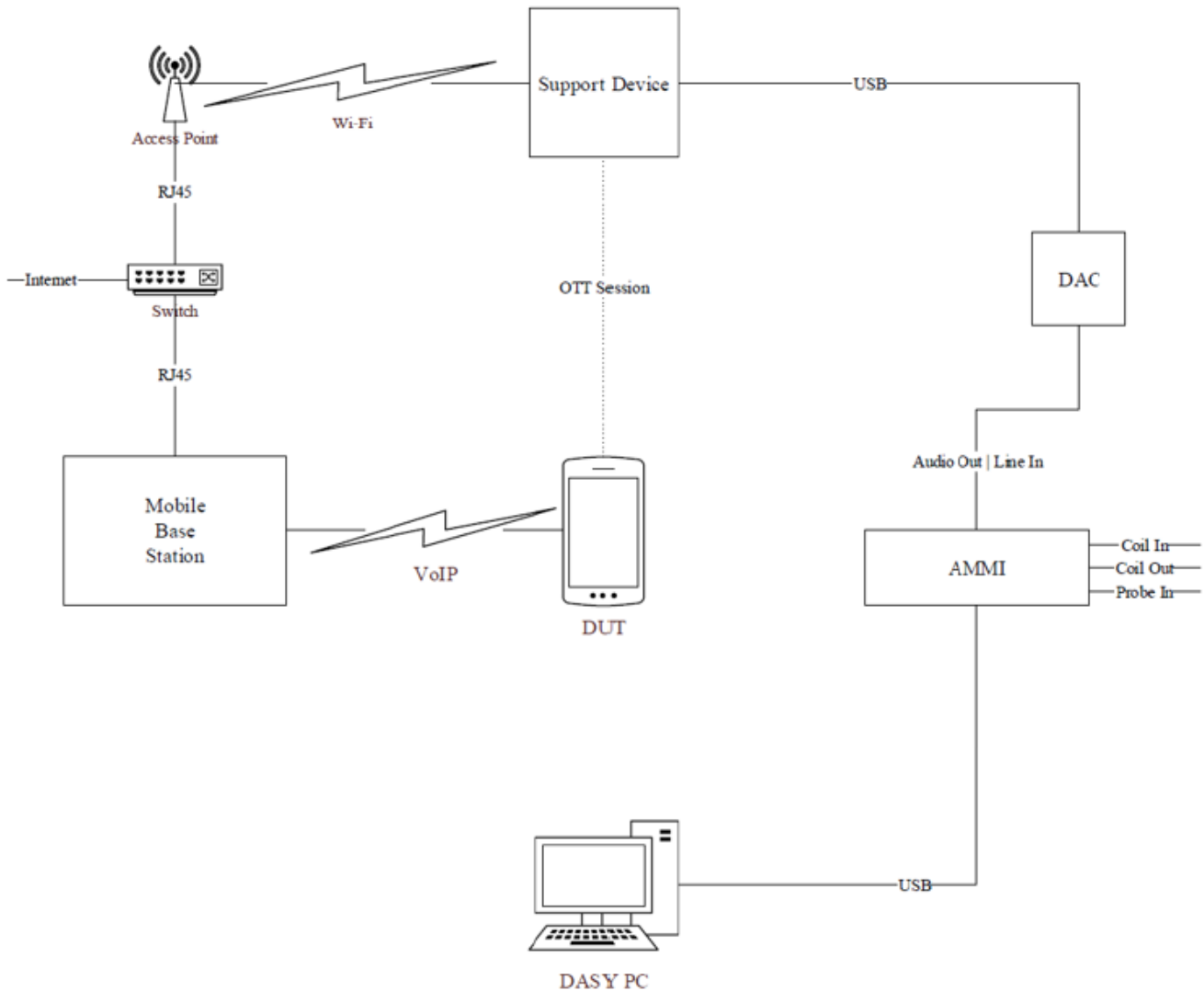

For the OTT call the calibrated audio card cannot be used so the AMMI is connected to an external Digital-Analog Converter (DAC) and the DAC is connected to the Support Device via USB. The test signal is sent from the DASY PC to the AMMI, from the AMMI to the DAC, from the DAC to the Support Device, and, via the VoIP call, to the DUT.

As this test set up uses an external DAC between the AMMI's audio output and support device the appropriate gain factor for the OTT call has to be determined. This is done by connecting the DAC between the AMMI Audio output and Coil input as shown below.

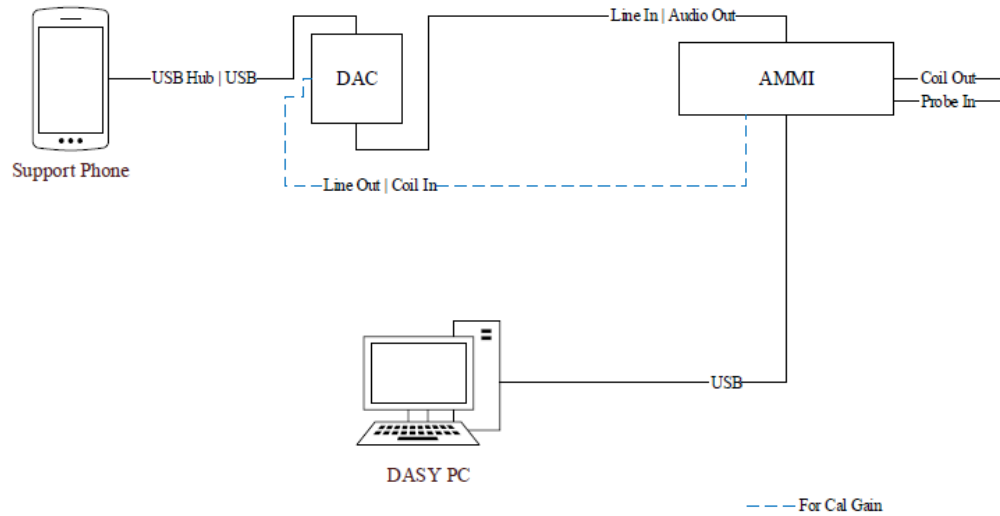

Using the metering function on the DAC, the DAC gain is adjusted until the volume reaches 0 dBFS (3.14 dBm0 based on TIA/EIA 810-A). SPEAG's "TN-LK-05042018-C-T-Coil\_Levels" document steps E through H are then followed to determine the adjusted gain values as detailed in section 6.4 so that the reference level is set 26.07 dB below full scale, i.e. at -20dBm0.

## 6. Audio Level and Gain Measurements

### 6.1. GSM / W-CDMA

Refer to the below table for the gains used to measure GSM and W-CDMA.

Signal Type	Audio Level [dBm0]	Gain [dB]	Gain [linear]
Voice 1 kHz	-16.00	27.69	<b>24.24</b>
Voice 300 - 3 kHz	-16.00	33.54	<b>47.53</b>

### 6.2. VoLTE

Refer to the below table for the gains used to measure VoLTE.

The following software/firmware was used to simulate the VoLTE server for testing:

Firmware	License Keys	Software Name
V3.7.30 for LTE	KS500	LTE FDD R8 SIG BASIC
	KS550	LTE TDD R8 SIG BASIC
V3.7.20 for Audio	KA100	IP APPL ENABLING IPv4
	KA150	IP APPL ENABLING IPv4
	KAA20	IP APPL IMS BASIC
	KM050	DATA APPL MEAS
	KS104	EVS SPEECH CODEC

Signal Type	Audio Level [dBm0]	Gain [dB]	Gain [linear]
Voice 1 kHz	-16.00	27.69	<b>24.24</b>
Voice 300 - 3 kHz	-16.00	33.54	<b>47.53</b>

### 6.3. VoWi-Fi

Refer to the below table for the gains used to measure VoWi-Fi.

Firmware	License Keys	Software Name
V3.7.50 for WLAN	KS650	WLAN A/B/G SIG BASIC
	KS651	WLAN N SIG BASIC
	KS656	WLAN IEEE 802.11ac
	KS657	WLAN IEEE 802.11ax
V3.7.20 for Audio	KA100	IP APPL ENABLING IPv4
	KA150	IP APPL ENABLING IPv4
	KAA20	IP APPL IMS BASIC
	KM050	DATA APPL MEAS
	KS104	EVS SPEECH CODEC

Signal Type	Audio Level [dBm0]	Gain [dB]	Gain [linear]
Voice 1 kHz	-20.00	23.69	<b>15.29</b>
Voice 300 - 3 kHz	-20.00	29.54	<b>29.99</b>

### 6.4. Over the Top (OTT)

For EDGE, HSPA, LTE, and Wi-Fi, the linear gain levels listed below were used. The results below are based on a reference input level of -20 dBm0.

To calibrate the DAC (refer section 5.2), three .wav audio files (sine wave, 1 kHz voice, and 300 to 3 kHz voice) are sent from the DASY5 PC to the AMMI, then to the DAC. The Helmholtz resonator measures the field strength, which represents the AMMI to DAC input sensitivity. After determining the input sensitivity, the adjusted linear gain values can then be calculated.

Signal Type	Audio Level [dBm0]	Gain [dB]	Gain [linear]
Voice 1 kHz	-20.00	26.07	<b>20.11</b>
Voice 300 - 3 kHz	-20.00	31.92	<b>39.45</b>

## 7. T-coil Measurement Criteria

### 7.1. Frequency Response

The frequency response of the axial component of the magnetic field, measured in 1/3 octave bands, shall follow the response curve, over the frequency range 300 Hz to 3000 Hz.

Figure 8.1 and Figure 8.2 provide the boundaries for the specified frequency. These response curves are for true field strength measurements of the T-Coil signal. Thus the 6 dB/octave probe response has been corrected from the raw readings.

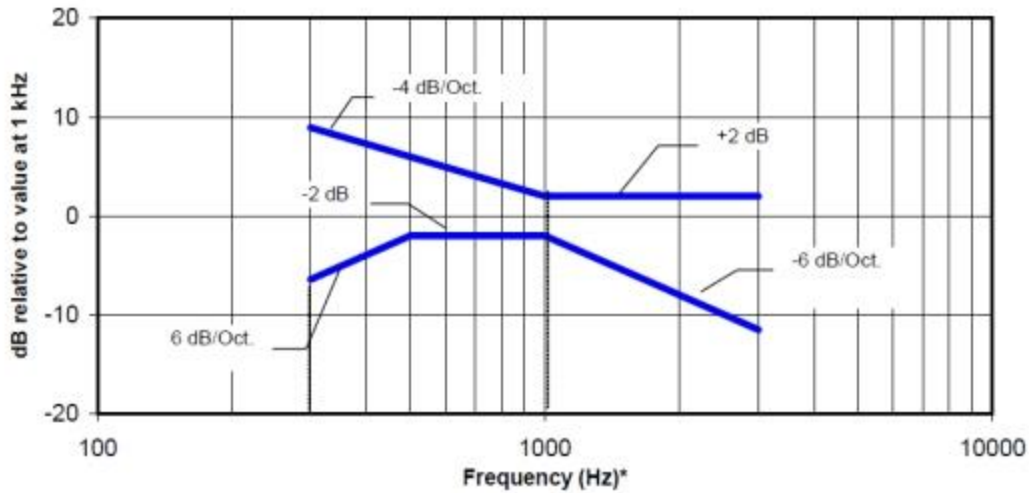

NOTE—The frequency response is between 300 Hz and 3000 Hz.

**Figure 8.1—Magnetic field frequency response for WDs with field strength  $\leq -15$  dB (A/m) at 1 kHz**

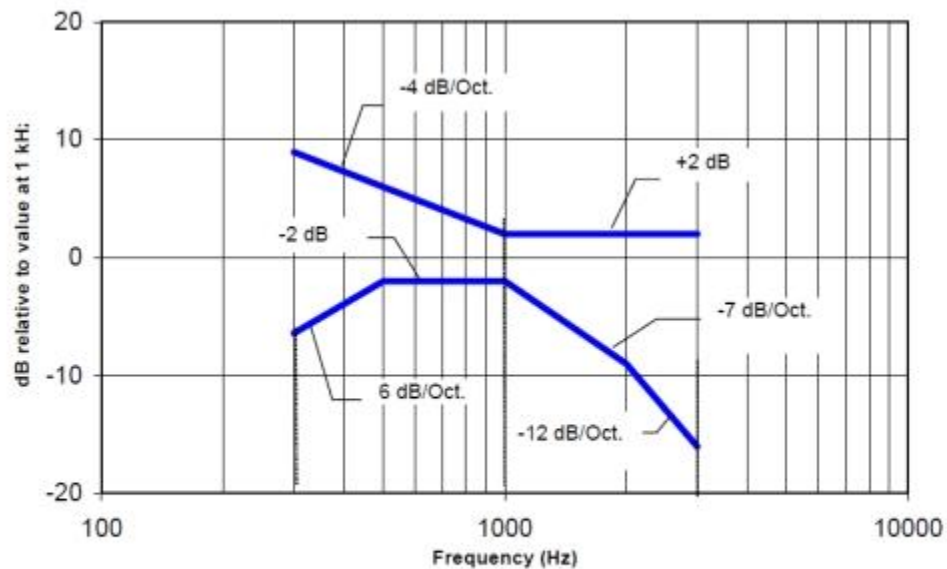

NOTE—The frequency response is between 300 Hz and 3000 Hz.

**Figure 8.2—Magnetic field frequency response for WDs with a field that exceeds  $-15$  dB(A/m) at 1 kHz**

## 7.2. Signal to Noise

This specifies the signal-to-noise quality requirement for the intended T-Coil signal from a WD. The worst signal to noise of the two T-Coil signal measurements, as determined in Clause 7, shall be used to determine the T-Coil mode category per Table 8.5.

Only the RF immunity of the hearing aid is measured in T-Coil mode. It is assumed that a hearing aid can have no immunity to an interference signal in the audio band, which is the intended reception band for this mode. So, the only criterion that can be measured is the RF immunity in T-Coil Mode. This is measured using the same procedure as for the audio coupling mode and at the same levels as specified in 6.4.

**Table 8.5—T-Coil signal-to-noise categories**

Category	Telephone parameters WD signal quality [(signal + noise)-to-noise ratio in decibels]
Category T1	0 dB to 10 dB
Category T2	10 dB to 20 dB
Category T3	20 dB to 30 dB
Category T4	>30 dB

Measurement locations and reference plane to be used for the T-coil measurements

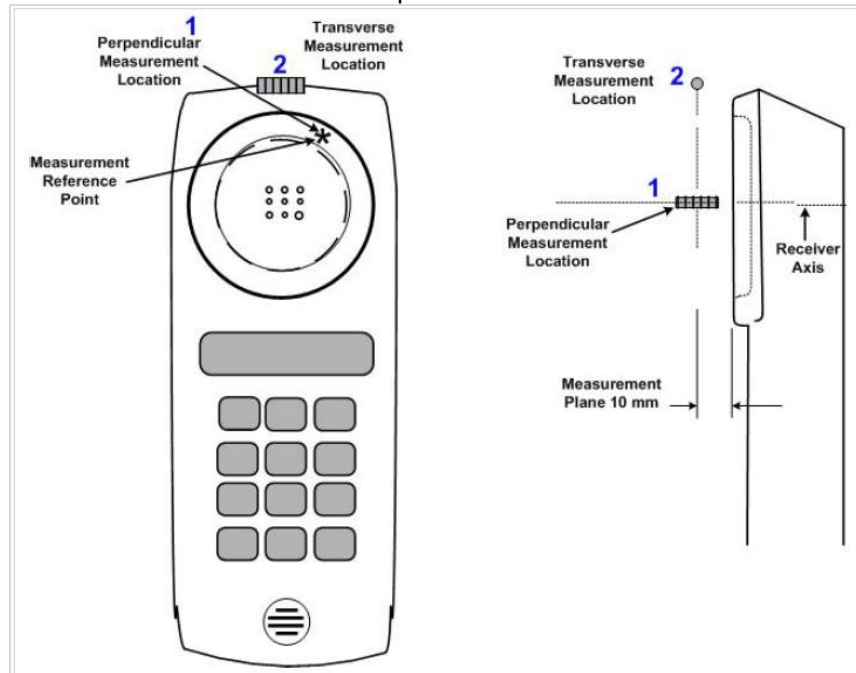

### 8. Device Under Test

Normal operation	Held to head				
Back Cover	The Back Cover is not removable				
Test sample information	<table border="0" style="width: 100%;"> <tr> <td style="text-align: center;"><b>S/N</b></td> <td style="text-align: center;"><b>Notes</b></td> </tr> <tr> <td style="text-align: center;">R3CR90Y67KK</td> <td style="text-align: center;">T-coil Test</td> </tr> </table>	<b>S/N</b>	<b>Notes</b>	R3CR90Y67KK	T-coil Test
<b>S/N</b>	<b>Notes</b>				
R3CR90Y67KK	T-coil Test				

#### 8.1. Air Interfaces and Operating Mode

Air Interface	Bands (MHz)	Type	C63.19 Tested	Simultaneous Transmitter	OTT Testing Required? Name of Voice Service	Audio Codecs Evaluated
GSM	850	VO	Yes	Wi-Fi and BT	NA	EFR
	1900					
	GPRS/EDGE	VD	Yes	Wi-Fi and BT	Yes Google Duo <sup>2</sup>	OPUS
W-CDMA (UMTS)	850 (V)	VO	Yes	Wi-Fi and BT	NA	AMR-NB & AMR-WB
	1700 (IV)					
	1900 (II)					
	HSPA	VD	Yes	Wi-Fi and BT	Yes Google Duo <sup>2</sup>	OPUS
LTE - FDD	700 (B12/13/17)	VD	Yes	Wi-Fi and BT	Yes <sup>1</sup> Google Duo <sup>2</sup>	VoLTE AMR-NB, AMR-WB, and EVS OTT OPUS
	850 (B5/26)					
	1700 (B4/66)					
	1900 (B2/25)					
LTE - TDD	2600 (B41)	VD	Yes	Wi-Fi and BT	Yes <sup>1</sup> Google Duo <sup>2</sup>	VoLTE AMR-NB, AMR-WB, and EVS OTT OPUS
Wi-Fi	2450	VD	Yes <sup>2,3</sup> (VoWiFi)	WWAN and Wi-Fi 5 GHz	Yes Google Duo <sup>2</sup>	VoWiFi AMR-NB, AMR-WB, and EVS OTT OPUS
	5200 (U-NII-1)			WWAN, Wi-Fi 2.4 GHz and BT		
	5300 (U-NII-2A)					
	5500 (U-NII-2C)					
	5800 (U-NII-3)					
BT	2450	DT	NA	WWAN and Wi-Fi 5 GHz	NA	NA

Type	Note:
VO: Legacy Cellular Voice Service	1. Ref Lev in accordance with the July 2012 VoLTE interpretation
DT: Digital Transport only (no voice)	2. Ref Lev -20 dBm0
VD: IP Voice Service over Digital Transport	
BT: Bluetooth	

**Note(s):**

- LTE Band 2 (1850 – 1910 MHz) is covered by LTE Band 25 (1850 – 1915 MHz) due to overlapping frequency range.
- LTE Band 4 (1710 – 1755 MHz) is covered by LTE Band 66 (1710 – 1780 MHz) due to overlapping frequency range.
- LTE Band 5 (824 – 849 MHz) is covered by LTE Band 26 (814 – 849 MHz) due to overlapping frequency range.
- LTE Band 17 (704 – 716 MHz) is covered by LTE Band 12 (699 – 716 MHz) due to overlapping frequency range.

## 9. HAC (T-coil) Test Results

### 9.1. Antenna Investigation

Mode:	Channel and Frequency	Bandwidth	Bandwidth / Modulation	Antenna	Orientation	ABM1 dB(A/m)	ABM2 dB(A/m)	Ambient Noise dB(A/m)	Freq. Response (dB)	ABM SNR (dB)	T-Rating	Margin	Position
802.11a Voice Wideband AMR Codec: 6.6 kbit/s	CH.40 5200 MHz	20 MHz	BPSK 6 Mbps	1	z (Axial)	11.97	-40.70	-49.13	1.37	52.67	T4	22.67	17.1, -3.3, 3.7
					y (Transversal)	4.47	-38.24	-49.22		42.71	T4	12.71	16.7, 5, 3.7
	CH.40 5200 MHz	20 MHz	BPSK 6 Mbps	2	z (Axial)	12.26	-40.69	-49.13	1.89	52.95	T4	22.95	17.1, -3.3, 3.7
					y (Transversal)	4.11	-40.47	-49.22		44.58	T4	14.58	16.7, 5, 3.7
802.11b Voice Wideband AMR Codec: 6.6 kbit/s	CH.6 2437 MHz	20 MHz	DSSS 1 Mbps	1	z (Axial)	8.11	-40.88	-49.32	2.00	48.99	T4	18.99	16.7, -4.6, 3.7
					y (Transversal)	0.46	-37.80	-49.32		38.26	T4	8.26	16.7, -15, 3.7
	CH.6 2437 MHz	20 MHz	DSSS 1 Mbps	2	z (Axial)	8.18	-41.02	-49.32	2.00	49.20	T4	19.20	16.7, -4.6, 3.7
					y (Transversal)	0.91	-37.97	-49.32		38.88	T4	8.88	16.7, -15, 3.7

**Note(s):**

Antenna 1 has been determined to be the worst-case antenna for both Wi-Fi 2.4 GHz and 5 GHz.

### 9.2. GSM/WCDMA/VoLTE Codec Investigation

An investigation between the various codec configurations (Low/Mid/High bit rates for Narrowband and Wideband) and specific parameters are documented (ABM1, ABM2, S+N/N, frequency response) to determine the worst-case bit rates for each voice service type. The table below compares the varying codec configurations.

A codec investigation was performed on one band of each GSM, W-CDMA, LTE FDD.

The highlighted results below were determined to be the worst case codec configuration(s) for GSM, WCDMA and LTE.

Codec Investigation				
Codec State	AMR-NB (kbit/s)		Orientation	Band/ BandWidth/ Channel
	FR V1	HR V1		
ABM1 (dB/m)	15.65	16.31	z (Axial)	GSM 850 CH.190
ABM2 (dBA/m)	-19.44	-22.08		
S+N/N (dB)	35.09	38.39		
Freq. Resposne (dB)	2.00	1.96		
ABM1 (dB/m)	7.86	8.19	y (Transversal)	
ABM2 (dBA/m)	-29.15	-31.95		
S+N/N (dB)	37.01	40.14		

**Note(s):**

A bitrate investigation was performed on the pre-install phone application to determine the worst-case bitrate;

- For GSM, it is observed that FR V1 is the worst-case.

Codec Investigation								
Codec State	AMR-NB (kbit/s)			AMR-WB (kbit/s)			Orientation	Band/ BandWidth/ Channel
	4.75	7.4	12.2	6.6	15.85	23.85		
ABM1 (dB/m)	15.18	15.89	15.95	12.22	13.11	13.32	z (Axial)	WCDMA Band IV Rel.99 CH.1413
ABM2 (dBA/m)	-47.45	-47.62	-47.73	-47.42	-47.36	-47.35		
S+N/N (dB)	62.63	63.51	63.68	59.64	60.47	60.67		
Freq. Resposne (dB)	1.89	2.00	1.97	2.00	2.00	2.00		
ABM1 (dB/m)	7.59	7.86	8.33	4.75	5.44	5.58	y (Transversal)	
ABM2 (dBA/m)	-45.56	-46.00	-45.82	-45.81	-45.90	-45.89		
S+N/N (dB)	53.15	53.86	54.15	50.56	51.34	51.47		

**Note(s):**

A bitrate investigation was performed on the pre-install phone application to determine the worst-case bitrate;

- For WCDMA, it is observed that AMR-WB 6.6 kbit/s is the worst-case.



Codec State	AMR-NB (kbit/s)			AMR-WB (kbit/s)			EVS nb (kbit/s)			EVS wb (kbit/s)			EVS swb (kbit/s)			Orientation	Band/ BandWidth/ Channel	
	4.75	7.4	12.2	6.6	15.85	23.85	5.9	13.2	24.4	5.9	13.2	24.4	9.6	16.4	24.4			
ABM1 (dB/m)	15.80	15.93	16.21	12.57	13.43	13.43	15.53	16.57	16.35	12.92	13.67	13.32	13.75	14.22	14.20	z (Axial)	LTE Band 66 CH.132322 20 MHz BW 16QAM RB 1/0	
ABM2 (dBA/m)	-43.45	-43.82	-42.81	-43.92	-42.74	-42.85	-31.03	-31.28	-30.08	-44.34	-44.36	-44.25	-43.75	-44.27	-44.05			
S+N/N (dB)	59.25	59.75	59.02	56.49	56.17	56.28	46.56	47.85	46.43	57.26	58.03	57.57	57.50	58.49	58.25			
Freq. Resposne (dB)	2.00	2.00	1.99	1.51	1.98	1.92	1.80	1.86	1.74	1.39	1.92	2.00	2.00	2.00	2.00			
ABM1 (dB/m)	7.47	8.20	8.26	4.93	5.47	5.73	8.36	8.75	8.85	5.71	6.17	5.31	5.72	6.45	6.57			y (Transversal)
ABM2 (dBA/m)	-47.00	-46.59	-46.83	-46.91	-47.14	-46.59	-37.98	-37.54	-37.80	-47.41	-46.58	-47.37	-46.82	-47.56	-47.20			
S+N/N (dB)	54.47	54.79	55.09	51.84	52.61	52.32	46.34	46.29	46.65	53.12	52.75	52.68	52.54	54.01	53.77			

Codec State	AMR-NB (kbit/s)			AMR-WB (kbit/s)			EVS nb (kbit/s)			EVS wb (kbit/s)			EVS swb (kbit/s)			Orientation	Band/ BandWidth/ Channel	
	4.75	7.4	12.2	6.6	15.85	23.85	5.9	13.2	24.4	5.9	13.2	24.4	9.6	16.4	24.4			
ABM1 (dB/m)	15.39	15.90	16.12	12.58	13.36	13.68	16.07	16.37	16.39	13.13	14.08	13.51	14.12	14.10	14.43	z (Axial)	LTE Band 41 CH.40620 20 MHz BW QPSK RB 1/0	
ABM2 (dBA/m)	-30.83	-30.85	-31.00	-29.17	-30.63	-30.82	-27.79	-31.11	-28.82	-31.01	-30.80	-31.02	-30.67	-30.90	-30.74			
S+N/N (dB)	46.22	46.75	47.12	41.75	43.99	44.50	43.86	47.48	45.21	44.14	44.88	44.53	44.79	45.00	45.17			
Freq. Resposne (dB)	1.44	1.91	2.00	1.46	2.00	1.80	1.66	2.00	1.77	1.82	2.00	2.00	2.00	2.00	2.00			
ABM1 (dB/m)	7.66	7.73	8.57	4.97	5.51	5.54	7.89	8.75	7.81	5.37	5.85	5.55	6.68	6.27	6.38			y (Transversal)
ABM2 (dBA/m)	-39.34	-40.50	-39.56	-40.28	-40.56	-40.28	-39.92	-40.45	-37.77	-40.45	-39.66	-40.25	-40.75	-40.43	-40.65			
S+N/N (dB)	47.00	48.23	48.13	45.25	46.07	45.82	47.81	49.20	45.58	45.82	45.51	45.80	47.43	46.70	47.03			

**Note(s):**

A bitrate investigation was performed on the pre-install phone application to determine the worst-case bitrate;

1. For LTE-FDD, it is observed that EVS nb 13.2 kbit/s is the worst-case.
2. For LTE-TDD, it is observed that AMR-WB 6.6 kbit/s is the worst-case.

### 9.3. GSM/WCDMA/VoLTE Air Interface Investigation

Using the worst-case bitrate found in Sec.9.2, a limited set of bands/channels/bandwidths were then tested to confirm that there is no effect to the T-rating when charging the band/channel/bandwidth.

#### GSM / W-CDMA (UMTS) Air interface Investigation:

Mode:	Channel and Frequency	Orientation	ABM1 dB(A/m)	ABM2 dB(A/m)	Ambient Noise dB(A/m)	Freq. Response (dB)	ABM SNR (dB)	T-Rating	Margin	Position
GSM 850 Voice Coder Speech Codec: FR V1	CH.128 824.2 MHz	z (Axial)	15.59	-20.34	-49.70	1.50	35.93	T4	5.93	16.7, -4.2, 3.7
		y (Transversal)	7.45	-30.14	-49.72		37.59	T4	7.59	16.7, 4.6, 3.7
	CH.190 836.6 MHz	z (Axial)	15.65	-19.44	-49.70	2.00	<b>35.09</b>	T4	5.09	16.7, -4.2, 3.7
		y (Transversal)	7.86	-29.15	-49.72		37.01	T4	7.01	16.7, 4.6, 3.7
	CH.251 848.6 MHz	z (Axial)	15.35	-20.35	-49.70	1.67	35.70	T4	5.70	16.7, -4.2, 3.7
		y (Transversal)	7.84	-29.15	-49.72		36.99	T4	6.99	16.7, 4.6, 3.7
GSM 1900 Voice Coder Speech Codec: FR V1	CH.661 1880.0 MHz	z (Axial)	15.73	-23.62	-49.70	1.73	39.35	T4	9.35	16.7, -4.6, 3.7
		y (Transversal)	7.72	-32.77	-49.72		40.49	T4	10.49	17.1, 5, 3.7
W-CDMA Band II Voice Wideband AMR Codec: 6.6 kbit/s	CH.9400 1880.0 MHz	z (Axial)	12.66	-47.81	-49.70	2.00	60.47	T4	30.47	16.7, -4.2, 3.7
		y (Transversal)	4.75	-46.03	-49.72		50.78	T4	20.78	17.1, 5, 3.7
W-CDMA Band IV Voice Wideband AMR Codec: 6.6 kbit/s	CH.1312 1712.4 MHz	z (Axial)	12.43	-47.37	-49.70	2.00	59.80	T4	29.80	17.5, -4.2, 3.7
		y (Transversal)	5.39	-45.83	-49.72		51.22	T4	21.22	17.1, 5.4, 3.7
	CH.1413 1732.6 MHz	z (Axial)	12.22	-47.42	-49.70	2.00	59.64	T4	29.64	17.5, -4.2, 3.7
		y (Transversal)	4.75	-45.81	-49.72		<b>50.56</b>	T4	20.56	17.1, 5.4, 3.7
	CH.1513 1752.6 MHz	z (Axial)	12.04	-47.25	-49.70	2.00	59.29	T4	29.29	17.5, -4.2, 3.7
		y (Transversal)	5.37	-45.89	-49.72		51.26	T4	21.26	17.1, 5.4, 3.7
W-CDMA Band V Voice Wideband AMR Codec: 6.6 kbit/s	CH.4183 836.6 MHz	z (Axial)	12.27	-47.55	-49.70	2.00	59.82	T4	29.82	17.1, -3.8, 3.7
		y (Transversal)	4.59	-48.52	-49.72		53.11	T4	23.11	17.5, -14.2, 3.7

**VoLTE (FDD) Air Interface Investigation:**

Mode:	Channel and Frequency	Bandwidth	Bandwidth / Modulation	RB configuration	Orientation	ABM1 dB(A/m)	ABM2 dB(A/m)	Ambient Noise dB(A/m)	Freq. Response (dB)	ABM SNR (dB)	T-Rating	Margin	Position		
LTE Band 66 Voice EVS-NB Codec: 13.2 kbit/s	CH.132322 1745 MHz	20MHz	QPSK	1/0	z (Axial)	16.39	-31.42	-49.13	1.91	47.81	T4	17.81	17.1, -3.8, 3.7		
					y (Transversal)	8.67	-38.97	-49.22		47.64	T4	17.64	17.1, -13.3, 3.7		
				1/49	z (Axial)	16.37	-31.95	-49.13	2.00	48.32	T4	18.32	17.1, -3.8, 3.7		
					y (Transversal)	8.67	-38.21	-49.22		46.88	T4	16.88	17.1, -13.3, 3.7		
				1/99	z (Axial)	16.41	-31.23	-49.13	1.91	47.64	T4	17.64	17.1, -3.8, 3.7		
					y (Transversal)	8.48	-39.25	-49.22		47.73	T4	17.73	17.1, -13.3, 3.7		
				50/0	z (Axial)	16.31	-30.75	-49.13	1.68	47.06	T4	17.06	17.1, -3.8, 3.7		
					y (Transversal)	8.69	-38.51	-49.22		47.20	T4	17.20	17.1, -13.3, 3.7		
				50/24	z (Axial)	16.37	-31.78	-49.13	1.93	48.15	T4	18.15	17.1, -3.8, 3.7		
					y (Transversal)	8.31	-39.05	-49.22		47.36	T4	17.36	17.1, -13.3, 3.7		
				50/50	z (Axial)	16.16	-31.38	-49.13	1.87	47.54	T4	17.54	17.1, -3.8, 3.7		
					y (Transversal)	8.74	-38.44	-49.22		47.18	T4	17.18	17.1, -13.3, 3.7		
		100/0	z (Axial)	16.55	-32.18	-49.13	1.88	48.73	T4	18.73	17.1, -3.8, 3.7				
			y (Transversal)	8.55	-38.98	-49.22		47.53	T4	17.53	17.1, -13.3, 3.7				
		16QAM	1/0	z (Axial)	16.57	-31.28	-49.13	1.86	47.85	T4	17.85	17.1, -3.8, 3.7			
				y (Transversal)	8.75	-37.54	-49.22		46.29	T4	16.29	17.1, -13.3, 3.7			
		64QAM	1/0	z (Axial)	16.39	-31.58	-49.13	1.90	47.97	T4	17.97	17.1, -3.8, 3.7			
				y (Transversal)	8.77	-38.57	-49.22		47.34	T4	17.34	17.1, -13.3, 3.7			
		256QAM	1/0	z (Axial)	16.35	-31.27	-49.13	1.29	47.62	T4	17.62	17.1, -3.8, 3.7			
				y (Transversal)	8.96	-38.70	-49.22		47.66	T4	17.66	17.1, -13.3, 3.7			
		15 MHz	16QAM	1/0	z (Axial)	16.71	-31.99	-49.13	1.88	48.70	T4	18.70	17.1, -3.8, 3.7		
					y (Transversal)	8.45	-38.64	-49.22		47.09	T4	17.09	17.1, -13.3, 3.7		
		10 MHz	16QAM	1/0	z (Axial)	16.30	-30.83	-49.13	1.91	47.13	T4	17.13	17.1, -3.8, 3.7		
					y (Transversal)	8.41	-38.55	-49.22		46.96	T4	16.96	17.1, -13.3, 3.7		
		5 MHz	16QAM	1/0	z (Axial)	16.67	-31.70	-49.13	2.00	48.37	T4	18.37	17.1, -3.8, 3.7		
					y (Transversal)	8.62	-38.60	-49.22		47.22	T4	17.22	17.1, -13.3, 3.7		
		3 MHz	16QAM	1/0	z (Axial)	16.29	-31.33	-49.13	2.00	47.62	T4	17.62	17.1, -3.8, 3.7		
					y (Transversal)	8.89	-38.47	-49.22		47.36	T4	17.36	17.1, -13.3, 3.7		
		1.4 MHz	16QAM	1/0	z (Axial)	16.74	-31.30	-49.13	1.53	48.04	T4	18.04	17.1, -3.8, 3.7		
					y (Transversal)	8.84	-38.84	-49.22		47.68	T4	17.68	17.1, -13.3, 3.7		
		CH.132072 1720 MHz	20 MHz	16QAM	1/0	z (Axial)	16.40	-31.16	-49.13	1.93	47.56	T4	17.56	17.1, -3.8, 3.7	
						y (Transversal)	8.75	-39.49	-49.22		48.24	T4	18.24	17.1, -13.3, 3.7	
		CH.132572 1770 MHz	20 MHz	16QAM	1/0	z (Axial)	16.58	-31.31	-49.13	1.84	47.89	T4	17.89	17.1, -3.8, 3.7	
						y (Transversal)	8.65	-38.78	-49.22		47.43	T4	17.43	17.1, -13.3, 3.7	
		LTE Band 12 Voice EVS-NB Codec: 13.2 kbit/s	CH.23095 707.5 MHz	10 MHz	16QAM	1/0	z (Axial)	16.30	-30.61	-49.13	1.97	46.91	T4	16.91	17.1, -4.2, 3.7
							y (Transversal)	8.67	-39.27	-49.22		47.94	T4	17.94	17.1, -13.3, 3.7
LTE Band 13 Voice EVS-NB Codec: 13.2 kbit/s	CH.23230 782 MHz	10 MHz	16QAM	1/0	z (Axial)	16.44	-30.41	-49.13	2.00	46.85	T4	16.85	17.1, -4.6, 3.7		
					y (Transversal)	8.85	-38.63	-49.22		47.48	T4	17.48	17.1, -13.3, 3.7		
LTE Band 25 Voice EVS-NB Codec: 13.2 kbit/s	CH.26365 1882.5 MHz	20 MHz	16QAM	1/0	z (Axial)	16.37	-30.96	-49.13	1.26	47.33	T4	17.33	17.1, -4.6, 3.7		
					y (Transversal)	8.81	-39.20	-49.22		48.01	T4	18.01	16.7, -13.3, 3.7		
LTE Band 26 Voice EVS-NB Codec: 13.2 kbit/s	CH.26865 831.5 MHz	15 MHz	16QAM	1/0	z (Axial)	16.33	-31.20	-49.13	2.00	47.53	T4	17.53	17.1, -5, 3.7		
					y (Transversal)	8.73	-38.64	-49.22		47.37	T4	17.37	17.1, -13.3, 3.7		

**VoLTE (TDD) Air Interface Investigation:**

Mode:	Channel and Frequency	Bandwidth	Bandwidth / Modulation	RB configuration	Orientation	ABM1 dB(A/m)	ABM2 dB(A/m)	Ambient Noise dB(A/m)	Freq. Response (dB)	ABM SNR (dB)	T-Rating	Margin	Position		
LTE Band 41 Voice Wideband AMR Codec: 6.6 kbit/s	CH.40620 2593 MHz	20MHz	QPSK	1/0	z (Axial)	12.58	-29.17	-49.21	1.46	41.75	T4	11.75	17.1, -4.2, 3.7		
					y (Transversal)	4.97	-40.28	-49.18		45.25	T4	15.25	17.1, 5, 3.7		
				1/49	z (Axial)	12.92	-30.75	-49.21	2.00	43.67	T4	13.67	17.1, -4.2, 3.7		
					y (Transversal)	4.29	-40.01	-49.18		44.30	T4	14.30	17.1, 5, 3.7		
				1/99	z (Axial)	12.83	-30.46	-49.21	2.00	43.29	T4	13.29	17.1, -4.2, 3.7		
					y (Transversal)	4.66	-39.62	-49.18		44.28	T4	14.28	17.1, 5, 3.7		
				50/0	z (Axial)	12.53	-32.21	-49.21	2.00	44.74	T4	14.74	17.1, -4.2, 3.7		
					y (Transversal)	4.99	-41.29	-49.18		46.28	T4	16.28	17.1, 5, 3.7		
				50/24	z (Axial)	12.46	-32.27	-49.21	2.00	44.73	T4	14.73	17.1, -4.2, 3.7		
					y (Transversal)	4.43	-41.54	-49.18		45.97	T4	15.97	17.1, 5, 3.7		
				50/50	z (Axial)	12.20	-32.18	-49.21	2.00	44.38	T4	14.38	17.1, -4.2, 3.7		
					y (Transversal)	4.55	-41.42	-49.18		45.97	T4	15.97	17.1, 5, 3.7		
				100/0	z (Axial)	12.63	-32.10	-49.21	2.00	44.73	T4	14.73	17.1, -4.2, 3.7		
					y (Transversal)	3.92	-41.37	-49.18		45.29	T4	15.29	17.1, 5, 3.7		
				16QAM	1/0	z (Axial)	12.41	-31.55	-49.21	1.72	43.96	T4	13.96	17.1, -4.2, 3.7	
						y (Transversal)	4.27	-40.66	-49.18		44.93	T4	14.93	17.1, 5, 3.7	
				64QAM	1/0	z (Axial)	12.95	-32.71	-49.21	2.00	45.66	T4	15.66	17.1, -4.2, 3.7	
						y (Transversal)	4.89	-41.40	-49.18		46.29	T4	16.29	17.1, 5, 3.7	
				256QAM	1/0	z (Axial)	12.98	-35.22	-49.21	1.92	48.20	T4	18.20	17.1, -4.2, 3.7	
						y (Transversal)	4.27	-42.38	-49.18		46.65	T4	16.65	17.1, 5, 3.7	
				15 MHz	QPSK	1/0	z (Axial)	12.53	-31.12	-49.21	2.00	43.65	T4	13.65	17.1, -4.2, 3.7
							y (Transversal)	4.26	-40.21	-49.18		44.47	T4	14.47	17.1, 5, 3.7
						1/0	z (Axial)	12.18	-31.21	-49.21	1.97	43.39	T4	13.39	17.1, -4.2, 3.7
							y (Transversal)	4.58	-40.56	-49.18		45.14	T4	15.14	17.1, 5, 3.7
	1/0	z (Axial)	12.22			-31.64	-49.21	2.00	43.86	T4	13.86	17.1, -4.2, 3.7			
		y (Transversal)	4.25			-41.04	-49.18		45.29	T4	15.29	17.1, 5, 3.7			
	20 MHz	QPSK	1/0	z (Axial)	12.44	-31.19	-49.21	1.73	43.63	T4	13.63	17.1, -4.2, 3.7			
				y (Transversal)	4.64	-39.43	-49.18		44.07	T4	14.07	17.1, 5, 3.7			
			1/0	z (Axial)	12.25	-31.49	-49.21	2.00	43.74	T4	13.74	17.1, -4.2, 3.7			
				y (Transversal)	4.64	-41.09	-49.18		45.73	T4	15.73	17.1, 5, 3.7			
			1/0	z (Axial)	12.84	-31.08	-49.21	2.00	43.92	T4	13.92	17.1, -4.2, 3.7			
				y (Transversal)	4.39	-40.92	-49.18		45.31	T4	15.31	17.1, 5, 3.7			
			1/0	z (Axial)	12.39	-30.63	-49.21	2.00	43.02	T4	13.02	17.1, -4.2, 3.7			
				y (Transversal)	4.51	-40.13	-49.18		44.64	T4	14.64	17.1, 5, 3.7			
	CH.39750 2506 MHz	20 MHz	QPSK	1/0	z (Axial)	12.44	-31.19	-49.21	1.73	43.63	T4	13.63	17.1, -4.2, 3.7		
	y (Transversal)				4.64	-39.43	-49.18		44.07	T4	14.07	17.1, 5, 3.7			
1/0	z (Axial)			12.25	-31.49	-49.21	2.00	43.74	T4	13.74	17.1, -4.2, 3.7				
	y (Transversal)			4.64	-41.09	-49.18		45.73	T4	15.73	17.1, 5, 3.7				
1/0	z (Axial)			12.84	-31.08	-49.21	2.00	43.92	T4	13.92	17.1, -4.2, 3.7				
	y (Transversal)			4.39	-40.92	-49.18		45.31	T4	15.31	17.1, 5, 3.7				
1/0	z (Axial)			12.39	-30.63	-49.21	2.00	43.02	T4	13.02	17.1, -4.2, 3.7				
	y (Transversal)			4.51	-40.13	-49.18		44.64	T4	14.64	17.1, 5, 3.7				
CH.40185 2549.5 MHz	20 MHz	QPSK	1/0	z (Axial)	12.44	-31.19	-49.21	1.73	43.63	T4	13.63	17.1, -4.2, 3.7			
y (Transversal)				4.64	-39.43	-49.18		44.07	T4	14.07	17.1, 5, 3.7				
1/0			z (Axial)	12.25	-31.49	-49.21	2.00	43.74	T4	13.74	17.1, -4.2, 3.7				
			y (Transversal)	4.64	-41.09	-49.18		45.73	T4	15.73	17.1, 5, 3.7				
1/0			z (Axial)	12.84	-31.08	-49.21	2.00	43.92	T4	13.92	17.1, -4.2, 3.7				
			y (Transversal)	4.39	-40.92	-49.18		45.31	T4	15.31	17.1, 5, 3.7				
1/0			z (Axial)	12.39	-30.63	-49.21	2.00	43.02	T4	13.02	17.1, -4.2, 3.7				
			y (Transversal)	4.51	-40.13	-49.18		44.64	T4	14.64	17.1, 5, 3.7				
CH.41055 2636.5 MHz	20 MHz	QPSK	1/0	z (Axial)	12.44	-31.19	-49.21	1.73	43.63	T4	13.63	17.1, -4.2, 3.7			
y (Transversal)				4.64	-39.43	-49.18		44.07	T4	14.07	17.1, 5, 3.7				
1/0			z (Axial)	12.25	-31.49	-49.21	2.00	43.74	T4	13.74	17.1, -4.2, 3.7				
			y (Transversal)	4.64	-41.09	-49.18		45.73	T4	15.73	17.1, 5, 3.7				
1/0			z (Axial)	12.84	-31.08	-49.21	2.00	43.92	T4	13.92	17.1, -4.2, 3.7				
			y (Transversal)	4.39	-40.92	-49.18		45.31	T4	15.31	17.1, 5, 3.7				
1/0			z (Axial)	12.39	-30.63	-49.21	2.00	43.02	T4	13.02	17.1, -4.2, 3.7				
			y (Transversal)	4.51	-40.13	-49.18		44.64	T4	14.64	17.1, 5, 3.7				
CH.41490 2680 MHz	20 MHz	QPSK	1/0	z (Axial)	12.44	-31.19	-49.21	1.73	43.63	T4	13.63	17.1, -4.2, 3.7			
y (Transversal)				4.64	-39.43	-49.18		44.07	T4	14.07	17.1, 5, 3.7				
1/0			z (Axial)	12.25	-31.49	-49.21	2.00	43.74	T4	13.74	17.1, -4.2, 3.7				
			y (Transversal)	4.64	-41.09	-49.18		45.73	T4	15.73	17.1, 5, 3.7				
1/0			z (Axial)	12.84	-31.08	-49.21	2.00	43.92	T4	13.92	17.1, -4.2, 3.7				
			y (Transversal)	4.39	-40.92	-49.18		45.31	T4	15.31	17.1, 5, 3.7				
1/0			z (Axial)	12.39	-30.63	-49.21	2.00	43.02	T4	13.02	17.1, -4.2, 3.7				
			y (Transversal)	4.51	-40.13	-49.18		44.64	T4	14.64	17.1, 5, 3.7				

### 9.4. VoWi-Fi Codec Investigation

An investigation between the various codec configurations (Low/High bit rates for Narrowband and Wideband) and specific parameters are documented (ABM1, ABM2, S+N/N, frequency response) to determine the worst-case bit rates for each voice service type. The table below compares the varying codec configurations. A codec investigation was performed for each Wi-Fi 2.4GHz and 5GHz.

The highlighted results below were determined to be the worst case codec configuration(s) for Wi-Fi 2.4GHz and 5GHz

Codec Investigation															Orientation	Band/ Bandwidth/ Channel	
Codec State	AMR-NB (kbit/s)			AMR-WB (kbit/s)			EVS nb (kbit/s)			EVS wb (kbit/s)			EVS swb (kbit/s)				
	4.75	7.4	12.2	6.6	15.85	23.85	5.9	13.2	24.4	5.9	13.2	24.4	9.6	16.4	24.4		
ABM1 (dB/m)	11.75	11.29	11.82	8.11	8.64	9.59	11.84	11.67	11.36	8.87	11.66	10.48	9.60	10.85	9.54	z (Axial)	802.11b CH.6 2412 MHz DSSS 1 Mbps
ABM2 (dBA/m)	-39.39	-39.09	-39.54	-40.88	-40.32	-39.84	-42.70	-41.66	-40.96	-44.10	-43.08	-44.79	-43.69	-42.68	-43.85		
S+N/N (dB)	51.14	50.38	51.36	48.99	48.96	49.43	54.54	53.33	52.32	52.97	54.74	55.27	53.29	53.53	53.39		
Freq. Resposne (dB)	1.44	1.73	1.91	2.00	1.40	1.54	1.70	2.00	1.82	1.70	1.76	1.62	2.00	2.00	2.00		
ABM1 (dB/m)	3.06	3.15	4.36	0.46	1.35	2.96	3.49	3.97	3.27	1.82	1.60	1.61	1.76	1.65	2.08		
ABM2 (dBA/m)	-42.76	-40.14	-42.53	-37.80	-42.97	-39.16	-41.28	-44.80	-42.25	-42.23	-44.88	-42.93	-41.14	-42.87	-44.75		
S+N/N (dB)	45.82	43.29	46.89	<b>38.26</b>	44.32	42.12	44.77	48.77	45.52	44.05	46.48	44.54	42.90	44.52	46.83	y (Transversal)	802.11a CH.40 5200 MHz BPSK 6 Mbps
ABM1 (dB/m)	15.37	15.35	15.82	11.97	13.10	12.92	15.84	15.95	16.28	12.79	13.18	12.89	14.42	14.04	14.40		
ABM2 (dBA/m)	-41.27	-41.50	-40.49	-40.70	-41.40	-41.48	-44.39	-42.13	-43.75	-43.30	-43.42	-43.61	-44.21	-44.39	-43.95		
S+N/N (dB)	56.64	56.85	56.31	52.67	54.50	54.40	60.23	58.08	60.03	56.09	56.60	56.50	58.63	58.43	58.35		
Freq. Resposne (dB)	2.00	2.00	2.00	1.37	1.84	1.80	2.00	1.78	1.79	1.23	1.94	1.66	2.00	2.00	2.00		
ABM1 (dB/m)	7.16	7.38	7.67	4.47	4.91	5.25	7.88	7.81	8.11	4.63	5.42	5.12	6.45	6.61	5.62		
ABM2 (dBA/m)	-39.66	-40.74	-39.89	-38.24	-40.22	-38.08	-42.59	-40.04	-41.89	-42.02	-41.51	-42.47	-41.58	-41.24	-41.77	z (Axial)	802.11a CH.40 5200 MHz BPSK 6 Mbps
S+N/N (dB)	46.82	48.12	47.56	<b>42.71</b>	45.13	43.33	50.47	47.85	50.00	46.65	46.93	47.59	48.03	47.85	47.39		
																y (Transversal)	802.11a CH.40 5200 MHz BPSK 6 Mbps

**Note(s):**

A bitrate investigation was performed on the pre-install phone application to determine the worst-case bitrate;

- For 802.11b and 802.11a, it is observed that AMR-WB 6.6 kbit/s is the worst-case.

### 9.5. VoWi-Fi Air Interface Investigation

Using the data from Sec.9.4, further testing was performed on the remaining 802.11 modes. The objective of these measurements is to ensure that changing the modulation, bandwidth, and data rate, whilst using the worst case codec configuration measured in Sec.9.4, yields no unexpected variations.

#### VoWi-Fi 2.4GHz Air Interface Investigation:

Mode:	Channel and Frequency	Bandwidth / Modulation	Orientation	ABM1 dB(A/m)	ABM2 dB(A/m)	Ambient Noise dB(A/m)	Freq. Response (dB)	ABM SNR (dB)	T-Rating	Margin	Position
802.11b Voice Wideband AMR Codec: 6.6 kbit/s	CH.6 2437 MHz	DSSS 1 Mbps	z (Axial)	8.11	-40.88	-49.32	2.00	48.99	T4	18.99	16.7, -4.6, 3.7
			y (Transversal)	0.46	-37.80	-49.32		<b>38.26</b>	T4	8.26	16.7, -15, 3.7
		CCK 5.5 Mbps	z (Axial)	9.22	-39.44	-49.32	2.00	48.66	T4	18.66	16.7, -4.6, 3.7
			y (Transversal)	1.29	-43.14	-49.32		44.43	T4	14.43	16.7, -15, 3.7
802.11g Voice Wideband AMR Codec: 6.6 kbit/s	CH.6 2437 MHz	BPSK 6 Mbps	z (Axial)	8.01	-40.14	-49.32	1.72	48.15	T4	18.15	16.7, -4.6, 3.7
			y (Transversal)	-0.20	-41.29	-49.32		41.09	T4	11.09	16.7, -15, 3.7
802.11n HT20 Voice Wideband AMR Codec: 6.6 kbit/s	CH.6 2437 MHz	MCS 0 6.5 Mbps	z (Axial)	6.74	-44.55	-49.32	1.52	51.29	T4	21.29	16.7, -4.6, 3.7
			y (Transversal)	0.17	-41.05	-49.32		41.22	T4	11.22	16.7, -15, 3.7
802.11ax HE20 Voice Wideband AMR Codec: 6.6 kbit/s	CH.6 2437 MHz	MCS 0 8.6 Mbps	z (Axial)	8.06	-39.98	-49.32	2.00	48.04	T4	18.04	16.7, -4.6, 3.7
			y (Transversal)	1.02	-42.73	-49.32		43.75	T4	13.75	16.7, -15, 3.7
802.11b Voice Wideband AMR Codec: 6.6 kbit/s	CH.1 2412 MHz	DSSS 1 Mbps	z (Axial)	7.27	-39.85	-49.32	1.79	47.12	T4	17.12	16.7, -4.6, 3.7
			y (Transversal)	-0.28	-40.57	-49.32		40.29	T4	10.29	16.7, -15, 3.7
	CH.11 2462 MHz		z (Axial)	7.27	-40.72	-49.32	2.00	47.99	T4	17.99	16.7, -4.6, 3.7
			y (Transversal)	0.52	-39.05	-49.32		39.57	T4	9.57	16.7, -15, 3.7
			z (Axial)	7.54	-40.25	-49.32	1.98	47.79	T4	17.79	16.7, -4.6, 3.7
			y (Transversal)	1.18	-39.24	-49.32		40.42	T4	10.42	16.7, -15, 3.7

**VoWi-Fi 5GHz Air Interface Investigation:**

Mode:	Channel and Frequency	Bandwidth / Modulation	Orientation	ABM1 dB(A/m)	ABM2 dB(A/m)	Ambient Noise dB(A/m)	Freq. Response (dB)	ABM SNR (dB)	T-Rating	Margin	Position
802.11a Voice Wideband AMR Codec: 6.6 kbit/s	CH.40 5200 MHz	BPSK 6 Mbps	z (Axial)	11.97	-40.70	-49.13	1.37	52.67	T4	22.67	17.1, -3.3, 3.7
			y (Transversal)	4.47	-38.24	-49.22		42.71	T4	12.71	16.7, 5, 3.7
		QPSK 18 Mbps	z (Axial)	12.32	-40.47	-49.13	2.00	52.79	T4	22.79	17.1, -3.3, 3.7
			y (Transversal)	4.30	-38.71	-49.22		43.01	T4	13.01	16.7, 5, 3.7
		64QAM 54 Mbps	z (Axial)	12.00	-40.76	-49.13	1.83	52.76	T4	22.76	17.1, -3.3, 3.7
			y (Transversal)	4.20	-38.90	-49.22		43.10	T4	13.10	16.7, 5, 3.7
802.11n HT20 Voice Wideband AMR Codec: 6.6 kbit/s	CH.40 5200 MHz	MCS 0 6.5 Mbps	z (Axial)	12.04	-39.27	-49.13	1.98	51.31	T4	21.31	17.1, -3.3, 3.7
			y (Transversal)	3.98	-39.03	-49.22		43.01	T4	13.01	16.7, 5, 3.7
		MCS 3 26 Mbps	z (Axial)	12.12	-41.23	-49.13	2.00	53.35	T4	23.35	17.1, -3.3, 3.7
			y (Transversal)	4.33	-39.44	-49.22		43.77	T4	13.77	16.7, 5, 3.7
		MCS 7 65 Mbps	z (Axial)	11.99	-44.09	-49.13	2.00	56.08	T4	26.08	17.1, -3.3, 3.7
			y (Transversal)	3.74	-39.36	-49.22		43.10	T4	13.10	16.7, 5, 3.7
802.11n HT40 Voice Wideband AMR Codec: 6.6 kbit/s	CH.38 5190 MHz	MCS 0 13.5 Mbps	z (Axial)	12.06	-43.36	-49.13	1.96	55.42	T4	25.42	17.1, -3.3, 3.7
			y (Transversal)	4.50	-40.10	-49.22		44.60	T4	14.60	16.7, 5, 3.7
		MCS 3 54 Mbps	z (Axial)	12.15	-44.40	-49.13	1.66	56.55	T4	26.55	17.1, -3.3, 3.7
			y (Transversal)	3.70	-43.07	-49.22		46.77	T4	16.77	16.7, 5, 3.7
		MCS 7 135 Mbps	z (Axial)	11.63	-44.79	-49.13	1.59	56.42	T4	26.42	17.1, -3.3, 3.7
			y (Transversal)	4.33	-42.91	-49.22		47.24	T4	17.24	16.7, 5, 3.7
802.11ac VHT20 Voice Wideband AMR Codec: 6.6 kbit/s	CH.40 5200 MHz	MCS 0 6.5 Mbps	z (Axial)	11.64	-40.04	-49.13	1.77	51.68	T4	21.68	17.1, -3.3, 3.7
			y (Transversal)	4.42	-38.95	-49.22		43.37	T4	13.37	16.7, 5, 3.7
		MCS 4 39 Mbps	z (Axial)	12.00	-41.26	-49.13	1.90	53.26	T4	23.26	17.1, -3.3, 3.7
			y (Transversal)	4.18	-39.28	-49.22		43.46	T4	13.46	16.7, 5, 3.7
		MCS 8 78 Mbps	z (Axial)	12.07	-40.94	-49.13	2.00	53.01	T4	23.01	17.1, -3.3, 3.7
			y (Transversal)	4.22	-39.97	-49.22		44.19	T4	14.19	16.7, 5, 3.7
802.11ac VHT40 Voice Wideband AMR Codec: 6.6 kbit/s	CH.38 5190 MHz	MCS 0 13.5 Mbps	z (Axial)	12.31	-39.23	-49.13	2.00	51.54	T4	21.54	17.1, -3.3, 3.7
			y (Transversal)	4.23	-39.01	-49.22		43.24	T4	13.24	16.7, 5, 3.7
		MCS 4 108 Mbps	z (Axial)	11.93	-40.90	-49.13	1.87	52.83	T4	22.83	17.1, -3.3, 3.7
			y (Transversal)	3.77	-39.84	-49.22		43.61	T4	13.61	16.7, 5, 3.7
		MCS 9 180 Mbps	z (Axial)	11.92	-41.40	-49.13	2.00	53.32	T4	23.32	17.1, -3.3, 3.7
			y (Transversal)	4.50	-38.64	-49.22		43.14	T4	13.14	16.7, 5, 3.7
802.11ac VHT80 Voice Wideband AMR Codec: 6.6 kbit/s	CH.42 5210 MHz	MCS 0 29.3 Mbps	z (Axial)	12.06	-39.77	-49.13	1.55	51.83	T4	21.83	17.1, -3.3, 3.7
			y (Transversal)	4.34	-38.98	-49.22		43.32	T4	13.32	16.7, 5, 3.7
		MCS 4 175.5 Mbps	z (Axial)	11.94	-40.77	-49.13	1.43	52.71	T4	22.71	17.1, -3.3, 3.7
			y (Transversal)	4.45	-43.75	-49.22		48.20	T4	18.20	16.7, 5, 3.7
		MCS 9 390 Mbps	z (Axial)	12.32	-44.84	-49.13	1.70	57.16	T4	27.16	17.1, -3.3, 3.7
			y (Transversal)	3.83	-43.70	-49.22		47.53	T4	17.53	16.7, 5, 3.7

**VoWi-Fi 5GHz Air Interface Investigation: (Continued)**

Mode:	Channel and Frequency	Bandwidth / Modulation	Orientation	ABM1 dB(A/m)	ABM2 dB(A/m)	Ambient Noise dB(A/m)	Freq. Response (dB)	ABM SNR (dB)	T-Rating	Margin	Position
802.11ax HE20 Voice Wideband AMR Codec: 6.6 kbit/s	CH.40 5200 MHz	MCS 0 8.6 Mbps	z (Axial)	12.21	-39.47	-49.13	1.82	51.68	T4	21.68	17.1, -3.3, 3.7
			y (Transversal)	4.34	-38.73	-49.22		43.07	T4	13.07	16.7, 5, 3.7
		MCS 6 77 Mbps	z (Axial)	12.30	-41.09	-49.13	2.00	53.39	T4	23.39	17.1, -3.3, 3.7
			y (Transversal)	3.78	-39.75	-49.22		43.53	T4	13.53	16.7, 5, 3.7
		MCS 11 143 Mbps	z (Axial)	11.77	-40.86	-49.13	1.92	52.63	T4	22.63	17.1, -3.3, 3.7
			y (Transversal)	4.39	-38.81	-49.22		43.20	T4	13.20	16.7, 5, 3.7
802.11ax HE40 Voice Wideband AMR Codec: 6.6 kbit/s	CH.38 5190 MHz	MCS 0 17.2 Mbps	z (Axial)	12.05	-39.11	-49.13	1.81	51.16	T4	21.16	17.1, -3.3, 3.7
			y (Transversal)	4.32	-38.48	-49.22		42.80	T4	12.80	16.7, 5, 3.7
		MCS 6 155 Mbps	z (Axial)	12.21	-41.27	-49.13	2.00	53.48	T4	23.48	17.1, -3.3, 3.7
			y (Transversal)	4.46	-39.49	-49.22		43.95	T4	13.95	16.7, 5, 3.7
		MCS 11 287 Mbps	z (Axial)	12.05	-41.15	-49.13	2.00	53.20	T4	23.20	17.1, -3.3, 3.7
			y (Transversal)	4.18	-38.59	-49.22		42.77	T4	12.77	16.7, 5, 3.7
802.11ax HE80 Voice Wideband AMR Codec: 6.6 kbit/s	CH.42 5210 MHz	MCS 0 36 Mbps	z (Axial)	12.49	-41.19	-49.13	1.51	53.68	T4	23.68	17.1, -3.3, 3.7
			y (Transversal)	4.37	-38.73	-49.22		43.10	T4	13.10	16.7, 5, 3.7
		MCS 6 324 Mbps	z (Axial)	12.39	-40.34	-49.13	2.00	52.73	T4	22.73	17.1, -3.3, 3.7
			y (Transversal)	4.54	-38.91	-49.22		43.45	T4	13.45	16.7, 5, 3.7
		MCS 11 600 Mbps	z (Axial)	12.13	-40.73	-49.13	2.00	52.86	T4	22.86	17.1, -3.3, 3.7
			y (Transversal)	4.53	-39.05	-49.22		43.58	T4	13.58	16.7, 5, 3.7
802.11a Voice Wideband AMR Codec: 6.6 kbit/s	CH.56 5280 MHz	BPSK 6 Mbps	z (Axial)	12.21	-45.79	-49.13	1.34	58.00	T4	28.00	17.1, -3.8, 3.7
			y (Transversal)	4.70	-38.30	-49.22		43.00	T4	13.00	17.1, -13.3, 3.7
	CH.120 5600 MHz		z (Axial)	12.26	-41.57	-49.13	1.46	53.83	T4	23.83	17.1, -4.2, 3.7
			y (Transversal)	4.75	-38.07	-49.22		42.82	T4	12.82	17.1, -12.9, 3.7
	CH.157 5785 MHz		z (Axial)	12.22	-40.10	-49.13	1.83	52.32	T4	22.32	17.1, -3.8, 3.7
			y (Transversal)	4.42	-39.38	-49.22		43.80	T4	13.80	17.1, 5.4, 3.7
	CH.36 5180 MHz		z (Axial)	12.14	-41.39	-49.13	1.43	53.53	T4	23.53	17.1, -3.3, 3.7
			y (Transversal)	4.47	-41.16	-49.22		45.63	T4	15.63	16.7, 5, 3.7
	CH.48 5240 MHz		z (Axial)	12.28	-40.48	-49.13	1.77	52.76	T4	22.76	17.1, -3.3, 3.7
			y (Transversal)	4.31	-40.45	-49.22		44.76	T4	14.76	16.7, 5, 3.7

### 9.6. OTT Codec Investigation

The DUT's nested OTT application supports range of codec bit rate 6 – 75 kbit/s, thus an investigation between the various codec configurations (6/40/75 as Low/Mid/High bit rates) and specific parameters are documented (ABM1, ABM2, S+N/N, frequency response) to determine the worst-case bit rates for each service type. The table below compares the varying codec configurations.

Codec Investigation					
Codec State	codec bit rate (kbit/s)			Orientation	Band/ BandWidth/ Channel
	6	40	75		
ABM1 (dB/m)	12.86	13.60	13.63	z (Axial)	GSM850 EGPRS 2slots CH.190
ABM2 (dBA/m)	-26.93	-26.15	-26.26		
S+N/N (dB)	39.79	<b>39.75</b>	39.89		
Freq. Resposne (dB)	2.00	2.00	2.00	y (Transversal)	
ABM1 (dB/m)	5.66	5.88	5.58		
ABM2 (dBA/m)	-34.15	-34.12	-34.53		
S+N/N (dB)	39.81	40.00	40.11	z (Axial)	WCDMA Band IV HSUPA Subtest1 CH.1413
ABM1 (dB/m)	14.88	14.86	15.10		
ABM2 (dBA/m)	-45.12	-45.24	-45.05		
S+N/N (dB)	60.00	60.10	60.15		
Freq. Resposne (dB)	2.00	1.88	2.00		
ABM1 (dB/m)	7.28	6.06	7.10		
ABM2 (dBA/m)	-46.74	-43.61	-43.56		
S+N/N (dB)	54.02	<b>49.67</b>	50.66		
ABM1 (dB/m)	14.97	13.49	14.82	z (Axial)	LTE FDD LTE Band 66 20MHz 16QAM RB1/0 CH.132322
ABM2 (dBA/m)	-44.53	-42.19	-43.35		
S+N/N (dB)	59.50	55.68	58.17		
Freq. Resposne (dB)	2.00	2.00	2.00	y (Transversal)	
ABM1 (dB/m)	6.70	6.45	7.03		
ABM2 (dBA/m)	-47.52	-42.17	-47.23		
S+N/N (dB)	54.22	<b>48.62</b>	54.26	z (Axial)	LTE TDD LTE Band 41 20MHz QPSK RB1/0 CH.40620
ABM1 (dB/m)	13.27	13.48	13.57		
ABM2 (dBA/m)	-33.95	-30.27	-31.12		
S+N/N (dB)	47.22	<b>43.75</b>	44.69		
Freq. Resposne (dB)	2.00	2.00	2.00		
ABM1 (dB/m)	7.24	7.10	6.73		
ABM2 (dBA/m)	-42.19	-39.78	-40.40		
S+N/N (dB)	49.43	46.88	47.13		
ABM1 (dB/m)	12.61	13.56	15.19	z (Axial)	WLAN 2.4GHz 802.11b 1Mbps CH.6 2437 MHz
ABM2 (dBA/m)	-40.64	-35.01	-39.75		
S+N/N (dB)	53.25	48.57	54.94		
Freq. Resposne (dB)	2.00	2.00	1.82	y (Transversal)	
ABM1 (dB/m)	6.12	5.69	7.51		
ABM2 (dBA/m)	-35.85	-35.45	-35.16		
S+N/N (dB)	41.97	<b>41.14</b>	42.67	z (Axial)	WLAN 5GHz 802.11a 6Mbps CH.40 5200 MHz
ABM1 (dB/m)	12.54	14.36	14.73		
ABM2 (dBA/m)	-43.71	-40.48	-43.88		
S+N/N (dB)	56.25	54.84	58.61		
Freq. Resposne (dB)	1.91	2.00	2.00		
ABM1 (dB/m)	6.26	7.02	6.96		
ABM2 (dBA/m)	-40.91	-35.08	-37.04		
S+N/N (dB)	47.17	<b>42.10</b>	44.00		

**Note(s):**

A bitrate investigation was performed on the pre-install phone application to determine the worst-case bitrate;

1. For GSM, W-CDMA, LTE-FDD, LTE-TDD and Wi-Fi 2.4GHz/5GHz, it is observed that 40 kbps is the worst-case.



### 9.7. OTT Air Interface Investigation

Mode:	Channel and Frequency	Bandwidth	Bandwidth / Modulation	RB configuration	Orientation	ABM1 dB(A/m)	ABM2 dB(A/m)	Ambient Noise dB(A/m)	Freq. Response (dB)	ABM SNR (dB)	T-Rating	Margin	Position
GSM850 EGPRS 2slots Codec : 40	CH.190 836.6 MHz	N/A	N/A	N/A	z (Axial)	13.60	-26.15	-49.13	2.00	39.75	T4	9.75	16.3, -3.8, 3.7
					y (Transversal)	5.88	-34.12	-49.13		40.00	T4	10.00	17.9, -13.3, 3.7
GSM1900 EGPRS 2slots Codec : 40	CH.661 1880.0 MHz	N/A	N/A	N/A	z (Axial)	11.64	-31.18	-49.13	2.00	42.82	T4	12.82	12.5, -4.2, 3.7
					y (Transversal)	4.77	-37.83	-49.13		42.60	T4	12.60	17.1, 8.3, 3.7
WCDMA Band II HSUPA Subtest1 Codec : 40	CH.9400 1880.0 MHz	N/A	N/A	N/A	z (Axial)	14.94	-45.83	-49.13	2.00	60.77	T4	30.77	16.3, -3.8, 3.7
					y (Transversal)	6.10	-44.84	-49.13		50.94	T4	20.94	14.2, 6.7, 3.7
WCDMA Band IV HSUPA Subtest1 Codec : 40	CH.1413 1732.6 MHz	N/A	N/A	N/A	z (Axial)	14.86	-45.24	-49.13	1.88	60.10	T4	30.10	16.7, -4.2, 3.7
					y (Transversal)	6.06	-43.61	-49.13		49.67	T4	19.67	15.4, 8.3, 3.7
WCDMA Band V HSUPA Subtest1 Codec : 40	CH.4183 836.6 MHz	N/A	N/A	N/A	z (Axial)	14.29	-45.99	-49.13	2.00	60.28	T4	30.28	15.8, -3.3, 3.7
					y (Transversal)	7.41	-46.90	-49.13		54.31	T4	24.31	17.9, -12.5, 3.7
LTE Band 12 Codec : 40	CH.23095 707.5 MHz	10 MHz	16QAM	1/0	z (Axial)	12.72	-46.17	-49.13	1.97	58.89	T4	28.89	13.8, -4.6, 3.7
					y (Transversal)	6.37	-45.99	-49.13		52.36	T4	22.36	16.7, -16.3, 3.7
LTE Band 13 Codec : 40	CH.23230 782 MHz	10 MHz	16QAM	1/0	z (Axial)	11.81	-40.23	-49.13	2.00	52.04	T4	22.04	18.3, -4.2, 3.7
					y (Transversal)	7.08	-41.91	-49.13		48.99	T4	18.99	17.5, 5.8, 3.7
LTE Band 25 Codec : 40	CH.26365 1882.5 MHz	20 MHz	16QAM	1/0	z (Axial)	14.89	-44.85	-49.13	1.89	59.74	T4	29.74	16.3, -4.2, 3.7
					y (Transversal)	6.97	-42.05	-49.13		49.02	T4	19.02	16.3, 5.8, 3.7
LTE Band 26 Codec : 40	CH.26865 831.5 MHz	15 MHz	16QAM	1/0	z (Axial)	14.73	-45.51	-49.13	1.87	60.24	T4	30.24	15.8, -4.2, 3.7
					y (Transversal)	6.39	-42.26	-49.13		48.65	T4	18.65	17.1, 4.6, 3.7
LTE Band 66 Codec : 40	CH.132322 1745 MHz	20 MHz	16QAM	1/0	z (Axial)	13.49	-42.19	-49.13	2.00	55.68	T4	25.68	19.2, -3.3, 3.7
					y (Transversal)	6.45	-42.17	-49.13		48.62	T4	18.62	16.7, 7.9, 3.7
LTE Band 41 Codec : 40	CH.40620 2593 MHz	20 MHz	QPSK	1/0	z (Axial)	13.48	-30.27	-49.13	2.00	43.75	T4	13.75	19.2, -1.3, 3.7
					y (Transversal)	7.10	-39.78	-49.13		46.88	T4	16.88	16.7, 5.8, 3.7
Wi-Fi 2.4 GHz Codec : 40	CH.6 2437 MHz	20 MHz	DSSS 1 Mbps	N/A	z (Axial)	13.56	-35.01	-49.13	2.00	48.57	T4	18.57	19.6, -5.8, 3.7
					y (Transversal)	5.69	-35.45	-49.13		41.14	T4	11.14	16.7, 4.6, 3.7
U-NII 1 Codec : 40	Ch.40 5200 MHz	20MHz	BPSK 6 Mbps	N/A	z (Axial)	14.36	-40.48	-49.13	2.00	54.84	T4	24.84	17.5, -7.1, 3.7
					y (Transversal)	7.02	-35.08	-49.13		42.10	T4	12.10	16.7, -13.3, 3.7
U-NII 2A Codec : 40	Ch.56 5280 MHz	20MHz	BPSK 6 Mbps	N/A	z (Axial)	13.20	-44.77	-49.13	1.86	57.97	T4	27.97	13.8, -4.2, 3.7
					y (Transversal)	6.44	-35.04	-49.13		41.48	T4	11.48	16.3, -13.8, 3.7
U-NII 2C Codec : 40	CH.120 5600 MHz	20MHz	BPSK 6 Mbps	N/A	z (Axial)	13.69	-39.28	-49.13	1.84	52.97	T4	22.97	18.8, -6.7, 3.7
					y (Transversal)	5.46	-36.99	-49.13		42.45	T4	12.45	12.9, -12.9, 3.7
U-NII 3 Codec : 40	CH.157 5785 MHz	20MHz	BPSK 6 Mbps	N/A	z (Axial)	12.83	-41.24	-49.13	2.00	54.07	T4	24.07	17.1, -6.3, 3.7
					y (Transversal)	6.36	-34.04	-49.13		40.40	T4	10.40	17.1, -12.9, 3.7

### 9.8. HAC (T-coil) Test Results

Mode:	Channel and Frequency	Bandwidth	Bandwidth / Modulation	RB configuration	Orientation	ABM1 dB(A/m)	ABM2 dB(A/m)	Ambient Noise dB(A/m)	Freq. Response (dB)	ABM SNR (dB)	T-Rating	Margin	Position	Plot page #
GSM 850 Voice Coder Speech Codec: FR V1	CH.190 836.6 MHz	N/A	N/A	N/A	z (Axial)	15.65	-19.44	-49.70	2.00	35.09	T4	5.09	16.7, -4.2, 3.7	1,2
					y (Transversal)	7.86	-29.15	-49.72		37.01	T4	7.01	16.7, 4.6, 3.7	3
GSM 1900 Voice Coder Speech Codec: FR V1	CH.661 1880.0 MHz	N/A	N/A	N/A	z (Axial)	15.73	-23.62	-49.70	1.73	39.35	T4	9.35	16.7, -4.6, 3.7	4,5
					y (Transversal)	7.72	-32.77	-49.72		40.49	T4	10.49	17.1, 5, 3.7	6
W-CDMA Band II Voice Wideband AMR Codec: 6.6 kbit/s	CH.9400 1880.0 MHz	N/A	N/A	N/A	z (Axial)	12.66	-47.81	-49.70	2.00	60.47	T4	30.47	16.7, -4.2, 3.7	7,8
					y (Transversal)	4.75	-46.03	-49.72		50.78	T4	20.78	17.1, 5, 3.7	9
W-CDMA Band IV Voice Wideband AMR Codec: 6.6 kbit/s	CH.1413 1732.6 MHz	N/A	N/A	N/A	z (Axial)	12.22	-47.42	-49.70	2.00	59.64	T4	29.64	17.5, -4.2, 3.7	10,11
					y (Transversal)	4.75	-45.81	-49.72		50.56	T4	20.56	17.1, 5.4, 3.7	12
W-CDMA Band V Voice Wideband AMR Codec: 6.6 kbit/s	CH.4183 836.6 MHz	N/A	N/A	N/A	z (Axial)	12.27	-47.55	-49.70	2.00	59.82	T4	29.82	17.1, -3.8, 3.7	13,14
					y (Transversal)	4.59	-48.52	-49.72		53.11	T4	23.11	17.5, -14.2, 3.7	15
LTE Band 12 Voice EVS-NB Codec: 13.2 kbit/s	CH.23095 707.5 MHz	10 MHz	16QAM	1/0	z (Axial)	16.30	-30.61	-49.13	1.97	46.91	T4	16.91	17.1, -4.2, 3.7	16,17
					y (Transversal)	8.67	-39.27	-49.22		47.94	T4	17.94	17.1, -13.3, 3.7	18
LTE Band 13 Voice EVS-NB Codec: 13.2 kbit/s	CH.23230 782 MHz	10 MHz	16QAM	1/0	z (Axial)	16.44	-30.41	-49.13	2.00	46.85	T4	16.85	17.1, -4.6, 3.7	19,20
					y (Transversal)	8.85	-38.63	-49.22		47.48	T4	17.48	17.1, -13.3, 3.7	21
LTE Band 25 Voice EVS-NB Codec: 13.2 kbit/s	CH.26365 1882.5 MHz	20 MHz	16QAM	1/0	z (Axial)	16.37	-30.96	-49.13	1.26	47.33	T4	17.33	17.1, -4.6, 3.7	22,23
					y (Transversal)	8.81	-39.20	-49.22		48.01	T4	18.01	16.7, -13.3, 3.7	24
LTE Band 26 Voice EVS-NB Codec: 13.2 kbit/s	CH.26865 831.5 MHz	15 MHz	16QAM	1/0	z (Axial)	16.33	-31.20	-49.13	2.00	47.53	T4	17.53	17.1, -5, 3.7	25,26
					y (Transversal)	8.73	-38.64	-49.22		47.37	T4	17.37	17.1, -13.3, 3.7	27
LTE Band 66 Voice EVS-NB Codec: 13.2 kbit/s	CH.132322 1745 MHz	20MHz	16QAM	1/0	z (Axial)	16.57	-31.28	-49.13	1.86	47.85	T4	17.85	17.1, -3.8, 3.7	28,29
					y (Transversal)	8.75	-37.54	-49.22		46.29	T4	16.29	17.1, -13.3, 3.7	30
LTE Band 41 Voice Wideband AMR Codec: 6.6 kbit/s	CH.40620 2593 MHz	20MHz	QPSK	1/0	z (Axial)	12.58	-29.17	-49.21	1.46	41.75	T4	11.75	17.1, -4.2, 3.7	31,32
					y (Transversal)	4.97	-40.28	-49.18		45.25	T4	15.25	17.1, 5, 3.7	33
802.11b Voice Wideband AMR Codec: 6.6 kbit/s	CH.6 2437 MHz	20 MHz	DSSS 1 Mbps	N/A	z (Axial)	8.11	-40.88	-49.32	2.00	48.99	T4	18.99	16.7, -4.6, 3.7	34,35
					y (Transversal)	0.46	-37.80	-49.32		38.26	T4	8.26	16.7, -15, 3.7	36
802.11a Voice Wideband AMR Codec: 6.6 kbit/s	CH.40 5200 MHz	20 MHz	BPSK 6 Mbps	N/A	z (Axial)	11.97	-40.70	-49.13	1.37	52.67	T4	22.67	17.1, -3.3, 3.7	37,38
					y (Transversal)	4.47	-38.24	-49.22		42.71	T4	12.71	16.7, 5, 3.7	39
	N/A			z (Axial)	12.21	-45.79	-49.13	1.34	58.00	T4	28.00	17.1, -3.8, 3.7	40,41	
				y (Transversal)	4.70	-38.30	-49.22		43.00	T4	13.00	17.1, -13.3, 3.7	42	
	N/A			z (Axial)	12.26	-41.57	-49.13	1.46	53.83	T4	23.83	17.1, -4.2, 3.7	43,44	
				y (Transversal)	4.75	-38.07	-49.22		42.82	T4	12.82	17.1, -12.9, 3.7	45	
	N/A			z (Axial)	12.22	-40.10	-49.13	1.83	52.32	T4	22.32	17.1, -3.8, 3.7	46,47	
				y (Transversal)	4.42	-39.38	-49.22		43.80	T4	13.80	17.1, 5.4, 3.7	48	

**Note:**  
The radial longitudinal (x axis) measurements are no longer required per ANSI C63.19

### HAC (T-coil) Test Results (Continued)

Mode:	Channel and Frequency	Bandwidth	Bandwidth / Modulation	RB configuration	Orientation	ABM1 dB(A/m)	ABM2 dB(A/m)	Ambient Noise dB(A/m)	Freq. Response (dB)	ABM SNR (dB)	T-Rating	Margin	Position	Plot page #
GSM850 EGPRS 2slots Codec : 40	CH.190 836.6 MHz	N/A	N/A	N/A	z (Axial)	13.60	-26.15	-49.13	2.00	39.75	T4	9.75	16.3, -3.8, 3.7	49,50
					y (Transversal)	5.88	-34.12	-49.13		40.00	T4	10.00	17.9, -13.3, 3.7	51
GSM1900 EGPRS 2slots Codec : 40	CH.661 1880.0 MHz	N/A	N/A	N/A	z (Axial)	11.64	-31.18	-49.13	2.00	42.82	T4	12.82	12.5, -4.2, 3.7	52,53
					y (Transversal)	4.77	-37.83	-49.13		42.60	T4	12.60	17.1, 8.3, 3.7	54
WCDMA Band II HSUPA Subtest1 Codec : 40	CH.9400 1880.0 MHz	N/A	N/A	N/A	z (Axial)	14.94	-45.83	-49.13	2.00	60.77	T4	30.77	16.3, -3.8, 3.7	55,56
					y (Transversal)	6.10	-44.84	-49.13		50.94	T4	20.94	14.2, 6.7, 3.7	57
WCDMA Band IV HSUPA Subtest1 Codec : 40	CH.1413 1732.6 MHz	N/A	N/A	N/A	z (Axial)	14.86	-45.24	-49.13	1.88	60.10	T4	30.10	16.7, -4.2, 3.7	58,59
					y (Transversal)	6.06	-43.61	-49.13		49.67	T4	19.67	15.4, 8.3, 3.7	60
WCDMA Band V HSUPA Subtest1 Codec : 40	CH.4183 836.6 MHz	N/A	N/A	N/A	z (Axial)	14.29	-45.99	-49.13	2.00	60.28	T4	30.28	15.8, -3.3, 3.7	61,62
					y (Transversal)	7.41	-46.90	-49.13		54.31	T4	24.31	17.9, -12.5, 3.7	63
LTE Band 12 Codec : 40	CH.23095 707.5 MHz	10 MHz	16QAM	1/0	z (Axial)	12.72	-46.17	-49.13	1.97	58.89	T4	28.89	13.8, -4.6, 3.7	64,65
					y (Transversal)	6.37	-45.99	-49.13		52.36	T4	22.36	16.7, -16.3, 3.7	66
LTE Band 13 Codec : 40	CH.23230 782 MHz	10 MHz	16QAM	1/0	z (Axial)	11.81	-40.23	-49.13	2.00	52.04	T4	22.04	18.3, -4.2, 3.7	67,68
					y (Transversal)	7.08	-41.91	-49.13		48.99	T4	18.99	17.5, 5.8, 3.7	69
LTE Band 25 Codec : 40	CH.26365 1882.5 MHz	20 MHz	16QAM	1/0	z (Axial)	14.89	-44.85	-49.13	1.89	59.74	T4	29.74	16.3, -4.2, 3.7	70,71
					y (Transversal)	6.97	-42.05	-49.13		49.02	T4	19.02	16.3, 5.8, 3.7	72
LTE Band 26 Codec : 40	CH.26865 831.5 MHz	15 MHz	16QAM	1/0	z (Axial)	14.73	-45.51	-49.13	1.87	60.24	T4	30.24	15.8, -4.2, 3.7	73,74
					y (Transversal)	6.39	-42.26	-49.13		48.65	T4	18.65	17.1, 4.6, 3.7	75
LTE Band 66 Codec : 40	CH.132322 1745 MHz	20 MHz	16QAM	1/0	z (Axial)	13.49	-42.19	-49.13	2.00	55.68	T4	25.68	19.2, -3.3, 3.7	76,77
					y (Transversal)	6.45	-42.17	-49.13		48.62	T4	18.62	16.7, 7.9, 3.7	78
LTE Band 41 Codec : 40	CH.40620 2593 MHz	20 MHz	QPSK	1/0	z (Axial)	13.48	-30.27	-49.13	2.00	43.75	T4	13.75	19.2, -1.3, 3.7	79,80
					y (Transversal)	7.10	-39.78	-49.13		46.88	T4	16.88	16.7, 5.8, 3.7	81
Wi-Fi 2.4 GHz Codec : 40	CH.6 2437 MHz	20 MHz	DSSS 1 Mbps	N/A	z (Axial)	13.56	-35.01	-49.13	2.00	48.57	T4	18.57	19.6, -5.8, 3.7	82,83
					y (Transversal)	5.69	-35.45	-49.13		41.14	T4	11.14	16.7, 4.6, 3.7	84
U-NII 1 Codec : 40	Ch.40 5200 MHz	20MHz	BPSK 6 Mbps	N/A	z (Axial)	14.36	-40.48	-49.13	2.00	54.84	T4	24.84	17.5, -7.1, 3.7	85,86
					y (Transversal)	7.02	-35.08	-49.13		42.10	T4	12.10	16.7, -13.3, 3.7	87
U-NII 2A Codec : 40	Ch.56 5280 MHz	20MHz	BPSK 6 Mbps	N/A	z (Axial)	13.20	-44.77	-49.13	1.86	57.97	T4	27.97	13.8, -4.2, 3.7	88,89
					y (Transversal)	6.44	-35.04	-49.13		41.48	T4	11.48	16.3, -13.8, 3.7	90
U-NII 2C Codec : 40	CH.120 5600 MHz	20MHz	BPSK 6 Mbps	N/A	z (Axial)	13.69	-39.28	-49.13	1.84	52.97	T4	22.97	18.8, -6.7, 3.7	91,92
					y (Transversal)	5.46	-36.99	-49.13		42.45	T4	12.45	12.9, -12.9, 3.7	93
U-NII 3 Codec : 40	CH.157 5785 MHz	20MHz	BPSK 6 Mbps	N/A	z (Axial)	12.83	-41.24	-49.13	2.00	54.07	T4	24.07	17.1, -6.3, 3.7	94,95
					y (Transversal)	6.36	-34.04	-49.13		40.40	T4	10.40	17.1, -12.9, 3.7	96

**Note:**

1. The radial longitudinal (x axis) measurements are no longer required per ANSI C63.19

### 9.9. Worst Case T-Coil Test Plot

Test Laboratory: UL Korea Ltd. Suwon Laboratory

Date: 2021-10-20

#### GSM

Communication System: UID 0, Generic GSM (0); Frequency: 836.6 MHz; Duty Cycle: 1:8.30042  
Phantom section: TCoil Section  
DASY5 Configuration:  
- Probe: AM1DV3 - 3137; ; Calibrated: 2021-07-26  
- Sensor-Surface: 0mm (Fix Surface)  
- Electronics: DAE4 Sn1447; Calibrated: 2021-03-23  
- Phantom: HAC Test Arch with AMCC; Type: SD HAC P01 BB  
- Measurement SW: DASY52, Version 52.10 (4);SEMCAD X Version 14.6.14 (7483)

**T-Coil scan (scan for ANSI C63.19 2011 compliance)/GSM850 Voice ch190 FR V1/z**  
**(axial) 4.2mm 50 x 50/ABM Interpolated Signal(x,y,z) (121x121x1):** Interpolated grid: dx=1.000 mm, dy=1.000 mm  
Signal Type: Audio File (.wav) 48k\_voice\_1kHz\_1s.wav  
Output Gain: 24.24  
Measure Window Start: 300ms  
Measure Window Length: 1000ms  
BWC applied: 0.16 dB  
Device Reference Point: 0, 0, -6.3 mm

**Cursor:**  
ABM1/ABM2 = 35.09 dB  
ABM1 = 15.65 dBA/m  
ABM2 = -19.44 dBA/m  
BWC Factor = 0.16 dB  
Location: 16.7, -4.2, 3.7 mm

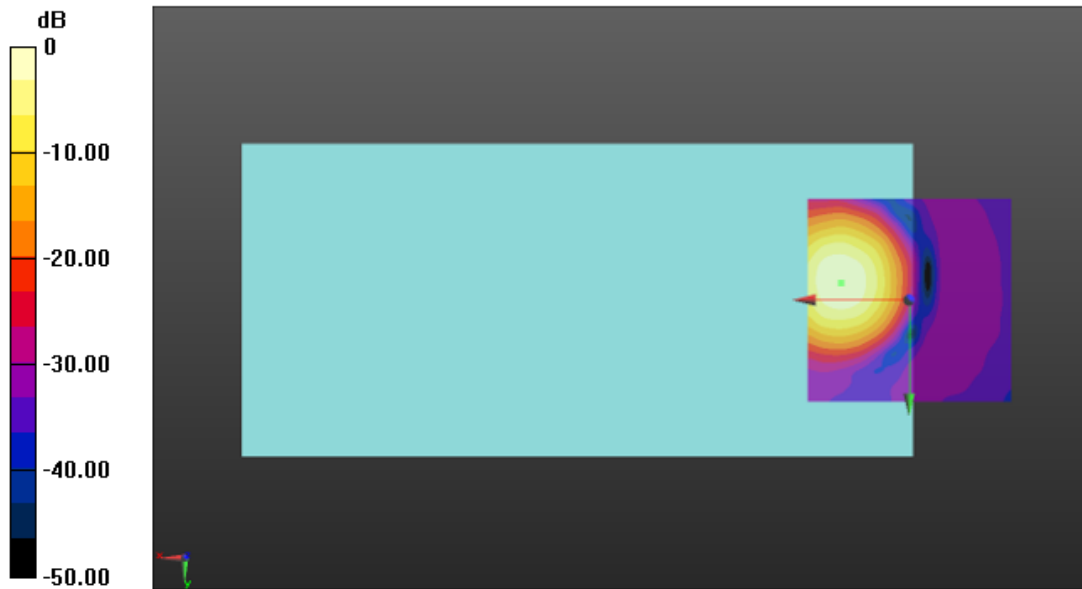

0 dB = 6.058 A/m = 15.65 dBA/m

## **Appendix**

**Refer to separated files for the following appendixes**

**4790136523-S3\_T-coil App A: Setup Photo**

**4790136523-S3\_T-coil App B: Test Plots**

**4790136523-S3\_T-coil App C: Probe Certificates**

**END OF REPORT**