



SAR EVALUATION REPORT

Applicant Name:
Samsung Electronics Co., Ltd.
129, Samsung-ro, Maetan dong,
Yeongtong-gu, Suwon-si
Gyeonggi-do, 16677, Korea

Date of Testing:
05/22/19 - 07/07/19
Test Site/Location:
PCTEST Lab, Columbia, MD, USA
Document Serial No.:
1M1905200079-01-R1.A3L

FCC ID: A3LSMN975U

APPLICANT: SAMSUNG ELECTRONICS CO., LTD.

DUT Type: Portable Handset
Application Type: Certification
FCC Rule Part(s): CFR §2.1093
Model: SM-N975U
Additional Model(s): SM-N975U1, SM-N975W, SM-N975XU

Equipment Class	Band & Mode	Tx Frequency	SAR			
			1g Head (W/kg)	1g Body-Worn (W/kg)	1g Hotspot (W/kg)	10g Phablet (W/kg)
PCE	CDMA/EVDO BC10 (990S)	817.90 - 823.10 MHz	0.19	0.29	0.79	N/A
PCE	CDMA/EVDO BC0 (822H)	824.70 - 848.31 MHz	0.19	0.33	0.86	N/A
PCE	GSM/GPRS/EDGE 850	824.20 - 848.80 MHz	0.13	0.24	0.75	N/A
PCE	UMTS 850	826.40 - 846.60 MHz	0.16	0.33	0.71	N/A
PCE	UMTS 1750	1712.4 - 1752.6 MHz	0.15	1.02	1.13	2.62
PCE	PCS CDMA/EVDO	1851.25 - 1906.75 MHz	0.11	0.66	0.90	3.06
PCE	GSM/GPRS/EDGE 1900	1850.20 - 1909.80 MHz	< 0.1	0.33	1.26	3.20
PCE	UMTS 1900	1852.4 - 1907.6 MHz	0.14	0.88	1.19	2.72
PCE	LTE Band 71	665.5 - 695.5 MHz	0.11	0.23	0.32	N/A
PCE	LTE Band 12	699.7 - 715.3 MHz	0.12	0.19	0.29	N/A
PCE	LTE Band 13	779.5 - 784.5 MHz	0.17	0.22	0.51	N/A
PCE	LTE Band 14	793.5 - 795.5 MHz	0.14	0.26	0.61	N/A
PCE	LTE Band 26 (Cell)	814.7 - 848.3 MHz	0.18	0.36	0.74	N/A
PCE	LTE Band 5 (Cell)	824.7 - 848.3 MHz	0.19	0.32	0.72	N/A
PCE	LTE Band 66 (AWS)	1710.7 - 1779.3 MHz	0.16	1.14	0.98	2.94
PCE	LTE Band 4 (AWS)	1710.7 - 1754.3 MHz	N/A	N/A	N/A	N/A
PCE	LTE Band 25 (PC5)	1850.7 - 1914.3 MHz	0.15	0.92	0.93	2.49
PCE	LTE Band 2 (PC5)	1850.7 - 1909.3 MHz	N/A	N/A	N/A	N/A
PCE	LTE Band 30	2307.5 - 2312.5 MHz	< 0.1	0.51	1.34	2.43
PCE	LTE Band 7	2502.5 - 2567.5 MHz	0.12	0.28	0.56	2.61
CBE	LTE Band 48	3552.5 - 3697.5 MHz	< 0.1	0.13	0.50	N/A
PCE	LTE Band 41	2498.5 - 2687.5 MHz	0.11	0.32	0.74	N/A
PCE	LTE Band 38	2572.5 - 2617.5 MHz	N/A	N/A	N/A	N/A
DTS	2.4 GHz WLAN	2412 - 2482 MHz	0.57	0.16	0.37	N/A
NII	U-NII-1	5180 - 5240 MHz	N/A	N/A	N/A	N/A
NII	U-NII-2A	5260 - 5320 MHz	0.15	0.14	N/A	1.76
NII	U-NII-2C	5500 - 5720 MHz	0.26	0.24	N/A	1.79
NII	U-NII-3	5745 - 5825 MHz	0.33	0.25	0.34	N/A
DSS/DTS	Bluetooth	2402 - 2480 MHz	0.32	< 0.1	< 0.1	N/A
Simultaneous SAR per KDB 690783 D01v01r03:			1.18	1.59	1.59	3.98

Note: This revised Test Report (S/N: 1M1905200079-01-R1.A3L) supersedes and replaces the previously issued test report on the same subject device for the same type of testing as indicated. Please discard or destroy the previously issued test report(s) and dispose of it accordingly.

This wireless portable device has been shown to be capable of compliance for localized specific absorption rate (SAR) for uncontrolled environment/general population exposure limits specified in ANSI/IEEE C95.1-1992 and has been tested in accordance with the measurement procedures specified in Section 1.8 of this report; for North American frequency bands only.

I attest to the accuracy of data. All measurements reported herein were performed by me or were made under my supervision and are correct to the best of my knowledge and belief. I assume full responsibility for the completeness of these measurements and vouch for the qualifications of all persons taking them. Test results reported herein relate only to the item(s) tested.

Randy Ortanez
President





The SAR Tick is an initiative of the Mobile & Wireless Forum (MWF). While a product may be considered eligible, use of the SAR Tick logo requires an agreement with the MWF. Further details can be obtained by emailing: sartick@mwfai.info.

FCC ID: A3LSMN975U		SAR EVALUATION REPORT		Approved by: Quality Manager
Document S/N: 1M1905200079-01-R1.A3L	Test Dates: 05/22/19 - 07/07/19	DUT Type: Portable Handset	Page 1 of 220	

TABLE OF CONTENTS



1	DEVICE UNDER TEST	3
2	LTE INFORMATION	22
3	INTRODUCTION	23
4	DOSIMETRIC ASSESSMENT	24
5	DEFINITION OF REFERENCE POINTS.....	25
6	TEST CONFIGURATION POSITIONS.....	26
7	RF EXPOSURE LIMITS	30
8	FCC MEASUREMENT PROCEDURES.....	31
9	RF CONDUCTED POWERS	39
10	SYSTEM VERIFICATION.....	146
11	SAR DATA SUMMARY	151
12	FCC MULTI-TX AND ANTENNA SAR CONSIDERATIONS.....	181
13	SAR MEASUREMENT VARIABILITY	204
14	ADDITIONAL TESTING PER FCC GUIDANCE	206
15	EQUIPMENT LIST.....	216
16	MEASUREMENT UNCERTAINTIES.....	217
17	CONCLUSION.....	218
18	REFERENCES	219
APPENDIX A: SAR TEST PLOTS		
APPENDIX B: SAR DIPOLE VERIFICATION PLOTS		
APPENDIX C: PROBE AND DIPOLE CALIBRATION CERTIFICATES		
APPENDIX D: SAR TISSUE SPECIFICATIONS		
APPENDIX E: SAR SYSTEM VALIDATION		
APPENDIX F: DUT ANTENNA DIAGRAM & SAR TEST SETUP PHOTOGRAPHS		
APPENDIX G: POWER REDUCTION VERIFICATION		
APPENDIX H: DOWNLINK LTE CA RF CONDUCTED POWERS		
APPENDIX I: IEEE 802.11AX RU SAR EXCLUSION		

FCC ID: A3LSMN975U		SAR EVALUATION REPORT		Approved by: Quality Manager
Document S/N: 1M1905200079-01-R1.A3L	Test Dates: 05/22/19 - 07/07/19	DUT Type: Portable Handset	Page 2 of 220	

1 DEVICE UNDER TEST

1.1 Device Overview

Band & Mode	Operating Modes	Tx Frequency
CDMA/EVDO BC10 (§90S)	Voice/Data	817.90 - 823.10 MHz
CDMA/EVDO BC0 (§22H)	Voice/Data	824.70 - 848.31 MHz
GSM/GPRS/EDGE 850	Voice/Data	824.20 - 848.80 MHz
UMTS 850	Voice/Data	826.40 - 846.60 MHz
UMTS 1750	Voice/Data	1712.4 - 1752.6 MHz
PCS CDMA/EVDO	Voice/Data	1851.25 - 1908.75 MHz
GSM/GPRS/EDGE 1900	Voice/Data	1850.20 - 1909.80 MHz
UMTS 1900	Voice/Data	1852.4 - 1907.6 MHz
LTE Band 71	Voice/Data	665.5 - 695.5 MHz
LTE Band 12	Voice/Data	699.7 - 715.3 MHz
LTE Band 13	Voice/Data	779.5 - 784.5 MHz
LTE Band 14	Voice/Data	790.5 - 795.5 MHz
LTE Band 26 (Cell)	Voice/Data	814.7 - 848.3 MHz
LTE Band 5 (Cell)	Voice/Data	824.7 - 848.3 MHz
LTE Band 66 (AWS)	Voice/Data	1710.7 - 1779.3 MHz
LTE Band 4 (AWS)	Voice/Data	1710.7 - 1754.3 MHz
LTE Band 25 (PCS)	Voice/Data	1850.7 - 1914.3 MHz
LTE Band 2 (PCS)	Voice/Data	1850.7 - 1909.3 MHz
LTE Band 30	Voice/Data	2307.5 - 2312.5 MHz
LTE Band 7	Voice/Data	2502.5 - 2567.5 MHz
LTE Band 48	Voice/Data	3552.5 - 3697.5 MHz
LTE Band 41	Voice/Data	2498.5 - 2687.5 MHz
LTE Band 38	Voice/Data	2572.5 - 2617.5 MHz
2.4 GHz WLAN	Voice/Data	2412 - 2462 MHz
U-NII-1	Voice/Data	5180 - 5240 MHz
U-NII-2A	Voice/Data	5260 - 5320 MHz
U-NII-2C	Voice/Data	5500 - 5720 MHz
U-NII-3	Voice/Data	5745 - 5825 MHz
Bluetooth	Data	2402 - 2480 MHz
NFC	Data	13.56 MHz
ANT+	Data	2402 - 2480 MHz
MST	Data	555 Hz - 8.33 kHz

FCC ID: A3LSMN975U	 PCTEST ENGINEERING LABORATORY, INC.	SAR EVALUATION REPORT		Approved by: Quality Manager
Document S/N: 1M1905200079-01-R1.A3L	Test Dates: 05/22/19 - 07/07/19	DUT Type: Portable Handset	Page 3 of 220	

1.2 Power Reduction for SAR

This device utilizes a power reduction mechanism for some wireless modes and bands for SAR compliance under portable hotspot conditions and under some conditions when the device is being used in close proximity to the user's hand and when headphones are inserted. All hotspot SAR evaluations for this device were performed at the maximum allowed output power when hotspot is enabled. FCC KDB Publication 616217 D04v01r02 Section 6 was used as a guideline for selecting SAR test distances for this device when being used in phablet use conditions. Detailed descriptions of the power reduction mechanism are included in the operational description.

This device uses an independent fixed level power reduction mechanism for WLAN operations during voice or VoIP held to ear scenarios. Per FCC Guidance, the held-to-ear exposure conditions were evaluated at reduced power according to the head SAR positions described in IEEE 1528-2013. Detailed descriptions of the power reduction mechanism are included in the operational description.



1.3 Nominal and Maximum Output Power Specifications

This device operates using the following maximum and nominal output power specifications. SAR values were scaled to the maximum allowed power to determine compliance per KDB Publication 447498 D01v06.



1.3.1 Maximum 2G/3G/4G Output Power

Mode / Band		Voice (dBm)	Burst Average GMSK (dBm)				Burst Average 8-PSK (dBm)			
		1 TX Slot	1 TX Slots	2 TX Slots	3 TX Slots	4 TX Slots	1 TX Slots	2 TX Slots	3 TX Slots	4 TX Slots
GSM/GPRS/EDGE 850	Maximum	33.5	33.5	32.5	30.5	28.5	28.0	26.0	24.0	23.0
	Nominal	32.5	32.5	31.5	29.5	27.5	27.0	25.0	23.0	22.0
GSM/GPRS/EDGE 1900	Maximum	30.0	30.0	29.0	27.0	25.0	26.5	24.5	22.5	21.5
	Nominal	29.0	29.0	28.0	26.0	24.0	25.5	23.5	21.5	20.5



Mode / Band		Modulated Average (dBm)			
		3GPP WCDMA	3GPP HSDPA	3GPP HSUPA	3GPP DC-HSDPA
UMTS Band 5 (850 MHz)	Maximum	25.5	24.5	24.5	24.5
	Nominal	24.5	23.5	23.5	23.5
UMTS Band 4 (1750 MHz)	Maximum	25.0	24.0	24.0	24.0
	Nominal	24.0	23.0	23.0	23.0
UMTS Band 2 (1900 MHz)	Maximum	25.0	24.0	24.0	24.0
	Nominal	24.0	23.0	23.0	23.0

FCC ID: A3LSMN975U	 PCTEST ENGINEERING LABORATORY, INC.	SAR EVALUATION REPORT		Approved by: Quality Manager
Document S/N: 1M1905200079-01-R1.A3L	Test Dates: 05/22/19 - 07/07/19	DUT Type: Portable Handset		Page 4 of 220

Mode / Band		Modulated Average (dBm)
CDMA/EVDO BC10 (§90S)	Maximum	26.3
	Nominal	25.3
CDMA/EVDO BC0 (§22H)	Maximum	26.3
	Nominal	25.3
PCS CDMA/EVDO	Maximum	25.0
	Nominal	24.0

FCC ID: A3LSMN975U	 PCTEST ENGINEERING LABORATORY, INC.	SAR EVALUATION REPORT		Approved by: Quality Manager
Document S/N: 1M1905200079-01-R1.A3L	Test Dates: 05/22/19 - 07/07/19	DUT Type: Portable Handset		Page 5 of 220

Mode / Band		Modulated Average (dBm)
LTE Band 71	Maximum	25.8
	Nominal	24.8
LTE Band 12	Maximum	25.8
	Nominal	24.8
LTE Band 13	Maximum	25.8
	Nominal	24.8
LTE Band 14	Maximum	25.8
	Nominal	24.8
LTE Band 26 (Cell)	Maximum	25.8
	Nominal	24.8
LTE Band 5 (Cell)	Maximum	25.8
	Nominal	24.8
LTE Band 66 (AWS)	Maximum	25.0
	Nominal	24.0
LTE Band 4 (AWS)	Maximum	25.0
	Nominal	24.0
LTE Band 25 (PCS)	Maximum	25.0
	Nominal	24.0
LTE Band 2 (PCS)	Maximum	25.0
	Nominal	24.0
LTE Band 30	Maximum	24.0
	Nominal	23.0
LTE Band 7	Maximum	24.5
	Nominal	23.5
LTE Band 48	Maximum	23.0
	Nominal	22.0
LTE Band 41 (PC3)	Maximum	24.5
	Nominal	23.5
LTE Band 41 (PC2)	Maximum	27.5
	Nominal	26.5
LTE Band 38	Maximum	22.5
	Nominal	21.5

FCC ID: A3LSMN975U	 PCTEST ENGINEERING LABORATORY, INC.	SAR EVALUATION REPORT		Approved by: Quality Manager
Document S/N: 1M1905200079-01-R1.A3L	Test Dates: 05/22/19 - 07/07/19	DUT Type: Portable Handset		Page 6 of 220



1.3.2

Reduced 2G/3G/4G Output Power – Hotspot Mode Active



Mode / Band		Burst Average GMSK (dBm)				Burst Average 8-PSK (dBm)			
		1 TX Slots	2 TX Slots	3 TX Slots	4 TX Slots	1 TX Slots	2 TX Slots	3 TX Slots	4 TX Slots
GPRS/EDGE 1900	Maximum	27.5	26.5	24.5	22.5	26.5	24.5	22.5	21.5
	Nominal	26.5	25.5	23.5	21.5	25.5	23.5	21.5	20.5

Mode / Band		Modulated Average (dBm)			
		3GPP WCDMA	3GPP HSDPA	3GPP HSUPA	3GPP DC-HSDPA
UMTS Band 4 (1750 MHz)	Maximum	20.0	19.0	19.0	19.0
	Nominal	19.0	18.0	18.0	18.0
UMTS Band 2 (1900 MHz)	Maximum	19.0	18.0	18.0	18.0
	Nominal	18.0	17.0	17.0	17.0

Mode / Band		Modulated Average (dBm)
PCS CDMA/EVDO	Maximum	18.5
	Nominal	17.5

FCC ID: A3LSMN975U	 PCTEST ENGINEERING LABORATORY, INC.	SAR EVALUATION REPORT		Approved by: Quality Manager
Document S/N: 1M1905200079-01-R1.A3L	Test Dates: 05/22/19 - 07/07/19	DUT Type: Portable Handset	Page 7 of 220	

Mode / Band		Modulated Average (dBm)
LTE Band 66 (AWS)	Maximum	20.0
	Nominal	19.0
LTE Band 4 (AWS)	Maximum	20.0
	Nominal	19.0
LTE Band 25 (PCS)	Maximum	18.5
	Nominal	17.5
LTE Band 2 (PCS)	Maximum	18.5
	Nominal	17.5
LTE Band 30	Maximum	20.5
	Nominal	19.5
LTE Band 7	Maximum	22.0
	Nominal	21.0
LTE Band 41 (PC3)	Maximum	22.5
	Nominal	21.5
LTE Band 41 (PC2)	Maximum	22.5
	Nominal	21.5

FCC ID: A3LSMN975U	 PCTEST ENGINEERING LABORATORY, INC.	SAR EVALUATION REPORT		Approved by: Quality Manager
Document S/N: 1M1905200079-01-R1.A3L	Test Dates: 05/22/19 - 07/07/19	DUT Type: Portable Handset		Page 8 of 220

1.3.3

Reduced 2G/3G/4G Output Power – Grip Sensor and/or Earjack Mode Active

Mode / Band		Modulated Average (dBm)			
		3GPP WCDMA	3GPP HSDPA	3GPP HSUPA	3GPP DC- HSDPA
UMTS Band 4 (1750 MHz)	Maximum	20.0	19.0	19.0	19.0
	Nominal	19.0	18.0	18.0	18.0
UMTS Band 2 (1900 MHz)	Maximum	20.5	19.5	19.5	19.5
	Nominal	19.5	18.5	18.5	18.5

Mode / Band		Modulated Average (dBm)
PCS CDMA/EVDO	Maximum	21.0
	Nominal	20.0

Mode / Band		Modulated Average (dBm)
LTE Band 66 (AWS)	Maximum	21.0
	Nominal	20.0
LTE Band 4 (AWS)	Maximum	21.0
	Nominal	20.0
LTE Band 25 (PCS)	Maximum	21.0
	Nominal	20.0
LTE Band 2 (PCS)	Maximum	21.0
	Nominal	20.0
LTE Band 30	Maximum	23.0
	Nominal	22.0
LTE Band 7	Maximum	22.0
	Nominal	21.0
LTE Band 41 (PC2)	Maximum	25.5
	Nominal	24.5



FCC ID: A3LSMN975U	 PCTEST ENGINEERING LABORATORY, INC.	SAR EVALUATION REPORT		Approved by: Quality Manager
Document S/N: 1M1905200079-01-R1.A3L	Test Dates: 05/22/19 - 07/07/19	DUT Type: Portable Handset		Page 9 of 220

1.3.4 Maximum Bluetooth and SISO/MIMO WLAN Output Power

Note: Targets for 802.11ax RU operations can be found in Appendix I.

Mode / Band		Modulated Average - Single Tx Chain (dBm)		
		Channel 1	2 - 10	11
IEEE 802.11b (2.4 GHz)	Maximum	21.0		
	Nominal	20.0		
IEEE 802.11g (2.4 GHz)	Maximum	14.0	18.5	15.5
	Nominal	13.0	17.5	14.5
IEEE 802.11n (2.4 GHz)	Maximum	14.0	18.5	15.5
	Nominal	13.0	17.5	14.5
IEEE 802.11ax SU (2.4 GHz)	Maximum	15.0	18.0	15.0
	Nominal	14.0	17.0	14.0



Mode / Band		Modulated Average - MIMO (dBm)		
		20 MHz Bandwidth		
		Channel 1	2 - 10	11
IEEE 802.11g (2.4 GHz)	Maximum	17.0	21.5	18.5
	Nominal	16.0	20.5	17.5
IEEE 802.11n (2.4 GHz)	Maximum	17.0	21.5	18.5
	Nominal	16.0	20.5	17.5
IEEE 802.11ax SU (2.4 GHz)	Maximum	15.0	18.0	15.0
	Nominal	14.0	17.0	14.0

FCC ID: A3LSMN975U	 PCTEST ENGINEERING LABORATORY, INC.	SAR EVALUATION REPORT		Approved by: Quality Manager
Document S/N: 1M1905200079-01-R1.A3L	Test Dates: 05/22/19 - 07/07/19	DUT Type: Portable Handset	Page 10 of 220	

Mode / Band		Modulated Average - Single Tx Chain (dBm)													
		20 MHz Bandwidth					40 MHz Bandwidth					80 MHz Bandwidth			
Channel		36	40-60	64	100	104-165	38	46-54	62	102	110-159	42	58	106	122-155
IEEE 802.11a (5 GHz)	Maximum	17.0	18.5	16.5	17.5	18.5									
	Nominal	16.0	17.5	15.5	16.5	17.5									
IEEE 802.11n (5 GHz)	Maximum	17.0	18.5	15.5	18.0	18.5	14.5	17.5	14.5	15.0	17.5				
	Nominal	16.0	17.5	14.5	17.0	17.5	13.5	16.5	13.5	14.0	16.5				
IEEE 802.11ac (5 GHz)	Maximum	17.0	18.5	15.5	18.0	18.5	14.5	17.5	14.5	15.0	17.5	13.5	14.0	13.0	16.5
	Nominal	16.0	17.5	14.5	17.0	17.5	13.5	16.5	13.5	14.0	16.5	12.5	13.0	12.0	15.5
IEEE 802.11ax SU (5 GHz)	Maximum	16.0	18.0	16.0	18.0	18.0	15.0	17.0	14.5	16.0	17.0	14.0	13.5	13.0	16.0
	Nominal	15.0	17.0	15.0	17.0	17.0	14.0	16.0	13.5	15.0	16.0	13.0	12.5	12.0	15.0

Mode / Band		Modulated Average - MIMO (dBm)													
		20 MHz Bandwidth					40 MHz Bandwidth					80 MHz Bandwidth			
Channel		36	40-60	64	100	104-165	38	46-54	62	102	110-159	42	58	106	122-155
IEEE 802.11a (5 GHz)	Maximum	20.0	21.5	19.5	20.5	21.5									
	Nominal	19.0	20.5	18.5	19.5	20.5									
IEEE 802.11n (5 GHz)	Maximum	20.0	21.5	18.5	21.0	21.5	17.5	20.5	17.5	18.0	20.5				
	Nominal	19.0	20.5	17.5	20.0	20.5	16.5	19.5	16.5	17.0	19.5				
IEEE 802.11ac (5 GHz)	Maximum	20.0	21.5	18.5	21.0	21.5	17.5	20.5	17.5	18.0	20.5	16.5	17.0	16.0	19.5
	Nominal	19.0	20.5	17.5	20.0	20.5	16.5	19.5	16.5	17.0	19.5	15.5	16.0	15.0	18.5
IEEE 802.11ax SU (5 GHz)	Maximum	16.0	18.0	16.0	18.0	18.0	15.0	17.0	14.5	16.0	17.0	14.0	13.5	13.0	16.0
	Nominal	15.0	17.0	15.0	17.0	17.0	14.0	16.0	13.5	15.0	16.0	13.0	12.5	12.0	15.0

Mode/Band		Modulated Average (dBm)
Bluetooth	Maximum	15.5
	Nominal	14.5
Bluetooth EDR	Maximum	13.0
	Nominal	12.0
Bluetooth LE	Maximum	9.0
	Nominal	8.0



FCC ID: A3LSMN975U	 PCTEST ENGINEERING LABORATORY, INC.	SAR EVALUATION REPORT		Approved by: Quality Manager
Document S/N: 1M1905200079-01-R1.A3L	Test Dates: 05/22/19 - 07/07/19	DUT Type: Portable Handset	Page 11 of 220	

1.3.5 Reduced SISO/MIMO WLAN Output Power

Note: Targets for 802.11ax RU operations can be found in Appendix I.

Mode / Band		Modulated Average - Single Tx Chain (dBm)		
		Channel 1	2 - 10	11
IEEE 802.11b (2.4 GHz)	Maximum	17.0		
	Nominal	16.0		
IEEE 802.11g (2.4 GHz)	Maximum	14.0	17.0	15.5
	Nominal	13.0	16.0	14.5
IEEE 802.11n (2.4 GHz)	Maximum	14.0	17.0	15.5
	Nominal	13.0	16.0	14.5
IEEE 802.11ax SU (2.4 GHz)	Maximum	15.0	17.0	15.0
	Nominal	14.0	16.0	14.0

Mode / Band		Modulated Average - MIMO (dBm)		
		20 MHz Bandwidth		
		Channel 1	2 - 10	11
IEEE 802.11g (2.4 GHz)	Maximum	17.0	20.0	18.5
	Nominal	16.0	19.0	17.5
IEEE 802.11n (2.4 GHz)	Maximum	17.0	20.0	18.5
	Nominal	16.0	19.0	17.5
IEEE 802.11ax SU (2.4 GHz)	Maximum	15.0	17.0	15.0
	Nominal	14.0	16.0	14.0

FCC ID: A3LSMN975U	 PCTEST ENGINEERING LABORATORY, INC.	SAR EVALUATION REPORT		Approved by: Quality Manager
Document S/N: 1M1905200079-01-R1.A3L	Test Dates: 05/22/19 - 07/07/19	DUT Type: Portable Handset	Page 12 of 220	



Mode / Band		Modulated Average - Single Tx Chain (dBm)										
		20 MHz Bandwidth			40 MHz Bandwidth			80 MHz Bandwidth				
	Channel	36 - 165			38 - 159			42	58	106	122-155	
IEEE 802.11a (5 GHz)	Maximum	14.0										
	Nominal	13.0										
IEEE 802.11n (5 GHz)	Maximum	14.0			14.0							
	Nominal	13.0			13.0							
IEEE 802.11ac (5 GHz)	Maximum	14.0			14.0			13.5	14.0	13.0	14.0	
	Nominal	13.0			13.0			12.5	13.0	12.0	13.0	
IEEE 802.11ax SU (5 GHz)	Maximum	14.0			14.0			14.0	13.5	13.0	14.0	
	Nominal	13.0			13.0			13.0	12.5	12.0	13.0	

Mode / Band		Modulated Average - MIMO (dBm)														
		20 MHz Bandwidth					40 MHz Bandwidth					80 MHz Bandwidth				
	Channel	36	40-60	64	100	104-165	38	46-54	62	102	110-159	42	58	106	122-155	
IEEE 802.11a (5 GHz)	Maximum	17.0														
	Nominal	16.0														
IEEE 802.11n (5 GHz)	Maximum	17.0					17.0									
	Nominal	16.0					16.0									
IEEE 802.11ac (5 GHz)	Maximum	17.0					17.0					16.5	17.0	16.0	17.0	
	Nominal	16.0					16.0					15.5	16.0	15.0	16.0	
IEEE 802.11ax SU (5 GHz)	Maximum	16.0	17.0	16.0	17.0	17.0	15.0	17.0	14.5	16.0	17.0	14.0	13.5	13.0	16.0	
	Nominal	15.0	16.0	15.0	16.0	16.0	14.0	16.0	13.5	15.0	16.0	13.0	12.5	12.0	15.0	

1.3.6 Maximum Output Power During Conditions with Simultaneous 2.4 GHz WLAN and 5 GHz WLAN

Note: Targets for 802.11ax RU operations can be found in Appendix I.



Mode / Band		Modulated Average - Single Tx Chain (dBm)		
		Channel 1	2 - 10	11
IEEE 802.11b (2.4 GHz)	Maximum	17.0		
	Nominal	16.0		
IEEE 802.11g (2.4 GHz)	Maximum	14.0	17.0	15.5
	Nominal	13.0	16.0	14.5
IEEE 802.11n (2.4 GHz)	Maximum	14.0	17.0	15.5
	Nominal	13.0	16.0	14.5
IEEE 802.11ax SU (2.4 GHz)	Maximum	15.0	17.0	15.0
	Nominal	14.0	16.0	14.0

FCC ID: A3LSMN975U	 PCTEST ENGINEERING LABORATORY, INC.	SAR EVALUATION REPORT		Approved by: Quality Manager
Document S/N: 1M1905200079-01-R1.A3L	Test Dates: 05/22/19 - 07/07/19	DUT Type: Portable Handset		Page 13 of 220

Mode / Band		Modulated Average - MIMO (dBm)		
		20 MHz Bandwidth		
Channel		1	2 - 10	11
IEEE 802.11g (2.4 GHz)	Maximum	17.0	20.0	18.5
	Nominal	16.0	19.0	17.5
IEEE 802.11n (2.4 GHz)	Maximum	17.0	20.0	18.5
	Nominal	16.0	19.0	17.5
IEEE 802.11ax SU (2.4 GHz)	Maximum	15.0	17.0	15.0
	Nominal	14.0	16.0	14.0

Mode / Band		Modulated Average - Single Tx Chain (dBm)								
		20 MHz Bandwidth		40 MHz Bandwidth			80 MHz Bandwidth			
Channel		36 - 165		38 - 159			42	58	106	122-155
IEEE 802.11a (5 GHz)	Maximum	14.0								
	Nominal	13.0								
IEEE 802.11n (5 GHz)	Maximum	14.0		14.0						
	Nominal	13.0		13.0						
IEEE 802.11ac (5 GHz)	Maximum	14.0		14.0			13.5	14.0	13.0	14.0
	Nominal	13.0		13.0			12.5	13.0	12.0	13.0
IEEE 802.11ax SU (5 GHz)	Maximum	14.0		14.0			14.0	13.5	13.0	14.0
	Nominal	13.0		13.0			13.0	12.5	12.0	13.0

Mode / Band		Modulated Average - MIMO (dBm)													
		20 MHz Bandwidth					40 MHz Bandwidth					80 MHz Bandwidth			
Channel		36	40-60	64	100	104-165	38	46-54	62	102	110-159	42	58	106	122-155
IEEE 802.11a (5 GHz)	Maximum	17.0													
	Nominal	16.0													
IEEE 802.11n (5 GHz)	Maximum	17.0					17.0								
	Nominal	16.0					16.0								
IEEE 802.11ac (5 GHz)	Maximum	17.0					17.0					16.5	17.0	16.0	17.0
	Nominal	16.0					16.0					15.5	16.0	15.0	16.0
IEEE 802.11ax SU (5 GHz)	Maximum	16.0	17.0	16.0	17.0	17.0	15.0	17.0	14.5	16.0	17.0	14.0	13.5	13.0	16.0
	Nominal	15.0	16.0	15.0	16.0	16.0	14.0	16.0	13.5	15.0	16.0	13.0	12.5	12.0	15.0

FCC ID: A3LSMN975U	 PCTEST ENGINEERING LABORATORY, INC.	SAR EVALUATION REPORT		Approved by: Quality Manager
Document S/N: 1M1905200079-01-R1.A3L	Test Dates: 05/22/19 - 07/07/19	DUT Type: Portable Handset	Page 14 of 220	



1.3.7

Reduced Output Power During Conditions with Simultaneous 2.4 GHz WLAN and 5 GHz WLAN

Note: Targets for 802.11ax RU operations can be found in Appendix I.



Mode / Band		Modulated Average - Single Tx Chain (dBm)
Channel		1-11
IEEE 802.11b (2.4 GHz)	Maximum	14.0
	Nominal	13.0
IEEE 802.11g (2.4 GHz)	Maximum	14.0
	Nominal	13.0
IEEE 802.11n (2.4 GHz)	Maximum	14.0
	Nominal	13.0
IEEE 802.11ax SU (2.4 GHz)	Maximum	14.0
	Nominal	13.0

Mode / Band		Modulated Average - MIMO (dBm)		
		20 MHz Bandwidth		
Channel		1	2 - 10	11
IEEE 802.11g (2.4 GHz)	Maximum	17.0		
	Nominal	16.0		
IEEE 802.11n (2.4 GHz)	Maximum	17.0		
	Nominal	16.0		
IEEE 802.11ax SU (2.4 GHz)	Maximum	15.0	17.0	15.0
	Nominal	14.0	16.0	14.0

FCC ID: A3LSMN975U		SAR EVALUATION REPORT		Approved by: Quality Manager
Document S/N: 1M1905200079-01-R1.A3L	Test Dates: 05/22/19 - 07/07/19	DUT Type: Portable Handset	Page 15 of 220	

Mode / Band		Modulated Average - Single Tx Chain (dBm)									
		20 MHz Bandwidth			40 MHz Bandwidth			80 MHz Bandwidth			
	Channel	36 - 165			38 - 159			42	58	106	122-155
IEEE 802.11a (5 GHz)	Maximum	14.0									
	Nominal	13.0									
IEEE 802.11n (5 GHz)	Maximum	14.0			14.0						
	Nominal	13.0			13.0						
IEEE 802.11ac (5 GHz)	Maximum	14.0			14.0			13.5	14.0	13.0	14.0
	Nominal	13.0			13.0			12.5	13.0	12.0	13.0
IEEE 802.11ax SU (5 GHz)	Maximum	14.0			14.0			14.0	13.5	13.0	14.0
	Nominal	13.0			13.0			13.0	12.5	12.0	13.0

Mode / Band		Modulated Average - MIMO (dBm)													
		20 MHz Bandwidth					40 MHz Bandwidth					80 MHz Bandwidth			
	Channel	36	40-60	64	100	104-165	38	46-54	62	102	110-159	42	58	106	122-155
IEEE 802.11a (5 GHz)	Maximum	17.0													
	Nominal	16.0													
IEEE 802.11n (5 GHz)	Maximum	17.0					17.0								
	Nominal	16.0					16.0								
IEEE 802.11ac (5 GHz)	Maximum	17.0					17.0					16.5	17.0	16.0	17.0
	Nominal	16.0					16.0					15.5	16.0	15.0	16.0
IEEE 802.11ax SU (5 GHz)	Maximum	16.0	17.0	16.0	17.0	17.0	15.0	17.0	14.5	16.0	17.0	14.0	13.5	13.0	16.0
	Nominal	15.0	16.0	15.0	16.0	16.0	14.0	16.0	13.5	15.0	16.0	13.0	12.5	12.0	15.0

FCC ID: A3LSMN975U	 PCTEST ENGINEERING LABORATORY, INC.	SAR EVALUATION REPORT		Approved by: Quality Manager
Document S/N: 1M1905200079-01-R1.A3L	Test Dates: 05/22/19 - 07/07/19	DUT Type: Portable Handset		Page 16 of 220

1.4 DUT Antenna Locations

The overall dimensions of this device are > 9 x 5 cm. A diagram showing the location of the device antennas can be found in Appendix F. Since the diagonal dimension of this device is > 160 mm and <200 mm, it is considered a “phablet.”



**Table 1-1
Device Edges/Sides for SAR Testing**

Mode	Back	Front	Top	Bottom	Right	Left
EVDO BC10 (§90S)	Yes	Yes	No	Yes	Yes	Yes
EVDO BC0 (§22H)	Yes	Yes	No	Yes	Yes	Yes
GPRS 850	Yes	Yes	No	Yes	Yes	Yes
UMTS 850	Yes	Yes	No	Yes	Yes	Yes
UMTS 1750	Yes	Yes	No	Yes	Yes	Yes
PCS EVDO	Yes	Yes	No	Yes	Yes	Yes
GPRS 1900	Yes	Yes	No	Yes	Yes	Yes
UMTS 1900	Yes	Yes	No	Yes	Yes	Yes
LTE Band 71	Yes	Yes	No	Yes	Yes	Yes
LTE Band 12	Yes	Yes	No	Yes	Yes	Yes
LTE Band 13	Yes	Yes	No	Yes	Yes	Yes
LTE Band 14	Yes	Yes	No	Yes	Yes	Yes
LTE Band 26 (Cell)	Yes	Yes	No	Yes	Yes	Yes
LTE Band 5 (Cell)	Yes	Yes	No	Yes	Yes	Yes
LTE Band 66 (AWS)	Yes	Yes	No	Yes	Yes	Yes
LTE Band 25 (PCS)	Yes	Yes	No	Yes	Yes	Yes
LTE Band 30	Yes	Yes	No	Yes	Yes	Yes
LTE Band 7	Yes	Yes	No	Yes	No	Yes
LTE Band 48	Yes	Yes	No	Yes	No	Yes
LTE Band 41	Yes	Yes	No	Yes	No	Yes
2.4 GHz WLAN Ant 1	Yes	Yes	Yes	No	No	Yes
2.4 GHz WLAN Ant 2	Yes	Yes	Yes	No	No	Yes
5 GHz WLAN Ant 1	Yes	Yes	Yes	No	No	Yes
5 GHz WLAN Ant 2	Yes	Yes	Yes	No	No	Yes
5 GHz WLAN MIMO	Yes	Yes	Yes	No	No	Yes
Bluetooth	Yes	Yes	Yes	No	No	Yes

Note: Particular DUT edges were not required to be evaluated for wireless router SAR or phablet SAR if the edges were greater than 2.5 cm from the transmitting antenna according to FCC KDB Publication 941225 D06v02r01 Section III and FCC KDB Publication 648474 D04v01r03. The distances between the transmit antennas and the edges of the device are included in the filing. When wireless router mode is enabled, U-NII-1, U-NII-2A, U-NII-2C operations are disabled.

1.5 Near Field Communications (NFC) Antenna

This DUT has NFC operations. The NFC antenna is integrated into the device for this model. Therefore, all SAR tests were performed with the device which already incorporates the NFC antenna. A diagram showing the location of the NFC antenna can be found in Appendix F.

FCC ID: A3LSMN975U		SAR EVALUATION REPORT		Approved by: Quality Manager
Document S/N: 1M1905200079-01-R1.A3L	Test Dates: 05/22/19 - 07/07/19	DUT Type: Portable Handset	Page 17 of 220	



1.6 Simultaneous Transmission Capabilities

According to FCC KDB Publication 447498 D01v06, transmitters are considered to be operating simultaneously when there is overlapping transmission, with the exception of transmissions during network hand-offs with maximum hand-off duration less than 30 seconds.

This device contains multiple transmitters that may operate simultaneously, and therefore requires a simultaneous transmission analysis according to FCC KDB Publication 447498 D01v06 4.3.2 procedures.

**Table 1-2
Simultaneous Transmission Scenarios**

No.	Capable Transmit Configuration	Head	Body-Worn Accessory	Wireless Router	Phablet	Notes
1	1x CDMA voice + 2.4 GHz Wi-Fi	Yes	Yes	N/A	Yes	
2	1x CDMA voice + 5 GHz Wi-Fi	Yes	Yes	N/A	Yes	
3	1x CDMA voice + 2.4 GHz Bluetooth	Yes^	Yes	N/A	Yes	^ Bluetooth Tethering is considered
4	1x CDMA voice + 2.4 GHz Bluetooth + 5GHz Wi-Fi	Yes^	Yes	N/A	Yes	^ Bluetooth Tethering is considered
5	1x CDMA voice + 2.4 GHz Wi-Fi MIMO	Yes	Yes	N/A	Yes	
6	1x CDMA voice + 5 GHz Wi-Fi MIMO	Yes	Yes	N/A	Yes	
7	1x CDMA voice + 2.4 GHz Wi-Fi + 5 GHz Wi-Fi	Yes	Yes	N/A	Yes	
8	1x CDMA voice + 2.4 GHz Wi-Fi MIMO + 5 GHz Wi-Fi MIMO	Yes	Yes	N/A	Yes	
9	1x CDMA voice + 2.4 GHz Bluetooth + 5 GHz Wi-Fi MIMO	Yes^	Yes	N/A	Yes	^ Bluetooth Tethering is considered
10	GSM voice + 2.4 GHz Wi-Fi	Yes	Yes	N/A	Yes	
11	GSM voice + 5 GHz Wi-Fi	Yes	Yes	N/A	Yes	
12	GSM voice + 2.4 GHz Bluetooth	Yes^	Yes	N/A	Yes	^ Bluetooth Tethering is considered
13	GSM voice + 2.4 GHz Bluetooth + 5 GHz Wi-Fi	Yes^	Yes	N/A	Yes	^ Bluetooth Tethering is considered
14	GSM voice + 2.4 GHz Wi-Fi MIMO	Yes	Yes	N/A	Yes	
15	GSM voice + 5 GHz Wi-Fi MIMO	Yes	Yes	N/A	Yes	
16	GSM voice + 2.4 GHz Wi-Fi + 5 GHz Wi-Fi	Yes	Yes	N/A	Yes	
17	GSM voice + 2.4 GHz Wi-Fi MIMO + 5 GHz Wi-Fi MIMO	Yes	Yes	N/A	Yes	
18	GSM voice + 2.4 GHz Bluetooth + 5 GHz Wi-Fi MIMO	Yes^	Yes	N/A	Yes	^ Bluetooth Tethering is considered
19	UMTS + 2.4 GHz Wi-Fi	Yes	Yes	Yes	Yes	
20	UMTS + 5 GHz Wi-Fi	Yes	Yes	Yes	Yes	
21	UMTS + 2.4 GHz Bluetooth	Yes^	Yes	Yes^	Yes	^ Bluetooth Tethering is considered
22	UMTS + 2.4 GHz Bluetooth + 5 GHz Wi-Fi	Yes^	Yes	Yes^	Yes	^ Bluetooth Tethering is considered
23	UMTS + 2.4 GHz Wi-Fi MIMO	Yes	Yes	Yes	Yes	
24	UMTS + 5 GHz Wi-Fi MIMO	Yes	Yes	Yes	Yes	
25	UMTS + 2.4 GHz Wi-Fi + 5 GHz Wi-Fi	Yes	Yes	Yes	Yes	
26	UMTS + 2.4 GHz Wi-Fi MIMO + 5 GHz Wi-Fi MIMO	Yes	Yes	Yes	Yes	
27	UMTS + 2.4 GHz Bluetooth + 5 GHz Wi-Fi MIMO	Yes^	Yes	Yes^	Yes	^ Bluetooth Tethering is considered
28	LTE + 2.4 GHz Wi-Fi	Yes	Yes	Yes	Yes	
29	LTE + 5 GHz Wi-Fi	Yes	Yes	Yes	Yes	
30	LTE + 2.4 GHz Bluetooth	Yes^	Yes	Yes^	Yes	^ Bluetooth Tethering is considered
31	LTE + 2.4 GHz Bluetooth + 5GHz Wi-Fi	Yes^	Yes	Yes^	Yes	^ Bluetooth Tethering is considered
32	LTE + 2.4 GHz Wi-Fi MIMO	Yes	Yes	Yes	Yes	
33	LTE + 5 GHz Wi-Fi MIMO	Yes	Yes	Yes	Yes	
34	LTE + 2.4 GHz Wi-Fi + 5 GHz Wi-Fi	Yes	Yes	Yes	Yes	
35	LTE + 2.4 GHz Wi-Fi MIMO + 5 GHz Wi-Fi MIMO	Yes	Yes	Yes	Yes	
36	LTE + 2.4 GHz Bluetooth + 5GHz Wi-Fi MIMO	Yes^	Yes	Yes^	Yes	^ Bluetooth Tethering is considered
37	CDMA/EVDO data + 2.4 GHz Wi-Fi	Yes*	Yes*	Yes	Yes	* Pre-installed VOIP applications are considered
38	CDMA/EVDO data + 5 GHz Wi-Fi	Yes*	Yes*	Yes	Yes	* Pre-installed VOIP applications are considered
39	CDMA/EVDO data + 2.4 GHz Bluetooth	Yes^	Yes*	Yes^	Yes	* Pre-installed VOIP applications are considered ^ Bluetooth Tethering is considered
40	CDMA/EVDO data + 2.4 GHz Bluetooth + 5GHz Wi-Fi	Yes^	Yes*	Yes^	Yes	* Pre-installed VOIP applications are considered ^ Bluetooth Tethering is considered
41	CDMA/EVDO data + 2.4 GHz Wi-Fi MIMO	Yes*	Yes*	Yes	Yes	* Pre-installed VOIP applications are considered
42	CDMA/EVDO data + 5 GHz Wi-Fi MIMO	Yes*	Yes*	Yes	Yes	* Pre-installed VOIP applications are considered
43	CDMA/EVDO data + 2.4 GHz Wi-Fi + 5 GHz Wi-Fi	Yes*	Yes*	Yes	Yes	* Pre-installed VOIP applications are considered
44	CDMA/EVDO data + 2.4 GHz Wi-Fi MIMO + 5 GHz Wi-Fi MIMO	Yes*	Yes*	Yes	Yes	* Pre-installed VOIP applications are considered
45	CDMA/EVDO data + 2.4 GHz Bluetooth + 5GHz Wi-Fi MIMO	Yes^	Yes*	Yes^	Yes	* Pre-installed VOIP applications are considered ^ Bluetooth Tethering is considered
46	GPRS/EDGE + 2.4 GHz Wi-Fi	N/A	N/A	Yes	Yes	
47	GPRS/EDGE + 5 GHz Wi-Fi	N/A	N/A	Yes	Yes	
48	GPRS/EDGE + 2.4 GHz Bluetooth	N/A	N/A	Yes^	Yes	^ Bluetooth Tethering is considered
49	GPRS/EDGE + 2.4 GHz Bluetooth + 5GHz Wi-Fi	N/A	N/A	Yes^	Yes	^ Bluetooth Tethering is considered
50	GPRS/EDGE + 2.4 GHz Wi-Fi MIMO	N/A	N/A	Yes	Yes	
51	GPRS/EDGE + 5 GHz Wi-Fi MIMO	N/A	N/A	Yes	Yes	
52	GPRS/EDGE + 2.4 GHz Wi-Fi + 5 GHz Wi-Fi	N/A	N/A	Yes	Yes	
53	GPRS/EDGE + 2.4 GHz Wi-Fi MIMO + 5 GHz Wi-Fi MIMO	N/A	N/A	Yes	Yes	
54	GPRS/EDGE + 2.4 GHz Bluetooth + 5GHz Wi-Fi MIMO	N/A	N/A	Yes^	Yes	^ Bluetooth Tethering is considered

FCC ID: A3LSMN975U		SAR EVALUATION REPORT		Approved by: Quality Manager
Document S/N: 1M1905200079-01-R1.A3L	Test Dates: 05/22/19 - 07/07/19	DUT Type: Portable Handset	Page 18 of 220	

1. 2.4 GHz WLAN and 2.4 GHz Bluetooth share the same antenna path and cannot transmit simultaneously.
2. All licensed modes share the same antenna path and cannot transmit simultaneously.
3. When the user utilizes multiple services in UMTS 3G mode it uses multi-Radio Access Bearer or multi-RAB. The power control is based on a physical control channel (Dedicated Physical Control Channel [DPCCH]) and power control will be adjusted to meet the needs of both services. Therefore, the UMTS+WLAN scenario also represents the UMTS Voice/DATA + WLAN Hotspot scenario.
4. Per the manufacturer, WIFI Direct is not expected to be used in conjunction with a held-to-ear or body-worn accessory voice call. Therefore, there are no simultaneous transmission scenarios involving WIFI direct beyond that listed in the above table. 5 GHz Wireless Router is only supported for the U-NII-3 by S/W, therefore U-NII-1, U-NII2A, and U-NII2C were not evaluated for wireless router conditions.
5. 5 GHz Wireless Router is only supported for the U-NII-3 by S/W, therefore U-NII-1, U-NII2A, and U-NII2C were not evaluated for wireless router conditions.
6. This device supports 2x2 MIMO Tx for WLAN 802.11a/g/n/ac/ax. 802.11a/g/n/ac/ax supports CDD and STBC and 802.11n/ac/ax additionally supports SDM. Each WLAN antenna can transmit independently or together when operating with MIMO.
7. This device supports VOLTE.
8. This device supports VOWIFI.
9. This device supports Bluetooth Tethering.

1.7 Miscellaneous SAR Test Considerations

(A) WIFI/BT

Since U-NII-1 and U-NII-2A bands have the same maximum output power and the highest reported SAR for U-NII-2A is less than 1.2 W/kg, SAR is not required for U-NII-1 band according to FCC KDB Publication 248227 D01v02r02.



Since Wireless Router operations are not allowed by the chipset firmware using U-NII-1, U-NII-2A & U-NII-2C WIFI, only 2.4 GHz and U-NII-3 WIFI Hotspot SAR tests and combinations are considered for SAR with respect to Wireless Router configurations according to FCC KDB 941225 D06v02r01.

This device supports IEEE 802.11ax with the following features:

- a) Up to 80 MHz Bandwidth only for 5 GHz
- b) Up to 20 MHz Bandwidth only for 2.4 GHz
- c) No aggregate channel configurations
- d) 2 Tx antenna output
- e) Up to 1024 QAM is supported
- f) TDWR and Band gap channels are supported for 5 GHz
- g) MU-MIMO UL Operations are not supported

Per FCC KDB Publication 648474 D04v01r03, this device is considered a "phablet" since the diagonal dimension is greater than 160mm and less than 200mm. Phablet SAR tests are required when wireless router mode does not apply or if wireless router 1g SAR > 1.2 W/kg. Because wireless router operations are not supported for U-NII-1, U-NII-2A & U-NII-2C WLAN, phablet SAR tests were performed. Phablet SAR was not evaluated for Bluetooth, 2.4 GHz and U-NII-3 WLAN operations since wireless router 1g SAR was < 1.2 W/kg.

Per April 2019 TCB Workshop Notes, SAR testing was not required for 802.11ax when applying the initial test configuration procedures of KDB 248227, with 802.11ax considered a higher order 802.11 mode.

FCC ID: A3LSMN975U		SAR EVALUATION REPORT		Approved by: Quality Manager
Document S/N: 1M1905200079-01-R1.A3L	Test Dates: 05/22/19 - 07/07/19	DUT Type: Portable Handset	Page 19 of 220	

(B) Licensed Transmitter(s)

GSM/GPRS/EDGE DTM is not supported for US bands. Therefore, the GSM Voice modes in this report do not transmit simultaneously with GPRS/EDGE Data.

This device is only capable of QPSK HSUPA in the uplink. Therefore, no additional SAR tests are required beyond that described for devices with HSUPA in KDB 941225 D01v03r01.

LTE SAR for the higher modulations and lower bandwidths were not tested since the maximum average output power of all required channels and configurations was not more than 0.5 dB higher than the highest bandwidth; and the reported LTE SAR for the highest bandwidth was less than 1.45 W/kg for all configurations according to FCC KDB 941225 D05v02r04.

CDMA 1X Advanced technology was not required for SAR since the maximum allowed output powers for 1x Advanced was not more than 0.25 dB higher than the maximum powers for 1x and the measured SAR in any 1x mode exposure conditions was not greater than 1.2 W/kg per FCC KDB Publication 941225 D01v03r01.

This device supports LTE Carrier Aggregation (CA) in the downlink. All uplink communications are identical to Release 8 specifications. Per FCC KDB Publication 941225 D05A v01r02, SAR for LTE CA operations was not needed since the maximum average output power in LTE CA mode was not >0.25 dB higher than the maximum output power when downlink carrier aggregation was inactive. The downlink carrier aggregation exclusion analysis can be found in Appendix H.



Per FCC KDB Publication 648474 D04v01r03, this device is considered a "phablet" since the diagonal dimension is greater than 160mm and less than 200mm. Therefore, phablet SAR tests are required when wireless router mode does not apply or if wireless router 1g SAR > 1.2 W/kg. Additional SAR tests for phablet SAR were evaluated per KDB 616217 Section 6 (See Section 6.9 for more information).

This device supports downlink 4x4 MIMO operations for some LTE Bands. Per May 2017 TCB Workshop Notes, SAR for 4x4 DL MIMO was not needed since the maximum average output power in 4x4 DL MIMO mode was not more than 0.25 dB higher than the maximum output power with 4x4 DL MIMO inactive. Additionally, SAR for 4x4 MIMO Downlink Carrier Aggregation was not needed since the maximum average output power in 4x4 MIMO Downlink Carrier Aggregation mode was not more than 0.25 dB higher than the maximum output power with 4x4 MIMO Downlink and downlink carrier aggregation inactive.

This device supports LTE capabilities with overlapping transmission frequency ranges. When the supported frequency range of an LTE Band falls completely within an LTE band with a larger transmission frequency range, both LTE bands have the same target power (or the band with the larger transmission frequency range has a higher target power), and both LTE bands share the same transmission path and signal characteristics, SAR was only assessed for the band with the larger transmission frequency range.

This device supports both Power Class 2 (PC2) and Power Class 3 (PC3) for LTE Band 41. Per May 2017 TCB Workshop Notes, SAR tests were performed with Power Class 3 (given the specific UL/DL limitations for Power Class 2). Additionally, SAR testing for the Power Class 2 condition was evaluated for the highest configuration in Power Class 3 for each test configuration to confirm the results were scalable linearly (See Section 14.2).

This device supports LTE Carrier Aggregation (CA) for LTE Band 5, LTE Band 66, and LTE Band 41 with two component carriers in the uplink. SAR Measurements and conducted powers were evaluated per 2017 Fall TCB Workshop Notes.

FCC ID: A3LSMN975U		SAR EVALUATION REPORT		Approved by: Quality Manager
Document S/N: 1M1905200079-01-R1.A3L	Test Dates: 05/22/19 - 07/07/19	DUT Type: Portable Handset		Page 20 of 220 REV 21.3 M 02/15/2019



This device supports 64QAM and 256QAM on the uplink and 256QAM on the downlink for LTE Operations. Conducted powers for 64QAM and 256QAM uplink configurations were measured per Section 5.1 of FCC KDB Publication 941225D05v02r05. SAR was not required for 64QAM or 256QAM since the highest maximum output power for 64QAM and 256QAM is $\leq \frac{1}{2}$ dB higher than the same configuration in QPSK and the reported SAR for the QPSK configuration is ≤ 1.45 W/kg, per Section 5.2.4 of FCC KDB Publication 941225 D05v02r05.

1.8 Guidance Applied



- IEEE 1528-2013
- FCC KDB Publication 941225 D01v03r01, D05v02r04, D05Av01r02, D06v02r01 (2G/3G/4G and Hotspot)
- FCC KDB Publication 248227 D01v02r02 (SAR Considerations for 802.11 Devices)
- FCC KDB Publication 447498 D01v06 (General SAR Guidance)
- FCC KDB Publication 865664 D01v01r04, D02v01r02 (SAR Measurements up to 6 GHz)
- FCC KDB Publication 648474 D04v01r03 (Phablet Procedures)
- FCC KDB Publication 616217 D04v01r02 (Proximity Sensor)
- October 2013 TCB Workshop Notes (GPRS Testing Considerations)
- May 2017 TCB Workshop Notes (LTE 4x4 Downlink MIMO, LTE Band 41 Power Class 2/3)
- April 2018 TCB Workshop Notes (LTE Carrier Aggregation)
- April 2019 TCB Workshop Notes (IEEE 802.11ax, Dynamic Antenna Tuning)

1.9 Device Serial Numbers

Several samples with identical hardware were used to support SAR testing. The manufacturer has confirmed that the device(s) tested have the same physical, mechanical and thermal characteristics and are within operational tolerances expected for production units. The serial numbers used for each test are indicated alongside the results in Section 11.

FCC ID: A3LSMN975U		SAR EVALUATION REPORT		Approved by: Quality Manager
Document S/N: 1M1905200079-01-R1.A3L	Test Dates: 05/22/19 - 07/07/19	DUT Type: Portable Handset	Page 21 of 220	

LTE Information					
Form Factor	Portable Handset				
Frequency Range of each LTE transmission band	LTE Band 71 (665.5 - 695.5 MHz)				
	LTE Band 12 (699.7 - 715.3 MHz)				
	LTE Band 13 (779.5 - 784.5 MHz)				
	LTE Band 14 (790.5 - 795.5 MHz)				
	LTE Band 26 (Cell) (814.7 - 848.3 MHz)				
	LTE Band 5 (Cell) (824.7 - 848.3 MHz)				
	LTE Band 66 (AWS) (1710.7 - 1779.3 MHz)				
	LTE Band 4 (AWS) (1710.7 - 1754.3 MHz)				
	LTE Band 25 (PCS) (1850.7 - 1909.3 MHz)				
	LTE Band 20 (2307.5 - 2312.5 MHz)				
	LTE Band 7 (2502.5 - 2567.5 MHz)				
	LTE Band 48 (3552.5 - 3697.5 MHz)				
	LTE Band 41 (2498.5 - 2687.5 MHz)				
	LTE Band 38 (2572.5 - 2617.5 MHz)				
	LTE Band 71: 5 MHz; 10 MHz; 15 MHz; 20 MHz				
	LTE Band 12: 1.4 MHz; 3 MHz; 5 MHz; 10 MHz				
	Channel Bandwidths	LTE Band 13: 5 MHz; 10 MHz			
		LTE Band 14: 5 MHz; 10 MHz			
LTE Band 26 (Cell): 1.4 MHz; 3 MHz; 5 MHz; 10 MHz; 15 MHz					
LTE Band 5 (Cell): 1.4 MHz; 3 MHz; 5 MHz; 10 MHz					
LTE Band 66 (AWS): 1.4 MHz; 3 MHz; 5 MHz; 10 MHz; 15 MHz; 20 MHz					
LTE Band 4 (AWS): 1.4 MHz; 3 MHz; 5 MHz; 10 MHz; 15 MHz; 20 MHz					
LTE Band 25 (PCS): 1.4 MHz; 3 MHz; 5 MHz; 10 MHz; 15 MHz; 20 MHz					
LTE Band 2 (PCS): 1.4 MHz; 3 MHz; 5 MHz; 10 MHz; 15 MHz; 20 MHz					
LTE Band 30: 5 MHz; 10 MHz					
LTE Band 7: 5 MHz; 10 MHz; 15 MHz; 20 MHz					
LTE Band 48: 5 MHz; 10 MHz; 15 MHz; 20 MHz					
LTE Band 41: 5 MHz; 10 MHz; 15 MHz; 20 MHz					
LTE Band 38: 5 MHz; 10 MHz; 15 MHz; 20 MHz					
Channel Numbers and Frequencies (MHz)		Low	Low-Mid	Mid-High	High
		LTE Band 71: 5 MHz			
LTE Band 71: 10 MHz					
LTE Band 71: 15 MHz					
LTE Band 71: 20 MHz					
LTE Band 12: 1.4 MHz					
LTE Band 12: 3 MHz					
LTE Band 12: 5 MHz					
LTE Band 12: 10 MHz					
LTE Band 13: 5 MHz					
LTE Band 13: 10 MHz					
LTE Band 14: 5 MHz					
LTE Band 14: 10 MHz					
LTE Band 26 (Cell): 1.4 MHz					
LTE Band 26 (Cell): 3 MHz					
LTE Band 26 (Cell): 5 MHz					
LTE Band 26 (Cell): 10 MHz					
LTE Band 26 (Cell): 15 MHz					
LTE Band 5 (Cell): 1.4 MHz					
LTE Band 5 (Cell): 3 MHz					
LTE Band 5 (Cell): 5 MHz					
LTE Band 5 (Cell): 10 MHz					
LTE Band 66 (AWS): 1.4 MHz					
LTE Band 66 (AWS): 3 MHz					
LTE Band 66 (AWS): 5 MHz					
LTE Band 66 (AWS): 10 MHz					
LTE Band 66 (AWS): 15 MHz					
LTE Band 66 (AWS): 20 MHz					
LTE Band 4 (AWS): 1.4 MHz					
LTE Band 4 (AWS): 3 MHz					
LTE Band 4 (AWS): 5 MHz					
LTE Band 4 (AWS): 10 MHz					
LTE Band 4 (AWS): 15 MHz					
LTE Band 4 (AWS): 20 MHz					
LTE Band 25 (PCS): 1.4 MHz					
LTE Band 25 (PCS): 3 MHz					
LTE Band 25 (PCS): 5 MHz					
LTE Band 25 (PCS): 10 MHz					
LTE Band 25 (PCS): 15 MHz					
LTE Band 25 (PCS): 20 MHz					
LTE Band 2 (PCS): 1.4 MHz					
LTE Band 2 (PCS): 3 MHz					
LTE Band 2 (PCS): 5 MHz					
LTE Band 2 (PCS): 10 MHz					
LTE Band 2 (PCS): 15 MHz					
LTE Band 2 (PCS): 20 MHz					
LTE Band 30: 5 MHz					
LTE Band 7: 5 MHz					
LTE Band 7: 10 MHz					
LTE Band 7: 15 MHz					
LTE Band 7: 20 MHz					
LTE Band 48: 5 MHz					
LTE Band 48: 10 MHz					
LTE Band 48: 15 MHz					
LTE Band 48: 20 MHz					
LTE Band 41: 5 MHz					
LTE Band 41: 10 MHz					
LTE Band 41: 15 MHz					
LTE Band 41: 20 MHz					
LTE Band 38: 5 MHz					
LTE Band 38: 10 MHz					
LTE Band 38: 15 MHz					
LTE Band 38: 20 MHz					
UE Category DL UE Cat 20, UL UE Cat 18					
Modulations Supported in UL QPSK, 16QAM, 64QAM, 256QAM					
LTE MPR Permanently implemented per 3GPP TS 36.101 section 6.2.3-6.2.57 (manufacturer attestation to be provided) YES					
A-MPR (Additional MPR) disabled for SAR Testing? YES					
LTE Carrier Aggregation Possible Combinations The technical description includes all the possible carrier aggregation combinations					
LTE Additional Information This device does not support full CA features on 3GPP Release 15. It supports carrier aggregation, downlink MIMO, LAA features as shown in Section 9 and Appendix H. All other uplink communications are identical to the Release 8 specifications. Uplink communications are done on the PCC unless otherwise specified. The following LTE Release 15 Features are not supported: Relay, HetNet, Enhanced eICIC, MDH, eMBMS, Cross-Carrier Scheduling, Enhanced SC-FDMA.					

FCC ID: A3LSMN975U		SAR EVALUATION REPORT		Approved by: Quality Manager
Document S/N: 1M1905200079-01-R1.A3L	Test Dates: 05/22/19 - 07/07/19	DUT Type: Portable Handset		Page 22 of 220

3 INTRODUCTION

The FCC and Innovation, Science, and Economic Development Canada have adopted the guidelines for evaluating the environmental effects of radio frequency (RF) radiation in ET Docket 93-62 on Aug. 6, 1996 and Health Canada Safety Code 6 to protect the public and workers from the potential hazards of RF emissions due to FCC-regulated portable devices. [1]

The safety limits used for the environmental evaluation measurements are based on the criteria published by the American National Standards Institute (ANSI) for localized specific absorption rate (SAR) in IEEE/ANSI C95.1-1992 Standard for Safety Levels with Respect to Human Exposure to Radio Frequency Electromagnetic Fields, 3 kHz to 300 GHz [3] and Health Canada RF Exposure Guidelines Safety Code 6 [22]. The measurement procedure described in IEEE/ANSI C95.3-2002 Recommended Practice for the Measurement of Potentially Hazardous Electromagnetic Fields - RF and Microwave [4] is used for guidance in measuring the Specific Absorption Rate (SAR) due to the RF radiation exposure from the Equipment Under Test (EUT). These criteria for SAR evaluation are similar to those recommended by the International Committee for Non-Ionizing Radiation Protection (ICNIRP) in Biological Effects and Exposure Criteria for Radiofrequency Electromagnetic Fields,” Report No. Vol 74. SAR is a measure of the rate of energy absorption due to exposure to an RF transmitting source. SAR values have been related to threshold levels for potential biological hazards.

3.1 SAR Definition

Specific Absorption Rate is defined as the time derivative (rate) of the incremental energy (dU) absorbed by (dissipated in) an incremental mass (dm) contained in a volume element (dV) of a given density (ρ). It is also defined as the rate of RF energy absorption per unit mass at a point in an absorbing body (see Equation 3-1).

Equation 3-1
SAR Mathematical Equation

$$SAR = \frac{d}{dt} \left(\frac{dU}{dm} \right) = \frac{d}{dt} \left(\frac{dU}{\rho dv} \right)$$



SAR is expressed in units of Watts per Kilogram (W/kg).

$$SAR = \frac{\sigma \cdot E^2}{\rho}$$

where:

- σ = conductivity of the tissue-simulating material (S/m)
- ρ = mass density of the tissue-simulating material (kg/m³)
- E = Total RMS electric field strength (V/m)

NOTE: The primary factors that control rate of energy absorption were found to be the wavelength of the incident field in relation to the dimensions and geometry of the irradiated organism, the orientation of the organism in relation to the polarity of field vectors, the presence of reflecting surfaces, and whether conductive contact is made by the organism with a ground plane.[6]

FCC ID: A3LSMN975U	 PCTEST ENGINEERING LABORATORY, INC.	SAR EVALUATION REPORT		Approved by: Quality Manager
Document S/N: 1M1905200079-01-R1.A3L	Test Dates: 05/22/19 - 07/07/19	DUT Type: Portable Handset	Page 23 of 220	

4 DOSIMETRIC ASSESSMENT

4.1 Measurement Procedure

The evaluation was performed using the following procedure compliant to FCC KDB Publication 865664 D01v01r04 and IEEE 1528-2013:

1. The SAR distribution at the exposed side of the head or body was measured at a distance no greater than 5.0 mm from the inner surface of the shell. The area covered the entire dimension of the device-head and body interface and the horizontal grid resolution was determined per FCC KDB Publication 865664 D01v01r04 (See Table 4-1) and IEEE 1528-2013.
2. The point SAR measurement was taken at the maximum SAR region determined from Step 1 to enable the monitoring of SAR fluctuations/drifts during the 1g/10g cube evaluation. SAR at this fixed point was measured and used as a reference value.
3. Based on the area scan data, the peak of the region with maximum SAR was determined by spline interpolation. Around this point, a volume was assessed according to the measurement resolution and volume size requirements of FCC KDB Publication 865664 D01v01r04 (See Table 4-1) and IEEE 1528-2013. On the basis of this data set, the spatial peak SAR value was evaluated with the following procedure (see references or the DASY manual online for more details):
 - a. SAR values at the inner surface of the phantom are extrapolated from the measured values along the line away from the surface with spacing no greater than that in Table 4-1. The extrapolation was based on a least-squares algorithm. A polynomial of the fourth order was calculated through the points in the z-axis (normal to the phantom shell).
 - b. After the maximum interpolated values were calculated between the points in the cube, the SAR was averaged over the spatial volume (1g or 10g) using a 3D-Spline interpolation algorithm. The 3D-spline is composed of three one-dimensional splines with the “Not a knot” condition (in x, y, and z directions). The volume was then integrated with the trapezoidal algorithm. One thousand points (10 x 10 x 10) were obtained through interpolation, in order to calculate the averaged SAR.
 - c. All neighboring volumes were evaluated until no neighboring volume with a higher average value was found.
4. The SAR reference value, at the same location as step 2, was re-measured after the zoom scan was complete to calculate the SAR drift. If the drift deviated by more than 5%, the SAR test and drift measurements were repeated.

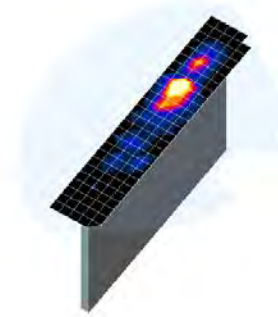



Figure 4-1
Sample SAR Area Scan

Table 4-1
Area and Zoom Scan Resolutions per FCC KDB Publication 865664 D01v01r04*

Frequency	Maximum Area Scan Resolution (mm) ($\Delta x_{area}, \Delta y_{area}$)	Maximum Zoom Scan Resolution (mm) ($\Delta x_{zoom}, \Delta y_{zoom}$)	Maximum Zoom Scan Spatial Resolution (mm)			Minimum Zoom Scan Volume (mm) (x,y,z)
			Uniform Grid	Graded Grid		
			$\Delta z_{zoom}(n)$	$\Delta z_{zoom}(1)^*$	$\Delta z_{zoom}(n>1)^*$	
≤ 2 GHz	≤ 15	≤ 8	≤ 5	≤ 4	≤ 1.5* $\Delta z_{zoom}(n-1)$	≥ 30
2-3 GHz	≤ 12	≤ 5	≤ 5	≤ 4	≤ 1.5* $\Delta z_{zoom}(n-1)$	≥ 30
3-4 GHz	≤ 12	≤ 5	≤ 4	≤ 3	≤ 1.5* $\Delta z_{zoom}(n-1)$	≥ 28
4-5 GHz	≤ 10	≤ 4	≤ 3	≤ 2.5	≤ 1.5* $\Delta z_{zoom}(n-1)$	≥ 25
5-6 GHz	≤ 10	≤ 4	≤ 2	≤ 2	≤ 1.5* $\Delta z_{zoom}(n-1)$	≥ 22

*Also compliant to IEEE 1528-2013 Table 6

FCC ID: A3LSMN975U		SAR EVALUATION REPORT		Approved by: Quality Manager
Document S/N: 1M1905200079-01-R1.A3L	Test Dates: 05/22/19 - 07/07/19	DUT Type: Portable Handset		Page 24 of 220

5 DEFINITION OF REFERENCE POINTS

5.1 EAR REFERENCE POINT

Figure 5-2 shows the front, back and side views of the SAM Twin Phantom. The point “M” is the reference point for the center of the mouth, “LE” is the left ear reference point (ERP), and “RE” is the right ERP. The ERP is 15mm posterior to the entrance to the ear canal (EEC) along the B-M line (Back-Mouth), as shown in Figure 5-1. The plane passing through the two ear canals and M is defined as the Reference Plane. The line N-F (Neck-Front), also called the Reference Pivoting Line, is not perpendicular to the reference plane (see Figure 5-1). Line B-M is perpendicular to the N-F line. Both N-F and B-M lines are marked on the external phantom shell to facilitate handset positioning [5].

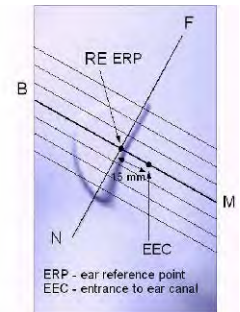

Figure 5-1
Close-Up Side view of ERP

5.2 HANDSET REFERENCE POINTS

Two imaginary lines on the handset were established: the vertical centerline and the horizontal line. The test device was placed in a normal operating position with the acoustic output located along the “vertical centerline” on the front of the device aligned to the “ear reference point” (See Figure 5-3). The acoustic output was then located at the same level as the center of the ear reference point. The test device was positioned so that the “vertical centerline” was bisecting the front surface of the handset at its top and bottom edges, positioning the “ear reference point” on the outer surface of the both the left and right head phantoms on the ear reference point.



Figure 5-2
Front, back and side view of SAM Twin Phantom

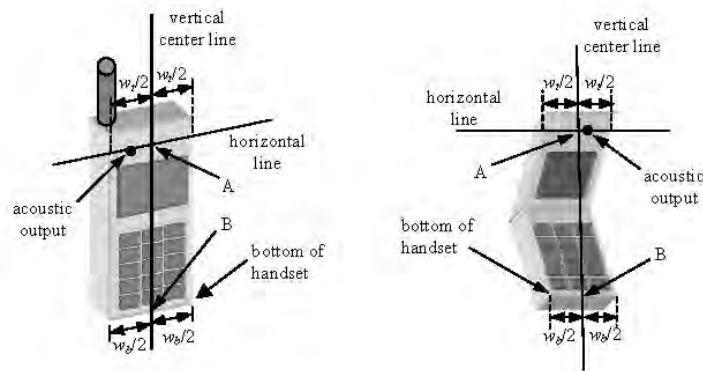



Figure 5-3
Handset Vertical Center & Horizontal Line Reference Points

FCC ID: A3LSMN975U	 PCTEST ENGINEERING LABORATORY, INC.	SAR EVALUATION REPORT		Approved by: Quality Manager
Document S/N: 1M1905200079-01-R1.A3L	Test Dates: 05/22/19 - 07/07/19	DUT Type: Portable Handset		Page 25 of 220

6 TEST CONFIGURATION POSITIONS

6.1 Device Holder

The device holder is made out of low-loss POM material having the following dielectric parameters: relative permittivity $\epsilon = 3$ and loss tangent $\delta = 0.02$.

6.2 Positioning for Cheek

1. The test device was positioned with the device close to the surface of the phantom such that point A is on the (virtual) extension of the line passing through points RE and LE on the phantom (see Figure 6-1), such that the plane defined by the vertical center line and the horizontal line of the phone is approximately parallel to the sagittal plane of the phantom.





Figure 6-1 Front, Side and Top View of Cheek Position

2. The handset was translated towards the phantom along the line passing through RE & LE until the handset touches the pinna.
3. While maintaining the handset in this plane, the handset was rotated around the LE-RE line until the vertical centerline was in the reference plane.
4. The phone was then rotated around the vertical centerline until the phone (horizontal line) was symmetrical with respect to the line NF.
5. While maintaining the vertical centerline in the reference plane, keeping point A on the line passing through RE and LE, and maintaining the device contact with the ear, the device was rotated about the NF line until any point on the handset made contact with a phantom point below the ear (cheek) (See Figure 6-2).

6.3 Positioning for Ear / 15° Tilt

With the test device aligned in the “Cheek Position”:

1. While maintaining the orientation of the phone, the phone was retracted parallel to the reference plane far enough to enable a rotation of the phone by 15 degrees.
2. The phone was then rotated around the horizontal line by 15 degrees.
3. While maintaining the orientation of the phone, the phone was moved parallel to the reference plane until any part of the handset touched the head. (In this position, point A was located on the line RE-LE). The tilted position is obtained when the contact is on the pinna. If the contact was at any location other than the pinna, the angle of the phone would then be reduced. In this situation, the tilted position was obtained when any part of the phone was in contact of the ear as well as a second part of the phone was in contact with the head (see Figure 6-2).

FCC ID: A3LSMN975U		SAR EVALUATION REPORT		Approved by: Quality Manager
Document S/N: 1M1905200079-01-R1.A3L	Test Dates: 05/22/19 - 07/07/19	DUT Type: Portable Handset		Page 26 of 220

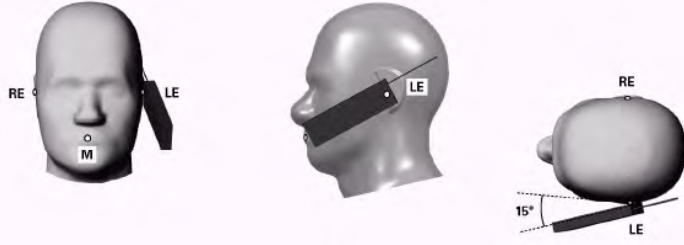

Figure 6-2 Front, Side and Top View of Ear/15° Tilt Position

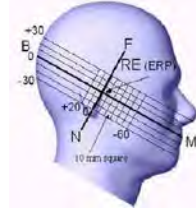

Figure 6-3 Side view w/ relevant markings

6.4 SAR Evaluations near the Mouth/Jaw Regions of the SAM Phantom

Antennas located near the bottom of a phone may require SAR measurements around the mouth and jaw regions of the SAM head phantom. This typically applies to clam-shell style phones that are generally longer in the unfolded normal use positions or to certain older style long rectangular phones. Per IEEE 1528-2013, a rotated SAM phantom is necessary to allow probe access to such regions. Both SAM heads of the TwinSAM-Chin20 are rotated 20 degrees around the NF line. Each head can be removed from the table for emptying and cleaning.

Under these circumstances, the following procedures apply, adopted from the FCC guidance on SAR handsets document FCC KDB Publication 648474 D04v01r03. The SAR required in these regions of SAM should be measured using a flat phantom. The phone should be positioned with a separation distance of 4 mm between the ear reference point (ERP) and the outer surface of the flat phantom shell. While maintaining this distance at the ERP location, the low (bottom) edge of the phone should be lowered from the phantom to establish the same separation distance between the peak SAR location identified by the truncated partial SAR distribution measured with the SAM phantom. The distance from the peak SAR location to the phone is determined by the straight line passing perpendicularly through the phantom surface. When it is not feasible to maintain 4 mm separation at the ERP while also establishing the required separation at the peak SAR location, the top edge of the phone will be allowed to touch the phantom with a separation < 4 mm at the ERP. The phone should not be tilted to the left or right while placed in this inclined position to the flat phantom.

6.5 Body-Worn Accessory Configurations

Body-worn operating configurations are tested with the belt-clips and holsters attached to the device and positioned against a flat phantom in a normal use configuration (see Figure 6-4). Per FCC KDB Publication 648474 D04v01r03, Body-worn accessory exposure is typically related to voice mode operations when handsets are carried in body-worn accessories. The body-worn accessory procedures in FCC KDB Publication 447498 D01v06 should be used to test for body-worn accessory SAR compliance, without a headset connected to it. This enables the test results for such configuration to be compatible with that required for hotspot mode when the body-worn accessory test separation distance is greater than or equal to that required for hotspot mode, when applicable. When the reported SAR for a body-worn accessory, measured without a headset connected to the handset, is > 1.2 W/kg, the highest reported SAR configuration for that wireless mode and frequency band should be repeated for that body-worn accessory with a headset attached to the handset.

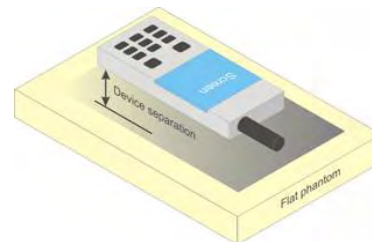



Figure 6-4 Sample Body-Worn Diagram

Accessories for Body-worn operation configurations are divided into two categories: those that do not contain metallic components and those that do contain metallic components. When multiple accessories that do not

FCC ID: A3LSMN975U		SAR EVALUATION REPORT		Approved by: Quality Manager
Document S/N: 1M1905200079-01-R1.A3L	Test Dates: 05/22/19 - 07/07/19	DUT Type: Portable Handset		Page 27 of 220

contain metallic components are supplied with the device, the device is tested with only the accessory that dictates the closest spacing to the body. Then multiple accessories that contain metallic components are tested with the device with each accessory. If multiple accessories share an identical metallic component (i.e. the same metallic belt-clip used with different holsters with no other metallic components) only the accessory that dictates the closest spacing to the body is tested.

Body-worn accessories may not always be supplied or available as options for some devices intended to be authorized for body-worn use. In this case, a test configuration with a separation distance between the back of the device and the flat phantom is used. Test position spacing was documented. Transmitters that are designed to operate in front of a person's face, as in push-to-talk configurations, are tested for SAR compliance with the front of the device positioned to face the flat phantom in head fluid. For devices that are carried next to the body such as a shoulder, waist or chest-worn transmitters, SAR compliance is tested with the accessories, including headsets and microphones, attached to the device and positioned against a flat phantom in a normal use configuration.

6.6 Extremity Exposure Configurations



Devices that are designed or intended for use on extremities or mainly operated in extremity only exposure conditions; i.e., hands, wrists, feet and ankles, may require extremity SAR evaluation. When the device also operates in close proximity to the user's body, SAR compliance for the body is also required. The 1g body and 10g extremity SAR Exclusion Thresholds found in KDB Publication 447498 D01v06 should be applied to determine SAR test requirements.

Per KDB Publication 447498 D01v06, Cell phones (handsets) are not normally designed to be used on extremities or operated in extremity only exposure conditions. The maximum output power levels of handsets generally do not require extremity SAR testing to show compliance. Therefore, extremity SAR was not evaluated for this device.

6.7 Wireless Router Configurations

Some battery-operated handsets have the capability to transmit and receive user data through simultaneous transmission of WIFI simultaneously with a separate licensed transmitter. The FCC has provided guidance in FCC KDB Publication 941225 D06v02r01 where SAR test considerations for handsets (L x W ≥ 9 cm x 5 cm) are based on a composite test separation distance of 10 mm from the front, back and edges of the device containing transmitting antennas within 2.5 cm of their edges, determined from general mixed use conditions for this type of devices. Since the hotspot SAR results may overlap with the body-worn accessory SAR requirements, the more conservative configurations can be considered, thus excluding some body-worn accessory SAR tests.

When the user enables the personal wireless router functions for the handset, actual operations include simultaneous transmission of both the WIFI transmitter and another licensed transmitter. Both transmitters often do not transmit at the same transmitting frequency and thus cannot be evaluated for SAR under actual use conditions due to the limitations of the SAR assessment probes. Therefore, SAR must be evaluated for each frequency transmission and mode separately and spatially summed with the WIFI transmitter according to FCC KDB Publication 447498 D01v06 procedures. The "Portable Hotspot" feature on the handset was NOT activated during SAR assessments, to ensure the SAR measurements were evaluated for a single transmission frequency RF signal at a time.

FCC ID: A3LSMN975U	 PCTEST ENGINEERING LABORATORY, INC.	SAR EVALUATION REPORT		Approved by: Quality Manager
Document S/N: 1M1905200079-01-R1.A3L	Test Dates: 05/22/19 - 07/07/19	DUT Type: Portable Handset	Page 28 of 220	

6.8 Phablet Configurations



For smart phones with a display diagonal dimension > 150 mm or an overall diagonal dimension > 160 mm that provide similar mobile web access and multimedia support found in mini-tablets or UMPC mini-tablets that support voice calls next to the ear, the phablets procedures outlined in KDB Publication 648474 D04v01r03 should be applied to evaluate SAR compliance. A device marketed as phablets, regardless of form factors and operating characteristics must be tested as a phablet to determine SAR compliance. In addition to the normally required head and body-worn accessory SAR test procedures required for handsets, the UMPC mini-tablet procedures must also be applied to test the SAR of all surfaces and edges with an antenna <=25 mm from that surface or edge, in direct contact with the phantom, for 10g SAR. The UMPC mini-tablet 1g SAR at 5 mm is not required. When hotspot mode applies, 10g SAR is required only for the surfaces and edges with hotspot mode 1g SAR > 1.2 W/kg.

6.9 Proximity Sensor Considerations

This device uses a power reduction mechanism to reduce output powers in certain use conditions when the device is used close the user's body.

When the device's antenna is within a certain distance of the user, the sensor activates and reduces the maximum allowed output power. However, the sensor is not active when the device is moved beyond the sensor triggering distance and the maximum output power is no longer limited. Therefore, additional evaluation is needed in the vicinity of the triggering distance to ensure SAR is compliant when the device is allowed to operate at a nonreduced output power level. FCC KDB Publication 616217 D04v01r02 Section 6 was used as a guideline for selecting SAR test distances for this device at these additional test positions. Sensor triggering distance summary data is included in Appendix G.

The sensor is designed to support sufficient detection range and sensitivity to cover regions of the sensors in all applicable directions since the sensor entirely covers the antennas.

FCC ID: A3LSMN975U		SAR EVALUATION REPORT		Approved by: Quality Manager
Document S/N: 1M1905200079-01-R1.A3L	Test Dates: 05/22/19 - 07/07/19	DUT Type: Portable Handset	Page 29 of 220	

7 RF EXPOSURE LIMITS

7.1 Uncontrolled Environment

UNCONTROLLED ENVIRONMENTS are defined as locations where there is the exposure of individuals who have no knowledge or control of their exposure. The general population/uncontrolled exposure limits are applicable to situations in which the general public may be exposed or in which persons who are exposed as a consequence of their employment may not be made fully aware of the potential for exposure or cannot exercise control over their exposure. Members of the general public would come under this category when exposure is not employment-related; for example, in the case of a wireless transmitter that exposes persons in its vicinity.



7.2 Controlled Environment

CONTROLLED ENVIRONMENTS are defined as locations where there is exposure that may be incurred by persons who are aware of the potential for exposure, (i.e. as a result of employment or occupation). In general, occupational/controlled exposure limits are applicable to situations in which persons are exposed as a consequence of their employment, who have been made fully aware of the potential for exposure and can exercise control over their exposure. This exposure category is also applicable when the exposure is of a transient nature due to incidental passage through a location where the exposure levels may be higher than the general population/uncontrolled limits, but the exposed person is fully aware of the potential for exposure and can exercise control over his or her exposure by leaving the area or by some other appropriate means.

**Table 7-1
SAR Human Exposure Specified in ANSI/IEEE C95.1-1992 and Health Canada Safety Code 6**

HUMAN EXPOSURE LIMITS		
	UNCONTROLLED ENVIRONMENT <i>General Population</i> (W/kg) or (mW/g)	CONTROLLED ENVIRONMENT <i>Occupational</i> (W/kg) or (mW/g)
Peak Spatial Average SAR Head	1.6	8.0
Whole Body SAR	0.08	0.4
Peak Spatial Average SAR Hands, Feet, Ankle, Wrists, etc.	4.0	20

1. The Spatial Peak value of the SAR averaged over any 1 gram of tissue (defined as a tissue volume in the shape of a cube) and over the appropriate averaging time.
2. The Spatial Average value of the SAR averaged over the whole body.
3. The Spatial Peak value of the SAR averaged over any 10 grams of tissue (defined as a tissue volume in the shape of a cube) and over the appropriate averaging time.

FCC ID: A3LSMN975U	 PCTEST ENGINEERING LABORATORY, INC.	SAR EVALUATION REPORT		Approved by: Quality Manager
Document S/N: 1M1905200079-01-R1.A3L	Test Dates: 05/22/19 - 07/07/19	DUT Type: Portable Handset		Page 30 of 220

8 FCC MEASUREMENT PROCEDURES

Power measurements for licensed transmitters are performed using a base station simulator under digital average power.

8.1 Measured and Reported SAR

Per FCC KDB Publication 447498 D01v06, when SAR is not measured at the maximum power level allowed for production units, the results must be scaled to the maximum tune-up tolerance limit according to the power applied to the individual channels tested to determine compliance. For simultaneous transmission, the measured aggregate SAR must be scaled according to the sum of the differences between the maximum tune-up tolerance and actual power used to test each transmitter. When SAR is measured at or scaled to the maximum tune-up tolerance limit, the results are referred to as *reported* SAR. The highest *reported* SAR results are identified on the grant of equipment authorization according to procedures in KDB 690783 D01v01r03.

8.2 3G SAR Test Reduction Procedure

In FCC KDB Publication 941225 D01v03r01, certain transmission modes within a frequency band and wireless mode evaluated for SAR are defined as primary modes. The equivalent modes considered for SAR test reduction are denoted as secondary modes. When the maximum output power including tune-up tolerance specified for production units in a secondary mode is ≤ 0.25 dB higher than the primary mode or when the highest reported SAR of the primary mode, scaled by the ratio of specified maximum output power and tune-up tolerance of secondary to primary mode, is ≤ 1.2 W/kg, SAR measurements are not required for the secondary mode. These criteria are referred to as the 3G SAR test reduction procedure. When the 3G SAR test reduction procedure is not satisfied, SAR measurements are additionally required for the secondary mode.

8.3 Procedures Used to Establish RF Signal for SAR

The following procedures are according to FCC KDB Publication 941225 D01v03r01 “3G SAR Measurement Procedures.”



The device is placed into a simulated call using a base station simulator in a RF shielded chamber. Establishing connections in this manner ensure a consistent means for testing SAR and are recommended for evaluating SAR [4]. Devices under test are evaluated prior to testing, with a fully charged battery and were configured to operate at maximum output power. In order to verify that the device is tested throughout the SAR test at maximum output power, the SAR measurement system measures a “point SAR” at an arbitrary reference point at the start and end of the 1 gram SAR evaluation, to assess for any power drifts during the evaluation. If the power drift deviates by more than 5%, the SAR test and drift measurements are repeated.

8.4 SAR Measurement Conditions for CDMA2000

The following procedures were performed according to FCC KDB Publication 941225 D01v03r01 “3G SAR Measurement Procedures.”

8.4.1 Output Power Verification

See 3GPP2 C.S0011/TIA-98-E as recommended by FCC KDB Publication 941225 D01v03r01 “3G SAR Measurement Procedures.” Maximum output power is verified on the High, Middle and Low channels according to procedures in section 4.4.5.2 of 3GPP2 C.S0011/TIA-98-E. SO55 tests were measured with power control bits in the “All Up” condition.

FCC ID: A3LSMN975U		SAR EVALUATION REPORT		Approved by: Quality Manager
Document S/N: 1M1905200079-01-R1.A3L	Test Dates: 05/22/19 - 07/07/19	DUT Type: Portable Handset		Page 31 of 220

1. If the mobile station (MS) supports Reverse TCH RC 1 and Forward TCH RC 1, set up a call using Fundamental Channel Test Mode 1 (RC=1/1) with 9600 bps data rate only.
2. Under RC1, C.S0011 Table 4.4.5.2-1, Table 8-1 parameters were applied.
3. If the MS supports the RC 3 Reverse FCH, RC3 Reverse SCH₀ and demodulation of RC 3,4, or 5, set up a call using Supplemental Channel Test Mode 3 (RC 3/3) with 9600 bps Fundamental Channel and 9600 bps SCH₀ data rate.
4. Under RC3, C.S0011 Table 4.4.5.2-2, Table 8-2 was applied.

Table 8-1
Parameters for Max. Power for RC1

Parameter	Units	Value
$\frac{I_{or}}{I_{or}}$	dBm/1.23 MHz	-104
$\frac{Pilot E_c}{I_{or}}$	dB	-7
$\frac{Traffic E_c}{I_{or}}$	dB	-7.4

Table 8-2
Parameters for Max. Power for RC3

Parameter	Units	Value
$\frac{I_{or}}{I_{or}}$	dBm/1.23 MHz	-86
$\frac{Pilot E_c}{I_{or}}$	dB	-7
$\frac{Traffic E_c}{I_{or}}$	dB	-7.4

5. FCHs were configured at full rate for maximum SAR with “All Up” power control bits.

8.4.2 Head SAR Measurements

SAR for next to the ear head exposure is measured in RC3 with the handset configured to transmit at fullrate in SO55. The 3G SAR test reduction procedure is applied to RC1 with RC3 as the primary mode; otherwise, SAR is required for the channel with maximum measured output in RC1 using the head exposure configuration that results in the highest reported SAR in RC3.

Head SAR is additionally evaluated using EVDO Rev. A to support compliance for VoIP operations. See Section 8.4.5 for EVDO Rev. A configuration parameters.

8.4.3 Body-worn SAR Measurements



SAR for body-worn exposure configurations is measured in RC3 with the DUT configured to transmit at full rate on FCH with all other code channels disabled using TDSO / SO32. The 3G SAR test reduction procedure is applied to the multiple code channel configuration (FCH+SCH_n), with FCH only as the primary mode. Otherwise, SAR is required for multiple code channel configuration (FCH + SCH_n), with FCH at full rate and SCH₀ enabled at 9600 bps, using the highest reported SAR configuration for FCH only. When multiple code channels are enabled, the transmitter output can shift by more than 0.5 dB and may lead to higher SAR drifts and SCH dropouts.

The 3G SAR test reduction procedure is applied to body-worn accessory SAR in RC1 with RC3 as the primary mode. Otherwise, SAR is required for RC1, with SO55 and full rate, using the highest reported SAR configuration for body-worn accessory exposure in RC3.

8.4.4 Body-worn SAR Measurements for EVDO Devices

For handsets with EVDO capabilities, the 3G SAR test reduction procedure is applied to EVDO Rev. 0 with 1x RTT RC3 as the primary mode to determine body-worn accessory test requirements. Otherwise, body-worn accessory SAR is required for Rev. 0, at 153.6 kbps, using the highest reported SAR configuration for body-worn accessory exposure in RC3.

The 3G SAR test reduction procedure is applied to Rev. A, with Rev. 0 as the primary mode to determine body-worn accessory SAR test requirements. When SAR is not required for Rev. 0, the 3G SAR test reduction is applied with 1x RTT RC3 as the primary mode.

FCC ID: A3LSMN975U		SAR EVALUATION REPORT		Approved by: Quality Manager
Document S/N: 1M1905200079-01-R1.A3L	Test Dates: 05/22/19 - 07/07/19	DUT Type: Portable Handset	Page 32 of 220	

When SAR is required for EVDO Rev. A, SAR is measured with a Reverse Data Channel payload size of 4096 bits and a Termination Target of 16 slots defined for Subtype 2 Physical Layer configurations, using the highest reported SAR configuration for body-worn accessory exposure in Rev. 0 or 1x RTT RC3, as appropriate.

8.4.5 Body SAR Measurements for EVDO Hotspot

Hotspot Body SAR is measured using Subtype 0/1 Physical Layer configurations for Rev. 0. The 3G SAR test reduction procedure is applied to Rev. A, Subtype 2 Physical layer configuration, with Rev. 0 as the primary mode; otherwise, SAR is measured for Rev. A using the highest reported SAR configuration for body-worn accessory exposure in Rev. 0. The AT is tested with a Reverse Data Channel rate of 153.6 kbps in Subtype 0/1 Physical Layer configurations; and a Reverse Data Channel payload size of 4096 bits and Termination Target of 16 slots in Subtype 2 Physical Layer configurations.

For EVDO data devices that also support 1x RTT voice and/or data operations, the 3G SAR test reduction procedure is applied to 1x RTT RC3 and RC1 with EVDO Rev. 0 and Rev. A as the respective primary modes. Otherwise, the 'Body-Worn Accessory SAR' procedures in the '3GPP2 CDMA 2000 1x Handsets' section are applied.

8.4.6 CDMA2000 1x Advanced

This device additionally supports 1x Advanced. Conducted powers are measured using SO75 with RC8 on the uplink and RC11 on the downlink per FCC KDB Publication 941225 D01v03r01. Smart blanking is disabled for all measurements. The EUT is configured with forward power control Mode 000 and reverse power control at 400 bps. Conducted powers are measured on an Agilent 8960 Series 10 Wireless Communications Test Set, Model E5515C using the CDMA2000 1x Advanced application, Option E1962B-410.

The 3G SAR test reduction procedure is applied to the 1x-Advanced transmission mode with 1x RTT RC3 as the primary mode. When SAR measurement is required, the 1x-Advanced power measurement configurations are used. The 1x Advanced SAR procedures are applied separately to head, body-worn accessory and other exposure conditions.



8.5 SAR Measurement Conditions for UMTS

8.5.1 Output Power Verification

Maximum output power is verified on the High, Middle and Low channels according to the general descriptions in section 5.2 of 3GPP TS 34.121, using the appropriate RMC with TPC (transmit power control) set to all "1s" or applying the required inner loop power control procedures to maintain maximum output power while HSUPA is active. Results for all applicable physical channel configurations (DPCCH, DPDCHn and spreading codes, HS-DPCCH etc) are tabulated in this test report. All configurations that are not supported by the DUT or cannot be measured due to technical or equipment limitations are identified.

8.5.2 Head SAR Measurements

SAR for next to the ear head exposure is measured using a 12.2 kbps RMC with TPC bits configured to all "1s". The 3G SAR test reduction procedure is applied to AMR configurations with 12.2 kbps RMC as the

FCC ID: A3LSMN975U	 PCTEST ENGINEERING LABORATORY, INC.	SAR EVALUATION REPORT		Approved by: Quality Manager
Document S/N: 1M1905200079-01-R1.A3L	Test Dates: 05/22/19 - 07/07/19	DUT Type: Portable Handset	Page 33 of 220	

primary mode. Otherwise, SAR is measured for 12.2 kbps AMR in 3.4 kbps SRB (signaling radio bearer) using the highest reported SAR configuration in 12.2 kbps RMC for head exposure.

8.5.3 Body SAR Measurements

SAR for body exposure configurations is measured using the 12.2 kbps RMC with the TPC bits all “1s”. The 3G SAR test reduction procedure is applied to other spreading codes and multiple DPDCH_n configurations supported by the handset with 12.2 kbps RMC as the primary mode. Otherwise, SAR is measured using an applicable RMC configuration with the corresponding spreading code or DPDCH_n, for the highest reported SAR configuration in 12.2 kbps RMC.

8.5.4 SAR Measurements with Rel 5 HSDPA

The 3G SAR test reduction procedure is applied to HSDPA body configurations with 12.2 kbps RMC as the primary mode. Otherwise, Body SAR for HSDPA is measured using an FRC with H-Set 1 in Sub-test 1 and a 12.2 kbps RMC configured in Test Loop Mode 1, for the highest reported SAR configuration in 12.2 kbps RMC without HSDPA. Handsets with both HSDPA and HSUPA are tested according to Release 6 HSPA test procedures.

8.5.5 SAR Measurements with Rel 6 HSUPA

The 3G SAR test reduction procedure is applied to HSPA (HSUPA/HSDPA with RMC) body configurations with 12.2 kbps RMC as the primary mode. Otherwise, Body SAR for HSPA is measured with E-DCH Sub-test 5, using H-Set 1 and QPSK for FRC and a 12.2 kbps RMC configured in Test Loop Mode 1 and power control algorithm 2, according to the highest reported body SAR configuration in 12.2 kbps RMC without HSPA.

When VOIP applies to head exposure, the 3G SAR test reduction procedure is applied with 12.2 kbps RMC as the primary mode; otherwise, the same HSPA configuration used for body SAR measurements are applied to head exposure testing.

8.5.6 SAR Measurement Conditions for DC-HSDPA



SAR is required for Rel. 8 DC-HSDPA when SAR is required for Rel. 5 HSDPA; otherwise, the 3G SAR test reduction procedure is applied to DC-HSDPA with 12.2 kbps RMC as the primary mode. Power is measured for DC-HSDPA according to the H-Set 12, FRC configuration in Table C.8.1.12 of 3GPP TS 34.121-1 to determine SAR test reduction. A primary and a secondary serving HS-DSCH Cell are required to perform the power measurement and for the results to be acceptable.

8.6 SAR Measurement Conditions for LTE

LTE modes are tested according to FCC KDB 941225 D05v02r04 publication. Establishing connections with base station simulators ensure a consistent means for testing SAR and are recommended for evaluating SAR [4]. The R&S CMW500 or Anritsu MT8820C simulators are used for LTE output power measurements and SAR testing. Closed loop power control was used so the UE transmits with maximum output power during SAR testing. SAR tests were performed with the same number of RB and RB offsets transmitting on all TTI frames (maximum TTI).

8.6.1 Spectrum Plots for RB Configurations

A properly configured base station simulator was used for SAR tests and power measurements. Therefore, spectrum plots for RB configurations were not required to be included in this report.

FCC ID: A3LSMN975U		SAR EVALUATION REPORT		Approved by: Quality Manager
Document S/N: 1M1905200079-01-R1.A3L	Test Dates: 05/22/19 - 07/07/19	DUT Type: Portable Handset	Page 34 of 220	

8.6.2 MPR

MPR is permanently implemented for this device by the manufacturer. The specific manufacturer target MPR is indicated alongside the SAR results. MPR is enabled for this device, according to 3GPP TS36.101 Section 6.2.3 – 6.2.5 under Table 6.2.3-1.

8.6.3 A-MPR

A-MPR (Additional MPR) has been disabled for all SAR tests by setting NS=01 on the base station simulator.



8.6.4 Required RB Size and RB Offsets for SAR Testing

According to FCC KDB 941225 D05v02r04:

- a. Per Section 5.2.1, SAR is required for QPSK 1 RB Allocation for the largest bandwidth
 - i. The required channel and offset combination with the highest maximum output power is required for SAR.
 - ii. When the reported SAR is ≤ 0.8 W/kg, testing of the remaining RB offset configurations and required test channels is not required. Otherwise, SAR is required for the remaining required test channels using the RB offset configuration with highest output power for that channel.
 - iii. When the reported SAR for a required test channel is > 1.45 W/kg, SAR is required for all RB offset configurations for that channel.
- b. Per Section 5.2.2, SAR is required for 50% RB allocation using the largest bandwidth following the same procedures outlined in Section 5.2.1.
- c. Per Section 5.2.3, QPSK SAR is not required for the 100% allocation when the highest maximum output power for the 100% allocation is less than the highest maximum output power of the 1 RB and 50% RB allocations and the reported SAR for the 1 RB and 50% RB allocations is < 0.8 W/kg.
- d. Per Section 5.2.4 and 5.3, SAR tests for higher order modulations and lower bandwidths configurations are not required when the conducted power of the required test configurations determined by Sections 5.2.1 through 5.2.3 is less than or equal to $\frac{1}{2}$ dB higher than the equivalent configuration using QPSK modulation and when the QPSK SAR for those configurations is < 1.45 W/kg.

8.6.5 TDD

LTE TDD testing is performed using the SAR test guidance provided in FCC KDB 941225 D05v02r04. TDD is tested at the highest duty factor using UL-DL configuration 0 with special subframe configuration 6 and applying the FDD LTE procedures in KDB 941225 D05v02r04. SAR testing is performed using the extended cyclic prefix listed in 3GPP TS 36.211 Section 4.

FCC ID: A3LSMN975U		SAR EVALUATION REPORT		Approved by: Quality Manager
Document S/N: 1M1905200079-01-R1.A3L	Test Dates: 05/22/19 - 07/07/19	DUT Type: Portable Handset		Page 35 of 220

8.6.6 Downlink Only Carrier Aggregation

Conducted power measurements with LTE Carrier Aggregation (CA) (downlink only) active are made in accordance to KDB Publication 941225 D05Av01r02. The RRC connection is only handled by one cell, the primary component carrier (PCC) for downlink and uplink communications. After making a data connection to the PCC, the UE device adds secondary component carrier(s) (SCC) on the downlink only. All uplink communications and acknowledgements remain identical to specifications when downlink carrier aggregation is inactive on the PCC. Additional conducted output powers are measured with the downlink carrier aggregation active for the configuration with highest measured maximum conducted power with downlink carrier aggregation inactive measured among the channel bandwidth, modulation, and RB combinations in each frequency band. Per FCC KDB Publication 941225 D05Av01r02, no SAR measurements are required for downlink only carrier aggregation configurations when the average output power with downlink only carrier aggregation active is not more than 0.25 dB higher than the average output power with downlink only carrier aggregation inactive.

8.7 SAR Testing with 802.11 Transmitters

The normal network operating configurations of 802.11 transmitters are not suitable for SAR measurements. Unpredictable fluctuations in network traffic and antenna diversity conditions can introduce undesirable variations in SAR results. The SAR for these devices should be measured using chipset based test mode software to ensure the results are consistent and reliable. See KDB Publication 248227 D01v02r02 for more details.



8.7.1 General Device Setup

Chipset based test mode software is hardware dependent and generally varies among manufacturers. The device operating parameters established in test mode for SAR measurements must be identical to those programmed in production units, including output power levels, amplifier gain settings and other RF performance tuning parameters.

A periodic duty factor is required for current generation SAR systems to measure SAR. When 802.11 frame gaps are accounted for in the transmission, a maximum transmission duty factor of 92 - 96% is typically achievable in most test mode configurations. A minimum transmission duty factor of 85% is required to avoid certain hardware and device implementation issues related to wide range SAR scaling. The reported SAR is scaled to 100% transmission duty factor to determine compliance at the maximum tune-up tolerance limit.

8.7.2 U-NII-1 and U-NII-2A

For devices that operate in both U-NII-1 and U-NII-2A bands, when the same maximum output power is specified for both bands, SAR measurement using OFDM SAR test procedures is not required for U-NII-1 unless the highest reported SAR for U-NII-2A is > 1.2 W/kg. When different maximum output powers are specified for the bands, SAR measurement for the U-NII band with the lower maximum output power is not required unless the highest reported SAR for the U-NII band with the higher maximum output power, adjusted by the ratio of lower to higher specified maximum output power for the two bands, is > 1.2 W/kg. When 10g SAR measurement is considered, a factor of 2.5 is applied to the thresholds above.

FCC ID: A3LSMN975U		SAR EVALUATION REPORT		Approved by: Quality Manager
Document S/N: 1M1905200079-01-R1.A3L	Test Dates: 05/22/19 - 07/07/19	DUT Type: Portable Handset		Page 36 of 220

8.7.3 U-NII-2C and U-NII-3

The frequency range covered by U-NII-2C and U-NII-3 is 380 MHz (5.47 – 5.85 GHz), which requires a minimum of at least two SAR probe calibration frequency points to support SAR measurements. When Terminal Doppler Weather Radar (TDWR) restriction applies, the channels at 5.60 – 5.65 GHz in U-NII-2C band must be disabled with acceptable mechanisms and documented in the equipment certification. Unless band gap channels are permanently disabled, SAR must be considered for these channels. Each band is tested independently according to the normally required OFDM SAR measurement and probe calibration frequency points requirements.

8.7.4 Initial Test Position Procedure

For exposure conditions with multiple test positions, such as handset operating next to the ear, devices with hotspot mode or UMPC mini-tablet, procedures for initial test position can be applied. Using the transmission mode determined by the DSSS procedure or initial test configuration, area scans are measured for all positions in an exposure condition. The test position with the highest extrapolated (peak) SAR is used as the initial test position. When reported SAR for the initial test position is ≤ 0.4 W/kg, no additional testing for the remaining test positions is required. Otherwise, SAR is evaluated at the subsequent highest peak SAR positions until the reported SAR result is ≤ 0.8 W/kg or all test positions are measured. When 10g SAR measurement is considered, a factor of 2.5 is applied to the thresholds above.

8.7.5 2.4 GHz SAR Test Requirements



SAR is measured for 2.4 GHz 802.11b DSSS using either the fixed test position or, when applicable, the initial test position procedure. SAR test reduction is determined according to the following:

- 1) When the reported SAR of the highest measured maximum output power channel for the exposure configuration is ≤ 0.8 W/kg, no further SAR testing is required for 802.11b DSSS in that exposure configuration.
- 2) When the reported SAR is > 0.8 W/kg, SAR is required for that position using the next highest measured output power channel. When any reported SAR is > 1.2 W/kg, SAR is required for the third channel; i.e., all channels require testing.

2.4 GHz 802.11 g/n/ax OFDM are additionally evaluated for SAR if the highest reported SAR for 802.11b, adjusted by the ratio of the OFDM to DSSS specified maximum output power, is > 1.2 W/kg. When SAR is required for OFDM modes in 2.4 GHz band, the Initial Test Configuration Procedures should be followed. When 10g SAR measurement is considered, a factor of 2.5 is applied to the thresholds above.

8.7.6 OFDM Transmission Mode and SAR Test Channel Selection

When the same maximum output power was specified for multiple OFDM transmission mode configurations in a frequency band or aggregated band, SAR is measured using the configuration with the largest channel bandwidth, lowest order modulation and lowest data rate. When the maximum output power of a channel is the same for equivalent OFDM configurations; for example, 802.11a, 802.11n and 802.11ac or 802.11g and 802.11n with the same channel bandwidth, modulation and data rate etc., the lower order 802.11 mode i.e., 802.11a, then 802.11n and 802.11ac or 802.11g then 802.11n, is used for SAR measurement. When the maximum output power are the same for multiple test channels, either according to the default or additional power measurement requirements, SAR is measured using the channel closest to the middle of the frequency band or aggregated band. When there are multiple channels with the same maximum output power, SAR is measured using the higher number channel.

FCC ID: A3LSMN975U		SAR EVALUATION REPORT		Approved by: Quality Manager
Document S/N: 1M1905200079-01-R1.A3L	Test Dates: 05/22/19 - 07/07/19	DUT Type: Portable Handset		Page 37 of 220

8.7.7 Initial Test Configuration Procedure

For OFDM, an initial test configuration is determined for each frequency band and aggregated band, according to the transmission mode with the highest maximum output power specified for SAR measurements. When the same maximum output power is specified for multiple OFDM transmission mode configurations in a frequency band or aggregated band, SAR is measured using the configuration(s) with the largest channel bandwidth, lowest order modulation, lowest data rate and lowest order IEEE 802.11 mode. The channel of the transmission mode with the highest average RF output conducted power will be the initial test configuration.



When the reported SAR is ≤ 0.8 W/kg, no additional measurements on other test channels are required. Otherwise, SAR is evaluated using the subsequent highest average RF output channel until the reported SAR result is ≤ 1.2 W/kg or all channels are measured. When there are multiple untested channels having the same subsequent highest average RF output power, the channel with higher frequency from the lowest 802.11 mode is considered for SAR measurements (See Section 8.7.6). When 10g SAR measurement is considered, a factor of 2.5 is applied to the thresholds above.

8.7.8 Subsequent Test Configuration Procedures

For OFDM configurations in each frequency band and aggregated band, SAR is evaluated for initial test configuration using the fixed test position or the initial test position procedure. When the highest reported SAR (for the initial test configuration), adjusted by the ratio of the specified maximum output power of the subsequent test configuration to initial test configuration, is ≤ 1.2 W/kg, no additional SAR tests for the subsequent test configurations are required. When 10g SAR measurement is considered, a factor of 2.5 is applied to the thresholds above.

8.7.9 MIMO SAR considerations

Per KDB Publication 248227 D01v02r02, the simultaneous SAR provisions in KDB Publication 447498 D01v06 should be applied to determine simultaneous transmission SAR test exclusion for WIFI MIMO. If the sum of 1g single transmission chain SAR measurements is < 1.6 W/kg, no additional SAR measurements for MIMO are required. Alternatively, SAR for MIMO can be measured with all antennas transmitting simultaneously at the specified maximum output power of MIMO operation. When 10g SAR measurement is considered, a factor of 2.5 is applied to the thresholds above.

FCC ID: A3LSMN975U	 PCTEST ENGINEERING LABORATORY, INC.	SAR EVALUATION REPORT		Approved by: Quality Manager
Document S/N: 1M1905200079-01-R1.A3L	Test Dates: 05/22/19 - 07/07/19	DUT Type: Portable Handset	Page 38 of 220	

9 RF CONDUCTED POWERS



9.1 CDMA Conducted Powers

**Table 9-1
Maximum Conducted Power**

Band	Channel	Rule Part	Frequency	SO55 [dBm]	SO55 [dBm]	SO75 [dBm]	TDSO SO32 [dBm]	TDSO SO32 [dBm]	1x EvDO Rev. 0 [dBm]	1x EvDO Rev. A [dBm]
	F-RC		MHz	RC1	RC3	RC11	FCH+SCH	FCH	(RTAP)	(RETAP)
Cellular	564	90S	820.1	25.02	25.12	25.09	25.08	25.10	25.21	25.20
Cellular	1013	22H	824.7	25.03	25.14	25.14	25.16	25.17	25.27	25.22
	384	22H	836.52	25.05	25.01	25.08	25.09	25.06	25.20	25.22
	777	22H	848.31	25.07	25.15	25.12	25.12	25.13	25.21	25.22
PCS	25	24E	1851.25	24.60	24.64	24.70	24.78	24.81	24.71	24.68
	600	24E	1880	24.66	24.65	24.67	24.76	24.67	24.62	24.49
	1175	24E	1908.75	24.72	24.78	24.60	24.80	24.81	24.81	24.78

**Table 9-2
Reduced Conducted Power – Hotspot Mode Active**

Band	Channel	Rule Part	Frequency	TDSO SO32 [dBm]	TDSO SO32 [dBm]	1x EvDO Rev. 0 [dBm]	1x EvDO Rev. A [dBm]
	F-RC		MHz	FCH+SCH	FCH	(RTAP)	(RETAP)
PCS	25	24E	1851.25	17.91	17.86	17.99	17.96
	600	24E	1880	17.90	17.86	18.00	17.98
	1175	24E	1908.75	17.87	17.79	17.93	17.93

FCC ID: A3LSMN975U	 PCTEST ENGINEERING LABORATORY, INC.	SAR EVALUATION REPORT		Approved by: Quality Manager
Document S/N: 1M1905200079-01-R1.A3L	Test Dates: 05/22/19 - 07/07/19	DUT Type: Portable Handset		Page 39 of 220



**Table 9-3
Reduced Conducted Power – Proximity Sensor and/or Earjack Mode Active**

Band	Channel	Rule Part	Frequency	SO55 [dBm]	SO55 [dBm]	SO75 [dBm]	TDSO SO32 [dBm]	TDSO SO32 [dBm]	1x EvDO Rev. 0 [dBm]	1x EvDO Rev. A [dBm]
	F-RC		MHz	RC1	RC3	RC11	FCH+SCH	FCH	(RTAP)	(RETAP)
PCS	25	24E	1851.25	20.38	20.44	20.56	20.45	20.45	20.54	20.51
	600	24E	1880	20.39	20.42	20.53	20.45	20.41	20.55	20.53
	1175	24E	1908.75	20.34	20.39	20.44	20.39	20.38	20.47	20.50

Note: RC1 is only applicable for IS-95 compatibility. For FCC Rule Part 90S, Per FCC KDB Publication 447498 D01v06 4.1.g), only one channel is required since the device operates within the transmission range of 817.90 – 823.10 MHz.



**Figure 9-1
Power Measurement Setup**

FCC ID: A3LSMN975U		SAR EVALUATION REPORT		Approved by: Quality Manager
Document S/N: 1M1905200079-01-R1.A3L	Test Dates: 05/22/19 - 07/07/19	DUT Type: Portable Handset	Page 40 of 220	



9.2 GSM Conducted Powers

**Table 9-4
Maximum Conducted Power**

Maximum Burst-Averaged Output Power										
Band	Channel	Voice	GPRS/EDGE Data (GMSK)				EDGE Data (8-PSK)			
		GSM [dBm] CS (1 Slot)	GPRS [dBm] 1 Tx Slot	GPRS [dBm] 2 Tx Slot	GPRS [dBm] 3 Tx Slot	GPRS [dBm] 4 Tx Slot	EDGE [dBm] 1 Tx Slot	EDGE [dBm] 2 Tx Slot	EDGE [dBm] 3 Tx Slot	EDGE [dBm] 4 Tx Slot
GSM 850	128	32.27	32.32	30.51	29.15	26.98	26.92	24.96	22.70	21.64
	190	32.18	32.24	30.50	29.35	26.96	26.76	24.81	23.00	21.90
	251	32.37	32.42	30.72	29.31	27.28	27.00	24.92	23.14	21.71
GSM 1900	512	28.07	28.08	27.09	25.02	23.02	24.70	22.62	20.64	19.29
	661	28.23	28.30	27.05	25.00	23.08	24.69	22.78	20.94	19.40
	810	28.58	28.60	27.26	25.20	23.00	24.96	22.60	21.04	19.44

Calculated Maximum Frame-Averaged Output Power										
Band	Channel	Voice	GPRS/EDGE Data (GMSK)				EDGE Data (8-PSK)			
		GSM [dBm] CS (1 Slot)	GPRS [dBm] 1 Tx Slot	GPRS [dBm] 2 Tx Slot	GPRS [dBm] 3 Tx Slot	GPRS [dBm] 4 Tx Slot	EDGE [dBm] 1 Tx Slot	EDGE [dBm] 2 Tx Slot	EDGE [dBm] 3 Tx Slot	EDGE [dBm] 4 Tx Slot
GSM 850	128	23.24	23.29	24.49	24.89	23.97	17.89	18.94	18.44	18.63
	190	23.15	23.21	24.48	25.09	23.95	17.73	18.79	18.74	18.89
	251	23.34	23.39	24.70	25.05	24.27	17.97	18.90	18.88	18.70
GSM 1900	512	19.04	19.05	21.07	20.76	20.01	15.67	16.60	16.38	16.28
	661	19.20	19.27	21.03	20.74	20.07	15.66	16.76	16.68	16.39
	810	19.55	19.57	21.24	20.94	19.99	15.93	16.58	16.78	16.43

GSM 850	Frame Avg.Targets:	23.47	23.47	25.48	25.24	24.49	17.97	18.98	18.74	18.99
GSM 1900		19.97	19.97	21.98	21.74	20.99	16.47	17.48	17.24	17.49



FCC ID: A3LSMN975U		SAR EVALUATION REPORT			Approved by: Quality Manager
Document S/N: 1M1905200079-01-R1.A3L	Test Dates: 05/22/19 - 07/07/19	DUT Type: Portable Handset		Page 41 of 220	

**Table 9-5
Reduced Conducted Power – Hotspot Mode Active**

Maximum Burst-Averaged Output Power									
Band	Channel	GPRS/EDGE Data (GMSK)				EDGE Data (8-PSK)			
		GPRS [dBm] 1 Tx Slot	GPRS [dBm] 2 Tx Slot	GPRS [dBm] 3 Tx Slot	GPRS [dBm] 4 Tx Slot	EDGE [dBm] 1 Tx Slot	EDGE [dBm] 2 Tx Slot	EDGE [dBm] 3 Tx Slot	EDGE [dBm] 4 Tx Slot
GSM 1900	512	27.05	25.39	23.59	21.67	25.34	23.22	21.53	20.22
	661	27.26	25.49	23.60	21.97	25.52	23.21	21.55	20.10
	810	27.14	25.38	23.48	21.97	25.16	23.71	21.61	20.67

Calculated Maximum Frame-Averaged Output Power									
Band	Channel	GPRS/EDGE Data (GMSK)				EDGE Data (8-PSK)			
		GPRS [dBm] 1 Tx Slot	GPRS [dBm] 2 Tx Slot	GPRS [dBm] 3 Tx Slot	GPRS [dBm] 4 Tx Slot	EDGE [dBm] 1 Tx Slot	EDGE [dBm] 2 Tx Slot	EDGE [dBm] 3 Tx Slot	EDGE [dBm] 4 Tx Slot
GSM 1900	512	18.02	19.37	19.33	18.66	16.31	17.20	17.27	17.21
	661	18.23	19.47	19.34	18.96	16.49	17.19	17.29	17.09
	810	18.11	19.36	19.22	18.96	16.13	17.69	17.35	17.66

GSM 1900	Frame Avg. Targets:	17.47	19.48	19.24	18.49	16.47	17.48	17.24	17.49
-----------------	--------------------------------	-------	-------	--------------	-------	-------	-------	-------	-------

FCC ID: A3LSMN975U		SAR EVALUATION REPORT		Approved by: Quality Manager
Document S/N: 1M1905200079-01-R1.A3L	Test Dates: 05/22/19 - 07/07/19	DUT Type: Portable Handset		Page 42 of 220

Note:

1. Both burst-averaged and calculated frame-averaged powers are included. Frame-averaged power was calculated from the measured burst-averaged power by converting the slot powers into linear units and calculating the energy over 8 timeslots.
2. GPRS/EDGE (GMSK) output powers were measured with coding scheme setting of 1 (CS1) on the base station simulator. CS1 was configured to measure GPRS output power measurements and SAR to ensure GMSK modulation in the signal. Our Investigation has shown that CS1 - CS4 settings do not have any impact on the output levels or modulation in the GPRS modes.
3. EDGE (8-PSK) output powers were measured with MCS7 on the base station simulator. MCS7 coding scheme was used to measure the output powers for EDGE since investigation has shown that choosing MCS7 coding scheme will ensure 8-PSK modulation. It has been shown that MCS levels that produce 8-PSK modulation do not have an impact on output power.

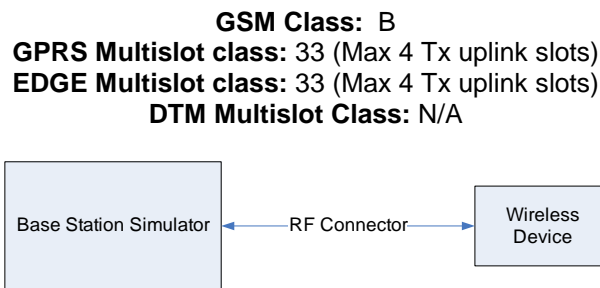



Figure 9-2
Power Measurement Setup

FCC ID: A3LSMN975U		SAR EVALUATION REPORT		Approved by: Quality Manager
Document S/N: 1M1905200079-01-R1.A3L	Test Dates: 05/22/19 - 07/07/19	DUT Type: Portable Handset	Page 43 of 220	



9.3 UMTS Conducted Powers

**Table 9-6
Maximum Conducted Power**

3GPP Release Version	Mode	3GPP 34.121 Subtest	Cellular Band [dBm]			AWS Band [dBm]			PCS Band [dBm]			3GPP MPR [dB]
			4132	4183	4233	1312	1412	1513	9262	9400	9538	
99	WCDMA	12.2 kbps RMC	24.87	24.89	24.93	24.24	24.35	24.47	23.63	23.78	23.75	-
99		12.2 kbps AMR	24.92	24.93	24.98	24.25	24.36	24.36	23.63	23.78	23.74	-
6	HSDPA	Subtest 1	23.79	23.77	23.83	23.15	23.26	23.27	22.68	22.76	22.63	0
6		Subtest 2	23.79	23.79	23.82	23.22	23.29	23.25	22.65	22.78	22.60	0
6		Subtest 3	23.28	23.29	23.36	22.82	22.77	22.79	22.15	22.22	22.09	0.5
6		Subtest 4	23.29	23.31	23.36	22.83	22.75	22.76	22.11	22.21	22.10	0.5
6	HSUPA	Subtest 1	23.78	23.81	23.81	23.22	23.31	23.34	22.67	22.75	22.67	0
6		Subtest 2	21.77	21.76	21.81	21.23	21.20	21.22	20.59	20.67	20.56	2
6		Subtest 3	22.80	22.78	22.84	22.26	22.19	22.21	21.60	21.67	21.58	1
6		Subtest 4	21.75	21.75	21.81	21.20	21.12	21.18	20.57	20.66	20.57	2
6		Subtest 5	23.78	23.81	23.83	23.32	23.24	23.29	22.69	22.74	22.66	0
8	DC-HSDPA	Subtest 1	23.79	23.68	23.87	23.29	23.23	23.36	22.66	22.72	22.62	0
8		Subtest 2	23.81	23.76	23.90	23.32	23.24	23.32	22.69	22.77	22.66	0
8		Subtest 3	23.27	23.29	23.35	22.79	22.73	22.74	22.15	22.28	22.22	0.5
8		Subtest 4	23.34	23.33	23.40	22.75	22.61	22.67	22.22	22.27	22.11	0.5

**Table 9-7
Reduced Conducted Power – Hotspot Mode Active**

3GPP Release Version	Mode	3GPP 34.121 Subtest	AWS Band [dBm]			PCS Band [dBm]			3GPP MPR [dB]
			1312	1412	1513	9262	9400	9538	
99	WCDMA	12.2 kbps RMC	19.28	19.25	19.33	18.58	18.74	18.72	-
99		12.2 kbps AMR	19.30	19.28	19.31	18.56	18.75	18.68	-
6	HSDPA	Subtest 1	18.36	18.29	18.36	17.58	17.66	17.56	0
6		Subtest 2	18.38	18.32	18.38	17.57	17.70	17.62	0
6		Subtest 3	17.81	17.83	17.76	17.08	17.16	17.03	0.5
6		Subtest 4	17.84	17.74	17.89	17.04	17.17	17.03	0.5
6	HSUPA	Subtest 1	18.37	18.33	18.37	17.61	17.71	17.57	0
6		Subtest 2	16.33	16.25	16.29	15.55	15.65	15.51	2
6		Subtest 3	17.29	17.23	17.28	16.53	16.62	16.51	1
6		Subtest 4	16.28	16.22	16.27	15.54	15.64	15.52	2
6		Subtest 5	18.38	18.31	18.34	17.63	17.66	17.55	0
8	DC-HSDPA	Subtest 1	18.31	18.34	18.31	17.64	17.69	17.55	0
8		Subtest 2	18.43	18.31	18.34	17.62	17.70	17.57	0
8		Subtest 3	17.88	17.80	17.84	17.11	17.18	17.12	0.5
8		Subtest 4	17.84	17.87	17.81	17.17	17.15	17.07	0.5

FCC ID: A3LSMN975U	 PCTEST ENGINEERING LABORATORY, INC.	SAR EVALUATION REPORT		Approved by: Quality Manager
Document S/N: 1M1905200079-01-R1.A3L	Test Dates: 05/22/19 - 07/07/19	DUT Type: Portable Handset		Page 44 of 220

**Table 9-8
Reduced Conducted Power – Proximity Sensor and/or Earjack Mode Active**

3GPP Release Version	Mode	3GPP 34.121 Subtest	AWS Band [dBm]			PCS Band [dBm]			3GPP MPR [dB]
			1312	1412	1513	9262	9400	9538	
99	WCDMA	12.2 kbps RMC	19.28	19.25	19.33	19.56	19.75	19.73	-
99		12.2 kbps AMR	19.30	19.28	19.31	19.54	19.72	19.65	-
6	HSDPA	Subtest 1	18.36	18.29	18.36	18.65	18.71	18.68	0
6		Subtest 2	18.38	18.32	18.38	18.64	18.76	18.67	0
6		Subtest 3	17.81	17.83	17.76	18.22	18.26	18.25	0.5
6		Subtest 4	17.84	17.74	17.89	18.27	18.19	18.14	0.5
6	HSUPA	Subtest 1	18.37	18.33	18.37	18.68	18.75	18.66	0
6		Subtest 2	16.33	16.25	16.29	16.65	16.72	16.61	2
6		Subtest 3	17.29	17.23	17.28	17.61	17.71	17.60	1
6		Subtest 4	16.28	16.22	16.27	16.62	16.75	16.61	2
6		Subtest 5	18.38	18.31	18.34	18.70	18.77	18.65	0
8	DC-HSDPA	Subtest 1	18.31	18.34	18.31	18.63	18.76	18.70	0
8		Subtest 2	18.43	18.31	18.34	18.61	18.78	18.73	0
8		Subtest 3	17.88	17.80	17.84	18.16	18.12	18.17	0.5
8		Subtest 4	17.84	17.87	17.81	18.16	18.27	18.23	0.5



DC-HSDPA considerations

- 3GPP Specification 34.121-1 Release 8 Ver 8.10.0 was used for DC-HSDPA guidance
- H-Set 12 (QPSK) was confirmed to be used during DC-HSDPA measurements
- The DUT supports UE category 24 for HSDPA

It is expected by the manufacturer that MPR for some HSPA subtests may be up to 2 dB more than specified by 3GPP, but also as low as 0 dB according to the chipset implementation in this model.



**Figure 9-3
Power Measurement Setup**

FCC ID: A3LSMN975U		SAR EVALUATION REPORT		Approved by: Quality Manager
Document S/N: 1M1905200079-01-R1.A3L	Test Dates: 05/22/19 - 07/07/19	DUT Type: Portable Handset	Page 45 of 220	

9.4 LTE Conducted Powers



9.4.1

LTE Band 71

Table 9-9
LTE Band 71 Conducted Powers - 20 MHz Bandwidth

LTE Band 71 20 MHz Bandwidth					
Modulation	RB Size	RB Offset	Mid Channel	MPR Allowed per 3GPP [dB]	MPR [dB]
			133297 (680.5 MHz)		
			Conducted Power [dBm]		
QPSK	1	0	25.05	0	0
	1	50	24.81		0
	1	99	24.71		0
	50	0	24.12	0-1	1
	50	25	24.06		1
	50	50	23.98		1
	100	0	24.05		1
16QAM	1	0	24.25	0-1	1
	1	50	24.18		1
	1	99	23.90		1
	50	0	23.07	0-2	2
	50	25	23.03		2
	50	50	23.04		2
	100	0	23.02		2
64QAM	1	0	23.25	0-2	2
	1	50	23.15		2
	1	99	22.98		2
	50	0	22.12	0-3	3
	50	25	22.06		3
	50	50	22.04		3
	100	0	22.01		3
256QAM	1	0	20.13	0-5	5
	1	50	19.95		5
	1	99	19.63		5
	50	0	20.06		5
	50	25	20.04		5
	50	50	19.95		5
	100	0	20.01		5

Note: LTE Band 71 at 20 MHz bandwidth does not support three non-overlapping channels. Per KDB Publication 941225 D05v02, when a device supports overlapping channel assignment in a channel bandwidth configuration, the middle channel of the group of overlapping channels should be selected for testing.

FCC ID: A3LSMN975U	 PCTEST ENGINEERING LABORATORY, INC.	SAR EVALUATION REPORT		Approved by: Quality Manager
Document S/N: 1M1905200079-01-R1.A3L	Test Dates: 05/22/19 - 07/07/19	DUT Type: Portable Handset		Page 46 of 220

**Table 9-10
LTE Band 71 Conducted Powers - 15 MHz Bandwidth**

LTE Band 71 15 MHz Bandwidth					
Modulation	RB Size	RB Offset	Mid Channel	MPR Allowed per 3GPP [dB]	MPR [dB]
			133297 (680.5 MHz)		
			Conducted Power [dBm]		
QPSK	1	0	24.95	0	0
	1	36	24.83		0
	1	74	24.77		0
	36	0	24.05	0-1	1
	36	18	24.04		1
	36	37	24.03		1
	75	0	24.01		1
16QAM	1	0	24.23	0-1	1
	1	36	24.03		1
	1	74	24.00		1
	36	0	23.06	0-2	2
	36	18	23.01		2
	36	37	22.97		2
	75	0	22.99		2
64QAM	1	0	23.20	0-2	2
	1	36	23.00		2
	1	74	22.93		2
	36	0	22.07	0-3	3
	36	18	22.01		3
	36	37	21.99		3
	75	0	22.02		3
256QAM	1	0	20.06	0-5	5
	1	36	19.98		5
	1	74	19.76		5
	36	0	20.06		5
	36	18	20.00		5
	36	37	19.98		5
	75	0	19.97		5

Note: LTE Band 71 at 15 MHz bandwidth does not support three non-overlapping channels. Per KDB Publication 941225 D05v02, when a device supports overlapping channel assignment in a channel bandwidth configuration, the middle channel of the group of overlapping channels should be selected for testing.



FCC ID: A3LSMN975U		SAR EVALUATION REPORT		Approved by: Quality Manager
Document S/N: 1M1905200079-01-R1.A3L	Test Dates: 05/22/19 - 07/07/19	DUT Type: Portable Handset		Page 47 of 220

Table 9-11
LTE Band 71 Conducted Powers - 10 MHz Bandwidth

LTE Band 71 10 MHz Bandwidth								
Modulation	RB Size	RB Offset	Low Channel	Mid Channel	High Channel	MPR Allowed per 3GPP [dB]	MPR [dB]	
			133172 (668.0 MHz)	133297 (680.5 MHz)	133422 (693.0 MHz)			
			Conducted Power [dBm]					
QPSK	1	0	24.71	24.76	24.72	0	0	
	1	25	24.88	24.72	24.58		0	
	1	49	24.76	24.57	24.51		0	
	25	0	24.02	23.87	23.77	0-1	1	
	25	12	24.04	23.88	23.75		1	
	25	25	23.98	23.83	23.70		1	
16QAM	50	0	24.01	23.85	23.73	0-1	1	
	1	0	23.85	24.12	23.90		0-1	1
	1	25	24.07	23.96	23.84			1
	1	49	23.97	23.77	23.68	0-2		1
	25	0	22.99	22.86	22.71		2	
	25	12	23.00	22.84	22.67		2	
64QAM	25	25	22.95	22.86	22.71	0-2	2	
	50	0	22.94	22.84	22.72		2	
	1	0	23.02	23.15	22.95		0-2	2
	1	25	23.01	23.02	22.91	2		
	1	49	23.01	22.87	22.68	2		
	256QAM	25	0	21.75	21.86	21.74	0-3	3
25		12	21.63	21.81	21.71	3		
25		25	21.79	21.80	21.71	3		
50		0	21.69	21.86	21.71	0-5	3	
1		0	20.14	19.97	19.76		5	
1		25	20.04	19.80	19.68		5	
256QAM	1	49	19.84	19.68	19.64	0-5	5	
	25	0	20.01	19.86	19.77		5	
	25	12	19.98	19.84	19.74		5	
	25	25	19.96	19.75	19.70	5		
	50	0	19.97	19.84	19.69	5		





FCC ID: A3LSMN975U		SAR EVALUATION REPORT		Approved by: Quality Manager
Document S/N: 1M1905200079-01-R1.A3L	Test Dates: 05/22/19 - 07/07/19	DUT Type: Portable Handset	Page 48 of 220	

Table 9-12
LTE Band 71 Conducted Powers - 5 MHz Bandwidth

LTE Band 71 5 MHz Bandwidth							
Modulation	RB Size	RB Offset	Low Channel	Mid Channel	High Channel	MPR Allowed per 3GPP [dB]	MPR [dB]
			133147 (665.5 MHz)	133297 (680.5 MHz)	133447 (695.5 MHz)		
			Conducted Power [dBm]				
QPSK	1	0	24.83	24.63	24.64	0	0
	1	12	24.95	24.76	24.56		0
	1	24	24.92	24.75	24.56		0
	12	0	23.77	23.82	23.63	0-1	1
	12	6	24.11	23.90	23.70		1
	12	13	24.11	23.94	23.72		1
16QAM	25	0	24.06	23.88	23.75	0-1	1
	1	0	23.85	23.92	23.79		1
	1	12	24.18	23.96	23.79		1
	1	24	24.22	24.02	23.80	0-2	1
	12	0	22.89	22.81	22.67		2
	12	6	23.11	22.90	22.65		2
64QAM	12	13	23.09	22.92	22.69	0-2	2
	25	0	23.03	22.84	22.69		2
	1	0	22.89	22.97	22.80		0-2
	1	12	22.70	23.02	22.86	2	
	1	24	22.63	22.99	22.83	2	
	256QAM	12	0	21.78	21.78	21.61	0-3
12		6	21.63	21.87	21.64	3	
12		13	21.52	21.86	21.69	3	
25		0	21.60	21.88	21.70	0-5	3
1		0	19.93	19.85	19.68		5
1		12	19.98	19.92	19.74		5
256QAM	1	24	20.06	19.88	19.69	0-5	5
	12	0	20.00	19.85	19.67		5
	12	6	20.09	19.91	19.67		5
	12	13	20.07	19.87	19.77	5	
	25	0	20.02	19.89	19.72	5	

FCC ID: A3LSMN975U	 PCTEST ENGINEERING LABORATORY, INC.	SAR EVALUATION REPORT		Approved by: Quality Manager
Document S/N: 1M1905200079-01-R1.A3L	Test Dates: 05/22/19 - 07/07/19	DUT Type: Portable Handset	Page 49 of 220	



9.4.2

LTE Band 12

Table 9-13
LTE Band 12 Conducted Powers - 10 MHz Bandwidth

LTE Band 12 10 MHz Bandwidth					
Modulation	RB Size	RB Offset	Mid Channel	MPR Allowed per 3GPP [dB]	MPR [dB]
			23095 (707.5 MHz)		
			Conducted Power [dBm]		
QPSK	1	0	24.86	0	0
	1	25	24.73		0
	1	49	24.68		0
	25	0	23.90	0-1	1
	25	12	23.89		1
	25	25	23.85		1
	50	0	23.88		1
16QAM	1	0	23.98	0-1	1
	1	25	24.00		1
	1	49	23.97		1
	25	0	22.89	0-2	2
	25	12	22.88		2
	25	25	22.81		2
	50	0	22.87		2
64QAM	1	0	23.00	0-2	2
	1	25	22.96		2
	1	49	22.91		2
	25	0	21.88	0-3	3
	25	12	21.89		3
	25	25	21.84		3
	50	0	21.86		3
256QAM	1	0	19.92	0-5	5
	1	25	19.89		5
	1	49	19.79		5
	25	0	19.85		5
	25	12	19.82		5
	25	25	19.80		5
	50	0	19.79		5

Note: LTE Band 12 at 10 MHz bandwidth does not support three non-overlapping channels. Per KDB Publication 941225 D05v02, when a device supports overlapping channel assignment in a channel bandwidth configuration, the middle channel of the group of overlapping channels should be selected for testing.

FCC ID: A3LSMN975U	 PCTEST ENGINEERING LABORATORY, INC.	SAR EVALUATION REPORT		Approved by: Quality Manager
Document S/N: 1M1905200079-01-R1.A3L	Test Dates: 05/22/19 - 07/07/19	DUT Type: Portable Handset	Page 50 of 220	

**Table 9-14
LTE Band 12 Conducted Powers - 5 MHz Bandwidth**

LTE Band 12 5 MHz Bandwidth								
Modulation	RB Size	RB Offset	Low Channel	Mid Channel	High Channel	MPR Allowed per 3GPP [dB]	MPR [dB]	
			23035 (701.5 MHz)	23095 (707.5 MHz)	23155 (713.5 MHz)			
			Conducted Power [dBm]					
QPSK	1	0	24.72	24.72	24.72	0	0	
	1	12	24.85	24.84	24.81		0	
	1	24	24.79	24.79	24.64		0	
	16QAM	12	0	23.88	23.89	23.87	0-1	1
		12	6	23.98	23.98	23.96		1
		12	13	23.93	23.94	23.93		1
		25	0	23.97	23.97	23.93		1
1		0	24.06	23.99	24.00	0-1		1
1	12	24.20	24.10	24.07	1			
1	24	24.06	24.06	24.11	1			
64QAM	12	0	22.95	22.93	22.89	0-2	2	
	12	6	23.01	23.00	22.97		2	
	12	13	22.98	22.95	22.97		2	
	25	0	22.95	22.93	22.93	0-3	2	
	1	0	22.99	22.96	23.01		2	
	1	12	22.75	23.11	23.09		2	
256QAM	1	24	22.81	23.03	22.86	0-2	2	
	12	0	21.95	21.82	21.93		0-3	3
	12	6	22.05	22.05	22.03			3
	12	13	21.88	21.98	21.78	3		
	25	0	21.98	21.97	21.94	3		
	1	0	20.04	19.69	19.85	0-5	5	
	1	12	19.84	19.78	19.98		5	
1	24	19.94	19.82	19.87	5			
12	0	19.74	19.78	19.80	5			
12	6	19.90	19.95	19.96	5			
12	13	20.01	19.77	19.61	5			
	25	0	19.89	19.74	19.86	5		



FCC ID: A3LSMN975U	 PCTEST ENGINEERING LABORATORY, INC.	SAR EVALUATION REPORT		Approved by: Quality Manager
Document S/N: 1M1905200079-01-R1.A3L	Test Dates: 05/22/19 - 07/07/19	DUT Type: Portable Handset	Page 51 of 220	

Table 9-15
LTE Band 12 Conducted Powers - 3 MHz Bandwidth

LTE Band 12 3 MHz Bandwidth							
Modulation	RB Size	RB Offset	Low Channel	Mid Channel	High Channel	MPR Allowed per 3GPP [dB]	MPR [dB]
			23025 (700.5 MHz)	23095 (707.5 MHz)	23165 (714.5 MHz)		
			Conducted Power [dBm]				
QPSK	1	0	24.79	24.75	24.77	0	0
	1	7	24.87	24.82	24.81		0
	1	14	24.86	24.78	24.59		0
	8	0	23.89	23.86	23.88	0-1	1
	8	4	23.99	23.95	23.91		1
	8	7	23.92	23.91	23.90		1
	15	0	23.97	23.96	23.90		1
16QAM	1	0	24.11	24.02	24.04	0-1	1
	1	7	24.17	24.14	24.09		1
	1	14	24.14	24.15	24.07		1
	8	0	23.00	22.91	22.93	0-2	2
	8	4	23.04	23.04	22.91		2
	8	7	23.03	22.98	23.00		2
	15	0	22.95	22.93	22.95		2
64QAM	1	0	23.11	23.02	23.08	0-2	2
	1	7	22.79	23.12	23.10		2
	1	14	22.76	23.07	22.71		2
	8	0	21.97	21.86	21.91	0-3	3
	8	4	22.08	22.07	22.04		3
	8	7	21.88	22.01	21.77		3
	15	0	21.99	21.94	21.97		3
256QAM	1	0	19.83	19.68	19.70	0-5	5
	1	7	19.90	19.81	19.77		5
	1	14	19.96	19.73	19.68		5
	8	0	19.91	19.74	19.88		5
	8	4	19.87	19.89	19.92		5
	8	7	19.94	19.87	19.84		5
	15	0	19.97	19.87	19.89		5





FCC ID: A3LSMN975U		SAR EVALUATION REPORT		Approved by: Quality Manager
Document S/N: 1M1905200079-01-R1.A3L	Test Dates: 05/22/19 - 07/07/19	DUT Type: Portable Handset		Page 52 of 220

Table 9-16
LTE Band 12 Conducted Powers -1.4 MHz Bandwidth

LTE Band 12 1.4 MHz Bandwidth							
Modulation	RB Size	RB Offset	Low Channel	Mid Channel	High Channel	MPR Allowed per 3GPP [dB]	MPR [dB]
			23017 (699.7 MHz)	23095 (707.5 MHz)	23173 (715.3 MHz)		
			Conducted Power [dBm]				
QPSK	1	0	24.77	24.70	24.67	0	0
	1	2	24.85	24.84	24.78		0
	1	5	24.80	24.78	24.55		0
	3	0	24.81	24.81	24.72		0
	3	2	24.89	24.85	24.80		0
	3	3	24.81	24.85	24.79		0
16QAM	1	0	24.12	24.07	24.00	0-1	1
	1	2	24.13	24.12	24.03		1
	1	5	24.05	23.99	24.00		1
	3	0	23.98	23.92	23.91		1
	3	2	24.03	24.04	23.94		1
	3	3	23.97	23.93	23.95		1
64QAM	1	0	23.06	22.99	22.74	0-2	2
	1	2	23.16	23.09	22.90		2
	1	5	23.10	23.04	22.78		2
	3	0	23.05	22.99	22.75		2
	3	2	23.08	23.03	22.84		2
	3	3	23.05	22.97	22.68		2
256QAM	1	0	21.93	21.90	21.71	0-3	3
	1	2	19.76	19.67	19.68		5
	1	5	19.92	19.74	19.60		5
	3	0	19.95	19.75	19.86		5
	3	2	19.74	19.84	19.77		5
	3	3	19.93	19.73	19.68		5
256QAM	3	0	19.74	19.84	19.77	0-5	5
	3	2	19.93	19.73	19.68		5
	3	3	19.82	19.79	19.90		5
	6	0	19.93	19.89	19.62		5



FCC ID: A3LSMN975U	 PCTEST ENGINEERING LABORATORY, INC.	SAR EVALUATION REPORT		Approved by: Quality Manager
Document S/N: 1M1905200079-01-R1.A3L	Test Dates: 05/22/19 - 07/07/19	DUT Type: Portable Handset	Page 53 of 220	

9.4.3

LTE Band 13

Table 9-17
LTE Band 13 Conducted Powers - 10 MHz Bandwidth



LTE Band 13 10 MHz Bandwidth						
Modulation	RB Size	RB Offset	Mid Channel	MPR Allowed per 3GPP [dB]	MPR [dB]	
			23230 (782.0 MHz)			
			Conducted Power [dBm]			
QPSK	1	0	24.63	0	0	
	1	25	24.52		0	
	1	49	24.42		0	
	16QAM	25	0	23.69	0-1	1
		25	12	23.68		1
		25	25	23.62		1
		50	0	23.64		1
64QAM	1	0	23.82	0-1	1	
	1	25	23.75		1	
	1	49	23.65		1	
	256QAM	25	0	22.64	0-2	2
		25	12	22.61		2
		25	25	22.55		2
		50	0	22.61		2
64QAM	1	0	22.62	0-2	2	
	1	25	22.77		2	
	1	49	22.67		2	
	256QAM	25	0	21.63	0-3	3
		25	12	21.60		3
		25	25	21.59		3
		50	0	21.64		3
256QAM	1	0	19.59	0-5	5	
	1	25	19.58		5	
	1	49	19.44		5	
	25	0	19.67		5	
	25	12	19.65		5	
	25	25	19.57		5	
	50	0	19.62		5	

FCC ID: A3LSMN975U	 PCTEST ENGINEERING LABORATORY, INC.	SAR EVALUATION REPORT		Approved by: Quality Manager
Document S/N: 1M1905200079-01-R1.A3L	Test Dates: 05/22/19 - 07/07/19	DUT Type: Portable Handset		Page 54 of 220

**Table 9-18
LTE Band 13 Conducted Powers - 5 MHz Bandwidth**

LTE Band 13 5 MHz Bandwidth					
Modulation	RB Size	RB Offset	Mid Channel	MPR Allowed per 3GPP [dB]	MPR [dB]
			23230 (782.0 MHz)		
			Conducted Power [dBm]		
QPSK	1	0	24.58	0	0
	1	12	24.54		0
	1	24	24.38		0
	12	0	23.70	0-1	1
	12	6	23.61		1
	12	13	23.57		1
	25	0	23.60		1
16QAM	1	0	23.77	0-1	1
	1	12	23.68		1
	1	24	23.55		1
	12	0	22.69	0-2	2
	12	6	22.61		2
	12	13	22.54		2
	25	0	22.56		2
64QAM	1	0	22.81	0-2	2
	1	12	22.74		2
	1	24	22.64		2
	12	0	21.63	0-3	3
	12	6	21.56		3
	12	13	21.47		3
	25	0	21.56		3
256QAM	1	0	19.58	0-5	5
	1	12	19.59		5
	1	24	19.42		5
	12	0	19.66		5
	12	6	19.58		5
	12	13	19.53		5
	25	0	19.56		5

Note: LTE Band 13 at 5 MHz bandwidth does not support three non-overlapping channels. Per KDB Publication 941225 D05v02, when a device supports overlapping channel assignment in a channel bandwidth configuration, the middle channel of the group of overlapping channels should be selected for testing.



FCC ID: A3LSMN975U	 PCTEST ENGINEERING LABORATORY, INC.	SAR EVALUATION REPORT		Approved by: Quality Manager
Document S/N: 1M1905200079-01-R1.A3L	Test Dates: 05/22/19 - 07/07/19	DUT Type: Portable Handset	Page 55 of 220	

9.4.4

LTE Band 14

Table 9-19
LTE Band 14 Conducted Powers - 10 MHz Bandwidth



LTE Band 14 10 MHz Bandwidth					
Modulation	RB Size	RB Offset	Mid Channel	MPR Allowed per 3GPP [dB]	MPR [dB]
			23330 (793.0 MHz)		
			Conducted Power [dBm]		
QPSK	1	0	24.50	0	0
	1	25	24.44		0
	1	49	24.25		0
	25	0	23.62	0-1	1
	25	12	23.58		1
	25	25	23.44		1
	50	0	23.51		1
16QAM	1	0	23.75	0-1	1
	1	25	23.74		1
	1	49	23.34		1
	25	0	22.64	0-2	2
	25	12	22.59		2
	25	25	22.46		2
	50	0	22.49		2
64QAM	1	0	22.41	0-2	2
	1	25	22.69		2
	1	49	22.37		2
	25	0	21.50	0-3	3
	25	12	21.59		3
	25	25	21.48		3
	50	0	21.49		3
256QAM	1	0	19.57	0-5	5
	1	25	19.56		5
	1	49	19.28		5
	25	0	19.57		5
	25	12	19.53		5
	25	25	19.41		5
	50	0	19.45		5

FCC ID: A3LSMN975U	 PCTEST ENGINEERING LABORATORY, INC.	SAR EVALUATION REPORT		Approved by: Quality Manager
Document S/N: 1M1905200079-01-R1.A3L	Test Dates: 05/22/19 - 07/07/19	DUT Type: Portable Handset	Page 56 of 220	

**Table 9-20
LTE Band 14 Conducted Powers - 5 MHz Bandwidth**

LTE Band 14 5 MHz Bandwidth					
Modulation	RB Size	RB Offset	Mid Channel	MPR Allowed per 3GPP [dB]	MPR [dB]
			23330 (793.0 MHz)		
			Conducted Power [dBm]		
QPSK	1	0	24.53	0	0
	1	12	24.50		0
	1	24	24.35		0
	12	0	23.63	0-1	1
	12	6	23.57		1
	12	13	23.60		1
	25	0	23.58		1
16QAM	1	0	23.74	0-1	1
	1	12	23.66		1
	1	24	23.74		1
	12	0	22.61	0-2	2
	12	6	22.66		2
	12	13	22.65		2
	25	0	22.59		2
64QAM	1	0	22.58	0-2	2
	1	12	22.81		2
	1	24	22.43		2
	12	0	21.60	0-3	3
	12	6	21.61		3
	12	13	21.49		3
	25	0	21.50		3
256QAM	1	0	19.51	0-5	5
	1	12	19.78		5
	1	24	19.47		5
	12	0	19.72		5
	12	6	19.49		5
	12	13	19.49		5
	25	0	19.57		5

Note: LTE Band 14 at 5 MHz bandwidth does not support three non-overlapping channels. Per KDB Publication 941225 D05v02, when a device supports overlapping channel assignment in a channel bandwidth configuration, the middle channel of the group of overlapping channels should be selected for testing.

FCC ID: A3LSMN975U		SAR EVALUATION REPORT		Approved by: Quality Manager
Document S/N: 1M1905200079-01-R1.A3L	Test Dates: 05/22/19 - 07/07/19	DUT Type: Portable Handset		Page 57 of 220

9.4.5

LTE Band 26 (Cell)

Table 9-21
 LTE Band 26 (Cell) Conducted Powers - 15 MHz Bandwidth

LTE Band 26 (Cell) 15 MHz Bandwidth					
Modulation	RB Size	RB Offset	Mid Channel	MPR Allowed per 3GPP [dB]	MPR [dB]
			26865 (831.5 MHz)		
			Conducted Power [dBm]		
QPSK	1	0	24.74	0	0
	1	36	24.65		0
	1	74	24.76		0
	36	0	23.81	0-1	1
	36	18	23.79		1
	36	37	23.82		1
	75	0	23.77		1
16QAM	1	0	23.95	0-1	1
	1	36	23.87		1
	1	74	24.02		1
	36	0	22.83	0-2	2
	36	18	22.81		2
	36	37	22.83		2
	75	0	22.78		2
64QAM	1	0	23.02	0-2	2
	1	36	23.05		2
	1	74	22.88		2
	36	0	21.80	0-3	3
	36	18	21.85		3
	36	37	21.85		3
	75	0	21.79		3
256QAM	1	0	19.77	0-5	5
	1	36	19.78		5
	1	74	19.85		5
	36	0	19.79		5
	36	18	19.77		5
	36	37	19.87		5
	75	0	19.83		5

Note: LTE Band 26 (Cell) at 15 MHz bandwidth does not support three non-overlapping channels. Per KDB Publication 941225 D05v02, when a device supports overlapping channel assignment in a channel bandwidth configuration, the middle channel of the group of overlapping channels should be selected for testing.



FCC ID: A3LSMN975U	 PCTEST ENGINEERING LABORATORY, INC.	SAR EVALUATION REPORT		Approved by: Quality Manager
Document S/N: 1M1905200079-01-R1.A3L	Test Dates: 05/22/19 - 07/07/19	DUT Type: Portable Handset	Page 58 of 220	

Table 9-22
LTE Band 26 (Cell) Conducted Powers - 10 MHz Bandwidth

LTE Band 26 (Cell) 10 MHz Bandwidth							
Modulation	RB Size	RB Offset	Low Channel	Mid Channel	High Channel	MPR Allowed per 3GPP [dB]	MPR [dB]
			26740 (819.0 MHz)	26865 (831.5 MHz)	26990 (844.0 MHz)		
			Conducted Power [dBm]				
QPSK	1	0	24.71	24.75	24.86	0	0
	1	25	24.64	24.62	24.85		0
	1	49	24.52	24.66	24.79		0
	25	0	23.70	23.71	23.91	0-1	1
	25	12	23.74	23.74	23.98		1
	25	25	23.70	23.65	23.94		1
16QAM	50	0	23.79	23.72	23.92	0-1	1
	1	0	23.96	23.93	24.00		1
	1	25	23.91	23.87	24.12		1
	1	49	23.78	23.95	24.07	0-2	1
	25	0	22.72	22.70	22.93		2
	25	12	22.73	22.72	22.95		2
64QAM	25	25	22.70	22.72	22.93	0-2	2
	50	0	22.72	22.68	22.93		2
	1	0	23.02	22.92	22.99		0-2
	1	25	22.90	22.85	22.79	2	
	1	49	22.81	22.82	22.69	2	
	256QAM	25	0	21.70	21.70	21.63	0-3
25		12	21.72	21.75	21.80	3	
25		25	21.53	21.70	21.89	3	
50		0	21.59	21.70	21.95	0-5	3
1		0	19.87	19.81	19.85		5
1		25	19.79	19.80	19.95		5
256QAM	1	49	19.65	19.81	19.89	0-5	5
	25	0	19.70	19.70	19.87		5
	25	12	19.66	19.74	19.91		5
	25	25	19.66	19.70	19.94	5	
	50	0	19.65	19.69	19.92	5	



FCC ID: A3LSMN975U	 PCTEST ENGINEERING LABORATORY, INC.	SAR EVALUATION REPORT		Approved by: Quality Manager
Document S/N: 1M1905200079-01-R1.A3L	Test Dates: 05/22/19 - 07/07/19	DUT Type: Portable Handset	Page 59 of 220	

Table 9-23
LTE Band 26 (Cell) Conducted Powers - 5 MHz Bandwidth

LTE Band 26 (Cell) 5 MHz Bandwidth							
Modulation	RB Size	RB Offset	Low Channel	Mid Channel	High Channel	MPR Allowed per 3GPP [dB]	MPR [dB]
			26715 (816.5 MHz)	26865 (831.5 MHz)	27015 (846.5 MHz)		
			Conducted Power [dBm]				
QPSK	1	0	24.56	24.50	24.72	0	0
	1	12	24.59	24.63	24.84		0
	1	24	24.63	24.63	24.78		0
	12	0	23.63	23.65	23.89	0-1	1
	12	6	23.76	23.70	23.95		1
	12	13	23.70	23.71	23.87		1
16QAM	25	0	23.67	23.68	23.86	0-1	1
	1	0	23.78	23.83	23.98		1
	1	12	23.92	23.81	23.94		1
	1	24	23.89	23.88	23.98	0-2	1
	12	0	22.70	22.70	22.93		2
	12	6	22.76	22.76	23.01		2
64QAM	12	13	22.71	22.69	22.99	0-2	2
	25	0	22.69	22.68	22.87		2
	1	0	22.82	22.84	22.83		0-2
	1	12	22.91	22.97	22.67	2	
	1	24	22.88	22.95	22.77	2	
	256QAM	12	0	21.66	21.64	21.88	0-3
12		6	21.69	21.76	22.01	3	
12		13	21.64	21.69	21.93	3	
25		0	21.67	21.70	21.91	0-5	3
1		0	19.65	19.58	19.83		5
1		12	19.86	19.77	20.12		5
256QAM	1	24	19.78	19.73	19.91	0-5	5
	12	0	19.66	19.67	19.85		5
	12	6	19.72	19.76	19.97		5
	12	13	19.65	19.74	19.96	5	
	25	0	19.64	19.71	19.85	5	



FCC ID: A3LSMN975U	 PCTEST ENGINEERING LABORATORY, INC.	SAR EVALUATION REPORT		Approved by: Quality Manager
Document S/N: 1M1905200079-01-R1.A3L	Test Dates: 05/22/19 - 07/07/19	DUT Type: Portable Handset	Page 60 of 220	

Table 9-24
LTE Band 26 (Cell) Conducted Powers - 3 MHz Bandwidth

LTE Band 26 (Cell) 3 MHz Bandwidth							
Modulation	RB Size	RB Offset	Low Channel	Mid Channel	High Channel	MPR Allowed per 3GPP [dB]	MPR [dB]
			26705 (815.5 MHz)	26865 (831.5 MHz)	27025 (847.5 MHz)		
			Conducted Power [dBm]				
QPSK	1	0	24.54	24.66	24.88	0	0
	1	7	24.68	24.73	24.88		0
	1	14	24.65	24.69	24.87		0
	8	0	23.73	23.78	24.02	0-1	1
	8	4	23.83	23.89	24.03		1
	8	7	23.77	23.81	24.02		1
16QAM	15	0	23.80	23.88	24.00	0-1	1
	1	0	23.87	23.97	24.20		1
	1	7	23.88	24.01	24.14		1
	1	14	23.88	24.01	24.19	0-2	1
	8	0	22.82	22.81	23.08		2
	8	4	22.89	22.95	23.10		2
64QAM	8	7	22.80	22.90	23.01	0-2	2
	15	0	22.81	22.87	22.99		2
	1	0	22.90	22.95	23.01		0-2
	1	7	22.99	22.99	23.09	2	
	1	14	22.92	23.02	22.78	2	
	256QAM	8	0	21.79	21.82	22.10	0-3
8		4	21.92	21.91	22.10	3	
8		7	21.88	21.90	22.02	3	
15		0	21.79	21.91	22.00	0-5	3
1		0	19.80	19.88	20.21		5
1		7	19.97	19.83	20.24		5
256QAM	1	14	19.84	19.99	20.12	0-5	5
	8	0	19.79	19.77	20.11		5
	8	4	19.94	19.88	20.17		5
	8	7	19.92	19.93	20.06	0-5	5
	15	0	19.86	19.92	20.07		5





FCC ID: A3LSMN975U	 PCTEST ENGINEERING LABORATORY, INC.	SAR EVALUATION REPORT		Approved by: Quality Manager
Document S/N: 1M1905200079-01-R1.A3L	Test Dates: 05/22/19 - 07/07/19	DUT Type: Portable Handset	Page 61 of 220	

Table 9-25
LTE Band 26 (Cell) Conducted Powers -1.4 MHz Bandwidth

LTE Band 26 (Cell) 1.4 MHz Bandwidth							
Modulation	RB Size	RB Offset	Low Channel	Mid Channel	High Channel	MPR Allowed per 3GPP [dB]	MPR [dB]
			26697 (814.7 MHz)	26865 (831.5 MHz)	27033 (848.3 MHz)		
			Conducted Power [dBm]				
QPSK	1	0	24.56	24.60	24.81	0	0
	1	2	24.68	24.73	24.86		0
	1	5	24.61	24.64	24.79		0
	3	0	24.64	24.61	24.87		0
	3	2	24.68	24.74	24.90		0
	3	3	24.59	24.70	24.87	0	
	6	0	23.74	23.82	23.94	0-1	1
16QAM	1	0	23.82	23.87	23.75	0-1	1
	1	2	23.97	24.00	24.17		1
	1	5	23.91	23.94	24.09		1
	3	0	23.79	23.74	23.96		1
	3	2	23.89	23.88	24.00		1
	3	3	23.75	23.82	23.96	1	
	6	0	22.80	22.87	22.97	0-2	2
64QAM	1	0	22.77	22.86	23.07	0-2	2
	1	2	22.95	22.98	23.17		2
	1	5	22.81	22.95	22.87		2
	3	0	22.86	22.84	23.08		2
	3	2	22.89	22.95	22.99		2
	3	3	22.79	22.88	22.80	2	
	6	0	21.76	21.78	21.83	0-3	3
256QAM	1	0	19.91	19.87	20.09	0-5	5
	1	2	19.94	20.20	20.14		5
	1	5	19.89	19.92	20.01		5
	3	0	19.86	19.92	20.06		5
	3	2	19.92	19.86	20.14		5
	3	3	19.76	19.97	20.10	5	
	6	0	19.76	19.81	19.96		5

FCC ID: A3LSMN975U	 PCTEST ENGINEERING LABORATORY, INC.	SAR EVALUATION REPORT		Approved by: Quality Manager
Document S/N: 1M1905200079-01-R1.A3L	Test Dates: 05/22/19 - 07/07/19	DUT Type: Portable Handset		Page 62 of 220

9.4.6

LTE Band 5 (Cell)

Table 9-26
 LTE Band 5 (Cell) Conducted Powers - 10 MHz Bandwidth

LTE Band 5 (Cell) 10 MHz Bandwidth					
Modulation	RB Size	RB Offset	Mid Channel	MPR Allowed per 3GPP [dB]	MPR [dB]
			20525 (836.5 MHz)		
			Conducted Power [dBm]		
QPSK	1	0	24.89	0	0
	1	25	24.79		0
	1	49	24.74		0
	25	0	23.92	0-1	1
	25	12	23.91		1
	25	25	23.84		1
	50	0	23.90		1
16QAM	1	0	24.14	0-1	1
	1	25	24.03		1
	1	49	23.99		1
	25	0	22.92	0-2	2
	25	12	22.90		2
	25	25	22.84		2
	50	0	22.89		2
64QAM	1	0	23.05	0-2	2
	1	25	23.00		2
	1	49	22.95		2
	25	0	21.96	0-3	3
	25	12	21.91		3
	25	25	21.85		3
	50	0	21.88		3
256QAM	1	0	20.00	0-5	5
	1	25	19.95		5
	1	49	19.96		5
	25	0	19.89		5
	25	12	19.87		5
	25	25	19.82		5
	50	0	19.84		5

Note: LTE Band 5 (Cell) at 10 MHz bandwidth does not support three non-overlapping channels. Per KDB Publication 941225 D05v02, when a device supports overlapping channel assignment in a channel bandwidth configuration, the middle channel of the group of overlapping channels should be selected for testing.





FCC ID: A3LSMN975U	 PCTEST ENGINEERING LABORATORY, INC.	SAR EVALUATION REPORT		Approved by: Quality Manager
Document S/N: 1M1905200079-01-R1.A3L	Test Dates: 05/22/19 - 07/07/19	DUT Type: Portable Handset	Page 63 of 220	

Table 9-27
LTE Band 5 (Cell) Conducted Powers - 5 MHz Bandwidth

LTE Band 5 (Cell) 5 MHz Bandwidth							
Modulation	RB Size	RB Offset	Low Channel	Mid Channel	High Channel	MPR Allowed per 3GPP [dB]	MPR [dB]
			20425 (826.5 MHz)	20525 (836.5 MHz)	20625 (846.5 MHz)		
			Conducted Power [dBm]				
QPSK	1	0	24.76	24.72	24.84	0	0
	1	12	24.87	24.83	24.88		0
	1	24	24.84	24.82	24.86		0
	12	0	23.84	23.80	23.96	0-1	1
	12	6	23.97	23.86	24.11		1
	12	13	23.97	23.96	24.10		1
	25	0	23.97	23.93	24.09		1
16QAM	1	0	24.04	24.03	24.14	0-1	1
	1	12	24.16	24.04	24.28		1
	1	24	24.11	24.09	24.24		1
	12	0	22.91	22.85	23.04	0-2	2
	12	6	23.05	22.95	23.16		2
	12	13	23.07	23.00	23.18		2
	25	0	22.98	22.96	23.09		2
64QAM	1	0	23.00	23.01	23.08	0-2	2
	1	12	23.15	23.12	23.27		2
	1	24	23.16	23.07	23.23		2
	12	0	21.93	21.91	21.99	0-3	3
	12	6	22.08	21.94	22.18		3
	12	13	22.06	22.02	22.21		3
	25	0	21.99	21.97	22.12		3
256QAM	1	0	19.65	19.86	19.94	0-5	5
	1	12	19.86	19.74	20.00		5
	1	24	19.74	19.87	19.99		5
	12	0	19.81	19.70	19.96		5
	12	6	19.79	19.80	19.98		5
	12	13	19.89	19.87	20.02		5
	25	0	19.94	19.79	19.98		5

FCC ID: A3LSMN975U		SAR EVALUATION REPORT		Approved by: Quality Manager
Document S/N: 1M1905200079-01-R1.A3L	Test Dates: 05/22/19 - 07/07/19	DUT Type: Portable Handset	Page 64 of 220	

**Table 9-28
LTE Band 5 (Cell) Conducted Powers - 3 MHz Bandwidth**

LTE Band 5 (Cell) 3 MHz Bandwidth							
Modulation	RB Size	RB Offset	Low Channel	Mid Channel	High Channel	MPR Allowed per 3GPP [dB]	MPR [dB]
			20415 (825.5 MHz)	20525 (836.5 MHz)	20635 (847.5 MHz)		
			Conducted Power [dBm]				
QPSK	1	0	24.73	24.67	24.83	0	0
	1	7	24.85	24.77	24.96		0
	1	14	24.86	24.84	25.01		0
	8	0	23.90	23.78	23.98	0-1	1
	8	4	23.98	23.93	24.10		1
	8	7	23.97	23.91	24.13		1
	15	0	23.97	23.95	24.04		1
16QAM	1	0	24.07	23.92	24.09	0-1	1
	1	7	24.17	24.03	24.28		1
	1	14	24.25	24.13	24.29		1
	8	0	22.97	22.86	23.06	0-2	2
	8	4	23.08	23.01	23.20		2
	8	7	23.05	23.00	23.18		2
	15	0	22.99	22.93	23.02		2
64QAM	1	0	22.96	22.97	23.12	0-2	2
	1	7	23.13	23.09	23.26		2
	1	14	23.16	23.07	23.27		2
	8	0	22.01	21.85	22.06	0-3	3
	8	4	22.09	21.98	22.19		3
	8	7	22.07	22.02	22.20		3
	15	0	22.00	21.93	22.07		3
256QAM	1	0	19.61	19.89	19.70	0-5	5
	1	7	19.75	19.74	19.86		5
	1	14	19.77	19.75	19.92		5
	8	0	19.65	19.75	19.68		5
	8	4	19.63	19.92	19.81		5
	8	7	19.77	19.84	19.75		5
	15	0	19.80	19.92	19.79		5





FCC ID: A3LSMN975U	 PCTEST ENGINEERING LABORATORY, INC.	SAR EVALUATION REPORT		Approved by: Quality Manager
Document S/N: 1M1905200079-01-R1.A3L	Test Dates: 05/22/19 - 07/07/19	DUT Type: Portable Handset	Page 65 of 220	

Table 9-29
LTE Band 5 (Cell) Conducted Powers -1.4 MHz Bandwidth

LTE Band 5 (Cell) 1.4 MHz Bandwidth							
Modulation	RB Size	RB Offset	Low Channel	Mid Channel	High Channel	MPR Allowed per 3GPP [dB]	MPR [dB]
			20407 (824.7 MHz)	20525 (836.5 MHz)	20643 (848.3 MHz)		
			Conducted Power [dBm]				
QPSK	1	0	24.67	24.62	24.81	0	0
	1	2	24.87	24.76	24.94		0
	1	5	24.81	24.76	24.97		0
	3	0	24.75	24.69	24.90		0
	3	2	24.82	24.84	25.00		0
	3	3	24.83	24.80	24.95		0
16QAM	1	0	24.08	23.98	24.14	0-1	1
	1	2	24.11	24.10	24.32		1
	1	5	24.11	24.09	24.22		1
	3	0	23.96	23.87	24.08		1
	3	2	24.08	24.03	24.19		1
	3	3	23.96	23.95	24.14		1
64QAM	1	0	22.98	22.92	23.13	0-2	2
	1	2	23.13	23.05	23.23		2
	1	5	23.10	23.02	23.24		2
	3	0	23.02	22.92	23.05		2
	3	2	23.07	23.06	23.21		2
	3	3	23.04	23.00	23.21		2
256QAM	1	0	19.64	19.60	19.81	0-3	3
	1	2	19.80	19.75	19.96		5
	1	5	19.82	19.80	19.99		5
	3	0	19.73	19.61	19.84		5
	3	2	19.79	19.69	19.77		5
	3	3	19.76	19.67	19.83		5
	6	0	19.80	19.71	19.73	5	

FCC ID: A3LSMN975U	 PCTEST ENGINEERING LABORATORY, INC.	SAR EVALUATION REPORT		Approved by: Quality Manager
Document S/N: 1M1905200079-01-R1.A3L	Test Dates: 05/22/19 - 07/07/19	DUT Type: Portable Handset		Page 66 of 220

9.4.7

LTE Band 66 (AWS)

Table 9-30
 LTE Band 66 (AWS) Maximum Conducted Powers - 20 MHz Bandwidth

LTE Band 66 (AWS) 20 MHz Bandwidth							
Modulation	RB Size	RB Offset	Low Channel	Mid Channel	High Channel	MPR Allowed per 3GPP [dB]	MPR [dB]
			132072 (1720.0 MHz)	132322 (1745.0 MHz)	132572 (1770.0 MHz)		
			Conducted Power [dBm]				
QPSK	1	0	23.63	24.10	24.27	0	0
	1	50	23.74	24.35	24.16		0
	1	99	24.06	24.38	24.23		0
	50	0	22.88	23.43	23.46	0-1	1
	50	25	22.94	23.50	23.48		1
	50	50	22.96	23.49	23.45		1
100	0	22.94	23.48	23.48	1	1	
16QAM	1	0	22.75	23.36	23.31	0-1	1
	1	50	22.99	23.43	23.49		1
	1	99	23.21	23.35	23.50		1
	50	0	21.84	22.40	22.49	0-2	2
	50	25	21.97	22.50	22.50		2
	50	50	21.99	22.49	22.41		2
100	0	21.95	22.35	22.48	2	2	
64QAM	1	0	21.70	21.92	22.49	0-2	2
	1	50	21.99	22.22	22.32		2
	1	99	22.34	22.49	22.12		2
	50	0	20.62	21.47	21.50	0-3	3
	50	25	20.82	21.25	21.29		3
	50	50	20.76	21.15	21.24		3
100	0	20.50	21.08	21.38	3	3	
256QAM	1	0	18.69	19.25	19.27	0-5	5
	1	50	18.79	19.35	19.34		5
	1	99	19.21	19.40	19.28		5
	50	0	18.88	19.38	19.45		5
	50	25	18.92	19.44	19.42		5
	50	50	18.95	19.46	19.45		5
100	0	18.93	19.50	19.44	5	5	



FCC ID: A3LSMN975U		SAR EVALUATION REPORT		Approved by: Quality Manager
Document S/N: 1M1905200079-01-R1.A3L	Test Dates: 05/22/19 - 07/07/19	DUT Type: Portable Handset		Page 67 of 220

Table 9-31
LTE Band 66 (AWS) Maximum Conducted Powers - 15 MHz Bandwidth

LTE Band 66 (AWS) 15 MHz Bandwidth							
Modulation	RB Size	RB Offset	Low Channel	Mid Channel	High Channel	MPR Allowed per 3GPP [dB]	MPR [dB]
			132047 (1717.5 MHz)	132322 (1745.0 MHz)	132597 (1772.5 MHz)		
			Conducted Power [dBm]				
QPSK	1	0	23.52	23.97	24.26	0	0
	1	36	23.63	24.21	24.05		0
	1	74	23.75	24.27	24.12		0
	36	0	22.66	23.39	23.41	0-1	1
	36	18	22.74	23.39	23.37		1
	36	37	22.83	23.49	23.34		1
	75	0	22.68	23.22	23.35		1
16QAM	1	0	22.60	23.05	23.50	0-1	1
	1	36	22.93	23.53	23.39		1
	1	74	22.99	23.49	23.42		1
	36	0	21.72	22.44	22.42	0-2	2
	36	18	21.79	22.40	22.38		2
	36	37	21.84	22.38	22.36		2
	75	0	21.84	22.37	22.38		2
64QAM	1	0	21.60	21.98	22.64	0-2	2
	1	36	21.58	22.28	22.01		2
	1	74	21.76	22.39	22.00		2
	36	0	20.80	21.13	21.35	0-3	3
	36	18	20.78	21.07	21.23		3
	36	37	20.59	20.74	20.88		3
	75	0	20.49	20.89	20.99		3
256QAM	1	0	18.74	19.30	19.31	0-5	5
	1	36	18.76	19.29	19.30		5
	1	74	18.77	19.27	19.17		5
	36	0	18.79	19.32	19.34		5
	36	18	18.78	19.33	19.30		5
	36	37	18.81	19.31	19.25		5
	75	0	18.82	19.34	19.30		5



FCC ID: A3LSMN975U		SAR EVALUATION REPORT		Approved by: Quality Manager
Document S/N: 1M1905200079-01-R1.A3L	Test Dates: 05/22/19 - 07/07/19	DUT Type: Portable Handset	Page 68 of 220	

Table 9-32
LTE Band 66 (AWS) Maximum Conducted Powers - 10 MHz Bandwidth

LTE Band 66 (AWS) 10 MHz Bandwidth								
Modulation	RB Size	RB Offset	Low Channel	Mid Channel	High Channel	MPR Allowed per 3GPP [dB]	MPR [dB]	
			132022 (1715.0 MHz)	132322 (1745.0 MHz)	132622 (1775.0 MHz)			
			Conducted Power [dBm]					
QPSK	1	0	23.30	23.62	23.97	0	0	
	1	25	23.39	23.98	24.12		0	
	1	49	23.43	24.36	24.09		0	
	25	0	22.53	23.20	23.25	0-1	1	
	25	12	22.55	23.23	23.24		1	
	25	25	22.56	23.19	23.17		1	
16QAM	50	0	22.49	23.16	23.11	0-1	1	
	1	0	22.40	23.41	23.34		0-1	1
	1	25	22.70	23.55	23.28			1
	1	49	22.81	23.57	23.41	0-2		1
	25	0	21.53	22.40	22.26		2	
	25	12	21.55	22.49	22.24		2	
64QAM	25	25	21.53	22.45	22.18	0-2	2	
	50	0	21.57	22.44	22.23		2	
	1	0	21.45	21.90	21.92		0-2	2
	1	25	21.22	21.95	21.82	2		
	1	49	21.72	22.38	21.86	0-3		2
	25	0	20.04	21.02	21.05		3	
25	12	20.20	21.02	21.02	3			
256QAM	25	25	20.15	20.87	20.78	0-3	3	
	50	0	19.96	20.85	20.82		3	
	1	0	18.76	19.27	19.26		0-5	5
	1	25	18.69	19.49	19.30	5		
	1	49	18.60	19.32	19.22	5		
	25	0	18.68	19.41	19.21	5		
25	12	18.71	19.44	19.20	5			
25	25	18.75	19.38	19.23	5			
	50	0	18.77	19.40	19.28	5		



FCC ID: A3LSMN975U	 PCTEST ENGINEERING LABORATORY, INC.	SAR EVALUATION REPORT		Approved by: Quality Manager
Document S/N: 1M1905200079-01-R1.A3L	Test Dates: 05/22/19 - 07/07/19	DUT Type: Portable Handset	Page 69 of 220	

Table 9-33
LTE Band 66 (AWS) Maximum Conducted Powers - 5 MHz Bandwidth

LTE Band 66 (AWS) 5 MHz Bandwidth							
Modulation	RB Size	RB Offset	Low Channel	Mid Channel	High Channel	MPR Allowed per 3GPP [dB]	MPR [dB]
			131997 (1712.5 MHz)	132322 (1745.0 MHz)	132647 (1777.5 MHz)		
Conducted Power [dBm]							
QPSK	1	0	23.27	23.96	24.08	0	0
	1	12	23.43	24.11	24.13		0
	1	24	23.52	24.20	24.12		0
	12	0	22.48	23.19	23.27	0-1	1
	12	6	22.62	23.20	23.29		1
	12	13	22.63	23.30	23.25		1
25	0	22.53	23.16	23.07		1	
16QAM	1	0	22.63	23.30	23.37	0-1	1
	1	12	22.76	23.40	23.39		1
	1	24	22.75	23.43	23.35		1
	12	0	21.52	22.24	22.25	0-2	2
	12	6	21.62	22.24	22.33		2
	12	13	21.67	22.30	22.31		2
25	0	21.58	22.20	22.22		2	
64QAM	1	0	21.01	21.50	21.68	0-2	2
	1	12	21.06	21.88	21.89		2
	1	24	21.49	22.14	21.72		2
	12	0	20.07	20.97	20.72	0-3	3
	12	6	20.18	21.06	20.78		3
	12	13	20.17	20.89	20.65		3
25	0	20.11	20.82	20.61		3	
256QAM	1	0	18.51	19.10	19.13	0-5	5
	1	12	18.72	19.14	19.19		5
	1	24	18.76	19.27	19.14		5
	12	0	18.66	19.10	19.15		5
	12	6	18.77	19.21	19.19		5
	12	13	18.80	19.18	19.20		5
25	0	18.75	19.19	19.22		5	



FCC ID: A3LSMN975U	 PCTEST ENGINEERING LABORATORY, INC.	SAR EVALUATION REPORT		Approved by: Quality Manager
Document S/N: 1M1905200079-01-R1.A3L	Test Dates: 05/22/19 - 07/07/19	DUT Type: Portable Handset	Page 70 of 220	

Table 9-34
LTE Band 66 (AWS) Maximum Conducted Powers - 3 MHz Bandwidth

LTE Band 66 (AWS) 3 MHz Bandwidth							
Modulation	RB Size	RB Offset	Low Channel	Mid Channel	High Channel	MPR Allowed per 3GPP [dB]	MPR [dB]
			131987 (1711.5 MHz)	132322 (1745.0 MHz)	132657 (1778.5 MHz)		
			Conducted Power [dBm]				
QPSK	1	0	23.39	24.03	24.08	0	0
	1	7	23.47	24.15	24.11		0
	1	14	23.50	24.15	24.17		0
	8	0	22.60	23.22	23.23	0-1	1
	8	4	22.65	23.26	23.28		1
	8	7	22.64	23.23	23.20		1
	15	0	22.64	23.24	23.18		1
16QAM	1	0	22.63	23.26	23.33	0-1	1
	1	7	22.73	23.44	23.35		1
	1	14	22.76	23.43	23.43		1
	8	0	21.63	22.24	22.31	0-2	2
	8	4	21.68	22.23	22.34		2
	8	7	21.67	22.28	22.34		2
	15	0	21.62	22.23	22.27		2
64QAM	1	0	21.28	21.74	21.79	0-2	2
	1	7	21.17	21.83	21.79		2
	1	14	21.24	22.02	21.75		2
	8	0	20.10	20.92	20.74	0-3	3
	8	4	20.29	21.11	20.82		3
	8	7	20.19	20.98	20.73		3
	15	0	20.12	20.93	20.82		3
256QAM	1	0	18.52	19.12	19.22	0-5	5
	1	7	18.60	19.20	19.22		5
	1	14	18.61	19.16	19.19		5
	8	0	18.74	19.10	19.20		5
	8	4	18.78	19.19	19.25		5
	8	7	18.73	19.20	19.26		5
	15	0	18.72	19.16	19.27		5



FCC ID: A3LSMN975U	 PCTEST ENGINEERING LABORATORY, INC.	SAR EVALUATION REPORT		Approved by: Quality Manager
Document S/N: 1M1905200079-01-R1.A3L	Test Dates: 05/22/19 - 07/07/19	DUT Type: Portable Handset	Page 71 of 220	

Table 9-35
LTE Band 66 (AWS) Maximum Conducted Powers – 1.4 MHz Bandwidth

LTE Band 66 (AWS) 1.4 MHz Bandwidth							
Modulation	RB Size	RB Offset	Low Channel	Mid Channel	High Channel	MPR Allowed per 3GPP [dB]	MPR [dB]
			131979 (1710.7 MHz)	132322 (1745.0 MHz)	132665 (1779.3 MHz)		
			Conducted Power [dBm]				
QPSK	1	0	23.29	23.93	24.03	0	0
	1	2	23.44	24.11	24.14		0
	1	5	23.41	24.07	24.04		0
	3	0	23.42	24.06	24.04		0
	3	2	23.49	24.13	24.09		0
	3	3	23.41	24.10	24.02		0
	6	0	22.50	23.14	23.15	0-1	1
16QAM	1	0	22.64	23.30	23.35	0-1	1
	1	2	22.70	23.42	23.29		1
	1	5	22.67	23.35	23.30		1
	3	0	22.57	23.14	23.21		1
	3	2	22.61	23.31	23.29		1
	3	3	22.56	23.24	23.29		1
	6	0	21.56	22.17	22.23	0-2	2
64QAM	1	0	21.26	21.93	21.74	0-2	2
	1	2	21.29	22.00	21.77		2
	1	5	21.20	21.99	21.69		2
	3	0	21.22	21.90	21.61		2
	3	2	21.28	21.93	21.51		2
	3	3	21.24	21.92	21.41		2
	6	0	20.18	20.89	20.67	0-3	3
256QAM	1	0	18.55	19.09	19.12	0-5	5
	1	2	18.62	19.25	19.20		5
	1	5	18.60	19.14	19.15		5
	3	0	18.63	19.26	19.19		5
	3	2	18.74	19.26	19.23		5
	3	3	18.74	19.23	19.22		5
	6	0	18.61	19.14	19.15	5	



FCC ID: A3LSMN975U		SAR EVALUATION REPORT		Approved by: Quality Manager
Document S/N: 1M1905200079-01-R1.A3L	Test Dates: 05/22/19 - 07/07/19	DUT Type: Portable Handset	Page 72 of 220	

Table 9-36
LTE Band 66 (AWS) Reduced Conducted Powers - 20 MHz Bandwidth – Hotspot Mode Active

LTE Band 66 (AWS) 20 MHz Bandwidth							
Modulation	RB Size	RB Offset	Low Channel	Mid Channel	High Channel	MPR Allowed per 3GPP [dB]	MPR [dB]
			132072 (1720.0 MHz)	132322 (1745.0 MHz)	132572 (1770.0 MHz)		
			Conducted Power [dBm]				
QPSK	1	0	19.29	19.76	19.81	0	0
	1	50	19.38	19.79	19.76		0
	1	99	19.60	19.84	19.85		0
	50	0	19.52	19.95	19.94	0-1	0
	50	25	19.61	19.92	19.96		0
	50	50	19.65	19.94	20.00		0
100	0	19.58	19.82	19.84	0		
16QAM	1	0	19.49	19.92	19.54	0-1	0
	1	50	19.57	19.94	19.50		0
	1	99	19.79	19.95	19.51		0
	50	0	19.42	19.88	19.52	0-2	0
	50	25	19.34	19.76	19.48		0
	50	50	19.47	19.94	19.52		0
100	0	19.45	19.85	19.49	0		
64QAM	1	0	19.56	19.99	19.51	0-2	0
	1	50	19.49	19.90	19.49		0
	1	99	19.81	19.90	19.32		0
	50	0	19.39	19.94	19.64	0-3	0
	50	25	19.50	19.92	19.46		0
	50	50	19.55	19.93	19.51		0
100	0	19.45	19.97	19.56	0		
256QAM	1	0	19.02	19.29	19.22	0-5	0
	1	50	18.99	19.20	19.04		0
	1	99	18.98	19.15	19.11		0
	50	0	18.90	19.11	19.02		0
	50	25	19.01	19.10	19.00		0
	50	50	18.91	19.14	19.02		0
100	0	18.92	19.16	19.06	0		



FCC ID: A3LSMN975U	 PCTEST ENGINEERING LABORATORY, INC.	SAR EVALUATION REPORT		Approved by: Quality Manager
Document S/N: 1M1905200079-01-R1.A3L	Test Dates: 05/22/19 - 07/07/19	DUT Type: Portable Handset	Page 73 of 220	

Table 9-37

LTE Band 66 (AWS) Reduced Conducted Powers - 15 MHz Bandwidth – Hotspot Mode Active

LTE Band 66 (AWS) 15 MHz Bandwidth							
Modulation	RB Size	RB Offset	Low Channel	Mid Channel	High Channel	MPR Allowed per 3GPP [dB]	MPR [dB]
			132047 (1717.5 MHz)	132322 (1745.0 MHz)	132597 (1772.5 MHz)		
			Conducted Power [dBm]				
QPSK	1	0	19.11	19.72	19.81	0	0
	1	36	19.15	19.68	19.77		0
	1	74	19.32	19.72	19.63		0
	36	0	19.28	19.91	19.92	0-1	0
	36	18	19.35	19.94	19.92		0
	36	37	19.42	19.91	19.90		0
	75	0	19.41	19.94	19.94		0
16QAM	1	0	19.42	19.92	19.94	0-1	0
	1	36	19.37	19.93	19.95		0
	1	74	19.53	19.94	19.97		0
	36	0	19.26	19.85	19.90	0-2	0
	36	18	19.31	19.90	19.88		0
	36	37	19.37	19.90	19.86		0
	75	0	19.39	19.94	19.92		0
64QAM	1	0	19.39	19.94	19.89	0-2	0
	1	36	19.38	20.00	19.92		0
	1	74	19.54	19.89	19.92		0
	36	0	19.39	19.98	19.98	0-3	0
	36	18	19.43	19.97	19.95		0
	36	37	19.44	19.95	19.89		0
	75	0	19.42	19.94	19.94		0
256QAM	1	0	18.96	19.25	19.18	0-5	0
	1	36	19.01	19.20	19.21		0
	1	74	18.89	19.12	19.25		0
	36	0	19.05	19.18	19.14		0
	36	18	18.97	19.16	19.23		0
	36	37	18.99	19.19	19.27		0
	75	0	19.05	19.15	19.22		0



FCC ID: A3LSMN975U	 PCTEST ENGINEERING LABORATORY, INC.	SAR EVALUATION REPORT		Approved by: Quality Manager
Document S/N: 1M1905200079-01-R1.A3L	Test Dates: 05/22/19 - 07/07/19	DUT Type: Portable Handset	Page 74 of 220	

Table 9-38

LTE Band 66 (AWS) Reduced Conducted Powers - 10 MHz Bandwidth – Hotspot Mode Active

LTE Band 66 (AWS) 10 MHz Bandwidth							
Modulation	RB Size	RB Offset	Low Channel	Mid Channel	High Channel	MPR Allowed per 3GPP [dB]	MPR [dB]
			132022 (1715.0 MHz)	132322 (1745.0 MHz)	132622 (1775.0 MHz)		
			Conducted Power [dBm]				
QPSK	1	0	19.12	19.66	19.76	0	0
	1	25	19.17	19.75	19.73		0
	1	49	19.26	19.62	19.75		0
	25	0	19.28	19.83	19.86	0-1	0
	25	12	19.33	19.87	19.87		0
	25	25	19.32	19.82	19.82		0
16QAM	50	0	19.31	19.85	19.85	0-1	0
	1	0	19.19	19.78	19.87		0
	1	25	19.26	19.91	19.88		0
	25	0	19.14	19.76	19.74	0-2	0
	25	12	19.19	19.79	19.74		0
	25	25	19.22	19.76	19.72		0
64QAM	50	0	19.19	19.76	19.72	0-2	0
	1	0	19.15	19.78	19.86		0
	1	25	19.21	19.81	19.82		0
	1	49	19.29	19.84	19.83	0-3	0
	25	0	19.16	19.78	19.76		0
	25	12	19.22	19.81	19.77		0
256QAM	25	25	19.24	19.79	19.76	0-5	0
	50	0	19.21	19.80	19.78		0
	1	0	19.07	19.25	19.24		0
	1	25	18.92	19.19	19.22	0-5	0
	1	49	18.88	19.26	18.98		0
	25	0	18.89	19.23	19.26		0
25	12	19.08	19.31	19.32	0		
25	25	19.11	19.27	19.30	0		
50	0	19.14	19.24	19.34	0		



FCC ID: A3LSMN975U		SAR EVALUATION REPORT		Approved by: Quality Manager
Document S/N: 1M1905200079-01-R1.A3L	Test Dates: 05/22/19 - 07/07/19	DUT Type: Portable Handset	Page 75 of 220	

Table 9-39
LTE Band 66 (AWS) Reduced Conducted Powers - 5 MHz Bandwidth – Hotspot Mode Active

LTE Band 66 (AWS)								
5 MHz Bandwidth								
Modulation	RB Size	RB Offset	Low Channel	Mid Channel	High Channel	MPR Allowed per 3GPP [dB]	MPR [dB]	
			131997 (1712.5 MHz)	132322 (1745.0 MHz)	132647 (1777.5 MHz)			
			Conducted Power [dBm]					
QPSK	1	0	18.90	19.58	19.64	0	0	
	1	12	19.06	19.70	19.65		0	
	1	24	19.12	19.77	19.73		0	
	12	0	19.08	19.72	19.79	0-1	0	
	12	6	19.20	19.82	19.80		0	
	12	13	19.25	19.87	19.77		0	
16QAM	25	0	19.18	19.82	19.80	0-1	0	
	1	0	19.20	19.84	19.93		0	
	1	12	19.25	19.93	19.91		0	
	1	24	19.34	19.97	19.94	0-2	0	
	12	0	19.08	19.76	19.80		0	
	12	6	19.08	19.75	19.77		0	
64QAM	12	13	19.11	19.75	19.78	0-2	0	
	25	0	19.21	19.74	19.80		0	
	1	0	19.17	19.85	19.84		0	
	1	12	19.33	19.94	19.87	0-2	0	
	1	24	19.34	19.94	19.92		0	
	12	0	19.09	19.76	19.81		0-3	0
12	6	19.09	19.77	19.79	0			
12	13	19.12	19.77	19.79	0			
256QAM	25	0	19.18	19.79	19.80	0-3	0	
	1	0	19.04	19.19	19.27		0-5	0
	1	12	18.96	19.31	19.00			0
	1	24	18.79	19.26	19.29	0		
	12	0	18.92	19.17	19.35	0		
	12	6	19.15	19.28	19.26	0		
12	13	19.18	19.13	19.18	0			
25	0	18.96	19.25	19.22	0			



FCC ID: A3LSMN975U		SAR EVALUATION REPORT		Approved by: Quality Manager
Document S/N: 1M1905200079-01-R1.A3L	Test Dates: 05/22/19 - 07/07/19	DUT Type: Portable Handset	Page 76 of 220	

Table 9-40
LTE Band 66 (AWS) Reduced Conducted Powers - 3 MHz Bandwidth – Hotspot Mode Active

LTE Band 66 (AWS) 3 MHz Bandwidth							
Modulation	RB Size	RB Offset	Low Channel	Mid Channel	High Channel	MPR Allowed per 3GPP [dB]	MPR [dB]
			131987 (1711.5 MHz)	132322 (1745.0 MHz)	132657 (1778.5 MHz)		
Conducted Power [dBm]							
QPSK	1	0	19.02	19.56	19.64	0	0
	1	7	19.06	19.66	19.60		0
	1	14	19.11	19.71	19.63		0
	8	0	19.10	19.71	19.76	0-1	0
	8	4	19.17	19.84	19.77		0
	8	7	19.13	19.80	19.79		0
	15	0	19.14	19.77	19.79	0	
16QAM	1	0	19.11	19.79	19.85	0-1	0
	1	7	19.25	19.96	19.89		0
	1	14	19.33	19.95	19.94		0
	8	0	19.14	19.79	19.77	0-2	0
	8	4	19.21	19.85	19.81		0
	8	7	19.18	19.87	19.80		0
	15	0	19.11	19.71	19.75	0	
64QAM	1	0	19.12	19.89	19.89	0-2	0
	1	7	19.25	19.87	19.90		0
	1	14	19.27	19.93	19.89		0
	8	0	19.12	19.78	19.78	0-3	0
	8	4	19.22	19.87	19.85		0
	8	7	19.20	19.84	19.81		0
	15	0	19.15	19.78	19.79	0	
256QAM	1	0	18.72	19.26	19.21	0-5	0
	1	7	18.89	19.22	19.20		0
	1	14	18.96	19.28	19.24		0
	8	0	18.75	19.31	19.23		0
	8	4	18.88	19.32	19.16		0
	8	7	18.97	19.27	19.12		0
	15	0	18.95	19.25	19.10	0	



FCC ID: A3LSMN975U		SAR EVALUATION REPORT		Approved by: Quality Manager
Document S/N: 1M1905200079-01-R1.A3L	Test Dates: 05/22/19 - 07/07/19	DUT Type: Portable Handset	Page 77 of 220	

Table 9-41

LTE Band 66 (AWS) Reduced Conducted Powers -1.4 MHz Bandwidth – Hotspot Mode Active

LTE Band 66 (AWS) 1.4 MHz Bandwidth							
Modulation	RB Size	RB Offset	Low Channel	Mid Channel	High Channel	MPR Allowed per 3GPP [dB]	MPR [dB]
			131979 (1710.7 MHz)	132322 (1745.0 MHz)	132665 (1779.3 MHz)		
			Conducted Power [dBm]				
QPSK	1	0	19.05	19.67	19.58	0	0
	1	2	19.00	19.69	19.64		0
	1	5	18.96	19.67	19.55		0
	3	0	18.97	19.65	19.61		0
	3	2	19.01	19.71	19.63		0
	3	3	18.99	19.67	19.60		0
	6	0	19.08	19.73	19.72	0-1	0
16QAM	1	0	19.12	19.84	19.50	0-1	0
	1	2	19.16	19.93	19.94		0
	1	5	19.20	19.89	19.85		0
	3	0	19.04	19.73	19.74		0
	3	2	19.13	19.83	19.79		0
	3	3	19.10	19.76	19.74		0
	6	0	19.09	19.78	19.75	0-2	0
64QAM	1	0	19.14	19.89	19.85	0-2	0
	1	2	19.17	19.89	19.87		0
	1	5	19.21	19.86	19.84		0
	3	0	19.06	19.80	19.78		0
	3	2	19.21	19.88	19.85		0
	3	3	19.18	19.85	19.79		0
	6	0	19.07	19.75	19.70	0-3	0
256QAM	1	0	18.79	19.33	19.15	0-5	0
	1	2	19.05	19.31	19.19		0
	1	5	18.94	19.25	19.27		0
	3	0	18.67	19.26	19.31		0
	3	2	18.91	19.27	19.34		0
	3	3	19.21	19.18	19.32		0
	6	0	19.15	19.21	19.29		0



FCC ID: A3LSMN975U	 PCTEST ENGINEERING LABORATORY, INC.	SAR EVALUATION REPORT		Approved by: Quality Manager
Document S/N: 1M1905200079-01-R1.A3L	Test Dates: 05/22/19 - 07/07/19	DUT Type: Portable Handset		Page 78 of 220

Table 9-42
LTE Band 66 (AWS) Reduced Conducted Powers - 20 MHz Bandwidth – Grip Sensor and/or Earjack Mode Active

LTE Band 66 (AWS) 20 MHz Bandwidth							
Modulation	RB Size	RB Offset	Low Channel	Mid Channel	High Channel	MPR Allowed per 3GPP [dB]	MPR [dB]
			132072 (1720.0 MHz)	132322 (1745.0 MHz)	132572 (1770.0 MHz)		
			Conducted Power [dBm]				
QPSK	1	0	19.84	20.42	20.57	0	0
	1	50	19.95	20.59	20.52		0
	1	99	20.25	20.65	20.47		0
	50	0	20.14	20.68	20.71	0-1	0
	50	25	20.19	20.71	20.77		0
	50	50	20.21	20.73	20.75		0
	100	0	20.17	20.64	20.63		0
16QAM	1	0	20.19	20.73	20.85	0-1	0
	1	50	20.19	20.79	20.85		0
	1	99	20.52	20.86	20.73		0
	50	0	20.14	20.73	20.72	0-2	0
	50	25	20.20	20.74	20.80		0
	50	50	20.22	20.72	20.74		0
	100	0	20.19	20.73	20.76		0
64QAM	1	0	20.01	20.74	20.82	0-2	0
	1	50	20.29	20.82	20.82		0
	1	99	20.61	20.84	20.73		0
	50	0	20.07	20.71	20.77	0-3	0
	50	25	20.23	20.71	20.78		0
	50	50	20.21	20.75	20.73		0
	100	0	20.17	20.70	20.75		0
256QAM	1	0	18.81	19.14	19.37	0-5	1
	1	50	18.89	19.31	19.36		1
	1	99	19.22	19.28	19.28		1
	50	0	19.06	19.30	19.45		1
	50	25	19.13	19.38	19.45		1
	50	50	19.07	19.37	19.41		1
	100	0	19.10	19.43	19.39		1



FCC ID: A3LSMN975U		SAR EVALUATION REPORT		Approved by: Quality Manager
Document S/N: 1M1905200079-01-R1.A3L	Test Dates: 05/22/19 - 07/07/19	DUT Type: Portable Handset	Page 79 of 220	

Table 9-43
LTE Band 66 (AWS) Reduced Conducted Powers - 15 MHz Bandwidth – Grip Sensor and/or Earjack Mode
Active

LTE Band 66 (AWS) 15 MHz Bandwidth							
Modulation	RB Size	RB Offset	Low Channel	Mid Channel	High Channel	MPR Allowed per 3GPP [dB]	MPR [dB]
			132047 (1717.5 MHz)	132322 (1745.0 MHz)	132597 (1772.5 MHz)		
			Conducted Power [dBm]				
QPSK	1	0	19.96	20.61	20.57	0	0
	1	36	20.21	20.78	20.54		0
	1	74	20.21	20.72	20.46		0
	36	0	20.15	20.79	20.75	0-1	0
	36	18	20.22	20.78	20.73		0
	36	37	20.21	20.74	20.65		0
16QAM	75	0	20.20	20.73	20.70	0-1	0
	1	0	19.58	20.80	20.82		0
	1	36	19.79	20.96	20.83		0
	1	74	19.84	20.82	20.60	0-2	0
	36	0	20.16	20.84	20.80		0
	36	18	20.19	20.87	20.80		0
64QAM	36	37	20.20	20.82	20.71	0-2	0
	75	0	20.20	20.80	20.76		0
	1	0	19.57	20.77	20.89		0
	1	36	19.79	20.95	20.95	0-3	0
	1	74	19.88	20.80	20.69		0
	36	0	20.16	20.87	20.76		0
256QAM	36	18	20.21	20.87	20.78	0-5	0
	36	37	20.20	20.83	20.71		0
	75	0	20.19	20.78	20.78		0
	1	0	19.01	19.32	19.35	0-5	1
	1	36	18.95	19.34	19.56		1
	1	74	19.17	19.28	19.21		1
256QAM	36	0	19.07	19.29	19.19	0-5	1
	36	18	19.02	19.29	19.32		1
	36	37	18.95	19.32	19.16		1
	75	0	19.05	19.27	19.30		1



FCC ID: A3LSMN975U		SAR EVALUATION REPORT		Approved by: Quality Manager
Document S/N: 1M1905200079-01-R1.A3L	Test Dates: 05/22/19 - 07/07/19	DUT Type: Portable Handset	Page 80 of 220	

Table 9-44
LTE Band 66 (AWS) Reduced Conducted Powers - 10 MHz Bandwidth – Grip Sensor and/or Earjack Mode
Active

LTE Band 66 (AWS) 10 MHz Bandwidth								
Modulation	RB Size	RB Offset	Low Channel	Mid Channel	High Channel	MPR Allowed per 3GPP [dB]	MPR [dB]	
			132022 (1715.0 MHz)	132322 (1745.0 MHz)	132622 (1775.0 MHz)			
			Conducted Power [dBm]					
QPSK	1	0	19.92	20.40	20.54	0	0	
	1	25	19.93	20.53	20.49		0	
	1	49	20.07	20.44	20.57		0	
	25	0	20.00	20.58	20.49	0-1	0	
	25	12	20.02	20.57	20.47		0	
	25	25	20.10	20.56	20.47		0	
16QAM	50	0	20.01	20.58	20.44	0-1	0	
	1	0	19.66	20.54	20.50		0-1	0
	1	25	19.62	20.59	20.45			0
	1	49	19.63	20.57	20.46	0-2		0
	25	0	19.90	20.59	20.55		0	
	25	12	19.94	20.62	20.54		0	
64QAM	25	25	20.00	20.58	20.48	0-2	0	
	50	0	19.86	20.56	20.50		0	
	1	0	19.66	20.63	20.64		0-2	0
	1	25	19.60	20.58	20.52	0-3		0
	1	49	19.73	20.71	20.58			0
	25	0	19.92	20.63	20.55		0	
256QAM	25	12	19.95	20.61	20.54	0-3	0	
	25	25	19.94	20.59	20.50		0	
	50	0	19.89	20.59	20.51		0-5	0
	1	0	19.18	19.24	19.41	0-5		1
	1	25	19.15	19.27	19.20			1
	1	49	19.17	19.29	19.30		1	
256QAM	25	0	19.14	19.58	19.28	0-5	1	
	25	12	19.07	19.36	19.32		1	
	25	25	19.05	19.26	19.20		1	
	50	0	19.10	19.28	19.21	0-5	1	



FCC ID: A3LSMN975U	 PCTEST ENGINEERING LABORATORY, INC.	SAR EVALUATION REPORT		Approved by: Quality Manager
Document S/N: 1M1905200079-01-R1.A3L	Test Dates: 05/22/19 - 07/07/19	DUT Type: Portable Handset	Page 81 of 220	

Table 9-45
LTE Band 66 (AWS) Reduced Conducted Powers - 5 MHz Bandwidth – Grip Sensor and/or Earjack Mode
Active

LTE Band 66 (AWS) 5 MHz Bandwidth							
Modulation	RB Size	RB Offset	Low Channel	Mid Channel	High Channel	MPR Allowed per 3GPP [dB]	MPR [dB]
			131997 (1712.5 MHz)	132322 (1745.0 MHz)	132647 (1777.5 MHz)		
Conducted Power [dBm]							
QPSK	1	0	19.88	20.42	20.27	0	0
	1	12	19.84	20.56	20.26		0
	1	24	20.02	20.64	20.26		0
	12	0	19.85	20.56	20.50	0-1	0
	12	6	19.98	20.58	20.55		0
	12	13	19.99	20.66	20.55		0
16QAM	25	0	19.93	20.59	20.54	0-1	0
	1	0	19.94	20.42	20.50		0
	1	12	20.11	20.52	20.50		0
	1	24	20.15	20.61	20.47	0-2	0
	12	0	19.88	20.60	20.52		0
	12	6	20.00	20.68	20.57		0
64QAM	12	13	19.99	20.70	20.54	0-2	0
	25	0	19.90	20.63	20.54		0
	1	0	19.83	20.82	20.53		0
	1	12	20.01	20.96	20.51	0-3	0
	1	24	20.09	20.92	20.48		0
	12	0	19.89	20.63	20.46		0
256QAM	12	6	19.95	20.65	20.49	0-5	0
	12	13	19.88	20.66	20.47		0
	25	0	19.74	20.57	20.48		0
	1	0	18.85	19.13	19.11	0-5	1
	1	12	19.09	19.31	19.22		1
	1	24	19.08	19.45	18.98		1
12	0	18.86	19.23	19.18	0-5	1	
12	6	18.94	19.24	19.14		1	
12	13	18.90	19.20	19.20		1	
25	0	18.90	19.27	19.24	0-5	1	



FCC ID: A3LSMN975U	 PCTEST ENGINEERING LABORATORY, INC.	SAR EVALUATION REPORT		Approved by: Quality Manager
Document S/N: 1M1905200079-01-R1.A3L	Test Dates: 05/22/19 - 07/07/19	DUT Type: Portable Handset	Page 82 of 220	

Table 9-46
LTE Band 66 (AWS) Reduced Conducted Powers - 3 MHz Bandwidth – Grip Sensor and/or Earjack Mode
Active

LTE Band 66 (AWS) 3 MHz Bandwidth							
Modulation	RB Size	RB Offset	Low Channel	Mid Channel	High Channel	MPR Allowed per 3GPP [dB]	MPR [dB]
			131987 (1711.5 MHz)	132322 (1745.0 MHz)	132657 (1778.5 MHz)		
			Conducted Power [dBm]				
QPSK	1	0	19.66	20.31	20.28	0	0
	1	7	19.74	20.39	20.29		0
	1	14	19.81	20.43	20.28		0
	8	0	19.80	20.50	20.47	0-1	0
	8	4	19.88	20.58	20.52		0
	8	7	19.85	20.62	20.46		0
16QAM	15	0	19.85	20.54	20.47		0
	1	0	19.61	20.63	20.52	0-1	0
	1	7	19.70	20.67	20.54		0
	1	14	19.65	20.66	20.51		0
	8	0	19.67	20.43	20.59	0-2	0
	8	4	19.75	20.46	20.56		0
8	7	19.72	20.48	20.52	0		
64QAM	15	0	19.82	20.56	20.59		0
	1	0	19.56	20.50	20.98	0-2	0
	1	7	19.65	20.52	20.95		0
	1	14	19.72	20.54	21.00		0
	8	0	19.95	20.53	20.62	0-3	0
	8	4	19.98	20.61	20.64		0
8	7	19.93	20.64	20.62	0		
256QAM	15	0	19.90	20.57	20.51		0
	1	0	18.93	19.27	19.24	0-5	1
	1	7	18.99	19.34	19.20		1
	1	14	18.87	19.27	19.25		1
	8	0	18.95	19.25	19.17		1
	8	4	18.93	19.30	19.25		1
8	7	18.97	19.33	19.26	1		
	15	0	18.91	19.27	19.27		1





FCC ID: A3LSMN975U		SAR EVALUATION REPORT		Approved by: Quality Manager
Document S/N: 1M1905200079-01-R1.A3L	Test Dates: 05/22/19 - 07/07/19	DUT Type: Portable Handset	Page 83 of 220	

Table 9-47

LTE Band 66 (AWS) Reduced Conducted Powers -1.4 MHz Bandwidth – Grip Sensor and/or Earjack Mode Active

LTE Band 66 (AWS) 1.4 MHz Bandwidth							
Modulation	RB Size	RB Offset	Low Channel	Mid Channel	High Channel	MPR Allowed per 3GPP [dB]	MPR [dB]
			131979 (1710.7 MHz)	132322 (1745.0 MHz)	132665 (1779.3 MHz)		
Conducted Power [dBm]							
QPSK	1	0	19.75	20.28	20.43	0	0
	1	2	19.73	20.38	20.49		0
	1	5	19.65	20.35	20.43		0
	3	0	19.63	20.37	20.30		0
	3	2	19.71	20.50	20.37		0
	3	3	19.69	20.47	20.30		0
	6	0	19.71	20.49	20.37	0-1	0
16QAM	1	0	19.59	20.54	20.44	0-1	0
	1	2	19.64	20.64	20.49		0
	1	5	19.63	20.60	20.46		0
	3	0	19.76	20.43	20.36		0
	3	2	19.78	20.55	20.45		0
	3	3	19.78	20.49	20.42		0
	6	0	19.66	20.46	20.32	0-2	0
64QAM	1	0	19.49	20.39	20.74	0-2	0
	1	2	19.68	20.50	20.84		0
	1	5	19.60	20.47	20.68		0
	3	0	19.78	20.34	20.35		0
	3	2	19.83	20.48	20.44		0
	3	3	19.81	20.45	20.37		0
	6	0	19.77	20.47	20.41	0-3	0
256QAM	1	0	18.93	19.29	19.16	0-5	1
	1	2	18.83	19.43	19.22		1
	1	5	18.65	19.45	19.12		1
	3	0	18.95	19.32	19.15		1
	3	2	18.99	19.36	19.23		1
	3	3	18.89	19.25	19.18		1
	6	0	18.86	19.38	19.20	1	

FCC ID: A3LSMN975U	 PCTEST ENGINEERING LABORATORY, INC.	SAR EVALUATION REPORT		Approved by: Quality Manager
Document S/N: 1M1905200079-01-R1.A3L	Test Dates: 05/22/19 - 07/07/19	DUT Type: Portable Handset		Page 84 of 220

9.4.1

LTE Band 25 (PCS)

Table 9-48
LTE Band 25 (PCS) Maximum Conducted Powers - 20 MHz Bandwidth

LTE Band 25 (PCS) 20 MHz Bandwidth							
Modulation	RB Size	RB Offset	Low Channel	Mid Channel	High Channel	MPR Allowed per 3GPP [dB]	MPR [dB]
			26140 (1860.0 MHz)	26365 (1882.5 MHz)	26590 (1905.0 MHz)		
Conducted Power [dBm]							
QPSK	1	0	23.98	24.20	23.94	0	0
	1	50	24.01	24.11	23.95		0
	1	99	24.10	24.10	24.05		0
	50	0	23.07	23.22	22.99	0-1	1
	50	25	23.16	23.25	23.06		1
	50	50	23.19	23.24	23.10		1
	100	0	23.13	23.21	23.05		1
16QAM	1	0	23.24	23.40	23.27	0-1	1
	1	50	23.25	23.41	23.26		1
	1	99	23.40	23.44	23.34		1
	50	0	22.07	22.17	21.97	0-2	2
	50	25	22.15	22.26	22.06		2
	50	50	22.19	22.27	22.15		2
	100	0	22.06	22.23	22.05		2
64QAM	1	0	22.17	22.36	22.18	0-2	2
	1	50	22.25	22.38	22.15		2
	1	99	22.33	22.43	22.30		2
	50	0	21.07	21.22	21.01	0-3	3
	50	25	21.16	21.29	21.09		3
	50	50	21.18	21.28	21.14		3
	100	0	21.09	21.22	21.06		3
256QAM	1	0	19.03	19.30	19.10	0-5	5
	1	50	19.14	19.24	19.06		5
	1	99	19.24	19.34	19.10		5
	50	0	19.04	19.22	18.95		5
	50	25	19.16	19.27	19.05		5
	50	50	19.15	19.31	19.14		5
	100	0	19.07	19.24	19.06		5



FCC ID: A3LSMN975U		SAR EVALUATION REPORT		Approved by: Quality Manager
Document S/N: 1M1905200079-01-R1.A3L	Test Dates: 05/22/19 - 07/07/19	DUT Type: Portable Handset	Page 85 of 220	

Table 9-49
LTE Band 25 (PCS) Maximum Conducted Powers - 15 MHz Bandwidth

LTE Band 25 (PCS) 15 MHz Bandwidth							
Modulation	RB Size	RB Offset	Low Channel	Mid Channel	High Channel	MPR Allowed per 3GPP [dB]	MPR [dB]
			26115 (1857.5 MHz)	26365 (1882.5 MHz)	26615 (1907.5 MHz)		
			Conducted Power [dBm]				
QPSK	1	0	23.85	24.22	23.97	0	0
	1	36	24.03	24.19	23.95		0
	1	74	24.13	24.19	23.89		0
	36	0	23.04	23.28	23.00	0-1	1
	36	18	23.14	23.35	23.14		1
	36	37	23.20	23.33	23.17		1
	75	0	23.20	23.33	23.12		1
16QAM	1	0	23.26	23.47	23.50	0-1	1
	1	36	23.35	23.22	23.26		1
	1	74	23.48	23.50	23.28		1
	36	0	22.12	22.30	22.03	0-2	2
	36	18	22.19	22.37	22.16		2
	36	37	22.24	22.37	22.21		2
	75	0	22.19	22.33	22.15		2
64QAM	1	0	22.00	22.19	22.22	0-2	2
	1	36	22.34	22.18	22.23		2
	1	74	22.45	22.09	22.15		2
	36	0	21.14	21.31	21.06	0-3	3
	36	18	21.22	21.37	21.17		3
	36	37	21.25	21.39	21.20		3
	75	0	21.19	21.34	21.13		3
256QAM	1	0	19.03	19.20	19.02	0-5	5
	1	36	19.05	19.18	19.04		5
	1	74	18.99	19.16	19.10		5
	36	0	19.04	19.09	18.86		5
	36	18	19.08	19.20	19.01		5
	36	37	19.10	19.31	19.04		5
	75	0	19.02	19.13	18.98		5



FCC ID: A3LSMN975U	 PCTEST ENGINEERING LABORATORY, INC.	SAR EVALUATION REPORT		Approved by: Quality Manager
Document S/N: 1M1905200079-01-R1.A3L	Test Dates: 05/22/19 - 07/07/19	DUT Type: Portable Handset	Page 86 of 220	

Table 9-50
LTE Band 25 (PCS) Maximum Conducted Powers - 10 MHz Bandwidth

LTE Band 25 (PCS) 10 MHz Bandwidth							
Modulation	RB Size	RB Offset	Low Channel	Mid Channel	High Channel	MPR Allowed per 3GPP [dB]	MPR [dB]
			26090 (1855.0 MHz)	26365 (1882.5 MHz)	26640 (1910.0 MHz)		
			Conducted Power [dBm]				
QPSK	1	0	23.84	24.06	23.82	0	0
	1	25	23.92	24.07	23.86		0
	1	49	23.92	24.04	23.74		0
	25	0	22.95	23.21	22.94	0-1	1
	25	12	23.02	23.22	23.02		1
	25	25	23.04	23.20	23.03		1
	50	0	23.08	23.23	23.00		1
16QAM	1	0	23.15	23.31	23.07	0-1	1
	1	25	23.29	23.33	23.08		1
	1	49	23.24	23.33	23.15		1
	25	0	22.03	22.23	21.95	0-2	2
	25	12	22.08	22.25	21.99		2
	25	25	22.10	22.24	22.04		2
	50	0	22.08	22.25	22.02		2
64QAM	1	0	21.82	22.33	22.07	0-2	2
	1	25	22.00	22.24	22.09		2
	1	49	22.22	22.13	22.10		2
	25	0	21.05	21.25	20.97	0-3	3
	25	12	21.12	21.27	21.04		3
	25	25	21.11	21.28	21.03		3
	50	0	21.07	21.28	21.04		3
256QAM	1	0	19.08	19.14	18.78	0-5	5
	1	25	18.95	19.09	18.87		5
	1	49	19.05	18.89	18.84		5
	25	0	18.85	19.02	18.80		5
	25	12	18.77	19.02	18.83		5
	25	25	18.91	19.01	18.84		5
	50	0	18.84	19.04	18.83		5



FCC ID: A3LSMN975U	 PCTEST ENGINEERING LABORATORY, INC.	SAR EVALUATION REPORT		Approved by: Quality Manager
Document S/N: 1M1905200079-01-R1.A3L	Test Dates: 05/22/19 - 07/07/19	DUT Type: Portable Handset	Page 87 of 220	

Table 9-51
LTE Band 25 (PCS) Maximum Conducted Powers - 5 MHz Bandwidth

LTE Band 25 (PCS) 5 MHz Bandwidth								
Modulation	RB Size	RB Offset	Low Channel	Mid Channel	High Channel	MPR Allowed per 3GPP [dB]	MPR [dB]	
			26065 (1852.5 MHz)	26365 (1882.5 MHz)	26665 (1912.5 MHz)			
			Conducted Power [dBm]					
QPSK	1	0	23.82	24.03	23.85	0	0	
	1	12	23.95	24.17	23.90		0	
	1	24	24.02	24.15	23.54		0	
	12	0	23.01	23.19	22.99	0-1	1	
	12	6	23.08	23.26	23.05		1	
	12	13	23.11	23.24	23.08		1	
16QAM	25	0	23.10	23.21	23.03	0-1	1	
	1	0	23.22	23.31	23.13		0-1	1
	1	12	23.23	23.47	23.23			1
	1	24	23.35	23.40	23.12	0-2		1
	12	0	22.05	22.21	22.02		2	
	12	6	22.15	22.24	22.12		2	
64QAM	12	13	22.13	22.31	22.11	0-2	2	
	25	0	22.06	22.25	22.05		2	
	1	0	21.82	22.15	22.13		0-2	2
	1	12	21.95	22.16	22.21	2		
	1	24	22.02	22.10	22.01	2		
	256QAM	12	0	21.05	21.23	21.06	0-3	3
12		6	21.07	21.22	21.06	3		
12		13	21.06	21.24	21.07	3		
25		0	21.08	21.21	21.05	0-3	3	
1		0	18.68	18.80	18.77		0-5	5
1		12	18.84	19.00	18.84			5
1	24	18.82	18.99	18.75	5			
12	0	18.62	18.84	18.68	5			
12	6	18.78	18.85	18.86	5			
12	13	18.73	18.92	18.73	5			
25	0	18.74	18.89	18.74	5			



FCC ID: A3LSMN975U	 PCTEST ENGINEERING LABORATORY, INC.	SAR EVALUATION REPORT		Approved by: Quality Manager
Document S/N: 1M1905200079-01-R1.A3L	Test Dates: 05/22/19 - 07/07/19	DUT Type: Portable Handset	Page 88 of 220	

Table 9-52
LTE Band 25 (PCS) Maximum Conducted Powers - 3 MHz Bandwidth

LTE Band 25 (PCS) 3 MHz Bandwidth								
Modulation	RB Size	RB Offset	Low Channel	Mid Channel	High Channel	MPR Allowed per 3GPP [dB]	MPR [dB]	
			26055 (1851.5 MHz)	26365 (1882.5 MHz)	26675 (1913.5 MHz)			
			Conducted Power [dBm]					
QPSK	1	0	23.83	23.99	23.77	0	0	
	1	7	23.96	24.17	23.86		0	
	1	14	23.97	24.08	23.65		0	
	8	0	22.97	23.16	22.98	0-1	1	
	8	4	23.05	23.25	23.07		1	
	8	7	23.07	23.22	23.02		1	
16QAM	15	0	23.05	23.26	23.07	0-1	1	
	1	0	23.07	23.24	23.06		0-1	1
	1	7	23.17	23.46	23.15			1
	1	14	23.24	23.34	23.11	0-2		1
	8	0	22.07	22.23	22.04		2	
	8	4	22.17	22.33	22.10		2	
64QAM	8	7	22.15	22.29	22.08	0-2	2	
	15	0	22.06	22.18	22.03		2	
	1	0	21.81	22.27	22.08		0-2	2
	1	7	21.91	22.20	22.11	2		
	1	14	21.89	22.19	22.12	2		
	256QAM	8	0	21.09	21.18	21.10	0-3	3
8		4	21.08	21.18	21.10	3		
8		7	21.08	21.17	21.09	3		
15		0	21.08	21.23	21.05	0-3	3	
1		0	18.74	18.85	18.73		0-5	5
1		7	18.84	19.03	18.78			5
1	14	18.82	19.03	18.80	5			
8	0	18.66	18.88	18.69	5			
8	4	18.71	18.91	18.70	5			
8	7	18.75	18.94	18.74	5			
15	0	18.72	18.88	18.71	5			



FCC ID: A3LSMN975U	 PCTEST ENGINEERING LABORATORY, INC.	SAR EVALUATION REPORT		Approved by: Quality Manager
Document S/N: 1M1905200079-01-R1.A3L	Test Dates: 05/22/19 - 07/07/19	DUT Type: Portable Handset	Page 89 of 220	

Table 9-53
LTE Band 25 (PCS) Maximum Conducted Powers -1.4 MHz Bandwidth

LTE Band 25 (PCS) 1.4 MHz Bandwidth							
Modulation	RB Size	RB Offset	Low Channel	Mid Channel	High Channel	MPR Allowed per 3GPP [dB]	MPR [dB]
			26047 (1850.7 MHz)	26365 (1882.5 MHz)	26683 (1914.3 MHz)		
			Conducted Power [dBm]				
QPSK	1	0	23.80	24.07	23.78	0	0
	1	2	23.93	24.16	23.86		0
	1	5	23.87	24.10	23.69		0
	3	0	23.85	24.10	23.85		0
	3	2	23.93	24.19	23.94		0
	3	3	23.90	24.15	23.81		0
	6	0	23.04	23.21	22.98	0-1	1
16QAM	1	0	23.16	23.32	23.50	0-1	1
	1	2	23.24	23.40	23.23		1
	1	5	23.18	23.45	23.02		1
	3	0	23.02	23.23	23.01		1
	3	2	23.07	23.33	23.07		1
	3	3	23.11	23.28	22.93		1
	6	0	22.08	22.27	22.08	0-2	2
64QAM	1	0	21.65	21.84	22.01	0-2	2
	1	2	21.88	21.90	22.10		2
	1	5	21.60	21.86	21.96		2
	3	0	21.71	21.73	21.83		2
	3	2	21.66	21.79	21.78		2
	3	3	21.74	21.69	21.65		2
	6	0	21.04	20.72	20.87	0-3	3
256QAM	1	0	18.65	18.71	18.96	0-5	5
	1	2	18.74	18.84	18.74		5
	1	5	18.69	18.72	18.70		5
	3	0	19.01	18.87	18.80		5
	3	2	19.04	18.85	18.72		5
	3	3	18.71	18.81	18.82		5
	6	0	18.96	18.75	18.91	5	



FCC ID: A3LSMN975U		SAR EVALUATION REPORT		Approved by: Quality Manager
Document S/N: 1M1905200079-01-R1.A3L	Test Dates: 05/22/19 - 07/07/19	DUT Type: Portable Handset	Page 90 of 220	

Table 9-54
LTE Band 25 (PCS) Reduced Conducted Powers - 20 MHz Bandwidth – Hotspot Mode Active

LTE Band 25 (PCS) 20 MHz Bandwidth							
Modulation	RB Size	RB Offset	Low Channel	Mid Channel	High Channel	MPR Allowed per 3GPP [dB]	MPR [dB]
			26140 (1860.0 MHz)	26365 (1882.5 MHz)	26590 (1905.0 MHz)		
			Conducted Power [dBm]				
QPSK	1	0	17.83	18.12	17.72	0	0
	1	50	17.88	18.17	17.77		0
	1	99	17.92	17.98	17.78		0
	50	0	18.01	18.09	17.72	0-1	0
	50	25	18.11	18.14	17.83		0
	50	50	18.13	18.09	17.86		0
	100	0	18.06	18.11	17.81		0
16QAM	1	0	18.40	18.46	18.15	0-1	0
	1	50	18.41	18.49	18.13		0
	1	99	18.50	18.38	18.24		0
	50	0	18.01	18.11	17.77	0-2	0
	50	25	18.12	18.17	17.84		0
	50	50	18.18	18.17	17.84		0
	100	0	18.11	18.13	17.86		0
64QAM	1	0	18.50	18.30	17.84	0-2	0
	1	50	18.50	18.29	18.21		0
	1	99	18.50	18.19	17.95		0
	50	0	18.01	18.09	17.99	0-3	0
	50	25	18.16	18.17	17.75		0
	50	50	18.20	18.14	17.83		0
	100	0	18.08	18.09	17.89		0
256QAM	1	0	18.50	18.26	18.16	0-5	0
	1	50	18.50	18.23	18.17		0
	1	99	18.50	18.20	18.17		0
	50	0	18.50	18.21	18.10		0
	50	25	18.50	18.23	18.17		0
	50	50	18.50	18.25	18.16		0
	100	0	18.50	18.24	18.24		0



FCC ID: A3LSMN975U	 PCTEST ENGINEERING LABORATORY, INC.	SAR EVALUATION REPORT		Approved by: Quality Manager
Document S/N: 1M1905200079-01-R1.A3L	Test Dates: 05/22/19 - 07/07/19	DUT Type: Portable Handset	Page 91 of 220	

Table 9-55

LTE Band 25 (PCS) Reduced Conducted Powers - 15 MHz Bandwidth - Hotspot Mode Active

LTE Band 25 (PCS) 15 MHz Bandwidth							
Modulation	RB Size	RB Offset	Low Channel	Mid Channel	High Channel	MPR Allowed per 3GPP [dB]	MPR [dB]
			26115 (1857.5 MHz)	26365 (1882.5 MHz)	26615 (1907.5 MHz)		
			Conducted Power [dBm]				
QPSK	1	0	17.86	18.11	17.86	0	0
	1	36	18.07	18.10	18.01		0
	1	74	18.04	18.07	18.03		0
	36	0	17.88	18.19	17.95	0-1	0
	36	18	18.03	18.26	18.08		0
	36	37	18.05	18.26	18.09		0
	75	0	17.98	18.20	18.03		0
16QAM	1	0	17.78	18.22	17.54	0-1	0
	1	36	17.97	18.31	17.66		0
	1	74	18.06	18.25	17.71		0
	36	0	17.93	18.17	17.92	0-2	0
	36	18	18.06	18.27	18.05		0
	36	37	18.09	18.26	18.08		0
	75	0	17.95	18.21	18.05		0
64QAM	1	0	18.21	18.09	17.74	0-2	0
	1	36	18.11	18.23	17.92		0
	1	74	18.15	18.17	17.96		0
	36	0	17.92	18.29	18.03	0-3	0
	36	18	18.03	18.35	18.17		0
	36	37	18.06	18.34	18.20		0
	75	0	18.03	18.18	18.04		0
256QAM	1	0	17.94	18.03	17.66	0-5	0
	1	36	17.99	18.04	17.67		0
	1	74	18.11	18.10	17.54		0
	36	0	17.87	17.94	17.49		0
	36	18	17.95	18.11	17.60		0
	36	37	18.00	18.14	17.67		0
	75	0	17.94	17.96	17.54		0



FCC ID: A3LSMN975U	 PCTEST ENGINEERING LABORATORY, INC.	SAR EVALUATION REPORT		Approved by: Quality Manager
Document S/N: 1M1905200079-01-R1.A3L	Test Dates: 05/22/19 - 07/07/19	DUT Type: Portable Handset		Page 92 of 220

Table 9-56
LTE Band 25 (PCS) Reduced Conducted Powers - 10 MHz Bandwidth - Hotspot Mode Active

LTE Band 25 (PCS) 10 MHz Bandwidth							
Modulation	RB Size	RB Offset	Low Channel	Mid Channel	High Channel	MPR Allowed per 3GPP [dB]	MPR [dB]
			26090 (1855.0 MHz)	26365 (1882.5 MHz)	26640 (1910.0 MHz)		
			Conducted Power [dBm]				
QPSK	1	0	17.64	17.79	17.58	0	0
	1	25	17.59	17.75	17.53		0
	1	49	17.77	17.75	17.68		0
	25	0	17.75	18.01	17.80	0-1	0
	25	12	17.81	18.04	17.82		0
	25	25	17.85	18.05	17.83		0
	50	0	17.79	18.03	17.83		0
16QAM	1	0	17.38	18.05	17.88	0-1	0
	1	25	17.33	17.95	17.82		0
	1	49	17.51	18.05	17.99		0
	25	0	17.83	18.01	17.82	0-2	0
	25	12	17.85	18.02	17.87		0
	25	25	17.90	18.07	17.89		0
	50	0	17.81	17.97	17.86		0
64QAM	1	0	17.64	17.97	18.18	0-2	0
	1	25	17.55	17.83	18.27		0
	1	49	17.73	17.98	18.34		0
	25	0	17.83	18.11	17.80	0-3	0
	25	12	17.89	18.14	17.81		0
	25	25	17.96	18.17	17.86		0
	50	0	17.83	18.03	17.83		0
256QAM	1	0	17.71	17.88	17.59	0-5	0
	1	25	18.09	17.78	17.42		0
	1	49	17.74	17.76	17.49		0
	25	0	17.70	17.75	17.44		0
	25	12	17.75	17.74	17.42		0
	25	25	17.76	17.79	17.49		0
	50	0	17.80	17.75	17.47		0



FCC ID: A3LSMN975U		SAR EVALUATION REPORT		Approved by: Quality Manager
Document S/N: 1M1905200079-01-R1.A3L	Test Dates: 05/22/19 - 07/07/19	DUT Type: Portable Handset	Page 93 of 220	

Table 9-57

LTE Band 25 (PCS) Reduced Conducted Powers - 5 MHz Bandwidth - Hotspot Mode Active

LTE Band 25 (PCS) 5 MHz Bandwidth							
Modulation	RB Size	RB Offset	Low Channel	Mid Channel	High Channel	MPR Allowed per 3GPP [dB]	MPR [dB]
			26065 (1852.5 MHz)	26365 (1882.5 MHz)	26665 (1912.5 MHz)		
			Conducted Power [dBm]				
QPSK	1	0	17.66	17.84	17.53	0	0
	1	12	17.78	17.97	17.62		0
	1	24	17.88	17.96	17.59		0
	12	0	17.74	17.95	17.76	0-1	0
	12	6	17.86	18.03	17.84		0
	12	13	17.89	18.01	17.84		0
	25	0	17.82	17.95	17.86		0
16QAM	1	0	17.90	17.77	17.72	0-1	0
	1	12	17.98	17.92	17.86		0
	1	24	18.02	17.90	17.72		0
	12	0	17.75	17.96	17.81	0-2	0
	12	6	17.88	18.00	17.85		0
	12	13	17.89	18.03	17.87		0
	25	0	17.78	18.00	17.80		0
64QAM	1	0	17.76	18.20	17.74	0-2	0
	1	12	17.87	18.32	17.86		0
	1	24	17.97	18.26	17.80		0
	12	0	17.76	17.97	17.73	0-3	0
	12	6	17.83	18.03	17.79		0
	12	13	17.86	18.07	17.83		0
	25	0	17.85	17.96	17.80		0
256QAM	1	0	17.75	17.79	17.58	0-5	0
	1	12	17.73	17.86	17.61		0
	1	24	17.86	17.83	17.51		0
	12	0	17.65	17.65	17.45		0
	12	6	17.91	17.74	17.53		0
	12	13	17.78	17.75	17.47		0
	25	0	17.71	17.70	17.48		0



FCC ID: A3LSMN975U	 PCTEST ENGINEERING LABORATORY, INC.	SAR EVALUATION REPORT		Approved by: Quality Manager
Document S/N: 1M1905200079-01-R1.A3L	Test Dates: 05/22/19 - 07/07/19	DUT Type: Portable Handset		Page 94 of 220

Table 9-58

LTE Band 25 (PCS) Reduced Conducted Powers - 3 MHz Bandwidth - Hotspot Mode Active

LTE Band 25 (PCS) 3 MHz Bandwidth							
Modulation	RB Size	RB Offset	Low Channel	Mid Channel	High Channel	MPR Allowed per 3GPP [dB]	MPR [dB]
			26055 (1851.5 MHz)	26365 (1882.5 MHz)	26675 (1913.5 MHz)		
			Conducted Power [dBm]				
QPSK	1	0	17.58	17.72	17.59	0	0
	1	7	17.72	17.87	17.64		0
	1	14	17.72	17.81	17.59		0
	8	0	17.70	17.93	17.82	0-1	0
	8	4	17.79	17.98	17.89		0
	8	7	17.75	17.95	17.82		0
	15	0	17.75	17.99	17.81		0
16QAM	1	0	17.33	17.93	17.77	0-1	0
	1	7	17.44	18.06	17.89		0
	1	14	17.43	18.04	17.81		0
	8	0	17.60	17.80	17.86	0-2	0
	8	4	17.68	17.87	17.91		0
	8	7	17.64	17.86	17.88		0
	15	0	17.74	17.97	17.90		0
64QAM	1	0	17.47	17.84	18.25	0-2	0
	1	7	17.59	17.94	18.32		0
	1	14	17.64	17.92	18.24		0
	8	0	17.83	17.97	17.92	0-3	0
	8	4	17.94	18.05	18.01		0
	8	7	17.93	18.02	17.98		0
	15	0	17.85	18.01	17.83		0
256QAM	1	0	17.62	17.41	17.47	0-5	0
	1	7	17.78	17.49	17.55		0
	1	14	17.83	17.54	17.49		0
	8	0	17.72	17.45	17.41		0
	8	4	17.81	17.48	17.45		0
	8	7	17.79	17.50	17.39		0
	15	0	17.79	17.46	17.40		0



FCC ID: A3LSMN975U	 PCTEST ENGINEERING LABORATORY, INC.	SAR EVALUATION REPORT		Approved by: Quality Manager
Document S/N: 1M1905200079-01-R1.A3L	Test Dates: 05/22/19 - 07/07/19	DUT Type: Portable Handset		Page 95 of 220

Table 9-59
LTE Band 25 (PCS) Reduced Conducted Powers -1.4 MHz Bandwidth - Hotspot Mode Active

LTE Band 25 (PCS) 1.4 MHz Bandwidth							
Modulation	RB Size	RB Offset	Low Channel	Mid Channel	High Channel	MPR Allowed per 3GPP [dB]	MPR [dB]
			26047 (1850.7 MHz)	26365 (1882.5 MHz)	26683 (1914.3 MHz)		
			Conducted Power [dBm]				
QPSK	1	0	17.59	17.78	17.78	0	0
	1	2	17.65	17.88	17.91		0
	1	5	17.64	17.79	17.74		0
	3	0	17.62	17.86	17.65		0
	3	2	17.71	17.93	17.73		0
	3	3	17.61	17.88	17.61		0
	6	0	17.71	18.00	17.77	0-1	0
16QAM	1	0	17.30	17.98	17.74	0-1	0
	1	2	17.42	18.06	17.89		0
	1	5	17.37	18.06	17.76		0
	3	0	17.67	17.86	17.72		0
	3	2	17.78	17.96	17.80		0
	3	3	17.72	17.89	17.71		0
	6	0	17.63	17.98	17.69	0-2	0
64QAM	1	0	17.51	17.88	18.11	0-2	0
	1	2	17.65	17.95	18.21		0
	1	5	17.51	17.91	18.03		0
	3	0	17.71	17.83	17.71		0
	3	2	17.82	17.93	17.83		0
	3	3	17.73	17.90	17.67		0
	6	0	17.70	17.99	17.58	0-3	0
256QAM	1	0	17.59	17.76	17.35	0-5	0
	1	2	17.63	17.94	17.64		0
	1	5	17.64	17.79	17.41		0
	3	0	17.63	17.80	17.39		0
	3	2	17.74	17.88	17.46		0
	3	3	17.72	17.75	17.38		0
	6	0	17.59	17.66	17.35	0	



FCC ID: A3LSMN975U		SAR EVALUATION REPORT		Approved by: Quality Manager
Document S/N: 1M1905200079-01-R1.A3L	Test Dates: 05/22/19 - 07/07/19	DUT Type: Portable Handset	Page 96 of 220	

Table 9-60

LTE Band 25 (PCS) Reduced Conducted Powers - 20 MHz Bandwidth – Grip Sensor and/or Earjack Mode Active

LTE Band 25 (PCS) 20 MHz Bandwidth							
Modulation	RB Size	RB Offset	Low Channel	Mid Channel	High Channel	MPR Allowed per 3GPP [dB]	MPR [dB]
			26140 (1860.0 MHz)	26365 (1882.5 MHz)	26590 (1905.0 MHz)		
			Conducted Power [dBm]				
QPSK	1	0	20.72	20.88	20.57	0	0
	1	50	20.84	20.98	20.62		0
	1	99	20.71	20.78	20.64		0
	50	0	20.78	20.98	20.70	0-1	0
	50	25	20.87	21.00	20.78		0
	50	50	20.89	20.62	20.86		0
	100	0	20.85	20.97	20.77		0
16QAM	1	0	20.93	20.94	20.96	0-1	0
	1	50	20.96	20.88	20.95		0
	1	99	21.00	20.89	21.00		0
	50	0	20.79	21.00	20.69	0-2	0
	50	25	20.89	20.98	20.82		0
	50	50	20.88	20.95	20.86		0
	100	0	20.84	21.00	20.76		0
64QAM	1	0	20.75	20.91	20.89	0-2	0
	1	50	20.83	20.93	20.85		0
	1	99	20.96	21.00	20.77		0
	50	0	20.74	20.88	20.74	0-3	0
	50	25	20.91	20.97	20.89		0
	50	50	20.92	21.00	20.85		0
	100	0	20.79	20.97	20.83		0
256QAM	1	0	19.38	19.46	19.30	0-5	1
	1	50	19.40	19.42	19.49		1
	1	99	19.49	19.46	19.48		1
	50	0	19.22	19.49	19.26		1
	50	25	19.39	19.47	19.39		1
	50	50	19.44	19.49	19.43		1
	100	0	19.32	19.47	19.34		1



FCC ID: A3LSMN975U	 PCTEST ENGINEERING LABORATORY, INC.	SAR EVALUATION REPORT		Approved by: Quality Manager
Document S/N: 1M1905200079-01-R1.A3L	Test Dates: 05/22/19 - 07/07/19	DUT Type: Portable Handset		Page 97 of 220

Table 9-61
LTE Band 25 (PCS) Reduced Conducted Powers - 15 MHz Bandwidth - Grip Sensor and/or Earjack Mode Active

LTE Band 25 (PCS) 15 MHz Bandwidth							
Modulation	RB Size	RB Offset	Low Channel	Mid Channel	High Channel	MPR Allowed per 3GPP [dB]	MPR [dB]
			26115 (1857.5 MHz)	26365 (1882.5 MHz)	26615 (1907.5 MHz)		
			Conducted Power [dBm]				
QPSK	1	0	20.78	20.67	20.69	0	0
	1	36	20.82	20.75	20.87		0
	1	74	20.89	20.68	20.83		0
	36	0	20.75	20.58	20.81	0-1	0
	36	18	20.87	20.69	20.91		0
	36	37	20.89	20.68	20.94		0
	75	0	20.80	20.65	20.88		0
16QAM	1	0	20.65	20.77	20.93	0-1	0
	1	36	20.60	20.78	20.91		0
	1	74	20.56	20.78	20.87		0
	36	0	20.76	20.64	20.83	0-2	0
	36	18	20.89	20.78	20.98		0
	36	37	20.94	20.76	21.00		0
	75	0	20.89	20.69	20.95		0
64QAM	1	0	20.68	20.71	20.62	0-2	0
	1	36	20.71	20.75	20.63		0
	1	74	20.83	20.60	20.69		0
	36	0	20.85	20.64	20.93	0-3	0
	36	18	20.99	20.74	20.71		0
	36	37	20.72	20.71	20.65		0
	75	0	20.87	20.72	20.88		0
256QAM	1	0	19.43	19.84	19.53	0-5	1
	1	36	19.52	19.91	19.47		1
	1	74	19.41	19.67	19.35		1
	36	0	19.38	19.65	19.33		1
	36	18	19.53	19.77	19.49		1
	36	37	19.55	19.78	19.52		1
	75	0	19.61	19.75	19.46		1



FCC ID: A3LSMN975U	 PCTEST ENGINEERING LABORATORY, INC.	SAR EVALUATION REPORT		Approved by: Quality Manager
Document S/N: 1M1905200079-01-R1.A3L	Test Dates: 05/22/19 - 07/07/19	DUT Type: Portable Handset		Page 98 of 220

Table 9-62
LTE Band 25 (PCS) Reduced Conducted Powers - 10 MHz Bandwidth - Grip Sensor and/or Earjack Mode Active

LTE Band 25 (PCS) 10 MHz Bandwidth								
Modulation	RB Size	RB Offset	Low Channel	Mid Channel	High Channel	MPR Allowed per 3GPP [dB]	MPR [dB]	
			26090 (1855.0 MHz)	26365 (1882.5 MHz)	26640 (1910.0 MHz)			
			Conducted Power [dBm]					
QPSK	1	0	20.52	20.71	20.49	0	0	
	1	25	20.61	20.57	20.45		0	
	1	49	20.67	20.70	20.58		0	
	25	0	20.62	20.85	20.60	0-1	0	
	25	12	20.63	20.86	20.67		0	
	25	25	20.73	20.88	20.68		0	
16QAM	50	0	20.67	20.87	20.63	0-1	0	
	1	0	20.45	20.80	20.65		0-1	0
	1	25	20.50	20.78	20.57			0
	1	49	20.66	20.82	20.81	0-2		0
	25	0	20.66	20.84	20.68		0	
	25	12	20.72	20.88	20.74		0	
64QAM	25	25	20.76	20.92	20.73	0-2	0	
	50	0	20.66	20.88	20.70		0-3	0
	1	0	20.68	20.78	20.78			0-2
	1	25	20.65	20.67	20.63	0		
	1	49	20.61	20.76	20.82	0		
	25	0	20.73	20.95	20.65	0-3	0	
25	12	20.74	20.96	20.70	0			
25	25	20.81	21.00	20.71	0			
256QAM	50	0	20.67	20.85	20.70	0-5	0	
	1	0	19.41	19.65	19.43		0-5	1
	1	25	19.39	19.68	19.38			1
	1	49	19.57	19.71	19.39	1		
	25	0	19.35	19.68	19.47	1		
	25	12	19.40	19.63	19.36	1		
25	25	19.33	19.72	19.32	1			
50	0	19.36	19.81	19.40	1			



FCC ID: A3LSMN975U	 PCTEST ENGINEERING LABORATORY, INC.	SAR EVALUATION REPORT		Approved by: Quality Manager
Document S/N: 1M1905200079-01-R1.A3L	Test Dates: 05/22/19 - 07/07/19	DUT Type: Portable Handset	Page 99 of 220	

Table 9-63
LTE Band 25 (PCS) Reduced Conducted Powers - 5 MHz Bandwidth - Grip Sensor and/or Earjack Mode Active

LTE Band 25 (PCS) 5 MHz Bandwidth							
Modulation	RB Size	RB Offset	Low Channel	Mid Channel	High Channel	MPR Allowed per 3GPP [dB]	MPR [dB]
			26065 (1852.5 MHz)	26365 (1882.5 MHz)	26665 (1912.5 MHz)		
			Conducted Power [dBm]				
QPSK	1	0	20.50	20.69	20.35	0	0
	1	12	20.59	20.85	20.43		0
	1	24	20.70	20.78	20.35		0
	12	0	20.64	20.79	20.61	0-1	0
	12	6	20.67	20.85	20.68		0
	12	13	20.71	20.84	20.66		0
	25	0	20.65	20.79	20.63		0
16QAM	1	0	20.70	20.60	20.56	0-1	0
	1	12	20.85	20.74	20.68		0
	1	24	20.88	20.79	20.55		0
	12	0	20.65	20.83	20.63	0-2	0
	12	6	20.74	20.92	20.73		0
	12	13	20.73	20.90	20.73		0
	25	0	20.64	20.79	20.65		0
64QAM	1	0	20.63	20.98	20.57	0-2	0
	1	12	20.76	20.88	20.68		0
	1	24	20.77	20.81	20.64		0
	12	0	20.63	20.83	20.62	0-3	0
	12	6	20.69	20.88	20.67		0
	12	13	20.74	20.85	20.67		0
	25	0	20.68	20.79	20.67		0
256QAM	1	0	19.37	19.62	19.28	0-5	1
	1	12	19.45	19.76	19.47		1
	1	24	19.46	19.63	19.36		1
	12	0	19.26	19.48	19.23		1
	12	6	19.39	19.55	19.32		1
	12	13	19.32	19.52	19.35		1
	25	0	19.35	19.56	19.33		1



FCC ID: A3LSMN975U		SAR EVALUATION REPORT		Approved by: Quality Manager
Document S/N: 1M1905200079-01-R1.A3L	Test Dates: 05/22/19 - 07/07/19	DUT Type: Portable Handset	Page 100 of 220	

Table 9-64
LTE Band 25 (PCS) Reduced Conducted Powers - 3 MHz Bandwidth - Grip Sensor and/or Earjack Mode Active

LTE Band 25 (PCS) 3 MHz Bandwidth							
Modulation	RB Size	RB Offset	Low Channel	Mid Channel	High Channel	MPR Allowed per 3GPP [dB]	MPR [dB]
			26055 (1851.5 MHz)	26365 (1882.5 MHz)	26675 (1913.5 MHz)		
			Conducted Power [dBm]				
QPSK	1	0	20.43	20.53	20.42	0	0
	1	7	20.55	20.66	20.52		0
	1	14	20.58	20.65	20.40		0
	8	0	20.57	20.75	20.61	0-1	0
	8	4	20.63	20.81	20.70		0
	8	7	20.60	20.78	20.67		0
16QAM	15	0	20.57	20.83	20.64	0-1	0
	1	0	20.22	20.77	20.62		0
	1	7	20.24	20.92	20.76		0
	1	14	20.25	20.89	20.63	0-2	0
	8	0	20.46	20.64	20.68		0
	8	4	20.55	20.76	20.78		0
64QAM	8	7	20.54	20.69	20.75	0-2	0
	15	0	20.60	20.81	20.78		0
	1	0	20.35	20.66	20.78		0-3
	1	7	20.43	20.84	20.61	0	
	1	14	20.50	20.75	20.83	0	
	8	0	20.70	20.78	20.73	0	
256QAM	8	4	20.77	20.85	20.87	0-3	0
	8	7	20.71	20.82	20.79		0
	15	0	20.69	20.82	20.69		0
	1	0	19.26	19.63	19.33	0-5	1
	1	7	19.35	19.72	19.44		1
	1	14	19.21	19.61	19.35		1
8	0	19.25	19.68	19.31	1		
8	4	19.37	19.59	19.32	1		
8	7	19.39	19.63	19.41	1		
15	0	19.28	19.72	19.45	1		





FCC ID: A3LSMN975U		SAR EVALUATION REPORT		Approved by: Quality Manager
Document S/N: 1M1905200079-01-R1.A3L	Test Dates: 05/22/19 - 07/07/19	DUT Type: Portable Handset	Page 101 of 220	

Table 9-65
LTE Band 25 (PCS) Reduced Conducted Powers -1.4 MHz Bandwidth - Grip Sensor and/or Earjack Mode Active

LTE Band 25 (PCS) 1.4 MHz Bandwidth							
Modulation	RB Size	RB Offset	Low Channel	Mid Channel	High Channel	MPR Allowed per 3GPP [dB]	MPR [dB]
			26047 (1850.7 MHz)	26365 (1882.5 MHz)	26683 (1914.3 MHz)		
			Conducted Power [dBm]				
QPSK	1	0	20.44	20.65	20.55	0	0
	1	2	20.51	20.72	20.67		0
	1	5	20.47	20.64	20.51		0
	3	0	20.42	20.68	20.47		0
	3	2	20.50	20.78	20.54		0
	3	3	20.46	20.70	20.42		0
	6	0	20.54	20.84	20.55	0-1	0
16QAM	1	0	20.47	20.84	20.61	0-1	0
	1	2	20.55	20.90	20.66		0
	1	5	20.64	20.92	20.60		0
	3	0	20.56	20.75	20.52		0
	3	2	20.64	20.80	20.62		0
	3	3	20.59	20.76	20.53		0
	6	0	20.49	20.83	20.54	0-2	0
64QAM	1	0	20.59	20.71	20.90	0-2	0
	1	2	20.67	20.77	20.86		0
	1	5	20.68	20.79	20.86		0
	3	0	20.56	20.70	20.56		0
	3	2	20.66	20.79	20.63		0
	3	3	20.60	20.74	20.50		0
	6	0	20.55	20.83	20.63	0-3	0
256QAM	1	0	19.34	19.77	19.55	0-5	1
	1	2	19.46	19.65	19.32		1
	1	5	19.42	19.51	19.31		1
	3	0	19.38	19.67	19.36		1
	3	2	19.45	19.66	19.35		1
	3	3	19.36	19.64	19.41		1
	6	0	19.49	19.68	19.44	1	



FCC ID: A3LSMN975U		SAR EVALUATION REPORT		Approved by: Quality Manager
Document S/N: 1M1905200079-01-R1.A3L	Test Dates: 05/22/19 - 07/07/19	DUT Type: Portable Handset	Page 102 of 220	

9.4.2

LTE Band 30

Table 9-66
LTE Band 30 Maximum Conducted Powers - 10 MHz Bandwidth



LTE Band 30 10 MHz Bandwidth					
Modulation	RB Size	RB Offset	Mid Channel	MPR Allowed per 3GPP [dB]	MPR [dB]
			27710 (2310.0 MHz)		
			Conducted Power [dBm]		
QPSK	1	0	23.41	0	0
	1	25	23.04		0
	1	49	23.60		0
	25	0	22.64	0-1	1
	25	12	22.43		1
	25	25	22.51		1
	50	0	22.39		1
16QAM	1	0	22.65	0-1	1
	1	25	22.72		1
	1	49	22.85		1
	25	0	21.64	0-2	2
	25	12	21.63		2
	25	25	21.60		2
	50	0	21.63		2
64QAM	1	0	21.45	0-2	2
	1	25	21.00		2
	1	49	21.54		2
	25	0	20.24	0-3	3
	25	12	20.36		3
	25	25	20.10		3
	50	0	20.20		3
256QAM	1	0	18.67	0-5	5
	1	25	18.63		5
	1	49	18.60		5
	25	0	18.63		5
	25	12	18.63		5
	25	25	18.60		5
	50	0	18.64		5

FCC ID: A3LSMN975U	 PCTEST ENGINEERING LABORATORY, INC.	SAR EVALUATION REPORT		Approved by: Quality Manager
Document S/N: 1M1905200079-01-R1.A3L	Test Dates: 05/22/19 - 07/07/19	DUT Type: Portable Handset	Page 103 of 220	

**Table 9-67
LTE Band 30 Maximum Conducted Powers - 5 MHz Bandwidth**



LTE Band 30 5 MHz Bandwidth					
Modulation	RB Size	RB Offset	Mid Channel	MPR Allowed per 3GPP [dB]	MPR [dB]
			27710		
			(2310.0 MHz) Conducted Power [dBm]		
QPSK	1	0	23.01	0	0
	1	12	22.99		0
	1	24	23.24		0
	12	0	22.37	0-1	1
	12	6	22.36		1
	12	13	22.32		1
	25	0	22.15		1
16QAM	1	0	22.67	0-1	1
	1	12	22.76		1
	1	24	22.58		1
	12	0	21.69	0-2	2
	12	6	21.63		2
	12	13	21.59		2
	25	0	21.45		2
64QAM	1	0	21.21	0-2	2
	1	12	20.88		2
	1	24	21.26		2
	12	0	19.97	0-3	3
	12	6	19.89		3
	12	13	19.93		3
	25	0	19.97		3
256QAM	1	0	18.79	0-5	5
	1	12	18.67		5
	1	24	18.51		5
	12	0	18.70		5
	12	6	18.73		5
	12	13	18.63		5
	25	0	18.68		5

Note: LTE Band 30 at 5 MHz bandwidth does not support three non-overlapping channels. Per KDB Publication 941225 D05v02, when a device supports overlapping channel assignment in a channel bandwidth configuration, the middle channel of the group of overlapping channels should be selected for testing.

FCC ID: A3LSMN975U	 PCTEST ENGINEERING LABORATORY, INC.	SAR EVALUATION REPORT		Approved by: Quality Manager
Document S/N: 1M1905200079-01-R1.A3L	Test Dates: 05/22/19 - 07/07/19	DUT Type: Portable Handset	Page 104 of 220	

**Table 9-68
LTE Band 30 Reduced Conducted Powers - 10 MHz Bandwidth - Hotspot Mode Active**

LTE Band 30 10 MHz Bandwidth					
Modulation	RB Size	RB Offset	Mid Channel	MPR Allowed per 3GPP [dB]	MPR [dB]
			27710		
			(2310.0 MHz) Conducted Power [dBm]		
QPSK	1	0	20.50	0	0
	1	25	20.16		0
	1	49	20.15		0
	25	0	20.27	0-1	0
	25	12	20.28		0
	25	25	20.26		0
	50	0	20.23		0
16QAM	1	0	20.48	0-1	0
	1	25	20.46		0
	1	49	20.45		0
	25	0	20.25	0-2	0
	25	12	20.30		0
	25	25	20.23		0
	50	0	20.27		0
64QAM	1	0	20.33	0-2	0
	1	25	20.34		0
	1	49	20.37		0
	25	0	19.93	0-3	0
	25	12	19.87		0
	25	25	19.60		0
	50	0	19.79		0
256QAM	1	0	18.15	0-5	1.5
	1	25	18.12		1.5
	1	49	18.09		1.5
	25	0	18.07		1.5
	25	12	18.05		1.5
	25	25	18.04		1.5
	50	0	18.04		1.5

FCC ID: A3LSMN975U	 PCTEST ENGINEERING LABORATORY, INC.	SAR EVALUATION REPORT		Approved by: Quality Manager
Document S/N: 1M1905200079-01-R1.A3L	Test Dates: 05/22/19 - 07/07/19	DUT Type: Portable Handset	Page 105 of 220	

**Table 9-69
LTE Band 30 Reduced Conducted Powers - 5 MHz Bandwidth - Hotspot Mode Active**

LTE Band 30 5 MHz Bandwidth					
Modulation	RB Size	RB Offset	Mid Channel	MPR Allowed per 3GPP [dB]	MPR [dB]
			27710		
			(2310.0 MHz) Conducted Power [dBm]		
QPSK	1	0	20.23	0	0
	1	12	19.98		0
	1	24	20.08		0
	12	0	20.22	0-1	0
	12	6	20.19		0
	12	13	20.21		0
	25	0	20.15		0
16QAM	1	0	20.23	0-1	0
	1	12	20.41		0
	1	24	20.36		0
	12	0	20.14	0-2	0
	12	6	20.17		0
	12	13	20.20		0
	25	0	20.14		0
64QAM	1	0	20.36	0-2	0
	1	12	20.24		0
	1	24	20.21		0
	12	0	20.32	0-3	0
	12	6	20.11		0
	12	13	20.04		0
	25	0	20.05		0
256QAM	1	0	18.22	0-5	1.5
	1	12	18.17		1.5
	1	24	18.14		1.5
	12	0	18.09		1.5
	12	6	18.15		1.5
	12	13	18.10		1.5
	25	0	18.12		1.5

Note: LTE Band 30 at 5 MHz bandwidth does not support three non-overlapping channels. Per KDB Publication 941225 D05v02, when a device supports overlapping channel assignment in a channel bandwidth configuration, the middle channel of the group of overlapping channels should be selected for testing.



FCC ID: A3LSMN975U	 PCTEST ENGINEERING LABORATORY, INC.	SAR EVALUATION REPORT		Approved by: Quality Manager
Document S/N: 1M1905200079-01-R1.A3L	Test Dates: 05/22/19 - 07/07/19	DUT Type: Portable Handset		Page 106 of 220

Table 9-70

LTE Band 30 Reduced Conducted Powers - 10 MHz Bandwidth - Grip Sensor and/or Earjack Mode Active

LTE Band 30 10 MHz Bandwidth					
Modulation	RB Size	RB Offset	Mid Channel	MPR Allowed per 3GPP [dB]	MPR [dB]
			27710		
			(2310.0 MHz) Conducted Power [dBm]		
QPSK	1	0	22.52	0	0
	1	25	22.55		0
	1	49	22.60		0
	25	0	22.64	0-1	0
	25	12	22.65		0
	25	25	22.67		0
	50	0	22.51		0
16QAM	1	0	22.79	0-1	0
	1	25	22.76		0
	1	49	22.77		0
	25	0	21.67	0-2	1
	25	12	21.64		1
	25	25	21.63		1
	50	0	21.62		1
64QAM	1	0	21.45	0-2	1
	1	25	21.34		1
	1	49	21.60		1
	25	0	20.62	0-3	2
	25	12	20.52		2
	25	25	20.40		2
	50	0	20.37		2
256QAM	1	0	18.75	0-5	4
	1	25	18.66		4
	1	49	18.64		4
	25	0	18.60		4
	25	12	18.57		4
	25	25	18.55		4
	50	0	18.89		4





FCC ID: A3LSMN975U	 PCTEST ENGINEERING LABORATORY, INC.	SAR EVALUATION REPORT		Approved by: Quality Manager
Document S/N: 1M1905200079-01-R1.A3L	Test Dates: 05/22/19 - 07/07/19	DUT Type: Portable Handset		Page 107 of 220

Table 9-71

LTE Band 30 Reduced Conducted Powers - 5 MHz Bandwidth - Grip Sensor and/or Earjack Mode Active

LTE Band 30 5 MHz Bandwidth					
Modulation	RB Size	RB Offset	Mid Channel	MPR Allowed per 3GPP [dB]	MPR [dB]
			27710		
			(2310.0 MHz) Conducted Power [dBm]		
QPSK	1	0	22.40	0	0
	1	12	22.57		0
	1	24	22.44		0
	12	0	22.63	0-1	0
	12	6	22.65		0
	12	13	22.54		0
	25	0	22.49		0
16QAM	1	0	22.67	0-1	0
	1	12	22.69		0
	1	24	22.72		0
	12	0	21.85	0-2	1
	12	6	21.67		1
	12	13	21.59		1
	25	0	21.64		1
64QAM	1	0	21.31	0-2	1
	1	12	21.21		1
	1	24	21.28		1
	12	0	20.42	0-3	2
	12	6	20.33		2
	12	13	20.30		2
	25	0	20.45		2
256QAM	1	0	18.93	0-5	4
	1	12	18.88		4
	1	24	18.92		4
	12	0	18.85		4
	12	6	18.81		4
	12	13	18.88		4
	25	0	18.77		4

Note: LTE Band 30 at 5 MHz bandwidth does not support three non-overlapping channels. Per KDB Publication 941225 D05v02, when a device supports overlapping channel assignment in a channel bandwidth configuration, the middle channel of the group of overlapping channels should be selected for testing.



FCC ID: A3LSMN975U	 PCTEST ENGINEERING LABORATORY, INC.	SAR EVALUATION REPORT		Approved by: Quality Manager
Document S/N: 1M1905200079-01-R1.A3L	Test Dates: 05/22/19 - 07/07/19	DUT Type: Portable Handset		Page 108 of 220

9.4.3

LTE Band 7



Table 9-72
 LTE Band 7 Maximum Conducted Powers - 20 MHz Bandwidth

LTE Band 7 20 MHz Bandwidth							
Modulation	RB Size	RB Offset	Low Channel	Mid Channel	High Channel	MPR Allowed per 3GPP [dB]	MPR [dB]
			20850 (2510.0 MHz)	21100 (2535.0 MHz)	21350 (2560.0 MHz)		
Conducted Power [dBm]							
QPSK	1	0	23.51	23.83	24.18	0	0
	1	50	23.55	23.75	24.10		0
	1	99	23.70	23.53	24.03		0
	50	0	22.61	22.87	23.32	0-1	1
	50	25	22.62	22.83	23.29		1
	50	50	22.57	22.51	23.12		1
16QAM	100	0	22.60	22.80	23.17	0-1	1
	1	0	22.73	23.10	23.24		1
	1	50	22.77	23.06	23.21		1
	1	99	22.93	22.97	23.14	0-2	1
	50	0	21.70	21.96	22.30		2
	50	25	21.76	22.06	22.23		2
64QAM	50	50	21.69	21.85	22.13	0-2	2
	100	0	21.67	21.91	22.20		2
	1	0	21.43	21.60	21.85		0-2
	1	50	21.57	21.57	21.99	2	
	1	99	21.55	21.50	21.68	0-3	
	50	0	20.51	20.83	21.00		3
50	25	20.74	20.51	21.11	3		
256QAM	50	50	20.54	20.50	21.00	0-3	3
	100	0	20.50	20.54	20.89		3
	1	0	19.30	19.30	19.32		0-5
	1	50	19.29	19.39	19.23	5	
	1	99	19.23	19.25	19.15	5	
	50	0	19.24	19.29	19.24	5	
50	25	19.31	19.20	19.18	5		
50	50	19.27	19.35	19.10	5		
100	0	19.28	19.20	19.15	5		

FCC ID: A3LSMN975U		SAR EVALUATION REPORT		Approved by: Quality Manager
Document S/N: 1M1905200079-01-R1.A3L	Test Dates: 05/22/19 - 07/07/19	DUT Type: Portable Handset	Page 109 of 220	

**Table 9-73
LTE Band 7 Maximum Conducted Powers - 15 MHz Bandwidth**

LTE Band 7 15 MHz Bandwidth							
Modulation	RB Size	RB Offset	Low Channel	Mid Channel	High Channel	MPR Allowed per 3GPP [dB]	MPR [dB]
			20825 (2507.5 MHz)	21100 (2535.0 MHz)	21375 (2562.5 MHz)		
			Conducted Power [dBm]				
QPSK	1	0	23.60	23.76	23.90	0	0
	1	36	23.54	23.74	23.85		0
	1	74	23.61	23.48	23.61		0
	36	0	22.69	23.30	23.21	0-1	1
	36	18	22.52	23.25	23.14		1
	36	37	22.45	22.63	22.91		1
	75	0	22.72	22.83	22.93		1
16QAM	1	0	23.02	23.12	23.35	0-1	1
	1	36	22.73	22.98	23.24		1
	1	74	22.97	22.82	23.10		1
	36	0	21.87	22.24	22.19	0-2	2
	36	18	21.69	22.19	22.13		2
	36	37	21.41	21.72	22.06		2
	75	0	21.52	21.87	22.05		2
64QAM	1	0	21.50	21.49	21.91	0-2	2
	1	36	21.62	21.37	21.79		2
	1	74	21.40	21.30	21.60		2
	36	0	20.35	20.67	21.06	0-3	3
	36	18	20.25	20.59	21.13		3
	36	37	20.29	20.55	20.45		3
	75	0	20.35	20.38	20.60		3
256QAM	1	0	18.92	19.30	19.21	0-5	5
	1	36	19.13	19.19	19.28		5
	1	74	19.17	19.18	18.95		5
	36	0	19.19	19.14	19.13		5
	36	18	19.13	19.16	19.05		5
	36	37	19.20	19.15	18.97		5
	75	0	19.16	19.23	19.03		5

FCC ID: A3LSMN975U	 PCTEST ENGINEERING LABORATORY, INC.	SAR EVALUATION REPORT		Approved by: Quality Manager
Document S/N: 1M1905200079-01-R1.A3L	Test Dates: 05/22/19 - 07/07/19	DUT Type: Portable Handset	Page 110 of 220	

**Table 9-74
LTE Band 7 Maximum Conducted Powers - 10 MHz Bandwidth**

LTE Band 7 10 MHz Bandwidth								
Modulation	RB Size	RB Offset	Low Channel	Mid Channel	High Channel	MPR Allowed per 3GPP [dB]	MPR [dB]	
			20800 (2505.0 MHz)	21100 (2535.0 MHz)	21400 (2565.0 MHz)			
			Conducted Power [dBm]					
QPSK	1	0	23.79	23.78	23.81	0	0	
	1	25	23.59	23.76	23.61		0	
	1	49	23.35	23.57	23.49		0	
	25	0	22.98	23.07	22.96	0-1	1	
	25	12	22.76	22.82	22.91		1	
	25	25	22.50	22.59	22.92		1	
16QAM	50	0	22.44	22.51	22.82	0-1	1	
	1	0	22.86	23.05	23.19		0-1	1
	1	25	22.79	23.04	23.05			1
	1	49	22.64	22.85	22.86	0-2		1
	25	0	21.84	22.07	21.95		2	
	25	12	22.01	22.10	21.95		2	
64QAM	25	25	21.54	21.74	21.66	0-2	2	
	50	0	21.54	21.72	21.83		0-2	2
	1	0	21.25	21.38	21.61			0-3
	1	25	21.24	21.29	21.66	0-3		
	1	49	21.20	21.17	21.44		0-3	
	25	0	20.34	20.34	20.44			0-3
256QAM	25	12	20.33	20.31	20.95	0-3		
	25	25	20.33	20.27	20.42		0-3	
	50	0	20.30	20.25	20.33			0-5
	1	0	18.88	19.03	19.07	0-5		
	1	25	19.03	19.10	18.88		5	
	1	49	18.99	19.05	18.85		5	
25	0	19.08	19.10	18.95	5			
25	12	19.05	19.08	18.93	5			
25	25	18.95	19.05	18.83	5			
50	0	18.89	19.10	18.90	5			



FCC ID: A3LSMN975U	 PCTEST ENGINEERING LABORATORY, INC.	SAR EVALUATION REPORT		Approved by: Quality Manager
Document S/N: 1M1905200079-01-R1.A3L	Test Dates: 05/22/19 - 07/07/19	DUT Type: Portable Handset	Page 111 of 220	

Table 9-75
LTE Band 7 Maximum Conducted Powers - 5 MHz Bandwidth

LTE Band 7 5 MHz Bandwidth							
Modulation	RB Size	RB Offset	Low Channel	Mid Channel	High Channel	MPR Allowed per 3GPP [dB]	MPR [dB]
			20775 (2502.5 MHz)	21100 (2535.0 MHz)	21425 (2567.5 MHz)		
			Conducted Power [dBm]				
QPSK	1	0	23.55	23.88	23.79	0	0
	1	12	23.48	23.79	23.69		0
	1	24	23.51	23.68	23.41		0
	12	0	22.68	22.87	22.96	0-1	1
	12	6	23.00	22.87	22.85		1
	12	13	22.87	22.69	22.95		1
	25	0	22.70	22.65	22.84		1
16QAM	1	0	22.97	22.92	23.01	0-1	1
	1	12	23.12	22.95	22.81		1
	1	24	22.91	22.85	22.79		1
	12	0	22.00	22.00	21.97	0-2	2
	12	6	22.15	22.08	21.88		2
	12	13	22.00	21.90	21.57		2
	25	0	21.88	21.78	21.64		2
64QAM	1	0	21.68	21.45	21.76	0-2	2
	1	12	21.60	21.40	21.65		2
	1	24	21.40	21.38	21.64		2
	12	0	20.30	20.40	20.70	0-3	3
	12	6	20.30	20.38	20.55		3
	12	13	20.22	20.30	20.50		3
	25	0	20.23	20.29	20.47		3
256QAM	1	0	18.90	19.15	18.93	0-5	5
	1	12	18.88	19.23	19.10		5
	1	24	18.80	19.20	19.06		5
	12	0	18.79	19.04	18.87		5
	12	6	18.75	19.12	18.96		5
	12	13	18.72	19.13	18.91		5
	25	0	18.84	19.12	18.91		5



FCC ID: A3LSMN975U	 PCTEST ENGINEERING LABORATORY, INC.	SAR EVALUATION REPORT		Approved by: Quality Manager
Document S/N: 1M1905200079-01-R1.A3L	Test Dates: 05/22/19 - 07/07/19	DUT Type: Portable Handset	Page 112 of 220	

Table 9-76

LTE Band 7 Reduced Conducted Powers - 20 MHz Bandwidth – Hotspot/Grip Sensor and/or Earjack Mode Active

LTE Band 7 20 MHz Bandwidth							
Modulation	RB Size	RB Offset	Low Channel	Mid Channel	High Channel	MPR Allowed per 3GPP [dB]	MPR [dB]
			20850 (2510.0 MHz)	21100 (2535.0 MHz)	21350 (2560.0 MHz)		
			Conducted Power [dBm]				
QPSK	1	0	20.78	20.93	20.89	0	0
	1	50	20.71	20.80	20.85		0
	1	99	20.86	20.70	20.88		0
	50	0	20.81	21.10	21.04	0-1	0
	50	25	20.87	20.96	20.93		0
	50	50	20.88	20.89	20.87		0
	100	0	20.85	20.92	20.91		0
16QAM	1	0	20.89	20.93	21.19	0-1	0
	1	50	20.97	21.04	21.06		0
	1	99	20.99	20.93	21.09		0
	50	0	20.78	21.03	21.00	0-2	0
	50	25	20.86	20.96	20.99		0
	50	50	20.85	20.89	20.89		0
	100	0	20.81	20.97	20.95		0
64QAM	1	0	20.74	21.12	21.18	0-2	0
	1	50	20.61	21.03	21.03		0
	1	99	20.98	20.78	21.03		0
	50	0	19.80	19.82	20.04	0-3	0.5
	50	25	19.86	19.94	19.98		0.5
	50	50	19.61	19.70	19.90		0.5
	100	0	19.60	19.96	19.95		0.5
256QAM	1	0	17.84	18.11	18.06	0-5	2.5
	1	50	17.78	17.96	18.02		2.5
	1	99	17.94	17.82	17.90		2.5
	50	0	17.86	18.00	18.01		2.5
	50	25	17.84	17.91	17.92		2.5
	50	50	17.83	17.86	17.87		2.5
	100	0	17.81	17.94	17.92		2.5



FCC ID: A3LSMN975U		SAR EVALUATION REPORT		Approved by: Quality Manager
Document S/N: 1M1905200079-01-R1.A3L	Test Dates: 05/22/19 - 07/07/19	DUT Type: Portable Handset	Page 113 of 220	

Table 9-77

LTE Band 7 Reduced Conducted Powers - 15 MHz Bandwidth – Hotspot/Grip Sensor and/or Earjack Mode Active

LTE Band 7 15 MHz Bandwidth								
Modulation	RB Size	RB Offset	Low Channel	Mid Channel	High Channel	MPR Allowed per 3GPP [dB]	MPR [dB]	
			20825 (2507.5 MHz)	21100 (2535.0 MHz)	21375 (2562.5 MHz)			
Conducted Power [dBm]								
QPSK	1	0	20.65	20.90	20.86	0	0	
	1	36	20.71	20.96	20.90		0	
	1	74	20.75	20.87	20.77		0	
	QPSK	36	0	20.75	21.00	20.98	0-1	0
		36	18	20.85	21.02	20.98		0
		36	37	20.85	20.95	20.95		0
		75	0	20.86	21.00	20.98		0
16QAM	1	0	20.75	20.96	21.10	0-1	0	
	1	36	20.80	21.10	21.16		0	
	1	74	20.88	20.96	20.99		0	
	16QAM	36	0	20.75	21.06	21.04	0-2	0
		36	18	20.89	21.09	21.04		0
		36	37	20.84	21.02	20.98		0
		75	0	20.84	20.98	21.02		0
64QAM	1	0	20.73	21.41	21.37	0-2	0	
	1	36	20.89	21.42	21.39		0	
	1	74	20.91	21.31	21.43		0	
	64QAM	36	0	19.86	20.04	20.11	0-3	0.5
		36	18	19.95	20.04	20.12		0.5
		36	37	19.80	19.96	20.07		0.5
		75	0	19.87	20.05	19.95		0.5
256QAM	1	0	17.78	17.96	17.97	0-5	2.5	
	1	36	17.75	17.94	17.95		2.5	
	1	74	17.89	17.97	17.99		2.5	
	36	0	17.80	17.92	17.98		2.5	
	36	18	17.82	17.93	17.96		2.5	
	36	37	17.78	17.94	17.94		2.5	
	75	0	17.75	17.94	18.01		2.5	



FCC ID: A3LSMN975U	 PCTEST ENGINEERING LABORATORY, INC.	SAR EVALUATION REPORT		Approved by: Quality Manager
Document S/N: 1M1905200079-01-R1.A3L	Test Dates: 05/22/19 - 07/07/19	DUT Type: Portable Handset	Page 114 of 220	

Table 9-78
LTE Band 7 Reduced Conducted Powers - 10 MHz Bandwidth – Hotspot/Grip Sensor and/or Earjack Mode Active

LTE Band 7 10 MHz Bandwidth							
Modulation	RB Size	RB Offset	Low Channel	Mid Channel	High Channel	MPR Allowed per 3GPP [dB]	MPR [dB]
			20800 (2505.0 MHz)	21100 (2535.0 MHz)	21400 (2565.0 MHz)		
			Conducted Power [dBm]				
QPSK	1	0	20.45	20.55	20.70	0	0
	1	25	20.44	20.56	20.60		0
	1	49	20.59	20.67	20.68		0
	25	0	20.58	20.87	20.82	0-1	0
	25	12	20.56	20.85	20.79		0
	25	25	20.58	20.80	20.79		0
16QAM	50	0	20.53	20.84	20.78	0-1	0
	1	0	20.50	20.82	20.97		0
	1	25	20.52	20.74	20.84		0
	1	49	20.58	20.76	20.89	0-2	0
	25	0	20.65	20.88	20.88		0
	25	12	20.66	20.87	20.88		0
64QAM	25	25	20.65	20.84	20.85	0-2	0
	50	0	20.59	20.83	20.86		0
	1	0	20.62	20.88	20.81		0-3
	1	25	20.61	20.76	20.69	0	
	1	49	20.75	20.80	20.86	0	
	256QAM	25	0	19.80	20.04	19.90	0-3
25		12	19.73	20.01	19.88	0.5	
25		25	19.71	19.94	19.86	0.5	
50		0	19.63	19.85	19.84	0-5	0.5
1		0	17.97	17.85	17.77		2.5
1		25	18.01	17.89	17.86		2.5
256QAM	1	49	18.09	17.85	17.91	0-5	2.5
	25	0	17.98	17.65	17.88		2.5
	25	12	17.85	17.96	17.87		2.5
	25	25	17.88	17.95	17.85	2.5	
	50	0	18.02	17.92	17.89	2.5	





FCC ID: A3LSMN975U	 PCTEST ENGINEERING LABORATORY, INC.	SAR EVALUATION REPORT		Approved by: Quality Manager
Document S/N: 1M1905200079-01-R1.A3L	Test Dates: 05/22/19 - 07/07/19	DUT Type: Portable Handset	Page 115 of 220	

Table 9-79

LTE Band 7 Reduced Conducted Powers - 5 MHz Bandwidth – Hotspot/Grip Sensor and/or Earjack Mode Active

LTE Band 7 5 MHz Bandwidth							
Modulation	RB Size	RB Offset	Low Channel	Mid Channel	High Channel	MPR Allowed per 3GPP [dB]	MPR [dB]
			20775 (2502.5 MHz)	21100 (2535.0 MHz)	21425 (2567.5 MHz)		
			Conducted Power [dBm]				
QPSK	1	0	20.64	20.71	20.55	0	0
	1	12	20.55	20.84	20.70		0
	1	24	20.63	20.85	20.69		0
	12	0	20.48	20.79	20.75	0-1	0
	12	6	20.62	20.86	20.87		0
	12	13	20.70	20.95	20.86		0
	25	0	20.60	20.81	20.83		0
16QAM	1	0	20.57	20.63	20.73	0-1	0
	1	12	20.80	20.79	20.89		0
	1	24	20.85	20.81	20.86		0
	12	0	20.54	20.82	20.82	0-2	0
	12	6	20.67	20.94	20.97		0
	12	13	20.72	20.97	20.91		0
	25	0	20.65	20.83	20.83		0
64QAM	1	0	20.51	21.09	20.80	0-2	0
	1	12	20.73	21.25	20.95		0
	1	24	20.80	21.19	20.70		0
	12	0	19.52	19.88	19.75	0-3	0.5
	12	6	19.70	19.93	19.88		0.5
	12	13	19.72	19.98	19.85		0.5
	25	0	19.66	19.80	19.82		0.5
256QAM	1	0	17.85	17.90	17.89	0-5	2.5
	1	12	17.89	17.91	17.83		2.5
	1	24	18.01	17.86	17.86		2.5
	12	0	17.85	17.82	17.85		2.5
	12	6	17.77	17.84	17.90		2.5
	12	13	17.89	17.82	17.84		2.5
	25	0	17.92	17.81	17.80		2.5



FCC ID: A3LSMN975U	 PCTEST ENGINEERING LABORATORY, INC.	SAR EVALUATION REPORT		Approved by: Quality Manager
Document S/N: 1M1905200079-01-R1.A3L	Test Dates: 05/22/19 - 07/07/19	DUT Type: Portable Handset	Page 116 of 220	

9.4.1

LTE Band 48



Table 9-80
LTE Band 48 Conducted Powers - 20 MHz Bandwidth

LTE Band 48 20 MHz Bandwidth								
Modulation	RB Size	RB Offset	Low Channel	Low-Mid Channel	Mid-High Channel	High Channel	MPR Allowed per 3GPP [dB]	MPR [dB]
			55340 (3560.0 MHz)	55773 (3603.3 MHz)	56207 (3646.7 MHz)	56640 (3690.0 MHz)		
			Conducted Power [dBm]					
QPSK	1	0	22.33	22.20	22.03	22.02	0	0
	1	50	22.32	22.18	22.09	22.05		0
	1	99	22.36	22.24	22.12	22.06		0
	50	0	21.62	21.62	21.32	21.34	0-1	1
	50	25	21.68	21.58	21.33	21.36		1
	50	50	21.65	21.50	21.34	21.35		1
	100	0	21.67	21.57	21.35	21.35		1
16QAM	1	0	21.50	21.36	21.24	21.24	0-1	1
	1	50	21.48	21.37	21.02	21.22		1
	1	99	21.49	21.37	21.27	21.22		1
	50	0	20.55	20.60	20.21	20.36	0-2	2
	50	25	20.59	20.64	20.37	20.37		2
	50	50	20.58	20.51	20.22	20.31		2
	100	0	20.59	20.98	20.34	20.39		2
64QAM	1	0	20.58	21.00	20.35	20.39	0-2	2
	1	50	20.57	20.52	20.37	20.36		2
	1	99	20.55	20.53	20.39	20.30		2
	50	0	19.56	19.61	19.33	19.35	0-3	3
	50	25	19.58	19.60	19.36	19.37		3
	50	50	19.59	19.51	19.34	19.32		3
	100	0	19.53	19.51	19.32	19.34		3
256QAM	1	0	17.05	17.50	16.70	16.73	0-5	5
	1	50	17.03	17.24	16.74	16.81		5
	1	99	17.04	17.15	16.78	16.66		5
	50	0	17.64	17.59	17.32	17.40		5
	50	25	17.80	17.64	17.27	17.41		5
	50	50	17.68	17.55	17.39	17.36		5
	100	0	17.76	17.57	17.30	17.35		5

FCC ID: A3LSMN975U	 PCTEST ENGINEERING LABORATORY, INC.	SAR EVALUATION REPORT		Approved by: Quality Manager
Document S/N: 1M1905200079-01-R1.A3L	Test Dates: 05/22/19 - 07/07/19	DUT Type: Portable Handset		Page 117 of 220



**Table 9-81
LTE Band 48 Conducted Powers - 15 MHz Bandwidth**

LTE Band 48 15 MHz Bandwidth									
Modulation	RB Size	RB Offset	Low Channel	Low-Mid Channel	Mid-High Channel	High Channel	MPR Allowed per 3GPP [dB]	MPR [dB]	
			55315 (3557.5 MHz)	55765 (3602.5 MHz)	56215 (3647.5 MHz)	56665 (3692.5 MHz)			
			Conducted Power [dBm]						
QPSK	1	0	22.31	22.26	22.10	22.05	0	0	
	1	36	22.34	22.25	22.13	22.04		0	
	1	74	22.30	22.33	22.09	22.19		0	
	36	0	21.64	21.52	21.22	21.17	0-1	1	
	36	18	21.64	21.54	21.30	21.31		1	
	36	37	21.59	21.50	21.28	21.24		1	
	75	0	21.61	21.51	21.27	21.32		1	
16QAM	1	0	21.69	21.55	21.38	21.39	0-1	1	
	1	36	21.65	21.53	21.34	21.41		1	
	1	74	21.67	21.63	21.17	21.43		1	
	36	0	20.54	20.49	20.22	20.32	0-2	2	
	36	18	20.59	20.51	20.28	20.26		2	
	36	37	20.53	20.49	20.25	20.28		2	
64QAM	75	0	20.57	20.56	20.28	20.19	0-2	2	
	1	0	20.51	20.35	20.16	20.29		0-2	2
	1	36	20.49	20.36	20.15	20.27			2
	1	74	20.52	20.47	20.22	20.32	0-3		2
	36	0	19.61	19.57	19.25	19.33		3	
	36	18	19.62	19.60	19.32	19.30		3	
256QAM	36	37	19.58	19.56	19.28	19.33	0-3	3	
	75	0	19.65	19.57	19.30	19.25		3	
	1	0	17.62	17.44	17.23	17.25		0-5	5
	1	36	17.61	17.41	17.24	17.29	5		
	1	74	17.60	17.55	17.21	17.36	5		
	36	0	17.64	17.62	17.17	17.33	5		
	36	18	17.69	17.62	17.35	17.37	5		
36	37	17.66	17.66	17.32	17.34	5			
75	0	17.69	17.68	17.33	17.28	5			

FCC ID: A3LSMN975U		SAR EVALUATION REPORT		Approved by: Quality Manager
Document S/N: 1M1905200079-01-R1.A3L	Test Dates: 05/22/19 - 07/07/19	DUT Type: Portable Handset	Page 118 of 220	



**Table 9-82
LTE Band 48 Conducted Powers - 10 MHz Bandwidth**

LTE Band 48 10 MHz Bandwidth								
Modulation	RB Size	RB Offset	Low Channel	Low-Mid Channel	Mid-High Channel	High Channel	MPR Allowed per 3GPP [dB]	MPR [dB]
			55290 (3555.0 MHz)	55757 (3601.7 MHz)	56223 (3648.3 MHz)	56690 (3695.0 MHz)		
			Conducted Power [dBm]					
QPSK	1	0	22.19	22.19	21.88	21.92	0	0
	1	25	22.32	22.33	21.90	21.98		0
	1	49	22.23	22.31	21.91	21.99		0
	25	0	21.46	21.39	21.05	21.12	0-1	1
	25	12	21.54	21.46	21.11	21.22		1
	25	25	21.57	21.51	21.16	21.22		1
	50	0	21.59	21.47	21.15	21.20		1
16QAM	1	0	21.50	21.56	21.19	21.22	0-1	1
	1	25	21.55	21.62	21.25	21.40		1
	1	49	21.61	21.60	21.24	21.27		1
	25	0	20.48	20.41	20.10	20.14	0-2	2
	25	12	20.52	20.50	20.05	20.19		2
	25	25	20.48	20.52	20.15	20.22		2
	50	0	20.56	20.47	20.11	20.21		2
64QAM	1	0	20.30	20.30	20.16	20.02	0-2	2
	1	25	20.41	20.33	19.91	20.05		2
	1	49	20.40	20.35	20.05	20.13		2
	25	0	19.44	19.35	19.08	19.12	0-3	3
	25	12	19.50	19.45	19.08	19.25		3
	25	25	19.52	19.44	19.11	19.23		3
	50	0	19.60	19.52	19.12	19.26		3
256QAM	1	0	17.42	17.35	17.06	17.08	0-5	5
	1	25	17.36	17.44	17.12	17.22		5
	1	49	17.38	17.46	17.13	17.18		5
	25	0	17.50	17.43	17.15	17.19		5
	25	12	17.55	17.33	17.21	17.17		5
	25	25	17.60	17.55	17.19	17.27		5
	50	0	17.56	17.56	17.21	17.32		5

FCC ID: A3LSMN975U		SAR EVALUATION REPORT		Approved by: Quality Manager
Document S/N: 1M1905200079-01-R1.A3L	Test Dates: 05/22/19 - 07/07/19	DUT Type: Portable Handset	Page 119 of 220	

**Table 9-83
LTE Band 48 Conducted Powers - 5 MHz Bandwidth**

LTE Band 48 5 MHz Bandwidth								
Modulation	RB Size	RB Offset	Low Channel	Low-Mid Channel	Mid-High Channel	High Channel	MPR Allowed per 3GPP [dB]	MPR [dB]
			55265 (3552.5 MHz)	55748 (3600.8 MHz)	56232 (3649.2 MHz)	56715 (3697.5 MHz)		
			Conducted Power [dBm]					
QPSK	1	0	22.28	22.20	21.89	21.93	0	0
	1	12	22.34	22.30	21.98	21.98		0
	1	24	22.35	22.26	21.84	22.01		0
	12	0	21.51	21.43	21.05	21.13	0-1	1
	12	6	21.59	21.44	21.12	21.21		1
	12	13	21.50	21.42	21.15	21.20		1
	25	0	21.54	21.44	21.12	21.21		1
16QAM	1	0	21.49	21.52	21.22	21.25	0-1	1
	1	12	21.52	21.64	21.19	21.27		1
	1	24	21.59	21.56	21.24	21.30		1
	12	0	20.61	20.37	20.03	20.10	0-2	2
	12	6	20.50	20.39	20.12	20.20		2
	12	13	20.50	20.39	20.12	20.22		2
	25	0	20.49	20.46	20.14	20.23		2
64QAM	1	0	20.30	20.29	19.97	20.02	0-2	2
	1	12	20.40	20.45	20.05	20.12		2
	1	24	20.48	20.35	20.01	20.14		2
	12	0	19.48	19.35	19.12	19.13	0-3	3
	12	6	19.56	19.42	19.22	19.22		3
	12	13	19.55	19.40	19.13	19.22		3
	25	0	19.53	19.42	19.12	19.16		3
256QAM	1	0	17.42	17.36	17.05	17.12	0-5	5
	1	12	17.53	17.49	17.12	17.18		5
	1	24	17.51	17.42	17.06	17.24		5
	12	0	17.61	17.51	17.22	17.31		5
	12	6	17.67	17.37	17.21	17.32		5
	12	13	17.63	17.63	17.30	17.45		5
	25	0	17.55	17.47	17.27	17.25		5

FCC ID: A3LSMN975U	 PCTEST ENGINEERING LABORATORY, INC.	SAR EVALUATION REPORT		Approved by: Quality Manager
Document S/N: 1M1905200079-01-R1.A3L	Test Dates: 05/22/19 - 07/07/19	DUT Type: Portable Handset	Page 120 of 220	

9.4.2

LTE Band 41

Table 9-84
LTE Band 41 PC3 Maximum Conducted Powers - 20 MHz Bandwidth

LTE Band 41 20 MHz Bandwidth									
Modulation	RB Size	RB Offset	Low Channel	Low-Mid Channel	Mid Channel	Mid-High Channel	High Channel	MPR Allowed per 3GPP [dB]	MPR [dB]
			39750 (2506.0 MHz)	40185 (2549.5 MHz)	40620 (2593.0 MHz)	41055 (2636.5 MHz)	41490 (2680.0 MHz)		
			Conducted Power [dBm]						
QPSK	1	0	23.15	23.82	23.05	23.22	23.15	0	0
	1	50	22.95	24.43	22.72	23.31	22.95		0
	1	99	23.01	24.14	22.82	23.22	22.83		0
	50	0	22.22	23.37	22.03	22.47	22.25	0-1	1
	50	25	22.23	23.50	22.00	22.56	22.20		1
	50	50	22.21	23.40	22.03	22.49	22.16		1
100	0	22.21	23.34	22.02	22.49	22.19	1		
16QAM	1	0	22.19	22.80	22.15	22.27	22.22	0-1	1
	1	50	22.03	23.29	21.80	22.40	22.00		1
	1	99	22.06	23.15	21.89	22.29	22.01		1
	50	0	21.23	22.32	21.06	21.50	21.22	0-2	2
	50	25	21.21	22.48	21.03	21.54	21.23		2
	50	50	21.22	22.40	21.02	21.53	21.15		2
100	0	21.21	22.36	21.03	21.51	21.24	2		
64QAM	1	0	20.91	21.51	20.88	21.02	20.94	0-2	2
	1	50	20.74	22.03	20.79	21.09	20.77		2
	1	99	20.76	21.85	20.61	21.00	20.77		2
	50	0	20.26	21.35	20.09	20.52	20.33	0-3	3
	50	25	20.28	21.50	20.04	20.59	20.26		3
	50	50	20.26	21.47	20.07	20.57	20.21		3
100	0	20.23	21.37	20.04	20.51	20.22	3		
256QAM	1	0	18.04	18.68	18.05	18.14	17.61	0-5	5
	1	50	17.89	19.23	17.69	18.25	17.63		5
	1	99	17.92	19.05	17.74	18.11	17.71		5
	50	0	18.27	19.31	18.09	18.51	18.07		5
	50	25	18.28	19.48	18.04	18.57	18.01		5
	50	50	18.29	19.44	18.06	18.56	18.04		5
100	0	18.24	19.33	18.02	18.50	18.00	5		



FCC ID: A3LSMN975U		SAR EVALUATION REPORT		Approved by: Quality Manager
Document S/N: 1M1905200079-01-R1.A3L	Test Dates: 05/22/19 - 07/07/19	DUT Type: Portable Handset	Page 121 of 220	

Table 9-85
LTE Band 41 PC3 Maximum Conducted Powers - 15 MHz Bandwidth

LTE Band 41 15 MHz Bandwidth										
Modulation	RB Size	RB Offset	Low Channel	Low-Mid Channel	Mid Channel	Mid-High Channel	High Channel	MPR Allowed per 3GPP [dB]	MPR [dB]	
			39750 (2506.0 MHz)	40185 (2549.5 MHz)	40620 (2593.0 MHz)	41055 (2636.5 MHz)	41490 (2680.0 MHz)			
			Conducted Power [dBm]							
QPSK	1	0	23.20	23.94	23.11	23.42	23.16	0	0	
	1	36	23.22	24.25	22.84	23.35	23.09		0	
	1	74	23.21	24.08	22.81	23.56	23.15		0	
	16QAM	36	0	22.32	23.25	22.13	22.67	22.30	0-1	1
		36	18	22.32	23.01	22.03	22.75	22.27		1
		36	37	22.36	23.31	22.12	22.69	22.23		1
		75	0	22.39	23.33	22.11	22.59	22.30		1
64QAM	1	0	22.26	23.01	22.14	22.47	22.44	0-1		1
	1	36	22.27	22.75	22.24	22.60	22.40			1
	1	74	22.24	22.62	22.04	22.49	22.41			1
	256QAM	36	0	21.26	22.39	21.09	21.55	21.27	0-2	2
		36	18	21.31	21.89	20.99	21.64	21.24		2
		36	37	21.35	21.69	21.08	21.63	21.19		2
		QPSK	75	0	21.36	21.60	21.11	21.61	21.32	0-2
1			0	21.00	21.69	20.95	21.32	21.27	2	
1			36	21.12	22.22	20.68	21.42	21.16	2	
16QAM	1		74	20.99	22.33	20.72	21.70	21.35	0-3	2
	36		0	20.33	20.98	20.14	20.52	20.30		3
	36		18	20.38	21.36	20.13	20.62	20.29		3
	64QAM		36	37	20.39	20.71	20.09	20.77	20.29	0-3
		75	0	20.37	20.62	20.17	20.81	20.33	3	
		1	0	18.20	18.87	18.11	18.00	18.26	0-5	
1		36	18.25	18.40	17.85	18.25	18.27	5		
1		74	18.19	18.54	17.89	18.36	18.16	5		
36	0	18.34	18.40	18.20	18.41	18.22	5			
36	18	18.36	18.65	18.07	18.47	18.32	5			
36	37	18.46	18.75	18.16	18.50	18.30	5			
75	0	18.39	18.58	18.13	18.69	18.28	5			



FCC ID: A3LSMN975U		SAR EVALUATION REPORT		Approved by: Quality Manager
Document S/N: 1M1905200079-01-R1.A3L	Test Dates: 05/22/19 - 07/07/19	DUT Type: Portable Handset	Page 122 of 220	

Table 9-86
LTE Band 41 PC3 Maximum Conducted Powers - 10 MHz Bandwidth

LTE Band 41 10 MHz Bandwidth										
Modulation	RB Size	RB Offset	Low Channel	Low-Mid Channel	Mid Channel	Mid-High Channel	High Channel	MPR Allowed per 3GPP [dB]	MPR [dB]	
			39750 (2506.0 MHz)	40185 (2549.5 MHz)	40620 (2593.0 MHz)	41055 (2636.5 MHz)	41490 (2680.0 MHz)			
			Conducted Power [dBm]							
QPSK	1	0	22.98	24.08	23.24	23.36	22.81	0	0	
	1	25	23.02	24.39	23.24	23.47	22.97		0	
	1	49	22.97	24.25	23.27	23.40	22.72		0	
	16QAM	25	0	22.30	23.30	22.50	22.60	22.02	0-1	1
		25	12	22.22	23.41	22.32	22.63	21.98		1
		25	25	22.16	23.33	22.25	22.63	21.99		1
		50	0	22.13	23.35	22.26	22.50	22.00		1
1		0	22.28	23.31	22.21	22.61	22.33	0-1		1
1	25	22.33	23.22	22.23	22.56	22.18	1			
1	49	22.17	23.21	22.29	22.71	22.13	1			
64QAM	25	0	21.14	22.20	21.50	21.56	21.08	0-2	2	
	25	12	21.21	22.36	21.45	21.62	21.00		2	
	25	25	21.11	22.38	21.31	21.60	21.06		2	
	256QAM	50	0	21.22	22.22	21.29	21.32	20.99	0-2	2
		1	0	21.05	22.20	21.32	22.11	20.96		2
		1	25	21.00	22.27	21.35	21.55	20.98		2
		64QAM	1	49	21.00	22.13	21.34	21.39	20.79	0-3
25			0	20.11	21.25	21.15	20.40	20.15	3	
25			12	20.15	21.27	20.65	20.60	20.03	3	
256QAM			25	25	20.15	21.15	20.50	20.62	20.24	0-5
	50		0	20.11	21.21	20.65	20.55	20.05	3	
	1		0	18.06	19.12	18.55	18.61	18.15	0-5	
	1		25	18.02	19.11	18.46	18.46	18.02		5
	1	49	18.02	19.04	18.49	18.47	18.03	5		
	25	0	18.16	19.08	18.53	18.75	17.89	5		
	25	12	18.26	19.12	18.66	18.65	18.08	5		
25	25	18.23	19.20	18.62	18.62	18.03	5			
50	0	18.21	19.14	18.66	18.73	18.05	5			



FCC ID: A3LSMN975U		SAR EVALUATION REPORT		Approved by: Quality Manager
Document S/N: 1M1905200079-01-R1.A3L	Test Dates: 05/22/19 - 07/07/19	DUT Type: Portable Handset	Page 123 of 220	

Table 9-87
LTE Band 41 PC3 Maximum Conducted Powers - 5 MHz Bandwidth

LTE Band 41 5 MHz Bandwidth										
Modulation	RB Size	RB Offset	Low Channel	Low-Mid Channel	Mid Channel	Mid-High Channel	High Channel	MPR Allowed per 3GPP [dB]	MPR [dB]	
			39750 (2506.0 MHz)	40185 (2549.5 MHz)	40620 (2593.0 MHz)	41055 (2636.5 MHz)	41490 (2680.0 MHz)			
			Conducted Power [dBm]							
QPSK	1	0	23.03	24.12	22.70	23.25	22.78	0	0	
	1	12	23.11	24.01	22.77	23.33	22.80		0	
	1	24	23.00	24.02	22.91	23.34	22.77		0	
	16QAM	12	0	22.15	23.00	21.98	22.36	21.85	0-1	1
		12	6	22.21	22.27	21.89	22.42	21.88		1
		12	13	22.14	23.01	21.86	22.43	21.92		1
		64QAM	25	0	22.21	22.95	21.99	22.39	21.90	0-1
1			0	22.32	23.00	21.98	22.34	21.86	1	
1			12	22.33	23.12	22.05	22.36	21.87	1	
256QAM			1	24	22.27	23.14	22.04	22.42	21.89	0-2
	12		0	21.38	22.04	20.86	21.27	20.85	2	
	12		6	20.98	21.98	20.93	21.33	20.87	2	
	64QAM		12	13	21.02	21.58	20.89	21.40	20.90	0-2
		25	0	21.19	21.45	20.90	21.40	20.91	2	
		1	0	21.12	21.99	20.88	20.99	20.80	2	
		256QAM	1	12	21.14	22.11	20.89	21.06	20.90	0-3
1			24	21.18	21.96	20.91	21.15	20.65	2	
12			0	20.16	20.85	20.02	20.32	20.60	3	
256QAM			12	6	20.15	20.89	19.99	20.33	20.62	0-3
	12		13	20.16	20.86	20.02	20.35	20.56	3	
	25		0	20.17	20.83	20.01	20.42	19.88	3	
	256QAM		1	0	18.09	18.98	18.10	18.39	18.03	0-5
		1	12	18.20	18.73	17.99	18.19	18.00	5	
		1	24	18.30	18.98	18.06	18.30	18.01	5	
		256QAM	12	0	18.20	19.01	17.90	18.29	17.99	0-5
12			6	18.31	19.05	18.04	18.46	18.07	5	
12			13	18.29	18.97	18.06	18.48	18.02	5	
25			0	18.16	18.97	17.98	18.55	18.11	5	



FCC ID: A3LSMN975U		SAR EVALUATION REPORT		Approved by: Quality Manager
Document S/N: 1M1905200079-01-R1.A3L	Test Dates: 05/22/19 - 07/07/19	DUT Type: Portable Handset	Page 124 of 220	

Table 9-88
LTE Band 41 PC2 Maximum Conducted Powers - 20 MHz Bandwidth

LTE Band 41 20 MHz Bandwidth										
Modulation	RB Size	RB Offset	Low Channel	Low-Mid Channel	Mid Channel	Mid-High Channel	High Channel	MPR Allowed per 3GPP [dB]	MPR [dB]	
			39750 (2506.0 MHz)	40185 (2549.5 MHz)	40620 (2593.0 MHz)	41055 (2636.5 MHz)	41490 (2680.0 MHz)			
			Conducted Power [dBm]							
QPSK	1	0	26.17	26.75	26.09	26.29	25.80	0	0	
	1	50	26.04	27.01	25.75	26.42	25.70		0	
	1	99	26.06	27.16	25.77	26.25	25.59		0	
	QPSK	50	0	25.27	26.25	25.02	25.56	24.96	0-1	1
		50	25	25.27	26.44	24.95	25.59	24.91		1
		50	50	25.28	26.42	24.94	25.57	24.87		1
		100	0	25.30	26.34	25.35	25.58	24.91		1
16QAM	1	0	25.46	26.09	25.38	25.63	25.07	0-1	1	
	1	50	25.33	26.50	24.98	25.74	24.99		1	
	1	99	25.30	26.49	24.99	25.59	24.96		1	
	16QAM	50	0	24.26	25.30	24.04	24.59	23.99	0-2	2
		50	25	24.24	25.49	23.95	24.64	23.97		2
		50	50	24.25	25.45	23.96	24.61	23.91		2
		100	0	24.26	25.37	24.00	24.62	23.93		2
64QAM	1	0	24.24	24.87	24.08	24.46	23.43	0-2	2	
	1	50	24.13	24.76	23.78	24.55	23.16		2	
	1	99	24.08	24.67	23.77	24.40	23.07		2	
	64QAM	50	0	23.29	23.92	23.05	23.64	22.63	0-3	3
		50	25	23.29	23.95	22.99	23.71	22.51		3
		50	50	23.29	23.84	22.98	23.69	22.28		3
		100	0	23.24	23.80	22.97	23.61	22.36		3
256QAM	1	0	21.24	21.83	21.24	21.44	20.98	0-5	5	
	1	50	21.09	22.43	20.78	21.56	20.83		5	
	1	99	21.08	22.29	20.85	21.45	20.73		5	
	50	0	21.26	22.34	21.06	21.64	21.02		5	
	50	25	21.23	22.50	20.96	21.68	21.01		5	
	50	50	21.28	22.49	20.97	21.67	20.96		5	
	100	0	21.23	22.38	20.98	21.60	20.93		5	



FCC ID: A3LSMN975U		SAR EVALUATION REPORT		Approved by: Quality Manager
Document S/N: 1M1905200079-01-R1.A3L	Test Dates: 05/22/19 - 07/07/19	DUT Type: Portable Handset	Page 125 of 220	

Table 9-89
LTE Band 41 PC2 Maximum Conducted Powers - 15 MHz Bandwidth

LTE Band 41 15 MHz Bandwidth										
Modulation	RB Size	RB Offset	Low Channel	Low-Mid Channel	Mid Channel	Mid-High Channel	High Channel	MPR Allowed per 3GPP [dB]	MPR [dB]	
			39750 (2506.0 MHz)	40185 (2549.5 MHz)	40620 (2593.0 MHz)	41055 (2636.5 MHz)	41490 (2680.0 MHz)			
Conducted Power [dBm]										
QPSK	1	0	26.10	26.92	25.72	26.51	25.61	0	0	
	1	36	26.10	26.60	25.64	26.55	25.54		0	
	1	74	26.13	27.14	25.68	26.47	25.67		0	
	QPSK	36	0	25.16	26.09	24.80	25.54	24.81	0-1	1
		36	18	25.24	25.79	24.80	25.62	24.73		1
		36	37	25.23	26.11	24.81	25.60	24.58		1
		75	0	25.22	26.01	24.78	25.59	24.78		1
16QAM	1	0	25.44	26.03	25.11	25.68	24.94	0-1	1	
	1	36	25.45	25.94	25.05	25.86	24.90		1	
	1	74	25.45	25.98	25.06	25.75	24.68		1	
	16QAM	36	0	24.13	25.11	23.71	24.66	23.80	0-2	2
		36	18	24.19	25.09	23.76	24.73	23.72		2
		36	37	24.17	25.13	23.77	24.70	23.54		2
		75	0	24.17	25.02	23.75	24.60	23.61		2
64QAM	1	0	24.83	24.19	24.25	24.26	23.45	0-2	2	
	1	36	24.89	24.42	24.33	24.66	23.42		2	
	1	74	24.84	24.33	24.12	24.65	24.17		2	
	64QAM	36	0	23.15	23.68	22.74	23.33	23.21	0-3	3
		36	18	23.20	23.78	22.77	23.58	23.12		3
		36	37	23.21	23.73	22.66	23.61	23.22		3
		75	0	23.18	23.57	22.68	23.46	23.20		3
256QAM	1	0	21.18	21.57	20.68	21.46	20.85	0-5	5	
	1	36	21.18	21.57	20.68	21.45	21.22		5	
	1	74	21.18	21.57	20.68	21.46	20.99		5	
	36	0	21.17	21.57	20.68	21.46	21.02		5	
	36	18	21.17	21.58	20.68	21.46	21.14		5	
	36	37	21.14	21.56	20.69	21.46	21.22		5	
75	0	21.18	21.53	20.69	21.47	20.98	5			





FCC ID: A3LSMN975U		SAR EVALUATION REPORT		Approved by: Quality Manager
Document S/N: 1M1905200079-01-R1.A3L	Test Dates: 05/22/19 - 07/07/19	DUT Type: Portable Handset	Page 126 of 220	

Table 9-90
LTE Band 41 PC2 Maximum Conducted Powers - 10 MHz Bandwidth

LTE Band 41 10 MHz Bandwidth										
Modulation	RB Size	RB Offset	Low Channel	Low-Mid Channel	Mid Channel	Mid-High Channel	High Channel	MPR Allowed per 3GPP [dB]	MPR [dB]	
			39750 (2506.0 MHz)	40185 (2549.5 MHz)	40620 (2593.0 MHz)	41055 (2636.5 MHz)	41490 (2680.0 MHz)			
			Conducted Power [dBm]							
QPSK	1	0	25.78	26.91	25.51	26.28	26.04	0	0	
	1	25	25.84	26.57	25.43	26.33	25.98		0	
	1	49	25.86	26.55	25.44	26.37	26.17		0	
	QPSK	25	0	25.04	25.97	24.64	25.51	25.70	0-1	1
		25	12	25.05	25.92	24.66	25.54	25.12		1
		25	25	24.99	26.08	24.63	25.54	25.11		1
		50	0	24.98	26.01	24.63	25.48	25.02		1
1		0	25.23	25.99	24.83	25.39	25.14	0-1		1
16QAM	1	25	25.19	26.16	24.78	25.46	25.04		1	
16QAM	1	49	25.21	25.89	24.86	25.56	25.02		1	
16QAM	25	0	24.07	24.89	23.68	24.56	24.01	0-2	2	
	25	12	24.05	25.11	23.68	24.59	24.22		2	
	25	25	24.03	24.96	23.66	24.58	24.14		2	
	50	0	24.03	24.98	23.65	24.57	24.79		2	
	1	0	24.67	24.45	24.20	24.05	24.14		0-2	2
64QAM	1	25	24.59	24.58	24.19	24.46	24.39	2		
	1	49	24.61	24.38	24.19	24.44	24.22	2		
	25	0	22.95	23.60	22.59	23.35	23.41	0-3	3	
	25	12	22.96	23.31	22.57	23.52	23.01		3	
	25	25	22.96	23.47	22.55	23.51	23.47		3	
256QAM	50	0	23.02	23.35	22.62	23.46	23.54	0-5	3	
	1	0	21.02	21.41	20.57	21.47	20.99		5	
	1	25	21.02	21.45	20.63	21.47	21.15		5	
	1	49	21.03	21.26	20.59	21.47	21.17		5	
	25	0	21.03	21.27	20.59	21.47	21.34		5	
	25	12	21.02	21.30	20.60	21.47	21.32		5	
	25	25	21.02	21.32	20.61	21.47	21.22		5	
50	0	21.02	21.25	20.61	21.47	21.31	5			

FCC ID: A3LSMN975U		SAR EVALUATION REPORT		Approved by: Quality Manager
Document S/N: 1M1905200079-01-R1.A3L	Test Dates: 05/22/19 - 07/07/19	DUT Type: Portable Handset	Page 127 of 220	

**Table 9-91
LTE Band 41 PC2 Maximum Conducted Powers - 5 MHz Bandwidth**

LTE Band 41 5 MHz Bandwidth										
Modulation	RB Size	RB Offset	Low Channel	Low-Mid Channel	Mid Channel	Mid-High Channel	High Channel	MPR Allowed per 3GPP [dB]	MPR [dB]	
			39750 (2506.0 MHz)	40185 (2549.5 MHz)	40620 (2593.0 MHz)	41055 (2636.5 MHz)	41490 (2680.0 MHz)			
			Conducted Power [dBm]							
QPSK	1	0	25.86	26.58	25.46	26.42	25.48	0	0	
	1	12	25.91	26.59	25.56	26.53	25.53		0	
	1	24	25.90	26.79	25.53	26.50	25.40		0	
	16QAM	12	0	25.01	26.24	24.61	25.48	24.64	0-1	1
		12	6	25.05	26.37	24.69	25.49	24.65		1
		12	13	25.06	26.14	24.66	25.56	24.54		1
		25	0	25.01	25.45	24.68	25.49	24.51		1
1		0	24.87	26.41	24.48	25.56	24.44	1		
64QAM	1	12	24.98	25.57	24.58	25.68	24.51	0-1	1	
	1	24	24.89	25.59	24.57	25.70	24.37		1	
	12	0	24.05	25.13	23.58	24.53	23.75		2	
	256QAM	12	6	24.07	25.24	23.67	24.62	23.78	0-2	2
		12	13	24.08	25.12	23.69	24.60	23.68		2
		25	0	24.12	25.04	23.73	24.54	23.69		2
		1	0	24.57	24.57	24.21	24.65	23.23		0-2
1		12	24.67	24.75	24.26	24.84	23.34	2		
1	24	24.63	24.76	24.23	24.83	23.21	2			
256QAM	12	0	23.04	23.67	22.60	23.60	22.99	0-3	3	
	12	6	23.03	23.80	22.70	23.67	23.12		3	
	12	13	23.03	23.74	22.67	23.70	23.11		3	
	25	0	23.00	23.65	22.62	23.44	23.04		3	
	1	0	20.98	21.65	20.61	21.44	20.98		0-5	5
1	12	21.03	21.66	20.61	21.44	21.12	5			
1	24	21.04	21.65	20.59	21.44	21.11	5			
12	0	21.02	21.65	20.64	21.44	20.99	5			
12	6	21.02	21.65	20.63	21.44	21.09	5			
12	13	21.03	21.66	20.61	21.44	21.14	5			
25	0	21.04	21.66	20.61	21.44	21.04	5			



FCC ID: A3LSMN975U		SAR EVALUATION REPORT		Approved by: Quality Manager
Document S/N: 1M1905200079-01-R1.A3L	Test Dates: 05/22/19 - 07/07/19	DUT Type: Portable Handset	Page 128 of 220	

Table 9-92
LTE Band 41 PC3 Reduced Conducted Powers - 20 MHz Bandwidth – Hotspot Mode Active

LTE Band 41 20 MHz Bandwidth										
Modulation	RB Size	RB Offset	Low Channel	Low-Mid Channel	Mid Channel	Mid-High Channel	High Channel	MPR Allowed per 3GPP [dB]	MPR [dB]	
			39750 (2506.0 MHz)	40185 (2549.5 MHz)	40620 (2593.0 MHz)	41055 (2636.5 MHz)	41490 (2680.0 MHz)			
Conducted Power [dBm]										
QPSK	1	0	20.96	21.82	20.82	20.91	20.77	0	0	
	1	50	20.94	22.02	20.51	21.04	20.63		0	
	1	99	20.95	21.97	20.54	20.93	20.61		0	
	QPSK	50	0	21.23	22.00	20.73	21.17	20.90	0-1	0
		50	25	21.21	21.99	20.64	21.22	20.88		0
		50	50	21.25	21.97	20.67	21.23	20.83		0
		100	0	21.12	21.99	20.71	21.21	20.87		0
16QAM	1	0	20.99	21.55	20.68	21.30	20.98	0-1	0	
	1	50	20.84	22.11	20.55	21.42	20.83		0	
	1	99	20.83	21.99	20.65	21.38	20.86		0	
	16QAM	50	0	21.04	22.06	20.58	21.58	21.09	0-2	0
		50	25	21.02	22.25	20.67	21.56	21.04		0
		50	50	21.02	22.22	20.75	21.55	21.01		0
		100	0	21.04	22.16	20.77	21.53	21.05		0
64QAM	1	0	20.72	21.76	20.55	21.00	20.81	0-2	0	
	1	50	20.59	22.19	20.45	21.07	20.72		0	
	1	99	20.58	21.99	20.61	21.01	20.70		0	
	64QAM	50	0	20.29	21.34	19.92	20.72	20.37	0-3	1
		50	25	20.26	21.46	19.93	20.80	20.32		1
		50	50	20.26	21.43	20.00	20.79	20.25		1
		100	0	20.23	21.38	19.88	20.73	20.27		1
256QAM	1	0	18.09	18.69	18.04	18.36	18.11	0-5	3	
	1	50	17.94	19.23	17.55	18.43	18.00		3	
	1	99	17.96	19.11	17.64	18.40	17.99		3	
	50	0	18.27	19.31	18.04	18.75	18.39		3	
	50	25	18.27	19.46	17.94	18.81	18.36		3	
	50	50	18.28	19.45	17.97	18.79	18.32		3	
	100	0	18.25	19.37	17.96	18.73	18.31		3	



FCC ID: A3LSMN975U		SAR EVALUATION REPORT		Approved by: Quality Manager
Document S/N: 1M1905200079-01-R1.A3L	Test Dates: 05/22/19 - 07/07/19	DUT Type: Portable Handset	Page 129 of 220	

Table 9-93

LTE Band 41 PC3 Reduced Conducted Powers - 15 MHz Bandwidth – Hotspot Mode Active

LTE Band 41 15 MHz Bandwidth										
Modulation	RB Size	RB Offset	Low Channel	Low-Mid Channel	Mid Channel	Mid-High Channel	High Channel	MPR Allowed per 3GPP [dB]	MPR [dB]	
			39750 (2506.0 MHz)	40185 (2549.5 MHz)	40620 (2593.0 MHz)	41055 (2636.5 MHz)	41490 (2680.0 MHz)			
Conducted Power [dBm]										
QPSK	1	0	20.85	21.80	20.60	20.98	20.76	0	0	
	1	36	20.83	22.11	20.48	21.25	20.83		0	
	1	74	20.88	22.00	20.66	21.17	20.77		0	
	QPSK	36	0	20.97	21.99	20.60	21.29	20.99	0-1	0
		36	18	21.06	22.15	20.66	21.34	20.99		0
		36	37	21.05	22.12	20.66	21.27	20.92		0
		75	0	20.98	22.02	20.64	21.30	20.91		0
16QAM	1	0	20.86	21.98	20.48	21.44	20.97	0-1	0	
	1	36	20.93	22.38	20.35	21.69	21.07		0	
	1	74	20.92	22.23	20.57	21.52	20.97		0	
	16QAM	36	0	20.94	22.01	20.44	21.26	21.16	0-2	0
		36	18	21.00	22.17	20.50	21.35	21.19		0
		36	37	21.02	22.17	20.52	21.25	21.12		0
		75	0	20.96	22.02	20.46	21.26	21.11		0
64QAM	1	0	20.80	22.05	20.39	21.15	20.89	0-2	0	
	1	36	20.85	22.37	20.26	21.29	21.03		0	
	1	74	20.88	22.23	20.45	21.37	20.90		0	
	64QAM	36	0	20.04	21.00	20.10	20.88	20.20	0-3	1
		36	18	20.08	21.20	20.12	20.97	20.25		1
		36	37	20.10	21.17	20.18	20.94	20.19		1
		75	0	19.96	21.08	19.98	20.74	20.15		1
256QAM	1	0	17.86	18.82	17.74	18.55	18.04	0-5	3	
	1	36	17.80	19.10	17.60	18.48	17.90		3	
	1	74	17.86	19.00	17.71	18.57	17.91		3	
	36	0	18.03	19.28	17.86	18.55	18.18		3	
	36	18	18.02	19.37	17.88	18.52	18.15		3	
	36	37	18.10	19.25	17.96	18.56	18.13		3	
	75	0	18.09	19.22	17.90	18.67	18.17		3	



FCC ID: A3LSMN975U		SAR EVALUATION REPORT		Approved by: Quality Manager
Document S/N: 1M1905200079-01-R1.A3L	Test Dates: 05/22/19 - 07/07/19	DUT Type: Portable Handset	Page 130 of 220	

Table 9-94

LTE Band 41 PC3 Reduced Conducted Powers - 10 MHz Bandwidth – Hotspot Mode Active

LTE Band 41 10 MHz Bandwidth										
Modulation	RB Size	RB Offset	Low Channel	Low-Mid Channel	Mid Channel	Mid-High Channel	High Channel	MPR Allowed per 3GPP [dB]	MPR [dB]	
			39750 (2506.0 MHz)	40185 (2549.5 MHz)	40620 (2593.0 MHz)	41055 (2636.5 MHz)	41490 (2680.0 MHz)			
Conducted Power [dBm]										
QPSK	1	0	20.79	21.84	20.56	21.01	20.75	0	0	
	1	25	20.75	22.00	20.55	21.01	20.54		0	
	1	49	20.81	21.93	20.60	21.02	20.49		0	
	16QAM	25	0	20.98	22.10	20.70	21.24	20.83	0-1	0
		25	12	20.98	22.20	20.74	21.26	20.80		0
		25	25	21.00	22.18	20.75	21.23	20.72	0	
		50	0	20.96	22.14	20.74	21.22	20.77	0	
1		0	21.16	21.89	20.57	21.37	20.97	0-1	0	
1	25	21.16	22.06	20.50	21.43	20.80	0			
1	49	21.13	22.03	20.62	21.50	20.73	0			
64QAM	25	0	21.02	22.12	20.39	21.46	20.87	0-2	0	
	25	12	21.04	22.20	20.40	21.48	20.83		0	
	25	25	21.02	22.18	20.42	21.49	20.74		0	
	50	0	20.96	22.13	20.39	21.47	20.78	0		
	1	0	21.06	21.83	20.42	21.40	21.08	0-2	0	
	1	25	20.99	21.93	20.33	21.39	20.93		0	
	1	49	21.07	21.95	20.43	21.41	20.85		0	
256QAM	25	0	19.94	21.16	19.87	20.72	20.12	0-3	1	
	25	12	19.91	21.25	19.90	20.74	20.11		1	
	25	25	19.92	21.20	19.93	20.74	20.07		1	
	50	0	19.94	21.14	19.94	20.72	20.14	1		
	1	0	18.05	18.95	17.49	18.20	17.99	0-5	3	
1	25	18.11	19.07	17.52	18.34	17.94	3			
1	49	18.01	19.04	17.53	18.21	17.91	3			
25	0	18.12	19.31	17.70	18.40	18.20	3			
25	12	17.99	19.40	17.73	18.49	18.21	3			
25	25	18.07	19.34	17.74	18.59	18.09	3			
50	0	18.01	19.39	17.82	18.56	18.21	3			



FCC ID: A3LSMN975U		SAR EVALUATION REPORT		Approved by: Quality Manager
Document S/N: 1M1905200079-01-R1.A3L	Test Dates: 05/22/19 - 07/07/19	DUT Type: Portable Handset	Page 131 of 220	

Table 9-95

LTE Band 41 PC3 Reduced Conducted Powers - 5 MHz Bandwidth – Hotspot Mode Active

LTE Band 41 5 MHz Bandwidth										
Modulation	RB Size	RB Offset	Low Channel	Low-Mid Channel	Mid Channel	Mid-High Channel	High Channel	MPR Allowed per 3GPP [dB]	MPR [dB]	
			39750 (2506.0 MHz)	40185 (2549.5 MHz)	40620 (2593.0 MHz)	41055 (2636.5 MHz)	41490 (2680.0 MHz)			
Conducted Power [dBm]										
QPSK	1	0	20.89	21.77	20.69	21.01	20.82	0	0	
	1	12	20.90	21.93	20.63	21.15	20.90		0	
	1	24	20.86	21.92	20.66	21.11	20.89		0	
	QPSK	12	0	21.01	21.87	20.69	21.01	20.97	0-1	0
		12	6	21.08	22.04	20.81	21.05	21.01		0
		12	13	21.06	22.00	20.83	21.10	20.99		0
		25	0	21.02	21.95	20.78	21.09	20.94		0
1		0	20.87	21.88	20.57	21.46	20.97	0		
16QAM	1	12	20.90	22.03	20.65	21.57	21.05	0-1	0	
	1	24	20.89	22.01	20.74	21.59	20.95		0	
	12	0	21.02	21.93	20.45	21.38	21.08		0	
	16QAM	12	6	21.01	21.99	20.40	21.41	21.13	0-2	0
		12	13	21.06	22.04	20.36	21.47	21.10		0
		25	0	21.11	21.96	20.41	21.40	21.16		0
64QAM	1	0	20.99	21.83	20.49	21.17	20.98	0-2	0	
	1	12	21.05	21.99	20.63	21.33	20.99		0	
	1	24	21.02	21.95	20.68	21.26	20.98		0	
	64QAM	12	0	20.01	21.23	19.98	20.77	20.24	0-3	1
		12	6	20.03	21.42	19.79	20.78	20.22		1
		12	13	20.01	21.40	20.00	20.90	20.29		1
		25	0	20.00	21.37	20.02	20.66	20.16		1
256QAM	1	0	18.02	18.89	17.55	18.62	18.08	0-5	3	
	1	12	17.99	19.01	17.65	18.52	18.05		3	
	1	24	18.09	18.96	17.69	18.56	17.97		3	
	12	0	18.06	19.11	17.62	18.61	18.05		3	
	12	6	18.04	19.07	17.78	18.41	18.02		3	
	12	13	18.02	18.96	17.81	18.45	18.11		3	
	25	0	18.00	19.03	17.85	18.49	18.10		3	



FCC ID: A3LSMN975U		SAR EVALUATION REPORT		Approved by: Quality Manager
Document S/N: 1M1905200079-01-R1.A3L	Test Dates: 05/22/19 - 07/07/19	DUT Type: Portable Handset	Page 132 of 220	

Table 9-96

LTE Band 41 PC2 Reduced Conducted Powers - 20 MHz Bandwidth – Hotspot Mode Active

LTE Band 41 20 MHz Bandwidth										
Modulation	RB Size	RB Offset	Low Channel	Low-Mid Channel	Mid Channel	Mid-High Channel	High Channel	MPR Allowed per 3GPP [dB]	MPR [dB]	
			39750 (2506.0 MHz)	40185 (2549.5 MHz)	40620 (2593.0 MHz)	41055 (2636.5 MHz)	41490 (2680.0 MHz)			
Conducted Power [dBm]										
QPSK	1	0	20.68	21.47	20.56	21.40	21.14	0	0	
	1	50	20.79	21.91	20.53	21.41	21.07		0	
	1	99	20.84	21.67	20.53	21.39	20.99		0	
	QPSK	50	0	20.76	21.93	20.59	21.56	21.22	0-1	0
		50	25	20.71	21.90	20.60	21.63	21.24		0
		50	50	20.67	21.92	20.65	21.66	21.25		0
		100	0	20.92	21.84	20.63	21.66	21.30		0
100		50	20.70	21.94	20.43	21.62	21.33	0		
16QAM	1	0	20.91	21.50	20.57	21.58	21.20	0-1	0	
	1	50	20.86	22.14	20.45	21.76	21.04		0	
	1	99	20.85	21.94	20.41	21.50	20.90		0	
	16QAM	50	0	20.75	21.87	20.40	21.55	21.34	0-2	0
		50	25	20.61	22.08	20.41	21.52	21.46		0
		50	50	20.65	22.04	20.47	21.52	21.30		0
		100	0	20.70	21.94	20.43	21.62	21.33		0
64QAM	1	0	20.76	21.84	20.60	21.36	21.26	0-2	0	
	1	50	20.53	21.92	20.26	21.46	21.30		0	
	1	99	20.41	21.73	20.45	21.42	21.38		0	
	64QAM	50	0	20.75	21.90	20.47	21.58	21.46	0-3	0
		50	25	20.80	22.09	20.45	21.67	21.46		0
		50	50	20.74	22.01	20.55	21.69	21.32		0
		100	0	20.71	22.05	20.44	21.60	21.29		0
256QAM	1	0	20.73	21.41	20.56	21.42	21.30	0-5	0	
	1	50	20.65	21.98	20.40	21.52	21.11		0	
	1	99	20.55	21.79	20.42	21.54	21.21		0	
	50	0	20.77	21.91	20.51	21.62	21.32		0	
	50	25	20.75	22.10	20.49	21.68	21.33		0	
	50	50	20.71	22.04	20.61	21.73	21.42		0	
	100	0	20.68	21.92	20.44	21.59	21.30		0	



FCC ID: A3LSMN975U		SAR EVALUATION REPORT		Approved by: Quality Manager
Document S/N: 1M1905200079-01-R1.A3L	Test Dates: 05/22/19 - 07/07/19	DUT Type: Portable Handset	Page 133 of 220	

Table 9-97
LTE Band 41 PC2 Reduced Conducted Powers - 15 MHz Bandwidth – Hotspot Mode Active

LTE Band 41 15 MHz Bandwidth										
Modulation	RB Size	RB Offset	Low Channel	Low-Mid Channel	Mid Channel	Mid-High Channel	High Channel	MPR Allowed per 3GPP [dB]	MPR [dB]	
			39750 (2506.0 MHz)	40185 (2549.5 MHz)	40620 (2593.0 MHz)	41055 (2636.5 MHz)	41490 (2680.0 MHz)			
Conducted Power [dBm]										
QPSK	1	0	20.64	21.52	20.61	21.43	21.00	0	0	
	1	36	20.69	22.04	20.68	21.60	21.05		0	
	1	74	20.66	21.85	20.78	21.52	21.08		0	
	QPSK	36	0	20.63	21.88	20.52	21.67	21.24	0-1	0
		36	18	20.68	22.00	20.62	21.42	21.23		0
		36	37	20.65	21.94	20.65	21.57	21.19		0
		75	0	20.66	21.93	20.49	21.53	21.24		0
1		0	20.82	21.80	20.62	21.51	21.13	0-1		0
1	36	20.80	22.21	20.67	21.70	21.14	0			
1	74	20.81	22.01	20.83	21.56	21.12	0			
16QAM	36	0	20.67	21.91	20.30	21.53	21.25	0-2	0	
	36	18	20.74	22.07	20.40	21.42	21.24		0	
	36	37	20.74	21.99	20.42	21.58	21.21		0	
	75	0	20.64	21.89	20.41	21.63	21.26		0	
	1	0	20.89	21.71	20.70	21.29	21.31		0-2	0
1	36	20.89	22.12	20.72	21.30	21.38	0			
1	74	20.87	21.90	20.88	21.39	21.32	0			
64QAM	36	0	20.66	21.90	20.31	21.59	21.20	0-3	0	
	36	18	20.76	22.05	20.43	21.49	21.23		0	
	36	37	20.72	21.97	20.40	21.47	21.16		0	
	75	0	20.71	21.92	20.38	21.43	21.13		0	
	1	0	20.81	21.60	20.48	21.67	21.38		0-5	0
1	36	20.85	21.65	20.45	21.66	21.30	0			
1	74	20.86	21.62	20.54	21.59	21.34	0			
36	0	20.82	21.61	20.54	21.71	21.35	0			
36	18	20.86	21.66	20.59	21.77	21.32	0			
256QAM	36	37	20.79	21.63	20.60	21.76	21.38	0-5	0	
	75	0	20.84	21.67	20.56	21.77	21.49		0	



FCC ID: A3LSMN975U		SAR EVALUATION REPORT		Approved by: Quality Manager
Document S/N: 1M1905200079-01-R1.A3L	Test Dates: 05/22/19 - 07/07/19	DUT Type: Portable Handset	Page 134 of 220	

Table 9-98
LTE Band 41 PC2 Reduced Conducted Powers - 10 MHz Bandwidth – Hotspot Mode Active

LTE Band 41 10 MHz Bandwidth										
Modulation	RB Size	RB Offset	Low Channel	Low-Mid Channel	Mid Channel	Mid-High Channel	High Channel	MPR Allowed per 3GPP [dB]	MPR [dB]	
			39750 (2506.0 MHz)	40185 (2549.5 MHz)	40620 (2593.0 MHz)	41055 (2636.5 MHz)	41490 (2680.0 MHz)			
Conducted Power [dBm]										
QPSK	1	0	20.61	21.58	20.39	21.41	21.06	0	0	
	1	25	20.54	21.92	20.38	21.53	20.96		0	
	1	49	20.62	21.66	20.52	21.52	20.90		0	
	QPSK	25	0	20.82	21.88	20.47	21.60	21.26	0-1	0
		25	12	20.82	21.93	20.50	21.64	21.23		0
		25	25	20.80	21.92	20.49	21.67	21.15		0
		50	0	20.79	21.88	20.47	21.58	21.19		0
50		12	20.79	21.88	20.47	21.58	21.19	0		
16QAM	1	0	20.76	21.75	20.49	21.52	21.10	0-1	0	
	1	25	20.75	21.83	20.50	21.61	21.00		0	
	1	49	20.79	21.84	20.62	21.68	20.95		0	
	16QAM	25	0	20.88	21.83	20.59	21.61	21.22	0-2	0
		25	12	20.88	21.88	20.63	21.64	21.17		0
		25	25	20.86	21.86	20.64	21.69	21.10		0
		50	0	20.82	21.82	20.60	21.64	21.11		0
64QAM	1	0	20.74	21.90	20.37	21.50	21.11	0-2	0	
	1	25	20.64	21.99	20.37	21.59	20.97		0	
	1	49	20.69	21.94	20.46	21.64	20.89		0	
	64QAM	25	0	20.91	21.91	20.61	21.55	21.26	0-3	0
		25	12	20.92	21.96	20.65	21.62	21.22		0
		25	25	20.90	21.93	20.67	21.63	21.16		0
		50	0	20.87	21.99	20.60	21.59	21.14		0
256QAM	1	0	20.86	21.62	20.56	21.54	21.35	0-5	0	
	1	25	20.89	21.86	20.46	21.56	21.20		0	
	1	49	20.88	21.74	20.55	21.55	21.11		0	
	25	0	20.93	21.84	20.50	21.68	21.30		0	
	25	12	20.85	21.82	20.52	21.68	21.25		0	
	25	25	20.79	21.81	20.51	21.65	21.22		0	
	50	0	20.96	21.75	20.53	21.70	21.28		0	





FCC ID: A3LSMN975U		SAR EVALUATION REPORT		Approved by: Quality Manager
Document S/N: 1M1905200079-01-R1.A3L	Test Dates: 05/22/19 - 07/07/19	DUT Type: Portable Handset	Page 135 of 220	

Table 9-99

LTE Band 41 PC2 Reduced Conducted Powers - 5 MHz Bandwidth – Hotspot Mode Active

LTE Band 41 5 MHz Bandwidth									
Modulation	RB Size	RB Offset	Low Channel	Low-Mid Channel	Mid Channel	Mid-High Channel	High Channel	MPR Allowed per 3GPP [dB]	MPR [dB]
			39750 (2506.0 MHz)	40185 (2549.5 MHz)	40620 (2593.0 MHz)	41055 (2636.5 MHz)	41490 (2680.0 MHz)		
Conducted Power [dBm]									
QPSK	1	0	20.61	21.67	20.42	21.39	21.02	0	0
	1	12	20.65	21.77	20.52	21.51	21.09		0
	1	24	20.64	21.83	20.52	21.57	21.08		0
	12	0	20.71	21.82	20.49	21.43	21.12	0-1	0
	12	6	20.74	21.98	20.58	21.46	21.12		0
	12	13	20.71	21.92	20.63	21.53	21.11		0
16QAM	25	0	20.73	21.89	20.58	21.46	21.06	0-1	0
	1	0	20.86	21.68	20.53	21.53	21.27		0
	1	12	20.88	21.87	20.64	21.62	21.30		0
	1	24	20.92	21.84	20.67	21.69	21.23	0-2	0
	12	0	20.73	21.91	20.36	21.48	21.06		0
	12	6	20.74	21.97	20.44	21.49	21.12		0
64QAM	12	13	20.73	22.02	20.49	21.55	21.12	0-2	0
	25	0	20.75	22.06	20.46	21.45	21.09		0
	1	0	20.83	22.02	20.59	21.52	21.24		0-3
	1	12	20.88	22.17	20.76	21.65	21.29	0	
	1	24	20.87	22.16	20.79	21.59	21.30	0	
	256QAM	12	0	20.76	21.71	20.49	21.30	21.12	0-3
12		6	20.81	21.88	20.62	21.33	21.11	0	
12		13	20.79	21.82	20.59	21.37	21.17	0	
25		0	20.76	21.80	20.57	21.12	21.12	0-5	0
1		0	20.65	21.69	20.51	21.32	21.19		0
1		12	20.86	21.72	20.49	21.45	21.24		0
256QAM	1	24	20.98	21.74	20.56	21.47	21.24	0-5	0
	12	0	21.01	21.78	20.53	21.45	21.24		0
	12	6	21.06	21.80	20.52	21.44	21.18		0
	12	13	20.99	21.77	20.44	21.62	21.18	0-5	0
	25	0	20.91	21.81	20.55	21.52	21.21		0

FCC ID: A3LSMN975U		SAR EVALUATION REPORT		Approved by: Quality Manager
Document S/N: 1M1905200079-01-R1.A3L	Test Dates: 05/22/19 - 07/07/19	DUT Type: Portable Handset	Page 136 of 220	

9.4.3 LTE Uplink Carrier Aggregation Conducted Powers

Table 9-100
LTE Uplink Carrier Aggregation Maximum Conducted Powers



Combination	PCC								SCC								Power			
	PCC Band	PCC Bandwidth [MHz]	PCC UL Channel	PCC (UL) Frequency [MHz]	PCC DL Channel	PCC DL Frequency [MHz]	Modulation	PCC UL# RB	PCC UL RB Offset	SCC Band	SCC Bandwidth [MHz]	SCC (UL) Channel	SCC (UL) Frequency [MHz]	SCC (DL) Channel	SCC (DL) Frequency [MHz]	Modulation	SCC UL# RB	SCC UL RB Offset	LTE Tx.Power with UL CA Enabled (dBm)	LTE Single Carrier Tx Power (dBm)
CA_5B	LTE B5	10	20525	836.5	2525	881.5	QPSK	1	0	LTE B5	5	20453	829.3	2453	874.3	QPSK	1	24	24.97	24.89
CA_66C	LTE B66	20	132322	1745.0	66786	2145.0	QPSK	1	99	LTE B66	20	132520	1764.8	66984	2164.8	QPSK	1	0	24.60	24.38
CA_66C	LTE B66	20	132572	1770.0	67036	2170.0	QPSK	1	0	LTE B66	20	132374	1750.2	66838	2150.2	QPSK	1	99	24.08	24.27
CA_66B	LTE B66	10	132322	1745.0	66786	2145.0	QPSK	1	49	LTE B66	10	132421	1754.9	66885	2154.9	QPSK	1	0	24.42	24.36
CA_66B	LTE B66	10	132622	1775.0	67086	2175.0	QPSK	1	0	LTE B66	10	132523	1765.1	66987	2165.1	QPSK	1	49	23.78	23.97
CA_41C	LTE B41	20	40185	2549.5	2549.5	2145.0	QPSK	1	99	LTE B41	20	40383	2569.3	2569.3	2145.0	QPSK	1	0	24.50	24.14
CA_41C	LTE B41 PC2	20	40185	2549.5	2549.5	2145.0	QPSK	1	99	LTE B41 PC2	20	40383	2569.3	2569.3	2145.0	QPSK	1	0	27.20	27.16

Table 9-101
LTE Uplink Carrier Aggregation Reduced Conducted Powers – Hotspot Mode Active

Combination	PCC								SCC								Power			
	PCC Band	PCC Bandwidth [MHz]	PCC (UL) Channel	PCC (UL) Frequency [MHz]	PCC (UL/DL) Channel	PCC (UL/DL) Frequency [MHz]	Modulation	PCC UL# RB	PCC UL RB Offset	SCC Band	SCC Bandwidth [MHz]	SCC (UL) Channel	SCC (UL) Frequency [MHz]	SCC (DL) Channel	SCC (DL) Frequency [MHz]	Modulation	SCC UL# RB	SCC UL RB Offset	LTE Tx.Power with UL CA Enabled (dBm)	LTE Single Carrier Tx Power (dBm)
CA_66C	LTE B66	20	132322	1745.0	66786	2145.0	QPSK	1	99	LTE B66	20	132520	1764.8	66984	2164.8	QPSK	1	0	19.70	19.84
CA_66B	LTE B66	10	132322	1745.0	66786	2145.0	QPSK	1	49	LTE B66	10	132421	1754.9	66885	2154.9	QPSK	1	0	19.60	19.62
CA_41C	LTE B41	20	40185	2549.5	2549.5	2145.0	QPSK	50	0	LTE B41	20	39987	2529.7	2529.7	2145.0	QPSK	50	50	22.50	22.00
CA_41C	LTE B41 PC2	20	40185	2549.5	2549.5	2145.0	QPSK	50	0	LTE B41 PC2	20	39987	2529.7	2529.7	2145.0	QPSK	50	50	22.36	21.93

Table 9-102
LTE Uplink Carrier Aggregation Reduced Conducted Powers – Grip Sensor and/or Earjack Mode Active

Combination	PCC								SCC								Power			
	PCC Band	PCC Bandwidth [MHz]	PCC (UL) Channel	PCC (UL) Frequency [MHz]	PCC (UL/DL) Channel	PCC (UL/DL) Frequency [MHz]	Modulation	PCC UL# RB	PCC UL RB Offset	SCC Band	SCC Bandwidth [MHz]	SCC (UL) Channel	SCC (UL) Frequency [MHz]	SCC (DL) Channel	SCC (DL) Frequency [MHz]	Modulation	SCC UL# RB	SCC UL RB Offset	LTE Tx.Power with UL CA Enabled (dBm)	LTE Single Carrier Tx Power (dBm)
CA_66C	LTE B66	20	132072	1720.0	66536	2120.0	QPSK	50	50	LTE B66	20	132270	1739.8	66734	2139.8	QPSK	50	0	20.41	20.21
CA_66B	LTE B66	10	132022	1715.0	66486	2115.0	QPSK	25	25	LTE B66	10	132121	1724.9	66734	2124.9	QPSK	25	0	20.23	20.10



FCC ID: A3LSMN975U		SAR EVALUATION REPORT		Approved by: Quality Manager
Document S/N: 1M1905200079-01-R1.A3L	Test Dates: 05/22/19 - 07/07/19	DUT Type: Portable Handset	Page 137 of 220	

Notes:

1. This device supports uplink carrier aggregation for LTE CA_5B, LTE CA_66B, LTE CA_66C, and LTE CA_41C with a maximum of two component carriers. For intraband contiguous carrier aggregation scenarios, 3GPP 36.101 Table 6.2.2A-1 specifies that the aggregate maximum allowed output power is equivalent to the single carrier scenario. 3GPP 36.101 6.2.3A allows for several dB of MPR to be applied when non-contiguous RB allocation is implemented. The conducted powers and MPR settings in this device are permanently implemented per the above 3GPP requirements.
2. Per FCC Guidance, the output power with uplink CA active was measured for the configuration with the highest reported SAR with single carrier for each exposure condition. The power was measured with wideband signal integration over both component carriers.



Figure 9-4
Power Measurement Setup

FCC ID: A3LSMN975U		SAR EVALUATION REPORT		Approved by: Quality Manager
Document S/N: 1M1905200079-01-R1.A3L	Test Dates: 05/22/19 - 07/07/19	DUT Type: Portable Handset	Page 138 of 220	

9.5 WLAN Conducted Powers

**Table 9-103
2.4 GHz WLAN Maximum Average RF Power – Ant 1**

2.4GHz Conducted Power [dBm]					
Freq [MHz]	Channel	IEEE Transmission Mode			
		802.11b	802.11g	802.11n	802.11ax
		Average	Average	Average	Average
2412	1	20.81	13.50	13.64	14.99
2417	2	N/A	18.10	18.39	17.78
2437	6	20.97	18.45	17.66	17.59
2457	10	N/A	18.37	18.38	17.69
2462	11	20.29	15.40	15.48	14.78

**Table 9-104
2.4 GHz WLAN Maximum Average RF Power – Ant 2**

2.4GHz Conducted Power [dBm]					
Freq [MHz]	Channel	IEEE Transmission Mode			
		802.11b	802.11g	802.11n	802.11ax
		Average	Average	Average	Average
2412	1	20.76	13.97	13.71	14.68
2417	2	N/A	18.07	18.36	17.85
2437	6	20.99	18.17	18.16	17.56
2457	10	N/A	18.33	18.49	17.98
2462	11	20.41	15.03	15.33	14.53



FCC ID: A3LSMN975U	 PCTEST ENGINEERING LABORATORY, INC.	SAR EVALUATION REPORT		Approved by: Quality Manager
Document S/N: 1M1905200079-01-R1.A3L	Test Dates: 05/22/19 - 07/07/19	DUT Type: Portable Handset		Page 139 of 220

Table 9-105
5 GHz WLAN Maximum Average RF Power – Ant 1

5GHz (20MHz) Conducted Power [dBm]					
Freq [MHz]	Channel	IEEE Transmission Mode			
		802.11a	802.11n	802.11ac	802.11ax
		Average	Average	Average	Average
5180	36	16.99	16.99	16.91	15.51
5200	40	18.20	18.21	18.27	17.66
5220	44	18.27	18.17	18.19	17.77
5240	48	18.10	18.26	18.26	17.69
5260	52	18.04	18.44	18.16	17.64
5280	56	18.07	18.47	18.13	17.53
5300	60	18.34	18.12	18.24	17.58
5320	64	15.95	15.01	14.94	15.22
5500	100	17.00	17.92	17.91	17.87
5520	104	18.00	18.03	18.01	N/A
5600	120	18.12	18.16	18.11	17.89
5620	124	18.14	18.14	18.17	17.91
5720	144	18.11	18.27	18.15	17.54
5745	149	18.30	18.37	18.32	17.71
5785	157	18.21	18.28	18.37	17.64
5825	165	18.17	18.16	18.11	17.91

Table 9-106
5 GHz WLAN Maximum Average RF Power – Ant 2

5GHz (20MHz) Conducted Power [dBm]					
Freq [MHz]	Channel	IEEE Transmission Mode			
		802.11a	802.11n	802.11ac	802.11ax
		Average	Average	Average	Average
5180	36	16.50	16.49	16.51	15.96
5200	40	18.19	18.26	18.22	17.57
5220	44	18.17	18.29	18.24	17.55
5240	48	18.16	18.22	18.26	17.52
5260	52	18.28	18.33	18.30	17.62
5280	56	18.17	18.18	18.34	17.69
5300	60	18.33	18.29	18.45	17.82
5320	64	15.97	15.38	15.36	15.77
5500	100	17.24	17.99	17.97	17.81
5520	104	18.04	18.20	18.03	N/A
5600	120	18.43	18.48	18.47	17.93
5620	124	18.33	18.41	18.42	17.86
5720	144	18.32	18.38	18.39	17.79
5745	149	18.25	18.33	18.22	17.71
5785	157	18.44	18.21	18.33	17.82
5825	165	18.21	18.19	18.19	17.65



FCC ID: A3LSMN975U		SAR EVALUATION REPORT		Approved by: Quality Manager
Document S/N: 1M1905200079-01-R1.A3L	Test Dates: 05/22/19 - 07/07/19	DUT Type: Portable Handset	Page 140 of 220	

Table 9-107
5 GHz WLAN Maximum Average RF Power – MIMO

5GHz (20MHz) 802.11n Conducted Power [dBm]				
Freq [MHz]	Channel	ANT1	ANT2	MIMO
5180	36	16.99	16.49	19.76
5200	40	18.21	18.26	21.25
5220	44	18.17	18.29	21.24
5240	48	18.26	18.22	21.25
5260	52	18.44	18.33	21.40
5280	56	18.47	18.18	21.34
5300	60	18.12	18.29	21.22
5320	64	15.01	15.38	18.21
5500	100	17.92	17.99	20.97
5520	104	18.03	18.20	21.13
5600	120	18.16	18.48	21.33
5620	124	18.14	18.41	21.29
5720	144	18.27	18.38	21.34
5745	149	18.37	18.33	21.36
5785	157	18.28	18.21	21.26
5825	165	18.16	18.19	21.19

Table 9-108
Maximum Output Powers During Conditions with 2.4 GHz and 5 GHz WLAN

5GHz (80MHz) 802.11ac Conducted Power [dBm]			
Freq [MHz]	Channel	ANT1	ANT2
5210	42	13.01	13.25
5290	58	13.48	13.28
5530	106	12.53	12.88
5610	122	13.94	13.94
5690	138	13.96	13.96
5775	155	13.76	13.57



FCC ID: A3LSMN975U		SAR EVALUATION REPORT		Approved by: Quality Manager
Document S/N: 1M1905200079-01-R1.A3L	Test Dates: 05/22/19 - 07/07/19	DUT Type: Portable Handset	Page 141 of 220	

Table 9-109
2.4 GHz WLAN Reduced Average RF Power – Ant 1



2.4GHz Conducted Power [dBm]					
Freq [MHz]	Channel	IEEE Transmission Mode			
		802.11b	802.11g	802.11n	802.11ax
		Average	Average	Average	Average
2412	1	16.44	13.50	13.64	14.99
2417	2	N/A	16.36	16.23	16.39
2437	6	16.55	16.51	16.69	16.19
2457	10	N/A	16.97	16.97	16.11
2462	11	16.10	15.40	15.48	14.78

Table 9-110
2.4 GHz WLAN Reduced Average RF Power – Ant 2

2.4GHz Conducted Power [dBm]					
Freq [MHz]	Channel	IEEE Transmission Mode			
		802.11b	802.11g	802.11n	802.11ax
		Average	Average	Average	Average
2412	1	16.32	13.97	13.71	14.68
2417	2	N/A	16.24	16.19	16.33
2437	6	16.56	16.48	16.62	16.78
2457	10	N/A	16.69	16.62	16.21
2462	11	16.44	15.03	15.33	14.62

Table 9-111
5 GHz WLAN Reduced Average RF Power – Ant 1

5GHz (80MHz) Conducted Power [dBm]			
Freq [MHz]	Channel	IEEE Transmission Mode	
		802.11ac	802.11ax
		Average	Average
5210	42	13.01	13.51
5290	58	13.48	13.01
5530	106	12.53	12.78
5610	122	13.94	13.73
5690	138	13.96	13.63
5775	155	13.76	13.59

FCC ID: A3LSMN975U		SAR EVALUATION REPORT		Approved by: Quality Manager
Document S/N: 1M1905200079-01-R1.A3L	Test Dates: 05/22/19 - 07/07/19	DUT Type: Portable Handset	Page 142 of 220	

**Table 9-112
5 GHz WLAN Reduced Average RF Power – Ant 2**



5GHz (80MHz) Conducted Power [dBm]			
Freq [MHz]	Channel	IEEE Transmission Mode	
		802.11ac	802.11ax
		Average	Average
5210	42	13.25	13.97
5290	58	13.28	13.02
5530	106	12.88	12.99
5610	122	13.94	13.99
5690	138	13.96	13.81
5775	155	13.57	13.97

Justification for test configurations for WLAN per KDB Publication 248227 D01v02r02:

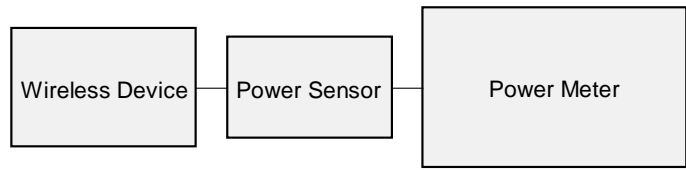
- Power measurements were performed for the transmission mode configuration with the highest maximum output power specified for production units.
- For transmission modes with the same maximum output power specification, powers were measured for the largest channel bandwidth, lowest order modulation and lowest data rate.
- For transmission modes with identical maximum specified output power, channel bandwidth, modulation and data rates, power measurements were required for all identical configurations.
- For each transmission mode configuration, powers were measured for the highest and lowest channels; and at the mid-band channel(s) when there were at least 3 channels supported. For configurations with multiple mid-band channels, due to an even number of channels, both channels were measured.



**Figure 9-5
Power Measurement Setup**



FCC ID: A3LSMN975U		SAR EVALUATION REPORT		Approved by: Quality Manager
Document S/N: 1M1905200079-01-R1.A3L	Test Dates: 05/22/19 - 07/07/19	DUT Type: Portable Handset	Page 143 of 220	

9.6 Bluetooth Conducted Powers

Table 9-113
Bluetooth Average RF Power

Frequency [MHz]	Data Rate [Mbps]	Channel No.	Avg Conducted Power	
			[dBm]	[mW]
2402	1.0	0	14.11	25.748
2441	1.0	39	15.41	34.738
2480	1.0	78	12.73	18.746
2402	2.0	0	11.78	15.067
2441	2.0	39	12.48	17.692
2480	2.0	78	9.75	9.433
2402	3.0	0	11.85	15.295
2441	3.0	39	12.61	18.222
2480	3.0	78	9.75	9.432

Note: The bolded data rates and channel above were tested for SAR.

FCC ID: A3LSMN975U		SAR EVALUATION REPORT		Approved by: Quality Manager
Document S/N: 1M1905200079-01-R1.A3L	Test Dates: 05/22/19 - 07/07/19	DUT Type: Portable Handset		Page 144 of 220

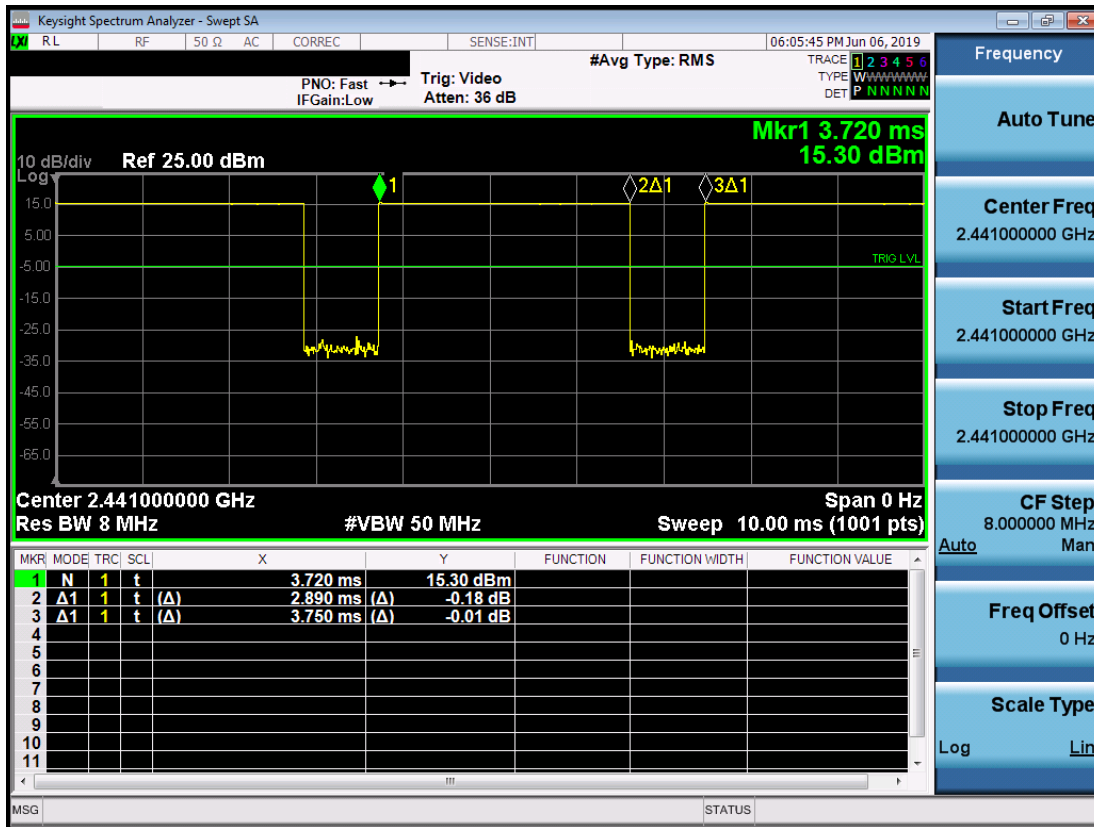

Figure 9-6
Bluetooth Transmission Plot

Equation 9-1
Bluetooth Duty Cycle Calculation

$$Duty\ Cycle = \frac{Pulse\ Width}{Period} * 100\% = \frac{2.89ms}{3.75ms} * 100\% = 77.1\%$$

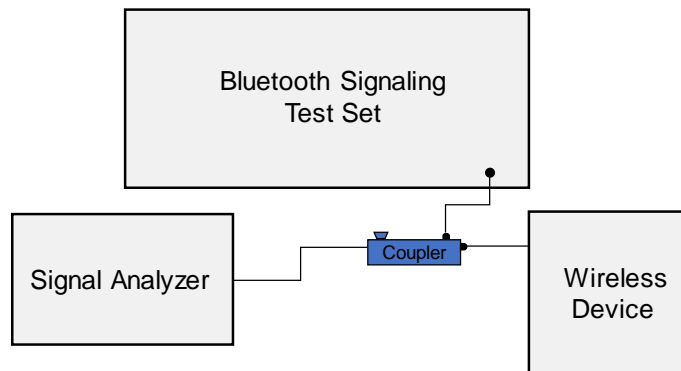

Figure 9-7
Power Measurement Setup



FCC ID: A3LSMN975U	PCTEST ENGINEERING LABORATORY, INC.	SAR EVALUATION REPORT	SAMSUNG	Approved by: Quality Manager
Document S/N: 1M1905200079-01-R1.A3L	Test Dates: 05/22/19 - 07/07/19	DUT Type: Portable Handset		Page 145 of 220

10 SYSTEM VERIFICATION

10.1 Tissue Verification



**Table 10-1
Measured Tissue Properties - Head**

Calibrated for Tests Performed on:	Tissue Type	Tissue Temp During Calibration (°C)	Measured Frequency (MHz)	Measured Conductivity, σ (S/m)	Measured Dielectric Constant, ϵ	TARGET Conductivity, σ (S/m)	TARGET Dielectric Constant, ϵ	% dev σ	% dev ϵ
5/28/2019	750H	22.0	680	0.889	43.122	0.888	42.305	0.11%	1.93%
			695	0.894	43.073	0.889	42.227	0.56%	2.00%
			700	0.895	43.059	0.889	42.201	0.67%	2.03%
			710	0.899	43.030	0.890	42.149	1.01%	2.09%
			740	0.910	42.953	0.893	41.994	1.90%	2.28%
			755	0.915	42.908	0.894	41.916	2.35%	2.37%
			770	0.920	42.862	0.895	41.838	2.79%	2.45%
			785	0.925	42.815	0.896	41.760	3.24%	2.53%
5/28/2019	835H	19.8	800	0.930	42.769	0.897	41.682	3.68%	2.61%
			820	0.884	40.650	0.899	41.578	-1.67%	-2.23%
			835	0.899	40.452	0.900	41.500	-0.11%	-2.53%
5/28/2019	1750H	21.0	850	0.914	40.261	0.916	41.500	-0.22%	-2.99%
			1710	1.345	40.422	1.348	40.142	-0.22%	0.70%
			1750	1.368	40.344	1.371	40.079	-0.22%	0.66%
6/3/2019	1750H	21.0	1790	1.389	40.279	1.394	40.016	-0.36%	0.66%
			1710	1.349	41.506	1.348	40.142	0.07%	3.40%
			1750	1.375	41.453	1.371	40.079	0.29%	3.43%
5/29/2019	1900H	21.5	1790	1.400	41.400	1.394	40.016	0.43%	3.46%
			1850	1.395	39.159	1.400	40.000	-0.36%	-2.10%
			1880	1.427	39.005	1.400	40.000	1.93%	-2.49%
5/30/2019	2450H	21.5	1910	1.458	38.868	1.400	40.000	4.14%	-2.83%
			2300	1.724	38.461	1.670	39.500	3.23%	-2.63%
			2310	1.731	38.447	1.679	39.480	3.10%	-2.62%
			2550	1.921	38.033	1.909	39.073	0.63%	-2.66%
6/3/2019	2450H	21.9	2600	1.963	37.947	1.964	39.009	-0.05%	-2.72%
			2500	1.892	38.102	1.855	39.136	1.99%	-2.64%
			2550	1.932	38.012	1.909	39.073	1.20%	-2.72%
6/17/2019	2450H	20.5	2600	1.972	37.919	1.964	39.009	0.41%	-2.79%
			2400	1.813	40.290	1.756	39.289	3.25%	2.55%
			2450	1.853	40.208	1.800	39.200	2.94%	2.57%
6/13/2019	3500H	20.8	2500	1.893	40.134	1.855	39.136	2.05%	2.55%
			3500	2.781	39.174	2.913	37.929	-4.53%	3.28%
			3550	2.833	39.095	2.964	37.871	-4.42%	3.23%
06/10/2019	5200H-5800H	20.7	3600	2.877	39.011	3.015	37.814	-4.58%	3.17%
			5240	4.578	34.841	4.696	35.940	-2.51%	-3.06%
			5260	4.601	34.796	4.717	35.917	-2.46%	-3.12%
			5280	4.624	34.757	4.737	35.894	-2.39%	-3.17%
			5300	4.647	34.721	4.758	35.871	-2.33%	-3.21%
			5680	5.069	34.032	5.147	35.437	-1.52%	-3.96%
			5700	5.089	33.994	5.168	35.414	-1.53%	-4.01%
			5745	5.145	33.909	5.214	35.363	-1.32%	-4.11%
			5765	5.164	33.879	5.234	35.340	-1.34%	-4.13%
			5785	5.188	33.846	5.255	35.317	-1.27%	-4.17%

FCC ID: A3LSMN975U		SAR EVALUATION REPORT		Approved by: Quality Manager
Document S/N: 1M1905200079-01-R1.A3L	Test Dates: 05/22/19 - 07/07/19	DUT Type: Portable Handset		Page 146 of 220

**Table 10-2
Measured Tissue Properties – Body**



Calibrated for Tests Performed on:	Tissue Type	Tissue Temp During Calibration (°C)	Measured Frequency (MHz)	Measured Conductivity, σ (S/m)	Measured Dielectric Constant, ϵ	TARGET Conductivity, σ (S/m)	TARGET Dielectric Constant, ϵ	% dev σ	% dev ϵ
5/22/2019	750B	23.6	680	0.913	57.168	0.958	55.804	-4.70%	2.44%
			695	0.919	57.124	0.959	55.745	-4.17%	2.47%
			700	0.921	57.110	0.959	55.726	-3.96%	2.48%
			710	0.924	57.083	0.960	55.687	-3.75%	2.51%
			740	0.936	57.015	0.963	55.570	-2.80%	2.60%
			755	0.941	56.989	0.964	55.512	-2.39%	2.66%
			770	0.946	56.955	0.965	55.453	-1.97%	2.71%
			785	0.951	56.915	0.966	55.395	-1.55%	2.74%
5/22/2019	835B	20.2	800	0.956	56.879	0.967	55.336	-1.14%	2.79%
			820	0.992	53.310	0.969	55.258	2.37%	-3.53%
			835	0.998	53.285	0.970	55.200	2.89%	-3.47%
5/27/2019	835B	19.9	850	1.004	53.256	0.988	55.154	1.62%	-3.44%
			820	0.981	53.913	0.969	55.258	1.24%	-2.43%
			835	0.987	53.895	0.970	55.200	1.75%	-2.36%
5/30/2019	835B	20.3	850	0.993	53.871	0.988	55.154	0.51%	-2.33%
			820	0.992	52.851	0.969	55.258	2.37%	-4.36%
			835	0.999	52.819	0.970	55.200	2.99%	-4.31%
6/10/2019	835B	20.0	850	1.005	52.790	0.988	55.154	1.72%	-4.29%
			820	0.977	54.093	0.969	55.258	0.83%	-2.11%
			835	0.983	54.072	0.970	55.200	1.34%	-2.04%
6/18/2019	835B	21.8	850	0.990	54.043	0.988	55.154	0.20%	-2.01%
			820	0.929	52.851	0.969	55.258	-4.13%	-4.36%
			835	0.945	52.698	0.970	55.200	-2.58%	-4.53%
6/5/2019	1750B	22.3	850	0.960	52.547	0.988	55.154	-2.83%	-4.73%
			1710	1.460	52.273	1.463	53.537	-0.21%	-2.36%
			1750	1.505	52.123	1.488	53.432	1.14%	-2.45%
6/8/2019	1750B	23.8	1790	1.549	51.969	1.514	53.326	2.31%	-2.54%
			1710	1.468	52.161	1.463	53.537	0.34%	-2.57%
			1750	1.515	52.021	1.488	53.432	1.81%	-2.64%
6/17/2019	1750B	20.0	1790	1.560	51.888	1.514	53.326	3.04%	-2.70%
			1710	1.476	51.781	1.463	53.537	0.89%	-3.28%
			1750	1.505	51.713	1.488	53.432	1.14%	-3.22%
6/19/2019	1750B	22.5	1790	1.533	51.637	1.514	53.326	1.25%	-3.17%
			1710	1.394	55.281	1.463	53.537	-4.72%	3.26%
			1750	1.420	55.258	1.488	53.432	-4.57%	3.42%
5/29/2019	1900B	23.3	1790	1.450	55.241	1.514	53.326	-4.23%	3.59%
			1850	1.527	52.433	1.520	53.300	0.46%	-1.63%
			1880	1.561	52.323	1.520	53.300	2.70%	-1.83%
6/3/2019	1900B	22.9	1910	1.595	52.210	1.520	53.300	4.93%	-2.05%
			1850	1.520	52.994	1.520	53.300	0.00%	-0.57%
			1880	1.554	52.895	1.520	53.300	2.24%	-0.76%
6/5/2019	1900B	23.5	1910	1.588	52.814	1.520	53.300	4.47%	-0.91%
			1850	1.514	52.064	1.520	53.300	-0.39%	-2.32%
			1880	1.548	51.975	1.520	53.300	1.84%	-2.49%
6/7/2019	1900B	23.4	1910	1.583	51.879	1.520	53.300	4.14%	-2.67%
			1850	1.512	52.376	1.520	53.300	-0.53%	-1.73%
			1880	1.545	52.296	1.520	53.300	1.64%	-1.88%
6/12/2019	1900B	23.2	1910	1.579	52.223	1.520	53.300	3.88%	-2.02%
			1850	1.510	51.888	1.520	53.300	-0.66%	-2.65%
			1880	1.542	51.791	1.520	53.300	1.45%	-2.83%
6/19/2019	1900B	23.0	1910	1.575	51.706	1.520	53.300	3.62%	-2.99%
			1850	1.510	52.301	1.520	53.300	-0.66%	-1.87%
			1880	1.542	52.214	1.520	53.300	1.45%	-2.04%
			1910	1.577	52.140	1.520	53.300	3.75%	-2.18%

FCC ID: A3LSMN975U		SAR EVALUATION REPORT		Approved by: Quality Manager
Document S/N: 1M1905200079-01-R1.A3L	Test Dates: 05/22/19 - 07/07/19	DUT Type: Portable Handset		Page 147 of 220

**Table 10-3
Measured Tissue Properties – Body**

Calibrated for Tests Performed on:	Tissue Type	Tissue Temp During Calibration (°C)	Measured Frequency (MHz)	Measured Conductivity, σ (S/m)	Measured Dielectric Constant, ϵ	TARGET Conductivity, σ (S/m)	TARGET Dielectric Constant, ϵ	% dev σ	% dev ϵ
6/5/2019	2450B	23.9	2300	1.842	51.200	1.809	52.900	1.82%	-3.21%
			2310	1.853	51.171	1.816	52.887	2.04%	-3.24%
			2320	1.865	51.143	1.826	52.873	2.14%	-3.27%
6/10/2019	2450B	23.1	2300	1.893	53.043	1.809	52.900	4.64%	0.27%
			2310	1.901	53.029	1.816	52.887	4.68%	0.27%
			2320	1.909	53.010	1.826	52.873	4.55%	0.26%
6/11/2019	2450B	24.5	2450	2.025	51.350	1.950	52.700	3.85%	-2.56%
			2500	2.083	51.193	2.021	52.636	3.07%	-2.74%
			2550	2.142	51.041	2.092	52.573	2.39%	-2.91%
			2600	2.200	50.900	2.163	52.509	1.71%	-3.06%
			2650	2.258	50.749	2.234	52.445	1.07%	-3.23%
			2700	2.319	50.615	2.305	52.382	0.61%	-3.37%
6/17/2019	2450B	23.6	2400	1.975	51.140	1.902	52.767	3.84%	-3.08%
			2450	2.035	50.996	1.950	52.700	4.36%	-3.23%
			2500	2.096	50.841	2.021	52.636	3.71%	-3.41%
7/7/2019	2450B	23.2	2450	2.012	51.233	1.950	52.700	3.18%	-2.78%
			2500	2.072	51.073	2.021	52.636	2.52%	-2.97%
			2550	2.130	50.926	2.092	52.573	1.82%	-3.13%
			2600	2.190	50.769	2.163	52.509	1.25%	-3.31%
6/12/2019	3500B	22.5	3500	3.377	51.089	3.314	51.321	1.90%	-0.45%
			3550	3.431	51.005	3.372	51.254	1.75%	-0.49%
			3600	3.485	50.935	3.431	51.186	1.57%	-0.49%
06/14/2019	5200B-5800B	22.4	5240	5.430	47.693	5.346	48.960	1.57%	-2.59%
			5260	5.457	47.651	5.369	48.933	1.64%	-2.62%
			5280	5.484	47.642	5.393	48.906	1.69%	-2.58%
			5300	5.508	47.594	5.416	48.879	1.70%	-2.63%
			5520	5.826	47.182	5.673	48.580	2.70%	-2.88%
			5600	5.950	47.025	5.766	48.471	3.19%	-2.98%
			5620	5.976	46.976	5.790	48.444	3.21%	-3.03%
			5680	6.074	46.859	5.860	48.363	3.65%	-3.11%
			5700	6.103	46.837	5.883	48.336	3.74%	-3.10%
			5745	6.171	46.752	5.936	48.275	3.96%	-3.15%
			5765	6.196	46.711	5.959	48.248	3.98%	-3.19%
5785	6.227	46.669	5.982	48.220	4.10%	-3.22%			

The above measured tissue parameters were used in the DASY software. The DASY software was used to perform interpolation to determine the dielectric parameters at the SAR test device frequencies (per KDB Publication 865664 D01v01r04 and IEEE 1528-2013 6.6.1.2). The tissue parameters listed in the SAR test plots may slightly differ from the table above due to significant digit rounding in the software.



FCC ID: A3LSMN975U		SAR EVALUATION REPORT		Approved by: Quality Manager
Document S/N: 1M1905200079-01-R1.A3L	Test Dates: 05/22/19 - 07/07/19	DUT Type: Portable Handset	Page 148 of 220	

10.2 Test System Verification

Prior to SAR assessment, the system is verified to $\pm 10\%$ of the SAR measurement on the reference dipole at the time of calibration by the calibration facility. Full system validation status and result summary can be found in Appendix E.

Table 10-4
System Verification Results – 1g

System Verification TARGET & MEASURED												
SAR System #	Tissue Frequency (MHz)	Tissue Type	Date	Amb. Temp (°C)	Liquid Temp (°C)	Input Power (W)	Source SN	Probe SN	Measured SAR _{1g} (W/kg)	1 W Target SAR _{1g} (W/kg)	1 W Normalized SAR _{1g} (W/kg)	Deviation _{1g} (%)
D	750	HEAD	05/28/2019	22.6	22.0	0.200	1161	3914	1.700	8.030	8.500	5.85%
H	835	HEAD	05/28/2019	20.0	19.8	0.200	4d132	7409	1.960	9.590	9.800	2.19%
I	1750	HEAD	05/28/2019	22.0	21.0	0.100	1008	7357	3.870	36.200	38.700	6.91%
I	1750	HEAD	06/03/2019	21.2	20.5	0.100	1008	7357	3.870	36.200	38.700	6.91%
L	1900	HEAD	05/29/2019	21.1	21.5	0.100	5d080	7308	4.250	39.800	42.500	6.78%
E	2300	HEAD	05/30/2019	22.7	21.5	0.100	1064	3589	5.100	47.600	51.000	7.14%
E	2450	HEAD	06/17/2019	22.5	20.5	0.100	797	3589	5.390	52.700	53.900	2.28%
E	2600	HEAD	05/30/2019	22.7	21.5	0.100	1071	3589	5.950	56.300	59.500	5.68%
E	2600	HEAD	06/03/2019	22.5	21.9	0.100	1071	3589	5.830	56.300	58.300	3.55%
E	3500	HEAD	06/13/2019	24.0	20.8	0.100	1055	3589	6.610	66.800	66.100	-1.05%
H	5250	HEAD	06/10/2019	21.6	20.7	0.050	1191	7406	3.960	78.900	79.200	0.38%
H	5750	HEAD	06/10/2019	21.6	20.7	0.050	1191	7406	3.770	79.100	75.400	-4.68%
I	750	BODY	05/22/2019	23.4	21.7	0.200	1003	7357	1.700	8.580	8.500	-0.93%
J	835	BODY	05/22/2019	19.8	20.1	0.200	4d132	7488	1.940	9.670	9.700	0.31%
J	835	BODY	05/27/2019	20.2	19.9	0.200	4d132	7488	1.980	9.670	9.900	2.38%
J	835	BODY	05/30/2019	20.1	20.3	0.200	4d133	7488	1.980	9.750	9.900	1.54%
J	835	BODY	06/10/2019	20.5	20.0	0.200	4d132	7488	1.900	9.670	9.500	-1.76%
D	835	BODY	06/18/2019	22.4	21.8	0.200	4d132	3914	2.050	9.670	10.250	6.00%
D	1750	BODY	06/05/2019	23.1	22.3	0.100	1008	3914	3.940	37.400	39.400	5.35%
D	1750	BODY	06/08/2019	22.7	21.8	0.100	1008	3914	3.940	37.400	39.400	5.35%
J	1750	BODY	06/17/2019	20.1	20.0	0.100	1008	7488	4.020	37.400	40.200	7.49%
G	1900	BODY	05/29/2019	23.1	21.6	0.100	5d148	7410	4.220	39.100	42.200	7.93%
G	1900	BODY	06/03/2019	21.9	22.3	0.100	5d148	7410	4.210	39.100	42.100	7.67%
G	1900	BODY	06/05/2019	22.8	23.5	0.100	5d148	7410	4.220	39.100	42.200	7.93%
G	1900	BODY	06/07/2019	22.2	22.5	0.100	5d148	7410	4.000	39.100	40.000	2.30%
G	1900	BODY	06/12/2019	22.6	22.0	0.100	5d149	7410	3.980	39.400	39.800	1.02%
G	1900	BODY	06/19/2019	22.6	22.3	0.100	5d149	7410	3.990	39.400	39.900	1.27%
K	2300	BODY	06/05/2019	23.5	22.9	0.100	1073	7417	4.850	47.700	48.500	1.68%
L	2300	BODY	06/10/2019	22.2	21.1	0.100	1064	7308	4.830	46.500	48.300	3.87%
K	2450	BODY	06/11/2019	24.6	24.5	0.100	719	7417	4.960	50.100	49.600	-1.00%
K	2450	BODY	06/17/2019	23.9	22.9	0.100	719	7417	5.130	50.100	51.300	2.40%
K	2600	BODY	06/11/2019	24.6	24.5	0.100	1004	7417	5.130	54.800	51.300	-6.39%
D	3500	BODY	06/12/2019	23.1	22.5	0.100	1055	3914	6.610	64.600	66.100	2.32%
L	5250	BODY	06/14/2019	22.8	20.9	0.050	1237	7308	3.600	75.600	72.000	-4.76%
L	5600	BODY	06/14/2019	22.8	20.9	0.050	1237	7308	4.100	78.500	82.000	4.46%
L	5750	BODY	06/14/2019	22.8	20.9	0.050	1237	7308	3.750	75.900	75.000	-1.19%

FCC ID: A3LSMN975U		SAR EVALUATION REPORT		Approved by: Quality Manager
Document S/N: 1M1905200079-01-R1.A3L	Test Dates: 05/22/19 - 07/07/19	DUT Type: Portable Handset	Page 149 of 220	

**Table 10-5
System Verification Results – 10g**

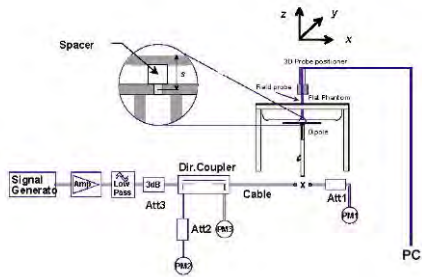

System Verification TARGET & MEASURED												
SAR System #	Tissue Frequency (MHz)	Tissue Type	Date	Amb. Temp (°C)	Liquid Temp (°C)	Input Power (W)	Source SN	Probe SN	Measured SAR _{10g} (W/kg)	1 W Target SAR _{10g} (W/kg)	1 W Normalized SAR _{10g} (W/kg)	Deviation _{10g} (%)
D	1750	BODY	06/05/2019	23.1	22.3	0.100	1008	3914	2.070	19.900	20.700	4.02%
I	1750	BODY	06/19/2019	22.2	22.5	0.100	1150	7357	2.060	19.400	20.600	6.19%
G	1900	BODY	06/03/2019	21.9	22.3	0.100	5d148	7410	2.170	20.500	21.700	5.85%
G	1900	BODY	06/05/2019	22.8	23.5	0.100	5d148	7410	2.180	20.500	21.800	6.34%
G	1900	BODY	06/07/2019	22.2	22.5	0.100	5d148	7410	2.070	20.500	20.700	0.98%
G	1900	BODY	06/12/2019	22.6	22.0	0.100	5d149	7410	2.050	20.700	20.500	-0.97%
K	2300	BODY	06/05/2019	23.5	22.9	0.100	1073	7417	2.300	23.200	23.000	-0.86%
K	2450	BODY	07/07/2019	23.0	22.1	0.100	719	7417	2.320	23.700	23.200	-2.11%
K	2600	BODY	07/07/2019	23.0	22.1	0.100	1004	7417	2.370	24.700	23.700	-4.05%
L	5250	BODY	06/14/2019	22.8	20.9	0.050	1237	7308	1.010	21.200	20.200	-4.72%
L	5600	BODY	06/14/2019	22.8	20.9	0.050	1237	7308	1.120	22.000	22.400	1.82%
L	5750	BODY	06/14/2019	22.8	20.9	0.050	1237	7308	1.040	21.200	20.800	-1.89%



**Figure 10-1
System Verification Setup Diagram**



**Figure 10-2
System Verification Setup Photo**

FCC ID: A3LSMN975U	 PCTEST <small>ENGINEERING LABORATORY, INC.</small>	SAR EVALUATION REPORT		Approved by: Quality Manager
Document S/N: 1M1905200079-01-R1.A3L	Test Dates: 05/22/19 - 07/07/19	DUT Type: Portable Handset	Page 150 of 220	

11 SAR DATA SUMMARY



11.1 Standalone Head SAR Data

**Table 11-1
CDMA BC10 (§90S) Head SAR**

MEASUREMENT RESULTS															
FREQUENCY		Mode	Service	Maximum Allowed Power [dBm]	Conducted Power [dBm]	Power Drift [dB]	Side	Test Position	Ant State	Device Serial Number	Duty Cycle	SAR (1g)	Scaling Factor	Reported SAR (1g)	Plot #
MHz	Ch.											(W/kg)		(W/kg)	
820.10	564	CDMA BC10 (§90S)	RC3 / SO55	26.3	25.12	-0.09	Right	Cheek	2	0119M	1:1	0.141	1.312	0.185	
820.10	564	CDMA BC10 (§90S)	RC3 / SO55	26.3	25.12	0.01	Right	Tilt	2	0119M	1:1	0.055	1.312	0.072	
820.10	564	CDMA BC10 (§90S)	RC3 / SO55	26.3	25.12	-0.06	Left	Cheek	2	0119M	1:1	0.091	1.312	0.119	
820.10	564	CDMA BC10 (§90S)	RC3 / SO55	26.3	25.12	-0.10	Left	Tilt	2	0119M	1:1	0.050	1.312	0.066	
820.10	564	CDMA BC10 (§90S)	EVDO Rev. A	26.3	25.20	0.04	Right	Cheek	2	0119M	1:1	0.150	1.288	0.193	A1
820.10	564	CDMA BC10 (§90S)	EVDO Rev. A	26.3	25.20	0.05	Right	Tilt	2	0119M	1:1	0.063	1.288	0.081	
820.10	564	CDMA BC10 (§90S)	EVDO Rev. A	26.3	25.20	0.05	Left	Cheek	2	0119M	1:1	0.098	1.288	0.126	
820.10	564	CDMA BC10 (§90S)	EVDO Rev. A	26.3	25.20	0.04	Left	Tilt	2	0119M	1:1	0.092	1.288	0.118	
ANSI / IEEE C95.1 1992 - SAFETY LIMIT Spatial Peak Uncontrolled Exposure/General Population							Head 1.6 W/kg (mW/g) averaged over 1 gram								

**Table 11-2
CDMA BC0 (§22H) Head SAR**

MEASUREMENT RESULTS															
FREQUENCY		Mode	Service	Maximum Allowed Power [dBm]	Conducted Power [dBm]	Power Drift [dB]	Side	Test Position	Ant State	Device Serial Number	Duty Cycle	SAR (1g)	Scaling Factor	Reported SAR (1g)	Plot #
MHz	Ch.											(W/kg)		(W/kg)	
836.52	384	CDMA BC0 (§22H)	RC3 / SO55	26.3	25.01	-0.03	Right	Cheek	2	0119M	1:1	0.144	1.346	0.194	A2
836.52	384	CDMA BC0 (§22H)	RC3 / SO55	26.3	25.01	-0.03	Right	Tilt	2	0119M	1:1	0.059	1.346	0.079	
836.52	384	CDMA BC0 (§22H)	RC3 / SO55	26.3	25.01	0.02	Left	Cheek	2	0119M	1:1	0.083	1.346	0.112	
836.52	384	CDMA BC0 (§22H)	RC3 / SO55	26.3	25.01	-0.08	Left	Tilt	2	0119M	1:1	0.050	1.346	0.067	
836.52	384	CDMA BC0 (§22H)	EVDO Rev. A	26.3	25.22	0.00	Right	Cheek	2	0119M	1:1	0.136	1.282	0.174	
836.52	384	CDMA BC0 (§22H)	EVDO Rev. A	26.3	25.22	0.04	Right	Tilt	2	0119M	1:1	0.076	1.282	0.097	
836.52	384	CDMA BC0 (§22H)	EVDO Rev. A	26.3	25.22	0.04	Left	Cheek	2	0119M	1:1	0.110	1.282	0.141	
836.52	384	CDMA BC0 (§22H)	EVDO Rev. A	26.3	25.22	0.15	Left	Tilt	2	0119M	1:1	0.072	1.282	0.092	
ANSI / IEEE C95.1 1992 - SAFETY LIMIT Spatial Peak Uncontrolled Exposure/General Population							Head 1.6 W/kg (mW/g) averaged over 1 gram								

FCC ID: A3LSMN975U		SAR EVALUATION REPORT		Approved by: Quality Manager
Document S/N: 1M1905200079-01-R1.A3L	Test Dates: 05/22/19 - 07/07/19	DUT Type: Portable Handset	Page 151 of 220	

**Table 11-3
GSM 850 Head SAR**



MEASUREMENT RESULTS														
FREQUENCY		Mode	Service	Maximum Allowed Power [dBm]	Conducted Power [dBm]	Power Drift [dB]	Side	Test Position	Device Serial Number	Duty Cycle	SAR (1g)	Scaling Factor	Reported SAR (1g)	Plot #
MHz	Ch.										(W/kg)		(W/kg)	
836.60	190	GSM 850	GSM	33.5	32.18	0.01	Right	Cheek	0119M	1:8.3	0.098	1.355	0.133	A3
836.60	190	GSM 850	GSM	33.5	32.18	-0.11	Right	Tilt	0119M	1:8.3	0.043	1.355	0.058	
836.60	190	GSM 850	GSM	33.5	32.18	0.10	Left	Cheek	0119M	1:8.3	0.064	1.355	0.087	
836.60	190	GSM 850	GSM	33.5	32.18	0.06	Left	Tilt	0119M	1:8.3	0.038	1.355	0.051	
ANSI / IEEE C95.1 1992 - SAFETY LIMIT Spatial Peak Uncontrolled Exposure/General Population								Head 1.6 W/kg (mW/g) averaged over 1 gram						

**Table 11-4
UMTS 850 Head SAR**

MEASUREMENT RESULTS															
FREQUENCY		Mode	Service	Maximum Allowed Power [dBm]	Conducted Power [dBm]	Power Drift [dB]	Side	Test Position	Ant State	Device Serial Number	Duty Cycle	SAR (1g)	Scaling Factor	Reported SAR (1g)	Plot #
MHz	Ch.											(W/kg)		(W/kg)	
836.60	4183	UMTS 850	RMC	25.5	24.89	-0.06	Right	Cheek	2	0119M	1:1	0.136	1.151	0.157	A4
836.60	4183	UMTS 850	RMC	25.5	24.89	-0.14	Right	Tilt	2	0119M	1:1	0.061	1.151	0.070	
836.60	4183	UMTS 850	RMC	25.5	24.89	-0.02	Left	Cheek	2	0119M	1:1	0.093	1.151	0.107	
836.60	4183	UMTS 850	RMC	25.5	24.89	0.03	Left	Tilt	2	0119M	1:1	0.051	1.151	0.059	
ANSI / IEEE C95.1 1992 - SAFETY LIMIT Spatial Peak Uncontrolled Exposure/General Population								Head 1.6 W/kg (mW/g) averaged over 1 gram							

**Table 11-5
UMTS 1750 Head SAR**

MEASUREMENT RESULTS															
FREQUENCY		Mode	Service	Maximum Allowed Power [dBm]	Conducted Power [dBm]	Power Drift [dB]	Side	Test Position	Ant State	Device Serial Number	Duty Cycle	SAR (1g)	Scaling Factor	Reported SAR (1g)	Plot #
MHz	Ch.											(W/kg)		(W/kg)	
1732.40	1412	UMTS 1750	RMC	25.0	24.35	0.07	Right	Cheek	30	0116M	1:1	0.085	1.161	0.099	
1732.40	1412	UMTS 1750	RMC	25.0	24.35	0.17	Right	Tilt	30	0116M	1:1	0.086	1.161	0.100	
1732.40	1412	UMTS 1750	RMC	25.0	24.35	0.16	Left	Cheek	30	0116M	1:1	0.127	1.161	0.147	A5
1732.40	1412	UMTS 1750	RMC	25.0	24.35	0.13	Left	Tilt	30	0116M	1:1	0.091	1.161	0.106	
ANSI / IEEE C95.1 1992 - SAFETY LIMIT Spatial Peak Uncontrolled Exposure/General Population								Head 1.6 W/kg (mW/g) averaged over 1 gram							

FCC ID: A3LSMN975U		SAR EVALUATION REPORT		Approved by: Quality Manager
Document S/N: 1M1905200079-01-R1.A3L	Test Dates: 05/22/19 - 07/07/19	DUT Type: Portable Handset		Page 152 of 220

**Table 11-6
PCS CDMA Head SAR**



MEASUREMENT RESULTS															
FREQUENCY		Mode	Service	Maximum Allowed Power [dBm]	Conducted Power [dBm]	Power Drift [dB]	Side	Test Position	Ant State	Device Serial Number	Duty Cycle	SAR (1g)	Scaling Factor	Reported SAR (1g)	Plot #
MHz	Ch.											(W/kg)		(W/kg)	
1880.00	600	PCS CDMA	RC3 / SO55	25.0	24.65	-0.10	Right	Cheek	0	0119M	1:1	0.083	1.084	0.090	
1880.00	600	PCS CDMA	RC3 / SO55	25.0	24.65	0.19	Right	Tilt	0	0119M	1:1	0.057	1.084	0.062	
1880.00	600	PCS CDMA	RC3 / SO55	25.0	24.65	-0.19	Left	Cheek	0	0119M	1:1	0.104	1.084	0.113	A6
1880.00	600	PCS CDMA	RC3 / SO55	25.0	24.65	0.13	Left	Tilt	0	0119M	1:1	0.046	1.084	0.050	
1880.00	600	PCS CDMA	EVDO Rev. A	25.0	24.49	-0.11	Right	Cheek	0	0119M	1:1	0.082	1.125	0.092	
1880.00	600	PCS CDMA	EVDO Rev. A	25.0	24.49	0.10	Right	Tilt	0	0119M	1:1	0.060	1.125	0.068	
1880.00	600	PCS CDMA	EVDO Rev. A	25.0	24.49	0.02	Left	Cheek	0	0119M	1:1	0.101	1.125	0.114	
1880.00	600	PCS CDMA	EVDO Rev. A	25.0	24.49	0.11	Left	Tilt	0	0119M	1:1	0.061	1.125	0.069	
ANSI / IEEE C95.1 1992 - SAFETY LIMIT Spatial Peak Uncontrolled Exposure/General Population							Head 1.6 W/kg (mW/g) averaged over 1 gram								

**Table 11-7
GSM 1900 Head SAR**

MEASUREMENT RESULTS														
FREQUENCY		Mode	Service	Maximum Allowed Power [dBm]	Conducted Power [dBm]	Power Drift [dB]	Side	Test Position	Device Serial Number	Duty Cycle	SAR (1g)	Scaling Factor	Reported SAR (1g)	Plot #
MHz	Ch.										(W/kg)		(W/kg)	
1909.80	810	GSM 1900	GSM	30.0	28.58	0.13	Right	Cheek	0119M	1:8.3	0.033	1.387	0.046	
1909.80	810	GSM 1900	GSM	30.0	28.58	-0.10	Right	Tilt	0119M	1:8.3	0.019	1.387	0.026	
1909.80	810	GSM 1900	GSM	30.0	28.58	0.17	Left	Cheek	0119M	1:8.3	0.038	1.387	0.053	A7
1909.80	810	GSM 1900	GSM	30.0	28.58	-0.14	Left	Tilt	0119M	1:8.3	0.018	1.387	0.025	
ANSI / IEEE C95.1 1992 - SAFETY LIMIT Spatial Peak Uncontrolled Exposure/General Population							Head 1.6 W/kg (mW/g) averaged over 1 gram							

**Table 11-8
UMTS 1900 Head SAR**

MEASUREMENT RESULTS															
FREQUENCY		Mode	Service	Maximum Allowed Power [dBm]	Conducted Power [dBm]	Power Drift [dB]	Side	Test Position	Ant State	Device Serial Number	Duty Cycle	SAR (1g)	Scaling Factor	Reported SAR (1g)	Plot #
MHz	Ch.											(W/kg)		(W/kg)	
1880.00	9400	UMTS 1900	RMC	25.0	23.78	0.17	Right	Cheek	0	0119M	1:1	0.088	1.324	0.117	
1880.00	9400	UMTS 1900	RMC	25.0	23.78	0.12	Right	Tilt	0	0119M	1:1	0.064	1.324	0.085	
1880.00	9400	UMTS 1900	RMC	25.0	23.78	0.06	Left	Cheek	0	0119M	1:1	0.105	1.324	0.139	A8
1880.00	9400	UMTS 1900	RMC	25.0	23.78	0.05	Left	Tilt	0	0119M	1:1	0.051	1.324	0.068	
ANSI / IEEE C95.1 1992 - SAFETY LIMIT Spatial Peak Uncontrolled Exposure/General Population							Head 1.6 W/kg (mW/g) averaged over 1 gram								

FCC ID: A3LSMN975U		SAR EVALUATION REPORT		Approved by: Quality Manager
Document S/N: 1M1905200079-01-R1.A3L	Test Dates: 05/22/19 - 07/07/19	DUT Type: Portable Handset		Page 153 of 220

**Table 11-9
LTE Band 71 Head SAR**



MEASUREMENT RESULTS																				
FREQUENCY		Mode	Bandwidth [MHz]	Ant State	Maximum Allowed Power [dBm]	Conducted Power [dBm]	Power Drift [dB]	MPR [dB]	Side	Test Position	Modulation	RB Size	RB Offset	Device Serial Number	Duty Cycle	SAR (1g)	Scaling Factor	Reported SAR (1g)	Plot #	
MHz	Ch.															(W/kg)		(W/kg)		
680.50	133297	Md	LTE Band 71	20	10	25.8	25.05	0.05	0	Right	Cheek	QPSK	1	0	0503M	1:1	0.090	1.189	0.107	
680.50	133297	Md	LTE Band 71	20	10	24.8	24.12	0.04	1	Right	Cheek	QPSK	50	0	0503M	1:1	0.072	1.169	0.084	
680.50	133297	Md	LTE Band 71	20	10	25.8	25.05	0.05	0	Right	Tilt	QPSK	1	0	0503M	1:1	0.047	1.189	0.056	
680.50	133297	Md	LTE Band 71	20	10	24.8	24.12	0.05	1	Right	Tilt	QPSK	50	0	0503M	1:1	0.032	1.169	0.037	
680.50	133297	Md	LTE Band 71	20	10	25.8	25.05	0.05	0	Left	Cheek	QPSK	1	0	0503M	1:1	0.096	1.189	0.114	A9
680.50	133297	Md	LTE Band 71	20	10	24.8	24.12	0.09	1	Left	Cheek	QPSK	50	0	0503M	1:1	0.062	1.169	0.072	
680.50	133297	Md	LTE Band 71	20	10	25.8	25.05	0.14	0	Left	Tilt	QPSK	1	0	0503M	1:1	0.052	1.189	0.062	
680.50	133297	Md	LTE Band 71	20	10	24.8	24.12	0.19	1	Left	Tilt	QPSK	50	0	0503M	1:1	0.032	1.169	0.037	
ANSI / IEEE C95.1 1992 - SAFETY LIMIT Spatial Peak Uncontrolled Exposure/General Population											Head 1.6 W/kg (mW/g) averaged over 1 gram									

**Table 11-10
LTE Band 12 Head SAR**

MEASUREMENT RESULTS																				
FREQUENCY		Mode	Bandwidth [MHz]	Ant State	Maximum Allowed Power [dBm]	Conducted Power [dBm]	Power Drift [dB]	MPR [dB]	Side	Test Position	Modulation	RB Size	RB Offset	Device Serial Number	Duty Cycle	SAR (1g)	Scaling Factor	Reported SAR (1g)	Plot #	
MHz	Ch.															(W/kg)		(W/kg)		
707.50	23095	Md	LTE Band 12	10	51	25.8	24.86	-0.05	0	Right	Cheek	QPSK	1	0	0503M	1:1	0.096	1.242	0.119	A10
707.50	23095	Md	LTE Band 12	10	51	24.8	23.90	0.06	1	Right	Cheek	QPSK	25	0	0503M	1:1	0.081	1.230	0.100	
707.50	23095	Md	LTE Band 12	10	51	25.8	24.86	-0.11	0	Right	Tilt	QPSK	1	0	0503M	1:1	0.048	1.242	0.060	
707.50	23095	Md	LTE Band 12	10	51	24.8	23.90	-0.03	1	Right	Tilt	QPSK	25	0	0503M	1:1	0.038	1.230	0.047	
707.50	23095	Md	LTE Band 12	10	51	25.8	24.86	0.21	0	Left	Cheek	QPSK	1	0	0503M	1:1	0.071	1.242	0.088	
707.50	23095	Md	LTE Band 12	10	51	24.8	23.90	0.07	1	Left	Cheek	QPSK	25	0	0503M	1:1	0.058	1.230	0.071	
707.50	23095	Md	LTE Band 12	10	51	25.8	24.86	0.16	0	Left	Tilt	QPSK	1	0	0503M	1:1	0.051	1.242	0.063	
707.50	23095	Md	LTE Band 12	10	51	24.8	23.90	0.08	1	Left	Tilt	QPSK	25	0	0503M	1:1	0.040	1.230	0.049	
ANSI / IEEE C95.1 1992 - SAFETY LIMIT Spatial Peak Uncontrolled Exposure/General Population											Head 1.6 W/kg (mW/g) averaged over 1 gram									

**Table 11-11
LTE Band 13 Head SAR**

MEASUREMENT RESULTS																				
FREQUENCY		Mode	Bandwidth [MHz]	Ant State	Maximum Allowed Power [dBm]	Conducted Power [dBm]	Power Drift [dB]	MPR [dB]	Side	Test Position	Modulation	RB Size	RB Offset	Device Serial Number	Duty Cycle	SAR (1g)	Scaling Factor	Reported SAR (1g)	Plot #	
MHz	Ch.															(W/kg)		(W/kg)		
782.00	23230	Md	LTE Band 13	10	57	25.8	24.63	0.04	0	Right	Cheek	QPSK	1	0	0503M	1:1	0.127	1.309	0.166	A11
782.00	23230	Md	LTE Band 13	10	57	24.8	23.69	0.03	1	Right	Cheek	QPSK	25	0	0503M	1:1	0.101	1.291	0.130	
782.00	23230	Md	LTE Band 13	10	57	25.8	24.63	0.09	0	Right	Tilt	QPSK	1	0	0503M	1:1	0.071	1.309	0.093	
782.00	23230	Md	LTE Band 13	10	57	24.8	23.69	0.08	1	Right	Tilt	QPSK	25	0	0503M	1:1	0.056	1.291	0.072	
782.00	23230	Md	LTE Band 13	10	57	25.8	24.63	0.15	0	Left	Cheek	QPSK	1	0	0503M	1:1	0.122	1.309	0.160	
782.00	23230	Md	LTE Band 13	10	57	24.8	23.69	0.05	1	Left	Cheek	QPSK	25	0	0503M	1:1	0.083	1.291	0.107	
782.00	23230	Md	LTE Band 13	10	57	25.8	24.63	-0.04	0	Left	Tilt	QPSK	1	0	0503M	1:1	0.078	1.309	0.102	
782.00	23230	Md	LTE Band 13	10	57	24.8	23.69	0.08	1	Left	Tilt	QPSK	25	0	0503M	1:1	0.054	1.291	0.070	
ANSI / IEEE C95.1 1992 - SAFETY LIMIT Spatial Peak Uncontrolled Exposure/General Population											Head 1.6 W/kg (mW/g) averaged over 1 gram									

FCC ID: A3LSMN975U		SAR EVALUATION REPORT		Approved by: Quality Manager
Document S/N: 1M1905200079-01-R1.A3L	Test Dates: 05/22/19 - 07/07/19	DUT Type: Portable Handset	Page 154 of 220	

**Table 11-12
LTE Band 14 Head SAR**

MEASUREMENT RESULTS																				
FREQUENCY		Mode	Bandwidth [MHz]	Ant State	Maximum Allowed Power [dBm]	Conducted Power [dBm]	Power Drift [dB]	MPR [dB]	Side	Test Position	Modulation	RB Size	RB Offset	Device Serial Number	Duty Cycle	SAR (1g)	Scaling Factor	Reported SAR (1g)	Plot #	
MHz	Ch.															(W/kg)		(W/kg)		
793.00	23330	Md	LTE Band 14	10	57	25.8	24.50	-0.01	0	Right	Cheek	QPSK	1	0	0503M	1:1	0.102	1.349	0.138	A12
793.00	23330	Md	LTE Band 14	10	57	24.8	23.62	0.00	1	Right	Cheek	QPSK	25	0	0503M	1:1	0.088	1.312	0.115	
793.00	23330	Md	LTE Band 14	10	57	25.8	24.50	0.19	0	Right	Tilt	QPSK	1	0	0503M	1:1	0.056	1.349	0.076	
793.00	23330	Md	LTE Band 14	10	57	24.8	23.62	0.07	1	Right	Tilt	QPSK	25	0	0503M	1:1	0.047	1.312	0.062	
793.00	23330	Md	LTE Band 14	10	57	25.8	24.50	0.13	0	Left	Cheek	QPSK	1	0	0503M	1:1	0.087	1.349	0.117	
793.00	23330	Md	LTE Band 14	10	57	24.8	23.62	0.09	1	Left	Cheek	QPSK	25	0	0503M	1:1	0.078	1.312	0.102	
793.00	23330	Md	LTE Band 14	10	57	25.8	24.50	0.06	0	Left	Tilt	QPSK	1	0	0503M	1:1	0.057	1.349	0.077	
793.00	23330	Md	LTE Band 14	10	57	24.8	23.62	0.13	1	Left	Tilt	QPSK	25	0	0503M	1:1	0.052	1.312	0.068	
ANSI / IEEE C95.1 1992 - SAFETY LIMIT Spatial Peak Uncontrolled Exposure/General Population											Head 1.6 W/kg (mW/g) averaged over 1 gram									

**Table 11-13
LTE Band 26 (Cell) Head SAR**

MEASUREMENT RESULTS																				
FREQUENCY		Mode	Bandwidth [MHz]	Ant State	Maximum Allowed Power [dBm]	Conducted Power [dBm]	Power Drift [dB]	MPR [dB]	Side	Test Position	Modulation	RB Size	RB Offset	Device Serial Number	Duty Cycle	SAR (1g)	Scaling Factor	Reported SAR (1g)	Plot #	
MHz	Ch.															(W/kg)		(W/kg)		
831.50	26865	Md	LTE Band 26 (Cell)	15	0	25.8	24.76	-0.19	0	Right	Cheek	QPSK	1	74	0503M	1:1	0.140	1.271	0.178	A13
831.50	26865	Md	LTE Band 26 (Cell)	15	0	24.8	23.82	-0.01	1	Right	Cheek	QPSK	36	37	0503M	1:1	0.112	1.253	0.140	
831.50	26865	Md	LTE Band 26 (Cell)	15	0	25.8	24.76	0.10	0	Right	Tilt	QPSK	1	74	0503M	1:1	0.068	1.271	0.086	
831.50	26865	Md	LTE Band 26 (Cell)	15	0	24.8	23.82	-0.17	1	Right	Tilt	QPSK	36	37	0503M	1:1	0.058	1.253	0.073	
831.50	26865	Md	LTE Band 26 (Cell)	15	0	25.8	24.76	-0.04	0	Left	Cheek	QPSK	1	74	0503M	1:1	0.106	1.271	0.135	
831.50	26865	Md	LTE Band 26 (Cell)	15	0	24.8	23.82	-0.17	1	Left	Cheek	QPSK	36	37	0503M	1:1	0.081	1.253	0.101	
831.50	26865	Md	LTE Band 26 (Cell)	15	0	25.8	24.76	0.07	0	Left	Tilt	QPSK	1	74	0503M	1:1	0.069	1.271	0.088	
831.50	26865	Md	LTE Band 26 (Cell)	15	0	24.8	23.82	0.12	1	Left	Tilt	QPSK	36	37	0503M	1:1	0.052	1.253	0.065	
ANSI / IEEE C95.1 1992 - SAFETY LIMIT Spatial Peak Uncontrolled Exposure/General Population											Head 1.6 W/kg (mW/g) averaged over 1 gram									

**Table 11-14
LTE Band 5 (Cell) Head SAR**

MEASUREMENT RESULTS																						
1 CC Uplink 2 CC Uplink	Component Carrier	FREQUENCY		Mode	Bandwidth [MHz]	Ant State	Maximum Allowed Power [dBm]	Conducted Power [dBm]	Power Drift [dB]	MPR [dB]	Side	Test Position	Modulation	RB Size	RB Offset	Device Serial Number	Duty Cycle	SAR (1g)	Scaling Factor	Reported SAR (1g)	Plot #	
		MHz	Ch.															(W/kg)		(W/kg)		
1 CC Uplink	N/A	836.50	20525	Md	LTE Band 5 (Cell)	10	0	25.8	24.89	0.05	0	Right	Cheek	QPSK	1	0	0503M	1:1	0.149	1.233	0.184	
1 CC Uplink	N/A	836.50	20525	Md	LTE Band 5 (Cell)	10	0	24.8	23.92	-0.01	1	Right	Cheek	QPSK	25	0	0503M	1:1	0.114	1.225	0.140	
2 CC Uplink	PCC	836.50	20525	Md	LTE Band 5 (Cell)	10	0	25.8	24.97	0.07	0	Right	Cheek	QPSK	1	0	0503M	1:1	0.153	1.211	0.185	A14
	SCC	829.30	20453	Md	LTE Band 5 (Cell)	5																
1 CC Uplink	N/A	836.50	20525	Md	LTE Band 5 (Cell)	10	0	25.8	24.89	0.11	0	Right	Tilt	QPSK	1	0	0503M	1:1	0.078	1.233	0.096	
1 CC Uplink	N/A	836.50	20525	Md	LTE Band 5 (Cell)	10	0	24.8	23.92	0.06	1	Right	Tilt	QPSK	25	0	0503M	1:1	0.058	1.225	0.071	
1 CC Uplink	N/A	836.50	20525	Md	LTE Band 5 (Cell)	10	0	25.8	24.89	-0.01	0	Left	Cheek	QPSK	1	0	0503M	1:1	0.106	1.233	0.131	
1 CC Uplink	N/A	836.50	20525	Md	LTE Band 5 (Cell)	10	0	24.8	23.92	-0.01	1	Left	Cheek	QPSK	25	0	0503M	1:1	0.081	1.225	0.099	
1 CC Uplink	N/A	836.50	20525	Md	LTE Band 5 (Cell)	10	0	25.8	24.89	0.17	0	Left	Tilt	QPSK	1	0	0503M	1:1	0.073	1.233	0.090	
1 CC Uplink	N/A	836.50	20525	Md	LTE Band 5 (Cell)	10	0	24.8	23.92	0.20	1	Left	Tilt	QPSK	25	0	0503M	1:1	0.054	1.225	0.066	
ANSI / IEEE C95.1 1992 - SAFETY LIMIT Spatial Peak Uncontrolled Exposure/General Population											Head 1.6 W/kg (mW/g) averaged over 1 gram											

FCC ID: A3LSMN975U		SAR EVALUATION REPORT		Approved by: Quality Manager
Document S/N: 1M1905200079-01-R1.A3L	Test Dates: 05/22/19 - 07/07/19	DUT Type: Portable Handset		Page 155 of 220

**Table 11-15
LTE Band 66 (AWS) Head SAR**

MEASUREMENT RESULTS																					
1 CC Uplink 2 CC Uplink	Component Carrier	FREQUENCY		Mode	Bandwidth [MHz]	Ant State	Maximum Allowed Power [dBm]	Conducted Power [dBm]	Power Drift [dB]	MPR [dB]	Side	Test Position	Modulation	RB Size	RB Offset	Device Serial Number	Duty Cycle	SAR (1g)	Scaling Factor	Reported SAR (1g)	Plot #
		MHz	Ch.															(W/kg)		(W/kg)	
1 CC Uplink	N/A	1745.00	132322	Mid	20	30	25.0	24.38	0.08	0	Right	Cheek	QPSK	1	99	0326M	1:1	0.092	1.153	0.106	
1 CC Uplink	N/A	1745.00	132322	Mid	20	30	24.0	23.50	0.07	1	Right	Cheek	QPSK	50	25	0326M	1:1	0.073	1.122	0.082	
1 CC Uplink	N/A	1745.00	132322	Mid	20	30	25.0	24.38	0.16	0	Right	Tilt	QPSK	1	99	0326M	1:1	0.069	1.153	0.080	
1 CC Uplink	N/A	1745.00	132322	Mid	20	30	24.0	23.50	0.13	1	Right	Tilt	QPSK	50	25	0326M	1:1	0.058	1.122	0.065	
1 CC Uplink	N/A	1745.00	132322	Mid	20	30	25.0	24.38	0.18	0	Left	Cheek	QPSK	1	99	0326M	1:1	0.133	1.153	0.153	
1 CC Uplink	N/A	1745.00	132322	Mid	20	30	24.0	23.50	0.08	1	Left	Cheek	QPSK	50	25	0326M	1:1	0.107	1.122	0.120	
1 CC Uplink	N/A	1745.00	132322	Mid	10	30	25.0	24.36	0.05	0	Left	Cheek	QPSK	1	49	0326M	1:1	0.128	1.159	0.148	
CA_66C 2 CC Uplink	PCC	1745.00	132322	Mid	20	30	25.0	24.60	0.16	0	Left	Cheek	QPSK	1	99	0326M	1:1	0.150	1.096	0.164	A15
	SCC	1764.80	132520	Mid	20										0						
CA_66B 2 CC Uplink	PCC	1745.00	132322	Mid	10	30	25.0	24.42	-0.08	0	Left	Cheek	QPSK	1	49	0326M	1:1	0.136	1.143	0.155	
	SCC	1754.90	132421	Mid	10										0						
1 CC Uplink	N/A	1745.00	132322	Mid	20	30	25.0	24.38	-0.02	0	Left	Tilt	QPSK	1	99	0326M	1:1	0.076	1.153	0.088	
1 CC Uplink	N/A	1745.00	132322	Mid	20	30	24.0	23.50	0.17	1	Left	Tilt	QPSK	50	25	0326M	1:1	0.065	1.122	0.073	
ANSI / IEEE C95.1 1992 - SAFETY LIMIT Spatial Peak Uncontrolled Exposure/General Population													Head 1.6 W/kg (mW/g) averaged over 1 gram								

**Table 11-16
LTE Band 25 (PCS) Head SAR**

MEASUREMENT RESULTS																				
FREQUENCY		Mode	Bandwidth [MHz]	Ant State	Maximum Allowed Power [dBm]	Conducted Power [dBm]	Power Drift [dB]	MPR [dB]	Side	Test Position	Modulation	RB Size	RB Offset	Device Serial Number	Duty Cycle	SAR (1g)	Scaling Factor	Reported SAR (1g)	Plot #	
MHz	Ch.															(W/kg)		(W/kg)		
1882.50	26365	Mid	20	0	25.0	24.20	-0.08	0	Right	Cheek	QPSK	1	0	0498M	1:1	0.105	1.202	0.126		
1882.50	26365	Mid	20	0	24.0	23.25	0.00	1	Right	Cheek	QPSK	50	25	0498M	1:1	0.083	1.189	0.099		
1882.50	26365	Mid	20	0	25.0	24.20	-0.12	0	Right	Tilt	QPSK	1	0	0498M	1:1	0.064	1.202	0.077		
1882.50	26365	Mid	20	0	24.0	23.25	0.15	1	Right	Tilt	QPSK	50	25	0498M	1:1	0.060	1.189	0.071		
1882.50	26365	Mid	20	0	25.0	24.20	0.07	0	Left	Cheek	QPSK	1	0	0498M	1:1	0.122	1.202	0.147	A16	
1882.50	26365	Mid	20	0	24.0	23.25	0.05	1	Left	Cheek	QPSK	50	25	0498M	1:1	0.100	1.189	0.119		
1882.50	26365	Mid	20	0	25.0	24.20	-0.13	0	Left	Tilt	QPSK	1	0	0498M	1:1	0.073	1.202	0.088		
1882.50	26365	Mid	20	0	24.0	23.25	0.06	1	Left	Tilt	QPSK	50	25	0498M	1:1	0.057	1.189	0.068		
ANSI / IEEE C95.1 1992 - SAFETY LIMIT Spatial Peak Uncontrolled Exposure/General Population													Head 1.6 W/kg (mW/g) averaged over 1 gram							

**Table 11-17
LTE Band 30 Head SAR**

MEASUREMENT RESULTS																				
FREQUENCY		Mode	Bandwidth [MHz]	Maximum Allowed Power [dBm]	Conducted Power [dBm]	Power Drift [dB]	MPR [dB]	Side	Test Position	Modulation	RB Size	RB Offset	Device Serial Number	Duty Cycle	SAR (1g)	Scaling Factor	Reported SAR (1g)	Plot #		
MHz	Ch.														(W/kg)		(W/kg)			
2310.00	27710	Mid	10	24.0	23.60	0.02	0	Right	Cheek	QPSK	1	49	0499M	1:1	0.042	1.096	0.046	A17		
2310.00	27710	Mid	10	23.0	22.64	0.13	1	Right	Cheek	QPSK	25	0	0499M	1:1	0.027	1.086	0.029			
2310.00	27710	Mid	10	24.0	23.60	0.15	0	Right	Tilt	QPSK	1	49	0499M	1:1	0.026	1.096	0.028			
2310.00	27710	Mid	10	23.0	22.64	0.09	1	Right	Tilt	QPSK	25	0	0499M	1:1	0.022	1.086	0.024			
2310.00	27710	Mid	10	24.0	23.60	0.17	0	Left	Cheek	QPSK	1	49	0499M	1:1	0.041	1.096	0.045			
2310.00	27710	Mid	10	23.0	22.64	0.12	1	Left	Cheek	QPSK	25	0	0499M	1:1	0.027	1.086	0.029			
2310.00	27710	Mid	10	24.0	23.60	0.15	0	Left	Tilt	QPSK	1	49	0499M	1:1	0.023	1.096	0.025			
2310.00	27710	Mid	10	23.0	22.64	0.12	1	Left	Tilt	QPSK	25	0	0499M	1:1	0.016	1.086	0.017			
ANSI / IEEE C95.1 1992 - SAFETY LIMIT Spatial Peak Uncontrolled Exposure/General Population													Head 1.6 W/kg (mW/g) averaged over 1 gram							





FCC ID: A3LSMN975U		SAR EVALUATION REPORT		Approved by: Quality Manager
Document S/N: 1M1905200079-01-R1.A3L	Test Dates: 05/22/19 - 07/07/19	DUT Type: Portable Handset	Page 156 of 220	

Table 11-18
LTE Band 7 Head SAR

MEASUREMENT RESULTS																			
FREQUENCY		Mode	Bandwidth [MHz]	Maximum Allowed Power [dBm]	Conducted Power [dBm]	Power Drift [dB]	MPR [dB]	Side	Test Position	Modulation	RB Size	RB Offset	Device Serial Number	Duty Cycle	SAR (1g)	Scaling Factor	Reported SAR (1g)	Plot #	
MHz	Ch.														(W/kg)		(W/kg)		
2560.00	21350	High	LTE Band 7	20	24.5	24.18	0.10	0	Right	Cheek	QPSK	1	0	0499M	1:1	0.095	1.076	0.102	
2560.00	21350	High	LTE Band 7	20	23.5	23.32	0.15	1	Right	Cheek	QPSK	50	0	0499M	1:1	0.077	1.042	0.080	
2560.00	21350	High	LTE Band 7	20	24.5	24.18	0.13	0	Right	Tilt	QPSK	1	0	0499M	1:1	0.109	1.076	0.117	A18
2560.00	21350	High	LTE Band 7	20	23.5	23.32	0.20	1	Right	Tilt	QPSK	50	0	0499M	1:1	0.084	1.042	0.088	
2560.00	21350	High	LTE Band 7	20	24.5	24.18	0.11	0	Left	Cheek	QPSK	1	0	0499M	1:1	0.099	1.076	0.107	
2560.00	21350	High	LTE Band 7	20	23.5	23.32	0.19	1	Left	Cheek	QPSK	50	0	0499M	1:1	0.087	1.042	0.091	
2560.00	21350	High	LTE Band 7	20	24.5	24.18	0.17	0	Left	Tilt	QPSK	1	0	0499M	1:1	0.064	1.076	0.069	
2560.00	21350	High	LTE Band 7	20	23.5	23.32	0.16	1	Left	Tilt	QPSK	50	0	0499M	1:1	0.052	1.042	0.054	
ANSI / IEEE C95.1 1992 - SAFETY LIMIT Spatial Peak Uncontrolled Exposure/General Population									Head 1.6 W/kg (mW/g) averaged over 1 gram										

Table 11-19
LTE Band 48 Head SAR

MEASUREMENT RESULTS																			
FREQUENCY		Mode	Bandwidth [MHz]	Maximum Allowed Power [dBm]	Conducted Power [dBm]	Power Drift [dB]	MPR [dB]	Side	Test Position	Modulation	RB Size	RB Offset	Device Serial Number	Duty Cycle	SAR (1g)	Scaling Factor	Reported SAR (1g)	Plot #	
MHz	Ch.														(W/kg)		(W/kg)		
3560.00	55340	Low	LTE Band 48	20	23.0	22.36	0.16	0	Right	Cheek	QPSK	1	99	0347M	1:1.58	0.012	1.159	0.014	
3560.00	55340	Low	LTE Band 48	20	22.0	21.68	-0.11	1	Right	Cheek	QPSK	50	25	0347M	1:1.58	0.009	1.076	0.010	
3560.00	55340	Low	LTE Band 48	20	23.0	22.36	0.12	0	Right	Tilt	QPSK	1	99	0347M	1:1.58	0.030	1.159	0.035	A19
3560.00	55340	Low	LTE Band 48	20	22.0	21.68	0.12	1	Right	Tilt	QPSK	50	25	0347M	1:1.58	0.020	1.076	0.022	
3560.00	55340	Low	LTE Band 48	20	23.0	22.36	0.10	0	Left	Cheek	QPSK	1	99	0347M	1:1.58	0.022	1.159	0.025	
3560.00	55340	Low	LTE Band 48	20	22.0	21.68	0.14	1	Left	Cheek	QPSK	50	25	0347M	1:1.58	0.017	1.076	0.018	
3560.00	55340	Low	LTE Band 48	20	23.0	22.36	0.16	0	Left	Tilt	QPSK	1	99	0347M	1:1.58	0.012	1.159	0.014	
3560.00	55340	Low	LTE Band 48	20	22.0	21.68	0.17	1	Left	Tilt	QPSK	50	25	0347M	1:1.58	0.009	1.076	0.010	
ANSI / IEEE C95.1 1992 - SAFETY LIMIT Spatial Peak Uncontrolled Exposure/General Population									Head 1.6 W/kg (mW/g) averaged over 1 gram										

FCC ID: A3LSMN975U		SAR EVALUATION REPORT		Approved by: Quality Manager
Document S/N: 1M1905200079-01-R1.A3L	Test Dates: 05/22/19 - 07/07/19	DUT Type: Portable Handset	Page 157 of 220	

**Table 11-20
LTE Band 41 Head SAR**

MEASUREMENT RESULTS																					
1 CC Uplink 2 CC Uplink, Power Class	Component Carrier	FREQUENCY		Mode	Bandwidth [MHz]	Maximum Allowed Power [dBm]	Conducted Power [dBm]	Power Drift [dB]	MPR [dB]	Side	Test Position	Modulation	RB Size	RB Offset	Device Serial Number	Duty Cycle	SAR (1g)	Scaling Factor	Reported SAR (1g)	Plot #	
		MHz	Ch.														(W/kg)		(W/kg)		
1 CC Uplink - Power Class 3	N/A	2549.50	40185	Low-Mid	LTE Band 41	20	24.5	24.43	0.17	0	Right	Cheek	QPSK	1	50	0499M	1:1.58	0.069	1.016	0.070	
1 CC Uplink - Power Class 3	N/A	2549.50	40185	Low-Mid	LTE Band 41	20	23.5	23.50	0.16	1	Right	Cheek	QPSK	50	25	0499M	1:1.58	0.053	1.000	0.053	
1 CC Uplink - Power Class 3	N/A	2549.50	40185	Low-Mid	LTE Band 41	20	24.5	24.43	0.13	0	Right	Tilt	QPSK	1	50	0499M	1:1.58	0.081	1.016	0.082	
1 CC Uplink - Power Class 3	N/A	2549.50	40185	Low-Mid	LTE Band 41	20	24.5	24.14	0.17	0	Right	Tilt	QPSK	1	99	0499M	1:1.58	0.078	1.086	0.085	
1 CC Uplink - Power Class 3	N/A	2549.50	40185	Low-Mid	LTE Band 41	20	23.5	23.50	0.13	1	Right	Tilt	QPSK	50	25	0499M	1:1.58	0.065	1.000	0.065	
1 CC Uplink - Power Class 2	N/A	2549.50	40185	Low-Mid	LTE Band 41	20	27.5	27.16	0.06	0	Right	Tilt	QPSK	1	99	0499M	1:2.31	0.103	1.081	0.111	A20
2 CC Uplink - Power Class 3	PCC	2549.50	40185	Low-Mid	LTE Band 41	20	24.5	24.50	0.18	0	Right	Tilt	QPSK	1	99	0499M	1:1.58	0.084	1.000	0.084	
	SCC	2569.30	40383	Low-Mid	LTE Band 41	20															
2 CC Uplink - Power Class 2	PCC	2549.50	40185	Low-Mid	LTE Band 41	20	27.5	27.20	0.16	0	Right	Tilt	QPSK	1	99	0499M	1:2.31	0.100	1.072	0.107	
	SCC	2569.30	40383	Low-Mid	LTE Band 41	20															
1 CC Uplink - Power Class 3	N/A	2549.50	40185	Low-Mid	LTE Band 41	20	24.5	24.43	0.07	0	Left	Cheek	QPSK	1	50	0499M	1:1.58	0.080	1.016	0.081	
1 CC Uplink - Power Class 3	N/A	2549.50	40185	Low-Mid	LTE Band 41	20	23.5	23.50	0.15	1	Left	Cheek	QPSK	50	25	0499M	1:1.58	0.062	1.000	0.062	
1 CC Uplink - Power Class 3	N/A	2549.50	40185	Low-Mid	LTE Band 41	20	24.5	24.43	0.11	0	Left	Tilt	QPSK	1	50	0499M	1:1.58	0.040	1.016	0.041	
1 CC Uplink - Power Class 3	N/A	2549.50	40185	Low-Mid	LTE Band 41	20	23.5	23.50	0.18	1	Left	Tilt	QPSK	50	25	0499M	1:1.58	0.029	1.000	0.029	
ANSI / IEEE C95.1 1992 - SAFETY LIMIT Spatial Peak Uncontrolled Exposure/General Population										Head 1.6 W/kg (mW/g) averaged over 1 gram											

**Table 11-21
DTS Head SAR**

MEASUREMENT RESULTS																			
FREQUENCY		Mode	Service	Bandwidth [MHz]	Maximum Allowed Power [dBm]	Conducted Power [dBm]	Power Drift [dB]	Side	Test Position	Antenna Config.	Device Serial Number	Data Rate (Mbps)	Duty Cycle (%)	Peak SAR of Area Scan	SAR (1g)	Scaling Factor (Power)	Scaling Factor (Duty Cycle)	Reported SAR (1g)	Plot #
MHz	Ch.													(W/kg)	(W/kg)			(W/kg)	
2437	6	802.11b	DSSS	22	17.0	16.55	0.13	Right	Cheek	1	0352M	1	100.0	0.458	0.358	1.109	1.000	0.397	
2437	6	802.11b	DSSS	22	17.0	16.55	0.20	Right	Tilt	1	0352M	1	100.0	0.786	0.510	1.109	1.000	0.566	A21
2437	6	802.11b	DSSS	22	17.0	16.55	0.11	Left	Cheek	1	0352M	1	100.0	0.090	-	1.109	1.000	-	
2437	6	802.11b	DSSS	22	17.0	16.55	0.19	Left	Tilt	1	0352M	1	100.0	0.115	-	1.109	1.000	-	
2437	6	802.11b	DSSS	22	17.0	16.56	0.10	Right	Cheek	2	0352M	1	100.0	0.052	0.031	1.107	1.000	0.034	
2437	6	802.11b	DSSS	22	17.0	16.56	0.15	Right	Tilt	2	0352M	1	100.0	0.020	-	1.107	1.000	-	
2437	6	802.11b	DSSS	22	17.0	16.56	0.17	Left	Cheek	2	0352M	1	100.0	0.013	-	1.107	1.000	-	
2437	6	802.11b	DSSS	22	17.0	16.56	-0.15	Left	Tilt	2	0352M	1	100.0	0.020	-	1.107	1.000	-	
ANSI / IEEE C95.1 1992 - SAFETY LIMIT Spatial Peak Uncontrolled Exposure/General Population										Head 1.6 W/kg (mW/g) averaged over 1 gram									

FCC ID: A3LSMN975U		SAR EVALUATION REPORT		Approved by: Quality Manager
Document S/N: 1M1905200079-01-R1.A3L	Test Dates: 05/22/19 - 07/07/19	DUT Type: Portable Handset	Page 158 of 220	

**Table 11-22
NII Head SAR**

MEASUREMENT RESULTS																			
FREQUENCY		Mode	Service	Bandwidth [MHz]	Maximum Allowed Power [dBm]	Conducted Power [dBm]	Power Drift [dB]	Side	Test Position	Antenna Config.	Device Serial Number	Data Rate (Mbps)	Duty Cycle (%)	Peak SAR of Area Scan	SAR (1g)	Scaling Factor (Power)	Scaling Factor (Duty Cycle)	Reported SAR (1g)	Plot #
MHz	Ch.													W/kg	(W/kg)			(W/kg)	
5290	58	802.11ac	OFDM	80	14.0	13.48	0.10	Right	Cheek	1	0352M	29.3	95.2	0.233	-	1.127	1.050	-	
5290	58	802.11ac	OFDM	80	14.0	13.48	0.18	Right	Tilt	1	0352M	29.3	95.2	0.344	0.125	1.127	1.050	0.148	
5290	58	802.11ac	OFDM	80	14.0	13.48	0.14	Left	Cheek	1	0352M	29.3	95.2	0.100	-	1.127	1.050	-	
5290	58	802.11ac	OFDM	80	14.0	13.48	0.19	Left	Tilt	1	0352M	29.3	95.2	0.144	-	1.127	1.050	-	
5290	58	802.11ac	OFDM	80	14.0	13.28	0.13	Right	Cheek	2	0352M	29.3	94.8	0.067	0.020	1.180	1.055	0.025	
5290	58	802.11ac	OFDM	80	14.0	13.28	0.19	Right	Tilt	2	0352M	29.3	94.8	0.053	-	1.180	1.055	-	
5290	58	802.11ac	OFDM	80	14.0	13.28	0.04	Left	Cheek	2	0352M	29.3	94.8	0.037	-	1.180	1.055	-	
5290	58	802.11ac	OFDM	80	14.0	13.28	0.16	Left	Tilt	2	0352M	29.3	94.8	0.043	-	1.180	1.055	-	
5690	138	802.11ac	OFDM	80	14.0	13.96	0.12	Right	Cheek	1	0352M	29.3	95.2	0.478	-	1.009	1.050	-	
5690	138	802.11ac	OFDM	80	14.0	13.96	0.10	Right	Tilt	1	0352M	29.3	95.2	0.635	0.245	1.009	1.050	0.260	
5690	138	802.11ac	OFDM	80	14.0	13.96	0.14	Left	Cheek	1	0352M	29.3	95.2	0.185	-	1.009	1.050	-	
5690	138	802.11ac	OFDM	80	14.0	13.96	0.15	Left	Tilt	1	0352M	29.3	95.2	0.252	-	1.009	1.050	-	
5690	138	802.11ac	OFDM	80	14.0	13.96	0.12	Right	Cheek	2	0352M	29.3	94.8	0.078	-	1.009	1.055	-	
5690	138	802.11ac	OFDM	80	14.0	13.96	0.18	Right	Tilt	2	0352M	29.3	94.8	0.099	-	1.009	1.055	-	
5690	138	802.11ac	OFDM	80	14.0	13.96	0.16	Left	Cheek	2	0352M	29.3	94.8	0.094	-	1.009	1.055	-	
5690	138	802.11ac	OFDM	80	14.0	13.96	0.15	Left	Tilt	2	0352M	29.3	94.8	0.111	0.053	1.009	1.055	0.056	
5775	155	802.11ac	OFDM	80	14.0	13.76	0.12	Right	Cheek	1	0352M	29.3	95.2	0.669	-	1.057	1.050	-	
5775	155	802.11ac	OFDM	80	14.0	13.76	0.14	Right	Tilt	1	0352M	29.3	95.2	0.826	0.294	1.057	1.050	0.326	A22
5775	155	802.11ac	OFDM	80	14.0	13.76	0.15	Left	Cheek	1	0352M	29.3	95.2	0.265	-	1.057	1.050	-	
5775	155	802.11ac	OFDM	80	14.0	13.76	0.16	Left	Tilt	1	0352M	29.3	95.2	0.387	-	1.057	1.050	-	
5775	155	802.11ac	OFDM	80	14.0	13.57	-0.14	Right	Cheek	2	0352M	29.3	94.8	0.034	-	1.104	1.055	-	
5775	155	802.11ac	OFDM	80	14.0	13.57	0.10	Right	Tilt	2	0352M	29.3	94.8	0.047	-	1.104	1.055	-	
5775	155	802.11ac	OFDM	80	14.0	13.57	0.15	Left	Cheek	2	0352M	29.3	94.8	0.045	-	1.104	1.055	-	
5775	155	802.11ac	OFDM	80	14.0	13.57	0.11	Left	Tilt	2	0352M	29.3	94.8	0.056	0.022	1.104	1.055	0.026	
ANSI / IEEE C95.1 1992 - SAFETY LIMIT Spatial Peak Uncontrolled Exposure/General Population										Head 1.6 W/kg (mW/g) averaged over 1 gram									

**Table 11-23
DSS Head SAR**



MEASUREMENT RESULTS																
FREQUENCY		Mode	Service	Maximum Allowed Power [dBm]	Conducted Power [dBm]	Power Drift [dB]	Side	Test Position	Device Serial Number	Data Rate (Mbps)	Duty Cycle (%)	SAR (1g)	Scaling Factor (Cond Power)	Scaling Factor (Duty Cycle)	Reported SAR (1g)	Plot #
MHz	Ch.											(W/kg)			(W/kg)	
2441.00	39	Bluetooth	FHSS	15.5	15.41	0.02	Right	Cheek	0459M	1	77.1	0.228	1.021	1.297	0.302	
2441.00	39	Bluetooth	FHSS	15.5	15.41	-0.03	Right	Tilt	0459M	1	77.1	0.242	1.021	1.297	0.320	A23
2441.00	39	Bluetooth	FHSS	15.5	15.41	0.02	Left	Cheek	0459M	1	77.1	0.040	1.021	1.297	0.053	
2441.00	39	Bluetooth	FHSS	15.5	15.41	0.08	Left	Tilt	0459M	1	77.1	0.056	1.021	1.297	0.074	
ANSI / IEEE C95.1 1992 - SAFETY LIMIT Spatial Peak Uncontrolled Exposure/General Population										Head 1.6 W/kg (mW/g) averaged over 1 gram						

FCC ID: A3LSMN975U		SAR EVALUATION REPORT		Approved by: Quality Manager
Document S/N: 1M1905200079-01-R1.A3L	Test Dates: 05/22/19 - 07/07/19	DUT Type: Portable Handset	Page 159 of 220	

11.2 Standalone Body-Worn SAR Data



**Table 11-24
GSM/UMTS/CDMA Body-Worn SAR Data**

MEASUREMENT RESULTS																
FREQUENCY		Mode	Service	Maximum Allowed Power [dBm]	Conducted Power [dBm]	Power Drift [dB]	Spacing	Ant State	Device Serial Number	Duty Cycle	Side	SAR (1g)	Scaling Factor	Reported SAR (1g)	Plot #	
MHz	Ch.											(W/kg)		(W/kg)		
820.10	564	CDMA BC10 (\$90S)	TDSO / SO32	26.3	25.10	0.02	15 mm	0	0116M	1:1	back	0.221	1.318	0.291	A24	
836.52	384	CDMA BC0 (\$22H)	TDSO / SO32	26.3	25.06	-0.02	15 mm	0	0116M	1:1	back	0.250	1.330	0.333	A26	
836.60	190	GSM 850	GSM	33.5	32.18	-0.05	15 mm	N/A	0116M	1:8.3	back	0.180	1.355	0.244	A28	
836.60	4183	UMTS 850	RMC	25.5	24.89	0.01	15 mm	0	0119M	1:1	back	0.283	1.151	0.326	A30	
1712.40	1312	UMTS 1750	RMC	25.0	24.24	0.01	15 mm	30	0116M	1:1	back	0.807	1.191	0.961		
1732.40	1412	UMTS 1750	RMC	25.0	24.35	0.01	15 mm	30	0116M	1:1	back	0.861	1.161	1.000		
1752.60	1513	UMTS 1750	RMC	25.0	24.47	0.02	15 mm	30	0116M	1:1	back	0.898	1.130	1.015	A32	
1851.25	25	PCS CDMA	TDSO / SO32	25.0	24.81	-0.02	15 mm	0	0119M	1:1	back	0.568	1.045	0.594		
1880.00	600	PCS CDMA	TDSO / SO32	25.0	24.67	0.03	15 mm	0	0119M	1:1	back	0.580	1.079	0.626		
1908.75	1175	PCS CDMA	TDSO / SO32	25.0	24.81	0.04	15 mm	0	0119M	1:1	back	0.628	1.045	0.656	A34	
1909.80	810	GSM 1900	GSM	30.0	28.58	0.05	15 mm	N/A	0119M	1:8.3	back	0.236	1.387	0.327	A36	
1852.40	9262	UMTS 1900	RMC	25.0	23.63	0.00	15 mm	30	0119M	1:1	back	0.639	1.371	0.876		
1880.00	9400	UMTS 1900	RMC	25.0	23.78	0.00	15 mm	30	0119M	1:1	back	0.608	1.324	0.805		
1907.60	9538	UMTS 1900	RMC	25.0	23.75	0.00	15 mm	30	0119M	1:1	back	0.648	1.334	0.864	A38	
ANSI / IEEE C95.1 1992 - SAFETY LIMIT Spatial Peak Uncontrolled Exposure/General Population							Body 1.6 W/kg (mW/g) averaged over 1 gram									

FCC ID: A3LSMN975U		SAR EVALUATION REPORT		Approved by: Quality Manager
Document S/N: 1M1905200079-01-R1.A3L	Test Dates: 05/22/19 - 07/07/19	DUT Type: Portable Handset	Page 160 of 220	

**Table 11-25
LTE Body-Worn SAR**

MEASUREMENT RESULTS																						
1 CC Uplink 2 CC Uplink	Component Carrier	FREQUENCY		Mode	Bandwidth [MHz]	Ant State	Maximum Allowed Power [dBm]	Conducted Power [dBm]	Power Drift [dB]	MPR [dB]	Device Serial Number	Modulation	RB Size	RB Offset	Spacing	Side	Duty Cycle	SAR (1g)	Scaling Factor	Reported SAR (1g) (W/kg)	Plot #	
		MHz	Ch.															(W/kg)				
1 CC Uplink	N/A	680.50	133297	Mid	LTE Band 71	20	9	25.8	25.05	0.00	0	0503M	QPSK	1	0	15 mm	back	1:1	0.197	1.189	0.234	A40
1 CC Uplink	N/A	680.50	133297	Mid	LTE Band 71	20	9	24.8	24.12	0.03	1	0503M	QPSK	50	0	15 mm	back	1:1	0.145	1.169	0.170	
1 CC Uplink	N/A	707.50	23095	Mid	LTE Band 12	10	51	25.8	24.86	-0.01	0	0503M	QPSK	1	0	15 mm	back	1:1	0.155	1.242	0.193	A42
1 CC Uplink	N/A	707.50	23095	Mid	LTE Band 12	10	51	24.8	23.90	0.04	1	0503M	QPSK	25	0	15 mm	back	1:1	0.125	1.230	0.154	
1 CC Uplink	N/A	782.00	23230	Mid	LTE Band 13	10	57	25.8	24.63	0.01	0	0503M	QPSK	1	0	15 mm	back	1:1	0.167	1.309	0.219	A44
1 CC Uplink	N/A	782.00	23230	Mid	LTE Band 13	10	57	24.8	23.69	0.01	1	0503M	QPSK	25	0	15 mm	back	1:1	0.157	1.291	0.203	
1 CC Uplink	N/A	793.00	23330	Mid	LTE Band 14	10	57	25.8	24.50	0.04	0	0503M	QPSK	1	0	15 mm	back	1:1	0.194	1.349	0.262	A46
1 CC Uplink	N/A	793.00	23330	Mid	LTE Band 14	10	57	24.8	23.62	0.05	1	0503M	QPSK	25	0	15 mm	back	1:1	0.174	1.312	0.228	
1 CC Uplink	N/A	831.50	26865	Mid	LTE Band 26 (Cell)	15	57	25.8	24.76	0.02	0	0503M	QPSK	1	74	15 mm	back	1:1	0.284	1.271	0.361	A48
1 CC Uplink	N/A	831.50	26865	Mid	LTE Band 26 (Cell)	15	57	24.8	23.82	0.03	1	0503M	QPSK	36	37	15 mm	back	1:1	0.214	1.253	0.268	
1 CC Uplink	N/A	836.50	20525	Mid	LTE Band 5 (Cell)	10	0	25.8	24.89	-0.04	0	0503M	QPSK	1	0	15 mm	back	1:1	0.258	1.233	0.318	
1 CC Uplink	N/A	836.50	20525	Mid	LTE Band 5 (Cell)	10	0	24.8	23.92	0.01	1	0503M	QPSK	25	0	15 mm	back	1:1	0.217	1.225	0.266	
2 CC Uplink	PCC	836.50	20525	Mid	LTE Band 5 (Cell)	10	0	25.8	24.97	-0.03	0	0503M	QPSK	1	0	15 mm	back	1:1	0.259	1.211	0.314	A50
	SCC	829.30	20453	Mid	LTE Band 5 (Cell)	5																
1 CC Uplink	N/A	1720.00	132072	Low	LTE Band 66 (AWS)	20	31	25.0	24.06	0.00	0	0326M	QPSK	1	99	15 mm	back	1:1	0.769	1.242	0.955	
1 CC Uplink	N/A	1745.00	132322	Mid	LTE Band 66 (AWS)	20	31	25.0	24.38	-0.16	0	0326M	QPSK	1	99	15 mm	back	1:1	0.937	1.153	1.080	
1 CC Uplink	N/A	1770.00	132572	High	LTE Band 66 (AWS)	20	31	25.0	24.27	0.03	0	0326M	QPSK	1	0	15 mm	back	1:1	0.948	1.183	1.121	A52
1 CC Uplink	N/A	1775.00	132622	High	LTE Band 66 (AWS)	10	31	25.0	23.97	-0.06	0	0326M	QPSK	1	0	15 mm	back	1:1	0.881	1.268	1.117	
1 CC Uplink	N/A	1745.00	132322	Mid	LTE Band 66 (AWS)	20	31	24.0	23.50	-0.07	1	0326M	QPSK	50	25	15 mm	back	1:1	0.699	1.122	0.784	
1 CC Uplink	N/A	1745.00	132322	Mid	LTE Band 66 (AWS)	20	31	24.0	23.48	-0.08	1	0326M	QPSK	100	0	15 mm	back	1:1	0.733	1.127	0.826	
CA_66C 2 CC Uplink	PCC	1770.00	132572	High	LTE Band 66 (AWS)	20	31	25.0	24.08	-0.06	0	0326M	QPSK	1	0	15 mm	back	1:1	0.913	1.236	1.128	
	SCC	1750.20	132374	High	LTE Band 66 (AWS)	20																
CA_66B 2 CC Uplink	PCC	1775.00	132622	High	LTE Band 66 (AWS)	10	31	25.0	23.78	-0.12	0	0326M	QPSK	1	49	15 mm	back	1:1	0.861	1.324	1.140	
	SCC	1765.10	132523	High	LTE Band 66 (AWS)	10																
1 CC Uplink	N/A	1860.00	26140	Low	LTE Band 25 (PCS)	20	0	25.0	24.10	0.06	0	0029M	QPSK	1	99	15 mm	back	1:1	0.745	1.230	0.916	A54
1 CC Uplink	N/A	1882.50	26365	Mid	LTE Band 25 (PCS)	20	0	25.0	24.20	-0.05	0	0029M	QPSK	1	0	15 mm	back	1:1	0.710	1.202	0.853	
1 CC Uplink	N/A	1905.00	26590	High	LTE Band 25 (PCS)	20	0	25.0	24.05	0.03	0	0029M	QPSK	1	99	15 mm	back	1:1	0.665	1.245	0.828	
1 CC Uplink	N/A	1882.50	26365	Mid	LTE Band 25 (PCS)	20	0	24.0	23.25	0.03	1	0029M	QPSK	50	25	15 mm	back	1:1	0.532	1.189	0.633	
1 CC Uplink	N/A	1882.50	26365	Mid	LTE Band 25 (PCS)	20	0	24.0	23.21	-0.01	1	0029M	QPSK	100	0	15 mm	back	1:1	0.553	1.199	0.663	
1 CC Uplink	N/A	2310.00	27710	Mid	LTE Band 30	10	N/A	24.0	23.60	0.02	0	0499M	QPSK	1	49	15 mm	back	1:1	0.468	1.096	0.513	A56
1 CC Uplink	N/A	2310.00	27710	Mid	LTE Band 30	10	N/A	23.0	22.64	0.04	1	0499M	QPSK	25	0	15 mm	back	1:1	0.375	1.086	0.407	
1 CC Uplink	N/A	2560.00	21350	High	LTE Band 7	20	N/A	24.5	24.18	-0.03	0	0358M	QPSK	1	0	15 mm	back	1:1	0.260	1.076	0.280	A58
1 CC Uplink	N/A	2560.00	21350	High	LTE Band 7	20	N/A	23.5	23.32	0.06	1	0358M	QPSK	50	0	15 mm	back	1:1	0.217	1.042	0.226	
1 CC Uplink	N/A	3560.00	55340	Low	LTE Band 48	20	N/A	23.0	22.36	0.17	0	0349M	QPSK	1	99	15 mm	back	1:1.58	0.114	1.159	0.132	A60
1 CC Uplink	N/A	3560.00	55340	Low	LTE Band 48	20	N/A	22.0	21.68	0.02	1	0349M	QPSK	50	25	15 mm	back	1:1.58	0.097	1.076	0.104	
ANSI / IEEE C95.1 1992 - SAFETY LIMIT												Body										
Spatial Peak												1.6 W/kg (mW/g)										
Uncontrolled Exposure/General Population												averaged over 1 gram										

FCC ID: A3LSMN975U		SAR EVALUATION REPORT		Approved by: Quality Manager
Document S/N: 1M1905200079-01-R1.A3L	Test Dates: 05/22/19 - 07/07/19	DUT Type: Portable Handset		Page 161 of 220

**Table 11-26
LTE Band 41 Body-Worn SAR**



MEASUREMENT RESULTS																					
1 CC Uplink 2 CC Uplink, Power Class	Component Carrier	FREQUENCY		Mode	Bandwidth [MHz]	Maximum Allowed Power [dBm]	Conducted Power [dBm]	Power Drift [dB]	MPR [dB]	Device Serial Number	Modulation	RB Size	RB Offset	Spacing	Side	Duty Cycle	SAR (1g) (W/kg)	Scaling Factor	Reported SAR (1g)	Plot #	
		MHz	Ch.																(W/kg)		
1 CC Uplink - Power Class 3	N/A	2549.50	40185	Low-Md	LTE Band 41	20	24.5	24.43	-0.15	0	0358M	QPSK	1	50	15 mm	back	1:1.58	0.244	1.016	0.248	
1 CC Uplink - Power Class 3	N/A	2549.50	40185	Low-Md	LTE Band 41	20	24.5	24.14	-0.02	0	0358M	QPSK	1	99	15 mm	back	1:1.58	0.227	1.086	0.247	
1 CC Uplink - Power Class 3	N/A	2549.50	40185	Low-Md	LTE Band 41	20	23.5	23.50	0.04	1	0358M	QPSK	50	25	15 mm	back	1:1.58	0.199	1.000	0.199	
1 CC Uplink - Power Class 2	N/A	2549.50	40185	Low-Md	LTE Band 41	20	27.5	27.01	-0.14	0	0358M	QPSK	1	50	15 mm	back	1:2.31	0.279	1.119	0.312	
1 CC Uplink - Power Class 2	N/A	2549.50	40185	Low-Md	LTE Band 41	20	27.5	27.16	-0.05	0	0358M	QPSK	1	99	15 mm	back	1:2.31	0.285	1.081	0.308	
2 CC Uplink - Power Class 3	PCC	2549.50	40185	Low-Md	LTE Band 41	20	24.5	24.50	0.15	0	0358M	QPSK	1	99	15 mm	back	1:1.58	0.258	1.000	0.258	
	SCC	2569.30	40383	Low-Md	LTE Band 41	20								0							
2 CC Uplink - Power Class 2	PCC	2549.50	40185	Low-Md	LTE Band 41	20	27.5	27.20	0.00	0	0358M	QPSK	1	99	15 mm	back	1:2.31	0.301	1.072	0.323	A62
	SCC	2569.30	40383	Low-Md	LTE Band 41	20								0							
ANSI / IEEE C95.1 1992 - SAFETY LIMIT Spatial Peak Uncontrolled Exposure/General Population										Body 1.6 W/kg (mW/g) averaged over 1 gram											

**Table 11-27
DTS Body-Worn SAR**

MEASUREMENT RESULTS																			
FREQUENCY		Mode	Service	Bandwidth [MHz]	Maximum Allowed Power [dBm]	Conducted Power [dBm]	Power Drift [dB]	Spacing	Antenna Config.	Device Serial Number	Data Rate (Mbps)	Side	Duty Cycle (%)	Peak SAR of Area Scan	SAR (1g)	Scaling Factor (Power)	Scaling Factor (Duty Cycle)	Reported SAR (1g)	Plot #
MHz	Ch.													(W/kg)	(W/kg)			(W/kg)	
2437	6	802.11b	DSSS	22	21.0	20.97	0.06	15 mm	1	0352M	1	back	100.0	0.222	0.156	1.007	1.000	0.157	A64
2437	6	802.11b	DSSS	22	21.0	20.99	0.20	15 mm	2	0324M	1	back	100.0	0.118	0.074	1.002	1.000	0.074	
ANSI / IEEE C95.1 1992 - SAFETY LIMIT Spatial Peak Uncontrolled Exposure/General Population										Body 1.6 W/kg (mW/g) averaged over 1 gram									

**Table 11-28
NII Body-Worn SAR**

MEASUREMENT RESULTS																			
FREQUENCY		Mode	Service	Bandwidth [MHz]	Maximum Allowed Power [dBm]	Conducted Power [dBm]	Power Drift [dB]	Spacing	Antenna Config.	Device Serial Number	Data Rate (Mbps)	Side	Duty Cycle (%)	Peak SAR of Area Scan	SAR (1g)	Scaling Factor (Power)	Scaling Factor (Duty Cycle)	Reported SAR (1g)	Plot #
MHz	Ch.													(W/kg)	(W/kg)			(W/kg)	
5300	60	802.11a	OFDM	20	18.5	18.34	-0.19	15 mm	1	0459M	6	back	98.9	0.317	0.132	1.038	1.011	0.139	
5300	60	802.11a	OFDM	20	18.5	18.33	-0.11	15 mm	2	0459M	6	back	98.8	0.244	0.107	1.040	1.012	0.113	
5620	124	802.11a	OFDM	20	18.5	18.14	-0.13	15 mm	1	0459M	6	back	98.9	0.540	0.216	1.086	1.011	0.237	
5600	120	802.11a	OFDM	20	18.5	18.43	-0.14	15 mm	2	0459M	6	back	98.8	0.347	0.148	1.016	1.012	0.152	
5745	149	802.11a	OFDM	20	18.5	18.30	-0.11	15 mm	1	0459M	6	back	98.9	0.588	0.233	1.047	1.011	0.247	A66
5785	157	802.11a	OFDM	20	18.5	18.44	-0.10	15 mm	2	0459M	6	back	98.8	0.273	0.117	1.014	1.012	0.120	
ANSI / IEEE C95.1 1992 - SAFETY LIMIT Spatial Peak Uncontrolled Exposure/General Population										Body 1.6 W/kg (mW/g) averaged over 1 gram									

FCC ID: A3LSMN975U		SAR EVALUATION REPORT		Approved by: Quality Manager
Document S/N: 1M1905200079-01-R1.A3L	Test Dates: 05/22/19 - 07/07/19	DUT Type: Portable Handset	Page 162 of 220	



**Table 11-29
NII Body-Worn SAR for Conditions with 2.4 GHz and 5 GHz WLAN SAR**

MEASUREMENT RESULTS																					
FREQUENCY		Mode	Service	Bandwidth [MHz]	Maximum Allowed Power [Ant 1] [dBm]	Conducted Power [Ant 1] [dBm]	Maximum Allowed Power [Ant 2] [dBm]	Conducted Power [Ant 2] [dBm]	Power Drift [dB]	Spacing	Antenna Config.	Device Serial Number	Data Rate (Mbps)	Side	Duty Cycle (%)	Peak SAR of Area Scan	SAR (1g)	Scaling Factor (Power)	Scaling Factor (Duty Cycle)	Reported SAR (1g)	Plot #
MHz	Ch.															(W/kg)	(W/kg)	(W/kg)	(W/kg)		
5290	58	802.11ac	OFDM	80	14.0	13.48	14.0	13.28	-0.13	15 mm	MIMO	0459M	58.5	back	89.6	0.167	0.067	1.180	1.116	0.088	
5690	138	802.11ac	OFDM	80	14.0	13.96	14.0	13.96	-0.19	15 mm	MIMO	0459M	58.5	back	89.6	0.314	0.127	1.009	1.116	0.143	
5775	155	802.11ac	OFDM	80	14.0	13.76	14.0	13.57	0.17	15 mm	MIMO	0459M	58.5	back	89.6	0.307	0.118	1.104	1.116	0.145	
ANSI / IEEE C95.1 1992 - SAFETY LIMIT										Body											
Spatial Peak										1.6 W/kg (mW/g)											
Uncontrolled Exposure/General Population										averaged over 1 gram											

NII MIMO was additionally evaluated at the maximum allowed output power during operations with Simultaneous 2.4 GHz and 5 GHz WLAN. 2.4 GHz WIFI was not transmitting during the above evaluations.

**Table 11-30
DSS Body-Worn SAR**

MEASUREMENT RESULTS																	
FREQUENCY		Mode	Service	Maximum Allowed Power [dBm]	Conducted Power [dBm]	Power Drift [dB]	Spacing	Device Serial Number	Data Rate (Mbps)	Side	Duty Cycle (%)	SAR (1g)	Scaling Factor (Cond Power)	Scaling Factor (Duty Cycle)	Reported SAR (1g)	Plot #	
MHz	Ch.											(W/kg)	(W/kg)	(W/kg)			
2441	39	Bluetooth	FHSS	15.5	15.41	0.13	15 mm	0352M	1	back	77.1	0.036	1.021	1.297	0.048	A68	
ANSI / IEEE C95.1 1992 - SAFETY LIMIT										Body							
Spatial Peak										1.6 W/kg (mW/g)							
Uncontrolled Exposure/General Population										averaged over 1 gram							

FCC ID: A3LSMN975U		SAR EVALUATION REPORT		Approved by: Quality Manager
Document S/N: 1M1905200079-01-R1.A3L	Test Dates: 05/22/19 - 07/07/19	DUT Type: Portable Handset		Page 163 of 220

11.3 Standalone Hotspot SAR Data

**Table 11-31
GPRS/UMTS/CDMA Hotspot SAR Data**

MEASUREMENT RESULTS																
FREQUENCY	Mode	Service	Maximum Allowed Power (dBm)	Conducted Power (dBm)	Power Drift (dB)	Spacing	Ant State	Device Serial Number	# of Time Slots	Duty Cycle	Side	SAR (1g)	Scaling Factor	Reported SAR (1g)	Plot #	
												(W/kg)		(W/kg)		
MHz	Ch.															
820.10	564	CDMA BC10 (900S)	EVDO Rev. 0	26.3	25.21	0.03	10 mm	0	0116M	N/A	1:1	back	0.615	1.285	0.790	A25
820.10	564	CDMA BC10 (900S)	EVDO Rev. 0	26.3	25.21	-0.11	10 mm	0	0116M	N/A	1:1	front	0.307	1.285	0.394	
820.10	564	CDMA BC10 (900S)	EVDO Rev. 0	26.3	25.21	-0.07	10 mm	0	0116M	N/A	1:1	bottom	0.333	1.285	0.428	
820.10	564	CDMA BC10 (900S)	EVDO Rev. 0	26.3	25.21	0.18	10 mm	0	0116M	N/A	1:1	right	0.146	1.285	0.188	
820.10	564	CDMA BC10 (900S)	EVDO Rev. 0	26.3	25.21	0.05	10 mm	0	0116M	N/A	1:1	left	0.065	1.285	0.084	
824.70	1013	CDMA BCO (\$22H)	EVDO Rev. 0	26.3	25.27	-0.11	10 mm	0	0116M	N/A	1:1	back	0.603	1.268	0.765	
836.52	384	CDMA BCO (\$22H)	EVDO Rev. 0	26.3	25.20	-0.03	10 mm	0	0116M	N/A	1:1	back	0.627	1.288	0.808	
848.31	777	CDMA BCO (\$22H)	EVDO Rev. 0	26.3	25.21	-0.13	10 mm	0	0116M	N/A	1:1	back	0.670	1.285	0.861	A27
836.52	384	CDMA BCO (\$22H)	EVDO Rev. 0	26.3	25.20	-0.03	10 mm	0	0116M	N/A	1:1	front	0.304	1.288	0.392	
836.52	384	CDMA BCO (\$22H)	EVDO Rev. 0	26.3	25.20	-0.04	10 mm	0	0116M	N/A	1:1	bottom	0.297	1.288	0.383	
836.52	384	CDMA BCO (\$22H)	EVDO Rev. 0	26.3	25.20	-0.03	10 mm	0	0116M	N/A	1:1	right	0.166	1.288	0.214	
836.52	384	CDMA BCO (\$22H)	EVDO Rev. 0	26.3	25.20	0.00	10 mm	0	0116M	N/A	1:1	left	0.063	1.288	0.081	
824.20	128	GSM 850	GPRS	30.5	29.15	-0.07	10 mm	N/A	0116M	3	1:2.76	back	0.529	1.365	0.722	
836.60	190	GSM 850	GPRS	30.5	29.35	-0.14	10 mm	N/A	0116M	3	1:2.76	back	0.534	1.303	0.696	
848.80	251	GSM 850	GPRS	30.5	29.31	-0.15	10 mm	N/A	0116M	3	1:2.76	back	0.571	1.315	0.751	A29
836.60	190	GSM 850	GPRS	30.5	29.35	-0.07	10 mm	N/A	0116M	3	1:2.76	front	0.277	1.303	0.361	
836.60	190	GSM 850	GPRS	30.5	29.35	-0.03	10 mm	N/A	0116M	3	1:2.76	bottom	0.239	1.303	0.311	
836.60	190	GSM 850	GPRS	30.5	29.35	-0.09	10 mm	N/A	0116M	3	1:2.76	right	0.159	1.303	0.207	
836.60	190	GSM 850	GPRS	30.5	29.35	-0.09	10 mm	N/A	0116M	3	1:2.76	left	0.057	1.303	0.074	
826.40	4132	UMTS 850	RMC	25.5	24.87	0.00	10 mm	0	0119M	N/A	1:1	back	0.607	1.156	0.702	
836.60	4183	UMTS 850	RMC	25.5	24.89	0.03	10 mm	0	0119M	N/A	1:1	back	0.616	1.151	0.709	A31
846.60	4233	UMTS 850	RMC	25.5	24.93	-0.01	10 mm	0	0119M	N/A	1:1	back	0.613	1.140	0.699	
836.60	4183	UMTS 850	RMC	25.5	24.89	0.02	10 mm	0	0119M	N/A	1:1	front	0.366	1.151	0.421	
836.60	4183	UMTS 850	RMC	25.5	24.89	-0.01	10 mm	0	0119M	N/A	1:1	bottom	0.298	1.151	0.343	
836.60	4183	UMTS 850	RMC	25.5	24.89	-0.06	10 mm	0	0119M	N/A	1:1	right	0.176	1.151	0.203	
836.60	4183	UMTS 850	RMC	25.5	24.89	0.01	10 mm	0	0119M	N/A	1:1	left	0.061	1.151	0.070	
1732.40	1412	UMTS 1750	RMC	20.0	19.25	0.03	10 mm	30	0116M	N/A	1:1	back	0.516	1.189	0.614	
1732.40	1412	UMTS 1750	RMC	20.0	19.25	0.03	10 mm	30	0116M	N/A	1:1	front	0.403	1.189	0.479	
1712.40	1312	UMTS 1750	RMC	20.0	19.28	0.01	10 mm	30	0116M	N/A	1:1	bottom	0.804	1.189	0.949	
1732.40	1412	UMTS 1750	RMC	20.0	19.25	0.00	10 mm	30	0116M	N/A	1:1	bottom	0.881	1.189	1.048	
1752.60	1513	UMTS 1750	RMC	20.0	19.33	-0.02	10 mm	30	0116M	N/A	1:1	bottom	0.969	1.167	1.131	A33
1732.40	1412	UMTS 1750	RMC	20.0	19.25	-0.02	10 mm	30	0116M	N/A	1:1	right	0.065	1.189	0.077	
1732.40	1412	UMTS 1750	RMC	20.0	19.25	0.00	10 mm	30	0116M	N/A	1:1	left	0.073	1.189	0.087	
1752.60	1513	UMTS 1750	RMC	20.0	19.33	-0.02	10 mm	30	0116M	N/A	1:1	bottom	0.830	1.167	0.969	
1880.00	600	PCS CDMA	EVDO Rev. 0	18.5	18.00	-0.01	10 mm	0	0119M	N/A	1:1	back	0.337	1.122	0.378	
1880.00	600	PCS CDMA	EVDO Rev. 0	18.5	18.00	0.04	10 mm	0	0119M	N/A	1:1	front	0.293	1.122	0.329	
1851.25	25	PCS CDMA	EVDO Rev. 0	18.5	17.99	-0.04	10 mm	0	0119M	N/A	1:1	bottom	0.733	1.125	0.825	
1880.00	600	PCS CDMA	EVDO Rev. 0	18.5	18.00	-0.05	10 mm	0	0119M	N/A	1:1	bottom	0.737	1.122	0.827	
1908.75	1175	PCS CDMA	EVDO Rev. 0	18.5	17.93	-0.05	10 mm	0	0119M	N/A	1:1	bottom	0.795	1.140	0.895	A35
1880.00	600	PCS CDMA	EVDO Rev. 0	18.5	18.00	-0.19	10 mm	0	0119M	N/A	1:1	right	0.039	1.122	0.044	
1880.00	600	PCS CDMA	EVDO Rev. 0	18.5	18.00	0.02	10 mm	0	0119M	N/A	1:1	left	0.059	1.122	0.066	
1880.00	661	GSM 1900	GPRS	24.5	23.60	0.00	10 mm	N/A	0119M	3	1:2.76	back	0.425	1.230	0.523	
1880.00	661	GSM 1900	GPRS	24.5	23.60	-0.06	10 mm	N/A	0119M	3	1:2.76	front	0.338	1.230	0.416	
1850.20	512	GSM 1900	GPRS	24.5	23.59	-0.03	10 mm	N/A	0119M	3	1:2.76	bottom	0.923	1.233	1.138	
1880.00	661	GSM 1900	GPRS	24.5	23.60	-0.02	10 mm	N/A	0119M	3	1:2.76	bottom	0.956	1.230	1.176	
1909.80	810	GSM 1900	GPRS	24.5	23.48	-0.16	10 mm	N/A	0119M	3	1:2.76	bottom	0.995	1.265	1.259	A37
1880.00	661	GSM 1900	GPRS	24.5	23.60	0.18	10 mm	N/A	0119M	3	1:2.76	right	0.048	1.230	0.059	
1880.00	661	GSM 1900	GPRS	24.5	23.60	0.00	10 mm	N/A	0119M	3	1:2.76	left	0.075	1.230	0.092	
1880.00	9400	UMTS 1900	RMC	19.0	18.74	-0.01	10 mm	30	0119M	N/A	1:1	back	0.443	1.062	0.470	
1880.00	9400	UMTS 1900	RMC	19.0	18.74	0.03	10 mm	30	0119M	N/A	1:1	front	0.392	1.062	0.416	
1852.40	8262	UMTS 1900	RMC	19.0	18.58	0.00	10 mm	30	0119M	N/A	1:1	bottom	1.070	1.102	1.179	
1880.00	9400	UMTS 1900	RMC	19.0	18.74	-0.03	10 mm	30	0119M	N/A	1:1	bottom	1.120	1.062	1.189	A39
1907.60	8538	UMTS 1900	RMC	19.0	18.72	0.00	10 mm	30	0119M	N/A	1:1	bottom	1.060	1.067	1.131	
1880.00	9400	UMTS 1900	RMC	19.0	18.74	0.10	10 mm	30	0119M	N/A	1:1	right	0.068	1.062	0.072	
1880.00	9400	UMTS 1900	RMC	19.0	18.74	0.00	10 mm	30	0119M	N/A	1:1	left	0.089	1.062	0.095	
1880.00	9400	UMTS 1900	RMC	19.0	18.74	-0.05	10 mm	30	0119M	N/A	1:1	bottom	1.110	1.062	1.179	

Note: Blue entry represents variability measurement.



FCC ID: A3LSMN975U		SAR EVALUATION REPORT		Approved by: Quality Manager
Document S/N: 1M1905200079-01-R1.A3L	Test Dates: 05/22/19 - 07/07/19	DUT Type: Portable Handset		Page 164 of 220

**Table 11-32
LTE Band 71 Hotspot SAR**

MEASUREMENT RESULTS																				
FREQUENCY		Mode	Bandwidth [MHz]	Ant State	Maximum Allowed Power [dBm]	Conducted Power [dBm]	Power Drift [dB]	MPR [dB]	Device Serial Number	Modulation	RB Size	RB Offset	Spacing	Side	Duty Cycle	SAR (1g)	Scaling Factor	Reported SAR (1g)	Plot #	
MHz	Ch.															(W/kg)		(W/kg)		
680.50	133297	Md	LTE Band 71	20	9	25.8	25.05	0.01	0	0503M	QPSK	1	0	10 mm	back	1:1	0.270	1.189	0.321	A41
680.50	133297	Md	LTE Band 71	20	9	24.8	24.12	0.01	1	0503M	QPSK	50	0	10 mm	back	1:1	0.212	1.169	0.248	
680.50	133297	Md	LTE Band 71	20	9	25.8	25.05	0.00	0	0503M	QPSK	1	0	10 mm	front	1:1	0.195	1.189	0.232	
680.50	133297	Md	LTE Band 71	20	9	24.8	24.12	0.01	1	0503M	QPSK	50	0	10 mm	front	1:1	0.148	1.169	0.173	
680.50	133297	Md	LTE Band 71	20	9	25.8	25.05	0.03	0	0503M	QPSK	1	0	10 mm	bottom	1:1	0.129	1.189	0.153	
680.50	133297	Md	LTE Band 71	20	9	24.8	24.12	0.04	1	0503M	QPSK	50	0	10 mm	bottom	1:1	0.105	1.169	0.123	
680.50	133297	Md	LTE Band 71	20	9	25.8	25.05	0.04	0	0503M	QPSK	1	0	10 mm	right	1:1	0.196	1.189	0.233	
680.50	133297	Md	LTE Band 71	20	9	24.8	24.12	0.03	1	0503M	QPSK	50	0	10 mm	right	1:1	0.126	1.169	0.147	
680.50	133297	Md	LTE Band 71	20	9	25.8	25.05	0.01	0	0503M	QPSK	1	0	10 mm	left	1:1	0.165	1.189	0.196	
680.50	133297	Md	LTE Band 71	20	9	24.8	24.12	0.00	1	0503M	QPSK	50	0	10 mm	left	1:1	0.107	1.169	0.125	
ANSI / IEEE C95.1 1992 - SAFETY LIMIT Spatial Peak Uncontrolled Exposure/General Population										Body 1.6 W/kg (mW/g) averaged over 1 gram										

**Table 11-33
LTE Band 12 Hotspot SAR**

MEASUREMENT RESULTS																				
FREQUENCY		Mode	Bandwidth [MHz]	Ant State	Maximum Allowed Power [dBm]	Conducted Power [dBm]	Power Drift [dB]	MPR [dB]	Device Serial Number	Modulation	RB Size	RB Offset	Spacing	Side	Duty Cycle	SAR (1g)	Scaling Factor	Reported SAR (1g)	Plot #	
MHz	Ch.															(W/kg)		(W/kg)		
707.50	23095	Md	LTE Band 12	10	51	25.8	24.86	-0.03	0	0503M	QPSK	1	0	10 mm	back	1:1	0.232	1.242	0.288	A43
707.50	23095	Md	LTE Band 12	10	51	24.8	23.90	0.01	1	0503M	QPSK	25	0	10 mm	back	1:1	0.191	1.230	0.235	
707.50	23095	Md	LTE Band 12	10	51	25.8	24.86	0.03	0	0503M	QPSK	1	0	10 mm	front	1:1	0.160	1.242	0.199	
707.50	23095	Md	LTE Band 12	10	51	24.8	23.90	0.03	1	0503M	QPSK	25	0	10 mm	front	1:1	0.130	1.230	0.160	
707.50	23095	Md	LTE Band 12	10	51	25.8	24.86	-0.03	0	0503M	QPSK	1	0	10 mm	bottom	1:1	0.138	1.242	0.171	
707.50	23095	Md	LTE Band 12	10	51	24.8	23.90	-0.01	1	0503M	QPSK	25	0	10 mm	bottom	1:1	0.111	1.230	0.137	
707.50	23095	Md	LTE Band 12	10	51	25.8	24.86	0.02	0	0503M	QPSK	1	0	10 mm	right	1:1	0.173	1.242	0.215	
707.50	23095	Md	LTE Band 12	10	51	24.8	23.90	-0.10	1	0503M	QPSK	25	0	10 mm	right	1:1	0.116	1.230	0.143	
707.50	23095	Md	LTE Band 12	10	51	25.8	24.86	0.04	0	0503M	QPSK	1	0	10 mm	left	1:1	0.112	1.242	0.139	
707.50	23095	Md	LTE Band 12	10	51	24.8	23.90	0.04	1	0503M	QPSK	25	0	10 mm	left	1:1	0.082	1.230	0.101	
ANSI / IEEE C95.1 1992 - SAFETY LIMIT Spatial Peak Uncontrolled Exposure/General Population										Body 1.6 W/kg (mW/g) averaged over 1 gram										



FCC ID: A3LSMN975U		SAR EVALUATION REPORT		Approved by: Quality Manager
Document S/N: 1M1905200079-01-R1.A3L	Test Dates: 05/22/19 - 07/07/19	DUT Type: Portable Handset	Page 165 of 220	

**Table 11-34
LTE Band 13 Hotspot SAR**

MEASUREMENT RESULTS																				
FREQUENCY		Mode	Bandwidth [MHz]	Ant State	Maximum Allowed Power [dBm]	Conducted Power [dBm]	Power Drift [dB]	MPR [dB]	Device Serial Number	Modulation	RB Size	RB Offset	Spacing	Side	Duty Cycle	SAR (1g)	Scaling Factor	Reported SAR (1g)	Plot #	
MHz	Ch.															(W/kg)		(W/kg)		
782.00	23230	Mid	LTE Band 13	10	57	25.8	24.63	0.00	0	0503M	QPSK	1	0	10 mm	back	1:1	0.386	1.309	0.505	A45
782.00	23230	Mid	LTE Band 13	10	57	24.8	23.69	-0.01	1	0503M	QPSK	25	0	10 mm	back	1:1	0.342	1.291	0.442	
782.00	23230	Mid	LTE Band 13	10	57	25.8	24.63	0.00	0	0503M	QPSK	1	0	10 mm	front	1:1	0.258	1.309	0.338	
782.00	23230	Mid	LTE Band 13	10	57	24.8	23.69	0.03	1	0503M	QPSK	25	0	10 mm	front	1:1	0.211	1.291	0.272	
782.00	23230	Mid	LTE Band 13	10	57	25.8	24.63	-0.01	0	0503M	QPSK	1	0	10 mm	bottom	1:1	0.255	1.309	0.334	
782.00	23230	Mid	LTE Band 13	10	57	24.8	23.69	-0.02	1	0503M	QPSK	25	0	10 mm	bottom	1:1	0.206	1.291	0.266	
782.00	23230	Mid	LTE Band 13	10	57	25.8	24.63	0.02	0	0503M	QPSK	1	0	10 mm	right	1:1	0.179	1.309	0.234	
782.00	23230	Mid	LTE Band 13	10	57	24.8	23.69	0.05	1	0503M	QPSK	25	0	10 mm	right	1:1	0.134	1.291	0.173	
782.00	23230	Mid	LTE Band 13	10	57	25.8	24.63	0.01	0	0503M	QPSK	1	0	10 mm	left	1:1	0.085	1.309	0.111	
782.00	23230	Mid	LTE Band 13	10	57	24.8	23.69	0.05	1	0503M	QPSK	25	0	10 mm	left	1:1	0.067	1.291	0.086	
ANSI / IEEE C95.1 1992 - SAFETY LIMIT Spatial Peak Uncontrolled Exposure/General Population										Body 1.6 W/kg (mW/g) averaged over 1 gram										

**Table 11-35
LTE Band 14 Hotspot SAR**

MEASUREMENT RESULTS																				
FREQUENCY		Mode	Bandwidth [MHz]	Ant State	Maximum Allowed Power [dBm]	Conducted Power [dBm]	Power Drift [dB]	MPR [dB]	Device Serial Number	Modulation	RB Size	RB Offset	Spacing	Side	Duty Cycle	SAR (1g)	Scaling Factor	Reported SAR (1g)	Plot #	
MHz	Ch.															(W/kg)		(W/kg)		
793.00	23330	Mid	LTE Band 14	10	57	25.8	24.50	0.02	0	0503M	QPSK	1	0	10 mm	back	1:1	0.449	1.349	0.606	A47
793.00	23330	Mid	LTE Band 14	10	57	24.8	23.62	0.00	1	0503M	QPSK	25	0	10 mm	back	1:1	0.386	1.312	0.506	
793.00	23330	Mid	LTE Band 14	10	57	25.8	24.50	0.01	0	0503M	QPSK	1	0	10 mm	front	1:1	0.275	1.349	0.371	
793.00	23330	Mid	LTE Band 14	10	57	24.8	23.62	0.00	1	0503M	QPSK	25	0	10 mm	front	1:1	0.234	1.312	0.307	
793.00	23330	Mid	LTE Band 14	10	57	25.8	24.50	-0.07	0	0503M	QPSK	1	0	10 mm	bottom	1:1	0.230	1.349	0.310	
793.00	23330	Mid	LTE Band 14	10	57	24.8	23.62	-0.01	1	0503M	QPSK	25	0	10 mm	bottom	1:1	0.218	1.312	0.286	
793.00	23330	Mid	LTE Band 14	10	57	25.8	24.50	0.03	0	0503M	QPSK	1	0	10 mm	right	1:1	0.150	1.349	0.202	
793.00	23330	Mid	LTE Band 14	10	57	24.8	23.62	0.00	1	0503M	QPSK	25	0	10 mm	right	1:1	0.127	1.312	0.167	
793.00	23330	Mid	LTE Band 14	10	57	25.8	24.50	0.05	0	0503M	QPSK	1	0	10 mm	left	1:1	0.069	1.349	0.093	
793.00	23330	Mid	LTE Band 14	10	57	24.8	23.62	0.07	1	0503M	QPSK	25	0	10 mm	left	1:1	0.053	1.312	0.070	
ANSI / IEEE C95.1 1992 - SAFETY LIMIT Spatial Peak Uncontrolled Exposure/General Population										Body 1.6 W/kg (mW/g) averaged over 1 gram										



FCC ID: A3LSMN975U		SAR EVALUATION REPORT		Approved by: Quality Manager
Document S/N: 1M1905200079-01-R1.A3L	Test Dates: 05/22/19 - 07/07/19	DUT Type: Portable Handset		Page 166 of 220

**Table 11-36
LTE Band 26 (Cell) Hotspot SAR**

MEASUREMENT RESULTS																				
FREQUENCY		Mode	Bandwidth [MHz]	Ant State	Maximum Allowed Power [dBm]	Conducted Power [dBm]	Power Drift [dB]	MPR [dB]	Device Serial Number	Modulation	RB Size	RB Offset	Spacing	Side	Duty Cycle	SAR (1g)	Scaling Factor	Reported SAR (1g)	Plot #	
MHz	Ch.															(W/kg)		(W/kg)		
831.50	26865	Mid	LTE Band 26 (Cell)	15	57	25.8	24.76	-0.01	0	0503M	QPSK	1	74	10 mm	back	1:1	0.583	1.271	0.741	A49
831.50	26865	Mid	LTE Band 26 (Cell)	15	57	24.8	23.82	-0.01	1	0503M	QPSK	36	37	10 mm	back	1:1	0.447	1.253	0.560	
831.50	26865	Mid	LTE Band 26 (Cell)	15	57	25.8	24.76	-0.02	0	0503M	QPSK	1	74	10 mm	front	1:1	0.402	1.271	0.511	
831.50	26865	Mid	LTE Band 26 (Cell)	15	57	24.8	23.82	-0.04	1	0503M	QPSK	36	37	10 mm	front	1:1	0.307	1.253	0.385	
831.50	26865	Mid	LTE Band 26 (Cell)	15	57	25.8	24.76	-0.03	0	0503M	QPSK	1	74	10 mm	bottom	1:1	0.323	1.271	0.411	
831.50	26865	Mid	LTE Band 26 (Cell)	15	57	24.8	23.82	-0.04	1	0503M	QPSK	36	37	10 mm	bottom	1:1	0.238	1.253	0.298	
831.50	26865	Mid	LTE Band 26 (Cell)	15	57	25.8	24.76	-0.02	0	0503M	QPSK	1	74	10 mm	right	1:1	0.147	1.271	0.187	
831.50	26865	Mid	LTE Band 26 (Cell)	15	57	24.8	23.82	0.06	1	0503M	QPSK	36	37	10 mm	right	1:1	0.114	1.253	0.143	
831.50	26865	Mid	LTE Band 26 (Cell)	15	57	25.8	24.76	0.08	0	0503M	QPSK	1	74	10 mm	left	1:1	0.056	1.271	0.071	
831.50	26865	Mid	LTE Band 26 (Cell)	15	57	24.8	23.82	0.03	1	0503M	QPSK	36	37	10 mm	left	1:1	0.049	1.253	0.061	
ANSI / IEEE C95.1 1992 - SAFETY LIMIT Spatial Peak Uncontrolled Exposure/General Population									Body 1.6 W/kg (mW/g) averaged over 1 gram											

**Table 11-37
LTE Band 5 (Cell) Hotspot SAR**

MEASUREMENT RESULTS																						
1 CC Uplink 2 CC Uplink	Component Carrier	FREQUENCY		Mode	Bandwidth [MHz]	Ant State	Maximum Allowed Power [dBm]	Conducted Power [dBm]	Power Drift [dB]	MPR [dB]	Device Serial Number	Modulation	RB Size	RB Offset	Spacing	Side	Duty Cycle	SAR (1g)	Scaling Factor	Reported SAR (1g)	Plot #	
		MHz	Ch.															(W/kg)		(W/kg)		
1 CC Uplink	N/A	836.50	20525	Mid	LTE Band 5 (Cell)	10	0	25.8	24.89	-0.01	0	0503M	QPSK	1	0	10 mm	back	1:1	0.581	1.233	0.716	
1 CC Uplink	N/A	836.50	20525	Mid	LTE Band 5 (Cell)	10	0	24.8	23.92	0.01	1	0503M	QPSK	25	0	10 mm	back	1:1	0.486	1.225	0.595	
2 CC Uplink	PCC	836.50	20525	Mid	LTE Band 5 (Cell)	10	0	25.8	24.97	-0.02	0	0503M	QPSK	1	0	10 mm	back	1:1	0.585	1.211	0.708	A51
	SCC	829.30	20453	Mid	LTE Band 5 (Cell)	5																
1 CC Uplink	N/A	836.50	20525	Mid	LTE Band 5 (Cell)	10	0	25.8	24.89	-0.05	0	0503M	QPSK	1	0	10 mm	front	1:1	0.378	1.233	0.466	
1 CC Uplink	N/A	836.50	20525	Mid	LTE Band 5 (Cell)	10	0	24.8	23.92	-0.02	1	0503M	QPSK	25	0	10 mm	front	1:1	0.312	1.225	0.382	
1 CC Uplink	N/A	836.50	20525	Mid	LTE Band 5 (Cell)	10	0	25.8	24.89	-0.02	0	0503M	QPSK	1	0	10 mm	bottom	1:1	0.309	1.233	0.381	
1 CC Uplink	N/A	836.50	20525	Mid	LTE Band 5 (Cell)	10	0	24.8	23.92	0.01	1	0503M	QPSK	25	0	10 mm	bottom	1:1	0.259	1.225	0.317	
1 CC Uplink	N/A	836.50	20525	Mid	LTE Band 5 (Cell)	10	0	25.8	24.89	-0.03	0	0503M	QPSK	1	0	10 mm	right	1:1	0.137	1.233	0.169	
1 CC Uplink	N/A	836.50	20525	Mid	LTE Band 5 (Cell)	10	0	24.8	23.92	-0.01	1	0503M	QPSK	25	0	10 mm	right	1:1	0.118	1.225	0.145	
1 CC Uplink	N/A	836.50	20525	Mid	LTE Band 5 (Cell)	10	0	25.8	24.89	-0.05	0	0503M	QPSK	1	0	10 mm	left	1:1	0.060	1.233	0.074	
1 CC Uplink	N/A	836.50	20525	Mid	LTE Band 5 (Cell)	10	0	24.8	23.92	-0.04	1	0503M	QPSK	25	0	10 mm	left	1:1	0.051	1.225	0.062	
ANSI / IEEE C95.1 1992 - SAFETY LIMIT Spatial Peak Uncontrolled Exposure/General Population									Body 1.6 W/kg (mW/g) averaged over 1 gram													

FCC ID: A3LSMN975U		SAR EVALUATION REPORT		Approved by: Quality Manager
Document S/N: 1M1905200079-01-R1.A3L	Test Dates: 05/22/19 - 07/07/19	DUT Type: Portable Handset	Page 167 of 220	

**Table 11-38
LTE Band 66 (AWS) Hotspot SAR**

MEASUREMENT RESULTS																						
1 CC Uplink 2 CC Uplink	Component Carrier	FREQUENCY		Mode	Bandwidth [MHz]	Ant State	Maximum Allowed Power [dBm]	Conducted Power [dBm]	Power Drift [dB]	MPR [dB]	Device Serial Number	Modulation	RB Size	RB Offset	Spacing	Side	Duty Cycle	SAR (1g)	Scaling Factor	Reported SAR (1g)	Plot #	
		MHz	Ch.															(W/kg)		(W/kg)		
1 CC Uplink	N/A	1770.00	132572	High	LTE Band 66 (AWS)	20	31	20.0	19.85	-0.05	0	0326M	QPSK	1	99	10 mm	back	1:1	0.699	1.035	0.723	
1 CC Uplink	N/A	1770.00	132572	High	LTE Band 66 (AWS)	20	31	20.0	20.00	0.00	0	0326M	QPSK	50	50	10 mm	back	1:1	0.708	1.000	0.708	
1 CC Uplink	N/A	1770.00	132572	High	LTE Band 66 (AWS)	20	31	20.0	19.85	-0.03	0	0326M	QPSK	1	99	10 mm	front	1:1	0.513	1.035	0.531	
1 CC Uplink	N/A	1770.00	132572	High	LTE Band 66 (AWS)	20	31	20.0	20.00	0.06	0	0326M	QPSK	50	50	10 mm	front	1:1	0.520	1.000	0.520	
1 CC Uplink	N/A	1720.00	132072	Low	LTE Band 66 (AWS)	20	31	20.0	19.60	-0.07	0	0326M	QPSK	1	99	10 mm	bottom	1:1	0.779	1.096	0.854	
1 CC Uplink	N/A	1745.00	132322	Mid	LTE Band 66 (AWS)	20	31	20.0	19.84	-0.04	0	0326M	QPSK	1	99	10 mm	bottom	1:1	0.926	1.038	0.961	A53
1 CC Uplink	N/A	1745.00	132322	Mid	LTE Band 66 (AWS)	10	31	20.0	19.62	0.02	0	0326M	QPSK	1	49	10 mm	bottom	1:1	0.831	1.091	0.907	
1 CC Uplink	N/A	1770.00	132572	High	LTE Band 66 (AWS)	20	31	20.0	19.85	-0.07	0	0326M	QPSK	1	99	10 mm	bottom	1:1	0.821	1.035	0.850	
1 CC Uplink	N/A	1720.00	132072	Low	LTE Band 66 (AWS)	20	31	20.0	19.65	-0.04	0	0326M	QPSK	50	50	10 mm	bottom	1:1	0.769	1.084	0.834	
1 CC Uplink	N/A	1745.00	132322	Mid	LTE Band 66 (AWS)	20	31	20.0	19.95	-0.03	0	0326M	QPSK	50	0	10 mm	bottom	1:1	0.880	1.012	0.891	
1 CC Uplink	N/A	1770.00	132572	High	LTE Band 66 (AWS)	20	31	20.0	20.00	0.01	0	0326M	QPSK	50	50	10 mm	bottom	1:1	0.836	1.000	0.836	
1 CC Uplink	N/A	1770.00	132572	High	LTE Band 66 (AWS)	20	31	20.0	19.84	-0.03	0	0326M	QPSK	100	0	10 mm	bottom	1:1	0.847	1.038	0.879	
CA_66C 2 CC Uplink	PCC	1745.00	132322	Mid	LTE Band 66 (AWS)	20	31	20.0	19.70	-0.10	0	0326M	QPSK	1	99	10 mm	bottom	1:1	0.911	1.072	0.977	
	SCC	1764.80	132520	Mid	LTE Band 66 (AWS)	20																
CA_66B 2 CC Uplink	PCC	1745.00	132322	Mid	LTE Band 66 (AWS)	10	31	20.0	19.60	-0.11	0	0326M	QPSK	1	49	10 mm	bottom	1:1	0.864	1.096	0.947	
	SCC	1754.90	132421	Mid	LTE Band 66 (AWS)	10																
1 CC Uplink	N/A	1770.00	132572	High	LTE Band 66 (AWS)	20	31	20.0	19.85	0.11	0	0326M	QPSK	1	99	10 mm	right	1:1	0.058	1.035	0.060	
1 CC Uplink	N/A	1770.00	132572	High	LTE Band 66 (AWS)	20	31	20.0	20.00	0.02	0	0326M	QPSK	50	50	10 mm	right	1:1	0.068	1.000	0.068	
1 CC Uplink	N/A	1770.00	132572	High	LTE Band 66 (AWS)	20	31	20.0	19.85	0.05	0	0326M	QPSK	1	99	10 mm	left	1:1	0.096	1.035	0.099	
1 CC Uplink	N/A	1770.00	132572	High	LTE Band 66 (AWS)	20	31	20.0	20.00	-0.06	0	0326M	QPSK	50	50	10 mm	left	1:1	0.107	1.000	0.107	
ANSI / IEEE C95.1 1992 - SAFETY LIMIT Spatial Peak Uncontrolled Exposure/General Population												Body 1.6 W/kg (mW/g) averaged over 1 gram										

**Table 11-39
LTE Band 25 (PCS) Hotspot SAR**

MEASUREMENT RESULTS																				
FREQUENCY	Mode	Bandwidth [MHz]	Ant State	Maximum Allowed Power [dBm]	Conducted Power [dBm]	Power Drift [dB]	MPR [dB]	Device Serial Number	Modulation	RB Size	RB Offset	Spacing	Side	Duty Cycle	SAR (1g)	Scaling Factor	Reported SAR (1g)	Plot #		
															MHz		Ch.		(W/kg)	(W/kg)
1882.50	26365	Mid	LTE Band 25 (PCS)	20	0	18.5	18.17	0.05	0	0347M	QPSK	1	50	10 mm	back	1:1	0.357	1.079	0.385	
1882.50	26365	Mid	LTE Band 25 (PCS)	20	0	18.5	18.14	0.02	0	0347M	QPSK	50	25	10 mm	back	1:1	0.381	1.086	0.414	
1882.50	26365	Mid	LTE Band 25 (PCS)	20	0	18.5	18.17	-0.01	0	0347M	QPSK	1	50	10 mm	front	1:1	0.248	1.079	0.268	
1882.50	26365	Mid	LTE Band 25 (PCS)	20	0	18.5	18.14	0.00	0	0347M	QPSK	50	25	10 mm	front	1:1	0.269	1.086	0.292	
1860.00	26140	Low	LTE Band 25 (PCS)	20	0	18.5	17.92	0.01	0	0347M	QPSK	1	99	10 mm	bottom	1:1	0.815	1.143	0.932	
1882.50	26365	Mid	LTE Band 25 (PCS)	20	0	18.5	18.17	-0.05	0	0347M	QPSK	1	50	10 mm	bottom	1:1	0.788	1.079	0.850	
1905.00	26590	High	LTE Band 25 (PCS)	20	0	18.5	17.78	-0.07	0	0347M	QPSK	1	99	10 mm	bottom	1:1	0.702	1.180	0.828	
1860.00	26140	Low	LTE Band 25 (PCS)	20	0	18.5	18.13	-0.06	0	0347M	QPSK	50	50	10 mm	bottom	1:1	0.824	1.089	0.897	A55
1882.50	26365	Mid	LTE Band 25 (PCS)	20	0	18.5	18.14	-0.10	0	0347M	QPSK	50	25	10 mm	bottom	1:1	0.778	1.086	0.845	
1905.00	26590	High	LTE Band 25 (PCS)	20	0	18.5	17.86	-0.05	0	0347M	QPSK	50	50	10 mm	bottom	1:1	0.672	1.159	0.779	
1882.50	26365	Mid	LTE Band 25 (PCS)	20	0	18.5	18.11	-0.05	0	0347M	QPSK	100	0	10 mm	bottom	1:1	0.774	1.094	0.847	
1882.50	26365	Mid	LTE Band 25 (PCS)	20	0	18.5	18.17	0.11	0	0347M	QPSK	1	50	10 mm	right	1:1	0.026	1.079	0.028	
1882.50	26365	Mid	LTE Band 25 (PCS)	20	0	18.5	18.14	-0.08	0	0347M	QPSK	50	25	10 mm	right	1:1	0.029	1.086	0.031	
1882.50	26365	Mid	LTE Band 25 (PCS)	20	0	18.5	18.17	0.15	0	0347M	QPSK	1	50	10 mm	left	1:1	0.027	1.079	0.029	
1882.50	26365	Mid	LTE Band 25 (PCS)	20	0	18.5	18.14	-0.14	0	0347M	QPSK	50	25	10 mm	left	1:1	0.027	1.086	0.029	
ANSI / IEEE C95.1 1992 - SAFETY LIMIT Spatial Peak Uncontrolled Exposure/General Population												Body 1.6 W/kg (mW/g) averaged over 1 gram								

FCC ID: A3LSMN975U		SAR EVALUATION REPORT		Approved by: Quality Manager
Document S/N: 1M1905200079-01-R1.A3L	Test Dates: 05/22/19 - 07/07/19	DUT Type: Portable Handset		Page 168 of 220



**Table 11-40
LTE Band 30 Hotspot SAR**

MEASUREMENT RESULTS																			
FREQUENCY		Mode	Bandwidth [MHz]	Maximum Allowed Power [dBm]	Conducted Power [dBm]	Power Drift [dB]	MPR [dB]	Device Serial Number	Modulation	RB Size	RB Offset	Spacing	Side	Duty Cycle	SAR (1g)	Scaling Factor	Reported SAR (1g)	Plot #	
MHz	Ch.														(W/kg)		(W/kg)		
2310.00	27710	Mid	LTE Band 30	10	20.5	20.50	-0.17	0	0373M	QPSK	1	0	10 mm	back	1:1	0.576	1.000	0.576	
2310.00	27710	Mid	LTE Band 30	10	20.5	20.28	-0.01	0	0373M	QPSK	25	12	10 mm	back	1:1	0.591	1.052	0.622	
2310.00	27710	Mid	LTE Band 30	10	20.5	20.50	0.01	0	0373M	QPSK	1	0	10 mm	front	1:1	0.450	1.000	0.450	
2310.00	27710	Mid	LTE Band 30	10	20.5	20.28	-0.06	0	0373M	QPSK	25	12	10 mm	front	1:1	0.457	1.052	0.481	
2310.00	27710	Mid	LTE Band 30	10	20.5	20.50	-0.08	0	0373M	QPSK	1	0	10 mm	bottom	1:1	1.230	1.000	1.230	
2310.00	27710	Mid	LTE Band 30	10	20.5	20.28	-0.06	0	0373M	QPSK	25	12	10 mm	bottom	1:1	1.270	1.052	1.336	A57
2310.00	27710	Mid	LTE Band 30	10	20.5	20.23	-0.09	0	0373M	QPSK	50	0	10 mm	bottom	1:1	1.260	1.064	1.341	
2310.00	27710	Mid	LTE Band 30	10	20.5	20.50	-0.10	0	0373M	QPSK	1	0	10 mm	right	1:1	0.042	1.000	0.042	
2310.00	27710	Mid	LTE Band 30	10	20.5	20.28	-0.11	0	0373M	QPSK	25	12	10 mm	right	1:1	0.044	1.052	0.046	
2310.00	27710	Mid	LTE Band 30	10	20.5	20.50	-0.17	0	0373M	QPSK	1	0	10 mm	left	1:1	0.069	1.000	0.069	
2310.00	27710	Mid	LTE Band 30	10	20.5	20.28	-0.10	0	0373M	QPSK	25	12	10 mm	left	1:1	0.071	1.052	0.075	
2310.00	27710	Mid	LTE Band 30	10	20.5	20.28	-0.12	0	0373M	QPSK	25	12	10 mm	bottom	1:1	1.200	1.052	1.262	
ANSI / IEEE C95.1 1992 - SAFETY LIMIT Spatial Peak Uncontrolled Exposure/General Population								Body 1.6 W/kg (mW/g) averaged over 1 gram											

Note: Blue entry represents variability measurement.

**Table 11-41
LTE Band 7 Hotspot SAR**

MEASUREMENT RESULTS																			
FREQUENCY		Mode	Bandwidth [MHz]	Maximum Allowed Power [dBm]	Conducted Power [dBm]	Power Drift [dB]	MPR [dB]	Device Serial Number	Modulation	RB Size	RB Offset	Spacing	Side	Duty Cycle	SAR (1g)	Scaling Factor	Reported SAR (1g)	Plot #	
MHz	Ch.														(W/kg)		(W/kg)		
2535.00	21100	Mid	LTE Band 7	20	22.0	20.93	0.05	0	0358M	QPSK	1	0	10 mm	back	1:1	0.365	1.279	0.467	
2535.00	21100	Mid	LTE Band 7	20	22.0	21.10	0.03	0	0358M	QPSK	50	0	10 mm	back	1:1	0.374	1.230	0.460	
2535.00	21100	Mid	LTE Band 7	20	22.0	20.93	0.04	0	0358M	QPSK	1	0	10 mm	front	1:1	0.285	1.279	0.365	
2535.00	21100	Mid	LTE Band 7	20	22.0	21.10	0.09	0	0358M	QPSK	50	0	10 mm	front	1:1	0.293	1.230	0.360	
2535.00	21100	Mid	LTE Band 7	20	22.0	20.93	-0.01	0	0358M	QPSK	1	0	10 mm	bottom	1:1	0.434	1.279	0.555	
2535.00	21100	Mid	LTE Band 7	20	22.0	21.10	0.00	0	0358M	QPSK	50	0	10 mm	bottom	1:1	0.450	1.230	0.554	A59
2535.00	21100	Mid	LTE Band 7	20	22.0	20.93	-0.12	0	0358M	QPSK	1	0	10 mm	left	1:1	0.124	1.279	0.159	
2535.00	21100	Mid	LTE Band 7	20	22.0	21.10	-0.07	0	0358M	QPSK	50	0	10 mm	left	1:1	0.125	1.230	0.154	
ANSI / IEEE C95.1 1992 - SAFETY LIMIT Spatial Peak Uncontrolled Exposure/General Population								Body 1.6 W/kg (mW/g) averaged over 1 gram											

FCC ID: A3LSMN975U		SAR EVALUATION REPORT		Approved by: Quality Manager
Document S/N: 1M1905200079-01-R1.A3L	Test Dates: 05/22/19 - 07/07/19	DUT Type: Portable Handset	Page 169 of 220	

**Table 11-42
LTE Band 48 Hotspot SAR**

MEASUREMENT RESULTS																			
FREQUENCY		Mode	Bandwidth [MHz]	Maximum Allowed Power [dBm]	Conducted Power [dBm]	Power Drift [dB]	MPR [dB]	Device Serial Number	Modulation	RB Size	RB Offset	Spacing	Side	Duty Cycle	SAR (1g)	Scaling Factor	Reported SAR (1g)	Plot #	
MHz	Ch.														(W/kg)		(W/kg)		
3560.00	55340	Low	LTE Band 48	20	23.0	22.36	0.10	0	0349M	QPSK	1	99	10 mm	back	1:1.58	0.216	1.159	0.250	
3560.00	55340	Low	LTE Band 48	20	22.0	21.68	0.02	1	0349M	QPSK	50	25	10 mm	back	1:1.58	0.181	1.076	0.195	
3560.00	55340	Low	LTE Band 48	20	23.0	22.36	0.02	0	0349M	QPSK	1	99	10 mm	front	1:1.58	0.176	1.159	0.204	
3560.00	55340	Low	LTE Band 48	20	22.0	21.68	0.04	1	0349M	QPSK	50	25	10 mm	front	1:1.58	0.148	1.076	0.159	
3560.00	55340	Low	LTE Band 48	20	23.0	22.36	-0.01	0	0349M	QPSK	1	99	10 mm	bottom	1:1.58	0.435	1.159	0.504	A61
3560.00	55340	Low	LTE Band 48	20	22.0	21.68	0.05	1	0349M	QPSK	50	25	10 mm	bottom	1:1.58	0.380	1.076	0.409	
3560.00	55340	Low	LTE Band 48	20	23.0	22.36	0.12	0	0349M	QPSK	1	99	10 mm	left	1:1.58	0.101	1.159	0.117	
3560.00	55340	Low	LTE Band 48	20	22.0	21.68	0.05	1	0349M	QPSK	50	25	10 mm	left	1:1.58	0.084	1.076	0.090	
ANSI / IEEE C95.1 1992 - SAFETY LIMIT Spatial Peak Uncontrolled Exposure/General Population								Body 1.6 W/kg (mW/g) averaged over 1 gram											

**Table 11-43
LTE Band 41 Hotspot SAR**

MEASUREMENT RESULTS																					
1 CC Uplink 2 CC Uplink, Power Class	Component Carrier	FREQUENCY		Mode	Bandwidth [MHz]	Maximum Allowed Power [dBm]	Conducted Power [dBm]	Power Drift [dB]	MPR [dB]	Device Serial Number	Modulation	RB Size	RB Offset	Spacing	Side	Duty Cycle	SAR (1g)	Scaling Factor	Reported SAR (1g)	Plot #	
		MHz	Ch.														(W/kg)		(W/kg)		
1 CC Uplink - Power Class 3	N/A	2549.50	40185	Low-Mid	LTE Band 41	20	22.5	22.02	0.01	0	0358M	QPSK	1	50	10 mm	back	1:1.58	0.280	1.117	0.313	
1 CC Uplink - Power Class 3	N/A	2549.50	40185	Low-Mid	LTE Band 41	20	22.5	22.00	0.02	0	0358M	QPSK	50	0	10 mm	back	1:1.58	0.292	1.122	0.328	
1 CC Uplink - Power Class 3	N/A	2549.50	40185	Low-Mid	LTE Band 41	20	22.5	22.02	0.00	0	0358M	QPSK	1	50	10 mm	front	1:1.58	0.221	1.117	0.247	
1 CC Uplink - Power Class 3	N/A	2549.50	40185	Low-Mid	LTE Band 41	20	22.5	22.00	0.00	0	0358M	QPSK	50	0	10 mm	front	1:1.58	0.225	1.122	0.252	
1 CC Uplink - Power Class 3	N/A	2506.00	39750	Low	LTE Band 41	20	22.5	20.96	-0.02	0	0358M	QPSK	1	0	10 mm	bottom	1:1.58	0.496	1.426	0.707	
1 CC Uplink - Power Class 3	N/A	2549.50	40185	Low-Mid	LTE Band 41	20	22.5	22.02	0.02	0	0358M	QPSK	1	50	10 mm	bottom	1:1.58	0.637	1.117	0.712	
1 CC Uplink - Power Class 3	N/A	2593.00	40620	Mid	LTE Band 41	20	22.5	20.82	0.11	0	0358M	QPSK	1	0	10 mm	bottom	1:1.58	0.335	1.472	0.493	
1 CC Uplink - Power Class 3	N/A	2636.50	41055	Mid-High	LTE Band 41	20	22.5	21.04	0.02	0	0358M	QPSK	1	50	10 mm	bottom	1:1.58	0.454	1.400	0.636	
1 CC Uplink - Power Class 3	N/A	2680.00	41490	High	LTE Band 41	20	22.5	20.77	0.03	0	0358M	QPSK	1	0	10 mm	bottom	1:1.58	0.342	1.489	0.509	
1 CC Uplink - Power Class 3	N/A	2506.00	39750	Low	LTE Band 41	20	22.5	21.25	0.04	0	0358M	QPSK	50	50	10 mm	bottom	1:1.58	0.555	1.334	0.740	
1 CC Uplink - Power Class 3	N/A	2549.50	40185	Low-Mid	LTE Band 41	20	22.5	22.00	0.01	0	0358M	QPSK	50	0	10 mm	bottom	1:1.58	0.660	1.122	0.741	
1 CC Uplink - Power Class 3	N/A	2593.00	40620	Mid	LTE Band 41	20	22.5	20.73	0.03	0	0358M	QPSK	50	0	10 mm	bottom	1:1.58	0.338	1.503	0.508	
1 CC Uplink - Power Class 3	N/A	2636.50	41055	Mid-High	LTE Band 41	20	22.5	21.23	0.03	0	0358M	QPSK	50	50	10 mm	bottom	1:1.58	0.452	1.340	0.606	
1 CC Uplink - Power Class 3	N/A	2680.00	41490	High	LTE Band 41	20	22.5	20.90	0.07	0	0358M	QPSK	50	0	10 mm	bottom	1:1.58	0.339	1.445	0.490	
1 CC Uplink - Power Class 3	N/A	2549.50	40185	Low-Mid	LTE Band 41	20	22.5	21.99	0.02	0	0358M	QPSK	100	0	10 mm	bottom	1:1.58	0.658	1.125	0.740	
1 CC Uplink - Power Class 2	N/A	2549.50	40185	Low-Mid	LTE Band 41	20	22.5	21.93	0.04	0	0358M	QPSK	50	0	10 mm	bottom	1:2.31	0.411	1.140	0.469	
2 CC Uplink - Power Class 3	PCC	2549.50	40185	Low-Mid	LTE Band 41	20	22.5	22.50	0.07	0	0358M	QPSK	50	0	10 mm	bottom	1:1.58	1.000	0.703	A63	
	SCC	2529.70	39987	Low-Mid	LTE Band 41	20	22.5							50							
2 CC Uplink - Power Class 2	PCC	2549.50	40185	Low-Mid	LTE Band 41	20	22.5	22.36	0.05	0	0358M	QPSK	50	0	10 mm	bottom	1:2.31	1.033	0.477		
	SCC	2529.70	39987	Low-Mid	LTE Band 41	20	22.5							50							
1 CC Uplink - Power Class 3	N/A	2549.50	40185	Low-Mid	LTE Band 41	20	22.5	22.02	-0.01	0	0358M	QPSK	1	50	10 mm	left	1:1.58	0.087	1.117	0.097	
1 CC Uplink - Power Class 3	N/A	2549.50	40185	Low-Mid	LTE Band 41	20	22.5	22.00	-0.04	0	0358M	QPSK	50	0	10 mm	left	1:1.58	0.086	1.122	0.096	
ANSI / IEEE C95.1 1992 - SAFETY LIMIT Spatial Peak Uncontrolled Exposure/General Population								Body 1.6 W/kg (mW/g) averaged over 1 gram													

FCC ID: A3LSMN975U		SAR EVALUATION REPORT		Approved by: Quality Manager
Document S/N: 1M1905200079-01-R1.A3L	Test Dates: 05/22/19 - 07/07/19	DUT Type: Portable Handset		Page 170 of 220

**Table 11-44
WLAN Hotspot SAR**

MEASUREMENT RESULTS																			
FREQUENCY		Mode	Service	Bandwidth [MHz]	Maximum Allowed Power [dBm]	Conducted Power [dBm]	Power Drift [dB]	Spacing	Antenna Config.	Device Serial Number	Data Rate (Mbps)	Side	Duty Cycle (%)	Peak SAR of Area Scan	SAR (1g)	Scaling Factor (Power)	Scaling Factor (Duty Cycle)	Reported SAR (1g)	Plot #
MHz	Ch.													W/kg	(W/kg)			(W/kg)	
2437	6	802.11b	DSSS	22	21.0	20.97	0.18	10 mm	1	0352M	1	back	100.0	0.401	0.320	1.007	1.000	0.322	
2437	6	802.11b	DSSS	22	21.0	20.97	0.14	10 mm	1	0352M	1	front	100.0	0.192	-	1.007	1.000	-	
2437	6	802.11b	DSSS	22	21.0	20.97	0.10	10 mm	1	0352M	1	top	100.0	0.571	0.363	1.007	1.000	0.366	A65
2437	6	802.11b	DSSS	22	21.0	20.97	0.16	10 mm	1	0352M	1	left	100.0	0.327	-	1.007	1.000	-	
2437	6	802.11b	DSSS	22	21.0	20.99	0.14	10 mm	2	0324M	1	back	100.0	0.276	0.184	1.002	1.000	0.184	
2437	6	802.11b	DSSS	22	21.0	20.99	0.11	10 mm	2	0324M	1	front	100.0	0.026	-	1.002	1.000	-	
2437	6	802.11b	DSSS	22	21.0	20.99	0.17	10 mm	2	0324M	1	top	100.0	0.063	-	1.002	1.000	-	
2437	6	802.11b	DSSS	22	21.0	20.99	0.13	10 mm	2	0324M	1	left	100.0	0.114	-	1.002	1.000	-	
5745	149	802.11a	OFDM	20	18.5	18.30	-0.10	10 mm	1	0459M	6	back	98.9	0.786	0.322	1.047	1.011	0.341	A67
5745	149	802.11a	OFDM	20	18.5	18.30	-0.12	10 mm	1	0459M	6	front	98.9	0.234	-	1.047	1.011	-	
5745	149	802.11a	OFDM	20	18.5	18.30	-0.01	10 mm	1	0459M	6	top	98.9	0.648	-	1.047	1.011	-	
5745	149	802.11a	OFDM	20	18.5	18.30	-0.13	10 mm	1	0459M	6	left	98.9	0.436	-	1.047	1.011	-	
5785	157	802.11a	OFDM	20	18.5	18.44	-0.10	10 mm	2	0459M	6	back	98.8	0.398	0.172	1.014	1.012	0.177	
5785	157	802.11a	OFDM	20	18.5	18.44	-0.19	10 mm	2	0459M	6	front	98.8	0.048	-	1.014	1.012	-	
5785	157	802.11a	OFDM	20	18.5	18.44	-0.12	10 mm	2	0459M	6	top	98.8	0.151	-	1.014	1.012	-	
5785	157	802.11a	OFDM	20	18.5	18.44	0.17	10 mm	2	0459M	6	left	98.8	0.192	-	1.014	1.012	-	
ANSI / IEEE C95.1 1992 - SAFETY LIMIT Spatial Peak Uncontrolled Exposure/General Population								Body 1.6 W/kg (mW/g) averaged over 1 gram											

**Table 11-45
WLAN Hotspot SAR for Conditions with 2.4 GHz and 5 GHz WLAN SAR**

MEASUREMENT RESULTS																					
FREQUENCY		Mode	Service	Bandwidth [MHz]	Maximum Allowed Power (Ant 1) [dBm]	Conducted Power (Ant 1) [dBm]	Maximum Allowed Power (Ant 2) [dBm]	Conducted Power (Ant 2) [dBm]	Power Drift [dB]	Spacing	Antenna Config.	Device Serial Number	Data Rate (Mbps)	Side	Duty Cycle (%)	Peak SAR of Area Scan	SAR (1g)	Scaling Factor (Power)	Scaling Factor (Duty Cycle)	Reported SAR (1g)	Plot #
MHz	Ch.															W/kg	(W/kg)			(W/kg)	
5775	155	802.11ac	OFDM	80	14.0	13.76	14.0	13.57	0.09	10 mm	MIMO	0459M	58.5	back	89.6	0.452	0.173	1.104	1.116	0.213	
5775	155	802.11ac	OFDM	80	14.0	13.76	14.0	13.57	-0.15	10 mm	MIMO	0459M	58.5	front	89.6	0.103	-	1.104	1.116	-	
5775	155	802.11ac	OFDM	80	14.0	13.76	14.0	13.57	-0.17	10 mm	MIMO	0459M	58.5	top	89.6	0.272	-	1.104	1.116	-	
5775	155	802.11ac	OFDM	80	14.0	13.76	14.0	13.57	-0.13	10 mm	MIMO	0459M	58.5	left	89.6	0.231	-	1.104	1.116	-	
ANSI / IEEE C95.1 1992 - SAFETY LIMIT Spatial Peak Uncontrolled Exposure/General Population								Body 1.6 W/kg (mW/g) averaged over 1 gram													

NII MIMO was additionally evaluated at the maximum allowed output power during operations with Simultaneous 2.4 GHz and 5 GHz WLAN. 2.4 GHz WIFI was not transmitting during the above evaluations.

**Table 11-46
DSS Hotspot SAR**

MEASUREMENT RESULTS																
FREQUENCY		Mode	Service	Maximum Allowed Power [dBm]	Conducted Power [dBm]	Power Drift [dB]	Spacing	Device Serial Number	Data Rate (Mbps)	Side	Duty Cycle (%)	SAR (1g)	Scaling Factor (Cond Power)	Scaling Factor (Duty Cycle)	Reported SAR (1g)	Plot #
MHz	Ch.											(W/kg)			(W/kg)	
2441	39	Bluetooth	FHSS	15.5	15.41	0.03	10 mm	0352M	1	back	77.1	0.067	1.021	1.297	0.089	
2441	39	Bluetooth	FHSS	15.5	15.41	0.19	10 mm	0352M	1	front	77.1	0.025	1.021	1.297	0.033	
2441	39	Bluetooth	FHSS	15.5	15.41	0.17	10 mm	0352M	1	top	77.1	0.069	1.021	1.297	0.091	A69
2441	39	Bluetooth	FHSS	15.5	15.41	0.12	10 mm	0352M	1	left	77.1	0.041	1.021	1.297	0.054	
ANSI / IEEE C95.1 1992 - SAFETY LIMIT Spatial Peak Uncontrolled Exposure/General Population								Body 1.6 W/kg (mW/g) averaged over 1 gram								



FCC ID: A3LSMN975U		SAR EVALUATION REPORT		Approved by: Quality Manager
Document S/N: 1M1905200079-01-R1.A3L	Test Dates: 05/22/19 - 07/07/19	DUT Type: Portable Handset		Page 171 of 220

11.4 Standalone Phablet SAR Data

**Table 11-47
GPRS/UMTS/CDMA Phablet SAR Data**

MEASUREMENT RESULTS																
FREQUENCY		Mode	Service	Maximum Allowed Power [dBm]	Conducted Power [dBm]	Power Drift [dB]	Spacing	Ant State	Device Serial Number	# of Time Slots	Duty Cycle	Side	SAR (10g)	Scaling Factor	Reported SAR (10g)	Plot #
Mhz	Ch.												(W/kg)		(W/kg)	
1732.40	1412	UMTS 1750	RMC	25.0	24.35	0.05	8 mm	30	0116M	N/A	1:1	back	1.410	1.161	1.637	
1732.40	1412	UMTS 1750	RMC	25.0	24.35	0.07	6 mm	30	0116M	N/A	1:1	front	1.250	1.161	1.451	
1732.40	1412	UMTS 1750	RMC	25.0	24.35	-0.01	11 mm	30	0116M	N/A	1:1	bottom	1.310	1.161	1.521	
1732.40	1412	UMTS 1750	RMC	25.0	24.35	0.02	0 mm	30	0116M	N/A	1:1	right	0.356	1.161	0.413	
1732.40	1412	UMTS 1750	RMC	25.0	24.35	-0.12	0 mm	30	0116M	N/A	1:1	left	0.581	1.161	0.675	
1732.40	1412	UMTS 1750	RMC	20.0	19.25	0.04	0 mm	30	0373M	N/A	1:1	back	1.520	1.189	1.807	
1732.40	1412	UMTS 1750	RMC	20.0	19.25	0.10	0 mm	30	0373M	N/A	1:1	front	1.160	1.189	1.379	
1712.40	1312	UMTS 1750	RMC	20.0	19.28	-0.16	0 mm	30	0373M	N/A	1:1	bottom	2.220	1.180	2.620	A70
1732.40	1412	UMTS 1750	RMC	20.0	19.25	0.00	0 mm	30	0373M	N/A	1:1	bottom	2.170	1.189	2.580	
1752.60	1513	UMTS 1750	RMC	20.0	19.33	-0.18	0 mm	30	0373M	N/A	1:1	bottom	2.150	1.167	2.509	
1880.00	600	PCS CDMA	EVDO Rev. 0	25.0	24.62	-0.03	8 mm	0	0119M	N/A	1:1	back	0.811	1.091	0.885	
1880.00	600	PCS CDMA	EVDO Rev. 0	25.0	24.62	-0.03	6 mm	0	0119M	N/A	1:1	front	0.919	1.091	1.003	
1880.00	600	PCS CDMA	EVDO Rev. 0	25.0	24.62	-0.04	11 mm	0	0119M	N/A	1:1	bottom	1.350	1.091	1.473	
1880.00	600	PCS CDMA	EVDO Rev. 0	25.0	24.62	0.01	0 mm	0	0119M	N/A	1:1	right	0.280	1.091	0.305	
1880.00	600	PCS CDMA	EVDO Rev. 0	25.0	24.62	-0.19	0 mm	0	0119M	N/A	1:1	left	0.506	1.091	0.552	
1880.00	600	PCS CDMA	EVDO Rev. 0	21.0	20.55	-0.05	0 mm	0	0119M	N/A	1:1	back	1.530	1.109	1.697	
1880.00	600	PCS CDMA	EVDO Rev. 0	21.0	20.55	-0.01	0 mm	0	0119M	N/A	1:1	front	1.540	1.109	1.708	
1851.25	25	PCS CDMA	EVDO Rev. 0	21.0	20.54	-0.10	0 mm	0	0119M	N/A	1:1	bottom	2.500	1.112	2.780	
1880.00	600	PCS CDMA	EVDO Rev. 0	21.0	20.55	-0.12	0 mm	0	0119M	N/A	1:1	bottom	2.200	1.109	2.440	
1908.75	1175	PCS CDMA	EVDO Rev. 0	21.0	20.47	-0.10	0 mm	0	0119M	N/A	1:1	bottom	2.570	1.130	2.904	
1908.75	1175	PCS CDMA	EVDO Rev. 0	21.0	20.47	-0.15	0 mm	0	0119M	N/A	1:1	bottom	2.710	1.130	3.062	A71
1850.20	512	GSM 1900	GPRS	27.0	25.02	-0.09	0 mm	N/A	0119M	3	1:2.76	bottom	2.030	1.578	3.203	
1880.00	661	GSM 1900	GPRS	27.0	25.00	-0.13	0 mm	N/A	0119M	3	1:2.76	bottom	1.920	1.585	3.043	
1909.80	810	GSM 1900	GPRS	27.0	25.20	-0.14	0 mm	N/A	0119M	3	1:2.76	bottom	2.050	1.514	3.104	A72
1880.00	9400	UMTS 1900	RMC	25.0	23.78	-0.02	8 mm	30	0119M	N/A	1:1	back	0.828	1.324	1.096	
1880.00	9400	UMTS 1900	RMC	25.0	23.78	0.03	6 mm	30	0119M	N/A	1:1	front	0.946	1.324	1.253	
1880.00	9400	UMTS 1900	RMC	25.0	23.78	0.02	11 mm	30	0119M	N/A	1:1	bottom	1.200	1.324	1.589	
1880.00	9400	UMTS 1900	RMC	25.0	23.78	0.00	0 mm	30	0119M	N/A	1:1	right	0.288	1.324	0.381	
1880.00	9400	UMTS 1900	RMC	25.0	23.78	-0.17	0 mm	30	0119M	N/A	1:1	left	0.566	1.324	0.749	
1880.00	9400	UMTS 1900	RMC	20.5	19.75	-0.21	0 mm	30	0119M	N/A	1:1	back	1.680	1.189	1.998	
1880.00	9400	UMTS 1900	RMC	20.5	19.75	0.07	0 mm	30	0119M	N/A	1:1	front	1.210	1.189	1.439	
1852.40	9262	UMTS 1900	RMC	20.5	19.56	-0.07	0 mm	30	0119M	N/A	1:1	bottom	2.190	1.242	2.720	A73
1880.00	9400	UMTS 1900	RMC	20.5	19.75	-0.11	0 mm	30	0119M	N/A	1:1	bottom	2.060	1.189	2.449	
1907.60	9538	UMTS 1900	RMC	20.5	19.73	-0.14	0 mm	30	0119M	N/A	1:1	bottom	2.130	1.194	2.543	
ANSI / IEEE C95.1 1992 - SAFETY LIMIT Spatial Peak Uncontrolled Exposure/General Population							Phablet 4.0 W/kg (mW/g) averaged over 10 grams									

Note: Blue entry represents variability measurement.

FCC ID: A3LSMN975U		SAR EVALUATION REPORT		Approved by: Quality Manager
Document S/N: 1M1905200079-01-R1.A3L	Test Dates: 05/22/19 - 07/07/19	DUT Type: Portable Handset	Page 172 of 220	

**Table 11-48
LTE Band 66 Phablet SAR**

MEASUREMENT RESULTS																						
1 CC Uplink 2 CC Uplink	Component Carrier	FREQUENCY		Mode	Bandwidth [MHz]	Ant State	Maximum Allowed Power [dBm]	Conducted Power [dBm]	Power Drift [dB]	MPR [dB]	Serial Number	Modulation	RB Size	RB Offset	Spacing	Side	Duty Cycle	SAR (10g)	Scaling Factor	Reported SAR (10g)	Plot #	
		MHz	Ch.															(W/kg)	(W/kg)	(W/kg)		
1 CC Uplink	N/A	1745.00	132322	Mid	LTE Band 66 (AWS)	20	31	25.0	24.38	0.04	0	0326M	QPSK	1	99	8 mm	back	1:1	1.380	1.153	1.591	
1 CC Uplink	N/A	1745.00	132322	Mid	LTE Band 66 (AWS)	20	31	24.0	23.50	0.04	1	0326M	QPSK	50	25	8 mm	back	1:1	1.150	1.122	1.290	
1 CC Uplink	N/A	1745.00	132322	Mid	LTE Band 66 (AWS)	20	31	25.0	24.38	0.07	0	0326M	QPSK	1	99	6 mm	front	1:1	1.280	1.153	1.476	
1 CC Uplink	N/A	1745.00	132322	Mid	LTE Band 66 (AWS)	20	31	24.0	23.50	0.11	1	0326M	QPSK	50	25	6 mm	front	1:1	1.050	1.122	1.178	
1 CC Uplink	N/A	1745.00	132322	Mid	LTE Band 66 (AWS)	20	31	25.0	24.38	-0.03	0	0326M	QPSK	1	99	11 mm	bottom	1:1	1.380	1.153	1.591	
1 CC Uplink	N/A	1745.00	132322	Mid	LTE Band 66 (AWS)	20	31	24.0	23.50	-0.07	1	0326M	QPSK	50	25	11 mm	bottom	1:1	1.090	1.122	1.223	
1 CC Uplink	N/A	1745.00	132322	Mid	LTE Band 66 (AWS)	20	31	25.0	24.38	0.07	0	0326M	QPSK	1	99	0 mm	right	1:1	0.346	1.153	0.399	
1 CC Uplink	N/A	1745.00	132322	Mid	LTE Band 66 (AWS)	20	31	24.0	23.50	0.10	1	0326M	QPSK	50	25	0 mm	right	1:1	0.286	1.122	0.321	
1 CC Uplink	N/A	1745.00	132322	Mid	LTE Band 66 (AWS)	20	31	25.0	24.38	-0.07	0	0326M	QPSK	1	99	0 mm	left	1:1	0.514	1.153	0.593	
1 CC Uplink	N/A	1745.00	132322	Mid	LTE Band 66 (AWS)	20	31	24.0	23.50	-0.09	1	0326M	QPSK	50	25	0 mm	left	1:1	0.439	1.122	0.493	
1 CC Uplink	N/A	1720.00	132072	Low	LTE Band 66 (AWS)	20	31	21.0	20.25	0.00	0	0326M	QPSK	1	99	0 mm	back	1:1	1.860	1.189	2.212	
1 CC Uplink	N/A	1745.00	132322	Mid	LTE Band 66 (AWS)	20	31	21.0	20.65	0.01	0	0326M	QPSK	1	99	0 mm	back	1:1	1.980	1.084	2.146	
1 CC Uplink	N/A	1770.00	132572	High	LTE Band 66 (AWS)	20	31	21.0	20.57	-0.01	0	0326M	QPSK	1	0	0 mm	back	1:1	1.960	1.104	2.164	
1 CC Uplink	N/A	1720.00	132072	Low	LTE Band 66 (AWS)	20	31	21.0	20.21	0.01	0	0326M	QPSK	50	50	0 mm	back	1:1	1.910	1.199	2.290	
1 CC Uplink	N/A	1745.00	132322	Mid	LTE Band 66 (AWS)	20	31	21.0	20.73	0.07	0	0326M	QPSK	50	50	0 mm	back	1:1	2.090	1.064	2.224	
1 CC Uplink	N/A	1770.00	132572	High	LTE Band 66 (AWS)	20	31	21.0	20.77	-0.02	0	0326M	QPSK	50	25	0 mm	back	1:1	2.030	1.054	2.140	
1 CC Uplink	N/A	1745.00	132322	Mid	LTE Band 66 (AWS)	20	31	21.0	20.64	0.03	0	0326M	QPSK	100	0	0 mm	back	1:1	2.120	1.086	2.302	
1 CC Uplink	N/A	1745.00	132322	Mid	LTE Band 66 (AWS)	20	31	21.0	20.65	0.09	0	0326M	QPSK	1	99	0 mm	front	1:1	1.690	1.084	1.832	
1 CC Uplink	N/A	1770.00	132572	High	LTE Band 66 (AWS)	20	31	21.0	20.77	0.17	0	0326M	QPSK	50	25	0 mm	front	1:1	1.650	1.054	1.739	
1 CC Uplink	N/A	1720.00	132072	Low	LTE Band 66 (AWS)	20	31	21.0	20.25	0.02	0	0326M	QPSK	1	99	0 mm	bottom	1:1	2.290	1.189	2.723	
1 CC Uplink	N/A	1745.00	132322	Mid	LTE Band 66 (AWS)	20	31	21.0	20.65	-0.13	0	0326M	QPSK	1	99	0 mm	bottom	1:1	2.390	1.084	2.591	
1 CC Uplink	N/A	1770.00	132572	High	LTE Band 66 (AWS)	20	31	21.0	20.57	-0.09	0	0326M	QPSK	1	0	0 mm	bottom	1:1	2.310	1.104	2.550	
1 CC Uplink	N/A	1720.00	132072	Low	LTE Band 66 (AWS)	20	31	21.0	20.21	0.13	0	0326M	QPSK	50	50	0 mm	bottom	1:1	2.450	1.199	2.938	
1 CC Uplink	N/A	1715.00	132022	Low	LTE Band 66 (AWS)	10	31	21.0	20.10	0.16	0	0326M	QPSK	25	25	0 mm	bottom	1:1	2.290	1.230	2.817	
1 CC Uplink	N/A	1745.00	132322	Mid	LTE Band 66 (AWS)	20	31	21.0	20.73	0.07	0	0326M	QPSK	50	50	0 mm	bottom	1:1	2.540	1.064	2.703	
1 CC Uplink	N/A	1770.00	132572	High	LTE Band 66 (AWS)	20	31	21.0	20.77	0.08	0	0326M	QPSK	50	25	0 mm	bottom	1:1	2.460	1.054	2.593	
1 CC Uplink	N/A	1745.00	132322	Mid	LTE Band 66 (AWS)	20	31	21.0	20.64	0.15	0	0326M	QPSK	100	0	0 mm	bottom	1:1	2.250	1.086	2.444	
CA_66C 2 CC Uplink	PCC	1720.00	132072	Low	LTE Band 66 (AWS)	20	31	21.0	20.41	0.13	0	0326M	QPSK	50	0	0 mm	bottom	1:1	2.560	1.146	2.934	A74
	SCC	1739.80	132270	Low	LTE Band 66 (AWS)	20																
CA_66B 2 CC Uplink	PCC	1715.00	132022	Low	LTE Band 66 (AWS)	10	31	21.0	20.23	0.15	0	0326M	QPSK	25	0	0 mm	bottom	1:1	2.250	1.194	2.687	
	SCC	1724.90	132121	Low	LTE Band 66 (AWS)	10																
CA_66C 2 CC Uplink	PCC	1720.00	132072	Low	LTE Band 66 (AWS)	20	31	21.0	20.41	0.00	0	0326M	QPSK	50	0	0 mm	bottom	1:1	2.490	1.146	2.854	
	SCC	1739.80	132270	Low	LTE Band 66 (AWS)	20																

ANSI / IEEE C95.1 1992 - SAFETY LIMIT
Spatial Peak
Uncontrolled Exposure/General Population

Phablet
4.0 W/kg (mW/g)
averaged over 10 grams

Note: Blue entry represents variability measurement.





FCC ID: A3LSMN975U		SAR EVALUATION REPORT		Approved by: Quality Manager
Document S/N: 1M1905200079-01-R1.A3L	Test Dates: 05/22/19 - 07/07/19	DUT Type: Portable Handset	Page 173 of 220	

Table 11-49
LTE Band 25 Phablet SAR



MEASUREMENT RESULTS																				
FREQUENCY		Mode	Bandwidth [MHz]	Ant State	Maximum Allowed Power [dBm]	Conducted Power [dBm]	Power Drift [dB]	MPR [dB]	Serial Number	Modulation	RB Size	RB Offset	Spacing	Side	Duty Cycle	SAR (10g)	Scaling Factor	Reported SAR (10g)	Plot #	
MHz	Ch.															(W/kg)		(W/kg)		
1882.50	26365	Mid	LTE Band 25 (PCS)	20	0	25.0	24.20	-0.05	0	0029M	QPSK	1	0	8 mm	back	1:1	1.050	1.202	1.262	
1882.50	26365	Mid	LTE Band 25 (PCS)	20	0	24.0	23.25	-0.01	1	0029M	QPSK	50	25	8 mm	back	1:1	0.856	1.189	1.018	
1882.50	26365	Mid	LTE Band 25 (PCS)	20	0	25.0	24.20	0.06	0	0029M	QPSK	1	0	6 mm	front	1:1	1.060	1.202	1.274	
1882.50	26365	Mid	LTE Band 25 (PCS)	20	0	24.0	23.25	-0.08	1	0029M	QPSK	50	25	6 mm	front	1:1	0.851	1.189	1.012	
1882.50	26365	Mid	LTE Band 25 (PCS)	20	0	25.0	24.20	-0.07	0	0029M	QPSK	1	0	11 mm	bottom	1:1	1.410	1.202	1.695	
1882.50	26365	Mid	LTE Band 25 (PCS)	20	0	24.0	23.25	-0.06	1	0029M	QPSK	50	25	11 mm	bottom	1:1	1.190	1.189	1.415	
1882.50	26365	Mid	LTE Band 25 (PCS)	20	0	25.0	24.20	0.04	0	0029M	QPSK	1	0	0 mm	right	1:1	0.314	1.202	0.377	
1882.50	26365	Mid	LTE Band 25 (PCS)	20	0	24.0	23.25	0.03	1	0029M	QPSK	50	25	0 mm	right	1:1	0.287	1.189	0.341	
1882.50	26365	Mid	LTE Band 25 (PCS)	20	0	25.0	24.20	-0.19	0	0029M	QPSK	1	0	0 mm	left	1:1	0.609	1.202	0.732	
1882.50	26365	Mid	LTE Band 25 (PCS)	20	0	24.0	23.25	-0.17	1	0029M	QPSK	50	25	0 mm	left	1:1	0.514	1.189	0.611	
1882.50	26365	Mid	LTE Band 25 (PCS)	20	0	21.0	20.98	0.06	0	0498M	QPSK	1	50	0 mm	back	1:1	1.590	1.005	1.598	
1882.50	26365	Mid	LTE Band 25 (PCS)	20	0	21.0	21.00	0.05	0	0498M	QPSK	50	25	0 mm	back	1:1	1.670	1.000	1.670	
1882.50	26365	Mid	LTE Band 25 (PCS)	20	0	21.0	20.98	0.05	0	0498M	QPSK	1	50	0 mm	front	1:1	1.410	1.005	1.417	
1882.50	26365	Mid	LTE Band 25 (PCS)	20	0	21.0	21.00	0.05	0	0498M	QPSK	50	25	0 mm	front	1:1	1.480	1.000	1.480	
1860.00	26140	Low	LTE Band 25 (PCS)	20	0	21.0	20.84	-0.09	0	0498M	QPSK	1	50	0 mm	bottom	1:1	2.180	1.038	2.263	
1882.50	26365	Mid	LTE Band 25 (PCS)	20	0	21.0	20.98	-0.12	0	0498M	QPSK	1	50	0 mm	bottom	1:1	2.340	1.005	2.352	
1905.00	26590	High	LTE Band 25 (PCS)	20	0	21.0	20.64	-0.13	0	0498M	QPSK	1	99	0 mm	bottom	1:1	2.080	1.086	2.259	
1860.00	26140	Low	LTE Band 25 (PCS)	20	0	21.0	20.89	-0.12	0	0498M	QPSK	50	50	0 mm	bottom	1:1	2.340	1.026	2.401	
1882.50	26365	Mid	LTE Band 25 (PCS)	20	0	21.0	21.00	-0.12	0	0498M	QPSK	50	25	0 mm	bottom	1:1	2.490	1.000	2.490	A75
1905.00	26590	High	LTE Band 25 (PCS)	20	0	21.0	20.86	-0.12	0	0498M	QPSK	50	50	0 mm	bottom	1:1	2.270	1.033	2.345	
1882.50	26365	Mid	LTE Band 25 (PCS)	20	0	21.0	20.97	-0.11	0	0498M	QPSK	100	0	0 mm	bottom	1:1	2.370	1.007	2.387	
ANSI / IEEE C95.1 1992 - SAFETY LIMIT Spatial Peak Uncontrolled Exposure/General Population										Phablet 4.0 W/kg (mW/g) averaged over 10 grams										

FCC ID: A3LSMN975U		SAR EVALUATION REPORT		Approved by: Quality Manager
Document S/N: 1M1905200079-01-R1.A3L	Test Dates: 05/22/19 - 07/07/19	DUT Type: Portable Handset		Page 174 of 220

**Table 11-50
LTE Band 30 Phablet SAR**

MEASUREMENT RESULTS																			
FREQUENCY		Mode	Bandwidth [MHz]	Maximum Allowed Power [dBm]	Conducted Power [dBm]	Power Drift [dB]	MPR [dB]	Serial Number	Modulation	RB Size	RB Offset	Spacing	Side	Duty Cycle	SAR (10g)	Scaling Factor	Reported SAR (10g)	Plot #	
MHz	Ch.														(W/kg)		(W/kg)		
2310.00	27710	Mid	LTE Band 30	10	24.0	23.60	-0.07	0	0499M	QPSK	1	49	8 mm	back	1:1	0.621	1.096	0.681	
2310.00	27710	Mid	LTE Band 30	10	23.0	22.64	0.00	1	0499M	QPSK	25	0	8 mm	back	1:1	0.512	1.086	0.556	
2310.00	27710	Mid	LTE Band 30	10	24.0	23.60	0.03	0	0499M	QPSK	1	49	6 mm	front	1:1	0.621	1.096	0.681	
2310.00	27710	Mid	LTE Band 30	10	23.0	22.64	-0.04	1	0499M	QPSK	25	0	6 mm	front	1:1	0.500	1.086	0.543	
2310.00	27710	Mid	LTE Band 30	10	24.0	23.60	-0.08	0	0499M	QPSK	1	49	11 mm	bottom	1:1	0.815	1.096	0.893	
2310.00	27710	Mid	LTE Band 30	10	23.0	22.64	-0.10	1	0499M	QPSK	25	0	11 mm	bottom	1:1	0.652	1.086	0.708	
2310.00	27710	Mid	LTE Band 30	10	24.0	23.60	0.14	0	0499M	QPSK	1	49	0 mm	right	1:1	0.121	1.096	0.133	
2310.00	27710	Mid	LTE Band 30	10	23.0	22.64	0.17	1	0499M	QPSK	25	0	0 mm	right	1:1	0.097	1.086	0.105	
2310.00	27710	Mid	LTE Band 30	10	24.0	23.60	-0.15	0	0499M	QPSK	1	49	0 mm	left	1:1	0.288	1.096	0.316	
2310.00	27710	Mid	LTE Band 30	10	23.0	22.64	-0.21	1	0499M	QPSK	25	0	0 mm	left	1:1	0.232	1.086	0.252	
2310.00	27710	Mid	LTE Band 30	10	23.0	22.60	-0.17	0	0499M	QPSK	1	49	0 mm	back	1:1	1.740	1.096	1.907	
2310.00	27710	Mid	LTE Band 30	10	23.0	22.67	-0.11	0	0499M	QPSK	25	25	0 mm	back	1:1	1.830	1.079	1.975	
2310.00	27710	Mid	LTE Band 30	10	23.0	22.60	-0.06	0	0499M	QPSK	1	49	0 mm	front	1:1	1.320	1.096	1.447	
2310.00	27710	Mid	LTE Band 30	10	23.0	22.67	-0.05	0	0499M	QPSK	25	25	0 mm	front	1:1	1.380	1.079	1.489	
2310.00	27710	Mid	LTE Band 30	10	23.0	22.60	0.04	0	0499M	QPSK	1	49	0 mm	bottom	1:1	2.020	1.096	2.214	
2310.00	27710	Mid	LTE Band 30	10	23.0	22.67	0.02	0	0499M	QPSK	25	25	0 mm	bottom	1:1	2.150	1.079	2.320	
2310.00	27710	Mid	LTE Band 30	10	23.0	22.51	-0.03	0	0499M	QPSK	50	0	0 mm	bottom	1:1	2.170	1.119	2.428	A76
2310.00	27710	Mid	LTE Band 30	10	23.0	22.51	0.00	0	0499M	QPSK	50	0	0 mm	bottom	1:1	2.160	1.119	2.417	
ANSI / IEEE C95.1 1992 - SAFETY LIMIT Spatial Peak Uncontrolled Exposure/General Population								Phablet 4.0 W/kg (mW/g) averaged over 10 grams											



Note: Blue entry represents variability measurement.

FCC ID: A3LSMN975U		SAR EVALUATION REPORT		Approved by: Quality Manager
Document S/N: 1M1905200079-01-R1.A3L	Test Dates: 05/22/19 - 07/07/19	DUT Type: Portable Handset	Page 175 of 220	

**Table 11-51
LTE Band 7 Phablet SAR**

MEASUREMENT RESULTS																			
FREQUENCY		Mode	Bandwidth [MHz]	Maximum Allowed Power [dBm]	Conducted Power [dBm]	Power Drift [dB]	MPR [dB]	Serial Number	Modulation	RB Size	RB Offset	Spacing	Side	Duty Cycle	SAR (10g)	Scaling Factor	Reported SAR (10g)	Plot #	
MHz	Ch.														(W/kg)		(W/kg)		
2560.00	21350	High	LTE Band 7	20	24.5	24.18	-0.12	0	0499M	QPSK	1	0	8 mm	back	1:1	0.461	1.076	0.496	
2560.00	21350	High	LTE Band 7	20	23.5	23.32	-0.15	1	0499M	QPSK	50	0	8 mm	back	1:1	0.379	1.042	0.395	
2560.00	21350	High	LTE Band 7	20	24.5	24.18	0.05	0	0499M	QPSK	1	0	6 mm	front	1:1	0.444	1.076	0.478	
2560.00	21350	High	LTE Band 7	20	23.5	23.32	-0.01	1	0499M	QPSK	50	0	6 mm	front	1:1	0.364	1.042	0.379	
2560.00	21350	High	LTE Band 7	20	24.5	24.18	-0.03	0	0499M	QPSK	1	0	11 mm	bottom	1:1	0.584	1.076	0.628	
2560.00	21350	High	LTE Band 7	20	23.5	23.32	-0.09	1	0499M	QPSK	50	0	11 mm	bottom	1:1	0.480	1.042	0.500	
2560.00	21350	High	LTE Band 7	20	24.5	24.18	-0.21	0	0499M	QPSK	1	0	0 mm	left	1:1	1.060	1.076	1.141	
2560.00	21350	High	LTE Band 7	20	23.5	23.32	0.14	1	0499M	QPSK	50	0	0 mm	left	1:1	0.833	1.042	0.868	
2510.00	20850	Low	LTE Band 7	20	22.0	20.86	-0.16	0	0349M	QPSK	1	99	0 mm	back	1:1	1.580	1.300	2.054	
2535.00	21100	Mid	LTE Band 7	20	22.0	20.93	-0.19	0	0349M	QPSK	1	0	0 mm	back	1:1	1.710	1.279	2.187	
2560.00	21350	High	LTE Band 7	20	22.0	20.89	-0.18	0	0349M	QPSK	1	0	0 mm	back	1:1	1.440	1.291	1.859	
2510.00	20850	Low	LTE Band 7	20	22.0	20.88	-0.14	0	0349M	QPSK	50	50	0 mm	back	1:1	1.660	1.294	2.148	
2535.00	21100	Mid	LTE Band 7	20	22.0	21.10	-0.19	0	0349M	QPSK	50	0	0 mm	back	1:1	1.760	1.230	2.165	
2560.00	21350	High	LTE Band 7	20	22.0	21.04	-0.14	0	0349M	QPSK	50	0	0 mm	back	1:1	1.520	1.247	1.895	
2535.00	21100	Mid	LTE Band 7	20	22.0	20.92	-0.19	0	0349M	QPSK	100	0	0 mm	back	1:1	1.580	1.282	2.026	
2510.00	20850	Low	LTE Band 7	20	22.0	20.86	-0.11	0	0349M	QPSK	1	99	0 mm	front	1:1	1.650	1.300	2.145	
2535.00	21100	Mid	LTE Band 7	20	22.0	20.93	-0.03	0	0349M	QPSK	1	0	0 mm	front	1:1	1.630	1.279	2.085	
2560.00	21350	High	LTE Band 7	20	22.0	20.89	-0.13	0	0349M	QPSK	1	0	0 mm	front	1:1	1.630	1.291	2.104	
2510.00	20850	Low	LTE Band 7	20	22.0	20.88	0.00	0	0349M	QPSK	50	50	0 mm	front	1:1	1.700	1.294	2.200	
2535.00	21100	Mid	LTE Band 7	20	22.0	21.10	-0.08	0	0349M	QPSK	50	0	0 mm	front	1:1	1.750	1.230	2.153	
2560.00	21350	High	LTE Band 7	20	22.0	21.04	-0.12	0	0349M	QPSK	50	0	0 mm	front	1:1	1.700	1.247	2.120	
2535.00	21100	Mid	LTE Band 7	20	22.0	20.92	-0.08	0	0349M	QPSK	100	0	0 mm	front	1:1	1.730	1.282	2.218	
2510.00	20850	Low	LTE Band 7	20	22.0	20.86	0.14	0	0349M	QPSK	1	99	0 mm	bottom	1:1	1.900	1.300	2.470	
2535.00	21100	Mid	LTE Band 7	20	22.0	20.93	-0.19	0	0349M	QPSK	1	0	0 mm	bottom	1:1	1.900	1.279	2.430	
2560.00	21350	High	LTE Band 7	20	22.0	20.89	0.00	0	0349M	QPSK	1	0	0 mm	bottom	1:1	1.710	1.291	2.208	
2510.00	20850	Low	LTE Band 7	20	22.0	20.88	0.19	0	0349M	QPSK	50	50	0 mm	bottom	1:1	2.020	1.294	2.614	A77
2535.00	21100	Mid	LTE Band 7	20	22.0	21.10	-0.13	0	0349M	QPSK	50	0	0 mm	bottom	1:1	1.890	1.230	2.325	
2560.00	21350	High	LTE Band 7	20	22.0	21.04	0.12	0	0349M	QPSK	50	0	0 mm	bottom	1:1	1.720	1.247	2.145	
2535.00	21100	Mid	LTE Band 7	20	22.0	20.92	0.14	0	0349M	QPSK	100	0	0 mm	bottom	1:1	1.930	1.282	2.474	
2510.00	20850	Low	LTE Band 7	20	22.0	20.88	-0.07	0	0349M	QPSK	50	50	0 mm	bottom	1:1	1.930	1.294	2.497	
ANSI / IEEE C95.1 1992 - SAFETY LIMIT Spatial Peak Uncontrolled Exposure/General Population								Phablet 4.0 W/kg (mW/g) averaged over 10 grams											

Note: Blue entry represents variability measurement.

FCC ID: A3LSMN975U		SAR EVALUATION REPORT		Approved by: Quality Manager
Document S/N: 1M1905200079-01-R1.A3L	Test Dates: 05/22/19 - 07/07/19	DUT Type: Portable Handset	Page 176 of 220	

**Table 11-52
WLAN Phablet SAR**



MEASUREMENT RESULTS																			
FREQUENCY		Mode	Service	Bandwidth [MHz]	Maximum Allowed Power [dBm]	Conducted Power [dBm]	Power Drift [dB]	Spacing	Antenna Config.	Device Serial Number	Data Rate (Mbps)	Side	Duty Cycle (%)	Peak SAR of Area Scan	SAR (10g)	Scaling Factor (Power)	Scaling Factor (Duty Cycle)	Reported SAR (10g)	Plot #
MHz	Ch.													W/kg	(W/kg)			(W/kg)	
5300	60	802.11a	OFDM	20	18.5	18.34	0.05	0 mm	1	0459M	6	back	98.9	9.258	1.240	1.038	1.011	1.301	
5300	60	802.11a	OFDM	20	18.5	18.34	-0.17	0 mm	1	0459M	6	front	98.9	1.505	0.153	1.038	1.011	0.161	
5300	60	802.11a	OFDM	20	18.5	18.34	-0.11	0 mm	1	0459M	6	top	98.9	4.617	-	1.038	1.011	-	
5300	60	802.11a	OFDM	20	18.5	18.34	-0.08	0 mm	1	0459M	6	left	98.9	4.792	0.386	1.038	1.011	0.405	
5260	52	802.11a	OFDM	20	18.5	18.28	-0.12	0 mm	2	0459M	6	back	98.8	9.855	1.600	1.052	1.012	1.703	
5280	56	802.11a	OFDM	20	18.5	18.17	-0.10	0 mm	2	0459M	6	back	98.8	11.837	1.610	1.079	1.012	1.758	
5300	60	802.11a	OFDM	20	18.5	18.33	-0.12	0 mm	2	0459M	6	back	98.8	10.069	1.590	1.040	1.012	1.673	
5300	60	802.11a	OFDM	20	18.5	18.33	-0.17	0 mm	2	0459M	6	front	98.8	0.309	0.047	1.040	1.012	0.049	
5300	60	802.11a	OFDM	20	18.5	18.33	-0.11	0 mm	2	0459M	6	top	98.8	0.705	-	1.040	1.012	-	
5300	60	802.11a	OFDM	20	18.5	18.33	-0.07	0 mm	2	0459M	6	left	98.8	2.005	0.211	1.040	1.012	0.222	
5520	104	802.11a	OFDM	20	18.5	18.00	0.06	0 mm	1	0459M	6	back	98.9	13.926	1.580	1.122	1.011	1.792	
5620	124	802.11a	OFDM	20	18.5	18.14	-0.13	0 mm	1	0459M	6	back	98.9	11.723	1.530	1.086	1.011	1.680	
5720	144	802.11a	OFDM	20	18.5	18.11	-0.02	0 mm	1	0459M	6	back	98.9	11.519	1.330	1.094	1.011	1.471	
5620	124	802.11a	OFDM	20	18.5	18.14	-0.15	0 mm	1	0459M	6	front	98.9	3.150	0.300	1.086	1.011	0.329	
5620	124	802.11a	OFDM	20	18.5	18.14	-0.12	0 mm	1	0459M	6	top	98.9	8.144	0.442	1.086	1.011	0.485	
5620	124	802.11a	OFDM	20	18.5	18.14	-0.16	0 mm	1	0459M	6	left	98.9	7.678	-	1.086	1.011	-	
5600	120	802.11a	OFDM	20	18.5	18.43	-0.13	0 mm	2	0459M	6	back	98.8	7.012	1.220	1.016	1.012	1.254	
5600	120	802.11a	OFDM	20	18.5	18.43	0.17	0 mm	2	0459M	6	front	98.8	0.168	0.029	1.016	1.012	0.030	
5600	120	802.11a	OFDM	20	18.5	18.43	0.01	0 mm	2	0459M	6	top	98.8	0.996	-	1.016	1.012	-	
5600	120	802.11a	OFDM	20	18.5	18.43	0.08	0 mm	2	0459M	6	left	98.8	1.553	0.174	1.016	1.012	0.179	
ANSI / IEEE C95.1 1992 - SAFETY LIMIT Spatial Peak Uncontrolled Exposure/General Population								Phablet 4.0 W/kg (mW/g) averaged over 10 grams											

**Table 11-53
WLAN MIMO Phablet SAR**

MEASUREMENT RESULTS																					
FREQUENCY		Mode	Service	Bandwidth [MHz]	Maximum Allowed Power (Ant 1) [dBm]	Conducted Power (Ant 1) [dBm]	Maximum Allowed Power (Ant 2) [dBm]	Conducted Power (Ant 2) [dBm]	Power Drift [dB]	Spacing	Antenna Config.	Device Serial Number	Data Rate (Mbps)	Side	Duty Cycle (%)	Peak SAR of Area Scan	SAR (10g)	Scaling Factor (Power)	Scaling Factor (Duty Cycle)	Reported SAR (10g)	Plot #
MHz	Ch.															W/kg	(W/kg)			(W/kg)	
5260	52	802.11n	OFDM	20	18.5	18.44	18.5	18.33	0.02	0 mm	MIMO	0459M	13	back	98.7	12.123	2.040	1.040	1.013	2.149	
5280	56	802.11n	OFDM	20	18.5	18.47	18.5	18.18	-0.17	0 mm	MIMO	0459M	13	back	98.7	11.187	2.100	1.076	1.013	2.289	
5260	52	802.11n	OFDM	20	18.5	18.44	18.5	18.33	0.11	0 mm	MIMO	0459M	13	front	98.7	1.244	0.159	1.040	1.013	0.168	
5260	52	802.11n	OFDM	20	18.5	18.44	18.5	18.33	-0.16	0 mm	MIMO	0459M	13	top	98.7	3.783	-	1.040	1.013	-	
5260	52	802.11n	OFDM	20	18.5	18.44	18.5	18.33	-0.13	0 mm	MIMO	0459M	13	left	98.7	5.313	0.600	1.040	1.013	0.632	
5520	104	802.11n	OFDM	20	18.5	18.03	18.5	18.20	0.14	0 mm	MIMO	0459M	13	back	98.7	17.222	2.230	1.114	1.013	2.517	A78
5600	120	802.11n	OFDM	20	18.5	18.16	18.5	18.48	0.13	0 mm	MIMO	0459M	13	back	98.7	13.973	2.110	1.081	1.013	2.311	
5720	144	802.11n	OFDM	20	18.5	18.27	18.5	18.38	-0.05	0 mm	MIMO	0459M	13	back	98.7	21.093	1.930	1.054	1.013	2.061	
5720	144	802.11n	OFDM	20	18.5	18.27	18.5	18.38	-0.14	0 mm	MIMO	0459M	13	front	98.7	2.946	0.361	1.054	1.013	0.385	
5720	144	802.11n	OFDM	20	18.5	18.27	18.5	18.38	-0.10	0 mm	MIMO	0459M	13	top	98.7	6.910	0.542	1.054	1.013	0.579	
5720	144	802.11n	OFDM	20	18.5	18.27	18.5	18.38	-0.18	0 mm	MIMO	0459M	13	left	98.7	6.385	-	1.054	1.013	-	
5280	56	802.11n	OFDM	20	18.5	18.47	18.5	18.18	-0.08	0 mm	MIMO	0459M	13	back	98.7	10.289	2.040	1.076	1.013	2.224	
5520	104	802.11n	OFDM	20	18.5	18.03	18.5	18.20	0.17	0 mm	MIMO	0459M	13	back	98.7	16.940	2.230	1.114	1.013	2.517	
ANSI / IEEE C95.1 1992 - SAFETY LIMIT Spatial Peak Uncontrolled Exposure/General Population								Phablet 4.0 W/kg (mW/g) averaged over 10 grams													

Note: 1) Blue entry represents variability measurement.

2) For channels 52, 56, 104, 120, and 144 to achieve the 21.5 dBm maximum allowed MIMO power shown in the documentation, each antenna transmits at a maximum allowed power of 18.5 dBm.

FCC ID: A3LSMN975U		SAR EVALUATION REPORT		Approved by: Quality Manager
Document S/N: 1M1905200079-01-R1.A3L	Test Dates: 05/22/19 - 07/07/19	DUT Type: Portable Handset		Page 177 of 220



11.5 SAR Test Notes

General Notes:

1. The test data reported are the worst-case SAR values according to test procedures specified in IEEE 1528-2013, and FCC KDB Publication 447498 D01v06.
2. Batteries are fully charged at the beginning of the SAR measurements.
3. Liquid tissue depth was at least 15.0 cm for all frequencies.
4. The manufacturer has confirmed that the device(s) tested have the same physical, mechanical and thermal characteristics and are within operational tolerances expected for production units.
5. SAR results were scaled to the maximum allowed power to demonstrate compliance per FCC KDB Publication 447498 D01v06.
6. Device was tested using a fixed spacing for body-worn accessory testing. A separation distance of 15 mm was considered because the manufacturer has determined that there will be body-worn accessories available in the marketplace for users to support this separation distance.
7. Per FCC KDB Publication 648474 D04v01r03, body-worn SAR was evaluated without a headset connected to the device. Since the standalone reported body-worn SAR was ≤ 1.2 W/kg, no additional body-worn SAR evaluations using a headset cable were required.
8. Per FCC KDB 865664 D01v01r04, variability SAR tests were performed when the measured SAR results for a frequency band were greater than or equal to 0.8 W/kg for 1g SAR and 2.0 W/kg for 10g SAR. Repeated SAR measurements are highlighted in the tables above for clarity. Please see Section 13 for variability analysis.
9. During SAR Testing for the Wireless Router conditions per FCC KDB Publication 941225 D06v02r01, the actual Portable Hotspot operation (with actual simultaneous transmission of a transmitter with WIFI) was not activated (See Section 6.7 for more details).
10. Per FCC KDB Publication 648474 D04v01r03, this device is considered a "phablet" since the diagonal dimension is > 160 mm and < 200 mm. Therefore, phablet SAR tests are required when wireless router mode does not apply or if wireless router 1g SAR > 1.2 W/kg.
11. This device supports dynamic antenna tuning for some bands. Per April 2019 Workshop Notes, SAR was measured according to the normally required SAR measurement configurations with tuner active. The auto-tune state determined by the device was verified before and after each SAR measurement and is listed in tables above. Please see Section 14 for supplemental data.
12. This device utilizes power reduction for some wireless modes and technologies, as outlined in Section 1.3. The maximum output power allowed for each transmitter and exposure condition was evaluated for SAR compliance based on expected use conditions and simultaneous transmission scenarios.
13. Unless otherwise noted, when 10g SAR measurement is considered, a factor of 2.5 is applied to the thresholds below.
14. Additional SAR tests for phablet SAR were evaluated per KDB 616217 Section 6 (See Section 6.9 for more information).

GSM Test Notes:

1. Body-Worn accessory testing is typically associated with voice operations. Therefore, GSM voice was evaluated for body-worn SAR.
2. Justification for reduced test configurations per KDB Publication 941225 D01v03r01 and October 2013 TCB Workshop Notes: The source-based frame-averaged output power was evaluated for all GPRS/EDGE slot configurations. The configuration with the highest target frame averaged output power was evaluated for hotspot SAR. When the maximum frame-averaged powers are equivalent across two or more slots (within 0.25 dB), the configuration with the most number of time slots was tested.
3. Per FCC KDB Publication 447498 D01v06, if the reported (scaled) SAR measured at the middle channel or highest output power channel for each test configuration is ≤ 0.8 W/kg for 1g evaluations then testing at the other channels is not required for such test configuration(s). When the maximum output power variation across the required test channels is $> \frac{1}{2}$ dB, instead of the middle channel, the highest output power channel was used.

FCC ID: A3LSMN975U		SAR EVALUATION REPORT		Approved by: Quality Manager
Document S/N: 1M1905200079-01-R1.A3L	Test Dates: 05/22/19 - 07/07/19	DUT Type: Portable Handset	Page 178 of 220	

CDMA Notes:



1. Head SAR for CDMA2000 mode was tested under RC3/SO55 per FCC KDB Publication 941225 D01v03r01.
2. Body-Worn SAR was tested with 1x RTT with TDSO / SO32 FCH Only. EVDO Rev0 and RevA and TDSO / SO32 FCH+SCH SAR tests were not required per the 3G SAR Test Reduction Procedure in FCC KDB Publication 941225 D01v03r01.
3. CDMA Wireless Router SAR is measured using Subtype 0/1 Physical Layer configurations for Rev. 0 according to KDB 941225 D01v03r01 procedures for data devices. Wireless Router SAR tests for Subtype 2 of Rev.A and 1x RTT configurations were not required per the 3G SAR Test Reduction Policy in KDB Publication 941225 D01v03r01.
4. Head SAR was additionally evaluated using EVDO Rev. A to determine compliance for VoIP operations.
5. Per FCC KDB Publication 447498 D01v06, if the reported (scaled) SAR measured at the middle channel or highest output power channel for each test configuration is ≤ 0.8 W/kg for 1g evaluations then testing at the other channels is not required for such test configuration(s). When the maximum output power variation across the required test channels is $> \frac{1}{2}$ dB, instead of the middle channel, the highest output power channel was used.
6. CDMA 1X Advanced technology was not required for SAR since the maximum allowed output powers for 1X Advanced was not more than 0.25 dB higher than the maximum powers for 1X.

UMTS Notes:

1. UMTS mode in was tested under RMC 12.2 kbps with HSPA Inactive per KDB Publication 941225 D01v03r01. AMR and HSPA SAR was not required per the 3G Test Reduction Procedure in KDB Publication 941225 D01v03r01.
2. Per FCC KDB Publication 447498 D01v06, if the reported (scaled) SAR measured at the middle channel or highest output power channel for each test configuration is ≤ 0.8 W/kg for 1g evaluations then testing at the other channels is not required for such test configuration(s). When the maximum output power variation across the required test channels is $> \frac{1}{2}$ dB, instead of the middle channel, the highest output power channel was used.

LTE Notes:

1. LTE Considerations: LTE test configurations are determined according to SAR Evaluation Considerations for LTE Devices in FCC KDB Publication 941225 D05v02r04. The general test procedures used for testing can be found in Section 8.6.4.
2. MPR is permanently implemented for this device by the manufacturer. The specific manufacturer target MPR is indicated alongside the SAR results. MPR is enabled for this device, according to 3GPP TS36.101 Section 6.2.3 – 6.2.5 under Table 6.2.3-1.
3. A-MPR was disabled for all SAR tests by setting NS=01 and MCC=001 on the base station simulator. SAR tests were performed with the same number of RB and RB offsets transmitting on all TTI frames (maximum TTI).
4. Per FCC KDB Publication 447498 D01v06, when the reported LTE Band 41 and LTE Band 48 SAR measured at the highest output power channel in a given a test configuration was > 0.6 W/kg for 1g evaluations, testing at the other channels was required for such test configurations.
5. TDD LTE was tested per the guidance provided in FCC KDB Publication 941225 D05v02r04. Testing was performed using UL-DL configuration 0 with 6 UL subframes and 2 S subframes using extended cyclic prefix only and special subframe configuration 6. SAR tests were performed at maximum output power and worst-case transmission duty factor in extended cyclic prefix. Per 3GPP 36.211 Section 4, the duty factor for special subframe configuration 6 using extended cyclic prefix is 0.633.
6. Per KDB Publication 941225 D05Av01r02, SAR for downlink only LTE CA operations was not needed since the maximum average output power in LTE CA mode was not >0.25 dB higher than the maximum output power when downlink carrier aggregation was inactive.

FCC ID: A3LSMN975U	 PCTEST ENGINEERING LABORATORY, INC.	SAR EVALUATION REPORT		Approved by: Quality Manager
Document S/N: 1M1905200079-01-R1.A3L	Test Dates: 05/22/19 - 07/07/19	DUT Type: Portable Handset	Page 179 of 220	



7. This device supports Power Class 2 and Power Class 3 operations for LTE Band 41. The highest available duty cycle for Power Class 2 operations is 43.3 % using UL-DL configuration 1. Per FCC Guidance, all SAR tests were performed using Power Class 3. SAR with power class 2 at the available duty factor was additionally performed for the power class 3 configuration with the highest SAR configuration for each exposure conditions. Please see Section 14 for linearity results.
8. For LTE Band 5, LTE Band 66, and LTE Band 41, per FCC guidance, SAR was first measured with only a single carrier active in the uplink (carrier aggregation not active). For each exposure condition, the uplink CA scenario with two component carriers was additionally tested for the configuration with the highest SAR when carrier aggregation was not active. The SCC was configured with the closest available contiguous channel. The two component carriers were configured so the resource blocks are physically allocated side by side to achieve the maximum output power.
9. This device supports ULCA active with Power Class 2. Highest SAR test configuration for each exposure condition in Power Class 3 with ULCA active was repeated with Power Class 2 with ULCA active.

WLAN Notes:

1. For held-to-ear, hotspot, and phablet operations, the initial test position procedures were applied. The test position with the highest extrapolated peak SAR will be used as the initial test position. When reported SAR for the initial test position is ≤ 0.4 W/kg for 1g evaluations, no additional testing for the remaining test positions was required. Otherwise, SAR is evaluated at the subsequent highest peak SAR positions until the reported SAR result is ≤ 0.8 W/kg or all test positions are measured.
2. Justification for test configurations for WLAN per KDB Publication 248227 D01v02r02 for 2.4 GHz WIFI single transmission chain operations, the highest measured maximum output power channel for DSSS was selected for SAR measurement. SAR for OFDM modes (2.4 GHz 802.11g/n/ax) was not required due to the maximum allowed powers and the highest reported DSSS SAR. See Section 8.7.5 for more information.
3. Justification for test configurations for WLAN per KDB Publication 248227 D01v02r02 for 5 GHz WIFI single transmission chain operations, the initial test configuration was selected according to the transmission mode with the highest maximum allowed powers. Other transmission modes were not investigated since the highest reported SAR for initial test configuration adjusted by the ratio of maximum output powers is less than 1.2 W/kg for 1g evaluations. See Section 8.7.6 for more information.
4. Per KDB Publication 248227 D01v02r02, SAR for MIMO was evaluated by following the simultaneous SAR provisions from KDB Publication 447498 D01v06 by either evaluating the sum of the 1g SAR values of each antenna transmitting independently or making a SAR measurement with both antennas transmitting simultaneously. Please see Section 12 for complete analysis.
5. When the maximum reported 1g averaged SAR is ≤ 0.8 W/kg, SAR testing on additional channels was not required. Otherwise, SAR for the next highest output power channel was required until the reported SAR result was ≤ 1.20 W/kg for 1g evaluations or all test channels were measured.
6. The device was configured to transmit continuously at the required data rate, channel bandwidth and signal modulation, using the highest transmission duty factor supported by the test mode tools. The reported SAR was scaled to the 100% transmission duty factor to determine compliance. Procedures used to measure the duty factor are identical to that in the associated EMC test reports.
7. When 10-g SAR measurement is considered, a factor of 2.5 is applied to the thresholds above.

Bluetooth Notes

1. Bluetooth SAR was measured with the device connected to a call box with hopping disabled with DH5 operation and Tx Tests test mode type. Per October 2016 TCB Workshop Notes, the reported SAR was scaled to the 100% transmission duty factor to determine compliance. See Section 9.6 for the time domain plot and calculation for the duty factor of the device.
2. Head and Hotspot Bluetooth SAR were evaluated for BT BR tethering applications.

FCC ID: A3LSMN975U	 PCTEST ENGINEERING LABORATORY, INC.	SAR EVALUATION REPORT		Approved by: Quality Manager
Document S/N: 1M1905200079-01-R1.A3L	Test Dates: 05/22/19 - 07/07/19	DUT Type: Portable Handset	Page 180 of 220	



12 FCC MULTI-TX AND ANTENNA SAR CONSIDERATIONS

12.1 Introduction

The following procedures adopted from FCC KDB Publication 447498 D01v06 are applicable to devices with built-in unlicensed transmitters such as 802.11 and Bluetooth devices which may simultaneously transmit with the licensed transmitter.

12.2 Simultaneous Transmission Procedures

This device contains transmitters that may operate simultaneously. Therefore, simultaneous transmission analysis is required. Per FCC KDB Publication 447498 D01v06 4.3.2 and IEEE 1528-2013 Section 6.3.4.1.2, simultaneous transmission SAR test exclusion may be applied when the sum of the 1g SAR for all the simultaneous transmitting antennas in a specific a physical test configuration is ≤ 1.6 W/kg. The different test positions in an exposure condition may be considered collectively to determine SAR test exclusion according to the sum of 1g or 10g SAR.

FCC ID: A3LSMN975U		SAR EVALUATION REPORT		Approved by: Quality Manager
Document S/N: 1M1905200079-01-R1.A3L	Test Dates: 05/22/19 - 07/07/19	DUT Type: Portable Handset		Page 181 of 220

12.3 Head SAR Simultaneous Transmission Analysis

Table 12-1
Simultaneous Transmission Scenario with 2.4 GHz WLAN (Held to Ear)

Exposure Condition	Mode	2G/3G/4G SAR (W/kg)	2.4 GHz WLAN Ant 1 SAR (W/kg)	2.4 GHz WLAN Ant 2 SAR (W/kg)	Σ SAR (W/kg)		
		1	2	3	1+2	1+3	1+2+3
Head SAR	CDMA/EVDO BC10 (§90S)	0.193	0.566	0.034	0.759	0.227	0.793
	CDMA/EVDO BC0 (§22H)	0.194	0.566	0.034	0.760	0.228	0.794
	GSM 850	0.133	0.566	0.034	0.699	0.167	0.733
	UMTS 850	0.157	0.566	0.034	0.723	0.191	0.757
	UMTS 1750	0.147	0.566	0.034	0.713	0.181	0.747
	PCS CDMA/EVDO	0.114	0.566	0.034	0.680	0.148	0.714
	GSM 1900	0.053	0.566	0.034	0.619	0.087	0.653
	UMTS 1900	0.139	0.566	0.034	0.705	0.173	0.739
	LTE Band 71	0.114	0.566	0.034	0.680	0.148	0.714
	LTE Band 12	0.119	0.566	0.034	0.685	0.153	0.719
	LTE Band 13	0.166	0.566	0.034	0.732	0.200	0.766
	LTE Band 14	0.138	0.566	0.034	0.704	0.172	0.738
	LTE Band 26 (Cell)	0.178	0.566	0.034	0.744	0.212	0.778
	LTE Band 5 (Cell)	0.185	0.566	0.034	0.751	0.219	0.785
	LTE Band 66 (AWS)	0.164	0.566	0.034	0.730	0.198	0.764
	LTE Band 25 (PCS)	0.147	0.566	0.034	0.713	0.181	0.747
	LTE Band 30	0.046	0.566	0.034	0.612	0.080	0.646
	LTE Band 7	0.117	0.566	0.034	0.683	0.151	0.717
	LTE Band 48	0.035	0.566	0.034	0.601	0.069	0.635
LTE Band 41	0.111	0.566	0.034	0.677	0.145	0.711	





FCC ID: A3LSMN975U	 PCTEST ENGINEERING LABORATORY, INC.	SAR EVALUATION REPORT		Approved by: Quality Manager
Document S/N: 1M1905200079-01-R1.A3L	Test Dates: 05/22/19 - 07/07/19	DUT Type: Portable Handset	Page 182 of 220	

Table 12-2
Simultaneous Transmission Scenario with 5 GHz WLAN (Held to Ear)

Exposure Condition	Mode	2G/3G/4G SAR (W/kg)	5 GHz WLAN Ant 1 SAR (W/kg)	5 GHz WLAN Ant 2 SAR (W/kg)	Σ SAR (W/kg)		
		1	2	3	1+2	1+3	1+2+3
Head SAR	CDMA/EVDO BC10 (§90S)	0.193	0.326	0.056	0.519	0.249	0.575
	CDMA/EVDO BC0 (§22H)	0.194	0.326	0.056	0.520	0.250	0.576
	GSM 850	0.133	0.326	0.056	0.459	0.189	0.515
	UMTS 850	0.157	0.326	0.056	0.483	0.213	0.539
	UMTS 1750	0.147	0.326	0.056	0.473	0.203	0.529
	PCS CDMA/EVDO	0.114	0.326	0.056	0.440	0.170	0.496
	GSM 1900	0.053	0.326	0.056	0.379	0.109	0.435
	UMTS 1900	0.139	0.326	0.056	0.465	0.195	0.521
	LTE Band 71	0.114	0.326	0.056	0.440	0.170	0.496
	LTE Band 12	0.119	0.326	0.056	0.445	0.175	0.501
	LTE Band 13	0.166	0.326	0.056	0.492	0.222	0.548
	LTE Band 14	0.138	0.326	0.056	0.464	0.194	0.520
	LTE Band 26 (Cell)	0.178	0.326	0.056	0.504	0.234	0.560
	LTE Band 5 (Cell)	0.185	0.326	0.056	0.511	0.241	0.567
	LTE Band 66 (AWS)	0.164	0.326	0.056	0.490	0.220	0.546
	LTE Band 25 (PCS)	0.147	0.326	0.056	0.473	0.203	0.529
	LTE Band 30	0.046	0.326	0.056	0.372	0.102	0.428
	LTE Band 7	0.117	0.326	0.056	0.443	0.173	0.499
LTE Band 48	0.035	0.326	0.056	0.361	0.091	0.417	
LTE Band 41	0.111	0.326	0.056	0.437	0.167	0.493	

FCC ID: A3LSMN975U	 PCTEST ENGINEERING LABORATORY, INC.	SAR EVALUATION REPORT		Approved by: Quality Manager
Document S/N: 1M1905200079-01-R1.A3L	Test Dates: 05/22/19 - 07/07/19	DUT Type: Portable Handset	Page 183 of 220	

**Table 12-3
Simultaneous Transmission Scenario with 2.4 GHz WLAN MIMO and 5 GHz WLAN MIMO (Held to Ear)**

Exposure Condition	Mode	2G/3G/4G SAR (W/kg)	2.4 GHz WLAN Ant 1 SAR (W/kg)	2.4 GHz WLAN Ant 2 SAR (W/kg)	5 GHz WLAN Ant 1 SAR (W/kg)	5 GHz WLAN Ant 2 SAR (W/kg)	Σ SAR (W/kg)
		1	2	3	4	5	1+2+3+4+5
Head SAR	CDMA/EVDO BC10 (§90S)	0.193	0.566	0.034	0.326	0.056	1.175
	CDMA/EVDO BC0 (§22H)	0.194	0.566	0.034	0.326	0.056	1.176
	GSM 850	0.133	0.566	0.034	0.326	0.056	1.115
	UMTS 850	0.157	0.566	0.034	0.326	0.056	1.139
	UMTS 1750	0.147	0.566	0.034	0.326	0.056	1.129
	PCS CDMA/EVDO	0.114	0.566	0.034	0.326	0.056	1.096
	GSM 1900	0.053	0.566	0.034	0.326	0.056	1.035
	UMTS 1900	0.139	0.566	0.034	0.326	0.056	1.121
	LTE Band 71	0.114	0.566	0.034	0.326	0.056	1.096
	LTE Band 12	0.119	0.566	0.034	0.326	0.056	1.101
	LTE Band 13	0.166	0.566	0.034	0.326	0.056	1.148
	LTE Band 14	0.138	0.566	0.034	0.326	0.056	1.120
	LTE Band 26 (Cell)	0.178	0.566	0.034	0.326	0.056	1.160
	LTE Band 5 (Cell)	0.185	0.566	0.034	0.326	0.056	1.167
	LTE Band 66 (AWS)	0.164	0.566	0.034	0.326	0.056	1.146
	LTE Band 25 (PCS)	0.147	0.566	0.034	0.326	0.056	1.129
	LTE Band 30	0.046	0.566	0.034	0.326	0.056	1.028
	LTE Band 7	0.117	0.566	0.034	0.326	0.056	1.099
LTE Band 48	0.035	0.566	0.034	0.326	0.056	1.017	
LTE Band 41	0.111	0.566	0.034	0.326	0.056	1.093	





FCC ID: A3LSMN975U	 PCTEST ENGINEERING LABORATORY, INC.	SAR EVALUATION REPORT		Approved by: Quality Manager
Document S/N: 1M1905200079-01-R1.A3L	Test Dates: 05/22/19 - 07/07/19	DUT Type: Portable Handset		Page 184 of 220



Table 12-4
Simultaneous Transmission Scenario with Bluetooth (Held to Ear)

Exposure Condition	Mode	2G/3G/4G SAR (W/kg)	Bluetooth SAR (W/kg)	Σ SAR (W/kg)
		1	2	1+2
Head SAR	CDMA/EVDO BC10 (§90S)	0.193	0.320	0.513
	CDMA/EVDO BC0 (§22H)	0.194	0.320	0.514
	GSM 850	0.133	0.320	0.453
	UMTS 850	0.157	0.320	0.477
	UMTS 1750	0.147	0.320	0.467
	PCS CDMA/EVDO	0.114	0.320	0.434
	GSM 1900	0.053	0.320	0.373
	UMTS 1900	0.139	0.320	0.459
	LTE Band 71	0.114	0.320	0.434
	LTE Band 12	0.119	0.320	0.439
	LTE Band 13	0.166	0.320	0.486
	LTE Band 14	0.138	0.320	0.458
	LTE Band 26 (Cell)	0.178	0.320	0.498
	LTE Band 5 (Cell)	0.185	0.320	0.505
	LTE Band 66 (AWS)	0.164	0.320	0.484
	LTE Band 25 (PCS)	0.147	0.320	0.467
	LTE Band 30	0.046	0.320	0.366
	LTE Band 7	0.117	0.320	0.437
LTE Band 48	0.035	0.320	0.355	
LTE Band 41	0.111	0.320	0.431	

FCC ID: A3LSMN975U	 PCTEST ENGINEERING LABORATORY, INC.	SAR EVALUATION REPORT		Approved by: Quality Manager
Document S/N: 1M1905200079-01-R1.A3L	Test Dates: 05/22/19 - 07/07/19	DUT Type: Portable Handset	Page 185 of 220	

**Table 12-5
Simultaneous Transmission Scenario with Bluetooth and 5 GHz WLAN (Held to Ear)**



Exposure Condition	Mode	2G/3G/4G SAR (W/kg)	Bluetooth SAR (W/kg)	5 GHz WLAN Ant 1 SAR (W/kg)	5 GHz WLAN Ant 2 SAR (W/kg)	Σ SAR (W/kg)
		1	2	3	4	1+2+3+4
Head SAR	CDMA/EVDO BC10 (§90S)	0.193	0.320	0.326	0.056	0.895
	CDMA/EVDO BC0 (§22H)	0.194	0.320	0.326	0.056	0.896
	GSM 850	0.133	0.320	0.326	0.056	0.835
	UMTS 850	0.157	0.320	0.326	0.056	0.859
	UMTS 1750	0.147	0.320	0.326	0.056	0.849
	PCS CDMA/EVDO	0.114	0.320	0.326	0.056	0.816
	GSM 1900	0.053	0.320	0.326	0.056	0.755
	UMTS 1900	0.139	0.320	0.326	0.056	0.841
	LTE Band 71	0.114	0.320	0.326	0.056	0.816
	LTE Band 12	0.119	0.320	0.326	0.056	0.821
	LTE Band 13	0.166	0.320	0.326	0.056	0.868
	LTE Band 14	0.138	0.320	0.326	0.056	0.840
	LTE Band 26 (Cell)	0.178	0.320	0.326	0.056	0.880
	LTE Band 5 (Cell)	0.185	0.320	0.326	0.056	0.887
	LTE Band 66 (AWS)	0.164	0.320	0.326	0.056	0.866
	LTE Band 25 (PCS)	0.147	0.320	0.326	0.056	0.849
	LTE Band 30	0.046	0.320	0.326	0.056	0.748
	LTE Band 7	0.117	0.320	0.326	0.056	0.819
LTE Band 48	0.035	0.320	0.326	0.056	0.737	
LTE Band 41	0.111	0.320	0.326	0.056	0.813	

FCC ID: A3LSMN975U		SAR EVALUATION REPORT		Approved by: Quality Manager
Document S/N: 1M1905200079-01-R1.A3L	Test Dates: 05/22/19 - 07/07/19	DUT Type: Portable Handset	Page 186 of 220	

12.4 Body-Worn Simultaneous Transmission Analysis

Table 12-6
Simultaneous Transmission Scenario with 2.4 GHz WLAN (Body-Worn at 1.5 cm)

Exposure Condition	Mode	2G/3G/4G SAR (W/kg)	2.4 GHz WLAN Ant 1 SAR (W/kg)	2.4 GHz WLAN Ant 2 SAR (W/kg)	Σ SAR (W/kg)		
		1	2	3	1+2	1+3	1+2+3
Body-Worn	CDMA BC10 (§90S)	0.291	0.157	0.074	0.448	0.365	0.522
	CDMA BC0 (§22H)	0.333	0.157	0.074	0.490	0.407	0.564
	GSM 850	0.244	0.157	0.074	0.401	0.318	0.475
	UMTS 850	0.326	0.157	0.074	0.483	0.400	0.557
	UMTS 1750	1.015	0.157	0.074	1.172	1.089	1.246
	PCS CDMA	0.656	0.157	0.074	0.813	0.730	0.887
	GSM 1900	0.327	0.157	0.074	0.484	0.401	0.558
	UMTS 1900	0.876	0.157	0.074	1.033	0.950	1.107
	LTE Band 71	0.234	0.157	0.074	0.391	0.308	0.465
	LTE Band 12	0.193	0.157	0.074	0.350	0.267	0.424
	LTE Band 13	0.219	0.157	0.074	0.376	0.293	0.450
	LTE Band 14	0.262	0.157	0.074	0.419	0.336	0.493
	LTE Band 26 (Cell)	0.361	0.157	0.074	0.518	0.435	0.592
	LTE Band 5 (Cell)	0.318	0.157	0.074	0.475	0.392	0.549
	LTE Band 66 (AWS)	1.140	0.157	0.074	1.297	1.214	1.371
	LTE Band 25 (PCS)	0.916	0.157	0.074	1.073	0.990	1.147
	LTE Band 30	0.513	0.157	0.074	0.670	0.587	0.744
	LTE Band 7	0.280	0.157	0.074	0.437	0.354	0.511
	LTE Band 48	0.132	0.157	0.074	0.289	0.206	0.363
LTE Band 41	0.323	0.157	0.074	0.480	0.397	0.554	

FCC ID: A3LSMN975U	 PCTEST ENGINEERING LABORATORY, INC.	SAR EVALUATION REPORT		Approved by: Quality Manager
Document S/N: 1M1905200079-01-R1.A3L	Test Dates: 05/22/19 - 07/07/19	DUT Type: Portable Handset		Page 187 of 220

**Table 12-7
Simultaneous Transmission Scenario with 5 GHz WLAN (Body-Worn at 1.5 cm)**

Exposure Condition	Mode	2G/3G/4G SAR (W/kg)	5 GHz WLAN Ant 1 SAR (W/kg)	5 GHz WLAN Ant 2 SAR (W/kg)	Σ SAR (W/kg)		
		1	2	3	1+2	1+3	1+2+3
Body-Worn	CDMA BC10 (§90S)	0.291	0.247	0.152	0.538	0.443	0.690
	CDMA BC0 (§22H)	0.333	0.247	0.152	0.580	0.485	0.732
	GSM 850	0.244	0.247	0.152	0.491	0.396	0.643
	UMTS 850	0.326	0.247	0.152	0.573	0.478	0.725
	UMTS 1750	1.015	0.247	0.152	1.262	1.167	1.414
	PCS CDMA	0.656	0.247	0.152	0.903	0.808	1.055
	GSM 1900	0.327	0.247	0.152	0.574	0.479	0.726
	UMTS 1900	0.876	0.247	0.152	1.123	1.028	1.275
	LTE Band 71	0.234	0.247	0.152	0.481	0.386	0.633
	LTE Band 12	0.193	0.247	0.152	0.440	0.345	0.592
	LTE Band 13	0.219	0.247	0.152	0.466	0.371	0.618
	LTE Band 14	0.262	0.247	0.152	0.509	0.414	0.661
	LTE Band 26 (Cell)	0.361	0.247	0.152	0.608	0.513	0.760
	LTE Band 5 (Cell)	0.318	0.247	0.152	0.565	0.470	0.717
	LTE Band 66 (AWS)	1.140	0.247	0.152	1.387	1.292	1.539
	LTE Band 25 (PCS)	0.916	0.247	0.152	1.163	1.068	1.315
	LTE Band 30	0.513	0.247	0.152	0.760	0.665	0.912
	LTE Band 7	0.280	0.247	0.152	0.527	0.432	0.679
	LTE Band 48	0.132	0.247	0.152	0.379	0.284	0.531
LTE Band 41	0.323	0.247	0.152	0.570	0.475	0.722	



FCC ID: A3LSMN975U		SAR EVALUATION REPORT		Approved by: Quality Manager
Document S/N: 1M1905200079-01-R1.A3L	Test Dates: 05/22/19 - 07/07/19	DUT Type: Portable Handset	Page 188 of 220	

Table 12-8
Simultaneous Transmission Scenario with 2.4 GHz WLAN MIMO and 5 GHz WLAN MIMO (Body-Worn at 1.5 cm)

Exposure Condition	Mode	2G/3G/4G SAR (W/kg)	2.4 GHz WLAN Ant 1 SAR (W/kg)	2.4 GHz WLAN Ant 2 SAR (W/kg)	5 GHz WLAN MIMO at 16 dBm SAR (W/kg)	Σ SAR (W/kg)
		1	2	3	4	1+2+3+4
Body-Worn	CDMA BC10 (§90S)	0.291	0.157	0.074	0.145	0.667
	CDMA BC0 (§22H)	0.333	0.157	0.074	0.145	0.709
	GSM 850	0.244	0.157	0.074	0.145	0.620
	UMTS 850	0.326	0.157	0.074	0.145	0.702
	UMTS 1750	1.015	0.157	0.074	0.145	1.391
	PCS CDMA	0.656	0.157	0.074	0.145	1.032
	GSM 1900	0.327	0.157	0.074	0.145	0.703
	UMTS 1900	0.876	0.157	0.074	0.145	1.252
	LTE Band 71	0.234	0.157	0.074	0.145	0.610
	LTE Band 12	0.193	0.157	0.074	0.145	0.569
	LTE Band 13	0.219	0.157	0.074	0.145	0.595
	LTE Band 14	0.262	0.157	0.074	0.145	0.638
	LTE Band 26 (Cell)	0.361	0.157	0.074	0.145	0.737
	LTE Band 5 (Cell)	0.318	0.157	0.074	0.145	0.694
	LTE Band 66 (AWS)	1.140	0.157	0.074	0.145	1.516
	LTE Band 25 (PCS)	0.916	0.157	0.074	0.145	1.292
	LTE Band 30	0.513	0.157	0.074	0.145	0.889
	LTE Band 7	0.280	0.157	0.074	0.145	0.656
LTE Band 48	0.132	0.157	0.074	0.145	0.508	
LTE Band 41	0.323	0.157	0.074	0.145	0.699	





FCC ID: A3LSMN975U		SAR EVALUATION REPORT		Approved by: Quality Manager
Document S/N: 1M1905200079-01-R1.A3L	Test Dates: 05/22/19 - 07/07/19	DUT Type: Portable Handset	Page 189 of 220	



Table 12-9
Simultaneous Transmission Scenario with Bluetooth (Body-Worn at 1.5 cm)

Exposure Condition	Mode	2G/3G/4G SAR (W/kg)	Bluetooth SAR (W/kg)	Σ SAR (W/kg)
		1	2	1+2
Body-Worn	CDMA BC10 (§90S)	0.291	0.048	0.339
	CDMA BC0 (§22H)	0.333	0.048	0.381
	GSM 850	0.244	0.048	0.292
	UMTS 850	0.326	0.048	0.374
	UMTS 1750	1.015	0.048	1.063
	PCS CDMA	0.656	0.048	0.704
	GSM 1900	0.327	0.048	0.375
	UMTS 1900	0.876	0.048	0.924
	LTE Band 71	0.234	0.048	0.282
	LTE Band 12	0.193	0.048	0.241
	LTE Band 13	0.219	0.048	0.267
	LTE Band 14	0.262	0.048	0.310
	LTE Band 26 (Cell)	0.361	0.048	0.409
	LTE Band 5 (Cell)	0.318	0.048	0.366
	LTE Band 66 (AWS)	1.140	0.048	1.188
	LTE Band 25 (PCS)	0.916	0.048	0.964
	LTE Band 30	0.513	0.048	0.561
	LTE Band 7	0.280	0.048	0.328
LTE Band 48	0.132	0.048	0.180	
LTE Band 41	0.323	0.048	0.371	

FCC ID: A3LSMN975U	 PCTEST ENGINEERING LABORATORY, INC.	SAR EVALUATION REPORT		Approved by: Quality Manager
Document S/N: 1M1905200079-01-R1.A3L	Test Dates: 05/22/19 - 07/07/19	DUT Type: Portable Handset	Page 190 of 220	

**Table 12-10
Simultaneous Transmission Scenario with Bluetooth and 5 GHz WLAN (Body-Worn at 1.5 cm)**

Exposure Condition	Mode	2G/3G/4G SAR (W/kg)	Bluetooth SAR (W/kg)	5 GHz WLAN Ant 1 SAR (W/kg)	5 GHz WLAN Ant 2 SAR (W/kg)	Σ SAR (W/kg)
		1	2	3	4	1+2+3+4
Body-Worn	CDMA BC10 (§90S)	0.291	0.048	0.247	0.152	0.738
	CDMA BC0 (§22H)	0.333	0.048	0.247	0.152	0.780
	GSM 850	0.244	0.048	0.247	0.152	0.691
	UMTS 850	0.326	0.048	0.247	0.152	0.773
	UMTS 1750	1.015	0.048	0.247	0.152	1.462
	PCS CDMA	0.656	0.048	0.247	0.152	1.103
	GSM 1900	0.327	0.048	0.247	0.152	0.774
	UMTS 1900	0.876	0.048	0.247	0.152	1.323
	LTE Band 71	0.234	0.048	0.247	0.152	0.681
	LTE Band 12	0.193	0.048	0.247	0.152	0.640
	LTE Band 13	0.219	0.048	0.247	0.152	0.666
	LTE Band 14	0.262	0.048	0.247	0.152	0.709
	LTE Band 26 (Cell)	0.361	0.048	0.247	0.152	0.808
	LTE Band 5 (Cell)	0.318	0.048	0.247	0.152	0.765
	LTE Band 66 (AWS)	1.140	0.048	0.247	0.152	1.587
	LTE Band 25 (PCS)	0.916	0.048	0.247	0.152	1.363
	LTE Band 30	0.513	0.048	0.247	0.152	0.960
	LTE Band 7	0.280	0.048	0.247	0.152	0.727
LTE Band 48	0.132	0.048	0.247	0.152	0.579	
LTE Band 41	0.323	0.048	0.247	0.152	0.770	

FCC ID: A3LSMN975U		SAR EVALUATION REPORT		Approved by: Quality Manager
Document S/N: 1M1905200079-01-R1.A3L	Test Dates: 05/22/19 - 07/07/19	DUT Type: Portable Handset	Page 191 of 220	



12.5 Hotspot SAR Simultaneous Transmission Analysis

Per FCC KDB Publication 941225 D06v02r01, the devices edges with antennas more than 2.5 cm from edge are not required to be evaluated for SAR (“-”).

(*) For test positions that were not required to be evaluated for WLAN SAR per FCC KDB publication 248227, the worst case WLAN SAR result for the applicable exposure conditions was used for simultaneous transmission analysis.

Table 12-11
Simultaneous Transmission Scenario with 2.4 GHz WLAN (Hotspot at 1.0 cm)

Exposure Condition	Mode	2G/3G/4G SAR (W/kg)	2.4 GHz WLAN Ant 1 SAR (W/kg)	2.4 GHz WLAN Ant 2 SAR (W/kg)	Σ SAR (W/kg)		
		1	2	3	1+2	1+3	1+2+3
Hotspot SAR	EVDO BC10 (§90S)	0.790	0.366	0.184	1.156	0.974	1.340
	EVDO BC0 (§22H)	0.861	0.366	0.184	1.227	1.045	1.411
	GPRS 850	0.751	0.366	0.184	1.117	0.935	1.301
	UMTS 850	0.709	0.366	0.184	1.075	0.893	1.259
	UMTS 1750	1.131	0.366	0.184	1.497	1.315	See Table Below
	PCS EVDO	0.895	0.366	0.184	1.261	1.079	1.445
	GPRS 1900	1.259	0.366	0.184	See Table Below	1.443	See Table Below
	UMTS 1900	1.189	0.366	0.184	1.555	1.373	See Table Below
	LTE Band 71	0.321	0.366	0.184	0.687	0.505	0.871
	LTE Band 12	0.288	0.366	0.184	0.654	0.472	0.838
	LTE Band 13	0.505	0.366	0.184	0.871	0.689	1.055
	LTE Band 14	0.606	0.366	0.184	0.972	0.790	1.156
	LTE Band 26 (Cell)	0.741	0.366	0.184	1.107	0.925	1.291
	LTE Band 5 (Cell)	0.716	0.366	0.184	1.082	0.900	1.266
	LTE Band 66 (AWS)	0.977	0.366	0.184	1.343	1.161	1.527
	LTE Band 25 (PCS)	0.932	0.366	0.184	1.298	1.116	1.482
	LTE Band 30	1.341	0.366	0.184	See Table Below	1.525	See Table Below
	LTE Band 7	0.555	0.366	0.184	0.921	0.739	1.105
	LTE Band 48	0.504	0.366	0.184	0.870	0.688	1.054
LTE Band 41	0.741	0.366	0.184	1.107	0.925	1.291	

FCC ID: A3LSMN975U	 PCTEST ENGINEERING LABORATORY, INC.	SAR EVALUATION REPORT		Approved by: Quality Manager
Document S/N: 1M1905200079-01-R1.A3L	Test Dates: 05/22/19 - 07/07/19	DUT Type: Portable Handset		Page 192 of 220

Simult Tx	Configuration	UMTS 1750 SAR (W/kg)	2.4 GHz WLAN Ant 1 SAR (W/kg)	2.4 GHz WLAN Ant 2 SAR (W/kg)	Σ SAR (W/kg)	Simult Tx	Configuration	GPRS 1900 SAR (W/kg)	2.4 GHz WLAN Ant 1 SAR (W/kg)	2.4 GHz WLAN Ant 2 SAR (W/kg)	Σ SAR (W/kg)		
		1	2	3	1+2+3			1	2	3	1+2	1+3	1+2+3
Hotspot SAR	Back	0.614	0.322	0.184	1.120	Hotspot SAR	Back	0.523	0.322	0.184	0.845	0.707	1.029
	Front	0.479	0.366*	0.184*	1.029		Front	0.416	0.366*	0.184*	0.782	0.600	0.966
	Top	-	0.366	0.184*	0.550		Top	-	0.366	0.184*	0.366	0.184	0.550
	Bottom	1.131	-	-	1.131		Bottom	1.259	-	-	1.259	1.259	1.259
	Right	0.077	-	-	0.077		Right	0.059	-	-	0.059	0.059	0.059
	Left	0.087	0.366*	0.184*	0.637		Left	0.092	0.366*	0.184*	0.458	0.276	0.642
Simult Tx	Configuration	UMTS 1900 SAR (W/kg)	2.4 GHz WLAN Ant 1 SAR (W/kg)	2.4 GHz WLAN Ant 2 SAR (W/kg)	Σ SAR (W/kg)	Simult Tx	Configuration	LTE Band 30 SAR (W/kg)	2.4 GHz WLAN Ant 1 SAR (W/kg)	2.4 GHz WLAN Ant 2 SAR (W/kg)	Σ SAR (W/kg)		
		1	2	3	1+2+3			1	2	3	1+2	1+3	1+2+3
Hotspot SAR	Back	0.470	0.322	0.184	0.976	Hotspot SAR	Back	0.622	0.322	0.184	0.944	0.806	1.128
	Front	0.416	0.366*	0.184*	0.966		Front	0.481	0.366*	0.184*	0.847	0.665	1.031
	Top	-	0.366	0.184*	0.550		Top	-	0.366	0.184*	0.366	0.184	0.550
	Bottom	1.189	-	-	1.189		Bottom	1.341	-	-	1.341	1.341	1.341
	Right	0.072	-	-	0.072		Right	0.046	-	-	0.046	0.046	0.046
	Left	0.095	0.366*	0.184*	0.645		Left	0.075	0.366*	0.184*	0.441	0.259	0.625



FCC ID: A3LSMN975U		SAR EVALUATION REPORT		Approved by: Quality Manager
Document S/N: 1M1905200079-01-R1.A3L	Test Dates: 05/22/19 - 07/07/19	DUT Type: Portable Handset		Page 193 of 220

Table 12-12
Simultaneous Transmission Scenario with 5 GHz WLAN (Hotspot at 1.0 cm)

Exposure Condition	Mode	2G/3G/4G SAR (W/kg)	5 GHz WLAN Ant 1 SAR (W/kg)	5 GHz WLAN Ant 2 SAR (W/kg)	Σ SAR (W/kg)		
		1	2	3	1+2	1+3	1+2+3
Hotspot SAR	EVDO BC10 (§90S)	0.790	0.341	0.177	1.131	0.967	1.308
	EVDO BC0 (§22H)	0.861	0.341	0.177	1.202	1.038	1.379
	GPRS 850	0.751	0.341	0.177	1.092	0.928	1.269
	UMTS 850	0.709	0.341	0.177	1.050	0.886	1.227
	UMTS 1750	1.131	0.341	0.177	1.472	1.308	See Table Below
	PCS EVDO	0.895	0.341	0.177	1.236	1.072	1.413
	GPRS 1900	1.259	0.341	0.177	See Table Below	1.436	See Table Below
	UMTS 1900	1.189	0.341	0.177	1.530	1.366	See Table Below
	LTE Band 71	0.321	0.341	0.177	0.662	0.498	0.839
	LTE Band 12	0.288	0.341	0.177	0.629	0.465	0.806
	LTE Band 13	0.505	0.341	0.177	0.846	0.682	1.023
	LTE Band 14	0.606	0.341	0.177	0.947	0.783	1.124
	LTE Band 26 (Cell)	0.741	0.341	0.177	1.082	0.918	1.259
	LTE Band 5 (Cell)	0.716	0.341	0.177	1.057	0.893	1.234
	LTE Band 66 (AWS)	0.977	0.341	0.177	1.318	1.154	1.495
	LTE Band 25 (PCS)	0.932	0.341	0.177	1.273	1.109	1.450
	LTE Band 30	1.341	0.341	0.177	See Table Below	1.518	See Table Below
	LTE Band 7	0.555	0.341	0.177	0.896	0.732	1.073
	LTE Band 48	0.504	0.341	0.177	0.845	0.681	1.022
LTE Band 41	0.741	0.341	0.177	1.082	0.918	1.259	

Simult Tx	Configuration	UMTS 1750 SAR (W/kg)	5 GHz WLAN Ant 1 SAR (W/kg)	5 GHz WLAN Ant 2 SAR (W/kg)	Σ SAR (W/kg)
		1	2	3	1+2+3
Hotspot SAR	Back	0.614	0.341	0.177	1.132
	Front	0.479	0.341*	0.177*	0.997
	Top	-	0.341*	0.177*	0.518
	Bottom	1.131	-	-	1.131
	Right	0.077	-	-	0.077
	Left	0.087	0.341*	0.177*	0.605

Simult Tx	Configuration	UMTS 1900 SAR (W/kg)	5 GHz WLAN Ant 1 SAR (W/kg)	5 GHz WLAN Ant 2 SAR (W/kg)	Σ SAR (W/kg)
		1	2	3	1+2+3
Hotspot SAR	Back	0.470	0.341	0.177	0.988
	Front	0.416	0.341*	0.177*	0.934
	Top	-	0.341*	0.177*	0.518
	Bottom	1.189	-	-	1.189
	Right	0.072	-	-	0.072
	Left	0.095	0.341*	0.177*	0.613

Simult Tx	Configuration	GPRS 1900 SAR (W/kg)	5 GHz WLAN Ant 1 SAR (W/kg)	5 GHz WLAN Ant 2 SAR (W/kg)	Σ SAR (W/kg)		
		1	2	3	1+2	1+3	1+2+3
Hotspot SAR	Back	0.523	0.341	0.177	0.864	0.700	1.041
	Front	0.416	0.341*	0.177*	0.757	0.593	0.934
	Top	-	0.341*	0.177*	0.341	0.177	0.518
	Bottom	1.259	-	-	1.259	1.259	1.259
	Right	0.059	-	-	0.059	0.059	0.059
	Left	0.092	0.341*	0.177*	0.433	0.269	0.610

Simult Tx	Configuration	LTE Band 30 SAR (W/kg)	5 GHz WLAN Ant 1 SAR (W/kg)	5 GHz WLAN Ant 2 SAR (W/kg)	Σ SAR (W/kg)		
		1	2	3	1+2	1+3	1+2+3
Hotspot SAR	Back	0.622	0.341	0.177	0.963	0.799	1.140
	Front	0.481	0.341*	0.177*	0.822	0.658	0.999
	Top	-	0.341*	0.177*	0.341	0.177	0.518
	Bottom	1.341	-	-	1.341	1.341	1.341
	Right	0.046	-	-	0.046	0.046	0.046
	Left	0.075	0.341*	0.177*	0.416	0.252	0.593



FCC ID: A3LSMN975U		SAR EVALUATION REPORT		Approved by: Quality Manager
Document S/N: 1M1905200079-01-R1.A3L	Test Dates: 05/22/19 - 07/07/19	DUT Type: Portable Handset	Page 194 of 220	

Table 12-13
Simultaneous Transmission Scenario with 2.4 GHz WLAN MIMO and 5 GHz WLAN MIMO (Hotspot at 1.0 cm)



Exposure Condition	Mode	2G/3G/4G SAR (W/kg)	2.4 GHz WLAN Ant 1 SAR (W/kg)	2.4 GHz WLAN Ant 2 SAR (W/kg)	5 GHz WLAN MIMO at 16 dBm SAR (W/kg)	Σ SAR (W/kg)
		1	2	3	4	1+2+3+4
Hotspot SAR	EVDO BC10 (§90S)	0.790	0.366	0.184	0.213	1.553
	EVDO BC0 (§22H)	0.861	0.366	0.184	0.213	See Table Below
	GPRS 850	0.751	0.366	0.184	0.213	1.514
	UMTS 850	0.709	0.366	0.184	0.213	1.472
	UMTS 1750	1.131	0.366	0.184	0.213	See Table Below
	PCS EVDO	0.895	0.366	0.184	0.213	See Table Below
	GPRS 1900	1.259	0.366	0.184	0.213	See Table Below
	UMTS 1900	1.189	0.366	0.184	0.213	See Table Below
	LTE Band 71	0.321	0.366	0.184	0.213	1.084
	LTE Band 12	0.288	0.366	0.184	0.213	1.051
	LTE Band 13	0.505	0.366	0.184	0.213	1.268
	LTE Band 14	0.606	0.366	0.184	0.213	1.369
	LTE Band 26 (Cell)	0.741	0.366	0.184	0.213	1.504
	LTE Band 5 (Cell)	0.716	0.366	0.184	0.213	1.479
	LTE Band 66 (AWS)	0.977	0.366	0.184	0.213	See Table Below
	LTE Band 25 (PCS)	0.932	0.366	0.184	0.213	See Table Below
	LTE Band 30	1.341	0.366	0.184	0.213	See Table Below
	LTE Band 7	0.555	0.366	0.184	0.213	1.318
	LTE Band 48	0.504	0.366	0.184	0.213	1.267
LTE Band 41	0.741	0.366	0.184	0.213	1.504	

Simult Tx	Configuration	EVDO BC0 (§22H) SAR (W/kg)	2.4 GHz WLAN Ant 1 SAR (W/kg)	2.4 GHz WLAN Ant 2 SAR (W/kg)	5 GHz WLAN MIMO at 16 dBm SAR (W/kg)	Σ SAR (W/kg)
		1	2	3	4	1+2+3+4
Hotspot SAR	Back	0.861	0.322	0.184	0.213	1.580
	Front	0.392	0.366*	0.184*	0.213*	1.155
	Top	-	0.366	0.184*	0.213*	0.763
	Bottom	0.383	-	-	-	0.383
	Right	0.214	-	-	-	0.214
	Left	0.081	0.366*	0.184*	0.213*	0.844

Simult Tx	Configuration	UMTS 1750 SAR (W/kg)	2.4 GHz WLAN Ant 1 SAR (W/kg)	2.4 GHz WLAN Ant 2 SAR (W/kg)	5 GHz WLAN MIMO at 16 dBm SAR (W/kg)	Σ SAR (W/kg)
		1	2	3	4	1+2+3+4
Hotspot SAR	Back	0.614	0.322	0.184	0.213	1.333
	Front	0.479	0.366*	0.184*	0.213*	1.242
	Top	-	0.366	0.184*	0.213*	0.763
	Bottom	1.131	-	-	-	1.131
	Right	0.077	-	-	-	0.077
	Left	0.087	0.366*	0.184*	0.213*	0.850

Simult Tx	Configuration	PCS EVDO SAR (W/kg)	2.4 GHz WLAN Ant 1 SAR (W/kg)	2.4 GHz WLAN Ant 2 SAR (W/kg)	5 GHz WLAN MIMO at 16 dBm SAR (W/kg)	Σ SAR (W/kg)
		1	2	3	4	1+2+3+4
Hotspot SAR	Back	0.378	0.322	0.184	0.213	1.097
	Front	0.329	0.366*	0.184*	0.213*	1.092
	Top	-	0.366	0.184*	0.213*	0.763
	Bottom	0.895	-	-	-	0.895
	Right	0.044	-	-	-	0.044
	Left	0.066	0.366*	0.184*	0.213*	0.829

Simult Tx	Configuration	GPRS 1900 SAR (W/kg)	2.4 GHz WLAN Ant 1 SAR (W/kg)	2.4 GHz WLAN Ant 2 SAR (W/kg)	5 GHz WLAN MIMO at 16 dBm SAR (W/kg)	Σ SAR (W/kg)
		1	2	3	4	1+2+3+4
Hotspot SAR	Back	0.523	0.322	0.184	0.213	1.242
	Front	0.416	0.366*	0.184*	0.213*	1.179
	Top	-	0.366	0.184*	0.213*	0.763
	Bottom	1.259	-	-	-	1.259
	Right	0.059	-	-	-	0.059
	Left	0.092	0.366*	0.184*	0.213*	0.855

FCC ID: A3LSMN975U		SAR EVALUATION REPORT		Approved by: Quality Manager
Document S/N: 1M1905200079-01-R1.A3L	Test Dates: 05/22/19 - 07/07/19	DUT Type: Portable Handset		Page 195 of 220

Simult Tx	Configuration	UMTS 1900 SAR (W/kg)	2.4 GHz WLAN Ant 1 SAR (W/kg)	2.4 GHz WLAN Ant 2 SAR (W/kg)	5 GHz WLAN MIMO at 16 dBm SAR (W/kg)	Σ SAR (W/kg)
		1	2	3	4	1+2+3+4
Hotspot SAR	Back	0.470	0.322	0.184	0.213	1.189
	Front	0.416	0.366*	0.184*	0.213*	1.179
	Top	-	0.366	0.184*	0.213*	0.763
	Bottom	1.189	-	-	-	1.189
	Right	0.072	-	-	-	0.072
	Left	0.095	0.366*	0.184*	0.213*	0.858
Simult Tx	Configuration	LTE Band 66 (AWS) SAR (W/kg)	2.4 GHz WLAN Ant 1 SAR (W/kg)	2.4 GHz WLAN Ant 2 SAR (W/kg)	5 GHz WLAN MIMO at 16 dBm SAR (W/kg)	Σ SAR (W/kg)
		1	2	3	4	1+2+3+4
Hotspot SAR	Back	0.723	0.322	0.184	0.213	1.442
	Front	0.531	0.366*	0.184*	0.213*	1.294
	Top	-	0.366	0.184*	0.213*	0.763
	Bottom	0.977	-	-	-	0.977
	Right	0.068	-	-	-	0.068
	Left	0.107	0.366*	0.184*	0.213*	0.870
Simult Tx	Configuration	LTE Band 25 (PCS) SAR (W/kg)	2.4 GHz WLAN Ant 1 SAR (W/kg)	2.4 GHz WLAN Ant 2 SAR (W/kg)	5 GHz WLAN MIMO at 16 dBm SAR (W/kg)	Σ SAR (W/kg)
		1	2	3	4	1+2+3+4
Hotspot SAR	Back	0.414	0.322	0.184	0.213	1.133
	Front	0.292	0.366*	0.184*	0.213*	1.055
	Top	-	0.366	0.184*	0.213*	0.763
	Bottom	0.932	-	-	-	0.932
	Right	0.031	-	-	-	0.031
	Left	0.029	0.366*	0.184*	0.213*	0.792
Simult Tx	Configuration	LTE Band 30 SAR (W/kg)	2.4 GHz WLAN Ant 1 SAR (W/kg)	2.4 GHz WLAN Ant 2 SAR (W/kg)	5 GHz WLAN MIMO at 16 dBm SAR (W/kg)	Σ SAR (W/kg)
		1	2	3	4	1+2+3+4
Hotspot SAR	Back	0.622	0.322	0.184	0.213	1.341
	Front	0.481	0.366*	0.184*	0.213*	1.244
	Top	-	0.366	0.184*	0.213*	0.763
	Bottom	1.341	-	-	-	1.341
	Right	0.046	-	-	-	0.046
	Left	0.075	0.366*	0.184*	0.213*	0.838

**Table 12-14
Simultaneous Transmission Scenario with Bluetooth (Hotspot at 1.0 cm)**

Exposure Condition	Mode	2G/3G/4G SAR (W/kg)	Bluetooth SAR (W/kg)	Σ SAR (W/kg)
		1	2	1+2
Hotspot SAR	EVDO BC10 (\$90S)	0.790	0.091	0.881
	EVDO BC0 (\$22H)	0.861	0.091	0.952
	GPRS 850	0.751	0.091	0.842
	UMTS 850	0.709	0.091	0.800
	UMTS 1750	1.131	0.091	1.222
	PCS EVDO	0.895	0.091	0.986
	GPRS 1900	1.259	0.091	1.350
	UMTS 1900	1.189	0.091	1.280
	LTE Band 71	0.321	0.091	0.412
	LTE Band 12	0.288	0.091	0.379
	LTE Band 13	0.505	0.091	0.596
	LTE Band 14	0.606	0.091	0.697
	LTE Band 26 (Cell)	0.741	0.091	0.832
	LTE Band 5 (Cell)	0.716	0.091	0.807
	LTE Band 66 (AWS)	0.977	0.091	1.068
	LTE Band 25 (PCS)	0.932	0.091	1.023
	LTE Band 30	1.341	0.091	1.432
	LTE Band 7	0.555	0.091	0.646
	LTE Band 48	0.504	0.091	0.595
LTE Band 41	0.741	0.091	0.832	





FCC ID: A3LSMN975U	 PCTEST ENGINEERING LABORATORY, INC.	SAR EVALUATION REPORT		Approved by: Quality Manager
Document S/N: 1M1905200079-01-R1.A3L	Test Dates: 05/22/19 - 07/07/19	DUT Type: Portable Handset		Page 196 of 220

Table 12-15
Simultaneous Transmission Scenario with Bluetooth and 5 GHz WLAN (Hotspot at 1.0 cm)

Exposure Condition	Mode	2G/3G/4G SAR (W/kg)	Bluetooth SAR (W/kg)	5 GHz WLAN Ant 1 SAR (W/kg)	5 GHz WLAN Ant 2 SAR (W/kg)	Σ SAR (W/kg)
		1	2	3	4	1+2+3+4
Hotspot SAR	EVDO BC10 (§90S)	0.790	0.091	0.341	0.177	1.399
	EVDO BC0 (§22H)	0.861	0.091	0.341	0.177	1.470
	GPRS 850	0.751	0.091	0.341	0.177	1.360
	UMTS 850	0.709	0.091	0.341	0.177	1.318
	UMTS 1750	1.131	0.091	0.341	0.177	See Table Below
	PCS EVDO	0.895	0.091	0.341	0.177	1.504
	GPRS 1900	1.259	0.091	0.341	0.177	See Table Below
	UMTS 1900	1.189	0.091	0.341	0.177	See Table Below
	LTE Band 71	0.321	0.091	0.341	0.177	0.930
	LTE Band 12	0.288	0.091	0.341	0.177	0.897
	LTE Band 13	0.505	0.091	0.341	0.177	1.114
	LTE Band 14	0.606	0.091	0.341	0.177	1.215
	LTE Band 26 (Cell)	0.741	0.091	0.341	0.177	1.350
	LTE Band 5 (Cell)	0.716	0.091	0.341	0.177	1.325
	LTE Band 66 (AWS)	0.977	0.091	0.341	0.177	1.586
	LTE Band 25 (PCS)	0.932	0.091	0.341	0.177	1.541
	LTE Band 30	1.341	0.091	0.341	0.177	See Table Below
	LTE Band 7	0.555	0.091	0.341	0.177	1.164
LTE Band 48	0.504	0.091	0.341	0.177	1.113	
LTE Band 41	0.741	0.091	0.341	0.177	1.350	

Simult Tx	Configuration	GPRS 1900 SAR (W/kg)	Bluetooth SAR (W/kg)	5 GHz WLAN Ant 1 SAR (W/kg)	5 GHz WLAN Ant 2 SAR (W/kg)	Σ SAR (W/kg)	Simult Tx	Configuration	UMTS 1750 SAR (W/kg)	Bluetooth SAR (W/kg)	5 GHz WLAN Ant 1 SAR (W/kg)	5 GHz WLAN Ant 2 SAR (W/kg)	Σ SAR (W/kg)	
		1	2	3	4	1+2+3+4			1	2	3	4	1+2+3+4	
Hotspot SAR	Back	0.523	0.089	0.341	0.177	1.130	Hotspot SAR	Back	0.614	0.089	0.341	0.177	1.221	
	Front	0.416	0.033	0.341*	0.177*	0.967		Front	0.479	0.033	0.341*	0.177*	1.030	
	Top	-	0.091	0.341*	0.177*	0.609		Top	-	0.091	0.341*	0.177*	0.609	
	Bottom	1.259	-	-	-	1.259		Bottom	1.131	-	-	-	-	1.131
	Right	0.059	-	-	-	0.059		Right	0.077	-	-	-	-	0.077
	Left	0.092	0.054	0.341*	0.177*	0.664		Left	0.087	0.054	0.341*	0.177*	0.659	
Simult Tx	Configuration	UMTS 1900 SAR (W/kg)	Bluetooth SAR (W/kg)	5 GHz WLAN Ant 1 SAR (W/kg)	5 GHz WLAN Ant 2 SAR (W/kg)	Σ SAR (W/kg)	Simult Tx	Configuration	LTE Band 30 SAR (W/kg)	Bluetooth SAR (W/kg)	5 GHz WLAN Ant 1 SAR (W/kg)	5 GHz WLAN Ant 2 SAR (W/kg)	Σ SAR (W/kg)	
		1	2	3	4	1+2+3+4			1	2	3	4	1+2+3+4	
Hotspot SAR	Back	0.470	0.089	0.341	0.177	1.077	Hotspot SAR	Back	0.622	0.089	0.341	0.177	1.229	
	Front	0.416	0.033	0.341*	0.177*	0.967		Front	0.481	0.033	0.341*	0.177*	1.032	
	Top	-	0.091	0.341*	0.177*	0.609		Top	-	0.091	0.341*	0.177*	0.609	
	Bottom	1.189	-	-	-	1.189		Bottom	1.341	-	-	-	-	1.341
	Right	0.072	-	-	-	0.072		Right	0.046	-	-	-	-	0.046
	Left	0.095	0.054	0.341*	0.177*	0.667		Left	0.075	0.054	0.341*	0.177*	0.647	

FCC ID: A3LSMN975U		SAR EVALUATION REPORT		Approved by: Quality Manager
Document S/N: 1M1905200079-01-R1.A3L	Test Dates: 05/22/19 - 07/07/19	DUT Type: Portable Handset	Page 197 of 220	

12.6 Phablet Simultaneous Transmission Analysis

Per FCC KDB Publication 941225 D06v02r01, the devices edges with antennas more than 2.5 cm from edge are not required to be evaluated for SAR (“-“).



(*) For test positions that were not required to be evaluated for WLAN SAR per FCC KDB publication 248227, the worst case WLAN SAR result for the applicable exposure conditions was used for simultaneous transmission analysis.

Per FCC KDB Publication 648474 D04 Handset SAR, Phablet SAR tests were not required if wireless router 1g SAR (scaled to the maximum output power, including tolerance) < 1.2 W/kg. Therefore, no further analysis beyond the tables included in this section was required to determine that possible simultaneous transmission scenarios would not exceed the SAR limit.

For SAR summation, the highest reported SAR across all test distances was used as the most conservative evaluation for simultaneous transmission analysis for each device edge.

Table 12-16
Simultaneous Transmission Scenario with 5 GHz WLAN SISO (Phablet)

Simult Tx	Configuration	UMTS 1750 SAR (W/kg)	5 GHz WLAN Ant 1 SAR (W/kg)	5 GHz WLAN Ant 2 SAR (W/kg)	Σ SAR (W/kg)	
		1	2	3	1+2	1+3
Phablet SAR	Back	1.807	1.792	1.758	3.599	3.565
	Front	1.451	0.329	0.049	1.780	1.500
	Top	-	0.485	1.758*	0.485	1.758
	Bottom	2.620	-	-	2.620	2.620
	Right	0.413	-	-	0.413	0.413
	Left	0.675	0.405	0.222	1.080	0.897
Simult Tx	Configuration	PCS EVDO SAR (W/kg)	5 GHz WLAN Ant 1 SAR (W/kg)	5 GHz WLAN Ant 2 SAR (W/kg)	Σ SAR (W/kg)	
		1	2	3	1+2	1+3
Phablet SAR	Back	1.697	1.792	1.758	3.489	3.455
	Front	1.708	0.329	0.049	2.037	1.757
	Top	-	0.485	1.758*	0.485	1.758
	Bottom	3.062	-	-	3.062	3.062
	Right	0.305	-	-	0.305	0.305
	Left	0.552	0.405	0.222	0.957	0.774
Simult Tx	Configuration	GPRS 1900 SAR (W/kg)	5 GHz WLAN Ant 1 SAR (W/kg)	5 GHz WLAN Ant 2 SAR (W/kg)	Σ SAR (W/kg)	
		1	2	3	1+2	1+3
Phablet SAR	Back	-	1.792	1.758	1.792	1.758
	Front	-	0.329	0.049	0.329	0.049
	Top	-	0.485	1.758*	0.485	1.758
	Bottom	3.203	-	-	3.203	3.203
	Right	-	-	-	-	-
	Left	-	0.405	0.222	0.405	0.222

FCC ID: A3LSMN975U		SAR EVALUATION REPORT		Approved by: Quality Manager
Document S/N: 1M1905200079-01-R1.A3L	Test Dates: 05/22/19 - 07/07/19	DUT Type: Portable Handset	Page 198 of 220	

Simult Tx	Configuration	UMTS 1900 SAR (W/kg)	5 GHz WLAN Ant 1 SAR (W/kg)	5 GHz WLAN Ant 2 SAR (W/kg)	Σ SAR (W/kg)	
		1	2	3	1+2	1+3
Phablet SAR	Back	1.998	1.792	1.758	3.790	3.756
	Front	1.439	0.329	0.049	1.768	1.488
	Top	-	0.485	1.758*	0.485	1.758
	Bottom	2.720	-	-	2.720	2.720
	Right	0.381	-	-	0.381	0.381
	Left	0.749	0.405	0.222	1.154	0.971

Simult Tx	Configuration	LTE Band 66 (AWS) SAR (W/kg)	5 GHz WLAN Ant 1 SAR (W/kg)	5 GHz WLAN Ant 2 SAR (W/kg)	Σ SAR (W/kg)		SPLSR	
		1	2	3	1+2	1+3	1+2	1+3
Phablet SAR	Back	2.302	1.792	1.758	See Note 1	See Note 1	0.05	0.05
	Front	1.832	0.329	0.049	2.161	1.881	N/A	N/A
	Top	-	0.485	1.758*	0.485	1.758	N/A	N/A
	Bottom	2.938	-	-	2.938	2.938	N/A	N/A
	Right	0.399	-	-	0.399	0.399	N/A	N/A
	Left	0.593	0.405	0.222	0.998	0.815	N/A	N/A

Simult Tx	Configuration	LTE Band 25 (PCS) SAR (W/kg)	5 GHz WLAN Ant 1 SAR (W/kg)	5 GHz WLAN Ant 2 SAR (W/kg)	Σ SAR (W/kg)	
		1	2	3	1+2	1+3
Phablet SAR	Back	1.670	1.792	1.758	3.462	3.428
	Front	1.480	0.329	0.049	1.809	1.529
	Top	-	0.485	1.758*	0.485	1.758
	Bottom	2.490	-	-	2.490	2.490
	Right	0.377	-	-	0.377	0.377
	Left	0.732	0.405	0.222	1.137	0.954

Simult Tx	Configuration	LTE Band 30 SAR (W/kg)	5 GHz WLAN Ant 1 SAR (W/kg)	5 GHz WLAN Ant 2 SAR (W/kg)	Σ SAR (W/kg)	
		1	2	3	1+2	1+3
Phablet SAR	Back	1.975	1.792	1.758	3.767	3.733
	Front	1.489	0.329	0.049	1.818	1.538
	Top	-	0.485	1.758*	0.485	1.758
	Bottom	2.428	-	-	2.428	2.428
	Right	0.133	-	-	0.133	0.133
	Left	0.316	0.405	0.222	0.721	0.538

Simult Tx	Configuration	LTE Band 7 SAR (W/kg)	5 GHz WLAN Ant 1 SAR (W/kg)	5 GHz WLAN Ant 2 SAR (W/kg)	Σ SAR (W/kg)	
		1	2	3	1+2	1+3
Phablet SAR	Back	2.187	1.792	1.758	3.979	3.945
	Front	2.218	0.329	0.049	2.547	2.267
	Top	-	0.485	1.758*	0.485	1.758
	Bottom	2.614	-	-	2.614	2.614
	Right	1.141	-	-	1.141	1.141
	Left	1.141	0.405	0.222	1.546	1.363

Notes:

- No evaluation was performed to determine the aggregate 10g SAR for these configurations as the SPLS ratio between the antenna pairs was not greater than 0.10 per FCC KDB 447498 D01v06. See Section 12.7 for detailed SPLS ratio analysis.



FCC ID: A3LSMN975U		SAR EVALUATION REPORT		Approved by: Quality Manager
Document S/N: 1M1905200079-01-R1.A3L	Test Dates: 05/22/19 - 07/07/19	DUT Type: Portable Handset		Page 199 of 220

Table 12-17
Simultaneous Transmission Scenario with 5 GHz WLAN MIMO (Phablet)

Simult Tx	Configuration	UMTS 1750 SAR (W/kg)	5 GHz WLAN MIMO SAR (W/kg)	Σ SAR (W/kg)	SPLSR	Simult Tx	Configuration	PCS EVDO SAR (W/kg)	5 GHz WLAN MIMO SAR (W/kg)	Σ SAR (W/kg)	SPLSR
		1	2	1+2	1+2			1	2	1+2	1+2
Phablet SAR	Back	1.807	2.517	See Note 1	0.05	Phablet SAR	Back	1.697	2.517	See Note 1	0.05
	Front	1.451	0.385	1.836	N/A		Front	1.708	0.385	2.093	N/A
	Top	-	0.579	0.579	N/A		Top	-	0.579	0.579	N/A
	Bottom	2.620	-	2.620	N/A		Bottom	3.062	-	3.062	N/A
	Right	0.413	-	0.413	N/A		Right	0.305	-	0.305	N/A
Left	0.675	0.632	1.307	N/A	Left	0.552	0.632	1.184	N/A		



Simult Tx	Configuration	GPRS 1900 SAR (W/kg)	5 GHz WLAN MIMO SAR (W/kg)	Σ SAR (W/kg)	SPLSR	Simult Tx	Configuration	UMTS 1900 SAR (W/kg)	5 GHz WLAN MIMO SAR (W/kg)	Σ SAR (W/kg)	SPLSR
		1	2	1+2				1+2	1	2	1+2
Phablet SAR	Back	-	2.517	2.517	Phablet SAR	Back	1.998	2.517	See Note 1	0.06	
	Front	-	0.385	0.385		Front	1.439	0.385	1.824	N/A	
	Top	-	0.579	0.579		Top	-	0.579	0.579	N/A	
	Bottom	3.203	-	3.203		Bottom	2.720	-	2.720	N/A	
	Left	-	0.632	0.632		Left	0.381	-	0.381	N/A	
Right	-	0.632	0.632	Right	0.749	0.632	1.381	N/A			

Simult Tx	Configuration	LTE Band 66 (AWS) SAR (W/kg)	5 GHz WLAN MIMO SAR (W/kg)	Σ SAR (W/kg)	SPLSR	Simult Tx	Configuration	LTE Band 25 (PCS) SAR (W/kg)	5 GHz WLAN MIMO SAR (W/kg)	Σ SAR (W/kg)	SPLSR
		1	2	1+2	1+2			1	2	1+2	1+2
Phablet SAR	Back	2.302	2.517	See Note 1	0.06	Phablet SAR	Back	1.670	2.517	See Note 1	0.05
	Front	1.832	0.385	2.217	N/A		Front	1.480	0.385	1.865	N/A
	Top	-	0.579	0.579	N/A		Top	-	0.579	0.579	N/A
	Bottom	2.938	-	2.938	N/A		Bottom	2.490	-	2.490	N/A
	Right	0.399	-	0.399	N/A		Right	0.377	-	0.377	N/A
Left	0.593	0.632	1.225	N/A	Left	0.732	0.632	1.364	N/A		

Simult Tx	Configuration	LTE Band 30 SAR (W/kg)	5 GHz WLAN MIMO SAR (W/kg)	Σ SAR (W/kg)	SPLSR	Simult Tx	Configuration	LTE Band 7 SAR (W/kg)	5 GHz WLAN MIMO SAR (W/kg)	Σ SAR (W/kg)	SPLSR
		1	2	1+2	1+2			1	2	1+2	1+2
Phablet SAR	Back	1.975	2.517	See Note 1	0.06	Phablet SAR	Back	2.187	2.517	See Note 1	0.07
	Front	1.489	0.385	1.874	N/A		Front	2.218	0.385	2.603	N/A
	Top	-	0.579	0.579	N/A		Top	-	0.579	0.579	N/A
	Bottom	2.428	-	2.428	N/A		Bottom	2.614	-	2.614	N/A
	Right	0.133	-	0.133	N/A		Right	1.141	0.632	1.773	N/A
Left	0.316	0.632	0.948	N/A	Left	1.141	0.632	1.773	N/A		

Notes:

1. No evaluation was performed to determine the aggregate 10g SAR for these configurations as the SPLS ratio between the antenna pairs was not greater than 0.10 per FCC KDB 447498 D01v06. See Section 12.7 for detailed SPLS ratio analysis.

FCC ID: A3LSMN975U	 PCTEST ENGINEERING LABORATORY, INC.	SAR EVALUATION REPORT		Approved by: Quality Manager
Document S/N: 1M1905200079-01-R1.A3L	Test Dates: 05/22/19 - 07/07/19	DUT Type: Portable Handset	Page 200 of 220	

12.7 SPLSR Evaluation and Analysis

Per FCC KDB Publication 447498 D01v06, when the sum of the standalone transmitters is more than 4 W/kg for 10g, the SAR sum to peak locations can be analyzed to determine SAR distribution overlaps. When the SAR peak to location ratio (shown below) for each pair of antennas is ≤ 0.10 for 10g, simultaneous SAR evaluation is not required. The distance between the transmitters was calculated using the following formula.



$$\text{Distance}_{Tx1 - Tx2} = R_i = \sqrt{(x_1 - x_2)^2 + (y_1 - y_2)^2} \text{ (Phablet)}$$

$$\text{SPLS Ratio} = \frac{(SAR_1 + SAR_2)^{1.5}}{R_i}$$

12.7.1 Back Side SPLSR Evaluation and Analysis

Table 12-18
Peak SAR Locations for Body Back Side

Mode/Band	x (mm)	y (mm)
5 GHz WLAN Ant 1	13.00	75.00
5 GHz WLAN Ant 2	12.00	60.00
5 GHz WLAN MIMO	12.00	74.00
UMTS 1750	-21.50	-87.00
PCS EVDO	-29.50	-81.00
UMTS 1900	-5.00	-76.50
LTE Band 66 (AWS)	-23.00	-85.50
LTE Band 25 (PCS)	-25.00	-84.00
LTE Band 30	-9.20	-76.80
LTE Band 7	-3.40	-80.60



FCC ID: A3LSMN975U		SAR EVALUATION REPORT		Approved by: Quality Manager
Document S/N: 1M1905200079-01-R1.A3L	Test Dates: 05/22/19 - 07/07/19	DUT Type: Portable Handset		Page 201 of 220

**Table 12-19
Back Side SAR to Peak Location Separation Ratio Calculations**

Antenna Pair		Standalone SAR (W/kg)		Standalone SAR Sum (W/kg)	Peak SAR Separation Distance (mm)	SPLS Ratio	Plot Number
Ant "a"	Ant "b"	a	b	a+b	D _{a-b}	$(a+b)^{1.5}/D_{a-b}$	
LTE Band 66 (AWS)	5 GHz WLAN Ant 1	2.302	1.792	4.094	164.49	0.05	1
LTE Band 66 (AWS)	5 GHz WLAN Ant 2	2.302	1.758	4.060	149.65	0.05	2
UMTS 1750	5 GHz WLAN MIMO	1.807	2.517	4.324	164.45	0.05	3
PCS EVDO	5 GHz WLAN MIMO	1.697	2.517	4.214	160.46	0.05	4
UMTS 1900	5 GHz WLAN MIMO	1.998	2.517	4.515	151.46	0.06	5
LTE Band 66 (AWS)	5 GHz WLAN MIMO	2.302	2.517	4.819	163.29	0.06	6
LTE Band 25 (PCS)	5 GHz WLAN MIMO	1.670	2.517	4.187	162.27	0.05	7
LTE Band 30	5 GHz WLAN MIMO	1.975	2.517	4.492	152.28	0.06	8
LTE Band 7	5 GHz WLAN MIMO	2.187	2.517	4.704	155.37	0.07	9

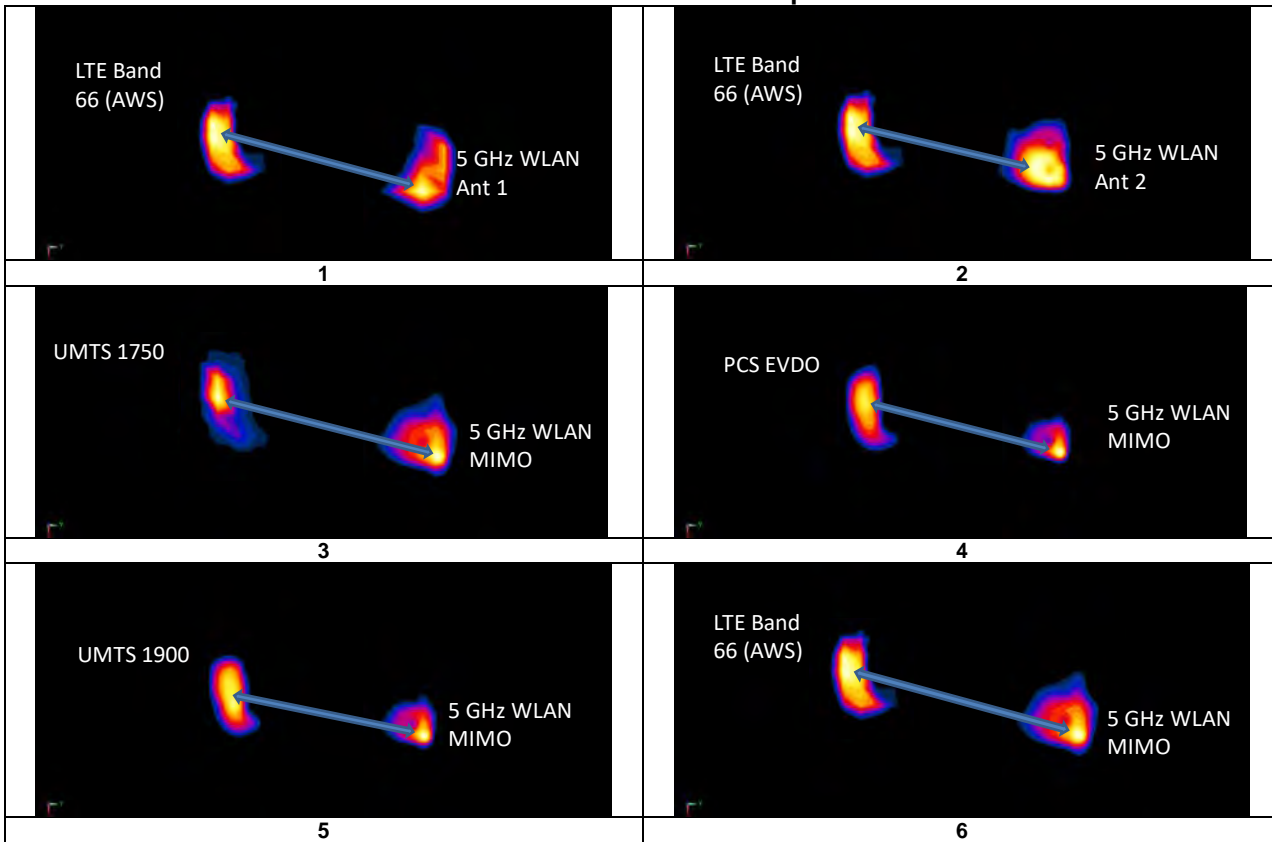
**Table 12-20
Back Side SAR to Peak Location Separation Ratio Plots**



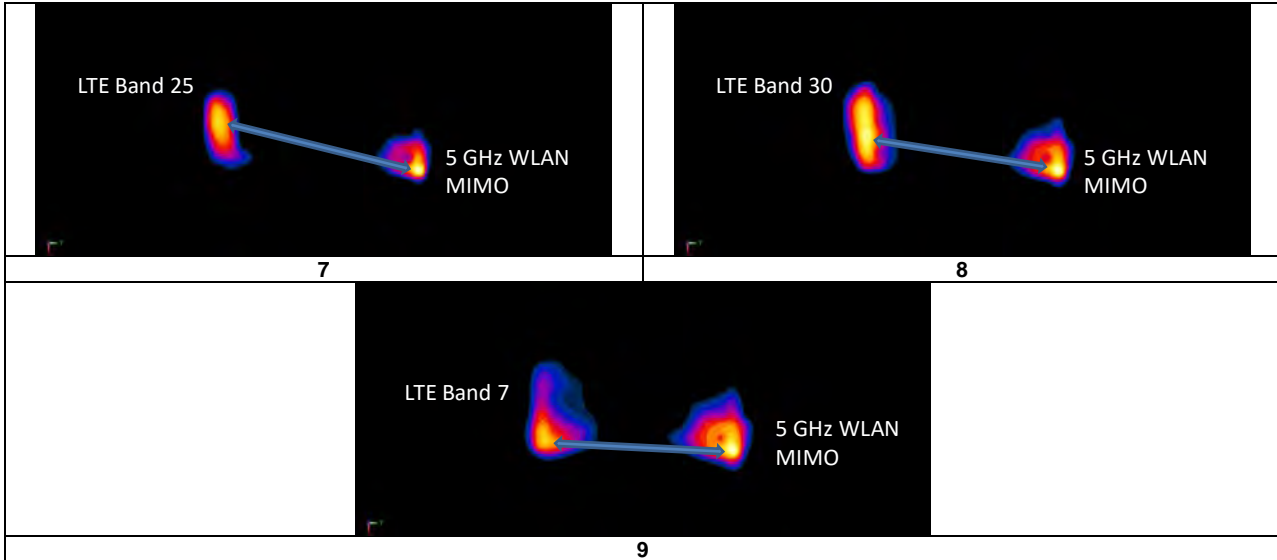

FCC ID: A3LSMN975U		SAR EVALUATION REPORT		Approved by: Quality Manager
Document S/N: 1M1905200079-01-R1.A3L	Test Dates: 05/22/19 - 07/07/19	DUT Type: Portable Handset	Page 202 of 220	



12.8 Simultaneous Transmission Conclusion

The above numerical summed SAR results and SPLSR analysis are sufficient to determine that simultaneous transmission cases will not exceed the SAR limit and therefore no measured volumetric simultaneous SAR summation is required per FCC KDB Publication 447498 D01v06 and IEEE 1528- 2013 Section 6.3.4.1.2.

FCC ID: A3LSMN975U		SAR EVALUATION REPORT		Approved by: Quality Manager
Document S/N: 1M1905200079-01-R1.A3L	Test Dates: 05/22/19 - 07/07/19	DUT Type: Portable Handset	Page 203 of 220	

13 SAR MEASUREMENT VARIABILITY

13.1 Measurement Variability



Per FCC KDB Publication 865664 D01v01r04, SAR measurement variability was assessed for each frequency band, which was determined by the SAR probe calibration point and tissue-equivalent medium used for the device measurements. When both head and body tissue-equivalent media were required for SAR measurements in a frequency band, the variability measurement procedures were applied to the tissue medium with the highest measured SAR, using the highest measured SAR configuration for that tissue-equivalent medium. These additional measurements were repeated after the completion of all measurements requiring the same head or body tissue-equivalent medium in a frequency band. The test device was returned to ambient conditions (normal room temperature) with the battery fully charged before it was re-mounted on the device holder for the repeated measurement(s) to minimize any unexpected variations in the repeated results.

SAR Measurement Variability was assessed using the following procedures for each frequency band:

- 1) When the original highest measured SAR is ≥ 0.80 W/kg, the measurement was repeated once.
- 2) A second repeated measurement was performed only if the ratio of largest to smallest SAR for the original and first repeated measurements was > 1.20 or when the original or repeated measurement was ≥ 1.45 W/kg (~ 10% from the 1g SAR limit).
- 3) A third repeated measurement was performed only if the original, first or second repeated measurement was ≥ 1.5 W/kg and the ratio of largest to smallest SAR for the original, first and second repeated measurements is > 1.20 .
- 4) Repeated measurements are not required when the original highest measured SAR is < 0.80 W/kg
- 5) When 10g SAR measurement is considered, a factor of 2.5 is applied to the thresholds above.

**Table 13-1
Body SAR Measurement Variability Results**

BODY VARIABILITY RESULTS													
Band	FREQUENCY		Mode	Service	Side	Spacing	Measured SAR (1g)	1st Repeated SAR (1g)	Ratio	2nd Repeated SAR (1g)	Ratio	3rd Repeated SAR (1g)	Ratio
	MHz	Ch.					(W/kg)	(W/kg)		(W/kg)		(W/kg)	
1750	1752.60	1513	UMTS 1750	RMC	bottom	10 mm	0.969	0.830	1.17	N/A	N/A	N/A	N/A
1900	1880.00	9400	UMTS 1900	RMC	bottom	10 mm	1.120	1.110	1.01	N/A	N/A	N/A	N/A
2300	2310.00	27710	LTE Band 30, 10 MHz Bandwidth	QPSK, 25 RB, 12 RB Offset	bottom	10 mm	1.270	1.200	1.06	N/A	N/A	N/A	N/A
ANSI / IEEE C95.1 1992 - SAFETY LIMIT Spatial Peak Uncontrolled Exposure/General Population							Body 1.6 W/kg (mW/g) averaged over 1 gram						



FCC ID: A3LSMN975U		SAR EVALUATION REPORT		Approved by: Quality Manager
Document S/N: 1M1905200079-01-R1.A3L	Test Dates: 05/22/19 - 07/07/19	DUT Type: Portable Handset		Page 204 of 220

**Table 13-2
Phablet SAR Measurement Variability Results**

PHABLET VARIABILITY RESULTS														
Band	FREQUENCY		Mode	Service	Data Rate (Mbps)	Side	Spacing	Measured SAR (10g)	1st Repeated SAR (10g)	Ratio	2nd Repeated SAR (10g)	Ratio	3rd Repeated SAR (10g)	Ratio
	MHz	Ch.						(W/kg)	(W/kg)		(W/kg)		(W/kg)	
1750	PCC: 1720.00	132072	LTE Band 66 (AWS), 20 MHz Bandwidth, ULCA	QPSK, 50 RB, 50 RB Offset	N/A	bottom	0 mm	2.560	2.490	1.03	N/A	N/A	N/A	N/A
	SCC: 1739.80	132270		QPSK, 50 RB, 0 RB Offset										
1900	1908.75	1175	PCS CDMA	EVDO Rev. 0	N/A	bottom	0 mm	2.570	2.710	1.05	N/A	N/A	N/A	N/A
2300	2310.00	27710	LTE Band 30, 10 MHz Bandwidth	QPSK, 50 RB, 0 RB Offset	N/A	bottom	0 mm	2.170	2.160	1.00	N/A	N/A	N/A	N/A
2450	2510.00	20850	LTE Band 7, 20 MHz Bandwidth	QPSK, 50 RB, 50 RB Offset	N/A	bottom	0 mm	2.020	1.930	1.05	N/A	N/A	N/A	N/A
5250	5280.00	56	802.11n, 20 MHz Bandwidth	OFDM, MIMO	13	back	0 mm	2.100	2.040	1.03	N/A	N/A	N/A	N/A
5600	5520.00	104	802.11n, 20 MHz Bandwidth	OFDM, MIMO	13	back	0 mm	2.230	2.230	1.00	N/A	N/A	N/A	N/A
ANSI / IEEE C95.1 1992 - SAFETY LIMIT Spatial Peak Uncontrolled Exposure/General Population							Phablet 4.0 W/kg (mW/g) averaged over 10 grams							

13.2 Measurement Uncertainty

The measured SAR was <1.5 W/kg for 1g and <3.75 W/kg for 10g for all frequency bands. Therefore, per KDB Publication 865664 D01v01r04, the extended measurement uncertainty analysis per IEEE 1528-2013 was not required.

FCC ID: A3LSMN975U		SAR EVALUATION REPORT		Approved by: Quality Manager
Document S/N: 1M1905200079-01-R1.A3L	Test Dates: 05/22/19 - 07/07/19	DUT Type: Portable Handset		Page 205 of 220

14 ADDITIONAL TESTING PER FCC GUIDANCE

14.1 Tuner Testing

The following test procedures were followed to demonstrate that the SAR results in Section 11 represented the appropriate SAR test conditions. For bands with dynamic tuning implemented, SAR was measured according to the required FCC SAR test procedures with the dynamic tuner active to allow the device to automatically tune to the antenna state for the respective RF exposure test configurations. Additional single point SAR time-sweep measurements were evaluated for other tuner states to determine that the other tuner configurations would result in equivalent or lower SAR values. The additional tuner hardware has no influence on the antenna characteristics, other than impedance matching.

Per April 2019 TCB Workshop notes, in order to evaluate all the tuner states, the 60 tuner states were divided among evenly among each supported band and exposure condition combination. Single point time-sweep measurements were performed at the peak SAR location determined by the zoom scan of the configuration with the highest reported SAR for each combination. The tuner state was able to be established remotely so that the device was not moved for the entire series of single point SAR for the tuner states in each combination. The SAR probe remained stationary at the same position throughout the entire series of single point measurements for each combination. When the single point SAR or 1g SAR was > 1.2 W/kg for a particular band/mode/exposure condition, point SAR measurements were made for all 60 states. Additionally, several bands/modes were combined to be treated as a single aggregate band. For CDMA BC0 and BC10, the highest reported SAR configuration per exposure condition was considered for point SAR measurements.

The operational description contains more information about the design and implementation of the dynamic antenna tuning.



FCC ID: A3LSMN975U		SAR EVALUATION REPORT		Approved by: Quality Manager
Document S/N: 1M1905200079-01-R1.A3L	Test Dates: 05/22/19 - 07/07/19	DUT Type: Portable Handset	Page 206 of 220	

Table 14-1
UMTS/CDMA Supplemental Head SAR Data

Supplemental Head SAR Data									
UMTS Band 5		UMTS Band 4		UMTS Band 2		CDMA BC0		CDMA BC1	
RMC		RMC		RMC		RC3/SO55		RC3/SO65	
Test Position	Right Cheek	Test Position	Left Cheek	Test Position	Left Cheek	Test Position	Right Cheek	Test Position	Left Cheek
Frequency (MHz)	836.6	Frequency (MHz)	1732.4	Frequency (MHz)	1880.0	Frequency (MHz)	836.52	Frequency (MHz)	1880.0
Channel	4183	Channel	1412	Channel	9400	Channel	384	Channel	600
Measured 1g SAR (W/kg)	0.136	Measured 1g SAR (W/kg)	0.127	Measured 1g SAR (W/kg)	0.105	Measured 1g SAR (W/kg)	0.144	Measured 1g SAR (W/kg)	0.104
Average Value of Time Sweep (W/kg)		Average Value of Time Sweep (W/kg)		Average Value of Time Sweep (W/kg)		Average Value of Time Sweep (W/kg)		Average Value of Time Sweep (W/kg)	
Auto-tune (State 2)	0.183	Auto-tune (State 30)	0.162	Auto-tune (State 0)	0.154	Auto-tune (State 2)	0.252	Auto-tune (State 0)	0.146
Default (State 0)	0.189	Default (State 30)	0.165	Default (State 0)	0.151	Default (State 0)	0.247	Default (State 0)	0.145
State 0	0.189	State 6	0.112	State 0	0.151	State 0	0.247	State 0	0.145
State 1	0.188	State 7	0.110	State 11	0.119	State 2	0.253	State 21	0.136
State 2	0.177	State 8	0.110	State 12	0.108	State 15	0.033	State 22	0.138
State 3	0.174	State 9	0.107	State 13	0.099	State 16	0.134	State 23	0.138
State 4	0.172	State 10	0.102	State 14	0.087	State 17	0.132	State 24	0.135
State 5	0.168	State 30	0.165	State 16	0.136	State 18	0.181	State 25	0.136
State 6	0.158	State 50	0.089	State 51	0.152	State 19	0.186	State 26	0.138

Table 14-2
LTE Supplemental Head SAR Data

Supplemental Head SAR Data															
LTE Band 71		LTE Band 12		LTE Band 13		LTE Band 14		LTE Band 5		LTE Band 26		LTE Band 66		LTE Band 25	
QPSK, 20 MHz Bandwidth, 1 RB, 0 RB Offsets		QPSK, 10 MHz Bandwidth, 1 RB, 0 RB Offsets		QPSK, 10 MHz Bandwidth, 1 RB, 0 RB Offsets		QPSK, 10 MHz Bandwidth, 1 RB, 0 RB Offsets		QPSK, 10 MHz Bandwidth, 1 RB, 0 RB Offsets		QPSK, 15 MHz Bandwidth, 1 RB, 74 RB Offsets		QPSK, 20 MHz Bandwidth, 1 RB, 99 RB Offsets		QPSK, 20 MHz Bandwidth, 1 RB, 0 RB Offsets	
Test Position	Left Cheek	Test Position	Right Cheek	Test Position	Right Cheek	Test Position	Right Cheek	Test Position	Right Cheek	Test Position	Right Cheek	Test Position	Left Cheek	Test Position	Left Cheek
Frequency (MHz)	680.5	Frequency (MHz)	707.5	Frequency (MHz)	782.0	Frequency (MHz)	793.0	Frequency (MHz)	836.5	Frequency (MHz)	831.5	Frequency (MHz)	1745.0	Frequency (MHz)	1882.5
Channel	133297	Channel	23095	Channel	23230	Channel	23330	Channel	20525	Channel	26965	Channel	132322	Channel	26365
Measured 1g SAR (W/kg)	0.096	Measured 1g SAR (W/kg)	0.086	Measured 1g SAR (W/kg)	0.127	Measured 1g SAR (W/kg)	0.102	Measured 1g SAR (W/kg)	0.149	Measured 1g SAR (W/kg)	0.140	Measured 1g SAR (W/kg)	0.133	Measured 1g SAR (W/kg)	0.122
Average Value of Time Sweep (W/kg)		Average Value of Time Sweep (W/kg)		Average Value of Time Sweep (W/kg)		Average Value of Time Sweep (W/kg)		Average Value of Time Sweep (W/kg)		Average Value of Time Sweep (W/kg)		Average Value of Time Sweep (W/kg)		Average Value of Time Sweep (W/kg)	
Auto-tune (State 10)	0.143	Auto-tune (State 51)	0.128	Auto-tune (State 57)	0.164	Auto-tune (State 57)	0.147	Auto-tune (State 0)	0.188	Auto-tune (State 0)	0.238	Auto-tune (State 30)	0.152	Auto-tune (State 0)	0.170
Default (State 0)	0.113	Default (State 0)	0.132	Default (State 0)	0.162	Default (State 0)	0.153	Default (State 0)	0.185	Default (State 0)	0.223	Default (State 30)	0.159	Default (State 0)	0.170
State 10	0.137	State 0	0.132	State 0	0.162	State 0	0.153	State 0	0.185	State 0	0.223	State 30	0.159	State 0	0.170
State 25	0.015	State 30	0.004	State 35	0.128	State 40	0.112	State 45	0.062	State 50	0.104	State 53	0.086	State 18	0.157
State 26	0.010	State 31	0.002	State 36	0.131	State 41	0.105	State 46	0.033	State 51	0.221	State 54	0.130	State 19	0.156
State 27	0.007	State 32	0.058	State 37	0.134	State 42	0.092	State 47	0.018	State 52	0.222	State 55	0.081	State 20	0.151
State 28	0.003	State 33	0.057	State 38	0.139	State 43	0.079	State 48	0.173	State 53	0.104	State 56	0.107	State 21	0.158
State 29	0.002	State 34	0.058	State 39	0.140	State 44	0.060	State 49	0.067	State 54	0.217	State 57	0.133	State 22	0.162
State 30	0.001	State 35	0.057	State 40	0.141	State 45	0.048	State 50	0.077	State 55	0.091	State 58	0.088	State 23	0.161
State 31	0.000	State 51	0.133	State 57	0.163	State 57	0.154	State 51	0.178	State 56	0.103	State 59	0.108	State 53	0.155





FCC ID: A3LSMN975U		SAR EVALUATION REPORT		Approved by: Quality Manager
Document S/N: 1M1905200079-01-R1.A3L	Test Dates: 05/22/19 - 07/07/19	DUT Type: Portable Handset	Page 207 of 220	



Table 14-3
UMTS/CDMA Supplemental Body SAR Data

Supplemental Body SAR Data									
UMTS Band 5		UMTS Band 4		UMTS Band 2		CDMA BC0		CDMA BC1	
RMC		RMC		RMC		EVDO Rev. 0		EVDO Rev. 0	
Test Position	Back	Test Position	Bottom	Test Position	Bottom	Test Position	Back	Test Position	Bottom
Spacing	10 mm	Spacing	10 mm	Spacing	10 mm	Spacing	10 mm	Spacing	10 mm
Frequency (MHz)	836.6	Frequency (MHz)	1752.6	Frequency (MHz)	1880.0	Frequency (MHz)	848.31	Frequency (MHz)	1908.75
Channel	4183	Channel	1513	Channel	9400	Channel	777	Channel	1175
Measured 1g SAR (W/kg)	0.616	Measured 1g SAR (W/kg)	0.969	Measured 1g SAR (W/kg)	1.120	Measured 1g SAR (W/kg)	0.670	Measured 1g SAR (W/kg)	0.785
Average Value of Time Sweep (W/kg)		Average Value of Time Sweep (W/kg)		Average Value of Time Sweep (W/kg)		Average Value of Time Sweep (W/kg)		Average Value of Time Sweep (W/kg)	
Auto-tune (State 0)	0.802	Auto-tune (State 30)	1.190	Auto-tune (State 30)	1.767	Auto-tune (State 0)	1.090	Auto-tune (State 0)	1.381
Default (State 0)	0.827	Default (State 30)	1.170	Default (State 0)	1.755	Default (State 0)	1.056	Default (State 0)	1.384
State 0	0.827	State 1	0.852	State 0	1.755	State 0	1.056	State 0	1.384
State 20	0.511	State 2	0.855	State 1	1.760	State 10	0.561	State 1	1.383
State 21	0.516	State 3	0.854	State 2	1.704	State 11	0.452	State 2	1.326
State 22	0.533	State 4	0.853	State 3	1.688	State 12	0.330	State 3	1.307
State 23	0.539	State 5	0.851	State 4	1.683	State 13	0.264	State 4	1.308
State 24	0.542	State 6	0.847	State 5	1.678	State 14	0.201	State 5	1.298
State 25	0.520	State 30	1.170	State 6	1.652	State 15	0.137	State 6	1.283
State 26	0.455	State 54	0.838	State 7	1.631	State 16	0.653	State 7	1.267
				State 8	1.649			State 8	1.269
				State 9	1.590			State 9	1.230
				State 10	1.536			State 10	1.077
				State 11	1.468			State 11	1.022
				State 12	1.359			State 12	0.936
				State 13	1.278			State 13	0.870
				State 14	1.163			State 14	0.783
				State 15	1.009			State 15	0.669
				State 16	1.364			State 16	1.059
				State 17	1.343			State 17	1.044
				State 18	1.451			State 18	1.110
				State 19	1.462			State 19	1.116
				State 20	1.472			State 20	1.120
				State 21	1.478			State 21	1.123
				State 22	1.504			State 22	1.136
				State 23	1.516			State 23	1.142
				State 24	1.510			State 24	1.138
				State 25	1.558			State 25	1.164
				State 26	1.600			State 26	1.181
				State 27	1.649			State 27	1.199
				State 28	1.707			State 28	1.206
				State 29	1.732			State 29	1.199
				State 30	1.760			State 30	1.165
				State 31	1.668			State 31	1.087
				State 32	1.547			State 32	1.110
				State 33	1.548			State 33	1.114
				State 34	1.504			State 34	1.073
				State 35	1.495			State 35	1.065
				State 36	1.491			State 36	1.062
				State 37	1.483			State 37	1.060
				State 38	1.464			State 38	1.041
				State 39	1.455			State 39	1.031
				State 40	1.452			State 40	1.034
				State 41	1.414			State 41	0.994
				State 42	1.373			State 42	0.961
				State 43	1.322			State 43	0.909
				State 44	1.241			State 44	0.845
				State 45	1.172			State 45	0.792
				State 46	1.079			State 46	0.713
				State 47	0.945			State 47	0.621
				State 48	1.605			State 48	1.120
				State 49	1.239			State 49	0.956
				State 50	1.384			State 50	0.974
				State 51	1.749			State 51	1.250
				State 52	1.356			State 52	1.047
				State 53	1.538			State 53	1.103
				State 54	1.730			State 54	1.207
				State 55	1.273			State 55	0.978
				State 56	1.489			State 56	1.055
				State 57	1.752			State 57	1.256
				State 58	1.355			State 58	1.050
				State 59	1.546			State 59	1.103

FCC ID: A3LSMN975U		SAR EVALUATION REPORT		Approved by: Quality Manager
Document S/N: 1M1905200079-01-R1.A3L	Test Dates: 05/22/19 - 07/07/19	DUT Type: Portable Handset		Page 208 of 220

**Table 14-4
LTE Supplemental Body SAR Data**

Supplemental Body SAR Data															
LTE Band 71		LTE Band 12		LTE Band 13		LTE Band 14		LTE Band 5		LTE Band 26		LTE Band 66		LTE Band 25	
QPSK, 20 MHz Bandwidth, 1 RB, 0 RB Offsets		QPSK, 10 MHz Bandwidth, 1 RB, 0 RB Offsets		QPSK, 10 MHz Bandwidth, 1 RB, 0 RB Offsets		QPSK, 10 MHz Bandwidth, 1 RB, 0 RB Offsets		QPSK, 10 MHz Bandwidth, 1 RB, 0 RB Offsets		QPSK, 15 MHz Bandwidth, 1 RB, 74 RB Offsets		QPSK, 20 MHz Bandwidth, 1 RB, 0 RB Offsets		QPSK, 20 MHz Bandwidth, 1 RB, 99 RB Offsets	
Test Position	Back	Test Position	Back	Test Position	Back	Test Position	Back	Test Position	Back	Test Position	Back	Test Position	Back	Test Position	Bottom
Spacing	10 mm	Spacing	10 mm	Spacing	10 mm	Spacing	10 mm	Spacing	10 mm	Spacing	10 mm	Spacing	15 mm	Spacing	10 mm
Frequency (MHz)	680.5	Frequency (MHz)	707.5	Frequency (MHz)	782.0	Frequency (MHz)	783.0	Frequency (MHz)	836.5	Frequency (MHz)	831.5	Frequency (MHz)	1770.0	Frequency (MHz)	1860.0
Channel	133297	Channel	23095	Channel	23230	Channel	23330	Channel	20525	Channel	26865	Channel	132572	Channel	26140
Measured 1g SAR (W/kg)	0.270	Measured 1g SAR (W/kg)	0.232	Measured 1g SAR (W/kg)	0.386	Measured 1g SAR (W/kg)	0.449	Measured 1g SAR (W/kg)	0.581	Measured 1g SAR (W/kg)	0.583	Measured 1g SAR (W/kg)	0.948	Measured 1g SAR (W/kg)	0.815
Average Value of Time Sweep (W/kg)		Average Value of Time Sweep (W/kg)		Average Value of Time Sweep (W/kg)		Average Value of Time Sweep (W/kg)		Average Value of Time Sweep (W/kg)		Average Value of Time Sweep (W/kg)		Average Value of Time Sweep (W/kg)		Average Value of Time Sweep (W/kg)	
Auto-tune (State 9)	0.444	Auto-tune (State 51)	0.411	Auto-tune (State 57)	0.689	Auto-tune (State 57)	0.747	Auto-tune (State 0)	0.900	Auto-tune (State 57)	0.973	Auto-tune (State 31)	1.250	Auto-tune (State 0)	1.313
Default (State 0)	0.352	Default (State 0)	0.396	Default (State 0)	0.679	Default (State 0)	0.706	Default (State 0)	0.866	Default (State 0)	0.961	Default (State 30)	1.213	Default (State 0)	1.290
State 0	0.352	State 0	0.396	State 0	0.679	State 0	0.706	State 0	0.866	State 0	0.961	State 0	0.923	State 0	1.290
State 9	0.440	State 16	0.428	State 30	0.059	State 35	0.551	State 40	0.636	State 45	0.229	State 1	0.925	State 1	1.289
State 20	0.111	State 25	0.333	State 31	0.034	State 36	0.556	State 41	0.645	State 46	0.157	State 2	0.859	State 2	1.224
State 21	0.107	State 26	0.258	State 32	0.313	State 37	0.565	State 42	0.600	State 47	0.056	State 3	0.852	State 3	1.214
State 22	0.093	State 27	0.195	State 33	0.308	State 38	0.583	State 43	0.431	State 48	0.843	State 4	0.847	State 4	1.201
State 23	0.095	State 28	0.128	State 34	0.482	State 39	0.500	State 44	0.338	State 49	0.423	State 5	0.844	State 5	1.204
State 24	0.077	State 29	0.095	State 35	0.501	State 40	0.585	State 45	0.251	State 50	0.472	State 6	0.827	State 6	1.181
State 25	0.055	State 51	0.420	State 57	0.677	State 57	0.719	State 46	0.167	State 57	0.955	State 7	0.821	State 7	1.165
												State 8	0.821	State 8	1.164
												State 9	0.793	State 9	1.134
												State 10	0.770	State 10	1.096
												State 11	0.739	State 11	1.027
												State 12	0.691	State 12	0.953
												State 13	0.653	State 13	0.891
												State 14	0.604	State 14	0.810
												State 15	0.558	State 15	0.700
												State 16	0.532	State 16	1.019
												State 17	0.518	State 17	0.998
												State 18	0.603	State 18	1.104
												State 19	0.614	State 19	1.121
												State 20	0.640	State 20	1.124
												State 21	0.646	State 21	1.127
												State 22	0.676	State 22	1.155
												State 23	0.689	State 23	1.169
												State 24	0.697	State 24	1.166
												State 25	0.744	State 25	1.213
												State 26	0.801	State 26	1.255
												State 27	0.884	State 27	1.304
												State 28	1.013	State 28	1.363
												State 29	1.105	State 29	1.372
												State 30	1.213	State 30	1.371
												State 31	1.251	State 31	1.282
												State 32	0.725	State 32	1.115
												State 33	0.723	State 33	1.114
												State 34	0.735	State 34	1.083
												State 35	0.736	State 35	1.084
												State 36	0.738	State 36	1.082
												State 37	0.738	State 37	1.090
												State 38	0.739	State 38	1.082
												State 39	0.740	State 39	1.075
												State 40	0.733	State 40	1.078
												State 41	0.736	State 41	1.050
												State 42	0.732	State 42	1.030
												State 43	0.728	State 43	0.960
												State 44	0.719	State 44	0.938
												State 45	0.712	State 45	0.897
												State 46	0.695	State 46	0.828
												State 47	0.666	State 47	0.738
												State 48	0.848	State 48	1.139
												State 49	0.482	State 49	0.805
												State 50	0.675	State 50	1.005
												State 51	0.899	State 51	1.256
												State 52	0.535	State 52	1.004
												State 53	0.719	State 53	1.105
												State 54	0.894	State 54	1.236
												State 55	0.902	State 55	0.937
												State 56	0.707	State 56	1.074
												State 57	0.902	State 57	1.263
												State 58	0.537	State 58	1.008
												State 59	0.721	State 59	1.121

FCC ID: A3LSMN975U		SAR EVALUATION REPORT		Approved by: Quality Manager
Document S/N: 1M1905200079-01-R1.A3L	Test Dates: 05/22/19 - 07/07/19	DUT Type: Portable Handset	Page 209 of 220	

14.2 LTE Band 41 Power Class 2 and Power Class 3 Linearity

This device supports Power Class 2 and Power Class 3 operations for LTE Band 41. The highest available duty cycle for Power Class 2 operations is 43.3 % using UL-DL configuration 1. Per May 2017 TCB Workshop Notes based on the device behavior, all SAR tests were performed using Power Class 3. SAR with Power Class 2 at the highest power and available duty factor was additionally performed for the Power Class 3 configuration with the highest SAR for each exposure condition. The linearity between the Power Class 2 and Power Class 3 SAR results and the respective frame averaged powers was calculated to determine that the results were linear. When ULCA is active, the linearity between the Power Class 2 with ULCA active and Power Class 3 with ULCA active SAR results and the respective frame averaged powers was calculated to determine that the results were linear. Per May 2017 TCB Workshop, no additional SAR measurements were required since the linearity between power classes was < 10% and all reported SAR values were < 1.4 W/kg for 1g and < 3.5 W/kg for 10g.

LTE Band 41 SAR testing with power class 2 at the highest power and available duty factor was additionally performed for the power class 3 configuration with the highest SAR for each exposure condition.

Table 14-5
LTE Band 41 Head Linearity Data

	LTE Band 41 PC3	LTE Band 41 PC2
Maximum Allowed Output Power (dBm)	24.50	27.50
Measured Output Power (dBm)	24.14	27.16
Measured SAR (W/kg)	0.078	0.103
Measured Power (mW)	259.42	520.00
Duty Cycle	63.3%	43.3%
Frame Averaged Output Power (mW)	164.21	225.16
% deviation from expected linearity		-3.82%

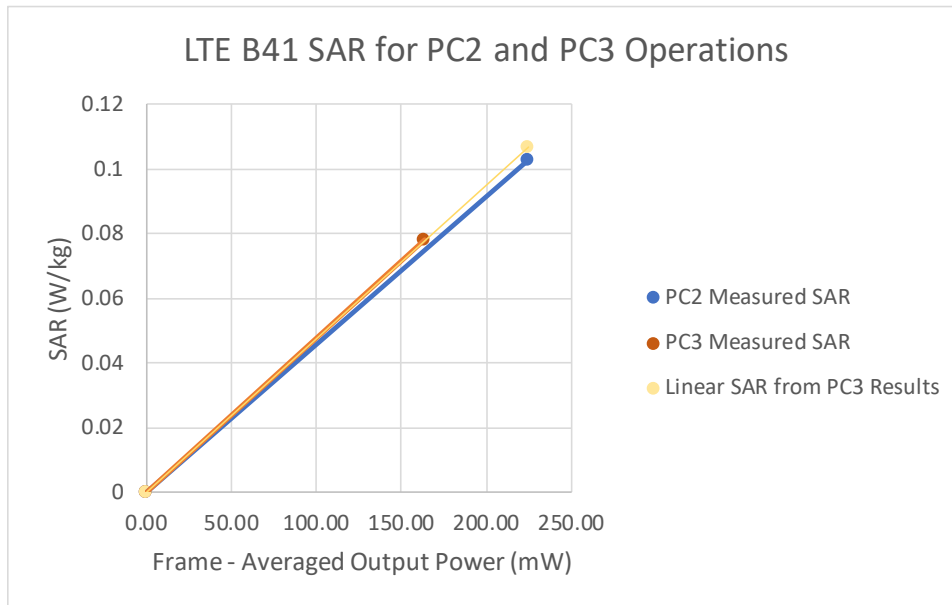

Figure 14-1
LTE Band 41 Head Linearity



FCC ID: A3LSMN975U	 PCTEST ENGINEERING LABORATORY, INC.	SAR EVALUATION REPORT		Approved by: Quality Manager
Document S/N: 1M1905200079-01-R1.A3L	Test Dates: 05/22/19 - 07/07/19	DUT Type: Portable Handset		Page 210 of 220

Table 14-6
LTE Band 41 ULCA Head Linearity Data

	LTE Band 41 PC3 ULCA	LTE Band 41 PC2 ULCA
Maximum Allowed Output Power (dBm)	24.50	27.50
Measured Output Power (dBm)	24.50	27.20
Measured SAR (W/kg)	0.084	0.100
Measured Power (mW)	281.84	524.81
Duty Cycle	63.3%	43.3%
Frame Averaged Output Power (mW)	178.40	227.24
% deviation from expected linearity		-6.43%

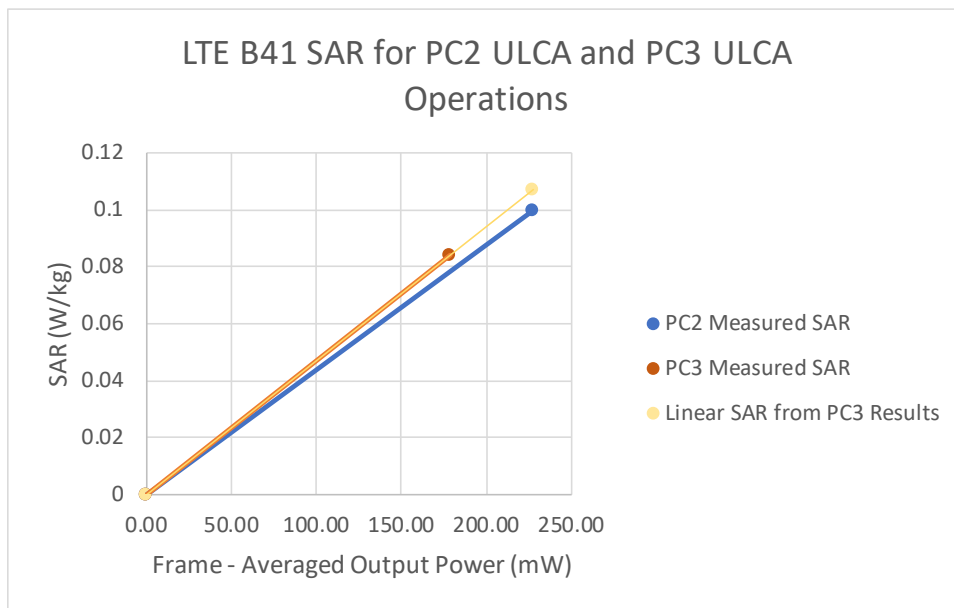

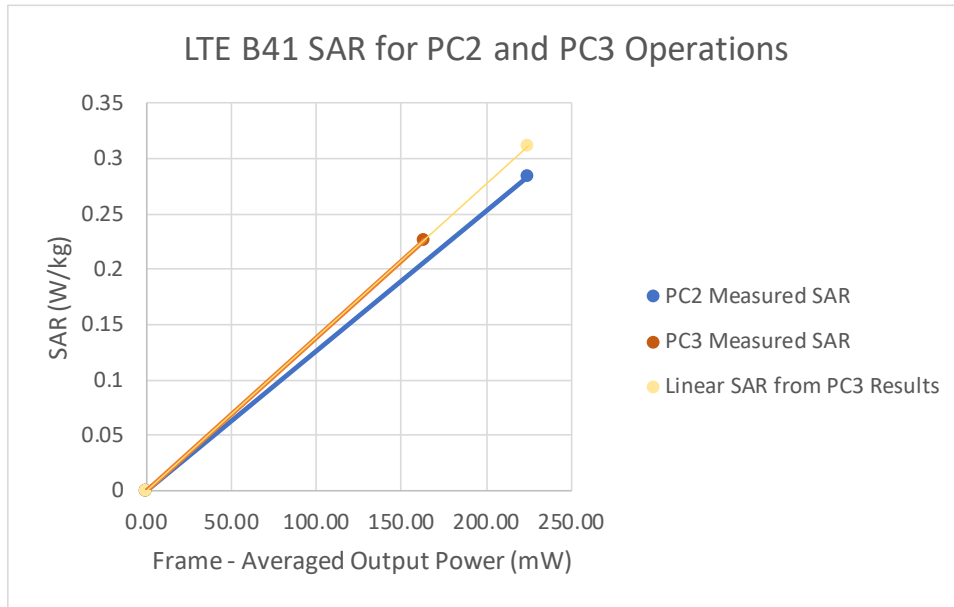

Figure 14-2
LTE Band 41 ULCA Head Linearity

FCC ID: A3LSMN975U		SAR EVALUATION REPORT		Approved by: Quality Manager
Document S/N: 1M1905200079-01-R1.A3L	Test Dates: 05/22/19 - 07/07/19	DUT Type: Portable Handset		Page 211 of 220

**Table 14-7
LTE Band 41 Body-Worn Linearity Data**

	LTE Band 41 PC3	LTE Band 41 PC2
Maximum Allowed Output Power (dBm)	24.50	27.50
Measured Output Power (dBm)	24.14	27.16
Measured SAR (W/kg)	0.227	0.285
Measured Power (mW)	259.42	520.00
Duty Cycle	63.3%	43.3%
Frame Averaged Output Power (mW)	164.21	225.16
% deviation from expected linearity		-8.43%



**Figure 14-3
LTE Band 41 Body-Worn Linearity**



FCC ID: A3LSMN975U		SAR EVALUATION REPORT		Approved by: Quality Manager
Document S/N: 1M1905200079-01-R1.A3L	Test Dates: 05/22/19 - 07/07/19	DUT Type: Portable Handset		Page 212 of 220

Table 14-8
LTE Band 41 ULCA Body-Worn Linearity Data

	LTE Band 41 PC3 ULCA	LTE Band 41 PC2 ULCA
Maximum Allowed Output Power (dBm)	24.50	27.50
Measured Output Power (dBm)	24.50	27.20
Measured SAR (W/kg)	0.258	0.301
Measured Power (mW)	281.84	524.81
Duty Cycle	63.3%	43.3%
Frame Averaged Output Power (mW)	178.40	227.24
% deviation from expected linearity		-8.41%

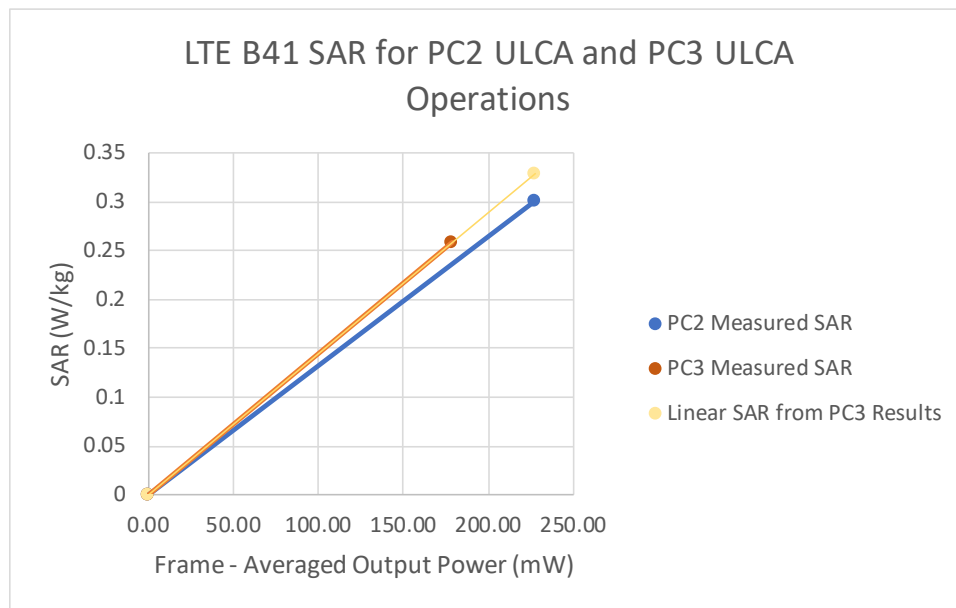

Figure 14-4
LTE Band 41 ULCA Body-Worn Linearity



FCC ID: A3LSMN975U		SAR EVALUATION REPORT		Approved by: Quality Manager
Document S/N: 1M1905200079-01-R1.A3L	Test Dates: 05/22/19 - 07/07/19	DUT Type: Portable Handset		Page 213 of 220

Table 14-9
LTE Band 41 Hotspot Linearity Data

	LTE Band 41 PC3	LTE Band 41 PC2
Maximum Allowed Output Power (dBm)	22.50	22.50
Measured Output Power (dBm)	22.00	21.93
Measured SAR (W/kg)	0.660	0.411
Measured Power (mW)	158.49	155.96
Duty Cycle	63.3%	43.3%
Frame Averaged Output Power (mW)	100.32	67.53
% deviation from expected linearity		-7.48%

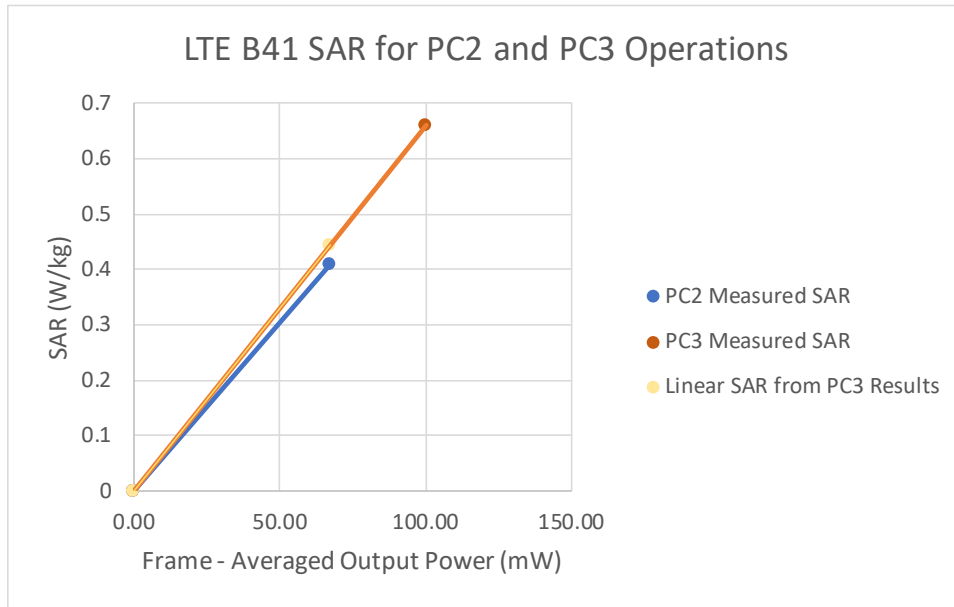

Figure 14-5
LTE Band 41 Hotspot Linearity



FCC ID: A3LSMN975U		SAR EVALUATION REPORT		Approved by: Quality Manager
Document S/N: 1M1905200079-01-R1.A3L	Test Dates: 05/22/19 - 07/07/19	DUT Type: Portable Handset		Page 214 of 220

Table 14-10
LTE Band 41 ULCA Hotspot Linearity Data

	LTE Band 41 PC3 ULCA	LTE Band 41 PC2 ULCA
Maximum Allowed Output Power (dBm)	22.50	22.50
Measured Output Power (dBm)	22.50	22.36
Measured SAR (W/kg)	0.703	0.462
Measured Power (mW)	177.83	172.19
Duty Cycle	63.3%	43.3%
Frame Averaged Output Power (mW)	112.57	74.56
% deviation from expected linearity		-0.78%

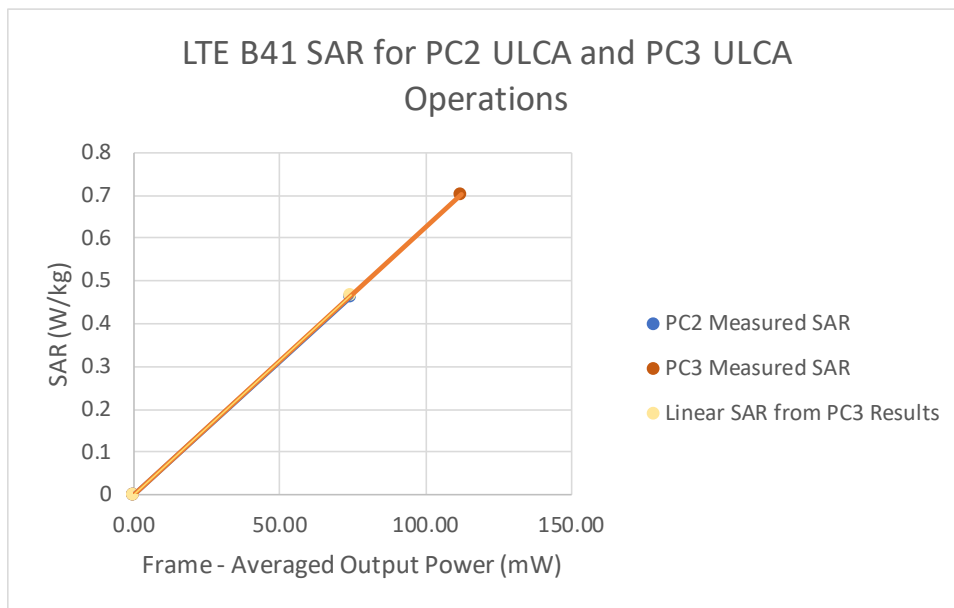



Figure 14-6
LTE Band 41 ULCA Hotspot Linearity



FCC ID: A3LSMN975U		SAR EVALUATION REPORT		Approved by: Quality Manager
Document S/N: 1M1905200079-01-R1.A3L	Test Dates: 05/22/19 - 07/07/19	DUT Type: Portable Handset		Page 215 of 220

15 EQUIPMENT LIST

Manufacturer	Model	Description	Cal Date	Cal Interval	Cal Due	Serial Number
Agilent	8594A	(9MHz-2.9GHz) Spectrum Analyzer	N/A	N/A	N/A	305140087
Agilent	8753E	(30kHz-6GHz) Network Analyzer	9/28/2018	Annual	9/28/2019	JP38001082
Agilent	E5151C	Wireless Communications Test Set	2/28/2018	Biennial	2/28/2020	GB44450275
Agilent	N9020A	MMA Signal Analyzer	4/20/2019	Annual	4/20/2020	US46470561
Agilent	N4010A	Wireless Connectivity Test Set	N/A	N/A	N/A	GB45120464
Agilent	N4010A	Wireless Connectivity Test Set	N/A	N/A	N/A	GB44450273
Agilent	E5151C	Wireless Communications Test Set	2/7/2018	Triennial	2/7/2021	GB43304447
Agilent	E5151C	Wireless Communications Test Set	5/22/2018	Biennial	5/22/2020	GB43181563
Agilent	N5182A	MXG Vector Signal Generator	11/28/2018	Annual	11/28/2019	MY47420603
Agilent	E4438C	ESG Vector Signal Generator	3/8/2019	Biennial	3/8/2021	MY42082386
Agilent	E4438C	ESG Vector Signal Generator	3/11/2019	Biennial	3/11/2021	MY45090700
Agilent	8753E	S-Parameter Network Analyzer	10/2/2018	Annual	10/2/2019	US39170118
Agilent	8753ES	S-Parameter Network Analyzer	7/30/2018	Annual	7/30/2019	MY40006670
Agilent	8753ES	Network Analyzer	3/19/2019	Annual	3/19/2020	MY40001472
Agilent	8753ES	S-Parameter Vector Network Analyzer	8/20/2018	Annual	8/20/2019	MY40003841
Agilent	8033B	3 5mm Standard Calibration Kit	8/13/2018	Annual	8/13/2019	MY53402352
Amplifier Research	35S1G6	Amplifier	CBT	N/A	CBT	433971
Amplifier Research	35S1G6	Amplifier	CBT	N/A	CBT	433972
Amplifier Research	35S1G6	Amplifier	CBT	N/A	CBT	433974
Anritsu	ML2495A	Power Meter	10/21/2018	Annual	10/21/2019	941001
Anritsu	ML2495A	Power Meter	11/20/2018	Annual	11/20/2019	103508
Anritsu	MT8821C	Radio Communication Analyzer	11/6/2018	Annual	11/6/2019	6200901190
Anritsu	MA24106A	USB Power Sensor	5/6/2019	Annual	5/6/2020	1231538
Anritsu	MA24106A	USB Power Sensor	5/22/2019	Annual	5/22/2020	1231535
Anritsu	MA24106A	USB Power Sensor	1/31/2019	Annual	1/31/2020	1244524
Anritsu	MT8820C	Radio Communication Analyzer	3/29/2019	Annual	3/29/2020	6201300731
Anritsu	MT8821C	Radio Communication Analyzer	7/26/2018	Annual	7/26/2019	6201144418
Anritsu	MT8821C	Radio Communication Analyzer	3/18/2019	Annual	3/18/2020	6201144419
Anritsu	MA2411B	Pulse Power Sensor	10/30/2018	Annual	10/30/2019	1207470
Anritsu	MA2411B	Pulse Power Sensor	11/20/2018	Annual	11/20/2019	1339007
Anritsu	MA2411B	Pulse Power Sensor	11/20/2018	Annual	11/20/2019	1339008
Anritsu	MT8821C	Radio Communication Analyzer	7/24/2018	Annual	7/24/2019	620164756
Anritsu	MT8821C	Radio Communication Analyzer	3/6/2019	Annual	3/6/2020	6201381794
Anritsu	MT8822A	Wireless Connectivity Test Set	7/3/2018	Annual	7/3/2019	6261782395
Anritsu	MT8821C	Radio Communication Analyzer	1/25/2019	Annual	1/25/2020	6261914237
Anritsu	MT8820A	Radio Communication Test Station	11/24/2018	Annual	11/24/2019	6261914237
COMTECH	ARR5729-5/S7598	Solid State Amplifier	CBT	N/A	CBT	M3W1A00-1002
COMTECH	ARR5729-5	Solid State Amplifier	CBT	N/A	CBT	M15SA00-009
Control Company	4040	Temperature / Humidity Monitor	2/28/2018	Biennial	2/28/2020	150761931
Control Company	4352	Ultra Long Stem Thermometer	8/2/2018	Biennial	8/2/2020	181334684
Control Company	4352	Ultra Long Stem Thermometer	8/2/2018	Biennial	8/2/2020	181334654
Control Company	4352	Ultra Long Stem Thermometer	8/2/2018	Biennial	8/2/2020	181292000
Control Company	4040	Therm / Clock/ Humidity Monitor	10/9/2018	Biennial	10/9/2020	181647811
Control Company	4040	Therm / Clock/ Humidity Monitor	10/9/2018	Biennial	10/9/2020	181647802
Control Company	4040	Therm / Clock/ Humidity Monitor	10/9/2018	Biennial	10/9/2020	181647812
Intelligent Weigh	R5-3000	Electronic Balance	N/A	N/A	N/A	11081534
Keylight	772D	Dual Directional Coupler	CBT	N/A	CBT	MY52180215
MCL	BW-N6W5+	6dB Attenuator	CBT	N/A	CBT	1139
MiniCircuits	SLP-2400+	Low Pass Filter	CBT	N/A	CBT	8897590093
MiniCircuits	VF-6000+	Low Pass Filter	CBT	N/A	CBT	N/A
MiniCircuits	VF-6000+	Low Pass Filter	CBT	N/A	CBT	N/A
Mini-Circuits	BW-N20W5+	DC to 18 GHz Precision Fixed 20 dB Attenuator	CBT	N/A	CBT	N/A
Mini-Circuits	NLP-2950+	Low Pass Filter DC to 2700 Mhz	CBT	N/A	CBT	N/A
Mini-Circuits	NLP-1200+	Low Pass Filter DC to 3000 Mhz	CBT	N/A	CBT	N/A
Mini-Circuits	BW-N20W5	Power Attenuator	CBT	N/A	CBT	1236
Minutyp	CG-FC5X	Digital Caliper	4/18/2018	Biennial	4/18/2020	13264165
Narda	4772-3	Attenuator (dB)	CBT	N/A	CBT	9406
Narda	BW-53W2	Attenuator (dB)	CBT	N/A	CBT	120
Narda	401AC-6	4 - 8 GHz SMA 6 dB Directional Coupler	CBT	N/A	CBT	N/A
Pasternack	PE2208-6	Bidirectional Coupler	CBT	N/A	CBT	N/A
Pasternack	PE2208-10	Bidirectional Coupler	CBT	N/A	CBT	N/A
Pasternack	NC-100	Torque Wrench	11/17/2017	Biennial	11/17/2019	N/A
Pasternack	NC-100	Torque Wrench	5/23/2018	Biennial	5/23/2020	N/A
Pasternack	PE5011-1	Torque Wrench	7/19/2017	Biennial	7/19/2019	N/A
Rohde & Schwarz	CMW500	Radio Communication Tester	11/14/2018	Annual	11/14/2019	100976
Rohde & Schwarz	CMW500	Radio Communication Tester	7/5/2018	Annual	7/5/2019	106578
Rohde & Schwarz	CMW500	Radio Communication Tester	10/4/2018	Annual	10/4/2019	109366
Rohde & Schwarz	CMW500	Radio Communication Tester	8/10/2018	Annual	8/10/2019	116743
Rohde & Schwarz	CMW500	Radio Communication Tester	4/19/2019	Annual	4/19/2020	128633
Rohde & Schwarz	CM1200	Base Station Simulator	6/3/2019	Annual	6/3/2020	108892
SPEAG	D750V2	750 MHz SAR Dipole	10/19/2018	Annual	10/19/2019	1161
SPEAG	D835V2	835 MHz SAR Dipole	1/22/2019	Annual	1/22/2020	4d132
SPEAG	D1765V2	1765 MHz SAR Dipole	5/23/2018	Biennial	5/23/2020	1068
SPEAG	D1900V2	1900 MHz SAR Dipole	10/23/2018	Annual	10/23/2019	5d80
SPEAG	D2200V2	2200 MHz SAR Dipole	13/8/2017	Biennial	13/8/2019	1064
SPEAG	D2500V2	2500 MHz SAR Dipole	9/11/2017	Biennial	9/11/2019	797
SPEAG	D2600V2	2600 MHz SAR Dipole	9/13/2016	Triennial	9/13/2019	1071
SPEAG	D3500V2	3500 MHz SAR Dipole	8/15/2018	Annual	8/15/2019	1055
SPEAG	D5GHV2	5 GHz SAR Dipole	9/21/2016	Triennial	9/21/2019	1191
SPEAG	D750V3	750 MHz SAR Dipole	3/15/2018	Biennial	10/10/2020	1093
SPEAG	D835V2	835 MHz SAR Dipole	10/19/2018	Annual	10/19/2019	4d133
SPEAG	D1750V2	1750 MHz SAR Dipole	10/22/2018	Annual	10/22/2019	1150
SPEAG	D1900V2	1900 MHz SAR Dipole	2/21/2019	Annual	2/21/2020	5d148
SPEAG	D1900V2	1900 MHz SAR Dipole	10/23/2018	Annual	10/23/2019	5d149
SPEAG	D2200V2	2200 MHz SAR Dipole	8/13/2018	Annual	8/13/2019	1073
SPEAG	D2500V2	2500 MHz SAR Dipole	8/17/2017	Biennial	8/17/2019	719
SPEAG	D2600V2	2600 MHz SAR Dipole	4/11/2018	Biennial	4/11/2020	1004
SPEAG	D5GHV2	5 GHz SAR Dipole	8/10/2018	Annual	8/10/2019	1237
SPEAG	EX30V4	SAR Probe	2/19/2019	Annual	2/19/2020	3914
SPEAG	EX30V4	SAR Probe	6/25/2018	Annual	6/25/2019	7489
SPEAG	EX30V4	SAR Probe	4/24/2019	Annual	4/24/2020	7357
SPEAG	EX30V4	SAR Probe	8/23/2018	Annual	8/23/2019	7308
SPEAG	EX30V4	SAR Probe	1/25/2019	Annual	1/25/2020	3589
SPEAG	EX30V4	SAR Probe	5/16/2019	Annual	5/16/2020	7406
SPEAG	EX30V4	SAR Probe	3/24/2019	Annual	1/24/2020	7488
SPEAG	EX30V4	SAR Probe	7/20/2018	Annual	7/20/2019	7410
SPEAG	EX30V4	SAR Probe	2/19/2019	Annual	2/19/2020	7417
SPEAG	DAE4	Dasy Data Acquisition Electronics	2/14/2019	Annual	2/14/2020	1272
SPEAG	DAE4	Dasy Data Acquisition Electronics	6/18/2018	Annual	6/18/2019	1334
SPEAG	DAE4	Dasy Data Acquisition Electronics	4/18/2019	Annual	4/18/2020	1407
SPEAG	DAE4	Dasy Data Acquisition Electronics	10/9/2018	Annual	10/9/2019	1558
SPEAG	DAE4	Dasy Data Acquisition Electronics	8/22/2018	Annual	8/22/2019	1450
SPEAG	DAE4	Dasy Data Acquisition Electronics	5/8/2019	Annual	5/8/2020	859
SPEAG	DAE4	Dasy Data Acquisition Electronics	1/15/2019	Annual	1/15/2020	1530
SPEAG	DAE4	Dasy Data Acquisition Electronics	7/11/2018	Annual	7/11/2019	1322
SPEAG	DAE4	Dasy Data Acquisition Electronics	2/13/2019	Annual	2/13/2020	665
SPEAG	DAK-3.5	Dielectric Assessment Kit	5/7/2019	Annual	5/7/2020	1070



Note: 1) CBT (Calibrated Before Testing). Prior to testing, the measurement paths containing a cable, amplifier, attenuator, coupler or filter were connected to a calibrated source (i.e. a signal generator) to determine the losses of the measurement path. The power meter offset was then adjusted to compensate for the measurement system losses. This level offset is stored within the power meter before measurements are made. This calibration verification procedure applies to the system verification and output power measurements. The calibrated reading is then taken directly from the power meter after compensation of the losses for all final power measurements.

2) Each equipment item was used solely within its respective calibration period.

FCC ID: A3LSMN975U		SAR EVALUATION REPORT			Approved by: Quality Manager
Document S/N: 1M1905200079-01-R1.A3L	Test Dates: 05/22/19 - 07/07/19	DUT Type: Portable Handset	Page 216 of 220		

16 MEASUREMENT UNCERTAINTIES

a	c	d	e= f(d,k)	f	g	h = c x f/e	i = c x g/e	k
Uncertainty Component	Tol. (± %)	Prob. Dist.	Div.	c _i 1gm	c _i 10 gms	1gm u _i (± %)	10gms u _i (± %)	v _i
Measurement System								
Probe Calibration	6.55	N	1	1.0	1.0	6.6	6.6	∞
Axial Isotropy	0.25	N	1	0.7	0.7	0.2	0.2	∞
Hemishperical Isotropy	1.3	N	1	0.7	0.7	0.9	0.9	∞
Boundary Effect	2.0	R	1.73	1.0	1.0	1.2	1.2	∞
Linearity	0.3	N	1	1.0	1.0	0.3	0.3	∞
System Detection Limits	0.25	R	1.73	1.0	1.0	0.1	0.1	∞
Readout Electronics	0.3	N	1	1.0	1.0	0.3	0.3	∞
Response Time	0.8	R	1.73	1.0	1.0	0.5	0.5	∞
Integration Time	2.6	R	1.73	1.0	1.0	1.5	1.5	∞
RF Ambient Conditions - Noise	3.0	R	1.73	1.0	1.0	1.7	1.7	∞
RF Ambient Conditions - Reflections	3.0	R	1.73	1.0	1.0	1.7	1.7	∞
Probe Positioner Mechanical Tolerance	0.4	R	1.73	1.0	1.0	0.2	0.2	∞
Probe Positioning w/ respect to Phantom	6.7	R	1.73	1.0	1.0	3.9	3.9	∞
Extrapolation, Interpolation & Integration algorithms for Max. SAR Evaluation	4.0	R	1.73	1.0	1.0	2.3	2.3	∞
Test Sample Related								
Test Sample Positioning	2.7	N	1	1.0	1.0	2.7	2.7	35
Device Holder Uncertainty	1.67	N	1	1.0	1.0	1.7	1.7	5
Output Power Variation - SAR drift measurement	5.0	R	1.73	1.0	1.0	2.9	2.9	∞
SAR Scaling	0.0	R	1.73	1.0	1.0	0.0	0.0	∞
Phantom & Tissue Parameters								
Phantom Uncertainty (Shape & Thickness tolerances)	7.6	R	1.73	1.0	1.0	4.4	4.4	∞
Liquid Conductivity - measurement uncertainty	4.2	N	1	0.78	0.71	3.3	3.0	10
Liquid Permittivity - measurement uncertainty	4.1	N	1	0.23	0.26	1.0	1.1	10
Liquid Conductivity - Temperature Uncertainty	3.4	R	1.73	0.78	0.71	1.5	1.4	∞
Liquid Permittivity - Temperature Uncertainty	0.6	R	1.73	0.23	0.26	0.1	0.1	∞
Liquid Conductivity - deviation from target values	5.0	R	1.73	0.64	0.43	1.8	1.2	∞
Liquid Permittivity - deviation from target values	5.0	R	1.73	0.60	0.49	1.7	1.4	∞
Combined Standard Uncertainty (k=1)	RSS					11.5	11.3	60
Expanded Uncertainty (95% CONFIDENCE LEVEL)	k=2					23.0	22.6	



FCC ID: A3LSMN975U		SAR EVALUATION REPORT		Approved by: Quality Manager
Document S/N: 1M1905200079-01-R1.A3L	Test Dates: 05/22/19 - 07/07/19	DUT Type: Portable Handset	Page 217 of 220	

17 CONCLUSION

17.1 Measurement Conclusion



The SAR evaluation indicates that the EUT complies with the RF radiation exposure limits of the FCC and Innovation, Science, and Economic Development Canada, with respect to all parameters subject to this test. These measurements were taken to simulate the RF effects of RF exposure under worst-case conditions. Precise laboratory measures were taken to assure repeatability of the tests. The results and statements relate only to the item(s) tested.

Please note that the absorption and distribution of electromagnetic energy in the body are very complex phenomena that depend on the mass, shape, and size of the body, the orientation of the body with respect to the field vectors, and the electrical properties of both the body and the environment. Other variables that may play a substantial role in possible biological effects are those that characterize the environment (e.g. ambient temperature, air velocity, relative humidity, and body insulation) and those that characterize the individual (e.g. age, gender, activity level, debilitation, or disease). Because various factors may interact with one another to vary the specific biological outcome of an exposure to electromagnetic fields, any protection guide should consider maximal amplification of biological effects as a result of field-body interactions, environmental conditions, and physiological variables. [3]



FCC ID: A3LSMN975U		SAR EVALUATION REPORT		Approved by: Quality Manager
Document S/N: 1M1905200079-01-R1.A3L	Test Dates: 05/22/19 - 07/07/19	DUT Type: Portable Handset	Page 218 of 220	

18 REFERENCES

- [1] Federal Communications Commission, ET Docket 93-62, Guidelines for Evaluating the Environmental Effects of Radiofrequency Radiation, Aug. 1996.
- [2] ANSI/IEEE C95.1-2005, American National Standard safety levels with respect to human exposure to radio frequency electromagnetic fields, 3kHz to 300GHz, New York: IEEE, 2006.
- [3] ANSI/IEEE C95.1-1992, American National Standard safety levels with respect to human exposure to radio frequency electromagnetic fields, 3kHz to 300GHz, New York: IEEE, Sept. 1992.
- [4] ANSI/IEEE C95.3-2002, IEEE Recommended Practice for the Measurement of Potentially Hazardous Electromagnetic Fields - RF and Microwave, New York: IEEE, December 2002.
- [5] IEEE Standards Coordinating Committee 39 –Standards Coordinating Committee 34 – IEEE Std. 1528-2013, IEEE Recommended Practice for Determining the Peak Spatial-Average Specific Absorption Rate (SAR) in the Human Head from Wireless Communications Devices: Measurement Techniques.
- [6] NCRP, National Council on Radiation Protection and Measurements, Biological Effects and Exposure Criteria for RadioFrequency Electromagnetic Fields, NCRP Report No. 86, 1986. Reprinted Feb. 1995.
- [7] T. Schmid, O. Egger, N. Kuster, Automated E-field scanning system for dosimetric assessments, IEEE Transaction on Microwave Theory and Techniques, vol. 44, Jan. 1996, pp. 105-113.
- [8] K. Pokovic, T. Schmid, N. Kuster, Robust setup for precise calibration of E-field probes in tissue simulating liquids at mobile communications frequencies, ICECOM97, Oct. 1997, pp. 1 -124.
- [9] K. Pokovic, T. Schmid, and N. Kuster, E-field Probe with improved isotropy in brain simulating liquids, Proceedings of the ELMAR, Zadar, Croatia, June 23-25, 1996, pp. 172-175.
- [10] Schmid & Partner Engineering AG, Application Note: Data Storage and Evaluation, June 1998, p2.
- [11] V. Hombach, K. Meier, M. Burkhardt, E. Kuhn, N. Kuster, The Dependence of EM Energy Absorption upon Human Modeling at 900 MHz, IEEE Transaction on Microwave Theory and Techniques, vol. 44 no. 10, Oct. 1996, pp. 1865-1873.
- [12] N. Kuster and Q. Balzano, Energy absorption mechanism by biological bodies in the near field of dipole antennas above 300MHz, IEEE Transaction on Vehicular Technology, vol. 41, no. 1, Feb. 1992, pp. 17-23.
- [13] G. Hartsgrove, A. Kraszewski, A. Surowiec, Simulated Biological Materials for Electromagnetic Radiation Absorption Studies, University of Ottawa, Bioelectromagnetics, Canada: 1987, pp. 29-36.
- [14] Q. Balzano, O. Garay, T. Manning Jr., Electromagnetic Energy Exposure of Simulated Users of Portable Cellular Telephones, IEEE Transactions on Vehicular Technology, vol. 44, no.3, Aug. 1995.
- [15] W. Gander, Computermathematick, Birkhaeuser, Basel, 1992.
- [16] W.H. Press, S.A. Teukolsky, W.T. Vetterling, and B.P. Flannery, Numerical Recipes in C, The Art of Scientific Computing, Second edition, Cambridge University Press, 1992.
- [17] N. Kuster, R. Kastle, T. Schmid, Dosimetric evaluation of mobile communications equipment with known precision, IEEE Transaction on Communications, vol. E80-B, no. 5, May 1997, pp. 645-652.

FCC ID: A3LSMN975U	 PCTEST ENGINEERING LABORATORY, INC.	SAR EVALUATION REPORT		Approved by: Quality Manager
Document S/N: 1M1905200079-01-R1.A3L	Test Dates: 05/22/19 - 07/07/19	DUT Type: Portable Handset		Page 219 of 220

- [18] CENELEC CLC/SC111B, European Prestandard (prENV 50166-2), Human Exposure to Electromagnetic Fields High-frequency: 10kHz-300GHz, Jan. 1995.
- [19] Prof. Dr. Niels Kuster, ETH, Eidgenössische Technische Hochschule Zürich, Dosimetric Evaluation of the Cellular Phone.
- [20] IEC 62209-1, Measurement procedure for the assessment of specific absorption rate of human exposure to radio frequency fields from hand-held and body-mounted wireless communication devices - Part 1: Devices used next to the ear (Frequency range of 300 MHz to 6 GHz), July 2016.
- [21] Innovation, Science, Economic Development Canada RSS-102 Radio Frequency Exposure Compliance of Radiocommunication Apparatus (All Frequency Bands) Issue 5, March 2015.
- [22] Health Canada Safety Code 6 Limits of Human Exposure to Radio Frequency Electromagnetic Fields in the Frequency Range from 3 kHz – 300 GHz, 2015
- [23] FCC SAR Test Procedures for 2G-3G Devices, Mobile Hotspot and UMPC Devices KDB Publications 941225, D01-D07
- [24] SAR Measurement Guidance for IEEE 802.11 Transmitters, KDB Publication 248227 D01
- [25] FCC SAR Considerations for Handsets with Multiple Transmitters and Antennas, KDB Publications 648474 D03-D04
- [26] FCC SAR Evaluation Considerations for Laptop, Notebook, Netbook and Tablet Computers, FCC KDB Publication 616217 D04
- [27] FCC SAR Measurement and Reporting Requirements for 100MHz – 6 GHz, KDB Publications 865664 D01-D02
- [28] FCC General RF Exposure Guidance and SAR Procedures for Dongles, KDB Publication 447498, D01-D02
- [29] Anexo à Resolução No. 533, de 10 de Setembro de 2009.
- [30] IEC 62209-2, Human exposure to radio frequency fields from hand-held and body-mounted wireless communication devices - Human models, instrumentation, and procedures - Part 2: Procedure to determine the specific absorption rate (SAR) for wireless communication devices used in close proximity to the human body (frequency range of 30 MHz to 6 GHz), Mar. 2010.

FCC ID: A3LSMN975U		SAR EVALUATION REPORT		Approved by: Quality Manager
Document S/N: 1M1905200079-01-R1.A3L	Test Dates: 05/22/19 - 07/07/19	DUT Type: Portable Handset	Page 220 of 220	

APPENDIX A: SAR TEST DATA

PCTEST ENGINEERING LABORATORY, INC.

DUT: A3LSMN975U; Type: Portable Handset; Serial: 0119M

Communication System: UID 0, Cellular CDMA; Frequency: 820.1 MHz; Duty Cycle: 1:1
Medium: 835 Head; Medium parameters used (interpolated):
 $f = 820.1 \text{ MHz}$; $\sigma = 0.884 \text{ S/m}$; $\epsilon_r = 40.649$; $\rho = 1000 \text{ kg/m}^3$
Phantom section: Right Section

Test Date: 05-28-2019; Ambient Temp: 20.0°C; Tissue Temp: 19.8°C

Probe: EX3DV4 - SN7409; ConvF(9.67, 9.67, 9.67) @ 820.1 MHz; Calibrated: 6/25/2018
Sensor-Surface: 1.4mm (Mechanical Surface Detection)
Electronics: DAE4 Sn1334; Calibrated: 6/18/2018
Phantom: Left 30-SAM V5.0; Type: QD 000 P40 CD; Serial: 1715
Measurement SW: DASY52, Version 52.10 (2);SEMCAD X Version 14.6.12 (7450)

Mode: Cell. EVDO Rev. A BC10, Rule Part 90S, Right Head, Cheek, Mid.ch

Area Scan (9x15x1): Measurement grid: dx=15mm, dy=15mm

Zoom Scan (5x5x7)/Cube 0: Measurement grid: dx=8mm, dy=8mm, dz=5mm

Reference Value = 13.23 V/m; Power Drift = 0.04 dB

Peak SAR (extrapolated) = 0.195 W/kg

SAR(1 g) = 0.150 W/kg

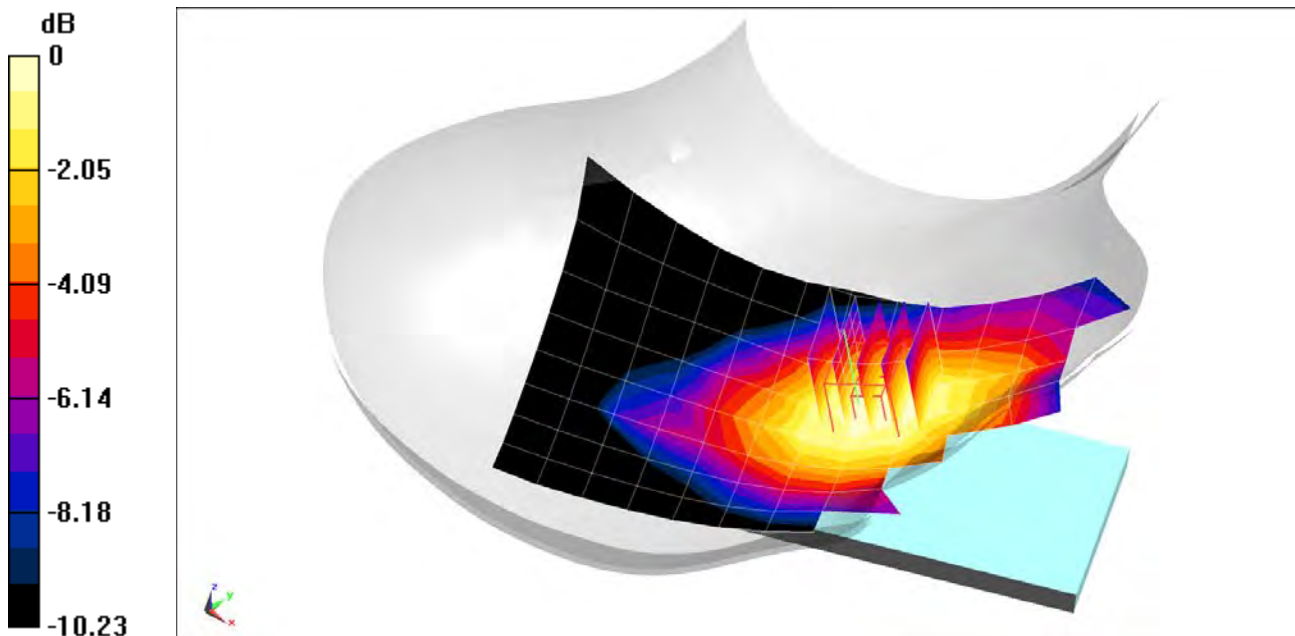

0 dB = 0.179 W/kg = -7.47 dBW/kg

PCTEST ENGINEERING LABORATORY, INC.

DUT: A3LSMN975U; Type: Portable Handset; Serial: 0119M

Communication System: UID 0, CDMA; Frequency: 836.52 MHz; Duty Cycle: 1:1
Medium: 835 Head; Medium parameters used (interpolated):
 $f = 836.52$ MHz; $\sigma = 0.901$ S/m; $\epsilon_r = 40.433$; $\rho = 1000$ kg/m³
Phantom section: Right Section

Test Date: 05-28-2019; Ambient Temp: 20.0°C; Tissue Temp: 19.8°C

Probe: EX3DV4 - SN7409; ConvF(9.67, 9.67, 9.67) @ 836.52 MHz; Calibrated: 6/25/2018
Sensor-Surface: 1.4mm (Mechanical Surface Detection)
Electronics: DAE4 Sn1334; Calibrated: 6/18/2018
Phantom: Left 30-SAM V5.0; Type: QD 000 P40 CD; Serial: 1715
Measurement SW: DASY52, Version 52.10 (2);SEMCAD X Version 14.6.12 (7450)

Mode: Cell. CDMA BC0, Rule Part 22H, Right Head, Cheek, Mid.ch

Area Scan (9x15x1): Measurement grid: dx=15mm, dy=15mm

Zoom Scan (5x5x7)/Cube 0: Measurement grid: dx=8mm, dy=8mm, dz=5mm

Reference Value = 12.98 V/m; Power Drift = -0.03 dB

Peak SAR (extrapolated) = 0.184 W/kg

SAR(1 g) = 0.144 W/kg

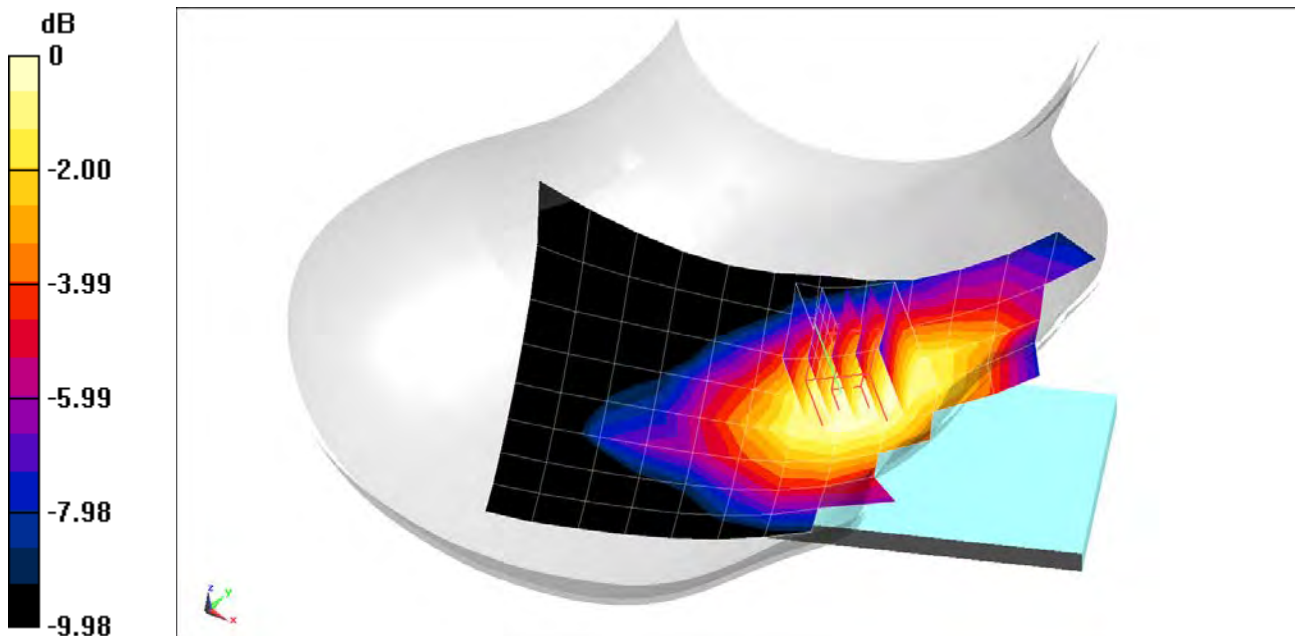

0 dB = 0.169 W/kg = -7.72 dBW/kg

PCTEST ENGINEERING LABORATORY, INC.

DUT: A3LSMN975U; Type: Portable Handset; Serial: 0119M

Communication System: UID 0, GSM; Frequency: 836.6 MHz; Duty Cycle: 1:8.3
Medium: 835 Head; Medium parameters used (interpolated):
 $f = 836.6 \text{ MHz}$; $\sigma = 0.901 \text{ S/m}$; $\epsilon_r = 40.432$; $\rho = 1000 \text{ kg/m}^3$
Phantom section: Right Section

Test Date: 05-28-2019; Ambient Temp: 20.0°C; Tissue Temp: 19.8°C

Probe: EX3DV4 - SN7409; ConvF(9.67, 9.67, 9.67) @ 836.6 MHz; Calibrated: 6/25/2018
Sensor-Surface: 1.4mm (Mechanical Surface Detection)
Electronics: DAE4 Sn1334; Calibrated: 6/18/2018
Phantom: Left 30-SAM V5.0; Type: QD 000 P40 CD; Serial: 1715
Measurement SW: DASY52, Version 52.10 (2);SEMCAD X Version 14.6.12 (7450)

Mode: GSM 850, Right Head, Cheek, Mid.ch

Area Scan (9x14x1): Measurement grid: dx=15mm, dy=15mm

Zoom Scan (6x6x7)/Cube 0: Measurement grid: dx=8mm, dy=8mm, dz=5mm

Reference Value = 10.38 V/m; Power Drift = 0.01 dB

Peak SAR (extrapolated) = 0.125 W/kg

SAR(1 g) = 0.098 W/kg

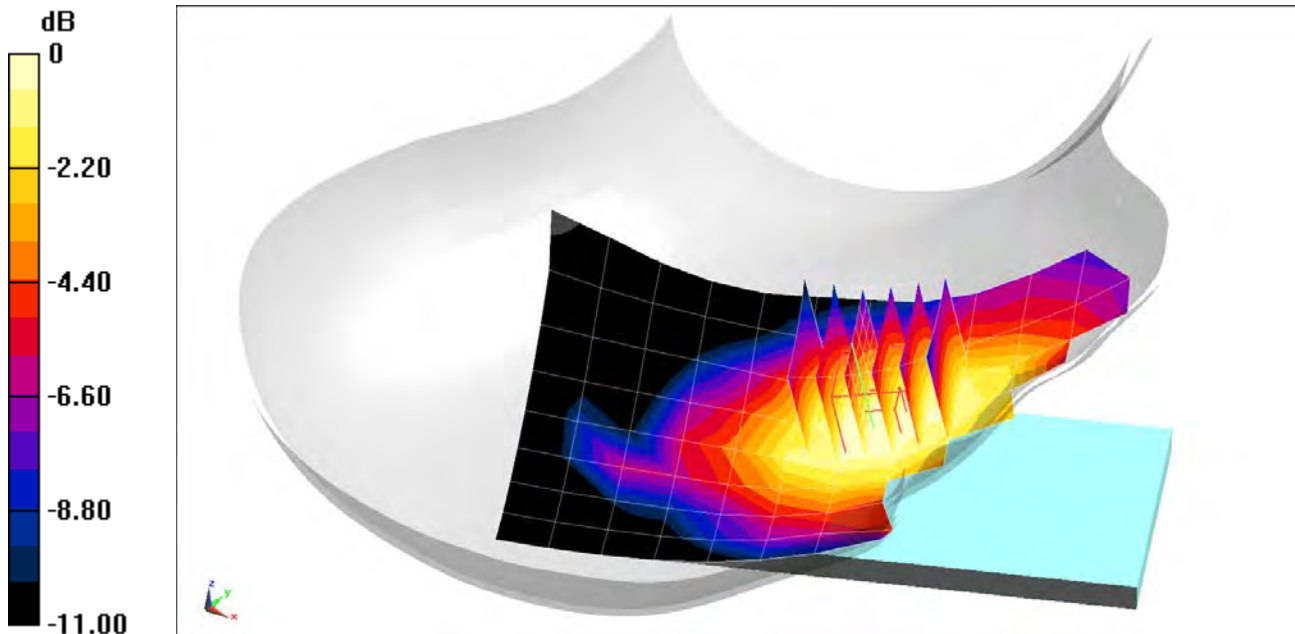

0 dB = 0.115 W/kg = -9.39 dBW/kg

PCTEST ENGINEERING LABORATORY, INC.

DUT: A3LSMN975U; Type: Portable Handset; Serial: 0119M

Communication System: UID 0, UMTS; Frequency: 836.6 MHz; Duty Cycle: 1:1
Medium: 835 Head; Medium parameters used (interpolated):
 $f = 836.6 \text{ MHz}$; $\sigma = 0.901 \text{ S/m}$; $\epsilon_r = 40.432$; $\rho = 1000 \text{ kg/m}^3$
Phantom section: Right Section

Test Date: 05-28-2019; Ambient Temp: 20.0°C; Tissue Temp: 19.8°C

Probe: EX3DV4 - SN7409; ConvF(9.67, 9.67, 9.67) @ 836.6 MHz; Calibrated: 6/25/2018
Sensor-Surface: 1.4mm (Mechanical Surface Detection)
Electronics: DAE4 Sn1334; Calibrated: 6/18/2018
Phantom: Left 30-SAM V5.0; Type: QD 000 P40 CD; Serial: 1715
Measurement SW: DASY52, Version 52.10 (2);SEMCAD X Version 14.6.12 (7450)

Mode: UMTS 850, Right Head, Cheek, Mid.ch

Area Scan (9x15x1): Measurement grid: dx=15mm, dy=15mm

Zoom Scan (6x5x7)/Cube 0: Measurement grid: dx=8mm, dy=8mm, dz=5mm

Reference Value = 12.48 V/m; Power Drift = -0.06 dB

Peak SAR (extrapolated) = 0.171 W/kg

SAR(1 g) = 0.136 W/kg

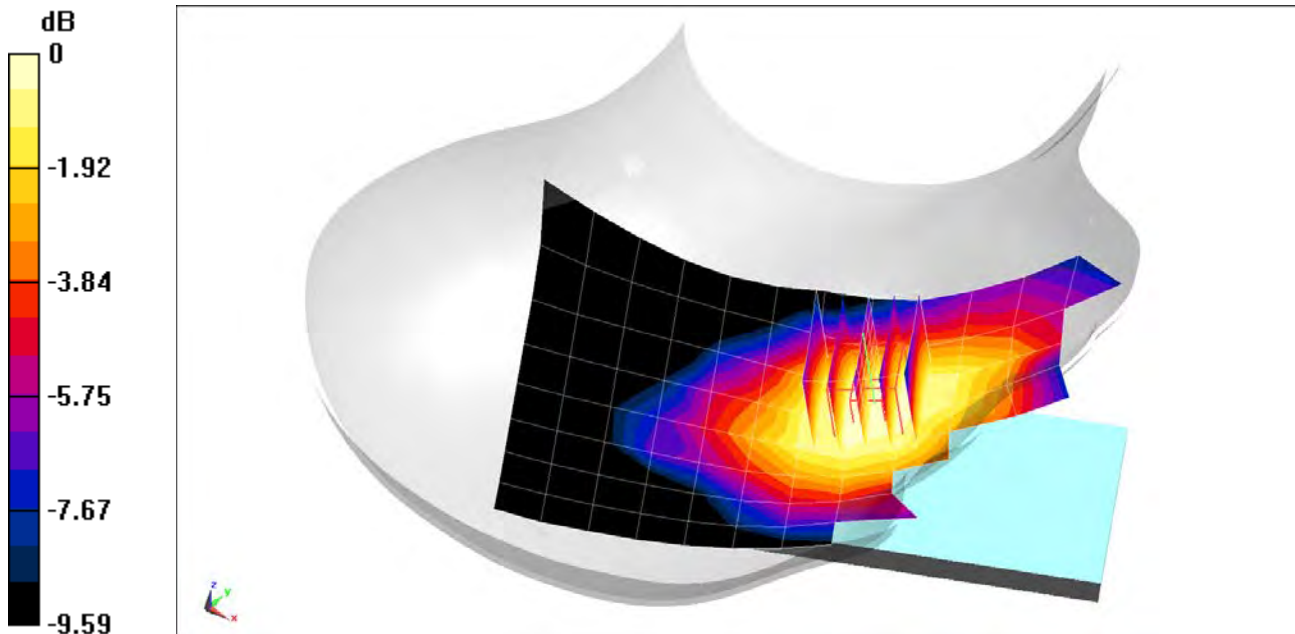

0 dB = 0.159 W/kg = -7.99 dBW/kg

PCTEST ENGINEERING LABORATORY, INC.

DUT: A3LSMN975U; Type: Portable Handset; Serial: 0116M

Communication System: UID 0, UMTS; Frequency: 1732.4 MHz; Duty Cycle: 1:1
Medium: 1750 Head; Medium parameters used (interpolated):
 $f = 1732.4$ MHz; $\sigma = 1.358$ S/m; $\epsilon_r = 40.378$; $\rho = 1000$ kg/m³
Phantom section: Left Section

Test Date: 05-28-2019; Ambient Temp: 22.0°C; Tissue Temp: 21.0°C

Probe: EX3DV4 - SN7357; ConvF(8.69, 8.69, 8.69) @ 1732.4 MHz; Calibrated: 4/24/2019
Sensor-Surface: 1.4mm (Mechanical Surface Detection)
Electronics: DAE4 Sn1407; Calibrated: 4/18/2019
Phantom: Twin-SAM V5.0 Back Right; Type: QD 000 P40 CD; Serial: 1692
Measurement SW: DASY52, Version 52.10 (2);SEMCAD X Version 14.6.12 (7450)

Mode: UMTS 1750, Left Head, Cheek, Mid.ch

Area Scan (9x15x1): Measurement grid: dx=15mm, dy=15mm

Zoom Scan (5x5x7)/Cube 0: Measurement grid: dx=8mm, dy=8mm, dz=5mm

Reference Value = 9.838 V/m; Power Drift = 0.16 dB

Peak SAR (extrapolated) = 0.198 W/kg

SAR(1 g) = 0.127 W/kg

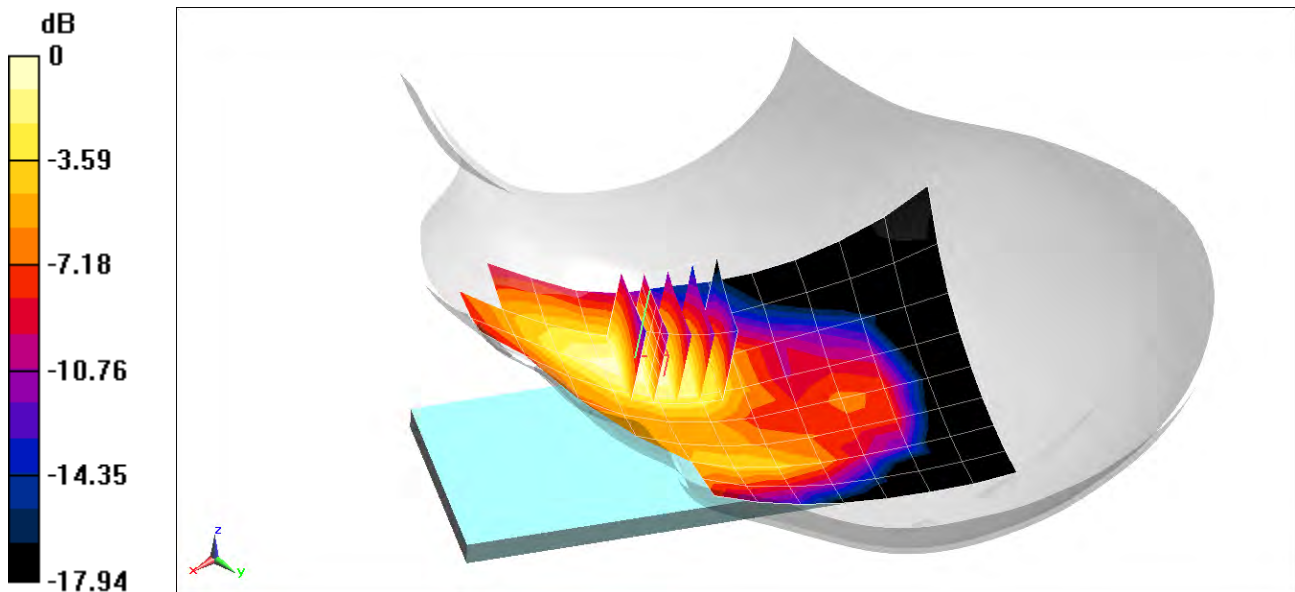

0 dB = 0.166 W/kg = -7.80 dBW/kg

PCTEST ENGINEERING LABORATORY, INC.

DUT: A3LSMN975U; Type: Portable Handset; Serial: 0119M

Communication System: UID 0, PCS CDMA; Frequency: 1880 MHz; Duty Cycle: 1:1

Medium: 1900 Head; Medium parameters used:

$f = 1880 \text{ MHz}$; $\sigma = 1.427 \text{ S/m}$; $\epsilon_r = 39.005$; $\rho = 1000 \text{ kg/m}^3$

Phantom section: Left Section

Test Date: 05-29-2019; Ambient Temp: 21.1°C; Tissue Temp: 21.5°C

Probe: EX3DV4 - SN7308; ConvF(8.26, 8.26, 8.26) @ 1880 MHz; Calibrated: 8/23/2018

Sensor-Surface: 1.4mm (Mechanical Surface Detection)

Electronics: DAE4 Sn1558; Calibrated: 10/3/2018

Phantom: Twin-SAM V8.0; Type: QD 000 P41 Ax; Serial: 1966

Measurement SW: DASY52, Version 52.10 (2);SEMCAD X Version 14.6.12 (7450)

Mode: PCS CDMA, Left Head, Cheek, Mid.ch

Area Scan (9x14x1): Measurement grid: dx=15mm, dy=15mm

Zoom Scan (5x5x7)/Cube 0: Measurement grid: dx=8mm, dy=8mm, dz=5mm

Reference Value = 9.557 V/m; Power Drift = -0.19 dB

Peak SAR (extrapolated) = 0.166 W/kg

SAR(1 g) = 0.104 W/kg

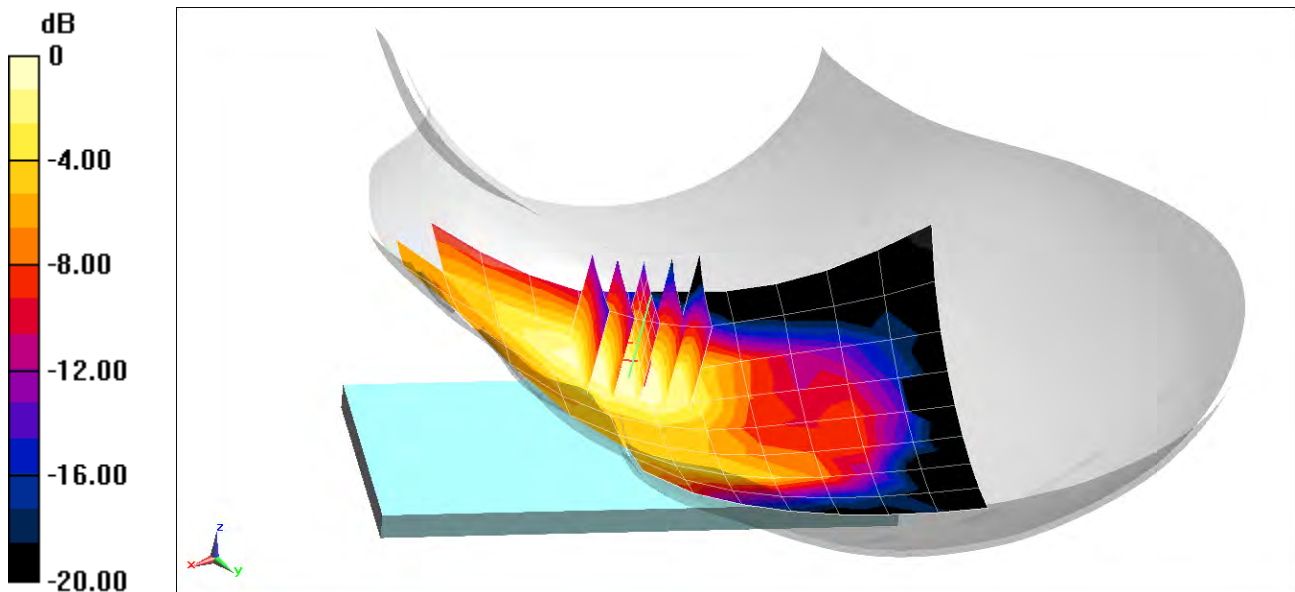

0 dB = 0.143 W/kg = -8.45 dBW/kg

PCTEST ENGINEERING LABORATORY, INC.

DUT: A3LSMN975U; Type: Portable Handset; Serial: 0119M

Communication System: UID 0, _GSM; Frequency: 1909.8 MHz; Duty Cycle: 1:8.3
Medium: 1900 Head; Medium parameters used:
 $f = 1910$ MHz; $\sigma = 1.458$ S/m; $\epsilon_r = 38.868$; $\rho = 1000$ kg/m³
Phantom section: Left Section

Test Date: 05-29-2019; Ambient Temp: 21.1°C; Tissue Temp: 21.5°C

Probe: EX3DV4 - SN7308; ConvF(8.26, 8.26, 8.26) @ 1909.8 MHz; Calibrated: 8/23/2018
Sensor-Surface: 1.4mm (Mechanical Surface Detection)
Electronics: DAE4 Sn1558; Calibrated: 10/3/2018
Phantom: Twin-SAM V8.0; Type: QD 000 P41 Ax; Serial: 1966
Measurement SW: DASY52, Version 52.10 (2);SEMCAD X Version 14.6.12 (7450)

Mode: GSM 1900, Left Head, Cheek, High.ch

Area Scan (9x15x1): Measurement grid: dx=15mm, dy=15mm

Zoom Scan (5x6x7)/Cube 0: Measurement grid: dx=8mm, dy=8mm, dz=5mm

Reference Value = 4.953 V/m; Power Drift = 0.17 dB

Peak SAR (extrapolated) = 0.0620 W/kg

SAR(1 g) = 0.038 W/kg

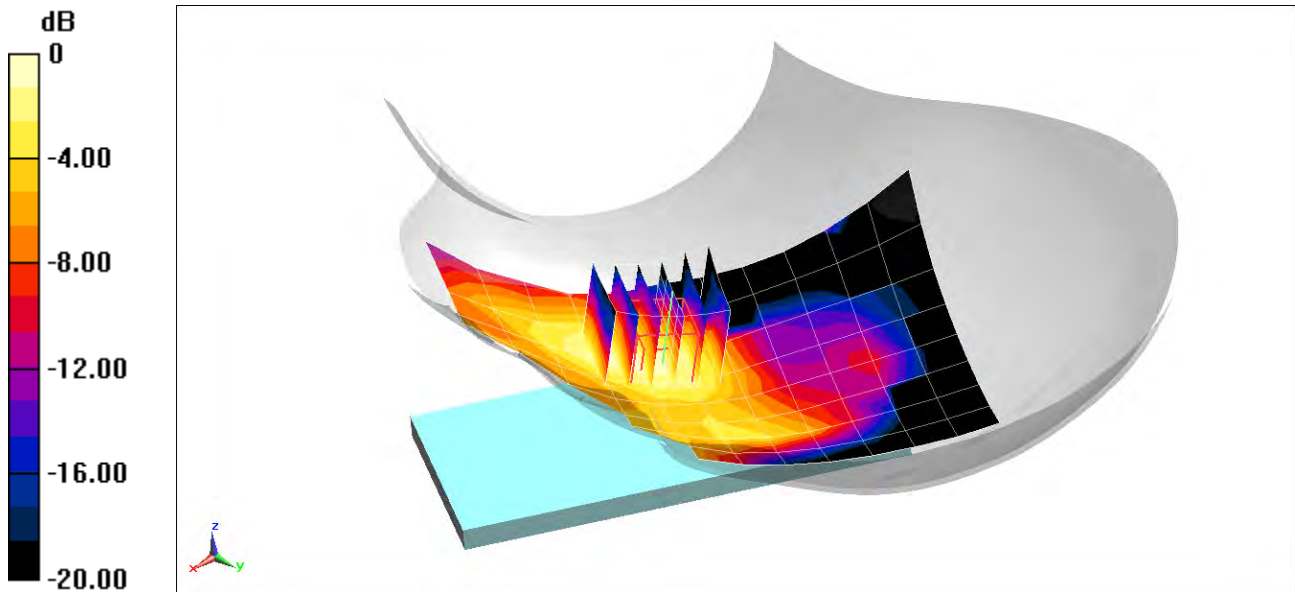

0 dB = 0.0533 W/kg = -12.73 dBW/kg

PCTEST ENGINEERING LABORATORY, INC.

DUT: A3LSMN975U; Type: Portable Handset; Serial: 0119M

Communication System: UID 0, UMTS; Frequency: 1880 MHz; Duty Cycle: 1:1
Medium: 1900 Head; Medium parameters used:
 $f = 1880 \text{ MHz}$; $\sigma = 1.427 \text{ S/m}$; $\epsilon_r = 39.005$; $\rho = 1000 \text{ kg/m}^3$
Phantom section: Left Section

Test Date: 05-29-2019; Ambient Temp: 21.1°C; Tissue Temp: 21.5°C

Probe: EX3DV4 - SN7308; ConvF(8.26, 8.26, 8.26) @ 1880 MHz; Calibrated: 8/23/2018
Sensor-Surface: 1.4mm (Mechanical Surface Detection)
Electronics: DAE4 Sn1558; Calibrated: 10/3/2018
Phantom: Twin-SAM V8.0; Type: QD 000 P41 Ax; Serial: 1966
Measurement SW: DASY52, Version 52.10 (2);SEMCAD X Version 14.6.12 (7450)

Mode: UMTS 1900, Left Head, Cheek, Mid.ch

Area Scan (9x14x1): Measurement grid: dx=15mm, dy=15mm

Zoom Scan (5x5x7)/Cube 0: Measurement grid: dx=8mm, dy=8mm, dz=5mm

Reference Value = 9.005 V/m; Power Drift = 0.06 dB

Peak SAR (extrapolated) = 0.166 W/kg

SAR(1 g) = 0.105 W/kg

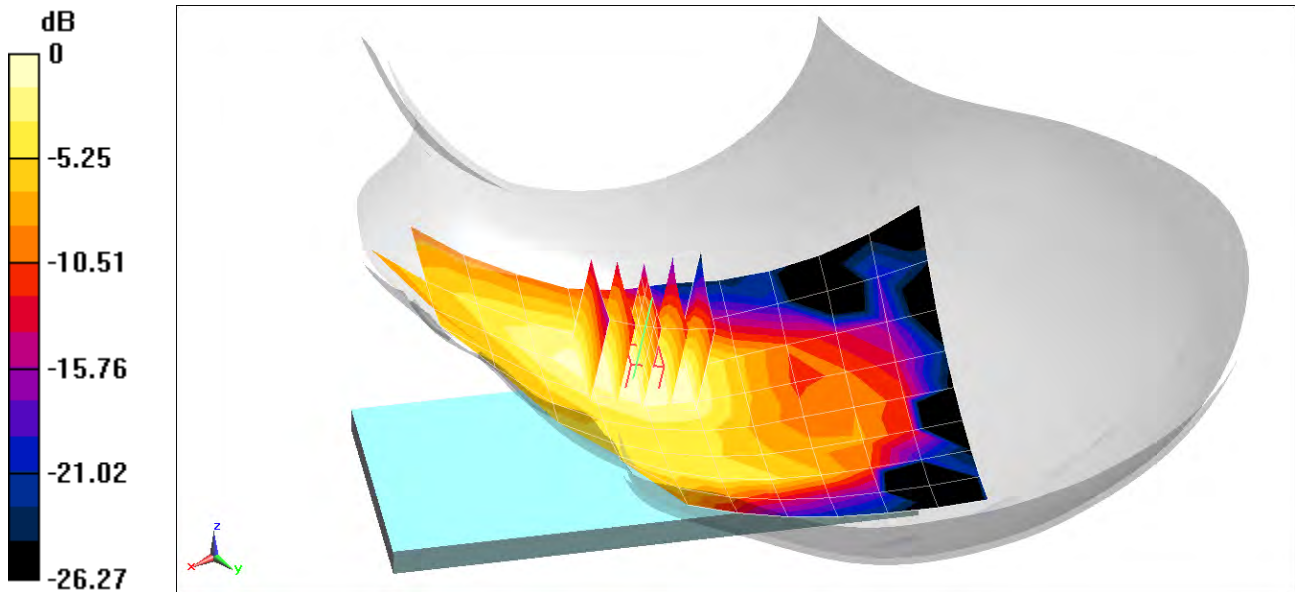

0 dB = 0.142 W/kg = -8.48 dBW/kg

PCTEST ENGINEERING LABORATORY, INC.

DUT: A3LSMN975U; Type: Portable Handset; Serial: 0503M

Communication System: UID 0, LTE Band 71; Frequency: 680.5 MHz; Duty Cycle: 1:1
Medium: 750 Head; Medium parameters used (interpolated):
 $f = 680.5 \text{ MHz}$; $\sigma = 0.889 \text{ S/m}$; $\epsilon_r = 43.12$; $\rho = 1000 \text{ kg/m}^3$
Phantom section: Left Section

Test Date: 05-28-2019; Ambient Temp: 22.6°C; Tissue Temp: 22.0°C

Probe: EX3DV4 - SN3914; ConvF(10, 10, 10) @ 680.5 MHz; Calibrated: 2/19/2019
Sensor-Surface: 1.4mm (Mechanical Surface Detection)
Electronics: DAE4 Sn1272; Calibrated: 2/14/2019
Phantom: Left For Head SAM with CRP v5.0; Type: QD000P40CD; Serial: TP:1687
Measurement SW: DASY52, Version 52.10 (2);SEMCAD X Version 14.6.12 (7450)

**Mode: LTE Band 71, Left Head, Cheek, Mid.ch,
20 MHz Bandwidth, QPSK, 1 RB, 0 RB Offset**

Area Scan (9x15x1): Measurement grid: dx=15mm, dy=15mm
Zoom Scan (6x6x7)/Cube 0: Measurement grid: dx=8mm, dy=8mm, dz=5mm
Reference Value = 10.73 V/m; Power Drift = 0.05 dB
Peak SAR (extrapolated) = 0.118 W/kg
SAR(1 g) = 0.096 W/kg

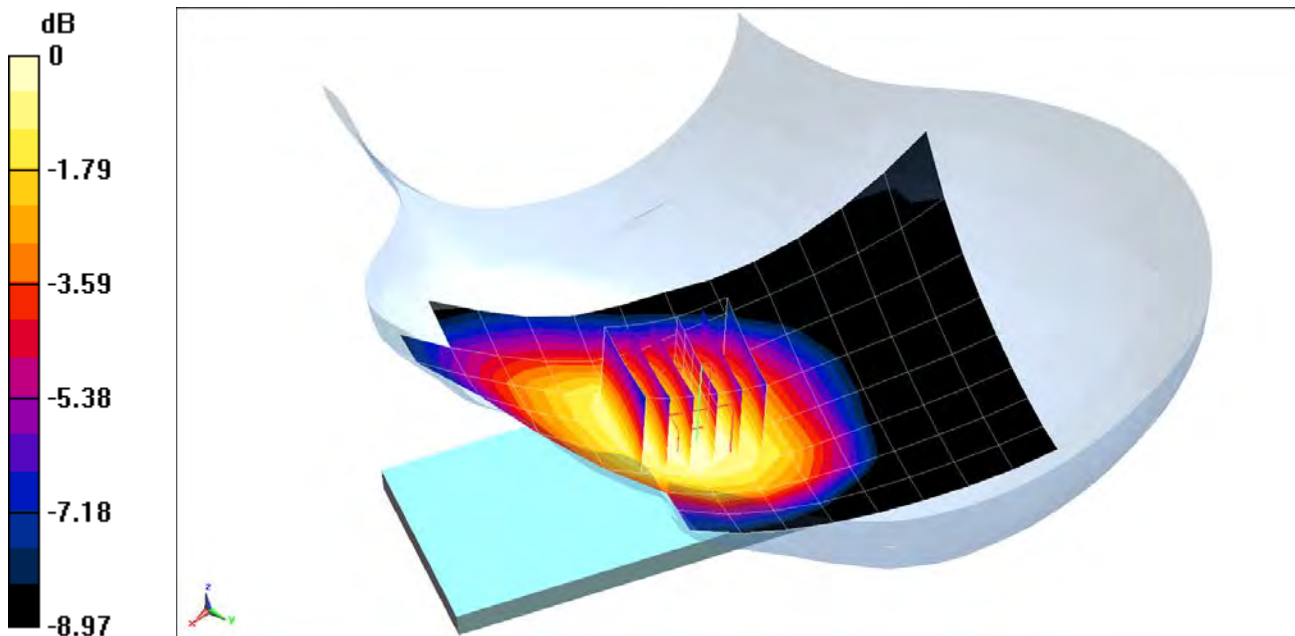

0 dB = 0.111 W/kg = -9.55 dBW/kg

PCTEST ENGINEERING LABORATORY, INC.

DUT: A3LSMN975U; Type: Portable Handset; Serial: 0503M

Communication System: UID 0, LTE Band 12; Frequency: 707.5 MHz; Duty Cycle: 1:1

Medium: 750 Head; Medium parameters used (interpolated):

$f = 707.5 \text{ MHz}$; $\sigma = 0.898 \text{ S/m}$; $\epsilon_r = 43.037$; $\rho = 1000 \text{ kg/m}^3$

Phantom section: Right Section

Test Date: 05-28-2019; Ambient Temp: 22.6°C; Tissue Temp: 22.0°C

Probe: EX3DV4 - SN3914; ConvF(10, 10, 10) @ 707.5 MHz; Calibrated: 2/19/2019

Sensor-Surface: 1.4mm (Mechanical Surface Detection)

Electronics: DAE4 Sn1272; Calibrated: 2/14/2019

Phantom: Left For Head SAM with CRP v5.0; Type: QD000P40CD; Serial: TP:1687

Measurement SW: DASY52, Version 52.10 (2);SEMCAD X Version 14.6.12 (7450)

**Mode: LTE Band 12, Right Head, Cheek, Mid.ch,
10 MHz Bandwidth, QPSK, 1 RB, 0 RB Offset**

Area Scan (9x13x1): Measurement grid: dx=15mm, dy=15mm

Zoom Scan (6x5x7)/Cube 0: Measurement grid: dx=8mm, dy=8mm, dz=5mm

Reference Value = 10.94 V/m; Power Drift = -0.05 dB

Peak SAR (extrapolated) = 0.125 W/kg

SAR(1 g) = 0.096 W/kg

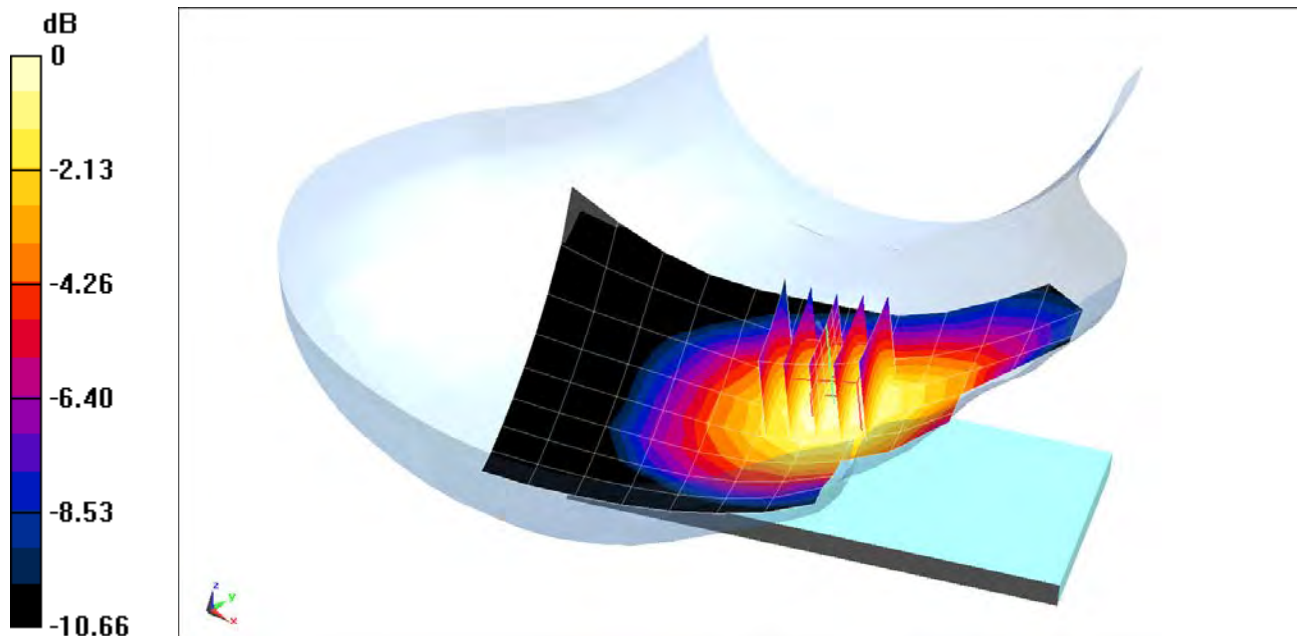

0 dB = 0.114 W/kg = -9.43 dBW/kg

PCTEST ENGINEERING LABORATORY, INC.

DUT: A3LSMN975U; Type: Portable Handset; Serial: 0503M

Communication System: UID 0, LTE Band 13; Frequency: 782 MHz; Duty Cycle: 1:1
Medium: 750 Head; Medium parameters used (interpolated):
 $f = 782 \text{ MHz}$; $\sigma = 0.924 \text{ S/m}$; $\epsilon_r = 42.824$; $\rho = 1000 \text{ kg/m}^3$
Phantom section: Right Section

Test Date: 05-28-2019; Ambient Temp: 22.6°C; Tissue Temp: 22.0°C

Probe: EX3DV4 - SN3914; ConvF(10, 10, 10) @ 782 MHz; Calibrated: 2/19/2019

Sensor-Surface: 1.4mm (Mechanical Surface Detection)

Electronics: DAE4 Sn1272; Calibrated: 2/14/2019

Phantom: Left For Head SAM with CRP v5.0; Type: QD000P40CD; Serial: TP: 1687

Measurement SW: DASY52, Version 52.10 (2);SEMCAD X Version 14.6.12 (7450)

**Mode: LTE Band 13, Right Head, Cheek, Mid.ch,
10 MHz Bandwidth, QPSK, 1 RB, 0 RB Offset**

Area Scan (8x14x1): Measurement grid: dx=15mm, dy=15mm

Zoom Scan (5x5x7)/Cube 0: Measurement grid: dx=8mm, dy=8mm, dz=5mm

Reference Value = 12.36 V/m; Power Drift = 0.04 dB

Peak SAR (extrapolated) = 0.159 W/kg

SAR(1 g) = 0.127 W/kg

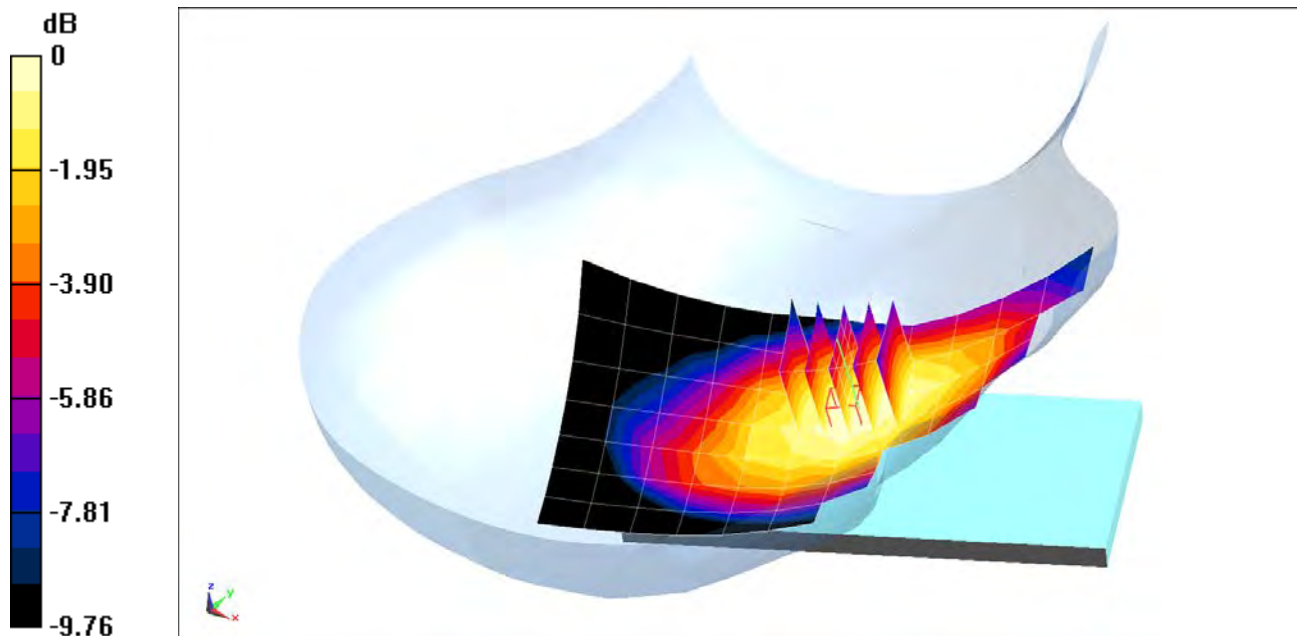

0 dB = 0.147 W/kg = -8.33 dBW/kg

PCTEST ENGINEERING LABORATORY, INC.

DUT: A3LSMN975U; Type: Portable Handset; Serial: 0503M

Communication System: UID 0, LTE Band 14; Frequency: 793 MHz; Duty Cycle: 1:1
Medium: 750 Head; Medium parameters used (interpolated):
 $f = 793 \text{ MHz}$; $\sigma = 0.928 \text{ S/m}$; $\epsilon_r = 42.79$; $\rho = 1000 \text{ kg/m}^3$
Phantom section: Right Section

Test Date: 05-28-2019; Ambient Temp: 22.6°C; Tissue Temp: 22.0°C

Probe: EX3DV4 - SN3914; ConvF(10, 10, 10) @ 793 MHz; Calibrated: 2/19/2019

Sensor-Surface: 1.4mm (Mechanical Surface Detection)

Electronics: DAE4 Sn1272; Calibrated: 2/14/2019

Phantom: Left For Head SAM with CRP v5.0; Type: QD000P40CD; Serial: TP: 1687

Measurement SW: DASY52, Version 52.10 (2);SEMCAD X Version 14.6.12 (7450)

**Mode: LTE Band 14, Right Head, Cheek, Mid.ch,
10 MHz Bandwidth, QPSK, 1 RB, 0 RB Offset**

Area Scan (9x13x1): Measurement grid: dx=15mm, dy=15mm

Zoom Scan (6x5x7)/Cube 0: Measurement grid: dx=8mm, dy=8mm, dz=5mm

Reference Value = 11.03 V/m; Power Drift = -0.01 dB

Peak SAR (extrapolated) = 0.131 W/kg

SAR(1 g) = 0.102 W/kg

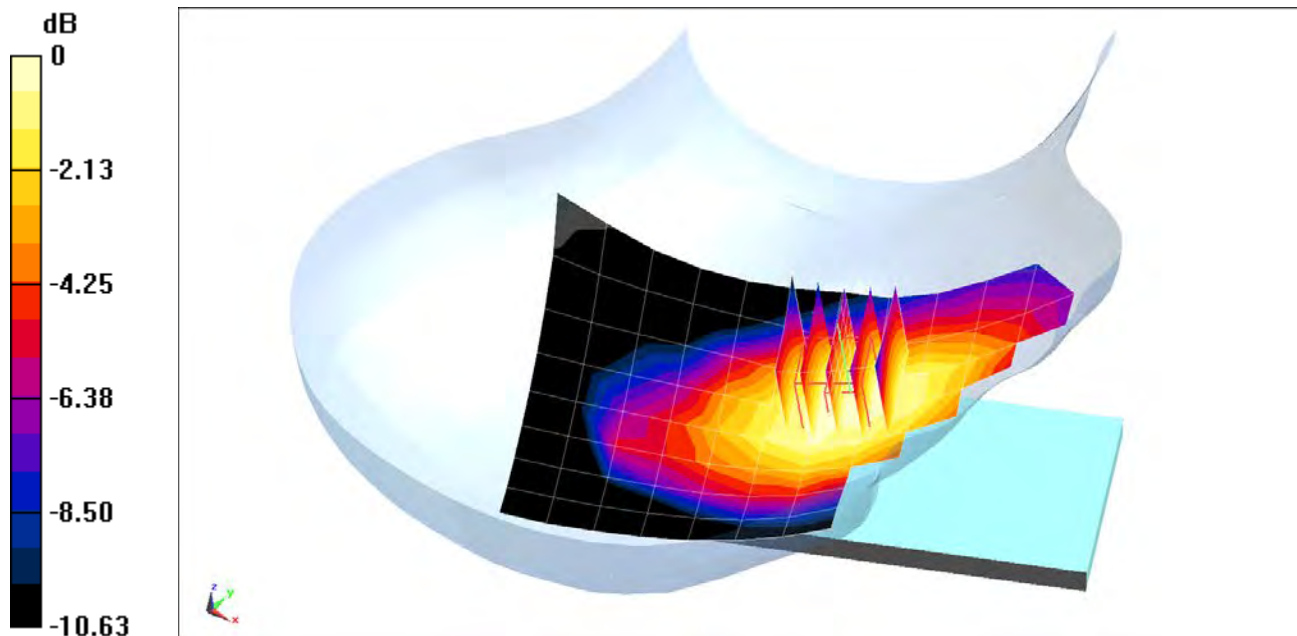

0 dB = 0.119 W/kg = -9.24 dBW/kg

PCTEST ENGINEERING LABORATORY, INC.

DUT: A3LSMN975U; Type: Portable Handset; Serial: 0503M

Communication System: UID 0, LTE Band 26; Frequency: 831.5 MHz; Duty Cycle: 1:1
Medium: 835 Head; Medium parameters used (interpolated):
 $f = 831.5$ MHz; $\sigma = 0.895$ S/m; $\epsilon_r = 40.498$; $\rho = 1000$ kg/m³
Phantom section: Right Section

Test Date: 05-28-2019; Ambient Temp: 20.0°C; Tissue Temp: 19.8°C

Probe: EX3DV4 - SN7409; ConvF(9.67, 9.67, 9.67) @ 831.5 MHz; Calibrated: 6/25/2018
Sensor-Surface: 1.4mm (Mechanical Surface Detection)
Electronics: DAE4 Sn1334; Calibrated: 6/18/2018
Phantom: Left 30-SAM V5.0; Type: QD 000 P40 CD; Serial: 1715
Measurement SW: DASY52, Version 52.10 (2);SEMCAD X Version 14.6.12 (7450)

**Mode: LTE Band 26 (Cell.), Right Head, Cheek, Mid.ch,
15 MHz Bandwidth, QPSK, 1 RB, 74 RB Offset**

Area Scan (9x14x1): Measurement grid: dx=15mm, dy=15mm
Zoom Scan (5x5x7)/Cube 0: Measurement grid: dx=8mm, dy=8mm, dz=5mm
Reference Value = 13.26 V/m; Power Drift = -0.19 dB
Peak SAR (extrapolated) = 0.177 W/kg
SAR(1 g) = 0.140 W/kg

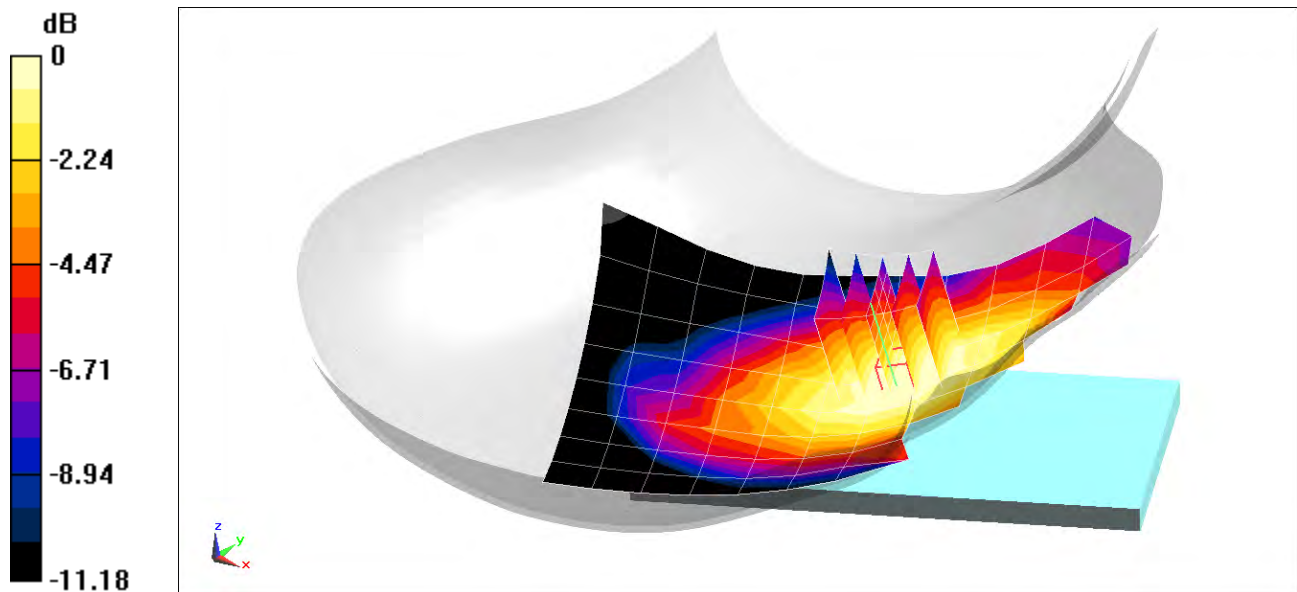

0 dB = 0.165 W/kg = -7.83 dBW/kg

PCTEST ENGINEERING LABORATORY, INC.

DUT: A3LSMN975U; Type: Portable Handset; Serial: 0503M

Communication System: UID 0, LTE Band 5 (Cell.); Frequency: 836.5 MHz; Duty Cycle: 1:1
Medium: 835 Head; Medium parameters used (interpolated):
 $f = 836.5 \text{ MHz}$; $\sigma = 0.9 \text{ S/m}$; $\epsilon_r = 40.433$; $\rho = 1000 \text{ kg/m}^3$
Phantom section: Right Section

Test Date: 05-28-2019; Ambient Temp: 20.0°C; Tissue Temp: 19.8°C

Probe: EX3DV4 - SN7409; ConvF(9.67, 9.67, 9.67) @ 836.5 MHz; Calibrated: 6/25/2018
Sensor-Surface: 1.4mm (Mechanical Surface Detection)
Electronics: DAE4 Sn1334; Calibrated: 6/18/2018
Phantom: Left 30-SAM V5.0; Type: QD 000 P40 CD; Serial: 1715
Measurement SW: DASY52, Version 52.10 (2);SEMCAD X Version 14.6.12 (7450)

Mode: LTE Band 5 (Cell.), ULCA, Right Head, Cheek,
PCC: 10 MHz Bandwidth, QPSK, Ch. 20525, 1 RB, 0 RB Offset
SCC: 5 MHz Bandwidth, QPSK, Ch. 20453, 1 RB, 24 RB Offset

Area Scan (9x14x1): Measurement grid: dx=15mm, dy=15mm
Zoom Scan (5x5x7)/Cube 0: Measurement grid: dx=8mm, dy=8mm, dz=5mm
Reference Value = 13.51 V/m; Power Drift = 0.07 dB
Peak SAR (extrapolated) = 0.199 W/kg
SAR(1 g) = 0.153 W/kg

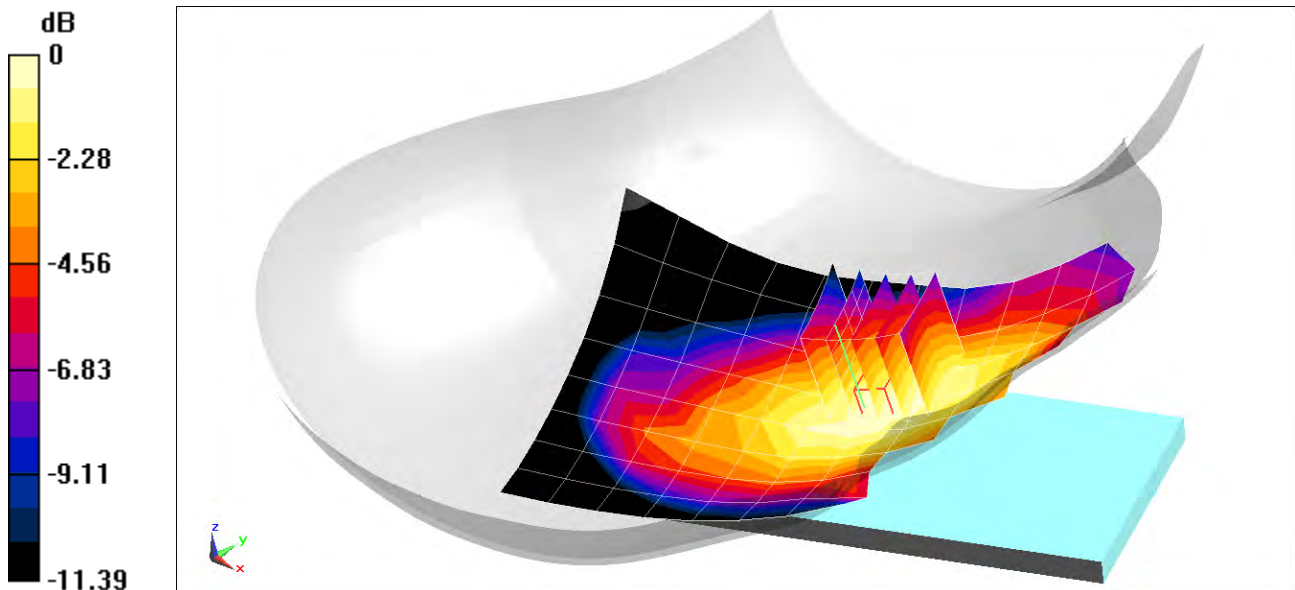

0 dB = 0.180 W/kg = -7.45 dBW/kg

PCTEST ENGINEERING LABORATORY, INC.

DUT: A3LSMN975U; Type: Portable Handset; Serial: 0326M

Communication System: UID 0, LTE Band 66 (AWS); Frequency: 1745 MHz; Duty Cycle: 1:1
Medium: 1750 Head; Medium parameters used (interpolated):
 $f = 1745 \text{ MHz}$; $\sigma = 1.372 \text{ S/m}$; $\epsilon_r = 41.46$; $\rho = 1000 \text{ kg/m}^3$
Phantom section: Left Section

Test Date: 06-03-2019; Ambient Temp: 21.2°C; Tissue Temp: 20.5°C

Probe: EX3DV4 - SN7357; ConvF(8.69, 8.69, 8.69) @ 1745 MHz; Calibrated: 4/24/2019
Sensor-Surface: 1.4mm (Mechanical Surface Detection)
Electronics: DAE4 Sn1407; Calibrated: 4/18/2019
Phantom: Twin-SAM V5.0 Back Right; Type: QD 000 P40 CD; Serial: 1692
Measurement SW: DASY52, Version 52.10 (2);SEMCAD X Version 14.6.12 (7450)

Mode: LTE Band 66 (AWS), ULCA, Left Head, Cheek,
PCC: 20 MHz Bandwidth, QPSK, Ch. 132322, 1 RB, 99 RB Offset
SCC: 20 MHz Bandwidth, QPSK, Ch. 132520, 1 RB, 0 RB Offset

Area Scan (9x15x1): Measurement grid: dx=15mm, dy=15mm
Zoom Scan (5x5x7)/Cube 0: Measurement grid: dx=8mm, dy=8mm, dz=5mm
Reference Value = 11.29 V/m; Power Drift = 0.16 dB
Peak SAR (extrapolated) = 0.228 W/kg
SAR(1 g) = 0.150 W/kg

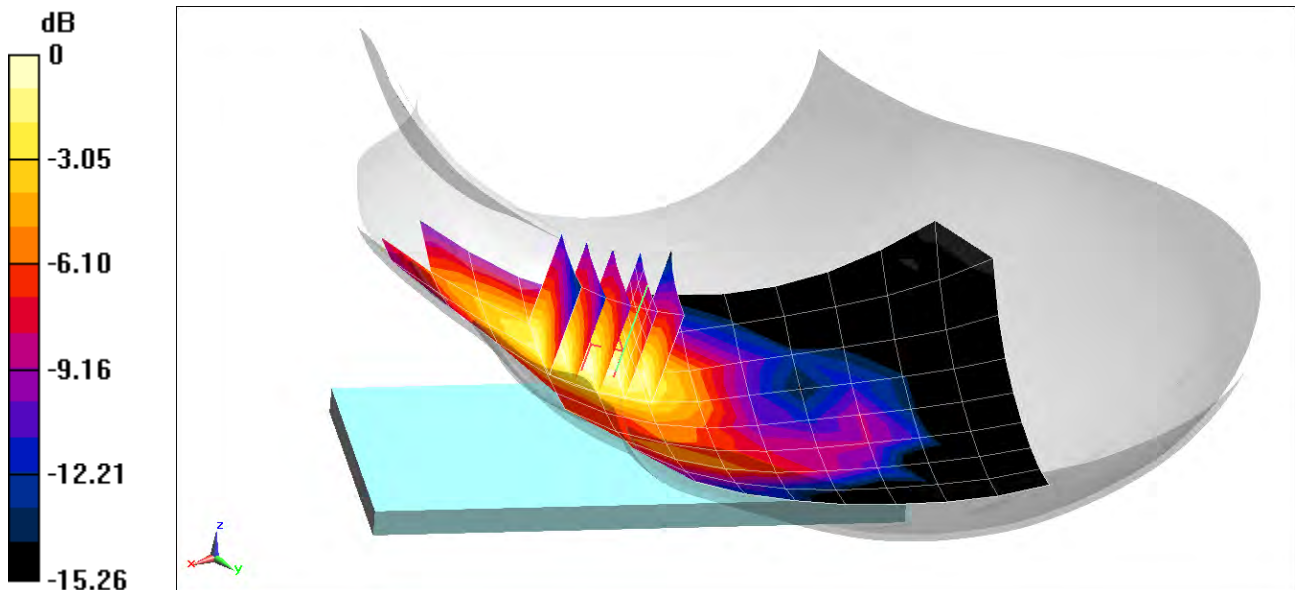

0 dB = 0.194 W/kg = -7.12 dBW/kg

PCTEST ENGINEERING LABORATORY, INC.

DUT: A3LSMN975U; Type: Portable Handset; Serial: 0498M

Communication System: UID 0, LTE Band 25 (PCS); Frequency: 1882.5 MHz; Duty Cycle: 1:1
Medium: 1900 Head; Medium parameters used (interpolated):
 $f = 1882.5 \text{ MHz}$; $\sigma = 1.43 \text{ S/m}$; $\epsilon_r = 38.994$; $\rho = 1000 \text{ kg/m}^3$
Phantom section: Left Section

Test Date: 05-29-2019; Ambient Temp: 21.1°C; Tissue Temp: 21.5°C

Probe: EX3DV4 - SN7308; ConvF(8.26, 8.26, 8.26) @ 1882.5 MHz; Calibrated: 8/23/2018
Sensor-Surface: 1.4mm (Mechanical Surface Detection)
Electronics: DAE4 Sn1558; Calibrated: 10/3/2018
Phantom: Twin-SAM V8.0; Type: QD 000 P41 Ax; Serial: 1966
Measurement SW: DASY52, Version 52.10 (2);SEMCAD X Version 14.6.12 (7450)

**Mode: LTE Band 25 (PCS), Left Head, Cheek, Mid.ch,
20 MHz Bandwidth, QPSK, 1 RB, 0 RB Offset**

Area Scan (8x14x1): Measurement grid: dx=15mm, dy=15mm
Zoom Scan (5x5x7)/Cube 0: Measurement grid: dx=8mm, dy=8mm, dz=5mm
Reference Value = 9.986 V/m; Power Drift = 0.07 dB
Peak SAR (extrapolated) = 0.198 W/kg
SAR(1 g) = 0.122 W/kg

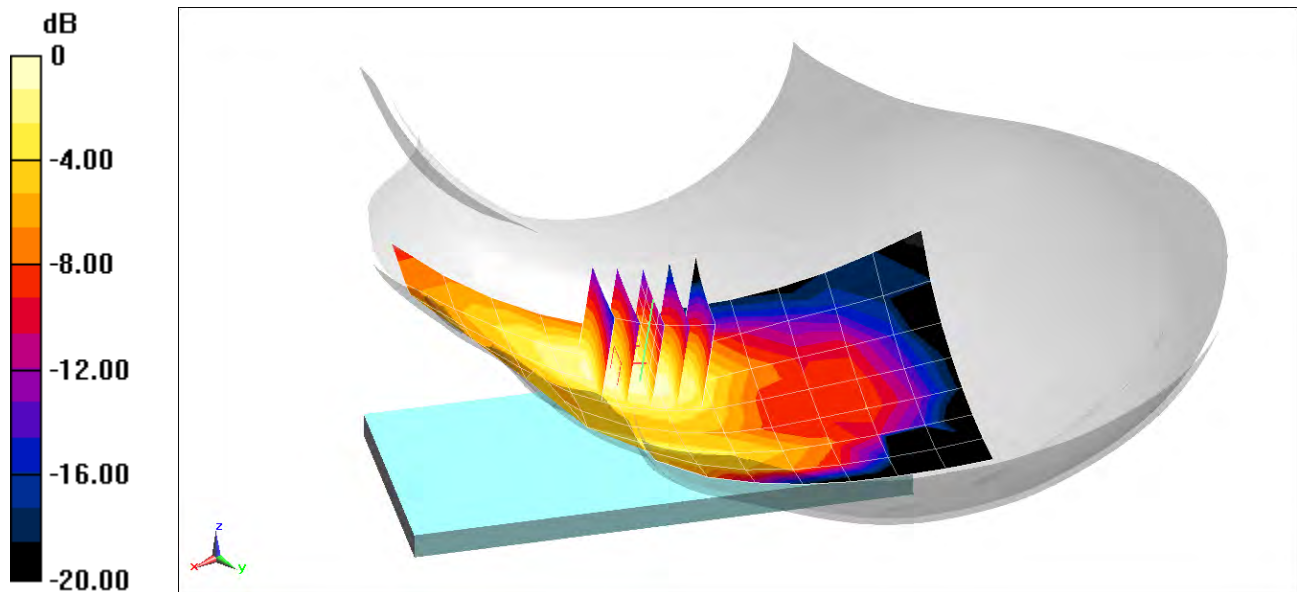

0 dB = 0.165 W/kg = -7.83 dBW/kg

PCTEST ENGINEERING LABORATORY, INC.

DUT: A3LSMN975U; Type: Portable Handset; Serial: 0499M

Communication System: UID 0, LTE Band 30; Frequency: 2310 MHz; Duty Cycle: 1:1

Medium: 2450 Head; Medium parameters used:

$f = 2310$ MHz; $\sigma = 1.731$ S/m; $\epsilon_r = 38.447$; $\rho = 1000$ kg/m³

Phantom section: Right Section

Test Date: 05-30-2019; Ambient Temp: 22.7°C; Tissue Temp: 21.5°C

Probe: EX3DV4 - SN3589; ConvF(6.77, 6.77, 6.77) @ 2310 MHz; Calibrated: 1/25/2019

Sensor-Surface: 1.4mm (Mechanical Surface Detection)

Electronics: DAE4 Sn1450; Calibrated: 8/22/2018

Phantom: Twin-SAM V5.0 (30); Type: QD 000 P40 CD; Serial: 1647

Measurement SW: DASY52, Version 52.10 (2);SEMCAD X Version 14.6.12 (7450)

**Mode: LTE Band 30, Right Head, Cheek, Mid.ch,
10 MHz Bandwidth, QPSK, 1 RB, 49 RB Offset**

Area Scan (11x18x1): Measurement grid: dx=12mm, dy=12mm

Zoom Scan (7x7x7)/Cube 0: Measurement grid: dx=5mm, dy=5mm, dz=5mm

Reference Value = 5.626 V/m; Power Drift = 0.02 dB

Peak SAR (extrapolated) = 0.0820 W/kg

SAR(1 g) = 0.042 W/kg

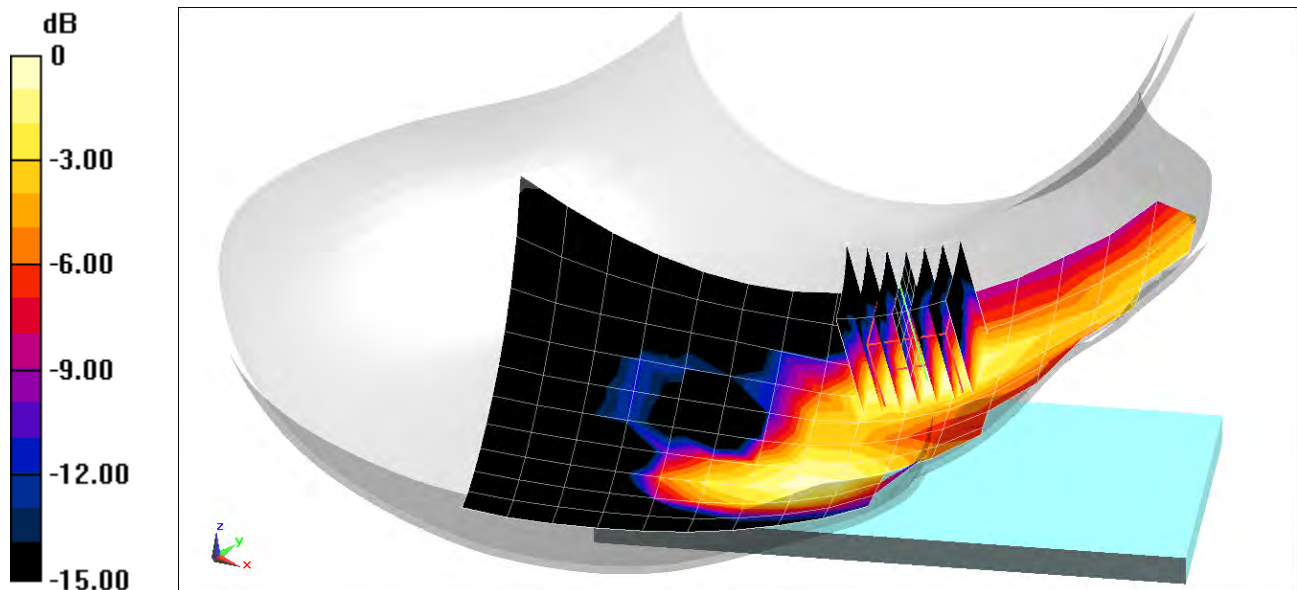

0 dB = 0.0654 W/kg = -11.84 dBW/kg

PCTEST ENGINEERING LABORATORY, INC.

DUT: A3LSMN975U; Type: Portable Handset; Serial: 0499M

Communication System: UID 0, _LTE Band 7; Frequency: 2560 MHz; Duty Cycle: 1:1
Medium: 2450 Head; Medium parameters used (interpolated):
 $f = 2560 \text{ MHz}$; $\sigma = 1.929 \text{ S/m}$; $\epsilon_r = 38.016$; $\rho = 1000 \text{ kg/m}^3$
Phantom section: Right Section

Test Date: 05-30-2019; Ambient Temp: 22.7°C; Tissue Temp: 21.5°C

Probe: EX3DV4 - SN3589; ConvF(6.25, 6.25, 6.25) @ 2560 MHz; Calibrated: 1/25/2019
Sensor-Surface: 1.4mm (Mechanical Surface Detection)
Electronics: DAE4 Sn1450; Calibrated: 8/22/2018
Phantom: Twin-SAM V5.0 (30); Type: QD 000 P40 CD; Serial: 1647
Measurement SW: DASY52, Version 52.10 (2);SEMCAD X Version 14.6.12 (7450)

**Mode: LTE Band 7, Right Head, Tilt, High.ch,
20 MHz Bandwidth, QPSK, 1 RB, 0 RB Offset**

Area Scan (11x18x1): Measurement grid: dx=12mm, dy=12mm

Zoom Scan (7x7x7)/Cube 0: Measurement grid: dx=5mm, dy=5mm, dz=5mm

Reference Value = 8.487 V/m; Power Drift = 0.13 dB

Peak SAR (extrapolated) = 0.209 W/kg

SAR(1 g) = 0.109 W/kg

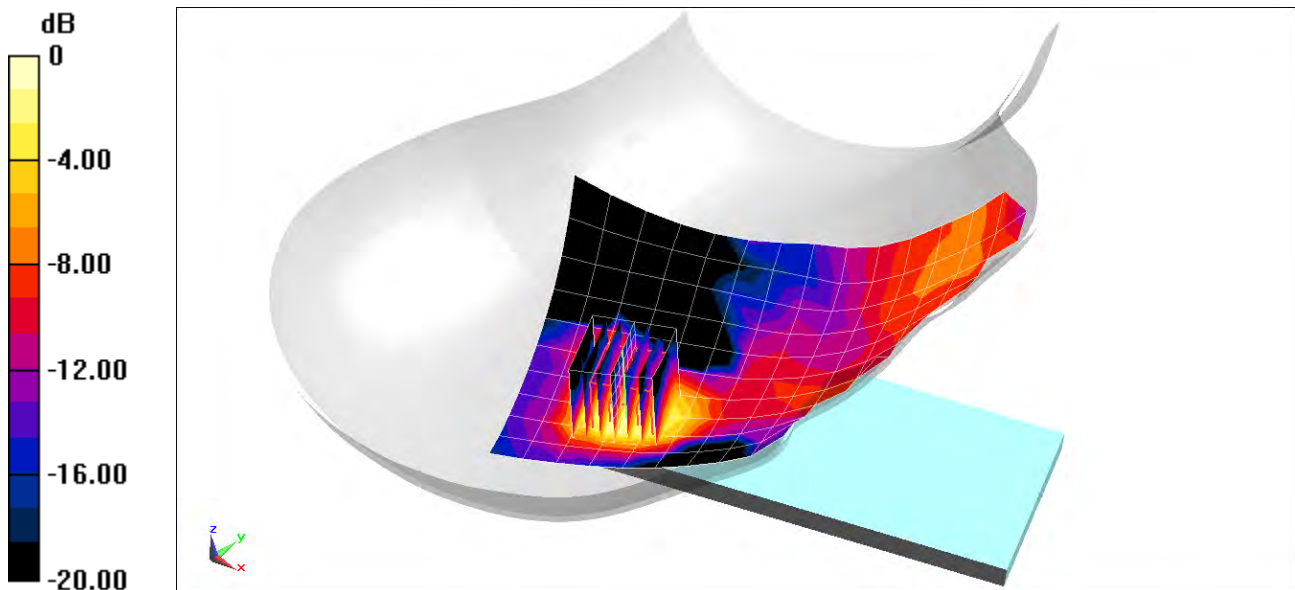

0 dB = 0.170 W/kg = -7.70 dBW/kg

PCTEST ENGINEERING LABORATORY, INC.

DUT: A3LSMN975U; Type: Portable Handset; Serial: 0347M

Communication System: UID 0, LTE Band 48; Frequency: 3560 MHz; Duty Cycle: 1:1.58
Medium: 3500 Head; Medium parameters used (interpolated):
 $f = 3560 \text{ MHz}$; $\sigma = 2.842 \text{ S/m}$; $\epsilon_r = 39.078$; $\rho = 1000 \text{ kg/m}^3$
Phantom section: Right Section

Test Date: 06-13-2019; Ambient Temp: 24.0°C; Tissue Temp: 20.8°C

Probe: EX3DV4 - SN3589; ConvF(6.16, 6.16, 6.16) @ 3560 MHz; Calibrated: 1/25/2019
Sensor-Surface: 1.4mm (Mechanical Surface Detection)
Electronics: DAE4 Sn1450; Calibrated: 8/22/2018
Phantom: Twin-SAM V5.0 (30); Type: QD 000 P40 CD; Serial: 1647
Measurement SW: DASY52, Version 52.10 (2); SEMCAD X Version 14.6.12 (7450)

**Mode: LTE Band 48, Right Head, Tilt, Low.ch,
20 MHz Bandwidth, QPSK, 1 RB, 99 RB Offset**

Area Scan (10x17x1): Measurement grid: dx=12mm, dy=12mm

Zoom Scan (8x9x8)/Cube 0: Measurement grid: dx=5mm, dy=5mm, dz=1.4mm; Graded Ratio: 1.4

Reference Value = 3.654 V/m; Power Drift = 0.12 dB

Peak SAR (extrapolated) = 0.0840 W/kg

SAR(1 g) = 0.030 W/kg

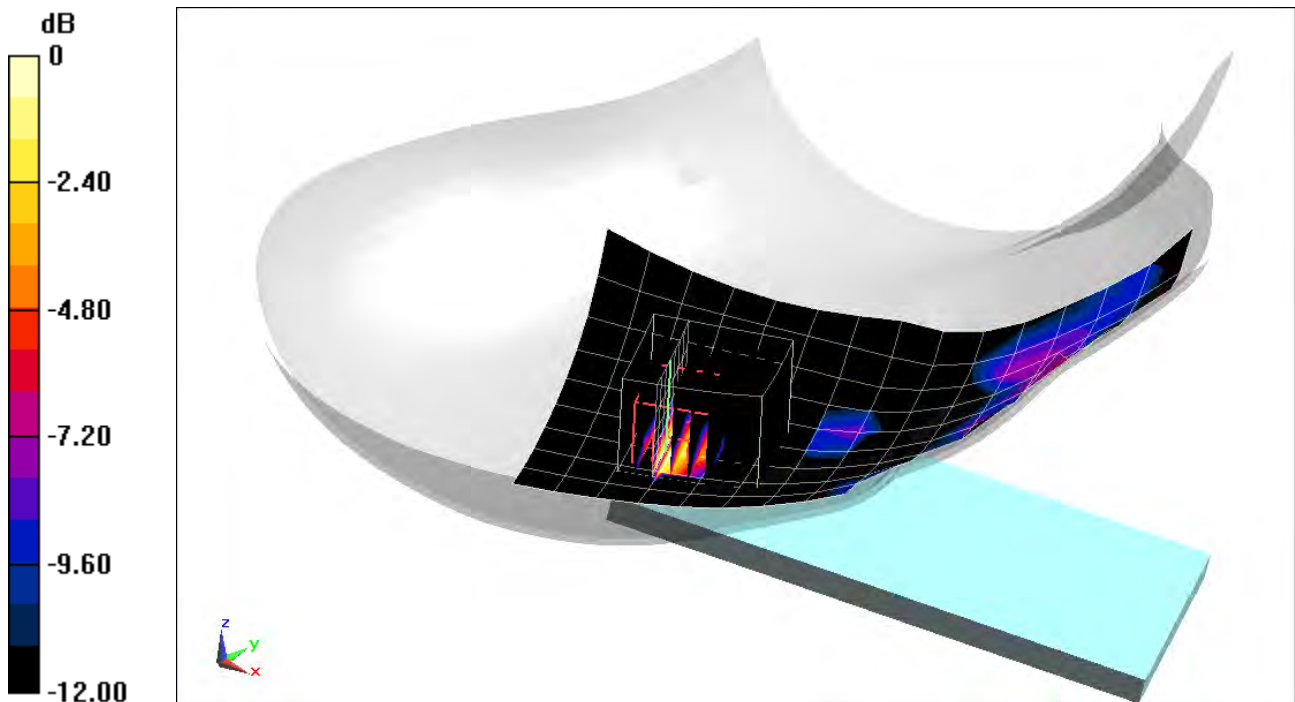

0 dB = 0.0596 W/kg = -12.25 dBW/kg

PCTEST ENGINEERING LABORATORY, INC.

DUT: A3LSMN975U; Type: Portable Handset; Serial: 0499M

Communication System: UID 0, _LTE Band 41 (Class 2); Frequency: 2549.5 MHz; Duty Cycle: 1:2.31

Medium: 2450 Head; Medium parameters used:

$f = 2550$ MHz; $\sigma = 1.932$ S/m; $\epsilon_r = 38.012$; $\rho = 1000$ kg/m³

Phantom section: Right Section

Test Date: 06-03-2019; Ambient Temp: 22.5°C; Tissue Temp: 21.9°C

Probe: EX3DV4 - SN3589; ConvF(6.25, 6.25, 6.25) @ 2549.5 MHz; Calibrated: 1/25/2019

Sensor-Surface: 1.4mm (Mechanical Surface Detection)

Electronics: DAE4 Sn1450; Calibrated: 8/22/2018

Phantom: Twin-SAM V5.0 (30); Type: QD 000 P40 CD; Serial: 1647

Measurement SW: DASY52, Version 52.10 (2);SEMCAD X Version 14.6.12 (7450)

**Mode: LTE Band 41 PC2, Right Head, Tilt, Low-Mid.ch,
20 MHz Bandwidth, QPSK, 1 RB, 99 RB Offset**

Area Scan (10x17x1): Measurement grid: dx=12mm, dy=12mm

Zoom Scan (7x8x7)/Cube 0: Measurement grid: dx=5mm, dy=5mm, dz=5mm

Reference Value = 8.464 V/m; Power Drift = 0.06 dB

Peak SAR (extrapolated) = 0.192 W/kg

SAR(1 g) = 0.103 W/kg

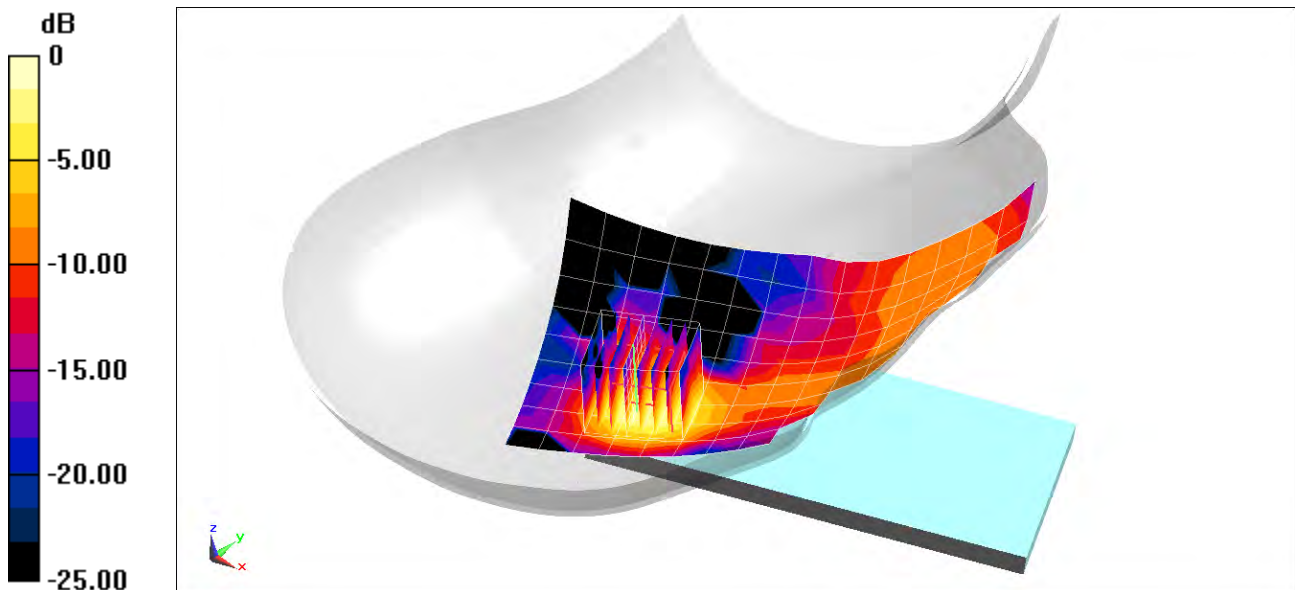

0 dB = 0.156 W/kg = -8.07 dBW/kg

PCTEST ENGINEERING LABORATORY, INC.

DUT: A3LSMN975U; Type: Portable Handset; Serial: 0352M

Communication System: UID 0, _IEEE 802.11b; Frequency: 2437 MHz; Duty Cycle: 1:1
Medium: 2450 Head; Medium parameters used (interpolated):
 $f = 2437 \text{ MHz}$; $\sigma = 1.843 \text{ S/m}$; $\epsilon_r = 40.229$; $\rho = 1000 \text{ kg/m}^3$
Phantom section: Right Section

Test Date: 06-17-2019; Ambient Temp: 22.5°C; Tissue Temp: 20.5°C

Probe: EX3DV4 - SN3589; ConvF(6.46, 6.46, 6.46) @ 2437 MHz; Calibrated: 1/25/2019
Sensor-Surface: 1.4mm (Mechanical Surface Detection)
Electronics: DAE4 Sn1450; Calibrated: 8/22/2018
Phantom: Twin-SAM V5.0 (30); Type: QD 000 P40 CD; Serial: 1647
Measurement SW: DASY52, Version 52.10 (2);SEMCAD X Version 14.6.12 (7450)

**Mode: IEEE 802.11b Ant 1, 22 MHz Bandwidth,
Right Head, Tilt, Ch 6, 1 Mbps**

Area Scan (11x18x1): Measurement grid: dx=12mm, dy=12mm

Zoom Scan (7x7x7)/Cube 0: Measurement grid: dx=5mm, dy=5mm, dz=5mm

Reference Value = 5.994 V/m; Power Drift = 0.20 dB

Peak SAR (extrapolated) = 1.45 W/kg

SAR(1 g) = 0.510 W/kg

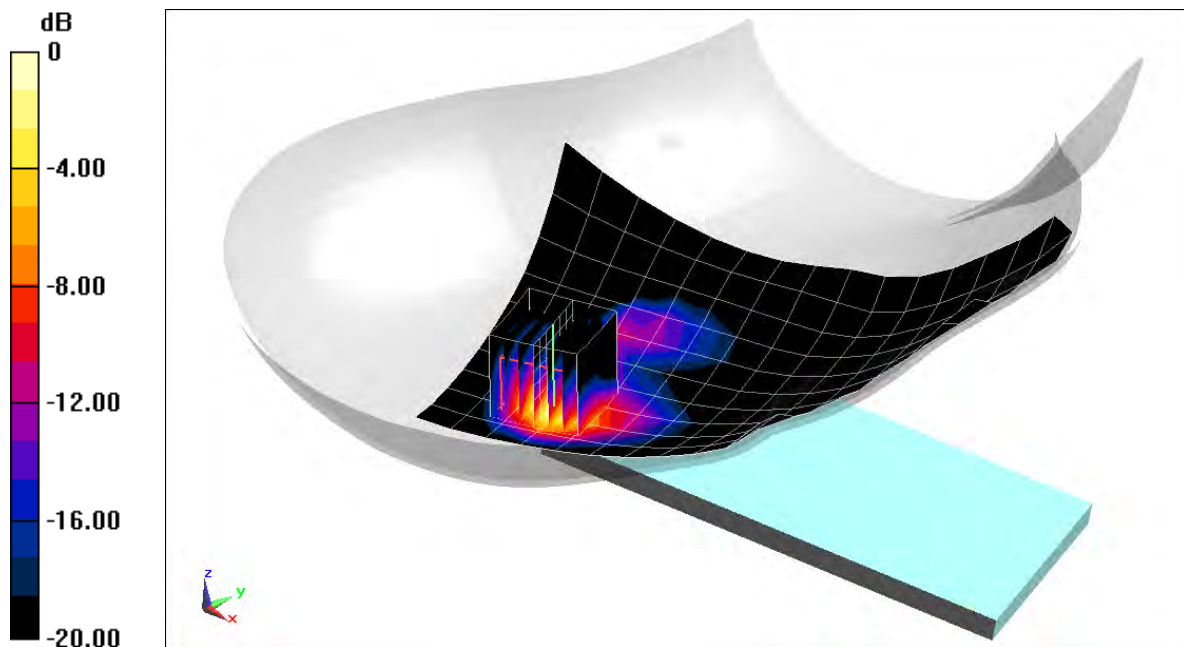

0 dB = 1.04 W/kg = 0.17 dBW/kg

PCTEST ENGINEERING LABORATORY, INC.

DUT: A3LSMN975U; Type: Portable Handset; Serial: 0352M

Communication System: UID 0, _IEEE 802.11ac; Frequency: 5775 MHz; Duty Cycle: 1:1
Medium: 5GHz Head; Medium parameters used (interpolated):
 $f = 5775 \text{ MHz}$; $\sigma = 5.176 \text{ S/m}$; $\epsilon_r = 33.862$; $\rho = 1000 \text{ kg/m}^3$
Phantom section: Right Section

Test Date: 06-10-2019; Ambient Temp: 21.6°C; Tissue Temp: 20.7°C

Probe: EX3DV4 - SN7406; ConvF(5.23, 5.23, 5.23) @ 5775 MHz; Calibrated: 5/16/2019
Sensor-Surface: 1.4mm (Mechanical Surface Detection)
Electronics: DAE4 Sn859; Calibrated: 5/8/2019
Phantom: SAM with CRP v5.0 (Right); Type: QD000P40CD; Serial: TP:1759
Measurement SW: DASY52, Version 52.10 (2);SEMCAD X Version 14.6.12 (7450)

**Mode: IEEE 802.11ac Ant 1, U-NII-3, 80 MHz Bandwidth,
Right Head, Tilt, Ch 155, 29.3 Mbps**

Area Scan (13x22x1): Measurement grid: dx=10mm, dy=10mm

Zoom Scan (8x8x7)/Cube 0: Measurement grid: dx=4mm, dy=4mm, dz=1.4mm; Graded Ratio: 1.4

Reference Value = 2.715 V/m; Power Drift = 0.14 dB

Peak SAR (extrapolated) = 1.58 W/kg

SAR(1 g) = 0.294 W/kg

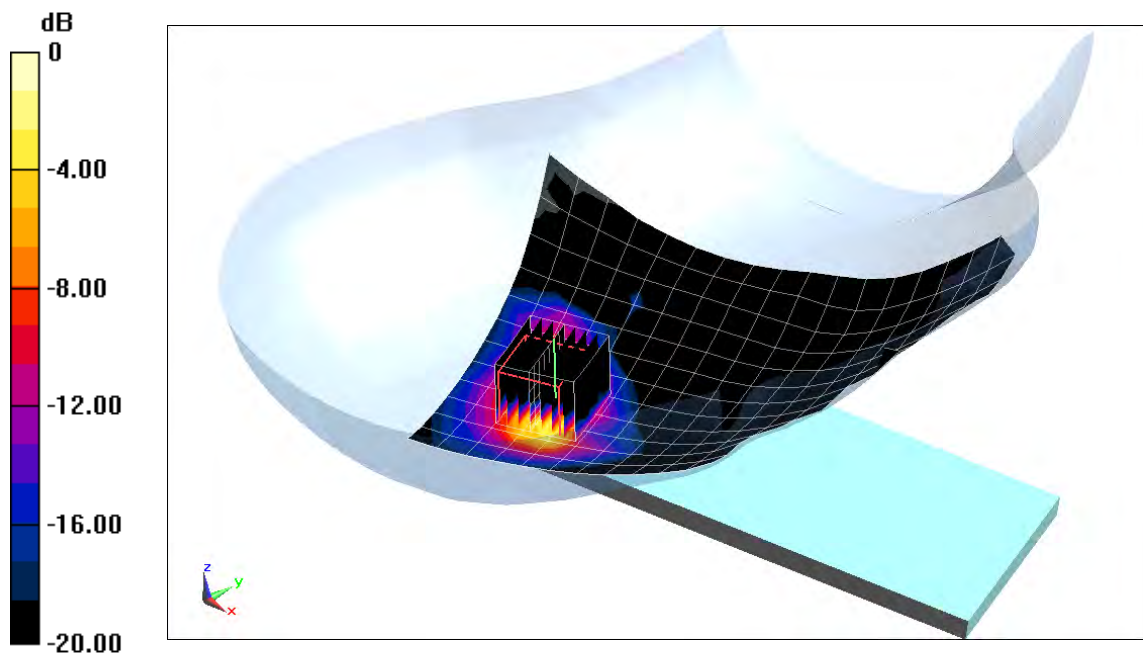

0 dB = 0.778 W/kg = -1.09 dBW/kg

PCTEST ENGINEERING LABORATORY, INC.

DUT: A3LSMN975U; Type: Portable Handset; Serial: 0459M

Communication System: UID 0, Bluetooth; Frequency: 2441 MHz; Duty Cycle: 1:1.297

Medium: 2450 Head; Medium parameters used (interpolated):

$f = 2441$ MHz; $\sigma = 1.846$ S/m; $\epsilon_r = 40.223$; $\rho = 1000$ kg/m³

Phantom section: Right Section

Test Date: 06-17-2019; Ambient Temp: 22.5°C; Tissue Temp: 20.5°C

Probe: EX3DV4 - SN3589; ConvF(6.46, 6.46, 6.46) @ 2441 MHz; Calibrated: 1/25/2019

Sensor-Surface: 1.4mm (Mechanical Surface Detection)

Electronics: DAE4 Sn1450; Calibrated: 8/22/2018

Phantom: Twin-SAM V5.0 (30); Type: QD 000 P40 CD; Serial: 1647

Measurement SW: DASY52, Version 52.10 (2);SEMCAD X Version 14.6.12 (7450)

Mode: Bluetooth, Right Head, Tilt, Ch 39, 1 Mbps

Area Scan (11x19x1): Measurement grid: dx=12mm, dy=12mm

Zoom Scan (7x7x7)/Cube 0: Measurement grid: dx=5mm, dy=5mm, dz=5mm

Reference Value = 12.60 V/m; Power Drift = -0.03 dB

Peak SAR (extrapolated) = 0.678 W/kg

SAR(1 g) = 0.242 W/kg

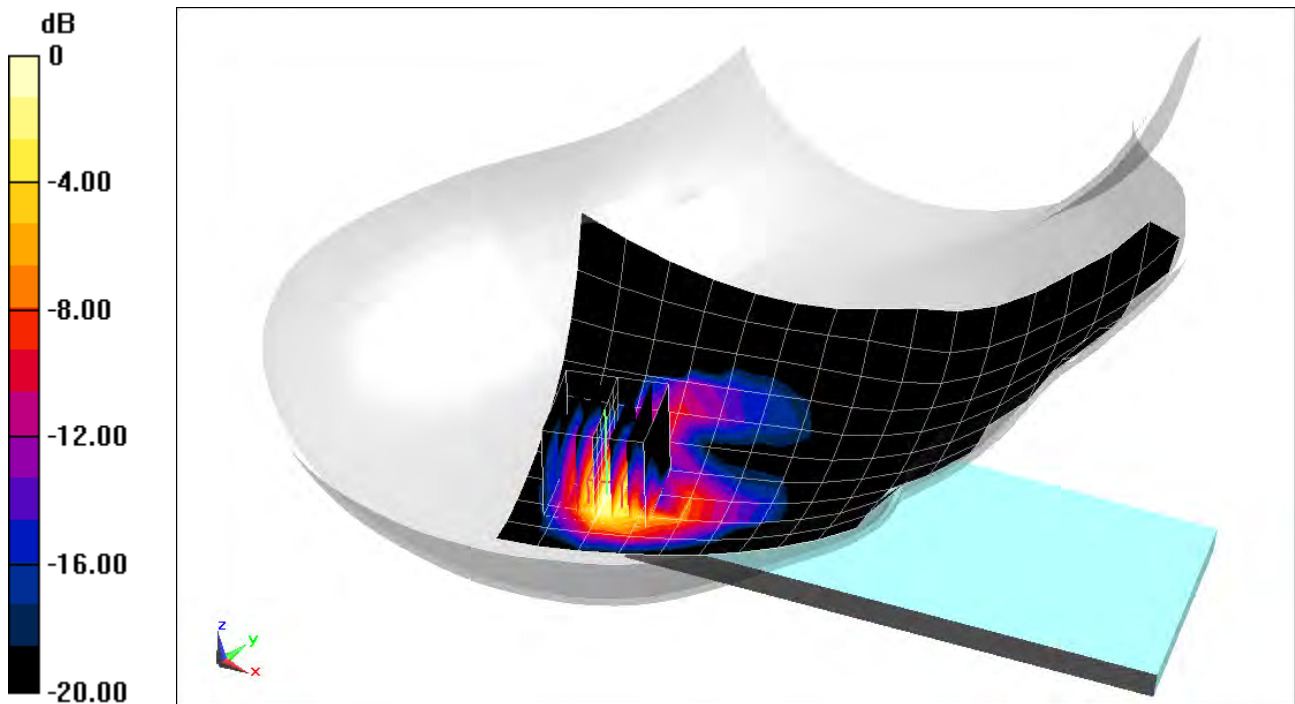

0 dB = 0.427 W/kg = -3.70 dBW/kg

PCTEST ENGINEERING LABORATORY, INC.

DUT: A3LSMN975U; Type: Portable Handset; Serial: 0116M

Communication System: UID 0, CDMA; Frequency: 820.1 MHz; Duty Cycle: 1:1
Medium: 835 Body Medium parameters used (interpolated):
 $f = 820.1 \text{ MHz}$; $\sigma = 0.977 \text{ S/m}$; $\epsilon_r = 54.093$; $\rho = 1000 \text{ kg/m}^3$
Phantom section: Flat Section; Space: 1.5 cm

Test Date: 06-10-2019; Ambient Temp: 20.5°C; Tissue Temp: 20.0°C

Probe: EX3DV4 - SN7488; ConvF(11.03, 11.03, 11.03) @ 820.1 MHz; Calibrated: 1/24/2019
Sensor-Surface: 1.4mm (Mechanical Surface Detection)
Electronics: DAE4 Sn1530; Calibrated: 1/15/2019
Phantom: Twin-SAM V5.0; Type: QD 000 P40 CD; Serial: 1800
Measurement SW: DASY52, Version 52.10 (2);SEMCAD X Version 14.6.12 (7450)

Mode: Cell. CDMA BC10, Rule Part 90S, Body SAR, Back side, Mid.ch

Area Scan (9x15x1): Measurement grid: dx=15mm, dy=15mm

Zoom Scan (5x5x7)/Cube 0: Measurement grid: dx=8mm, dy=8mm, dz=5mm

Reference Value = 15.50 V/m; Power Drift = 0.02 dB

Peak SAR (extrapolated) = 0.357 W/kg

SAR(1 g) = 0.221 W/kg

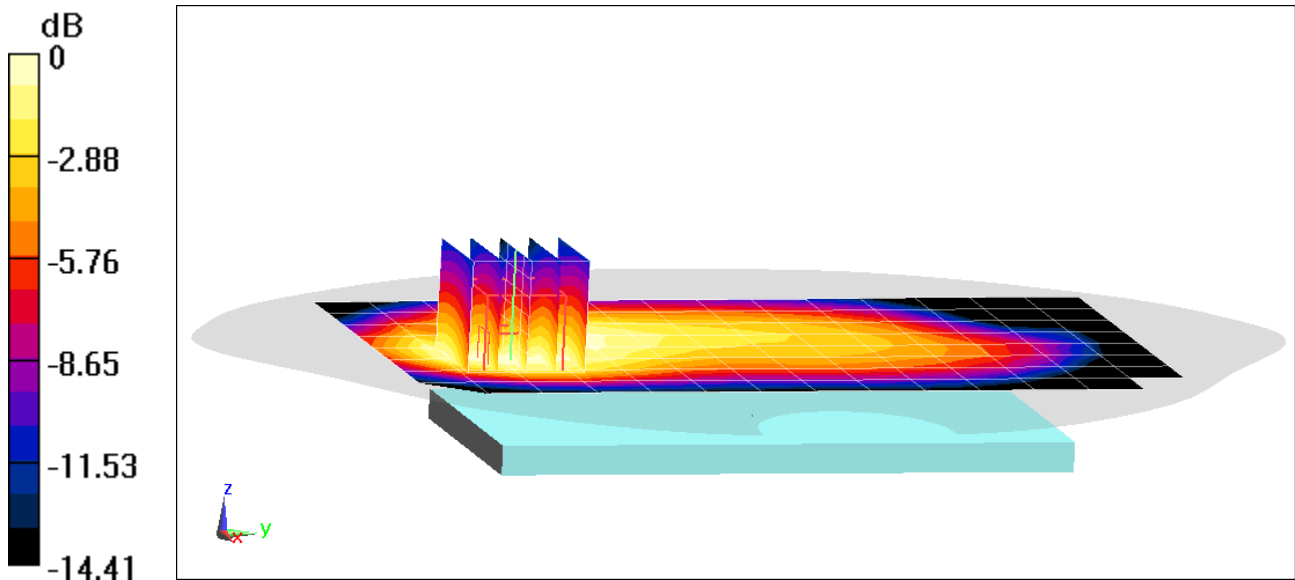

0 dB = 0.303 W/kg = -5.19 dBW/kg

PCTEST ENGINEERING LABORATORY, INC.

DUT: A3LSMN975U; Type: Portable Handset; Serial: 0116M

Communication System: UID 0, CDMA; Frequency: 820.1 MHz; Duty Cycle: 1:1
Medium: 835 Body Medium parameters used (interpolated):
 $f = 820.1 \text{ MHz}$; $\sigma = 0.977 \text{ S/m}$; $\epsilon_r = 54.093$; $\rho = 1000 \text{ kg/m}^3$
Phantom section: Flat Section; Space: 1.0 cm

Test Date: 06-10-2019; Ambient Temp: 20.5°C; Tissue Temp: 20.0°C

Probe: EX3DV4 - SN7488; ConvF(11.03, 11.03, 11.03) @ 820.1 MHz; Calibrated: 1/24/2019
Sensor-Surface: 1.4mm (Mechanical Surface Detection)
Electronics: DAE4 Sn1530; Calibrated: 1/15/2019
Phantom: Twin-SAM V5.0; Type: QD 000 P40 CD; Serial: 1800
Measurement SW: DASY52, Version 52.10 (2);SEMCAD X Version 14.6.12 (7450)

Mode: Cell. EVDO Rev. 0 BC10, Rule Part 90S, Body SAR, Back side, Mid.ch

Area Scan (9x15x1): Measurement grid: dx=15mm, dy=15mm

Zoom Scan (5x5x7)/Cube 0: Measurement grid: dx=8mm, dy=8mm, dz=5mm

Reference Value = 25.16 V/m; Power Drift = 0.03 dB

Peak SAR (extrapolated) = 1.07 W/kg

SAR(1 g) = 0.615 W/kg

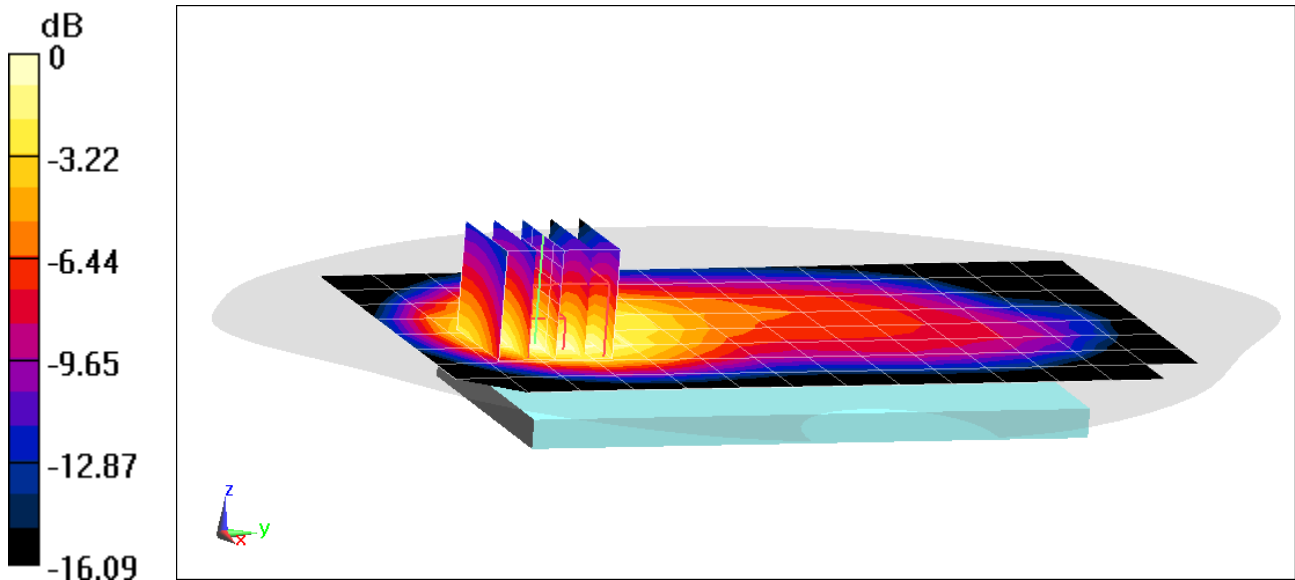

0 dB = 0.899 W/kg = -0.46 dBW/kg

PCTEST ENGINEERING LABORATORY, INC.

DUT: A3LSMN975U; Type: Portable Handset; Serial: 0116M

Communication System: UID 0, CDMA; Frequency: 836.52 MHz; Duty Cycle: 1:1
Medium: 835 Body; Medium parameters used (interpolated):
 $f = 836.52 \text{ MHz}$; $\sigma = 0.988 \text{ S/m}$; $\epsilon_r = 53.893$; $\rho = 1000 \text{ kg/m}^3$
Phantom section: Flat Section; Space: 1.5 cm

Test Date: 05-27-2019; Ambient Temp: 20.2°C; Tissue Temp: 19.9°C

Probe: EX3DV4 - SN7488; ConvF(11.03, 11.03, 11.03) @ 836.52 MHz; Calibrated: 1/24/2019
Sensor-Surface: 1.4mm (Mechanical Surface Detection)
Electronics: DAE4 Sn1530; Calibrated: 1/15/2019
Phantom: Twin-SAM V5.0; Type: QD 000 P40 CD; Serial: 1800
Measurement SW: DASY52, Version 52.10 (2);SEMCAD X Version 14.6.12 (7450)

Mode: Cell. CDMA BC0, Rule Part 22H, Body SAR, Back side, Mid.ch

Area Scan (9x15x1): Measurement grid: $dx=15\text{mm}$, $dy=15\text{mm}$

Zoom Scan (5x5x7)/Cube 0: Measurement grid: $dx=8\text{mm}$, $dy=8\text{mm}$, $dz=5\text{mm}$

Reference Value = 16.44 V/m; Power Drift = -0.02 dB

Peak SAR (extrapolated) = 0.411 W/kg

SAR(1 g) = 0.250 W/kg

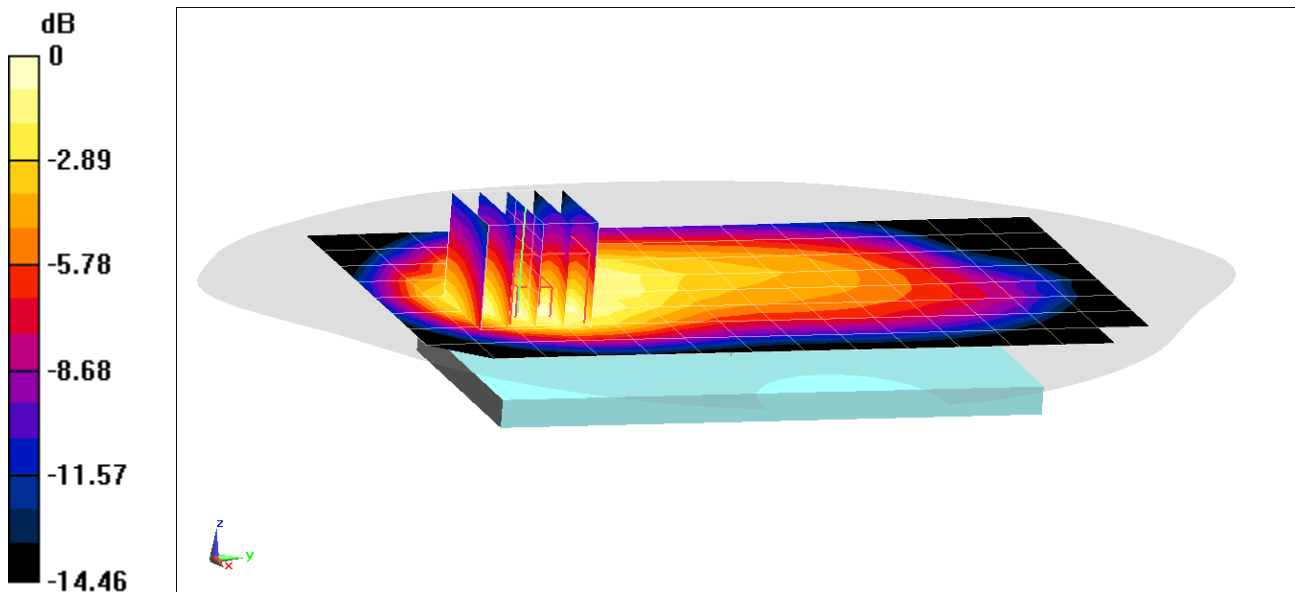

0 dB = 0.350 W/kg = -4.56 dBW/kg

PCTEST ENGINEERING LABORATORY, INC.

DUT: A3LSMN975U; Type: Portable Handset; Serial: 0116M

Communication System: UID 0, CDMA; Frequency: 848.31 MHz; Duty Cycle: 1:1
Medium: 835 Body Medium parameters used (interpolated):
 $f = 848.31 \text{ MHz}$; $\sigma = 0.958 \text{ S/m}$; $\epsilon_r = 52.564$; $\rho = 1000 \text{ kg/m}^3$
Phantom section: Flat Section; Space: 1.0 cm

Test Date: 06-18-2019; Ambient Temp: 22.4°C; Tissue Temp: 21.8°C

Probe: EX3DV4 - SN3914; ConvF(9.46, 9.46, 9.46) @ 848.31 MHz; Calibrated: 2/19/2019
Sensor-Surface: 1.4mm (Mechanical Surface Detection)
Electronics: DAE4 Sn1272; Calibrated: 2/14/2019
Phantom: SAM with CRP v5.0 Left; Type: QD000P40CD; Serial: 1687
Measurement SW: DASY52, Version 52.10 (2);SEMCAD X Version 14.6.12 (7450)

Mode: Cell. EVDO Rev. 0 BC0, Rule Part 22H, Body SAR, Back side, High.ch

Area Scan (9x15x1): Measurement grid: dx=15mm, dy=15mm

Zoom Scan (5x5x7)/Cube 0: Measurement grid: dx=8mm, dy=8mm, dz=5mm

Reference Value = 26.94 V/m; Power Drift = -0.13 dB

Peak SAR (extrapolated) = 1.18 W/kg

SAR(1 g) = 0.670 W/kg

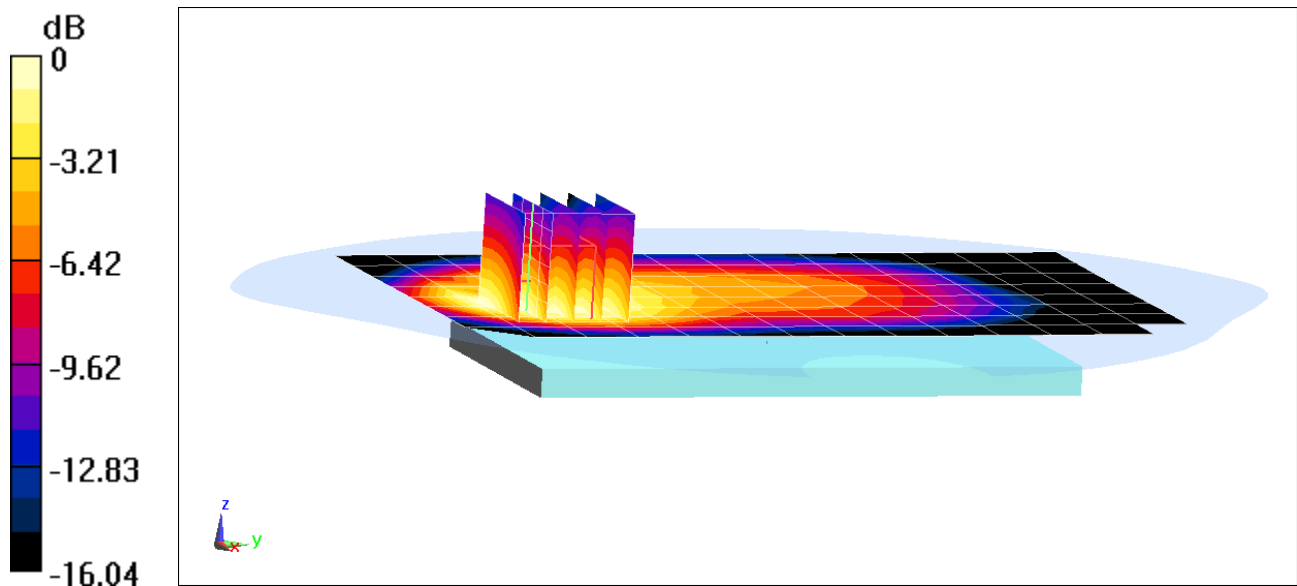

0 dB = 0.943 W/kg = -0.25 dBW/kg

PCTEST ENGINEERING LABORATORY, INC.

DUT: A3LSMN975U; Type: Portable Handset; Serial: 0116M

Communication System: UID 0, GSM; Frequency: 836.6 MHz; Duty Cycle: 1:8.3
Medium: 835 Body; Medium parameters used (interpolated):
 $f = 836.6 \text{ MHz}$; $\sigma = 0.988 \text{ S/m}$; $\epsilon_r = 53.892$; $\rho = 1000 \text{ kg/m}^3$
Phantom section: Flat Section; Space: 1.5 cm

Test Date: 05-27-2019; Ambient Temp: 20.2°C; Tissue Temp: 19.9°C

Probe: EX3DV4 - SN7488; ConvF(11.03, 11.03, 11.03) @ 836.6 MHz; Calibrated: 1/24/2019
Sensor-Surface: 1.4mm (Mechanical Surface Detection)
Electronics: DAE4 Sn1530; Calibrated: 1/15/2019
Phantom: Twin-SAM V5.0; Type: QD 000 P40 CD; Serial: 1800
Measurement SW: DASY52, Version 52.10 (2);SEMCAD X Version 14.6.12 (7450)

Mode: GSM 850, Body SAR, Back side, Mid.ch

Area Scan (9x15x1): Measurement grid: dx=15mm, dy=15mm

Zoom Scan (6x6x7)/Cube 0: Measurement grid: dx=8mm, dy=8mm, dz=5mm

Reference Value = 13.90 V/m; Power Drift = -0.05 dB

Peak SAR (extrapolated) = 0.298 W/kg

SAR(1 g) = 0.180 W/kg

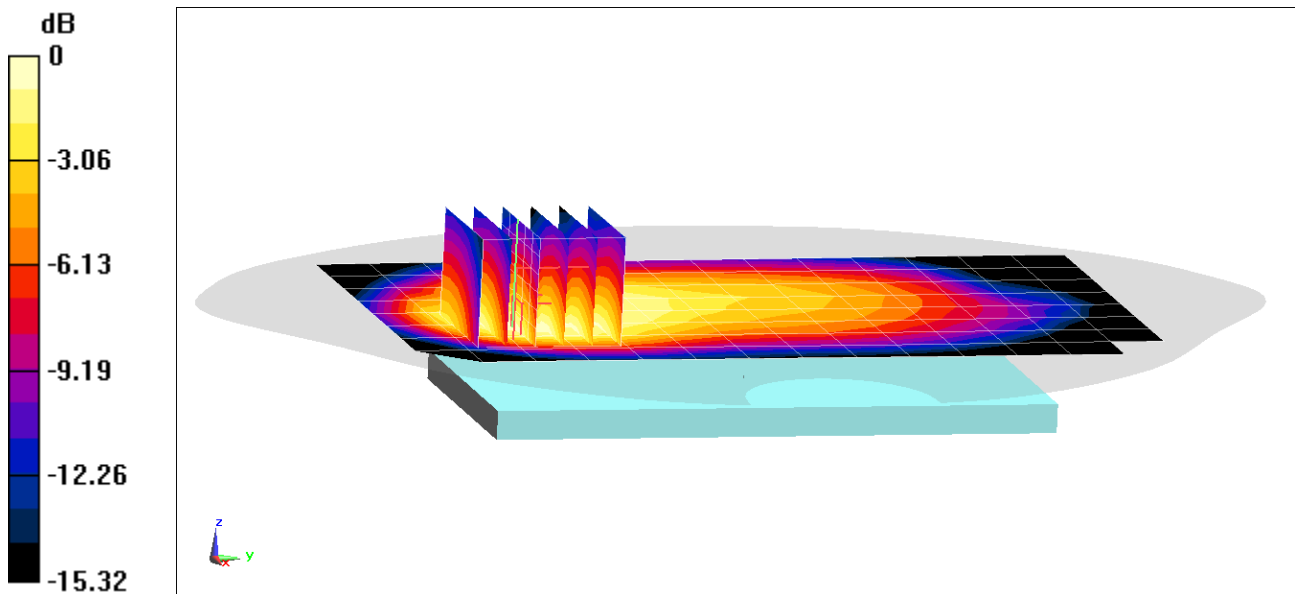

0 dB = 0.251 W/kg = -6.00 dBW/kg

PCTEST ENGINEERING LABORATORY, INC.

DUT: A3LSMN975U; Type: Portable Handset; Serial: 0116M

Communication System: UID 0, GSM GPRS; 3 Tx slots; Frequency: 848.8 MHz; Duty Cycle: 1:2.76
Medium: 835 Body Medium parameters used (interpolated):
 $f = 848.8 \text{ MHz}$; $\sigma = 0.959 \text{ S/m}$; $\epsilon_r = 52.559$; $\rho = 1000 \text{ kg/m}^3$
Phantom section: Flat Section; Space: 1.0 cm

Test Date: 06-18-2019; Ambient Temp: 22.4°C; Tissue Temp: 21.8°C

Probe: EX3DV4 - SN3914; ConvF(9.46, 9.46, 9.46) @ 848.8 MHz; Calibrated: 2/19/2019
Sensor-Surface: 1.4mm (Mechanical Surface Detection)
Electronics: DAE4 Sn1272; Calibrated: 2/14/2019
Phantom: SAM with CRP v5.0 Left; Type: QD000P40CD; Serial: 1687
Measurement SW: DASY52, Version 52.10 (2);SEMCAD X Version 14.6.12 (7450)

Mode: GPRS 850, Body SAR, Back side, High.ch, 3 Tx Slots

Area Scan (9x15x1): Measurement grid: dx=15mm, dy=15mm
Zoom Scan (5x6x7)/Cube 0: Measurement grid: dx=8mm, dy=8mm, dz=5mm
Reference Value = 24.60 V/m; Power Drift = -0.15 dB
Peak SAR (extrapolated) = 0.998 W/kg
SAR(1 g) = 0.571 W/kg

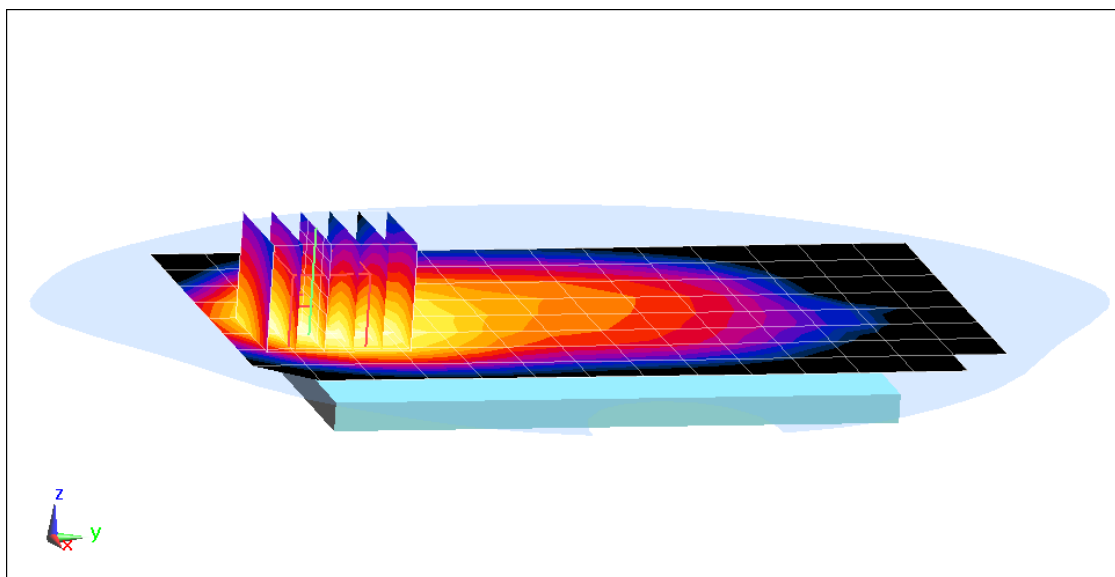

0 dB = 0.814 W/kg = -0.89 dBW/kg

PCTEST ENGINEERING LABORATORY, INC.

DUT: A3LSMN975U; Type: Portable Handset; Serial: 0119M

Communication System: UID 0, UMTS; Frequency: 836.6 MHz; Duty Cycle: 1:1
Medium: 835 Body; Medium parameters used (interpolated):
 $f = 836.6 \text{ MHz}$; $\sigma = 0.999 \text{ S/m}$; $\epsilon_r = 53.282$; $\rho = 1000 \text{ kg/m}^3$
Phantom section: Flat Section; Space: 1.5 cm

Test Date: 05-22-2019; Ambient Temp: 19.8°C; Tissue Temp: 20.1°C

Probe: EX3DV4 - SN7488; ConvF(11.03, 11.03, 11.03) @ 836.6 MHz; Calibrated: 1/24/2019
Sensor-Surface: 1.4mm (Mechanical Surface Detection)
Electronics: DAE4 Sn1530; Calibrated: 1/15/2019
Phantom: Twin-SAM V5.0; Type: QD 000 P40 CD; Serial: 1800
Measurement SW: DASY52, Version 52.10 (2);SEMCAD X Version 14.6.12 (7450)

Mode: UMTS 850, Body SAR, Back side, Mid.ch

Area Scan (9x15x1): Measurement grid: dx=15mm, dy=15mm

Zoom Scan (5x5x7)/Cube 0: Measurement grid: dx=8mm, dy=8mm, dz=5mm

Reference Value = 17.47 V/m; Power Drift = 0.01 dB

Peak SAR (extrapolated) = 0.463 W/kg

SAR(1 g) = 0.283 W/kg

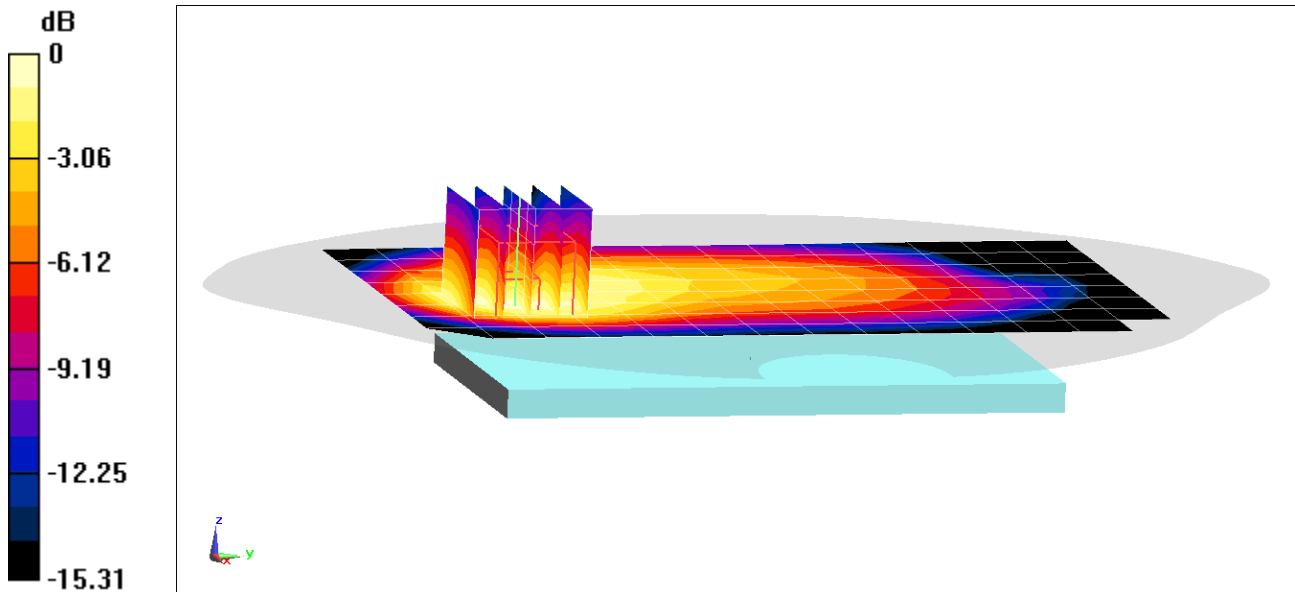

0 dB = 0.398 W/kg = -4.00 dBW/kg

PCTEST ENGINEERING LABORATORY, INC.

DUT: A3LSMN975U; Type: Portable Handset; Serial: 0119M

Communication System: UID 0, UMTS; Frequency: 836.6 MHz; Duty Cycle: 1:1
Medium: 835 Body; Medium parameters used (interpolated):
 $f = 836.6 \text{ MHz}$; $\sigma = 0.999 \text{ S/m}$; $\epsilon_r = 53.282$; $\rho = 1000 \text{ kg/m}^3$
Phantom section: Flat Section; Space: 1.0 cm

Test Date: 05-22-2019; Ambient Temp: 19.8°C; Tissue Temp: 20.1°C

Probe: EX3DV4 - SN7488; ConvF(11.03, 11.03, 11.03) @ 836.6 MHz; Calibrated: 1/24/2019
Sensor-Surface: 1.4mm (Mechanical Surface Detection)
Electronics: DAE4 Sn1530; Calibrated: 1/15/2019
Phantom: Twin-SAM V5.0; Type: QD 000 P40 CD; Serial: 1800
Measurement SW: DASY52, Version 52.10 (2);SEMCAD X Version 14.6.12 (7450)

Mode: UMTS 850, Body SAR, Back side, Mid.ch

Area Scan (9x15x1): Measurement grid: dx=15mm, dy=15mm

Zoom Scan (5x5x7)/Cube 0: Measurement grid: dx=8mm, dy=8mm, dz=5mm

Reference Value = 25.71 V/m; Power Drift = 0.03 dB

Peak SAR (extrapolated) = 1.06 W/kg

SAR(1 g) = 0.616 W/kg

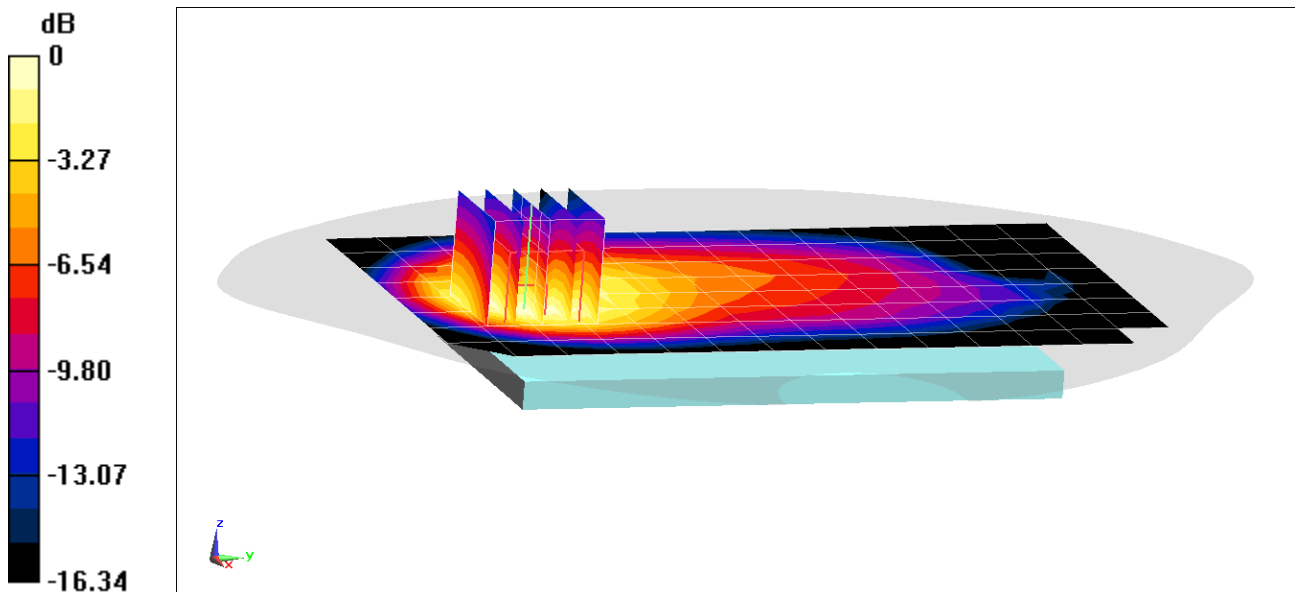

0 dB = 0.890 W/kg = -0.51 dBW/kg

PCTEST ENGINEERING LABORATORY, INC.

DUT: A3LSMN975U; Type: Portable Handset; Serial: 0116M

Communication System: UID 0, UMTS; Frequency: 1752.6 MHz; Duty Cycle: 1:1
Medium: 1750 Body Medium parameters used (interpolated):
 $f = 1752.6$ MHz; $\sigma = 1.518$ S/m; $\epsilon_r = 52.012$; $\rho = 1000$ kg/m³
Phantom section: Flat Section; Space: 1.5 cm

Test Date: 06-08-2019; Ambient Temp: 22.7°C; Tissue Temp: 21.8°C

Probe: EX3DV4 - SN3914; ConvF(7.89, 7.89, 7.89) @ 1752.6 MHz; Calibrated: 2/19/2019
Sensor-Surface: 1.4mm (Mechanical Surface Detection)
Electronics: DAE4 Sn1272; Calibrated: 2/14/2019
Phantom: SAM with CRP v5.0 Front; Type: QD000P40CD; Serial: 1646
Measurement SW: DASY52, Version 52.10 (2);SEMCAD X Version 14.6.12 (7450)

Mode: UMTS 1750, Body SAR, Back side, High.ch

Area Scan (9x15x1): Measurement grid: dx=15mm, dy=15mm

Zoom Scan (5x5x7)/Cube 0: Measurement grid: dx=8mm, dy=8mm, dz=5mm

Reference Value = 25.35 V/m; Power Drift = 0.02 dB

Peak SAR (extrapolated) = 1.49 W/kg

SAR(1 g) = 0.898 W/kg

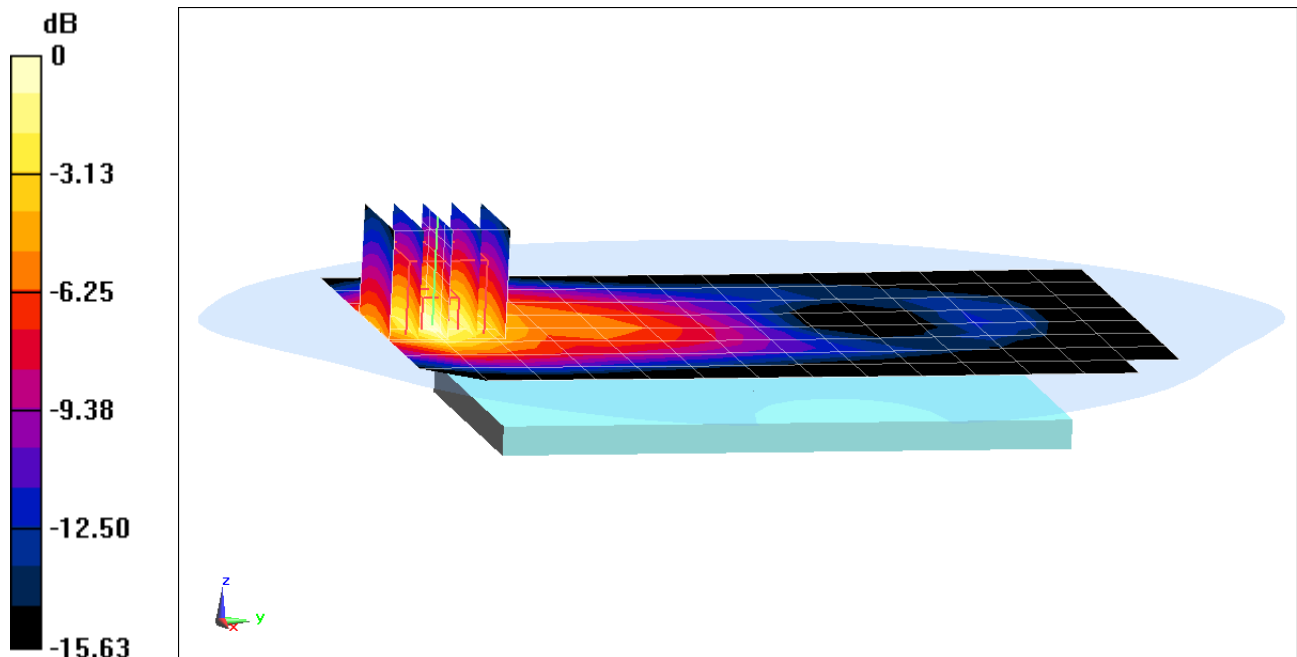

0 dB = 1.28 W/kg = 1.07 dBW/kg

PCTEST ENGINEERING LABORATORY, INC.

DUT: A3LSMN975U; Type: Portable Handset; Serial: 0116M

Communication System: UID 0, UMTS; Frequency: 1752.6 MHz; Duty Cycle: 1:1
Medium: 1750 Body Medium parameters used (interpolated):
 $f = 1752.6$ MHz; $\sigma = 1.518$ S/m; $\epsilon_r = 52.012$; $\rho = 1000$ kg/m³
Phantom section: Flat Section; Space: 1.0 cm

Test Date: 06-08-2019; Ambient Temp: 22.7°C; Tissue Temp: 21.8°C

Probe: EX3DV4 - SN3914; ConvF(7.89, 7.89, 7.89) @ 1752.6 MHz; Calibrated: 2/19/2019
Sensor-Surface: 1.4mm (Mechanical Surface Detection)
Electronics: DAE4 Sn1272; Calibrated: 2/14/2019
Phantom: SAM with CRP v5.0 Front; Type: QD000P40CD; Serial: 1646
Measurement SW: DASY52, Version 52.10 (2);SEMCAD X Version 14.6.12 (7450)

Mode: UMTS 1750, Body SAR, Bottom Edge, High.ch

Area Scan (10x7x1): Measurement grid: dx=5mm, dy=15mm

Zoom Scan (5x5x7)/Cube 0: Measurement grid: dx=8mm, dy=8mm, dz=5mm

Reference Value = 26.55 V/m; Power Drift = -0.02 dB

Peak SAR (extrapolated) = 1.75 W/kg

SAR(1 g) = 0.969 W/kg

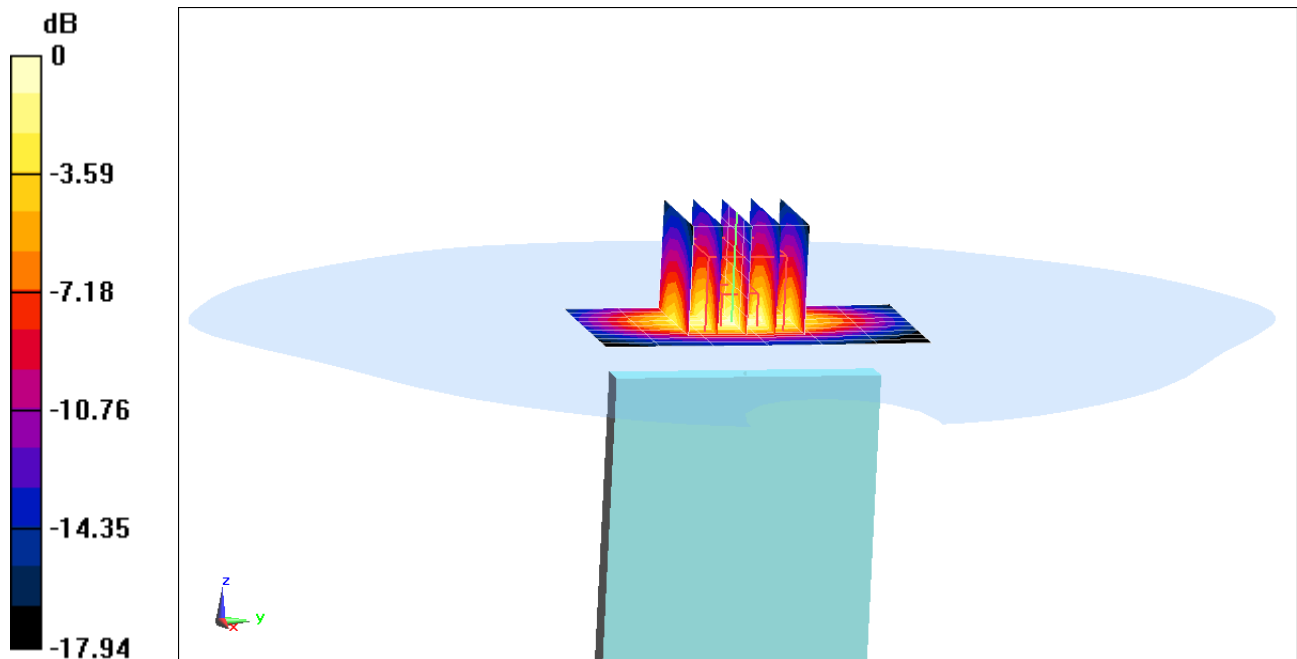

0 dB = 1.47 W/kg = 1.67 dBW/kg

PCTEST ENGINEERING LABORATORY, INC.

DUT: A3LSMN975U; Type: Portable Handset; Serial: 0119M

Communication System: UID 0, CDMA; Frequency: 1908.75 MHz; Duty Cycle: 1:1
Medium: 1900 Body; Medium parameters used (interpolated):
 $f = 1908.75 \text{ MHz}$; $\sigma = 1.574 \text{ S/m}$; $\epsilon_r = 51.71$; $\rho = 1000 \text{ kg/m}^3$
Phantom section: Flat Section; Space: 1.5 cm

Test Date: 06-12-2019; Ambient Temp: 22.6°C; Tissue Temp: 22.0°C

Probe: EX3DV4 - SN7410; ConvF(7.78, 7.78, 7.78) @ 1908.75 MHz; Calibrated: 7/20/2018
Sensor-Surface: 1.4mm (Mechanical Surface Detection)
Electronics: DAE4 Sn1322; Calibrated: 7/11/2018
Phantom: Front; Type: QD 000 P40 CD; Serial: 1686
Measurement SW: DASY52, Version 52.10 (2);SEMCAD X Version 14.6.12 (7450)

Mode: PCS CDMA, Body SAR, Back side, High.ch

Area Scan (9x15x1): Measurement grid: dx=15mm, dy=15mm

Zoom Scan (5x5x7)/Cube 0: Measurement grid: dx=8mm, dy=8mm, dz=5mm

Reference Value = 20.88 V/m; Power Drift = 0.04 dB

Peak SAR (extrapolated) = 1.03 W/kg

SAR(1 g) = 0.628 W/kg

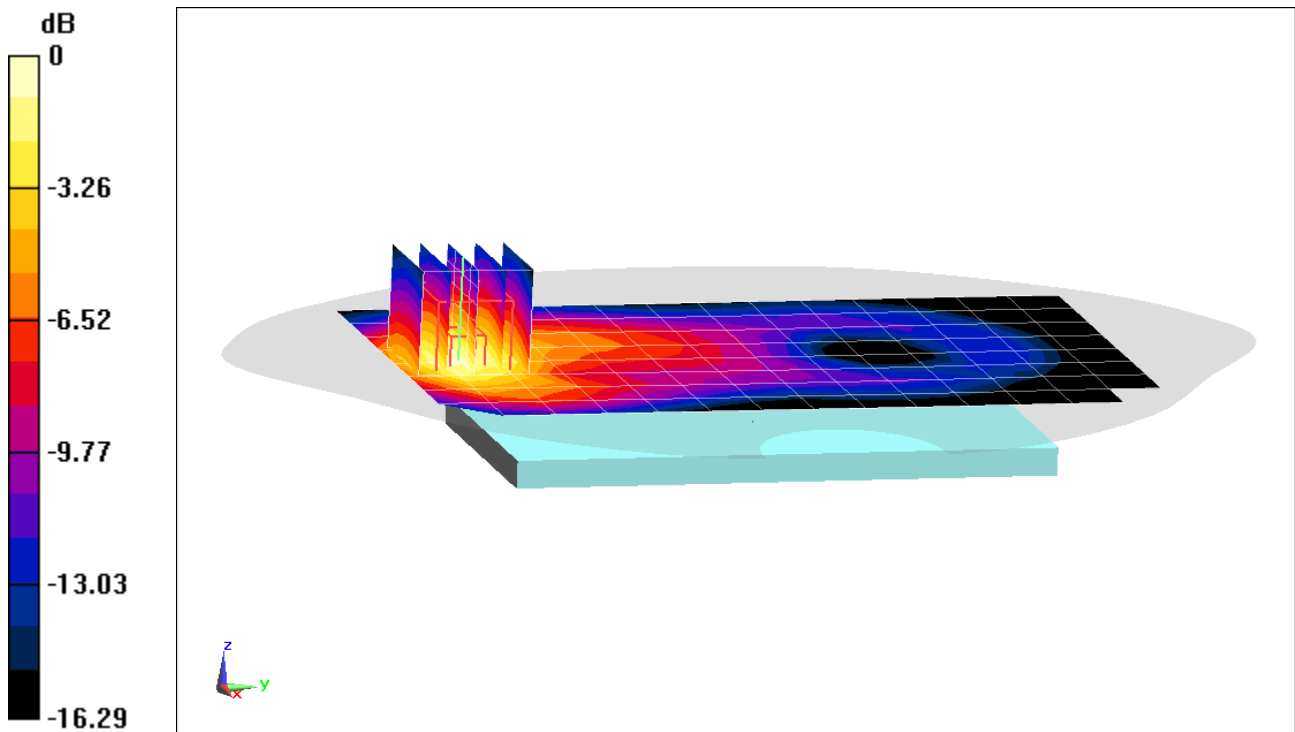

0 dB = 0.894 W/kg = -0.49 dBW/kg

PCTEST ENGINEERING LABORATORY, INC.

DUT: A3LSMN975U; Type: Portable Handset; Serial: 0119M

Communication System: UID 0, CDMA; Frequency: 1908.75 MHz; Duty Cycle: 1:1
Medium: 1900 Body Medium parameters used (interpolated):
 $f = 1908.75 \text{ MHz}$; $\sigma = 1.578 \text{ S/m}$; $\epsilon_r = 52.226$; $\rho = 1000 \text{ kg/m}^3$
Phantom section: Flat Section; Space: 1.0 cm

Test Date: 06-07-2019; Ambient Temp: 22.2°C; Tissue Temp: 22.5°C

Probe: EX3DV4 - SN7410; ConvF(7.78, 7.78, 7.78) @ 1908.75 MHz; Calibrated: 7/20/2018
Sensor-Surface: 1.4mm (Mechanical Surface Detection)
Electronics: DAE4 Sn1322; Calibrated: 7/11/2018
Phantom: Front; Type: QD 000 P40 CD; Serial: 1686
Measurement SW: DASY52, Version 52.10 (2);SEMCAD X Version 14.6.12 (7450)

Mode: PCS EVDO Rev.0, Body SAR, Bottom Edge, High.ch

Area Scan (10x7x1): Measurement grid: $dx=5\text{mm}$, $dy=15\text{mm}$
Zoom Scan (5x5x7)/Cube 0: Measurement grid: $dx=8\text{mm}$, $dy=8\text{mm}$, $dz=5\text{mm}$
Reference Value = 23.64 V/m; Power Drift = -0.05 dB
Peak SAR (extrapolated) = 1.42 W/kg
SAR(1 g) = 0.785 W/kg

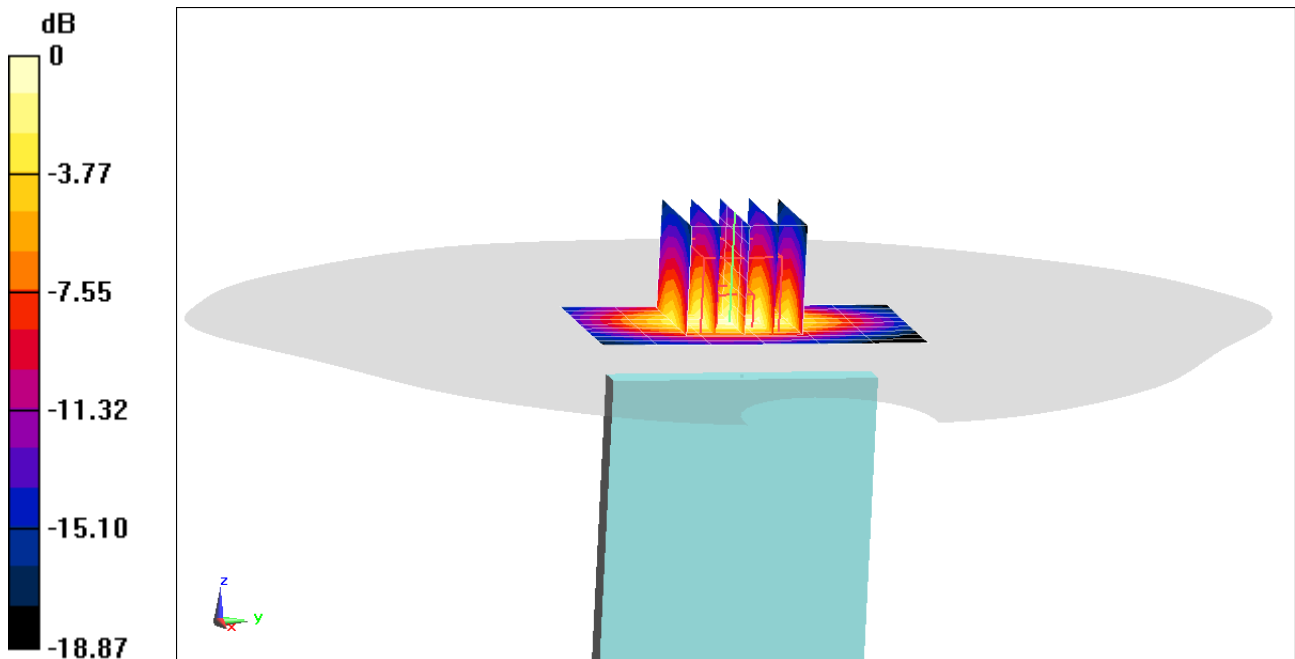

0 dB = 1.20 W/kg = 0.79 dBW/kg

PCTEST ENGINEERING LABORATORY, INC.

DUT: A3LSMN975U; Type: Portable Handset; Serial: 0119M

Communication System: UID 0, GSM; Frequency: 1909.8 MHz; Duty Cycle: 1:8.3

Medium: 1900 Body Medium parameters used:

$f = 1910$ MHz; $\sigma = 1.583$ S/m; $\epsilon_r = 51.879$; $\rho = 1000$ kg/m³

Phantom section: Flat Section; Space: 1.5 cm

Test Date: 06-05-2019; Ambient Temp: 22.8°C; Tissue Temp: 23.5°C

Probe: EX3DV4 - SN7410; ConvF(7.78, 7.78, 7.78) @ 1909.8 MHz; Calibrated: 7/20/2018

Sensor-Surface: 1.4mm (Mechanical Surface Detection)

Electronics: DAE4 Sn1322; Calibrated: 7/11/2018

Phantom: Front; Type: QD 000 P40 CD; Serial: 1686

Measurement SW: DASY52, Version 52.10 (2);SEMCAD X Version 14.6.12 (7450)

Mode: GSM 1900, Body SAR, Back side, High.ch

Area Scan (9x15x1): Measurement grid: dx=15mm, dy=15mm

Zoom Scan (5x5x7)/Cube 0: Measurement grid: dx=8mm, dy=8mm, dz=5mm

Reference Value = 12.78 V/m; Power Drift = 0.05 dB

Peak SAR (extrapolated) = 0.388 W/kg

SAR(1 g) = 0.236 W/kg

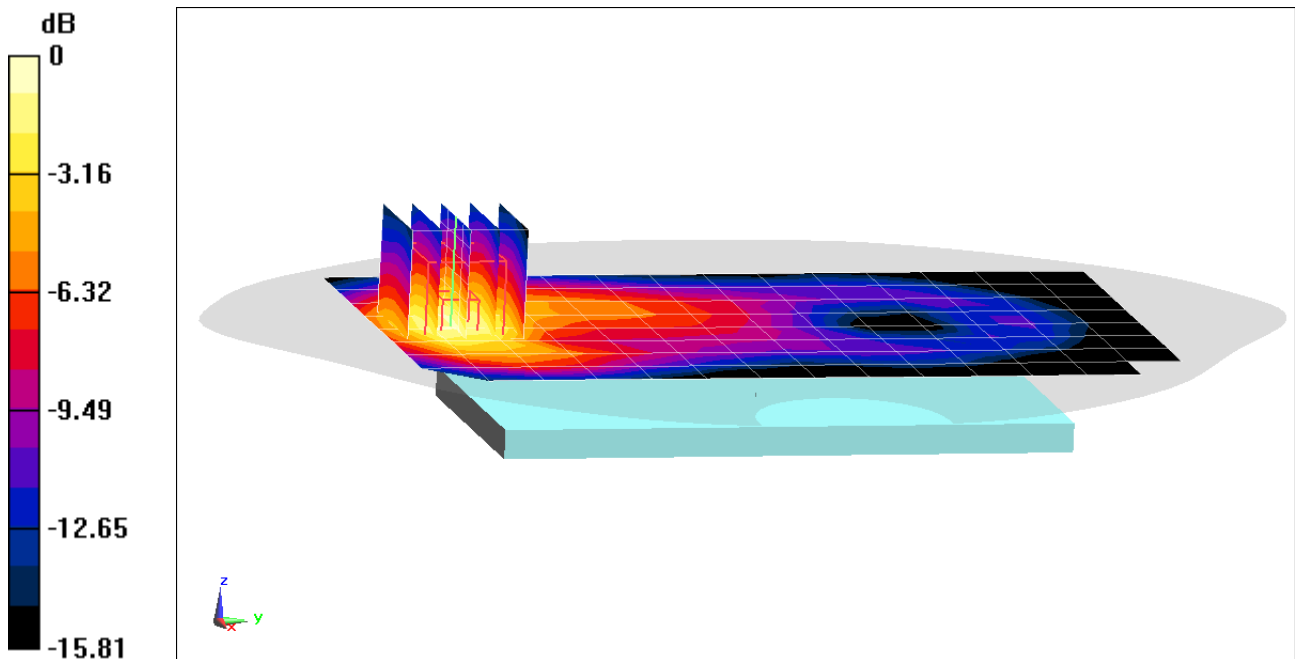

0 dB = 0.337 W/kg = -4.72 dBW/kg

PCTEST ENGINEERING LABORATORY, INC.

DUT: A3LSMN975U; Type: Portable Handset; Serial: 0119M

Communication System: UID 0, _GSM GPRS; 3 Tx slots; Frequency: 1909.8 MHz; Duty Cycle: 1:2.76

Medium: 1900 Body Medium parameters used:

$f = 1910$ MHz; $\sigma = 1.583$ S/m; $\epsilon_r = 51.879$; $\rho = 1000$ kg/m³

Phantom section: Flat Section; Space: 1.0 cm

Test Date: 06-05-2019; Ambient Temp: 22.8°C; Tissue Temp: 23.5°C

Probe: EX3DV4 - SN7410; ConvF(7.78, 7.78, 7.78) @ 1909.8 MHz; Calibrated: 7/20/2018

Sensor-Surface: 1.4mm (Mechanical Surface Detection)

Electronics: DAE4 Sn1322; Calibrated: 7/11/2018

Phantom: Front; Type: QD 000 P40 CD; Serial: 1686

Measurement SW: DASY52, Version 52.10 (2);SEMCAD X Version 14.6.12 (7450)

Mode: GPRS 1900, Body SAR, Bottom Edge, High.ch, 3 Tx Slots

Area Scan (10x7x1): Measurement grid: dx=5mm, dy=15mm

Zoom Scan (5x5x7)/Cube 0: Measurement grid: dx=8mm, dy=8mm, dz=5mm

Reference Value = 26.72 V/m; Power Drift = -0.16 dB

Peak SAR (extrapolated) = 1.81 W/kg

SAR(1 g) = 0.995 W/kg

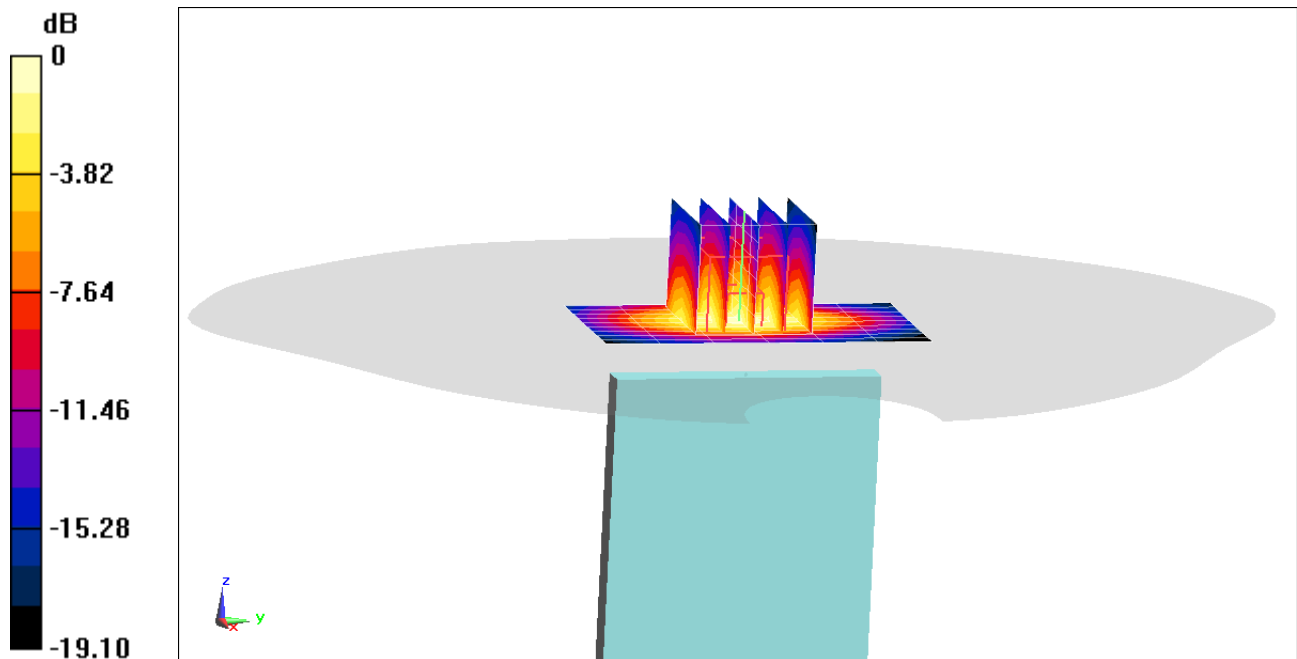

0 dB = 1.53 W/kg = 1.85 dBW/kg

PCTEST ENGINEERING LABORATORY, INC.

DUT: A3LSMN975U; Type: Portable Handset; Serial: 0119M

Communication System: UID 0, UMTS; Frequency: 1907.6 MHz; Duty Cycle: 1:1
Medium: 1900 Body Medium parameters used (interpolated):
 $f = 1907.6 \text{ MHz}$; $\sigma = 1.585 \text{ S/m}$; $\epsilon_r = 52.82$; $\rho = 1000 \text{ kg/m}^3$
Phantom section: Flat Section; Space: 1.5 cm

Test Date: 06-03-2019; Ambient Temp: 21.9°C; Tissue Temp: 22.3°C

Probe: EX3DV4 - SN7410; ConvF(7.78, 7.78, 7.78) @ 1907.6 MHz; Calibrated: 7/20/2018
Sensor-Surface: 1.4mm (Mechanical Surface Detection)
Electronics: DAE4 Sn1322; Calibrated: 7/11/2018
Phantom: Front; Type: QD 000 P40 CD; Serial: 1686
Measurement SW: DASY52, Version 52.10 (2);SEMCAD X Version 14.6.12 (7450)

Mode: UMTS 1900, Body SAR, Back side, High.ch

Area Scan (9x15x1): Measurement grid: $dx=15\text{mm}$, $dy=15\text{mm}$

Zoom Scan (5x5x7)/Cube 0: Measurement grid: $dx=8\text{mm}$, $dy=8\text{mm}$, $dz=5\text{mm}$

Reference Value = 21.20 V/m; Power Drift = 0.00 dB

Peak SAR (extrapolated) = 1.06 W/kg

SAR(1 g) = 0.648 W/kg

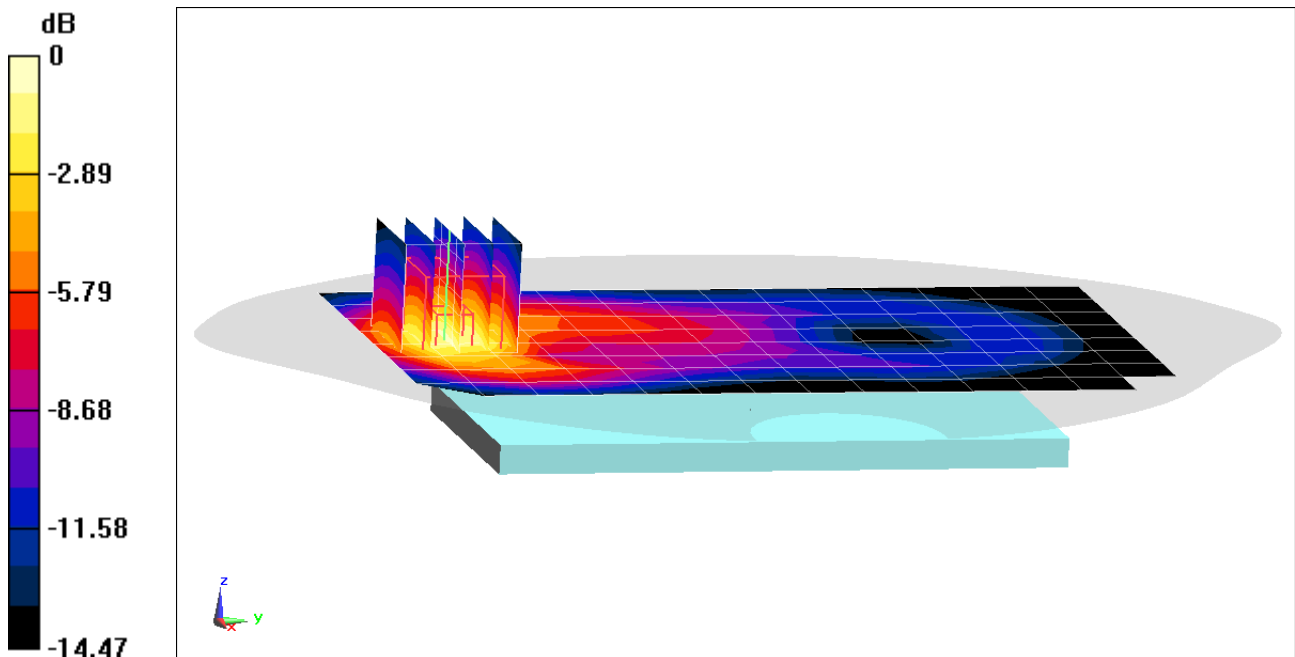

0 dB = 0.913 W/kg = -0.40 dBW/kg

PCTEST ENGINEERING LABORATORY, INC.

DUT: A3LSMN975U; Type: Portable Handset; Serial: 0119M

Communication System: UID 0, UMTS; Frequency: 1880 MHz; Duty Cycle: 1:1

Medium: 1900 Body Medium parameters used:

$f = 1880 \text{ MHz}$; $\sigma = 1.554 \text{ S/m}$; $\epsilon_r = 52.895$; $\rho = 1000 \text{ kg/m}^3$

Phantom section: Flat Section; Space: 1.0 cm

Test Date: 06-03-2019; Ambient Temp: 21.9°C; Tissue Temp: 22.3°C

Probe: EX3DV4 - SN7410; ConvF(7.78, 7.78, 7.78) @ 1880 MHz; Calibrated: 7/20/2018

Sensor-Surface: 1.4mm (Mechanical Surface Detection)

Electronics: DAE4 Sn1322; Calibrated: 7/11/2018

Phantom: Front; Type: QD 000 P40 CD; Serial: 1686

Measurement SW: DASY52, Version 52.10 (2);SEMCAD X Version 14.6.12 (7450)

Mode: UMTS 1900, Body SAR, Bottom Edge, Mid.ch

Area Scan (10x7x1): Measurement grid: dx=5mm, dy=15mm

Zoom Scan (5x5x7)/Cube 0: Measurement grid: dx=8mm, dy=8mm, dz=5mm

Reference Value = 28.37 V/m; Power Drift = -0.03 dB

Peak SAR (extrapolated) = 1.95 W/kg

SAR(1 g) = 1.12 W/kg

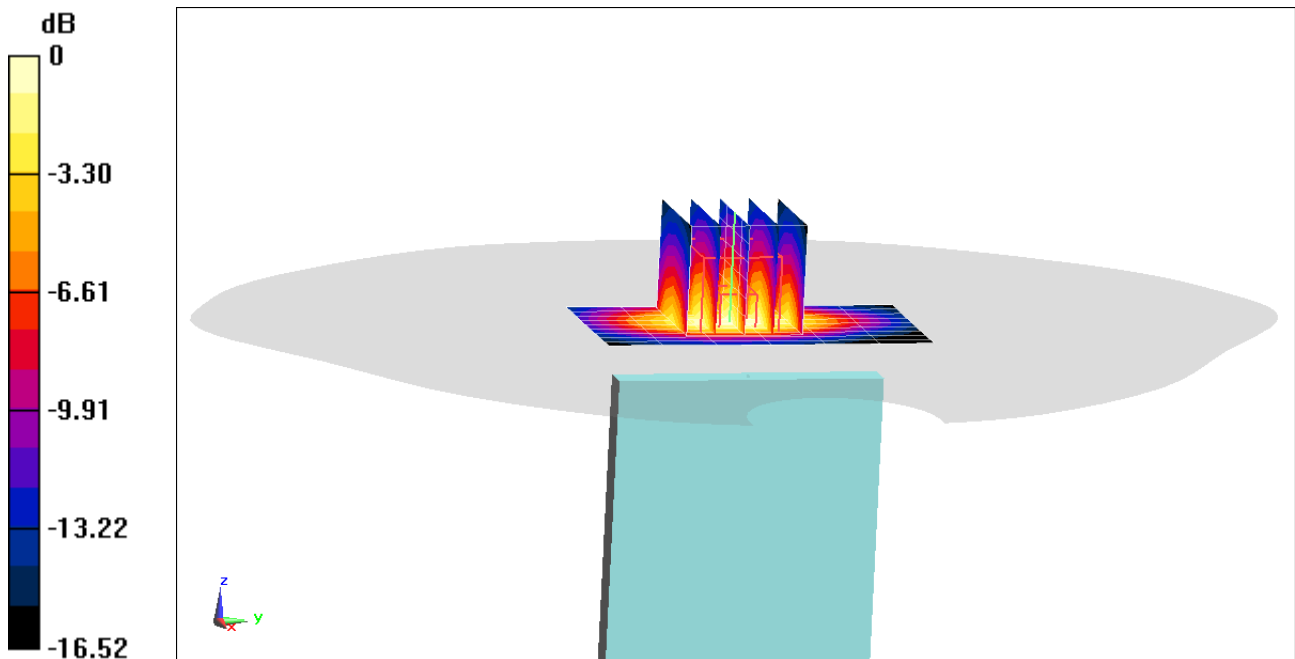

0 dB = 1.67 W/kg = 2.23 dBW/kg

PCTEST ENGINEERING LABORATORY, INC.

DUT: A3LSMN975U; Type: Portable Handset; Serial: 0503M

Communication System: UID 0, LTE Band 71; Frequency: 680.5 MHz; Duty Cycle: 1:1

Medium: 750 Body; Medium parameters used (interpolated):

$f = 680.5 \text{ MHz}$; $\sigma = 0.913 \text{ S/m}$; $\epsilon_r = 57.167$; $\rho = 1000 \text{ kg/m}^3$

Phantom section: Flat Section; Space: 1.5 cm

Test Date: 05-22-2019; Ambient Temp: 23.4°C; Tissue Temp: 21.7°C

Probe: EX3DV4 - SN7357; ConvF(10.19, 10.19, 10.19) @ 680.5 MHz; Calibrated: 4/24/2019

Sensor-Surface: 1.4mm (Mechanical Surface Detection)

Electronics: DAE4 Sn1407; Calibrated: 4/18/2019

Phantom: Twin-SAM V4.0 Front Right; Type: QD 000 P40 CC; Serial: 1167

Measurement SW: DASY52, Version 52.10 (2);SEMCAD X Version 14.6.12 (7450)

**Mode: LTE Band 71, Body SAR, Back side, Mid.ch,
20 MHz Bandwidth, QPSK, 1 RB, 0 RB Offset**

Area Scan (9x15x1): Measurement grid: dx=15mm, dy=15mm

Zoom Scan (5x5x7)/Cube 0: Measurement grid: dx=8mm, dy=8mm, dz=5mm

Reference Value = 14.89 V/m; Power Drift = 0.00 dB

Peak SAR (extrapolated) = 0.264 W/kg

SAR(1 g) = 0.197 W/kg

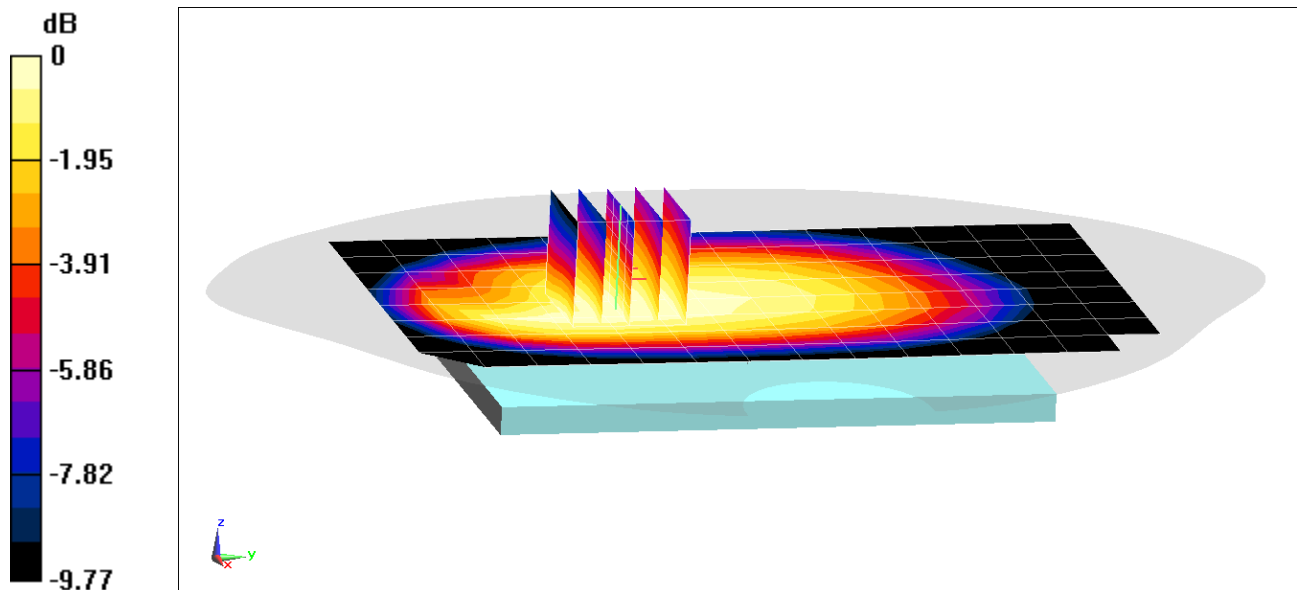

0 dB = 0.239 W/kg = -6.22 dBW/kg

PCTEST ENGINEERING LABORATORY, INC.

DUT: A3LSMN975U; Type: Portable Handset; Serial: 0503M

Communication System: UID 0, LTE Band 71; Frequency: 680.5 MHz; Duty Cycle: 1:1

Medium: 750 Body; Medium parameters used (interpolated):

$f = 680.5 \text{ MHz}$; $\sigma = 0.913 \text{ S/m}$; $\epsilon_r = 57.167$; $\rho = 1000 \text{ kg/m}^3$

Phantom section: Flat Section; Space: 1.0 cm

Test Date: 05-22-2019; Ambient Temp: 23.4°C; Tissue Temp: 21.7°C

Probe: EX3DV4 - SN7357; ConvF(10.19, 10.19, 10.19) @ 680.5 MHz; Calibrated: 4/24/2019

Sensor-Surface: 1.4mm (Mechanical Surface Detection)

Electronics: DAE4 Sn1407; Calibrated: 4/18/2019

Phantom: Twin-SAM V4.0 Front Right; Type: QD 000 P40 CC; Serial: 1167

Measurement SW: DASY52, Version 52.10 (2);SEMCAD X Version 14.6.12 (7450)

**Mode: LTE Band 71, Body SAR, Back side, Mid.ch,
20 MHz Bandwidth, QPSK, 1 RB, 0 RB Offset**

Area Scan (9x15x1): Measurement grid: dx=15mm, dy=15mm

Zoom Scan (5x5x7)/Cube 0: Measurement grid: dx=8mm, dy=8mm, dz=5mm

Reference Value = 17.74 V/m; Power Drift = 0.01 dB

Peak SAR (extrapolated) = 0.468 W/kg

SAR(1 g) = 0.270 W/kg

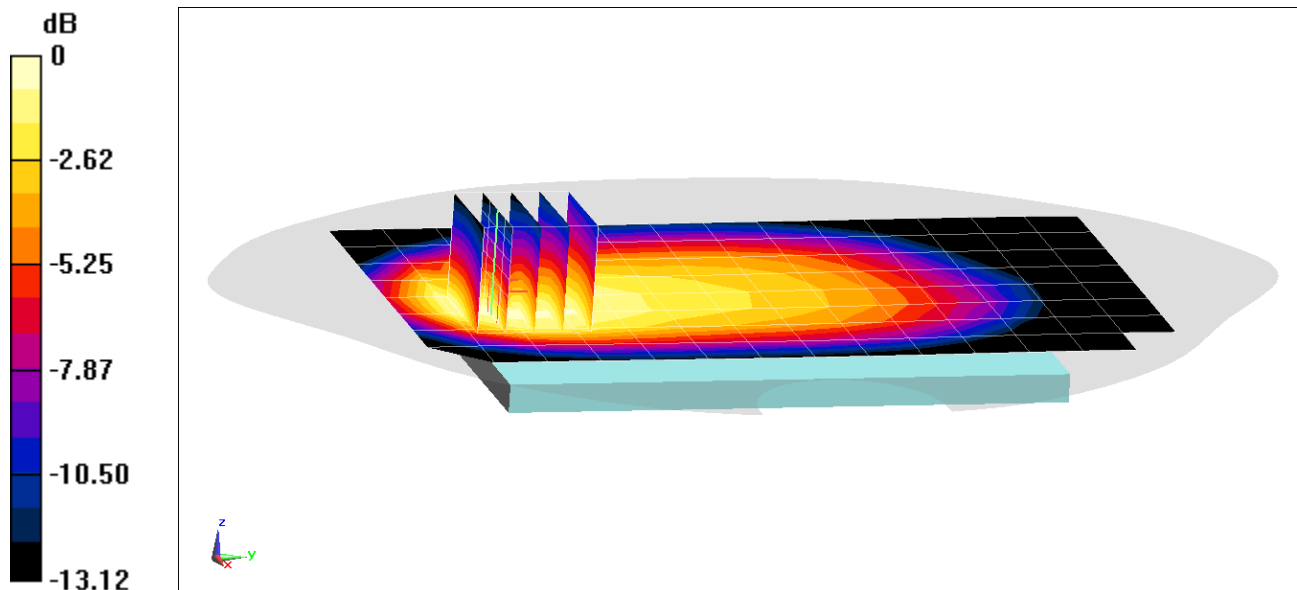

0 dB = 0.390 W/kg = -4.09 dBW/kg

PCTEST ENGINEERING LABORATORY, INC.

DUT: A3LSMN975U; Type: Portable Handset; Serial: 0503M

Communication System: UID 0, LTE Band 12; Frequency: 707.5 MHz; Duty Cycle: 1:1

Medium: 750 Body; Medium parameters used (interpolated):

$f = 707.5 \text{ MHz}$; $\sigma = 0.923 \text{ S/m}$; $\epsilon_r = 57.09$; $\rho = 1000 \text{ kg/m}^3$

Phantom section: Flat Section; Space: 1.5 cm

Test Date: 05-22-2019; Ambient Temp: 23.4°C; Tissue Temp: 21.7°C

Probe: EX3DV4 - SN7357; ConvF(10.19, 10.19, 10.19) @ 707.5 MHz; Calibrated: 4/24/2019

Sensor-Surface: 1.4mm (Mechanical Surface Detection)

Electronics: DAE4 Sn1407; Calibrated: 4/18/2019

Phantom: Twin-SAM V4.0 Front Right; Type: QD 000 P40 CC; Serial: 1167

Measurement SW: DASY52, Version 52.10 (2);SEMCAD X Version 14.6.12 (7450)

**Mode: LTE Band 12, Body SAR, Back side, Mid.ch,
10 MHz Bandwidth, QPSK, 1 RB, 0 RB Offset**

Area Scan (9x15x1): Measurement grid: dx=15mm, dy=15mm

Zoom Scan (5x5x7)/Cube 0: Measurement grid: dx=8mm, dy=8mm, dz=5mm

Reference Value = 13.11 V/m; Power Drift = -0.01 dB

Peak SAR (extrapolated) = 0.202 W/kg

SAR(1 g) = 0.155 W/kg

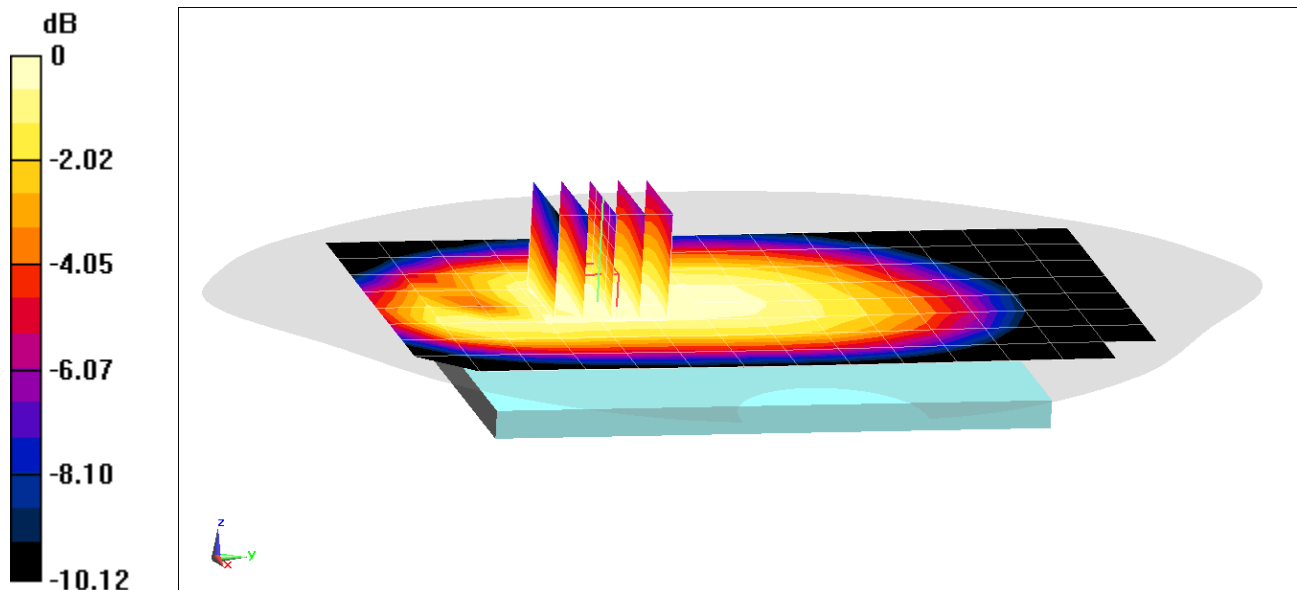

0 dB = 0.186 W/kg = -7.30 dBW/kg

PCTEST ENGINEERING LABORATORY, INC.

DUT: A3LSMN975U; Type: Portable Handset; Serial: 0503M

Communication System: UID 0, LTE Band 12; Frequency: 707.5 MHz; Duty Cycle: 1:1

Medium: 750 Body; Medium parameters used (interpolated):

$f = 707.5$ MHz; $\sigma = 0.923$ S/m; $\epsilon_r = 57.09$; $\rho = 1000$ kg/m³

Phantom section: Flat Section; Space: 1.0 cm

Test Date: 05-22-2019; Ambient Temp: 23.4°C; Tissue Temp: 21.7°C

Probe: EX3DV4 - SN7357; ConvF(10.19, 10.19, 10.19) @ 707.5 MHz; Calibrated: 4/24/2019

Sensor-Surface: 1.4mm (Mechanical Surface Detection)

Electronics: DAE4 Sn1407; Calibrated: 4/18/2019

Phantom: Twin-SAM V4.0 Front Right; Type: QD 000 P40 CC; Serial: 1167

Measurement SW: DASY52, Version 52.10 (2);SEMCAD X Version 14.6.12 (7450)

**Mode: LTE Band 12, Body SAR, Back side, Mid.ch,
10 MHz Bandwidth, QPSK, 1 RB, 0 RB Offset**

Area Scan (9x15x1): Measurement grid: dx=15mm, dy=15mm

Zoom Scan (6x6x7)/Cube 0: Measurement grid: dx=8mm, dy=8mm, dz=5mm

Reference Value = 16.40 V/m; Power Drift = -0.03 dB

Peak SAR (extrapolated) = 0.415 W/kg

SAR(1 g) = 0.232 W/kg

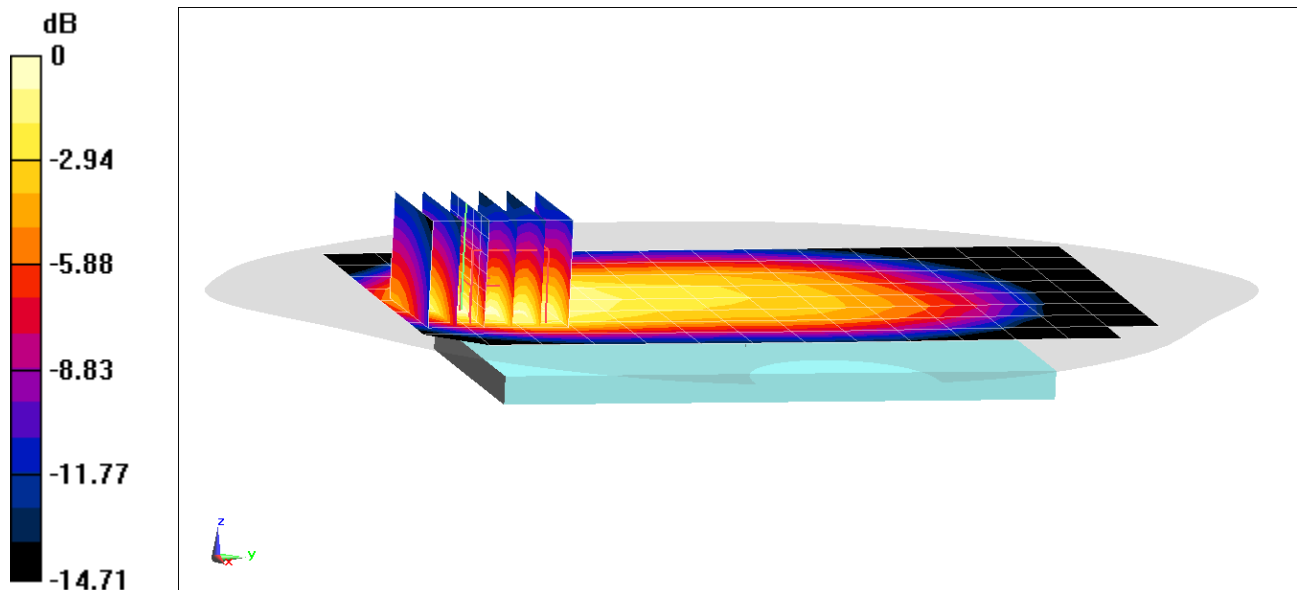

0 dB = 0.341 W/kg = -4.67 dBW/kg

PCTEST ENGINEERING LABORATORY, INC.

DUT: A3LSMN975U; Type: Portable Handset; Serial: 0503M

Communication System: UID 0, LTE Band 13; Frequency: 782 MHz; Duty Cycle: 1:1

Medium: 750 Body; Medium parameters used (interpolated):

$f = 782 \text{ MHz}$; $\sigma = 0.95 \text{ S/m}$; $\epsilon_r = 56.923$; $\rho = 1000 \text{ kg/m}^3$

Phantom section: Flat Section; Space: 1.5 cm

Test Date: 05-22-2019; Ambient Temp: 23.4°C; Tissue Temp: 21.7°C

Probe: EX3DV4 - SN7357; ConvF(10.19, 10.19, 10.19) @ 782 MHz; Calibrated: 4/24/2019

Sensor-Surface: 1.4mm (Mechanical Surface Detection)

Electronics: DAE4 Sn1407; Calibrated: 4/18/2019

Phantom: Twin-SAM V4.0 Front Right; Type: QD 000 P40 CC; Serial: 1167

Measurement SW: DASY52, Version 52.10 (2);SEMCAD X Version 14.6.12 (7450)

**Mode: LTE Band 13, Body SAR, Back side, Mid.ch,
10 MHz Bandwidth, QPSK, 1 RB, 0 RB Offset**

Area Scan (9x15x1): Measurement grid: dx=15mm, dy=15mm

Zoom Scan (5x5x7)/Cube 0: Measurement grid: dx=8mm, dy=8mm, dz=5mm

Reference Value = 13.52 V/m; Power Drift = 0.01 dB

Peak SAR (extrapolated) = 0.228 W/kg

SAR(1 g) = 0.167 W/kg

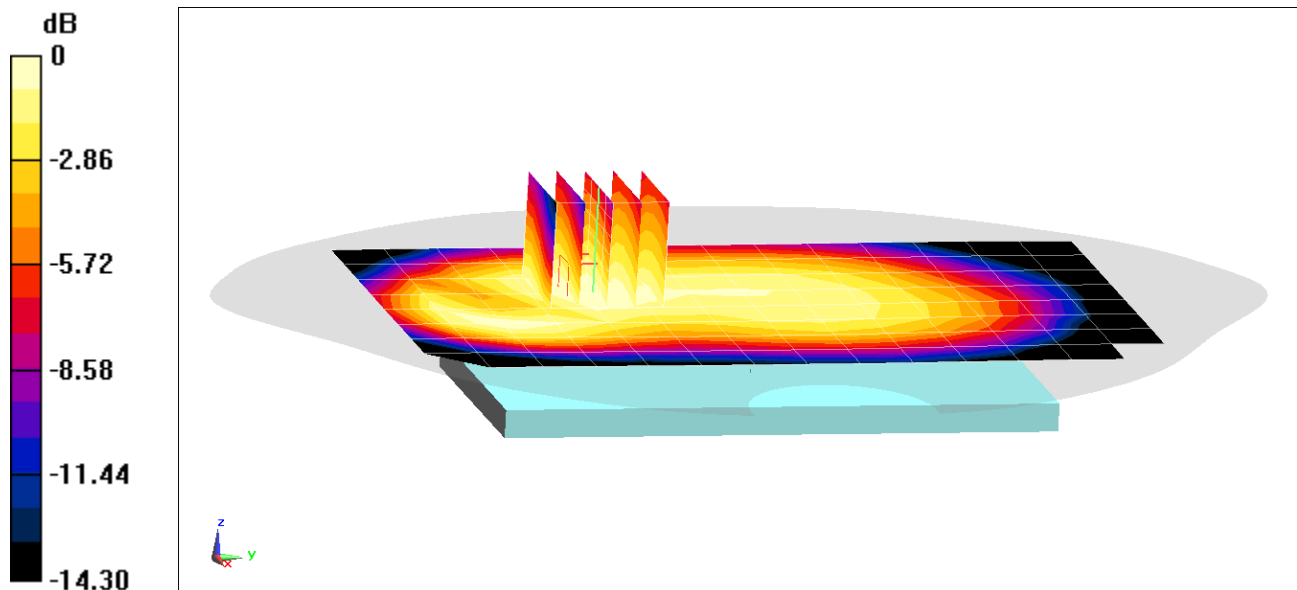

0 dB = 0.202 W/kg = -6.95 dBW/kg

PCTEST ENGINEERING LABORATORY, INC.

DUT: A3LSMN975U; Type: Portable Handset; Serial: 0503M

Communication System: UID 0, LTE Band 13; Frequency: 782 MHz; Duty Cycle: 1:1

Medium: 750 Body; Medium parameters used (interpolated):

$f = 782 \text{ MHz}$; $\sigma = 0.95 \text{ S/m}$; $\epsilon_r = 56.923$; $\rho = 1000 \text{ kg/m}^3$

Phantom section: Flat Section; Space: 1.0 cm

Test Date: 05-22-2019; Ambient Temp: 23.4°C; Tissue Temp: 21.7°C

Probe: EX3DV4 - SN7357; ConvF(10.19, 10.19, 10.19) @ 782 MHz; Calibrated: 4/24/2019

Sensor-Surface: 1.4mm (Mechanical Surface Detection)

Electronics: DAE4 Sn1407; Calibrated: 4/18/2019

Phantom: Twin-SAM V4.0 Front Right; Type: QD 000 P40 CC; Serial: 1167

Measurement SW: DASY52, Version 52.10 (2);SEMCAD X Version 14.6.12 (7450)

**Mode: LTE Band 13, Body SAR, Back side, Mid.ch,
10 MHz Bandwidth, QPSK, 1 RB, 0 RB Offset**

Area Scan (9x15x1): Measurement grid: dx=15mm, dy=15mm

Zoom Scan (5x5x7)/Cube 0: Measurement grid: dx=8mm, dy=8mm, dz=5mm

Reference Value = 20.90 V/m; Power Drift = 0.00 dB

Peak SAR (extrapolated) = 0.666 W/kg

SAR(1 g) = 0.386 W/kg

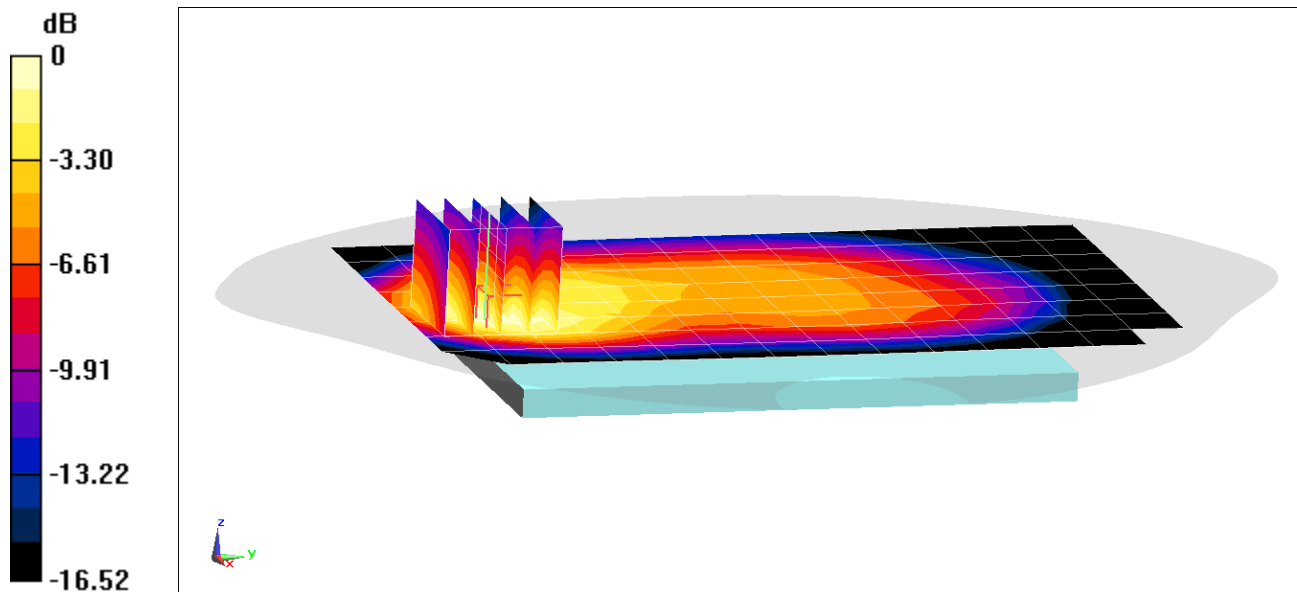

0 dB = 0.555 W/kg = -2.56 dBW/kg

PCTEST ENGINEERING LABORATORY, INC.

DUT: A3LSMN975U; Type: Portable Handset; Serial: 0503M

Communication System: UID 0, LTE Band 14; Frequency: 793 MHz; Duty Cycle: 1:1

Medium: 750 Body; Medium parameters used (interpolated):

$f = 793 \text{ MHz}$; $\sigma = 0.954 \text{ S/m}$; $\epsilon_r = 56.896$; $\rho = 1000 \text{ kg/m}^3$

Phantom section: Flat Section; Space: 1.5 cm

Test Date: 05-22-2019; Ambient Temp: 23.4°C; Tissue Temp: 21.7°C

Probe: EX3DV4 - SN7357; ConvF(10.19, 10.19, 10.19) @ 793 MHz; Calibrated: 4/24/2019

Sensor-Surface: 1.4mm (Mechanical Surface Detection)

Electronics: DAE4 Sn1407; Calibrated: 4/18/2019

Phantom: Twin-SAM V4.0 Front Right; Type: QD 000 P40 CC; Serial: 1167

Measurement SW: DASY52, Version 52.10 (2);SEMCAD X Version 14.6.12 (7450)

**Mode: LTE Band 14, Body SAR, Back side, Mid.ch,
10 MHz Bandwidth, QPSK, 1 RB, 0 RB Offset**

Area Scan (9x15x1): Measurement grid: dx=15mm, dy=15mm

Zoom Scan (5x5x7)/Cube 0: Measurement grid: dx=8mm, dy=8mm, dz=5mm

Reference Value = 14.69 V/m; Power Drift = 0.04 dB

Peak SAR (extrapolated) = 0.310 W/kg

SAR(1 g) = 0.194 W/kg

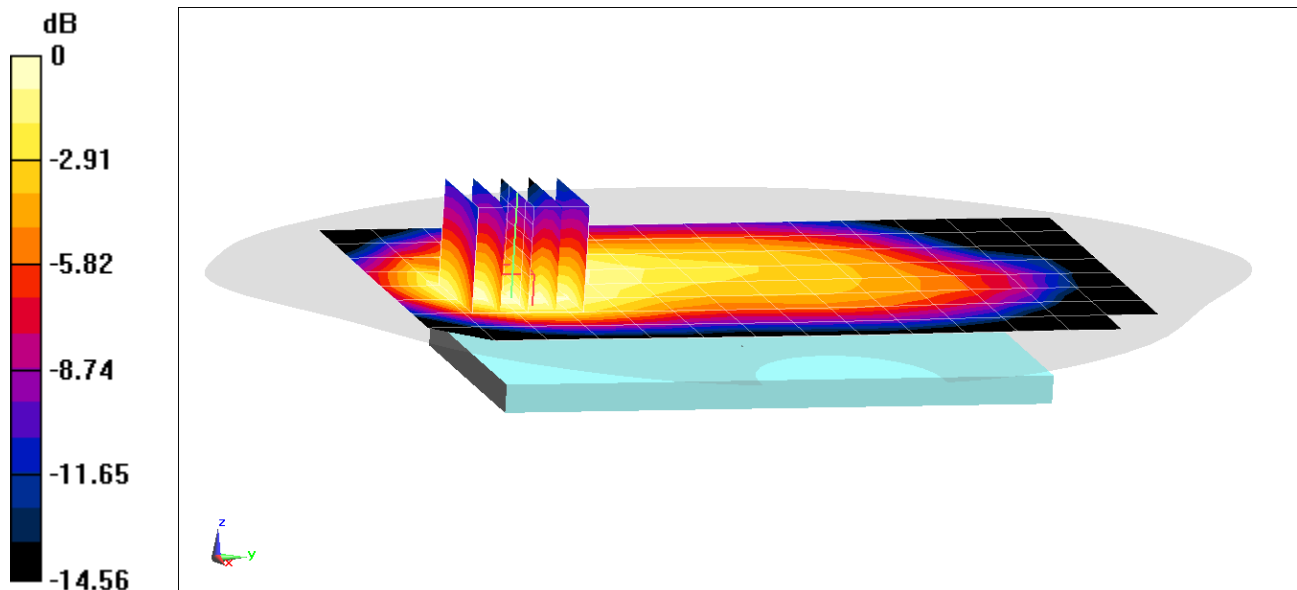

0 dB = 0.266 W/kg = -5.75 dBW/kg

PCTEST ENGINEERING LABORATORY, INC.

DUT: A3LSMN975U; Type: Portable Handset; Serial: 0503M

Communication System: UID 0, LTE Band 14; Frequency: 793 MHz; Duty Cycle: 1:1

Medium: 750 Body; Medium parameters used (interpolated):

$f = 793 \text{ MHz}$; $\sigma = 0.954 \text{ S/m}$; $\epsilon_r = 56.896$; $\rho = 1000 \text{ kg/m}^3$

Phantom section: Flat Section; Space: 1.0 cm

Test Date: 05-22-2019; Ambient Temp: 23.4°C; Tissue Temp: 21.7°C

Probe: EX3DV4 - SN7357; ConvF(10.19, 10.19, 10.19) @ 793 MHz; Calibrated: 4/24/2019

Sensor-Surface: 1.4mm (Mechanical Surface Detection)

Electronics: DAE4 Sn1407; Calibrated: 4/18/2019

Phantom: Twin-SAM V4.0 Front Right; Type: QD 000 P40 CC; Serial: 1167

Measurement SW: DASY52, Version 52.10 (2);SEMCAD X Version 14.6.12 (7450)

**Mode: LTE Band 14, Body SAR, Back side, Mid.ch,
10 MHz Bandwidth, QPSK, 1 RB, 0 RB Offset**

Area Scan (9x15x1): Measurement grid: dx=15mm, dy=15mm

Zoom Scan (5x5x7)/Cube 0: Measurement grid: dx=8mm, dy=8mm, dz=5mm

Reference Value = 22.33 V/m; Power Drift = 0.02 dB

Peak SAR (extrapolated) = 0.762 W/kg

SAR(1 g) = 0.449 W/kg

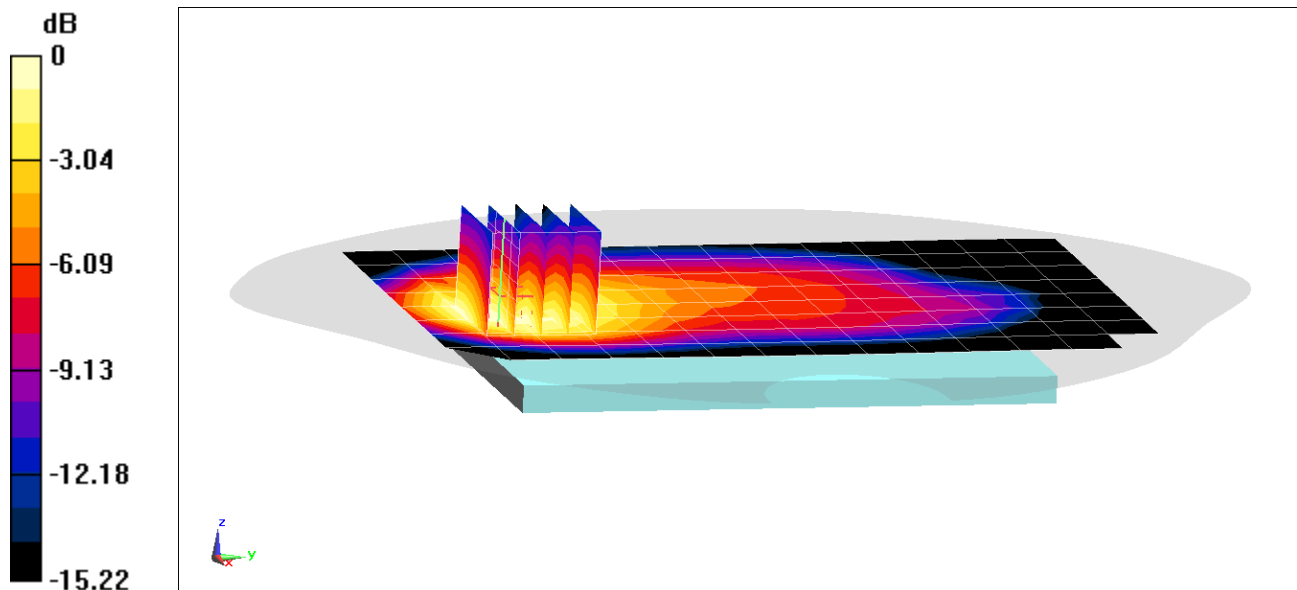

0 dB = 0.632 W/kg = -1.99 dBW/kg

PCTEST ENGINEERING LABORATORY, INC.

DUT: A3LSMN975U; Type: Portable Handset; Serial: 0503M

Communication System: UID 0, LTE Band 26; Frequency: 831.5 MHz; Duty Cycle: 1:1

Medium: 835 Body; Medium parameters used (interpolated):

$f = 831.5 \text{ MHz}$; $\sigma = 0.997 \text{ S/m}$; $\epsilon_r = 52.826$; $\rho = 1000 \text{ kg/m}^3$

Phantom section: Flat Section; Space: 1.5 cm

Test Date: 5-30-2019; Ambient Temp: 20.1°C; Tissue Temp: 20.3°C

Probe: EX3DV4 - SN7488; ConvF(11.03, 11.03, 11.03) @ 831.5 MHz; Calibrated: 1/24/2019

Sensor-Surface: 1.4mm (Mechanical Surface Detection)

Electronics: DAE4 Sn1530; Calibrated: 1/15/2019

Phantom: Twin-SAM V5.0; Type: QD 000 P40 CD; Serial: 1800

Measurement SW: DASY52, Version 52.10 (2);SEMCAD X Version 14.6.12 (7450)

**Mode: LTE Band 26 (Cell.), Body SAR, Back side, Mid.ch,
15 MHz Bandwidth, QPSK, 1 RB, 74 RB Offset**

Area Scan (9x15x1): Measurement grid: dx=15mm, dy=15mm

Zoom Scan (5x5x7)/Cube 0: Measurement grid: dx=8mm, dy=8mm, dz=5mm

Reference Value = 17.47 V/m; Power Drift = 0.02 dB

Peak SAR (extrapolated) = 0.460 W/kg

SAR(1 g) = 0.284 W/kg

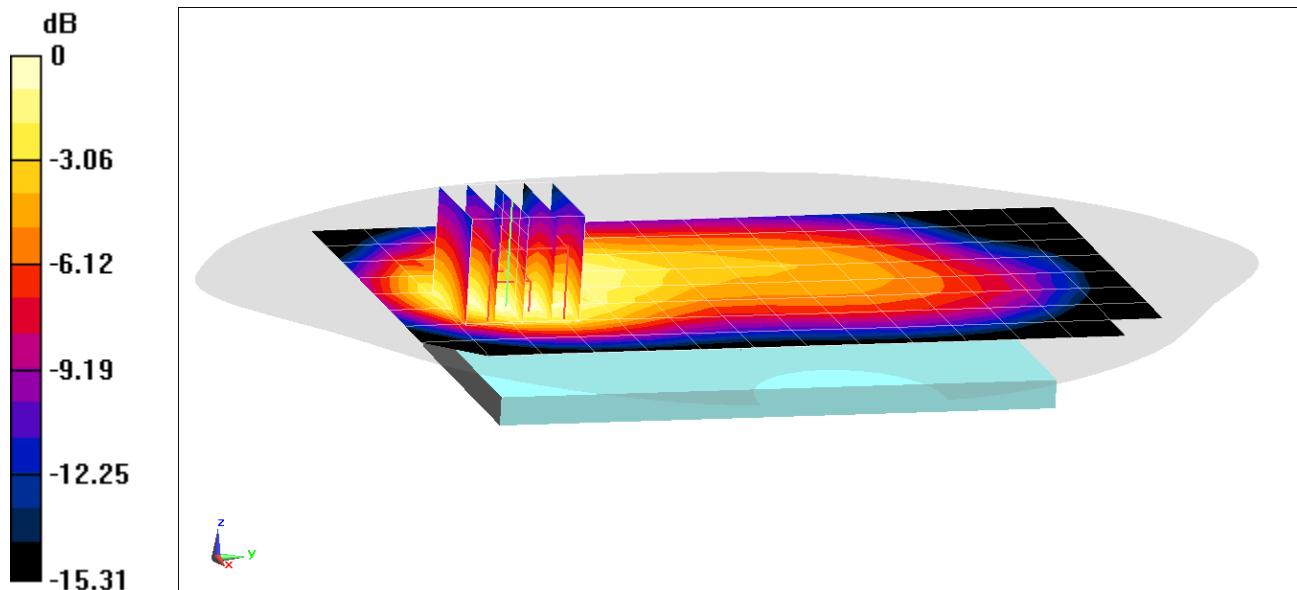

0 dB = 0.395 W/kg = -4.03 dBW/kg

PCTEST ENGINEERING LABORATORY, INC.

DUT: A3LSMN975U; Type: Portable Handset; Serial: 0503M

Communication System: UID 0, LTE Band 26; Frequency: 831.5 MHz; Duty Cycle: 1:1

Medium: 835 Body; Medium parameters used (interpolated):

$f = 831.5 \text{ MHz}$; $\sigma = 0.997 \text{ S/m}$; $\epsilon_r = 52.826$; $\rho = 1000 \text{ kg/m}^3$

Phantom section: Flat Section; Space: 1.0 cm

Test Date: 5-30-2019; Ambient Temp: 20.1°C; Tissue Temp: 20.3°C

Probe: EX3DV4 - SN7488; ConvF(11.03, 11.03, 11.03) @ 831.5 MHz; Calibrated: 1/24/2019

Sensor-Surface: 1.4mm (Mechanical Surface Detection)

Electronics: DAE4 Sn1530; Calibrated: 1/15/2019

Phantom: Twin-SAM V5.0; Type: QD 000 P40 CD; Serial: 1800

Measurement SW: DASY52, Version 52.10 (2);SEMCAD X Version 14.6.12 (7450)

**Mode: LTE Band 26 (Cell.), Body SAR, Back side, Mid.ch,
15 MHz Bandwidth, QPSK, 1 RB, 74 RB Offset**

Area Scan (9x15x1): Measurement grid: dx=15mm, dy=15mm

Zoom Scan (5x5x7)/Cube 0: Measurement grid: dx=8mm, dy=8mm, dz=5mm

Reference Value = 25.07 V/m; Power Drift = -0.01 dB

Peak SAR (extrapolated) = 0.986 W/kg

SAR(1 g) = 0.583 W/kg

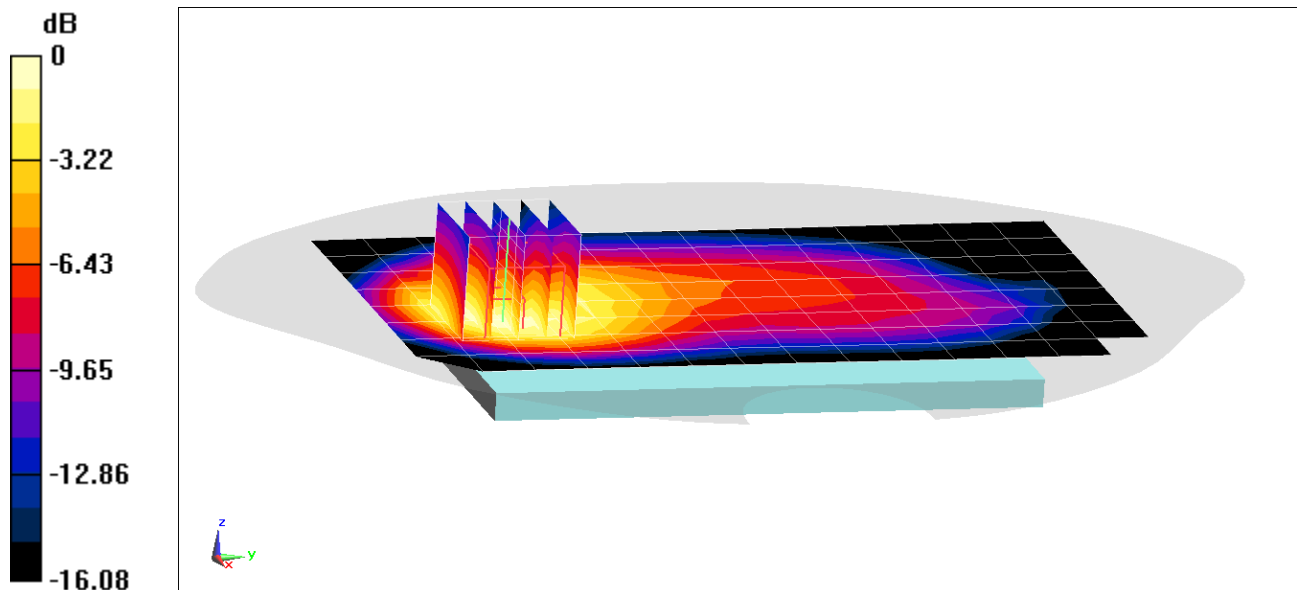

0 dB = 0.828 W/kg = -0.82 dBW/kg

PCTEST ENGINEERING LABORATORY, INC.

DUT: A3LSMN975U; Type: Portable Handset; Serial: 0503M

Communication System: UID 0, LTE Band 5; Frequency: 836.5 MHz; Duty Cycle: 1:1
Medium: 835 Body Medium parameters used (interpolated):
 $f = 836.5 \text{ MHz}$; $\sigma = 0.984 \text{ S/m}$; $\epsilon_r = 54.069$; $\rho = 1000 \text{ kg/m}^3$
Phantom section: Flat Section; Space: 1.5 cm

Test Date: 06-10-2019; Ambient Temp: 20.5°C; Tissue Temp: 20.0°C

Probe: EX3DV4 - SN7488; ConvF(11.03, 11.03, 11.03) @ 836.5 MHz; Calibrated: 1/24/2019
Sensor-Surface: 1.4mm (Mechanical Surface Detection)
Electronics: DAE4 Sn1530; Calibrated: 1/15/2019
Phantom: Twin-SAM V5.0; Type: QD 000 P40 CD; Serial: 1800
Measurement SW: DASY52, Version 52.10 (2);SEMCAD X Version 14.6.12 (7450)

Mode: LTE Band 5 (Cell.), ULCA, Body SAR, Back side,
PCC: 10 MHz Bandwidth, Ch. 20525, QPSK, 1 RB, 0 RB Offset
SCC: 5 MHz Bandwidth, Ch. 20453, QPSK, 1 RB, 24 RB Offset

Area Scan (9x15x1): Measurement grid: dx=15mm, dy=15mm
Zoom Scan (5x5x7)/Cube 0: Measurement grid: dx=8mm, dy=8mm, dz=5mm
Reference Value = 16.78 V/m; Power Drift = -0.03 dB
Peak SAR (extrapolated) = 0.416 W/kg
SAR(1 g) = 0.259 W/kg

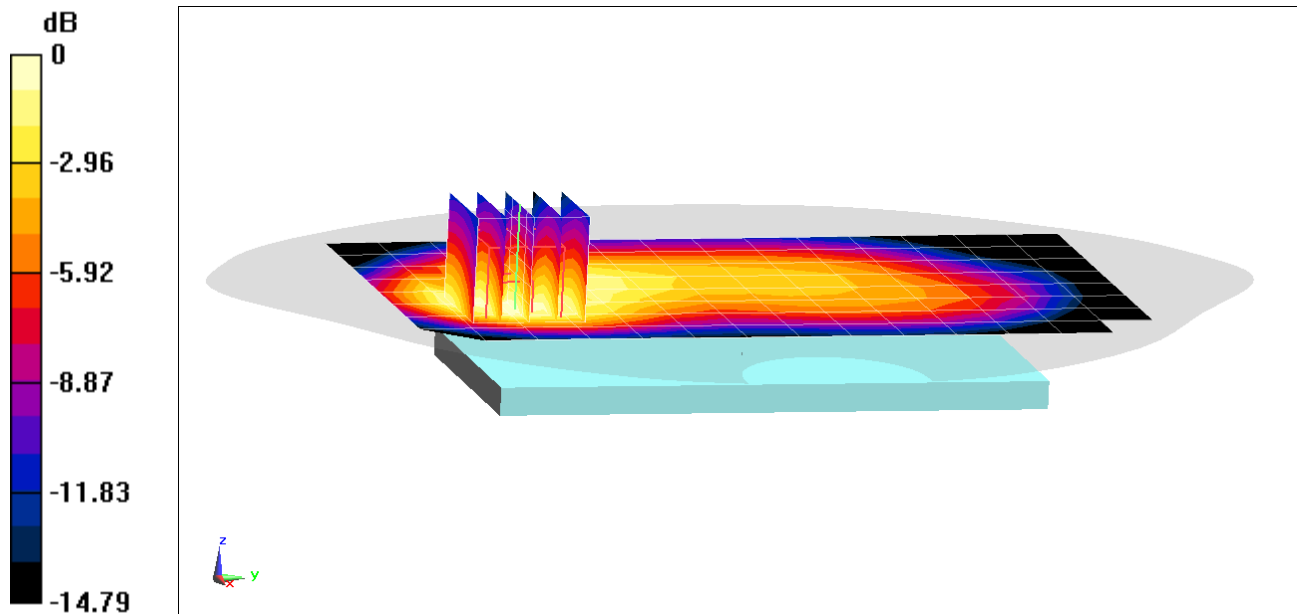

0 dB = 0.355 W/kg = -4.50 dBW/kg

PCTEST ENGINEERING LABORATORY, INC.

DUT: A3LSMN975U; Type: Portable Handset; Serial: 0503M

Communication System: UID 0, LTE Band 5; Frequency: 836.5 MHz; Duty Cycle: 1:1
Medium: 835 Body Medium parameters used (interpolated):
 $f = 836.5 \text{ MHz}$; $\sigma = 0.984 \text{ S/m}$; $\epsilon_r = 54.069$; $\rho = 1000 \text{ kg/m}^3$
Phantom section: Flat Section; Space: 1.0 cm

Test Date: 06-10-2019; Ambient Temp: 20.5°C; Tissue Temp: 20.0°C

Probe: EX3DV4 - SN7488; ConvF(11.03, 11.03, 11.03) @ 836.5 MHz; Calibrated: 1/24/2019
Sensor-Surface: 1.4mm (Mechanical Surface Detection)
Electronics: DAE4 Sn1530; Calibrated: 1/15/2019
Phantom: Twin-SAM V5.0; Type: QD 000 P40 CD; Serial: 1800
Measurement SW: DASY52, Version 52.10 (2);SEMCAD X Version 14.6.12 (7450)

Mode: LTE Band 5 (Cell.), ULCA, Body SAR, Back side,
PCC: 10 MHz Bandwidth, Ch. 20525, QPSK, 1 RB, 0 RB Offset
SCC: 5 MHz Bandwidth, Ch. 20453, QPSK, 1 RB, 24 RB Offset

Area Scan (9x15x1): Measurement grid: dx=15mm, dy=15mm
Zoom Scan (5x5x7)/Cube 0: Measurement grid: dx=8mm, dy=8mm, dz=5mm
Reference Value = 24.73 V/m; Power Drift = -0.02 dB
Peak SAR (extrapolated) = 1.01 W/kg
SAR(1 g) = 0.585 W/kg

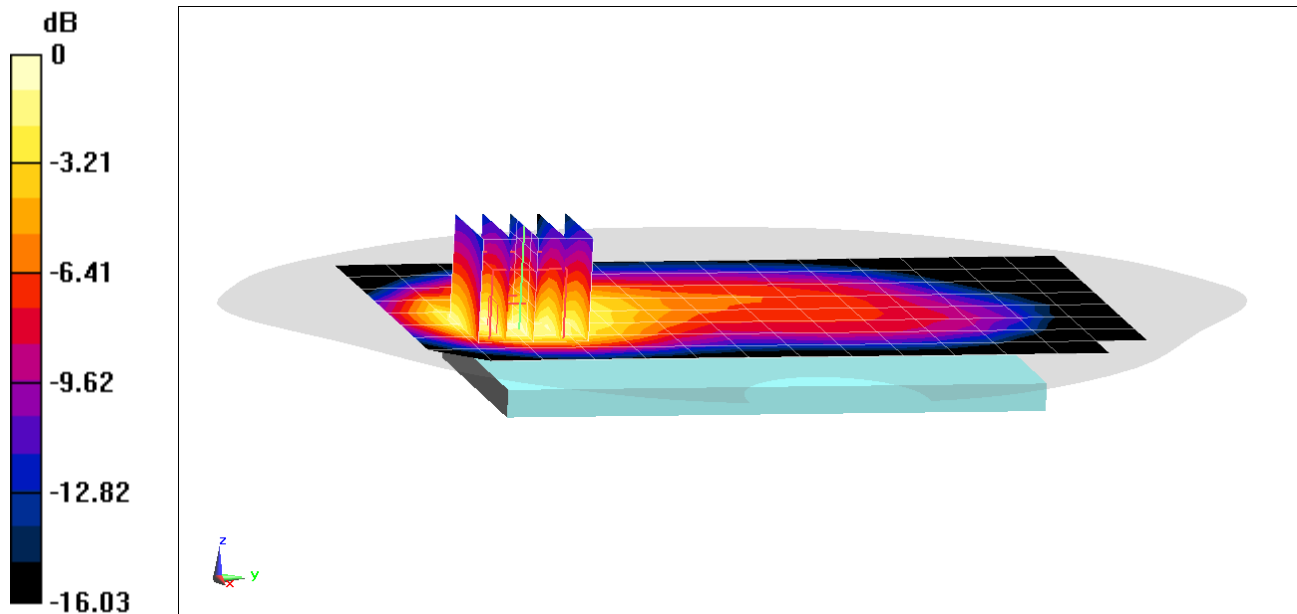

0 dB = 0.832 W/kg = -0.80 dBW/kg

PCTEST ENGINEERING LABORATORY, INC.

DUT: A3LSMN975U; Type: Portable Handset; Serial: 0326M

Communication System: UID 0, LTE Band 66 (AWS); Frequency: 1770 MHz; Duty Cycle: 1:1

Medium: 1750 Body; Medium parameters used (interpolated):

$f = 1770 \text{ MHz}$; $\sigma = 1.527 \text{ S/m}$; $\epsilon_r = 52.046$; $\rho = 1000 \text{ kg/m}^3$

Phantom section: Flat Section; Space: 1.5 cm

Test Date: 06-05-2019; Ambient Temp: 23.1°C; Tissue Temp: 22.3°C

Probe: EX3DV4 - SN3914; ConvF(7.89, 7.89, 7.89) @ 1770 MHz; Calibrated: 2/19/2019

Sensor-Surface: 1.4mm (Mechanical Surface Detection)

Electronics: DAE4 Sn1272; Calibrated: 2/14/2019

Phantom: SAM with CRP v5.0 Front; Type: QD000P40CD; Serial: 1646

Measurement SW: DASY52, Version 52.10 (2);SEMCAD X Version 14.6.12 (7450)

**Mode: LTE Band 66 (AWS), Body SAR, Back side, High.ch,
20 MHz Bandwidth, QPSK, 1 RB, 0 RB Offset**

Area Scan (9x15x1): Measurement grid: dx=15mm, dy=15mm

Zoom Scan (5x5x7)/Cube 0: Measurement grid: dx=8mm, dy=8mm, dz=5mm

Reference Value = 25.83 V/m; Power Drift = 0.03 dB

Peak SAR (extrapolated) = 1.57 W/kg

SAR(1 g) = 0.948 W/kg

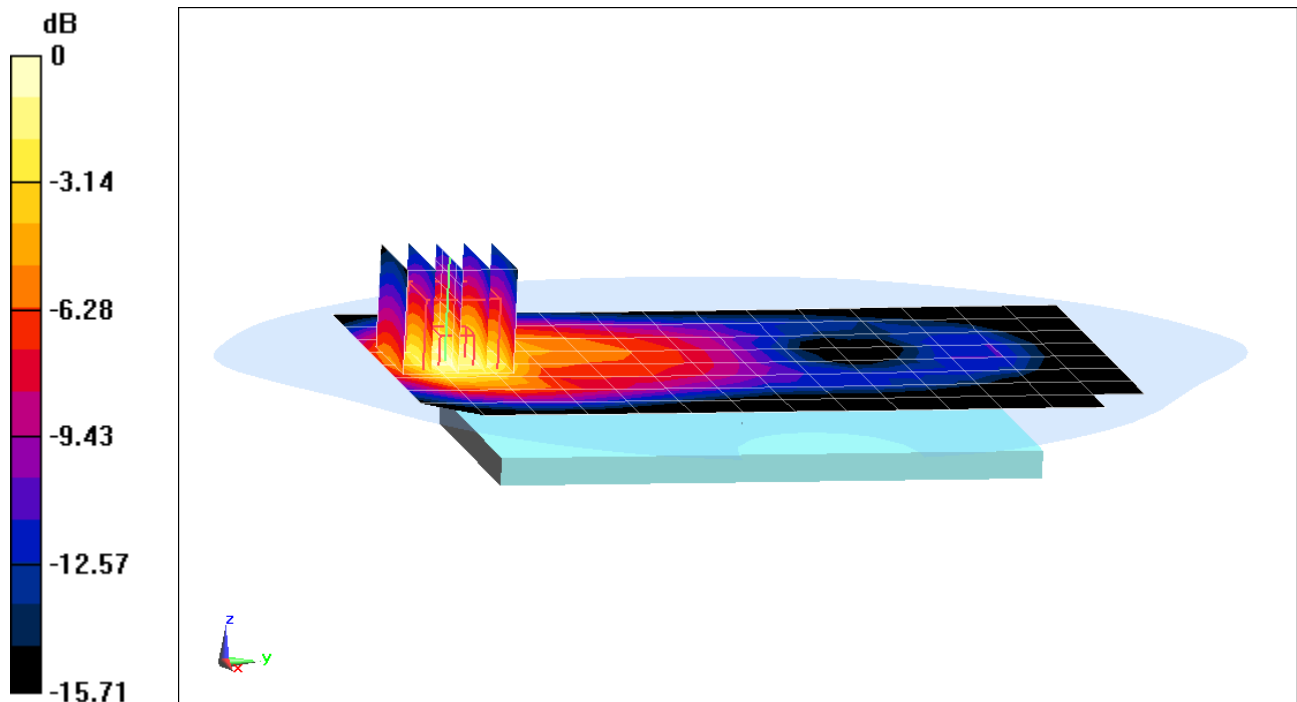

0 dB = 1.33 W/kg = 1.24 dBW/kg

PCTEST ENGINEERING LABORATORY, INC.

DUT: A3LSMN975U; Type: Portable Handset; Serial: 0326M

Communication System: UID 0, LTE Band 66 (AWS); Frequency: 1745 MHz; Duty Cycle: 1:1

Medium: 1750 Body; Medium parameters used (interpolated):

$f = 1745 \text{ MHz}$; $\sigma = 1.501 \text{ S/m}$; $\epsilon_r = 51.721$; $\rho = 1000 \text{ kg/m}^3$

Phantom section: Flat Section; Space: 1.0 cm

Test Date: 06-17-2019; Ambient Temp: 20.1°C; Tissue Temp: 20.0°C

Probe: EX3DV4 - SN7488; ConvF(8.68, 8.68, 8.68) @ 1745 MHz; Calibrated: 1/24/2019

Sensor-Surface: 1.4mm (Mechanical Surface Detection)

Electronics: DAE4 Sn1530; Calibrated: 1/15/2019

Phantom: Twin-SAM V5.0; Type: QD 000 P40 CD; Serial: 1800

Measurement SW: DASY52, Version 52.10 (2);SEMCAD X Version 14.6.12 (7450)

**Mode: LTE Band 66 (AWS), Body SAR, Bottom Edge, Mid.ch,
20 MHz Bandwidth, QPSK, 1 RB, 99 RB Offset**

Area Scan (11x9x1): Measurement grid: dx=5mm, dy=15mm

Zoom Scan (5x5x7)/Cube 0: Measurement grid: dx=8mm, dy=8mm, dz=5mm

Reference Value = 26.19 V/m; Power Drift = -0.04 dB

Peak SAR (extrapolated) = 1.63 W/kg

SAR(1 g) = 0.926 W/kg

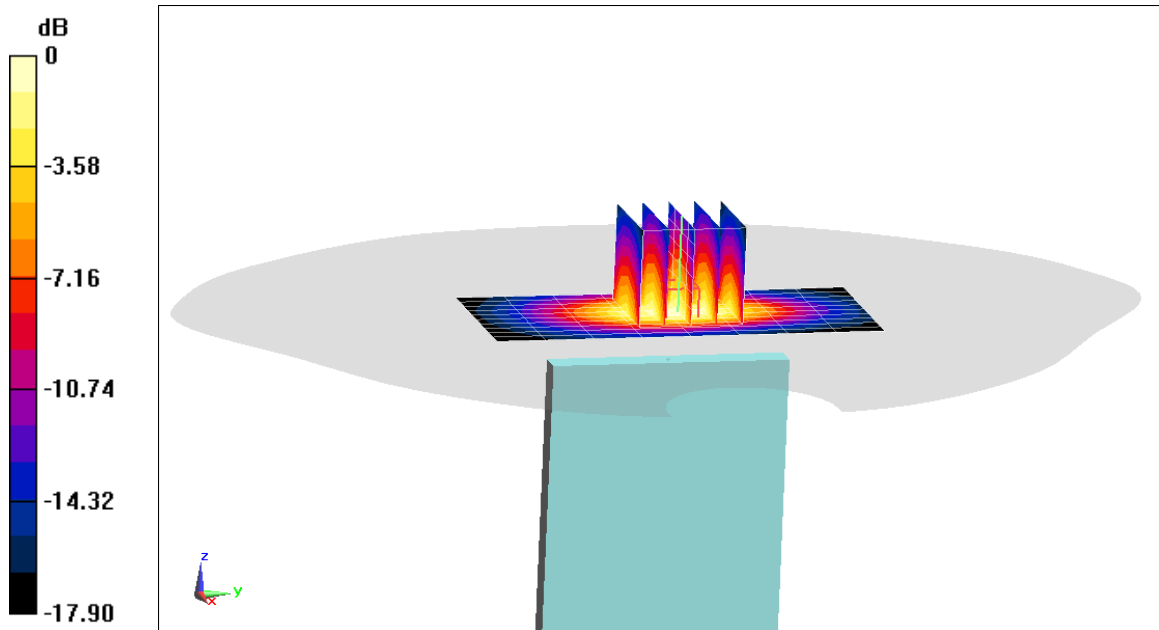

0 dB = 1.39 W/kg = 1.43 dBW/kg

PCTEST ENGINEERING LABORATORY, INC.

DUT: A3LSMN975U; Type: Portable Handset; Serial: 0029M

Communication System: UID 0, LTE Band 25 (PCS); Frequency: 1860 MHz; Duty Cycle: 1:1
Medium: 1900 Body Medium parameters used (interpolated):
 $f = 1860 \text{ MHz}$; $\sigma = 1.538 \text{ S/m}$; $\epsilon_r = 52.396$; $\rho = 1000 \text{ kg/m}^3$
Phantom section: Flat Section; Space: 1.5 cm

Test Date: 05-29-2019; Ambient Temp: 23.1°C; Tissue Temp: 21.6°C

Probe: EX3DV4 - SN7410; ConvF(7.78, 7.78, 7.78) @ 1860 MHz; Calibrated: 7/20/2018
Sensor-Surface: 1.4mm (Mechanical Surface Detection)
Electronics: DAE4 Sn1322; Calibrated: 7/11/2018
Phantom: Front; Type: QD 000 P40 CD; Serial: 1686
Measurement SW: DASY52, Version 52.10 (2);SEMCAD X Version 14.6.12 (7450)

**Mode: LTE Band 25 (PCS), Body SAR, Back side, Low.ch,
20 MHz Bandwidth, QPSK, 1 RB, 99 RB Offset**

Area Scan (9x15x1): Measurement grid: dx=15mm, dy=15mm

Zoom Scan (5x5x7)/Cube 0: Measurement grid: dx=8mm, dy=8mm, dz=5mm

Reference Value = 22.91 V/m; Power Drift = 0.06 dB

Peak SAR (extrapolated) = 1.21 W/kg

SAR(1 g) = 0.745 W/kg

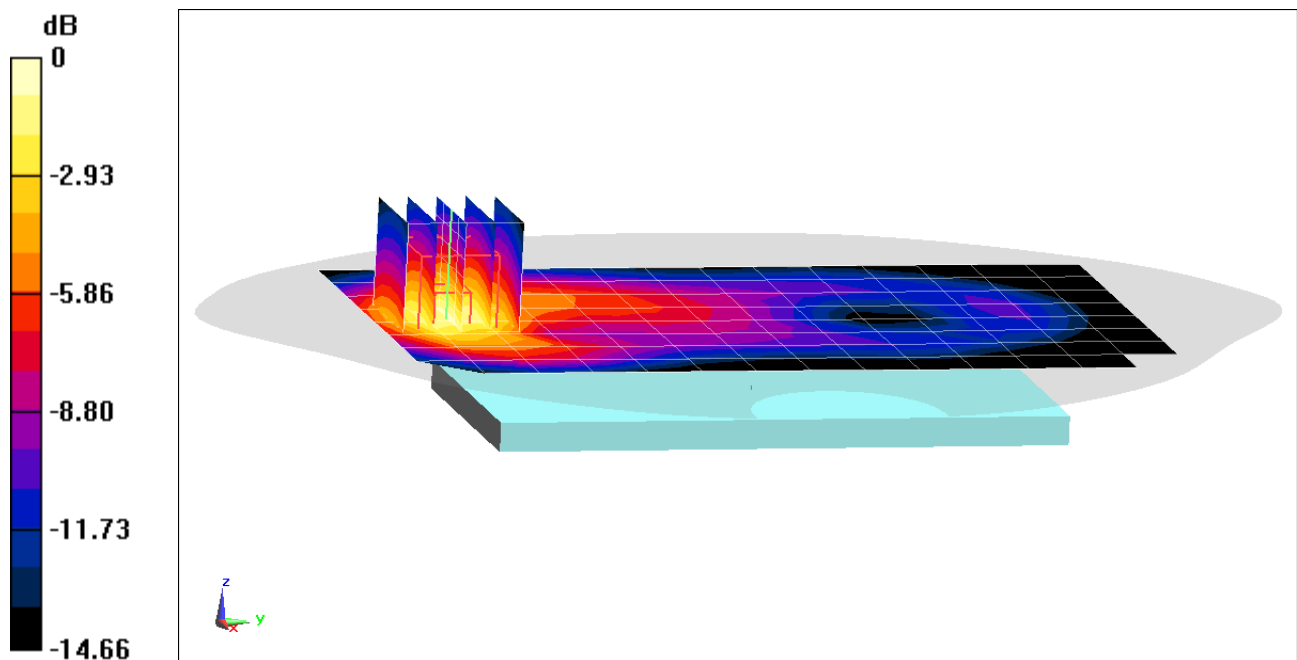

0 dB = 1.05 W/kg = 0.21 dBW/kg

PCTEST ENGINEERING LABORATORY, INC.

DUT: A3LSMN975U; Type: Portable Handset; Serial: 0347M

Communication System: UID 0, LTE Band 25 (PCS); Frequency: 1860 MHz; Duty Cycle: 1:1
Medium: 1900 Body; Medium parameters used (interpolated):
 $f = 1860 \text{ MHz}$; $\sigma = 1.521 \text{ S/m}$; $\epsilon_r = 52.272$; $\rho = 1000 \text{ kg/m}^3$
Phantom section: Flat Section; Space: 1.0 cm

Test Date: 06-19-2019; Ambient Temp: 22.6°C; Tissue Temp: 22.3°C

Probe: EX3DV4 - SN7410; ConvF(7.78, 7.78, 7.78) @ 1860 MHz; Calibrated: 7/20/2018
Sensor-Surface: 1.4mm (Mechanical Surface Detection)
Electronics: DAE4 Sn1322; Calibrated: 7/11/2018
Phantom: Front; Type: QD 000 P40 CD; Serial: 1686
Measurement SW: DASY52, Version 52.10 (2);SEMCAD X Version 14.6.12 (7450)

**Mode: LTE Band 25 (PCS), Body SAR, Bottom Edge, Low.ch,
20 MHz Bandwidth, QPSK, 50 RB, 50 RB Offset**

Area Scan (9x7x1): Measurement grid: dx=5mm, dy=15mm

Zoom Scan (5x5x7)/Cube 0: Measurement grid: dx=8mm, dy=8mm, dz=5mm

Reference Value = 24.72 V/m; Power Drift = -0.06 dB

Peak SAR (extrapolated) = 1.46 W/kg

SAR(1 g) = 0.824 W/kg

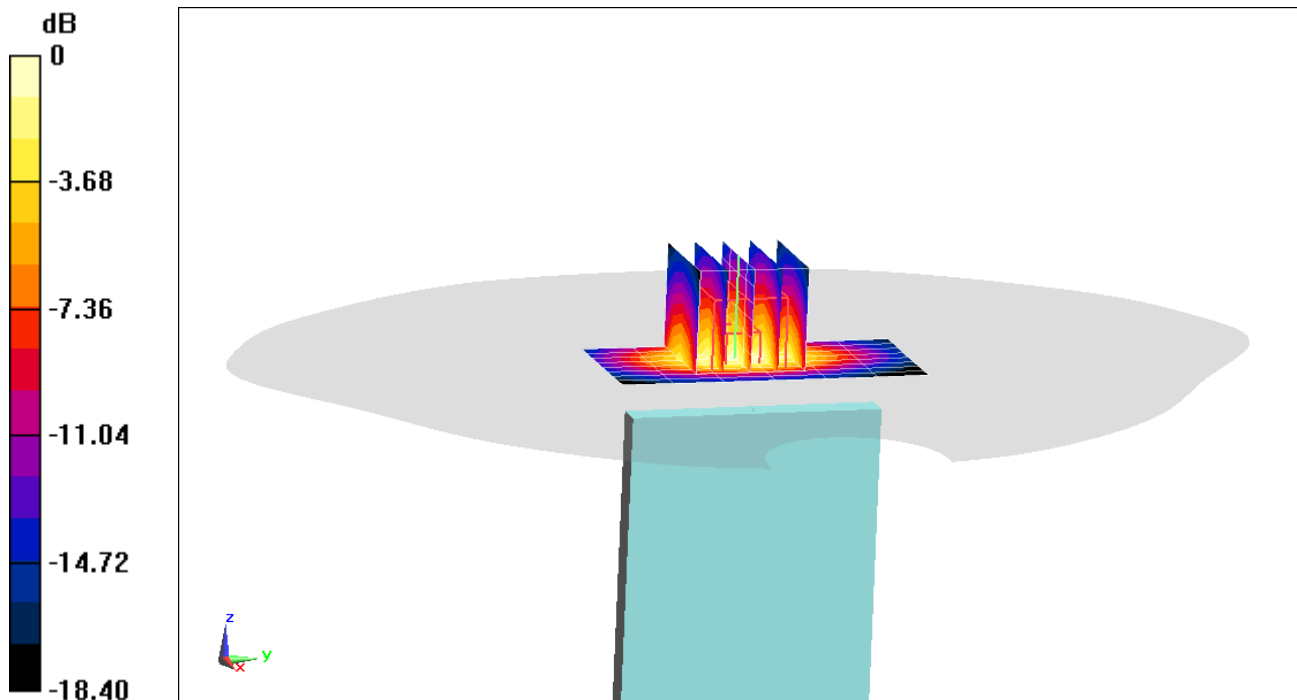

0 dB = 1.24 W/kg = 0.93 dBW/kg

PCTEST ENGINEERING LABORATORY, INC.

DUT: A3LSMN975U; Type: Portable Handset; Serial: 0499M

Communication System: UID 0, LTE Band 30; Frequency: 2310 MHz; Duty Cycle: 1:1

Medium: 2450 Body Medium parameters used:

$f = 2310 \text{ MHz}$; $\sigma = 1.853 \text{ S/m}$; $\epsilon_r = 51.171$; $\rho = 1000 \text{ kg/m}^3$

Phantom section: Flat Section; Space: 1.5 cm

Test Date: 06-05-2019; Ambient Temp: 23.5°C; Tissue Temp: 22.9°C

Probe: EX3DV4 - SN7417; ConvF(7.64, 7.64, 7.64) @ 2310 MHz; Calibrated: 2/19/2019

Sensor-Surface: 1.4mm (Mechanical Surface Detection)

Electronics: DAE4 Sn665; Calibrated: 2/13/2019

Phantom: LeftTwin-SAM V5.0; Type: QD 000 P40 CD; Serial: TP1375

Measurement SW: DASY52, Version 52.10 (2);SEMCAD X Version 14.6.12 (7450)

**Mode: LTE Band 30, Body SAR, Back side, Mid.ch,
10 MHz Bandwidth, QPSK, 1 RB, 49 RB Offset**

Area Scan (11x18x1): Measurement grid: dx=12mm, dy=12mm

Zoom Scan (7x7x7)/Cube 0: Measurement grid: dx=5mm, dy=5mm, dz=5mm

Reference Value = 16.76 V/m; Power Drift = 0.02 dB

Peak SAR (extrapolated) = 0.842 W/kg

SAR(1 g) = 0.468 W/kg

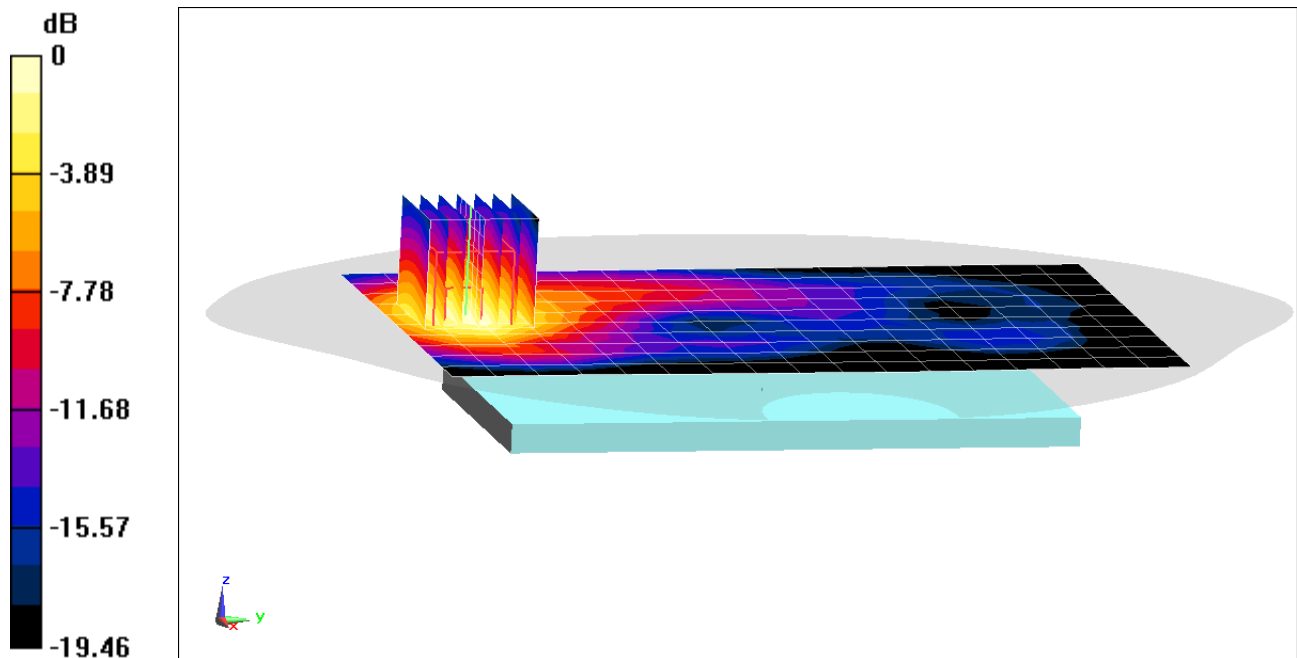

PCTEST ENGINEERING LABORATORY, INC.

DUT: A3LSMN975U; Type: Portable Handset; Serial: 0373M

Communication System: UID 0, LTE Band 30; Frequency: 2310 MHz; Duty Cycle: 1:1
Medium: 2450 MHz Body Medium parameters used:
 $f = 2310 \text{ MHz}$; $\sigma = 1.901 \text{ S/m}$; $\epsilon_r = 53.029$; $\rho = 1000 \text{ kg/m}^3$
Phantom section: Flat Section; Space: 1.0 cm

Test Date: 06-10-2019; Ambient Temp: 22.2°C; Tissue Temp: 21.1°C

Probe: EX3DV4 - SN7308; ConvF(7.73, 7.73, 7.73) @ 2310 MHz; Calibrated: 8/23/2018
Sensor-Surface: 1.4mm (Mechanical Surface Detection)
Electronics: DAE4 Sn1558; Calibrated: 10/3/2018
Phantom: Twin-SAM V5.0; Type: QD 000 P40 CD; Serial: 1630
Measurement SW: DASY52, Version 52.10 (2);SEMCAD X Version 14.6.12 (7450)

**Mode: LTE Band 30, Body SAR, Bottom Edge, Mid.ch,
10 MHz Bandwidth, QPSK, 25 RB, 12 RB Offset**

Area Scan (11x10x1): Measurement grid: dx=5mm, dy=12mm

Zoom Scan (7x7x7)/Cube 0: Measurement grid: dx=5mm, dy=5mm, dz=5mm

Reference Value = 27.20 V/m; Power Drift = -0.06 dB

Peak SAR (extrapolated) = 2.50 W/kg

SAR(1 g) = 1.27 W/kg

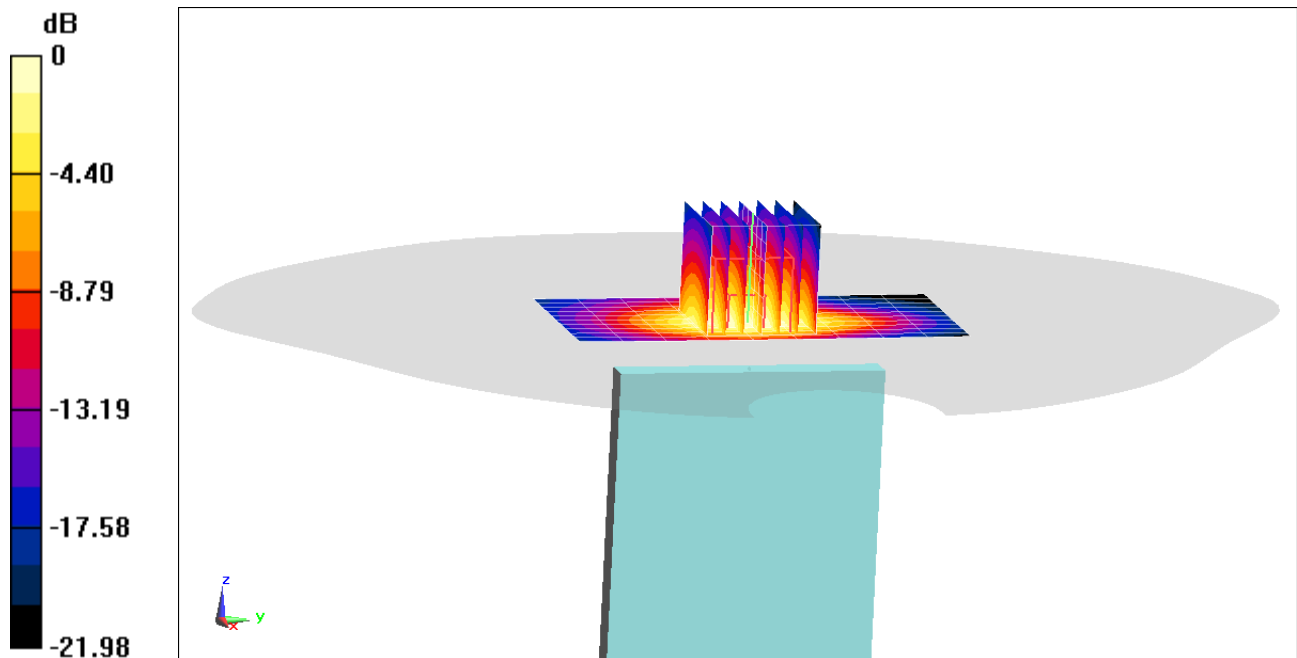

0 dB = 2.01 W/kg = 3.03 dBW/kg

PCTEST ENGINEERING LABORATORY, INC.

DUT: A3LSMN975U; Type: Portable Handset; Serial: 0358M

Communication System: UID 0, LTE Band 7; Frequency: 2560 MHz; Duty Cycle: 1:1
Medium: 2450 Body; Medium parameters used (interpolated):
 $f = 2560 \text{ MHz}$; $\sigma = 2.154 \text{ S/m}$; $\epsilon_r = 51.013$; $\rho = 1000 \text{ kg/m}^3$
Phantom section: Flat Section; Space: 1.5 cm

Test Date: 06-11-2019; Ambient Temp: 24.6°C; Tissue Temp: 24.5°C

Probe: EX3DV4 - SN7417; ConvF(7.37, 7.37, 7.37) @ 2560 MHz; Calibrated: 2/19/2019
Sensor-Surface: 1.4mm (Mechanical Surface Detection)
Electronics: DAE4 Sn665; Calibrated: 2/13/2019
Phantom: LeftTwin-SAM V5.0; Type: QD 000 P40 CD; Serial: TP1375
Measurement SW: DASY52, Version 52.10 (2);SEMCAD X Version 14.6.12 (7450)

**Mode: LTE Band 7, Body SAR, Back side, High.ch,
20 MHz Bandwidth, QPSK, 1 RB, 0 RB Offset**

Area Scan (11x18x1): Measurement grid: dx=12mm, dy=12mm

Zoom Scan (7x7x7)/Cube 0: Measurement grid: dx=5mm, dy=5mm, dz=5mm

Reference Value = 11.57 V/m; Power Drift = -0.03 dB

Peak SAR (extrapolated) = 0.519 W/kg

SAR(1 g) = 0.260 W/kg

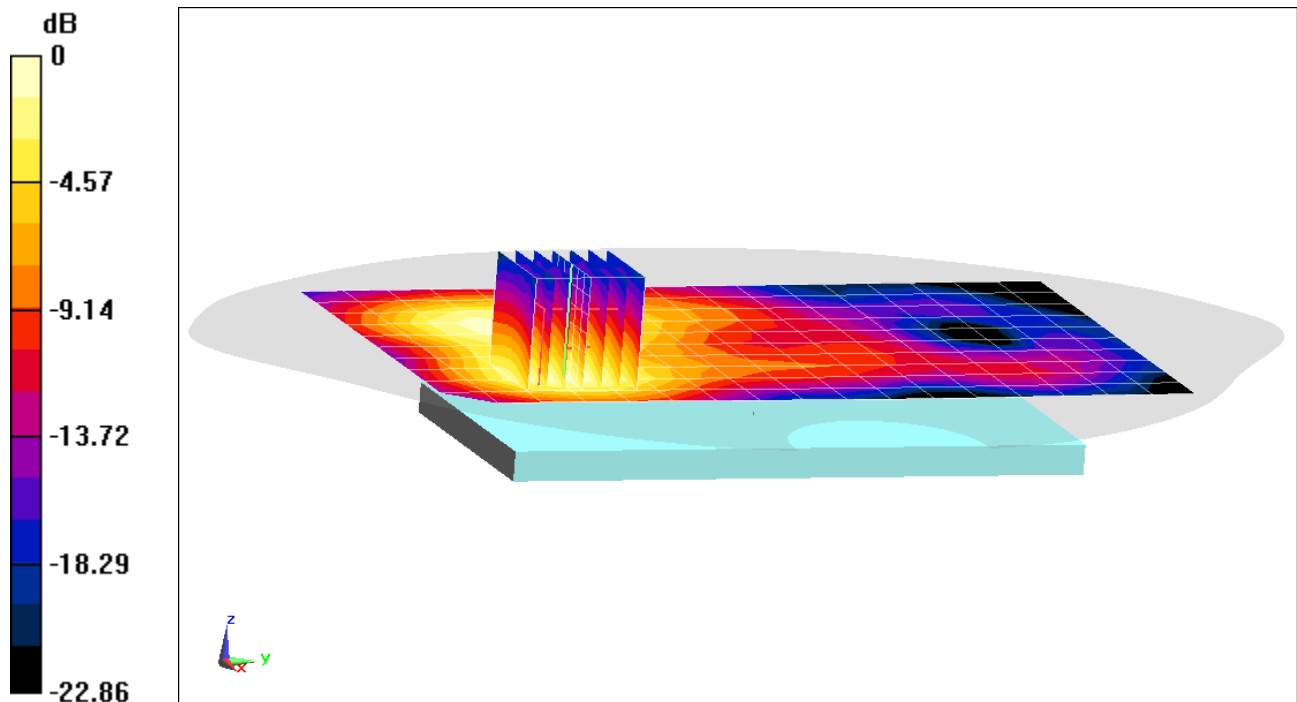

0 dB = 0.412 W/kg = -3.85 dBW/kg

PCTEST ENGINEERING LABORATORY, INC.

DUT: A3LSMN975U; Type: Portable Handset; Serial: 0358M

Communication System: UID 0, LTE Band 7; Frequency: 2535 MHz; Duty Cycle: 1:1
Medium: 2450 Body; Medium parameters used (interpolated):
 $f = 2535 \text{ MHz}$; $\sigma = 2.124 \text{ S/m}$; $\epsilon_r = 51.087$; $\rho = 1000 \text{ kg/m}^3$
Phantom section: Flat Section; Space: 1.0 cm

Test Date: 06-11-2019; Ambient Temp: 24.6°C; Tissue Temp: 24.5°C

Probe: EX3DV4 - SN7417; ConvF(7.37, 7.37, 7.37) @ 2535 MHz; Calibrated: 2/19/2019
Sensor-Surface: 1.4mm (Mechanical Surface Detection)
Electronics: DAE4 Sn665; Calibrated: 2/13/2019
Phantom: LeftTwin-SAM V5.0; Type: QD 000 P40 CD; Serial: TP1375
Measurement SW: DASY52, Version 52.10 (2);SEMCAD X Version 14.6.12 (7450)

**Mode: LTE Band 7, Body SAR, Bottom Edge, Mid.ch,
20 MHz Bandwidth, QPSK, 50 RB, 0 RB Offset**

Area Scan (15x11x1): Measurement grid: dx=5mm, dy=12mm

Zoom Scan (7x7x7)/Cube 0: Measurement grid: dx=5mm, dy=5mm, dz=5mm

Reference Value = 15.32 V/m; Power Drift = 0.00 dB

Peak SAR (extrapolated) = 0.889 W/kg

SAR(1 g) = 0.450 W/kg

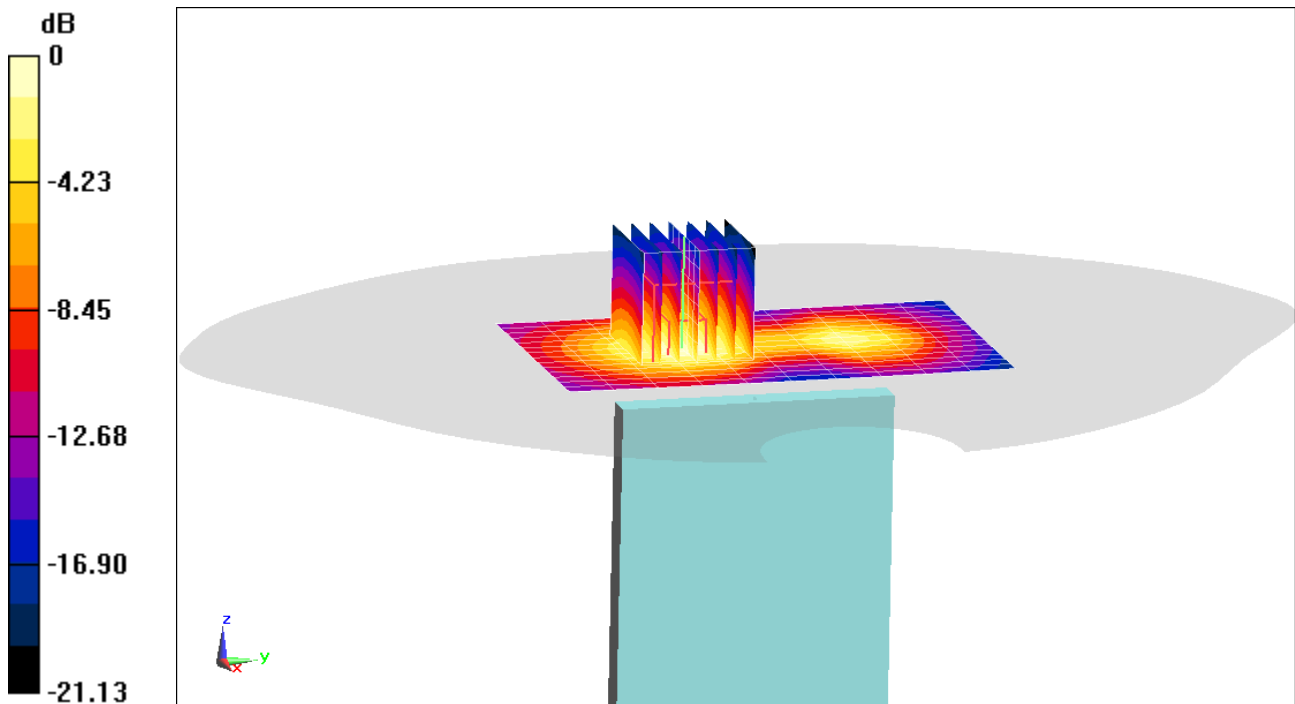

0 dB = 0.690 W/kg = -1.61 dBW/kg

PCTEST ENGINEERING LABORATORY, INC.

DUT: A3LSMN975U; Type: Portable Handset; Serial: 0349M

Communication System: UID 0, LTE Band 48; Frequency: 3560 MHz; Duty Cycle: 1:1.58

Medium: 3500 Body; Medium parameters used (interpolated):

$f = 3560$ MHz; $\sigma = 3.442$ S/m; $\epsilon_r = 50.991$; $\rho = 1000$ kg/m³

Phantom section: Flat Section; Space: 1.5 cm

Test Date: 06-12-2019; Ambient Temp: 23.1°C; Tissue Temp: 22.5°C

Probe: EX3DV4 - SN3914; ConvF(6.88, 6.88, 6.88) @ 3560 MHz; Calibrated: 2/19/2019

Sensor-Surface: 1.4mm (Mechanical Surface Detection)

Electronics: DAE4 Sn1272; Calibrated: 2/14/2019

Phantom: SAM with CRP v5.0 Front; Type: QD000P40CD; Serial: 1646

Measurement SW: DASY52, Version 52.10 (2);SEMCAD X Version 14.6.12 (7450)

**Mode: LTE Band 48, Body SAR, Back side, Low.ch,
20 MHz Bandwidth, QPSK, 1 RB, 99 RB Offset**

Area Scan (11x18x1): Measurement grid: dx=12mm, dy=12mm

Zoom Scan (7x7x8)/Cube 0: Measurement grid: dx=5mm, dy=5mm, dz=1.4mm; Graded Ratio: 1.4

Reference Value = 5.880 V/m; Power Drift = 0.17 dB

Peak SAR (extrapolated) = 0.297 W/kg

SAR(1 g) = 0.114 W/kg

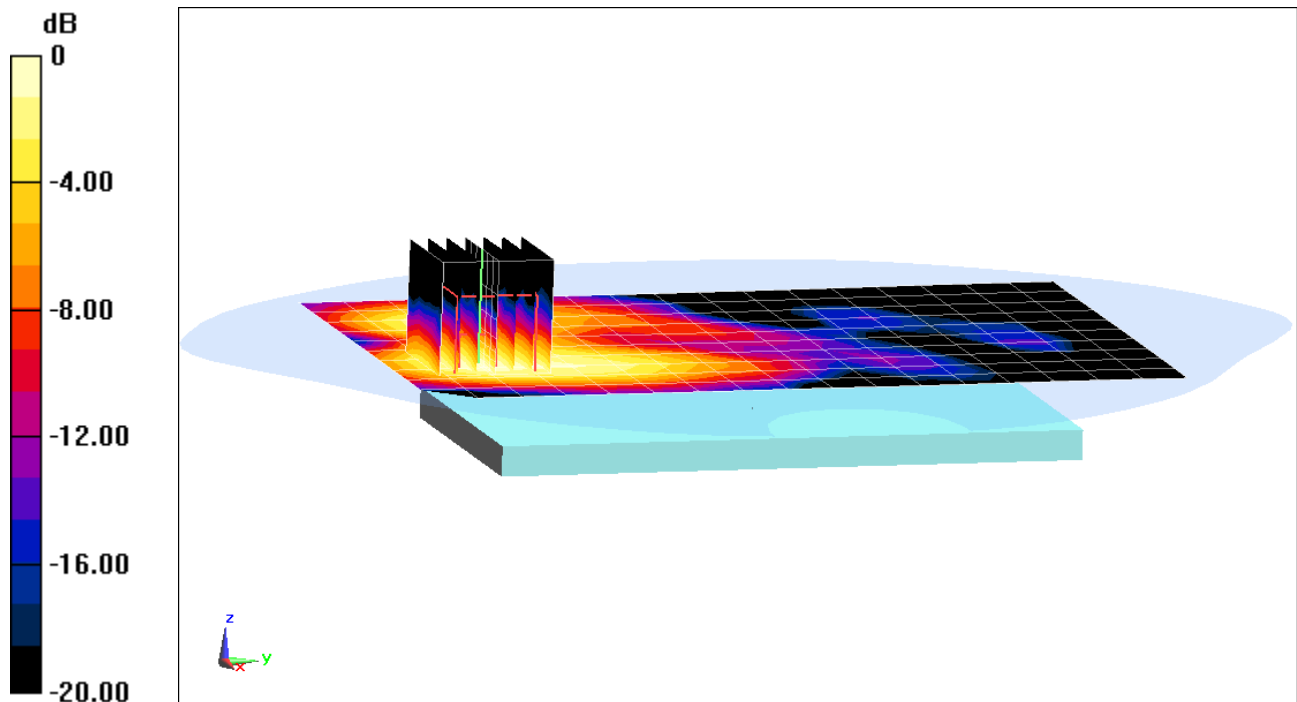

0 dB = 0.206 W/kg = -6.86 dBW/kg

PCTEST ENGINEERING LABORATORY, INC.

DUT: A3LSMN975U; Type: Portable Handset; Serial: 0349M

Communication System: UID 0, LTE Band 48; Frequency: 3560 MHz; Duty Cycle: 1:1.58

Medium: 3500 Body; Medium parameters used (interpolated):

$f = 3560$ MHz; $\sigma = 3.442$ S/m; $\epsilon_r = 50.991$; $\rho = 1000$ kg/m³

Phantom section: Flat Section; Space: 1.0 cm

Test Date: 06-12-2019; Ambient Temp: 23.1°C; Tissue Temp: 22.5°C

Probe: EX3DV4 - SN3914; ConvF(6.88, 6.88, 6.88) @ 3560 MHz; Calibrated: 2/19/2019

Sensor-Surface: 1.4mm (Mechanical Surface Detection)

Electronics: DAE4 Sn1272; Calibrated: 2/14/2019

Phantom: SAM with CRP v5.0 Front; Type: QD000P40CD; Serial: 1646

Measurement SW: DASY52, Version 52.10 (2);SEMCAD X Version 14.6.12 (7450)

**Mode: LTE Band 48, Body SAR, Bottom Edge, Low.ch,
20 MHz Bandwidth, QPSK, 1 RB, 99 RB Offset**

Area Scan (11x11x1): Measurement grid: dx=5mm, dy=12mm

Zoom Scan (7x7x8)/Cube 0: Measurement grid: dx=5mm, dy=5mm, dz=1.4mm; Graded Ratio: 1.4

Reference Value = 11.77 V/m; Power Drift = -0.01 dB

Peak SAR (extrapolated) = 1.25 W/kg

SAR(1 g) = 0.435 W/kg

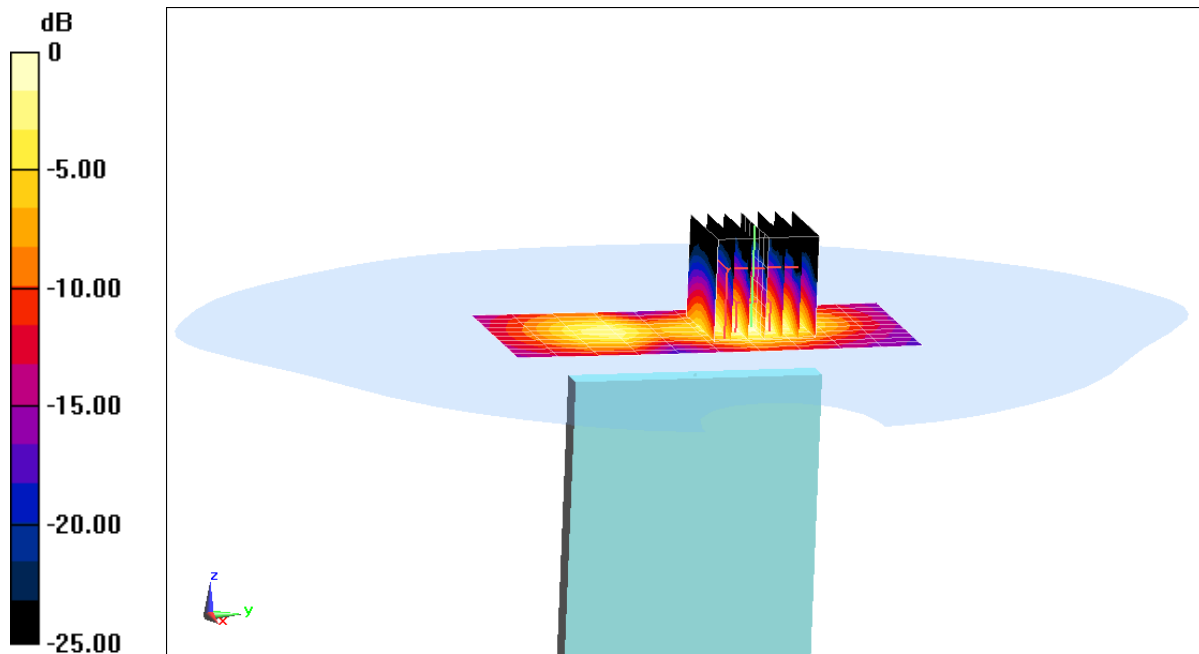

0 dB = 0.849 W/kg = -0.71 dBW/kg

PCTEST ENGINEERING LABORATORY, INC.

DUT: A3LSMN975U; Type: Portable Handset; Serial: 0358M

Communication System: UID 0, _LTE Band 41 (Class 2); Frequency: 2549.5 MHz; Duty Cycle: 1:2.31

Medium: 2450 Body; Medium parameters used:

$f = 2550$ MHz; $\sigma = 2.142$ S/m; $\epsilon_r = 51.041$; $\rho = 1000$ kg/m³

Phantom section: Flat Section; Space: 1.5 cm

Test Date: 06-11-2019; Ambient Temp: 24.6°C; Tissue Temp: 24.5°C

Probe: EX3DV4 - SN7417; ConvF(7.37, 7.37, 7.37) @ 2549.5 MHz; Calibrated: 2/19/2019

Sensor-Surface: 1.4mm (Mechanical Surface Detection)

Electronics: DAE4 Sn665; Calibrated: 2/13/2019

Phantom: LeftTwin-SAM V5.0; Type: QD 000 P40 CD; Serial: TP1375

Measurement SW: DASY52, Version 52.10 (2);SEMCAD X Version 14.6.12 (7450)

Mode: LTE Band 41 PC2 with ULCA, Body SAR, Back side,
PCC: 20 MHz Bandwidth, Ch. 40185, QPSK, 1 RB, 99 RB Offset
SCC: 20 MHz Bandwidth, Ch. 40383, QPSK, 1 RB, 0 RB Offset

Area Scan (10x17x1): Measurement grid: dx=12mm, dy=12mm

Zoom Scan (8x7x7)/Cube 0: Measurement grid: dx=5mm, dy=5mm, dz=5mm

Reference Value = 11.92 V/m; Power Drift = 0.00 dB

Peak SAR (extrapolated) = 0.581 W/kg

SAR(1 g) = 0.301 W/kg

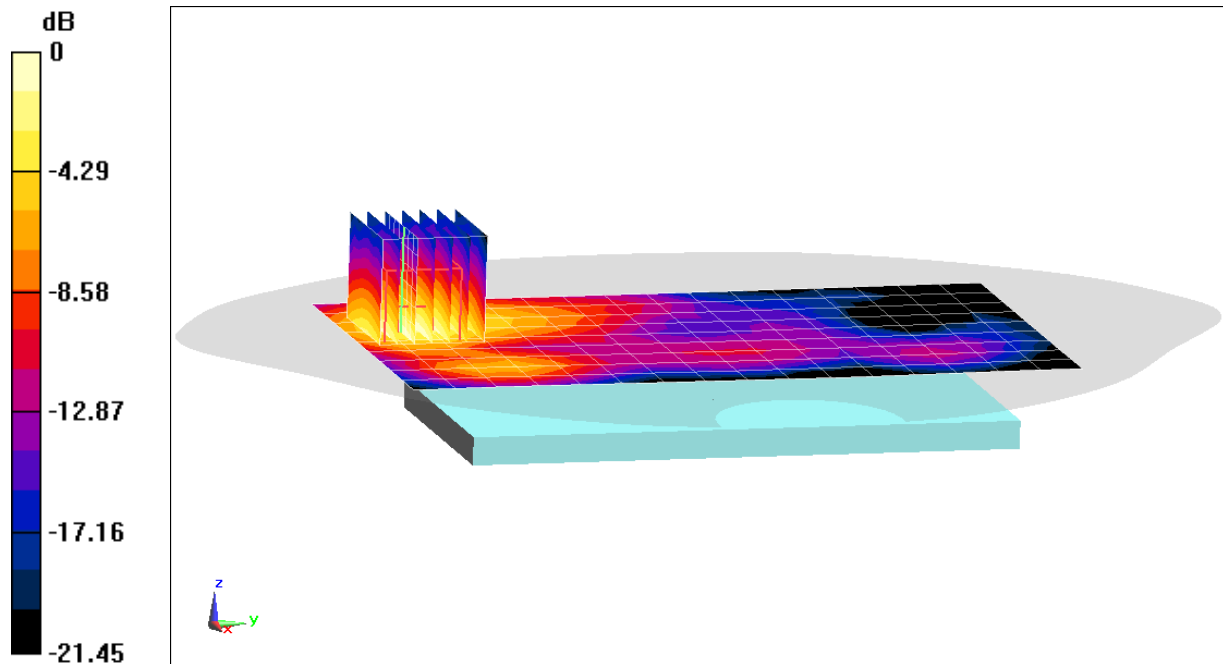

0 dB = 0.464 W/kg = -3.33 dBW/kg

PCTEST ENGINEERING LABORATORY, INC.

DUT: A3LSMN975U; Type: Portable Handset; Serial: 0358M

Communication System: UID 0, LTE Band 41 (Class 3); Frequency: 2549.5 MHz; Duty Cycle: 1:1.58

Medium: 2450 Body; Medium parameters used:

$f = 2550$ MHz; $\sigma = 2.142$ S/m; $\epsilon_r = 51.041$; $\rho = 1000$ kg/m³

Phantom section: Flat Section; Space: 1.0 cm

Test Date: 06-11-2019; Ambient Temp: 24.6°C; Tissue Temp: 24.5°C

Probe: EX3DV4 - SN7417; ConvF(7.37, 7.37, 7.37) @ 2549.5 MHz; Calibrated: 2/19/2019

Sensor-Surface: 1.4mm (Mechanical Surface Detection)

Electronics: DAE4 Sn665; Calibrated: 2/13/2019

Phantom: LeftTwin-SAM V5.0; Type: QD 000 P40 CD; Serial: TP1375

Measurement SW: DASY52, Version 52.10 (2);SEMCAD X Version 14.6.12 (7450)

Mode: LTE Band 41 ULCA, Body SAR, Bottom Edge,

PCC: 20 MHz Bandwidth, Ch. 40185, QPSK, 50 RB, 0 RB Offset

SCC: 20 MHz Bandwidth, Ch. 39987, QPSK, 50 RB, 50 RB Offset

Area Scan (10x9x1): Measurement grid: dx=5mm, dy=12mm

Zoom Scan (7x7x7)/Cube 0: Measurement grid: dx=5mm, dy=5mm, dz=5mm

Reference Value = 19.11 V/m; Power Drift = 0.07 dB

Peak SAR (extrapolated) = 1.44 W/kg

SAR(1 g) = 0.703 W/kg

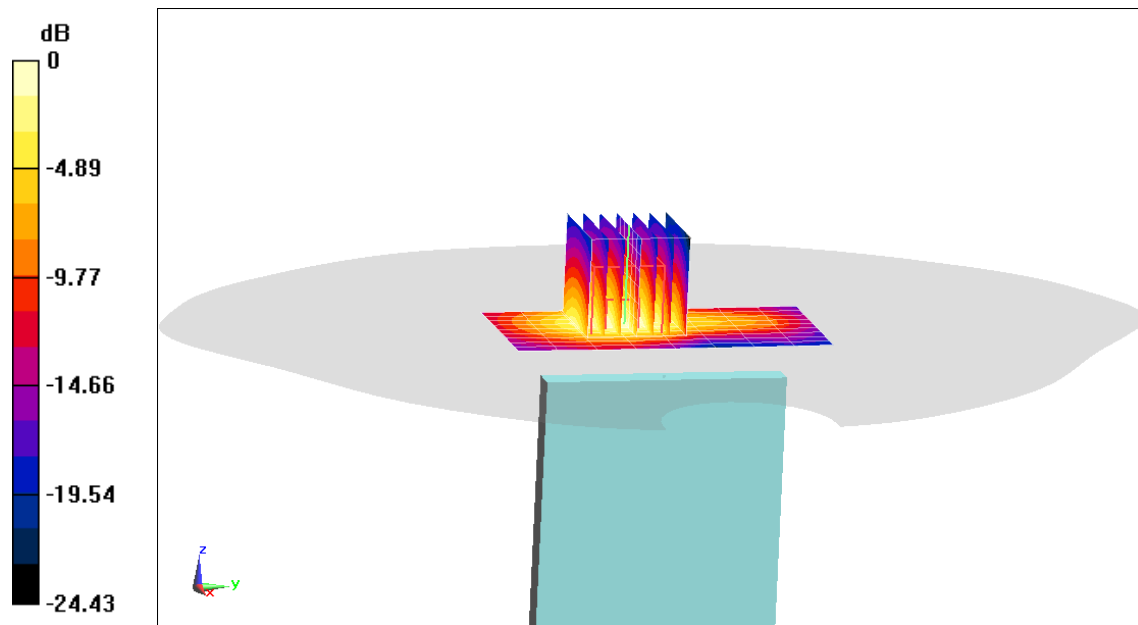

0 dB = 1.15 W/kg = 0.61 dBW/kg

PCTEST ENGINEERING LABORATORY, INC.

DUT: A3LSMN975U; Type: Portable Handset; Serial: 0352M

Communication System: UID 0, _IEEE 802.11b; Frequency: 2437 MHz; Duty Cycle: 1:1
Medium: 2450 Body; Medium parameters used (interpolated):
 $f = 2437 \text{ MHz}$; $\sigma = 2.019 \text{ S/m}$; $\epsilon_r = 51.033$; $\rho = 1000 \text{ kg/m}^3$
Phantom section: Flat Section; Space: 1.5 cm

Test Date: 06-17-2019; Ambient Temp: 23.9°C; Tissue Temp: 22.9°C

Probe: EX3DV4 - SN7417; ConvF(7.51, 7.51, 7.51) @ 2437 MHz; Calibrated: 2/19/2019
Sensor-Surface: 1.4mm (Mechanical Surface Detection)
Electronics: DAE4 Sn665; Calibrated: 2/13/2019
Phantom: LeftTwin-SAM V5.0; Type: QD 000 P40 CD; Serial: TP1375
Measurement SW: DASY52, Version 52.10 (2);SEMCAD X Version 14.6.12 (7450)

**Mode: IEEE 802.11b Ant 1, 22 MHz Bandwidth,
Body SAR, Ch 6, 1 Mbps, Back Side**

Area Scan (11x17x1): Measurement grid: dx=12mm, dy=12mm

Zoom Scan (7x7x7)/Cube 0: Measurement grid: dx=5mm, dy=5mm, dz=5mm

Reference Value = 9.331 V/m; Power Drift = 0.06 dB

Peak SAR (extrapolated) = 0.294 W/kg

SAR(1 g) = 0.156 W/kg

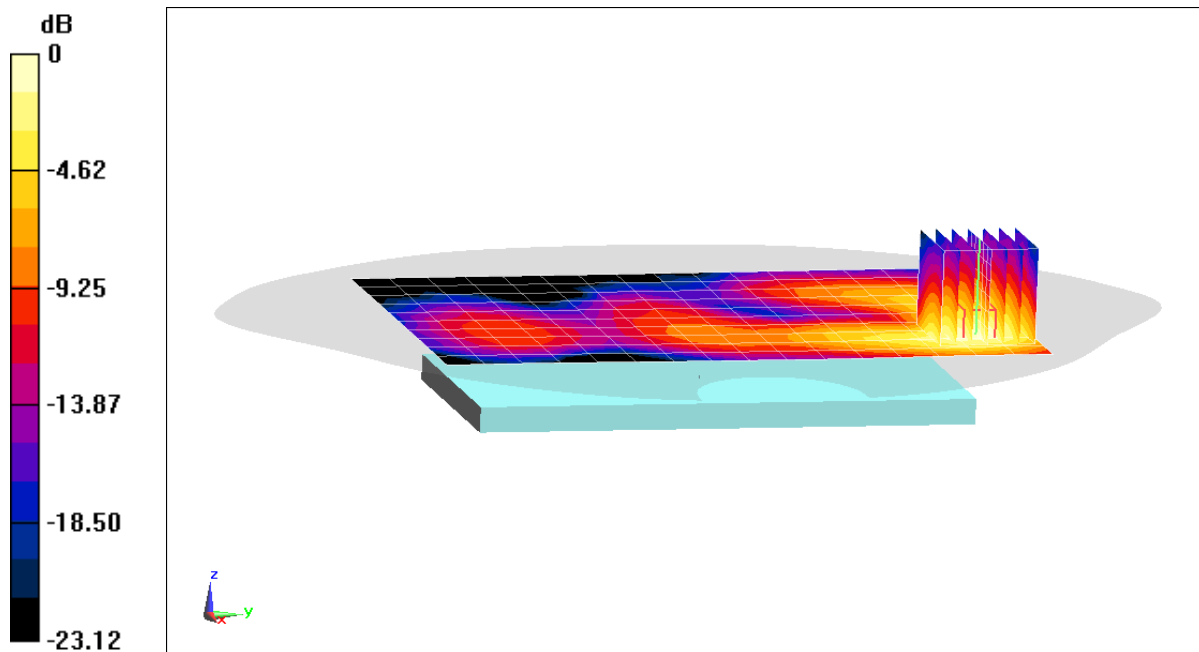

0 dB = 0.242 W/kg = -6.16 dBW/kg

PCTEST ENGINEERING LABORATORY, INC.

DUT: A3LSMN975U; Type: Portable Handset; Serial: 0352M

Communication System: UID 0, _IEEE 802.11b; Frequency: 2437 MHz; Duty Cycle: 1:1
Medium: 2450 Body; Medium parameters used (interpolated):
 $f = 2437 \text{ MHz}$; $\sigma = 2.019 \text{ S/m}$; $\epsilon_r = 51.033$; $\rho = 1000 \text{ kg/m}^3$
Phantom section: Flat Section; Space: 1.0 cm

Test Date: 06-17-2019; Ambient Temp: 23.9°C; Tissue Temp: 22.9°C

Probe: EX3DV4 - SN7417; ConvF(7.51, 7.51, 7.51) @ 2437 MHz; Calibrated: 2/19/2019
Sensor-Surface: 1.4mm (Mechanical Surface Detection)
Electronics: DAE4 Sn665; Calibrated: 2/13/2019
Phantom: LeftTwin-SAM V5.0; Type: QD 000 P40 CD; Serial: TP1375
Measurement SW: DASY52, Version 52.10 (2);SEMCAD X Version 14.6.12 (7450)

**Mode: IEEE 802.11b Ant 1, 22 MHz Bandwidth,
Body SAR, Ch 6, 1 Mbps, Top Edge**

Area Scan (10x9x1): Measurement grid: dx=5mm, dy=12mm

Zoom Scan (7x7x7)/Cube 0: Measurement grid: dx=5mm, dy=5mm, dz=5mm

Reference Value = 7.089 V/m; Power Drift = 0.10 dB

Peak SAR (extrapolated) = 0.781 W/kg

SAR(1 g) = 0.363 W/kg

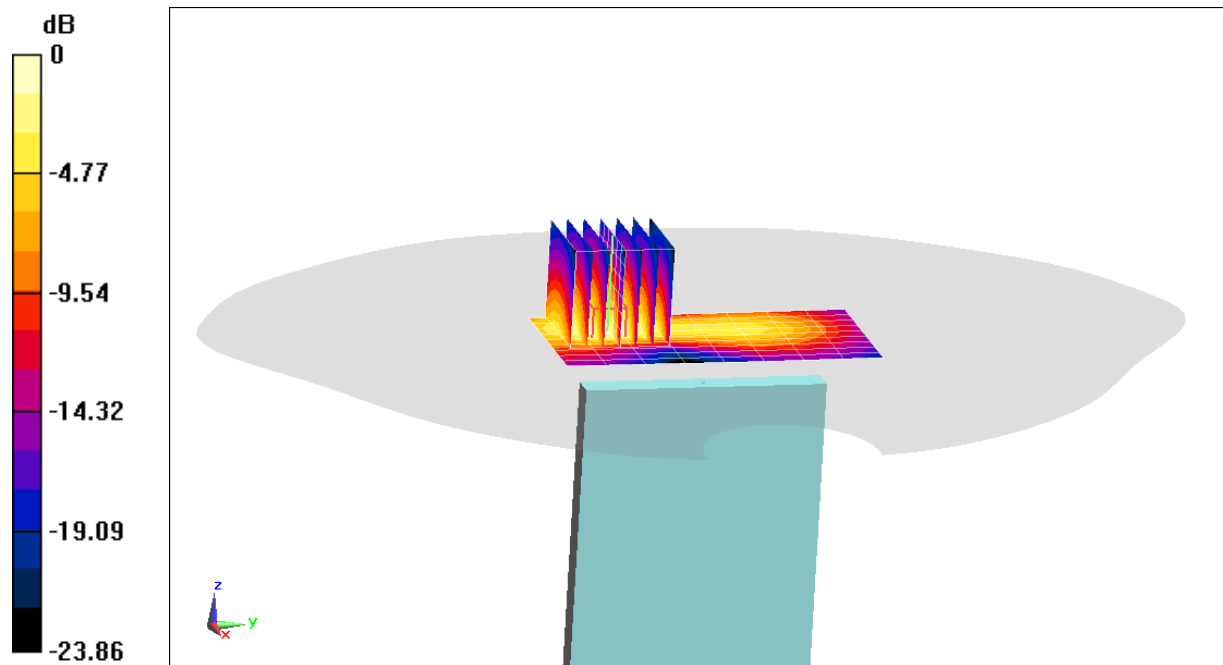

0 dB = 0.627 W/kg = -2.03 dBW/kg

PCTEST ENGINEERING LABORATORY, INC.

DUT: A3LSMN975U; Type: Portable Handset; Serial: 0459M

Communication System: UID 0, 802.11a 5.2-5.8 GHz Band; Frequency: 5745 MHz; Duty Cycle: 1:1

Medium: 5GHz Body; Medium parameters used:

$f = 5745 \text{ MHz}$; $\sigma = 6.171 \text{ S/m}$; $\epsilon_r = 46.752$; $\rho = 1000 \text{ kg/m}^3$

Phantom section: Flat Section; Space: 1.5 cm

Test Date: 06-14-2019; Ambient Temp: 22.8°C; Tissue Temp: 20.9°C

Probe: EX3DV4 - SN7308; ConvF(4.18, 4.18, 4.18) @ 5745 MHz; Calibrated: 8/23/2018

Sensor-Surface: 1.4mm (Mechanical Surface Detection)

Electronics: DAE4 Sn1558; Calibrated: 10/3/2018

Phantom: Twin-SAM V5.0; Type: QD 000 P40 CD; Serial: 1630

Measurement SW: DASY52, Version 52.10 (2);SEMCAD X Version 14.6.12 (7450)

**Mode: IEEE 802.11a Ant 1, UNII-3, 20 MHz Bandwidth,
Body SAR, Ch 149, 6 Mbps, Back Side**

Area Scan (12x20x1): Measurement grid: dx=10mm, dy=10mm

Zoom Scan (7x7x7)/Cube 0: Measurement grid: dx=4mm, dy=4mm, dz=1.4mm; Graded Ratio: 1.4

Reference Value = 6.298 V/m; Power Drift = -0.11 dB

Peak SAR (extrapolated) = 0.968 W/kg

SAR(1 g) = 0.233 W/kg

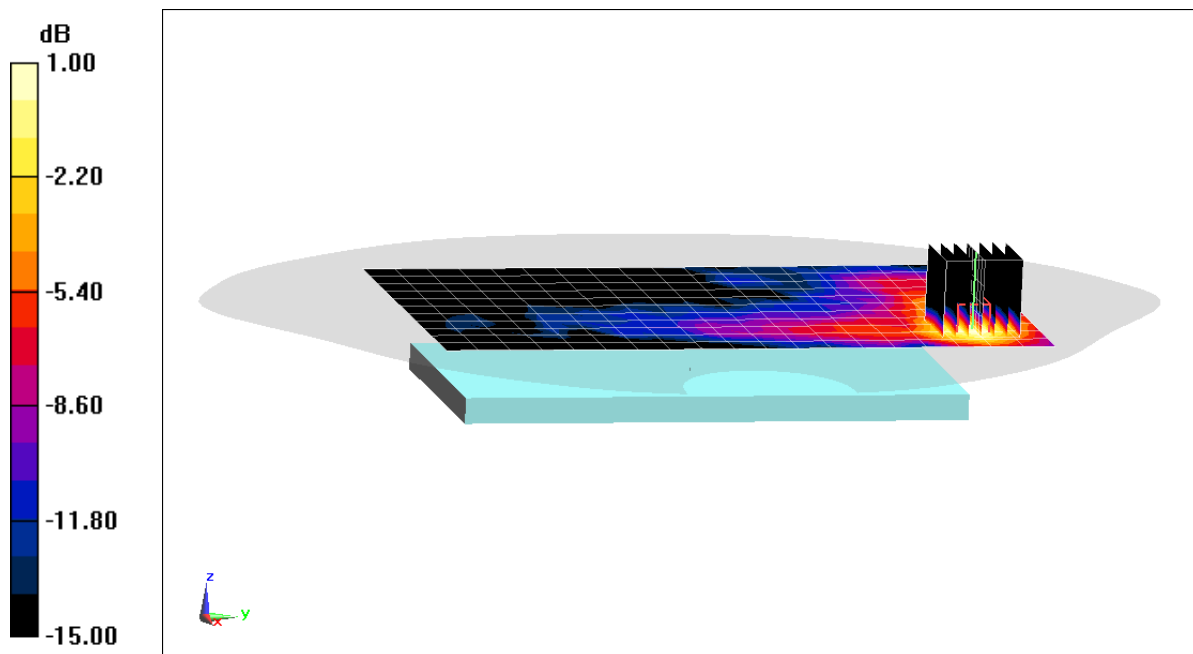

0 dB = 0.570 W/kg = -2.44 dBW/kg

PCTEST ENGINEERING LABORATORY, INC.

DUT: A3LSMN975U; Type: Portable Handset; Serial: 0459M

Communication System: UID 0, 802.11a 5.2-5.8 GHz Band; Frequency: 5745 MHz; Duty Cycle: 1:1

Medium: 5GHz Body; Medium parameters used:

$f = 5745 \text{ MHz}$; $\sigma = 6.171 \text{ S/m}$; $\epsilon_r = 46.752$; $\rho = 1000 \text{ kg/m}^3$

Phantom section: Flat Section; Space: 1.0 cm

Test Date: 06-14-2019; Ambient Temp: 22.8°C; Tissue Temp: 20.9°C

Probe: EX3DV4 - SN7308; ConvF(4.18, 4.18, 4.18) @ 5745 MHz; Calibrated: 8/23/2018

Sensor-Surface: 1.4mm (Mechanical Surface Detection)

Electronics: DAE4 Sn1558; Calibrated: 10/3/2018

Phantom: Twin-SAM V5.0; Type: QD 000 P40 CD; Serial: 1630

Measurement SW: DASY52, Version 52.10 (2);SEMCAD X Version 14.6.12 (7450)

**Mode: IEEE 802.11a Ant 1, UNII-3, 20 MHz Bandwidth,
Body SAR, Ch 149, 6 Mbps, Back Side**

Area Scan (12x20x1): Measurement grid: dx=10mm, dy=10mm

Zoom Scan (7x7x7)/Cube 0: Measurement grid: dx=4mm, dy=4mm, dz=1.4mm; Graded Ratio: 1.4

Reference Value = 7.513 V/m; Power Drift = -0.10 dB

Peak SAR (extrapolated) = 1.42 W/kg

SAR(1 g) = 0.322 W/kg

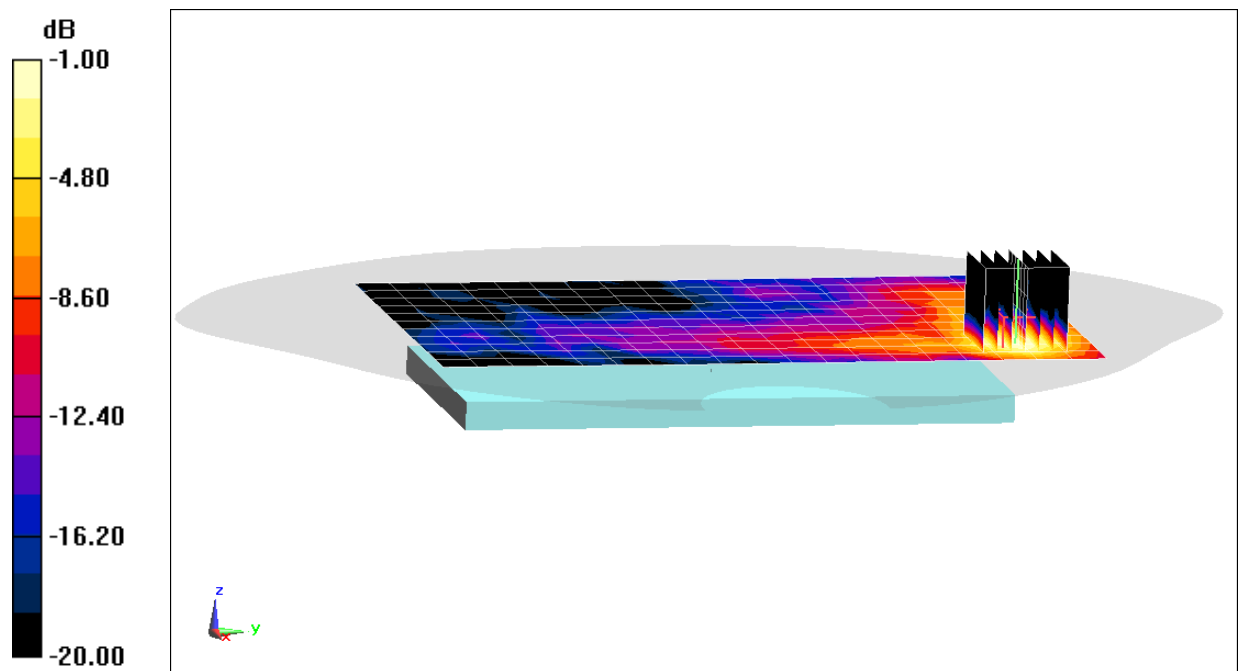

0 dB = 0.815 W/kg = -0.89 dBW/kg

PCTEST ENGINEERING LABORATORY, INC.

DUT: A3LSMN975U; Type: Portable Handset; Serial: 0352M

Communication System: UID 0, Bluetooth; Frequency: 2441 MHz; Duty Cycle: 1:1.297

Medium: 2450 Body; Medium parameters used (interpolated):

$f = 2441 \text{ MHz}$; $\sigma = 2.024 \text{ S/m}$; $\epsilon_r = 51.022$; $\rho = 1000 \text{ kg/m}^3$

Phantom section: Flat Section; Space: 1.5 cm

Test Date: 06-17-2019; Ambient Temp: 23.9°C; Tissue Temp: 22.9°C

Probe: EX3DV4 - SN7417; ConvF(7.51, 7.51, 7.51) @ 2441 MHz; Calibrated: 2/19/2019

Sensor-Surface: 1.4mm (Mechanical Surface Detection)

Electronics: DAE4 Sn665; Calibrated: 2/13/2019

Phantom: LeftTwin-SAM V5.0; Type: QD 000 P40 CD; Serial: TP1375

Measurement SW: DASY52, Version 52.10 (2);SEMCAD X Version 14.6.12 (7450)

Mode: Bluetooth, Body SAR, Ch 39, 1 Mbps, Back Side

Area Scan (11x17x1): Measurement grid: dx=12mm, dy=12mm

Zoom Scan (7x7x7)/Cube 0: Measurement grid: dx=5mm, dy=5mm, dz=5mm

Reference Value = 4.409 V/m; Power Drift = 0.13 dB

Peak SAR (extrapolated) = 0.0680 W/kg

SAR(1 g) = 0.036 W/kg

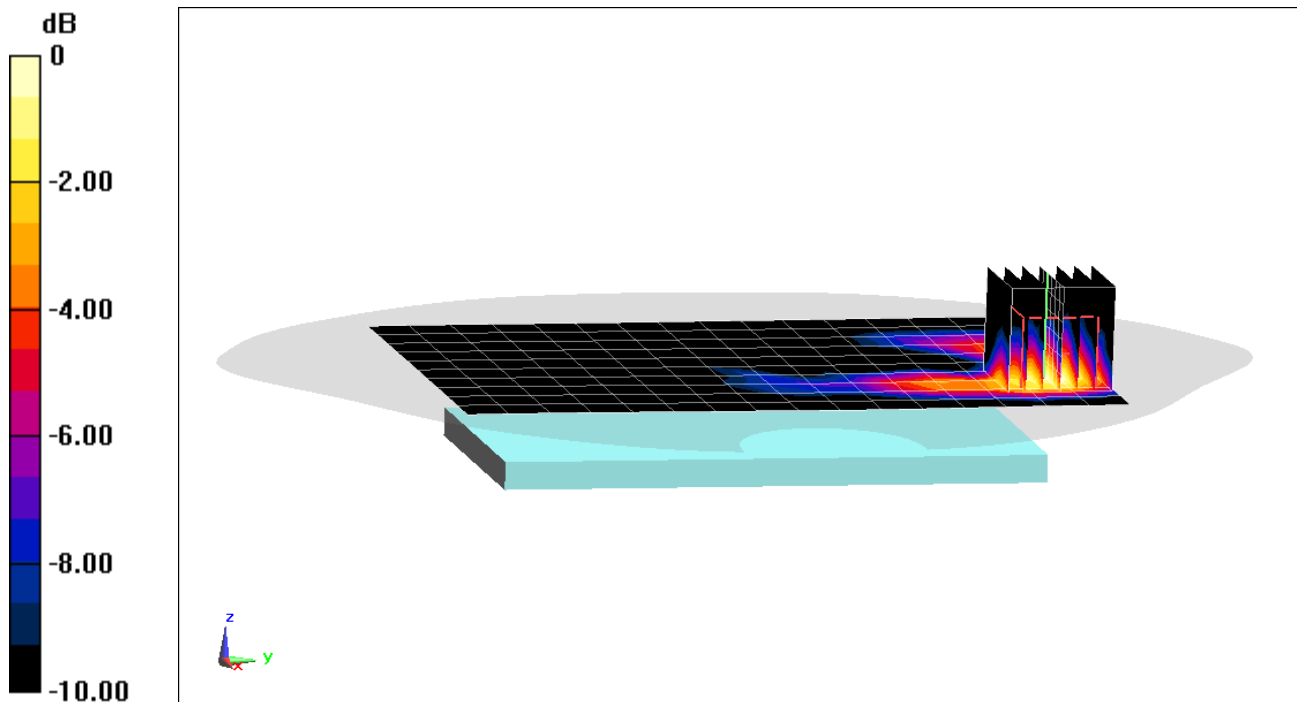

0 dB = 0.0544 W/kg = -12.64 dBW/kg

PCTEST ENGINEERING LABORATORY, INC.

DUT: A3LSMN975U; Type: Portable Handset; Serial: 0352M

Communication System: UID 0, Bluetooth; Frequency: 2441 MHz; Duty Cycle: 1:1.297

Medium: 2450 Body; Medium parameters used (interpolated):

$f = 2441 \text{ MHz}$; $\sigma = 2.024 \text{ S/m}$; $\epsilon_r = 51.022$; $\rho = 1000 \text{ kg/m}^3$

Phantom section: Flat Section; Space: 1.0 cm

Test Date: 06-17-2019; Ambient Temp: 23.9°C; Tissue Temp: 22.9°C

Probe: EX3DV4 - SN7417; ConvF(7.51, 7.51, 7.51) @ 2441 MHz; Calibrated: 2/19/2019

Sensor-Surface: 1.4mm (Mechanical Surface Detection)

Electronics: DAE4 Sn665; Calibrated: 2/13/2019

Phantom: LeftTwin-SAM V5.0; Type: QD 000 P40 CD; Serial: TP1375

Measurement SW: DASY52, Version 52.10 (2);SEMCAD X Version 14.6.12 (7450)

Mode: Bluetooth, Body SAR, Ch 39, 1 Mbps, Top Edge

Area Scan (10x11x1): Measurement grid: dx=5mm, dy=12mm

Zoom Scan (7x7x7)/Cube 0: Measurement grid: dx=5mm, dy=5mm, dz=5mm

Reference Value = 6.351 V/m; Power Drift = 0.17 dB

Peak SAR (extrapolated) = 0.147 W/kg

SAR(1 g) = 0.069 W/kg

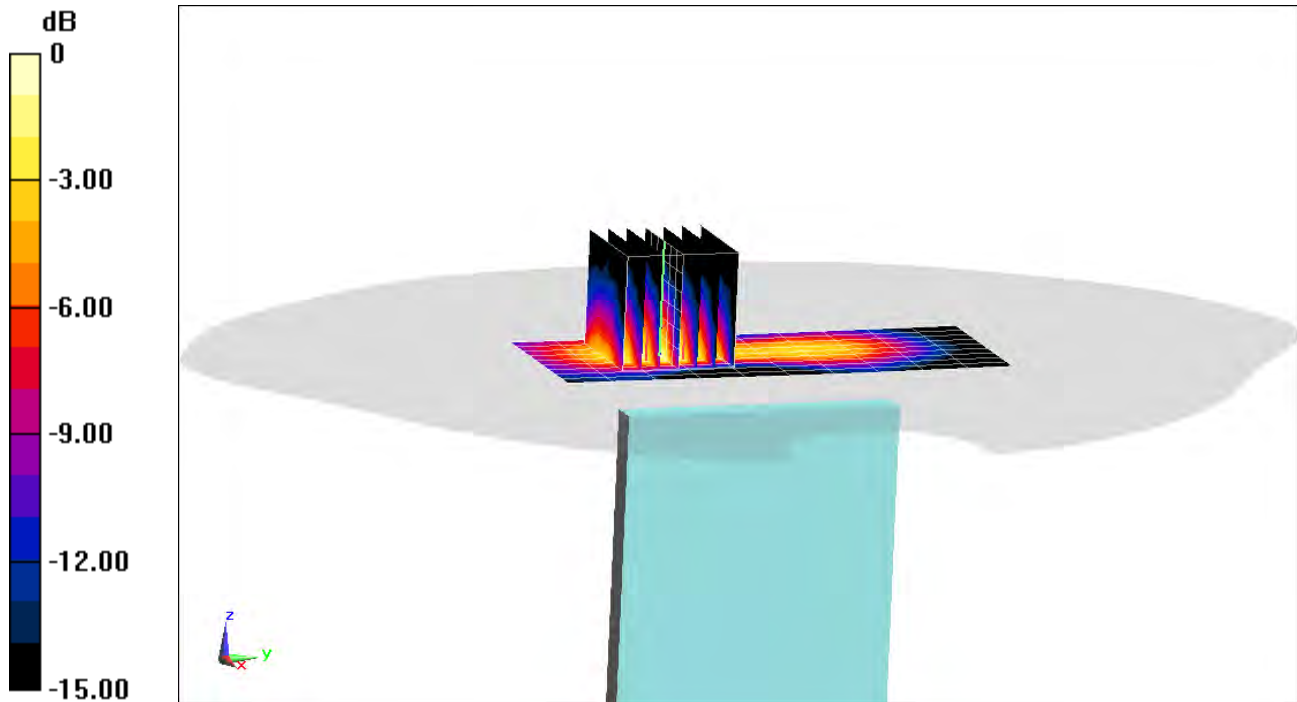

0 dB = 0.116 W/kg = -9.36 dBW/kg

PCTEST ENGINEERING LABORATORY, INC.

DUT: A3LSMN975U; Type: Portable Handset; Serial: 0373M

Communication System: UID 0, UMTS; Frequency: 1712.4 MHz; Duty Cycle: 1:1
Medium: 1750 Body; Medium parameters used (interpolated):
 $f = 1712.4 \text{ MHz}$; $\sigma = 1.396 \text{ S/m}$; $\epsilon_r = 55.28$; $\rho = 1000 \text{ kg/m}^3$
Phantom section: Flat Section; Space: 0.0 cm

Test Date: 06-19-2019; Ambient Temp: 22.2°C; Tissue Temp: 22.5°C

Probe: EX3DV4 - SN7357; ConvF(8.26, 8.26, 8.26) @ 1712.4 MHz; Calibrated: 4/24/2019
Sensor-Surface: 1.4mm (Mechanical Surface Detection)
Electronics: DAE4 Sn1407; Calibrated: 4/18/2019
Phantom: Twin-SAM V4.0 Front Right; Type: QD 000 P40 CC; Serial: 1167
Measurement SW: DASY52, Version 52.10 (2);SEMCAD X Version 14.6.12 (7450)

Mode: UMTS 1750, Phablet SAR, Bottom Edge, Low.ch

Area Scan (11x9x1): Measurement grid: $dx=5\text{mm}$, $dy=15\text{mm}$
Zoom Scan (5x6x7)/Cube 0: Measurement grid: $dx=8\text{mm}$, $dy=8\text{mm}$, $dz=5\text{mm}$
Reference Value = 60.09 V/m; Power Drift = -0.16 dB
Peak SAR (extrapolated) = 10.3 W/kg
SAR(10 g) = 2.22 W/kg

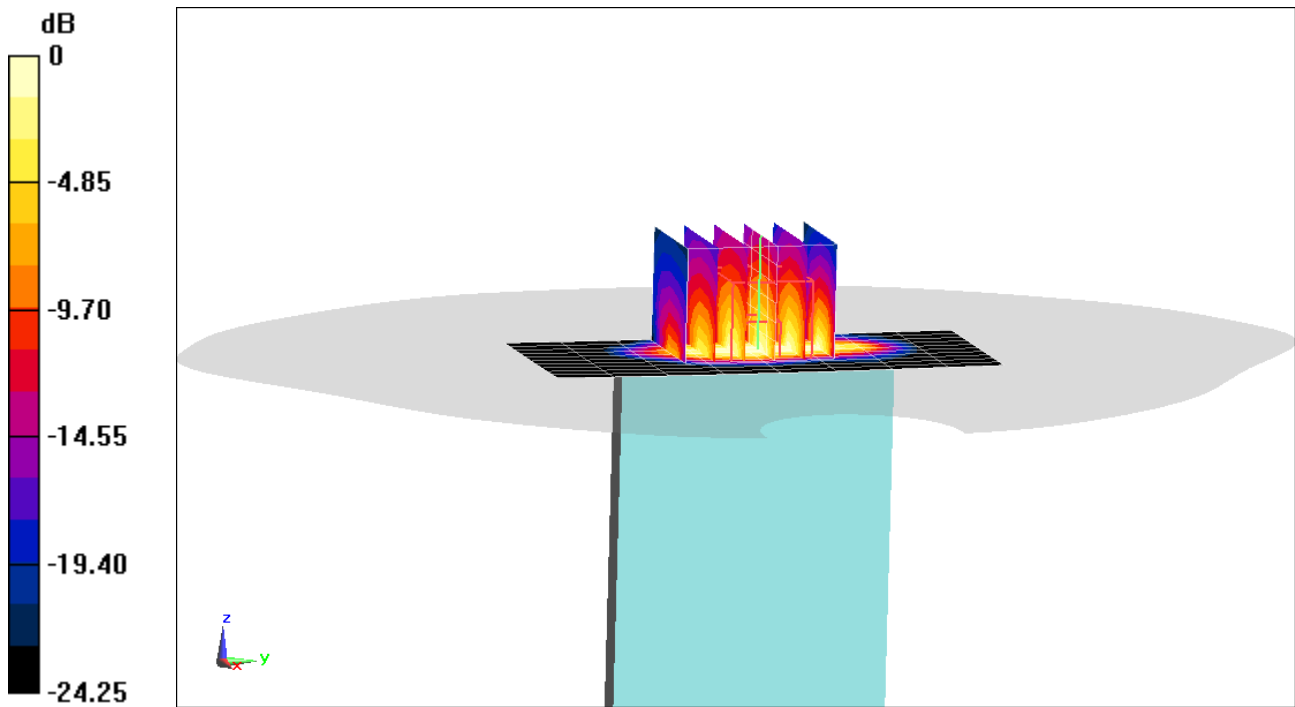

0 dB = 7.46 W/kg = 8.73 dBW/kg

PCTEST ENGINEERING LABORATORY, INC.

DUT: A3LSMN975U; Type: Portable Handset; Serial: 0119M

Communication System: UID 0, CDMA; Frequency: 1908.75 MHz; Duty Cycle: 1:1
Medium: 1900 Body; Medium parameters used (interpolated):
 $f = 1908.75$ MHz; $\sigma = 1.574$ S/m; $\epsilon_r = 51.71$; $\rho = 1000$ kg/m³
Phantom section: Flat Section; Space: 0.0 cm

Test Date: 06-12-2019; Ambient Temp: 22.6°C; Tissue Temp: 22.0°C

Probe: EX3DV4 - SN7410; ConvF(7.78, 7.78, 7.78) @ 1908.75 MHz; Calibrated: 7/20/2018
Sensor-Surface: 1.4mm (Mechanical Surface Detection)
Electronics: DAE4 Sn1322; Calibrated: 7/11/2018
Phantom: Front; Type: QD 000 P40 CD; Serial: 1686
Measurement SW: DASY52, Version 52.10 (2);SEMCAD X Version 14.6.12 (7450)

Mode: PCS EVDO Rev.0, Phablet SAR, Bottom Edge, High.ch

Area Scan (10x7x1): Measurement grid: dx=5mm, dy=15mm
Zoom Scan (5x6x7)/Cube 0: Measurement grid: dx=8mm, dy=8mm, dz=5mm
Reference Value = 69.54 V/m; Power Drift = -0.15 dB
Peak SAR (extrapolated) = 20.6 W/kg
SAR(10 g) = 2.71 W/kg

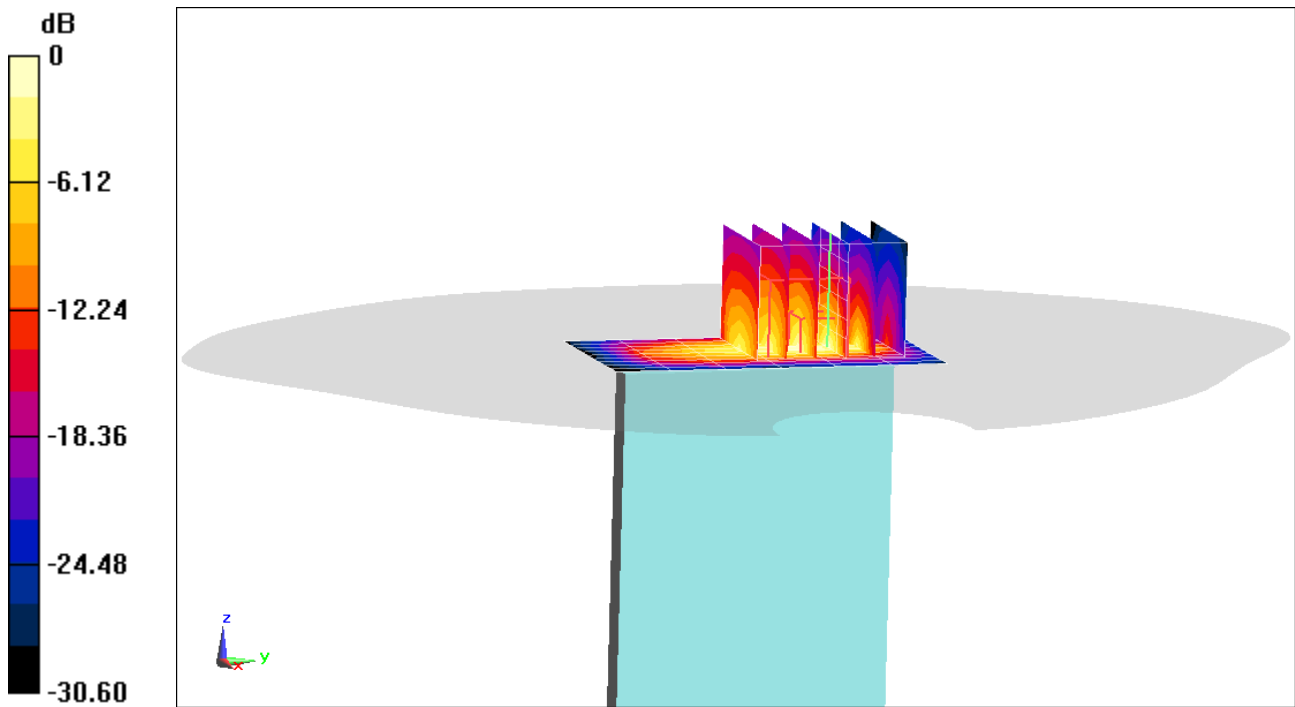

PCTEST ENGINEERING LABORATORY, INC.

DUT: A3LSMN975U; Type: Portable Handset; Serial: 0119M

Communication System: UID 0, _GSM GPRS; 3 Tx slots; Frequency: 1909.8 MHz; Duty Cycle: 1:2.76

Medium: 1900 Body Medium parameters used:

$f = 1910 \text{ MHz}$; $\sigma = 1.579 \text{ S/m}$; $\epsilon_r = 52.223$; $\rho = 1000 \text{ kg/m}^3$

Phantom section: Flat Section; Space: 0.0 cm

Test Date: 06-07-2019; Ambient Temp: 22.2°C; Tissue Temp: 22.5°C

Probe: EX3DV4 - SN7410; ConvF(7.78, 7.78, 7.78) @ 1909.8 MHz; Calibrated: 7/20/2018

Sensor-Surface: 1.4mm (Mechanical Surface Detection)

Electronics: DAE4 Sn1322; Calibrated: 7/11/2018

Phantom: Front; Type: QD 000 P40 CD; Serial: 1686

Measurement SW: DASY52, Version 52.10 (2);SEMCAD X Version 14.6.12 (7450)

Mode: GPRS 1900, Phablet SAR, Bottom Edge, High.ch, 3 Tx Slots

Area Scan (10x9x1): Measurement grid: dx=5mm, dy=15mm

Zoom Scan (5x6x7)/Cube 0: Measurement grid: dx=8mm, dy=8mm, dz=5mm

Reference Value = 61.01 V/m; Power Drift = -0.14 dB

Peak SAR (extrapolated) = 15.4 W/kg

SAR(10 g) = 2.05 W/kg

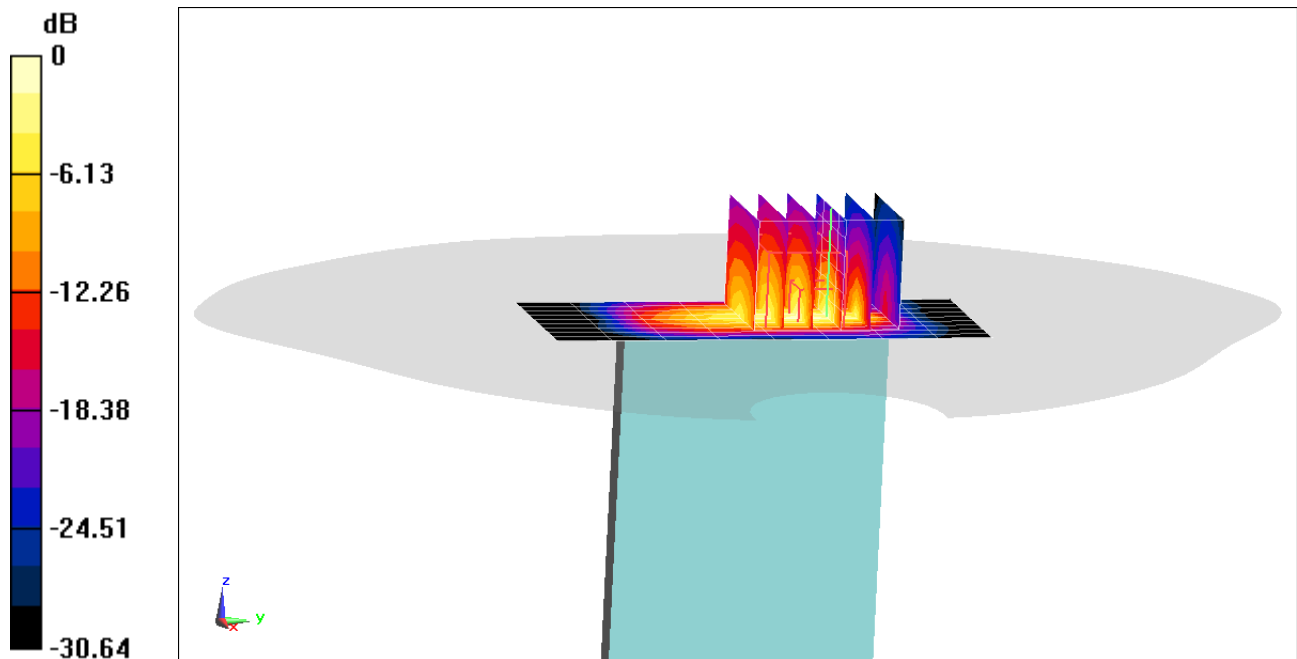

0 dB = 11.1 W/kg = 10.45 dBW/kg

PCTEST ENGINEERING LABORATORY, INC.

DUT: A3LSMN975U; Type: Portable Handset; Serial: 0119M

Communication System: UID 0, _UMTS; Frequency: 1852.4 MHz; Duty Cycle: 1:1
Medium: 1900 Body Medium parameters used (interpolated):
 $f = 1852.4 \text{ MHz}$; $\sigma = 1.517 \text{ S/m}$; $\epsilon_r = 52.057$; $\rho = 1000 \text{ kg/m}^3$
Phantom section: Flat Section; Space: 0.0 cm

Test Date: 06-05-2019; Ambient Temp: 22.8°C; Tissue Temp: 23.5°C

Probe: EX3DV4 - SN7410; ConvF(7.78, 7.78, 7.78) @ 1852.4 MHz; Calibrated: 7/20/2018
Sensor-Surface: 1.4mm (Mechanical Surface Detection)
Electronics: DAE4 Sn1322; Calibrated: 7/11/2018
Phantom: Front; Type: QD 000 P40 CD; Serial: 1686
Measurement SW: DASY52, Version 52.10 (2);SEMCAD X Version 14.6.12 (7450)

Mode: UMTS 1900, Phablet SAR, Bottom Edge, Low.ch

Area Scan (11x9x1): Measurement grid: dx=5mm, dy=15mm

Zoom Scan (5x6x7)/Cube 0: Measurement grid: dx=8mm, dy=8mm, dz=5mm

Reference Value = 62.15 V/m; Power Drift = -0.07 dB

Peak SAR (extrapolated) = 16.9 W/kg

SAR(10 g) = 2.19 W/kg

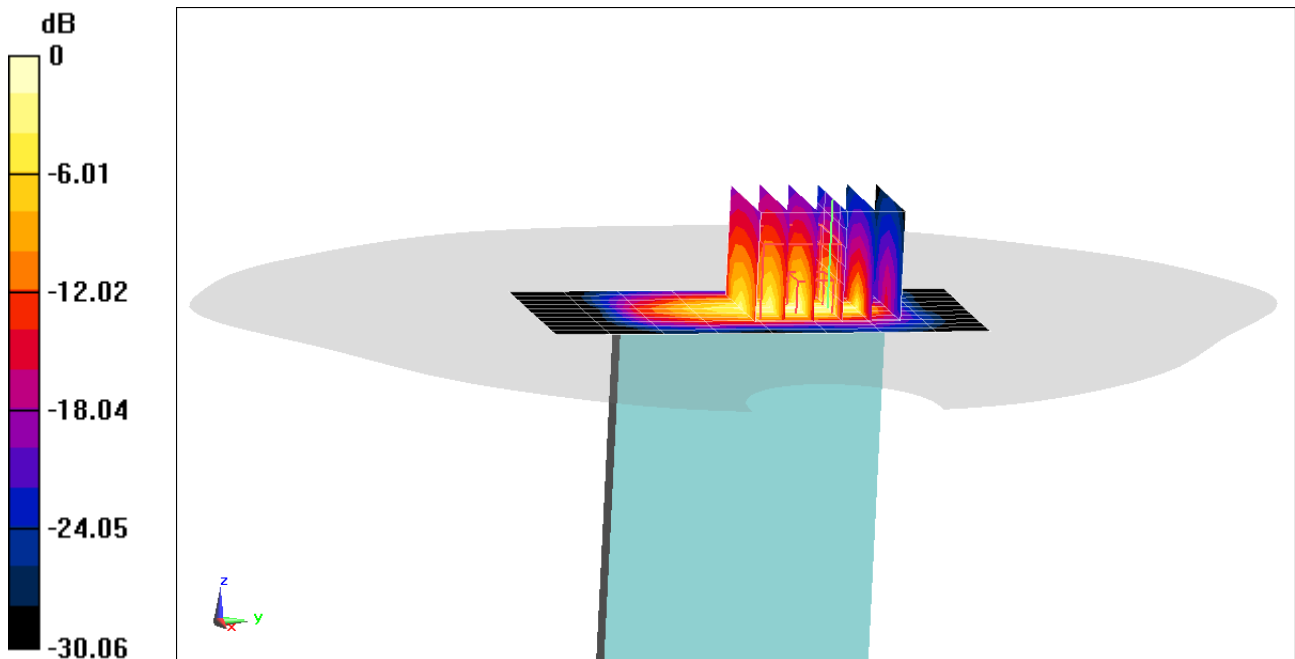

0 dB = 11.9 W/kg = 10.76 dBW/kg

PCTEST ENGINEERING LABORATORY, INC.

DUT: A3LSMN975U; Type: Portable Handset; Serial: 0326M

Communication System: UID 0, LTE Band 66 (AWS); Frequency: 1720 MHz; Duty Cycle: 1:1
Medium: 1750 Body; Medium parameters used (interpolated):
 $f = 1720 \text{ MHz}$; $\sigma = 1.471 \text{ S/m}$; $\epsilon_r = 52.236$; $\rho = 1000 \text{ kg/m}^3$
Phantom section: Flat Section; Space: 0.0 cm

Test Date: 06-05-2019; Ambient Temp: 23.1°C; Tissue Temp: 22.3°C

Probe: EX3DV4 - SN3914; ConvF(7.89, 7.89, 7.89) @ 1720 MHz; Calibrated: 2/19/2019
Sensor-Surface: 1.4mm (Mechanical Surface Detection)
Electronics: DAE4 Sn1272; Calibrated: 2/14/2019
Phantom: SAM with CRP v5.0 Front; Type: QD000P40CD; Serial: 1646
Measurement SW: DASY52, Version 52.10 (2);SEMCAD X Version 14.6.12 (7450)

**Mode: LTE Band 66 (AWS) ULCA, Phablet SAR, Bottom Edge,
PCC: 20 MHz Bandwidth, Ch. 132072, QPSK, 50 RB, 50 RB Offset
SCC: 20 MHz Bandwidth, Ch. 132270, QPSK, 50 RB, 0 RB Offset**

Area Scan (11x9x1): Measurement grid: dx=5mm, dy=15mm
Zoom Scan (5x6x7)/Cube 0: Measurement grid: dx=8mm, dy=8mm, dz=5mm
Reference Value = 57.08 V/m; Power Drift = 0.13 dB
Peak SAR (extrapolated) = 13.7 W/kg
SAR(10 g) = 2.56 W/kg

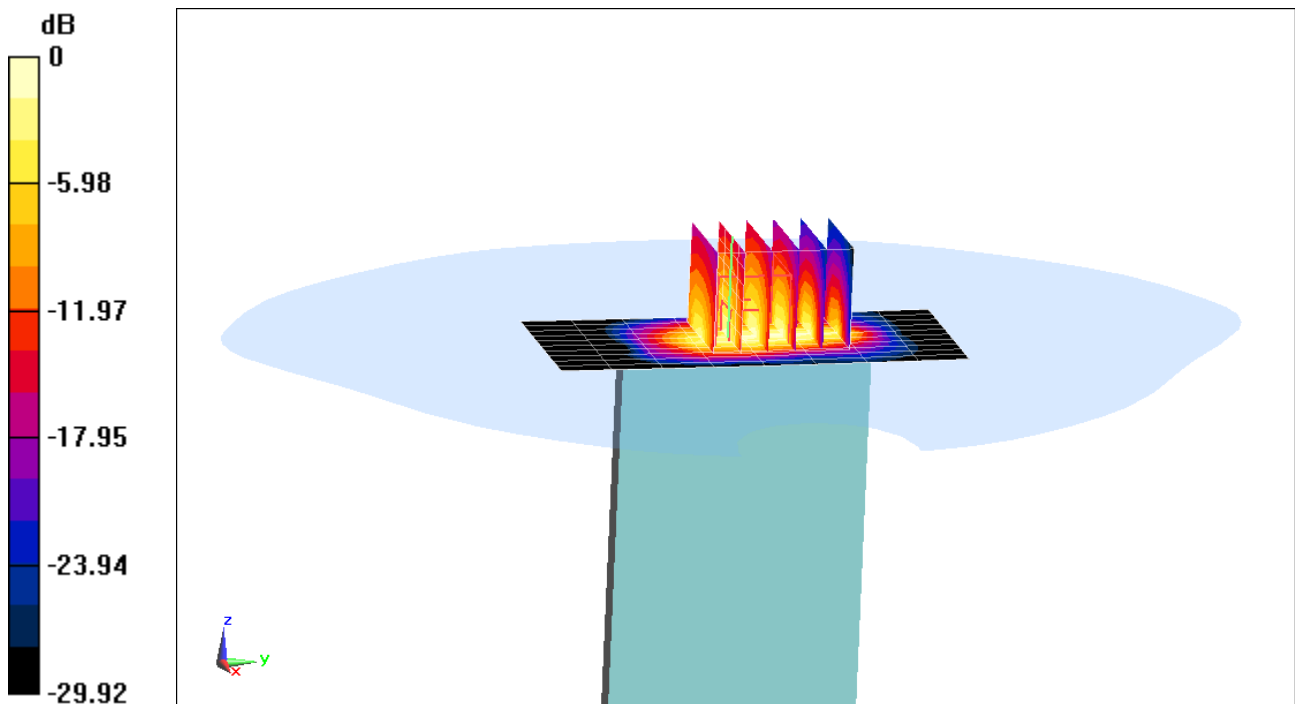

0 dB = 9.29 W/kg = 9.68 dBW/kg

PCTEST ENGINEERING LABORATORY, INC.

DUT: A3LSMN975U; Type: Portable Handset; Serial: 0498M

Communication System: UID 0, LTE Band 25 (PCS); Frequency: 1882.5 MHz; Duty Cycle: 1:1
Medium: 1900 Body; Medium parameters used (interpolated):
 $f = 1882.5 \text{ MHz}$; $\sigma = 1.557 \text{ S/m}$; $\epsilon_r = 52.888$; $\rho = 1000 \text{ kg/m}^3$
Phantom section: Flat Section; Space: 0.0 cm

Test Date: 06-03-2019; Ambient Temp: 21.9°C; Tissue Temp: 22.3°C

Probe: EX3DV4 - SN7410; ConvF(7.78, 7.78, 7.78) @ 1882.5 MHz; Calibrated: 7/20/2018
Sensor-Surface: 1.4mm (Mechanical Surface Detection)
Electronics: DAE4 Sn1322; Calibrated: 7/11/2018
Phantom: Front; Type: QD 000 P40 CD; Serial: 1686
Measurement SW: DASY52, Version 52.10 (2);SEMCAD X Version 14.6.12 (7450)

**Mode: LTE Band 25 (PCS), Phablet SAR, Bottom Edge, Mid.ch,
20 MHz Bandwidth, QPSK, 50 RB, 25 RB Offset**

Area Scan (10x7x1): Measurement grid: $dx=5\text{mm}$, $dy=15\text{mm}$

Zoom Scan (5x6x7)/Cube 0: Measurement grid: $dx=8\text{mm}$, $dy=8\text{mm}$, $dz=5\text{mm}$

Reference Value = 65.75 V/m; Power Drift = -0.12 dB

Peak SAR (extrapolated) = 19.3 W/kg

SAR(10 g) = 2.49 W/kg

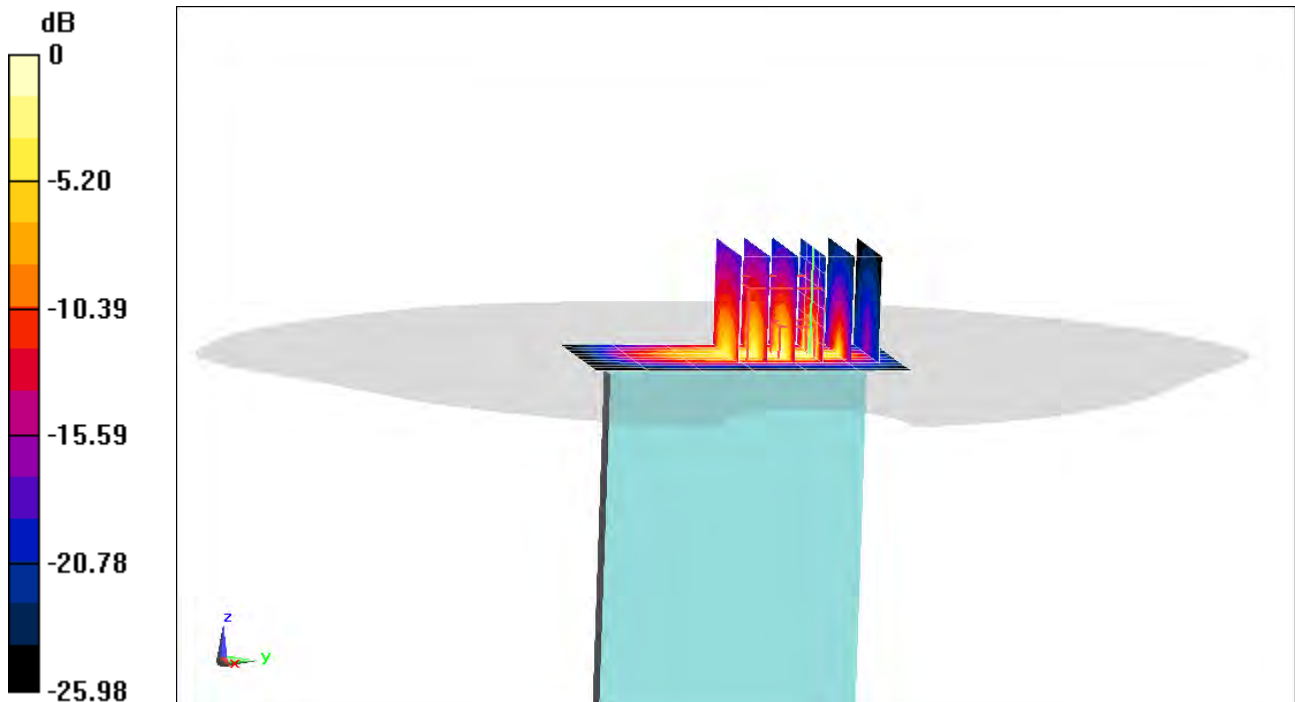

0 dB = 13.3 W/kg = 11.24 dBW/kg

PCTEST ENGINEERING LABORATORY, INC.

DUT: A3LSMN975U; Type: Portable Handset; Serial: 0499M

Communication System: UID 0, LTE Band 30; Frequency: 2310 MHz; Duty Cycle: 1:1
Medium: 2450 Body; Medium parameters used:
 $f = 2310 \text{ MHz}$; $\sigma = 1.853 \text{ S/m}$; $\epsilon_r = 51.171$; $\rho = 1000 \text{ kg/m}^3$
Phantom section: Flat Section; Space: 0.0 cm

Test Date: 06-05-2019; Ambient Temp: 23.5°C; Tissue Temp: 22.9°C

Probe: EX3DV4 - SN7417; ConvF(7.64, 7.64, 7.64) @ 2310 MHz; Calibrated: 2/19/2019
Sensor-Surface: 1.4mm (Mechanical Surface Detection)
Electronics: DAE4 Sn665; Calibrated: 2/13/2019
Phantom: LeftTwin-SAM V5.0; Type: QD 000 P40 CD; Serial: TP1375
Measurement SW: DASY52, Version 52.10 (2);SEMCAD X Version 14.6.12 (7450)

**Mode: LTE Band 30, Phablet SAR, Bottom Edge, Mid.ch,
10 MHz Bandwidth, QPSK, 50 RB, 0 RB Offset**

Area Scan (11x10x1): Measurement grid: dx=5mm, dy=12mm
Zoom Scan (7x9x7)/Cube 0: Measurement grid: dx=5mm, dy=5mm, dz=5mm
Reference Value = 56.92 V/m; Power Drift = -0.03 dB
Peak SAR (extrapolated) = 18.5 W/kg
SAR(10 g) = 2.17 W/kg

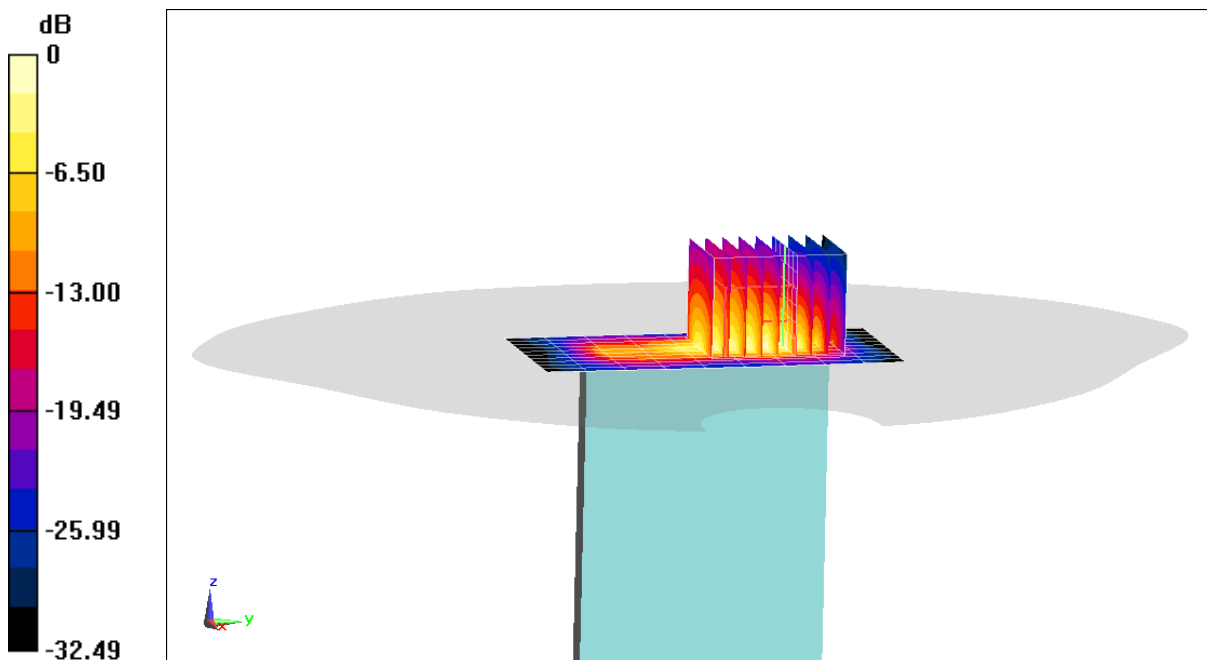

0 dB = 12.7 W/kg = 11.04 dBW/kg

PCTEST ENGINEERING LABORATORY, INC.

DUT: A3LSMN975U; Type: Portable Handset; Serial: 0349M

Communication System: UID 0, _LTE Band 7; Frequency: 2510 MHz; Duty Cycle: 1:1
Medium: 2450 Body Medium parameters used (interpolated):
 $f = 2510 \text{ MHz}$; $\sigma = 2.084 \text{ S/m}$; $\epsilon_r = 51.044$; $\rho = 1000 \text{ kg/m}^3$
Phantom section: Flat Section; Space: 0.0 cm

Test Date: 07-07-2019; Ambient Temp: 23.0°C; Tissue Temp: 22.1°C

Probe: EX3DV4 - SN7417; ConvF(7.51, 7.51, 7.51) @ 2510 MHz; Calibrated: 2/19/2019
Sensor-Surface: 1.4mm (Mechanical Surface Detection)
Electronics: DAE4 Sn665; Calibrated: 2/13/2019
Phantom: LeftTwin-SAM V5.0; Type: QD 000 P40 CD; Serial: TP1375
Measurement SW: DASY52, Version 52.10 (2);SEMCAD X Version 14.6.12 (7450)

**Mode: LTE Band 7, Phablet SAR, Bottom Edge, Low.ch,
20 MHz Bandwidth, QPSK, 50 RB, 50 RB Offset**

Area Scan (10x11x1): Measurement grid: dx=5mm, dy=12mm
Zoom Scan (7x7x7)/Cube 0: Measurement grid: dx=5mm, dy=5mm, dz=5mm
Reference Value = 59.86 V/m; Power Drift = 0.19 dB
Peak SAR (extrapolated) = 21.1 W/kg
SAR(10 g) = 2.02 W/kg

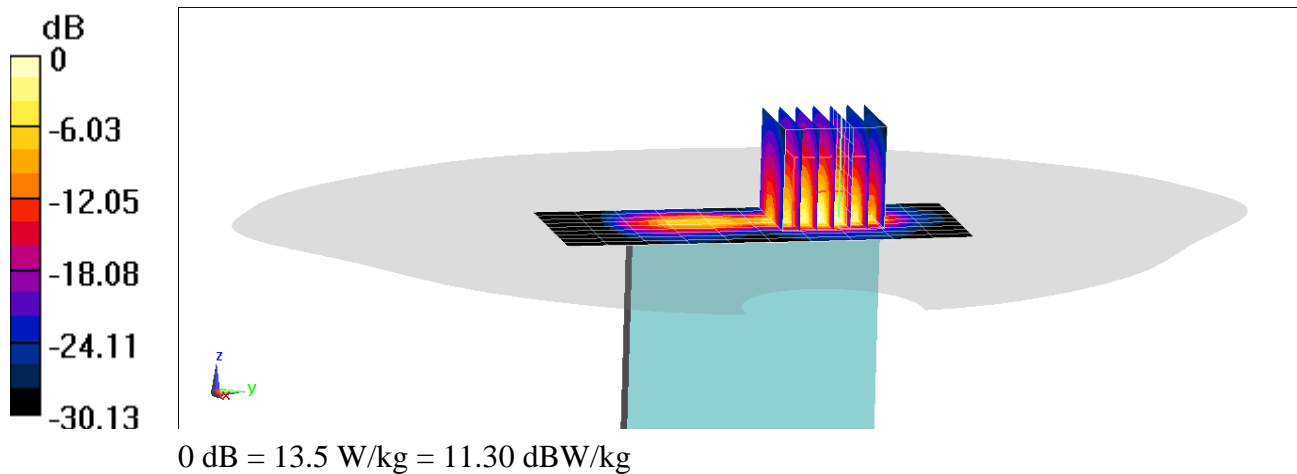

PCTEST ENGINEERING LABORATORY, INC.

DUT: A3LSMN975U; Type: Portable Handset; Serial: 0459M

Communication System: UID 0, 802.11n 5.2-5.8 GHz Band; Frequency: 5520 MHz; Duty Cycle: 1:1

Medium: 5GHz Body Medium parameters used:

$f = 5520 \text{ MHz}$; $\sigma = 5.826 \text{ S/m}$; $\epsilon_r = 47.182$; $\rho = 1000 \text{ kg/m}^3$

Phantom section: Flat Section; Space: 0.0 cm

Test Date: 06-14-2019; Ambient Temp: 22.8°C; Tissue Temp: 20.9°C

Probe: EX3DV4 - SN7308; ConvF(4, 4, 4) @ 5520 MHz; Calibrated: 8/23/2018

Sensor-Surface: 1.4mm (Mechanical Surface Detection)

Electronics: DAE4 Sn1558; Calibrated: 10/3/2018

Phantom: Twin-SAM V5.0; Type: QD 000 P40 CD; Serial: 1630

Measurement SW: DASY52, Version 52.10 (2);SEMCAD X Version 14.6.12 (7450)

**Mode: IEEE 802.11n MIMO, UNII-2C, 20 MHz Bandwidth,
Phablet SAR, Ch 104, 13 Mbps, Back Side**

Area Scan (13x20x1): Measurement grid: dx=10mm, dy=10mm

Zoom Scan (9x9x7)/Cube 0: Measurement grid: dx=4mm, dy=4mm, dz=1.4mm; Graded Ratio: 1.4

Reference Value = 28.45 V/m; Power Drift = 0.14 dB

Peak SAR (extrapolated) = 42.5 W/kg

SAR(10 g) = 2.23 W/kg

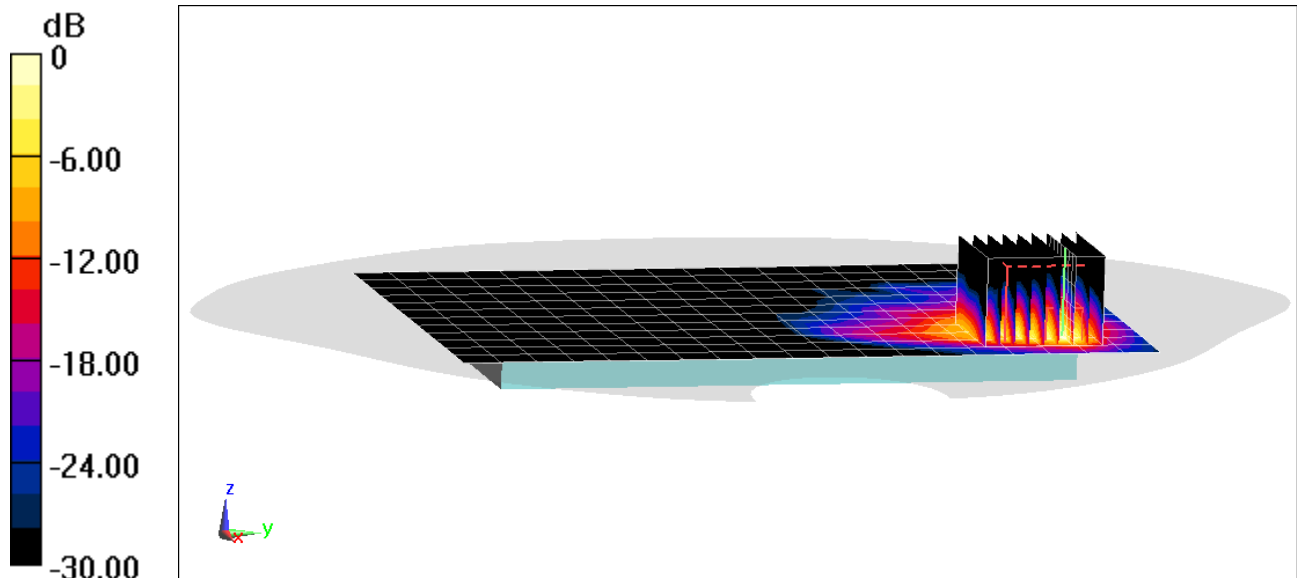

0 dB = 21.3 W/kg = 13.28 dBW/kg

APPENDIX B: SYSTEM VERIFICATION

PCTEST ENGINEERING LABORATORY, INC.

DUT: Dipole 750 MHz; Type: D750V3; Serial: 1161

Communication System: UID 0, CW; Frequency: 750 MHz; Duty Cycle: 1:1

Medium: 750 Head Medium parameters used (interpolated):

$f = 750 \text{ MHz}$; $\sigma = 0.913 \text{ S/m}$; $\epsilon_r = 42.923$; $\rho = 1000 \text{ kg/m}^3$

Phantom section: Flat Section; Space: 1.5 cm

Test Date: 05-28-2019; Ambient Temp: 22.6°C; Tissue Temp: 22.0°C

Probe: EX3DV4 - SN3914; ConvF(10, 10, 10) @ 750 MHz; Calibrated: 2/19/2019

Sensor-Surface: 1.4mm (Mechanical Surface Detection)

Electronics: DAE4 Sn1272; Calibrated: 2/14/2019

Phantom: Left For Head SAM with CRP v5.0; Type: QD000P40CD; Serial: TP:1687

Measurement SW: DASY52, Version 52.10 (2);SEMCAD X Version 14.6.12 (7450)

750 MHz System Verification at 23.0 dBm (200 mW)

Area Scan (7x15x1): Measurement grid: dx=15mm, dy=15mm

Zoom Scan (5x5x7)/Cube 0: Measurement grid: dx=8mm, dy=8mm, dz=5mm

Peak SAR (extrapolated) = 2.57 W/kg

SAR(1 g) = 1.7 W/kg

Deviation(1 g) = 5.85%

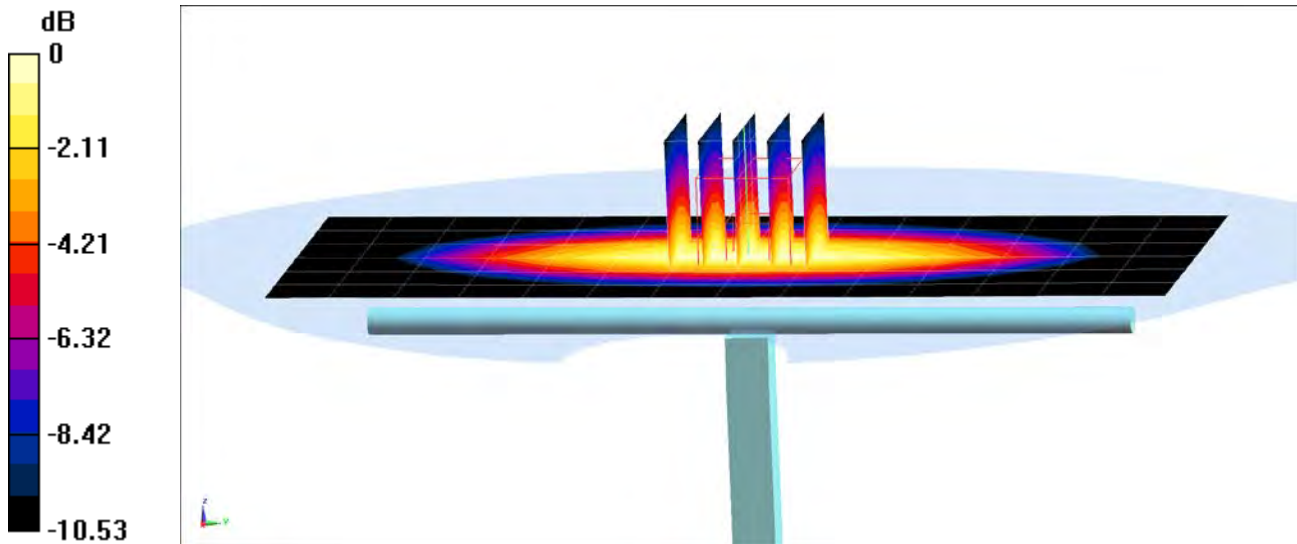

0 dB = 2.28 W/kg = 3.58 dBW/kg

PCTEST ENGINEERING LABORATORY, INC.

DUT: Dipole 835 MHz; Type: D835V2; Serial: 4d132

Communication System: UID 0, CW; Frequency: 835 MHz; Duty Cycle: 1:1

Medium: 835 Head Medium parameters used:

$f = 835 \text{ MHz}$; $\sigma = 0.899 \text{ S/m}$; $\epsilon_r = 40.452$; $\rho = 1000 \text{ kg/m}^3$

Phantom section: Flat Section; Space: 1.5 cm

Test Date: 05-28-2019; Ambient Temp: 20.0°C; Tissue Temp: 19.8°C

Probe: EX3DV4 - SN7409; ConvF(9.67, 9.67, 9.67) @ 835 MHz; Calibrated: 6/25/2018

Sensor-Surface: 1.4mm (Mechanical Surface Detection)

Electronics: DAE4 Sn1334; Calibrated: 6/18/2018

Phantom: Left 30-SAM V5.0; Type: QD 000 P40 CD; Serial: 1715

Measurement SW: DASY52, Version 52.10 (2);SEMCAD X Version 14.6.12 (7450)

835 MHz System Verification at 23.0 dBm (200 mW)

Area Scan (7x14x1): Measurement grid: dx=15mm, dy=15mm

Zoom Scan (5x5x7)/Cube 0: Measurement grid: dx=8mm, dy=8mm, dz=5mm

Peak SAR (extrapolated) = 3.08 W/kg

SAR(1 g) = 1.96 W/kg

Deviation(1 g) = 2.19%

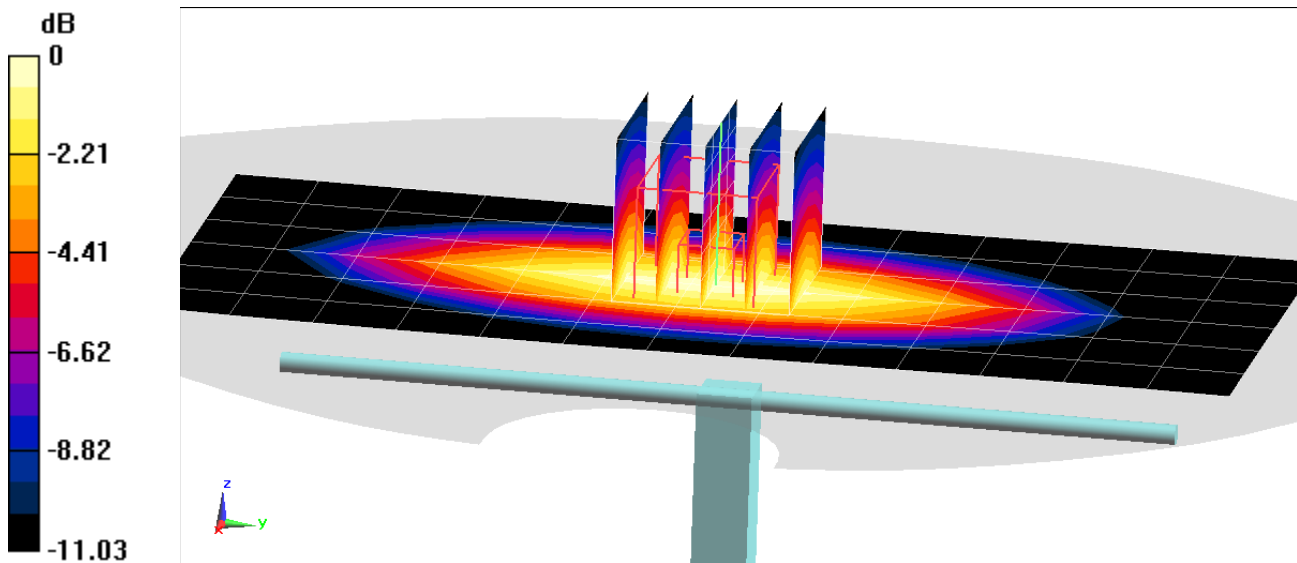

PCTEST ENGINEERING LABORATORY, INC.

DUT: Dipole 1750 MHz; Type: D1765V2; Serial: 1008

Communication System: UID 0, CW; Frequency: 1750 MHz; Duty Cycle: 1:1

Medium: 1750 Head; Medium parameters used:

$f = 1750 \text{ MHz}$; $\sigma = 1.368 \text{ S/m}$; $\epsilon_r = 40.344$; $\rho = 1000 \text{ kg/m}^3$

Phantom section: Flat Section; Space: 1.0 cm

Test Date: 05-28-2019; Ambient Temp: 22.0°C; Tissue Temp: 21.0°C

Probe: EX3DV4 - SN7357; ConvF(8.69, 8.69, 8.69) @ 1750 MHz; Calibrated: 4/24/2019

Sensor-Surface: 1.4mm (Mechanical Surface Detection)

Electronics: DAE4 Sn1407; Calibrated: 4/18/2019

Phantom: Twin-SAM V5.0 Back Right; Type: QD 000 P40 CD; Serial: 1692

Measurement SW: DASY52, Version 52.10 (2);SEMCAD X Version 14.6.12 (7450)

1750 MHz System Verification at 20.0 dBm (100 mW)

Area Scan (7x9x1): Measurement grid: dx=15mm, dy=15mm

Zoom Scan (5x5x7)/Cube 0: Measurement grid: dx=8mm, dy=8mm, dz=5mm

Peak SAR (extrapolated) = 7.25 W/kg

SAR(1 g) = 3.87 W/kg

Deviation(1 g) = 6.91%

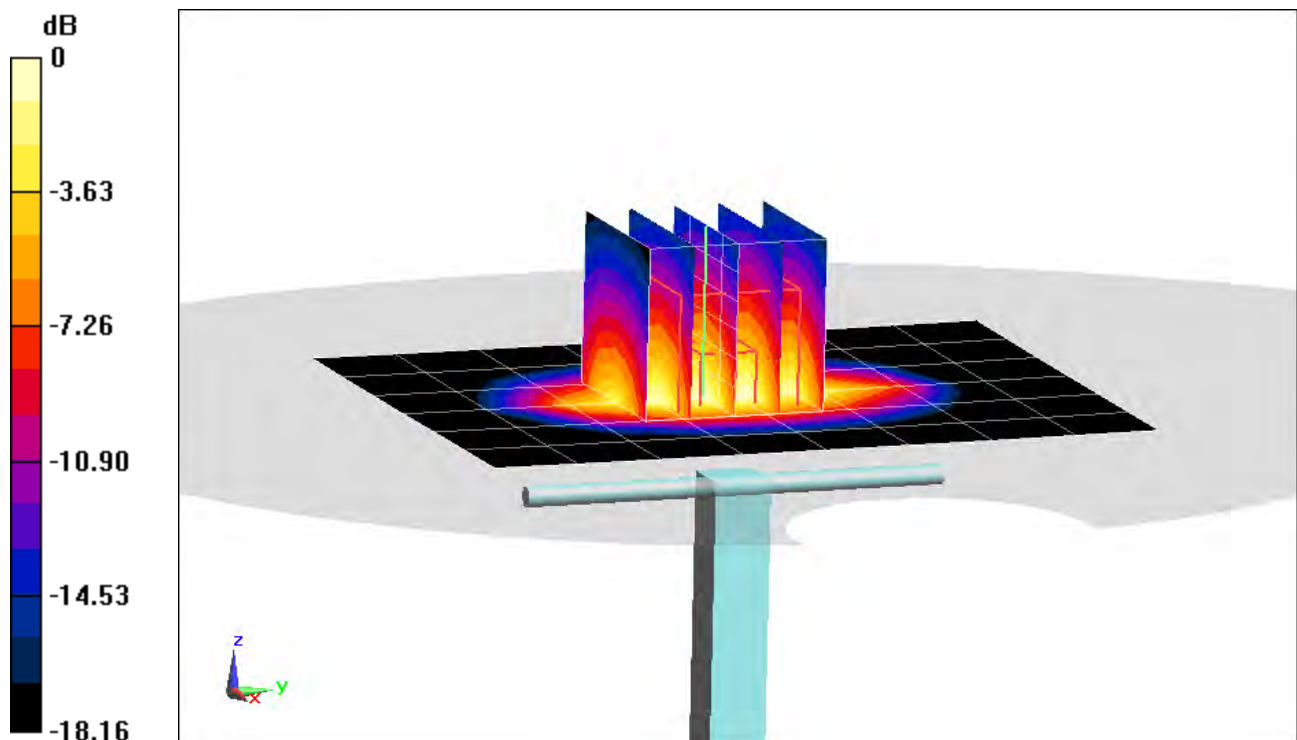

0 dB = 5.99 W/kg = 7.77 dBW/kg

PCTEST ENGINEERING LABORATORY, INC.

DUT: Dipole 1750 MHz; Type: D1765V2; Serial: 1008

Communication System: UID 0, CW; Frequency: 1750 MHz; Duty Cycle: 1:1

Medium: 1750 Head; Medium parameters used:

$f = 1750 \text{ MHz}$; $\sigma = 1.375 \text{ S/m}$; $\epsilon_r = 41.453$; $\rho = 1000 \text{ kg/m}^3$

Phantom section: Flat Section; Space: 1.0 cm

Test Date: 06-03-2019; Ambient Temp: 21.2°C; Tissue Temp: 20.5°C

Probe: EX3DV4 - SN7357; ConvF(8.69, 8.69, 8.69) @ 1750 MHz; Calibrated: 4/24/2019

Sensor-Surface: 1.4mm (Mechanical Surface Detection)

Electronics: DAE4 Sn1407; Calibrated: 4/18/2019

Phantom: Twin-SAM V5.0 Back Right; Type: QD 000 P40 CD; Serial: 1692

Measurement SW: DASY52, Version 52.10 (2);SEMCAD X Version 14.6.12 (7450)

1750 MHz System Verification at 20.0 dBm (100 mW)

Area Scan (7x9x1): Measurement grid: dx=15mm, dy=15mm

Zoom Scan (5x5x7)/Cube 0: Measurement grid: dx=8mm, dy=8mm, dz=5mm

Peak SAR (extrapolated) = 7.34 W/kg

SAR(1 g) = 3.87 W/kg

Deviation(1 g) = 6.91%

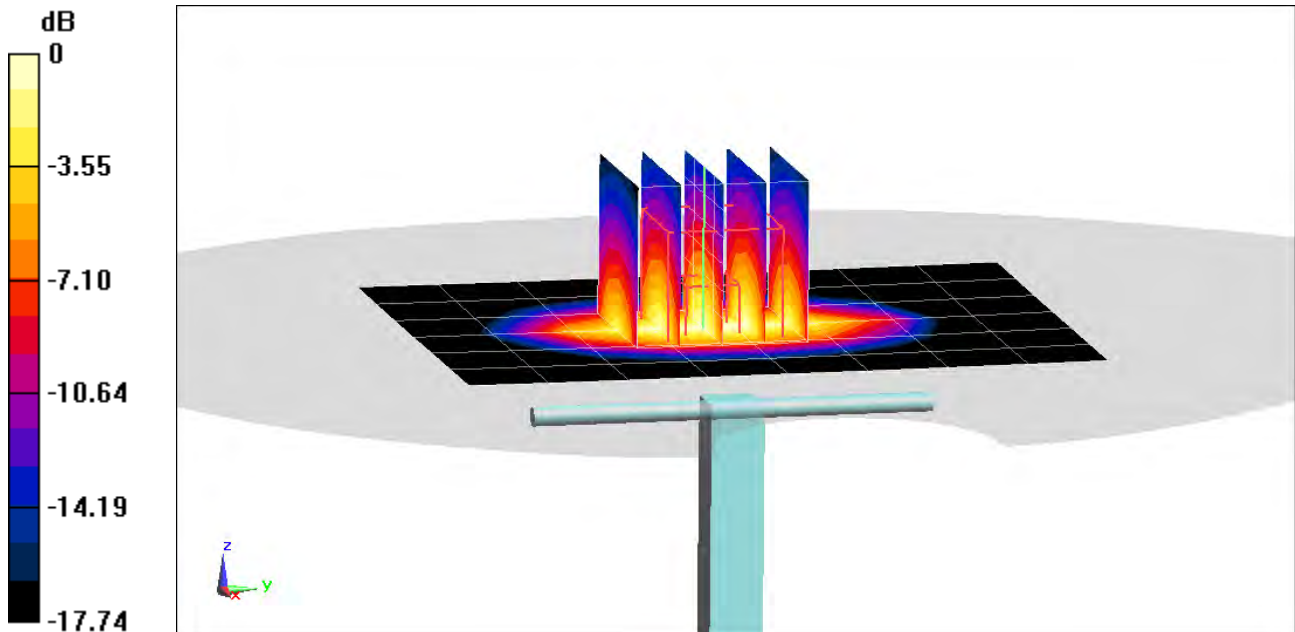

0 dB = 6.08 W/kg = 7.84 dBW/kg

PCTEST ENGINEERING LABORATORY, INC.

DUT: Dipole 1900 MHz; Type: D1900V2; Serial: 5d080

Communication System: UID 0, CW; Frequency: 1900 MHz; Duty Cycle: 1:1

Medium: 1900 Head Medium parameters used (interpolated):

$f = 1900 \text{ MHz}$; $\sigma = 1.448 \text{ S/m}$; $\epsilon_r = 38.914$; $\rho = 1000 \text{ kg/m}^3$

Phantom section: Flat Section; Space: 1.0 cm

Test Date: 05-29-2019; Ambient Temp: 21.1°C; Tissue Temp: 21.5°C

Probe: EX3DV4 - SN7308; ConvF(8.26, 8.26, 8.26) @ 1900 MHz; Calibrated: 8/23/2018

Sensor-Surface: 1.4mm (Mechanical Surface Detection)

Electronics: DAE4 Sn1558; Calibrated: 10/3/2018

Phantom: Twin-SAM V8.0; Type: QD 000 P41 Ax; Serial: 1966

Measurement SW: DASY52, Version 52.10 (2); SEMCAD X Version 14.6.12 (7450)

1900 MHz System Verification at 20.0 dBm (100 mW)

Area Scan (7x11x1): Measurement grid: dx=15mm, dy=15mm

Zoom Scan (5x5x7)/Cube 0: Measurement grid: dx=8mm, dy=8mm, dz=5mm

Peak SAR (extrapolated) = 8.55 W/kg

SAR(1 g) = 4.25 W/kg

Deviation(1 g) = 6.78%

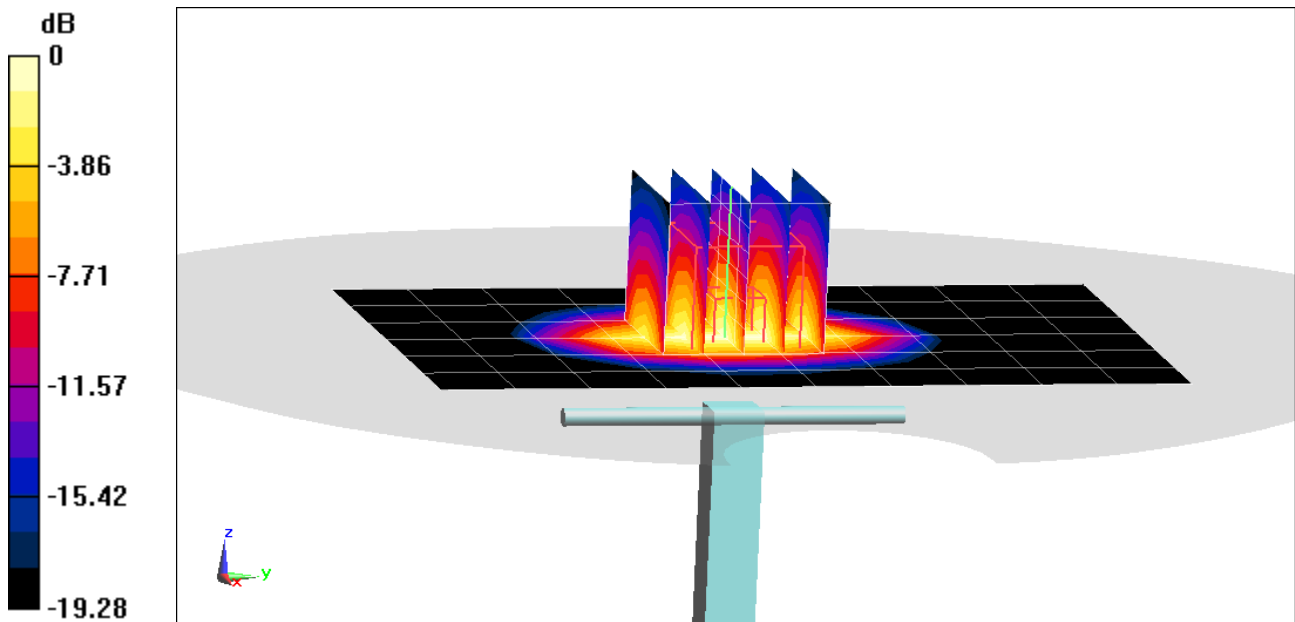

0 dB = 6.86 W/kg = 8.36 dBW/kg

PCTEST ENGINEERING LABORATORY, INC.

DUT: Dipole 2300 MHz; Type: D2300V2; Serial: 1064

Communication System: UID 0, CW; Frequency: 2300 MHz; Duty Cycle: 1:1

Medium: 2450 Head Medium parameters used:

$f = 2300$ MHz; $\sigma = 1.724$ S/m; $\epsilon_r = 38.461$; $\rho = 1000$ kg/m³

Phantom section: Flat Section; Space: 1.0 cm

Test Date: 05-30-2019; Ambient Temp: 22.7°C; Tissue Temp: 21.5°C

Probe: EX3DV4 - SN3589; ConvF(6.77, 6.77, 6.77) @ 2300 MHz; Calibrated: 1/25/2019

Sensor-Surface: 1.4mm (Mechanical Surface Detection)

Electronics: DAE4 Sn1450; Calibrated: 8/22/2018

Phantom: Twin-SAM V5.0 (30); Type: QD 000 P40 CD; Serial: 1647

Measurement SW: DASY52, Version 52.10 (2); SEMCAD X Version 14.6.12 (7450)

2300 MHz System Verification at 20.0 dBm (100 mW)

Area Scan (8x9x1): Measurement grid: dx=12mm, dy=12mm

Zoom Scan (7x7x7)/Cube 0: Measurement grid: dx=5mm, dy=5mm, dz=5mm

Peak SAR (extrapolated) = 10.7 W/kg

SAR(1 g) = 5.1 W/kg

Deviation(1 g) = 7.14%

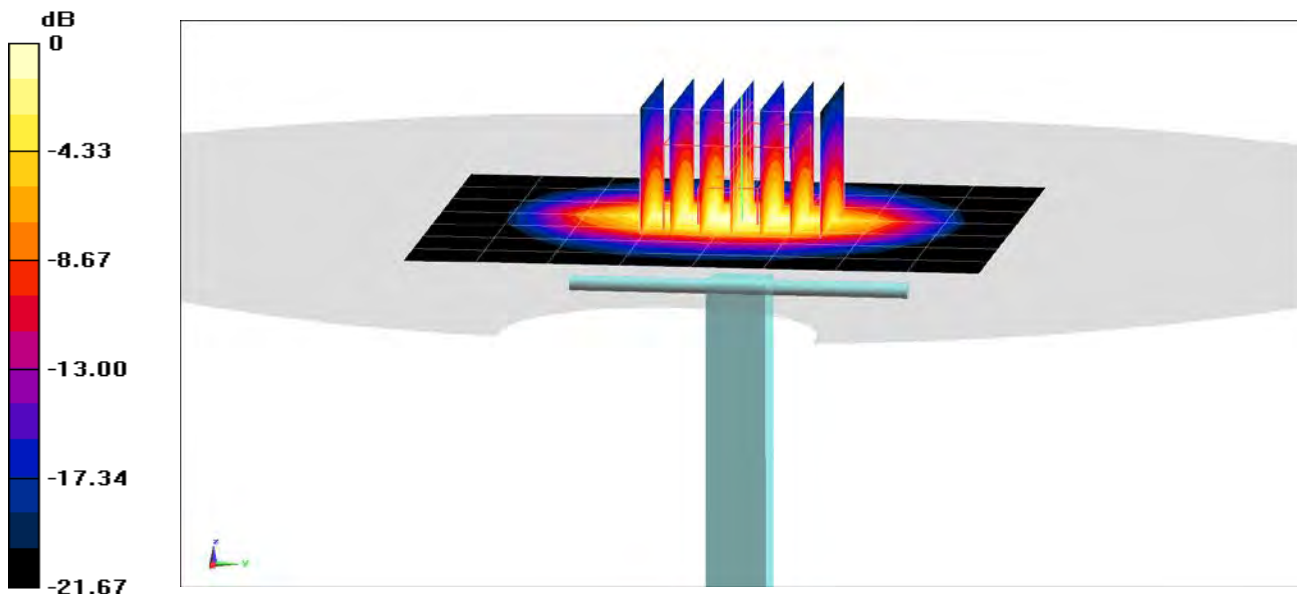

0 dB = 8.52 W/kg = 9.30 dBW/kg

PCTEST ENGINEERING LABORATORY, INC.

DUT: Dipole 2450 MHz; Type: D2450V2; Serial: 797

Communication System: UID 0, CW; Frequency: 2450 MHz; Duty Cycle: 1:1

Medium: 2450 Head Medium parameters used:

$f = 2450 \text{ MHz}$; $\sigma = 1.853 \text{ S/m}$; $\epsilon_r = 40.208$; $\rho = 1000 \text{ kg/m}^3$

Phantom section: Flat Section; Space: 1.0 cm

Test Date: 06-17-2019; Ambient Temp: 22.5°C; Tissue Temp: 20.5°C

Probe: EX3DV4 - SN3589; ConvF(6.46, 6.46, 6.46) @ 2450 MHz; Calibrated: 1/25/2019

Sensor-Surface: 1.4mm (Mechanical Surface Detection)

Electronics: DAE4 Sn1450; Calibrated: 8/22/2018

Phantom: Twin-SAM V5.0 (30); Type: QD 000 P40 CD; Serial: 1647

Measurement SW: DASY52, Version 52.10 (2); SEMCAD X Version 14.6.12 (7450)

2450 MHz System Verification at 20.0 dBm (100 mW)

Area Scan (8x9x1): Measurement grid: dx=12mm, dy=12mm

Zoom Scan (7x7x7)/Cube 0: Measurement grid: dx=5mm, dy=5mm, dz=5mm

Peak SAR (extrapolated) = 11.6 W/kg

SAR(1 g) = 5.39 W/kg

Deviation(1 g) = 2.28%

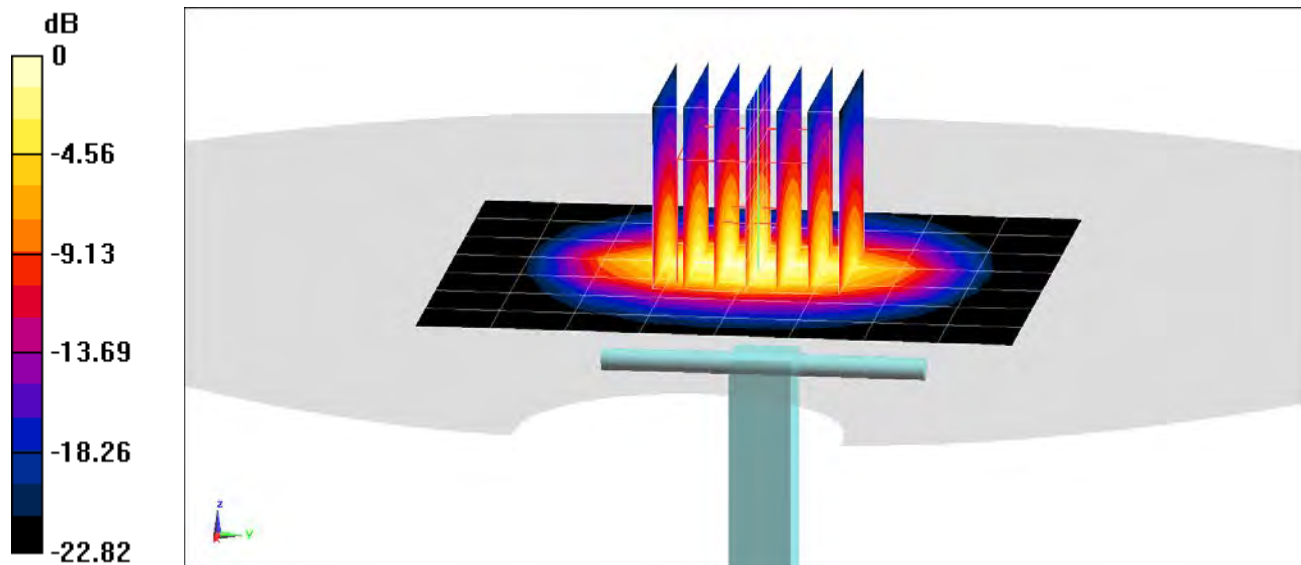

0 dB = 9.10 W/kg = 9.59 dBW/kg

PCTEST ENGINEERING LABORATORY, INC.

DUT: Dipole 2600 MHz; Type: D2600V2; Serial: 1071

Communication System: UID 0, CW; Frequency: 2600 MHz; Duty Cycle: 1:1

Medium: 2450 Head Medium parameters used:

$f = 2600 \text{ MHz}$; $\sigma = 1.963 \text{ S/m}$; $\epsilon_r = 37.947$; $\rho = 1000 \text{ kg/m}^3$

Phantom section: Flat Section; Space: 1.0 cm

Test Date: 05-30-2019; Ambient Temp: 22.7°C; Tissue Temp: 21.5°C

Probe: EX3DV4 - SN3589; ConvF(6.25, 6.25, 6.25) @ 2600 MHz; Calibrated: 1/25/2019

Sensor-Surface: 1.4mm (Mechanical Surface Detection)

Electronics: DAE4 Sn1450; Calibrated: 8/22/2018

Phantom: Twin-SAM V5.0 (30); Type: QD 000 P40 CD; Serial: 1647

Measurement SW: DASY52, Version 52.10 (2); SEMCAD X Version 14.6.12 (7450)

2600 MHz System Verification at 20.0 dBm (100 mW)

Area Scan (8x9x1): Measurement grid: dx=12mm, dy=12mm

Zoom Scan (7x7x7)/Cube 0: Measurement grid: dx=5mm, dy=5mm, dz=5mm

Peak SAR (extrapolated) = 13.2 W/kg

SAR(1 g) = 5.95 W/kg

Deviation(1 g) = 5.68%

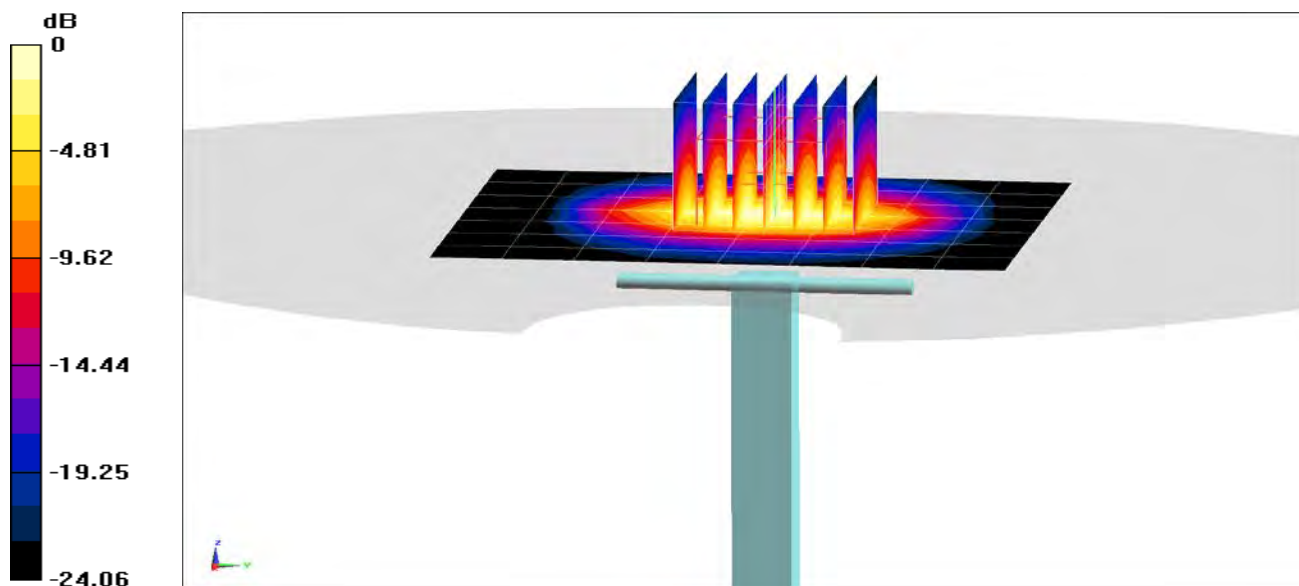

0 dB = 10.3 W/kg = 10.13 dBW/kg

PCTEST ENGINEERING LABORATORY, INC.

DUT: Dipole 2600 MHz; Type: D2600V2; Serial: 1071

Communication System: UID 0, CW; Frequency: 2600 MHz; Duty Cycle: 1:1

Medium: 2450 Head Medium parameters used:

$f = 2600 \text{ MHz}$; $\sigma = 1.972 \text{ S/m}$; $\epsilon_r = 37.919$; $\rho = 1000 \text{ kg/m}^3$

Phantom section: Flat Section; Space: 1.0 cm

Test Date: 06-03-2019; Ambient Temp: 22.5°C; Tissue Temp: 21.9°C

Probe: EX3DV4 - SN3589; ConvF(6.25, 6.25, 6.25) @ 2600 MHz; Calibrated: 1/25/2019

Sensor-Surface: 1.4mm (Mechanical Surface Detection)

Electronics: DAE4 Sn1450; Calibrated: 8/22/2018

Phantom: Twin-SAM V5.0 (30); Type: QD 000 P40 CD; Serial: 1647

Measurement SW: DASY52, Version 52.10 (2); SEMCAD X Version 14.6.12 (7450)

2600 MHz System Verification at 20.0 dBm (100 mW)

Area Scan (8x9x1): Measurement grid: dx=12mm, dy=12mm

Zoom Scan (7x7x7)/Cube 0: Measurement grid: dx=5mm, dy=5mm, dz=5mm

Peak SAR (extrapolated) = 12.8 W/kg

SAR(1 g) = 5.83 W/kg

Deviation(1 g) = 3.55%

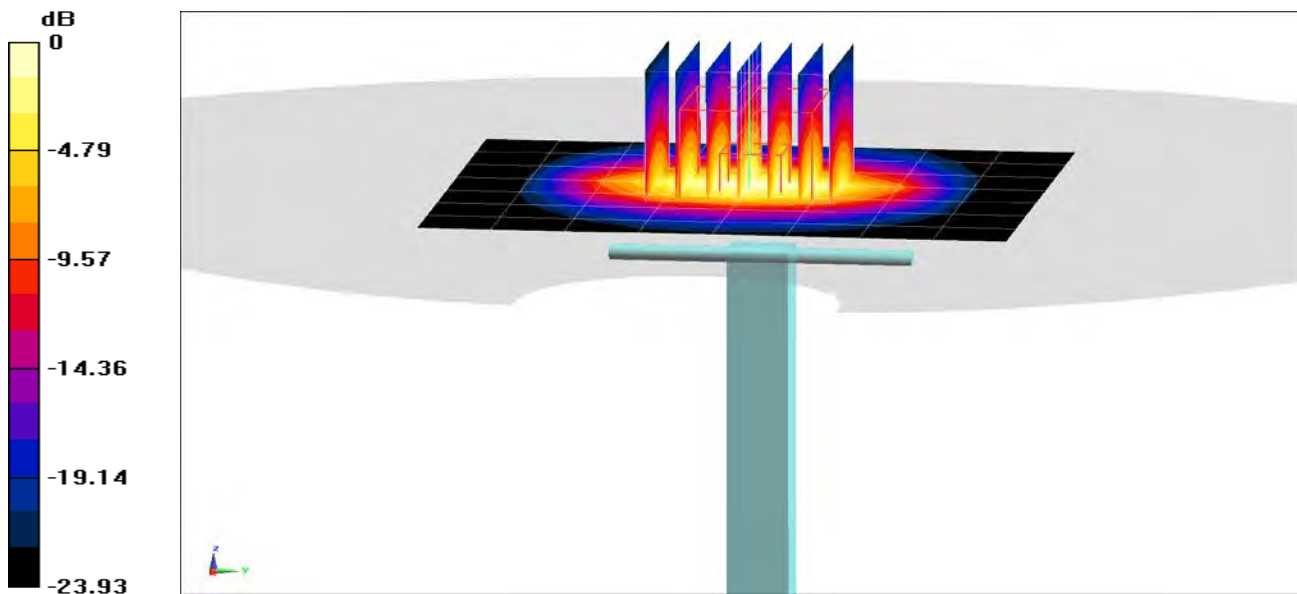

0 dB = 10.1 W/kg = 10.04 dBW/kg

PCTEST ENGINEERING LABORATORY, INC.

DUT: Dipole 3500 MHz; Type: D3500V2; Serial: 1055

Communication System: UID 0, CW; Frequency: 3500 MHz; Duty Cycle: 1:1

Medium: 3500 Head Medium parameters used:

$f = 3500 \text{ MHz}$; $\sigma = 2.781 \text{ S/m}$; $\epsilon_r = 39.174$; $\rho = 1000 \text{ kg/m}^3$

Phantom section: Flat Section; Space: 1.0 cm

Test Date: 06-13-2019; Ambient Temp: 24.0°C; Tissue Temp: 20.8°C

Probe: EX3DV4 - SN3589; ConvF(6.16, 6.16, 6.16) @ 3500 MHz; Calibrated: 1/25/2019

Sensor-Surface: 1.4mm (Mechanical Surface Detection)

Electronics: DAE4 Sn1450; Calibrated: 8/22/2018

Phantom: Twin-SAM V5.0 (30); Type: QD 000 P40 CD; Serial: 1647

Measurement SW: DASY52, Version 52.10 (2); SEMCAD X Version 14.6.12 (7450)

3500 MHz System Verification at 20.0 dBm (100 mW)

Area Scan (8x9x1): Measurement grid: dx=12mm, dy=12mm

Zoom Scan (7x7x8)/Cube 0: Measurement grid: dx=5mm, dy=5mm, dz=1.4mm; Graded Ratio: 1.4

Peak SAR (extrapolated) = 18.2 W/kg

SAR(1 g) = 6.61 W/kg

Deviation(1 g) = -1.05%

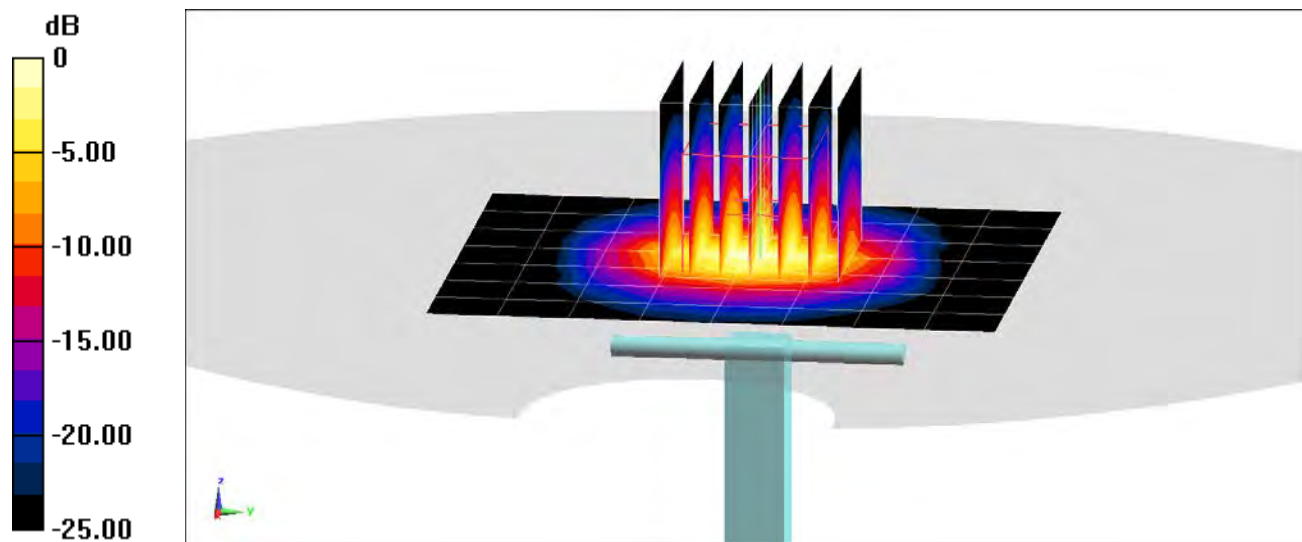

0 dB = 12.9 W/kg = 11.11 dBW/kg

PCTEST ENGINEERING LABORATORY, INC.

DUT: Dipole 5 GHz; Type: D5GHzV2; Serial: 1191

Communication System: UID 0, CW; Frequency: 5250 MHz; Duty Cycle: 1:1
Medium: 5GHz Head Medium parameters used (interpolated):
 $f = 5250 \text{ MHz}$; $\sigma = 4.589 \text{ S/m}$; $\epsilon_r = 34.819$; $\rho = 1000 \text{ kg/m}^3$
Phantom section: Flat Section; Space: 1.0 cm

Test Date: 06-10-2019; Ambient Temp: 21.6°C; Tissue Temp: 20.7°C

Probe: EX3DV4 - SN7406; ConvF(5.54, 5.54, 5.54) @ 5250 MHz; Calibrated: 5/16/2019
Sensor-Surface: 1.4mm (Mechanical Surface Detection)
Electronics: DAE4 Sn859; Calibrated: 5/8/2019
Phantom: SAM with CRP v5.0 (Right); Type: QD000P40CD; Serial: TP:1759
Measurement SW: DASY52, Version 52.10 (2);SEMCAD X Version 14.6.12 (7450)

5250 MHz System Verification at 17.0 dBm (50 mW)

Area Scan (7x7x1): Measurement grid: dx=10mm, dy=10mm

Zoom Scan (8x8x7)/Cube 0: Measurement grid: dx=4mm, dy=4mm, dz=1.4mm; Graded Ratio: 1.4

Peak SAR (extrapolated) = 16.2 W/kg

SAR(1 g) = 3.96 W/kg

Deviation(1 g) = 0.38%

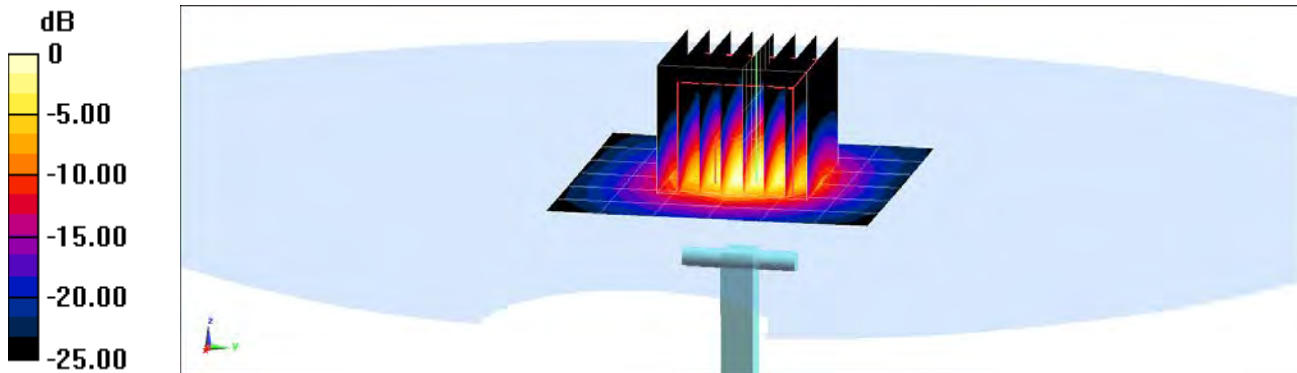

0 dB = 9.26 W/kg = 9.67 dBW/kg

PCTEST ENGINEERING LABORATORY, INC.

DUT: Dipole 5 GHz; Type: D5GHzV2; Serial: 1191

Communication System: UID 0, CW; Frequency: 5750 MHz; Duty Cycle: 1:1

Medium: 5GHz Head Medium parameters used (interpolated):

$f = 5750 \text{ MHz}$; $\sigma = 5.15 \text{ S/m}$; $\epsilon_r = 33.901$; $\rho = 1000 \text{ kg/m}^3$

Phantom section: Flat Section; Space: 1.0 cm

Test Date: 06-10-2019; Ambient Temp: 21.6°C; Tissue Temp: 20.7°C

Probe: EX3DV4 - SN7406; ConvF(5.23, 5.23, 5.23) @ 5750 MHz; Calibrated: 5/16/2019

Sensor-Surface: 1.4mm (Mechanical Surface Detection)

Electronics: DAE4 Sn859; Calibrated: 5/8/2019

Phantom: SAM with CRP v5.0 (Right); Type: QD000P40CD; Serial: TP:1759

Measurement SW: DASY52, Version 52.10 (2);SEMCAD X Version 14.6.12 (7450)

5750 MHz System Verification at 17.0 dBm (50 mW)

Area Scan (7x7x1): Measurement grid: dx=10mm, dy=10mm

Zoom Scan (8x8x7)/Cube 0: Measurement grid: dx=4mm, dy=4mm, dz=1.4mm; Graded Ratio: 1.4

Peak SAR (extrapolated) = 17.3 W/kg

SAR(1 g) = 3.77 W/kg

Deviation(1 g) = -4.68%

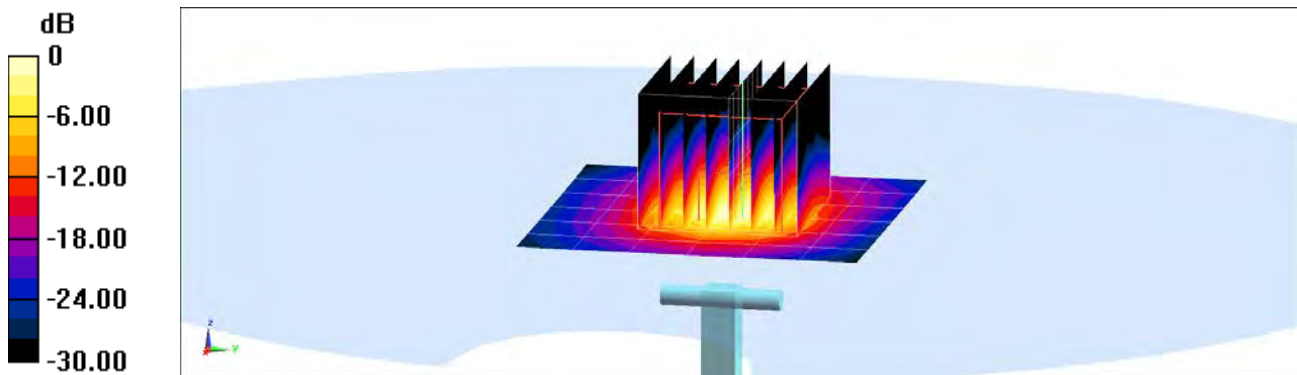

0 dB = 9.45 W/kg = 9.75 dBW/kg

PCTEST ENGINEERING LABORATORY, INC.

DUT: Dipole 750 MHz; Type: D750V3; Serial: 1003

Communication System: UID 0, CW; Frequency: 750 MHz; Duty Cycle: 1:1
Medium: 750 Body; Medium parameters used (interpolated):
 $f = 750 \text{ MHz}$; $\sigma = 0.939 \text{ S/m}$; $\epsilon_r = 56.998$; $\rho = 1000 \text{ kg/m}^3$
Phantom section: Flat Section; Space: 1.5 cm

Test Date: 05-22-2019; Ambient Temp: 23.4°C; Tissue Temp: 21.7°C

Probe: EX3DV4 - SN7357; ConvF(10.19, 10.19, 10.19) @ 750 MHz; Calibrated: 4/24/2019
Sensor-Surface: 1.4mm (Mechanical Surface Detection)
Electronics: DAE4 Sn1407; Calibrated: 4/18/2019
Phantom: Twin-SAM V4.0 Front Right; Type: QD 000 P40 CC; Serial: 1167
Measurement SW: DASY52, Version 52.10 (2);SEMCAD X Version 14.6.12 (7450)

750 MHz System Verification at 23.0 dBm (200 mW)

Area Scan (7x15x1): Measurement grid: dx=15mm, dy=15mm
Zoom Scan (5x5x7)/Cube 0: Measurement grid: dx=8mm, dy=8mm, dz=5mm
Peak SAR (extrapolated) = 2.52 W/kg
SAR(1 g) = 1.7 W/kg
Deviation(1 g) = -0.93%

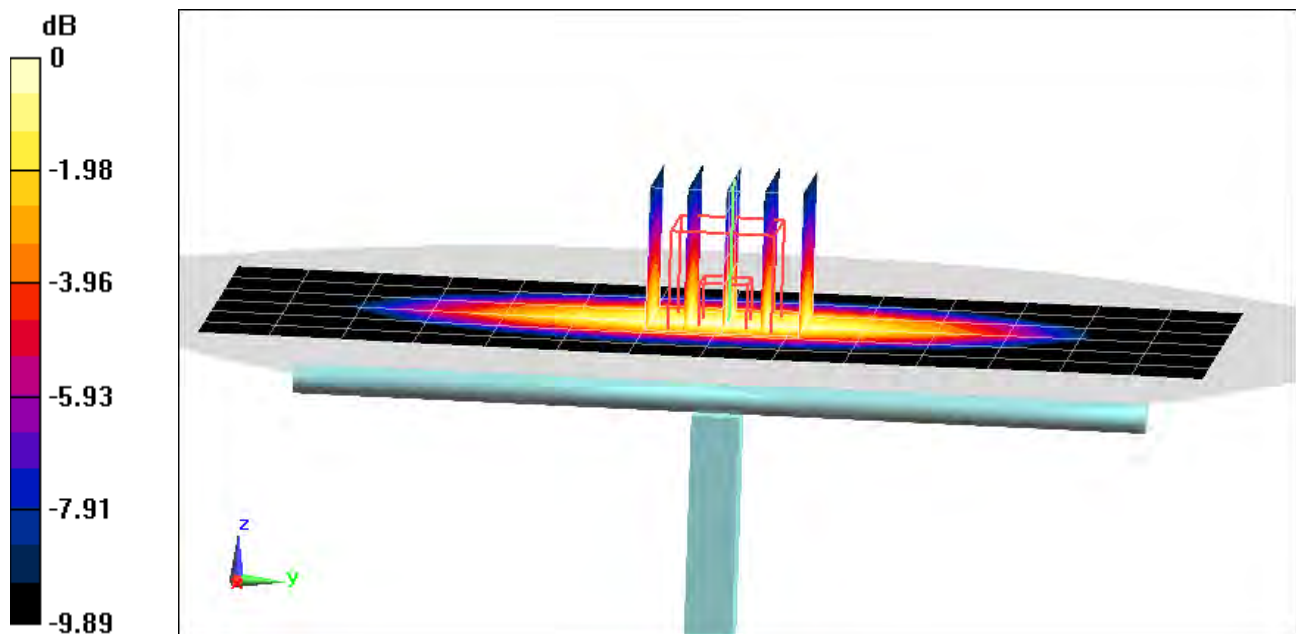

0 dB = 2.25 W/kg = 3.52 dBW/kg

PCTEST ENGINEERING LABORATORY, INC.

DUT: Dipole 835 MHz; Type: D835V2; Serial: 4d132

Communication System: UID 0, CW; Frequency: 835 MHz; Duty Cycle: 1:1

Medium: 835 Body Medium parameters used:

$f = 835 \text{ MHz}$; $\sigma = 0.998 \text{ S/m}$; $\epsilon_r = 53.285$; $\rho = 1000 \text{ kg/m}^3$

Phantom section: Flat Section; Space: 1.5 cm

Test Date: 05-22-2019; Ambient Temp: 19.8°C; Tissue Temp: 20.1°C

Probe: EX3DV4 - SN7488; ConvF(11.03, 11.03, 11.03) @ 835 MHz; Calibrated: 1/24/2019

Sensor-Surface: 1.4mm (Mechanical Surface Detection)

Electronics: DAE4 Sn1530; Calibrated: 1/15/2019

Phantom: Twin-SAM V5.0; Type: QD 000 P40 CD; Serial: 1800

Measurement SW: DASY52, Version 52.10 (2); SEMCAD X Version 14.6.12 (7450)

835 MHz System Verification at 23.0 dBm (200 mW)

Area Scan (7x14x1): Measurement grid: dx=15mm, dy=15mm

Zoom Scan (5x5x7)/Cube 0: Measurement grid: dx=8mm, dy=8mm, dz=5mm

Peak SAR (extrapolated) = 2.97 W/kg

SAR(1 g) = 1.94 W/kg

Deviation(1 g) = 0.31%

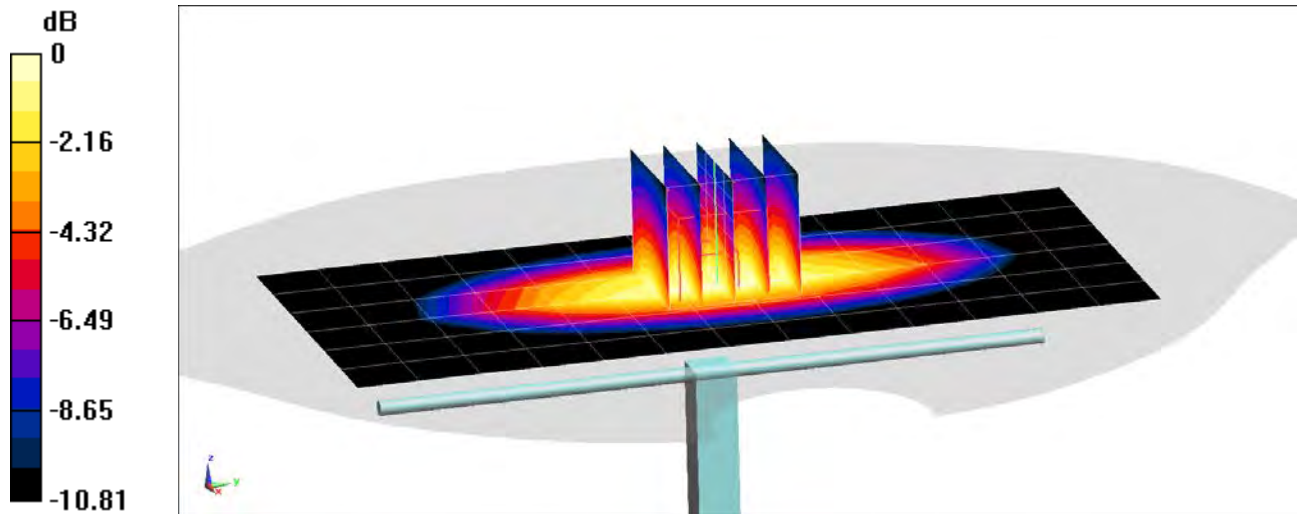

0 dB = 2.61 W/kg = 4.17 dBW/kg

PCTEST ENGINEERING LABORATORY, INC.

DUT: Dipole 835 MHz; Type: D835V2; Serial: 4d132

Communication System: UID 0, CW; Frequency: 835 MHz; Duty Cycle: 1:1

Medium: 835 Body Medium parameters used:

$f = 835 \text{ MHz}$; $\sigma = 0.987 \text{ S/m}$; $\epsilon_r = 53.895$; $\rho = 1000 \text{ kg/m}^3$

Phantom section: Flat Section; Space: 1.5 cm

Test Date: 05-27-2019; Ambient Temp: 20.2°C; Tissue Temp: 19.9°C

Probe: EX3DV4 - SN7488; ConvF(11.03, 11.03, 11.03) @ 835 MHz; Calibrated: 1/24/2019

Sensor-Surface: 1.4mm (Mechanical Surface Detection)

Electronics: DAE4 Sn1530; Calibrated: 1/15/2019

Phantom: Twin-SAM V5.0; Type: QD 000 P40 CD; Serial: 1800

Measurement SW: DASY52, Version 52.10 (2); SEMCAD X Version 14.6.12 (7450)

835 MHz System Verification at 23.0 dBm (200 mW)

Area Scan (7x14x1): Measurement grid: dx=15mm, dy=15mm

Zoom Scan (5x5x7)/Cube 0: Measurement grid: dx=8mm, dy=8mm, dz=5mm

Peak SAR (extrapolated) = 3.03 W/kg

SAR(1 g) = 1.98 W/kg

Deviation(1 g) = 2.38%

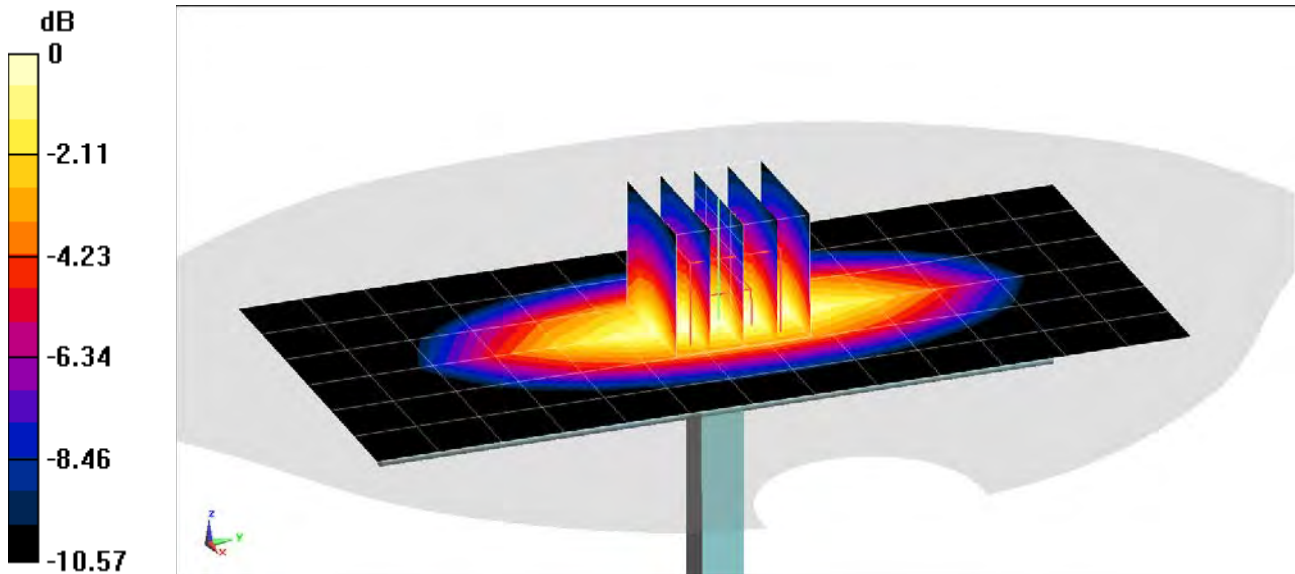

0 dB = 2.66 W/kg = 4.25 dBW/kg

PCTEST ENGINEERING LABORATORY, INC.

DUT: Dipole 835 MHz; Type: D835V2; Serial: 4d133

Communication System: UID 0, CW; Frequency: 835 MHz; Duty Cycle: 1:1

Medium: 835 Body Medium parameters used:

$f = 835 \text{ MHz}$; $\sigma = 0.999 \text{ S/m}$; $\epsilon_r = 52.819$; $\rho = 1000 \text{ kg/m}^3$

Phantom section: Flat Section; Space: 1.5 cm

Test Date: 05-30-2019; Ambient Temp: 20.1°C; Tissue Temp: 20.3°C

Probe: EX3DV4 - SN7488; ConvF(11.03, 11.03, 11.03) @ 835 MHz; Calibrated: 1/24/2019

Sensor-Surface: 1.4mm (Mechanical Surface Detection)

Electronics: DAE4 Sn1530; Calibrated: 1/15/2019

Phantom: Twin-SAM V5.0; Type: QD 000 P40 CD; Serial: 1800

Measurement SW: DASY52, Version 52.10 (2);SEMCAD X Version 14.6.12 (7450)

835 MHz System Verification at 23.0 dBm (200 mW)

Area Scan (7x14x1): Measurement grid: dx=15mm, dy=15mm

Zoom Scan (5x5x7)/Cube 0: Measurement grid: dx=8mm, dy=8mm, dz=5mm

Peak SAR (extrapolated) = 3.04 W/kg

SAR(1 g) = 1.98 W/kg

Deviation(1 g) = 1.54%

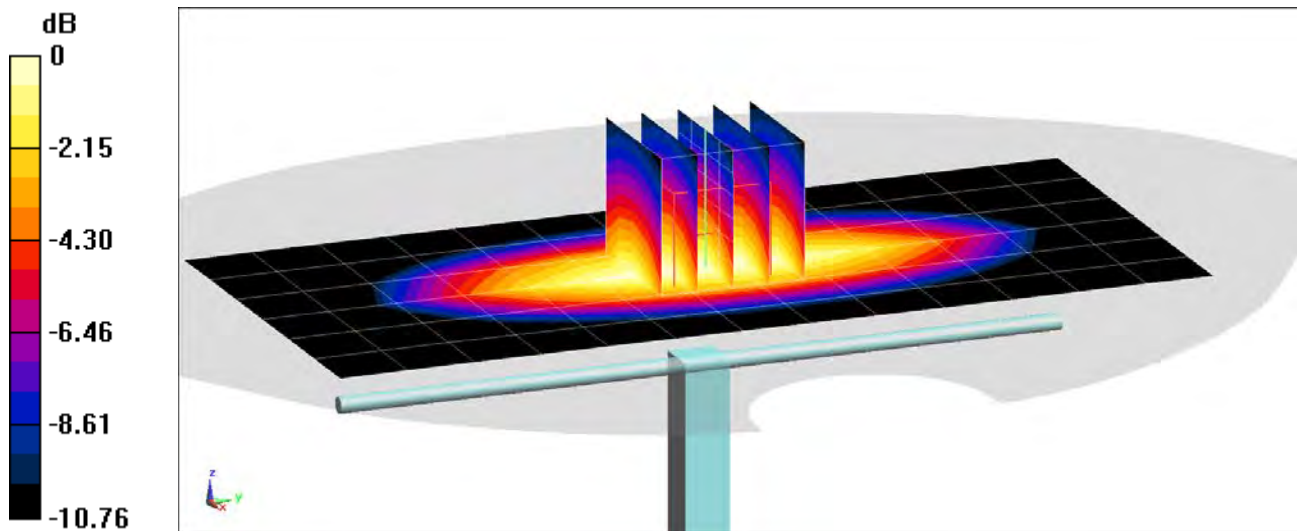

0 dB = 2.67 W/kg = 4.27 dBW/kg

PCTEST ENGINEERING LABORATORY, INC.

DUT: Dipole 835 MHz; Type: D835V2; Serial: 4d132

Communication System: UID 0, CW; Frequency: 835 MHz; Duty Cycle: 1:1

Medium: 835 Body Medium parameters used:

$f = 835 \text{ MHz}$; $\sigma = 0.983 \text{ S/m}$; $\epsilon_r = 54.072$; $\rho = 1000 \text{ kg/m}^3$

Phantom section: Flat Section; Space: 1.5 cm

Test Date: 06-10-2019; Ambient Temp: 20.5°C; Tissue Temp: 20.0°C

Probe: EX3DV4 - SN7488; ConvF(11.03, 11.03, 11.03) @ 835 MHz; Calibrated: 1/24/2019

Sensor-Surface: 1.4mm (Mechanical Surface Detection)

Electronics: DAE4 Sn1530; Calibrated: 1/15/2019

Phantom: Twin-SAM V5.0; Type: QD 000 P40 CD; Serial: 1800

Measurement SW: DASY52, Version 52.10 (2);SEMCAD X Version 14.6.12 (7450)

835 MHz System Verification at 23.0 dBm (200 mW)

Area Scan (7x14x1): Measurement grid: dx=15mm, dy=15mm

Zoom Scan (5x5x7)/Cube 0: Measurement grid: dx=8mm, dy=8mm, dz=5mm

Peak SAR (extrapolated) = 2.99 W/kg

SAR(1 g) = 1.9 W/kg

Deviation(1 g) = -1.76%

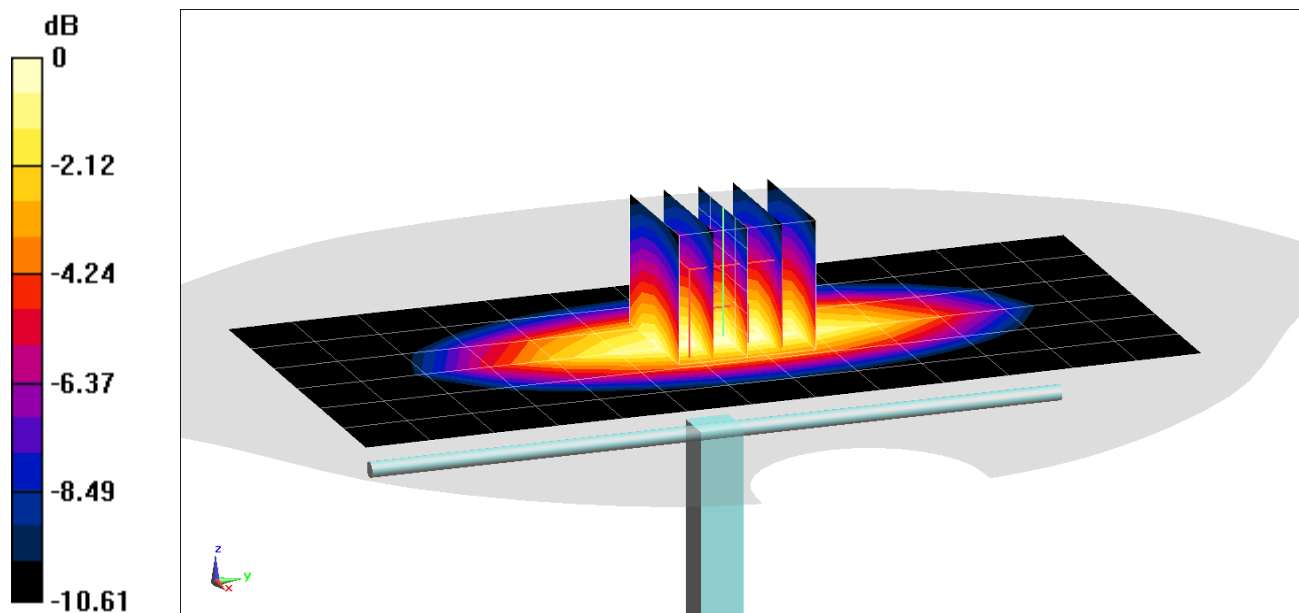

0 dB = 2.59 W/kg = 4.13 dBW/kg

PCTEST ENGINEERING LABORATORY, INC.

DUT: Dipole 835 MHz; Type: D835V2; Serial: 4d132

Communication System: UID 0, CW; Frequency: 835 MHz; Duty Cycle: 1:1

Medium: 835 Body; Medium parameters used:

$f = 835 \text{ MHz}$; $\sigma = 0.945 \text{ S/m}$; $\epsilon_r = 52.698$; $\rho = 1000 \text{ kg/m}^3$

Phantom section: Flat Section; Space: 1.5 cm

Test Date: 06-18-2019; Ambient Temp: 22.4°C; Tissue Temp: 21.8°C

Probe: EX3DV4 - SN3914; ConvF(9.46, 9.46, 9.46) @ 835 MHz; Calibrated: 2/19/2019

Sensor-Surface: 1.4mm (Mechanical Surface Detection)

Electronics: DAE4 Sn1272; Calibrated: 2/14/2019

Phantom: SAM with CRP v5.0 Left; Type: QD000P40CD; Serial: 1687

Measurement SW: DASY52, Version 52.10 (2);SEMCAD X Version 14.6.12 (7450)

835 MHz System Verification at 23.0 dBm (200 mW)

Area Scan (7x14x1): Measurement grid: dx=15mm, dy=15mm

Zoom Scan (5x5x7)/Cube 0: Measurement grid: dx=8mm, dy=8mm, dz=5mm

Peak SAR (extrapolated) = 3.15 W/kg

SAR(1 g) = 2.05 W/kg

Deviation(1 g) = 6.00%

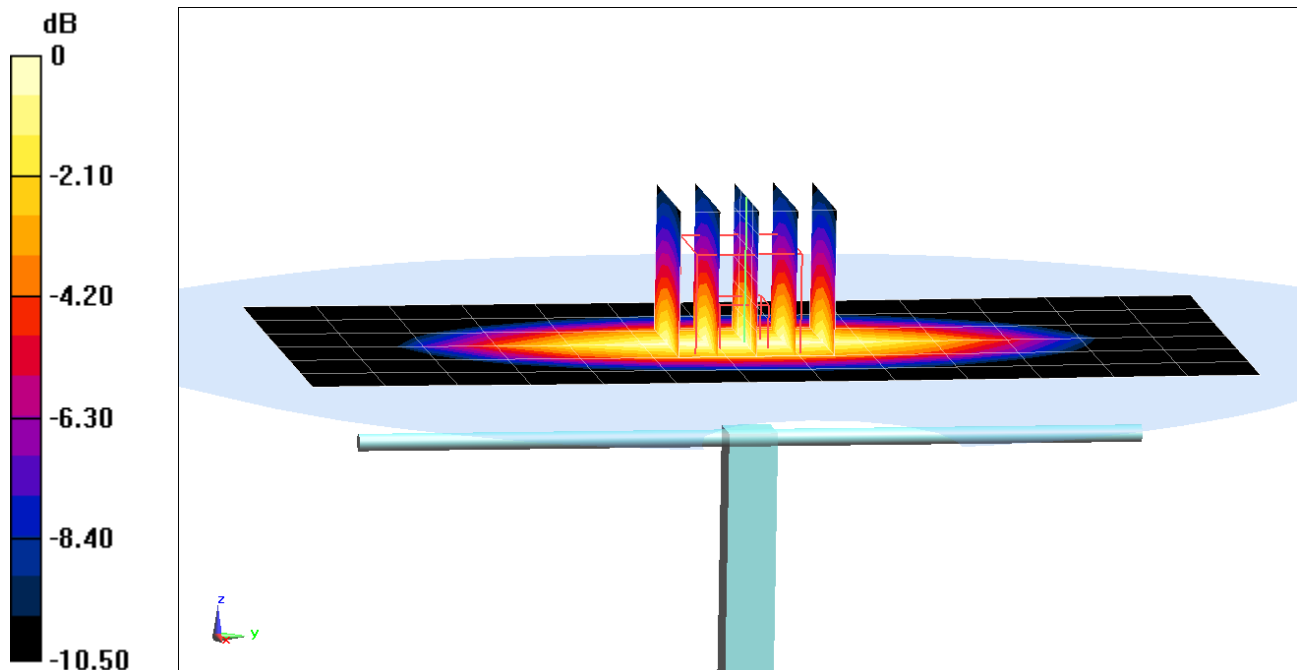

0 dB = 2.77 W/kg = 4.42 dBW/kg

PCTEST ENGINEERING LABORATORY, INC.

DUT: Dipole 1750 MHz; Type: D1765V2; Serial: 1008

Communication System: UID 0, CW; Frequency: 1750 MHz; Duty Cycle: 1:1

Medium: 1750 Body Medium parameters used:

$f = 1750 \text{ MHz}$; $\sigma = 1.505 \text{ S/m}$; $\epsilon_r = 52.123$; $\rho = 1000 \text{ kg/m}^3$

Phantom section: Flat Section; Space: 1.0 cm

Test Date: 06-05-2019; Ambient Temp: 23.1°C; Tissue Temp: 22.3°C

Probe: EX3DV4 - SN3914; ConvF(7.89, 7.89, 7.89) @ 1750 MHz; Calibrated: 2/19/2019

Sensor-Surface: 1.4mm (Mechanical Surface Detection)

Electronics: DAE4 Sn1272; Calibrated: 2/14/2019

Phantom: SAM with CRP v5.0 Front; Type: QD000P40CD; Serial: 1646

Measurement SW: DASY52, Version 52.10 (2);SEMCAD X Version 14.6.12 (7450)

1750 MHz System Verification at 20.0 dBm (100 mW)

Area Scan (7x9x1): Measurement grid: dx=15mm, dy=15mm

Zoom Scan (5x5x7)/Cube 0: Measurement grid: dx=8mm, dy=8mm, dz=5mm

Peak SAR (extrapolated) = 7.35 W/kg

SAR(1 g) = 3.94 W/kg; SAR(10 g) = 2.07 W/kg

Deviation(1 g) = 5.35%; Deviation(10 g) = 4.02%

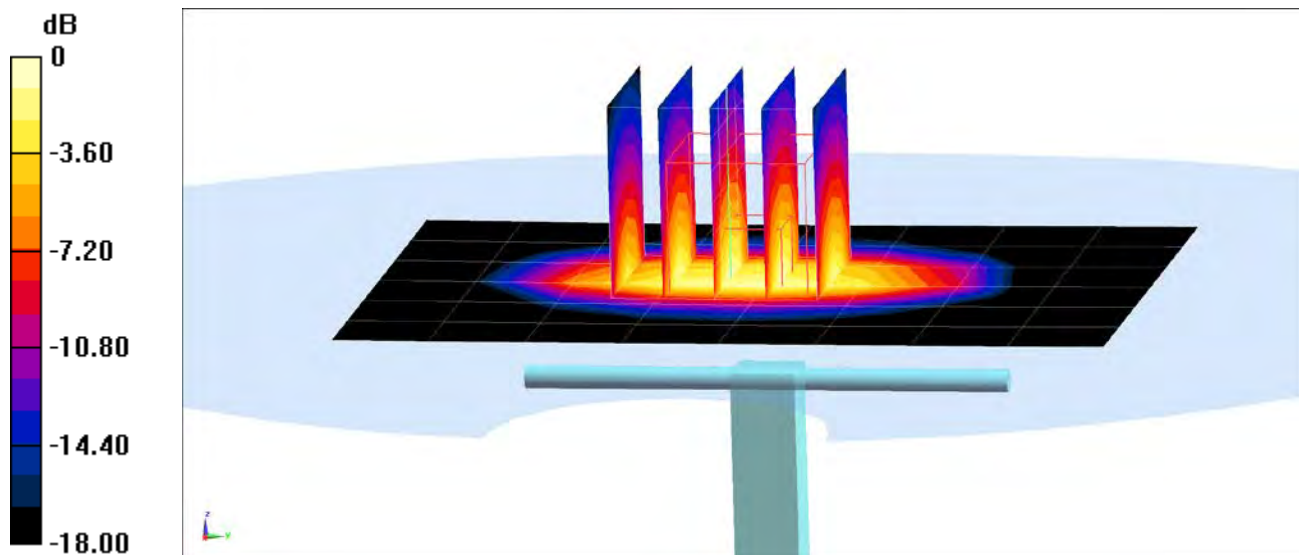

0 dB = 6.04 W/kg = 7.81 dBW/kg

PCTEST ENGINEERING LABORATORY, INC.

DUT: Dipole 1750 MHz; Type: D1765V2; Serial: 1008

Communication System: UID 0, CW; Frequency: 1750 MHz; Duty Cycle: 1:1

Medium: 1750 Body Medium parameters used:

$f = 1750 \text{ MHz}$; $\sigma = 1.515 \text{ S/m}$; $\epsilon_r = 52.021$; $\rho = 1000 \text{ kg/m}^3$

Phantom section: Flat Section; Space: 1.0 cm

Test Date: 06-08-2019; Ambient Temp: 22.7°C; Tissue Temp: 21.8°C

Probe: EX3DV4 - SN3914; ConvF(7.89, 7.89, 7.89) @ 1750 MHz; Calibrated: 2/19/2019

Sensor-Surface: 1.4mm (Mechanical Surface Detection)

Electronics: DAE4 Sn1272; Calibrated: 2/14/2019

Phantom: SAM with CRP v5.0 Front; Type: QD000P40CD; Serial: 1646

Measurement SW: DASY52, Version 52.10 (2);SEMCAD X Version 14.6.12 (7450)

1750 MHz System Verification at 20.0 dBm (100 mW)

Area Scan (7x9x1): Measurement grid: dx=15mm, dy=15mm

Zoom Scan (5x5x7)/Cube 0: Measurement grid: dx=8mm, dy=8mm, dz=5mm

Peak SAR (extrapolated) = 7.30 W/kg

SAR(1 g) = 3.94 W/kg

Deviation(1 g) = 5.35%

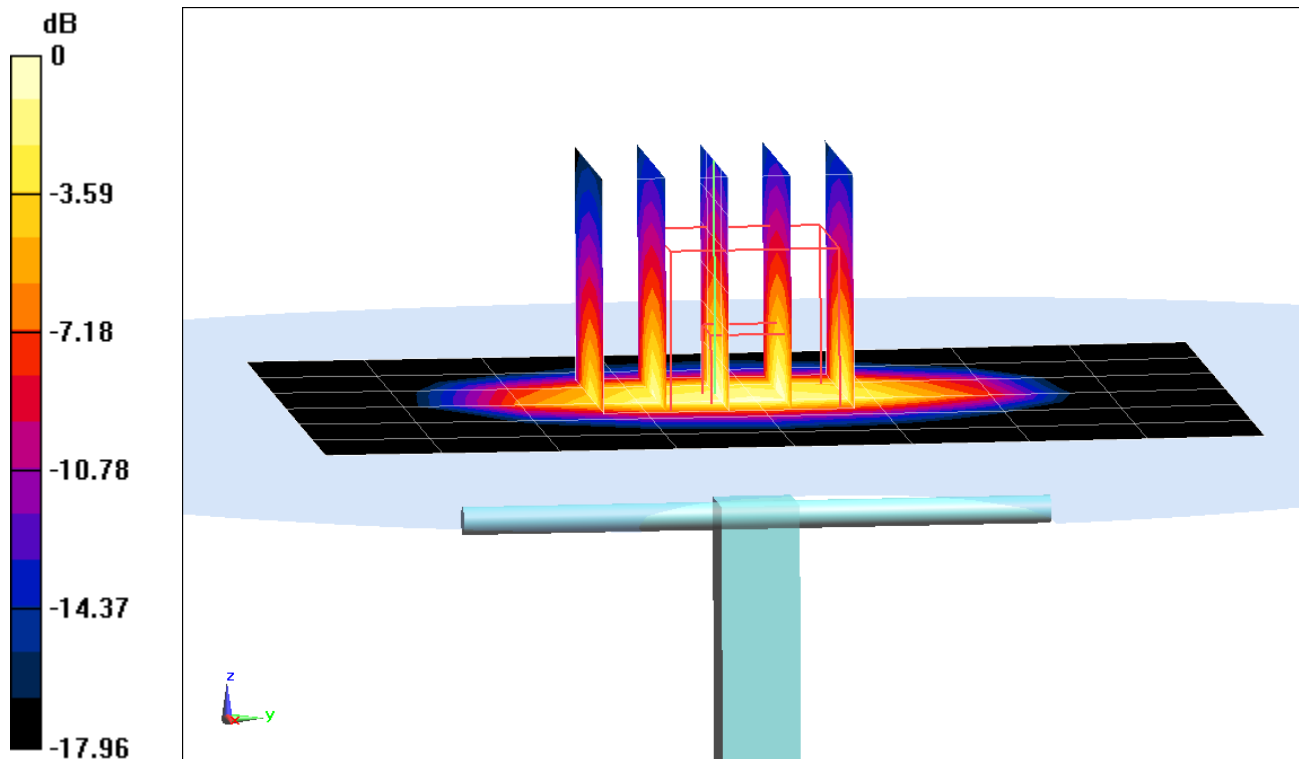

0 dB = 5.66 W/kg = 7.53 dBW/kg

PCTEST ENGINEERING LABORATORY, INC.

DUT: Dipole 1750 MHz; Type: D1765V2; Serial: 1008

Communication System: UID 0, CW; Frequency: 1750 MHz; Duty Cycle: 1:1

Medium: 1750 Body Medium parameters used:

$f = 1750 \text{ MHz}$; $\sigma = 1.505 \text{ S/m}$; $\epsilon_r = 51.713$; $\rho = 1000 \text{ kg/m}^3$

Phantom section: Flat Section; Space: 1.0 cm

Test Date: 06-17-2019; Ambient Temp: 20.1°C; Tissue Temp: 20.0°C

Probe: EX3DV4 - SN7488; ConvF(8.68, 8.68, 8.68) @ 1750 MHz; Calibrated: 1/24/2019

Sensor-Surface: 1.4mm (Mechanical Surface Detection)

Electronics: DAE4 Sn1530; Calibrated: 1/15/2019

Phantom: Twin-SAM V5.0; Type: QD 000 P40 CD; Serial: 1800

Measurement SW: DASY52, Version 52.10 (2);SEMCAD X Version 14.6.12 (7450)

1750 MHz System Verification at 20.0 dBm (100 mW)

Area Scan (7x9x1): Measurement grid: dx=15mm, dy=15mm

Zoom Scan (5x5x7)/Cube 0: Measurement grid: dx=8mm, dy=8mm, dz=5mm

Peak SAR (extrapolated) = 7.31 W/kg

SAR(1 g) = 4.02 W/kg

Deviation(1 g) = 7.49%

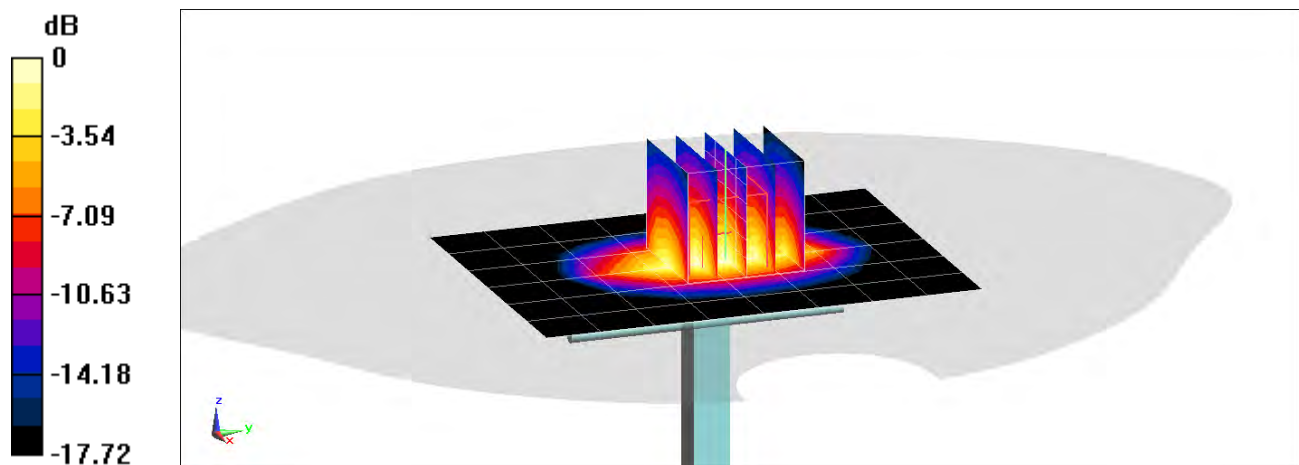

0 dB = 6.12 W/kg = 7.87 dBW/kg

PCTEST ENGINEERING LABORATORY, INC.

DUT: Dipole 1750 MHz; Type: D1750V2; Serial: 1150

Communication System: UID 0, CW; Frequency: 1750 MHz; Duty Cycle: 1:1

Medium: 1750 Body; Medium parameters used:

$f = 1750 \text{ MHz}$; $\sigma = 1.42 \text{ S/m}$; $\epsilon_r = 55.258$; $\rho = 1000 \text{ kg/m}^3$

Phantom section: Flat Section; Space: 1.0 cm

Test Date: 06-19-2019; Ambient Temp: 22.2°C; Tissue Temp: 22.5°C

Probe: EX3DV4 - SN7357; ConvF(8.26, 8.26, 8.26) @ 1750 MHz; Calibrated: 4/24/2019

Sensor-Surface: 1.4mm (Mechanical Surface Detection)

Electronics: DAE4 Sn1407; Calibrated: 4/18/2019

Phantom: Twin-SAM V4.0 Front Right; Type: QD 000 P40 CC; Serial: 1167

Measurement SW: DASY52, Version 52.10 (2);SEMCAD X Version 14.6.12 (7450)

1750 MHz System Verification at 20.0 dBm (100 mW)

Area Scan (7x9x1): Measurement grid: dx=15mm, dy=15mm

Zoom Scan (5x5x7)/Cube 0: Measurement grid: dx=8mm, dy=8mm, dz=5mm

Peak SAR (extrapolated) = 6.85 W/kg

SAR(10 g) = 2.06 W/kg

Deviation(10 g) = 6.19%

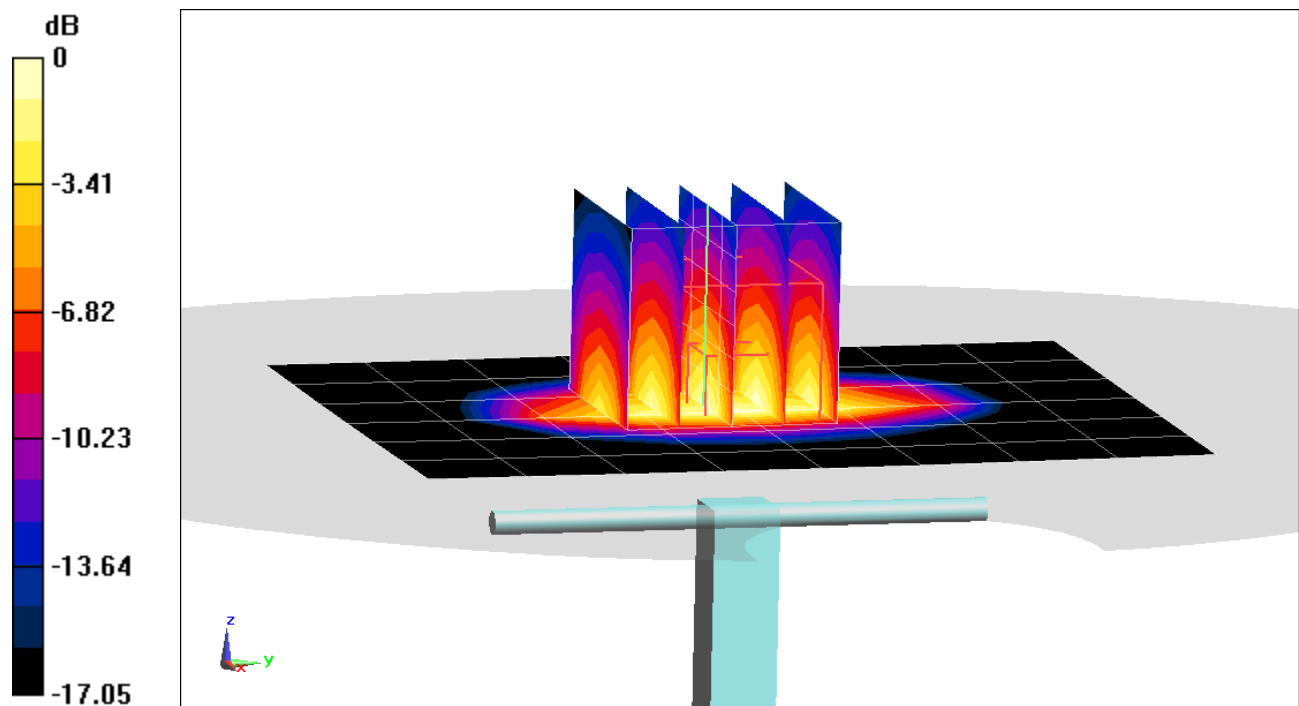

0 dB = 5.72 W/kg = 7.57 dBW/kg

PCTEST ENGINEERING LABORATORY, INC.

DUT: Dipole 1900 MHz; Type: D1900V2; Serial: 5d148

Communication System: UID 0, CW; Frequency: 1900 MHz; Duty Cycle: 1:1

Medium: 1900 Body Medium parameters used (interpolated):

$f = 1900 \text{ MHz}$; $\sigma = 1.584 \text{ S/m}$; $\epsilon_r = 52.248$; $\rho = 1000 \text{ kg/m}^3$

Phantom section: Flat Section; Space: 1.0 cm

Test Date: 05-29-2019; Ambient Temp: 23.1°C; Tissue Temp: 21.6°C

Probe: EX3DV4 - SN7410; ConvF(7.78, 7.78, 7.78) @ 1900 MHz; Calibrated: 7/20/2018

Sensor-Surface: 1.4mm (Mechanical Surface Detection)

Electronics: DAE4 Sn1322; Calibrated: 7/11/2018

Phantom: Front; Type: QD 000 P40 CD; Serial: 1686

Measurement SW: DASY52, Version 52.10 (2);SEMCAD X Version 14.6.12 (7450)

1900 MHz System Verification at 20.0 dBm (100 mW)

Area Scan (7x11x1): Measurement grid: dx=15mm, dy=15mm

Zoom Scan (7x6x7)/Cube 0: Measurement grid: dx=8mm, dy=8mm, dz=5mm

Peak SAR (extrapolated) = 7.75 W/kg

SAR(1 g) = 4.22 W/kg

Deviation(1 g) = 7.93%

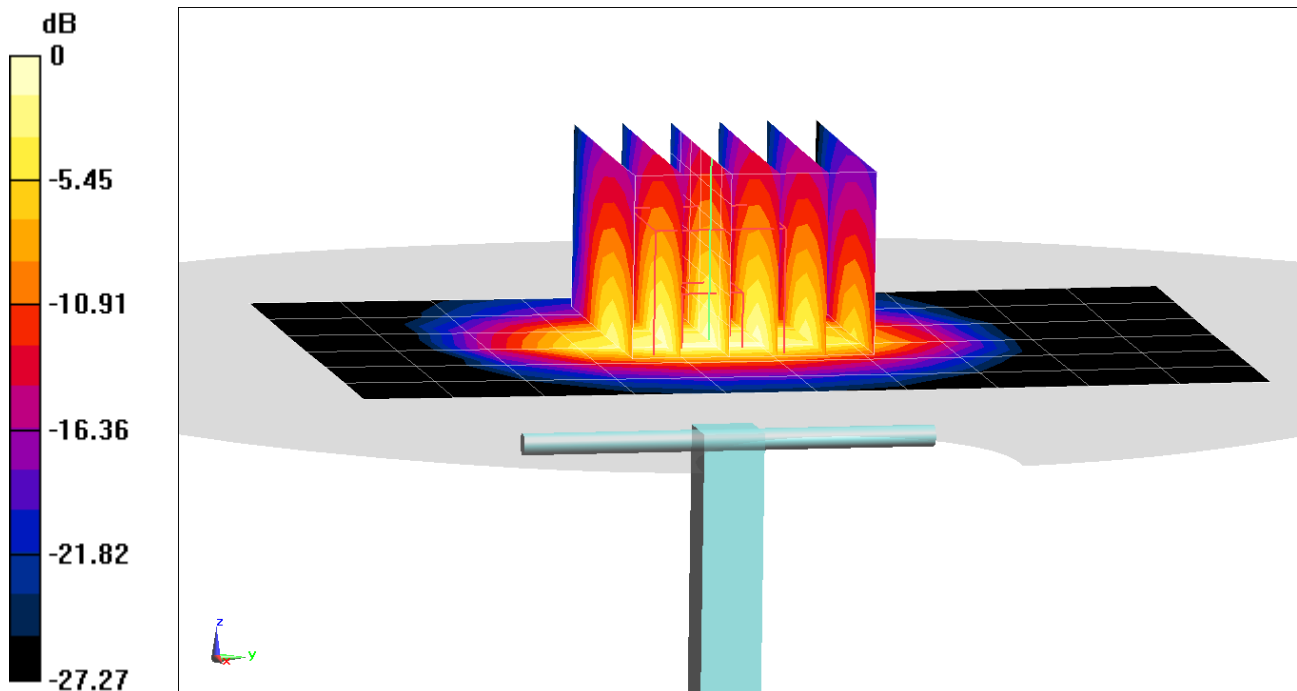

0 dB = 6.58 W/kg = 8.18 dBW/kg

PCTEST ENGINEERING LABORATORY, INC.

DUT: Dipole 1900 MHz; Type: D1900V2; Serial: 5d148

Communication System: UID 0, CW; Frequency: 1900 MHz; Duty Cycle: 1:1

Medium: 1900 Body Medium parameters used (interpolated):

$f = 1900 \text{ MHz}$; $\sigma = 1.577 \text{ S/m}$; $\epsilon_r = 52.841$; $\rho = 1000 \text{ kg/m}^3$

Phantom section: Flat Section; Space: 1.0 cm

Test Date: 06-03-2019; Ambient Temp: 21.9°C; Tissue Temp: 22.3°C

Probe: EX3DV4 - SN7410; ConvF(7.78, 7.78, 7.78) @ 1900 MHz; Calibrated: 7/20/2018

Sensor-Surface: 1.4mm (Mechanical Surface Detection)

Electronics: DAE4 Sn1322; Calibrated: 7/11/2018

Phantom: Front; Type: QD 000 P40 CD; Serial: 1686

Measurement SW: DASY52, Version 52.10 (2); SEMCAD X Version 14.6.12 (7450)

1900 MHz System Verification at 20.0 dBm (100 mW)

Area Scan (7x11x1): Measurement grid: dx=15mm, dy=15mm

Zoom Scan (5x5x7)/Cube 0: Measurement grid: dx=8mm, dy=8mm, dz=5mm

Peak SAR (extrapolated) = 7.74 W/kg

SAR(1 g) = 4.21 W/kg; SAR(10 g) = 2.17 W/kg

Deviation(1 g) = 7.67%; Deviation(10 g) = 5.85%

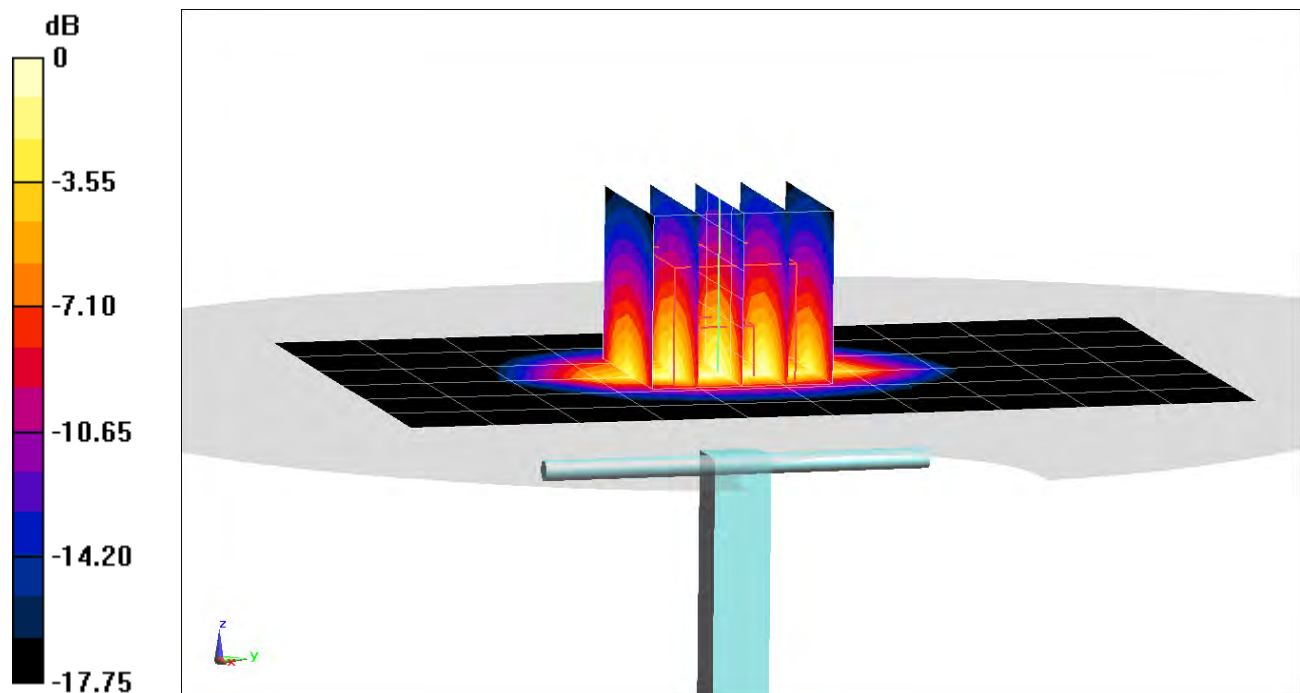

0 dB = 6.56 W/kg = 8.17 dBW/kg

PCTEST ENGINEERING LABORATORY, INC.

DUT: Dipole 1900 MHz; Type: D1900V2; Serial: 5d148

Communication System: UID 0, CW; Frequency: 1900 MHz; Duty Cycle: 1:1

Medium: 1900 Body Medium parameters used (interpolated):

$f = 1900 \text{ MHz}$; $\sigma = 1.571 \text{ S/m}$; $\epsilon_r = 51.911$; $\rho = 1000 \text{ kg/m}^3$

Phantom section: Flat Section; Space: 1.0 cm

Test Date: 06-05-2019; Ambient Temp: 22.8°C; Tissue Temp: 23.5°C

Probe: EX3DV4 - SN7410; ConvF(7.78, 7.78, 7.78) @ 1900 MHz; Calibrated: 7/20/2018

Sensor-Surface: 1.4mm (Mechanical Surface Detection)

Electronics: DAE4 Sn1322; Calibrated: 7/11/2018

Phantom: Front; Type: QD 000 P40 CD; Serial: 1686

Measurement SW: DASY52, Version 52.10 (2); SEMCAD X Version 14.6.12 (7450)

1900 MHz System Verification at 20.0 dBm (100 mW)

Area Scan (7x11x1): Measurement grid: dx=15mm, dy=15mm

Zoom Scan (5x5x7)/Cube 0: Measurement grid: dx=8mm, dy=8mm, dz=5mm

Peak SAR (extrapolated) = 7.78 W/kg

SAR(1 g) = 4.22 W/kg; SAR(10 g) = 2.18 W/kg

Deviation(1 g) = 7.93%; Deviation(10 g) = 6.34%

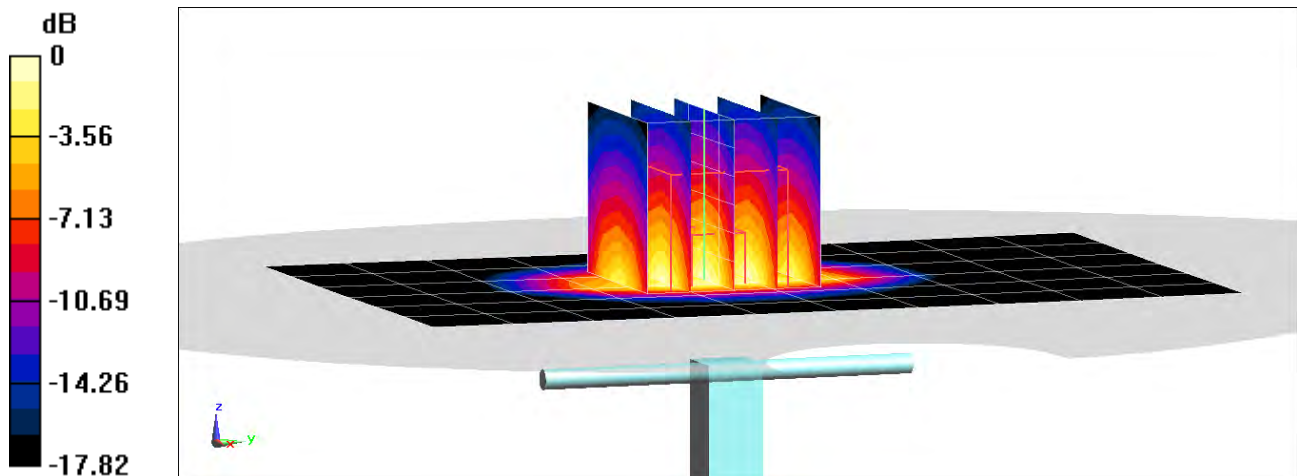

0 dB = 6.56 W/kg = 8.17 dBW/kg

PCTEST ENGINEERING LABORATORY, INC.

DUT: Dipole 1900 MHz; Type: D1900V2; Serial: 5d148

Communication System: UID 0, CW; Frequency: 1900 MHz; Duty Cycle: 1:1

Medium: 1900 Body Medium parameters used (interpolated):

$f = 1900$ MHz; $\sigma = 1.568$ S/m; $\epsilon_r = 52.247$; $\rho = 1000$ kg/m³

Phantom section: Flat Section; Space: 1.0 cm

Test Date: 06-07-2019; Ambient Temp: 22.2°C; Tissue Temp: 22.5°C

Probe: EX3DV4 - SN7410; ConvF(7.78, 7.78, 7.78) @ 1900 MHz; Calibrated: 7/20/2018

Sensor-Surface: 1.4mm (Mechanical Surface Detection)

Electronics: DAE4 Sn1322; Calibrated: 7/11/2018

Phantom: Front; Type: QD 000 P40 CD; Serial: 1686

Measurement SW: DASY52, Version 52.10 (2);SEMCAD X Version 14.6.12 (7450)

1900 MHz System Verification at 20.0 dBm (100 mW)

Area Scan (7x11x1): Measurement grid: dx=15mm, dy=15mm

Zoom Scan (5x5x7)/Cube 0: Measurement grid: dx=8mm, dy=8mm, dz=5mm

Peak SAR (extrapolated) = 7.28 W/kg

SAR(1 g) = 4 W/kg; SAR(10 g) = 2.07 W/kg

Deviation(1 g) = 2.30%; Deviation(10 g) = 0.98%

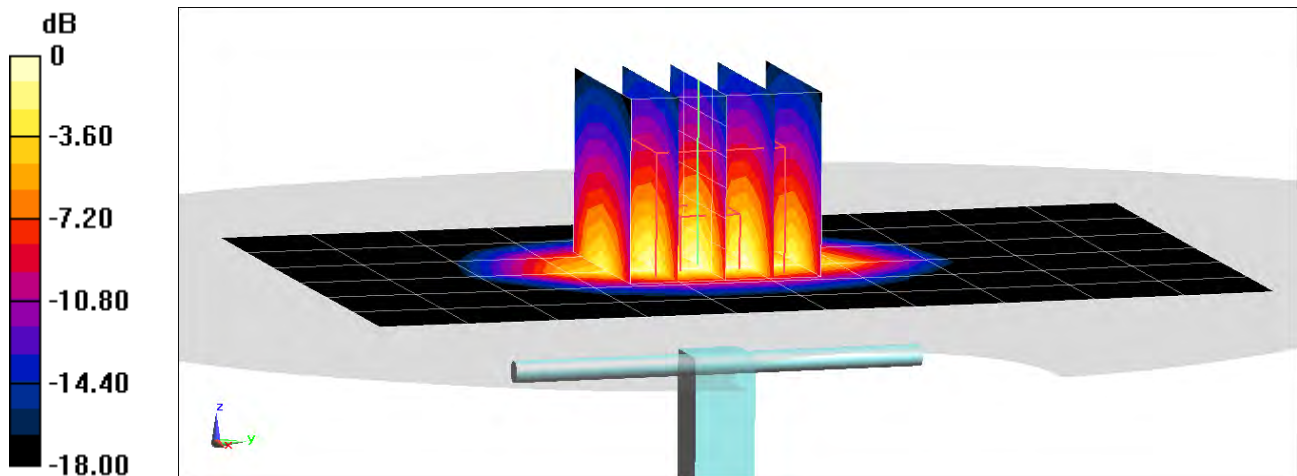

0 dB = 6.18 W/kg = 7.91 dBW/kg

PCTEST ENGINEERING LABORATORY, INC.

DUT: Dipole 1900 MHz; Type: D1900V2; Serial: 5d149

Communication System: UID 0, CW; Frequency: 1900 MHz; Duty Cycle: 1:1

Medium: 1900 Body Medium parameters used (interpolated):

$f = 1900$ MHz; $\sigma = 1.564$ S/m; $\epsilon_r = 51.734$; $\rho = 1000$ kg/m³

Phantom section: Flat Section; Space: 1.0 cm

Test Date: 06-12-2019; Ambient Temp: 22.6°C; Tissue Temp: 22.0°C

Probe: EX3DV4 - SN7410; ConvF(7.78, 7.78, 7.78) @ 1900 MHz; Calibrated: 7/20/2018

Sensor-Surface: 1.4mm (Mechanical Surface Detection)

Electronics: DAE4 Sn1322; Calibrated: 7/11/2018

Phantom: Front; Type: QD 000 P40 CD; Serial: 1686

Measurement SW: DASY52, Version 52.10 (2); SEMCAD X Version 14.6.12 (7450)

1900 MHz System Verification at 20.0 dBm (100 mW)

Area Scan (7x11x1): Measurement grid: dx=15mm, dy=15mm

Zoom Scan (5x5x7)/Cube 0: Measurement grid: dx=8mm, dy=8mm, dz=5mm

Peak SAR (extrapolated) = 7.41 W/kg

SAR(1 g) = 3.98 W/kg; SAR(10 g) = 2.05 W/kg

Deviation(1 g) = 1.02%; Deviation(10 g) = -0.97%

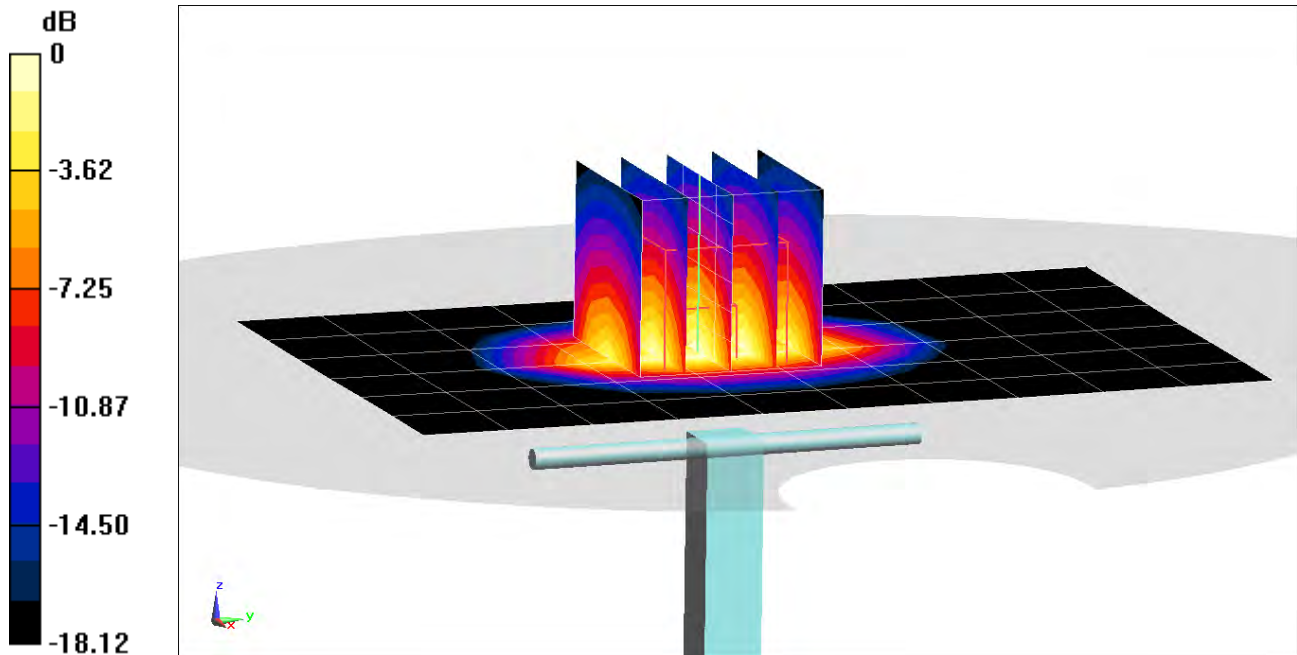

0 dB = 6.24 W/kg = 7.95 dBW/kg

PCTEST ENGINEERING LABORATORY, INC.

DUT: Dipole 1900 MHz; Type: D1900V2; Serial: 5d149

Communication System: UID 0, CW; Frequency: 1900 MHz; Duty Cycle: 1:1

Medium: 1900 Body Medium parameters used (interpolated):

$f = 1900$ MHz; $\sigma = 1.565$ S/m; $\epsilon_r = 52.165$; $\rho = 1000$ kg/m³

Phantom section: Flat Section; Space: 1.0 cm

Test Date: 06-19-2019; Ambient Temp: 22.6°C; Tissue Temp: 22.3°C

Probe: EX3DV4 - SN7410; ConvF(7.78, 7.78, 7.78) @ 1900 MHz; Calibrated: 7/20/2018

Sensor-Surface: 1.4mm (Mechanical Surface Detection)

Electronics: DAE4 Sn1322; Calibrated: 7/11/2018

Phantom: Front; Type: QD 000 P40 CD; Serial: 1686

Measurement SW: DASY52, Version 52.10 (2);SEMCAD X Version 14.6.12 (7450)

1900 MHz System Verification at 20.0 dBm (100 mW)

Area Scan (7x11x1): Measurement grid: dx=15mm, dy=15mm

Zoom Scan (5x5x7)/Cube 0: Measurement grid: dx=8mm, dy=8mm, dz=5mm

Peak SAR (extrapolated) = 7.43 W/kg

SAR(1 g) = 3.99 W/kg

Deviation(1 g) = 1.27%

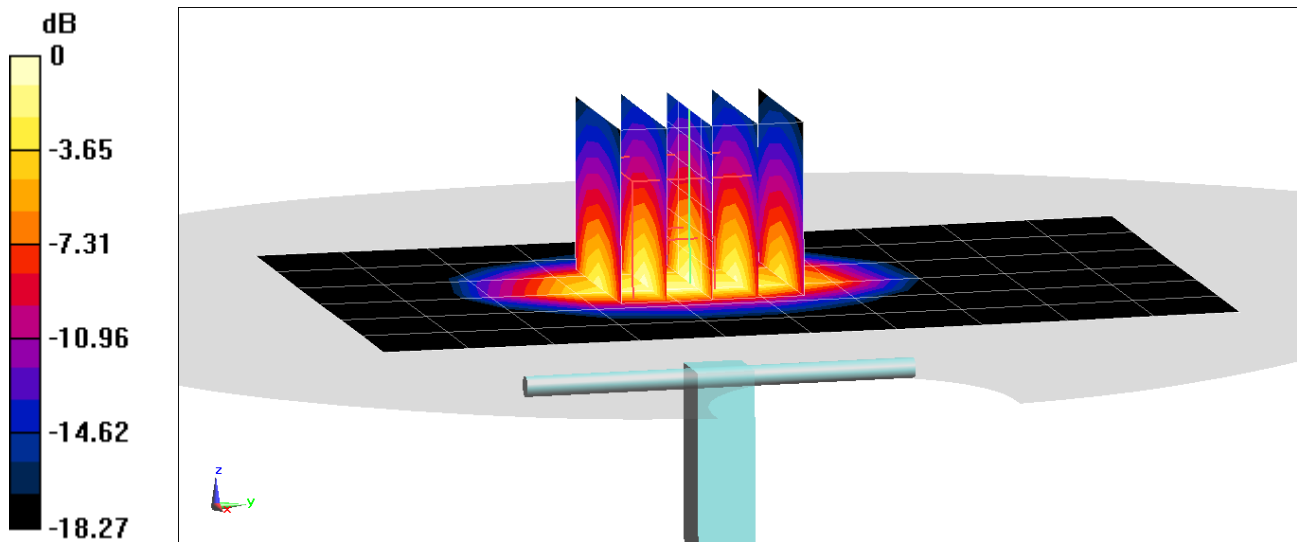

0 dB = 6.22 W/kg = 7.94 dBW/kg

PCTEST ENGINEERING LABORATORY, INC.

DUT: Dipole 2300 MHz; Type: D2300V2; Serial: 1073

Communication System: UID 0, CW; Frequency: 2300 MHz; Duty Cycle: 1:1

Medium: 2450 Body; Medium parameters used:

$f = 2300$ MHz; $\sigma = 1.842$ S/m; $\epsilon_r = 51.2$; $\rho = 1000$ kg/m³

Phantom section: Flat Section; Space: 1.0 cm

Test Date: 06-05-2019; Ambient Temp: 23.5°C; Tissue Temp: 22.9°C

Probe: EX3DV4 - SN7417; ConvF(7.64, 7.64, 7.64) @ 2300 MHz; Calibrated: 2/19/2019

Sensor-Surface: 1.4mm (Mechanical Surface Detection)

Electronics: DAE4 Sn665; Calibrated: 2/13/2019

Phantom: LeftTwin-SAM V5.0; Type: QD 000 P40 CD; Serial: TP1375

Measurement SW: DASY52, Version 52.10 (2);SEMCAD X Version 14.6.12 (7450)

2300 MHz System Verification at 20.0 dBm (100 mW)

Area Scan (8x9x1): Measurement grid: dx=12mm, dy=12mm

Zoom Scan (7x7x7)/Cube 0: Measurement grid: dx=5mm, dy=5mm, dz=5mm

Peak SAR (extrapolated) = 9.81 W/kg

SAR(1 g) = 4.85 W/kg; SAR(10 g) = 2.3 W/kg

Deviation(1 g) = 1.68%; Deviation(10 g) = -0.86%

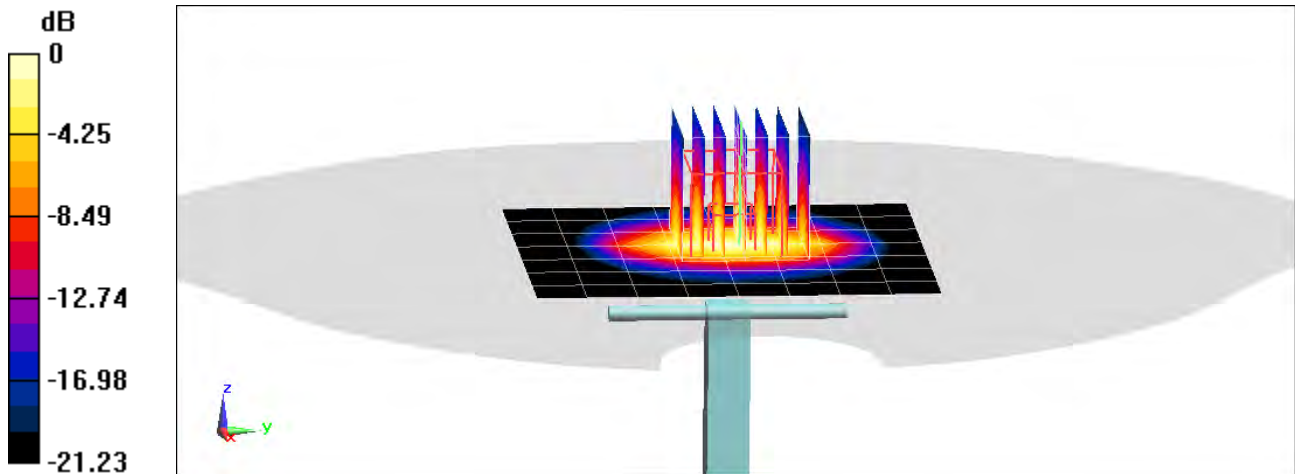

0 dB = 7.97 W/kg = 9.01 dBW/kg

PCTEST ENGINEERING LABORATORY, INC.

DUT: Dipole 2300 MHz; Type: D2300V2; Serial: 1064

Communication System: UID 0, CW; Frequency: 2300 MHz; Duty Cycle: 1:1

Medium: 2450 MHz Body Medium parameters used:

$f = 2300$ MHz; $\sigma = 1.893$ S/m; $\epsilon_r = 53.043$; $\rho = 1000$ kg/m³

Phantom section: Flat Section; Space: 1.0 cm

Test Date: 06-10-2019; Ambient Temp: 22.2°C; Tissue Temp: 21.1°C

Probe: EX3DV4 - SN7308; ConvF(7.73, 7.73, 7.73) @ 2300 MHz; Calibrated: 8/23/2018

Sensor-Surface: 1.4mm (Mechanical Surface Detection)

Electronics: DAE4 Sn1558; Calibrated: 10/3/2018

Phantom: Twin-SAM V5.0; Type: QD 000 P40 CD; Serial: 1630

Measurement SW: DASY52, Version 52.10 (2);SEMCAD X Version 14.6.12 (7450)

2300 MHz System Verification at 20.0 dBm (100 mW)

Area Scan (8x9x1): Measurement grid: dx=12mm, dy=12mm

Zoom Scan (7x7x7)/Cube 0: Measurement grid: dx=5mm, dy=5mm, dz=5mm

Peak SAR (extrapolated) = 9.99 W/kg

SAR(1 g) = 4.83 W/kg

Deviation(1 g) = 3.87%

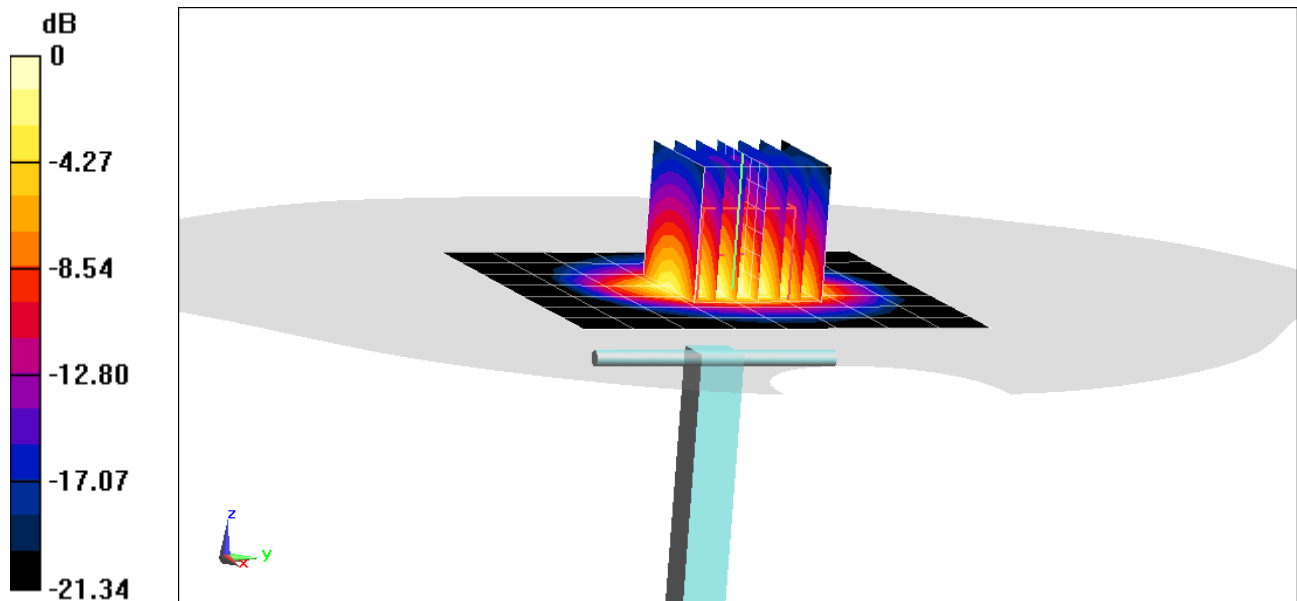

0 dB = 8.01 W/kg = 9.04 dBW/kg

PCTEST ENGINEERING LABORATORY, INC.

DUT: Dipole 2450 MHz; Type: D2450V2; Serial: 719

Communication System: UID 0, CW; Frequency: 2450 MHz; Duty Cycle: 1:1

Medium: 2450 Body; Medium parameters used:

$f = 2450 \text{ MHz}$; $\sigma = 2.025 \text{ S/m}$; $\epsilon_r = 51.35$; $\rho = 1000 \text{ kg/m}^3$

Phantom section: Flat Section; Space: 1.0 cm

Test Date: 06-11-2019; Ambient Temp: 24.6°C; Tissue Temp: 24.5°C

Probe: EX3DV4 - SN7417; ConvF(7.51, 7.51, 7.51) @ 2450 MHz; Calibrated: 2/19/2019

Sensor-Surface: 1.4mm (Mechanical Surface Detection)

Electronics: DAE4 Sn665; Calibrated: 2/13/2019

Phantom: LeftTwin-SAM V5.0; Type: QD 000 P40 CD; Serial: TP1375

Measurement SW: DASY52, Version 52.10 (2);SEMCAD X Version 14.6.12 (7450)

2450 MHz System Verification at 20.0 dBm (100 mW)

Area Scan (8x9x1): Measurement grid: dx=12mm, dy=12mm

Zoom Scan (7x7x7)/Cube 0: Measurement grid: dx=5mm, dy=5mm, dz=5mm

Peak SAR (extrapolated) = 10.3 W/kg

SAR(1 g) = 4.96 W/kg

Deviation(1 g) = -1.00%

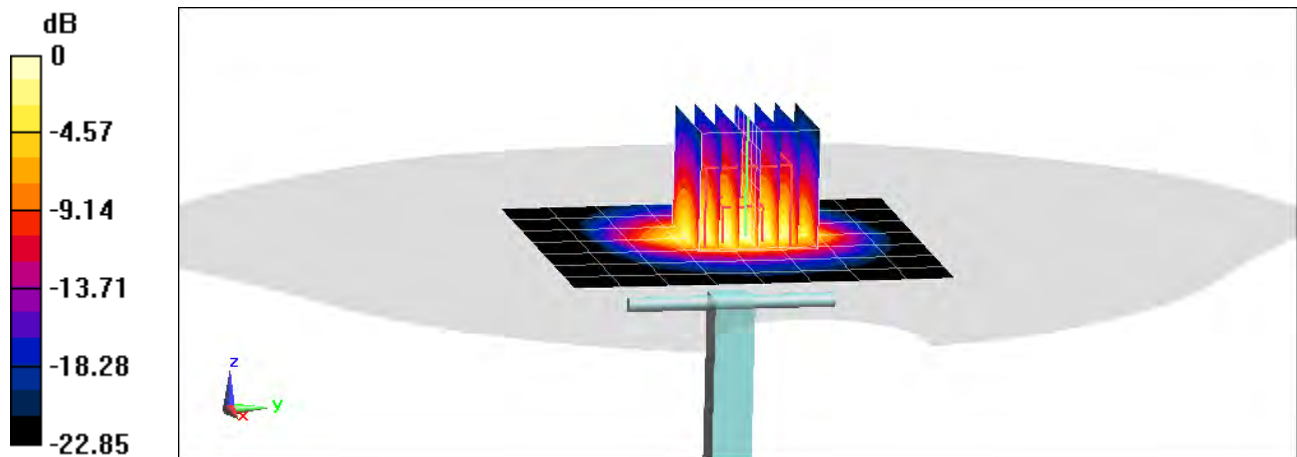

0 dB = 8.29 W/kg = 9.19 dBW/kg

PCTEST ENGINEERING LABORATORY, INC.

DUT: Dipole 2450 MHz; Type: D2450V2; Serial: 719

Communication System: UID 0, CW; Frequency: 2450 MHz; Duty Cycle: 1:1

Medium: 2450 Body; Medium parameters used:

$f = 2450 \text{ MHz}$; $\sigma = 2.035 \text{ S/m}$; $\epsilon_r = 50.996$; $\rho = 1000 \text{ kg/m}^3$

Phantom section: Flat Section; Space: 1.0 cm

Test Date: 06-17-2019; Ambient Temp: 23.9°C; Tissue Temp: 22.9°C

Probe: EX3DV4 - SN7417; ConvF(7.51, 7.51, 7.51) @ 2450 MHz; Calibrated: 2/19/2019

Sensor-Surface: 1.4mm (Mechanical Surface Detection)

Electronics: DAE4 Sn665; Calibrated: 2/13/2019

Phantom: LeftTwin-SAM V5.0; Type: QD 000 P40 CD; Serial: TP1375

Measurement SW: DASY52, Version 52.10 (2);SEMCAD X Version 14.6.12 (7450)

2450 MHz System Verification at 20.0 dBm (100 mW)

Area Scan (8x9x1): Measurement grid: dx=12mm, dy=12mm

Zoom Scan (7x7x7)/Cube 0: Measurement grid: dx=5mm, dy=5mm, dz=5mm

Peak SAR (extrapolated) = 10.8 W/kg

SAR(1 g) = 5.13 W/kg

Deviation(1 g) = 2.40%

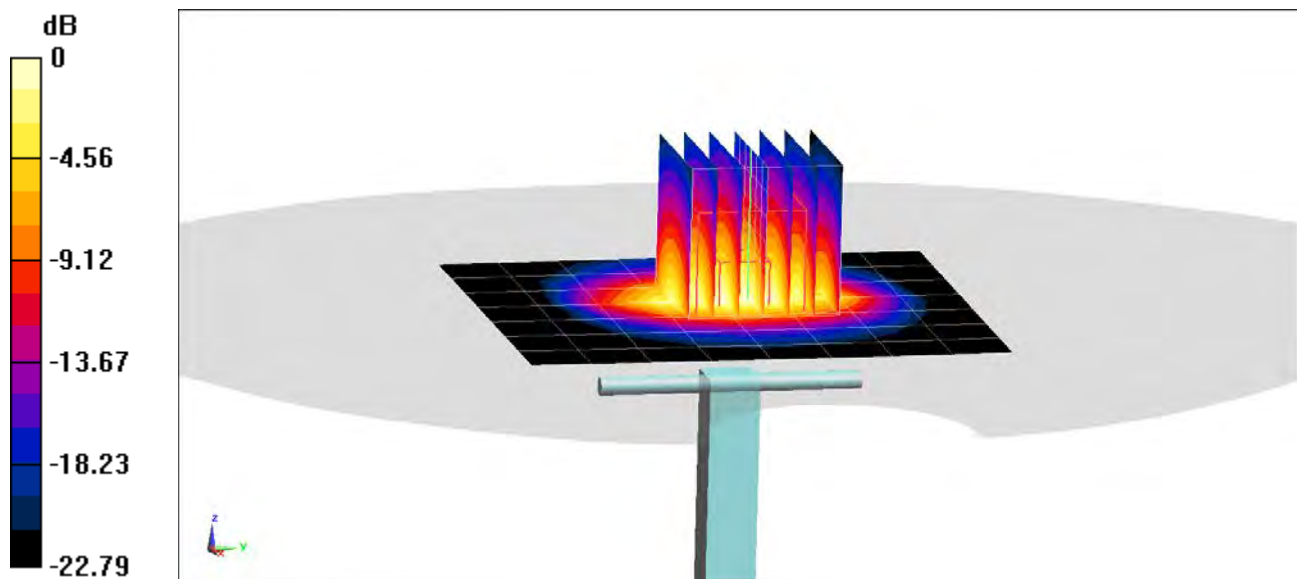

0 dB = 8.60 W/kg = 9.34 dBW/kg

PCTEST ENGINEERING LABORATORY, INC.

DUT: Dipole 2450 MHz; Type: D2450V2; Serial: 719

Communication System: UID 0, CW; Frequency: 2450 MHz; Duty Cycle: 1:1

Medium: 2450 Body; Medium parameters used:

$f = 2450$ MHz; $\sigma = 2.012$ S/m; $\epsilon_r = 51.233$; $\rho = 1000$ kg/m³

Phantom section: Flat Section; Space: 1.0 cm

Test Date: 07-07-2019; Ambient Temp: 23.0°C; Tissue Temp: 22.1°C

Probe: EX3DV4 - SN7417; ConvF(7.51, 7.51, 7.51) @ 2450 MHz; Calibrated: 2/19/2019

Sensor-Surface: 1.4mm (Mechanical Surface Detection)

Electronics: DAE4 Sn665; Calibrated: 2/13/2019

Phantom: LeftTwin-SAM V5.0; Type: QD 000 P40 CD; Serial: TP1375

Measurement SW: DASY52, Version 52.10 (2);SEMCAD X Version 14.6.12 (7450)

Mode: 2450 MHz System Verification at 20.0 dBm (100 mW)

Area Scan (8x9x1): Measurement grid: dx=12mm, dy=12mm

Zoom Scan (7x7x7)/Cube 0: Measurement grid: dx=5mm, dy=5mm, dz=5mm

Peak SAR (extrapolated) = 10.3 W/kg

SAR(10 g) = 2.32 W/kg

Deviation(10 g) = -2.11%

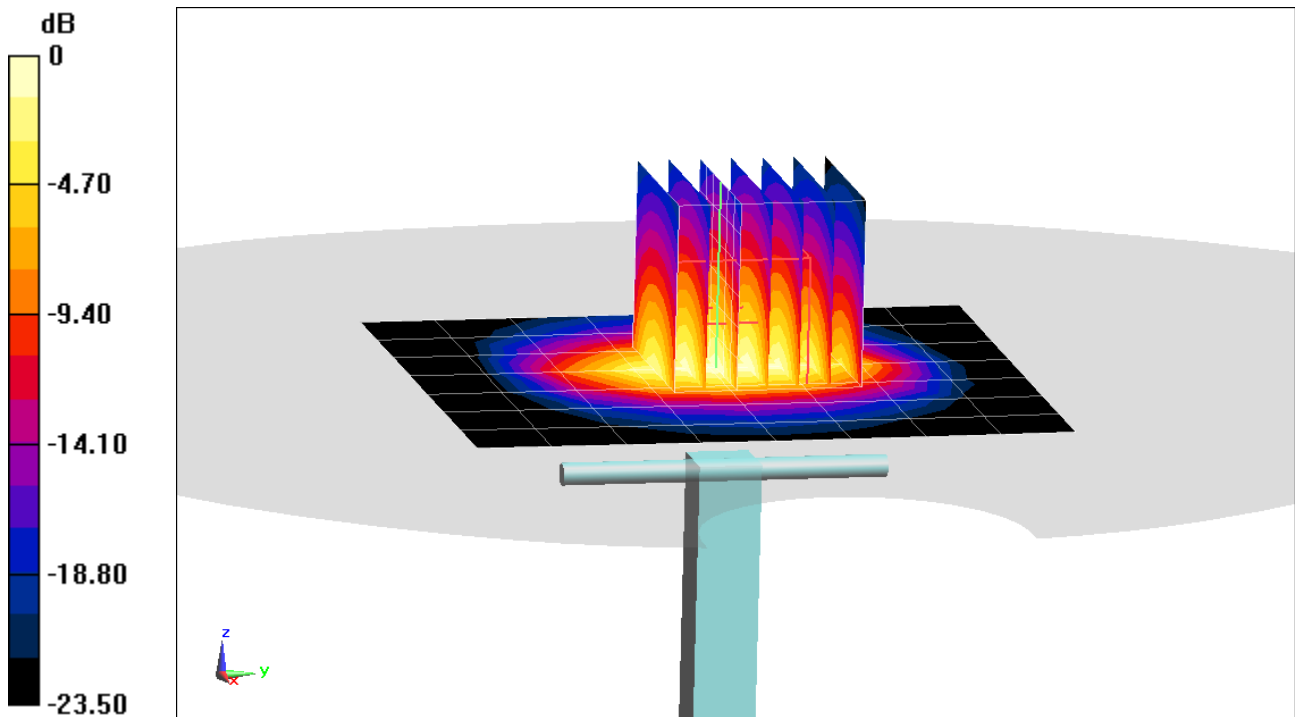

0 dB = 8.35 W/kg = 9.22 dBW/kg

PCTEST ENGINEERING LABORATORY, INC.

DUT: Dipole 2600 MHz; Type: D2600V2; Serial: 1004

Communication System: UID 0, CW; Frequency: 2600 MHz; Duty Cycle: 1:1

Medium: 2450 Body; Medium parameters used:

$f = 2600 \text{ MHz}$; $\sigma = 2.2 \text{ S/m}$; $\epsilon_r = 50.9$; $\rho = 1000 \text{ kg/m}^3$

Phantom section: Flat Section; Space: 1.0 cm

Test Date: 06-11-2019; Ambient Temp: 24.6°C; Tissue Temp: 24.5°C

Probe: EX3DV4 - SN7417; ConvF(7.37, 7.37, 7.37) @ 2600 MHz; Calibrated: 2/19/2019

Sensor-Surface: 1.4mm (Mechanical Surface Detection)

Electronics: DAE4 Sn665; Calibrated: 2/13/2019

Phantom: LeftTwin-SAM V5.0; Type: QD 000 P40 CD; Serial: TP1375

Measurement SW: DASY52, Version 52.10 (2);SEMCAD X Version 14.6.12 (7450)

2600 MHz System Verification at 20.0 dBm (100 mW)

Area Scan (8x9x1): Measurement grid: dx=12mm, dy=12mm

Zoom Scan (7x7x7)/Cube 0: Measurement grid: dx=5mm, dy=5mm, dz=5mm

Peak SAR (extrapolated) = 11.1 W/kg

SAR(1 g) = 5.13 W/kg

Deviation(1 g) = -6.39%

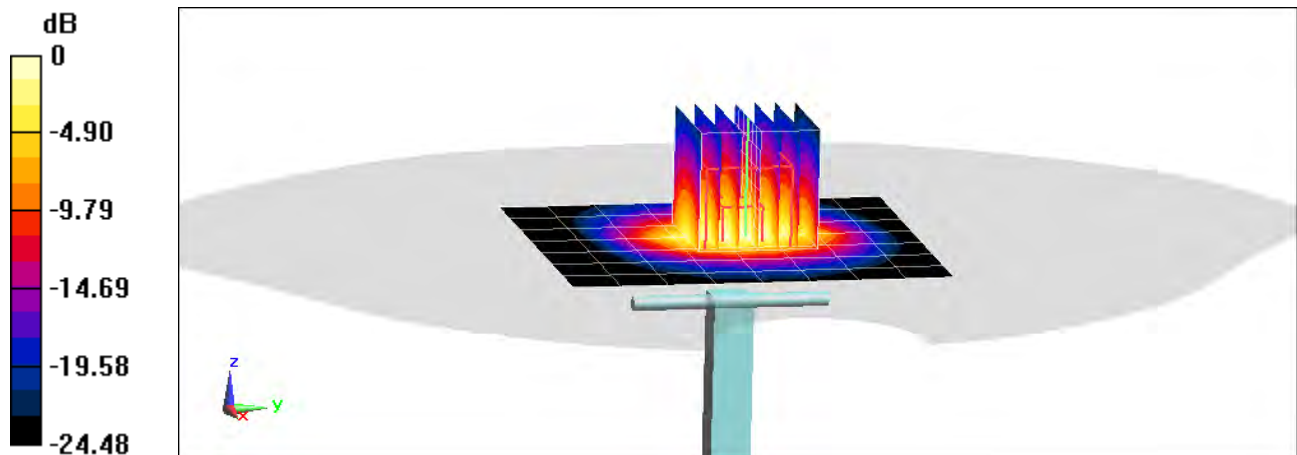

0 dB = 8.79 W/kg = 9.44 dBW/kg

PCTEST ENGINEERING LABORATORY, INC.

DUT: Dipole 2600 MHz; Type: D2600V2; Serial: 1004

Communication System: UID 0, CW; Frequency: 2600 MHz; Duty Cycle: 1:1

Medium: 2450 Body; Medium parameters used:

$f = 2600 \text{ MHz}$; $\sigma = 2.19 \text{ S/m}$; $\epsilon_r = 50.769$; $\rho = 1000 \text{ kg/m}^3$

Phantom section: Flat Section; Space: 1.0 cm

Test Date: 07-07-2019; Ambient Temp: 23.0°C; Tissue Temp: 22.1°C

Probe: EX3DV4 - SN7417; ConvF(7.37, 7.37, 7.37) @ 2600 MHz; Calibrated: 2/19/2019

Sensor-Surface: 1.4mm (Mechanical Surface Detection)

Electronics: DAE4 Sn665; Calibrated: 2/13/2019

Phantom: LeftTwin-SAM V5.0; Type: QD 000 P40 CD; Serial: TP1375

Measurement SW: DASY52, Version 52.10 (2);SEMCAD X Version 14.6.12 (7450)

Mode: 2600 MHz System Verification at 20.0 dBm (100 mW)

Area Scan (8x9x1): Measurement grid: dx=12mm, dy=12mm

Zoom Scan (7x7x7)/Cube 0: Measurement grid: dx=5mm, dy=5mm, dz=5mm

Peak SAR (extrapolated) = 11.6 W/kg

SAR(10 g) = 2.37 W/kg

Deviation(10 g) = -4.05%

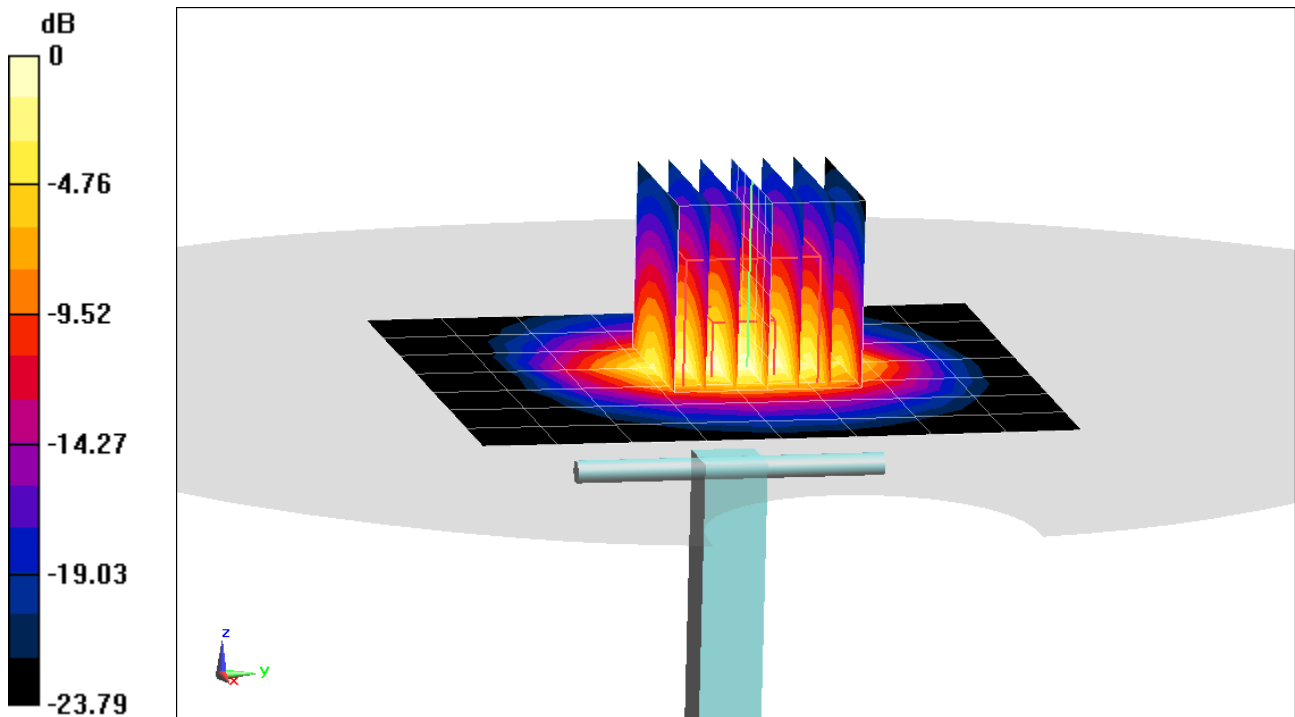

0 dB = 9.22 W/kg = 9.65 dBW/kg

PCTEST ENGINEERING LABORATORY, INC.

DUT: Dipole 3500 MHz; Type: D3500V2; Serial: 1055

Communication System: UID 0, CW; Frequency: 3500 MHz; Duty Cycle: 1:1

Medium: 3500 Body Medium parameters used:

$f = 3500 \text{ MHz}$; $\sigma = 3.377 \text{ S/m}$; $\epsilon_r = 51.089$; $\rho = 1000 \text{ kg/m}^3$

Phantom section: Flat Section; Space: 1.0 cm

Test Date: 06-12-2019; Ambient Temp: 23.1°C; Tissue Temp: 22.5°C

Probe: EX3DV4 - SN3914; ConvF(6.88, 6.88, 6.88) @ 3500 MHz; Calibrated: 2/19/2019

Sensor-Surface: 1.4mm (Mechanical Surface Detection)

Electronics: DAE4 Sn1272; Calibrated: 2/14/2019

Phantom: SAM with CRP v5.0 Front; Type: QD000P40CD; Serial: 1646

Measurement SW: DASY52, Version 52.10 (2);SEMCAD X Version 14.6.12 (7450)

3500 MHz System Verification at 20.0 dBm (100 mW)

Area Scan (8x9x1): Measurement grid: dx=12mm, dy=12mm

Zoom Scan (7x7x8)/Cube 0: Measurement grid: dx=5mm, dy=5mm, dz=1.4mm; Graded Ratio: 1.4

Peak SAR (extrapolated) = 19.4 W/kg

SAR(1 g) = 6.61 W/kg

Deviation(1 g) = 2.32%

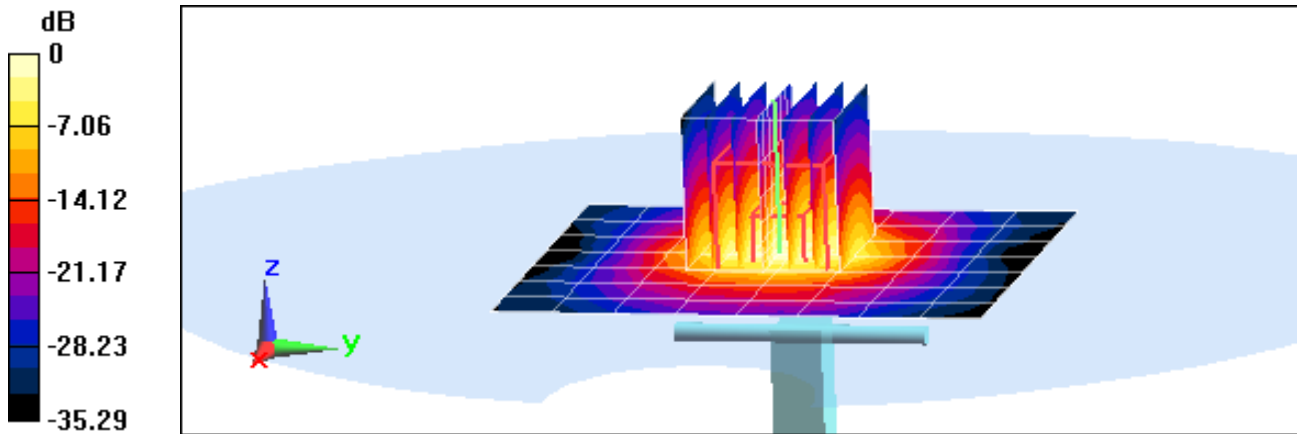

0 dB = 13.3 W/kg = 11.24 dBW/kg

PCTEST ENGINEERING LABORATORY, INC.

DUT: Dipole 5 GHz; Type: D5GHzV2; Serial: 1237

Communication System: UID 0, CW; Frequency: 5250 MHz; Duty Cycle: 1:1

Medium: 5GHz Body Medium parameters used (interpolated):

$f = 5250 \text{ MHz}$; $\sigma = 5.443 \text{ S/m}$; $\epsilon_r = 47.672$; $\rho = 1000 \text{ kg/m}^3$

Phantom section: Flat Section; Space: 1.0 cm

Test Date: 06-14-2019; Ambient Temp: 22.8°C; Tissue Temp: 20.9°C

Probe: EX3DV4 - SN7308; ConvF(4.48, 4.48, 4.48) @ 5250 MHz; Calibrated: 8/23/2018

Sensor-Surface: 1.4mm (Mechanical Surface Detection)

Electronics: DAE4 Sn1558; Calibrated: 10/3/2018

Phantom: Twin-SAM V5.0; Type: QD 000 P40 CD; Serial: 1630

Measurement SW: DASY52, Version 52.10 (2);SEMCAD X Version 14.6.12 (7450)

5250 MHz System Verification at 17.0 dBm (50 mW)

Area Scan (7x7x1): Measurement grid: dx=10mm, dy=10mm

Zoom Scan (8x8x7)/Cube 0: Measurement grid: dx=4mm, dy=4mm, dz=1.4mm; Graded Ratio: 1.4

Peak SAR (extrapolated) = 15.0 W/kg

SAR(1 g) = 3.6 W/kg; SAR(10 g) = 1.01 W/kg

Deviation(1 g) = -4.76%; Deviation(10 g) = -4.72%

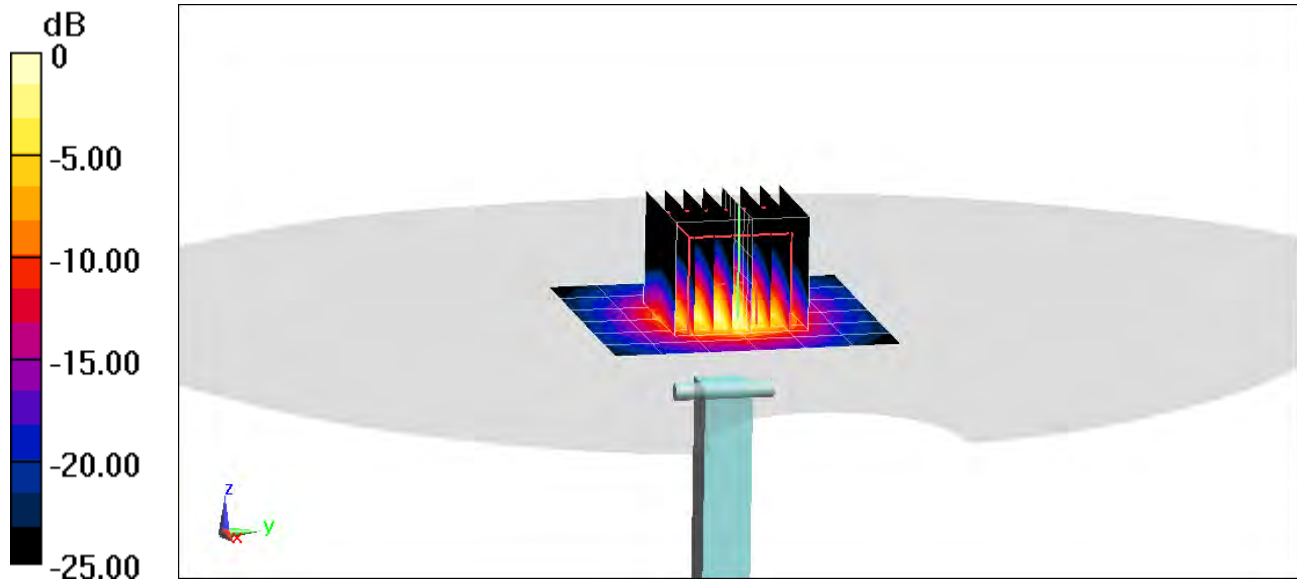

0 dB = 8.58 W/kg = 9.33 dBW/kg

PCTEST ENGINEERING LABORATORY, INC.

DUT: Dipole 5 GHz; Type: D5GHzV2; Serial: 1237

Communication System: UID 0, CW; Frequency: 5600 MHz; Duty Cycle: 1:1

Medium: 5GHz Body Medium parameters used:

$f = 5600 \text{ MHz}$; $\sigma = 5.95 \text{ S/m}$; $\epsilon_r = 47.025$; $\rho = 1000 \text{ kg/m}^3$

Phantom section: Flat Section; Space: 1.0 cm

Test Date: 06-14-2019; Ambient Temp: 22.8°C; Tissue Temp: 20.9°C

Probe: EX3DV4 - SN7308; ConvF(4, 4, 4) @ 5600 MHz; Calibrated: 8/23/2018

Sensor-Surface: 1.4mm (Mechanical Surface Detection)

Electronics: DAE4 Sn1558; Calibrated: 10/3/2018

Phantom: Twin-SAM V5.0; Type: QD 000 P40 CD; Serial: 1630

Measurement SW: DASY52, Version 52.10 (2); SEMCAD X Version 14.6.12 (7450)

5600 MHz System Verification at 17.0 dBm (50 mW)

Area Scan (7x7x1): Measurement grid: dx=10mm, dy=10mm

Zoom Scan (8x8x7)/Cube 0: Measurement grid: dx=4mm, dy=4mm, dz=1.4mm; Graded Ratio: 1.4

Peak SAR (extrapolated) = 18.4 W/kg

SAR(1 g) = 4.1 W/kg; SAR(10 g) = 1.12 W/kg

Deviation(1 g) = 4.46%; Deviation(10 g) = 1.82%

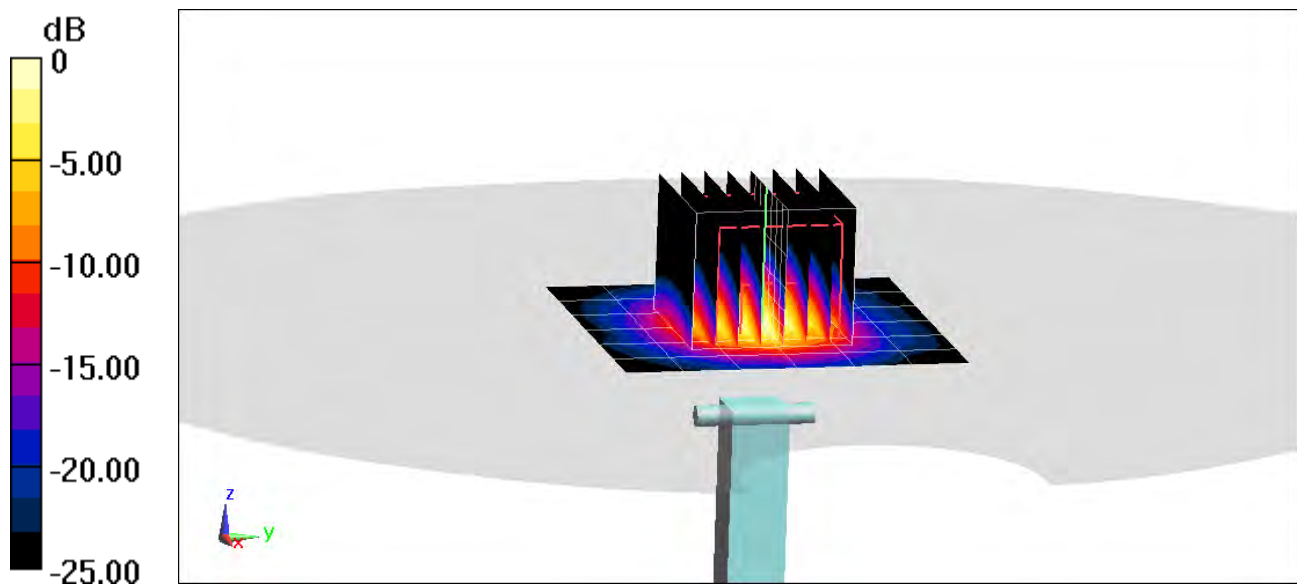

0 dB = 10.6 W/kg = 10.25 dBW/kg

PCTEST ENGINEERING LABORATORY, INC.

DUT: Dipole 5 GHz; Type: D5GHzV2; Serial: 1237

Communication System: UID 0, CW; Frequency: 5750 MHz; Duty Cycle: 1:1

Medium: 5GHz Body Medium parameters used (interpolated):

$f = 5750 \text{ MHz}$; $\sigma = 6.177 \text{ S/m}$; $\epsilon_r = 46.742$; $\rho = 1000 \text{ kg/m}^3$

Phantom section: Flat Section; Space: 1.0 cm

Test Date: 06-14-2019; Ambient Temp: 22.8°C; Tissue Temp: 20.9°C

Probe: EX3DV4 - SN7308; ConvF(4.18, 4.18, 4.18) @ 5750 MHz; Calibrated: 8/23/2018

Sensor-Surface: 1.4mm (Mechanical Surface Detection)

Electronics: DAE4 Sn1558; Calibrated: 10/3/2018

Phantom: Twin-SAM V5.0; Type: QD 000 P40 CD; Serial: 1630

Measurement SW: DASY52, Version 52.10 (2);SEMCAD X Version 14.6.12 (7450)

5750 MHz System Verification at 17.0 dBm (50 mW)

Area Scan (7x7x1): Measurement grid: dx=10mm, dy=10mm

Zoom Scan (8x8x7)/Cube 0: Measurement grid: dx=4mm, dy=4mm, dz=1.4mm; Graded Ratio: 1.4

Peak SAR (extrapolated) = 17.5 W/kg

SAR(1 g) = 3.75 W/kg; SAR(10 g) = 1.04 W/kg

Deviation(1 g) = -1.19%; Deviation(10 g) = -1.89%

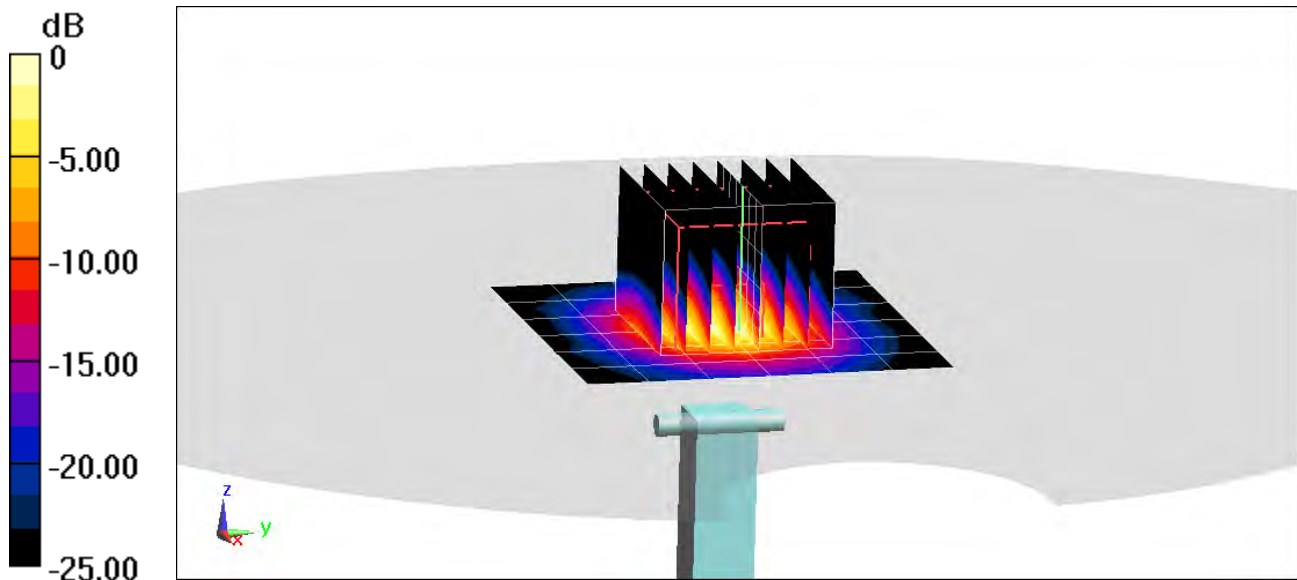

0 dB = 9.16 W/kg = 9.62 dBW/kg

APPENDIX C: PROBE CALIBRATION



Accredited by the Swiss Accreditation Service (SAS)
The Swiss Accreditation Service is one of the signatories to the EA
Multilateral Agreement for the recognition of calibration certificates

Accreditation No.: **SCS 0108**

Client **PC Test**

Certificate No: **D750V3-1161_Oct18**

CALIBRATION CERTIFICATE

Object **D750V3 - SN:1161**

Calibration procedure(s) **QA CAL-05.v10
Calibration procedure for dipole validation kits above 700 MHz**

Calibration date: **October 19, 2018**

*BN ✓
10-30-2018*

This calibration certificate documents the traceability to national standards, which realize the physical units of measurements (SI).
The measurements and the uncertainties with confidence probability are given on the following pages and are part of the certificate.

All calibrations have been conducted in the closed laboratory facility: environment temperature (22 ± 3)°C and humidity < 70%.

Calibration Equipment used (M&TE critical for calibration)

Primary Standards	ID #	Cal Date (Certificate No.)	Scheduled Calibration
Power meter NRP	SN: 104778	04-Apr-18 (No. 217-02672/02673)	Apr-19
Power sensor NRP-Z91	SN: 103244	04-Apr-18 (No. 217-02672)	Apr-19
Power sensor NRP-Z91	SN: 103245	04-Apr-18 (No. 217-02673)	Apr-19
Reference 20 dB Attenuator	SN: 5058 (20k)	04-Apr-18 (No. 217-02682)	Apr-19
Type-N mismatch combination	SN: 5047.2 / 06327	04-Apr-18 (No. 217-02683)	Apr-19
Reference Probe EX3DV4	SN: 7349	30-Dec-17 (No. EX3-7349_Dec17)	Dec-18
DAE4	SN: 601	04-Oct-18 (No. DAE4-601_Oct18)	Oct-19

Secondary Standards	ID #	Check Date (in house)	Scheduled Check
Power meter EPM-442A	SN: GB37480704	07-Oct-15 (in house check Oct-18)	In house check: Oct-20
Power sensor HP 8481A	SN: US37292783	07-Oct-15 (in house check Oct-18)	In house check: Oct-20
Power sensor HP 8481A	SN: MY41092317	07-Oct-15 (in house check Oct-18)	In house check: Oct-20
RF generator R&S SMT-06	SN: 100972	15-Jun-15 (in house check Oct-18)	In house check: Oct-20
Network Analyzer Agilent E8358A	SN: US41080477	31-Mar-14 (in house check Oct-18)	In house check: Oct-19

Calibrated by: **Manu Seitz** Name: **Manu Seitz** Function: **Laboratory Technician**

Approved by: **Katja Pokovic** Name: **Katja Pokovic** Function: **Technical Manager**

Issued: October 22, 2018

This calibration certificate shall not be reproduced except in full without written approval of the laboratory.



Accredited by the Swiss Accreditation Service (SAS)

The Swiss Accreditation Service is one of the signatories to the EA
Multilateral Agreement for the recognition of calibration certificates

Accreditation No.: **SCS 0108**

Glossary:

TSL	tissue simulating liquid
ConvF	sensitivity in TSL / NORM x,y,z
N/A	not applicable or not measured

Calibration is Performed According to the Following Standards:

- IEEE Std 1528-2013, "IEEE Recommended Practice for Determining the Peak Spatial-Averaged Specific Absorption Rate (SAR) in the Human Head from Wireless Communications Devices: Measurement Techniques", June 2013
- IEC 62209-1, "Measurement procedure for the assessment of Specific Absorption Rate (SAR) from hand-held and body-mounted devices used next to the ear (frequency range of 300 MHz to 6 GHz)", July 2016
- IEC 62209-2, "Procedure to determine the Specific Absorption Rate (SAR) for wireless communication devices used in close proximity to the human body (frequency range of 30 MHz to 6 GHz)", March 2010
- KDB 865664, "SAR Measurement Requirements for 100 MHz to 6 GHz"

Additional Documentation:

- DASY4/5 System Handbook

Methods Applied and Interpretation of Parameters:

- Measurement Conditions:** Further details are available from the Validation Report at the end of the certificate. All figures stated in the certificate are valid at the frequency indicated.
- Antenna Parameters with TSL:** The dipole is mounted with the spacer to position its feed point exactly below the center marking of the flat phantom section, with the arms oriented parallel to the body axis.
- Feed Point Impedance and Return Loss:** These parameters are measured with the dipole positioned under the liquid filled phantom. The impedance stated is transformed from the measurement at the SMA connector to the feed point. The Return Loss ensures low reflected power. No uncertainty required.
- Electrical Delay:** One-way delay between the SMA connector and the antenna feed point. No uncertainty required.
- SAR measured:** SAR measured at the stated antenna input power.
- SAR normalized:** SAR as measured, normalized to an input power of 1 W at the antenna connector.
- SAR for nominal TSL parameters:** The measured TSL parameters are used to calculate the nominal SAR result.

The reported uncertainty of measurement is stated as the standard uncertainty of measurement multiplied by the coverage factor $k=2$, which for a normal distribution corresponds to a coverage probability of approximately 95%.

Measurement Conditions

DASY system configuration, as far as not given on page 1.

DASY Version	DASY5	V52.10.2
Extrapolation	Advanced Extrapolation	
Phantom	Modular Flat Phantom	
Distance Dipole Center - TSL	15 mm	with Spacer
Zoom Scan Resolution	dx, dy, dz = 5 mm	
Frequency	750 MHz ± 1 MHz	

Head TSL parameters

The following parameters and calculations were applied.

	Temperature	Permittivity	Conductivity
Nominal Head TSL parameters	22.0 °C	41.9	0.89 mho/m
Measured Head TSL parameters	(22.0 ± 0.2) °C	40.8 ± 6 %	0.89 mho/m ± 6 %
Head TSL temperature change during test	< 0.5 °C	----	----

SAR result with Head TSL

SAR averaged over 1 cm³ (1 g) of Head TSL	Condition	
SAR measured	250 mW input power	2.02 W/kg
SAR for nominal Head TSL parameters	normalized to 1W	8.03 W/kg ± 17.0 % (k=2)

SAR averaged over 10 cm³ (10 g) of Head TSL	condition	
SAR measured	250 mW input power	1.32 W/kg
SAR for nominal Head TSL parameters	normalized to 1W	5.26 W/kg ± 16.5 % (k=2)

Body TSL parameters

The following parameters and calculations were applied.

	Temperature	Permittivity	Conductivity
Nominal Body TSL parameters	22.0 °C	55.5	0.96 mho/m
Measured Body TSL parameters	(22.0 ± 0.2) °C	55.1 ± 6 %	0.96 mho/m ± 6 %
Body TSL temperature change during test	< 0.5 °C	----	----

SAR result with Body TSL

SAR averaged over 1 cm³ (1 g) of Body TSL	Condition	
SAR measured	250 mW input power	2.11 W/kg
SAR for nominal Body TSL parameters	normalized to 1W	8.43 W/kg ± 17.0 % (k=2)

SAR averaged over 10 cm³ (10 g) of Body TSL	condition	
SAR measured	250 mW input power	1.39 W/kg
SAR for nominal Body TSL parameters	normalized to 1W	5.55 W/kg ± 16.5 % (k=2)

Appendix (Additional assessments outside the scope of SCS 0108)

Antenna Parameters with Head TSL

Impedance, transformed to feed point	55.6 Ω - 1.9 j Ω
Return Loss	- 25.0 dB

Antenna Parameters with Body TSL

Impedance, transformed to feed point	50.6 Ω - 4.2 j Ω
Return Loss	- 27.6 dB

General Antenna Parameters and Design

Electrical Delay (one direction)	1.032 ns
----------------------------------	----------

After long term use with 100W radiated power, only a slight warming of the dipole near the feedpoint can be measured.

The dipole is made of standard semirigid coaxial cable. The center conductor of the feeding line is directly connected to the second arm of the dipole. The antenna is therefore short-circuited for DC-signals. On some of the dipoles, small end caps are added to the dipole arms in order to improve matching when loaded according to the position as explained in the "Measurement Conditions" paragraph. The SAR data are not affected by this change. The overall dipole length is still according to the Standard.

No excessive force must be applied to the dipole arms, because they might bend or the soldered connections near the feedpoint may be damaged.

Additional EUT Data

Manufactured by	SPEAG
Manufactured on	November 19, 2015

DASY5 Validation Report for Head TSL

Date: 19.10.2018

Test Laboratory: SPEAG, Zurich, Switzerland

DUT: Dipole 750 MHz; Type: D750V3; Serial: D750V3 - SN:1161

Communication System: UID 0 - CW; Frequency: 750 MHz

Medium parameters used: $f = 750$ MHz; $\sigma = 0.89$ S/m; $\epsilon_r = 40.8$; $\rho = 1000$ kg/m³

Phantom section: Flat Section

Measurement Standard: DASY5 (IEEE/IEC/ANSI C63.19-2011)

DASY52 Configuration:

- Probe: EX3DV4 - SN7349; ConvF(10.22, 10.22, 10.22) @ 750 MHz; Calibrated: 30.12.2017
- Sensor-Surface: 1.4mm (Mechanical Surface Detection)
- Electronics: DAE4 Sn601; Calibrated: 04.10.2018
- Phantom: Flat Phantom 4.9 (front); Type: QD 00L P49 AA; Serial: 1001
- DASY52 52.10.2(1495); SEMCAD X 14.6.12(7450)

Dipole Calibration for Head Tissue/Pin=250 mW, d=15mm/Zoom Scan (7x7x7)/Cube 0:

Measurement grid: dx=5mm, dy=5mm, dz=5mm

Reference Value = 58.51 V/m; Power Drift = -0.04 dB

Peak SAR (extrapolated) = 3.04 W/kg

SAR(1 g) = 2.02 W/kg; SAR(10 g) = 1.32 W/kg

Maximum value of SAR (measured) = 2.70 W/kg

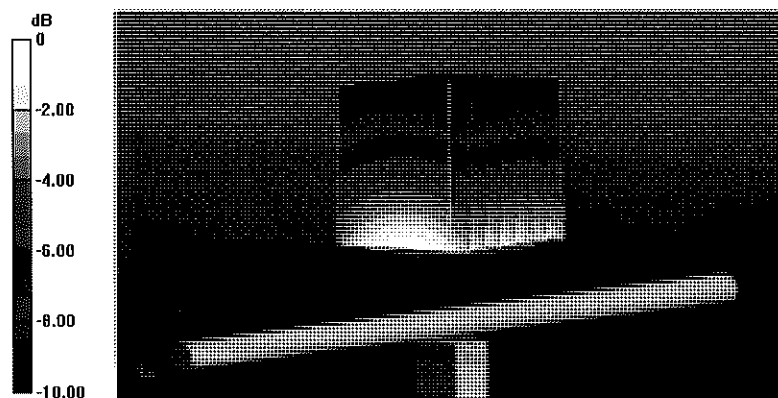

0 dB = 2.70 W/kg = 4.31 dBW/kg

Impedance Measurement Plot for Head TSL

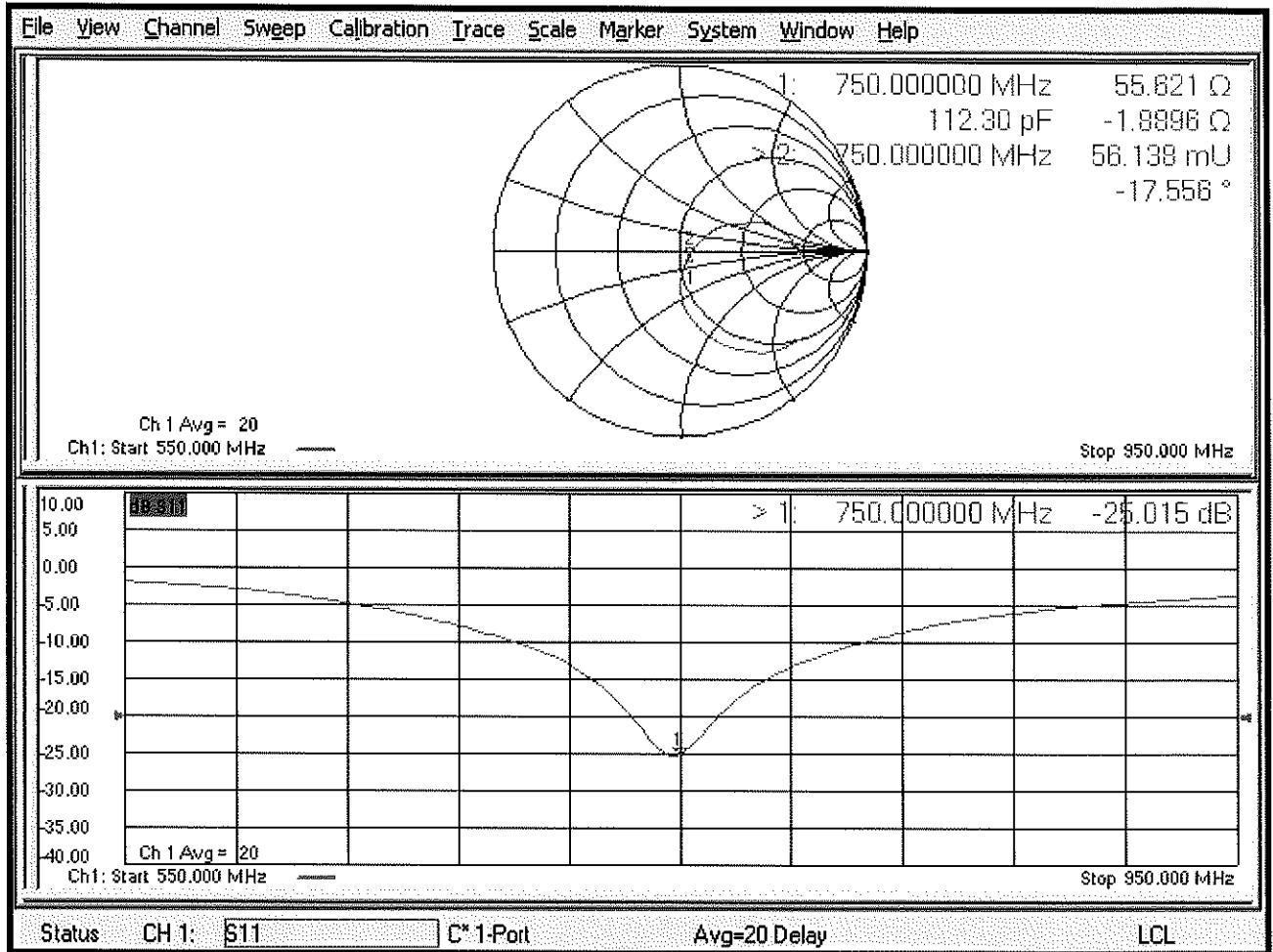

DASY5 Validation Report for Body TSL

Date: 19.10.2018

Test Laboratory: SPEAG, Zurich, Switzerland

DUT: Dipole 750 MHz; Type: D750V3; Serial: D750V3 - SN:1161

Communication System: UID 0 - CW; Frequency: 750 MHz

Medium parameters used: $f = 750$ MHz; $\sigma = 0.96$ S/m; $\epsilon_r = 55.1$; $\rho = 1000$ kg/m³

Phantom section: Flat Section

Measurement Standard: DASY5 (IEEE/IEC/ANSI C63.19-2011)

DASY52 Configuration:

- Probe: EX3DV4 - SN7349; ConvF(10.19, 10.19, 10.19) @ 750 MHz; Calibrated: 30.12.2017
- Sensor-Surface: 1.4mm (Mechanical Surface Detection)
- Electronics: DAE4 Sn601; Calibrated: 04.10.2018
- Phantom: Flat Phantom 4.9 (Back); Type: QD 00R P49 AA; Serial: 1005
- DASY52 52.10.2(1495); SEMCAD X 14.6.12(7450)

Dipole Calibration for Body Tissue/Pin=250 mW, d=15mm/Zoom Scan (7x7x7)/Cube 0:

Measurement grid: dx=5mm, dy=5mm, dz=5mm

Reference Value = 57.57 V/m; Power Drift = -0.02 dB

Peak SAR (extrapolated) = 3.18 W/kg

SAR(1 g) = 2.11 W/kg; SAR(10 g) = 1.39 W/kg

Maximum value of SAR (measured) = 2.83 W/kg

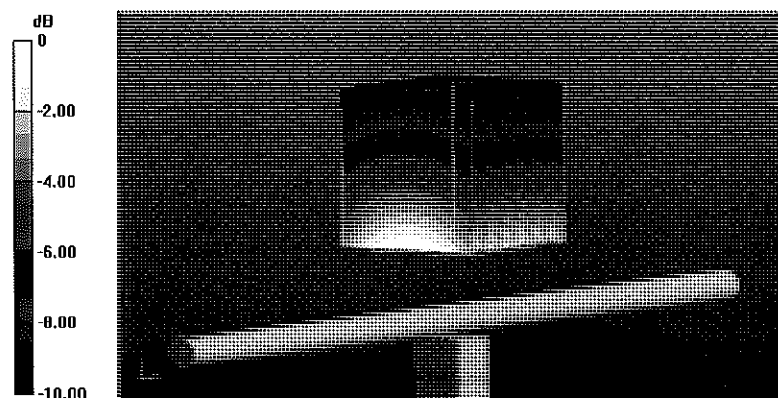

0 dB = 2.83 W/kg = 4.52 dBW/kg

Impedance Measurement Plot for Body TSL

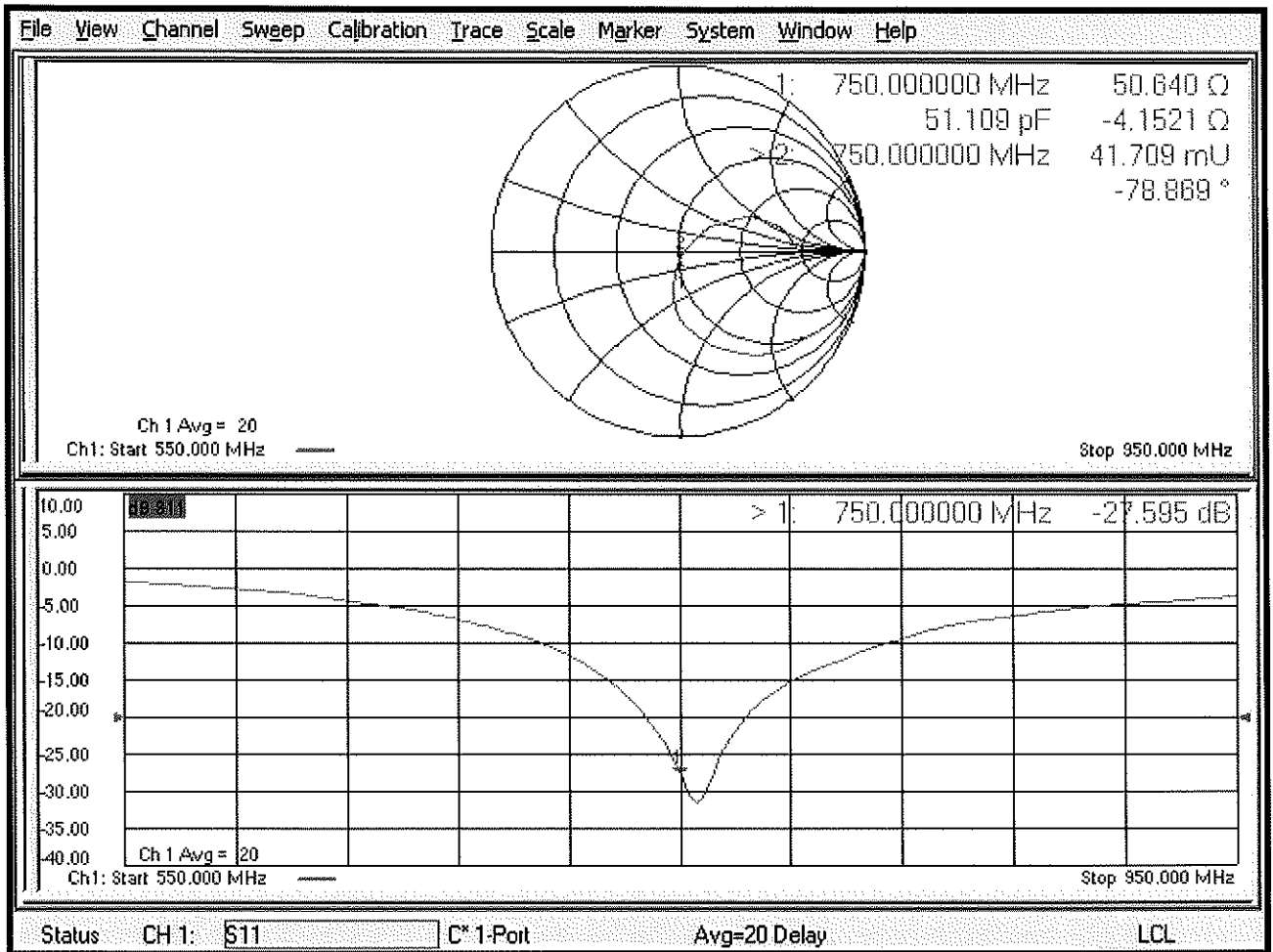



Accredited by the Swiss Accreditation Service (SAS)
The Swiss Accreditation Service is one of the signatories to the EA
Multilateral Agreement for the recognition of calibration certificates

Accreditation No.: **SCS 0108**

Client **PC Test**

Certificate No: **D835V2-4d132_Jan19**

CALIBRATION CERTIFICATE

Object **D835V2 - SN:4d132**

Calibration procedure(s) **QA CAL-05.v11
Calibration Procedure for SAR Validation Sources between 0.7-3 GHz**

*BN ✓
02/06/2019*

Calibration date: **January 22, 2019**

This calibration certificate documents the traceability to national standards, which realize the physical units of measurements (SI).
The measurements and the uncertainties with confidence probability are given on the following pages and are part of the certificate.

All calibrations have been conducted in the closed laboratory facility: environment temperature (22 ± 3)°C and humidity < 70%.

Calibration Equipment used (M&TE critical for calibration)

Primary Standards	ID #	Cal Date (Certificate No.)	Scheduled Calibration
Power meter NRP	SN: 104778	04-Apr-18 (No. 217-02672/02673)	Apr-19
Power sensor NRP-Z91	SN: 103244	04-Apr-18 (No. 217-02672)	Apr-19
Power sensor NRP-Z91	SN: 103245	04-Apr-18 (No. 217-02673)	Apr-19
Reference 20 dB Attenuator	SN: 5058 (20k)	04-Apr-18 (No. 217-02682)	Apr-19
Type-N mismatch combination	SN: 5047.2 / 06327	04-Apr-18 (No. 217-02683)	Apr-19
Reference Probe EX3DV4	SN: 7349	31-Dec-18 (No. EX3-7349_Dec18)	Dec-19
DAE4	SN: 601	04-Oct-18 (No. DAE4-601_Oct18)	Oct-19

Secondary Standards	ID #	Check Date (in house)	Scheduled Check
Power meter EPM-442A	SN: GB37480704	07-Oct-15 (in house check Oct-18)	In house check: Oct-20
Power sensor HP 8481A	SN: US37292783	07-Oct-15 (in house check Oct-18)	In house check: Oct-20
Power sensor HP 8481A	SN: MY41092317	07-Oct-15 (in house check Oct-18)	In house check: Oct-20
RF generator R&S SMT-06	SN: 100972	15-Jun-15 (in house check Oct-18)	In house check: Oct-20
Network Analyzer Agilent E8358A	SN: US41080477	31-Mar-14 (in house check Oct-18)	In house check: Oct-19

Calibrated by: **Leif Klynsner** Name: **Leif Klynsner** Function: **Laboratory Technician**

Signature

Approved by: **Katja Pokovic** Name: **Katja Pokovic** Function: **Technical Manager**

Issued: January 22, 2019

This calibration certificate shall not be reproduced except in full without written approval of the laboratory.



Accredited by the Swiss Accreditation Service (SAS)

The Swiss Accreditation Service is one of the signatories to the EA Multilateral Agreement for the recognition of calibration certificates

Accreditation No.: **SCS 0108**

Glossary:

TSL	tissue simulating liquid
ConvF	sensitivity in TSL / NORM x,y,z
N/A	not applicable or not measured

Calibration is Performed According to the Following Standards:

- IEEE Std 1528-2013, "IEEE Recommended Practice for Determining the Peak Spatial-Averaged Specific Absorption Rate (SAR) in the Human Head from Wireless Communications Devices: Measurement Techniques", June 2013
- IEC 62209-1, "Measurement procedure for the assessment of Specific Absorption Rate (SAR) from hand-held and body-mounted devices used next to the ear (frequency range of 300 MHz to 6 GHz)", July 2016
- IEC 62209-2, "Procedure to determine the Specific Absorption Rate (SAR) for wireless communication devices used in close proximity to the human body (frequency range of 30 MHz to 6 GHz)", March 2010
- KDB 865664, "SAR Measurement Requirements for 100 MHz to 6 GHz"

Additional Documentation:

- DASY4/5 System Handbook

Methods Applied and Interpretation of Parameters:

- Measurement Conditions:** Further details are available from the Validation Report at the end of the certificate. All figures stated in the certificate are valid at the frequency indicated.
- Antenna Parameters with TSL:** The dipole is mounted with the spacer to position its feed point exactly below the center marking of the flat phantom section, with the arms oriented parallel to the body axis.
- Feed Point Impedance and Return Loss:** These parameters are measured with the dipole positioned under the liquid filled phantom. The impedance stated is transformed from the measurement at the SMA connector to the feed point. The Return Loss ensures low reflected power. No uncertainty required.
- Electrical Delay:** One-way delay between the SMA connector and the antenna feed point. No uncertainty required.
- SAR measured:** SAR measured at the stated antenna input power.
- SAR normalized:** SAR as measured, normalized to an input power of 1 W at the antenna connector.
- SAR for nominal TSL parameters:** The measured TSL parameters are used to calculate the nominal SAR result.

The reported uncertainty of measurement is stated as the standard uncertainty of measurement multiplied by the coverage factor $k=2$, which for a normal distribution corresponds to a coverage probability of approximately 95%.

Measurement Conditions

DASY system configuration, as far as not given on page 1.

DASY Version	DASY5	V52.10.2
Extrapolation	Advanced Extrapolation	
Phantom	Modular Flat Phantom	
Distance Dipole Center - TSL	15 mm	with Spacer
Zoom Scan Resolution	dx, dy, dz = 5.0 mm	
Frequency	835 MHz \pm 1 MHz	

Head TSL parameters

The following parameters and calculations were applied.

	Temperature	Permittivity	Conductivity
Nominal Head TSL parameters	22.0 °C	41.5	0.90 mho/m
Measured Head TSL parameters	(22.0 \pm 0.2) °C	41.3 \pm 6 %	0.92 mho/m \pm 6 %
Head TSL temperature change during test	< 0.5 °C	----	----

SAR result with Head TSL

SAR averaged over 1 cm³ (1 g) of Head TSL	Condition	
SAR measured	250 mW input power	2.44 W/kg
SAR for nominal Head TSL parameters	normalized to 1W	9.59 W/kg \pm 17.0 % (k=2)

SAR averaged over 10 cm³ (10 g) of Head TSL	condition	
SAR measured	250 mW input power	1.58 W/kg
SAR for nominal Head TSL parameters	normalized to 1W	6.23 W/kg \pm 16.5 % (k=2)

Body TSL parameters

The following parameters and calculations were applied.

	Temperature	Permittivity	Conductivity
Nominal Body TSL parameters	22.0 °C	55.2	0.97 mho/m
Measured Body TSL parameters	(22.0 \pm 0.2) °C	54.6 \pm 6 %	0.99 mho/m \pm 6 %
Body TSL temperature change during test	< 0.5 °C	----	----

SAR result with Body TSL

SAR averaged over 1 cm³ (1 g) of Body TSL	Condition	
SAR measured	250 mW input power	2.46 W/kg
SAR for nominal Body TSL parameters	normalized to 1W	9.67 W/kg \pm 17.0 % (k=2)

SAR averaged over 10 cm³ (10 g) of Body TSL	condition	
SAR measured	250 mW input power	1.61 W/kg
SAR for nominal Body TSL parameters	normalized to 1W	6.35 W/kg \pm 16.5 % (k=2)

Appendix (Additional assessments outside the scope of SCS 0108)

Antenna Parameters with Head TSL

Impedance, transformed to feed point	49.6 Ω - 3.6 j Ω
Return Loss	- 28.7 dB

Antenna Parameters with Body TSL

Impedance, transformed to feed point	47.4 Ω - 6.2 j Ω
Return Loss	- 23.2 dB

General Antenna Parameters and Design

Electrical Delay (one direction)	1.387 ns
----------------------------------	----------

After long term use with 100W radiated power, only a slight warming of the dipole near the feedpoint can be measured.

The dipole is made of standard semirigid coaxial cable. The center conductor of the feeding line is directly connected to the second arm of the dipole. The antenna is therefore short-circuited for DC-signals. On some of the dipoles, small end caps are added to the dipole arms in order to improve matching when loaded according to the position as explained in the "Measurement Conditions" paragraph. The SAR data are not affected by this change. The overall dipole length is still according to the Standard.

No excessive force must be applied to the dipole arms, because they might bend or the soldered connections near the feedpoint may be damaged.

Additional EUT Data

Manufactured by	SPEAG
-----------------	-------

Appendix (Additional assessments outside the scope of SCS 0108)

Measurement Conditions

DASY system configuration, as far as not given on page 1 and 3.

Phantom	SAM Head Phantom	For usage with cSAR3DV2-R/L
---------	------------------	-----------------------------

SAR result with SAM Head (Top)

SAR averaged over 1 cm ³ (1 g) of Head TSL	Condition	
SAR measured	250 mW input power	2.35 W/kg
SAR for nominal Head TSL parameters	normalized to 1W	9.38 W/kg ± 17.5 % (k=2)

SAR averaged over 10 cm ³ (10 g) of Head TSL	condition	
SAR measured	250 mW input power	1.57 W/kg
SAR for nominal Head TSL parameters	normalized to 1W	6.26 W/kg ± 16.9 % (k=2)

SAR result with SAM Head (Mouth)

SAR averaged over 1 cm ³ (1 g) of Head TSL	Condition	
SAR measured	250 mW input power	2.47 W/kg
SAR for nominal Head TSL parameters	normalized to 1W	9.86 W/kg ± 17.5 % (k=2)

SAR averaged over 10 cm ³ (10 g) of Head TSL	condition	
SAR measured	250 mW input power	1.65 W/kg
SAR for nominal Head TSL parameters	normalized to 1W	6.58 W/kg ± 16.9 % (k=2)

SAR result with SAM Head (Neck)

SAR averaged over 1 cm ³ (1 g) of Head TSL	Condition	
SAR measured	250 mW input power	2.36 W/kg
SAR for nominal Head TSL parameters	normalized to 1W	9.42 W/kg ± 17.5 % (k=2)

SAR averaged over 10 cm ³ (10 g) of Head TSL	condition	
SAR measured	250 mW input power	1.60 W/kg
SAR for nominal Head TSL parameters	normalized to 1W	6.38 W/kg ± 16.9 % (k=2)

SAR result with SAM Head (Ear)

SAR averaged over 1 cm ³ (1 g) of Head TSL	Condition	
SAR measured	250 mW input power	2.02 W/kg
SAR for nominal Head TSL parameters	normalized to 1W	8.06 W/kg ± 17.5 % (k=2)

SAR averaged over 10 cm ³ (10 g) of Head TSL	condition	
SAR measured	250 mW input power	1.36 W/kg
SAR for nominal Head TSL parameters	normalized to 1W	5.42 W/kg ± 16.9 % (k=2)

DASY5 Validation Report for Head TSL

Date: 17.01.2019

Test Laboratory: SPEAG, Zurich, Switzerland

DUT: Dipole 835 MHz; Type: D835V2; Serial: D835V2 - SN:4d132

Communication System: UID 0 - CW; Frequency: 835 MHz

Medium parameters used: $f = 835$ MHz; $\sigma = 0.92$ S/m; $\epsilon_r = 41.3$; $\rho = 1000$ kg/m³

Phantom section: Flat Section

Measurement Standard: DASY5 (IEEE/IEC/ANSI C63.19-2011)

DASY52 Configuration:

- Probe: EX3DV4 - SN7349; ConvF(10, 10, 10) @ 835 MHz; Calibrated: 31.12.2018
- Sensor-Surface: 1.4mm (Mechanical Surface Detection)
- Electronics: DAE4 Sn601; Calibrated: 04.10.2018
- Phantom: Flat Phantom 4.9 (front); Type: QD 00L P49 AA; Serial: 1001
- DASY52 52.10.2(1495); SEMCAD X 14.6.12(7450)

Dipole Calibration for Head Tissue/Pin=250 mW, d=15mm/Zoom Scan (7x7x7)/Cube 0:

Measurement grid: dx=5mm, dy=5mm, dz=5mm

Reference Value = 34.24 V/m; Power Drift = -0.00 dB

Peak SAR (extrapolated) = 3.73 W/kg

SAR(1 g) = 2.44 W/kg; SAR(10 g) = 1.58 W/kg

Maximum value of SAR (measured) = 3.28 W/kg

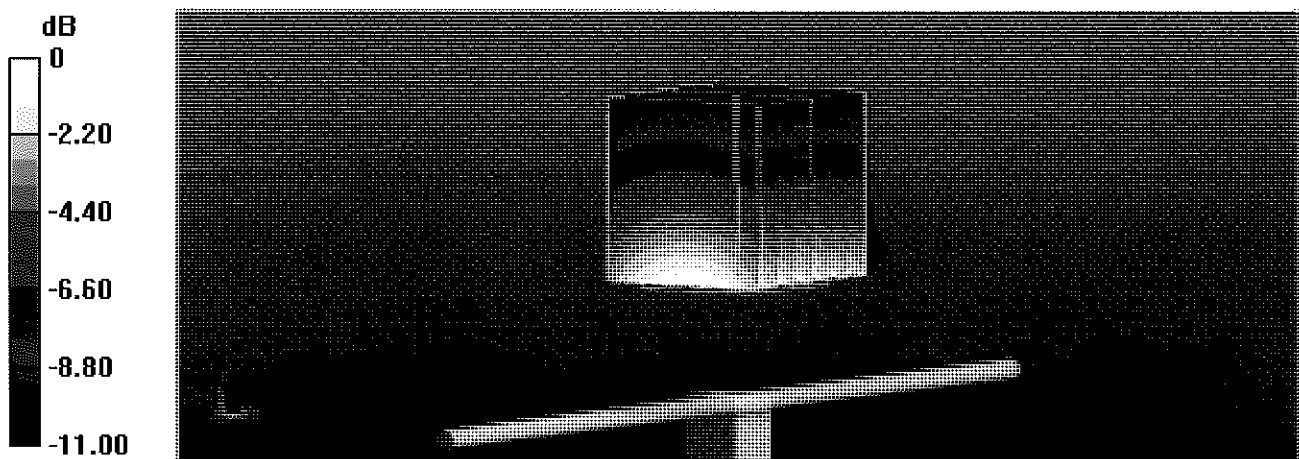

0 dB = 3.28 W/kg = 5.16 dBW/kg

Impedance Measurement Plot for Head TSL

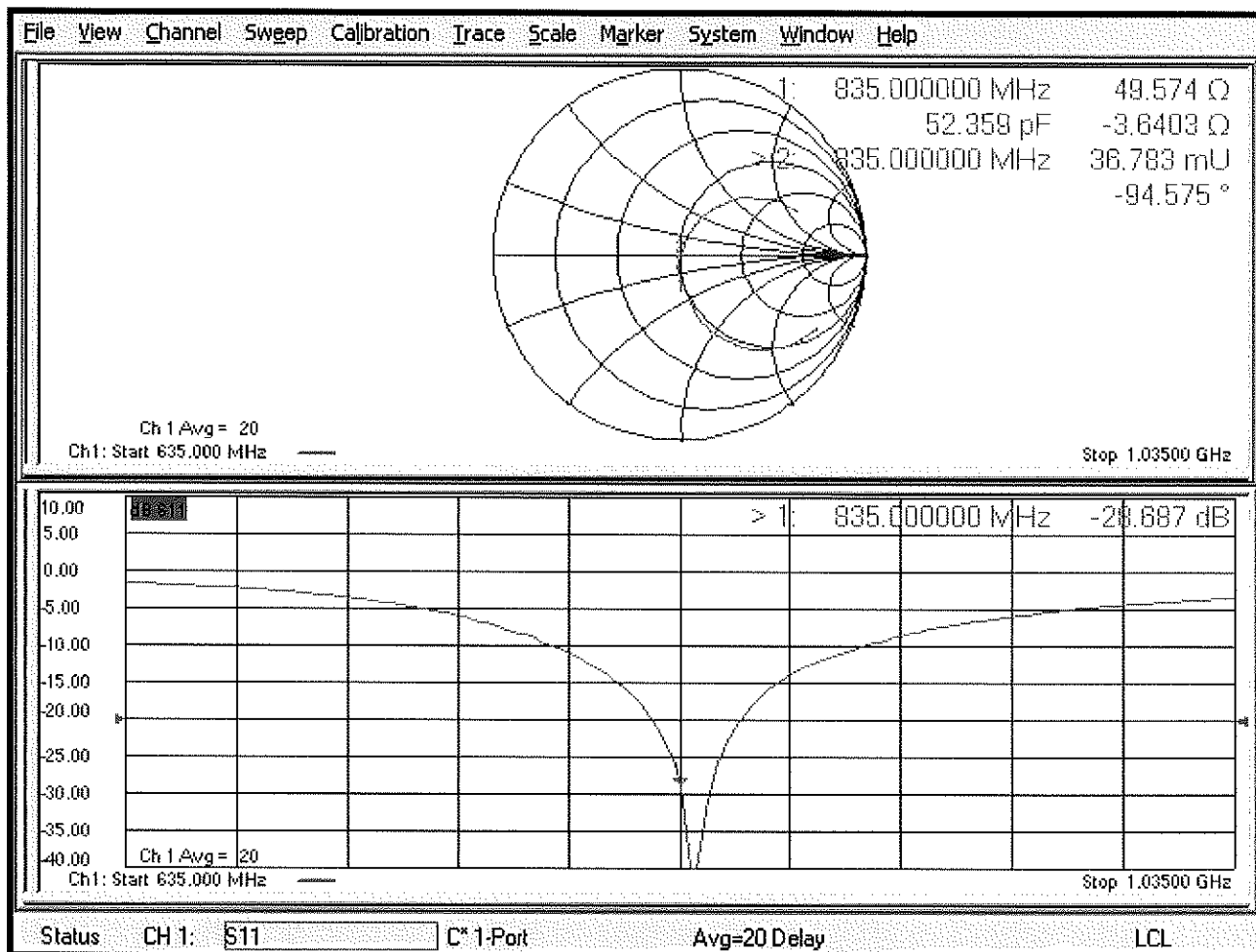

DASY5 Validation Report for Body TSL

Date: 17.01.2019

Test Laboratory: SPEAG, Zurich, Switzerland

DUT: Dipole 835 MHz; Type: D835V2; Serial: D835V2 - SN:4d132

Communication System: UID 0 - CW; Frequency: 835 MHz

Medium parameters used: $f = 835$ MHz; $\sigma = 0.99$ S/m; $\epsilon_r = 54.6$; $\rho = 1000$ kg/m³

Phantom section: Flat Section

Measurement Standard: DASY5 (IEEE/IEC/ANSI C63.19-2011)

DASY52 Configuration:

- Probe: EX3DV4 - SN7349; ConvF(10.15, 10.15, 10.15) @ 835 MHz; Calibrated: 31.12.2018
- Sensor-Surface: 1.4mm (Mechanical Surface Detection)
- Electronics: DAE4 Sn601; Calibrated: 04.10.2018
- Phantom: Flat Phantom 4.9 (Back); Type: QD 00R P49 AA; Serial: 1005
- DASY52 52.10.2(1495); SEMCAD X 14.6.12(7450)

Dipole Calibration for Body Tissue/Pin=250 mW, d=15mm/Zoom Scan (7x7x7)/Cube 0:

Measurement grid: dx=5mm, dy=5mm, dz=5mm

Reference Value = 63.32 V/m; Power Drift = -0.07 dB

Peak SAR (extrapolated) = 3.64 W/kg

SAR(1 g) = 2.46 W/kg; SAR(10 g) = 1.61 W/kg

Maximum value of SAR (measured) = 3.26 W/kg

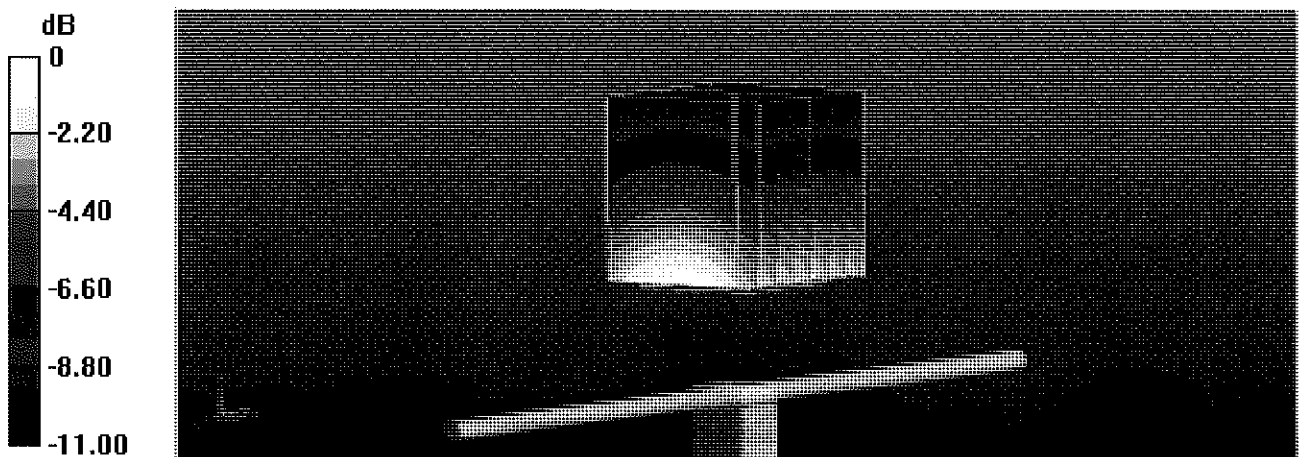

0 dB = 3.26 W/kg = 5.13 dBW/kg

Impedance Measurement Plot for Body TSL

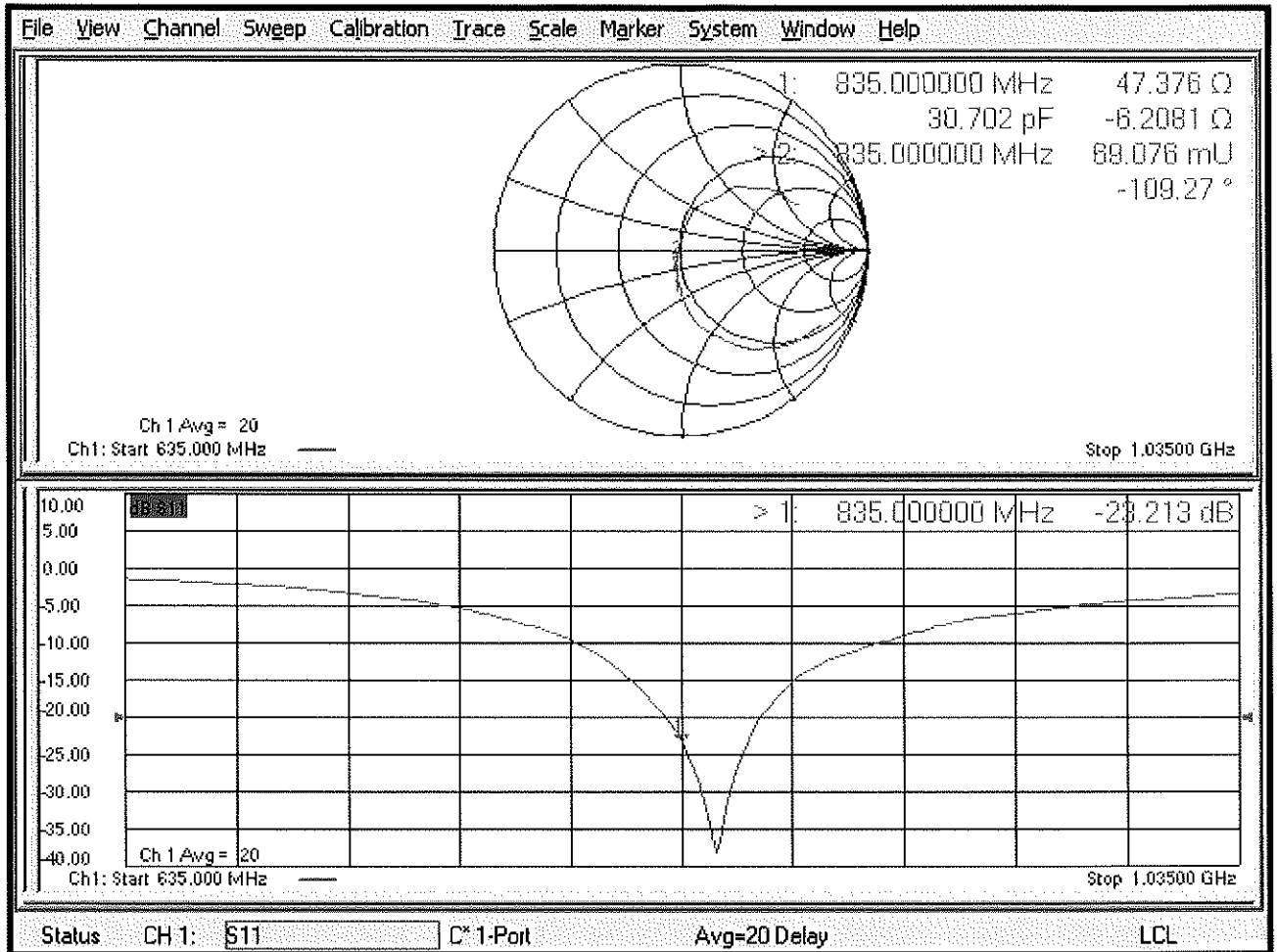

DASY5 Validation Report for SAM Head

Date: 22.01.2019

Test Laboratory: SPEAG, Zurich, Switzerland

DUT: Dipole 835 MHz; Type: D835V2; Serial: D835V2 - SN:4d132

Communication System: UID 0 - CW; Frequency: 835 MHz

Medium parameters used: $f = 835$ MHz; $\sigma = 0.92$ S/m; $\epsilon_r = 44.4$; $\rho = 1000$ kg/m³

Measurement Standard: DASY5 (IEEE/IEC/ANSI C63.19-2011)

DASY52 Configuration:

- Probe: EX3DV4 - SN7349; ConvF(10, 10, 10) @ 835 MHz; Calibrated: 31.12.2018
- Sensor-Surface: 1.4mm (Mechanical Surface Detection)
- Electronics: DAE4 Sn601; Calibrated: 04.10.2018
- Phantom: SAM Head
- DASY52 52.10.2(1495); SEMCAD X 14.6.12(7450)

SAM/Head/Top/Zoom Scan (7x7x7)/Cube 0: Measurement grid: dx=5mm, dy=5mm, dz=5mm

Reference Value = 61.32 V/m; Power Drift = -0.04 dB

Peak SAR (extrapolated) = 3.51 W/kg

SAR(1 g) = 2.35 W/kg; SAR(10 g) = 1.57 W/kg

Maximum value of SAR (measured) = 3.12 W/kg

SAM/Head/Mouth/Zoom Scan (7x7x7)/Cube 0: Measurement grid: dx=5mm, dy=5mm, dz=5mm

Reference Value = 62.25 V/m; Power Drift = 0.01 dB

Peak SAR (extrapolated) = 3.67 W/kg

SAR(1 g) = 2.47 W/kg; SAR(10 g) = 1.65 W/kg

Maximum value of SAR (measured) = 3.24 W/kg

SAM/Head/Neck/Zoom Scan (7x7x7)/Cube 0: Measurement grid: dx=5mm, dy=5mm, dz=5mm

Reference Value = 60.69 V/m; Power Drift = 0.05 dB

Peak SAR (extrapolated) = 3.43 W/kg

SAR(1 g) = 2.36 W/kg; SAR(10 g) = 1.6 W/kg

Maximum value of SAR (measured) = 3.08 W/kg

SAM/Head/Ear/Zoom Scan (8x7x7)/Cube 0: Measurement grid: dx=5mm, dy=5mm, dz=5mm

Reference Value = 55.79 V/m; Power Drift = 0.05 dB

Peak SAR (extrapolated) = 2.94 W/kg

SAR(1 g) = 2.02 W/kg; SAR(10 g) = 1.36 W/kg

Maximum value of SAR (measured) = 2.62 W/kg

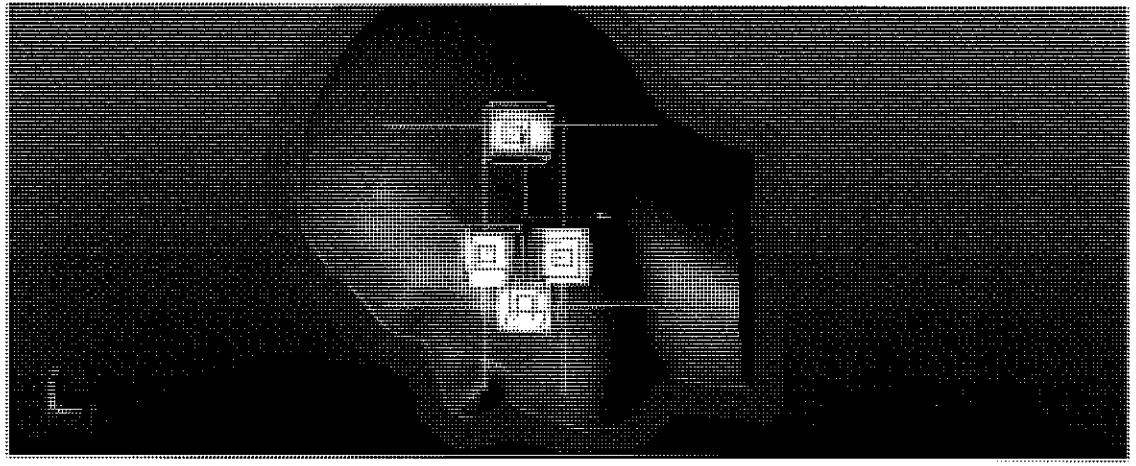
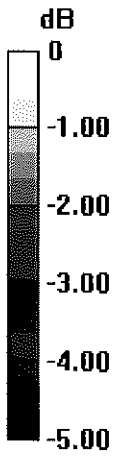

0 dB = 2.62 W/kg = 4.18 dBW/kg



Accredited by the Swiss Accreditation Service (SAS)
The Swiss Accreditation Service is one of the signatories to the EA
Multilateral Agreement for the recognition of calibration certificates

Accreditation No.: **SCS 0108**

Client **PC Test**

Certificate No: **D1765V2-1008_May18**

CALIBRATION CERTIFICATE

Object: **D1765V2 - SN:1008**

Calibration procedure(s): **QA CAL-05.v10
Calibration procedure for dipole validation kits above 700 MHz**

Calibration date: **May 23, 2018**

BN ✓
7/16/2018
BN ✓
05/20/2019

This calibration certificate documents the traceability to national standards, which realize the physical units of measurements (SI).
The measurements and the uncertainties with confidence probability are given on the following pages and are part of the certificate.

All calibrations have been conducted in the closed laboratory facility: environment temperature (22 ± 3)°C and humidity < 70%.

Calibration Equipment used (M&TE critical for calibration)

Primary Standards	ID #	Cal Date (Certificate No.)	Scheduled Calibration
Power meter NRP	SN: 104778	04-Apr-18 (No. 217-02672/02673)	Apr-19
Power sensor NRP-Z91	SN: 103244	04-Apr-18 (No. 217-02672)	Apr-19
Power sensor NRP-Z91	SN: 103245	04-Apr-18 (No. 217-02673)	Apr-19
Reference 20 dB Attenuator	SN: 5058 (20k)	04-Apr-18 (No. 217-02682)	Apr-19
Type-N mismatch combination	SN: 5047.2 / 06327	04-Apr-18 (No. 217-02683)	Apr-19
Reference Probe EX3DV4	SN: 7349	30-Dec-17 (No. EX3-7349_Dec17)	Dec-18
DAE4	SN: 601	26-Oct-17 (No. DAE4-601_Oct17)	Oct-18

Secondary Standards	ID #	Check Date (in house)	Scheduled Check
Power meter EPM-442A	SN: GB37480704	07-Oct-15 (in house check Oct-16)	In house check: Oct-18
Power sensor HP 8481A	SN: US37292783	07-Oct-15 (in house check Oct-16)	In house check: Oct-18
Power sensor HP 8481A	SN: MY41092317	07-Oct-15 (in house check Oct-16)	In house check: Oct-18
RF generator R&S SMT-06	SN: 100972	15-Jun-15 (in house check Oct-16)	In house check: Oct-18
Network Analyzer HP 8753E	SN: US37390585	18-Oct-01 (in house check Oct-17)	In house check: Oct-18

Calibrated by: **Manu Seitz** (Name), **Laboratory Technician** (Function), *[Signature]* (Signature)

Approved by: **Katja Pokovic** (Name), **Technical Manager** (Function), *[Signature]* (Signature)

Issued: May 23, 2018

This calibration certificate shall not be reproduced except in full without written approval of the laboratory.



Accredited by the Swiss Accreditation Service (SAS)

The Swiss Accreditation Service is one of the signatories to the EA
Multilateral Agreement for the recognition of calibration certificates

Accreditation No.: **SCS 0108**

Glossary:

TSL	tissue simulating liquid
ConvF	sensitivity in TSL / NORM x,y,z
N/A	not applicable or not measured

Calibration is Performed According to the Following Standards:

- IEEE Std 1528-2013, "IEEE Recommended Practice for Determining the Peak Spatial-Averaged Specific Absorption Rate (SAR) in the Human Head from Wireless Communications Devices: Measurement Techniques", June 2013
- IEC 62209-1, "Measurement procedure for the assessment of Specific Absorption Rate (SAR) from hand-held and body-mounted devices used next to the ear (frequency range of 300 MHz to 6 GHz)", July 2016
- IEC 62209-2, "Procedure to determine the Specific Absorption Rate (SAR) for wireless communication devices used in close proximity to the human body (frequency range of 30 MHz to 6 GHz)", March 2010
- KDB 865664, "SAR Measurement Requirements for 100 MHz to 6 GHz"

Additional Documentation:

- DASY4/5 System Handbook

Methods Applied and Interpretation of Parameters:

- Measurement Conditions:** Further details are available from the Validation Report at the end of the certificate. All figures stated in the certificate are valid at the frequency indicated.
- Antenna Parameters with TSL:** The dipole is mounted with the spacer to position its feed point exactly below the center marking of the flat phantom section, with the arms oriented parallel to the body axis.
- Feed Point Impedance and Return Loss:** These parameters are measured with the dipole positioned under the liquid filled phantom. The impedance stated is transformed from the measurement at the SMA connector to the feed point. The Return Loss ensures low reflected power. No uncertainty required.
- Electrical Delay:** One-way delay between the SMA connector and the antenna feed point. No uncertainty required.
- SAR measured:** SAR measured at the stated antenna input power.
- SAR normalized:** SAR as measured, normalized to an input power of 1 W at the antenna connector.
- SAR for nominal TSL parameters:** The measured TSL parameters are used to calculate the nominal SAR result.

The reported uncertainty of measurement is stated as the standard uncertainty of measurement multiplied by the coverage factor $k=2$, which for a normal distribution corresponds to a coverage probability of approximately 95%.

Measurement Conditions

DASY system configuration, as far as not given on page 1.

DASY Version	DASY5	V52.10.1
Extrapolation	Advanced Extrapolation	
Phantom	Modular Flat Phantom	
Distance Dipole Center - TSL	10 mm	with Spacer
Zoom Scan Resolution	dx, dy, dz = 5.0 mm	
Frequency	1750 MHz \pm 1 MHz	

Head TSL parameters

The following parameters and calculations were applied.

	Temperature	Permittivity	Conductivity
Nominal Head TSL parameters	22.0 °C	40.1	1.37 mho/m
Measured Head TSL parameters	(22.0 \pm 0.2) °C	39.0 \pm 6 %	1.34 mho/m \pm 6 %
Head TSL temperature change during test	< 0.5 °C	----	----

SAR result with Head TSL

SAR averaged over 1 cm³ (1 g) of Head TSL	Condition	
SAR measured	250 mW input power	8.94 W/kg
SAR for nominal Head TSL parameters	normalized to 1W	36.2 W/kg \pm 17.0 % (k=2)

SAR averaged over 10 cm³ (10 g) of Head TSL	condition	
SAR measured	250 mW input power	4.71 W/kg
SAR for nominal Head TSL parameters	normalized to 1W	19.0 W/kg \pm 16.5 % (k=2)

Body TSL parameters

The following parameters and calculations were applied.

	Temperature	Permittivity	Conductivity
Nominal Body TSL parameters	22.0 °C	53.4	1.49 mho/m
Measured Body TSL parameters	(22.0 \pm 0.2) °C	53.2 \pm 6 %	1.46 mho/m \pm 6 %
Body TSL temperature change during test	< 0.5 °C	----	----

SAR result with Body TSL

SAR averaged over 1 cm³ (1 g) of Body TSL	Condition	
SAR measured	250 mW input power	9.21 W/kg
SAR for nominal Body TSL parameters	normalized to 1W	37.4 W/kg \pm 17.0 % (k=2)

SAR averaged over 10 cm³ (10 g) of Body TSL	condition	
SAR measured	250 mW input power	4.92 W/kg
SAR for nominal Body TSL parameters	normalized to 1W	19.9 W/kg \pm 16.5 % (k=2)

Appendix (Additional assessments outside the scope of SCS 0108)

Antenna Parameters with Head TSL

Impedance, transformed to feed point	47.7 Ω - 6.5 j Ω
Return Loss	- 23.0 dB

Antenna Parameters with Body TSL

Impedance, transformed to feed point	43.3 Ω - 6.0 j Ω
Return Loss	- 20.3 dB

General Antenna Parameters and Design

Electrical Delay (one direction)	1.210 ns
----------------------------------	----------

After long term use with 100W radiated power, only a slight warming of the dipole near the feedpoint can be measured.

The dipole is made of standard semirigid coaxial cable. The center conductor of the feeding line is directly connected to the second arm of the dipole. The antenna is therefore short-circuited for DC-signals. On some of the dipoles, small end caps are added to the dipole arms in order to improve matching when loaded according to the position as explained in the "Measurement Conditions" paragraph. The SAR data are not affected by this change. The overall dipole length is still according to the Standard.

No excessive force must be applied to the dipole arms, because they might bend or the soldered connections near the feedpoint may be damaged.

Additional EUT Data

Manufactured by	SPEAG
Manufactured on	October 06, 2005

Appendix (Additional assessments outside the scope of SCS 0108)

Measurement Conditions

DASY system configuration, as far as not given on page 1 and 3.

Phantom	SAM Head Phantom	For usage with cSAR3DV2-R/L
---------	------------------	-----------------------------

SAR result with SAM Head (Top)

SAR averaged over 1 cm ³ (1 g) of Head TSL	Condition	
SAR measured	250 mW input power	9.26 W/kg
SAR for nominal Head TSL parameters	normalized to 1W	37.4 W/kg ± 17.5 % (k=2)

SAR averaged over 10 cm ³ (10 g) of Head TSL	condition	
SAR measured	250 mW input power	4.95 W/kg
SAR for nominal Head TSL parameters	normalized to 1W	19.9 W/kg ± 16.9 % (k=2)

SAR result with SAM Head (Mouth)

SAR averaged over 1 cm ³ (1 g) of Head TSL	Condition	
SAR measured	250 mW input power	9.47 W/kg
SAR for nominal Head TSL parameters	normalized to 1W	38.2 W/kg ± 17.5 % (k=2)

SAR averaged over 10 cm ³ (10 g) of Head TSL	condition	
SAR measured	250 mW input power	5.06 W/kg
SAR for nominal Head TSL parameters	normalized to 1W	20.4 W/kg ± 16.9 % (k=2)

SAR result with SAM Head (Neck)

SAR averaged over 1 cm ³ (1 g) of Head TSL	Condition	
SAR measured	250 mW input power	9.26 W/kg
SAR for nominal Head TSL parameters	normalized to 1W	37.4 W/kg ± 17.5 % (k=2)

SAR averaged over 10 cm ³ (10 g) of Head TSL	condition	
SAR measured	250 mW input power	5.02 W/kg
SAR for nominal Head TSL parameters	normalized to 1W	20.2 W/kg ± 16.9 % (k=2)

SAR result with SAM Head (Ear)

SAR averaged over 1 cm ³ (1 g) of Head TSL	Condition	
SAR measured	250 mW input power	7.12 W/kg
SAR for nominal Head TSL parameters	normalized to 1W	28.7 W/kg ± 17.5 % (k=2)

SAR averaged over 10 cm ³ (10 g) of Head TSL	condition	
SAR measured	250 mW input power	4.01 W/kg
SAR for nominal Head TSL parameters	normalized to 1W	16.1 W/kg ± 16.9 % (k=2)

DASY5 Validation Report for Head TSL

Date: 15.05.2018

Test Laboratory: SPEAG, Zurich, Switzerland

DUT: Dipole 1765 MHz; Type: D1765V2; Serial: D1765V2 - SN:1008

Communication System: UID 0 - CW; Frequency: 1750 MHz

Medium parameters used: $f = 1750$ MHz; $\sigma = 1.34$ S/m; $\epsilon_r = 39$; $\rho = 1000$ kg/m³

Phantom section: Flat Section

Measurement Standard: DASY5 (IEEE/IEC/ANSI C63.19-2011)

DASY52 Configuration:

- Probe: EX3DV4 - SN7349; ConvF(8.5, 8.5, 8.5) @ 1750 MHz; Calibrated: 30.12.2017
- Sensor-Surface: 1.4mm (Mechanical Surface Detection)
- Electronics: DAE4 Sn601; Calibrated: 26.10.2017
- Phantom: Flat Phantom 5.0 (front); Type: QD 000 P50 AA; Serial: 1001
- DASY52 52.10.1(1476); SEMCAD X 14.6.11(7439)

Dipole Calibration for Head Tissue/Pin=250 mW, d=10mm/Zoom Scan (7x7x7)/Cube 0:

Measurement grid: dx=5mm, dy=5mm, dz=5mm

Reference Value = 106.6 V/m; Power Drift = -0.02 dB

Peak SAR (extrapolated) = 16.4 W/kg

SAR(1 g) = 8.94 W/kg; SAR(10 g) = 4.71 W/kg

Maximum value of SAR (measured) = 13.8 W/kg

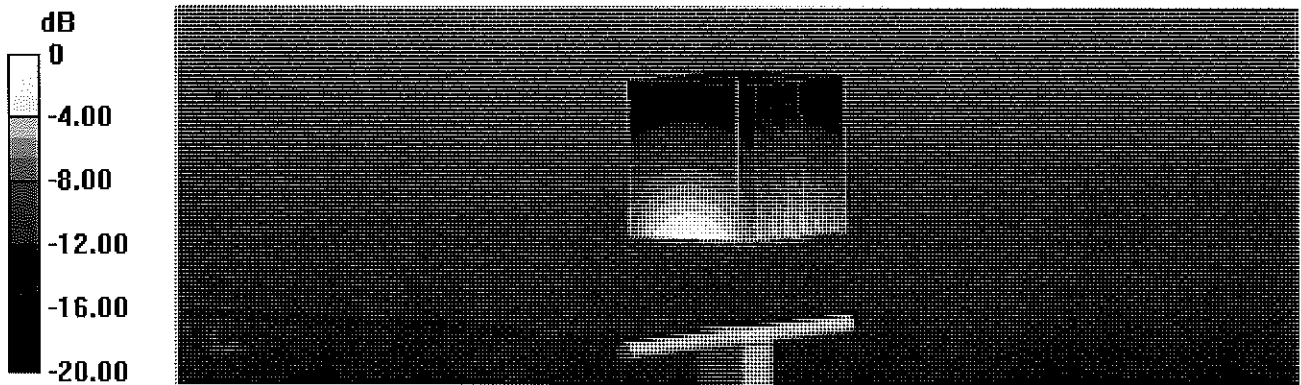

Impedance Measurement Plot for Head TSL

15 May 2018 11:19:20

CH1 S11 1 U FS 1: 47.658 Ω -6.5039 Ω 13.983 pF 1 750.000 000 MHz

*
De1
CA
Avg
16
H1d

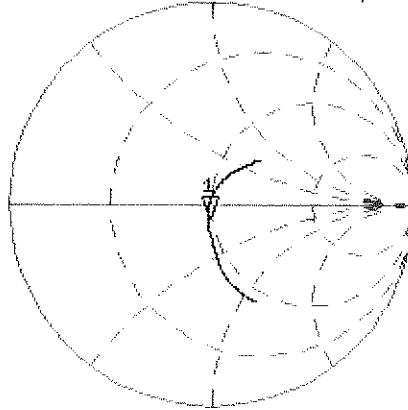

CH2 S11 LOG 5 dB/REF -20 dB 1:-23.017 dB 1 750.000 000 MHz

CA
Avg
16
H1d

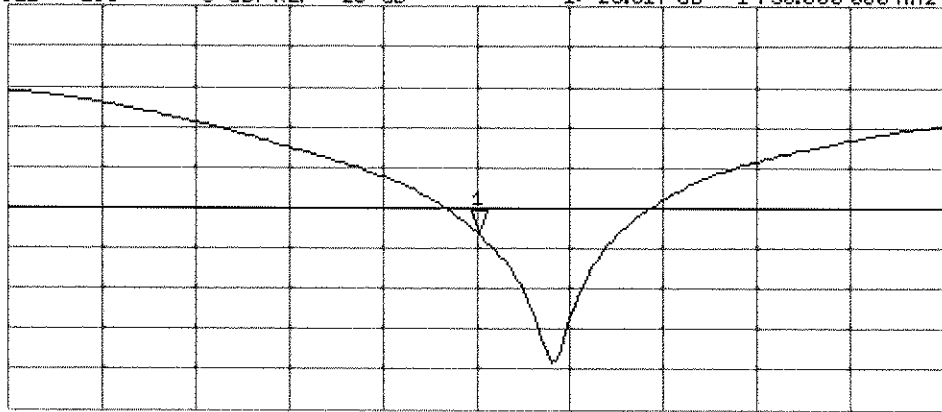

START 1 550.000 000 MHz

STOP 1 950.000 000 MHz

DASY5 Validation Report for Body TSL

Date: 15.05.2018

Test Laboratory: SPEAG, Zurich, Switzerland

DUT: Dipole 1765 MHz; Type: D1765V2; Serial: D1765V2 - SN:1008

Communication System: UID 0 - CW; Frequency: 1750 MHz

Medium parameters used: $f = 1750$ MHz; $\sigma = 1.46$ S/m; $\epsilon_r = 53.2$; $\rho = 1000$ kg/m³

Phantom section: Flat Section

Measurement Standard: DASY5 (IEEE/IEC/ANSI C63.19-2011)

DASY52 Configuration:

- Probe: EX3DV4 - SN7349; ConvF(8.35, 8.35, 8.35) @ 1750 MHz; Calibrated: 30.12.2017
- Sensor-Surface: 1.4mm (Mechanical Surface Detection)
- Electronics: DAE4 Sn601; Calibrated: 26.10.2017
- Phantom: Flat Phantom 5.0 (back); Type: QD 000 P50 AA; Serial: 1002
- DASY52 52.10.1(1476); SEMCAD X 14.6.11(7439)

Dipole Calibration for Body Tissue/Pin=250 mW, d=10mm/Zoom Scan (7x7x7)/Cube 0:

Measurement grid: dx=5mm, dy=5mm, dz=5mm

Reference Value = 102.4 V/m; Power Drift = -0.06 dB

Peak SAR (extrapolated) = 16.1 W/kg

SAR(1 g) = 9.21 W/kg; SAR(10 g) = 4.92 W/kg

Maximum value of SAR (measured) = 13.7 W/kg

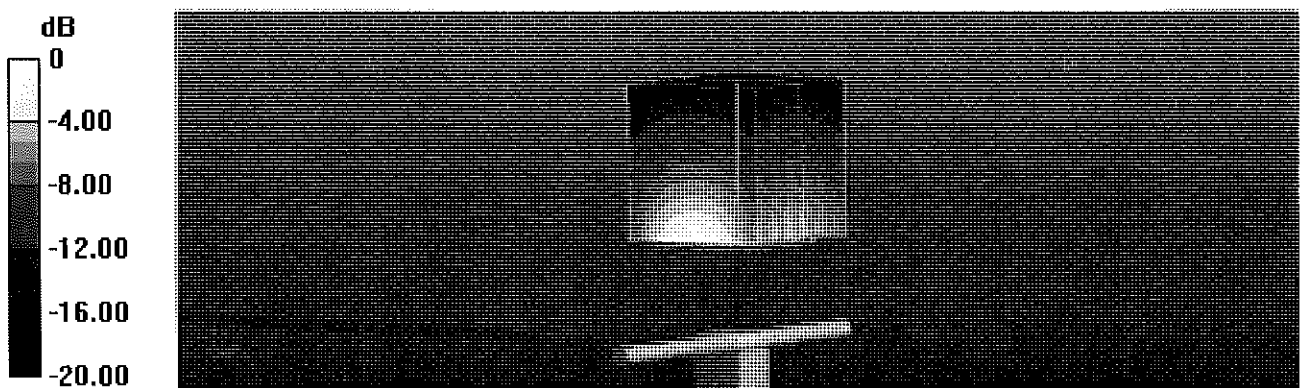

Impedance Measurement Plot for Body TSL

15 May 2018 11:18:17

CH1 S11 1 U FS 1: 43.322 Ω -6.0117 Ω 15.128 pF 1 750.000 000 MHz

*
De1
CA
Avg
16
H1d

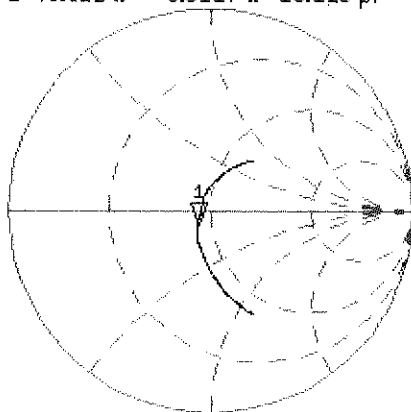

CH2 S11 LOG 5 dB/REF -20 dB 1:-20.349 dB 1 750.000 000 MHz

CA
Avg
16
H1d

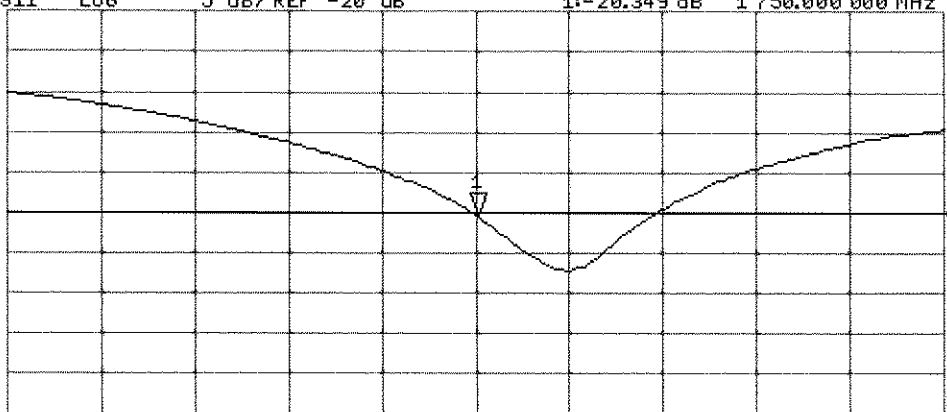

START 1 550.000 000 MHz

STOP 1 950.000 000 MHz

DASY5 Validation Report for SAM Head

Date: 23.05.2018

Test Laboratory: SPEAG, Zurich, Switzerland

DUT: Dipole 1765 MHz; Type: D1765V2; Serial: D1765V2 - SN:1008

Communication System: UID 0 - CW; Frequency: 1750 MHz

Medium parameters used: $f = 1750$ MHz; $\sigma = 1.37$ S/m; $\epsilon_r = 41.8$; $\rho = 1000$ kg/m³

Measurement Standard: DASY5 (IEEE/IEC/ANSI C63.19-2011)

DASY52 Configuration:

- Probe: EX3DV4 - SN7349; ConvF(8.5, 8.5, 8.5) @ 1750 MHz; Calibrated: 30.12.2017
- Sensor-Surface: 1.4mm (Mechanical Surface Detection)
- Electronics: DAE4 Sn601; Calibrated: 26.10.2017
- Phantom: SAM Head
- DASY52 52.10.1(1476); SEMCAD X 14.6.11(7439)

SAM/Head/Top/Zoom Scan (7x7x7)/Cube 0: Measurement grid: dx=5mm, dy=5mm, dz=5mm

Reference Value = 105.8 V/m; Power Drift = 0.02 dB

Peak SAR (extrapolated) = 16.4 W/kg

SAR(1 g) = 9.26 W/kg; SAR(10 g) = 4.95 W/kg

Maximum value of SAR (measured) = 13.9 W/kg

SAM/Head/Mouth/Zoom Scan (7x7x7)/Cube 0: Measurement grid: dx=5mm, dy=5mm, dz=5mm

Reference Value = 104.2 V/m; Power Drift = -0.04 dB

Peak SAR (extrapolated) = 16.6 W/kg

SAR(1 g) = 9.47 W/kg; SAR(10 g) = 5.06 W/kg

Maximum value of SAR (measured) = 13.7 W/kg

SAM/Head/Neck/Zoom Scan (7x7x7)/Cube 0: Measurement grid: dx=5mm, dy=5mm, dz=5mm

Reference Value = 104.7 V/m; Power Drift = 0.02 dB

Peak SAR (extrapolated) = 15.8 W/kg

SAR(1 g) = 9.26 W/kg; SAR(10 g) = 5.02 W/kg

Maximum value of SAR (measured) = 13.8 W/kg

SAM/Head/Ear/Zoom Scan (7x7x7)/Cube 0: Measurement grid: dx=5mm, dy=5mm, dz=5mm

Reference Value = 90.46 V/m; Power Drift = -0.02 dB

Peak SAR (extrapolated) = 11.8 W/kg

SAR(1 g) = 7.12 W/kg; SAR(10 g) = 4.01 W/kg

Maximum value of SAR (measured) = 10.3 W/kg

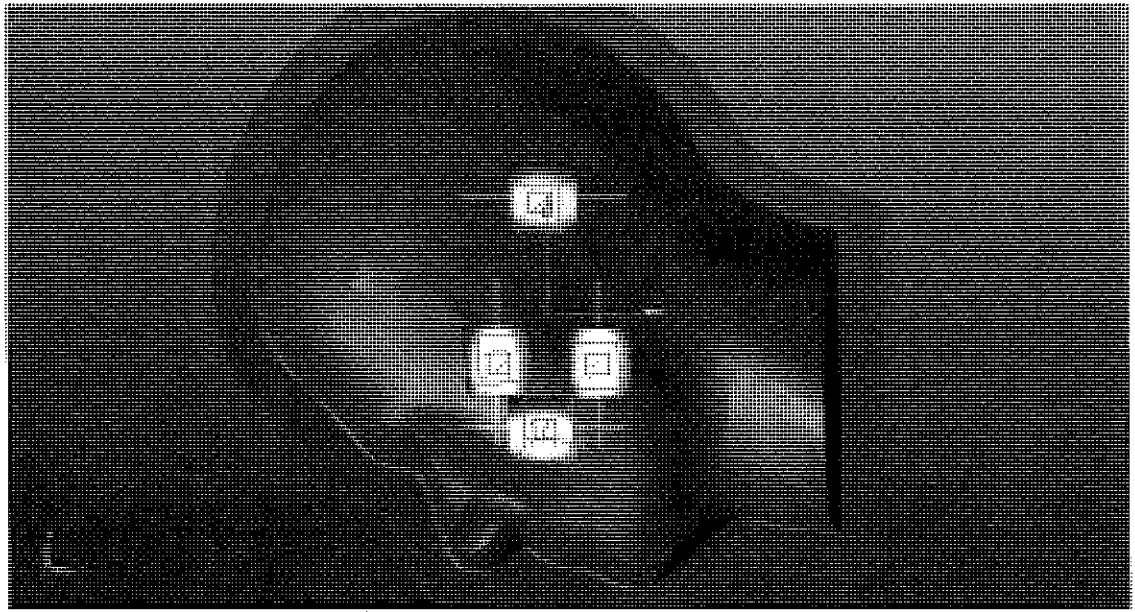
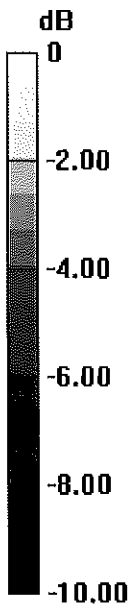

0 dB = 10.3 W/kg = 10.13 dBW/kg

Certification of Calibration

Object: D1765V2 – SN: 1008

Calibration procedure(s): Procedure for Calibration Extension for SAR Dipoles.

Extension Calibration date: 5/17/2019

Description: SAR Validation Dipole at 1750 MHz.

Calibration Equipment used:

Manufacturer	Model	Description	Cal Date	Cal Interval	Cal Due	Serial Number
Agilent	8753ES	S-Parameter Network Analyzer	3/11/2019	Annual	3/11/2020	US39170122
Agilent	N5182A	MXG Vector Signal Generator	11/28/2018	Annual	11/28/2019	MY47420603
Amplifier Research	15S1G6	Amplifier	CBT	N/A	CBT	433971
Anritsu	MA2411B	Pulse Power Sensor	11/20/2018	Annual	11/20/2019	1027293
Anritsu	MA2411B	Pulse Power Sensor	10/30/2018	Annual	10/30/2019	1126066
Anritsu	ML2495A	Power Meter	10/21/2018	Annual	10/21/2019	941001
Control Company	4040	Therm./ Clock/ Humidity Monitor	10/9/2018	Biennial	10/9/2020	181647811
Control Company	4352	Ultra Long Stem Thermometer	6/6/2018	Biennial	6/6/2020	181334678
Keysight	772D	Dual Directional Coupler	CBT	N/A	CBT	MY52180215
Keysight Technologies	85033E	Standard Mechanical Calibration Kit (DC to 9GHz, 3.5mm)	6/4/2018	Annual	6/4/2019	MY53401181
MiniCircuits	VLF-6000+	Low Pass Filter	CBT	N/A	CBT	N/A
Mini-Circuits	BW-N20W5+	DC to 18 GHz Precision Fixed 20 dB Attenuator	CBT	N/A	CBT	N/A
Narda	4772-3	Attenuator (3dB)	CBT	N/A	CBT	9406
Pasternack	PE2209-10	Bidirectional Coupler	CBT	N/A	CBT	N/A
Seekonk	NC-100	Torque Wrench	7/11/2018	Annual	7/11/2019	N/A
SPEAG	EX3DV4	SAR Probe	6/25/2018	Annual	6/25/2019	7409
SPEAG	DAE4	Dasy Data Acquisition Electronics	6/18/2018	Annual	6/18/2019	1334
SPEAG	EX3DV4	SAR Probe	2/19/2019	Annual	2/19/2020	3914
SPEAG	DAE4	Dasy Data Acquisition Electronics	2/14/2019	Annual	2/14/2020	1272
SPEAG	DAK-3.5	Dielectric Assessment Kit	9/11/2018	Annual	9/11/2019	1091

Measurement Uncertainty = $\pm 23\%$ (k=2)

	Name	Function	Signature
Calibrated By:	Brodie Halfoster	Test Engineer	<i>BRODIE HALFOSTER</i>
Approved By:	Kaitlin O'Keefe	Senior Technical Manager	<i>KOK</i>