



SAR EVALUATION REPORT

Applicant Name:
 Samsung Electronics, Co. Ltd.
 129, Samsung-ro, Maetan dong,
 Yeongtong-gu, Suwon-si
 Gyeonggi-do 443-742, Korea

Date of Testing:
 08/14/14 - 08/23/14
Test Site/Location:
 PCTEST Lab, Columbia, MD, USA
Document Serial No.:
 OY1408181741.A3L

FCC ID: A3LSMN915X

APPLICANT: SAMSUNG ELECTRONICS, CO. LTD.

DUT Type: Portable Handset
Application Type: Certification
FCC Rule Part(s): CFR §2.1093
Model(s): SM-N915X

| Equipment Class | Band & Mode | Tx Frequency | SAR | | |
|---|--------------|-----------------|------------------|-----------------------|------------------------|
| | | | 1 gm Head (W/kg) | 1 gm Body-Worn (W/kg) | 10 gm Extremity (W/kg) |
| DTS | 2.4 GHz WLAN | 2412 - 2462 MHz | 0.21 | < 0.1 | 0.32 |
| DTS | 5.8 GHz WLAN | 5745 - 5825 MHz | < 0.1 | 0.19 | 0.32 |
| NII | 5.2 GHz WLAN | 5180 - 5240 MHz | < 0.1 | 0.39 | 0.62 |
| NII | 5.3 GHz WLAN | 5260 - 5320 MHz | < 0.1 | 0.40 | 0.71 |
| NII | 5.5 GHz WLAN | 5500 - 5700 MHz | 0.11 | 0.43 | 1.33 |
| DSS/DTS | Bluetooth | 2402 - 2480 MHz | N/A | | |
| Simultaneous SAR per KDB 690783 D01v01r03: | | | 0.08 | 0.16 | 0.18 |

This wireless portable device has been shown to be capable of compliance for localized specific absorption rate (SAR) for uncontrolled environment/general population exposure limits specified in ANSI/IEEE C95.1-1992 and has been tested in accordance with the measurement procedures specified in Section 1.8 of this report; for North American frequency bands only.



I attest to the accuracy of data. All measurements reported herein were performed by me or were made under my supervision and are correct to the best of my knowledge and belief. I assume full responsibility for the completeness of these measurements and vouch for the qualifications of all persons taking them. Test results reported herein relate only to the item(s) tested.



Randy Ortanez
 President





The SAR Tick is an initiative of the Mobile Manufacturers Forum (MMF). While a product may be considered eligible, use of the SAR Tick logo requires an agreement with the MMF. Further details can be obtained by emailing: sartick@mmfai.info.

| | | | | |
|--|---|--------------------------------------|---|--|
| FCC ID: A3LSMN915X |  | SAR EVALUATION REPORT |  | Reviewed by: Quality Manager |
| Document S/N: OY1408181741.A3L | Test Dates: 08/14/14 - 08/23/14 | DUT Type: Portable Handset | Page 1 of 40 | |

T A B L E O F C O N T E N T S

| | | |
|---|---|----|
| 1 | DEVICE UNDER TEST | 3 |
| 2 | INTRODUCTION | 8 |
| 3 | DOSIMETRIC ASSESSMENT | 9 |
| 4 | DEFINITION OF REFERENCE POINTS | 10 |
| 5 | TEST CONFIGURATION POSITIONS FOR HANDSETS | 11 |
| 6 | RF EXPOSURE LIMITS | 14 |
| 7 | FCC MEASUREMENT PROCEDURES | 15 |
| 8 | RF CONDUCTED POWERS | 16 |
| 9 | SYSTEM VERIFICATION | 26 |
| 10 | SAR DATA SUMMARY | 28 |
| 11 | SAR MEASUREMENT VARIABILITY | 34 |
| 12 | EQUIPMENT LIST | 35 |
| 13 | MEASUREMENT UNCERTAINTIES | 36 |
| 14 | CONCLUSION | 38 |
| 15 | REFERENCES | 39 |
| APPENDIX A: SAR TEST PLOTS | | |
| APPENDIX B: SAR DIPOLE VERIFICATION PLOTS | | |
| APPENDIX C: PROBE AND DIPOLE CALIBRATION CERTIFICATES | | |
| APPENDIX D: SAR TISSUE SPECIFICATIONS | | |
| APPENDIX E: SAR SYSTEM VALIDATION | | |
| APPENDIX F: SAR TEST SETUP PHOTOGRAPHS | | |

| | | | | |
|-----------------------------------|---|-------------------------------|---|---------------------------------|
| FCC ID: A3LSMN915X |  | SAR EVALUATION REPORT |  | Reviewed by: Quality Manager |
| Document S/N: OY1408181741.A3L | Test Dates: 08/14/14 - 08/23/14 | DUT Type: Portable Handset | Page 2 of 40 | |

1 DEVICE UNDER TEST

1.1 Device Overview

| Band & Mode | Operating Modes | Tx Frequency |
|--------------|-----------------|-----------------|
| 2.4 GHz WLAN | Data | 2412 - 2462 MHz |
| 5.8 GHz WLAN | Data | 5745 - 5825 MHz |
| 5.2 GHz WLAN | Data | 5180 - 5240 MHz |
| 5.3 GHz WLAN | Data | 5260 - 5320 MHz |
| 5.5 GHz WLAN | Data | 5500 - 5700 MHz |
| Bluetooth | Data | 2402 - 2480 MHz |
| NFC | Data | 13.56 MHz |
| ANT+ | Data | 2402 - 2480 MHz |

1.2 Nominal and Maximum Output Power Specifications

This device operates using the following maximum and nominal output power specifications. SAR values were scaled to the maximum allowed power to determine compliance per KDB Publication 447498 D01v05.

Antenna 1 and Antenna 2



| Mode / Band | | Modulated Average (dBm) |
|----------------------------------|---------|-------------------------|
| IEEE 802.11b (2.4 GHz) | Maximum | 17.5 |
| | Nominal | 17.0 |
| IEEE 802.11g (2.4 GHz) | Maximum | 14.5 |
| | Nominal | 14.0 |
| IEEE 802.11n (2.4 GHz) | Maximum | 13.5 |
| | Nominal | 13.0 |
| IEEE 802.11a (5 GHz) | Maximum | 14.5 |
| | Nominal | 14.0 |
| IEEE 802.11n (5 GHz, 20 MHz BW) | Maximum | 13.5 |
| | Nominal | 13.0 |
| IEEE 802.11n (5 GHz, 40 MHz BW) | Maximum | 12.5 |
| | Nominal | 12.0 |
| IEEE 802.11ac (5 GHz, 80 MHz BW) | Maximum | 11.5 |
| | Nominal | 11.0 |

BT

| | | |
|--------------|---------|------|
| Bluetooth | Maximum | 12.0 |
| | Nominal | 11.5 |
| Bluetooth LE | Maximum | 9.5 |
| | Nominal | 9.0 |

MIMO

| Mode / Band | | Modulated Average (dBm) |
|----------------------------------|---------|-------------------------|
| IEEE 802.11n (2.4 GHz) | Maximum | 16.5 |
| | Nominal | 16.0 |
| IEEE 802.11n (5 GHz, 20 MHz BW) | Maximum | 13.5 |
| | Nominal | 13.0 |
| IEEE 802.11n (5 GHz, 40 MHz BW) | Maximum | 12.0 |
| | Nominal | 11.5 |
| IEEE 802.11ac (5 GHz, 80 MHz BW) | Maximum | 11.5 |
| | Nominal | 11.0 |

| | | | | |
|-----------------------------------|---|-------------------------------|---|---------------------------------|
| FCC ID: A3LSMN915X |  PCTEST ENGINEERING LABORATORY, INC. | SAR EVALUATION REPORT |  | Reviewed by: Quality Manager |
| Document S/N: OY1408181741.A3L | Test Dates: 08/14/14 - 08/23/14 | DUT Type: Portable Handset | | Page 3 of 40 |

DUT Antenna Locations

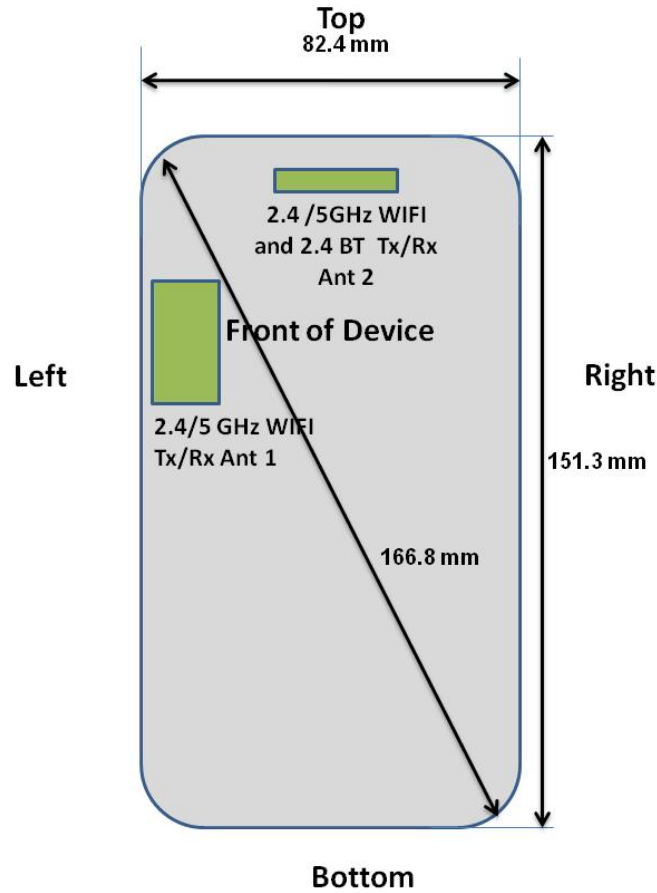



Note: Exact antenna dimensions and separation distances are shown in the Technical Descriptions in the FCC Filing. Since the diagonal dimension of this device is > 160 mm and <200 mm, it is considered a "phablet."

Figure 1-1
DUT Antenna Locations

Table 1-1
Sides for SAR Testing

| Mode | Back | Front | Top | Bottom | Right | Left |
|--------------------|------|-------|-----|--------|-------|------|
| 2.4 GHz WLAN Ant 1 | Yes | Yes | Yes | No | No | Yes |
| 2.4 GHz WLAN Ant 2 | Yes | Yes | Yes | No | No | No |
| 2.4 GHz WLAN MIMO | Yes | Yes | Yes | No | No | Yes |
| 5 GHz WLAN Ant 1 | Yes | Yes | Yes | No | No | Yes |
| 5 GHz WLAN Ant 2 | Yes | Yes | Yes | No | No | No |
| 5 GHz WLAN MIMO | Yes | Yes | Yes | No | No | Yes |

Note: Particular DUT edges were not required to be evaluated for Extremity SAR if the edges were greater than 2.5 cm from the transmitting antenna according to FCC KDB 648474 D04v01r01. The distances between the transmit antennas and the edges of the device are included in the filing.

| | | | | |
|--|---|--------------------------------------|---|--|
| FCC ID: A3LSMN915X |  PCTEST ENGINEERING LABORATORY, INC. | SAR EVALUATION REPORT |  | Reviewed by: Quality Manager |
| Document S/N: OY1408181741.A3L | Test Dates: 08/14/14 - 08/23/14 | DUT Type: Portable Handset | Page 4 of 40 | |

1.3 Near Field Communications (NFC) Antenna

This DUT has NFC operations. The NFC antenna is integrated into the specialized battery. The SAR tests were performed with the specialized battery (model: EB-BN915BBE).

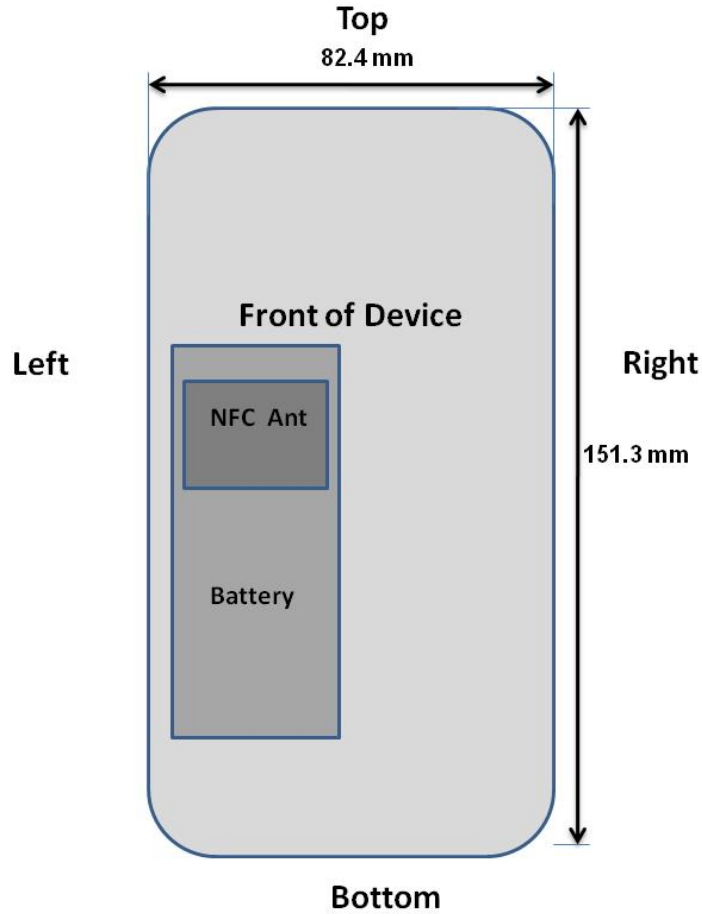



Figure 1-2
NFC Antenna Locations

1.4 Simultaneous Transmission Capabilities

This device is capable of using both antennas independently or using 2x2 MIMO operations with 2.4/5 GHz IEEE 802.11n and 5 GHz IEEE 802.11ac. There are no additional simultaneous transmission capabilities.

| | | | | |
|-----------------------------------|---|-------------------------------|---|---------------------------------|
| FCC ID: A3LSMN915X |  PCTEST ENGINEERING LABORATORY, INC. | SAR EVALUATION REPORT |  | Reviewed by: Quality Manager |
| Document S/N: OY1408181741.A3L | Test Dates: 08/14/14 - 08/23/14 | DUT Type: Portable Handset | | Page 5 of 40 |

1.5 SAR Test Exclusions Applied

(A) WIFI/BT

Per FCC KDB 447498 D01v05, the 1g SAR exclusion threshold for distances <50mm is defined by the following equation:

$$\frac{\text{Max Power of Channel (mW)}}{\text{Test Separation Dist (mm)}} * \sqrt{\text{Frequency(GHz)}} \leq 3.0$$

Based on the maximum conducted power of Bluetooth (rounded to the nearest mW) and the antenna to user separation distance, body-worn Bluetooth SAR was not required; $[(16/10) * \sqrt{2.480}] = 2.5 < 3.0$. Per KDB Publication 447498 D01v05, the maximum power of the channel was rounded to the nearest mW before calculation.

Per FCC KDB 447498 D01v05, the 10g SAR exclusion threshold for distances <50mm is defined by the following equation:

$$\frac{\text{Max Power of Channel (mW)}}{\text{Test Separation Dist (mm)}} * \sqrt{\text{Frequency(GHz)}} \leq 7.5$$



Based on the maximum conducted power of Bluetooth (rounded to the nearest mW) and the antenna to user separation distance, extremity Bluetooth SAR was not required; $[(16/5) * \sqrt{2.480}] = 5 < 7.5$. Per KDB Publication 447498 D01v05, the maximum power of the channel was rounded to the nearest mW before calculation.

This device supports 20 MHz and 40 MHz Bandwidths for IEEE 802.11n for 5 GHz WIFI only. IEEE 802.11n was not evaluated for SAR since the average output power of 20 MHz and 40 MHz bandwidths was not more than 0.25 dB higher than the average output power of IEEE 802.11a.

This device supports IEEE 802.11ac with the following features:

- a) Up to 80 MHz Bandwidth only
- b) No aggregate channel configurations
- c) 2 Tx antenna output
- d) 256 QAM is supported
- e) No new 5 GHz channels

Per FCC KDB Publication 648474 D04v01r01, this device is considered a "phablet" since the diagonal dimension is greater than 160mm and less than 200mm. Extremity SAR tests are required when wireless router mode does not apply or if wireless router 1g SAR > 1.2 W/kg. Because wireless router operations are not supported, extremity SAR tests were performed.

| | | | | |
|--|---|--------------------------------------|---|--|
| FCC ID: A3LSMN915X |  PCTEST ENGINEERING LABORATORY, INC. | SAR EVALUATION REPORT |  | Reviewed by: Quality Manager |
| Document S/N: OY1408181741.A3L | Test Dates: 08/14/14 - 08/23/14 | DUT Type: Portable Handset | Page 6 of 40 | |

1.6 Power Reduction for SAR

There is no power reduction used for any band/mode implemented in this device for SAR purposes.



1.7 Guidance Applied

- IEEE 1528-2003
- FCC KDB Publication 248227 D01v01r02 (SAR Considerations for 802.11 Devices)
- FCC KDB Publication 447498 D01v05r02 (General SAR Guidance)
- FCC KDB Publication 865664 D01v01r03, D02v01r01 (SAR Measurements up to 6 GHz)
- FCC KDB Publication 648474 D03-D04 (Phablet Procedures)
- April 2013 TCB Workshop Notes (IEEE 802.11ac)

1.8 Device Serial Numbers

Several samples were used with identical hardware to support SAR testing. The manufacturer has confirmed that the device(s) tested have the same physical, mechanical and thermal characteristics and are within operational tolerances expected for production units.

| | Head Serial Number | Body-Worn Serial Number | Extremity Serial Number |
|--------------|--------------------|-------------------------|-------------------------|
| 2.4 GHz WLAN | F2279 | F2279 | F2279 |
| 5 GHz WLAN | F238A | F227C | F227C |

| | | | | |
|--|---|--------------------------------------|---|--|
| FCC ID: A3LSMN915X |  PCTEST ENGINEERING LABORATORY, INC. | SAR EVALUATION REPORT |  | Reviewed by: Quality Manager |
| Document S/N: OY1408181741.A3L | Test Dates: 08/14/14 - 08/23/14 | DUT Type: Portable Handset | | Page 7 of 40 |

2 INTRODUCTION

The FCC and Industry Canada have adopted the guidelines for evaluating the environmental effects of radio frequency (RF) radiation in ET Docket 93-62 on Aug. 6, 1996 and Health Canada Safety Code 6 to protect the public and workers from the potential hazards of RF emissions due to FCC-regulated portable devices. [1]

The safety limits used for the environmental evaluation measurements are based on the criteria published by the American National Standards Institute (ANSI) for localized specific absorption rate (SAR) in IEEE/ANSI C95.1-1992 Standard for Safety Levels with Respect to Human Exposure to Radio Frequency Electromagnetic Fields, 3 kHz to 300 GHz [3] and Health Canada RF Exposure Guidelines Safety Code 6 [22]. The measurement procedure described in IEEE/ANSI C95.3-2002 Recommended Practice for the Measurement of Potentially Hazardous Electromagnetic Fields - RF and Microwave [4] is used for guidance in measuring the Specific Absorption Rate (SAR) due to the RF radiation exposure from the Equipment Under Test (EUT). These criteria for SAR evaluation are similar to those recommended by the International Committee for Non-Ionizing Radiation Protection (ICNIRP) in "Biological Effects and Exposure Criteria for Radiofrequency Electromagnetic Fields," Report No. Vol 74. SAR is a measure of the rate of energy absorption due to exposure to an RF transmitting source. SAR values have been related to threshold levels for potential biological hazards.

2.1 SAR Definition

Specific Absorption Rate is defined as the time derivative (rate) of the incremental energy (dU) absorbed by (dissipated in) an incremental mass (dm) contained in a volume element (dV) of a given density (ρ). It is also defined as the rate of RF energy absorption per unit mass at a point in an absorbing body (see Equation 2-1).

Equation 2-1
SAR Mathematical Equation

$$SAR = \frac{d}{dt} \left(\frac{dU}{dm} \right) = \frac{d}{dt} \left(\frac{dU}{\rho dv} \right)$$



SAR is expressed in units of Watts per Kilogram (W/kg).

$$SAR = \frac{\sigma \cdot E^2}{\rho}$$

where:

- σ = conductivity of the tissue-simulating material (S/m)
- ρ = mass density of the tissue-simulating material (kg/m³)
- E = Total RMS electric field strength (V/m)

NOTE: The primary factors that control rate of energy absorption were found to be the wavelength of the incident field in relation to the dimensions and geometry of the irradiated organism, the orientation of the organism in relation to the polarity of field vectors, the presence of reflecting surfaces, and whether conductive contact is made by the organism with a ground plane.[6]

| | | | | |
|--|---|--------------------------------------|---|--|
| FCC ID: A3LSMN915X |  PCTEST ENGINEERING LABORATORY, INC. | SAR EVALUATION REPORT |  | Reviewed by: Quality Manager |
| Document S/N: OY1408181741.A3L | Test Dates: 08/14/14 - 08/23/14 | DUT Type: Portable Handset | Page 8 of 40 | |

3 DOSIMETRIC ASSESSMENT

3.1 Measurement Procedure

The evaluation was performed using the following procedure compliant to FCC KDB Publication 865664 D01v01 and IEEE 1528-2013:

1. The SAR distribution at the exposed side of the head or body was measured at a distance no greater than 5.0 mm from the inner surface of the shell. The area covered the entire dimension of the device-head and body interface and the horizontal grid resolution was determined per FCC KDB Publication 865664 D01v01 (See Table 3-1) and IEEE 1528-2013.
2. The point SAR measurement was taken at the maximum SAR region determined from Step 1 to enable the monitoring of SAR fluctuations/drifts during the 1g/10g cube evaluation. SAR at this fixed point was measured and used as a reference value.
3. Based on the area scan data, the peak of the region with maximum SAR was determined by spline interpolation. Around this point, a volume was assessed according to the measurement resolution and volume size requirements of FCC KDB Publication 865664 D01v01 (See Table 3-1) and IEEE 1528-2013. On the basis of this data set, the spatial peak SAR value was evaluated with the following procedure (see references or the DASy manual online for more details):
 - a. SAR values at the inner surface of the phantom are extrapolated from the measured values along the line away from the surface with spacing no greater than that in Table 3-1. The extrapolation was based on a least-squares algorithm. A polynomial of the fourth order was calculated through the points in the z-axis (normal to the phantom shell).
 - b. After the maximum interpolated values were calculated between the points in the cube, the SAR was averaged over the spatial volume (1g or 10g) using a 3D-Spline interpolation algorithm. The 3D-spline is composed of three one-dimensional splines with the “Not a knot” condition (in x, y, and z directions). The volume was then integrated with the trapezoidal algorithm. One thousand points (10 x 10 x 10) were obtained through interpolation, in order to calculate the averaged SAR.
 - c. All neighboring volumes were evaluated until no neighboring volume with a higher average value was found.
4. The SAR reference value, at the same location as step 2, was re-measured after the zoom scan was complete to calculate the SAR drift. If the drift deviated by more than 5%, the SAR test and drift measurements were repeated.

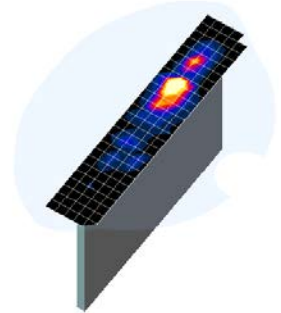



Figure 3-1
Sample SAR Area Scan

Table 3-1
Area and Zoom Scan Resolutions per FCC KDB Publication 865664 D01v01*

| Frequency | Maximum Area Scan Resolution (mm) ($\Delta x_{area}, \Delta y_{area}$) | Maximum Zoom Scan Resolution (mm) ($\Delta x_{zoom}, \Delta y_{zoom}$) | Maximum Zoom Scan Spatial Resolution (mm) | | | Minimum Zoom Scan Volume (mm) (x,y,z) |
|-----------|---|---|---|------------------------|-------------------------------|--|
| | | | Uniform Grid $\Delta z_{zoom}(n)$ | Graded Grid | | |
| | | | | $\Delta z_{zoom}(1)^*$ | $\Delta z_{zoom}(n>1)^*$ | |
| ≤ 2 GHz | ≤ 15 | ≤ 8 | ≤ 5 | ≤ 4 | ≤ 1.5* $\Delta z_{zoom}(n-1)$ | ≥ 30 |
| 2-3 GHz | ≤ 12 | ≤ 5 | ≤ 5 | ≤ 4 | ≤ 1.5* $\Delta z_{zoom}(n-1)$ | ≥ 30 |
| 3-4 GHz | ≤ 12 | ≤ 5 | ≤ 4 | ≤ 3 | ≤ 1.5* $\Delta z_{zoom}(n-1)$ | ≥ 28 |
| 4-5 GHz | ≤ 10 | ≤ 4 | ≤ 3 | ≤ 2.5 | ≤ 1.5* $\Delta z_{zoom}(n-1)$ | ≥ 25 |
| 5-6 GHz | ≤ 10 | ≤ 4 | ≤ 2 | ≤ 2 | ≤ 1.5* $\Delta z_{zoom}(n-1)$ | ≥ 22 |

*Also compliant to IEEE 1528-2013 Table 6

| | | | | |
|--|---|--------------------------------------|---|--|
| FCC ID: A3LSMN915X |  | SAR EVALUATION REPORT |  | Reviewed by: Quality Manager |
| Document S/N: OY1408181741.A3L | Test Dates: 08/14/14 - 08/23/14 | DUT Type: Portable Handset | Page 9 of 40 | |

4 DEFINITION OF REFERENCE POINTS

4.1 EAR REFERENCE POINT

Figure 4-2 shows the front, back and side views of the SAM Twin Phantom. The point “M” is the reference point for the center of the mouth, “LE” is the left ear reference point (ERP), and “RE” is the right ERP. The ERP is 15mm posterior to the entrance to the ear canal (EEC) along the B-M line (Back-Mouth), as shown in Figure 4-1. The plane passing through the two ear canals and M is defined as the Reference Plane. The line N-F (Neck-Front), also called the Reference Pivoting Line, is not perpendicular to the reference plane (see Figure 4-1). Line B-M is perpendicular to the N-F line. Both N-F and B-M lines are marked on the external phantom shell to facilitate handset positioning [5].

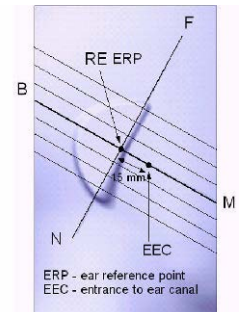

Figure 4-1
Close-Up Side view of ERP

4.2 HANDSET REFERENCE POINTS

Two imaginary lines on the handset were established: the vertical centerline and the horizontal line. The test device was placed in a normal operating position with the acoustic output located along the “vertical centerline” on the front of the device aligned to the “ear reference point” (See Figure 4-3). The acoustic output was then located at the same level as the center of the ear reference point. The test device was positioned so that the “vertical centerline” was bisecting the front surface of the handset at its top and bottom edges, positioning the “ear reference point” on the outer surface of the both the left and right head phantoms on the ear reference point.



Figure 4-2
Front, back and side view of SAM Twin Phantom

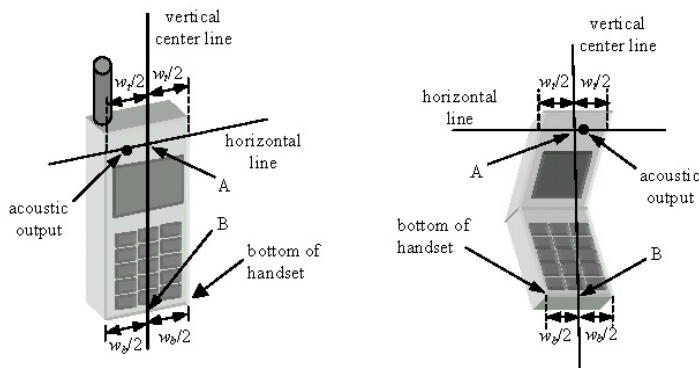



Figure 4-3
Handset Vertical Center & Horizontal Line Reference Points

| | | | | |
|-----------------------------------|--|-------------------------------|---|---------------------------------|
| FCC ID: A3LSMN915X |  PCTEST Engineering Laboratory, Inc. | SAR EVALUATION REPORT |  | Reviewed by: Quality Manager |
| Document S/N: OY1408181741.A3L | Test Dates: 08/14/14 - 08/23/14 | DUT Type: Portable Handset | | Page 10 of 40 |

5 TEST CONFIGURATION POSITIONS FOR HANDSETS

5.1 Device Holder

The device holder is made out of low-loss POM material having the following dielectric parameters: relative permittivity $\epsilon = 3$ and loss tangent $\delta = 0.02$.

5.2 Positioning for Cheek

1. The test device was positioned with the device close to the surface of the phantom such that point A is on the (virtual) extension of the line passing through points RE and LE on the phantom (see Figure 5-1), such that the plane defined by the vertical center line and the horizontal line of the phone is approximately parallel to the sagittal plane of the phantom.

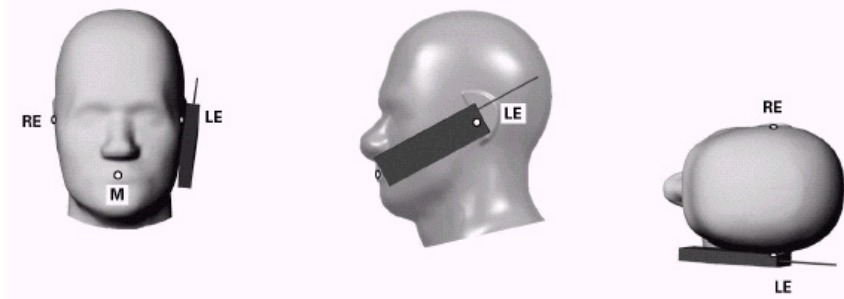



Figure 5-1 Front, Side and Top View of Cheek Position

2. The handset was translated towards the phantom along the line passing through RE & LE until the handset touches the pinna.
3. While maintaining the handset in this plane, the handset was rotated around the LE-RE line until the vertical centerline was in the reference plane.
4. The phone was then rotated around the vertical centerline until the phone (horizontal line) was symmetrical with respect to the line NF.
5. While maintaining the vertical centerline in the reference plane, keeping point A on the line passing through RE and LE, and maintaining the device contact with the ear, the device was rotated about the NF line until any point on the handset made contact with a phantom point below the ear (cheek) (See Figure 5-2).

5.3 Positioning for Ear / 15° Tilt

With the test device aligned in the “Cheek Position”:

1. While maintaining the orientation of the phone, the phone was retracted parallel to the reference plane far enough to enable a rotation of the phone by 15 degrees.
2. The phone was then rotated around the horizontal line by 15 degrees.
3. While maintaining the orientation of the phone, the phone was moved parallel to the reference plane until any part of the handset touched the head. (In this position, point A was located on the line RE-LE). The tilted position is obtained when the contact is on the pinna. If the contact was at any location other than the pinna, the angle of the phone would then be reduced. In this situation, the tilted position was obtained when any part of the phone was in contact of the ear as well as a second part of the phone was in contact with the head (see Figure 5-2).

| | | | | |
|-----------------------------------|--|-------------------------------|---|---------------------------------|
| FCC ID: A3LSMN915X |  PCTEST ENGINEERING LABORATORY, INC. | SAR EVALUATION REPORT |  | Reviewed by: Quality Manager |
| Document S/N: OY1408181741.A3L | Test Dates: 08/14/14 - 08/23/14 | DUT Type: Portable Handset | | Page 11 of 40 |

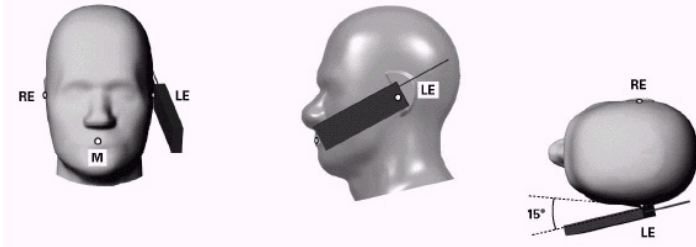

Figure 5-2 Front, Side and Top View of Ear/15° Tilt Position

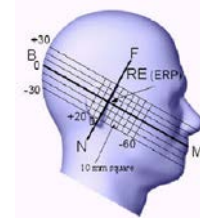

Figure 5-3 Side view w/ relevant markings

5.4 SAR Evaluations near the Mouth/Jaw Regions of the SAM Phantom

Antennas located near the bottom of a phone may require SAR measurements around the mouth and jaw regions of the SAM head phantom. This typically applies to clam-shell style phones that are generally longer in the unfolded normal use positions or to certain older style long rectangular phones. Per IEEE 1528-2013, a rotated SAM phantom is necessary to allow probe access to such regions. Both SAM heads of the TwinSAM-Chin20 are rotated 20 degrees around the NF line. Each head can be removed from the table for emptying and cleaning.

Under these circumstances, the following procedures apply, adopted from the FCC guidance on SAR handsets document FCC KDB Publication 648474 D04_v01. The SAR required in these regions of SAM should be measured using a flat phantom. The phone should be positioned with a separation distance of 4 mm between the ear reference point (ERP) and the outer surface of the flat phantom shell. While maintaining this distance at the ERP location, the low (bottom) edge of the phone should be lowered from the phantom to establish the same separation distance between the peak SAR location identified by the truncated partial SAR distribution measured with the SAM phantom. The distance from the peak SAR location to the phone is determined by the straight line passing perpendicularly through the phantom surface. When it is not feasible to maintain 4 mm separation at the ERP while also establishing the required separation at the peak SAR location, the top edge of the phone will be allowed to touch the phantom with a separation < 4 mm at the ERP. The phone should not be tilted to the left or right while placed in this inclined position to the flat phantom.

5.5 Body-Worn Accessory Configurations

Body-worn operating configurations are tested with the belt-clips and holsters attached to the device and positioned against a flat phantom in a normal use configuration (see Figure 5-4). Per FCC KDB Publication 648474 D04v01, Body-worn accessory exposure is typically related to voice mode operations when handsets are carried in body-worn accessories. The body-worn accessory procedures in FCC KDB Publication 447498 D01v05 should be used to test for body-worn accessory SAR compliance, without a headset connected to it. This enables the test results for such configuration to be compatible with that required for hotspot mode when the body-worn accessory test separation distance is greater than or equal to that required for hotspot mode, when applicable. When the reported SAR for a body-worn accessory, measured without a headset connected to the handset, is > 1.2 W/kg, the highest reported SAR configuration for that wireless mode and frequency band should be repeated for that body-worn accessory with a headset attached to the handset.

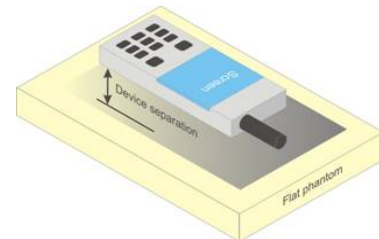



Figure 5-4 Sample Body-Worn Diagram

Accessories for Body-worn operation configurations are divided into two categories: those that do not contain metallic components and those that do contain metallic components. When multiple accessories that do not contain metallic components are supplied with the device, the device is tested with only the

| | | | | |
|-----------------------------------|--|-------------------------------|---|---------------------------------|
| FCC ID: A3LSMN915X |  PCTEST Engineering Laboratory, Inc. | SAR EVALUATION REPORT |  SAMSUNG | Reviewed by: Quality Manager |
| Document S/N: OY1408181741.A3L | Test Dates: 08/14/14 - 08/23/14 | DUT Type: Portable Handset | | Page 12 of 40 |



accessory that dictates the closest spacing to the body. Then multiple accessories that contain metallic components are tested with the device with each accessory. If multiple accessories share an identical metallic component (i.e. the same metallic belt-clip used with different holsters with no other metallic components) only the accessory that dictates the closest spacing to the body is tested.

Body-worn accessories may not always be supplied or available as options for some devices intended to be authorized for body-worn use. In this case, a test configuration with a separation distance between the back of the device and the flat phantom is used. Test position spacing was documented. Transmitters that are designed to operate in front of a person's face, as in push-to-talk configurations, are tested for SAR compliance with the front of the device positioned to face the flat phantom in head fluid. For devices that are carried next to the body such as a shoulder, waist or chest-worn transmitters, SAR compliance is tested with the accessories, including headsets and microphones, attached to the device and positioned against a flat phantom in a normal use configuration.

5.6 Extremity Exposure Configurations

Devices that are designed or intended for use on extremities or mainly operated in extremity only exposure conditions; i.e., hands, wrists, feet and ankles, may require extremity SAR evaluation. When the device also operates in close proximity to the user's body, SAR compliance for the body is also required. The 1-g body and 10-g extremity SAR Exclusion Thresholds found in KDB Publication 44798 D01v05 should be applied to determine SAR test requirements.

For smart phones with a display diagonal dimension > 15.0 cm or an overall diagonal dimension > 16.0 cm that provide similar mobile web access and multimedia support found in mini-tablets or UMPC minitables that support voice calls next to the ear, the phablets procedures outlined in KDB Publication 648474 D04 v01r01DR04 should be applied to evaluate SAR compliance. A device marketed as phablets, regardless of form factors and operating characteristics must be tested as a phablet to determine SAR compliance. In addition to the normally required head and body-worn accessory SAR test procedures required for handsets, the UMPC mini-tablet procedures must also be applied to test the SAR of all surfaces and edges with an antenna ≤ 25 mm from that surface or edge, in direct contact with the phantom, for 10-g SAR. The UMPC mini-tablet 1-g SAR at 5 mm is not required. When hotspot mode applies, 10-g SAR is required only for the surfaces and edges with hotspot mode 1-g SAR > 1.2 W/kg.

| | | | |
|-----------------------------------|--|-------------------------------|---------------------------------|
| FCC ID: A3LSMN915X |  SAR EVALUATION REPORT  | | Reviewed by: Quality Manager |
| Document S/N: 0Y1408181741.A3L | Test Dates: 08/14/14 - 08/23/14 | DUT Type: Portable Handset | Page 13 of 40 |

6 RF EXPOSURE LIMITS

6.1 Uncontrolled Environment

UNCONTROLLED ENVIRONMENTS are defined as locations where there is the exposure of individuals who have no knowledge or control of their exposure. The general population/uncontrolled exposure limits are applicable to situations in which the general public may be exposed or in which persons who are exposed as a consequence of their employment may not be made fully aware of the potential for exposure or cannot exercise control over their exposure. Members of the general public would come under this category when exposure is not employment-related; for example, in the case of a wireless transmitter that exposes persons in its vicinity.



6.2 Controlled Environment

CONTROLLED ENVIRONMENTS are defined as locations where there is exposure that may be incurred by persons who are aware of the potential for exposure, (i.e. as a result of employment or occupation). In general, occupational/controlled exposure limits are applicable to situations in which persons are exposed as a consequence of their employment, who have been made fully aware of the potential for exposure and can exercise control over their exposure. This exposure category is also applicable when the exposure is of a transient nature due to incidental passage through a location where the exposure levels may be higher than the general population/uncontrolled limits, but the exposed person is fully aware of the potential for exposure and can exercise control over his or her exposure by leaving the area or by some other appropriate means.

Table 6-1
SAR Human Exposure Specified in ANSI/IEEE C95.1-1992 and Health Canada Safety Code 6

| HUMAN EXPOSURE LIMITS | | |
|---|---|---|
| | UNCONTROLLED ENVIRONMENT <i>General Population</i> (W/kg) or (mW/g) | CONTROLLED ENVIRONMENT <i>Occupational</i> (W/kg) or (mW/g) |
| Peak Spatial Average SAR Head | 1.6 | 8.0 |
| Whole Body SAR | 0.08 | 0.4 |
| Peak Spatial Average SAR Hands, Feet, Ankle, Wrists, etc. | 4.0 | 20 |

1. The Spatial Peak value of the SAR averaged over any 1 gram of tissue (defined as a tissue volume in the shape of a cube) and over the appropriate averaging time.
2. The Spatial Average value of the SAR averaged over the whole body.
3. The Spatial Peak value of the SAR averaged over any 10 grams of tissue (defined as a tissue volume in the shape of a cube) and over the appropriate averaging time.

| | | | | |
|-----------------------------------|--|-------------------------------|---|---------------------------------|
| FCC ID: A3LSMN915X |  PCTEST ENGINEERING LABORATORY, INC. | SAR EVALUATION REPORT |  | Reviewed by: Quality Manager |
| Document S/N: OY1408181741.A3L | Test Dates: 08/14/14 - 08/23/14 | DUT Type: Portable Handset | | Page 14 of 40 |

7 FCC MEASUREMENT PROCEDURES

7.1 Measured and Reported SAR

Per FCC KDB Publication 447498 D01v05, When SAR is not measured at the maximum power level allowed for production units, the results must be scaled to the maximum tune-up tolerance limit according to the power applied to the individual channels tested to determine compliance. For simultaneous transmission, the measured aggregate SAR must be scaled according to the sum of the differences between the maximum tune-up tolerance and actual power used to test each transmitter. When SAR is measured at or scaled to the maximum tune-up tolerance limit, the results are referred to as *reported* SAR. The highest *reported* SAR results are identified on the grant of equipment authorization according to procedures in KDB 690783 D01v01r02.

7.2 SAR Testing with 802.11 Transmitters

Normal network operating configurations are not suitable for measuring the SAR of 802.11 a/b/g/n/ac transmitters. Unpredictable fluctuations in network traffic and antenna diversity conditions can introduce undesirable variations in SAR results. The SAR for these devices should be measured using chipset based test mode software to ensure the results are consistent and reliable. See KDB Publication 248227 D01v01r02 for more details.

7.2.1 General Device Setup

Chipset based test mode software is hardware dependent and generally varies among manufacturers. The device operating parameters established in test mode for SAR measurements must be identical to those programmed in production units, including output power levels, amplifier gain settings and other RF performance tuning parameters. The test frequencies should correspond to actual channel frequencies defined for domestic use. SAR for devices with switched diversity should be measured with only one antenna transmitting at a time during each SAR measurement, according to a fixed modulation and data rate. The same data pattern should be used for all measurements.

7.2.2 Frequency Channel Configurations [24]



For 2.4 GHz, the highest average RF output power channel between the low, mid and high channel at the lowest data rate was selected for SAR evaluation in 802.11b mode. 802.11g/n modes and higher data rates for 802.11b were additionally evaluated for SAR if the output power of the respective mode was 0.25 dB or higher than the powers of the SAR configurations tested in the 802.11b mode.

For 5 GHz, the highest average RF output power channel across the default test channels at the lowest data rate was selected for SAR evaluation in 802.11a. When the adjacent channels are higher in power than the default channels, these "required channels" were considered instead of the default channels for SAR testing. 802.11n modes and higher data rates for 802.11a/n were evaluated only if the respective mode was higher than 0.25 dB or more than the 802.11a mode. 802.11ac SAR was evaluated for highest 802.11a configuration in each 5 GHz band and each exposure condition. 802.11ac modes were additionally evaluated for SAR if the output power for the respective mode was more than 0.25 dB higher than powers of 802.11a modes.

If the maximum extrapolated peak SAR of the zoom scan for the highest output channel was less than 1.6 W/kg and if the 1g averaged SAR was less than 0.8 W/kg, SAR testing was not required for the other test channels in the band.

7.2.3 MIMO SAR considerations

Per KDB 248227, SAR for MIMO was measured with both transmitting simultaneously and was evaluated independently of SISO operation. For 2.4 and 5 GHz MIMO, 802.11n 20 MHz BW was evaluated. Other IEEE 802.11 modes and bandwidths were not investigated for MIMO operations since the maximum allowed output power (including tolerance) was not higher for these modes.

| | | | | |
|-----------------------------------|---|-------------------------------|---|---------------------------------|
| FCC ID: A3LSMN915X |  | SAR EVALUATION REPORT |  | Reviewed by: Quality Manager |
| Document S/N: OY1408181741.A3L | Test Dates: 08/14/14 - 08/23/14 | DUT Type: Portable Handset | | Page 15 of 40 |

8 RF CONDUCTED POWERS

8.1 WLAN Conducted Powers

Table 8-1
IEEE 802.11b Average RF Power – Antenna 1

| Mode | Freq [MHz] | Channel | 802.11b Conducted Power [dBm] | | | |
|---------|------------|---------|-------------------------------|-------|-------|-------|
| | | | Data Rate [Mbps] | | | |
| | | | 1 | 2 | 5.5 | 11 |
| 802.11b | 2412 | 1* | 16.95 | 17.26 | 17.27 | 17.22 |
| 802.11b | 2437 | 6* | 17.20 | 17.42 | 17.37 | 17.30 |
| 802.11b | 2462 | 11* | 16.60 | 16.81 | 16.83 | 16.91 |

Table 8-2
IEEE 802.11b Average RF Power – Antenna 2

| Mode | Freq [MHz] | Channel | 802.11b Conducted Power [dBm] | | | |
|---------|------------|---------|-------------------------------|-------|-------|-------|
| | | | Data Rate [Mbps] | | | |
| | | | 1 | 2 | 5.5 | 11 |
| 802.11b | 2412 | 1* | 17.33 | 16.50 | 16.53 | 16.54 |
| 802.11b | 2437 | 6* | 16.89 | 16.10 | 16.09 | 16.12 |
| 802.11b | 2462 | 11* | 17.31 | 16.48 | 16.44 | 16.50 |

Table 8-3
IEEE 802.11g Average RF Power – Antenna 1

| Mode | Freq [MHz] | Channel | 802.11g Conducted Power [dBm] | | | | | | | |
|---------|------------|---------|-------------------------------|-------|-------|-------|-------|-------|-------|-------|
| | | | Data Rate [Mbps] | | | | | | | |
| | | | 6 | 9 | 12 | 18 | 24 | 36 | 48 | 54 |
| 802.11g | 2412 | 1 | 14.26 | 14.19 | 14.21 | 14.12 | 14.41 | 14.34 | 14.49 | 14.37 |
| 802.11g | 2437 | 6 | 13.65 | 13.48 | 13.57 | 13.50 | 13.76 | 13.73 | 13.93 | 13.64 |
| 802.11g | 2462 | 11 | 13.92 | 13.85 | 13.91 | 13.75 | 14.13 | 14.02 | 14.23 | 14.05 |



| | | | | |
|-----------------------------------|--|-------------------------------|---|---------------------------------|
| FCC ID: A3LSMN915X |  PCTEST ENGINEERING LABORATORY, INC. | SAR EVALUATION REPORT |  | Reviewed by: Quality Manager |
| Document S/N: OY1408181741.A3L | Test Dates: 08/14/14 - 08/23/14 | DUT Type: Portable Handset | | Page 16 of 40 |

Table 8-4
IEEE 802.11g Average RF Power – Antenna 2

| Mode | Freq [MHz] | Channel | 802.11g Conducted Power [dBm] | | | | | | | |
|---------|------------|---------|-------------------------------|-------|-------|-------|-------|-------|-------|-------|
| | | | Data Rate [Mbps] | | | | | | | |
| | | | 6 | 9 | 12 | 18 | 24 | 36 | 48 | 54 |
| 802.11g | 2412 | 1 | 14.32 | 14.34 | 14.27 | 14.33 | 14.48 | 14.45 | 13.74 | 13.64 |
| 802.11g | 2437 | 6 | 13.89 | 13.93 | 13.83 | 13.91 | 14.04 | 14.07 | 13.33 | 13.16 |
| 802.11g | 2462 | 11 | 14.14 | 14.16 | 14.12 | 14.17 | 14.27 | 14.29 | 13.62 | 13.39 |

Table 8-5
IEEE 802.11n Average RF Power – Antenna 1

| Mode | Freq [MHz] | Channel | 802.11n (2.4GHz) Conducted Power [dBm] | | | | | | | |
|---------|------------|---------|--|-------|-------|-------|-------|-------|-------|-------|
| | | | Data Rate [Mbps] | | | | | | | |
| | | | 6.5 | 13 | 19.5 | 26 | 39 | 52 | 58.5 | 65 |
| 802.11n | 2412 | 1 | 13.14 | 13.16 | 13.17 | 13.44 | 13.45 | 13.43 | 13.48 | 13.43 |
| 802.11n | 2437 | 6 | 12.60 | 12.47 | 12.59 | 12.77 | 12.85 | 12.78 | 12.80 | 12.76 |
| 802.11n | 2462 | 11 | 13.11 | 13.07 | 13.06 | 13.30 | 13.37 | 13.27 | 13.35 | 13.25 |

Table 8-6
IEEE 802.11n Average RF Power – Antenna 2

| Mode | Freq [MHz] | Channel | 802.11n (2.4GHz) Conducted Power [dBm] | | | | | | | |
|---------|------------|---------|--|-------|-------|-------|-------|-------|-------|-------|
| | | | Data Rate [Mbps] | | | | | | | |
| | | | 6.5 | 13 | 19.5 | 26 | 39 | 52 | 58.5 | 65 |
| 802.11n | 2412 | 1 | 13.20 | 13.23 | 13.10 | 13.43 | 13.39 | 13.43 | 13.48 | 13.46 |
| 802.11n | 2437 | 6 | 12.80 | 12.83 | 12.72 | 13.03 | 13.01 | 13.04 | 13.15 | 12.99 |
| 802.11n | 2462 | 11 | 13.06 | 13.12 | 12.94 | 13.20 | 13.20 | 13.35 | 13.30 | 13.33 |

Table 8-7
IEEE 802.11n Average RF Power – MIMO

| Mode | Freq [MHz] | Channel | Data Rate (Mbps) |
|---------|------------|---------|------------------|
| | | | 13 |
| 802.11n | 2412 | 1 | 16.18 |
| 802.11n | 2437 | 6 | 15.71 |
| 802.11n | 2462 | 11 | 16.10 |



| | | | | |
|-----------------------------------|---|-------------------------------|---|---------------------------------|
| FCC ID: A3LSMN915X |  | SAR EVALUATION REPORT |  | Reviewed by: Quality Manager |
| Document S/N: OY1408181741.A3L | Test Dates: 08/14/14 - 08/23/14 | DUT Type: Portable Handset | | Page 17 of 40 |

Table 8-8
IEEE 802.11a Average RF Power – Antenna 1

| Mode | Freq [MHz] | Channel | 802.11a Conducted Power [dBm] | | | | | | | |
|---------|------------|---------|-------------------------------|-------|-------|-------|-------|-------|-------|-------|
| | | | Data Rate [Mbps] | | | | | | | |
| | | | 6 | 9 | 12 | 18 | 24 | 36 | 48 | 54 |
| 802.11a | 5180 | 36* | 13.63 | 13.42 | 13.53 | 13.39 | 13.74 | 13.67 | 13.85 | 13.56 |
| 802.11a | 5200 | 40 | 13.62 | 13.41 | 13.43 | 13.30 | 13.75 | 13.74 | 13.86 | 13.59 |
| 802.11a | 5220 | 44 | 13.58 | 13.36 | 13.52 | 13.38 | 13.63 | 13.66 | 13.80 | 13.52 |
| 802.11a | 5240 | 48* | 13.47 | 13.17 | 13.35 | 13.16 | 13.60 | 13.52 | 13.67 | 13.42 |
| 802.11a | 5260 | 52* | 13.98 | 13.76 | 13.84 | 13.78 | 14.01 | 13.99 | 14.17 | 13.91 |
| 802.11a | 5280 | 56 | 13.92 | 13.66 | 13.75 | 13.72 | 13.95 | 13.95 | 14.05 | 13.91 |
| 802.11a | 5300 | 60 | 13.86 | 13.64 | 13.64 | 13.63 | 13.93 | 13.93 | 14.05 | 13.81 |
| 802.11a | 5320 | 64* | 13.82 | 13.57 | 13.65 | 13.58 | 13.87 | 13.80 | 13.96 | 13.70 |
| 802.11a | 5500 | 100 | 13.65 | 13.50 | 13.57 | 13.53 | 13.72 | 13.71 | 13.85 | 13.69 |
| 802.11a | 5520 | 104* | 13.62 | 13.43 | 13.51 | 13.48 | 13.74 | 13.68 | 13.83 | 13.62 |
| 802.11a | 5540 | 108 | 13.61 | 13.48 | 13.52 | 13.47 | 13.64 | 13.70 | 13.73 | 13.64 |
| 802.11a | 5560 | 112 | 13.58 | 13.51 | 13.49 | 13.45 | 13.72 | 13.64 | 13.78 | 13.70 |
| 802.11a | 5580 | 116* | 13.54 | 13.31 | 13.45 | 13.44 | 13.59 | 13.54 | 13.69 | 13.63 |
| 802.11a | 5600 | 120 | N/A | N/A | N/A | N/A | N/A | N/A | N/A | N/A |
| 802.11a | 5620 | 124 | N/A | N/A | N/A | N/A | N/A | N/A | N/A | N/A |
| 802.11a | 5640 | 128 | N/A | N/A | N/A | N/A | N/A | N/A | N/A | N/A |
| 802.11a | 5660 | 132 | 13.51 | 13.32 | 13.49 | 13.38 | 13.60 | 13.62 | 13.75 | 13.51 |
| 802.11a | 5680 | 136* | 13.45 | 13.26 | 13.43 | 13.30 | 13.57 | 13.47 | 13.69 | 13.47 |
| 802.11a | 5700 | 140 | 13.53 | 13.47 | 13.40 | 13.45 | 13.67 | 13.53 | 13.80 | 13.55 |
| 802.11a | 5745 | 149* | 13.58 | 13.53 | 13.58 | 13.48 | 13.66 | 13.64 | 13.80 | 13.60 |
| 802.11a | 5765 | 153 | 13.57 | 13.57 | 13.61 | 13.52 | 13.74 | 13.69 | 13.65 | 13.64 |
| 802.11a | 5785 | 157* | 13.55 | 13.50 | 13.50 | 13.43 | 13.60 | 13.57 | 13.76 | 13.57 |
| 802.11a | 5805 | 161 | 13.55 | 13.46 | 13.55 | 13.44 | 13.62 | 13.60 | 13.81 | 13.65 |
| 802.11a | 5825 | 165* | 13.55 | 13.47 | 13.59 | 13.46 | 13.61 | 13.68 | 13.80 | 13.55 |

Per FCC KDB Publication 443999 and RSS-210 A9.2(3), transmission on channels which overlap the 5600-5650 MHz is prohibited as a client. This device does not transmit any beacons or initiate any transmissions in 5.3 and 5.5 GHz Band.

(*) – indicates default channels per KDB Publication 248227 D01v01r02. When the adjacent channels are higher in power than the default channels, these “required channels” are considered for SAR testing instead of the default channels.



| | | | | |
|-----------------------------------|---|-------------------------------|---|---------------------------------|
| FCC ID: A3LSMN915X |  | SAR EVALUATION REPORT |  | Reviewed by: Quality Manager |
| Document S/N: OY1408181741.A3L | Test Dates: 08/14/14 - 08/23/14 | DUT Type: Portable Handset | Page 18 of 40 | |

Table 8-9
IEEE 802.11a Average RF Power – Antenna 2

| Mode | Freq [MHz] | Channel | 802.11a Conducted Power [dBm] | | | | | | | |
|---------|------------|---------|-------------------------------|-------|-------|-------|-------|-------|-------|-------|
| | | | Data Rate [Mbps] | | | | | | | |
| | | | 6 | 9 | 12 | 18 | 24 | 36 | 48 | 54 |
| 802.11a | 5180 | 36* | 14.14 | 14.00 | 14.05 | 14.09 | 14.25 | 14.15 | 14.38 | 14.23 |
| 802.11a | 5200 | 40 | 13.90 | 13.71 | 13.84 | 13.89 | 14.09 | 13.92 | 14.19 | 13.92 |
| 802.11a | 5220 | 44 | 13.97 | 13.83 | 13.91 | 13.90 | 14.05 | 14.06 | 14.20 | 14.05 |
| 802.11a | 5240 | 48* | 13.75 | 13.66 | 13.72 | 13.71 | 13.85 | 13.79 | 13.96 | 13.77 |
| 802.11a | 5260 | 52* | 13.70 | 13.58 | 13.60 | 13.58 | 13.75 | 13.67 | 13.90 | 13.76 |
| 802.11a | 5280 | 56 | 13.54 | 13.46 | 13.48 | 13.38 | 13.57 | 13.55 | 13.77 | 13.62 |
| 802.11a | 5300 | 60 | 13.52 | 13.36 | 13.39 | 13.41 | 13.59 | 13.53 | 13.64 | 13.62 |
| 802.11a | 5320 | 64* | 13.42 | 13.36 | 13.24 | 13.30 | 13.53 | 13.38 | 13.58 | 13.51 |
| 802.11a | 5500 | 100 | 13.60 | 13.52 | 13.56 | 13.58 | 13.70 | 13.61 | 13.82 | 13.67 |
| 802.11a | 5520 | 104* | 13.41 | 13.35 | 13.42 | 13.36 | 13.51 | 13.50 | 13.59 | 13.45 |
| 802.11a | 5540 | 108 | 13.48 | 13.41 | 13.48 | 13.50 | 13.55 | 13.44 | 13.61 | 13.57 |
| 802.11a | 5560 | 112 | 13.44 | 13.39 | 13.34 | 13.38 | 13.59 | 13.53 | 13.74 | 13.47 |
| 802.11a | 5580 | 116* | 13.40 | 13.38 | 13.35 | 13.43 | 13.42 | 13.40 | 13.55 | 13.41 |
| 802.11a | 5600 | 120 | N/A | N/A | N/A | N/A | N/A | N/A | N/A | N/A |
| 802.11a | 5620 | 124 | N/A | N/A | N/A | N/A | N/A | N/A | N/A | N/A |
| 802.11a | 5640 | 128 | N/A | N/A | N/A | N/A | N/A | N/A | N/A | N/A |
| 802.11a | 5660 | 132 | 13.40 | 13.30 | 13.36 | 13.37 | 13.43 | 13.34 | 13.61 | 13.44 |
| 802.11a | 5680 | 136* | 13.36 | 13.28 | 13.41 | 13.31 | 13.43 | 13.43 | 13.50 | 13.49 |
| 802.11a | 5700 | 140 | 14.21 | 14.13 | 14.20 | 14.16 | 14.36 | 14.26 | 14.36 | 14.20 |
| 802.11a | 5745 | 149* | 14.09 | 14.18 | 14.12 | 14.15 | 14.26 | 14.16 | 14.30 | 14.29 |
| 802.11a | 5765 | 153 | 14.15 | 14.20 | 14.12 | 14.18 | 14.29 | 14.23 | 14.34 | 14.36 |
| 802.11a | 5785 | 157* | 14.10 | 14.21 | 14.15 | 14.09 | 14.28 | 14.16 | 14.36 | 14.32 |
| 802.11a | 5805 | 161 | 14.06 | 14.16 | 14.12 | 14.07 | 14.21 | 14.08 | 14.35 | 14.33 |
| 802.11a | 5825 | 165* | 14.22 | 14.34 | 14.22 | 14.19 | 14.46 | 14.37 | 14.41 | 14.38 |

Per FCC KDB Publication 443999 and RSS-210 A9.2(3), transmission on channels which overlap the 5600-5650 MHz is prohibited as a client. This device does not transmit any beacons or initiate any transmissions in 5.3 and 5.5 GHz Band.

(*) – indicates default channels per KDB Publication 248227 D01v01r02. When the adjacent channels are higher in power then the default channels, these “required channels” are considered for SAR testing instead of the default channels.



| | | | | |
|-----------------------------------|---|-------------------------------|---|---------------------------------|
| FCC ID: A3LSMN915X |  | SAR EVALUATION REPORT |  | Reviewed by: Quality Manager |
| Document S/N: OY1408181741.A3L | Test Dates: 08/14/14 - 08/23/14 | DUT Type: Portable Handset | Page 19 of 40 | |

Table 8-10
IEEE 802.11n Average RF Power – 20 MHz Bandwidth – Antenna 1

| Mode | Freq [MHz] | Channel | 20MHz BW 802.11n (5GHz) Conducted Power [dBm] | | | | | | | |
|---------|------------|---------|---|-------|-------|-------|-------|-------|-------|-------|
| | | | Data Rate [Mbps] | | | | | | | |
| | | | 6.5 | 13 | 19.5 | 26 | 39 | 52 | 58.5 | 65 |
| 802.11n | 5180 | 36 | 13.01 | 13.01 | 13.02 | 13.18 | 13.21 | 13.20 | 13.28 | 13.21 |
| 802.11n | 5200 | 40 | 13.02 | 13.01 | 13.03 | 13.19 | 13.16 | 13.17 | 13.24 | 13.27 |
| 802.11n | 5220 | 44 | 12.99 | 12.99 | 12.98 | 13.16 | 13.20 | 13.14 | 13.19 | 13.26 |
| 802.11n | 5240 | 48 | 12.87 | 12.78 | 12.89 | 13.01 | 13.09 | 13.08 | 13.18 | 13.01 |
| 802.11n | 5260 | 52 | 13.09 | 13.02 | 12.99 | 13.28 | 13.28 | 13.24 | 13.28 | 13.30 |
| 802.11n | 5280 | 56 | 13.06 | 13.00 | 12.95 | 13.22 | 13.26 | 13.19 | 13.29 | 13.28 |
| 802.11n | 5300 | 60 | 13.06 | 13.02 | 13.04 | 13.24 | 13.21 | 13.21 | 13.23 | 13.24 |
| 802.11n | 5320 | 64 | 12.91 | 12.85 | 12.89 | 13.13 | 13.05 | 13.08 | 13.12 | 13.05 |
| 802.11n | 5500 | 100 | 12.52 | 12.43 | 12.43 | 12.67 | 12.71 | 12.66 | 12.68 | 12.68 |
| 802.11n | 5520 | 104 | 12.42 | 12.26 | 12.31 | 12.58 | 12.60 | 12.60 | 12.61 | 12.54 |
| 802.11n | 5540 | 108 | 12.43 | 12.30 | 12.31 | 12.55 | 12.59 | 12.56 | 12.61 | 12.58 |
| 802.11n | 5560 | 112 | 12.45 | 12.44 | 12.37 | 12.54 | 12.62 | 12.61 | 12.64 | 12.63 |
| 802.11n | 5580 | 116 | 12.43 | 12.34 | 12.39 | 12.63 | 12.60 | 12.60 | 12.54 | 12.55 |
| 802.11n | 5600 | 120 | N/A | N/A | N/A | N/A | N/A | N/A | N/A | N/A |
| 802.11n | 5620 | 124 | N/A | N/A | N/A | N/A | N/A | N/A | N/A | N/A |
| 802.11n | 5640 | 128 | N/A | N/A | N/A | N/A | N/A | N/A | N/A | N/A |
| 802.11n | 5660 | 132 | 12.37 | 12.29 | 12.29 | 12.47 | 12.58 | 12.44 | 12.51 | 12.54 |
| 802.11n | 5680 | 136 | 12.41 | 12.36 | 12.36 | 12.55 | 12.67 | 12.56 | 12.64 | 12.57 |
| 802.11n | 5700 | 140 | 12.33 | 12.18 | 12.28 | 12.48 | 12.57 | 12.52 | 12.53 | 12.53 |
| 802.11n | 5745 | 149 | 12.72 | 12.74 | 12.72 | 13.03 | 12.99 | 12.95 | 13.02 | 12.97 |
| 802.11n | 5765 | 153 | 12.72 | 12.79 | 12.78 | 13.03 | 12.97 | 13.03 | 13.07 | 12.96 |
| 802.11n | 5785 | 157 | 12.73 | 12.80 | 12.67 | 13.01 | 12.94 | 13.00 | 12.96 | 13.04 |
| 802.11n | 5805 | 161 | 12.80 | 12.84 | 12.71 | 13.12 | 13.08 | 13.08 | 13.14 | 13.01 |
| 802.11n | 5825 | 165 | 12.77 | 12.81 | 12.84 | 13.12 | 12.98 | 12.98 | 13.08 | 13.02 |



| | | | | |
|--|--|--------------------------------------|---|--|
| FCC ID: A3LSMN915X |  PCTEST <small>ENGINEERING LABORATORY, INC.</small> | SAR EVALUATION REPORT |  | Reviewed by: Quality Manager |
| Document S/N: OY1408181741.A3L | Test Dates: 08/14/14 - 08/23/14 | DUT Type: Portable Handset | Page 20 of 40 | |

Table 8-11
IEEE 802.11n Average RF Power – 20 MHz Bandwidth – Antenna 2

| Mode | Freq [MHz] | Channel | 20MHz BW 802.11n (5GHz) Conducted Power [dBm] | | | | | | | |
|---------|------------|---------|---|-------|-------|-------|-------|-------|-------|-------|
| | | | Data Rate [Mbps] | | | | | | | |
| | | | 6.5 | 13 | 19.5 | 26 | 39 | 52 | 58.5 | 65 |
| 802.11n | 5180 | 36 | 13.08 | 13.04 | 13.09 | 13.25 | 13.29 | 13.15 | 13.29 | 13.28 |
| 802.11n | 5200 | 40 | 13.15 | 13.09 | 13.13 | 13.32 | 13.36 | 13.27 | 13.40 | 13.37 |
| 802.11n | 5220 | 44 | 12.87 | 12.87 | 12.93 | 13.03 | 13.09 | 12.95 | 13.09 | 13.07 |
| 802.11n | 5240 | 48 | 12.99 | 12.91 | 13.01 | 13.12 | 13.14 | 13.12 | 13.15 | 13.18 |
| 802.11n | 5260 | 52 | 12.66 | 12.55 | 12.58 | 12.75 | 12.76 | 12.81 | 12.79 | 12.84 |
| 802.11n | 5280 | 56 | 12.56 | 12.40 | 12.39 | 12.72 | 12.71 | 12.71 | 12.69 | 12.73 |
| 802.11n | 5300 | 60 | 12.50 | 12.44 | 12.47 | 12.57 | 12.60 | 12.65 | 12.68 | 12.61 |
| 802.11n | 5320 | 64 | 13.29 | 13.15 | 13.29 | 13.32 | 13.43 | 13.46 | 13.37 | 13.43 |
| 802.11n | 5500 | 100 | 12.60 | 12.65 | 12.60 | 12.83 | 12.81 | 12.71 | 12.83 | 12.78 |
| 802.11n | 5520 | 104 | 12.63 | 12.74 | 12.61 | 12.93 | 12.83 | 12.71 | 12.90 | 12.80 |
| 802.11n | 5540 | 108 | 12.45 | 12.49 | 12.38 | 12.71 | 12.67 | 12.47 | 12.60 | 12.64 |
| 802.11n | 5560 | 112 | 12.48 | 12.47 | 12.47 | 12.71 | 12.74 | 12.52 | 12.77 | 12.69 |
| 802.11n | 5580 | 116 | 12.51 | 12.54 | 12.48 | 12.73 | 12.74 | 12.63 | 12.67 | 12.65 |
| 802.11n | 5600 | 120 | N/A | N/A | N/A | N/A | N/A | N/A | N/A | N/A |
| 802.11n | 5620 | 124 | N/A | N/A | N/A | N/A | N/A | N/A | N/A | N/A |
| 802.11n | 5640 | 128 | N/A | N/A | N/A | N/A | N/A | N/A | N/A | N/A |
| 802.11n | 5660 | 132 | 12.40 | 12.45 | 12.36 | 12.62 | 12.63 | 12.49 | 12.59 | 12.60 |
| 802.11n | 5680 | 136 | 12.38 | 12.44 | 12.35 | 12.57 | 12.66 | 12.46 | 12.60 | 12.55 |
| 802.11n | 5700 | 140 | 12.54 | 12.58 | 12.54 | 12.80 | 12.73 | 12.67 | 12.77 | 12.68 |
| 802.11n | 5745 | 149 | 13.28 | 13.06 | 13.13 | 13.32 | 13.40 | 13.32 | 13.36 | 13.39 |
| 802.11n | 5765 | 153 | 13.31 | 13.05 | 13.16 | 13.31 | 13.42 | 13.35 | 13.37 | 13.38 |
| 802.11n | 5785 | 157 | 13.11 | 12.91 | 12.91 | 13.16 | 13.29 | 13.17 | 13.12 | 13.21 |
| 802.11n | 5805 | 161 | 13.10 | 12.87 | 12.91 | 13.16 | 13.20 | 13.06 | 13.14 | 13.21 |
| 802.11n | 5825 | 165 | 13.13 | 13.00 | 12.98 | 13.25 | 13.24 | 13.16 | 13.23 | 13.25 |



| | | | | |
|--|--|--------------------------------------|---|--|
| FCC ID: A3LSMN915X |  PCTEST <small>ENGINEERING LABORATORY, INC.</small> | SAR EVALUATION REPORT |  | Reviewed by: Quality Manager |
| Document S/N: OY1408181741.A3L | Test Dates: 08/14/14 - 08/23/14 | DUT Type: Portable Handset | Page 21 of 40 | |

Table 8-12
IEEE 802.11n Average RF Power – 20 MHz Bandwidth – MIMO

| Mode | Freq [MHz] | Channel | Data Rate (Mbps) |
|---------|------------|---------|------------------|
| | | | 13 |
| 802.11n | 5180 | 36 | 12.55 |
| 802.11n | 5200 | 40 | 12.59 |
| 802.11n | 5220 | 44 | 12.46 |
| 802.11n | 5240 | 48 | 12.43 |
| 802.11n | 5260 | 52 | 12.30 |
| 802.11n | 5280 | 56 | 12.25 |
| 802.11n | 5300 | 60 | 12.23 |
| 802.11n | 5320 | 64 | 12.44 |
| 802.11n | 5500 | 100 | 12.63 |
| 802.11n | 5520 | 104 | 12.57 |
| 802.11n | 5540 | 108 | 12.52 |
| 802.11n | 5560 | 112 | 12.54 |
| 802.11n | 5580 | 116 | 12.54 |
| 802.11n | 5600 | 120 | N/A |
| 802.11n | 5620 | 124 | N/A |
| 802.11n | 5640 | 128 | N/A |
| 802.11n | 5660 | 132 | 12.47 |
| 802.11n | 5680 | 136 | 12.48 |
| 802.11n | 5700 | 140 | 12.49 |
| 802.11n | 5745 | 149 | 12.99 |
| 802.11n | 5765 | 153 | 13.01 |
| 802.11n | 5785 | 157 | 12.94 |
| 802.11n | 5805 | 161 | 12.98 |
| 802.11n | 5825 | 165 | 12.98 |



| | | | | |
|--|---|--------------------------------------|---|--|
| FCC ID: A3LSMN915X |  | SAR EVALUATION REPORT |  | Reviewed by: Quality Manager |
| Document S/N: OY1408181741.A3L | Test Dates: 08/14/14 - 08/23/14 | DUT Type: Portable Handset | Page 22 of 40 | |

Table 8-13
IEEE 802.11n Average RF Power – 40 MHz Bandwidth – Antenna 1

| Mode | Freq [MHz] | Channel | 40MHz BW 802.11n (5GHz) Conducted Power [dBm] | | | | | | | |
|---------|------------|---------|---|-------|-------|-------|-------|-------|-------|-------|
| | | | Data Rate [Mbps] | | | | | | | |
| | | | 13.5 | 27 | 40.5 | 54 | 81 | 108 | 121.5 | 135 |
| 802.11n | 5190 | 38 | 12.21 | 12.23 | 12.28 | 12.44 | 12.45 | 12.47 | 12.49 | 12.40 |
| 802.11n | 5230 | 46 | 12.04 | 11.99 | 12.09 | 12.23 | 12.27 | 12.30 | 12.33 | 12.25 |
| 802.11n | 5270 | 54 | 12.14 | 12.22 | 12.30 | 12.37 | 12.45 | 12.34 | 12.44 | 12.45 |
| 802.11n | 5310 | 62 | 12.08 | 12.22 | 12.21 | 12.26 | 12.42 | 12.26 | 12.40 | 12.41 |
| 802.11n | 5510 | 102 | 11.90 | 11.91 | 11.90 | 12.09 | 12.14 | 12.13 | 12.18 | 12.14 |
| 802.11n | 5550 | 110 | 11.90 | 11.90 | 11.83 | 12.09 | 12.14 | 12.13 | 12.17 | 12.06 |
| 802.11n | 5590 | 118 | N/A | N/A | N/A | N/A | N/A | N/A | N/A | N/A |
| 802.11n | 5630 | 126 | N/A | N/A | N/A | N/A | N/A | N/A | N/A | N/A |
| 802.11n | 5670 | 134 | 11.77 | 11.72 | 11.80 | 12.02 | 11.98 | 11.98 | 11.99 | 11.99 |
| 802.11n | 5755 | 151 | 11.91 | 11.88 | 11.76 | 12.12 | 12.03 | 12.10 | 12.09 | 12.03 |
| 802.11n | 5795 | 159 | 11.86 | 11.82 | 11.71 | 12.09 | 12.01 | 12.06 | 12.01 | 12.03 |

Table 8-14
IEEE 802.11n Average RF Power – 40 MHz Bandwidth – Antenna 2

| Mode | Freq [MHz] | Channel | 40MHz BW 802.11n (5GHz) Conducted Power [dBm] | | | | | | | |
|---------|------------|---------|---|-------|-------|-------|-------|-------|-------|-------|
| | | | Data Rate [Mbps] | | | | | | | |
| | | | 13.5 | 27 | 40.5 | 54 | 81 | 108 | 121.5 | 135 |
| 802.11n | 5190 | 38 | 11.64 | 11.70 | 11.60 | 11.80 | 11.81 | 11.78 | 11.83 | 11.84 |
| 802.11n | 5230 | 46 | 11.51 | 11.60 | 11.53 | 11.73 | 11.67 | 11.65 | 11.65 | 11.68 |
| 802.11n | 5270 | 54 | 12.13 | 12.08 | 12.09 | 12.22 | 12.18 | 12.21 | 12.23 | 12.17 |
| 802.11n | 5310 | 62 | 12.16 | 12.13 | 12.08 | 12.27 | 12.21 | 12.21 | 12.31 | 12.19 |
| 802.11n | 5510 | 102 | 12.08 | 12.21 | 12.17 | 12.22 | 12.33 | 12.28 | 12.27 | 12.22 |
| 802.11n | 5550 | 110 | 12.05 | 12.13 | 12.12 | 12.19 | 12.25 | 12.24 | 12.23 | 12.19 |
| 802.11n | 5590 | 118 | N/A | N/A | N/A | N/A | N/A | N/A | N/A | N/A |
| 802.11n | 5630 | 126 | N/A | N/A | N/A | N/A | N/A | N/A | N/A | N/A |
| 802.11n | 5670 | 134 | 11.98 | 12.11 | 12.02 | 12.11 | 12.22 | 12.24 | 12.18 | 12.14 |
| 802.11n | 5755 | 151 | 11.75 | 11.72 | 11.60 | 11.86 | 11.88 | 11.87 | 11.90 | 11.84 |
| 802.11n | 5795 | 159 | 11.73 | 11.73 | 11.58 | 11.80 | 11.91 | 11.86 | 11.95 | 11.81 |

Table 8-15
IEEE 802.11n Average RF Power – 40 MHz Bandwidth – MIMO

| Mode | Freq [MHz] | Channel | Data Rate (Mbps) |
|---------|------------|---------|------------------|
| | | | 27 |
| 802.11n | 5190 | 38 | 11.65 |
| 802.11n | 5230 | 46 | 11.49 |
| 802.11n | 5270 | 54 | 11.81 |
| 802.11n | 5310 | 62 | 11.79 |
| 802.11n | 5510 | 102 | 11.65 |
| 802.11n | 5550 | 110 | 11.64 |
| 802.11n | 5590 | 118 | N/A |
| 802.11n | 5630 | 126 | N/A |
| 802.11n | 5670 | 134 | 11.54 |
| 802.11n | 5755 | 151 | 11.52 |
| 802.11n | 5795 | 159 | 11.48 |

Table 8-16
IEEE 802.11ac Average RF Power – 80 MHz Bandwidth – Antenna 1

| Mode | Freq [MHz] | Channel | 80MHz BW 802.11ac (5GHz) Conducted Power [dBm] | | | | | | | | | |
|----------|------------|---------|--|-------|-------|-------|-------|-------|-------|-------|-------|-------|
| | | | Data Rate [Mbps] | | | | | | | | | |
| | | | 29.3 | 58.5 | 87.8 | 117 | 175.5 | 234 | 263.3 | 292.5 | 351 | 390 |
| 802.11ac | 5210 | 42 | 11.05 | 10.91 | 10.80 | 10.41 | 10.45 | 10.41 | 10.42 | 10.46 | 11.28 | 10.50 |
| 802.11ac | 5290 | 58 | 10.56 | 10.73 | 10.02 | 10.53 | 10.65 | 10.71 | 10.66 | 10.63 | 10.51 | 10.61 |
| 802.11ac | 5530 | 106 | 10.90 | 11.08 | 11.06 | 10.48 | 10.92 | 10.93 | 11.10 | 11.06 | 11.01 | 11.08 |
| 802.11ac | 5775 | 155 | 10.76 | 10.85 | 10.66 | 10.92 | 10.99 | 10.98 | 10.99 | 10.74 | 10.99 | 10.96 |

Table 8-17
IEEE 802.11ac Average RF Power – 80 MHz Bandwidth – Antenna 2

| Mode | Freq [MHz] | Channel | 80MHz BW 802.11ac (5GHz) Conducted Power [dBm] | | | | | | | | | |
|----------|------------|---------|--|-------|-------|-------|-------|-------|-------|-------|-------|-------|
| | | | Data Rate [Mbps] | | | | | | | | | |
| | | | 29.3 | 58.5 | 87.8 | 117 | 175.5 | 234 | 263.3 | 292.5 | 351 | 390 |
| 802.11ac | 5210 | 42 | 11.11 | 11.09 | 10.97 | 10.51 | 10.56 | 10.61 | 10.61 | 10.59 | 10.50 | 10.65 |
| 802.11ac | 5290 | 58 | 10.70 | 10.68 | 10.45 | 10.92 | 10.92 | 10.92 | 10.91 | 10.88 | 10.94 | 10.94 |
| 802.11ac | 5530 | 106 | 10.73 | 10.58 | 10.45 | 10.92 | 10.94 | 10.83 | 10.83 | 10.84 | 10.92 | 10.96 |
| 802.11ac | 5775 | 155 | 11.19 | 11.04 | 11.07 | 10.64 | 10.73 | 10.52 | 10.50 | 10.60 | 10.61 | 10.58 |



| | | | | |
|-----------------------------------|---|-------------------------------|---|---------------------------------|
| FCC ID: A3LSMN915X |  | SAR EVALUATION REPORT |  | Reviewed by: Quality Manager |
| Document S/N: OY1408181741.A3L | Test Dates: 08/14/14 - 08/23/14 | DUT Type: Portable Handset | | Page 24 of 40 |

Table 8-18
IEEE 802.11ac Average RF Power – 80 MHz Bandwidth – MIMO

| Mode | Freq [MHz] | Channel | Data Rate (Mbps) |
|----------|------------|---------|------------------|
| | | | 58.5 |
| 802.11ac | 5210 | 42 | 10.95 |
| 802.11ac | 5290 | 58 | 10.97 |
| 802.11ac | 5530 | 106 | 11.18 |
| 802.11ac | 5775 | 155 | 11.29 |

Justification for reduced test configurations for WIFI channels per KDB Publication 248227 D01v01r02 and October 2012/April 2013 FCC/TCB Meeting Notes:

- For 2.4 GHz SISO operations, highest average RF output power channel for the lowest data rate for IEEE 802.11b were selected for SAR evaluation. Other IEEE 802.11 SISO modes (including 802.11g/n) were not investigated since the average output powers over all channels and data rates were not more than 0.25 dB higher than the tested channel in the lowest data rate of IEEE 802.11b mode.
- For 5 GHz SISO operations, highest average RF output power channel for the lowest data rate for IEEE 802.11a were selected for SAR evaluation. Other IEEE 802.11 SISO modes (including 802.11n 20 MHz and 40 MHz) were not investigated since the average output powers over all channels and data rates were not more than 0.25 dB higher than the tested channel in the lowest data rate of IEEE 802.11a mode.
- Full SAR tests for all SISO IEEE 802.11ac configurations were not required because the average output power was not more than 0.25 dB higher than IEEE 802.11a mode. IEEE 802.11ac in SISO mode was evaluated for the highest IEEE 802.11a position in each 5 GHz band and exposure condition.
- For MIMO 2.4 GHz and 5 GHz operations, the highest average RF output power channel for the lowest data rate for IEEE 802.11n (20 MHz bandwidth) was selected for SAR evaluation. Other IEEE 802.11 modes and bandwidths were not investigated for MIMO operations since the maximum allowed output power (including tolerance) was not higher for these modes.
- The individual spectra for each 2x2 MIMO WIFI Antenna were summed mathematically in linear power units for the MIMO output power measurements.
- When the maximum extrapolated peak SAR of the zoom scan for the maximum output channel is <1.6 W/kg and the reported 1g averaged SAR is <0.8 W/kg, SAR testing on other channels is not required. Otherwise, the other default (or corresponding required) test channels were additionally tested using the lowest data rate.
- The bolded data rate and channel above were tested for SAR.

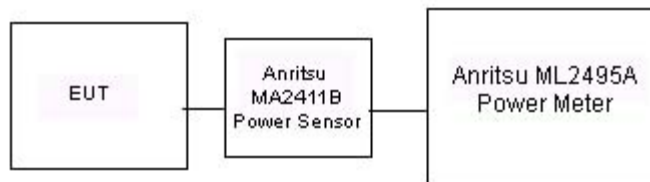

Figure 8-1
Power Measurement Setup for Bandwidths < 50 MHz

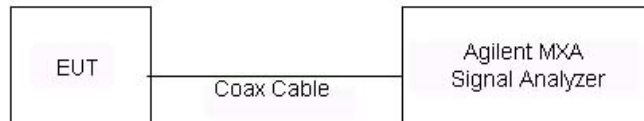



Figure 8-2
Power Measurement Setup for Bandwidths > 50 MHz

| | | | | |
|-----------------------------------|---|-------------------------------|---|---------------------------------|
| FCC ID: A3LSMN915X |  | SAR EVALUATION REPORT |  | Reviewed by: Quality Manager |
| Document S/N: OY1408181741.A3L | Test Dates: 08/14/14 - 08/23/14 | DUT Type: Portable Handset | Page 25 of 40 | |



9 SYSTEM VERIFICATION

9.1 Tissue Verification

**Table 9-1
Measured Tissue Properties**

| Calibrated for Tests Performed on: | Tissue Type | Tissue Temp During Calibration (C°) | Measured Frequency (MHz) | Measured Conductivity, σ (S/m) | Measured Dielectric Constant, ϵ | TARGET Conductivity, σ (S/m) | TARGET Dielectric Constant, ϵ | % dev σ | % dev ϵ |
|------------------------------------|-------------|-------------------------------------|--------------------------|---------------------------------------|--|-------------------------------------|--|----------------|------------------|
| 8/18/2014 | 2450H | 22.0 | 2401 | 1.740 | 40.746 | 1.756 | 39.287 | -0.91% | 3.71% |
| | | | 2450 | 1.790 | 40.574 | 1.800 | 39.200 | -0.56% | 3.51% |
| | | | 2499 | 1.845 | 40.408 | 1.853 | 39.138 | -0.43% | 3.24% |
| 08/14/2014 | 5200H-5800H | 23.4 | 5180 | 4.544 | 37.113 | 4.635 | 36.009 | -1.96% | 3.07% |
| | | | 5200 | 4.567 | 37.076 | 4.655 | 35.986 | -1.89% | 3.03% |
| | | | 5220 | 4.590 | 37.007 | 4.676 | 35.963 | -1.84% | 2.90% |
| | | | 5260 | 4.637 | 37.018 | 4.717 | 35.917 | -1.70% | 3.07% |
| | | | 5280 | 4.648 | 36.982 | 4.737 | 35.894 | -1.88% | 3.03% |
| | | | 5300 | 4.660 | 36.974 | 4.758 | 35.871 | -2.06% | 3.07% |
| | | | 5320 | 4.693 | 36.897 | 4.778 | 35.849 | -1.78% | 2.92% |
| | | | 5500 | 4.871 | 36.690 | 4.963 | 35.643 | -1.85% | 2.94% |
| | | | 5520 | 4.900 | 36.663 | 4.983 | 35.620 | -1.67% | 2.93% |
| | | | 5540 | 4.913 | 36.639 | 5.004 | 35.597 | -1.82% | 2.93% |
| | | | 5600 | 4.976 | 36.541 | 5.065 | 35.529 | -1.76% | 2.85% |
| | | | 5700 | 5.082 | 36.438 | 5.168 | 35.414 | -1.66% | 2.89% |
| | | | 5745 | 5.150 | 36.373 | 5.214 | 35.363 | -1.23% | 2.86% |
| | | | 5765 | 5.162 | 36.362 | 5.234 | 35.340 | -1.38% | 2.89% |
| | | | 5785 | 5.171 | 36.364 | 5.255 | 35.317 | -1.60% | 2.96% |
| | | | 8/18/2014 | 2450B | 23.2 | 2401 | 1.908 | 52.115 | 1.903 |
| 2450 | 1.970 | 51.945 | | | | 1.950 | 52.700 | 1.03% | -1.43% |
| 2499 | 2.037 | 51.768 | | | | 2.019 | 52.638 | 0.89% | -1.65% |
| 8/23/2014 | 2450B | 22.0 | 2401 | 1.972 | 52.198 | 1.903 | 52.765 | 3.63% | -1.07% |
| | | | 2450 | 2.045 | 52.023 | 1.950 | 52.700 | 4.87% | -1.28% |
| | | | 2499 | 2.110 | 51.815 | 2.019 | 52.638 | 4.51% | -1.56% |
| 08/18/2014 | 5200B-5800B | 20.5 | 5180 | 5.086 | 47.247 | 5.276 | 49.041 | -3.60% | -3.66% |
| | | | 5200 | 5.106 | 47.285 | 5.299 | 49.014 | -3.64% | -3.53% |
| | | | 5220 | 5.119 | 47.231 | 5.323 | 48.987 | -3.83% | -3.58% |
| | | | 5260 | 5.168 | 47.140 | 5.369 | 48.933 | -3.74% | -3.66% |
| | | | 5280 | 5.210 | 47.109 | 5.393 | 48.906 | -3.39% | -3.67% |
| | | | 5300 | 5.228 | 47.061 | 5.416 | 48.879 | -3.47% | -3.72% |
| | | | 5320 | 5.256 | 47.071 | 5.439 | 48.851 | -3.36% | -3.64% |
| | | | 5500 | 5.509 | 46.844 | 5.650 | 48.607 | -2.50% | -3.63% |
| | | | 5520 | 5.544 | 46.831 | 5.673 | 48.580 | -2.27% | -3.60% |
| | | | 5540 | 5.560 | 46.766 | 5.696 | 48.553 | -2.39% | -3.68% |
| | | | 5600 | 5.653 | 46.714 | 5.766 | 48.471 | -1.96% | -3.62% |
| | | | 5700 | 5.780 | 46.550 | 5.883 | 48.336 | -1.75% | -3.69% |
| | | | 5745 | 5.829 | 46.499 | 5.936 | 48.275 | -1.80% | -3.68% |
| | | | 5765 | 5.845 | 46.465 | 5.959 | 48.248 | -1.91% | -3.70% |
| | | | 5785 | 5.834 | 46.393 | 5.982 | 48.220 | -2.47% | -3.79% |
| | | | 5800 | 5.842 | 46.461 | 6.000 | 48.200 | -2.63% | -3.61% |
| 5825 | 5.890 | 46.409 | 6.029 | 48.166 | -2.31% | -3.65% | | | |

The above measured tissue parameters were used in the DASY software. The DASY software was used to perform interpolation to determine the dielectric parameters at the SAR test device frequencies (per KDB Publication 865664 and IEEE 1528-2013 6.6.1.2). The tissue parameters listed in the SAR test plots may slightly differ from the table above due to significant digit rounding in the software.

| | | | | |
|--|---|--------------------------------------|---|--|
| FCC ID: A3LSMN915X |  PCTEST ENGINEERING LABORATORY, INC. | SAR EVALUATION REPORT |  | Reviewed by: Quality Manager |
| Document S/N: OY1408181741.A3L | Test Dates: 08/14/14 - 08/23/14 | DUT Type: Portable Handset | Page 26 of 40 | |

9.2 Test System Verification

Prior to SAR assessment, the system is verified to $\pm 10\%$ of the SAR measurement on the reference dipole at the time of calibration by the calibration facility. Full system validation status and result summary can be found in Appendix E.

**Table 9-2
System Verification Results (1g)**

| System Verification TARGET & MEASURED | | | | | | | | | | | | |
|--|------------------------|-------------|------------|----------------|------------------|-----------------|-----------|----------|-----------------------------------|-------------------------------------|---|-----------------------------|
| SAR System # | Tissue Frequency (MHz) | Tissue Type | Date: | Amb. Temp (°C) | Liquid Temp (°C) | Input Power (W) | Dipole SN | Probe SN | Measured SAR _{1g} (W/kg) | 1 W Target SAR _{1g} (W/kg) | 1 W Normalized SAR _{1g} (W/kg) | Deviation _{1g} (%) |
| H | 2450 | HEAD | 08/18/2014 | 24.5 | 22.0 | 0.100 | 797 | 3319 | 5.330 | 51.800 | 53.300 | 2.90% |
| E | 5200 | HEAD | 08/14/2014 | 24.4 | 23.6 | 0.100 | 1057 | 3914 | 7.540 | 78.000 | 75.400 | -3.33% |
| E | 5300 | HEAD | 08/14/2014 | 24.4 | 23.6 | 0.100 | 1057 | 3914 | 8.140 | 83.000 | 81.400 | -1.93% |
| E | 5500 | HEAD | 08/14/2014 | 24.3 | 23.7 | 0.100 | 1057 | 3914 | 8.230 | 84.300 | 82.300 | -2.37% |
| E | 5600 | HEAD | 08/14/2014 | 24.2 | 23.8 | 0.100 | 1057 | 3914 | 8.180 | 83.500 | 81.800 | -2.04% |
| E | 5800 | HEAD | 08/14/2014 | 24.3 | 23.6 | 0.100 | 1057 | 3914 | 7.390 | 79.300 | 73.900 | -6.81% |
| H | 2450 | BODY | 08/18/2014 | 24.5 | 23.2 | 0.100 | 797 | 3319 | 4.930 | 49.400 | 49.300 | -0.20% |
| A | 5200 | BODY | 08/18/2014 | 23.4 | 21.8 | 0.100 | 1007 | 3920 | 7.490 | 72.600 | 74.900 | 3.17% |
| A | 5300 | BODY | 08/18/2014 | 23.4 | 21.8 | 0.100 | 1007 | 3920 | 7.620 | 74.700 | 76.200 | 2.01% |
| A | 5500 | BODY | 08/18/2014 | 23.4 | 21.8 | 0.100 | 1007 | 3920 | 7.670 | 75.900 | 76.700 | 1.05% |
| A | 5600 | BODY | 08/18/2014 | 23.4 | 21.8 | 0.100 | 1007 | 3920 | 7.740 | 77.300 | 77.400 | 0.13% |
| A | 5800 | BODY | 08/18/2014 | 23.4 | 21.8 | 0.100 | 1007 | 3920 | 7.120 | 72.900 | 71.200 | -2.33% |

**Table 9-3
System Verification Results (10g)**

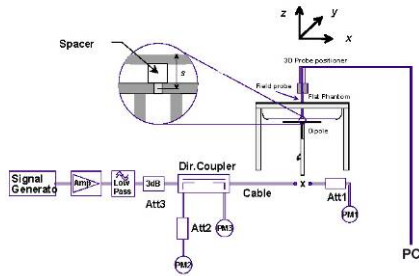

| System Verification TARGET & MEASURED | | | | | | | | | | | | |
|--|------------------------|-------------|------------|----------------|------------------|-----------------|-----------|----------|------------------------------------|--------------------------------------|--|------------------------------|
| SAR System # | Tissue Frequency (MHz) | Tissue Type | Date: | Amb. Temp (°C) | Liquid Temp (°C) | Input Power (W) | Dipole SN | Probe SN | Measured SAR _{10g} (W/kg) | 1 W Target SAR _{10g} (W/kg) | 1 W Normalized SAR _{10g} (W/kg) | Deviation _{10g} (%) |
| G | 2450 | BODY | 08/23/2014 | 24.3 | 22.0 | 0.100 | 797 | 3258 | 2.380 | 23.100 | 23.800 | 3.03% |
| A | 5200 | BODY | 08/18/2014 | 23.4 | 21.8 | 0.100 | 1007 | 3920 | 2.130 | 20.200 | 21.300 | 5.45% |
| A | 5300 | BODY | 08/18/2014 | 23.4 | 21.8 | 0.100 | 1007 | 3920 | 2.130 | 20.800 | 21.300 | 2.40% |
| A | 5500 | BODY | 08/18/2014 | 23.4 | 21.8 | 0.100 | 1007 | 3920 | 2.160 | 21.000 | 21.600 | 2.86% |
| A | 5600 | BODY | 08/18/2014 | 23.4 | 21.8 | 0.100 | 1007 | 3920 | 2.170 | 21.500 | 21.700 | 0.93% |
| A | 5800 | BODY | 08/18/2014 | 23.4 | 21.8 | 0.100 | 1007 | 3920 | 1.960 | 20.100 | 19.600 | -2.49% |



**Figure 9-1
System Verification Setup Diagram**



**Figure 9-2
System Verification Setup Photo**



| | | | | |
|-----------------------------------|---|-------------------------------|---|---------------------------------|
| FCC ID: A3LSMN915X |  | SAR EVALUATION REPORT |  | Reviewed by: Quality Manager |
| Document S/N: OY1408181741.A3L | Test Dates: 08/14/14 - 08/23/14 | DUT Type: Portable Handset | | Page 27 of 40 |

10 SAR DATA SUMMARY

10.1 Standalone Head SAR Data



**Table 10-1
DTS Head SAR**

| MEASUREMENT RESULTS | | | | | | | | | | | | | | | | |
|---|-----|---------------|---------|-----------------------------|-----------------------|------------------|-------|---------------|---|----------------------|------------------|------------|----------|----------------|-----------------|--------|
| FREQUENCY | | Mode | Service | Maximum Allowed Power [dBm] | Conducted Power [dBm] | Power Drift [dB] | Side | Test Position | Antenna Config. | Device Serial Number | Data Rate (Mbps) | Duty Cycle | SAR (1g) | Scaling Factor | Scaled SAR (1g) | Plot # |
| MHz | Ch. | | | | | | | | | | | | (W/kg) | | (W/kg) | |
| 2437 | 6 | IEEE 802.11b | DSSS | 17.5 | 17.20 | 0.21 | Right | Cheek | 1 | F2279 | 1 | 1:1 | 0.061 | 1.072 | 0.065 | |
| 2437 | 6 | IEEE 802.11b | DSSS | 17.5 | 17.20 | 0.13 | Right | Tilt | 1 | F2279 | 1 | 1:1 | 0.045 | 1.072 | 0.048 | |
| 2437 | 6 | IEEE 802.11b | DSSS | 17.5 | 17.20 | 0.12 | Left | Cheek | 1 | F2279 | 1 | 1:1 | 0.019 | 1.072 | 0.020 | |
| 2437 | 6 | IEEE 802.11b | DSSS | 17.5 | 17.20 | 0.18 | Left | Tilt | 1 | F2279 | 1 | 1:1 | 0.019 | 1.072 | 0.020 | |
| 2412 | 1 | IEEE 802.11b | DSSS | 17.5 | 17.33 | 0.06 | Right | Cheek | 2 | F2279 | 1 | 1:1 | 0.197 | 1.040 | 0.205 | A1 |
| 2412 | 1 | IEEE 802.11b | DSSS | 17.5 | 17.33 | 0.04 | Right | Tilt | 2 | F2279 | 1 | 1:1 | 0.128 | 1.040 | 0.133 | |
| 2412 | 1 | IEEE 802.11b | DSSS | 17.5 | 17.33 | 0.14 | Left | Cheek | 2 | F2279 | 1 | 1:1 | 0.128 | 1.040 | 0.133 | |
| 2412 | 1 | IEEE 802.11b | DSSS | 17.5 | 17.33 | 0.13 | Left | Tilt | 2 | F2279 | 1 | 1:1 | 0.102 | 1.040 | 0.106 | |
| 2412 | 1 | IEEE 802.11n | OFDM | 16.5 | 16.18 | 0.13 | Right | Cheek | MIMO | F2279 | 13 | 1:1 | 0.077 | 1.076 | 0.083 | |
| 2412 | 1 | IEEE 802.11n | OFDM | 16.5 | 16.18 | 0.15 | Right | Tilt | MIMO | F2279 | 13 | 1:1 | 0.054 | 1.076 | 0.058 | |
| 2412 | 1 | IEEE 802.11n | OFDM | 16.5 | 16.18 | 0.14 | Left | Cheek | MIMO | F2279 | 13 | 1:1 | 0.049 | 1.076 | 0.053 | |
| 2412 | 1 | IEEE 802.11n | OFDM | 16.5 | 16.18 | 0.18 | Left | Tilt | MIMO | F2279 | 13 | 1:1 | 0.038 | 1.076 | 0.041 | |
| 5745 | 149 | IEEE 802.11a | OFDM | 14.5 | 13.58 | 0.13 | Right | Cheek | 1 | F238A | 6 | 1:1 | 0.034 | 1.236 | 0.042 | |
| 5775 | 155 | IEEE 802.11ac | OFDM | 11.5 | 10.76 | 0.20 | Right | Cheek | 1 | F238A | 29.3 | 1:1 | 0.009 | 1.186 | 0.011 | |
| 5745 | 149 | IEEE 802.11a | OFDM | 14.5 | 13.58 | -0.20 | Right | Tilt | 1 | F238A | 6 | 1:1 | 0.000 | 1.236 | 0.000 | |
| 5745 | 149 | IEEE 802.11a | OFDM | 14.5 | 13.58 | 0.00 | Left | Cheek | 1 | F238A | 6 | 1:1 | 0.004 | 1.236 | 0.005 | |
| 5745 | 149 | IEEE 802.11a | OFDM | 14.5 | 13.58 | -0.20 | Left | Tilt | 1 | F238A | 6 | 1:1 | 0.000 | 1.236 | 0.000 | |
| 5825 | 165 | IEEE 802.11a | OFDM | 14.5 | 14.22 | 0.17 | Right | Cheek | 2 | F238A | 6 | 1:1 | 0.083 | 1.067 | 0.089 | A2 |
| 5775 | 155 | IEEE 802.11ac | OFDM | 11.5 | 11.19 | 0.20 | Right | Cheek | 2 | F238A | 29.3 | 1:1 | 0.025 | 1.074 | 0.027 | |
| 5825 | 165 | IEEE 802.11a | OFDM | 14.5 | 14.22 | 0.15 | Right | Tilt | 2 | F238A | 6 | 1:1 | 0.067 | 1.067 | 0.071 | |
| 5825 | 165 | IEEE 802.11a | OFDM | 14.5 | 14.22 | 0.15 | Left | Cheek | 2 | F238A | 6 | 1:1 | 0.053 | 1.067 | 0.057 | |
| 5825 | 165 | IEEE 802.11a | OFDM | 14.5 | 14.22 | -0.15 | Left | Tilt | 2 | F238A | 6 | 1:1 | 0.048 | 1.067 | 0.051 | |
| 5765 | 153 | IEEE 802.11n | OFDM | 13.5 | 13.01 | 0.00 | Right | Cheek | MIMO | F238A | 13 | 1:1 | 0.006 | 1.119 | 0.007 | |
| 5765 | 153 | IEEE 802.11n | OFDM | 13.5 | 13.01 | 0.20 | Right | Tilt | MIMO | F238A | 13 | 1:1 | 0.001 | 1.119 | 0.001 | |
| 5765 | 153 | IEEE 802.11n | OFDM | 13.5 | 13.01 | 0.20 | Left | Cheek | MIMO | F238A | 13 | 1:1 | 0.002 | 1.119 | 0.002 | |
| 5765 | 153 | IEEE 802.11n | OFDM | 13.5 | 13.01 | 0.20 | Left | Tilt | MIMO | F238A | 13 | 1:1 | 0.003 | 1.119 | 0.003 | |
| ANSI / IEEE C95.1 1992 - SAFETY LIMIT Spatial Peak Uncontrolled Exposure/General Population | | | | | | | | | Head 1.6 W/kg (mW/g) averaged over 1 gram | | | | | | | |

| | | | | |
|-----------------------------------|---|-------------------------------|---|---------------------------------|
| FCC ID: A3LSMN915X |  PCTEST ENGINEERING LABORATORY, INC. | SAR EVALUATION REPORT |  | Reviewed by: Quality Manager |
| Document S/N: OY1408181741.A3L | Test Dates: 08/14/14 - 08/23/14 | DUT Type: Portable Handset | Page 28 of 40 | |

**Table 10-2
NII Head SAR**

| MEASUREMENT RESULTS | | | | | | | | | | | | | | | | |
|---|-----|---------------|---------|-----------------------------|-----------------------|------------------|-------|---|-----------------|----------------------|------------------|------------|----------|----------------|-----------------|--------|
| FREQUENCY | | Mode | Service | Maximum Allowed Power [dBm] | Conducted Power [dBm] | Power Drift [dB] | Side | Test Position | Antenna Config. | Device Serial Number | Data Rate (Mbps) | Duty Cycle | SAR (1g) | Scaling Factor | Scaled SAR (1g) | Plot # |
| MHz | Ch. | | | | | | | | | | | | (W/kg) | | (W/kg) | |
| 5180 | 36 | IEEE 802.11a | OFDM | 14.5 | 13.63 | 0.12 | Right | Cheek | 1 | F238A | 6 | 1:1 | 0.071 | 1.222 | 0.087 | |
| 5210 | 42 | IEEE 802.11ac | OFDM | 11.5 | 11.05 | 0.11 | Right | Cheek | 1 | F238A | 29.3 | 1:1 | 0.012 | 1.109 | 0.013 | |
| 5180 | 36 | IEEE 802.11a | OFDM | 14.5 | 13.63 | -0.15 | Right | Tilt | 1 | F238A | 6 | 1:1 | 0.012 | 1.222 | 0.015 | |
| 5180 | 36 | IEEE 802.11a | OFDM | 14.5 | 13.63 | 0.17 | Left | Cheek | 1 | F238A | 6 | 1:1 | 0.020 | 1.222 | 0.024 | |
| 5180 | 36 | IEEE 802.11a | OFDM | 14.5 | 13.63 | 0.00 | Left | Tilt | 1 | F238A | 6 | 1:1 | 0.001 | 1.222 | 0.001 | |
| 5260 | 52 | IEEE 802.11a | OFDM | 14.5 | 13.98 | 0.08 | Right | Cheek | 1 | F238A | 6 | 1:1 | 0.057 | 1.127 | 0.064 | |
| 5290 | 58 | IEEE 802.11ac | OFDM | 11.5 | 10.56 | -0.20 | Right | Cheek | 1 | F238A | 29.3 | 1:1 | 0.009 | 1.242 | 0.011 | |
| 5260 | 52 | IEEE 802.11a | OFDM | 14.5 | 13.98 | 0.14 | Right | Tilt | 1 | F238A | 6 | 1:1 | 0.012 | 1.127 | 0.014 | |
| 5260 | 52 | IEEE 802.11a | OFDM | 14.5 | 13.98 | 0.12 | Left | Cheek | 1 | F238A | 6 | 1:1 | 0.018 | 1.127 | 0.020 | |
| 5260 | 52 | IEEE 802.11a | OFDM | 14.5 | 13.98 | 0.13 | Left | Tilt | 1 | F238A | 6 | 1:1 | 0.000 | 1.127 | 0.000 | |
| 5500 | 100 | IEEE 802.11a | OFDM | 14.5 | 13.65 | 0.18 | Right | Cheek | 1 | F238A | 6 | 1:1 | 0.021 | 1.216 | 0.026 | |
| 5530 | 106 | IEEE 802.11ac | OFDM | 11.5 | 10.90 | 0.00 | Right | Cheek | 1 | F238A | 29.3 | 1:1 | 0.009 | 1.148 | 0.010 | |
| 5500 | 100 | IEEE 802.11a | OFDM | 14.5 | 13.65 | 0.20 | Right | Tilt | 1 | F238A | 6 | 1:1 | 0.000 | 1.216 | 0.000 | |
| 5500 | 100 | IEEE 802.11a | OFDM | 14.5 | 13.65 | 0.20 | Left | Cheek | 1 | F238A | 6 | 1:1 | 0.004 | 1.216 | 0.005 | |
| 5500 | 100 | IEEE 802.11a | OFDM | 14.5 | 13.65 | 0.00 | Left | Tilt | 1 | F238A | 6 | 1:1 | 0.000 | 1.216 | 0.000 | |
| 5180 | 36 | IEEE 802.11a | OFDM | 14.5 | 14.14 | 0.13 | Right | Cheek | 2 | F238A | 6 | 1:1 | 0.072 | 1.086 | 0.078 | |
| 5180 | 36 | IEEE 802.11a | OFDM | 14.5 | 14.14 | 0.18 | Right | Tilt | 2 | F238A | 6 | 1:1 | 0.059 | 1.086 | 0.064 | |
| 5180 | 36 | IEEE 802.11a | OFDM | 14.5 | 14.14 | 0.16 | Left | Cheek | 2 | F238A | 6 | 1:1 | 0.083 | 1.086 | 0.090 | |
| 5210 | 42 | IEEE 802.11ac | OFDM | 11.5 | 11.11 | 0.15 | Left | Cheek | 2 | F238A | 29.3 | 1:1 | 0.023 | 1.094 | 0.025 | |
| 5180 | 36 | IEEE 802.11a | OFDM | 14.5 | 14.14 | 0.17 | Left | Tilt | 2 | F238A | 6 | 1:1 | 0.069 | 1.086 | 0.075 | |
| 5260 | 52 | IEEE 802.11a | OFDM | 14.5 | 13.70 | 0.21 | Right | Cheek | 2 | F238A | 6 | 1:1 | 0.076 | 1.202 | 0.091 | |
| 5290 | 58 | IEEE 802.11ac | OFDM | 11.5 | 10.70 | 0.16 | Right | Cheek | 2 | F238A | 29.3 | 1:1 | 0.027 | 1.202 | 0.032 | |
| 5260 | 52 | IEEE 802.11a | OFDM | 14.5 | 13.70 | 0.14 | Right | Tilt | 2 | F238A | 6 | 1:1 | 0.068 | 1.202 | 0.082 | |
| 5260 | 52 | IEEE 802.11a | OFDM | 14.5 | 13.70 | 0.19 | Left | Cheek | 2 | F238A | 6 | 1:1 | 0.070 | 1.202 | 0.084 | |
| 5260 | 52 | IEEE 802.11a | OFDM | 14.5 | 13.70 | 0.12 | Left | Tilt | 2 | F238A | 6 | 1:1 | 0.072 | 1.202 | 0.087 | |
| 5700 | 140 | IEEE 802.11a | OFDM | 14.5 | 14.21 | 0.11 | Right | Cheek | 2 | F238A | 6 | 1:1 | 0.098 | 1.069 | 0.105 | A3 |
| 5530 | 106 | IEEE 802.11ac | OFDM | 11.5 | 10.73 | 0.12 | Right | Cheek | 2 | F238A | 29.3 | 1:1 | 0.029 | 1.194 | 0.035 | |
| 5700 | 140 | IEEE 802.11a | OFDM | 14.5 | 14.21 | 0.19 | Right | Tilt | 2 | F238A | 6 | 1:1 | 0.078 | 1.069 | 0.083 | |
| 5700 | 140 | IEEE 802.11a | OFDM | 14.5 | 14.21 | 0.14 | Left | Cheek | 2 | F238A | 6 | 1:1 | 0.075 | 1.069 | 0.080 | |
| 5700 | 140 | IEEE 802.11a | OFDM | 14.5 | 14.21 | 0.15 | Left | Tilt | 2 | F238A | 6 | 1:1 | 0.060 | 1.069 | 0.064 | |
| 5200 | 40 | IEEE 802.11n | OFDM | 13.5 | 12.59 | 0.16 | Right | Cheek | MIMO | F238A | 13 | 1:1 | 0.011 | 1.233 | 0.014 | |
| 5200 | 40 | IEEE 802.11n | OFDM | 13.5 | 12.59 | -0.16 | Right | Tilt | MIMO | F238A | 13 | 1:1 | 0.008 | 1.233 | 0.010 | |
| 5200 | 40 | IEEE 802.11n | OFDM | 13.5 | 12.59 | 0.14 | Left | Cheek | MIMO | F238A | 13 | 1:1 | 0.013 | 1.233 | 0.016 | |
| 5200 | 40 | IEEE 802.11n | OFDM | 13.5 | 12.59 | 0.18 | Left | Tilt | MIMO | F238A | 13 | 1:1 | 0.013 | 1.233 | 0.016 | |
| 5320 | 64 | IEEE 802.11n | OFDM | 13.5 | 12.44 | 0.19 | Right | Cheek | MIMO | F238A | 13 | 1:1 | 0.012 | 1.276 | 0.015 | |
| 5320 | 64 | IEEE 802.11n | OFDM | 13.5 | 12.44 | -0.16 | Right | Tilt | MIMO | F238A | 13 | 1:1 | 0.014 | 1.276 | 0.018 | |
| 5320 | 64 | IEEE 802.11n | OFDM | 13.5 | 12.44 | 0.19 | Left | Cheek | MIMO | F238A | 13 | 1:1 | 0.014 | 1.276 | 0.018 | |
| 5320 | 64 | IEEE 802.11n | OFDM | 13.5 | 12.44 | 0.02 | Left | Tilt | MIMO | F238A | 13 | 1:1 | 0.012 | 1.276 | 0.015 | |
| 5500 | 100 | IEEE 802.11n | OFDM | 13.5 | 12.63 | 0.20 | Right | Cheek | MIMO | F238A | 13 | 1:1 | 0.010 | 1.222 | 0.012 | |
| 5500 | 100 | IEEE 802.11n | OFDM | 13.5 | 12.63 | 0.10 | Right | Tilt | MIMO | F238A | 13 | 1:1 | 0.014 | 1.222 | 0.017 | |
| 5500 | 100 | IEEE 802.11n | OFDM | 13.5 | 12.63 | 0.12 | Left | Cheek | MIMO | F238A | 13 | 1:1 | 0.011 | 1.222 | 0.013 | |
| 5500 | 100 | IEEE 802.11n | OFDM | 13.5 | 12.63 | -0.16 | Left | Tilt | MIMO | F238A | 13 | 1:1 | 0.009 | 1.222 | 0.011 | |
| ANSI / IEEE C95.1 1992 - SAFETY LIMIT Spatial Peak Uncontrolled Exposure/General Population | | | | | | | | Head 1.6 W/kg (mW/g) averaged over 1 gram | | | | | | | | |

| | | | | |
|-----------------------------------|---|-------------------------------|---|---------------------------------|
| FCC ID: A3LSMN915X |  | SAR EVALUATION REPORT |  | Reviewed by: Quality Manager |
| Document S/N: OY1408181741.A3L | Test Dates: 08/14/14 - 08/23/14 | DUT Type: Portable Handset | Page 29 of 40 | |



10.2 Standalone Body-Worn SAR Data

**Table 10-3
DTS Body-Worn SAR**

| MEASUREMENT RESULTS | | | | | | | | | | | | | | | | |
|---|-----|---------------|---------|-----------------------------|-----------------------|------------------|---|-----------------|----------------------|------------------|------|------------|----------|----------------|-----------------|--------|
| FREQUENCY | | Mode | Service | Maximum Allowed Power [dBm] | Conducted Power [dBm] | Power Drift [dB] | Spacing | Antenna Config. | Device Serial Number | Data Rate (Mbps) | Side | Duty Cycle | SAR (1g) | Scaling Factor | Scaled SAR (1g) | Plot # |
| MHz | Ch. | | | | | | | | | | | | (W/kg) | | (W/kg) | |
| 2437 | 6 | IEEE 802.11b | DSSS | 17.5 | 17.20 | 0.04 | 10 mm | 1 | F2279 | 1 | back | 1:1 | 0.069 | 1.072 | 0.074 | A4 |
| 2412 | 1 | IEEE 802.11b | DSSS | 17.5 | 17.33 | 0.05 | 10 mm | 2 | F2279 | 1 | back | 1:1 | 0.052 | 1.040 | 0.054 | |
| 2412 | 1 | IEEE 802.11n | OFDM | 16.5 | 16.18 | 0.13 | 10 mm | MIMO | F2279 | 13 | back | 1:1 | 0.025 | 1.076 | 0.027 | |
| 5745 | 149 | IEEE 802.11a | OFDM | 14.5 | 13.58 | 0.14 | 10 mm | 1 | F227C | 6 | back | 1:1 | 0.153 | 1.236 | 0.189 | A5 |
| 5775 | 155 | IEEE 802.11ac | OFDM | 11.5 | 10.76 | 0.19 | 10 mm | 1 | F227C | 29.3 | back | 1:1 | 0.042 | 1.186 | 0.050 | |
| 5825 | 165 | IEEE 802.11a | OFDM | 14.5 | 14.22 | 0.18 | 10 mm | 2 | F227C | 6 | back | 1:1 | 0.137 | 1.067 | 0.146 | |
| 5775 | 155 | IEEE 802.11ac | OFDM | 11.5 | 11.19 | 0.18 | 10 mm | 2 | F227C | 29.3 | back | 1:1 | 0.072 | 1.074 | 0.077 | |
| 5765 | 153 | IEEE 802.11n | OFDM | 13.5 | 13.01 | 0.12 | 10 mm | MIMO | F227C | 13 | back | 1:1 | 0.023 | 1.119 | 0.026 | |
| ANSI / IEEE C95.1 1992 - SAFETY LIMIT Spatial Peak Uncontrolled Exposure/General Population | | | | | | | Body 1.6 W/kg (mW/g) averaged over 1 gram | | | | | | | | | |

**Table 10-4
NII Body-Worn SAR**



| MEASUREMENT RESULTS | | | | | | | | | | | | | | | | |
|---|-----|---------------|---------|-----------------------------|-----------------------|------------------|---|-----------------|----------------------|------------------|------|------------|----------|----------------|-----------------|--------|
| FREQUENCY | | Mode | Service | Maximum Allowed Power [dBm] | Conducted Power [dBm] | Power Drift [dB] | Spacing | Antenna Config. | Device Serial Number | Data Rate (Mbps) | Side | Duty Cycle | SAR (1g) | Scaling Factor | Scaled SAR (1g) | Plot # |
| MHz | Ch. | | | | | | | | | | | | (W/kg) | | (W/kg) | |
| 5180 | 36 | IEEE 802.11a | OFDM | 14.5 | 13.63 | 0.10 | 10 mm | 1 | F227C | 6 | back | 1:1 | 0.231 | 1.222 | 0.282 | |
| 5210 | 42 | IEEE 802.11ac | OFDM | 11.5 | 11.05 | 0.15 | 10 mm | 1 | F227C | 29.3 | back | 1:1 | 0.073 | 1.109 | 0.081 | |
| 5260 | 52 | IEEE 802.11a | OFDM | 14.5 | 13.98 | 0.15 | 10 mm | 1 | F227C | 6 | back | 1:1 | 0.159 | 1.127 | 0.179 | |
| 5290 | 58 | IEEE 802.11ac | OFDM | 11.5 | 10.56 | -0.02 | 10 mm | 1 | F227C | 29.3 | back | 1:1 | 0.069 | 1.242 | 0.086 | |
| 5500 | 100 | IEEE 802.11a | OFDM | 14.5 | 13.65 | 0.17 | 10 mm | 1 | F227C | 6 | back | 1:1 | 0.154 | 1.216 | 0.187 | |
| 5530 | 106 | IEEE 802.11ac | OFDM | 11.5 | 10.90 | 0.14 | 10 mm | 1 | F227C | 29.3 | back | 1:1 | 0.045 | 1.148 | 0.052 | |
| 5180 | 36 | IEEE 802.11a | OFDM | 14.5 | 14.14 | 0.15 | 10 mm | 2 | F227C | 6 | back | 1:1 | 0.359 | 1.086 | 0.390 | |
| 5210 | 42 | IEEE 802.11ac | OFDM | 11.5 | 11.11 | 0.14 | 10 mm | 2 | F227C | 29.3 | back | 1:1 | 0.144 | 1.094 | 0.158 | |
| 5260 | 52 | IEEE 802.11a | OFDM | 14.5 | 13.70 | 0.16 | 10 mm | 2 | F227C | 6 | back | 1:1 | 0.333 | 1.202 | 0.400 | |
| 5290 | 58 | IEEE 802.11ac | OFDM | 11.5 | 10.70 | 0.04 | 10 mm | 2 | F227C | 29.3 | back | 1:1 | 0.145 | 1.202 | 0.174 | |
| 5700 | 140 | IEEE 802.11a | OFDM | 14.5 | 14.21 | -0.18 | 10 mm | 2 | F227C | 6 | back | 1:1 | 0.403 | 1.069 | 0.431 | A6 |
| 5530 | 106 | IEEE 802.11ac | OFDM | 11.5 | 10.73 | -0.15 | 10 mm | 2 | F227C | 29.3 | back | 1:1 | 0.105 | 1.194 | 0.125 | |
| 5200 | 40 | IEEE 802.11n | OFDM | 13.5 | 12.59 | 0.14 | 10 mm | MIMO | F227C | 13 | back | 1:1 | 0.128 | 1.233 | 0.158 | |
| 5320 | 64 | IEEE 802.11n | OFDM | 13.5 | 12.44 | -0.17 | 10 mm | MIMO | F227C | 13 | back | 1:1 | 0.063 | 1.276 | 0.080 | |
| 5500 | 100 | IEEE 802.11n | OFDM | 13.5 | 12.63 | -0.21 | 10 mm | MIMO | F227C | 13 | back | 1:1 | 0.046 | 1.222 | 0.056 | |
| ANSI / IEEE C95.1 1992 - SAFETY LIMIT Spatial Peak Uncontrolled Exposure/General Population | | | | | | | Body 1.6 W/kg (mW/g) averaged over 1 gram | | | | | | | | | |

| | | | | |
|-----------------------------------|--|-------------------------------|---|---------------------------------|
| FCC ID: A3LSMN915X |  PCTEST ENGINEERING LABORATORY, INC. | SAR EVALUATION REPORT |  | Reviewed by: Quality Manager |
| Document S/N: OY1408181741.A3L | Test Dates: 08/14/14 - 08/23/14 | DUT Type: Portable Handset | Page 30 of 40 | |

10.3 Standalone Hand SAR Data



**Table 10-5
DTS WLAN Hand SAR**

| MEASUREMENT RESULTS | | | | | | | | | | | | | | | | |
|---|-----|---------------|---------|-----------------------------|-----------------------|------------------|---|-----------------|----------------------|------------------|-------|------------|------------------|----------------|-------------------------|--------|
| FREQUENCY | | Mode | Service | Maximum Allowed Power [dBm] | Conducted Power [dBm] | Power Drift [dB] | Spacing | Antenna Config. | Device Serial Number | Data Rate (Mbps) | Side | Duty Cycle | SAR (10g) (W/kg) | Scaling Factor | Scaled SAR (10g) (W/kg) | Plot # |
| MHz | Ch. | | | | | | | | | | | | | | | |
| 2437 | 6 | IEEE 802.11b | DSSS | 17.5 | 17.20 | 0.10 | 0 mm | 1 | F2279 | 1 | back | 1:1 | 0.302 | 1.072 | 0.324 | A7 |
| 2437 | 6 | IEEE 802.11b | DSSS | 17.5 | 17.20 | 0.17 | 0 mm | 1 | F2279 | 1 | front | 1:1 | 0.027 | 1.072 | 0.029 | |
| 2437 | 6 | IEEE 802.11b | DSSS | 17.5 | 17.20 | 0.09 | 0 mm | 1 | F2279 | 1 | top | 1:1 | 0.026 | 1.072 | 0.028 | |
| 2437 | 6 | IEEE 802.11b | DSSS | 17.5 | 17.20 | -0.13 | 0 mm | 1 | F2279 | 1 | left | 1:1 | 0.071 | 1.072 | 0.076 | |
| 2412 | 1 | IEEE 802.11b | DSSS | 17.5 | 17.33 | -0.04 | 0 mm | 2 | F2279 | 1 | back | 1:1 | 0.181 | 1.040 | 0.188 | |
| 2412 | 1 | IEEE 802.11b | DSSS | 17.5 | 17.33 | 0.14 | 0 mm | 2 | F2279 | 1 | front | 1:1 | 0.113 | 1.040 | 0.118 | |
| 2412 | 1 | IEEE 802.11b | DSSS | 17.5 | 17.33 | 0.21 | 0 mm | 2 | F2279 | 1 | top | 1:1 | 0.018 | 1.040 | 0.019 | |
| 2412 | 1 | IEEE 802.11n | OFDM | 16.5 | 16.18 | 0.17 | 0 mm | MIMO | F2279 | 13 | back | 1:1 | 0.067 | 1.076 | 0.072 | |
| 2412 | 1 | IEEE 802.11n | OFDM | 16.5 | 16.18 | 0.20 | 0 mm | MIMO | F2279 | 13 | front | 1:1 | 0.037 | 1.076 | 0.040 | |
| 2412 | 1 | IEEE 802.11n | OFDM | 16.5 | 16.18 | 0.12 | 0 mm | MIMO | F2279 | 13 | top | 1:1 | 0.006 | 1.076 | 0.006 | |
| 2412 | 1 | IEEE 802.11n | OFDM | 16.5 | 16.18 | 0.15 | 0 mm | MIMO | F2279 | 13 | left | 1:1 | 0.010 | 1.076 | 0.011 | |
| 5745 | 149 | IEEE 802.11a | OFDM | 14.5 | 13.58 | 0.12 | 0 mm | 1 | F227C | 6 | back | 1:1 | 0.259 | 1.236 | 0.320 | A8 |
| 5775 | 155 | IEEE 802.11ac | OFDM | 11.5 | 10.76 | 0.12 | 0 mm | 1 | F227C | 29.3 | back | 1:1 | 0.105 | 1.186 | 0.125 | |
| 5745 | 149 | IEEE 802.11a | OFDM | 14.5 | 13.58 | 0.12 | 0 mm | 1 | F227C | 6 | front | 1:1 | 0.062 | 1.236 | 0.077 | |
| 5745 | 149 | IEEE 802.11a | OFDM | 14.5 | 13.58 | 0.16 | 0 mm | 1 | F227C | 6 | top | 1:1 | 0.017 | 1.236 | 0.021 | |
| 5745 | 149 | IEEE 802.11a | OFDM | 14.5 | 13.58 | 0.18 | 0 mm | 1 | F227C | 6 | left | 1:1 | 0.057 | 1.236 | 0.070 | |
| 5825 | 165 | IEEE 802.11a | OFDM | 14.5 | 14.22 | 0.08 | 0 mm | 2 | F227C | 6 | back | 1:1 | 0.180 | 1.067 | 0.192 | |
| 5775 | 155 | IEEE 802.11ac | OFDM | 11.5 | 11.19 | -0.21 | 0 mm | 2 | F227C | 29.3 | back | 1:1 | 0.103 | 1.074 | 0.111 | |
| 5825 | 165 | IEEE 802.11a | OFDM | 14.5 | 14.22 | -0.17 | 0 mm | 2 | F227C | 6 | front | 1:1 | 0.134 | 1.067 | 0.143 | |
| 5825 | 165 | IEEE 802.11a | OFDM | 14.5 | 14.22 | 0.19 | 0 mm | 2 | F227C | 6 | top | 1:1 | 0.076 | 1.067 | 0.081 | |
| 5765 | 153 | IEEE 802.11n | OFDM | 13.5 | 13.01 | 0.20 | 0 mm | MIMO | F227C | 13 | back | 1:1 | 0.124 | 1.119 | 0.139 | |
| 5765 | 153 | IEEE 802.11n | OFDM | 13.5 | 13.01 | -0.04 | 0 mm | MIMO | F227C | 13 | front | 1:1 | 0.017 | 1.119 | 0.019 | |
| 5765 | 153 | IEEE 802.11n | OFDM | 13.5 | 13.01 | 0.13 | 0 mm | MIMO | F227C | 13 | top | 1:1 | 0.024 | 1.119 | 0.027 | |
| 5765 | 153 | IEEE 802.11n | OFDM | 13.5 | 13.01 | 0.05 | 0 mm | MIMO | F227C | 13 | left | 1:1 | 0.049 | 1.119 | 0.055 | |
| ANSI / IEEE C95.1 1992 - SAFETY LIMIT Spatial Peak Uncontrolled Exposure/General Population | | | | | | | Hand 4.0 W/kg (mW/g) averaged over 10 grams | | | | | | | | | |

| | | | | |
|-----------------------------------|---|-------------------------------|---|---------------------------------|
| FCC ID: A3LSMN915X |  PCTEST ENGINEERING LABORATORY, INC. | SAR EVALUATION REPORT |  | Reviewed by: Quality Manager |
| Document S/N: OY1408181741.A3L | Test Dates: 08/14/14 - 08/23/14 | DUT Type: Portable Handset | Page 31 of 40 | |

**Table 10-6
NII WLAN Hand SAR**

| MEASUREMENT RESULTS | | | | | | | | | | | | | | | | |
|---|-----|---------------|---------|-----------------------------|-----------------------|------------------|---------|---|----------------------|------------------|-------|------------|-----------|----------------|------------------|--------|
| FREQUENCY | | Mode | Service | Maximum Allowed Power [dBm] | Conducted Power [dBm] | Power Drift [dB] | Spacing | Antenna Config. | Device Serial Number | Data Rate (Mbps) | Side | Duty Cycle | SAR (10g) | Scaling Factor | Scaled SAR (10g) | Plot # |
| MHz | Ch. | | | | | | | | | | | | (W/kg) | | (W/kg) | |
| 5180 | 36 | IEEE 802.11a | OFDM | 14.5 | 13.63 | -0.04 | 0 mm | 1 | F227C | 6 | back | 1:1 | 0.451 | 1.222 | 0.551 | |
| 5210 | 42 | IEEE 802.11ac | OFDM | 11.5 | 11.05 | 0.09 | 0 mm | 1 | F227C | 29.3 | back | 1:1 | 0.167 | 1.109 | 0.185 | |
| 5180 | 36 | IEEE 802.11a | OFDM | 14.5 | 13.63 | 0.14 | 0 mm | 1 | F227C | 6 | front | 1:1 | 0.119 | 1.222 | 0.145 | |
| 5180 | 36 | IEEE 802.11a | OFDM | 14.5 | 13.63 | 0.09 | 0 mm | 1 | F227C | 6 | top | 1:1 | 0.026 | 1.222 | 0.032 | |
| 5180 | 36 | IEEE 802.11a | OFDM | 14.5 | 13.63 | -0.20 | 0 mm | 1 | F227C | 6 | left | 1:1 | 0.174 | 1.222 | 0.213 | |
| 5260 | 52 | IEEE 802.11a | OFDM | 14.5 | 13.98 | -0.05 | 0 mm | 1 | F227C | 6 | back | 1:1 | 0.540 | 1.127 | 0.609 | |
| 5290 | 58 | IEEE 802.11ac | OFDM | 11.5 | 10.56 | 0.08 | 0 mm | 1 | F227C | 29.3 | back | 1:1 | 0.169 | 1.242 | 0.210 | |
| 5260 | 52 | IEEE 802.11a | OFDM | 14.5 | 13.98 | 0.14 | 0 mm | 1 | F227C | 6 | front | 1:1 | 0.052 | 1.127 | 0.059 | |
| 5260 | 52 | IEEE 802.11a | OFDM | 14.5 | 13.98 | 0.19 | 0 mm | 1 | F227C | 6 | top | 1:1 | 0.021 | 1.127 | 0.024 | |
| 5260 | 52 | IEEE 802.11a | OFDM | 14.5 | 13.98 | -0.16 | 0 mm | 1 | F227C | 6 | left | 1:1 | 0.123 | 1.127 | 0.139 | |
| 5500 | 100 | IEEE 802.11a | OFDM | 14.5 | 13.65 | 0.09 | 0 mm | 1 | F227C | 6 | back | 1:1 | 0.355 | 1.216 | 0.432 | |
| 5530 | 106 | IEEE 802.11ac | OFDM | 11.5 | 10.90 | 0.15 | 0 mm | 1 | F227C | 29.3 | back | 1:1 | 0.139 | 1.148 | 0.160 | |
| 5500 | 100 | IEEE 802.11a | OFDM | 14.5 | 13.65 | 0.13 | 0 mm | 1 | F227C | 6 | front | 1:1 | 0.038 | 1.216 | 0.046 | |
| 5500 | 100 | IEEE 802.11a | OFDM | 14.5 | 13.65 | 0.18 | 0 mm | 1 | F227C | 6 | top | 1:1 | 0.016 | 1.216 | 0.019 | |
| 5500 | 100 | IEEE 802.11a | OFDM | 14.5 | 13.65 | -0.16 | 0 mm | 1 | F227C | 6 | left | 1:1 | 0.066 | 1.216 | 0.080 | |
| 5180 | 36 | IEEE 802.11a | OFDM | 14.5 | 14.14 | 0.14 | 0 mm | 2 | F227C | 6 | back | 1:1 | 0.569 | 1.086 | 0.618 | |
| 5210 | 42 | IEEE 802.11ac | OFDM | 11.5 | 11.11 | -0.16 | 0 mm | 2 | F227C | 29.3 | back | 1:1 | 0.301 | 1.094 | 0.329 | |
| 5180 | 36 | IEEE 802.11a | OFDM | 14.5 | 14.14 | -0.18 | 0 mm | 2 | F227C | 6 | front | 1:1 | 0.110 | 1.086 | 0.119 | |
| 5180 | 36 | IEEE 802.11a | OFDM | 14.5 | 14.14 | 0.00 | 0 mm | 2 | F227C | 6 | top | 1:1 | 0.166 | 1.086 | 0.180 | |
| 5260 | 52 | IEEE 802.11a | OFDM | 14.5 | 13.70 | 0.12 | 0 mm | 2 | F227C | 6 | back | 1:1 | 0.589 | 1.202 | 0.708 | |
| 5290 | 58 | IEEE 802.11ac | OFDM | 11.5 | 10.70 | -0.16 | 0 mm | 2 | F227C | 29.3 | back | 1:1 | 0.306 | 1.202 | 0.368 | |
| 5260 | 52 | IEEE 802.11a | OFDM | 14.5 | 13.70 | 0.19 | 0 mm | 2 | F227C | 6 | front | 1:1 | 0.096 | 1.202 | 0.115 | |
| 5260 | 52 | IEEE 802.11a | OFDM | 14.5 | 13.70 | -0.06 | 0 mm | 2 | F227C | 6 | top | 1:1 | 0.163 | 1.202 | 0.196 | |
| 5700 | 140 | IEEE 802.11a | OFDM | 14.5 | 14.21 | -0.12 | 0 mm | 2 | F227C | 6 | back | 1:1 | 1.240 | 1.069 | 1.326 | A9 |
| 5530 | 106 | IEEE 802.11ac | OFDM | 11.5 | 10.73 | -0.14 | 0 mm | 2 | F227C | 29.3 | back | 1:1 | 0.218 | 1.194 | 0.260 | |
| 5700 | 140 | IEEE 802.11a | OFDM | 14.5 | 14.21 | -0.20 | 0 mm | 2 | F227C | 6 | front | 1:1 | 0.133 | 1.069 | 0.142 | |
| 5700 | 140 | IEEE 802.11a | OFDM | 14.5 | 14.21 | -0.13 | 0 mm | 2 | F227C | 6 | top | 1:1 | 0.120 | 1.069 | 0.128 | |
| 5200 | 40 | IEEE 802.11n | OFDM | 13.5 | 12.59 | 0.02 | 0 mm | MIMO | F227C | 13 | back | 1:1 | 0.142 | 1.233 | 0.175 | |
| 5200 | 40 | IEEE 802.11n | OFDM | 13.5 | 12.59 | 0.19 | 0 mm | MIMO | F227C | 13 | front | 1:1 | 0.040 | 1.233 | 0.049 | |
| 5200 | 40 | IEEE 802.11n | OFDM | 13.5 | 12.59 | 0.03 | 0 mm | MIMO | F227C | 13 | top | 1:1 | 0.047 | 1.233 | 0.058 | |
| 5200 | 40 | IEEE 802.11n | OFDM | 13.5 | 12.59 | 0.16 | 0 mm | MIMO | F227C | 13 | left | 1:1 | 0.064 | 1.233 | 0.079 | |
| 5320 | 64 | IEEE 802.11n | OFDM | 13.5 | 12.44 | 0.15 | 0 mm | MIMO | F227C | 13 | back | 1:1 | 0.128 | 1.276 | 0.163 | |
| 5320 | 64 | IEEE 802.11n | OFDM | 13.5 | 12.44 | 0.15 | 0 mm | MIMO | F227C | 13 | front | 1:1 | 0.040 | 1.276 | 0.051 | |
| 5320 | 64 | IEEE 802.11n | OFDM | 13.5 | 12.44 | -0.10 | 0 mm | MIMO | F227C | 13 | top | 1:1 | 0.050 | 1.276 | 0.064 | |
| 5320 | 64 | IEEE 802.11n | OFDM | 13.5 | 12.44 | 0.15 | 0 mm | MIMO | F227C | 13 | left | 1:1 | 0.041 | 1.276 | 0.052 | |
| 5500 | 100 | IEEE 802.11n | OFDM | 13.5 | 12.63 | 0.15 | 0 mm | MIMO | F227C | 13 | back | 1:1 | 0.130 | 1.222 | 0.159 | |
| 5500 | 100 | IEEE 802.11n | OFDM | 13.5 | 12.63 | 0.13 | 0 mm | MIMO | F227C | 13 | front | 1:1 | 0.037 | 1.222 | 0.045 | |
| 5500 | 100 | IEEE 802.11n | OFDM | 13.5 | 12.63 | -0.06 | 0 mm | MIMO | F227C | 13 | top | 1:1 | 0.044 | 1.222 | 0.054 | |
| 5500 | 100 | IEEE 802.11n | OFDM | 13.5 | 12.63 | 0.11 | 0 mm | MIMO | F227C | 13 | left | 1:1 | 0.036 | 1.222 | 0.044 | |
| ANSI / IEEE C95.1 1992 - SAFETY LIMIT Spatial Peak Uncontrolled Exposure/General Population | | | | | | | | Hand 4.0 W/kg (mW/g) averaged over 10 grams | | | | | | | | |

| | | | | |
|-----------------------------------|---|-------------------------------|---|---------------------------------|
| FCC ID: A3LSMN915X |  | SAR EVALUATION REPORT |  | Reviewed by: Quality Manager |
| Document S/N: OY1408181741.A3L | Test Dates: 08/14/14 - 08/23/14 | DUT Type: Portable Handset | Page 32 of 40 | |



10.4 SAR Test Notes

General Notes:

1. The test data reported are the worst-case SAR values according to test procedures specified in IEEE 1528-2003, and FCC KDB Publication 447498 D01v05.
2. Batteries are fully charged at the beginning of the SAR measurements.
3. Liquid tissue depth was at least 15.0 cm for all frequencies.
4. The manufacturer has confirmed that the device(s) tested have the same physical, mechanical and thermal characteristics and are within operational tolerances expected for production units.
5. SAR results were scaled to the maximum allowed power to demonstrate compliance per FCC KDB Publication 447498 D01v05.
6. Device was tested using a fixed spacing for body-worn accessory testing. A separation distance of 10 mm was considered because the manufacturer has determined that there will be body-worn accessories available in the marketplace for users to support this separation distance.
7. Per FCC KDB Publication 648474 D04v01, body-worn SAR was evaluated without a headset connected to the device. Since the standalone reported body-worn SAR was ≤ 1.2 W/kg, no additional body-worn SAR evaluations using a headset cable were required.
8. Per FCC KDB 865664 D01 v01, variability SAR tests were not performed since the measured SAR results for a frequency band were less than 0.8 W/kg for 1g SAR and 2.0 W/kg for 10g SAR. Please see Section 11 for variability analysis.
9. Per FCC KDB Publication 648474 D04v01r01, this device is considered a "phablet" since the diagonal dimension is > 160 mm and less than 200 mm. Therefore, hand SAR tests are required when wireless router mode does not apply or if wireless router 1g SAR > 1.2 W/kg.

WLAN Notes:

1. Justification for reduced test configurations for WIFI channels per KDB Publication 248227 D01v01r02 and October 2012 FCC/TCB Meeting Notes for 2.4 GHz WIFI SISO operations: Highest average RF output power channel for the lowest data rate was selected for SAR evaluation in 802.11b. Other SISO IEEE 802.11 modes (including 802.11g/n) were not investigated since the average output powers over all channels and data rates were not more than 0.25 dB higher than the tested channel in the lowest data rate of IEEE 802.11b mode.
2. Justification for reduced test configurations for WIFI channels per KDB Publication 248227 D01v01r02 and October 2012 FCC/TCB Meeting Notes for SISO 5 GHz WIFI operations: Highest average RF output power channel for the lowest data rate was selected for SAR evaluation in 802.11a. Other IEEE SISO 802.11 modes (including 802.11n 20 MHz and 40 MHz bandwidths) were not investigated since the average output powers over all channels and data rates were not more than 0.25 dB higher than the tested channel in the lowest data rate of IEEE 802.11a mode.
3. Per April 2013 TCB Workshop notes, full SISO SAR tests for all IEEE 802.11ac configurations were not required because the average output power was not more than 0.25 dB higher than IEEE 802.11a mode. IEEE 802.11ac SISO was evaluated for the highest IEEE 802.11a position in each 5 GHz band and exposure condition.
4. Per KDB 248227, SAR for MIMO was measured with both transmitting simultaneously and was evaluated in dependently of SISO operation. For 2.4 GHz MIMO, 802.11n was evaluated. For 5 GHz MIMO, 802.11n 20 MHz BW was evaluated.
5. WIFI transmission was verified using an uncalibrated spectrum analyzer.
6. Since the maximum extrapolated peak SAR of the zoom scan for the maximum output channel for 1g SAR is < 1.6 W/kg and the reported 1g averaged SAR is < 0.8 W/kg, SAR testing on other default channels was not required. Since the maximum reported 10g averaged SAR is < 2.0 W/kg, SAR testing on other default channels was not required.

| | | | | |
|-----------------------------------|--|-------------------------------|---|---------------------------------|
| FCC ID: A3LSMN915X |  PCTEST ENGINEERING LABORATORY, INC. | SAR EVALUATION REPORT |  | Reviewed by: Quality Manager |
| Document S/N: OY1408181741.A3L | Test Dates: 08/14/14 - 08/23/14 | DUT Type: Portable Handset | | Page 33 of 40 |



11 SAR MEASUREMENT VARIABILITY

11.1 Measurement Variability

Per FCC KDB Publication 865664 D01v01, SAR measurement variability was not assessed since measured 1g SAR each frequency band was below 0.8 W/kg and measured 10g SAR for each frequency band was below 2.0 W/kg.

11.2 Measurement Uncertainty



The measured SAR was <1.5 W/kg for all frequency bands. Therefore, per KDB Publication 865664 D01v01, the extended measurement uncertainty analysis per IEEE 1528-2003 was not required.

| | | | | |
|--|---|--------------------------------------|---|--|
| FCC ID: A3LSMN915X |  PCTEST ENGINEERING LABORATORY, INC. | SAR EVALUATION REPORT |  | Reviewed by: Quality Manager |
| Document S/N: OY1408181741.A3L | Test Dates: 08/14/14 - 08/23/14 | DUT Type: Portable Handset | Page 34 of 40 | |

12 EQUIPMENT LIST

| Manufacturer | Model | Description | Cal Date | Cal Interval | Cal Due | Serial Number |
|--------------------|------------|---|------------|--------------|------------|---------------|
| Agilent | 8594A | (9kHz-2.9GHz) Spectrum Analyzer | N/A | N/A | N/A | 3051A00187 |
| Agilent | 8648D | (9kHz-4GHz) Signal Generator | 4/15/2014 | Annual | 4/15/2015 | 3629U00687 |
| Agilent | 8753ES | S-Parameter Network Analyzer | 5/22/2014 | Annual | 5/22/2015 | US39170118 |
| Agilent | 8753ES | S-Parameter Network Analyzer | 10/29/2013 | Annual | 10/29/2014 | US39170122 |
| Agilent | E4438C | ESG Vector Signal Generator | 4/25/2014 | Annual | 4/25/2015 | MY42082385 |
| Agilent | E4438C | ESG Vector Signal Generator | 3/31/2014 | Annual | 3/31/2015 | MY42082659 |
| Agilent | E8257D | (250kHz-20GHz) Signal Generator | 4/15/2014 | Annual | 4/15/2015 | MY45470194 |
| Agilent | N5182A | MXG Vector Signal Generator | 4/15/2014 | Annual | 4/15/2015 | MY47420651 |
| Agilent | N5182A | MXG Vector Signal Generator | 4/15/2014 | Annual | 4/15/2015 | MY47420800 |
| Agilent | N9020A | MXA Signal Analyzer | 10/29/2013 | Annual | 10/29/2014 | US46470561 |
| Amplifier Research | 1551G6 | Amplifier | CBT | N/A | CBT | 433971 |
| Amplifier Research | 1551G6 | Amplifier | CBT | N/A | CBT | 433972 |
| Anritsu | MA24106A | USB Power Sensor | 5/14/2014 | Annual | 5/14/2015 | 1231535 |
| Anritsu | MA24106A | USB Power Sensor | 5/14/2014 | Annual | 5/14/2015 | 1231538 |
| Anritsu | MA24106A | USB Power Sensor | 5/15/2014 | Annual | 5/15/2015 | 1244512 |
| Anritsu | MA24106A | USB Power Sensor | 5/14/2014 | Annual | 5/14/2015 | 1244515 |
| Anritsu | MA2411B | Pulse Power Sensor | 11/14/2013 | Annual | 11/14/2014 | 1126066 |
| Anritsu | MA2411B | Pulse Power Sensor | 3/25/2014 | Annual | 3/25/2015 | 1207470 |
| Anritsu | ML2495A | Power Meter | 10/31/2013 | Annual | 10/31/2014 | 1039008 |
| Control Company | 4052 | Long Stem Thermometer | 9/27/2013 | Biennial | 9/27/2015 | 130567447 |
| Control Company | 36934-158 | Wall-Mounted Thermometer | 4/29/2014 | Biennial | 4/29/2016 | 122014488 |
| Fisher Scientific | 15-077-960 | Digital Thermometer | 11/6/2012 | Biennial | 11/6/2014 | 122640025 |
| MCL | BW-N6W5+ | 6dB Attenuator | CBT | N/A | CBT | 1139 |
| MiniCircuits | SLP-2400+ | Low Pass Filter | CBT | N/A | CBT | R8979500903 |
| MiniCircuits | VLF-6000+ | Low Pass Filter | CBT | N/A | CBT | N/A |
| MiniCircuits | VLF-6000+ | Low Pass Filter | CBT | N/A | CBT | N/A |
| Mini-Circuits | BW-N20W5 | Power Attenuator | CBT | N/A | CBT | 1226 |
| Mini-Circuits | BW-N20W5+ | DC to 18 GHz Precision Fixed 20 dB Attenuator | CBT | N/A | CBT | N/A |
| Mini-Circuits | NLP-1200+ | Low Pass Filter DC to 1000 MHz | CBT | N/A | CBT | N/A |
| Mini-Circuits | NLP-2950+ | Low Pass Filter DC to 2700 MHz | CBT | N/A | CBT | N/A |
| Mitutoyo | CD-6"CSX | Digital Caliper | 5/8/2014 | Biennial | 5/8/2016 | 13264162 |
| Narda | 4014C-6 | 4 - 8 GHz SMA 6 dB Directional Coupler | CBT | N/A | CBT | N/A |
| Narda | 4772-3 | Attenuator (3dB) | CBT | N/A | CBT | 9406 |
| Narda | BW-S3W2 | Attenuator (3dB) | CBT | N/A | CBT | 120 |
| Pasternack | PE2208-6 | Bidirectional Coupler | CBT | N/A | CBT | N/A |
| Pasternack | PE2209-10 | Bidirectional Coupler | CBT | N/A | CBT | N/A |
| Seekonk | NC-100 | Torque Wrench | 3/18/2014 | Biennial | 3/18/2016 | 22313 |
| Seekonk | NC-100 | Torque Wrench 5/16", 8" lbs | 3/18/2014 | Biennial | 3/18/2016 | N/A |
| SPEAG | D2450V2 | 2450 MHz SAR Dipole | 1/21/2014 | Annual | 1/21/2015 | 797 |
| SPEAG | D5GHZV2 | 5 GHz SAR Dipole | 9/23/2013 | Annual | 9/23/2014 | 1007 |
| SPEAG | D5GHZV2 | 5 GHz SAR Dipole | 1/27/2014 | Annual | 1/27/2015 | 1057 |
| SPEAG | DAE4 | Dasy Data Acquisition Electronics | 12/12/2013 | Annual | 12/12/2014 | 649 |
| SPEAG | DAE4 | Dasy Data Acquisition Electronics | 2/26/2014 | Annual | 2/26/2015 | 665 |
| SPEAG | DAE4 | Dasy Data Acquisition Electronics | 11/19/2013 | Annual | 11/19/2014 | 1333 |
| SPEAG | DAE4 | Dasy Data Acquisition Electronics | 4/11/2014 | Annual | 4/11/2015 | 1368 |
| SPEAG | DAK-3.5 | Dielectric Assessment Kit | 5/6/2014 | Annual | 5/6/2015 | 1070 |
| SPEAG | DAK-3.5 | Dielectric Assessment Kit | 11/13/2013 | Annual | 11/13/2014 | 1091 |
| SPEAG | ES3DV3 | SAR Probe | 2/25/2014 | Annual | 2/25/2015 | 3258 |
| SPEAG | ES3DV3 | SAR Probe | 4/17/2014 | Annual | 4/17/2015 | 3319 |
| SPEAG | EX3DV4 | SAR Probe | 10/23/2013 | Annual | 10/23/2014 | 3914 |
| SPEAG | EX3DV4 | SAR Probe | 12/18/2013 | Annual | 12/18/2014 | 3920 |
| VWR | 36934-158 | Wall-Mounted Thermometer | 4/29/2014 | Biennial | 4/29/2016 | 111859323 |

Note: CBT (Calibrated Before Testing). Prior to testing, the measurement paths containing a cable, amplifier, attenuator, coupler or filter were connected to a calibrated source (i.e. a signal generator) to determine the losses of the measurement path. The power meter offset was then adjusted to compensate for the measurement system losses. This level offset is stored within the power meter before measurements are made. This calibration verification procedure applies to the system verification and output power measurements. The calibrated reading is then taken directly from the power meter after compensation of the losses for all final power measurements.



| | | | | |
|--|---|--------------------------------------|---|--|
| FCC ID: A3LSMN915X |  PCTEST ENGINEERING LABORATORY, INC. | SAR EVALUATION REPORT |  | Reviewed by: Quality Manager |
| Document S/N: OY1408181741.A3L | Test Dates: 08/14/14 - 08/23/14 | DUT Type: Portable Handset | Page 35 of 40 | |

13 MEASUREMENT UNCERTAINTIES

Applicable for frequencies less than 3000 MHz.

| a | b | c | d | e= f(d,k) | f | g | h = c x f/e | i = c x g/e | k | |
|---|----------------------|---------------|----------------|--------------|-----------------------|--------------------------|--------------------------------|----------------------------------|----------------|-----|
| Uncertainty Component | IEEE 1528 Sec. | Tol. (± %) | Prob. Dist. | Div. | c _i 1gm | c _i 10 gms | 1gm u _i (± %) | 10gms u _i (± %) | v _i | |
| Measurement System | | | | | | | | | | |
| Probe Calibration | E.2.1 | 6.0 | N | 1 | 1.0 | 1.0 | 6.0 | 6.0 | ∞ | |
| Axial Isotropy | E.2.2 | 0.25 | N | 1 | 0.7 | 0.7 | 0.2 | 0.2 | ∞ | |
| Hemishperical Isotropy | E.2.2 | 1.3 | N | 1 | 1.0 | 1.0 | 1.3 | 1.3 | ∞ | |
| Boundary Effect | E.2.3 | 0.4 | N | 1 | 1.0 | 1.0 | 0.4 | 0.4 | ∞ | |
| Linearity | E.2.4 | 0.3 | N | 1 | 1.0 | 1.0 | 0.3 | 0.3 | ∞ | |
| System Detection Limits | E.2.5 | 5.1 | N | 1 | 1.0 | 1.0 | 5.1 | 5.1 | ∞ | |
| Readout Electronics | E.2.6 | 1.0 | N | 1 | 1.0 | 1.0 | 1.0 | 1.0 | ∞ | |
| Response Time | E.2.7 | 0.8 | R | 1.73 | 1.0 | 1.0 | 0.5 | 0.5 | ∞ | |
| Integration Time | E.2.8 | 2.6 | R | 1.73 | 1.0 | 1.0 | 1.5 | 1.5 | ∞ | |
| RF Ambient Conditions | E.6.1 | 3.0 | R | 1.73 | 1.0 | 1.0 | 1.7 | 1.7 | ∞ | |
| Probe Positioner Mechanical Tolerance | E.6.2 | 0.4 | R | 1.73 | 1.0 | 1.0 | 0.2 | 0.2 | ∞ | |
| Probe Positioning w/ respect to Phantom | E.6.3 | 2.9 | R | 1.73 | 1.0 | 1.0 | 1.7 | 1.7 | ∞ | |
| Extrapolation, Interpolation & Integration algorithms for Max. SAR Evaluation | E.5 | 1.0 | R | 1.73 | 1.0 | 1.0 | 0.6 | 0.6 | ∞ | |
| Test Sample Related | | | | | | | | | | |
| Test Sample Positioning | E.4.2 | 6.0 | N | 1 | 1.0 | 1.0 | 6.0 | 6.0 | 287 | |
| Device Holder Uncertainty | E.4.1 | 3.32 | R | 1.73 | 1.0 | 1.0 | 1.9 | 1.9 | ∞ | |
| Output Power Variation - SAR drift measurement | 6.6.2 | 5.0 | R | 1.73 | 1.0 | 1.0 | 2.9 | 2.9 | ∞ | |
| Phantom & Tissue Parameters | | | | | | | | | | |
| Phantom Uncertainty (Shape & Thickness tolerances) | E.3.1 | 4.0 | R | 1.73 | 1.0 | 1.0 | 2.3 | 2.3 | ∞ | |
| Liquid Conductivity - deviation from target values | E.3.2 | 5.0 | R | 1.73 | 0.64 | 0.43 | 1.8 | 1.2 | ∞ | |
| Liquid Conductivity - measurement uncertainty | E.3.3 | 3.8 | N | 1 | 0.64 | 0.43 | 2.4 | 1.6 | 6 | |
| Liquid Permittivity - deviation from target values | E.3.2 | 5.0 | R | 1.73 | 0.60 | 0.49 | 1.7 | 1.4 | ∞ | |
| Liquid Permittivity - measurement uncertainty | E.3.3 | 4.5 | N | 1 | 0.60 | 0.49 | 2.7 | 2.2 | 6 | |
| Combined Standard Uncertainty (k=1) | | | | | | | RSS | 12.1 | 11.7 | 299 |
| Expanded Uncertainty (95% CONFIDENCE LEVEL) | | | | | | | k=2 | 24.2 | 23.5 | |



The above measurement uncertainties are according to IEEE Std. 1528-2003

| | | | | |
|--|---|--------------------------------------|---|--|
| FCC ID: A3LSMN915X |  PCTEST ENGINEERING LABORATORY, INC. | SAR EVALUATION REPORT |  | Reviewed by: Quality Manager |
| Document S/N: OY1408181741.A3L | Test Dates: 08/14/14 - 08/23/14 | DUT Type: Portable Handset | Page 36 of 40 | |

Applicable for frequencies up to 6 GHz.

| a | b | c | d | e= f(d,k) | f | g | h= c x f/e | i= c x g/e | k | |
|---|----------------------|---------------|----------------|--------------|-----------------------|--------------------------|--------------------------------|----------------------------------|----------------|-----|
| Uncertainty Component | IEEE 1528 Sec. | Tol. (± %) | Prob. Dist. | Div. | c _i 1gm | c _i 10 gms | 1gm u _i (± %) | 10gms u _i (± %) | v _i | |
| Measurement System | | | | | | | | | | |
| Probe Calibration | E.2.1 | 6.55 | N | 1 | 1.0 | 1.0 | 6.6 | 6.6 | ∞ | |
| Axial Isotropy | E.2.2 | 0.25 | N | 1 | 0.7 | 0.7 | 0.2 | 0.2 | ∞ | |
| Hemishperical Isotropy | E.2.2 | 1.3 | N | 1 | 1.0 | 1.0 | 1.3 | 1.3 | ∞ | |
| Boundary Effect | E.2.3 | 0.4 | N | 1 | 1.0 | 1.0 | 0.4 | 0.4 | ∞ | |
| Linearity | E.2.4 | 0.3 | N | 1 | 1.0 | 1.0 | 0.3 | 0.3 | ∞ | |
| System Detection Limits | E.2.5 | 5.1 | N | 1 | 1.0 | 1.0 | 5.1 | 5.1 | ∞ | |
| Readout Electronics | E.2.6 | 1.0 | N | 1 | 1.0 | 1.0 | 1.0 | 1.0 | ∞ | |
| Response Time | E.2.7 | 0.8 | R | 1.73 | 1.0 | 1.0 | 0.5 | 0.5 | ∞ | |
| Integration Time | E.2.8 | 2.6 | R | 1.73 | 1.0 | 1.0 | 1.5 | 1.5 | ∞ | |
| RF Ambient Conditions | E.6.1 | 3.0 | R | 1.73 | 1.0 | 1.0 | 1.7 | 1.7 | ∞ | |
| Probe Positioner Mechanical Tolerance | E.6.2 | 0.4 | R | 1.73 | 1.0 | 1.0 | 0.2 | 0.2 | ∞ | |
| Probe Positioning w/ respect to Phantom | E.6.3 | 2.9 | R | 1.73 | 1.0 | 1.0 | 1.7 | 1.7 | ∞ | |
| Extrapolation, Interpolation & Integration algorithms for Max. SAR Evaluation | E.5 | 1.0 | R | 1.73 | 1.0 | 1.0 | 0.6 | 0.6 | ∞ | |
| Test Sample Related | | | | | | | | | | |
| Test Sample Positioning | E.4.2 | 6.0 | N | 1 | 1.0 | 1.0 | 6.0 | 6.0 | 287 | |
| Device Holder Uncertainty | E.4.1 | 3.32 | R | 1.73 | 1.0 | 1.0 | 1.9 | 1.9 | ∞ | |
| Output Power Variation - SAR drift measurement | 6.6.2 | 5.0 | R | 1.73 | 1.0 | 1.0 | 2.9 | 2.9 | ∞ | |
| Phantom & Tissue Parameters | | | | | | | | | | |
| Phantom Uncertainty (Shape & Thickness tolerances) | E.3.1 | 4.0 | R | 1.73 | 1.0 | 1.0 | 2.3 | 2.3 | ∞ | |
| Liquid Conductivity - deviation from target values | E.3.2 | 5.0 | R | 1.73 | 0.64 | 0.43 | 1.8 | 1.2 | ∞ | |
| Liquid Conductivity - measurement uncertainty | E.3.3 | 3.8 | N | 1 | 0.64 | 0.43 | 2.4 | 1.6 | 6 | |
| Liquid Permittivity - deviation from target values | E.3.2 | 5.0 | R | 1.73 | 0.60 | 0.49 | 1.7 | 1.4 | ∞ | |
| Liquid Permittivity - measurement uncertainty | E.3.3 | 4.5 | N | 1 | 0.60 | 0.49 | 2.7 | 2.2 | 6 | |
| Combined Standard Uncertainty (k=1) | | | | | | | RSS | 12.4 | 12.0 | 299 |
| Expanded Uncertainty (95% CONFIDENCE LEVEL) | | | | | | | k=2 | 24.7 | 24.0 | |

The above measurement uncertainties are according to IEEE Std. 1528-2003



| | | | | |
|--|---|--------------------------------------|---|--|
| FCC ID: A3LSMN915X |  PCTEST ENGINEERING LABORATORY, INC. | SAR EVALUATION REPORT |  | Reviewed by: Quality Manager |
| Document S/N: OY1408181741.A3L | Test Dates: 08/14/14 - 08/23/14 | DUT Type: Portable Handset | Page 37 of 40 | |

14 CONCLUSION

14.1 Measurement Conclusion



The SAR evaluation indicates that the EUT complies with the RF radiation exposure limits of the FCC and Industry Canada, with respect to all parameters subject to this test. These measurements were taken to simulate the RF effects of RF exposure under worst-case conditions. Precise laboratory measures were taken to assure repeatability of the tests. The results and statements relate only to the item(s) tested.

Please note that the absorption and distribution of electromagnetic energy in the body are very complex phenomena that depend on the mass, shape, and size of the body, the orientation of the body with respect to the field vectors, and the electrical properties of both the body and the environment. Other variables that may play a substantial role in possible biological effects are those that characterize the environment (e.g. ambient temperature, air velocity, relative humidity, and body insulation) and those that characterize the individual (e.g. age, gender, activity level, debilitation, or disease). Because various factors may interact with one another to vary the specific biological outcome of an exposure to electromagnetic fields, any protection guide should consider maximal amplification of biological effects as a result of field-body interactions, environmental conditions, and physiological variables. [3]



| | | | | |
|--|---|--------------------------------------|---|--|
| FCC ID: A3LSMN915X |  PCTEST ENGINEERING LABORATORY, INC. | SAR EVALUATION REPORT |  | Reviewed by: Quality Manager |
| Document S/N: OY1408181741.A3L | Test Dates: 08/14/14 - 08/23/14 | DUT Type: Portable Handset | | Page 38 of 40 |

15 REFERENCES

- [1] Federal Communications Commission, ET Docket 93-62, Guidelines for Evaluating the Environmental Effects of Radiofrequency Radiation, Aug. 1996.
- [2] ANSI/IEEE C95.1-2005, American National Standard safety levels with respect to human exposure to radio frequency electromagnetic fields, 3kHz to 300GHz, New York: IEEE, 2006.
- [3] ANSI/IEEE C95.1-1992, American National Standard safety levels with respect to human exposure to radio frequency electromagnetic fields, 3kHz to 300GHz, New York: IEEE, Sept. 1992.
- [4] ANSI/IEEE C95.3-2002, IEEE Recommended Practice for the Measurement of Potentially Hazardous Electromagnetic Fields - RF and Microwave, New York: IEEE, December 2002.
- [5] IEEE Standards Coordinating Committee 39 –Standards Coordinating Committee 34 – IEEE Std. 1528-2003, Recommended Practice for Determining the Peak Spatial-Average Specific Absorption Rate (SAR) in the Human Head Due to Wireless Communications Devices: Measurement Techniques.
- [6] NCRP, National Council on Radiation Protection and Measurements, Biological Effects and Exposure Criteria for RadioFrequency Electromagnetic Fields, NCRP Report No. 86, 1986. Reprinted Feb. 1995.
- [7] T. Schmid, O. Egger, N. Kuster, Automated E-field scanning system for dosimetric assessments, IEEE Transaction on Microwave Theory and Techniques, vol. 44, Jan. 1996, pp. 105-113.
- [8] K. Pokovic, T. Schmid, N. Kuster, Robust setup for precise calibration of E-field probes in tissue simulating liquids at mobile communications frequencies, ICECOM97, Oct. 1997, pp. -124.
- [9] K. Pokovic, T. Schmid, and N. Kuster, E-field Probe with improved isotropy in brain simulating liquids, Proceedings of the ELMAR, Zadar, Croatia, June 23-25, 1996, pp. 172-175.
- [10] Schmid & Partner Engineering AG, Application Note: Data Storage and Evaluation, June 1998, p2.
- [11] V. Hombach, K. Meier, M. Burkhardt, E. Kuhn, N. Kuster, The Dependence of EM Energy Absorption upon Human Modeling at 900 MHz, IEEE Transaction on Microwave Theory and Techniques, vol. 44 no. 10, Oct. 1996, pp. 1865-1873.
- [12] N. Kuster and Q. Balzano, Energy absorption mechanism by biological bodies in the near field of dipole antennas above 300MHz, IEEE Transaction on Vehicular Technology, vol. 41, no. 1, Feb. 1992, pp. 17-23.
- [13] G. Hartsgrove, A. Kraszewski, A. Surowiec, Simulated Biological Materials for Electromagnetic Radiation Absorption Studies, University of Ottawa, Bioelectromagnetics, Canada: 1987, pp. 29-36.
- [14] Q. Balzano, O. Garay, T. Manning Jr., Electromagnetic Energy Exposure of Simulated Users of Portable Cellular Telephones, IEEE Transactions on Vehicular Technology, vol. 44, no.3, Aug. 1995.
- [15] W. Gander, Computermathematick, Birkhaeuser, Basel, 1992.
- [16] W.H. Press, S.A. Teukolsky, W.T. Vetterling, and B.P. Flannery, Numerical Recipes in C, The Art of Scientific Computing, Second edition, Cambridge University Press, 1992.
- [17] N. Kuster, R. Kastle, T. Schmid, Dosimetric evaluation of mobile communications equipment with known precision, IEEE Transaction on Communications, vol. E80-B, no. 5, May 1997, pp. 645-652.

| | | | | |
|--|---|--------------------------------------|---|--|
| FCC ID: A3LSMN915X |  PCTEST Engineering Laboratory, Inc. | SAR EVALUATION REPORT |  | Reviewed by: Quality Manager |
| Document S/N: OY1408181741.A3L | Test Dates: 08/14/14 - 08/23/14 | DUT Type: Portable Handset | Page 39 of 40 | |

- [18] CENELEC CLC/SC111B, European Prestandard (prENV 50166-2), Human Exposure to Electromagnetic Fields High-frequency: 10kHz-300GHz, Jan. 1995.
- [19] Prof. Dr. Niels Kuster, ETH, Eidgenössische Technische Hochschule Zürich, Dosimetric Evaluation of the Cellular Phone.
- [20] IEC 62209-1, Human exposure to radio frequency fields from hand-held and body-mounted wireless communication devices - Human models, instrumentation, and procedures - Part 1: Procedure to determine the specific absorption rate (SAR) for hand-held devices used in close proximity to the ear (frequency range of 300 MHz to 3 GHz), Feb. 2005.
- [21] Industry Canada RSS-102 Radio Frequency Exposure Compliance of Radiocommunication Apparatus (All Frequency Bands) Issue 4, March 2010.
- [22] Health Canada Safety Code 6 Limits of Human Exposure to Radio Frequency Electromagnetic Fields in the Frequency Range from 3 kHz – 300 GHz, 2009
- [23] FCC SAR Test Procedures for 2G-3G Devices, Mobile Hotspot and UMPC Devices KDB Publications 941225, D01-D07
- [24] SAR Measurement procedures for IEEE 802.11a/b/g KDB Publication 248227 D01v01r02
- [25] FCC SAR Considerations for Handsets with Multiple Transmitters and Antennas, KDB Publications 648474 D02-D04
- [26] FCC SAR Evaluation Considerations for Laptop, Notebook, Netbook and Tablet Computers, FCC KDB Publication 616217 D04
- [27] FCC SAR Measurement and Reporting Requirements for 100MHz – 6 GHz, KDB Publications 865664 D01-D02
- [28] FCC General RF Exposure Guidance and SAR Procedures for Dongles, KDB Publication 447498, D01-D02
- [29] Anexo à Resolução No. 533, de 10 de Setembro de 2009.
- [30] IEC 62209-2, Human exposure to radio frequency fields from hand-held and body-mounted wireless communication devices - Human models, instrumentation, and procedures - Part 2: Procedure to determine the specific absorption rate (SAR) for wireless communication devices used in close proximity to the human body (frequency range of 30 MHz to 6 GHz), Mar. 2010.

| | | | |
|--|--|--------------------------------------|--|
| FCC ID: A3LSMN915X |  SAR EVALUATION REPORT  | | Reviewed by: Quality Manager |
| Document S/N: OY1408181741.A3L | Test Dates: 08/14/14 - 08/23/14 | DUT Type: Portable Handset | Page 40 of 40 |

APPENDIX A: SAR TEST DATA

PCTEST ENGINEERING LABORATORY, INC.

DUT: A3LSMN915X; Type: Portable Handset; Serial: F2279

Communication System: UID 0, IEEE 802.11b; Frequency: 2412 MHz; Duty Cycle: 1:1

Medium: 2450 Head Medium parameters used (interpolated):

$f = 2412 \text{ MHz}$; $\sigma = 1.751 \text{ S/m}$; $\epsilon_r = 40.707$; $\rho = 1000 \text{ kg/m}^3$

Phantom section: Right Section

Test Date: 08-18-2014; Ambient Temp: 24.5°C; Tissue Temp: 22.0°C

Probe: ES3DV3 - SN3319; ConvF(4.45, 4.45, 4.45); Calibrated: 4/17/2014;

Sensor-Surface: 3mm (Mechanical Surface Detection)

Electronics: DAE4 Sn1368; Calibrated: 4/11/2014

Phantom: SAM; Type: QD000P40CD; Serial: TP:1758

Measurement SW: DASY52, Version 52.8 (8); SEMCAD X Version 14.6.10 (7331)

Mode: IEEE 802.11b, Ant 2, Right Head, Cheek, Ch 01, 1 Mbps

Area Scan (11x17x1): Measurement grid: dx=12mm, dy=12mm

Zoom Scan (7x7x7)/Cube 0: Measurement grid: dx=5mm, dy=5mm, dz=5mm

Reference Value = 11.56 V/m; Power Drift = 0.06 dB

Peak SAR (extrapolated) = 0.474 W/kg

SAR(1 g) = 0.197 W/kg

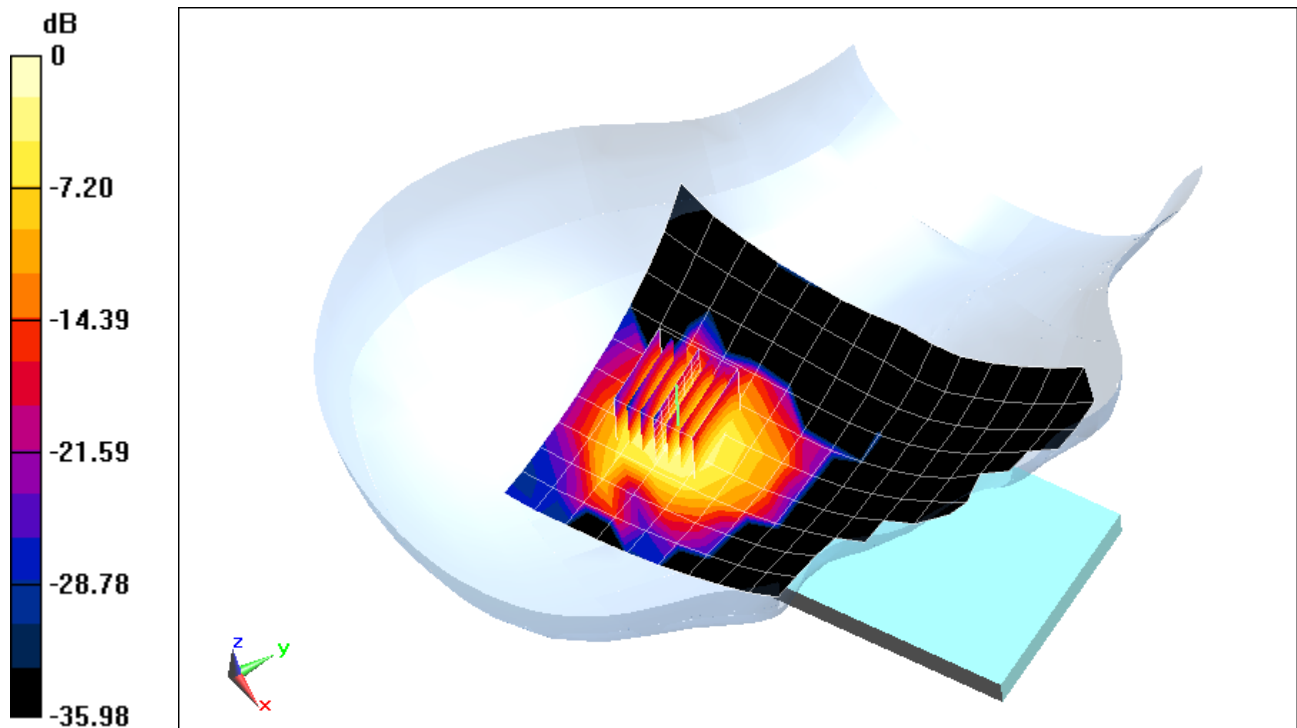

0 dB = 0.260 W/kg = -5.85 dBW/kg

PCTEST ENGINEERING LABORATORY, INC.

DUT: A3LSMN915X; Type: Portable Handset; Serial: F238A

Communication System: UID 0, IEEE 802.11a; Frequency: 5825 MHz; Duty Cycle: 1:1

Medium: 5 GHz Head Medium parameters used:

$f = 5825 \text{ MHz}$; $\sigma = 5.21 \text{ S/m}$; $\epsilon_r = 36.244$; $\rho = 1000 \text{ kg/m}^3$

Phantom section: Right Section

Test Date: 08-14-2014; Ambient Temp: 24.3°C; Tissue Temp: 23.6°C

Probe: EX3DV4 - SN3914; ConvF(4.52, 4.52, 4.52); Calibrated: 10/23/2013;

Sensor-Surface: 1.4mm (Mechanical Surface Detection)

Electronics: DAE4 Sn1333; Calibrated: 11/19/2013

Phantom: SAM V5.0 Right; Type: QD000P40CD; Serial: 1647

Measurement SW: DASY52, Version 52.8 (8); SEMCAD X Version 14.6.10 (7331)

Mode: IEEE 802.11a, Ant 2, 5.8 GHz, Right Head, Cheek, Ch 165, 6 Mbps

Area Scan (13x22x1): Measurement grid: dx=10mm, dy=10mm

Zoom Scan (7x7x7)/Cube 0: Measurement grid: dx=4mm, dy=4mm, dz=1.4mm; Graded Ratio: 1.4

Reference Value = 4.050 V/m; Power Drift = 0.174 dB

Peak SAR (extrapolated) = 0.503 W/kg

SAR(1 g) = 0.083 W/kg

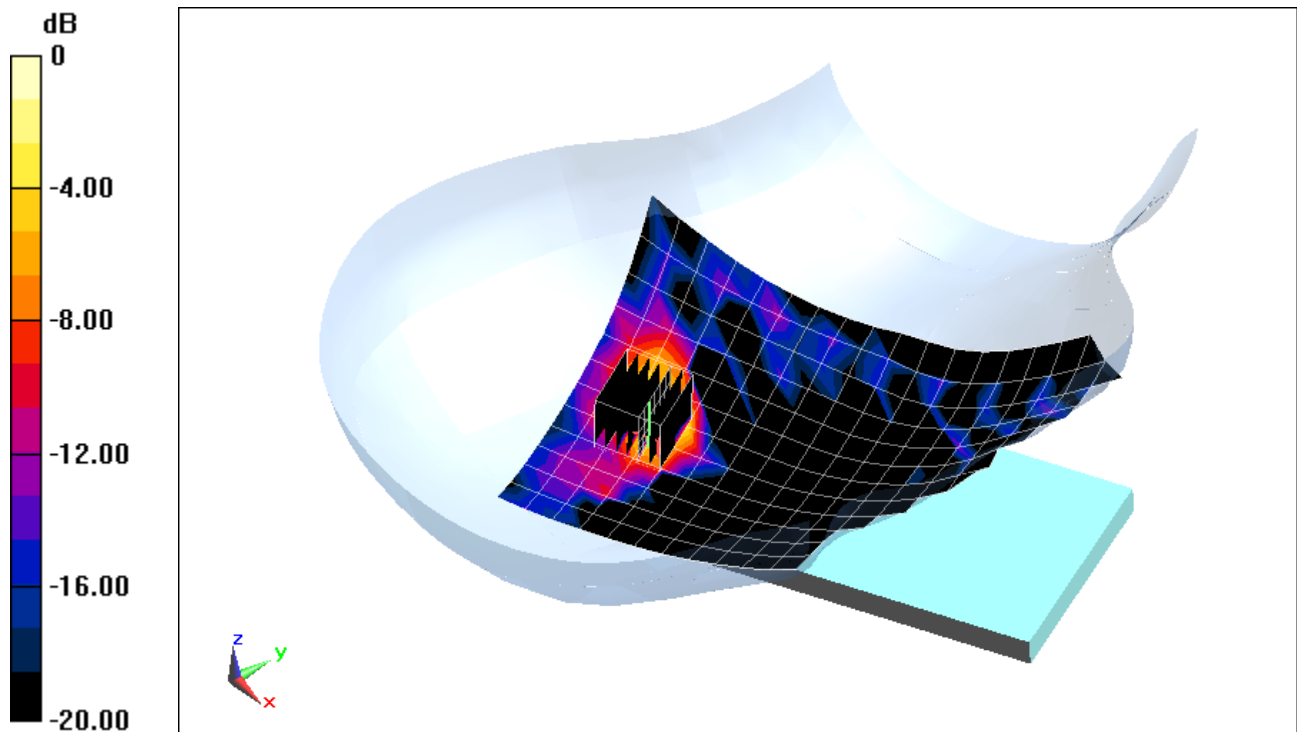

0 dB = 0.298 W/kg = -5.26 dBW/kg

PCTEST ENGINEERING LABORATORY, INC.

DUT: A3LSMN915X; Type: Portable Handset; Serial: F238A

Communication System: UID 0, IEEE 802.11a; Frequency: 5700 MHz; Duty Cycle: 1:1

Medium: 5 GHz Head Medium parameters used:

$f = 5700 \text{ MHz}$; $\sigma = 5.082 \text{ S/m}$; $\epsilon_r = 36.438$; $\rho = 1000 \text{ kg/m}^3$

Phantom section: Right Section

Test Date: 08-14-2014; Ambient Temp: 24.2°C; Tissue Temp: 23.8°C

Probe: EX3DV4 - SN3914; ConvF(4.37, 4.37, 4.37); Calibrated: 10/23/2013;

Sensor-Surface: 1.4mm (Mechanical Surface Detection)

Electronics: DAE4 Sn1333; Calibrated: 11/19/2013

Phantom: SAM V5.0 Right; Type: QD000P40CD; Serial: 1647

Measurement SW: DASY52, Version 52.8 (8); SEMCAD X Version 14.6.10 (7331)

Mode: IEEE 802.11a, 5.5 GHz, Ant 2, Right Head, Cheek, Ch 140, 6 Mbps

Area Scan (13x22x1): Measurement grid: dx=10mm, dy=10mm

Zoom Scan (7x7x7)/Cube 0: Measurement grid: dx=4mm, dy=4mm, dz=1.4mm; Graded Ratio:1.4

Reference Value = 4.558 V/m; Power Drift = 0.11 dB

Peak SAR (extrapolated) = 0.571 W/kg

SAR(1 g) = 0.098 W/kg

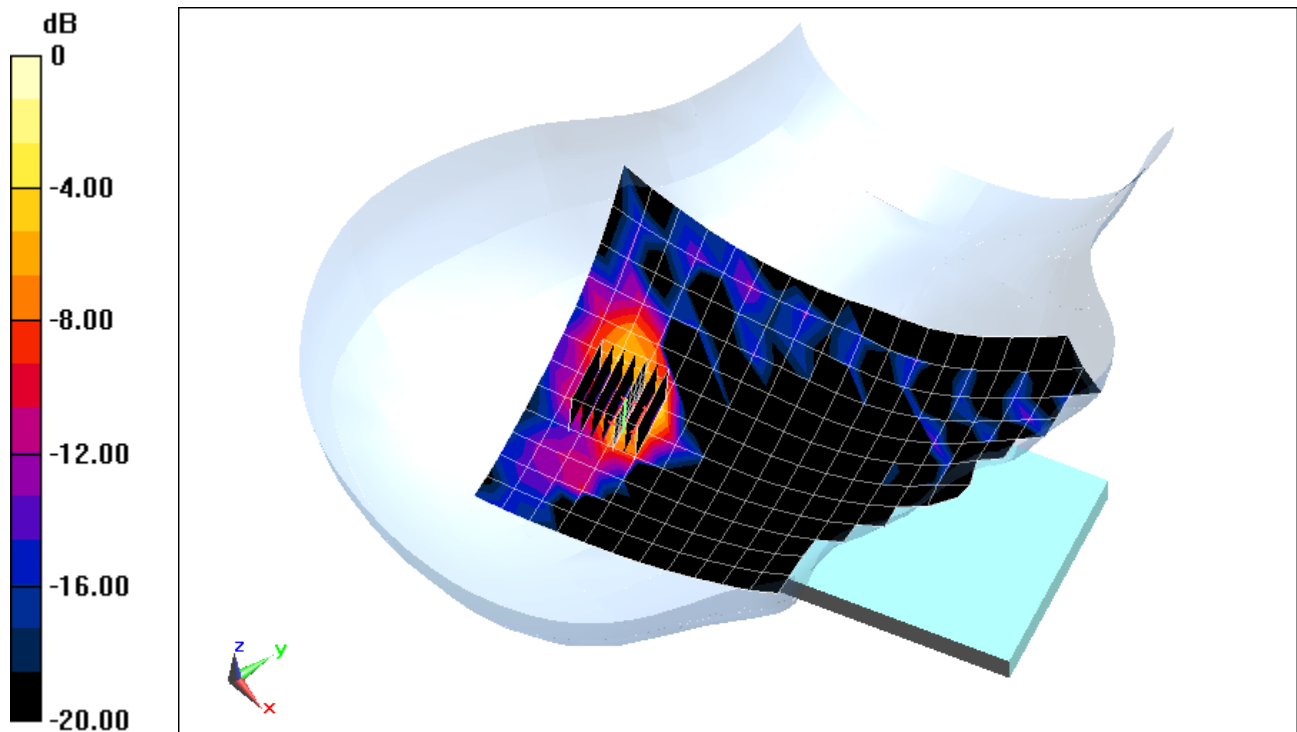

PCTEST ENGINEERING LABORATORY, INC.

DUT: A3LSMN915X; Type: Portable Handset; Serial: F2279

Communication System: UID 0, IEEE 802.11b; Frequency: 2437 MHz; Duty Cycle: 1:1

Medium: 2450 Body Medium parameters used (interpolated):

$f = 2437 \text{ MHz}$; $\sigma = 1.954 \text{ S/m}$; $\epsilon_r = 51.99$; $\rho = 1000 \text{ kg/m}^3$

Phantom section: Flat Section; Space: 1.0 cm

Test Date: 08-18-2014; Ambient Temp: 24.5°C; Tissue Temp: 23.2°C

Probe: ES3DV3 - SN3319; ConvF(4.24, 4.24, 4.24); Calibrated: 4/17/2014;

Sensor-Surface: 3mm (Mechanical Surface Detection)

Electronics: DAE4 Sn1368; Calibrated: 4/11/2014

Phantom: ELI left; Type: QDOVA002AA; Serial: TP:1202

Measurement SW: DASY52, Version 52.8 (8); SEMCAD X Version 14.6.10 (7331)

Mode: IEEE 802.11b, Ant 1, Body SAR, Ch 06, 1 Mbps, Back Side

Area Scan (11x18x1): Measurement grid: dx=12mm, dy=12mm

Zoom Scan (7x7x7)/Cube 0: Measurement grid: dx=5mm, dy=5mm, dz=5mm

Reference Value = 6.340 V/m; Power Drift = 0.04 dB

Peak SAR (extrapolated) = 0.143 W/kg

SAR(1 g) = 0.069 W/kg

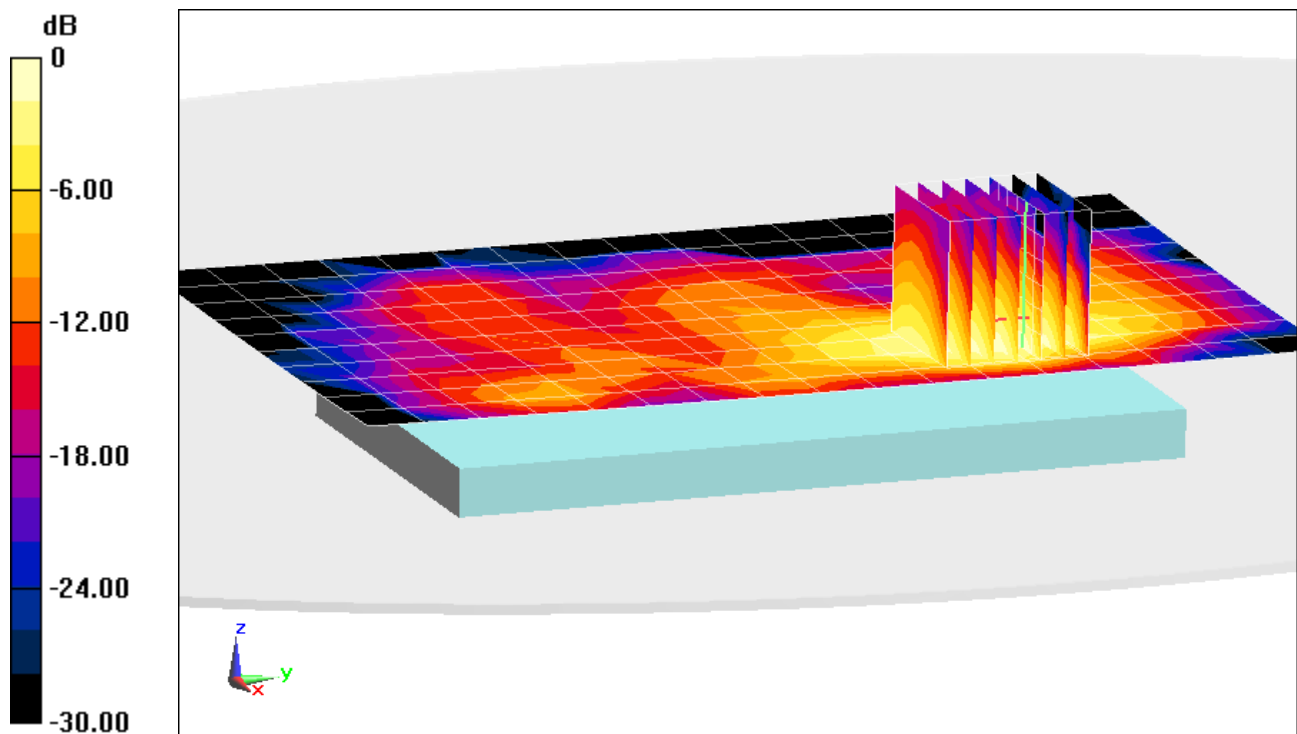

0 dB = 0.0879 W/kg = -10.56 dBW/kg

PCTEST ENGINEERING LABORATORY, INC.

DUT: A3LSMN915X; Type: Portable Handset; Serial: F227C

Communication System: UID 0, IEEE 802.11a 5.2-5.8 GHz Band; Frequency: 5745 MHz; Duty Cycle: 1:1

Medium: 5 GHz Body Medium parameters used:

$$f = 5745 \text{ MHz}; \sigma = 5.829 \text{ S/m}; \epsilon_r = 46.499; \rho = 1000 \text{ kg/m}^3$$

Phantom section: Flat Section; Space: 1.0 cm

Test Date: 08-18-2014; Ambient Temp: 23.4°C; Tissue Temp: 21.8°C

Probe: EX3DV4 - SN3920; ConvF(4, 4, 4); Calibrated: 12/18/2013;

Sensor-Surface: 1.4mm (Mechanical Surface Detection)

Electronics: DAE4 Sn649; Calibrated: 12/12/2013

Phantom: SAM Sub; Type: SAM 4.0; Serial: TP-1357

Measurement SW: DASY4, Version 4.7 (80); SEMCAD X Version 14.6.10 (7331)

Mode: IEEE 802.11a, Ant 1, 5.8 GHz, Body SAR, Ch 149, 6 Mbps, Back Side

Area Scan (13x21x1): Measurement grid: dx=10mm, dy=10mm

Zoom Scan (8x8x7)/Cube 0: Measurement grid: dx=4mm, dy=4mm, dz=1.4mm; Graded Ratio: 1.4

Reference Value = 5.535 V/m; Power Drift = 0.14 dB

Peak SAR (extrapolated) = 0.862 W/kg

SAR(1 g) = 0.153 W/kg

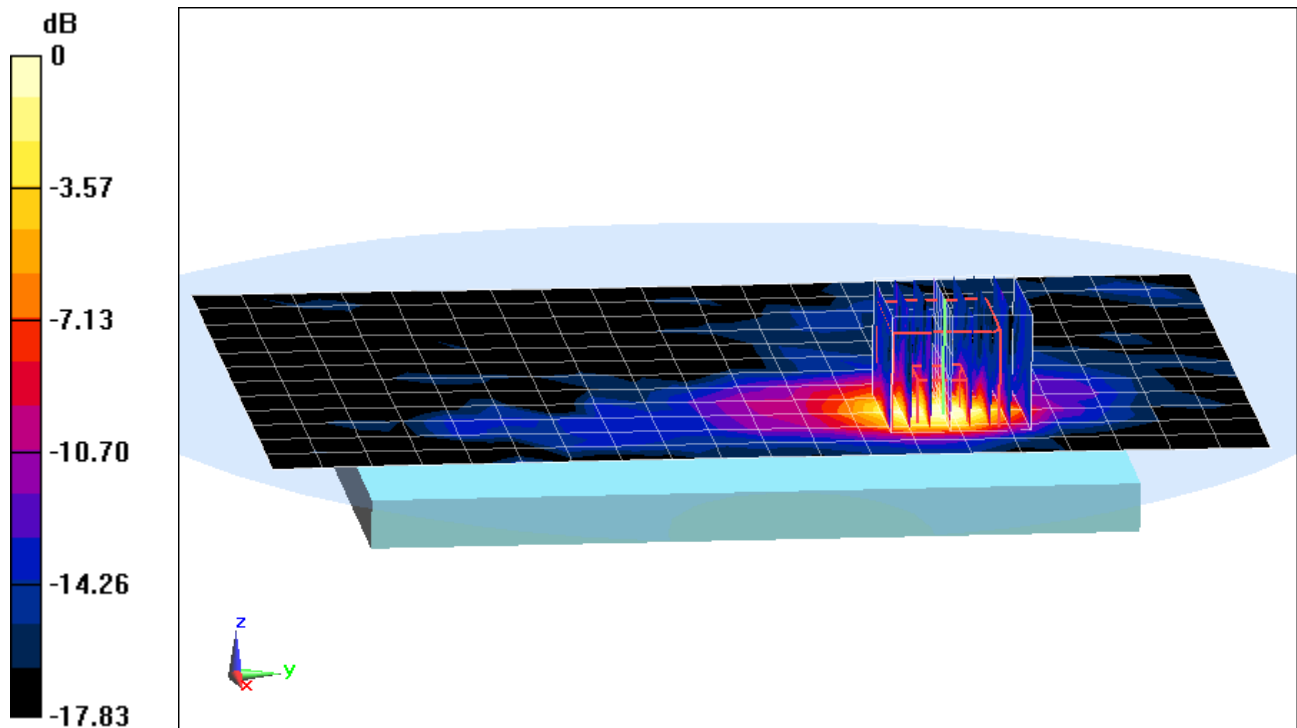

0 dB = 0.363 W/kg = -4.40 dBW/kg

PCTEST ENGINEERING LABORATORY, INC.

DUT: A3LSMN915X; Type: Portable Handset; Serial: F227C

Communication System: UID 0, IEEE 802.11a 5.2-5.8 GHz Band; Frequency: 5700 MHz; Duty Cycle: 1:1

Medium: 5 GHz Body Medium parameters used:

$f = 5700 \text{ MHz}$; $\sigma = 5.78 \text{ S/m}$; $\epsilon_r = 46.55$; $\rho = 1000 \text{ kg/m}^3$

Phantom section: Flat Section; Space: 1.0 cm

Test Date: 08-18-2014; Ambient Temp: 23.4°C; Tissue Temp: 21.8°C

Probe: EX3DV4 - SN3920; ConvF(3.62, 3.62, 3.62); Calibrated: 12/18/2013;

Sensor-Surface: 1.4mm (Mechanical Surface Detection)

Electronics: DAE4 Sn649; Calibrated: 12/12/2013

Phantom: SAM Sub; Type: SAM 4.0; Serial: TP-1357

Measurement SW: DASY4, Version 4.7 (80); SEMCAD X Version 14.6.10 (7331)

Mode: IEEE 802.11a, Ant 2, 5.5 GHz, Body SAR, Ch 140, 6 Mbps, Back Side

Area Scan (13x21x1): Measurement grid: dx=10mm, dy=10mm

Zoom Scan (8x8x7)/Cube 0: Measurement grid: dx=4mm, dy=4mm, dz=1.4mm; Graded Ratio: 1.4

Reference Value = 8.851 V/m; Power Drift = -0.18 dB

Peak SAR (extrapolated) = 1.59 W/kg

SAR(1 g) = 0.403 W/kg

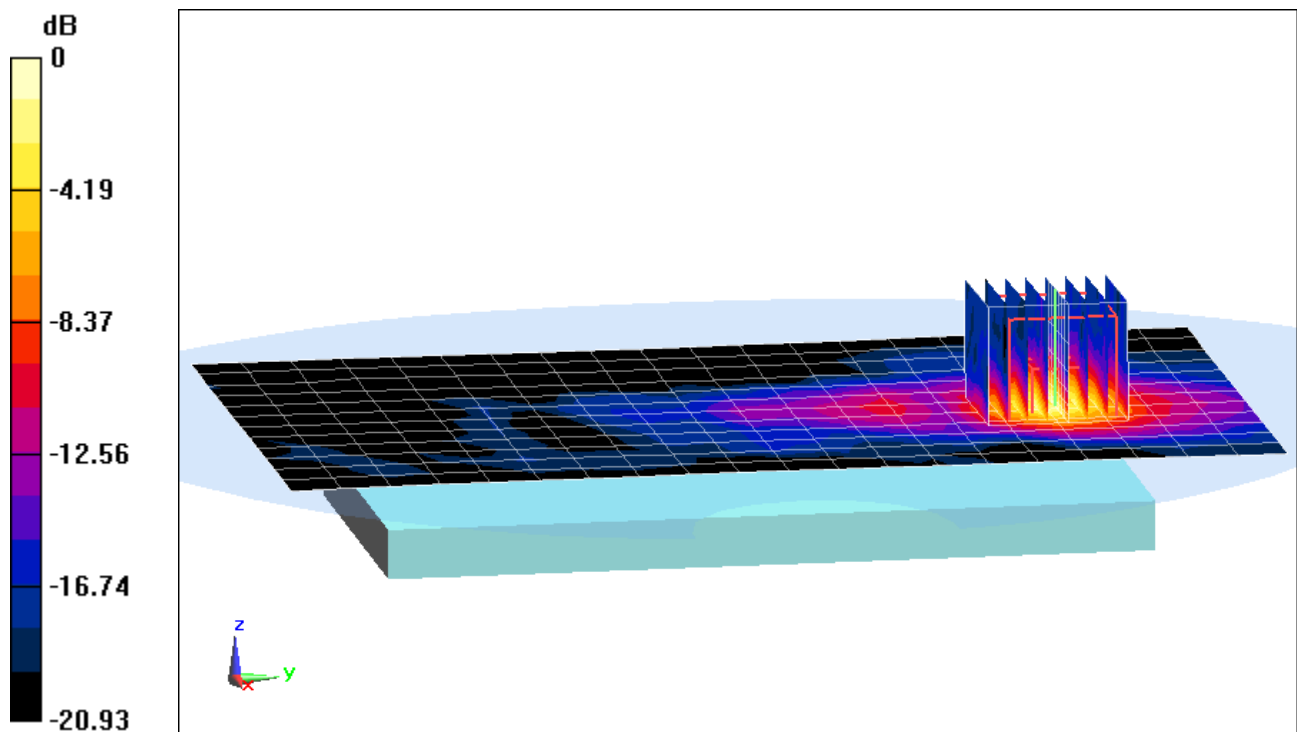

0 dB = 1.03 W/kg = 0.13 dBW/kg

PCTEST ENGINEERING LABORATORY, INC.

DUT: A3LSMN915X; Type: Portable Handset; Serial: F2279

Communication System: UID 0, IEEE 802.11b; Frequency: 2437 MHz; Duty Cycle: 1:1

Medium: 2450 Body Medium parameters used (interpolated):

$f = 2437 \text{ MHz}$; $\sigma = 2.026 \text{ S/m}$; $\epsilon_r = 52.069$; $\rho = 1000 \text{ kg/m}^3$

Phantom section: Flat Section; Space: 0.0 cm

Test Date: 08-23-2014; Ambient Temp: 24.3°C; Tissue Temp: 22.0°C

Probe: ES3DV3 - SN3258; ConvF(4.14, 4.14, 4.14); Calibrated: 2/25/2014;

Sensor-Surface: 3mm (Mechanical Surface Detection)

Electronics: DAE4 Sn665; Calibrated: 2/26/2014

Phantom: SAM Front; Type: SAM; Serial: 1686

Measurement SW: DASY52, Version 52.8 (8); SEMCAD X Version 14.6.10 (7331)

Mode: IEEE 802.11b, Ant 1, Hand SAR, Ch 06, 1 Mbps, Back Side

Area Scan (10x17x1): Measurement grid: dx=12mm, dy=12mm

Zoom Scan (7x9x7)/Cube 0: Measurement grid: dx=5mm, dy=5mm, dz=5mm

Reference Value = 18.82 V/m; Power Drift = 0.10 dB

Peak SAR (extrapolated) = 2.55 W/kg

SAR(10 g) = 0.302 W/kg

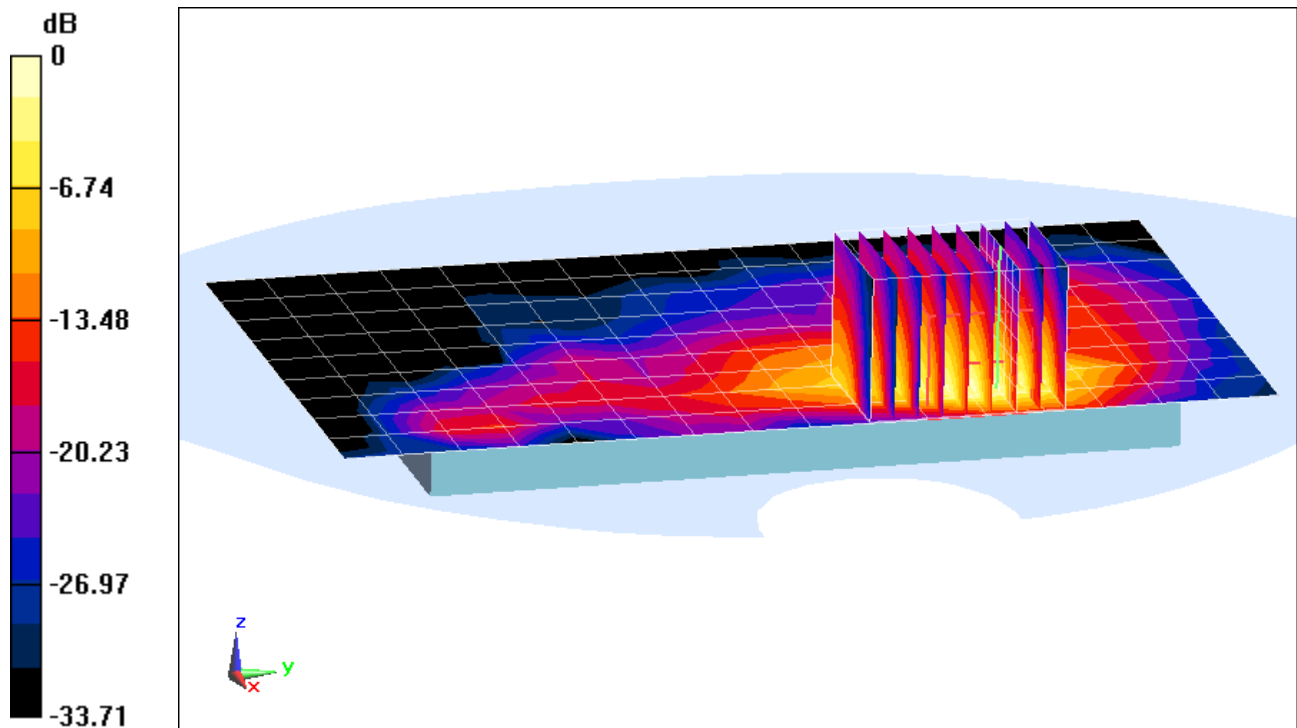

0 dB = 1.27 W/kg = 1.04 dBW/kg

PCTEST ENGINEERING LABORATORY, INC.

DUT: A3LSMN915X; Type: Portable Handset; Serial: F227C

Communication System: UID 0, IEEE 802.11a 5.2-5.8 GHz Band; Frequency: 5745 MHz; Duty Cycle: 1:1

Medium: 5 GHz Body Medium parameters used:

$f = 5745 \text{ MHz}$; $\sigma = 5.829 \text{ S/m}$; $\epsilon_r = 46.499$; $\rho = 1000 \text{ kg/m}^3$

Phantom section: Flat Section; Space: 0.0 cm

Test Date: 08-18-2014; Ambient Temp: 23.4°C; Tissue Temp: 21.8°C

Probe: EX3DV4 - SN3920; ConvF(4, 4, 4); Calibrated: 12/18/2013;

Sensor-Surface: 1.4mm (Mechanical Surface Detection)

Electronics: DAE4 Sn649; Calibrated: 12/12/2013

Phantom: SAM Sub; Type: SAM 4.0; Serial: TP-1357

Measurement SW: DASY4, Version 4.7 (80); SEMCAD X Version 14.6.10 (7331)

Mode: IEEE 802.11a, Ant 1, 5.8 GHz, Hand SAR, Ch 149, 6 Mbps, Back Side

Area Scan (13x21x1): Measurement grid: dx=10mm, dy=10mm

Zoom Scan (10x10x7)/Cube 0: Measurement grid: dx=4mm, dy=4mm, dz=1.4mm; Graded Ratio: 1.4

Reference Value = 17.41 V/m; Power Drift = 0.12 dB

Peak SAR (extrapolated) = 17.1 W/kg

SAR(10 g) = 0.259 W/kg

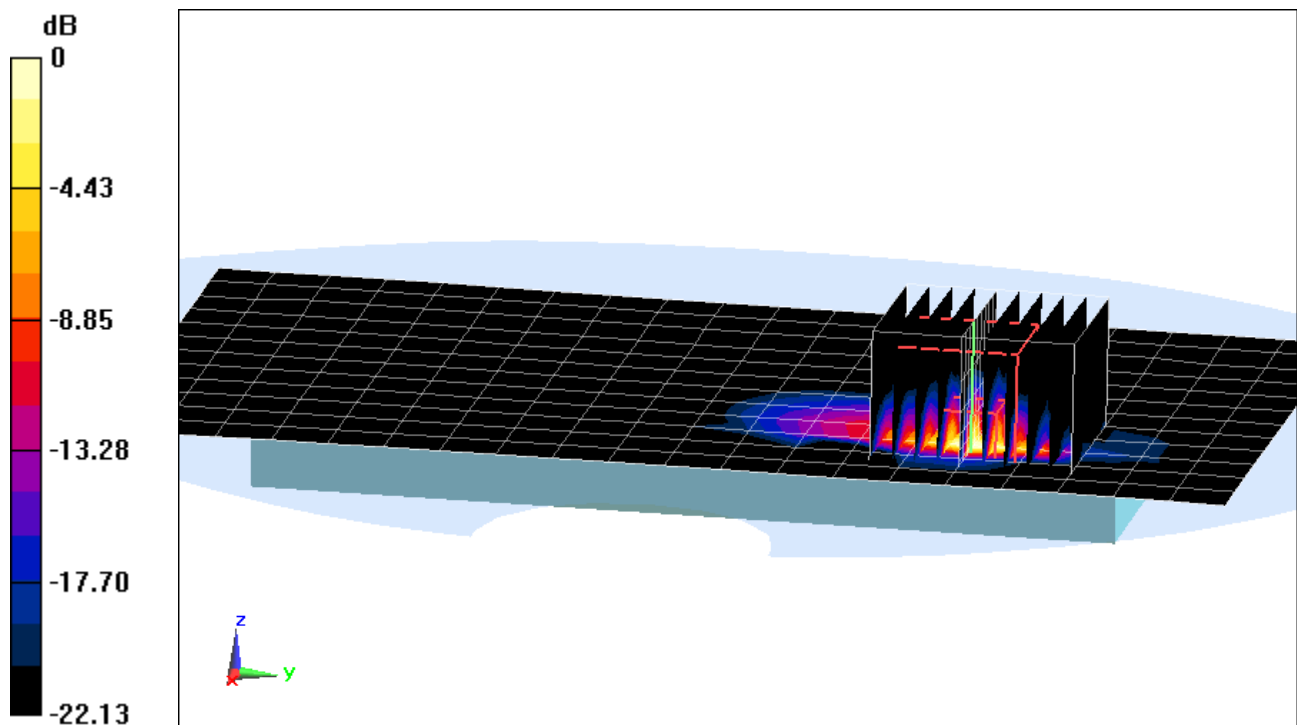

0 dB = 3.22 W/kg = 5.08 dBW/kg

PCTEST ENGINEERING LABORATORY, INC.

DUT: A3LSMN915X; Type: Portable Handset; Serial: F227C

Communication System: UID 0, IEEE 802.11a 5.2-5.8 GHz Band; Frequency: 5700 MHz; Duty Cycle: 1:1

Medium: 5 GHz Body Medium parameters used:

$f = 5700 \text{ MHz}$; $\sigma = 5.78 \text{ S/m}$; $\epsilon_r = 46.55$; $\rho = 1000 \text{ kg/m}^3$

Phantom section: Flat Section; Space: 0.0 cm

Test Date: 08-18-2014; Ambient Temp: 23.4°C; Tissue Temp: 21.8°C

Probe: EX3DV4 - SN3920; ConvF(3.62, 3.62, 3.62); Calibrated: 12/18/2013;

Sensor-Surface: 1.4mm (Mechanical Surface Detection)

Electronics: DAE4 Sn649; Calibrated: 12/12/2013

Phantom: SAM Sub; Type: SAM 4.0; Serial: TP-1357

Measurement SW: DASY4, Version 4.7 (80); SEMCAD X Version 14.6.10 (7331)

Mode: IEEE 802.11a, Ant 2, 5.5 GHz, Hand SAR, Ch 140, 6 Mbps, Back Side

Area Scan (13x21x1): Measurement grid: dx=10mm, dy=10mm

Zoom Scan (9x9x7)/Cube 0: Measurement grid: dx=4mm, dy=4mm, dz=1.4mm; Graded Ratio: 1.4

Reference Value = 35.70 V/m; Power Drift = -0.12 dB

Peak SAR (extrapolated) = 46.6 W/kg

SAR(10 g) = 1.24 W/kg

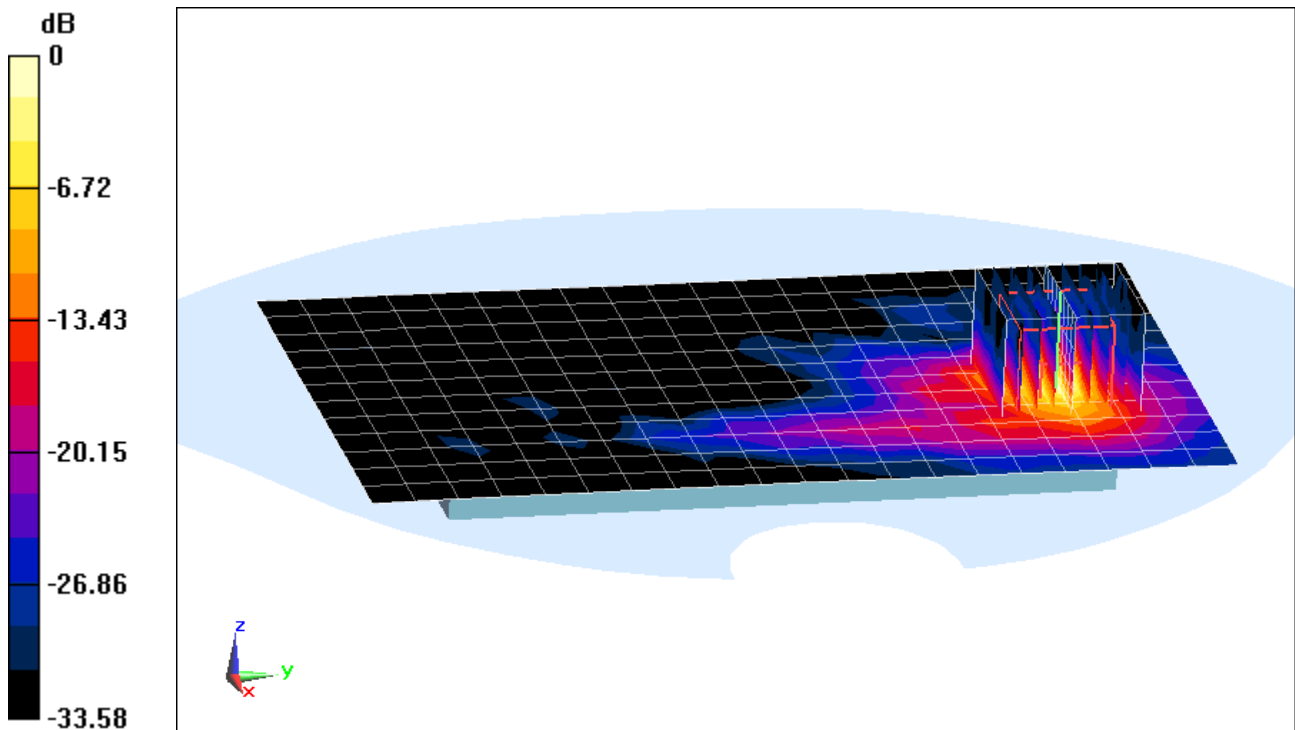

0 dB = 13.9 W/kg = 11.43 dBW/kg

APPENDIX B: SYSTEM VERIFICATION

PCTEST ENGINEERING LABORATORY, INC.

DUT: Dipole 2450 MHz; Type: D2450V2; Serial: 797

Communication System: UID 0, CW; Frequency: 2450 MHz; Duty Cycle: 1:1

Medium: 2450 Head Medium parameters used:

$f = 2450 \text{ MHz}$; $\sigma = 1.79 \text{ S/m}$; $\epsilon_r = 40.574$; $\rho = 1000 \text{ kg/m}^3$

Phantom section: Flat Section; Space: 1.0 cm

Test Date: 08-18-2014; Ambient Temp: 24.5°C; Tissue Temp: 22.0°C

Probe: ES3DV3 - SN3319; ConvF(4.45, 4.45, 4.45); Calibrated: 4/17/2014;

Sensor-Surface: 3mm (Mechanical Surface Detection)

Electronics: DAE4 Sn1368; Calibrated: 4/11/2014

Phantom: SAM; Type: QD000P40CD; Serial: TP:1758

Measurement SW: DASY52, Version 52.8 (8); SEMCAD X Version 14.6.10 (7331)

2450 MHz System Verification

Area Scan (8x9x1): Measurement grid: dx=12mm, dy=12mm

Zoom Scan (7x7x7)/Cube 0: Measurement grid: dx=5mm, dy=5mm, dz=5mm

Input Power = 20 dBm (100 mW)

Peak SAR (extrapolated) = 10.8 W/kg

SAR(1 g) = 5.33 W/kg

Deviation = 2.90%

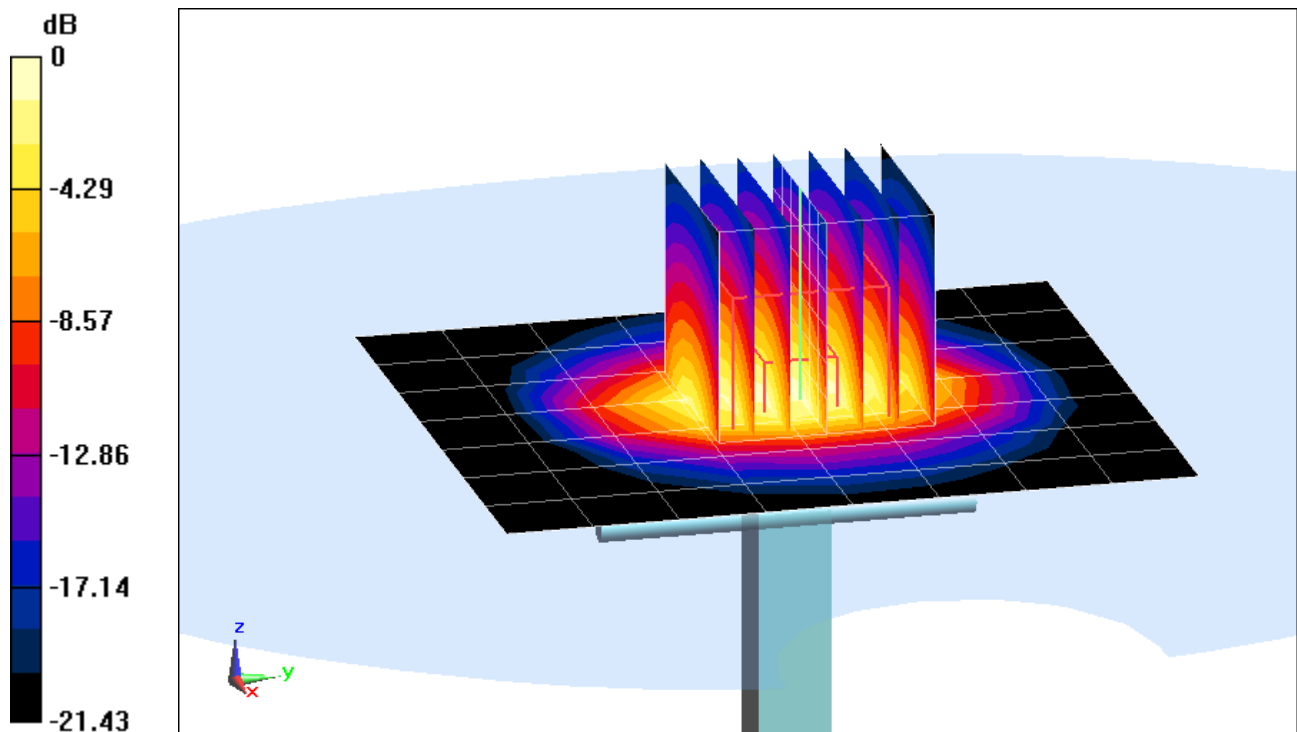

0 dB = 6.95 W/kg = 8.42 dBW/kg

PCTEST ENGINEERING LABORATORY, INC.

DUT: SAR Dipole 5200 MHz; Type: D5GHzV2; Serial: 1057

Communication System: UID 0, CW; Frequency: 5200 MHz; Duty Cycle: 1:1

Medium: 5 GHz Head Medium parameters used:

$f = 5200 \text{ MHz}$; $\sigma = 4.567 \text{ S/m}$; $\epsilon_r = 37.076$; $\rho = 1000 \text{ kg/m}^3$

Phantom section: Flat Section; Space: 1.0 cm

Test Date: 08-14-2014; Ambient Temp: 24.4°C; Tissue Temp: 23.6°C

Probe: EX3DV4 - SN3914; ConvF(4.99, 4.99, 4.99); Calibrated: 10/23/2013;

Sensor-Surface: 1.4mm (Mechanical Surface Detection)

Electronics: DAE4 Sn1333; Calibrated: 11/19/2013

Phantom: SAM V5.0 Right; Type: QD000P40CD; Serial: 1647

Measurement SW: DASY52, Version 52.8 (8); SEMCAD X Version 14.6.10 (7331)

5200 MHz System Verification

Area Scan (7x8x1): Measurement grid: dx=10mm, dy=10mm

Zoom Scan (7x7x7)/Cube 0: Measurement grid: dx=4mm, dy=4mm, dz=1.4mm; Graded Ratio: 1.4

Input Power = 20 dBm (100 mW)

Peak SAR (extrapolated) = 32.4 W/kg

SAR(1 g) = 7.54 W/kg

Deviation = -3.33%

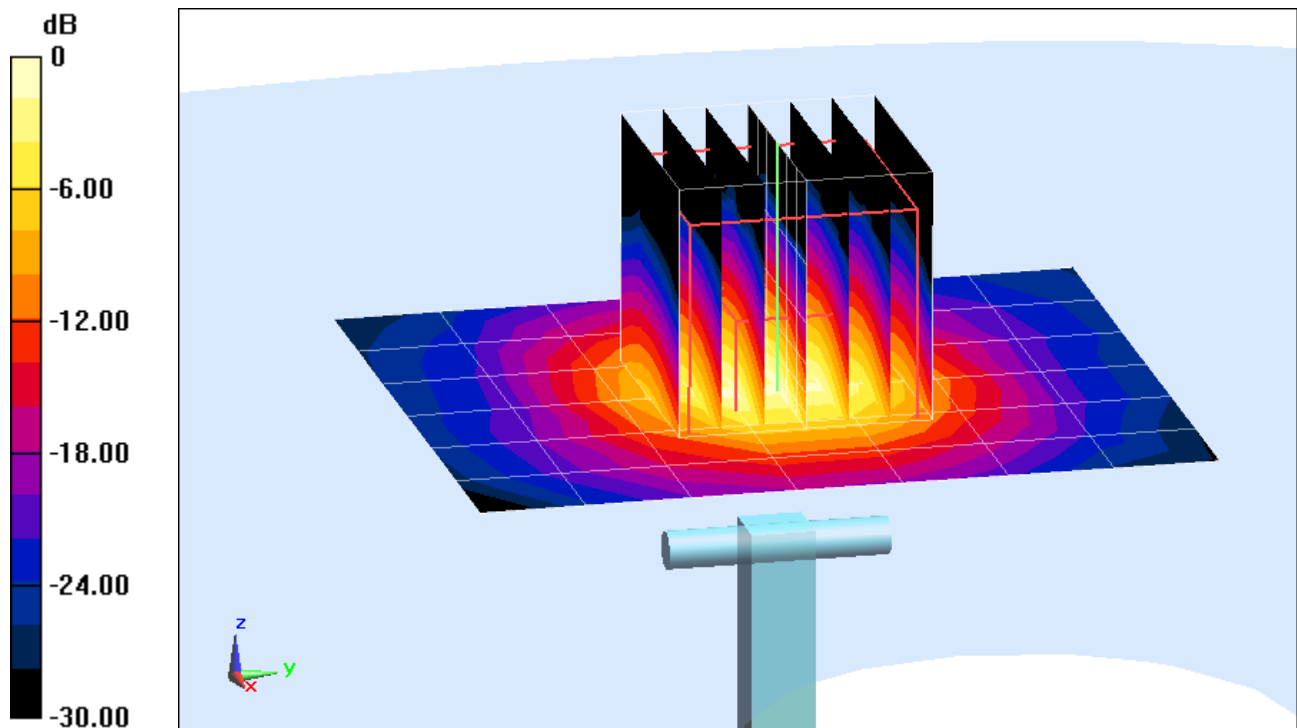

0 dB = 19.3 W/kg = 12.86 dBW/kg

PCTEST ENGINEERING LABORATORY, INC.

DUT: SAR Dipole 5300 MHz; Type: D5GHzV2; Serial: 1057

Communication System: UID 0, CW; Frequency: 5300 MHz; Duty Cycle: 1:1

Medium: 5 GHz Head Medium parameters used:

$f = 5300 \text{ MHz}$; $\sigma = 4.66 \text{ S/m}$; $\epsilon_r = 36.974$; $\rho = 1000 \text{ kg/m}^3$

Phantom section: Flat Section; Space: 1.0 cm

Test Date: 08-14-2014; Ambient Temp: 24.4°C; Tissue Temp: 23.6°C

Probe: EX3DV4 - SN3914; ConvF(4.82, 4.82, 4.82); Calibrated: 10/23/2013;

Sensor-Surface: 1.4mm (Mechanical Surface Detection)

Electronics: DAE4 Sn1333; Calibrated: 11/19/2013

Phantom: SAM V5.0 Right; Type: QD000P40CD; Serial: 1647

Measurement SW: DASY52, Version 52.8 (8); SEMCAD X Version 14.6.10 (7331)

5300 MHz System Verification

Area Scan (7x8x1): Measurement grid: dx=10mm, dy=10mm

Zoom Scan (7x7x7)/Cube 0: Measurement grid: dx=4mm, dy=4mm, dz=1.4mm; Graded Ratio: 1.4

Input Power = 20 dBm (100 mW)

Peak SAR (extrapolated) = 35.6 W/kg

SAR(1 g) = 8.14 W/kg

Deviation = -1.93%

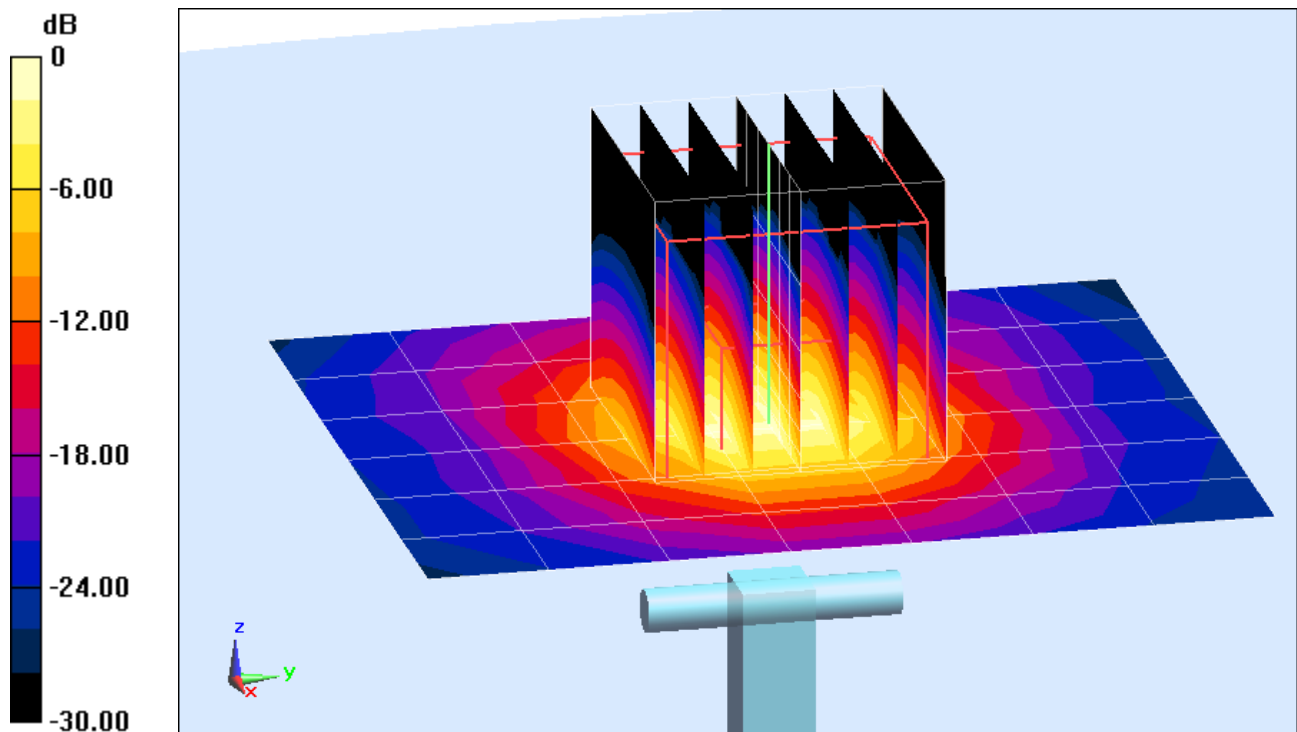

0 dB = 21.0 W/kg = 13.22 dBW/kg

PCTEST ENGINEERING LABORATORY, INC.

DUT: SAR Dipole 5500 MHz; Type: D5GHzV2; Serial: 1057

Communication System: UID 0, CW; Frequency: 5500 MHz; Duty Cycle: 1:1

Medium: 5 GHz Head Medium parameters used:

$f = 5500 \text{ MHz}$; $\sigma = 4.871 \text{ S/m}$; $\epsilon_r = 36.69$; $\rho = 1000 \text{ kg/m}^3$

Phantom section: Flat Section; Space: 1.0 cm

Test Date: 08-14-2014; Ambient Temp: 24.3°C; Tissue Temp: 23.7°C

Probe: EX3DV4 - SN3914; ConvF(4.55, 4.55, 4.55); Calibrated: 10/23/2013;

Sensor-Surface: 1.4mm (Mechanical Surface Detection)

Electronics: DAE4 Sn1333; Calibrated: 11/19/2013

Phantom: SAM V5.0 Right; Type: QD000P40CD; Serial: 1647

Measurement SW: DASY52, Version 52.8 (8); SEMCAD X Version 14.6.10 (7331)

5500 MHz System Verification

Area Scan (7x8x1): Measurement grid: dx=10mm, dy=10mm

Zoom Scan (7x7x7)/Cube 0: Measurement grid: dx=4mm, dy=4mm, dz=1.4mm; Graded Ratio: 1.4

Input Power = 20 dBm (100 mW)

Peak SAR (extrapolated) = 36.7 W/kg

SAR(1 g) = 8.23 W/kg

Deviation -2.37%

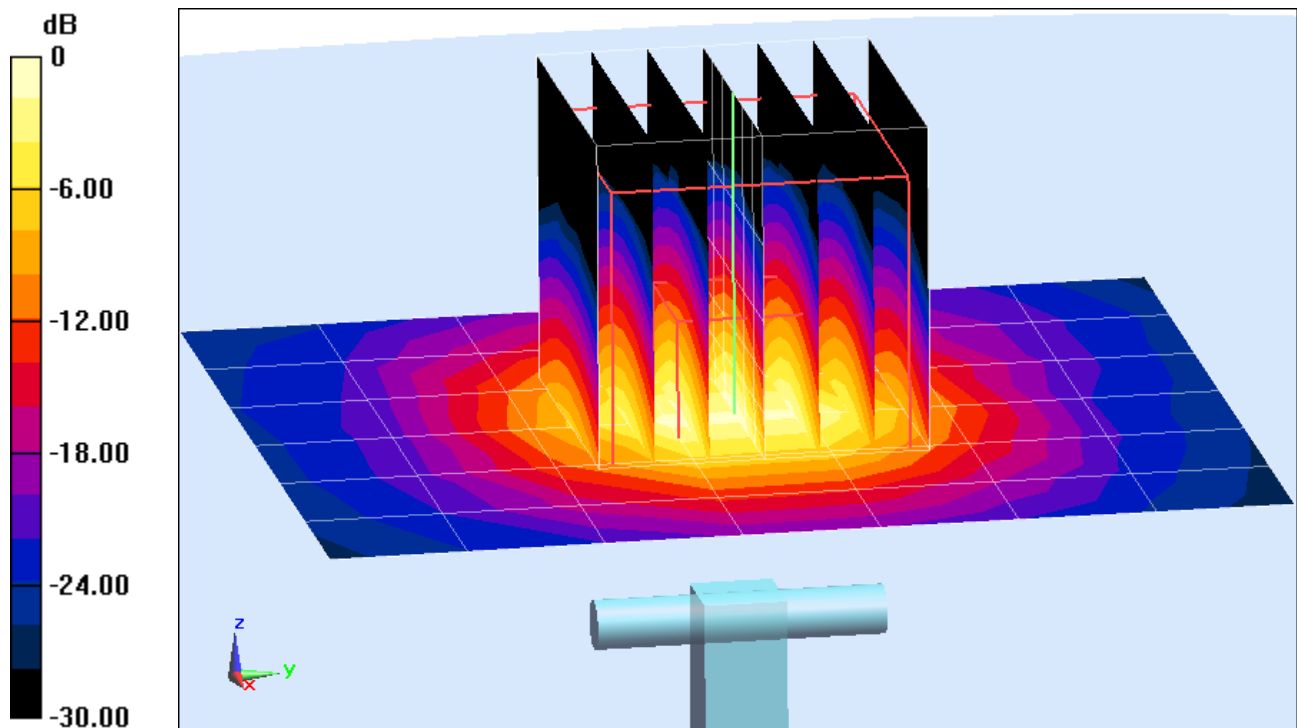

0 dB = 21.5 W/kg = 13.32 dBW/kg

PCTEST ENGINEERING LABORATORY, INC.

DUT: SAR Dipole 5600 MHz; Type: D5GHzV2; Serial: 1057

Communication System: UID 0, CW; Frequency: 5600 MHz; Duty Cycle: 1:1

Medium: 5 GHz Head Medium parameters used:

$f = 5600 \text{ MHz}$; $\sigma = 4.976 \text{ S/m}$; $\epsilon_r = 36.541$; $\rho = 1000 \text{ kg/m}^3$

Phantom section: Flat Section; Space: 1.0 cm

Test Date: 08-14-2014; Ambient Temp: 24.2°C; Tissue Temp: 23.8°C

Probe: EX3DV4 - SN3914; ConvF(4.37, 4.37, 4.37); Calibrated: 10/23/2013;

Sensor-Surface: 1.4mm (Mechanical Surface Detection)

Electronics: DAE4 Sn1333; Calibrated: 11/19/2013

Phantom: SAM V5.0 Right; Type: QD000P40CD; Serial: 1647

Measurement SW: DASY52, Version 52.8 (8); SEMCAD X Version 14.6.10 (7331)

5600 MHz System Verification

Area Scan (7x8x1): Measurement grid: dx=10mm, dy=10mm

Zoom Scan (7x7x7)/Cube 0: Measurement grid: dx=4mm, dy=4mm, dz=1.4mm; Graded Ratio: 1.4

Input Power = 20 dBm (100 mW)

Peak SAR (extrapolated) = 36.8 W/kg

SAR(1 g) = 8.18 W/kg

Deviation = -2.04%

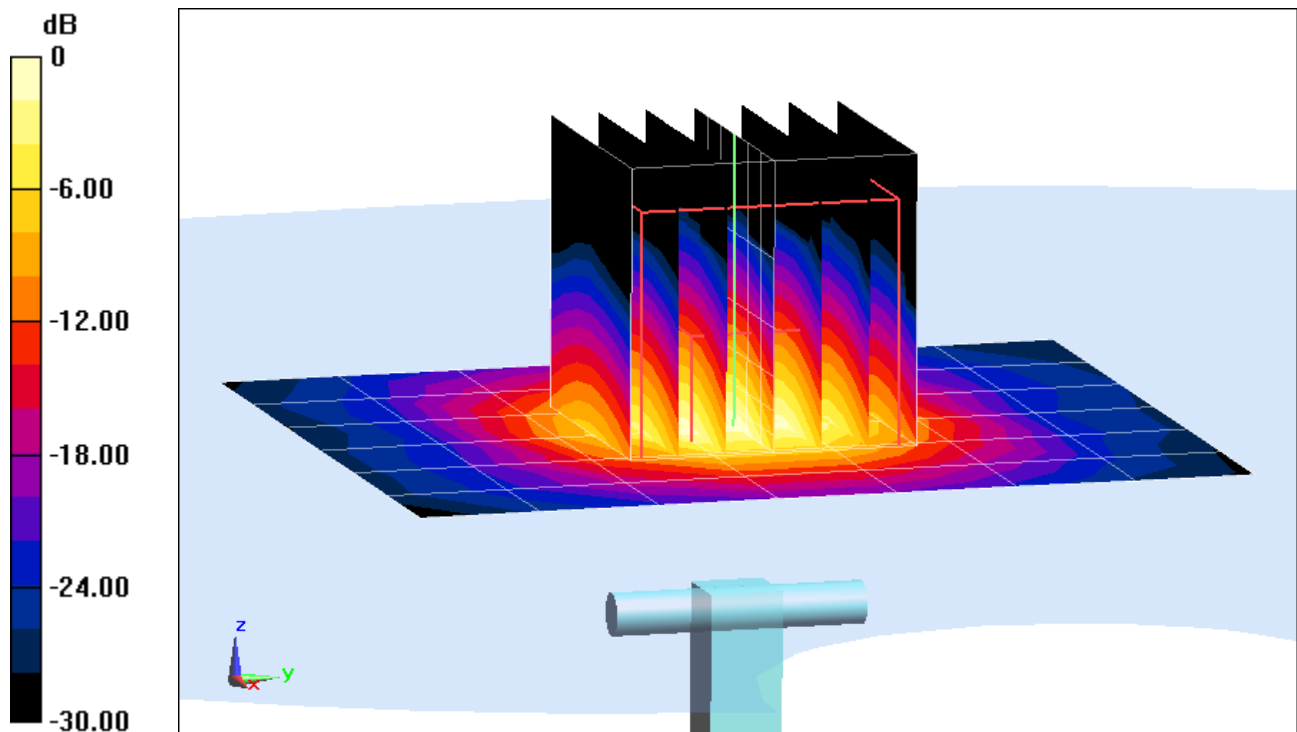

0 dB = 21.3 W/kg = 13.28 dBW/kg

PCTEST ENGINEERING LABORATORY, INC.

DUT: SAR Dipole 5800 MHz; Type: D5GHzV2; Serial: 1057

Communication System: UID 0, CW; Frequency: 5800 MHz; Duty Cycle: 1:1

Medium: 5 GHz Head Medium parameters used:

$f = 5800 \text{ MHz}$; $\sigma = 5.18 \text{ S/m}$; $\epsilon_r = 36.307$; $\rho = 1000 \text{ kg/m}^3$

Phantom section: Flat Section; Space: 1.0 cm

Test Date: 08-14-2014; Ambient Temp: 24.3°C; Tissue Temp: 23.6°C

Probe: EX3DV4 - SN3914; ConvF(4.52, 4.52, 4.52); Calibrated: 10/23/2013;

Sensor-Surface: 1.4mm (Mechanical Surface Detection)

Electronics: DAE4 Sn1333; Calibrated: 11/19/2013

Phantom: SAM V5.0 Right; Type: QD000P40CD; Serial: 1647

Measurement SW: DASY52, Version 52.8 (8); SEMCAD X Version 14.6.10 (7331)

5800 MHz System Verification

Area Scan (7x8x1): Measurement grid: dx=10mm, dy=10mm

Zoom Scan (7x7x7)/Cube 0: Measurement grid: dx=4mm, dy=4mm, dz=1.4mm; Graded Ratio: 1.4

Input Power = 20 dBm (100 mW)

Peak SAR (extrapolated) = 35.1 W/kg

SAR(1 g) = 7.39 W/kg

Deviation = -6.81%

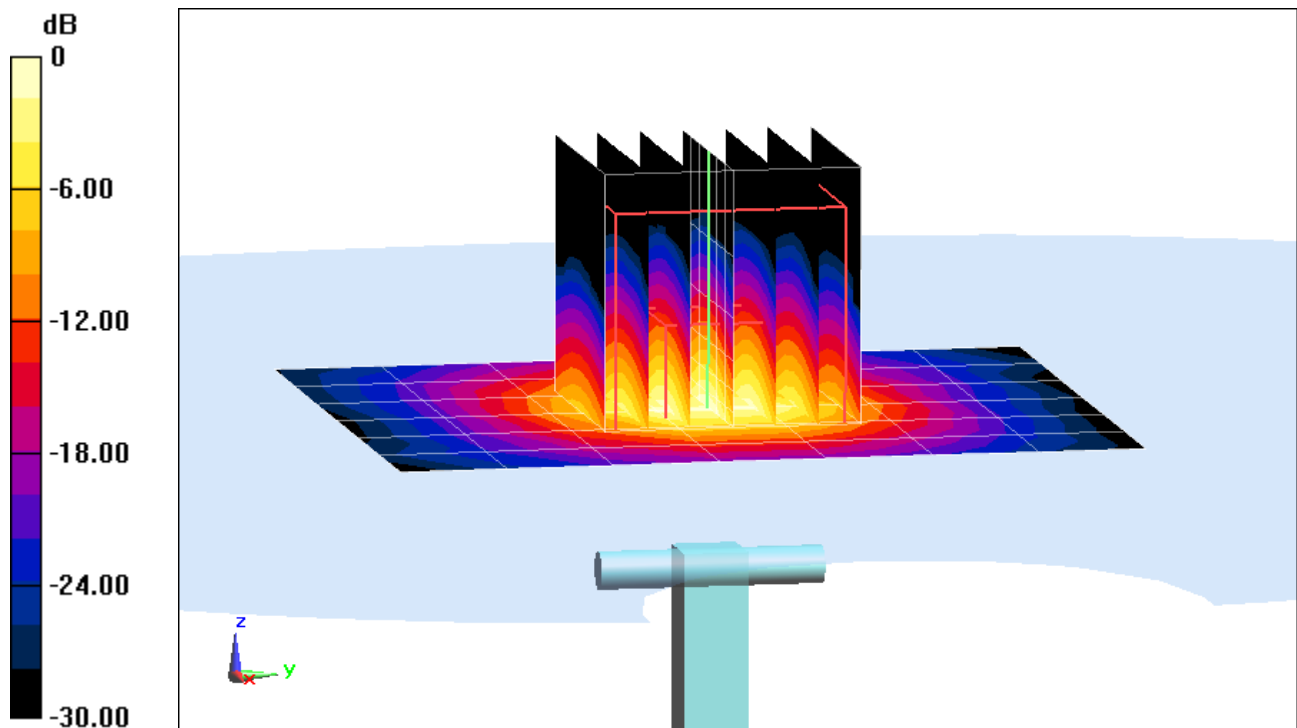

0 dB = 19.6 W/kg = 12.92 dBW/kg

PCTEST ENGINEERING LABORATORY, INC.

DUT: SAR Dipole 2450 MHz; Type: D2450V2; Serial: 797

Communication System: UID 0, CW; Frequency: 2450 MHz; Duty Cycle: 1:1

Medium: 2450 Body Medium parameters used:

$f = 2450 \text{ MHz}$; $\sigma = 1.97 \text{ S/m}$; $\epsilon_r = 51.945$; $\rho = 1000 \text{ kg/m}^3$

Phantom section: Flat Section; Space: 1.0 cm

Test Date: 08-18-2014; Ambient Temp: 24.5°C; Tissue Temp: 23.2°C

Probe: ES3DV3 - SN3319; ConvF(4.24, 4.24, 4.24); Calibrated: 4/17/2014;

Sensor-Surface: 3mm (Mechanical Surface Detection)

Electronics: DAE4 Sn1368; Calibrated: 4/11/2014

Phantom: ELI left; Type: QDOVA002AA; Serial: TP:1202

Measurement SW: DASY52, Version 52.8 (8); SEMCAD X Version 14.6.10 (7331)

2450 MHz System Verification

Area Scan (8x9x1): Measurement grid: dx=12mm, dy=12mm

Zoom Scan (7x7x7)/Cube 0: Measurement grid: dx=5mm, dy=5mm, dz=5mm

Input Power = 20 dBm (100 mW)

Peak SAR (extrapolated) = 10.3 W/kg

SAR(1 g) = 4.93 W/kg

Deviation = -0.20%

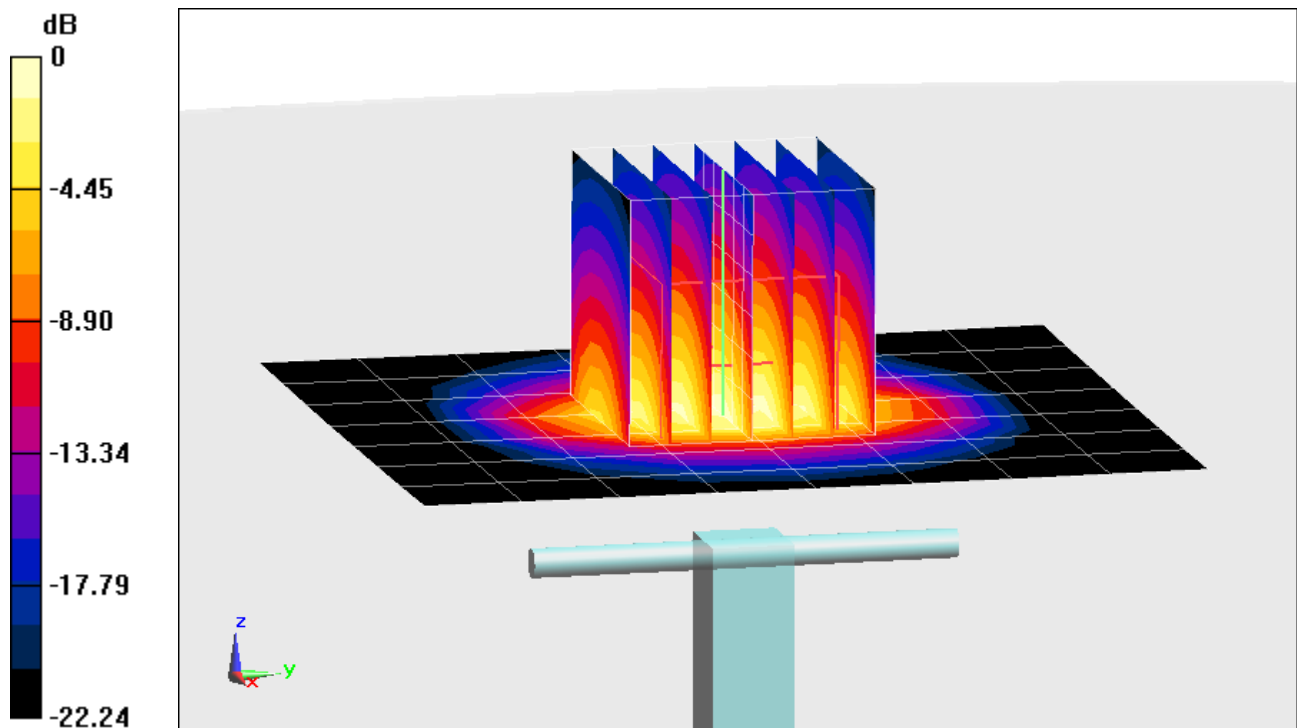

0 dB = 6.46 W/kg = 8.10 dBW/kg

PCTEST ENGINEERING LABORATORY, INC.

DUT: Dipole 2450 MHz; Type: D2450V2; Serial: 797

Communication System: UID 0, CW; Frequency: 2450 MHz; Duty Cycle: 1:1

Medium: 2450 Body Medium parameters used:

$f = 2450 \text{ MHz}$; $\sigma = 2.045 \text{ S/m}$; $\epsilon_r = 52.023$; $\rho = 1000 \text{ kg/m}^3$

Phantom section: Flat Section; Space: 1.0 cm

Test Date: 08-23-2014; Ambient Temp: 24.3°C; Tissue Temp: 22.0°C

Probe: ES3DV3 - SN3258; ConvF(4.14, 4.14, 4.14); Calibrated: 2/25/2014;

Sensor-Surface: 3mm (Mechanical Surface Detection)

Electronics: DAE4 Sn665; Calibrated: 2/26/2014

Phantom: SAM Front; Type: SAM; Serial: 1686

Measurement SW: DASY52, Version 52.8 (8); SEMCAD X Version 14.6.10 (7331)

2450 MHz System Verification

Area Scan (8x9x1): Measurement grid: dx=12mm, dy=12mm

Zoom Scan (7x7x7)/Cube 0: Measurement grid: dx=5mm, dy=5mm, dz=5mm

Input Power = 20 dBm (100 mW)

Peak SAR (extrapolated) = 10.9 W/kg

SAR(10 g) = 2.38 W/kg

Deviation = 3.03%

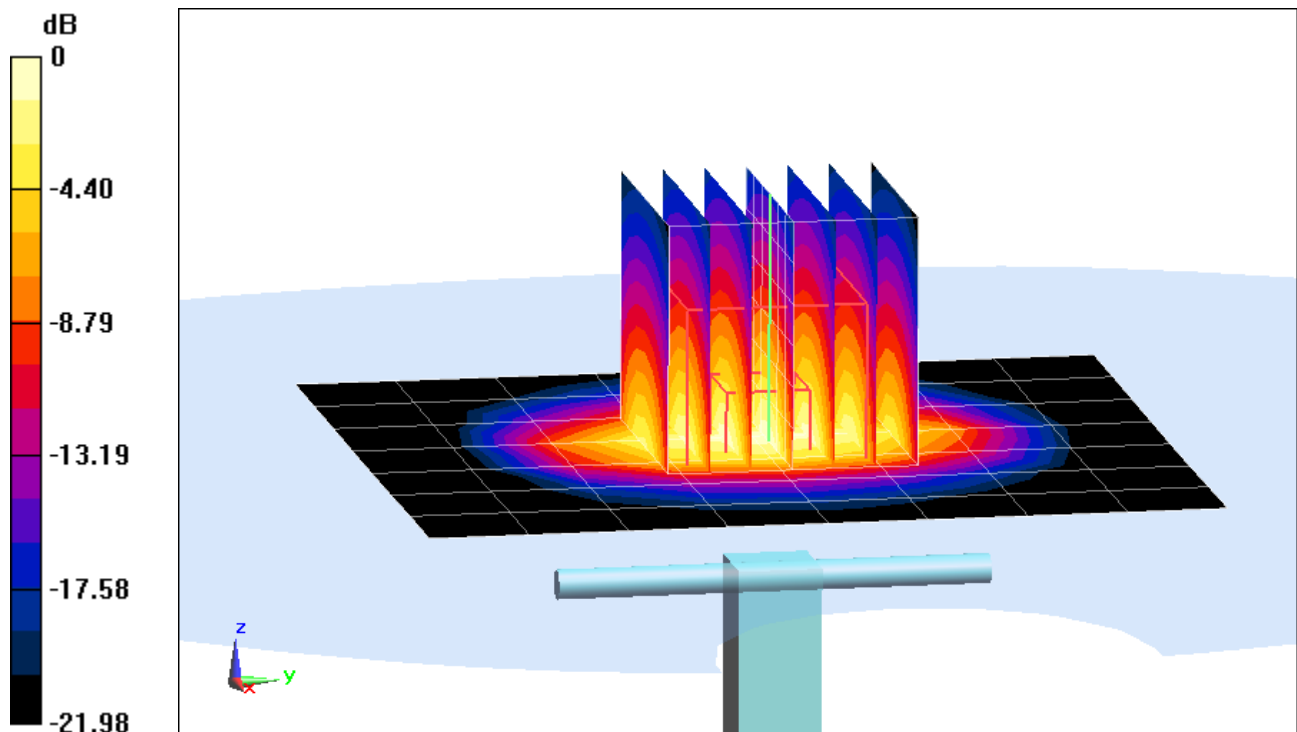

0 dB = 6.77 W/kg = 8.31 dBW/kg

PCTEST ENGINEERING LABORATORY, INC.

DUT: Dipole 5200 MHz; Type: D5GHzV2; Serial: 1007

Communication System: UID 0, CW; Frequency: 5200 MHz; Duty Cycle: 1:1

Medium: 5 GHz Body Medium parameters used:

$f = 5200 \text{ MHz}$; $\sigma = 5.106 \text{ S/m}$; $\epsilon_r = 47.285$; $\rho = 1000 \text{ kg/m}^3$

Phantom section: Flat Section; Space: 1.0 cm

Test Date: 08-18-2014; Ambient Temp: 23.4°C; Tissue Temp: 21.8°C

Probe: EX3DV4 - SN3920; ConvF(4.23, 4.23, 4.23); Calibrated: 12/18/2013;

Sensor-Surface: 1.4mm (Mechanical Surface Detection)

Electronics: DAE4 Sn649; Calibrated: 12/12/2013

Phantom: SAM Sub; Type: SAM 4.0; Serial: TP-1357

Measurement SW: DASY4, Version 4.7 (80); SEMCAD X Version 14.6.10 (7331)

5200MHz System Verification

Area Scan (7x9x1): Measurement grid: dx=10mm, dy=10mm

Zoom Scan (9x9x7)/Cube 0: Measurement grid: dx=4mm, dy=4mm, dz=1.4mm; Graded Ratio: 1.4

Input Power = 20 dBm (100 mW)

Peak SAR (extrapolated) = 27.9 W/kg

SAR(1 g) = 7.49 W/kg; SAR(10 g) = 2.13 W/kg

Deviation (1g) = 3.17%; Deviation (10g) = 5.45%

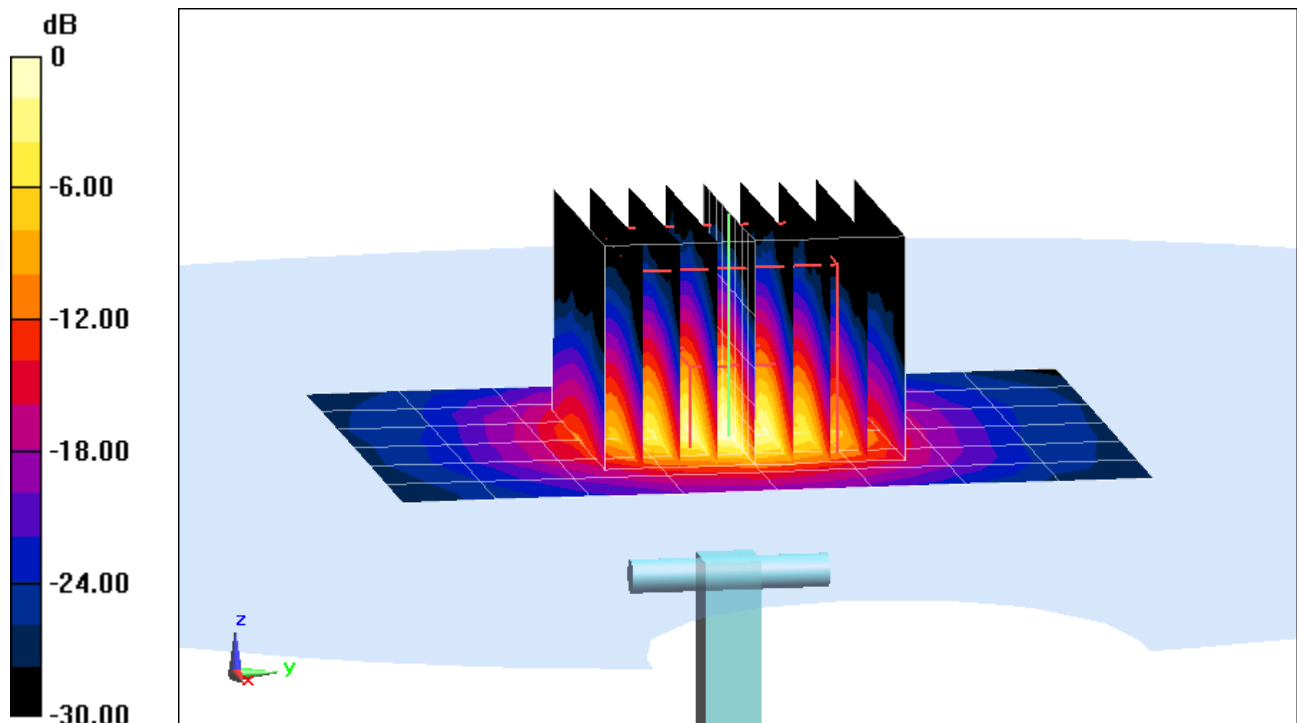

0 dB = 18.8 W/kg = 12.74 dBW/kg

PCTEST ENGINEERING LABORATORY, INC.

DUT: Dipole 5300 MHz; Type: D5GHzV2; Serial: 1007

Communication System: UID 0, CW; Frequency: 5300 MHz; Duty Cycle: 1:1

Medium: 5 GHz Body Medium parameters used:

$f = 5300 \text{ MHz}$; $\sigma = 5.228 \text{ S/m}$; $\epsilon_r = 47.061$; $\rho = 1000 \text{ kg/m}^3$

Phantom section: Flat Section; Space: 1.0 cm

Test Date: 08-18-2014; Ambient Temp: 23.4°C; Tissue Temp: 21.8°C

Probe: EX3DV4 - SN3920; ConvF(4.11, 4.11, 4.11); Calibrated: 12/18/2013;

Sensor-Surface: 1.4mm (Mechanical Surface Detection)

Electronics: DAE4 Sn649; Calibrated: 12/12/2013

Phantom: SAM Sub; Type: SAM 4.0; Serial: TP-1357

Measurement SW: DASY4, Version 4.7 (80); SEMCAD X Version 14.6.10 (7331)

5300MHz System Verification

Area Scan (7x9x1): Measurement grid: dx=10mm, dy=10mm

Zoom Scan (9x9x7)/Cube 0: Measurement grid: dx=4mm, dy=4mm, dz=1.4mm; Graded Ratio: 1.4

Input Power = 20 dBm (100 mW)

Peak SAR (extrapolated) = 28.9 W/kg

SAR(1 g) = 7.62 W/kg; SAR(10 g) = 2.13 W/kg

Deviation (1g) = 2.01%; Deviation (10g) = 2.40%

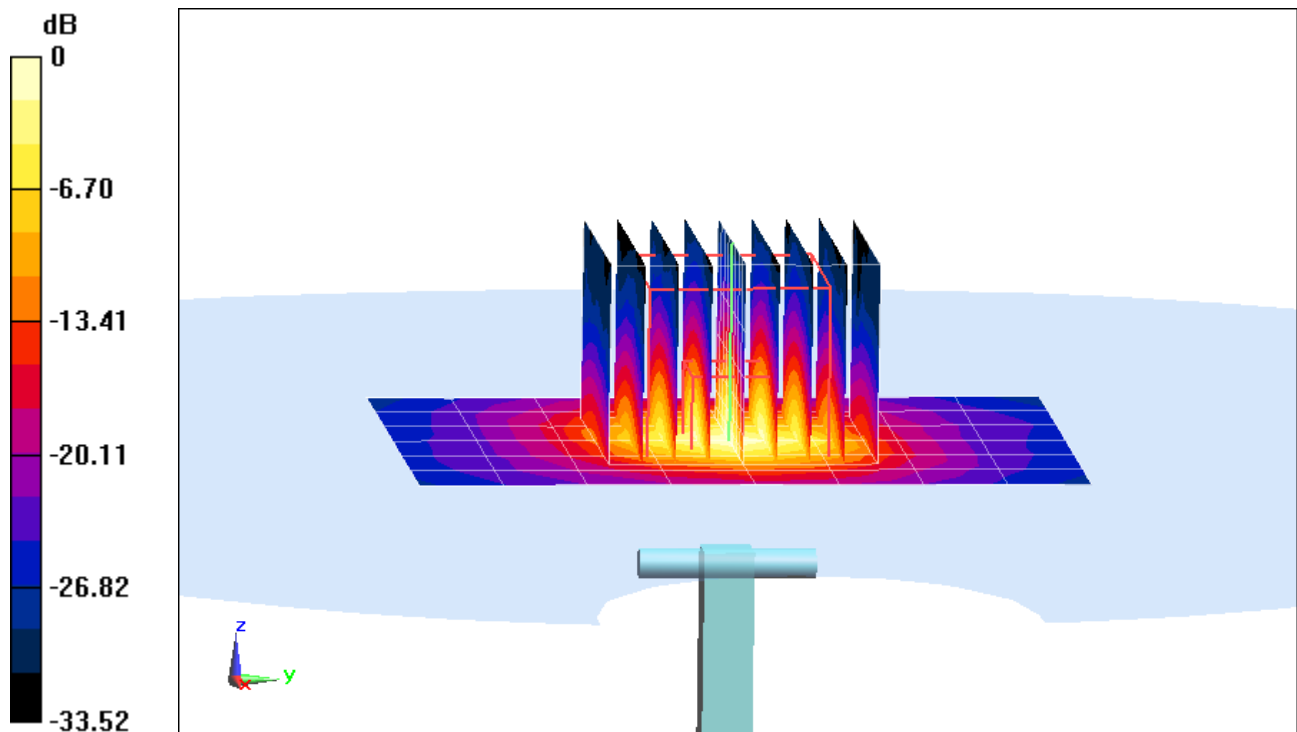

0 dB = 18.9 W/kg = 12.76 dBW/kg

PCTEST ENGINEERING LABORATORY, INC.

DUT: Dipole 5500 MHz; Type: D5GHzV2; Serial: 1007

Communication System: UID 0, CW; Frequency: 5500 MHz; Duty Cycle: 1:1

Medium: 5 GHz Body Medium parameters used:

$f = 5500 \text{ MHz}$; $\sigma = 5.509 \text{ S/m}$; $\epsilon_r = 46.844$; $\rho = 1000 \text{ kg/m}^3$

Phantom section: Flat Section; Space: 1.0 cm

Test Date: 08-18-2014; Ambient Temp: 23.4°C; Tissue Temp: 21.8°C

Probe: EX3DV4 - SN3920; ConvF(3.8, 3.8, 3.8); Calibrated: 12/18/2013;

Sensor-Surface: 1.4mm (Mechanical Surface Detection)

Electronics: DAE4 Sn649; Calibrated: 12/12/2013

Phantom: SAM Sub; Type: SAM 4.0; Serial: TP-1357

Measurement SW: DASY4, Version 4.7 (80); SEMCAD X Version 14.6.10 (7331)

5500MHz System Verification

Area Scan (7x9x1): Measurement grid: dx=10mm, dy=10mm

Zoom Scan (9x9x7)/Cube 0: Measurement grid: dx=4mm, dy=4mm, dz=1.4mm; Graded Ratio: 1.4

Input Power = 20 dBm (100 mW)

Peak SAR (extrapolated) = 32.3 W/kg

SAR(1 g) = 7.67 W/kg; SAR(10 g) = 2.16 W/kg

Deviation (1g) = 1.05%; Deviation (10g) = 2.86%

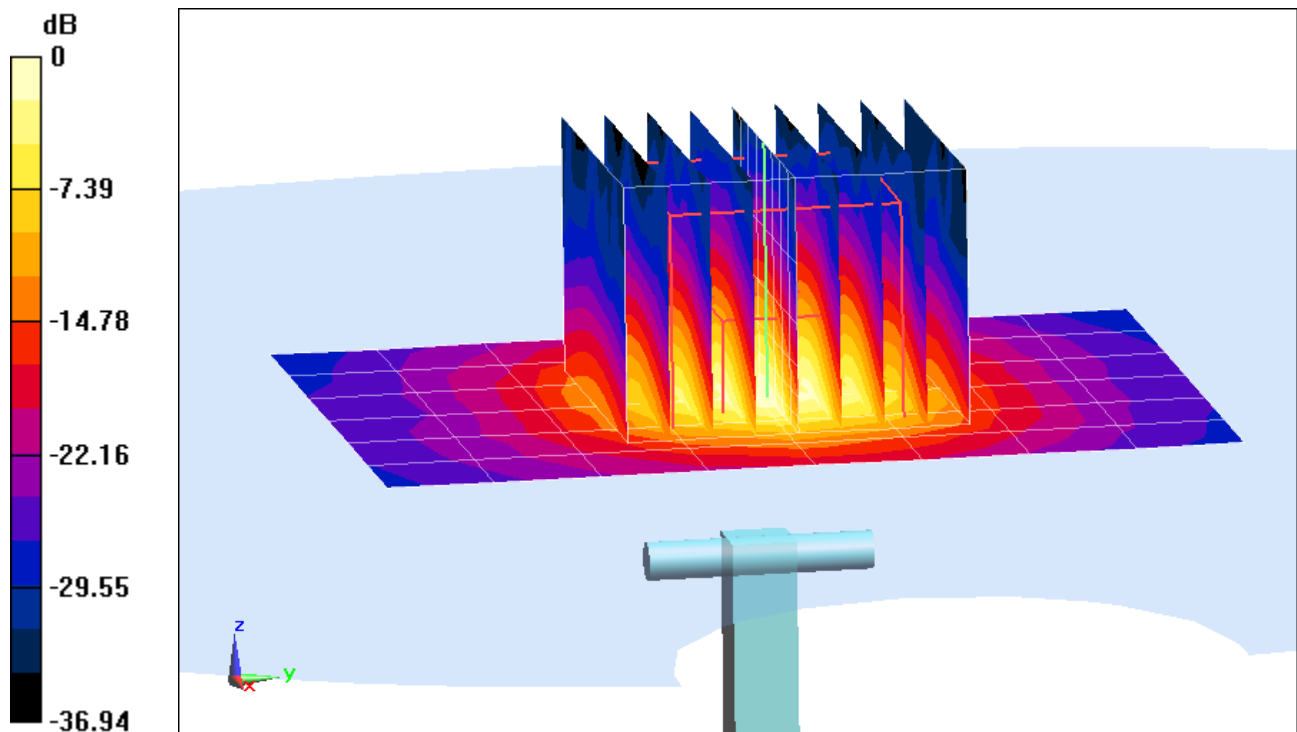

0 dB = 19.1 W/kg = 12.81 dBW/kg

PCTEST ENGINEERING LABORATORY, INC.

DUT: Dipole 5600 MHz; Type: D5GHzV2; Serial: 1007

Communication System: UID 0, CW; Frequency: 5600 MHz; Duty Cycle: 1:1

Medium: 5 GHz Body Medium parameters used:

$f = 5600 \text{ MHz}$; $\sigma = 5.653 \text{ S/m}$; $\epsilon_r = 46.714$; $\rho = 1000 \text{ kg/m}^3$

Phantom section: Flat Section; Space: 1.0 cm

Test Date: 08-18-2014; Ambient Temp: 23.4°C; Tissue Temp: 21.8°C

Probe: EX3DV4 - SN3920; ConvF(3.62, 3.62, 3.62); Calibrated: 12/18/2013;

Sensor-Surface: 1.4mm (Mechanical Surface Detection)

Electronics: DAE4 Sn649; Calibrated: 12/12/2013

Phantom: SAM Sub; Type: SAM 4.0; Serial: TP-1357

Measurement SW: DASY4, Version 4.7 (80); SEMCAD X Version 14.6.10 (7331)

5600MHz System Verification

Area Scan (7x9x1): Measurement grid: dx=10mm, dy=10mm

Zoom Scan (9x9x7)/Cube 0: Measurement grid: dx=4mm, dy=4mm, dz=1.4mm; Graded Ratio: 1.4

Input Power = 20 dBm (100 mW)

Peak SAR (extrapolated) = 32.6 W/kg

SAR(1 g) = 7.74 W/kg; SAR(10 g) = 2.17 W/kg

Deviation (1g) = 0.13%; Deviation (10g) = 0.93%

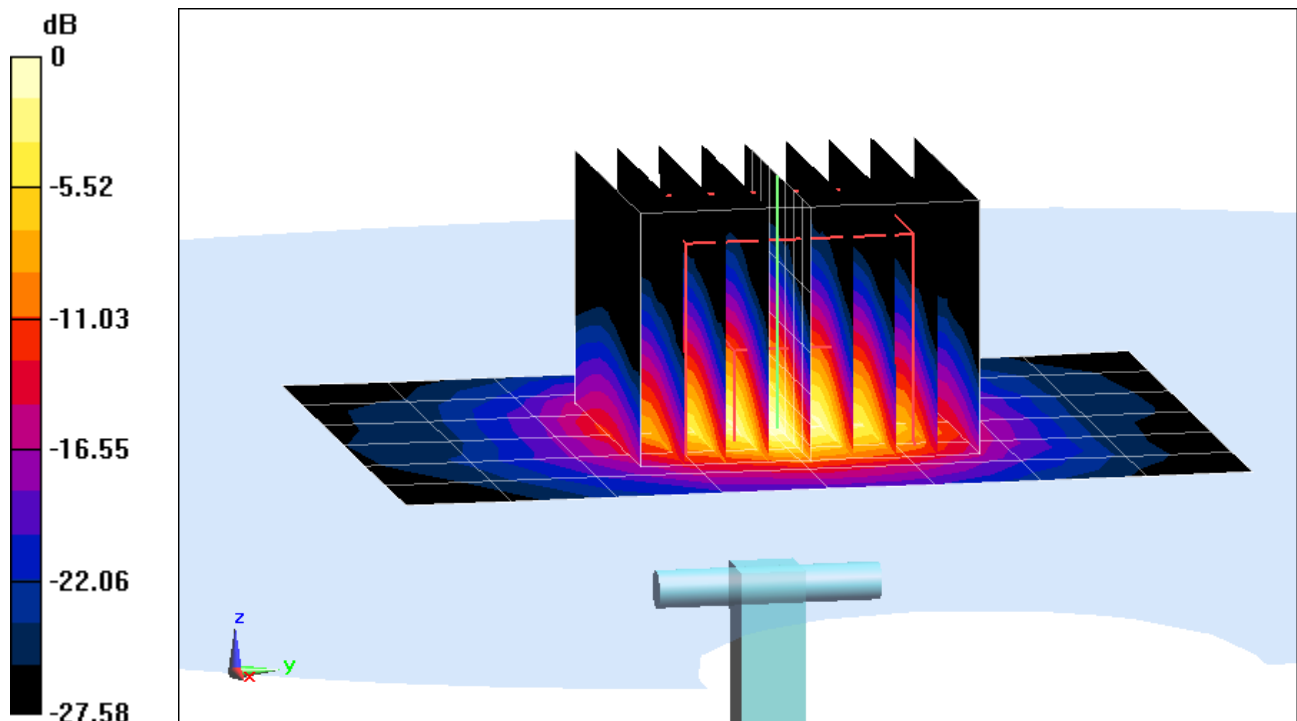

0 dB = 19.8 W/kg = 12.97 dBW/kg

PCTEST ENGINEERING LABORATORY, INC.

DUT: Dipole 5800 MHz; Type: D5GHzV2; Serial: 1007

Communication System: UID 0, CW; Frequency: 5800 MHz; Duty Cycle: 1:1

Medium: 5 GHz Body Medium parameters used:

$f = 5800 \text{ MHz}$; $\sigma = 5.842 \text{ S/m}$; $\epsilon_r = 46.461$; $\rho = 1000 \text{ kg/m}^3$

Phantom section: Flat Section; Space: 1.0 cm

Test Date: 08-18-2014; Ambient Temp: 23.4°C; Tissue Temp: 21.8°C

Probe: EX3DV4 - SN3920; ConvF(4, 4, 4); Calibrated: 12/18/2013;

Sensor-Surface: 1.4mm (Mechanical Surface Detection)

Electronics: DAE4 Sn649; Calibrated: 12/12/2013

Phantom: SAM Sub; Type: SAM 4.0; Serial: TP-1357

Measurement SW: DASY4, Version 4.7 (80); SEMCAD X Version 14.6.10 (7331)

5800MHz System Verification

Area Scan (7x9x1): Measurement grid: dx=10mm, dy=10mm

Zoom Scan (9x9x7)/Cube 0: Measurement grid: dx=4mm, dy=4mm, dz=1.4mm; Graded Ratio: 1.4

Input Power = 20 dBm (100 mW)

Peak SAR (extrapolated) = 32.5 W/kg

SAR(1 g) = 7.12 W/kg; SAR(10 g) = 1.96 W/kg

Deviation (1g) = -2.33; Deviation (10g) = -2.49%

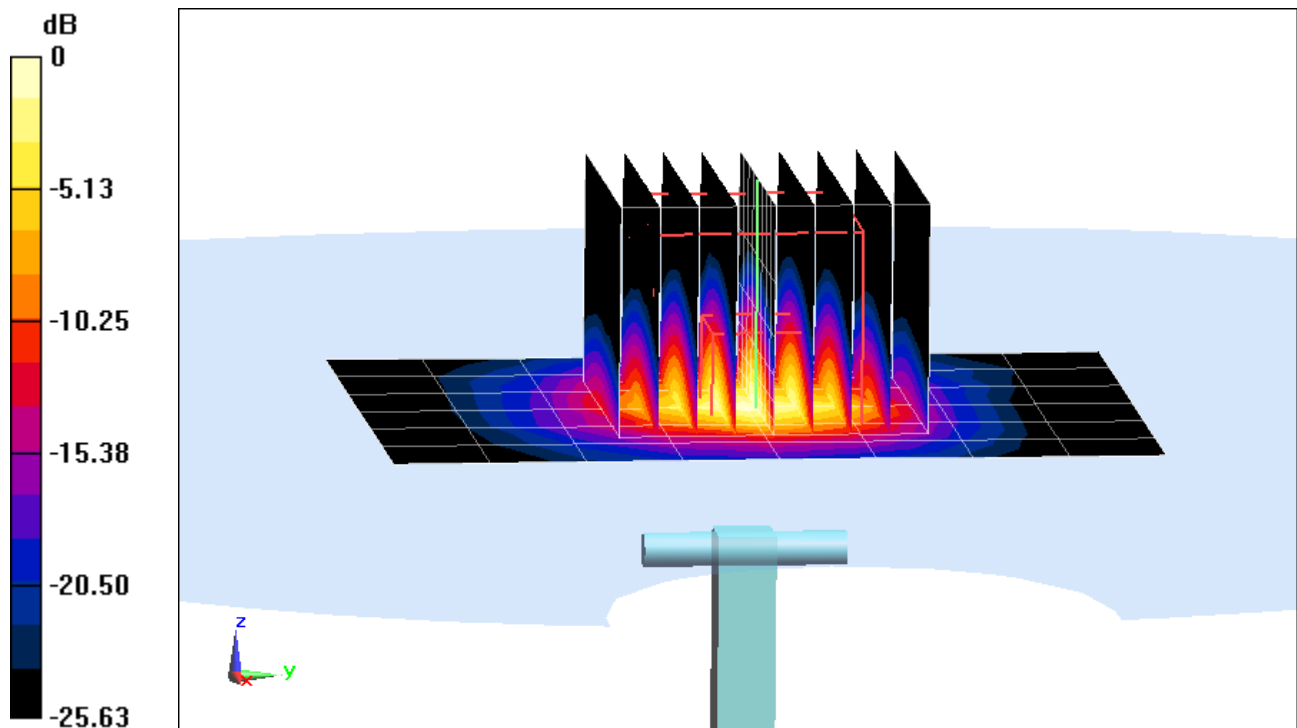

APPENDIX C: PROBE CALIBRATION



Accredited by the Swiss Accreditation Service (SAS)
The Swiss Accreditation Service is one of the signatories to the EA
Multilateral Agreement for the recognition of calibration certificates

Accreditation No.: **SCS 108**

Client **PC Test**

Certificate No: **ES3-3258_Feb14**

CALIBRATION CERTIFICATE

Object **ES3DV3 - SN:3258**

Calibration procedure(s) **QA CAL-01.v9, QA CAL-23.v5, QA CAL-25.v6
Calibration procedure for dosimetric E-field probes** *CCV 3/16/14*

Calibration date: **February 25, 2014**

This calibration certificate documents the traceability to national standards, which realize the physical units of measurements (SI).
The measurements and the uncertainties with confidence probability are given on the following pages and are part of the certificate.

All calibrations have been conducted in the closed laboratory facility: environment temperature (22 ± 3)°C and humidity < 70%.

Calibration Equipment used (M&TE critical for calibration)

| Primary Standards | ID | Cal Date (Certificate No.) | Scheduled Calibration |
|----------------------------|-----------------|-----------------------------------|------------------------|
| Power meter E4419B | GB41293874 | 04-Apr-13 (No. 217-01733) | Apr-14 |
| Power sensor E4412A | MY41498087 | 04-Apr-13 (No. 217-01733) | Apr-14 |
| Reference 3 dB Attenuator | SN: S5054 (3c) | 04-Apr-13 (No. 217-01737) | Apr-14 |
| Reference 20 dB Attenuator | SN: S5277 (20x) | 04-Apr-13 (No. 217-01735) | Apr-14 |
| Reference 30 dB Attenuator | SN: S5129 (30b) | 04-Apr-13 (No. 217-01738) | Apr-14 |
| Reference Probe ES3DV2 | SN: 3013 | 30-Dec-13 (No. ES3-3013_Dec13) | Dec-14 |
| DAE4 | SN: 660 | 13-Dec-13 (No. DAE4-660_Dec13) | Dec-14 |
| Secondary Standards | ID | Check Date (in house) | Scheduled Check |
| RF generator HP 8648C | US3642U01700 | 4-Aug-99 (in house check Apr-13) | In house check: Apr-16 |
| Network Analyzer HP 8753E | US37390585 | 18-Oct-01 (in house check Oct-13) | In house check: Oct-14 |

| | | | |
|----------------|-------------------------------|--|------------------------------------|
| Calibrated by: | Name Israe El-Naouq | Function Laboratory Technician | Signature <i>Israe El-Naouq</i> |
| Approved by: | Katja Pokovic | Technical Manager | <i>Katja Pokovic</i> |

Issued: February 27, 2014

This calibration certificate shall not be reproduced except in full without written approval of the laboratory.

PCT# 80615



Accredited by the Swiss Accreditation Service (SAS)

Accreditation No.: **SCS 108**

The Swiss Accreditation Service is one of the signatories to the EA Multilateral Agreement for the recognition of calibration certificates

Glossary:

| | |
|--------------------------|---|
| TSL | tissue simulating liquid |
| NORM _{x,y,z} | sensitivity in free space |
| ConvF | sensitivity in TSL / NORM _{x,y,z} |
| DCP | diode compression point |
| CF | crest factor (1/duty_cycle) of the RF signal |
| A, B, C, D | modulation dependent linearization parameters |
| Polarization φ | φ rotation around probe axis |
| Polarization ϑ | ϑ rotation around an axis that is in the plane normal to probe axis (at measurement center), i.e., $\vartheta = 0$ is normal to probe axis |
| Connector Angle | information used in DASY system to align probe sensor X to the robot coordinate system |

Calibration is Performed According to the Following Standards:

- IEEE Std 1528-2013, "IEEE Recommended Practice for Determining the Peak Spatial-Averaged Specific Absorption Rate (SAR) in the Human Head from Wireless Communications Devices: Measurement Techniques", June 2013
- IEC 62209-1, "Procedure to measure the Specific Absorption Rate (SAR) for hand-held devices used in close proximity to the ear (frequency range of 300 MHz to 3 GHz)", February 2005

Methods Applied and Interpretation of Parameters:

- NORM_{x,y,z}:** Assessed for E-field polarization $\vartheta = 0$ ($f \leq 900$ MHz in TEM-cell; $f > 1800$ MHz: R22 waveguide). NORM_{x,y,z} are only intermediate values, i.e., the uncertainties of NORM_{x,y,z} does not affect the E²-field uncertainty inside TSL (see below ConvF).
- NORM(f)_{x,y,z} = NORM_{x,y,z} * frequency_response** (see Frequency Response Chart). This linearization is implemented in DASY4 software versions later than 4.2. The uncertainty of the frequency response is included in the stated uncertainty of ConvF.
- DCP_{x,y,z}:** DCP are numerical linearization parameters assessed based on the data of power sweep with CW signal (no uncertainty required). DCP does not depend on frequency nor media.
- PAR:** PAR is the Peak to Average Ratio that is not calibrated but determined based on the signal characteristics
- A_{x,y,z}; B_{x,y,z}; C_{x,y,z}; D_{x,y,z}; VR_{x,y,z}:** A, B, C, D are numerical linearization parameters assessed based on the data of power sweep for specific modulation signal. The parameters do not depend on frequency nor media. VR is the maximum calibration range expressed in RMS voltage across the diode.
- ConvF and Boundary Effect Parameters:** Assessed in flat phantom using E-field (or Temperature Transfer Standard for $f \leq 800$ MHz) and inside waveguide using analytical field distributions based on power measurements for $f > 800$ MHz. The same setups are used for assessment of the parameters applied for boundary compensation (alpha, depth) of which typical uncertainty values are given. These parameters are used in DASY4 software to improve probe accuracy close to the boundary. The sensitivity in TSL corresponds to NORM_{x,y,z} * ConvF whereby the uncertainty corresponds to that given for ConvF. A frequency dependent ConvF is used in DASY version 4.4 and higher which allows extending the validity from ± 50 MHz to ± 100 MHz.
- Spherical isotropy (3D deviation from isotropy):** in a field of low gradients realized using a flat phantom exposed by a patch antenna.
- Sensor Offset:** The sensor offset corresponds to the offset of virtual measurement center from the probe tip (on probe axis). No tolerance required.
- Connector Angle:** The angle is assessed using the information gained by determining the NORM_x (no uncertainty required).

Probe ES3DV3

SN:3258

Manufactured: January 25, 2010
Calibrated: February 25, 2014

Calibrated for DASY/EASY Systems
(Note: non-compatible with DASY2 system!)

DASY/EASY - Parameters of Probe: ES3DV3 - SN:3258

Basic Calibration Parameters

| | Sensor X | Sensor Y | Sensor Z | Unc (k=2) |
|---------------------------------------|----------|----------|----------|-----------|
| Norm ($\mu V/(V/m)^2$) ^A | 1.29 | 1.19 | 1.23 | ± 10.1 % |
| DCP (mV) ^B | 104.5 | 107.0 | 103.0 | |

Modulation Calibration Parameters

| UID | Communication System Name | | A dB | B dB√μV | C | D dB | VR mV | Unc ^E (k=2) |
|-----------|--|---|---------|------------|------|---------|----------|---------------------------|
| 0 | CW | X | 0.0 | 0.0 | 1.0 | 0.00 | 222.4 | ±3.8 % |
| | | Y | 0.0 | 0.0 | 1.0 | | 202.2 | |
| | | Z | 0.0 | 0.0 | 1.0 | | 207.1 | |
| 10010-CAA | SAR Validation (Square, 100ms, 10ms) | X | 5.09 | 65.6 | 14.1 | 10.00 | 44.8 | ±1.9 % |
| | | Y | 1.68 | 57.4 | 9.3 | | 40.7 | |
| | | Z | 4.01 | 62.4 | 13.0 | | 51.1 | |
| 10011-CAB | UMTS-FDD (WCDMA) | X | 3.34 | 67.5 | 18.9 | 2.91 | 131.2 | ±0.5 % |
| | | Y | 3.43 | 67.9 | 18.7 | | 137.1 | |
| | | Z | 3.42 | 67.8 | 19.0 | | 146.0 | |
| 10012-CAA | IEEE 802.11b WiFi 2.4 GHz (DSSS, 1 Mbps) | X | 3.40 | 70.9 | 19.8 | 1.87 | 134.2 | ±0.7 % |
| | | Y | 3.19 | 70.2 | 19.2 | | 137.9 | |
| | | Z | 3.46 | 70.8 | 19.6 | | 149.6 | |
| 10021-DAB | GSM-FDD (TDMA, GMSK) | X | 30.24 | 99.7 | 28.7 | 9.39 | 131.2 | ±1.4 % |
| | | Y | 12.91 | 88.5 | 23.9 | | 147.5 | |
| | | Z | 30.37 | 99.5 | 28.9 | | 128.0 | |
| 10023-DAB | GPRS-FDD (TDMA, GMSK, TN 0) | X | 29.88 | 100.0 | 29.0 | 9.57 | 123.0 | ±1.9 % |
| | | Y | 16.02 | 92.5 | 25.4 | | 140.7 | |
| | | Z | 30.01 | 100.0 | 29.4 | | 125.8 | |
| 10024-DAB | GPRS-FDD (TDMA, GMSK, TN 0-1) | X | 44.57 | 99.7 | 25.9 | 6.56 | 119.6 | ±1.7 % |
| | | Y | 28.97 | 95.3 | 23.2 | | 127.6 | |
| | | Z | 43.72 | 99.8 | 26.3 | | 120.1 | |
| 10027-DAB | GPRS-FDD (TDMA, GMSK, TN 0-1-2) | X | 53.52 | 99.7 | 24.4 | 4.80 | 129.4 | ±2.2 % |
| | | Y | 54.55 | 99.9 | 22.9 | | 143.3 | |
| | | Z | 51.63 | 99.7 | 24.8 | | 127.5 | |
| 10028-DAB | GPRS-FDD (TDMA, GMSK, TN 0-1-2-3) | X | 58.93 | 99.8 | 23.4 | 3.55 | 133.4 | ±2.2 % |
| | | Y | 77.54 | 99.7 | 21.3 | | 125.3 | |
| | | Z | 56.64 | 99.8 | 23.8 | | 130.8 | |
| 10032-CAA | IEEE 802.15.1 Bluetooth (GFSK, DH5) | X | 47.03 | 99.5 | 21.3 | 1.16 | 136.3 | ±1.7 % |
| | | Y | 95.86 | 95.2 | 17.1 | | 138.2 | |
| | | Z | 39.68 | 100.0 | 22.2 | | 132.3 | |
| 10039-CAB | CDMA2000 (1xRTT, RC1) | X | 4.84 | 66.8 | 19.1 | 4.57 | 131.3 | ±0.9 % |
| | | Y | 4.75 | 67.0 | 18.9 | | 135.2 | |
| | | Z | 4.86 | 66.7 | 19.0 | | 127.2 | |

| | | | | | | | | |
|-----------|---|---|-------|------|------|------|-------|--------|
| 10081-CAB | CDMA2000 (1xRTT, RC3) | X | 4.06 | 66.8 | 19.0 | 3.97 | 148.4 | ±0.7 % |
| | | Y | 3.96 | 66.6 | 18.6 | | 134.7 | |
| | | Z | 4.13 | 66.9 | 19.1 | | 143.4 | |
| 10098-CAB | UMTS-FDD (HSUPA, Subtest 2) | X | 4.63 | 66.8 | 18.7 | 3.98 | 137.3 | ±0.7 % |
| | | Y | 4.75 | 67.5 | 18.8 | | 148.4 | |
| | | Z | 4.65 | 66.7 | 18.7 | | 133.2 | |
| 10100-CAB | LTE-FDD (SC-FDMA, 100% RB, 20 MHz, QPSK) | X | 6.66 | 68.5 | 20.3 | 5.67 | 144.0 | ±1.2 % |
| | | Y | 6.27 | 67.1 | 19.3 | | 130.6 | |
| | | Z | 6.62 | 68.2 | 20.1 | | 140.5 | |
| 10108-CAB | LTE-FDD (SC-FDMA, 100% RB, 10 MHz, QPSK) | X | 6.53 | 68.0 | 20.2 | 5.80 | 142.6 | ±1.4 % |
| | | Y | 6.17 | 66.8 | 19.3 | | 129.2 | |
| | | Z | 6.52 | 67.8 | 20.1 | | 139.0 | |
| 10110-CAB | LTE-FDD (SC-FDMA, 100% RB, 5 MHz, QPSK) | X | 6.19 | 67.3 | 19.9 | 5.75 | 137.9 | ±1.4 % |
| | | Y | 6.12 | 67.3 | 19.6 | | 149.5 | |
| | | Z | 6.19 | 67.1 | 19.8 | | 136.1 | |
| 10114-CAA | IEEE 802.11n (HT Greenfield, 13.5 Mbps, BPSK) | X | 10.49 | 69.5 | 21.7 | 8.10 | 132.4 | ±2.5 % |
| | | Y | 10.23 | 69.1 | 21.3 | | 144.3 | |
| | | Z | 10.45 | 69.3 | 21.6 | | 129.5 | |
| 10117-CAA | IEEE 802.11n (HT Mixed, 13.5 Mbps, BPSK) | X | 10.46 | 69.5 | 21.7 | 8.07 | 133.9 | ±2.5 % |
| | | Y | 10.26 | 69.2 | 21.3 | | 147.4 | |
| | | Z | 10.47 | 69.4 | 21.7 | | 130.5 | |
| 10151-CAB | LTE-TDD (SC-FDMA, 50% RB, 20 MHz, QPSK) | X | 11.61 | 77.4 | 26.8 | 9.28 | 118.8 | ±3.0 % |
| | | Y | 9.89 | 75.2 | 25.7 | | 144.9 | |
| | | Z | 12.01 | 77.8 | 26.9 | | 119.6 | |
| 10154-CAB | LTE-FDD (SC-FDMA, 50% RB, 10 MHz, QPSK) | X | 6.20 | 67.3 | 19.9 | 5.75 | 139.2 | ±1.2 % |
| | | Y | 5.86 | 66.2 | 19.0 | | 128.5 | |
| | | Z | 6.22 | 67.3 | 19.9 | | 136.3 | |
| 10160-CAB | LTE-FDD (SC-FDMA, 50% RB, 15 MHz, QPSK) | X | 6.63 | 67.8 | 20.1 | 5.82 | 144.1 | ±1.4 % |
| | | Y | 6.31 | 66.8 | 19.3 | | 133.1 | |
| | | Z | 6.66 | 67.7 | 20.0 | | 140.9 | |
| 10169-CAB | LTE-FDD (SC-FDMA, 1 RB, 20 MHz, QPSK) | X | 5.25 | 67.5 | 20.2 | 5.73 | 143.6 | ±1.2 % |
| | | Y | 4.92 | 66.7 | 19.5 | | 131.0 | |
| | | Z | 5.29 | 67.4 | 20.2 | | 140.7 | |
| 10172-CAB | LTE-TDD (SC-FDMA, 1 RB, 20 MHz, QPSK) | X | 13.49 | 87.5 | 31.6 | 9.21 | 139.0 | ±2.7 % |
| | | Y | 7.83 | 75.5 | 26.0 | | 124.9 | |
| | | Z | 13.47 | 86.5 | 31.1 | | 137.8 | |
| 10175-CAB | LTE-FDD (SC-FDMA, 1 RB, 10 MHz, QPSK) | X | 5.22 | 67.4 | 20.1 | 5.72 | 144.3 | ±1.4 % |
| | | Y | 5.08 | 67.5 | 19.9 | | 147.9 | |
| | | Z | 5.26 | 67.2 | 20.0 | | 139.6 | |
| 10181-CAB | LTE-FDD (SC-FDMA, 1 RB, 15 MHz, QPSK) | X | 5.24 | 67.5 | 20.1 | 5.72 | 144.5 | ±1.2 % |
| | | Y | 5.06 | 67.4 | 19.8 | | 147.0 | |
| | | Z | 5.29 | 67.3 | 20.1 | | 139.2 | |

| | | | | | | | | |
|-----------|--|---|-------|------|------|------|-------|--------|
| 10193-CAA | IEEE 802.11n (HT Greenfield, 6.5 Mbps, BPSK) | X | 10.12 | 69.1 | 21.6 | 8.09 | 128.8 | ±2.2 % |
| | | Y | 9.76 | 68.4 | 21.0 | | 132.8 | |
| | | Z | 10.08 | 68.9 | 21.5 | | 123.4 | |
| 10196-CAA | IEEE 802.11n (HT Mixed, 6.5 Mbps, BPSK) | X | 10.15 | 69.2 | 21.7 | 8.10 | 130.2 | ±2.2 % |
| | | Y | 9.77 | 68.5 | 21.0 | | 134.1 | |
| | | Z | 10.10 | 69.0 | 21.5 | | 124.0 | |
| 10219-CAA | IEEE 802.11n (HT Mixed, 7.2 Mbps, BPSK) | X | 10.02 | 69.0 | 21.5 | 8.03 | 128.7 | ±2.2 % |
| | | Y | 9.67 | 68.5 | 21.0 | | 133.3 | |
| | | Z | 10.02 | 68.9 | 21.5 | | 123.9 | |
| 10222-CAA | IEEE 802.11n (HT Mixed, 15 Mbps, BPSK) | X | 10.46 | 69.6 | 21.7 | 8.06 | 134.0 | ±2.2 % |
| | | Y | 10.09 | 68.8 | 21.1 | | 139.7 | |
| | | Z | 10.40 | 69.3 | 21.6 | | 128.7 | |
| 10225-CAB | UMTS-FDD (HSPA+) | X | 7.09 | 67.1 | 19.6 | 5.97 | 131.2 | ±1.4 % |
| | | Y | 6.98 | 67.2 | 19.4 | | 138.0 | |
| | | Z | 7.06 | 66.8 | 19.4 | | 127.2 | |
| 10237-CAB | LTE-TDD (SC-FDMA, 1 RB, 10 MHz, QPSK) | X | 13.63 | 87.8 | 31.7 | 9.21 | 141.6 | ±3.0 % |
| | | Y | 7.85 | 75.5 | 26.0 | | 126.5 | |
| | | Z | 13.99 | 87.7 | 31.6 | | 141.4 | |
| 10252-CAB | LTE-TDD (SC-FDMA, 50% RB, 10 MHz, QPSK) | X | 12.86 | 81.4 | 28.9 | 9.24 | 142.1 | ±3.0 % |
| | | Y | 8.91 | 73.4 | 24.8 | | 129.9 | |
| | | Z | 13.15 | 81.4 | 28.8 | | 142.0 | |
| 10267-CAB | LTE-TDD (SC-FDMA, 100% RB, 10 MHz, QPSK) | X | 11.63 | 77.5 | 26.8 | 9.30 | 118.7 | ±3.0 % |
| | | Y | 9.62 | 74.3 | 25.2 | | 138.4 | |
| | | Z | 11.96 | 77.7 | 26.9 | | 119.3 | |
| 10274-CAB | UMTS-FDD (HSUPA, Subtest 5, 3GPP Rel8.10) | X | 6.14 | 67.4 | 19.3 | 4.87 | 149.9 | ±0.9 % |
| | | Y | 5.90 | 66.9 | 18.7 | | 132.8 | |
| | | Z | 6.20 | 67.5 | 19.3 | | 146.6 | |
| 10275-CAB | UMTS-FDD (HSUPA, Subtest 5, 3GPP Rel8.4) | X | 4.45 | 66.9 | 18.9 | 3.96 | 130.1 | ±0.7 % |
| | | Y | 4.50 | 67.2 | 18.8 | | 137.9 | |
| | | Z | 4.64 | 67.6 | 19.3 | | 149.2 | |
| 10291-AAB | CDMA2000, RC3, SO55, Full Rate | X | 3.79 | 67.5 | 19.2 | 3.46 | 145.3 | ±0.7 % |
| | | Y | 3.74 | 67.5 | 18.9 | | 128.2 | |
| | | Z | 3.78 | 67.3 | 19.1 | | 139.1 | |
| 10292-AAB | CDMA2000, RC3, SO32, Full Rate | X | 3.77 | 67.8 | 19.3 | 3.39 | 147.0 | ±0.5 % |
| | | Y | 3.69 | 67.7 | 18.9 | | 130.1 | |
| | | Z | 3.73 | 67.3 | 19.0 | | 141.3 | |
| 10297-AAA | LTE-FDD (SC-FDMA, 50% RB, 20 MHz, QPSK) | X | 6.52 | 67.9 | 20.1 | 5.81 | 141.4 | ±1.4 % |
| | | Y | 6.41 | 67.6 | 19.7 | | 147.4 | |
| | | Z | 6.51 | 67.7 | 20.1 | | 135.4 | |
| 10311-AAA | LTE-FDD (SC-FDMA, 100% RB, 15 MHz, QPSK) | X | 7.17 | 68.7 | 20.7 | 6.06 | 147.7 | ±1.4 % |
| | | Y | 6.69 | 67.2 | 19.6 | | 128.6 | |
| | | Z | 7.12 | 68.4 | 20.5 | | 142.0 | |

| | | | | | | | | |
|-----------|---|---|------|------|------|------|-------|--------|
| 10315-AAA | IEEE 802.11b WiFi 2.4 GHz (DSSS, 1 Mbps, 96pc duty cycle) | X | 3.04 | 70.0 | 19.6 | 1.71 | 129.8 | ±0.5 % |
| | | Y | 3.25 | 71.3 | 19.7 | | 136.9 | |
| | | Z | 3.09 | 69.9 | 19.5 | | 148.7 | |
| 10403-AAB | CDMA2000 (1xEV-DO, Rev. 0) | X | 4.73 | 67.3 | 18.6 | 3.76 | 135.7 | ±0.5 % |
| | | Y | 4.93 | 69.1 | 19.0 | | 141.5 | |
| | | Z | 4.73 | 67.1 | 18.4 | | 132.7 | |
| 10404-AAB | CDMA2000 (1xEV-DO, Rev. A) | X | 4.67 | 67.5 | 18.6 | 3.77 | 134.0 | ±0.5 % |
| | | Y | 4.92 | 69.4 | 19.1 | | 139.8 | |
| | | Z | 4.65 | 67.1 | 18.5 | | 130.7 | |

The reported uncertainty of measurement is stated as the standard uncertainty of measurement multiplied by the coverage factor k=2, which for a normal distribution corresponds to a coverage probability of approximately 95%.

^A The uncertainties of NormX,Y,Z do not affect the E²-field uncertainty inside TSL (see Pages 8 and 9).

^B Numerical linearization parameter: uncertainty not required.

^E Uncertainty is determined using the max. deviation from linear response applying rectangular distribution and is expressed for the square of the field value.

DASY/EASY - Parameters of Probe: ES3DV3 - SN:3258

Calibration Parameter Determined in Head Tissue Simulating Media

| f (MHz) ^C | Relative Permittivity ^F | Conductivity (S/m) ^F | ConvF X | ConvF Y | ConvF Z | Alpha ^G | Depth (mm) ^G | Unct. (k=2) |
|----------------------|------------------------------------|---------------------------------|---------|---------|---------|--------------------|-------------------------|-------------|
| 750 | 41.9 | 0.89 | 6.53 | 6.53 | 6.53 | 0.40 | 1.60 | ± 12.0 % |
| 835 | 41.5 | 0.90 | 6.27 | 6.27 | 6.27 | 0.80 | 1.17 | ± 12.0 % |
| 1750 | 40.1 | 1.37 | 5.19 | 5.19 | 5.19 | 0.80 | 1.10 | ± 12.0 % |
| 1900 | 40.0 | 1.40 | 5.04 | 5.04 | 5.04 | 0.68 | 1.27 | ± 12.0 % |
| 2450 | 39.2 | 1.80 | 4.52 | 4.52 | 4.52 | 0.78 | 1.23 | ± 12.0 % |
| 2600 | 39.0 | 1.96 | 4.34 | 4.34 | 4.34 | 0.76 | 1.33 | ± 12.0 % |

^C Frequency validity of ± 100 MHz only applies for DASY v4.4 and higher (see Page 2), else it is restricted to ± 50 MHz. The uncertainty is the RSS of the ConvF uncertainty at calibration frequency and the uncertainty for the indicated frequency band.

^F At frequencies below 3 GHz, the validity of tissue parameters (ϵ and σ) can be relaxed to ± 10% if liquid compensation formula is applied to measured SAR values. At frequencies above 3 GHz, the validity of tissue parameters (ϵ and σ) is restricted to ± 5%. The uncertainty is the RSS of the ConvF uncertainty for indicated target tissue parameters.

^G Alpha/Depth are determined during calibration. SPEAG warrants that the remaining deviation due to the boundary effect after compensation is always less than ± 1% for frequencies below 3 GHz and below ± 2% for frequencies between 3-6 GHz at any distance larger than half the probe tip diameter from the boundary.

DASY/EASY - Parameters of Probe: ES3DV3 - SN:3258

Calibration Parameter Determined in Body Tissue Simulating Media

| f (MHz) ^c | Relative Permittivity ^F | Conductivity (S/m) ^F | ConvF X | ConvF Y | ConvF Z | Alpha ^G | Depth ^G (mm) | Unct. (k=2) |
|----------------------|------------------------------------|---------------------------------|---------|---------|---------|--------------------|-------------------------|-------------|
| 750 | 55.5 | 0.96 | 6.15 | 6.15 | 6.15 | 0.61 | 1.32 | ± 12.0 % |
| 835 | 55.2 | 0.97 | 6.11 | 6.11 | 6.11 | 0.80 | 1.15 | ± 12.0 % |
| 1750 | 53.4 | 1.49 | 4.83 | 4.83 | 4.83 | 0.47 | 1.74 | ± 12.0 % |
| 1900 | 53.3 | 1.52 | 4.61 | 4.61 | 4.61 | 0.55 | 1.59 | ± 12.0 % |
| 2450 | 52.7 | 1.95 | 4.14 | 4.14 | 4.14 | 0.80 | 1.11 | ± 12.0 % |
| 2600 | 52.5 | 2.16 | 3.91 | 3.91 | 3.91 | 0.80 | 1.00 | ± 12.0 % |

^c Frequency validity of ± 100 MHz only applies for DASY v4.4 and higher (see Page 2), else it is restricted to ± 50 MHz. The uncertainty is the RSS of the ConvF uncertainty at calibration frequency and the uncertainty for the indicated frequency band.

^F At frequencies below 3 GHz, the validity of tissue parameters (ϵ and σ) can be relaxed to ± 10% if liquid compensation formula is applied to measured SAR values. At frequencies above 3 GHz, the validity of tissue parameters (ϵ and σ) is restricted to ± 5%. The uncertainty is the RSS of the ConvF uncertainty for indicated target tissue parameters.

^G Alpha/Depth are determined during calibration. SPEAG warrants that the remaining deviation due to the boundary effect after compensation is always less than ± 1% for frequencies below 3 GHz and below ± 2% for frequencies between 3-6 GHz at any distance larger than half the probe tip diameter from the boundary.

Frequency Response of E-Field (TEM-Cell: ifi110 EXX, Waveguide: R22)

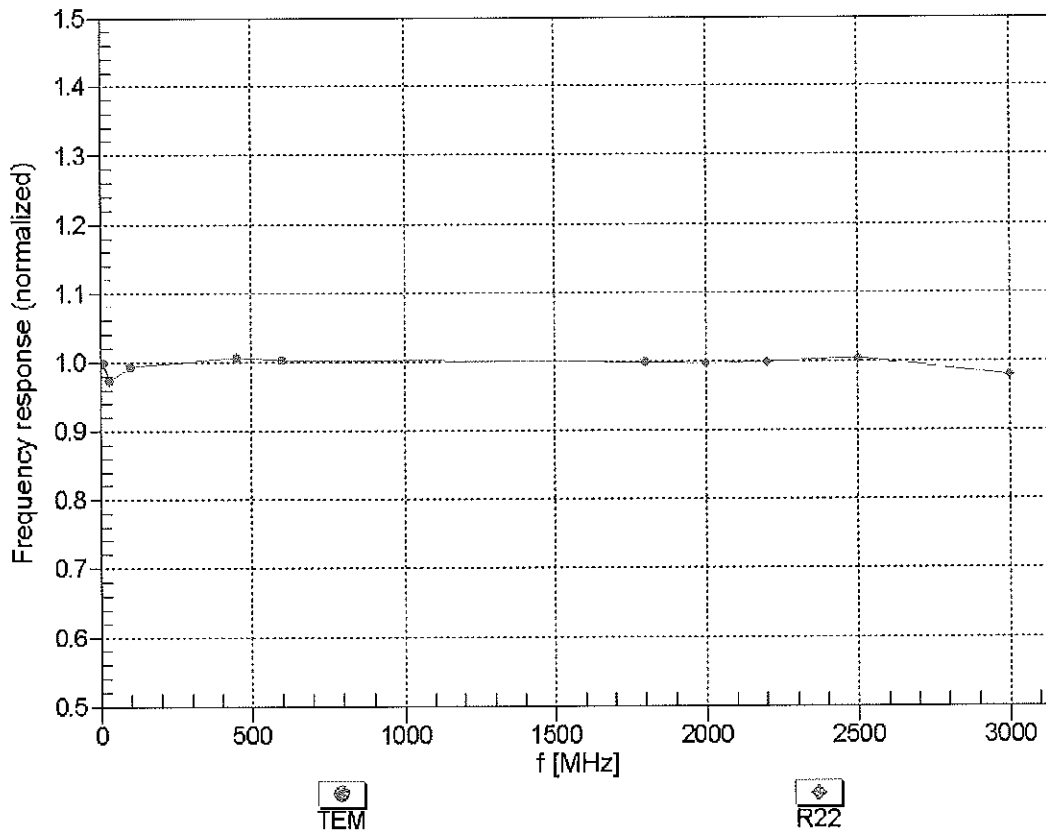

Uncertainty of Frequency Response of E-field: $\pm 6.3\%$ (k=2)

Receiving Pattern (ϕ), $\theta = 0^\circ$

f=600 MHz,TEM

f=1800 MHz,R22

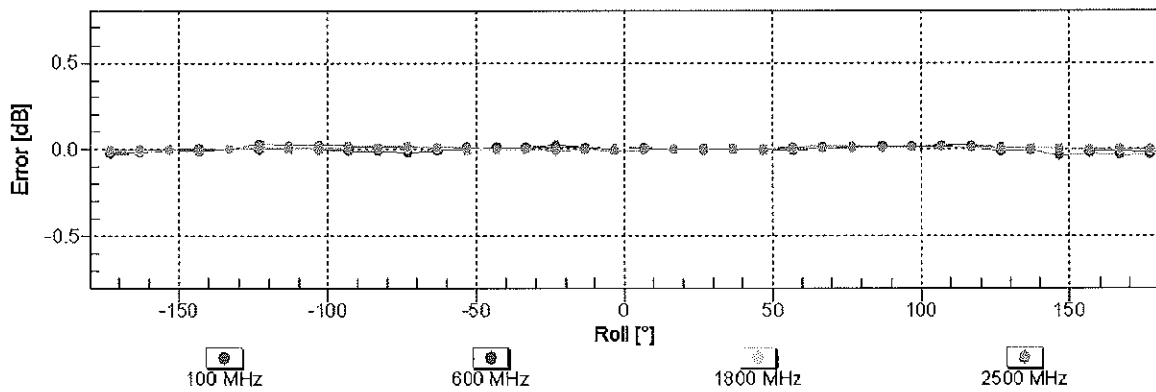
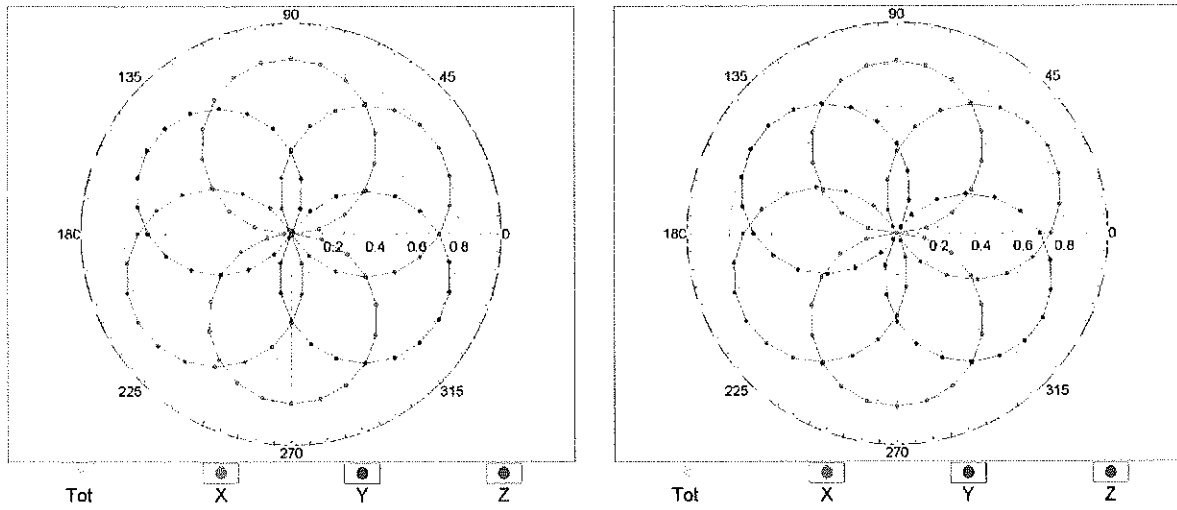

Uncertainty of Axial Isotropy Assessment: $\pm 0.5\%$ ($k=2$)

Dynamic Range f(SAR_{head}) (TEM cell , f_{eval}= 1900 MHz)

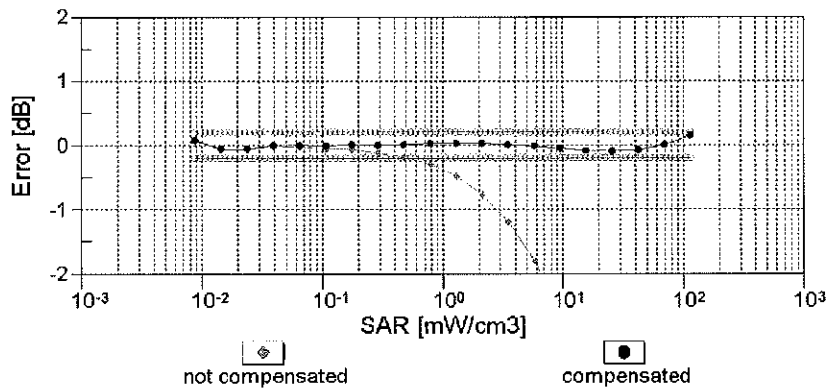
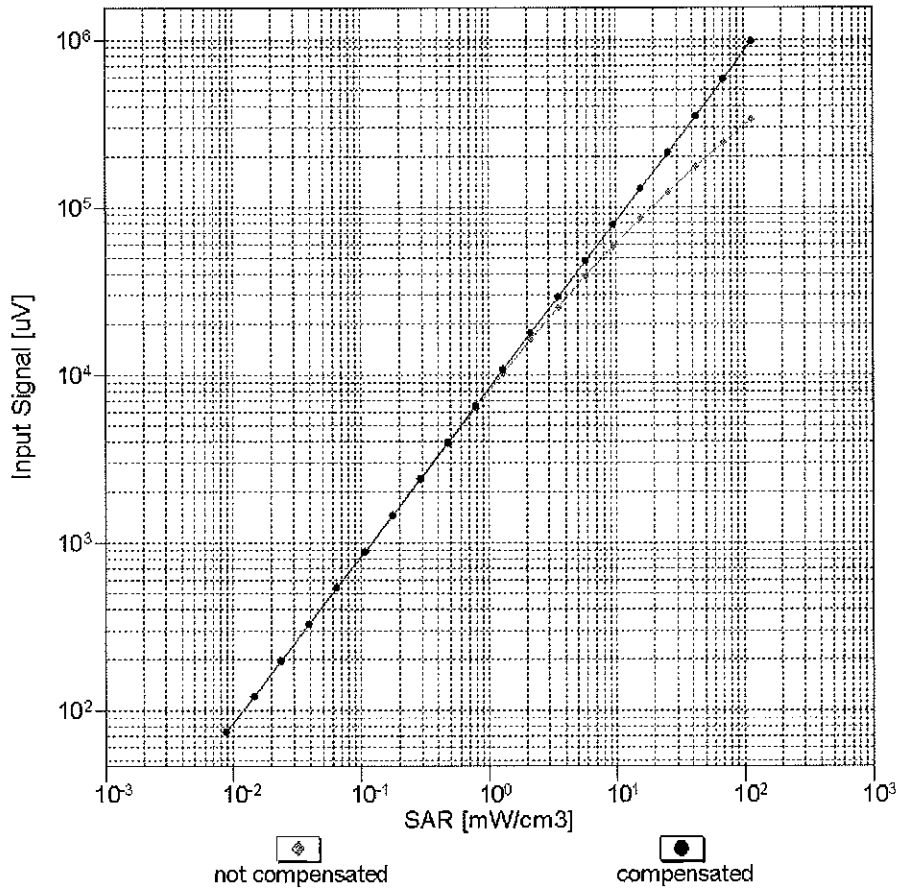

Uncertainty of Linearity Assessment: ± 0.6% (k=2)

Conversion Factor Assessment

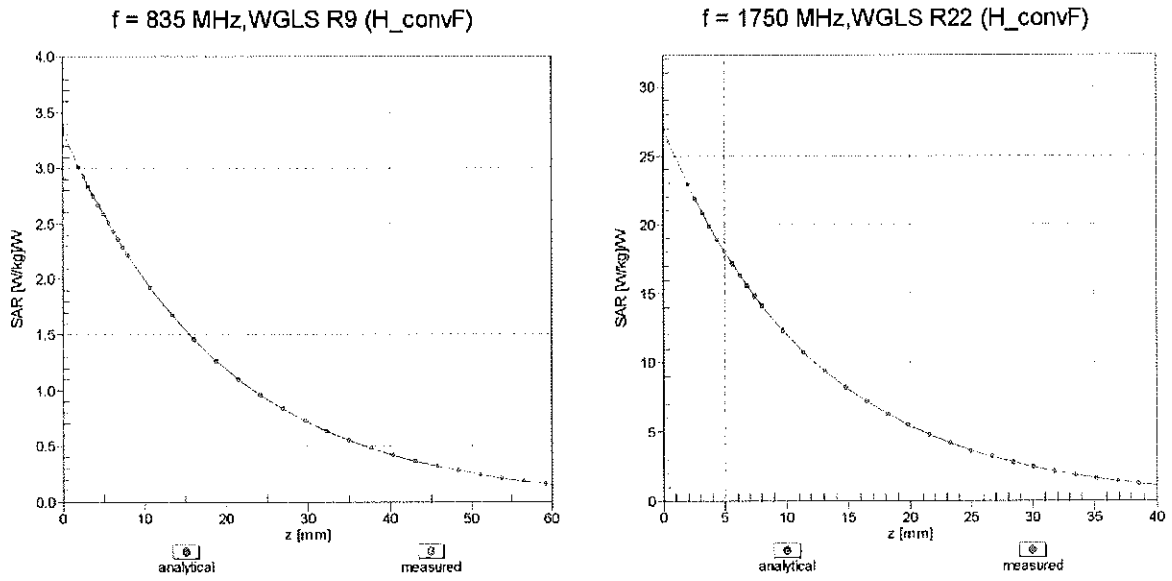

Deviation from Isotropy in Liquid Error (ϕ, ϑ), f = 900 MHz

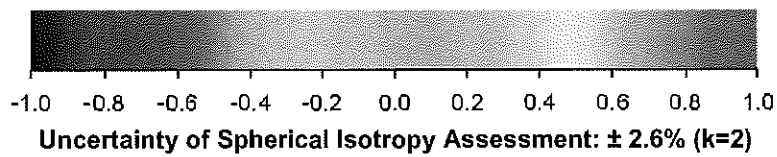
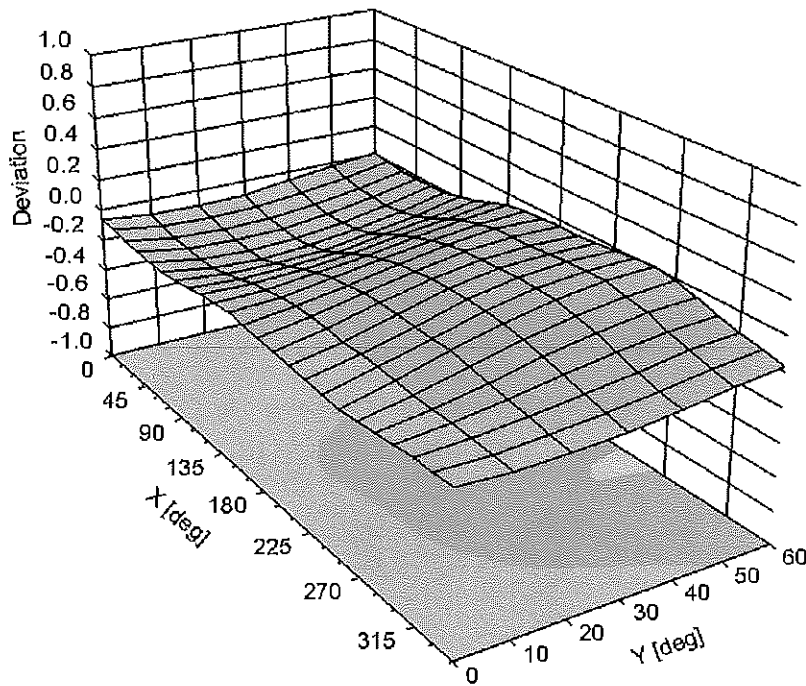

DASY/EASY - Parameters of Probe: ES3DV3 - SN:3258

Other Probe Parameters

| | |
|---|------------|
| Sensor Arrangement | Triangular |
| Connector Angle (°) | -123.1 |
| Mechanical Surface Detection Mode | enabled |
| Optical Surface Detection Mode | disabled |
| Probe Overall Length | 337 mm |
| Probe Body Diameter | 10 mm |
| Tip Length | 10 mm |
| Tip Diameter | 4 mm |
| Probe Tip to Sensor X Calibration Point | 2 mm |
| Probe Tip to Sensor Y Calibration Point | 2 mm |
| Probe Tip to Sensor Z Calibration Point | 2 mm |
| Recommended Measurement Distance from Surface | 3 mm |



Accredited by the Swiss Accreditation Service (SAS)
The Swiss Accreditation Service is one of the signatories to the EA
Multilateral Agreement for the recognition of calibration certificates

Accreditation No.: **SCS 108**

Client **PC Test**

Certificate No: **ES3-3319_Apr14**

CALIBRATION CERTIFICATE

Object **ES3DV3 - SN:3319**

Calibration procedure(s) **QA CAL-01.v9, QA CAL-23.v5, QA CAL-25.v6
Calibration procedure for dosimetric E-field probes**

*CCV
5/7/14*

Calibration date: **April 17, 2014**

This calibration certificate documents the traceability to national standards, which realize the physical units of measurements (SI).
The measurements and the uncertainties with confidence probability are given on the following pages and are part of the certificate.

All calibrations have been conducted in the closed laboratory facility: environment temperature (22 ± 3)°C and humidity < 70%.

Calibration Equipment used (M&TE critical for calibration)

| Primary Standards | ID | Cal Date (Certificate No.) | Scheduled Calibration |
|----------------------------|-----------------|-----------------------------------|------------------------|
| Power meter E4419B | GB41293874 | 03-Apr-14 (No. 217-01911) | Apr-15 |
| Power sensor E4412A | MY41498087 | 03-Apr-14 (No. 217-01911) | Apr-15 |
| Reference 3 dB Attenuator | SN: S5054 (3c) | 03-Apr-14 (No. 217-01915) | Apr-15 |
| Reference 20 dB Attenuator | SN: S5277 (20x) | 03-Apr-14 (No. 217-01919) | Apr-15 |
| Reference 30 dB Attenuator | SN: S5129 (30b) | 03-Apr-14 (No. 217-01920) | Apr-15 |
| Reference Probe ES3DV2 | SN: 3013 | 30-Dec-13 (No. ES3-3013_Dec13) | Dec-14 |
| DAE4 | SN: 660 | 13-Dec-13 (No. DAE4-660_Dec13) | Dec-14 |
| Secondary Standards | ID | Check Date (in house) | Scheduled Check |
| RF generator HP 8648C | US3642U01700 | 4-Aug-99 (in house check Apr-13) | In house check: Apr-16 |
| Network Analyzer HP 8753E | US37390585 | 18-Oct-01 (in house check Oct-13) | In house check: Oct-14 |

| | | | |
|----------------|-------------------------|-----------------------------------|---------------|
| Calibrated by: | Name Claudio Leubler | Function Laboratory Technician | Signature |
| Approved by: | Katja Pokovic | Technical Manager | |

Issued: April 21, 2014

This calibration certificate shall not be reproduced except in full without written approval of the laboratory.



Accredited by the Swiss Accreditation Service (SAS)

Accreditation No.: SCS 108

The Swiss Accreditation Service is one of the signatories to the EA
Multilateral Agreement for the recognition of calibration certificates

Glossary:

| | |
|--------------------------|---|
| TSL | tissue simulating liquid |
| NORM _{x,y,z} | sensitivity in free space |
| ConvF | sensitivity in TSL / NORM _{x,y,z} |
| DCP | diode compression point |
| CF | crest factor (1/duty_cycle) of the RF signal |
| A, B, C, D | modulation dependent linearization parameters |
| Polarization φ | φ rotation around probe axis |
| Polarization ϑ | ϑ rotation around an axis that is in the plane normal to probe axis (at measurement center), i.e., $\vartheta = 0$ is normal to probe axis |
| Connector Angle | information used in DASY system to align probe sensor X to the robot coordinate system |

Calibration is Performed According to the Following Standards:

- IEEE Std 1528-2013, "IEEE Recommended Practice for Determining the Peak Spatial-Averaged Specific Absorption Rate (SAR) in the Human Head from Wireless Communications Devices: Measurement Techniques", June 2013
- IEC 62209-1, "Procedure to measure the Specific Absorption Rate (SAR) for hand-held devices used in close proximity to the ear (frequency range of 300 MHz to 3 GHz)", February 2005

Methods Applied and Interpretation of Parameters:

- NORM_{x,y,z}**: Assessed for E-field polarization $\vartheta = 0$ ($f \leq 900$ MHz in TEM-cell; $f > 1800$ MHz: R22 waveguide). NORM_{x,y,z} are only intermediate values, i.e., the uncertainties of NORM_{x,y,z} does not affect the E²-field uncertainty inside TSL (see below ConvF).
- NORM(f)_{x,y,z}** = NORM_{x,y,z} * frequency_response (see Frequency Response Chart). This linearization is implemented in DASY4 software versions later than 4.2. The uncertainty of the frequency response is included in the stated uncertainty of ConvF.
- DCP_{x,y,z}**: DCP are numerical linearization parameters assessed based on the data of power sweep with CW signal (no uncertainty required). DCP does not depend on frequency nor media.
- PAR**: PAR is the Peak to Average Ratio that is not calibrated but determined based on the signal characteristics
- A_{x,y,z}; B_{x,y,z}; C_{x,y,z}; D_{x,y,z}; VR_{x,y,z}; A, B, C, D** are numerical linearization parameters assessed based on the data of power sweep for specific modulation signal. The parameters do not depend on frequency nor media. VR is the maximum calibration range expressed in RMS voltage across the diode.
- ConvF and Boundary Effect Parameters**: Assessed in flat phantom using E-field (or Temperature Transfer Standard for $f \leq 800$ MHz) and inside waveguide using analytical field distributions based on power measurements for $f > 800$ MHz. The same setups are used for assessment of the parameters applied for boundary compensation (alpha, depth) of which typical uncertainty values are given. These parameters are used in DASY4 software to improve probe accuracy close to the boundary. The sensitivity in TSL corresponds to NORM_{x,y,z} * ConvF whereby the uncertainty corresponds to that given for ConvF. A frequency dependent ConvF is used in DASY version 4.4 and higher which allows extending the validity from ± 50 MHz to ± 100 MHz.
- Spherical isotropy (3D deviation from isotropy)**: in a field of low gradients realized using a flat phantom exposed by a patch antenna.
- Sensor Offset**: The sensor offset corresponds to the offset of virtual measurement center from the probe tip (on probe axis). No tolerance required.
- Connector Angle**: The angle is assessed using the information gained by determining the NORM_x (no uncertainty required).

Probe ES3DV3

SN:3319

| | |
|---------------|------------------|
| Manufactured: | January 10, 2012 |
| Repaired: | April 11, 2014 |
| Calibrated: | April 17, 2014 |

Calibrated for DASY/EASY Systems
(Note: non-compatible with DASY2 system!)

DASY/EASY - Parameters of Probe: ES3DV3 - SN:3319

Basic Calibration Parameters

| | Sensor X | Sensor Y | Sensor Z | Unc (k=2) |
|---|----------|----------|----------|--------------|
| Norm ($\mu\text{V}/(\text{V}/\text{m})^2$) ^A | 1.11 | 1.08 | 1.15 | $\pm 10.1\%$ |
| DCP (mV) ^B | 102.6 | 104.2 | 103.7 | |

Modulation Calibration Parameters

| UID | Communication System Name | | A dB | B dB $\sqrt{\mu\text{V}}$ | C | D dB | VR mV | Unc ^E (k=2) |
|---------------|--|---|---------|------------------------------|------|---------|----------|---------------------------|
| 0 | CW | X | 0.0 | 0.0 | 1.0 | 0.00 | 199.6 | $\pm 3.5\%$ |
| | | Y | 0.0 | 0.0 | 1.0 | | 188.8 | |
| | | Z | 0.0 | 0.0 | 1.0 | | 178.5 | |
| 10010- CAA | SAR Validation (Square, 100ms, 10ms) | X | 3.31 | 63.3 | 12.9 | 10.00 | 42.6 | $\pm 2.2\%$ |
| | | Y | 5.10 | 68.0 | 14.1 | | 38.8 | |
| | | Z | 2.84 | 61.7 | 12.1 | | 44.3 | |
| 10011- CAB | UMTS-FDD (WCDMA) | X | 3.30 | 66.9 | 18.4 | 2.91 | 136.7 | $\pm 0.5\%$ |
| | | Y | 3.32 | 67.1 | 18.4 | | 127.0 | |
| | | Z | 3.45 | 68.0 | 19.1 | | 145.1 | |
| 10012- CAA | IEEE 802.11b WiFi 2.4 GHz (DSSS, 1 Mbps) | X | 3.12 | 69.3 | 19.0 | 1.87 | 138.7 | $\pm 0.7\%$ |
| | | Y | 3.22 | 70.2 | 19.3 | | 127.0 | |
| | | Z | 3.40 | 71.3 | 19.9 | | 146.4 | |
| 10021- DAB | GSM-FDD (TDMA, GMSK) | X | 25.66 | 99.7 | 28.3 | 9.39 | 139.0 | $\pm 1.4\%$ |
| | | Y | 16.30 | 92.5 | 25.7 | | 141.7 | |
| | | Z | 25.20 | 99.5 | 28.1 | | 144.9 | |
| 10023- DAB | GPRS-FDD (TDMA, GMSK, TN 0) | X | 25.81 | 100.0 | 28.5 | 9.57 | 128.3 | $\pm 2.2\%$ |
| | | Y | 13.99 | 89.5 | 24.6 | | 129.0 | |
| | | Z | 25.39 | 99.7 | 28.3 | | 141.2 | |
| 10024- DAB | GPRS-FDD (TDMA, GMSK, TN 0-1) | X | 37.04 | 99.8 | 25.7 | 6.56 | 131.4 | $\pm 2.2\%$ |
| | | Y | 37.62 | 99.7 | 25.0 | | 139.6 | |
| | | Z | 38.36 | 99.8 | 25.3 | | 145.5 | |
| 10027- DAB | GPRS-FDD (TDMA, GMSK, TN 0-1-2) | X | 48.04 | 99.6 | 23.8 | 4.80 | 144.6 | $\pm 1.9\%$ |
| | | Y | 29.62 | 94.2 | 22.1 | | 129.3 | |
| | | Z | 43.87 | 99.7 | 24.0 | | 129.9 | |
| 10028- DAB | GPRS-FDD (TDMA, GMSK, TN 0-1-2-3) | X | 54.95 | 99.9 | 22.9 | 3.55 | 149.6 | $\pm 1.7\%$ |
| | | Y | 57.76 | 99.6 | 22.2 | | 138.2 | |
| | | Z | 54.27 | 99.8 | 22.7 | | 137.3 | |
| 10032- CAA | IEEE 802.15.1 Bluetooth (GFSK, DH5) | X | 44.58 | 99.9 | 21.1 | 1.16 | 134.6 | $\pm 1.7\%$ |
| | | Y | 96.74 | 98.9 | 18.8 | | 149.0 | |
| | | Z | 59.46 | 99.9 | 20.4 | | 149.1 | |
| 10039- CAB | CDMA2000 (1xRTT, RC1) | X | 4.70 | 66.3 | 18.7 | 4.57 | 130.9 | $\pm 0.9\%$ |
| | | Y | 4.85 | 67.1 | 19.0 | | 147.5 | |
| | | Z | 4.88 | 67.3 | 19.3 | | 147.2 | |

| | | | | | | | | |
|-----------|---|---|-------|------|------|------|-------|--------|
| 10081-CAB | CDMA2000 (1xRTT, RC3) | X | 3.90 | 65.8 | 18.4 | 3.97 | 130.0 | ±0.7 % |
| | | Y | 4.00 | 66.5 | 18.6 | | 140.8 | |
| | | Z | 3.99 | 66.5 | 18.7 | | 142.5 | |
| 10098-CAB | UMTS-FDD (HSUPA, Subtest 2) | X | 4.64 | 66.7 | 18.6 | 3.98 | 143.1 | ±0.9 % |
| | | Y | 4.58 | 66.5 | 18.4 | | 132.8 | |
| | | Z | 4.60 | 66.7 | 18.6 | | 131.9 | |
| 10100-CAB | LTE-FDD (SC-FDMA, 100% RB, 20 MHz, QPSK) | X | 6.32 | 67.1 | 19.5 | 5.67 | 125.8 | ±1.4 % |
| | | Y | 6.41 | 67.4 | 19.5 | | 138.4 | |
| | | Z | 6.51 | 67.9 | 19.9 | | 143.6 | |
| 10108-CAB | LTE-FDD (SC-FDMA, 100% RB, 10 MHz, QPSK) | X | 6.48 | 67.7 | 20.0 | 5.80 | 148.0 | ±1.4 % |
| | | Y | 6.28 | 66.9 | 19.4 | | 135.8 | |
| | | Z | 6.39 | 67.4 | 19.8 | | 141.0 | |
| 10110-CAB | LTE-FDD (SC-FDMA, 100% RB, 5 MHz, QPSK) | X | 6.17 | 67.2 | 19.8 | 5.75 | 141.0 | ±1.4 % |
| | | Y | 5.94 | 66.3 | 19.1 | | 132.2 | |
| | | Z | 6.08 | 67.0 | 19.6 | | 137.9 | |
| 10114-CAA | IEEE 802.11n (HT Greenfield, 13.5 Mbps, BPSK) | X | 10.35 | 69.2 | 21.5 | 8.10 | 133.6 | ±2.2 % |
| | | Y | 9.93 | 68.1 | 20.7 | | 124.5 | |
| | | Z | 10.29 | 69.2 | 21.5 | | 131.9 | |
| 10117-CAA | IEEE 802.11n (HT Mixed, 13.5 Mbps, BPSK) | X | 10.42 | 69.4 | 21.6 | 8.07 | 140.6 | ±2.2 % |
| | | Y | 9.93 | 68.1 | 20.7 | | 125.5 | |
| | | Z | 10.28 | 69.1 | 21.5 | | 132.6 | |
| 10151-CAB | LTE-TDD (SC-FDMA, 50% RB, 20 MHz, QPSK) | X | 11.18 | 78.2 | 27.5 | 9.28 | 143.6 | ±3.3 % |
| | | Y | 9.33 | 73.0 | 24.5 | | 124.3 | |
| | | Z | 10.45 | 76.4 | 26.6 | | 132.7 | |
| 10154-CAB | LTE-FDD (SC-FDMA, 50% RB, 10 MHz, QPSK) | X | 6.16 | 67.2 | 19.8 | 5.75 | 145.7 | ±1.4 % |
| | | Y | 5.96 | 66.4 | 19.1 | | 133.0 | |
| | | Z | 6.08 | 66.9 | 19.6 | | 138.6 | |
| 10160-CAB | LTE-FDD (SC-FDMA, 50% RB, 15 MHz, QPSK) | X | 6.32 | 66.6 | 19.4 | 5.82 | 126.2 | ±1.4 % |
| | | Y | 6.40 | 66.9 | 19.4 | | 137.3 | |
| | | Z | 6.51 | 67.4 | 19.8 | | 143.8 | |
| 10169-CAB | LTE-FDD (SC-FDMA, 1 RB, 20 MHz, QPSK) | X | 5.12 | 67.3 | 20.0 | 5.73 | 147.9 | ±1.2 % |
| | | Y | 4.90 | 66.4 | 19.4 | | 134.4 | |
| | | Z | 5.07 | 67.2 | 20.0 | | 141.5 | |
| 10172-CAB | LTE-TDD (SC-FDMA, 1 RB, 20 MHz, QPSK) | X | 9.44 | 80.0 | 28.6 | 9.21 | 128.7 | ±3.3 % |
| | | Y | 8.63 | 77.8 | 27.1 | | 143.9 | |
| | | Z | 10.62 | 83.7 | 30.3 | | 148.2 | |
| 10175-CAB | LTE-FDD (SC-FDMA, 1 RB, 10 MHz, QPSK) | X | 5.04 | 66.9 | 19.8 | 5.72 | 140.4 | ±1.4 % |
| | | Y | 4.92 | 66.6 | 19.5 | | 133.7 | |
| | | Z | 5.01 | 66.9 | 19.8 | | 134.9 | |
| 10181-CAB | LTE-FDD (SC-FDMA, 1 RB, 15 MHz, QPSK) | X | 5.05 | 67.0 | 19.9 | 5.72 | 140.6 | ±1.4 % |
| | | Y | 4.90 | 66.5 | 19.4 | | 132.4 | |
| | | Z | 4.97 | 66.7 | 19.7 | | 134.1 | |

| | | | | | | | | |
|-----------|--|---|-------|------|------|------|-------|--------|
| 10193-CAA | IEEE 802.11n (HT Greenfield, 6.5 Mbps, BPSK) | X | 9.98 | 68.8 | 21.4 | 8.09 | 131.1 | ±2.5 % |
| | | Y | 10.00 | 68.8 | 21.2 | | 145.5 | |
| | | Z | 10.14 | 69.4 | 21.7 | | 144.7 | |
| 10196-CAA | IEEE 802.11n (HT Mixed, 6.5 Mbps, BPSK) | X | 9.99 | 68.9 | 21.5 | 8.10 | 132.0 | ±2.7 % |
| | | Y | 10.05 | 69.0 | 21.3 | | 148.1 | |
| | | Z | 10.16 | 69.5 | 21.8 | | 145.8 | |
| 10219-CAA | IEEE 802.11n (HT Mixed, 7.2 Mbps, BPSK) | X | 9.88 | 68.8 | 21.4 | 8.03 | 131.3 | ±2.5 % |
| | | Y | 9.96 | 69.0 | 21.3 | | 147.8 | |
| | | Z | 10.03 | 69.3 | 21.6 | | 144.7 | |
| 10222-CAA | IEEE 802.11n (HT Mixed, 15 Mbps, BPSK) | X | 10.34 | 69.3 | 21.6 | 8.06 | 137.1 | ±2.2 % |
| | | Y | 9.93 | 68.2 | 20.8 | | 127.8 | |
| | | Z | 10.07 | 68.6 | 21.2 | | 125.1 | |
| 10225-CAB | UMTS-FDD (HSPA+) | X | 6.97 | 66.8 | 19.4 | 5.97 | 133.6 | ±1.4 % |
| | | Y | 6.90 | 66.7 | 19.2 | | 129.7 | |
| | | Z | 7.14 | 67.5 | 19.8 | | 147.4 | |
| 10237-CAB | LTE-TDD (SC-FDMA, 1 RB, 10 MHz, QPSK) | X | 9.18 | 79.3 | 28.2 | 9.21 | 128.1 | ±3.5 % |
| | | Y | 8.54 | 77.6 | 27.0 | | 144.1 | |
| | | Z | 9.99 | 81.9 | 29.4 | | 141.7 | |
| 10252-CAB | LTE-TDD (SC-FDMA, 50% RB, 10 MHz, QPSK) | X | 9.65 | 75.1 | 26.1 | 9.24 | 126.1 | ±3.5 % |
| | | Y | 9.34 | 74.2 | 25.3 | | 141.3 | |
| | | Z | 10.46 | 77.6 | 27.3 | | 144.1 | |
| 10267-CAB | LTE-TDD (SC-FDMA, 100% RB, 10 MHz, QPSK) | X | 10.46 | 76.2 | 26.5 | 9.30 | 133.6 | ±3.5 % |
| | | Y | 9.23 | 72.7 | 24.4 | | 122.8 | |
| | | Z | 9.90 | 74.8 | 25.7 | | 123.8 | |
| 10274-CAB | UMTS-FDD (HSUPA, Subtest 5, 3GPP Rel8.10) | X | 6.04 | 67.1 | 19.0 | 4.87 | 149.9 | ±1.2 % |
| | | Y | 6.02 | 67.1 | 18.9 | | 142.8 | |
| | | Z | 6.00 | 67.1 | 19.0 | | 141.0 | |
| 10275-CAB | UMTS-FDD (HSUPA, Subtest 5, 3GPP Rel8.4) | X | 4.22 | 65.6 | 18.1 | 3.96 | 131.0 | ±0.9 % |
| | | Y | 4.49 | 66.9 | 18.6 | | 144.3 | |
| | | Z | 4.55 | 67.3 | 19.1 | | 147.0 | |
| 10291-AAB | CDMA2000, RC3, SO55, Full Rate | X | 3.74 | 67.2 | 18.9 | 3.46 | 145.6 | ±0.5 % |
| | | Y | 3.66 | 66.8 | 18.5 | | 136.7 | |
| | | Z | 3.71 | 67.2 | 18.9 | | 136.5 | |
| 10292-AAB | CDMA2000, RC3, SO32, Full Rate | X | 3.65 | 67.0 | 18.7 | 3.39 | 147.2 | ±0.7 % |
| | | Y | 3.61 | 66.8 | 18.4 | | 139.6 | |
| | | Z | 3.64 | 67.1 | 18.8 | | 139.6 | |
| 10297-AAA | LTE-FDD (SC-FDMA, 50% RB, 20 MHz, QPSK) | X | 6.37 | 67.3 | 19.8 | 5.81 | 140.5 | ±1.4 % |
| | | Y | 6.24 | 66.8 | 19.3 | | 134.0 | |
| | | Z | 6.33 | 67.2 | 19.8 | | 134.8 | |
| 10311-AAA | LTE-FDD (SC-FDMA, 100% RB, 15 MHz, QPSK) | X | 7.00 | 68.0 | 20.2 | 6.06 | 146.8 | ±1.7 % |
| | | Y | 6.82 | 67.4 | 19.7 | | 140.3 | |
| | | Z | 6.90 | 67.8 | 20.1 | | 141.4 | |

| | | | | | | | | |
|-----------|---|---|------|------|------|------|-------|--------|
| 10315-AAA | IEEE 802.11b WiFi 2.4 GHz (DSSS, 1 Mbps, 96pc duty cycle) | X | 2.85 | 68.5 | 18.8 | 1.71 | 129.5 | ±0.5 % |
| | | Y | 3.09 | 70.0 | 19.2 | | 146.1 | |
| | | Z | 3.15 | 70.6 | 19.8 | | 146.8 | |
| 10403-AAB | CDMA2000 (1xEV-DO, Rev. 0) | X | 4.73 | 67.9 | 18.7 | 3.76 | 137.5 | ±0.5 % |
| | | Y | 4.77 | 68.3 | 18.7 | | 126.5 | |
| | | Z | 4.77 | 68.1 | 18.8 | | 128.1 | |
| 10404-AAB | CDMA2000 (1xEV-DO, Rev. A) | X | 4.55 | 67.6 | 18.6 | 3.77 | 132.0 | ±0.7 % |
| | | Y | 4.89 | 69.1 | 19.1 | | 148.8 | |
| | | Z | 4.90 | 69.1 | 19.3 | | 148.0 | |

The reported uncertainty of measurement is stated as the standard uncertainty of measurement multiplied by the coverage factor k=2, which for a normal distribution corresponds to a coverage probability of approximately 95%.

^A The uncertainties of NormX,Y,Z do not affect the E²-field uncertainty inside TSL (see Pages 8 and 9).
^B Numerical linearization parameter: uncertainty not required.
^E Uncertainty is determined using the max. deviation from linear response applying rectangular distribution and is expressed for the square of the field value.

DASY/EASY - Parameters of Probe: ES3DV3 - SN:3319

Calibration Parameter Determined in Head Tissue Simulating Media

| f (MHz) ^C | Relative Permittivity ^F | Conductivity (S/m) ^F | ConvF X | ConvF Y | ConvF Z | Alpha ^G | Depth ^G (mm) | Unct. (k=2) |
|----------------------|------------------------------------|---------------------------------|---------|---------|---------|--------------------|-------------------------|-------------|
| 750 | 41.9 | 0.89 | 6.48 | 6.48 | 6.48 | 0.28 | 2.09 | ± 12.0 % |
| 835 | 41.5 | 0.90 | 6.27 | 6.27 | 6.27 | 0.34 | 1.72 | ± 12.0 % |
| 1750 | 40.1 | 1.37 | 5.24 | 5.24 | 5.24 | 0.80 | 1.14 | ± 12.0 % |
| 1900 | 40.0 | 1.40 | 5.05 | 5.05 | 5.05 | 0.72 | 1.24 | ± 12.0 % |
| 2450 | 39.2 | 1.80 | 4.45 | 4.45 | 4.45 | 0.77 | 1.23 | ± 12.0 % |
| 2600 | 39.0 | 1.96 | 4.29 | 4.29 | 4.29 | 0.80 | 1.27 | ± 12.0 % |

^C Frequency validity of ± 100 MHz only applies for DASY v4.4 and higher (see Page 2), else it is restricted to ± 50 MHz. The uncertainty is the RSS of the ConvF uncertainty at calibration frequency and the uncertainty for the indicated frequency band.

^F At frequencies below 3 GHz, the validity of tissue parameters (ϵ and σ) can be relaxed to ± 10% if liquid compensation formula is applied to measured SAR values. At frequencies above 3 GHz, the validity of tissue parameters (ϵ and σ) is restricted to ± 5%. The uncertainty is the RSS of the ConvF uncertainty for indicated target tissue parameters.

^G Alpha/Depth are determined during calibration. SPEAG warrants that the remaining deviation due to the boundary effect after compensation is always less than ± 1% for frequencies below 3 GHz and below ± 2% for frequencies between 3-6 GHz at any distance larger than half the probe tip diameter from the boundary.

DASY/EASY - Parameters of Probe: ES3DV3 - SN:3319

Calibration Parameter Determined in Body Tissue Simulating Media

| f (MHz) ^c | Relative Permittivity ^F | Conductivity (S/m) ^F | ConvF X | ConvF Y | ConvF Z | Alpha ^G | Depth ^G (mm) | Unct. (k=2) |
|----------------------|------------------------------------|---------------------------------|---------|---------|---------|--------------------|-------------------------|-------------|
| 750 | 55.5 | 0.96 | 6.25 | 6.25 | 6.25 | 0.39 | 1.65 | ± 12.0 % |
| 835 | 55.2 | 0.97 | 6.18 | 6.18 | 6.18 | 0.56 | 1.37 | ± 12.0 % |
| 1750 | 53.4 | 1.49 | 4.85 | 4.85 | 4.85 | 0.57 | 1.46 | ± 12.0 % |
| 1900 | 53.3 | 1.52 | 4.67 | 4.67 | 4.67 | 0.53 | 1.58 | ± 12.0 % |
| 2450 | 52.7 | 1.95 | 4.24 | 4.24 | 4.24 | 0.74 | 1.10 | ± 12.0 % |
| 2600 | 52.5 | 2.16 | 4.05 | 4.05 | 4.05 | 0.80 | 1.02 | ± 12.0 % |

^c Frequency validity of ± 100 MHz only applies for DASY v4.4 and higher (see Page 2), else it is restricted to ± 50 MHz. The uncertainty is the RSS of the ConvF uncertainty at calibration frequency and the uncertainty for the indicated frequency band.

^F At frequencies below 3 GHz, the validity of tissue parameters (ϵ and σ) can be relaxed to ± 10% if liquid compensation formula is applied to measured SAR values. At frequencies above 3 GHz, the validity of tissue parameters (ϵ and σ) is restricted to ± 5%. The uncertainty is the RSS of the ConvF uncertainty for indicated target tissue parameters.

^G Alpha/Depth are determined during calibration. SPEAG warrants that the remaining deviation due to the boundary effect after compensation is always less than ± 1% for frequencies below 3 GHz and below ± 2% for frequencies between 3-6 GHz at any distance larger than half the probe tip diameter from the boundary.

Frequency Response of E-Field (TEM-Cell:ifi110 EXX, Waveguide: R22)

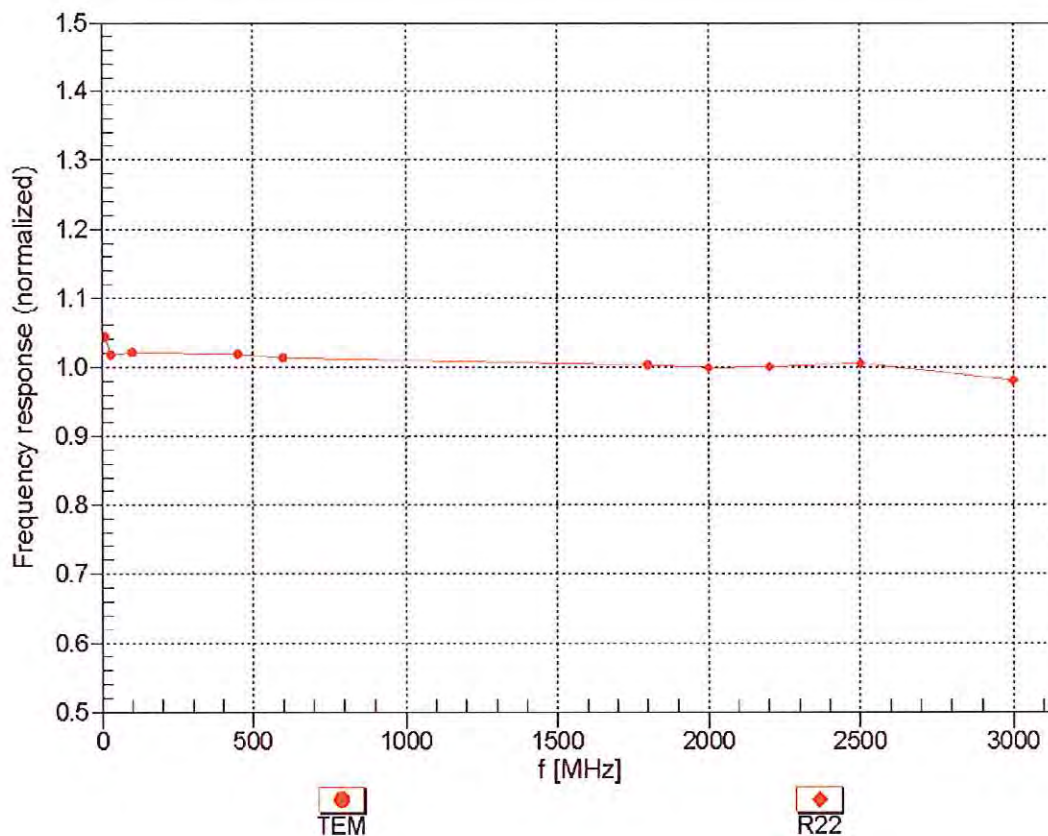

Uncertainty of Frequency Response of E-field: $\pm 6.3\%$ (k=2)

Receiving Pattern (ϕ), $\vartheta = 0^\circ$

f=600 MHz,TEM

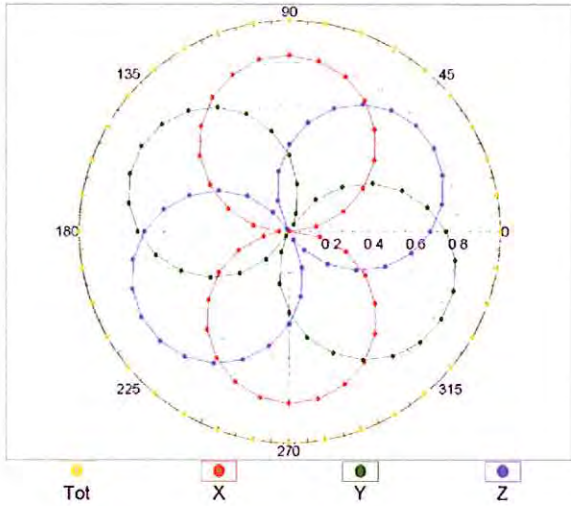

f=1800 MHz,R22

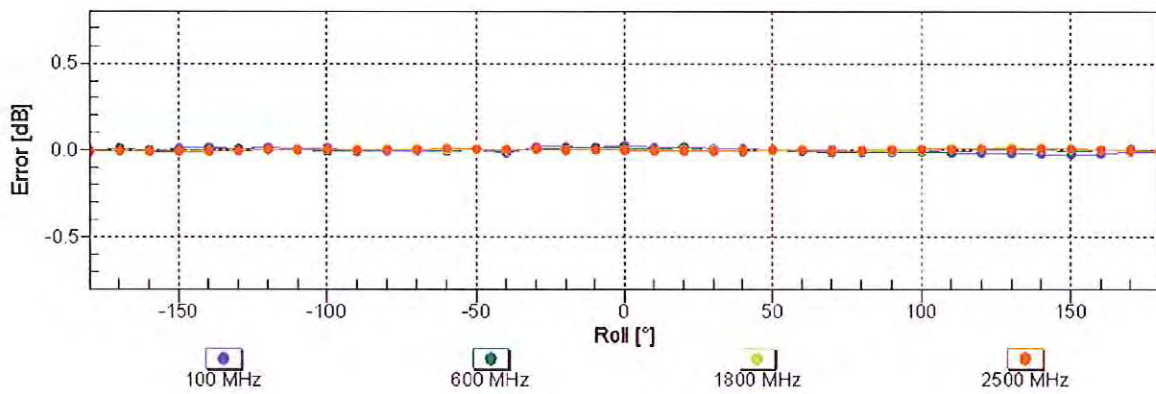
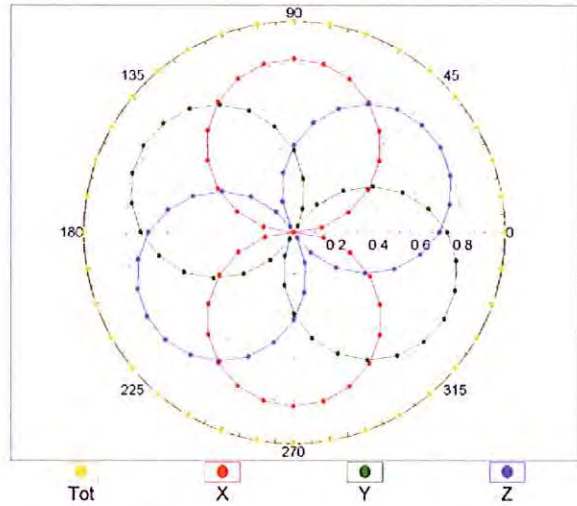

Uncertainty of Axial Isotropy Assessment: $\pm 0.5\%$ (k=2)

Dynamic Range $f(SAR_{head})$ (TEM cell , $f_{eval}= 1900$ MHz)

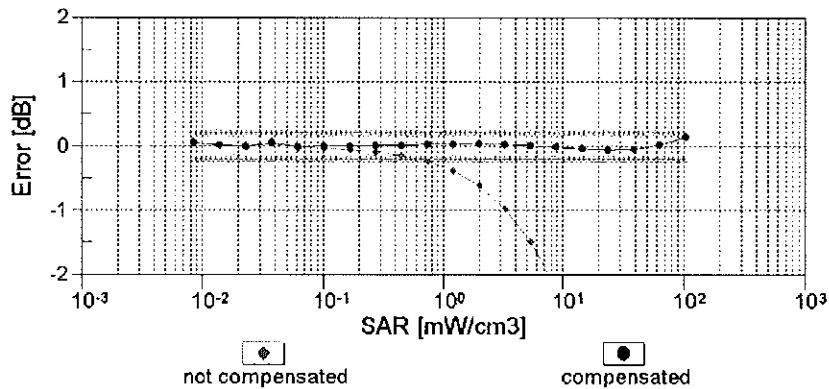
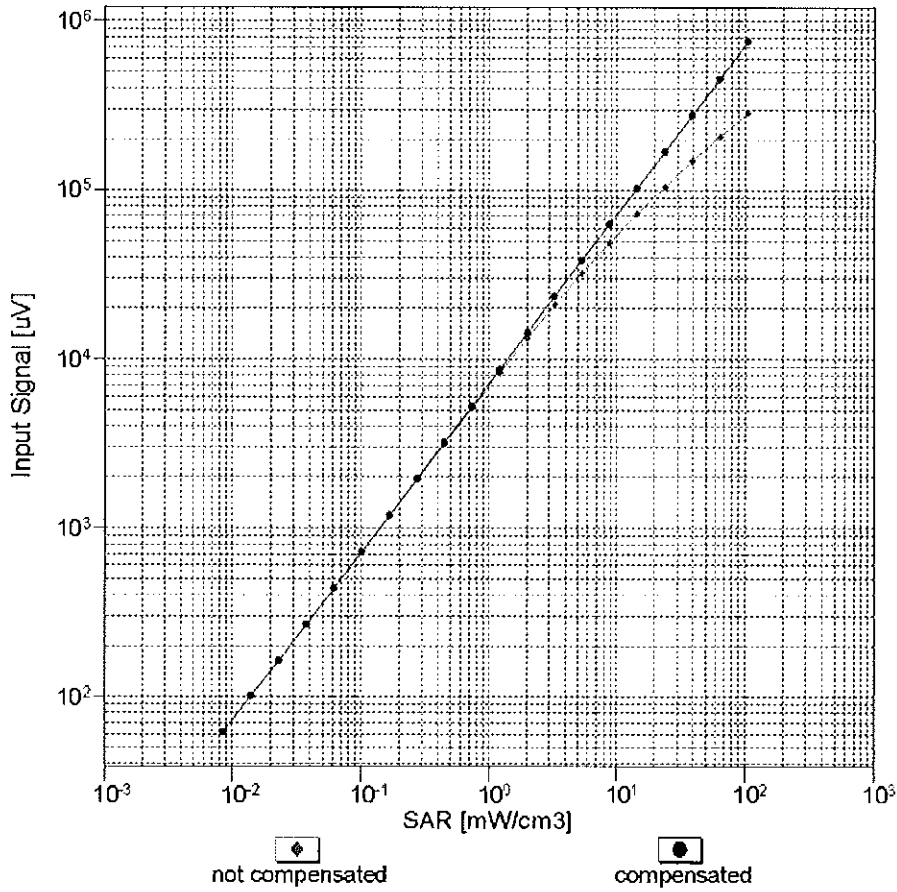

Uncertainty of Linearity Assessment: $\pm 0.6\%$ (k=2)

Conversion Factor Assessment

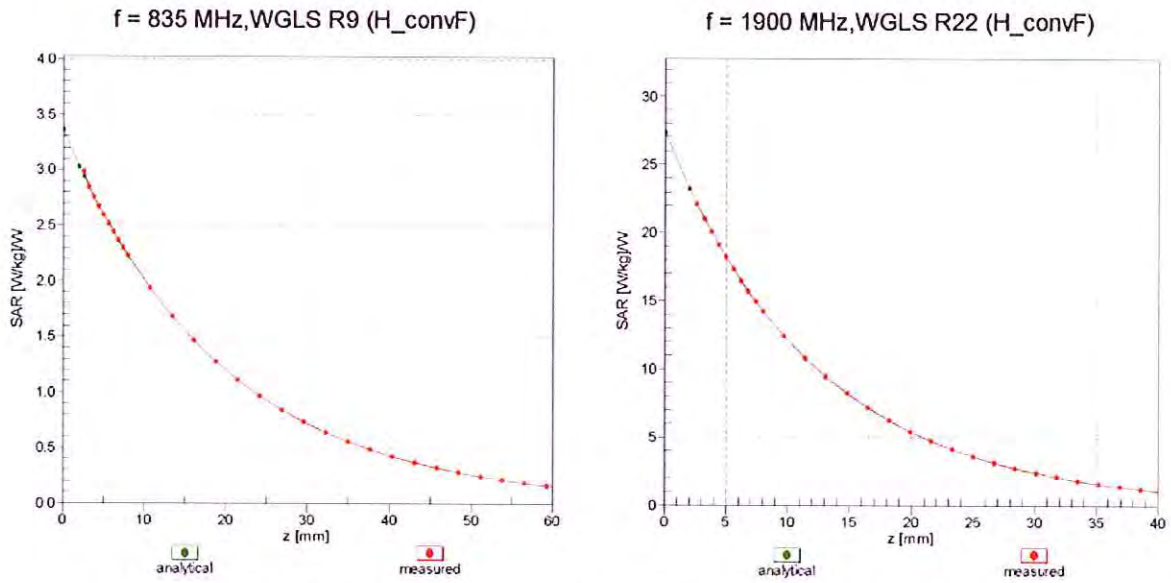

Deviation from Isotropy in Liquid Error (ϕ, ϑ), f = 900 MHz

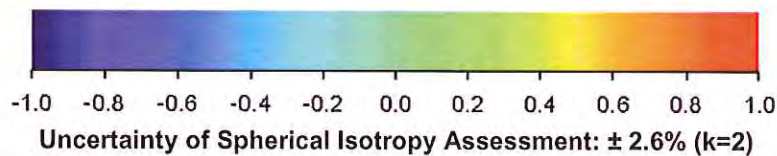
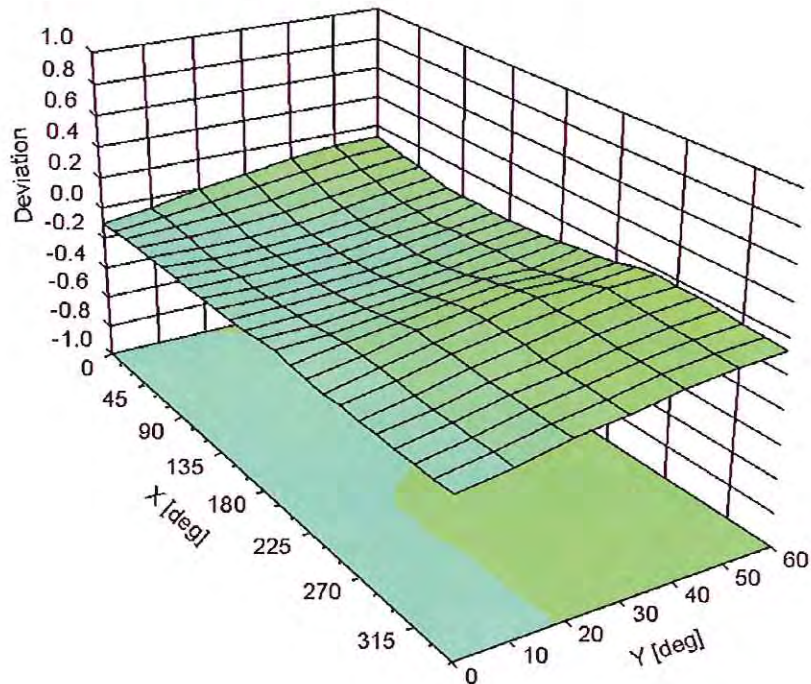

DASY/EASY - Parameters of Probe: ES3DV3 - SN:3319**Other Probe Parameters**

| | |
|---|------------|
| Sensor Arrangement | Triangular |
| Connector Angle (°) | -119.8 |
| Mechanical Surface Detection Mode | enabled |
| Optical Surface Detection Mode | disabled |
| Probe Overall Length | 337 mm |
| Probe Body Diameter | 10 mm |
| Tip Length | 10 mm |
| Tip Diameter | 4 mm |
| Probe Tip to Sensor X Calibration Point | 2 mm |
| Probe Tip to Sensor Y Calibration Point | 2 mm |
| Probe Tip to Sensor Z Calibration Point | 2 mm |
| Recommended Measurement Distance from Surface | 3 mm |

**Calibration Laboratory of
Schmid & Partner
Engineering AG**
Zeughausstrasse 43, 8004 Zurich, Switzerland



SCS Schweizerischer Kalibrierdienst
Service suisse d'étalonnage
Servizio svizzero di taratura
Swiss Calibration Service

Accredited by the Swiss Accreditation Service (SAS)
The Swiss Accreditation Service is one of the signatories to the EA
Multilateral Agreement for the recognition of calibration certificates

Accreditation No.: **SCS 108**

Client **PC Test**

Certificate No: **EX3-3914_Oct13**

CALIBRATION CERTIFICATE

Object **EX3DV4 - SN:3914**

Calibration procedure(s) **DIA CAL-01 v3, GA CAL-14 v4, GA CAL-23 v5, DIA CAL-25 v6
Calibration procedure for dielectric E-field probes**

Calibration date: **October 23, 2013** VCC
11/20/2013

This calibration certificate documents the traceability to national standards, which realize the physical units of measurements (SI).
The measurements and the uncertainties with confidence probability are given on the following pages and are part of the certificate.

All calibrations have been conducted in the closed laboratory facility: environment temperature (22 ± 3)°C and humidity < 70%.

Calibration Equipment used (M&TE critical for calibration)

| Primary Standards | ID | Cal Date (Certificate No.) | Scheduled Calibration |
|----------------------------|-----------------|-----------------------------------|------------------------|
| Power meter E4419B | GB41293874 | 04-Apr-13 (No. 217-01733) | Apr-14 |
| Power sensor E4412A | MY41498087 | 04-Apr-13 (No. 217-01733) | Apr-14 |
| Reference 3 dB Attenuator | SN: S5054 (3c) | 04-Apr-13 (No. 217-01737) | Apr-14 |
| Reference 20 dB Attenuator | SN: S5277 (20x) | 04-Apr-13 (No. 217-01735) | Apr-14 |
| Reference 30 dB Attenuator | SN: S5129 (30b) | 04-Apr-13 (No. 217-01738) | Apr-14 |
| Reference Probe ES3DV2 | SN: 3013 | 28-Dec-12 (No. ES3-3013_Dec12) | Dec-13 |
| DAE4 | SN: 660 | 4-Sep-13 (No. DAE4-660_Sep13) | Sep-14 |
| Secondary Standards | ID | Check Date (in house) | Scheduled Check |
| RF generator HP 8648C | US3642U01700 | 4-Aug-99 (in house check Apr-13) | In house check: Apr-15 |
| Network Analyzer HP 8753E | US37390585 | 18-Oct-01 (in house check Oct-13) | In house check: Oct-14 |

| | | | |
|----------------|------------------------------|--|----------------------|
| Calibrated by: | Name Leif Klysner | Function Laboratory Technician | Signature |
| Approved by: | Name Katja Pokovic | Function Technical Manager | Signature |

Issued: October 25, 2013

This calibration certificate shall not be reproduced except in full without written approval of the laboratory.

PCT # 81072



Accredited by the Swiss Accreditation Service (SAS)
The Swiss Accreditation Service is one of the signatories to the EA
Multilateral Agreement for the recognition of calibration certificates

Accreditation No.: **SCS 108**

Glossary:

| | |
|--------------------------|---|
| TSL | tissue simulating liquid |
| NORM _{x,y,z} | sensitivity in free space |
| ConvF | sensitivity in TSL / NORM _{x,y,z} |
| DCP | diode compression point |
| CF | crest factor (1/duty_cycle) of the RF signal |
| A, B, C, D | modulation dependent linearization parameters |
| Polarization φ | φ rotation around probe axis |
| Polarization ϑ | ϑ rotation around an axis that is in the plane normal to probe axis (at measurement center), i.e., $\vartheta = 0$ is normal to probe axis |
| Connector Angle | information used in DASY system to align probe sensor X to the robot coordinate system |

Calibration is Performed According to the Following Standards:

- IEEE Std 1528-2013, "IEEE Recommended Practice for Determining the Peak Spatial-Averaged Specific Absorption Rate (SAR) in the Human Head from Wireless Communications Devices: Measurement Techniques", June 2013
- IEC 62209-1, "Procedure to measure the Specific Absorption Rate (SAR) for hand-held devices used in close proximity to the ear (frequency range of 300 MHz to 3 GHz)", February 2005

Methods Applied and Interpretation of Parameters:

- NORM_{x,y,z}**: Assessed for E-field polarization $\vartheta = 0$ ($f \leq 900$ MHz in TEM-cell; $f > 1800$ MHz: R22 waveguide). NORM_{x,y,z} are only intermediate values, i.e., the uncertainties of NORM_{x,y,z} does not affect the E²-field uncertainty inside TSL (see below *ConvF*).
- NORM(f)_{x,y,z}** = NORM_{x,y,z} * frequency_response (see Frequency Response Chart). This linearization is implemented in DASY4 software versions later than 4.2. The uncertainty of the frequency response is included in the stated uncertainty of *ConvF*.
- DCP_{x,y,z}**: DCP are numerical linearization parameters assessed based on the data of power sweep with CW signal (no uncertainty required). DCP does not depend on frequency nor media.
- PAR**: PAR is the Peak to Average Ratio that is not calibrated but determined based on the signal characteristics
- A_{x,y,z}; B_{x,y,z}; C_{x,y,z}; D_{x,y,z}; VR_{x,y,z}; A, B, C, D** are numerical linearization parameters assessed based on the data of power sweep for specific modulation signal. The parameters do not depend on frequency nor media. VR is the maximum calibration range expressed in RMS voltage across the diode.
- ConvF and Boundary Effect Parameters**: Assessed in flat phantom using E-field (or Temperature Transfer Standard for $f \leq 800$ MHz) and inside waveguide using analytical field distributions based on power measurements for $f > 800$ MHz. The same setups are used for assessment of the parameters applied for boundary compensation (alpha, depth) of which typical uncertainty values are given. These parameters are used in DASY4 software to improve probe accuracy close to the boundary. The sensitivity in TSL corresponds to NORM_{x,y,z} * ConvF whereby the uncertainty corresponds to that given for ConvF. A frequency dependent ConvF is used in DASY version 4.4 and higher which allows extending the validity from ± 50 MHz to ± 100 MHz.
- Spherical isotropy (3D deviation from isotropy)**: in a field of low gradients realized using a flat phantom exposed by a patch antenna.
- Sensor Offset**: The sensor offset corresponds to the offset of virtual measurement center from the probe tip (on probe axis). No tolerance required.
- Connector Angle**: The angle is assessed using the information gained by determining the NORM_x (no uncertainty required).

Probe EX3DV4

SN:3914

Manufactured: December 18, 2012
Calibrated: October 23, 2013

Calibrated for DASY/EASY Systems
(Note: non-compatible with DASY2 system!)

DASY/EASY - Parameters of Probe: EX3DV4 - SN:3914

Basic Calibration Parameters

| | Sensor X | Sensor Y | Sensor Z | Unc (k=2) |
|---|----------|----------|----------|---------------|
| Norm ($\mu\text{V}/(\text{V}/\text{m})^2$) ^A | 0.47 | 0.49 | 0.51 | $\pm 10.1 \%$ |
| DCP (mV) ^B | 99.2 | 98.9 | 98.2 | |

Modulation Calibration Parameters

| UID | Communication System Name | | A dB | B dB $\sqrt{\mu\text{V}}$ | C | D dB | VR mV | Unc ^E (k=2) |
|---------------|--|---|---------|------------------------------|------|---------|----------|---------------------------|
| 0 | CW | X | 0.0 | 0.0 | 1.0 | 0.00 | 158.3 | $\pm 3.0 \%$ |
| | | Y | 0.0 | 0.0 | 1.0 | | 154.6 | |
| | | Z | 0.0 | 0.0 | 1.0 | | 170.8 | |
| 10010- CAA | SAR Validation (Square, 100ms, 10ms) | X | 0.71 | 53.3 | 6.1 | 10.00 | 48.4 | $\pm 2.5 \%$ |
| | | Y | 2.43 | 67.0 | 13.8 | | 39.9 | |
| | | Z | 4.18 | 68.7 | 13.8 | | 45.7 | |
| 10011- CAA | UMTS-FDD (WCDMA) | X | 3.05 | 64.4 | 16.5 | 2.91 | 122.4 | $\pm 0.5 \%$ |
| | | Y | 3.31 | 66.5 | 18.2 | | 123.5 | |
| | | Z | 3.34 | 66.3 | 17.8 | | 136.6 | |
| 10012- CAA | IEEE 802.11b WiFi 2.4 GHz (DSSS, 1 Mbps) | X | 2.49 | 64.8 | 16.1 | 1.87 | 120.6 | $\pm 0.5 \%$ |
| | | Y | 2.94 | 68.6 | 18.7 | | 123.6 | |
| | | Z | 2.63 | 65.9 | 17.0 | | 135.4 | |
| 10021- DAA | GSM-FDD (TDMA, GMSK) | X | 1.52 | 61.5 | 10.9 | 9.39 | 83.6 | $\pm 1.2 \%$ |
| | | Y | 2.22 | 67.4 | 15.0 | | 116.0 | |
| | | Z | 2.47 | 66.8 | 14.7 | | 95.9 | |
| 10023- DAA | GPRS-FDD (TDMA, GMSK, TN 0) | X | 1.73 | 63.3 | 11.9 | 9.57 | 81.5 | $\pm 1.7 \%$ |
| | | Y | 2.11 | 66.2 | 14.2 | | 111.8 | |
| | | Z | 2.76 | 69.0 | 16.0 | | 93.6 | |
| 10024- DAA | GPRS-FDD (TDMA, GMSK, TN 0-1) | X | 1.34 | 62.1 | 9.4 | 6.56 | 121.0 | $\pm 1.2 \%$ |
| | | Y | 4.24 | 78.6 | 17.9 | | 130.0 | |
| | | Z | 2.91 | 70.7 | 14.9 | | 141.4 | |
| 10027- DAA | GPRS-FDD (TDMA, GMSK, TN 0-1-2) | X | 1.25 | 63.5 | 9.7 | 4.80 | 143.5 | $\pm 1.4 \%$ |
| | | Y | 1.59 | 66.9 | 12.2 | | 149.7 | |
| | | Z | 2.98 | 71.5 | 14.0 | | 123.3 | |
| 10028- DAA | GPRS-FDD (TDMA, GMSK, TN 0-1-2-3) | X | 0.51 | 58.3 | 7.4 | 3.55 | 113.4 | $\pm 1.2 \%$ |
| | | Y | 25.43 | 100.0 | 22.6 | | 121.3 | |
| | | Z | 38.67 | 97.5 | 20.6 | | 133.3 | |
| 10032- CAA | IEEE 802.15.1 Bluetooth (GFSK, DH5) | X | 0.28 | 58.6 | 5.3 | 1.16 | 134.7 | $\pm 0.9 \%$ |
| | | Y | 65.75 | 99.6 | 18.6 | | 141.3 | |
| | | Z | 0.20 | 55.6 | 4.1 | | 112.1 | |
| 10039- CAA | CDMA2000 (1xRTT, RC1) | X | 4.33 | 64.6 | 17.4 | 4.57 | 113.8 | $\pm 0.7 \%$ |
| | | Y | 4.55 | 66.0 | 18.6 | | 120.8 | |
| | | Z | 4.85 | 66.2 | 18.4 | | 135.9 | |
| 10062- CAA | IEEE 802.11a/h WiFi 5 GHz (OFDM, 6 Mbps) | X | 9.83 | 67.6 | 20.7 | 8.68 | 109.0 | $\pm 2.5 \%$ |
| | | Y | 10.06 | 68.4 | 21.5 | | 118.2 | |
| | | Z | 10.66 | 69.2 | 21.7 | | 134.0 | |

| | | | | | | | | |
|-----------|---|---|-------|------|------|------|-------|--------|
| 10081-CAA | CDMA2000 (1xRTT, RC3) | X | 3.59 | 63.9 | 16.9 | 3.97 | 113.6 | ±0.7 % |
| | | Y | 3.84 | 65.6 | 18.2 | | 119.6 | |
| | | Z | 3.95 | 65.4 | 17.8 | | 134.5 | |
| 10098-CAA | UMTS-FDD (HSUPA, Subtest 2) | X | 4.41 | 65.2 | 17.3 | 3.98 | 126.0 | ±0.7 % |
| | | Y | 4.73 | 66.9 | 18.6 | | 132.5 | |
| | | Z | 4.51 | 65.5 | 17.7 | | 105.6 | |
| 10100-CAB | LTE-FDD (SC-FDMA, 100% RB, 20 MHz, QPSK) | X | 6.26 | 66.2 | 18.6 | 5.67 | 130.5 | ±1.2 % |
| | | Y | 6.61 | 67.7 | 19.8 | | 139.3 | |
| | | Z | 6.21 | 66.0 | 18.7 | | 107.7 | |
| 10108-CAB | LTE-FDD (SC-FDMA, 100% RB, 10 MHz, QPSK) | X | 6.13 | 65.8 | 18.6 | 5.80 | 126.3 | ±1.2 % |
| | | Y | 6.40 | 67.1 | 19.6 | | 135.6 | |
| | | Z | 6.10 | 65.5 | 18.5 | | 107.4 | |
| 10110-CAB | LTE-FDD (SC-FDMA, 100% RB, 5 MHz, QPSK) | X | 5.78 | 65.3 | 18.3 | 5.75 | 123.1 | ±1.2 % |
| | | Y | 5.97 | 66.3 | 19.2 | | 131.5 | |
| | | Z | 5.86 | 65.3 | 18.4 | | 104.9 | |
| 10114-CAA | IEEE 802.11n (HT Greenfield, 13.5 Mbps, BPSK) | X | 9.92 | 67.7 | 20.3 | 8.10 | 115.7 | ±2.5 % |
| | | Y | 10.25 | 68.7 | 21.2 | | 126.8 | |
| | | Z | 10.71 | 69.4 | 21.3 | | 146.0 | |
| 10117-CAA | IEEE 802.11n (HT Mixed, 13.5 Mbps, BPSK) | X | 9.95 | 67.8 | 20.3 | 8.07 | 116.6 | ±2.5 % |
| | | Y | 10.26 | 68.7 | 21.1 | | 128.3 | |
| | | Z | 10.70 | 69.4 | 21.3 | | 146.9 | |
| 10151-CAB | LTE-TDD (SC-FDMA, 50% RB, 20 MHz, QPSK) | X | 7.19 | 67.3 | 21.5 | 9.28 | 145.0 | ±2.2 % |
| | | Y | 7.40 | 68.3 | 22.4 | | 110.8 | |
| | | Z | 7.79 | 68.4 | 22.0 | | 128.0 | |
| 10154-CAB | LTE-FDD (SC-FDMA, 50% RB, 10 MHz, QPSK) | X | 5.79 | 65.3 | 18.3 | 5.75 | 124.2 | ±1.2 % |
| | | Y | 6.03 | 66.5 | 19.4 | | 131.9 | |
| | | Z | 6.29 | 66.9 | 19.3 | | 149.7 | |
| 10160-CAB | LTE-FDD (SC-FDMA, 50% RB, 15 MHz, QPSK) | X | 6.23 | 65.9 | 18.6 | 5.82 | 128.3 | ±1.2 % |
| | | Y | 6.51 | 67.2 | 19.7 | | 136.9 | |
| | | Z | 6.24 | 65.7 | 18.6 | | 107.3 | |
| 10169-CAB | LTE-FDD (SC-FDMA, 1 RB, 20 MHz, QPSK) | X | 4.83 | 66.0 | 18.9 | 5.73 | 147.5 | ±1.2 % |
| | | Y | 4.72 | 65.8 | 19.2 | | 113.8 | |
| | | Z | 5.03 | 66.1 | 19.1 | | 129.7 | |
| 10172-CAB | LTE-TDD (SC-FDMA, 1 RB, 20 MHz, QPSK) | X | 5.83 | 69.2 | 22.8 | 9.21 | 149.9 | ±1.9 % |
| | | Y | 5.81 | 69.4 | 23.4 | | 120.3 | |
| | | Z | 6.38 | 70.0 | 23.2 | | 137.2 | |
| 10175-CAB | LTE-FDD (SC-FDMA, 1 RB, 10 MHz, QPSK) | X | 4.86 | 66.1 | 18.9 | 5.72 | 149.8 | ±1.2 % |
| | | Y | 4.72 | 65.8 | 19.2 | | 113.3 | |
| | | Z | 5.09 | 66.4 | 19.1 | | 126.0 | |
| 10181-CAB | LTE-FDD (SC-FDMA, 1 RB, 15 MHz, QPSK) | X | 4.83 | 66.0 | 18.9 | 5.72 | 146.3 | ±1.2 % |
| | | Y | 4.69 | 65.6 | 19.1 | | 112.2 | |
| | | Z | 5.02 | 66.1 | 19.0 | | 125.1 | |
| 10193-CAA | IEEE 802.11n (HT Greenfield, 6.5 Mbps, BPSK) | X | 9.51 | 67.4 | 20.2 | 8.09 | 108.6 | ±2.5 % |
| | | Y | 9.72 | 68.1 | 20.9 | | 118.2 | |
| | | Z | 10.30 | 68.9 | 21.1 | | 135.0 | |

| | | | | | | | | |
|-----------|---|---|-------|------|------|------|-------|--------|
| 10196-CAA | IEEE 802.11n (HT Mixed, 6.5 Mbps, BPSK) | X | 9.52 | 67.4 | 20.2 | 8.10 | 111.6 | ±2.5 % |
| | | Y | 9.79 | 68.3 | 21.1 | | 121.3 | |
| | | Z | 10.30 | 68.9 | 21.2 | | 139.2 | |
| 10219-CAA | IEEE 802.11n (HT Mixed, 7.2 Mbps, BPSK) | X | 9.47 | 67.4 | 20.2 | 8.03 | 111.8 | ±2.2 % |
| | | Y | 9.67 | 68.3 | 21.0 | | 120.0 | |
| | | Z | 10.20 | 68.9 | 21.1 | | 138.0 | |
| 10222-CAA | IEEE 802.11n (HT Mixed, 15 Mbps, BPSK) | X | 9.96 | 67.9 | 20.4 | 8.06 | 118.4 | ±2.5 % |
| | | Y | 10.25 | 68.8 | 21.2 | | 128.2 | |
| | | Z | 10.65 | 69.3 | 21.3 | | 144.5 | |
| 10225-CAA | UMTS-FDD (HSPA+) | X | 6.96 | 66.7 | 18.9 | 5.97 | 140.0 | ±1.4 % |
| | | Y | 7.23 | 67.9 | 20.0 | | 148.9 | |
| | | Z | 7.03 | 66.4 | 18.9 | | 115.6 | |
| 10237-CAB | LTE-TDD (SC-FDMA, 1 RB, 10 MHz, QPSK) | X | 5.51 | 67.5 | 21.8 | 9.21 | 114.2 | ±1.9 % |
| | | Y | 5.82 | 69.4 | 23.4 | | 123.0 | |
| | | Z | 6.49 | 70.6 | 23.6 | | 140.2 | |
| 10252-CAB | LTE-TDD (SC-FDMA, 50% RB, 10 MHz, QPSK) | X | 6.83 | 67.1 | 21.4 | 9.24 | 136.6 | ±1.9 % |
| | | Y | 7.30 | 69.4 | 23.2 | | 147.3 | |
| | | Z | 7.36 | 68.1 | 22.0 | | 117.5 | |
| 10267-CAB | LTE-TDD (SC-FDMA, 100% RB, 10 MHz, QPSK) | X | 7.26 | 67.5 | 21.6 | 9.30 | 142.7 | ±1.9 % |
| | | Y | 7.44 | 68.4 | 22.4 | | 110.5 | |
| | | Z | 7.84 | 68.7 | 22.2 | | 122.6 | |
| 10274-CAA | UMTS-FDD (HSUPA, Subtest 5, 3GPP Rel8.10) | X | 5.86 | 66.2 | 18.2 | 4.87 | 135.4 | ±0.9 % |
| | | Y | 6.12 | 67.5 | 19.2 | | 142.3 | |
| | | Z | 5.91 | 65.9 | 18.2 | | 107.6 | |
| 10275-CAA | UMTS-FDD (HSUPA, Subtest 5, 3GPP Rel8.4) | X | 4.17 | 64.8 | 17.3 | 3.96 | 115.6 | ±0.7 % |
| | | Y | 4.42 | 66.4 | 18.5 | | 124.6 | |
| | | Z | 4.47 | 66.0 | 18.0 | | 132.6 | |
| 10291-AAA | CDMA2000, RC3, SO55, Full Rate | X | 3.36 | 64.7 | 17.1 | 3.46 | 109.4 | ±0.5 % |
| | | Y | 3.55 | 66.2 | 18.3 | | 118.2 | |
| | | Z | 3.60 | 65.6 | 17.7 | | 120.9 | |
| 10292-AAA | CDMA2000, RC3, SO32, Full Rate | X | 3.34 | 64.9 | 17.2 | 3.39 | 110.1 | ±0.5 % |
| | | Y | 3.57 | 66.7 | 18.5 | | 121.0 | |
| | | Z | 3.54 | 65.6 | 17.7 | | 123.9 | |
| 10297-AAA | LTE-FDD (SC-FDMA, 50% RB, 20 MHz, QPSK) | X | 6.14 | 65.8 | 18.6 | 5.81 | 125.1 | ±1.2 % |
| | | Y | 6.44 | 67.2 | 19.7 | | 135.7 | |
| | | Z | 6.52 | 67.0 | 19.3 | | 142.2 | |
| 10311-AAA | LTE-FDD (SC-FDMA, 100% RB, 15 MHz, QPSK) | X | 6.76 | 66.6 | 19.1 | 6.06 | 131.8 | ±1.4 % |
| | | Y | 7.03 | 67.8 | 20.0 | | 142.5 | |
| | | Z | 7.15 | 67.7 | 19.7 | | 148.6 | |
| 10315-AAA | IEEE 802.11b WiFi 2.4 GHz (DSSS, 1 Mbps, 96pc duty cycle) | X | 2.42 | 64.6 | 16.1 | 1.71 | 116.8 | ±0.5 % |
| | | Y | 3.00 | 69.3 | 19.0 | | 126.9 | |
| | | Z | 2.61 | 66.3 | 17.2 | | 128.2 | |
| 10317-AAA | IEEE 802.11a WiFi 5 GHz (OFDM, 6 Mbps, 96pc duty cycle) | X | 9.71 | 67.6 | 20.5 | 8.36 | 111.7 | ±2.5 % |
| | | Y | 9.99 | 68.6 | 21.4 | | 122.2 | |
| | | Z | 10.38 | 68.9 | 21.3 | | 129.5 | |

| | | | | | | | | |
|-----------|---|---|-------|------|------|------|-------|--------|
| 10400-AAA | IEEE 802.11ac WiFi (20MHz, 64-QAM, 99pc duty cycle) | X | 9.83 | 67.8 | 20.6 | 8.37 | 112.9 | ±2.5 % |
| | | Y | 10.09 | 68.7 | 21.4 | | 123.9 | |
| | | Z | 10.48 | 68.9 | 21.3 | | 130.5 | |
| 10402-AAA | IEEE 802.11ac WiFi (80MHz, 64-QAM, 99pc duty cycle) | X | 10.61 | 68.3 | 20.7 | 8.53 | 121.1 | ±2.5 % |
| | | Y | 11.25 | 70.0 | 21.9 | | 135.4 | |
| | | Z | 11.15 | 69.4 | 21.4 | | 137.4 | |
| 10403-AAA | CDMA2000 (1xEV-DO, Rev. 0) | X | 4.51 | 67.4 | 17.8 | 3.76 | 119.2 | ±0.5 % |
| | | Y | 4.91 | 69.5 | 19.3 | | 128.3 | |
| | | Z | 4.84 | 67.5 | 18.1 | | 135.4 | |
| 10404-AAA | CDMA2000 (1xEV-DO, Rev. A) | X | 4.51 | 67.7 | 18.0 | 3.77 | 117.4 | ±0.5 % |
| | | Y | 4.92 | 69.8 | 19.5 | | 125.4 | |
| | | Z | 4.71 | 67.3 | 18.0 | | 131.9 | |

The reported uncertainty of measurement is stated as the standard uncertainty of measurement multiplied by the coverage factor $k=2$, which for a normal distribution corresponds to a coverage probability of approximately 95%.

^A The uncertainties of NormX,Y,Z do not affect the E^2 -field uncertainty inside TSL (see Pages 8 and 9).

^B Numerical linearization parameter: uncertainty not required.

^E Uncertainty is determined using the max. deviation from linear response applying rectangular distribution and is expressed for the square of the field value.

DASY/EASY - Parameters of Probe: EX3DV4 - SN:3914

Calibration Parameter Determined in Head Tissue Simulating Media

| f (MHz) ^C | Relative Permittivity ^F | Conductivity (S/m) ^F | ConvF X | ConvF Y | ConvF Z | Alpha ^G | Depth ^G (mm) | Unct. (k=2) |
|----------------------|------------------------------------|---------------------------------|---------|---------|---------|--------------------|-------------------------|-------------|
| 750 | 41.9 | 0.89 | 9.70 | 9.70 | 9.70 | 0.34 | 1.01 | ± 12.0 % |
| 835 | 41.5 | 0.90 | 9.34 | 9.34 | 9.34 | 0.67 | 0.67 | ± 12.0 % |
| 1750 | 40.1 | 1.37 | 7.99 | 7.99 | 7.99 | 0.79 | 0.56 | ± 12.0 % |
| 1900 | 40.0 | 1.40 | 7.69 | 7.69 | 7.69 | 0.80 | 0.58 | ± 12.0 % |
| 2450 | 39.2 | 1.80 | 6.95 | 6.95 | 6.95 | 0.41 | 0.77 | ± 12.0 % |
| 2600 | 39.0 | 1.96 | 6.79 | 6.79 | 6.79 | 0.40 | 0.82 | ± 12.0 % |
| 5200 | 36.0 | 4.66 | 4.99 | 4.99 | 4.99 | 0.30 | 1.80 | ± 13.1 % |
| 5300 | 35.9 | 4.76 | 4.82 | 4.82 | 4.82 | 0.30 | 1.80 | ± 13.1 % |
| 5500 | 35.6 | 4.96 | 4.55 | 4.55 | 4.55 | 0.35 | 1.80 | ± 13.1 % |
| 5600 | 35.5 | 5.07 | 4.37 | 4.37 | 4.37 | 0.35 | 1.80 | ± 13.1 % |
| 5800 | 35.3 | 5.27 | 4.52 | 4.52 | 4.52 | 0.35 | 1.80 | ± 13.1 % |

^C Frequency validity of ± 100 MHz only applies for DASY v4.4 and higher (see Page 2), else it is restricted to ± 50 MHz. The uncertainty is the RSS of the ConvF uncertainty at calibration frequency and the uncertainty for the indicated frequency band.

^F At frequencies below 3 GHz, the validity of tissue parameters (ϵ and σ) can be relaxed to ± 10% if liquid compensation formula is applied to measured SAR values. At frequencies above 3 GHz, the validity of tissue parameters (ϵ and σ) is restricted to ± 5%. The uncertainty is the RSS of the ConvF uncertainty for indicated target tissue parameters.

^G Alpha/Depth are determined during calibration. SPEAG warrants that the remaining deviation due to the boundary effect after compensation is always less than ± 1% for frequencies below 3 GHz and below ± 2% for frequencies between 3-6 GHz at any distance larger than half the probe tip diameter from the boundary.

DASY/EASY - Parameters of Probe: EX3DV4 - SN:3914

Calibration Parameter Determined in Body Tissue Simulating Media

| f (MHz) ^C | Relative Permittivity ^F | Conductivity (S/m) ^F | ConvF X | ConvF Y | ConvF Z | Alpha ^G | Depth ^G (mm) | Unct. (k=2) |
|----------------------|------------------------------------|---------------------------------|---------|---------|---------|--------------------|-------------------------|-------------|
| 750 | 55.5 | 0.96 | 9.39 | 9.39 | 9.39 | 0.63 | 0.74 | ± 12.0 % |
| 835 | 55.2 | 0.97 | 9.31 | 9.31 | 9.31 | 0.56 | 0.76 | ± 12.0 % |
| 1750 | 53.4 | 1.49 | 7.89 | 7.89 | 7.89 | 0.32 | 1.03 | ± 12.0 % |
| 1900 | 53.3 | 1.52 | 7.51 | 7.51 | 7.51 | 0.51 | 0.76 | ± 12.0 % |
| 2450 | 52.7 | 1.95 | 7.02 | 7.02 | 7.02 | 0.80 | 0.50 | ± 12.0 % |
| 2600 | 52.5 | 2.16 | 6.81 | 6.81 | 6.81 | 0.80 | 0.50 | ± 12.0 % |
| 5200 | 49.0 | 5.30 | 4.52 | 4.52 | 4.52 | 0.35 | 1.90 | ± 13.1 % |
| 5300 | 48.9 | 5.42 | 4.32 | 4.32 | 4.32 | 0.35 | 1.90 | ± 13.1 % |
| 5500 | 48.6 | 5.65 | 4.07 | 4.07 | 4.07 | 0.35 | 1.90 | ± 13.1 % |
| 5600 | 48.5 | 5.77 | 3.97 | 3.97 | 3.97 | 0.35 | 1.90 | ± 13.1 % |
| 5800 | 48.2 | 6.00 | 4.14 | 4.14 | 4.14 | 0.40 | 1.90 | ± 13.1 % |

^C Frequency validity of ± 100 MHz only applies for DASY v4.4 and higher (see Page 2), else it is restricted to ± 50 MHz. The uncertainty is the RSS of the ConvF uncertainty at calibration frequency and the uncertainty for the indicated frequency band.

^F At frequencies below 3 GHz, the validity of tissue parameters (ϵ and σ) can be relaxed to ± 10% if liquid compensation formula is applied to measured SAR values. At frequencies above 3 GHz, the validity of tissue parameters (ϵ and σ) is restricted to ± 5%. The uncertainty is the RSS of the ConvF uncertainty for indicated target tissue parameters.

^G Alpha/Depth are determined during calibration. SPEAG warrants that the remaining deviation due to the boundary effect after compensation is always less than ± 1% for frequencies below 3 GHz and below ± 2% for frequencies between 3-6 GHz at any distance larger than half the probe tip diameter from the boundary.

Frequency Response of E-Field

(TEM-Cell:ifi110 EXX, Waveguide: R22)

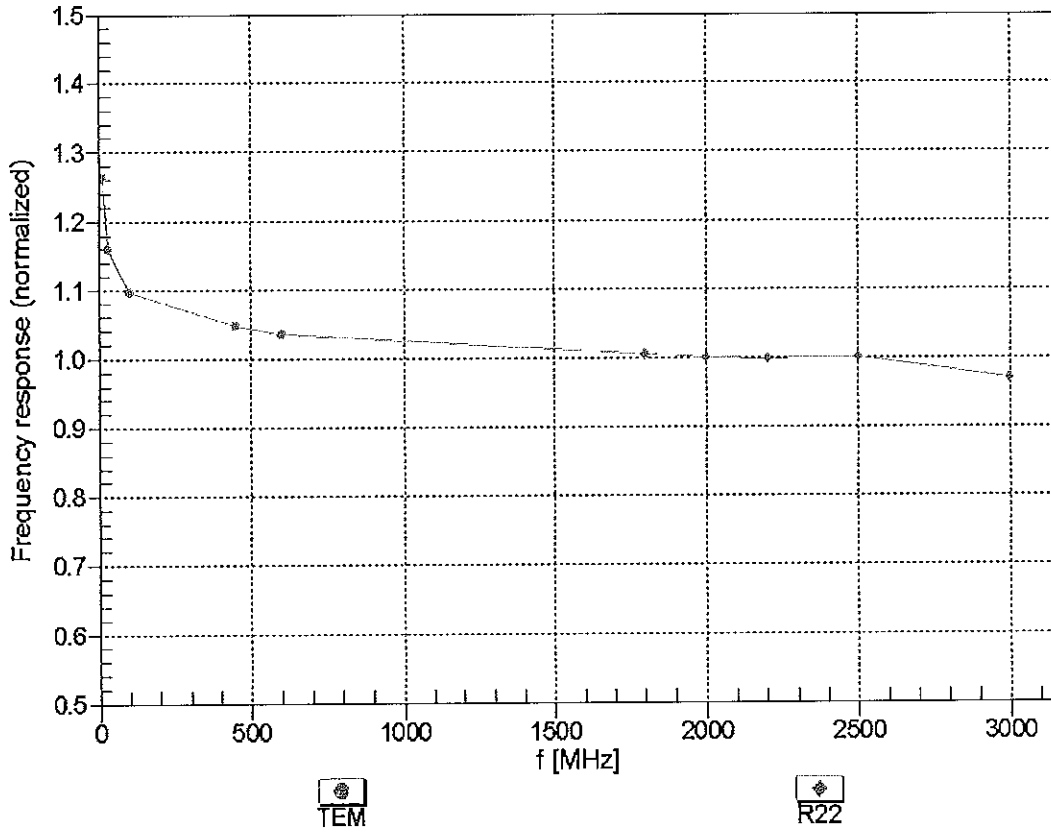

Uncertainty of Frequency Response of E-field: $\pm 6.3\%$ (k=2)

Receiving Pattern (ϕ), $\theta = 0^\circ$

f=600 MHz,TEM

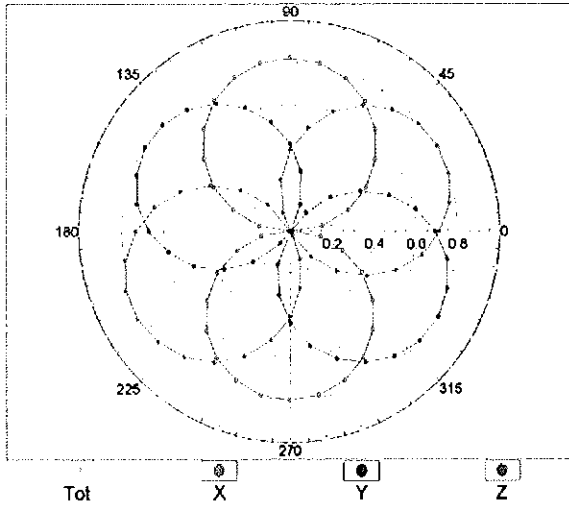

f=1800 MHz,R22

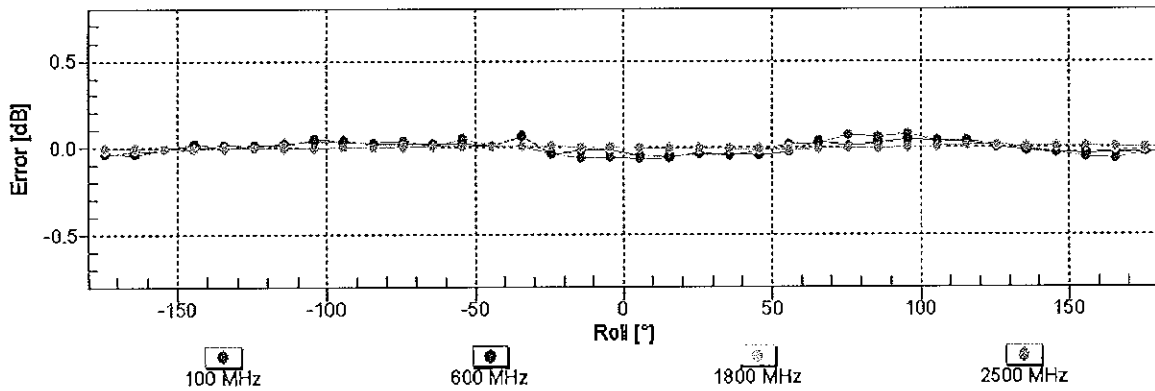
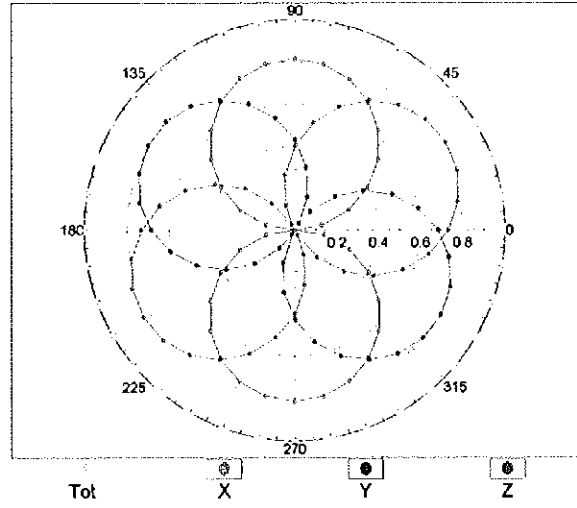

Uncertainty of Axial Isotropy Assessment: $\pm 0.5\%$ ($k=2$)

Dynamic Range $f(\text{SAR}_{\text{head}})$ (TEM cell , $f = 900 \text{ MHz}$)

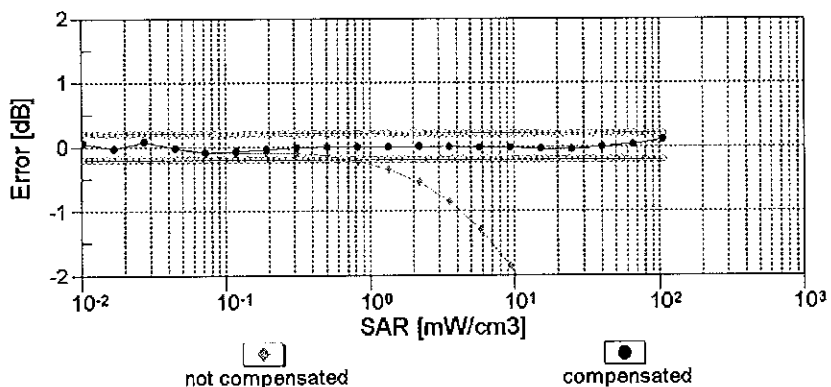
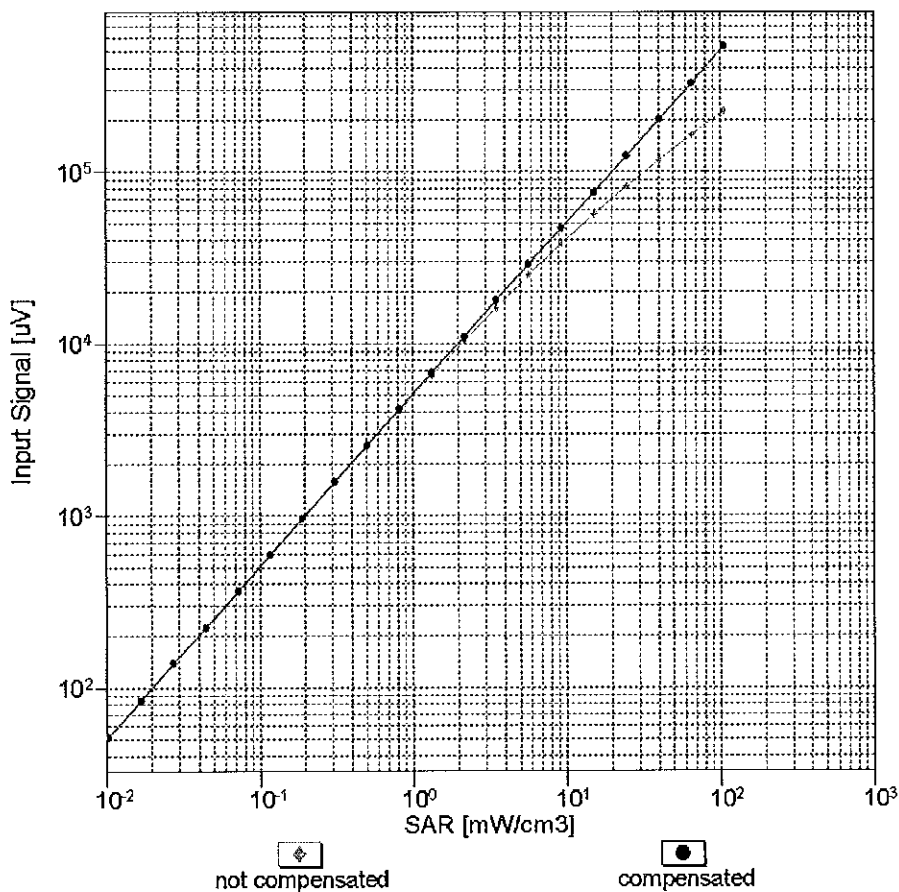

Uncertainty of Linearity Assessment: $\pm 0.6\%$ ($k=2$)

Conversion Factor Assessment

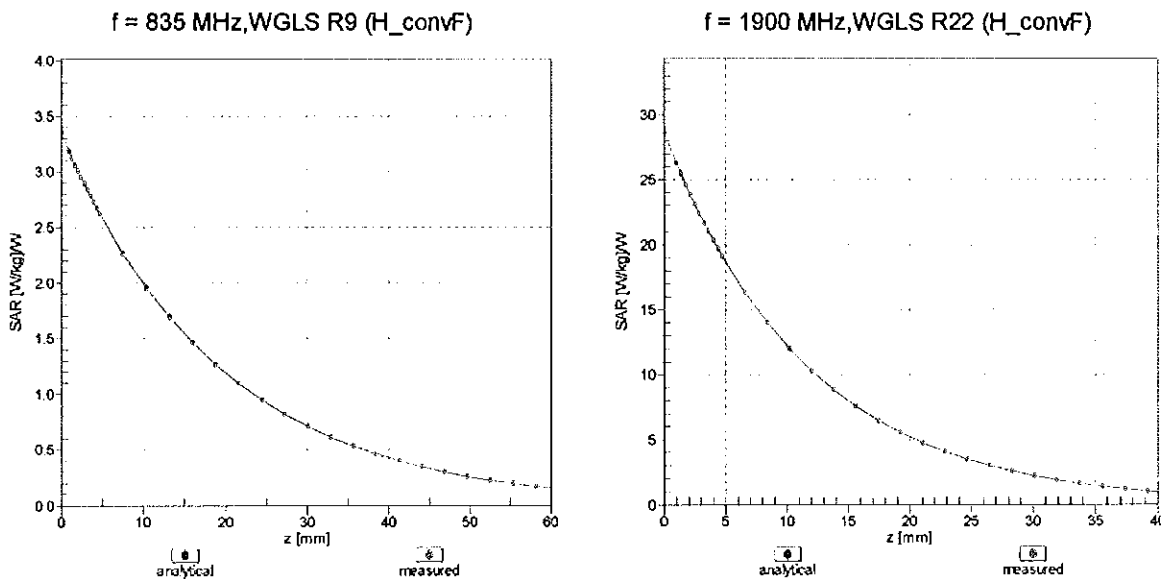

Deviation from Isotropy in Liquid

Error (ϕ, θ), f = 900 MHz

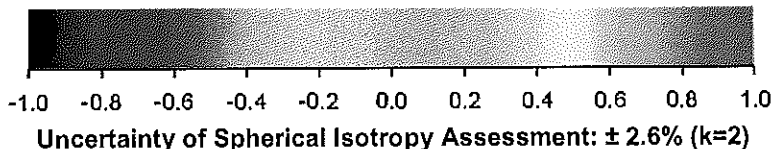
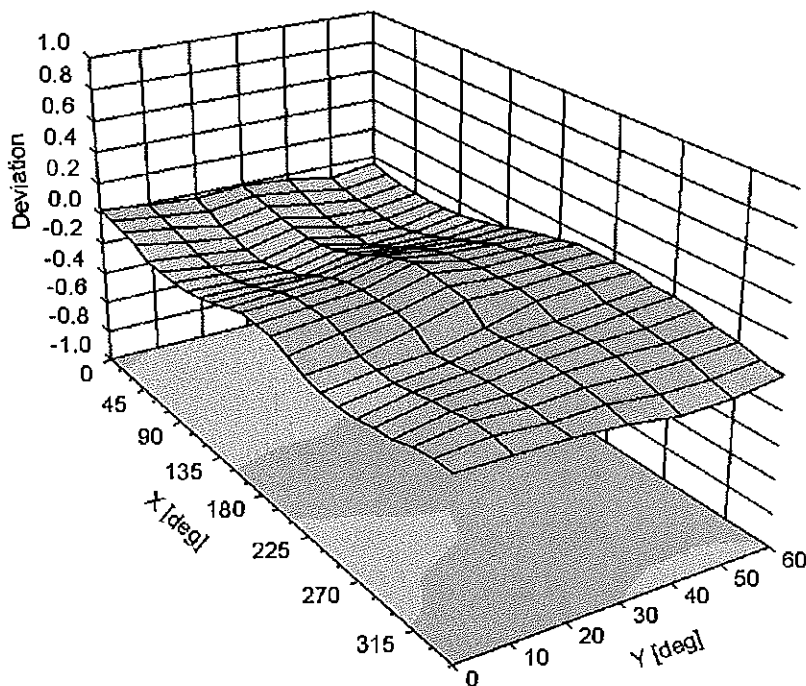

DASY/EASY - Parameters of Probe: EX3DV4 - SN:3914**Other Probe Parameters**

| | |
|---|------------|
| Sensor Arrangement | Triangular |
| Connector Angle (°) | -24.3 |
| Mechanical Surface Detection Mode | enabled |
| Optical Surface Detection Mode | disabled |
| Probe Overall Length | 337 mm |
| Probe Body Diameter | 10 mm |
| Tip Length | 9 mm |
| Tip Diameter | 2.5 mm |
| Probe Tip to Sensor X Calibration Point | 1 mm |
| Probe Tip to Sensor Y Calibration Point | 1 mm |
| Probe Tip to Sensor Z Calibration Point | 1 mm |
| Recommended Measurement Distance from Surface | 2 mm |



Accredited by the Swiss Accreditation Service (SAS)
The Swiss Accreditation Service is one of the signatories to the EA
Multilateral Agreement for the recognition of calibration certificates

Accreditation No.: **SCS 108**

Client **PC Test**

Certificate No: **EX3-3920_Dec13**

CALIBRATION CERTIFICATE

Object **EX3DV4 - SN:3920**

Calibration procedure(s) **QA CAL-01.v9, QA CAL-14.v4, QA CAL-23.v5, QA CAL-25.v6
Calibration procedure for dosimetric E-field probes**

Calibration date: **December 18, 2013** VCC
1/12/14

This calibration certificate documents the traceability to national standards, which realize the physical units of measurements (SI).
The measurements and the uncertainties with confidence probability are given on the following pages and are part of the certificate.

All calibrations have been conducted in the closed laboratory facility: environment temperature (22 ± 3)°C and humidity < 70%.

Calibration Equipment used (M&TE critical for calibration)

| Primary Standards | ID | Cal Date (Certificate No.) | Scheduled Calibration |
|----------------------------|-----------------|-----------------------------------|------------------------|
| Power meter E4419B | GB41293874 | 04-Apr-13 (No. 217-01733) | Apr-14 |
| Power sensor E4412A | MY41498087 | 04-Apr-13 (No. 217-01733) | Apr-14 |
| Reference 3 dB Attenuator | SN: S5054 (3c) | 04-Apr-13 (No. 217-01737) | Apr-14 |
| Reference 20 dB Attenuator | SN: S5277 (20x) | 04-Apr-13 (No. 217-01735) | Apr-14 |
| Reference 30 dB Attenuator | SN: S5129 (30b) | 04-Apr-13 (No. 217-01738) | Apr-14 |
| Reference Probe ES3DV2 | SN: 3013 | 28-Dec-12 (No. ES3-3013_Dec12) | Dec-13 |
| DAE4 | SN: 660 | 13-Dec-13 (No. DAE4-660_Dec13) | Dec-14 |
| Secondary Standards | ID | Check Date (in house) | Scheduled Check |
| RF generator HP 8648C | US3642U01700 | 4-Aug-99 (in house check Apr-13) | In house check: Apr-15 |
| Network Analyzer HP 8753E | US37390585 | 18-Oct-01 (in house check Oct-13) | In house check: Oct-14 |

| | Name | Function | Signature |
|----------------|---------------|-----------------------|-----------|
| Calibrated by: | Leif Klysner | Laboratory Technician | |
| Approved by: | Katja Pokovic | Technical Manager | |

Issued: December 19, 2013

This calibration certificate shall not be reproduced except in full without written approval of the laboratory.



Accredited by the Swiss Accreditation Service (SAS)

Accreditation No.: **SCS 108**

The Swiss Accreditation Service is one of the signatories to the EA
Multilateral Agreement for the recognition of calibration certificates

Glossary:

| | |
|--------------------------|---|
| TSL | tissue simulating liquid |
| NORM _{x,y,z} | sensitivity in free space |
| ConvF | sensitivity in TSL / NORM _{x,y,z} |
| DCP | diode compression point |
| CF | crest factor (1/duty_cycle) of the RF signal |
| A, B, C, D | modulation dependent linearization parameters |
| Polarization φ | φ rotation around probe axis |
| Polarization ϑ | ϑ rotation around an axis that is in the plane normal to probe axis (at measurement center), i.e., $\vartheta = 0$ is normal to probe axis |
| Connector Angle | information used in DASY system to align probe sensor X to the robot coordinate system |

Calibration is Performed According to the Following Standards:

- IEEE Std 1528-2013, "IEEE Recommended Practice for Determining the Peak Spatial-Averaged Specific Absorption Rate (SAR) in the Human Head from Wireless Communications Devices: Measurement Techniques", June 2013
- IEC 62209-1, "Procedure to measure the Specific Absorption Rate (SAR) for hand-held devices used in close proximity to the ear (frequency range of 300 MHz to 3 GHz)", February 2005

Methods Applied and Interpretation of Parameters:

- NORM_{x,y,z}**: Assessed for E-field polarization $\vartheta = 0$ ($f \leq 900$ MHz in TEM-cell; $f > 1800$ MHz: R22 waveguide). NORM_{x,y,z} are only intermediate values, i.e., the uncertainties of NORM_{x,y,z} does not affect the E^2 -field uncertainty inside TSL (see below ConvF).
- NORM(f)_{x,y,z}** = NORM_{x,y,z} * frequency_response (see Frequency Response Chart). This linearization is implemented in DASY4 software versions later than 4.2. The uncertainty of the frequency response is included in the stated uncertainty of ConvF.
- DCP_{x,y,z}**: DCP are numerical linearization parameters assessed based on the data of power sweep with CW signal (no uncertainty required). DCP does not depend on frequency nor media.
- PAR**: PAR is the Peak to Average Ratio that is not calibrated but determined based on the signal characteristics
- A_{x,y,z}; B_{x,y,z}; C_{x,y,z}; D_{x,y,z}; VR_{x,y,z}; A, B, C, D** are numerical linearization parameters assessed based on the data of power sweep for specific modulation signal. The parameters do not depend on frequency nor media. VR is the maximum calibration range expressed in RMS voltage across the diode.
- ConvF and Boundary Effect Parameters**: Assessed in flat phantom using E-field (or Temperature Transfer Standard for $f \leq 800$ MHz) and inside waveguide using analytical field distributions based on power measurements for $f > 800$ MHz. The same setups are used for assessment of the parameters applied for boundary compensation (alpha, depth) of which typical uncertainty values are given. These parameters are used in DASY4 software to improve probe accuracy close to the boundary. The sensitivity in TSL corresponds to NORM_{x,y,z} * ConvF whereby the uncertainty corresponds to that given for ConvF. A frequency dependent ConvF is used in DASY version 4.4 and higher which allows extending the validity from ± 50 MHz to ± 100 MHz.
- Spherical isotropy (3D deviation from isotropy)**: in a field of low gradients realized using a flat phantom exposed by a patch antenna.
- Sensor Offset**: The sensor offset corresponds to the offset of virtual measurement center from the probe tip (on probe axis). No tolerance required.
- Connector Angle**: The angle is assessed using the information gained by determining the NORM_x (no uncertainty required).

Probe EX3DV4

SN:3920

Manufactured: December 18, 2012
Calibrated: December 18, 2013

Calibrated for DASY/EASY Systems
(Note: non-compatible with DASY2 system!)

DASY/EASY - Parameters of Probe: EX3DV4 - SN:3920

Basic Calibration Parameters

| | Sensor X | Sensor Y | Sensor Z | Unc (k=2) |
|---|----------|----------|----------|--------------|
| Norm ($\mu\text{V}/(\text{V}/\text{m})^2$) ^A | 0.34 | 0.50 | 0.49 | $\pm 10.1\%$ |
| DCP (mV) ^B | 102.9 | 99.5 | 98.3 | |

Modulation Calibration Parameters

| UID | Communication System Name | | A dB | B dB $\sqrt{\mu\text{V}}$ | C | D dB | VR mV | Unc ^E (k=2) |
|---------------|--|---|---------|------------------------------|------|---------|----------|---------------------------|
| 0 | CW | X | 0.0 | 0.0 | 1.0 | 0.00 | 182.5 | $\pm 2.7\%$ |
| | | Y | 0.0 | 0.0 | 1.0 | | 164.9 | |
| | | Z | 0.0 | 0.0 | 1.0 | | 153.0 | |
| 10010- CAA | SAR Validation (Square, 100ms, 10ms) | X | 0.76 | 53.8 | 6.5 | 10.00 | 44.1 | $\pm 2.2\%$ |
| | | Y | 2.33 | 62.8 | 11.4 | | 43.7 | |
| | | Z | 1.15 | 55.6 | 7.5 | | 53.0 | |
| 10011- CAA | UMTS-FDD (WCDMA) | X | 3.36 | 66.5 | 17.5 | 2.91 | 142.4 | $\pm 0.5\%$ |
| | | Y | 3.15 | 65.0 | 16.7 | | 131.4 | |
| | | Z | 3.26 | 66.0 | 17.7 | | 121.6 | |
| 10012- CAA | IEEE 802.11b WiFi 2.4 GHz (DSSS, 1 Mbps) | X | 2.69 | 66.4 | 16.9 | 1.87 | 138.1 | $\pm 0.5\%$ |
| | | Y | 2.56 | 65.1 | 16.2 | | 130.7 | |
| | | Z | 2.72 | 66.6 | 17.2 | | 121.4 | |
| 10021- DAA | GSM-FDD (TDMA, GMSK) | X | 2.06 | 63.4 | 11.7 | 9.39 | 99.7 | $\pm 1.9\%$ |
| | | Y | 2.43 | 66.1 | 14.1 | | 94.7 | |
| | | Z | 2.90 | 69.9 | 16.1 | | 121.8 | |
| 10023- DAA | GPRS-FDD (TDMA, GMSK, TN 0) | X | 1.94 | 62.4 | 11.3 | 9.57 | 95.1 | $\pm 1.9\%$ |
| | | Y | 2.31 | 64.8 | 13.1 | | 90.1 | |
| | | Z | 2.98 | 70.4 | 16.4 | | 117.0 | |
| 10024- DAA | GPRS-FDD (TDMA, GMSK, TN 0-1) | X | 2.19 | 67.1 | 12.2 | 6.56 | 140.1 | $\pm 1.4\%$ |
| | | Y | 2.35 | 67.0 | 12.9 | | 134.0 | |
| | | Z | 3.45 | 73.5 | 16.1 | | 131.4 | |
| 10027- DAA | GPRS-FDD (TDMA, GMSK, TN 0-1-2) | X | 1.18 | 61.7 | 8.5 | 4.80 | 121.6 | $\pm 1.2\%$ |
| | | Y | 1.57 | 63.4 | 10.0 | | 116.0 | |
| | | Z | 1.57 | 65.5 | 11.9 | | 109.2 | |
| 10028- DAA | GPRS-FDD (TDMA, GMSK, TN 0-1-2-3) | X | 3.80 | 74.5 | 13.3 | 3.55 | 130.3 | $\pm 0.9\%$ |
| | | Y | 1.00 | 60.5 | 8.0 | | 123.9 | |
| | | Z | 1.58 | 66.1 | 11.1 | | 119.0 | |
| 10032- CAA | IEEE 802.15.1 Bluetooth (GFSK, DH5) | X | 0.18 | 55.2 | 3.4 | 1.16 | 111.6 | $\pm 0.7\%$ |
| | | Y | 0.34 | 57.4 | 4.4 | | 143.6 | |
| | | Z | 0.40 | 59.2 | 5.7 | | 136.6 | |
| 10039- CAA | CDMA2000 (1xRTT, RC1) | X | 4.49 | 65.9 | 18.1 | 4.57 | 131.8 | $\pm 0.9\%$ |
| | | Y | 4.57 | 65.1 | 17.5 | | 123.0 | |
| | | Z | 4.66 | 65.9 | 18.3 | | 118.6 | |
| 10062- CAA | IEEE 802.11a/h WiFi 5 GHz (OFDM, 6 Mbps) | X | 10.09 | 68.6 | 21.3 | 8.68 | 126.5 | $\pm 2.5\%$ |
| | | Y | 10.31 | 68.5 | 21.1 | | 121.9 | |
| | | Z | 10.12 | 68.3 | 21.3 | | 115.8 | |

| | | | | | | | | |
|-----------|---|---|-------|------|------|------|-------|--------|
| 10098-CAA | UMTS-FDD (HSUPA, Subtest 2) | X | 4.64 | 66.6 | 18.1 | 3.98 | 144.6 | ±0.7 % |
| | | Y | 4.54 | 65.4 | 17.4 | | 133.9 | |
| | | Z | 4.60 | 66.1 | 18.0 | | 128.0 | |
| 10100-CAB | LTE-FDD (SC-FDMA, 100% RB, 20 MHz, QPSK) | X | 6.00 | 65.5 | 18.3 | 5.67 | 104.2 | ±1.4 % |
| | | Y | 6.44 | 66.7 | 18.8 | | 138.2 | |
| | | Z | 6.54 | 67.4 | 19.4 | | 134.7 | |
| 10108-CAB | LTE-FDD (SC-FDMA, 100% RB, 10 MHz, QPSK) | X | 6.37 | 67.0 | 19.2 | 5.80 | 149.0 | ±1.4 % |
| | | Y | 6.40 | 66.6 | 18.9 | | 141.2 | |
| | | Z | 6.40 | 66.9 | 19.4 | | 132.1 | |
| 10110-CAB | LTE-FDD (SC-FDMA, 100% RB, 5 MHz, QPSK) | X | 5.96 | 66.3 | 18.9 | 5.75 | 142.3 | ±1.4 % |
| | | Y | 6.05 | 66.1 | 18.7 | | 136.6 | |
| | | Z | 6.03 | 66.3 | 19.1 | | 128.2 | |
| 10114-CAA | IEEE 802.11n (HT Greenfield, 13.5 Mbps, BPSK) | X | 10.28 | 68.7 | 20.9 | 8.10 | 137.3 | ±2.5 % |
| | | Y | 10.32 | 68.5 | 20.7 | | 131.3 | |
| | | Z | 10.24 | 68.5 | 20.9 | | 124.5 | |
| 10117-CAA | IEEE 802.11n (HT Mixed, 13.5 Mbps, BPSK) | X | 10.29 | 68.8 | 20.9 | 8.07 | 138.5 | ±2.5 % |
| | | Y | 10.34 | 68.6 | 20.8 | | 131.9 | |
| | | Z | 10.26 | 68.5 | 20.9 | | 125.5 | |
| 10151-CAB | LTE-TDD (SC-FDMA, 50% RB, 20 MHz, QPSK) | X | 7.20 | 67.5 | 21.6 | 9.28 | 118.6 | ±2.2 % |
| | | Y | 7.59 | 67.9 | 21.6 | | 116.7 | |
| | | Z | 7.78 | 69.2 | 22.7 | | 110.7 | |
| 10154-CAB | LTE-FDD (SC-FDMA, 50% RB, 10 MHz, QPSK) | X | 5.98 | 66.4 | 18.9 | 5.75 | 142.7 | ±1.2 % |
| | | Y | 5.97 | 65.7 | 18.4 | | 132.7 | |
| | | Z | 6.06 | 66.4 | 19.1 | | 128.6 | |
| 10160-CAB | LTE-FDD (SC-FDMA, 50% RB, 15 MHz, QPSK) | X | 6.41 | 66.8 | 19.1 | 5.82 | 147.7 | ±1.4 % |
| | | Y | 6.48 | 66.5 | 18.8 | | 137.3 | |
| | | Z | 6.53 | 67.0 | 19.4 | | 134.9 | |
| 10169-CAB | LTE-FDD (SC-FDMA, 1 RB, 20 MHz, QPSK) | X | 4.59 | 65.5 | 18.6 | 5.73 | 120.3 | ±1.2 % |
| | | Y | 4.76 | 65.0 | 18.2 | | 113.9 | |
| | | Z | 4.82 | 65.6 | 18.9 | | 112.0 | |
| 10172-CAB | LTE-TDD (SC-FDMA, 1 RB, 20 MHz, QPSK) | X | 5.77 | 69.3 | 22.7 | 9.21 | 128.1 | ±1.9 % |
| | | Y | 6.15 | 69.3 | 22.6 | | 123.8 | |
| | | Z | 6.22 | 70.3 | 23.6 | | 120.8 | |
| 10175-CAB | LTE-FDD (SC-FDMA, 1 RB, 10 MHz, QPSK) | X | 4.62 | 65.6 | 18.7 | 5.72 | 120.2 | ±0.9 % |
| | | Y | 4.75 | 65.0 | 18.2 | | 113.5 | |
| | | Z | 4.80 | 65.6 | 18.8 | | 110.7 | |
| 10181-CAB | LTE-FDD (SC-FDMA, 1 RB, 15 MHz, QPSK) | X | 4.57 | 65.4 | 18.6 | 5.72 | 118.9 | ±0.9 % |
| | | Y | 4.72 | 64.8 | 18.1 | | 113.1 | |
| | | Z | 4.81 | 65.6 | 18.8 | | 110.4 | |
| 10193-CAA | IEEE 802.11n (HT Greenfield, 6.5 Mbps, BPSK) | X | 9.77 | 68.3 | 20.8 | 8.09 | 128.1 | ±2.5 % |
| | | Y | 9.84 | 67.9 | 20.5 | | 117.1 | |
| | | Z | 9.80 | 68.1 | 20.8 | | 116.6 | |
| 10196-CAA | IEEE 802.11n (HT Mixed, 6.5 Mbps, BPSK) | X | 9.78 | 68.4 | 20.8 | 8.10 | 128.4 | ±2.5 % |
| | | Y | 9.86 | 68.0 | 20.5 | | 120.3 | |
| | | Z | 9.82 | 68.1 | 20.9 | | 119.1 | |

| | | | | | | | | |
|-----------|---|---|-------|------|------|------|-------|--------|
| 10219-CAA | IEEE 802.11n (HT Mixed, 7.2 Mbps, BPSK) | X | 9.70 | 68.4 | 20.8 | 8.03 | 128.0 | ±2.5 % |
| | | Y | 9.79 | 68.0 | 20.5 | | 119.6 | |
| | | Z | 9.72 | 68.1 | 20.8 | | 118.7 | |
| 10222-CAA | IEEE 802.11n (HT Mixed, 15 Mbps, BPSK) | X | 10.27 | 68.8 | 20.9 | 8.06 | 137.0 | ±2.5 % |
| | | Y | 10.18 | 68.3 | 20.6 | | 125.2 | |
| | | Z | 10.20 | 68.5 | 20.9 | | 124.8 | |
| 10225-CAA | UMTS-FDD (HSPA+) | X | 6.64 | 66.1 | 18.7 | 5.97 | 108.8 | ±1.4 % |
| | | Y | 7.23 | 67.1 | 19.1 | | 148.9 | |
| | | Z | 7.31 | 67.7 | 19.7 | | 146.5 | |
| 10237-CAB | LTE-TDD (SC-FDMA, 1 RB, 10 MHz, QPSK) | X | 5.82 | 69.6 | 23.0 | 9.21 | 130.2 | ±1.9 % |
| | | Y | 6.14 | 69.2 | 22.6 | | 123.9 | |
| | | Z | 6.25 | 70.4 | 23.7 | | 122.2 | |
| 10252-CAB | LTE-TDD (SC-FDMA, 50% RB, 10 MHz, QPSK) | X | 6.85 | 67.5 | 21.7 | 9.24 | 112.9 | ±2.2 % |
| | | Y | 7.54 | 69.0 | 22.4 | | 149.2 | |
| | | Z | 7.80 | 70.6 | 23.7 | | 147.3 | |
| 10267-CAB | LTE-TDD (SC-FDMA, 100% RB, 10 MHz, QPSK) | X | 7.23 | 67.6 | 21.6 | 9.30 | 118.3 | ±2.2 % |
| | | Y | 7.55 | 67.7 | 21.5 | | 111.5 | |
| | | Z | 7.79 | 69.2 | 22.7 | | 109.6 | |
| 10274-CAA | UMTS-FDD (HSUPA, Subtest 5, 3GPP Rel8.10) | X | 5.64 | 65.9 | 18.1 | 4.87 | 105.5 | ±1.2 % |
| | | Y | 6.04 | 66.4 | 18.2 | | 142.6 | |
| | | Z | 6.09 | 66.9 | 18.7 | | 138.4 | |
| 10275-CAA | UMTS-FDD (HSUPA, Subtest 5, 3GPP Rel8.4) | X | 4.42 | 66.3 | 18.1 | 3.96 | 135.8 | ±0.7 % |
| | | Y | 4.26 | 65.0 | 17.3 | | 119.3 | |
| | | Z | 4.40 | 65.9 | 18.0 | | 120.4 | |
| 10291-AAA | CDMA2000, RC3, SO55, Full Rate | X | 3.62 | 66.7 | 18.1 | 3.46 | 123.6 | ±0.7 % |
| | | Y | 3.38 | 64.3 | 16.7 | | 112.5 | |
| | | Z | 3.59 | 66.0 | 17.9 | | 114.3 | |
| 10292-AAA | CDMA2000, RC3, SO32, Full Rate | X | 3.46 | 66.0 | 17.7 | 3.39 | 127.3 | ±0.5 % |
| | | Y | 3.35 | 64.5 | 16.8 | | 113.7 | |
| | | Z | 3.50 | 65.7 | 17.7 | | 115.4 | |
| 10297-AAA | LTE-FDD (SC-FDMA, 50% RB, 20 MHz, QPSK) | X | 6.35 | 66.9 | 19.2 | 5.81 | 145.7 | ±1.2 % |
| | | Y | 6.26 | 66.1 | 18.7 | | 129.2 | |
| | | Z | 6.42 | 67.0 | 19.4 | | 131.3 | |
| 10311-AAA | LTE-FDD (SC-FDMA, 100% RB, 15 MHz, QPSK) | X | 6.45 | 65.9 | 18.7 | 6.06 | 103.7 | ±1.7 % |
| | | Y | 6.90 | 66.9 | 19.1 | | 137.2 | |
| | | Z | 7.04 | 67.7 | 19.8 | | 137.5 | |
| 10315-AAA | IEEE 802.11b WiFi 2.4 GHz (DSSS, 1 Mbps, 96pc duty cycle) | X | 2.85 | 67.8 | 17.7 | 1.71 | 135.6 | ±0.5 % |
| | | Y | 2.45 | 64.7 | 16.0 | | 121.4 | |
| | | Z | 2.75 | 67.3 | 17.6 | | 122.1 | |
| 10317-AAA | IEEE 802.11a WiFi 5 GHz (OFDM, 6 Mbps, 96pc duty cycle) | X | 9.93 | 68.5 | 21.0 | 8.36 | 128.1 | ±2.7 % |
| | | Y | 10.02 | 68.1 | 20.7 | | 117.9 | |
| | | Z | 10.01 | 68.3 | 21.1 | | 119.4 | |
| 10400-AAA | IEEE 802.11ac WiFi (20MHz, 64-QAM, 99pc duty cycle) | X | 10.09 | 68.8 | 21.2 | 8.37 | 134.9 | ±2.5 % |
| | | Y | 10.16 | 68.3 | 20.8 | | 119.8 | |
| | | Z | 10.14 | 68.5 | 21.2 | | 121.0 | |

| | | | | | | | | |
|-----------|---|---|-------|------|------|------|-------|--------|
| 10402-AAA | IEEE 802.11ac WiFi (80MHz, 64-QAM, 99pc duty cycle) | X | 11.18 | 69.8 | 21.5 | 8.53 | 147.1 | ±2.7 % |
| | | Y | 10.79 | 68.6 | 20.8 | | 126.5 | |
| | | Z | 11.17 | 69.6 | 21.6 | | 131.4 | |
| 10403-AAA | CDMA2000 (1xEV-DO, Rev. 0) | X | 4.83 | 69.6 | 18.9 | 3.76 | 139.6 | ±0.5 % |
| | | Y | 4.70 | 67.1 | 17.6 | | 128.1 | |
| | | Z | 4.90 | 68.4 | 18.6 | | 127.8 | |
| 10404-AAA | CDMA2000 (1xEV-DO, Rev. A) | X | 4.73 | 69.5 | 18.9 | 3.77 | 134.8 | ±0.5 % |
| | | Y | 4.62 | 67.1 | 17.7 | | 124.9 | |
| | | Z | 4.67 | 67.7 | 18.1 | | 125.9 | |

The reported uncertainty of measurement is stated as the standard uncertainty of measurement multiplied by the coverage factor $k=2$, which for a normal distribution corresponds to a coverage probability of approximately 95%.

^A The uncertainties of NormX,Y,Z do not affect the E^2 -field uncertainty inside TSL (see Pages 8 and 9).

^B Numerical linearization parameter: uncertainty not required.

^E Uncertainty is determined using the max. deviation from linear response applying rectangular distribution and is expressed for the square of the field value.

DASY/EASY - Parameters of Probe: EX3DV4 - SN:3920

Calibration Parameter Determined in Head Tissue Simulating Media

| f (MHz) ^C | Relative Permittivity ^F | Conductivity (S/m) ^F | ConvF X | ConvF Y | ConvF Z | Alpha ^G | Depth ^G (mm) | Unct. (k=2) |
|----------------------|------------------------------------|---------------------------------|---------|---------|---------|--------------------|-------------------------|-------------|
| 750 | 41.9 | 0.89 | 10.05 | 10.05 | 10.05 | 0.27 | 1.13 | ± 12.0 % |
| 835 | 41.5 | 0.90 | 9.69 | 9.69 | 9.69 | 0.50 | 0.76 | ± 12.0 % |
| 1750 | 40.1 | 1.37 | 7.91 | 7.91 | 7.91 | 0.72 | 0.62 | ± 12.0 % |
| 1900 | 40.0 | 1.40 | 7.70 | 7.70 | 7.70 | 0.77 | 0.61 | ± 12.0 % |
| 2450 | 39.2 | 1.80 | 6.98 | 6.98 | 6.98 | 0.37 | 0.86 | ± 12.0 % |
| 2600 | 39.0 | 1.96 | 6.74 | 6.74 | 6.74 | 0.34 | 0.97 | ± 12.0 % |
| 5200 | 36.0 | 4.66 | 4.87 | 4.87 | 4.87 | 0.40 | 1.80 | ± 13.1 % |
| 5300 | 35.9 | 4.76 | 4.66 | 4.66 | 4.66 | 0.40 | 1.80 | ± 13.1 % |
| 5500 | 35.6 | 4.96 | 4.54 | 4.54 | 4.54 | 0.40 | 1.80 | ± 13.1 % |
| 5600 | 35.5 | 5.07 | 4.37 | 4.37 | 4.37 | 0.40 | 1.80 | ± 13.1 % |
| 5800 | 35.3 | 5.27 | 4.11 | 4.11 | 4.11 | 0.50 | 1.80 | ± 13.1 % |

^C Frequency validity of ± 100 MHz only applies for DASY v4.4 and higher (see Page 2), else it is restricted to ± 50 MHz. The uncertainty is the RSS of the ConvF uncertainty at calibration frequency and the uncertainty for the indicated frequency band.

^F At frequencies below 3 GHz, the validity of tissue parameters (ϵ and σ) can be relaxed to ± 10% if liquid compensation formula is applied to measured SAR values. At frequencies above 3 GHz, the validity of tissue parameters (ϵ and σ) is restricted to ± 5%. The uncertainty is the RSS of the ConvF uncertainty for indicated target tissue parameters.

^G Alpha/Depth are determined during calibration. SPEAG warrants that the remaining deviation due to the boundary effect after compensation is always less than ± 1% for frequencies below 3 GHz and below ± 2% for frequencies between 3-6 GHz at any distance larger than half the probe tip diameter from the boundary.

DASY/EASY - Parameters of Probe: EX3DV4 - SN:3920

Calibration Parameter Determined in Body Tissue Simulating Media

| f (MHz) ^C | Relative Permittivity ^F | Conductivity (S/m) ^F | ConvF X | ConvF Y | ConvF Z | Alpha ^G | Depth ^G (mm) | Unct. (k=2) |
|----------------------|------------------------------------|---------------------------------|---------|---------|---------|--------------------|-------------------------|-------------|
| 750 | 55.5 | 0.96 | 9.54 | 9.54 | 9.54 | 0.32 | 1.07 | ± 12.0 % |
| 835 | 55.2 | 0.97 | 9.47 | 9.47 | 9.47 | 0.45 | 0.85 | ± 12.0 % |
| 1750 | 53.4 | 1.49 | 7.77 | 7.77 | 7.77 | 0.59 | 0.74 | ± 12.0 % |
| 1900 | 53.3 | 1.52 | 7.50 | 7.50 | 7.50 | 0.37 | 0.91 | ± 12.0 % |
| 2450 | 52.7 | 1.95 | 7.18 | 7.18 | 7.18 | 0.80 | 0.56 | ± 12.0 % |
| 2600 | 52.5 | 2.16 | 6.91 | 6.91 | 6.91 | 0.80 | 0.57 | ± 12.0 % |
| 5200 | 49.0 | 5.30 | 4.23 | 4.23 | 4.23 | 0.50 | 1.90 | ± 13.1 % |
| 5300 | 48.9 | 5.42 | 4.11 | 4.11 | 4.11 | 0.50 | 1.90 | ± 13.1 % |
| 5500 | 48.6 | 5.65 | 3.80 | 3.80 | 3.80 | 0.50 | 1.90 | ± 13.1 % |
| 5600 | 48.5 | 5.77 | 3.62 | 3.62 | 3.62 | 0.50 | 1.90 | ± 13.1 % |
| 5800 | 48.2 | 6.00 | 4.00 | 4.00 | 4.00 | 0.50 | 1.90 | ± 13.1 % |

^C Frequency validity of ± 100 MHz only applies for DASY v4.4 and higher (see Page 2), else it is restricted to ± 50 MHz. The uncertainty is the RSS of the ConvF uncertainty at calibration frequency and the uncertainty for the indicated frequency band.

^F At frequencies below 3 GHz, the validity of tissue parameters (ϵ and σ) can be relaxed to ± 10% if liquid compensation formula is applied to measured SAR values. At frequencies above 3 GHz, the validity of tissue parameters (ϵ and σ) is restricted to ± 5%. The uncertainty is the RSS of the ConvF uncertainty for indicated target tissue parameters.

^G Alpha/Depth are determined during calibration. SPEAG warrants that the remaining deviation due to the boundary effect after compensation is always less than ± 1% for frequencies below 3 GHz and below ± 2% for frequencies between 3-6 GHz at any distance larger than half the probe tip diameter from the boundary.

Frequency Response of E-Field (TEM-Cell:ifi110 EXX, Waveguide: R22)

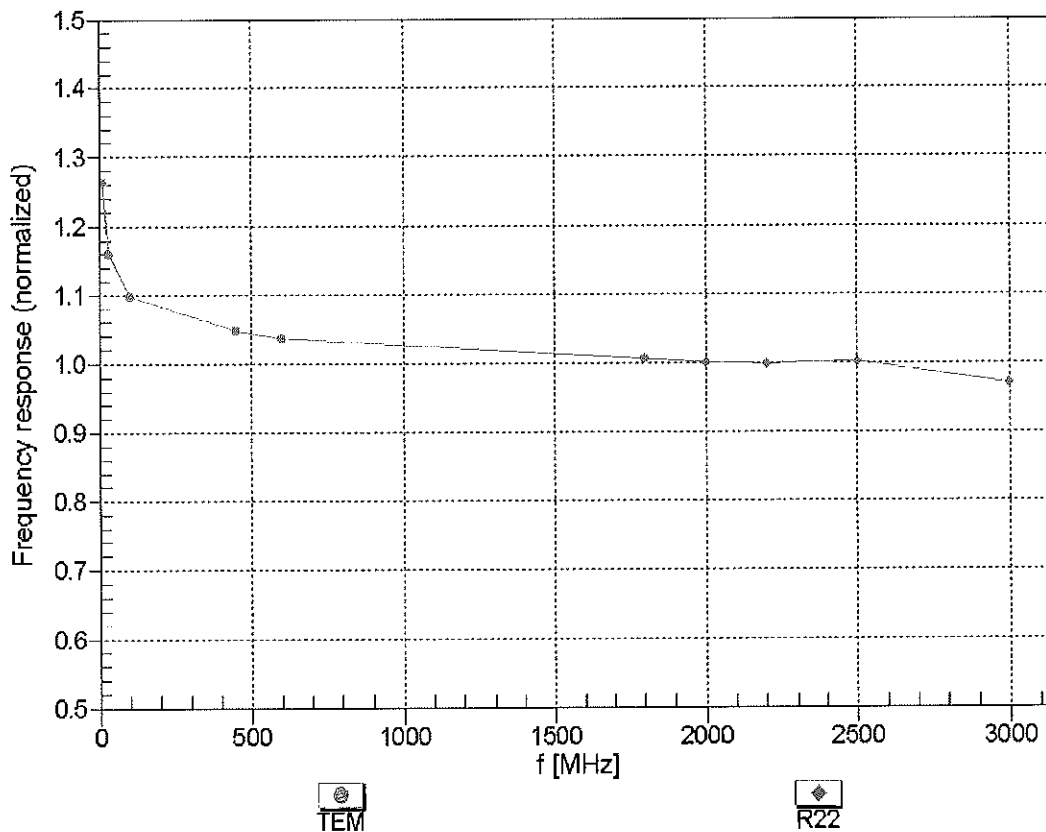

Uncertainty of Frequency Response of E-field: $\pm 6.3\%$ (k=2)

Receiving Pattern (ϕ), $\theta = 0^\circ$

f=600 MHz,TEM

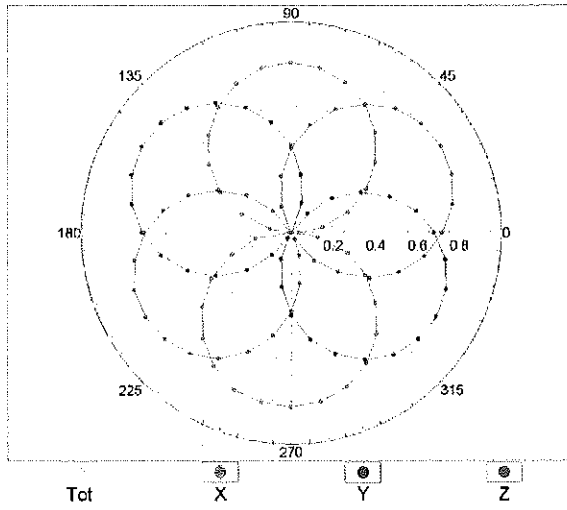

f=1800 MHz,R22

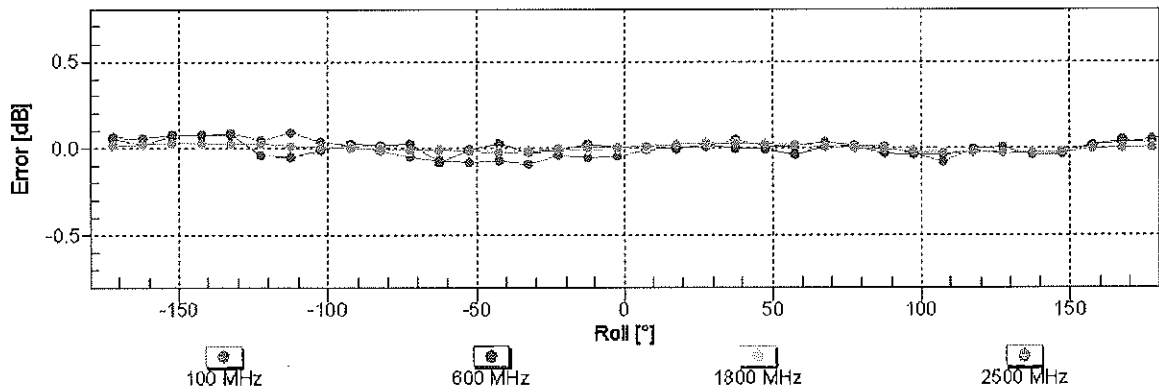
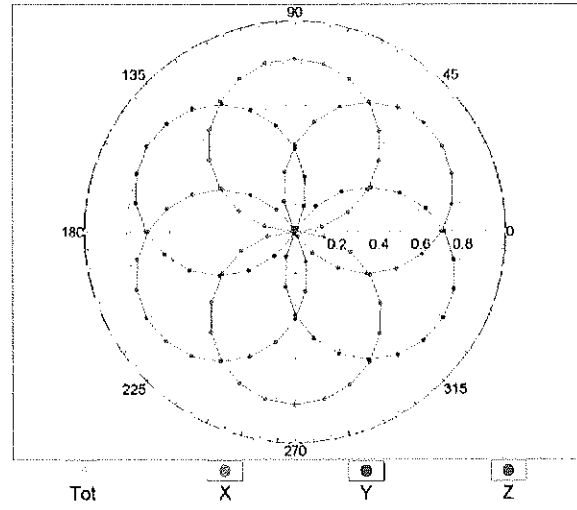

Uncertainty of Axial Isotropy Assessment: $\pm 0.5\%$ (k=2)

Dynamic Range $f(SAR_{head})$ (TEM cell , $f = 900$ MHz)

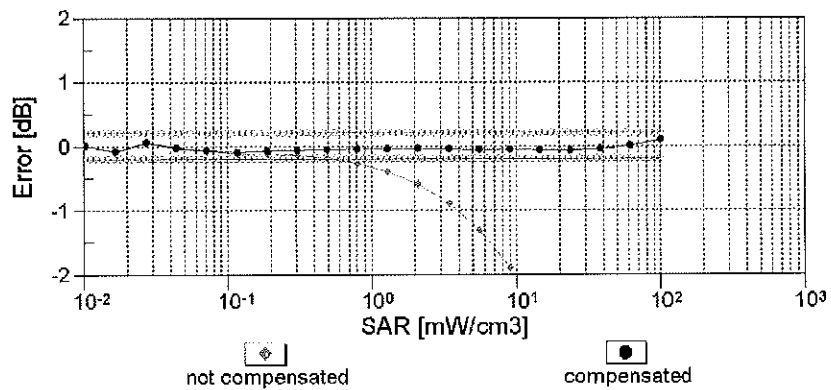
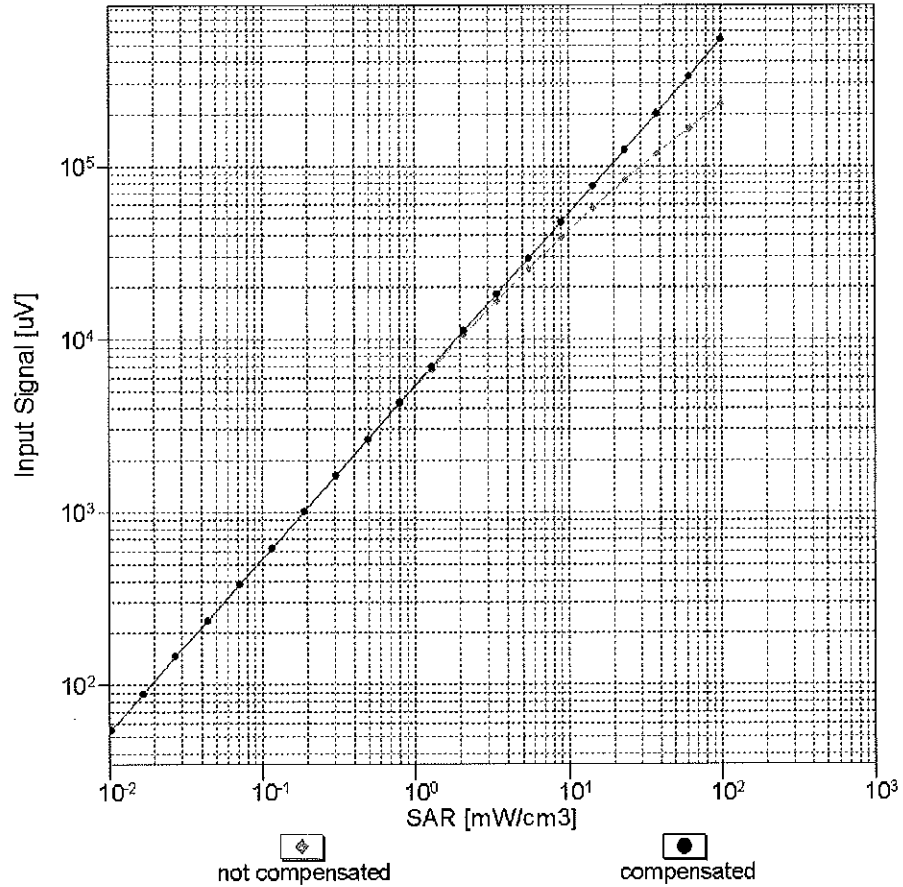

Uncertainty of Linearity Assessment: $\pm 0.6\%$ ($k=2$)

Conversion Factor Assessment

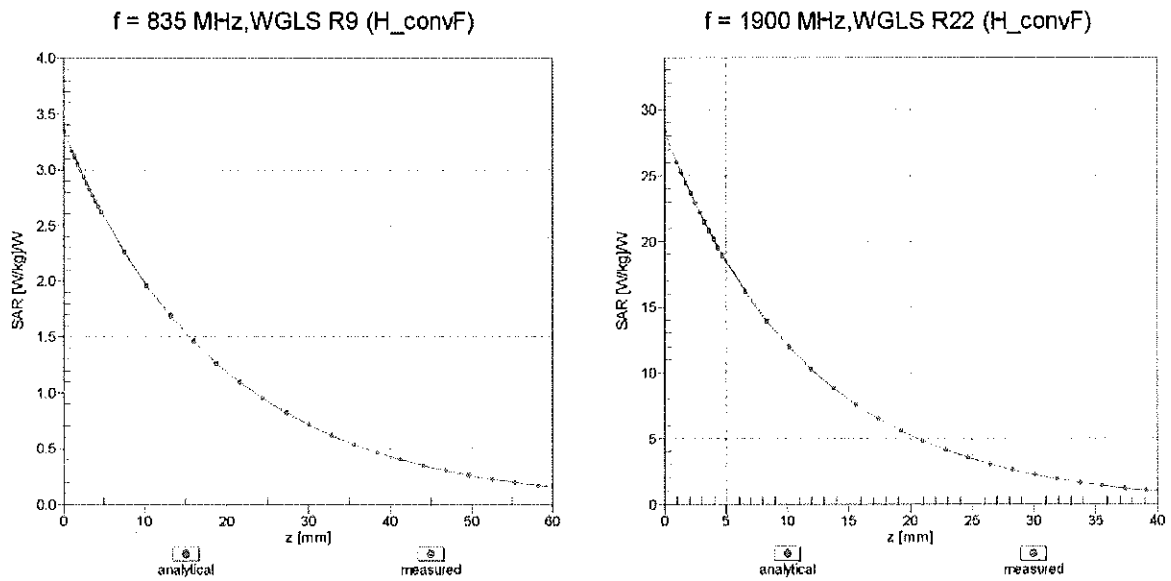

Deviation from Isotropy in Liquid Error (ϕ, θ), f = 900 MHz

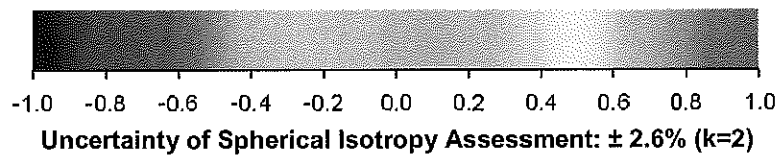
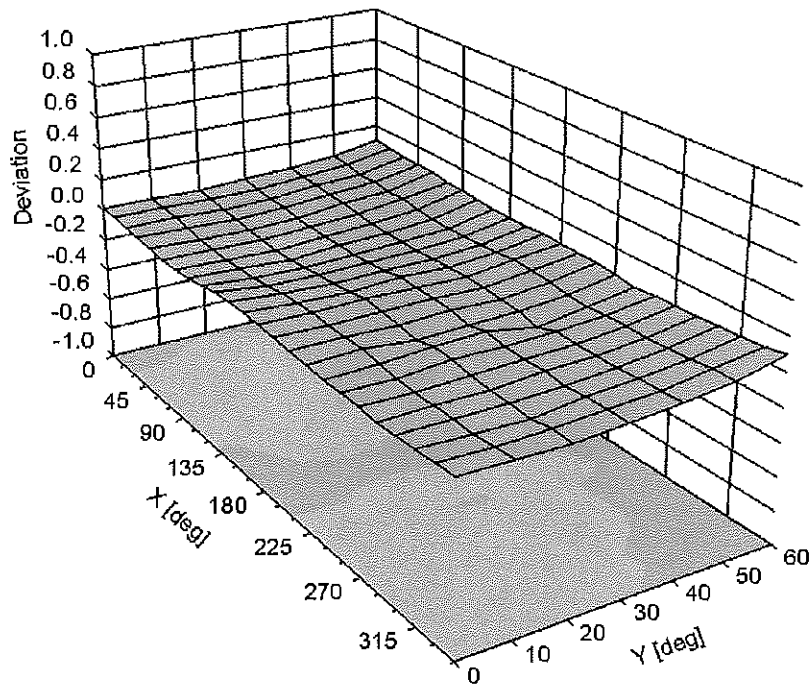

DASY/EASY - Parameters of Probe: EX3DV4 - SN:3920

Other Probe Parameters

| | |
|---|------------|
| Sensor Arrangement | Triangular |
| Connector Angle (°) | -22.4 |
| Mechanical Surface Detection Mode | enabled |
| Optical Surface Detection Mode | disabled |
| Probe Overall Length | 337 mm |
| Probe Body Diameter | 10 mm |
| Tip Length | 9 mm |
| Tip Diameter | 2.5 mm |
| Probe Tip to Sensor X Calibration Point | 1 mm |
| Probe Tip to Sensor Y Calibration Point | 1 mm |
| Probe Tip to Sensor Z Calibration Point | 1 mm |
| Recommended Measurement Distance from Surface | 2 mm |



Accredited by the Swiss Accreditation Service (SAS)
The Swiss Accreditation Service is one of the signatories to the EA
Multilateral Agreement for the recognition of calibration certificates

Accreditation No.: **SCS 108**

Client **PC Test**

Certificate No: **D2450V2-797_Jan14**

CALIBRATION CERTIFICATE

Object **D2450V2 - SN: 797**

Calibration procedure(s) **QA CAL-05.v9
Calibration procedure for dipole validation kits above 700 MHz**

Calibration date: **January 21, 2014**

*CC ✓
2/5/14*

This calibration certificate documents the traceability to national standards, which realize the physical units of measurements (SI).
The measurements and the uncertainties with confidence probability are given on the following pages and are part of the certificate.

All calibrations have been conducted in the closed laboratory facility: environment temperature (22 ± 3)°C and humidity < 70%.

Calibration Equipment used (M&TE critical for calibration)

| Primary Standards | ID # | Cal Date (Certificate No.) | Scheduled Calibration |
|-----------------------------|--------------------|-----------------------------------|------------------------|
| Power meter EPM-442A | GB37480704 | 09-Oct-13 (No. 217-01827) | Oct-14 |
| Power sensor HP 8481A | US37292783 | 09-Oct-13 (No. 217-01827) | Oct-14 |
| Power sensor HP 8481A | MY41092317 | 09-Oct-13 (No. 217-01828) | Oct-14 |
| Reference 20 dB Attenuator | SN: 5058 (20k) | 04-Apr-13 (No. 217-01736) | Apr-14 |
| Type-N mismatch combination | SN: 5047.3 / 06327 | 04-Apr-13 (No. 217-01739) | Apr-14 |
| Reference Probe ES3DV3 | SN: 3205 | 30-Dec-13 (No. ES3-3205_Dec13) | Dec-14 |
| DAE4 | SN: 601 | 25-Apr-13 (No. DAE4-601_Apr13) | Apr-14 |
| Secondary Standards | ID # | Check Date (in house) | Scheduled Check |
| RF generator R&S SMT-06 | 100005 | 04-Aug-99 (in house check Oct-13) | In house check: Oct-16 |
| Network Analyzer HP 8753E | US37390585 S4206 | 18-Oct-01 (in house check Oct-13) | In house check: Oct-14 |

| | | | |
|----------------|----------------|-----------------------|-----------------------|
| | Name | Function | Signature |
| Calibrated by: | Israe El-Naouq | Laboratory Technician | <i>Israe El-Naouq</i> |
| Approved by: | Katja Pokovic | Technical Manager | <i>Katja Pokovic</i> |

Issued: January 21, 2014

This calibration certificate shall not be reproduced except in full without written approval of the laboratory.



Accredited by the Swiss Accreditation Service (SAS)

Accreditation No.: **SCS 108**

The Swiss Accreditation Service is one of the signatories to the EA
Multilateral Agreement for the recognition of calibration certificates

Glossary:

| | |
|-------|---------------------------------|
| TSL | tissue simulating liquid |
| ConvF | sensitivity in TSL / NORM x,y,z |
| N/A | not applicable or not measured |

Calibration is Performed According to the Following Standards:

- IEEE Std 1528-2013, "IEEE Recommended Practice for Determining the Peak Spatial-Averaged Specific Absorption Rate (SAR) in the Human Head from Wireless Communications Devices: Measurement Techniques", June 2013
- IEC 62209-1, "Procedure to measure the Specific Absorption Rate (SAR) for hand-held devices used in close proximity to the ear (frequency range of 300 MHz to 3 GHz)", February 2005
- KDB 865664, "SAR Measurement Requirements for 100 MHz to 6 GHz"

Additional Documentation:

- DASY4/5 System Handbook

Methods Applied and Interpretation of Parameters:

- Measurement Conditions:** Further details are available from the Validation Report at the end of the certificate. All figures stated in the certificate are valid at the frequency indicated.
- Antenna Parameters with TSL:** The dipole is mounted with the spacer to position its feed point exactly below the center marking of the flat phantom section, with the arms oriented parallel to the body axis.
- Feed Point Impedance and Return Loss:** These parameters are measured with the dipole positioned under the liquid filled phantom. The impedance stated is transformed from the measurement at the SMA connector to the feed point. The Return Loss ensures low reflected power. No uncertainty required.
- Electrical Delay:** One-way delay between the SMA connector and the antenna feed point. No uncertainty required.
- SAR measured:** SAR measured at the stated antenna input power.
- SAR normalized:** SAR as measured, normalized to an input power of 1 W at the antenna connector.
- SAR for nominal TSL parameters:** The measured TSL parameters are used to calculate the nominal SAR result.

The reported uncertainty of measurement is stated as the standard uncertainty of measurement multiplied by the coverage factor $k=2$, which for a normal distribution corresponds to a coverage probability of approximately 95%.

Measurement Conditions

DASY system configuration, as far as not given on page 1.

| | | |
|-------------------------------------|------------------------|-------------|
| DASY Version | DASY5 | V52.8.7 |
| Extrapolation | Advanced Extrapolation | |
| Phantom | Modular Flat Phantom | |
| Distance Dipole Center - TSL | 10 mm | with Spacer |
| Zoom Scan Resolution | dx, dy, dz = 5 mm | |
| Frequency | 2450 MHz ± 1 MHz | |

Head TSL parameters

The following parameters and calculations were applied.

| | Temperature | Permittivity | Conductivity |
|--|-----------------|--------------|------------------|
| Nominal Head TSL parameters | 22.0 °C | 39.2 | 1.80 mho/m |
| Measured Head TSL parameters | (22.0 ± 0.2) °C | 38.7 ± 6 % | 1.86 mho/m ± 6 % |
| Head TSL temperature change during test | < 0.5 °C | --- | --- |

SAR result with Head TSL

| SAR averaged over 1 cm³ (1 g) of Head TSL | Condition | |
|---|--------------------|---------------------------------|
| SAR measured | 250 mW input power | 13.2 W/kg |
| SAR for nominal Head TSL parameters | normalized to 1W | 51.8 W/kg ± 17.0 % (k=2) |

| SAR averaged over 10 cm³ (10 g) of Head TSL | condition | |
|---|--------------------|---------------------------------|
| SAR measured | 250 mW input power | 6.13 W/kg |
| SAR for nominal Head TSL parameters | normalized to 1W | 24.3 W/kg ± 16.5 % (k=2) |

Body TSL parameters

The following parameters and calculations were applied.

| | Temperature | Permittivity | Conductivity |
|--|-----------------|--------------|------------------|
| Nominal Body TSL parameters | 22.0 °C | 52.7 | 1.95 mho/m |
| Measured Body TSL parameters | (22.0 ± 0.2) °C | 51.3 ± 6 % | 2.04 mho/m ± 6 % |
| Body TSL temperature change during test | < 0.5 °C | --- | --- |

SAR result with Body TSL

| SAR averaged over 1 cm³ (1 g) of Body TSL | Condition | |
|---|--------------------|---------------------------------|
| SAR measured | 250 mW input power | 12.7 W/kg |
| SAR for nominal Body TSL parameters | normalized to 1W | 49.4 W/kg ± 17.0 % (k=2) |

| SAR averaged over 10 cm³ (10 g) of Body TSL | condition | |
|---|--------------------|---------------------------------|
| SAR measured | 250 mW input power | 5.86 W/kg |
| SAR for nominal Body TSL parameters | normalized to 1W | 23.1 W/kg ± 16.5 % (k=2) |

Appendix

Antenna Parameters with Head TSL

| | |
|--------------------------------------|-----------------------------|
| Impedance, transformed to feed point | $53.5 \Omega + 3.2 j\Omega$ |
| Return Loss | - 26.7 dB |

Antenna Parameters with Body TSL

| | |
|--------------------------------------|-----------------------------|
| Impedance, transformed to feed point | $50.0 \Omega + 4.9 j\Omega$ |
| Return Loss | - 26.2 dB |

General Antenna Parameters and Design

| | |
|----------------------------------|----------|
| Electrical Delay (one direction) | 1.151 ns |
|----------------------------------|----------|

After long term use with 100W radiated power, only a slight warming of the dipole near the feedpoint can be measured.

The dipole is made of standard semirigid coaxial cable. The center conductor of the feeding line is directly connected to the second arm of the dipole. The antenna is therefore short-circuited for DC-signals. On some of the dipoles, small end caps are added to the dipole arms in order to improve matching when loaded according to the position as explained in the "Measurement Conditions" paragraph. The SAR data are not affected by this change. The overall dipole length is still according to the Standard.

No excessive force must be applied to the dipole arms, because they might bend or the soldered connections near the feedpoint may be damaged.

Additional EUT Data

| | |
|-----------------|------------------|
| Manufactured by | SPEAG |
| Manufactured on | January 24, 2006 |

DASY5 Validation Report for Head TSL

Date: 21.01.2014

Test Laboratory: SPEAG, Zurich, Switzerland

DUT: Dipole 2450 MHz; Type: D2450V2; Serial: D2450V2 - SN: 797

Communication System: UID 0 - CW; Frequency: 2450 MHz

Medium parameters used: $f = 2450$ MHz; $\sigma = 1.86$ S/m; $\epsilon_r = 38.7$; $\rho = 1000$ kg/m³

Phantom section: Flat Section

Measurement Standard: DASY5 (IEEE/IEC/ANSI C63.19-2007)

DASY52 Configuration:

- Probe: ES3DV3 - SN3205; ConvF(4.53, 4.53, 4.53); Calibrated: 30.12.2013;
- Sensor-Surface: 3mm (Mechanical Surface Detection)
- Electronics: DAE4 Sn601; Calibrated: 25.04.2013
- Phantom: Flat Phantom 5.0 (front); Type: QD000P50AA; Serial: 1001
- DASY52 52.8.7(1137); SEMCAD X 14.6.10(7164)

Dipole Calibration for Head Tissue/Pin=250 mW, d=10mm/Zoom Scan (7x7x7)/Cube 0:

Measurement grid: dx=5mm, dy=5mm, dz=5mm

Reference Value = 99.151 V/m; Power Drift = 0.05 dB

Peak SAR (extrapolated) = 27.5 W/kg

SAR(1 g) = 13.2 W/kg; SAR(10 g) = 6.13 W/kg

Maximum value of SAR (measured) = 16.9 W/kg

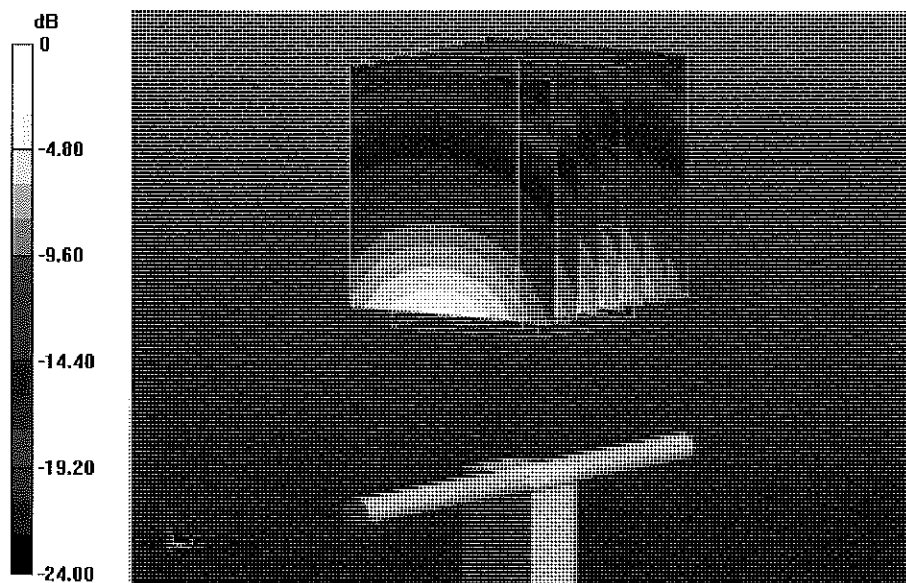

0 dB = 16.9 W/kg = 12.28 dBW/kg

Impedance Measurement Plot for Head TSL

21 Jan 2014 11:31:52

CHI S11 1 U FS 2: 53.512 Δ 3.2285 Δ 209.73 pH 2 450.000 000 MHz

*
De1

CA

Avg
1E

H1d

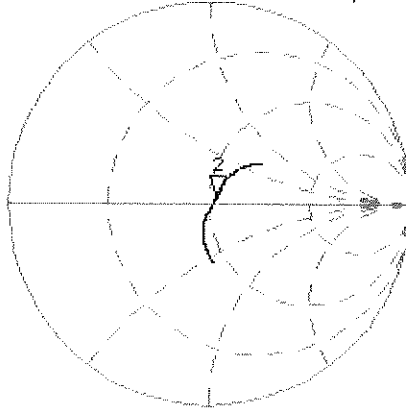

CH2 S11 LOG 5 dB/REF -20 dB 2:-26.730 dB 2 450.000 000 MHz

CA

Avg
1E

H1d

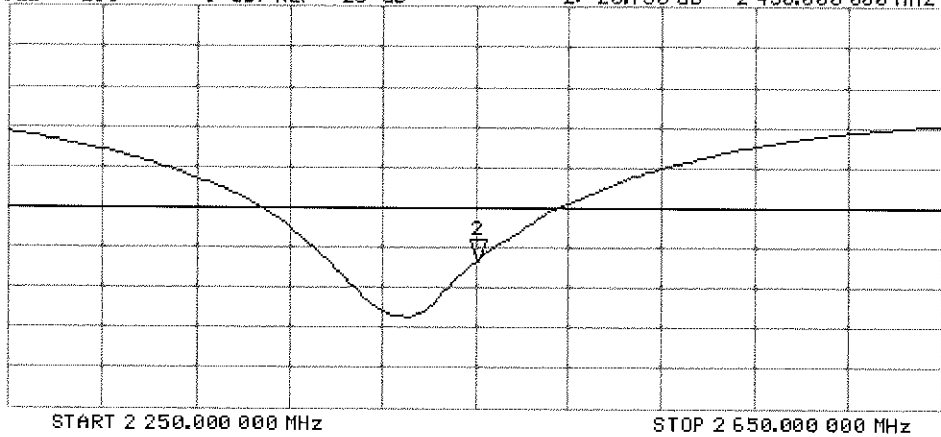

DASY5 Validation Report for Body TSL

Date: 21.01.2014

Test Laboratory: SPEAG, Zurich, Switzerland

DUT: Dipole 2450 MHz; Type: D2450V2; Serial: D2450V2 - SN: 797

Communication System: UID 0 - CW; Frequency: 2450 MHz

Medium parameters used: $f = 2450$ MHz; $\sigma = 2.04$ S/m; $\epsilon_r = 51.3$; $\rho = 1000$ kg/m³

Phantom section: Flat Section

Measurement Standard: DASY5 (IEEE/IEC/ANSI C63.19-2007)

DASY52 Configuration:

- Probe: ES3DV3 - SN3205; ConvF(4.35, 4.35, 4.35); Calibrated: 30.12.2013;
- Sensor-Surface: 3mm (Mechanical Surface Detection)
- Electronics: DAE4 Sn601; Calibrated: 25.04.2013
- Phantom: Flat Phantom 5.0 (back); Type: QD000P50AA; Serial: 1002
- DASY52 52.8.7(1137); SEMCAD X 14.6.10(7164)

Dipole Calibration for Body Tissue/Pin=250 mW, d=10mm/Zoom Scan (7x7x7)/Cube 0:

Measurement grid: dx=5mm, dy=5mm, dz=5mm

Reference Value = 93.709 V/m; Power Drift = 0.01 dB

Peak SAR (extrapolated) = 26.4 W/kg

SAR(1 g) = 12.7 W/kg; SAR(10 g) = 5.86 W/kg

Maximum value of SAR (measured) = 16.8 W/kg

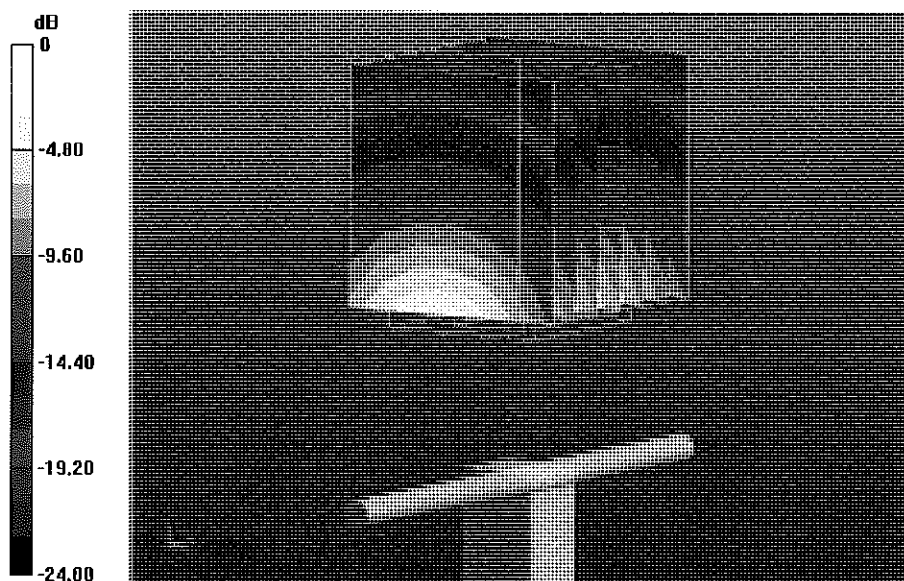

0 dB = 16.8 W/kg = 12.25 dBW/kg

Impedance Measurement Plot for Body TSL

21 Jan 2014 11:31:29

CH1 S11 1 U FS 2: 49.994 Ω 4.9258 Ω 319.98 μH 2 450.000 000 MHz

*
De l
C Δ

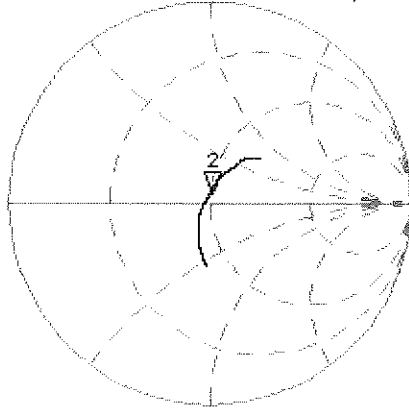

Avg
16

H1 d

CH2 S11 LOG 5 dB/REF -20 dB 2:-26.162 dB 2 450.000 000 MHz

C Δ

Avg
16

H1 d

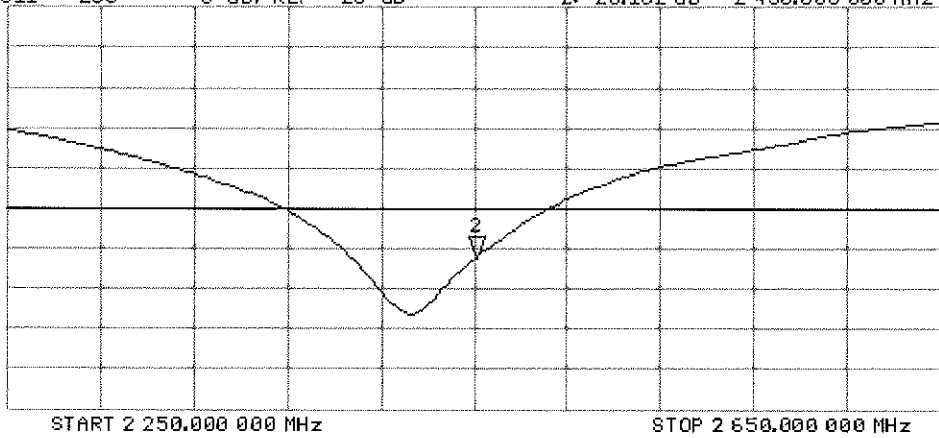

START 2 250.000 000 MHz

STOP 2 650.000 000 MHz



Accredited by the Swiss Accreditation Service (SAS)
The Swiss Accreditation Service is one of the signatories to the EA
Multilateral Agreement for the recognition of calibration certificates

Accreditation No.: **SCS 108**

Client **PC Test**

Certificate No: **D5GHzV2-1007_Sep13/2**

CALIBRATION CERTIFICATE (Replacement of No: D5GHzV2-1007_Sep13)

Object **D5GHzV2 - SN: 1007**

Calibration procedure(s) **QA CAL-22.v2
Calibration procedure for dipole validation kits between 3-6 GHz**

CCV
10/15/13

Calibration date: **September 23, 2013**

This calibration certificate documents the traceability to national standards, which realize the physical units of measurements (SI).
The measurements and the uncertainties with confidence probability are given on the following pages and are part of the certificate.

All calibrations have been conducted in the closed laboratory facility: environment temperature (22 ± 3)°C and humidity < 70%.

Calibration Equipment used (M&TE critical for calibration)

| Primary Standards | ID # | Cal Date (Certificate No.) | Scheduled Calibration |
|-----------------------------|--------------------|-----------------------------------|------------------------|
| Power meter EPM-442A | GB37480704 | 01-Nov-12 (No. 217-01640) | Oct-13 |
| Power sensor HP 8481A | US37292783 | 01-Nov-12 (No. 217-01640) | Oct-13 |
| Reference 20 dB Attenuator | SN: 5058 (20k) | 04-Apr-13 (No. 217-01736) | Apr-14 |
| Type-N mismatch combination | SN: 5047.3 / 06327 | 04-Apr-13 (No. 217-01739) | Apr-14 |
| Reference Probe EX3DV4 | SN: 3503 | 28-Dec-12 (No. EX3-3503_Dec12) | Dec-13 |
| DAE4 | SN: 601 | 25-Apr-13 (No. DAE4-601_Apr13) | Apr-14 |
| Secondary Standards | ID # | Check Date (in house) | Scheduled Check |
| Power sensor HP 8481A | MY41092317 | 18-Oct-02 (in house check Oct-11) | In house check: Oct-13 |
| RF generator R&S SMT-06 | 100005 | 04-Aug-99 (in house check Oct-11) | In house check: Oct-13 |
| Network Analyzer HP 8753E | US37390585 S4206 | 18-Oct-01 (in house check Oct-12) | In house check: Oct-13 |

| | | | |
|----------------|-----------------------------|--|---------------|
| Calibrated by: | Name Leif Klysner | Function Laboratory Technician | Signature |
| Approved by: | Katja Pokovic | Technical Manager | |

Issued: October 4, 2013

This calibration certificate shall not be reproduced except in full without written approval of the laboratory.



Accredited by the Swiss Accreditation Service (SAS)
The Swiss Accreditation Service is one of the signatories to the EA
Multilateral Agreement for the recognition of calibration certificates

Accreditation No.: **SCS 108**

Glossary:

| | |
|-------|---------------------------------|
| TSL | tissue simulating liquid |
| ConvF | sensitivity in TSL / NORM x,y,z |
| N/A | not applicable or not measured |

Calibration is Performed According to the Following Standards:

- IEC 62209-2, "Evaluation of Human Exposure to Radio Frequency Fields from Handheld and Body-Mounted Wireless Communication Devices in the Frequency Range of 30 MHz to 6 GHz: Human models, Instrumentation, and Procedures"; Part 2: "Procedure to determine the Specific Absorption Rate (SAR) for including accessories and multiple transmitters", March 2010
- KDB 865664, "SAR Measurement Requirements for 100 MHz to 6 GHz"
- IEEE Std 1528-2013, "IEEE Recommended Practice for Determining the Peak Spatial-Averaged Specific Absorption Rate (SAR) in the Human Head from Wireless Communications Devices: Measurement Techniques", June 2013

Additional Documentation:

- DASY4/5 System Handbook

Methods Applied and Interpretation of Parameters:

- Measurement Conditions:** Further details are available from the Validation Report at the end of the certificate. All figures stated in the certificate are valid at the frequency indicated.
- Antenna Parameters with TSL:** The dipole is mounted with the spacer to position its feed point exactly below the center marking of the flat phantom section, with the arms oriented parallel to the body axis.
- Feed Point Impedance and Return Loss:** These parameters are measured with the dipole positioned under the liquid filled phantom. The impedance stated is transformed from the measurement at the SMA connector to the feed point. The Return Loss ensures low reflected power. No uncertainty required.
- Electrical Delay:** One-way delay between the SMA connector and the antenna feed point. No uncertainty required.
- SAR measured:** SAR measured at the stated antenna input power.
- SAR normalized:** SAR as measured, normalized to an input power of 1 W at the antenna connector.
- SAR for nominal TSL parameters:** The measured TSL parameters are used to calculate the nominal SAR result.

The reported uncertainty of measurement is stated as the standard uncertainty of measurement multiplied by the coverage factor $k=2$, which for a normal distribution corresponds to a coverage probability of approximately 95%.

Measurement Conditions

DASY system configuration, as far as not given on page 1.

| | | |
|-------------------------------------|--|----------------------------------|
| DASY Version | DASY5 | V52.8.7 |
| Extrapolation | Advanced Extrapolation | |
| Phantom | Modular Flat Phantom V5.0 | |
| Distance Dipole Center - TSL | 10 mm | with Spacer |
| Zoom Scan Resolution | dx, dy = 4.0 mm, dz = 1.4 mm | Graded Ratio = 1.4 (Z direction) |
| Frequency | 5200 MHz ± 1 MHz 5300 MHz ± 1 MHz 5500 MHz ± 1 MHz 5600 MHz ± 1 MHz 5800 MHz ± 1 MHz | |

Head TSL parameters at 5200 MHz

The following parameters and calculations were applied.

| | Temperature | Permittivity | Conductivity |
|--|-----------------|--------------|------------------|
| Nominal Head TSL parameters | 22.0 °C | 36.0 | 4.66 mho/m |
| Measured Head TSL parameters | (22.0 ± 0.2) °C | 35.8 ± 6 % | 4.48 mho/m ± 6 % |
| Head TSL temperature change during test | < 0.5 °C | ---- | ---- |

SAR result with Head TSL at 5200 MHz

| SAR averaged over 1 cm³ (1 g) of Head TSL | Condition | |
|---|--------------------|---------------------------------|
| SAR measured | 100 mW input power | 7.77 W/kg |
| SAR for nominal Head TSL parameters | normalized to 1W | 77.5 W/kg ± 19.9 % (k=2) |

| SAR averaged over 10 cm³ (10 g) of Head TSL | condition | |
|---|--------------------|---------------------------------|
| SAR measured | 100 mW input power | 2.23 W/kg |
| SAR for nominal Head TSL parameters | normalized to 1W | 22.2 W/kg ± 19.5 % (k=2) |

Head TSL parameters at 5300 MHz

The following parameters and calculations were applied.

| | Temperature | Permittivity | Conductivity |
|---|-----------------|--------------|------------------|
| Nominal Head TSL parameters | 22.0 °C | 35.9 | 4.76 mho/m |
| Measured Head TSL parameters | (22.0 ± 0.2) °C | 35.6 ± 6 % | 4.62 mho/m ± 6 % |
| Head TSL temperature change during test | < 0.5 °C | ---- | ---- |

SAR result with Head TSL at 5300 MHz

| SAR averaged over 1 cm ³ (1 g) of Head TSL | Condition | |
|---|--------------------|-----------------------------------|
| SAR measured | 100 mW input power | 8.04 W/kg |
| SAR for nominal Head TSL parameters | normalized to 1W | 80.2 W / kg ± 19.9 % (k=2) |

| SAR averaged over 10 cm ³ (10 g) of Head TSL | condition | |
|---|--------------------|---------------------------------|
| SAR measured | 100 mW input power | 2.30 W/kg |
| SAR for nominal Head TSL parameters | normalized to 1W | 22.9 W/kg ± 19.5 % (k=2) |

Head TSL parameters at 5500 MHz

The following parameters and calculations were applied.

| | Temperature | Permittivity | Conductivity |
|---|-----------------|--------------|------------------|
| Nominal Head TSL parameters | 22.0 °C | 35.6 | 4.96 mho/m |
| Measured Head TSL parameters | (22.0 ± 0.2) °C | 35.4 ± 6 % | 4.76 mho/m ± 6 % |
| Head TSL temperature change during test | < 0.5 °C | ---- | ---- |

SAR result with Head TSL at 5500 MHz

| SAR averaged over 1 cm ³ (1 g) of Head TSL | Condition | |
|---|--------------------|---------------------------------|
| SAR measured | 100 mW input power | 8.17 W/kg |
| SAR for nominal Head TSL parameters | normalized to 1W | 81.4 W/kg ± 19.9 % (k=2) |

| SAR averaged over 10 cm ³ (10 g) of Head TSL | condition | |
|---|--------------------|---------------------------------|
| SAR measured | 100 mW input power | 2.32 W/kg |
| SAR for nominal Head TSL parameters | normalized to 1W | 23.1 W/kg ± 19.5 % (k=2) |

Head TSL parameters at 5600 MHz

The following parameters and calculations were applied.

| | Temperature | Permittivity | Conductivity |
|---|-----------------|--------------|------------------|
| Nominal Head TSL parameters | 22.0 °C | 35.5 | 5.07 mho/m |
| Measured Head TSL parameters | (22.0 ± 0.2) °C | 35.2 ± 6 % | 4.86 mho/m ± 6 % |
| Head TSL temperature change during test | < 0.5 °C | ---- | ---- |

SAR result with Head TSL at 5600 MHz

| SAR averaged over 1 cm ³ (1 g) of Head TSL | Condition | |
|---|--------------------|---------------------------------|
| SAR measured | 100 mW input power | 8.03 W/kg |
| SAR for nominal Head TSL parameters | normalized to 1W | 80.0 W/kg ± 19.9 % (k=2) |

| SAR averaged over 10 cm ³ (10 g) of Head TSL | condition | |
|---|--------------------|---------------------------------|
| SAR measured | 100 mW input power | 2.28 W/kg |
| SAR for nominal Head TSL parameters | normalized to 1W | 22.7 W/kg ± 19.5 % (k=2) |

Head TSL parameters at 5800 MHz

The following parameters and calculations were applied.

| | Temperature | Permittivity | Conductivity |
|---|-----------------|--------------|------------------|
| Nominal Head TSL parameters | 22.0 °C | 35.3 | 5.27 mho/m |
| Measured Head TSL parameters | (22.0 ± 0.2) °C | 35.0 ± 6 % | 5.07 mho/m ± 6 % |
| Head TSL temperature change during test | < 0.5 °C | ---- | ---- |

SAR result with Head TSL at 5800 MHz

| SAR averaged over 1 cm ³ (1 g) of Head TSL | Condition | |
|---|--------------------|---------------------------------|
| SAR measured | 100 mW input power | 7.78 W/kg |
| SAR for nominal Head TSL parameters | normalized to 1W | 77.5 W/kg ± 19.9 % (k=2) |

| SAR averaged over 10 cm ³ (10 g) of Head TSL | condition | |
|---|--------------------|---------------------------------|
| SAR measured | 100 mW input power | 2.20 W/kg |
| SAR for nominal Head TSL parameters | normalized to 1W | 21.9 W/kg ± 19.5 % (k=2) |

Body TSL parameters at 5200 MHz

The following parameters and calculations were applied.

| | Temperature | Permittivity | Conductivity |
|---|-----------------|--------------|------------------|
| Nominal Body TSL parameters | 22.0 °C | 49.0 | 5.30 mho/m |
| Measured Body TSL parameters | (22.0 ± 0.2) °C | 48.3 ± 6 % | 5.36 mho/m ± 6 % |
| Body TSL temperature change during test | < 0.5 °C | ---- | ---- |

SAR result with Body TSL at 5200 MHz

| SAR averaged over 1 cm ³ (1 g) of Body TSL | Condition | |
|---|--------------------|---------------------------------|
| SAR measured | 100 mW input power | 7.28 W/kg |
| SAR for nominal Body TSL parameters | normalized to 1W | 72.6 W/kg ± 19.9 % (k=2) |

| SAR averaged over 10 cm ³ (10 g) of Body TSL | condition | |
|---|--------------------|---------------------------------|
| SAR measured | 100 mW input power | 2.03 W/kg |
| SAR for nominal Body TSL parameters | normalized to 1W | 20.2 W/kg ± 19.5 % (k=2) |

Body TSL parameters at 5300 MHz

The following parameters and calculations were applied.

| | Temperature | Permittivity | Conductivity |
|---|-----------------|--------------|------------------|
| Nominal Body TSL parameters | 22.0 °C | 48.9 | 5.42 mho/m |
| Measured Body TSL parameters | (22.0 ± 0.2) °C | 48.1 ± 6 % | 5.56 mho/m ± 6 % |
| Body TSL temperature change during test | < 0.5 °C | ---- | ---- |

SAR result with Body TSL at 5300 MHz

| SAR averaged over 1 cm ³ (1 g) of Body TSL | Condition | |
|---|--------------------|---------------------------------|
| SAR measured | 100 mW input power | 7.49 W/kg |
| SAR for nominal Body TSL parameters | normalized to 1W | 74.7 W/kg ± 19.9 % (k=2) |

| SAR averaged over 10 cm ³ (10 g) of Body TSL | condition | |
|---|--------------------|---------------------------------|
| SAR measured | 100 mW input power | 2.09 W/kg |
| SAR for nominal Body TSL parameters | normalized to 1W | 20.8 W/kg ± 19.5 % (k=2) |

Body TSL parameters at 5500 MHz

The following parameters and calculations were applied.

| | Temperature | Permittivity | Conductivity |
|---|-----------------|--------------|------------------|
| Nominal Body TSL parameters | 22.0 °C | 48.6 | 5.65 mho/m |
| Measured Body TSL parameters | (22.0 ± 0.2) °C | 47.8 ± 6 % | 5.75 mho/m ± 6 % |
| Body TSL temperature change during test | < 0.5 °C | ---- | ---- |

SAR result with Body TSL at 5500 MHz

| SAR averaged over 1 cm ³ (1 g) of Body TSL | Condition | |
|---|--------------------|--------------------------|
| SAR measured | 100 mW input power | 7.61 W/kg |
| SAR for nominal Body TSL parameters | normalized to 1W | 75.9 W/kg ± 19.9 % (k=2) |

| SAR averaged over 10 cm ³ (10 g) of Body TSL | condition | |
|---|--------------------|--------------------------|
| SAR measured | 100 mW input power | 2.11 W/kg |
| SAR for nominal Body TSL parameters | normalized to 1W | 21.0 W/kg ± 19.5 % (k=2) |

Body TSL parameters at 5600 MHz

The following parameters and calculations were applied.

| | Temperature | Permittivity | Conductivity |
|---|-----------------|--------------|------------------|
| Nominal Body TSL parameters | 22.0 °C | 48.5 | 5.77 mho/m |
| Measured Body TSL parameters | (22.0 ± 0.2) °C | 47.6 ± 6 % | 5.88 mho/m ± 6 % |
| Body TSL temperature change during test | < 0.5 °C | ---- | ---- |

SAR result with Body TSL at 5600 MHz

| SAR averaged over 1 cm ³ (1 g) of Body TSL | Condition | |
|---|--------------------|--------------------------|
| SAR measured | 100 mW input power | 7.75 W/kg |
| SAR for nominal Body TSL parameters | normalized to 1W | 77.3 W/kg ± 19.9 % (k=2) |

| SAR averaged over 10 cm ³ (10 g) of Body TSL | condition | |
|---|--------------------|--------------------------|
| SAR measured | 100 mW input power | 2.16 W/kg |
| SAR for nominal Body TSL parameters | normalized to 1W | 21.5 W/kg ± 19.5 % (k=2) |

Body TSL parameters at 5800 MHz

The following parameters and calculations were applied.

| | Temperature | Permittivity | Conductivity |
|---|-----------------|--------------|------------------|
| Nominal Body TSL parameters | 22.0 °C | 48.2 | 6.00 mho/m |
| Measured Body TSL parameters | (22.0 ± 0.2) °C | 47.3 ± 6 % | 6.17 mho/m ± 6 % |
| Body TSL temperature change during test | < 0.5 °C | ---- | ---- |

SAR result with Body TSL at 5800 MHz

| SAR averaged over 1 cm ³ (1 g) of Body TSL | Condition | |
|---|--------------------|---------------------------------|
| SAR measured | 100 mW input power | 7.31 W/kg |
| SAR for nominal Body TSL parameters | normalized to 1W | 72.9 W/kg ± 19.9 % (k=2) |

| SAR averaged over 10 cm ³ (10 g) of Body TSL | condition | |
|---|--------------------|---------------------------------|
| SAR measured | 100 mW input power | 2.02 W/kg |
| SAR for nominal Body TSL parameters | normalized to 1W | 20.1 W/kg ± 19.5 % (k=2) |

Appendix

Antenna Parameters with Head TSL at 5200 MHz

| | |
|--------------------------------------|---------------------------------|
| Impedance, transformed to feed point | 52.4 Ω - 11.0 j Ω |
| Return Loss | - 19.2 dB |

Antenna Parameters with Head TSL at 5300 MHz

| | |
|--------------------------------------|--------------------------------|
| Impedance, transformed to feed point | 56.8 Ω - 4.4 j Ω |
| Return Loss | - 22.3 dB |

Antenna Parameters with Head TSL at 5500 MHz

| | |
|--------------------------------------|--------------------------------|
| Impedance, transformed to feed point | 48.8 Ω - 5.4 j Ω |
| Return Loss | - 25.1 dB |

Antenna Parameters with Head TSL at 5600 MHz

| | |
|--------------------------------------|--------------------------------|
| Impedance, transformed to feed point | 57.3 Ω - 8.7 j Ω |
| Return Loss | - 19.5 dB |

Antenna Parameters with Head TSL at 5800 MHz

| | |
|--------------------------------------|--------------------------------|
| Impedance, transformed to feed point | 56.9 Ω + 1.6 j Ω |
| Return Loss | - 23.5 dB |

Antenna Parameters with Body TSL at 5200 MHz

| | |
|--------------------------------------|---------------------------------|
| Impedance, transformed to feed point | 53.1 Ω - 10.3 j Ω |
| Return Loss | - 19.7 dB |

Antenna Parameters with Body TSL at 5300 MHz

| | |
|--------------------------------------|--------------------------------|
| Impedance, transformed to feed point | 54.3 Ω - 1.5 j Ω |
| Return Loss | - 27.2 dB |

Antenna Parameters with Body TSL at 5500 MHz

| | |
|--------------------------------------|--------------------------------|
| Impedance, transformed to feed point | 49.7 Ω - 3.6 j Ω |
| Return Loss | - 28.7 dB |

Antenna Parameters with Body TSL at 5600 MHz

| | |
|--------------------------------------|--------------------------------|
| Impedance, transformed to feed point | 58.2 Ω - 5.2 j Ω |
| Return Loss | - 20.9 dB |

Antenna Parameters with Body TSL at 5800 MHz

| | |
|--------------------------------------|--------------------------------|
| Impedance, transformed to feed point | 58.7 Ω + 3.9 j Ω |
| Return Loss | - 21.1 dB |

General Antenna Parameters and Design

| | |
|----------------------------------|----------|
| Electrical Delay (one direction) | 1.201 ns |
|----------------------------------|----------|

After long term use with 100W radiated power, only a slight warming of the dipole near the feedpoint can be measured.

The dipole is made of standard semirigid coaxial cable. The center conductor of the feeding line is directly connected to the second arm of the dipole. The antenna is therefore short-circuited for DC-signals. On some of the dipoles, small end caps are added to the dipole arms in order to improve matching when loaded according to the position as explained in the "Measurement Conditions" paragraph. The SAR data are not affected by this change. The overall dipole length is still according to the Standard.

No excessive force must be applied to the dipole arms, because they might bend or the soldered connections near the feedpoint may be damaged.

Additional EUT Data

| | |
|-----------------|-----------------|
| Manufactured by | SPEAG |
| Manufactured on | August 28, 2003 |

DASY5 Validation Report for Head TSL

Date: 23.09.2013

Test Laboratory: SPEAG, Zurich, Switzerland

DUT: Dipole 5GHz; Type: D5GHzV2; Serial: D5GHzV2 - SN: 1007

Communication System: UID 0 - CW ; Frequency: 5200 MHz, Frequency: 5300 MHz, Frequency: 5500 MHz, Frequency: 5600 MHz, Frequency: 5800 MHz

Medium parameters used: $f = 5200$ MHz; $\sigma = 4.48$ S/m; $\epsilon_r = 35.8$; $\rho = 1000$ kg/m³, Medium parameters used: $f = 5300$ MHz; $\sigma = 4.62$ S/m; $\epsilon_r = 35.6$; $\rho = 1000$ kg/m³, Medium parameters used: $f = 5500$ MHz; $\sigma = 4.76$ S/m; $\epsilon_r = 35.4$; $\rho = 1000$ kg/m³, Medium parameters used: $f = 5600$ MHz; $\sigma = 4.86$ S/m; $\epsilon_r = 35.2$; $\rho = 1000$ kg/m³, Medium parameters used: $f = 5800$ MHz; $\sigma = 5.07$ S/m; $\epsilon_r = 35$; $\rho = 1000$ kg/m³

Phantom section: Flat Section

Measurement Standard: DASY5 (IEEE/IEC/ANSI C63.19-2007)

DASY52 Configuration:

- Probe: EX3DV4 - SN3503; ConvF(5.41, 5.41, 5.41); Calibrated: 28.12.2012, ConvF(5.1, 5.1, 5.1); Calibrated: 28.12.2012, ConvF(4.91, 4.91, 4.91); Calibrated: 28.12.2012, ConvF(4.76, 4.76, 4.76); Calibrated: 28.12.2012, ConvF(4.81, 4.81, 4.81); Calibrated: 28.12.2012;
- Sensor-Surface: 1.4mm (Mechanical Surface Detection)
- Electronics: DAE4 Sn601; Calibrated: 25.04.2013
- Phantom: Flat Phantom 5.0 (front); Type: QD000P50AA; Serial: 1001
- DASY52 52.8.7(1137); SEMCAD X 14.6.10(7164)

Dipole Calibration for Head Tissue/Pin=100mW, dist=10mm, f=5200 MHz/Zoom Scan, dist=1.4mm (8x8x7)/Cube 0: Measurement grid: dx=4mm, dy=4mm, dz=1.4mm

Reference Value = 63.505 V/m; Power Drift = 0.07 dB

Peak SAR (extrapolated) = 28.1 W/kg

SAR(1 g) = 7.77 W/kg; SAR(10 g) = 2.23 W/kg

Maximum value of SAR (measured) = 18.1 W/kg

Dipole Calibration for Head Tissue/Pin=100mW, dist=10mm, f=5300 MHz/Zoom Scan, dist=1.4mm (8x8x7)/Cube 0: Measurement grid: dx=4mm, dy=4mm, dz=1.4mm

Reference Value = 63.817 V/m; Power Drift = 0.07 dB

Peak SAR (extrapolated) = 29.7 W/kg

SAR(1 g) = 8.04 W/kg; SAR(10 g) = 2.3 W/kg

Maximum value of SAR (measured) = 18.7 W/kg

Dipole Calibration for Head Tissue/Pin=100mW, dist=10mm, f=5500 MHz/Zoom Scan, dist=1.4mm (8x8x7)/Cube 0: Measurement grid: dx=4mm, dy=4mm, dz=1.4mm

Reference Value = 64.029 V/m; Power Drift = 0.07 dB

Peak SAR (extrapolated) = 32.0 W/kg

SAR(1 g) = 8.17 W/kg; SAR(10 g) = 2.32 W/kg

Maximum value of SAR (measured) = 19.7 W/kg

Dipole Calibration for Head Tissue/Pin=100mW, dist=10mm, f=5600 MHz/Zoom Scan,

dist=1.4mm (8x8x7)/Cube 0: Measurement grid: dx=4mm, dy=4mm, dz=1.4mm

Reference Value = 63.403 V/m; Power Drift = 0.05 dB

Peak SAR (extrapolated) = 31.3 W/kg

SAR(1 g) = 8.03 W/kg; SAR(10 g) = 2.28 W/kg

Maximum value of SAR (measured) = 19.3 W/kg

Dipole Calibration for Head Tissue/Pin=100mW, dist=10mm, f=5800 MHz/Zoom Scan,

dist=1.4mm (8x8x7)/Cube 0: Measurement grid: dx=4mm, dy=4mm, dz=1.4mm

Reference Value = 60.987 V/m; Power Drift = 0.06 dB

Peak SAR (extrapolated) = 31.9 W/kg

SAR(1 g) = 7.78 W/kg; SAR(10 g) = 2.2 W/kg

Maximum value of SAR (measured) = 19.0 W/kg

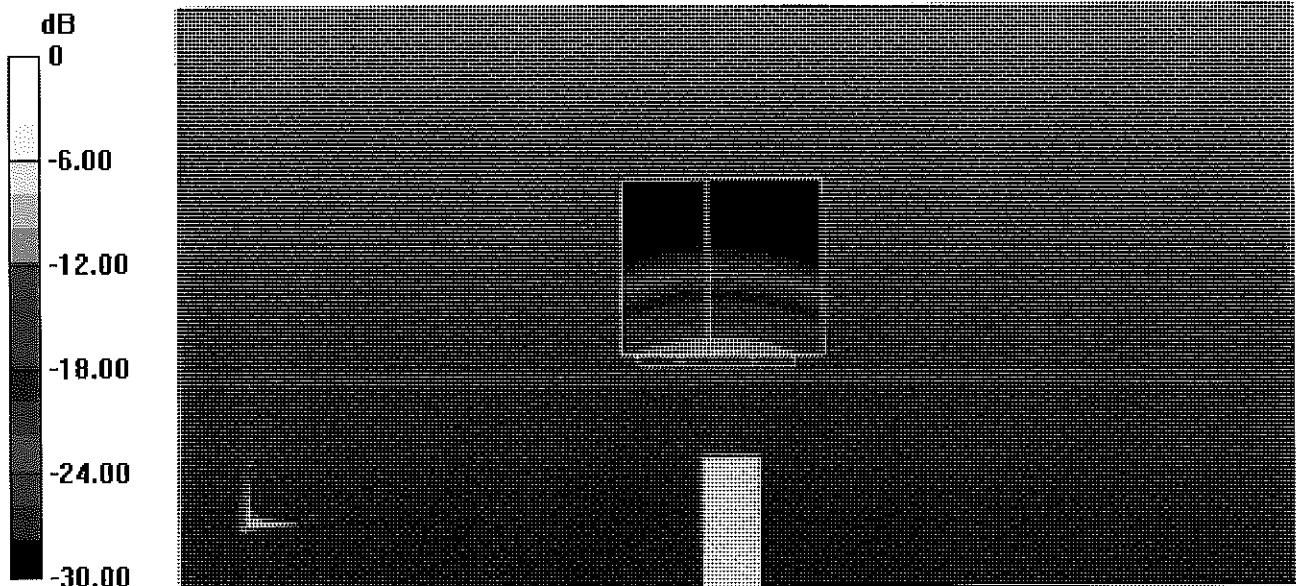

0 dB = 19.0 W/kg = 12.79 dBW/kg

Impedance Measurement Plot for Head TSL

23 Sep 2013 11:11:14

CH1 S11 1 U FS 1: 52.408 Ω -10.990 Ω 2.7849 pF 5 200.000 000 MHz

*
Del
Cor
Avg
16
H1d

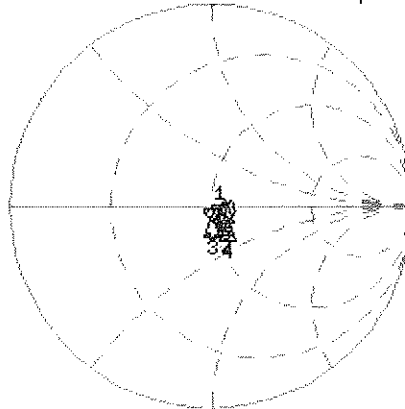

CH1 Markers

- 2: 56.846 Ω
-4.4492 Ω
5.30000 GHz
- 3: 48.834 Ω
-5.3730 Ω
5.50000 GHz
- 4: 57.303 Ω
-8.6738 Ω
5.60000 GHz
- 5: 56.939 Ω
1.5527 Ω
5.80000 GHz

CH2 S11 L00 5 dB/REF -20 dB 1:-19.232 dB 5 200.000 000 MHz

Cor
Avg
16
H1d

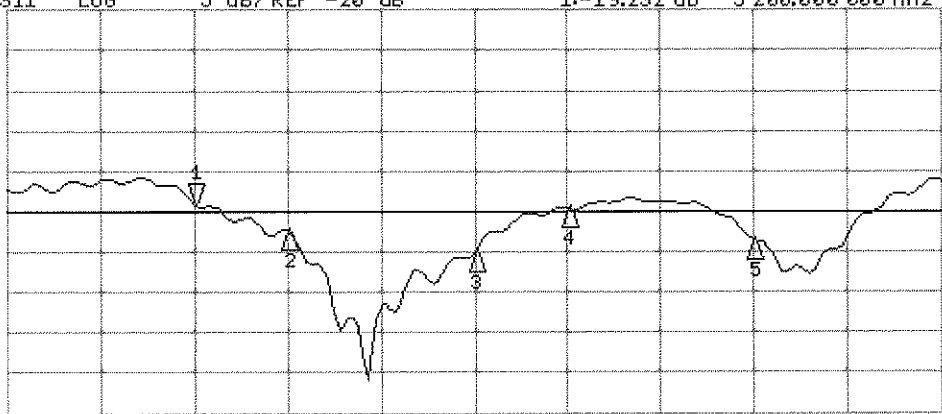

CH2 Markers

- 2: -22.341 dB
5.30000 GHz
- 3: -25.105 dB
5.50000 GHz
- 4: -19.547 dB
5.60000 GHz
- 5: -23.545 dB
5.80000 GHz

START 5 000.000 000 MHz

STOP 6 000.000 000 MHz

DASY5 Validation Report for Body TSL

Date: 20.09.2013

Test Laboratory: SPEAG, Zurich, Switzerland

DUT: Dipole 5GHz; Type: D5GHzV2; Serial: D5GHzV2 - SN: 1007

Communication System: UID 0 - CW ; Frequency: 5200 MHz, Frequency: 5300 MHz, Frequency: 5500 MHz, Frequency: 5600 MHz, Frequency: 5800 MHz

Medium parameters used: $f = 5200$ MHz; $\sigma = 5.36$ S/m; $\epsilon_r = 48.3$; $\rho = 1000$ kg/m³, Medium parameters used: $f = 5300$ MHz; $\sigma = 5.56$ S/m; $\epsilon_r = 48.1$; $\rho = 1000$ kg/m³, Medium parameters used: $f = 5500$ MHz; $\sigma = 5.75$ S/m; $\epsilon_r = 47.8$; $\rho = 1000$ kg/m³, Medium parameters used: $f = 5600$ MHz; $\sigma = 5.88$ S/m; $\epsilon_r = 47.6$; $\rho = 1000$ kg/m³, Medium parameters used: $f = 5800$ MHz; $\sigma = 6.17$ S/m; $\epsilon_r = 47.3$; $\rho = 1000$ kg/m³

Phantom section: Flat Section

Measurement Standard: DASY5 (IEEE/IEC/ANSI C63.19-2007)

DASY52 Configuration:

- Probe: EX3DV4 - SN3503; ConvF(4.91, 4.91, 4.91); Calibrated: 28.12.2012, ConvF(4.67, 4.67, 4.67); Calibrated: 28.12.2012, ConvF(4.43, 4.43, 4.43); Calibrated: 28.12.2012, ConvF(4.22, 4.22, 4.22); Calibrated: 28.12.2012, ConvF(4.38, 4.38, 4.38); Calibrated: 28.12.2012;
- Sensor-Surface: 1.4mm (Mechanical Surface Detection)
- Electronics: DAE4 Sn601; Calibrated: 25.04.2013
- Phantom: Flat Phantom 5.0 (back); Type: QD000P50AA; Serial: 1002
- DASY52 52.8.7(1137); SEMCAD X 14.6.10(7164)

Dipole Calibration for Body Tissue/Pin=100mW, dist=10mm, f=5200 MHz/Zoom Scan, dist=1.4mm (8x8x7)/Cube 0: Measurement grid: dx=4mm, dy=4mm, dz=1.4mm

Reference Value = 58.606 V/m; Power Drift = -0.02 dB

Peak SAR (extrapolated) = 28.6 W/kg

SAR(1 g) = 7.28 W/kg; SAR(10 g) = 2.03 W/kg

Maximum value of SAR (measured) = 17.2 W/kg

Dipole Calibration for Body Tissue/Pin=100mW, dist=10mm, f=5300 MHz/Zoom Scan, dist=1.4mm (8x8x7)/Cube 0: Measurement grid: dx=4mm, dy=4mm, dz=1.4mm

Reference Value = 58.305 V/m; Power Drift = 0.01 dB

Peak SAR (extrapolated) = 30.3 W/kg

SAR(1 g) = 7.49 W/kg; SAR(10 g) = 2.09 W/kg

Maximum value of SAR (measured) = 17.8 W/kg

Dipole Calibration for Body Tissue/Pin=100mW, dist=10mm, f=5500 MHz/Zoom Scan, dist=1.4mm (8x8x7)/Cube 0: Measurement grid: dx=4mm, dy=4mm, dz=1.4mm

Reference Value = 58.471 V/m; Power Drift = -0.00 dB

Peak SAR (extrapolated) = 32.4 W/kg

SAR(1 g) = 7.61 W/kg; SAR(10 g) = 2.11 W/kg

Maximum value of SAR (measured) = 18.5 W/kg

Dipole Calibration for Body Tissue/Pin=100mW, dist=10mm, f=5600 MHz/Zoom Scan, dist=1.4mm (8x8x7)/Cube 0: Measurement grid: dx=4mm, dy=4mm, dz=1.4mm

Reference Value = 58.333 V/m; Power Drift = -0.01 dB

Peak SAR (extrapolated) = 33.8 W/kg

SAR(1 g) = 7.75 W/kg; SAR(10 g) = 2.16 W/kg

Maximum value of SAR (measured) = 19.1 W/kg

Dipole Calibration for Body Tissue/Pin=100mW, dist=10mm, f=5800 MHz/Zoom Scan, dist=1.4mm (8x8x7)/Cube 0: Measurement grid: dx=4mm, dy=4mm, dz=1.4mm

Reference Value = 55.389 V/m; Power Drift = 0.00 dB

Peak SAR (extrapolated) = 34.1 W/kg

SAR(1 g) = 7.31 W/kg; SAR(10 g) = 2.02 W/kg

Maximum value of SAR (measured) = 18.3 W/kg

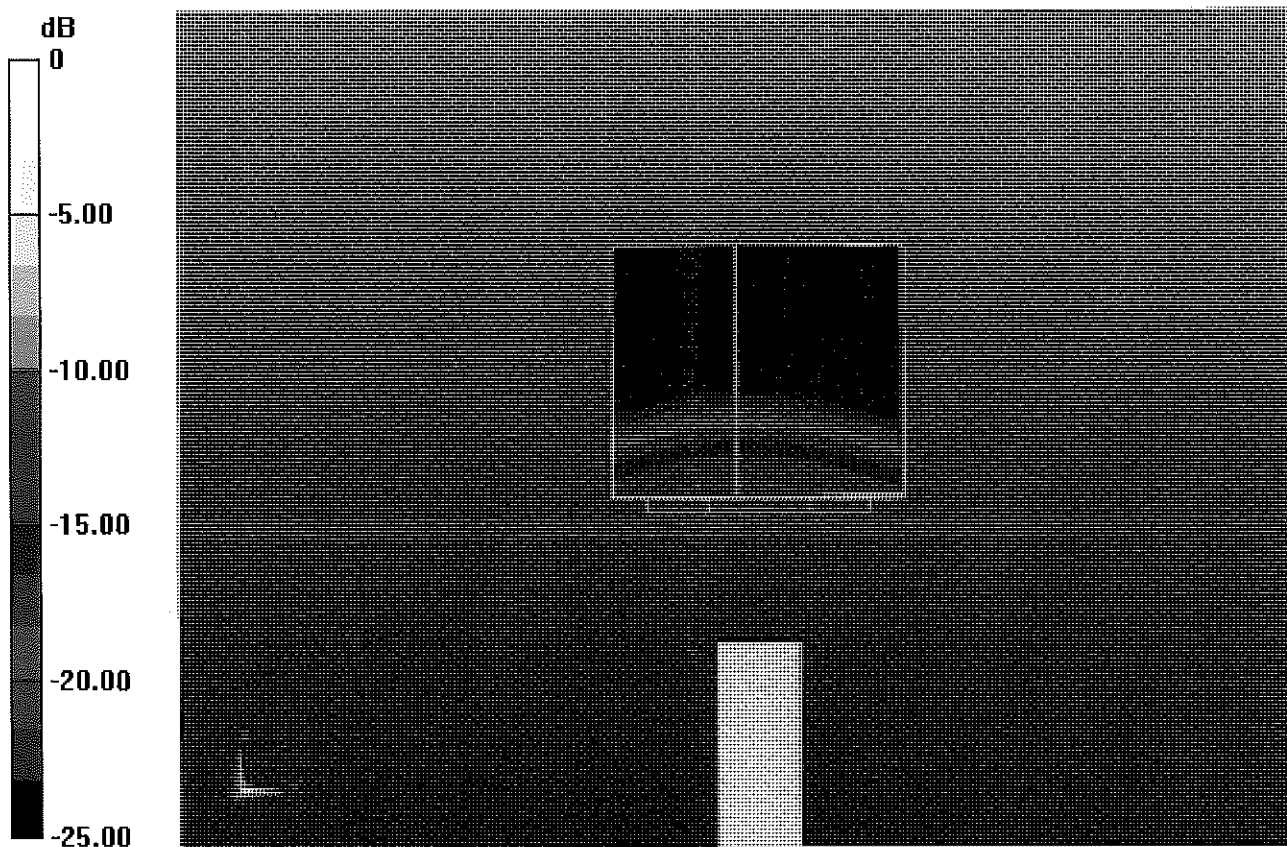

0 dB = 18.3 W/kg = 12.62 dBW/kg

Impedance Measurement Plot for Body TSL

19 Sep 2013 15:38:51

CH1 S11 1 U FS 1: 53.098 Ω -10.264 Ω 2.9820 pF 5 200.000 000 MHz

De1
Cor
Avg
0
H1d

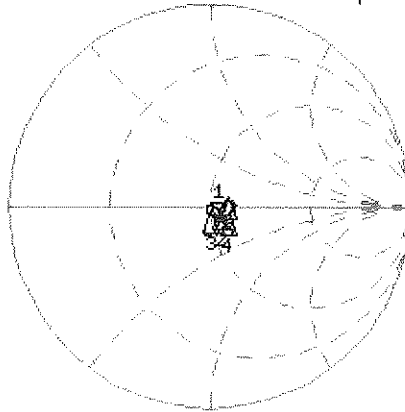

CH1 Markers

- 2: 54.285 Ω
-1.5293 Ω
5.30000 GHz
- 3: 49.717 Ω
-3.6367 Ω
5.50000 GHz
- 4: 58.225 Ω
-5.2344 Ω
5.60000 GHz
- 5: 58.725 Ω
3.9121 Ω
5.80000 GHz

CH2 S11 LOG 5 dB/REF -20 dB 1: -19.701 dB 5 200.000 000 MHz

Cor
Avg
0
H1d

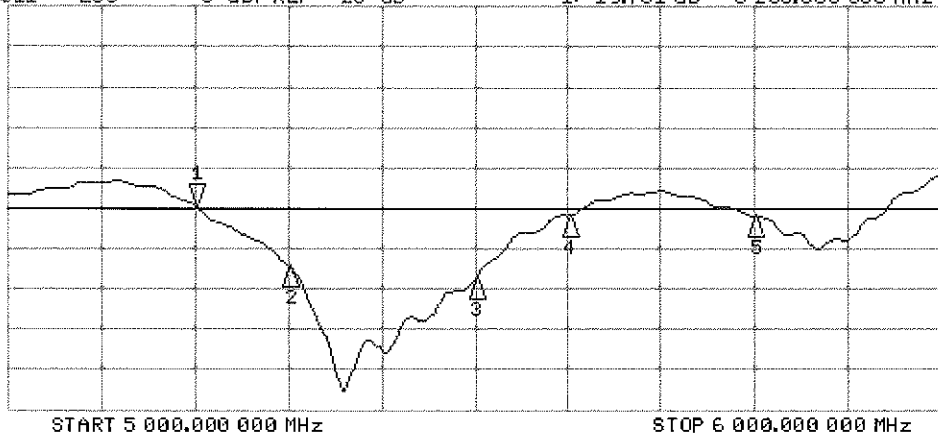

CH2 Markers

- 2: -27.201 dB
5.30000 GHz
- 3: -28.741 dB
5.50000 GHz
- 4: -20.917 dB
5.60000 GHz
- 5: -21.121 dB
5.80000 GHz



Accredited by the Swiss Accreditation Service (SAS)
The Swiss Accreditation Service is one of the signatories to the EA
Multilateral Agreement for the recognition of calibration certificates

Accreditation No.: **SCS 108**

Client **PC Test**

Certificate No: **D5GHzV2-1057_Jan14**

CALIBRATION CERTIFICATE

Object **D5GHzV2 - SN: 1057**

Calibration procedure(s) **QA CAL-22.v2
Calibration procedure for dipole validation kits between 3-6 GHz**

Calibration date: **January 27, 2014**

CC
2/5/14 ✓

This calibration certificate documents the traceability to national standards, which realize the physical units of measurements (SI).
The measurements and the uncertainties with confidence probability are given on the following pages and are part of the certificate.

All calibrations have been conducted in the closed laboratory facility: environment temperature (22 ± 3)°C and humidity < 70%.

Calibration Equipment used (M&TE critical for calibration)

| Primary Standards | ID # | Cal Date (Certificate No.) | Scheduled Calibration |
|-----------------------------|--------------------|-----------------------------------|------------------------|
| Power meter EPM-442A | GB37480704 | 09-Oct-13 (No. 217-01827) | Oct-14 |
| Power sensor HP 8481A | US37292783 | 09-Oct-13 (No. 217-01827) | Oct-14 |
| Power sensor HP 8481A | MY41092317 | 09-Oct-13 (No. 217-01828) | Oct-14 |
| Reference 20 dB Attenuator | SN: 5058 (20k) | 04-Apr-13 (No. 217-01736) | Apr-14 |
| Type-N mismatch combination | SN: 5047.3 / 06327 | 04-Apr-13 (No. 217-01739) | Apr-14 |
| Reference Probe EX3DV4 | SN: 3503 | 30-Dec-13 (No. EX3-3503_Dec13) | Dec-14 |
| DAE4 | SN: 601 | 25-Apr-13 (No. DAE4-601_Apr13) | Apr-14 |
| Secondary Standards | ID # | Check Date (in house) | Scheduled Check |
| RF generator R&S SMT-06 | 100005 | 04-Aug-99 (in house check Oct-13) | In house check: Oct-16 |
| Network Analyzer HP 8753E | US37390585 S4206 | 18-Oct-01 (in house check Oct-13) | In house check: Oct-14 |

Calibrated by: **Israe El-Naouq** Name: **Israe El-Naouq** Function: **Laboratory Technician**

Approved by: **Kalja Pokovic** Name: **Kalja Pokovic** Technical Manager

Signature: *Israe El-Naouq*

Signature: *Kalja Pokovic*

Issued: January 27, 2014

This calibration certificate shall not be reproduced except in full without written approval of the laboratory.



Accredited by the Swiss Accreditation Service (SAS)

The Swiss Accreditation Service is one of the signatories to the EA
Multilateral Agreement for the recognition of calibration certificates

Glossary:

| | |
|-------|---------------------------------|
| TSL | tissue simulating liquid |
| ConvF | sensitivity in TSL / NORM x,y,z |
| N/A | not applicable or not measured |

Calibration is Performed According to the Following Standards:

- IEC 62209-2, "Evaluation of Human Exposure to Radio Frequency Fields from Handheld and Body-Mounted Wireless Communication Devices in the Frequency Range of 30 MHz to 6 GHz: Human models, Instrumentation, and Procedures"; Part 2: "Procedure to determine the Specific Absorption Rate (SAR) for including accessories and multiple transmitters", March 2010
- KDB 865664, "SAR Measurement Requirements for 100 MHz to 6 GHz"
- IEEE Std 1528-2013, "IEEE Recommended Practice for Determining the Peak Spatial-Averaged Specific Absorption Rate (SAR) in the Human Head from Wireless Communications Devices: Measurement Techniques", June 2013

Additional Documentation:

- DASY4/5 System Handbook

Methods Applied and Interpretation of Parameters:

- Measurement Conditions:** Further details are available from the Validation Report at the end of the certificate. All figures stated in the certificate are valid at the frequency indicated.
- Antenna Parameters with TSL:** The dipole is mounted with the spacer to position its feed point exactly below the center marking of the flat phantom section, with the arms oriented parallel to the body axis.
- Feed Point Impedance and Return Loss:** These parameters are measured with the dipole positioned under the liquid filled phantom. The impedance stated is transformed from the measurement at the SMA connector to the feed point. The Return Loss ensures low reflected power. No uncertainty required.
- Electrical Delay:** One-way delay between the SMA connector and the antenna feed point. No uncertainty required.
- SAR measured:** SAR measured at the stated antenna input power.
- SAR normalized:** SAR as measured, normalized to an input power of 1 W at the antenna connector.
- SAR for nominal TSL parameters:** The measured TSL parameters are used to calculate the nominal SAR result.

The reported uncertainty of measurement is stated as the standard uncertainty of measurement multiplied by the coverage factor $k=2$, which for a normal distribution corresponds to a coverage probability of approximately 95%.

Measurement Conditions

DASY system configuration, as far as not given on page 1.

| | | |
|-------------------------------------|--|----------------------------------|
| DASY Version | DASY5 | V52.8.7 |
| Extrapolation | Advanced Extrapolation | |
| Phantom | Modular Flat Phantom V5.0 | |
| Distance Dipole Center - TSL | 10 mm | with Spacer |
| Zoom Scan Resolution | dx, dy = 4.0 mm, dz = 1.4 mm | Graded Ratio = 1.4 (Z direction) |
| Frequency | 5200 MHz ± 1 MHz 5300 MHz ± 1 MHz 5500 MHz ± 1 MHz 5600 MHz ± 1 MHz 5800 MHz ± 1 MHz | |

Head TSL parameters at 5200 MHz

The following parameters and calculations were applied.

| | Temperature | Permittivity | Conductivity |
|--|-----------------|--------------|------------------|
| Nominal Head TSL parameters | 22.0 °C | 36.0 | 4.66 mho/m |
| Measured Head TSL parameters | (22.0 ± 0.2) °C | 35.0 ± 6 % | 4.45 mho/m ± 6 % |
| Head TSL temperature change during test | < 0.5 °C | ---- | ---- |

SAR result with Head TSL at 5200 MHz

| SAR averaged over 1 cm³ (1 g) of Head TSL | Condition | |
|---|--------------------|---------------------------------|
| SAR measured | 100 mW input power | 7.85 W/kg |
| SAR for nominal Head TSL parameters | normalized to 1W | 78.0 W/kg ± 19.9 % (k=2) |

| SAR averaged over 10 cm³ (10 g) of Head TSL | condition | |
|---|--------------------|---------------------------------|
| SAR measured | 100 mW input power | 2.25 W/kg |
| SAR for nominal Head TSL parameters | normalized to 1W | 22.3 W/kg ± 19.5 % (k=2) |

Head TSL parameters at 5300 MHz

The following parameters and calculations were applied.

| | Temperature | Permittivity | Conductivity |
|---|-----------------|--------------|------------------|
| Nominal Head TSL parameters | 22.0 °C | 35.9 | 4.76 mho/m |
| Measured Head TSL parameters | (22.0 ± 0.2) °C | 34.9 ± 6 % | 4.54 mho/m ± 6 % |
| Head TSL temperature change during test | < 0.5 °C | ---- | ---- |

SAR result with Head TSL at 5300 MHz

| SAR averaged over 1 cm ³ (1 g) of Head TSL | Condition | |
|---|--------------------|-----------------------------------|
| SAR measured | 100 mW input power | 8.36 W/kg |
| SAR for nominal Head TSL parameters | normalized to 1W | 83.0 W / kg ± 19.9 % (k=2) |

| SAR averaged over 10 cm ³ (10 g) of Head TSL | condition | |
|---|--------------------|---------------------------------|
| SAR measured | 100 mW input power | 2.40 W/kg |
| SAR for nominal Head TSL parameters | normalized to 1W | 23.8 W/kg ± 19.5 % (k=2) |

Head TSL parameters at 5500 MHz

The following parameters and calculations were applied.

| | Temperature | Permittivity | Conductivity |
|---|-----------------|--------------|------------------|
| Nominal Head TSL parameters | 22.0 °C | 35.6 | 4.96 mho/m |
| Measured Head TSL parameters | (22.0 ± 0.2) °C | 34.6 ± 6 % | 4.74 mho/m ± 6 % |
| Head TSL temperature change during test | < 0.5 °C | ---- | ---- |

SAR result with Head TSL at 5500 MHz

| SAR averaged over 1 cm ³ (1 g) of Head TSL | Condition | |
|---|--------------------|---------------------------------|
| SAR measured | 100 mW input power | 8.50 W/kg |
| SAR for nominal Head TSL parameters | normalized to 1W | 84.3 W/kg ± 19.9 % (k=2) |

| SAR averaged over 10 cm ³ (10 g) of Head TSL | condition | |
|---|--------------------|---------------------------------|
| SAR measured | 100 mW input power | 2.42 W/kg |
| SAR for nominal Head TSL parameters | normalized to 1W | 24.0 W/kg ± 19.5 % (k=2) |

Head TSL parameters at 5600 MHz

The following parameters and calculations were applied.

| | Temperature | Permittivity | Conductivity |
|---|-----------------|--------------|------------------|
| Nominal Head TSL parameters | 22.0 °C | 35.5 | 5.07 mho/m |
| Measured Head TSL parameters | (22.0 ± 0.2) °C | 34.5 ± 6 % | 4.86 mho/m ± 6 % |
| Head TSL temperature change during test | < 0.5 °C | ---- | ---- |

SAR result with Head TSL at 5600 MHz

| SAR averaged over 1 cm ³ (1 g) of Head TSL | Condition | |
|---|--------------------|---------------------------------|
| SAR measured | 100 mW input power | 8.42 W/kg |
| SAR for nominal Head TSL parameters | normalized to 1W | 83.5 W/kg ± 19.9 % (k=2) |

| SAR averaged over 10 cm ³ (10 g) of Head TSL | condition | |
|---|--------------------|---------------------------------|
| SAR measured | 100 mW input power | 2.40 W/kg |
| SAR for nominal Head TSL parameters | normalized to 1W | 23.8 W/kg ± 19.5 % (k=2) |

Head TSL parameters at 5800 MHz

The following parameters and calculations were applied.

| | Temperature | Permittivity | Conductivity |
|---|-----------------|--------------|------------------|
| Nominal Head TSL parameters | 22.0 °C | 35.3 | 5.27 mho/m |
| Measured Head TSL parameters | (22.0 ± 0.2) °C | 34.2 ± 6 % | 5.07 mho/m ± 6 % |
| Head TSL temperature change during test | < 0.5 °C | ---- | ---- |

SAR result with Head TSL at 5800 MHz

| SAR averaged over 1 cm ³ (1 g) of Head TSL | Condition | |
|---|--------------------|---------------------------------|
| SAR measured | 100 mW input power | 8.00 W/kg |
| SAR for nominal Head TSL parameters | normalized to 1W | 79.3 W/kg ± 19.9 % (k=2) |

| SAR averaged over 10 cm ³ (10 g) of Head TSL | condition | |
|---|--------------------|---------------------------------|
| SAR measured | 100 mW input power | 2.28 W/kg |
| SAR for nominal Head TSL parameters | normalized to 1W | 22.6 W/kg ± 19.5 % (k=2) |

Body TSL parameters at 5200 MHz

The following parameters and calculations were applied.

| | Temperature | Permittivity | Conductivity |
|---|-----------------|--------------|------------------|
| Nominal Body TSL parameters | 22.0 °C | 49.0 | 5.30 mho/m |
| Measured Body TSL parameters | (22.0 ± 0.2) °C | 47.3 ± 6 % | 5.44 mho/m ± 6 % |
| Body TSL temperature change during test | < 0.5 °C | ---- | ---- |

SAR result with Body TSL at 5200 MHz

| SAR averaged over 1 cm ³ (1 g) of Body TSL | Condition | |
|---|--------------------|---------------------------------|
| SAR measured | 100 mW input power | 7.58 W/kg |
| SAR for nominal Body TSL parameters | normalized to 1W | 75.3 W/kg ± 19.9 % (k=2) |

| SAR averaged over 10 cm ³ (10 g) of Body TSL | condition | |
|---|--------------------|---------------------------------|
| SAR measured | 100 mW input power | 2.12 W/kg |
| SAR for nominal Body TSL parameters | normalized to 1W | 21.0 W/kg ± 19.5 % (k=2) |

Body TSL parameters at 5300 MHz

The following parameters and calculations were applied.

| | Temperature | Permittivity | Conductivity |
|---|-----------------|--------------|------------------|
| Nominal Body TSL parameters | 22.0 °C | 48.9 | 5.42 mho/m |
| Measured Body TSL parameters | (22.0 ± 0.2) °C | 47.2 ± 6 % | 5.57 mho/m ± 6 % |
| Body TSL temperature change during test | < 0.5 °C | ---- | ---- |

SAR result with Body TSL at 5300 MHz

| SAR averaged over 1 cm ³ (1 g) of Body TSL | Condition | |
|---|--------------------|---------------------------------|
| SAR measured | 100 mW input power | 7.79 W/kg |
| SAR for nominal Body TSL parameters | normalized to 1W | 77.4 W/kg ± 19.9 % (k=2) |

| SAR averaged over 10 cm ³ (10 g) of Body TSL | condition | |
|---|--------------------|---------------------------------|
| SAR measured | 100 mW input power | 2.17 W/kg |
| SAR for nominal Body TSL parameters | normalized to 1W | 21.5 W/kg ± 19.5 % (k=2) |

Body TSL parameters at 5500 MHz

The following parameters and calculations were applied.

| | Temperature | Permittivity | Conductivity |
|---|-----------------|--------------|------------------|
| Nominal Body TSL parameters | 22.0 °C | 48.6 | 5.65 mho/m |
| Measured Body TSL parameters | (22.0 ± 0.2) °C | 46.8 ± 6 % | 5.84 mho/m ± 6 % |
| Body TSL temperature change during test | < 0.5 °C | ---- | ---- |

SAR result with Body TSL at 5500 MHz

| SAR averaged over 1 cm ³ (1 g) of Body TSL | Condition | |
|---|--------------------|---------------------------------|
| SAR measured | 100 mW input power | 7.96 W/kg |
| SAR for nominal Body TSL parameters | normalized to 1W | 79.1 W/kg ± 19.9 % (k=2) |

| SAR averaged over 10 cm ³ (10 g) of Body TSL | condition | |
|---|--------------------|---------------------------------|
| SAR measured | 100 mW input power | 2.22 W/kg |
| SAR for nominal Body TSL parameters | normalized to 1W | 22.0 W/kg ± 19.5 % (k=2) |

Body TSL parameters at 5600 MHz

The following parameters and calculations were applied.

| | Temperature | Permittivity | Conductivity |
|---|-----------------|--------------|------------------|
| Nominal Body TSL parameters | 22.0 °C | 48.5 | 5.77 mho/m |
| Measured Body TSL parameters | (22.0 ± 0.2) °C | 46.6 ± 6 % | 5.98 mho/m ± 6 % |
| Body TSL temperature change during test | < 0.5 °C | ---- | ---- |

SAR result with Body TSL at 5600 MHz

| SAR averaged over 1 cm ³ (1 g) of Body TSL | Condition | |
|---|--------------------|---------------------------------|
| SAR measured | 100 mW input power | 8.07 W/kg |
| SAR for nominal Body TSL parameters | normalized to 1W | 80.2 W/kg ± 19.9 % (k=2) |

| SAR averaged over 10 cm ³ (10 g) of Body TSL | condition | |
|---|--------------------|---------------------------------|
| SAR measured | 100 mW input power | 2.24 W/kg |
| SAR for nominal Body TSL parameters | normalized to 1W | 22.2 W/kg ± 19.5 % (k=2) |

Body TSL parameters at 5800 MHz

The following parameters and calculations were applied.

| | Temperature | Permittivity | Conductivity |
|---|-----------------|--------------|------------------|
| Nominal Body TSL parameters | 22.0 °C | 48.2 | 6.00 mho/m |
| Measured Body TSL parameters | (22.0 ± 0.2) °C | 46.3 ± 6 % | 6.23 mho/m ± 6 % |
| Body TSL temperature change during test | < 0.5 °C | ---- | ---- |

SAR result with Body TSL at 5800 MHz

| SAR averaged over 1 cm ³ (1 g) of Body TSL | Condition | |
|---|--------------------|---------------------------------|
| SAR measured | 100 mW input power | 7.48 W/kg |
| SAR for nominal Body TSL parameters | normalized to 1W | 74.3 W/kg ± 19.9 % (k=2) |

| SAR averaged over 10 cm ³ (10 g) of Body TSL | condition | |
|---|--------------------|---------------------------------|
| SAR measured | 100 mW input power | 2.06 W/kg |
| SAR for nominal Body TSL parameters | normalized to 1W | 20.4 W/kg ± 19.5 % (k=2) |

Appendix

Antenna Parameters with Head TSL at 5200 MHz

| | |
|--------------------------------------|--------------------------------|
| Impedance, transformed to feed point | 43.1 Ω - 4.6 j Ω |
| Return Loss | - 21.0 dB |

Antenna Parameters with Head TSL at 5300 MHz

| | |
|--------------------------------------|--------------------------------|
| Impedance, transformed to feed point | 46.5 Ω - 1.3 j Ω |
| Return Loss | - 28.1 dB |

Antenna Parameters with Head TSL at 5500 MHz

| | |
|--------------------------------------|--------------------------------|
| Impedance, transformed to feed point | 46.2 Ω - 2.5 j Ω |
| Return Loss | - 26.4 dB |

Antenna Parameters with Head TSL at 5600 MHz

| | |
|--------------------------------------|--------------------------------|
| Impedance, transformed to feed point | 48.9 Ω - 5.7 j Ω |
| Return Loss | - 24.6 dB |

Antenna Parameters with Head TSL at 5800 MHz

| | |
|--------------------------------------|--------------------------------|
| Impedance, transformed to feed point | 48.7 Ω - 3.1 j Ω |
| Return Loss | - 29.5 dB |

Antenna Parameters with Body TSL at 5200 MHz

| | |
|--------------------------------------|--------------------------------|
| Impedance, transformed to feed point | 49.4 Ω - 7.7 j Ω |
| Return Loss | - 22.2 dB |

Antenna Parameters with Body TSL at 5300 MHz

| | |
|--------------------------------------|--------------------------------|
| Impedance, transformed to feed point | 49.6 Ω - 3.0 j Ω |
| Return Loss | - 30.3 dB |

Antenna Parameters with Body TSL at 5500 MHz

| | |
|--------------------------------------|--------------------------------|
| Impedance, transformed to feed point | 50.8 Ω - 3.9 j Ω |
| Return Loss | - 28.0 dB |

Antenna Parameters with Body TSL at 5600 MHz

| | |
|--------------------------------------|--------------------------------|
| Impedance, transformed to feed point | 55.4 Ω - 2.5 j Ω |
| Return Loss | - 25.0 dB |

Antenna Parameters with Body TSL at 5800 MHz

| | |
|--------------------------------------|--------------------------------|
| Impedance, transformed to feed point | 52.3 Ω - 0.7 j Ω |
| Return Loss | - 32.5 dB |

General Antenna Parameters and Design

| | |
|----------------------------------|----------|
| Electrical Delay (one direction) | 1.186 ns |
|----------------------------------|----------|

After long term use with 100W radiated power, only a slight warming of the dipole near the feedpoint can be measured.

The dipole is made of standard semirigid coaxial cable. The center conductor of the feeding line is directly connected to the second arm of the dipole. The antenna is therefore short-circuited for DC-signals. On some of the dipoles, small end caps are added to the dipole arms in order to improve matching when loaded according to the position as explained in the "Measurement Conditions" paragraph. The SAR data are not affected by this change. The overall dipole length is still according to the Standard.

No excessive force must be applied to the dipole arms, because they might bend or the soldered connections near the feedpoint may be damaged.

Additional EUT Data

| | |
|-----------------|-------------------|
| Manufactured by | SPEAG |
| Manufactured on | November 27, 2006 |

DASY5 Validation Report for Head TSL

Date: 27.01.2014

Test Laboratory: SPEAG, Zurich, Switzerland

DUT: Dipole 5GHz; Type: D5GHzV2; Serial: D5GHzV2 - SN: 1057

Communication System: UID 0 - CW; Frequency: 5200 MHz, Frequency: 5300 MHz, Frequency: 5500 MHz, Frequency: 5600 MHz, Frequency: 5800 MHz

Medium parameters used: $f = 5200$ MHz; $\sigma = 4.45$ S/m; $\epsilon_r = 35$; $\rho = 1000$ kg/m³, Medium parameters used: $f = 5300$ MHz; $\sigma = 4.54$ S/m; $\epsilon_r = 34.9$; $\rho = 1000$ kg/m³, Medium parameters used: $f = 5500$ MHz; $\sigma = 4.74$ S/m; $\epsilon_r = 34.6$; $\rho = 1000$ kg/m³, Medium parameters used: $f = 5600$ MHz; $\sigma = 4.86$ S/m; $\epsilon_r = 34.5$; $\rho = 1000$ kg/m³, Medium parameters used: $f = 5800$ MHz; $\sigma = 5.07$ S/m; $\epsilon_r = 34.2$; $\rho = 1000$ kg/m³

Phantom section: Flat Section

Measurement Standard: DASY5 (IEEE/IEC/ANSI C63.19-2007)

DASY52 Configuration:

- Probe: EX3DV4 - SN3503; ConvF(5.52, 5.52, 5.52); Calibrated: 30.12.2013, ConvF(5.2, 5.2, 5.2); Calibrated: 30.12.2013, ConvF(5.01, 5.01, 5.01); Calibrated: 30.12.2013, ConvF(4.86, 4.86, 4.86); Calibrated: 30.12.2013, ConvF(4.91, 4.91, 4.91); Calibrated: 30.12.2013;
- Sensor-Surface: 1.4mm (Mechanical Surface Detection)
- Electronics: DAE4 Sn601; Calibrated: 25.04.2013
- Phantom: Flat Phantom 5.0 (front); Type: QD000P50AA; Serial: 1001
- DASY52 52.8.7(1137); SEMCAD X 14.6.10(7164)

Dipole Calibration for Head Tissue/Pin=100mW, dist=10mm, f=5200 MHz/Zoom Scan,

dist=1.4mm (8x8x7)/Cube 0: Measurement grid: dx=4mm, dy=4mm, dz=1.4mm

Reference Value = 63.497 V/m; Power Drift = 0.04 dB

Peak SAR (extrapolated) = 28.2 W/kg

SAR(1 g) = 7.85 W/kg; SAR(10 g) = 2.25 W/kg

Maximum value of SAR (measured) = 18.6 W/kg

Dipole Calibration for Head Tissue/Pin=100mW, dist=10mm, f=5300 MHz/Zoom Scan,

dist=1.4mm (8x8x7)/Cube 0: Measurement grid: dx=4mm, dy=4mm, dz=1.4mm

Reference Value = 64.444 V/m; Power Drift = 0.07 dB

Peak SAR (extrapolated) = 31.2 W/kg

SAR(1 g) = 8.36 W/kg; SAR(10 g) = 2.4 W/kg

Maximum value of SAR (measured) = 20.1 W/kg

Dipole Calibration for Head Tissue/Pin=100mW, dist=10mm, f=5500 MHz/Zoom Scan,

dist=1.4mm (8x8x7)/Cube 0: Measurement grid: dx=4mm, dy=4mm, dz=1.4mm

Reference Value = 63.807 V/m; Power Drift = 0.07 dB

Peak SAR (extrapolated) = 33.0 W/kg

SAR(1 g) = 8.5 W/kg; SAR(10 g) = 2.42 W/kg

Maximum value of SAR (measured) = 20.8 W/kg

Dipole Calibration for Head Tissue/Pin=100mW, dist=10mm, f=5600 MHz/Zoom Scan, dist=1.4mm (8x8x7)/Cube 0: Measurement grid: dx=4mm, dy=4mm, dz=1.4mm
Reference Value = 63.194 V/m; Power Drift = 0.06 dB
Peak SAR (extrapolated) = 33.2 W/kg
SAR(1 g) = 8.42 W/kg; SAR(10 g) = 2.4 W/kg

Dipole Calibration for Head Tissue/Pin=100mW, dist=10mm, f=5800 MHz/Zoom Scan, dist=1.4mm (8x8x7)/Cube 0: Measurement grid: dx=4mm, dy=4mm, dz=1.4mm
Reference Value = 60.646 V/m; Power Drift = 0.08 dB
Peak SAR (extrapolated) = 32.9 W/kg
SAR(1 g) = 8 W/kg; SAR(10 g) = 2.28 W/kg
Maximum value of SAR (measured) = 19.9 W/kg

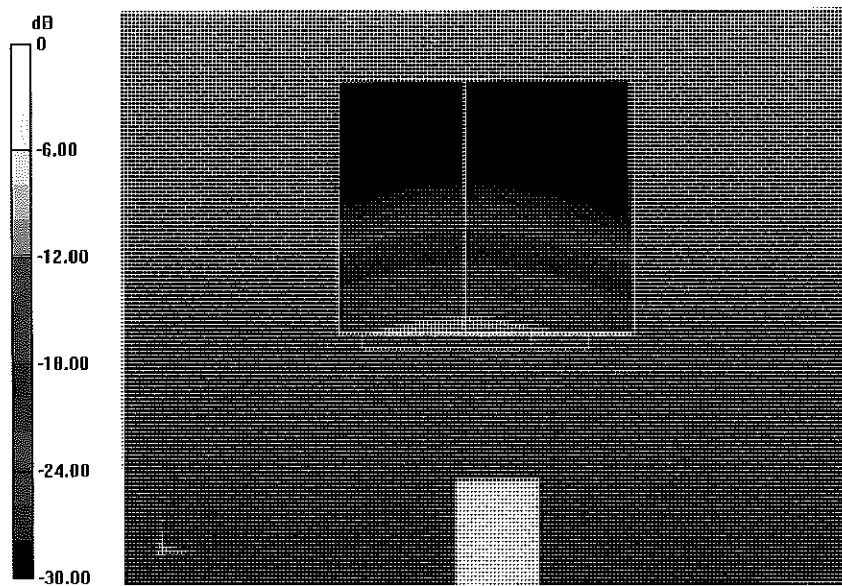

0 dB = 19.9 W/kg = 12.99 dBW/kg

Impedance Measurement Plot for Head TSL

27 Jan 2014 17:12:04

CH1 S11 1 U FS

1: 43.092 Ω -4.5938 Ω 6.6627 pF

5 200.000 000 MHz

*
De1
Cor
Avg
16
H1d

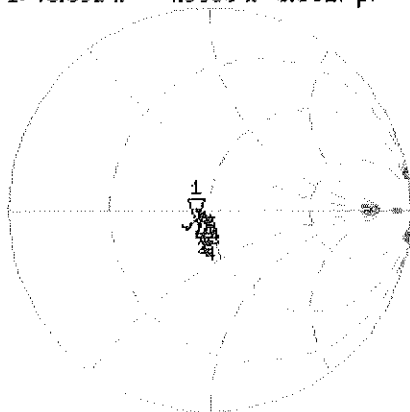

CH1 Markers

- 2: 46.475 Ω
-1.3496 Ω
5.30000 GHz
- 3: 46.150 Ω
-2.5078 Ω
5.50000 GHz
- 4: 48.900 Ω
-5.6992 Ω
5.60000 GHz
- 5: 48.734 Ω
-3.0762 Ω
5.80000 GHz

CH2 S11 LOG 5 dB/REF -20 dB 1:-21.014 dB 5 200.000 000 MHz

De1
Cor
Avg
16
H1d

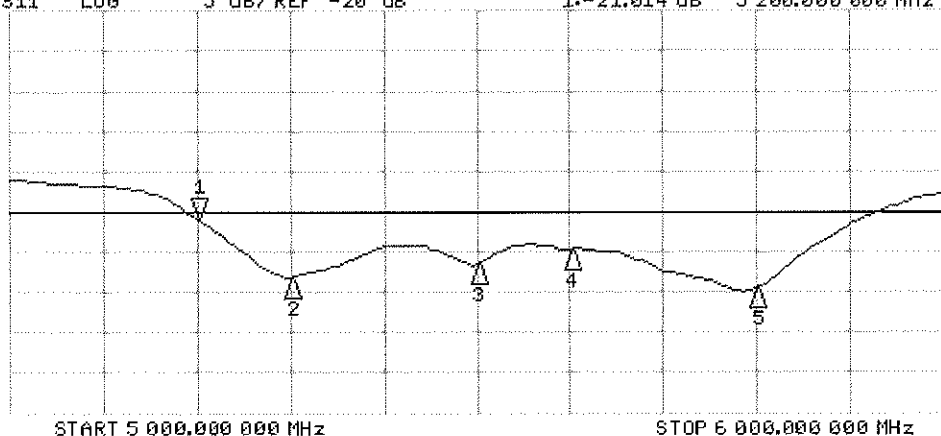

CH2 Markers

- 2: -28.145 dB
5.30000 GHz
- 3: -26.415 dB
5.50000 GHz
- 4: -24.640 dB
5.60000 GHz
- 5: -29.464 dB
5.80000 GHz

START 5 000.000 000 MHz

STOP 6 000.000 000 MHz

DASY5 Validation Report for Body TSL

Date: 24.01.2014

Test Laboratory: SPEAG, Zurich, Switzerland

DUT: Dipole 5GHz; Type: D5GHzV2; Serial: D5GHzV2 - SN: 1057

Communication System: UID 0 - CW; Frequency: 5200 MHz, Frequency: 5300 MHz, Frequency: 5500 MHz, Frequency: 5600 MHz, Frequency: 5800 MHz

Medium parameters used: $f = 5200$ MHz; $\sigma = 5.44$ S/m; $\epsilon_r = 47.3$; $\rho = 1000$ kg/m³, Medium parameters used: $f = 5300$ MHz; $\sigma = 5.57$ S/m; $\epsilon_r = 47.2$; $\rho = 1000$ kg/m³, Medium parameters used: $f = 5500$ MHz; $\sigma = 5.84$ S/m; $\epsilon_r = 46.8$; $\rho = 1000$ kg/m³, Medium parameters used: $f = 5600$ MHz; $\sigma = 5.98$ S/m; $\epsilon_r = 46.6$; $\rho = 1000$ kg/m³, Medium parameters used: $f = 5800$ MHz; $\sigma = 6.23$ S/m; $\epsilon_r = 46.3$; $\rho = 1000$ kg/m³

Phantom section: Flat Section

Measurement Standard: DASY5 (IEEE/IEC/ANSI C63.19-2007)

DASY52 Configuration:

- Probe: EX3DV4 - SN3503; ConvF(5.01, 5.01, 5.01); Calibrated: 30.12.2013, ConvF(4.76, 4.76, 4.76); Calibrated: 30.12.2013, ConvF(4.52, 4.52, 4.52); Calibrated: 30.12.2013, ConvF(4.3, 4.3, 4.3); Calibrated: 30.12.2013, ConvF(4.47, 4.47, 4.47); Calibrated: 30.12.2013;
- Sensor-Surface: 1.4mm (Mechanical Surface Detection)
- Electronics: DAE4 Sn601; Calibrated: 25.04.2013
- Phantom: Flat Phantom 5.0 (back); Type: QD000P50AA; Serial: 1002
- DASY52 52.8.7(1137); SEMCAD X 14.6.10(7164)

Dipole Calibration for Body Tissue/Pin=100mW, dist=10mm, f=5200 MHz/Zoom Scan, dist=1.4mm (8x8x7)/Cube 0: Measurement grid: dx=4mm, dy=4mm, dz=1.4mm

Reference Value = 58.809 V/m; Power Drift = -0.05 dB

Peak SAR (extrapolated) = 30.1 W/kg

SAR(1 g) = 7.58 W/kg; SAR(10 g) = 2.12 W/kg

Maximum value of SAR (measured) = 18.2 W/kg

Dipole Calibration for Body Tissue/Pin=100mW, dist=10mm, f=5300 MHz/Zoom Scan, dist=1.4mm (8x8x7)/Cube 0: Measurement grid: dx=4mm, dy=4mm, dz=1.4mm

Reference Value = 58.585 V/m; Power Drift = -0.00 dB

Peak SAR (extrapolated) = 32.2 W/kg

SAR(1 g) = 7.79 W/kg; SAR(10 g) = 2.17 W/kg

Maximum value of SAR (measured) = 19.1 W/kg

Dipole Calibration for Body Tissue/Pin=100mW, dist=10mm, f=5500 MHz/Zoom Scan, dist=1.4mm (8x8x7)/Cube 0: Measurement grid: dx=4mm, dy=4mm, dz=1.4mm

Reference Value = 58.364 V/m; Power Drift = -0.01 dB

Peak SAR (extrapolated) = 34.4 W/kg

SAR(1 g) = 7.96 W/kg; SAR(10 g) = 2.22 W/kg

Maximum value of SAR (measured) = 19.4 W/kg

Dipole Calibration for Body Tissue/Pin=100mW, dist=10mm, f=5600 MHz/Zoom Scan, dist=1.4mm (8x8x7)/Cube 0: Measurement grid: dx=4mm, dy=4mm, dz=1.4mm

Reference Value = 57.864 V/m; Power Drift = 0.01 dB

Peak SAR (extrapolated) = 35.8 W/kg

SAR(1 g) = 8.07 W/kg; SAR(10 g) = 2.24 W/kg

Maximum value of SAR (measured) = 19.8 W/kg

Dipole Calibration for Body Tissue/Pin=100mW, dist=10mm, f=5800 MHz/Zoom Scan, dist=1.4mm (8x8x7)/Cube 0: Measurement grid: dx=4mm, dy=4mm, dz=1.4mm

Reference Value = 54.817 V/m; Power Drift = -0.01 dB

Peak SAR (extrapolated) = 35.1 W/kg

SAR(1 g) = 7.48 W/kg; SAR(10 g) = 2.06 W/kg

Maximum value of SAR (measured) = 18.8 W/kg

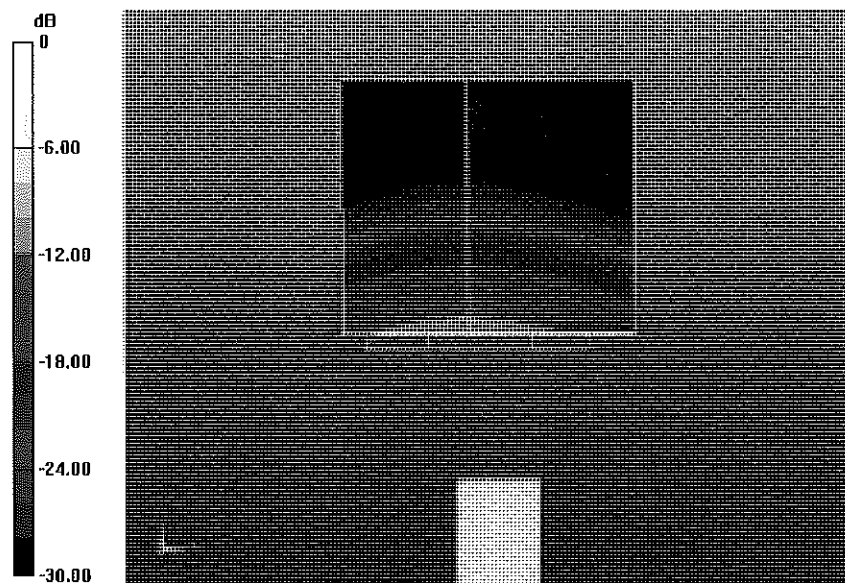

0 dB = 18.8 W/kg = 12.74 dBW/kg

Impedance Measurement Plot for Body TSL

24 Jan 2014 15:50:22

CH1 S11 1 U FS 1: 49.354 Ω -7.7188 Ω 3.9652 pF 5 200.000 000 MHz

*
De1
Cor
Avg
16
H1d

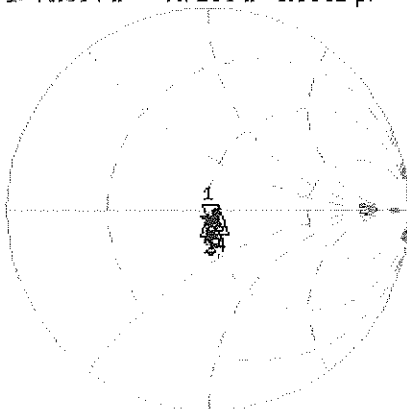

CH1 Markers
2: 49.559 Ω
-3.0176 Ω
5.30000 GHz
3: 50.793 Ω
-3.9160 Ω
5.50000 GHz
4: 55.393 Ω
-2.5176 Ω
5.60000 GHz
5: 52.320 Ω
-716.80 m Ω
5.80000 GHz

CH2 S11 L06 5 dB/REF -20 dB 1: -22.190 dB 5 200.000 000 MHz

Cor
Avg
16
H1d

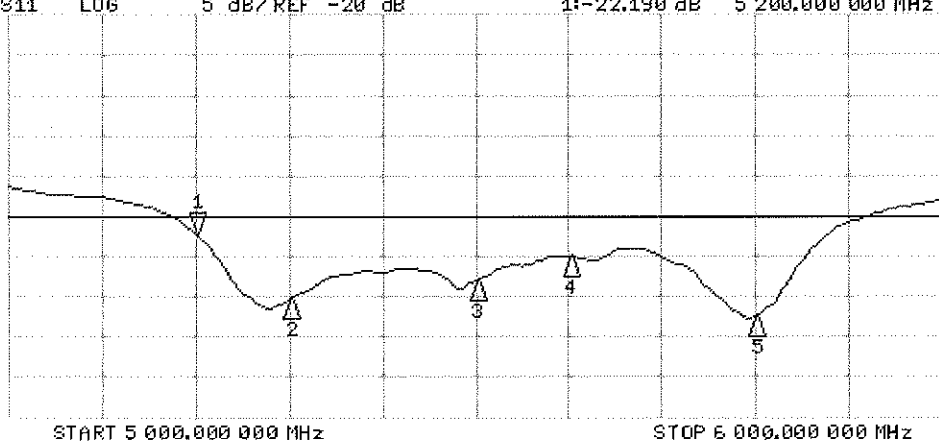

CH2 Markers
2: -30.277 dB
5.30000 GHz
3: -28.039 dB
5.50000 GHz
4: -24.950 dB
5.60000 GHz
5: -32.401 dB
5.80000 GHz

APPENDIX D: SAR TISSUE SPECIFICATIONS

Measurement Procedure for Tissue verification:



- 1) The network analyzer and probe system was configured and calibrated.
- 2) The probe was immersed in the tissue. The tissue was placed in a nonmetallic container. Trapped air bubbles beneath the flange were minimized by placing the probe at a slight angle.
- 3) The complex admittance with respect to the probe aperture was measured
- 4) The complex relative permittivity ϵ can be calculated from the below equation (Pournaropoulos and Misra):

$$Y = \frac{j2\omega\epsilon_r\epsilon_0}{[\ln(b/a)]^2} \int_a^b \int_a^b \int_0^\pi \cos\phi' \frac{\exp[-j\omega r(\mu_0\epsilon_r'\epsilon_0)^{1/2}]}{r} d\phi' d\rho' d\rho$$

where Y is the admittance of the probe in contact with the sample, the primed and unprimed coordinates refer to source and observation points, respectively, $r^2 = \rho^2 + \rho'^2 - 2\rho\rho' \cos\phi'$, ω is the angular frequency, and $j = \sqrt{-1}$.

**Table D-1
Composition of the Tissue Equivalent Matter**

| Frequency (MHz) | 2450 | 2450 | 5200-5800 | 5200-5800 |
|---------------------------|------------|------|------------|-----------|
| Tissue | Head | Body | Head | Body |
| Ingredients (% by weight) | | | | |
| DGBE | See page 2 | 26.7 | See page 3 | |
| NaCl | | 0.1 | | |
| Polysorbate (Tween) 80 | | | | 20 |
| Water | | 73.2 | | 80 |

| | | | | |
|------------------------------------|---|------------------------------|---|---------------------------------|
| FCC ID: A3LSMN915X |  PCTEST <small>ENGINEERING LABORATORY, INC.</small> | SAR EVALUATION REPORT |  | Reviewed by: Quality Manager |
| Test Dates: 08/14/14 - 08/23/14 | DUT Type: Portable Handset | | | APPENDIX D: Page 1 of 3 |

2 Composition / Information on ingredients

The Item is composed of the following ingredients:

| | |
|---------|---|
| H2O | Water, 52 – 75% |
| C8H18O3 | Diethylene glycol monobutyl ether (DGBE), 25 – 48% (CAS-No. 112-34-5, EC-No. 203-961-6, EC-index-No. 603-096-00-8) Relevant for safety; Refer to the respective Safety Data Sheet*. |
| NaCl | Sodium Chloride, <1.0% |

Figure D-1
Composition of 2.4 GHz Head Tissue Equivalent Matter

Note: 2.4 GHz head liquid recipes are proprietary SPEAG. Since the composition is approximate to the actual liquids utilized, the manufacturer tissue-equivalent liquid data sheets are provided below.

Measurement Certificate / Material Test

| | |
|--------------|---|
| Item Name | Head Tissue Simulating Liquid (HSL2450V2) |
| Product No. | SL AAH 245 BA (Charge: 130212-2) |
| Manufacturer | SPEAG |

Measurement Method

TSL dielectric parameters measured using calibrated OCP probe.

Setup Validation

Validation results were within $\pm 2.5\%$ towards the target values of Methanol.

Target Parameters

Target parameters as defined in the IEEE 1528 and IEC 62209 compliance standards.

Test Condition

| | |
|-----------------|---|
| Ambient | Environment temperatur (22 ± 3)°C and humidity < 70%. |
| TSL Temperature | 23°C |
| Test Date | 13-Feb-13 |
| Operator | DI |

Additional Information

| | |
|-------------------|-------------------------|
| TSL Density | 0.988 g/cm ³ |
| TSL Heat-capacity | 3.680 kJ/(kg*K) |

| f (MHz) | Measured | | | Target | | | Diff. to Target [%] | |
|-------------|-------------|--------------|-------------|-------------|-------------|-------------|---------------------|--|
| | HP-e' | HP-e'' | sigma | eps | sigma | delta-eps | delta-sigma | |
| 1900 | 40.4 | 11.94 | 1.26 | 40.0 | 1.40 | 1.0 | -0.9 | |
| 1925 | 40.3 | 12.02 | 1.29 | 40.0 | 1.40 | 0.7 | -8.0 | |
| 1950 | 40.2 | 12.11 | 1.31 | 40.0 | 1.40 | 0.5 | -8.2 | |
| 1975 | 40.1 | 12.20 | 1.34 | 40.0 | 1.40 | 0.2 | -4.2 | |
| 2000 | 40.0 | 12.29 | 1.37 | 40.0 | 1.40 | -0.1 | -2.3 | |
| 2025 | 39.9 | 12.39 | 1.40 | 40.0 | 1.42 | -0.2 | -1.9 | |
| 2050 | 39.8 | 12.49 | 1.42 | 39.9 | 1.44 | -0.4 | -1.4 | |
| 2075 | 39.6 | 12.57 | 1.45 | 39.9 | 1.47 | -0.6 | -1.1 | |
| 2100 | 39.5 | 12.65 | 1.48 | 39.8 | 1.49 | -0.7 | -0.7 | |
| 2125 | 39.4 | 12.74 | 1.51 | 39.8 | 1.51 | -0.9 | -0.4 | |
| 2150 | 39.3 | 12.82 | 1.53 | 39.7 | 1.53 | -1.0 | 0.0 | |
| 2175 | 39.2 | 12.89 | 1.56 | 39.7 | 1.56 | -1.2 | 0.3 | |
| 2200 | 39.1 | 12.97 | 1.59 | 39.6 | 1.58 | -1.3 | 0.6 | |
| 2225 | 39.0 | 13.04 | 1.61 | 39.6 | 1.60 | -1.5 | 0.9 | |
| 2250 | 38.9 | 13.11 | 1.64 | 39.6 | 1.62 | -1.7 | 1.2 | |
| 2275 | 38.8 | 13.20 | 1.67 | 39.5 | 1.64 | -1.8 | 1.6 | |
| 2300 | 38.7 | 13.28 | 1.70 | 39.5 | 1.67 | -2.0 | 2.0 | |
| 2325 | 38.6 | 13.35 | 1.73 | 39.4 | 1.69 | -2.1 | 2.3 | |
| 2350 | 38.5 | 13.42 | 1.75 | 39.4 | 1.71 | -2.3 | 2.6 | |
| 2375 | 38.4 | 13.50 | 1.78 | 39.3 | 1.73 | -2.4 | 2.9 | |
| 2400 | 38.3 | 13.58 | 1.81 | 39.3 | 1.75 | -2.6 | 3.3 | |
| 2425 | 38.2 | 13.65 | 1.84 | 39.2 | 1.78 | -2.7 | 3.6 | |
| 2450 | 38.1 | 13.73 | 1.87 | 39.2 | 1.80 | -2.9 | 4.0 | |
| 2475 | 38.0 | 13.79 | 1.90 | 39.2 | 1.83 | -3.1 | 3.9 | |
| 2500 | 37.9 | 13.85 | 1.93 | 39.1 | 1.85 | -3.3 | 3.9 | |
| 2525 | 37.8 | 13.94 | 1.96 | 39.1 | 1.88 | -3.4 | 4.0 | |
| 2550 | 37.7 | 14.02 | 1.99 | 39.1 | 1.91 | -3.6 | 4.2 | |
| 2575 | 37.6 | 14.09 | 2.02 | 39.0 | 1.94 | -3.8 | 4.3 | |
| 2600 | 37.5 | 14.17 | 2.05 | 39.0 | 1.96 | -4.0 | 4.4 | |
| 2625 | 37.4 | 14.23 | 2.08 | 39.0 | 1.99 | -4.2 | 4.4 | |
| 2650 | 37.3 | 14.29 | 2.11 | 38.9 | 2.02 | -4.3 | 4.4 | |
| 2675 | 37.1 | 14.36 | 2.14 | 38.9 | 2.05 | -4.5 | 4.5 | |
| 2700 | 37.0 | 14.43 | 2.17 | 38.9 | 2.07 | -4.8 | 4.6 | |

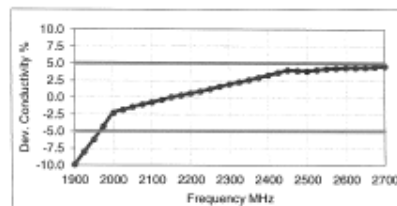
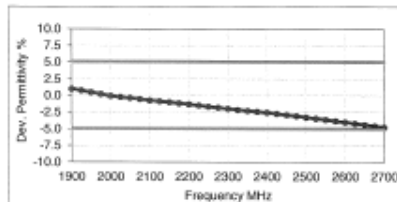



Figure D-2
2.4 GHz Head Tissue Equivalent Matter

| | | | | |
|------------------------------------|---|-----------------------|---|---------------------------------|
| FCC ID: A3LSMN915X |  | SAR EVALUATION REPORT |  | Reviewed by: Quality Manager |
| Test Dates: 08/14/14 - 08/23/14 | DUT Type: Portable Handset | | | APPENDIX D: Page 2 of 3 |

2 Composition / Information on ingredients

The Item is composed of the following ingredients:

| | |
|-------------|----------|
| Water | 50 – 65% |
| Mineral oil | 10 – 30% |
| Emulsifiers | 8 – 25% |
| Sodium salt | 0 – 1.5% |

Figure D-3
Composition of 5 GHz Head Tissue Equivalent Matter

Note: 5GHz head liquid recipes are proprietary SPEAG. Since the composition is approximate to the actual liquids utilized, the manufacturer tissue-equivalent liquid data sheets are provided below.

Measurement Certificate / Material Test

| | |
|--------------|---|
| Item Name | Head Tissue Simulating Liquid (HBBL3500-5800V5) |
| Product No. | SL AAH 502 AC (Charge: 130903-1) |
| Manufacturer | SPEAG |

Measurement Method

TSL dielectric parameters measured using calibrated OCP probe.

Setup Validation

Validation results were within $\pm 2.5\%$ towards the target values of Methanol.

Target Parameters

Target parameters as defined in the IEEE 1528 and IEC 62209 compliance standards.

Test Condition

Ambient Environment temperature (22 ± 3)°C and humidity < 70%.
 TSL Temperature 22°C
 Test Date 4-Sep-13
 Operator IEN

Additional Information

TSL Density 0.985 g/cm³
 TSL Heat-capacity 3.383 kJ/(kg*K)

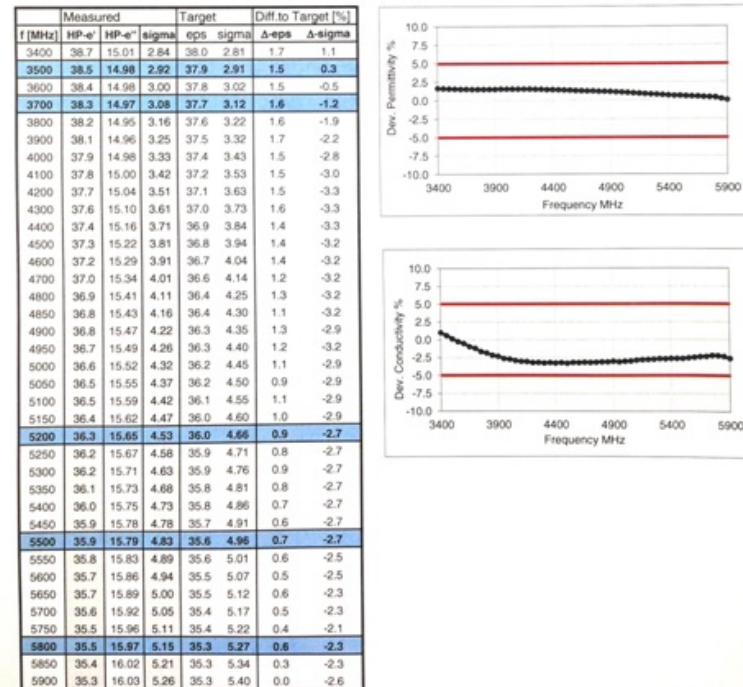

Figure D-4
5GHz Head Tissue Equivalent Matter

| | | | | |
|------------------------------------|-------------------------------|-----------------------|--|---------------------------------|
| FCC ID: A3LSMN915X | | SAR EVALUATION REPORT | | Reviewed by: Quality Manager |
| Test Dates: 08/14/14 - 08/23/14 | DUT Type: Portable Handset | | | APPENDIX D: Page 3 of 3 |

APPENDIX E: SAR SYSTEM VALIDATION

Per FCC KDB 865664 D02v01, SAR system validation status should be documented to confirm measurement accuracy. The SAR systems (including SAR probes, system components and software versions) used for this device were validated against its performance specifications prior to the SAR measurements. Reference dipoles were used with the required tissue- equivalent media for system validation, according to the procedures outlined in FCC KDB 865664 D01 v01 and IEEE 1528-2013. Since SAR probe calibrations are frequency dependent, each probe calibration point was validated at a frequency within the valid frequency range of the probe calibration point, using the system that normally operates with the probe for routine SAR measurements and according to the required tissue-equivalent media.

A tabulated summary of the system validation status including the validation date(s), measurement frequencies, SAR probes and tissue dielectric parameters has been included.



**Table E-I
SAR System Validation Summary**

| SAR SYSTEM # | FREQ. [MHz] | DATE | PROBE SN | PROBE TYPE | PROBE CAL. POINT | | COND. | PERM. | CW VALIDATION | | | MOD. VALIDATION | | |
|--------------|-------------|-----------|----------|------------|------------------|------|-------|-------------------|---------------|-----------------|----------------|-----------------|-------------|------|
| | | | | | | | (σ) | (ε _r) | SENSI-TIVITY | PROBE LINEARITY | PROBE ISOTROPY | MOD. TYPE | DUTY FACTOR | PAR |
| H | 2450 | 6/19/2014 | 3319 | ES3DV3 | 2450 | Head | 1.788 | 39.78 | PASS | PASS | PASS | OFDM | N/A | PASS |
| E | 5200 | 12/3/2013 | 3914 | EX3DV4 | 5200 | Head | 4.482 | 34.70 | PASS | PASS | PASS | OFDM | N/A | PASS |
| E | 5300 | 12/3/2013 | 3914 | EX3DV4 | 5300 | Head | 4.604 | 34.60 | PASS | PASS | PASS | OFDM | N/A | PASS |
| E | 5500 | 12/3/2013 | 3914 | EX3DV4 | 5500 | Head | 4.821 | 34.28 | PASS | PASS | PASS | OFDM | N/A | PASS |
| E | 5600 | 12/3/2013 | 3914 | EX3DV4 | 5600 | Head | 4.907 | 34.13 | PASS | PASS | PASS | OFDM | N/A | PASS |
| E | 5800 | 12/3/2013 | 3914 | EX3DV4 | 5800 | Head | 5.133 | 33.89 | PASS | PASS | PASS | OFDM | N/A | PASS |
| H | 2450 | 6/12/2014 | 3319 | ES3DV3 | 2450 | Body | 1.981 | 51.57 | PASS | PASS | PASS | OFDM | N/A | PASS |
| A | 5200 | 1/13/2014 | 3920 | EX3DV4 | 5200 | Body | 5.344 | 47.27 | PASS | PASS | PASS | OFDM | N/A | PASS |
| A | 5300 | 1/13/2014 | 3920 | EX3DV4 | 5300 | Body | 5.500 | 46.91 | PASS | PASS | PASS | OFDM | N/A | PASS |
| A | 5500 | 1/13/2014 | 3920 | EX3DV4 | 5500 | Body | 5.826 | 46.38 | PASS | PASS | PASS | OFDM | N/A | PASS |
| A | 5600 | 1/13/2014 | 3920 | EX3DV4 | 5600 | Body | 5.991 | 46.16 | PASS | PASS | PASS | OFDM | N/A | PASS |
| A | 5800 | 1/13/2014 | 3920 | EX3DV4 | 5800 | Body | 6.282 | 46.05 | PASS | PASS | PASS | OFDM | N/A | PASS |

**Table E-II
SAR System Validation Summary – 10g Extremity SAR**

| SAR SYSTEM # | FREQ. [MHz] | DATE | PROBE SN | PROBE TYPE | PROBE CAL. POINT | | COND. | PERM. | CW VALIDATION | | | MOD. VALIDATION | | |
|--------------|-------------|-----------|----------|------------|------------------|------|-------|-------------------|---------------|-----------------|----------------|-----------------|-------------|------|
| | | | | | | | (σ) | (ε _r) | SENSI-TIVITY | PROBE LINEARITY | PROBE ISOTROPY | MOD. TYPE | DUTY FACTOR | PAR |
| G | 2450 | 3/5/2014 | 3258 | ES3DV3 | 2450 | Body | 2.044 | 51.30 | PASS | PASS | PASS | OFDM | N/A | PASS |
| A | 5200 | 1/13/2014 | 3920 | EX3DV4 | 5200 | Body | 5.344 | 47.27 | PASS | PASS | PASS | OFDM | N/A | PASS |
| A | 5300 | 1/13/2014 | 3920 | EX3DV4 | 5300 | Body | 5.500 | 46.91 | PASS | PASS | PASS | OFDM | N/A | PASS |
| A | 5500 | 1/13/2014 | 3920 | EX3DV4 | 5500 | Body | 5.826 | 46.38 | PASS | PASS | PASS | OFDM | N/A | PASS |
| A | 5600 | 1/13/2014 | 3920 | EX3DV4 | 5600 | Body | 5.991 | 46.16 | PASS | PASS | PASS | OFDM | N/A | PASS |
| A | 5800 | 1/13/2014 | 3920 | EX3DV4 | 5800 | Body | 6.282 | 46.05 | PASS | PASS | PASS | OFDM | N/A | PASS |

NOTE: While the probes have been calibrated for both CW and modulated signals, all measurements were performed using communication systems calibrated for CW signals only. Modulations in the table above represent test configurations for which the measurement system has been validated per FCC KDB Publication 865664 D01v01 for scenarios when CW probe calibrations are used with other signal types. SAR systems were validated for modulated signals with a periodic duty cycle, such as GMSK, or with a high peak to average ratio (>5 dB), such as OFDM according to KDB 865664.

| | | | | |
|------------------------------------|---|-----------------------|---|---------------------------------|
| FCC ID: A3LSMN915X |  | SAR EVALUATION REPORT |  | Reviewed by: Quality Manager |
| Test Dates: 08/14/14 - 08/23/14 | DUT Type: Portable Handset | | | APPENDIX E: Page 1 of 1 |