



**FCC CFR47 PART 22 SUBPART H
FCC CFR47 PART 24 SUBPART E**

CERTIFICATION TEST REPORT

FOR

**GSM/WCDMA Phone + Bluetooth &
WLAN (2.4GHz & 5GHz) and NFC BAR PHONE**

MODEL NUMBER: SM-N9008V

FCC ID: A3LSMN9008V

REPORT NUMBER: 13U16263-1, Revision A

ISSUE DATE: NOVEMBER 21, 2013

Prepared for

**SAMSUNG ELECTRONICS CO., LTD.
416, MAETAN 3-DONG, YEONGTONG-GU
SUWON-CITY, GYEONGGI-DO 443-742, SOUTH KOREA**

Prepared by

**UL VERIFICATION SERVICES
47173 BENICIA STREET
FREMONT, CA 94538, U.S.A.
TEL: (510) 771-1000
FAX: (510) 661-0888**

Revision History

Rev.	Date	Revisions	Revised By
--	11/14/13	Initial Issue	P. Kim
A	11/21/13	Update statement for power table and 9.2 band edge; update summary table; Update the section 10 radiated measurement method; Update the section 8 PAR;	P. Kim

Table of Content

1.	ATTESTATION OF TEST RESULTS	5
1.1.	DESCRIPTION OF AVAILABLE ANTENNAS	6
1.2.	DESCRIPTION OF TEST SETUP.....	7
2.	TEST METHODOLOGY	10
3.	FACILITIES AND ACCREDITATION	10
4.	TEST AND MEASUREMENT EQUIPMENT	10
5.	MAXIMUM OUTPUT POWER	11
6.	SUMMARY TABLE.....	12
7.	RF POWER OUTPUT VERIFICATION.....	13
7.1.	GSM/GPRS/EDGE.....	13
7.1.1.	GSM OUTPUT POWER RESULT.....	14
7.2.	UMTS REL 99	15
7.2.1.	UMTS REL 99 OUTPUT POWER RESULT.....	15
7.3.	UMTS HSDPA.....	16
7.3.1.	UMTS HSDPA OUTPUT POWER RESULT	17
7.3.2.	UMTS HSUPA.....	18
7.3.3.	UMTS HSUPA OUTPUT POWER RESULT	19
7.3.4.	DC-HSDPA.....	20
8.	PEAK TO AVERAGE RATIO	24
8.1.	CONDUCTED PEAK TO AVERAGE RESULT	24
9.	LIMITS AND CONDUCTED RESULTS.....	25
9.1.	OCCUPIED BANDWIDTH.....	25
9.1.1.	OCCUPIED BANDWIDTH RESULTS	28
9.1.1.	OCCUPIED BANDWIDTH PLOTS.....	29
9.2.	BAND EDGE EMISSIONS	33
9.2.1.	BAND EDGE PLOTS	34
9.3.	OUT OF BAND EMISSIONS.....	39
9.3.1.	OUT OF BAND EMISSIONS RESULT.....	40

9.3.2.	OUT OF BAND EMISSIONS PLOTS	41
9.4.	<i>FREQUENCY STABILITY</i>	45
9.4.1.	FREQUENCY STABILITY RESULTS	46
10.	RADIATED TEST RESULTS	50
10.1.	<i>RADIATED POWER (ERP & EIRP)</i>	50
10.1.1.	ERP/EIRP Results	52
10.1.2.	ERP/EIRP PLOTS	54
10.2.	<i>FIELD STRENGTH OF SPURIOUS RADIATION</i>	62
10.2.1.	SPURIOUS RADIATION PLOTS.....	64
11.	SETUP PHOTOS	72

1. ATTESTATION OF TEST RESULTS

COMPANY NAME: SAMSUNG ELECTRONICS CO., LTD.
416, MAETAN 3-DONG, YEONGTONG-GU
SUWON-CITY, GYEONGGI-DO 443-742, SOUTH KOREA

EUT DESCRIPTION: GSM/WCDMA + Bluetooth & WLAN (2.4GHz & 5 GHz) Phone
MODEL: SM-N9008V

SERIAL NUMBER: FK-314-A, FK-314-C, FK-314-E, FK-314-F & FK-314-G

DATE TESTED: October 15- November 14, 2013

APPLICABLE STANDARDS	
STANDARD	TEST RESULTS
FCC PART 22H, 24E	PASS

UL Verification Services Inc. tested the above equipment in accordance with the requirements set forth in the above standards. All indications of Pass/Fail in this report are opinions expressed by UL Verification Services Inc. based on interpretations and/or observations of test results. Measurement Uncertainties were not taken into account and are published for informational purposes only. The test results show that the equipment tested is capable of demonstrating compliance with the requirements as documented in this report.

Note: The results documented in this report apply only to the tested sample, under the conditions and modes of operation as described herein. This document may not be altered or revised in any way unless done so by UL Verification Services Inc. and all revisions are duly noted in the revisions section. Any alteration of this document not carried out by UL Verification Services Inc. will constitute fraud and shall nullify the document. This report must not be used by the client to claim product certification, approval, or endorsement by NVLAP, NIST, any agency of the Federal Government, or any agency of any government.

Approved & Released For UL Verification Services Inc. By: Tested By:



PHILIP KIM
WISE PROGRAM MANAGER
UL Verification Services Inc.

CHARLES VERGONIO
WISE LAB TECHNICIAN
UL Verification Services Inc.

1.1. DESCRIPTION OF AVAILABLE ANTENNAS

The radio utilizes a PIFA antenna for the [List the bands supported] with a maximum peak gain as follow:

Frequency (MHz)	Peak Gain (dBi)
GSM1900, 1850~1910MHz	-4.1
GSM850, 824~849MHz	-9.5
Band 5, 824~849MHz	-9.5
Band 2, 1850~1910MHz	-2.2

1.2. DESCRIPTION OF TEST SETUP

SUPPORT EQUIPMENT

Support Equipment List				
Description	Manufacturer	Model	Serial Number	FCC ID
AC Adapter	Samsung	EP-TA10CBC	N/A	N/A
Headset	Samsung	N/A	N/A	N/A

I/O CABLES (CONDUCTED SETUP)

I/O Cable List						
Cable No	Port	# of identical ports	Connector Type	Cable Type	Cable Length (m)	Remarks
1	RF Out	1	Spectrum Analyzer	Shielded	None	NA
2	Antenna Port	1	EUT	Shielded	0.1m	NA
3	RF In/Out	1	Communication Test Set	Shielded	1m	NA

I/O CABLES (RADIATED SETUP)

I/O CABLE LIST						
Cable No.	Port	# of Identical Ports	Connector Type	Cable Type	Cable Length	Remarks
1	USB	1	AC Adapter	Un-shielded	1.2m	No
2	Jack	1	Headset	Shielded	1m	No
3	RF In/out	1	Communication Test Set	Un-shielded	2m	Yes

TEST SETUP

The EUT is continuously communicated to the call box during the tests.

SETUP DIAGRAM FOR TESTS (CONDUCTED TEST SETUP)

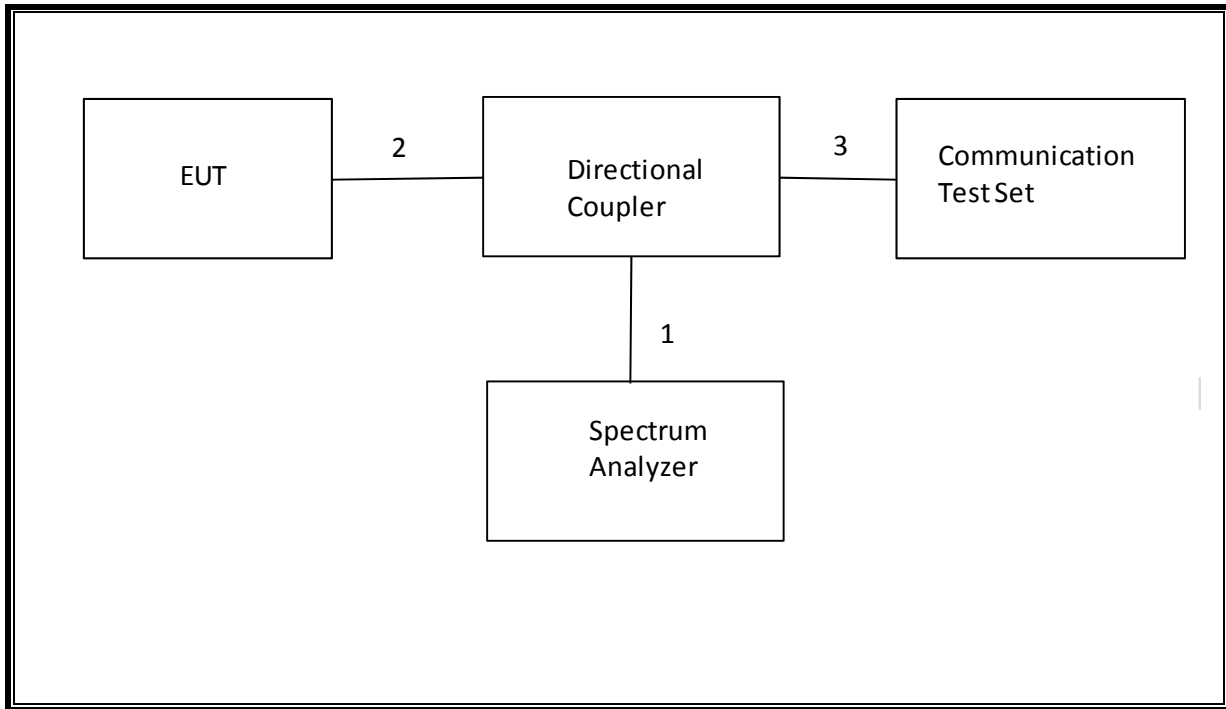

SETUP DIAGRAM FOR TESTS (RADIATED TEST SETUP)

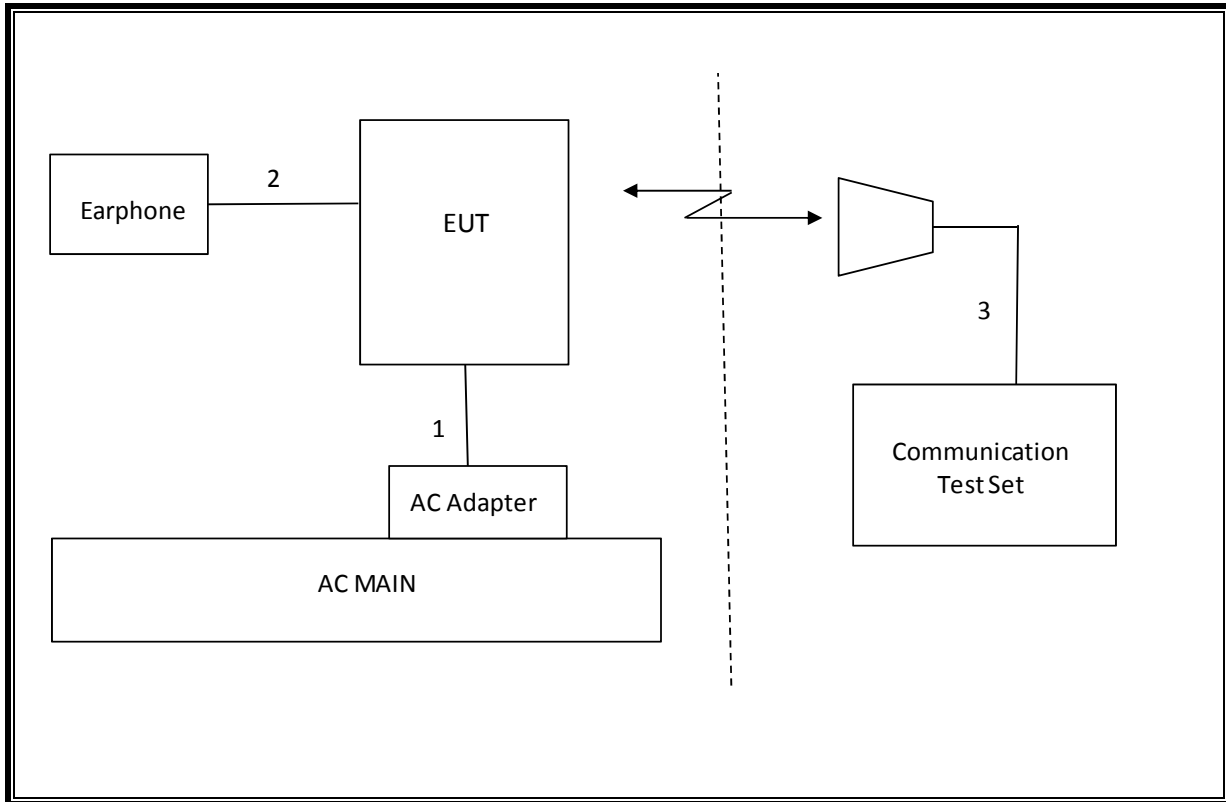

2. TEST METHODOLOGY

The tests documented in this report were performed in accordance with TIA-603-C, FCC CFR 47 Part 2, FCC CFR 47 Part 22, and FCC CFR Part 24.

3. FACILITIES AND ACCREDITATION

The test sites and measurement facilities used to collect data are located at 47173 Benicia Street, Fremont, California, USA.

UL Verification Services Inc. is accredited by NVLAP, Laboratory Code 200065-0. The full scope of accreditation can be viewed at <http://www.ccsemc.com>.

4. TEST AND MEASUREMENT EQUIPMENT

The following test and measurement equipment was utilized for the tests documented in this report:

TEST EQUIPMENT LIST				
Description	Manufacturer	Model	Asset	Cal Due
Spectrum Analyzer, 44 GHz	Agilent / HP	E4446A	C01179	02/26/14
Antenna, Bilog, 2 GHz	Sunol Sciences	JB1	C01011	08/14/14
Antenna, Horn, 18 GHz	EMCO	3115	C00783	10/25/14
Highpass Filter, 2.7 GHz	Micro-Tronics	HPM13194	N02687	CNR
Highpass Filter, 1.5 GHz	Micro-Tronics	HPM13193	N02688	CNR
Temperature / Humidity Chamber	Thermotron	SE 600-10-10	C00930	01/09/14
Communications Test Set	R&S	CMW500	T159	07/02/14
DC power supply, 8 V @ 3 A or 15 V	Agilent / HP	E3610A	None	CNR
Vector signal generator, 6 GHz	Agilent / HP	E4438C	None	07/06/14
Antenna, Tuned Dipole 400~1000	ETS	3121C DB4	C00993	02/14/14
Directional Coupler	RF-Lambda	RFDC5M06G15	None	CNR

5. MAXIMUM OUTPUT POWER

The transmitter has a maximum peak conducted and ERP / EIRP output powers as follows:

Part 22 Cell Band			
Frequency range (MHz)	Modulation	ERP	
		dBm	mW
824.2 - 848.8	GMSK/GPRS	22.88	194.1
824.2 - 848.8	EGPRS	23.37	217.3

Part 24 PCS Band			
Frequency range (MHz)	Modulation	EIRP	
		dBm	mW
1850.2 - 1909.8	GMSK/GPRS	26.19	415.9
1850.2 - 1909.8	EGPRS	27.24	529.7

Part 22/24 Band			
Frequency range (MHz)	Modulation	ERP/EIRP	
		dBm	mW
826.4 - 846	REL 99	9.79	9.5
1852.4 - 1907.6		19.78	95.1

Part 22/24 Band			
Frequency range (MHz)	Modulation	ERP/EIRP	
		dBm	mW
826.4 - 846	HSDPA	12.40	17.4
1852.4 - 1907.6		20.72	118.0

6. SUMMARY TABLE

FCC Part Section	RSS Section(s)	Test Description	Test Limit	Test Condition	Test Result	Worst Case	Note
2.1049	N/A	Occupied Band width (99%)	N/A	Conducted	Pass	4.1681 MHz	WCDMA
22.917(a) 24.238(a)	RSS-132(4.5.1) RSS-133(6.5.1) RSS-139(6.5.1)	Band Edge / Conducted Spurious Emission	-13dBm		Pass	-16.59 dBm	GSM 1900
2.1046	N/A	Conducted output power	N/A		Pass	33.2 dBm	GSM 850
24.232		Peak to average ratio	13dBm		Pass	3.77dB	WCDMA
22.355 24.235	RSS-132(4.3) RSS-133(6.3) RSS-139(6.3) RSS-199(4.3)	Frequency Stability	2.5PPM		Pass	0.006	GSM 1900
22.913(a)(2)	RSS-132(4.4)	Effective Radiated Power	38 dBm	Radiated	Pass	23.37 dBm	GSM 1900
24.232(c)	RSS-133(6.4) RSS-199(4.4)	Equivalent Isotropic Radiated Power	33dBm		Pass	27.24 dBm	
22.917(a) 24.238(a)	RSS-132(4.5.1) RSS-133(6.5.1) RSS-139(6.5.1)	Radiated Spurious Emission	-13dBm		Pass	-41.5 dBm	GSM 1900

7. RF POWER OUTPUT VERIFICATION

7.1. GSM/GPRS/EDGE

Function: Menu select > GSM Mobile Station > GSM 850/900/1800/1900
Press Connection control to choose the different menus
Press RESET > choose all to reset all settings
Connection Press Signal Off to turn off the signal and change settings
Network Support > GSM+GPRS or GSM+EGPRS
Main Service > Packet Data
Service selection > Test Mode A – Auto Slot Config. off
MS Signal Press Slot Config bottom on the right twice to select and change the number of time slots and power setting
 > Slot configuration > Uplink/Gamma
 > 33 dBm for GPRS 850/900
 > 30 dBm for GPRS1800/1900
BS Signal Enter the same channel number for TCH channel (test channel) and BCCH channel
Frequency Offset > + 0 Hz
Mode > BCCH and TCH
BCCH Level > -85 dBm (May need to adjust if link is not stable)
BCCH Channel > choose desire test channel [Enter the same channel number for TCH channel (test channel) and BCCH channel]
Channel Type > Off
P0> 4 dB
Slot Config > Unchanged (if already set under MS Signal)
TCH > choose desired test channel
Hopping > Off
Main Timeslot > 3 (Default)
Network Coding Scheme > CS4 (GPRS) and MCS9 (EGPRS)
 Bit Stream > 2E9-1PSR Bit Pattern
AF/RF Enter appropriate offsets for Ext. Att. Output and Ext. Att. Input
Connection Press Signal On to turn on the signal and change settings

7.1.1. GSM OUTPUT POWER RESULT

Band	Mode	Ch.	f(MHz)	1 time slot	2 time slot	3 time slot	4 time slot
				Peak (dBm)	Peak (dBm)	Peak (dBm)	Peak (dBm)
GSM850	GMSK	128	824.2	33.00			
		190	836.6	32.90			
		251	848.8	33.20			
	GPRS	128	824.2	32.70	32.70	32.40	32.10
		190	836.6	32.90	32.80	32.50	32.20
		251	848.8	33.20	32.90	32.60	32.30
	EGPRS	128	824.2	28.00	27.50	27.30	27.10
		190	836.6	28.10	27.80	27.60	27.40
		251	848.8	29.30	27.80	27.60	27.40

Band	Mode	Ch.	f(MHz)	1 time slot	2 time slot	3 time slot	4 time slot
				Peak (dBm)	Peak (dBm)	Peak (dBm)	Peak (dBm)
GSM1900	GMSK	512	1850.2	28.6			
		661	1880	28.4			
		810	1909.8	28.3			
	GPRS	512	1850.2	28.6	26.60	24.50	22.60
		661	1880	28.40	26.50	24.60	22.50
		810	1909.8	28.30	26.40	24.50	22.50
	EGPRS	512	1850.2	26.40	26.10	26.70	20.20
		661	1880	26.50	26.40	27.00	20.00
		810	1909.8	25.90	25.80	26.20	0.00

7.2. UMTS REL 99

TEST PROCEDURE

The following summary of these settings are illustrated below:

	Mode	Rel99
	Subtest	-
WCDMA General Settings	Loopback Mode	Test Mode 1
	Rel99 RMC	12.2kbps RMC
	HSDPA FRC	Not Applicable
	HSUPA Test	Not Applicable
	Power Control Algorithm	Algorithm2
	β_c	Not Applicable
	β_d	Not Applicable
	β_{ec}	Not Applicable
	β_c/β_d	8/15
	β_{hs}	Not Applicable
	β_{ed}	Not Applicable

7.2.1. UMTS REL 99 OUTPUT POWER RESULT

Band	Mode	Ch.	f(MHz)	Conducted Power (dBm)
				Avg (dBm)
Band 5	REL99	4145	826.6	23.2
		4183	836.6	23.3
		4220	846.4	23.5
Band 2	REL99	9275	1852.6	22.2
		9400	1880	22.5
		9525	1907.4	22.0

7.3. UMTS HSDPA

The following 4 Sub-tests were completed according to Release 5 procedures in section 5.2 of 3GPP TS34.121. A summary of these settings are illustrated below:

	Mode	Rel5 HSDPA			
	Subtest	1	2	3	4
WCDMA General Settings	Loopback Mode	Test Mode 1			
	Rel99 RMC	12.2kbps RMC			
	HSDPA FRC	H-Set1			
	Power Control Algorithm	Algorithm 2			
	β_c	2/15	12/15	15/15	15/15
	β_d	15/15	15/15	8/15	4/15
	Bd (SF)	64			
	β_c/β_d	2/15	12/15	15/8	15/4
	β_{hs}	4/15	24/15	30/15	30/15
MPR (dB)	0	0	0.5	0.5	
HSDPA Specific Settings	D_{ACK}	8			
	D_{NAK}	8			
	DCQI	8			
	Ack-Nack repetition factor	3			
	CQI Feedback (Table 5.2B.4)	4ms			
	CQI Repetition Factor (Table 5.2B.4)	2			
	$A_{hs} = \beta_{hs}/\beta_c$	30/15			

7.3.1. UMTS HSDPA OUTPUT POWER RESULT

Band	Mode	Subset	Ch.	f(MHz)	Conducted Power (dBm)
					Avg (dBm)
Band 5	HSDPA	1	4145	826.6	22.3
			4183	836.6	22.3
			4220	846.4	22.5
		2	4145	826.6	21.9
			4183	836.6	21.9
			4220	846.4	22.1
		3	4145	826.6	21.8
			4183	836.6	21.8
			4220	846.4	22.0
		4	4145	826.6	21.7
			4183	836.6	21.8
			4220	846.4	22.0
Band 2	HSDPA	1	9275	1852.6	21.4
			9400	1880	21.5
			9525	1907.4	20.9
		2	9275	1852.6	20.9
			9400	1880	21.1
			9525	1907.4	20.6
		3	9275	1852.6	20.7
			9400	1880	21.0
			9525	1907.4	20.5
		4	9275	1852.6	20.7
			9400	1880	21.0
			9525	1907.4	20.5

7.3.2. UMTS HSUPA

TEST PROCEDURE

The following summary of these settings are illustrated below: (ETSI TS 134.121-1 Table C.11.1)

	Mode	Rel6 HSUPA	Rel6 HSUPA	Rel6 HSUPA	Rel6 HSUPA	Rel6 HSUPA
	Subtest	1	2	3	4	5
WCDMA General Settings	Loopback Mode	Test Mode 1				
	P-CPICH (dB)	-10				
	P-CCPCH (dB)	-12				
	SCH (dB)	-12				
	PICH(dB)	-15				
	DPCH (dB)	-9				
	HS-SCCH_1 (dB)	-8				
	HS-PDSCH (dB)	-3				
	Rel99 RMC	12.2kbps RMC				
	HSDPA FRC	H-Set1				
	HSUPA Test	HSUPA Loopback				
	Power Control Algorithm	Algorithm2				
	Bc	11/15	6/15	15/15	2/15	15/15
	Bd	15/15	15/15	9/15	15/15	15/15
	Bec	209/225	12/15	30/15	2/15	5/15
	β_c/β_d	11/15	6/15	15/9	2/15	15/15
Bhs	22/15	12/15	30/15	4/15	30/15	
β_{ed} (note1)	1309/225	94/75	47/15 47/15	56/75	134/15	
MPR	0	2	1	2	0	
HSDPA Specific Settings	DACK	8				
	DNAK	8				
	DCQI	8				
	Ack-Nack repetition factor	3				
	CQI Feedback (Table 5.2B.4)	4ms				
	CQI Repetition Factor (Table 5.2B.4)	2				
	Ahs = β_{hs}/β_c	30/15				
HSUPA Specific Settings	D E-DPCCH	6	8	8	5	7
	DHARQ	0	0	0	0	0
	AG Index	20	12	15	17	21
	Reference E-TFCIs	5	5	2	5	5
	ETFCI (from 34.121 Table C.11.1.3)	75	67	92	71	81
	Associated Max UL Data Rate kbps	242.1	174.9	482.8	205.8	308.9
	Reference E_TFCIs	E-TFCI 11 E-TFCI PO 4 E-TFCI 67 E-TFCI PO 18 E-TFCI 71 E-TFCI PO 23 E-TFCI 75 E-TFCI PO 26 E-TFCI 81 E-TFCI PO 27		E-TFCI 11 E-TFCI PO 4 E-TFCI 92 E-TFCI PO 18		E-TFCI 11 E-TFCI PO 4 E-TFCI 67 E-TFCI PO 18 E-TFCI 71 E-TFCI PO 23 E-TFCI 75 E-TFCI PO 26 E-TFCI 81 E-TFCI PO 27

Note1: β_{ed} cannot be set directly, it is set by Absolute Grant Value.

7.3.3. UMTS HSUPA OUTPUT POWER RESULT

Band	Mode	Subset	Ch.	f(MHz)	Conducted Power
					(dBm) Avg (dBm)
Band 5	HSUPA	1	4145	826.6	22.3
			4183	836.6	22.3
			4220	846.4	22.5
		2	4145	826.6	21.7
			4183	836.6	21.8
			4220	846.4	21.9
		3	4145	826.6	22.3
			4183	836.6	22.3
			4220	846.4	22.5
		4	4145	826.6	22.2
			4183	836.6	22.2
			4220	846.4	22.4
		5	4145	826.6	22.2
			4183	836.6	22.3
			4220	846.4	22.5
Band 2	HSUPA	1	9275	1852.6	21.3
			9400	1880	21.5
			9525	1907.4	21.0
		2	9275	1852.6	20.6
			9400	1880	21.0
			9525	1907.4	20.5
		3	9275	1852.6	21.4
			9400	1880	21.5
			9525	1907.4	21.0
		4	9275	1852.6	21.3
			9400	1880	21.5
			9525	1907.4	21.0
		5	9275	1852.6	21.3
			9400	1880	21.5
			9525	1907.4	21.0

7.3.4. DC-HSDPA

The following tests were completed according to procedures in section 7.3.13 of 3GPP TS34.108 v9.5.0. A summary of these settings are illustrated below:

Downlink Physical Channels are set as per 3GPP TS34.121-1 v9.0.0 E.5.0

Table E.5.0: Levels for HSDPA connection setup

Parameter During Connection setup	Unit	Value
P-CPICH_Ec/Ior	dB	-10
P-CCPCH and SCH_Ec/Ior	dB	-12
PICH_Ec/Ior	dB	-15
HS-PDSCH	dB	off
HS-SCCH_1	dB	off
DPCH_Ec/Ior	dB	-5
OCNS_Ec/Ior	dB	-3.1

Call is set up as per 3GPP TS34.108 v9.5.0 sub clause 7.3.13

The configurations of the fixed reference channels for HSDPA RF tests are described in 3GPP TS 34.121, annex C for FDD and 3GPP TS 34.122.

Table C.8.1.12: Fixed Reference Channel H-Set 12

Parameter	Unit	Value
Nominal Avg. Inf. Bit Rate	kbps	60
Inter-TTI Distance	TTI's	1
Number of HARQ Processes	Processes	6
Information Bit Payload (N_{INF})	Bits	120
Number Code Blocks	Blocks	1
Binary Channel Bits Per TTI	Bits	960
Total Available SML's in UE	SML's	19200
Number of SML's per HARQ Proc.	SML's	3200
Coding Rate		0.15
Number of Physical Channel Codes	Codes	1
Modulation		QPSK
Note 1: The RMC is intended to be used for DC-HSDPA mode and both cells shall transmit with identical parameters as listed in the table. Note 2: Maximum number of transmission is limited to 1, i.e., retransmission is not allowed. The redundancy and constellation version 0 shall be used.		

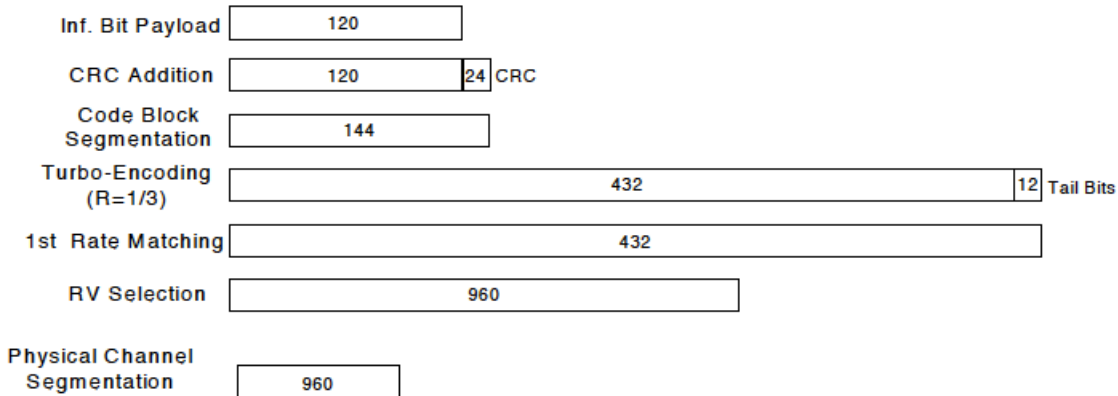

Figure C.8.19: Coding rate for Fixed reference Channel H-Set 12 (QPSK)

The following 4 Sub-tests for HSDPA were completed according to Release 6 procedures in section 5.2 of 3GPP TS34.121. A summary of subtest settings are illustrated below:

	Mode	Rel6 HSDPA	Rel6 HSDPA	Rel6 HSDPA	Rel6 HSDPA
	Subtest	1	2	3	4
WCDMA General Settings	Loopback Mode	Test Mode 1			
	Rel99 RMC	12.2kbps RMC			
	HSDPA FRC	H-Set1			
	Power Control Algorithm	Algorithm2			
	β_c	2/15	12/15	15/15	15/15
	β_d	15/15	15/15	8/15	4/15
β_d (SF)	64				

	β_c/β_d	2/15	12/15	15/8	15/4
	β_{hs}	4/15	24/15	30/15	30/15
	MPR	0	0	0.5	0.5
HSDPA Specific Settings	DACK	8			
	DNAK	8			
	DCQI	8			
	Ack-Nack Repetition factor	3			
	CQI Feedback	4ms			
	CQI Repetition Factor	2			
	A _{hs} = β_{hs}/β_c	30/15			

Up commands are set continuously to set the UE to Max power.

Band	Mode	Subset	Ch.	f(MHz)	Conducted Power (dBm)
					Avg (dBm)
Band 5	DC-HSDPA	1	4145	826.6	22.2
			4183	836.6	22.3
			4220	846.4	22.5
		2	4145	826.6	21.4
			4183	836.6	21.9
			4220	846.4	22.1
		3	4145	826.6	21.7
			4183	836.6	21.8
			4220	846.4	22.0
		4	4145	826.6	21.6
			4183	836.6	21.7
			4220	846.4	22.0
Band 2	DC-HSDPA	1	9275	1852.6	21.3
			9400	1880	21.6
			9525	1907.4	21.1
		2	9275	1852.6	20.9
			9400	1880	21.2
			9525	1907.4	20.6
		3	9275	1852.6	20.8
			9400	1880	21.1
			9525	1907.4	20.6
		4	9275	1852.6	20.8
			9400	1880	21.0
			9525	1907.4	20.6

8. PEAK TO AVERAGE RATIO

Test Procedure

Per KDB 971168 D01 Power Meas License Digital Systems v02r01

Test Spec

In addition, when the transmitter power is measured in terms of average value, the peak-to-average ratio of the power shall not exceed 13 dB.

8.1. CONDUCTED PEAK TO AVERAGE RESULT

Note: GSM mode is using Peak burst power measurement method, so no peak to average ratio needed.

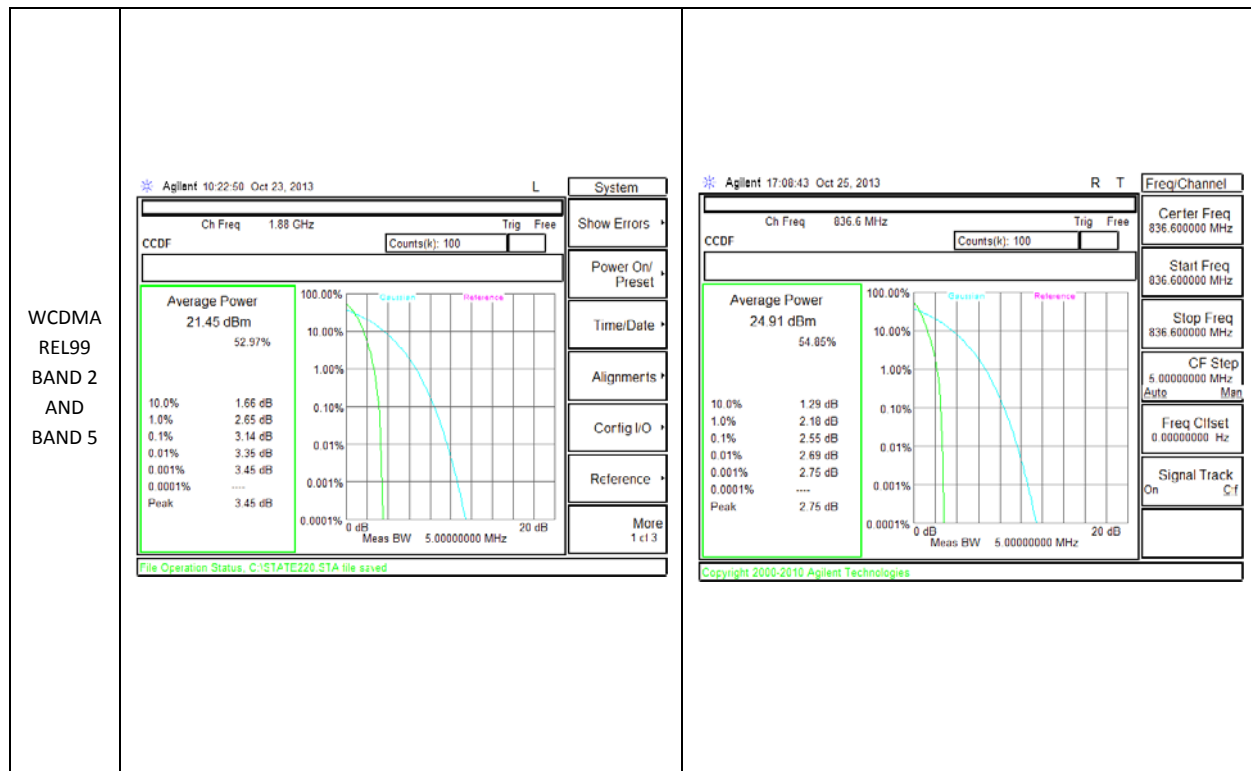

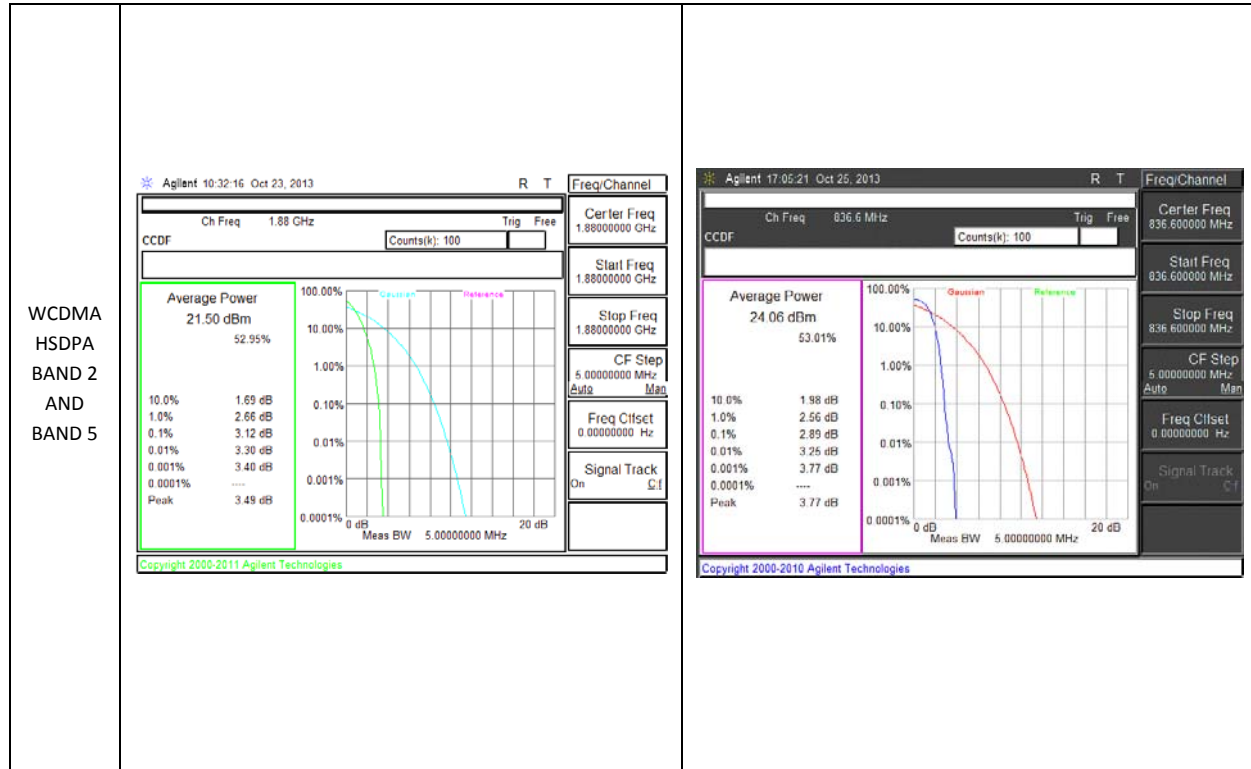

9. LIMITS AND CONDUCTED RESULTS

9.1. OCCUPIED BANDWIDTH

RULE PART(S)

FCC: §2.1049

IC: RSS-132, 4.5; RSS-133, 6.5

LIMITS

For reporting purposes only

TEST PROCEDURE

The transmitter output was connected to a calibrated coaxial cable and coupler, the other end of which was connected to a spectrum analyzer. The occupied bandwidth was measured with the spectrum analyzer at the low, middle and high channel in each band. The -26dB bandwidth was also measured and recorded.

(KDB 971168 D01 Power Meas License Digital Systems v02r01 - 06/07/2013)

Occupied bandwidth – relative measurement procedure (26dB)

The reference value is the highest level of the spectral envelope of the modulated signal.

- a) The spectrum analyzer center frequency is set to the nominal EUT channel center frequency. The span range for the spectrum analyzer shall be between two and five times the anticipated OBW.
- b) The nominal resolution bandwidth (RBW) shall be in the range of 1 to 5 % of the anticipated OBW, and the VBW shall be at least 3 times the RBW.
- c) Set the reference level of the instrument as required to prevent the signal from exceeding the maximum input mixer level for linear operation. In general, the peak of the spectral envelope must be at least $10\log(\text{OBW} / \text{RBW})$ below the reference level.
- d) NOTE—*Steps a) through c) may require iteration to adjust within the specified tolerances.*
- e) The dynamic range of the spectrum analyzer at the selected RBW shall be at least 10 dB below the target “-X dB down” requirement (*i.e.*, if the requirement calls for measuring the -26 dB OBW, the spectrum analyzer noise floor at the selected RBW shall be at least 36 dB below the reference value).
- f) Set the detection mode to peak, and the trace mode to max hold.
- g) Determine the reference value: Set the EUT to transmit a modulated signal. Allow the trace to stabilize. Set the spectrum analyzer marker to the highest level of the displayed trace (this is the reference value).
- h) Determine the “-X dB down amplitude” as equal to (Reference Value - X). Alternatively, this calculation can be performed by the analyzer by using the marker-delta function.
- i) Place two markers, one at the lowest and the other at the highest frequency of the envelope of the spectral display such that each marker is at or slightly below the “-X dB down amplitude” determined in step g). If a marker is below this “-X dB down amplitude” value it shall be placed as close as possible to this value. The OBW is the positive frequency difference between the two markers.
- j) The occupied bandwidth shall be reported by providing plot(s) of the measuring instrument display. The frequency and amplitude axes and scale shall be clearly labeled. Tabular data may be reported in addition to the plot(s).

2. Occupied bandwidth – power bandwidth (99%) measurement procedure

The following procedure shall be used for measuring (99 %) power bandwidth per KDB 971168 D01 Power Meas License Digital Systems v02r01 4

- a) The spectrum analyzer center frequency is set to the nominal EUT channel center frequency. The frequency span for the spectrum analyzer shall be set wide enough to capture all modulation products including the emission skirts (*i.e.*, two to five times the OBW).
- b) The nominal IF filter bandwidth (3 dB RBW) shall be in the range of 1 to 5 % of the anticipated OBW, and the VBW shall be at least 3 times the RBW.

c) Set the reference level of the instrument as required to keep the signal from exceeding the maximum input mixer level for linear operation. In general, the peak of the spectral envelope must be at least $10\log(\text{OBW} / \text{RBW})$ below the reference level.

d) NOTE—*Steps a) through c) may require iteration to adjust within the specified tolerances.*

e) Set the detection mode to peak, and the trace mode to max hold..

f) Use the 99 % power bandwidth function of the spectrum analyzer (if available) and report the measured bandwidth.

g) If the instrument does not have a 99 % power bandwidth function, the trace data points are to be recovered and directly summed in linear power terms. The recovered amplitude data points, beginning at the lowest frequency, are placed in a running sum until 0.5 % of the total is reached; that frequency is recorded as the lower frequency. The process is repeated until 99.5 % of the total is reached; that frequency is recorded as the upper frequency. The 99 % power bandwidth is the difference between these two frequencies.

h) The OBW shall be reported by providing plot(s) of the measuring instrument display. The frequency and amplitude axes and scale shall be clearly labeled. Tabular data may be reported in addition to the plot(s). Record the displayed OBW value. MODES TESTED

9.1.1. OCCUPIED BANDWIDTH RESULTS

Band	Mode	Channel	f (MHz)	99% BW (MHz)	-26dB BW (MHz)
GSM850	GMSK	128	824.2	0.246	0.321
		190	836.6	0.246	0.315
		251	848.8	0.247	0.308
	EGPRS	128	824.2	0.246	0.316
		190	836.6	0.242	0.307
		251	848.8	0.241	0.300
GSM1900	GMSK	512	1850.2	0.237	0.318
		661	1880	0.242	0.31
		810	1909.8	0.239	0.32
	EGPRS	512	1850.2	0.236	0.3
		661	1880	0.252	0.322
		810	1909.8	0.24	0.31
Band 5	REL99	4145	826.6	4.121	4.608
		4183	836.6	4.1531	4.607
		4220	846.4	4.1567	4.658
	HSDPA	4145	826.6	4.1681	4.627
		4183	836.6	4.1521	4.616
		4220	846.4	4.1333	4.625
Band 2	REL99	9275	1852.6	4.1364	4.615
		9400	1880	4.1488	4.619
		9525	1907.4	4.1401	4.625
	HSDPA	9275	1852.6	4.1631	4.634
		9400	1880	4.136	4.64
		9525	1907.4	4.1415	4.67

9.1.1. OCCUPIED BANDWIDTH PLOTS

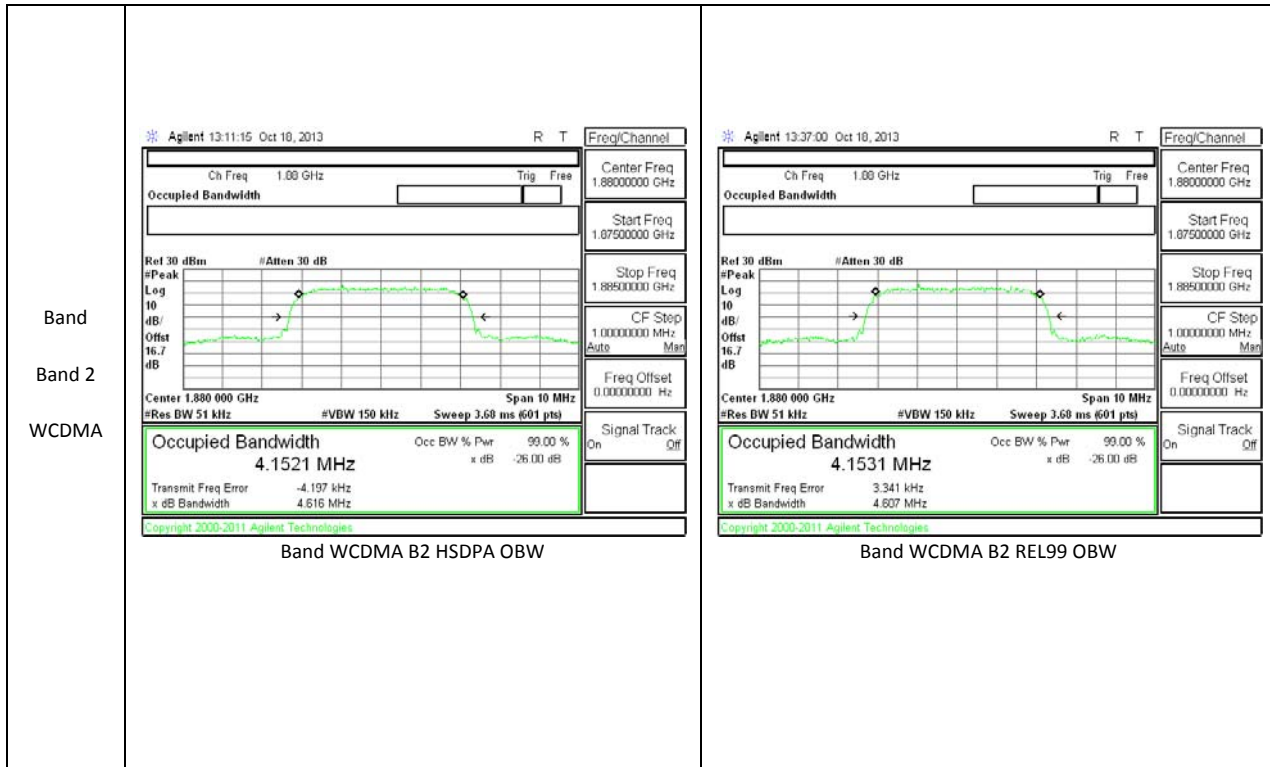

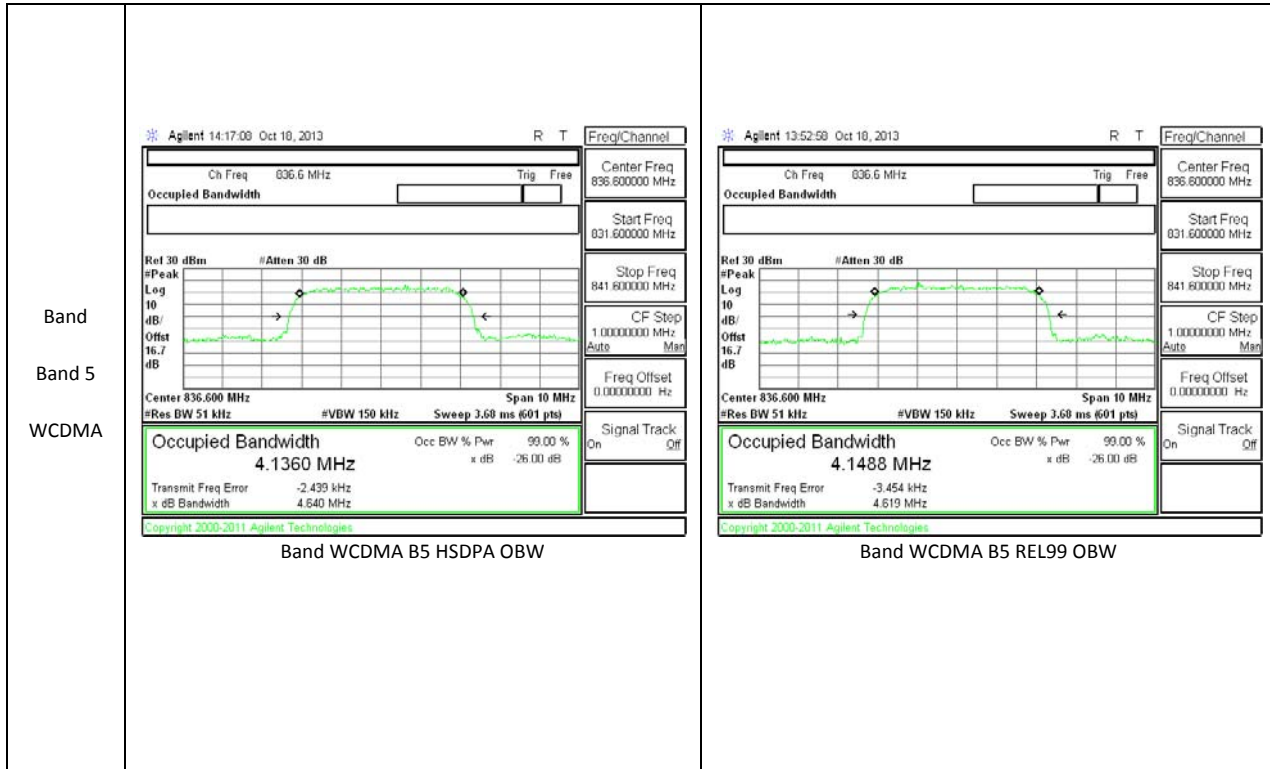

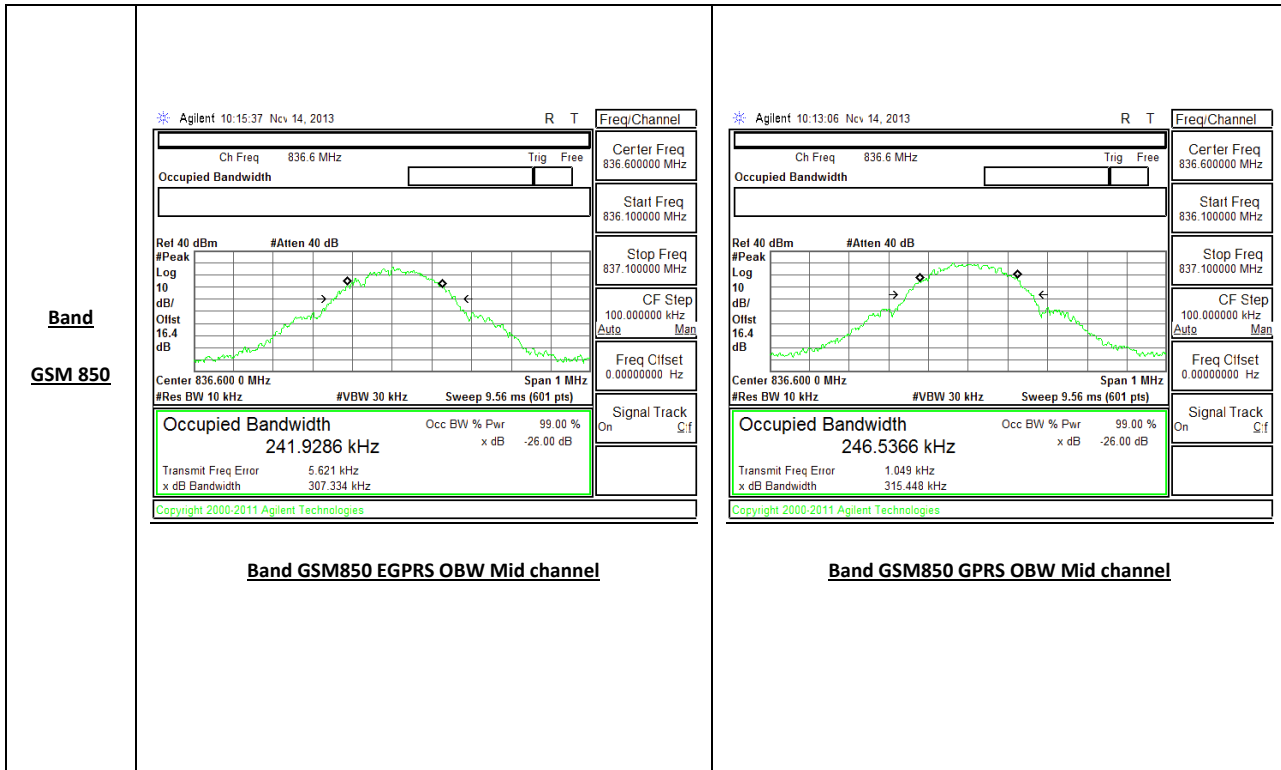

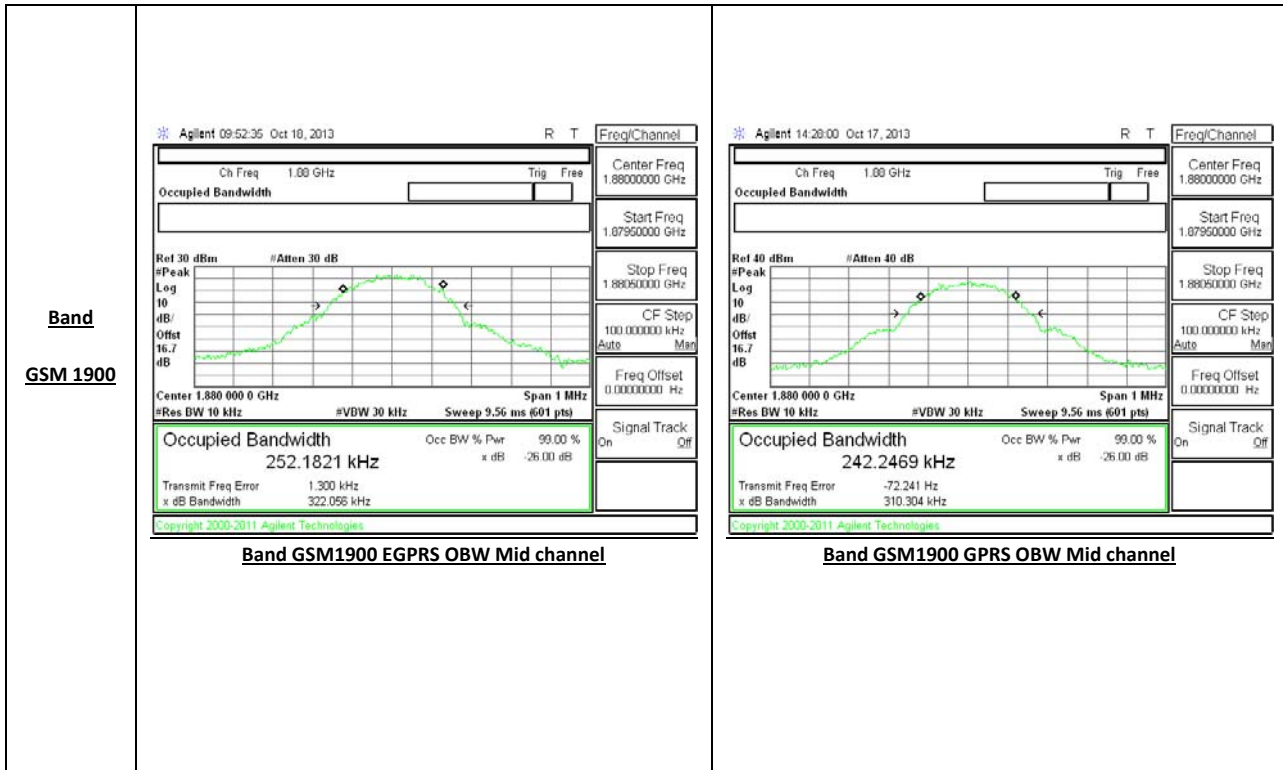

9.2. BAND EDGE EMISSIONS

RULE PART(S)

FCC: §22.359, §24.238

LIMITS

The power of any emission outside of the authorized operating frequency ranges must be attenuated below the transmitting power (P) by a factor of at least $43 + 10 \log (P)$ dB.

TEST PROCEDURE

Per KDB 971168 D01 Power Meas License Digital Systems v02r01

The transmitter output was connected to an Agilent 8960 or a CMW500 Test Set and configured to operate at maximum power. The band edge emissions were measured at the required operating frequencies in each band on the Spectrum Analyzer.

For each band edge measurement:

- Set the spectrum analyzer span to include the block edge frequency (824, 849, 1850, 1910 and 1915MHz)
- Set a marker to point the corresponding band edge frequency in each test case.
- Set display line at -13 dBm.
- Set resolution bandwidth to at least 1% of emission bandwidth.
- (m)(6) Compliance with these rules is based on the user of measurement instrumentation employing a resolution bandwidth of 1MHz or greater. However, in the 1MHz bands immediately outside and adjacent to the frequency block a resolution bandwidth of at least 1 percent of the emission bandwidth may be employed.

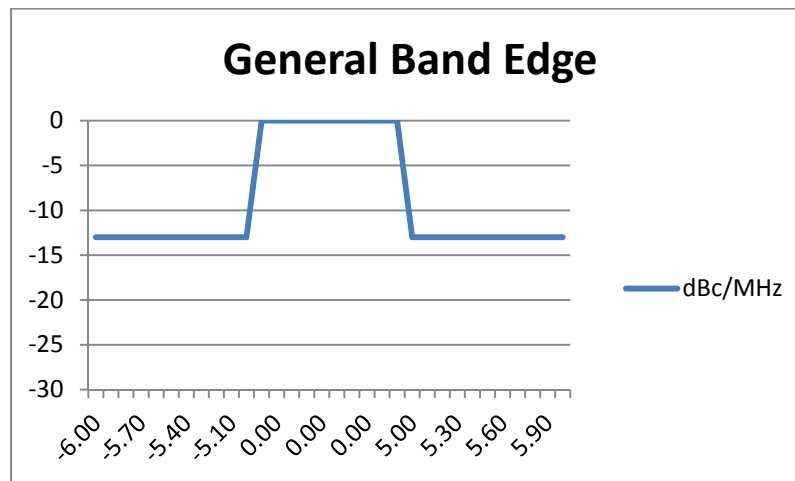

MODES TESTED

GPRS, EGPRS 1900 & 850

WCDMA REL 99, HSDPA Band 2 and 5

RESULTS

9.2.1.BAND EDGE PLOTS

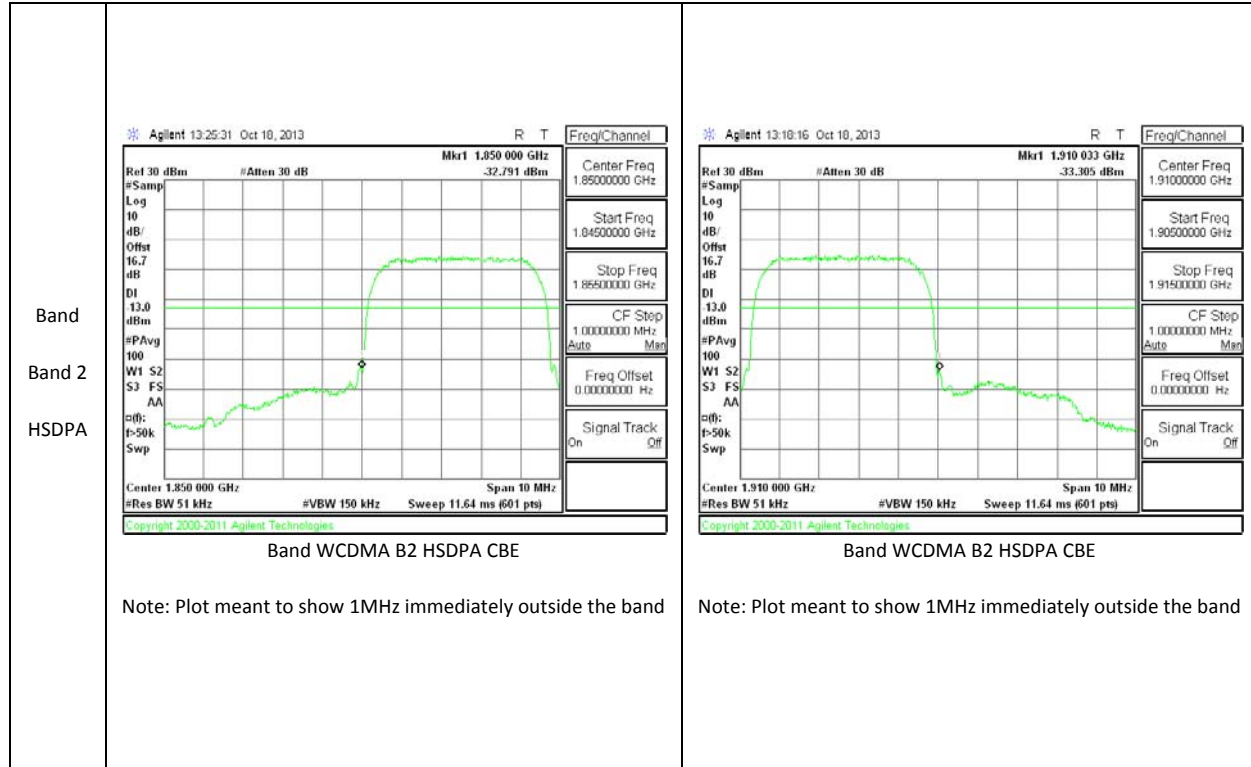

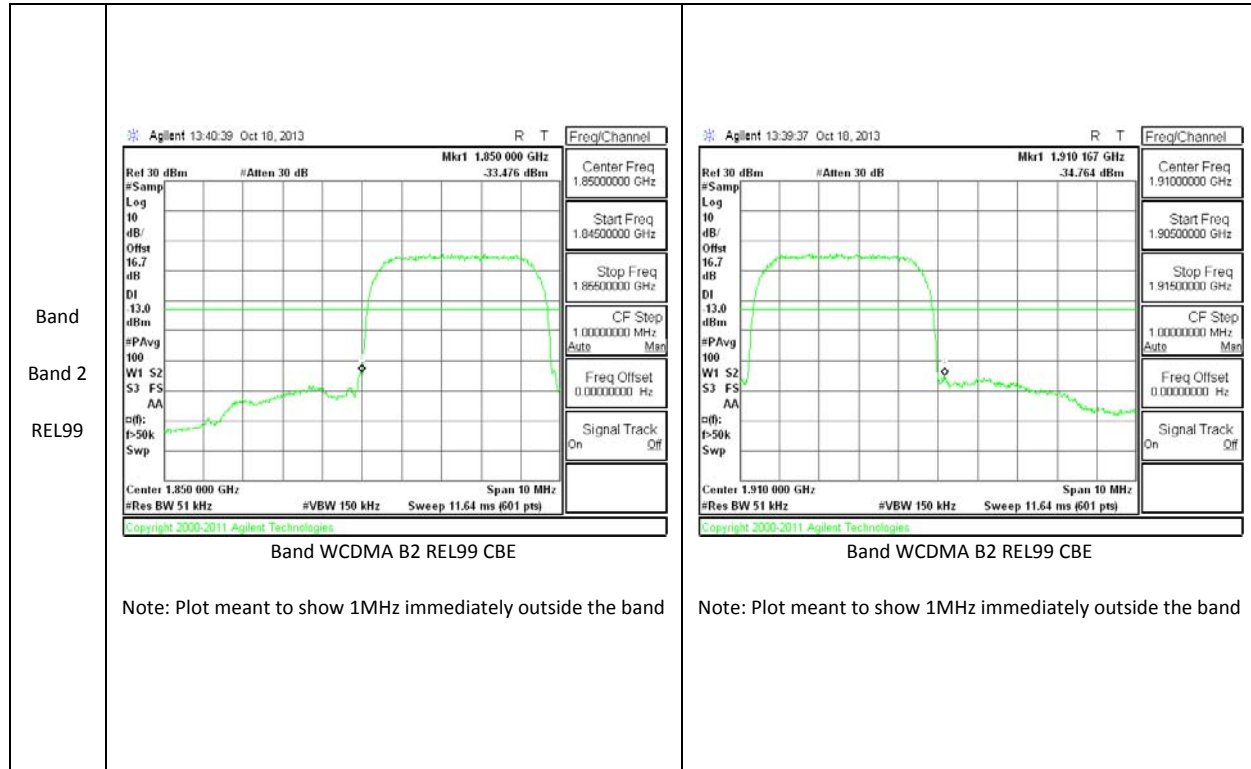

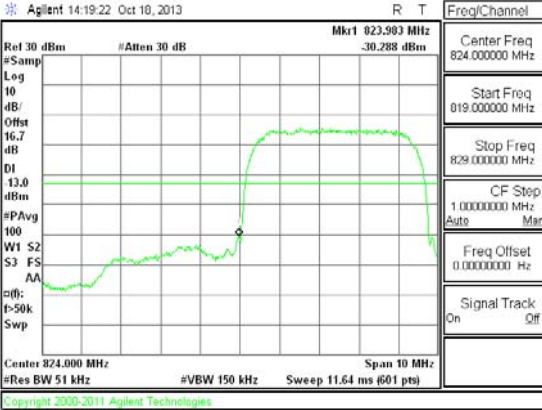
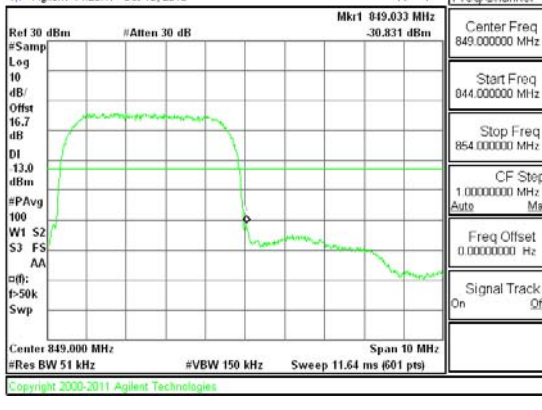
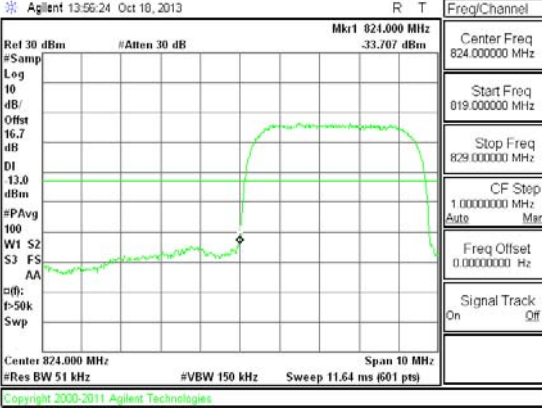
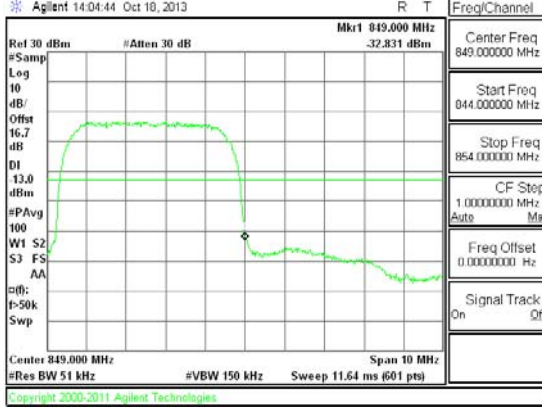
<p>Band Band 5 HSDPA</p>	 <p style="text-align: center;">Band WCDMA B5 HSDPA CBE</p> <p>Note: Plot meant to show 1MHz immediately outside the band</p>	 <p style="text-align: center;">Band WCDMA B5 REL99 CBE</p> <p>Note: Plot meant to show 1MHz immediately outside the band</p>
<p>Band Band 5 REL99</p>	 <p style="text-align: center;">Band WCDMA B5 REL99 CBE Low Channel</p> <p>Note: Plot meant to show 1MHz immediately outside the band</p>	 <p style="text-align: center;">Band WCDMA B5 REL99 CBE High Channel</p> <p>Note: Plot meant to show 1MHz immediately outside the band</p>

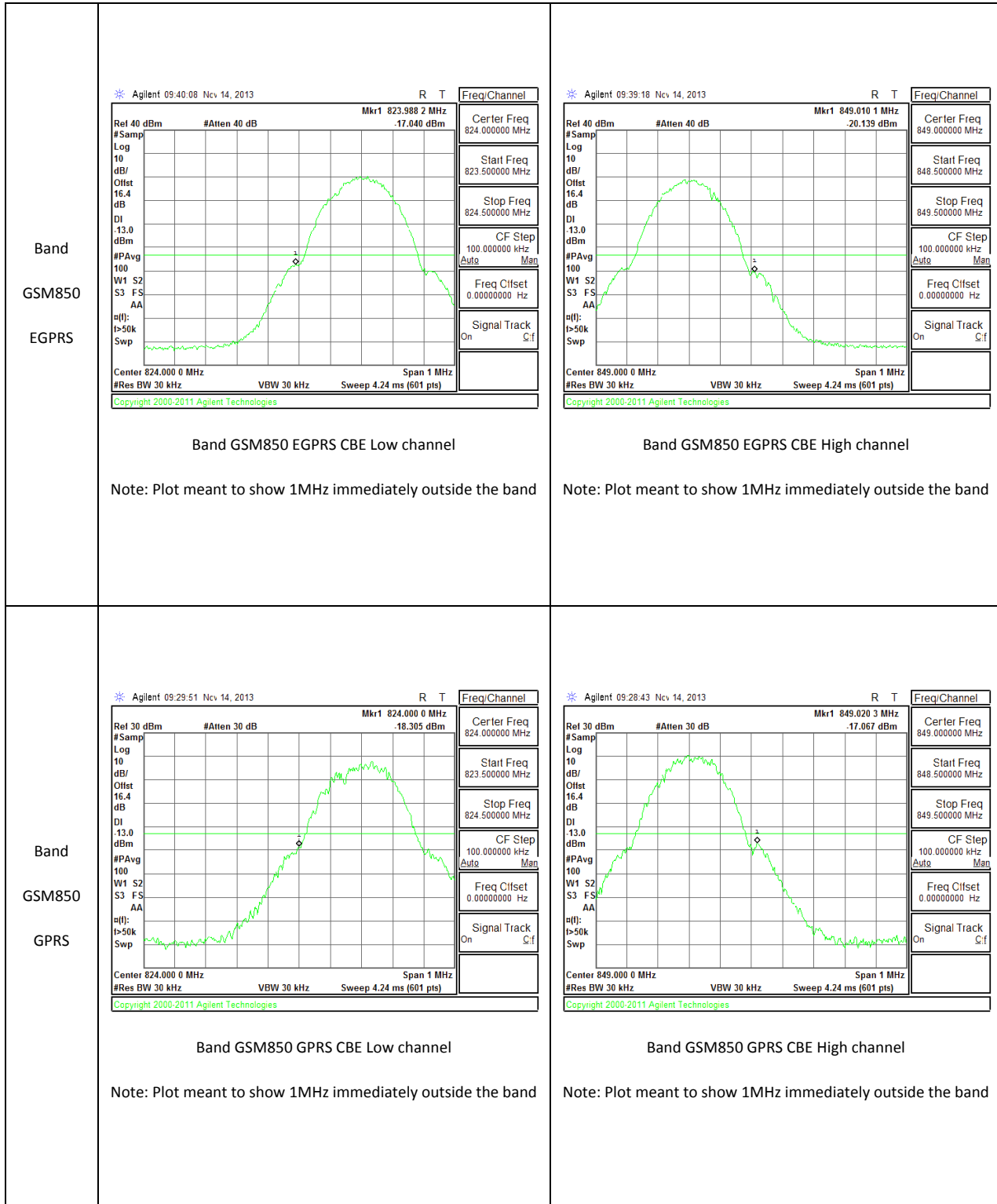

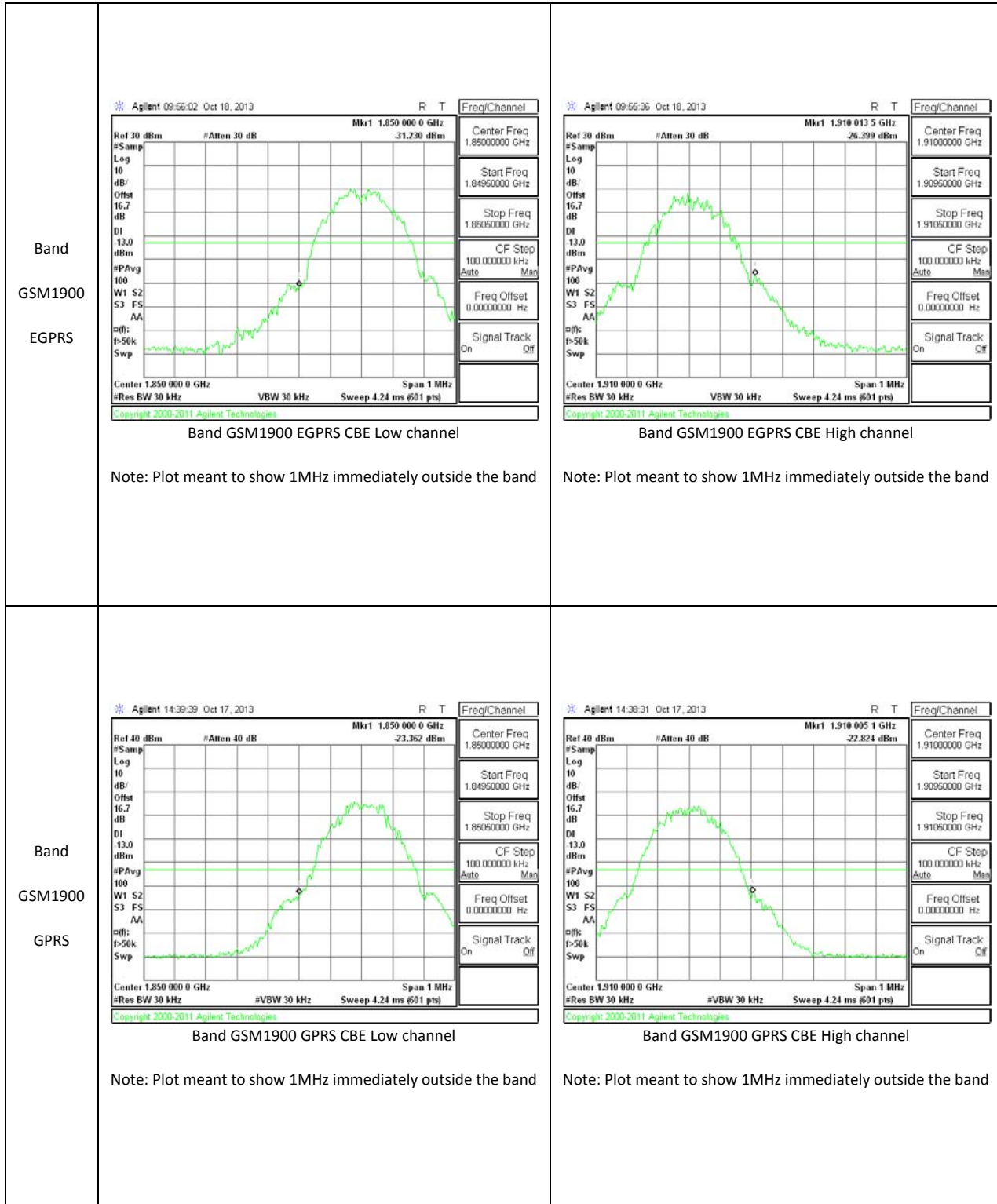

9.3. OUT OF BAND EMISSIONS

RULE PART(S)

FCC: §2.1051, §22.901, §22.917, §24.238

LIMITS

The power of any emission outside of the authorized operating frequency ranges must be attenuated below the transmitting power (P) by a factor of at least $43 + 10 \log (P)$ dB.

TEST PROCEDURE

Per KDB 971168 D01 Power Meas License Digital Systems v02r01

The RF output of the transmitter was connected to a spectrum analyzer through a calibrated coaxial cable. Sufficient scans were taken to show the out-of-band Emissions, if any, up to 10th harmonic. Multiple sweeps were recorded in maximum hold mode using a peak detector to ensure that the worst-case emissions were caught.

For each out of band emissions measurement:

- Set display line at -13 dBm
- Set RBW & VBW to 100 kHz for the measurement below 1 GHz, and 1 MHz for the measurement above 1 GHz.

MODES TESTED

RESULTS

9.3.1. OUT OF BAND EMISSIONS RESULT

Band	Mode	f (MHz)	Spur (dBm)	Spec (dBm)	Delta (dB)
GSM850	GPRS	824.2	-21.64	-13	8.64
		936.6	-21.02	-13	8.02
		848.8	-17.91	-13	4.91
	EGPRS	824.2	-18.36	-13	5.36
		936.6	-19.12	-13	6.12
		848.8	-18.72	-13	5.72
GSM1900	GPRS	1850.2	-17.54	-13	4.54
		1880	-17.18	-13	4.18
		1909.8	-16.59	-13	3.59
	EGPRS	1850.2	-27.63	-13	14.63
		1880	-26.55	-13	13.55
		1909.8	-29.55	-13	16.55
Band 5	REL99	826.6	-28.9	-13	15.9
		836.6	-28.3	-13	15.3
		846.4	-27.28	-13	14.28
	HSDPA	826.6	-27.32	-13	14.32
		836.6	-26.98	-13	13.98
		846.4	-29.35	-13	16.35
Band 2	REL99	1852.6	-28.9	-13	15.9
		1880	-28.3	-13	15.3
		1907.4	-27.28	-13	14.28
	HSDPA	1852.6	-27.32	-13	14.32
		1880	-26.98	-13	13.98
		1907.4	-29.35	-13	16.35

9.3.2. OUT OF BAND EMISSIONS PLOTS

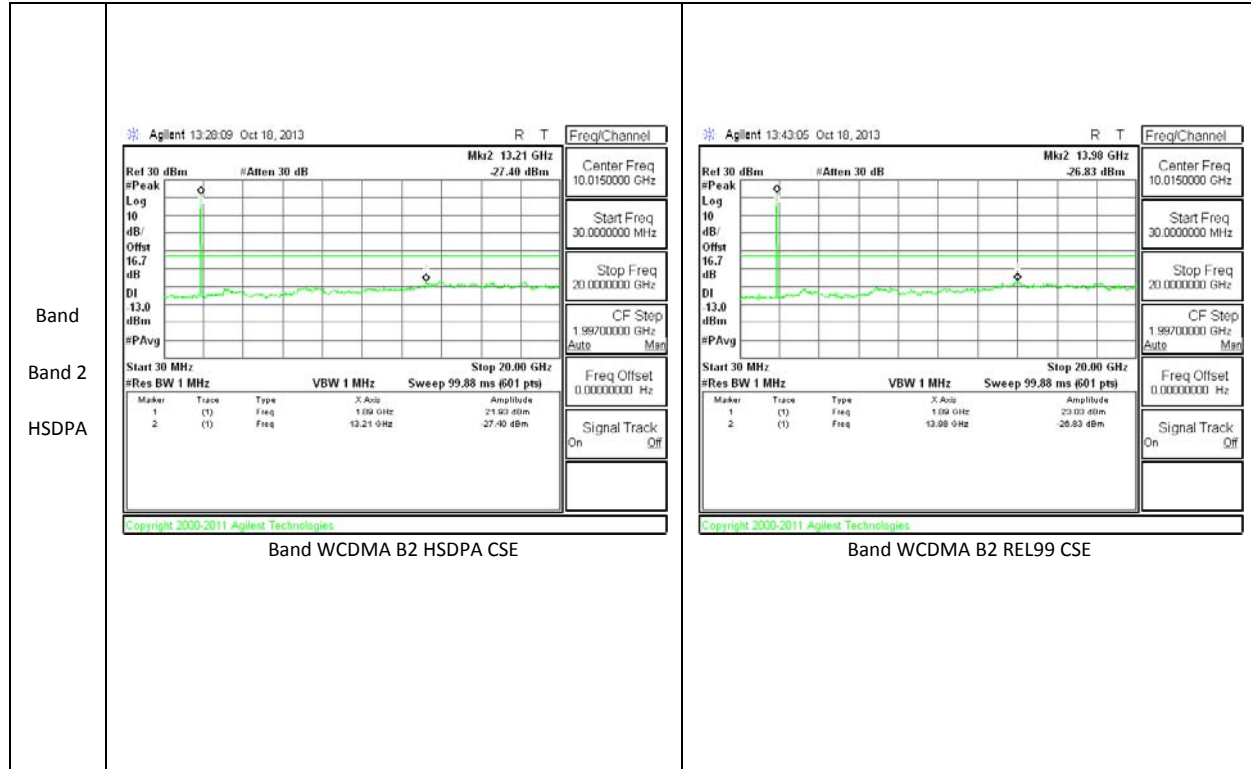

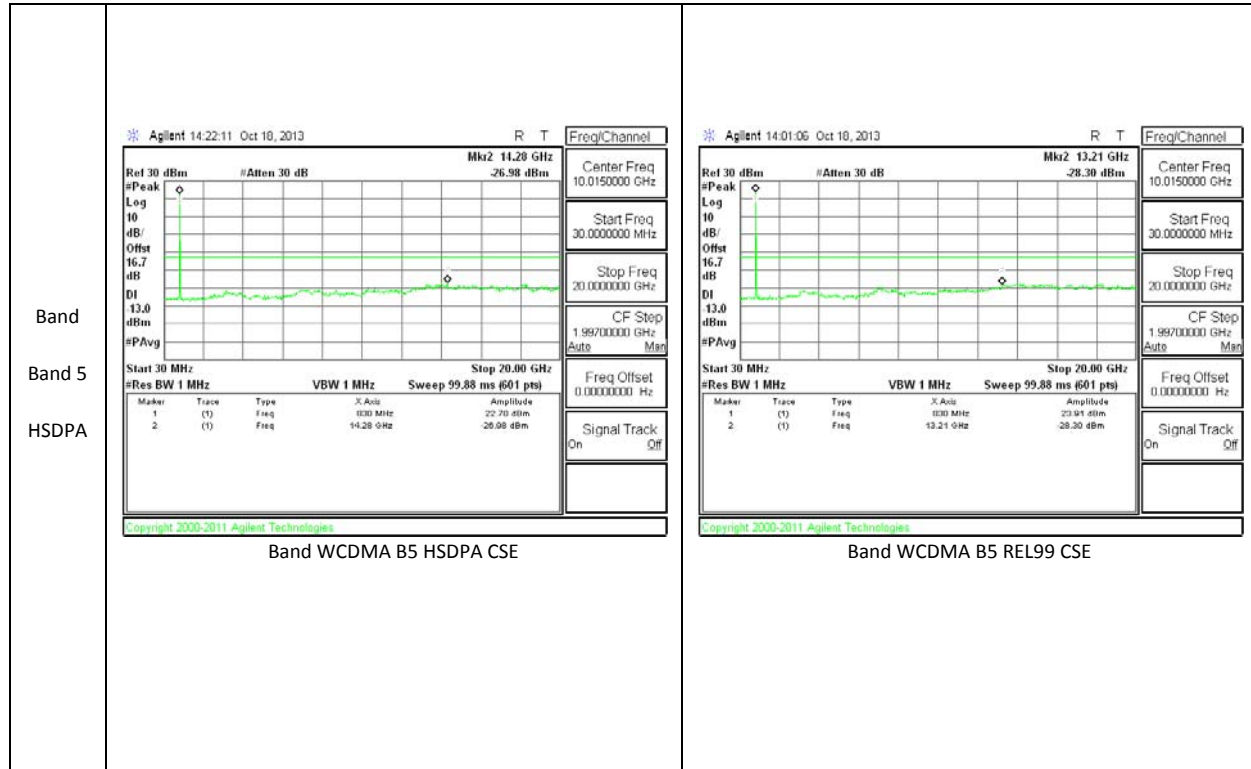

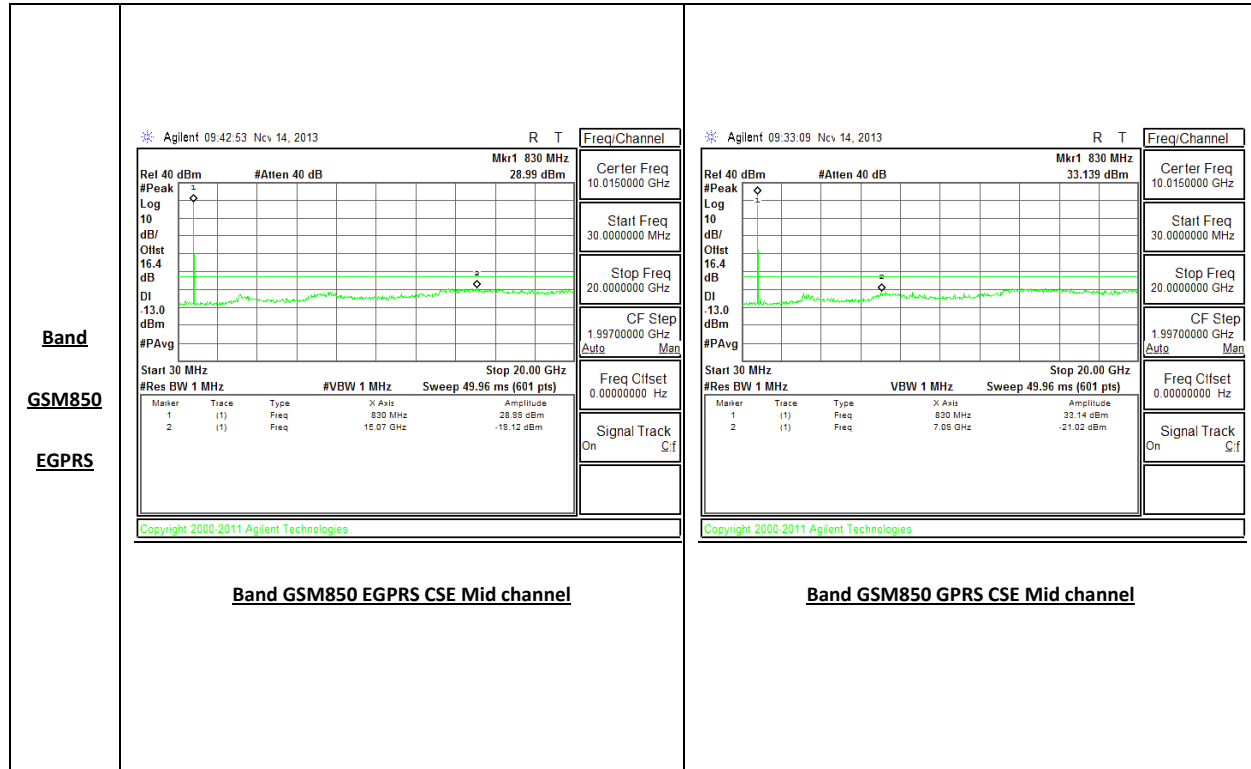

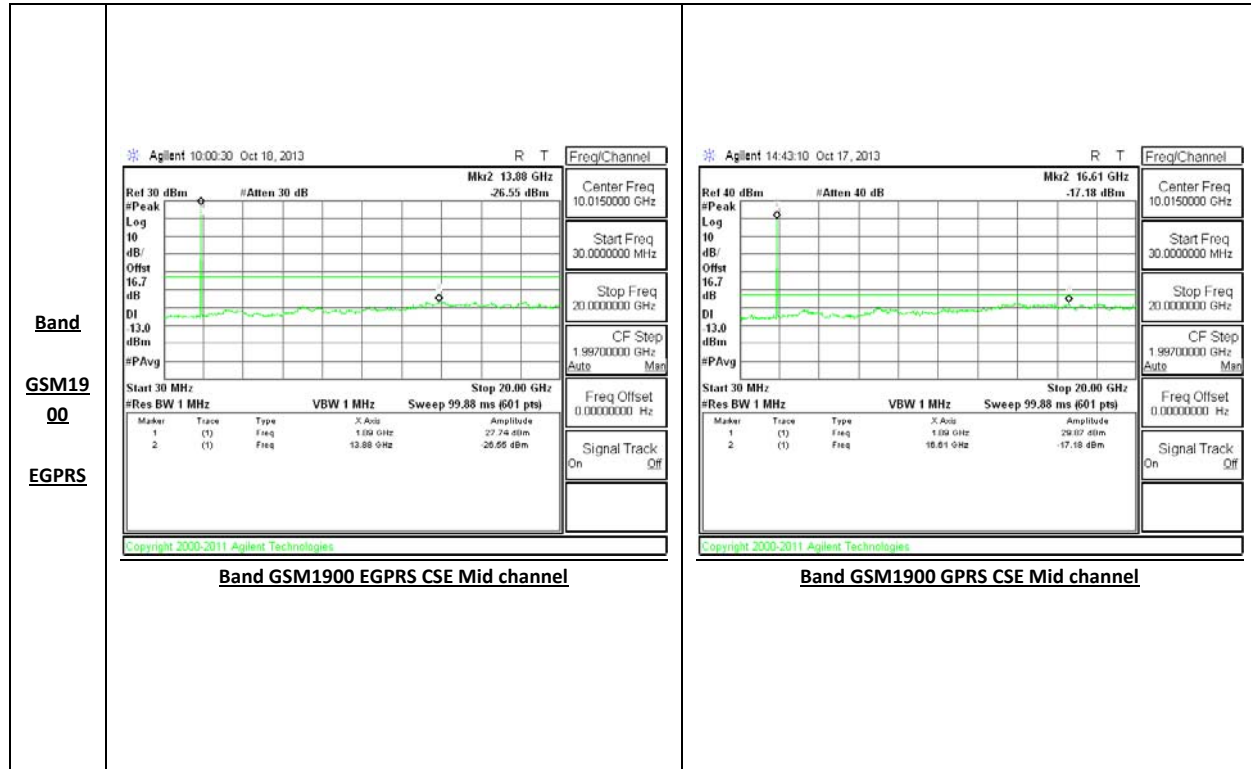

9.4. FREQUENCY STABILITY

RULE PART(S)

FCC: §2.1055, §22.355, §24.235, and §27.54

LIMITS

§22.355 - The carrier frequency shall not depart from the reference frequency in excess of ± 2.5 ppm for mobile stations.

§24.235 - The frequency stability shall be sufficient to ensure that the fundamental emission stays within the authorized frequency block.

§27.54 - The frequency stability shall be sufficient to ensure that the fundamental emissions stay within the authorized bands of operation.

TEST PROCEDURE

Per KDB 971168 D01 Power Meas License Digital Systems v02r01

Frequency Stability vs Temperature:

The EUT is placed inside a temperature chamber. The temperature is set to 20°C and allowed to stabilize. After sufficient soak time, the transmitting frequency error is measured. The temperature is increased by 10 degrees, allowed to stabilize and soak, and then the measurement is repeated. This is repeated until +50°C is reached. Reference power supply voltage for these tests is 3.8Vdc.

Frequency Stability vs Voltage:

The peak frequency error is recorded (worst-case). The test voltage ranges from 3.30 to 4.20 VDC.

MODES TESTED

RESULTS

See the following pages.

9.4.1. FREQUENCY STABILITY RESULTS

WCDMA

Reference Frequency: PC S Mid Channel 1880MHz @ 20°C				
Limit: to stay +- 2.5 ppm = 4700.000 Hz				
Power Supply (Vdc)	Environment Temperature (°C)	Frequency Deviation Measured with Time Elapse		
		(MHz)	Delta (ppm)	Limit (ppm)
3.80	50	1879.999985	0.002	2.5
3.80	40	1879.999986	0.001	2.5
3.80	30	1879.999987	0.001	2.5
3.80	20	1879.999988	0	2.5
3.80	10	1879.999989	-0.001	2.5
3.80	0	1879.999984	0.002	2.5
3.80	-10	1879.999986	0.001	2.5
3.80	-20	1879.999987	0.001	2.5
3.80	-30	1879.999988	0.000	2.5

Reference Frequency: PCS Mid Channel 1880 MHz @ 20°C				
Limit: to stay +- 2.5 ppm = 4700.000 Hz				
Power Supply (Vdc)	Environment Temperature (°C)	Frequency Deviation Measured with Time Elapse		
		(MHz)	Delta (ppm)	Limit (ppm)
3.80	20	1879.999988	0	2.5
4.20	20	1879.999995	-0.004	2.5
3.30	20	1879.999993	-0.003	2.5
End Volt(3.2)	20	1879.999991	-0.002	2.5

BAND V, Channel 4183, Freq: 836.6MHz – MID CHANNEL

Reference Frequency: Cell Mid Channel 836.6 MHz @ 20°C				
Limit: +- 2.5 ppm = 2091.500 Hz				
Power Supply (Vdc)	Environment Temperature (*C)	Frequency Deviation Measured with Time Elapse		
		(MHz)	Delta (ppm)	Limit (ppm)
3.80	50	836.599995	0.001	2.5
3.80	40	836.599996	0.000	2.5
3.80	30	836.599997	-0.001	2.5
3.80	20	836.599996	0	2.5
3.80	10	836.599997	-0.001	2.5
3.80	0	836.599995	0.001	2.5
3.80	-10	836.599996	0.000	2.5
3.80	-20	836.599997	-0.001	2.5
3.80	-30	836.599997	-0.001	2.5

Reference Frequency: PCS Mid Channel 1880 MHz @ 20°C				
Limit: +- 2.5 ppm = 4700.000 Hz				
Power Supply (Vdc)	Environment Temperature (*C)	Frequency Deviation Measured with Time Elapse		
		(MHz)	Delta (ppm)	Limit (ppm)
3.80	20	836.599996	0.00000	2.5
4.20	20	836.599995	0.00053	2.5
3.30	20	836.600011	-0.008	2.5
End Volt(3.2)	20	836.600010	-0.007	2.5

GSM850, Channel 190 Freq: 836.6MHz- MID CHANNEL

Reference Frequency: Cellular Mid Channel 835.999984 MHz @ 20°C Limit: to stay +/- 2.5 ppm = 2091.500 Hz				
Power Supply (Vdc)	Environment Temperature (°C)	Frequency Deviation Measured with Time Elapse		
		(MHz)	Delta (ppm)	Limit (ppm)
3.80	50	836.600009	-0.008	2.5
3.80	40	836.600007	-0.006	2.5
3.80	30	836.600006	-0.005	2.5
3.80	20	836.600002	0	2.5
3.80	10	836.600008	-0.007	2.5
3.80	0	836.600005	-0.004	2.5
3.80	-10	836.600006	-0.005	2.5
3.80	-20	836.600003	-0.001	2.5
3.80	-30	836.600007	-0.006	2.5

Reference Frequency: Cellular Mid Channel 835.999984 MHz @ 20°C Limit: to stay +/- 2.5 ppm = 2091.500 Hz				
Power Supply (Vdc)	Environment Temperature (°C)	Frequency Deviation Measured with Time Elapse		
		(MHz)	Delta (ppm)	Limit (ppm)
3.80	20	836.600002	0	2.5
4.30	20	836.600007	-0.006	2.5
3.30	20	836.600011	-0.011	2.5
End Volt(3.2)	20	836.600010	-0.010	2.5

GSM1900, Channel 661 Freq: 1880MHz– MID CHANNEL

Reference Frequency: PCS Mid Channel 1880MHz @ 20°C				
Limit: to stay +- 2.5 ppm = 4700.000 Hz				
Power Supply (Vdc)	Environment Temperature (°C)	Frequency Deviation Measured with Time Elapse		
		(MHz)	Delta (ppm)	Limit (ppm)
3.80	50	1879.999982	0.003	2.5
3.80	40	1879.999986	0.001	2.5
3.80	30	1879.999987	0.001	2.5
3.80	20	1879.999988	0	2.5
3.80	10	1879.999983	0.003	2.5
3.80	0	1879.999989	-0.001	2.5
3.80	-10	1879.999991	-0.002	2.5
3.80	-20	1879.999997	-0.005	2.5
3.80	-30	1879.999999	-0.006	2.5

Reference Frequency: PCS Mid Channel 1880 MHz @ 20°C				
Limit: to stay +- 2.5 ppm = 4700.000 Hz				
Power Supply (Vdc)	Environment Temperature (°C)	Frequency Deviation Measured with Time Elapse		
		(MHz)	Delta (ppm)	Limit (ppm)
3.80	20	1879.999988	0	2.5
4.20	20	1879.999989	-0.001	2.5
3.30	20	1879.999981	0.004	2.5
End Volt(3.2)	20	1879.999981	0.004	2.5

10. RADIATED TEST RESULTS

10.1. RADIATED POWER (ERP & EIRP)

RULE PART(S)

FCC: §2.1046, §22.913, §24.232, and § 90.635.

LIMITS

22.913(a) - The ERP of mobile transmitters and auxiliary test transmitters must not exceed 7 Watts.

24.232(c) - Mobile/portable stations are limited to 2 watts e.i.r.p. peak power and the equipment must employ means to limit the power to the minimum necessary for successful communications.

In addition, when the transmitter power is measured in terms of average value, the peak-to-average ratio of the power shall not exceed 13dB.

TEST PROCEDURE

ANSI / TIA / EIA 603C Clause 2.2.17

Please refer to the fundamental measurement template on completing the radiated power measurement: (Please refer to the figure 5A)

1. Once peak position has been achieved and has been entered under "SA Reading (dBm)"
2. Perform Substitute measurement by following the setup described below:
 - a. For Low Band (below 1GHz):
 - i. Obtain the calibrated dipole antenna from the warehouse (Dipole S/N: 00022117)
 - ii. Set the output power of the signal generator to 0dBm + cable loss (cable connecting signal generator and horn antenna)
 - iii. Find the peak position again.
 - iv. Calculate the path loss by 0dBm - SA reading and enter new path loss information under "Path loss" section of the template. (Figure 5A)
 - b. For High Band (above 1GHz):
 - i. Obtain the calibrated Horn T217 antenna from the warehouse.
 - ii. Set the output power of the signal generator to 0dBm + cable loss (Cable connecting signal generator and horn antenna)
 - iii. Find the peak position again.
 - iv. Increase SG output power until SG value equals that of current "SA reading (dBm)" column.
 - v. Enter the SG output power under "SG reading (dBm)" and template will calculate the proper EIRP value. (Refer to Figure 5B)

Following is the sample data sheet for data calculation:

f MHz	SG reading (dBm)	Ant. Pol. (H/V)	Cable Loss (dB)	Antenna Gain (dBd)	ERP (dBm)	Limit (dBm)	Margin (dB)	Notes	SA reading (dBm)	Pass Loss
Low Ch										
824.20		V	0.5	0.0		38.5				34.5
824.20		H	0.5	0.0		38.5				31.9
X										
836.60		V	0.5	0.0		38.5			-14.80	34.6
836.60	24.81	H	0.5	0.0	24.31	38.5	-14.1		-6.19	31.0
Y										
836.60	28.21	V	0.5	0.0	27.71	38.5	-10.7		-6.43	34.6
836.60	11.41	H	0.5	0.0	10.91	38.5	-27.5		-19.59	31.0
Z										
836.60		V	0.5	0.0		38.5				34.6
836.60	24.49	H	0.5	0.0	23.99	38.5	-14.5		-6.51	31.0

Figure 5A (ERP Example)

f GHz	SG reading (dBm)	Ant. Pol. (H/V)	Cable Loss (dB)	Antenna Gain (dBi)	EIRP (dBm)	Limit (dBm)	Delta (dB)	Notes	SA reading (dBm)
Low Ch									
1.850		V	0.85	8.62		33.0			
1.850		H	0.85	8.47		33.0			
Mid Ch									
1.880		V	0.85	8.46		33.0		X	
1.880	17.5	H	0.85	8.36	25.05	33.0	-8.0	X	-17.51
1.880		v	0.85	8.36		33.0			
1.880	20.8	H	0.85	8.36	28.32	33.0	-4.7	X W/ WIRELESS CHARGER +HEADSET	-14.24
1.880		v	0.85	8.36		33.0			
1.880	18.9	H	0.85	8.36	26.37	33.0	-6.6	X W/ WIRELESS CHARGER	-16.19

Figure 5B (ERIP Example)

MODES TESTED

- GPRS/EGPRS 1900 & 850
- WCDMA REL99 and HSDPA Bands 2 & 5

TEST RESULTS

10.1.1. ERP/EIRP Results

Band	Mode	Channel	f(MHz)	ERP / EIRP	
				dBm	mW
Band 2	REL99	9275	1852.6	19.78	95.06
		9400	1880	19.16	82.41
		9525	1907.4	17.25	53.09
	HSDPA	9275	1852.6	20.72	118.03
		9400	1880	18.81	76.03
		9525	1907.4	16.79	47.75

Band	Mode	Channel	f(MHz)	ERP / EIRP	
				dBm	mW
Band 5	REL99	4145	826.6	8.39	6.90
		4183	836.6	9.79	9.53
		4220	846.4	9.76	9.46
	HSDPA	4145	826.6	11.06	12.76
		4183	836.6	12.09	16.18
		4220	846.4	12.40	17.38

Band	Mode	Channel	f(MHz)	ERP / EIRP	
				dBm	mW
GSM850	GPRS	128	824.2	20.61	115.08
		190	836.6	21.33	135.83
		251	848.8	22.88	194.08
	EGPRS	128	824.2	20.36	108.64
		190	836.6	22.08	161.43
		251	848.8	23.37	227.27

Band	Mode	Channel	f(MHz)	ERP / EIRP	
				dBm	mW
GSM1900	GPRS	512	1850.2	26.19	415.91
		661	1880	25.99	397.19
		810	1909.8	24.44	277.97
	EGPRS	512	1850.2	27.24	529.66
		661	1880	25.44	349.95
		810	1909.8	23.61	229.61

10.1.2. ERP/EIRP PLOTS

Band Band 2 HSDPA	High Frequency Fundamental Measurement Compliance Certification Services Chamber C								
	Company: Samsung Project #: 13U16263 Date: 10/17/13 Test Engineer: K.Kedida Configuration: EUT, Z pos with charger Mode: HSDPA 1900 , PCS								
	Test Equipment: Receiving: T120, and Chamber D SMA Cables Substitution: Horn T60 Substitution, 4ft SMA Cable (244639001) Warehouse								
	f GHz	SG reading (dBm)	Ant. Pol. (H/V)	Cable Loss (dB)	Antenna Gain (dBi)	EIRP (dBm)	Limit (dBm)	Delta (dB)	Notes
	Low Ch								
	1.852	11.5	V	1.50	7.94	17.89	33.0	-15.1	
	1.852	14.1	H	1.50	8.14	20.72	33.0	-12.3	
	Mid Ch								
	1.880	9.9	V	1.50	7.95	16.35	33.0	-16.7	
	1.880	12.1	H	1.50	8.26	18.81	33.0	-14.2	
High Ch									
1.908	8.8	V	1.50	7.97	15.22	33.0	-17.8		
1.908	9.9	H	1.50	8.38	16.79	33.0	-16.2		
Rev. 3.17.11									

Band Band 2 REL99	High Frequency Fundamental Measurement Compliance Certification Services Chamber C								
	Company:		Samsung						
	Project #:		13U16263						
	Date:		10/17/13						
	Test Engineer:		K.Kedida						
	Configuration:		EUT, Z pos with charger						
	Mode:		Rel 99, PCS						
	Test Equipment:								
	Receiving: T120, and Chamber D SMA Cables								
	Substitution: Horn T60 Substitution, 4ft SMA Cable (244639001) Warehouse								
	f GHz	SG reading (dBm)	Ant. Pol. (H/V)	Cable Loss (dB)	Antenna Gain (dBi)	EIRP (dBm)	Limit (dBm)	Delta (dB)	Notes
	Low Ch								
	1.852	11.6	V	1.50	7.94	18.06	33.0	-14.9	
	1.852	13.1	H	1.50	8.14	19.78	33.0	-13.2	
	Mid Ch								
	1.880	9.5	V	1.50	7.95	15.97	33.0	-17.0	
	1.880	12.4	H	1.50	8.26	19.16	33.0	-13.8	
	High Ch								
	1.908	7.9	V	1.50	7.97	14.37	33.0	-18.6	
	1.908	10.4	H	1.50	8.38	17.25	33.0	-15.8	
	Rev. 3.17.11								

Band Band 5 HSDPA	High Frequency Substitution Measurement Compliance Certification Services Chamber C								
	Company: Samsung Project #: 13U16263 Date: 10/17/13 Test Engineer: K Kedida Configuration: EUT, Z pos with charger Mode: WCDMA TX, UMTS HSDPA 850								
	Test Equipment: Receiving: Horn T120, and Chamber F SMA Cables Substitution: Dipole S/N: 00022117, 4ft SMA Cable (SN # 245200 001) Warehouse.								
	f MHz	SG reading (dBm)	Ant. Pol. (H/V)	Cable Loss (dB)	Antenna Gain (dBd)	ERP (dBm)	Limit (dBm)	Margin (dB)	Notes
	Low Ch								
	826.40	4.26	V	0.9	0.0	3.36	38.5	-35.1	
	826.40	11.96	H	0.9	0.0	11.06	38.5	-27.4	
	Mid Ch								
	836.60	5.71	V	0.9	0.0	4.81	38.5	-33.6	
	836.60	12.99	H	0.9	0.0	12.09	38.5	-26.4	
High Ch									
846.60	6.26	V	0.9	0.0	5.36	38.5	-33.1		
846.60	13.30	H	0.9	0.0	12.40	38.5	-26.0		
Rev. 3.17.11									

Band Band 5 REL99	High Frequency Substitution Measurement Compliance Certification Services Chamber C																																																																																																	
	Company: Samsung																																																																																																	
	Project #: 13U16263																																																																																																	
	Date: 10/17/13																																																																																																	
	Test Engineer: K.Kedida																																																																																																	
	Configuration: EUT, Z pos with charger																																																																																																	
	Mode: WCDMA																																																																																																	
			TX, UMTS REL 99 850																																																																																															
	Test Equipment:																																																																																																	
	Receiving: Horn T120, and Chamber F SMA Cables																																																																																																	
Substitution: Dipole S/N: 00022117, 4ft SMA Cable (SN # 245200 001) Warehouse.																																																																																																		
<table border="1"> <thead> <tr> <th>f MHz</th> <th>SG reading (dBm)</th> <th>Ant. Pol. (H/V)</th> <th>Cable Loss (dB)</th> <th>Antenna Gain (dBd)</th> <th>ERP (dBm)</th> <th>Limit (dBm)</th> <th>Margin (dB)</th> <th>Notes</th> </tr> </thead> <tbody> <tr> <td colspan="9">Low Ch</td> </tr> <tr> <td>826.40</td> <td>1.22</td> <td>V</td> <td>0.9</td> <td>0.0</td> <td>0.32</td> <td>38.5</td> <td>-38.1</td> <td></td> </tr> <tr> <td>826.40</td> <td>9.29</td> <td>H</td> <td>0.9</td> <td>0.0</td> <td>8.39</td> <td>38.5</td> <td>-30.1</td> <td></td> </tr> <tr> <td colspan="9">Mid Ch</td> </tr> <tr> <td>836.60</td> <td>2.26</td> <td>V</td> <td>0.9</td> <td>0.0</td> <td>1.36</td> <td>38.5</td> <td>-37.1</td> <td></td> </tr> <tr> <td>836.60</td> <td>10.69</td> <td>H</td> <td>0.9</td> <td>0.0</td> <td>9.79</td> <td>38.5</td> <td>-28.7</td> <td></td> </tr> <tr> <td colspan="9">High Ch</td> </tr> <tr> <td>846.60</td> <td>3.47</td> <td>V</td> <td>0.9</td> <td>0.0</td> <td>2.57</td> <td>38.5</td> <td>-35.9</td> <td></td> </tr> <tr> <td>846.60</td> <td>10.66</td> <td>H</td> <td>0.9</td> <td>0.0</td> <td>9.76</td> <td>38.5</td> <td>-28.7</td> <td></td> </tr> </tbody> </table>									f MHz	SG reading (dBm)	Ant. Pol. (H/V)	Cable Loss (dB)	Antenna Gain (dBd)	ERP (dBm)	Limit (dBm)	Margin (dB)	Notes	Low Ch									826.40	1.22	V	0.9	0.0	0.32	38.5	-38.1		826.40	9.29	H	0.9	0.0	8.39	38.5	-30.1		Mid Ch									836.60	2.26	V	0.9	0.0	1.36	38.5	-37.1		836.60	10.69	H	0.9	0.0	9.79	38.5	-28.7		High Ch									846.60	3.47	V	0.9	0.0	2.57	38.5	-35.9		846.60	10.66	H	0.9	0.0	9.76	38.5	-28.7	
f MHz	SG reading (dBm)	Ant. Pol. (H/V)	Cable Loss (dB)	Antenna Gain (dBd)	ERP (dBm)	Limit (dBm)	Margin (dB)	Notes																																																																																										
Low Ch																																																																																																		
826.40	1.22	V	0.9	0.0	0.32	38.5	-38.1																																																																																											
826.40	9.29	H	0.9	0.0	8.39	38.5	-30.1																																																																																											
Mid Ch																																																																																																		
836.60	2.26	V	0.9	0.0	1.36	38.5	-37.1																																																																																											
836.60	10.69	H	0.9	0.0	9.79	38.5	-28.7																																																																																											
High Ch																																																																																																		
846.60	3.47	V	0.9	0.0	2.57	38.5	-35.9																																																																																											
846.60	10.66	H	0.9	0.0	9.76	38.5	-28.7																																																																																											
Rev. 3.17.11																																																																																																		

Band
GSM850
EGPRS

High Frequency Substitution Measurement Compliance Certification Services Chamber C								
Company:		Samsung						
Project #:		13116623						
Date:		11/13/13						
Test Engineer:		Kiya Kedida						
Configuration:		X Position, AC Charger						
Mode:		EGRPS 850MHz						
Test Equipment:								
Receiving: Sunol T185, and 3m Chamber N-type Cable (Setup this one for testing EUT)								
Substitution: Dipole S/N: 00022117, 4ft SMA Cable (SN # 245200 001) Warehouse.								
f MHz	SG reading (dBm)	Ant. Pol. (H/V)	Cable Loss (dB)	Antenna Gain (dBd)	ERP (dBm)	Limit (dBm)	Margin (dB)	Notes
Low Ch								
824.20	11.71	V	0.9	0.0	10.81	38.5	-27.6	
824.20	21.26	H	0.9	0.0	20.36	38.5	-18.1	
Mid Ch								
836.60	11.52	V	0.9	0.0	10.62	38.5	-27.8	
836.60	22.98	H	0.9	0.0	22.08	38.5	-16.4	
High Ch								
848.80	11.39	V	0.9	0.0	10.49	38.5	-28.0	
848.80	24.27	H	0.9	0.0	23.37	38.5	-15.1	
Rev. 3.17.11								

Band GSM850 GPRS	High Frequency Substitution Measurement Compliance Certification Services Chamber B																																																																																																
	Company:		Samsung																																																																																														
	Project #:		13116623																																																																																														
	Date:		11/13/13																																																																																														
	Test Engineer:		Kiya Kedida																																																																																														
	Configuration:		X Position, AC Charger																																																																																														
	Mode:		GRPS 850MHz																																																																																														
	Test Equipment:																																																																																																
	Receiving: Sunol T243, and Chamber B N-type Cable (Setup this one for testing EUT)																																																																																																
	Substitution: Dipole S/N: 00022117, 4ft SMA Cable (SN # 208947003) Warehouse.																																																																																																
<table border="1"> <thead> <tr> <th>f MHz</th> <th>SG reading (dBm)</th> <th>Ant. Pol. (H/V)</th> <th>Cable Loss (dB)</th> <th>Antenna Gain (dBd)</th> <th>ERP (dBm)</th> <th>Limit (dBm)</th> <th>Margin (dB)</th> <th>Notes</th> </tr> </thead> <tbody> <tr> <td colspan="9">Low Ch</td> </tr> <tr> <td>824.20</td> <td>12.42</td> <td>V</td> <td>0.9</td> <td>0.0</td> <td>11.52</td> <td>38.5</td> <td>-26.9</td> <td></td> </tr> <tr> <td>824.20</td> <td>21.51</td> <td>H</td> <td>0.9</td> <td>0.0</td> <td>20.61</td> <td>38.5</td> <td>-17.8</td> <td></td> </tr> <tr> <td colspan="9">Mid Ch</td> </tr> <tr> <td>836.60</td> <td>11.59</td> <td>V</td> <td>0.9</td> <td>0.0</td> <td>10.69</td> <td>38.5</td> <td>-27.8</td> <td></td> </tr> <tr> <td>836.60</td> <td>22.23</td> <td>H</td> <td>0.9</td> <td>0.0</td> <td>21.33</td> <td>38.5</td> <td>-17.1</td> <td></td> </tr> <tr> <td colspan="9">High Ch</td> </tr> <tr> <td>848.80</td> <td>12.00</td> <td>V</td> <td>0.9</td> <td>0.0</td> <td>11.10</td> <td>38.5</td> <td>-27.3</td> <td></td> </tr> <tr> <td>848.80</td> <td>23.78</td> <td>H</td> <td>0.9</td> <td>0.0</td> <td>22.88</td> <td>38.5</td> <td>-15.6</td> <td></td> </tr> </tbody> </table>								f MHz	SG reading (dBm)	Ant. Pol. (H/V)	Cable Loss (dB)	Antenna Gain (dBd)	ERP (dBm)	Limit (dBm)	Margin (dB)	Notes	Low Ch									824.20	12.42	V	0.9	0.0	11.52	38.5	-26.9		824.20	21.51	H	0.9	0.0	20.61	38.5	-17.8		Mid Ch									836.60	11.59	V	0.9	0.0	10.69	38.5	-27.8		836.60	22.23	H	0.9	0.0	21.33	38.5	-17.1		High Ch									848.80	12.00	V	0.9	0.0	11.10	38.5	-27.3		848.80	23.78	H	0.9	0.0	22.88	38.5	-15.6	
f MHz	SG reading (dBm)	Ant. Pol. (H/V)	Cable Loss (dB)	Antenna Gain (dBd)	ERP (dBm)	Limit (dBm)	Margin (dB)	Notes																																																																																									
Low Ch																																																																																																	
824.20	12.42	V	0.9	0.0	11.52	38.5	-26.9																																																																																										
824.20	21.51	H	0.9	0.0	20.61	38.5	-17.8																																																																																										
Mid Ch																																																																																																	
836.60	11.59	V	0.9	0.0	10.69	38.5	-27.8																																																																																										
836.60	22.23	H	0.9	0.0	21.33	38.5	-17.1																																																																																										
High Ch																																																																																																	
848.80	12.00	V	0.9	0.0	11.10	38.5	-27.3																																																																																										
848.80	23.78	H	0.9	0.0	22.88	38.5	-15.6																																																																																										
Rev. 3.17.11																																																																																																	

Band GSM1900 EGPRS	High Frequency Fundamental Measurement Compliance Certification Services Chamber F																																																																																																	
	Company:		Samsung																																																																																															
	Project #:		13U16263																																																																																															
	Date:		10/17/13																																																																																															
	Test Engineer:		R. Alegre																																																																																															
	Configuration:		EUT, Z pos w/ hs & charger																																																																																															
	Mode:		EGPRS 1900MHz																																																																																															
	Test Equipment:																																																																																																	
	Receiving: T120, and Chamber D SMA Cables																																																																																																	
	Substitution: Horn T60 Substitution, 4ft SMA Cable (244639001) Warehouse																																																																																																	
<table border="1"> <thead> <tr> <th>f GHz</th> <th>SG reading (dBm)</th> <th>Ant. Pol. (H/V)</th> <th>Cable Loss (dB)</th> <th>Antenna Gain (dBi)</th> <th>EIRP (dBm)</th> <th>Limit (dBm)</th> <th>Delta (dB)</th> <th>Notes</th> </tr> </thead> <tbody> <tr> <td colspan="9">Low Ch</td> </tr> <tr> <td>1.850</td> <td>18.3</td> <td>V</td> <td>0.85</td> <td>7.94</td> <td>25.40</td> <td>33.0</td> <td>-7.6</td> <td></td> </tr> <tr> <td>1.850</td> <td>19.3</td> <td>H</td> <td>0.85</td> <td>8.80</td> <td>27.24</td> <td>33.0</td> <td>-5.8</td> <td></td> </tr> <tr> <td colspan="9">Mid Ch</td> </tr> <tr> <td>1.880</td> <td>16.4</td> <td>V</td> <td>0.85</td> <td>7.95</td> <td>23.54</td> <td>33.0</td> <td>-9.5</td> <td></td> </tr> <tr> <td>1.880</td> <td>17.6</td> <td>H</td> <td>0.85</td> <td>8.68</td> <td>25.44</td> <td>33.0</td> <td>-7.6</td> <td></td> </tr> <tr> <td colspan="9">High Ch</td> </tr> <tr> <td>1.910</td> <td>16.5</td> <td>V</td> <td>0.85</td> <td>7.97</td> <td>23.61</td> <td>33.0</td> <td>-9.4</td> <td></td> </tr> <tr> <td>1.910</td> <td>15.6</td> <td>H</td> <td>0.85</td> <td>8.57</td> <td>23.28</td> <td>33.0</td> <td>-9.7</td> <td></td> </tr> </tbody> </table>									f GHz	SG reading (dBm)	Ant. Pol. (H/V)	Cable Loss (dB)	Antenna Gain (dBi)	EIRP (dBm)	Limit (dBm)	Delta (dB)	Notes	Low Ch									1.850	18.3	V	0.85	7.94	25.40	33.0	-7.6		1.850	19.3	H	0.85	8.80	27.24	33.0	-5.8		Mid Ch									1.880	16.4	V	0.85	7.95	23.54	33.0	-9.5		1.880	17.6	H	0.85	8.68	25.44	33.0	-7.6		High Ch									1.910	16.5	V	0.85	7.97	23.61	33.0	-9.4		1.910	15.6	H	0.85	8.57	23.28	33.0	-9.7	
f GHz	SG reading (dBm)	Ant. Pol. (H/V)	Cable Loss (dB)	Antenna Gain (dBi)	EIRP (dBm)	Limit (dBm)	Delta (dB)	Notes																																																																																										
Low Ch																																																																																																		
1.850	18.3	V	0.85	7.94	25.40	33.0	-7.6																																																																																											
1.850	19.3	H	0.85	8.80	27.24	33.0	-5.8																																																																																											
Mid Ch																																																																																																		
1.880	16.4	V	0.85	7.95	23.54	33.0	-9.5																																																																																											
1.880	17.6	H	0.85	8.68	25.44	33.0	-7.6																																																																																											
High Ch																																																																																																		
1.910	16.5	V	0.85	7.97	23.61	33.0	-9.4																																																																																											
1.910	15.6	H	0.85	8.57	23.28	33.0	-9.7																																																																																											
Rev. 3.17.11																																																																																																		

Band GSM1900 GPRS	High Frequency Fundamental Measurement Compliance Certification Services Chamber F																																																																																																
	Company:		Samsung																																																																																														
	Project #:		13U16263																																																																																														
	Date:		10/17/13																																																																																														
	Test Engineer:		R. Alegew																																																																																														
	Configuration:		EUT, Z pos w/ hs & charger																																																																																														
	Mode:		GPRS 1900MHz																																																																																														
	Test Equipment:																																																																																																
	Receiving: T120, and Chamber D SMA Cables																																																																																																
	Substitution: Horn T60 Substitution, 4ft SMA Cable (244639001) Warehouse																																																																																																
<table border="1"> <thead> <tr> <th>f GHz</th> <th>SG reading (dBm)</th> <th>Ant. Pol. (H/V)</th> <th>Cable Loss (dB)</th> <th>Antenna Gain (dBi)</th> <th>EIRP (dBm)</th> <th>Limit (dBm)</th> <th>Delta (dB)</th> <th>Notes</th> </tr> </thead> <tbody> <tr> <td colspan="9">Low Ch</td> </tr> <tr> <td>1.850</td> <td>18.2</td> <td>V</td> <td>0.85</td> <td>7.94</td> <td>25.29</td> <td>33.0</td> <td>-7.7</td> <td></td> </tr> <tr> <td>1.850</td> <td>18.2</td> <td>H</td> <td>0.85</td> <td>8.80</td> <td>26.19</td> <td>33.0</td> <td>-6.8</td> <td></td> </tr> <tr> <td colspan="9">Mid Ch</td> </tr> <tr> <td>1.880</td> <td>17.3</td> <td>V</td> <td>0.85</td> <td>7.95</td> <td>24.35</td> <td>33.0</td> <td>-8.7</td> <td></td> </tr> <tr> <td>1.880</td> <td>18.2</td> <td>H</td> <td>0.85</td> <td>8.68</td> <td>25.99</td> <td>33.0</td> <td>-7.0</td> <td></td> </tr> <tr> <td colspan="9">High Ch</td> </tr> <tr> <td>1.910</td> <td>17.3</td> <td>V</td> <td>0.85</td> <td>7.97</td> <td>24.44</td> <td>33.0</td> <td>-8.6</td> <td></td> </tr> <tr> <td>1.910</td> <td>14.9</td> <td>H</td> <td>0.85</td> <td>8.67</td> <td>22.59</td> <td>33.0</td> <td>-10.4</td> <td></td> </tr> </tbody> </table>								f GHz	SG reading (dBm)	Ant. Pol. (H/V)	Cable Loss (dB)	Antenna Gain (dBi)	EIRP (dBm)	Limit (dBm)	Delta (dB)	Notes	Low Ch									1.850	18.2	V	0.85	7.94	25.29	33.0	-7.7		1.850	18.2	H	0.85	8.80	26.19	33.0	-6.8		Mid Ch									1.880	17.3	V	0.85	7.95	24.35	33.0	-8.7		1.880	18.2	H	0.85	8.68	25.99	33.0	-7.0		High Ch									1.910	17.3	V	0.85	7.97	24.44	33.0	-8.6		1.910	14.9	H	0.85	8.67	22.59	33.0	-10.4	
f GHz	SG reading (dBm)	Ant. Pol. (H/V)	Cable Loss (dB)	Antenna Gain (dBi)	EIRP (dBm)	Limit (dBm)	Delta (dB)	Notes																																																																																									
Low Ch																																																																																																	
1.850	18.2	V	0.85	7.94	25.29	33.0	-7.7																																																																																										
1.850	18.2	H	0.85	8.80	26.19	33.0	-6.8																																																																																										
Mid Ch																																																																																																	
1.880	17.3	V	0.85	7.95	24.35	33.0	-8.7																																																																																										
1.880	18.2	H	0.85	8.68	25.99	33.0	-7.0																																																																																										
High Ch																																																																																																	
1.910	17.3	V	0.85	7.97	24.44	33.0	-8.6																																																																																										
1.910	14.9	H	0.85	8.67	22.59	33.0	-10.4																																																																																										
Rev. 3.17.11																																																																																																	

10.2. FIELD STRENGTH OF SPURIOUS RADIATION

RULE PART(S)

FCC: §2.1053, §22.917, §24.238, and §90.691

LIMIT

§22.917 (e) and §24.238 (a): Out of band emissions. The power of any emission outside of the authorized operating frequency ranges must be attenuated below the transmitting power (P) by a factor of at least $43 + 10 \log(P)$ dB

TEST PROCEDURE

For Cellular equipment - Compliance with these rules is based on the use of measurement instrumentation employing a resolution bandwidth of 100 kHz or greater. In the 1 MHz bands immediately outside and adjacent to the frequency block a resolution bandwidth of at least one percent of the emission bandwidth of the fundamental emission of the transmitter may be employed. A narrower resolution bandwidth is permitted in all cases to improve measurement accuracy provided the measured power is integrated over the full required measurement bandwidth (i.e. 100 kHz or 1 percent of emission bandwidth, as specified). The emission bandwidth is defined as the width of the signal between two points, one below the carrier center frequency and one above the carrier center frequency, outside of which all emissions are attenuated at least 26 dB below the transmitter power.

For PCS equipment - Compliance with these rules is based on the use of measurement instrumentation employing a resolution bandwidth of 1 MHz or greater. However, in the 1 MHz bands immediately outside and adjacent to the frequency block a resolution bandwidth of at least one percent of the emission bandwidth of the fundamental emission of the transmitter may be employed. A narrower resolution bandwidth is permitted in all cases to improve measurement accuracy provided the measured power is integrated over the full required measurement bandwidth (i.e. 1 MHz or 1 percent of emission bandwidth, as specified). The emission bandwidth is defined as the width of the signal between two points, one below the carrier center frequency and one above the carrier center frequency, outside of which all emissions are attenuated at least 26 dB below the transmitter power.

MODES TESTED

RESULTS

10.2.1. SPURIOUS RADIATION PLOTS

Compliance Certification Services
Above 1GHz High Frequency Substitution Measurement

Company: Samsung
Project #: 13U16263
Date: 10/16/13
Test Engineer: Steven Tran
Configuration: X Position-AC Adapter
Mode: TX, UMTS 1900, HSDPA

Chamber

Pre-amplifier

Filter

Limit

5m Chamber B

T145 8449B

Filter 1

Part 24

	f GHz	SG reading (dBm)	Ant. Pol. (H/V)	Distance (m)	Preamp (dB)	Filter (dB)	EIRP (dBm)	Limit (dBm)	Delta (dB)	Notes
	Low Ch, 1852.4MHz									
Band	3.704	-21.9	V	3.0	35.4	1.0	-56.3	-13.0	-43.3	
Band 2	5.557	-19.7	V	3.0	35.4	1.0	-54.1	-13.0	-41.1	
	7.409	-20.0	V	3.0	35.7	1.0	-54.7	-13.0	-41.7	
HSDPA	3.704	-21.9	H	3.0	35.4	1.0	-56.2	-13.0	-43.2	
	5.557	-17.6	H	3.0	35.4	1.0	-52.0	-13.0	-39.0	
	7.409	-18.4	H	3.0	35.7	1.0	-53.1	-13.0	-40.1	
	Mid Ch, 1880.0MHz									
	3.760	-21.7	V	3.0	35.3	1.0	-56.0	-13.0	-43.0	
	5.640	-19.1	V	3.0	35.4	1.0	-53.5	-13.0	-40.5	
	7.520	-20.0	V	3.0	35.7	1.0	-54.7	-13.0	-41.7	
	3.760	-21.4	H	3.0	35.3	1.0	-55.7	-13.0	-42.7	
	5.640	-19.7	H	3.0	35.4	1.0	-54.2	-13.0	-41.2	
	7.520	-18.1	H	3.0	35.7	1.0	-52.8	-13.0	-39.8	
	High Ch, 1907.6MHz									
	3.815	-22.3	V	3.0	35.3	1.0	-56.6	-13.0	-43.6	
	5.772	-19.5	V	3.0	35.5	1.0	-54.0	-13.0	-41.0	
	7.630	-19.2	V	3.0	35.7	1.0	-53.9	-13.0	-40.9	
	3.815	-22.7	H	3.0	35.3	1.0	-57.0	-13.0	-44.0	
	5.772	-17.8	H	3.0	35.5	1.0	-52.3	-13.0	-39.3	
	7.630	-17.0	H	3.0	35.7	1.0	-51.6	-13.0	-38.6	

Rev. 03.03.09

Compliance Certification Services Above 1GHz High Frequency Substitution Measurement										
Company:		Samsung								
Project #:		13U16263								
Date:		10/16/13								
Test Engineer:		Steven Tran								
Configuration:		X Position-AC Adapter								
Mode:		TX, UMTS 1900, REL 99								
Chamber		Pre-amplifer			Filter		Limit			
5m Chamber B		T145 8449B			Filter 1		Part 24			
Band	f GHz	SG reading (dBm)	Ant. Pol. (H/V)	Distance (m)	Preamp (dB)	Filter (dB)	EIRP (dBm)	Limit (dBm)	Delta (dB)	Notes
	Low Ch, 1852.4MHz									
	3.704	-22.4	V	3.0	35.4	1.0	-56.7	-13.0	-43.7	
Band 2	5.557	-19.3	V	3.0	35.4	1.0	-53.7	-13.0	-40.7	
	7.409	-19.6	V	3.0	35.7	1.0	-54.3	-13.0	-41.3	
REL99	3.704	-21.9	H	3.0	35.4	1.0	-56.3	-13.0	-43.3	
	5.557	-18.7	H	3.0	35.4	1.0	-53.1	-13.0	-40.1	
	7.409	-18.2	H	3.0	35.7	1.0	-52.9	-13.0	-39.9	
	Mid Ch, 1880.0MHz									
	3.760	-21.5	V	3.0	35.3	1.0	-55.9	-13.0	-42.9	
	5.640	-20.6	V	3.0	35.4	1.0	-55.0	-13.0	-42.0	
	7.520	-19.4	V	3.0	35.7	1.0	-54.1	-13.0	-41.1	
	3.760	-20.9	H	3.0	35.3	1.0	-55.2	-13.0	-42.2	
	5.640	-19.6	H	3.0	35.4	1.0	-54.0	-13.0	-41.0	
	7.520	-17.7	H	3.0	35.7	1.0	-52.4	-13.0	-39.4	
	High Ch, 1907.6MHz									
	3.815	-22.6	V	3.0	35.3	1.0	-56.9	-13.0	-43.9	
	5.772	-19.1	V	3.0	35.5	1.0	-53.5	-13.0	-40.5	
	7.630	-18.5	V	3.0	35.7	1.0	-53.2	-13.0	-40.2	
	3.815	-22.4	H	3.0	35.3	1.0	-56.7	-13.0	-43.7	
	5.772	-18.5	H	3.0	35.5	1.0	-53.0	-13.0	-40.0	
	7.630	-17.0	H	3.0	35.7	1.0	-51.6	-13.0	-38.6	
Rev. 03.03.09										

Compliance Certification Services
Above 1GHz High Frequency Substitution Measurement

Company: Samsung
Project #: 13U16263
Date: 10/18/13
Test Engineer: R.Alegre
Configuration: Z Position-AC Adapter
Mode: TX, UMTS 850 , REL 99

Chamber

3m Chamber

Pre-amplifer

T145 8449B

Filter

Filter 1

Limit

Part 24

	f GHz	SG reading (dBm)	Ant. Pol. (H/V)	Distance (m)	Preamp (dB)	Filter (dB)	EIRP (dBm)	Limit (dBm)	Delta (dB)	Notes	
Band	Low Ch, 826.6MHz										
		1.657	-27.7	V	3.0	35.5	1.0	-62.2	-13.0	-49.2	
	Band 5	2.506	-23.9	V	3.0	35.4	1.0	-58.3	-13.0	-45.3	
		3.335	-21.7	V	3.0	35.5	1.0	-56.3	-13.0	-43.3	
REL99		1.656	-28.6	H	3.0	35.5	1.0	-63.2	-13.0	-50.2	
		2.494	-24.9	H	3.0	35.4	1.0	-59.3	-13.0	-46.3	
		3.334	-22.0	H	3.0	35.5	1.0	-56.5	-13.0	-43.5	
	Mid Ch, 836.6MHz										
		1.677	-27.5	V	3.0	35.5	1.0	-62.0	-13.0	-49.0	
		2.507	-24.2	V	3.0	35.4	1.0	-58.6	-13.0	-45.6	
		3.343	-22.5	V	3.0	35.5	1.0	-57.0	-13.0	-44.0	
		1.673	-26.9	H	3.0	35.5	1.0	-61.5	-13.0	-48.5	
		2.513	-23.0	H	3.0	35.4	1.0	-57.5	-13.0	-44.5	
		3.341	-22.0	H	3.0	35.5	1.0	-56.5	-13.0	-43.5	
	High Ch, 846.4MHz										
		1.691	-25.9	V	3.0	35.5	1.0	-60.5	-13.0	-47.5	
		2.523	-24.1	V	3.0	35.4	1.0	-58.5	-13.0	-45.5	
		3.366	-22.4	V	3.0	35.5	1.0	-56.9	-13.0	-43.9	
		1.692	-27.6	H	3.0	35.5	1.0	-62.1	-13.0	-49.1	
		2.522	-26.2	H	3.0	35.4	1.0	-60.6	-13.0	-47.6	
		3.357	-22.9	H	3.0	35.5	1.0	-57.4	-13.0	-44.4	

Rev. 03.03.09

Compliance Certification Services Above 1GHz High Frequency Substitution Measurement										
Company:		Samsung								
Project #:		13U16263								
Date:		10/18/13								
Test Engineer:		R.Alegre								
Configuration:		Z Position-AC Adapter								
Mode:		TX, UMTS 850, HSDPA								
Chamber		Pre-amplifier			Filter		Limit			
3m Chamber		T145 8449B			Filter 1		Part 24			
f GHz	SG reading (dBm)	Ant. Pol. (H/V)	Distance (m)	Preamp (dB)	Filter (dB)	EIRP (dBm)	Limit (dBm)	Delta (dB)	Notes	
Band 5										
HSDPA										
Low Ch, 826.6MHz										
1.656	-27.5	V	3.0	35.5	1.0	-62.1	-13.0	-49.1		
2.505	-24.3	V	3.0	35.4	1.0	-58.7	-13.0	-45.7		
3.334	-22.2	V	3.0	35.5	1.0	-56.7	-13.0	-43.7		
1.654	-27.6	H	3.0	35.5	1.0	-62.1	-13.0	-49.1		
2.492	-25.7	H	3.0	35.4	1.0	-60.1	-13.0	-47.1		
3.333	-22.1	H	3.0	35.5	1.0	-56.6	-13.0	-43.6		
Mid Ch, 836.6MHz										
1.673	-26.8	V	3.0	35.5	1.0	-61.4	-13.0	-48.4		
2.510	-22.4	V	3.0	35.4	1.0	-56.8	-13.0	-43.8		
3.346	-22.5	V	3.0	35.5	1.0	-57.0	-13.0	-44.0		
1.673	-27.2	H	3.0	35.5	1.0	-61.8	-13.0	-48.8		
2.510	-25.3	H	3.0	35.4	1.0	-59.7	-13.0	-46.7		
3.346	-22.2	H	3.0	35.5	1.0	-56.8	-13.0	-43.8		
High Ch, 846.4MHz										
1.693	-27.4	V	3.0	35.5	1.0	-62.0	-13.0	-49.0		
2.524	-22.9	V	3.0	35.4	1.0	-57.3	-13.0	-44.3		
3.347	-21.0	V	3.0	35.5	1.0	-55.5	-13.0	-42.5		
1.690	-27.3	H	3.0	35.5	1.0	-61.8	-13.0	-48.8		
2.523	-25.4	H	3.0	35.4	1.0	-59.8	-13.0	-46.8		
3.354	-22.6	H	3.0	35.5	1.0	-57.1	-13.0	-44.1		
Rev. 03.03.09										
Note: No other emissions were detected above the system noise floor.										

Compliance Certification Services Above 1GHz High Frequency Substitution Measurement									
Company:		Samsung							
Project #:		13I16623							
Date:		11/13/13							
Test Engineer:		Kiya Kedida							
Configuration:		X Position, AC Charger and headphone							
Mode:		EGPRS 850							
Chamber		Pre-amplifier		Filter		Limit			
Chamber B		T34 8449B		Filter 1		Part 24			
f GHz	SG reading (dBm)	Ant. Pol. (H/V)	Distance (m)	Preamp (dB)	Filter (dB)	EIRP (dBm)	Limit (dBm)	Delta (dB)	Notes
Band									
GSM850									
EGPRS									
Low Ch, 824.2MHz									
1.648	-22.0	V	3.0	37.4	1.0	-58.4	-13.0	-45.4	
2.473	-17.9	V	3.0	36.4	1.0	-53.3	-13.0	-40.3	
3.297	-16.5	V	3.0	35.8	1.0	-51.3	-13.0	-38.3	
1.648	-22.1	H	3.0	37.4	1.0	-58.5	-13.0	-45.5	
2.473	-19.7	H	3.0	36.4	1.0	-55.1	-13.0	-42.1	
3.297	-16.0	H	3.0	35.8	1.0	-50.8	-13.0	-37.8	
Mid Ch, 836.6MHz									
1.673	-21.5	V	3.0	37.3	1.0	-57.8	-13.0	-44.8	
2.510	-17.8	V	3.0	36.4	1.0	-53.1	-13.0	-40.1	
3.346	-16.5	V	3.0	35.8	1.0	-51.2	-13.0	-38.2	
1.673	-21.6	H	3.0	37.3	1.0	-57.9	-13.0	-44.9	
2.510	-19.4	H	3.0	36.4	1.0	-54.7	-13.0	-41.7	
3.346	-16.5	H	3.0	35.8	1.0	-51.2	-13.0	-38.2	
High Ch, 848.8MHz									
1.698	-20.7	V	3.0	37.3	1.0	-57.0	-13.0	-44.0	
2.547	-17.8	V	3.0	36.3	1.0	-53.2	-13.0	-40.2	
3.395	-16.5	V	3.0	35.7	1.0	-51.2	-13.0	-38.2	
1.698	-22.0	H	3.0	37.3	1.0	-58.3	-13.0	-45.3	
2.547	-20.4	H	3.0	36.3	1.0	-55.7	-13.0	-42.7	
3.395	-15.9	H	3.0	35.7	1.0	-50.6	-13.0	-37.6	
Rev. 03.03.09									
Note: No other emissions were detected above the system noise floor.									

	Compliance Certification Services Above 1GHz High Frequency Substitution Measurement											
Band GSM850 GPRS	Company:		Samsung									
	Project #:		13116623									
	Date:		11/13/13									
	Test Engineer:		Kiya Kedida									
	Configuration:		X Position, AC Charger and headphone									
	Mode:		GPRS 850									
			Chamber	Pre-amplifier	Filter	Limit						
			Chamber B	T34 8449B	Filter 1	Part 24						
			f GHz	SG reading (dBm)	Ant. Pol. (H/V)	Distance (m)	Preamp (dB)	Filter (dB)	EIRP (dBm)	Limit (dBm)	Delta (dB)	Notes
			Low Ch, 824.2MHz									
		1.648	-22.3	V	3.0	37.4	1.0	-58.7	-13.0	-45.7		
		2.472	-17.7	V	3.0	36.4	1.0	-53.1	-13.0	-40.1		
		3.297	-15.2	V	3.0	35.8	1.0	-50.0	-13.0	-37.0		
		1.648	-22.7	H	3.0	37.4	1.0	-59.1	-13.0	-46.1		
		2.472	-19.6	H	3.0	36.4	1.0	-55.0	-13.0	-42.0		
		3.297	-16.9	H	3.0	35.8	1.0	-51.7	-13.0	-38.7		
		Mid Ch, 836.6MHz										
		1.673	-21.2	V	3.0	37.3	1.0	-57.5	-13.0	-44.5		
		2.511	-17.2	V	3.0	36.4	1.0	-52.6	-13.0	-39.6		
		3.348	-16.1	V	3.0	35.7	1.0	-50.9	-13.0	-37.9		
		1.674	-21.3	H	3.0	37.3	1.0	-57.7	-13.0	-44.7		
		2.508	-19.5	H	3.0	36.4	1.0	-54.8	-13.0	-41.8		
		3.348	-16.1	H	3.0	35.7	1.0	-50.9	-13.0	-37.9		
		High Ch, 848.8MHz										
		1.697	-22.1	V	3.0	37.3	1.0	-58.4	-13.0	-45.4		
		2.546	-17.4	V	3.0	36.3	1.0	-52.7	-13.0	-39.7		
		3.384	-15.9	V	3.0	35.7	1.0	-50.6	-13.0	-37.6		
		1.697	-20.8	H	3.0	37.3	1.0	-57.1	-13.0	-44.1		
		2.546	-18.8	H	3.0	36.3	1.0	-54.1	-13.0	-41.1		
		3.384	-15.9	H	3.0	35.7	1.0	-50.6	-13.0	-37.6		
		Rev. 03.03.09										
		Note: No other emissions were detected above the system noise floor.										

Compliance Certification Services
Above 1GHz High Frequency Substitution Measurement

Company: Samsung
Project #: 13U16263
Date: 10/16/13
Test Engineer: Steven Tran
Configuration: X Position, AC Charger
Mode: EGPRS 1900

Chamber
 5m Chamber B

Pre-amplifier
 T343 8449B

Filter
 Filter 1

Limit
 Part 24

f GHz	SG reading (dBm)	Ant. Pol. (H/V)	Distance (m)	Preamp (dB)	Filter (dB)	EIRP (dBm)	Limit (dBm)	Delta (dB)	Notes
Low Ch, 1850MHz									
3.700	-12.9	V	3.0	35.4	1.0	-47.3	-13.0	-34.3	
5.550	-8.5	V	3.0	34.7	1.0	-42.2	-13.0	-29.2	
7.400	-17.2	V	3.0	34.9	1.0	-51.1	-13.0	-38.1	
3.700	-11.2	H	3.0	35.4	1.0	-45.6	-13.0	-32.6	
5.550	-11.7	H	3.0	34.7	1.0	-45.4	-13.0	-32.4	
7.400	-17.3	H	3.0	34.9	1.0	-51.2	-13.0	-38.2	
Mid Ch, 1880.0MHz									
3.760	-11.7	V	3.0	35.3	1.0	-46.0	-13.0	-33.0	
5.640	-9.3	V	3.0	34.7	1.0	-43.0	-13.0	-30.0	
7.520	-17.5	V	3.0	34.9	1.0	-51.4	-13.0	-38.4	
3.760	-8.9	H	3.0	35.3	1.0	-43.3	-13.0	-30.3	
5.640	-11.8	H	3.0	34.7	1.0	-45.6	-13.0	-32.6	
7.520	-17.2	H	3.0	34.9	1.0	-51.1	-13.0	-38.1	
High Ch, 1909.8 MHz									
3.820	-11.6	V	3.0	35.3	1.0	-45.9	-13.0	-32.9	
5.729	-7.8	V	3.0	34.7	1.0	-41.5	-13.0	-28.5	
7.640	-16.8	V	3.0	35.0	1.0	-50.8	-13.0	-37.8	
3.820	-13.4	H	3.0	35.3	1.0	-47.7	-13.0	-34.7	
5.729	-9.0	H	3.0	34.7	1.0	-42.8	-13.0	-29.8	
7.640	-15.8	H	3.0	35.0	1.0	-49.8	-13.0	-36.8	

Rev. 03.03.09

Band
GSM1900
EGPRS

Compliance Certification Services Above 1GHz High Frequency Substitution Measurement									
Company:		Samsung							
Project #:		13U16263							
Date:		10/16/13							
Test Engineer:		Steven Tran							
Configuration:		X Position, AC Charger							
Mode:		GPRS 1900							
Chamber		Pre-amplifier		Filter		Limit			
5m Chamber B		T343 8449B		Filter 1		Part 24			
f GHz	SG reading (dBm)	Ant. Pol. (H/V)	Distance (m)	Preamp (dB)	Filter (dB)	EIRP (dBm)	Limit (dBm)	Delta (dB)	Notes
Low Ch, 1850MHz									
3.700	-13.6	V	3.0	35.4	1.0	-48.0	-13.0	-35.0	
5.550	-9.1	V	3.0	34.7	1.0	-42.8	-13.0	-29.8	
7.400	-18.3	V	3.0	34.9	1.0	-52.2	-13.0	-39.2	
3.700	-11.0	H	3.0	35.4	1.0	-45.4	-13.0	-32.4	
5.550	-13.7	H	3.0	34.7	1.0	-47.4	-13.0	-34.4	
7.400	-17.8	H	3.0	34.9	1.0	-51.7	-13.0	-38.7	
Mid Ch, 1880.0MHz									
3.760	-9.6	V	3.0	35.3	1.0	-43.9	-13.0	-30.9	
5.640	-9.7	V	3.0	34.7	1.0	-43.4	-13.0	-30.4	
7.520	-15.8	V	3.0	34.9	1.0	-49.8	-13.0	-36.8	
3.760	-9.3	H	3.0	35.3	1.0	-43.6	-13.0	-30.6	
5.640	-17.4	H	3.0	34.7	1.0	-51.1	-13.0	-38.1	
7.520	-17.6	H	3.0	34.9	1.0	-51.5	-13.0	-38.5	
High Ch, 1909.8 MHz									
3.822	-10.4	V	3.0	35.3	1.0	-44.6	-13.0	-31.6	
5.729	-8.8	V	3.0	34.7	1.0	-42.5	-13.0	-29.5	
7.640	-15.2	V	3.0	35.0	1.0	-49.2	-13.0	-36.2	
3.822	-12.3	H	3.0	35.3	1.0	-46.6	-13.0	-33.6	
5.729	-9.5	H	3.0	34.7	1.0	-43.2	-13.0	-30.2	
7.640	-16.2	H	3.0	35.0	1.0	-50.1	-13.0	-37.1	
Rev. 03.03.09									

Band
GSM1900
GPRS