



TEST REPORT

Report Number. : 13094578-E8V2

Applicant : Samsung Electronics Co., Ltd.
129 Samsung-Ro, Yeongtong-Gu,
Suwon-Si, Gyeonggi-Do, 16677, Korea

Model : SM-N770F and SM-N770F/DS

FCC ID : A3LSMN770F

EUT Description : GSM/WCDMA/LTE Phablet with BT, DTS/UNII a/b/g/n/ac, NFC
ANT+ and WPT

Test Standard(s) : FCC 47 CFR PART 15 SUBPART C

Date Of Issue:

November 26, 2019

Prepared by:

UL Verification Services Inc.
47173 Benicia Street
Fremont, CA 94538 U.S.A.
TEL: (510) 771-1000
FAX: (510) 661-0888



NVLAP Lab code: 200065-0

REPORT REVISION HISTORY

| Rev. | Issue Date | Revisions | Revised By |
|------|------------|------------------------------|-------------|
| V1 | 11/19/2019 | Initial Issue | |
| V2 | 11/26/2019 | Updated Section 1, 2 and 5.3 | Steven Tran |

TABLE OF CONTENTS

| | |
|---|-----------|
| REPORT REVISION HISTORY | 2 |
| TABLE OF CONTENTS | 3 |
| 1. ATTESTATION OF TEST RESULTS | 4 |
| 2. TEST METHODOLOGY | 6 |
| 3. FACILITIES AND ACCREDITATION | 6 |
| 4. CALIBRATION AND UNCERTAINTY | 7 |
| 4.1. <i>MEASURING INSTRUMENT CALIBRATION</i> | <i>7</i> |
| 4.2. <i>SAMPLE CALCULATION</i> | <i>7</i> |
| 4.3. <i>MEASUREMENT UNCERTAINTY</i> | <i>7</i> |
| 5. EQUIPMENT UNDER TEST | 8 |
| 5.1. <i>EUT DESCRIPTION</i> | <i>8</i> |
| 5.2. <i>MAXIMUM FUNDAMENTAL FIELD STRENGTH</i> | <i>8</i> |
| 5.3. <i>DESCRIPTION OF AVAILABLE ANTENNAS</i> | <i>8</i> |
| 5.4. <i>SOFTWARE AND FIRMWARE</i> | <i>8</i> |
| 5.5. <i>WORST-CASE CONFIGURATION AND MODE</i> | <i>8</i> |
| 5.6. <i>DESCRIPTION OF TEST SETUP</i> | <i>9</i> |
| 6. TEST AND MEASUREMENT EQUIPMENT | 12 |
| 7. MEASUREMENT METHODS | 13 |
| 8. ANTENNA PORT TEST RESULTS | 14 |
| 8.1. <i>ON TIME AND DUTY CYCLE</i> | <i>14</i> |
| 8.2. <i>20dB BANDWIDTH</i> | <i>16</i> |
| 9. RADIATED TEST RESULTS | 18 |
| 9.1. <i>TRANSMITTER ABOVE 1 GHz</i> | <i>20</i> |
| 9.2. <i>FUNDAMENTAL FREQUENCY RADIATED EMISSION</i> | <i>30</i> |
| 9.3. <i>WORST CASE BELOW 30 MHz</i> | <i>31</i> |
| 9.4. <i>WORST CASE BELOW 1 GHz</i> | <i>32</i> |
| 9.5. <i>WORST CASE 18-26 GHz</i> | <i>34</i> |
| 10. AC POWER LINE CONDUCTED EMISSIONS | 36 |
| 11. SETUP PHOTOS | 39 |

1. ATTESTATION OF TEST RESULTS

COMPANY NAME: Samsung Electronics Co., Ltd.
129 Samsung-Ro, Yeongtong-Gu,
Suwon-Si, Gyeonggi-Do, 16677, Korea

EUT DESCRIPTION: GSM/WCDMA/LTE Phablet with BT, DTS/UNII a/b/g/n/ac,
NFC, ANT+ and WPT

MODEL: SM-N770F and SM-N770F/DS

SERIAL NUMBER: Conducted: R38MA039RER
Radiated: R38MA039SFP

DATE TESTED: November 6 – 14, 2019

| APPLICABLE STANDARDS | |
|--------------------------|--------------|
| STANDARD | TEST RESULTS |
| CFR 47 Part 15 Subpart C | Complies |

UL Verification Services Inc. tested the above equipment in accordance with the requirements set forth in the above standards. The test results show that the equipment tested is capable of demonstrating compliance with the requirements as documented in this report.

The results documented in this report apply only to the tested sample, under the conditions and modes of operation as described herein. It is the manufacturer's responsibility to assure that additional production units of this model are manufactured with identical electrical and mechanical components. All samples tested were in good operating condition throughout the entire test program. Measurement Uncertainties are published for informational purposes only and were not taken into account unless noted otherwise.

This document may not be altered or revised in any way unless done so by UL Verification Services Inc. and all revisions are duly noted in the revisions section. Any alteration of this document not carried out by UL Verification Services Inc. will constitute fraud and shall nullify the document. This report must not be used by the client to claim product certification, approval, or endorsement by NVLAP, NIST, any agency of the Federal Government, or any agency of the U.S. government.

Approved & Released For
UL Verification Services Inc. By:



Dan Corona
Operations Leader
Consumer Technology Division
UL Verification Services Inc.

Prepared By:



Glenn Escano
Test Engineer
Consumer Technology Division
UL Verification Services Inc.

Reviewed By:



Steven Tran
Project Engineer
Consumer Technology Division
UL Verification Services Inc.

2. TEST METHODOLOGY

The tests documented in this report were performed in accordance with FCC CFR 47 Part 2, FCC CFR 47 Part 15, ANSI C63.10-2013, KDB 414788 D01 Radiated Test Site v01r01, and KDB 558074 D01 15.247 Meas Guidance v05r02.

3. FACILITIES AND ACCREDITATION

The test sites and measurement facilities used to collect data are located at 47173 and 47266 Benicia Street, and 47658 Kato Road, Fremont, California, USA. Line conducted emissions are measured only at the 47173 address. The following table identifies which facilities were utilized for radiated emission measurements documented in this report. Specific facilities are also identified in the test results sections.

| 47173 Benicia Street | 47266 Benicia Street | 47658 Kato Rd |
|------------------------------------|------------------------------------|---|
| <input type="checkbox"/> Chamber A | <input type="checkbox"/> Chamber D | <input type="checkbox"/> Chamber I |
| <input type="checkbox"/> Chamber B | <input type="checkbox"/> Chamber E | <input type="checkbox"/> Chamber J |
| <input type="checkbox"/> Chamber C | <input type="checkbox"/> Chamber F | <input checked="" type="checkbox"/> Chamber K |
| | <input type="checkbox"/> Chamber G | <input type="checkbox"/> Chamber L |
| | <input type="checkbox"/> Chamber H | <input type="checkbox"/> Chamber M |

The above test sites and facilities are covered under FCC Test Firm Registration # 208313. Chambers above are covered under Industry Canada company address and respective code: 2324A.

UL Verification Services Inc. is accredited by NVLAP, Laboratory Code 200065-0

4. CALIBRATION AND UNCERTAINTY

4.1. MEASURING INSTRUMENT CALIBRATION

The measuring equipment utilized to perform the tests documented in this report has been calibrated in accordance with the manufacturer's recommendations, and is traceable to recognized national standards.

4.2. SAMPLE CALCULATION

RADIATED EMISSIONS

Where relevant, the following sample calculation is provided:

Field Strength (dBuV/m) = Measured Voltage (dBuV) + Antenna Factor (dB/m) + Cable Loss (dB) – Preamp Gain (dB)

$$36.5 \text{ dBuV} + 18.7 \text{ dB/m} + 0.6 \text{ dB} - 26.9 \text{ dB} = 28.9 \text{ dBuV/m}$$

MAINS CONDUCTED EMISSIONS

Where relevant, the following sample calculation is provided:

Final Voltage (dBuV) = Measured Voltage (dBuV) + Cable Loss (dB) + Limiter Factor (dB) + LISN Insertion Loss.

$$36.5 \text{ dBuV} + 0 \text{ dB} + 10.1 \text{ dB} + 0 \text{ dB} = 46.6 \text{ dBuV}$$

4.3. MEASUREMENT UNCERTAINTY

Where relevant, the following measurement uncertainty levels have been estimated for tests performed on the apparatus:

| PARAMETER | UNCERTAINTY |
|---|-------------|
| Worst Case Conducted Disturbance, 9KHz to 0.15 MHz | 3.84 dB |
| Worst Case Conducted Disturbance, 0.15 to 30 MHz | 3.65 dB |
| Worst Case Radiated Disturbance, 9KHz to 30 MHz | 3.15 dB |
| Worst Case Radiated Disturbance, 30 to 1000 MHz | 5.36 dB |
| Worst Case Radiated Disturbance, 1000 to 18000 MHz | 4.32 dB |
| Worst Case Radiated Disturbance, 18000 to 26000 MHz | 4.45 dB |
| Worst Case Radiated Disturbance, 26000 to 40000 MHz | 5.24 dB |

Uncertainty figures are valid to a confidence level of 95%.

5. EQUIPMENT UNDER TEST

5.1. EUT DESCRIPTION

The EUT is a GSM/WCDMA/LTE Phablet with BT, DTS/UNII a/b/g/n/ac, NFC, ANT+ and WPT. The model SM-N770F was used for final testing and is representative of the test results in this report.

5.2. MAXIMUM FUNDAMENTAL FIELD STRENGTH

The transmitter has a maximum peak fundamental field strength as follows:

| Frequency Range (MHz) | Mode | Peak E-field Strength (dBuV/m) | Avg E-field Strength (dBuV/m) | Distance (m) |
|--------------------------|-------|-----------------------------------|----------------------------------|-----------------|
| 2402 - 2480 | ANT + | 99.56 | 68.88 | 3.00 |

5.3. DESCRIPTION OF AVAILABLE ANTENNAS

The radio utilizes an internal antenna, with a maximum gain of -5.1 dBi.

5.4. SOFTWARE AND FIRMWARE

The test utility software used during testing was N770F.001.

5.5. WORST-CASE CONFIGURATION AND MODE

Radiated emissions below 1GHz, above 18GHz, and power line conducted emission were performed with the EUT set to transmit at the channel with highest output power as worst-case scenario.

Band edge and radiated emissions between 1GHz and 18GHz were performed with the EUT set to transmit at the highest power on low, middle and high channels.

The fundamental of the EUT was investigated in three orthogonal orientations X,Y,Z, it was determined that Y orientation was worst-case orientation; therefore, all final radiated testing was performed with the EUT in Y orientation.

All radios that can be transmitted simultaneously have been evaluated for radiated for all possible combinations of transmission and found to be in compliance.

5.6. DESCRIPTION OF TEST SETUP

SUPPORT EQUIPMENT

| Support Equipment List | | | | |
|------------------------|--------------|----------|----------------|--------|
| Description | Manufacturer | Model | Serial Number | FCC ID |
| AC Adapter | Samsung | EP-TA800 | R37M3531XX1SE3 | N/A |
| Earphone | Samsung | N/A | N/A | N/A |

I/O CABLES (CONDUCTED TEST)

| I/O Cable List | | | | | | |
|----------------|---------|----------------------|----------------|-------------|------------------|----------------------|
| Cable No | Port | # of identical ports | Connector Type | Cable Type | Cable Length (m) | Remarks |
| 1 | Antenna | 1 | RF | Shielded | 0.2 | To spectrum Analyzer |
| 2 | USB | 1 | USB | Un-shielded | 1 | EUT to AC Mains |

I/O CABLES (RADIATED AND CONDUCTED EMISSIONS)

| I/O Cable List | | | | | | |
|----------------|----------|----------------------|----------------|-------------|------------------|---------|
| Cable No | Port | # of identical ports | Connector Type | Cable Type | Cable Length (m) | Remarks |
| 1 | USB | 1 | USB | Shielded | 1 | N/A |
| 2 | Earphone | 1 | 3.5mm | Un-shielded | 1 | N/A |

CONDUCTED TEST SETUP DIAGRAM

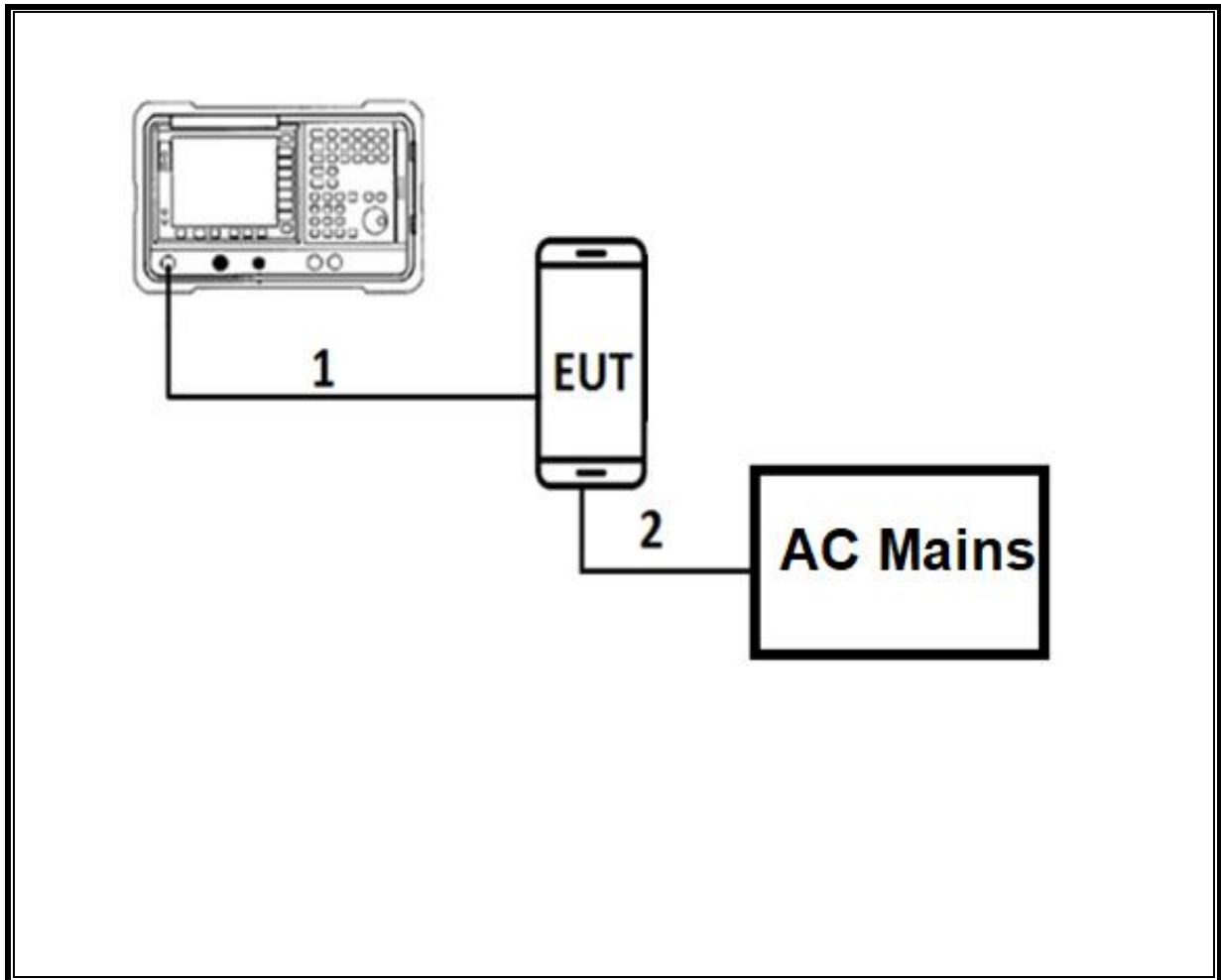

TEST SETUP

For conducted tests: the EUT was stand alone. The test software exercises the radio.

RADIATED AND AC LINE CONDUCTED EMISSIONS SETUP DIAGRAM

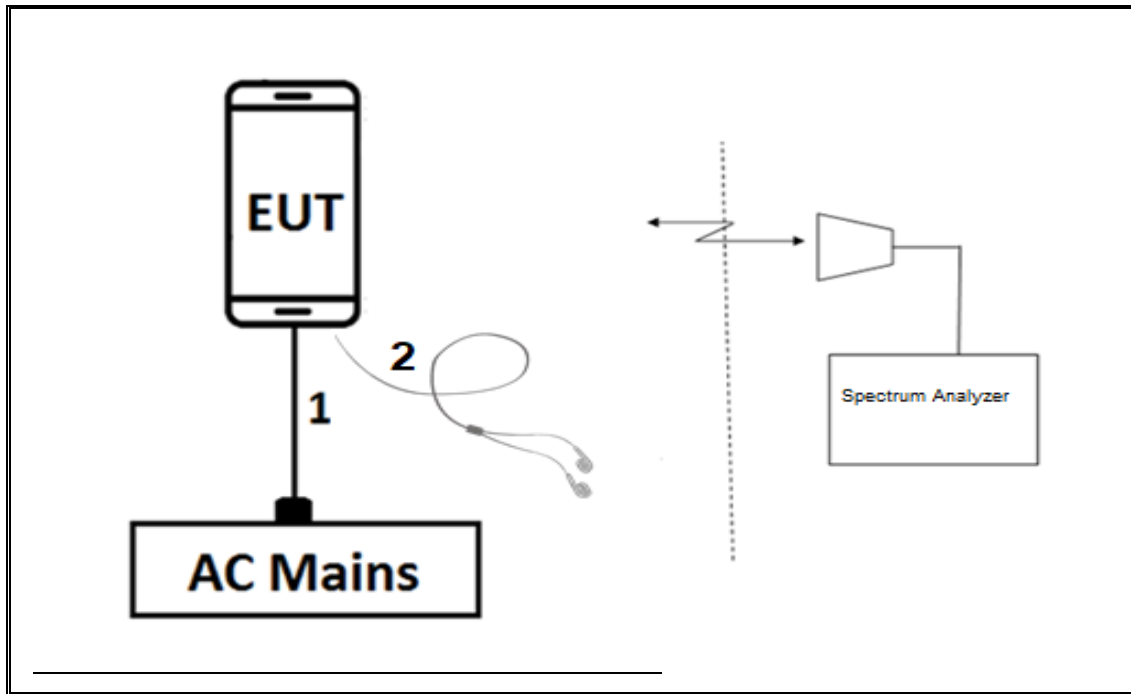

TEST SETUP

For radiated tests: EUT is connected to earphone. The test software exercises the radio.

6. TEST AND MEASUREMENT EQUIPMENT

The following test and measurement equipment was utilized for the tests documented in this report:

| TEST EQUIPMENT LIST | | | | |
|--|---------------------|-----------------|------------------------|----------------|
| Description | Manufacturer | Model | Asset | Cal Due |
| Antenna, Passive Loop 30Hz to 1MHz | ELETRO METRICS | EM-6871 | PRE0179466 | 05/31/2020 |
| Antenna, Passive Loop 100KHz to 30MHz | ELETRO METRICS | EM-6872 | PRE0179468 | 05/31/2020 |
| Antenna, Horn 1-18GHz | ETS Lindgren | 3117 | EMC4249 / PRE0100034 | 06/14/2020 |
| Amplifier, 1 to 18GHz | Amplical | AMP1G18-35 | T1569 | 05/04/2020 |
| Antenna, Broadband Hybrid, 30MHz to 3GHz | Sunol Sciences | JB3 | PRE0181574 | 10/14/2020 |
| Amplifier, 9KHz to 1GHz, 32dB | SONOMA INSTRUMENT | 310 | PRE175953 | 12/13/2019 |
| Spectrum Analyzer, PSA, 3Hz to 44GHz | Keysight | E4446A | T146 | 01/28/2020 |
| Antenna Horn, 18 to 26.5GHz | ARA | MWH-1826/B | T447 | 08/13/2020 |
| Pre-Amp 1-26.5 GHz | AMPLICAL | AMP18G26.5-60 | PRE0181238 | 05/01/2020 |
| EMI Test Receiver | Rohde&Schwarz | ESW44 | PRE0179372 | 02/16/2020 |
| Filter, HPF 3.0GHz | MICRO-TRONICS | HPM17543 | T897 | 05/04/2020 |
| AC Line Conducted | | | | |
| EMI Receiver | Rohde & Schwarz | ESR | T1436 | 02/14/2020 |
| LISN for Conducted Emissions CISPR-16 | FCC INC. | FCC LISN 50/250 | T1310 | 01/24/2020 |
| UL AUTOMATION SOFTWARE | | | | |
| Radiated Software | UL | UL EMC | Ver 9.5, June 15, 2019 | |
| Antenna Port Software | UL | UL RF | Ver 10.4, Oct 10, 2019 | |
| AC Line Conducted Software | UL | UL EMC | Ver 9.5, May 26, 2015 | |

NOTES:

1. Equipment listed above that calibrated during the testing period was set for test after the calibration.
2. Equipment listed above that has a calibration due date during the testing period, the testing is completed before equipment expiration date.

7. MEASUREMENT METHODS

On Time and Duty Cycle: ANSI C63.10-2013 Section 11.6

Occupied BW (20dB): ANSI C63.10-2013 Section 6.9.2

Radiated Spurious Emissions 30-1000MHz: ANSI C63.10-2013 Section 6.3 and 6.5

Radiated Spurious Emissions above 1GHz: ANSI C63.10-2013 Section 6.3 and 6.6

Radiated Spurious Emissions Below 30MHz: ANSI C63.10-2013 Section 6.4

Radiated Band-edge: ANSI C63.10-2013 Section 6.10.5

AC Power-line conducted emissions: ANSI C63.10-2013, Section 6.2.

8. ANTENNA PORT TEST RESULTS

8.1. ON TIME AND DUTY CYCLE

LIMITS

None; for reporting purposes only.

PROCEDURE

ANSI C63.10, Section 11.6 : Zero-Span Spectrum Analyzer Method.

ON TIME AND DUTY CYCLE RESULTS

NOTE: For ON TIME measurement:

ON Time over 1msec period x No. of pulses over 100msec period = ON TIME

225us x 13 pulses = 2.925msec

| Mode | ON Time B (msec) | Period (msec) | Duty Cycle x (linear) | Duty Cycle (%) | Duty Cycle Correction Factor for Average Measurements (dB) |
|-------------|------------------------|------------------|-----------------------------|----------------------|--|
| 2.4GHz Band | | | | | |
| ANT+ | 2.925 | 100.00 | 0.029 | 2.93% | -30.68 |

DUTY CYCLE PLOTS

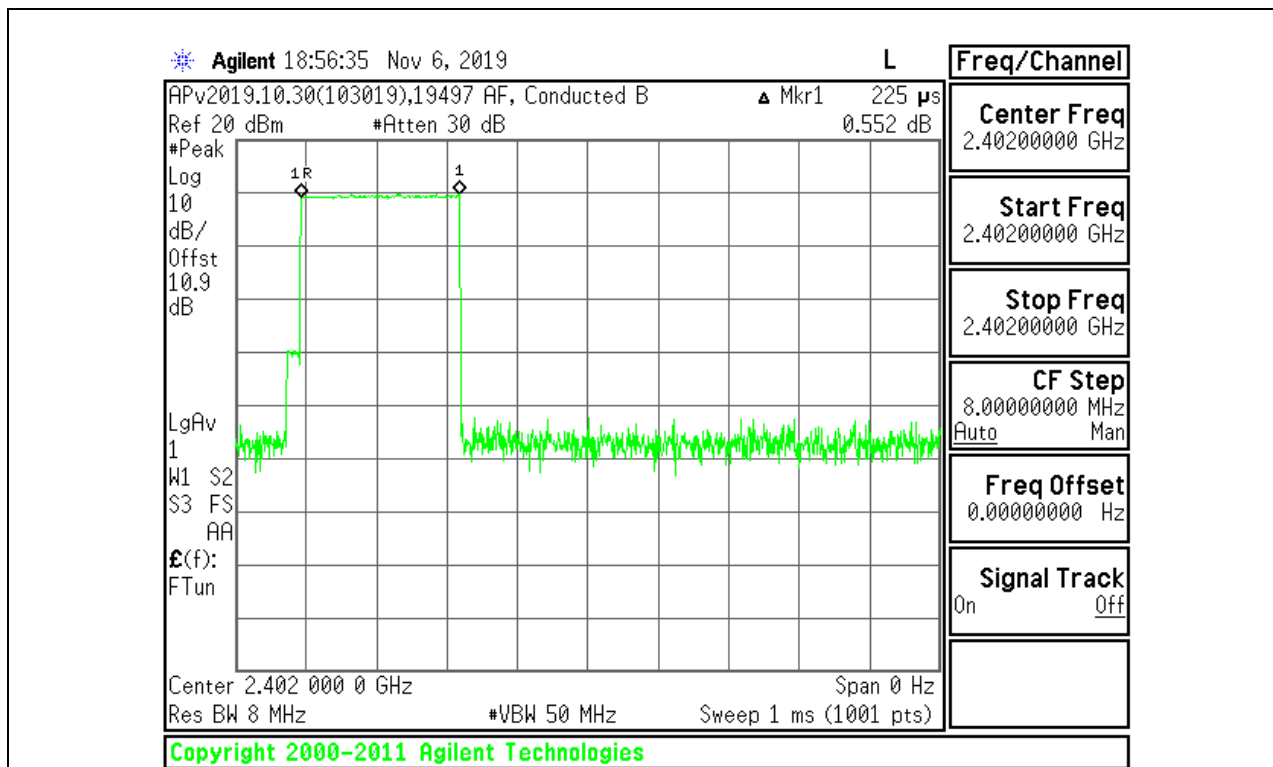

ANT+ ON TIME

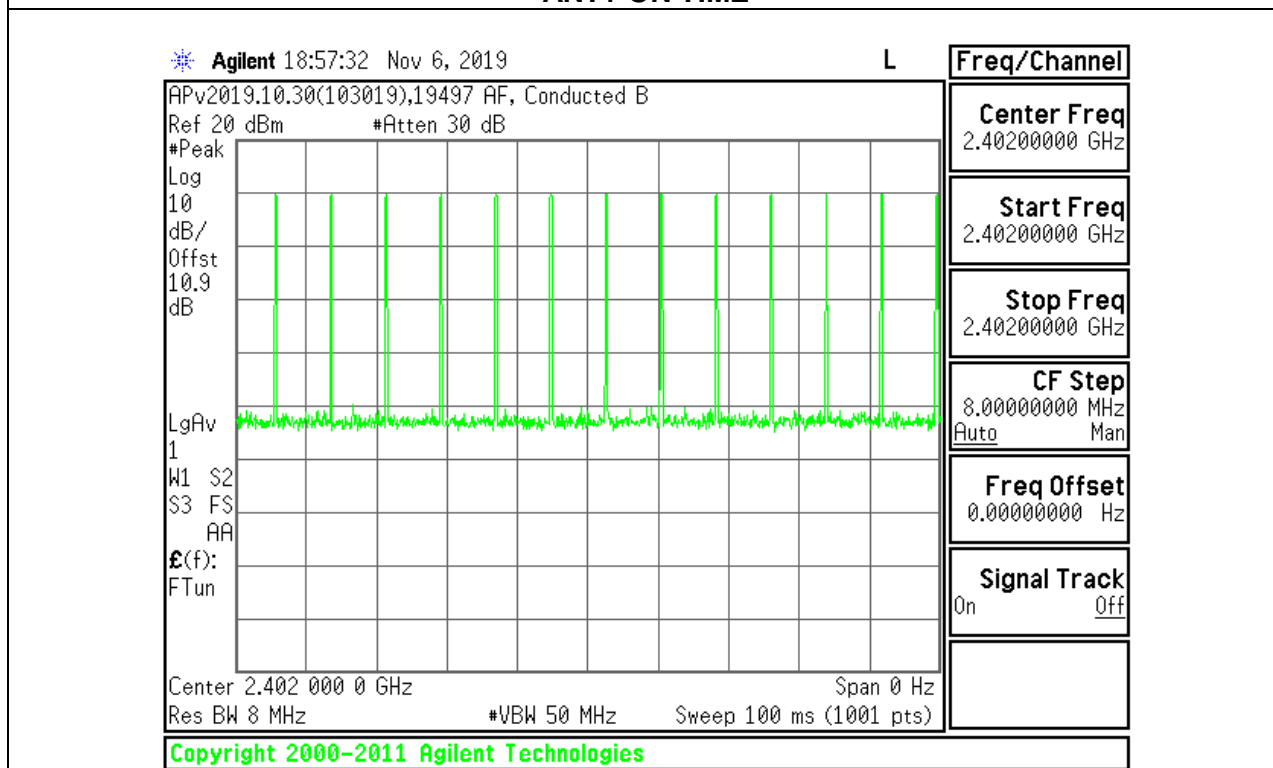

ANT+ 100ms PERIOD

8.2. 20dB BANDWIDTH

LIMITS

None; for reporting purposes only.

TEST PROCEDURE

The transmitter output is connected to a spectrum analyzer. The RBW is set to 1% to 5% of the 20 dB bandwidth. The VBW is set to approximately three times RBW. The sweep time is coupled

RESULTS

| Channel | Frequency (MHz) | 20dB Bandwidth (MHz) | Frequency Edge (MHz) | Limit (MHz) | Margin (MHz) |
|---------|-----------------|----------------------|----------------------|-------------|--------------|
| Low | 2402 | 1.065 | 2401.4675 | 2400 | -1.47 |
| Mid | 2441 | 1.065 | N/A | N/A | N/A |
| High | 2480 | 1.065 | 2480.5325 | 2483.5 | -2.97 |

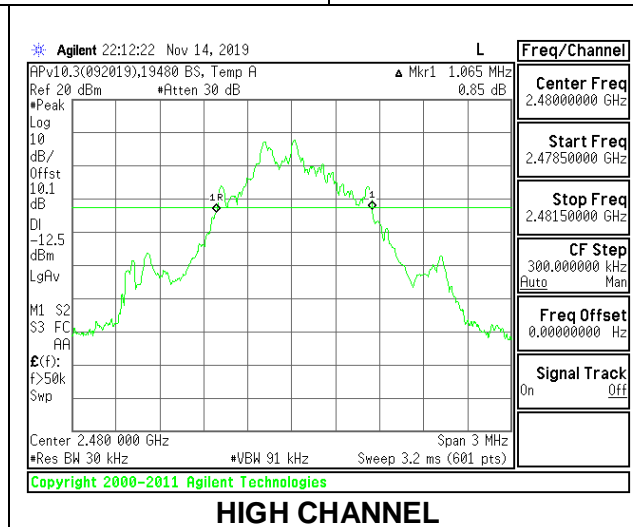
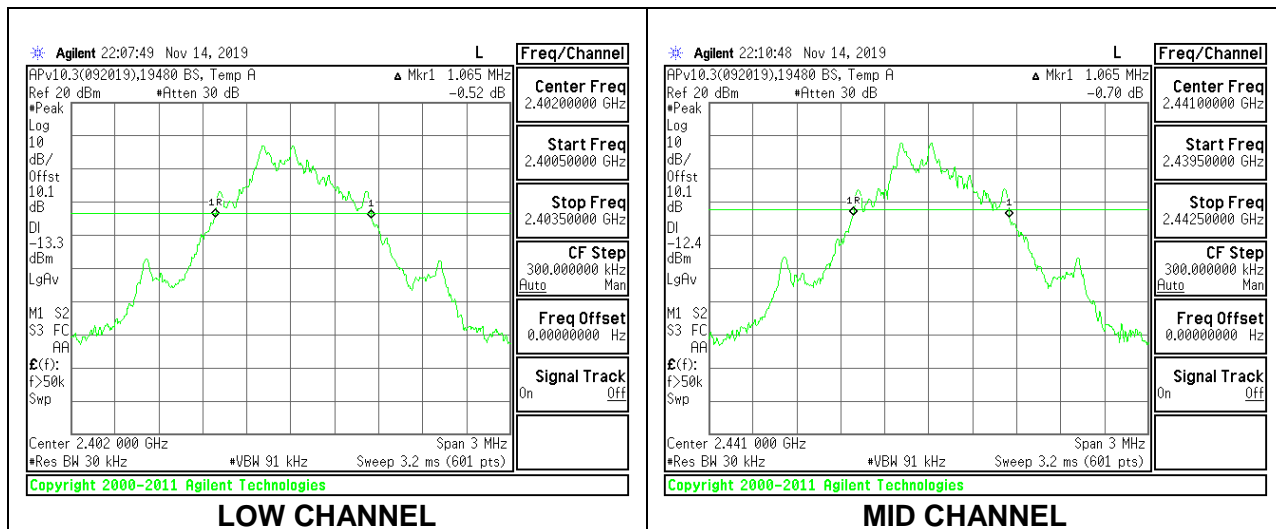

9. RADIATED TEST RESULTS

LIMITS

FCC §15.249

FCC §15.205 and §15.209

Operation within the bands 902–928 MHz, 2400–2483.5 MHz, 5725–5875 MHz, and 24.0–24.25 GHz.

(a) Except as provided in paragraph (b) of this section, the field strength of emissions from intentional radiators operated within these frequency bands shall comply with the following:

| Fundamental frequency | Field strength of fundamental (millivolts/ meter) | Field strength of harmonics (microvolts/ meter) |
|-----------------------|---|---|
| 902–928 MHz | 50 | 500 |
| 2400–2483.5 MHz | 50 | 500 |
| 5725–5875 MHz | 50 | 500 |
| 24.0–24.25 GHz | 250 | 2500 |

(d) Emissions radiated outside of the specified frequency bands, except for harmonics, shall be attenuated by at least 50 dB below the level of the fundamental or to the general radiated emission limits in § 15.209, whichever is the lesser attenuation.

(e) As shown in Sec. 15.35(b), for frequencies above 1000 MHz, the field strength limits in paragraphs (a) and (b) of this section are based on average limits. However, the peak field strength of any emission shall not exceed the maximum permitted average limits specified above by more than 20 dB under any condition of modulation.

| Frequency Range (MHz) | Field Strength Limit (uV/m) at 3 m | Field Strength Limit (dBuV/m) at 3 m |
|-----------------------|------------------------------------|--------------------------------------|
| 0.009-0.490 | 2400/F(kHz) @ 300 m | - |
| 0.490-1.705 | 24000/F(kHz) @ 30 m | - |
| 1.705 - 30 | 30 @ 30m | - |
| 30 - 88 | 100 | 40 |
| 88 - 216 | 150 | 43.5 |
| 216 - 960 | 200 | 46 |
| Above 960 | 500 | 54 |

TEST PROCEDURE

The EUT is placed on a non-conducting table 80 cm above the ground plane for measurement below 1GHz; 1.5 m above the ground plane for measurement above 1GHz. The antenna to EUT distance is 3 meters. The EUT is configured in accordance with ANSI C63.10. The EUT is set to transmit in a continuous mode.

For measurements below 1 GHz the resolution bandwidth is set to 100 kHz for peak detection measurements or 120 kHz for quasi-peak detection measurements. Peak detection is used unless otherwise noted as quasi-peak.

For pre-scans above 1 GHz the resolution bandwidth is set to 1 MHz; the video bandwidth is set to 30 KHz for peak measurements.

For final measurements above 1 GHz the resolution bandwidth is set to 1 MHz; the video bandwidth is set to 3 MHz for peak measurements and 1 MHz resolution bandwidth with 1/T (500 Hz) video bandwidth with peak detector for average measurements.

The spectrum from 1 GHz to 18 GHz is investigated with the transmitter set to the lowest, middle, and highest channels in each applicable band. Below 1GHz and above 18GHz emissions, the channel with the highest output power was tested.

The frequency range of interest is monitored at a fixed antenna height and EUT azimuth. The EUT is rotated through 360 degrees to maximize emissions received. The antenna is scanned from 1 to 4 meters above the ground plane to further maximize the emission. Measurements are made with the antenna polarized in both the vertical and the horizontal positions.

2D antenna use - For below 30MHz testing, investigation was done on three antenna orientations (parallel, perpendicular, and ground-parallel), parallel and perpendicular are the worst orientations, therefore testing was performed on these two orientations only.

KDB 414788 OFS and Chamber Correlation Justification

Base on FCC 15.31 (f) (2): measurements may be performed at a distance closer than that specified in the regulations; however, an attempt should be made to avoid making measurements in the near field.

OFS and chamber correlation testing had been performed and chamber measured test result is the worst case test result.

9.1. TRANSMITTER ABOVE 1 GHz

BANDEDGE (LOW CHANNEL)

HORIZONTAL RESULT

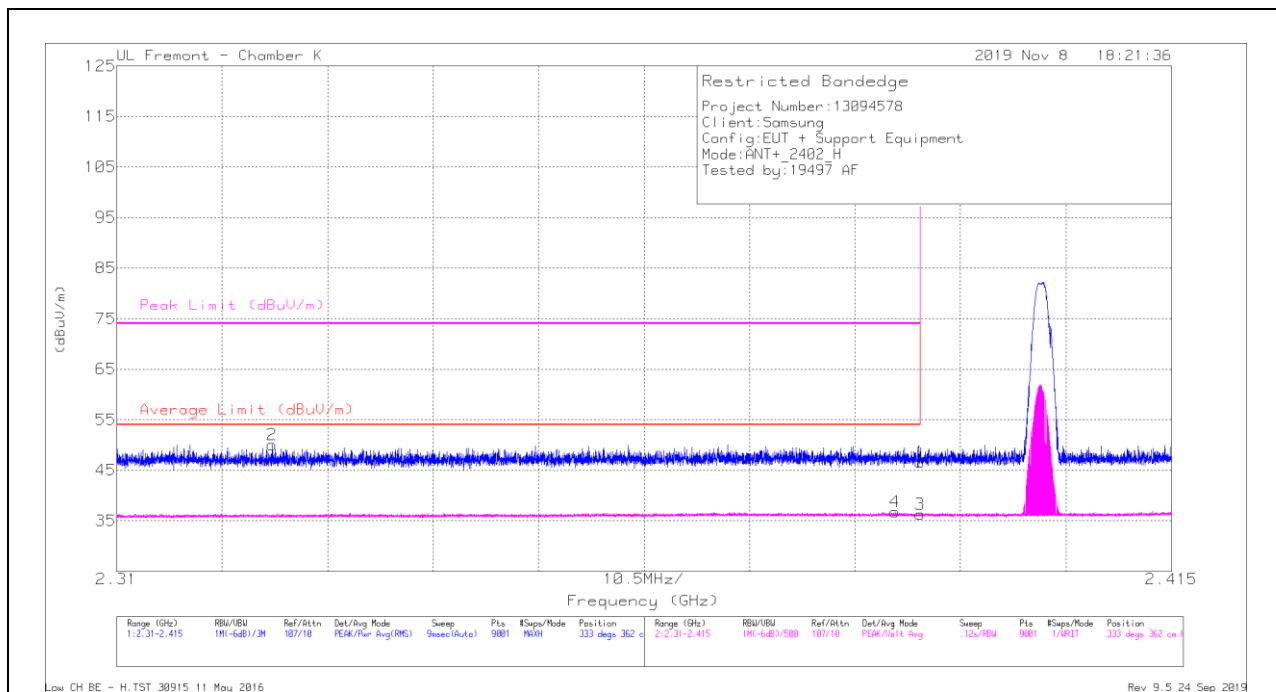

Trace Markers

| Marker | Frequency (GHz) | Meter Reading (dBuV) | Det | AF EMC4294 (dB/m) | Amp/Cbl/Filtr/Pad (dB) | Corrected Reading (dBuV/m) | Average Limit (dBuV/m) | Margin (dB) | Peak Limit (dBuV/m) | PK Margin (dB) | Azimuth (Degs) | Height (cm) | Polarity |
|--------|-----------------|----------------------|------|-------------------|------------------------|----------------------------|------------------------|-------------|---------------------|----------------|----------------|-------------|----------|
| 1 | * 2.38999 | 39.31 | Pk | 31.9 | -24.7 | 46.51 | - | - | 74 | -27.49 | 333 | 362 | H |
| 2 | * 2.32545 | 43.02 | Pk | 31.7 | -24.7 | 50.02 | - | - | 74 | -23.98 | 333 | 362 | H |
| 3 | * 2.38999 | 29.05 | VA1T | 31.9 | -24.7 | 36.25 | 54 | -17.75 | - | - | 333 | 362 | H |
| 4 | * 2.3875 | 29.41 | VA1T | 31.9 | -24.6 | 36.71 | 54 | -17.29 | - | - | 333 | 362 | H |

* - indicates frequency in CFR47 Pt 15 / IC RSS-Restricted Band

Pk - Peak detector

VA1T - FHSS: Linear Voltage Average $VB=1/T_{on}$ where: T_{on} is transmit duration

VERTICAL RESULT

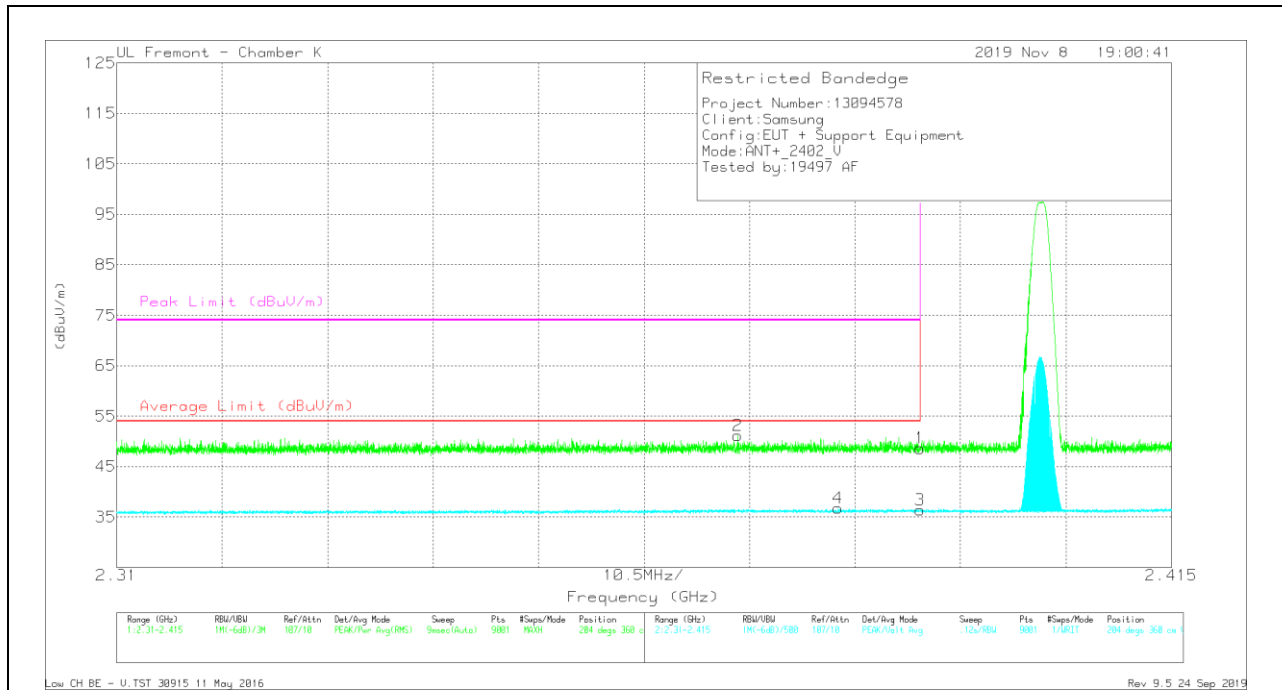

Trace Markers

| Marker | Frequency (GHz) | Meter Reading (dBuV) | Det | AF EMC4294 (dB/m) | Amp/Cbl/Filtr/Pad (dB) | Corrected Reading (dBuV/m) | Average Limit (dBuV/m) | Margin (dB) | Peak Limit (dBuV/m) | PK Margin (dB) | Azimuth (Degs) | Height (cm) | Polarity |
|--------|-----------------|----------------------|------|-------------------|------------------------|----------------------------|------------------------|-------------|---------------------|----------------|----------------|-------------|----------|
| 1 | * 2.38999 | 41.42 | Pk | 31.9 | -24.7 | 48.62 | - | - | 74 | -25.38 | 204 | 360 | V |
| 2 | * 2.37185 | 43.91 | Pk | 31.9 | -24.6 | 51.21 | - | - | 74 | -22.79 | 204 | 360 | V |
| 3 | * 2.38999 | 29.21 | VA1T | 31.9 | -24.7 | 36.41 | 54 | -17.59 | - | - | 204 | 360 | V |
| 4 | * 2.3818 | 29.51 | VA1T | 31.9 | -24.7 | 36.71 | 54 | -17.29 | - | - | 204 | 360 | V |

* - indicates frequency in CFR47 Pt 15 / IC RSS-Restricted Band

Pk - Peak detector

VA1T - FHSS: Linear Voltage Average $V_B=1/T_{on}$ where: T_{on} is transmit duration

BANDEDGE (HIGH CHANNEL)

HORIZONTAL RESULT

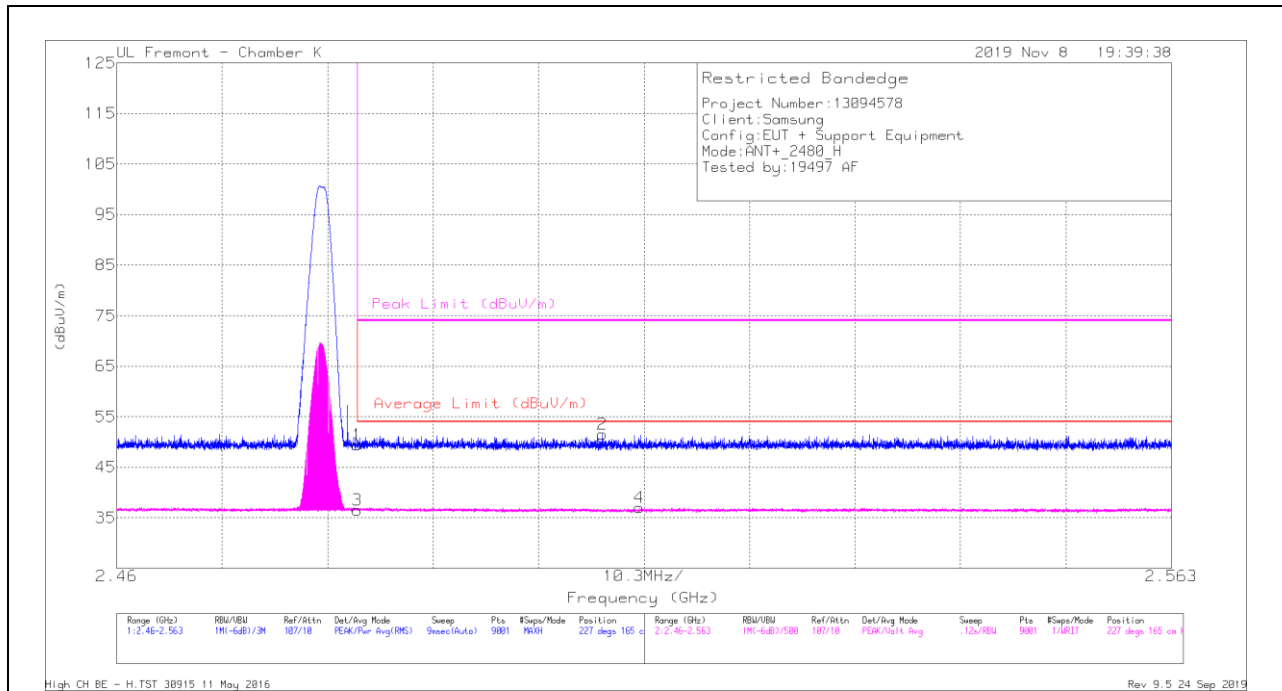

Trace Markers

| Marker | Frequency (GHz) | Meter Reading (dBuV) | Det | AF EMC4294 (dB/m) | Amp/Cbl/Filtr/Pad (dB) | Corrected Reading (dBuV/m) | Average Limit (dBuV/m) | Margin (dB) | Peak Limit (dBuV/m) | PK Margin (dB) | Azimuth (Degs) | Height (cm) | Polarity |
|--------|-----------------|----------------------|------|-------------------|------------------------|----------------------------|------------------------|-------------|---------------------|----------------|----------------|-------------|----------|
| 1 | * 2.48351 | 41.73 | Pk | 32.5 | -24.8 | 49.43 | - | - | 74 | -24.57 | 227 | 165 | H |
| 2 | 2.50745 | 44.06 | Pk | 32.3 | -24.8 | 51.56 | - | - | 74 | -22.44 | 227 | 165 | H |
| 3 | * 2.48351 | 28.86 | VA1T | 32.5 | -24.8 | 36.56 | 54 | -17.44 | - | - | 227 | 165 | H |
| 4 | 2.51106 | 29.42 | VA1T | 32.4 | -24.8 | 37.02 | 54 | -16.98 | - | - | 227 | 165 | H |

* - indicates frequency in CFR47 Pt 15 / IC RSS-Restricted Band

Pk - Peak detector

VA1T - FHSS: Linear Voltage Average $V_B=1/T_{on}$ where: T_{on} is transmit duration

VERTICAL RESULT

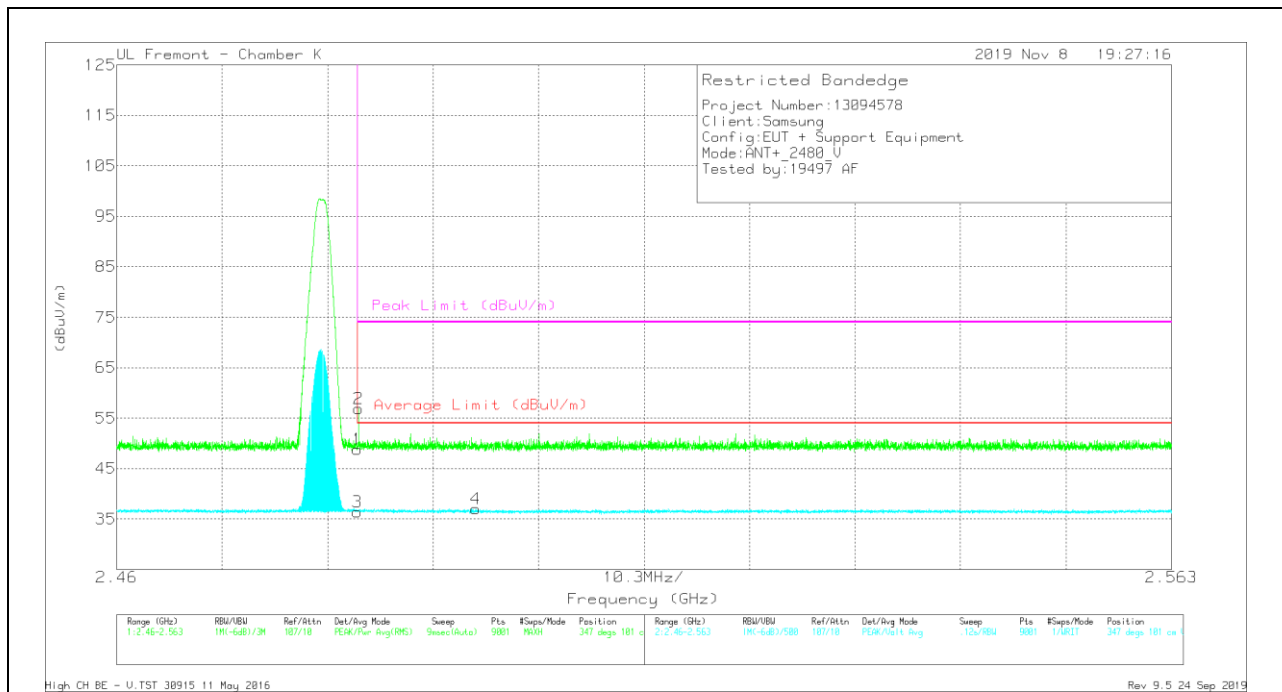

Trace Markers

| Marker | Frequency (GHz) | Meter Reading (dBuV) | Det | AF EMC4294 (dB/m) | Amp/Cbl/Filtr/Pad (dB) | Corrected Reading (dBuV/m) | Average Limit (dBuV/m) | Margin (dB) | Peak Limit (dBuV/m) | PK Margin (dB) | Azimuth (Degs) | Height (cm) | Polarity |
|--------|-----------------|----------------------|------|-------------------|------------------------|----------------------------|------------------------|-------------|---------------------|----------------|----------------|-------------|----------|
| 1 | * 2.48351 | 41.06 | Pk | 32.5 | -24.8 | 48.76 | - | - | 74 | -25.24 | 347 | 101 | V |
| 2 | * 2.48361 | 49.12 | Pk | 32.5 | -24.8 | 56.82 | - | - | 74 | -17.18 | 347 | 101 | V |
| 3 | * 2.48351 | 28.69 | VA1T | 32.5 | -24.8 | 36.39 | 54 | -17.61 | - | - | 347 | 101 | V |
| 4 | * 2.49505 | 29.44 | VA1T | 32.4 | -24.8 | 37.04 | 54 | -16.96 | - | - | 347 | 101 | V |

* - indicates frequency in CFR47 Pt 15 / IC RSS-Restricted Band

Pk - Peak detector

VA1T - FHSS: Linear Voltage Average $V_B=1/T_{on}$ where: T_{on} is transmit duration

HARMONICS AND SPURIOUS EMISSIONS

LOW CHANNEL RESULTS

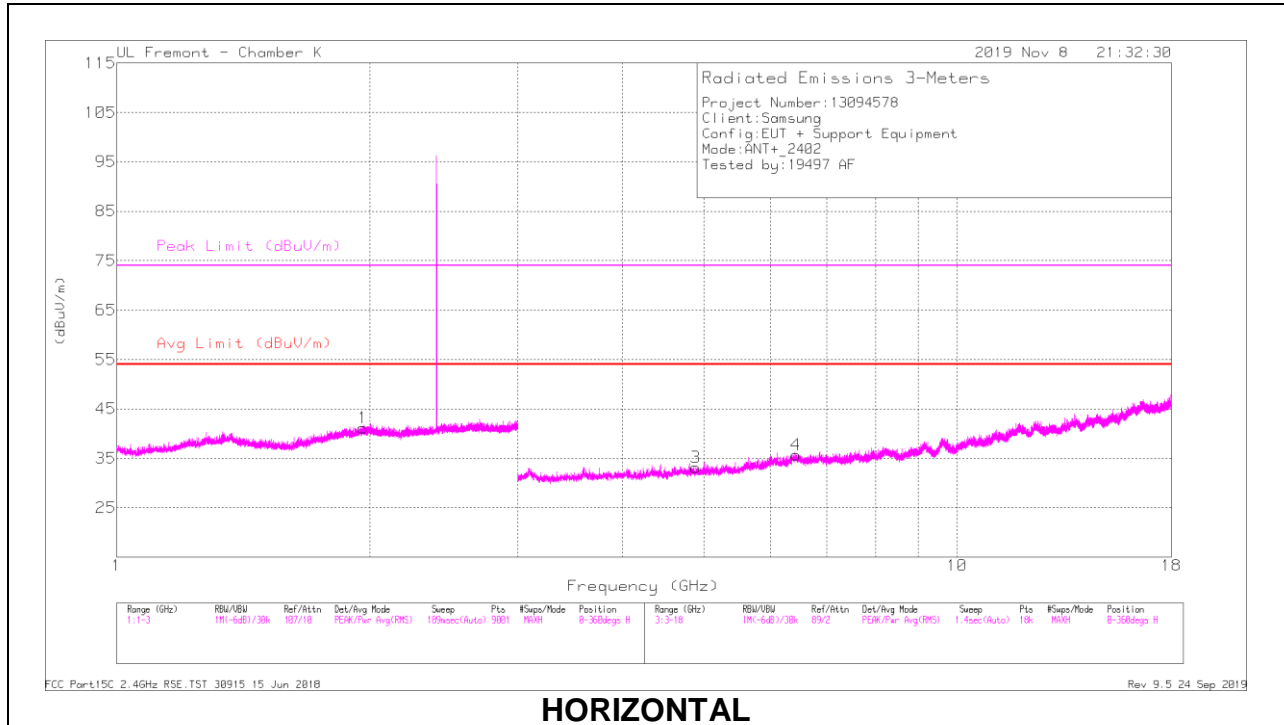

HORIZONTAL

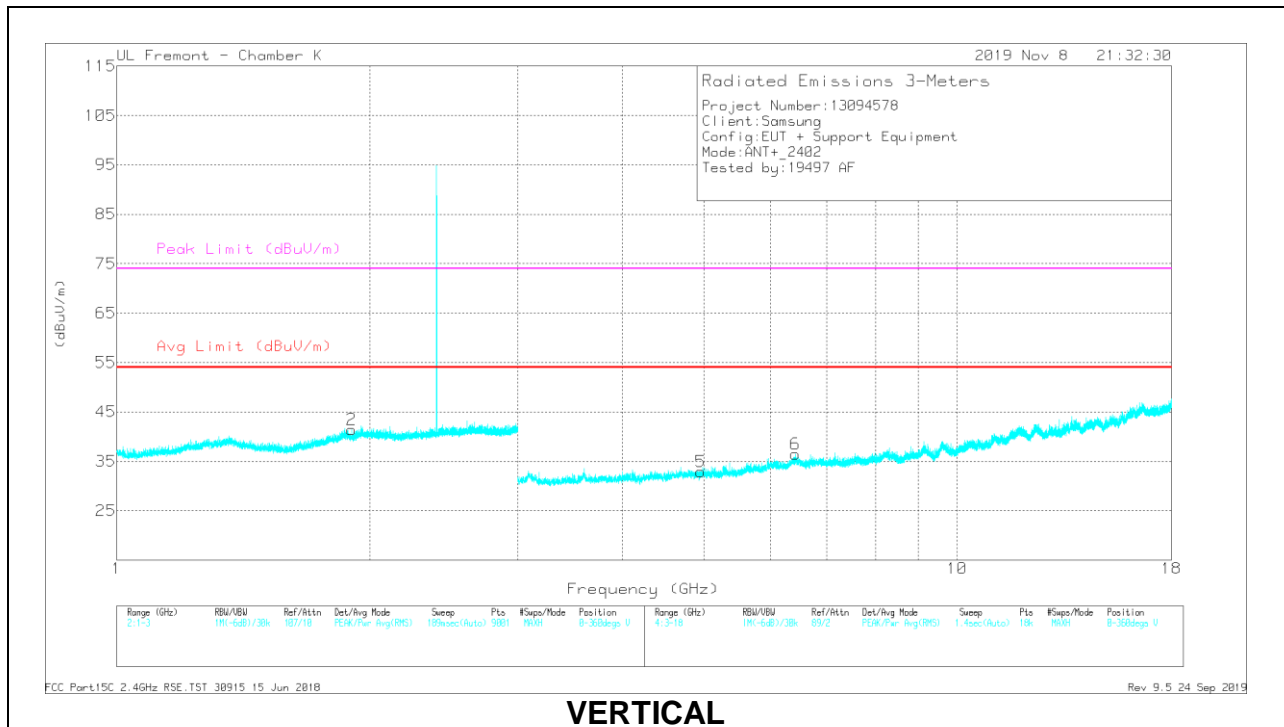

VERTICAL

RADIATED EMISSIONS

| Marker | Frequency (GHz) | Meter Reading (dBuV) | Det | AF EMC4294 (dB/m) | Amp/Cbl/Fitr/Pad (dB) | Corrected Reading (dBuV/m) | Avg Limit (dBuV/m) | Margin (dB) | Peak Limit (dBuV/m) | PK Margin (dB) | Azimuth (Degs) | Height (cm) | Polarity |
|--------|-----------------|----------------------|------|-------------------|-----------------------|----------------------------|--------------------|-------------|---------------------|----------------|----------------|-------------|----------|
| 1 | 1.96467 | 33.89 | Pk | 31.6 | -24.3 | 41.19 | - | - | - | - | 0-360 | 201 | H |
| 2 | 1.90511 | 34.72 | Pk | 31 | -24.3 | 41.42 | - | - | - | - | 0-360 | 101 | V |
| 3 | * 4.88624 | 37.74 | PKFH | 34.1 | -30.5 | 41.34 | - | - | 74 | -32.66 | 87 | 215 | H |
| | * 4.8865 | 24.56 | VA1T | 34.1 | -30.5 | 28.16 | 54 | -25.84 | - | - | 87 | 215 | H |
| 4 | 6.43436 | 26.27 | Pk | 35.7 | -26.3 | 35.67 | - | - | - | - | 0-360 | 200 | H |
| 5 | * 4.95686 | 38.53 | PKFH | 34.1 | -30.6 | 42.03 | - | - | 74 | -31.97 | 238 | 319 | V |
| | * 4.95489 | 24.9 | VA1T | 34.1 | -30.6 | 28.4 | 54 | -25.6 | - | - | 238 | 319 | V |
| 6 | 6.41769 | 27.16 | Pk | 35.7 | -26.4 | 36.46 | - | - | - | - | 0-360 | 100 | V |

* - indicates frequency in CFR47 Pt 15 / IC RSS-Restricted Band

Pk - Peak detector

PKFH FHSS/BT RB=100k for Frequencies<1GHz / RB=1MHz for Frequencies>1GHz, VB=3 x RB, Peak

VA1T - FHSS: Linear Voltage Average VB=1/Ton where: Ton is transmit duration

MID CHANNEL RESULTS

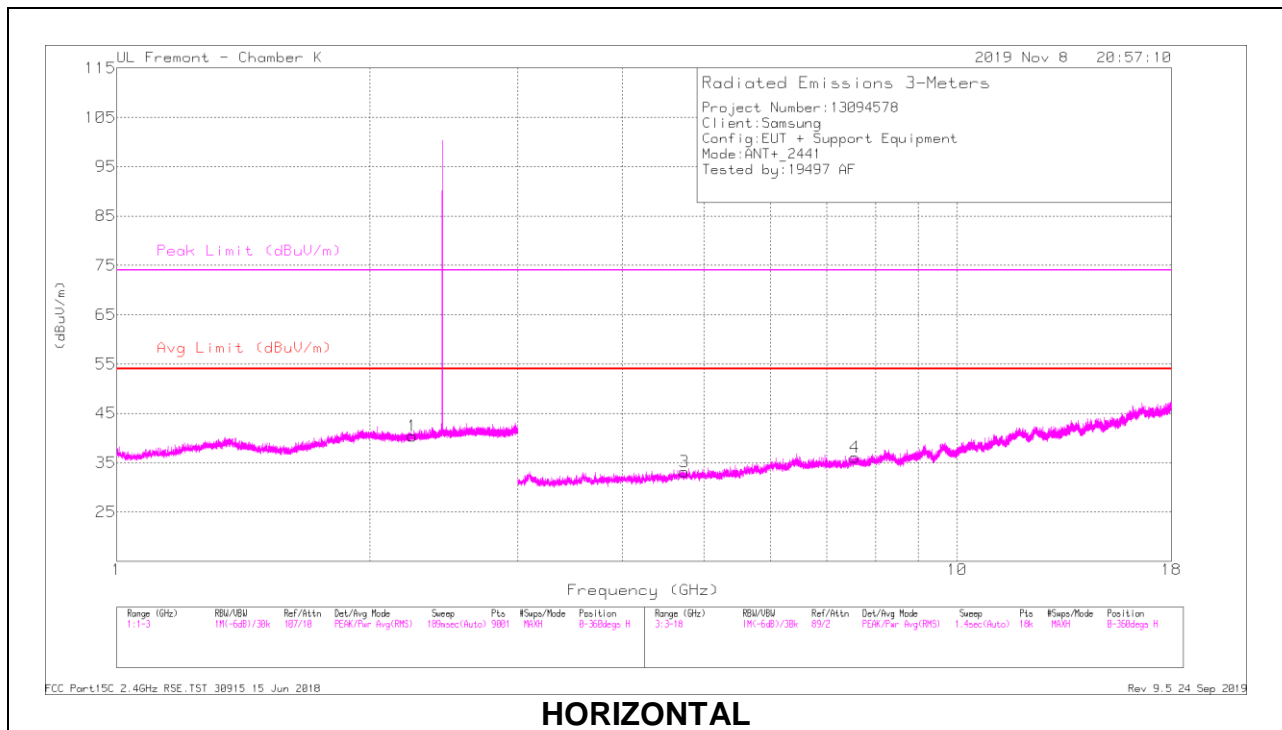

HORIZONTAL

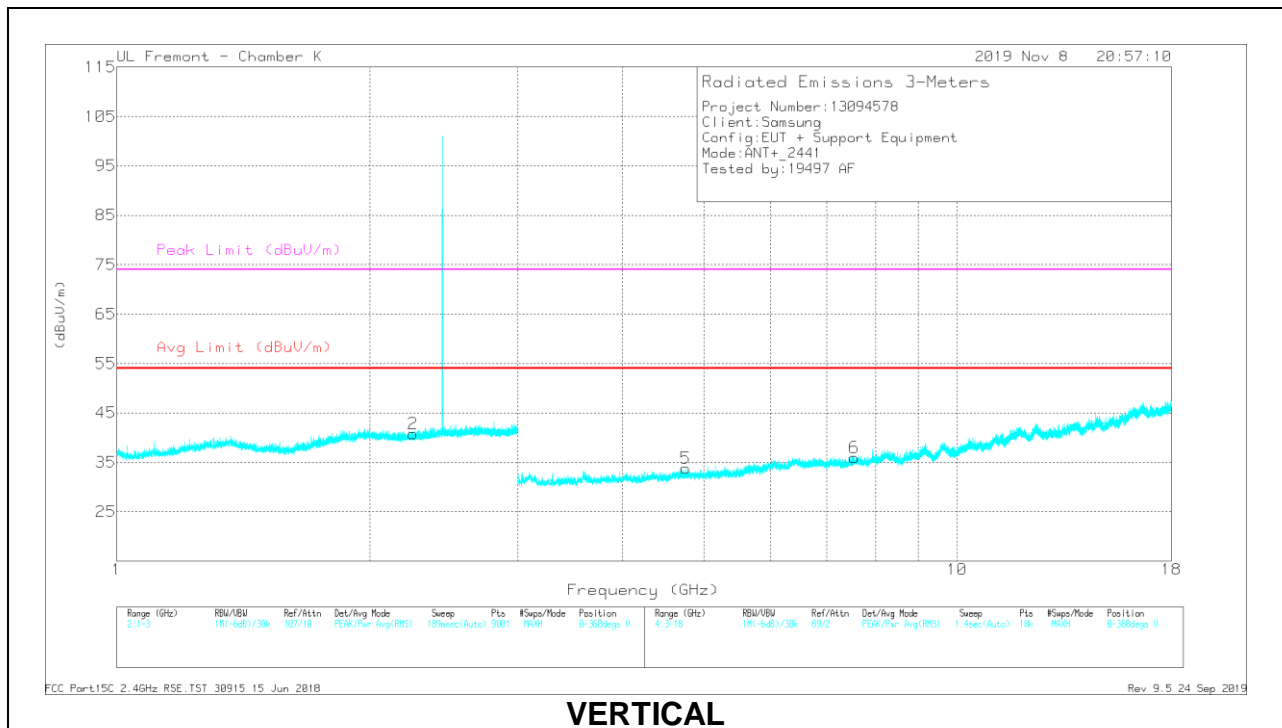

VERTICAL

RADIATED EMISSIONS

| Marker | Frequency (GHz) | Meter Reading (dBuV) | Det | AF EMC4294 (dB/m) | Amp/Cbl/Fitr/Pad (dB) | Corrected Reading (dBuV/m) | Avg Limit (dBuV/m) | Margin (dB) | Peak Limit (dBuV/m) | PK Margin (dB) | Azimuth (Degs) | Height (cm) | Polarity |
|--------|-----------------|----------------------|------|-------------------|-----------------------|----------------------------|--------------------|-------------|---------------------|----------------|----------------|-------------|----------|
| 1 | * 2.2506 | 42.64 | PKFH | 31.5 | -24.7 | 49.44 | - | - | 74 | -24.56 | 116 | 231 | H |
| | * 2.2503 | 29.35 | VA1T | 31.5 | -24.7 | 36.15 | 54 | -17.85 | - | - | 116 | 231 | H |
| 2 | * 2.25075 | 42.73 | PKFH | 31.5 | -24.7 | 49.53 | - | - | 74 | -24.47 | 86 | 219 | V |
| | * 2.25158 | 29.37 | VA1T | 31.5 | -24.7 | 36.17 | 54 | -17.83 | - | - | 86 | 219 | V |
| 3 | * 4.73754 | 38.28 | PKFH | 33.9 | -30.2 | 41.98 | - | - | 74 | -32.02 | 7 | 276 | H |
| | * 4.73688 | 24.67 | VA1T | 33.9 | -30.2 | 28.37 | 54 | -25.63 | - | - | 7 | 276 | H |
| 4 | * 7.55827 | 34.26 | PKFH | 35.7 | -25.4 | 44.56 | - | - | 74 | -29.44 | 360 | 198 | H |
| | * 7.56024 | 20.96 | VA1T | 35.6 | -25.4 | 31.16 | 54 | -22.84 | - | - | 360 | 198 | H |
| 5 | * 4.75095 | 37.97 | PKFH | 34 | -30.3 | 41.67 | - | - | 74 | -32.33 | 340 | 373 | V |
| | * 4.75259 | 24.56 | VA1T | 34 | -30.3 | 28.26 | 54 | -25.74 | - | - | 340 | 373 | V |
| 6 | * 7.55015 | 34.18 | PKFH | 35.7 | -25.5 | 44.38 | - | - | 74 | -29.62 | 318 | 190 | V |
| | * 7.55005 | 21.05 | VA1T | 35.7 | -25.5 | 31.25 | 54 | -22.75 | - | - | 318 | 190 | V |

* - indicates frequency in CFR47 Pt 15 / IC RSS-Restricted Band

PKFH FHSS/BT RB=100k for Frequencies<1GHz / RB=1MHz for Frequencies>1GHz, VB=3 x RB, Peak

VA1T - FHSS: Linear Voltage Average VB=1/Ton where: Ton is transmit duration

HIGH CHANNEL RESULTS

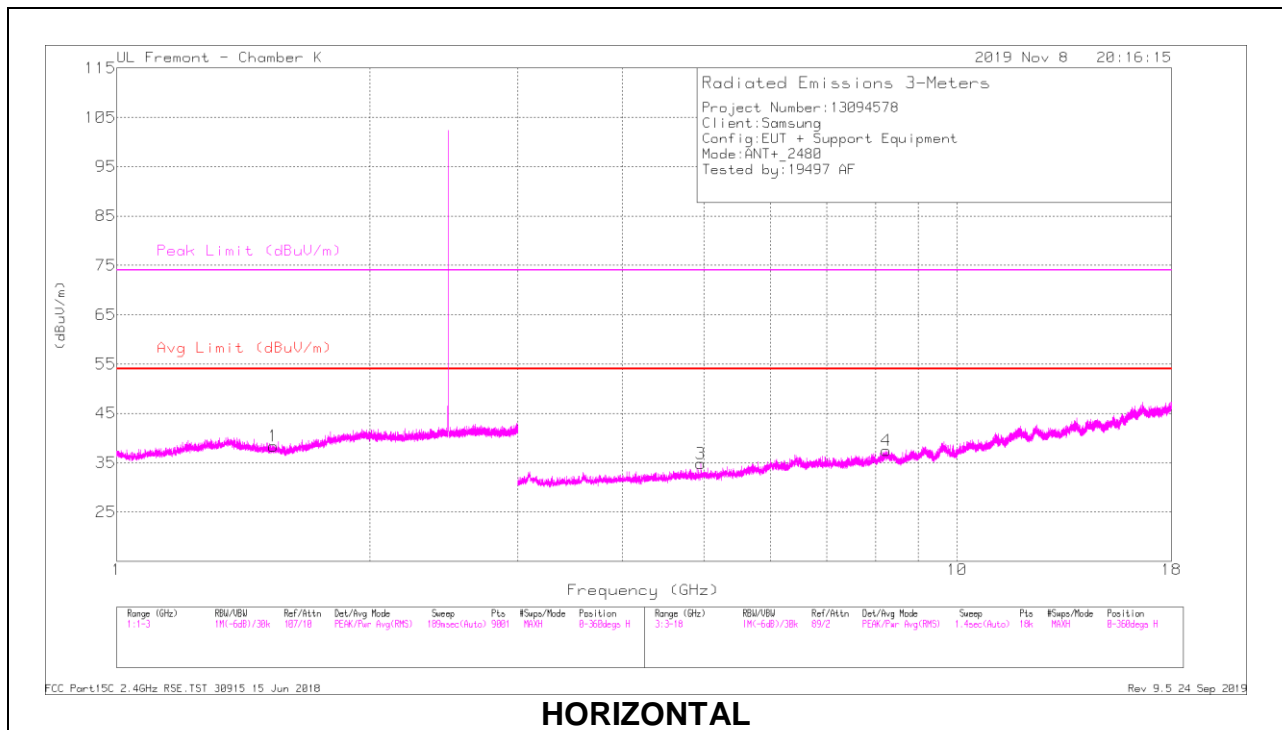

HORIZONTAL

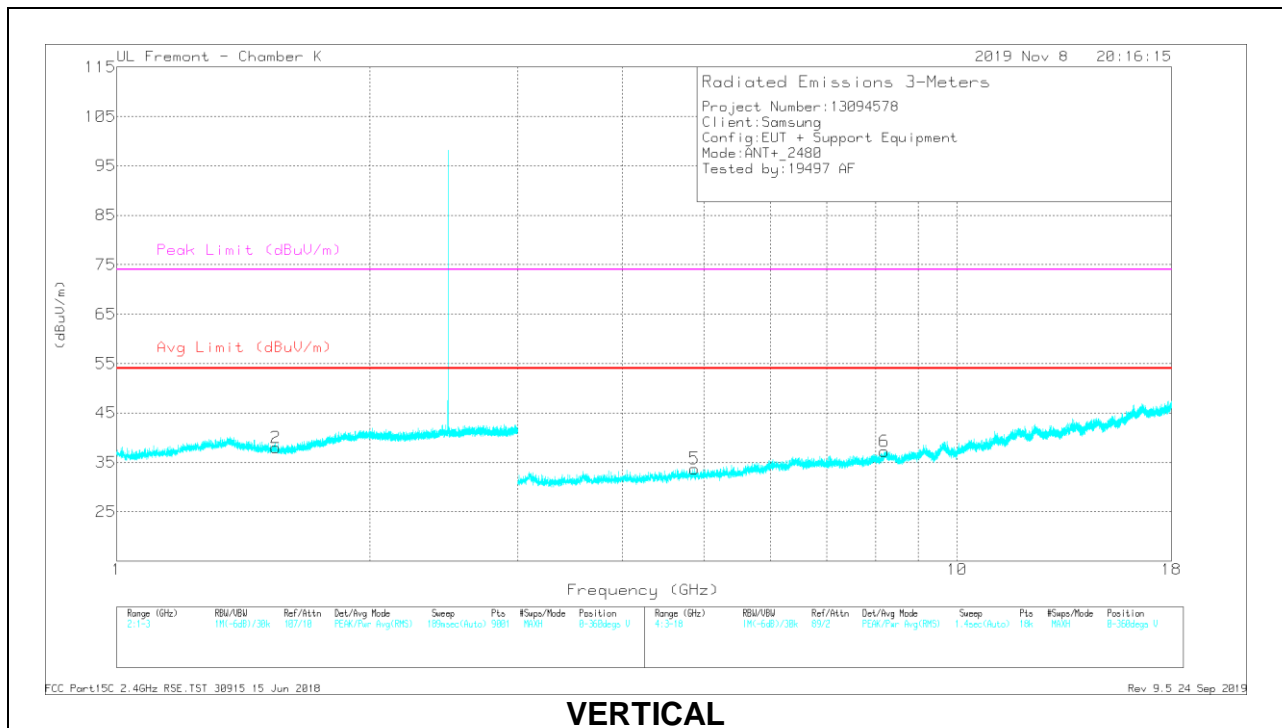

VERTICAL

RADIATED EMISSIONS

| Marker | Frequency (GHz) | Meter Reading (dBuV) | Det | AF EMC4294 (dB/m) | Amp/Cbl/Fitr/Pad (dB) | Corrected Reading (dBuV/m) | Avg Limit (dBuV/m) | Margin (dB) | Peak Limit (dBuV/m) | PK Margin (dB) | Azimuth (Degs) | Height (cm) | Polarity |
|--------|-----------------|----------------------|------|-------------------|-----------------------|----------------------------|--------------------|-------------|---------------------|----------------|----------------|-------------|----------|
| 1 | * 1.53546 | 42.73 | PKFH | 28.2 | -24 | 46.93 | - | - | 74 | -27.07 | 314 | 369 | H |
| | * 1.53629 | 29.4 | VA1T | 28.2 | -24 | 33.6 | 54 | -20.4 | - | - | 314 | 369 | H |
| 2 | * 1.54457 | 43.09 | PKFH | 28.2 | -24 | 47.29 | - | - | 74 | -26.71 | 238 | 239 | V |
| | * 1.5482 | 29.38 | VA1T | 28.2 | -24 | 33.58 | 54 | -20.42 | - | - | 238 | 239 | V |
| 3 | * 4.95972 | 39.64 | PKFH | 34.1 | -30.6 | 43.14 | - | - | 74 | -30.86 | 26 | 112 | H |
| | * 4.96002 | 26.72 | VA1T | 34.1 | -30.6 | 30.22 | 54 | -23.78 | - | - | 26 | 112 | H |
| 4 | * 8.24216 | 34.72 | PKFH | 35.9 | -24.8 | 45.82 | - | - | 74 | -28.18 | 47 | 106 | H |
| | * 8.24011 | 21.42 | VA1T | 35.9 | -24.8 | 32.52 | 54 | -21.48 | - | - | 47 | 106 | H |
| 5 | * 4.86996 | 38.19 | PKFH | 34.1 | -30.5 | 41.79 | - | - | 74 | -32.21 | 230 | 396 | V |
| | * 4.87088 | 24.67 | VA1T | 34.1 | -30.5 | 28.27 | 54 | -25.73 | - | - | 230 | 396 | V |
| 6 | * 8.20008 | 35.64 | PKFH | 35.9 | -25.1 | 46.44 | - | - | 74 | -27.56 | 137 | 248 | V |
| | * 8.201 | 21.67 | VA1T | 35.9 | -25.1 | 32.47 | 54 | -21.53 | - | - | 137 | 248 | V |

* - indicates frequency in CFR47 Pt 15 / IC RSS-Restricted Band

PKFH FHSS/BT RB=100k for Frequencies<1GHz / RB=1MHz for Frequencies>1GHz, VB=3 x RB, Peak

VA1T - FHSS: Linear Voltage Average VB=1/Ton where: Ton is transmit duration

9.2. FUNDAMENTAL FREQUENCY RADIATED EMISSION

| Frequency (GHz) | Meter Reading (dBuV) | Det | AF EMC4294 (dB/m) | Amp/Cbl/Filtr/Pad (dB) | DC Corr (dB) | Corrected Reading (dBuV/m) | Avg Limit (dBuV/m) | Margin (dB) | Peak Limit (dBuV/m) | PK Margin (dB) | Azimuth (Degs) | Height (cm) | Polarity |
|-----------------|----------------------|------|-------------------|------------------------|--------------|----------------------------|--------------------|-------------|---------------------|----------------|----------------|-------------|----------|
| 2.402 | 89.94 | PKFH | 31.9 | -24.7 | 0 | 97.14 | - | - | 114 | -16.86 | 110 | 298 | H |
| | 89.94 | AVG | 31.9 | -24.7 | -30.68 | 66.46 | 94 | -27.54 | - | - | 110 | 298 | H |
| | 87.56 | PKFH | 31.9 | -24.7 | 0 | 94.76 | - | - | 114 | -19.24 | 27 | 182 | V |
| | 87.56 | AVG | 31.9 | -24.7 | -30.68 | 64.08 | 94 | -29.92 | - | - | 27 | 182 | V |
| 2.441 | 90.86 | PKFH | 32.3 | -24.7 | 0 | 98.46 | - | - | 114 | -15.54 | 125 | 290 | H |
| | 90.86 | AVG | 32.3 | -24.7 | -30.68 | 67.78 | 94 | -26.22 | - | - | 125 | 290 | H |
| | 89.52 | PKFH | 32.3 | -24.7 | 0 | 97.12 | - | - | 114 | -16.88 | 25 | 185 | V |
| | 89.52 | AVG | 32.3 | -24.7 | -30.68 | 66.44 | 94 | -27.56 | - | - | 25 | 185 | V |
| 2.480 | 91.86 | PKFH | 32.5 | -24.8 | 0 | 99.56 | - | - | 114 | -14.44 | 116 | 108 | H |
| | 91.86 | AVG | 32.5 | -24.8 | -30.68 | 68.88 | 94 | -25.12 | - | - | 116 | 108 | H |
| | 91.68 | PKFH | 32.5 | -24.8 | 0 | 99.38 | - | - | 114 | -14.62 | 112 | 100 | V |
| | 91.68 | AVG | 32.5 | -24.8 | -30.68 | 68.7 | 94 | -25.3 | - | - | 112 | 100 | V |

PKFH - FHSS: RB=1MHz VB=3 x RB, Peak
 AVG = Peak Reading + Duty Cycle Correction Factor
 Duty Cycle Correction Factor = -30.68 dB

| | |
|-------------------|------------|
| Tested By: | 19497 AF |
| Date: | 11/08/2019 |

9.3. WORST CASE BELOW 30 MHz

SPURIOUS EMISSIONS 9 kHz TO 30 MHz (WORST-CASE CONFIGURATION)

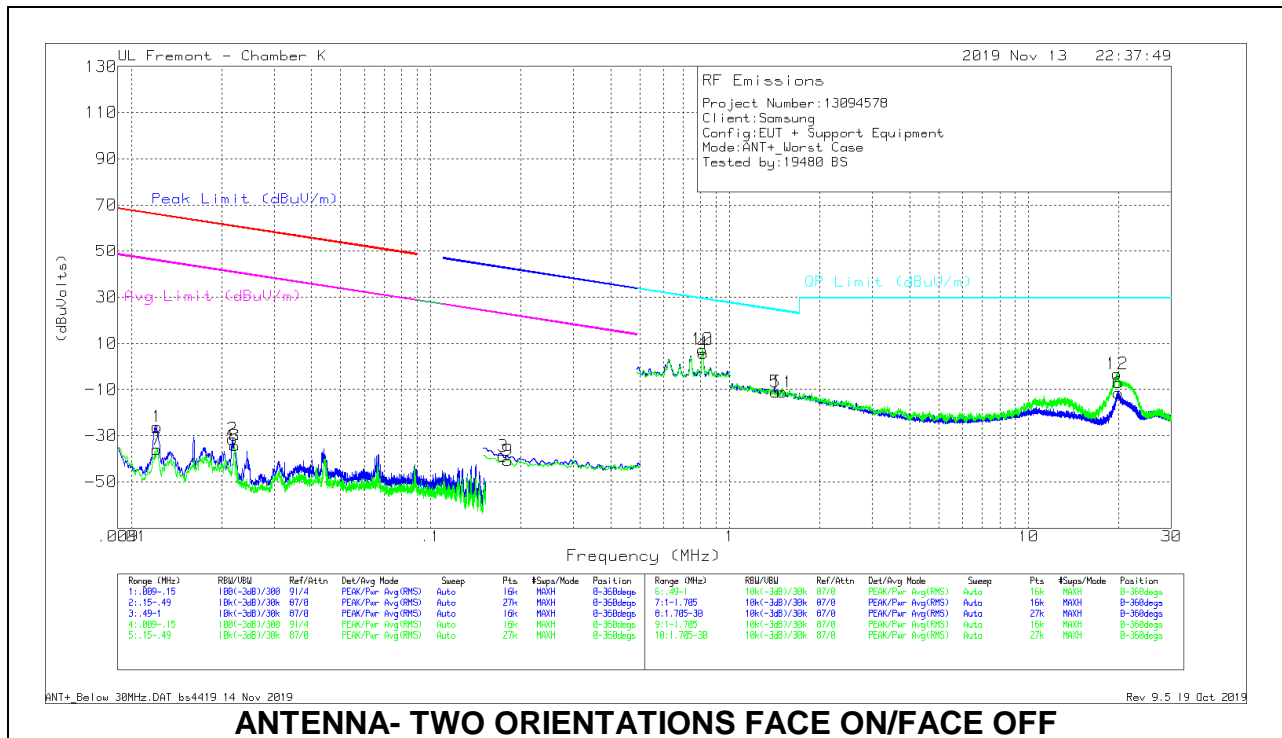

ANTENNA- TWO ORIENTATIONS FACE ON/FACE OFF

Below 30 MHz Data

| Marker | Frequency (MHz) | Meter Reading (dBuV) | Det | Loop Antenna (ACF) | Cables w/ PRE0186650 | Dist Corr 300m | Corrected Reading (dBuVolts) | Peak Limit (dBuV/m) | Margin (dB) | Avg Limit (dBuV/m) | Margin (dB) | Peak Limit (dBuV/m) | Margin (dB) | Avg Limit (dBuV/m) | Margin (dB) | Azimuth (Degs) |
|--------|-----------------|----------------------|-----|--------------------|----------------------|----------------|------------------------------|---------------------|-------------|--------------------|-------------|---------------------|-------------|--------------------|-------------|----------------|
| 1 | .01216 | 25.72 | Pk | 59.9 | -31.8 | -80 | -26.18 | 65.89 | -92.07 | 45.89 | -72.07 | - | - | - | - | 0-360 |
| 2 | .02161 | 22.09 | Pk | 58.6 | -32.1 | -80 | -31.41 | 60.81 | -92.22 | 40.81 | -72.22 | - | - | - | - | 0-360 |
| 3 | .17513 | 17.33 | Pk | 55.9 | -32.1 | -80 | -38.87 | - | - | - | - | 42.75 | -81.62 | 22.75 | -81.62 | 0-360 |
| 7 | .01214 | 16.02 | Pk | 59.9 | -31.8 | -80 | -35.88 | 65.9 | -101.78 | 45.9 | -81.78 | - | - | - | - | 0-360 |
| 8 | .02213 | 19.24 | Pk | 58.6 | -32.1 | -80 | -34.26 | 60.68 | -94.94 | 40.68 | -74.94 | - | - | - | - | 0-360 |
| 9 | .18127 | 15.3 | Pk | 56 | -32.1 | -80 | -40.8 | - | - | - | - | 42.45 | -83.25 | 22.45 | -83.25 | 0-360 |

Pk - Peak detector

| Marker | Frequency (MHz) | Meter Reading (dBuV) | Det | Loop Antenna (ACF) | Cables w/ PRE0186650 | Dist Corr 30m (dB) 40Log | Corrected Reading (dBuVolts) | QP Limit (dBuV/m) | Margin (dB) | Azimuth (Degs) |
|--------|-----------------|----------------------|-----|--------------------|----------------------|--------------------------|------------------------------|-------------------|-------------|----------------|
| 4 | .81515 | 21.69 | Pk | 56.1 | -32.1 | -40 | 5.69 | 29.39 | -23.7 | 0-360 |
| 10 | .81126 | 23.32 | Pk | 56.1 | -32.1 | -40 | 7.32 | 29.43 | -22.11 | 0-360 |
| 5 | 1.42577 | 16.42 | Pk | 44.6 | -32.1 | -40 | -11.08 | 24.55 | -35.63 | 0-360 |
| 6 | 19.94963 | 26.09 | Pk | 34.1 | -31.7 | -40 | -11.51 | 29.5 | -41.01 | 0-360 |
| 11 | 1.50345 | 16.66 | Pk | 44.2 | -32 | -40 | -11.14 | 24.09 | -35.23 | 0-360 |
| 12 | 19.74422 | 34.37 | Pk | 34.1 | -31.7 | -40 | -3.23 | 29.5 | -32.73 | 0-360 |

Pk - Peak detector

9.4. WORST CASE BELOW 1 GHz

SPURIOUS EMISSIONS 30 TO 1000 MHz (WORST-CASE CONFIGURATION)

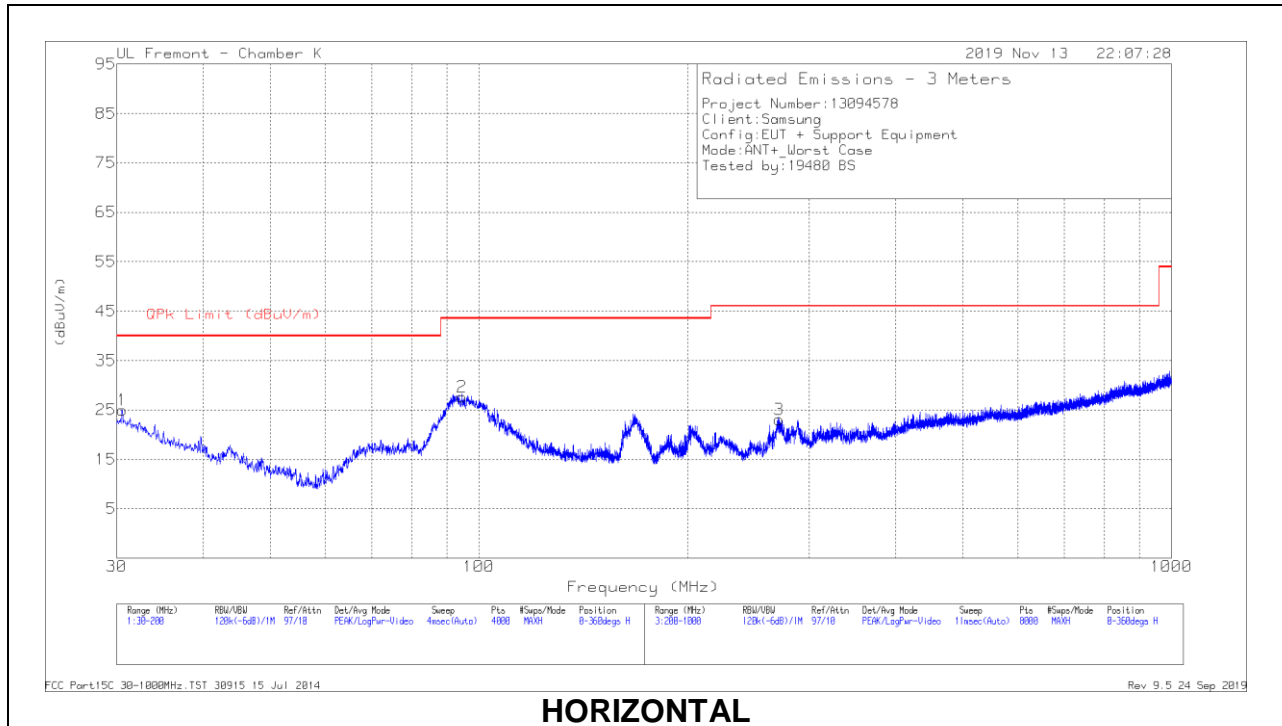

HORIZONTAL

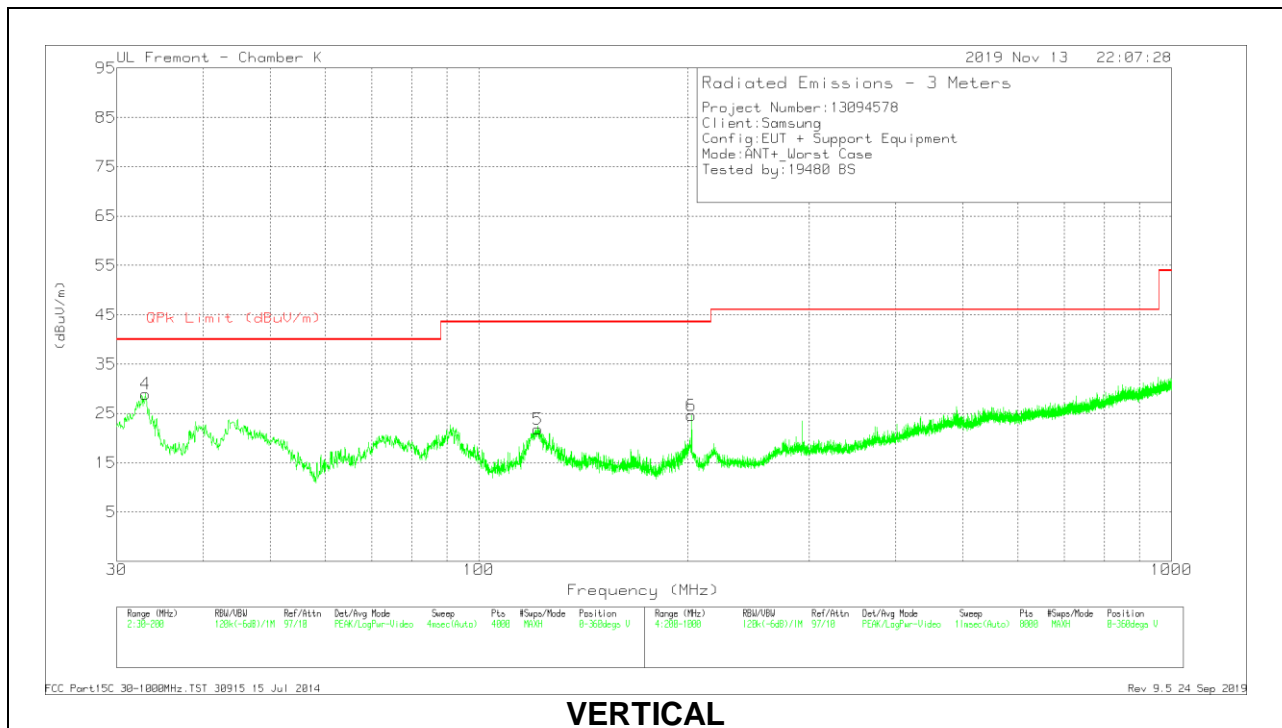

VERTICAL

Below 1GHz Data

| Marker | Frequency (MHz) | Meter Reading (dBuV) | Det | AF PRE0181574 (dB/m) | Amp/Cbl (dB) | Corrected Reading (dBuV/m) | QPk Limit (dBuV/m) | Margin (dB) | Azimuth (Degs) | Height (cm) | Polarity |
|--------|-----------------|----------------------|-----|----------------------|--------------|----------------------------|--------------------|-------------|----------------|-------------|----------|
| 1 | 30.5314 | 29.97 | Pk | 26.6 | -31.6 | 24.97 | 40 | -15.03 | 0-360 | 299 | H |
| 2 | 94.6167 | 43.89 | Pk | 14.7 | -30.9 | 27.69 | 43.52 | -15.83 | 0-360 | 199 | H |
| 4 | 33.0997 | 35.5 | Pk | 24.9 | -31.5 | 28.9 | 40 | -11.1 | 202 | 99 | V |
| | 33.0997 | 29.27 | Qp | 24.9 | -31.5 | 22.67 | 40 | -17.33 | 202 | 99 | V |
| 5 | * 121.6112 | 32.82 | Pk | 19.8 | -30.8 | 21.82 | 43.52 | -21.7 | 0-360 | 95 | V |
| 3 | * 271.3093 | 34 | Pk | 19.1 | -30 | 23.1 | 46.02 | -22.92 | 0-360 | 99 | H |
| 6 | 202.8004 | 37.21 | Pk | 17.7 | -30.3 | 24.61 | 43.52 | -18.91 | 0-360 | 99 | V |

* - indicates frequency in CFR47 Pt 15 / IC RSS-Restricted Band

Pk - Peak detector

Qp - Quasi-Peak detector

9.5. WORST CASE 18-26 GHz

SPURIOUS EMISSIONS 18-26 GHz (WORST-CASE CONFIGURATION)

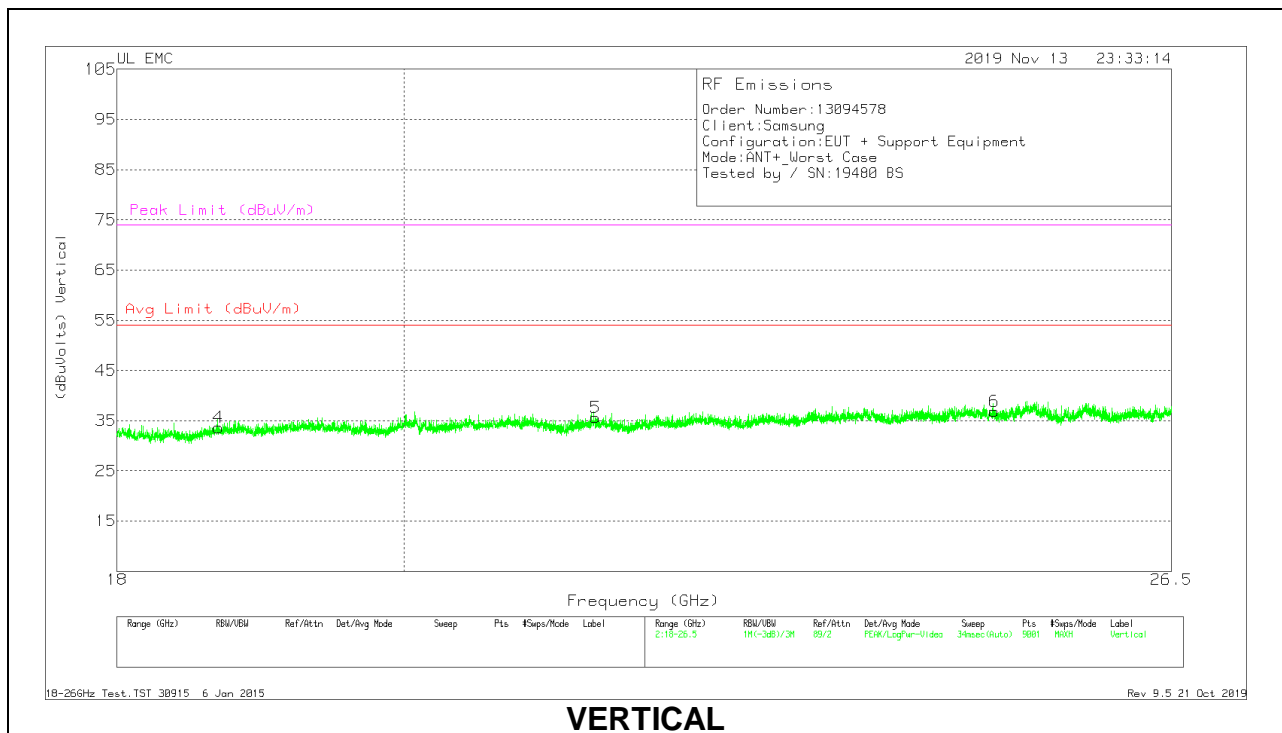
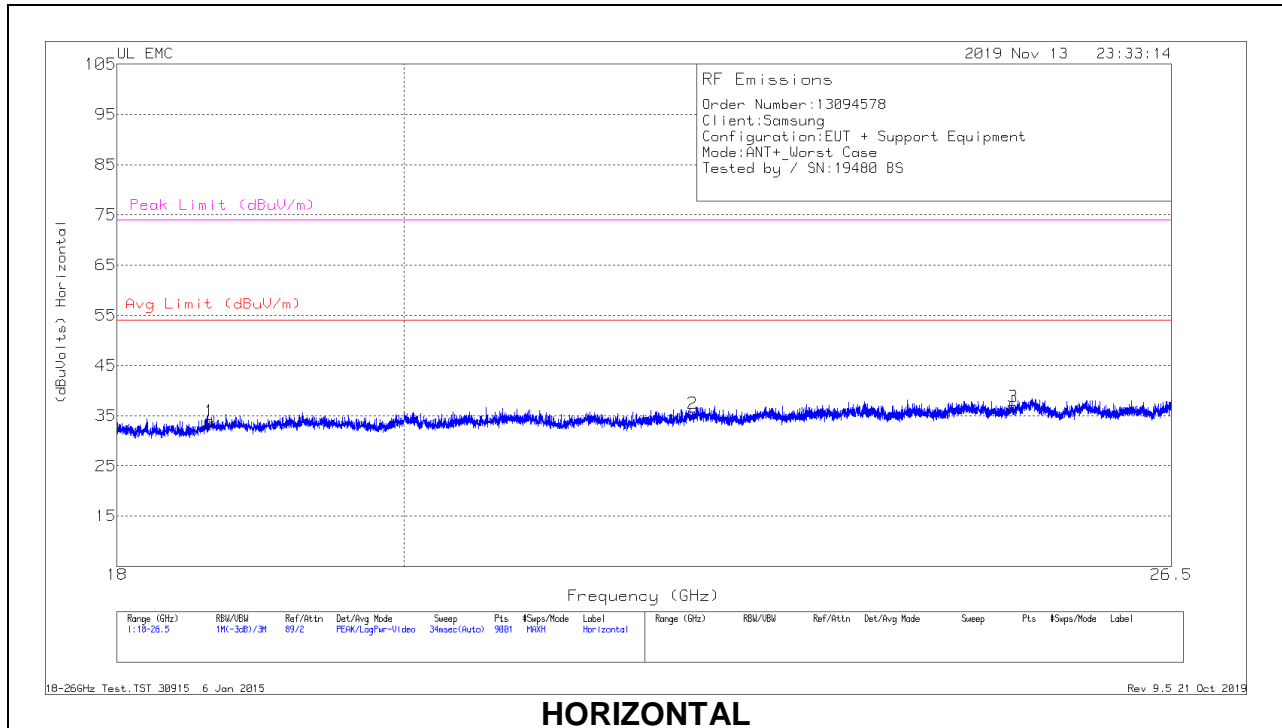

18 – 26GHz DATA

| Marker | Frequency (GHz) | Meter Reading (dBuV) | Det | T447 AF (dB/m) | Amp/Cbl (dB) | Dist Corr (dB) | Corrected Reading (dBuVolts) | Avg Limit (dBuV/m) | Margin (dB) | Peak Limit (dBuV/m) | PK Margin (dB) |
|--------|-----------------|----------------------|-----|----------------|--------------|----------------|------------------------------|--------------------|-------------|---------------------|----------------|
| 1 | 18.62144 | 69.81 | Pk | 32.4 | -58.8 | -9.5 | 33.91 | 54 | -20.09 | 74 | -40.09 |
| 2 | 22.23394 | 68.9 | Pk | 33.6 | -57.6 | -9.5 | 35.4 | 54 | -18.6 | 74 | -38.6 |
| 3 | 25.00683 | 67.05 | Pk | 34.6 | -55.4 | -9.5 | 36.75 | 54 | -17.25 | 74 | -37.25 |
| 4 | 18.68189 | 69.43 | Pk | 32.4 | -58.7 | -9.5 | 33.63 | 54 | -20.37 | 74 | -40.37 |
| 5 | 21.45289 | 69.12 | Pk | 33.2 | -57.2 | -9.5 | 35.62 | 54 | -18.38 | 74 | -38.38 |
| 6 | 24.83305 | 67.45 | Pk | 34.5 | -55.6 | -9.5 | 36.85 | 54 | -17.15 | 74 | -37.15 |

Pk - Peak detector

10. AC POWER LINE CONDUCTED EMISSIONS

LIMITS

FCC §15.207 (a)

| Frequency of Emission (MHz) | Conducted Limit (dBuV) | |
|-----------------------------|------------------------|-----------|
| | Quasi-peak | Average |
| 0.15-0.5 | 66 to 56* | 56 to 46* |
| 0.5-5 | 56 | 46 |
| 5-30 | 60 | 50 |

*Decreases with the logarithm of the frequency.

TEST PROCEDURE

The EUT is placed on a non-conducting table 40 cm from the vertical ground plane and 80 cm above the horizontal ground plane. The EUT is configured in accordance with ANSI C63.10.

The receiver is set to a resolution bandwidth of 9 kHz. Peak detection is used unless otherwise noted as quasi-peak or average.

Line conducted data is recorded for both NEUTRAL and HOT lines.

RESULTS

AC Power Line Norm

LINE 1 RESULTS

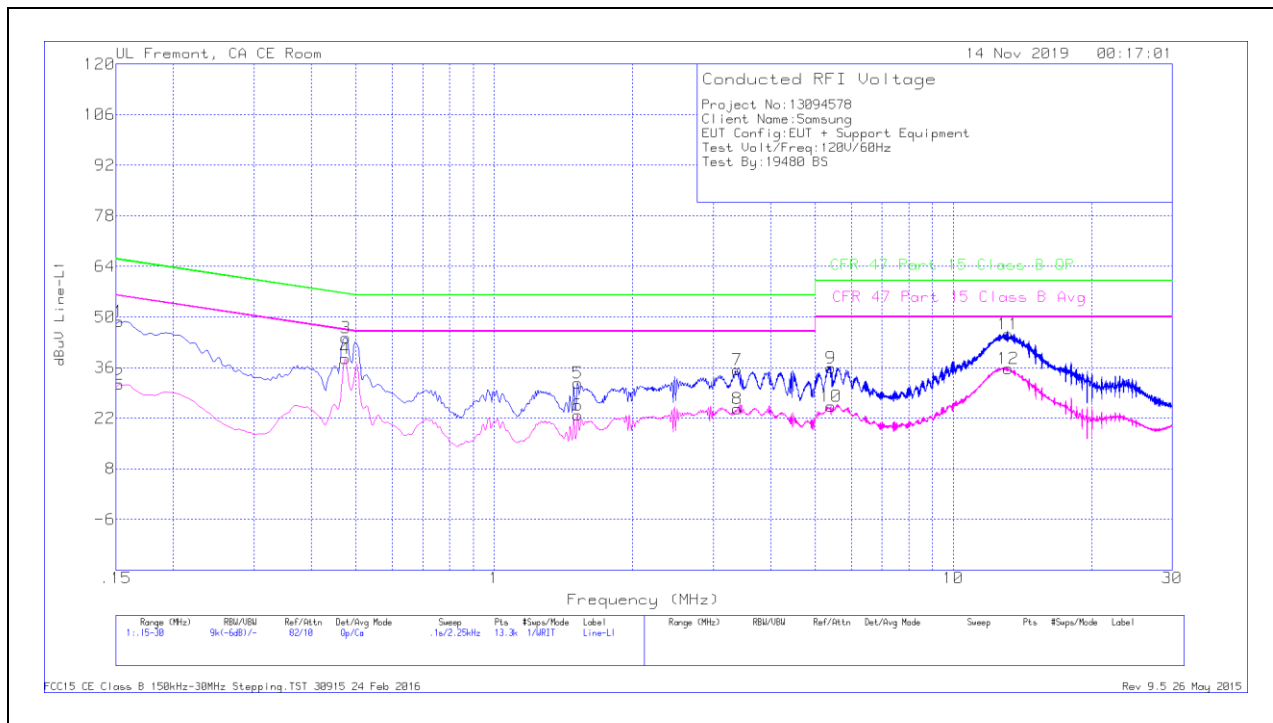

Trace Markers

| Range 1: Line-L1 .15 - 30MHz | | | | | | | | | | | |
|------------------------------|-----------------|----------------------|-----|---------|-----------------|--------------|------------------------|---------------------------|----------------|----------------------------|-----------------------|
| Marker | Frequency (MHz) | Meter Reading (dBuV) | Det | LISN L1 | LC Cables C1&C3 | Limiter (dB) | Corrected Reading dBuV | CFR 47 Part 15 Class B QP | QP Margin (dB) | CFR 47 Part 15 Class B Avg | Av(CISPR) Margin (dB) |
| 1 | .15225 | 38.64 | Qp | .1 | 0 | 10.1 | 48.84 | 65.88 | -17.04 | - | - |
| 2 | .15225 | 21.15 | Ca | .1 | 0 | 10.1 | 31.35 | - | - | 55.88 | -24.53 |
| 3 | .47512 | 34.15 | Qp | 0 | 0 | 10.1 | 44.25 | 56.42 | -12.17 | - | - |
| 4 | .474 | 28.39 | Ca | 0 | 0 | 10.1 | 38.49 | - | - | 46.44 | -7.95 |
| 5 | 1.52025 | 21.49 | Qp | 0 | .1 | 10.1 | 31.69 | 56 | -24.31 | - | - |
| 6 | 1.52025 | 12.75 | Ca | 0 | .1 | 10.1 | 22.95 | - | - | 46 | -23.05 |
| 7 | 3.38325 | 25.21 | Qp | 0 | .1 | 10.1 | 35.41 | 56 | -20.59 | - | - |
| 8 | 3.3855 | 14.44 | Ca | 0 | .1 | 10.1 | 24.64 | - | - | 46 | -21.36 |
| 9 | 5.41388 | 25.66 | Qp | 0 | .1 | 10.1 | 35.86 | 60 | -24.14 | - | - |
| 10 | 5.41725 | 15.16 | Ca | 0 | .1 | 10.1 | 25.36 | - | - | 50 | -24.64 |
| 11 | 13.17075 | 34.74 | Qp | .1 | .2 | 10.2 | 45.24 | 60 | -14.76 | - | - |
| 12 | 13.173 | 25.17 | Ca | .1 | .2 | 10.2 | 35.67 | - | - | 50 | -14.33 |

Qp - Quasi-Peak detector

Ca - CISPR average detection

LINE 2 RESULTS

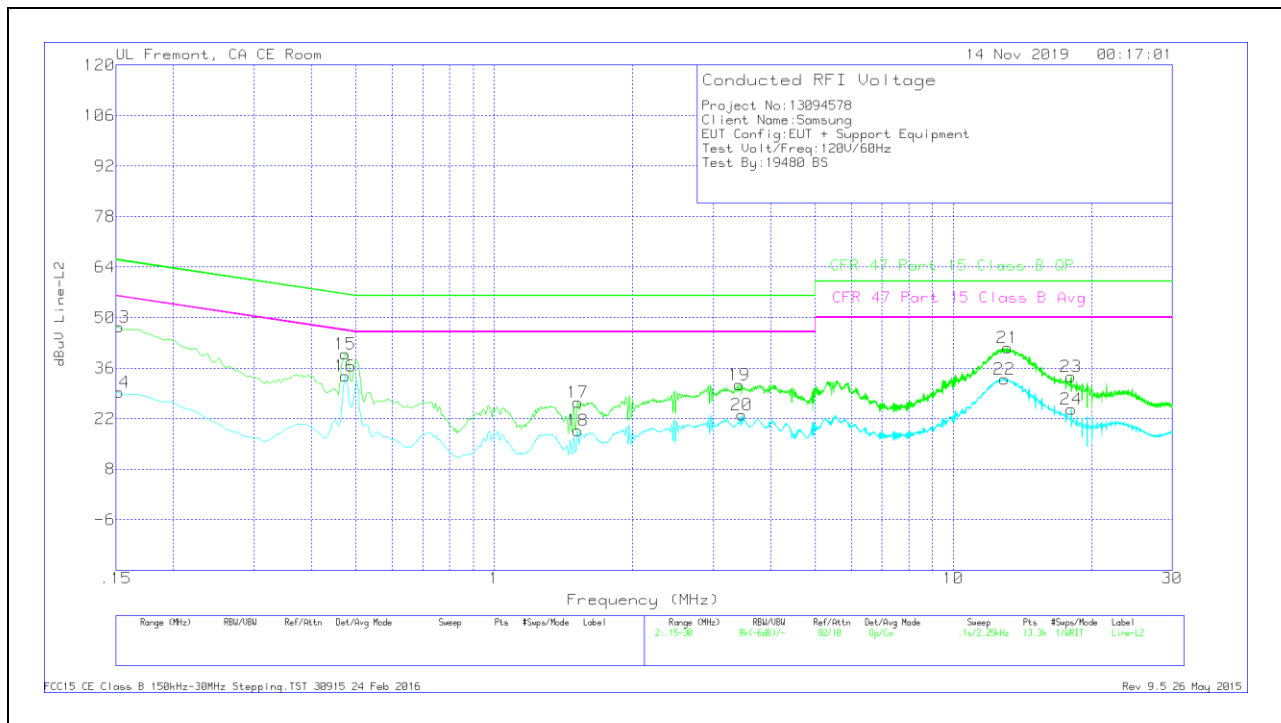

Trace Markers

| Range 2: Line-L2 .15 - 30MHz | | | | | | | | | | | |
|------------------------------|-----------------|----------------------|-----|---------|-----------------|--------------|------------------------|---------------------------|----------------|----------------------------|-----------------------|
| Marker | Frequency (MHz) | Meter Reading (dBuV) | Det | LISN L2 | LC Cables C2&C3 | Limiter (dB) | Corrected Reading dBuV | CFR 47 Part 15 Class B QP | QP Margin (dB) | CFR 47 Part 15 Class B Avg | Av(CISPR) Margin (dB) |
| 13 | .15225 | 37.22 | Qp | .1 | 0 | 10.1 | 47.42 | 65.88 | -18.46 | - | - |
| 14 | .15225 | 19.04 | Ca | .1 | 0 | 10.1 | 29.24 | - | - | 55.88 | -26.64 |
| 15 | .474 | 29.78 | Qp | 0 | 0 | 10.1 | 39.88 | 56.44 | -16.56 | - | - |
| 16 | .474 | 23.81 | Ca | 0 | 0 | 10.1 | 33.91 | - | - | 46.44 | -12.53 |
| 17 | 1.5225 | 16.38 | Qp | 0 | .1 | 10.1 | 26.58 | 56 | -29.42 | - | - |
| 18 | 1.52025 | 8.47 | Ca | 0 | .1 | 10.1 | 18.67 | - | - | 46 | -27.33 |
| 19 | 3.417 | 21.2 | Qp | 0 | .1 | 10.1 | 31.4 | 56 | -24.6 | - | - |
| 20 | 3.45975 | 12.9 | Ca | 0 | .1 | 10.1 | 23.1 | - | - | 46 | -22.9 |
| 21 | 13.11675 | 31.13 | Qp | .1 | .2 | 10.2 | 41.63 | 60 | -18.37 | - | - |
| 22 | 12.91425 | 22.54 | Ca | .1 | .2 | 10.2 | 33.04 | - | - | 50 | -16.96 |
| 23 | 18.04875 | 22.97 | Qp | .1 | .3 | 10.3 | 33.67 | 60 | -26.33 | - | - |
| 24 | 18.08025 | 13.85 | Ca | .1 | .3 | 10.3 | 24.55 | - | - | 50 | -25.45 |

Qp - Quasi-Peak detector
 Ca - CISPR average detection