



# **TEST REPORT**

**Report Number. :** 13094578-E2V2

**Applicant :** Samsung Electronics Co., Ltd.  
129 Samsung-Ro, Yeongtong-Gu,  
Suwon-Si, Gyeonggi-Do, 16677, Korea

**Model :** SM-N770F and SM-N770F/DS

**FCC ID :** A3LSMN770F

**EUT Description :** GSM/WCDMA/LTE Phablet with BT, DTS/UNII a/b/g/n/ac, NFC,  
ANT+ and WPT

**Test Standard(s) :** FCC 47 CFR PART 15 SUBPART C

**Date Of Issue:**

November 26, 2019

**Prepared by:**

UL Verification Services Inc.  
47173 Benicia Street  
Fremont, CA 94538 U.S.A.  
TEL: (510) 319-4000  
FAX: (510) 661-0888



NVLAP Lab code: 200065-0

---

## REPORT REVISION HISTORY

Rev.	Issue Date	Revisions	Revised By
V1	11/19/2019	Initial Issue	
V2	11/26/2019	Updated Section 1, 2 and 5	Steven Tran

## TABLE OF CONTENTS

<b>REPORT REVISION HISTORY .....</b>	<b>2</b>
<b>TABLE OF CONTENTS .....</b>	<b>3</b>
<b>1. ATTESTATION OF TEST RESULTS .....</b>	<b>5</b>
<b>2. TEST METHODOLOGY .....</b>	<b>7</b>
<b>3. FACILITIES AND ACCREDITATION .....</b>	<b>7</b>
<b>4. CALIBRATION AND UNCERTAINTY .....</b>	<b>8</b>
4.1. <i>MEASURING INSTRUMENT CALIBRATION .....</i>	<i>8</i>
4.2. <i>SAMPLE CALCULATION .....</i>	<i>8</i>
4.3. <i>MEASUREMENT UNCERTAINTY.....</i>	<i>8</i>
<b>5. EQUIPMENT UNDER TEST.....</b>	<b>9</b>
5.1. <i>EUT DESCRIPTION .....</i>	<i>9</i>
5.2. <i>MAXIMUM OUTPUT POWER.....</i>	<i>9</i>
5.3. <i>DESCRIPTION OF AVAILABLE ANTENNAS .....</i>	<i>9</i>
5.4. <i>SOFTWARE .....</i>	<i>9</i>
5.5. <i>WORST-CASE CONFIGURATION AND MODE.....</i>	<i>9</i>
5.6. <i>DESCRIPTION OF TEST SETUP.....</i>	<i>10</i>
<b>6. TEST AND MEASUREMENT EQUIPMENT .....</b>	<b>13</b>
<b>7. MEASUREMENT METHODS .....</b>	<b>14</b>
<b>8. ANTENNA PORT TEST RESULTS.....</b>	<b>15</b>
8.1. <i>ON TIME AND DUTY CYCLE.....</i>	<i>15</i>
8.2. <i>20 dB AND 99% BANDWIDTH .....</i>	<i>17</i>
8.2.1. <i>BLUETOOTH BASIC DATA RATE GFSK MODULATION .....</i>	<i>18</i>
8.2.2. <i>BLUETOOTH ENHANCED DATA RATE 8PSK MODULATION.....</i>	<i>19</i>
8.3. <i>HOPPING FREQUENCY SEPARATION .....</i>	<i>20</i>
8.3.1. <i>BLUETOOTH BASIC DATA RATE GFSK MODULATION .....</i>	<i>21</i>
8.3.2. <i>BLUETOOTH ENHANCED DATA RATE 8PSK MODULATION.....</i>	<i>22</i>
8.4. <i>NUMBER OF HOPPING CHANNELS.....</i>	<i>23</i>
8.4.1. <i>BLUETOOTH BASIC DATA RATE GFSK MODULATION .....</i>	<i>24</i>
8.4.2. <i>BLUETOOTH ENHANCED DATA RATE 8PSK MODULATION.....</i>	<i>26</i>
8.5. <i>AVERAGE TIME OF OCCUPANCY.....</i>	<i>28</i>
8.5.1. <i>BLUETOOTH BASIC DATA RATE GFSK MODULATION .....</i>	<i>29</i>
8.5.2. <i>BLUETOOTH ENHANCED DATA RATE 8PSK MODULATION.....</i>	<i>31</i>
8.6. <i>OUTPUT POWER.....</i>	<i>33</i>
8.6.1. <i>BLUETOOTH BASIC DATA RATE GFSK MODULATION .....</i>	<i>34</i>
8.6.2. <i>BLUETOOTH ENHANCED DATA RATE DQPSK MODULATION .....</i>	<i>34</i>

---

8.6.3.	BLUETOOTH ENHANCED DATA RATE 8PSK MODULATION.....	34
8.7.	<i>AVERAGE POWER</i> .....	35
8.7.1.	BLUETOOTH BASIC DATA RATE GFSK MODULATION .....	36
8.7.2.	BLUETOOTH ENHANCED DATA RATE DQPSK MODULATION .....	36
8.7.3.	BLUETOOTH ENHANCED DATA RATE 8PSK MODULATION.....	36
8.8.	<i>CONDUCTED SPURIOUS EMISSIONS</i> .....	37
8.8.1.	BLUETOOTH BASIC DATA RATE GFSK MODULATION .....	38
8.8.2.	BLUETOOTH ENHANCED DATA RATE 8PSK MODULATION.....	40
<b>9.</b>	<b>RADIATED TEST RESULTS</b> .....	<b>42</b>
9.1.	<i>TRANSMITTER ABOVE 1 GHz</i> .....	44
9.1.1.	BLUETOOTH BASIC DATA RATE GFSK MODULATION .....	44
9.1.2.	BLUETOOTH ENHANCED DATA RATE 8PSK MODULATION.....	54
9.2.	<i>WORST CASE BELOW 30MHZ</i> .....	64
9.3.	<i>WORST CASE BELOW 1 GHZ</i> .....	65
9.4.	<i>WORST CASE 18-26 GHZ</i> .....	67
<b>10.</b>	<b>AC POWER LINE CONDUCTED EMISSIONS</b> .....	<b>69</b>
<b>11.</b>	<b>SETUP PHOTOS</b> .....	<b>72</b>

## 1. ATTESTATION OF TEST RESULTS

**COMPANY NAME:** Samsung Electronics Co., Ltd.  
129 Samsung-Ro, Yeongtong-Gu,  
Suwon-Si, Gyeonggi-Do, 16677, Korea

**EUT DESCRIPTION:** GSM/WCDMA/LTE Phablet with BT, DTS/UNII a/b/g/n/ac, NFC,  
ANT+ and WPT

**MODEL:** SM-N770F and SM-N770F/DS

**SERIAL NUMBER:** Conducted: R38MA039RER  
Radiated: R38MA039SFP

**DATE TESTED:** October 31 – November 13, 2019

APPLICABLE STANDARDS	
STANDARD	TEST RESULTS
CFR 47 Part 15 Subpart C	Complies

UL Verification Services Inc. tested the above equipment in accordance with the requirements set forth in the above standards. The test results show that the equipment tested is capable of demonstrating compliance with the requirements as documented in this report.

The results documented in this report apply only to the tested sample, under the conditions and modes of operation as described herein. It is the manufacturer's responsibility to assure that additional production units of this model are manufactured with identical electrical and mechanical components. All samples tested were in good operating condition throughout the entire test program. Measurement Uncertainties are published for informational purposes only and were not taken into account unless noted otherwise.

This document may not be altered or revised in any way unless done so by UL Verification Services Inc. and all revisions are duly noted in the revisions section. Any alteration of this document not carried out by UL Verification Services Inc. will constitute fraud and shall nullify the document. This report must not be used by the client to claim product certification, approval, or endorsement by NVLAP, NIST, any agency of the Federal Government, or any agency of the U.S. government.

Approved & Released For  
UL Verification Services Inc. By:



---

Dan Corona  
Operations Leader  
Consumer Technology Division  
UL Verification Services Inc.

Prepared By:



---

Glenn Escano  
Test Engineer  
Consumer Technology Division  
UL Verification Services Inc.

Reviewed By:



---

Steven Tran  
Project Engineer  
Consumer Technology Division  
UL Verification Services Inc.

## 2. TEST METHODOLOGY

The tests documented in this report were performed in accordance with FCC CFR 47 Part 2, FCC CFR 47 Part 15, ANSI C63.10-2013, KDB 558074 D01 15.247 Meas Guidance v05r02, and KDB 414788 D01 Radiated Test Site v01r01 .

## 3. FACILITIES AND ACCREDITATION

The test sites and measurement facilities used to collect data are located at 47173 and 47266 Benicia Street, and 47658 Kato Road, Fremont, California, USA. Line conducted emissions are measured only at the 47173 address. The following table identifies which facilities were utilized for radiated emission measurements documented in this report. Specific facilities are also identified in the test results sections.

47173 Benicia Street	47266 Benicia Street	47658 Kato Rd
<input type="checkbox"/> Chamber A	<input type="checkbox"/> Chamber D	<input type="checkbox"/> Chamber I
<input type="checkbox"/> Chamber B	<input type="checkbox"/> Chamber E	<input checked="" type="checkbox"/> Chamber J
<input type="checkbox"/> Chamber C	<input type="checkbox"/> Chamber F	<input checked="" type="checkbox"/> Chamber K
	<input type="checkbox"/> Chamber G	<input type="checkbox"/> Chamber L
	<input type="checkbox"/> Chamber H	<input type="checkbox"/> Chamber M

The above test sites and facilities are covered under FCC Test Firm Registration # 208313. Chambers above are covered under Industry Canada company address and respective code: 2324A.

UL Verification Services Inc. is accredited by NVLAP, Laboratory Code 200065-0

## 4. CALIBRATION AND UNCERTAINTY

### 4.1. MEASURING INSTRUMENT CALIBRATION

The measuring equipment utilized to perform the tests documented in this report has been calibrated in accordance with the manufacturer's recommendations, and is traceable to recognized national standards.

### 4.2. SAMPLE CALCULATION

#### **RADIATED EMISSIONS**

Where relevant, the following sample calculation is provided:

Field Strength (dBuV/m) = Measured Voltage (dBuV) + Antenna Factor (dB/m) + Cable Loss (dB) – Preamp Gain (dB)

$$36.5 \text{ dBuV} + 18.7 \text{ dB/m} + 0.6 \text{ dB} - 26.9 \text{ dB} = 28.9 \text{ dBuV/m}$$

#### **MAINS CONDUCTED EMISSIONS**

Where relevant, the following sample calculation is provided:

Final Voltage (dBuV) = Measured Voltage (dBuV) + Cable Loss (dB) + Limiter Factor (dB) + LISN Insertion Loss.

$$36.5 \text{ dBuV} + 0 \text{ dB} + 10.1 \text{ dB} + 0 \text{ dB} = 46.6 \text{ dBuV}$$

### 4.3. MEASUREMENT UNCERTAINTY

Where relevant, the following measurement uncertainty levels have been estimated for tests performed on the apparatus:

PARAMETER	UNCERTAINTY
Worst Case Conducted Disturbance, 9KHz to 0.15 MHz	3.84 dB
Worst Case Conducted Disturbance, 0.15 to 30 MHz	3.65 dB
Worst Case Radiated Disturbance, 9KHz to 30 MHz	2.52 dB
Worst Case Radiated Disturbance, 30 to 1000 MHz	4.88 dB
Worst Case Radiated Disturbance, 1000 to 18000 MHz	4.24 dB
Worst Case Radiated Disturbance, 18000 to 26000 MHz	4.37 dB
Worst Case Radiated Disturbance, 26000 to 40000 MHz	5.17 dB

Uncertainty figures are valid to a confidence level of 95%.

## 5. EQUIPMENT UNDER TEST

### 5.1. EUT DESCRIPTION

The EUT is a GSM/WCDMA/LTE Phablet with BT, DTS/UNII a/b/g/n/ac, NFC, ANT+ and WPT. The model SM-N770F was used for final testing and is representative of the test results in this reports.

### 5.2. MAXIMUM OUTPUT POWER

The transmitter has a maximum peak conducted output power as follows:

Frequency Range (MHz)	Mode	Output Power (dBm)	Output Power (mW)
2402 - 2480	Basic GFSK	16.00	39.81
2402 - 2480	Enhanced DQPSK	8.60	7.24
2402 - 2480	Enhanced 8PSK	8.80	7.59

Note: GFSK, DQPSK, 8PSK average Power are all investigated, The GFSK & 8PSK Power are the worst case. Testing is based on these modes to showing compliance.

For average power data please refer to section 8.7.

### 5.3. DESCRIPTION OF AVAILABLE ANTENNAS

The radio utilizes an internal antenna, with a maximum gain of -5.1 dBi.

### 5.4. SOFTWARE

The test utility software used during testing was N770F.001.

### 5.5. WORST-CASE CONFIGURATION AND MODE

Radiated emissions below 1GHz, above 18GHz, and power line conducted emission were performed with the EUT set to transmit at the channel with highest output power as worst-case scenario.

Band edge and radiated emissions between 1GHz and 18GHz were performed with the EUT set to transmit at the highest power on low, middle and high channels.

The fundamental of the EUT was investigated in three orthogonal orientations X,Y,Z, it was determined that Y orientation was worst-case orientation; therefore, all final radiated testing was performed with the EUT in Y orientation.

Worst-case data rates as provided by the client were:

GFSK mode: DH5  
 8PSK mode: 3-DH5

## 5.6. DESCRIPTION OF TEST SETUP

### SUPPORT EQUIPMENT

Support Equipment List				
Description	Manufacturer	Model	Serial Number	FCC ID
AC Adapter	Samsung	EP-TA800	R37M3531XX1SE3	N/A
Earphone	Samsung	N/A	N/A	N/A

### I/O CABLES (CONDUCTED TEST)

I/O Cable List						
Cable No	Port	# of identical ports	Connector Type	Cable Type	Cable Length (m)	Remarks
1	Antenna	1	RF	Shielded	0.2	To PSA and BT Tester
2	USB	1	USB	Un-shielded	1	EUT to AC Mains

### I/O CABLES (RADIATED AND CONDUCTED EMISSIONS)

I/O Cable List						
Cable No	Port	# of identical ports	Connector Type	Cable Type	Cable Length (m)	Remarks
1	USB	1	USB	Shielded	1	N/A
2	earphone	1	3.5mm	Un-shielded	1	N/A

**CONDUCTED TEST SETUP DIAGRAM**

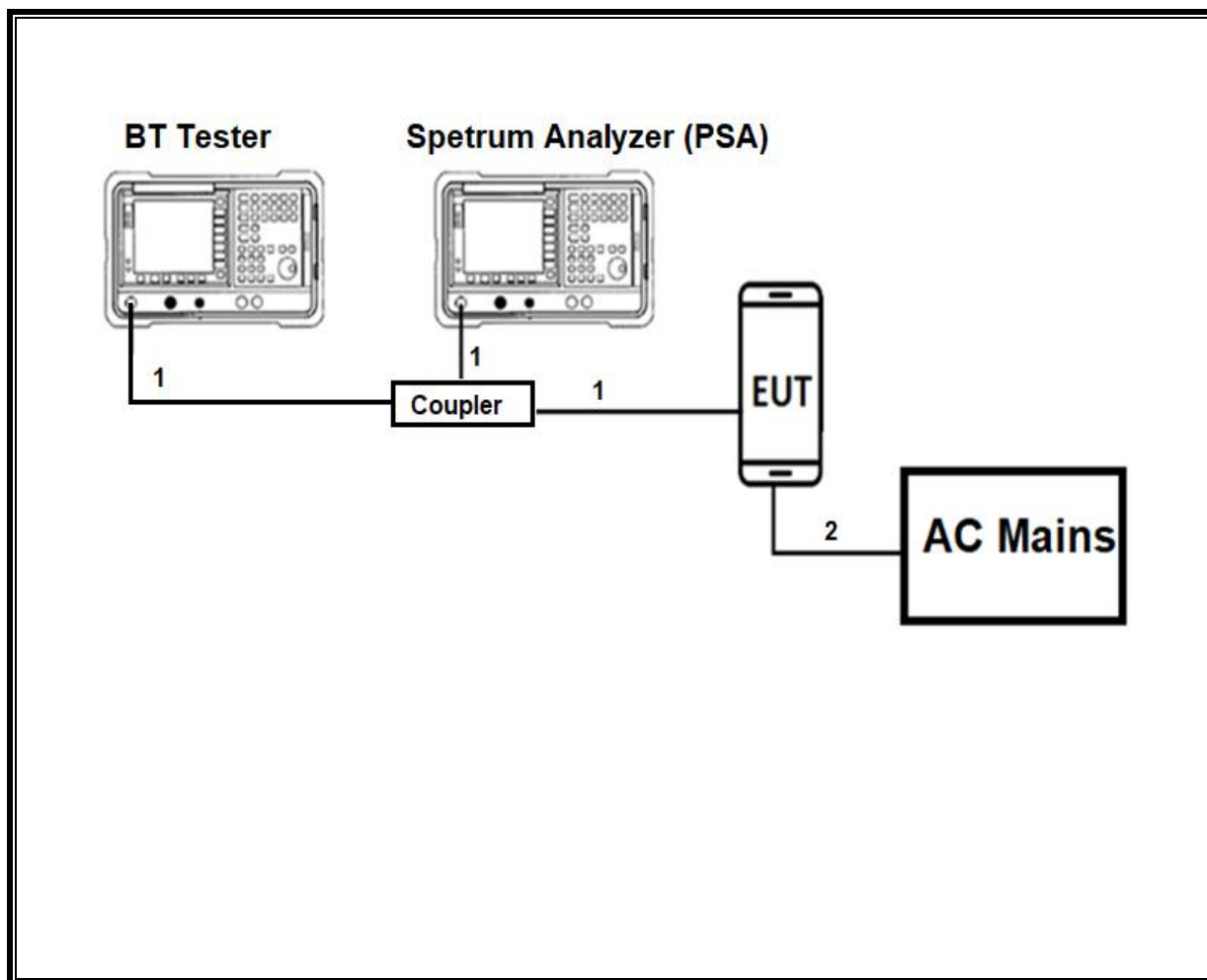

**TEST SETUP**

For conducted tests: the EUT was stand alone. The test software exercises the radio.

**RADIATED AND AC LINE CONDUCTED EMISSIONS SETUP DIAGRAM**

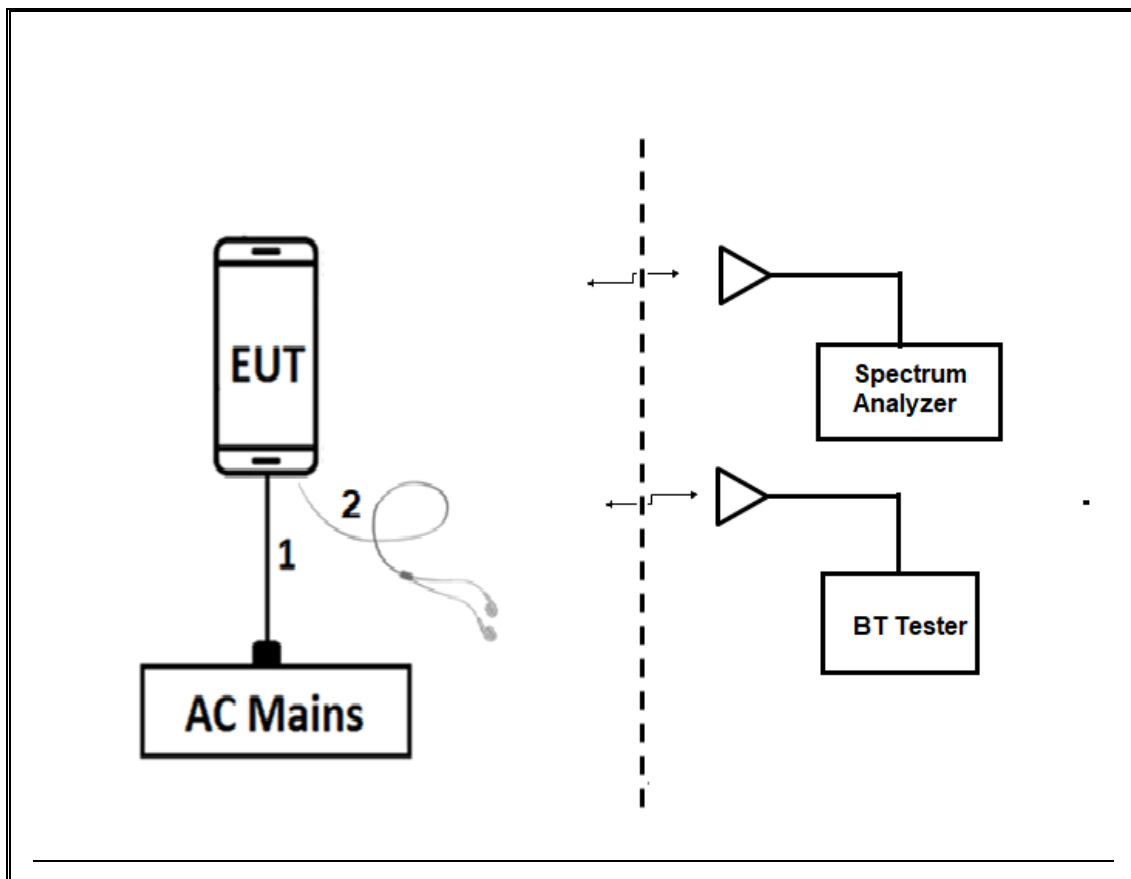

**TEST SETUP**

For radiated tests: EUT is connected to earphone. The test software exercises the radio.

## 6. TEST AND MEASUREMENT EQUIPMENT

The following test and measurement equipment was utilized for the tests documented in this report:

<b>TEST EQUIPMENT LIST</b>				
<b>Description</b>	<b>Manufacturer</b>	<b>Model</b>	<b>Asset</b>	<b>Cal Due</b>
Antenna, Passive Loop 30Hz to 1MHz	ELETRO METRICS	EM-6871	PRE0179466	05/31/2020
Antenna, Passive Loop 100KHz to 30MHz	ELETRO METRICS	EM-6872	PRE0179468	05/31/2020
Bluetooth Tester	Rohde&Schwarz	CBT	T258	02/14/2020
Antenna, Horn 1-18GHz	ETS Lindgren	3117	EMC4249 / PRE0100034	06/14/2020
Antenna, Horn 1-18GHz	ETS Lindgren	3117	T344	05/07/2020
Amplifier, 1 to 18GHz	Amplical	AMP1G18-35	T1569	05/04/2020
Amplifier, 1 to 18GHz	Amplical	AMP1G18-35	T1571	05/28/2020
Antenna, Broadband Hybrid, 30MHz to 3GHz	Sunol Sciences	JB3	PRE0181574	10/14/2020
Amplifier, 9KHz to 1GHz, 32dB	SONOMA INSTRUMENT	310	PRE175953	12/13/2019
Spectrum Analyzer, PSA, 3Hz to 44GHz	Keysight	E4446A	T146	01/28/2020
Antenna Horn, 18 to 26.5GHz	ARA	MWH-1826/B	T447	08/13/2020
Pre-Amp 1-26.5 GHz	AMPLICAL	AMP18G26.5-60	PRE0181238	05/01/2020
EMI Test Receiver	Rohde&Schwarz	ESW44	PRE0179367	05/16/2020
EMI Test Receiver	Rohde&Schwarz	ESW44	PRE0179372	02/16/2020
Filter, HPF 3.0GHz	MICRO-TRONICS	HPM17543	T897	05/04/2020
Filter, HPF 3.0GHz	MICRO-TRONICS	HPM17543	TPRE171901	05/28/2020
Power Meter, P-series single channel	Agilent (Keysight) Technologies	N1911A	T229	01/31/2020
Power Sensor, P-series, 50MHz to 18GHz, Wideband	Agilent (Keysight) Technologies	N1921A	T1226	02/06/2020
<b>AC Line Conducted</b>				
EMI Receiver	Rohde & Schwarz	ESR	T1436	02/14/2020
LISN for Conducted Emissions CISPR-16	FCC INC.	FCC LISN 50/250	T1310	01/24/2020
<b>UL AUTOMATION SOFTWARE</b>				
Radiated Software	UL	UL EMC	Ver 9.5, June 15, 2019	
Antenna Port Software	UL	UL RF	Ver 10.4, Oct 10, 2019	
AC Line Conducted Software	UL	UL EMC	Ver 9.5, May 26, 2015	

### **NOTES:**

1. Equipment listed above that calibrated during the testing period was set for test after the calibration.
2. Equipment listed above that has a calibration due date during the testing period, the testing is completed before equipment expiration date.

---

## 7. MEASUREMENT METHODS

On Time and Duty Cycle: ANSI C63.10-2013 Section 11.6

Occupied BW (20dB): ANSI C63.10-2013 Section 6.9.2

Occupied BW (99%): ANSI C63.10-2013 Section 6.9.3

Carrier Frequency Separation: ANSI C63.10-2013 Section 7.8.2

Number of Hopping Frequencies: ANSI C63.10-2013 Section 7.8.3

Time of Occupancy (Dwell Time): ANSI C63.10-2013 Section 7.8.4

Peak Output Power: ANSI C63.10-2013 Section 7.8.5

Conducted Spurious Emissions: ANSI C63.10-2013 Section 7.8.8

Conducted Band-Edge: ANSI C63.10-2013 Section 6.10.4

Radiated Spurious Emissions Below 30MHz: ANSI C63.10-2013 Section 6.4

Radiated Spurious Emissions 30-1000MHz: ANSI C63.10-2013 Section 6.3 and 6.5

Radiated Spurious Emissions above 1GHz: ANSI C63.10-2013 Section 6.3 and 6.6

Radiated Band-edge: ANSI C63.10-2013 Section 6.10.5

AC Power-line conducted emissions: ANSI C63.10-2013, Section 6.2.

## 8. ANTENNA PORT TEST RESULTS

### 8.1. ON TIME AND DUTY CYCLE

#### LIMITS

None; for reporting purposes only.

#### PROCEDURE

ANSI C63.10, Section 11.6 : Zero-Span Spectrum Analyzer Method.

#### ON TIME AND DUTY CYCLE RESULTS

Mode	ON Time B (msec)	Period (msec)	Duty Cycle x (linear)	Duty Cycle (%)	Duty Cycle Correction Factor (dB)	1/T Minimum VBW (kHz)
Bluetooth GFSK	2.853	3.723	0.766	76.6%	1.16	0.351
Bluetooth 8PSK	2.866	3.725	0.769	76.9%	1.14	0.349

### DUTY CYCLE PLOTS

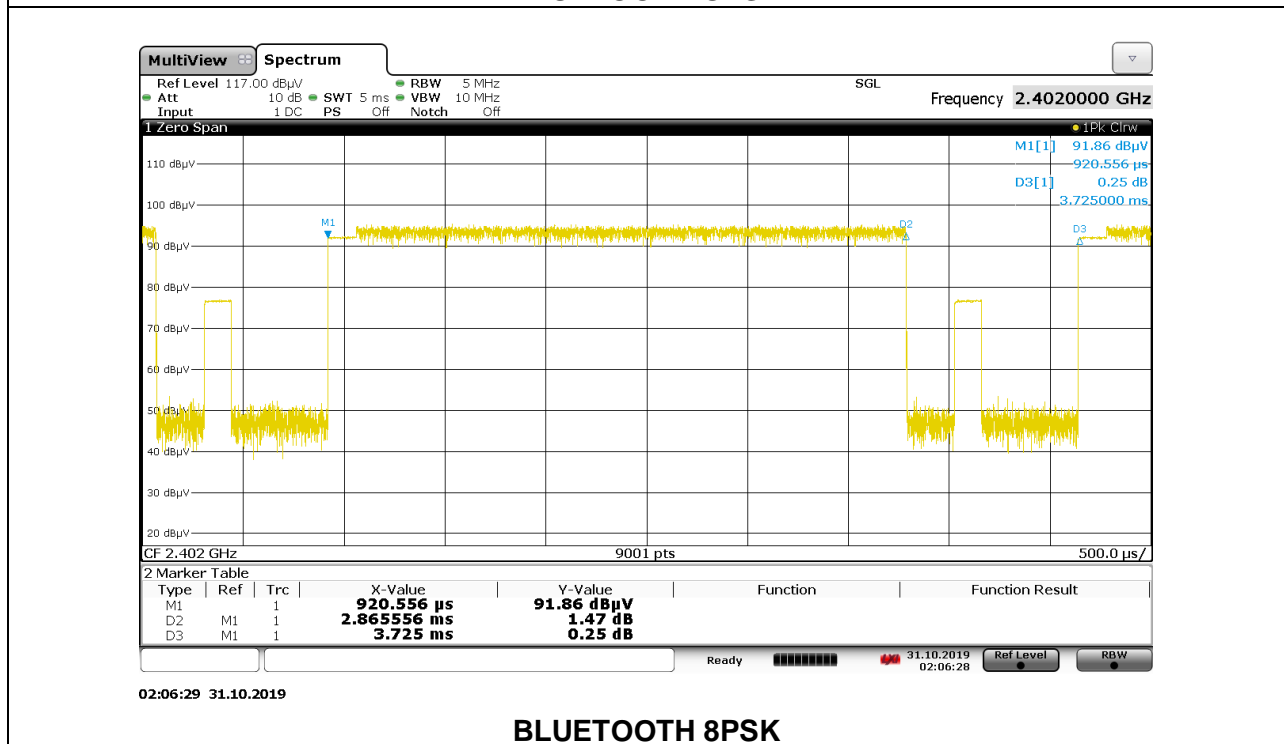
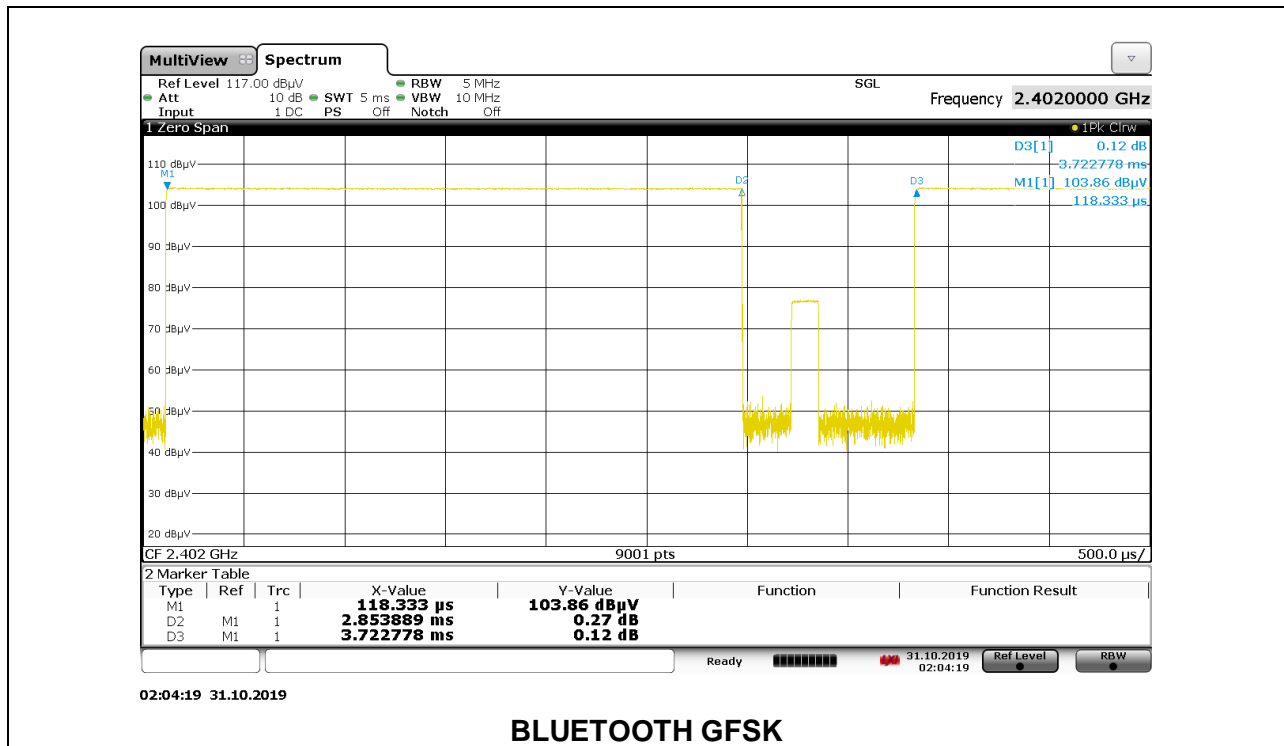

<b>Tested By:</b>	19497 AF
<b>Date:</b>	10/31/2019

## **8.2. 20 dB AND 99% BANDWIDTH**

### **LIMITS**

None; for reporting purposes only.

### **TEST PROCEDURE**

The transmitter output is connected to a spectrum analyzer. The RBW is set to  $\geq 1\%$  of the 20 dB bandwidth. The VBW is set to  $\geq$  RBW. The sweep time is coupled.

### **RESULTS**

### 8.2.1. BLUETOOTH BASIC DATA RATE GFSK MODULATION

Channel	Frequency (MHz)	20dB Bandwidth (MHz)	99% Bandwidth (MHz)
Low	2402	0.698	0.858
Mid	2441	0.695	0.845
High	2480	0.700	0.842

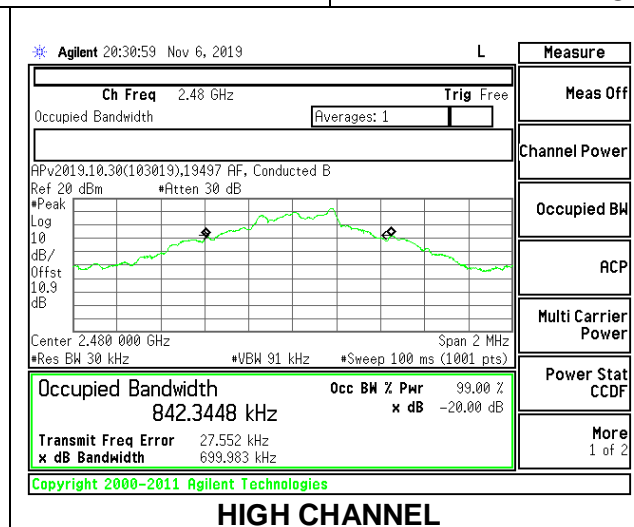
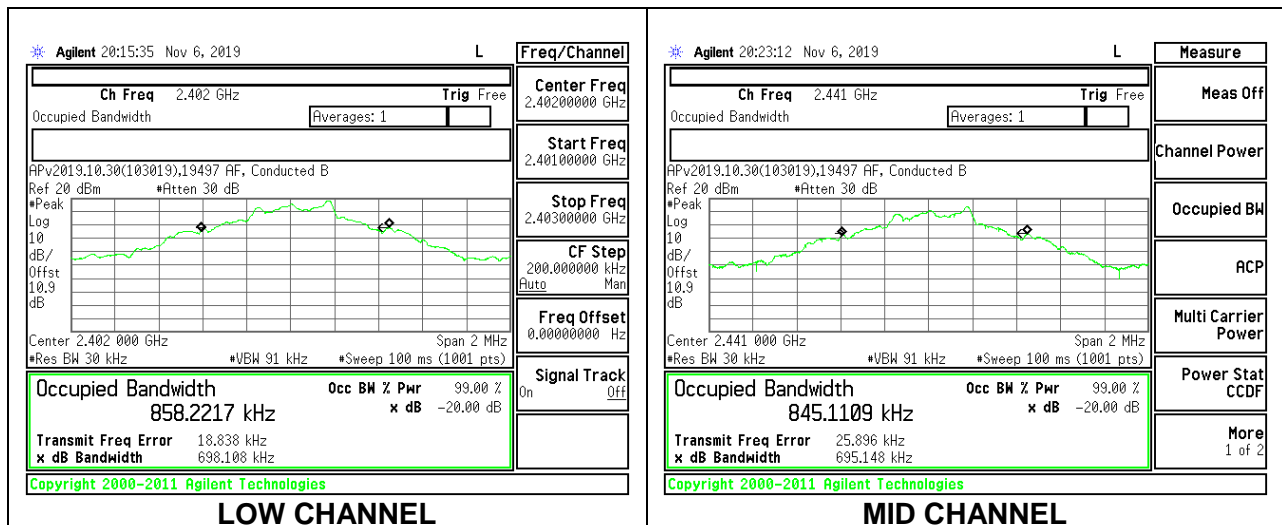

### 8.2.2. BLUETOOTH ENHANCED DATA RATE 8PSK MODULATION

Channel	Frequency (MHz)	20dB Bandwidth (MHz)	99% Bandwidth (MHz)
Low	2402	1.227	1.1817
Mid	2441	1.228	1.1792
High	2480	1.230	1.1821

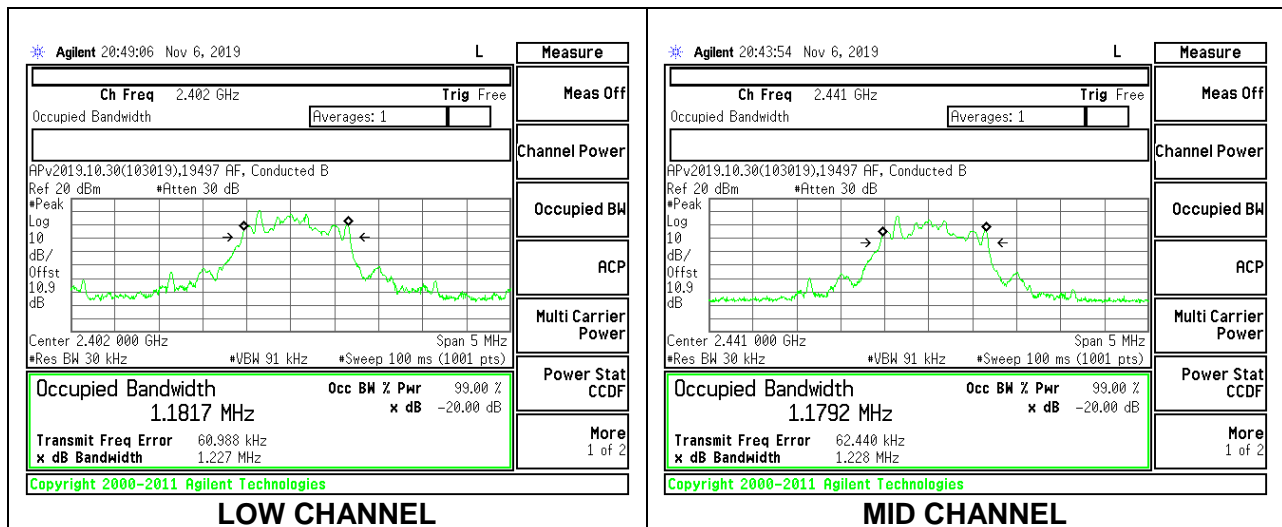

**LOW CHANNEL**

**MID CHANNEL**

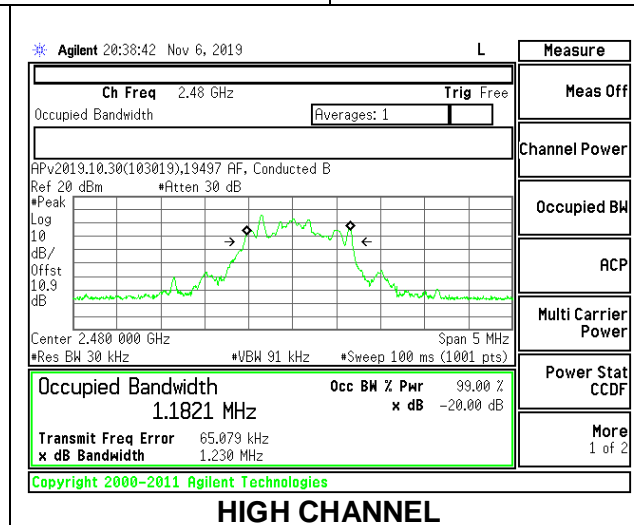

**HIGH CHANNEL**

---

### **8.3. HOPPING FREQUENCY SEPARATION**

#### **LIMITS**

FCC §15.247 (a) (1)

Frequency hopping systems shall have hopping channel carrier frequencies separated by a minimum of 25 kHz or the 20 dB bandwidth of the hopping channel, whichever is greater.

Alternatively, frequency hopping systems operating in the 2400-2483.5 MHz band may have hopping channel carrier frequencies that are separated by 25 kHz or two-thirds of the 20 dB bandwidth of the hopping channel, whichever is greater, provided the systems operate with an output power no greater than 125 mW.

#### **TEST PROCEDURE**

The transmitter output is connected to a spectrum analyzer. The RBW is set to 300 kHz and the VBW is set to  $VBW \geq RBW$ . The sweep time is coupled.

#### **RESULTS**

### 8.3.1. BLUETOOTH BASIC DATA RATE GFSK MODULATION

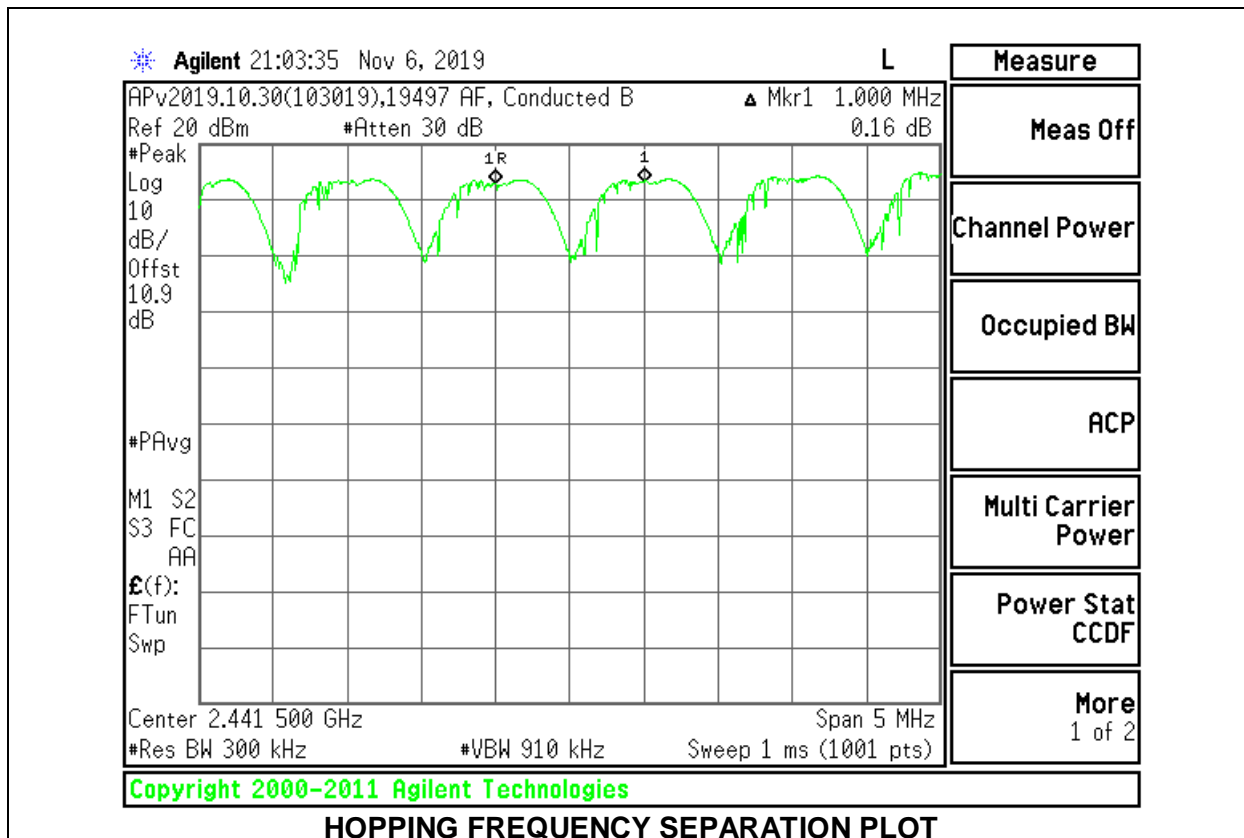

### 8.3.2. BLUETOOTH ENHANCED DATA RATE 8PSK MODULATION

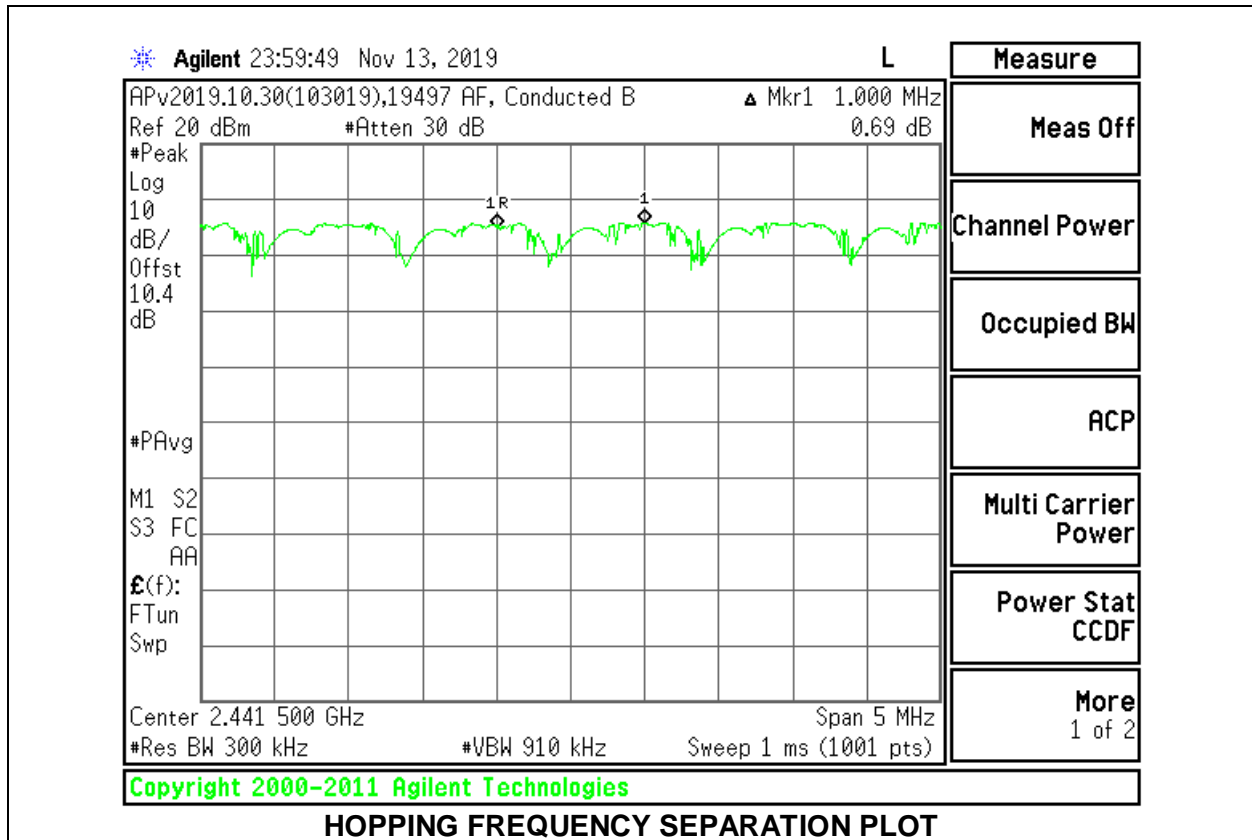

## **8.4. NUMBER OF HOPPING CHANNELS**

### **LIMITS**

FCC §15.247 (a) (1) (iii)

Frequency hopping systems in the 2400 – 2483.5 MHz band shall use at least 15 non-overlapping channels.

### **TEST PROCEDURE**

The transmitter output is connected to a spectrum analyzer. The span is set to cover the entire authorized band, in either a single sweep or in multiple contiguous sweeps. The RBW is set to a maximum of 1 % of the span. The analyzer is set to Max Hold.

### **RESULTS**

Normal Mode: 79 Channels Observed

### 8.4.1. BLUETOOTH BASIC DATA RATE GFSK MODULATION

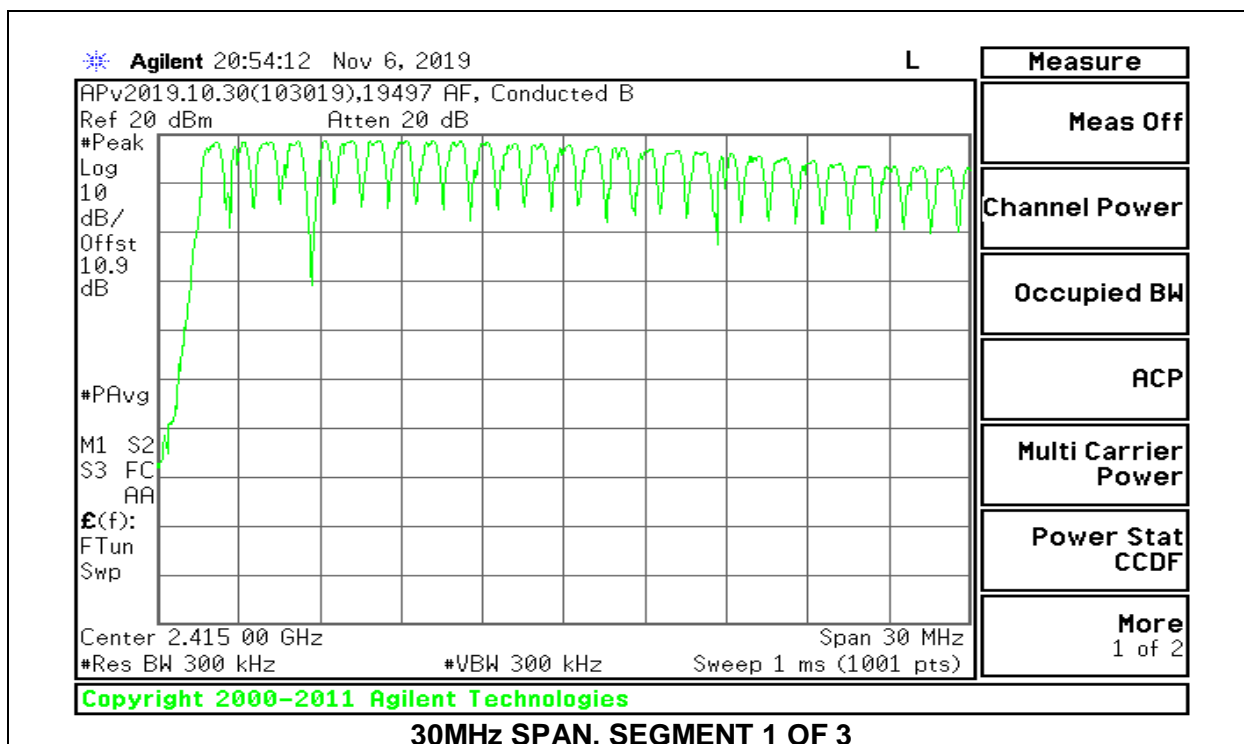
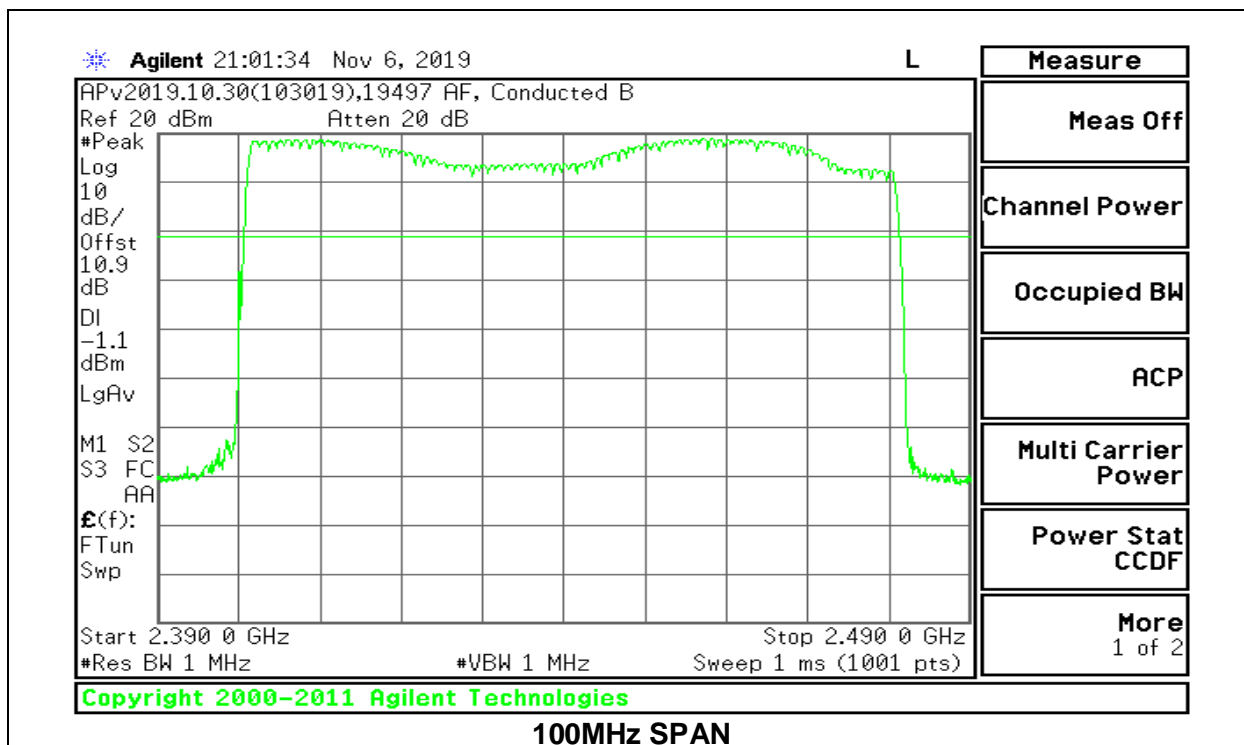

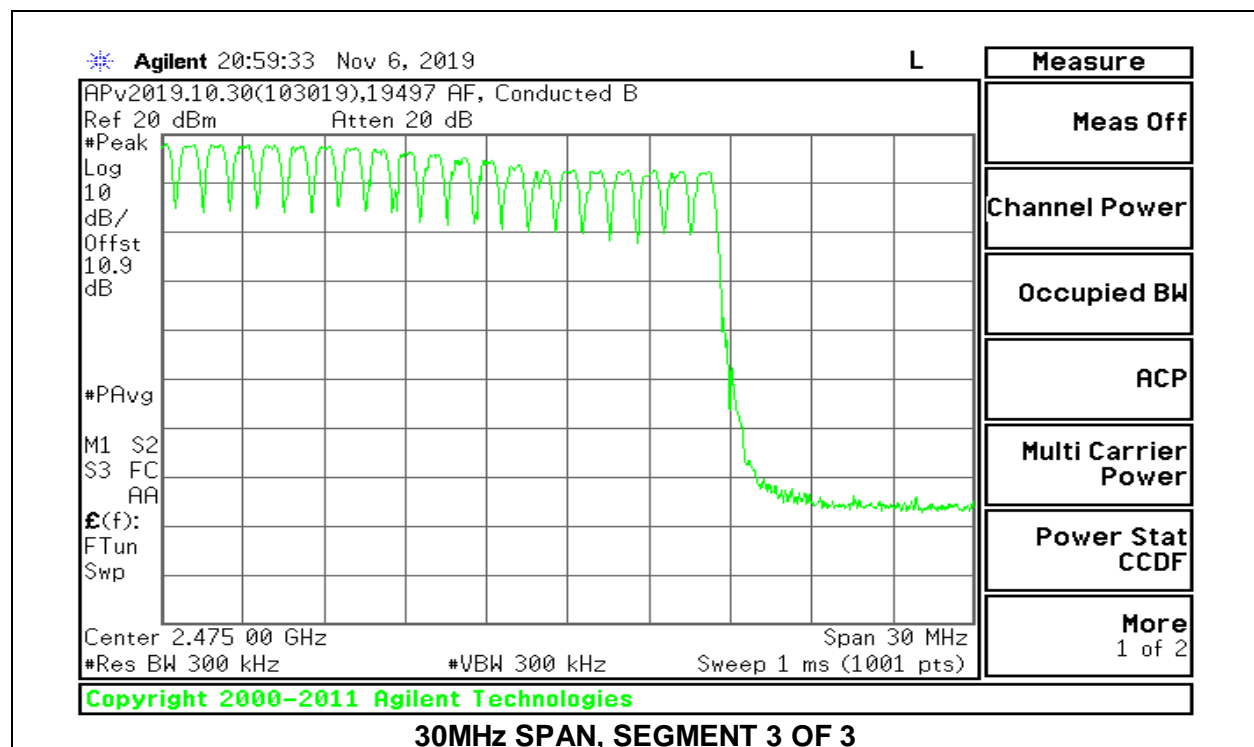
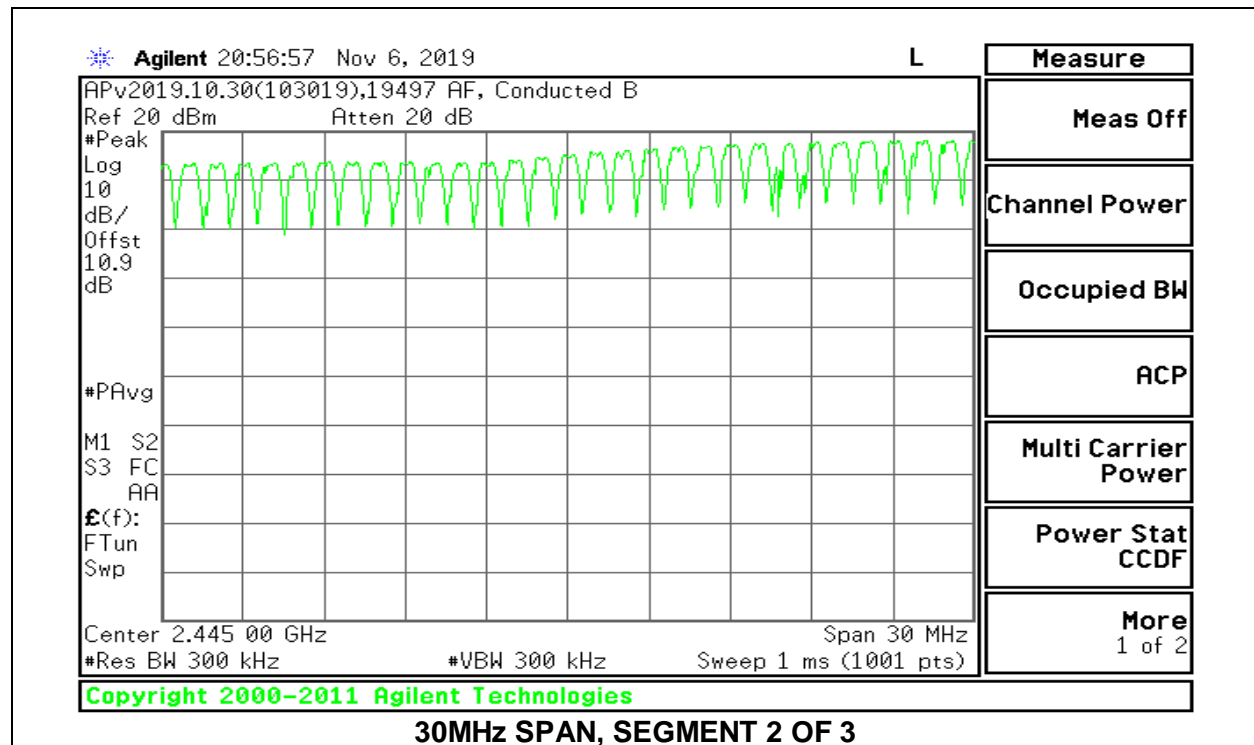

### 8.4.2. BLUETOOTH ENHANCED DATA RATE 8PSK MODULATION

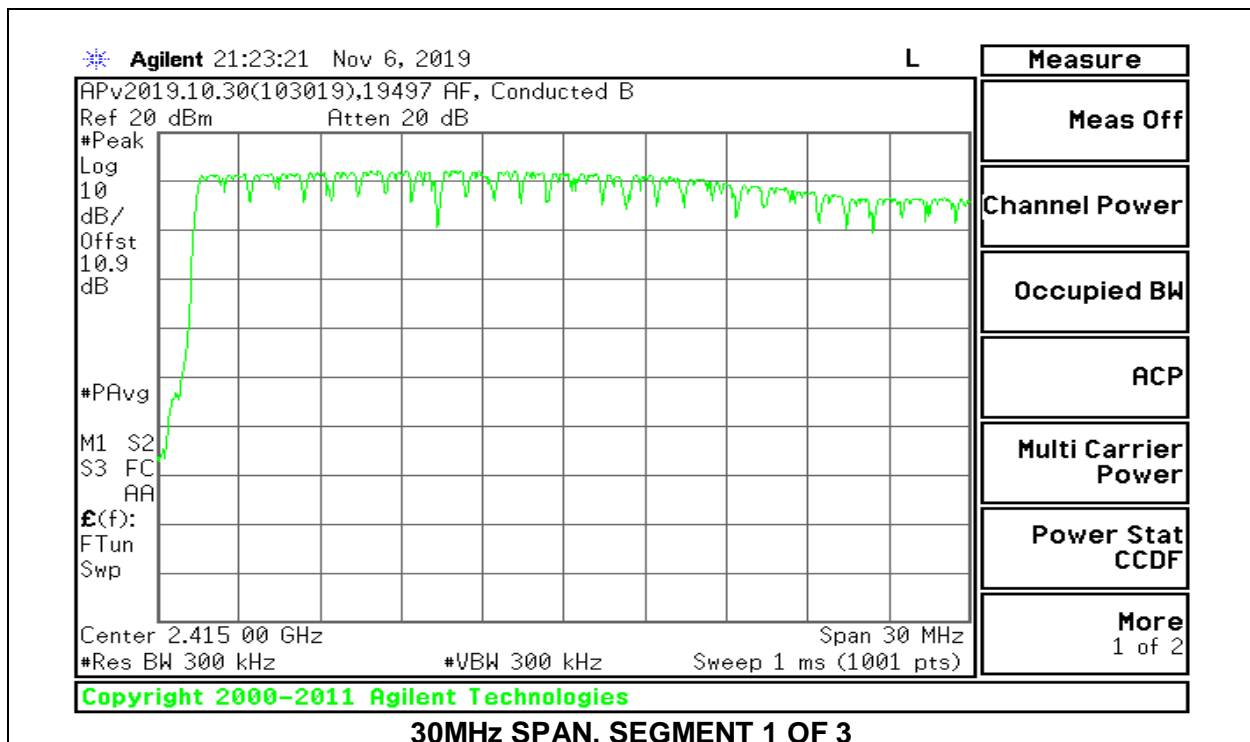
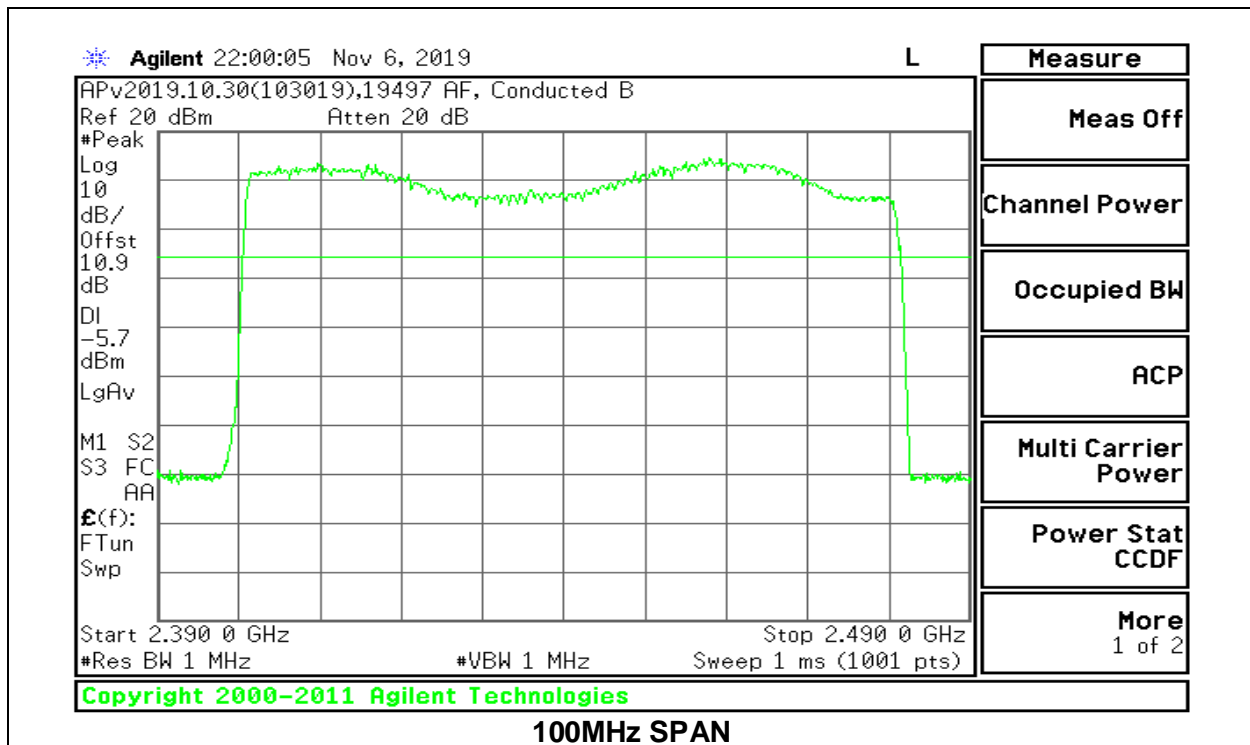

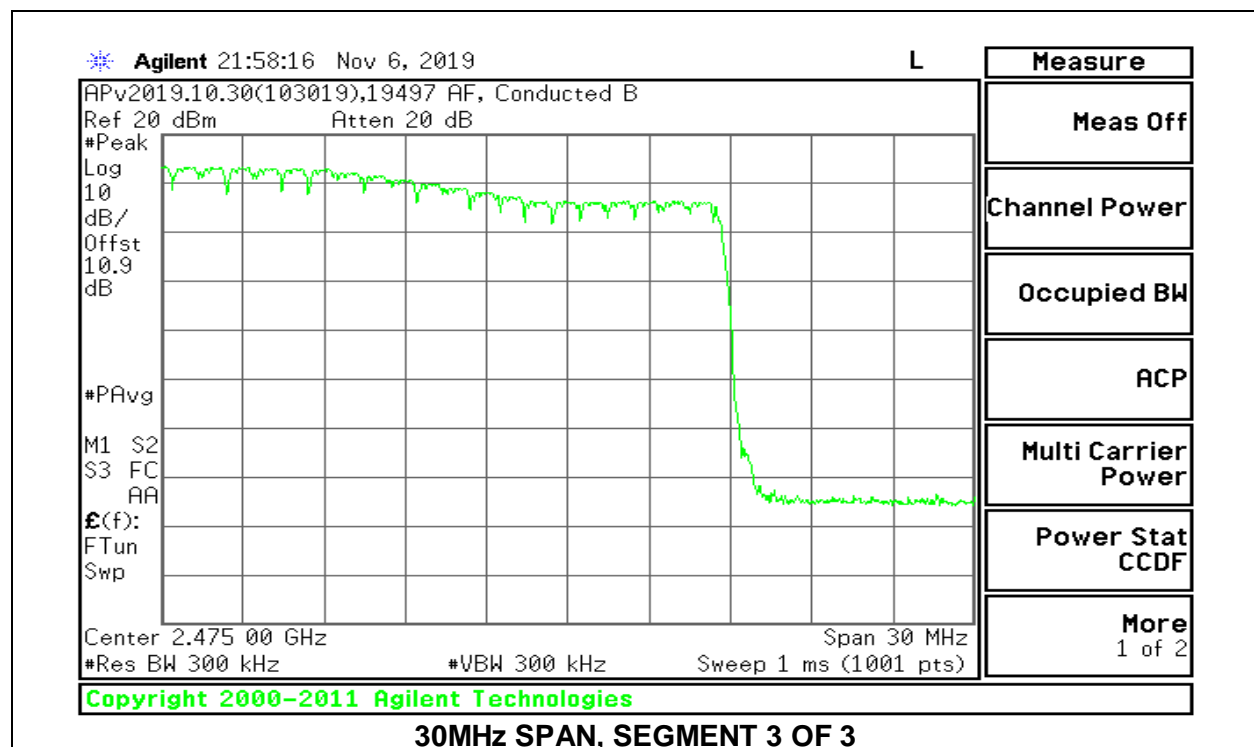
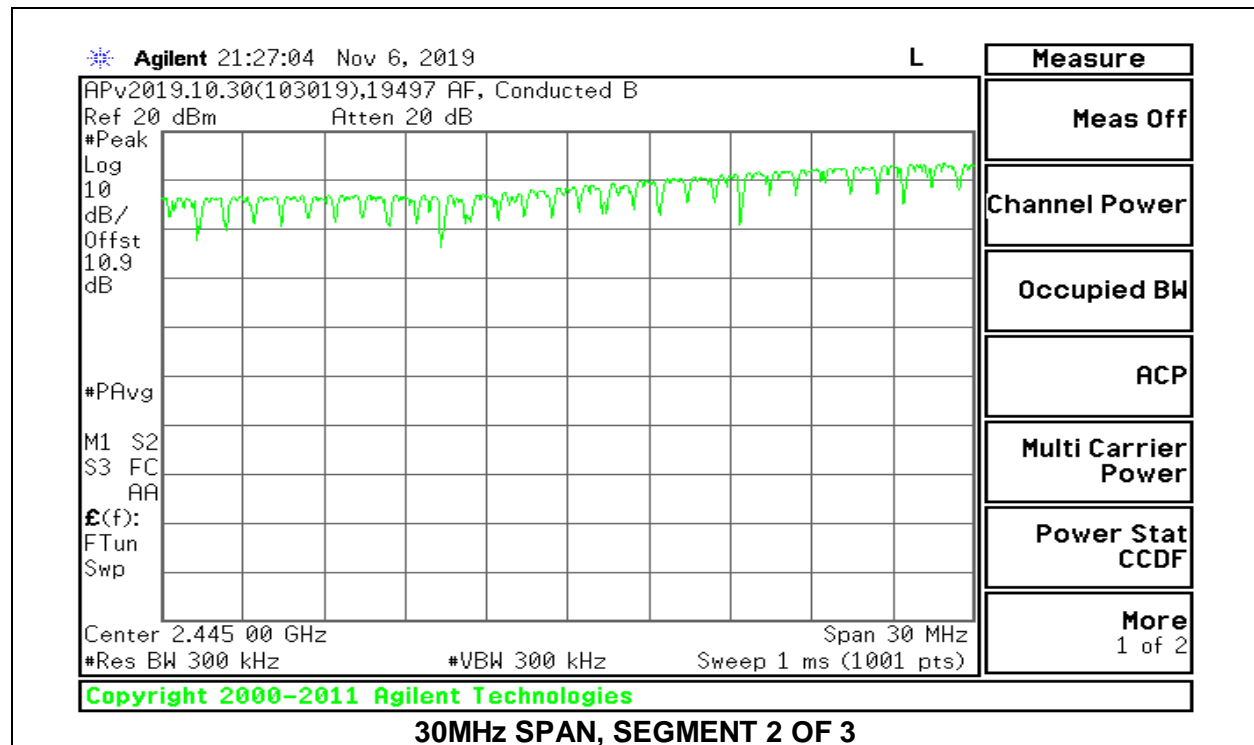

## **8.5. AVERAGE TIME OF OCCUPANCY**

### **LIMITS**

FCC §15.247 (a) (1) (iii)

The average time of occupancy on any channel shall not be greater than 0.4 seconds within a period of 0.4 seconds multiplied by the number of hopping channels employed.

### **TEST PROCEDURE**

The transmitter output is connected to a spectrum analyzer. The span is set to 0 Hz, centered on a single, selected hopping channel. The width of a single pulse is measured in a fast scan. The number of pulses is measured in a 3.16 second scan, to enable resolution of each occurrence.

The average time of occupancy in the specified 3.16 second period (79 channels \* 0.4 s) is equal to  $10 * (\# \text{ of pulses in } 3.16 \text{ s}) * \text{ pulse width}$ .

For AFH mode, the average time of occupancy in the specified 8 second period (20 channels \* 0.4 seconds) is equal to  $10 * (\# \text{ of pulses in } 0.8 \text{ s}) * \text{ pulse width}$ .

### **RESULTS**

### 8.5.1. BLUETOOTH BASIC DATA RATE GFSK MODULATION

DH Packet	Pulse Width (msec)	Number of Pulses in 3.16 seconds	Average Time of Occupancy (sec)	Limit (sec)	Margin (sec)
<b>GFSK Normal Mode</b>					
DH1	0.38	32	0.1216	0.4	-0.2784
DH3	1.634	18	0.2941	0.4	-0.1059
DH5	2.884	7	0.2019	0.4	-0.1981
<b>GFSK AFH Mode</b>					
DH Packet	Pulse Width (sec)	Number of Pulses in 0.8 seconds	Average Time of Occupancy (sec)	Limit (sec)	Margin (sec)
DH1	0.38	8	0.03040	0.4	-0.3696
DH3	1.634	4.5	0.07353	0.4	-0.3265
DH5	2.884	1.75	0.05047	0.4	-0.3495

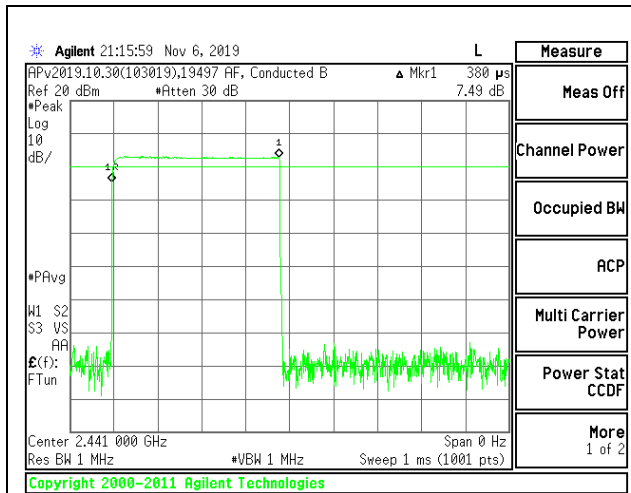

**PULSE WIDTH – DH1**

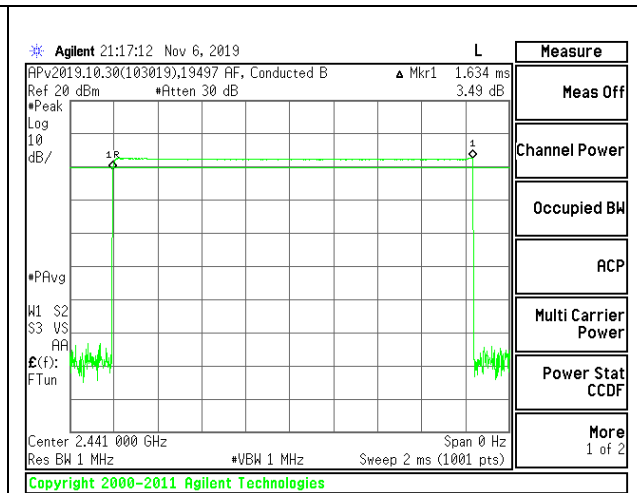

**PULSE WIDTH – DH3**

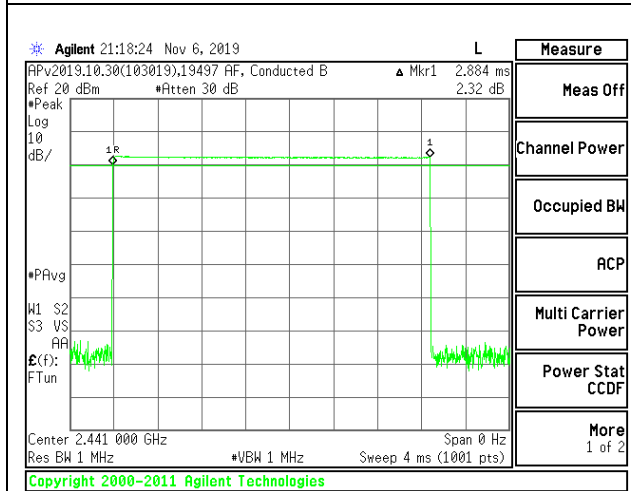

**PULSE WIDTH – DH5**

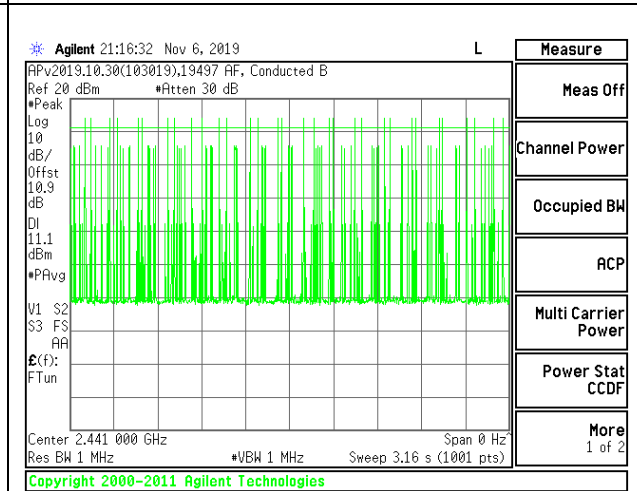

**NUMBER OF PULSES IN 3.16 SECOND OBSERVATION PERIOD – DH1**

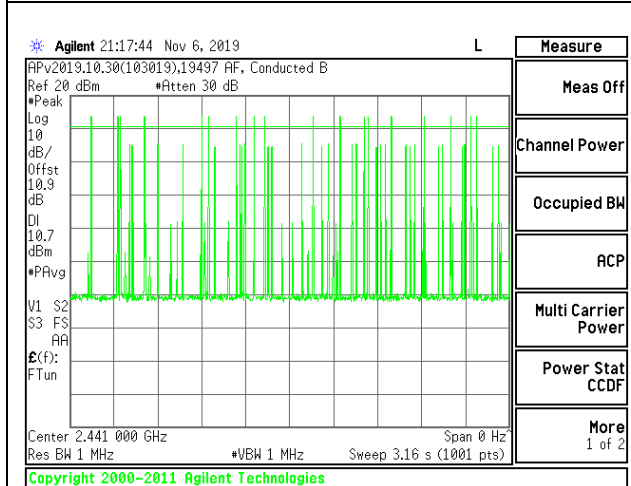

**NUMBER OF PULSES IN 3.16 SECOND OBSERVATION PERIOD – DH3**

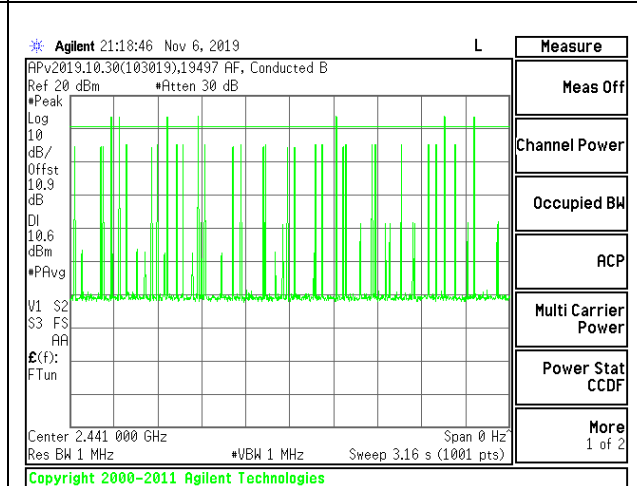

**NUMBER OF PULSES IN 3.16 SECOND OBSERVATION PERIOD – DH5**

## 8.5.2. BLUETOOTH ENHANCED DATA RATE 8PSK MODULATION

DH Packet	Pulse Width (msec)	Number of Pulses in 3.16 seconds	Average Time of Occupancy (sec)	Limit (sec)	Margin (sec)
8PSK Normal Mode					
3DH1	0.384	32	0.12288	0.4	-0.27712
3DH3	1.634	16	0.26144	0.4	-0.13856
3DH5	2.884	6	0.17304	0.4	-0.22696

Note: for AFH(8PSK) mode, please refer to the results of AFH(GFSK) mode; the channel selection and hopping rate are the same for both EDR and Basic Rate operation, data for Basic Rate demonstrates compliance with channel occupancy when AFH is employed.

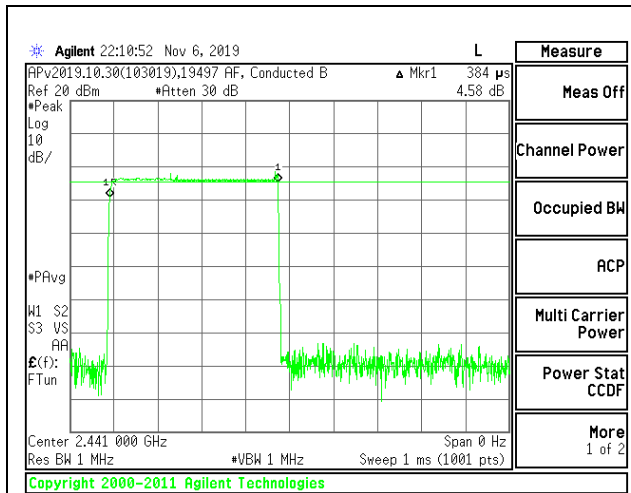

**PULSE WIDTH – 3DH1**

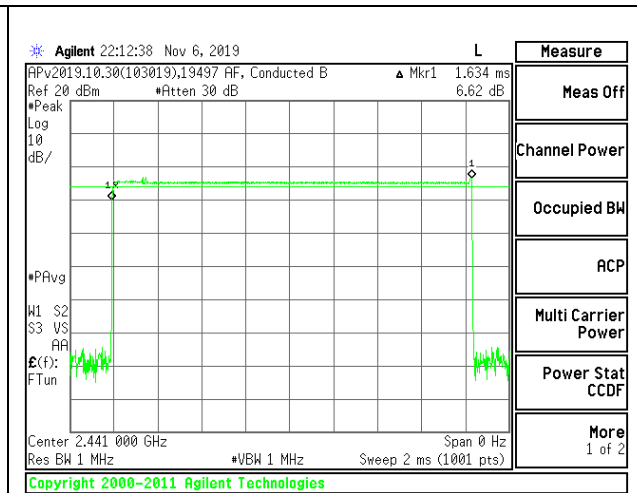

**PULSE WIDTH – 3DH3**

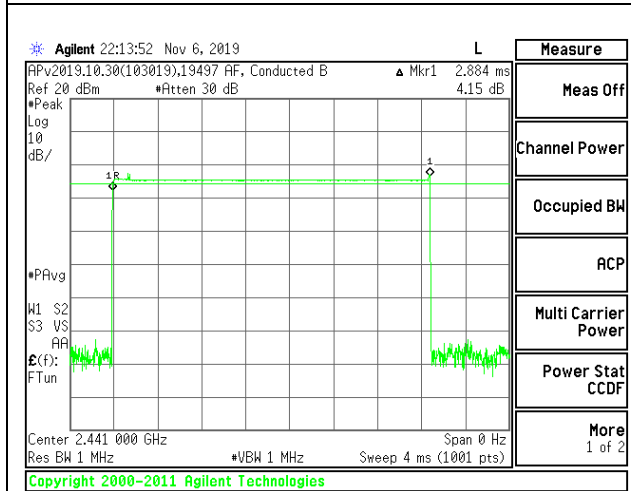

**PULSE WIDTH – 3DH5**

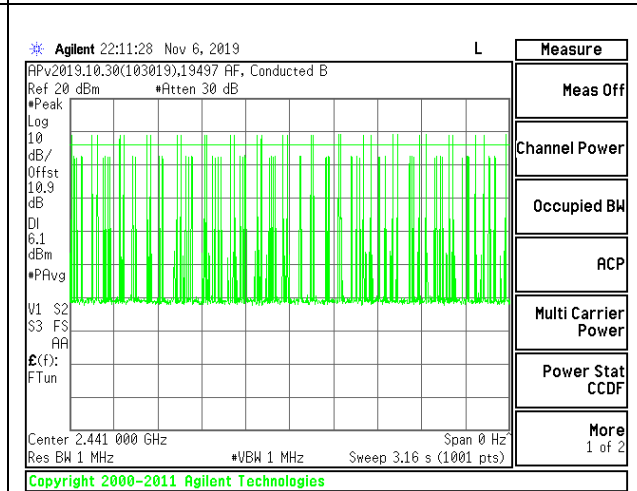

**NUMBER OF PULSES IN 3.16 SECOND OBSERVATION PERIOD – 3DH1**

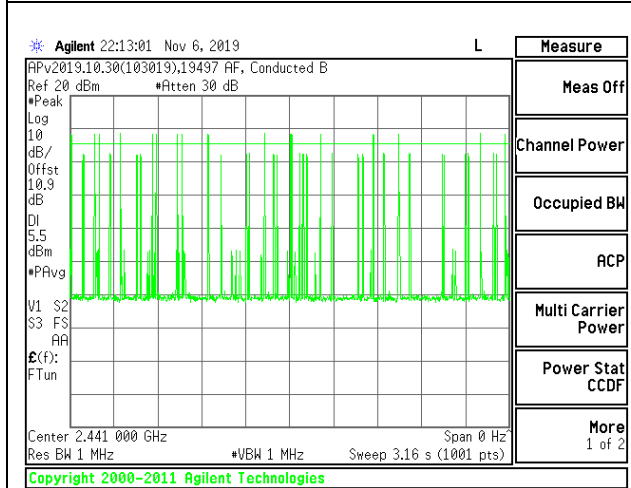

**NUMBER OF PULSES IN 3.16 SECOND OBSERVATION PERIOD – 3DH3**

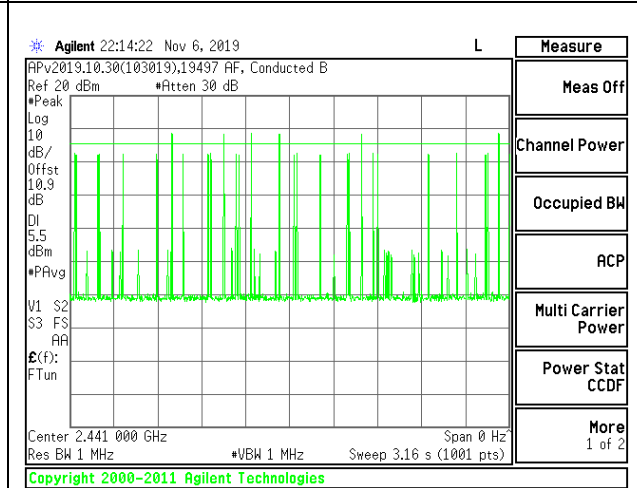

**NUMBER OF PULSES IN 3.16 SECOND OBSERVATION PERIOD – 3DH5**

## **8.6. OUTPUT POWER**

### **LIMITS**

§15.247 (b) (1)

The maximum antenna gain is less than 6 dBi, therefore the limit is 30 dBm. Alternatively, frequency hopping systems operating in the 2400-2483.5 MHz band may have hopping channel carrier frequencies that are separated by 25 kHz or two-thirds of the 20 dB bandwidth of the hopping channel, whichever is greater, provided the systems operate with an output power no greater than 125 mW.

For frequency hopping systems operating in the 2400-2483.5 MHz band employing at least 75 non-overlapping hopping channels, and all frequency hopping systems in the 5725-5850 MHz band: 1 watt. For all other frequency hopping systems in the 2400-2483.5 MHz band: 0.125 watts

### **TEST PROCEDURE**

Measurements perform using a wideband gated RF power meter.  
The cable assembly insertion loss was entered as an offset in the power meter to allow for a gated peak reading of power.

### **RESULTS**

### 8.6.1. BLUETOOTH BASIC DATA RATE GFSK MODULATION

Tested By:	16080 ZS
Date:	11/12/2019

Channel	Frequency (MHz)	Output Power (dBm)	Limit (dBm)	Margin (dB)
Low	2402	16.00	21.00	-5.00
Middle	2441	15.90	21.00	-5.10
High	2480	14.90	21.00	-6.10

### 8.6.2. BLUETOOTH ENHANCED DATA RATE DQPSK MODULATION

Tested By:	16080 ZS
Date:	11/12/2019

Channel	Frequency (MHz)	Output Power (dBm)	Limit (dBm)	Margin (dB)
Low	2402	8.10	21	-12.9
Middle	2441	8.60	21	-12.4
High	2480	8.40	21	-12.6

### 8.6.3. BLUETOOTH ENHANCED DATA RATE 8PSK MODULATION

Tested By:	16080 ZS
Date:	11/12/2019

Channel	Frequency (MHz)	Output Power (dBm)	Limit (dBm)	Margin (dB)
Low	2402	8.30	21	-12.7
Middle	2441	8.80	21	-12.2
High	2480	8.50	21	-12.5

## **8.7. AVERAGE POWER**

### **LIMITS**

None; for reporting purposes only

### **TEST PROCEDURE**

Measurements perform using a wideband gated RF power meter. The cable assembly insertion loss was entered as an offset in the power meter to allow for a gated average reading of power.

### **RESULTS**

### 8.7.1. BLUETOOTH BASIC DATA RATE GFSK MODULATION

Tested By:	16080 ZS
Date	11/12/2019

Channel	Frequency (MHz)	Average Power (dBm)
Low	2402	15.60
Middle	2441	15.40
High	2480	14.50

### 8.7.2. BLUETOOTH ENHANCED DATA RATE DQPSK MODULATION

Tested By:	16080 ZS
Date	11/12/2019

Channel	Frequency (MHz)	Average Power (dBm)
Low	2402	5.80
Middle	2441	6.20
High	2480	6.00

### 8.7.3. BLUETOOTH ENHANCED DATA RATE 8PSK MODULATION

Tested By:	16080 ZS
Date	11/12/2019

Channel	Frequency (MHz)	Average Power (dBm)
Low	2402	5.80
Middle	2441	6.20
High	2480	6.10

---

## **8.8. CONDUCTED SPURIOUS EMISSIONS**

### **LIMITS**

FCC §15.247 (d)

Limit = -20 dBc

### **TEST PROCEDURE**

The transmitter output is connected to a spectrum analyzer. The resolution bandwidth is set to 100 kHz. The video bandwidth is set to 300 kHz.

The spectrum from 30 MHz to 26 GHz is investigated with the transmitter set to the lowest, middle, and highest channels.

The bandedges at 2.4 and 2.4835 GHz are investigated with the transmitter set to the normal hopping mode.

### **RESULTS**

### 8.8.1. BLUETOOTH BASIC DATA RATE GFSK MODULATION

#### Antenna 1 SPURIOUS EMISSIONS, NON-HOPPING

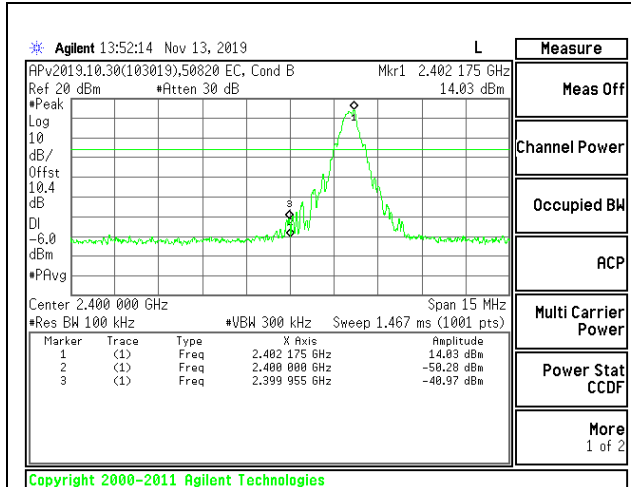

**LOW CHANNEL BANDEDGE**

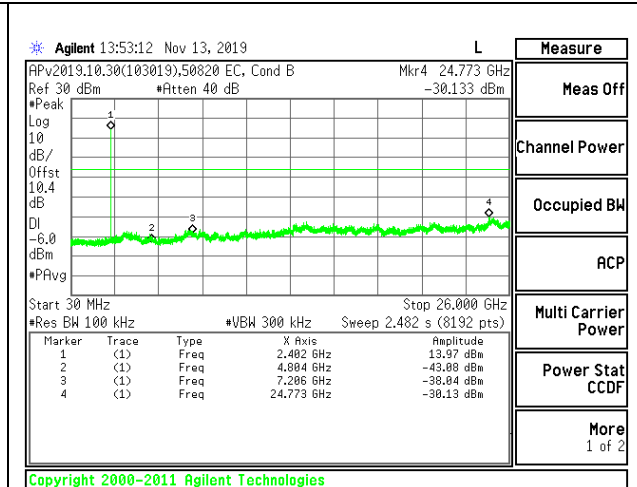

**OUT-OF-BAND LOW CHANNEL**

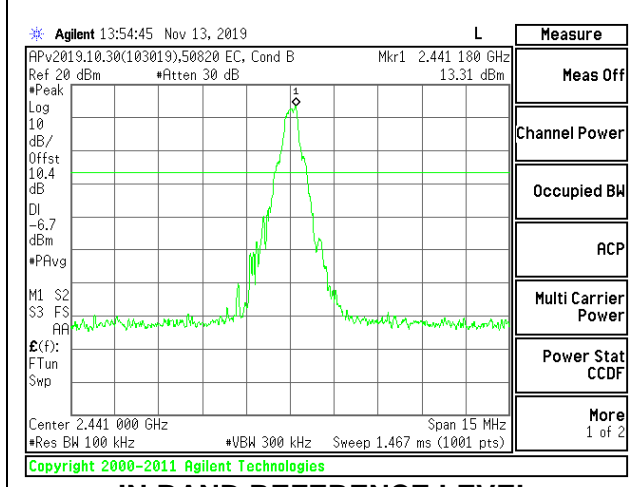

**IN-BAND REFERENCE LEVEL**

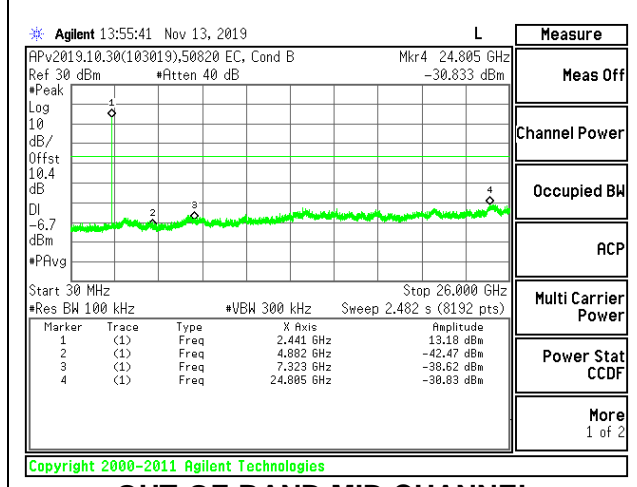

**OUT-OF-BAND MID CHANNEL**

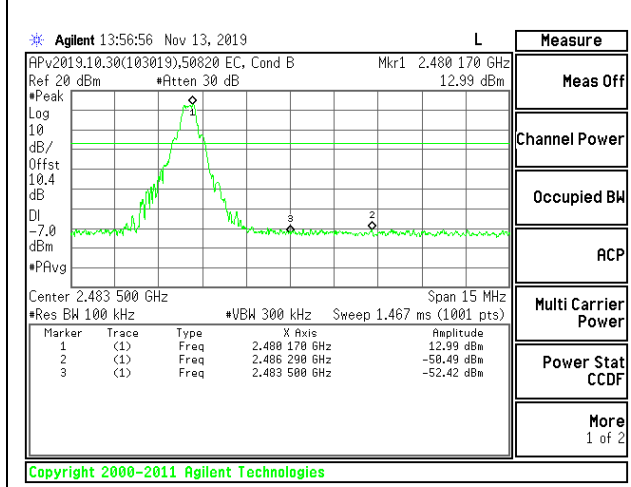

**HIGH CHANNEL BANDEDGE**

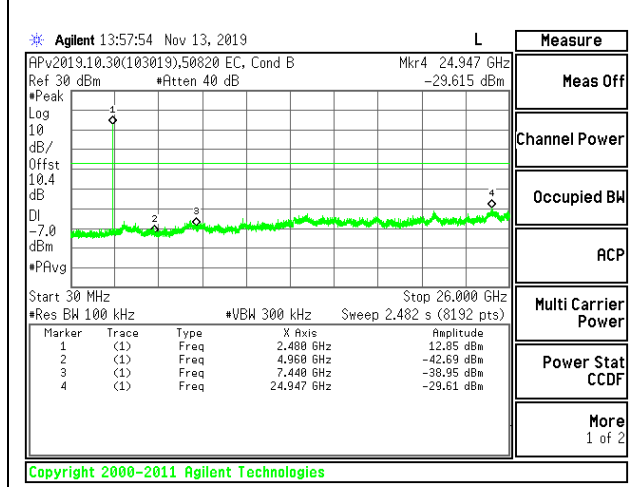

**OUT-OF-BAND HIGH CHANNEL**

**Antenna 1 SPURIOUS BANDEDGE EMISSIONS WITH HOPPING ON**

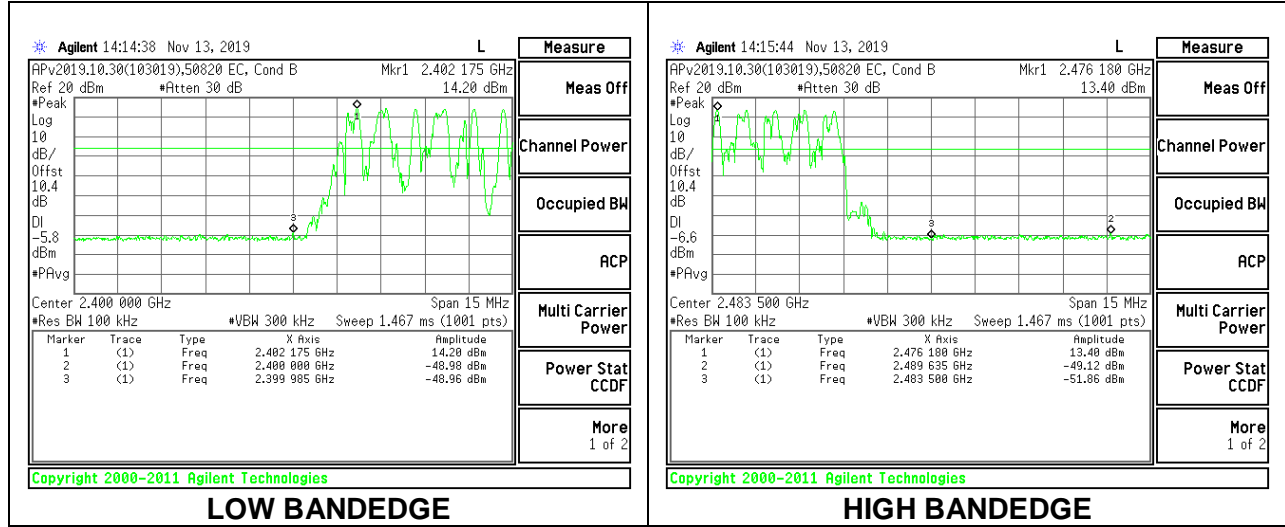

## 8.8.2. BLUETOOTH ENHANCED DATA RATE 8PSK MODULATION

### Antenna 1 SPURIOUS EMISSIONS, NON-HOPPING

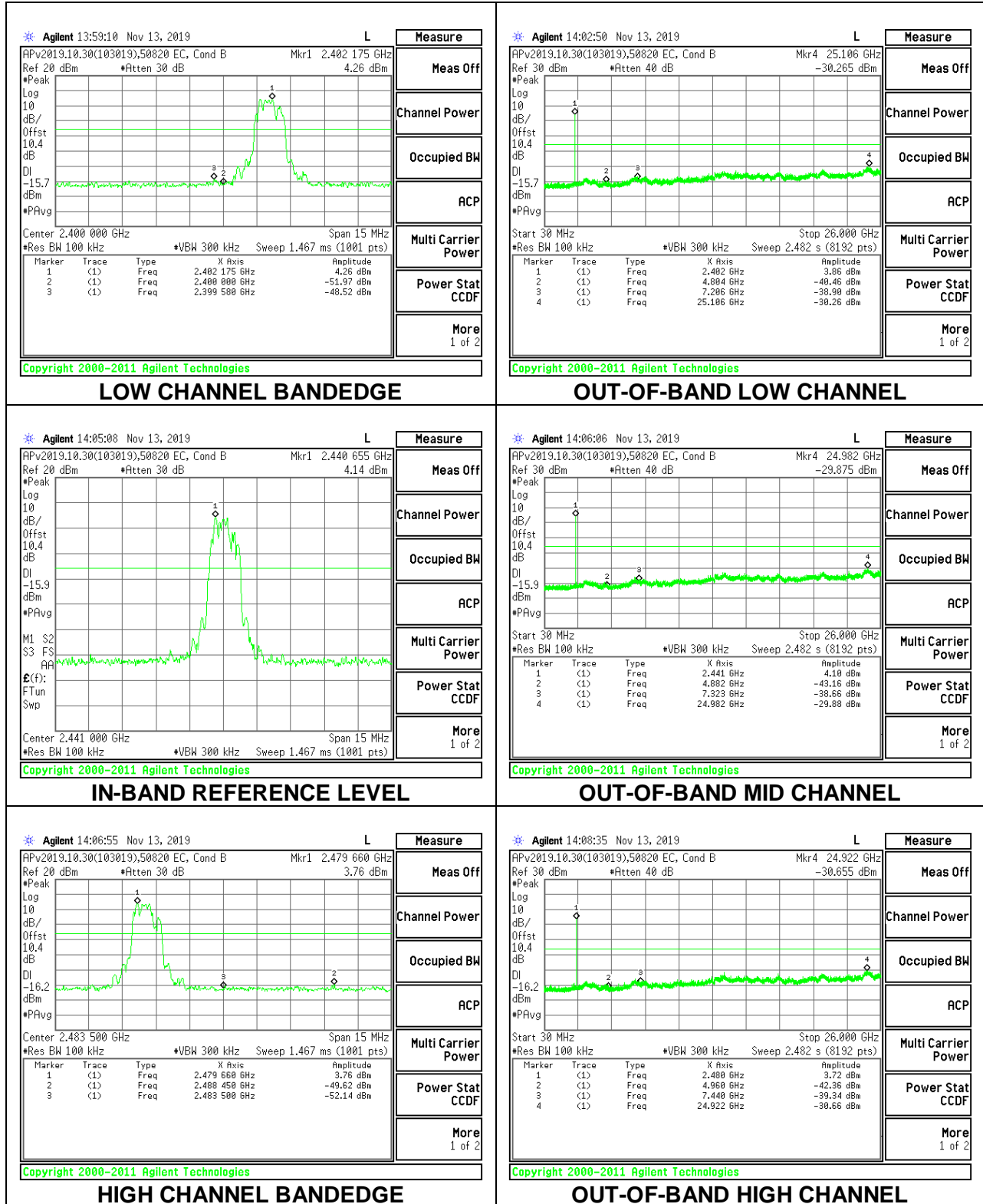

**Antenna 1 SPURIOUS BANDEDGE EMISSIONS WITH HOPPING ON**

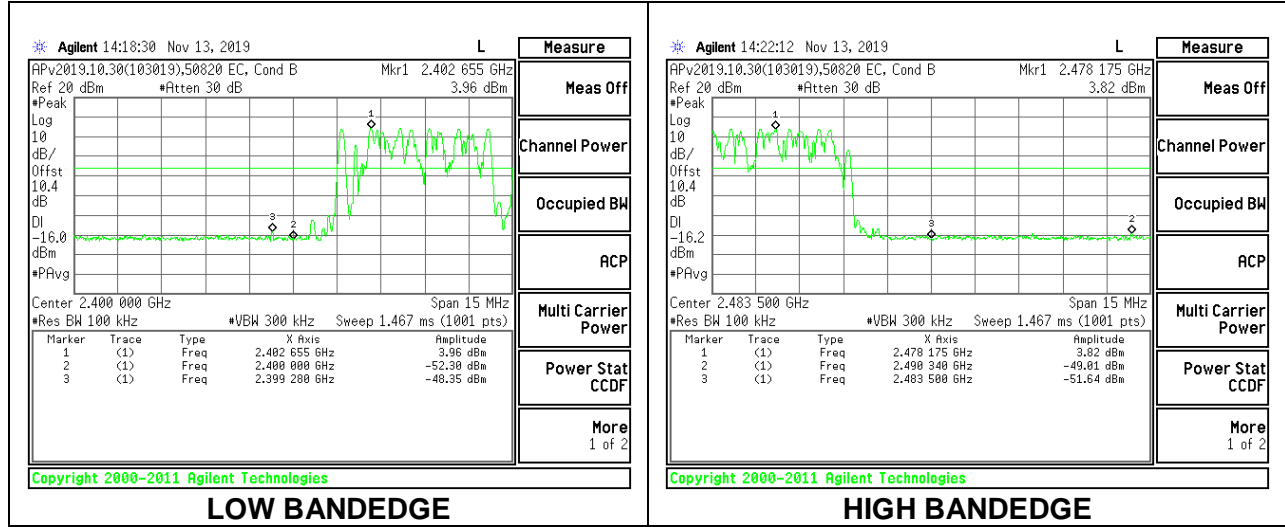

## 9. RADIATED TEST RESULTS

### LIMITS

FCC §15.205 and §15.209

Frequency Range (MHz)	Field Strength Limit (uV/m) at 3 m	Field Strength Limit (dBuV/m) at 3 m
0.009-0.490	2400/F(kHz) @ 300 m	-
0.490-1.705	24000/F(kHz) @ 30 m	-
1.705 - 30	30 @ 30m	-
30 - 88	100	40
88 - 216	150	43.5
216 - 960	200	46
Above 960	500	54

### TEST PROCEDURE

The EUT is placed on a non-conducting table 80 cm above the ground plane for measurement below 1GHz; 1.5 m above the ground plane for measurement above 1GHz. The antenna to EUT distance is 3 meters. The EUT is configured in accordance with ANSI C63.10. The EUT is set to transmit in a continuous mode.

For measurements below 1 GHz the resolution bandwidth is set to 100 kHz for peak detection measurements or 120 kHz for quasi-peak detection measurements. Peak detection is used unless otherwise noted as quasi-peak.

For pre-scans above 1 GHz the resolution bandwidth is set to 1 MHz; the video bandwidth is set to 30 KHz for peak measurements.

For final measurements above 1 GHz the resolution bandwidth is set to 1 MHz; the video bandwidth is set to 3 MHz for peak measurements and 1 MHz resolution bandwidth with 1/T video bandwidth with peak detector for average measurements.

The spectrum from 1 GHz to 18 GHz is investigated with the transmitter set to the lowest, middle, and highest channels in each applicable band. Below 1GHz and above 18GHz emissions, the channel with the highest output power was tested.

The frequency range of interest is monitored at a fixed antenna height and EUT azimuth. The EUT is rotated through 360 degrees to maximize emissions received. The antenna is scanned from 1 to 4 meters above the ground plane to further maximize the emission. Measurements are made with the antenna polarized in both the vertical and the horizontal positions.

2D antenna use - For below 30MHz testing, investigation was done on three antenna orientations (parallel, perpendicular, and ground-parallel), parallel and perpendicular are the worst orientations, therefore testing was performed on these two orientations only.

**KDB 414788 Open Field Site(OFS) and Chamber Correlation Justification**

Base on FCC 15.31 (f) (2): measurements may be performed at a distance closer than that specified in the regulations; however, an attempt should be made to avoid making measurements in the near field.

OFS and chamber correlation testing had been performed and chamber measured test result is the worst case test result.

## 9.1. TRANSMITTER ABOVE 1 GHz

### 9.1.1. BLUETOOTH BASIC DATA RATE GFSK MODULATION

#### BANDEDGE (LOW CHANNEL)

#### HORIZONTAL RESULT

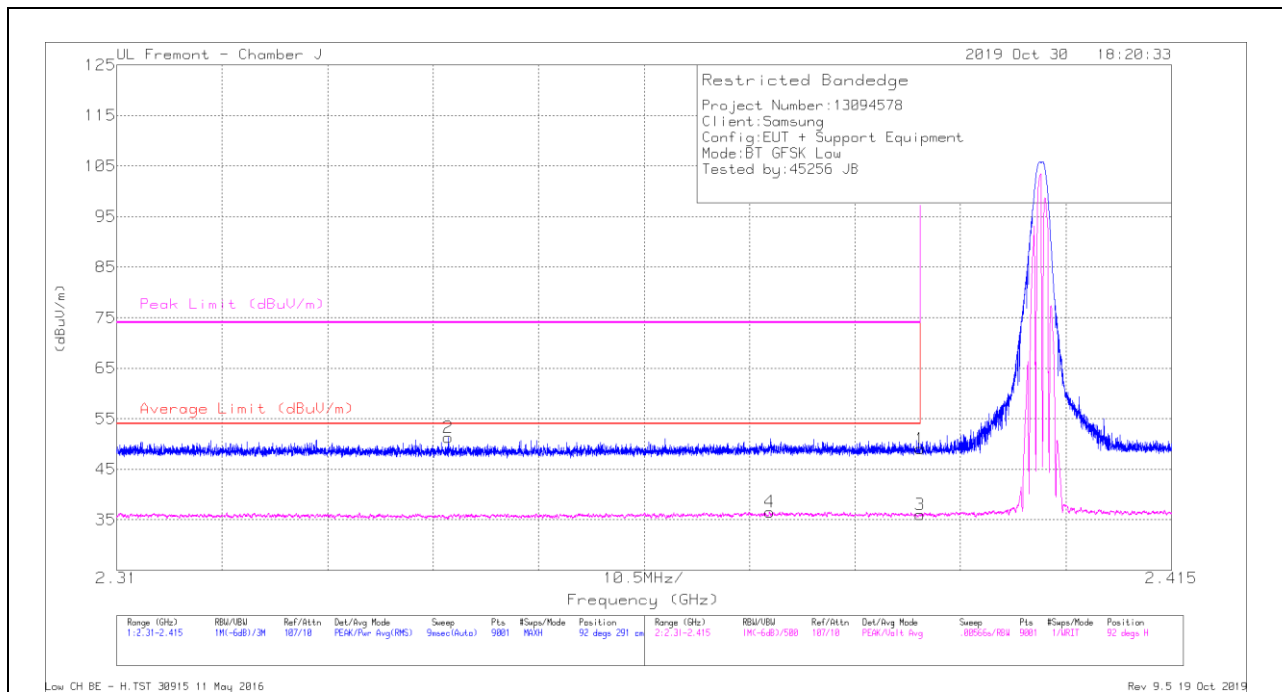

#### Trace Markers

Marker	Frequency (GHz)	Meter Reading (dBuV)	Det	AF T344 (dB/m)	Amp/Cb/Filtr/Pad (dB)	Corrected Reading (dBuV/m)	Average Limit (dBuV/m)	Margin (dB)	Peak Limit (dBuV/m)	PK Margin (dB)	Azimuth (Degs)	Height (cm)	Polarity
1	* 2.38999	42.62	Pk	31.9	-25.5	49.02	-	-	74	-24.98	92	291	H
2	* 2.34301	45.25	Pk	31.6	-25.6	51.25	-	-	74	-22.75	92	291	H
3	* 2.38999	29.63	VA1T	31.9	-25.5	36.03	54	-17.97	-	-	92	291	H
4	* 2.375	30.27	VA1T	31.8	-25.5	36.57	54	-17.43	-	-	92	291	H

\* - indicates frequency in CFR47 Pt 15 / IC RSS-Restricted Band

Pk - Peak detector

VA1T - FHSS: Linear Voltage Average  $V_B=1/T_{on}$  where:  $T_{on}$  is transmit duration

### VERTICAL RESULT

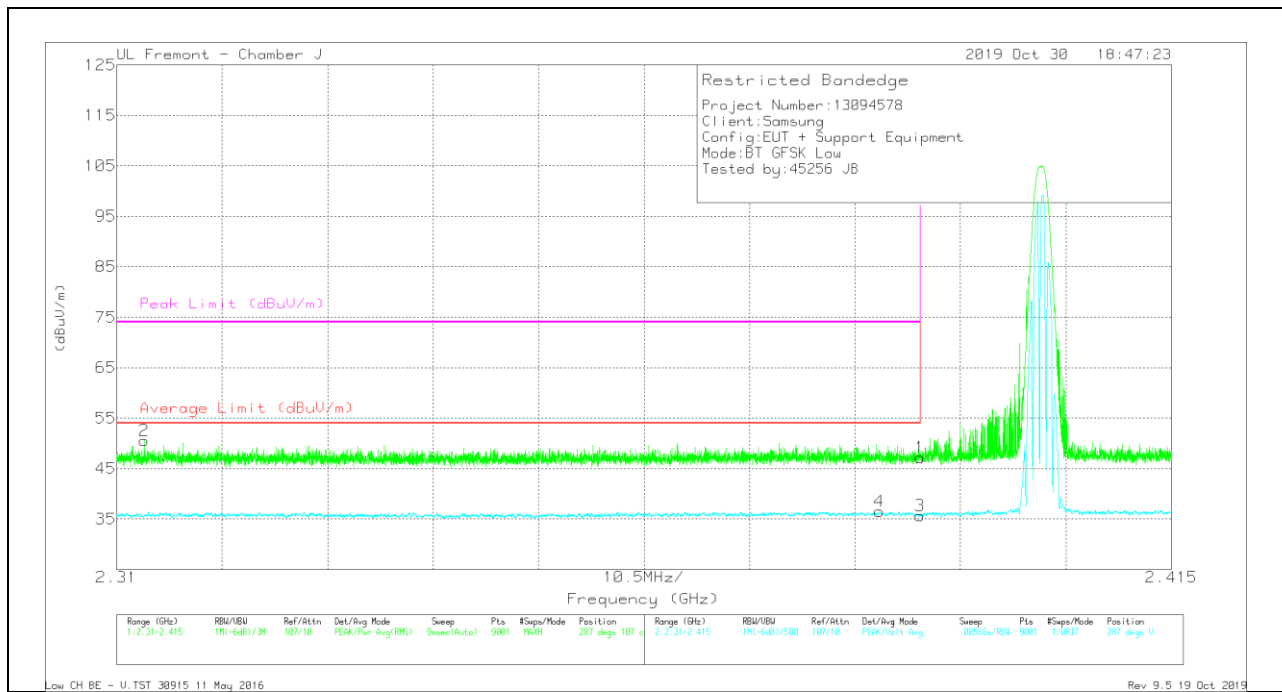

### Trace Markers

Marker	Frequency (GHz)	Meter Reading (dBuV)	Det	AF T344 (dB/m)	Amp/Cb/Fltr/Pad (dB)	Corrected Reading (dBuV/m)	Average Limit (dBuV/m)	Margin (dB)	Peak Limit (dBuV/m)	PK Margin (dB)	Azimuth (Degs)	Height (cm)	Polarity
1	* 2.38999	40.79	Pk	31.9	-25.5	47.19	-	-	74	-26.81	287	187	V
2	* 2.31275	44.43	Pk	31.7	-25.6	50.53	-	-	74	-23.47	287	187	V
3	* 2.38999	29.27	VA1T	31.9	-25.5	35.67	54	-18.33	-	-	287	186	V
4	* 2.38592	30.17	VA1T	31.8	-25.5	36.47	54	-17.53	-	-	287	186	V

\* - indicates frequency in CFR47 Pt 15 / IC RSS-Restricted Band

Pk - Peak detector

VA1T - FHSS: Linear Voltage Average  $V_B=1/T_{on}$  where:  $T_{on}$  is transmit duration

**BANDEDGE (HIGH CHANNEL)**

**HORIZONTAL RESULT**

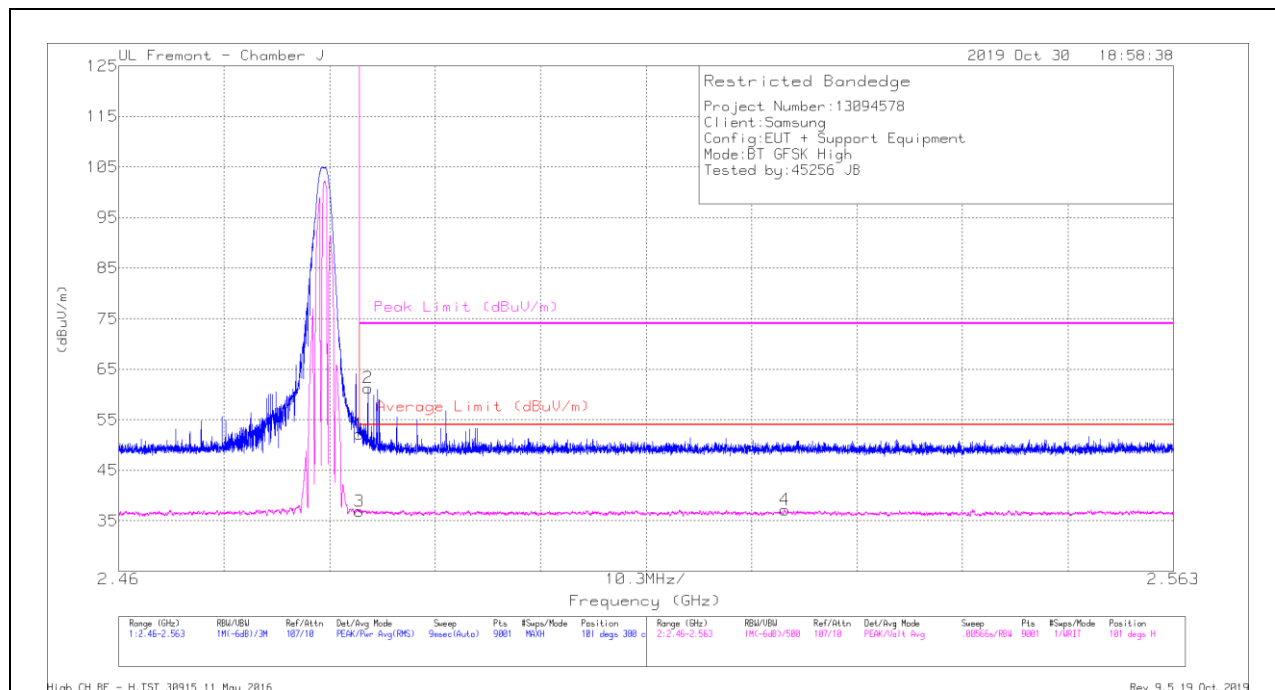

**Trace Markers**

Marker	Frequency (GHz)	Meter Reading (dBuV)	Det	AF T344 (dB/m)	Amp/Cb/Fitr/Pad (dB)	Corrected Reading (dBuV/m)	Average Limit (dBuV/m)	Margin (dB)	Peak Limit (dBuV/m)	PK Margin (dB)	Azimuth (Degs)	Height (cm)	Polarity
1	* 2.48351	45.37	Pk	32.3	-25.5	52.17	-	-	74	-21.83	101	380	H
2	* 2.48433	54.48	Pk	32.3	-25.5	61.28	-	-	74	-12.72	101	380	H
3	* 2.48351	30.09	VA1T	32.3	-25.5	36.89	54	-17.11	-	-	101	380	H
4	2.52502	30.29	VA1T	32.3	-25.4	37.19	54	-16.81	-	-	101	380	H

\* - indicates frequency in CFR47 Pt 15 / IC RSS-Restricted Band

Pk - Peak detector

VA1T - FHSS: Linear Voltage Average VB=1/Ton where: Ton is transmit duration

### VERTICAL RESULT

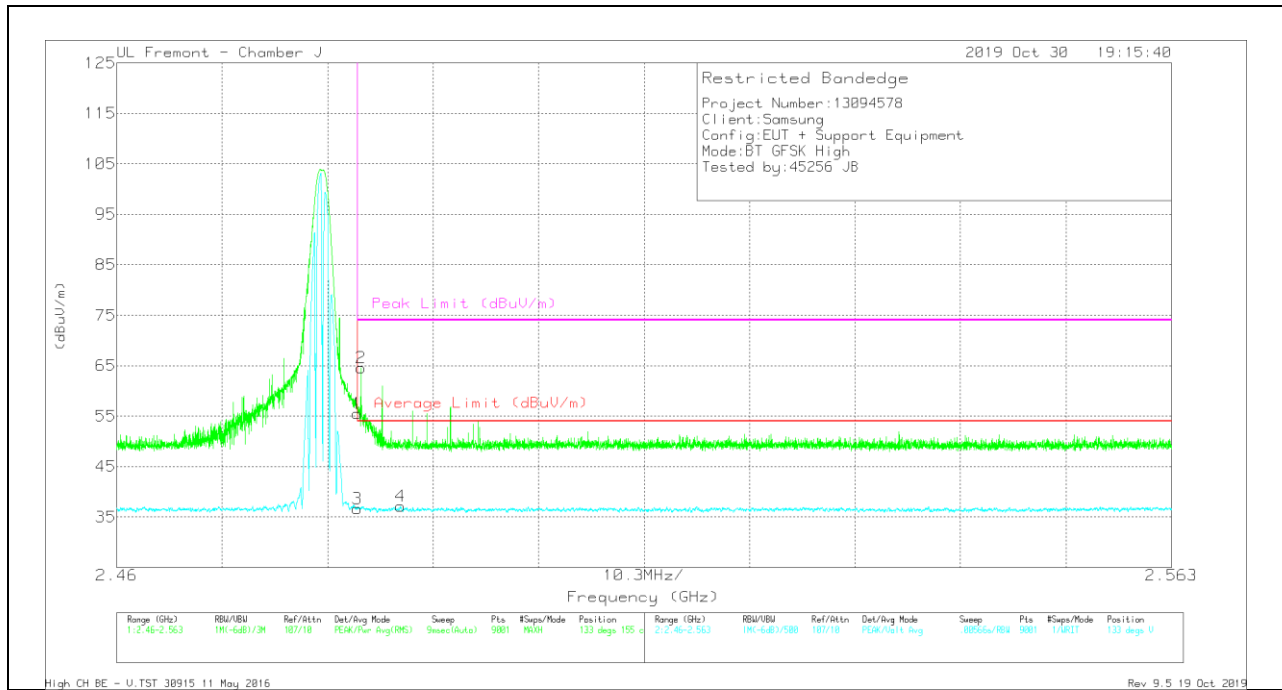

### Trace Markers

Marker	Frequency (GHz)	Meter Reading (dBuV)	Det	AF T344 (dB/m)	Amp/Cb/Fltr/Pad (dB)	Corrected Reading (dBuV/m)	Average Limit (dBuV/m)	Margin (dB)	Peak Limit (dBuV/m)	PK Margin (dB)	Azimuth (Degs)	Height (cm)	Polarity
1	* 2.48351	48.72	Pk	32.3	-25.5	55.52	-	-	74	-18.48	133	155	V
2	* 2.48385	57.77	Pk	32.3	-25.5	64.57	-	-	74	-9.43	133	155	V
3	* 2.48351	29.79	VA1T	32.3	-25.5	36.59	54	-17.41	-	-	133	155	V
4	* 2.48772	30.29	VA1T	32.3	-25.5	37.09	54	-16.91	-	-	133	155	V

\* - indicates frequency in CFR47 Pt 15 / IC RSS-Restricted Band

Pk - Peak detector

VA1T - FHSS: Linear Voltage Average  $V_B=1/T_{on}$  where:  $T_{on}$  is transmit duration

# HARMONICS AND SPURIOUS EMISSIONS

## LOW CHANNEL RESULTS

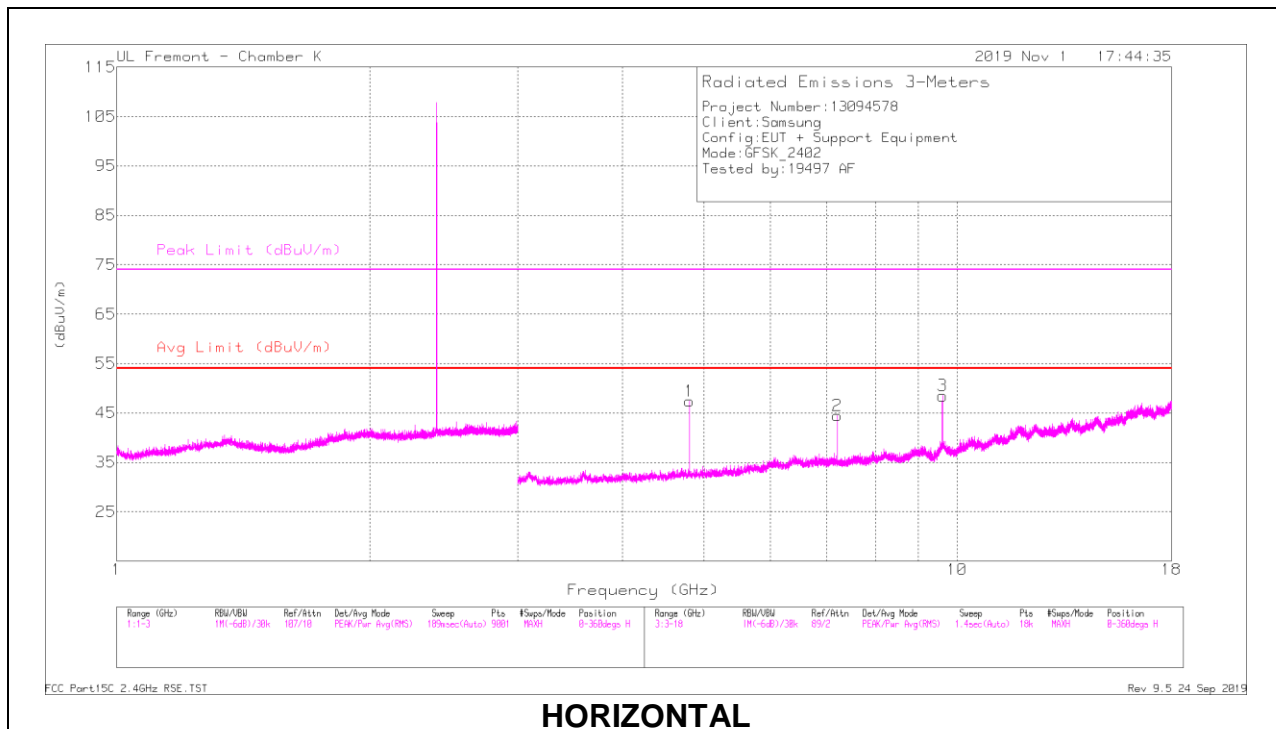

**HORIZONTAL**

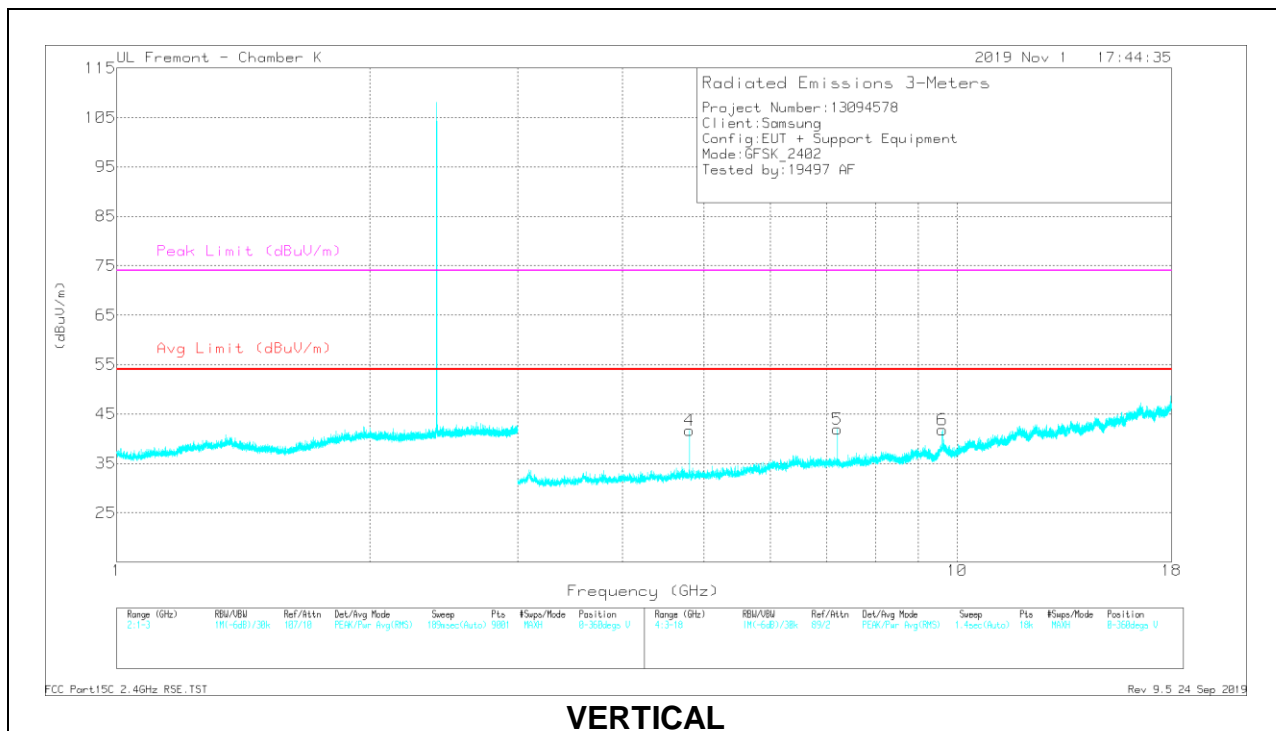

**VERTICAL**

**RADIATED EMISSIONS**

Marker	Frequency (GHz)	Meter Reading (dBuV)	Det	AF EMC4294 (dB/m)	Amp/Cb/Filtr/Pad (dB)	Corrected Reading (dBuV/m)	Avg Limit (dBuV/m)	Margin (dB)	Peak Limit (dBuV/m)	PK Margin (dB)	Azimuth (Degs)	Height (cm)	Polarity
1	* 4.80399	40.32	PKFH	34.2	-30.3	44.22	-	-	74	-29.78	59	152	H
	* 4.80392	41.47	VA1T	34.2	-30.3	45.37	54	-8.63	-	-	59	152	H
2	7.20607	34.96	Pk	35.6	-26.1	44.46	-	-	-	-	0-360	100	H
3	9.6087	34.36	Pk	37	-22.9	48.46	-	-	-	-	0-360	100	H
4	* 4.803	38.52	PKFH	34.2	-30.3	42.42	-	-	74	-31.58	263	266	V
	* 4.8041	26.92	VA1T	34.2	-30.3	30.82	54	-23.18	-	-	263	266	V
5	7.20524	32.44	Pk	35.6	-26.1	41.94	-	-	-	-	0-360	200	V
6	9.60787	27.64	Pk	37	-22.9	41.74	-	-	-	-	0-360	100	V

\* - indicates frequency in CFR47 Pt 15 / IC RSS-Restricted Band

Pk - Peak detector

PKFH FHSS/BT RB=100k for Frequencies<1GHz / RB=1MHz for Frequencies>1GHz, VB=3 x RB, Peak

VA1T - FHSS: Linear Voltage Average VB=1/Ton where: Ton is transmit duration

### MID CHANNEL RESULTS

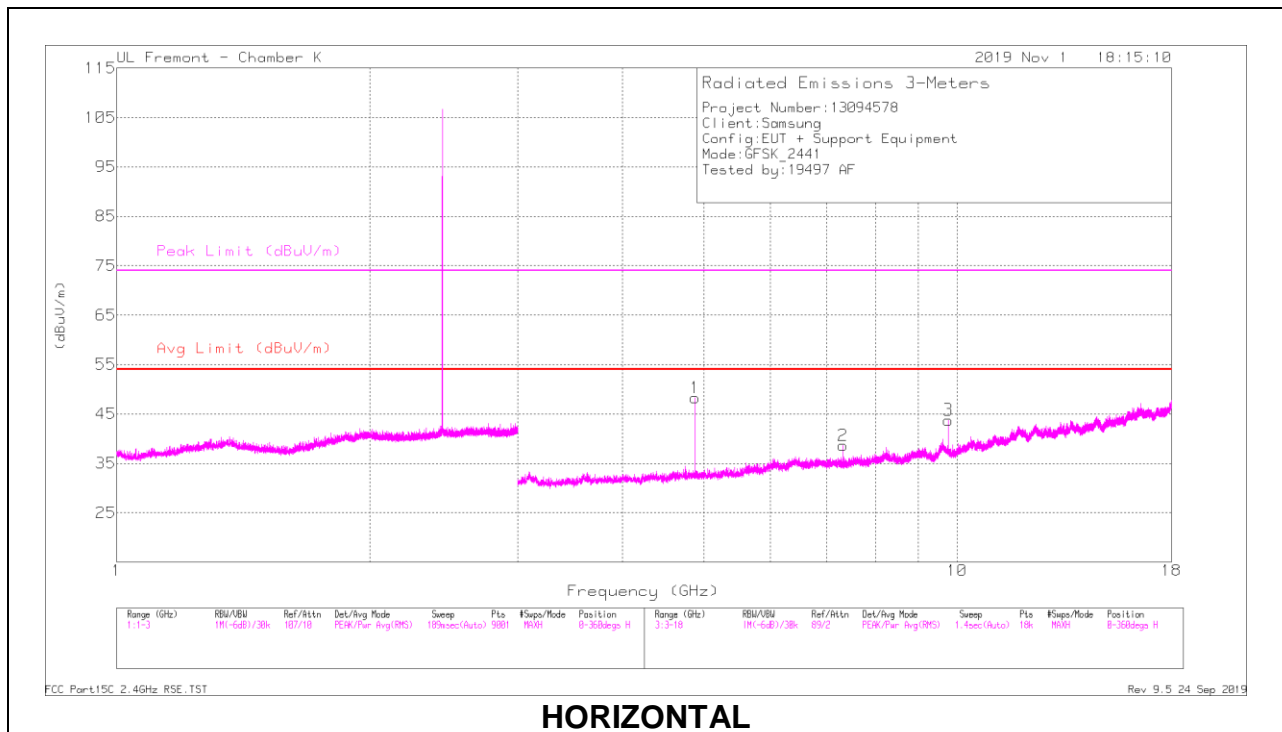

### HORIZONTAL

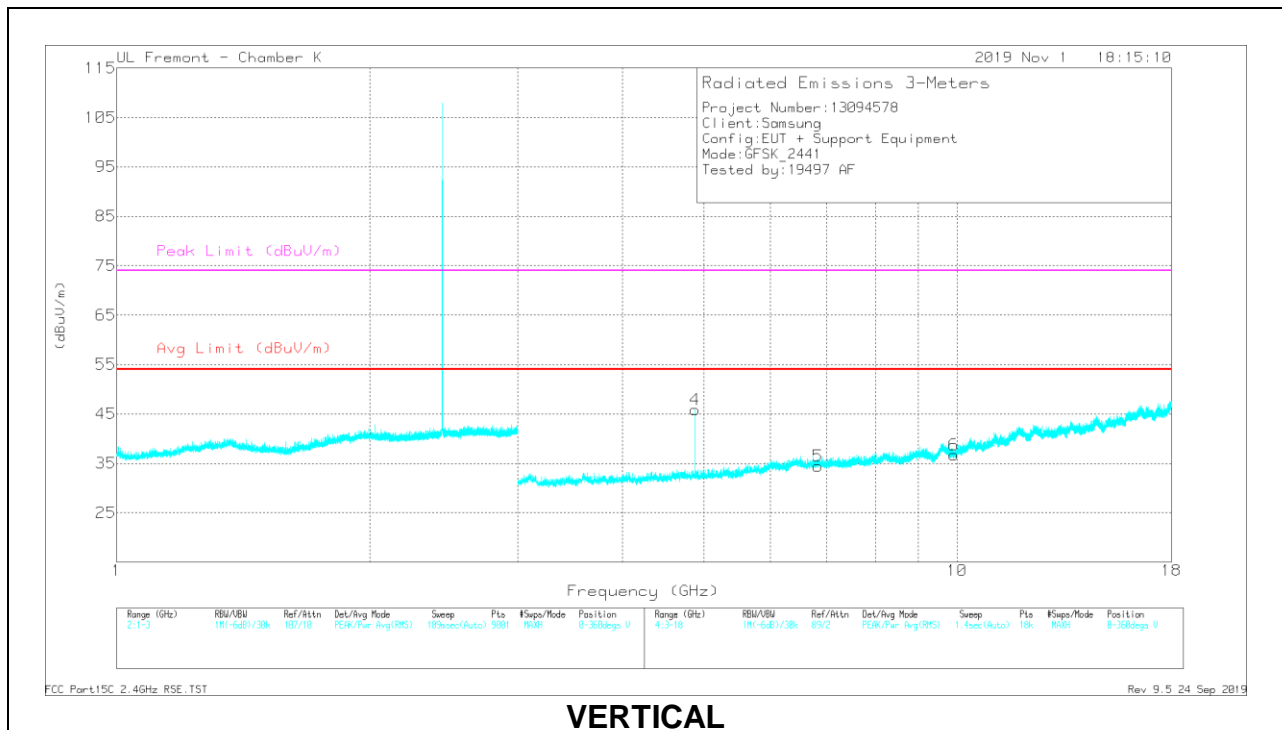

### VERTICAL

**RADIATED EMISSIONS**

Marker	Frequency (GHz)	Meter Reading (dBuV)	Det	AF EMC4294 (dB/m)	Amp/Cb/Filtr/Pad (dB)	Corrected Reading (dBuV/m)	Avg Limit (dBuV/m)	Margin (dB)	Peak Limit (dBuV/m)	PK Margin (dB)	Azimuth (Degs)	Height (cm)	Polarity
1	* 4.88216	47.57	PKFH	34.1	-30.5	51.17	-	-	74	-22.83	56	99	H
	* 4.88208	44.08	VA1T	34.1	-30.5	47.68	54	-6.32	-	-	56	99	H
2	* 7.32365	36.48	PKFH	35.6	-26.4	45.68	-	-	74	-28.32	64	99	H
	* 7.32302	26.78	VA1T	35.6	-26.4	35.98	54	-18.02	-	-	64	99	H
3	9.76455	30.06	Pk	37.1	-23.4	43.76	-	-	-	-	0-360	100	H
4	* 4.8823	42.71	PKFH	34.1	-30.5	46.31	-	-	74	-27.69	25	170	V
	* 4.88184	36.27	VA1T	34.1	-30.5	39.87	54	-14.13	-	-	25	170	V
5	6.83188	25.19	Pk	35.7	-26.5	34.39	-	-	-	-	0-360	101	V
6	9.91789	22.57	Pk	37.1	-22.9	36.77	-	-	-	-	0-360	200	V

\* - indicates frequency in CFR47 Pt 15 / IC RSS-Restricted Band

Pk - Peak detector

PKFH FHSS/BT RB=100k for Frequencies<1GHz / RB=1MHz for Frequencies>1GHz, VB=3 x RB, Peak

VA1T - FHSS: Linear Voltage Average VB=1/Ton where: Ton is transmit duration

### HIGH CHANNEL RESULTS

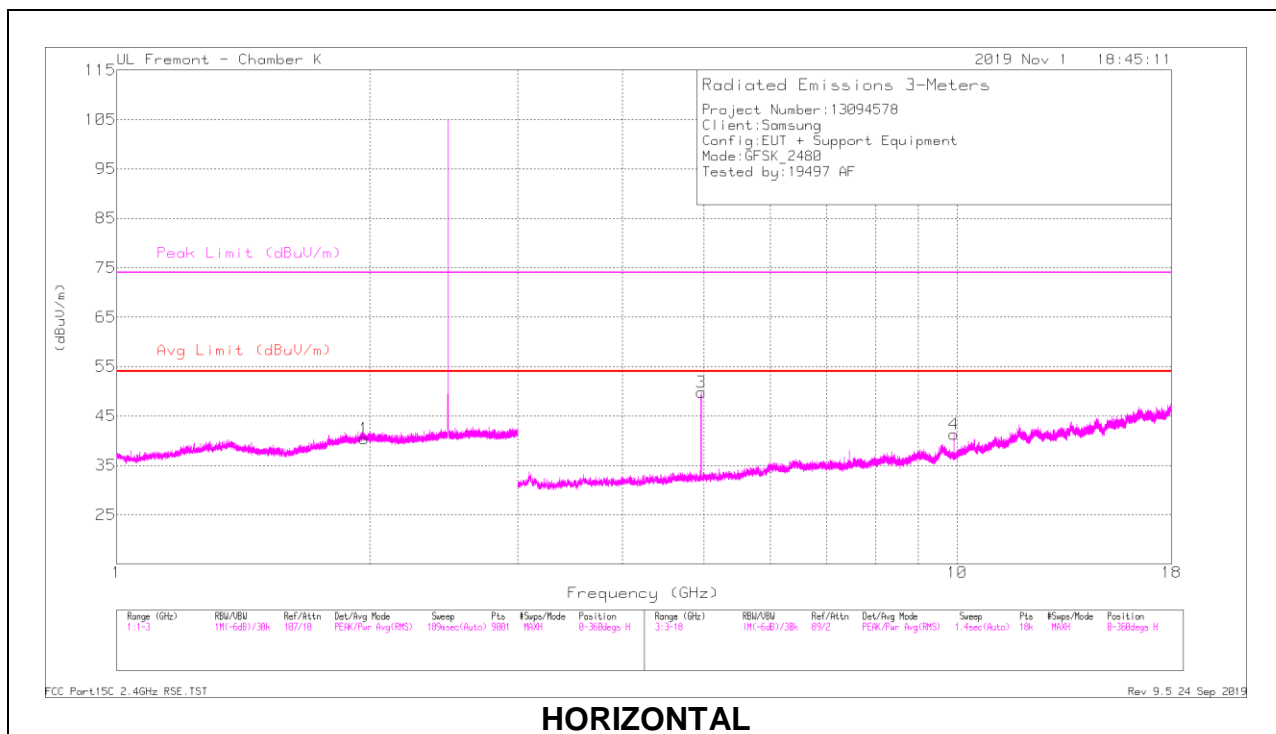

**HORIZONTAL**

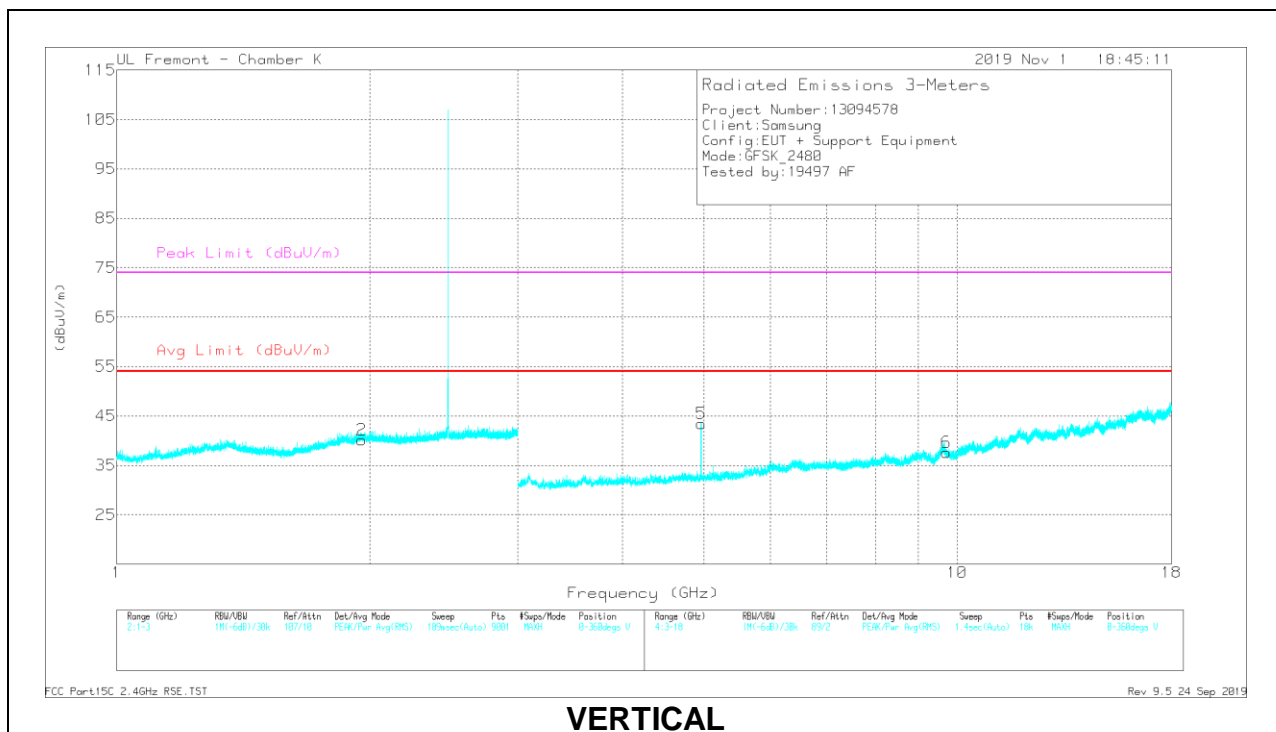

**VERTICAL**

**RADIATED EMISSIONS**

Marker	Frequency (GHz)	Meter Reading (dBuV)	Det	AF EMC4294 (dB/m)	Amp/Cb/Filtr/Pad (dB)	Corrected Reading (dBuV/m)	Avg Limit (dBuV/m)	Margin (dB)	Peak Limit (dBuV/m)	PK Margin (dB)	Azimuth (Degs)	Height (cm)	Polarity
1	1.97044	33.28	Pk	31.5	-24.4	40.38	-	-	-	-	0-360	100	H
2	1.95689	32.83	Pk	31.5	-24.2	40.13	-	-	-	-	0-360	200	V
3	* 4.95975	48.49	PKFH	34.1	-30.6	51.99	-	-	74	-22.01	54	96	H
	* 4.96005	45.53	VA1T	34.1	-30.6	49.03	54	-4.97	-	-	54	96	H
4	9.91955	27.16	Pk	37	-22.9	41.26	-	-	-	-	0-360	101	H
5	* 4.95979	43.18	PKFH	34.1	-30.6	46.68	-	-	74	-27.32	355	120	V
	* 4.95999	36.82	VA1T	34.1	-30.6	40.32	54	-13.68	-	-	355	120	V
6	9.71538	24.06	Pk	37.1	-23.6	37.56	-	-	-	-	0-360	100	V

\* - indicates frequency in CFR47 Pt 15 / IC RSS-Restricted Band

Pk - Peak detector

PKFH FHSS/BT RB=100k for Frequencies<1GHz / RB=1MHz for Frequencies>1GHz, VB=3 x RB, Peak

VA1T - FHSS: Linear Voltage Average VB=1/Ton where: Ton is transmit duration

## 9.1.2. BLUETOOTH ENHANCED DATA RATE 8PSK MODULATION

### BANDEDGE (LOW CHANNEL)

### HORIZONTAL RESULT

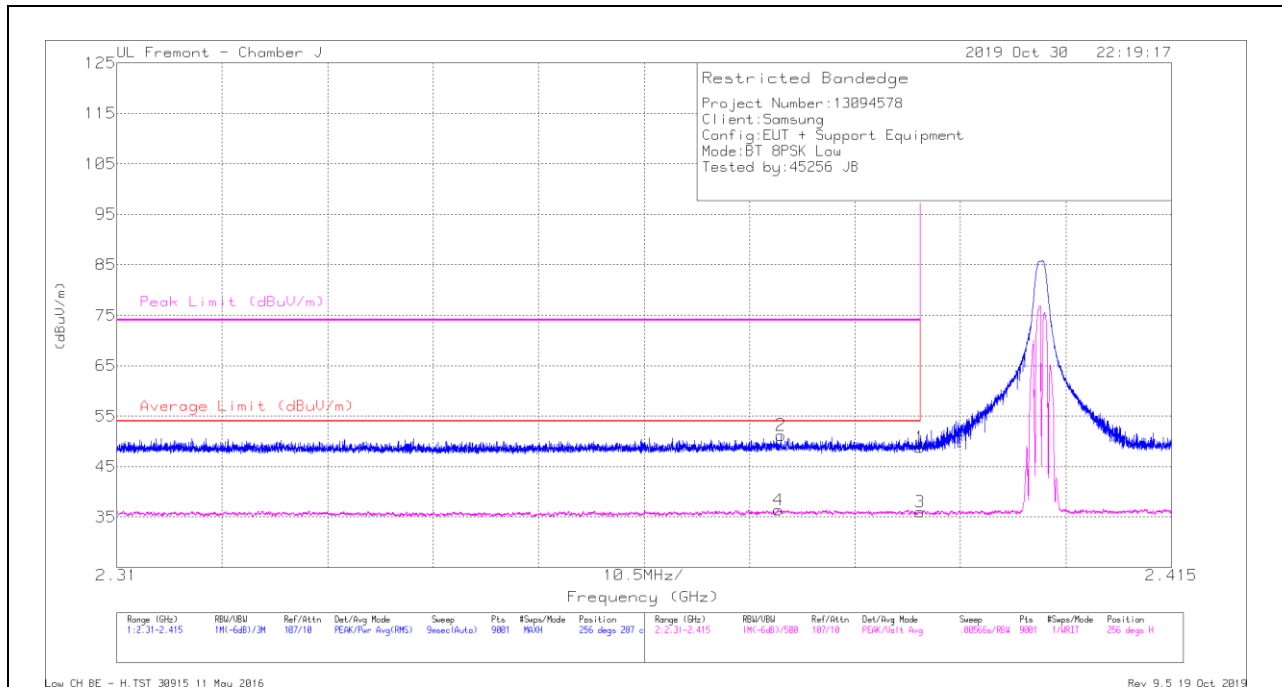

### Trace Markers

Marker	Frequency (GHz)	Meter Reading (dBuV)	Det	AF T344 (dB/m)	Amp/Cb/Filtr /Pad (dB)	Corrected Reading (dBuV/m)	Average Limit (dBuV/m)	Margin (dB)	Peak Limit (dBuV/m)	PK Margin (dB)	Azimuth (Degs)	Height (cm)	Polarit y
1	* 2.38999	42.43	Pk	31.9	-25.5	48.83	-	-	74	-25.17	256	287	H
2	* 2.37614	44.92	Pk	31.8	-25.5	51.22	-	-	74	-22.78	256	287	H
3	* 2.38999	29.58	VA1T	31.9	-25.5	35.98	54	-18.02	-	-	256	287	H
4	* 2.37585	30.14	VA1T	31.8	-25.5	36.44	54	-17.56	-	-	256	287	H

\* - indicates frequency in CFR47 Pt 15 / IC RSS-Restricted Band

Pk - Peak detector

VA1T - FHSS: Linear Voltage Average  $V_B=1/T_{on}$  where:  $T_{on}$  is transmit duration

### VERTICAL RESULT

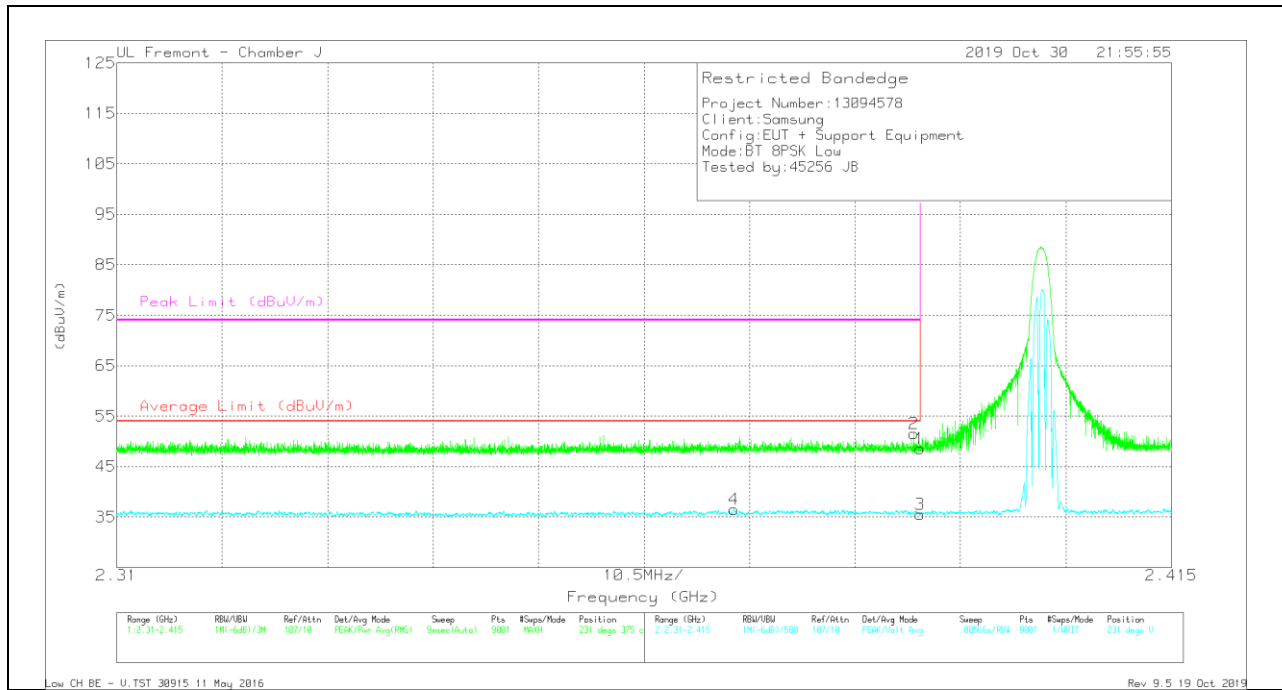

### Trace Markers

Marker	Frequency (GHz)	Meter Reading (dBuV)	Det	AF T344 (dB/m)	Amp/Cb/Fltr/Pad (dB)	Corrected Reading (dBuV/m)	Average Limit (dBuV/m)	Margin (dB)	Peak Limit (dBuV/m)	PK Margin (dB)	Azimuth (Degs)	Height (cm)	Polarity
1	* 2.38999	42.11	Pk	31.9	-25.5	48.51	-	-	74	-25.49	231	375	V
2	* 2.38935	45.11	Pk	31.9	-25.5	51.51	-	-	74	-22.49	231	375	V
3	* 2.38999	29.06	VA1T	31.9	-25.5	35.46	54	-18.54	-	-	231	375	V
4	* 2.37145	30.25	VA1T	31.8	-25.5	36.55	54	-17.45	-	-	231	375	V

\* - indicates frequency in CFR47 Pt 15 / IC RSS-Restricted Band

Pk - Peak detector

VA1T - FHSS: Linear Voltage Average  $V_B=1/T_{on}$  where:  $T_{on}$  is transmit duration

**BANDEDGE (HIGH CHANNEL)**

**HORIZONTAL RESULT**

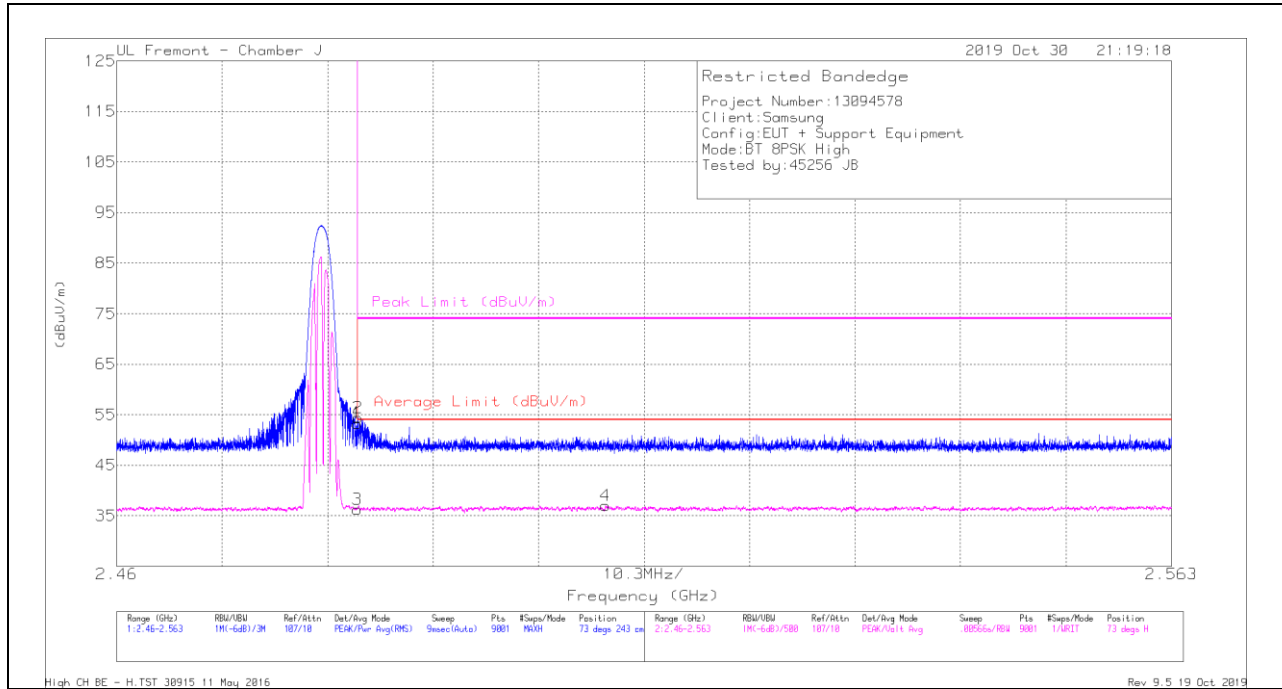

**Trace Markers**

Marker	Frequency (GHz)	Meter Reading (dBuV)	Det	AF T344 (dB/m)	Amp/Cb/Fitr/Pad (dB)	Corrected Reading (dBuV/m)	Average Limit (dBuV/m)	Margin (dB)	Peak Limit (dBuV/m)	PK Margin (dB)	Azimuth (Degs)	Height (cm)	Polarity
1	* 2.48351	46.53	Pk	32.3	-25.5	53.33	-	-	74	-20.67	73	243	H
2	* 2.48353	47.6	Pk	32.3	-25.5	54.4	-	-	74	-19.6	73	243	H
3	* 2.48351	29.48	VA1T	32.3	-25.5	36.28	54	-17.72	-	-	73	243	H
4	2.50773	30.14	VA1T	32.4	-25.5	37.04	54	-16.96	-	-	73	243	H

\* - indicates frequency in CFR47 Pt 15 / IC RSS-Restricted Band

Pk - Peak detector

VA1T - FHSS: Linear Voltage Average  $V_B=1/T_{on}$  where:  $T_{on}$  is transmit duration

### VERTICAL RESULT

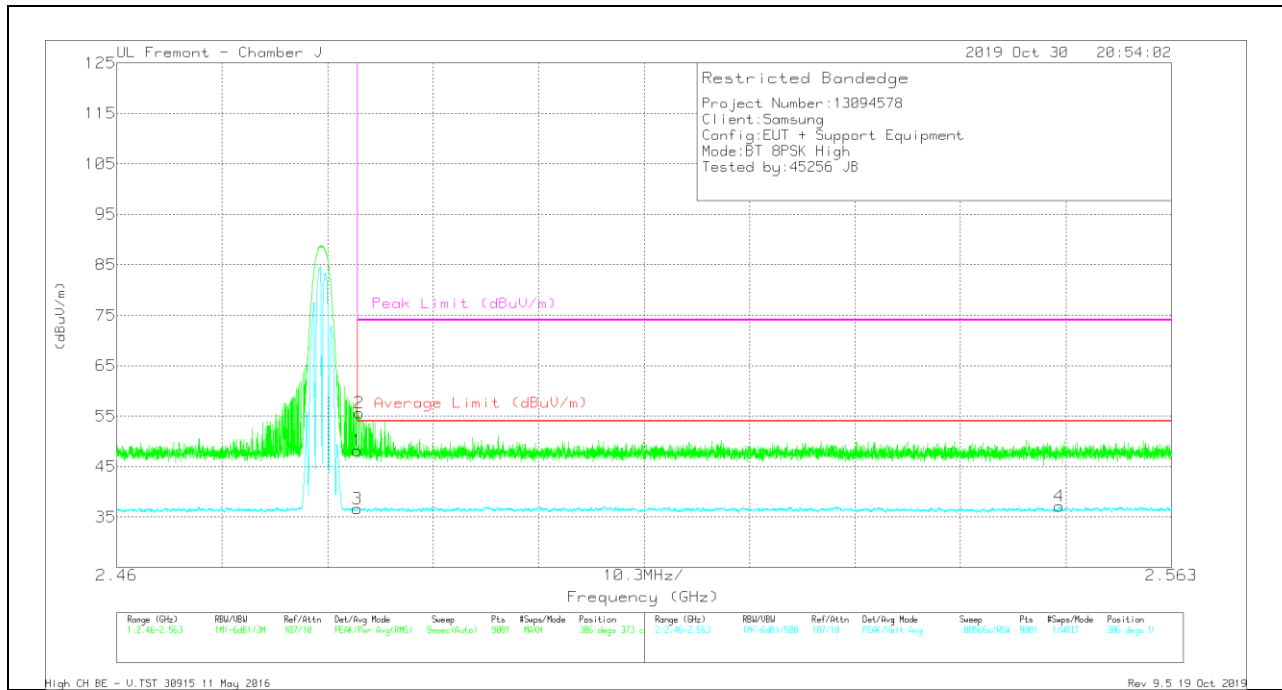

### Trace Markers

Marker	Frequency (GHz)	Meter Reading (dBuV)	Det	AF T344 (dB/m)	Amp/Cb/Fltr/Pad (dB)	Corrected Reading (dBuV/m)	Average Limit (dBuV/m)	Margin (dB)	Peak Limit (dBuV/m)	PK Margin (dB)	Azimuth (Degs)	Height (cm)	Polarity
1	* 2.48351	41.42	Pk	32.3	-25.5	48.22	-	-	74	-25.78	306	373	V
2	* 2.48369	48.85	Pk	32.3	-25.5	55.65	-	-	74	-18.35	306	373	V
3	* 2.48351	29.79	VA1T	32.3	-25.5	36.59	54	-17.41	-	-	306	373	V
4	2.55203	30.23	VA1T	32.3	-25.4	37.13	54	-16.87	-	-	306	373	V

\* - indicates frequency in CFR47 Pt 15 / IC RSS-Restricted Band

Pk - Peak detector

VA1T - FHSS: Linear Voltage Average  $V_B=1/T_{on}$  where:  $T_{on}$  is transmit duration

# HARMONICS AND SPURIOUS EMISSIONS

## LOW CHANNEL RESULTS

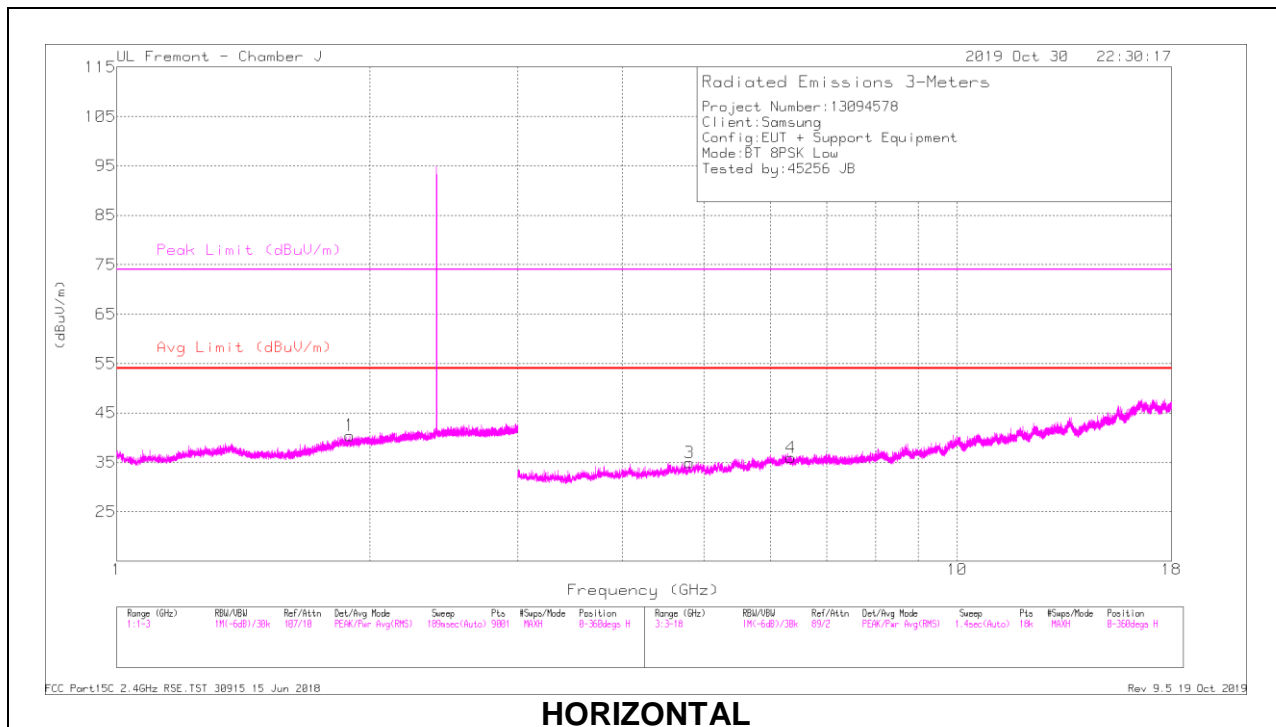

**HORIZONTAL**

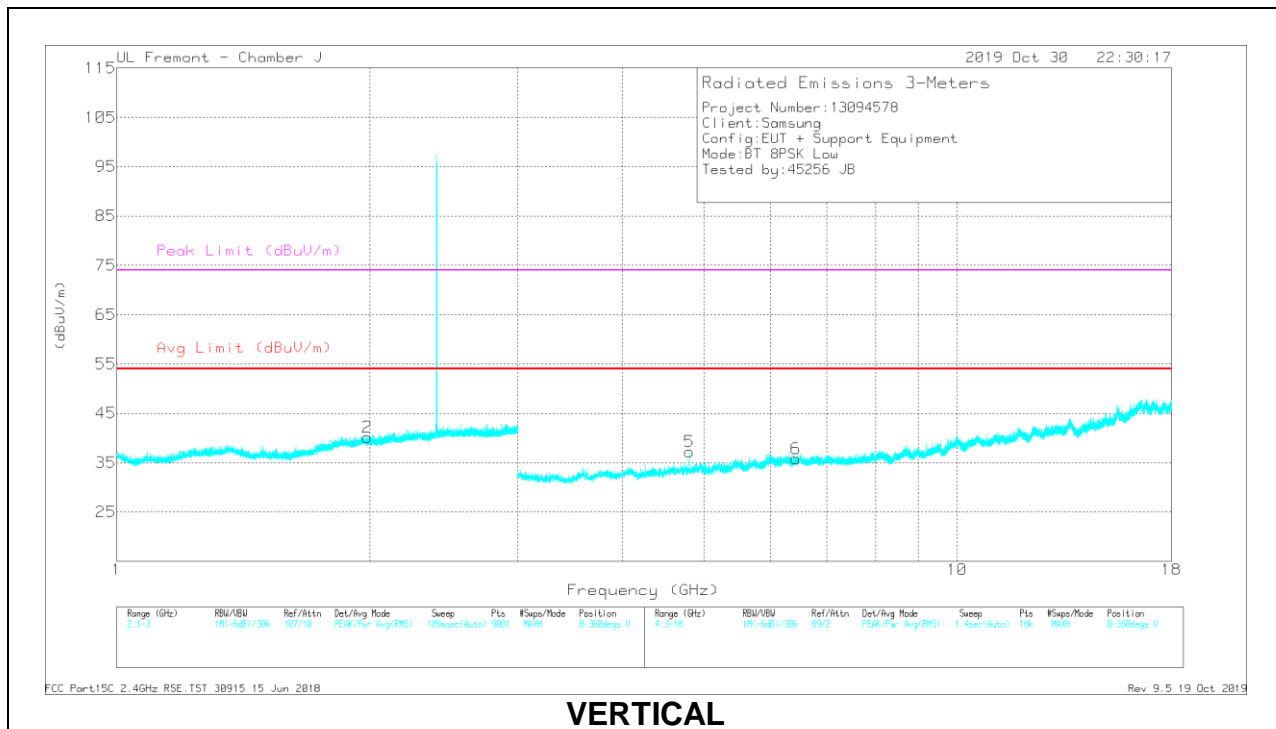

**VERTICAL**

**RADIATED EMISSIONS**

Marker	Frequency (GHz)	Meter Reading (dBuV)	Det	AF T344 (dB/m)	Amp/Cbl/Filtr/Pad (dB)	Corrected Reading (dBuV/m)	Avg Limit (dBuV/m)	Margin (dB)	Peak Limit (dBuV/m)	PK Margin (dB)	Azimuth (Degs)	Height (cm)	Polarity
1	1.89511	35.76	Pk	30.5	-25.8	40.46	-	-	-	-	0-360	199	H
2	1.98733	34.83	Pk	31	-25.7	40.13	-	-	-	-	0-360	199	V
3	* 4.80482	38.67	PKFH	34.3	-30.8	42.17	-	-	74	-31.83	216	136	H
	* 4.80402	26.74	VA1T	34.2	-30.8	30.14	54	-23.86	-	-	216	136	H
4	6.34685	28.78	Pk	35.5	-28.3	35.98	-	-	-	-	0-360	102	H
5	* 4.80281	38.1	PKFH	34.2	-30.8	41.5	-	-	74	-32.5	273	201	V
	* 4.80178	26.05	VA1T	34.2	-30.8	29.45	54	-24.55	-	-	273	201	V
6	6.43519	28.49	Pk	35.5	-28.2	35.79	-	-	-	-	0-360	199	V

\* - indicates frequency in CFR47 Pt 15 / IC RSS-Restricted Band

Pk - Peak detector

PKFH FHSS/BT RB=100k for Frequencies<1GHz / RB=1MHz for Frequencies>1GHz, VB=3 x RB, Peak

VA1T - FHSS: Linear Voltage Average VB=1/Ton where: Ton is transmit duration

### MID CHANNEL RESULTS

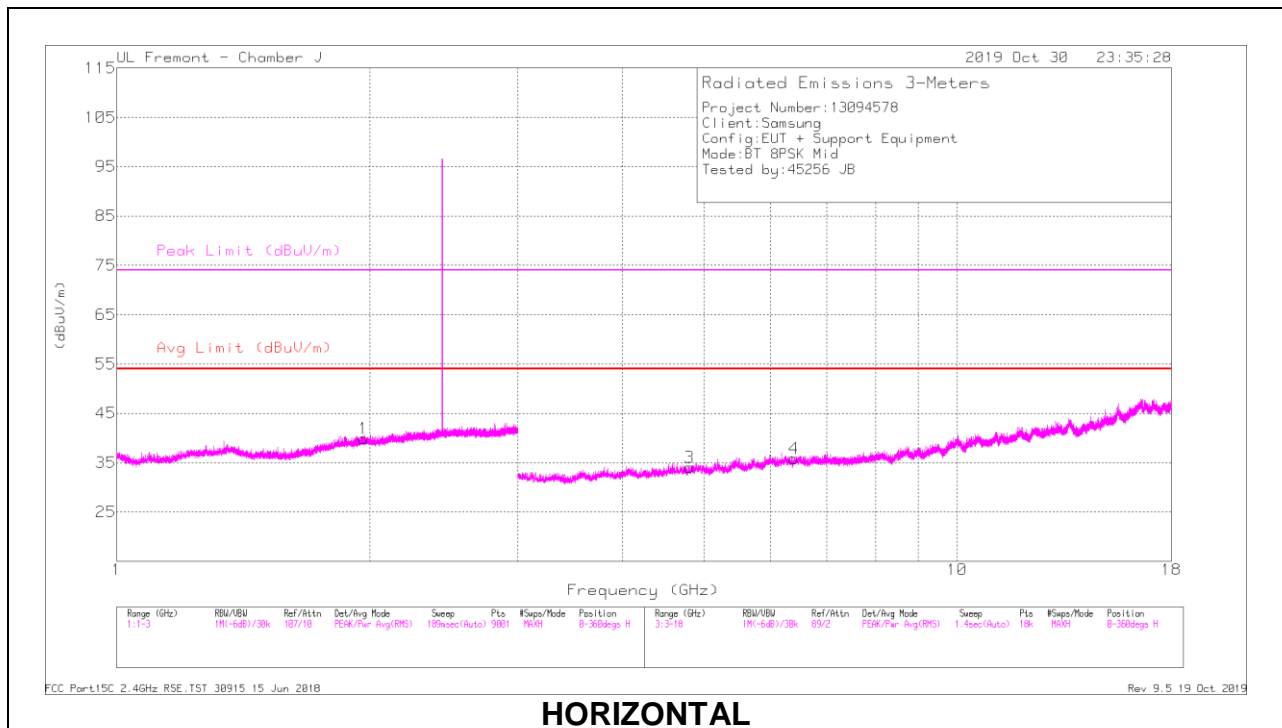

**HORIZONTAL**

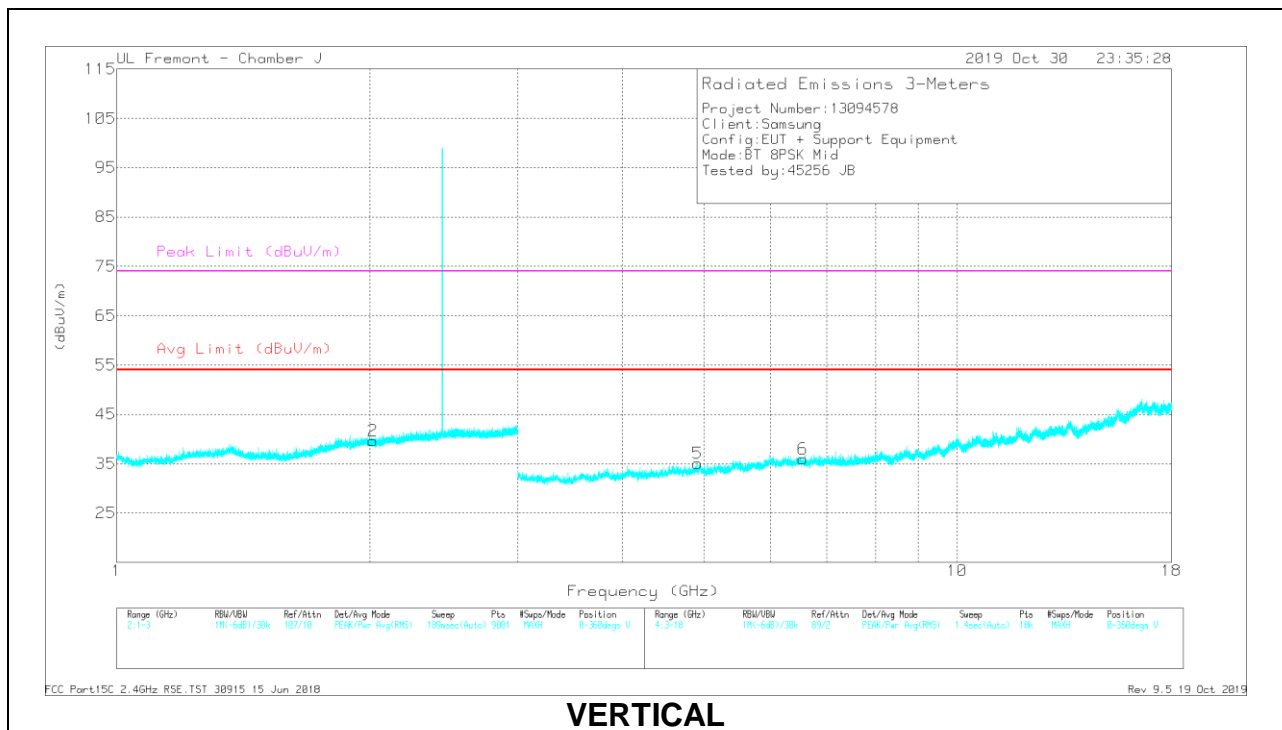

**VERTICAL**

**RADIATED EMISSIONS**

Marker	Frequency (GHz)	Meter Reading (dBuV)	Det	AF T344 (dB/m)	Amp/Cb/Filtr/Pad (dB)	Corrected Reading (dBuV/m)	Avg Limit (dBuV/m)	Margin (dB)	Peak Limit (dBuV/m)	PK Margin (dB)	Azimuth (Degs)	Height (cm)	Polarity
1	1.96733	34.57	Pk	31	-25.7	39.87	-	-	-	-	0-360	199	H
2	2.01867	34.49	Pk	30.9	-25.7	39.69	-	-	-	-	0-360	101	V
3	* 4.80961	38.26	PKFH	34.2	-30.8	41.66	-	-	74	-32.34	302	248	H
	* 4.80857	25.83	VA1T	34.2	-30.8	29.23	54	-24.77	-	-	302	248	H
4	6.39936	28.88	Pk	35.5	-28.5	35.88	-	-	-	-	0-360	101	H
5	* 4.91006	38.62	PKFH	34.1	-30.6	42.12	-	-	74	-31.88	101	284	V
	* 4.91157	25.99	VA1T	34.1	-30.6	29.49	54	-24.51	-	-	101	284	V
6	6.5577	27.85	Pk	35.6	-27.5	35.95	-	-	-	-	0-360	199	V

\* - indicates frequency in CFR47 Pt 15 / IC RSS-Restricted Band

Pk - Peak detector

PKFH FHSS/BT RB=100k for Frequencies<1GHz / RB=1MHz for Frequencies>1GHz, VB=3 x RB, Peak

VA1T - FHSS: Linear Voltage Average VB=1/Ton where: Ton is transmit duration

### HIGH CHANNEL RESULTS

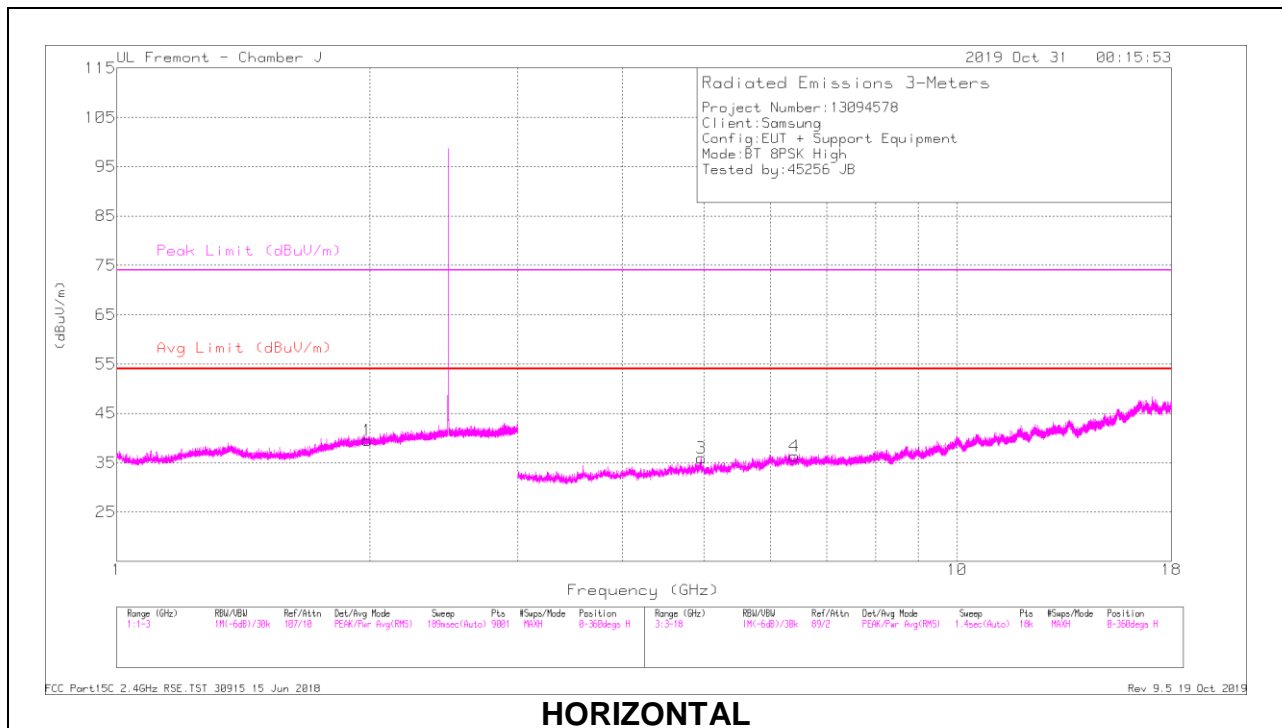

**HORIZONTAL**

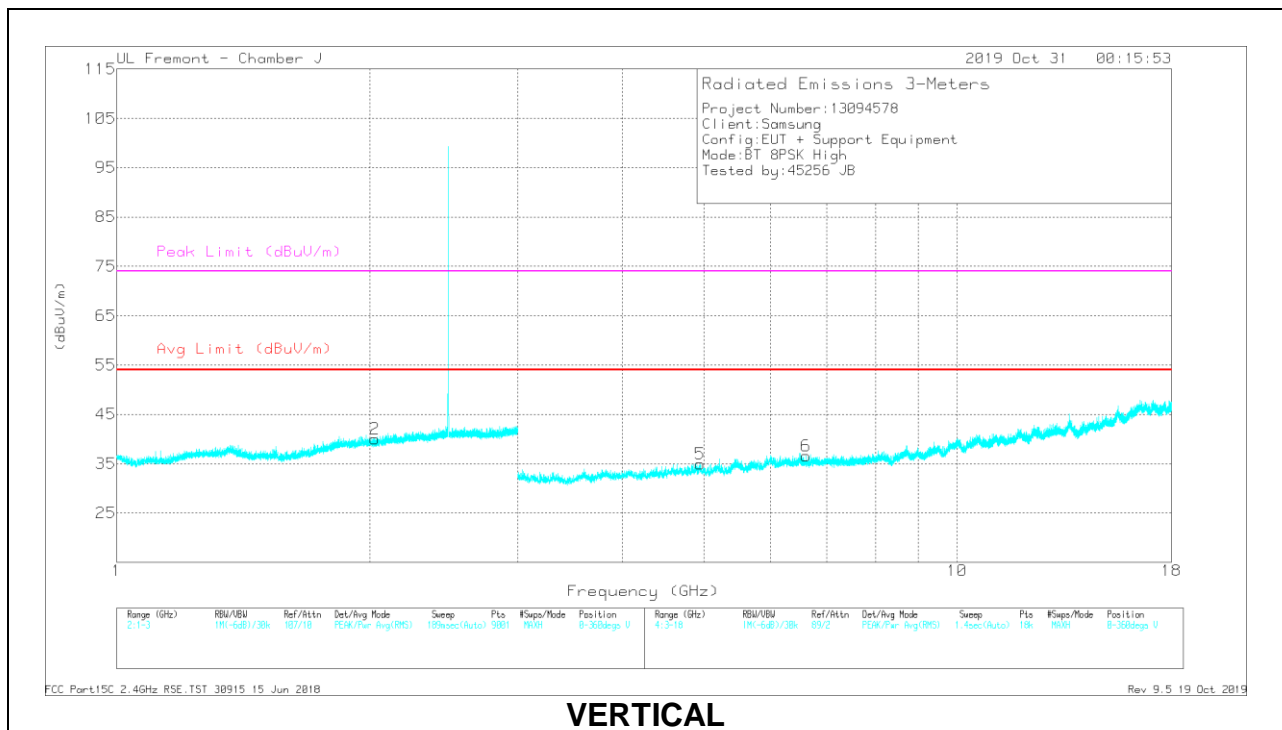

**VERTICAL**

**RADIATED EMISSIONS**

Marker	Frequency (GHz)	Meter Reading (dBuV)	Det	AF T344 (dB/m)	Amp/Cb/Filtr/Pad (dB)	Corrected Reading (dBuV/m)	Avg Limit (dBuV/m)	Margin (dB)	Peak Limit (dBuV/m)	PK Margin (dB)	Azimuth (Degs)	Height (cm)	Polarity
1	1.98822	34.16	Pk	31	-25.7	39.46	-	-	-	-	0-360	199	H
2	2.02978	34.93	Pk	30.8	-25.7	40.03	-	-	-	-	0-360	199	V
3	* 4.95999	39.45	PKFH	34.1	-30	43.55	-	-	74	-30.45	105	104	H
	* 4.96005	27.52	VA1T	34.1	-30	31.62	54	-22.38	-	-	105	104	H
4	6.40602	29.35	Pk	35.5	-28.5	36.35	-	-	-	-	0-360	101	H
5	* 4.94222	38.13	PKFH	34	-30	42.13	-	-	74	-31.87	170	113	V
	* 4.94431	26.06	VA1T	34	-29.9	30.16	54	-23.84	-	-	170	113	V
6	6.60854	28.9	Pk	35.5	-27.8	36.6	-	-	-	-	0-360	199	V

\* - indicates frequency in CFR47 Pt 15 / IC RSS-Restricted Band

Pk - Peak detector

PKFH FHSS/BT RB=100k for Frequencies<1GHz / RB=1MHz for Frequencies>1GHz, VB=3 x RB, Peak

VA1T - FHSS: Linear Voltage Average VB=1/Ton where: Ton is transmit duration

## 9.2. WORST CASE BELOW 30MHZ

### SPURIOUS EMISSIONS BELOW 30 MHz (WORST-CASE CONFIGURATION)

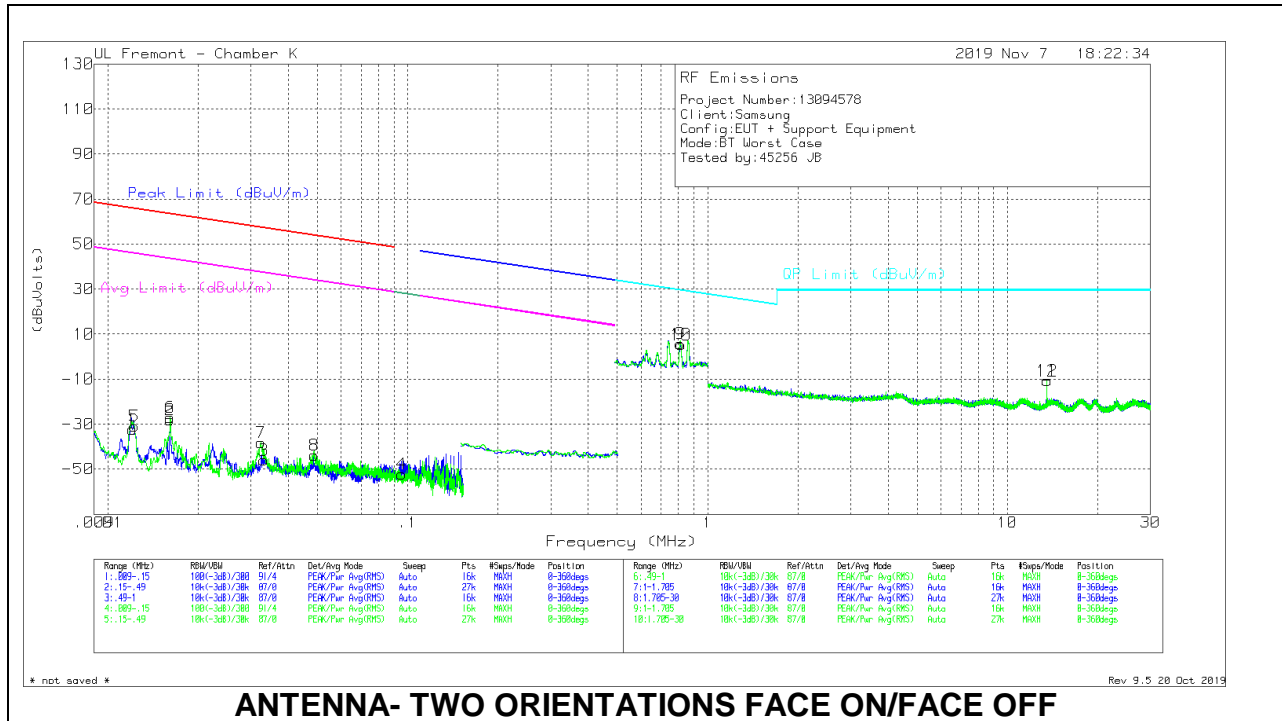

### ANTENNA- TWO ORIENTATIONS FACE ON/FACE OFF

#### Below 30MHz Data

Marker	Frequency (MHz)	Meter Reading (dBuV)	Det	Loop Antenna (ACF)	Cables w/ PRE0186650	Dist Corr 300m	Corrected Reading (dBuVolts)	Peak Limit (dBuV/m)	Margin (dB)	Avg Limit (dBuV/m)	Margin (dB)	QP Limit (dBuV/m)	Margin (dB)	Azimuth (Degs)
1	.01207	19.74	Pk	59.9	-31.8	-80	-32.16	65.95	-98.11	45.95	-78.11	-	-	0-360
2	.01612	24.65	Pk	59.3	-31.9	-80	-27.95	63.44	-91.39	43.44	-71.39	-	-	0-360
3	.03306	8.67	Pk	57.5	-32.2	-80	-46.03	57.2	-103.23	37.2	-83.23	-	-	0-360
4	.09545	4.53	Pk	55.5	-32.2	-80	-52.17	-	-	-	-	28	-80.17	0-360
5	.01225	21.02	Pk	59.9	-31.8	-80	-30.88	65.82	-96.7	45.82	-76.7	-	-	0-360
6	.01612	25.6	Pk	59.3	-31.9	-80	-27	63.44	-90.44	43.44	-70.44	-	-	0-360
7	.03243	16.63	Pk	57.5	-32.2	-80	-38.07	57.37	-95.44	37.37	-75.44	-	-	0-360
8	.04884	11.53	Pk	56.9	-32.2	-80	-43.77	53.81	-97.58	33.81	-77.58	-	-	0-360

Pk - Peak detector

Marker	Frequency (MHz)	Meter Reading (dBuV)	Det	Loop Antenna (ACF)	Cables w/ PRE0186650	Dist Corr 30m (dB) 40Log	Corrected Reading (dBuVolts)	QP Limit (dBuV/m)	Margin (dB)	Azimuth (Degs)
9	.81088	21.75	Pk	56.1	-32.1	-40	5.75	29.44	-23.69	0-360
10	.81477	21.33	Pk	56.1	-32.1	-40	5.33	29.4	-24.07	0-360
11	13.55998	27.18	Pk	34.1	-31.8	-40	-10.52	29.5	-40.02	0-360
12	13.55998	26.89	Pk	34.1	-31.8	-40	-10.81	29.5	-40.31	0-360

Pk - Peak detector

### 9.3. WORST CASE BELOW 1 GHZ

#### SPURIOUS EMISSIONS 30 TO 1000 MHz (WORST-CASE CONFIGURATION)

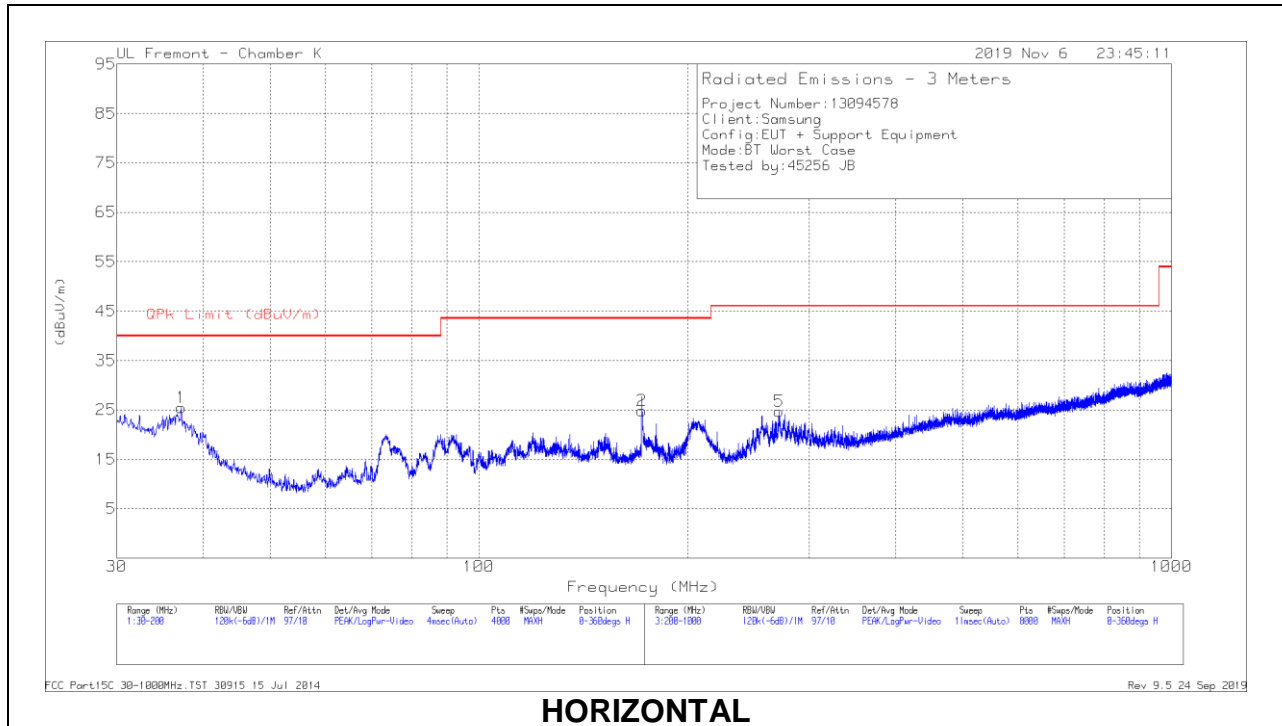

**HORIZONTAL**

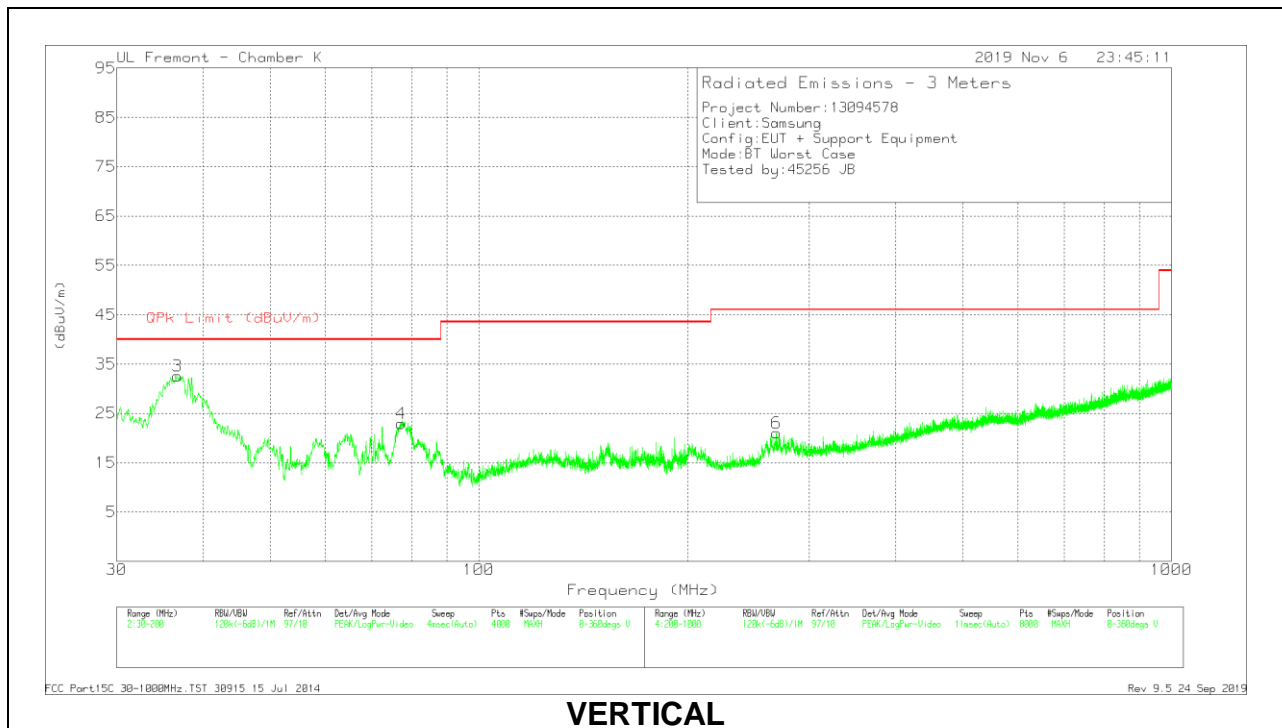

**VERTICAL**

**Below 1GHz Data**

Marker	Frequency (MHz)	Meter Reading (dBuV)	Det	AF PRE0181574 (dB/m)	Amp/Cbl (dB)	Corrected Reading (dBuV/m)	QPk Limit (dBuV/m)	Margin (dB)	Azimuth (Degs)	Height (cm)	Polarity
1	37.1418	35.07	Pk	21.9	-31.5	25.47	40	-14.53	0-360	399	H
2	* 172.0718	37.81	Pk	17.5	-30.5	24.81	43.52	-18.71	0-360	299	H
3	36.8579	43.34	Pk	22.1	-31.5	33.94	40	-6.06	46	106	V
	36.8579	38.33	Qp	22.1	-31.5	28.93	40	-11.07	46	106	V
4	77.1872	40.27	Pk	13.8	-31.1	22.97	40	-17.03	0-360	100	V
5	* 271.2093	35.6	Pk	19.1	-30	24.7	46.02	-21.32	0-360	100	H
6	* 268.8089	31.95	Pk	19.1	-30	21.05	46.02	-24.97	0-360	199	V

\* - indicates frequency in CFR47 Pt 15 / IC RSS-Restricted Band

Pk - Peak detector

Qp - Quasi-Peak detector

### 9.4. WORST CASE 18-26 GHZ

#### SPURIOUS EMISSIONS 18-26 GHZ (WORST-CASE CONFIGURATION)

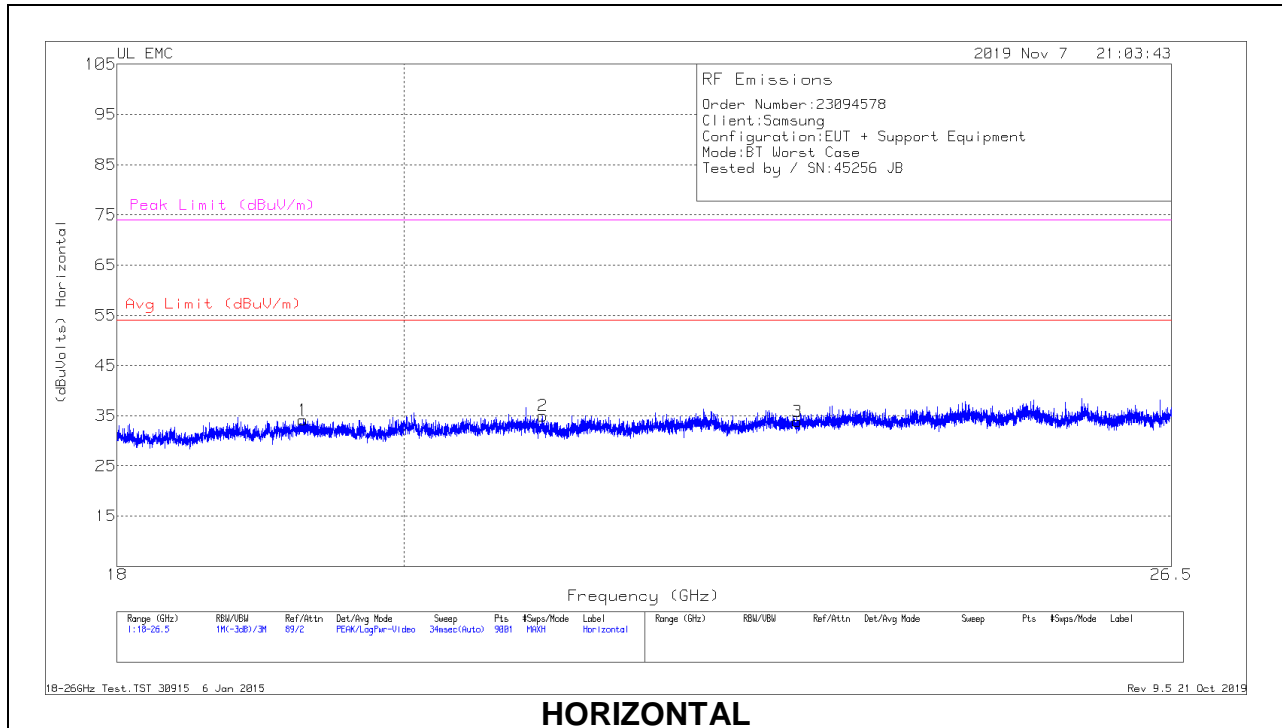

**HORIZONTAL**

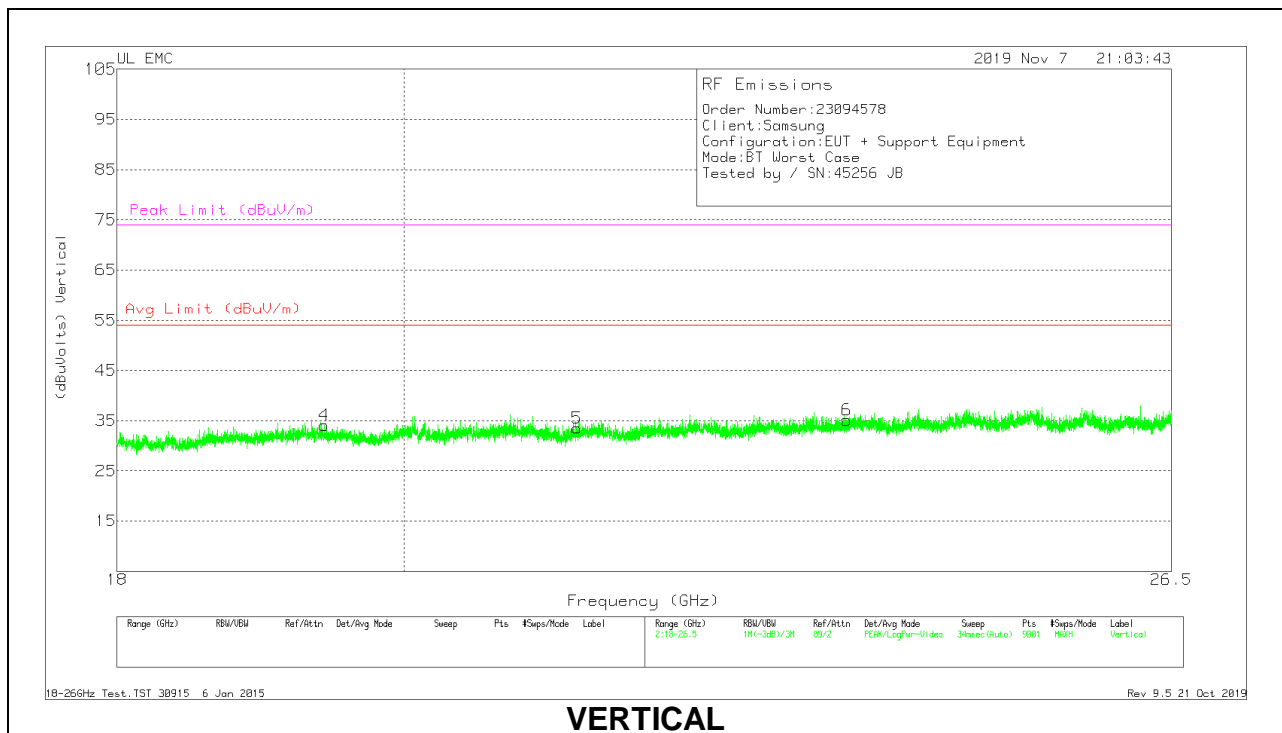

**VERTICAL**

**18 – 26GHz DATA**

Marker	Frequency (GHz)	Meter Reading (dBuV)	Det	T447 AF (dB/m)	Amp/Cbl (dB)	Dist Corr (dB)	Corrected Reading (dBuVolts)	Avg Limit (dBuV/m)	Margin (dB)	Peak Limit (dBuV/m)	PK Margin (dB)
1	19.27122	68.25	Pk	32.7	-57.3	-9.5	34.15	54	-19.85	74	-39.85
2	21.04205	68.06	Pk	33.3	-56.9	-9.5	34.96	54	-19.04	74	-39.04
3	23.10189	67.25	Pk	33.8	-57.7	-9.5	33.85	54	-20.15	74	-40.15
4	19.42139	67.99	Pk	32.7	-57.1	-9.5	34.09	54	-19.91	74	-39.91
5	21.30839	67.23	Pk	33.1	-57.3	-9.5	33.53	54	-20.47	74	-40.47
6	23.52311	67.62	Pk	34.3	-57.3	-9.5	35.12	54	-18.88	74	-38.88

Pk - Peak detector

## 10. AC POWER LINE CONDUCTED EMISSIONS

### LIMITS

FCC §15.207 (a)

Frequency of Emission (MHz)	Conducted Limit (dBuV)	
	Quasi-peak	Average
0.15-0.5	66 to 56*	56 to 46*
0.5-5	56	46
5-30	60	50

\*Decreases with the logarithm of the frequency.

### TEST PROCEDURE

The EUT is placed on a non-conducting table 40 cm from the vertical ground plane and 80 cm above the horizontal ground plane. The EUT is configured in accordance with ANSI C63.4.

The receiver is set to a resolution bandwidth of 9 kHz. Peak detection is used unless otherwise noted as quasi-peak or average.

Line conducted data is recorded for both NEUTRAL and HOT lines.

### RESULTS

AC Power Line Norm

LINE 1 RESULTS

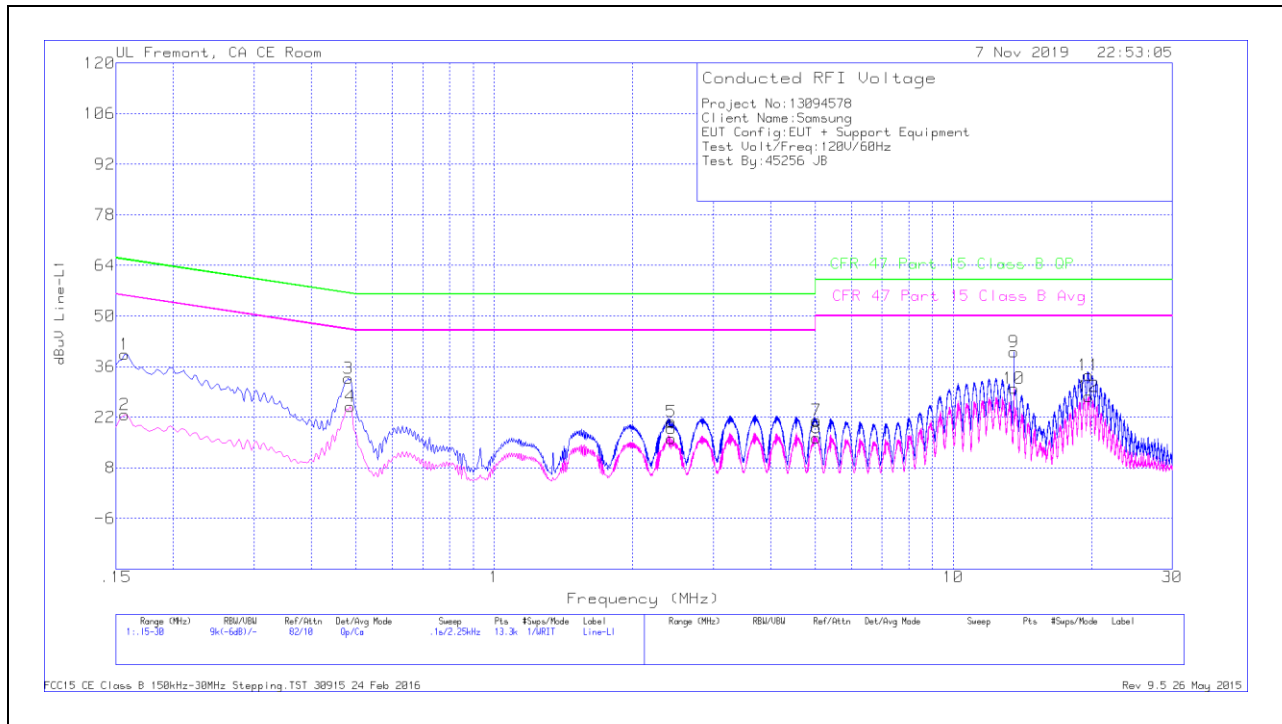

Trace Markers

Range 1: Line-L1 .15 - 30MHz											
Marker	Frequency (MHz)	Meter Reading (dBuV)	Det	LISN L1	LC Cables C1&C3	Limiter (dB)	Corrected Reading dBuV	CFR 47 Part 15 Class B QP	QP Margin (dB)	CFR 47 Part 15 Class B Avg	Av(CISPR) Margin (dB)
1	.15675	29.19	Qp	.1	0	10.1	39.39	65.63	-26.24	-	-
2	.15675	12.54	Ca	.1	0	10.1	22.74	-	-	55.63	-32.89
3	.48075	22.7	Qp	0	0	10.1	32.8	56.33	-23.53	-	-
4	.48525	14.87	Ca	0	0	10.1	24.97	-	-	46.25	-21.28
5	2.4315	10.67	Qp	0	.1	10.1	20.87	56	-35.13	-	-
6	2.4315	5.92	Ca	0	.1	10.1	16.12	-	-	46	-29.88
7	5.03475	10.96	Qp	0	.1	10.1	21.16	60	-38.84	-	-
8	5.03475	6.14	Ca	0	.1	10.1	16.34	-	-	50	-33.66
9	13.56	29.56	Qp	.1	.2	10.2	40.06	60	-19.94	-	-
10	13.56	19.54	Ca	.1	.2	10.2	30.04	-	-	50	-19.96
11	19.716	22.97	Qp	.1	.3	10.3	33.67	60	-26.33	-	-
12	19.7295	17.01	Ca	.1	.3	10.3	27.71	-	-	50	-22.29

Qp - Quasi-Peak detector

Ca - CISPR average detection

NOTE: Markers 9 and 10, 13.56MHz is an external NFC signal unrelated to the EUT.

### LINE 2 RESULTS

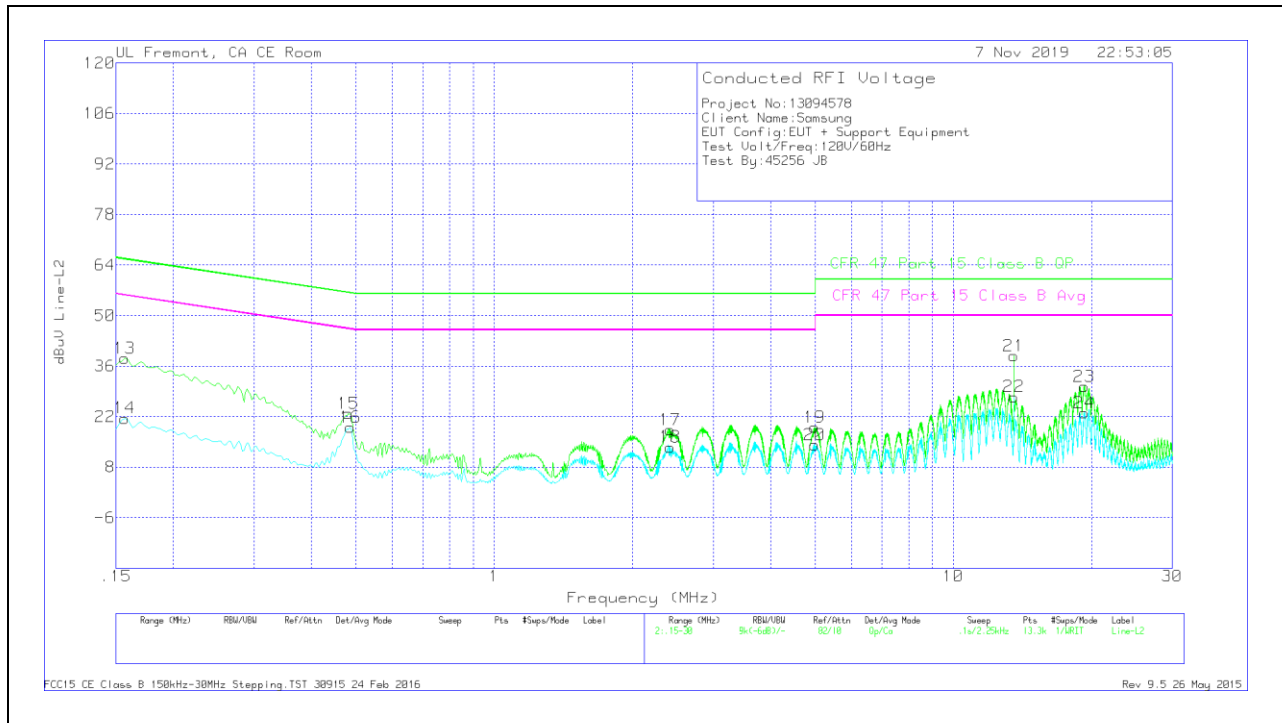

#### Trace Markers

Range 2: Line-L2 .15 - 30MHz											
Marker	Frequency (MHz)	Meter Reading (dBuV)	Det	LISN L2	LC Cables C2&C3	Limiter (dB)	Corrected Reading dBuV	CFR 47 Part 15 Class B QP	QP Margin (dB)	CFR 47 Part 15 Class B Avg	Av(CISPR) Margin (dB)
13	.15675	28.02	Qp	.1	0	10.1	38.22	65.63	-27.41	-	-
14	.15675	11.38	Ca	.1	0	10.1	21.58	-	-	55.63	-34.05
15	.48075	12.84	Qp	0	0	10.1	22.94	56.33	-33.39	-	-
16	.48525	9.03	Ca	0	0	10.1	19.13	-	-	46.25	-27.12
17	2.418	8.21	Qp	0	.1	10.1	18.41	56	-37.59	-	-
18	2.418	3.38	Ca	0	.1	10.1	13.58	-	-	46	-32.42
19	4.99425	8.82	Qp	0	.1	10.1	19.02	56	-36.98	-	-
20	4.99425	4.01	Ca	0	.1	10.1	14.21	-	-	46	-31.79
21	13.56	28.45	Qp	.1	.2	10.2	38.95	60	-21.05	-	-
22	13.56	16.99	Ca	.1	.2	10.2	27.49	-	-	50	-22.51
23	19.29525	19.73	Qp	.1	.3	10.3	30.43	60	-29.57	-	-
24	19.2975	12.39	Ca	.1	.3	10.3	23.09	-	-	50	-26.91

Qp - Quasi-Peak detector

Ca - CISPR average detection

NOTE: Markers 21 and 22, 13.56MHz is an external NFC signal unrelated to the EUT.