



**HAC RF EMISSIONS TEST REPORT**

**FCC 47 CFR § 20.19  
ANSI C63.19-2011**

*For*

**GSM/WCDMA/LTE Phablet with BT, DTS/UNII a/b/g/n/ac, NFC, ANT+ and WPT**

**FCC ID: A3LSMN770F  
Model Name: SM-N770F & SM-N770F/DS**

**Report Number: 13094578-S3V2  
Issue Date: 12/2/2019**

*Prepared for*

**SAMSUNG ELECTRONICS CO., LTD.  
129 SAMSUNG-RO, YEONGTONG-GU,  
SUWON-SI, GYEONGGI-DO, 16677, KOREA**

*Prepared by*

**UL VERIFICATION SERVICES INC.  
47173 BENICIA STREET  
FREMONT, CA 94538, U.S.A.  
TEL: (510) 319-4000  
FAX: (510) 661-0888**



NVLAP LAB CODE 200065-0

**Revision History**

Rev.	Date	Revisions	Revised By
V1	11/15/2019	Initial Issue	--
V2	12/2/2019	Updated Model Names and EUT Description Section 8.1: Updated table	Coltyce Sanders

## Table of Contents

<b>1. Attestation of Test Results</b> .....	<b>4</b>
<b>2. Test Methodology</b> .....	<b>5</b>
<b>3. Facilities and Accreditation</b> .....	<b>5</b>
<b>4. Calibration and Uncertainty</b> .....	<b>5</b>
4.1. <i>Measuring Instrument Calibration</i> .....	5
4.2. <i>Measurement Uncertainty</i> .....	6
<b>5. System Specifications</b> .....	<b>7</b>
<b>6. System Validation</b> .....	<b>8</b>
6.1. <i>System Validation Results</i> .....	8
<b>7. Average Antenna Input Power &amp; Evaluation for Low-power Exemption</b> .....	<b>9</b>
<b>8. Device Under Test</b> .....	<b>10</b>
8.1. <i>Air Interfaces and Operating Mode</i> .....	10
<b>9. Modulation Interference Factor (MIF)</b> .....	<b>11</b>
<b>10. HAC RF Emissions Test Procedure</b> .....	<b>12</b>
<b>11. RF Emissions Measurement Criteria</b> .....	<b>15</b>
<b>12. HAC (RF Emissions) Test Results</b> .....	<b>15</b>
12.1. <i>Worst Case RF Emission Test Plot</i> .....	16
<b>Appendixes</b> .....	<b>17</b>
<i>Appendix A: RF-E Setup Photo</i> .....	17
<i>Appendix B: RF-E System Validation Plots</i> .....	17
<i>Appendix C: RF-E Test Plots</i> .....	17
<i>Appendix D: RF-E MIF Attestation Letter</i> .....	17
<i>Appendix E: RF-E Probe Certificate</i> .....	17
<i>Appendix F: RF-E Dipole Certificates</i> .....	17
<i>Appendix G: RF-E UID Specifications</i> .....	17

## 1. Attestation of Test Results

Applicant Name	SAMSUNG ELECTRONICS CO., LTD.
FCC ID	A3LSMN770F
Model Name	SM-N770F & SM-N770F/DS (Model SM-N770F was used for testing)
Applicable Standards	FCC 47 CFR § 20.19 ANSI C63.19-2011
HAC Rating	M4
Date Tested	11/4/2019
Test Results	Pass

UL Verification Services Inc. tested the above equipment in accordance with the requirements set forth in the above standards. The test results show that the equipment tested is capable of demonstrating compliance with the requirements as documented in this report.

The results documented in this report apply only to the tested sample, under the conditions and modes of operation as described herein. It is the manufacturer's responsibility to assure that additional production units of this model are manufactured with identical electrical and mechanical components. All samples tested were in good operating condition throughout the entire test program. Measurement Uncertainties are published for informational purposes only and were not taken into account unless noted otherwise.

This document may not be altered or revised in any way unless done so by UL Verification Services Inc. and all revisions are duly noted in the revisions section. Any alteration of this document not carried out by UL Verification Services Inc. will constitute fraud and shall nullify the document. This report must not be used by the client to claim product certification, approval, or endorsement by NVLAP, NIST, any agency of the Federal Government, or any agency of the U.S. government.

Approved & Released By:



Devin Chang  
Senior Test Engineer  
UL Verification Services Inc.

Prepared By:



Remi Rodberg  
Laboratory Technician  
UL Verification Services Inc.

## 2. Test Methodology

The tests documented in this report were performed in accordance with ANSI C63.19-2011 Methods of Measurement of Compatibility between Wireless Communications Devices and Hearing Aids and FCC Published procedure

KDB 285076 D01 HAC Guidance v05

KDB 285076 D03 HAC FAQ v01

TCB workshop updates

## 3. Facilities and Accreditation

The test sites and measurement facilities used to collect data are located at

47266 Benicia Street
SAR Lab 3
SAR Lab 7

UL Verification Services Inc. is accredited by NVLAP, Laboratory Code 200065-0.

## 4. Calibration and Uncertainty

### 4.1. Measuring Instrument Calibration

The measuring equipment utilized to perform the tests documented in this report has been calibrated in accordance with the manufacturer's recommendations, and is traceable to recognized national standards.

Name of Equipment	Manufacturer	Type/Model	Serial No.	Cal. Due Date
Synthesized Signal Generator	Agilent	N5181A	MY50140630	1/31/2020
Power Meter	HP	437B	3125U11364	1/29/2020
Power Meter	HP	437B	3125U16345	1/30/2020
Power Sensor	HP	8481A	1926A207048	2/7/2020
Power Sensor	HP	8481A	2237A31744	8/22/2020
Amplifier	MITEQ	AMF-4D-00400600-50-30P	1795093	N/A
Directional coupler	Werlatone	C8060-102	2710	N/A
DC Power Supply	HP	6296A	2841A-05955	N/A
Data Acquisition Electronics	SPEAG	DAE4	1472	3/21/2020
E-Field Probe <sup>1</sup>	SPEAG	EF3DV3	4041	3/22/2020
Calibration Dipole	SPEAG	CD835V3	1175	5/16/2020
Calibration Dipole	SPEAG	CD1880V3	1159	5/16/2020
Calibration Dipole	SPEAG	CD2450V3	1171	1/15/2020
Calibration Dipole	SPEAG	CD2600V3	1014	8/23/2020
Radio Communication Tester	R & S	CMW 500	137873	2/16/2020

#### Note(s):

1: According to SPEAG's Technical Report, "MIF Verification", Doc # TR-FB-12.09.04-1, issued date: 9/4/2012. E-field probes are calibrated with specified uncertainty according to ISO 17025 as described in their calibration certificate. The MIF according to the definition in ANSI C63.19 is specific for a modulation and can therefore be used as a constant value if the probe has been PMR calibrated.

## 4.2. Measurement Uncertainty

Error Description	Uncertainty value (±%)	Probe Dist.	Div.	(Ci) E	Std. Unc.(±%) E
<b>Measurement System</b>					
Probe Calibration	5.1	N	1	1	5.1
Axial Isotropy	4.7	R	1.732	1	2.7
Sensor Displacement	16.5	R	1.732	1	9.5
Boundary Effects	2.4	R	1.732	1	1.4
Phantom Boundary Effects	7.2	R	1.732	1	4.1
Linearity	4.7	R	1.732	1	2.7
Scaling to PMR Calibration	10.0	R	1.732	1	5.8
System Detection Limit	1.0	R	1.732	1	0.6
Readout Electronics	0.3	N	1	1	0.3
Response Time	0.8	R	1.732	1	0.5
Integration Time	2.6	R	1.732	1	1.5
RF Ambient Conditions	3.0	R	1.732	1	1.7
RF Reflections	12.0	R	1.732	1	6.9
Probe Positioner	1.2	R	1.732	1	0.7
Probe Positioning	4.7	R	1.732	1	2.7
Extrapolation and Interpolation	1.0	R	1.732	1	0.6
<b>Test sample Related</b>					
Test Positioning Vertical	4.7	R	1.732	1	2.7
Test Positioning Lateral	1.0	R	1.732	1	0.6
Device Holder and Phantom	2.4	R	1.732	1	1.4
Power Drift	5.0	R	1.732	1	2.9
<b>Phantom and Setup Related</b>					
Phantom Thickness	2.4	R	1.732	1	1.4
Combined Std. Uncertainty					16.3
<b>Expanded Std. Uncertainty on Power (Coverage Factor for 95%, k = 2)</b>					<b>32.6</b>
<b>Expanded Std. Uncertainty on Field</b>					<b>16.3</b>
Notes for table					
1. N - Nomal					
2. R - Rectangular					
3. Div. - Divisor used to obtain standard uncertainty					
4. Ci - is te sensitivity coefficient					

## 5. System Specifications

E-field measurements are performed using the DASY52 automated dosimetric assessment system. The DASY52 is made by Schmid & Partner Engineering AG (SPEAG) in Zurich, Switzerland.

The DASY52 HAC Extension consists of the following parts:

### Test Arch Phantom

The specially designed Test Arch allows high precision positioning of both the device and any of the validation dipoles.

### EF3DV3 Isotropic E-Field Probe

Construction:	One dipole parallel, two dipoles normal to probe axis Interleaved sensors Built-in shielding against static charges PEEK enclosure material
Calibration:	In air from 100 MHz to 3.0 GHz (absolute accuracy $\pm 6.0\%$ , $k=2$ ) ISO/IEC 17025 <u>calibration service</u> available.
Frequency:	40 MHz – >6 GHz (can be extended to < 20 MHz); Linearity: $\pm 0.2$ dB (100 MHz – 3 GHz)
Directivity:	$\pm 0.2$ dB in air (rotation around probe axis) $\pm 0.4$ dB in air (rotation normal to probe axis)
Dynamic Range:	2 V/m to > 1000 V/m; Linearity: $\pm 0.2$ dB
Dimensions:	Overall length: 337 mm (Tip: 20 mm) Tip diameter: 3.9 mm (Body: 12 mm) Distance from probe tip to dipole centers: 1.5 mm Sensor displacement to probe's calibration point: <0.7 mm
Application:	General near-field measurements up to 6 GHz HAC measurements up to 6 GHz Field component measurements Fast automatic scanning in phantoms

## 6. System Validation

The test setup was validated when first configured and verified periodically thereafter to ensure proper function. The procedure provided in this section is a validation procedure using dipole antennas for which the field levels were computed by numeric modeling.

Procedure:

Place a dipole antenna meeting the requirements given in ANSI C63.19 in the normally occupied by the WD.

The dipole antenna serves as a known source for an electrical and magnetic output. Position the E-field probe so that the following occurs:

- The probes and their cables are parallel to the coaxial feed of the dipole antenna
- The probe cables and the coaxial feed of the dipole antenna approach the measurement area from opposite directions
- The center point of the probe element(s) is 15 mm from the closest surface of the dipole elements.

Scan the length of the dipole with the E-field probe and record the two maximum values found near the dipole ends. Average the two readings and compare the reading to the expected value in the calibration certificate or the expected value in this standard.

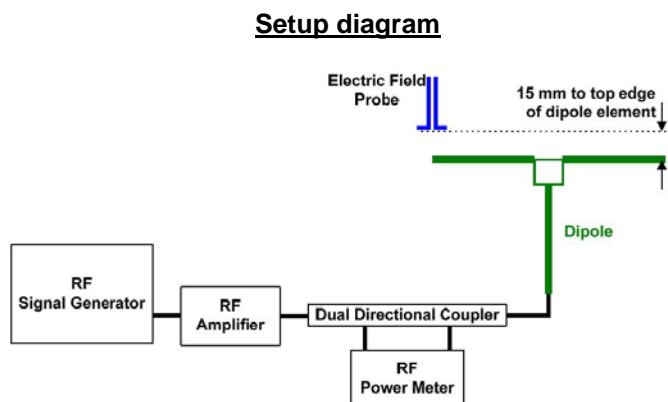

### 6.1. System Validation Results

SAR Lab	Date	Dipole Type_Serial #_Freq.	Dipole Cal. Due Data	Max. measured from		Average max. above arm (V/m)	Target (V/m) (From SPEAG)	Deviation (note 1) ± %	Plot No.
				above high end (V/m)	above low end (V/m)				
3	11/4/2019	CD835V3_SN:1175_(835 MHz)	5/16/2020	41.07	42.30	121.71	105.80	15.04	1
3	11/4/2019	CD1880V3_SN:1159_(1880 MHz)	5/16/2020	39.38	39.80	95.42	86.20	10.69	2
3	11/4/2019	CD2450V3_SN:1171_(2450 MHz)	1/15/2020	39.12	39.06	90.05	84.10	2.80	3
3	11/4/2019	CD2600V3_SN:1014_(2600 MHz)	8/23/2020	39.19	39.36	92.00	84.70	8.61	4

#### Notes:

- 1) Delta (Deviation) % = 100 \* (Measured value minus Target value) divided by the Target value. Deltas within ±25% are acceptable, of which 12% is deviation and 13% is measurement uncertainty.
- 2) The maximum E-field or were evaluated and compared to the target values provided by SPEAG in the calibration certificate of specific dipoles.
- 3) Please refer to the appendix for detailed measurement data and plots.

## 7. Average Antenna Input Power & Evaluation for Low-power Exemption

An RF air interface technology of a device is exempt from testing when its average antenna input power plus its **MIF is  $\leq 17$  dBm** for any of its operating modes. If a device supports multiple RF air interfaces, each RF air interface shall be evaluated individually.

Air-Interface	Average Antenna Input Power (dBm) <sup>1</sup>	Worst Case MIF (dB)	Input Power plus its MIF (dBm)	HAC Tested
GSM850	33.5	3.63	37.13	Yes
GSM1900	30.5	3.63	34.13	Yes
W-CDMA Band II	25.0	-27.23	-2.23	No
W-CDMA Band IV	25.0	-27.23	-2.23	No
W-CDMA Band V	25.0	-27.23	-2.23	No
LTE Band 2	25.5	-9.76	15.74	No
LTE Band 4	25.0	-9.76	15.24	No
LTE Band 5	25.5	-9.76	15.74	No
LTE Band 12	25.5	-9.76	15.74	No
LTE Band 13	25.0	-9.76	15.24	No
LTE Band 17	25.5	-9.76	15.74	No
LTE Band 41	25.0	-1.44	23.56	Yes
LTE Band 66	25.0	-9.76	15.24	No
802.11b	16.0	-2.02	13.98	No
802.11g/n	16.0	0.12	16.12	No
802.11a/n/ac	14.0	-3.15	10.85	No
Bluetooth GFSK DH1	16.0	1.02	17.02	Yes
Bluetooth GFSK DH5	16.0	-3.98	12.02	No

### Note(s):

1. Max tune-up limit
2. WLAN supports power reduction during a voice call.

### 8. Device Under Test

Normal operation	Held to head		
Back Cover	The Back Cover is not removable		
Test sample information	<b>S/N</b> R38MA039RMJ	<b>IMEI</b> 352339110058415 352340110058413	<b>Notes</b> HAC Radiated

### 8.1. Air Interfaces and Operating Mode

Air Interface	Bands (MHz)	Type	C63.19 Tested	Simultaneous Transmitter	Name of Voice Service	Power Reduction
GSM	850	VO	Yes	Wi-Fi, BT	CMRS	N/A
	1900					No
	GPRS/EDGE	DT	No <sup>1</sup>	Wi-Fi, BT	Google Duo	N/A
W-CDMA (UMTS)	850	VO	Yes	Wi-Fi, BT	CMRS	N/A
	1700					
	1900	VD	No <sup>1</sup>	Wi-Fi, BT	Google Duo	N/A
HSPA						
LTE - FDD	700 (B12/13/17)	VD	No <sup>1</sup>	Wi-Fi, BT	Google Duo & VoLTE	N/A
	850 (B5)					
	1700 (B4/66)					
	1900 (B2)					
LTE - TDD	2600 (41)	VD	Yes	Wi-Fi, BT	Google Duo & VoLTE	N/A
Wi-Fi	2450	VD	No <sup>1</sup>	WWAN and Wi-Fi 5GHz	Google Duo & Wi-Fi calling	N/A
	5200 (U-NII-1)			WWAN, BT and Wi-Fi 2.4GHz		
	5300 (U-NII-2A)					
	5500 (U-NII-2C)					
	5800 (U-NII-3)					
BT	2450	DT	Yes	WWAN, Wi-Fi (5 GHz bands)	NA	N/A

<p>Type</p> <p>VO: Legacy Cellular Voice Service</p> <p>DT: Digital Transport only (no voice)</p> <p>VD: IP Voice Service over Digital Transport</p> <p>CMRS: Commercial Mobile Radio Service</p>	<p>Note:</p> <p>1. Evaluated for MIF and low power exemption</p>
---	--

## 9. Modulation Interference Factor (MIF)

The HAC Standard ANSI C63.19 defines a new scaling using the Modulation Interference Factor (MIF) which replaces the need for the Articulation Weighting Factor (AWF) during the evaluation and is applicable to any modulation scheme.

The Modulation Interference factor (MIF, in dB) is added to the measured average E-field (in dBV/m) and converts it to the RF Audio Interference level (in dBV/m). This level considers the audible amplitude modulation components in the RF E-field. CW fields without amplitude modulation are assumed to not interfere with the hearing aid electronics. Modulations without time slots and low fluctuations at low frequencies have low MIF values, TDMA modulations with narrow transmission and repetition rates of few 100 Hz have high MIF values and give similar classifications as ANSI C63.19.

### Definitions

E-field probes have a bandwidth <10 kHz and can therefore not evaluate the RF envelope in the full audio band. DASY52 is therefore using the "indirect" measurement method according to ANSI C63.19 which is the primary method. These near field probes read the averaged E-field measurement. Especially for the new high peak-to-average (PAR) signal types, the probes shall be linearized by probe modulation response (PMR) calibration in order to not overestimate the field reading.

The evaluation method of the MIF is defined in ANSI C63.19 section D.7. An RMS demodulated RF signal is fed to a spectral filter (similar to an A weighting filter) and forwarded to a temporal filter acting as a quasi-peak detector. The averaged output of these filtering is called to a 1 kHz 80% AM signal as reference. MIF measurement requires additional instrumentation and is not well suited for evaluation by the end user with reasonable uncertainty. It may alternatively be determined through analysis and simulation, because it is constraint and characteristic for a communication signal. DASY52 uses well defined signals for PMR calibration. The MIF of these signals has been determined by simulation and is automatically applied.

MIF values were not tested by a probe or as specified in the standards but are based on analysis provided by SPEAG for all the air interfaces (GSM, WCDMA, LTE, and Wi-Fi). The data included in this report are for the worst case operating modes. The UIDs used are listed below:

UID	Communication System Name	MIF (dB)
10021-DAC	GSM-FDD (TDMA, GMSK)	3.63
10011-CAB	UMTS-FDD (WCDMA)	-27.23
10170-CAE	LTE-FDD (SC-FDMA, 1 RB, 20 MHz, 16QAM)	-9.76
10182-CAE	LTE-FDD (SC-FDMA, 1 RB, 15 MHz, 16QAM)	-9.76
10176-CAF	LTE-FDD (SC-FDMA, 1 RB, 10 MHz, 16QAM)	-9.76
10178-CAF	LTE-FDD (SC-FDMA, 1 RB, 5 MHz, 16QAM)	-9.76
10173-CAF	LTE-TDD (SC-FDMA, 1 RB, 20 MHz, 16QAM)	-1.44
10061-CAB	IEEE 802.11b WiFi 2.4 GHz (DSSS, 11 Mbps)	-2.02
10077-CAB	IEEE 802.11g WiFi 2.4 GHz (DSSS/OFDM, 54 Mbps)	0.12
10069-CAC	IEEE 802.11a/n WiFi 5 GHz (OFDM, 54 Mbps)	-3.15
10030-CAA	IEEE 802.15.1 Bluetooth (GFSK, DH1)	1.02
10032-CAA	IEEE 802.15.1 Bluetooth (GFSK, DH5)	-3.98

A PMR calibrated probe is linearized for the selected waveform over the full dynamic range within the uncertainty specified in its calibration certificate. E-field probes have a bandwidth <10 kHz and can therefore not evaluate the RF envelope in the full audio band. DASY52 is therefore using the "indirect" measurement method according to ANSI C63.19 which is the primary method. These near field probes read the averaged E-field measurement. Especially for the new high peak-to-average (PAR) signal types, the probes shall be linearized by PMR calibration in order to not overestimate the field reading.

The MIF measurement uncertainty is estimated as follows, for modulation frequencies from slotted waveforms with fundamental frequency and at least 2 harmonics within 10 kHz:

- 0.2 dB for MIF -7 to +5 dB,
- 0.5 dB for MIF -13 to +11 dB
- 1 dB for MIF > -20 dB

## 10. HAC RF Emissions Test Procedure

The following are step-by-step test procedures.

- a) Confirm proper operation of the field probe, probe measurement system and other instrumentation and the positioning system.
- b) Position the WD in its intended test position.
- c) Set the WD to transmit a fixed and repeatable combination of signal power and modulation characteristic that is representative of the worst case (highest interference potential) encountered in normal use. Transiently occurring start-up, changeover, or termination conditions, or other operations likely to occur less than 1% of the time during normal operation, may be excluded from consideration.
- d) The center sub-grid shall be centered on the T-Coil mode perpendicular measurement point or the acoustic output, as appropriate. Locate the field probe at the initial test position in the 50 mm by 50 mm grid, which is contained in the measurement plane, refer to illustrated in Figure 1. If the field alignment method is used, align the probe for maximum field reception.
- e) Record the reading at the output of the measurement system
- f) Scan the entire 50 mm by 50 mm region in equally spaced increments and record the reading at each measurement point. The distance between measurement points shall be sufficient to assure the identification of the maximum reading.
- g) Identify the five contiguous sub-grids around the center sub-grid whose maximum reading is the lowest of all available choices. This eliminates the three sub-grids with the maximum readings. Thus, the six areas to be used to determine the WD's highest emissions are identified.
- h) Identify the maximum reading within the non-excluded sub-grids identified in step g).
- i) Convert the highest field reading within identified in step h) to RF audio interference level, in V/m, by taking the square root of the reading and then dividing it by the measurement system transfer function, established in 5.5.1.1 Convert this result to dB(V/m) by taking the base-10 logarithm and multiplying by 20.

Indirect measurement method

Replacing step i), the RF audio interference level in dB (V/m) is obtained by adding the MIF (in dB) to the maximum steady-state rms field-strength reading, in dB (V/m), from step h). Use this result to determine the category rating

- j) Compare this RF audio interference level with the categories in Clause 8 (ANSI C63.19) and record the resulting WD category rating
- k) For the T-Coil mode M-rating assessment, determine whether the chosen perpendicular measurement point is contained in an included sub-grid of the first scan. If so, then a second scan is not necessary. The first scan and resultant category rating may be used for the T-Coil mode M rating.

Otherwise, repeat step a) through step i), with the grid shifted so that it is centered on the perpendicular measurement point. Record the WD category rating.



Figure 1 - WD reference and plane for RF emission measurements

## Test flowchart Per ANSI-63.19-2011

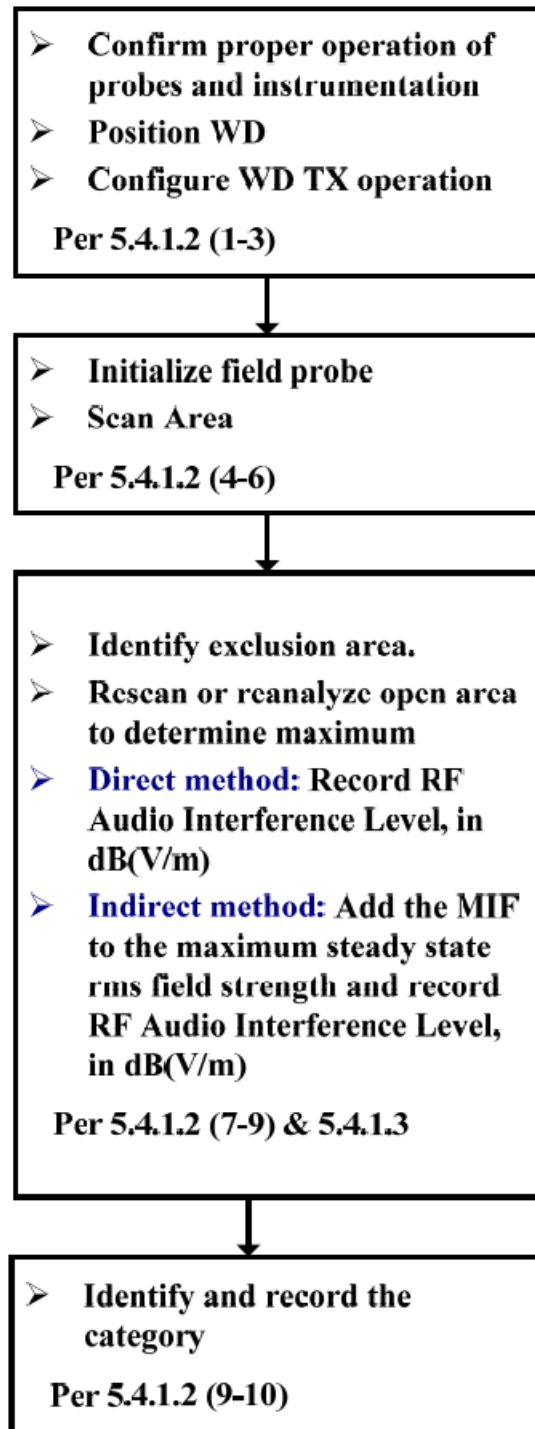

## 11. RF Emissions Measurement Criteria

WD RF audio interference level categories in logarithmic units

Emission Categories	E-field emissions	
	< 960 MHz	> 960 MHz
Category M1	50 to 55 dB (V/m)	40 to 45 dB (V/m)
Category M2	45 to 50 dB (V/m)	35 to 40 dB (V/m)
Category M3	40 to 45 dB (V/m)	30 to 35 dB (V/m)
Category M4	<40 dB (V/m)	<30 dB (V/m)

## 12. HAC (RF Emissions) Test Results

MIF values were not tested by a probe or as specified in the standards but are based on analysis provided by SPEAG for the following User Identifiers and air interfaces.

The data included in this report are for the worst case operating modes. Refer to Appendix D and G for the MIF values that represent the worst case operation modes.

Refer to Section 7 Evaluation for Low-power Exemption. RF Emission testing for this device is required only for GSM, LTE-TDD, and Bluetooth. All other applicable air-interfaces are exempt from testing in accordance with C63.19 Clause 4.4 and are rated M4.

Air-Interface	Ch. No.	Freq. (MHz)	Results* (dB V/m)	Results plus 0.2dB uncertainty (dB V/m)	Margin (dB)	M-Rating	Plot No.
GSM850	128	824.2	31.21	31.41	8.59	M4	1
	190	836.6	32.53	32.73	7.27	M4	2
	251	848.8	33.03	33.23	6.77	M4	3
GSM1900	512	1850.2	21.23	21.43	8.57	M4	4
	661	1880	20.60	20.80	9.20	M4	5
	810	1909.8	20.17	20.37	9.63	M4	6
LTE-TDD Band 41	39750	2506	13.57	13.77	16.23	M4	7
	40185	2549.5	14.03	14.23	15.77	M4	8
	40620	2593	15.13	15.33	14.67	M4	9
	41055	2636.5	15.32	15.52	14.48	M4	10
	41490	2680	15.56	15.76	14.24	M4	11
Bluetooth GFSK DH1	0	2402	17.99	18.19	11.81	M4	12
	39	2441	18.32	18.52	11.48	M4	13
	78	2480	17.90	18.10	11.90	M4	14

### Note(s):

\*: Measured Audio Interference level in dB (V/m): indirect method (max rms field strength Plus MIF)

## 12.1. Worst Case RF Emission Test Plot

Test Laboratory: UL Verification Services Inc., SAR Lab 3

Date: 11/4/2019

### HAC-RF Emission

Communication System: UID 10021 - CAA, GSM-FDD (TDMA, GMSK); Frequency: 848.6 MHz; Duty Cycle: 1:8.6896

Phantom section: RF Section

DASY5 Configuration:

- Probe: EF3DV3 - SN4041; ConvF(1, 1, 1) @ 848.6 MHz; Calibrated: 3/22/2019

- Sensor-Surface: (Fix Surface)

- Electronics: DAE4 Sn1472; Calibrated: 3/21/2019

- Phantom: HAC Test Arch with AMCC; Type: SD HAC P01 BB

- Measurement SW: DASY52, Version 52.10 (2);SEMCAD X Version 14.6.12 (7470)

### GSM850 E-Field measurement/Voice\_ch 251/Hearing Aid Compatibility Test

**(101x101x1)**: Interpolated grid: dx=0.5000 mm, dy=0.5000 mm

Device Reference Point: 0, 0, -6.3 mm

Reference Value = 38.47 V/m; Power Drift = -0.07 dB

Applied MIF = 3.63 dB

RF audio interference level = 33.03 dBV/m

Emission category: **M4**

MIF scaled E-field

Grid 1 <b>M4</b> <b>30.76 dBV/m</b>	Grid 2 <b>M4</b> <b>32.06 dBV/m</b>	Grid 3 <b>M4</b> <b>31.88 dBV/m</b>
Grid 4 <b>M4</b> <b>31.77 dBV/m</b>	Grid 5 <b>M4</b> <b>33.03 dBV/m</b>	Grid 6 <b>M4</b> <b>32.89 dBV/m</b>
Grid 7 <b>M4</b> <b>32.92 dBV/m</b>	Grid 8 <b>M4</b> <b>33.86 dBV/m</b>	Grid 9 <b>M4</b> <b>33.62 dBV/m</b>

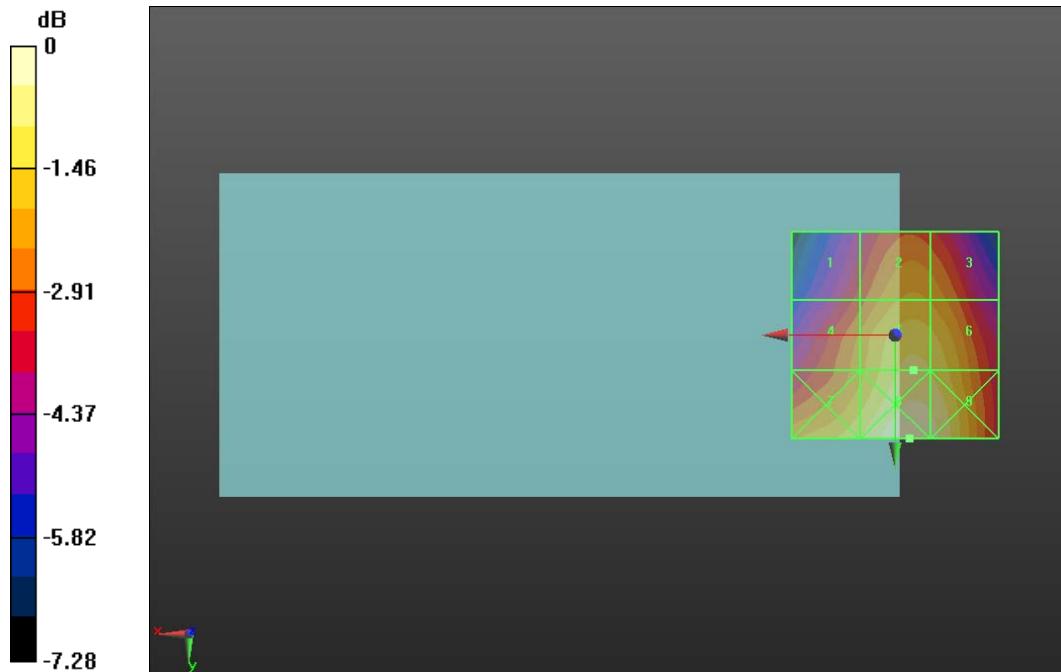

0 dB = 49.32 V/m = 33.86 dBV/m

## **Appendixes**

**Refer to separated files for the following appendixes**

**Appendix A: RF-E Setup Photo**

**Appendix B: RF-E System Validation Plots**

**Appendix C: RF-E Test Plots**

**Appendix D: RF-E MIF Attestation Letter**

**Appendix E: RF-E Probe Certificate**

**Appendix F: RF-E Dipole Certificates**

**Appendix G: RF-E UID Specifications**

**END OF REPORT**