



TEST REPORT

Report Number. : 13094578-E4V2

Applicant : Samsung Electronics Co., Ltd.
129 Samsung-Ro, Yeongtong-Gu,
Suwon-Si, Gyeonggi-Do, 16677, Korea

Model : SM-N770F and SM-N770F/DS

FCC ID : A3LSMN770F

EUT Description : GSM/WCDMA/LTE Phablet with BT, DTS/UNII a/b/g/n/ac, NFC
ANT+, and WPT

Test Standard(s) : FCC 47 CFR PART 15 SUBPART C

Date Of Issue:

December 02, 2019

Prepared by:

UL Verification Services Inc.
47173 Benicia Street
Fremont, CA 94538 U.S.A.
TEL: (510) 319-4000
FAX: (510) 661-0888



NVLAP Lab code: 200065-0

REPORT REVISION HISTORY

<u>Rev.</u>	<u>Issue Date</u>	<u>Revisions</u>	<u>Revised By</u>
V1	11/19/2019	Initial Issue	
V2	12/2/2019	Updated Section 1, 2, 5, 6, 8, and 9	Steven Tran

TABLE OF CONTENTS

REPORT REVISION HISTORY	2
TABLE OF CONTENTS	3
1. ATTESTATION OF TEST RESULTS	5
2. TEST METHODOLOGY	7
3. FACILITIES AND ACCREDITATION	7
4. CALIBRATION AND UNCERTAINTY	8
4.1. MEASURING INSTRUMENT CALIBRATION	8
4.2. SAMPLE CALCULATION	8
4.3. MEASUREMENT UNCERTAINTY	8
5. EQUIPMENT UNDER TEST	9
5.1. EUT DESCRIPTION	9
5.2. MAXIMUM OUTPUT POWER	9
5.3. DESCRIPTION OF AVAILABLE ANTENNAS	9
5.4. SOFTWARE	9
5.5. WORST-CASE CONFIGURATION AND MODE	10
5.6. DESCRIPTION OF TEST SETUP	11
6. MEASUREMENT METHOD	14
7. TEST AND MEASUREMENT EQUIPMENT	15
8. ANTENNA PORT TEST RESULTS	16
8.1. ON TIME AND DUTY CYCLE	16
8.2. 6 dB BANDWIDTH	18
8.2.1. 802.11b MODE	19
8.2.2. 802.11g MODE	23
8.2.3. 802.11n HT20 MODE	26
8.3. OUTPUT POWER	29
8.3.1. 802.11b MODE	30
8.3.2. 802.11g MODE	32
8.3.3. 802.11n HT20 MODE	33
8.4. POWER SPECTRAL DENSITY	34
8.4.1. 802.11b MODE	35
8.4.2. 802.11g MODE	39
8.4.3. 802.11n HT20 MODE	42
8.5. CONDUCTED SPURIOUS EMISSIONS	45
8.5.1. 802.11b MODE	46
8.5.2. 802.11g MODE	50

8.5.3.	802.11n HT20 MODE	54
9.	RADIATED TEST RESULTS.....	58
9.1.	TRANSMITTER ABOVE 1 GHz	60
9.2.	SPURIOUS EMISSIONS FOR SIMULTANEOUS TRANSMISSION.....	116
9.2.1.	TEST CASE 1.....	117
9.2.2.	TEST CASE 2.....	119
9.2.3.	TEST CASE 3.....	121
9.3.	WORST CASE BELOW 30MHZ	123
9.4.	WORST CASE BELOW 1 GHZ.....	124
9.5.	WORST CASE 18-26 GHZ.....	126
10.	AC POWER LINE CONDUCTED EMISSIONS	128
11.	SETUP PHOTOS	131

1. ATTESTATION OF TEST RESULTS

COMPANY NAME: Samsung Electronics Co., Ltd.
129 Samsung-Ro, Yeongtong-Gu,
Suwon-Si, Gyeonggi-Do, 16677, Korea

EUT DESCRIPTION: GSM/WCDMA/LTE Phablet with BT, DTS/UNII a/b/g/n/ac, NFC,
ANT+, and WPT

MODEL: SM-N770F and SM-N770F/DS

SERIAL NUMBER: Conducted: R38MA039RER
Radiated: R38MA039SFP

DATE TESTED: OCTOBER 31 – NOVEMBER 27, 2019

APPLICABLE STANDARDS	
STANDARD	TEST RESULTS
CFR 47 Part 15 Subpart C	Complies

UL Verification Services Inc. tested the above equipment in accordance with the requirements set forth in the above standards. The test results show that the equipment tested is capable of demonstrating compliance with the requirements as documented in this report.

The results documented in this report apply only to the tested sample, under the conditions and modes of operation as described herein. It is the manufacturer's responsibility to assure that additional production units of this model are manufactured with identical electrical and mechanical components. All samples tested were in good operating condition throughout the entire test program. Measurement Uncertainties are published for informational purposes only and were not taken into account unless noted otherwise.

This document may not be altered or revised in any way unless done so by UL Verification Services Inc. and all revisions are duly noted in the revisions section. Any alteration of this document not carried out by UL Verification Services Inc. will constitute fraud and shall nullify the document. This report must not be used by the client to claim product certification, approval, or endorsement by NVLAP, NIST, any agency of the Federal Government, or any agency of the U.S. government.

Approved & Released For
UL Verification Services Inc. By:



Dan Corona
Operations Leader
Consumer Technology Division
UL Verification Services Inc.

Prepared By:



Glenn Escano
Test Engineer
Consumer Technology Division
UL Verification Services Inc.

Reviewed By:



Steven Tran
Project Engineer
Consumer Technology Division
UL Verification Services Inc.

2. TEST METHODOLOGY

The tests documented in this report were performed in accordance with FCC CFR 47 Part 2, FCC CFR 47 Part 15, ANSI C63.10-2013, KDB 414788 D01 Radiated Test Site v01r01, and KDB 558074 D01 15.247 Meas Guidance v05r02.

3. FACILITIES AND ACCREDITATION

The test sites and measurement facilities used to collect data are located at 47173 and 47266 Benicia Street, and 47658 Kato Road, Fremont, California, USA. Line conducted emissions are measured only at the 47173 address. The following table identifies which facilities were utilized for radiated emission measurements documented in this report. Specific facilities are also identified in the test results sections.

47173 Benicia Street	47266 Benicia Street	47658 Kato Rd
<input type="checkbox"/> Chamber A	<input type="checkbox"/> Chamber D	<input checked="" type="checkbox"/> Chamber I
<input type="checkbox"/> Chamber B	<input type="checkbox"/> Chamber E	<input type="checkbox"/> Chamber J
<input type="checkbox"/> Chamber C	<input type="checkbox"/> Chamber F	<input checked="" type="checkbox"/> Chamber K
	<input type="checkbox"/> Chamber G	<input type="checkbox"/> Chamber L
	<input type="checkbox"/> Chamber H	<input type="checkbox"/> Chamber M

The above test sites and facilities are covered under FCC Test Firm Registration # 208313. Chambers above are covered under Industry Canada company address and respective code: 2324A.

UL Verification Services Inc. is accredited by NVLAP, Laboratory Code 200065-0

4. CALIBRATION AND UNCERTAINTY

4.1. MEASURING INSTRUMENT CALIBRATION

The measuring equipment utilized to perform the tests documented in this report has been calibrated in accordance with the manufacturer's recommendations, and is traceable to recognized national standards.

4.2. SAMPLE CALCULATION

RADIATED EMISSIONS

Where relevant, the following sample calculation is provided:

Field Strength (dBuV/m) = Measured Voltage (dBuV) + Antenna Factor (dB/m) + Cable Loss (dB) – Preamp Gain (dB)

$$36.5 \text{ dBuV} + 18.7 \text{ dB/m} + 0.6 \text{ dB} - 26.9 \text{ dB} = 28.9 \text{ dBuV/m}$$

MAINS CONDUCTED EMISSIONS

Where relevant, the following sample calculation is provided:

Final Voltage (dBuV) = Measured Voltage (dBuV) + Cable Loss (dB) + Limiter Factor (dB) + LISN Insertion Loss.

$$36.5 \text{ dBuV} + 0 \text{ dB} + 10.1 \text{ dB} + 0 \text{ dB} = 46.6 \text{ dBuV}$$

4.3. MEASUREMENT UNCERTAINTY

Where relevant, the following measurement uncertainty levels have been estimated for tests performed on the apparatus:

PARAMETER	UNCERTAINTY
Worst Case Conducted Disturbance, 9KHz to 0.15 MHz	3.39 dB
Worst Case Conducted Disturbance, 0.15 to 30 MHz	3.07 dB
Worst Case Radiated Disturbance, 9KHz to 30 MHz	2.52 dB
Worst Case Radiated Disturbance, 30 to 1000 MHz	4.88 dB
Worst Case Radiated Disturbance, 1000 to 18000 MHz	4.24 dB
Worst Case Radiated Disturbance, 18000 to 26000 MHz	4.37 dB
Worst Case Radiated Disturbance, 26000 to 40000 MHz	5.17 dB

Uncertainty figures are valid to a confidence level of 95%.

5. EQUIPMENT UNDER TEST

5.1. EUT DESCRIPTION

The EUT is a GSM/WCDMA/LTE Phablet with BT, DTS/UNII a/b/g/n/ac, NFC and ANT+. The model SM-N770F was used for final testing and is representative of the test results in this report.

5.2. MAXIMUM OUTPUT POWER

The transmitter has a maximum conducted output power as follows:

Frequency Range (MHz)	Mode	Output Power (dBm)	Output Power (mW)
2412 - 2472	802.11b Chain 0 - 1TX	18.62	72.78
2412 - 2472	802.11b Chain 1 - 1TX	18.56	71.78
2412 - 2472	802.11g CDD - 2TX	19.24	83.95
2412 - 2472	802.11n HT20 CDD -2TX	18.33	68.08

5.3. DESCRIPTION OF AVAILABLE ANTENNAS

The radio utilizes an internal antenna, with a maximum gain as follows:

Frequency Range (MHz)	Chain 0 Peak Antenna Gain (dBi)	Chain 1 Peak Antenna Gain (dBi)
2412 -2472	-5.10	-8.09

NOTE:

Antenna 1 = Chain 0 = WIFI1

Antenna 2 = Chain 1 = WIFI2

5.4. SOFTWARE

The test utility software used during testing was N770F.001.

5.5. WORST-CASE CONFIGURATION AND MODE

Radiated emissions below 1GHz, above 18GHz, and power line conducted emission were performed with the EUT set to transmit at the channel with highest output power as worst-case scenario.

Band edge and radiated emissions between 1GHz and 18GHz were performed with the EUT set to transmit at the highest power on low, middle and high channels.

For SISO (Antenna, Chain 0), the fundamental of the EUT was investigated in three orthogonal orientations X,Y,Z, it was determined that Z orientation was worst-case orientation; therefore, all final radiated testing was performed with the EUT in Z orientation.

For SISO (Antenna, Chain 1), the fundamental of the EUT was investigated in three orthogonal orientations X,Y,Z, it was determined that X orientation was worst-case orientation; therefore, all final radiated testing was performed with the EUT in X orientation.

For MIMO, the fundamental of the EUT was investigated in three orthogonal orientations X,Y,Z, it was determined that Y orientation was worst-case orientation; therefore, all final radiated testing was performed with the EUT in Y orientation.

Worst-case data rates as provided by the client were:

802.11b mode: 11 Mbps

802.11g mode: 6 Mbps

802.11n HT20mode: MCS0

All radios that can be transmitted simultaneously have been evaluated for radiated for all possible combinations of transmission and found to be in compliance.

5.6. DESCRIPTION OF TEST SETUP

SUPPORT EQUIPMENT

Support Equipment List				
Description	Manufacturer	Model	Serial Number	FCC ID
AC Adapter	Samsung	EP-TA800	R37M3531XX1SE3	N/A
Earphone	Samsung	N/A	N/A	N/A

I/O CABLES (CONDUCTED TEST)

I/O Cable List						
Cable No	Port	# of identical ports	Connector Type	Cable Type	Cable Length (m)	Remarks
1	Antenna	1	RF	Shielded	0.2	To spectrum Analyzer
2	USB	1	USB	Un-shielded	1	EUT to AC Mains

I/O CABLES (RADIATED AND CONDUCTED EMISSIONS)

I/O Cable List						
Cable No	Port	# of identical ports	Connector Type	Cable Type	Cable Length (m)	Remarks
1	USB	1	USB	Shielded	1	N/A
2	Earphone	1	3.5mm	Un-shielded	1	N/A

TEST SETUP

The EUT is a stand alone unit. Test software exercised the radio card.

CONDUCTED TEST SETUP DIAGRAM

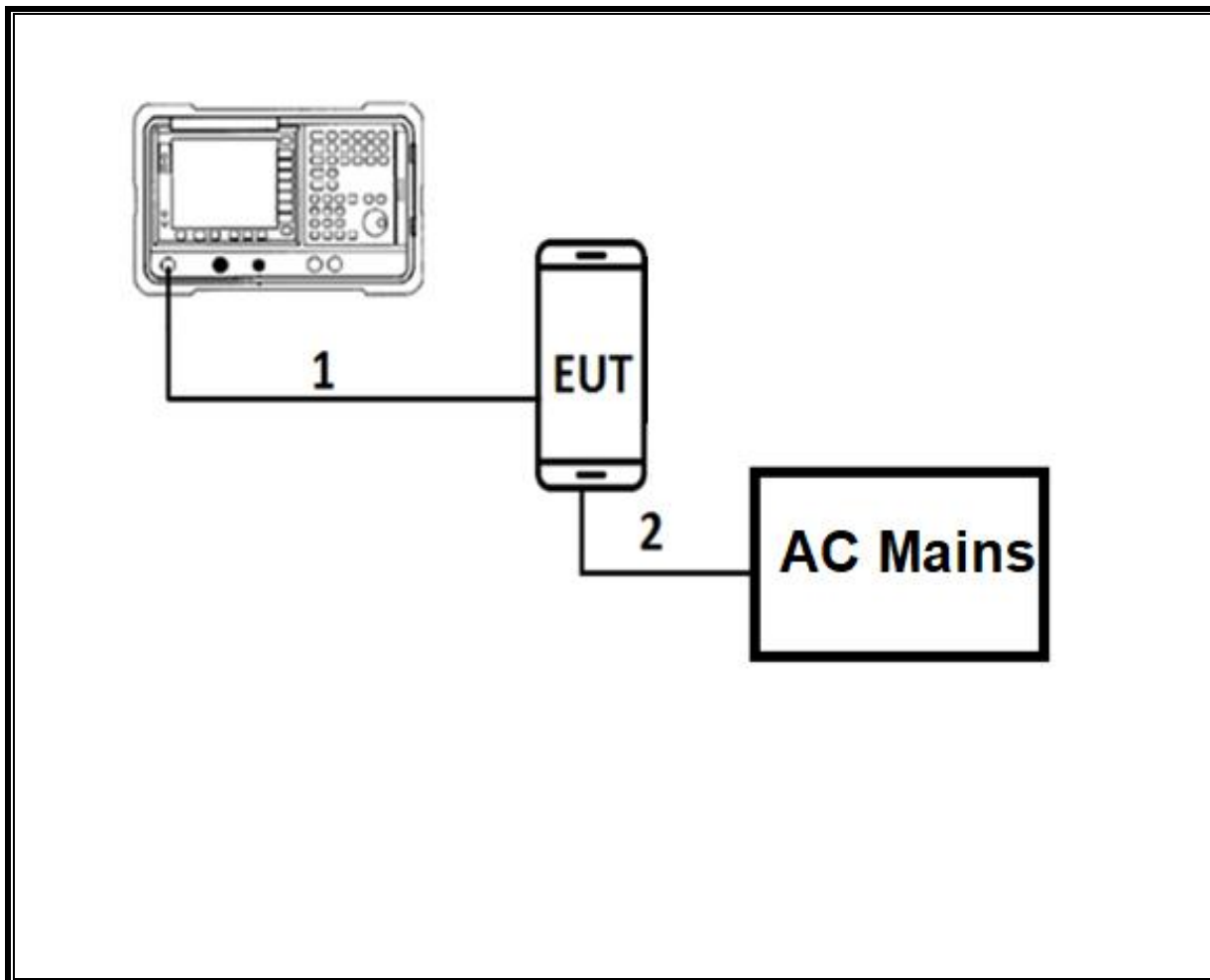

TEST SETUP

For conducted tests: the EUT was stand alone. The test software exercises the radio.

RADIATED AND AC LINE CONDUCTED EMISSIONS SETUP DIAGRAM

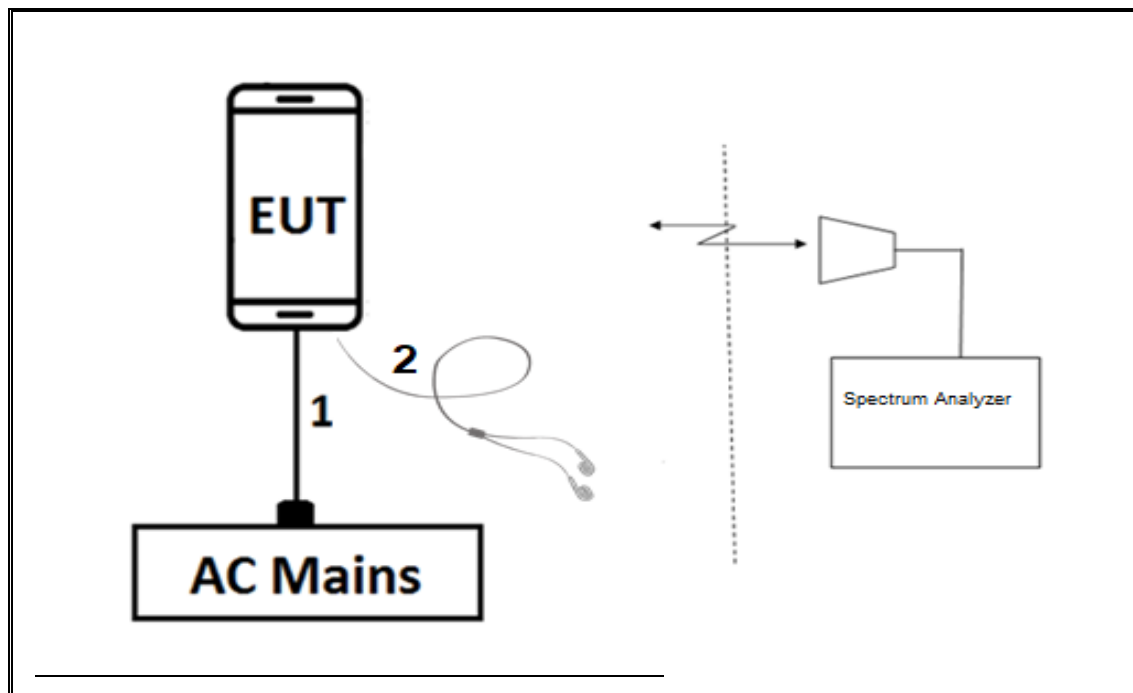

TEST SETUP

For radiated tests, the EUT is stand alone unit and the test software exercises the radio.

6. MEASUREMENT METHOD

On Time and Duty Cycle: ANSI C63.10 Section 11.6

6 dB BW: ANSI C63.10 Subclause -11.8.1 RBW \geq DTS BW

Output Power: ANSI C63.10 Subclause -11.9.2.3.2 Method AVGPM-G (Measurement using a gated RF average-reading power meter)

Conducted emissions in restricted frequency bands: ANSI C63.10 Subclause -11.12.2

PSD: ANSI C63.10 Subclause -11.10.2 Method PKPSD (peak PSD)

Band-edge: ANSI C63.10 Subclause 6.10

Radiated emissions non-restricted frequency bands: ANSI C63.10 Subclause -11.11

Radiated emissions restricted frequency bands: ANSI C63.10 Subclause -11.12.1

Radiated Spurious Emissions Below 30MHz: ANSI C63.10-2013 Subclause 6.4

AC Power Line Conducted Emissions: ANSI C63.10-2013, Subclause 6.2.

7. TEST AND MEASUREMENT EQUIPMENT

The following test and measurement equipment was utilized for the tests documented in this report:

TEST EQUIPMENT LIST				
Description	Manufacturer	Model	Asset	Cal Due
Antenna, Passive Loop 30Hz to 1MHz	ELETRO METRICS	EM-6871	PRE0179466	05/31/2020
Antenna, Passive Loop 100KHz to 30MHz	ELETRO METRICS	EM-6872	PRE0179468	05/31/2020
Antenna, Horn 1-18GHz	ETS Lindgren	3117	EMC4249 / PRE0100034	06/14/2020
Antenna, Horn 1-18GHz	ETS Lindgren	3117	T862	06/05/2020
Amplifier, 1 to 18GHz	MITEQ	AFS42-00101800-25-S-42	PRE171460	08/24/2020
Amplifier, 1 to 18GHz	Amplical	AMP1G18-35	T1569	05/04/2020
Antenna, Broadband Hybrid, 30MHz to 3GHz	Sunol Sciences	JB3	PRE0181574	10/14/2020
Amplifier, 9KHz to 1GHz, 32dB	SONOMA INSTRUMENT	310	PRE175953	12/13/2019
Spectrum Analyzer, PSA, 3Hz to 44GHz	Keysight	E4446A	T146	01/28/2020
Antenna Horn, 18 to 26.5GHz	ARA	MWH-1826/B	T447	08/13/2020
Pre-Amp 1-26.5 GHz	AMPLICAL	AMP18G26.5-60	PRE0181238	05/01/2020
EMI Test Receiver	Rohde&Schwarz	ESW44	PRE0179376	02/14/2020
EMI Test Receiver	Rohde&Schwarz	ESW44	PRE0179372	02/16/2020
Filter, HPF 6.0HPF	MICRO-TRONICS	HPS17542	T894	05/04/2020
Filter, HPF 3.0GHz	MICRO-TRONICS	HPM17543	T897	05/04/2020
Filter, LPF 5.0GHz	MICRO-TRONICS	LPS17541	T891	05/04/2020
Power Meter, P-series single channel	Agilent (Keysight) Technologies	N1911A	T229	01/31/2020
Power Sensor, P-series, 50MHz to 18GHz, Wideband	Agilent (Keysight) Technologies	N1921A	T1226	02/06/2020
AC Line Conducted				
EMI Receiver	Rohde & Schwarz	ESR	T1436	02/14/2020
LISN for Conducted Emissions CISPR-16	FCC INC.	FCC LISN 50/250	T1310	01/24/2020
UL AUTOMATION SOFTWARE				
Radiated Software	UL	UL EMC	Ver 9.5, June 15, 2019	
Antenna Port Software	UL	UL RF	Ver 10.4, Oct 10, 2019	
AC Line Conducted Software	UL	UL EMC	Ver 9.5, May 26, 2015	

NOTES:

1. Equipment listed above that calibrated during the testing period was set for test after the calibration.
2. Equipment listed above that has a calibration due date during the testing period, the testing is completed before equipment expiration date.

8. ANTENNA PORT TEST RESULTS

8.1. ON TIME AND DUTY CYCLE

LIMITS

None; for reporting purposes only.

PROCEDURE

KDB 558074 Zero-Span Spectrum Analyzer Method.

ON TIME AND DUTY CYCLE RESULTS

Mode	ON Time B (msec)	Period (msec)	Duty Cycle x (linear)	Duty Cycle (%)	Duty Cycle Correction Factor (dB)	1/B Minimum VBW (kHz)
2.4GHz Band						
802.11b 1TX	0.861	0.956	0.901	90.11%	0.45	1.161
802.11g CDD	1.415	1.530	0.925	92.48%	0.34	0.707
802.11n HT20 CDD	1.325	1.445	0.917	91.70%	0.38	0.755

DUTY CYCLE PLOTS

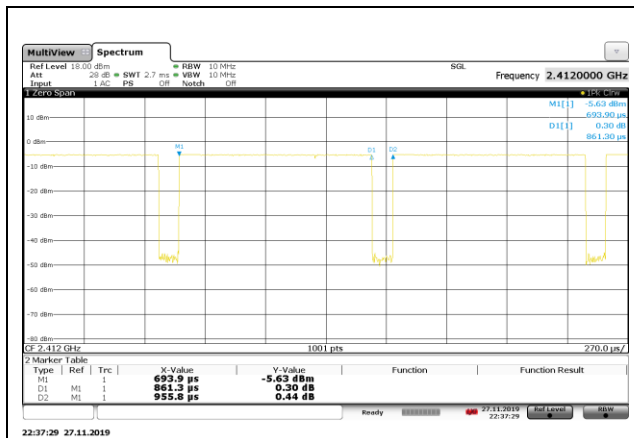

802.11b

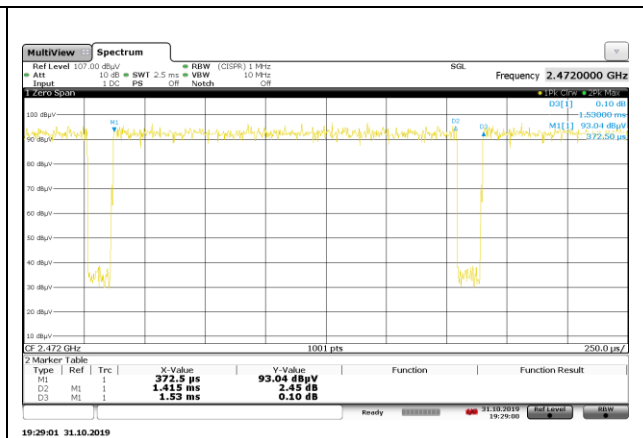

802.11g

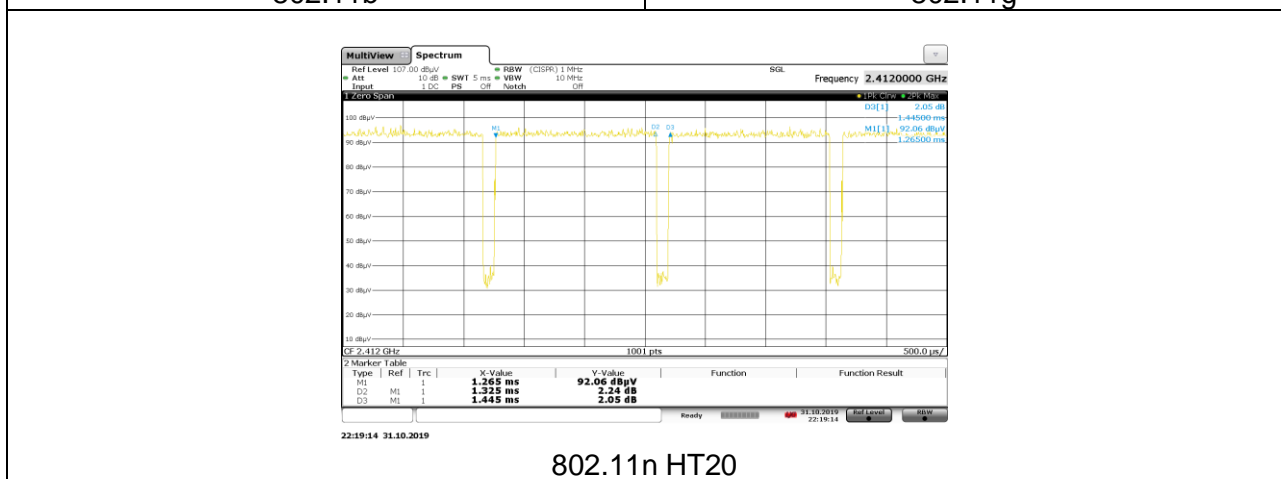

802.11n HT20

Tested By:	19497 AF
Date:	10/3, 11/01, and 11/27/2019

8.2. 6 dB BANDWIDTH

LIMITS

FCC §15.247 (a) (2)

The minimum 6 dB bandwidth shall be at least 500 kHz.

RESULTS

8.2.1. 802.11b MODE

1TX Chain 0 MODE

Channel	Frequency (MHz)	6 dB Bandwidth (MHz)	Minimum Limit (MHz)
Low 1	2412	7.56	0.5
Mid 6	2437	7.56	0.5
High 11	2462	7.32	0.5
High 12	2467	7.32	0.5
High 13	2472	7.60	0.5

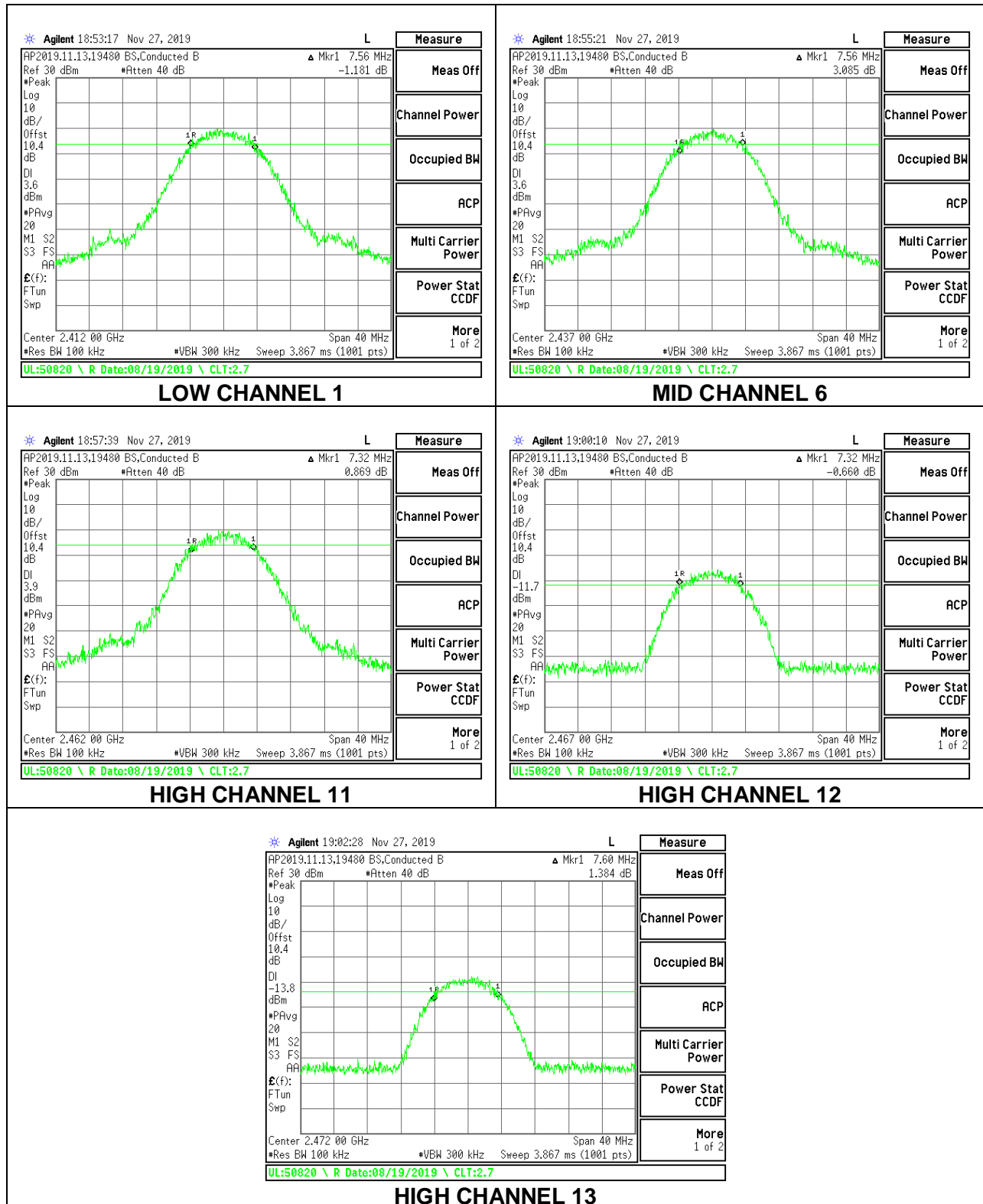

1TX Chain 1 MODE

Channel	Frequency (MHz)	6 dB Bandwidth (MHz)	Minimum Limit (MHz)
Low 1	2412	7.48	0.5
Mid 6	2437	7.68	0.5
High 11	2462	7.28	0.5
High 12	2467	7.68	0.5
High 13	2472	7.48	0.5

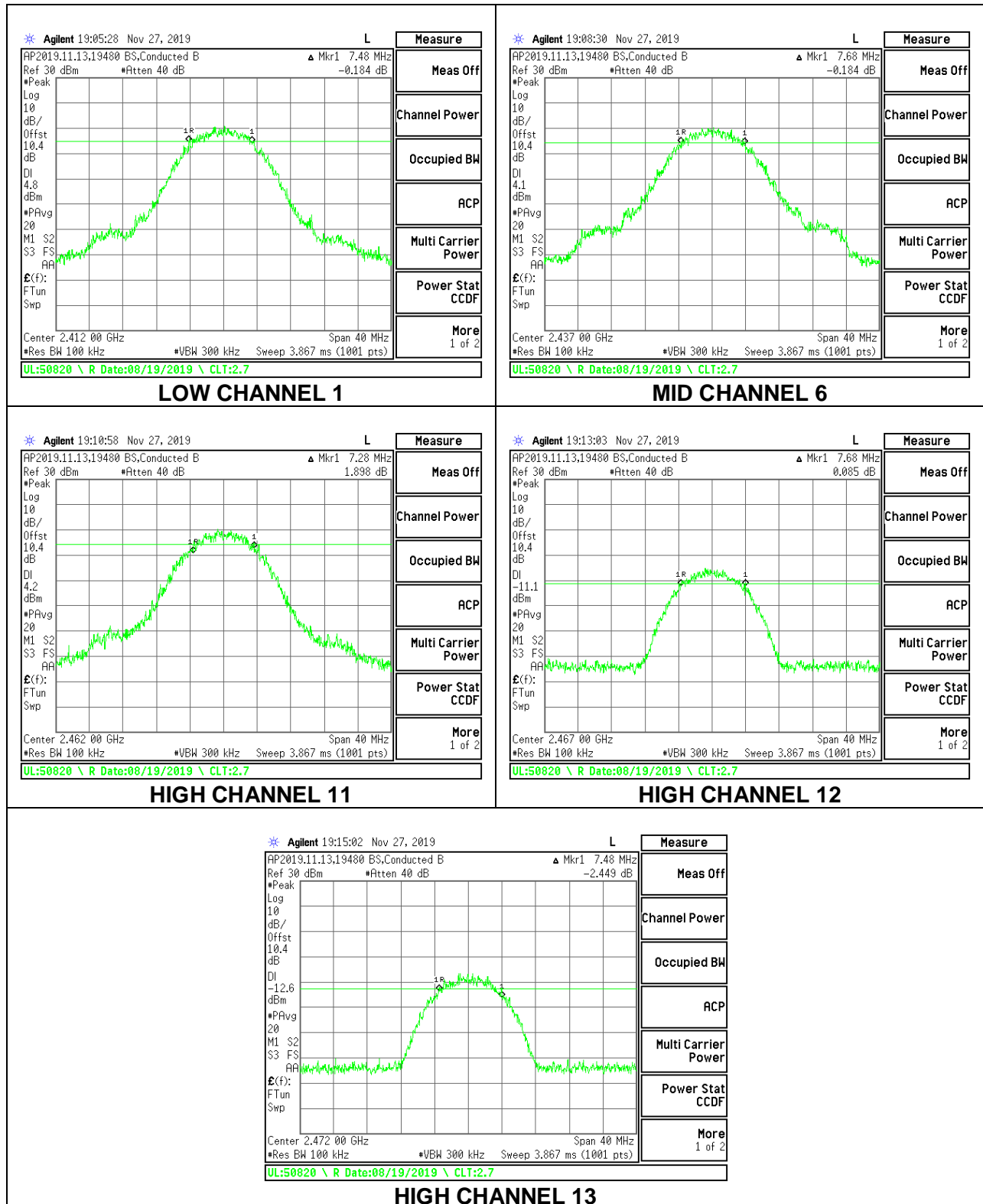

8.2.2. 802.11g MODE

2TX Chain 0 + Chain 1 CDD MODE

Channel	Frequency (MHz)	6 dB BW Antenna 1 (MHz)	6 dB BW Antenna 2 (MHz)	Minimum Limit (MHz)
Low 1	2412	16.04	16.00	0.5
Mid 6	2437	16.40	16.20	0.5
High 11	2462	16.28	16.36	0.5
High 12	2467	16.16	16.40	0.5
High 13	2472	16.16	16.08	0.5

LOW CHANNEL 1

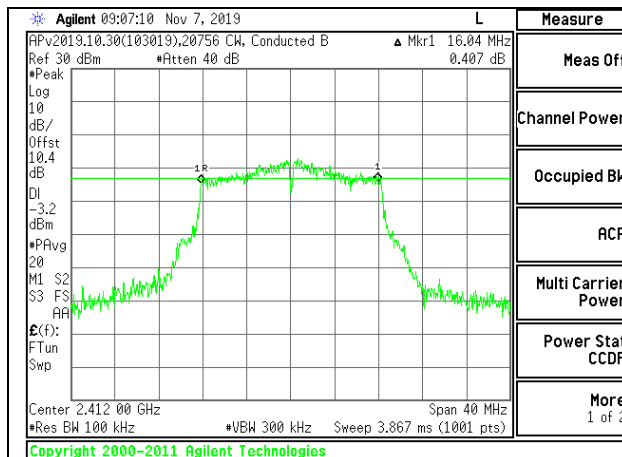

LOW CHANNEL 1 CHAIN 0

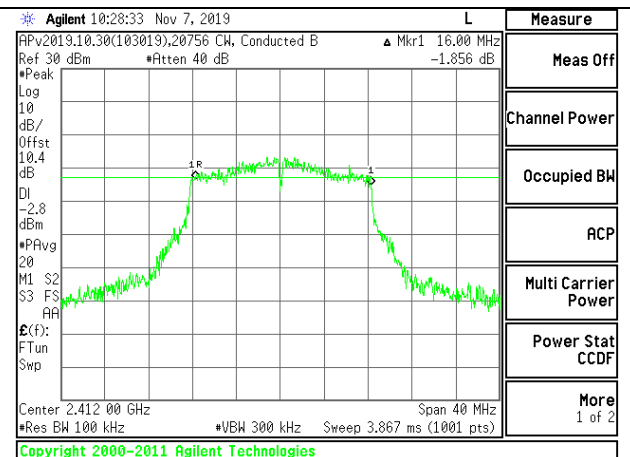

LOW CHANNEL 1 CHAIN 1

MID CHANNEL 6

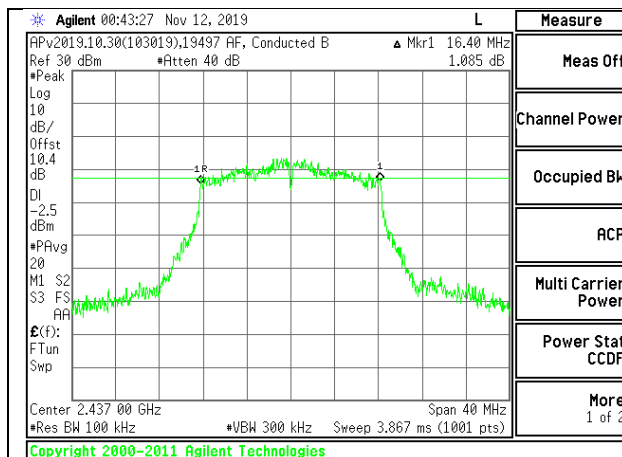

MID CHANNEL 6 CHAIN 0

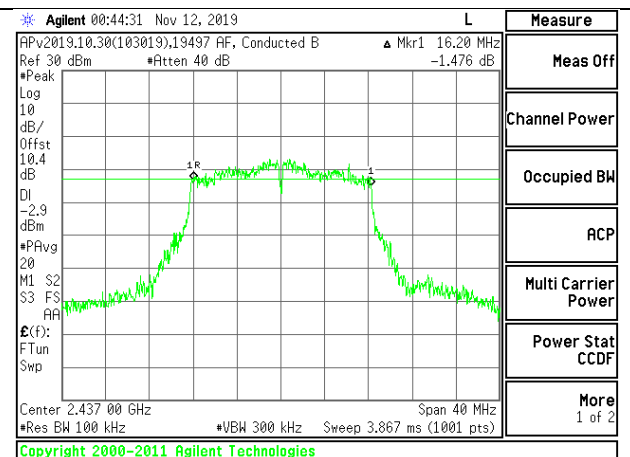

MID CHANNEL 6 CHAIN 1

HIGH CHANNEL 11

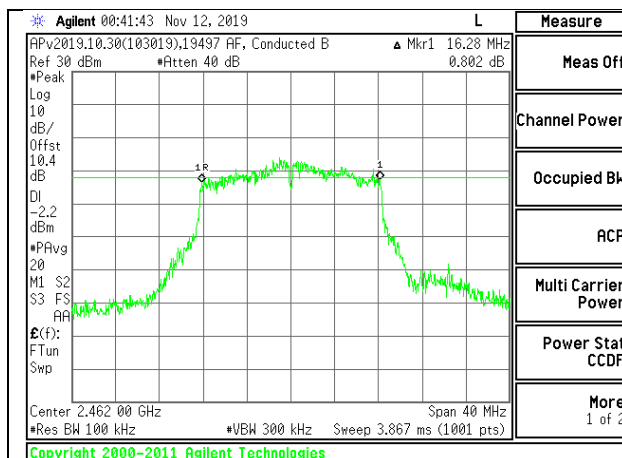

HIGH CHANNEL 11 CHAIN 0

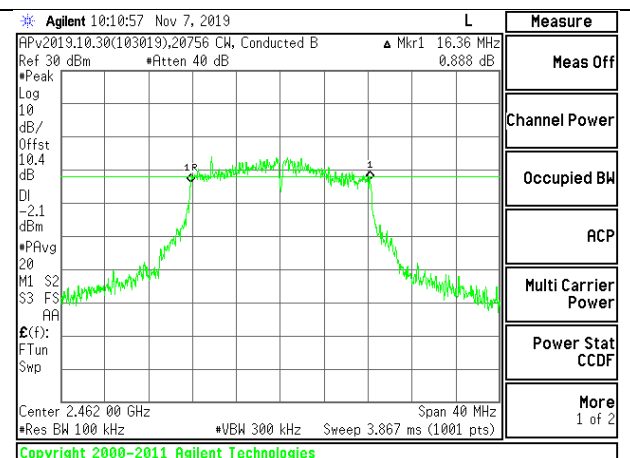

HIGH CHANNEL 11 CHAIN 1

HIGH CHANNEL 12

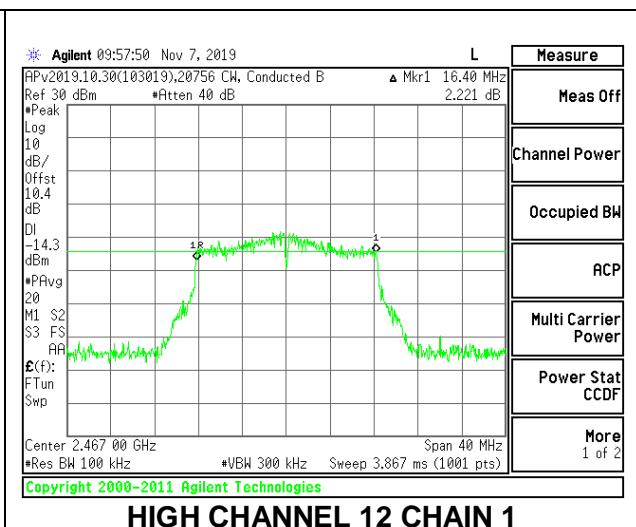
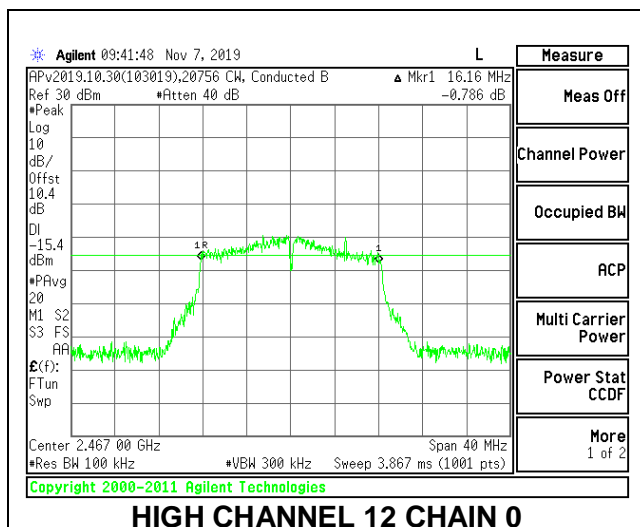

HIGH CHANNEL 13

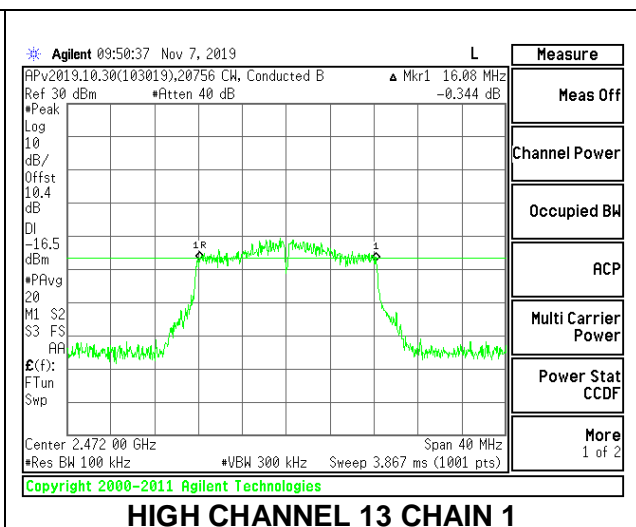
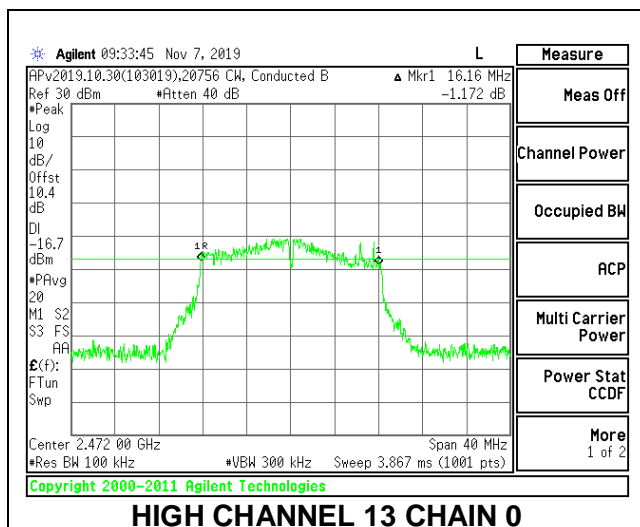

8.2.3. 802.11n HT20 MODE

2TX Chain 0 + Chain 1 CDD MODE

Channel	Frequency (MHz)	6 dB BW Antenna 1 (MHz)	6 dB BW Antenna 2 (MHz)	Minimum Limit (MHz)
Low 1	2412	17.60	17.60	0.5
Mid 6	2437	17.60	17.68	0.5
High 11	2462	17.64	17.24	0.5
High 12	2467	17.56	17.68	0.5
High 13	2472	17.52	17.40	0.5

LOW CHANNEL 1

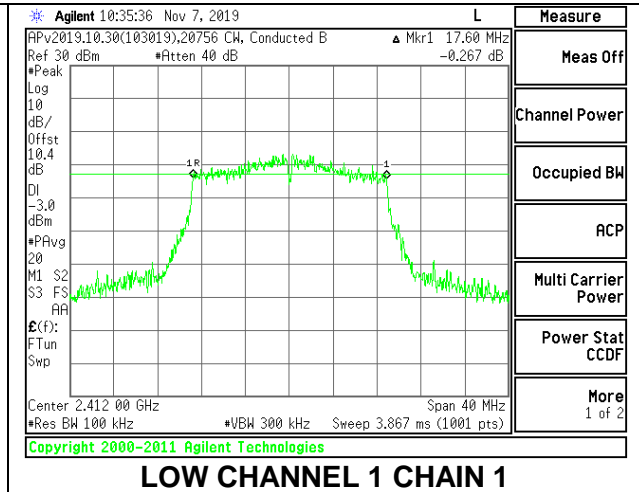
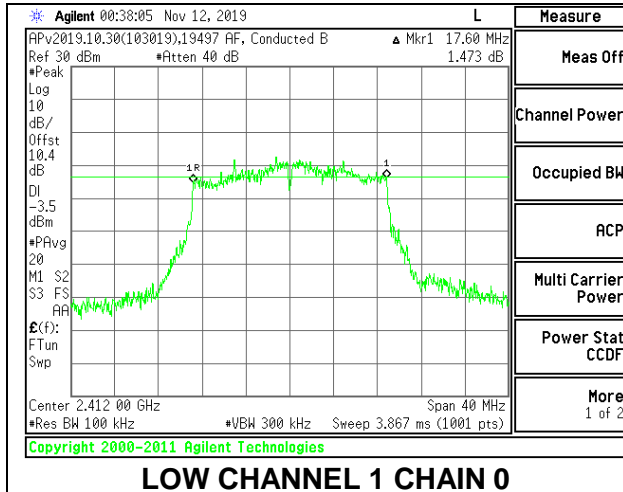

MID CHANNEL 6

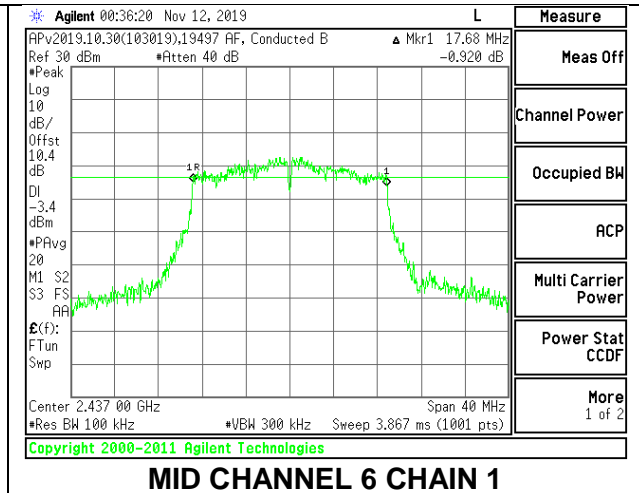
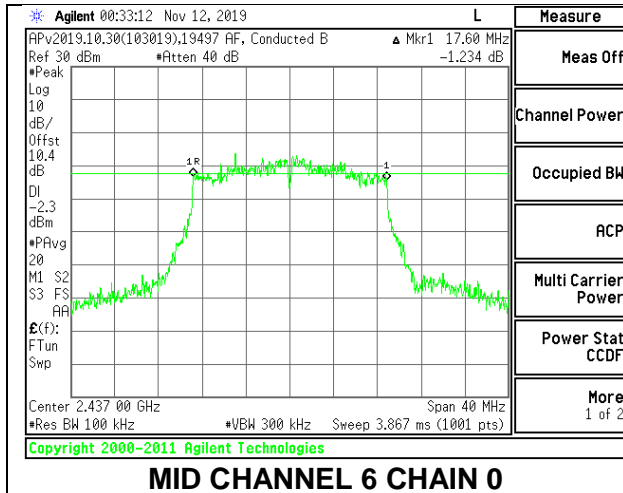

HIGH CHANNEL 11

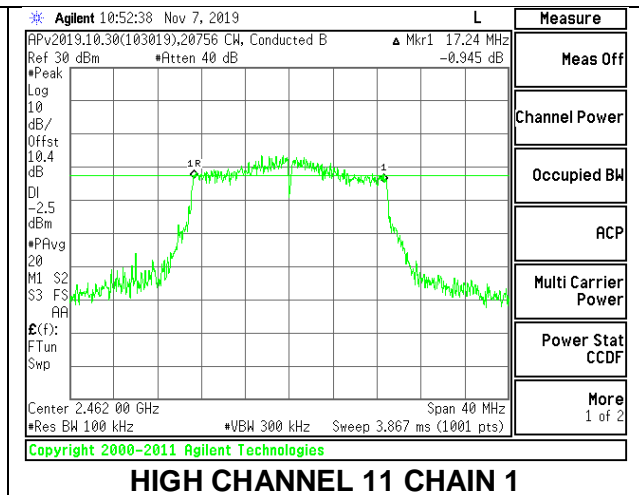
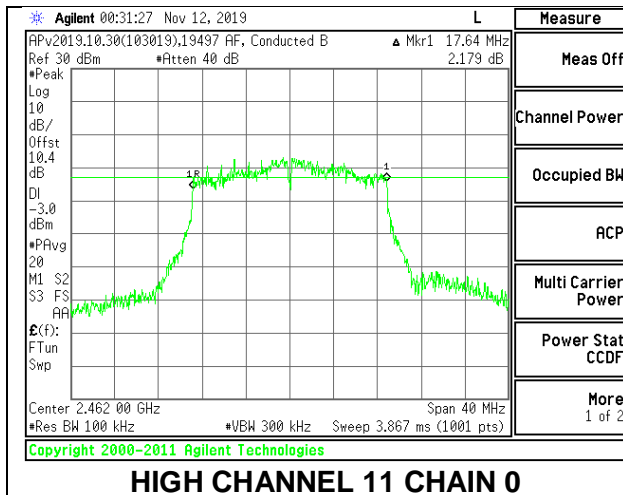

HIGH CHANNEL 12

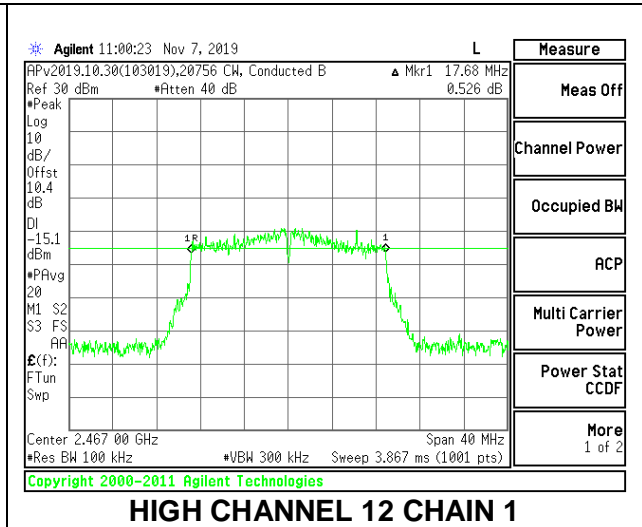
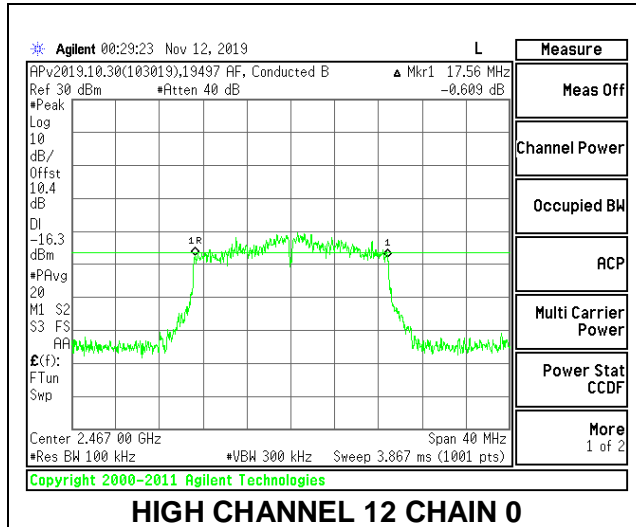

HIGH CHANNEL 13

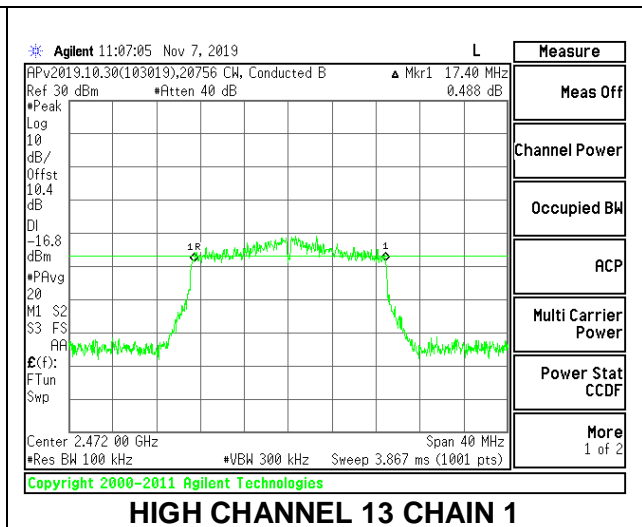
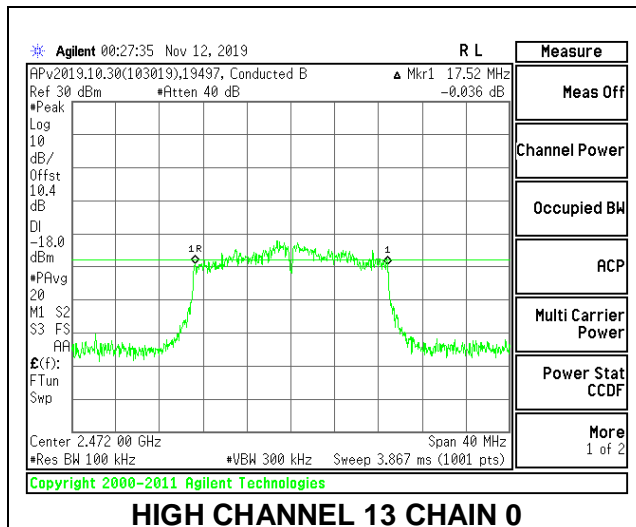

8.3. OUTPUT POWER

LIMITS

FCC §15.247 (b) (3)

For systems using digital modulation in the 902–928 MHz, 2400–2483.5 MHz, and 5725–5850 MHz bands: 1 Watt, based on the use of antennas with directional gains that do not exceed 6 dBi. If transmitting antennas of directional gain greater than 6 dBi are used, the conducted output power from the intentional radiator shall be reduced by the amount in dB that the directional gain of the antenna exceeds 6 dBi.

TEST PROCEDURE

The transmitter output is connected to a power meter. The cable assembly insertion loss was entered as an offset in the power meter to allow for a gated average reading of power.

DIRECTIONAL ANTENNA GAIN

Tx chains are uncorrelated for power and correlated for PSD due to the device supporting CDD in all MIMO modes. The directional gains are as follows:

Band (GHz)	Chain 0 Antenna Gain (dBi)	Chain 1 Antenna Gain (dBi)	Uncorrelated Chains Directional Gain (dBi)	Correlated Chains Directional Gain (dBi)
2.4	-5.10	-8.09	-6.34	-3.46

RESULTS

Tested By:	12981 KW
Date:	11/27/2019

8.3.1. 802.11b MODE

1TX Chain 0 MODE

	(MHz)	(dBi)	Limit (dBm)	Limit (dBm)	Limit (dBm)	(dBm)
Low 1	2412	-5.10	30.00	30	36	30.00
Mid 6	2437	-5.10	30.00	30	36	30.00
High 11	2462	-5.10	30.00	30	36	30.00
High 12	2467	-5.10	30.00	30	36	30.00
High 13	2472	-5.10	30.00	30	36	30.00

Results

Channel	Frequency (MHz)	Meas Power (dBm)	Total Corr'd Power (dBm)	Power Limit (dBm)	Margin (dB)
Low 1	2412	18.44	18.44	30.00	-11.56
Mid 6	2437	18.53	18.53	30.00	-11.47
High 11	2462	18.62	18.62	30.00	-11.38
High 12	2467	3.46	3.46	30.00	-26.54
High 13	2472	1.15	1.15	30.00	-28.85

1TX Chain 1 MODE

Limits

Channel	Frequency (MHz)	Directional Gain (dBi)	FCC Power Limit (dBm)	ISED Power Limit (dBm)	ISED EIRP Limit (dBm)	Max Power (dBm)
Low 1	2412	-8.09	30.00	30	36	30.00
Mid 6	2437	-8.09	30.00	30	36	30.00
High 11	2462	-8.09	30.00	30	36	30.00
High 12	2467	-8.09	30.00	30	36	30.00
High 13	2472	-8.09	30.00	30	36	30.00

Results

Channel	Frequency (MHz)	Meas Power (dBm)	Total Corr'd Power (dBm)	Power Limit (dBm)	Margin (dB)
Low 1	2412	18.56	18.37	30.00	-11.63
Mid 6	2437	18.51	18.49	30.00	-11.51
High 11	2462	18.55	18.51	30.00	-11.49
High 12	2467	2.95	2.95	30.00	-27.05
High 13	2472	1.11	1.11	30.00	-28.89

8.3.2. 802.11g MODE

2TX Chain 0 + Chain 1 CDD MODE

Limits

Channel	Frequency (MHz)	Directional Gain (dBi)	FCC/ISED Power Limit (dBm)	ISED EIRP Limit (dBm)	Max Power (dBm)
Low 1	2412	-6.34	30.00	36	30.00
Mid 6	2437	-6.34	30.00	36	30.00
High 11	2462	-6.34	30.00	36	30.00
High 12	2467	-6.34	30.00	36	30.00
High 13	2472	-6.34	30.00	36	30.00

Results

Channel	Frequency (MHz)	Antenna 1 Meas Power (dBm)	Antenna 2 Meas Power (dBm)	Total Corr'd Power (dBm)	Power Limit (dBm)	Margi (dB)
Low 1	2412	15.30	15.87	18.60	30.00	-11.40
Mid 6	2437	16.68	15.73	19.24	30.00	-10.76
High 11	2462	16.02	15.96	19.00	30.00	-11.00
High 12	2467	3.01	3.35	6.19	30.00	-23.81
High 13	2472	1.12	0.73	3.94	30.00	-26.06

8.3.3. 802.11n HT20 MODE

2TX Chain 0 + Chain 1 CDD MODE

Limits

Channel	Frequency (MHz)	Directional Gain (dBi)	FCC/ISED Power Limit (dBm)	ISED EIRP Limit (dBm)	Max Power (dBm)
Low 1	2412	-6.34	30.00	36	30.00
Mid 6	2437	-6.34	30.00	36	30.00
High 11	2462	-6.34	30.00	36	30.00
High 12	2467	-6.34	30.00	36	30.00
High 13	2472	-6.34	30.00	36	30.00

Results

Channel	Frequency (MHz)	Antenna 1 Meas Power (dBm)	Antenna 2 Meas Power (dBm)	Total Corr'd Power (dBm)	Power Limit (dBm)	Margi (dB)
Low 1	2412	14.30	15.23	17.80	30.00	-12.20
Mid 6	2437	15.29	14.66	18.00	30.00	-12.00
High 11	2462	14.92	15.68	18.33	30.00	-11.67
High 12	2467	2.89	3.31	6.12	30.00	-23.88
High 13	2472	0.90	0.55	3.74	30.00	-26.26

8.4. POWER SPECTRAL DENSITY

LIMITS

FCC §15.247 (e)

The power spectral density conducted from the transmitter to the antenna shall not be greater than 8 dBm in any 3 kHz band during any time interval of continuous transmission.

RESULTS

8.4.1. 802.11b MODE

1TX Chain 0 MODE

Duty Cycle CF (dB)	0.45	Included in Calculations of Corr'd PSD
--------------------	------	--

PSD Results

Channel	Frequency (MHz)	Chain 1 Meas (dBm/ 3kHz)	Total Corr'd PSD (dBm/ 3kHz)	Limit (dBm/ 3kHz)	Margin (dB)
Low 1	2412	-4.287	-3.837	8.0	-11.84
Mid 6	2437	-3.433	-2.983	8.0	-10.98
High 11	2462	-4.397	-3.947	8.0	-11.95
High 12	2467	-18.581	-18.131	8.0	-26.13
High 13	2472	-21.220	-20.770	8.0	-28.77

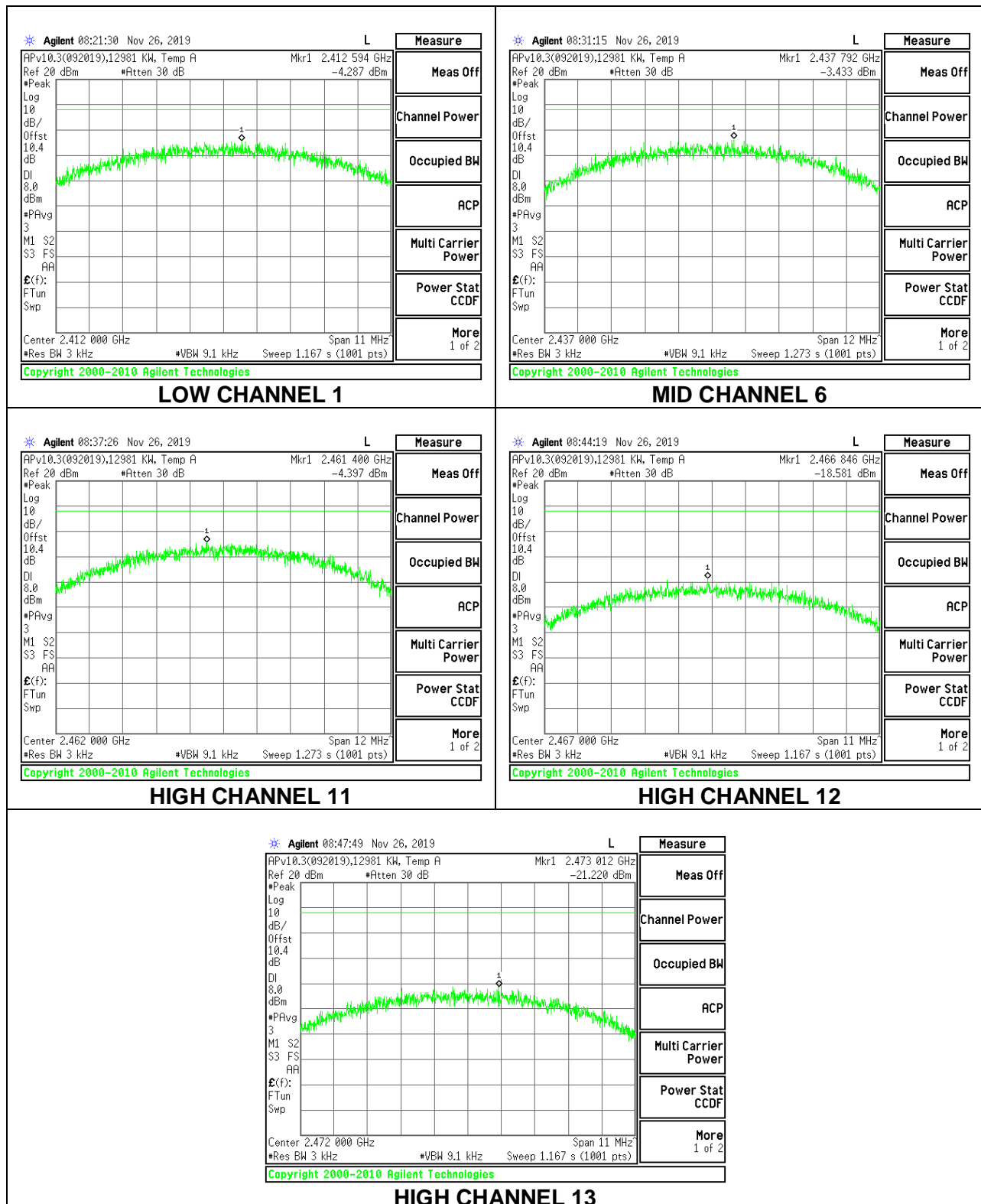

1TX Chain 1 MODE

Duty Cycle CF (dB)	0.45	Included in Calculations of Corr'd PSD
---------------------------	------	---

PSD Results

Channel	Frequency (MHz)	Chain 1 Meas (dBm/ 3kHz)	Total Corr'd PSD (dBm/ 3kHz)	Limit (dBm/ 3kHz)	Margin (dB)
Low 1	2412	-4.204	-3.754	8.0	-11.75
Mid 6	2437	-4.287	-3.837	8.0	-11.84
High 11	2462	-4.567	-4.117	8.0	-12.12
High 12	2467	-20.046	-19.596	8.0	-27.60
High 13	2472	-21.433	-20.983	8.0	-28.98

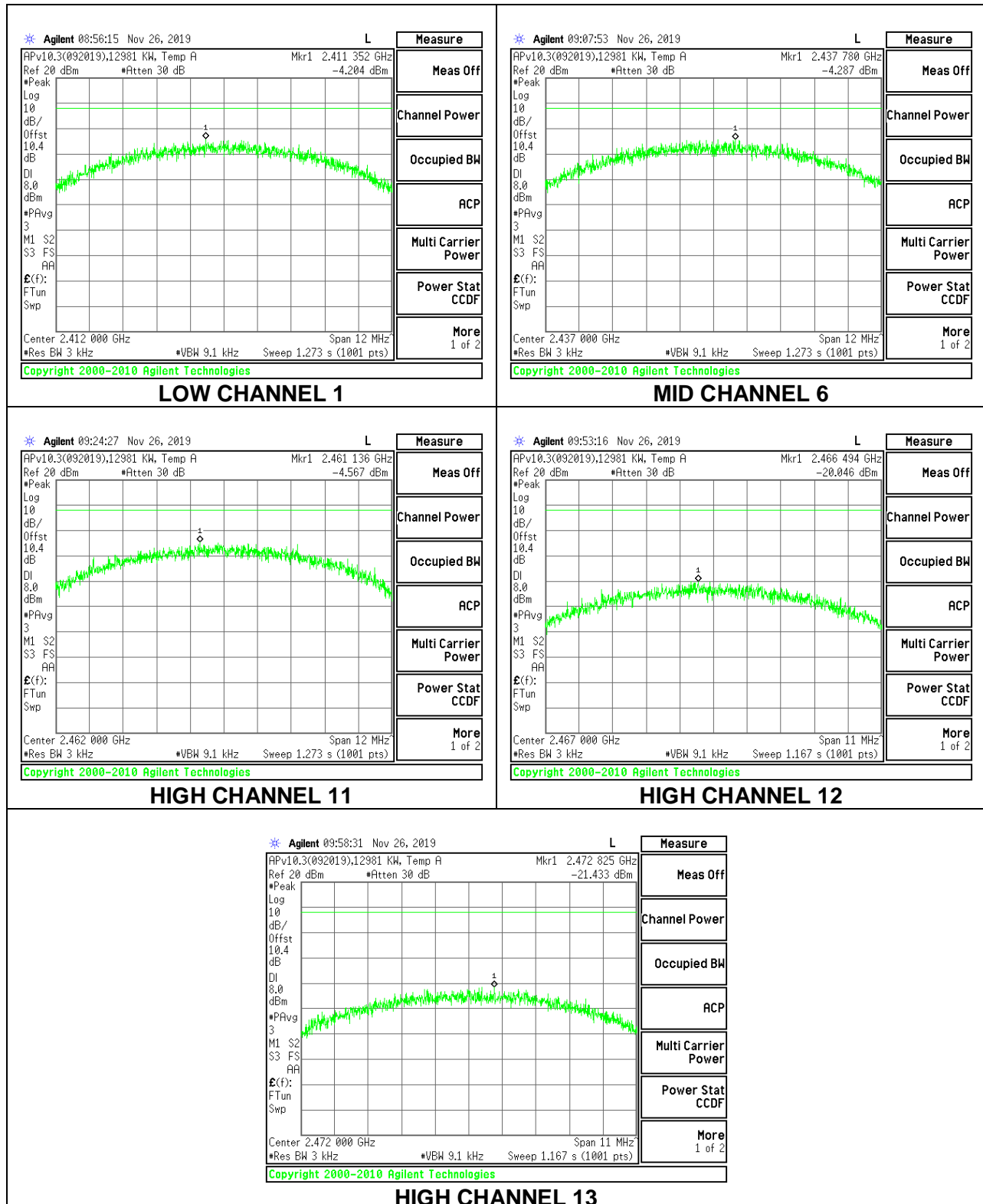

8.4.2. 802.11g MODE

2TX Chain 0 + Chain 1 CDD MODE

Duty Cycle CF (dB)	0.34	Included in Calculations of Corr'd PSD
---------------------------	------	---

PSD Results

Channel	Frequency (MHz)	Antenna 1 Meas (dBm/ 3kHz)	Antenna 2 Meas (dBm/ 3kHz)	Total Corr'd PSD (dBm/ 3kHz)	Limit (dBm/ 3kHz)	Margin (dB)
Low 1	2412	-8.138	-7.478	-4.45	8.0	-12.45
Mid 6	2437	-6.224	-7.317	-3.39	8.0	-11.39
High 11	2462	-8.399	-7.038	-4.32	8.0	-12.32
High 12	2467	-19.759	-19.653	-16.36	8.0	-24.36
High 13	2472	-21.218	-21.181	-17.85	8.0	-25.85

LOW CHANNEL 1

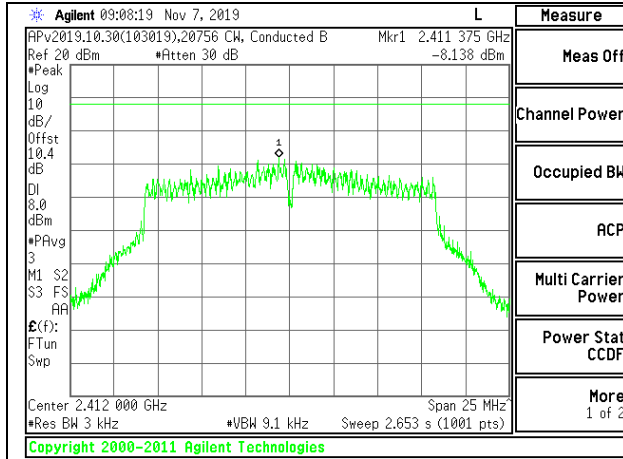

LOW CHANNEL 1 CHAIN 0

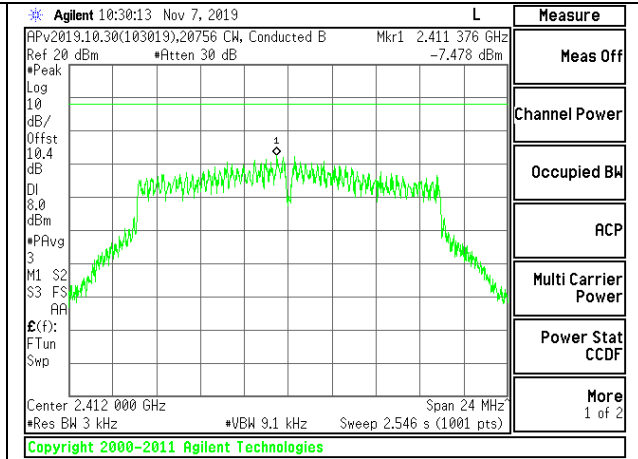

LOW CHANNEL 1 CHAIN 1

MID CHANNEL 6

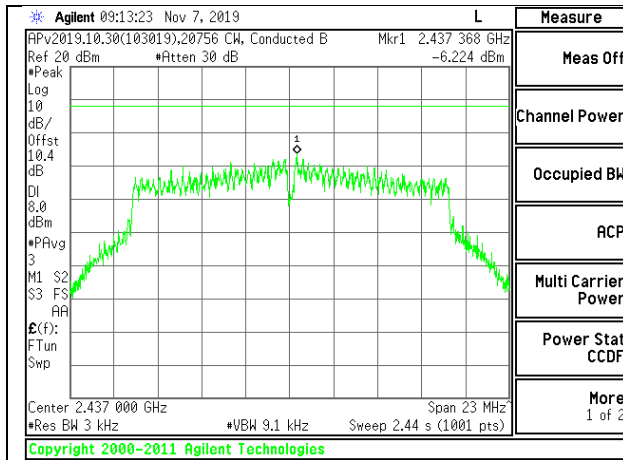

MID CHANNEL 6 CHAIN 0

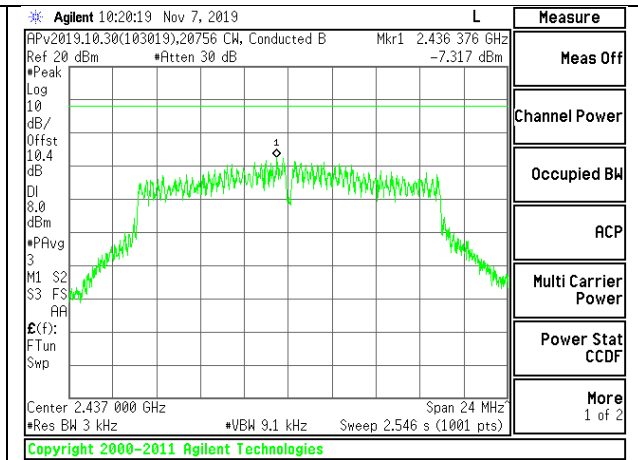

MID CHANNEL 6 CHAIN 1

HIGH CHANNEL 11

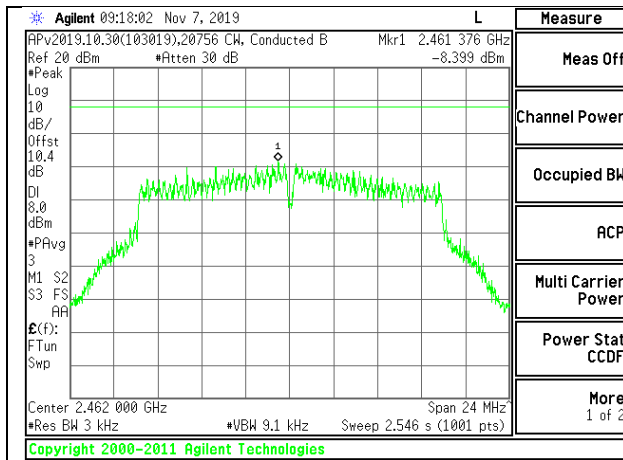

HIGH CHANNEL 11 CHAIN 0

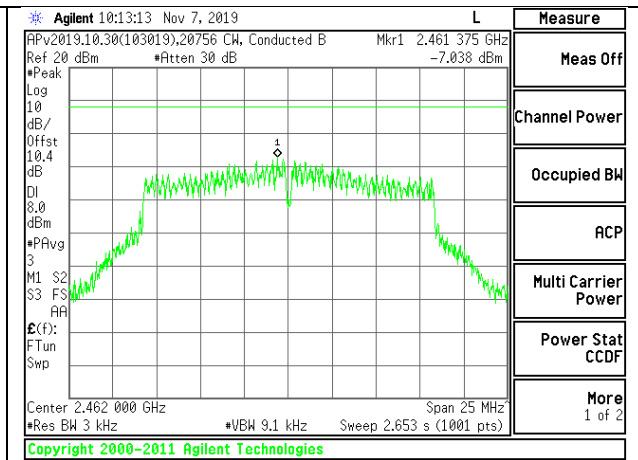

HIGH CHANNEL 11 CHAIN 1

HIGH CHANNEL 12

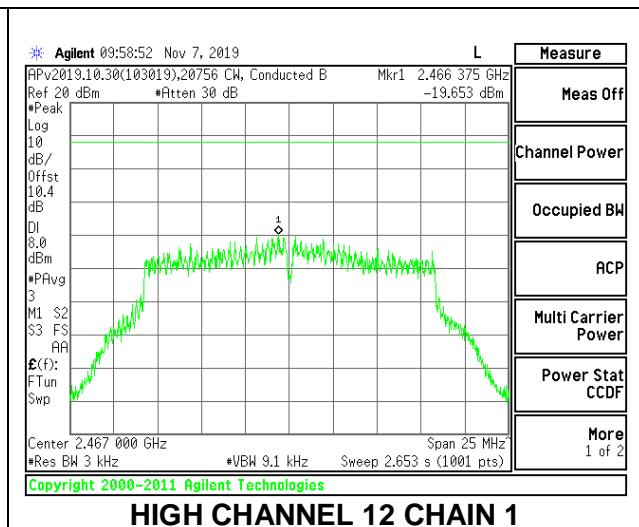
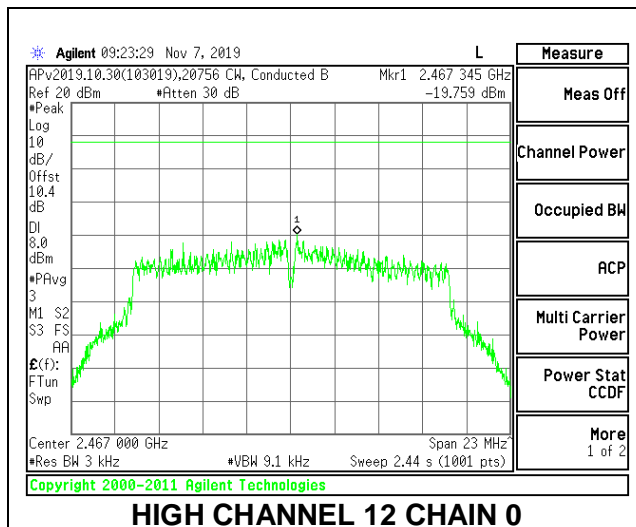

HIGH CHANNEL 13

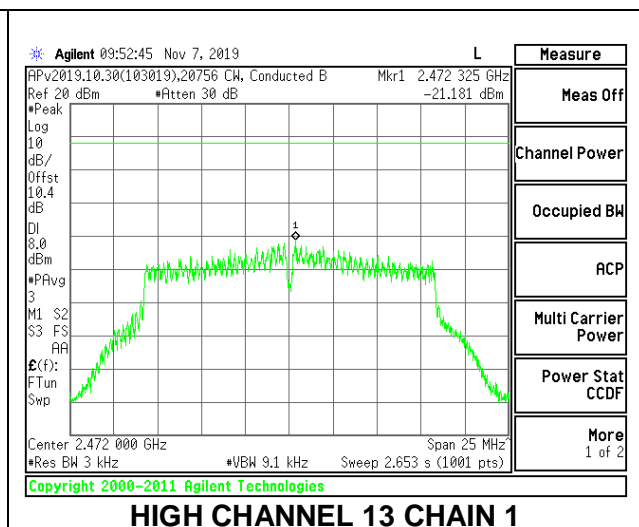
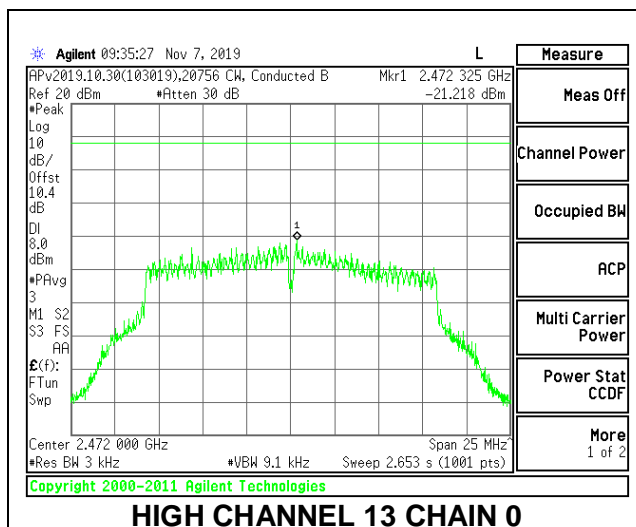

8.4.3. 802.11n HT20 MODE

2TX Chain 0 + Chain 1 CDD MODE

Duty Cycle CF (dB)	0.38	Included in Calculations of Corr'd PSD
---------------------------	------	---

PSD Results

Channel	Frequency (MHz)	Antenna 1 Meas (dBm/ 3kHz)	Antenna 2 Meas (dBm/ 3kHz)	Total Corr'd PSD (dBm/ 3kHz)	Limit (dBm/ 3kHz)	Margin (dB)
Low 1	2412	-9.796	-8.704	-5.83	8.0	-13.83
Mid 6	2437	-8.320	-8.939	-5.23	8.0	-13.23
High 11	2462	-9.466	-8.131	-5.36	8.0	-13.36
High 12	2467	-21.548	-19.900	-17.26	8.0	-25.26
High 13	2472	-21.670	-22.068	-18.47	8.0	-26.47

LOW CHANNEL 1

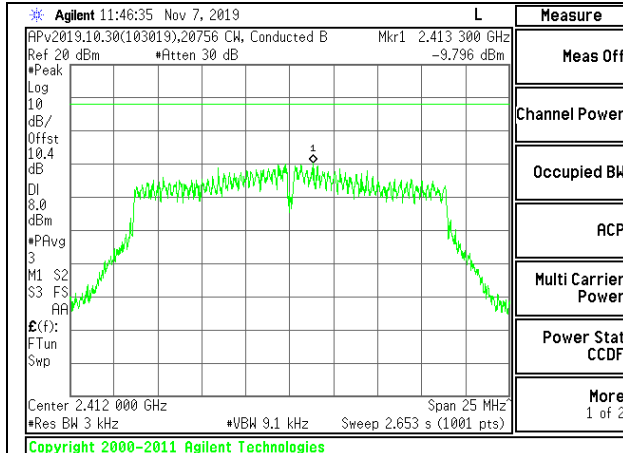

LOW CHANNEL 1 CHAIN 0

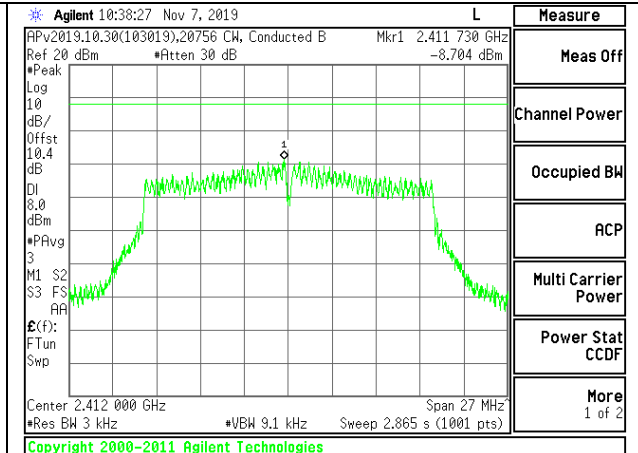

LOW CHANNEL 1 CHAIN 1

MID CHANNEL 6

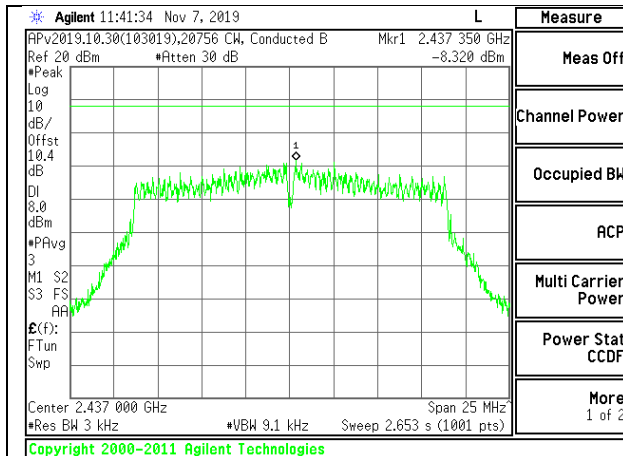

MID CHANNEL 6 CHAIN 0

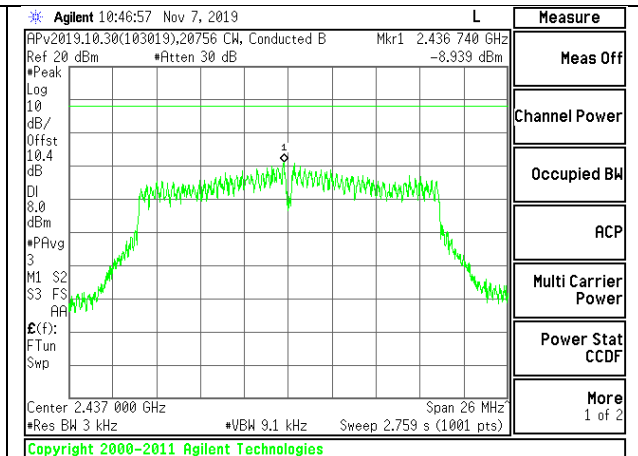

MID CHANNEL 6 CHAIN 1

HIGH CHANNEL 11

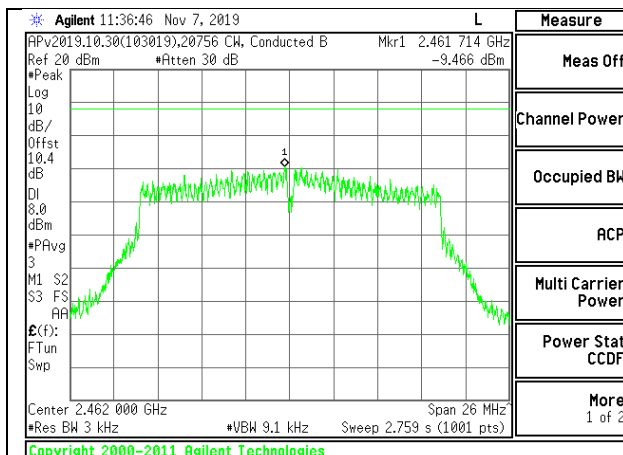

HIGH CHANNEL 11 CHAIN 0

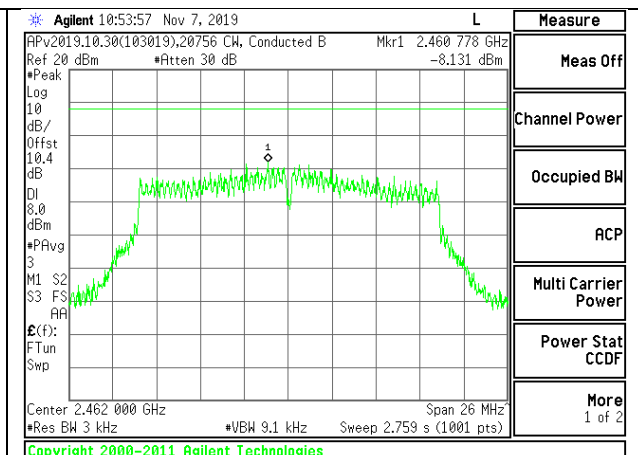

HIGH CHANNEL 11 CHAIN 1

HIGH CHANNEL 12

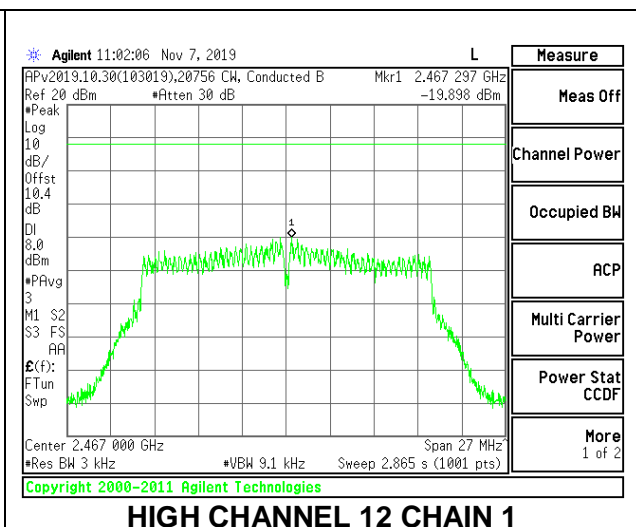
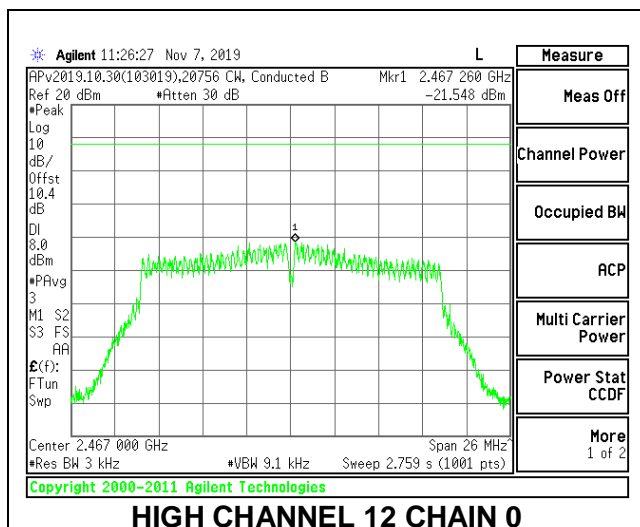

HIGH CHANNEL 13

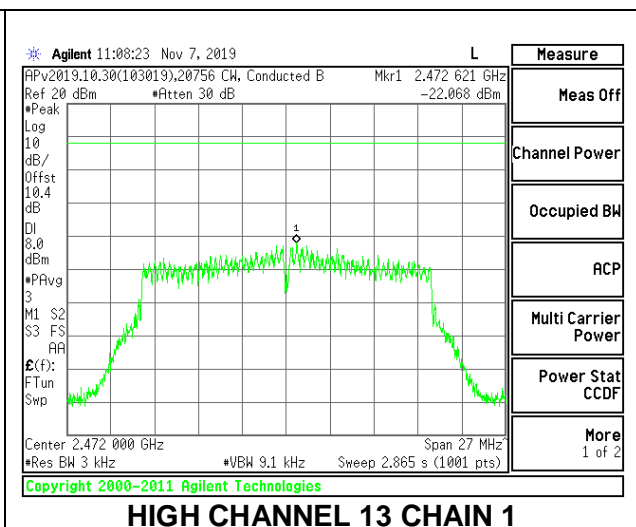
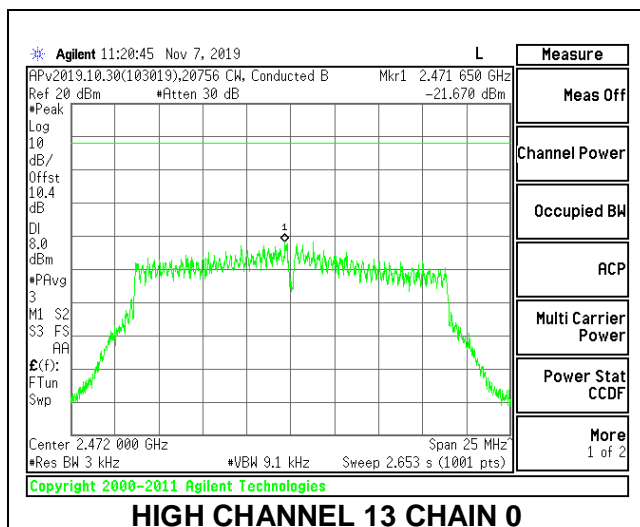

8.5. CONDUCTED SPURIOUS EMISSIONS

LIMITS

FCC §15.247 (d)

Output power was measured based on the use of peak measurement, therefore the required attenuation is 20 dB.

RESULTS

8.5.1. 802.11b MODE

1TX Chain 0 MODE

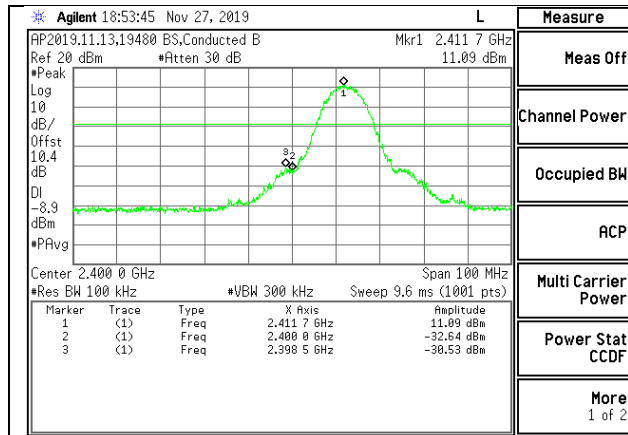

LOW CHANNEL 1 BANDEDGE

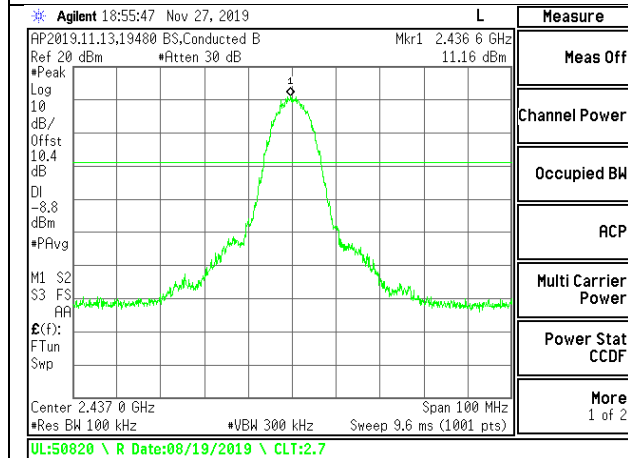

IN-BAND REFERENCE LEVEL

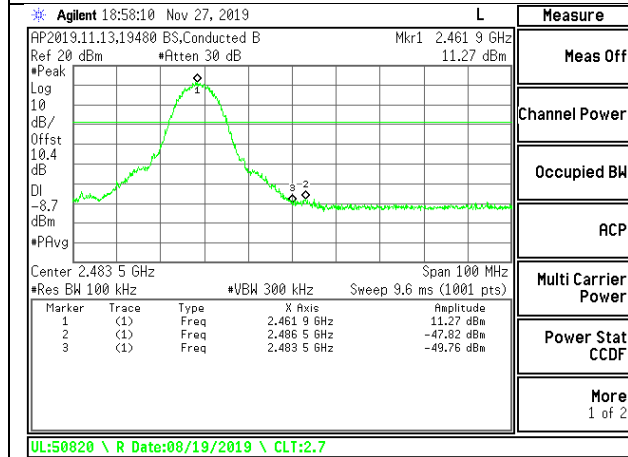

HIGH CHANNEL 11 BANDEDGE

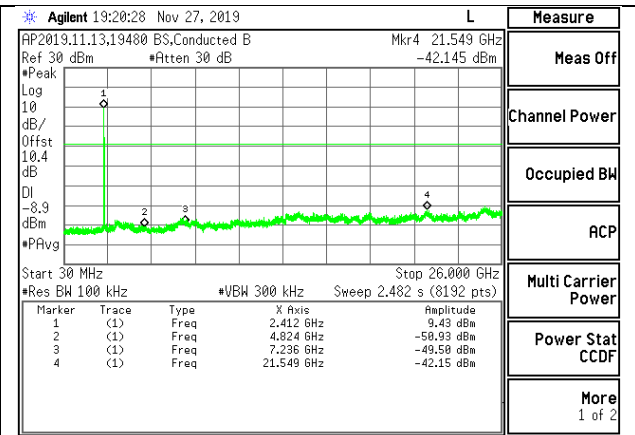

OUT-OF-BAND LOW CHANNEL 1

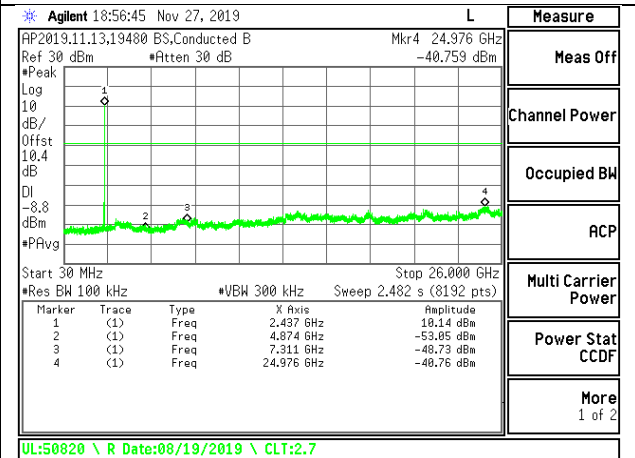

OUT-OF-BAND MID CHANNEL

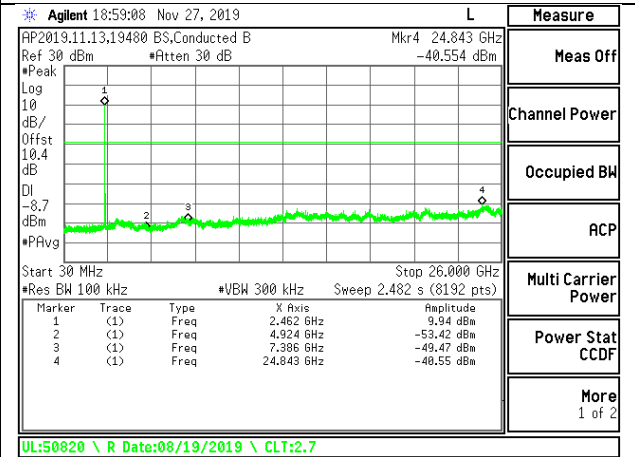

OUT-OF-BAND HIGH CHANNEL 11

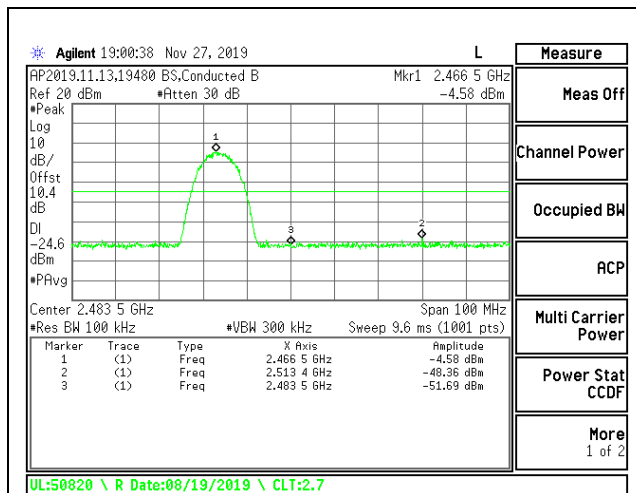

HIGH CHANNEL 12 BANDEDGE

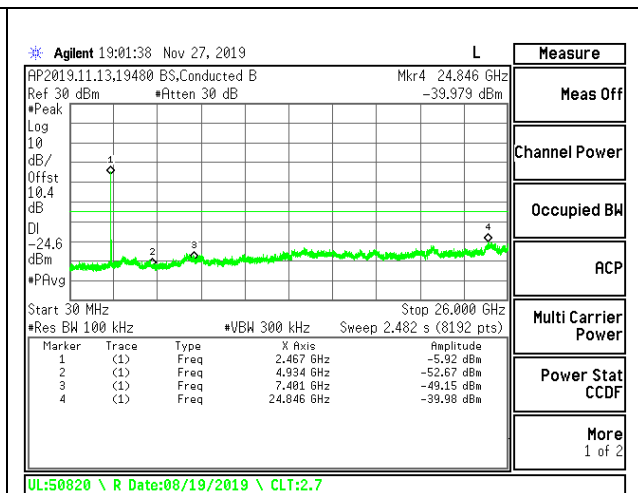

OUT-OF-BAND HIGH CHANNEL 12

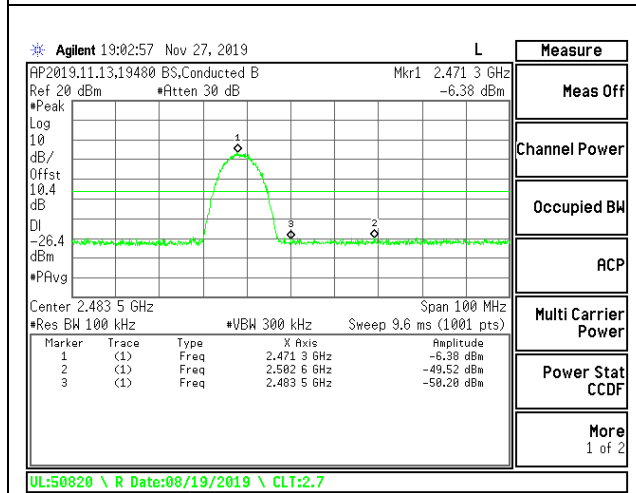

HIGH CHANNEL 13 BANDEDGE

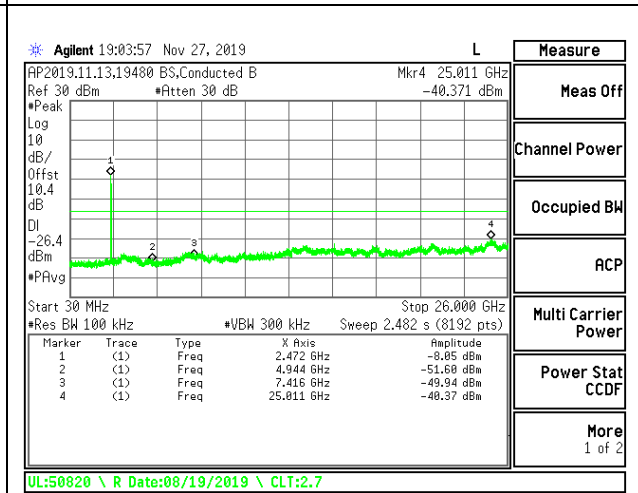

OUT-OF-BAND HIGH CHANNEL 13

1TX Chain 1 MODE

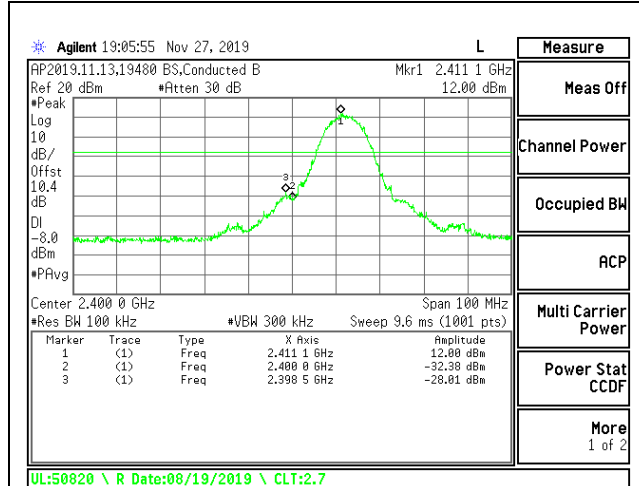

LOW CHANNEL 1 BANDEDGE

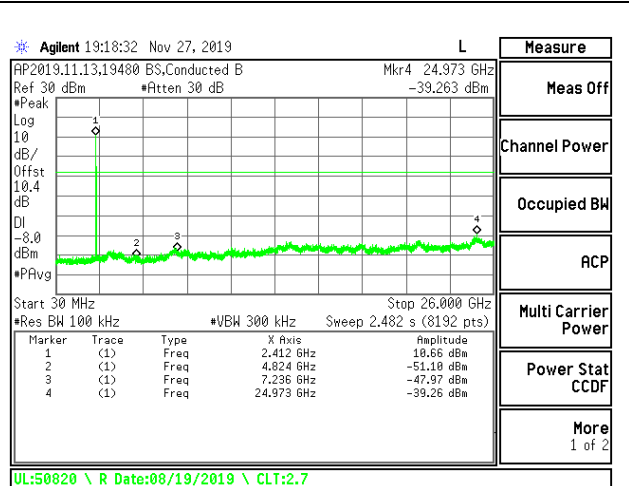

OUT-OF-BAND LOW CHANNEL 1

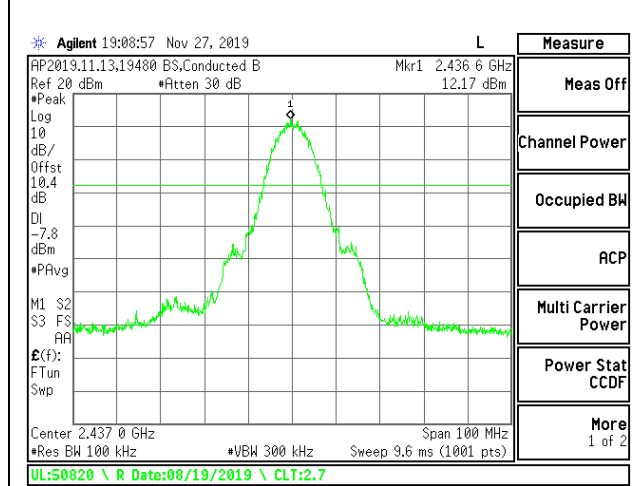

IN-BAND REFERENCE LEVEL

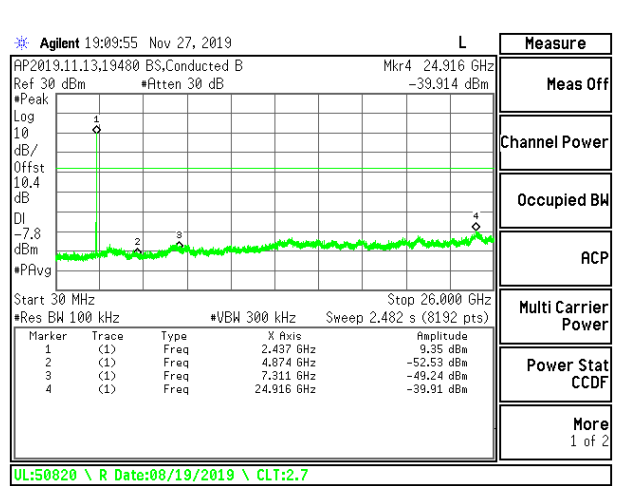

OUT-OF-BAND MID CHANNEL

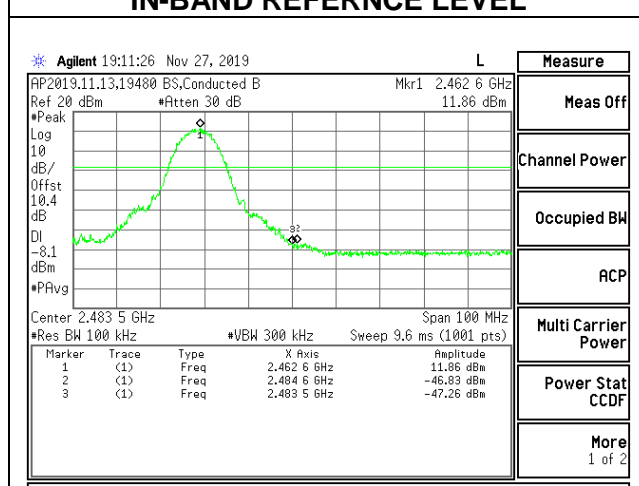

HIGH CHANNEL 11 BANDEDGE

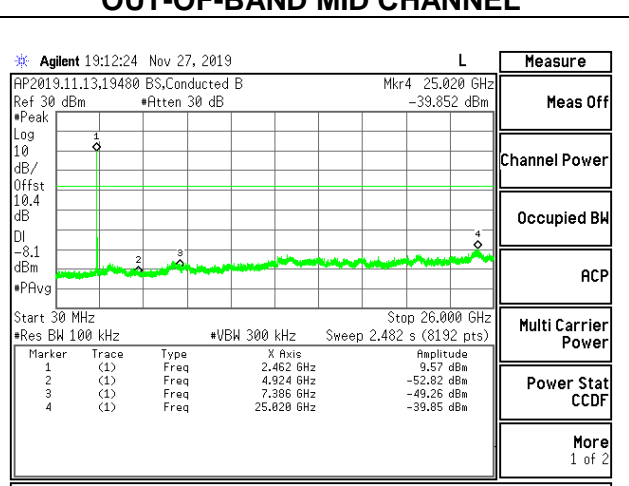

OUT-OF-BAND HIGH CHANNEL 11

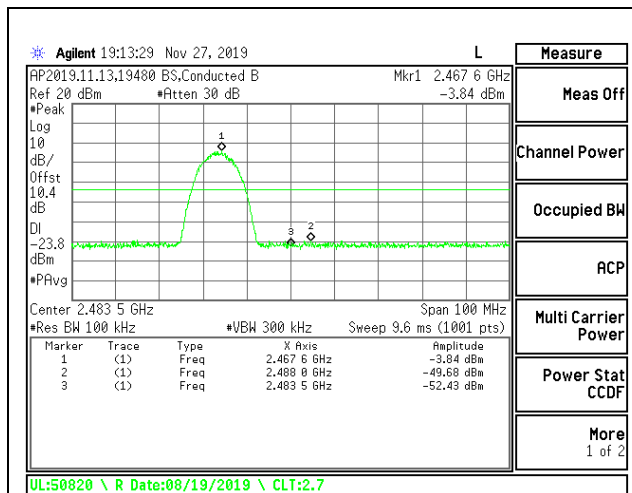

HIGH CHANNEL 12 BANDEDGE

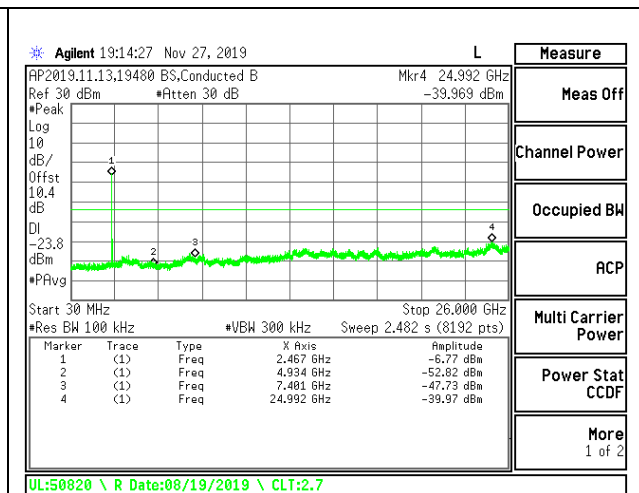

OUT-OF-BAND HIGH CHANNEL 12

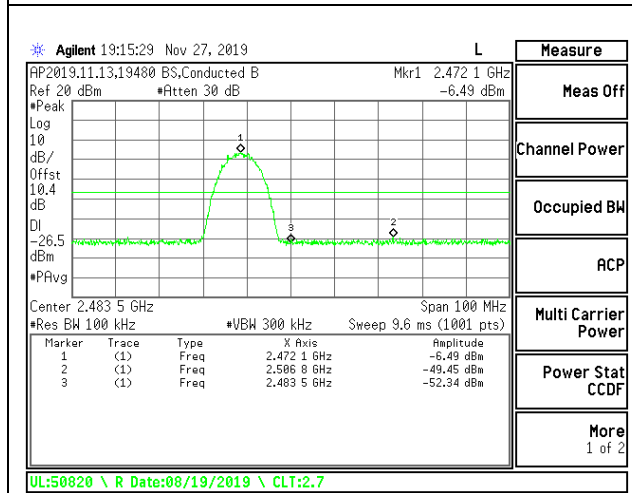

HIGH CHANNEL 13 BANDEDGE

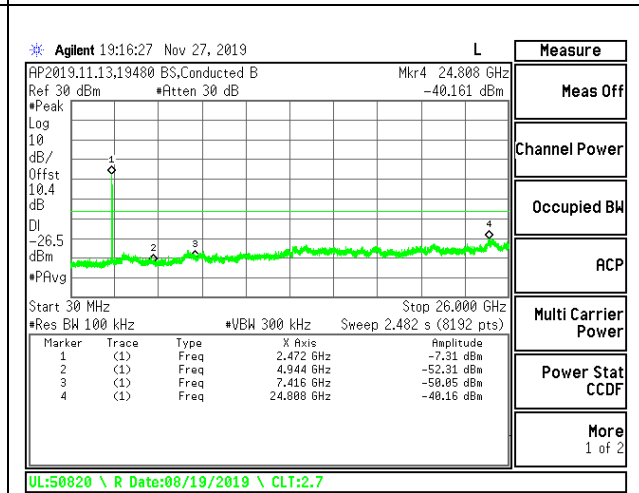

OUT-OF-BAND HIGH CHANNEL 13

8.5.2. 802.11g MODE

2TX Chain 0 + Chain 1 CDD MODE

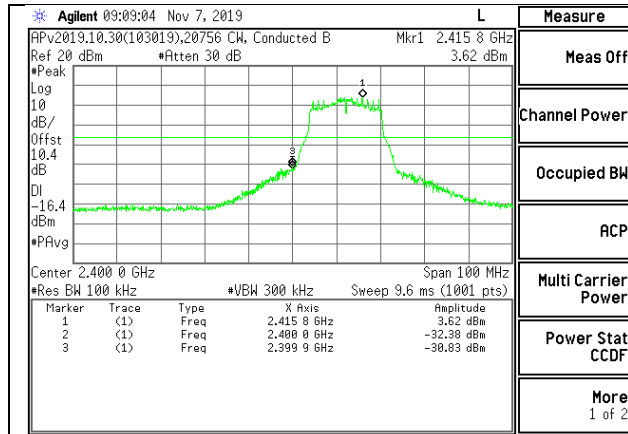

LOW CHANNEL 1 BANDEDGE CHAIN 0

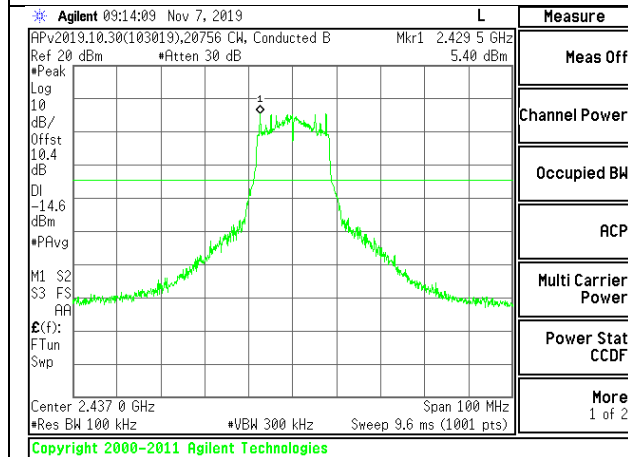

IN-BAND REFERENCE LEVEL CHAIN 0

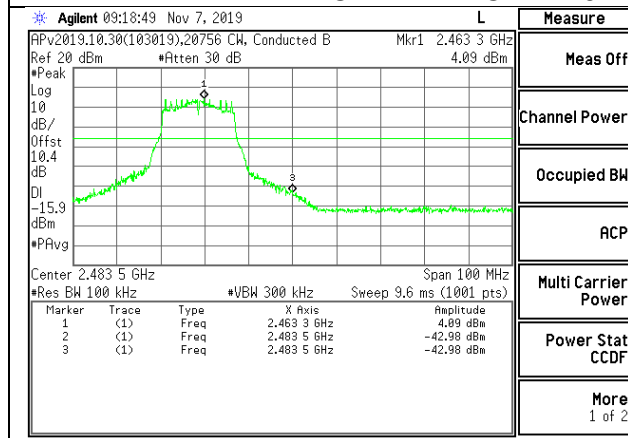

HIGH CHANNEL 11 BANDEDGE CHAIN 0

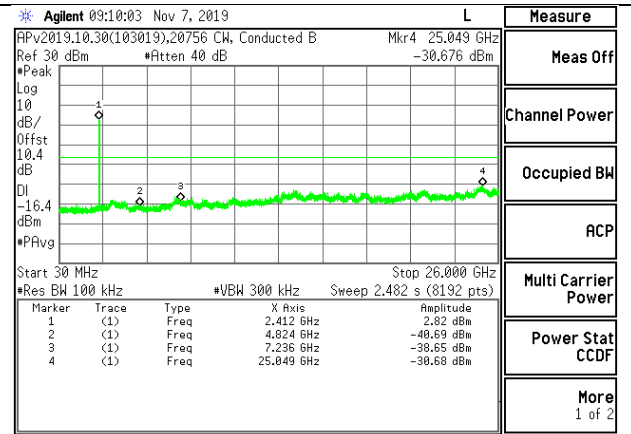

OUT-OF-BAND LOW CHANNEL 1 CHAIN 0

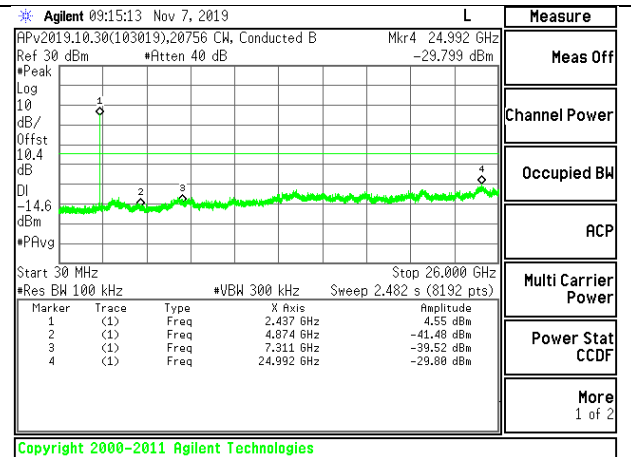

OUT-OF-BAND MID CHANNEL CHAIN 0

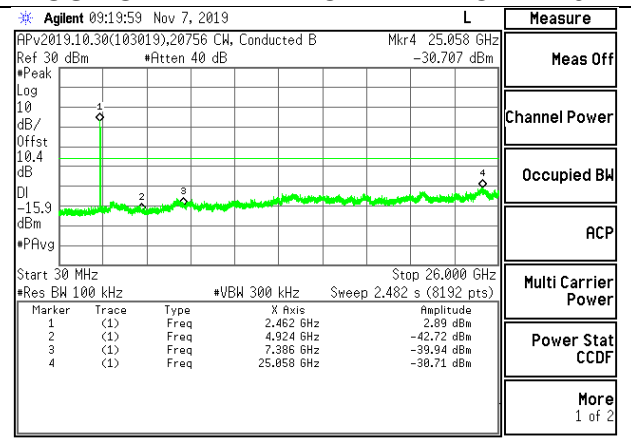

OUT-OF-BAND HIGH CHANNEL 11 CHAIN 0

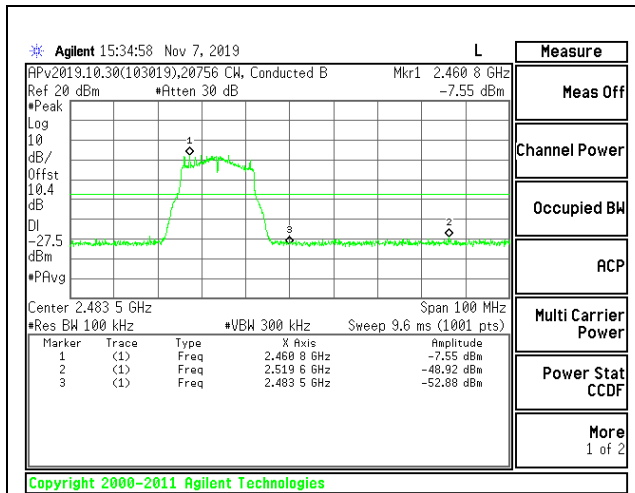

HIGH CHANNEL 12 BANDEDGE CHAIN 0

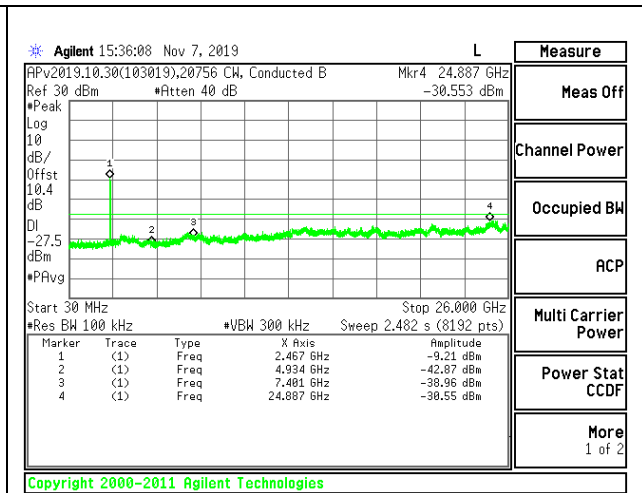

OUT-OF-BAND HIGH CHANNEL 12 CHAIN 0

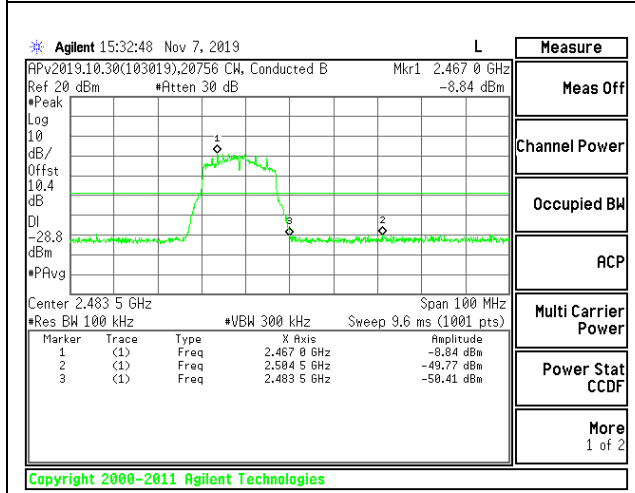

HIGH CHANNEL 13 BANDEDGE CHAIN 0

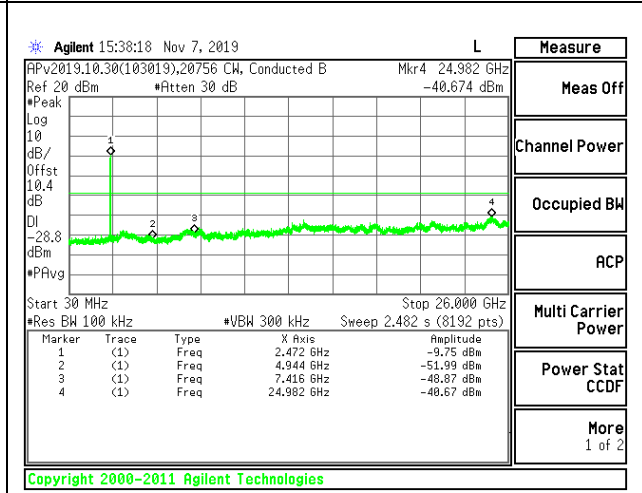

OUT-OF-BAND HIGH CHANNEL 13 CHAIN 0

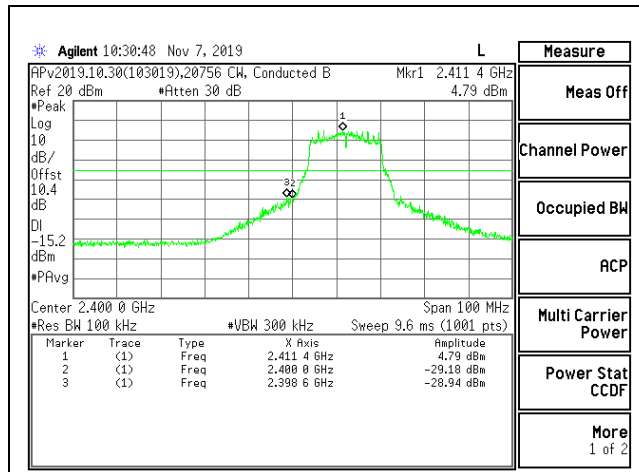

LOW CHANNEL 1 BANDEDGE CHAIN 1

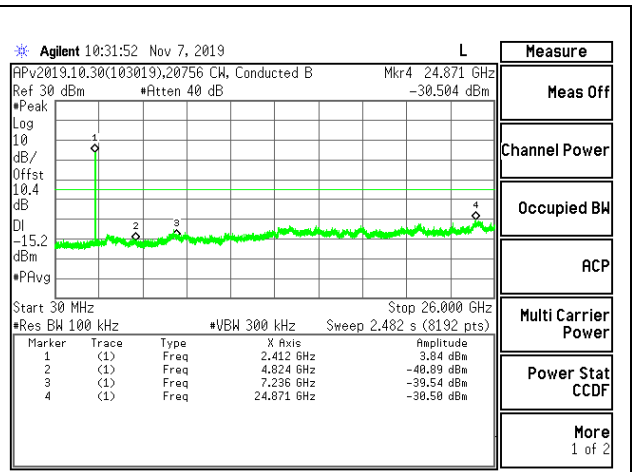

OUT-OF-BAND LOW CHANNEL 1 CHAIN 1

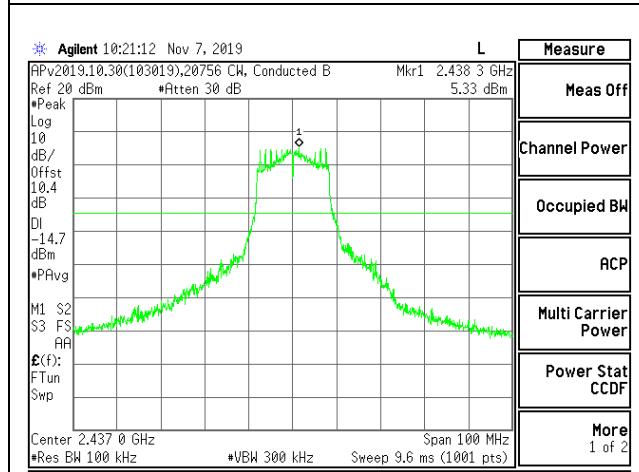

IN-BAND REFERENCE LEVEL CHAIN 1

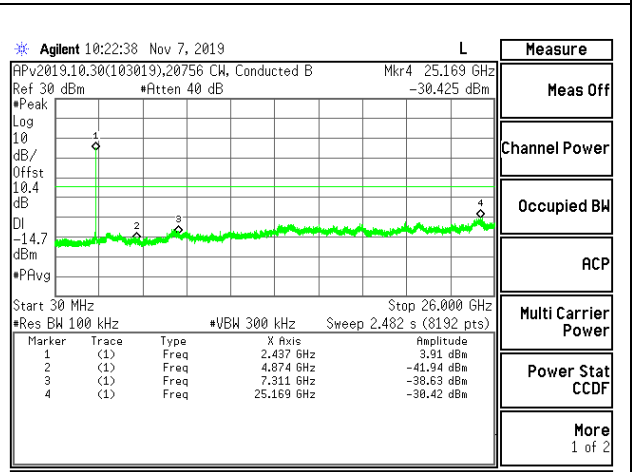

OUT-OF-BAND MID CHANNEL 1 CHAIN 1

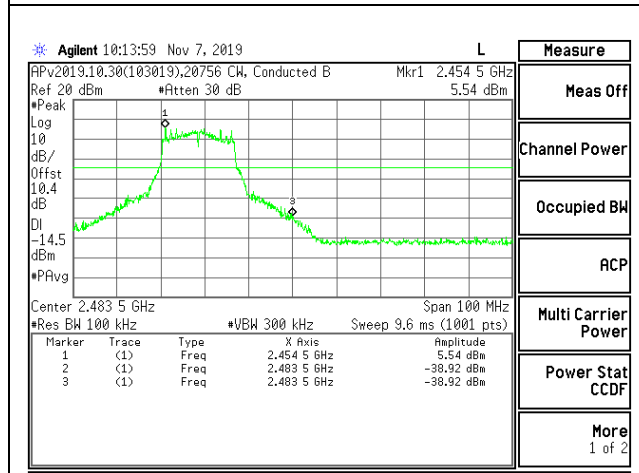

HIGH CHANNEL 11 BANDEDGE CHAIN 1

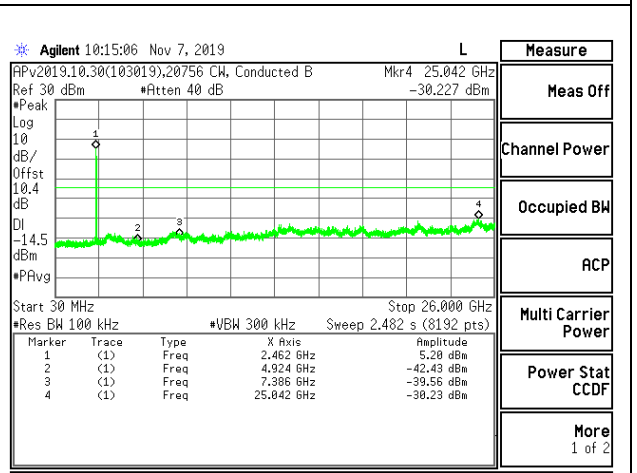

OUT-OF-BAND HIGH CHANNEL 11 CHAIN 1

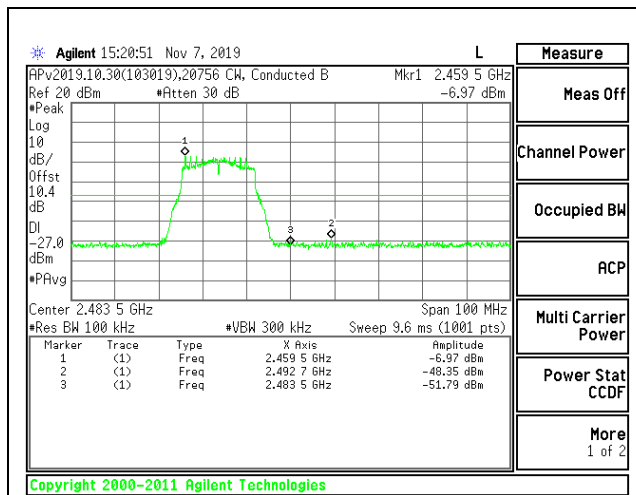

HIGH CHANNEL 12 BANDEDGE CHAIN 1

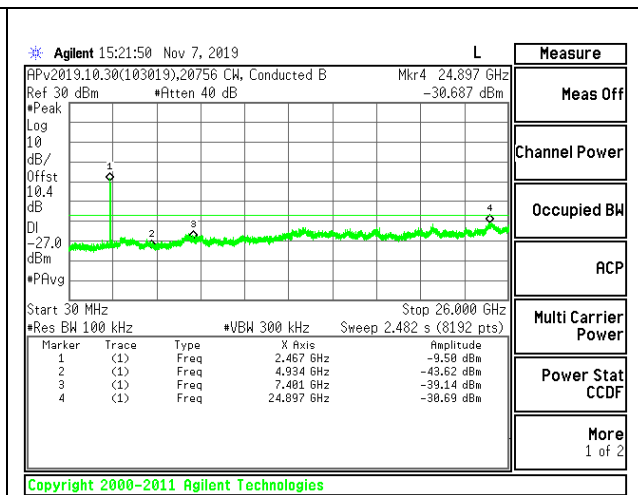

OUT-OF-BAND HIGH CHANNEL 12 CHAIN 1

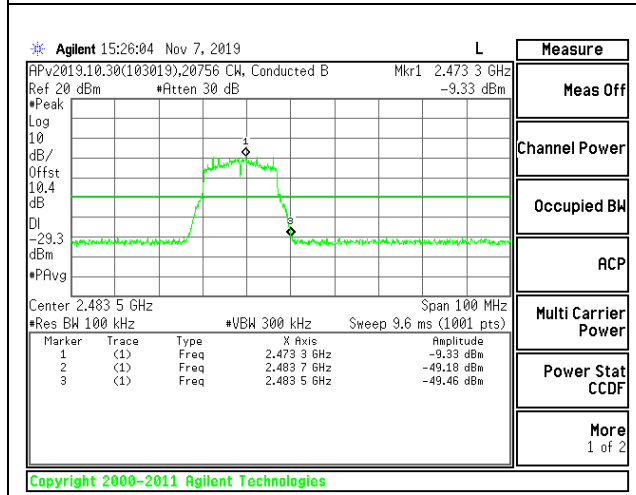

HIGH CHANNEL 13 BANDEDGE CHAIN 1

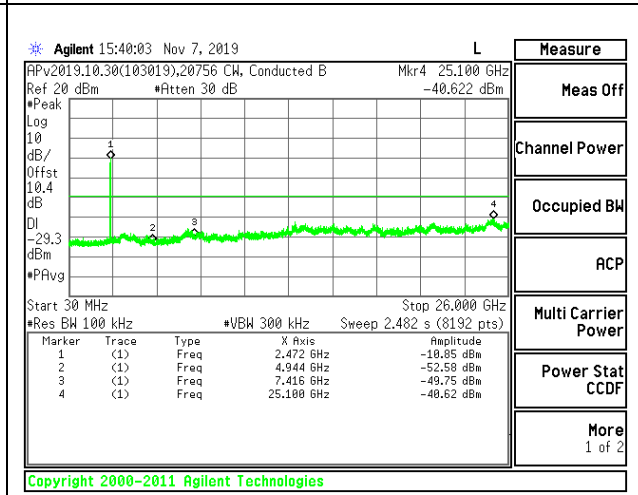

OUT-OF-BAND HIGH CHANNEL 13 CHAIN 1

8.5.3. 802.11n HT20 MODE

2TX Chain 0 + Chain 1 CDD MODE

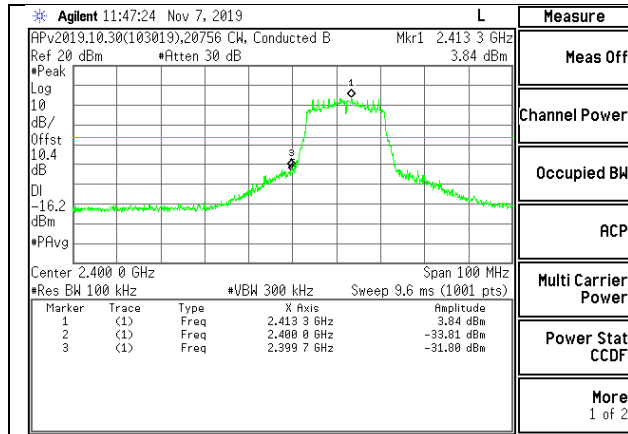

Copyright 2000-2011 Agilent Technologies
LOW CHANNEL 1 BANDEDGE CHAIN 0

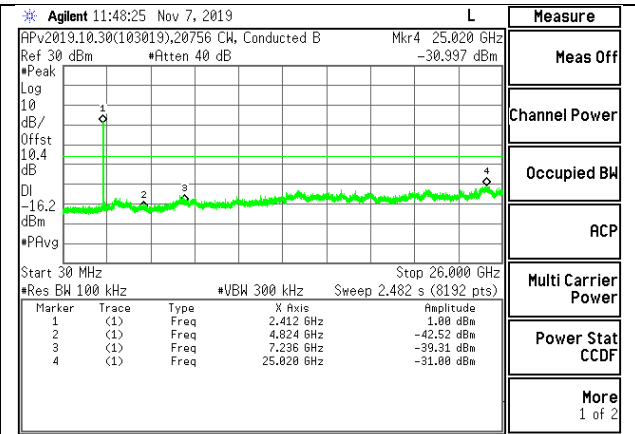

Copyright 2000-2011 Agilent Technologies
OUT-OF-BAND LOW CHANNEL 1 CHAIN 0

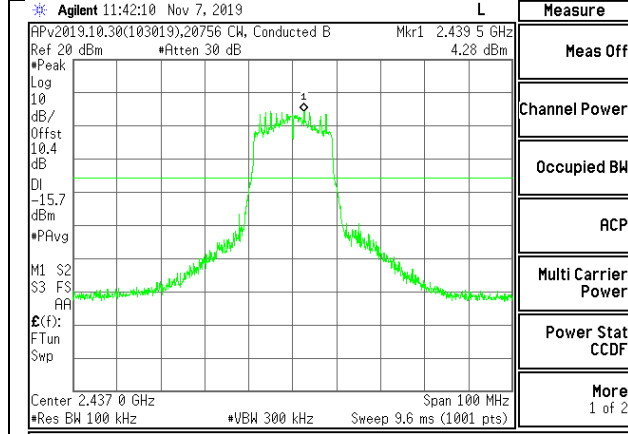

Copyright 2000-2011 Agilent Technologies
IN-BAND REFERENCE LEVEL CHAIN 0

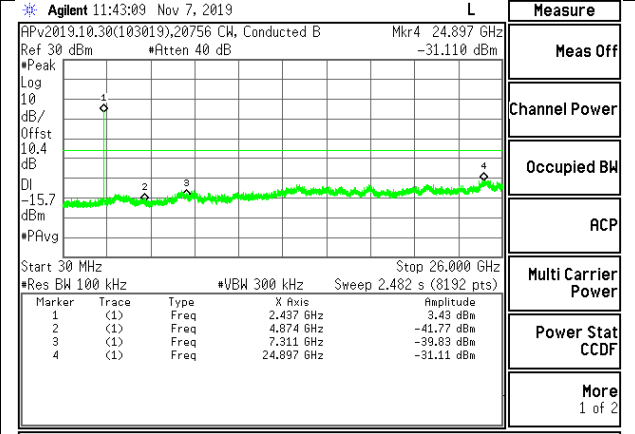

Copyright 2000-2011 Agilent Technologies
OUT-OF-BAND MID CHANNEL CHAIN 0

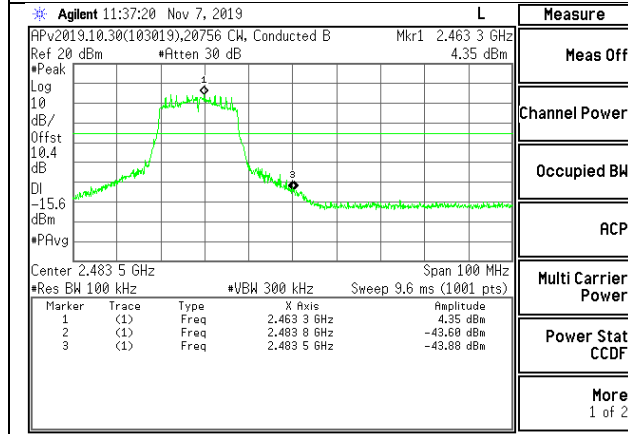

Copyright 2000-2011 Agilent Technologies
HIGH CHANNEL 11 BANDEDGE CHAIN 0

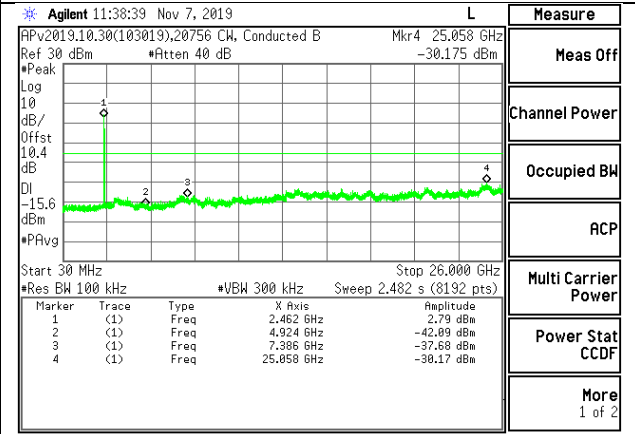

Copyright 2000-2011 Agilent Technologies
OUT-OF-BAND HIGH CHANNEL 11 CHAIN 0

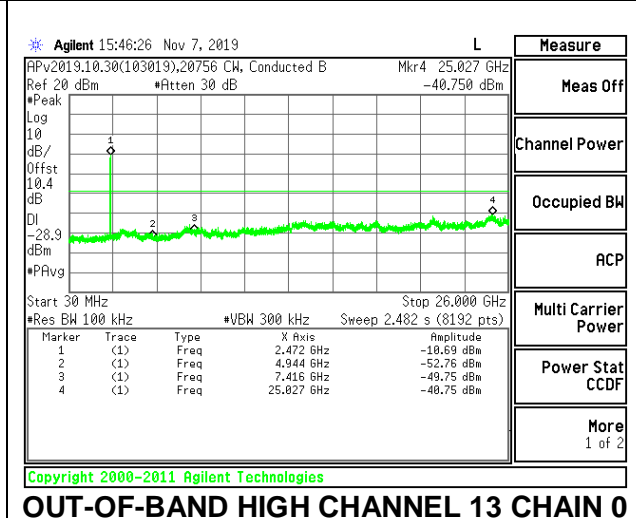
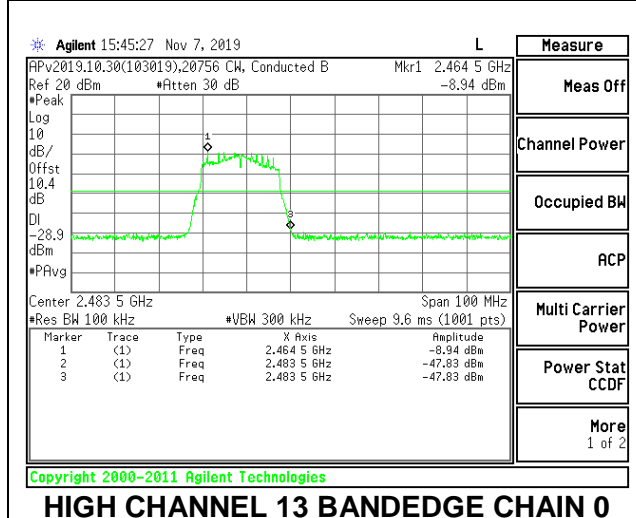
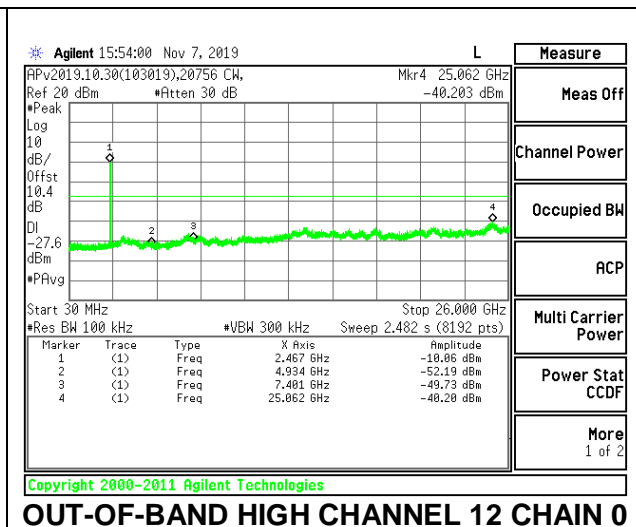
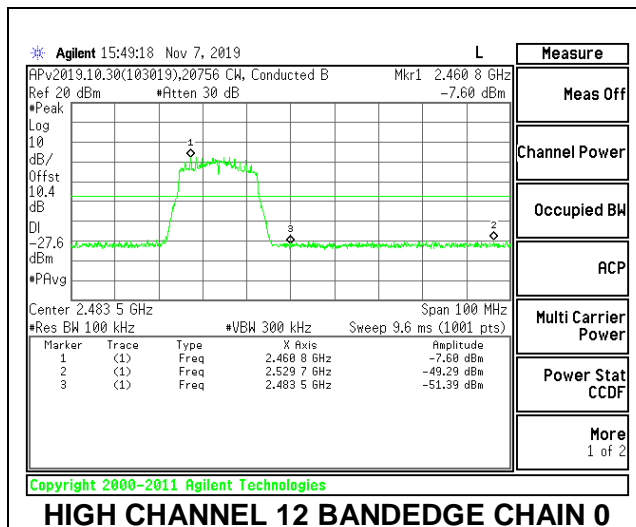

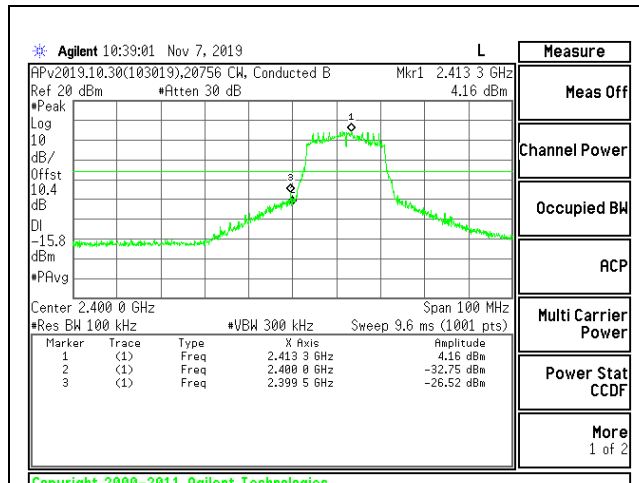

LOW CHANNEL 1 BANDEDGE CHAIN 1

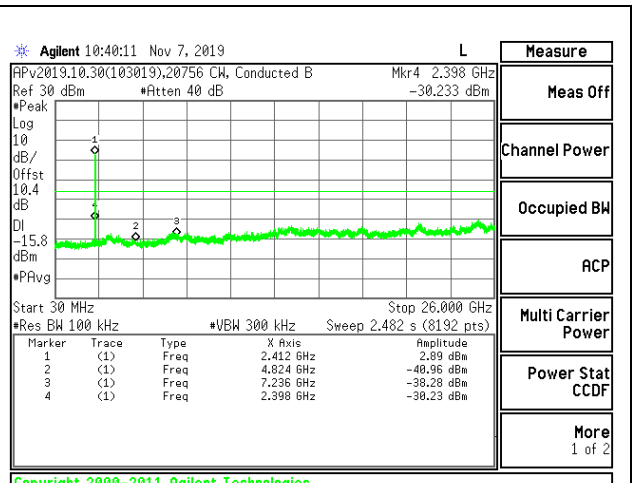

OUT-OF-BAND LOW CHANNEL 1 CHAIN 1

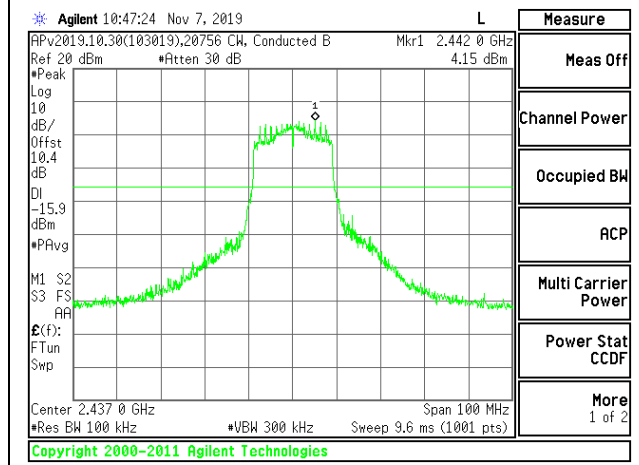

IN-BAND REFERENCE LEVEL CHAIN 1

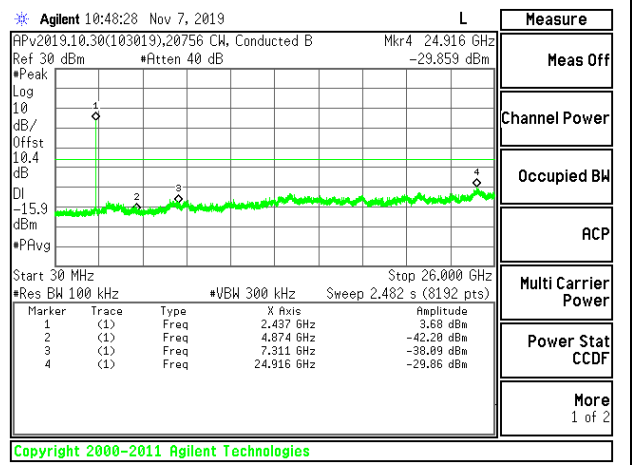

OUT-OF-BAND MID CHANNEL CHAIN 1

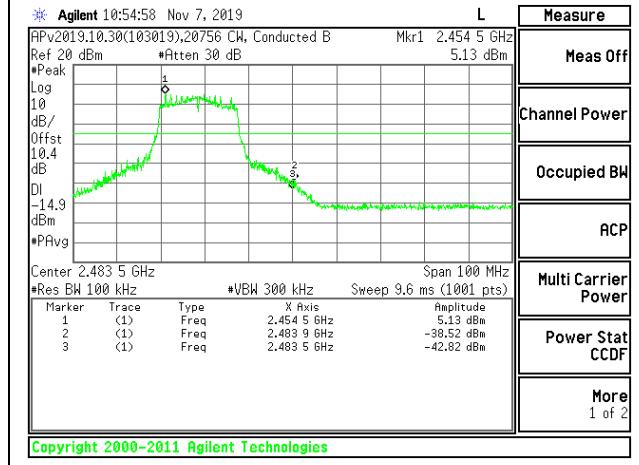

HIGH CHANNEL 11 BANDEDGE CHAIN 1

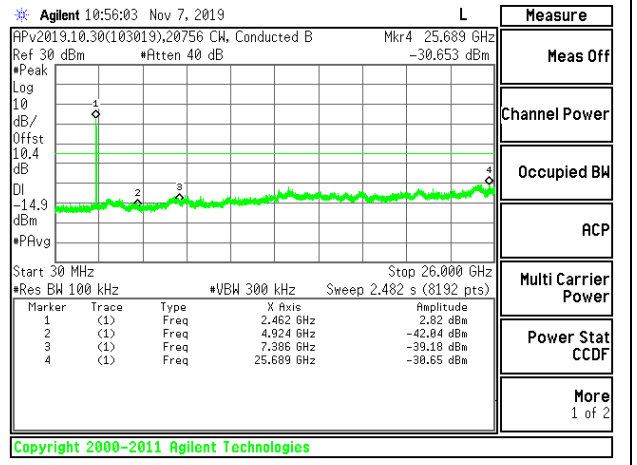

OUT-OF-BAND HIGH CHANNEL 11 CHAIN 1

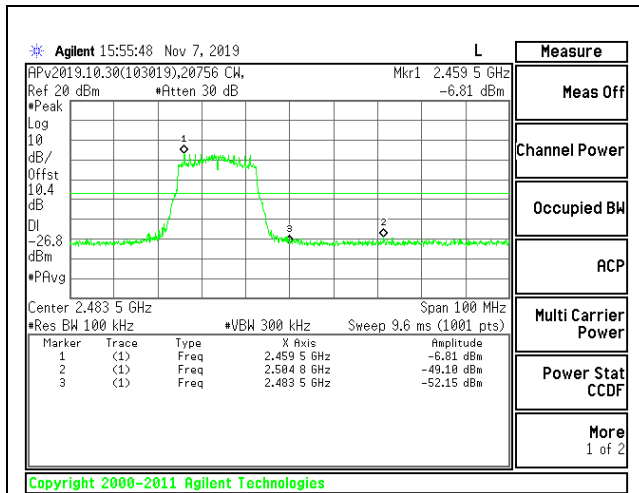

HIGH CHANNEL 12 BANDEDGE CHAIN 1

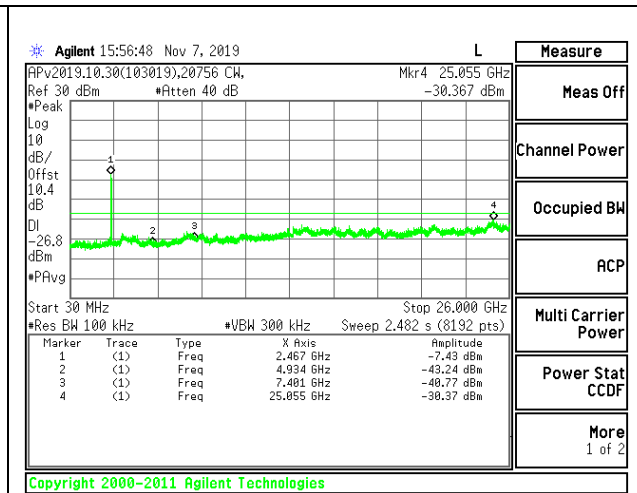

OUT-OF-BAND HIGH CHANNEL 12 CHAIN 1

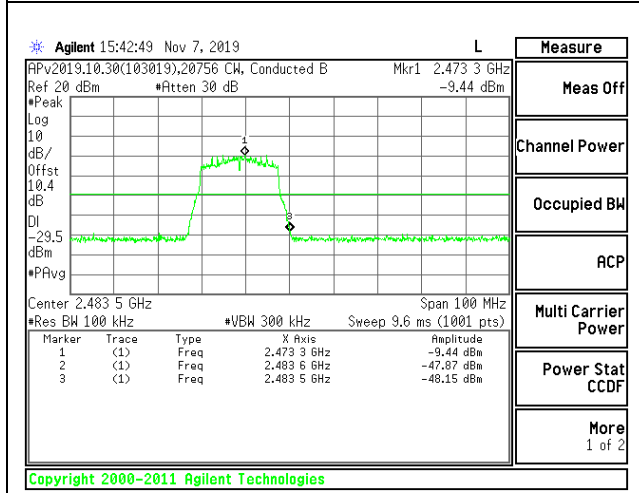

HIGH CHANNEL 13 BANDEDGE CHAIN 1

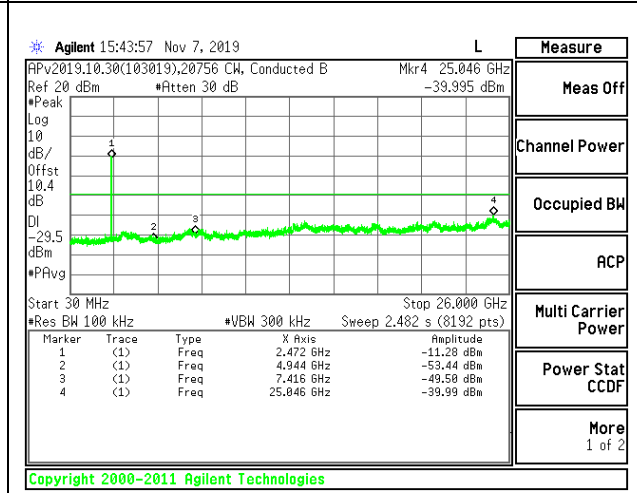

OUT-OF-BAND HIGH CHANNEL 13 CHAIN 1

9. RADIATED TEST RESULTS

LIMITS

FCC §15.205 and §15.209

Frequency Range (MHz)	Field Strength Limit (uV/m) at 3 m	Field Strength Limit (dBuV/m) at 3 m
0.009-0.490	2400/F(kHz) @ 300 m	-
0.490-1.705	24000/F(kHz) @ 30 m	-
1.705 - 30	30 @ 30m	-
30 - 88	100	40
88 - 216	150	43.5
216 - 960	200	46
Above 960	500	54

TEST PROCEDURE

The EUT is placed on a non-conducting table 80 cm above the ground plane for measurement below 1GHz; 1.5 m above the ground plane for measurement above 1GHz. The antenna to EUT distance is 3 meters. The EUT is configured in accordance with ANSI C63.10. The EUT is set to transmit in a continuous mode.

For measurements below 1 GHz the resolution bandwidth is set to 100 kHz for peak detection measurements or 120 kHz for quasi-peak detection measurements. Peak detection is used unless otherwise noted as quasi-peak.

For pre-scans above 1 GHz the resolution bandwidth is set to 1 MHz; the video bandwidth is set to 30 KHz for peak measurements.

For final measurements above 1 GHz the resolution bandwidth is set to 1 MHz; the video bandwidth is set to 3 MHz for peak measurements and as applicable for average measurements.

The spectrum from 1 GHz to 18 GHz is investigated with the transmitter set to the lowest, middle, and highest channels in each applicable band. Below 1GHz and above 18GHz emissions, the channel with the highest output power was tested.

The frequency range of interest is monitored at a fixed antenna height and EUT azimuth. The EUT is rotated through 360 degrees to maximize emissions received. The antenna is scanned from 1 to 4 meters above the ground plane to further maximize the emission. Measurements are made with the antenna polarized in both the vertical and the horizontal positions.

2D antenna use - For below 30MHz testing, investigation was done on three antenna orientations (parallel, perpendicular, and ground-parallel), parallel and perpendicular are the worst orientations, therefore testing was performed on these two orientations only.

KDB 414788 Open Field Site(OFS) and Chamber Correlation Justification

Base on FCC 15.31 (f) (2): measurements may be performed at a distance closer than that specified in the regulations; however, an attempt should be made to avoid making measurements in the near field.

OFS and chamber correlation testing had been performed and chamber measured test result is the worst case test result.

9.1. TRANSMITTER ABOVE 1 GHz

9.1.1. TX ABOVE 1 GHz 802.11b MODE IN THE 2.4 GHz BAND

1TX Chain 0 MODE

BANDEDGE (LOW CHANNEL, CH 1)

HORIZONTAL RESULT

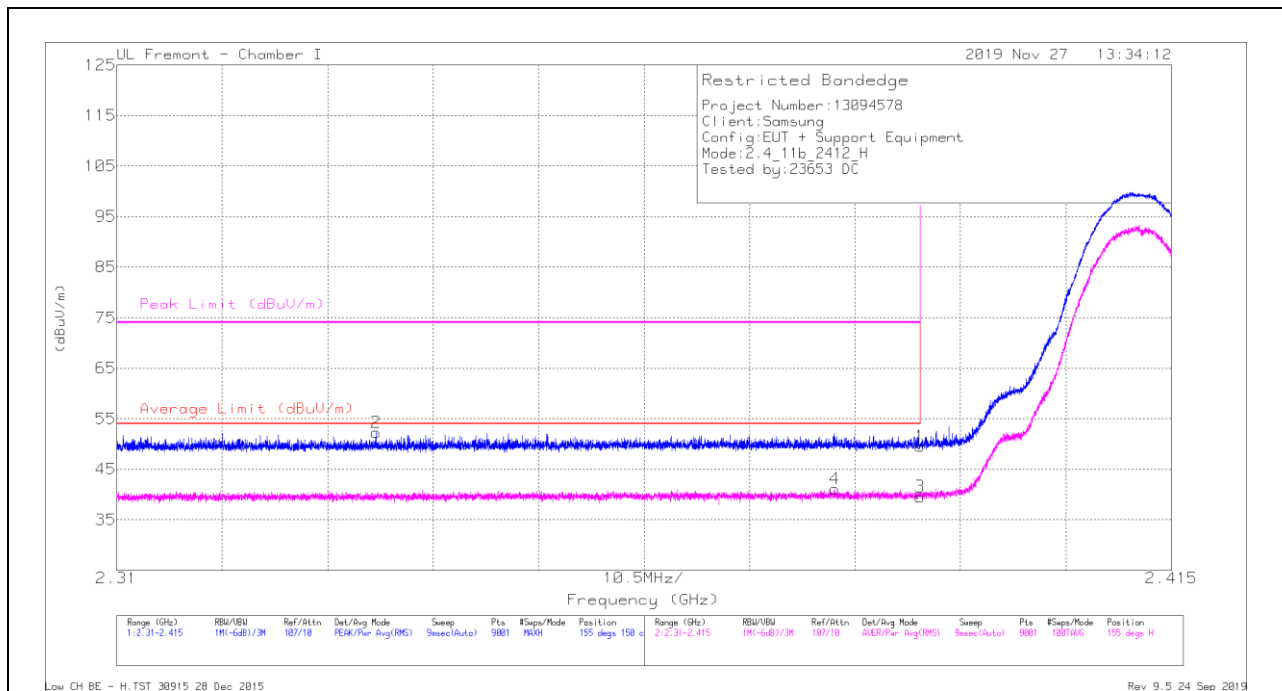

Trace Markers

Marker	Frequency (GHz)	Meter Reading (dBuV)	Det	AF T862 (dB/m)	Amp/Cb/Filtr/Pad (dB)	DC Corr (dB)	Corrected Reading (dBuV/m)	Average Limit (dBuV/m)	Margin (dB)	Peak Limit (dBuV/m)	PK Margin (dB)	Azimuth (Degs)	Height (cm)	Polarity
1	* 2.38999	37.29	Pk	31.9	-19.7	0	49.49	-	-	74	-24.51	155	150	H
2	* 2.3358	40.19	Pk	31.6	-19.5	0	52.29	-	-	74	-21.71	155	150	H
3	* 2.38999	26.9	RMS	31.9	-19.7	.45	39.55	54	-14.45	-	-	155	150	H
4	* 2.38148	28.31	RMS	31.9	-19.6	.45	41.06	54	-12.94	-	-	155	150	H

* - indicates frequency in CFR47 Pt 15 / IC RSS-Restricted Band

Pk - Peak detector

RMS - RMS detection

VERTICAL RESULT

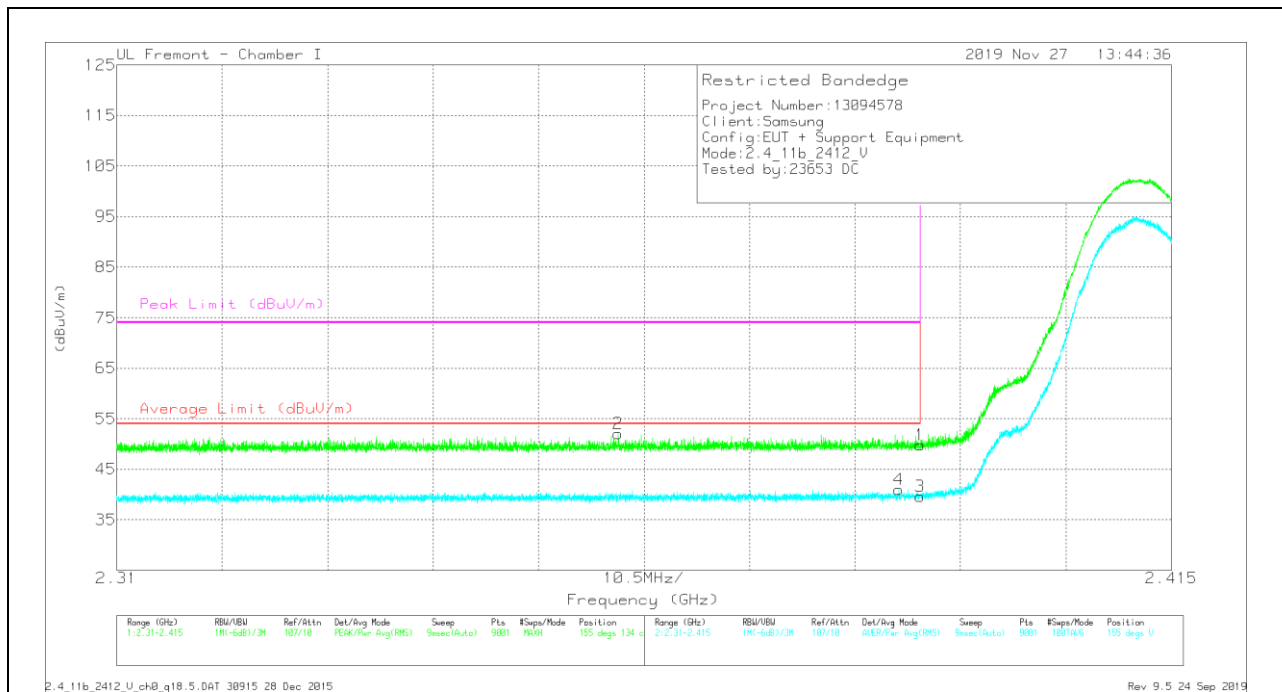

Trace Markers

Marker	Frequency (GHz)	Meter Reading (dBuV)	Det	AF T862 (dB/m)	Amp/Cb/Filtr/Pad (dB)	DC Corr (dB)	Corrected Reading (dBuV/m)	Average Limit (dBuV/m)	Margin (dB)	Peak Limit (dBuV/m)	PK Margin (dB)	Azimuth (Degs)	Height (cm)	Polarity
1	* 2.38999	37.64	Pk	31.9	-19.7	0	49.84	-	-	74	-24.16	155	134	V
2	* 2.35993	39.73	Pk	31.8	-19.5	0	52.03	-	-	74	-21.97	155	134	V
3	* 2.38999	27.01	RMS	31.9	-19.7	.45	39.66	54	-14.34	-	-	155	134	V
4	* 2.38785	28.33	RMS	31.9	-19.7	.45	40.98	54	-13.02	-	-	155	134	V

* - indicates frequency in CFR47 Pt 15 / IC RSS-Restricted Band
 Pk - Peak detector
 RMS - RMS detection

BANDEDGE (HIGH CHANNEL, CH 11)

HORIZONTAL RESULT

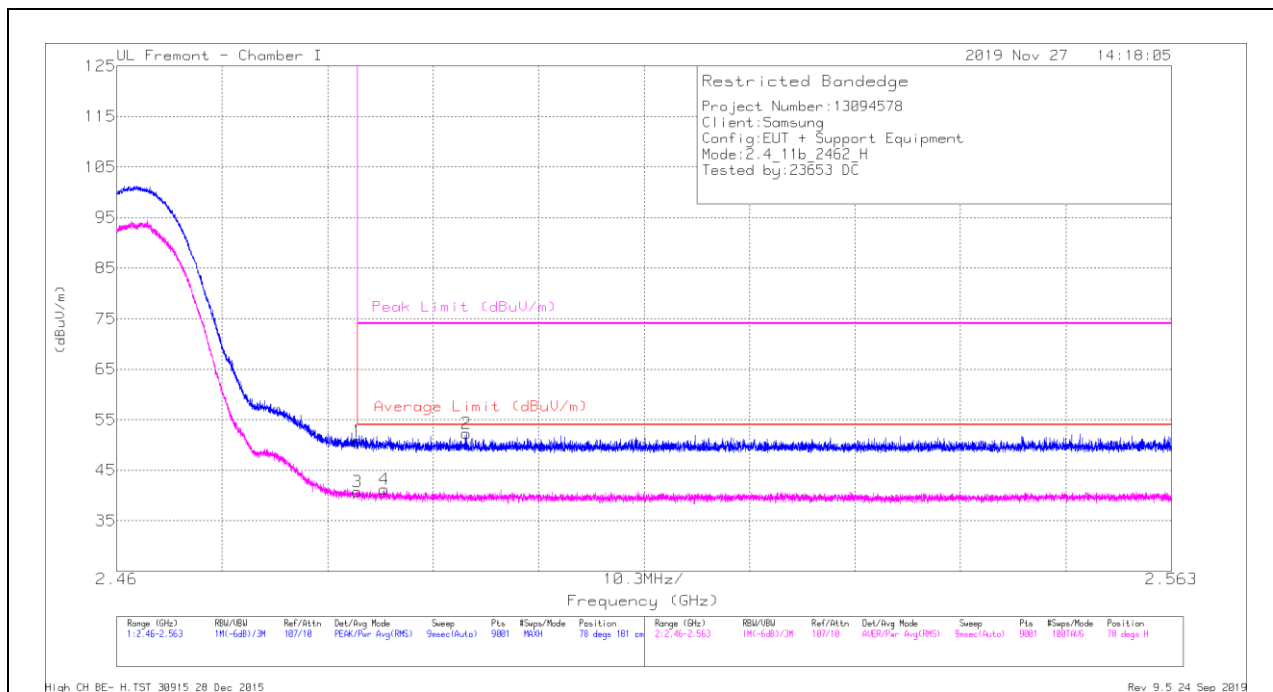

Trace Markers

Marker	Frequency (GHz)	Meter Reading (dBuV)	Det	AF T862 (dB/m)	Amp/Cb/Filtr/Pad (dB)	DC Corr (dB)	Corrected Reading (dBuV/m)	Average Limit (dBuV/m)	Margin (dB)	Peak Limit (dBuV/m)	PK Margin (dB)	Azimuth (Degs)	Height (cm)	Polarity
1	* 2.48351	38.42	Pk	32.4	-20	0	50.82	-	-	74	-23.18	78	181	H
2	* 2.49414	39.96	Pk	32.3	-20	0	52.26	-	-	74	-21.74	78	181	H
3	* 2.48351	27.91	RMS	32.4	-20	.45	40.76	54	-13.24	-	-	78	181	H
4	* 2.48612	28.33	RMS	32.4	-20	.45	41.18	54	-12.82	-	-	78	181	H

* - indicates frequency in CFR47 Pt 15 / IC RSS-Restricted Band

Pk - Peak detector

RMS - RMS detection

VERTICAL RESULT

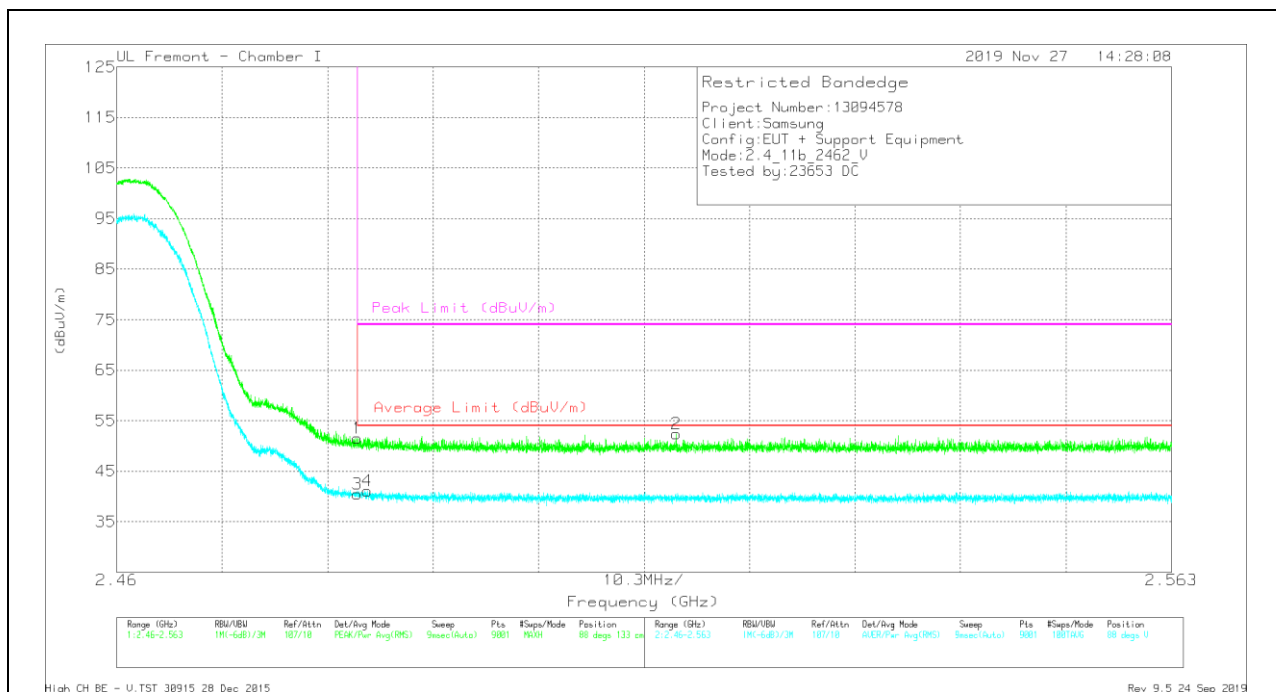

Trace Markers

Marker	Frequency (GHz)	Meter Reading (dBuV)	Det	AF T862 (dB/m)	Amp/Cb/Filtr/Pad (dB)	DC Corr (dB)	Corrected Reading (dBuV/m)	Average Limit (dBuV/m)	Margin (dB)	Peak Limit (dBuV/m)	PK Margin (dB)	Azimuth (Degs)	Height (cm)	Polarity
1	* 2.48351	39.09	Pk	32.4	-20	0	51.49	-	-	74	-22.51	88	133	V
2	2.51462	40.2	Pk	32.3	-20.1	0	52.4	-	-	74	-21.6	88	133	V
3	* 2.48351	27.65	RMS	32.4	-20	.45	40.5	54	-13.5	-	-	88	133	V
4	* 2.48448	28.29	RMS	32.4	-20	.45	41.14	54	-12.86	-	-	88	133	V

* - indicates frequency in CFR47 Pt 15 / IC RSS-Restricted Band
 Pk - Peak detector
 RMS - RMS detection

BANDEDGE (HIGH CHANNEL, CH 12)

HORIZONTAL RESULT

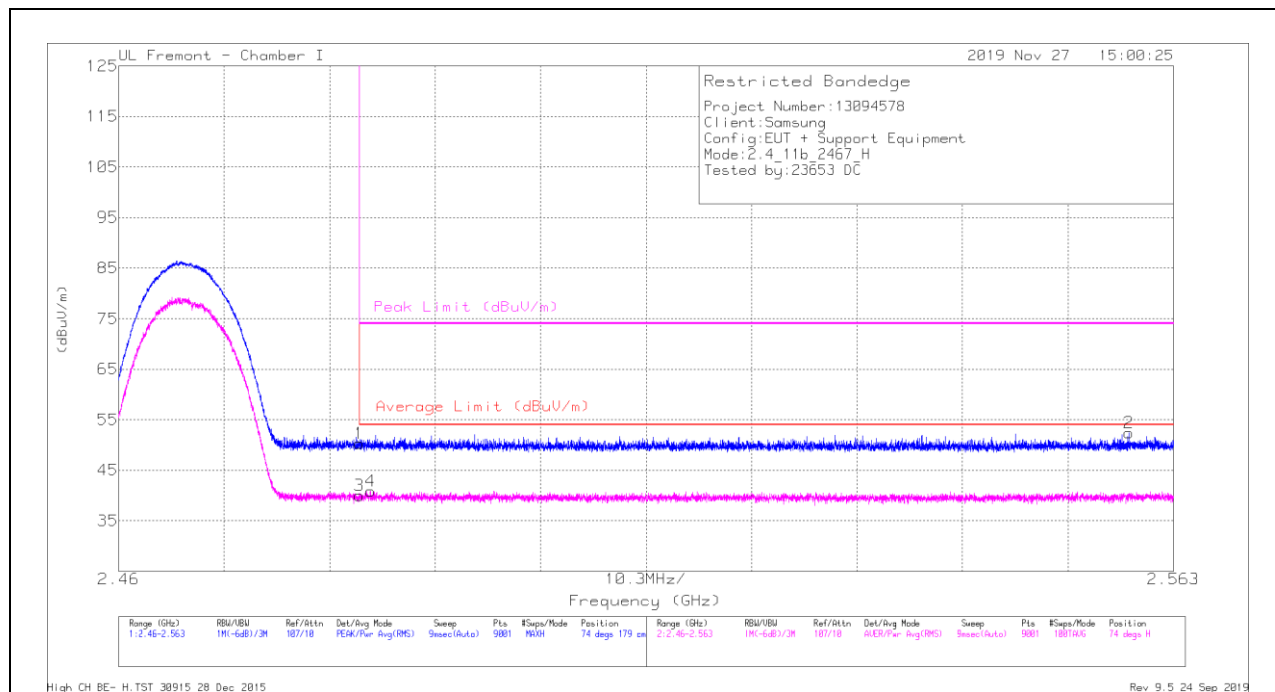

Trace Markers

Marker	Frequency (GHz)	Meter Reading (dBuV)	Det	AF T862 (dB/m)	Amp/Cb/Filtr/Pad (dB)	DC Corr (dB)	Corrected Reading (dBuV/m)	Average Limit (dBuV/m)	Margin (dB)	Peak Limit (dBuV/m)	PK Margin (dB)	Azimuth (Degs)	Height (cm)	Polarity
1	* 2.48351	37.88	Pk	32.4	-20	0	50.28	-	-	74	-23.72	74	179	H
2	2.55867	40.09	Pk	32.3	-20	0	52.39	-	-	74	-21.61	74	179	H
3	* 2.48351	27.14	RMS	32.4	-20	.45	39.99	54	-14.01	-	-	74	179	H
4	* 2.48457	28.04	RMS	32.4	-20	.45	40.89	54	-13.11	-	-	74	179	H

* - indicates frequency in CFR47 Pt 15 / IC RSS-Restricted Band

Pk - Peak detector

RMS - RMS detection

VERTICAL RESULT

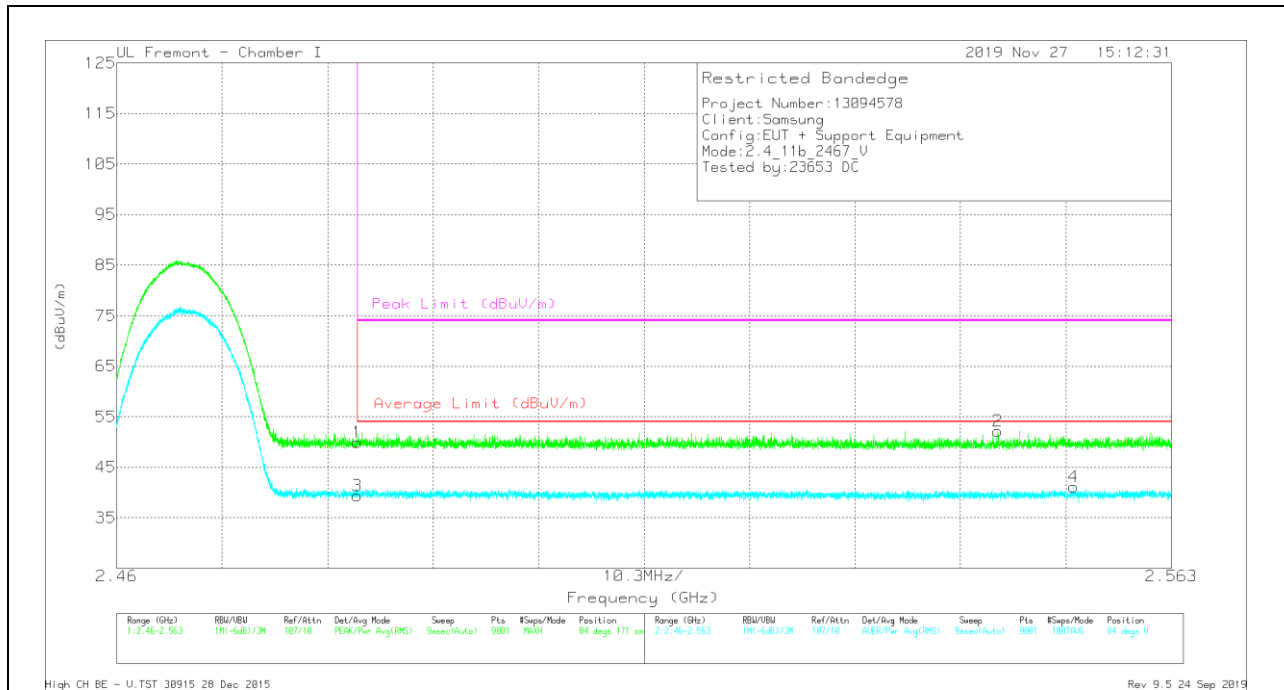

Trace Markers

Marker	Frequency (GHz)	Meter Reading (dBuV)	Det	AF T862 (dB/m)	Amp/Cb/Filtr/Pad (dB)	DC Corr (dB)	Corrected Reading (dBuV/m)	Average Limit (dBuV/m)	Margin (dB)	Peak Limit (dBuV/m)	PK Margin (dB)	Azimuth (Degs)	Height (cm)	Polarity
1	* 2.48351	37.53	Pk	32.4	-20	0	49.93	-	-	74	-24.07	84	171	V
2	2.54607	39.93	Pk	32.3	-20.1	0	52.13	-	-	74	-21.87	84	171	V
3	* 2.48351	26.54	RMS	32.4	-20	.45	39.39	54	-14.61	-	-	84	171	V
4	2.55345	28.44	RMS	32.3	-20.1	.45	41.09	54	-12.91	-	-	84	171	V

* - indicates frequency in CFR47 Pt 15 / IC RSS-Restricted Band
 Pk - Peak detector
 RMS - RMS detection

BANDEDGE (HIGH CHANNEL, CH 13)

HORIZONTAL RESULT

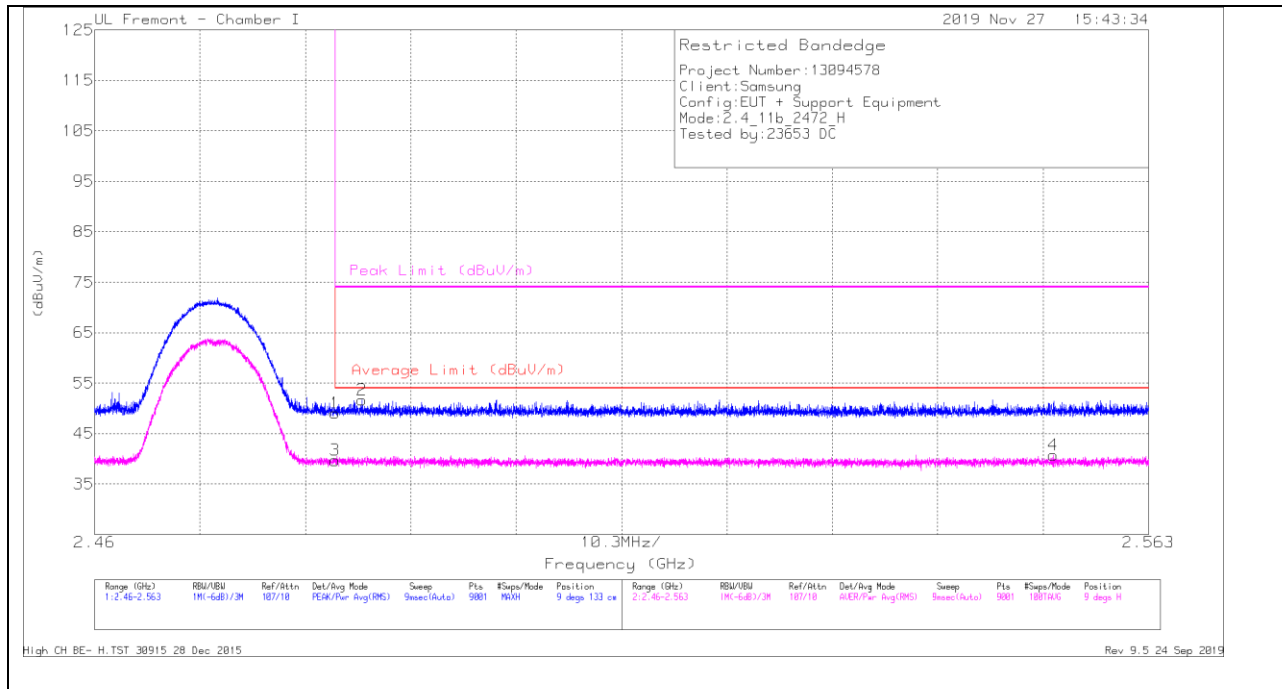

Trace Markers

Marker	Frequency (GHz)	Meter Reading (dBuV)	Det	AF T862 (dB/m)	Amp/Cb/Filtr/Pad (dB)	DC Corr (dB)	Corrected Reading (dBuV/m)	Average Limit (dBuV/m)	Margin (dB)	Peak Limit (dBuV/m)	PK Margin (dB)	Azimuth (Degs)	Height (cm)	Polarity
1	* 2.48351	36.68	Pk	32.4	-20	0	49.08	-	-	74	-24.92	9	133	H
2	* 2.48613	39.29	Pk	32.4	-20	0	51.69	-	-	74	-22.31	9	133	H
3	* 2.48351	26.83	RMS	32.4	-20	.45	39.68	54	-14.32	-	-	9	133	H
4	2.55367	28.07	RMS	32.3	-20.1	.45	40.72	54	-13.28	-	-	9	133	H

* - indicates frequency in CFR47 Pt 15 / IC RSS-Restricted Band

Pk - Peak detector

RMS - RMS detection

VERTICAL RESULT

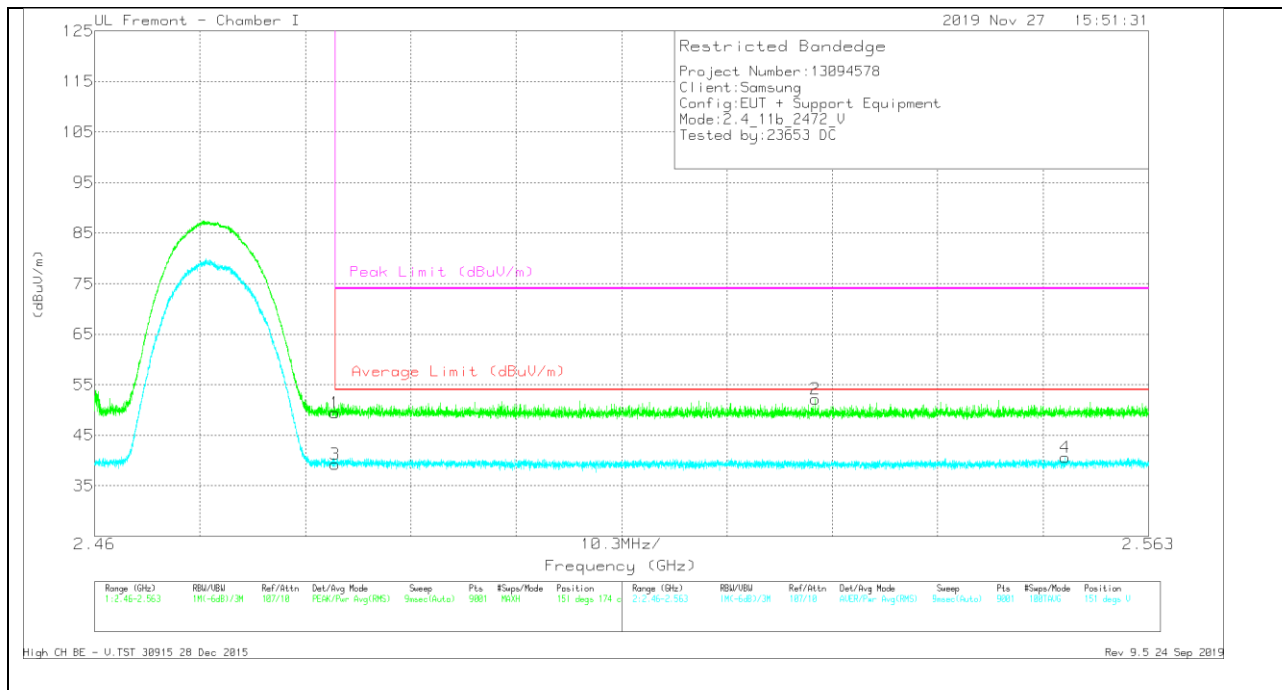

Trace Markers

Marker	Frequency (GHz)	Meter Reading (dBuV)	Det	AF T862 (dB/m)	Amp/Cb/Fitr/Pad (dB)	DC Corr (dB)	Corrected Reading (dBuV/m)	Average Limit (dBuV/m)	Margin (dB)	Peak Limit (dBuV/m)	PK Margin (dB)	Azimuth (Degs)	Height (cm)	Polarity
1	* 2.48351	37.05	Pk	32.4	-20	0	49.45	-	-	74	-24.55	151	174	V
2	2.53044	40.05	Pk	32.2	-20.1	0	52.15	-	-	74	-21.85	151	174	V
3	* 2.48351	26.39	RMS	32.4	-20	.45	39.24	54	-14.76	-	-	151	174	V
4	2.55487	27.82	RMS	32.3	-20	.45	40.57	54	-13.43	-	-	151	174	V

* - indicates frequency in CFR47 Pt 15 / IC RSS-Restricted Band
 Pk - Peak detector
 RMS - RMS detection

HARMONICS AND SPURIOUS EMISSIONS

LOW CHANNEL, CH 1 RESULTS

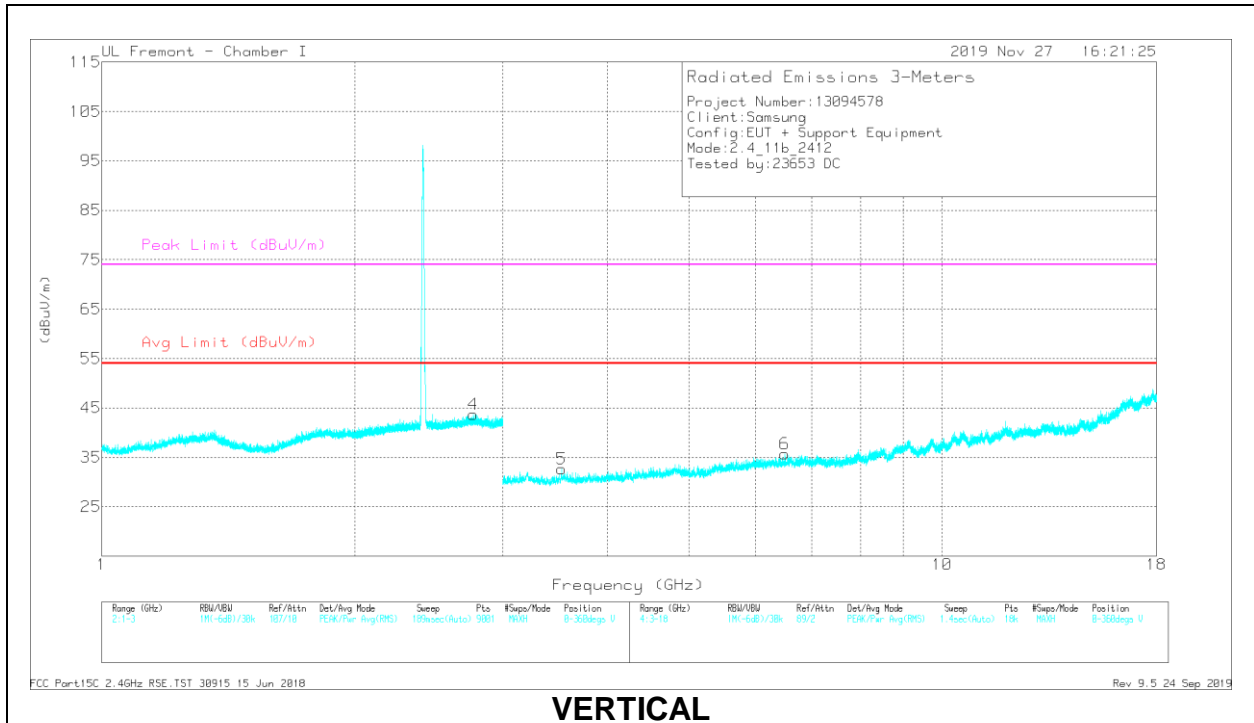
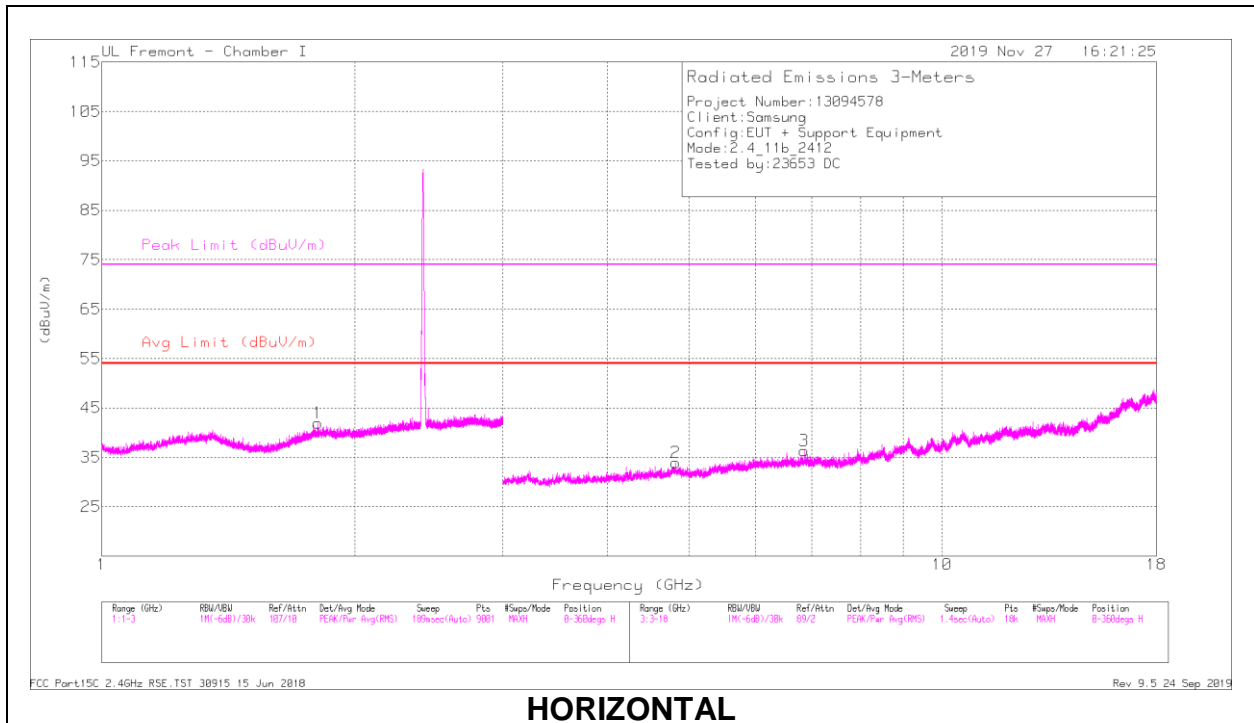

RADIATED EMISSIONS

Marker	Frequency (GHz)	Meter Reading (dBuV)	Det	AF T862 (dB/m)	Amp/Cb/Filtr/Pad (dB)	DC Corr (dB)	Corrected Reading (dBuV/m)	Avg Limit (dBuV/m)	Margin (dB)	Peak Limit (dBuV/m)	PK Margin (dB)	Azimuth (Degs)	Height (cm)	Polarity
1	1.81066	26.64	PK2	30.4	-20.1	0	36.94	-	-	-	-	321	153	H
4	* 2.76792	23.03	PK2	32.5	-19.1	0	36.43	-	-	74	-37.57	153	148	V
	* 2.76895	27.1	MAv1	32.5	-19	.45	41.05	54	-12.95	-	-	153	148	V
3	6.85888	19.77	PK2	35.6	-23.2	0	32.17	-	-	-	-	153	152	H
2	* 4.8215	32.5	PK2	34.1	-25.9	0	40.7	-	-	74	-33.3	153	160	H
	* 4.82109	22.46	MAv1	34.2	-25.9	.45	31.21	54	-22.79	-	-	153	160	H
6	6.50502	19.64	PK2	35.6	-24.5	0	30.74	-	-	-	-	153	152	V
5	* 3.52396	33.38	PK2	32.9	-27.1	0	39.18	-	-	74	-34.82	153	148	V
	* 3.527	23.55	MAv1	32.9	-27.1	.45	29.8	54	-24.2	-	-	153	148	V

* - indicates frequency in CFR47 Pt 15 / IC RSS-Restricted Band

PK2 - KDB558074 Method: Maximum Peak

MAv1 - KDB558074 Option 1 Maximum RMS Average

MID CHANNEL, CH 6 RESULTS

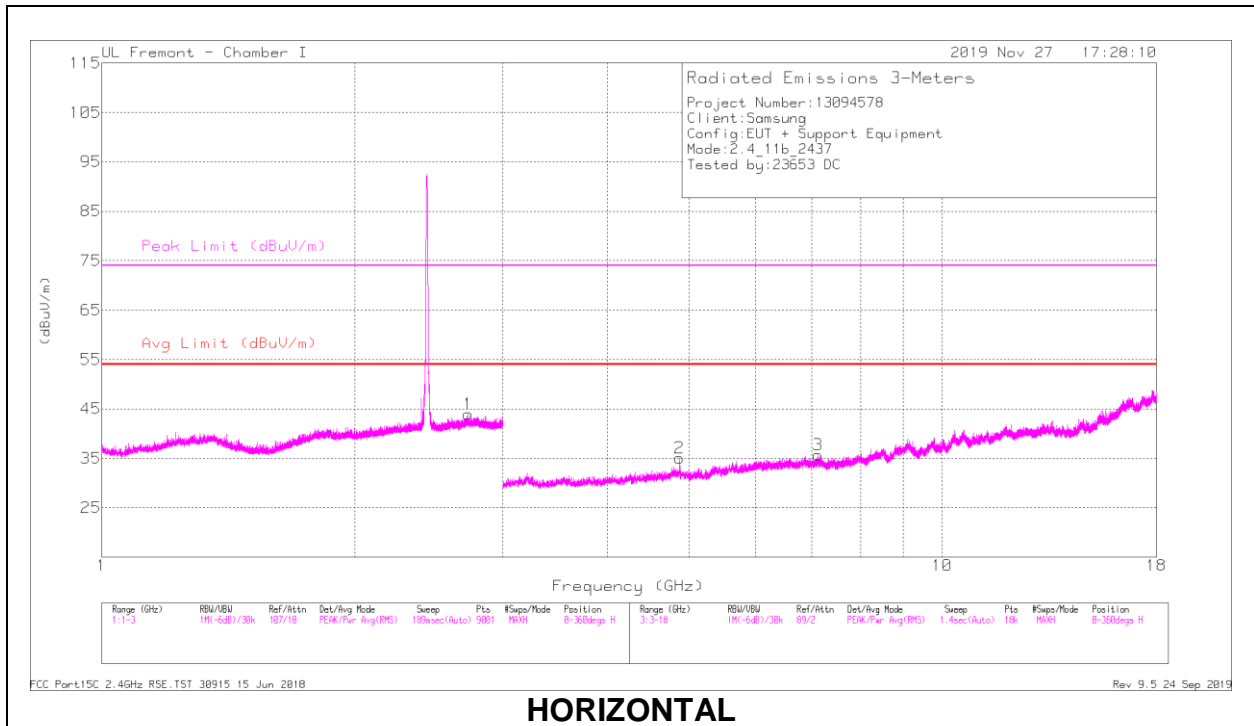

HORIZONTAL

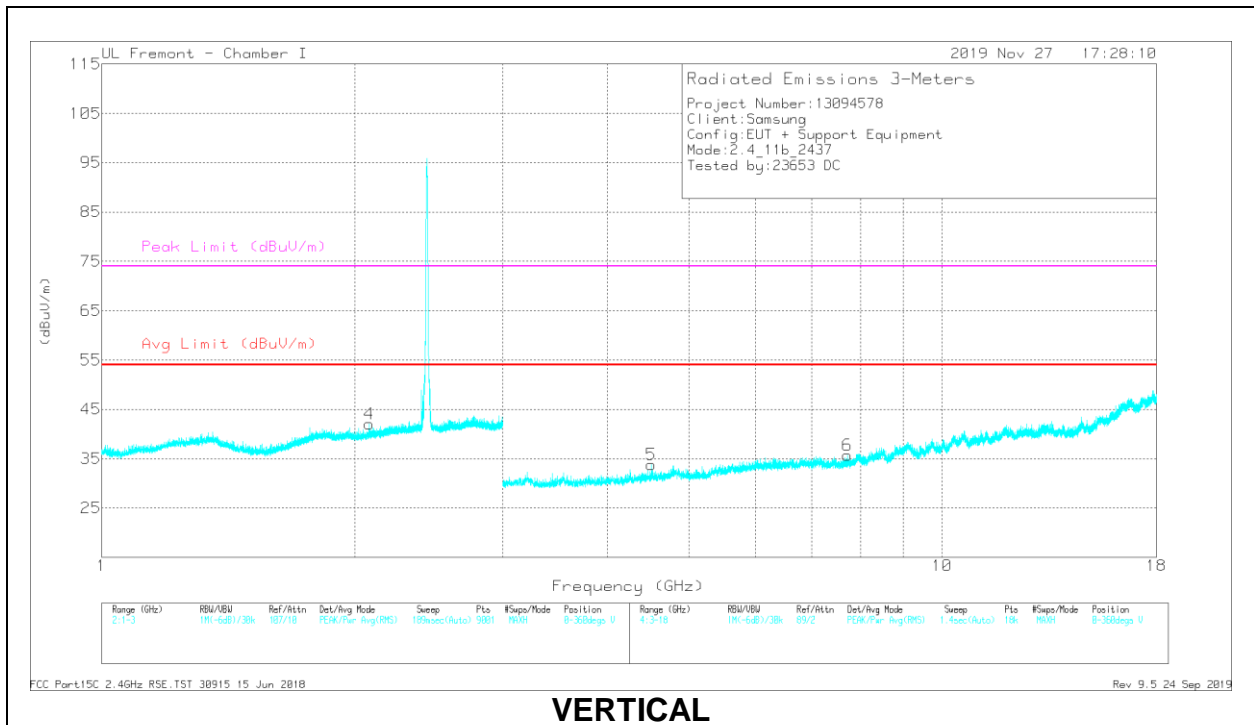

VERTICAL

RADIATED EMISSIONS

Marker	Frequency (GHz)	Meter Reading (dBuV)	Det	AF T862 (dB/m)	Amp/Cb/Filtr/Pad (dB)	DC Corr (dB)	Corrected Reading (dBuV/m)	Avg Limit (dBuV/m)	Margin (dB)	Peak Limit (dBuV/m)	PK Margin (dB)	Azimuth (Degs)	Height (cm)	Polarity
1	* 2.72931	36.79	PK2	32.5	-19.2	0	50.09	-	-	74	-23.91	153	101	H
	* 2.72859	27.65	MAv1	32.5	-19.2	.45	41.4	54	-12.6	-	-	153	101	H
4	2.07889	37.94	PK2	31.1	-20.8	0	48.24	-	-	-	-	208	153	V
3	7.11971	30.57	PK2	35.7	-23.3	0	42.97	-	-	-	-	153	150	H
2	* 4.87404	34.32	PK2	34.1	-26.3	0	42.12	-	-	74	-31.88	273	104	H
	* 4.87418	24.58	MAv1	34.1	-26.3	.45	32.83	54	-21.17	-	-	273	104	H
5	* 4.50545	33.25	PK2	33.7	-27.1	0	39.85	-	-	74	-34.15	273	103	V
	* 4.50601	23.68	MAv1	33.7	-27.1	.45	30.73	54	-23.27	-	-	273	103	V
6	* 7.7134	30.47	PK2	35.6	-22.9	0	43.17	-	-	74	-30.83	175	142	V
	* 7.71379	19.5	MAv1	35.6	-23	.45	32.55	54	-21.45	-	-	175	142	V

* - indicates frequency in CFR47 Pt 15 / IC RSS-Restricted Band
 PK2 - KDB558074 Method: Maximum Peak
 MAv1 - KDB558074 Option 1 Maximum RMS Average

HIGH CHANNEL, CH 11 RESULTS

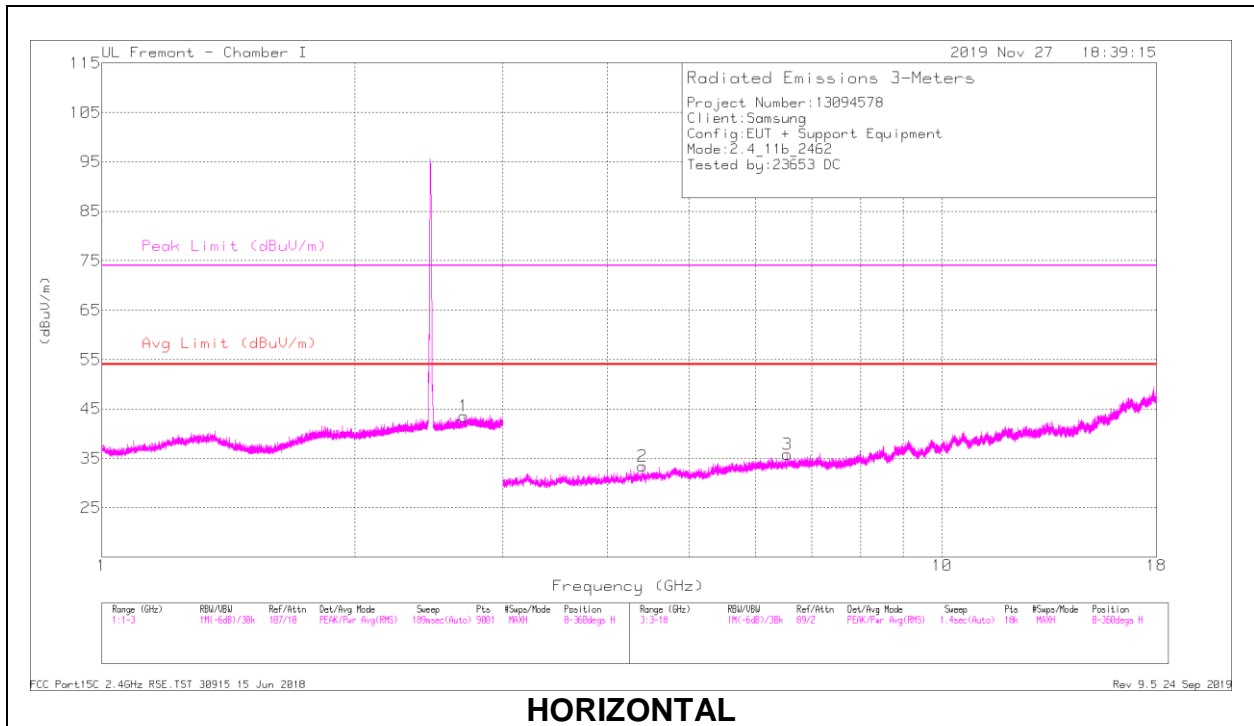

HORIZONTAL

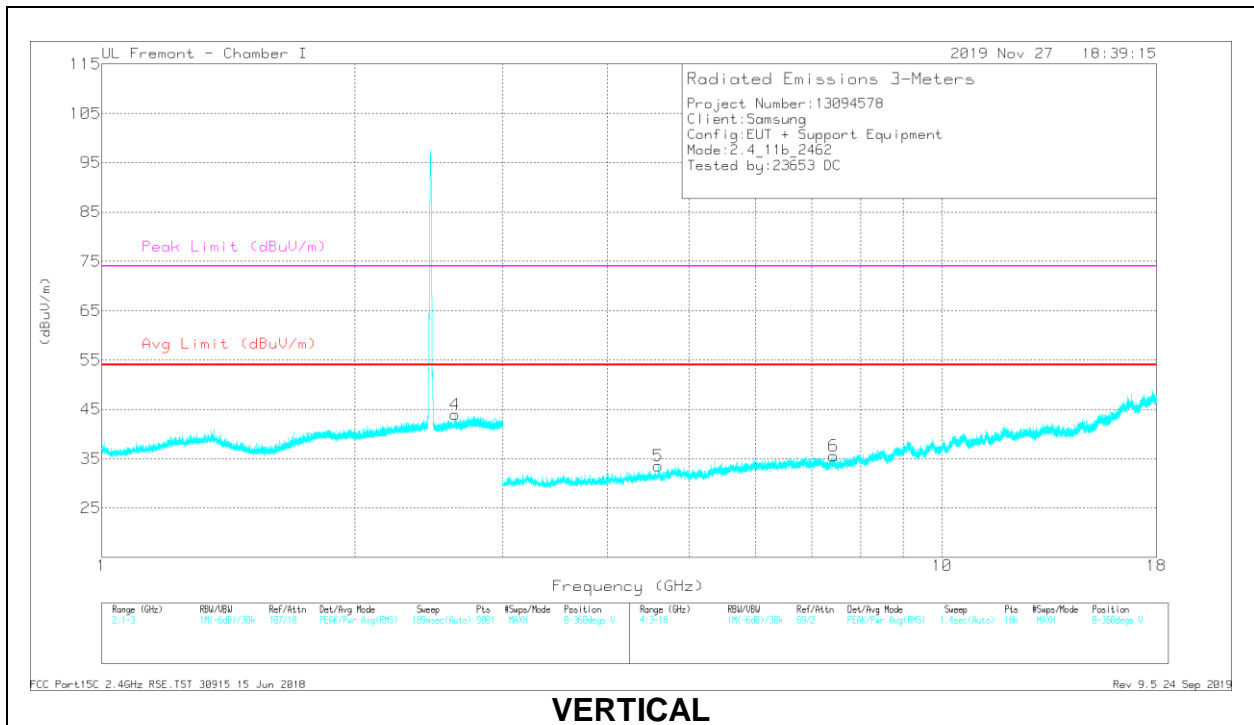

VERTICAL

RADIATED EMISSIONS

Marker	Frequency (GHz)	Meter Reading (dBuV)	Det	AF T862 (dB/m)	Amp/Cb/Filtr/Pad (dB)	DC Corr (dB)	Corrected Reading (dBuV/m)	Avg Limit (dBuV/m)	Margin (dB)	Peak Limit (dBuV/m)	PK Margin (dB)	Azimuth (Degs)	Height (cm)	Polarity
1	* 2.69689	37.74	PK2	32.4	-19.4	0	50.74	-	-	74	-23.26	146	149	H
	* 2.69489	27.13	MAv1	32.4	-19.4	.45	40.58	54	-13.42	-	-	146	149	H
4	2.63734	37.58	PK2	32.5	-19.8	0	50.28	-	-	-	-	140	180	V
2	4.40211	33.87	PK2	33.7	-27.1	0	40.47	-	-	-	-	151	146	H
3	6.54399	30.39	PK2	35.6	-23.8	0	42.19	-	-	-	-	176	113	H
5	* 4.59935	34.58	PK2	33.9	-27	0	41.48	-	-	74	-32.52	120	114	V
	* 4.59853	23.37	MAv1	33.9	-26.9	.45	30.82	54	-23.18	-	-	120	114	V
6	* 7.43084	31.25	PK2	35.5	-22.9	0	43.85	-	-	74	-30.15	167	138	V
	* 7.4318	20.16	MAv1	35.5	-22.9	.45	33.21	54	-20.79	-	-	167	138	V

* - indicates frequency in CFR47 Pt 15 / IC RSS-Restricted Band

PK2 - KDB558074 Method: Maximum Peak

MAv1 - KDB558074 Option 1 Maximum RMS Average

1TX Chain 1 MODE

BANDEDGE (LOW CHANNEL, CH 1)

HORIZONTAL RESULT

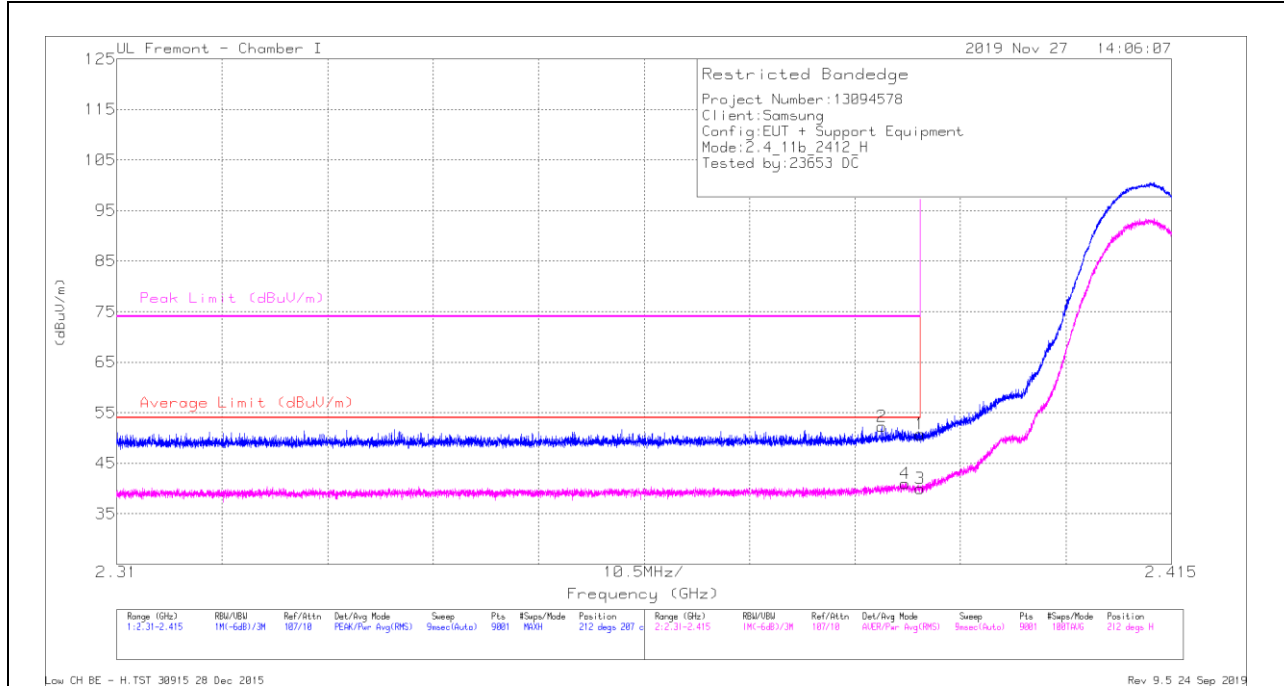

Trace Markers

Marker	Frequency (GHz)	Meter Reading (dBuV)	Det	AF T862 (dB/m)	Amp/Cb/Filtr/Pad (dB)	DC Corr (dB)	Corrected Reading (dBuV/m)	Average Limit (dBuV/m)	Margin (dB)	Peak Limit (dBuV/m)	PK Margin (dB)	Azimuth (Degs)	Height (cm)	Polarity
1	* 2.38999	38.53	Pk	31.9	-19.7	0	50.73	-	-	74	-23.27	212	207	H
2	* 2.38617	39.94	Pk	31.9	-19.6	0	52.24	-	-	74	-21.76	212	207	H
3	* 2.38999	27.37	RMS	31.9	-19.7	.45	40.02	54	-13.98	-	-	212	207	H
4	* 2.38847	28.36	RMS	31.9	-19.7	.45	41.01	54	-12.99	-	-	212	207	H

* - indicates frequency in CFR47 Pt 15 / IC RSS-Restricted Band
 Pk - Peak detector
 RMS - RMS detection

VERTICAL RESULT

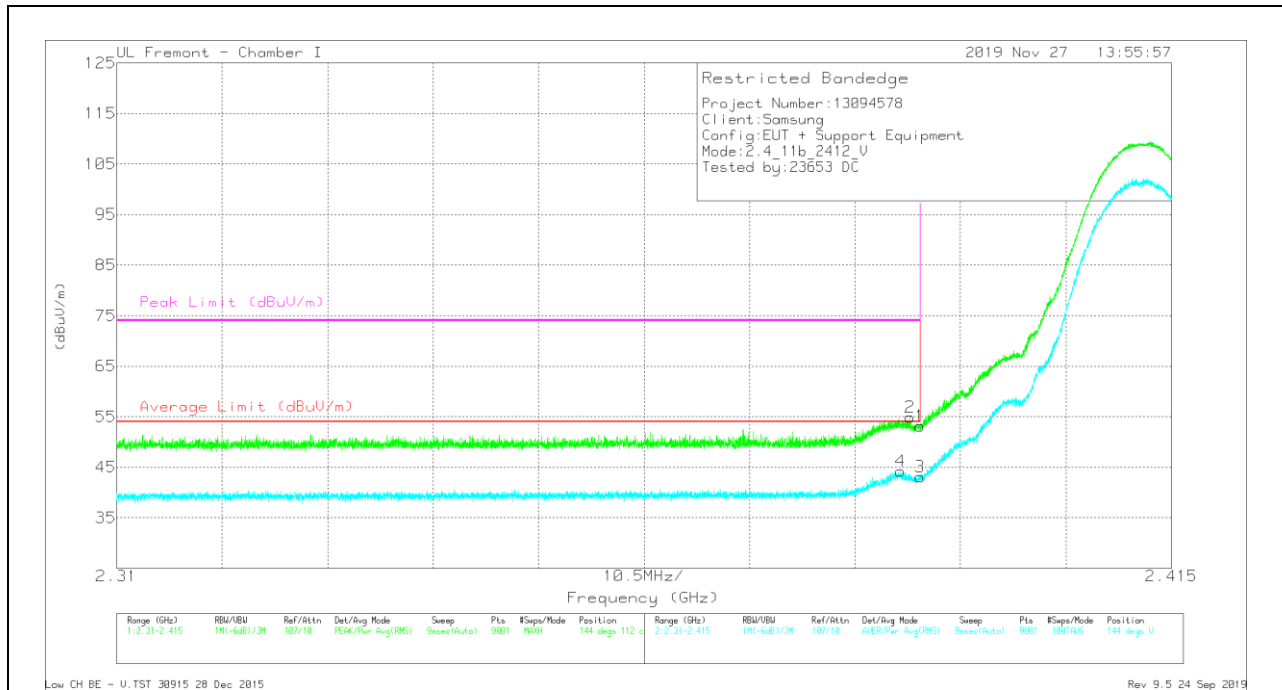

Trace Markers

Marker	Frequency (GHz)	Meter Reading (dBuV)	Det	AF T862 (dB/m)	Amp/Cb/Filtr/Pad (dB)	DC Corr (dB)	Corrected Reading (dBuV/m)	Average Limit (dBuV/m)	Margin (dB)	Peak Limit (dBuV/m)	PK Margin (dB)	Azimuth (Degs)	Height (cm)	Polarity
1	* 2.38999	40.99	Pk	31.9	-19.7	0	53.19	-	-	74	-20.81	144	112	V
2	* 2.38896	42.7	Pk	31.9	-19.7	0	54.9	-	-	74	-19.1	144	112	V
3	* 2.38999	30.48	RMS	31.9	-19.7	.45	43.13	54	-10.87	-	-	144	112	V
4	* 2.38803	31.41	RMS	31.9	-19.6	.45	44.16	54	-9.84	-	-	144	112	V

* - indicates frequency in CFR47 Pt 15 / IC RSS-Restricted Band
 Pk - Peak detector
 RMS - RMS detection

BANDEDGE (HIGH CHANNEL, CH 11)

HORIZONTAL RESULT

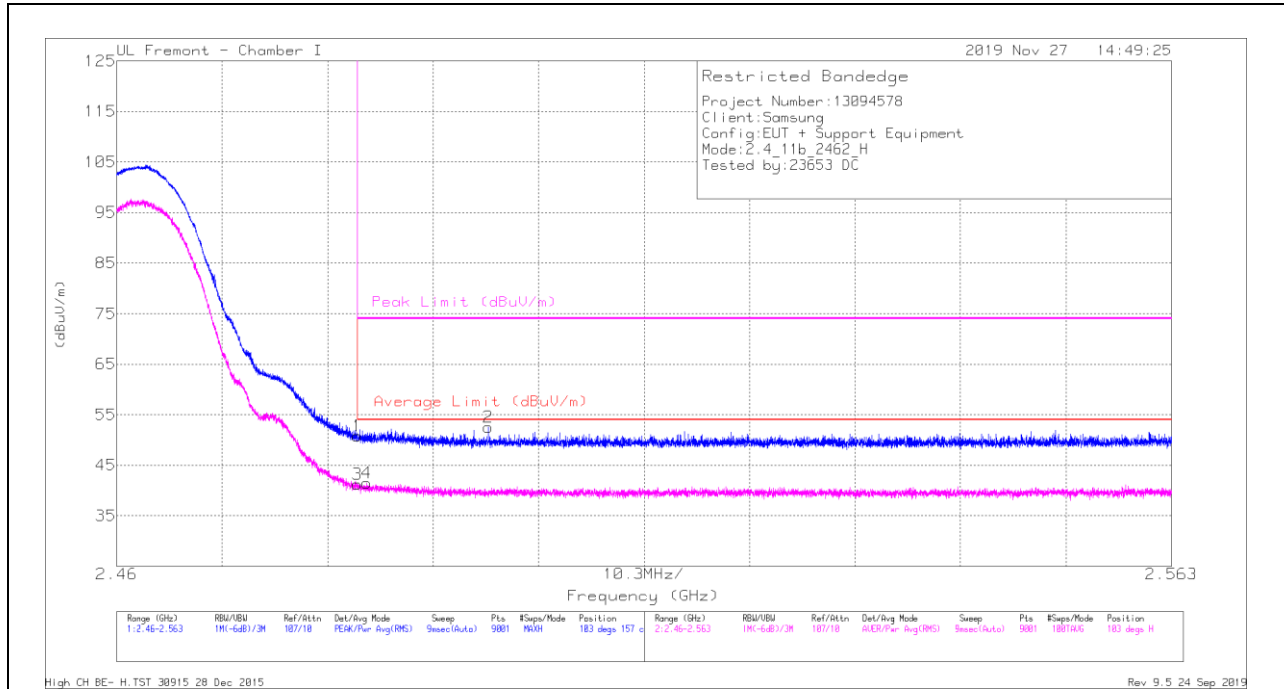

Trace Markers

Marker	Frequency (GHz)	Meter Reading (dBuV)	Det	AF T862 (dB/m)	Amp/Cb/Filtr/Pad (dB)	DC Corr (dB)	Corrected Reading (dBuV/m)	Average Limit (dBuV/m)	Margin (dB)	Peak Limit (dBuV/m)	PK Margin (dB)	Azimuth (Degs)	Height (cm)	Polarity
1	* 2.48351	38.39	Pk	32.4	-20	0	50.79	-	-	74	-23.21	103	157	H
2	* 2.49628	40.38	Pk	32.3	-20.1	0	52.58	-	-	74	-21.42	103	157	H
3	* 2.48351	28.38	RMS	32.4	-20	.45	41.23	54	-12.77	-	-	103	157	H
4	* 2.48442	28.66	RMS	32.4	-20	.45	41.51	54	-12.49	-	-	103	157	H

* - indicates frequency in CFR47 Pt 15 / IC RSS-Restricted Band

Pk - Peak detector

RMS - RMS detection

VERTICAL RESULT

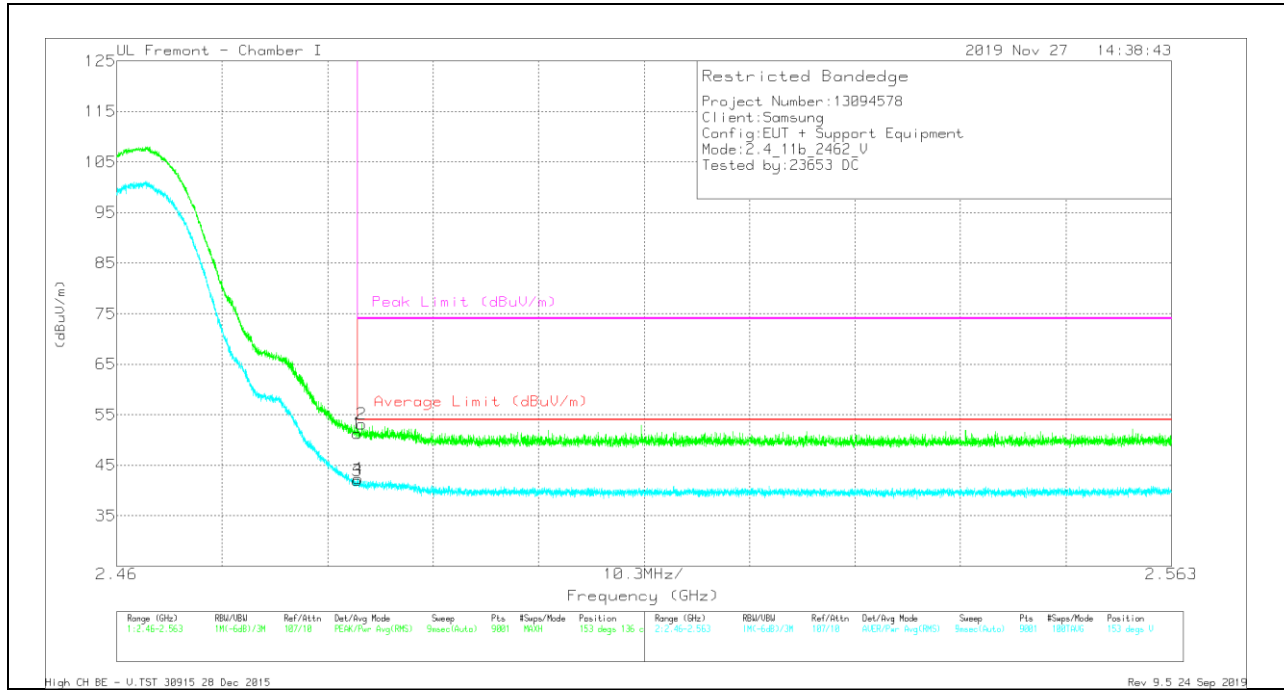

Trace Markers

Marker	Frequency (GHz)	Meter Reading (dBuV)	Det	AF T862 (dB/m)	Amp/Cb/Filtr/Pad (dB)	DC Corr (dB)	Corrected Reading (dBuV/m)	Average Limit (dBuV/m)	Margin (dB)	Peak Limit (dBuV/m)	PK Margin (dB)	Azimuth (Degs)	Height (cm)	Polarity
1	* 2.48351	38.89	Pk	32.4	-20	0	51.29	-	-	74	-22.71	153	136	V
2	* 2.48391	40.73	Pk	32.4	-20	0	53.13	-	-	74	-20.87	153	136	V
3	* 2.48351	29.07	RMS	32.4	-20	.45	41.92	54	-12.08	-	-	153	136	V
4	* 2.48357	29.51	RMS	32.4	-20	.45	42.36	54	-11.64	-	-	153	136	V

* - indicates frequency in CFR47 Pt 15 / IC RSS-Restricted Band

Pk - Peak detector

RMS - RMS detection

BANDEDGE (HIGH CHANNEL, CH 12)

HORIZONTAL RESULT

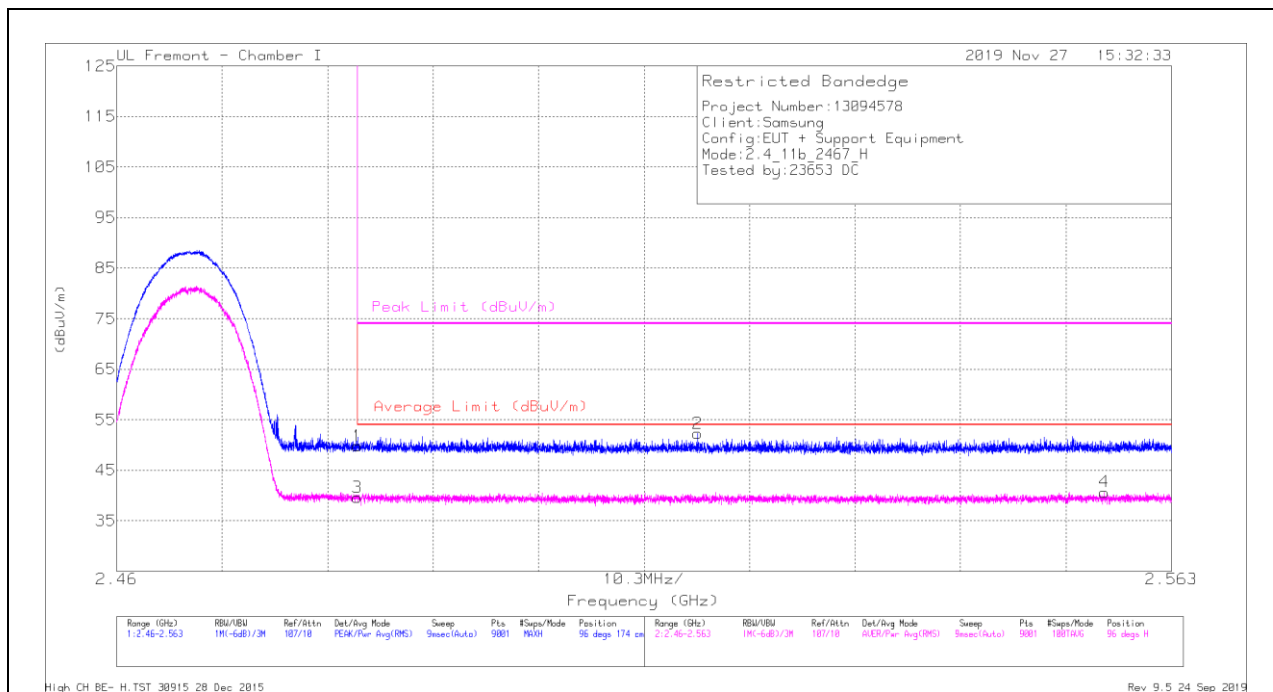

Trace Markers

Marker	Frequency (GHz)	Meter Reading (dBuV)	Det	AF T862 (dB/m)	Amp/Cb/Filtr/Pad (dB)	DC Corr (dB)	Corrected Reading (dBuV/m)	Average Limit (dBuV/m)	Margin (dB)	Peak Limit (dBuV/m)	PK Margin (dB)	Azimuth (Degs)	Height (cm)	Polarity
1	* 2.48351	37.37	Pk	32.4	-20	0	49.77	-	-	74	-24.23	96	174	H
2	2.51674	40	Pk	32.4	-20.1	0	52.3	-	-	74	-21.7	96	174	H
3	* 2.48351	26.8	RMS	32.4	-20	.45	39.65	54	-14.35	-	-	96	174	H
4	2.55644	28.02	RMS	32.3	-20.1	.45	40.67	54	-13.33	-	-	96	174	H

* - indicates frequency in CFR47 Pt 15 / IC RSS-Restricted Band

Pk - Peak detector

RMS - RMS detection

VERTICAL RESULT

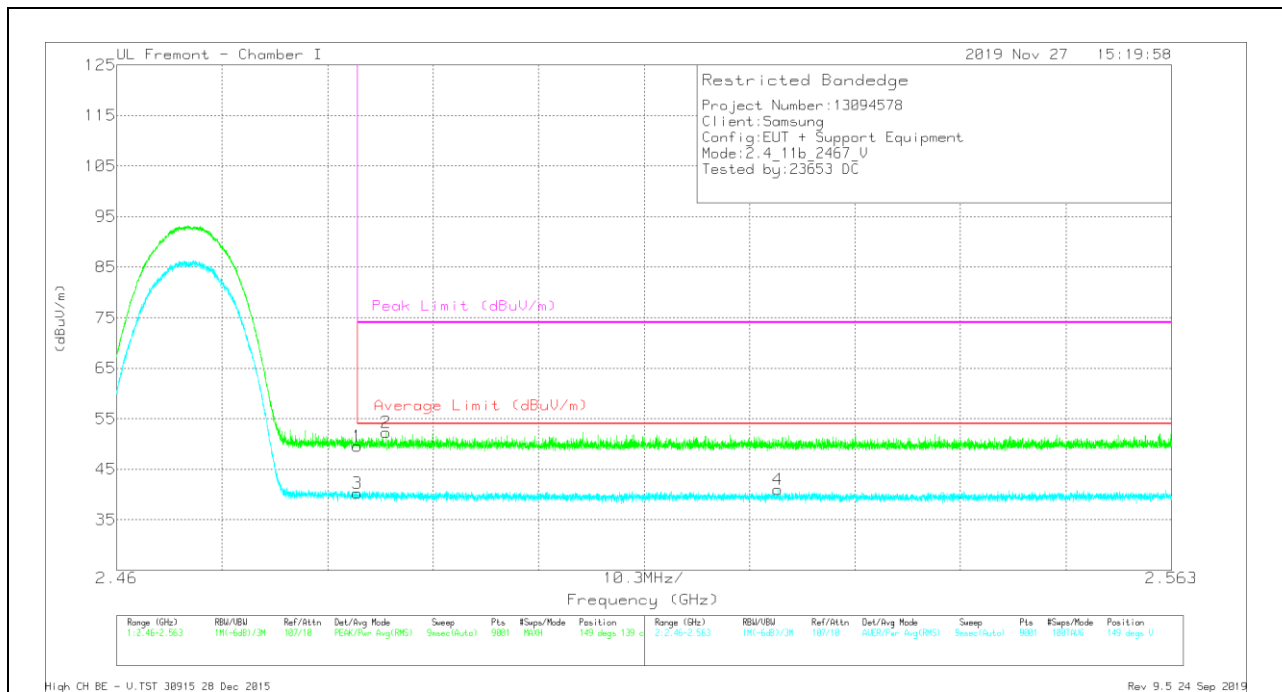

Trace Markers

Marker	Frequency (GHz)	Meter Reading (dBuV)	Det	AF T862 (dB/m)	Amp/Cb/Filtr/Pad (dB)	DC Corr (dB)	Corrected Reading (dBuV/m)	Average Limit (dBuV/m)	Margin (dB)	Peak Limit (dBuV/m)	PK Margin (dB)	Azimuth (Degs)	Height (cm)	Polarity
1	* 2.48351	37.15	Pk	32.4	-20	0	49.55	-	-	74	-24.45	149	139	V
2	* 2.48631	39.91	Pk	32.4	-20	0	52.31	-	-	74	-21.69	149	139	V
3	* 2.48351	27.36	RMS	32.4	-20	.45	40.21	54	-13.79	-	-	149	139	V
4	2.52458	28.29	RMS	32.3	-20.1	.45	40.94	54	-13.06	-	-	149	139	V

* - indicates frequency in CFR47 Pt 15 / IC RSS-Restricted Band
 Pk - Peak detector
 RMS - RMS detection

BANDEDGE (HIGH CHANNEL, CH 13)

HORIZONTAL RESULT

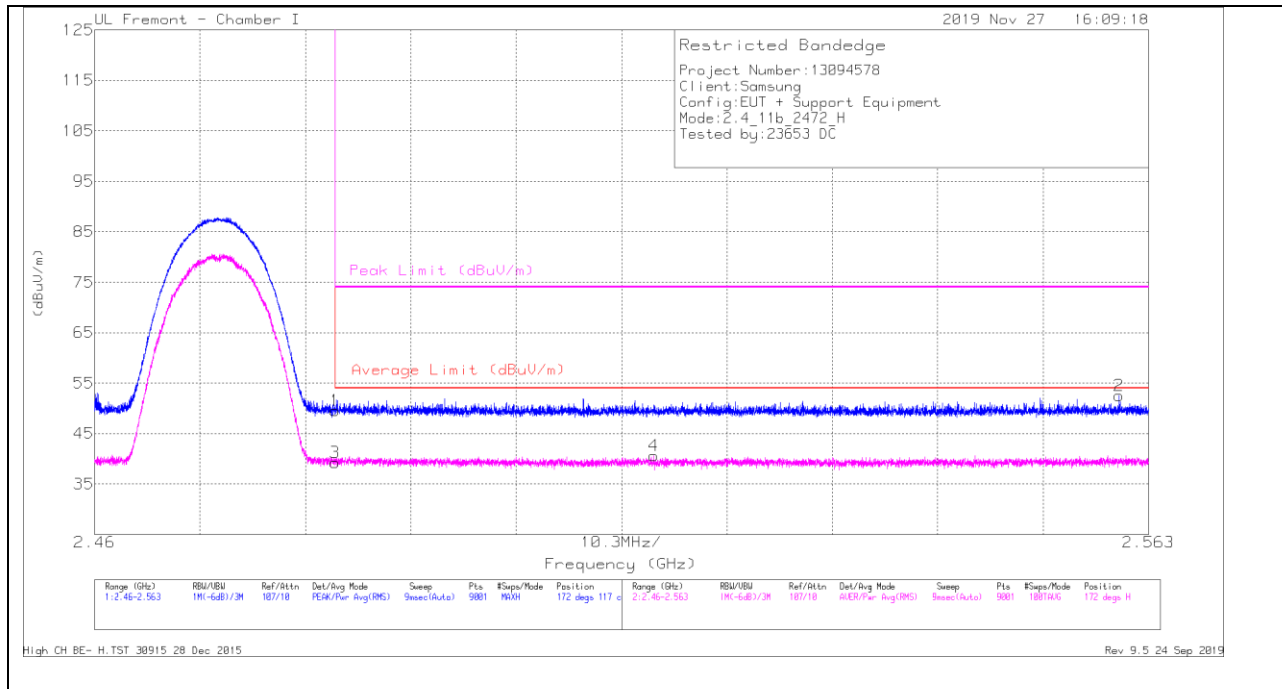

Trace Markers

Marker	Frequency (GHz)	Meter Reading (dBuV)	Det	AF T862 (dB/m)	Amp/Cb/Filtr/Pad (dB)	DC Corr (dB)	Corrected Reading (dBuV/m)	Average Limit (dBuV/m)	Margin (dB)	Peak Limit (dBuV/m)	PK Margin (dB)	Azimuth (Degs)	Height (cm)	Polarity
1	* 2.48351	37.09	Pk	32.4	-20	0	49.49	-	-	74	-24.51	172	117	H
2	2.56015	40.37	Pk	32.3	-20.1	0	52.57	-	-	74	-21.43	172	117	H
3	* 2.48351	26.36	RMS	32.4	-20	.45	39.21	54	-14.79	-	-	172	117	H
4	2.51467	28.1	RMS	32.3	-20.2	.45	40.65	54	-13.35	-	-	172	117	H

* - indicates frequency in CFR47 Pt 15 / IC RSS-Restricted Band

Pk - Peak detector

RMS - RMS detection

VERTICAL RESULT

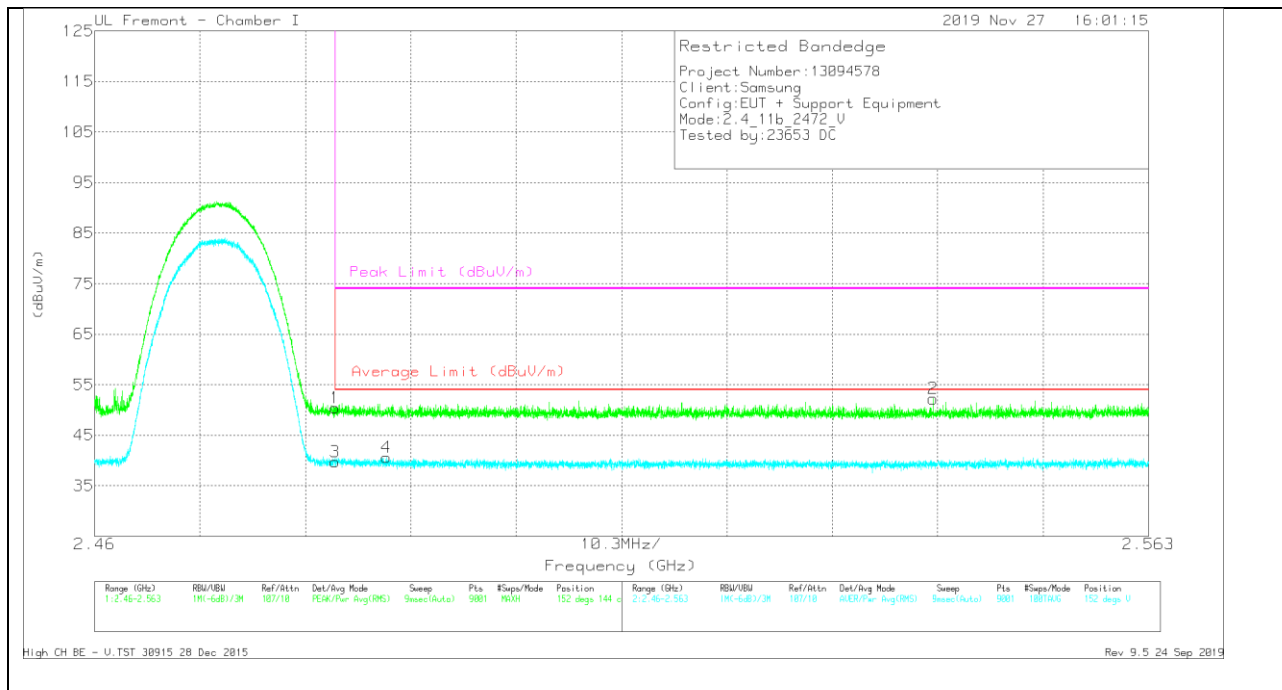

Trace Markers

Marker	Frequency (GHz)	Meter Reading (dBuV)	Det	AF T862 (dB/m)	Amp/Cb/Fitr/Pad (dB)	DC Corr (dB)	Corrected Reading (dBuV/m)	Average Limit (dBuV/m)	Margin (dB)	Peak Limit (dBuV/m)	PK Margin (dB)	Azimuth (Degs)	Height (cm)	Polarity
1	* 2.48351	37.99	Pk	32.4	-20	0	50.39	-	-	74	-23.61	152	144	V
2	2.54195	40.12	Pk	32.2	-20.1	0	52.22	-	-	74	-21.78	152	144	V
3	* 2.48351	26.89	RMS	32.4	-20	.45	39.74	54	-14.26	-	-	152	144	V
4	* 2.4885	27.9	RMS	32.3	-20	.45	40.65	54	-13.35	-	-	152	144	V

* - indicates frequency in CFR47 Pt 15 / IC RSS-Restricted Band
 Pk - Peak detector
 RMS - RMS detection

HARMONICS AND SPURIOUS EMISSIONS

LOW CHANNEL, CH 1 RESULTS

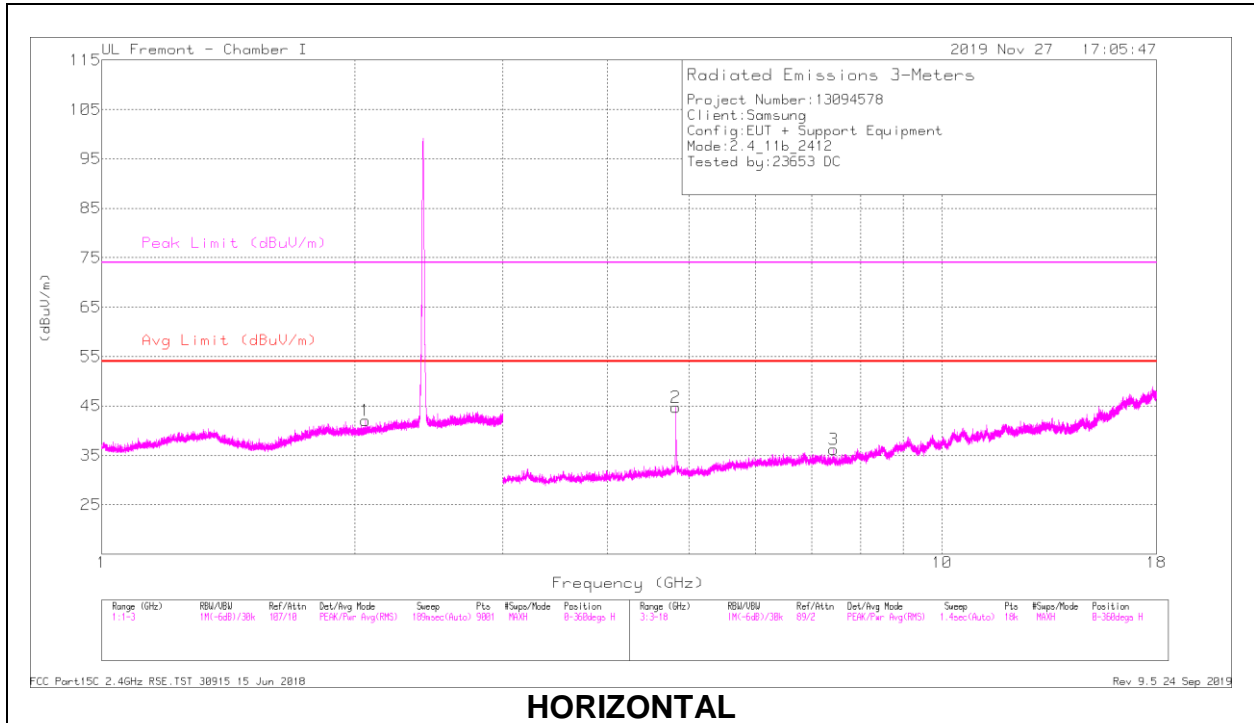

HORIZONTAL

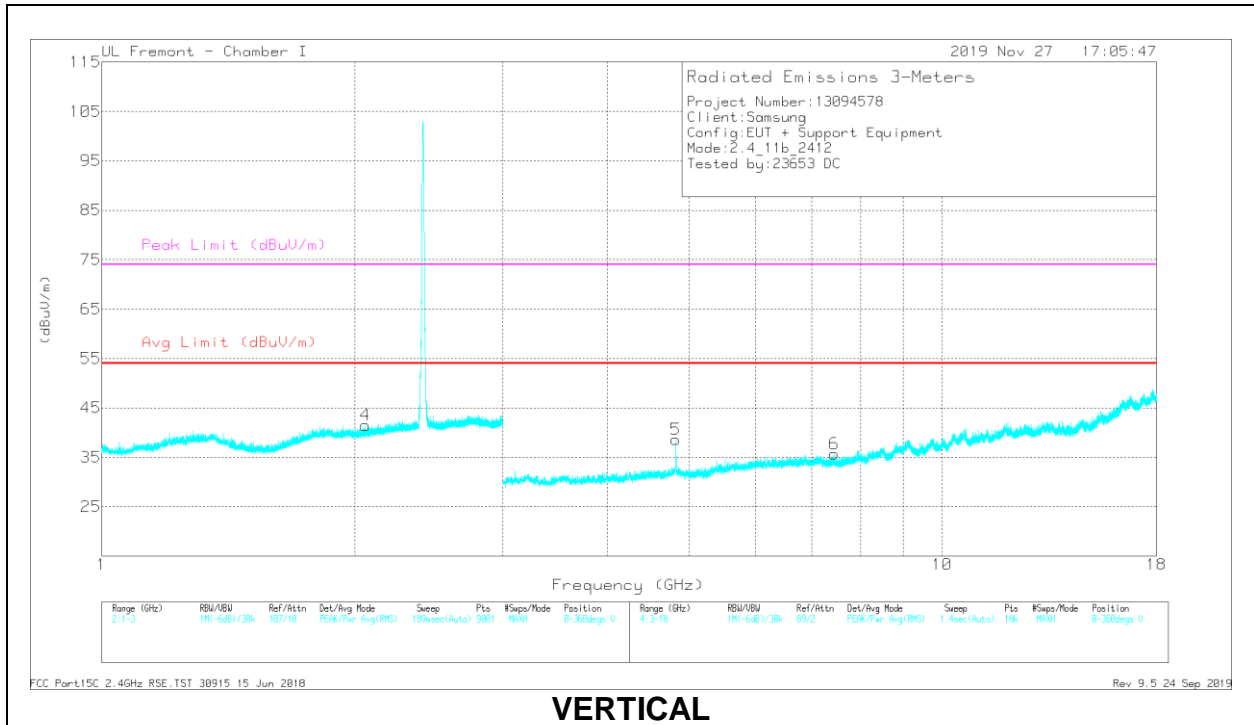

VERTICAL

RADIATED EMISSIONS

Marker	Frequency (GHz)	Meter Reading (dBuV)	Det	AF T862 (dB/m)	Amp/Cb/Filtr/Pad (dB)	DC Corr (dB)	Corrected Reading (dBuV/m)	Avg Limit (dBuV/m)	Margin (dB)	Peak Limit (dBuV/m)	PK Margin (dB)	Azimuth (Degs)	Height (cm)	Polarity
1	2.0631	37.71	PK2	31.1	-20.8	0	48.01	-	-	-	-	139	161	H
4	2.05778	37	PK2	31.1	-20.8	0	47.3	-	-	-	-	196	147	V
2	* 4.82401	39.93	PK2	34.1	-25.9	0	48.13	-	-	74	-25.87	176	101	H
	* 4.82431	29.58	MAv1	34.1	-25.9	.45	38.23	54	-15.77	-	-	176	101	H
3	* 7.43677	30.01	PK2	35.6	-23	0	42.61	-	-	74	-31.39	153	148	H
	* 7.4368	20.09	MAv1	35.6	-23	.45	33.14	54	-20.86	-	-	153	148	H
5	* 4.82409	37.17	PK2	34.1	-25.9	0	45.37	-	-	74	-28.63	129	105	V
	* 4.82411	26.59	MAv1	34.1	-25.9	.45	35.24	54	-18.76	-	-	129	105	V
6	* 7.44312	30.25	PK2	35.5	-23	0	42.75	-	-	74	-31.25	139	159	V
	* 7.44021	19.86	MAv1	35.6	-23	.45	32.91	54	-21.09	-	-	139	159	V

* - indicates frequency in CFR47 Pt 15 / IC RSS-Restricted Band
 PK2 - KDB558074 Method: Maximum Peak
 MAv1 - KDB558074 Option 1 Maximum RMS Average

MID CHANNEL, CH 6 RESULTS

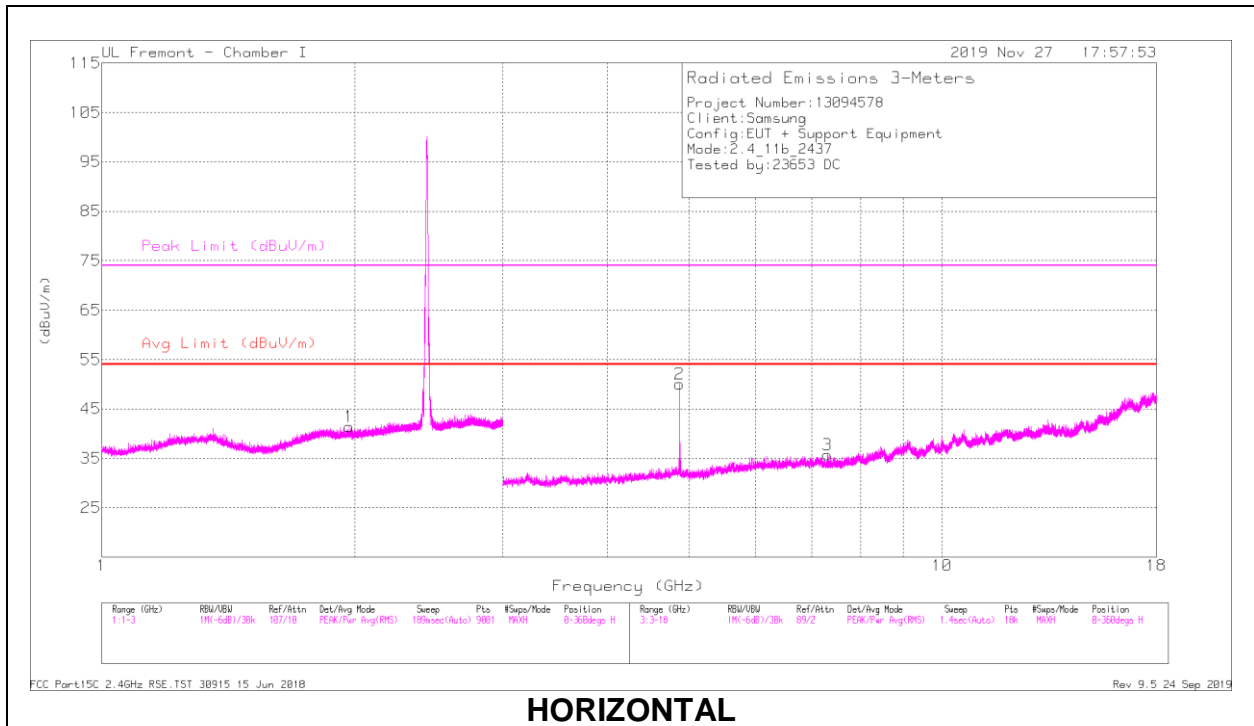

HORIZONTAL

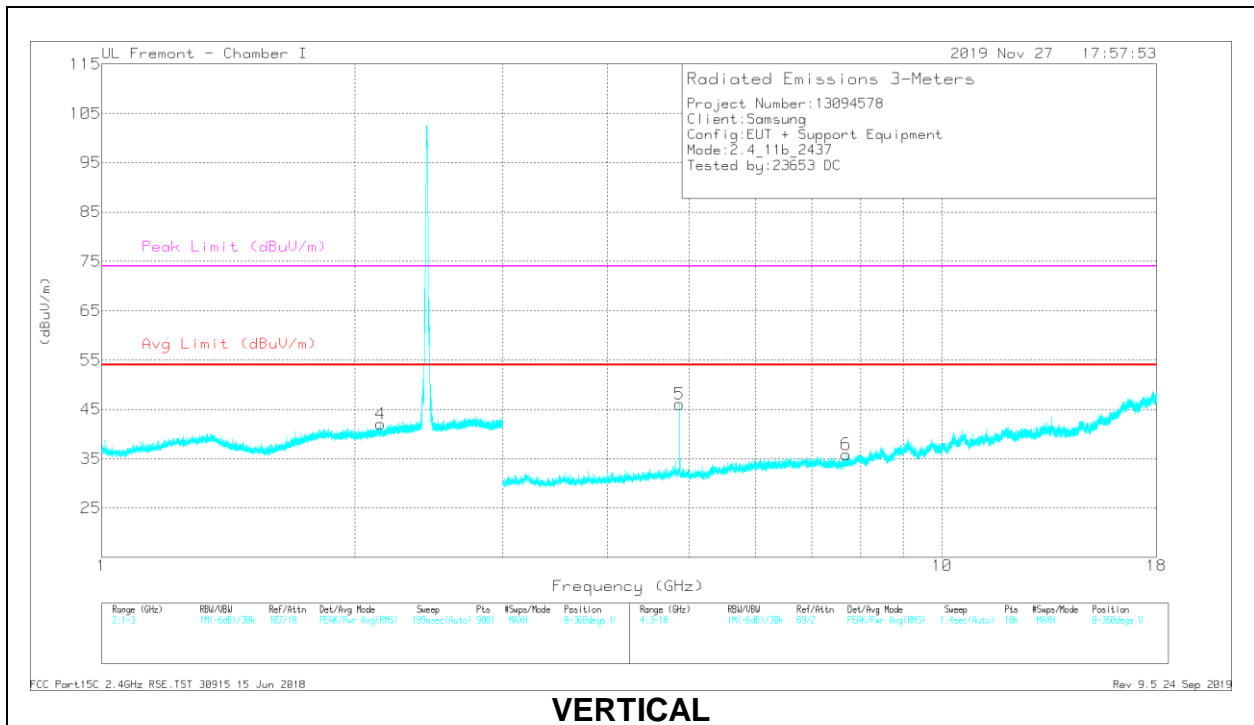

VERTICAL

RADIATED EMISSIONS

Marker	Frequency (GHz)	Meter Reading (dBuV)	Det	AF T862 (dB/m)	Amp/Cb/Filtr/Pad (dB)	DC Corr (dB)	Corrected Reading (dBuV/m)	Avg Limit (dBuV/m)	Margin (dB)	Peak Limit (dBuV/m)	PK Margin (dB)	Azimuth (Degs)	Height (cm)	Polarity
1	1.97033	37.16	PK2	31	-20.8	0	47.36	-	-	-	-	152	101	H
4	2.14564	37.26	PK2	31.1	-20.3	0	48.06	-	-	-	-	176	148	V
2	* 4.874	43.85	PK2	34.1	-26.3	0	51.65	-	-	74	-22.35	161	102	H
	* 4.87402	41.04	MAv1	34.1	-26.3	.45	49.29	54	-4.71	-	-	161	102	H
3	* 7.31141	31.79	PK2	35.5	-24.1	0	43.19	-	-	74	-30.81	138	152	H
	* 7.31141	22.18	MAv1	35.5	-24.1	.45	34.03	54	-19.97	-	-	138	152	H
5	* 4.87404	40.79	PK2	34.1	-26.3	0	48.59	-	-	74	-25.41	129	113	V
	* 4.87402	38.3	MAv1	34.1	-26.3	.45	46.55	54	-7.45	-	-	129	113	V
6	* 7.69102	30.07	PK2	35.6	-23	0	42.67	-	-	74	-31.33	124	156	V
	* 7.69015	19.97	MAv1	35.6	-23	.45	33.02	54	-20.98	-	-	124	156	V

* - indicates frequency in CFR47 Pt 15 / IC RSS-Restricted Band

PK2 - KDB558074 Method: Maximum Peak

MAv1 - KDB558074 Option 1 Maximum RMS Average

HIGH CHANNEL, CH 11 RESULTS

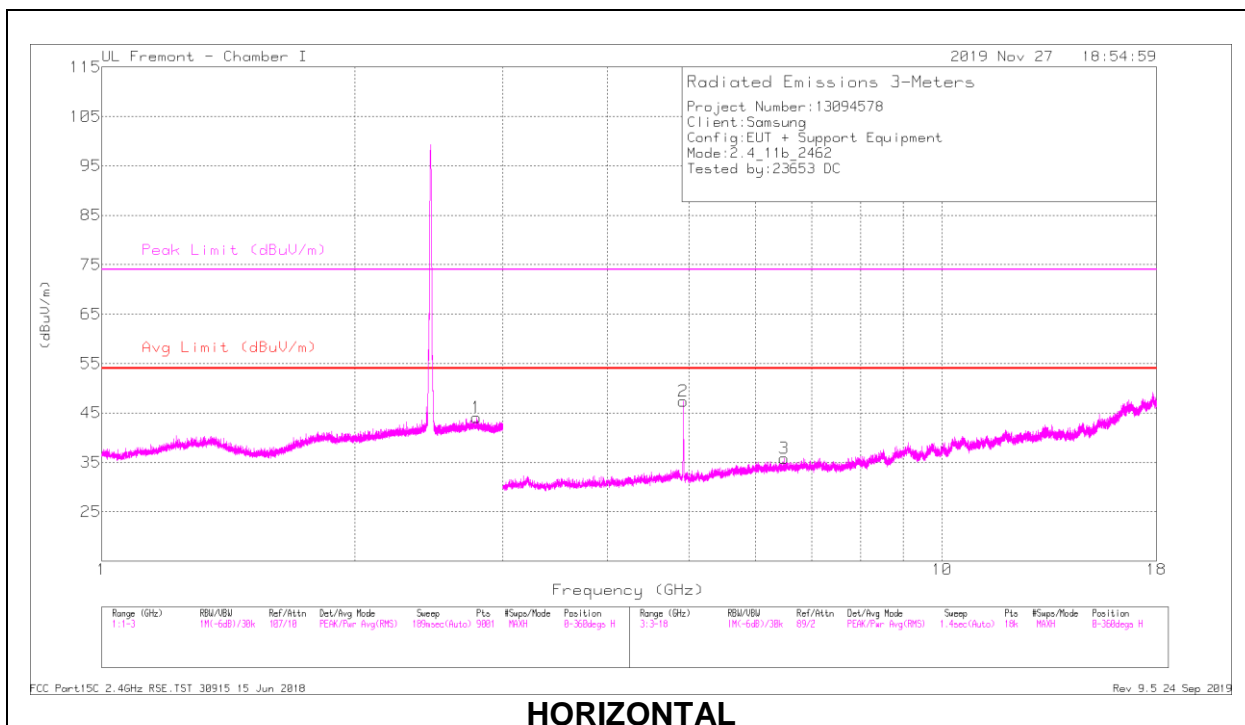

HORIZONTAL

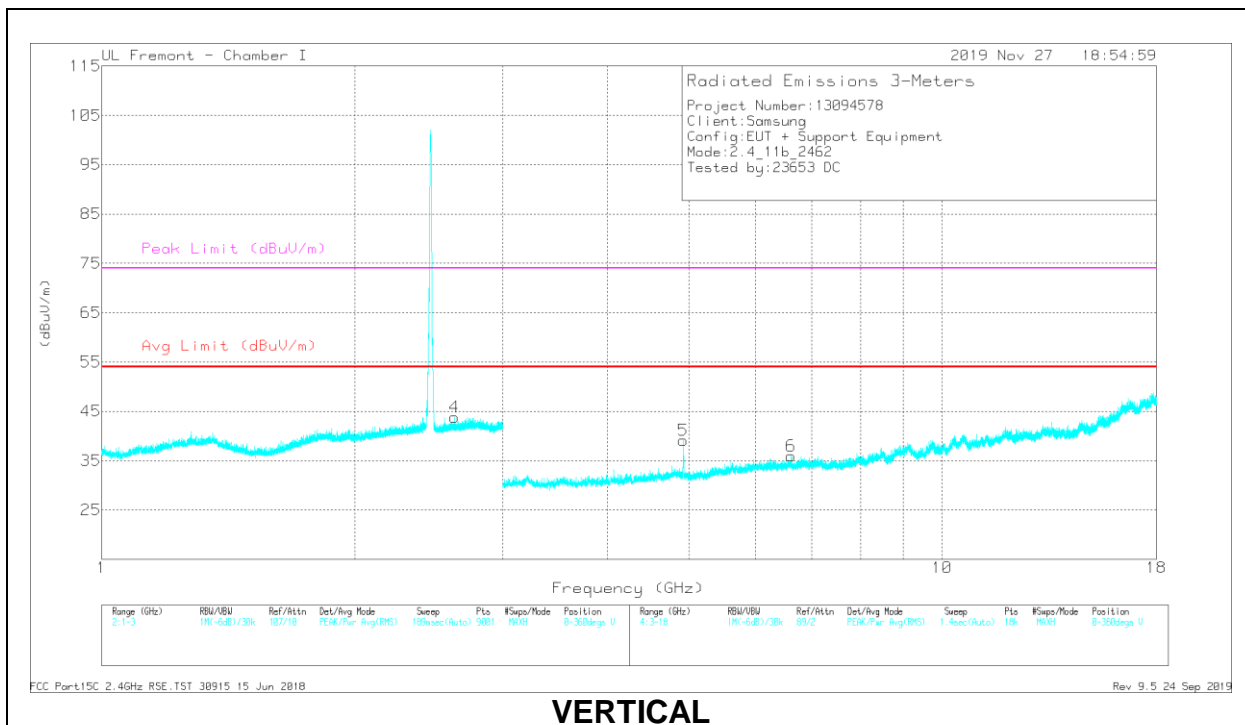

VERTICAL

RADIATED EMISSIONS

Marker	Frequency (GHz)	Meter Reading (dBuV)	Det	AF T862 (dB/m)	Amp/Cb/Filtr/Pad (dB)	DC Corr (dB)	Corrected Reading (dBuV/m)	Avg Limit (dBuV/m)	Margin (dB)	Peak Limit (dBuV/m)	PK Margin (dB)	Azimuth (Degs)	Height (cm)	Polarity
1	* 2.79256	37.14	PK2	32.3	-18.9	0	50.54	-	-	74	-23.46	310	135	H
	* 2.79222	26.92	MAv1	32.3	-18.9	.45	40.77	54	-13.23	-	-	310	135	H
4	2.62556	36.75	PK2	32.5	-19.8	0	49.45	-	-	-	-	217	126	V
3	6.49596	30.48	PK2	35.6	-24.5	0	41.58	-	-	-	-	134	152	H
2	* 4.92401	41.84	PK2	34.1	-26.8	0	49.14	-	-	74	-24.86	157	118	H
	* 4.92439	32.39	MAv1	34.1	-26.7	.45	40.24	54	-13.76	-	-	157	118	H
6	6.61603	31.36	PK2	35.7	-24.1	0	42.96	-	-	-	-	209	166	V
5	* 4.924	39.42	PK2	34.1	-26.8	0	46.72	-	-	74	-27.28	129	109	V
	* 4.92388	30.29	MAv1	34.1	-26.8	.45	38.04	54	-15.96	-	-	129	109	V

* - indicates frequency in CFR47 Pt 15 / IC RSS-Restricted Band

PK2 - KDB558074 Method: Maximum Peak

MAv1 - KDB558074 Option 1 Maximum RMS Average

9.1.2. TX ABOVE 1 GHz 802.11g MODE IN THE 2.4 GHz BAND

2TX Chain 0 + Chain 1 CDD MODE

BANDEDGE (LOW CHANNEL, CH 1)

HORIZONTAL RESULT

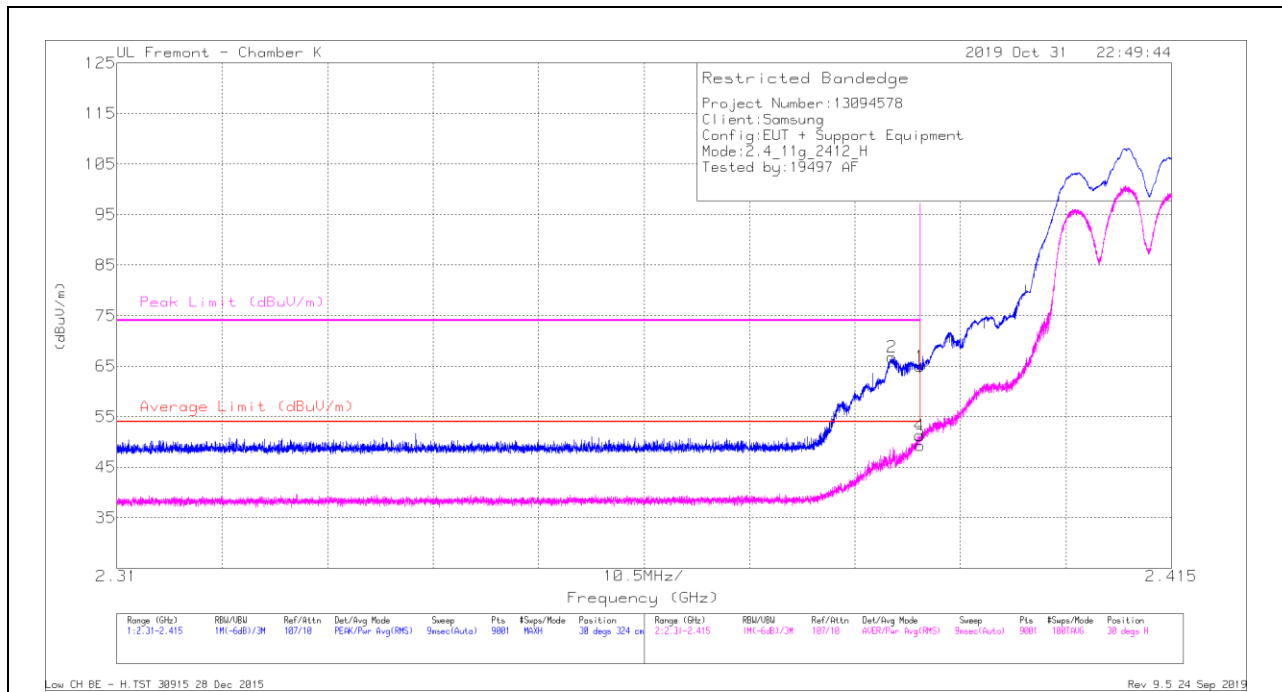

Trace Markers

Marker	Frequency (GHz)	Meter Reading (dBuV)	Det	AF EMC4294 (dB/m)	Amp/Cb/Filtr/Pad (dB)	DC Corr (dB)	Corrected Reading (dBuV/m)	Average Limit (dBuV/m)	Margin (dB)	Peak Limit (dBuV/m)	PK Margin (dB)	Azimuth (Degs)	Height (cm)	Polarity
1	* 2.38999	57.77	Pk	31.9	-24.7	0	64.97	-	-	74	-9.03	30	324	H
2	* 2.3872	59.48	Pk	31.9	-24.6	0	66.78	-	-	74	-7.22	30	324	H
3	* 2.38999	41.72	RMS	31.9	-24.7	.34	49.26	54	-4.74	-	-	30	324	H
4	* 2.38994	43.77	RMS	31.9	-24.7	.34	51.31	54	-2.69	-	-	30	324	H

* - indicates frequency in CFR47 Pt 15 / IC RSS-Restricted Band

Pk - Peak detector

RMS - RMS detection

VERTICAL RESULT

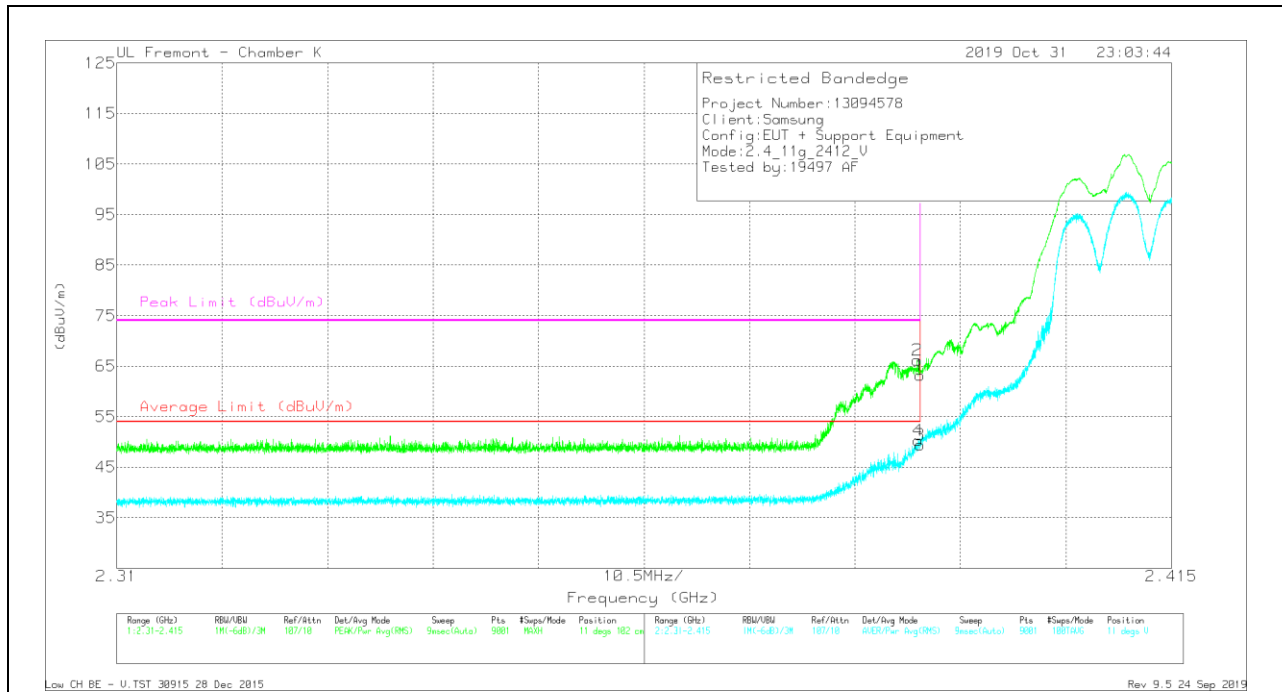

Trace Markers

Marker	Frequency (GHz)	Meter Reading (dBuV)	Det	AF EMC4294 (dB/m)	Amp/Cb/Filtr/Pad (dB)	DC Corr (dB)	Corrected Reading (dBuV/m)	Average Limit (dBuV/m)	Margin (dB)	Peak Limit (dBuV/m)	PK Margin (dB)	Azimuth (Degs)	Height (cm)	Polarity
1	* 2.38999	55.98	Pk	31.9	-24.7	0	63.18	-	-	74	-10.82	11	102	V
2	* 2.3897	58.99	Pk	31.9	-24.7	0	66.19	-	-	74	-7.81	11	102	V
3	* 2.38999	41.86	RMS	31.9	-24.7	.34	49.4	54	-4.6	-	-	11	102	V
4	* 2.38979	42.79	RMS	31.9	-24.7	.34	50.33	54	-3.67	-	-	11	102	V

* - indicates frequency in CFR47 Pt 15 / IC RSS-Restricted Band

Pk - Peak detector

RMS - RMS detection

BANDEDGE (HIGH CHANNEL, CH 11)

HORIZONTAL RESULT

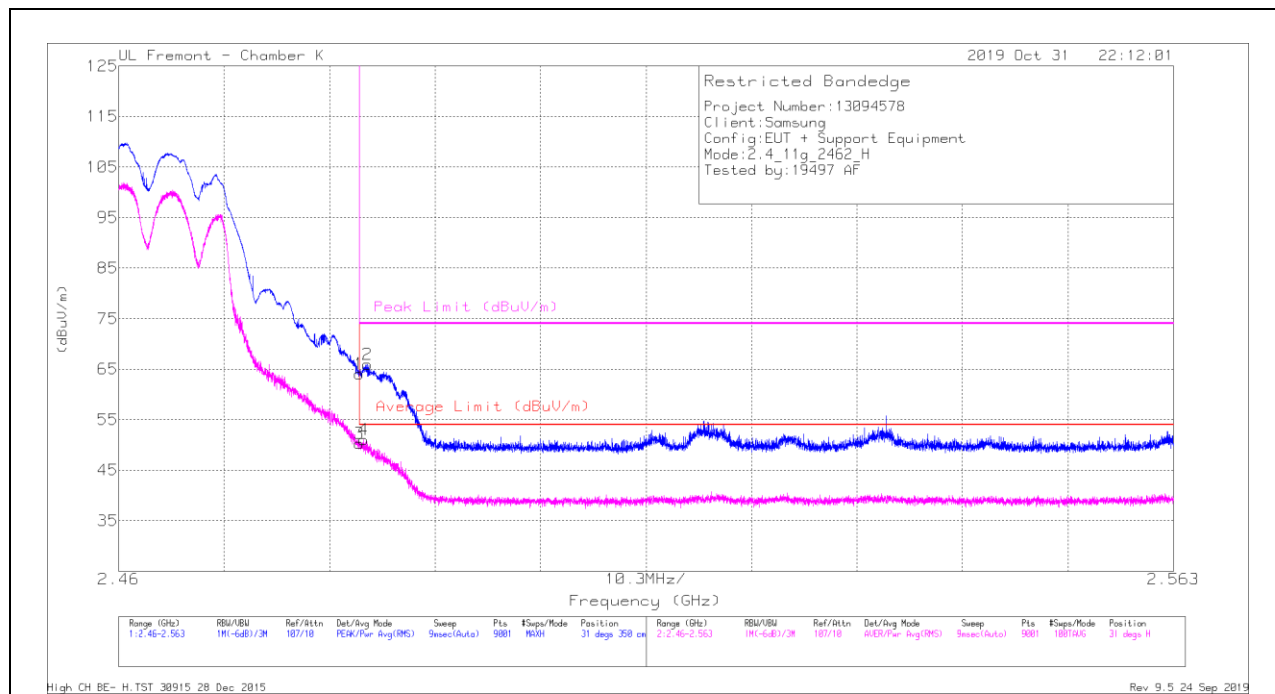

Trace Markers

Marker	Frequency (GHz)	Meter Reading (dBuV)	Det	AF EMC4294 (dB/m)	Amp/Cb/Filtr/Pad (dB)	DC Corr (dB)	Corrected Reading (dBuV/m)	Average Limit (dBuV/m)	Margin (dB)	Peak Limit (dBuV/m)	PK Margin (dB)	Azimuth (Degs)	Height (cm)	Polarity
1	* 2.48351	56.34	Pk	32.5	-24.8	0	64.04	-	-	74	-9.96	31	350	H
2	* 2.48427	58.18	Pk	32.5	-24.8	0	65.88	-	-	74	-8.12	31	350	H
3	* 2.48351	42.2	RMS	32.5	-24.8	.34	50.24	54	-3.76	-	-	31	350	H
4	* 2.48394	42.98	RMS	32.5	-24.8	.34	51.02	54	-2.98	-	-	31	350	H

* - indicates frequency in CFR47 Pt 15 / IC RSS-Restricted Band

Pk - Peak detector

RMS - RMS detection