



**FCC CFR47 PART 22 SUBPART H
FCC CFR47 PART 24 SUBPART E**

CERTIFICATION TEST REPORT

FOR

GSM/WCDMA/LTE PHONE + BLUETOOTH, DTS/UNII A/B/G/N/AC, NFC & ANT

MODEL NUMBER: SM-N7505

FCC ID: A3LSMN7505

REPORT NUMBER: 13U16698-1

ISSUE DATE: JANUARY 8, 2013

Prepared for

**SAMSUNG ELECTRONICS CO., LTD.
416, MAETAN 3-DONG, YEONGTONG-GU
SUWON-CITY
GYEONGGI-DO, 443-742, SOUTH KOREA**

Prepared by

**UL VERIFICATION SERVICES
47173 BENICIA STREET
FREMONT, CA 94538, U.S.A.
TEL: (510) 771-1000
FAX: (510) 661-0888**



NVLAP LAB CODE 200065-0

Revision History

Rev.	Date	Revisions	Revised By
--	1/8/14	Initial Issue	P. Kim

TABLE OF CONTENTS

1.	ATTESTATION OF TEST RESULTS	5
2.	TEST METHODOLOGY	6
3.	FACILITIES AND ACCREDITATION	6
4.	CALIBRATION AND UNCERTAINTY	6
4.1.	<i>MEASURING INSTRUMENT CALIBRATION</i>	6
4.2.	<i>SAMPLE CALCULATION</i>	6
4.3.	<i>MEASUREMENT UNCERTAINTY</i>	6
5.	EQUIPMENT UNDER TEST	7
5.1.	<i>DESCRIPTION OF EUT</i>	7
5.2.	<i>MAXIMUM OUTPUT POWER</i>	7
5.3.	<i>MAXIMUM OUTPUT POWER (LTE)</i>	8
5.4.	<i>DESCRIPTION OF AVAILABLE ANTENNAS</i>	9
5.5.	<i>DESCRIPTION OF TEST SETUP</i>	10
6.	TEST AND MEASUREMENT EQUIPMENT	13
7.	Summary Table	14
8.	RF POWER OUTPUT VERIFICATION	15
8.1.	<i>GSM/GPRS/EDGE</i>	15
8.1.1.	<i>GSM OUTPUT POWER RESULT</i>	16
8.2.	<i>UMTS REL 99</i>	17
8.2.1.	<i>UMTS REL 99 OUTPUT POWER RESULT</i>	17
8.3.	<i>UMTS HSDPA</i>	18
8.3.1.	<i>UMTS HSDPA OUTPUT POWER RESULT</i>	19
8.3.2.	<i>UMTS HSUPA</i>	20
8.3.3.	<i>UMTS HSUPA OUTPUT POWER RESULT</i>	21
8.4.	<i>LTE OUTPUT VERIFICATION</i>	22
8.4.1.	<i>LTE OUTPUT RESULT</i>	22
9.	PEAK TO AVERAGE RATIO	26
9.1.	<i>CONDUCTED PEAK TO AVERAGE RESULT</i>	26
10.	LIMITS AND CONDUCTED RESULTS	30
10.1.	<i>OCCUPIED BANDWIDTH</i>	30

10.1.1.	OCCUPIED BANDWIDTH RESULTS	31
10.1.2.	LTE OCCUPIED BANDWIDTH RESULTS	32
10.1.1.	OCCUPIED BANDWIDTH PLOTS	34
10.2.	<i>BAND EDGE EMISSIONS</i>	39
10.2.1.	BAND EDGE PLOTS	40
10.3.	<i>OUT OF BAND EMISSIONS</i>	52
10.3.1.	OUT OF BAND EMISSIONS RESULT	53
10.3.2.	OUT OF BAND EMISSIONS PLOTS.....	55
10.4.	<i>FREQUENCY STABILITY</i>	59
10.4.1.	FREQUENCY STABILITY RESULTS.....	60
11.	RADIATED TEST RESULTS.....	62
11.1.	<i>RADIATED POWER (ERP & EIRP)</i>	62
11.1.1.	ERP/EIRP Results	63
11.1.2.	LTE ERP/EIRP Results	64
11.1.3.	ERP/EIRP PLOTS	66
11.2.	<i>FIELD STRENGTH OF SPURIOUS RADIATION</i>	82
11.2.1.	SPURIOUS RADIATION PLOTS.....	83
12.	SETUP PHOTOS.....	99

1. ATTESTATION OF TEST RESULTS

COMPANY NAME: SAMSUNG ELECTRONICS CO., LTD.
416, MAETAN 3-DONG, YEONGTONG-GU
SUWON-CITY, GYEONGGI-DO, 443-742, SOUTH KOREA

EUT DESCRIPTION: GSM/WCDMA/LTE Phone + Bluetooth, DTS/UNII a/b/g/n/ac, NFC & ANT

MODEL: SM-N7505

SERIAL NUMBER: R31DB1SV13P

DATE TESTED: DECEMBER 9, 2013 – JANUARY 8, 2014

APPLICABLE STANDARDS	
STANDARD	TEST RESULTS
FCC PART 22H, 24E	PASS

UL Verification Services Inc. tested the above equipment in accordance with the requirements set forth in the above standards. All indications of Pass/Fail in this report are opinions expressed by UL Verification Services Inc. based on interpretations and/or observations of test results. Measurement Uncertainties were not taken into account and are published for informational purposes only. The test results show that the equipment tested is capable of demonstrating compliance with the requirements as documented in this report.

Note: The results documented in this report apply only to the tested sample, under the conditions and modes of operation as described herein. This document may not be altered or revised in any way unless done so by UL Verification Services Inc. and all revisions are duly noted in the revisions section. Any alteration of this document not carried out by UL Verification Services Inc. will constitute fraud and shall nullify the document. This report must not be used by the client to claim product certification, approval, or endorsement by NVLAP, NIST, any agency of the Federal Government, or any agency of any government.

Approved & Released For

UL Verification Services Inc. By:



PHILIP KIM
WISE OPERATIONS MANAGER
UL VERIFICATION SERVICES

Tested By:



STEVEN TRAN
WISE LAB TECHNICIAN
UL VERIFICATION SERVICES

2. TEST METHODOLOGY

The tests documented in this report were performed in accordance with TIA-603-C, FCC CFR 47 Part 22, FCC CFR Part 24.

3. FACILITIES AND ACCREDITATION

The test sites and measurement facilities used to collect data are located at 47173 Benicia Street, Fremont, California, USA.

UL Verification Services Inc. is accredited by NVLAP, Laboratory Code 200065-0. The full scope of accreditation can be viewed at <http://www.ccsemc.com>.

4. CALIBRATION AND UNCERTAINTY

4.1. MEASURING INSTRUMENT CALIBRATION

The measuring equipment utilized to perform the tests documented in this report has been calibrated in accordance with the manufacturer's recommendations, and is traceable to recognized national standards

4.2. SAMPLE CALCULATION

Where relevant, the following sample calculation is provided:

$$\text{Field Strength (dBuV/m)} = \text{Measured Voltage (dBuV)} + \text{Antenna Factor (dB/m)} + \text{Cable Loss (dB)} - \text{Preamp Gain (dB)}$$

$$36.5 \text{ dBuV} + 18.7 \text{ dB/m} + 0.6 \text{ dB} - 26.9 \text{ dB} = 28.9 \text{ dBuV/m}$$

4.3. MEASUREMENT UNCERTAINTY

Where relevant, the following measurement uncertainty levels have been estimated for tests performed on the apparatus:

PARAMETER	UNCERTAINTY
Conducted Disturbance, 0.15 to 30 MHz	3.52 dB
Radiated Disturbance, 30 to 18000 MHz	4.94 dB

Uncertainty figures are valid to a confidence level of 95%.

5. EQUIPMENT UNDER TEST

5.1. DESCRIPTION OF EUT

The EUT is a GSM/WCDMA/LTE Phone + Bluetooth, DTS/UNII a/b/g/n/ac, NFC & ANT.

5.2. MAXIMUM OUTPUT POWER

The transmitter has a maximum peak conducted and radiated ERP / EIRP output powers as follows:

FCC Part 22/24						
Band	Frequency Range(MHz)	Modulation Peak	Conducted		Radiated	
			Peak (dBm)	Peak (mW)	Peak (dBm)	Peak (mW)
GSM850	824~849	GMSK	32.8	1905		
	824~849	GPRS	32.8	1905	28.44	698.2
	824~849	EGPRS	27.1	513	25.11	324.3
GSM1900	1850~1910	GMSK	29.6	912		
	1850~1910	GPRS	29.6	912	28.22	663.74
	1850~1910	EGPRS	26.3	427	25.66	368.13
Band 5	824~849	REL99	22.37	173	20.54	113.2
	824~849	HSDPA	22.22	167	20.56	113.8
	824~849	HSUPA	22.21	166		
Band 2	1850~1910	REL99	22.36	172	20.68	117
	1850~1910	HSDPA	21.72	149	19.90	98
	1850~1910	HSUPA	21.71	148		

5.3. MAXIMUM OUTPUT POWER (LTE)

The transmitter has a maximum peak conducted and radiated ERP/EIRP output powers as follows:

FCC Part 22/2 4/27							
Band	Frequency Range(MHz)	BandWidth (MHz)	Modulation Peak	Conducted		Radiated	
				Peak (dBm)	Peak (mW)	Peak (dBm)	Peak (mW)
LTE5	824~849	10MHz	QPSK	22.17	165	20.70	117.52
			16QAM	21.43	139	19.70	93.35

FCC Part 22/2 4/27							
Band	Frequency Range(MHz)	BandWidth (MHz)	Modulation Peak	Conducted		Radiated	
				Peak (dBm)	Peak (mW)	Peak (dBm)	Peak (mW)
LTE5	824~849	5MHz	QPSK	22.37	173	21.48	140.64
			16QAM	21.78	151	20.50	112.23

FCC Part 22/2 4/27							
Band	Frequency Range(MHz)	BandWidth (MHz)	Modulation Peak	Conducted		Radiated	
				Peak (dBm)	Peak (mW)	Peak (dBm)	Peak (mW)
LTE5	824~849	3MHz	QPSK	22.15	164	20.30	107.18
			16QAM	21.40	138	19.60	91.22

FCC Part 22/2 4/27							
Band	Frequency Range(MHz)	BandWidth (MHz)	Modulation Peak	Conducted		Radiated	
				Peak (dBm)	Peak (mW)	Peak (dBm)	Peak (mW)
LTE5	824~849	1.4MHz	QPSK	22.19	166	19.91	97.97
			16QAM	21.49	141	18.70	74.15

5.4. DESCRIPTION OF AVAILABLE ANTENNAS

The radio utilizes a PIFA antenna for the [List the bands supported] with a maximum peak gain as follow:

Frequency (MHz)	Peak Gain (dBi)
Band 5;GSM850, 824~849MHz	-3.65
Band 2; GSM1900, 1850~1910MHz	-1.22
LTE5, 824~849MHz	-3.65

5.5. DESCRIPTION OF TEST SETUP

SUPPORT EQUIPMENT

Support Equipment List				
Description	Manufacturer	Model	Serial Number	FCC ID
AC Adapter	Samsung	SM-N7505	DK4DA09TS	N/A
Earphone	Samsung	SM-N7505	N/A	N/A

I/O CABLES (CONDUCTED SETUP)

I/O Cable List						
Cable No	Port	# of identical ports	Connector Type	Cable Type	Cable Length (m)	Remarks
1	RF Out	1	Spectrum Analyzer	Shielded	None	NA
2	Antenna Port	1	EUT	Shielded	0.1m	NA
3	RF In/Out	1	Communication Test Set	Shielded	1m	NA

I/O CABLES (RADIATED SETUP)

I/O CABLE LIST						
Cable No.	Port	# of Identical Ports	Connector Type	Cable Type	Cable Length	Remarks
1	USB	1	AC Adapter	Un-shielded	1.2m	No
2	Jack	1	Headset	Shielded	1m	No
3	RF In/out	1	Communication Test Set	Un-shielded	2m	Yes

TEST SETUP

The EUT is continuously communicated to the call box during the tests.

SETUP DIAGRAM FOR TESTS (CONDUCTED TEST SETUP)

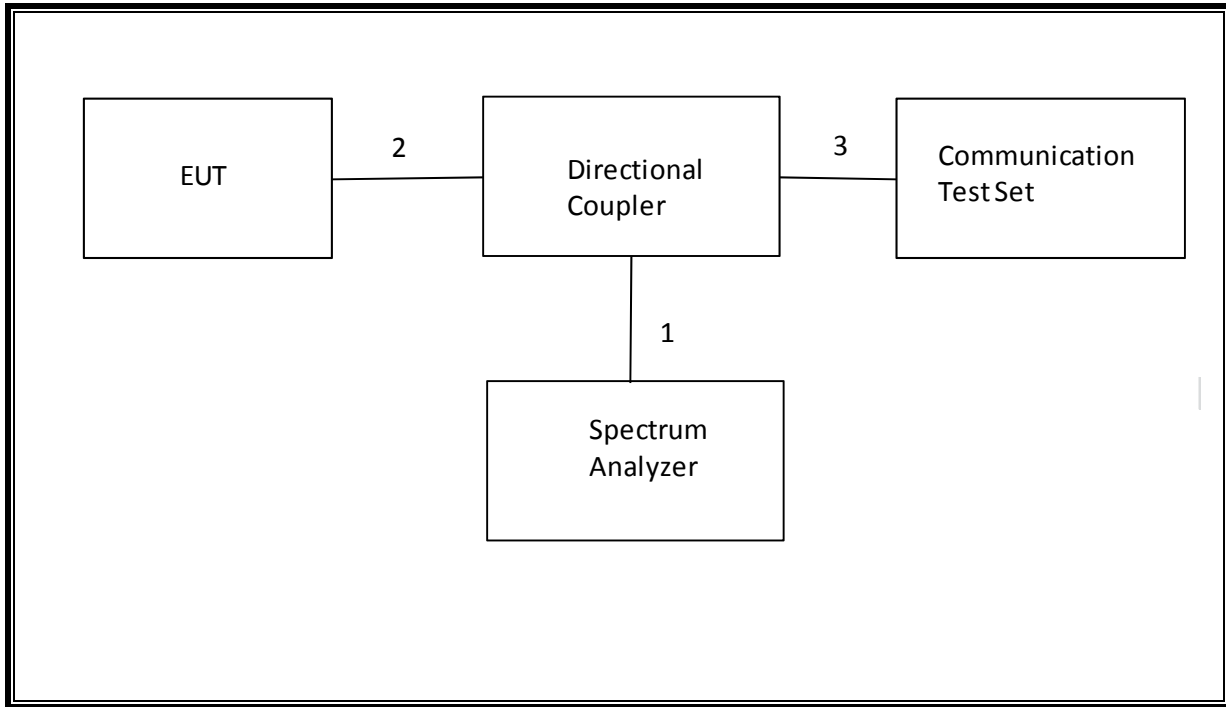

SETUP DIAGRAM FOR TESTS (RADIATED TEST SETUP)

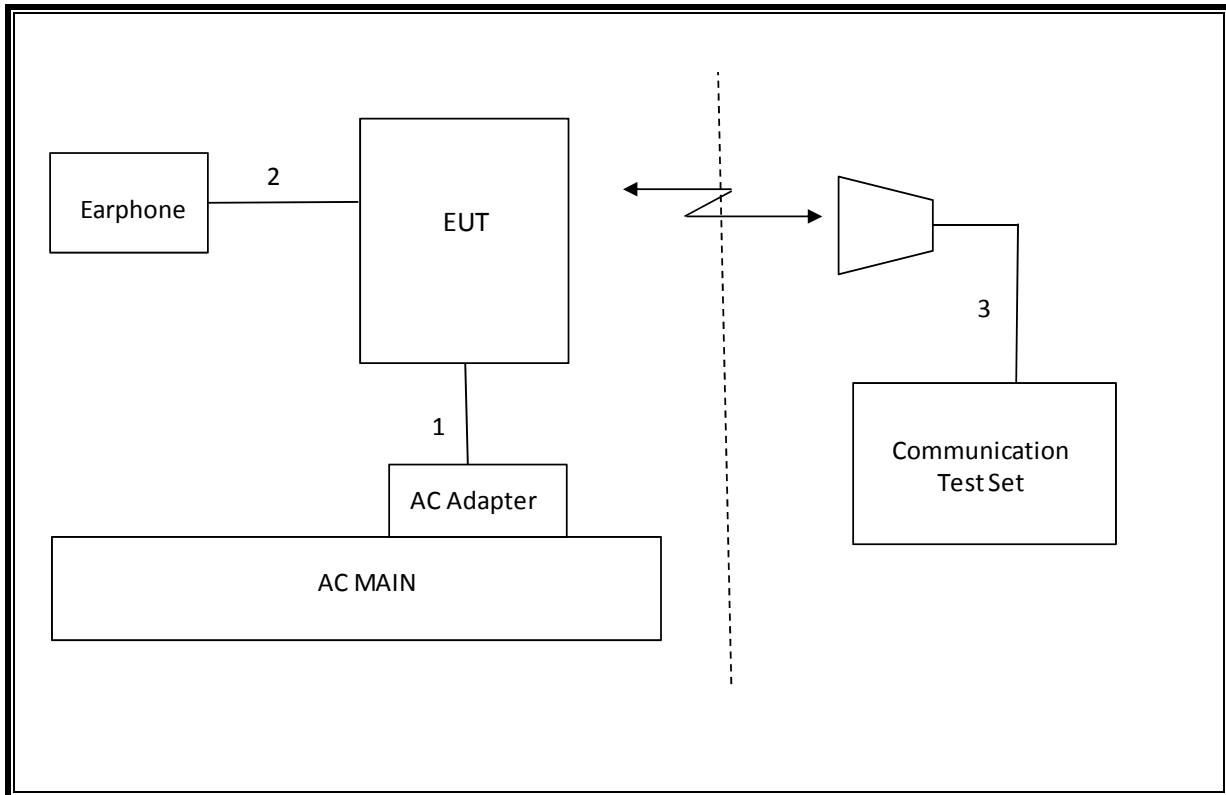

6. TEST AND MEASUREMENT EQUIPMENT

The following test and measurement equipment was utilized for the tests documented in this report:

TEST EQUIPMENT LIST				
Description	Manufacturer	Model	Asset	Cal Due
Spectrum Analyzer, 44 GHz	Agilent / HP	E4446A	C01179	02/26/14
Antenna, Bilog, 2 GHz	Sunol Sciences	JB1	C01011	08/14/14
Antenna, Horn, 18 GHz	EMCO	3115	C00783	10/25/14
Antenna, Horn, 18 GHz	EMCO	3115	C00784	09/25/14
Highpass Filter, 2.7 GHz	Micro-Tronics	HPM13194	N02687	CNR
Highpass Filter, 1.5 GHz	Micro-Tronics	HPM13193	N02688	CNR
Temperature / Humidity Chamber	Thermotron	SE 600-10-10	C00930	01/09/14
Communications Test Set	R&S	CMW500	T159	07/02/14
DC power supply, 8 V @ 3 A or 15 V	Agilent / HP	E3610A	None	CNR
Vector signal generator, 6 GHz	Agilent / HP	E4438C	None	07/06/14
Antenna, Tuned Dipole 400~1000	ETS	3121C DB4	C00993	02/14/14
Directional Coupler	RF-Lambda	RFDC5M06G15	None	CNR

7. Summary Table

FCC Part Section	RSS Section(s)	Test Description	Test Limit	Test Condition	Test Result	Worst Case
2.1049	N/A	Occupied Band width (99%)	N/A	Conducted	Pass	8.965MHz
22.917(a) 24.238(a)	RSS-132(4.5.1) RSS-133(6.5.1)	Band Edge / Conducted Spurious Emission	-13dBm		Pass	-13.032dBm
2.1046	N/A	Conducted output power	N/A		Pass	32.8dBm
22.355 24.235	RSS-132(4.3) RSS-133(6.3)	Frequency Stability	2.5PPM		Pass	0.011PPM
22.913(a)(2)	RSS-132(4.4)	Effective Radiated Power	38 dBm	Radiated	Pass	28.44dBm
24.232(c)	RSS-133(6.4)	Equivalent Isotropic Radiated Power	33dBm		Pass	28.22dBm
22.917(a) 24.238(a)	RSS-132(4.5.1) RSS-133(6.5.1)	Radiated Spurious Emission	-13dBm		Pass	-19.2dBm

8. RF POWER OUTPUT VERIFICATION

8.1. GSM/GPRS/EDGE

Function: Menu select > GSM Mobile Station > GSM 850/900/1800/1900
Press Connection control to choose the different menus
Press RESET > choose all to reset all settings
Connection Press Signal Off to turn off the signal and change settings
Network Support > GSM+GPRS or GSM+EGPRS
Main Service > Packet Data
Service selection > Test Mode A – Auto Slot Config. off
MS Signal Press Slot Config bottom on the right twice to select and change the number of time slots and power setting
 > Slot configuration > Uplink/Gamma
 > 33 dBm for GPRS 850/900
 > 30 dBm for GPRS1800/1900
BS Signal Enter the same channel number for TCH channel (test channel) and BCCH channel
Frequency Offset > + 0 Hz
Mode > BCCH and TCH
BCCH Level > -85 dBm (May need to adjust if link is not stable)
BCCH Channel > choose desire test channel [Enter the same channel number for TCH channel (test channel) and BCCH channel]
Channel Type > Off
P0> 4 dB
Slot Config > Unchanged (if already set under MS Signal)
TCH > choose desired test channel
Hopping > Off
Main Timeslot > 3 (Default)
Network Coding Scheme > CS4 (GPRS) and MCS9 (EGPRS)
Bit Stream > 2E9-1PSR Bit Pattern
AF/RF Enter appropriate offsets for Ext. Att. Output and Ext. Att. Input
Connection Press Signal On to turn on the signal and change settings

8.1.1. GSM OUTPUT POWER RESULT

Band	Mode	Ch.	f(MHz)	1 time slot	2 time slot	3 time slot	4 time slot
				Peak (dBm)	Peak (dBm)	Peak (dBm)	Peak (dBm)
GSM850	GMSK	128	824.2	32.7			
		190	836.6	32.8			
		251	848.8	32.8			
	GPRS	128	824.2	32.7	31.2	30.0	28.5
		190	836.6	32.8	31.3	30.1	28.6
		251	848.8	32.8	31.3	30.1	28.6
	EGPRS	128	824.2	27.1	26.1	25.1	23.5
		190	836.6	27.0	26.0	25.1	23.5
		251	848.8	27.0	26.0	25.0	23.5
GSM1900	GMSK	512	1850.2	29.5			
		661	1880	29.6			
		810	1909.8	29.5			
	GPRS	512	1850.2	29.5	28.5	27.4	25.7
		661	1880	29.6	28.5	27.4	25.8
		810	1909.8	29.5	28.5	27.3	25.7
	EGPRS	512	1850.2	26.3	25.4	24.3	22.7
		661	1880	26.3	25.4	24.3	22.7
		810	1909.8	26.2	25.3	24.3	22.6

8.2. UMTS REL 99

TEST PROCEDURE

The following summary of these settings are illustrated below:

	Mode	Rel99
	Subtest	-
WCDMA General Settings	Loopback Mode	Test Mode 1
	Rel99 RMC	12.2kbps RMC
	HSDPA FRC	Not Applicable
	HSUPA Test	Not Applicable
	Power Control Algorithm	Algorithm2
	β_c	Not Applicable
	β_d	Not Applicable
	β_{ec}	Not Applicable
	β_c/β_d	8/15
	β_{hs}	Not Applicable
	β_{ed}	Not Applicable

8.2.1. UMTS REL 99 OUTPUT POWER RESULT

Band	Mode	Ch.	f(MHz)	Conducted Power (dBm)
				Avg (dBm)
Band 5	REL99	4145	826.6	22.18
		4183	836.6	22.37
		4220	846.4	22.37
Band 2	REL99	9275	1852.6	22.14
		9400	1880	22.36
		9525	1907.4	22.35

8.3. UMTS HSDPA

The following 4 Sub-tests were completed according to Release 5 procedures in section 5.2 of 3GPP TS34.121. A summary of these settings are illustrated below:

	Mode	Rel5 HSDPA			
	Subtest	1	2	3	4
WCDMA General Settings	Loopback Mode	Test Mode 1			
	Rel99 RMC	12.2kbps RMC			
	HSDPA FRC	H-Set1			
	Power Control Algorithm	Algorithm 2			
	β_c	2/15	12/15	15/15	15/15
	β_d	15/15	15/15	8/15	4/15
	Bd (SF)	64			
	β_c/β_d	2/15	12/15	15/8	15/4
	β_{hs}	4/15	24/15	30/15	30/15
	MPR (dB)	0	0	0.5	0.5
HSDPA Specific Settings	D_{ACK}	8			
	D_{NAK}	8			
	DCQI	8			
	Ack-Nack repetition factor	3			
	CQI Feedback (Table 5.2B.4)	4ms			
	CQI Repetition Factor (Table 5.2B.4)	2			
	$A_{hs} = \beta_{hs}/\beta_c$	30/15			

8.3.1. UMTS HSDPA OUTPUT POWER RESULT

Band	Mode	Subset	Ch.	f(MHz)	Conducted Power (dBm)
					Avg (dBm)
Band 5	HSDPA	1	4145	826.6	22.01
			4183	836.6	22.22
			4220	846.4	22.18
		2	4145	826.6	21.88
			4183	836.6	22.03
			4220	846.4	21.94
		3	4145	826.6	21.66
			4183	836.6	21.81
			4220	846.4	21.77
		4	4145	826.6	21.47
			4183	836.6	21.63
			4220	846.4	21.61
Band 2	HSDPA	1	9275	1852.6	21.66
			9400	1880	21.72
			9525	1907.4	21.62
		2	9275	1852.6	21.55
			9400	1880	21.54
			9525	1907.4	21.54
		3	9275	1852.6	21.32
			9400	1880	21.29
			9525	1907.4	21.28
		4	9275	1852.6	21.12
			9400	1880	21.12
			9525	1907.4	21.11

8.3.2. UMTS HSUPA

TEST PROCEDURE

The following summary of these settings are illustrated below: (ETSI TS 134.121-1 Table C.11.1)

	Mode	Rel6 HSUPA	Rel6 HSUPA	Rel6 HSUPA	Rel6 HSUPA	Rel6 HSUPA
	Subtest	1	2	3	4	5
WCDMA General Settings	Loopback Mode	Test Mode 1				
	P-CPICH (dB)	-10				
	P-CCPCH (dB)	-12				
	SCH (dB)	-12				
	PICH(dB)	-15				
	DPCH (dB)	-9				
	HS-SCCH 1 (dB)	-8				
	HS-PDSCH (dB)	-3				
	Rel99 RMC	12.2kbps RMC				
	HSDPA FRC	H-Set1				
	HSUPA Test	HSUPA Loopback				
	Power Control Algorithm	Algorithm2				
	Bc	11/15	6/15	15/15	2/15	15/15
	Bd	15/15	15/15	9/15	15/15	15/15
	Bec	209/225	12/15	30/15	2/15	5/15
	β_c/β_d	11/15	6/15	15/9	2/15	15/15
	Bhs	22/15	12/15	30/15	4/15	30/15
β_{ed} (note1)	1309/225	94/75	47/15	56/75	134/15	
MPR	0	2	1	2	0	
HSDPA Specific Settings	DACK	8				
	DNAK	8				
	DCQI	8				
	Ack-Nack repetition factor	3				
	CQI Feedback (Table 5.2B.4)	4ms				
	CQI Repetition Factor (Table 5.2B.4)	2				
	Ahs = β_{hs}/β_c	30/15				
HSUPA Specific Settings	D E-DPCCH	6	8	8	5	7
	DHARQ	0	0	0	0	0
	AG Index	20	12	15	17	21
	Reference E-TFCIs	5	5	2	5	5
	ETFCI (from 34.121 Table C.11.1.3)	75	67	92	71	81
	Associated Max UL Data Rate kbps	242.1	174.9	482.8	205.8	308.9
	Reference E_TFCIs	E-TFCI 11 E-TFCI PO 4 E-TFCI 67 E-TFCI PO 18 E-TFCI 71 E-TFCI PO 23 E-TFCI 75 E-TFCI PO 26 E-TFCI 81 E-TFCI PO 27		E-TFCI 11 E-TFCI PO 4 E-TFCI 92 E-TFCI PO 18	E-TFCI 11 E-TFCI PO 4 E-TFCI 67 E-TFCI PO 18 E-TFCI 71 E-TFCI PO 23 E-TFCI 75 E-TFCI PO 26 E-TFCI 81 E-TFCI PO 27	

Note1: β_{ed} cannot be set directly, it is set by Absolute Grant Value.

8.3.3. UMTS HSUPA OUTPUT POWER RESULT

Band	Mode	Subset	Ch.	f(MHz)	Conducted Power (dBm)
					Avg (dBm)
Band 5	HSUPA	1	4145	826.6	21.72
			4183	836.6	21.91
			4220	846.4	22.16
		2	4145	826.6	21.76
			4183	836.6	22.21
			4220	846.4	22.18
		3	4145	826.6	21.69
			4183	836.6	21.87
			4220	846.4	21.80
		4	4145	826.6	21.89
			4183	836.6	22.21
			4220	846.4	22.21
		5	4145	826.6	21.60
			4183	836.6	22.01
			4220	846.4	21.96
Band 2	HSUPA	1	9275	1852.6	21.71
			9400	1880	21.71
			9525	1907.4	21.69
		2	9275	1852.6	21.53
			9400	1880	21.71
			9525	1907.4	21.65
		3	9275	1852.6	21.28
			9400	1880	21.28
			9525	1907.4	21.29
		4	9275	1852.6	21.63
			9400	1880	21.62
			9525	1907.4	21.71
		5	9275	1852.6	21.61
			9400	1880	21.56
			9525	1907.4	21.53

8.4. LTE OUTPUT VERIFICATION

8.4.1. LTE OUTPUT RESULT

Band	Frequency	Modulation	BW (MHz)	RB Size	RB Offset	Average
LTE5	829	QPSK	10	1	0	22.17
				1	24	22.16
				1	49	21.95
				25	0	21.24
				25	11	21.17
				25	24	21.07
	829	16QAM		50	0	21.15
				1	0	21.11
				1	24	21.02
				1	49	20.93
				25	0	20.22
				25	11	20.15
	836.5	QPSK		25	24	20.08
				50	0	20.10
				1	0	22.08
				1	24	22.05
				1	49	21.77
				25	0	21.01
	836.5	16QAM		25	11	21.02
				25	24	20.87
				50	0	20.97
				1	0	21.43
				1	24	21.31
				1	49	21.28
	844	QPSK		25	0	20.07
				25	11	20.01
				25	24	19.91
				50	0	19.96
				1	0	22.08
				1	24	22.00
	844	16QAM		1	49	21.79
				25	0	21.03
				25	11	20.94
				25	24	20.89
				50	0	20.91
				1	0	20.97
		1	24	20.84		
		1	49	20.58		
		25	0	20.03		
		25	11	19.96		
		25	24	19.89		
		50	0	19.91		

Band	Frequency	Modulation	BW (MHz)	RB Size	RB Offset	Average
LTE5	826.5	QPSK	5	1	0	22.27
				1	11	22.37
				1	24	22.26
				12	0	21.26
				12	5	21.27
				12	11	21.25
	25	0		21.20		
	826.5	16QAM		1	0	21.25
				1	11	21.42
				1	24	21.25
				12	0	20.22
				12	5	20.24
				12	11	20.17
	836.5	QPSK		25	0	20.26
				1	0	22.17
				1	11	22.12
				1	24	22.03
				12	0	21.07
				12	5	21.06
	836.5	16QAM		12	11	21.00
				25	0	21.07
				1	0	21.44
				1	11	21.35
				1	24	21.43
				12	0	20.12
	846.5	QPSK		12	5	20.06
				12	11	20.08
				25	0	19.99
				1	0	21.95
				1	11	21.96
				1	24	21.96
	846.5	16QAM		12	0	20.98
				12	5	20.95
				12	11	20.86
				25	0	20.97
				1	0	21.78
1			11	21.72		
		1	24	21.56		
		12	0	19.99		
		12	5	19.94		
		12	11	19.92		
		25	0	19.85		

Band	Frequency	Modulation	BW (MHz)	RB Size	RB Offset	Average
LTE5	825.5	QPSK	3	1	0	22.13
				1	7	22.13
				1	14	22.15
				7	0	21.26
				7	2	21.23
				7	6	21.20
	15	0		21.21		
	825.5	16QAM		1	0	21.06
				1	7	21.10
				1	14	21.18
				7	0	20.31
				7	2	20.32
				7	6	20.29
	15	0		20.21		
	836.5	QPSK		1	0	22.07
				1	7	22.04
				1	14	21.97
				7	0	21.12
				7	2	21.04
				7	6	20.92
	15	0		21.05		
	836.5	16QAM		1	0	21.33
				1	7	21.40
				1	14	21.33
				7	0	19.94
				7	2	19.90
				7	6	19.90
	15	0		20.04		
	847.5	QPSK		1	0	21.95
				1	7	21.95
				1	14	21.85
				7	0	20.93
				7	2	20.88
				7	6	20.94
	15	0		20.86		
	847.5	16QAM		1	0	20.88
1			7	21.00		
1			14	20.88		
7			0	20.10		
7			2	20.08		
7			6	20.04		
15	0	19.80				

Band	Frequency	Modulation	BW (MHz)	RB Size	RB Offset	Average
LTE5	824.7	QPSK	1.4	1	0	22.18
				1	2	22.17
				1	5	22.19
				3	0	22.24
				3	0	22.24
				3	2	22.21
	6	0		21.23		
	824.7	16QAM		1	0	21.28
				1	2	21.33
				1	5	21.28
				3	0	21.35
				3	0	21.34
				3	2	21.28
	836.5	QPSK		6	0	20.31
				1	0	22.09
				1	2	22.12
				1	5	22.08
				3	0	22.10
				3	0	22.09
	836.5	16QAM		3	2	22.10
				6	0	21.09
				1	0	21.49
				1	2	21.46
				1	5	21.45
				3	0	21.22
	848.3	QPSK		3	0	21.23
				3	2	21.14
				6	0	19.89
				1	0	21.88
				1	2	21.86
1			5	21.87		
848.3	16QAM	3	0	21.91		
		3	0	21.91		
		3	2	21.91		
		6	0	20.89		
		1	0	21.12		
		1	2	21.10		
		1	5	20.99		
		3	0	21.04		
		3	0	21.04		
		3	2	20.89		
		6	0	19.98		
		6	0	19.98		

9. PEAK TO AVERAGE RATIO

Test Procedure

Per KDB 971168 D01 Power Meas License Digital Systems v02r01

Test Spec

In addition, when the transmitter power is measured in terms of average value, the peak-to-average ratio of the power shall not exceed 13 dB.

9.1. CONDUCTED PEAK TO AVERAGE RESULT

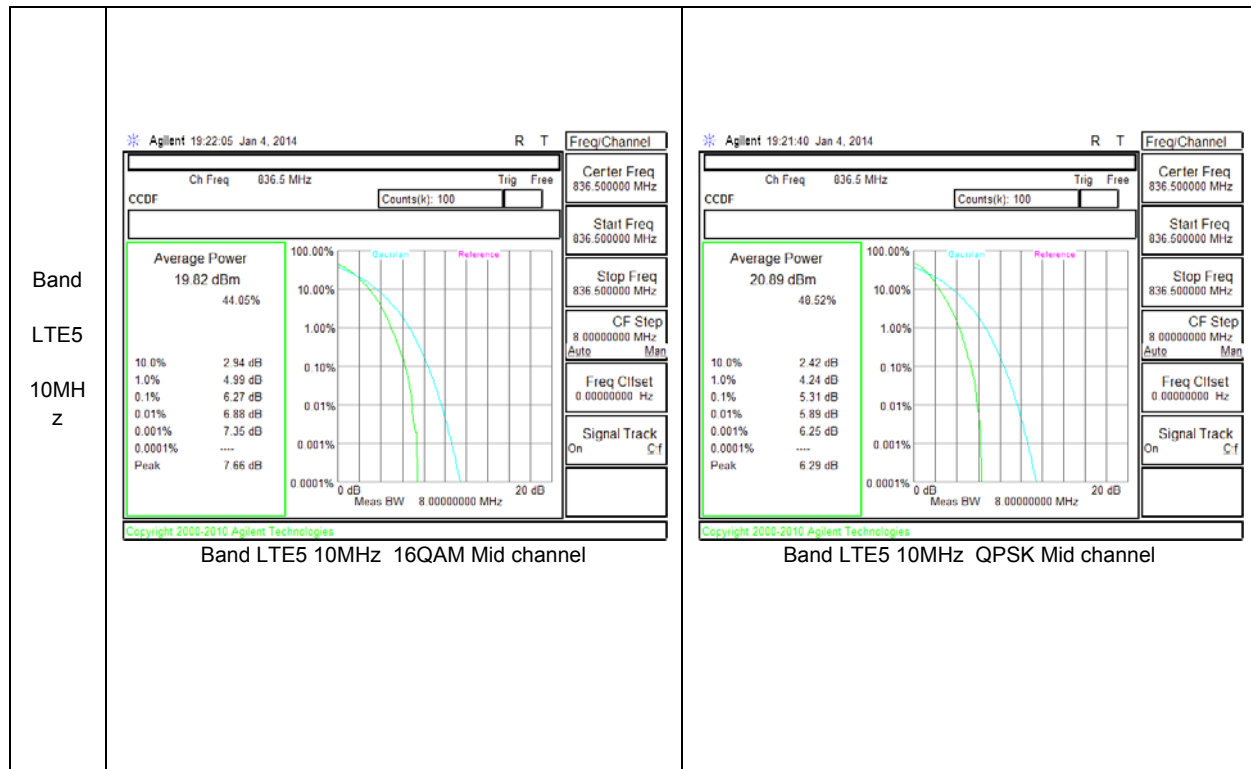

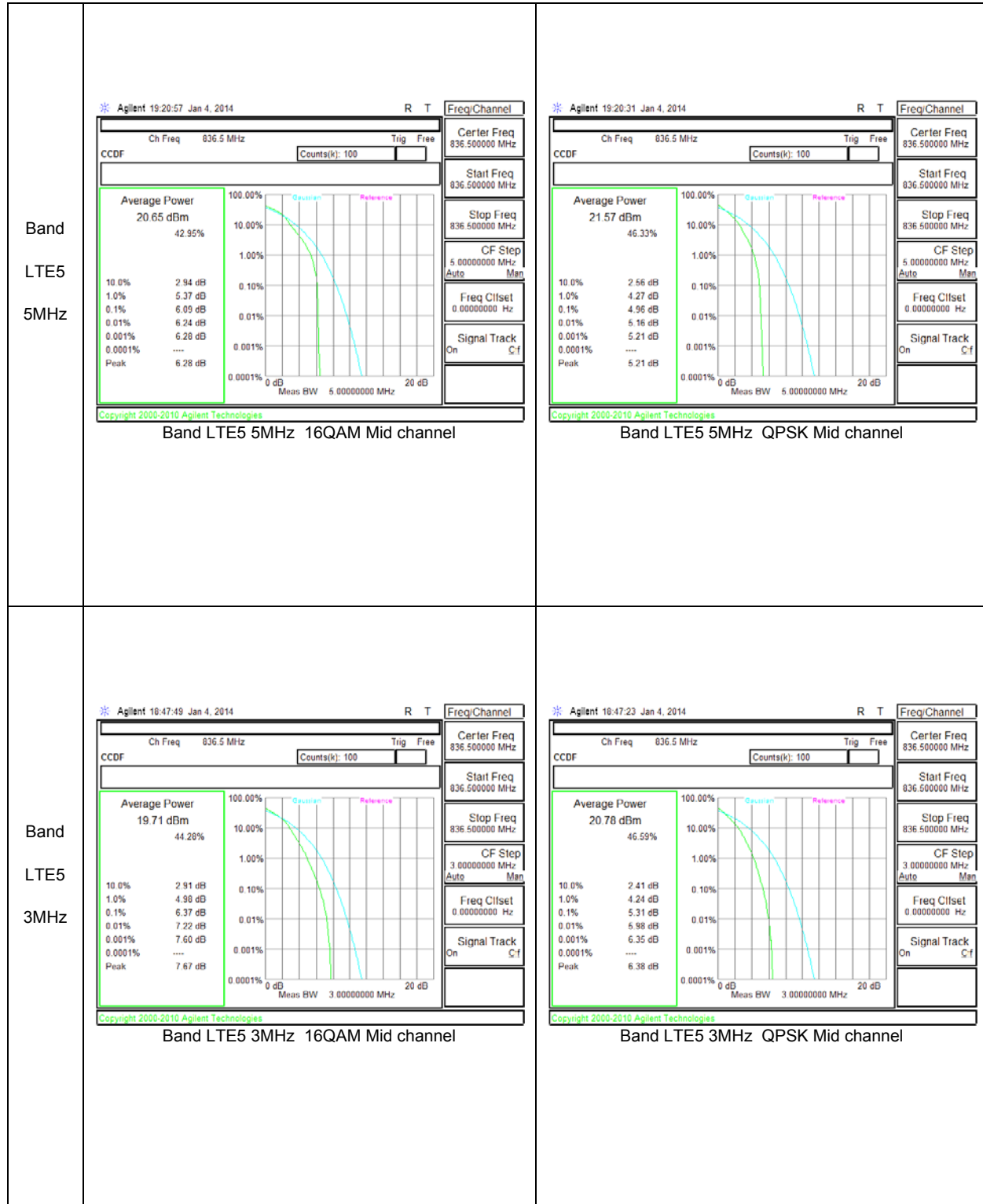

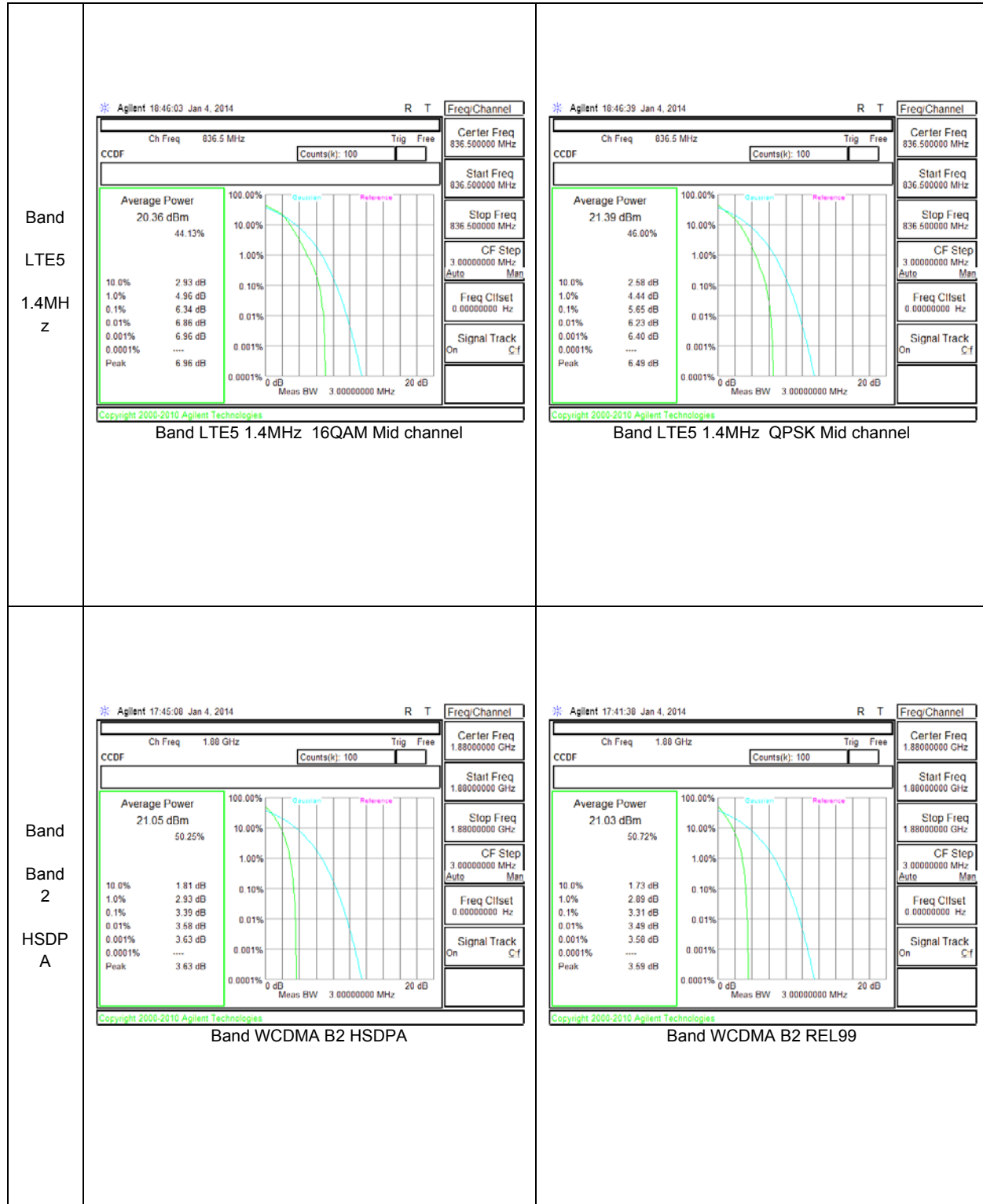

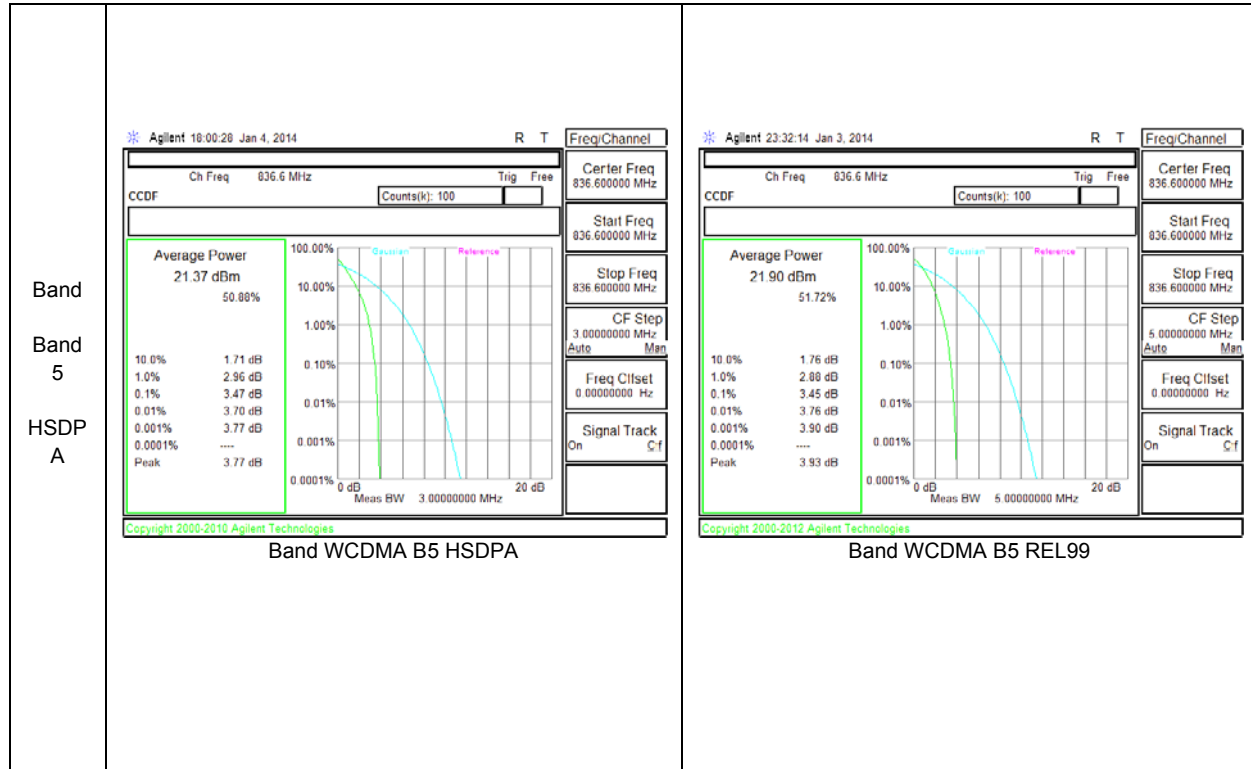

10. LIMITS AND CONDUCTED RESULTS

10.1. OCCUPIED BANDWIDTH

RULE PART(S)

FCC: §2.1049

IC: RSS-132, 4.5; RSS-133, 6.5

LIMITS

For reporting purposes only

TEST PROCEDURE

The transmitter output was connected to a calibrated coaxial cable and coupler, the other end of which was connected to a spectrum analyzer. The occupied bandwidth was measured with the spectrum analyzer at the low, middle and high channel in each band. The -26dB bandwidth was also measured and recorded.

(KDB 971168 D01 Power Meas License Digital Systems v02r01 - 06/07/2013)

10.1.1. OCCUPIED BANDWIDTH RESULTS

Band	Mode	Channel	f (MHz)	99% BW (KHz)	-26dB BW (KHz)
GSM850	GPRS	128	824.2	243	312
		190	836.6	246	317
		251	848.8	251	318
	EGPRS	128	824.2	246	325
		190	836.6	238	303
		251	848.8	243	312
GSM1900	GPRS	512	1850.2	246	317
		661	1880	249	319
		810	1909.8	241	321
	EGPRS	512	1850.2	249	319
		661	1880	252	314
		810	1909.8	243	309
Band 5	REL99	4145	826.6	4065	4631
		4183	836.6	4086	4570
		4220	846.4	4073	4556
	HSDPA	4145	826.6	4054	4630
		4183	836.6	4051	4612
		4220	846.4	4071	4646
Band 2	REL99	9275	1852.6	4081	4700
		9400	1880	4075	4667
		9525	1907.4	4090	4679
	HSDPA	9275	1852.6	4089	4728
		9400	1880	4087	4634
		9525	1907.4	4106	4668

10.1.2. LTE OCCUPIED BANDWIDTH RESULTS

Band	BW(MHz)	Mode	RB/RB Size	f (MHz)	99% BW (MHz)	-26dB BW (MHz)
LTE5	10	QPSK	50/0	829	8.957	10.084
			50/0	836.5	8.965	10.079
			50/0	844	8.946	10.072
		16QAM	50/0	829	8.941	9.803
			50/0	836.5	8.959	9.992
			50/0	844	8.946	9.859

Band	BW(MHz)	Mode	RB/RB Size	f (MHz)	99% BW (MHz)	-26dB BW (MHz)
LTE5	5	QPSK	25/0	826.5	4.463	5.025
			25/0	836.5	4.470	5.142
			25/0	846.5	4.465	5.203
		16QAM	25/0	826.5	4.477	5.000
			25/0	836.5	4.492	5.304
			25/0	846.5	4.482	5.147

Band	BW(MHz)	Mode	RB/RB Size	f (MHz)	99% BW (KHz)	-26dB BW (KHz)
LTE5	3	QPSK	15/0	825.5	2.675	2.961
			15/0	836.5	2.677	2.980
			15/0	847.5	2.685	2.956
		16QAM	15/0	825.5	2.679	2.954
			15/0	836.5	2.689	3.015
			15/0	847.5	2.679	2.992

Band	BW(MHz)	Mode	RB/RB Size	f (MHz)	99% BW (KHz)	-26dB BW (KHz)
LTE5	1.4	QPSK	6/0	824.7	1.146	1.854
			6/0	836.5	1.172	1.881
			6/0	848.3	1.159	1.856
		16QAM	6/0	824.7	1.150	1.858

			6/0	836.5	1.134	1.839
			6/0	848.3	1.142	1.803

10.1.1. OCCUPIED BANDWIDTH PLOTS

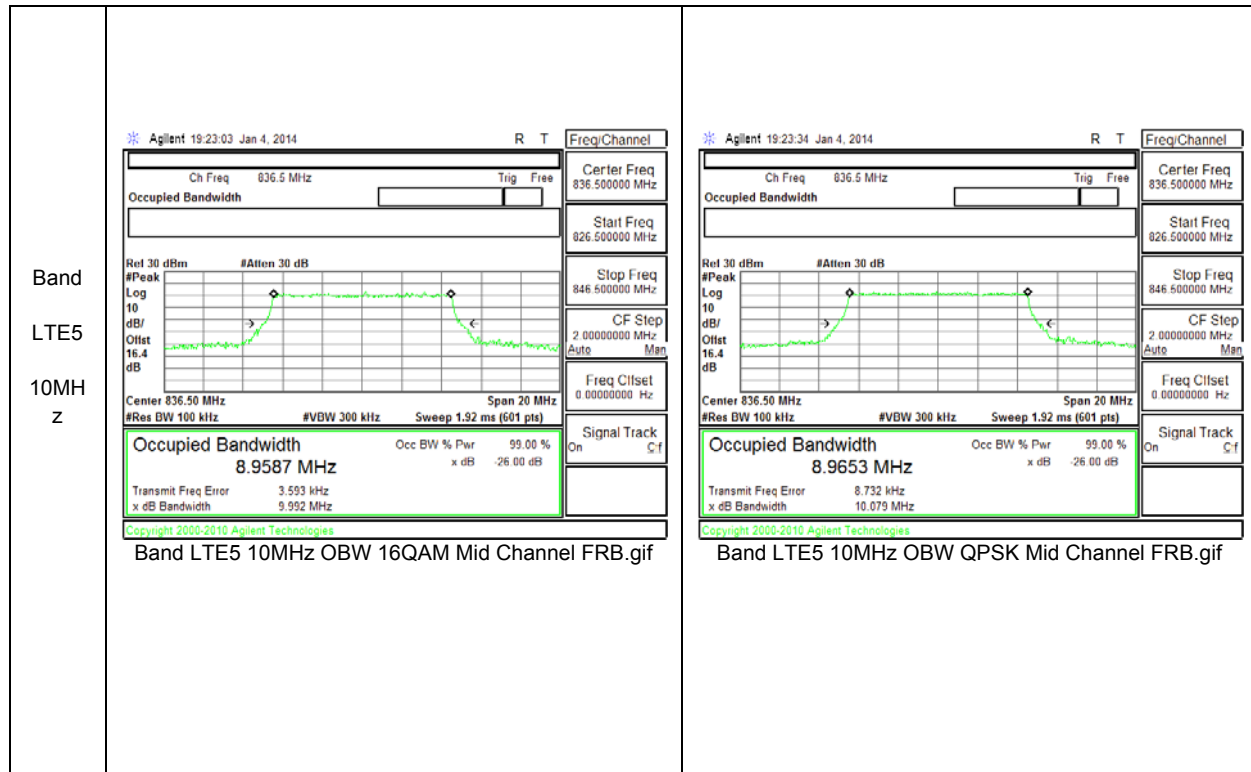

<p>Band LTE5 5MHz</p>	<p>Agilent 19:05:41 Jan 4, 2014</p> <p>Center Freq 836.5 MHz</p> <p>Occupied Bandwidth 4.4922 MHz</p> <p>Transmit Freq Error 4.599 kHz</p> <p>x dB Bandwidth 5.304 MHz</p> <p>Band LTE5 5MHz OBW 16QAM Mid Channel FRB.gif</p>	<p>Agilent 19:05:04 Jan 4, 2014</p> <p>Center Freq 836.5 MHz</p> <p>Occupied Bandwidth 4.4696 MHz</p> <p>Transmit Freq Error 4.497 kHz</p> <p>x dB Bandwidth 5.142 MHz</p> <p>Band LTE5 5MHz OBW QPSK Mid Channel FRB.gif</p>
<p>Band LTE5 3MHz</p>	<p>Agilent 18:48:36 Jan 4, 2014</p> <p>Center Freq 836.5 MHz</p> <p>Occupied Bandwidth 2.6885 MHz</p> <p>Transmit Freq Error -1.339 kHz</p> <p>x dB Bandwidth 3.015 MHz</p> <p>Band LTE5 3MHz OBW 16QAM Mid Channel FRB.gif</p>	<p>Agilent 18:48:58 Jan 4, 2014</p> <p>Center Freq 836.5 MHz</p> <p>Occupied Bandwidth 2.6770 MHz</p> <p>Transmit Freq Error 4.334 kHz</p> <p>x dB Bandwidth 2.980 MHz</p> <p>Band LTE5 3MHz OBW QPSK Mid Channel FRB.gif</p>

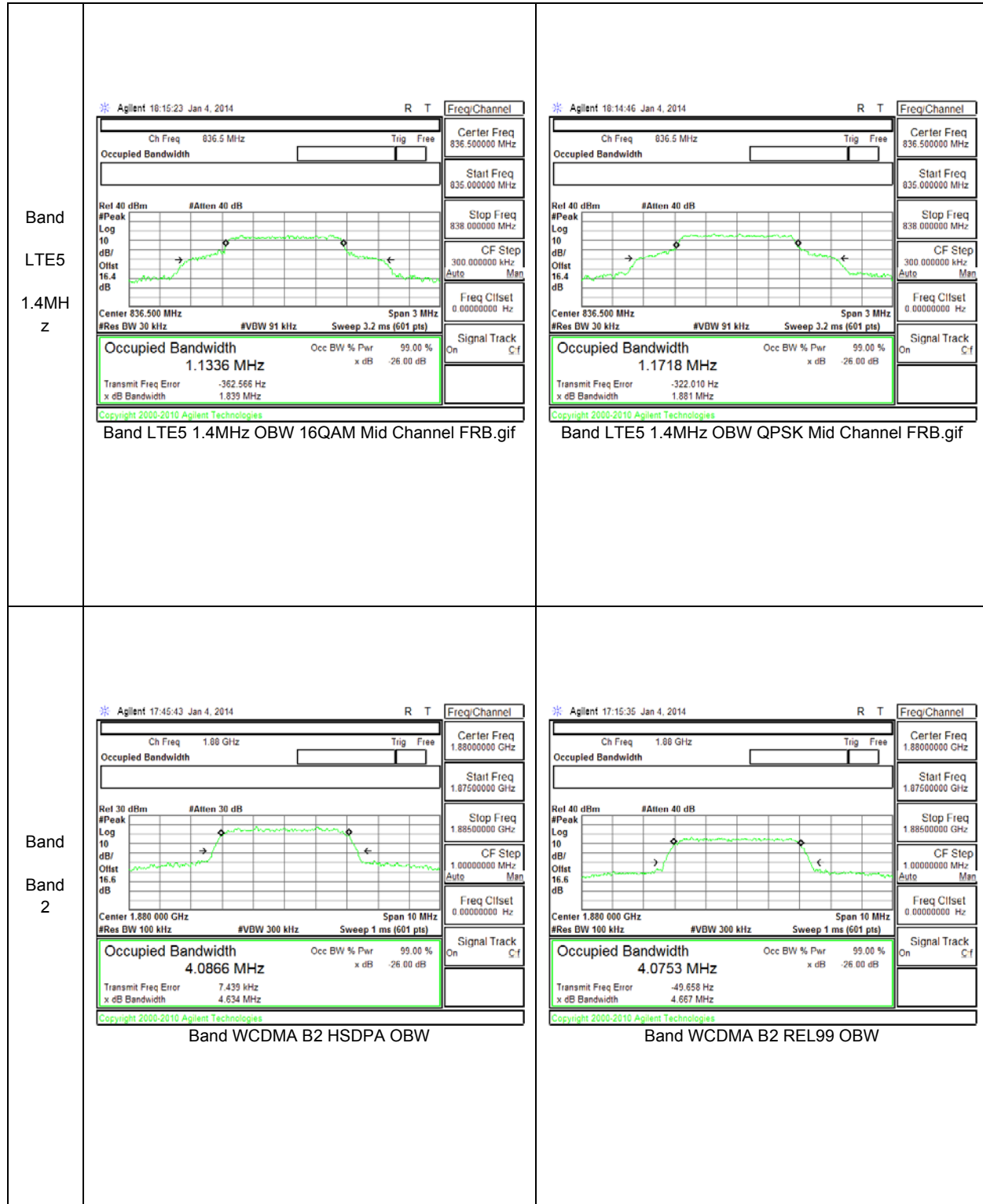

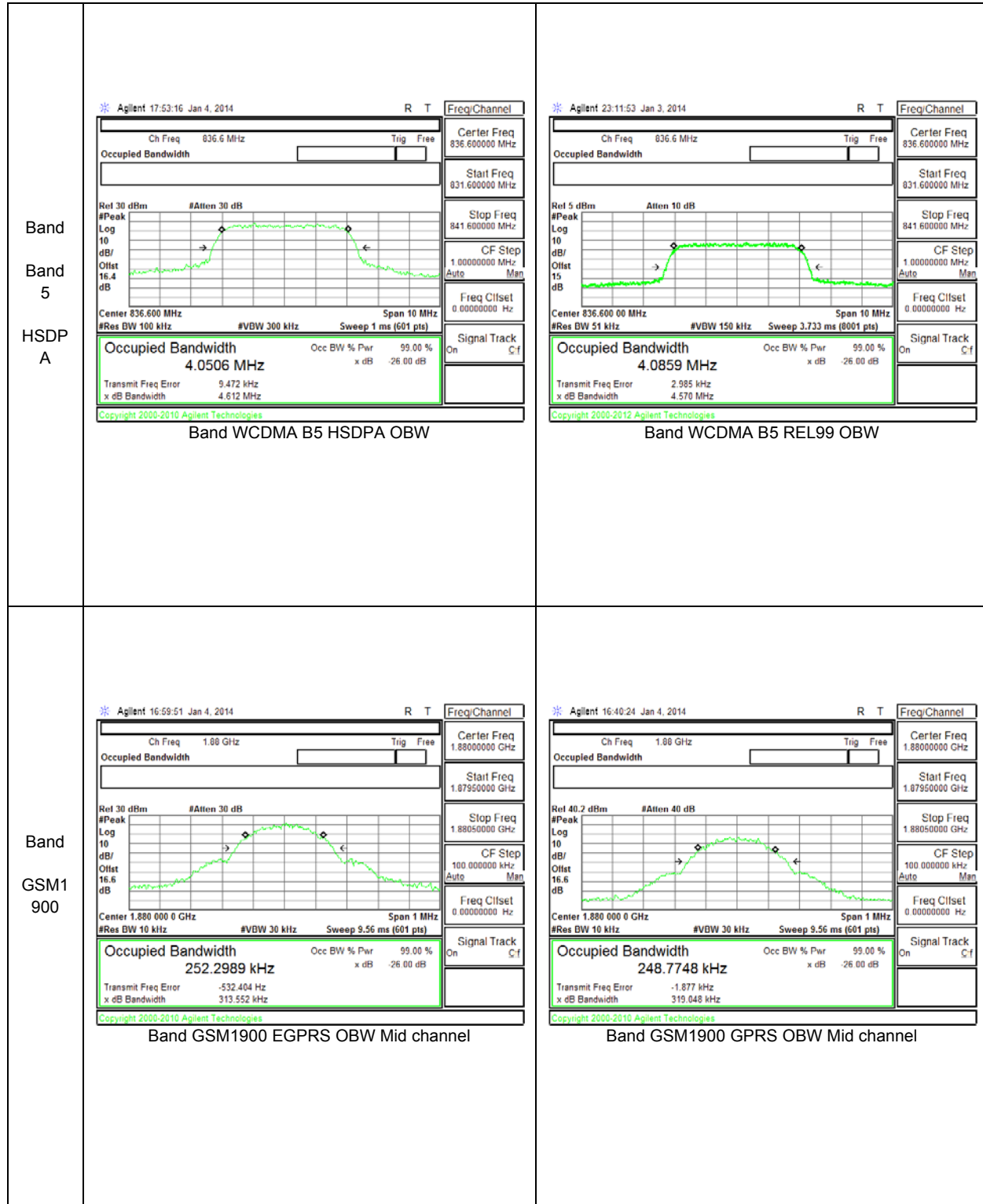

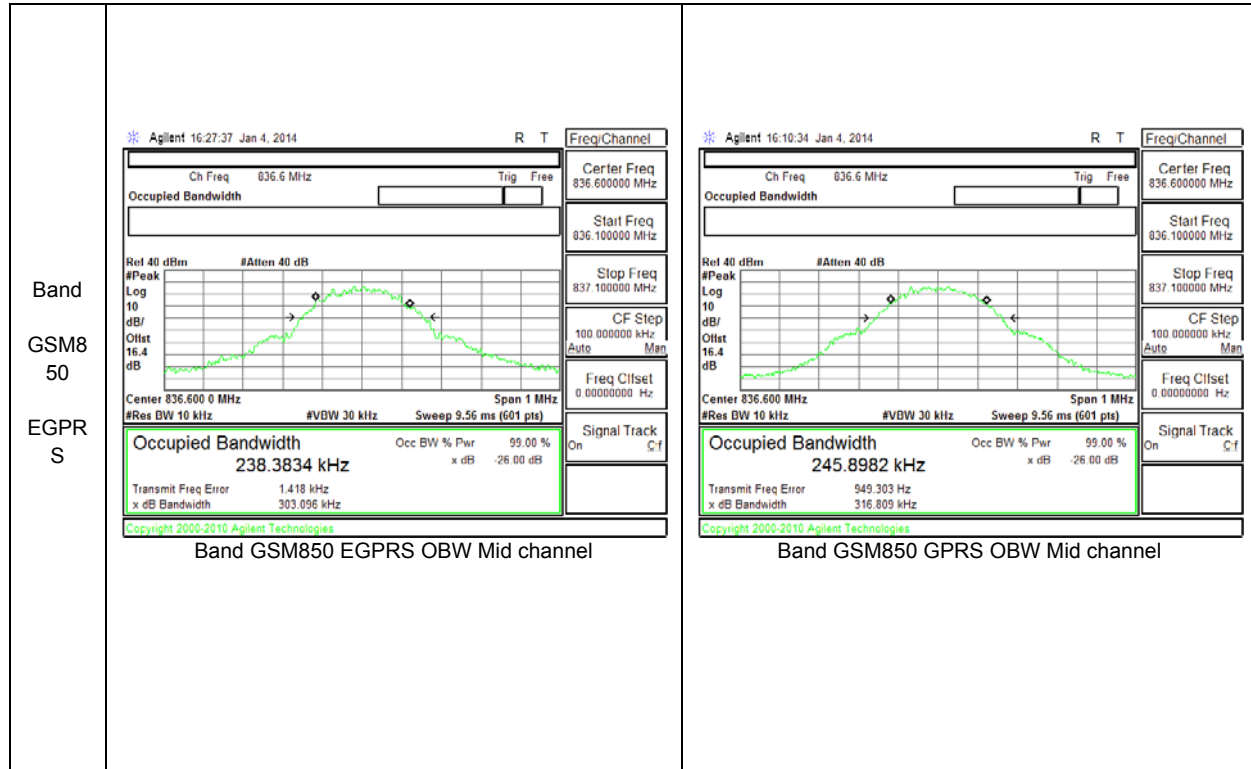

10.2. BAND EDGE EMISSIONS

RULE PART(S)

FCC: §22.359, §24.238

LIMITS

The power of any emission outside of the authorized operating frequency ranges must be attenuated below the transmitting power (P) by a factor of at least $43 + 10 \log (P)$ dB.

TEST PROCEDURE

Per KDB 971168 D01 Power Meas License Digital Systems v02r01

The transmitter output was connected to an Agilent 8960 or a CMW500 Test Set and configured to operate at maximum power. The band edge emissions were measured at the required operating frequencies in each band on the Spectrum Analyzer.

For each band edge measurement:

- Set the spectrum analyzer span to include the block edge frequency (824, 849, 1850, 1910 and 1915MHz)
- Set a marker to point the corresponding band edge frequency in each test case.
- Set display line at -13 dBm.
- Set resolution bandwidth to at least 1% of emission bandwidth.
- (m)(6) Compliance with these rules is based on the user of measurement instrumentation employing a resolution bandwidth of 1MHz or greater. However, in the 1MHz bands immediately outside and adjacent to the frequency block a resolution bandwidth of at least 1 percent of the emission bandwidth may be employed.

MODES TESTED

GSM 850/1900 & WCDMA B2/B5 & LTE B5

RESULTS

10.2.1. BAND EDGE PLOTS

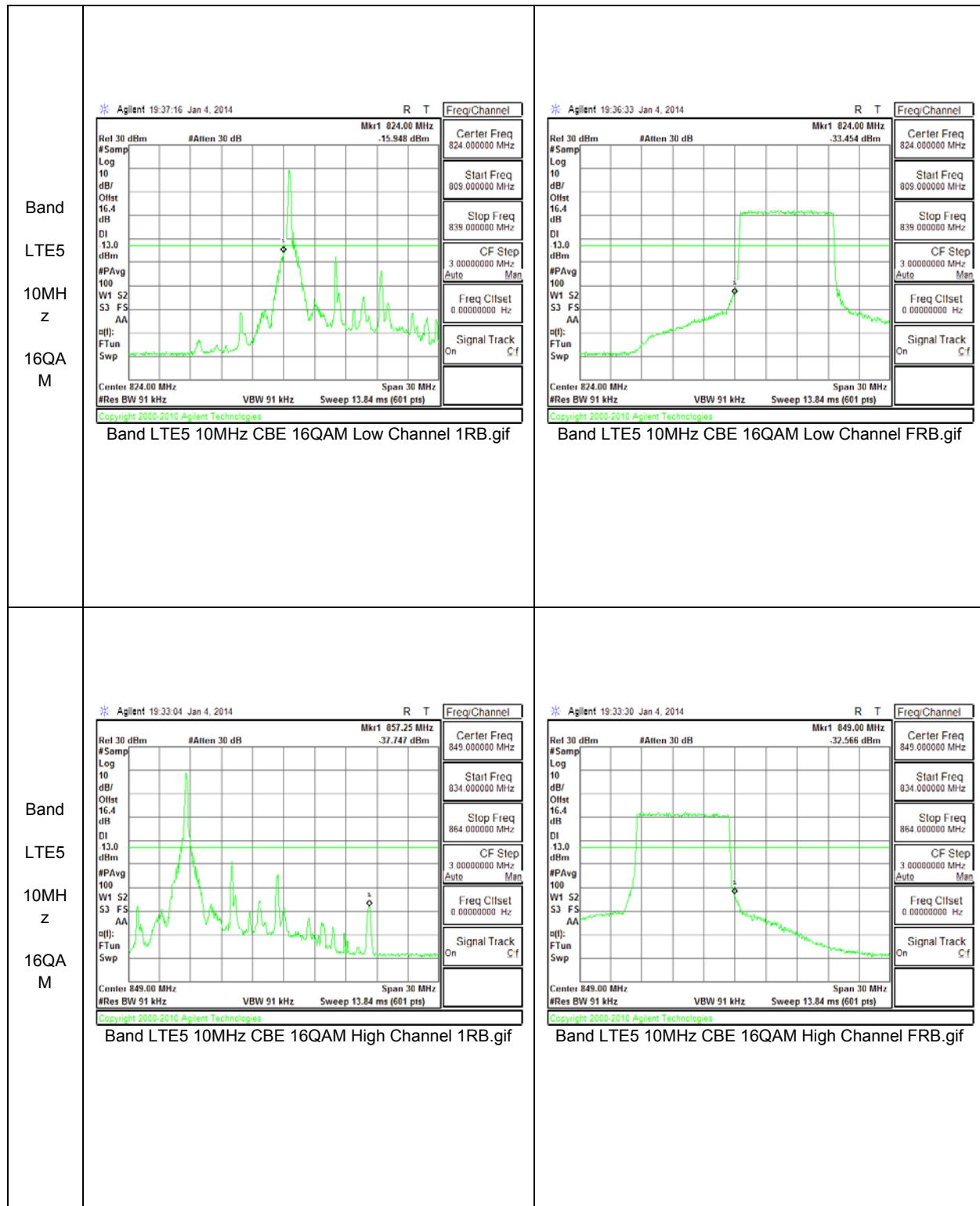

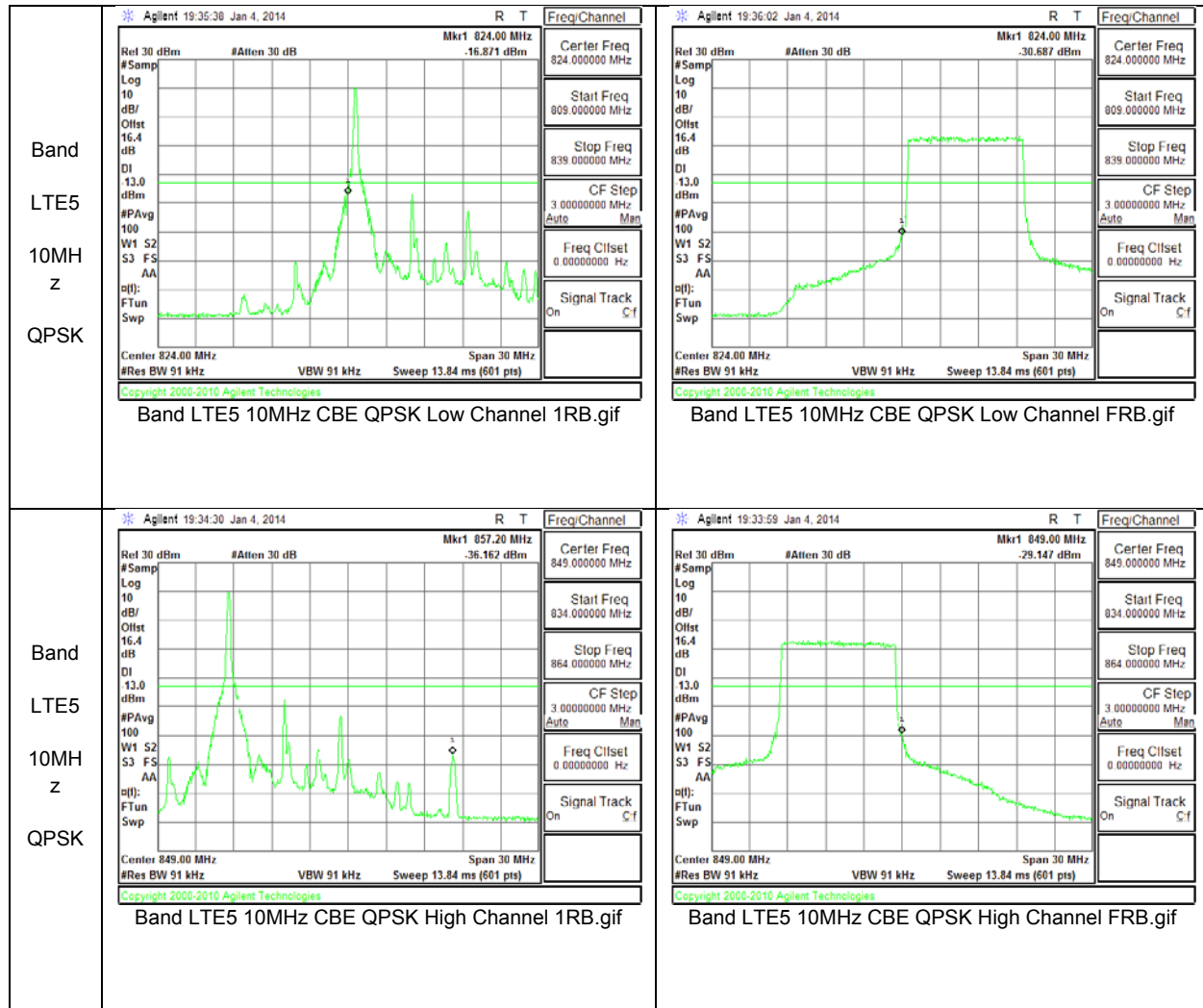

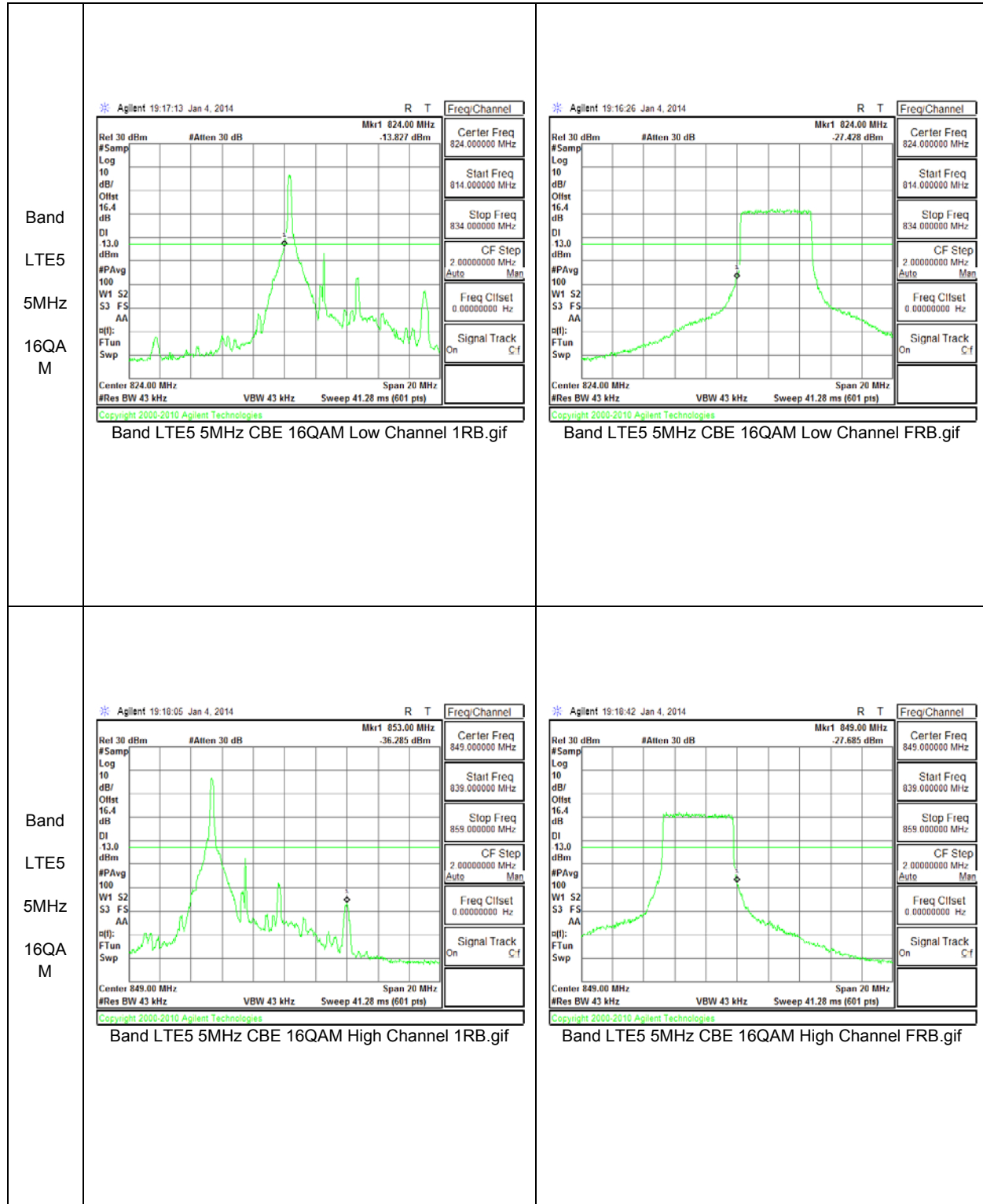

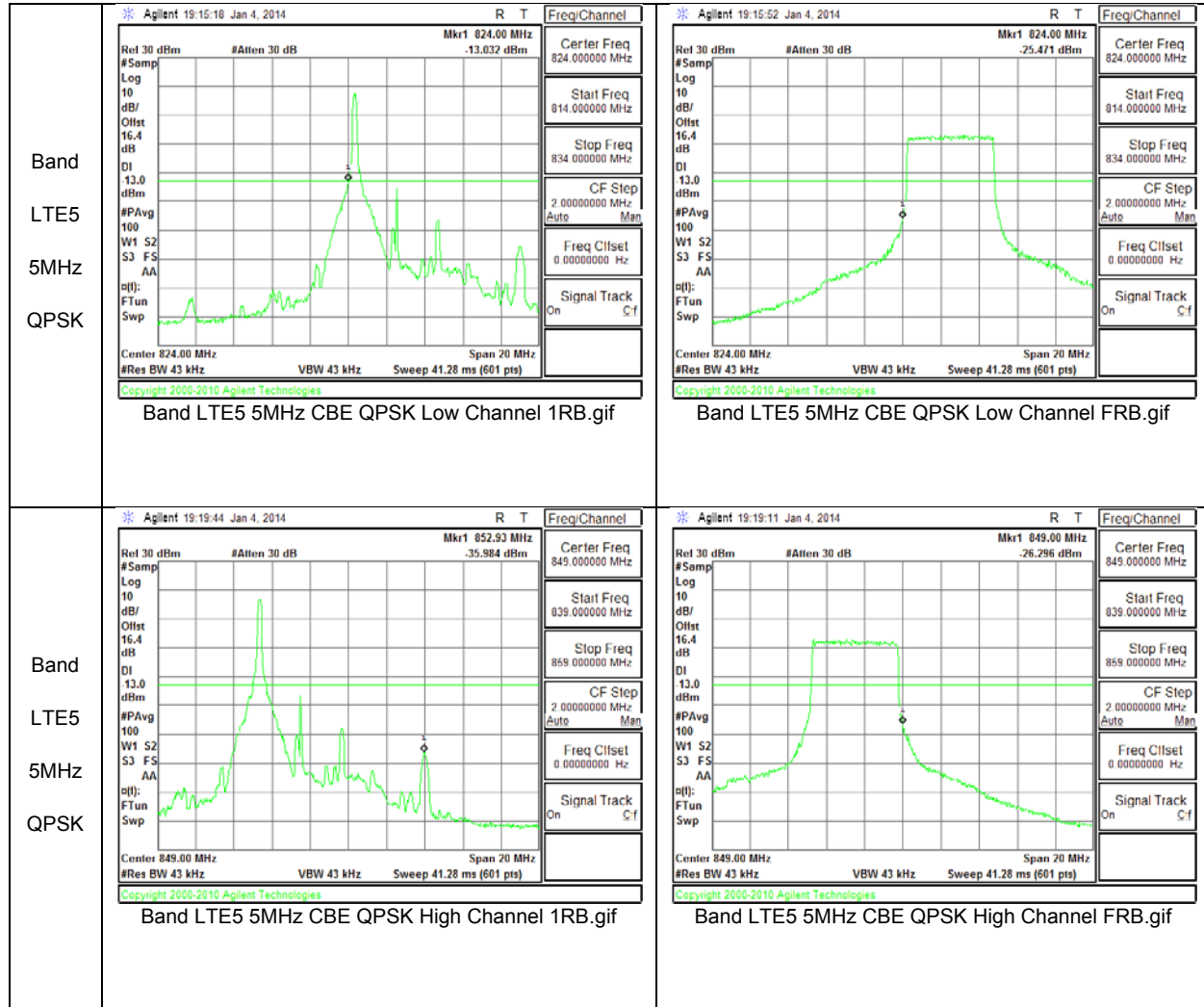

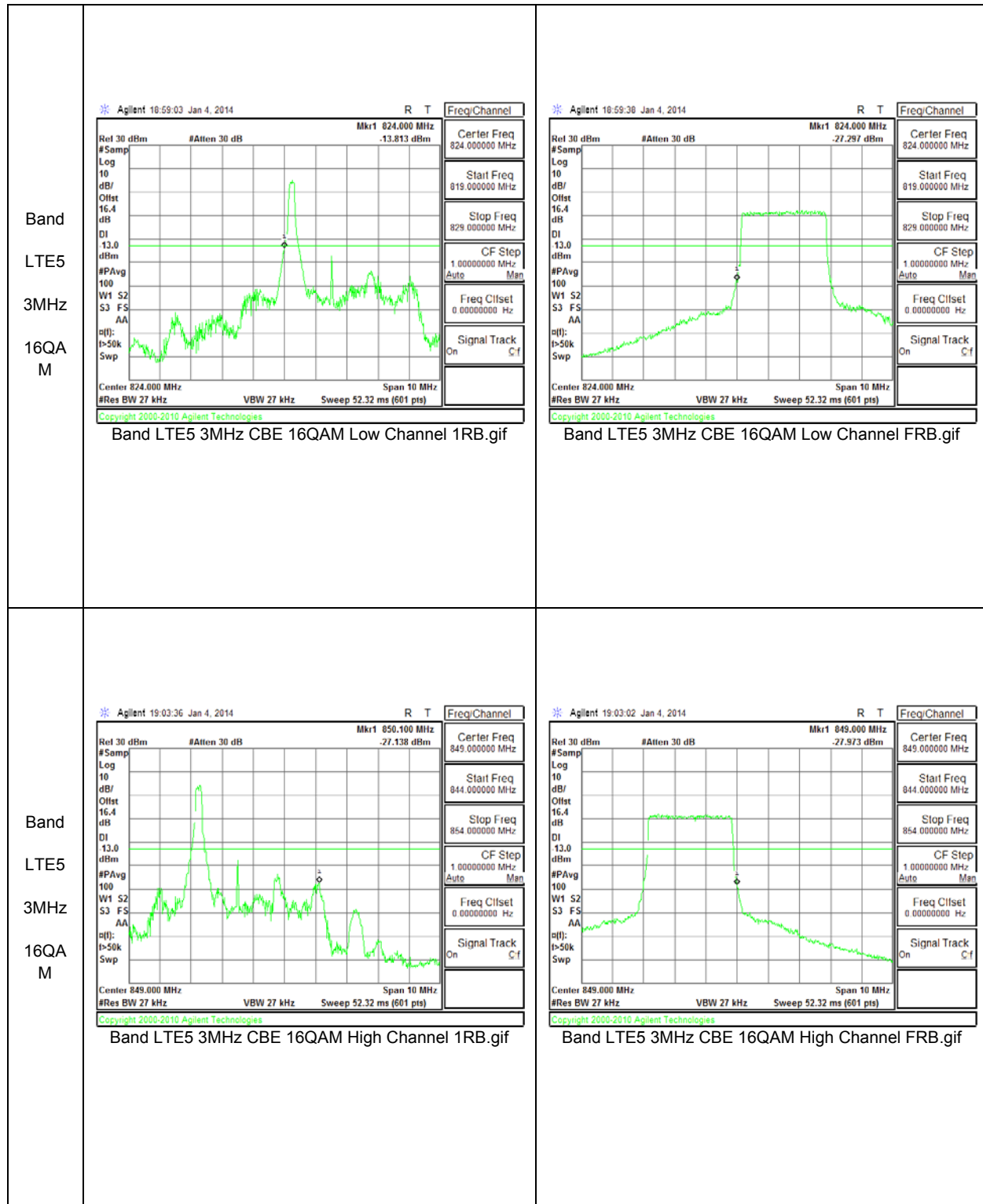

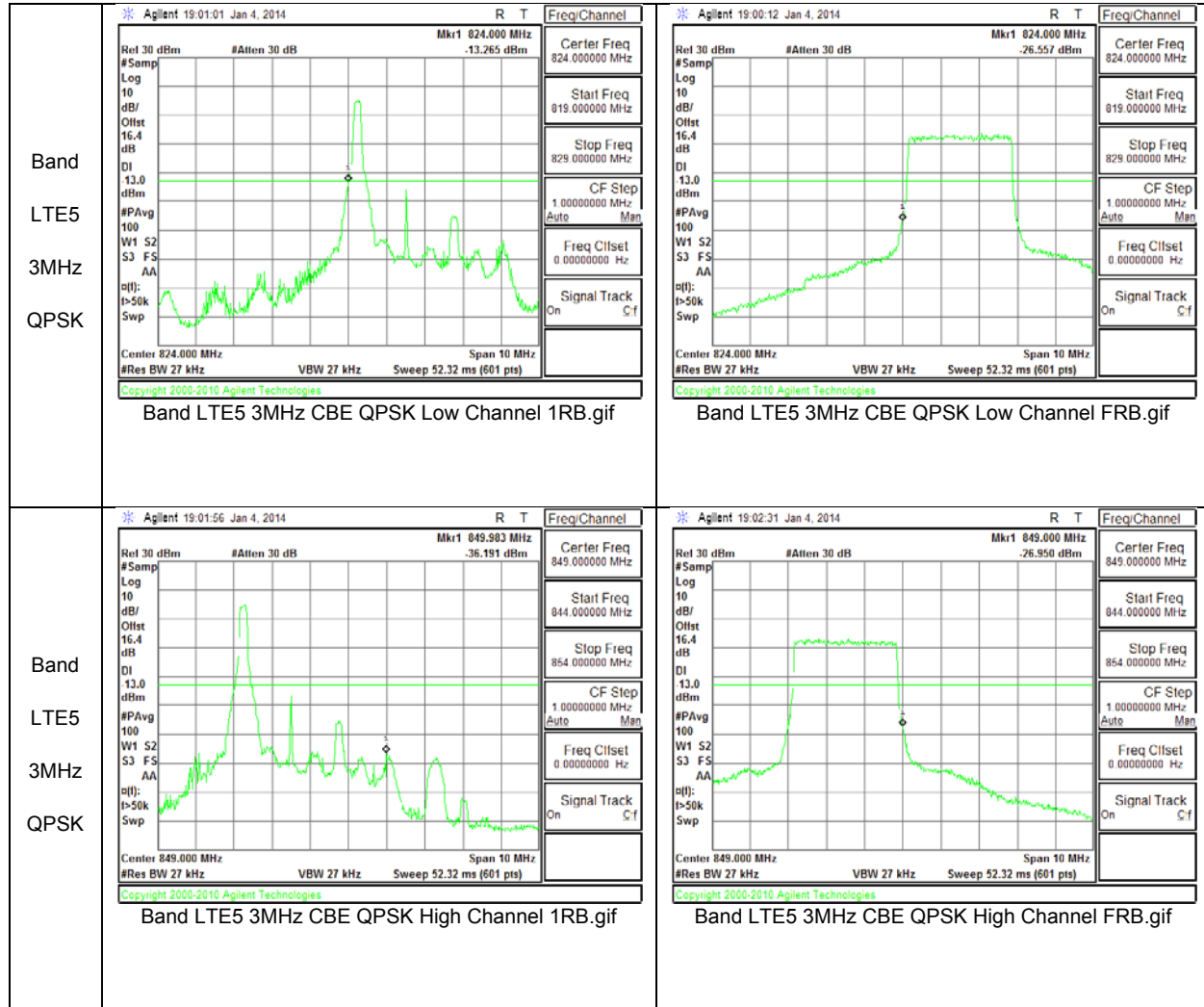

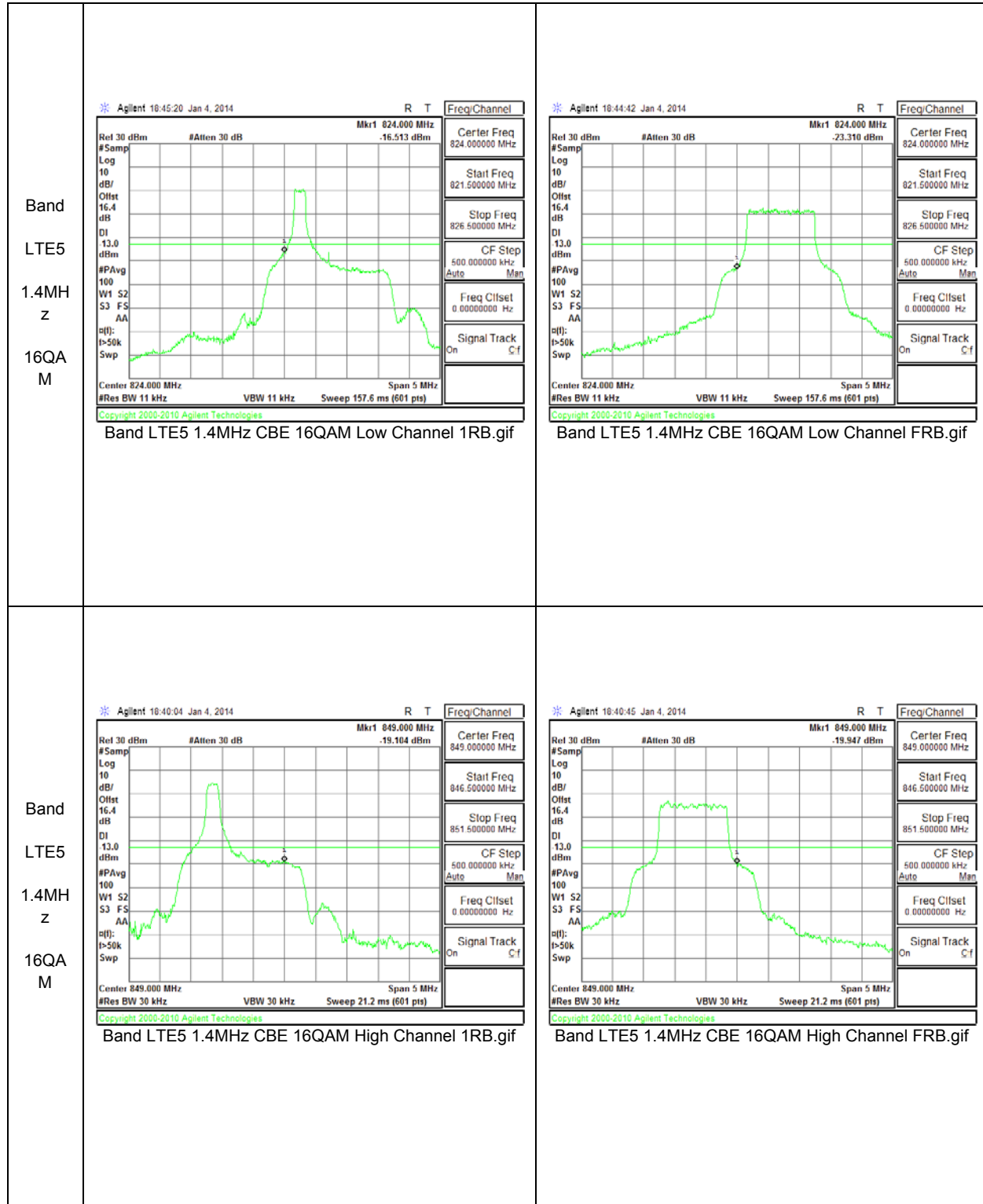

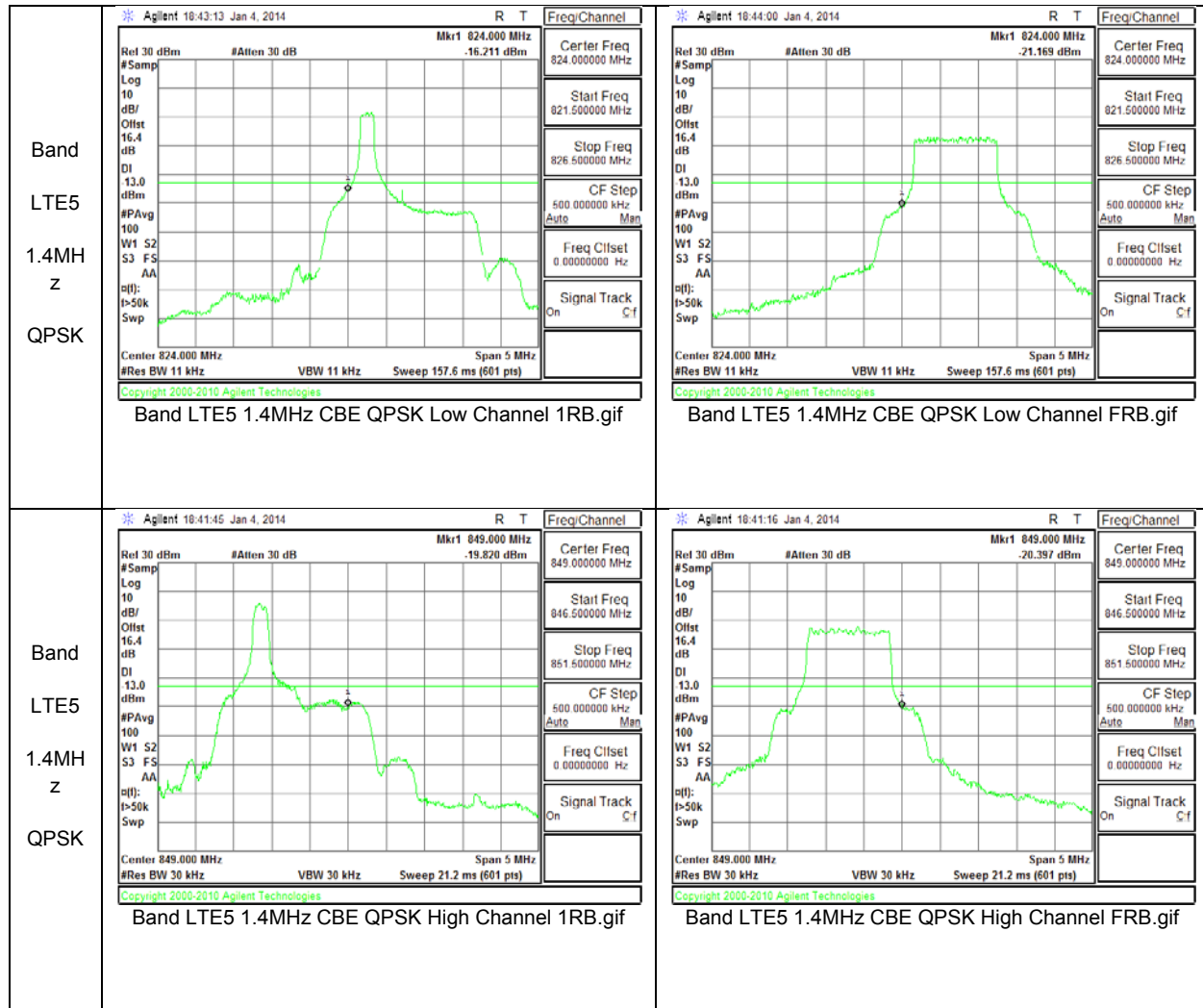

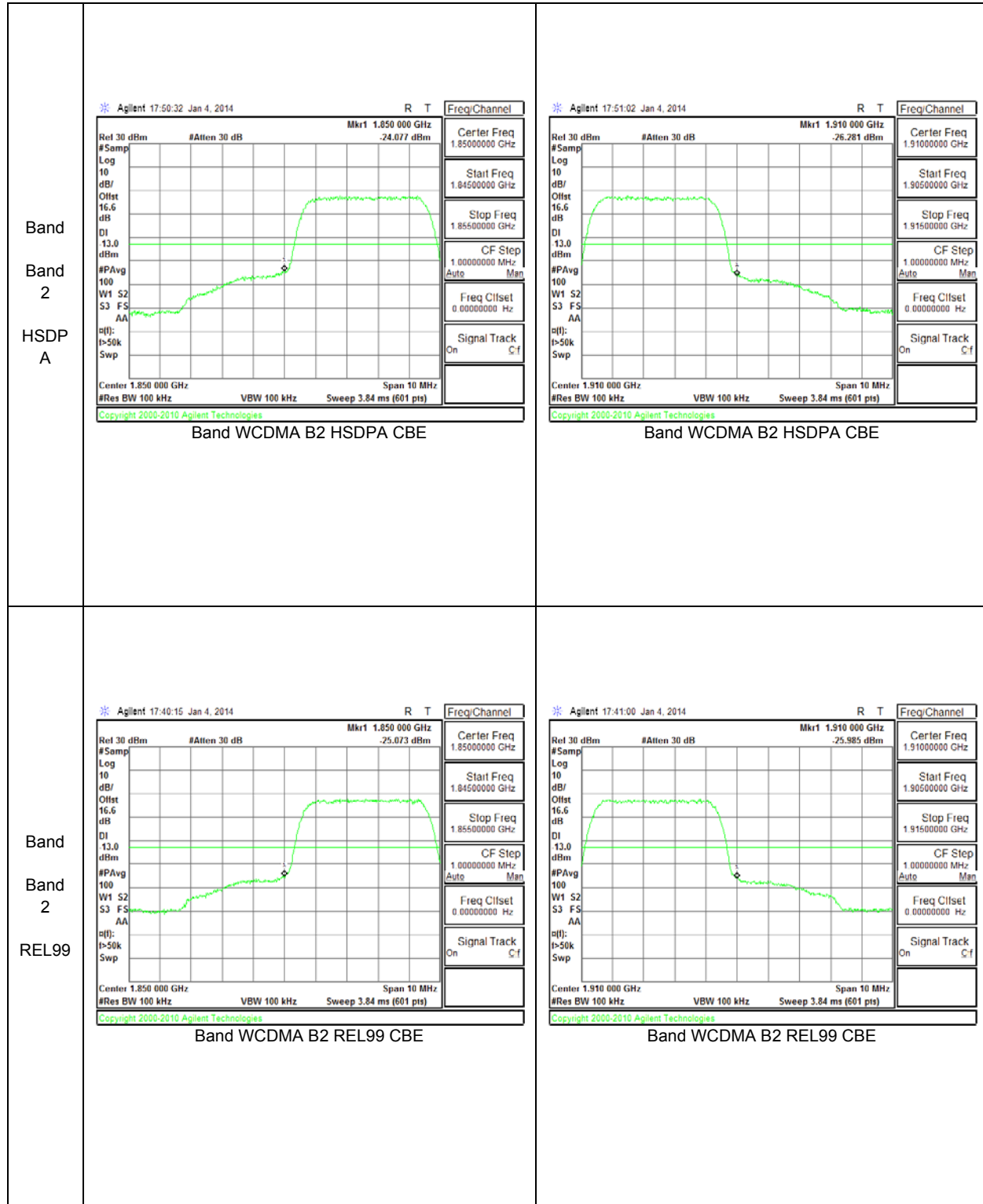

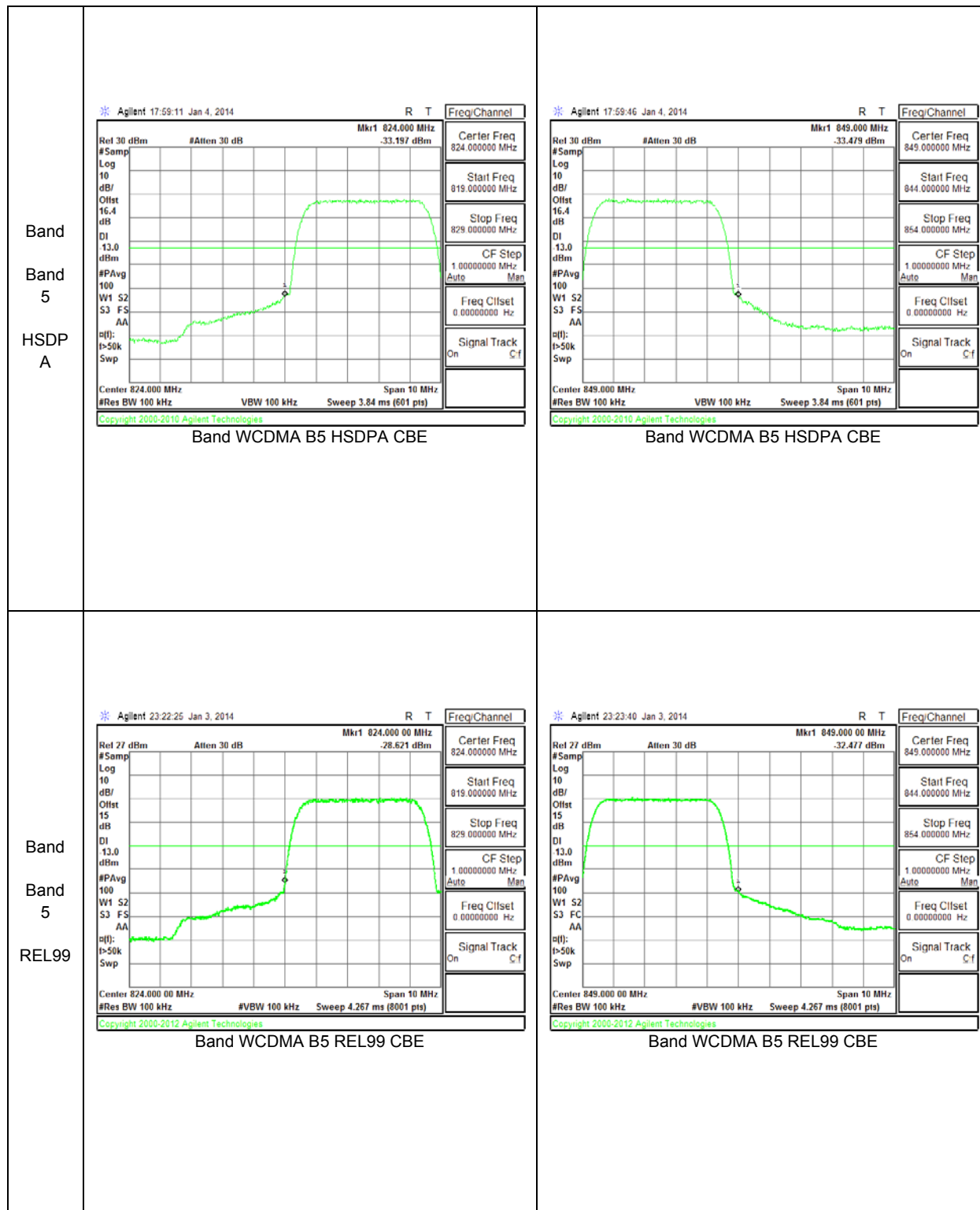

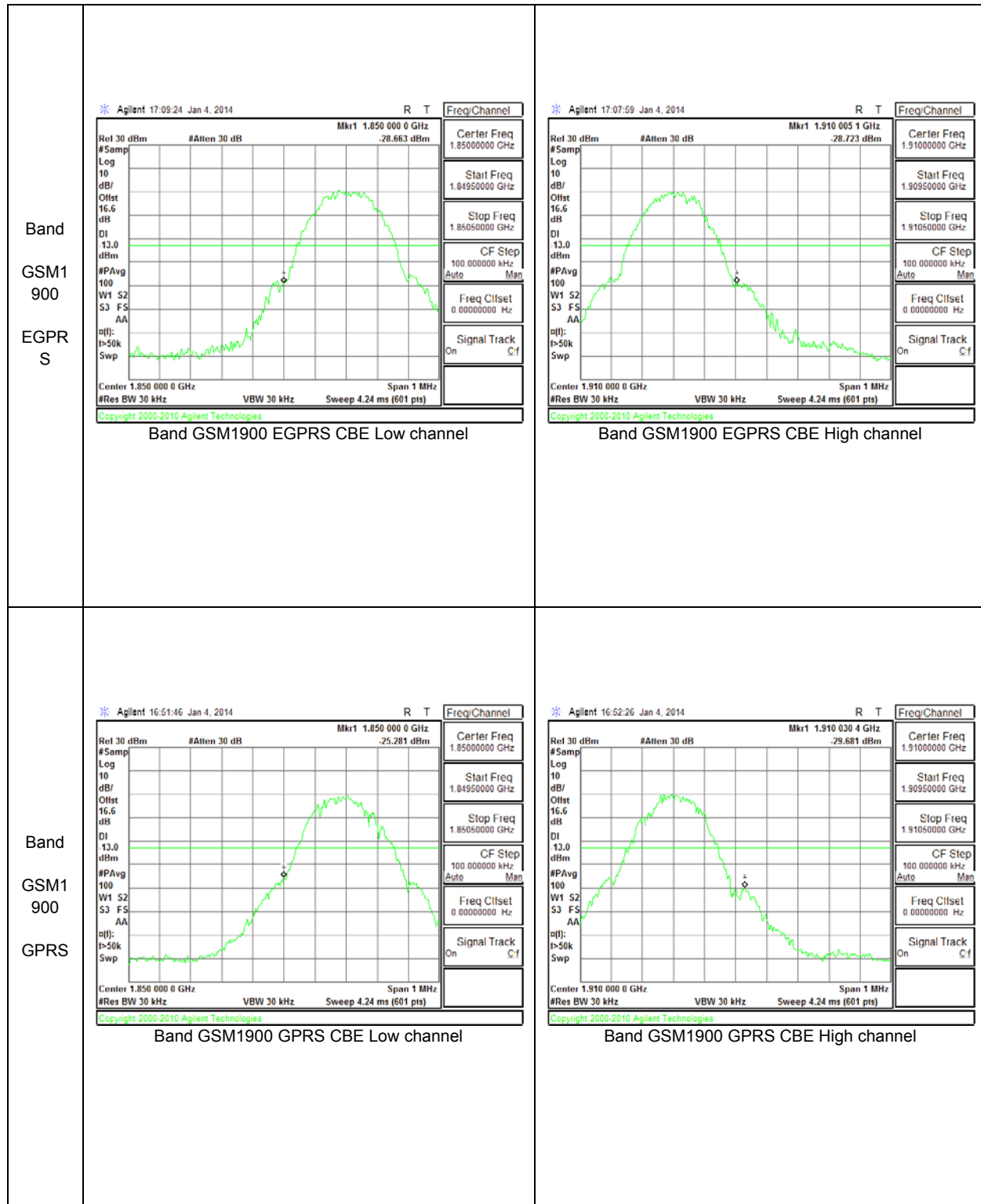

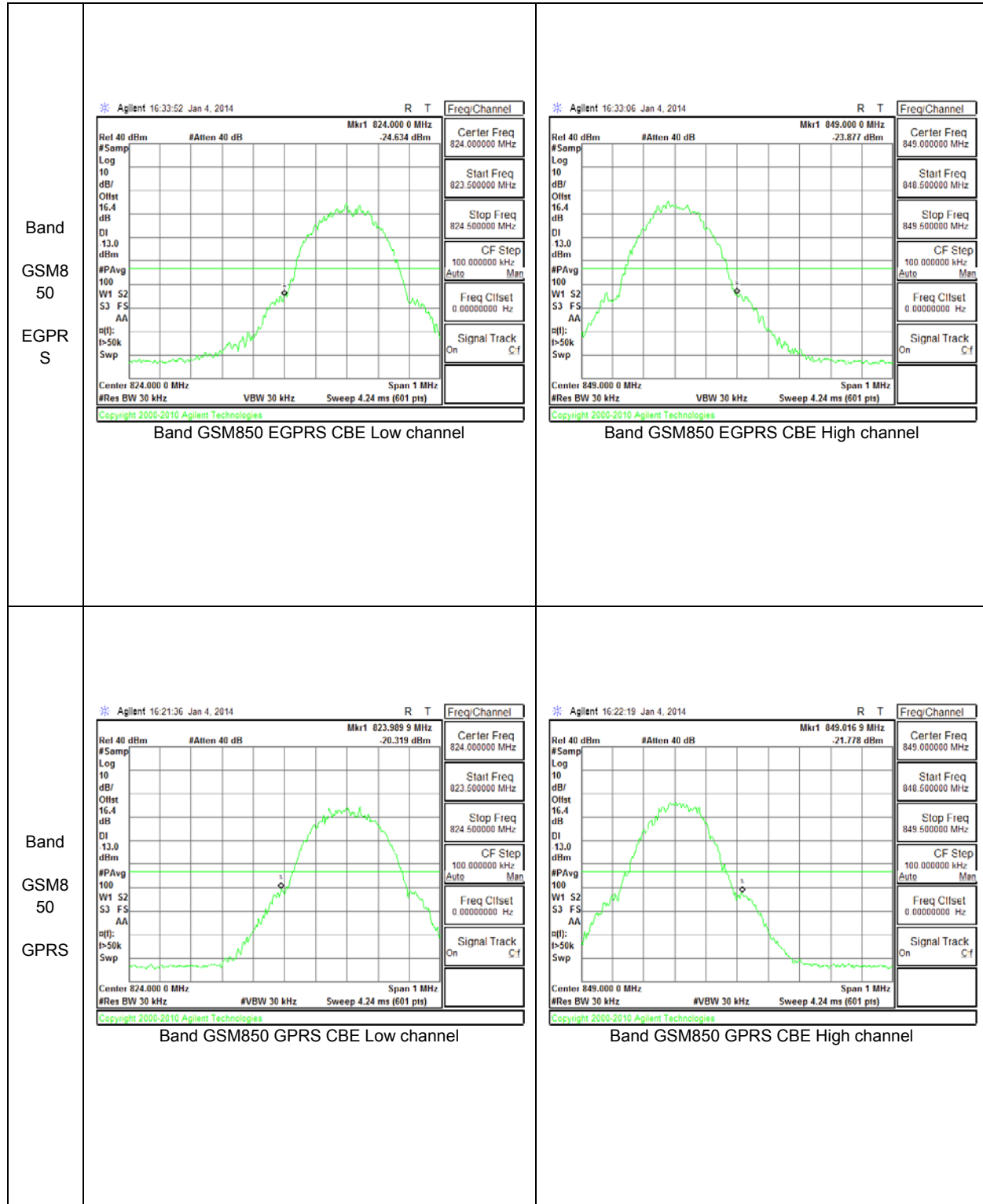

10.3. OUT OF BAND EMISSIONS

RULE PART(S)

FCC: §2.1051, §22.901, §22.917, §24.238

LIMITS

The power of any emission outside of the authorized operating frequency ranges must be attenuated below the transmitting power (P) by a factor of at least $43 + 10 \log (P)$ dB.

TEST PROCEDURE

Per KDB 971168 D01 Power Meas License Digital Systems v02r01

The RF output of the transmitter was connected to a spectrum analyzer through a calibrated coaxial cable. Sufficient scans were taken to show the out-of-band Emissions, if any, up to 10th harmonic. Multiple sweeps were recorded in maximum hold mode using a peak detector to ensure that the worst-case emissions were caught.

For each out of band emissions measurement:

- Set display line at -13 dBm
- Set RBW & VBW to 100 kHz for the measurement below 1 GHz, and 1 MHz for the measurement above 1 GHz.

MODES TESTED

GSM850/1900 & WCDMA B2/B5 & LTE B5

RESULTS

10.3.1. OUT OF BAND EMISSIONS RESULT

Band	BW (MHz)	Mode	f (MHz)	Spur (dBm)	Spec (dBm)	Delta (dB)
LTE5	10	QPSK	829	-29.72	-13	-16.72
			836.5	-29.49	-13	-16.49
			844	-30.53	-13	-17.53
		16QAM	829	-30.21	-13	-17.21
			836.5	-30.23	-13	-17.23
			844	-29.99	-13	-16.99

Band	BW (MHz)	Mode	f (MHz)	Spur (dBm)	Spec (dBm)	Delta (dB)
LTE5	5	QPSK	826.5	-29.93	-13	-16.93
			836.5	-31.12	-13	-18.12
			846.5	-29.25	-13	-16.25
		16QAM	826.5	-30.14	-13	-17.14
			836.5	-29.71	-13	-16.71
			846.5	-30.92	-13	-17.92

Band	BW (MHz)	Mode	f (MHz)	Spur (dBm)	Spec (dBm)	Delta (dB)
LTE5	3	QPSK	825.5	-29.93	-13	-16.93
			836.5	-29.58	-13	-16.58
			847.5	-30.78	-13	-17.78
		16QAM	825.5	-31.57	-13	-18.57
			836.5	-29.75	-13	-16.75
			847.5	-30.29	-13	-17.29

Band	BW (MHz)	Mode	f (MHz)	Spur (dBm)	Spec (dBm)	Delta (dB)
LTE5	1.4	QPSK	824.7	-28.83	-13	-15.83
			836.5	-30.14	-13	-17.14
			848.3	-30.11	-13	-17.11
		16QAM	824.7	-29.91	-13	-16.91
			836.5	-29.80	-13	-16.8
			848.3	-29.76	-13	-16.76

Band	Mode	f (MHz)	Spur (dBm)	Spec (dBm)	Delta (dB)
GSM850	GPRS	824.2	-20.20	-13	-7.2
		836.6	-20.29	-13	-7.29
		848.8	-19.55	-13	-6.55
	EGPRS	824.2	-19.27	-13	-6.27
		836.6	-19.48	-13	-6.48
		848.8	-20.33	-13	-7.33
GSM1900	GPRS	1850.2	-30.57	-13	-17.57
		1880	-30.08	-13	-17.08
		1909.8	-29.38	-13	-16.38
	EGPRS	1850.2	-28.94	-13	-15.94
		1880	-30.24	-13	-17.24
		1909.8	-29.68	-13	-16.68
Band 5	REL99	826.6	-37.79	-13	-24.79
		836.6	-42.94	-13	-29.94
		846.4	-38.76	-13	-25.76
	HSDPA	826.6	-30.40	-13	-17.4
		836.6	-29.98	-13	-16.98
		846.4	-30.51	-13	-17.51
Band 2	REL99	1852.6	-30.25	-13	-17.25
		1880	-30.75	-13	-17.75
		1907.4	-29.81	-13	-16.81
	HSDPA	1852.6	-30.56	-13	-17.56
		1880	-30.41	-13	-17.41
		1907.4	-29.86	-13	-16.86

10.3.2. OUT OF BAND EMISSIONS PLOTS

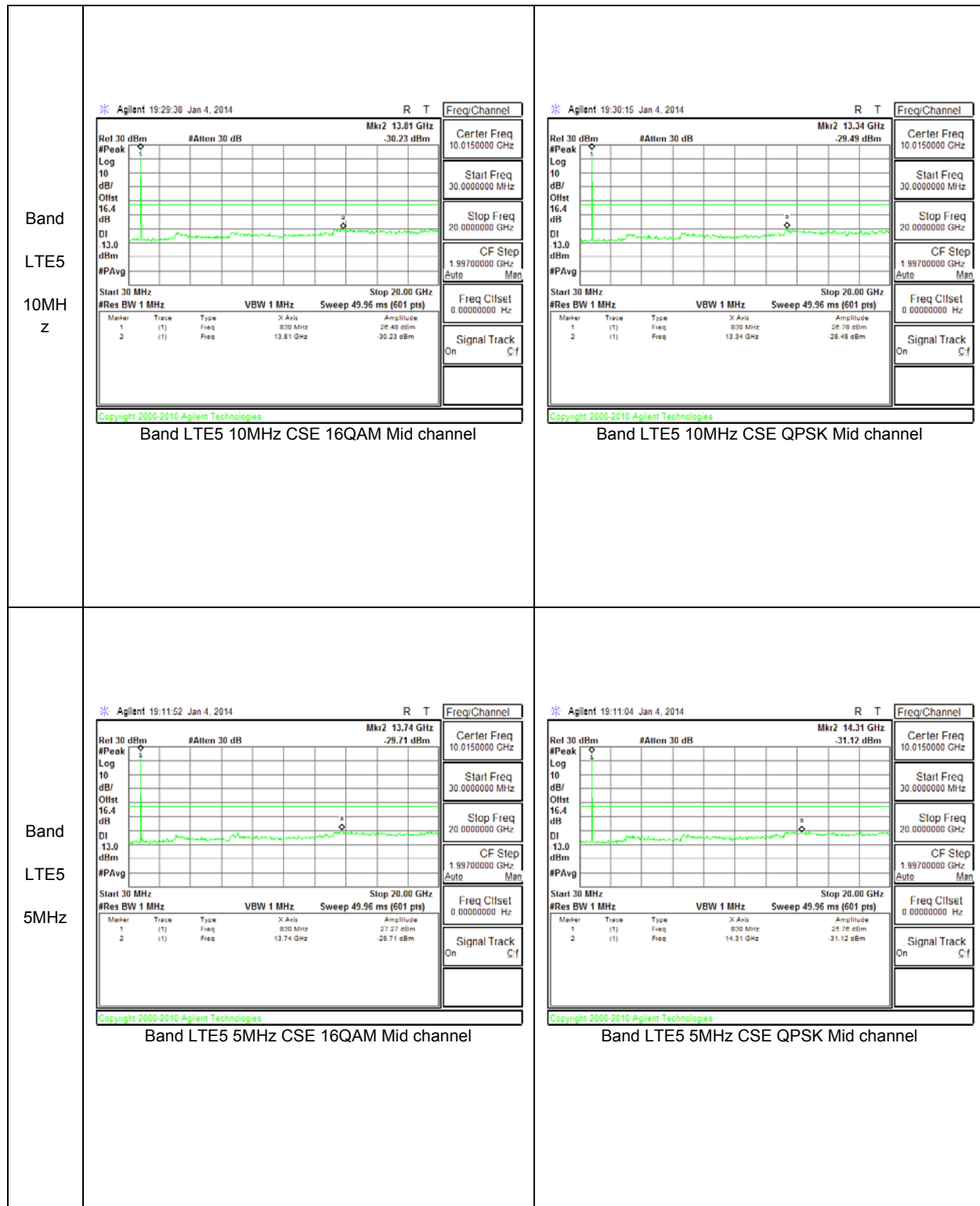

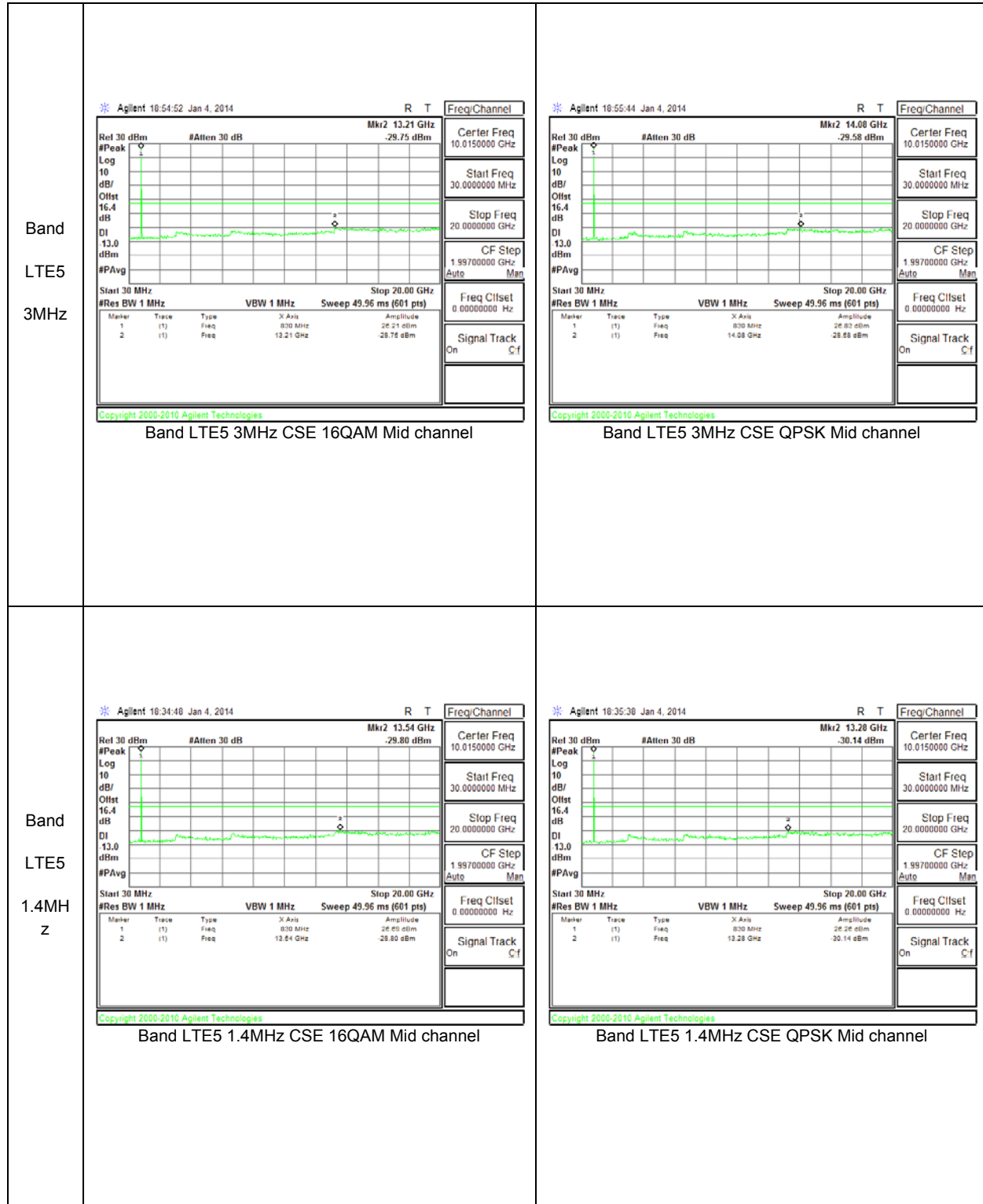

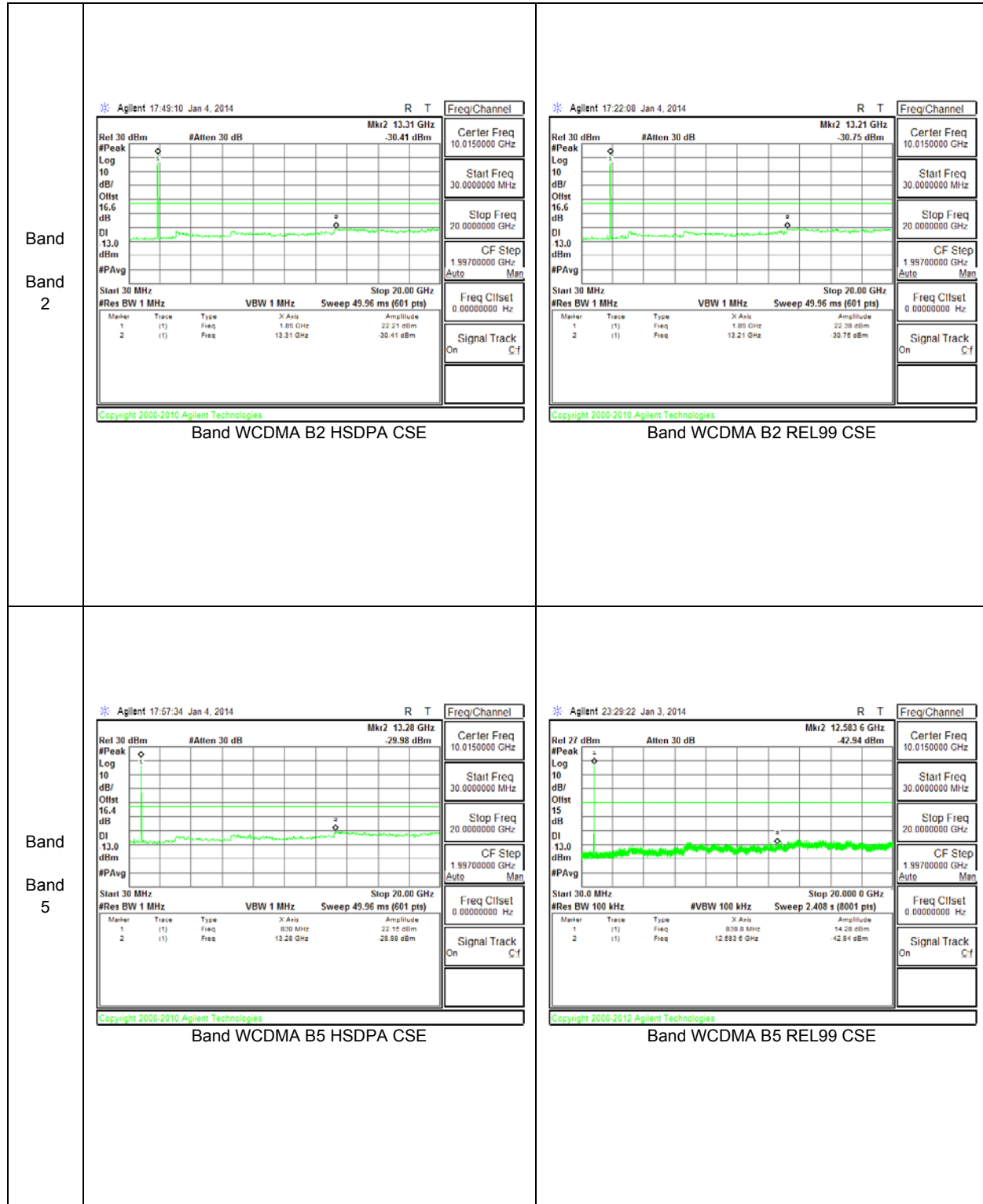

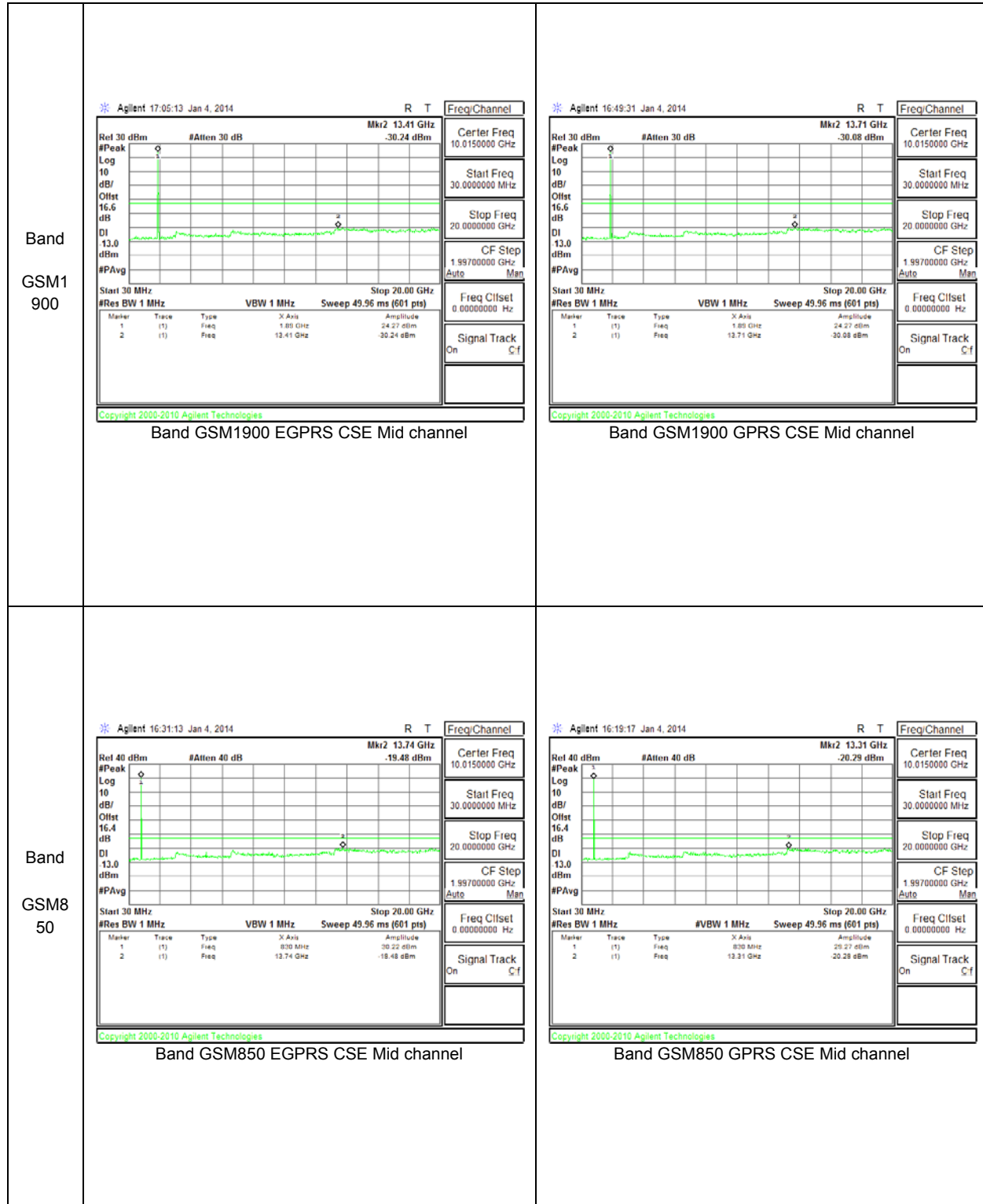

10.4. FREQUENCY STABILITY

RULE PART(S)

FCC: §2.1055, §22.355, §24.235

LIMITS

§22.355 - The carrier frequency shall not depart from the reference frequency in excess of ± 2.5 ppm for mobile stations.

§24.235 - The frequency stability shall be sufficient to ensure that the fundamental emission stays within the authorized frequency block.

TEST PROCEDURE

Per KDB 971168 D01 Power Meas License Digital Systems v02r01

Frequency Stability vs Temperature:

The EUT is placed inside a temperature chamber. The temperature is set to 20°C and allowed to stabilize. After sufficient soak time, the transmitting frequency error is measured. The temperature is increased by 10 degrees, allowed to stabilize and soak, and then the measurement is repeated. This is repeated until +50°C is reached. Reference power supply voltage for these tests is 3.7Vdc.

Frequency Stability vs Voltage:

The peak frequency error is recorded (worst-case). The test voltage ranges from 3.50 to 4.26 VDC.

MODES TESTED

GSM850/1900 & LTE B5

RESULTS

See the following pages.

10.4.1. FREQUENCY STABILITY RESULTS

CELL BAND, MID CHANNEL, Frequency 836.6MHz

Reference Frequency: Cell Mid Channel 836.6 MHz @ 20°C				
Limit: +- 2.5 ppm = 2091.500 Hz				
Power Supply (Vdc)	Environment Temperature (°C)	Frequency Deviation Measured with Time Elapse		
		(MHz)	Delta (ppm)	Limit (ppm)
3.70	50	836.600002	0.005	2.5
3.70	40	836.600003	0.004	2.5
3.70	30	836.600006	0.000	2.5
3.70	20	836.600006	0	2.5
3.70	10	836.600011	-0.006	2.5
3.70	0	836.600001	0.006	2.5
3.70	-10	836.600009	-0.004	2.5
3.70	-20	836.600012	-0.007	2.5
3.70	-30	836.600003	0.004	2.5

Reference Frequency: Cell Mid Channel 836.6 MHz @ 20°C				
Limit: +- 2.5 ppm = 2091.500 Hz				
Power Supply (Vdc)	Environment Temperature (°C)	Frequency Deviation Measured with Time Elapse		
		(MHz)	Delta (ppm)	Limit (ppm)
3.70	20	836.600007	0.00000	2.5
4.20	20	836.600002	0.00598	2.5
3.20	20	836.600012	-0.00598	2.5

PCS Band, MID CHANNEL Freq: 1880MHz

Reference Frequency: PCS Mid Channel 1880MHz @ 20°C				
Limit: to stay +- 2.5 ppm = 4700.000 Hz				
Power Supply (Vdc)	Environment Temperature (°C)	Frequency Deviation Measured with Time Elapse		
		(MHz)	Delta (ppm)	Limit (ppm)
3.70	50	1880.000016	0.008	2.5
3.70	40	1880.000019	0.006	2.5
3.70	30	1880.000022	0.005	2.5
3.70	20	1880.000031	0	2.5
3.70	10	1880.00004	-0.005	2.5
3.70	0	1880.000033	-0.001	2.5
3.70	-10	1880.000041	-0.005	2.5
3.70	-20	1880.000052	-0.011	2.5
3.70	-30	1880.000035	-0.002	2.5

Reference Frequency: PCS Mid Channel 1880 MHz @ 20°C				
Limit: to stay +- 2.5 ppm = 4700.000 Hz				
Power Supply (Vdc)	Environment Temperature (°C)	Frequency Deviation Measured with Time Elapse		
		(MHz)	Delta (ppm)	Limit (ppm)
3.70	20	1880.000028	0	2.5
4.20	20	1880.000017	0.006	2.5
3.20	20	1880.000047	-0.010	2.5

LTE 5, Channel 20524, Freq: 836.5MHz – MID CHANNEL

Reference Frequency: Cell Mid Channel 836.5 MHz @ 20°C				
Limit: +/- 2.5 ppm = 2091.250 Hz				
Power Supply (Vdc)	Environment Temperature (*C)	Frequency Deviation Measured with Time Elapse		
		(MHz)	Delta (ppm)	Limit (ppm)
3.70	50	836.500010	-0.002	2.5
3.70	40	836.500009	-0.001	2.5
3.70	30	836.500009	-0.001	2.5
3.70	20	836.500008	0	2.5
3.70	10	836.500009	-0.001	2.5
3.70	0	836.500008	0.000	2.5
3.70	-10	836.500010	-0.002	2.5
3.70	-20	836.500010	-0.002	2.5
3.70	-30	836.500012	-0.005	2.5

Reference Frequency: PCS Mid Channel 1880 MHz @ 20°C				
Limit: +/- 2.5 ppm = 4700.000 Hz				
Power Supply (Vdc)	Environment Temperature (*C)	Frequency Deviation Measured with Time Elapse		
		(MHz)	Delta (ppm)	Limit (ppm)
3.70	20	836.500008	0.00000	2.5
4.20	20	836.500010	-0.00106	2.5
3.20	20	836.500008	0.00000	2.5

11. RADIATED TEST RESULTS

11.1. RADIATED POWER (ERP & EIRP)

RULE PART(S)

FCC: §2.1046, §22.913, §24.232

LIMITS

22.913(a) - The ERP of mobile transmitters and auxiliary test transmitters must not exceed 7 Watts.

24.232(c) - Mobile/portable stations are limited to 2 watts e.i.r.p. peak power and the equipment must employ means to limit the power to the minimum necessary for successful communications.

In addition, when the transmitter power is measured in terms of average value, the peak-to-average ratio of the power shall not exceed 13dB.

TEST PROCEDURE

ANSI / TIA / EIA 603C Clause 2.2.17

MODES TESTED

GSM850/1900 & WCDMA B2/B5 & LTE B5

TEST RESULTS

11.1.1. ERP/EIRP Results

Band	Mode	Channel	f(MHz)	EIRP	
				dBm	mW
Band 2	REL99	9275	1852.6	19.33	85.7
		9400	1880	20.42	110.15
		9525	1907.4	20.68	116.9
	HSDPA	9275	1852.6	19.03	79.98
		9400	1880	19.90	97.72
		9525	1907.4	19.10	81.25

Band	Mode	Channel	f(MHz)	ERP	
				dBm	mW
Band 5	REL99	4145	826.6	20.54	113.2
		4183	836.6	20.27	106.4
		4220	846.4	19.11	81.5
	HSDPA	4145	826.6	20.50	112.2
		4183	836.6	20.56	113.8
		4220	846.4	19.11	81.5

Band	Mode	Channel	f(MHz)	EIRP	
				dBm	mW
GSM1900	GPRS	512	1850.2	28.22	663.74
		661	1880	28.08	642.69
		810	1909.8	27.86	610.66
	EGPRS	512	1850.2	25.66	368.13
		661	1880	25.64	366.44
		810	1909.8	24.83	303.95

Band	Mode	Channel	f(MHz)	ERP	
				dBm	mW
GSM850	GPRS	128	824.2	28.25	668.3
		190	836.6	28.44	698.2
		251	848.8	27.51	563.6
	EGPRS	128	824.2	23.71	235.0
		190	836.6	25.00	316.2
		251	848.8	22.59	181.6

11.1.2. LTE ERP/EIRP Results

Band	BW (MHz)	Mode	RB/RB Size	f (MHz)	ERP / EIRP	
					dBm	mW
LTE5	10	QPSK	1/0	829	19.90	97.75
			1/0	836.5	20.70	117.52
			1/0	844	20.00	100.02
		16QAM	1/0	829	18.70	74.15
			1/0	836.5	19.70	93.35
			1/0	844	18.90	77.64

Band	BW (MHz)	Mode	RB/RB Size	f (MHz)	ERP / EIRP	
					dBm	mW
LTE5	5	QPSK	1/0	826.5	20.55	113.53
			1/0	836.5	21.48	140.64
			1/0	846.5	20.23	105.46
		16QAM	1/0	826.5	19.60	91.22
			1/0	836.5	20.50	112.23
			1/0	846.5	19.10	81.3

Band	BW (MHz)	Mode	RB/RB Size	f (MHz)	ERP / EIRP	
					dBm	mW
LTE5	3	QPSK	1/0	825.5	19.60	91.22
			1/0	836.5	20.30	107.18
			1/0	847.5	19.25	84.16
		16QAM	1/0	825.5	18.40	69.2
			1/0	836.5	19.60	91.22
			1/0	847.5	18.50	70.81

Band	BW (MHz)	Mode	RB/RB Size	f (MHz)	ERP / EIRP	
					dBm	mW
LTE5	1.4	QPSK	1/0	824.7	19.10	81.3
			1/0	836.5	19.91	97.97
			1/0	848.3	19.30	85.13
		16QAM	1/0	824.7	18.30	67.62
			1/0	836.5	18.70	74.15
			1/0	848.3	18.50	70.81

11.1.3. ERP/EIRP PLOTS

Band LTE5 10MHz z 16QAM	High Frequency Substitution Measurement Compliance Certification Services Chamber C																																																																																																
	Company:		SAMSUNG																																																																																														
	Project #:		13U16698																																																																																														
	Date:		01/04/14																																																																																														
	Test Engineer:		Kiya Kedida																																																																																														
	Configuration:		EUT Only																																																																																														
	Mode:		LTE Band 5_10MHz_ 16QAM																																																																																														
	Test Equipment:																																																																																																
	Receiving: Sunol T345, and 3m Chamber N-type Cable (Setup this one for testing EUT)																																																																																																
	Substitution: Dipole S/N: 00022117, 4ft SMA Cable (SN # 245200 001) Warehouse.																																																																																																
<table border="1"> <thead> <tr> <th>f MHz</th> <th>SG reading (dBm)</th> <th>Ant. Pol. (H/V)</th> <th>Cable Loss (dB)</th> <th>Antenna Gain (dBd)</th> <th>ERP (dBm)</th> <th>Limit (dBm)</th> <th>Margin (dB)</th> <th>Notes</th> </tr> </thead> <tbody> <tr> <td colspan="9">Low Ch</td> </tr> <tr> <td>829.00</td> <td>11.40</td> <td>V</td> <td>0.5</td> <td>0.0</td> <td>10.90</td> <td>38.5</td> <td>-27.5</td> <td></td> </tr> <tr> <td>829.00</td> <td>19.20</td> <td>H</td> <td>0.5</td> <td>0.0</td> <td>18.70</td> <td>38.5</td> <td>-19.7</td> <td></td> </tr> <tr> <td colspan="9">Mid Ch</td> </tr> <tr> <td>836.50</td> <td>12.00</td> <td>V</td> <td>0.5</td> <td>0.0</td> <td>11.50</td> <td>38.5</td> <td>-26.9</td> <td></td> </tr> <tr> <td>836.50</td> <td>20.20</td> <td>H</td> <td>0.5</td> <td>0.0</td> <td>19.70</td> <td>38.5</td> <td>-18.7</td> <td></td> </tr> <tr> <td colspan="9">High Ch</td> </tr> <tr> <td>844.00</td> <td>12.40</td> <td>V</td> <td>0.5</td> <td>0.0</td> <td>11.90</td> <td>38.5</td> <td>-26.5</td> <td></td> </tr> <tr> <td>844.00</td> <td>19.40</td> <td>H</td> <td>0.5</td> <td>0.0</td> <td>18.90</td> <td>38.5</td> <td>-19.5</td> <td></td> </tr> </tbody> </table>								f MHz	SG reading (dBm)	Ant. Pol. (H/V)	Cable Loss (dB)	Antenna Gain (dBd)	ERP (dBm)	Limit (dBm)	Margin (dB)	Notes	Low Ch									829.00	11.40	V	0.5	0.0	10.90	38.5	-27.5		829.00	19.20	H	0.5	0.0	18.70	38.5	-19.7		Mid Ch									836.50	12.00	V	0.5	0.0	11.50	38.5	-26.9		836.50	20.20	H	0.5	0.0	19.70	38.5	-18.7		High Ch									844.00	12.40	V	0.5	0.0	11.90	38.5	-26.5		844.00	19.40	H	0.5	0.0	18.90	38.5	-19.5	
f MHz	SG reading (dBm)	Ant. Pol. (H/V)	Cable Loss (dB)	Antenna Gain (dBd)	ERP (dBm)	Limit (dBm)	Margin (dB)	Notes																																																																																									
Low Ch																																																																																																	
829.00	11.40	V	0.5	0.0	10.90	38.5	-27.5																																																																																										
829.00	19.20	H	0.5	0.0	18.70	38.5	-19.7																																																																																										
Mid Ch																																																																																																	
836.50	12.00	V	0.5	0.0	11.50	38.5	-26.9																																																																																										
836.50	20.20	H	0.5	0.0	19.70	38.5	-18.7																																																																																										
High Ch																																																																																																	
844.00	12.40	V	0.5	0.0	11.90	38.5	-26.5																																																																																										
844.00	19.40	H	0.5	0.0	18.90	38.5	-19.5																																																																																										
Rev. 3.17.11																																																																																																	

Band LTE5 10MHz z QPSK	High Frequency Substitution Measurement Compliance Certification Services Chamber C																																																																																																
	Company:		SAMSUNG																																																																																														
	Project #:		13U16698																																																																																														
	Date:		01/04/14																																																																																														
	Test Engineer:		Kiya Kedida																																																																																														
	Configuration:		EUT Only																																																																																														
	Mode:		LTE Band 5_10MHz_QPSK																																																																																														
	Test Equipment:																																																																																																
	Receiving: Sunol T345, and 3m Chamber N-type Cable (Setup this one for testing EUT)																																																																																																
	Substitution: Dipole S/N: 00022117, 4ft SMA Cable (SN # 245200 001) Warehouse.																																																																																																
<table border="1"> <thead> <tr> <th>f MHz</th> <th>SG reading (dBm)</th> <th>Ant. Pol. (H/V)</th> <th>Cable Loss (dB)</th> <th>Antenna Gain (dBd)</th> <th>ERP (dBm)</th> <th>Limit (dBm)</th> <th>Margin (dB)</th> <th>Notes</th> </tr> </thead> <tbody> <tr> <td colspan="9">Low Ch</td> </tr> <tr> <td>829.00</td> <td>12.29</td> <td>V</td> <td>0.5</td> <td>0.0</td> <td>11.79</td> <td>38.5</td> <td>-26.7</td> <td></td> </tr> <tr> <td>829.00</td> <td>20.40</td> <td>H</td> <td>0.5</td> <td>0.0</td> <td>19.90</td> <td>38.5</td> <td>-18.5</td> <td></td> </tr> <tr> <td colspan="9">Mid Ch</td> </tr> <tr> <td>836.50</td> <td>13.20</td> <td>V</td> <td>0.5</td> <td>0.0</td> <td>12.70</td> <td>38.5</td> <td>-25.7</td> <td></td> </tr> <tr> <td>836.50</td> <td>21.20</td> <td>H</td> <td>0.5</td> <td>0.0</td> <td>20.70</td> <td>38.5</td> <td>-17.7</td> <td></td> </tr> <tr> <td colspan="9">High Ch</td> </tr> <tr> <td>844.00</td> <td>13.30</td> <td>V</td> <td>0.5</td> <td>0.0</td> <td>12.80</td> <td>38.5</td> <td>-25.6</td> <td></td> </tr> <tr> <td>844.00</td> <td>20.50</td> <td>H</td> <td>0.5</td> <td>0.0</td> <td>20.00</td> <td>38.5</td> <td>-18.4</td> <td></td> </tr> </tbody> </table>								f MHz	SG reading (dBm)	Ant. Pol. (H/V)	Cable Loss (dB)	Antenna Gain (dBd)	ERP (dBm)	Limit (dBm)	Margin (dB)	Notes	Low Ch									829.00	12.29	V	0.5	0.0	11.79	38.5	-26.7		829.00	20.40	H	0.5	0.0	19.90	38.5	-18.5		Mid Ch									836.50	13.20	V	0.5	0.0	12.70	38.5	-25.7		836.50	21.20	H	0.5	0.0	20.70	38.5	-17.7		High Ch									844.00	13.30	V	0.5	0.0	12.80	38.5	-25.6		844.00	20.50	H	0.5	0.0	20.00	38.5	-18.4	
f MHz	SG reading (dBm)	Ant. Pol. (H/V)	Cable Loss (dB)	Antenna Gain (dBd)	ERP (dBm)	Limit (dBm)	Margin (dB)	Notes																																																																																									
Low Ch																																																																																																	
829.00	12.29	V	0.5	0.0	11.79	38.5	-26.7																																																																																										
829.00	20.40	H	0.5	0.0	19.90	38.5	-18.5																																																																																										
Mid Ch																																																																																																	
836.50	13.20	V	0.5	0.0	12.70	38.5	-25.7																																																																																										
836.50	21.20	H	0.5	0.0	20.70	38.5	-17.7																																																																																										
High Ch																																																																																																	
844.00	13.30	V	0.5	0.0	12.80	38.5	-25.6																																																																																										
844.00	20.50	H	0.5	0.0	20.00	38.5	-18.4																																																																																										
Rev. 3.17.11																																																																																																	

Band
 LTE5
 5MHz
 16QAM

**High Frequency Substitution Measurement
 Compliance Certification Services Chamber C**

Company: SAMSUNG
Project #: 13U16698
Date: 01/04/14
Test Engineer: Kiya Kedida
Configuration: EUT Only
Mode: LTE Band 5_5MHz_ 16QAM

Test Equipment:

Receiving: Sunol T345, and 3m Chamber N-type Cable (Setup this one for testing EUT)
Substitution: Dipole S/N: 00022117, 4ft SMA Cable (SN # 245200 001) Warehouse.

f MHz	SG reading (dBm)	Ant. Pol. (H/V)	Cable Loss (dB)	Antenna Gain (dBd)	ERP (dBm)	Limit (dBm)	Margin (dB)	Notes
Low Ch								
826.50	11.30	V	0.5	0.0	10.80	38.5	-27.6	
826.50	20.10	H	0.5	0.0	19.60	38.5	-18.8	
Mid Ch								
836.50	11.70	V	0.5	0.0	11.20	38.5	-27.2	
836.50	21.00	H	0.5	0.0	20.50	38.5	-17.9	
High Ch								
846.50	11.60	V	0.5	0.0	11.10	38.5	-27.3	
846.50	19.60	H	0.5	0.0	19.10	38.5	-19.3	

Rev. 3.17.11

Band LTE5 5MHz QPSK	High Frequency Substitution Measurement Compliance Certification Services Chamber C								
	Company: SAMSUNG Project #: 13U16698 Date: 01/04/14 Test Engineer: Kiya Kedida Configuration: EUT Only Mode: LTE Band 5_5MHz_QPSK,								
	Test Equipment: Receiving: Sunol T345, and 3m Chamber N-type Cable (Setup this one for testing EUT) Substitution: Dipole S/N: 00022117, 4ft SMA Cable (SN # 245200 001) Warehouse.								
	f MHz	SG reading (dBm)	Ant. Pol. (H/V)	Cable Loss (dB)	Antenna Gain (dBd)	ERP (dBm)	Limit (dBm)	Margin (dB)	Notes
	Low Ch								
	826.50	12.49	V	0.5	0.0	11.99	38.5	-26.5	
	826.50	21.05	H	0.5	0.0	20.55	38.5	-17.9	
	Mid Ch								
	836.50	12.62	V	0.5	0.0	12.12	38.5	-26.3	
	836.50	21.98	H	0.5	0.0	21.48	38.5	-17.0	
High Ch									
846.50	12.45	V	0.5	0.0	11.95	38.5	-26.5		
846.50	20.73	H	0.5	0.0	20.23	38.5	-18.2		
Rev. 3.17.11									

Band
 LTE5
 3MHz
 16QAM

**High Frequency Substitution Measurement
 Compliance Certification Services Chamber C**

Company: SAMSUNG
Project #: 13U16698
Date: 01/04/14
Test Engineer: Kiya Kedida
Configuration: EUT Only
Mode: LTE Band 5_3MHz_ 16QAM

Test Equipment:

Receiving: Sunol T345, and 3m Chamber N-type Cable (Setup this one for testing EUT)
Substitution: Dipole S/N: 00022117, 4ft SMA Cable (SN # 245200 001) Warehouse.

f MHz	SG reading (dBm)	Ant. Pol. (H/V)	Cable Loss (dB)	Antenna Gain (dBd)	ERP (dBm)	Limit (dBm)	Margin (dB)	Notes
Low Ch								
825.50	11.30	V	0.5	0.0	10.80	38.5	-27.6	
825.50	18.90	H	0.5	0.0	18.40	38.5	-20.0	
Mid Ch								
836.50	12.10	V	0.5	0.0	11.60	38.5	-26.8	
836.50	20.10	H	0.5	0.0	19.60	38.5	-18.8	
High Ch								
847.50	12.10	V	0.5	0.0	11.60	38.5	-26.8	
847.50	19.00	H	0.5	0.0	18.50	38.5	-19.9	

Rev. 3.17.11

Band LTE5 3MHz QPSK	High Frequency Substitution Measurement Compliance Certification Services Chamber C								
	Company:		SAMSUNG						
	Project #:		13U16698						
	Date:		01/04/14						
	Test Engineer:		Kiya Kedida						
	Configuration:		EUT Only						
	Mode:		LTE Band 5_3MHz_QPSK						
	Test Equipment:								
	Receiving: Sunol T345, and 3m Chamber N-type Cable (Setup this one for testing EUT)								
	Substitution: Dipole S/N: 00022117, 4ft SMA Cable (SN # 245200 001) Warehouse.								
	f MHz	SG reading (dBm)	Ant. Pol. (H/V)	Cable Loss (dB)	Antenna Gain (dBd)	ERP (dBm)	Limit (dBm)	Margin (dB)	Notes
	Low Ch								
	825.50	12.22	V	0.5	0.0	11.72	38.5	-26.7	
	825.50	20.10	H	0.5	0.0	19.60	38.5	-18.8	
	Mid Ch								
	836.50	12.97	V	0.5	0.0	12.47	38.5	-26.0	
	836.50	20.80	H	0.5	0.0	20.30	38.5	-18.1	
	High Ch								
	847.50	12.86	V	0.5	0.0	12.36	38.5	-26.1	
	847.50	19.75	H	0.5	0.0	19.25	38.5	-19.2	
	Rev. 3.17.11								

Band LTE5 1.4MHz z 16QAM M	High Frequency Substitution Measurement Compliance Certification Services Chamber C																																																																																																	
	Company:		SAMSUNG																																																																																															
	Project #:		13U16698																																																																																															
	Date:		01/04/14																																																																																															
	Test Engineer:		Kiya Kedida																																																																																															
	Configuration:		EUT Only																																																																																															
	Mode:		LTE Band 5_1.4MHz_16QAM																																																																																															
	Test Equipment:																																																																																																	
	Receiving: Sunol T185, and 3m Chamber N-type Cable (Setup this one for testing EUT)																																																																																																	
	Substitution: Dipole S/N: 00022117, 4ft SMA Cable (SN # 245200 001) Warehouse.																																																																																																	
<table border="1"> <thead> <tr> <th>f MHz</th> <th>SG reading (dBm)</th> <th>Ant. Pol. (H/V)</th> <th>Cable Loss (dB)</th> <th>Antenna Gain (dBd)</th> <th>ERP (dBm)</th> <th>Limit (dBm)</th> <th>Margin (dB)</th> <th>Notes</th> </tr> </thead> <tbody> <tr> <td colspan="9">Low Ch</td> </tr> <tr> <td>824.70</td> <td>10.60</td> <td>V</td> <td>0.5</td> <td>0.0</td> <td>10.10</td> <td>38.5</td> <td>-28.3</td> <td></td> </tr> <tr> <td>824.70</td> <td>18.80</td> <td>H</td> <td>0.5</td> <td>0.0</td> <td>18.30</td> <td>38.5</td> <td>-20.1</td> <td></td> </tr> <tr> <td colspan="9">Mid Ch</td> </tr> <tr> <td>836.50</td> <td>11.70</td> <td>V</td> <td>0.5</td> <td>0.0</td> <td>11.20</td> <td>38.5</td> <td>-27.2</td> <td></td> </tr> <tr> <td>836.50</td> <td>19.20</td> <td>H</td> <td>0.5</td> <td>0.0</td> <td>18.70</td> <td>38.5</td> <td>-19.7</td> <td></td> </tr> <tr> <td colspan="9">High Ch</td> </tr> <tr> <td>848.30</td> <td>11.70</td> <td>V</td> <td>0.5</td> <td>0.0</td> <td>11.20</td> <td>38.5</td> <td>-27.2</td> <td></td> </tr> <tr> <td>848.30</td> <td>19.00</td> <td>H</td> <td>0.5</td> <td>0.0</td> <td>18.50</td> <td>38.5</td> <td>-19.9</td> <td></td> </tr> </tbody> </table>									f MHz	SG reading (dBm)	Ant. Pol. (H/V)	Cable Loss (dB)	Antenna Gain (dBd)	ERP (dBm)	Limit (dBm)	Margin (dB)	Notes	Low Ch									824.70	10.60	V	0.5	0.0	10.10	38.5	-28.3		824.70	18.80	H	0.5	0.0	18.30	38.5	-20.1		Mid Ch									836.50	11.70	V	0.5	0.0	11.20	38.5	-27.2		836.50	19.20	H	0.5	0.0	18.70	38.5	-19.7		High Ch									848.30	11.70	V	0.5	0.0	11.20	38.5	-27.2		848.30	19.00	H	0.5	0.0	18.50	38.5	-19.9	
f MHz	SG reading (dBm)	Ant. Pol. (H/V)	Cable Loss (dB)	Antenna Gain (dBd)	ERP (dBm)	Limit (dBm)	Margin (dB)	Notes																																																																																										
Low Ch																																																																																																		
824.70	10.60	V	0.5	0.0	10.10	38.5	-28.3																																																																																											
824.70	18.80	H	0.5	0.0	18.30	38.5	-20.1																																																																																											
Mid Ch																																																																																																		
836.50	11.70	V	0.5	0.0	11.20	38.5	-27.2																																																																																											
836.50	19.20	H	0.5	0.0	18.70	38.5	-19.7																																																																																											
High Ch																																																																																																		
848.30	11.70	V	0.5	0.0	11.20	38.5	-27.2																																																																																											
848.30	19.00	H	0.5	0.0	18.50	38.5	-19.9																																																																																											
Rev. 3.17.11																																																																																																		

Band LTE5 1.4MHz z QPSK	High Frequency Substitution Measurement Compliance Certification Services Chamber C																																																																																																
	Company:		SAMSUNG																																																																																														
	Project #:		13U16698																																																																																														
	Date:		01/04/14																																																																																														
	Test Engineer:		Kiya Kedida																																																																																														
	Configuration:		EUT Only																																																																																														
	Mode:		LTE Band 5_1.4MHz_QPSK																																																																																														
	Test Equipment:																																																																																																
	Receiving: Sunol T185, and 3m Chamber N-type Cable (Setup this one for testing EUT)																																																																																																
	Substitution: Dipole S/N: 00022117, 4ft SMA Cable (SN # 245200 001) Warehouse.																																																																																																
<table border="1"> <thead> <tr> <th>f MHz</th> <th>SG reading (dBm)</th> <th>Ant. Pol. (H/V)</th> <th>Cable Loss (dB)</th> <th>Antenna Gain (dBd)</th> <th>ERP (dBm)</th> <th>Limit (dBm)</th> <th>Margin (dB)</th> <th>Notes</th> </tr> </thead> <tbody> <tr> <td colspan="9">Low Ch</td> </tr> <tr> <td>824.70</td> <td>11.28</td> <td>V</td> <td>0.5</td> <td>0.0</td> <td>10.78</td> <td>38.5</td> <td>-27.7</td> <td></td> </tr> <tr> <td>824.70</td> <td>19.60</td> <td>H</td> <td>0.5</td> <td>0.0</td> <td>19.10</td> <td>38.5</td> <td>-19.3</td> <td></td> </tr> <tr> <td colspan="9">Mid Ch</td> </tr> <tr> <td>836.50</td> <td>12.60</td> <td>V</td> <td>0.5</td> <td>0.0</td> <td>12.10</td> <td>38.5</td> <td>-26.3</td> <td></td> </tr> <tr> <td>836.50</td> <td>20.41</td> <td>H</td> <td>0.5</td> <td>0.0</td> <td>19.91</td> <td>38.5</td> <td>-18.5</td> <td></td> </tr> <tr> <td colspan="9">High Ch</td> </tr> <tr> <td>848.30</td> <td>12.56</td> <td>V</td> <td>0.5</td> <td>0.0</td> <td>12.06</td> <td>38.5</td> <td>-26.4</td> <td></td> </tr> <tr> <td>848.30</td> <td>19.80</td> <td>H</td> <td>0.5</td> <td>0.0</td> <td>19.30</td> <td>38.5</td> <td>-19.1</td> <td></td> </tr> </tbody> </table>								f MHz	SG reading (dBm)	Ant. Pol. (H/V)	Cable Loss (dB)	Antenna Gain (dBd)	ERP (dBm)	Limit (dBm)	Margin (dB)	Notes	Low Ch									824.70	11.28	V	0.5	0.0	10.78	38.5	-27.7		824.70	19.60	H	0.5	0.0	19.10	38.5	-19.3		Mid Ch									836.50	12.60	V	0.5	0.0	12.10	38.5	-26.3		836.50	20.41	H	0.5	0.0	19.91	38.5	-18.5		High Ch									848.30	12.56	V	0.5	0.0	12.06	38.5	-26.4		848.30	19.80	H	0.5	0.0	19.30	38.5	-19.1	
f MHz	SG reading (dBm)	Ant. Pol. (H/V)	Cable Loss (dB)	Antenna Gain (dBd)	ERP (dBm)	Limit (dBm)	Margin (dB)	Notes																																																																																									
Low Ch																																																																																																	
824.70	11.28	V	0.5	0.0	10.78	38.5	-27.7																																																																																										
824.70	19.60	H	0.5	0.0	19.10	38.5	-19.3																																																																																										
Mid Ch																																																																																																	
836.50	12.60	V	0.5	0.0	12.10	38.5	-26.3																																																																																										
836.50	20.41	H	0.5	0.0	19.91	38.5	-18.5																																																																																										
High Ch																																																																																																	
848.30	12.56	V	0.5	0.0	12.06	38.5	-26.4																																																																																										
848.30	19.80	H	0.5	0.0	19.30	38.5	-19.1																																																																																										
Rev. 3.17.11																																																																																																	

Band 2 HSDP A	High Frequency Fundamental Measurement Compliance Certification Services Chamber C																																																																																																
	Company:		Samsung																																																																																														
	Project #:		13I16698																																																																																														
	Date:		01/04/14																																																																																														
	Test Engineer:		Kiya Kedida																																																																																														
	Configuration:		EUT, x position																																																																																														
	Mode:		WCDMA_HSDPA_1900																																																																																														
	Test Equipment:																																																																																																
	Receiving: Horn T712, and Chamber C SMA Cables																																																																																																
	Substitution: Horn T711 Substitution, 4ft SMA Cable (244639001) Warehouse																																																																																																
<table border="1"> <thead> <tr> <th>f GHz</th> <th>SG reading (dBm)</th> <th>Ant. Pol. (H/V)</th> <th>Cable Loss (dB)</th> <th>Antenna Gain (dBi)</th> <th>EIRP (dBm)</th> <th>Limit (dBm)</th> <th>Delta (dB)</th> <th>Notes</th> </tr> </thead> <tbody> <tr> <td colspan="9">Low Ch</td> </tr> <tr> <td>1.8526</td> <td>9.5</td> <td>V</td> <td>0.85</td> <td>5.58</td> <td>14.25</td> <td>33.0</td> <td>-18.8</td> <td></td> </tr> <tr> <td>1.8526</td> <td>14.3</td> <td>H</td> <td>0.85</td> <td>5.58</td> <td>19.03</td> <td>33.0</td> <td>-14.0</td> <td></td> </tr> <tr> <td colspan="9">Mid Ch</td> </tr> <tr> <td>1.8800</td> <td>9.3</td> <td>V</td> <td>0.85</td> <td>5.60</td> <td>14.01</td> <td>33.0</td> <td>-19.0</td> <td></td> </tr> <tr> <td>1.8800</td> <td>15.2</td> <td>H</td> <td>0.85</td> <td>5.60</td> <td>19.90</td> <td>33.0</td> <td>-13.1</td> <td></td> </tr> <tr> <td colspan="9">High Ch</td> </tr> <tr> <td>1.9074</td> <td>9.3</td> <td>V</td> <td>0.85</td> <td>5.63</td> <td>14.04</td> <td>33.0</td> <td>-19.0</td> <td></td> </tr> <tr> <td>1.9074</td> <td>14.3</td> <td>H</td> <td>0.85</td> <td>5.63</td> <td>19.10</td> <td>33.0</td> <td>-13.9</td> <td></td> </tr> </tbody> </table>								f GHz	SG reading (dBm)	Ant. Pol. (H/V)	Cable Loss (dB)	Antenna Gain (dBi)	EIRP (dBm)	Limit (dBm)	Delta (dB)	Notes	Low Ch									1.8526	9.5	V	0.85	5.58	14.25	33.0	-18.8		1.8526	14.3	H	0.85	5.58	19.03	33.0	-14.0		Mid Ch									1.8800	9.3	V	0.85	5.60	14.01	33.0	-19.0		1.8800	15.2	H	0.85	5.60	19.90	33.0	-13.1		High Ch									1.9074	9.3	V	0.85	5.63	14.04	33.0	-19.0		1.9074	14.3	H	0.85	5.63	19.10	33.0	-13.9	
f GHz	SG reading (dBm)	Ant. Pol. (H/V)	Cable Loss (dB)	Antenna Gain (dBi)	EIRP (dBm)	Limit (dBm)	Delta (dB)	Notes																																																																																									
Low Ch																																																																																																	
1.8526	9.5	V	0.85	5.58	14.25	33.0	-18.8																																																																																										
1.8526	14.3	H	0.85	5.58	19.03	33.0	-14.0																																																																																										
Mid Ch																																																																																																	
1.8800	9.3	V	0.85	5.60	14.01	33.0	-19.0																																																																																										
1.8800	15.2	H	0.85	5.60	19.90	33.0	-13.1																																																																																										
High Ch																																																																																																	
1.9074	9.3	V	0.85	5.63	14.04	33.0	-19.0																																																																																										
1.9074	14.3	H	0.85	5.63	19.10	33.0	-13.9																																																																																										
Rev. 3.17.11																																																																																																	

Band Band 2 REL99	High Frequency Fundamental Measurement Compliance Certification Services Chamber C																																																																																																	
	Company: Samsung																																																																																																	
	Project #: 13I16698																																																																																																	
	Date: 01/04/14																																																																																																	
	Test Engineer: Kiya Kedida																																																																																																	
	Configuration: EUT, x position																																																																																																	
	Mode: WCDMA_Rel 99_1900																																																																																																	
	Test Equipment: Receiving: Horn T712, and Chamber C SMA Cables Substitution: Horn T711 Substitution, 4ft SMA Cable (244639001) Warehouse																																																																																																	
	<table border="1"> <thead> <tr> <th>f GHz</th> <th>SG reading (dBm)</th> <th>Ant. Pol. (H/V)</th> <th>Cable Loss (dB)</th> <th>Antenna Gain (dBi)</th> <th>EIRP (dBm)</th> <th>Limit (dBm)</th> <th>Delta (dB)</th> <th>Notes</th> </tr> </thead> <tbody> <tr> <td colspan="9">Low Ch</td> </tr> <tr> <td>1.8526</td> <td>9.7</td> <td>V</td> <td>0.85</td> <td>5.58</td> <td>14.40</td> <td>33.0</td> <td>-18.6</td> <td></td> </tr> <tr> <td>1.8526</td> <td>14.6</td> <td>H</td> <td>0.85</td> <td>5.58</td> <td>19.33</td> <td>33.0</td> <td>-13.7</td> <td></td> </tr> <tr> <td colspan="9">Mid Ch</td> </tr> <tr> <td>1.8800</td> <td>9.9</td> <td>V</td> <td>0.85</td> <td>5.60</td> <td>14.68</td> <td>33.0</td> <td>-18.3</td> <td></td> </tr> <tr> <td>1.8800</td> <td>15.7</td> <td>H</td> <td>0.85</td> <td>5.60</td> <td>20.42</td> <td>33.0</td> <td>-12.6</td> <td></td> </tr> <tr> <td colspan="9">High Ch</td> </tr> <tr> <td>1.9074</td> <td>10.5</td> <td>V</td> <td>0.85</td> <td>5.63</td> <td>15.26</td> <td>33.0</td> <td>-17.7</td> <td></td> </tr> <tr> <td>1.9074</td> <td>15.9</td> <td>H</td> <td>0.85</td> <td>5.63</td> <td>20.68</td> <td>33.0</td> <td>-12.3</td> <td></td> </tr> </tbody> </table>								f GHz	SG reading (dBm)	Ant. Pol. (H/V)	Cable Loss (dB)	Antenna Gain (dBi)	EIRP (dBm)	Limit (dBm)	Delta (dB)	Notes	Low Ch									1.8526	9.7	V	0.85	5.58	14.40	33.0	-18.6		1.8526	14.6	H	0.85	5.58	19.33	33.0	-13.7		Mid Ch									1.8800	9.9	V	0.85	5.60	14.68	33.0	-18.3		1.8800	15.7	H	0.85	5.60	20.42	33.0	-12.6		High Ch									1.9074	10.5	V	0.85	5.63	15.26	33.0	-17.7		1.9074	15.9	H	0.85	5.63	20.68	33.0	-12.3	
	f GHz	SG reading (dBm)	Ant. Pol. (H/V)	Cable Loss (dB)	Antenna Gain (dBi)	EIRP (dBm)	Limit (dBm)	Delta (dB)	Notes																																																																																									
Low Ch																																																																																																		
1.8526	9.7	V	0.85	5.58	14.40	33.0	-18.6																																																																																											
1.8526	14.6	H	0.85	5.58	19.33	33.0	-13.7																																																																																											
Mid Ch																																																																																																		
1.8800	9.9	V	0.85	5.60	14.68	33.0	-18.3																																																																																											
1.8800	15.7	H	0.85	5.60	20.42	33.0	-12.6																																																																																											
High Ch																																																																																																		
1.9074	10.5	V	0.85	5.63	15.26	33.0	-17.7																																																																																											
1.9074	15.9	H	0.85	5.63	20.68	33.0	-12.3																																																																																											
Rev. 3.17.11																																																																																																		

Band
 Band
 5
 HSDP
 A

**High Frequency Substitution Measurement
 Compliance Certification Services Chamber C**

Company: Samsung
Project #: 13U16698
Date: 01/08/14
Test Engineer: Charles Vergonio
Configuration: EUT X Position
Mode: WCDMA
 TX, UMTS HSDPA 850

Test Equipment:

Receiving: Horn T185, and Chamber F SMA Cables
Substitution: Dipole S/N: 00022117, 4ft SMA Cable (SN # 245200 001) Warehouse.

f MHz	SG reading (dBm)	Ant. Pol. (H/V)	Cable Loss (dB)	Antenna Gain (dBd)	ERP (dBm)	Limit (dBm)	Margin (dB)	Notes
Low Ch								
826.40	17.47	V	0.9	0.0	16.57	38.5	-21.9	
826.40	21.40	H	0.9	0.0	20.50	38.5	-17.9	
Mid Ch								
836.60	16.19	V	0.9	0.0	15.29	38.5	-23.2	
836.60	21.46	H	0.9	0.0	20.56	38.5	-17.9	
High Ch								
846.60	16.59	V	0.9	0.0	15.69	38.5	-22.8	
846.60	20.01	H	0.9	0.0	19.11	38.5	-19.3	

Rev. 3.17.11

Band Band 5 REL99	High Frequency Substitution Measurement Compliance Certification Services Chamber C																																																																																																
	Company: Samsung																																																																																																
	Project #: 13U16698																																																																																																
	Date: 01/08/14																																																																																																
	Test Engineer: Charles Vergonio																																																																																																
	Configuration: EUT X Position																																																																																																
	Mode: WCDMA																																																																																																
			TX, UMTS REL 99 850																																																																																														
	Test Equipment: Receiving: Horn T185, and Chamber F SMA Cables Substitution: Dipole S/N: 00022117, 4ft SMA Cable (SN # 245200 001) Warehouse.																																																																																																
	<table border="1"> <thead> <tr> <th>f MHz</th> <th>SG reading (dBm)</th> <th>Ant. Pol. (H/V)</th> <th>Cable Loss (dB)</th> <th>Antenna Gain (dBd)</th> <th>ERP (dBm)</th> <th>Limit (dBm)</th> <th>Margin (dB)</th> <th>Notes</th> </tr> </thead> <tbody> <tr> <td colspan="9">Low Ch</td> </tr> <tr> <td>826.40</td> <td>17.80</td> <td>V</td> <td>0.9</td> <td>0.0</td> <td>16.90</td> <td>38.5</td> <td>-21.5</td> <td></td> </tr> <tr> <td>826.40</td> <td>21.44</td> <td>H</td> <td>0.9</td> <td>0.0</td> <td>20.54</td> <td>38.5</td> <td>-17.9</td> <td></td> </tr> <tr> <td colspan="9">Mid Ch</td> </tr> <tr> <td>836.60</td> <td>15.65</td> <td>V</td> <td>0.9</td> <td>0.0</td> <td>14.75</td> <td>38.5</td> <td>-23.7</td> <td></td> </tr> <tr> <td>836.60</td> <td>21.17</td> <td>H</td> <td>0.9</td> <td>0.0</td> <td>20.27</td> <td>38.5</td> <td>-18.2</td> <td></td> </tr> <tr> <td colspan="9">High Ch</td> </tr> <tr> <td>846.60</td> <td>16.83</td> <td>V</td> <td>0.9</td> <td>0.0</td> <td>15.93</td> <td>38.5</td> <td>-22.5</td> <td></td> </tr> <tr> <td>846.60</td> <td>20.01</td> <td>H</td> <td>0.9</td> <td>0.0</td> <td>19.11</td> <td>38.5</td> <td>-19.3</td> <td></td> </tr> </tbody> </table>								f MHz	SG reading (dBm)	Ant. Pol. (H/V)	Cable Loss (dB)	Antenna Gain (dBd)	ERP (dBm)	Limit (dBm)	Margin (dB)	Notes	Low Ch									826.40	17.80	V	0.9	0.0	16.90	38.5	-21.5		826.40	21.44	H	0.9	0.0	20.54	38.5	-17.9		Mid Ch									836.60	15.65	V	0.9	0.0	14.75	38.5	-23.7		836.60	21.17	H	0.9	0.0	20.27	38.5	-18.2		High Ch									846.60	16.83	V	0.9	0.0	15.93	38.5	-22.5		846.60	20.01	H	0.9	0.0	19.11	38.5	-19.3
f MHz	SG reading (dBm)	Ant. Pol. (H/V)	Cable Loss (dB)	Antenna Gain (dBd)	ERP (dBm)	Limit (dBm)	Margin (dB)	Notes																																																																																									
Low Ch																																																																																																	
826.40	17.80	V	0.9	0.0	16.90	38.5	-21.5																																																																																										
826.40	21.44	H	0.9	0.0	20.54	38.5	-17.9																																																																																										
Mid Ch																																																																																																	
836.60	15.65	V	0.9	0.0	14.75	38.5	-23.7																																																																																										
836.60	21.17	H	0.9	0.0	20.27	38.5	-18.2																																																																																										
High Ch																																																																																																	
846.60	16.83	V	0.9	0.0	15.93	38.5	-22.5																																																																																										
846.60	20.01	H	0.9	0.0	19.11	38.5	-19.3																																																																																										
Rev. 3.17.11																																																																																																	

Band GSM1 900 EGPRS	High Frequency Fundamental Measurement Compliance Certification Services Chamber C								
	Company:		Samsung						
	Project #:		13I16698						
	Date:		01/04/14						
	Test Engineer:		Trina Noor						
	Configuration:		EUT, x position						
	Mode:		EGPRS_1900						
	Test Equipment:								
	Receiving: Horn T712, and Chamber C SMA Cables								
	Substitution: Horn T711 Substitution, 4ft SMA Cable (244639001) Warehouse								
	f	SG reading	Ant. Pol.	Cable Loss	Antenna Gain	EIRP	Limit	Delta	Notes
	GHz	(dBm)	(H/V)	(dB)	(dBi)	(dBm)	(dBm)	(dB)	
	Low Ch								
	1.8502	16.9	V	0.85	5.58	21.66	33.0	-11.3	
	1.8502	20.9	H	0.85	5.58	25.66	33.0	-7.3	
	Mid Ch								
	1.8800	17.6	V	0.85	5.60	22.37	33.0	-10.6	
	1.8800	20.9	H	0.85	5.60	25.64	33.0	-7.4	
	High Ch								
	1.9098	17.2	V	0.85	5.63	22.02	33.0	-11.0	
	1.9098	20.1	H	0.85	5.63	24.83	33.0	-8.2	
	Rev. 3.17.11								

Band GSM1 900 GPRS	High Frequency Fundamental Measurement Compliance Certification Services Chamber C								
	Company:		Samsung						
	Project #:		13I16698						
	Date:		01/04/14						
	Test Engineer:		Trina Noor						
	Configuration:		EUT, x position						
	Mode:		GPRS_1900						
	Test Equipment:								
	Receiving: Horn T712, and Chamber C SMA Cables								
	Substitution: Horn T711 Substitution, 4ft SMA Cable (244639001) Warehouse								
	f GHz	SG reading (dBm)	Ant. Pol. (H/V)	Cable Loss (dB)	Antenna Gain (dBi)	EIRP (dBm)	Limit (dBm)	Delta (dB)	Notes
	Low Ch								
	1.8502	18.9	V	0.85	5.58	23.66	33.0	-9.3	
	1.8502	23.5	H	0.85	5.58	28.22	33.0	-4.8	
	Mid Ch								
	1.8800	19.8	V	0.85	5.60	24.59	33.0	-8.4	
	1.8800	23.3	H	0.85	5.60	28.08	33.0	-4.9	
	High Ch								
	1.9098	17.5	V	0.85	5.63	22.24	33.0	-10.8	
	1.9098	23.1	H	0.85	5.63	27.86	33.0	-5.1	
	Rev. 3.17.11								

Band GSM8 50 EGPR S	High Frequency Substitution Measurement Compliance Certification Services Chamber C																																																																																																
	Company: Samsung																																																																																																
	Project #: 13U16698																																																																																																
	Date: 01/08/14																																																																																																
	Test Engineer: Charles Vergonio																																																																																																
	Configuration: EUT X Position																																																																																																
	Mode: EGRPS 850MHz																																																																																																
	Test Equipment:																																																																																																
	Receiving: Sunol T185, and 3m Chamber N-type Cable (Setup this one for testing EUT)																																																																																																
	Substitution: Dipole S/N: 00022117, 4ft SMA Cable (SN # 245200 001) Warehouse.																																																																																																
<table border="1"> <thead> <tr> <th>f MHz</th> <th>SG reading (dBm)</th> <th>Ant. Pol. (H/V)</th> <th>Cable Loss (dB)</th> <th>Antenna Gain (dBd)</th> <th>ERP (dBm)</th> <th>Limit (dBm)</th> <th>Margin (dB)</th> <th>Notes</th> </tr> </thead> <tbody> <tr> <td colspan="9">Low Ch</td> </tr> <tr> <td>824.20</td> <td>24.34</td> <td>V</td> <td>0.9</td> <td>0.0</td> <td>23.44</td> <td>38.5</td> <td>-15.0</td> <td></td> </tr> <tr> <td>824.20</td> <td>24.61</td> <td>H</td> <td>0.9</td> <td>0.0</td> <td>23.71</td> <td>38.5</td> <td>-14.7</td> <td></td> </tr> <tr> <td colspan="9">Mid Ch</td> </tr> <tr> <td>836.60</td> <td>22.13</td> <td>V</td> <td>0.9</td> <td>0.0</td> <td>21.23</td> <td>38.5</td> <td>-17.2</td> <td></td> </tr> <tr> <td>836.60</td> <td>25.90</td> <td>H</td> <td>0.9</td> <td>0.0</td> <td>25.00</td> <td>38.5</td> <td>-13.4</td> <td></td> </tr> <tr> <td colspan="9">High Ch</td> </tr> <tr> <td>848.80</td> <td>22.24</td> <td>V</td> <td>0.9</td> <td>0.0</td> <td>21.34</td> <td>38.5</td> <td>-17.1</td> <td></td> </tr> <tr> <td>848.80</td> <td>23.49</td> <td>H</td> <td>0.9</td> <td>0.0</td> <td>22.59</td> <td>38.5</td> <td>-15.9</td> <td></td> </tr> </tbody> </table>								f MHz	SG reading (dBm)	Ant. Pol. (H/V)	Cable Loss (dB)	Antenna Gain (dBd)	ERP (dBm)	Limit (dBm)	Margin (dB)	Notes	Low Ch									824.20	24.34	V	0.9	0.0	23.44	38.5	-15.0		824.20	24.61	H	0.9	0.0	23.71	38.5	-14.7		Mid Ch									836.60	22.13	V	0.9	0.0	21.23	38.5	-17.2		836.60	25.90	H	0.9	0.0	25.00	38.5	-13.4		High Ch									848.80	22.24	V	0.9	0.0	21.34	38.5	-17.1		848.80	23.49	H	0.9	0.0	22.59	38.5	-15.9	
f MHz	SG reading (dBm)	Ant. Pol. (H/V)	Cable Loss (dB)	Antenna Gain (dBd)	ERP (dBm)	Limit (dBm)	Margin (dB)	Notes																																																																																									
Low Ch																																																																																																	
824.20	24.34	V	0.9	0.0	23.44	38.5	-15.0																																																																																										
824.20	24.61	H	0.9	0.0	23.71	38.5	-14.7																																																																																										
Mid Ch																																																																																																	
836.60	22.13	V	0.9	0.0	21.23	38.5	-17.2																																																																																										
836.60	25.90	H	0.9	0.0	25.00	38.5	-13.4																																																																																										
High Ch																																																																																																	
848.80	22.24	V	0.9	0.0	21.34	38.5	-17.1																																																																																										
848.80	23.49	H	0.9	0.0	22.59	38.5	-15.9																																																																																										
Rev. 3.17.11																																																																																																	

Band GSM8 50 GPRS	High Frequency Substitution Measurement Compliance Certification Services Chamber C								
	Company:		Samsung						
	Project #:		13U16698						
	Date:		01/08/14						
	Test Engineer:		Charles Vergonio						
	Configuration:		EUT X Position						
	Mode:		GRPS 850MHz						
	Test Equipment:								
	Receiving: Sunol T185, and 3m Chamber N-type Cable (Setup this one for testing EUT)								
	Substitution: Dipole S/N: 00022117, 4ft SMA Cable (SN # 245200 001) Warehouse.								
	f MHz	SG reading (dBm)	Ant. Pol. (H/V)	Cable Loss (dB)	Antenna Gain (dBd)	ERP (dBm)	Limit (dBm)	Margin (dB)	Notes
	Low Ch								
	824.20	29.07	V	0.9	0.0	28.17	38.5	-10.3	
	824.20	29.15	H	0.9	0.0	28.25	38.5	-10.2	
	Mid Ch								
	836.60	27.02	V	0.9	0.0	26.12	38.5	-12.3	
	836.60	29.34	H	0.9	0.0	28.44	38.5	-10.0	
	High Ch								
	848.80	27.29	V	0.9	0.0	26.39	38.5	-12.1	
	848.80	28.41	H	0.9	0.0	27.51	38.5	-10.9	
	Rev. 3.17.11								

11.2. FIELD STRENGTH OF SPURIOUS RADIATION

RULE PART(S)

FCC: §2.1053, §22.917, §24.238

LIMIT

§22.917 (e) and §24.238 (a): Out of band emissions. The power of any emission outside of the authorized operating frequency ranges must be attenuated below the transmitting power (P) by a factor of at least $43 + 10 \log (P)$ dB

TEST PROCEDURE

For Cellular equipment - Compliance with these rules is based on the use of measurement instrumentation employing a resolution bandwidth of 100 kHz or greater. In the 1 MHz bands immediately outside and adjacent to the frequency block a resolution bandwidth of at least one percent of the emission bandwidth of the fundamental emission of the transmitter may be employed. A narrower resolution bandwidth is permitted in all cases to improve measurement accuracy provided the measured power is integrated over the full required measurement bandwidth (i.e. 100 kHz or 1 percent of emission bandwidth, as specified). The emission bandwidth is defined as the width of the signal between two points, one below the carrier center frequency and one above the carrier center frequency, outside of which all emissions are attenuated at least 26 dB below the transmitter power.

For PCS equipment - Compliance with these rules is based on the use of measurement instrumentation employing a resolution bandwidth of 1 MHz or greater. However, in the 1 MHz bands immediately outside and adjacent to the frequency block a resolution bandwidth of at least one percent of the emission bandwidth of the fundamental emission of the transmitter may be employed. A narrower resolution bandwidth is permitted in all cases to improve measurement accuracy provided the measured power is integrated over the full required measurement bandwidth (i.e. 1 MHz or 1 percent of emission bandwidth, as specified). The emission bandwidth is defined as the width of the signal between two points, one below the carrier center frequency and one above the carrier center frequency, outside of which all emissions are attenuated at least 26 dB below the transmitter power.

MODES TESTED

GSM850/1900 & WCDMA B2/B5 & LTE B5

RESULTS

11.2.1. SPURIOUS RADIATION PLOTS

Compliance Certification Services Above 1GHz High Frequency Substitution Measurement										
Company:		Samsung								
Project #:		13116698								
Date:		01/04/14								
Test Engineer:		Trina Noor								
Configuration:		X Position, AC Charger								
Mode:		TX, LTE BAND 5, 10MHz BW, 16QAM								
Chamber		Pre-amplifer			Filter		Limit			
3m Chamber		T34 8449B			Filter 1		Part 24			
Band	f GHz	SG reading (dBm)	Ant. Pol. (H/V)	Distance (m)	Preamp (dB)	Filter (dB)	EIRP (dBm)	Limit (dBm)	Delta (dB)	Notes
LTE5 10MHz z 16QAM	Low Channel (826.5MHz)									
	1.653	-27.6	V	3.0	37.4	1.0	-64.0	-13.0	-51.0	
	2.479	-25.0	V	3.0	36.4	1.0	-60.4	-13.0	-47.4	
	3.306	-22.6	V	3.0	35.8	1.0	-57.4	-13.0	-44.4	
	1.653	-22.5	H	3.0	37.4	1.0	-58.8	-13.0	-45.8	
	2.479	-25.7	H	3.0	36.4	1.0	-61.1	-13.0	-48.1	
	3.306	-22.1	H	3.0	35.8	1.0	-56.8	-13.0	-43.8	
	Mid Channel (836.5MHz)									
	1.673	-26.6	V	3.0	37.3	1.0	-62.9	-13.0	-49.9	
	2.509	-23.4	V	3.0	36.4	1.0	-58.7	-13.0	-45.7	
	3.346	-22.4	V	3.0	35.8	1.0	-57.2	-13.0	-44.2	
	1.673	-27.7	H	3.0	37.3	1.0	-64.1	-13.0	-51.1	
	2.509	-25.1	H	3.0	36.4	1.0	-60.5	-13.0	-47.5	
	3.346	-22.6	H	3.0	35.8	1.0	-57.3	-13.0	-44.3	
	High Channel (846.5MHz)									
	1.693	-27.3	V	3.0	37.3	1.0	-63.6	-13.0	-50.6	
	2.539	-23.5	V	3.0	36.3	1.0	-58.8	-13.0	-45.8	
	3.386	-22.9	V	3.0	35.7	1.0	-57.7	-13.0	-44.7	
1.693	-27.5	H	3.0	37.3	1.0	-63.8	-13.0	-50.8		
2.539	-25.3	H	3.0	36.3	1.0	-60.6	-13.0	-47.6		
3.386	-22.5	H	3.0	35.7	1.0	-57.2	-13.0	-44.2		
Rev. 03.03.09										
Note: No other emissions were detected above the system noise floor.										
1.0										

Compliance Certification Services
Above 1GHz High Frequency Substitution Measurement

Company: Samsung
Project #: 13116698
Date: 01/04/14
Test Engineer: Trina Noor
Configuration: X Position, AC Charger
Mode: TX, LTE BAND 5, 10MHz BW,QPSK

Chamber
 3m Chamber

Pre-amplifier
 T34 8449B

Filter
 Filter 1

Limit
 Part 24

Band	f GHz	SG reading (dBm)	Ant. Pol. (H/V)	Distance (m)	Preamp (dB)	Filter (dB)	EIRP (dBm)	Limit (dBm)	Delta (dB)	Notes
LTE5 10MH z QPSK	Low Channel (826.5MHz)									
	1.653	-28.1	V	3.0	37.4	1.0	-64.5	-13.0	-51.5	
	2.479	-24.3	V	3.0	36.4	1.0	-59.7	-13.0	-46.7	
	3.306	-22.7	V	3.0	35.8	1.0	-57.5	-13.0	-44.5	
	1.653	-28.8	H	3.0	37.4	1.0	-65.2	-13.0	-52.2	
	2.479	-26.3	H	3.0	36.4	1.0	-61.6	-13.0	-48.6	
	3.306	-22.6	H	3.0	35.8	1.0	-57.4	-13.0	-44.4	
	Mid Channel (836.5MHz)									
	1.673	-27.4	V	3.0	37.3	1.0	-63.8	-13.0	-50.8	
	2.509	-23.5	V	3.0	36.4	1.0	-58.8	-13.0	-45.8	
	3.346	-22.9	V	3.0	35.8	1.0	-57.7	-13.0	-44.7	
	1.673	-28.0	H	3.0	37.3	1.0	-64.4	-13.0	-51.4	
	2.509	-24.8	H	3.0	36.4	1.0	-60.2	-13.0	-47.2	
	3.346	-22.8	H	3.0	35.8	1.0	-57.5	-13.0	-44.5	
	High Channel (846.5MHz)									
	1.693	-26.7	V	3.0	37.3	1.0	-63.0	-13.0	-50.0	
	2.539	-23.8	V	3.0	36.3	1.0	-59.2	-13.0	-46.2	
	3.386	-22.7	V	3.0	35.7	1.0	-57.4	-13.0	-44.4	
	1.693	-26.9	H	3.0	37.3	1.0	-63.2	-13.0	-50.2	
	2.539	-25.3	H	3.0	36.3	1.0	-60.7	-13.0	-47.7	
	3.386	-22.6	H	3.0	35.7	1.0	-57.3	-13.0	-44.3	

Rev. 03.03.09
 Note: No other emissions were detected above the system noise floor.

1.0

Compliance Certification Services
Above 1GHz High Frequency Substitution Measurement

Company: Samsung
Project #: 13116698
Date: 01/04/14
Test Engineer: Trina Noor
Configuration: X Position, AC Charger
Mode: TX, LTE BAND 5, 5MHz BW,16QAM

Chamber
 3m Chamber

Pre-amplifier
 T34 8449B

Filter
 Filter 1

Limit
 Part 24

Band	f GHz	SG reading (dBm)	Ant. Pol. (H/V)	Distance (m)	Preamp (dB)	Filter (dB)	EIRP (dBm)	Limit (dBm)	Delta (dB)	Notes		
LTE5 5MHz 16QAM	Low Channel (826.5MHz)											
		1.653	-26.4	V	3.0	37.4	1.0	-62.8	-13.0	-49.8		
		2.479	-22.6	V	3.0	36.4	1.0	-57.9	-13.0	-44.9		
		3.306	-22.8	V	3.0	35.8	1.0	-57.6	-13.0	-44.6		
		1.653	-27.1	H	3.0	37.4	1.0	-63.5	-13.0	-50.5		
		2.479	-26.4	H	3.0	36.4	1.0	-61.8	-13.0	-48.8		
		3.306	-22.1	H	3.0	35.8	1.0	-56.9	-13.0	-43.9		
		Mid Channel (836.5MHz)										
		1.673	-27.8	V	3.0	37.3	1.0	-64.2	-13.0	-51.2		
		2.509	-24.1	V	3.0	36.4	1.0	-59.5	-13.0	-46.5		
		3.346	-23.3	V	3.0	35.8	1.0	-58.1	-13.0	-45.1		
		1.673	-28.1	H	3.0	37.3	1.0	-64.4	-13.0	-51.4		
		2.509	-25.8	H	3.0	36.4	1.0	-61.2	-13.0	-48.2		
		3.346	-22.9	H	3.0	35.8	1.0	-57.6	-13.0	-44.6		
		High Channel (846.5MHz)										
		1.693	-27.7	V	3.0	37.3	1.0	-64.0	-13.0	-51.0		
		2.539	-23.5	V	3.0	36.3	1.0	-58.8	-13.0	-45.8		
		3.386	-22.5	V	3.0	35.7	1.0	-57.2	-13.0	-44.2		
	1.693	-19.3	H	3.0	37.3	1.0	-55.6	-13.0	-42.6			
	2.539	-25.7	H	3.0	36.3	1.0	-61.0	-13.0	-48.0			
	3.386	-22.9	H	3.0	35.7	1.0	-57.6	-13.0	-44.6			

Rev. 03.03.09
 Note: No other emissions were detected above the system noise floor.

1.0

Compliance Certification Services
Above 1GHz High Frequency Substitution Measurement

Company: Samsung
Project #: 13116698
Date: 01/04/14
Test Engineer: Trina Noor
Configuration: X Position, AC Charger
Mode: TX, LTE BAND 5, 5MHz BW,QPSK

Chamber	Pre-amplifier	Filter	Limit
3m Chamber	T34 8449B	Filter 1	Part 24

Band	f GHz	SG reading (dBm)	Ant. Pol. (H/V)	Distance (m)	Preamp (dB)	Filter (dB)	EIRP (dBm)	Limit (dBm)	Delta (dB)	Notes
Low Channel (826.5MHz)										
LTE5	1.653	-25.4	V	3.0	37.4	1.0	-61.8	-13.0	-48.8	
	2.479	-22.8	V	3.0	36.4	1.0	-58.2	-13.0	-45.2	
5MHz	3.306	-22.6	V	3.0	35.8	1.0	-57.4	-13.0	-44.4	
	1.653	-21.5	H	3.0	37.4	1.0	-57.9	-13.0	-44.9	
QPSK	2.479	-26.0	H	3.0	36.4	1.0	-61.4	-13.0	-48.4	
	3.306	-23.0	H	3.0	35.8	1.0	-57.8	-13.0	-44.8	
Mid Channel (836.5MHz)										
	1.673	-27.2	V	3.0	37.3	1.0	-63.5	-13.0	-50.5	
	2.509	-23.8	V	3.0	36.4	1.0	-59.2	-13.0	-46.2	
	3.346	-23.3	V	3.0	35.8	1.0	-58.1	-13.0	-45.1	
	1.673	-28.0	H	3.0	37.3	1.0	-64.4	-13.0	-51.4	
	2.509	-25.9	H	3.0	36.4	1.0	-61.2	-13.0	-48.2	
	3.346	-22.6	H	3.0	35.8	1.0	-57.4	-13.0	-44.4	
High Channel (846.5MHz)										
	1.693	-28.2	V	3.0	37.3	1.0	-64.5	-13.0	-51.5	
	2.539	-24.5	V	3.0	36.3	1.0	-59.8	-13.0	-46.8	
	3.386	-23.1	V	3.0	35.7	1.0	-57.8	-13.0	-44.8	
	1.693	-26.7	H	3.0	37.3	1.0	-63.0	-13.0	-50.0	
	2.539	-25.5	H	3.0	36.3	1.0	-60.8	-13.0	-47.8	
	3.386	-22.7	H	3.0	35.7	1.0	-57.4	-13.0	-44.4	

Rev. 03.03.09
 Note: No other emissions were detected above the system noise floor.

1.0

Compliance Certification Services
Above 1GHz High Frequency Substitution Measurement

Company: Samsung
Project #: 13116698
Date: 01/03/14
Test Engineer: Trina Noor
Configuration: X Position, AC Charger
Mode: TX, LTE BAND 5, 3MHz BW,16QAM

Chamber
 3m Chamber

Pre-amplifier
 T34 8449B

Filter
 Filter 1

Limit
 Part 24

Band	f GHz	SG reading (dBm)	Ant. Pol. (H/V)	Distance (m)	Preamp (dB)	Filter (dB)	EIRP (dBm)	Limit (dBm)	Delta (dB)	Notes	
LTE5 3MHz 16QA M	Low Channel (826.5MHz)										
	1.653	-27.9	V	3.0	37.4	1.0	-64.3	-13.0	-51.3		
	2.479	-23.5	V	3.0	36.4	1.0	-58.8	-13.0	-45.8		
	3.306	-22.5	V	3.0	35.8	1.0	-57.3	-13.0	-44.3		
	1.653	-26.2	H	3.0	37.4	1.0	-62.6	-13.0	-49.6		
	2.479	-26.0	H	3.0	36.4	1.0	-61.4	-13.0	-48.4		
	3.306	-23.4	H	3.0	35.8	1.0	-58.2	-13.0	-45.2		
	Mid Channel (836.5MHz)										
	1.673	-26.7	V	3.0	37.3	1.0	-63.0	-13.0	-50.0		
	2.509	-23.6	V	3.0	36.4	1.0	-58.9	-13.0	-45.9		
	3.346	-22.2	V	3.0	35.8	1.0	-57.0	-13.0	-44.0		
	1.673	-27.6	H	3.0	37.3	1.0	-64.0	-13.0	-51.0		
	2.509	-25.8	H	3.0	36.4	1.0	-61.1	-13.0	-48.1		
	3.346	-23.3	H	3.0	35.8	1.0	-58.1	-13.0	-45.1		
	High Channel (846.5MHz)										
	1.693	-26.6	V	3.0	37.3	1.0	-63.0	-13.0	-50.0		
	2.539	-23.4	V	3.0	36.3	1.0	-58.7	-13.0	-45.7		
	3.386	-22.4	V	3.0	35.7	1.0	-57.2	-13.0	-44.2		
	1.693	-19.2	H	3.0	37.3	1.0	-55.5	-13.0	-42.5		
	2.539	-25.2	H	3.0	36.3	1.0	-60.5	-13.0	-47.5		
	3.386	-23.0	H	3.0	35.7	1.0	-57.7	-13.0	-44.7		
	Rev. 03.03.09										
	Note: No other emissions were detected above the system noise floor.										

1.0

Compliance Certification Services
Above 1GHz High Frequency Substitution Measurement

Company: Samsung
Project #: 13116698
Date: 01/03/14
Test Engineer: Trina Noor
Configuration: X Position, AC Charger
Mode: TX, LTE BAND 5, 3MHz BW,QPSK

Chamber
 3m Chamber

Pre-amplifier
 T34 8449B

Filter
 Filter 1

Limit
 Part 24

Band	f GHz	SG reading (dBm)	Ant. Pol. (H/V)	Distance (m)	Preamp (dB)	Filter (dB)	EIRP (dBm)	Limit (dBm)	Delta (dB)	Notes
Low Channel (826.5MHz)										
LTE5	1.653	-28.5	V	3.0	37.4	1.0	-64.9	-13.0	-51.9	
	2.479	-23.3	V	3.0	36.4	1.0	-58.7	-13.0	-45.7	
3MHz	3.306	-23.1	V	3.0	35.8	1.0	-57.9	-13.0	-44.9	
	1.653	-26.0	H	3.0	37.4	1.0	-62.4	-13.0	-49.4	
QPSK	2.479	-25.7	H	3.0	36.4	1.0	-61.1	-13.0	-48.1	
	3.306	-23.1	H	3.0	35.8	1.0	-57.9	-13.0	-44.9	
Mid Channel (836.5MHz)										
	1.673	-27.3	V	3.0	37.3	1.0	-63.7	-13.0	-50.7	
	2.509	-24.1	V	3.0	36.4	1.0	-59.5	-13.0	-46.5	
	3.346	-22.4	V	3.0	35.8	1.0	-57.2	-13.0	-44.2	
	1.673	-27.1	H	3.0	37.3	1.0	-63.4	-13.0	-50.4	
	2.509	-25.1	H	3.0	36.4	1.0	-60.4	-13.0	-47.4	
	3.346	-22.8	H	3.0	35.8	1.0	-57.5	-13.0	-44.5	
High Channel (846.5MHz)										
	1.693	-27.4	V	3.0	37.3	1.0	-63.7	-13.0	-50.7	
	2.539	-24.4	V	3.0	36.3	1.0	-59.7	-13.0	-46.7	
	3.386	-22.8	V	3.0	35.7	1.0	-57.5	-13.0	-44.5	
	1.693	-19.9	H	3.0	37.3	1.0	-56.2	-13.0	-43.2	
	2.539	-25.9	H	3.0	36.3	1.0	-61.3	-13.0	-48.3	
	3.386	-22.9	H	3.0	35.7	1.0	-57.7	-13.0	-44.7	

Rev. 03.03.09
 Note: No other emissions were detected above the system noise floor.

1.0

Compliance Certification Services
Above 1GHz High Frequency Substitution Measurement

Company: Samsung
Project #: 13116698
Date: 01/03/14
Test Engineer: Trina Noor
Configuration: X Position, AC Charger
Mode: TX, LTE BAND 5, 1.4MHz BW, 16QAM

Chamber
 3m Chamber

Pre-amplifier
 T34 8449B

Filter
 Filter 1

Limit
 Part 24

	f GHz	SG reading (dBm)	Ant. Pol. (H/V)	Distance (m)	Preamp (dB)	Filter (dB)	EIRP (dBm)	Limit (dBm)	Delta (dB)	Notes		
Band LTE5 1.4MHz z 16QA M	Low Channel (826.5MHz)											
		1.653	-27.9	V	3.0	37.4	1.0	-64.3	-13.0	-51.3		
		2.479	-22.1	V	3.0	36.4	1.0	-57.5	-13.0	-44.5		
		3.306	-22.5	V	3.0	35.8	1.0	-57.3	-13.0	-44.3		
		1.653	-22.3	H	3.0	37.4	1.0	-58.7	-13.0	-45.7		
		2.479	-25.5	H	3.0	36.4	1.0	-60.8	-13.0	-47.8		
		3.306	-23.4	H	3.0	35.8	1.0	-58.2	-13.0	-45.2		
		Mid Channel (836.5MHz)										
		1.673	-28.1	V	3.0	37.3	1.0	-64.5	-13.0	-51.5		
		2.509	-24.0	V	3.0	36.4	1.0	-59.4	-13.0	-46.4		
		3.346	-21.7	V	3.0	35.8	1.0	-56.5	-13.0	-43.5		
		1.673	-27.2	H	3.0	37.3	1.0	-63.5	-13.0	-50.5		
		2.509	-25.6	H	3.0	36.4	1.0	-61.0	-13.0	-48.0		
		3.346	-23.2	H	3.0	35.8	1.0	-58.0	-13.0	-45.0		
		High Channel (846.5MHz)										
		1.693	-26.3	V	3.0	37.3	1.0	-62.6	-13.0	-49.6		
		2.539	-23.8	V	3.0	36.3	1.0	-59.1	-13.0	-46.1		
		3.386	-23.2	V	3.0	35.7	1.0	-57.9	-13.0	-44.9		
		1.693	-21.4	H	3.0	37.3	1.0	-57.7	-13.0	-44.7		
		2.539	-25.8	H	3.0	36.3	1.0	-61.2	-13.0	-48.2		
		3.386	-23.1	H	3.0	35.7	1.0	-57.8	-13.0	-44.8		
		Rev. 03.03.09										
		Note: No other emissions were detected above the system noise floor.										

1.0

Compliance Certification Services
Above 1GHz High Frequency Substitution Measurement

Company: Samsung
Project #: 13116698
Date: 01/03/14
Test Engineer: Trina Noor
Configuration: X Position, AC Charger
Mode: TX, LTE BAND 5, 1.4MHz BW,QPSK

Chamber
 3m Chamber

Pre-amplifier
 T34 8449B

Filter
 Filter 1

Limit
 Part 24

Band	f GHz	SG reading (dBm)	Ant. Pol. (H/V)	Distance (m)	Preamp (dB)	Filter (dB)	EIRP (dBm)	Limit (dBm)	Delta (dB)	Notes	
LTE5 1.4MHz z QPSK	Low Channel (826.5MHz)										
	1.653	-27.8	V	3.0	37.4	1.0	-64.2	-13.0	-51.2		
	2.479	-23.3	V	3.0	36.4	1.0	-58.7	-13.0	-45.7		
	3.306	-23.2	V	3.0	35.8	1.0	-58.0	-13.0	-45.0		
	1.653	-24.5	H	3.0	37.4	1.0	-60.9	-13.0	-47.9		
	2.479	-16.6	H	3.0	36.4	1.0	-52.0	-13.0	-39.0		
	3.306	-21.9	H	3.0	35.8	1.0	-56.7	-13.0	-43.7		
	Mid Channel (836.5MHz)										
	1.673	-27.6	V	3.0	37.3	1.0	-64.0	-13.0	-51.0		
	2.509	-22.7	V	3.0	36.4	1.0	-58.1	-13.0	-45.1		
	3.346	-22.1	V	3.0	35.8	1.0	-56.8	-13.0	-43.8		
	1.673	-24.8	H	3.0	37.3	1.0	-61.1	-13.0	-48.1		
	2.509	-25.0	H	3.0	36.4	1.0	-60.4	-13.0	-47.4		
	3.346	-22.8	H	3.0	35.8	1.0	-57.5	-13.0	-44.5		
	High Channel (846.5MHz)										
	1.693	-26.9	V	3.0	37.3	1.0	-63.2	-13.0	-50.2		
	2.539	-24.4	V	3.0	36.3	1.0	-59.7	-13.0	-46.7		
	3.386	-22.4	V	3.0	35.7	1.0	-57.1	-13.0	-44.1		
	1.693	-21.5	H	3.0	37.3	1.0	-57.8	-13.0	-44.8		
	2.539	-26.3	H	3.0	36.3	1.0	-61.7	-13.0	-48.7		
	3.386	-23.8	H	3.0	35.7	1.0	-58.6	-13.0	-45.6		

Rev. 03.03.09
 Note: No other emissions were detected above the system noise floor.

1.0

Compliance Certification Services Above 1GHz High Frequency Substitution Measurement										
Company:		Samsung								
Project #:		13I16698								
Date:		12/10/13								
Test Engineer:		Trina Noor								
Configuration:		X Position, AC Charger								
Mode:		WCDMA_HSDPA 1900								
Chamber		Pre-amplifer			Filter		Limit			
3m Chamber		T343 8449B			Filter 1		Part 24			
Band	f GHz	SG reading (dBm)	Ant. Pol. (H/V)	Distance (m)	Preamp (dB)	Filter (dB)	EIRP (dBm)	Limit (dBm)	Delta (dB)	Notes
Band 2 HSDP A	Low Ch, 1852.4MHz									
	3.705	-23.6	V	3.0	35.4	1.0	-58.0	-13.0	-45.0	
	5.557	-18.8	V	3.0	34.7	1.0	-52.5	-13.0	-39.5	
	7.409	-20.3	V	3.0	34.9	1.0	-54.2	-13.0	-41.2	
	3.705	-24.1	H	3.0	35.4	1.0	-58.5	-13.0	-45.5	
	5.557	-19.4	H	3.0	34.7	1.0	-53.2	-13.0	-40.2	
	7.409	-17.9	H	3.0	34.9	1.0	-51.8	-13.0	-38.8	
	Mid Ch, 1880.0MHz									
	3.760	-23.4	V	3.0	35.3	1.0	-57.8	-13.0	-44.8	
	5.640	-17.9	V	3.0	34.7	1.0	-51.6	-13.0	-38.6	
	7.520	-18.6	V	3.0	34.9	1.0	-52.5	-13.0	-39.5	
	3.760	-23.5	H	3.0	35.3	1.0	-57.9	-13.0	-44.9	
	5.640	-20.3	H	3.0	34.7	1.0	-54.1	-13.0	-41.1	
	7.520	-17.5	H	3.0	34.9	1.0	-51.4	-13.0	-38.4	
High Ch, 1907.6 MHz										
3.820	-24.3	V	3.0	35.3	1.0	-58.6	-13.0	-45.6		
5.723	-17.9	V	3.0	34.7	1.0	-51.6	-13.0	-38.6		
7.630	-19.4	V	3.0	34.9	1.0	-53.4	-13.0	-40.4		
3.820	-23.6	H	3.0	35.3	1.0	-57.9	-13.0	-44.9		
5.723	-17.8	H	3.0	34.7	1.0	-51.6	-13.0	-38.6		
7.630	-17.7	H	3.0	34.9	1.0	-51.7	-13.0	-38.7		
Rev. 03.03.09										
Note: No other emissions were detected above the system noise floor.										

Compliance Certification Services Above 1GHz High Frequency Substitution Measurement									
Company:		Samsung							
Project #:		13I16698							
Date:		12/10/13							
Test Engineer:		Trina Noor							
Configuration:		X Position, AC Charger							
Mode:		WCDMA_REL_99 1900							
Chamber		Pre-amplifer			Filter		Limit		
3m Chamber		T343 8449B			Filter 1		Part 24		
f GHz	SG reading (dBm)	Ant. Pol. (H/V)	Distance (m)	Preamp (dB)	Filter (dB)	EIRP (dBm)	Limit (dBm)	Delta (dB)	Notes
Low Ch, 1852.4MHz									
3.705	-23.0	V	3.0	35.4	1.0	-57.4	-13.0	-44.4	
5.557	-18.4	V	3.0	34.7	1.0	-52.1	-13.0	-39.1	
7.409	-20.3	V	3.0	34.9	1.0	-54.2	-13.0	-41.2	
3.705	-24.5	H	3.0	35.4	1.0	-58.9	-13.0	-45.9	
5.557	-19.0	H	3.0	34.7	1.0	-52.7	-13.0	-39.7	
7.409	-18.3	H	3.0	34.9	1.0	-52.2	-13.0	-39.2	
Mid Ch, 1880.0MHz									
3.760	-22.6	V	3.0	35.3	1.0	-57.0	-13.0	-44.0	
5.640	-17.4	V	3.0	34.7	1.0	-51.1	-13.0	-38.1	
7.520	-19.2	V	3.0	34.9	1.0	-53.1	-13.0	-40.1	
3.760	-24.4	H	3.0	35.3	1.0	-58.7	-13.0	-45.7	
5.640	-19.7	H	3.0	34.7	1.0	-53.4	-13.0	-40.4	
7.520	-18.9	H	3.0	34.9	1.0	-52.9	-13.0	-39.9	
High Ch, 1907.6 MHz									
3.820	-24.3	V	3.0	35.3	1.0	-58.6	-13.0	-45.6	
5.723	-17.3	V	3.0	34.7	1.0	-51.1	-13.0	-38.1	
7.630	-19.9	V	3.0	34.9	1.0	-53.9	-13.0	-40.9	
3.820	-24.7	H	3.0	35.3	1.0	-59.0	-13.0	-46.0	
5.723	-19.3	H	3.0	34.7	1.0	-53.0	-13.0	-40.0	
7.630	-19.2	H	3.0	34.9	1.0	-53.1	-13.0	-40.1	
Rev. 03.03.09									
Note: No other emissions were detected above the system noise floor.									

Compliance Certification Services Above 1GHz High Frequency Substitution Measurement									
Company:		Samsung							
Project #:		1U16698							
Date:		12/10/13							
Test Engineer:		Trina Noor							
Configuration:		X Position, w/AC adapter							
Mode:		WCDMA_HSDPA_850							
Chamber		Pre-amplifier			Filter		Limit		
3m Chamber		T34 8449B			Filter 1		Part 24		
f GHz	SG reading (dBm)	Ant. Pol. (H/V)	Distance (m)	Preamp (dB)	Filter (dB)	EIRP (dBm)	Limit (dBm)	Delta (dB)	Notes
Band 5									
HSDP A									
Low Ch, 826.40MHz									
1.652	-28.6	V	3.0	37.4	1.0	-65.0	-13.0	-52.0	
2.479	-21.6	V	3.0	36.4	1.0	-57.0	-13.0	-44.0	
3.306	-25.1	V	3.0	35.8	1.0	-59.9	-13.0	-46.9	
1.652	-28.7	H	3.0	37.4	1.0	-65.0	-13.0	-52.0	
2.479	-23.9	H	3.0	36.4	1.0	-59.3	-13.0	-46.3	
3.306	-25.2	H	3.0	35.8	1.0	-60.0	-13.0	-47.0	
Mid Ch, 836.6MHz									
1.673	-28.4	V	3.0	37.3	1.0	-64.8	-13.0	-51.8	
2.510	-22.2	V	3.0	36.4	1.0	-57.6	-13.0	-44.6	
3.346	-24.8	V	3.0	35.8	1.0	-59.5	-13.0	-46.5	
1.673	-29.3	H	3.0	37.3	1.0	-65.6	-13.0	-52.6	
2.510	-24.3	H	3.0	36.4	1.0	-59.6	-13.0	-46.6	
3.346	-24.5	H	3.0	35.8	1.0	-59.2	-13.0	-46.2	
High Ch, 846.6MHz									
1.693	-28.2	V	3.0	37.3	1.0	-64.5	-13.0	-51.5	
2.539	-21.3	V	3.0	36.3	1.0	-56.6	-13.0	-43.6	
3.386	-24.6	V	3.0	35.7	1.0	-59.4	-13.0	-46.4	
1.693	-27.2	H	3.0	37.3	1.0	-63.5	-13.0	-50.5	
2.539	-26.1	H	3.0	36.3	1.0	-61.4	-13.0	-48.4	
3.386	-25.2	H	3.0	35.7	1.0	-59.9	-13.0	-46.9	
Rev. 03.03.09									
Note: No other emissions were detected above the system noise floor.									

Compliance Certification Services
Above 1GHz High Frequency Substitution Measurement

Company: Samsung
 Project #: 1U16698
 Date: 12/09/13
 Test Engineer: Isador
 Configuration: X Position, HS
 Mode: WCDMA_HSDPA_850

Chamber
 3m Chamber

Pre-amplifer
 T34 8449B

Filter
 Filter 1

Limit
 Part 24

	f GHz	SG reading (dBm)	Ant. Pol. (H/V)	Distance (m)	Preamp (dB)	Filter (dB)	EIRP (dBm)	Limit (dBm)	Delta (dB)	Notes	
Band	Low Ch, 826.40MHz										
		1.652	-24.5	V	3.0	37.4	1.0	-60.9	-13.0	-47.9	
		2.479	-21.3	V	3.0	36.4	1.0	-56.6	-13.0	-43.6	
Band 5	3.306										
		3.306	-17.4	V	3.0	35.8	1.0	-52.2	-13.0	-39.2	
		1.652	-26.2	H	3.0	37.4	1.0	-62.6	-13.0	-49.6	
REL99	2.479										
		2.479	-22.6	H	3.0	36.4	1.0	-58.0	-13.0	-45.0	
		3.306	-16.9	H	3.0	35.8	1.0	-51.7	-13.0	-38.7	
Mid Ch, 836.6MHz											
	1.673	-26.0	V	3.0	37.3	1.0	-62.3	-13.0	-49.3		
	2.510	-21.2	V	3.0	36.4	1.0	-56.5	-13.0	-43.5		
	3.346	-18.0	V	3.0	35.8	1.0	-52.7	-13.0	-39.7		
	1.673	-26.3	H	3.0	37.3	1.0	-62.6	-13.0	-49.6		
	2.510	-22.2	H	3.0	36.4	1.0	-57.5	-13.0	-44.5		
	3.346	-17.0	H	3.0	35.8	1.0	-51.7	-13.0	-38.7		
High Ch, 846.6MHz											
	1.693	-25.0	V	3.0	37.3	1.0	-61.3	-13.0	-48.3		
	2.539	-21.1	V	3.0	36.3	1.0	-56.5	-13.0	-43.5		
	3.386	-16.6	V	3.0	35.7	1.0	-51.3	-13.0	-38.3		
	1.693	-26.2	H	3.0	37.3	1.0	-62.5	-13.0	-49.5		
	2.539	-21.6	H	3.0	36.3	1.0	-56.9	-13.0	-43.9		
	3.386	-17.0	H	3.0	35.7	1.0	-51.7	-13.0	-38.7		

Rev. 03.03.09
 Note: No other emissions were detected above the system noise floor.

Compliance Certification Services Above 1GHz High Frequency Substitution Measurement										
Company:		Samsung								
Project #:		13I16698								
Date:		12/10/13								
Test Engineer:		Trina Noor								
Configuration:		X Position, AC Charger								
Mode:		EGPRS 1900								
Chamber		Pre-amplifer			Filter		Limit			
3m Chamber		T343 8449B			Filter 1		Part 24			
Band	f GHz	SG reading (dBm)	Ant. Pol. (H/V)	Distance (m)	Preamp (dB)	Filter (dB)	EIRP (dBm)	Limit (dBm)	Delta (dB)	Notes
GSM1900 EGPRS	Low Ch, 1850.2MHz									
	3.700	-24.0	V	3.0	35.4	1.0	-58.4	-13.0	-45.4	
	5.550	-22.5	V	3.0	34.7	1.0	-56.2	-13.0	-43.2	
	7.400	-19.5	V	3.0	34.9	1.0	-53.4	-13.0	-40.4	
	3.700	-25.0	H	3.0	35.4	1.0	-59.4	-13.0	-46.4	
	5.550	-22.3	H	3.0	34.7	1.0	-56.0	-13.0	-43.0	
	7.400	-18.6	H	3.0	34.9	1.0	-52.5	-13.0	-39.5	
	Mid Ch, 1880.0MHz									
	3.760	-24.4	V	3.0	35.3	1.0	-58.7	-13.0	-45.7	
	5.640	-22.5	V	3.0	34.7	1.0	-56.2	-13.0	-43.2	
	7.520	-19.6	V	3.0	34.9	1.0	-53.5	-13.0	-40.5	
	3.760	-24.2	H	3.0	35.3	1.0	-58.5	-13.0	-45.5	
	5.640	-21.1	H	3.0	34.7	1.0	-54.8	-13.0	-41.8	
	7.520	-18.9	H	3.0	34.9	1.0	-52.8	-13.0	-39.8	
	High Ch, 1909.8 MHz									
	3.820	-24.2	V	3.0	35.3	1.0	-58.5	-13.0	-45.5	
	5.729	-22.3	V	3.0	34.7	1.0	-56.0	-13.0	-43.0	
	7.640	-19.3	V	3.0	35.0	1.0	-53.3	-13.0	-40.3	
3.820	-24.0	H	3.0	35.3	1.0	-58.3	-13.0	-45.3		
5.729	-20.9	H	3.0	34.7	1.0	-54.6	-13.0	-41.6		
7.640	-18.5	H	3.0	35.0	1.0	-52.4	-13.0	-39.4		
Rev. 03.03.09										
Note: No other emissions were detected above the system noise floor.										

Compliance Certification Services Above 1GHz High Frequency Substitution Measurement										
Company:		Samsung								
Project #:		13116698								
Date:		12/10/13								
Test Engineer:		Trina Noor								
Configuration:		X Position, AC Charger								
Mode:		GPRS 1900								
Chamber		Pre-amplifer		Filter		Limit				
3m Chamber		T343 8449B		Filter 1		Part 24				
Band	f GHz	SG reading (dBm)	Ant. Pol. (H/V)	Distance (m)	Preamp (dB)	Filter (dB)	EIRP (dBm)	Limit (dBm)	Delta (dB)	Notes
	Low Ch, 1850.2MHz									
GSM1900	3.700	-24.1	V	3.0	35.4	1.0	-58.5	-13.0	-45.5	
	5.550	-22.9	V	3.0	34.7	1.0	-56.6	-13.0	-43.6	
GPRS	7.400	-21.0	V	3.0	34.9	1.0	-54.9	-13.0	-41.9	
	3.700	-24.4	H	3.0	35.4	1.0	-58.8	-13.0	-45.8	
	5.550	-22.2	H	3.0	34.7	1.0	-56.0	-13.0	-43.0	
	7.400	-19.9	H	3.0	34.9	1.0	-53.8	-13.0	-40.8	
		Mid Ch, 1880.0MHz								
	3.760	-23.5	V	3.0	35.3	1.0	-57.9	-13.0	-44.9	
	5.640	-22.8	V	3.0	34.7	1.0	-56.6	-13.0	-43.6	
	7.520	-19.5	V	3.0	34.9	1.0	-53.5	-13.0	-40.5	
	3.760	-24.6	H	3.0	35.3	1.0	-58.9	-13.0	-45.9	
	5.640	-21.3	H	3.0	34.7	1.0	-55.1	-13.0	-42.1	
	7.520	-19.1	H	3.0	34.9	1.0	-53.0	-13.0	-40.0	
	High Ch, 1909.8 MHz									
	3.820	-24.2	V	3.0	35.3	1.0	-58.5	-13.0	-45.5	
	5.729	-23.2	V	3.0	34.7	1.0	-57.0	-13.0	-44.0	
	7.640	-19.5	V	3.0	35.0	1.0	-53.5	-13.0	-40.5	
	3.820	-23.9	H	3.0	35.3	1.0	-58.2	-13.0	-45.2	
	5.729	-21.6	H	3.0	34.7	1.0	-55.3	-13.0	-42.3	
	7.640	-19.3	H	3.0	35.0	1.0	-53.2	-13.0	-40.2	
Rev. 03.03.09										
Note: No other emissions were detected above the system noise floor.										

Compliance Certification Services
Above 1GHz High Frequency Substitution Measurement

Company: Samsung
Project #: 13116698
Date: 01/04/14
Test Engineer: Trina Noor
Configuration: X Position, AC Charger
Mode: EGPRS 850

Chamber
 3m Chamber

Pre-amplifier
 T34 8449B

Filter
 Filter 1

Limit
 Part 24

Band	f GHz	SG reading (dBm)	Ant. Pol. (H/V)	Distance (m)	Preamp (dB)	Filter (dB)	EIRP (dBm)	Limit (dBm)	Delta (dB)	Notes	
GSM8 50 EGPRS	Low Ch, 824.2MHz										
		1.648	14.1	V	3.0	37.4	1.0	-22.3	-13.0	-9.3	
		2.473	-7.7	V	3.0	36.4	1.0	-43.1	-13.0	-30.1	
		3.297	-21.4	V	3.0	35.8	1.0	-56.2	-13.0	-43.2	
		1.648	11.2	H	3.0	37.4	1.0	-25.2	-13.0	-12.2	
		2.473	-0.5	H	3.0	36.4	1.0	-35.9	-13.0	-22.9	
		3.297	-22.4	H	3.0	35.8	1.0	-57.2	-13.0	-44.2	
		Mid Ch, 836.6MHz									
		1.673	17.1	V	3.0	37.3	1.0	-19.2	-13.0	-6.2	
		2.510	-10.0	V	3.0	36.4	1.0	-45.4	-13.0	-32.4	
		3.346	-21.3	V	3.0	35.8	1.0	-56.1	-13.0	-43.1	
		1.673	17.0	H	3.0	37.3	1.0	-19.3	-13.0	-6.3	
		2.510	-4.9	H	3.0	36.4	1.0	-40.2	-13.0	-27.2	
		3.346	-22.4	H	3.0	35.8	1.0	-57.1	-13.0	-44.1	
		High Ch, 848.8MHz									
	1.698	16.6	V	3.0	37.3	1.0	-19.7	-13.0	-6.7		
	2.547	-12.6	V	3.0	36.3	1.0	-47.9	-13.0	-34.9		
	3.395	-22.0	V	3.0	35.7	1.0	-56.7	-13.0	-43.7		
	1.698	18.8	H	3.0	37.3	1.0	-17.5	-13.0	-4.5		
	2.547	-10.1	H	3.0	36.3	1.0	-45.4	-13.0	-32.4		
	3.395	-21.4	H	3.0	35.7	1.0	-56.1	-13.0	-43.1		

Rev. 03.03.09
 Note: No other emissions were detected above the system noise floor.

Compliance Certification Services Above 1GHz High Frequency Substitution Measurement										
Company:		Samsung								
Project #:		13116698								
Date:		01/04/14								
Test Engineer:		Trina Noor								
Configuration:		X Position, AC Charger								
Mode:		GPRS 850								
Chamber		Pre-amplifier			Filter		Limit			
3m Chamber		T34 8449B			Filter 1		Part 24			
Band	f GHz	SG reading (dBm)	Ant. Pol. (H/V)	Distance (m)	Preamp (dB)	Filter (dB)	EIRP (dBm)	Limit (dBm)	Delta (dB)	Notes
	Low Ch, 824.2MHz									
GSM850	1.648	8.8	V	3.0	37.4	1.0	-27.6	-13.0	-14.6	
	2.473	-5.6	V	3.0	36.4	1.0	-40.9	-13.0	-27.9	
	3.297	-21.5	V	3.0	35.8	1.0	-56.3	-13.0	-43.3	
GPRS	1.648	7.1	H	3.0	37.4	1.0	-29.3	-13.0	-16.3	
	2.473	1.1	H	3.0	36.4	1.0	-34.3	-13.0	-21.3	
	3.297	-22.4	H	3.0	35.8	1.0	-57.2	-13.0	-44.2	
	Mid Ch, 836.6MHz									
	1.673	10.6	V	3.0	37.3	1.0	-25.7	-13.0	-12.7	
	2.510	-12.2	V	3.0	36.4	1.0	-47.6	-13.0	-34.6	
	3.346	-22.3	V	3.0	35.8	1.0	-57.1	-13.0	-44.1	
	1.673	5.6	H	3.0	37.3	1.0	-30.7	-13.0	-17.7	
	2.510	-3.3	H	3.0	36.4	1.0	-38.7	-13.0	-25.7	
	3.346	-22.8	H	3.0	35.8	1.0	-57.5	-13.0	-44.5	
	High Ch, 848.8MHz									
	1.698	7.2	V	3.0	37.3	1.0	-29.1	-13.0	-16.1	
	2.547	-11.3	V	3.0	36.3	1.0	-46.7	-13.0	-33.7	
	3.395	-21.7	V	3.0	35.7	1.0	-56.4	-13.0	-43.4	
	1.698	5.9	H	3.0	37.3	1.0	-30.4	-13.0	-17.4	
	2.547	-8.9	H	3.0	36.3	1.0	-44.3	-13.0	-31.3	
	3.395	-22.8	H	3.0	35.7	1.0	-57.5	-13.0	-44.5	
Rev. 03.03.09										
Note: No other emissions were detected above the system noise floor.										