

EMI TEST REPORT

FCC CERTIFICATION

Applicant:

SAMSUNG Electronics Co., Ltd.
129, Samsung-ro, Yeongtong-gu, Suwon-si,
Gyeonggi-do, 16677, Korea

Date of Issue: May 23, 2023

Test Report No. HCT-EM-2305-FC005

Test Site: HCT CO., LTD.

FCC ID :

A3LSMM346B

Rule Part(s) / Standard(s) : 47 CFR PART 15 Subpart B Class B
ANSI C63.4-2014

Product Name : Mobile Phone

Model Name : SM-M346B/DS

Date of Test : May 08, 2023 to May 09, 2023

The device bearing the trade name and model specified above, has been shown to comply with the applicable technical standards as indicated in the measurement report and was tested in accordance with the measurement procedures specified in ANSI C63.4-2014. (See Test Report if any modifications were made for compliance)

I attest to the accuracy of data. All measurements reported herein were performed by me or were made under my supervision and are correct to the best of my knowledge and belief. I assume full responsibility for the completeness of these measurements and vouch for the qualifications of all persons taking them.

Tested By



Wook Yi
Test Engineer
EMC Team
Certification Division

Reviewed

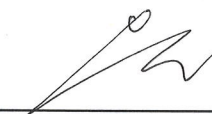

Gu-Cheol Yoon
Technical Manager
EMC Team
Certification Division

This report only responds to the tested sample and may not be reproduced, except in full, without written approval of the HCT Co., Ltd.



REVISION HISTORY

The revision history for this document is shown in table.

| Rev No. | Issue Date | Information About Changes |
|----------------|-------------------|----------------------------------|
| 0 | May 23, 2023 | Initial Release |

The above Test Report is not related to the accredited test result by (KS Q) ISO/IEC 17025 and KOLAS (Korea Laboratory Accreditation Scheme), which signed the ILAC-MRA.

If this report is required to confirmation of authenticity, please contact to www.hct.co.kr



TABLE OF CONTENTS

| | PAGE |
|--|------|
| 1. GENERAL INFORMATION | 4 |
| 1.1 Description of EUT | 4 |
| 1.2 Tested System Details | 4 |
| 1.3 Cable Description | 5 |
| 1.4 Noise Suppression Parts on Cable. (I/O Cable)..... | 5 |
| 1.5 Test Facility | 6 |
| 1.6 Calibration of Measuring Instrument | 6 |
| 1.7 Measurement Uncertainty | 6 |
| 2. LIST OF TEST EQUIPMENT | 7 |
| 3. DESCRIPTION OF TEST | 8 |
| 3.1 Measurement of Conducted Emission..... | 8 |
| 3.2 Measurement of Radiated Emission..... | 9 |
| 3.3 Configuration of Tested System | 10 |
| 4. OPERATION OF THE EUT | 10 |
| 4.1 Conducted Emission (Not Applicable)..... | 11 |
| 4.2 Radiated Emission..... | 11 |
| 5. EMI TEST SUMMARY | 12 |
| 5.1 Conducted Emission (Not Applicable)..... | 12 |
| 5.1.1 Test Condition | 12 |
| 5.1.2 Measuring Data..... | 12 |
| 5.2 Radiated Emission Below 1 GHz | 12 |
| 5.2.1 Test Condition | 13 |
| 5.2.2 Measuring Data..... | 14 |
| 5.3 Radiated Emission Above 1 GHz | 17 |
| 5.3.1 Test Condition | 17 |
| 5.3.2 Measuring Data..... | 18 |
| 6 APPENDIX A. TEST SETUP PHOTO..... | 20 |



1. GENERAL INFORMATION

1.1 Description of EUT

| | |
|---------------------------|--|
| FCC ID | A3LSMM346B |
| Model Name | SM-M346B/DS |
| Product Name | Mobile Phone |
| Testing Freq. Band | GSM 850/1900, WCDMA B2/4/5, LTE B2/4/5/12/17/26/41/66, NR n5/41/66, BT/BTLE, WLAN 802.11 a/b/g/n/ac(SISO), NFC, S/T |

1.2 Tested System Details

All equipment descriptions used in the tested system (including inserted cards) are:

| Device Type | Model Name | Serial Number | Manufacturer |
|--------------------|-------------------|----------------------|---------------------|
| Mobile Phone | SM-M346B/DS | - | SAMSUNG |
| TA* | EP-TA800 | - | DONGYANG E&P |
| Data Cable | EP-DN980 | - | CRESYN |
| Earphone | EHS64AVFWE | - | CRESYN |

[*] Input: 100~240 V, 50~60 Hz, 0.7 A

Output: (PDO)5.0 V, 3.0 A or 9.0 V, 2.77 A (PPS)3.3~5.9 V, 3.0 A or 3.3~11.0 V, 2.25 A



1.3 Cable Description

| Product Name | Port | Power Cord Shielded (Y/N) | I/O Cable Shielded (Y/N) | Length (m) |
|--------------|-------------------------|---------------------------|--------------------------|------------|
| EUT | USB Type C (Data Cable) | Y | N/A | (P) 1.0 |
| | 3.5ø Earjack | N/A | N | (D) 1.2 |

"(D)" Data Cable and "(P)" Power Cable.

1.4 Noise Suppression Parts on Cable. (I/O Cable)

| Product Name | Port | Ferrite Bead (Y/N) | Location | Metal Hood (Y/N) | Location |
|--------------|-------------------------|--------------------|----------|------------------|----------|
| EUT | Data Cable (USB Type C) | N | N/A | Y | Both End |
| | 3.5ø Earjack | N | N/A | Y | EUT End |



1.5 Test Facility

Test site is located at 74, Seoicheon-ro 578beon-gil, Majang-myeon, Icheon-si, Gyeonggi-do, Korea. Those measurement facilities are constructed in conformance with the requirements of ANSI C63.4-2014. The Normalized site attenuations (30 MHz to 1 GHz) and Site validation (1 GHz to 18 GHz) were performed in accordance with the standard in ANSI C63.4-2014 and ANSI C63.4a-2017. Our laboratories are accredited and designated in accordance with the provisions of Radio Waves ACT and International Standard ISO/IEC 17025:2017. (National Radio Research Agency, CABID No. KR0032)

1.6 Calibration of Measuring Instrument

The measuring equipment, which was utilized in performing the tests documented herein, has been calibrated in accordance with the manufacturers recommendations for utilizing calibration equipment, which is traceable to recognized national standards.

Especially, all antenna for measurement is calibrated in accordance with the requirements of C63.5:2017.

1.7 Measurement Uncertainty

The measurement uncertainties shown below were calculated in accordance with the requirements of ANSI C63.4-2014.

All measurement uncertainty values are shown with a coverage factor of $k = 2$ to indicate a 95 % level of confidence. The measurement data shown herein meets or exceeds the U_{CISPR} measurement uncertainty values specified in CISPR 16-4-2 and, thus, can be compared directly to specified limits to determine compliance.

| Test Item | Test Site (Chamber) | Expanded Uncertainty |
|--------------------------------------|------------------------------|----------------------|
| Radiated Emission (30 MHz to 1 GHz) | 3 m Semi Anechoic Chamber #1 | 5.9 dB |
| Radiated Emission (1 GHz to 18 GHz) | 3 m Semi Anechoic Chamber #1 | 4.8 dB |
| Radiated Emission (18 GHz to 40 GHz) | 3 m Semi Anechoic Chamber #1 | 5.8 dB |



2. LIST OF TEST EQUIPMENT

| <u>Type</u> | <u>Model Name</u> | <u>Manufacturer</u> | <u>Serial Number</u> | <u>Calibration Cycle</u> | <u>Next Calibration Date</u> |
|--|-------------------|---------------------|---------------------------|--------------------------|------------------------------|
| Conducted Emission | | | | | |
| <input type="checkbox"/> EMI Test Receiver | ESR7 | Rohde & Schwarz | 101910 | 1 year | 06.07.2023 |
| <input type="checkbox"/> LISN | ENV216 | Rohde & Schwarz | 102245 | 1 year | 08.22.2023 |
| <input type="checkbox"/> Antenna (for Communication) | HyperLOG7060 | Aaronia | 66450 | - | - |
| <input type="checkbox"/> Antenna (for Communication) | HyperLOG7060 | Aaronia | 66451 | - | - |
| <input type="checkbox"/> Software | EMC32 | Rohde & Schwarz | - | - | - |
| Radiated Emission | | | | | |
| -For measurement below 1 GHz | | | | | |
| <input checked="" type="checkbox"/> EMI Test Receiver | ESU40 | Rohde & Schwarz | 100524 | 1 year | 05.09.2024 |
| <input type="checkbox"/> EMI Test Receiver | ESCI3 | Rohde & Schwarz | 100584 | 1 year | 05.30.2023 |
| <input checked="" type="checkbox"/> Bi-Log Antenna | VULB9168 | Schwarzbeck | 255 | 2 year | 03.15.2025 |
| <input checked="" type="checkbox"/> Antenna master | MA4640-XP-ET | INNCO SYSTEM | - | N/A | - |
| <input checked="" type="checkbox"/> Antenna master controller | CO3000 | INNCO SYSTEM | CO3000/870/ 35990515/L | N/A | - |
| <input checked="" type="checkbox"/> Turn Table | 1060 | INNCO SYSTEM | - | N/A | - |
| <input checked="" type="checkbox"/> Turn Table controller | CO2000 | INNCO SYSTEM | CO2000/095/ 7590304/L | N/A | - |
| <input checked="" type="checkbox"/> UNIVERSAL RADIO COMMUNICATION TESTER | CMU200 | Rohde & Schwarz | 107488 | 1 year | 09.13.2023 |
| <input checked="" type="checkbox"/> MOBILE COMMUNICATION TEST SET | CMW500 | Rohde & Schwarz | 103246 | 1 year | 08.24.2023 |
| <input checked="" type="checkbox"/> Radio communication analyzer | MT8821C | ANRITSU | 6262192376 | 1 year | 10.20.2023 |
| <input checked="" type="checkbox"/> Antenna (for Communication) | HyperLOG7060 | Aaronia | 66450 | - | - |
| <input checked="" type="checkbox"/> Radio communication analyzer | MT8000A | ANRITSU | 6262208294 | 1 year | 10.20.2023 |
| <input checked="" type="checkbox"/> Antenna (for Communication) | HyperLOG7060 | Aaronia | 66451 | - | - |
| <input checked="" type="checkbox"/> Software | EMC32 | Rohde & Schwarz | - | - | - |
| -For measurement above 1 GHz | | | | | |
| <input checked="" type="checkbox"/> EMI Test Receiver | ESU40 | Rohde & Schwarz | 100524 | 1 year | 05.09.2024 |
| <input checked="" type="checkbox"/> Antenna master | MA4640-XP-ET | INNCO SYSTEM | - | N/A | - |
| <input checked="" type="checkbox"/> Antenna master controller | CO3000 | INNCO SYSTEM | CO3000/870/ 35990515/L | N/A | - |
| <input checked="" type="checkbox"/> Turn Table | 1060 | INNCO SYSTEM | - | N/A | - |
| <input checked="" type="checkbox"/> Turn Table controller | CO2000 | INNCO SYSTEM | CO2000/095/ 7590304/L | N/A | - |
| <input checked="" type="checkbox"/> Low Noise Amplifier | TK-PA18H | TESTEK | 170034-L | 1 year | 11.04.2023 |
| <input type="checkbox"/> Low Noise Amplifier | TK-PA18H | TESTEK | 170012-L | 1 year | 12.13.2023 |
| <input checked="" type="checkbox"/> Low Noise Amplifier | TK-PA1840H | TESTEK | 170030-L | 1 year | 02.22.2024 |
| <input checked="" type="checkbox"/> Horn Antenna | BBHA 9120D | Schwarzbeck | 01836 | 1 year | 07.21.2023 |
| <input checked="" type="checkbox"/> Horn Antenna | BBHA 9170 | Schwarzbeck | BBHA 9170 #786 | 1 year | 11.17.2023 |
| <input checked="" type="checkbox"/> Radio communication analyzer | MT8821C | ANRITSU | 6262192376 | 1 year | 10.20.2023 |
| <input checked="" type="checkbox"/> MOBILE COMMUNICATION TEST SET | CMW500 | Rohde & Schwarz | 103246 | 1 year | 08.24.2023 |
| <input checked="" type="checkbox"/> UNIVERSAL RADIO COMMUNICATION TESTER | CMU200 | Rohde & Schwarz | 107488 | 1 year | 09.13.2023 |
| <input checked="" type="checkbox"/> Antenna (for Communication) | HyperLOG7060 | Aaronia | 66450 | - | - |
| <input checked="" type="checkbox"/> Radio communication analyzer | MT8000A | ANRITSU | 6262208294 | 1 year | 10.20.2023 |
| <input checked="" type="checkbox"/> Antenna (for Communication) | HyperLOG7060 | Aaronia | 66451 | - | - |
| <input checked="" type="checkbox"/> Software | EMC32 | Rohde & Schwarz | - | - | - |



3. DESCRIPTION OF TEST

3.1 Measurement of Conducted Emission

The test procedure was in accordance with ANSI C63.4-2014, Clause 7.3

- a. The EUT was placed 0.4 meters from the conducting wall of the shielded room with EUT being connected to the power mains through a line impedance stabilization network (LISN).
If the EUT is connected to the PC through USB, the AC power-line adapter of the PC is directly connected to a line impedance stabilization network (LISN).
Other support units were connected to the power mains through another LISN. The two LISNs provide 50 Ohm/50uH of coupling impedance for the measuring instrument.
- b. Both conducted lines are measured in Quasi-Peak and Average mode, including the worst-case data points for each tested configuration.
- c. The frequency ranges from 150 kHz to 30 MHz was searched.

Conducted Emission Limits

| Frequency (MHz) | Resolution Bandwidth (kHz) | Quasi-Peak (dB(μ V)) | Average (dB(μ V)) |
|-----------------|----------------------------|---------------------------|------------------------|
| 0.15 to 0.5 | 9 | 66 to 56* | 56 to 46* |
| 0.5 to 5 | 9 | 56 | 46 |
| 5 to 30 | 9 | 60 | 50 |

**Decreases with the logarithm of the frequency.*



3.2 Measurement of Radiated Emission

The test procedure was in accordance with ANSI C63.4-2014, Clause 8.3

- The EUT was placed on the top of a turn table 0.8 meters above the ground at a semi-anechoic chamber. The table was rotated 360 degrees to determine the position of the highest radiation.
- The EUT was set 3 m away from the interference-receiving antenna, which was mounted on the top of a variable-height antenna tower.
- The antenna height is varied from 1 m to 4 m above the ground to determine the maximum value of the field strength. Both horizontal and vertical polarizations of the antenna are set to make the measurement.
- For each suspected emission, the EUT was arranged to its worst case and then the antenna was tuned to heights from 1 m to 4 m and the turn table was turned from 0 degrees to 360 degrees to find the maximum reading.
- The test-receiver system was set to Quasi-Peak detect function and specified bandwidth with maximum hold mode when the test frequency is below 1 GHz.
- The test-receiver system was set to Peak and Average detect function and specified bandwidth with maximum hold mode when the test frequency is above 1 GHz.
- Place the measurement antenna away from each area of the EUT determined to be a source of emissions at the specified measurement distance, while keeping the measurement antenna aimed at the source of emissions at each frequency of significant emissions, with polarization oriented for maximum response. (1 GHz to 40 GHz)

Radiated Emission Limits

| Frequency (MHz) | Antenna Distance (m) | Field Strength ($\mu\text{V}/\text{m}$) | Quasi-Peak (dB $\mu\text{V}/\text{m}$) |
|-----------------|----------------------|---|---|
| 30 to 88 | 3 | 100 | 40.0 |
| 88 to 216 | 3 | 150 | 43.5 |
| 216 to 960 | 3 | 200 | 46.0 |
| Above 960 | 3 | 500 | 54.0 |

| Frequency (MHz) | Antenna Distance (m) | Peak (dB $\mu\text{V}/\text{m}$) | Average (dB $\mu\text{V}/\text{m}$) |
|-----------------|----------------------|-----------------------------------|--------------------------------------|
| Above 1 000 | 3 | 74 | 54 |



3.2.1 Frequency Range of Radiated Measurements

An unintentional radiator, including a digital device, the spectrum shall be investigated from the lowest radio frequency signal generated or used in the device, without going below the lowest frequency for which a Radiated Emission limit is specified, up to the frequency shown in the following table.

| Highest frequency generated or used in the device or on which the device operates or tunes (MHz) | Upper frequency of measurement range (MHz) |
|--|---|
| Below 1.705 | 30 |
| 1.705 to 108 | 1 000 |
| 108 to 500 | 2 000 |
| 500 to 1 000 | 5 000 |
| Above 1 000 | 5 th harmonic of the highest frequency or 40 GHz, whichever is lower |

3.3 Configuration of Tested System

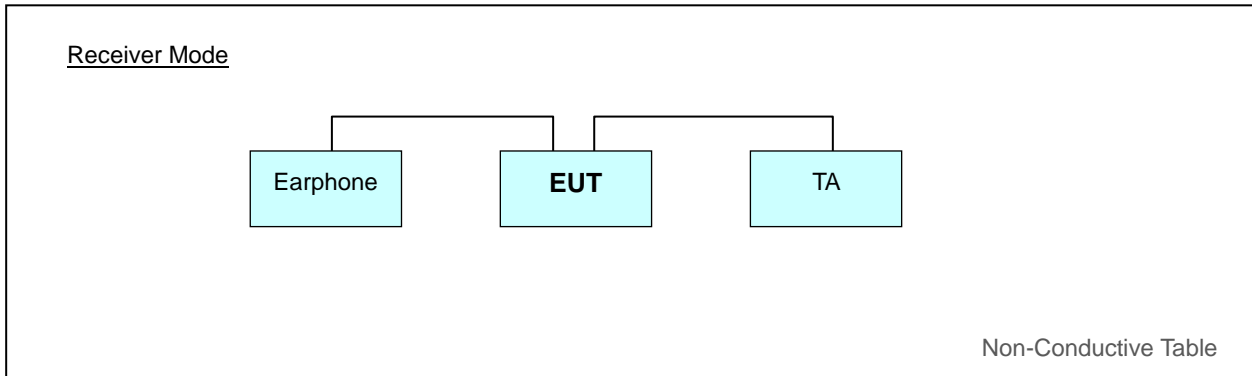



4. OPERATION OF THE EUT

During preliminary tests, the following operating mode was investigated.

Receiver mode(GSM 850 Low/Middle/High ch Idle)
 Receiver mode(WCDMA B5 Low/Middle/High ch Idle)
 Receiver mode(LTE B5_Low/Middle/High ch)
 Receiver mode(LTE B12_Low/Middle/High ch)
 Receiver mode(LTE B17_Low/Middle/High ch)
 Receiver mode(LTE B26_Low/Middle/High ch)
 Receiver mode(5G NR n5_Low/Middle/High ch)

NOTE. The worst case is tested.

4.1 Conducted Emission (Not Applicable)

Operating Mode: Not applicable

NOTE. Conducted emission for receiver mode is covered by JBP report.

4.2 Radiated Emission

It was final tested the following operating mode, after connecting all peripheral devices.

Operating Mode:

Radiated Emission below 1 GHz:

- LTE B5+5G NR n5 Low ch Idle*
- LTE B5+5G NR n5 Middle ch Idle
- LTE B5+5G NR n5 High ch Idle
- LTE B12(B17) Low ch Idle
- LTE B12(B17) Middle ch Idle*
- LTE B12(B17) High ch Idle
- LTE B26 Low ch Idle
- LTE B26 Middle ch Idle
- LTE B26 High ch Idle*

Radiated Emission above 1 GHz:

- LTE B5+5G NR n5 Low ch Idle
- LTE B12(B17) Middle ch Idle
- LTE B26 High ch Idle*

NOTE.

1. Three orientations have been investigated and the worst-case orientation (x-axis: The display of EUT placed on the table is facing upwards) is reported.
2. The worst case of operating mode is reported. [*].
3. Frequency bands adjacent to each other are tested as one mode.



5. EMI TEST SUMMARY

5.1 Conducted Emission

5.1.1 Test Condition

The test results of conducted emission at mains ports provide the following information:

| | |
|---------------------------|---|
| Used Test Standard | 47 CFR PART 15 Subpart B Class B ANSI C63.4-2014 |
| Frequency Range | 150 kHz to 30 MHz |
| Detector | Quasi-Peak, CISPR-Average |
| Bandwidth | 9 kHz (6 dB) |
| Operating Mode | - |
| Test Site | EMI Shield Room |
| Temperature | min. - °C, max. - °C |
| Humidity | min. - % R.H., max. - % R.H. |
| Test Date | - |

Calculation Formula:

1. Conductor L1 = Hot, Conductor N = Neutral
2. Corr. = LISN Factor+Cable Loss
3. QuasiPeak or CAverage= Receiver Reading+Corr.
4. Margin = Limit – QuasiPeak or CAverage

5.1.2 Measuring Data

Not applicable



5.2 Radiated Emission Below 1 GHz

5.2.1 Test Condition

The test results of radiated emission provide the following information:

| | |
|-------------------------------------|--|
| Used Test Standard | 47 CFR PART 15 Subpart B Class B ANSI C63.4-2014 |
| Frequency Range | 30 MHz to 1 000 MHz |
| Detector / Bandwidth | Detector type: Quasi-Peak Bandwidth: 120 kHz (6 dB) |
| Operating Mode of Worst case | LTE B5+5G NR n5 Low ch Idle LTE B12(B17) Middle ch Idle LTE B26 High ch Idle |
| Measurement Distance | 3 m |
| Antenna Measurement Height | 1 m to 4 m |
| Test Site | 3 m Semi Anechoic Chamber #1 |
| Temperature | min. 23.1 °C, max. 24.1 °C |
| Humidity | min. 30.9 % R.H., max. 33.2 % R.H. |
| Test Date | May 08, 2023 |

Calculation Formula:

1. POL. H = Horizontal, POL. V = Vertical
2. QuasiPeak = Reading (Receiver Reading)+Corr.
3. Corr. (Correction Factor) = Antenna Factor+Cable Loss
4. Margin = Limit - QuasiPeak



5.2.2 Measuring Data

Figure 1: LTE B5+5G NR n5 Low ch Idle

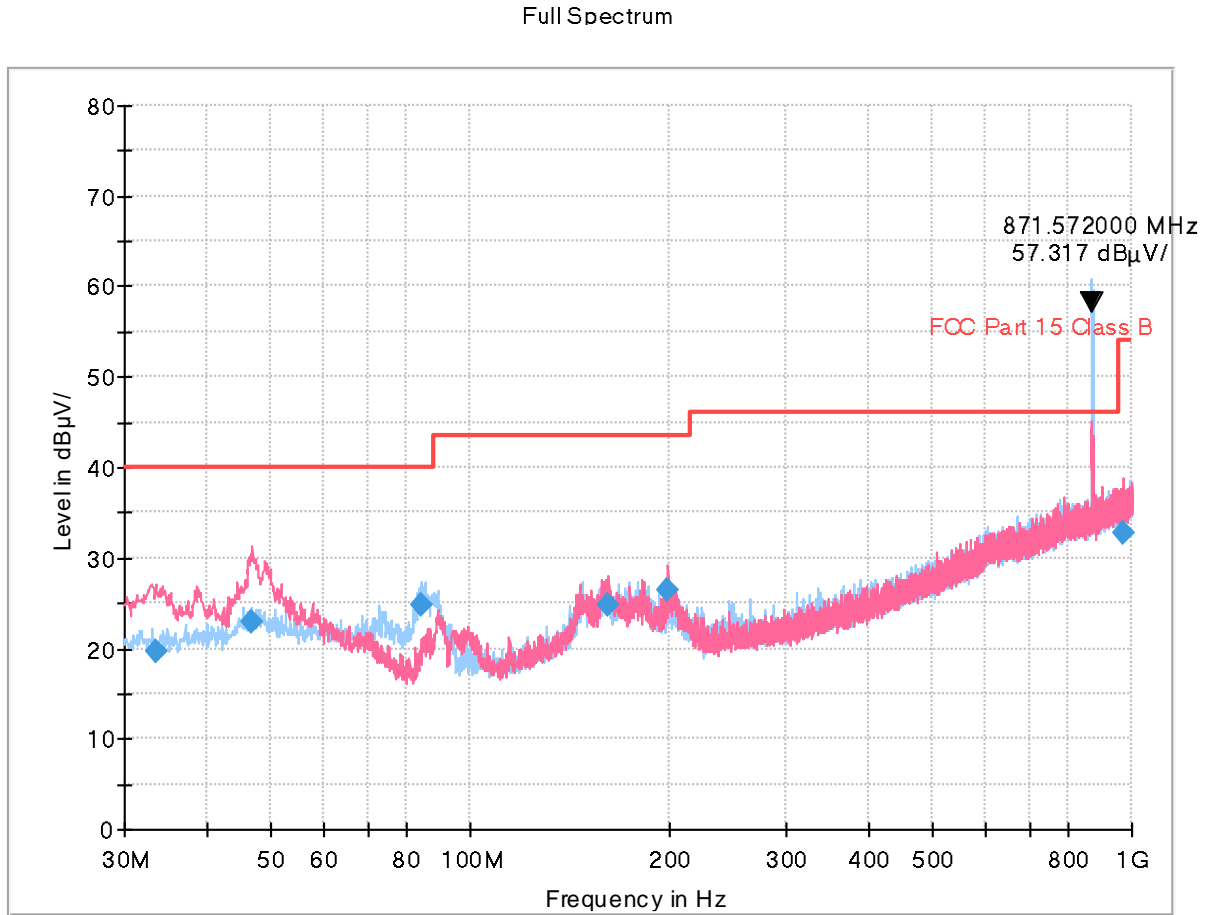

NOTE. 1. Carrier Frequency: Rx 871.572 MHz
 2. These are signals for fundamental frequency from the base station

| Frequency (MHz) | Quasi Peak (dBµV/m) | Limit (dBµV/m) | Margin (dB) | Antenna Height (cm) | POL. (H/V) | Azimuth (deg) | Corr. (dB) |
|-----------------|---------------------|----------------|-------------|---------------------|------------|---------------|------------|
| 33.5225 | 19.56 | 40.00 | 20.44 | 100.0 | V | 333.0 | 18.8 |
| 46.8525 | 22.91 | 40.00 | 17.09 | 118.1 | V | 190.0 | 19.9 |
| 84.3986 | 24.85 | 40.00 | 15.15 | 225.2 | H | 113.0 | 15.1 |
| 161.9837 | 24.84 | 43.50 | 18.66 | 100.0 | V | 103.0 | 19.6 |
| 199.2760 | 26.47 | 43.50 | 17.03 | 100.0 | V | 168.0 | 17.1 |
| 968.6020 | 32.64 | 54.00 | 21.36 | 100.0 | V | 287.0 | 32.4 |



Figure 2: LTE B12(B17) Middle ch Idle

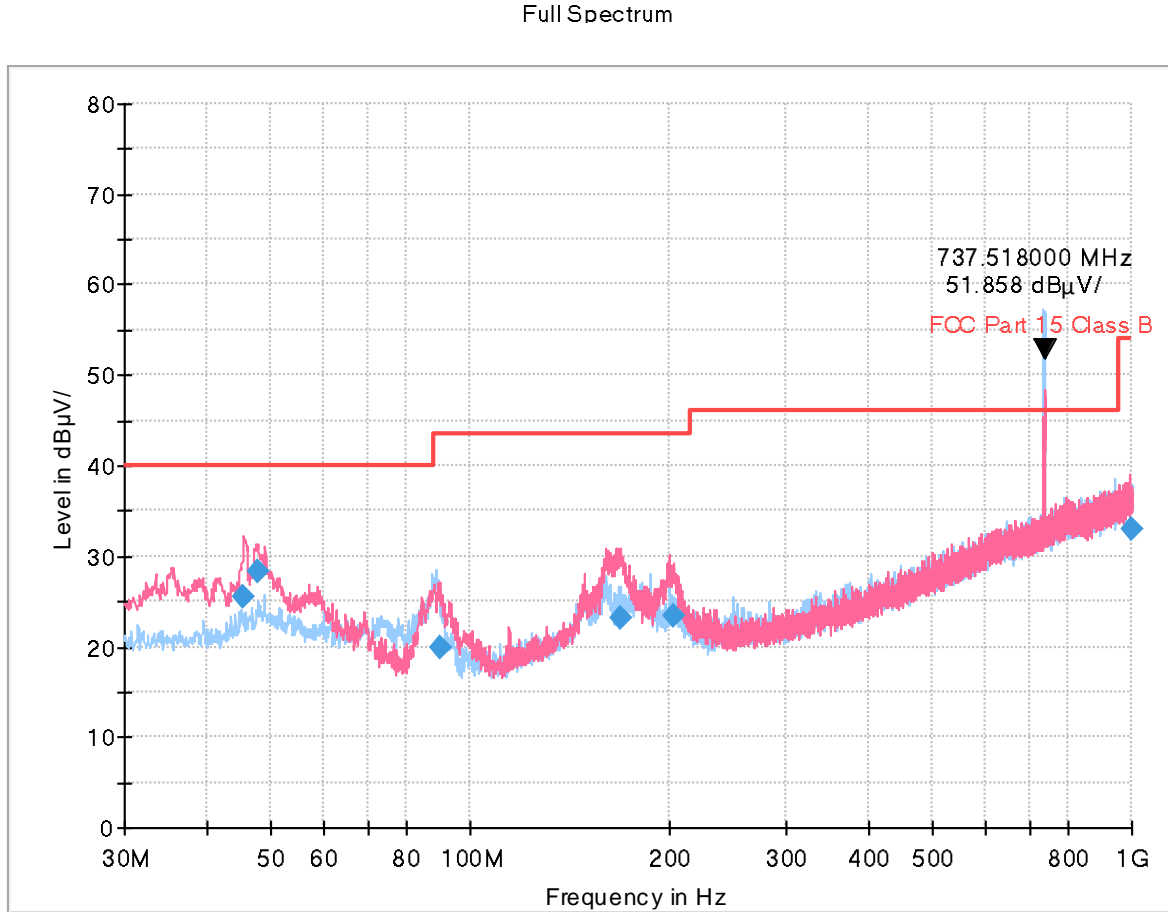

NOTE. 1. Carrier Frequency: Rx 737.518 MHz
 2. These are signals for fundamental frequency from the base station

| Frequency (MHz) | Quasi Peak (dBµV/m) | Limit (dBµV/m) | Margin (dB) | Antenna Height (cm) | POL. (H/V) | Azimuth (deg) | Corr. (dB) |
|-----------------|---------------------|----------------|-------------|---------------------|------------|---------------|------------|
| 45.4837 | 25.40 | 40.00 | 14.60 | 104.5 | V | 196.0 | 19.8 |
| 47.7327 | 28.29 | 40.00 | 11.71 | 100.0 | V | 209.0 | 20.0 |
| 89.8824 | 19.97 | 43.50 | 23.53 | 125.2 | V | 284.0 | 14.6 |
| 168.2749 | 23.16 | 43.50 | 20.34 | 100.0 | V | 192.0 | 19.1 |
| 202.7945 | 23.49 | 43.50 | 20.01 | 100.0 | V | 178.0 | 17.2 |
| 999.0585 | 33.06 | 54.00 | 20.94 | 174.4 | H | 30.0 | 32.8 |



Figure 3: LTE B26 High ch Idle

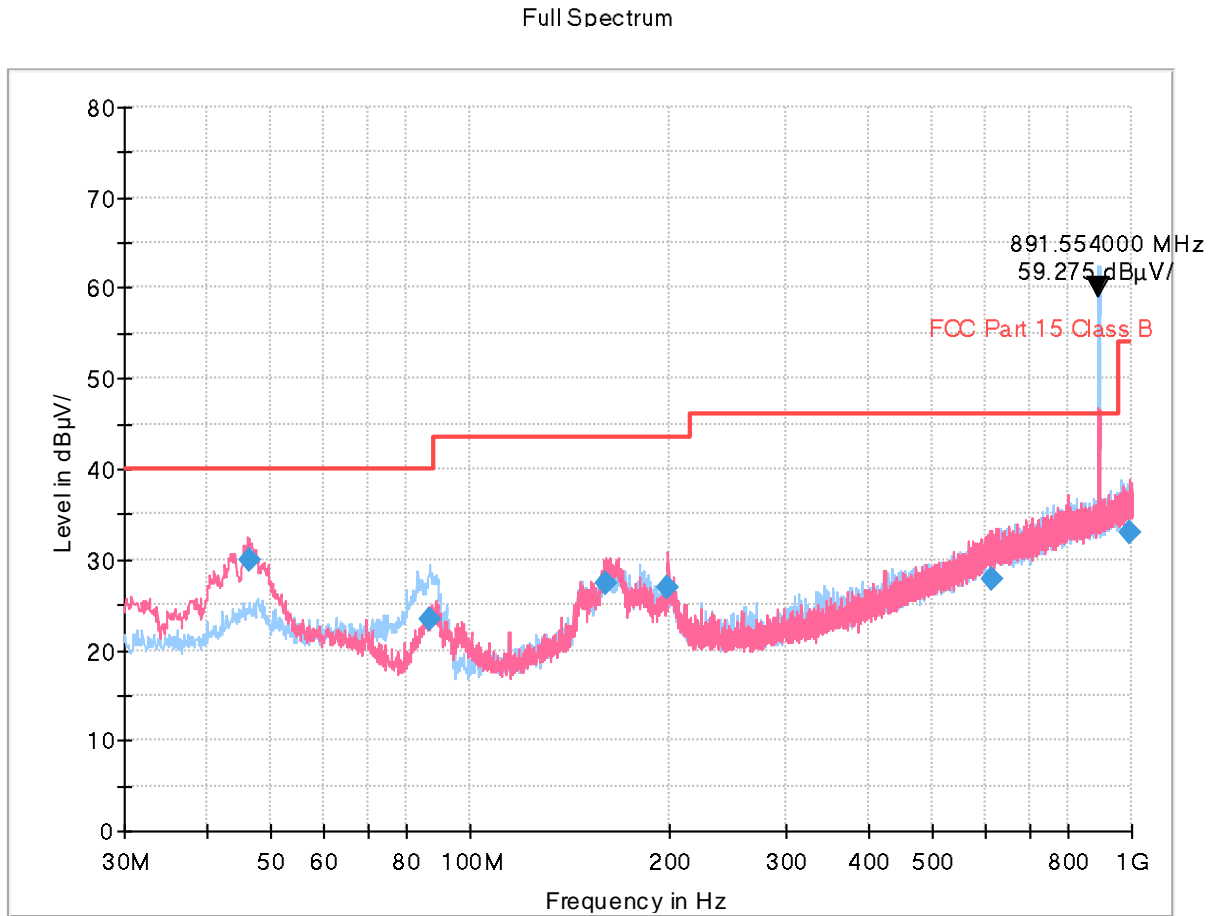

NOTE. 1. Carrier Frequency: Rx 891.554 MHz
 2. These are signals for fundamental frequency from the base station

| Frequency (MHz) | Quasi Peak (dBµV/m) | Limit (dBµV/m) | Margin (dB) | Antenna Height (cm) | POL. (H/V) | Azimuth (deg) | Corr. (dB) |
|-----------------|---------------------|----------------|-------------|---------------------|------------|---------------|------------|
| 46.2440 | 29.92 | 40.00 | 10.08 | 100.0 | V | 199.0 | 19.9 |
| 86.9886 | 23.32 | 40.00 | 16.68 | 274.7 | H | 120.0 | 14.8 |
| 160.2570 | 27.36 | 43.50 | 16.14 | 100.0 | V | 119.0 | 19.8 |
| 199.1727 | 26.79 | 43.50 | 16.71 | 125.3 | H | 6.0 | 17.1 |
| 614.5415 | 27.75 | 46.00 | 18.25 | 119.9 | H | 140.0 | 27.7 |
| 991.8560 | 33.00 | 54.00 | 21.00 | 225.1 | V | 242.0 | 32.7 |



5.3 Radiated Emission Above 1 GHz

5.3.1 Test Condition

The test results of radiated emission provide the following information:

| | |
|-------------------------------------|--|
| Used Test Standard | 47 CFR PART 15 Subpart B Class B ANSI C63.4-2014 |
| Detector / Bandwidth | Detector type: Peak, CISPR-Average Bandwidth: 1 MHz |
| Highest Frequency | 5 825 MHz |
| Tested Frequency Range | 1 GHz to 40 GHz |
| Operating Mode of Worst case | LTE B26 High ch Idle |
| Measurement Distance | 3 m |
| Antenna Measurement Height | 1 m to 4 m |
| Test Site | 3 m Semi Anechoic Chamber #1 |
| Temperature | min. 23.1 °C, max. 24.6 °C |
| Humidity | min. 30.9 % R.H., max. 33.8 % R.H. |
| Test Date | May 08, 2023 to May 09, 2023 |

Calculation Formula:

1. POL. H = Horizontal, POL. V = Vertical
2. Peak or CAverage = Reading (Receiver Reading)+Corr.
3. Corr. (Correction Factor) = Antenna Factor+ Cable Loss –Amplifier Gain
4. Margin = Limit - Peak or CAverage



5.3.2 Measuring Data

Figure 4: LTE B26 High ch Idle

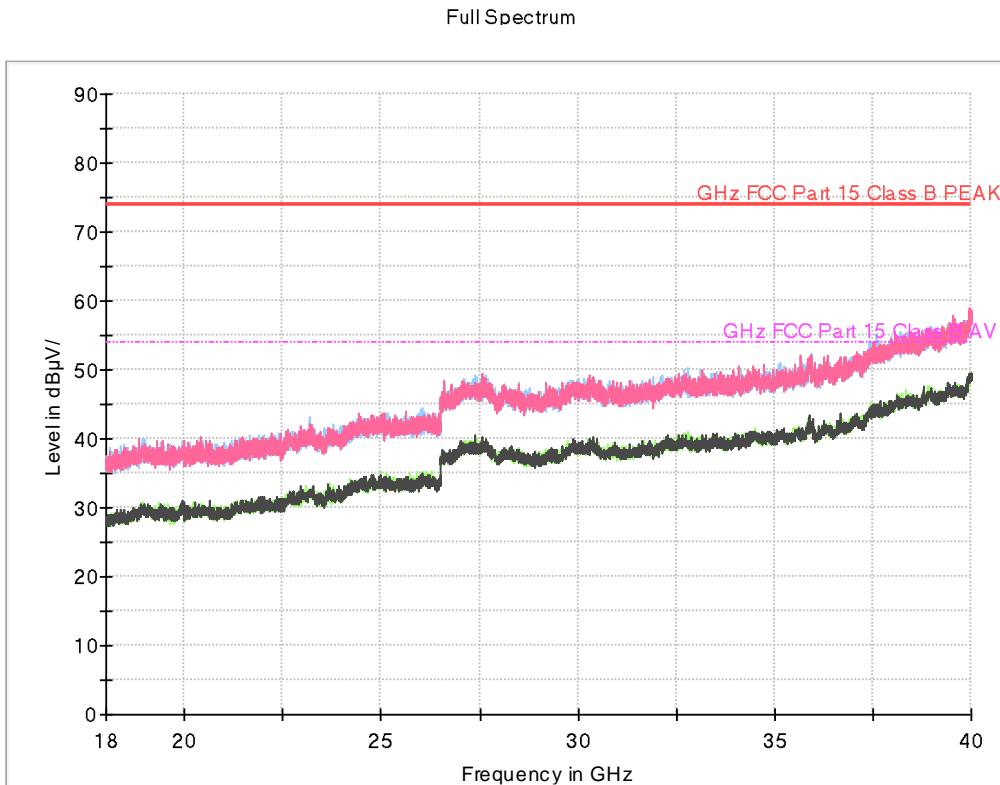
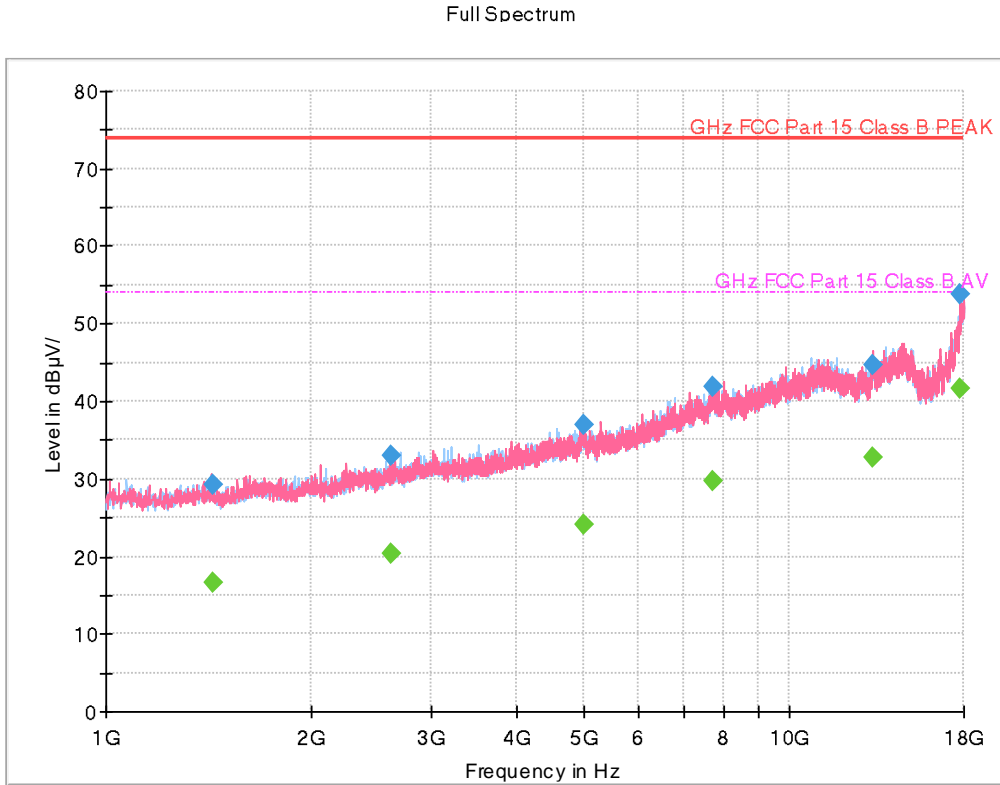



| Frequency (MHz) | Peak (dB μ V/m) | Limit (dB μ V/m) | Margin (dB) | Antenna Height (cm) | POL. (H/V) | Azimuth (deg) | Corr. (dB) |
|-----------------|---------------------|----------------------|-------------|---------------------|------------|---------------|------------|
| 1435.8400 | 29.25 | 74.00 | 44.75 | 336.8 | V | 190.0 | -30.0 |
| 2622.9350 | 32.98 | 74.00 | 41.02 | 110.5 | V | 294.0 | -25.5 |
| 4995.3600 | 36.84 | 74.00 | 37.16 | 150.1 | H | 239.0 | -17.9 |
| 7733.3000 | 41.86 | 74.00 | 32.14 | 350.1 | V | 262.0 | -10.3 |
| 13215.9450 | 44.70 | 74.00 | 29.30 | 117.4 | V | 188.0 | -3.1 |
| 17819.6550 | 53.77 | 74.00 | 20.23 | 250.1 | V | 54.0 | 8.8 |

| Frequency (MHz) | CAverage (dB μ V/m) | Limit (dB μ V/m) | Margin (dB) | Antenna Height (cm) | POL. (H/V) | Azimuth (deg) | Corr. (dB) |
|-----------------|-------------------------|----------------------|-------------|---------------------|------------|---------------|------------|
| 1435.8400 | 16.65 | 54.00 | 37.35 | 336.8 | V | 190.0 | -30.0 |
| 2622.9350 | 20.31 | 54.00 | 33.69 | 110.5 | V | 294.0 | -25.5 |
| 4995.3600 | 24.18 | 54.00 | 29.82 | 150.1 | H | 239.0 | -17.9 |
| 7733.3000 | 29.63 | 54.00 | 24.37 | 350.1 | V | 262.0 | -10.3 |
| 13215.9450 | 32.72 | 54.00 | 21.28 | 117.4 | V | 188.0 | -3.1 |
| 17819.6550 | 41.59 | 54.00 | 12.41 | 250.1 | V | 54.0 | 8.8 |



6. APPENDIX A. TEST SETUP PHOTO

Please refer to EMI Test Setup Photo and test setup photo file no. as follows;

| Rev. No. | Issue Date | File No. |
|-----------------|-------------------|---------------------|
| 0 | May 23, 2023 | HCT-EM-2305-FC005-P |

End of report