

FCC REPORT

Class II Permissive Change

Applicant Name:
SAMSUNG Electronics Co., Ltd.

Date of Issue:
December 05, 2018

Address:
129, Samsung-ro, Yeongtong-gu, Suwon-si,
Gyeonggi-do, 16677, Rep. of Korea

Location of test lab:
HCT CO., LTD.,
74, Seoicheon-ro 578beon-gil, Majang-myeon,
Icheon-si, Gyeonggi-do, 17383, Rep. of KOREA

Report No.: HCT-RF-1812-FC009

FCC ID: A3LSMM-2LD0581902

APPLICANT: SAMSUNG Electronics Co.,Ltd.

Model: SMM-2LD0581900

EUT Type: Remote Radio Head

Frequency Ranges: 1 930 MHz ~ 1 995 MHz

Output Power: 160 W (40 W * 4)

Emission Designator:

Modulation	Frequency (MHz)	Emission Designator	
		QPSK (G7W)	16QAM/64QAM/256QAM (D7W)
LTE (3 MHz)	1 930 ~ 1 995	2M71G7W	2M72D7W
LTE (5 MHz)	1 930 ~ 1 995	4M50G7W	4M51D7W
LTE (20 MHz)	1 930 ~ 1 995	18M0G7W	18M0D7W

※ 10 MHz and 15 MHz emission designator can be found in previously issued report

Date of Test: November 11, 2018 ~ November 22, 2018

FCC Rule Part(s): CFR 47 Part 2, Part 24

Note: Refer to existing report 'HCTR1108FR14', 'HCTR1108FR15', 'HCTR1210FR28',
'HCTR1305FR15' and 'HCT-RF-1801-FC005' for data not included.

The measurements shown in this report were made in accordance with the procedures indicated, and the emissions from this equipment were found to be within the limits applicable. I assume full responsibility for the accuracy and completeness of these measurements, and for the qualifications of all persons taking them. It is further stated that upon the basis of the measurements made, the equipment tested is capable of operation in accordance with the requirements of the FCC Rules under normal use and maintenance.



Report prepared by : Kwang il Yoon
Engineer of telecommunication testing center



Approved by : Jong Seok Lee
Manager of telecommunication testing center

This report only responds to the tested sample and may not be reproduced, except in full, without written approval of the HCT Co., Ltd.

Version

TEST REPORT NO.	DATE	DESCRIPTION
HCT-RF-1812-FC009	December 04, 2018	- First Approval Report

Table of Contents

1. GENERAL INFORMATION.....	4
1.1. APPLICANT INFORMATION.....	4
1.2. PRODUCT INFORMATION	4
1.3. TEST INFORMATION	4
2. FACILITIES AND ACCREDITATIONS	5
2.1. FACILITIES	5
2.2. EQUIPMENT	5
3. TEST SPECIFICATIONS.....	6
3.1. STANDARDS	6
3.2. ADDITIONAL DESCRIPTIONS ABOUT TEST	7
3.3. MAXIMUM MEASUREMENTUNCERTAINTY	8
3.4. STANDARDS ENVIRONMENTAL TEST CONDITIONS.....	8
3.5. TEST DIAGRAMS.....	9
4. TEST EQUIPMENTS.....	11
5. TEST RESULT	12
5.1. RF OUTPUT POWER	12
5.2. OCCUPIED BANDWIDTH	94
5.3. UNWANTED CONDUCTED EMISSIONS	132
5.4. RADIATED EMISSIONS	411
5.5. FREQUENCY STABILITY.....	414
6. Annex A_EUT AND TEST SETUP PHOTO	418

1. GENERAL INFORMATION

1.1. APPLICANT INFORMATION

Company Name	Samsung Electronics Co., Ltd.
Company Address	129, Samsung-ro, Yeongtong-gu, Suwon-si, Gyeonggi-do, 16677, Rep. of Korea

1.2. PRODUCT INFORMATION

EUT Type	Remote Radio Head		
Power Supply	DC -48 V		
Emission Designator	Modulation	Frequency (MHz)	Emission Designator
			QPSK (G7W) 16QAM/64QAM/256QAM (D7W)
	LTE (3 MHz)	1 930 ~ 1 995	2M71G7W 2M72D7W
	LTE (5 MHz)	1 930 ~ 1 995	4M50G7W 4M51D7W
	LTE (20 MHz)	1 930 ~ 1 995	18M0G7W 18M0D7W
※ 10 MHz and 15 MHz emission designator can be found in previously issued report			
Frequency Range	1 930 MHz ~ 1 995 MHz		
Output Power	160 W (40W * 4)		
Channel Bandwidths	LTE Band 25, 3 MHz / 5 MHz / 20 MHz Bandwidth		
Modulation Type	QPSK, 16QAM, 64QAM, 256QAM		
Antenna Specification	Manufacturer does not provide an antenna.		

1.3. TEST INFORMATION

FCC Rule Parts	CFR 47 Part 2, Part 24
Measurement standards	ANSI C63.26-2015, KDB 662911 D01 v02r01
Place of Test	HCT CO., LTD. 74, Seoicheon-ro 578beon-gil, Majang-myeon, Icheon-si, Gyeonggi-do, 17383, Rep. of KOREA

2. FACILITIES AND ACCREDITATIONS

2.1. FACILITIES

The SAC(Semi-Anechoic Chamber) and conducted measurement facility used to collect the radiated data are located at the 74, Seoicheon-ro 578beon-gil, Majang-myeon, Icheon-si, Gyeonggi-do, 17383, Rep. of KOREA.

The site is constructed in conformance with the requirements of ANSI C63.4 (Version: 2014) and CISPR Publication 22.

Detailed description of test facility was submitted to the Commission and accepted dated April 02, 2018 (Registration Number: KR0032).

2.2. EQUIPMENT

Radiated emissions are measured with one or more of the following types of linearly polarized antennas: tuned dipole, bi-conical, log periodic, bi-log, and/or ridged waveguide, horn. Spectrum analyzers with pre-selectors and quasi-peak detectors are used to perform radiated measurements.

Calibrated wideband preamplifiers, coaxial cables, and coaxial attenuators are also used for making measurements.

All receiving equipment conforms to CISPR Publication 16-1, "Radio Interference Measuring Apparatus and Measurement Methods."

3. TEST SPECIFICATIONS

3.1. STANDARDS

The following tests were conducted on a sample of the equipment for the purpose of demonstrating compliance with FCC Part 2, Part 24

Description	Reference	Results
RF Output Power	§2.1046, §24.232	Compliant
Occupied Bandwidth	§2.1049	Compliant
Unwanted Conducted Emissions	§2.1051, §24.238	Compliant
Radiated Emissions	§2.1053, §24.238	Compliant
Frequency Stability	§2.1055, §24.235	Compliant

3.2. ADDITIONAL DESCRIPTIONS ABOUT TEST

- The EUT was operated in a manner representative of the typical usage of the equipment.
- During all testing, system components were manipulated within the confines of typical usage to maximize each emission.
- All LTE modulation types (QPSK, 16QAM, 64QAM, 256QAM) supported by the EUT have been tested.
- The dummy loads were connected to the RF output ports for radiated spurious emission testing.
- The tests results in plots are already including the actual value of loss for the attenuator and cable combination. Please check correction factors below table.

Correction factor table			
Frequency (MHz)	Factor (dB)	Frequency (MHz)	Factor (dB)
50	30.446	7 000	32.582
100	30.587	8 000	32.854
200	30.566	9 000	32.730
300	30.749	10 000	32.956
400	30.863	11 000	32.251
500	30.853	12 000	32.887
600	30.863	13 000	32.314
700	30.899	14 000	32.732
750	30.929	15 000	33.380
800	31.137	16 000	32.487
850	31.124	17 000	33.139
900	30.566	18 000	33.185
1 000	30.749	19 000	33.761
1 500	31.318	20 000	33.907
2 000	31.330	21 000	36.554
2 500	31.511	22 000	35.316
3 000	31.806	23 000	38.528
3 500	31.348	24 000	40.021
4 000	32.374	25 000	35.730
5 000	32.165	26 000	33.979
6 000	32.436	26 500	34.522

3.3. MAXIMUM MEASUREMENT UNCERTAINTY

The value of the measurement uncertainty for the measurement of each parameter.

Coverage factor $k = 2$, Confidence levels of 95 %

Description	Condition	Uncertainty
RF Output Power	-	± 0.72 dB
Occupied Bandwidth	-	± 0.58 MHz
Unwanted Conducted Emissions	-	± 1.08 dB
Radiated Emissions	$f \leq 1$ GHz	± 4.80 dB
	$f > 1$ GHz	± 6.07 dB
Frequency Stability	-	$\pm 1.22 \times 10^{-6}$

3.4. STANDARDS ENVIRONMENTAL TEST CONDITIONS

Temperature :	+15 °C to +35 °C
Relative humidity:	30 % to 60 %
Air pressure	860 mbar to 1 060 mbar

3.5. TEST DIAGRAMS

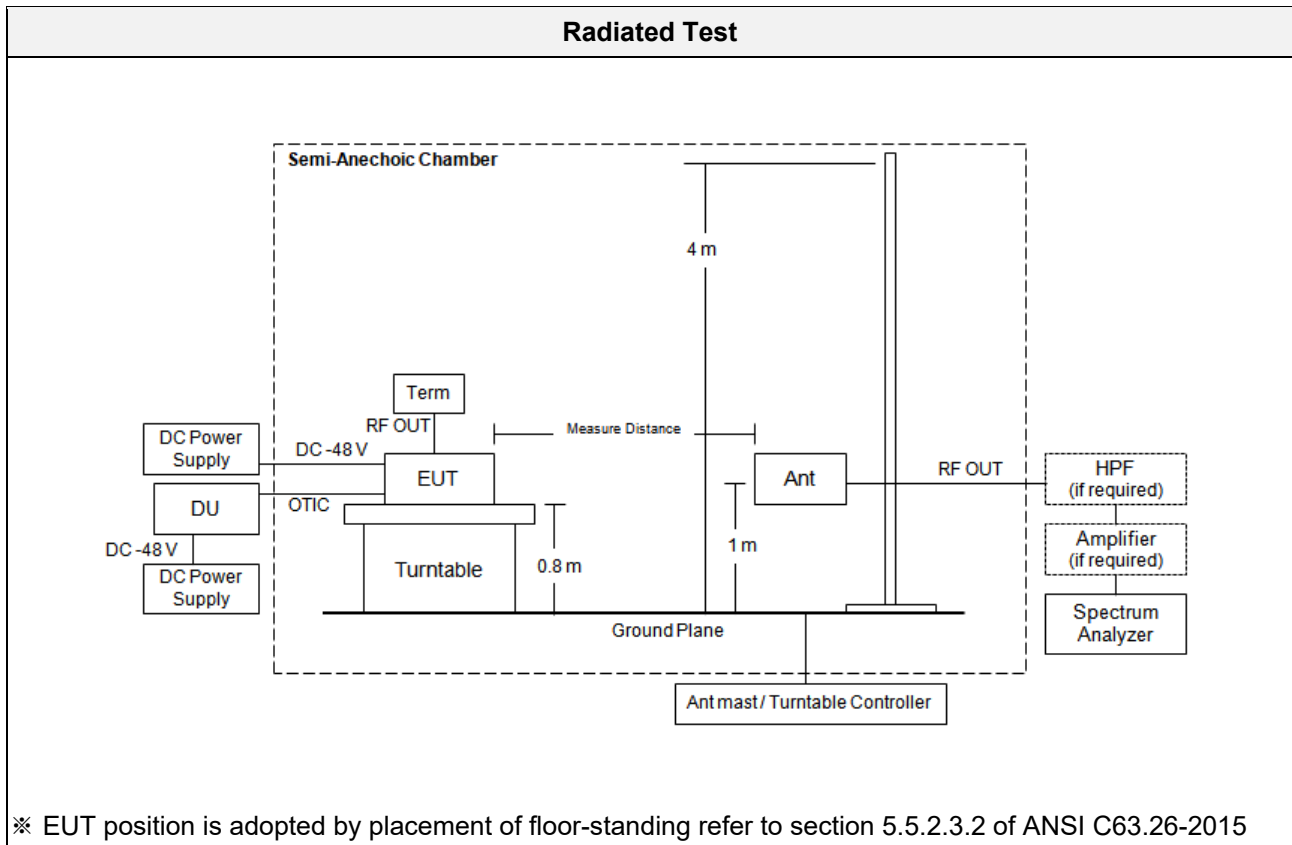
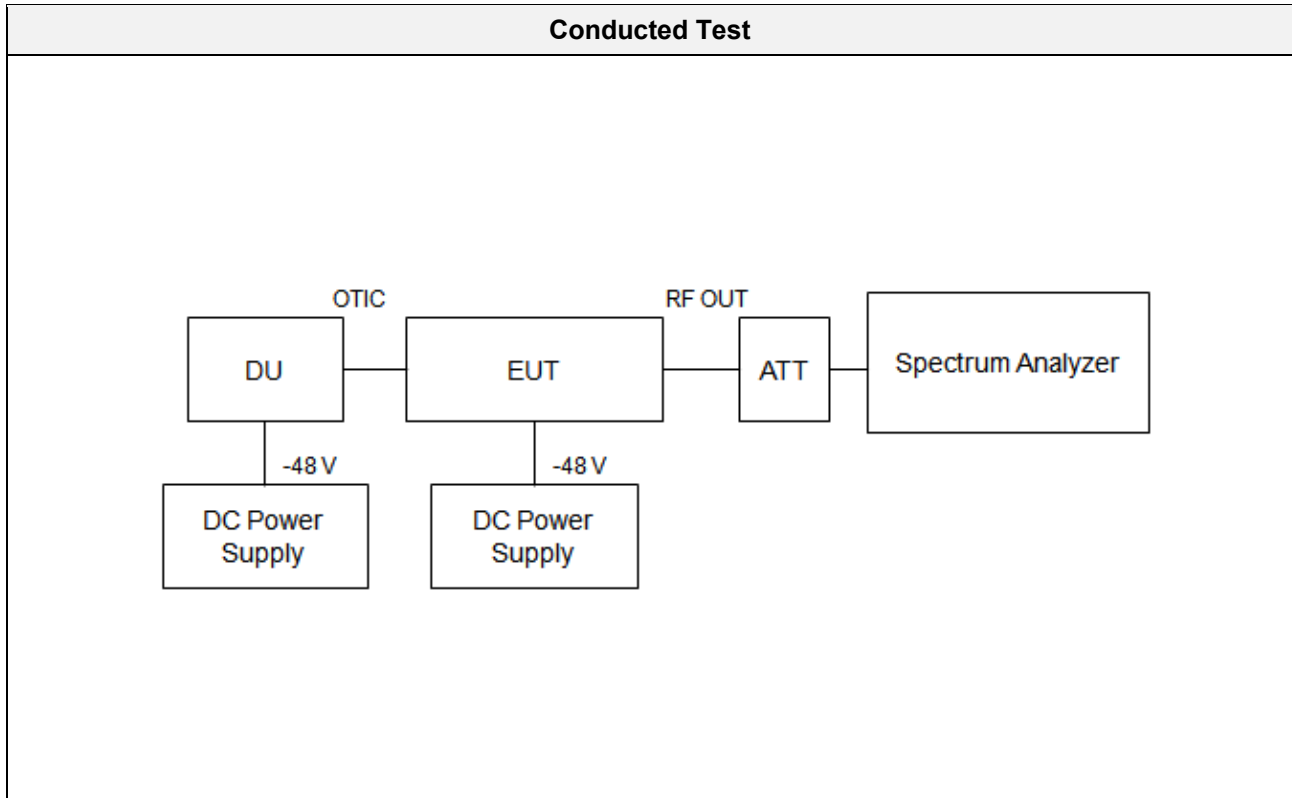

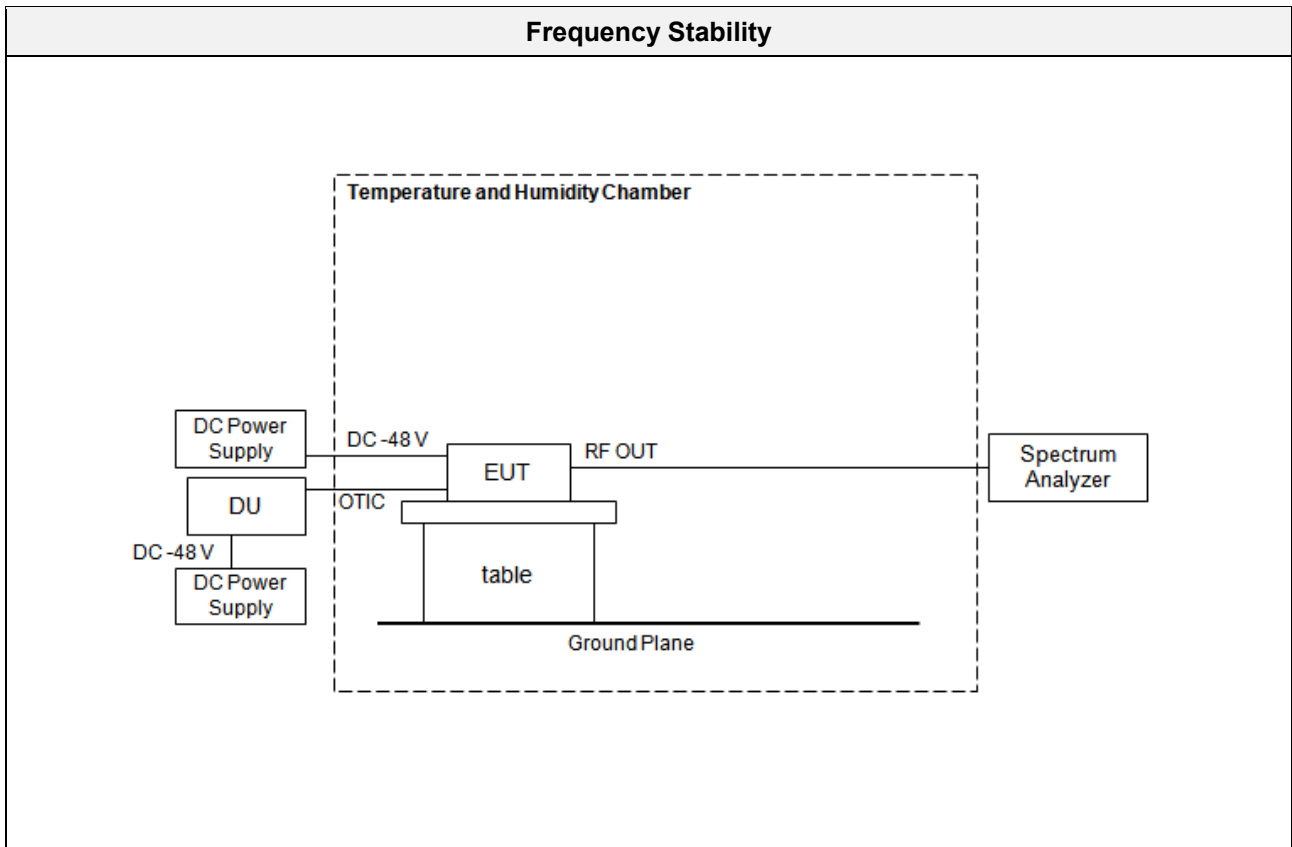

4. TEST EQUIPMENTS

Manufacturer	Model / Equipment	Calibration Date	Calibration Interval	Serial No.
Agilent	N9020A / Spectrum Analyzer	09/05/2018	Annual	MY46471250
AGILENT	8498A / Coaxial Attenuator	09/06/2018	Annual	51162
AGILENT	6674A / DC Power Supply	08/02/2018	Annual	3501A00901
KIKUSUI	PWR800L / DC Power Supply	02/27/2018	Annual	RE001149
NANGYEUL CO., LTD.	NY-THR18750 / Temperature and Humidity Chamber	10/30/2018	Annual	NY-2009012201A
Innco system	CO3000 / Controller(Antenna mast)	N/A	N/A	CO3000-4p
Innco system	MA4640/800-XP-EP / Antenna Position Tower	N/A	N/A	N/A
Emco	2090 / Controller	N/A	N/A	060520
Ets	- / Turn Table	N/A	N/A	N/A
Rohde&Schwarz	- / Loop Antenna	04/19/2017	Biennial	1513-175
Schwarzbeck	VULB 9168 / Hybrid Antenna	04/06/2017	Biennial	760
Schwarzbeck	BBHA 9120D / Horn Antenna	06/30/2017	Biennial	9120D-1300
Schwarzbeck	BBHA9170 / Horn Antenna(15 GHz ~ 40 GHz)	04/25/2017	Biennial	BBHA9170124
Rohde&Schwarz	FSP / Spectrum Analyzer	09/19/2018	Annual	836650/016
Wainwright Instruments	WHKX10-900-1000-15000-40SS / High Pass Filter	07/20/2018	Annual	5
Wainwright Instruments	WHKX10-2700-3000-18000-40SS / High Pass Filter	07/20/2018	Annual	3
CERNEX	CBLU1183540 / Power Amplifier	01/03/2018	Annual	24613
CERNEX	CBL06185030 / Power Amplifier	01/03/2018	Annual	24615

5. TEST RESULT

5.1. RF OUTPUT POWER

Test Requirements:

§ 2.1046 Measurements required: RF power output.

(a) For transmitters other than single sideband, independent sideband and controlled carrier radiotelephone, power output shall be measured at the RF output terminals when the transmitter is adjusted in accordance with the tune-up procedure to give the values of current and voltage on the circuit elements specified in §2.1033(c)(8). The electrical characteristics of the radio frequency load attached to the output terminals when this test is made shall be stated.

(b) For single sideband, independent sideband, and single channel, controlled carrier radiotelephone transmitters the procedure specified in paragraph (a) of this section shall be employed and, in addition, the transmitter shall be modulated during the test as specified and applicable in § 2.1046 (b) (1-5). In all tests, the input level of the modulating signal shall be such as to develop rated peak envelope power or carrier power, as appropriate, for the transmitter.

(c) For measurements conducted pursuant to paragraphs (a) and (b) of this section, all calculations and methods used by the applicant for determining carrier power or peak envelope power, as appropriate, on the basis of measured power in the radio frequency load attached to the transmitter output terminals shall be shown. Under the test conditions specified, no components of the emission spectrum shall exceed the limits specified in the applicable rule parts as necessary for meeting occupied bandwidth or emission limitations.

§ 24.232 Power and antenna height limits.

(a)(1) Base stations with an emission bandwidth of 1 MHz or less are limited to 1640 watts equivalent isotropically radiated power (EIRP) with an antenna height up to 300 meters HAAT, except as described in paragraph (b) below.

(2) Base stations with an emission bandwidth greater than 1 MHz are limited to 1640 watts/MHz equivalent isotropically radiated power (EIRP) with an antenna height up to 300 meters HAAT, except as described in paragraph (b) below.

(3) Base station antenna heights may exceed 300 meters HAAT with a corresponding reduction in power; see Tables 1 and 2 of this section.

(4) The service area boundary limit and microwave protection criteria specified in §§24.236 and 24.237 apply.

Table 1—Reduced Power for Base Station Antenna Heights Over 300 Meters, With Emission Bandwidth of 1 MHz or Less

HAAT in meters	Maximum EIRP watts
≤300	1640

≤500	1070
≤1000	490
≤1500	270
≤2000	160

Table 2—Reduced Power for Base Station Antenna Heights Over 300 Meters, With Emission Bandwidth Greater Than 1 MHz

HAAT in meters	Maximum EIRP watts/MHz
≤300	1640
≤500	1070
≤1000	490
≤1500	270
≤2000	160

(b)(1) Base stations that are located in counties with population densities of 100 persons or fewer per square mile, based upon the most recently available population statistics from the Bureau of the Census, with an emission bandwidth of 1 MHz or less are limited to 3280 watts equivalent isotropically radiated power (EIRP) with an antenna height up to 300 meters HAAT.

(2) Base stations that are located in counties with population densities of 100 persons or fewer per square mile, based upon the most recently available population statistics from the Bureau of the Census, with an emission bandwidth greater than 1 MHz are limited to 3280 watts/MHz equivalent isotropically radiated power (EIRP) with an antenna height up to 300 meters HAAT.

(3) Base station antenna heights may exceed 300 meters HAAT with a corresponding reduction in power; see Tables 3 and 4 of this section.

(4) The service area boundary limit and microwave protection criteria specified in §§24.236 and 24.237 apply.

(5) Operation under this paragraph (b) at power limits greater than permitted under paragraph (a) of this section must be coordinated in advance with all broadband PCS licensees authorized to operate on adjacent frequency blocks within 120 kilometers (75 miles) of the base station and is limited to base stations located more than 120 kilometers (75 miles) from the Canadian border and more than 75 kilometers (45 miles) from the Mexican border.

Table 3—Reduced Power for Base Station Antenna Heights Over 300 Meters, With Emission Bandwidth of 1 MHz or Less

HAAT in meters	Maximum EIRP watts
≤300	3280
≤500	2140
≤1000	980
≤1500	540
≤2000	320

Table 4—Reduced Power for Base Station Antenna Heights Over 300 Meters, With Emission Bandwidth Greater Than 1 MHz

HAAT in meters	Maximum EIRP watts/MHz
≤300	3280
≤500	2140
≤1000	980
≤1500	540
≤2000	320

(c) Mobile and portable stations are limited to 2 watts EIRP and the equipment must employ a means for limiting power to the minimum necessary for successful communications.

(d) Power measurements for transmissions by stations authorized under this section may be made either in accordance with a Commission-approved average power technique or in compliance with paragraph (e) of this section. In both instances, equipment employed must be authorized in accordance with the provisions of §24.51. In measuring transmissions in this band using an average power technique, the peak-to-average ratio (PAR) of the transmission may not exceed 13 dB.

(e) Peak transmit power must be measured over any interval of continuous transmission using instrumentation calibrated in terms of an rms-equivalent voltage. The measurement results shall be properly adjusted for any instrument limitations, such as detector response times, limited resolution bandwidth capability when compared to the emission bandwidth, sensitivity, etc., so as to obtain a true peak measurement for the emission in question over the full bandwidth of the channel.

Note to §24.232: Height above average terrain (HAAT) is to be calculated using the method set forth in §24.53 of this part.

Test Procedures:

The measurement is performed in accordance with Section 5.2.4.4.1 of ANSI C63.26.

- a) Set span to 2 × to 3 × the OBW.
- b) Set RBW = 1 % to 5 % of the OBW.
- c) Set VBW ≥ 3 × RBW.
- d) Set number of measurement points in sweep ≥ 2 × span / RBW.
- e) Sweep time:
 - 1) Set = auto-couple, or
 - 2) Set ≥ [10 × (number of points in sweep) × (transmission symbol period)] for single sweep (automation-compatible) measurement.
- f) Detector = power averaging (rms).
- g) If the EUT can be configured to transmit continuously, then set the trigger to free run.
- h) If the EUT cannot be configured to transmit continuously, then use a sweep trigger with the level set to enable triggering only on full power bursts and configure the EUT to transmit at full power for the entire duration of each sweep. Verify that the sweep time is less than or equal to the transmission burst duration.

Time gating can also be used under similar constraints (i.e., configured such that measurement data is collected only during active full-power transmissions).

- i) Trace average at least 100 traces in power averaging (rms) mode if sweep is set to auto-couple. To accurately determine the average power over multiple symbols, it can be necessary to increase the number of traces to be averaged above 100 or, if using a manually configured sweep time, increase the sweep time.
- j) Compute the power by integrating the spectrum across the OBW of the signal using the instrument's band or channel power measurement function, with the band/channel limits set equal to the OBW band edges. If the instrument does not have a band or channel power function, then sum the spectrum levels (in linear power units) at intervals equal to the RBW extending across the entire OBW of the spectrum.

Note:

- 1) The conducted emission level is measured at each antenna port and then summed mathematically to determine the total emission level from the device.
- 2) Maximum ERP is sufficient level to pass the limit.
- 3) Sum data is in a tolerance of specification provided from manufacturer.

RF Output power tolerance: ± 1 dB (each port)

Maximum output power for one port: 50.362 W (46.02 dBm + 1 dB)

*Maximum output sum power: 50.362 W * 4 = 201.448 W*

Measured sum maximum power: 182.590 W

The measured value is lower than the specification value.

Test Results:

3 MHz Bandwidth / 1 Carrier

Port	Modulation	Channel	Frequency (MHz)	Measured Output Power	
				(dBm)	(W)
Port 0	QPSK	Low	1 931.50	41.24	13.30
		Middle	1 962.50	41.04	12.71
		High	1 993.50	41.39	13.77
	16QAM	Low	1 931.50	41.29	13.47
		Middle	1 962.50	41.02	12.63
		High	1 993.50	41.46	13.98
	64QAM	Low	1 931.50	41.32	13.55
		Middle	1 962.50	40.89	12.27
		High	1 993.50	41.40	13.79
	256QAM	Low	1 931.50	41.28	13.43
		Middle	1 962.50	41.01	12.61
		High	1 993.50	41.36	13.67
Port 1	QPSK	Low	1 931.50	40.95	12.46
		Middle	1 962.50	40.89	12.26
		High	1 993.50	40.98	12.53
	16QAM	Low	1 931.50	41.11	12.91
		Middle	1 962.50	40.89	12.27
		High	1 993.50	41.05	12.74
	64QAM	Low	1 931.50	41.02	12.65
		Middle	1 962.50	40.89	12.28
		High	1 993.50	41.06	12.76
	256QAM	Low	1 931.50	41.02	12.65
		Middle	1 962.50	41.05	12.74
		High	1 993.50	41.01	12.62
Port 2	QPSK	Low	1 931.50	41.04	12.71
		Middle	1 962.50	40.83	12.11
		High	1 993.50	40.95	12.46
	16QAM	Low	1 931.50	41.14	13.01
		Middle	1 962.50	40.78	11.98
		High	1 993.50	40.95	12.45

Port	Modulation	Channel	Frequency (MHz)	Measured Output Power	
				(dBm)	(W)
	64QAM	Low	1 931.50	41.05	12.73
		Middle	1 962.50	40.92	12.35
		High	1 993.50	40.99	12.57
	256QAM	Low	1 931.50	41.14	13.00
		Middle	1 962.50	40.77	11.95
		High	1 993.50	41.09	12.85
Port 3	QPSK	Low	1 931.50	40.87	12.23
		Middle	1 962.50	40.83	12.09
		High	1 993.50	41.02	12.66
	16QAM	Low	1 931.50	40.98	12.52
		Middle	1 962.50	40.84	12.12
		High	1 993.50	41.10	12.89
	64QAM	Low	1 931.50	40.94	12.41
		Middle	1 962.50	40.72	11.80
		High	1 993.50	41.07	12.80
	256QAM	Low	1 931.50	40.90	12.31
		Middle	1 962.50	40.92	12.37
		High	1 993.50	41.11	12.90

* This test report only contains the worst case plot data for each port and modulation.

Sum data of all port

Modulation	Channel	Frequency (MHz)	Summed Output Power (W)
QPSK	Low	1 931.50	50.70
	Middle	1 962.50	49.17
	High	1 993.50	51.42
16QAM	Low	1 931.50	51.91
	Middle	1 962.50	49.00
	High	1 993.50	52.06
64QAM	Low	1 931.50	51.34
	Middle	1 962.50	48.70
	High	1 993.50	51.92
256QAM	Low	1 931.50	51.39
	Middle	1 962.50	49.67
	High	1 993.50	52.04

3 MHz Bandwidth + 5 MHz Bandwidth / 2 Carriers

Port	Modulation	Channel	Frequency (MHz)	Measured Output Power	
				(dBm)	(W)
Port 0	QPSK	Low	1 934.00	45.69	37.05
		Middle	1 962.50	45.42	34.84
		High	1 991.00	45.78	37.87
	16QAM	Low	1 934.00	45.61	36.42
		Middle	1 962.50	45.44	35.03
		High	1 991.00	45.82	38.17
	64QAM	Low	1 934.00	45.72	37.31
		Middle	1 962.50	45.44	34.99
		High	1 991.00	45.84	38.34
	256QAM	Low	1 934.00	45.68	37.02
		Middle	1 962.50	45.39	34.61
		High	1 991.00	45.87	38.65
Port 1	QPSK	Low	1 934.00	45.57	36.08
		Middle	1 962.50	45.39	34.61
		High	1 991.00	45.48	35.35
	16QAM	Low	1 934.00	45.66	36.81
		Middle	1 962.50	45.48	35.34
		High	1 991.00	45.57	36.07
	64QAM	Low	1 934.00	45.63	36.55
		Middle	1 962.50	45.40	34.67
		High	1 991.00	45.51	35.56
	256QAM	Low	1 934.00	45.56	36.00
		Middle	1 962.50	45.45	35.09
		High	1 991.00	45.56	35.95
Port 2	QPSK	Low	1 934.00	45.60	36.33
		Middle	1 962.50	45.31	33.94
		High	1 991.00	45.19	33.05
	16QAM	Low	1 934.00	45.47	35.23
		Middle	1 962.50	45.20	33.08
		High	1 991.00	45.35	34.25

Port	Modulation	Channel	Frequency (MHz)	Measured Output Power	
				(dBm)	(W)
	64QAM	Low	1 934.00	45.56	35.97
		Middle	1 962.50	45.20	33.11
		High	1 991.00	45.44	35.03
	256QAM	Low	1 934.00	45.54	35.85
		Middle	1 962.50	45.18	32.99
		High	1 991.00	45.34	34.21
Port 3	QPSK	Low	1 934.00	45.22	33.29
		Middle	1 962.50	45.24	33.40
		High	1 991.00	45.42	34.82
	16QAM	Low	1 934.00	45.41	34.72
		Middle	1 962.50	45.17	32.91
		High	1 991.00	45.48	35.29
	64QAM	Low	1 934.00	45.47	35.27
		Middle	1 962.50	45.21	33.23
		High	1 991.00	45.35	34.24
	256QAM	Low	1 934.00	45.39	34.60
		Middle	1 962.50	45.22	33.30
		High	1 991.00	45.52	35.62

* This test report only contains the worst case plot data for each port and modulation.

Sum data of all port

Modulation	Channel	Frequency (MHz)	Summed Output Power (W)
QPSK	Low	1934.00	142.75
	Middle	1962.50	136.79
	High	1991.00	141.09
16QAM	Low	1934.00	143.18
	Middle	1962.50	136.36
	High	1991.00	143.78
64QAM	Low	1934.00	145.10
	Middle	1962.50	136.00
	High	1991.00	143.17
256QAM	Low	1934.00	143.47
	Middle	1962.50	135.99
	High	1991.00	144.43

20 MHz Bandwidth / 1 Carrier

Port	Modulation	Channel	Frequency (MHz)	Measured Output Power	
				(dBm)	(W)
Port 0	QPSK	Low	1 940.00	46.45	44.17
		Middle	1 962.50	46.08	40.59
		High	1 985.00	46.52	44.83
	16QAM	Low	1 940.00	46.34	43.02
		Middle	1 962.50	46.20	41.65
		High	1 985.00	46.51	44.74
	64QAM	Low	1 940.00	46.41	43.77
		Middle	1 962.50	46.11	40.86
		High	1 985.00	46.49	44.59
	256QAM	Low	1 940.00	46.44	44.06
		Middle	1 962.50	46.03	40.09
		High	1 985.00	46.52	44.92
Port 1	QPSK	Low	1 940.00	46.44	44.02
		Middle	1 962.50	46.18	41.51
		High	1 985.00	46.24	42.12
	16QAM	Low	1 940.00	46.43	44.00
		Middle	1 962.50	46.22	41.87
		High	1 985.00	46.31	42.79
	64QAM	Low	1 940.00	46.41	43.76
		Middle	1 962.50	46.19	41.61
		High	1 985.00	46.29	42.58
	256QAM	Low	1 940.00	46.37	43.33
		Middle	1 962.50	46.13	41.02
		High	1 985.00	46.27	42.36
Port 2	QPSK	Low	1 940.00	46.16	41.31
		Middle	1 962.50	46.01	39.90
		High	1 985.00	46.13	41.02
	16QAM	Low	1 940.00	46.18	41.51
		Middle	1 962.50	46.01	39.89
		High	1 985.00	46.28	42.51

Port	Modulation	Channel	Frequency (MHz)	Measured Output Power	
				(dBm)	(W)
	64QAM	Low	1 940.00	46.21	41.83
		Middle	1 962.50	46.01	39.91
		High	1 985.00	46.11	40.84
	256QAM	Low	1 940.00	46.22	41.89
		Middle	1 962.50	45.99	39.69
		High	1 985.00	46.15	41.25
Port 3	QPSK	Low	1 940.00	46.12	40.95
		Middle	1 962.50	46.07	40.42
		High	1 985.00	46.24	42.10
	16QAM	Low	1 940.00	46.15	41.17
		Middle	1 962.50	46.02	39.97
		High	1 985.00	46.27	42.37
	64QAM	Low	1 940.00	46.14	41.12
		Middle	1 962.50	46.06	40.41
		High	1 985.00	46.32	42.87
	256QAM	Low	1 940.00	46.13	41.03
		Middle	1 962.50	45.92	39.08
		High	1 985.00	46.26	42.26

* This test report only contains the worst case plot data for each port and modulation.

Sum data of all port

Modulation	Channel	Frequency (MHz)	Summed Output Power (W)
QPSK	Low	1 940.00	170.45
	Middle	1 962.50	162.42
	High	1 985.00	170.07
16QAM	Low	1 940.00	169.70
	Middle	1 962.50	163.38
	High	1 985.00	172.41
64QAM	Low	1 940.00	170.48
	Middle	1 962.50	162.79
	High	1 985.00	170.88
256QAM	Low	1 940.00	170.31
	Middle	1 962.50	159.88
	High	1 985.00	170.79

20 MHz Bandwidth + 5 MHz Bandwidth / 2 Carriers

Port	Modulation	Channel	Frequency (MHz)	Measured Output Power	
				(dBm)	(W)
Port 0	QPSK	Low	1 942.50	46.60	45.70
		Middle	1 962.50	46.47	44.31
		High	1 982.50	46.64	46.13
	16QAM	Low	1 942.50	46.65	46.25
		Middle	1 962.50	46.51	44.82
		High	1 982.50	46.80	47.90
	64QAM	Low	1 942.50	46.65	46.25
		Middle	1 962.50	46.42	43.87
		High	1 982.50	46.77	47.56
	256QAM	Low	1 942.50	46.67	46.40
		Middle	1 962.50	46.41	43.72
		High	1 982.50	46.72	46.96
Port 1	QPSK	Low	1 942.50	46.72	47.01
		Middle	1 962.50	46.21	41.76
		High	1 982.50	46.47	44.39
	16QAM	Low	1 942.50	46.71	46.85
		Middle	1 962.50	46.36	43.23
		High	1 982.50	46.53	45.01
	64QAM	Low	1 942.50	46.69	46.68
		Middle	1 962.50	46.39	43.60
		High	1 982.50	46.50	44.65
	256QAM	Low	1 942.50	46.63	46.05
		Middle	1 962.50	46.41	43.71
		High	1 982.50	46.53	45.03
Port 2	QPSK	Low	1 942.50	46.52	44.84
		Middle	1 962.50	46.32	42.82
		High	1 982.50	46.41	43.72
	16QAM	Low	1 942.50	46.46	44.28
		Middle	1 962.50	46.22	41.86
		High	1 982.50	46.37	43.39

Port	Modulation	Channel	Frequency (MHz)	Measured Output Power	
				(dBm)	(W)
	64QAM	Low	1 942.50	46.53	44.94
		Middle	1 962.50	46.26	42.30
		High	1 982.50	46.38	43.46
	256QAM	Low	1 942.50	46.53	45.01
		Middle	1 962.50	46.32	42.84
		High	1 982.50	46.34	43.09
Port 3	QPSK	Low	1 942.50	46.43	43.91
		Middle	1 962.50	46.38	43.47
		High	1 982.50	46.37	43.37
	16QAM	Low	1 942.50	46.55	45.21
		Middle	1 962.50	46.32	42.89
		High	1 982.50	46.50	44.64
	64QAM	Low	1 942.50	46.41	43.80
		Middle	1 962.50	46.34	43.09
		High	1 982.50	46.49	44.57
	256QAM	Low	1 942.50	46.53	44.95
		Middle	1 962.50	46.35	43.11
		High	1 982.50	46.49	44.52

* This test report only contains the worst case plot data for each port and modulation.

Sum data of all port

Modulation	Channel	Frequency (MHz)	Summed Output Power (W)
QPSK	Low	1 942.50	181.46
	Middle	1 962.50	172.36
	High	1 982.50	177.61
16QAM	Low	1 942.50	182.59
	Middle	1 962.50	172.80
	High	1 982.50	180.94
64QAM	Low	1 942.50	181.67
	Middle	1 962.50	172.86
	High	1 982.50	180.24
256QAM	Low	1 942.50	182.41
	Middle	1 962.50	173.38
	High	1 982.50	179.60

5 MHz Bandwidth / 1 Carrier

Port	Modulation	Channel	Frequency (MHz)	Measured Output Power	
				(dBm)	(W)
Port 0	QPSK	Low	1 932.50	43.30	21.39
		Middle	1 962.50	42.94	19.69
		High	1 992.50	43.34	21.56
	16QAM	Low	1 932.50	43.28	21.26
		Middle	1 962.50	43.05	20.17
		High	1 992.50	43.34	21.58
	64QAM	Low	1 932.50	43.23	21.05
		Middle	1 962.50	43.05	20.20
		High	1 992.50	43.42	21.97
	256QAM	Low	1 932.50	43.18	20.81
		Middle	1 962.50	42.98	19.87
		High	1 992.50	43.32	21.47
Port 1	QPSK	Low	1 932.50	43.12	20.53
		Middle	1 962.50	42.96	19.79
		High	1 992.50	43.07	20.26
	16QAM	Low	1 932.50	43.13	20.54
		Middle	1 962.50	42.87	19.37
		High	1 992.50	43.01	19.99
	64QAM	Low	1 932.50	43.15	20.66
		Middle	1 962.50	42.99	19.92
		High	1 992.50	43.08	20.32
	256QAM	Low	1 932.50	43.12	20.52
		Middle	1 962.50	42.92	19.57
		High	1 992.50	43.04	20.15
Port 2	QPSK	Low	1 932.50	43.07	20.29
		Middle	1 962.50	42.84	19.24
		High	1 992.50	42.85	19.28
	16QAM	Low	1 932.50	42.94	19.66
		Middle	1 962.50	42.80	19.05
		High	1 992.50	42.96	19.77

Port	Modulation	Channel	Frequency (MHz)	Measured Output Power	
				(dBm)	(W)
	64QAM	Low	1 932.50	43.21	20.96
		Middle	1 962.50	42.75	18.86
		High	1 992.50	42.90	19.51
	256QAM	Low	1 932.50	43.05	20.20
		Middle	1 962.50	42.77	18.91
		High	1 992.50	42.91	19.54
Port 3	QPSK	Low	1 932.50	42.95	19.75
		Middle	1 962.50	42.92	19.61
		High	1 992.50	42.83	19.17
	16QAM	Low	1 932.50	42.94	19.69
		Middle	1 962.50	42.99	19.90
		High	1 992.50	42.85	19.30
	64QAM	Low	1 932.50	42.94	19.66
		Middle	1 962.50	42.77	18.92
		High	1 992.50	42.91	19.53
	256QAM	Low	1 932.50	42.98	19.86
		Middle	1 962.50	42.82	19.16
		High	1 992.50	42.86	19.33

* This test report only contains the worst case plot data for each port and modulation.

Sum data of all port

Modulation	Channel	Frequency (MHz)	Summed Output Power (W)
QPSK	Low	1 932.50	81.96
	Middle	1 962.50	78.33
	High	1 992.50	80.27
16QAM	Low	1 932.50	81.15
	Middle	1 962.50	78.49
	High	1 992.50	80.64
64QAM	Low	1 932.50	82.33
	Middle	1 962.50	77.90
	High	1 992.50	81.33
256QAM	Low	1 932.50	81.39
	Middle	1 962.50	77.51
	High	1 992.50	80.49

5 MHz Bandwidth + 5 MHz Bandwidth / 2 Carriers

Port	Modulation	Channel	Frequency (MHz)	Measured Output Power	
				(dBm)	(W)
Port 0	QPSK	Low	1 935.00	46.46	44.23
		Middle	1 962.50	46.18	41.47
		High	1 990.00	46.48	44.50
	16QAM	Low	1 935.00	46.46	44.31
		Middle	1 962.50	46.22	41.84
		High	1 990.00	46.56	45.33
	64QAM	Low	1 935.00	46.49	44.60
		Middle	1 962.50	46.18	41.53
		High	1 990.00	46.63	45.99
	256QAM	Low	1 935.00	46.54	45.09
		Middle	1 962.50	46.26	42.28
		High	1 990.00	46.61	45.83
Port 1	QPSK	Low	1 935.00	46.36	43.26
		Middle	1 962.50	46.11	40.85
		High	1 990.00	46.35	43.14
	16QAM	Low	1 935.00	46.35	43.14
		Middle	1 962.50	46.19	41.58
		High	1 990.00	46.41	43.75
	64QAM	Low	1 935.00	46.32	42.82
		Middle	1 962.50	46.20	41.66
		High	1 990.00	46.40	43.62
	256QAM	Low	1 935.00	46.31	42.75
		Middle	1 962.50	46.00	39.80
		High	1 990.00	46.44	44.01
Port 2	QPSK	Low	1 935.00	46.24	42.05
		Middle	1 962.50	46.02	39.99
		High	1 990.00	46.24	42.10
	16QAM	Low	1 935.00	46.29	42.60
		Middle	1 962.50	46.04	40.18
		High	1 990.00	46.25	42.17

Port	Modulation	Channel	Frequency (MHz)	Measured Output Power	
				(dBm)	(W)
	64QAM	Low	1 935.00	46.30	42.66
		Middle	1 962.50	46.05	40.29
		High	1 990.00	46.27	42.41
	256QAM	Low	1 935.00	46.24	42.05
		Middle	1 962.50	46.01	39.88
		High	1 990.00	46.21	41.79
Port 3	QPSK	Low	1 935.00	46.09	40.63
		Middle	1 962.50	46.07	40.44
		High	1 990.00	46.19	41.64
	16QAM	Low	1 935.00	46.12	40.94
		Middle	1 962.50	46.07	40.45
		High	1 990.00	46.29	42.60
	64QAM	Low	1 935.00	46.22	41.93
		Middle	1 962.50	46.03	40.09
		High	1 990.00	46.20	41.64
	256QAM	Low	1 935.00	46.17	41.42
		Middle	1 962.50	46.06	40.35
		High	1 990.00	46.24	42.10

* This test report only contains the worst case plot data for each port and modulation.

Sum data of all port

Modulation	Channel	Frequency (MHz)	Summed Output Power (W)
QPSK	Low	1 935.00	170.17
	Middle	1 962.50	162.75
	High	1 990.00	171.38
16QAM	Low	1 935.00	170.99
	Middle	1 962.50	164.05
	High	1 990.00	173.85
64QAM	Low	1 935.00	172.01
	Middle	1 962.50	163.57
	High	1 990.00	173.66
256QAM	Low	1 935.00	171.31
	Middle	1 962.50	162.31
	High	1 990.00	173.73

Tabular data of PAPR

3 MHz Bandwidth / 1 Carrier

Port	Modulation	Channel	Frequency (MHz)	0.1 % PAPR (dB)
Port 0	QPSK	Low	1 931.50	8.19
		Middle	1 962.50	8.21
		High	1 993.50	8.21
	16QAM	Low	1 931.50	8.12
		Middle	1 962.50	8.14
		High	1 993.50	8.11
	64QAM	Low	1 931.50	8.10
		Middle	1 962.50	8.04
		High	1 993.50	8.02
	256QAM	Low	1 931.50	8.12
		Middle	1 962.50	8.09
		High	1 993.50	8.11
Port 1	QPSK	Low	1 931.50	8.16
		Middle	1 962.50	8.16
		High	1 993.50	8.19
	16QAM	Low	1 931.50	8.19
		Middle	1 962.50	8.16
		High	1 993.50	8.19
	64QAM	Low	1 931.50	8.03
		Middle	1 962.50	8.08
		High	1 993.50	8.12
	256QAM	Low	1 931.50	8.12
		Middle	1 962.50	8.08
		High	1 993.50	8.05
Port 2	QPSK	Low	1 931.50	8.20
		Middle	1 962.50	8.24
		High	1 993.50	8.14
	16QAM	Low	1 931.50	8.17
		Middle	1 962.50	8.17
		High	1 993.50	8.08

Port	Modulation	Channel	Frequency (MHz)	0.1 % PAPR (dB)
	64QAM	Low	1 931.50	8.13
		Middle	1 962.50	8.04
		High	1 993.50	8.09
	256QAM	Low	1 931.50	8.09
		Middle	1 962.50	8.09
		High	1 993.50	8.09
Port 3	QPSK	Low	1 931.50	8.08
		Middle	1 962.50	8.19
		High	1 993.50	8.09
	16QAM	Low	1 931.50	8.16
		Middle	1 962.50	8.20
		High	1 993.50	8.18
	64QAM	Low	1 931.50	8.11
		Middle	1 962.50	8.06
		High	1 993.50	8.12
	256QAM	Low	1 931.50	8.05
		Middle	1 962.50	8.08
		High	1 993.50	8.10

* This test report only contains the worst case plot data for each port and modulation

3 MHz Bandwidth + 5 MHz Bandwidth / 2 Carriers

Port	Modulation	Channel	Frequency (MHz)	0.1 % PAPR (dB)
Port 0	QPSK	Low	1 934.00	6.93
		Middle	1 962.50	6.89
		High	1 991.00	6.90
	16QAM	Low	1 934.00	6.98
		Middle	1 962.50	6.91
		High	1 991.00	6.99
	64QAM	Low	1 934.00	6.97
		Middle	1 962.50	6.91
		High	1 991.00	7.02
	256QAM	Low	1 934.00	6.97
		Middle	1 962.50	6.92
		High	1 991.00	7.00
Port 1	QPSK	Low	1 934.00	7.00
		Middle	1 962.50	6.92
		High	1 991.00	6.97
	16QAM	Low	1 934.00	6.98
		Middle	1 962.50	6.91
		High	1 991.00	6.97
	64QAM	Low	1 934.00	6.97
		Middle	1 962.50	6.91
		High	1 991.00	6.98
	256QAM	Low	1 934.00	6.99
		Middle	1 962.50	6.92
		High	1 991.00	7.02
Port 2	QPSK	Low	1 934.00	6.98
		Middle	1 962.50	6.92
		High	1 991.00	6.98
	16QAM	Low	1 934.00	6.97
		Middle	1 962.50	6.92
		High	1 991.00	7.00

Port	Modulation	Channel	Frequency (MHz)	0.1 % PAPR (dB)
	64QAM	Low	1 934.00	6.98
		Middle	1 962.50	6.92
		High	1 991.00	6.98
	256QAM	Low	1 934.00	6.99
		Middle	1 962.50	6.93
		High	1 991.00	7.00
Port 3	QPSK	Low	1 934.00	6.97
		Middle	1 962.50	6.92
		High	1 991.00	6.88
	16QAM	Low	1 934.00	6.98
		Middle	1 962.50	6.96
		High	1 991.00	6.96
	64QAM	Low	1 934.00	6.97
		Middle	1 962.50	6.91
		High	1 991.00	6.99
	256QAM	Low	1 934.00	6.99
		Middle	1 962.50	6.93
		High	1 991.00	6.96

* This test report only contains the worst case plot data for each port and modulation

20 MHz Bandwidth / 1 Carrier

Port	Modulation	Channel	Frequency (MHz)	0.1 % PAPR (dB)
Port 0	QPSK	Low	1 940.00	7.19
		Middle	1 962.50	6.80
		High	1 985.00	7.09
	16QAM	Low	1 940.00	7.17
		Middle	1 962.50	6.85
		High	1 985.00	7.07
	64QAM	Low	1 940.00	7.16
		Middle	1 962.50	6.87
		High	1 985.00	7.10
	256QAM	Low	1 940.00	7.16
		Middle	1 962.50	6.82
		High	1 985.00	7.10
Port 1	QPSK	Low	1 940.00	7.23
		Middle	1 962.50	6.85
		High	1 985.00	7.02
	16QAM	Low	1 940.00	7.21
		Middle	1 962.50	6.86
		High	1 985.00	7.07
	64QAM	Low	1 940.00	7.21
		Middle	1 962.50	6.87
		High	1 985.00	7.10
	256QAM	Low	1 940.00	7.20
		Middle	1 962.50	6.86
		High	1 985.00	7.12
Port 2	QPSK	Low	1 940.00	7.15
		Middle	1 962.50	6.86
		High	1 985.00	7.02
	16QAM	Low	1 940.00	7.16
		Middle	1 962.50	6.85
		High	1 985.00	7.07

Port	Modulation	Channel	Frequency (MHz)	0.1 % PAPR (dB)
	64QAM	Low	1 940.00	7.19
		Middle	1 962.50	6.86
		High	1 985.00	7.07
	256QAM	Low	1 940.00	7.17
		Middle	1 962.50	6.88
		High	1 985.00	7.08
Port 3	QPSK	Low	1 940.00	7.20
		Middle	1 962.50	6.82
		High	1 985.00	6.99
	16QAM	Low	1 940.00	7.19
		Middle	1 962.50	6.86
		High	1 985.00	7.05
	64QAM	Low	1 940.00	7.17
		Middle	1 962.50	6.86
		High	1 985.00	7.05
	256QAM	Low	1 940.00	7.18
		Middle	1 962.50	6.87
		High	1 985.00	7.07

* This test report only contains the worst case plot data for each port and modulation

20 MHz Bandwidth + 5 MHz Bandwidth / 2 Carriers

Port	Modulation	Channel	Frequency (MHz)	0.1 % PAPR (dB)
Port 0	QPSK	Low	1 942.50	7.27
		Middle	1 962.50	6.84
		High	1 982.50	7.17
	16QAM	Low	1 942.50	7.29
		Middle	1 962.50	6.91
		High	1 982.50	7.21
	64QAM	Low	1 942.50	7.28
		Middle	1 962.50	6.90
		High	1 982.50	7.22
	256QAM	Low	1 942.50	7.26
		Middle	1 962.50	6.90
		High	1 982.50	7.23
Port 1	QPSK	Low	1 942.50	7.29
		Middle	1 962.50	6.86
		High	1 982.50	7.18
	16QAM	Low	1 942.50	7.27
		Middle	1 962.50	6.90
		High	1 982.50	7.22
	64QAM	Low	1 942.50	7.27
		Middle	1 962.50	6.89
		High	1 982.50	7.25
	256QAM	Low	1 942.50	7.28
		Middle	1 962.50	6.91
		High	1 982.50	7.27
Port 2	QPSK	Low	1 942.50	7.23
		Middle	1 962.50	6.88
		High	1 982.50	7.26
	16QAM	Low	1 942.50	7.28
		Middle	1 962.50	6.91
		High	1 982.50	7.24

Port	Modulation	Channel	Frequency (MHz)	0.1 % PAPR (dB)
	64QAM	Low	1 942.50	7.24
		Middle	1 962.50	6.91
		High	1 982.50	7.22
	256QAM	Low	1 942.50	7.25
		Middle	1 962.50	6.92
		High	1 982.50	7.23
Port 3	QPSK	Low	1 942.50	7.24
		Middle	1 962.50	6.87
		High	1 982.50	7.18
	16QAM	Low	1 942.50	7.23
		Middle	1 962.50	6.89
		High	1 982.50	7.20
	64QAM	Low	1 942.50	7.26
		Middle	1 962.50	6.89
		High	1 982.50	7.24
	256QAM	Low	1 942.50	7.27
		Middle	1 962.50	6.91
		High	1 982.50	7.22

* This test report only contains the worst case plot data for each port and modulation

5 MHz Bandwidth / 1 Carrier

Port	Modulation	Channel	Frequency (MHz)	0.1 % PAPR (dB)
Port 0	QPSK	Low	1 932.50	8.20
		Middle	1 962.50	8.26
		High	1 992.50	8.20
	16QAM	Low	1 932.50	8.23
		Middle	1 962.50	8.22
		High	1 992.50	8.23
	64QAM	Low	1 932.50	8.24
		Middle	1 962.50	8.21
		High	1 992.50	8.19
	256QAM	Low	1 932.50	8.23
		Middle	1 962.50	8.19
		High	1 992.50	8.28
Port 1	QPSK	Low	1 932.50	8.22
		Middle	1 962.50	8.24
		High	1 992.50	8.19
	16QAM	Low	1 932.50	8.27
		Middle	1 962.50	8.23
		High	1 992.50	8.30
	64QAM	Low	1 932.50	8.20
		Middle	1 962.50	8.18
		High	1 992.50	8.20
	256QAM	Low	1 932.50	8.22
		Middle	1 962.50	8.22
		High	1 992.50	8.21
Port 2	QPSK	Low	1 932.50	8.21
		Middle	1 962.50	8.19
		High	1 992.50	8.26
	16QAM	Low	1 932.50	8.15
		Middle	1 962.50	8.25
		High	1 992.50	8.21

Port	Modulation	Channel	Frequency (MHz)	0.1 % PAPR (dB)
	64QAM	Low	1 932.50	8.20
		Middle	1 962.50	8.23
		High	1 992.50	8.21
	256QAM	Low	1 932.50	8.26
		Middle	1 962.50	8.20
		High	1 992.50	8.23
Port 3	QPSK	Low	1 932.50	8.24
		Middle	1 962.50	8.23
		High	1 992.50	8.22
	16QAM	Low	1 932.50	8.26
		Middle	1 962.50	8.20
		High	1 992.50	8.22
	64QAM	Low	1 932.50	8.19
		Middle	1 962.50	8.19
		High	1 992.50	8.20
	256QAM	Low	1 932.50	8.29
		Middle	1 962.50	8.30
		High	1 992.50	8.30

* This test report only contains the worst case plot data for each port and modulation

5 MHz Bandwidth + 5 MHz Bandwidth / 2 Carriers

Port	Modulation	Channel	Frequency (MHz)	0.1 % PAPR (dB)
Port 0	QPSK	Low	1 935.00	7.09
		Middle	1 962.50	7.00
		High	1 990.00	6.93
	16QAM	Low	1 935.00	7.10
		Middle	1 962.50	7.01
		High	1 990.00	6.99
	64QAM	Low	1 935.00	7.12
		Middle	1 962.50	7.01
		High	1 990.00	7.04
	256QAM	Low	1 935.00	7.12
		Middle	1 962.50	7.05
		High	1 990.00	7.07
Port 1	QPSK	Low	1 935.00	7.14
		Middle	1 962.50	7.02
		High	1 990.00	7.05
	16QAM	Low	1 935.00	7.13
		Middle	1 962.50	7.03
		High	1 990.00	7.06
	64QAM	Low	1 935.00	7.15
		Middle	1 962.50	7.03
		High	1 990.00	7.08
	256QAM	Low	1 935.00	7.15
		Middle	1 962.50	7.04
		High	1 990.00	7.09
Port 2	QPSK	Low	1 935.00	7.12
		Middle	1 962.50	7.02
		High	1 990.00	7.05
	16QAM	Low	1 935.00	7.14
		Middle	1 962.50	7.02
		High	1 990.00	7.07

Port	Modulation	Channel	Frequency (MHz)	0.1 % PAPR (dB)
	64QAM	Low	1 935.00	7.13
		Middle	1 962.50	7.03
		High	1 990.00	7.05
	256QAM	Low	1 935.00	7.16
		Middle	1 962.50	7.05
		High	1 990.00	7.10
Port 3	QPSK	Low	1 935.00	7.13
		Middle	1 962.50	7.02
		High	1 990.00	7.08
	16QAM	Low	1 935.00	7.13
		Middle	1 962.50	7.02
		High	1 990.00	7.05
	64QAM	Low	1 935.00	7.14
		Middle	1 962.50	7.03
		High	1 990.00	7.06
	256QAM	Low	1 935.00	7.14
		Middle	1 962.50	7.04
		High	1 990.00	7.08

* This test report only contains the worst case plot data for each port and modulation

Plots of Output Power - 3 MHz Bandwidth / 1 Carrier

Port 0

Modulation:	QPSK	Modulation:	16QAM
Channel:	High	Channel:	High

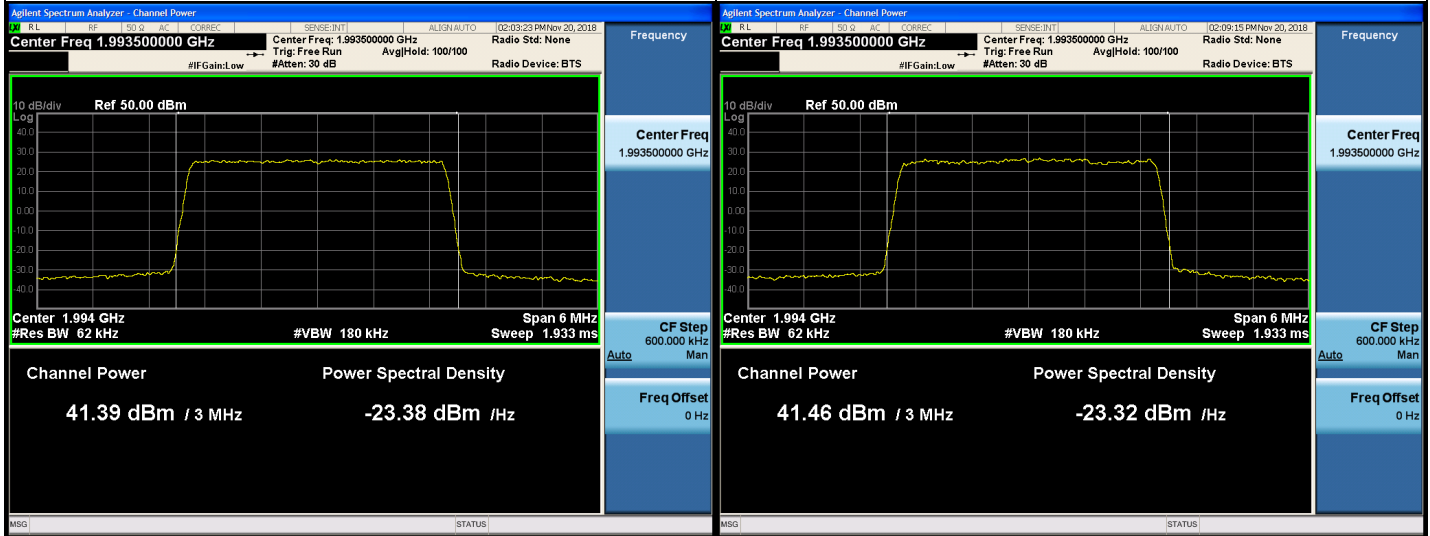

Modulation:	64QAM	Modulation:	256QAM
Channel:	High	Channel:	High

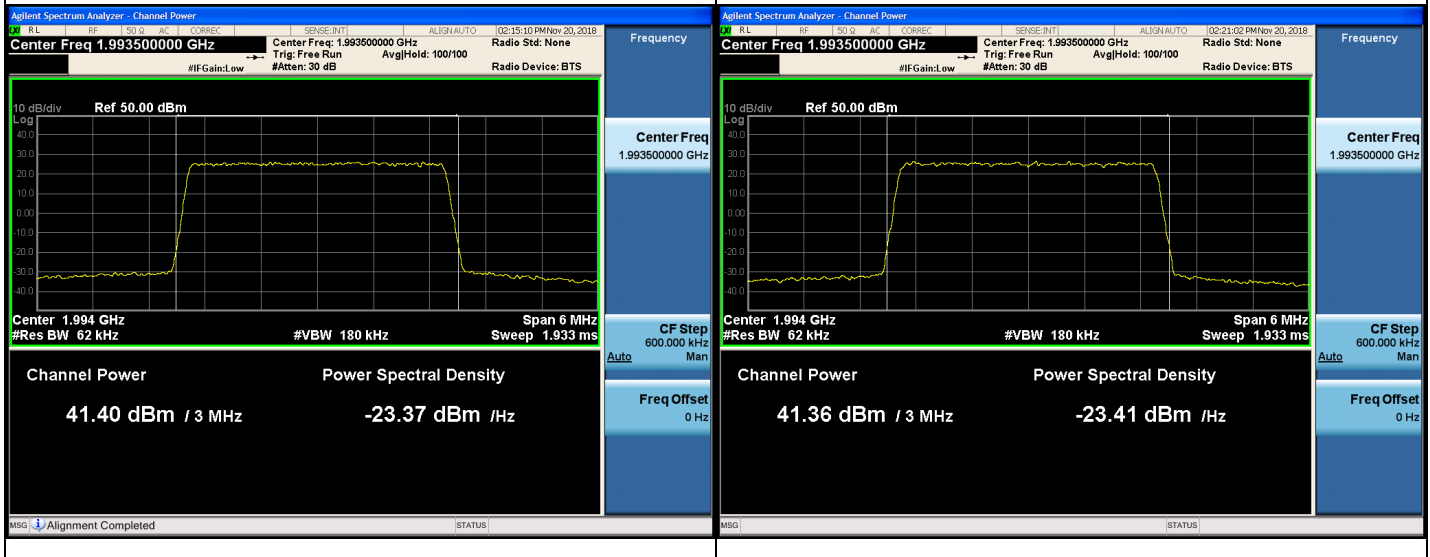

Port 1

Modulation:	QPSK	Modulation:	16QAM
Channel:	High	Channel:	Low

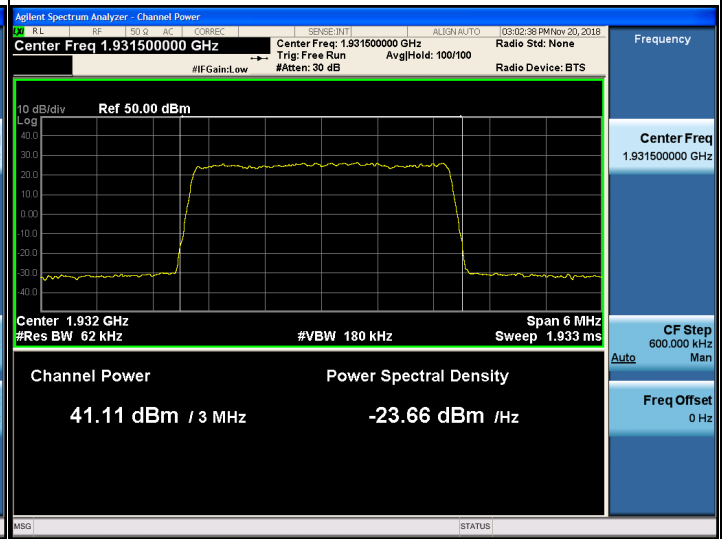
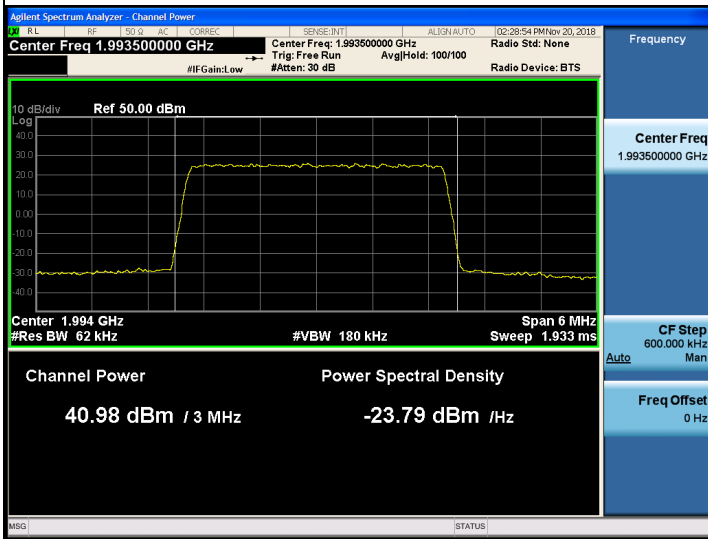

Modulation:	64QAM	Modulation:	256QAM
Channel:	High	Channel:	Middle

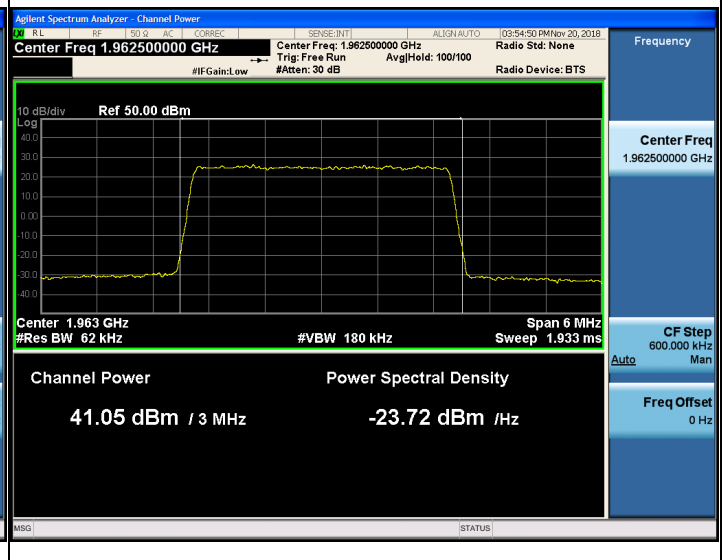
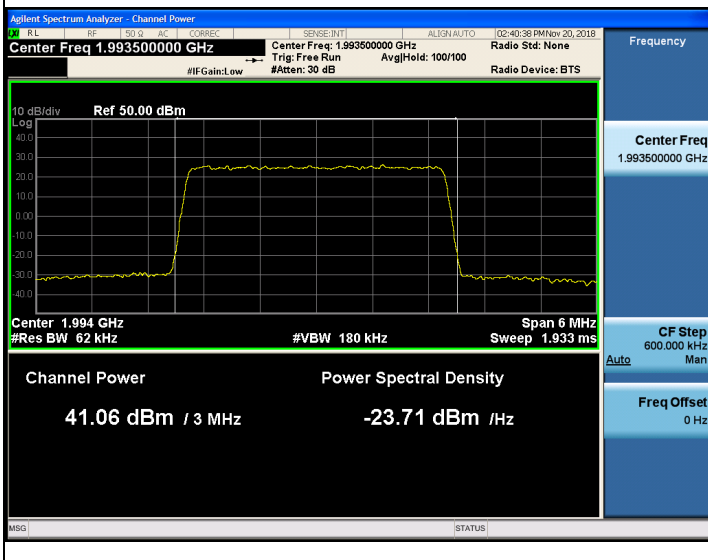

Port 2

Modulation:	QPSK	Modulation:	16QAM
Channel:	Low	Channel:	Low

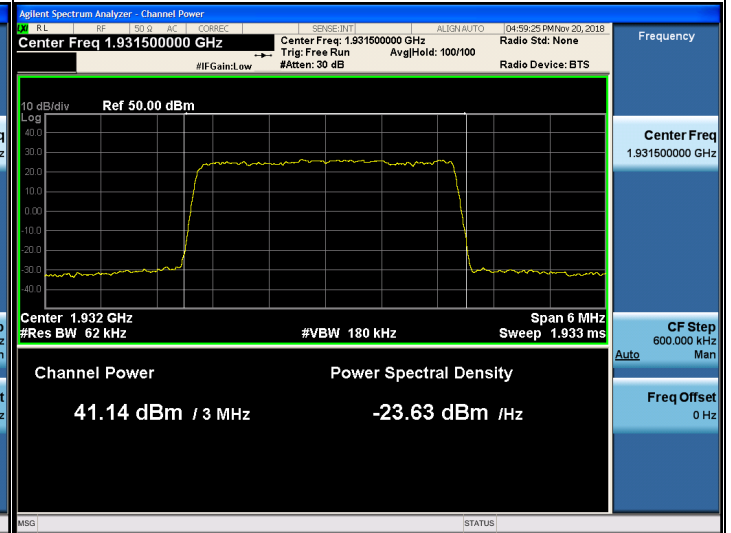
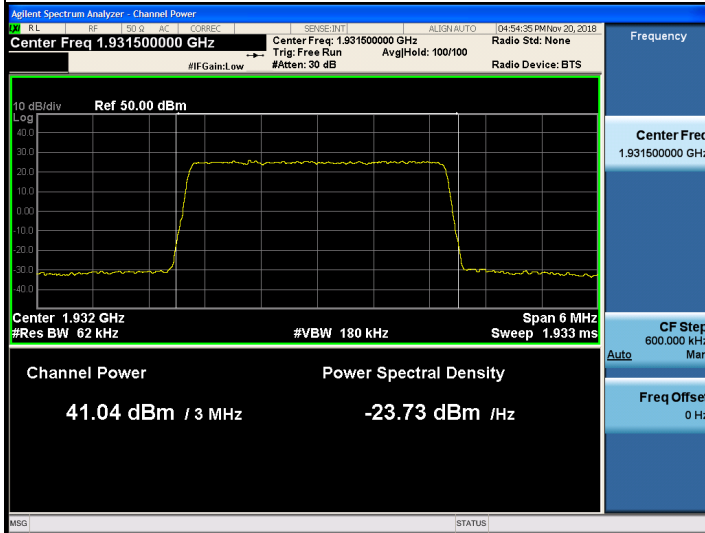

Modulation:	64QAM	Modulation:	256QAM
Channel:	Low	Channel:	Low

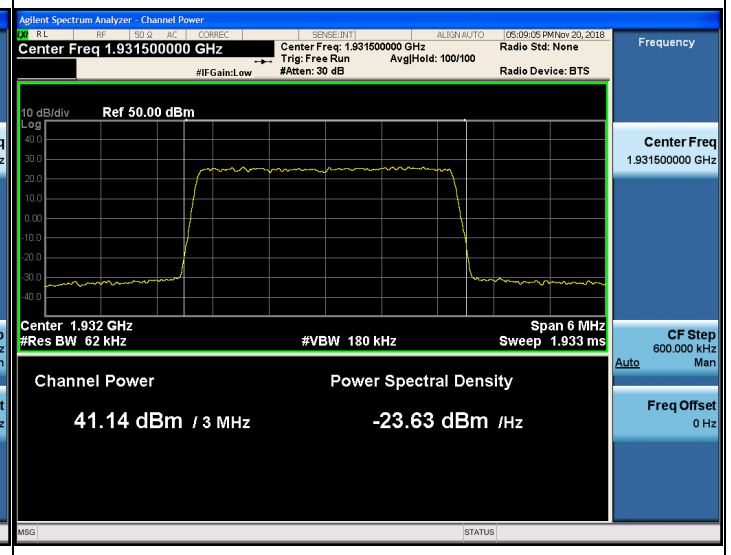
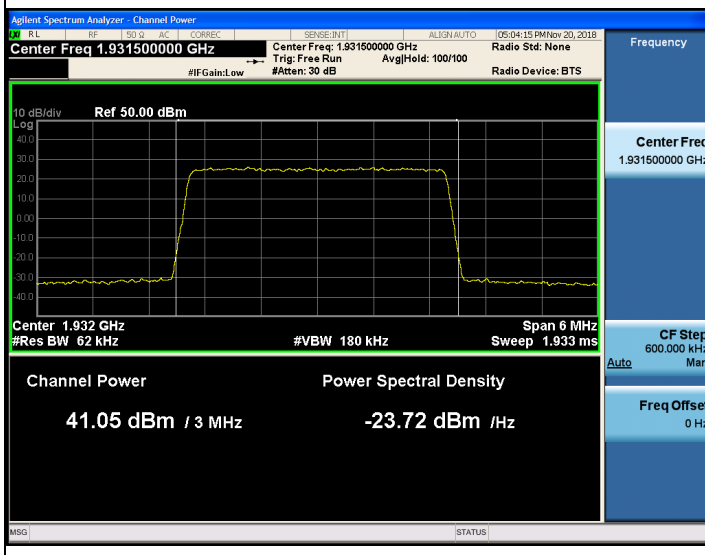

Port 3

Modulation:	QPSK	Modulation:	16QAM
Channel:	High	Channel:	High

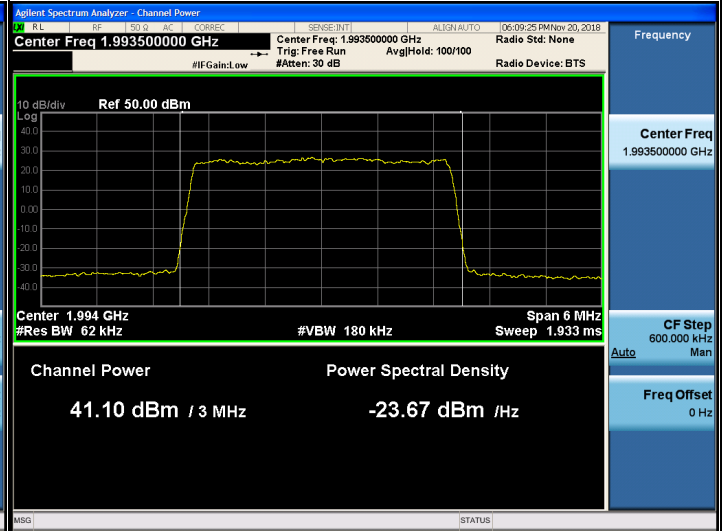
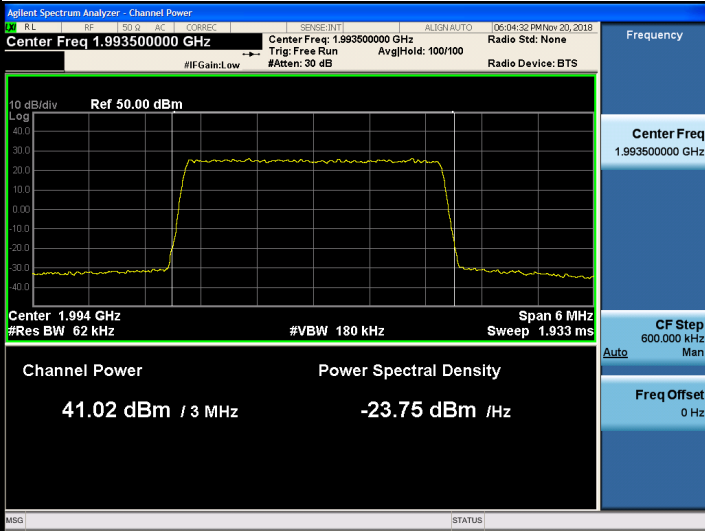

Modulation:	64QAM	Modulation:	256QAM
Channel:	High	Channel:	High

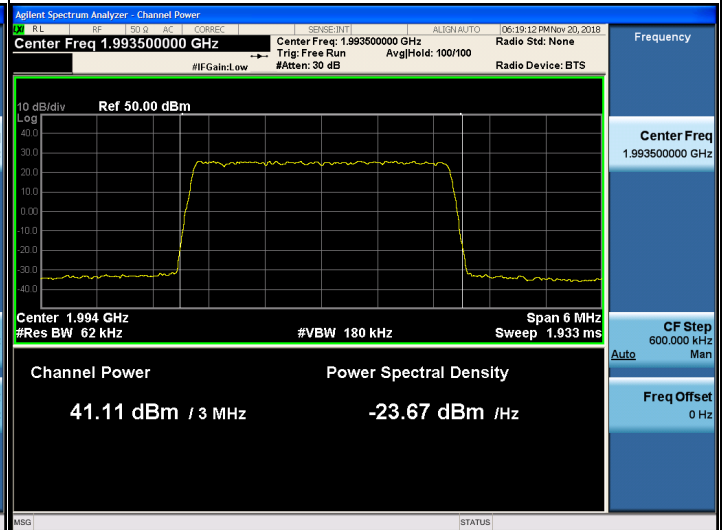
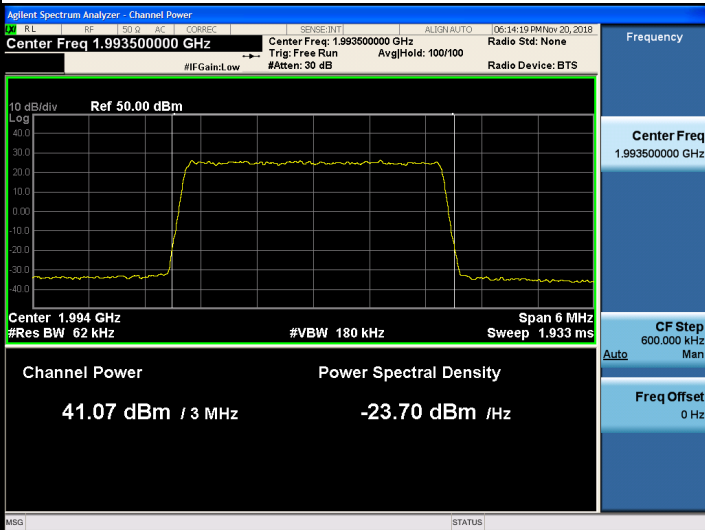

Plots of Output Power - 3 MHz Bandwidth + 5 MHz Bandwidth / 2 Carriers

Port 0

Modulation:		QPSK		Modulation:		16QAM	
Channel:		High		Channel:		High	
Modulation:		64QAM		Modulation:		256QAM	
Channel:		High		Channel:		High	

Port 1

Modulation:	QPSK	Modulation:	16QAM
Channel:	Low	Channel:	Low

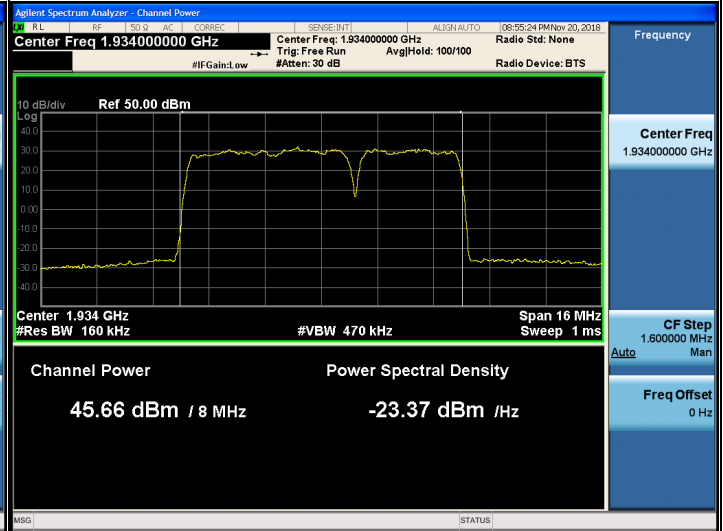
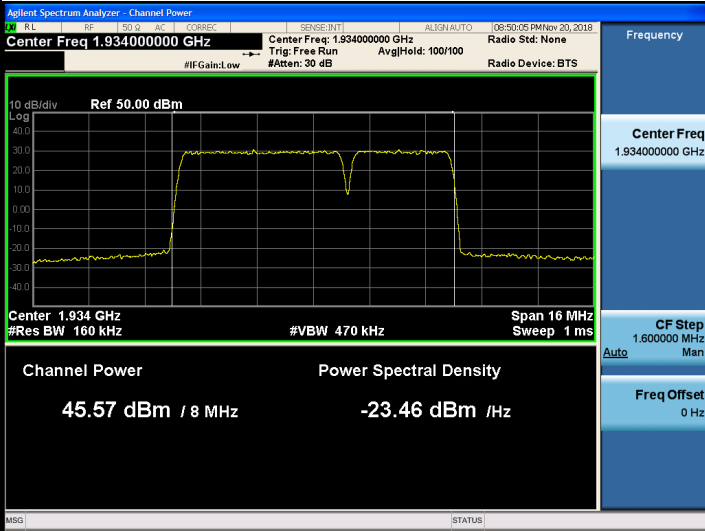

Modulation:	64QAM	Modulation:	256QAM
Channel:	Low	Channel:	Low

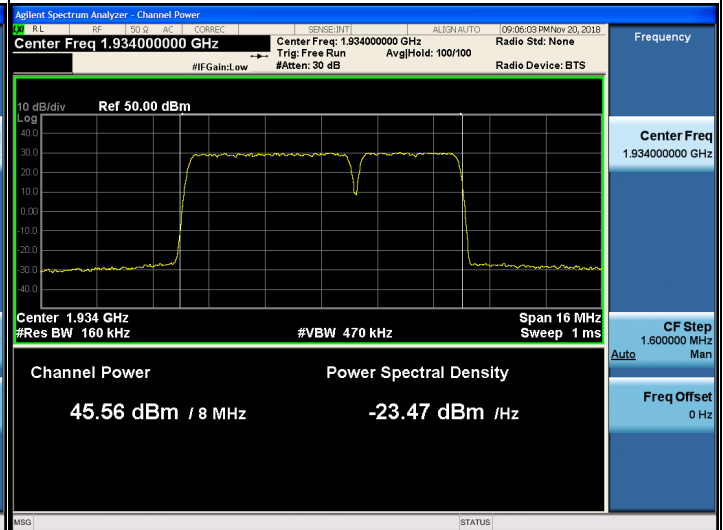
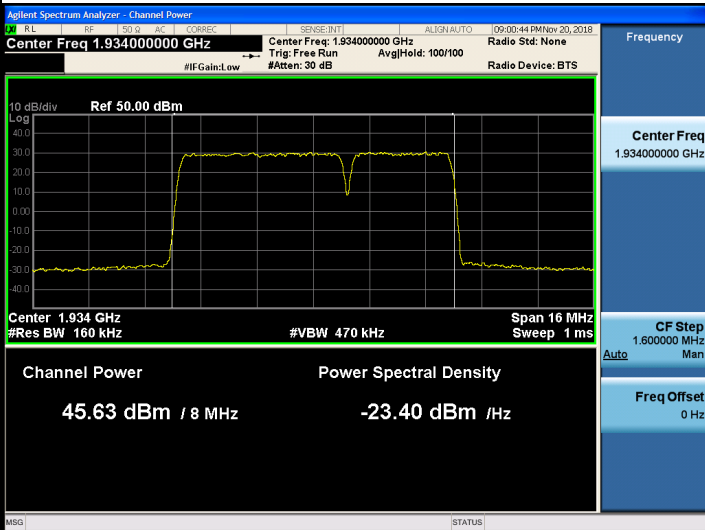

Port 2

Modulation:	QPSK	Modulation:	16QAM
Channel:	Low	Channel:	Low

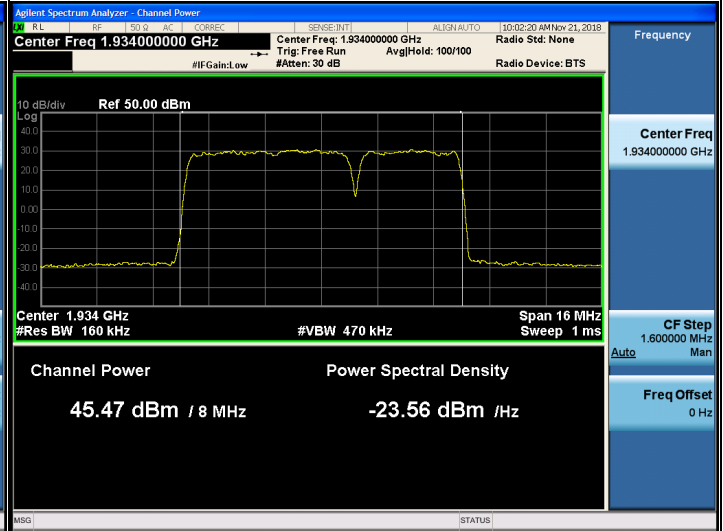
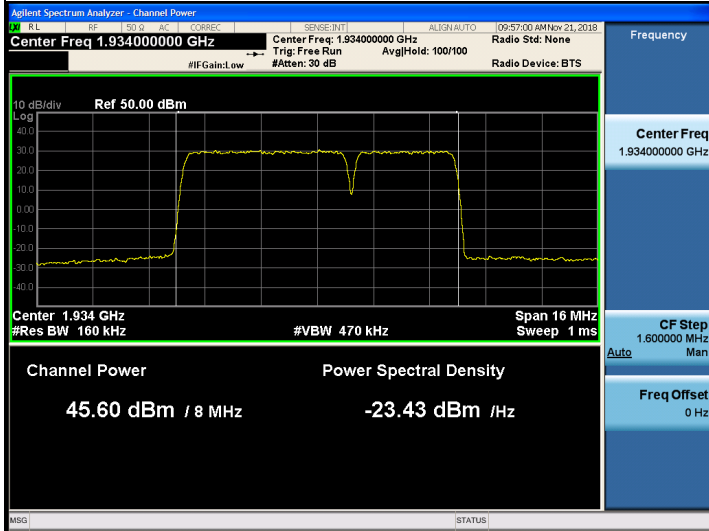

Modulation:	64QAM
Channel:	Low

Modulation:	256QAM
Channel:	Low

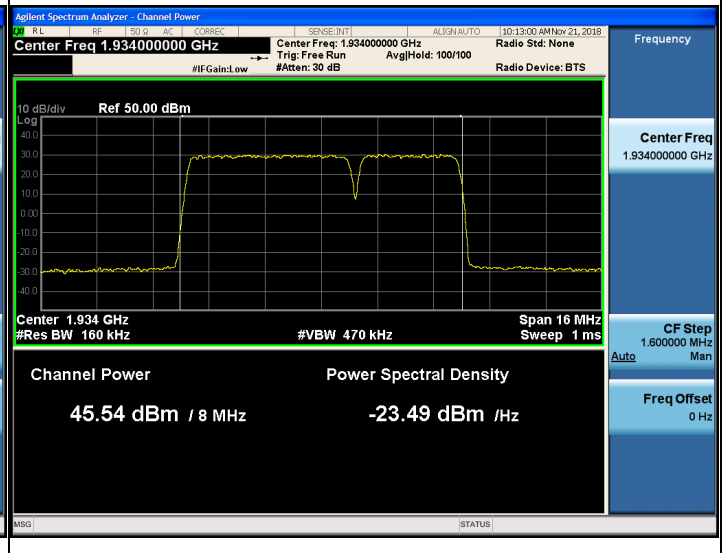
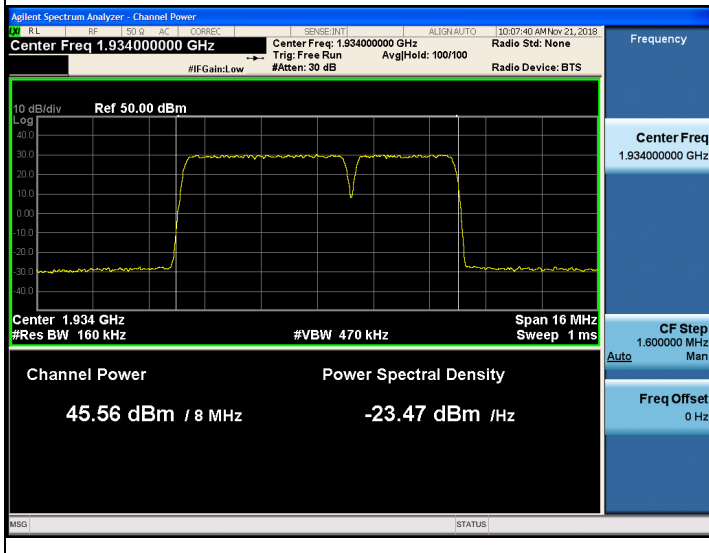

Port 3

Modulation:	QPSK	Modulation:	16QAM
Channel:	High	Channel:	High

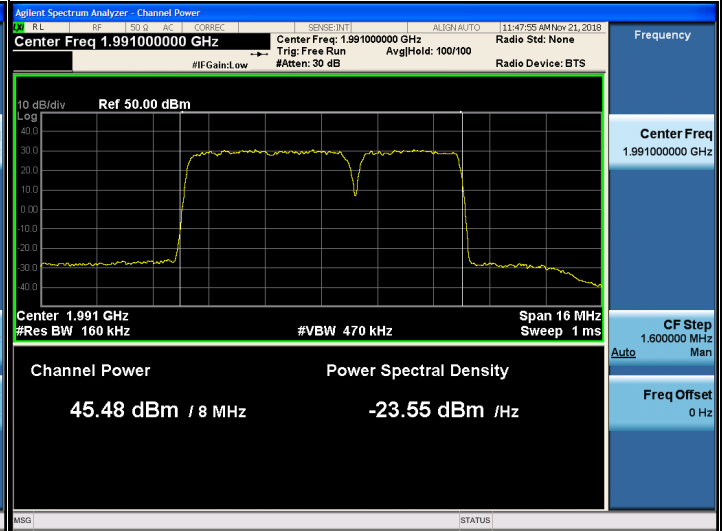
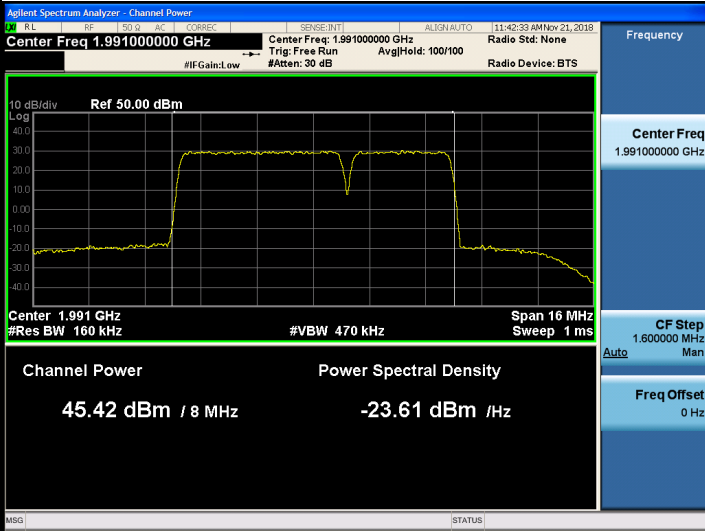

Modulation:	64QAM
Channel:	Low

Modulation:	256QAM
Channel:	High

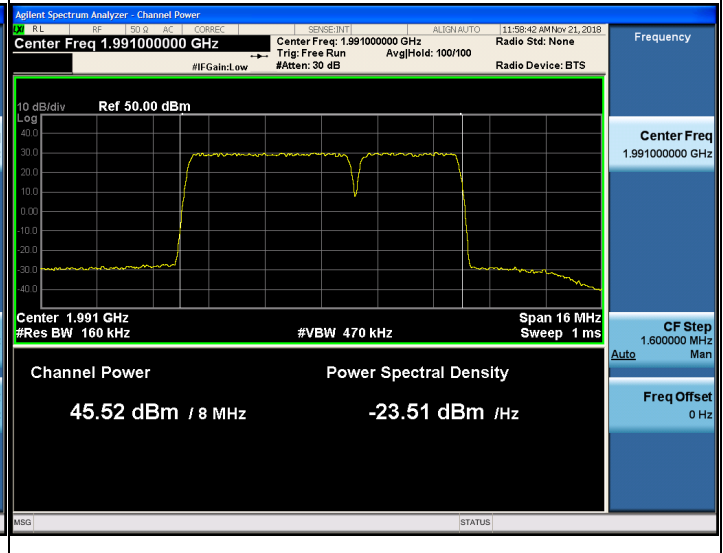
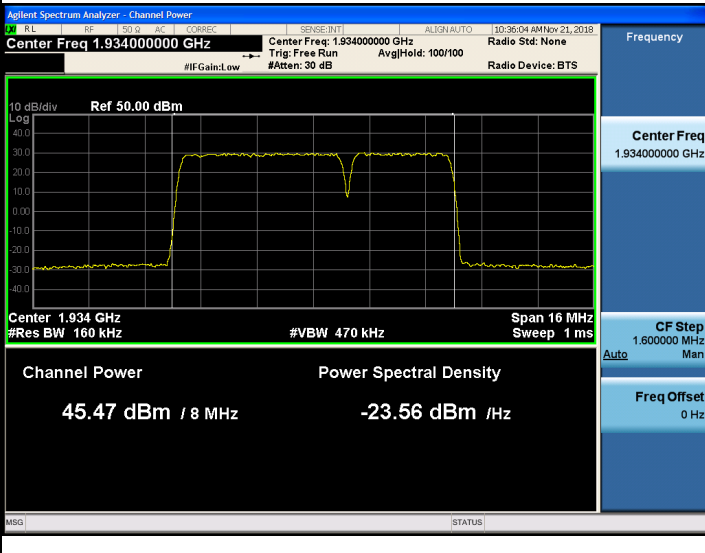

Plots of Output Power - 20 MHz Bandwidth / 1 Carrier

Port 0

Modulation:	QPSK	Modulation:	16QAM
Channel:	High	Channel:	High

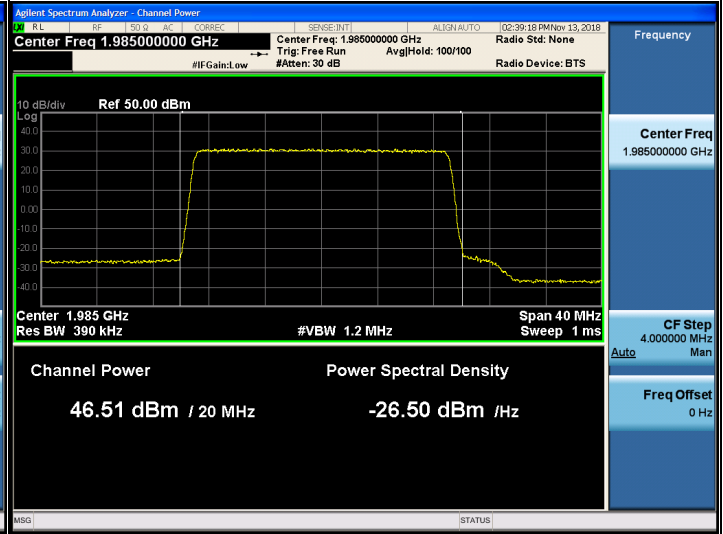
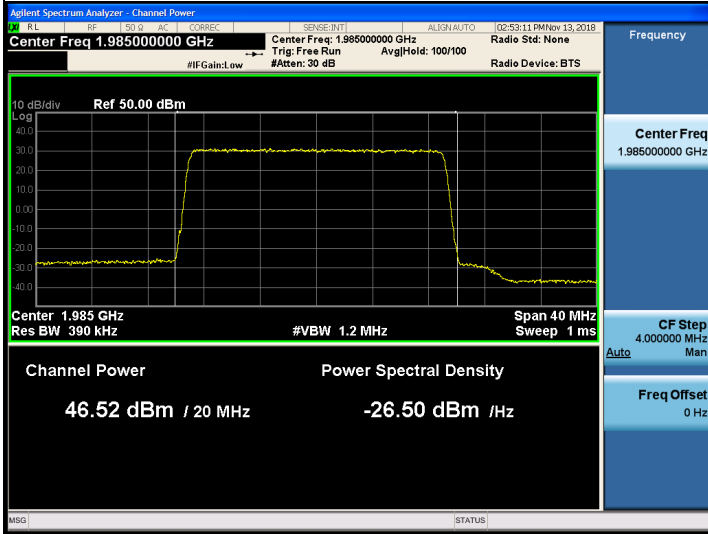

Modulation:	64QAM	Modulation:	256QAM
Channel:	High	Channel:	High

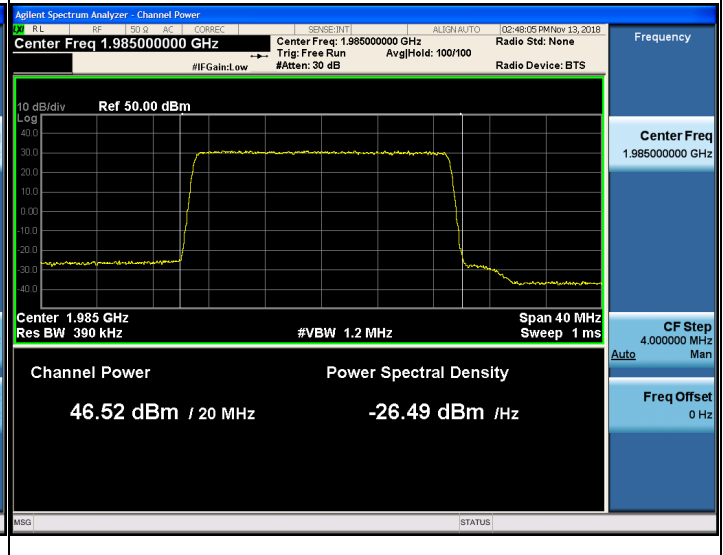
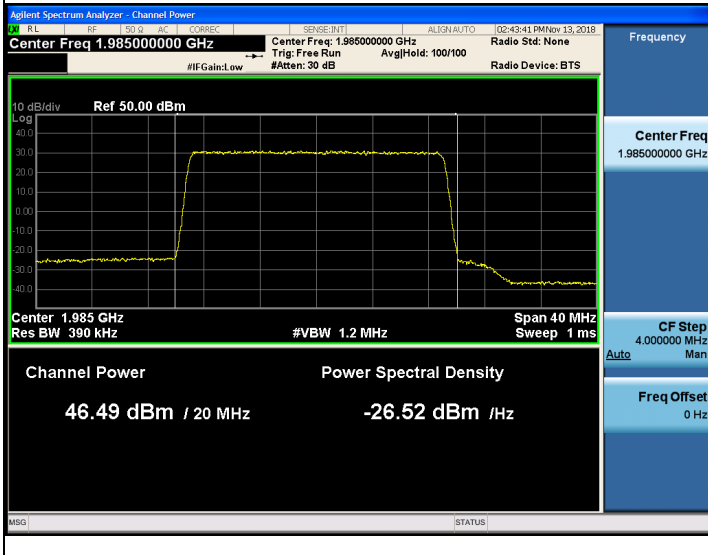

Port 1

Modulation:	QPSK	Modulation:	16QAM
Channel:	Low	Channel:	Low

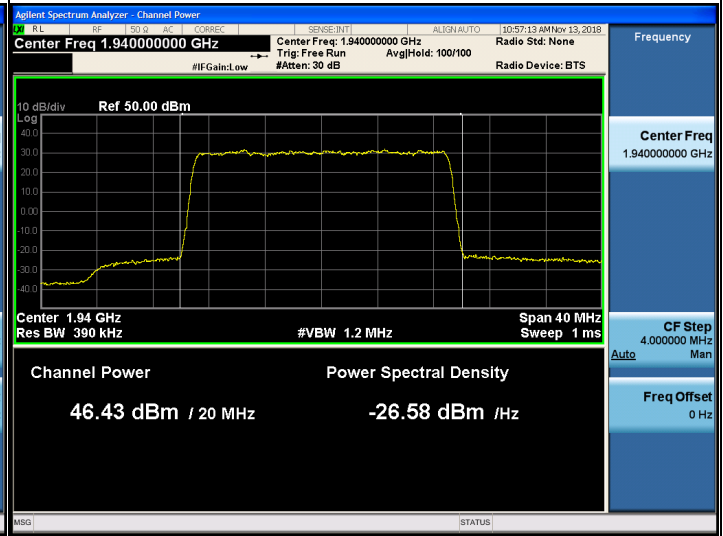
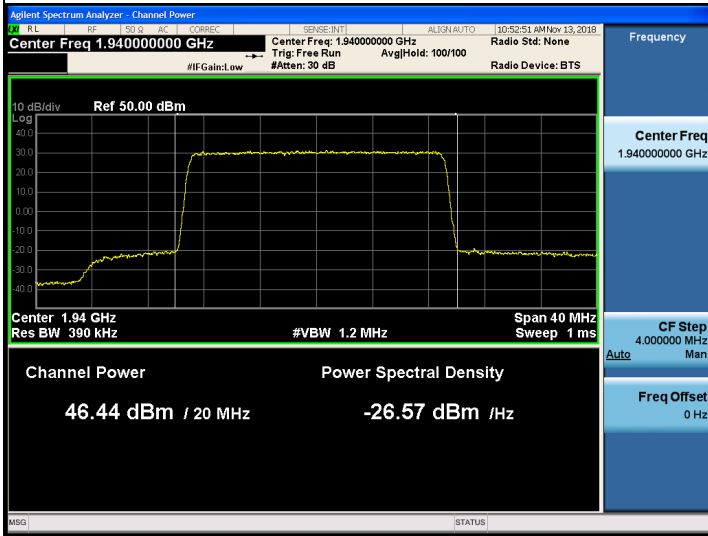

Modulation:	64QAM	Modulation:	256QAM
Channel:	Low	Channel:	Low

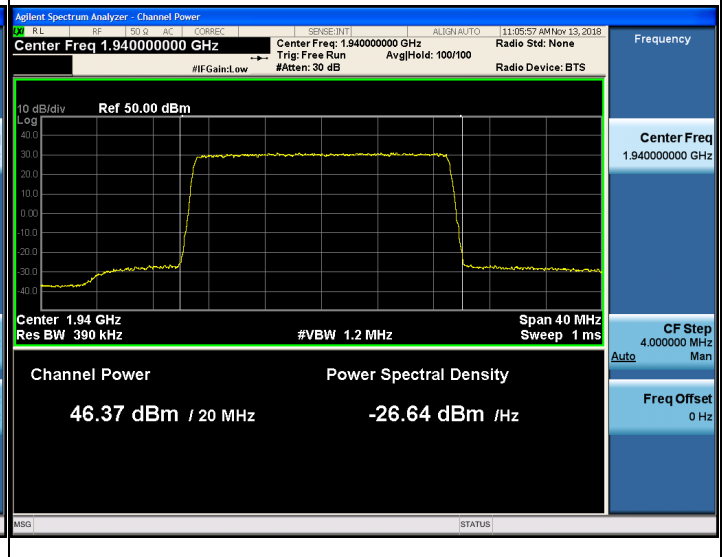
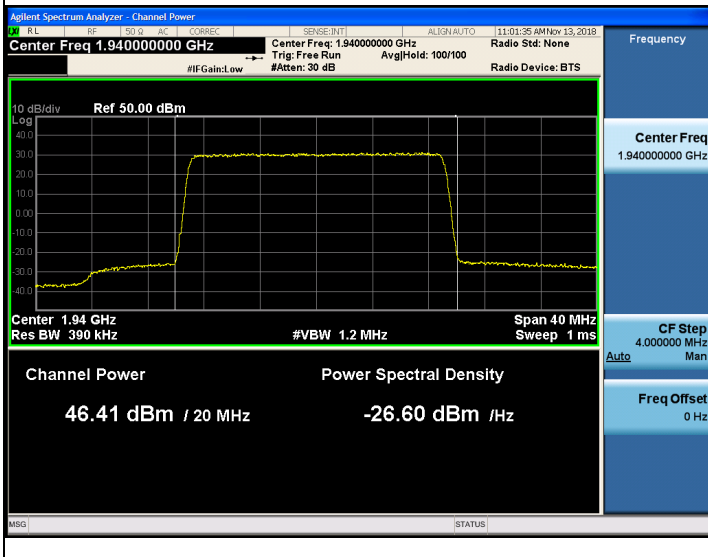

Port 2

Modulation:	QPSK	Modulation:	16QAM
Channel:	Low	Channel:	High

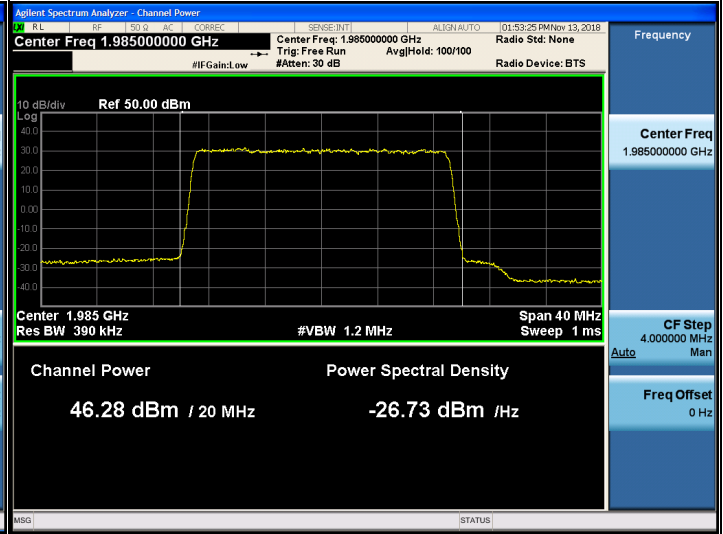
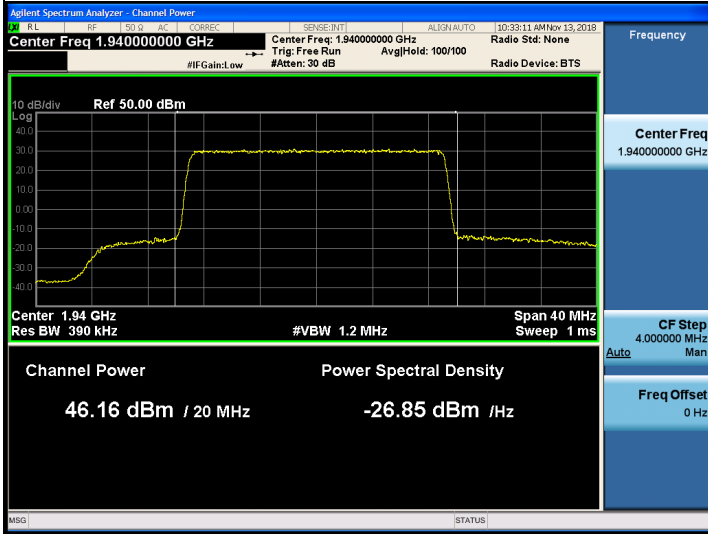

Modulation:	64QAM	Modulation:	256QAM
Channel:	Low	Channel:	Low

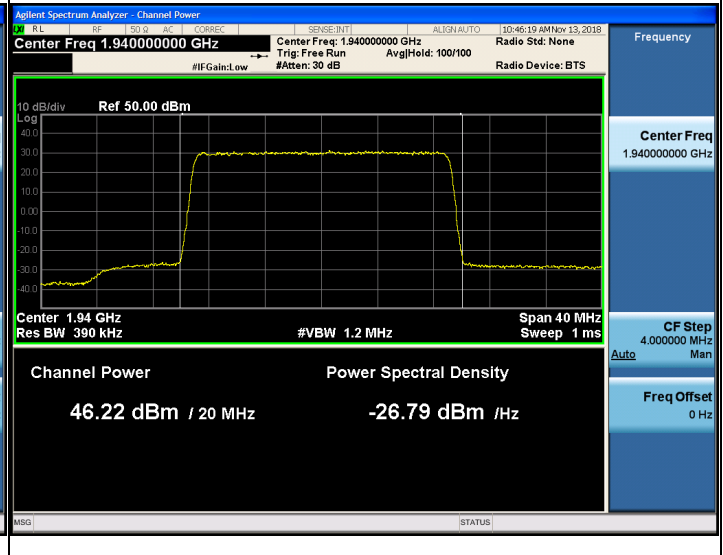
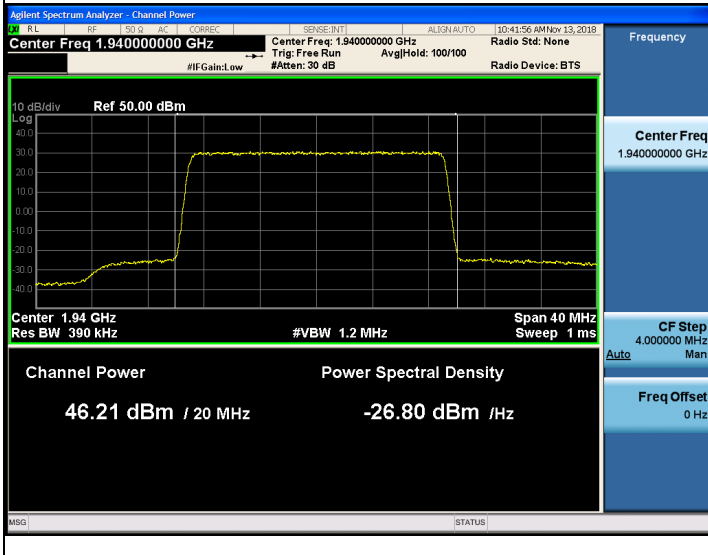

Port 3

Modulation:	QPSK	Modulation:	16QAM
Channel:	High	Channel:	High

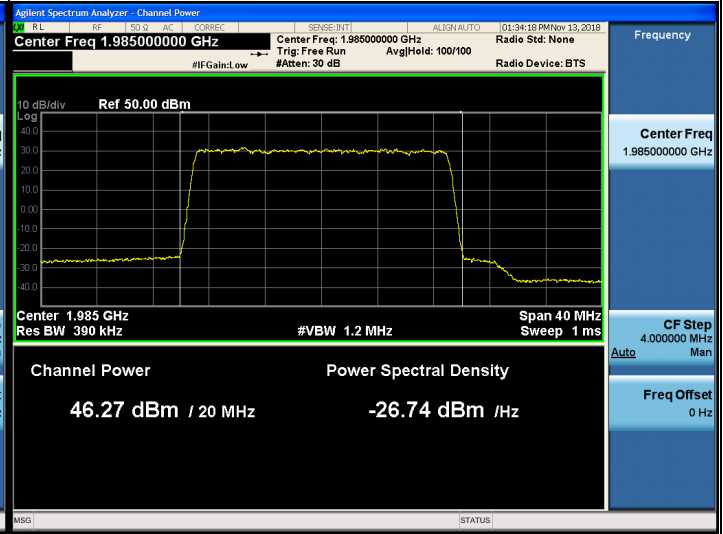
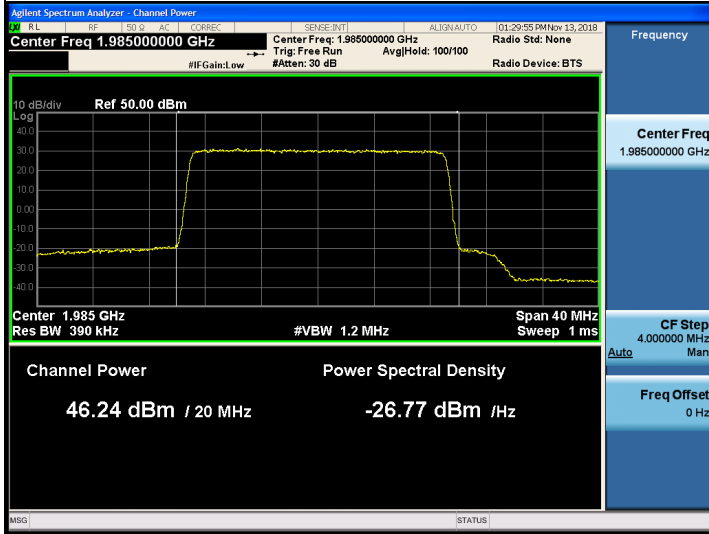

Modulation:	64QAM	Modulation:	256QAM
Channel:	High	Channel:	High

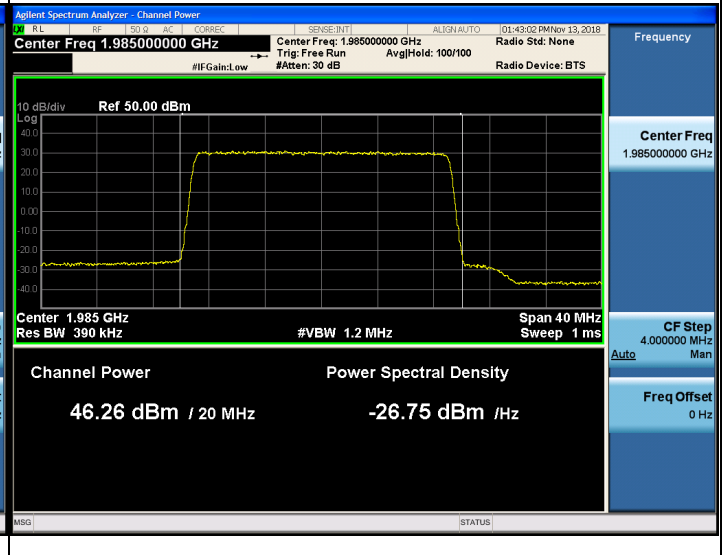
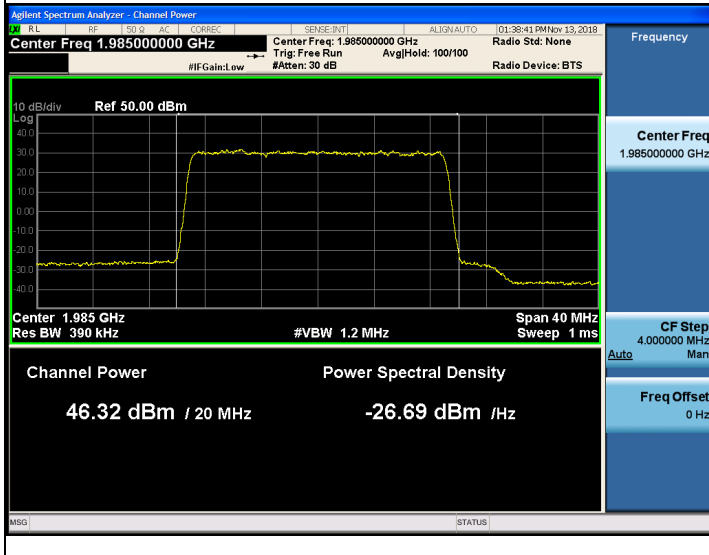

Plots of Output Power - 20 MHz Bandwidth + 5 MHz Bandwidth / 2 Carriers

Port 0

Modulation:		QPSK	Modulation:		16QAM
Channel:		High	Channel:		High
Modulation:		64QAM	Modulation:		256QAM
Channel:		High	Channel:		High

Port 1

Modulation:	QPSK	Modulation:	16QAM
Channel:	Low	Channel:	Low

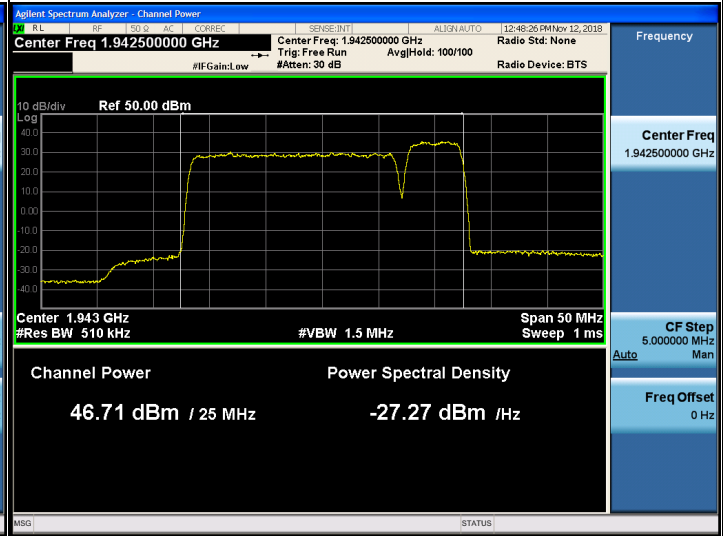
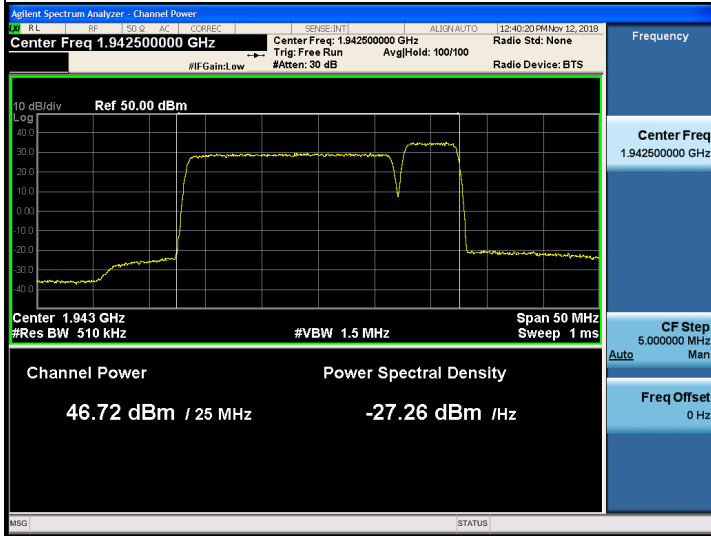

Modulation:	64QAM	Modulation:	256QAM
Channel:	Low	Channel:	Low

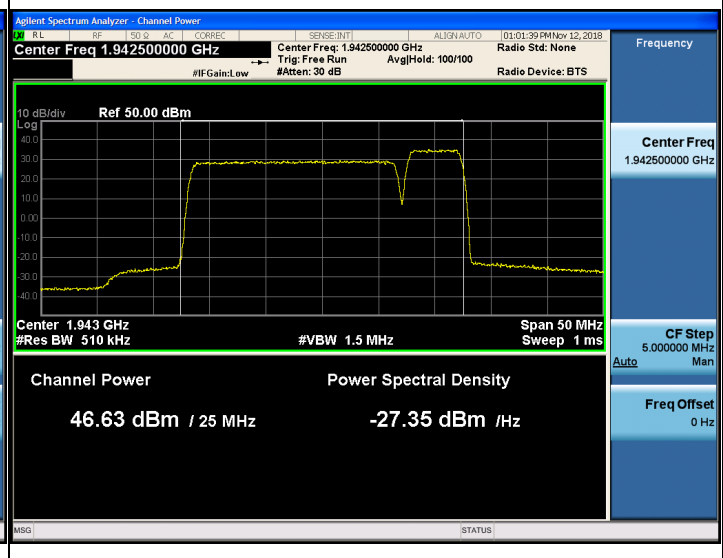
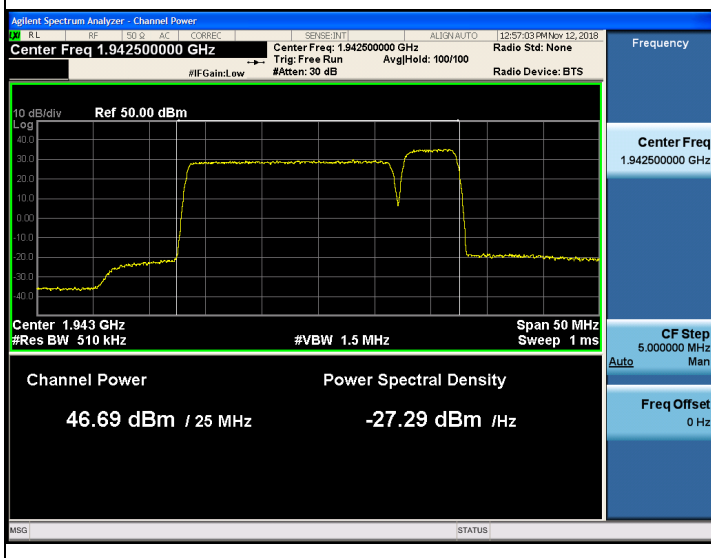

Port 2

Modulation:	QPSK	Modulation:	16QAM
Channel:	Low	Channel:	Low

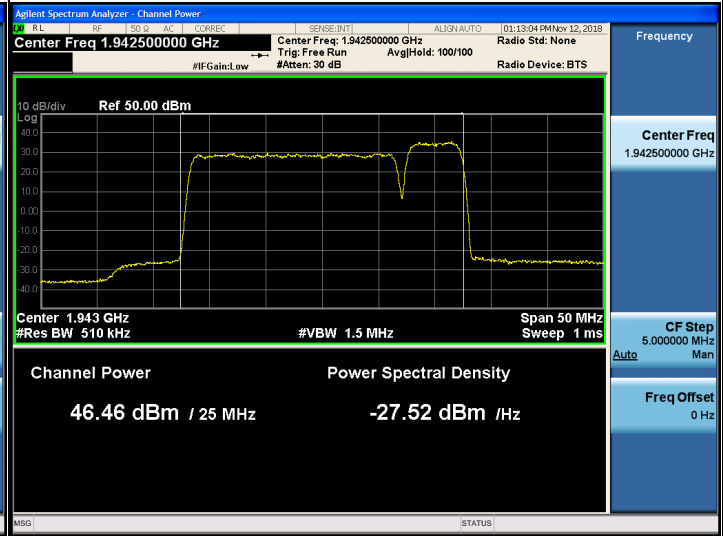
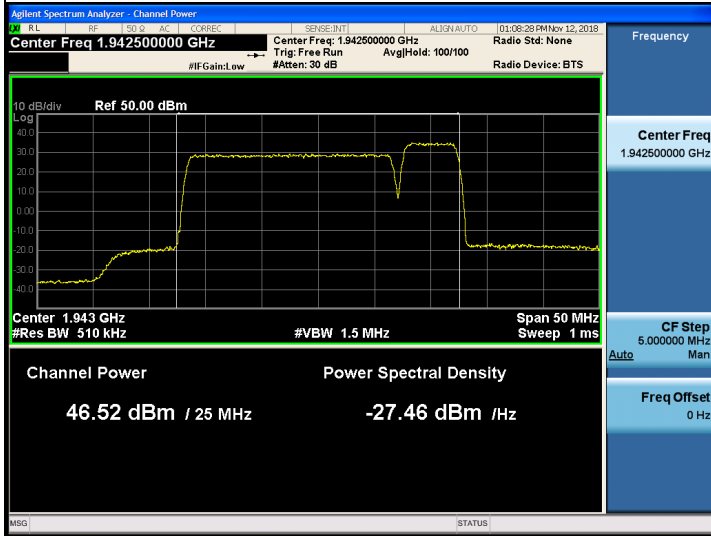

Modulation:	64QAM	Modulation:	256QAM
Channel:	Low	Channel:	Low

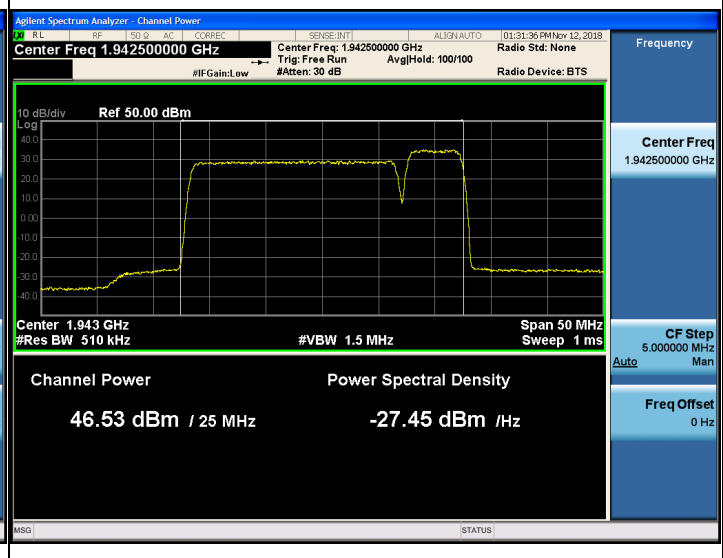
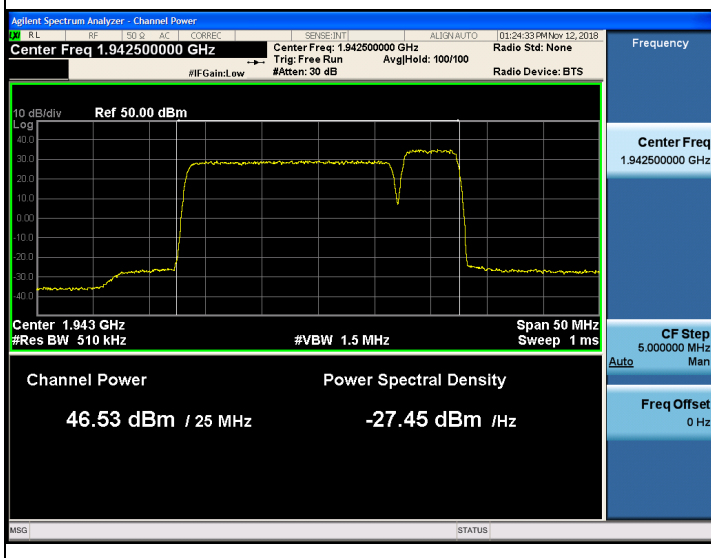

Port 3

Modulation:	QPSK	Modulation:	16QAM
Channel:	Low	Channel:	Low

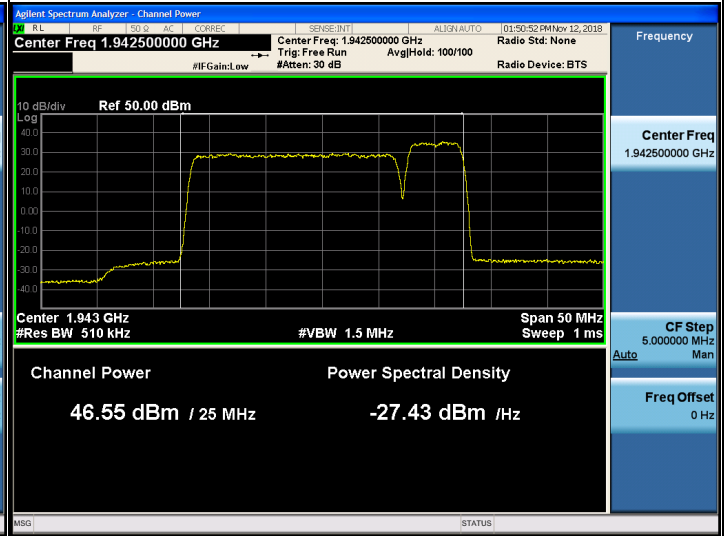
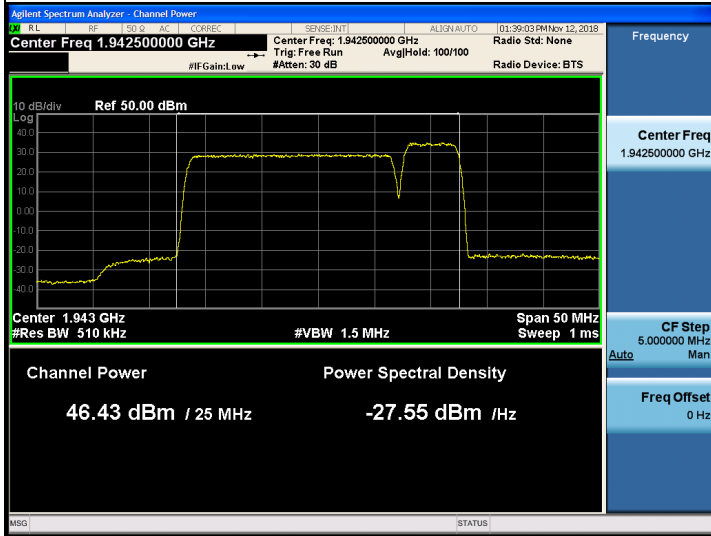

Modulation:	64QAM	Modulation:	256QAM
Channel:	High	Channel:	Low

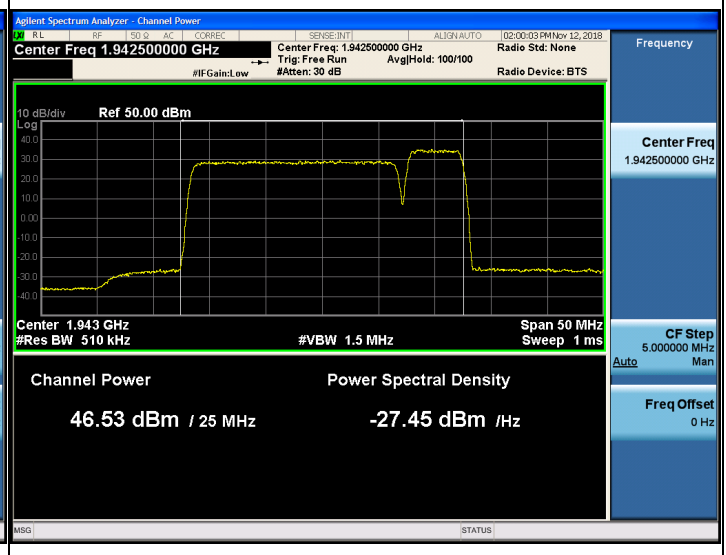
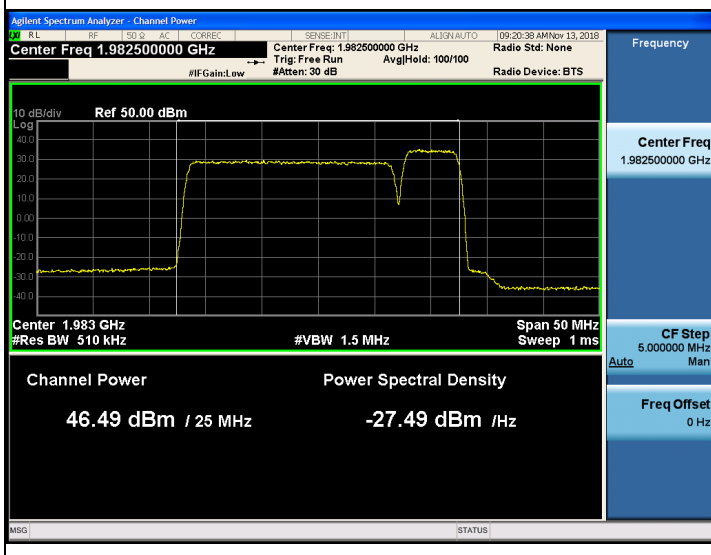

Plots of Output Power - 5 MHz Bandwidth / 1 Carrier

Port 0

Modulation:		QPSK	Modulation:		16QAM
Channel:		High	Channel:		High
Modulation:		64QAM	Modulation:		256QAM
Channel:		High	Channel:		High

Port 1

Modulation:	QPSK	Modulation:	16QAM
Channel:	Low	Channel:	Low

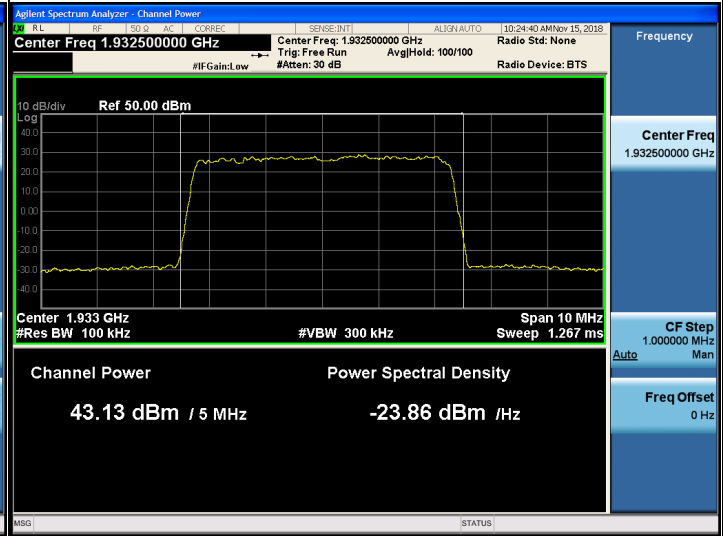
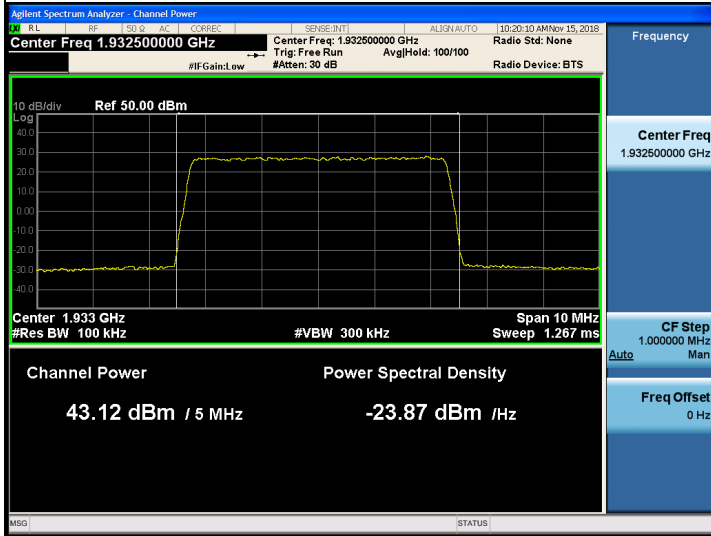

Modulation:	64QAM	Modulation:	256QAM
Channel:	Low	Channel:	Low

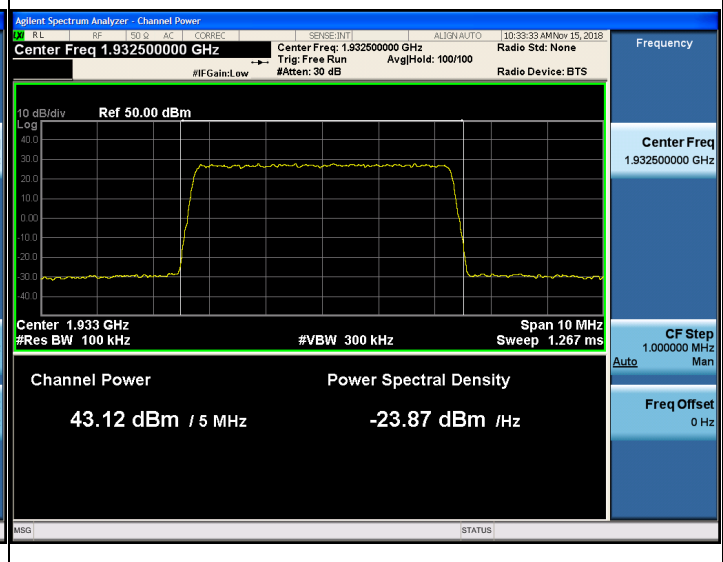
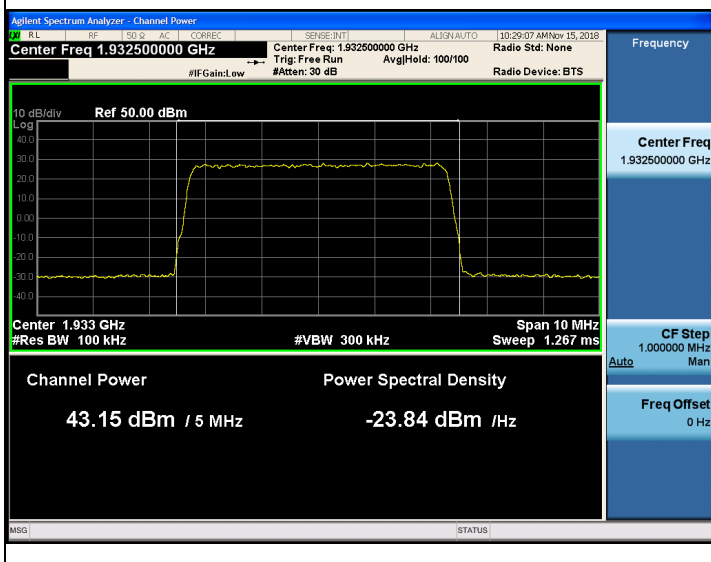

Port 2

Modulation:	QPSK	Modulation:	16QAM
Channel:	Low	Channel:	High

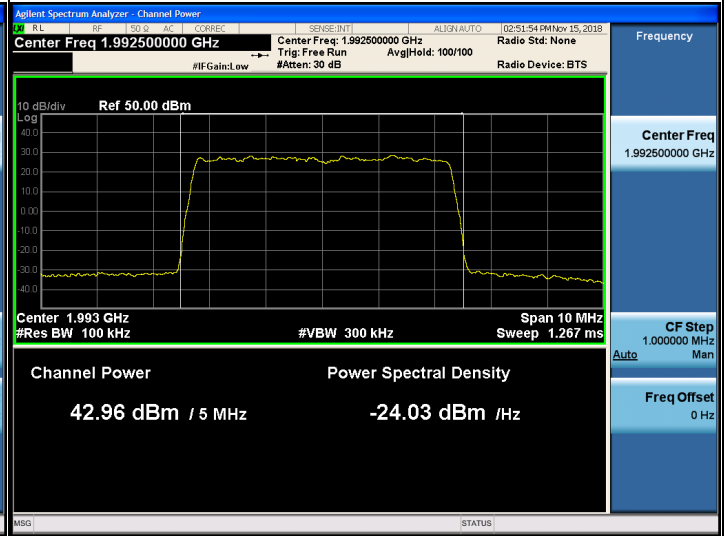
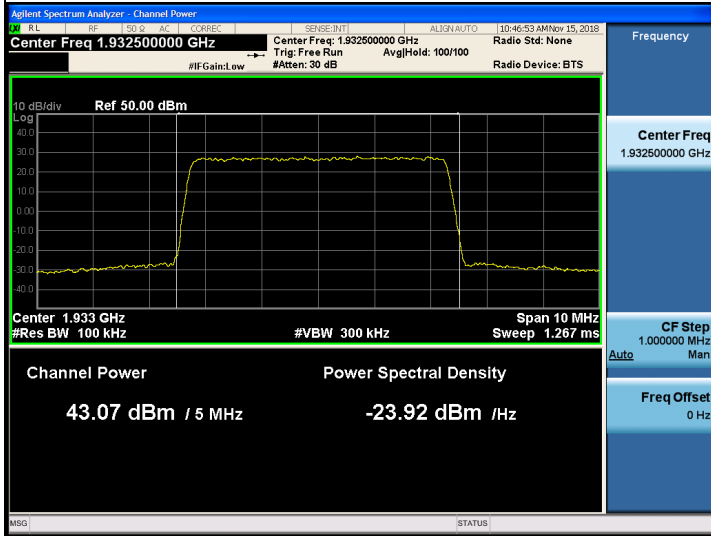

Modulation:	64QAM	Modulation:	256QAM
Channel:	Low	Channel:	Low

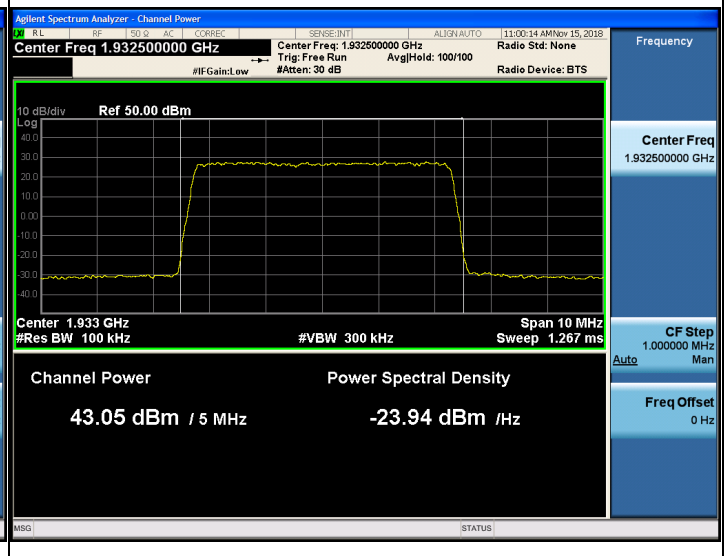
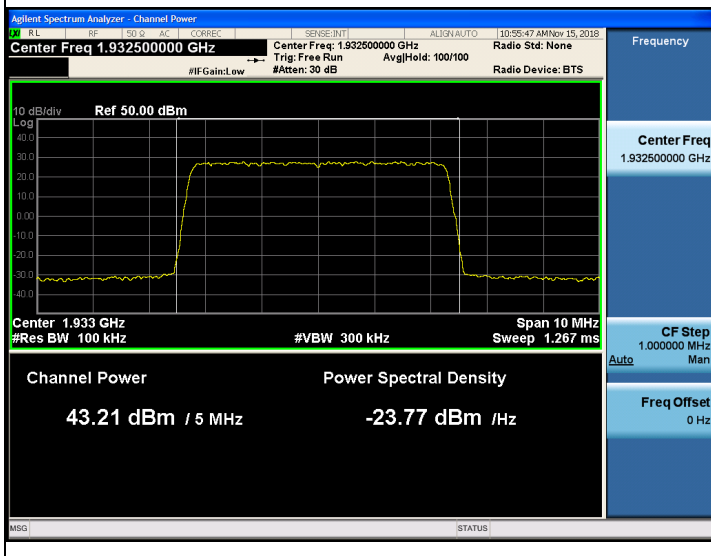

Port 3

Modulation: QPSK		Modulation: 16QAM	
Channel: Low		Channel: Middle	
Modulation: 64QAM		Modulation: 256QAM	
Channel: Low		Channel: Low	

Plots of Output Power - 5 MHz Bandwidth + 5 MHz Bandwidth / 2 Carriers

Port 0

Modulation:		QPSK	Modulation:		16QAM
Channel:		High	Channel:		High
<p>Agilent Spectrum Analyzer - Channel Power Center Freq 1.990000000 GHz #Res BW 200 kHz #VBW 620 kHz Span 20 MHz Sweep 1 ms Channel Power: 46.48 dBm / 10 MHz Power Spectral Density: -23.52 dBm / Hz</p>			<p>Agilent Spectrum Analyzer - Channel Power Center Freq 1.990000000 GHz #Res BW 200 kHz #VBW 620 kHz Span 20 MHz Sweep 1 ms Channel Power: 46.56 dBm / 10 MHz Power Spectral Density: -23.44 dBm / Hz</p>		
Modulation:		64QAM	Modulation:		256QAM
Channel:		High	Channel:		High
<p>Agilent Spectrum Analyzer - Channel Power Center Freq 1.990000000 GHz #Res BW 200 kHz #VBW 620 kHz Span 20 MHz Sweep 1 ms Channel Power: 46.63 dBm / 10 MHz Power Spectral Density: -23.37 dBm / Hz</p>			<p>Agilent Spectrum Analyzer - Channel Power Center Freq 1.990000000 GHz #Res BW 200 kHz #VBW 620 kHz Span 20 MHz Sweep 1 ms Channel Power: 46.61 dBm / 10 MHz Power Spectral Density: -23.39 dBm / Hz</p>		

Port 1

Modulation:	QPSK	Modulation:	16QAM
Channel:	Low	Channel:	High

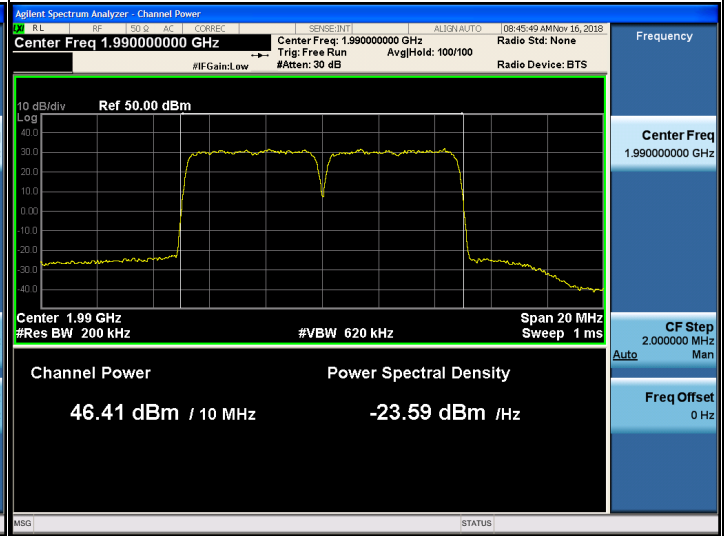
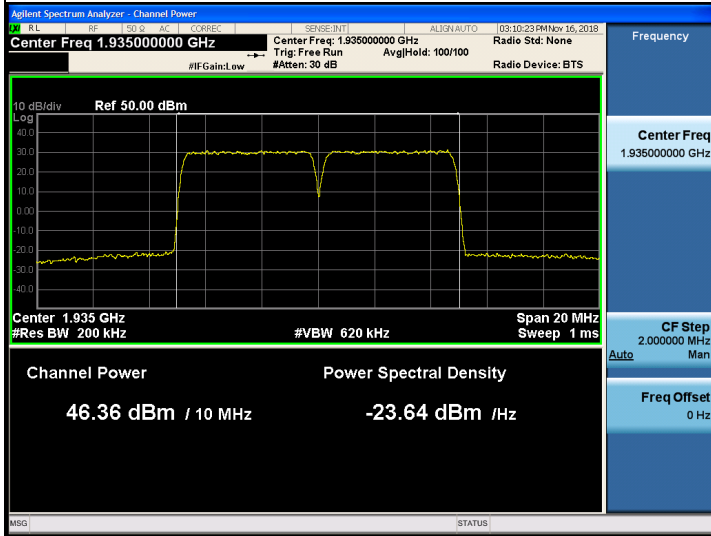

Modulation:	64QAM	Modulation:	256QAM
Channel:	High	Channel:	High

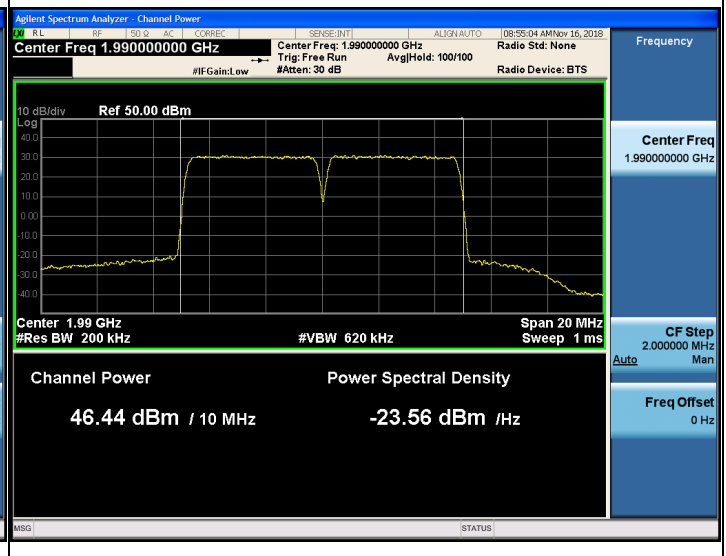
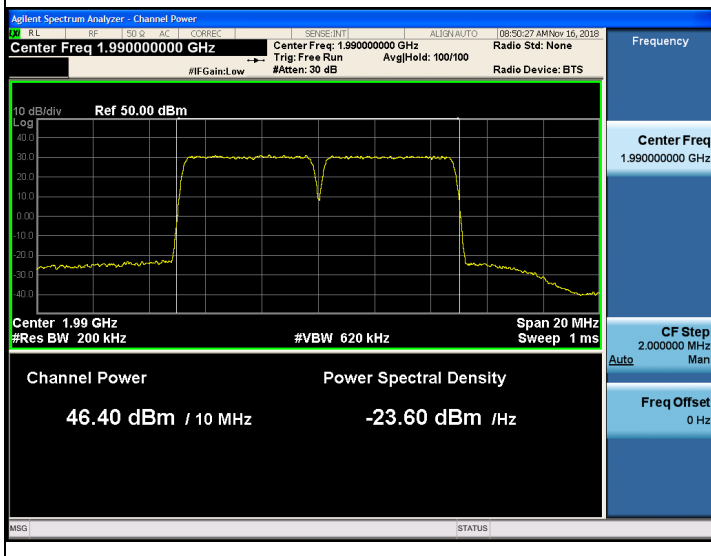

Port 2

Modulation:		QPSK		Modulation:		16QAM	
Channel:		High		Channel:		Low	
Modulation:		64QAM		Modulation:		256QAM	
Channel:		Low		Channel:		Low	

Port 3

Modulation:	QPSK	Modulation:	16QAM
Channel:	High	Channel:	High

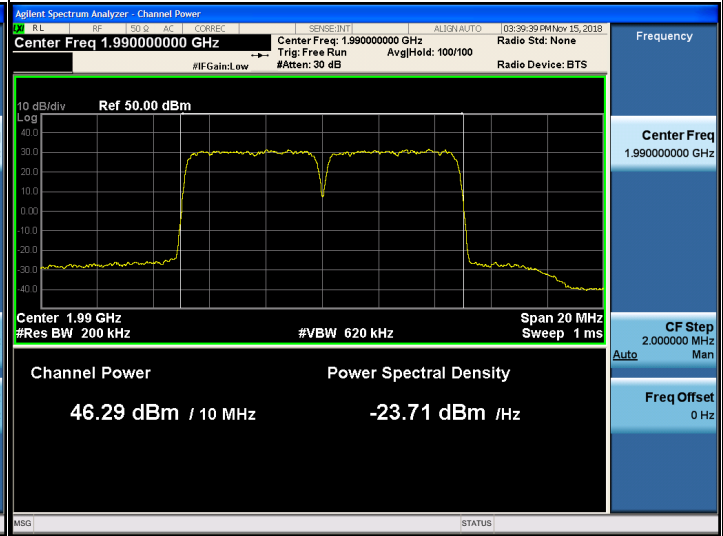
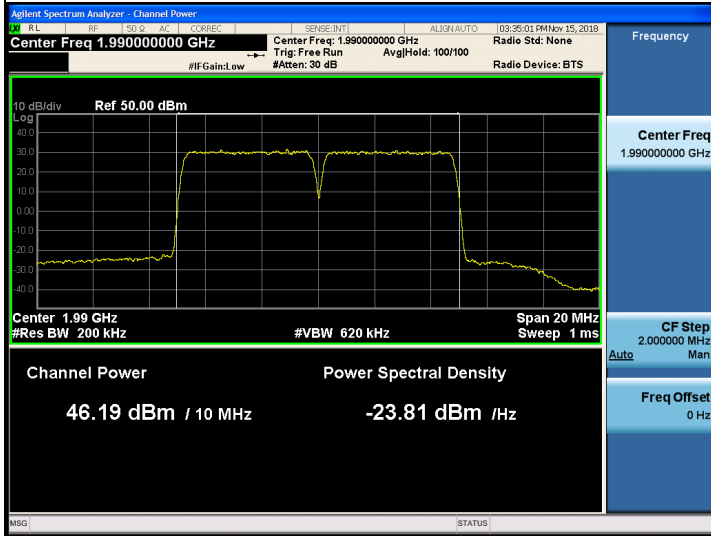

Modulation:	64QAM	Modulation:	256QAM
Channel:	Low	Channel:	High

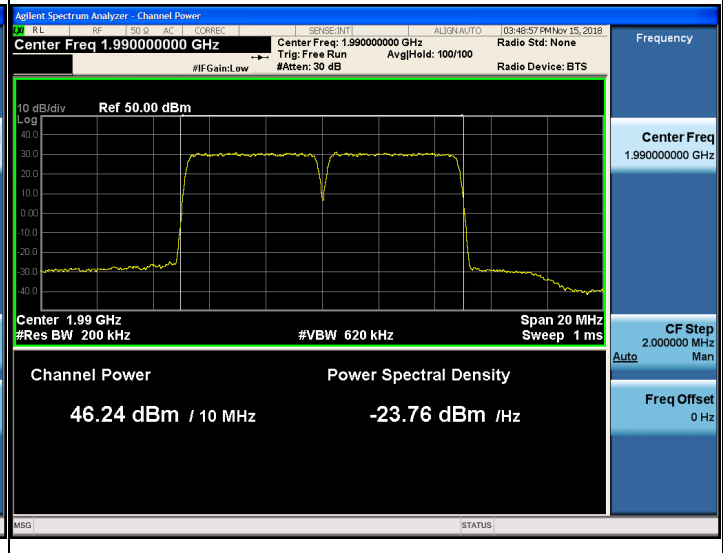
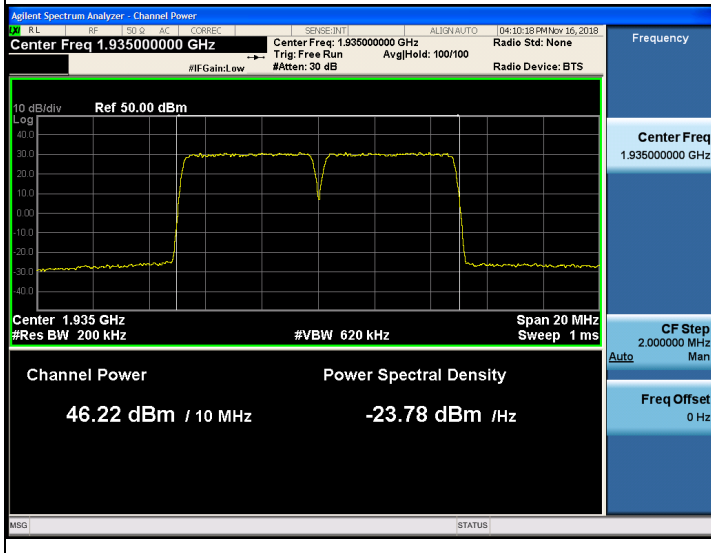

Plot data of PAPR - 3 MHz Bandwidth / 1 Carrier

Port 0

Modulation:		QPSK		Modulation:		16QAM	
Channel:		High		Channel:		Middle	
Modulation:		64QAM		Modulation:		256QAM	
Channel:		Low		Channel:		Low	

Port 1

Modulation:	QPSK	Modulation:	16QAM
Channel:	High	Channel:	Low

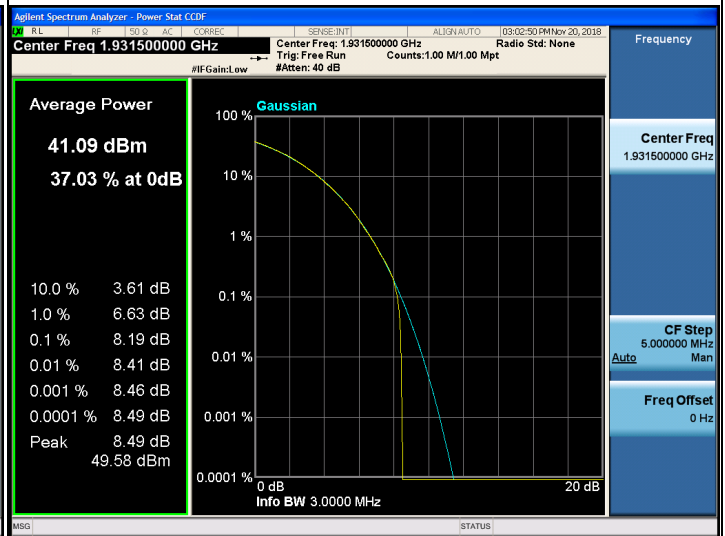
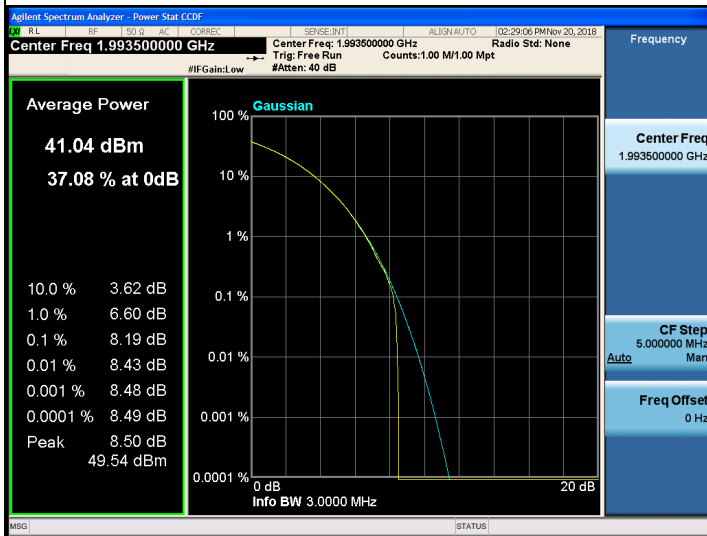

Modulation:	64QAM	Modulation:	256QAM
Channel:	High	Channel:	Low

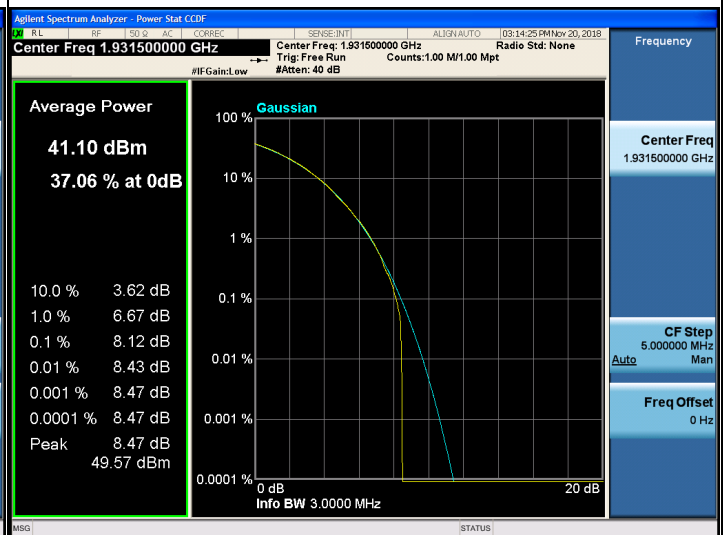
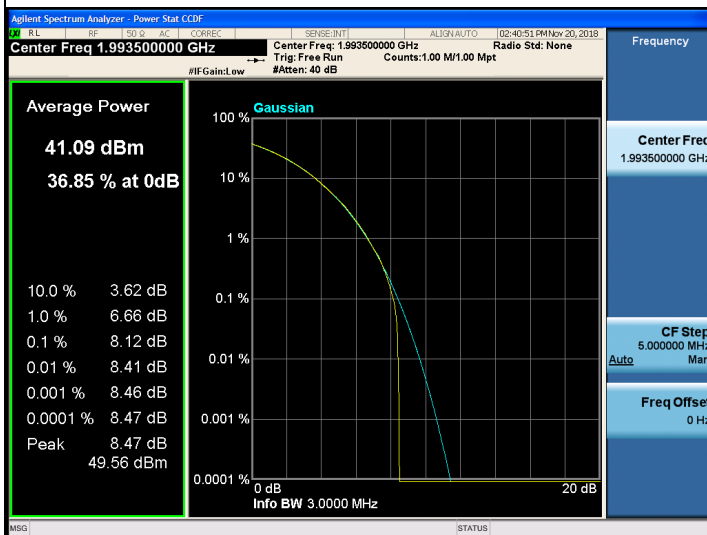

Port 2

Modulation:	QPSK	Modulation:	16QAM
Channel:	Middle	Channel:	Low

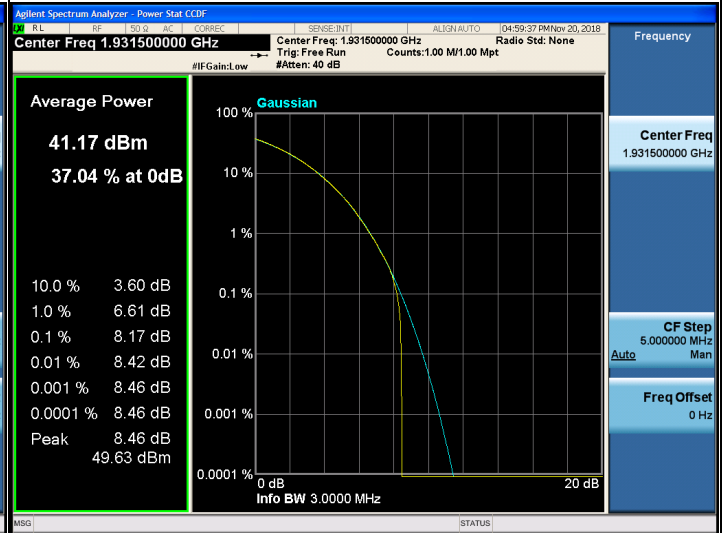
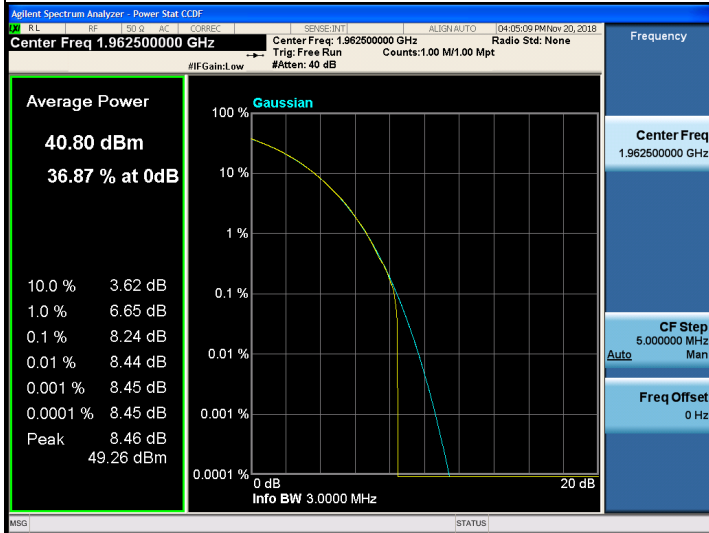

Modulation:	64QAM	Modulation:	256QAM
Channel:	Low	Channel:	High

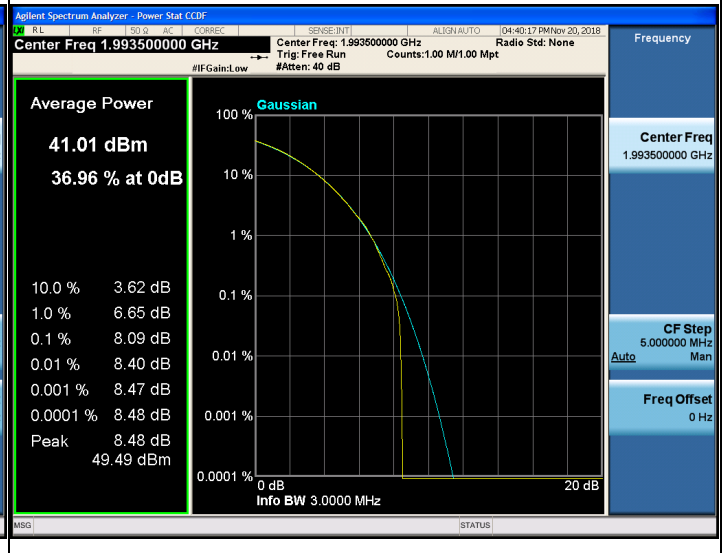
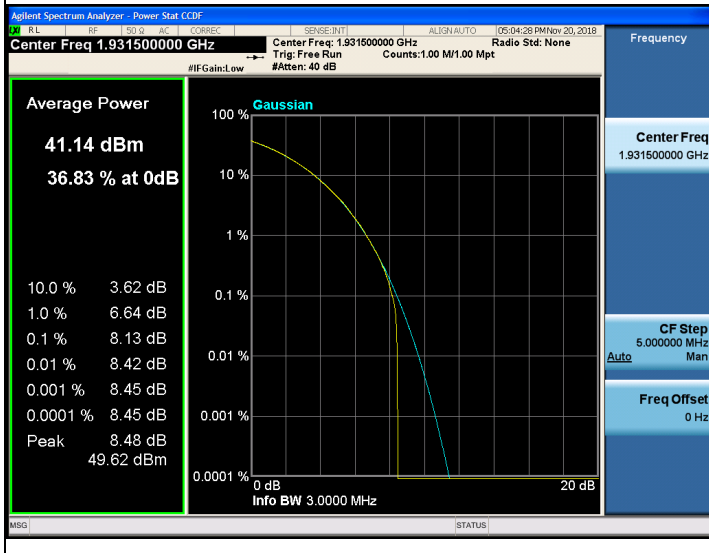

Port 3

Modulation:	QPSK	Modulation:	16QAM
Channel:	Middle	Channel:	Middle

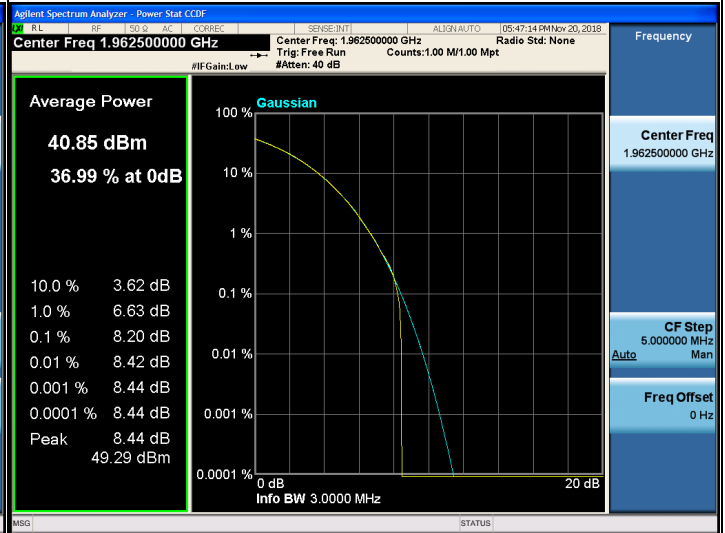
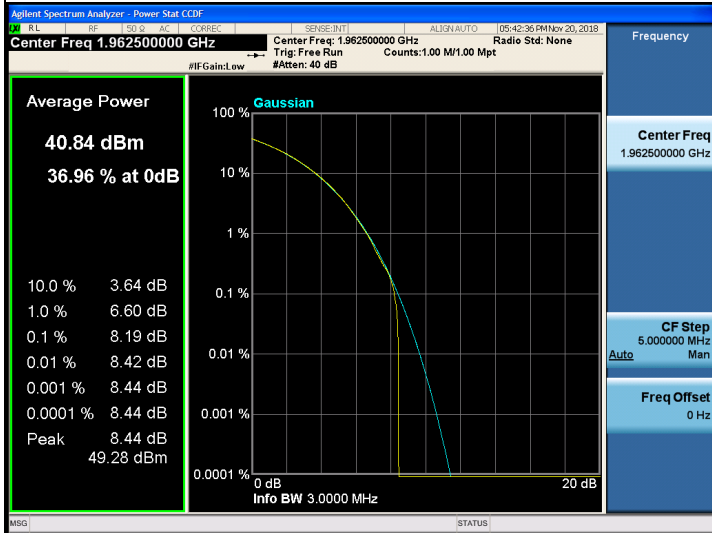

Modulation:	64QAM	Modulation:	256QAM
Channel:	High	Channel:	High

