

# FCC NFC REPORT

## Certification

<b>Applicant Name:</b> SAMSUNG Electronics Co., Ltd.	<b>Date of Issue:</b> December 18, 2023
<b>Address:</b> 129, Samsung-ro, Yeongtong-gu, Suwon-si, Gyeonggi-do, 16677, Rep. of Korea	<b>Test Site/Location:</b> 74, Seoicheon-ro 578beon-gil, Majang-myeon, Icheon- si, Gyeonggi-do, 17383 KOREA
	<b>Report No.:</b> HCT-RF-2312-FC007

<b>FCC ID:</b>	<b>A3LSMM156B</b>
<b>APPLICANT:</b>	<b>SAMSUNG Electronics Co., Ltd.</b>

<b>Model:</b>	SM-M156B/DSN
<b>Additional Model:</b>	-
<b>EUT Type:</b>	Mobile Phone
<b>RF Output Field Strength:</b>	14.02 dB $\mu$ V/m @30 m
<b>Frequency of Operation:</b>	13.56 MHz
<b>Modulation type:</b>	ASK
<b>FCC Classification:</b>	Low Power Communication Device Transmitter (DXX)
<b>FCC Rule Part(s):</b>	FCC Part 15.225 Subpart C

Engineering Statement:

The measurements shown in this report were made in accordance with the procedures indicated, and the emissions from this equipment were found to be within the limits applicable. I assume full responsibility for the accuracy and completeness of these measurements, and for the qualifications of all persons taking them. It is further stated that upon the basis of the measurements made, the equipment tested is capable of operation in accordance with the requirements of the FCC Rules under normal use and maintenance.

Report No.: HCT-RF-2312-FC007

---

**REVIEWED BY**



---

Report prepared by : Sang Hoon Lee  
Engineer of Telecommunication Testing Center

---

Report approved by : Jong Seok Lee  
Manager of Telecommunication Testing Center

The result shown in this test report refer only to the sample(s) tested unless otherwise stated.  
This test results were applied only to the test methods required by the standard.

**Test Report Statement:**

The above Test Report is not related to the accredited test result by (KS Q) ISO/IEC 17025 and KOLAS(Korea Laboratory Accreditation Scheme), which signed the ILAC-MRA.

The report shall not be reproduced except in full(only partly) without approval of the laboratory.

## Version

TEST REPORT NO.	DATE	DESCRIPTION
HCT-RF-2312-FC007	December 18, 2023	- First Approval Report

# Table of Contents

REVIEWED BY .....	2
1. EUT DESCRIPTION .....	5
2. TEST METHODOLOGY .....	6
EUT CONFIGURATION .....	6
EUT EXERCISE .....	6
GENERAL TEST PROCEDURES .....	6
DESCRIPTION OF TEST MODES .....	6
3. INSTRUMENT CALIBRATION.....	7
4. FACILITIES AND ACCREDITATIONS .....	7
FACILITIES .....	7
EQUIPMENT .....	7
5. ANTENNA REQUIREMENTS .....	7
6. MEASUREMENT UNCERTAINTY .....	8
7. DESCRIPTION OF TESTS.....	9
8. TEST SUMMARY .....	17
9. TEST RESULT .....	18
9.1. Operation within the band 13.110 MHz – 14.010 MHz.....	18
9.2. Radiated Emission 9kHz – 30 MHz .....	20
9.3. Radiated Emission 30MHz – 1000 MHz .....	21
9.4. 20 dB Bandwidth .....	22
9.5. Frequency Stability .....	23
9.6. POWERLINE CONDUCTED EMISSIONS .....	27
10. LIST OF TEST EQUIPMENT .....	29
11. ANNEX A_ TEST SETUP PHOTO .....	31

## 1. EUT DESCRIPTION

<b>Model</b>	SM-M156B/DSN
<b>Additional Model</b>	-
<b>EUT Type</b>	Mobile Phone
<b>Power Supply</b>	DC 4.20 V
<b>Frequency of Operation</b>	13.56 MHz
<b>Transmit Power</b>	14.02 dB $\mu$ V/m @30 m
<b>Modulation Type</b>	ASK
<b>Date(s) of Tests</b>	November 14, 2023 ~ December 14, 2023
<b>Serial number</b>	Radiated : R3CWA0QSXYD

## **2. TEST METHODOLOGY**

The measurement procedure described in the American National Standard of Procedures for Compliance Testing of Unlicensed Wireless Devices (ANSI C63.10-2013) is used in the measurement of the test device.

### **EUT CONFIGURATION**

The EUT configuration for testing is installed on RF field strength measurement to meet the Commissions requirement and operating in a manner that intends to maximize its emission characteristics in a continuous normal application.

### **EUT EXERCISE**

The EUT was operated in the engineering mode to fix the Tx frequency that was for the purpose of the measurements. According to its specifications, the EUT must comply with the requirements of the Section 15.207, 15.209 and 15.225 under the FCC Rules Part 15 Subpart C.

## **GENERAL TEST PROCEDURES**

### **Conducted Emissions**

The EUT is placed on the turntable, which is 0.8 m above ground plane. According to the requirements in Section 6.2 of ANSI C63.10. (Version :2013) Conducted emissions from the EUT measured in the frequency range between 0.15 MHz and 30MHz using CISPR Quasi-peak and average detector modes.

### **Radiated Emissions**

The EUT is placed on a turn table, which is 0.8 m above ground plane. The turntable shall rotate 360 degrees to determine the position of maximum emission level. EUT is set 3 m away from the receiving antenna, which varied from 1 m to 4 m to find out the highest emission. And also, each emission was to be maximized by changing the polarization of receiving antenna both horizontal and vertical. In order to find out the max. emission, the relative positions of this hand-held transmitter (EUT) was rotated through three orthogonal axes according to the requirements in Section 6.6.5 of ANSI C63.10. (Version: 2013).

## **DESCRIPTION OF TEST MODES**

The EUT has been tested under operating condition. Test program used to control the EUT for staying in continuous transmitting and receiving mode is programmed.

### 3. INSTRUMENT CALIBRATION

The measuring equipment, which was utilized in performing the tests documented herein, has been calibrated in accordance with the manufacturer's recommendations for utilizing calibration equipment, which is traceable to recognized national standards.

Especially, all antenna for measurement is calibrated in accordance with the requirements of C63.5 (Version : 2017).

### 4. FACILITIES AND ACCREDITATIONS

#### FACILITIES

The SAC(Semi-Anechoic Chamber) and conducted measurement facility used to collect the radiated data are located at the 74, Seoicheon-ro 578beon-gil, Majang-myeon, Icheon-si, Gyeonggi-do, 17383, Rep. of KOREA.

The site is constructed in conformance with the requirements of ANSI C63.4. (Version :2014) and CISPR Publication 22.

Detailed description of test facility was submitted to the Commission and accepted dated March 31, 2022 (Registration Number: KR0032).

#### EQUIPMENT

Radiated emissions are measured with one or more of the following types of Linearly polarized antennas: tuned dipole, bi-conical, log periodic, bi-log, and/or ridged waveguide, horn. Spectrum analyzers with pre-selectors and quasi-peak detectors are used to perform radiated measurements.

Conducted emissions are measured with Line Impedance Stabilization Networks and EMI Test Receivers. Calibrated wideband preamplifiers, coaxial cables, and coaxial attenuators are also used for making measurements.

All receiving equipment conforms to CISPR Publication 16-1, "Radio Interference Measuring Apparatus and Measurement Methods."

### 5. ANTENNA REQUIREMENTS

#### According to FCC 47 CFR §15.203:

"An intentional radiator antenna shall be designed to ensure that no antenna other than that furnished by the responsible party can be used with the device. The use of a permanently attached antenna or of an antenna that uses a unique coupling to the intentional radiator shall be considered sufficient to comply with the provisions of this section."

(1) The antennas of this E.U.T are permanently attached.

(2)The E.U.T Complies with the requirement of §15.203

## 6. MEASUREMENT UNCERTAINTY

The measurement uncertainties shown below were calculated in accordance with the requirements of ANSI C63.10-2013.

All measurement uncertainty values are shown with a coverage factor of  $k = 2$  to indicate a 95 % level of confidence.

The measurement data shown herein meets or exceeds the  $U_{\text{CISPR}}$  measurement uncertainty values specified in CISPR 16-4-2 and, thus, can be compared directly to specified limits to determine compliance.

Parameter	Expanded Uncertainty (dB)
Conducted Disturbance (150 kHz ~ 30 MHz)	1.90 ( Confidence level about 95 %, $k=2$ )
Radiated Disturbance (9 kHz ~ 30 MHz)	4.14 ( Confidence level about 95 %, $k=2$ )
Radiated Disturbance (30 MHz ~ 1 GHz)	5.82 ( Confidence level about 95 %, $k=2$ )
Radiated Disturbance (1 GHz ~ 18 GHz)	5.74 ( Confidence level about 95 %, $k=2$ )
Radiated Disturbance (18 GHz ~ 40 GHz)	5.76 ( Confidence level about 95 %, $k=2$ )
Radiated Disturbance (Above 40 GHz)	5.52 ( Confidence level about 95 %, $k=2$ )



## 7. DESCRIPTION OF TESTS

### 7.1. Radiated Test

#### Limit (Operation within the band 13.110 MHz – 14.010 MHz)

Frequency (MHz)	Field Strength ( $\mu\text{V/m}$ )	Measurement Distance (m)
13.553 – 13.567	15,848	30
13.410 $\leq$ f $\leq$ 13.553 13.567 $\leq$ f $\leq$ 13.710	334	30
13.110 $\leq$ f $\leq$ 13.410 13.710 $\leq$ f $\leq$ 14.010	106	30

Note:

1. 15,848  $\mu\text{V/m}$  = 84.0dB $\mu\text{V/m}$
2. 334  $\mu\text{V/m}$  = 50.47 dB $\mu\text{V/m}$
3. 106 $\mu\text{V/m}$  = 40.51dB $\mu\text{V/m}$

#### Limit(Radiated Spurious Emissions)

Frequency (MHz)	Field Strength ( $\mu\text{V/m}$ )	Measurement Distance (m)
0.009 – 0.490	2400/F(kHz)	300
0.490 – 1.705	24000/F(kHz)	30
1.705 – 30	30	30
30-88	* 100	3
88-216	* 150	3
216-960	* 200	3
Above 960	500	3

※.

Except as provided in 15.209(g), fundamental emissions from intentional radiators operating under this Section shall not be located in the frequency bands 54-72MHz, 76-88MHz, 174-216MHz or 470-806MHz. However, operation within these frequency bands is permitted under other sections of this Part, e.g. 15.231 and 15.241.

## Test Configuration

Below 30 MHz

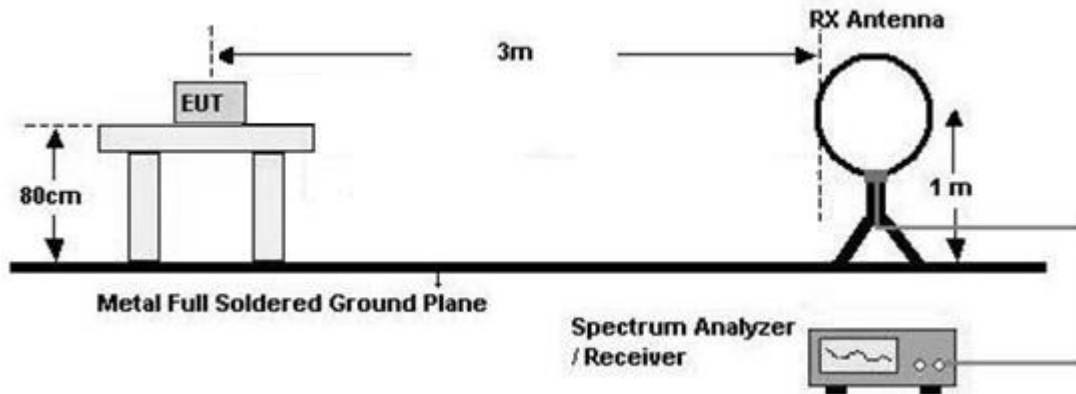

30 MHz - 1 GHz

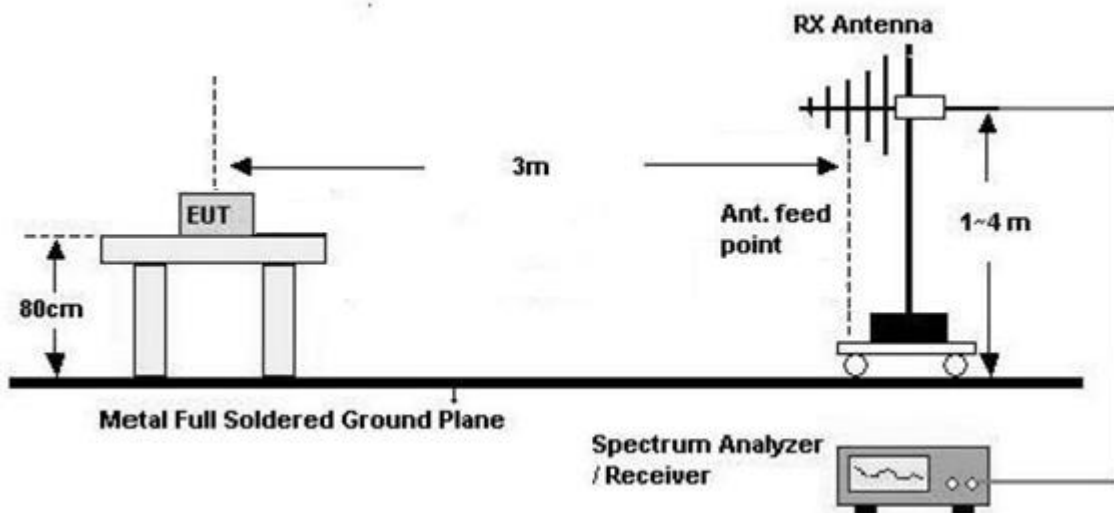

## Test Procedure of in-band

1. The EUT was placed on a non-conductive table located on semi-anechoic chamber.
2. The loop antenna was placed at a location 3 m from the EUT
3. The EUT is placed on a turntable, which is 0.8m above ground plane.
4. We have done x, y, z planes in EUT and horizontal and vertical polarization and Parallel to the ground plane in detecting antenna.
5. The turntable shall be rotated for 360 degrees to determine the position of maximum emission level.
6. Distance Correction Factor =  $40\log(3\text{ m}/30\text{ m}) = -40\text{ dB}$   
Measurement Distance : 3 m (Below 30 MHz)
7. Spectrum Setting

1) Frequency Range = 9 kHz ~ 150 kHz

- Detector = Peak
- Trace = Maxhold
- RBW = 300 Hz
- VBW  $\geq$  3 x RBW

2) Frequency Range = 150 kHz ~ 30 MHz

- Detector = Peak
- Trace = Maxhold
- RBW = 10 kHz
- VBW  $\geq$  3 x RBW

8.Total = Measured Value + Antenna Factor(A.F) + Cable Loss(C.L) + Distance Factor(D.F)

### **Test Procedure of Radiated spurious emissions (Below 30 MHz)**

1. The EUT was placed on a non-conductive table located on semi-anechoic chamber.
2. The loop antenna was placed at a location 3 m from the EUT
3. The EUT is placed on a turntable, which is 0.8m above ground plane.
4. We have done x, y, z planes in EUT and horizontal and vertical polarization and Parallel to the ground plane in detecting antenna.
5. The turntable shall be rotated for 360 degrees to determine the position of maximum emission level.
6. Distance Correction Factor(0.009 MHz – 0.490 MHz) =  $40\log(3 \text{ m}/300 \text{ m}) = - 80 \text{ dB}$   
Measurement Distance : 3 m
7. Distance Correction Factor(0.490 MHz – 30 MHz) =  $40\log(3 \text{ m}/30 \text{ m}) = - 40 \text{ dB}$   
Measurement Distance : 3 m

#### 8. Spectrum Setting

1) Frequency Range = 9 kHz ~ 150 kHz

- Detector = Peak
- Trace = Maxhold
- RBW = 300 Hz
- VBW  $\geq$  3 x RBW

2) Frequency Range = 150 kHz ~ 30 MHz

- Detector = Peak
- Trace = Maxhold
- RBW = 10 kHz
- VBW  $\geq$  3 x RBW

#### 9. Total(Measurement Type : Peak)

= Peak Measured Value + Antenna Factor(A.F) + Cable Loss(C.L) + Distance Factor(D.F)

10. Measurement value only up to 6 maximum emissions noted, or would be lesser if no specific emissions from the EUT are recorded (ie: margin > 20 dB from the applicable limit) and considered that's already beyond the background noise floor.

**KDB 414788 OFS and Chamber Correlation Justification**

Base on FCC 15.31 (f) (2): measurements may be performed at a distance closer than that specified in the regulations; however, an attempt should be made to avoid making measurements in the near field.

OFS and chamber correlation testing had been performed and chamber measured test result is the worst case test result.

**Test Procedure of Radiated spurious emissions (Above 30 MHz)**

1. The EUT was placed on a non-conductive table located on semi-anechoic chamber.
2. The EUT is placed on a turntable, which is 0.8m above ground plane.
3. The Hybrid antenna was placed at a location 3 m from the EUT, which is varied from 1m to 4m to find out the highest emissions.
4. We have done x, y, z planes in EUT and horizontal and vertical polarization in detecting antenna.
5. The turntable shall be rotated for 360 degrees to determine the position of maximum emission level.
6. Spectrum Setting
  - Frequency Range = 30 MHz ~ 1 GHz
  - Detector = Peak
  - Trace = Maxhold
  - RBW = 100 kHz
  - VBW  $\geq$  3 x RBW
7. Total = Measured Value + Antenna Factor(A.F) + Cable Loss(C.L)
8. Measurement value only up to 6 maximum emissions noted, or would be lesser if no specific emissions from the EUT are recorded (ie: margin > 20 dB from the applicable limit) and considered that's already beyond the background noise floor.

## 7.2. 20 dB Bandwidth

### Test Configuration

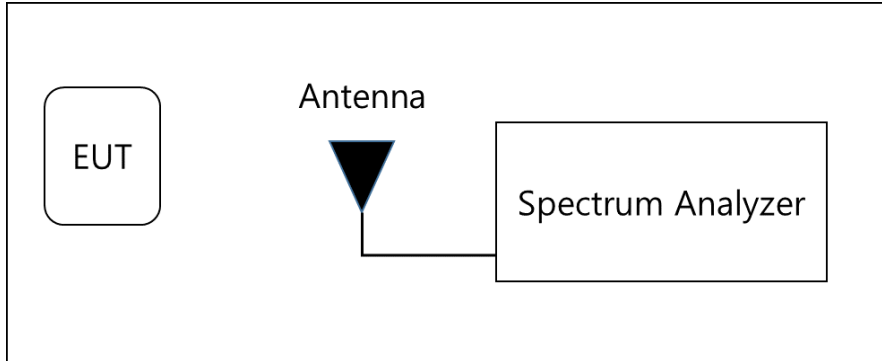

### Test Procedure

The 20 dB bandwidth was measured by using a spectrum analyzer.

(Procedure 6.9.2 in ANSI 63.10-2013)

- 1) RBW = 1 %~5 % of the OBW
- 2) VBW = approximately three times RBW
- 3) Span = between two times and five times the OBW
- 4) Detector = Peak
- 5) Trace mode = Max hold
- 6) Allow the trace to stabilize

Note :

We tested Occupied Bandwidth using the automatic bandwidth measurement capability of a spectrum analyzer.

### 7.3. Frequency Stability

#### Limit

The frequency tolerance of the carrier signal shall be maintained within  $\pm 0.01\%$  of the operating frequency.

#### Test Configuration

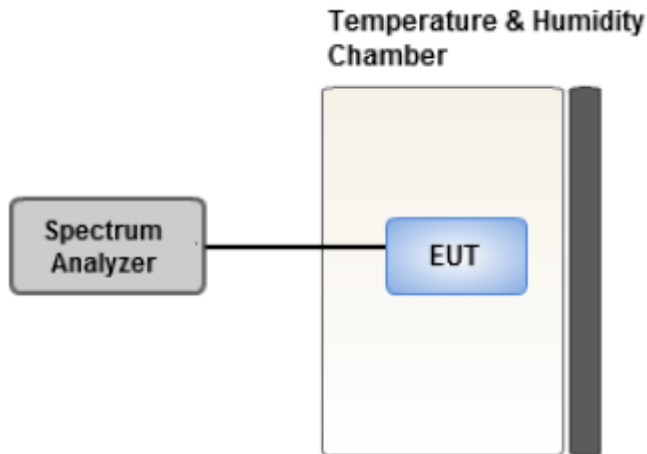

#### Test Procedure.

For battery operated equipment, the equipment tests shall be performed using a new battery.

- 1) Turn the EUT OFF and place it inside the environmental temperature chamber.  
For devices that have oscillator heaters, energize only the heater circuit.
- 2) Set the temperature control on the chamber to the highest specified in the regulatory requirements for the type of device and allow the oscillator heater and the chamber temperature to stabilize.
- 3) While maintaining a constant temperature inside the environmental chamber, turn the EUT ON and record the operating frequency at startup, and at 2 minutes, 5 minutes, and 10 minutes after the EUT is energized. Four measurements in total are made.
- 4) The frequency tolerance of the carrier signal shall be maintained within  $\pm 0.01\%$  of the operating frequency.

#### Note:

- 1) Temperature:  
The temperature is varied from  $-20\text{ }^{\circ}\text{C}$  to  $+50\text{ }^{\circ}\text{C}$  using an environmental chamber.
- 2) Primary Supply Voltage :  
The primary supply voltage is varied from 85 % to 115 % of the nominal value for non hand-carried battery and AC powered equipment.  
For hand-carried, battery-powered equipment, primary supply voltage is reduced to the battery operating end point which shall be specified by the manufacturer.

## 7.4. AC Power line Conducted Emissions

### Limit

For an intentional radiator that is designed to be connected to the public utility (AC) power line, the radio frequency voltage that is conducted back onto the AC power line on any frequency or frequencies, within the band 150 kHz to 30 MHz, shall not exceed the limits in the following table, as measured using a 50  $\mu$ H/50 ohms line impedance stabilization network (LISN).

Frequency Range (MHz)	Limits (dB $\mu$ V)	
	Quasi-peak	Average
0.15 to 0.50	66 to 56 <sup>(a)</sup>	56 to 46 <sup>(a)</sup>
0.50 to 5	56	46
5 to 30	60	50

<sup>(a)</sup>Decreases with the logarithm of the frequency.

Compliance with this provision shall be based on the measurement of the radio frequency voltage between each power line (LINE and NEUTRAL) and ground at the power terminals.

### Test Configuration

See test photographs attached in Annex A for the actual connections between EUT and support equipment.

### Test Procedure

1. The EUT is placed on a wooden table 80 cm above the reference ground plane.
2. The EUT is connected via LISN to a test power supply.
3. The measurement results are obtained as described below:
4. Detectors : Quasi Peak and Average Detector.
5. The EUT is the device operating below 30 MHz.
  - For unterminated the Antenna, the AC line conducted tests are performed with the antenna connected
  - For terminated the Antenna, the AC line conducted tests are performed with a dummy load connected to the EUT antenna output terminal.

### Sample Calculation

Quasi-peak(Final Result) = Measured Value + Correction Factor

## 7.5. Worst case configuration and mode

### **Radiated test**

1. All modes of operation were investigated and the worst case configuration results are reported.
  - Mode : Stand alone, Stand alone + external accessories(Earphone, etc)
  - Worst case : Stand alone
2. EUT Axis : Y
3. All type and bitrate were investigated and the worst case results are reported.
  - Worst case : Type A, 106 kbps
4. All mode of without tag and with tag were investigated and the worst case configuration results are reported.
  - Worst case : Without Tag
5. All position of loop antenna were investigated and the worst case configuration results are reported.
  - Position : Horizontal, Vertical, Parallel to the ground plane
  - Worst case : Horizontal

### **AC Power line Conducted Emissions**

1. All modes of operation were investigated and the worst case configuration results are reported.
  - Mode : Stand alone + Earphone + Travel Adapter, Stand alone + Travel Adapter
  - Worst case : Stand alone + Travel Adapter

### **20 dB Bandwidth & Frequency Stability**

1. All type and bitrate were investigated and the worst case results are reported.
  - Worst case : Type A, 106 kbps



## 8. TEST SUMMARY

Regulation	Requirement	Result
Part 15.225 (a)	Radiated Electric Field Emissions (13.553 MHz to 13.567 MHz)	Pass
Part 15.225 (b)	Radiated Electric Field Emissions ( $13.410 \leq f \leq 13.553$ , $13.567 \leq f \leq 13.710$ )	Pass
Part 15.225 (c)	Radiated Electric Field Emissions ( $13.110 \leq f \leq 13.410$ , $13.710 \leq f \leq 14.010$ )	Pass
Part 15.209	Radiated Electric Field Emissions (9 kHz to 30 MHz)	Pass
Part 15.209	Radiated Electric Field Emissions (30 MHz to 1 GHz)	Pass
Part 15.225 (e)	Frequency Stability	Pass
Part 15.207	AC power conducted emissions (150 kHz to 30 MHz)	Pass
Part 15.215 (c)	20 dB Bandwidth	Pass

## 9. TEST RESULT

### 9.1. Operation within the band 13.110 MHz – 14.010 MHz

Measured Frequency Range : 13.553 MHz-13.567 MHz							
Frequency (MHz)	Measured Value (dB $\mu$ V/m) @3 m	Ant. Factor +Cable Loss (dB/m)	Ant. POL (H/V)	Distance Correction (dB)	Total (dB $\mu$ V/m) @30 m	Limit (dB $\mu$ V/m) @30 m	Margin (dB)
13.5600	33.70	20.32	H	-40.00	14.02	84.00	69.98
13.5602	29.27	20.32	V	-40.00	9.59	84.00	74.41

Measured Frequency Range : 13.410 MHz-13.553 MHz and 13.567 MHz-13.710 MHz							
Frequency (MHz)	Measured Value (dB $\mu$ V/m) @3 m	Ant. Factor +Cable Loss (dB/m)	Ant. POL (H/V)	Distance Correction (dB)	Total (dB $\mu$ V/m) @30 m	Limit (dB $\mu$ V/m) @30 m	Margin (dB)
13.5529	28.18	20.32	H	-40.00	8.50	50.47	41.97
13.5671	27.56	20.32	V	-40.00	7.88	50.47	42.59

Measured Frequency Range : 13.110 MHz – 13.410 MHz and 13.710 MHz-14.010 MHz							
Frequency (MHz)	Measured Value (dB $\mu$ V/m) @3 m	Ant. Factor +Cable Loss (dB/m)	Ant. POL (H/V)	Distance Correction (dB)	Total (dB $\mu$ V/m) @30 m	Limit (dB $\mu$ V/m) @30 m	Margin (dB)
13.3486	19.86	20.32	H	-40.00	0.18	40.51	40.33
13.7706	18.96	20.32	V	-40.00	-0.72	40.51	41.23

## Test Plot

13.553 MHz ~ 13.567 MHz

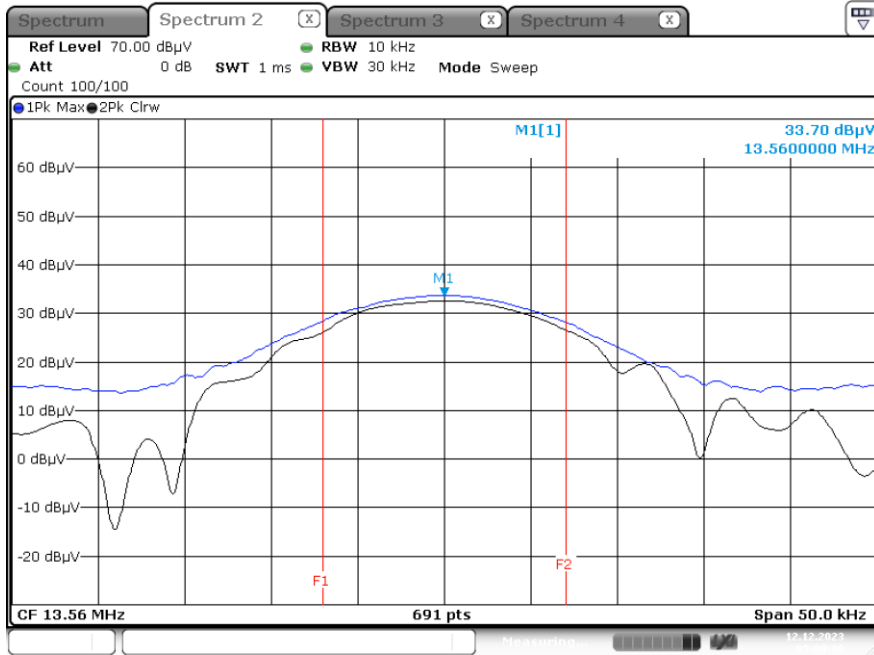

Worst Case (13.110 MHz – 13.410 MHz)

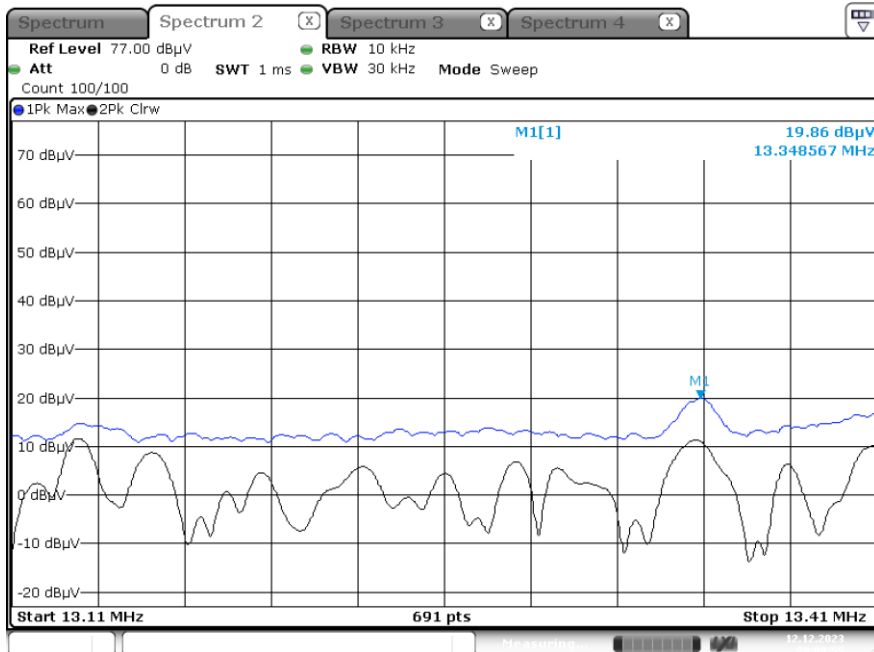

### Note:

Plot of worst case are only reported.

**9.2. Radiated Emission 9kHz – 30 MHz**

Measured Frequency Range : 9 kHz - 30 MHz							
Frequency (kHz)	Measured Value (dB $\mu$ V/m) @3 m	Ant. Factor +Cable Loss (dB/m)	Ant. POL (H/V)	Distance Correction (dB)	Total (dB $\mu$ V/m) @300 m	Limit (dB $\mu$ V/m) @300 m	Margin (dB)
9.9984	10.95	20.26	Y-H	-40.00	-8.79	29.54	38.33
14.0910	11.43	20.33	Y-H	-40.00	-8.24	29.54	37.78
27.1237	9.91	20.72	Y-H	-40.00	-9.37	29.54	38.91
27.1183	8.75	20.72	Y-H	-40.00	-10.53	29.54	40.07

### 9.3. Radiated Emission 30MHz – 1000 MHz

Measured Frequency Range : 30 MHz - 1000 MHz							
Frequency (MHz)	Measured Value (dBμV/m) @3 m	Ant. Factor (dB/m)	Cable Loss (dB)	Ant. Pol (H/V)	Total (dBμV/m)	Limit (dBμV/m)	Margin (dB)
#37.5263	1.745	18.90	0.77	H	21.42	40.00	18.58
55.1000	2.528	19.20	0.83	H	22.56	40.00	17.44
97.1432	2.509	14.50	1.16	V	18.17	43.50	25.33
#120.6710	2.573	16.70	1.26	H	20.53	43.5	22.97
#125.8800	3.112	16.50	1.27	H	20.88	43.50	22.62
147.6747	2.018	18.90	1.39	V	22.31	43.50	21.19

**Note:**

1. # is the result for restricted band.

**Test Plot**

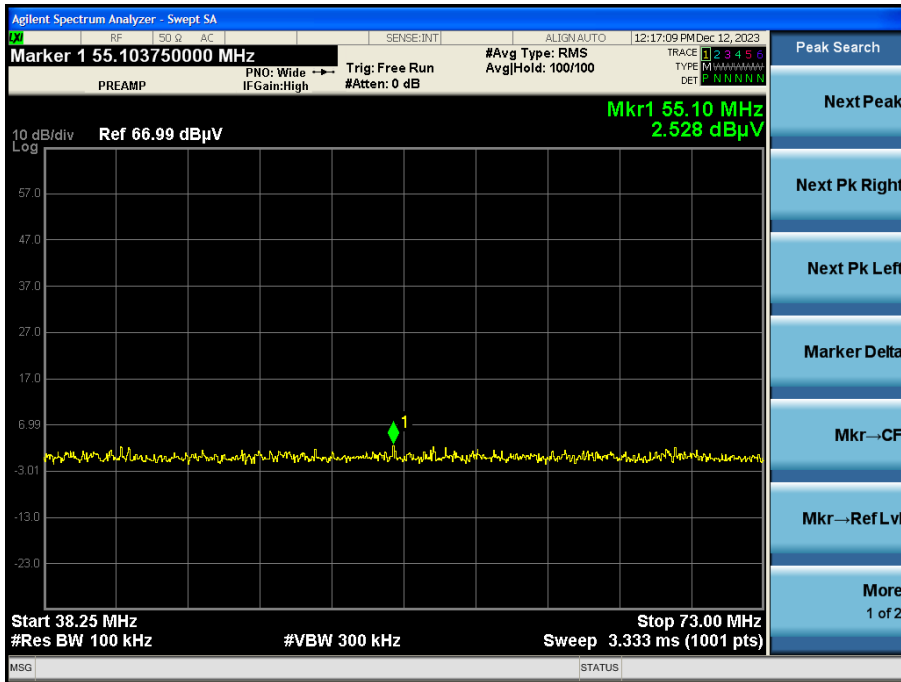

**Note:**

Plot of worst case are only reported

### 9.4. 20 dB Bandwidth

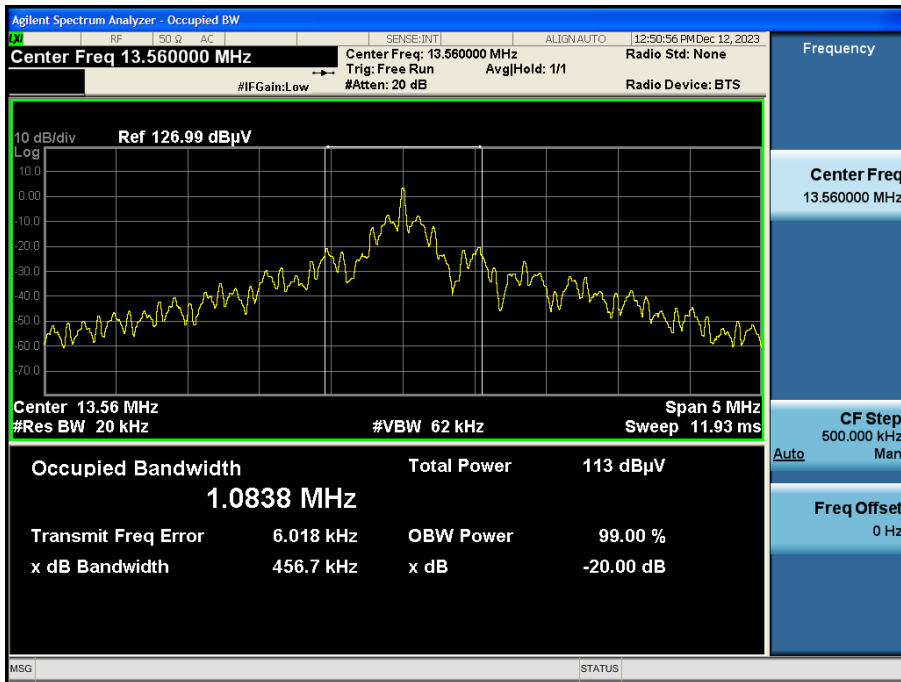

## 9.5. Frequency Stability

### Startup

PERATING FREQUENCY: 13.56 MHz  
REFERENCE VOLTAGE: 4.20 VDC  
DEVIATION LIMIT: ±0.01 % = ± 1356 Hz

Voltage (%)	Power (VDC)	Temp. (°C)	Frequency (MHz)	Frequency Dev. (Hz)	Frequency Dev (%)
100%	4.20	-20	13.560014	14	0.0001006
100%		-10	13.560017	17	0.0001223
100%		0	13.560023	23	0.0001681
100%		+10	13.560030	30	0.0002221
100%		+20(Ref.)	13.560032	32	0.0002388
100%		+30	13.560036	36	0.0002634
100%		+40	13.560050	50	0.0003677
100%		+50	13.560051	51	0.0003763
HIGH	4.40	+20	13.560035	35	0.0002557
LOW	3.80	+20	13.560035	35	0.0002594

**2 minutes**

PERATING FREQUENCY: 13.56 MHz  
REFERENCE VOLTAGE: 4.20 VDC  
DEVIATION LIMIT: ±0.01 % = ± 1356 Hz

Voltage (%)	Power (VDC)	Temp. (°C)	Frequency (MHz)	Frequency Dev. (Hz)	Frequency Dev (%)
100%	4.20	-20	13.560015	15	0.0001123
100%		-10	13.560020	20	0.0001452
100%		0	13.560022	22	0.0001599
100%		+10	13.560026	26	0.0001889
100%		+20(Ref.)	13.560035	35	0.0002554
100%		+30	13.560038	38	0.0002790
100%		+40	13.560044	44	0.0003235
100%		+50	13.560060	60	0.0004446
HIGH	4.40	+20	13.560031	31	0.0002257
LOW	3.80	+20	13.560034	34	0.0002488



**5 minutes**

PERATING FREQUENCY: 13.56 MHz  
REFERENCE VOLTAGE: 4.20 VDC  
DEVIATION LIMIT: ±0.01 % = ± 1356 Hz

Voltage (%)	Power (VDC)	Temp. (°C)	Frequency (MHz)	Frequency Dev. (Hz)	Frequency Dev (%)
100%	4.20	-20	13.560012	12	0.0000853
100%		-10	13.560020	20	0.0001493
100%		0	13.560021	21	0.0001584
100%		+10	13.560027	27	0.0001974
100%		+20(Ref.)	13.560033	33	0.0002466
100%		+30	13.560039	39	0.0002856
100%		+40	13.560050	50	0.0003686
100%		+50	13.560055	55	0.0004052
HIGH	4.40	+20	13.560036	36	0.0002642
LOW	3.80	+20	13.560030	30	0.0002221

**10 minutes**OPERATING FREQUENCY: 13.56 MHzREFERENCE VOLTAGE: 4.20 VDCDEVIATION LIMIT: ±0.01 % = ± 1356 Hz

Voltage (%)	Power (VDC)	Temp. (°C)	Frequency (MHz)	Frequency Dev. (Hz)	Frequency Dev (%)
100%	4.20	-20	13.560016	16	0.0001152
100%		-10	13.560016	16	0.0001153
100%		0	13.560022	22	0.0001653
100%		+10	13.560026	26	0.0001893
100%		+20(Ref.)	13.560031	31	0.0002257
100%		+30	13.560039	39	0.0002867
100%		+40	13.560043	43	0.0003157
100%		+50	13.560061	61	0.0004497
HIGH	4.40	+20	13.560031	31	0.0002264
LOW	3.80	+20	13.560036	36	0.0002645

## 9.6. POWERLINE CONDUCTED EMISSIONS

### Conducted Emissions

NFC MODE

1 / 2

## Test Report

### Common Information

EUT : SM-M156B/DSN  
 Operating Conditions : NFC MODE

Full Spectrum

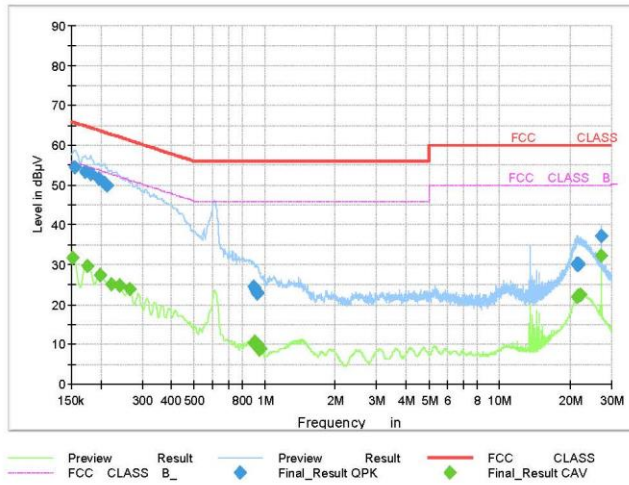

### Final Result QPK

Frequency (MHz)	QuasiPeak (dBµV)	Limit (dBµV)	Margin (dB)	Bandwidth (kHz)	Line	Corr. (dB)
0.1545	54.56	65.75	11.19	9.000	L1	9.7
0.1725	53.41	64.84	11.42	9.000	L1	9.7
0.1815	52.67	64.42	11.75	9.000	L1	9.7
0.1973	51.59	63.73	12.14	9.000	L1	9.7
0.2085	50.39	63.27	12.88	9.000	L1	9.7
0.2130	49.91	63.09	13.17	9.000	N	9.7
0.8983	24.50	56.00	31.50	9.000	N	9.8
0.9028	24.07	56.00	31.93	9.000	N	9.8
0.9140	23.31	56.00	32.69	9.000	N	9.8
0.9230	23.07	56.00	32.93	9.000	N	9.8
0.9275	22.91	56.00	33.09	9.000	N	9.8
0.9320	22.88	56.00	33.12	9.000	N	9.8
21.4858	29.94	60.00	30.06	9.000	L1	10.9
21.5128	30.15	60.00	29.85	9.000	L1	10.9
21.5398	30.28	60.00	29.72	9.000	L1	10.9
21.5915	30.16	60.00	29.84	9.000	L1	10.9
21.5983	29.92	60.00	30.08	9.000	L1	10.9
27.1198	37.32	60.00	22.68	9.000	L1	11.1

2023-12-08

오전 9:01:38

NFC MODE

2 / 2

**Final Result CAV**

Frequency (MHz)	CAverage (dBμV)	Limit (dBμV)	Margin (dB)	Bandwidth (kHz)	Line	Corr. (dB)
0.1523	31.60	55.88	24.28	9.000	L1	9.7
0.1748	29.80	54.73	24.93	9.000	L1	9.7
0.1995	27.29	53.63	26.34	9.000	L1	9.7
0.2220	25.24	52.74	27.51	9.000	L1	9.7
0.2400	24.95	52.10	27.15	9.000	L1	9.7
0.2648	23.87	51.28	27.41	9.000	L1	9.7
0.9005	10.44	46.00	35.56	9.000	L1	9.8
0.9073	10.56	46.00	35.44	9.000	L1	9.8
0.9253	9.80	46.00	36.20	9.000	L1	9.8
0.9320	10.00	46.00	36.00	9.000	L1	9.8
0.9455	8.66	46.00	37.34	9.000	L1	9.8
0.9568	8.85	46.00	37.15	9.000	L1	9.8
21.4610	22.03	50.00	27.97	9.000	L1	10.9
21.4858	22.05	50.00	27.95	9.000	L1	10.9
21.6230	22.21	50.00	27.79	9.000	L1	10.9
22.0258	22.37	50.00	27.63	9.000	L1	10.9
22.1180	22.36	50.00	27.64	9.000	L1	10.9
27.1198	32.39	50.00	17.61	9.000	L1	11.1

2023-12-08

오전 9:01:38

## 10. LIST OF TEST EQUIPMENT

### Conducted Test

Equipment	Model	Manufacturer	Serial No.	Due to Calibration	Calibration Interval
LISN	ENV216	Rohde & Schwarz	102245	08/02/2024	Annual
EMI Test Receiver	ESR	Rohde & Schwarz	101910	05/26/2024	Annual
Temperature Chamber	SU-642	ESPEC	0093008124	02/22/2024	Annual
Signal Analyzer	N9030A	Agilent	MY49432108	03/02/2024	Annual
DC Power Supply	E3632A	Agilent	KR75303243	04/24/2024	Annual
Attenuator(10 dB)(DC-26.5 GHz)	8493C	HP	08285	06/02/2024	Annual
Software	EMC32	Rohde & Schwarz	N/A	N/A	N/A

### Note:

1. Equipment listed above that calibrated during the testing period was set for test after the calibration.
2. Equipment listed above that has a calibration due date during the testing period, the testing is completed before equipment expiration date.

**Radiated Test**

Equipment	Model	Manufacturer	Serial No.	Due to Calibration	Calibration Interval
Controller(Antenna mast)	CO3000	Innco system	CO3000-4p	N/A	N/A
Antenna Position Tower	MA4640/800-XP-EP	Innco system	N/A	N/A	N/A
EM1000 / Controller	EM1000	Audix	060520	N/A	N/A
Turn Table	N/A	Audix	N/A	N/A	N/A
Loop Antenna	1513	Schwarzbeck	1513-333	03/17/2024	Biennial
Hybrid Antenna	VULB 9168	Schwarzbeck	9168-0895	08/16/2024	Biennial
Horn Antenna	BBHA 9120D	Schwarzbeck	9120D-1300	01/18/2024	Biennial
Spectrum Analyzer	FSV(10 Hz ~ 40 GHz)	Rohde & Schwarz	101055	05/12/2024	Annual
Signal Analyzer	N9030A	Agilent	MY49432108	03/02/2024	Annual
RF Switching System	FMSR -05B (ATT(10dB) + LNA1(1~18GHz))	T&M system	S1L2	01/17/2024	Annual
RF Switching System	FMSR -05B (ATT(3dB) + LNA1(1~18GHz))	T&M system	S1L3	01/17/2024	Annual
Power Amplifier	CBL18265035	CERNEX	22966	11/17/2024	Annual
Power Amplifier	CBL26405040	CERNEX	25956	03/02/2024	Annual

**Note:**

1. Equipment listed above that calibrated during the testing period was set for test after the calibration.
2. Equipment listed above that has a calibration due date during the testing period, the testing is completed before equipment expiration date.
3. Especially, all antenna for measurement is calibrated in accordance with the requirements of C63.5(Version : 2017).

## 11. ANNEX A\_ TEST SETUP PHOTO

Please refer to test setup photo file no. as follows;

No.	Description
1	HCT-RF-2312-FC007-P