

Test results

Test mode: LTE B7

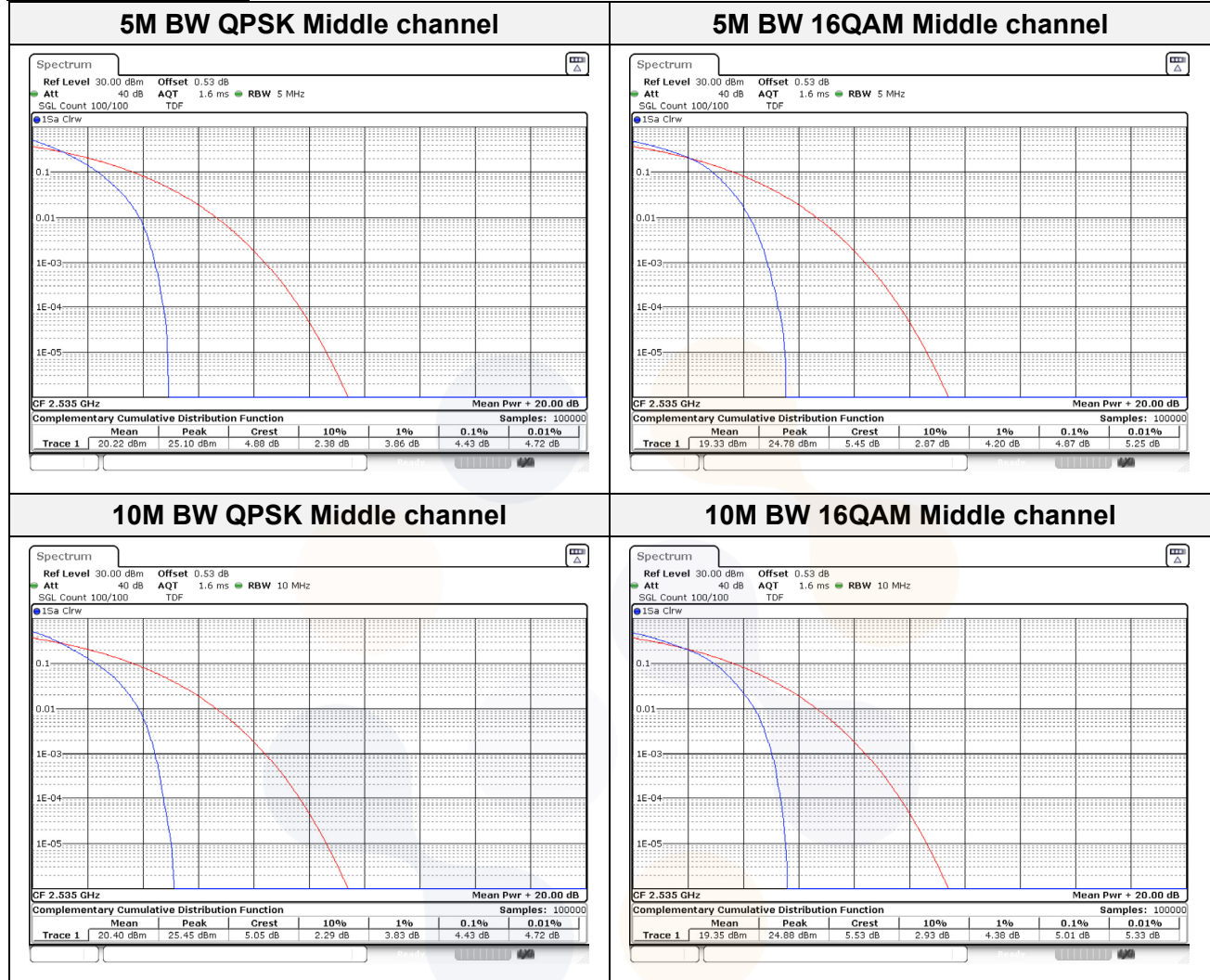

15M BW QPSK Middle channel

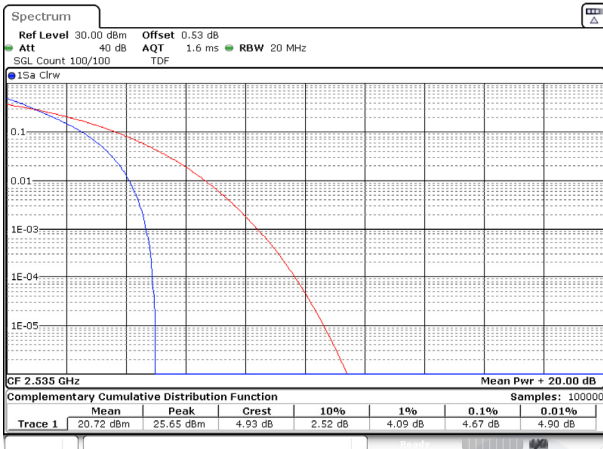

15M BW 16QAM Middle channel

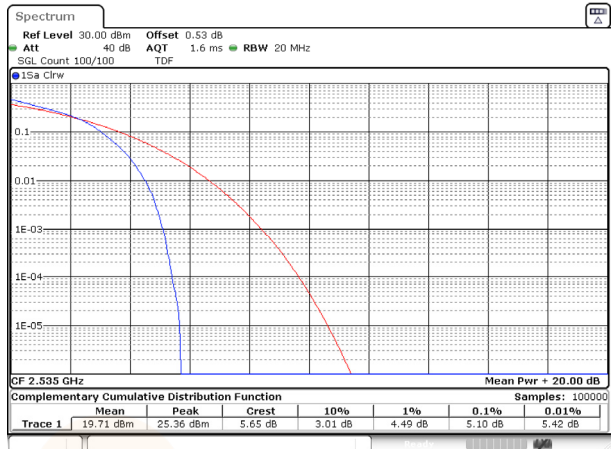

20M BW QPSK Middle channel

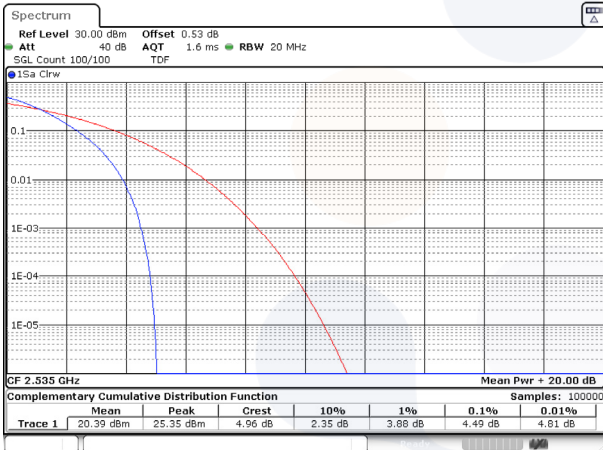

20M BW 16QAM Middle channel

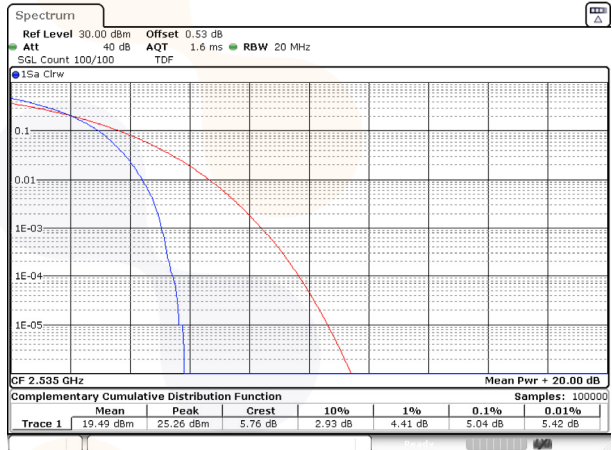

7.6. Frequency stability

Test setup

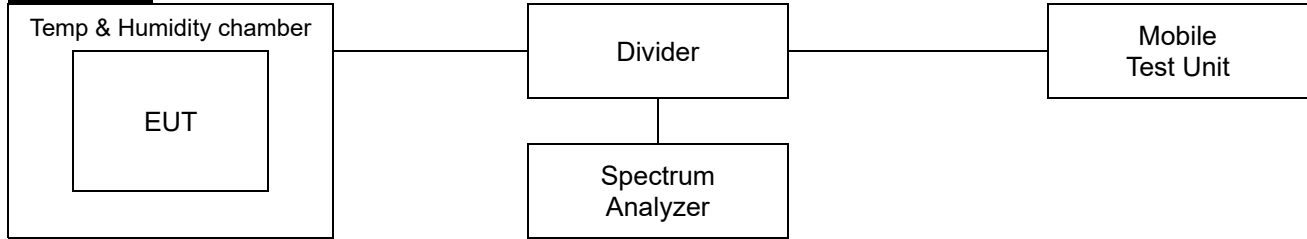

Limit

According to §2.1055(a),

The frequency stability shall be measured with variation of ambient temperature as follows:

- 1) From -30° to $+50^{\circ}$ centigrade for all equipment except that specified in paragraphs (a) (2) and (3) of this section.
- 2) From -20° to $+50^{\circ}$ centigrade for equipment to be licensed for use in the maritime services under part 80 of this chapter, except for class A, B, and S emergency position indicating radiobeacons (EPIRBS), and equipment to be licensed for use above 952 MHz at operational fixed stations in all services, stations in the local television transmission service and point-to-point microwave radio service under part 21 of this chapter, equipment licensed for use aboard aircraft in the aviation services under part 87 of this chapter, and equipment authorized for use in the family radio service under part 95 of this chapter.
- 3) From 0° to $+50^{\circ}$ centigrade for equipment to be licensed for use in the radio broadcast Services under part 73 of this chapter.

According to §2.1055(d),

The frequency stability shall be measured with variation of primary supply Voltage as follows:

- 1) Vary primary supply voltage from 85 to 115 percent of the nominal value for other than hand carried battery equipment.
- 2) For hand carried, battery powered equipment, reduce primary supply voltage to the battery operating and point which shall be specified by the manufacturer.
- 3) The supply voltage shall be measured at the input to the cable normally provided with the equipment, or at the power supply terminals if cables are not normally provided. Effects on frequency of transmitter keying (except for broadcast transmitters) and any heating element cycling at the nominal supply voltage and at each extreme also shall be shown.

According to §27.54,

The frequency stability shall be sufficient to ensure that the fundamental emission stays within the authorized bands of operation.

Test procedure

ANSI 63.26-2015 – Section 5.6

Test settings

- 1) The carrier frequency of the transmitter is measured at room temperature. (20°C to provide a reference)
- 2) The equipment is turned on in a “standby” condition for one minute before applying power to the transmitter. Measurement of the carrier frequency of the transmitter is made within one minute after applying power to the transmitter.
- 3) Frequency measurements are made at 10°C intervals ranging from -30°C to +50°C. A period of at least one half-hour is provided to allow stabilization of the equipment at each Temperature level.



Test results

Test mode : LTE B7
 Frequency (Hz) : 2 535 000 000
 Channel : 21100
 Deviation limit : The frequency stability shall be sufficient to ensure that the fundamental emissions stay within the authorized bands of operation.

Voltage (%)	Power (V)	Temp. (°C)	Frequency (Hz)	Frequency error (Hz)	Deviation	
					(ppm)	(%)
100%	3.88	+21.5(Ref)	2,534,999,996	-4.30	0.0	0.000 000
		-30	2,534,999,994	-5.63	0.0	0.000 000
		-20	2,534,999,995	-4.65	0.0	0.000 000
		-10	2,534,999,992	-8.20	0.0	0.000 000
		0	2,534,999,995	-5.32	0.0	0.000 000
		+10	2,534,999,996	-4.39	0.0	0.000 000
		+20	2,534,999,997	-2.63	0.0	0.000 000
		+30	2,534,999,996	-3.87	0.0	0.000 000
		+40	2,534,999,992	-7.69	0.0	0.000 000
		+50	2,534,999,995	-4.79	0.0	0.000 000
115%	4.46	+21.5(Ref)	2,534,999,997	-2.64	0.0	0.000 000
End point	3.40	+21.5(Ref)	2,534,999,993	-7.05	0.0	0.000 000

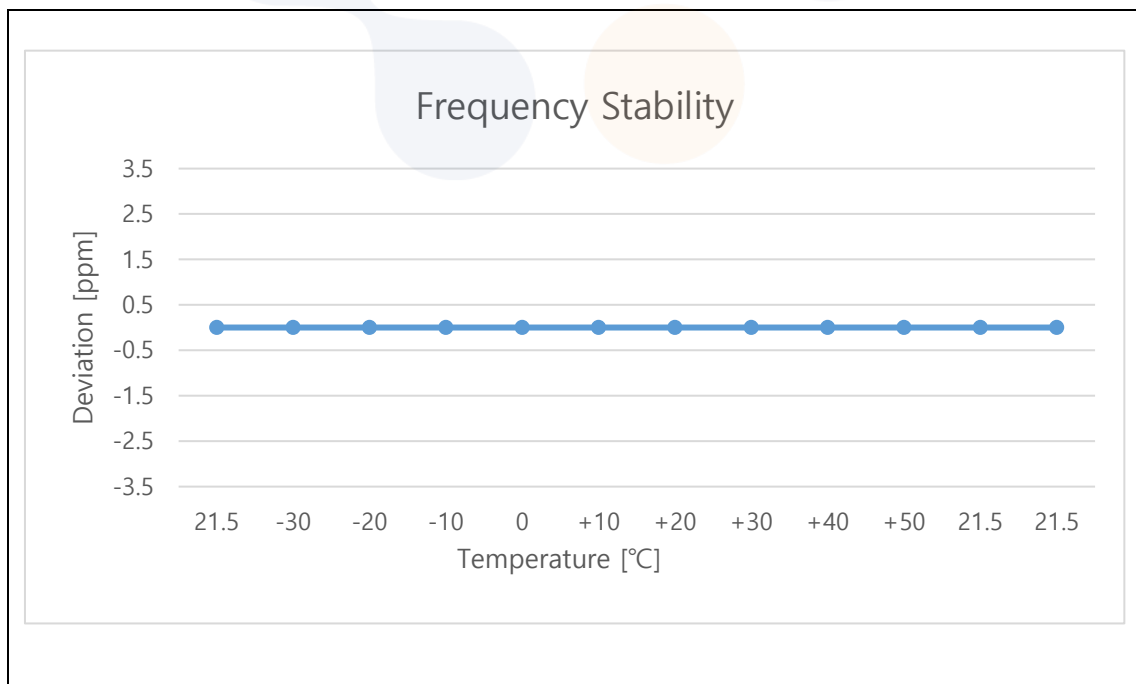

7.7. Radiated Power (EIRP)

Test setup

The diagram below shows the test setup that is utilized to make the measurements for emission from 30 MHz to 1 GHz emissions.

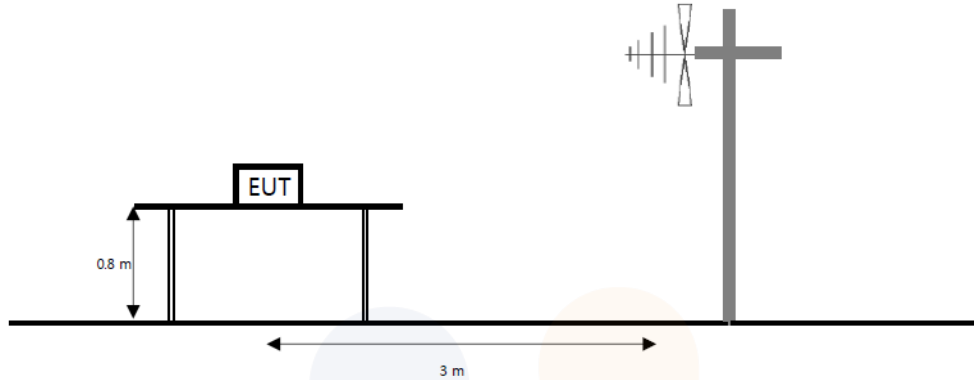

The diagram below shows the test setup that is utilized to make the measurements for emission from 1 GHz to the tenth harmonic of the highest fundamental frequency or to 40 GHz emissions, whichever is lower.

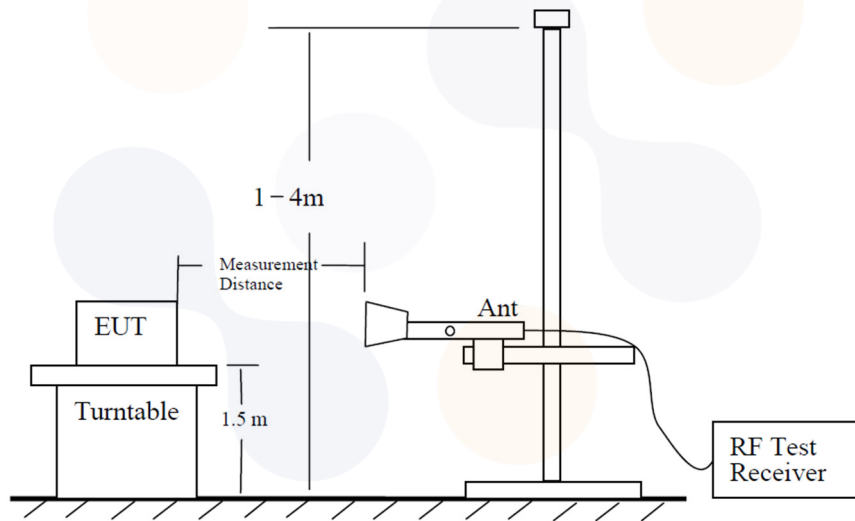

The diagram below shows the test setup for substituted method.

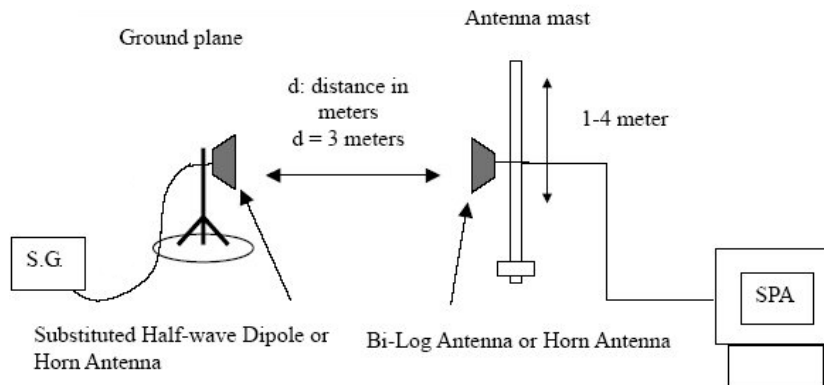

Limit

According to §27.50(h),

Mobile stations are limited to 2.0 watts EIRP. All user stations are limited to 2.0 watts transmitter output power.

Test procedure

412172 D01 v01r01



971168 D01 v03r01 - Section 5.2 and 5.8

ANSI 63.26-2015 – Section 5.2

ANSI/TIA-603-E-2016 - Section 2.2.17

Test settings

- 1) RBW = 1 % to 5 % of the OBW.
- 2) VBW $\geq 3 \times$ RBW.
- 3) SPAN = 2 \times to 3 \times the OBW.
- 4) Number of measurement points in sweep $\geq 2 \times$ span / RBW.
- 5) Sweep time :
 - 1) Auto couple, or
 - 2) $\geq [10 \times (\text{number of points in sweep}) \times (\text{transmission period})]$ for single sweep (automation-compatible) measurement. Transmission period is the on and off time of the transmitter.
- 6) Detector = RMS
- 7) If the EUT can be configured to transmit continuously, then set the trigger to free run.
- 8) If the EUT cannot be configured to transmit continuously, then use a sweep trigger with the level set to enable triggering only on full power bursts and configure the EUT to transmit at full power for the entire duration of each sweep. Verify that the sweep time is less than or equal to the transmission burst duration. Time gating can also be used under similar constraints (i.e., configured such that measurement data is collected only during active full-power transmissions).
- 9) Trace mode = trace averaging (RMS) over 100 sweeps.
- 10) Compute the power by integrating the spectrum across the OBW of the signal using the instrument's band or channel power measurement function, with the band/channel limits set equal to the OBW band edges. If the instrument does not have a band or channel power function, then sum the spectrum levels (in linear power units) at intervals equal to the RBW extending across the entire OBW of the spectrum.
- 11) Allow trace to fully stabilize.

<p>Eurofins KCTL Co.,Ltd. 65, Sinwon-ro, Yeongtong-gu, Suwon-si, Gyeonggi-do, 16677, Korea TEL: 82-70-5008-1021 FAX: 82-505-299-8311 www.kctl.co.kr</p>	<p>Report No.: KR24-SRF0101 Page (42) of (47)</p>	 
--	---	---

Notes:

1. On a test site, the EUT shall be placed at 80 cm or 1.5 m height on a turn table, and in the position close to normal use as declared by the applicant.
2. The test antenna shall be oriented initially for vertical polarization located 3 m from EUT to correspond to the fundamental frequency of the transmitter.
3. The turntable is rotated through 360°, and the receiving antenna scans in order to determine the Level of the maximized emission.
4. The test antenna shall be raised and lowered again through the specified range of height until the maximum signal level is detected by the measuring receiver.
5. The maximum signal level detected by the measuring receiver shall be noted.
6. The EUT was replaced by half-wave dipole (1 GHz below) or horn antenna (1 GHz above) connected to a signal generator.
The power is calculated by the following formula;

$$Pd(\text{dBm}) = Pg(\text{dBm}) - \text{Cable loss (dB)} + \text{Antenna gain (dB)}$$
Note. Pd is the dipole equivalent power and Pg is the generator output power into the substitution antenna.
7. The test antenna shall be raised and lowered through the specified range of height to ensure that the maximum signal is received.
The input signal to the substitution antenna shall be adjusted to the level that produces a level detected by the measuring corrected for the change of input attenuator setting of the measuring Receiver.
8. The input level to the substitution antenna shall be recorded as power level in dBm, corrected for Any change of input attenuator setting of the measuring receiver.
9. The measurement shall be repeated with the test antenna and the substitution antenna Orientated for horizontal polarization.

Test results

Test mode: LTE B7

Bandwidth [MHz]	Modulation	Channel	Pol.	Antenna Gain	C.L	Substitute Level	EIRP	
			[V/H]	[dBi]	[dB]	[dBm]	[dBm]	[W]
5	QPSK	Low	V	6.01	10.77	11.37	6.60	0.005
		Middle	V	6.09	10.78	9.93	5.24	0.003
		High	V	6.18	10.81	10.04	5.41	0.003
	16QAM	Low	V	6.01	10.77	10.32	5.56	0.004
		Middle	V	6.09	10.78	8.83	4.14	0.003
		High	V	6.18	10.81	8.96	4.33	0.003
10	QPSK	Low	V	6.01	10.74	12.62	7.89	0.006
		Middle	V	6.09	10.78	10.16	5.47	0.004
		High	V	6.17	10.81	9.77	5.13	0.003
	16QAM	Low	V	6.01	10.74	11.57	6.85	0.005
		Middle	V	6.09	10.78	9.36	4.67	0.003
		High	V	6.17	10.81	8.78	4.13	0.003
15	QPSK	Low	V	6.02	10.74	12.14	7.42	0.006
		Middle	V	6.09	10.78	10.47	5.78	0.004
		High	V	6.16	10.82	10.31	5.65	0.004
	16QAM	Low	V	6.02	10.74	11.30	6.58	0.005
		Middle	V	6.09	10.78	9.37	4.68	0.003
		High	V	6.16	10.82	9.34	4.68	0.003
20	QPSK	Low	V	6.03	10.75	12.02	7.30	0.005
		Middle	V	6.09	10.78	10.44	5.75	0.004
		High	V	6.16	10.81	11.28	6.63	0.005
	16QAM	Low	V	6.03	10.75	11.08	6.35	0.004
		Middle	V	6.09	10.78	9.51	4.82	0.003
		High	V	6.16	10.81	10.40	5.75	0.004

Note.

1. $E.I.R.P(dBm) = \text{Substitute Level}(dB) + \text{Antenna gain}(dBi) - C.L(\text{Cable loss})(dB)$

7.8. Radiated Spurious Emissions

Test setup

The diagram below shows the test setup that is utilized to make the measurements for emission from 30 MHz to 1 GHz emissions.

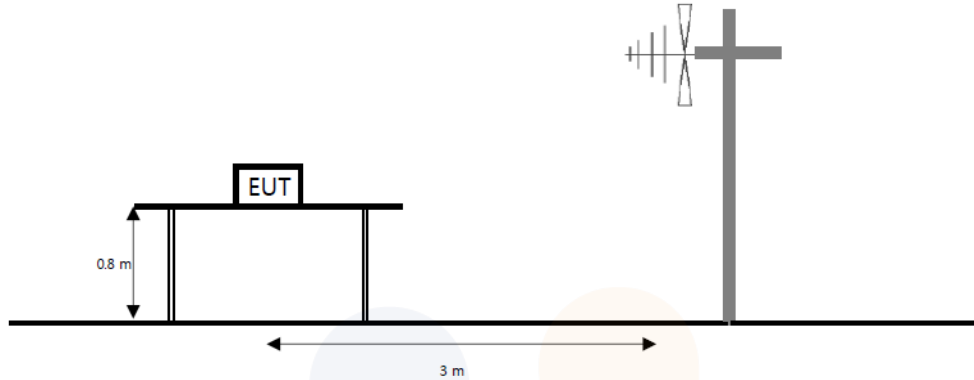

The diagram below shows the test setup that is utilized to make the measurements for emission from 1 GHz to the tenth harmonic of the highest fundamental frequency or to 40 GHz emissions, whichever is lower.

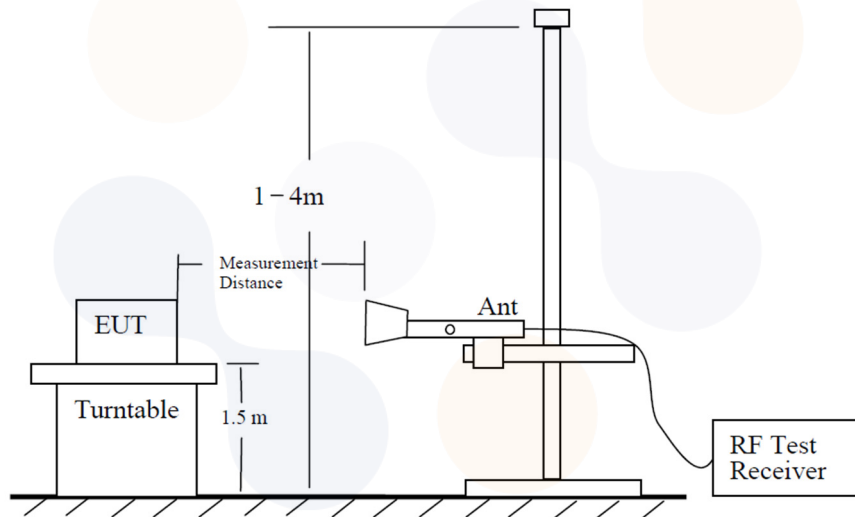

The diagram below shows the test setup for substituted method.

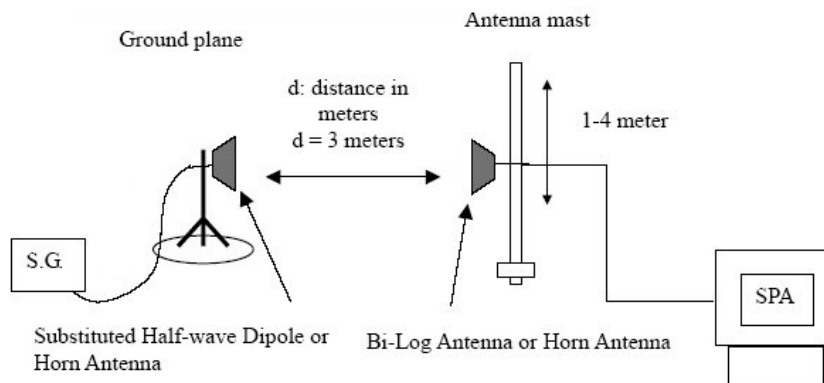

Limit

According to §27.53(m)(4),

The minimum permissible attenuation level of any spurious emission is $55 + 10\log(P_{[Watts]})$ dB.

Test procedure

971168 D01 v03r01 - Section 6.2

ANSI 63.26-2015 – Section 5.5

ANSI/TIA-603-E-2016 - Section 2.2.12

Test settings

- 1) RBW = 100 kHz for below 1 GHz and 1 MHz for above 1 GHz.
- 2) VBW $\geq 3 \times$ RBW.
- 3) Detector = RMS
- 4) Trace mode = Max hold
- 5) Sweep time = Auto couple
- 6) Number of sweep points $\geq 2 \times$ span / RBW
- 7) Allow trace to fully stabilize.

Notes:

1. On a test site, the EUT shall be placed at 80 cm or 1.5 m height on a turn table, and in the position close to normal use as declared by the applicant.
2. The test antenna shall be oriented initially for vertical polarization located 3 m from EUT to correspond to the fundamental frequency of the transmitter.
3. The turntable is rotated through 360°, and the receiving antenna scans in order to determine the Level of the maximized emission.
4. The test antenna shall be raised and lowered again through the specified range of height until the maximum signal level is detected by the measuring receiver.
5. The maximum signal level detected by the measuring receiver shall be noted.
6. The EUT was replaced by half-wave dipole (1 GHz below) or horn antenna (1 GHz above) connected to a signal generator.
7. The test antenna shall be raised and lowered through the specified range of height to ensure that The maximum signal is received.
8. The input signal to the substitution antenna shall be adjusted to the level that produces a level Detected by the measuring corrected for the change of input attenuator setting of the measuring Receiver.
9. The input level to the substitution antenna shall be recorded as power level in dBm, corrected for Any change of input attenuator setting of the measuring receiver.
10. The measurement shall be repeated with the test antenna and the substitution antenna Orientated for horizontal polarization.

Test results (Above 1 000 MHz)

Test mode : LTE B7

Frequency(MHz) : 2 505

Channel : 20800

Bandwidth(MHz) : 10

Mode	Frequency	Pol.	Antenna Gain	Cable loss	Substitute Level	Level	Limit	Margin
	[MHz]	[V/H]	[dBi]	[dB]	[dBm]	[dBm]	[dBm]	[dB]
QPSK	5 022.21	V	10.31	15.68	-47.03	-52.40	-25.00	27.40
	7 530.19	H	12.12	19.32	-41.80	-49.00	-25.00	24.00
	10 042.00	H	13.11	22.33	-35.98	-45.20	-25.00	20.20
	12 549.98	H	13.22	25.55	-30.37	-42.70	-25.00	17.70

Test mode : LTE B7

Frequency(MHz) : 2 535

Channel : 21100

Bandwidth(MHz) : 10

Mode	Frequency	Pol.	Antenna Gain	Cable loss	Substitute Level	Level	Limit	Margin
	[MHz]	[V/H]	[dBi]	[dB]	[dBm]	[dBm]	[dBm]	[dB]
QPSK	5 061.15	V	10.34	15.73	-45.31	-50.70	-25.00	25.70
	7 592.11	H	12.17	19.40	-42.27	-49.50	-25.00	24.50
	10 121.15	H	13.12	22.76	-36.06	-45.70	-25.00	20.70
	12 652.11	H	13.26	25.48	-30.38	-42.60	-25.00	17.60

Test mode : LTE B7

Frequency(MHz) : 2 565

Channel : 21400

Bandwidth(MHz) : 10

Mode	Frequency	Pol.	Antenna Gain	Cable loss	Substitute Level	Level	Limit	Margin
	[MHz]	[V/H]	[dBi]	[dB]	[dBm]	[dBm]	[dBm]	[dB]
QPSK	5 122.43	H	10.37	16.70	-46.27	-52.60	-25.00	27.60
	7 680.20	V	12.24	19.61	-42.23	-49.60	-25.00	24.60
	10 238.61	V	13.15	22.84	-36.01	-45.70	-25.00	20.70
	12 801.48	V	13.32	25.61	-29.31	-41.60	-25.00	16.60

Note.

- E.I.R.P(dBm) = Substitute Level(dB) + Antenna gain(dBi) - C.L(Cable loss) (dB)

8. Measurement equipment

Equipment Name	Manufacturer	Model No.	Serial No.	Next Cal. Date
Spectrum Analyzer	R&S	FSV40-N	101462	24.10.12
Spectrum Analyzer	Agilent	N9040B	US55230151	24.07.03
Divider	Marki Microwave, Inc.	PD-0040	D0006	24.07.04
DC Power Supply	AGILENT	E3632A	KR75304571	25.04.24*
Wideband Radio Communication Tester	R&S	CMW500	168683	25.02.13
Wideband Radio Communication Tester	R&S	CMW500	141780	25.01.18
Signal Generator	R&S	SMB100A	176206	25.01.18
Temp & Humid Chamber	Myeongseong R&P	CTHC-50P-DT	20150824-2	25.01.18
Bi-log Antenna	Teseq GmbH	CBL 6112D	62027	24.11.17
Bi-log Antenna	ETS-LINDGREN	3143B	00228420	25.07.20
Horn Antenna	ETS-LINDGREN	3117	00251528	25.01.26
Horn Antenna	ETS-LINDGREN	3117	00227509	24.07.12
Horn Antenna	ETS-LINDGREN	3116C	00251516	25.02.01
Horn Antenna	ETS-LINDGREN	3116	00086635	25.01.25
Amplifier	SONOMA INSTRUMENT	310N	421822	24.10.12
Amplifier	B&Z Technologies	BZRT-00504000-481055-382525	26299-27735	24.07.04
Amplifier	B&Z Technologies	BZR-0050400-551028-252525	27736	24.07.04
High pass Filter	Wainwright Instruments GmbH	WHKX12-2805-3000-18000-40SS	32	24.07.04

*This equipment was calibrated during the test period, and was used after calibration.

End of test report