





TEST REPORT

<p>Eurofins KCTL Co.,Ltd. 65, Sinwon-ro, Yeongtong-gu, Suwon-si, Gyeonggi-do, 16677, Korea TEL: 82-70-5008-1021 FAX: 82-505-299-8311 www.kctl.co.kr</p>	<p>Report No.: KR24-SRF0098-A Page(1) of (62)</p>	 
--	---	---

1. Client

- Name : Samsung Electronics Co., Ltd.
- Address : 129, Samsung-ro, Yeongtong-gu, Suwon-si, Gyeonggi-do, 16677, Rep. of Korea
- Date of Receipt : 2024-03-28

2. Use of Report : Certification

3. Name of Product / Model : Smart Wearable / SM-L705U

4. Derivative Model : SM-L705F

5. Manufacturer / Country of Origin : Samsung Electronics Co., Ltd. / Vietnam

6. FCC ID : A3LSML705

7. Date of Test : 2024-04-01 to 2024-05-20

8. Location of Test : Permanent Testing Lab On Site Testing
 (Address:65, Sinwon-ro, Yeongtong-gu, Suwon-si, Gyeonggi-do, 16677, Korea)

9. Test method used : FCC Part 2
 FCC Part 22 Subpart H

10. Test Result : Refer to the test result in the test report

Affirmation	Tested by	Technical Manager
	Name : Kwonse Kim (Signature)	Name : Seungyong Kim (Signature)

2024-05-24

Eurofins KCTL Co.,Ltd.

As a test result of the sample which was submitted from the client, this report does not guarantee the whole product quality. This test report should not be used and copied without a written agreement by Eurofins KCTL Co.,Ltd.

<p>Eurofins KCTL Co.,Ltd. 65, Sinwon-ro, Yeongtong-gu, Suwon-si, Gyeonggi-do, 16677, Korea TEL: 82-70-5008-1021 FAX: 82-505-299-8311 www.kctl.co.kr</p>	<p>Report No.: KR24-SRF0098-A Page (2) of (62)</p>	
--	--	---

REPORT REVISION HISTORY

Date	Revision	Page No
2024-05-22	Originally issued	-
2024-05-24	Revised the conducted output power	13

This report shall not be reproduced except in full, without the written approval of Eurofins KCTL Co.,Ltd. This document may be altered or revised by Eurofins KCTL Co.,Ltd. personnel only, and shall be noted in the revision section of the document. Any alteration of this document not carried out by Eurofins KCTL Co.,Ltd. will constitute fraud and shall nullify the document. This test report is a general report that does not use the KOLAS accreditation mark and is not related to KS Q ISO/IEC 17025 and KOLAS accreditation.

Note. The report No. KR24-SRF0098 is superseded by the report No. KR24-SRF0098-A.

General remarks for test reports

Statement concerning the uncertainty of the measurement systems used for the tests

(may be required by the product standard or client)

Internal procedure used for type testing through which traceability of the measuring uncertainty has been established:

Procedure number, issue date and title:

Calculations leading to the reported values are on file with the testing laboratory that conducted the testing.

Statement not required by the standard or client used for type testing

CONTENTS

1.	General information	4
2.	Device information	4
2.1.	Accessory information	4
2.2.	Frequency/channel operations.....	5
3.	Maximum ERP power	6
4.	Summary of tests.....	7
4.1.	Worst case orientation	8
5.	Measurement uncertainty	10
6.	Measurement results explanation example	11
7.	Test results	12
7.1.	Conducted output power.....	12
7.2.	99% Occupied Bandwidth & 26dB Bandwidth	17
7.3.	Band Edge Emissions at Antenna Terminal	27
7.4.	Spurious Emissions at Antenna Terminal.....	40
7.5.	Peak to Average Power Ratio (PAPR)	45
7.6.	Frequency stability	49
7.7.	Radiated Power (ERP)	53
7.8.	Radiated Spurious Emissions.....	58
8.	Measurement equipment.....	62

<p align="center">Eurofins KCTL Co.,Ltd. 65, Sinwon-ro, Yeongtong-gu, Suwon-si, Gyeonggi-do, 16677, Korea TEL: 82-70-5008-1021 FAX: 82-505-299-8311 www.kctl.co.kr</p>	<p align="center">Report No.: KR24-SRF0098-A Page (4) of (62)</p>	
---	---	---

1. General information

Client : Samsung Electronics Co., Ltd.
Address : 129, Samsung-ro, Yeongtong-gu, Suwon-si, Gyeonggi-do, 16677, Rep. of Korea
Manufacturer : Samsung Electronics Co., Ltd.
Address : 129, Samsung-ro, Yeongtong-gu, Suwon-si, Gyeonggi-do, 16677, Rep. of Korea
Factory 1 : AG TECH CO.,LTD
Address 1 : Lot G3, Que Vo Industrial Park(Expanded Area), Nam son Ward, Bac Ninh Province, Vietnam
Factory 2 : ALMUS VINA
Address 2 : Lot CN07A, Phu Ha Industrial Park, Ha Thach Commune, Phu Tho Town, Phu Tho Province, Vietnam
Laboratory : Eurofins KCTL Co.,Ltd.
Address : 65, Sinwon-ro, Yeongtong-gu, Suwon-si, Gyeonggi-do, 16677, Korea
Accreditations : FCC Site Designation No: KR0040, FCC Site Registration No: 687132
VCCI Registration No. : R-20080, G-20078, C-20059, T-20056
CAB Identifier: KR0040
ISED Number: 8035A
KOLAS No.: KT231

2. Device information

Equipment under test : Smart Wearable
Model : SM-L705U
Derivative model : SM-L705F
Modulation technique : WCDMA : QPSK
LTE : QPSK, 16QAM
Power source : DC 3.88 V
Antenna specification : PIFA + FPCB Antenna
Antenna gain : -14.9 dBi
Frequency range : WCDMA 850 : 826.4 MHz ~ 846.6 MHz
LTE B5 : 824.7 MHz ~ 848.3 MHz
LTE B26 : 824.7 MHz ~ 848.3 MHz
Bandwidth : LTE B5 : 1.4/3/5/10 MHz
LTE B26 : 1.4/3/5/10/15 MHz
Software version : L705U.001
Hardware version : REV1.0
Test device serial No. : Conducted : R3AX200WYAD
Radiated : R3AX200WYLH, R3AX200WYCR,
R3AX200WYKB, R3AX402DJKP
Operation Temperature : 0 °C ~ 35 °C

Note.

1. The product equality letter includes detailed information about the differences between SM-L705U and SM-L705F model.

2.1. Accessory information

Equipment	Manufacturer	Model	Serial No.	Power source	FCC ID & IC
Wireless charger	RF TECH	EP-OL300	-	5.0 V, 2.0 A	FCC ID : A3LEPOL300 IC : 649E-EPOL300

2.2. Frequency/channel operations

This device contains the following capabilities:

WCDMA 850, LTE B5/26

WCDMA 850

Ch.	Frequency (MHz)
4132	826.4
4183	836.6
4233	846.6

Table 2.2-1. RMC/HSDPA/HSUPA/DC-HSDPA

LTE B5

Ch.	Frequency (MHz)
20407	824.7
20525	836.5
20643	848.3

Table 2.2-2. 1.4M BW

Ch.	Frequency (MHz)
20415	825.5
20525	836.5
20635	847.5

Table 2.2-3. 3M BW

Ch.	Frequency (MHz)
20425	826.5
20525	836.5
20625	846.5

Table 2.2-4. 5M BW

Ch.	Frequency (MHz)
20450	829.0
20525	836.5
20600	844.0

Table 2.2-5. 10M BW

LTE B26

Ch.	Frequency (MHz)
26797	824.7
26915	836.5
27033	848.3

Table 2.2-6. 1.4M BW

Ch.	Frequency (MHz)
26805	825.5
26915	836.5
27025	847.5

Table 2.2-7. 3M BW

Ch.	Frequency (MHz)
26815	826.5
26915	836.5
27015	846.5

Table 2.2-8. 5M BW

Ch.	Frequency (MHz)
26840	829.0
26915	836.5
26990	844.0

Table 2.2-9. 10M BW

Ch.	Frequency (MHz)
26865	831.5
26915	836.5
26965	841.5

Table 2.2-10. 15M BW

Notes:

1. LTE B5(824 - 849 MHz) overlaps the entire frequency range of LTE B26(824 - 849 MHz) and they have same maximum tune-up power. Therefore, B26 was tested as a representative and the test data provided in this report covers B26 as well as B5 subpart to Part22.

3. Maximum ERP power

WCDMA 850

Mode	Tx frequency (MHz)	Emission designator	ERP	
			Max. power (dBm)	Max. power (W)
WCDMA 850	826.4 ~ 846.6	4M21F9W	12.71	0.019

LTE B26/5

Mode	Tx frequency (MHz)	Emission designator	ERP	
			Max. power (dBm)	Max. power (W)
LTE B26/5	824.7 ~ 848.3	1M12G7D	11.69	0.015
		1M10W7D	10.58	0.011
	825.5 ~ 847.5	2M71G7D	11.51	0.014
		2M72W7D	10.65	0.012
	826.5 ~ 846.5	4M53G7D	11.67	0.015
		4M56W7D	10.60	0.011
	829.0 ~ 844.0	9M12G7D	11.62	0.015
		9M07W7D	10.63	0.012
831.5 ~ 841.5	13M5G7D	11.77	0.015	
	13M5W7D	10.75	0.012	

4. Summary of tests

FCC Part section(s)	Parameter	Test Limit	Test Condition	Test results
2.1046	Conducted Output Power	N/A	Conducted	Pass
2.1049	Occupied Bandwidth & 26 dB Bandwidth	N/A		Pass
2.1051 22.917(a)	B Edge Emissions at Antenna Terminal	<43 + 10Log ₁₀ (P) dB at Band edge and for all out of band emissions		Pass
	Spurious Emissions at Antenna Terminal			Pass
-	Peak to Average Power Ratio	<13 dB		Pass
2.1055 22.355	Frequency stability	< 2.5 ppm		Pass
22.913(a)(5)	Effective Radiated Power	< 7 Watts max. ERP	Radiated	Pass
2.1053 22.917(a)	Radiated Spurious Emissions	<43 + 10Log ₁₀ (P) dB for all out of band emissions		Pass

Notes:

- The test procedure(s) in this report were performed in accordance as following.
 - ◆ ANSI C63.26-2015
 - ◆ ANSI/TIA-603-E-2016
 - ◆ KDB 971168 D01 v03r01
 - ◆ KDB 971168 D02 v02r02

4.1. Worst case orientation

1. All modes of operation were investigated and the worst case emissions are reported with the EUT positioning, modulations, RB sizes and offsets, and channel Bandwidth configurations in the test data.
2. In the case of radiated spurious emissions, only the worst case Bandwidth results were reported.
3. Output power measurements were measured on all of modulation. All tests except output power was performed with below modulation with highest power.
 - 1) WCDMA: RMC
 - 2) LTE: QPSK, 16QAM
4. However, the PAPR was evaluated for all wave forms and modulations during pre-test, then all Bandwidth was performed for the modulations with the highest result.
 - 1) LTE: QPSK, 16QAM
5. All configurations have been performed (Stand-alone, Stand-alone with TA and Strap).
6. The fundamental of the EUT was investigated in three orthogonal orientations X, Y and Z and all of the radiated tests have been performed with the accessories as below. It was determined that below orientation was worst case orientation for each band.

Band	Strap	With charger	Without charger		
		X-axis	X-axis	Y-axis	Z-axis
WCDMA 850	With strap	O	-	-	-
	Without strap	-	-	-	-
LTE B26/5	With strap	O	-	-	-
	Without strap	-	-	-	-

7. Test Condition

- The measurement was performed with various configurations then worst results are reported.
- 1) Radiated measurement

Test Description	Mode	Condition		Test Channel
Effective Radiated Power	WCDMA	RMC (12.2 kbps)		Low, Middle, High
	LTE	QPSK, 16QAM	RB Size: 1	
Radiated Spurious Emissions	WCDMA	RMC (12.2 kbps)		Low, Middle, High
	LTE	QPSK	RB Size: 1	

Band	Bandwidth (MHz)	RB size	RB offset
LTE B26/5	1.4, 3, 5, 10, 15	1	Low, Middle, High

2) Conducted measurement

Test Description	Mode	Condition		Test Channel
OBW & 26 dB BW	WCDMA	RMC (12.2 kbps)		Low, Middle, High
	LTE	QPSK, 16QAM	RB Size: Full	
PAPR	WCDMA	RMC (12.2 kbps)		Middle
	LTE	QPSK, 16QAM	RB Size: Full	
Band Edge	WCDMA	RMC (12.2 kbps)		Low, High
	LTE	QPSK	RB Size: 1, Full	
Spurious Emissions	WCDMA	RMC (12.2 kbps)		Low, Middle, High
	LTE	QPSK	RB Size: 1	

Band	Bandwidth (MHz)	RB size	RB offset
LTE B26/5	1.4, 3, 5, 10, 15	1	0, 5, 14, 24, 49, 74
		Full	0

5. Measurement uncertainty

The measurement uncertainties shown below were calculated in accordance with the requirements of ANSI C63.4-2014.

All measurement uncertainty values are shown with a coverage factor of $k=2$ to indicated a 95 % level of confidence. The measurement data shown herein meets or exceeds the U_{CISPR} measurement uncertainty values specified in CISPR 16-4-2 and thus, can be compared directly to specified limits to determine compliance.

Parameter	Expanded uncertainty (\pm)	
Conducted RF power	0.9 dB	
Conducted spurious emissions	1.9 dB	
Radiated spurious emissions	Below 1 000 MHz	2.5 dB
	1 000 MHz ~ 18 000 MHz	2.5 dB
	Above 1 8000 MHz	2.6 dB

6. Measurement results explanation example

Frequency (MHz)	Factor(dB)	Frequency (MHz)	Factor(dB)
30	5.82	16 000	9.29
50	6.09	17 000	9.50
100	6.15	18 000	9.55
200	6.09	19 000	9.31
300	6.28	20 000	8.51
400	6.51	21 000	9.00
500	6.57	22 000	9.52
600	6.62	23 000	9.53
700	6.67	24 000	9.95
800	6.70	25 000	10.82
900	6.74	26 000	10.60
1 000	6.76	26 500	10.73
2 000	7.06	27 000	10.59
3 000	7.25	28 000	11.48
4 000	7.39	29 000	10.38
5 000	7.54	30 000	10.69
6 000	7.94	31 000	11.57
7 000	8.10	32 000	11.70
8 000	8.21	33 000	12.00
9 000	8.26	34 000	11.88
10 000	7.36	35 000	11.65
11 000	8.35	36 000	11.80
12 000	8.40	37 000	11.51
13 000	8.62	38 000	10.82
14 000	8.71	39 000	11.00
15 000	9.02	40 000	11.30

Note.

- Offset(dB) = RF cable loss(dB) + Divider (dB)

7. Test results

7.1. Conducted output power

Test setup

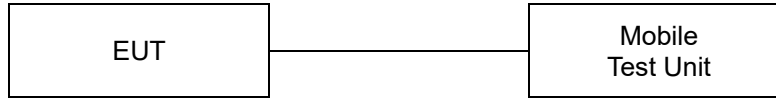

Test procedure

971168 D01 v03r01 – Section 5.2
ANSI C63.26-2015 – Section 5.2.4.2
CFR 47 - Section §2.1046

Test settings

When an average power meter is used to perform RF output power measurements, the fundamental condition that measurement be performed only over durations of active transmissions at maximum output power level applies. Thus, an average power meter can always be used to perform the measurement when the EUT can be configured to transmit continuously.

If the EUT cannot be configured to transmit continuously (i.e., burst duty cycle < 98%), then the following options can be implemented to facilitate measurement of the average power with an average power meter:

- a) A gated average power meter can be used to perform the measurement if the gating parameters can be adjusted such that the power is measured only during active transmission bursts at maximum output power levels.
- b) A conventional average power meter with no signal gating capability can also be used if the measured burst duty cycle is constant (i.e., duty cycle variations are less than or equal to $\pm 2\%$) by performing the measurement over the on/off burst cycles and then correcting (increasing) the measured level by a factor equal to $[10\log(1/\text{duty cycle})]$. See 5.2.4.3.4 for guidance with respect to measuring the transmitter duty cycle.

See item r) of 4.1 for more information regarding power meter functional requirements and limitations, and consult the instrumentation-specific application literature for proper set-up and use.

Note:

1. $\text{Offset}(\text{dB}) = \text{RF cable loss}(\text{dB})$

Test results

Test Band	Test mode	Maximum Average Power (dBm)		
		Channel		
		Low	Middle	High
WCDMA 850	RMC	23.02	22.93	22.85
	HSDPA-Subtest 1	21.84	21.85	21.68
	HSDPA-Subtest 2	20.51	20.53	20.36
	HSDPA-Subtest 3	19.95	19.84	19.77
	HSDPA-Subtest 4	19.90	19.83	19.74
	HSUPA-Subtest 1	19.91	19.79	19.69
	HSUPA-Subtest 2	17.74	17.74	17.70
	HSUPA-Subtest 3	18.85	18.76	18.70
	HSUPA-Subtest 4	17.69	17.65	17.58
	HSUPA-Subtest 5	21.39	21.25	21.19
	DC-HSDPA-Subtest 1	21.60	21.83	21.56
	DC-HSDPA-Subtest 2	20.55	20.61	20.32
	DC-HSDPA-Subtest 3	20.33	20.34	19.55
	DC-HSDPA-Subtest 4	20.42	20.36	19.58

Test Band	Bandwidth (MHz)	Test mode	RB size	RB offset	Maximum Average Power (dBm)			
					Channel			
					Low	Middle	High	
LTE B5	1.4	QPSK	1	0	22.22	22.21	21.87	
			1	3	22.23	22.30	21.84	
			1	5	22.36	22.30	21.87	
			3	0	22.40	22.37	22.27	
			3	1	22.44	22.40	22.31	
			3	3	22.42	22.38	22.26	
		6	0	21.72	21.67	21.57		
		16QAM	1	0	21.72	21.73	21.51	
			1	3	21.68	21.62	21.46	
			1	5	21.69	21.71	21.47	
			3	0	21.73	21.63	21.53	
			3	1	21.74	21.62	21.52	
			3	3	21.71	21.60	21.46	
		3	QPSK	6	0	20.73	20.68	20.63
				1	0	22.19	22.05	22.03
				1	8	22.16	21.93	22.00
				1	14	22.08	21.92	21.99
				8	0	21.72	21.68	21.59
	8			4	21.73	21.66	21.58	
	8		7	21.72	21.67	21.54		
	15		0	21.72	21.63	21.56		
	16QAM		1	0	21.83	21.72	21.37	
			1	8	21.59	21.55	21.36	
			1	14	21.70	21.54	21.43	
			8	0	20.80	20.57	20.53	
			8	4	20.79	20.63	20.58	
			8	7	20.76	20.60	20.53	
	15		0	20.75	20.69	20.57		
	5		QPSK	1	0	22.15	22.26	22.15
				1	12	22.13	22.01	21.81
				1	24	22.08	21.97	21.85
		12		0	21.76	21.70	21.66	
		12		7	21.73	21.65	21.60	
		12		13	21.71	21.60	21.58	
		25	0	21.72	21.68	21.57		
		16QAM	1	0	21.67	21.68	21.63	
			1	12	21.67	21.61	21.52	
			1	24	21.66	21.59	21.52	
			12	0	20.74	20.61	20.55	
			12	7	20.66	20.61	20.54	
			12	13	20.64	20.59	20.53	
		25	0	20.68	20.60	20.57		
		10	QPSK	1	0	22.06	22.16	21.97
				1	25	21.82	22.04	21.86
				1	49	21.80	21.90	21.80
				25	0	21.68	21.69	21.63
	25			12	21.58	21.60	21.56	
	25			25	21.56	21.56	21.52	
	50		0	21.58	21.59	21.55		
	16QAM		1	0	21.84	21.07	21.34	
1			25	21.63	20.79	21.01		
1			49	21.61	20.56	20.98		
25			0	20.62	20.65	20.66		
25			12	20.54	20.59	20.56		
25			25	20.51	20.54	20.51		
50	0		20.61	20.62	20.59			

Test Band	Bandwidth (MHz)	Test mode	RB size	RB offset	Maximum Average Power (dBm)			
					Channel			
					Low	Middle	High	
LTE B26	1.4	QPSK	1	0	22.24	22.35	22.21	
			1	3	21.73	21.85	22.12	
			1	5	21.74	21.97	22.15	
			3	0	21.36	21.87	22.22	
			3	1	21.57	21.53	22.23	
			3	3	21.71	21.82	22.22	
		16QAM	6	0	21.70	21.60	21.55	
			1	0	21.08	21.07	20.87	
			1	3	20.58	20.93	20.80	
			1	5	20.71	21.02	21.07	
			3	0	20.51	20.85	21.48	
			3	1	20.16	20.35	21.46	
		3	QPSK	3	3	20.68	20.31	21.40
				6	0	20.83	20.69	20.45
				1	0	22.12	21.89	22.00
				1	8	21.85	21.99	21.90
				1	14	21.91	21.76	21.93
				8	0	21.78	21.92	21.54
	16QAM		8	4	21.92	21.71	21.49	
			8	7	21.57	21.31	21.50	
			15	0	21.40	21.79	21.57	
			1	0	20.94	21.21	20.92	
			1	8	20.92	20.91	20.99	
			1	14	20.71	21.14	20.91	
	5		QPSK	8	0	20.83	20.78	20.44
				8	4	20.42	20.38	20.38
				8	7	20.77	20.44	20.41
				15	0	20.55	20.37	20.51
				1	0	21.79	22.37	21.92
				1	12	21.87	21.90	21.70
		16QAM	1	24	22.12	21.96	21.77	
			12	0	21.62	21.63	21.60	
			12	7	21.90	21.85	21.51	
			12	13	21.82	21.69	21.52	
			25	0	21.57	21.88	21.51	
			1	0	20.83	21.07	21.17	
		10	QPSK	1	12	20.61	20.44	20.69
				1	24	20.83	20.95	21.03
				12	0	20.84	20.65	20.45
				12	7	20.35	20.24	20.45
				12	13	20.12	20.28	20.45
				25	0	20.80	20.86	20.49
	16QAM		1	0	22.13	22.01	22.13	
			1	25	22.14	22.16	21.96	
			1	49	21.51	21.63	22.00	
			25	0	21.70	21.42	21.64	
			25	12	21.74	21.64	21.56	
			25	25	21.28	21.36	21.49	
	QPSK		50	0	21.21	21.47	21.58	
			1	0	20.75	20.85	20.89	
1			25	20.62	20.65	20.98		
1			49	20.83	20.75	20.92		
25			0	20.62	20.77	20.54		
25			12	20.40	20.84	20.47		
16QAM	25	25	20.14	20.74	20.43			
	50	0	20.76	20.52	20.51			

Test Band	Bandwidth (MHz)	Test mode	RB size	RB offset	Maximum Average Power (dBm)		
					Channel		
					Low	Middle	High
LTE B26	15	QPSK	1	0	22.32	21.93	22.26
			1	36	21.95	21.82	21.69
			1	74	21.92	21.77	21.98
			36	0	21.76	21.39	21.62
			36	18	21.66	21.36	21.51
			36	37	21.60	21.71	21.42
			75	0	21.66	21.85	21.52
		16QAM	1	0	21.31	20.76	21.12
			1	36	20.56	20.38	20.91
			1	74	20.97	21.16	20.51
			36	0	20.68	20.86	20.55
			36	18	20.58	20.18	20.46
			36	37	20.52	20.25	20.39
			75	0	20.57	20.38	20.53

7.2. 99% Occupied Bandwidth & 26dB Bandwidth

Test setup

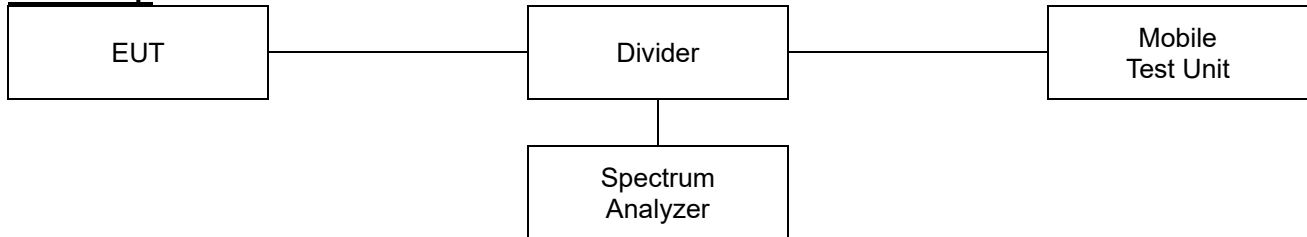

Limit

According to §2.1049,

The occupied bandwidth, that is the frequency bandwidth such that, below its lower and above its upper frequency limits, the mean powers radiated are each equal to 0.5 percent of the total mean power radiated by a given emission shall be measured.



Test procedure

971168 D01 v03r01 – Section 4.2 and 4.3
ANSI C63.26-2015 – Section 5.4.3 and 5.4.4

Test settings

◆ 26dB Bandwidth

- a) The spectrum analyzer center frequency is set to the nominal EUT channel center frequency. The span range for the spectrum analyzer shall be wide enough to see sufficient roll off of the signal to make the measurement.
- b) The nominal RBW shall be in the range of 1% to 5% of the anticipated OBW, and the VBW shall be set $\geq 3 \times$ RBW.
- c) Set the reference level of the instrument as required to prevent the signal amplitude from exceeding the maximum spectrum analyzer input mixer level for linear operation. See guidance provided in 4.2.3.
- d) The dynamic range of the spectrum analyzer at the selected RBW shall be more than 10 dB below the target “-X dB” requirement, i.e., if the requirement calls for measuring the -26 dB OBW, the spectrum analyzer noise floor at the selected RBW shall be at least 36 dB below the reference level.
- e) Set spectrum analyzer detection mode to peak, and the trace mode to max hold.
- f) Determine the reference value by either of the following:
 - 1) Set the EUT to transmit a modulated signal. Allow the trace to stabilize. Set the spectrum analyzer marker to the highest level of the displayed trace (this is the reference value).
 - 2) Set the EUT to transmit an unmodulated carrier. Set the spectrum analyzer marker to the level of the carrier.
- g) Determine the “-X dB amplitude” as equal to (Reference Value - X). Alternatively, this calculation can be performed on the spectrum analyzer using the delta-marker measurement function.
- h) If the reference value was determined using an unmodulated carrier, turn the EUT modulation on, then either clear the existing trace or start a new trace on the spectrum analyzer and allow the new trace to stabilize. Otherwise the trace from step f) shall be used for step i).

<p>Eurofins KCTL Co.,Ltd. 65, Sinwon-ro, Yeongtong-gu, Suwon-si, Gyeonggi-do, 16677, Korea TEL: 82-70-5008-1021 FAX: 82-505-299-8311 www.kctl.co.kr</p>	<p>Report No.: KR24-SRF0098-A Page (18) of (62)</p>	 
--	---	---

- i) Place two markers, one at the lowest and the other at the highest frequency of the envelope of the spectral display such that each marker is at or slightly below the “-X dB amplitude” determined in step f). If a marker is below this “-X dB amplitude” value it should be as close as possible to this value. The OBW is the positive frequency difference between the two markers.
- j) The spectral envelope can cross the “-X dB amplitude” at multiple points. The lowest or highest frequency shall be selected as the frequencies that are the farthest away from the center frequency at which the spectral envelope crosses the “-X dB amplitude.”
- k) The OBW shall be reported by providing plot(s) of the measuring instrument display, to include markers depicting the relevant frequency and amplitude information (e.g., marker table). The frequency and amplitude axis and scale shall be clearly labeled. Tabular data may be reported in addition to the plot(s).

◆ 99% Occupied Bandwidth

- a) The spectrum analyzer center frequency is set to the nominal EUT channel center frequency. The frequency span for the spectrum analyzer shall be set wide enough to capture all modulation products including the emission skirts (typically a span of $1.5 \times \text{OBW}$ is sufficient).
- b) The nominal IF filter 3 dB Bandwidth (RBW) shall be in the range of 1% to 5% of the anticipated OBW, and the VBW shall be set $\geq 3 \times \text{RBW}$.
- c) Set the reference level of the instrument as required to prevent the signal amplitude from exceeding the maximum spectrum analyzer input mixer level for linear operation. See guidance provided in 4.2.3.
- d) Set the detection mode to peak, and the trace mode to max-hold.
- e) If the instrument does not have a 99% OBW function, recover the trace data points and sum directly in linear power terms. Place the recovered amplitude data points, beginning at the lowest frequency, in a running sum until 0.5% of the total is reached. Record that frequency as the lower OBW frequency. Repeat the process until 99.5% of the total is reached and record that frequency as the upper OBW frequency. The 99% power OBW can be determined by computing the difference these two frequencies.
- f) The OBW shall be reported and plot(s) of the measuring instrument display shall be provided with the test report. The frequency and amplitude axis and scale shall be clearly labeled. Tabular data can be reported in addition to the plot(s).

Notes:

1. The EUT was setup to maximum output power with all Bandwidth and modulation.

Test results

Test mode		Channel	26 dB Bandwidth (MHz)	99 % Bandwidth (MHz)
WCDMA 850	RMC	Low	4.78	4.17
		Middle	4.78	4.17
		High	4.78	4.21



Test Band	Bandwidth (MHz)	Channel	Test mode	26dB Bandwidth (MHz)	99 % Bandwidth (MHz)
LTE B26/5	1.4	Low	QPSK	1.34	1.12
			16QAM	1.33	1.10
		Middle	QPSK	1.35	1.10
			16QAM	1.33	1.10
		High	QPSK	1.36	1.10
			16QAM	1.34	1.10
	3	Low	QPSK	3.11	2.71
			16QAM	3.12	2.71
		Middle	QPSK	3.09	2.70
			16QAM	3.16	2.72
		High	QPSK	3.09	2.70
			16QAM	3.12	2.72
	5	Low	QPSK	5.35	4.53
			16QAM	5.46	4.52
		Middle	QPSK	5.41	4.53
			16QAM	5.30	4.53
		High	QPSK	5.37	4.53
			16QAM	5.43	4.56
	10	Low	QPSK	10.51	9.12
			16QAM	10.54	9.07
		Middle	QPSK	10.24	9.02
			16QAM	10.42	9.02
		High	QPSK	10.49	9.02
			16QAM	10.29	9.02
15	Low	QPSK	15.29	13.49	
		16QAM	15.06	13.49	
	Middle	QPSK	15.36	13.49	
		16QAM	15.06	13.45	
	High	QPSK	15.47	13.49	
		16QAM	14.91	13.49	

In order to simplify the report, only Middle channel test plots are attached

26dB Bandwidth

Test mode: WCDMA 850

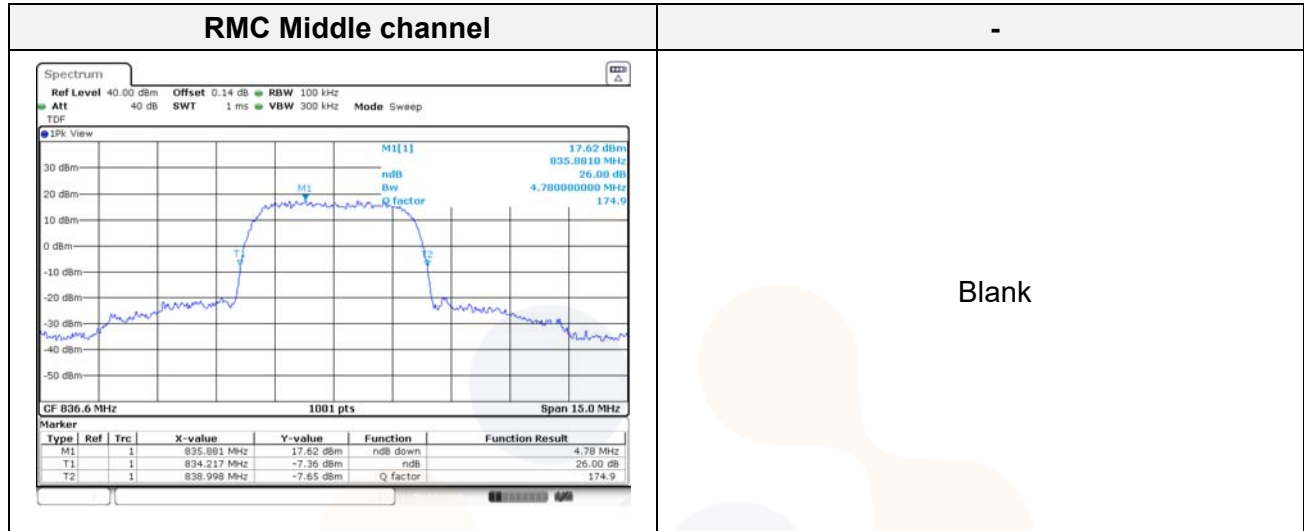

Test mode: LTE B26/5

1.4M BW QPSK Middle channel

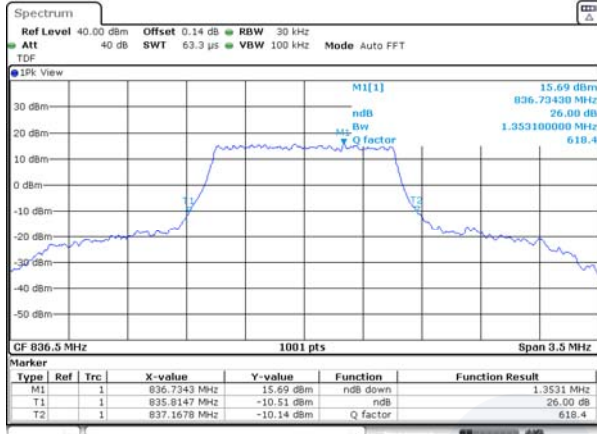

1.4M BW 16QAM Middle channel

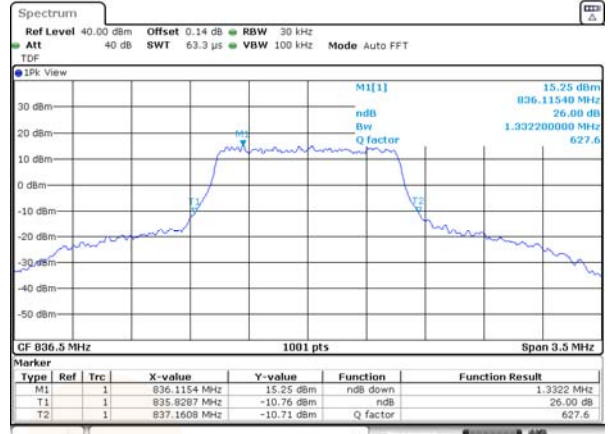

3M BW QPSK Middle channel

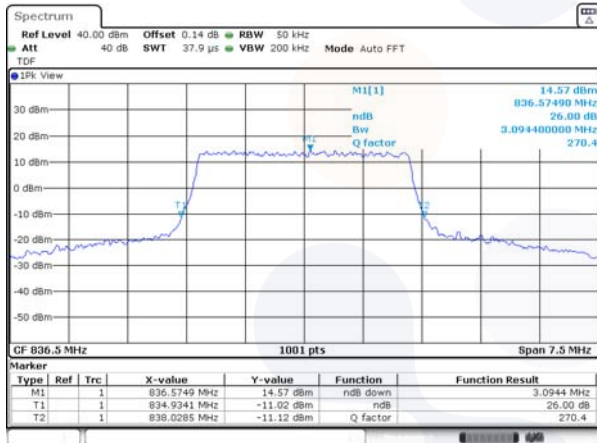

3M BW 16QAM Middle channel

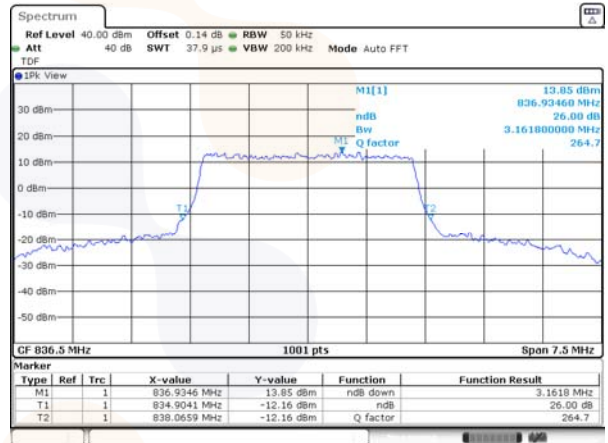

5M BW QPSK Middle channel

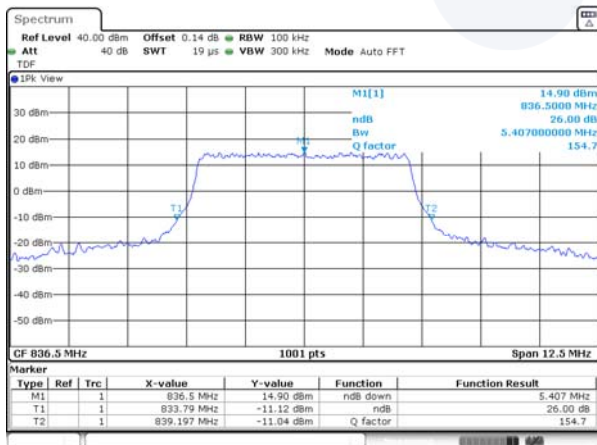

5M BW 16QAM Middle channel

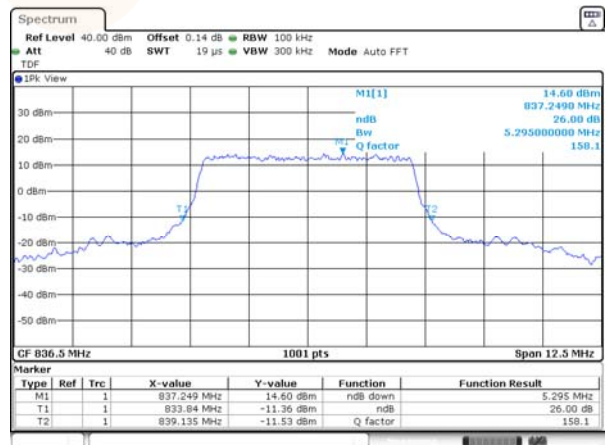

10M BW QPSK Middle channel

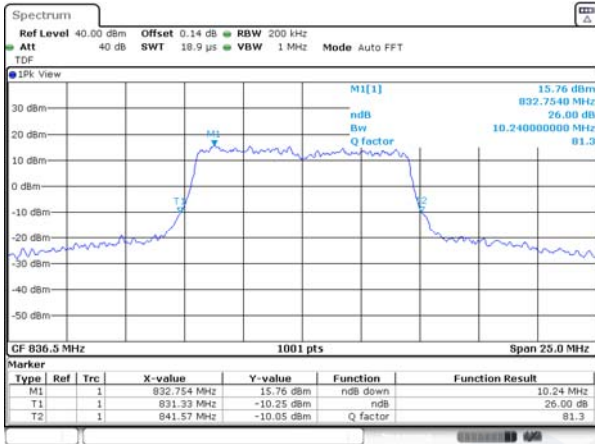

10M BW 16QAM Middle channel

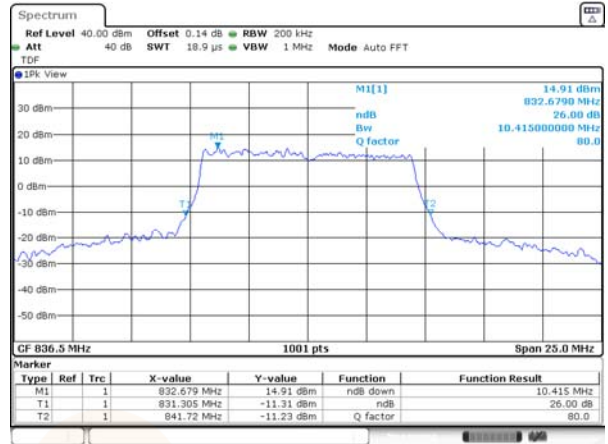

15M BW QPSK Middle channel

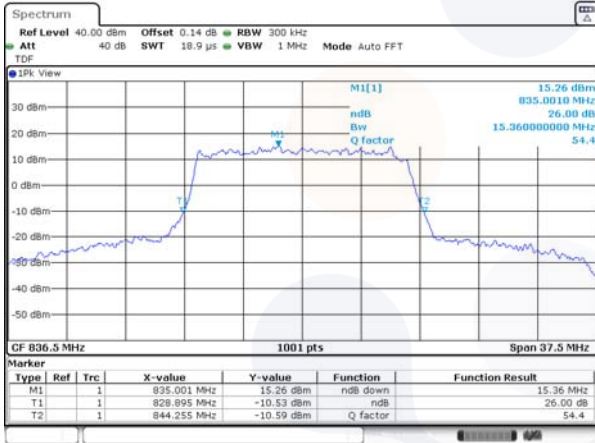

15M BW 16QAM Middle channel



99% Occupied Bandwidth

Test mode: WCDMA 850

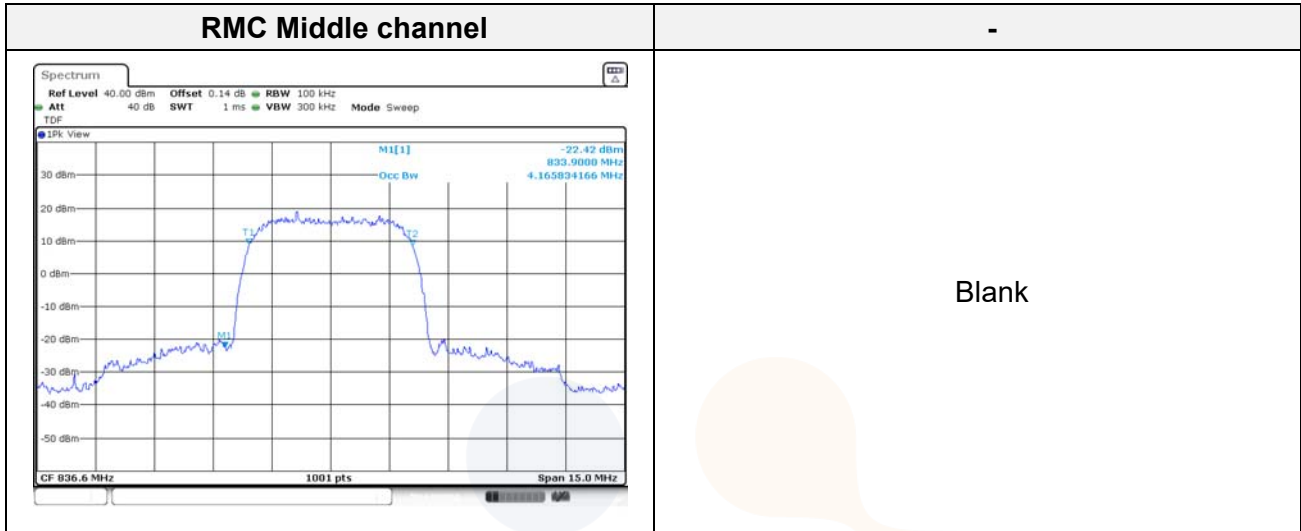

Test mode: LTE B26/5

1.4M BW QPSK Middle channel

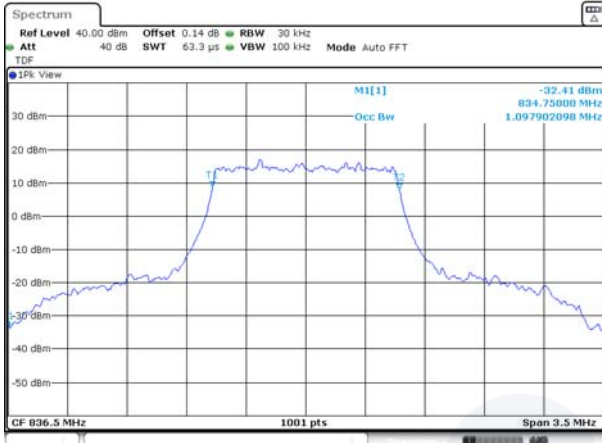

1.4M BW 16QAM Middle channel

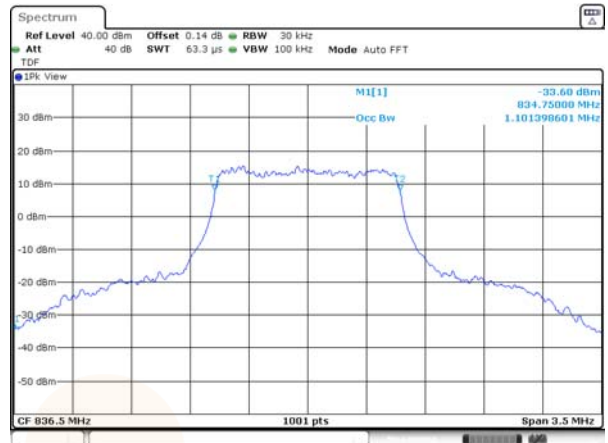

3M BW QPSK Middle channel



3M BW 16QAM Middle channel

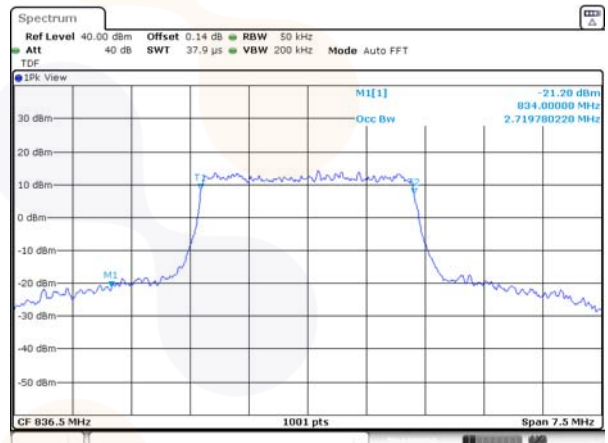

5M BW QPSK Middle channel

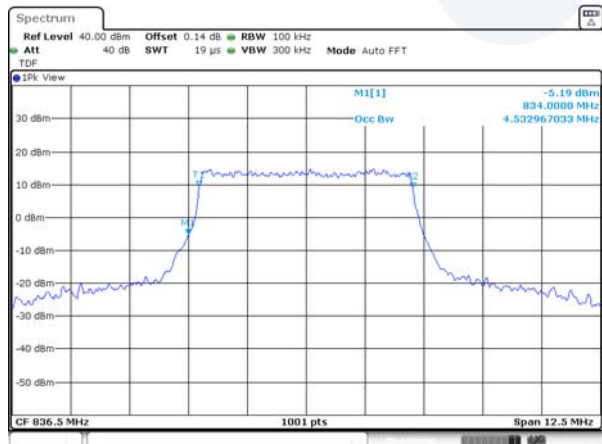

5M BW 16QAM Middle channel

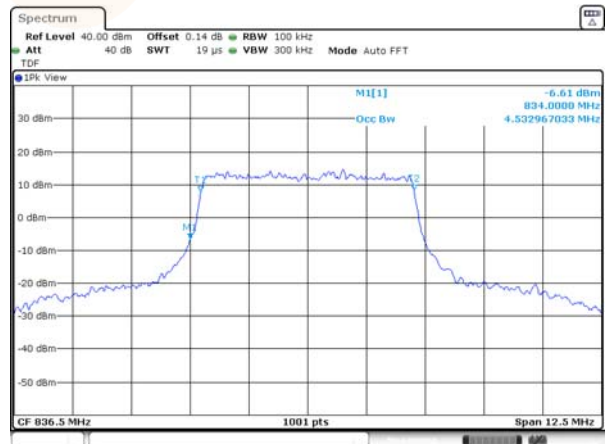

10M BW QPSK Middle channel

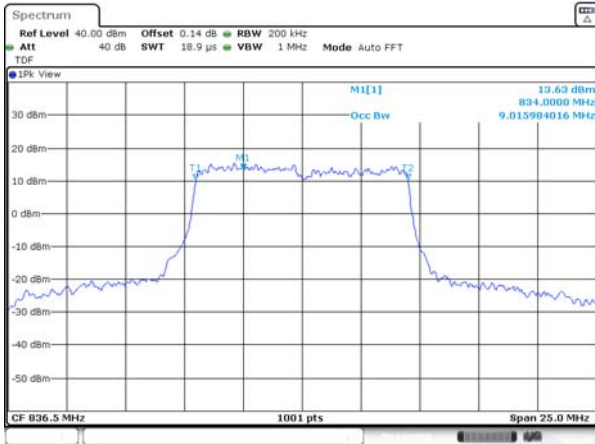

10M BW 16QAM Middle channel

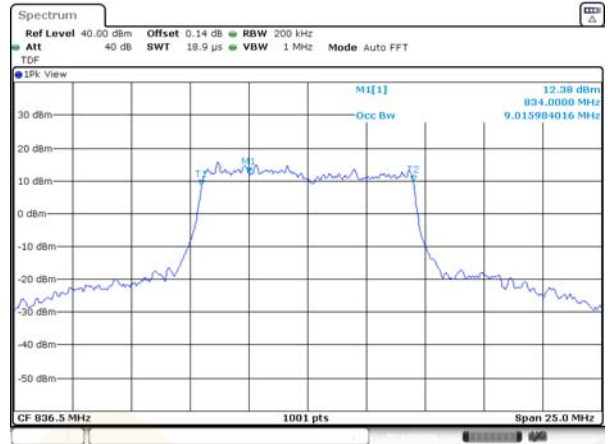

15M BW QPSK Middle channel

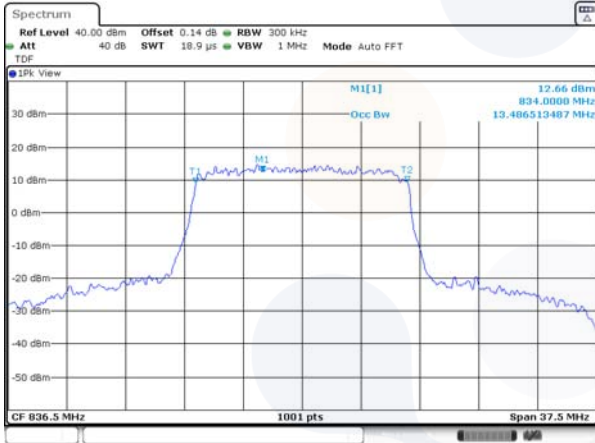

15M BW 16QAM Middle channel

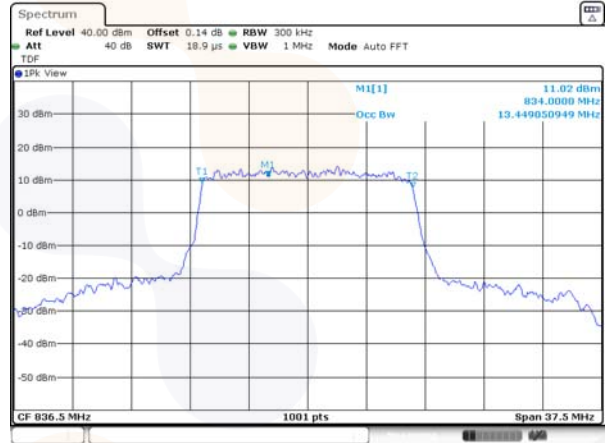

7.3. Band Edge Emissions at Antenna Terminal

Test setup

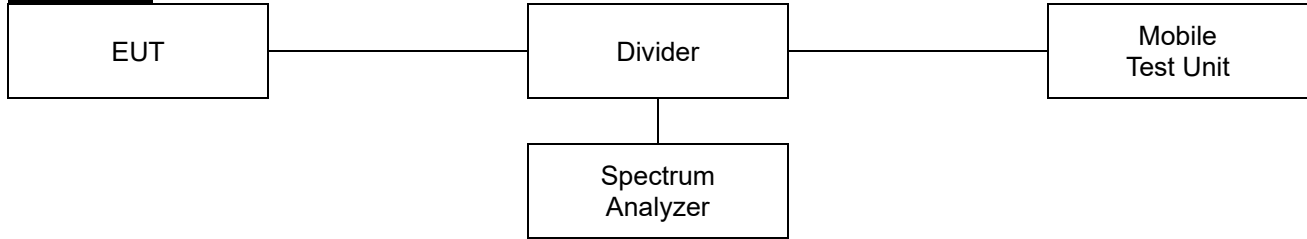

Limit

According to §22.917(a),

The power of any emission outside of the authorized operating frequency ranges must be attenuated below the transmitting power (P) by a factor of at least $43 + 10\log(P)$ dB.



Test procedure

971168 D01 v03r01 - Section 6

ANSI C63.26-2015 – Section 5.7

Test settings

- 1) Start and stop frequency were set such that the band edge would be placed in the center of the plot
- 2) Span was set large enough so as to capture all out of band emissions near the band edge.
- 3) Set the RBW > 1% of the emission Bandwidth.
- 4) Set the VBW $\geq 3 \times$ RBW.
- 5) Set the number of sweep points $\geq 2 \times$ Span/RBW
- 6) Detector = RMS
- 7) Trace mode = trace average
- 8) Sweep time should be auto for peak detection. For RMS detection the sweep time should be set as follows:
 - a) If the device can be configured to transmit continuously (duty cycle $\geq 98\%$), set the (sweep time) > (number of points in sweep) \times (symbol period) (e.g., by a factor of $10 \times$ symbol period \times number of points) Increasing the sweep time (i.e., slowing the sweep speed) will allow for averaging over multiple symbols.
 - b) If the device cannot transmit continuously (duty cycle < 98%), a gated sweep shall be used when possible (i.e., gate triggered such that the analyzer only sweeps when the device is transmitting at full power), set the sweep time > (number of points in sweep) \times (symbol period) but the sweep time shall always be maintained at a value that is less than or equal to the minimum transmission time
 - c) If the device cannot be configured to transmit continuously (duty cycle > 98%), and a free-running sweep must be used, set the sweep time so that the averaging is performed over multiple on/off cycles by setting the sweep time > (number of points in sweep) \times (transmitter period) (i.e., the transmit on-time + the off-time). The spectrum analyzer readings shall subsequently be corrected by $[10 \log (1/\text{duty cycle})]$. This assumes that the transmission period and duty cycle is relatively constant (duty cycle variation $\leq \pm 2\%$).
 - d) If the device cannot be configured to transmit continuously and a free-running

<p>Eurofins KCTL Co.,Ltd. 65, Sinwon-ro, Yeongtong-gu, Suwon-si, Gyeonggi-do, 16677, Korea TEL: 82-70-5008-1021 FAX: 82-505-299-8311 www.kctl.co.kr</p>	<p>Report No.: KR24-SRF0098-A Page (28) of (62)</p>	 
--	---	---

sweep must be used, and if the transmissions exhibit a non-constant duty cycle (duty cycle variations $> \pm 2\%$), set the sweep time so that the averaging is performed over the on-period by setting the sweep time $> (\text{symbol period}) \times (\text{number of points})$, while also maintaining the sweep time $< (\text{transmitter on-time})$. The trace mode shall be set to max hold, since not every display point will be averaged only over just the on-time. Thus, multiple sweeps (e.g., 100) in maximum hold art necessary to ensure that the maximum power is measured.

- 9) Allow trace to fully stabilize.

Notes:

1. Per 22.917(b), compliance with these rules is based on the use of measurement instrumentation employing a resolution bandwidth of 1 MHz or greater. however in the 1 MHz bands immediately outside and adjacent to the frequency block a resolution bandwidth of at least one percent of the emission bandwidth of the fundamental emission of the transmitter may be may be employed. The emission bandwidth is defined as the width of the signal between two points, one below the carrier center frequency and one above the carrier center frequency, outside of which all emissions are attenuated at least 26 dB below the transmitter power.
2. The EUT was setup to maximum output power as its lowest and highest channel with all bandwidth, modulation and RB configurations.

Test results

Test mode: WCDMA 850

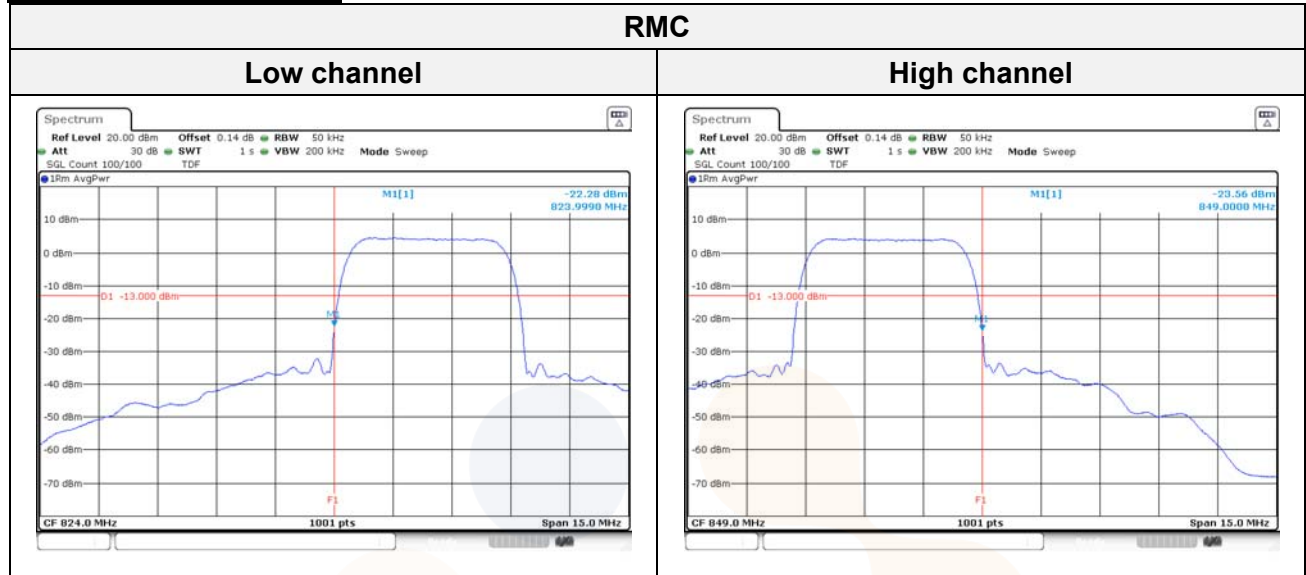

Test mode: LTE B26/5

1.4M BW QPSK

Low channel 1RB

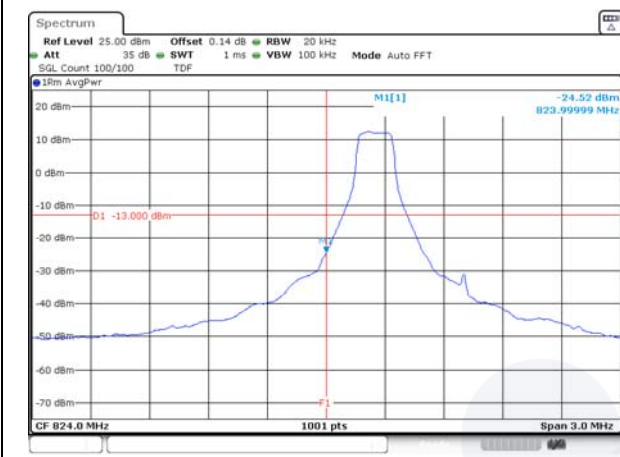

High channel 1RB

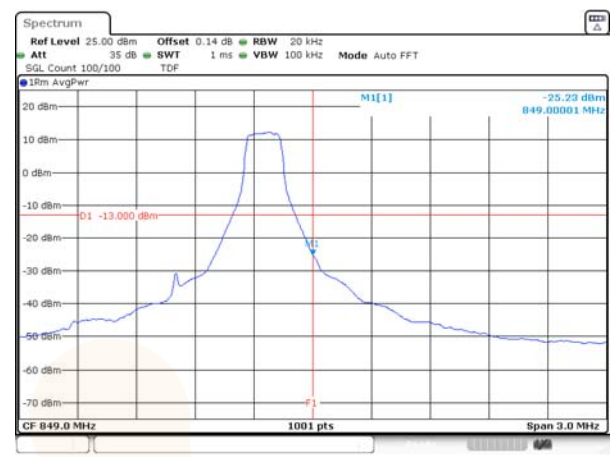

Low channel FRB



High channel FRB



1.4M BW QPSK

Lower extended 1RB

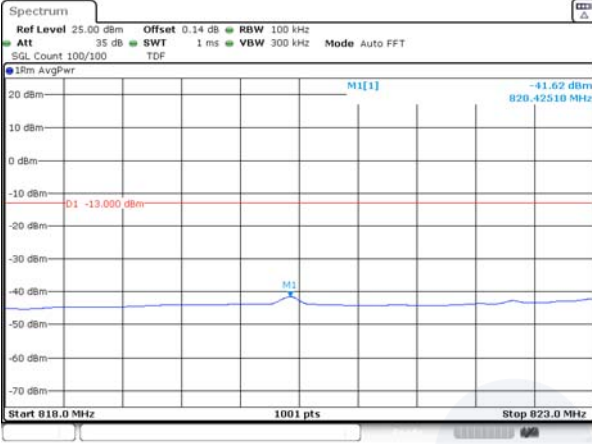

Upper extended 1RB

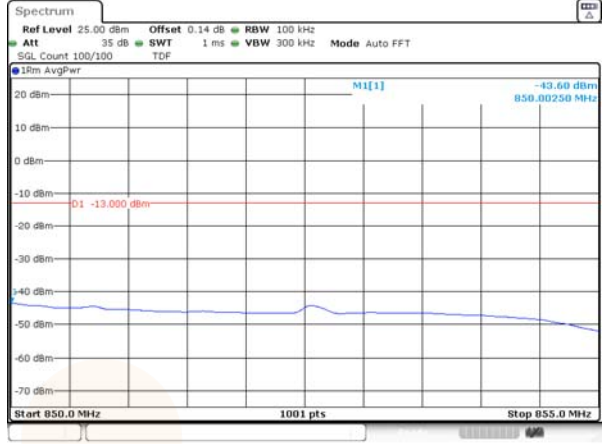

Lower extended FRB

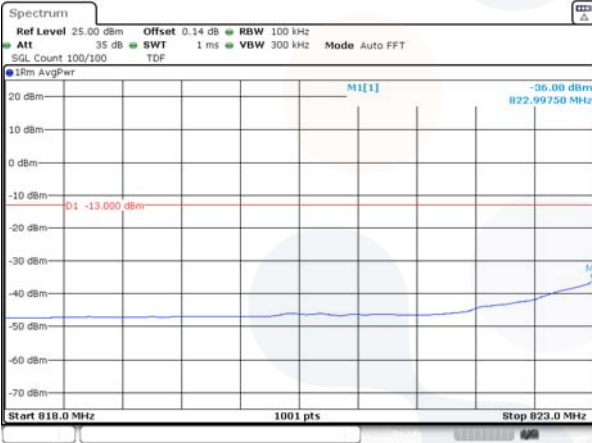

Upper extended FRB

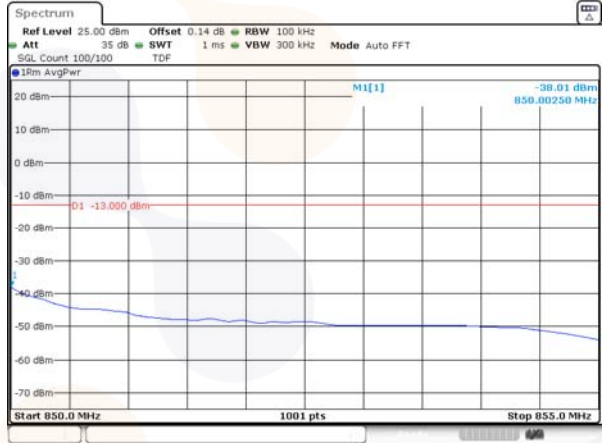

3M BW QPSK

Low channel 1RB

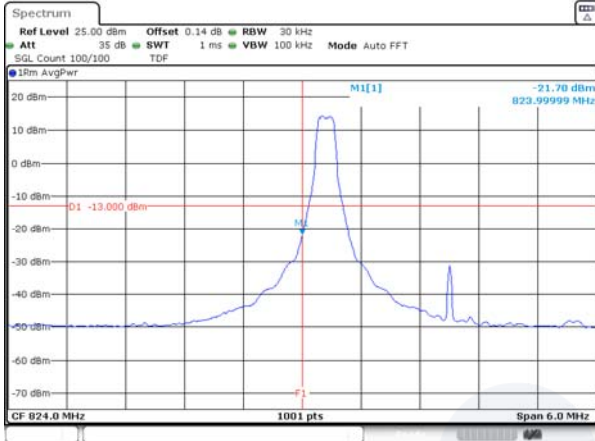

High channel 1RB

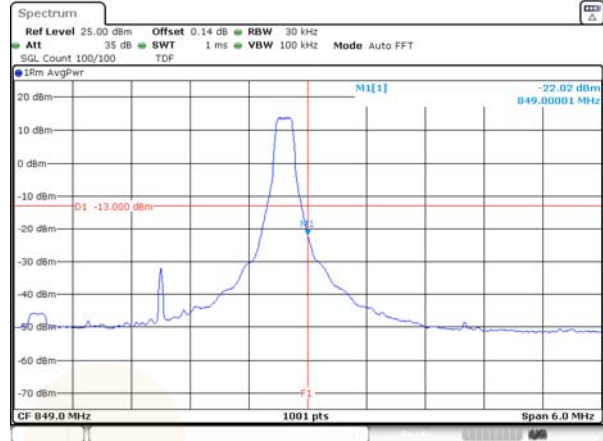

Low channel FRB

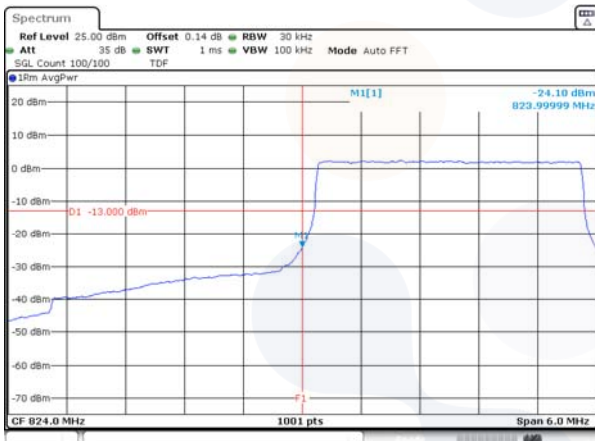

High channel FRB

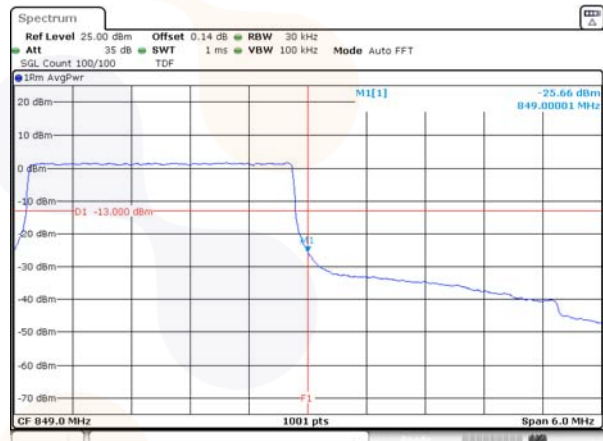

3M BW QPSK

Lower extended 1RB

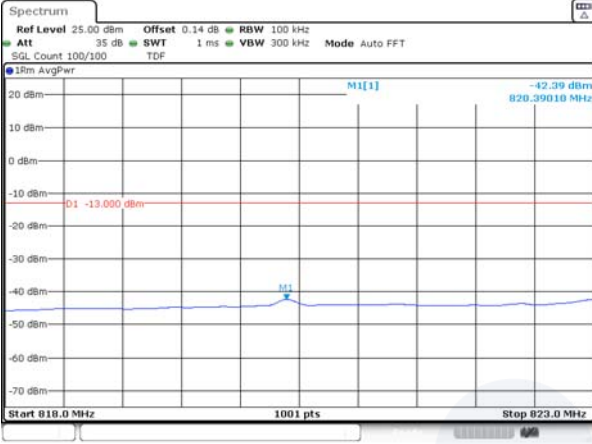

Upper extended 1RB

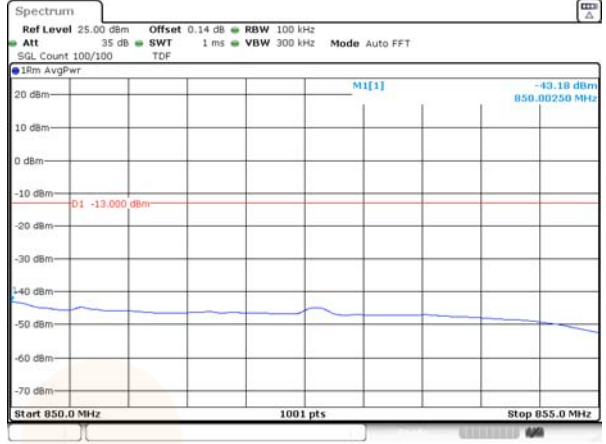

Lower extended FRB



Upper extended FRB



5M BW QPSK

Low channel 1RB

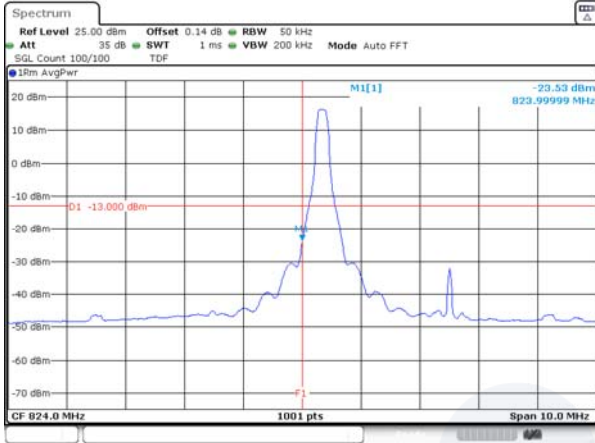

High channel 1RB

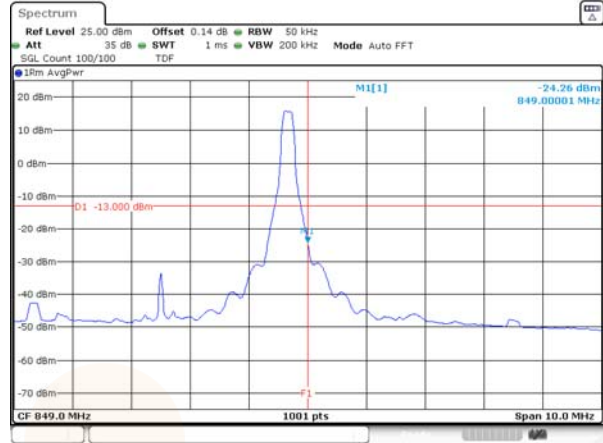

Low channel FRB



High channel FRB

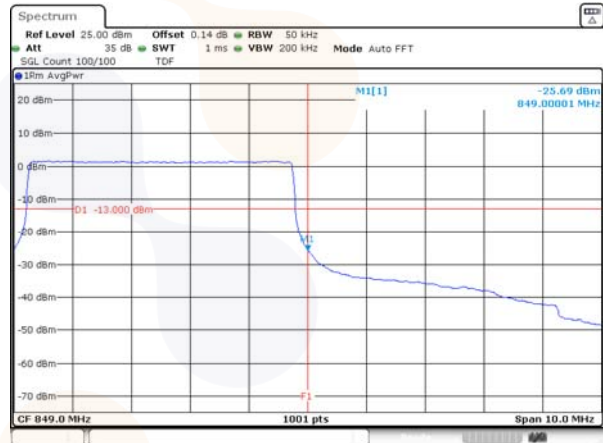

5M BW QPSK

Lower extended 1RB

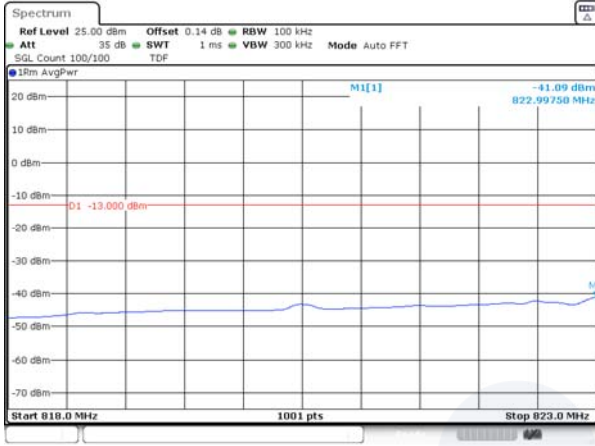

Upper extended 1RB

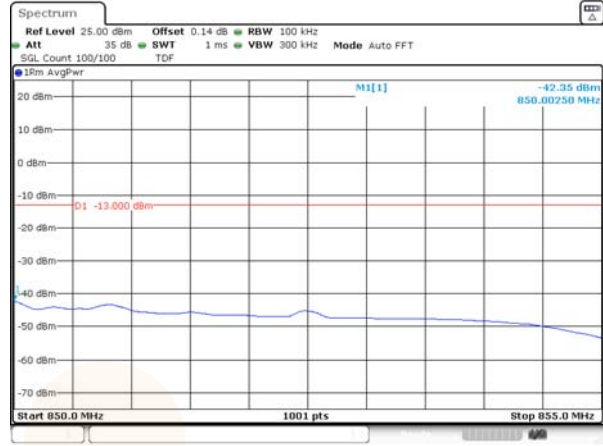

Lower extended FRB

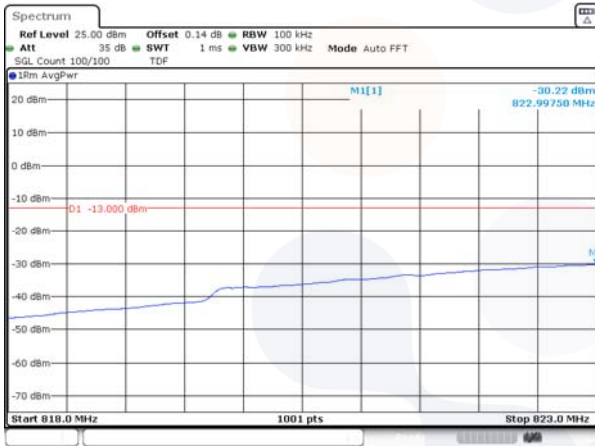

Upper extended FRB

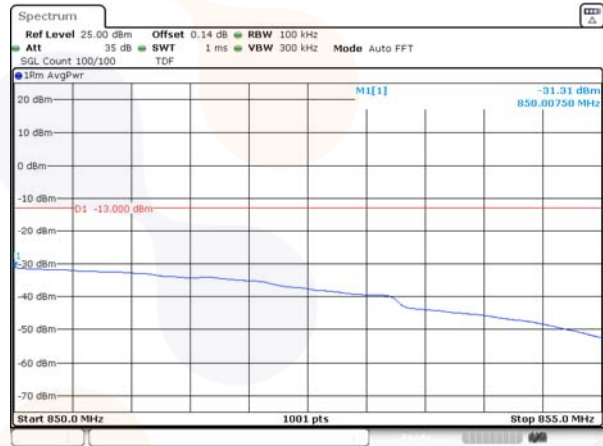

10M BW QPSK

Low channel 1RB

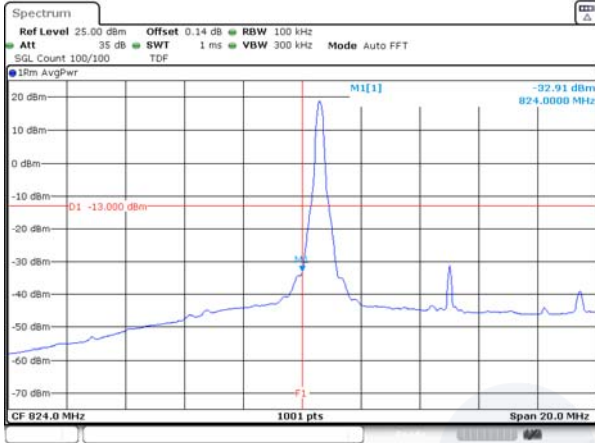

High channel 1RB

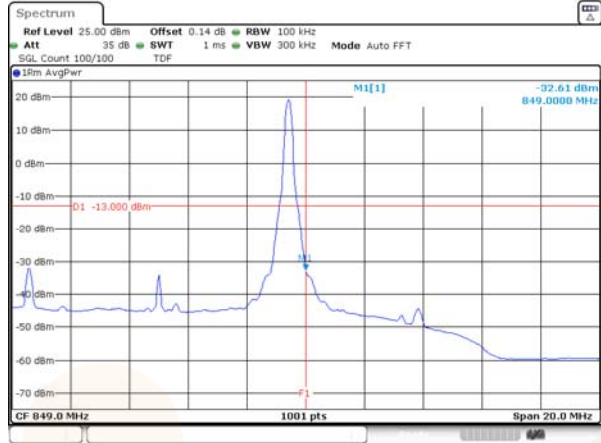

Low channel FRB

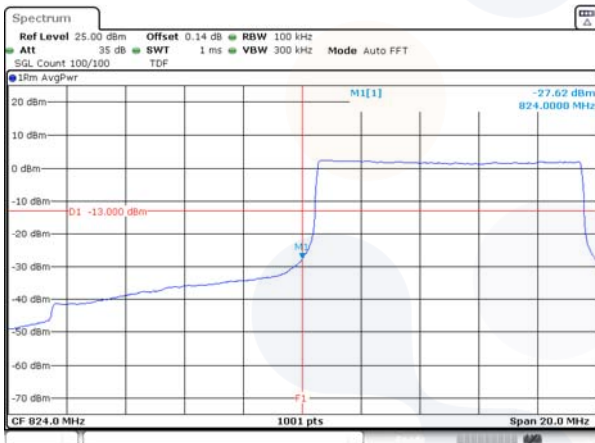

High channel FRB

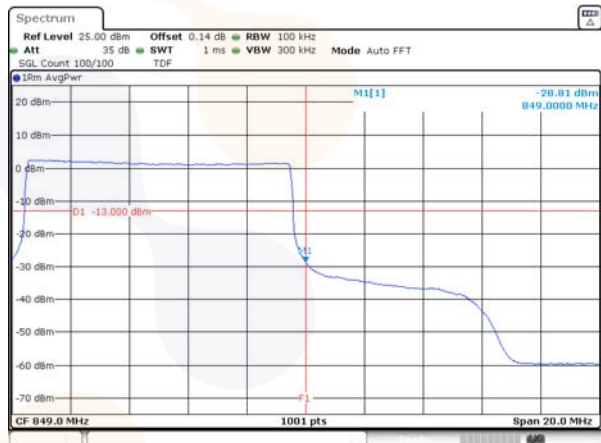

10M BW QPSK

Lower extended 1RB

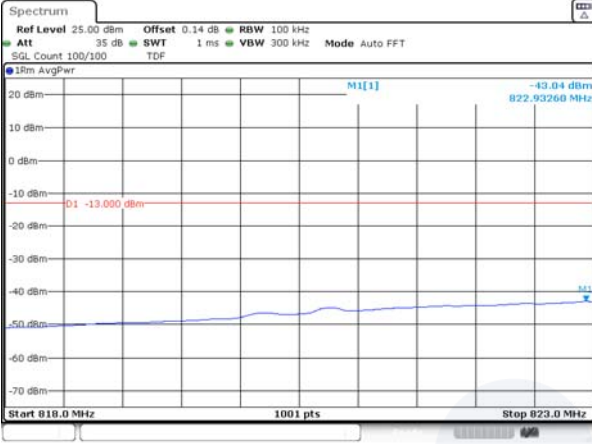

Upper extended 1RB

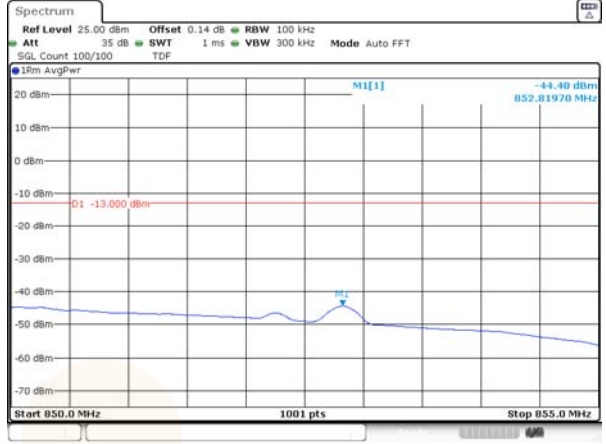

Lower extended FRB

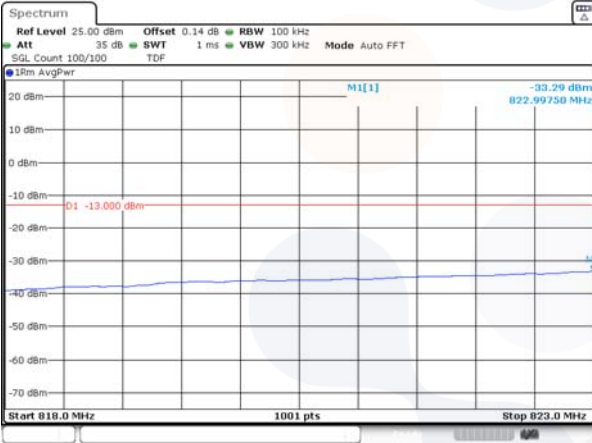

Upper extended FRB

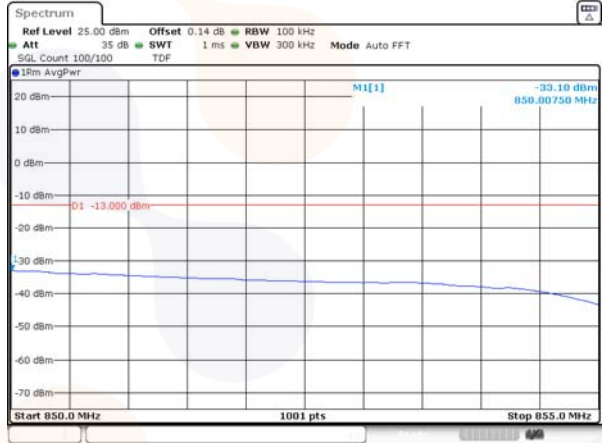

15M BW QPSK

Low channel 1RB

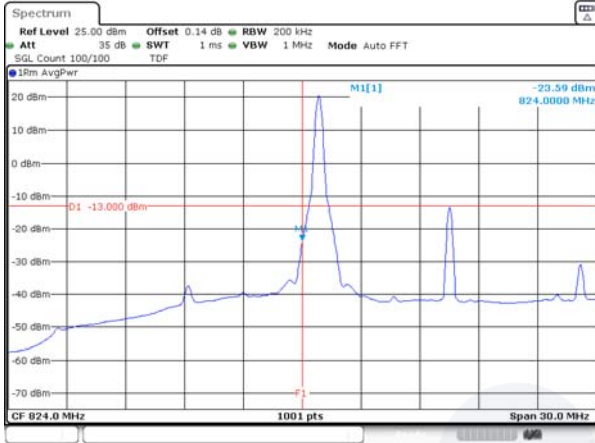

High channel 1RB

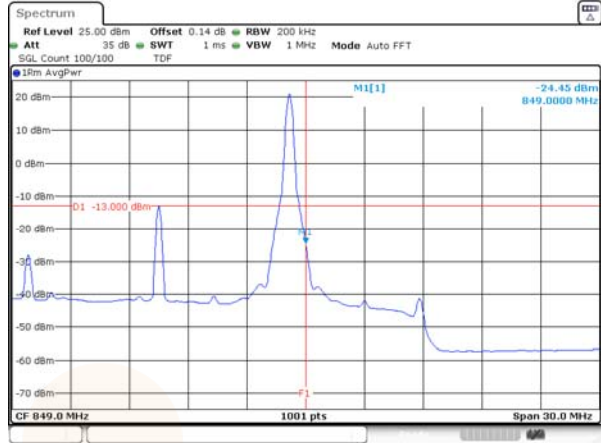

Low channel FRB

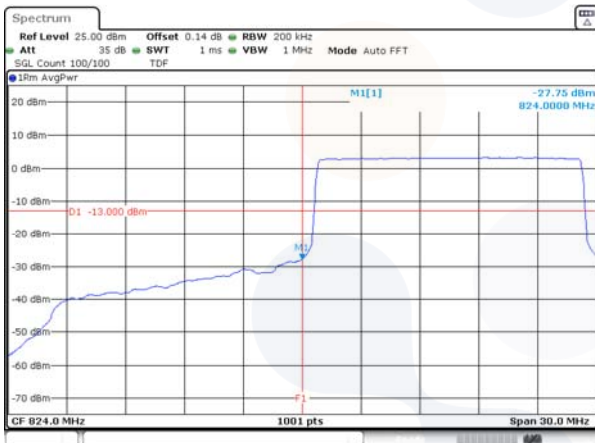

High channel FRB



15M BW QPSK

Lower extended 1RB

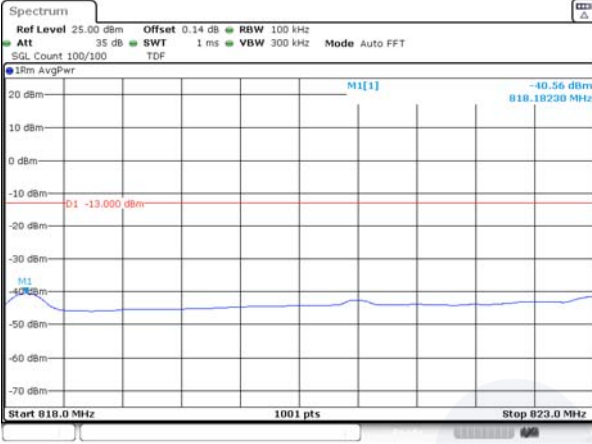

Upper extended 1RB

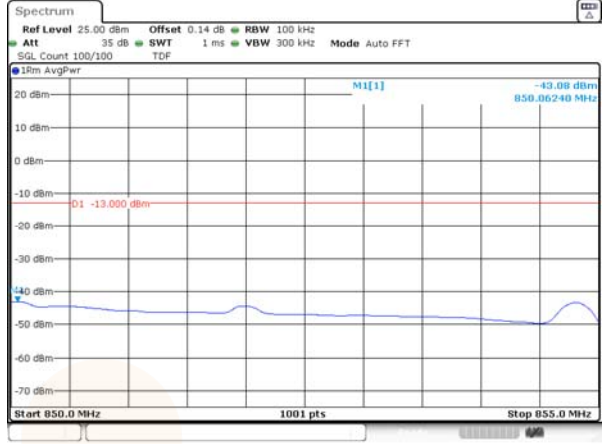

Lower extended FRB

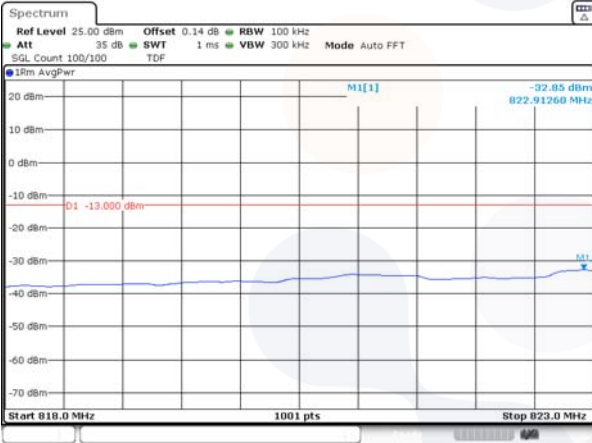

Upper extended FRB

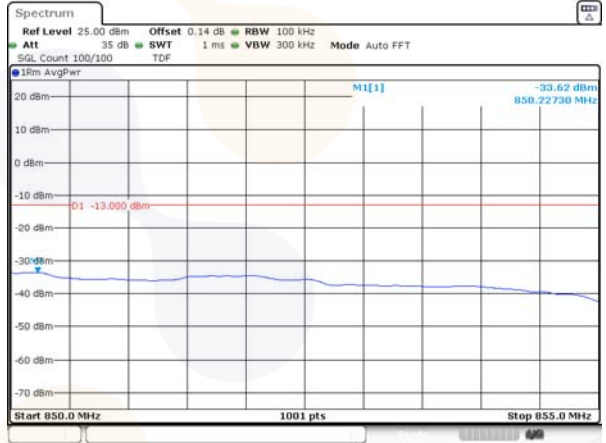

7.4. Spurious Emissions at Antenna Terminal

Test setup

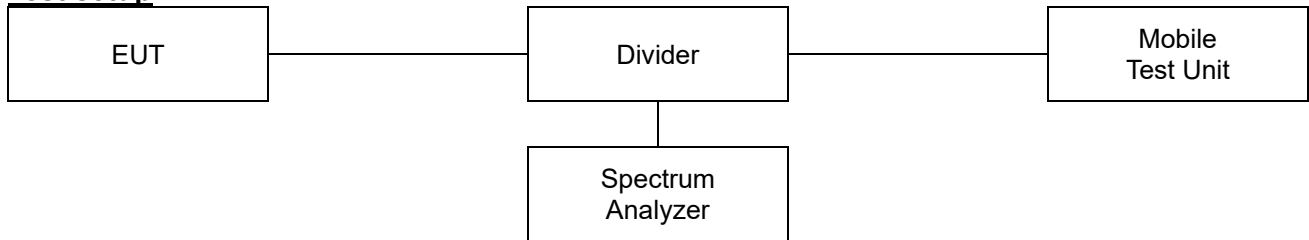

Limit

According to §22.917(a),

The power of any emission outside of the authorized operating frequency ranges must be attenuated below the transmitting power (P) by a factor of at least $43 + 10\log(P)$ dB.

Test procedure

971168 D01 v03r01 - Section 6
ANSI 63.26-2015 – Section 5.7

Test settings

- 1) Start frequency was set to 30 MHz and stop frequency was set to at least 10th the fundamental frequency.
- 2) Detector = RMS
- 3) Sweep time = auto couple.
- 4) Trace mode = trace average
- 5) Allow trace to fully stabilize.
- 6) Please see test notes below RBW and VBW settings.

Notes:

1. Per 22.917(b), compliance with these provisions is based on the use of measurement instrumentation employing a resolution Bandwidth of 100 kHz or greater for frequencies less than 1 GHz and 1 MHz or greater for frequencies greater than 1 GHz. The emission Bandwidth is defined as the width of the signal between two points, one below the carrier center frequency and one above the carrier center frequency, outside of which all emissions are attenuated at least 26 dB below the transmitter power.
2. All modes of operation were investigated and the worst-case configuration results are reported.

Test results

Test mode: WCDMA 850

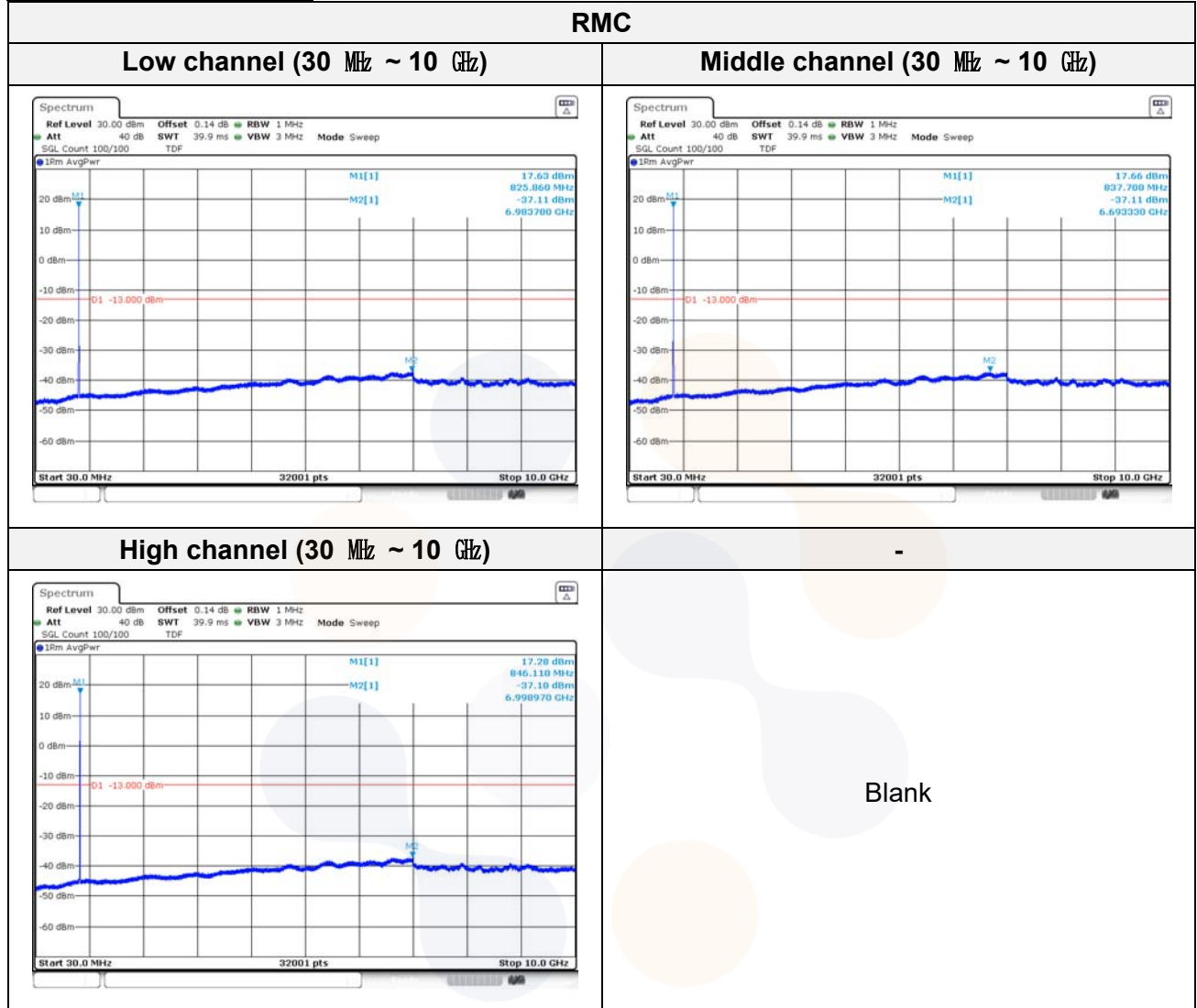

Test mode: LTE B26/5

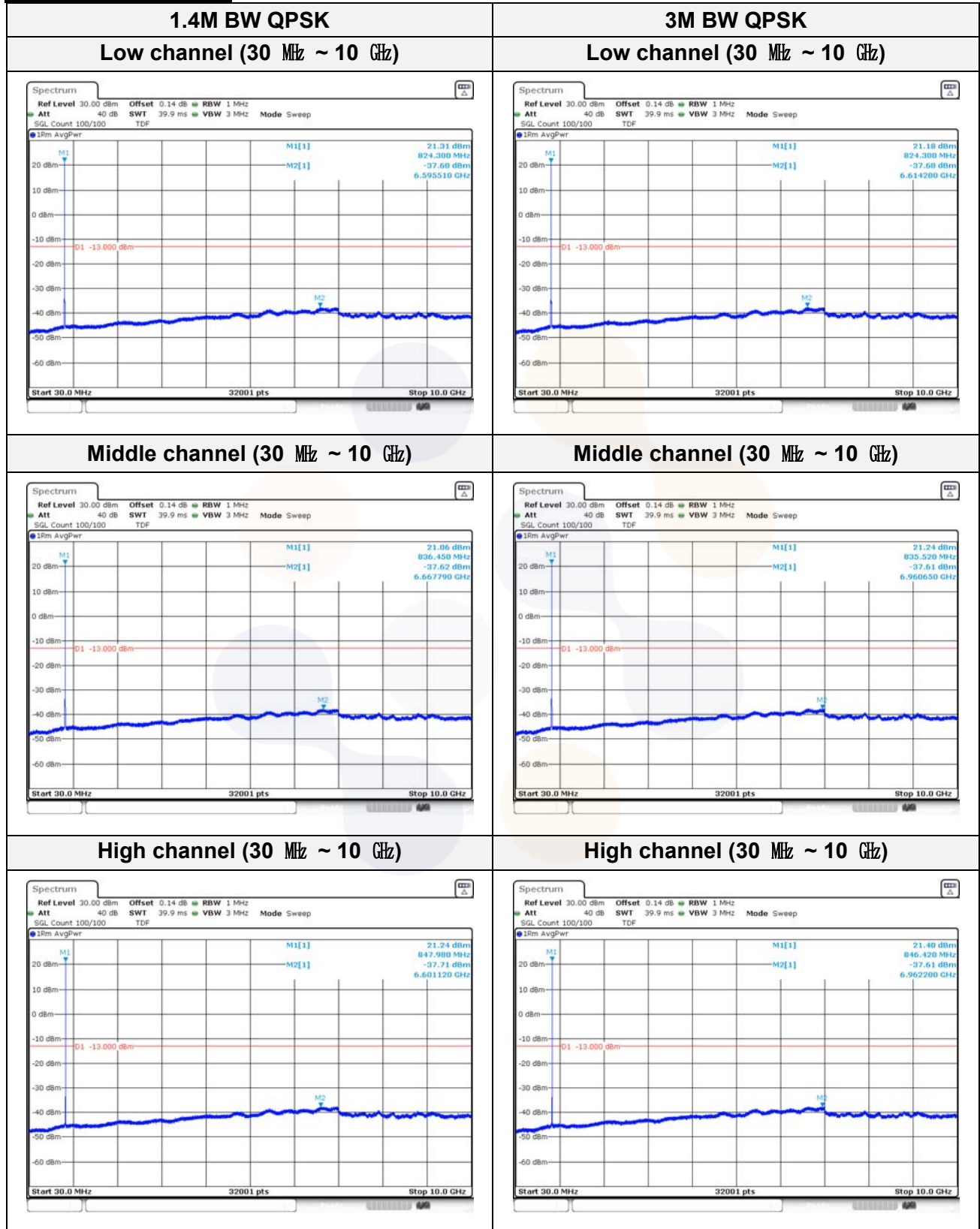

5M BW QPSK

Low channel (30 MHz ~ 10 GHz)

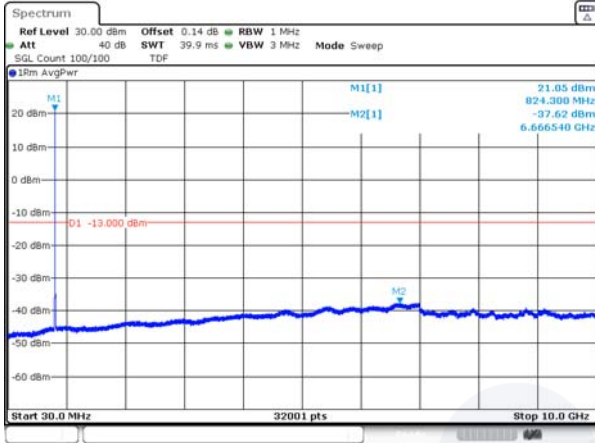

10M BW QPSK

Low channel (30 MHz ~ 10 GHz)

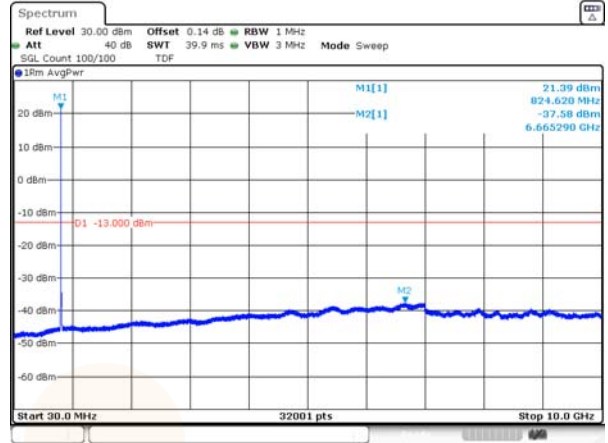

Middle channel (30 MHz ~ 10 GHz)

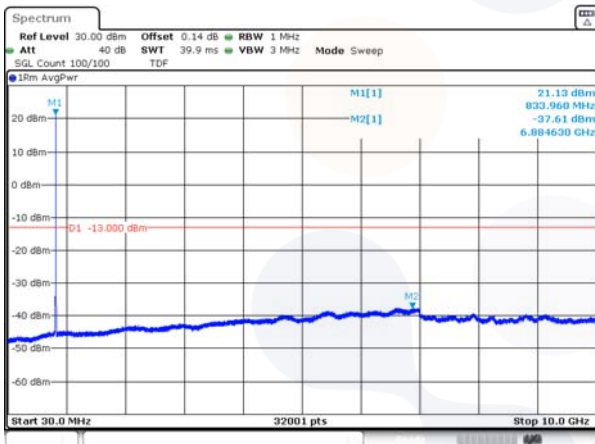

Middle channel (30 MHz ~ 10 GHz)

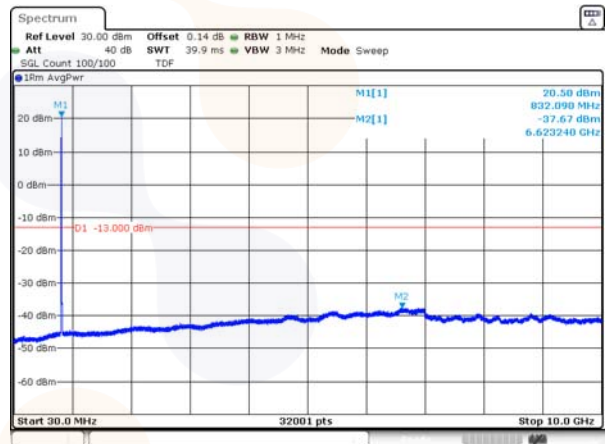

High channel (30 MHz ~ 10 GHz)

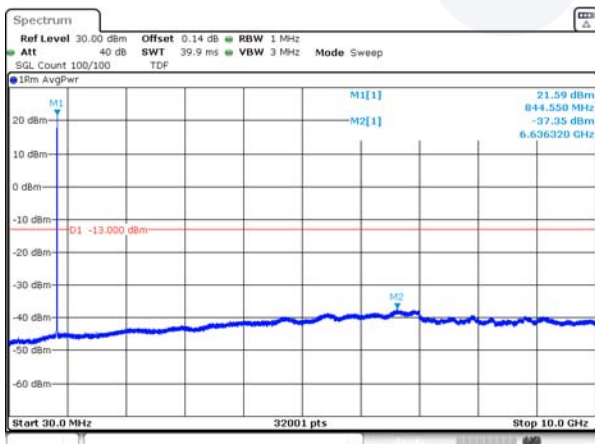

High channel (30 MHz ~ 10 GHz)

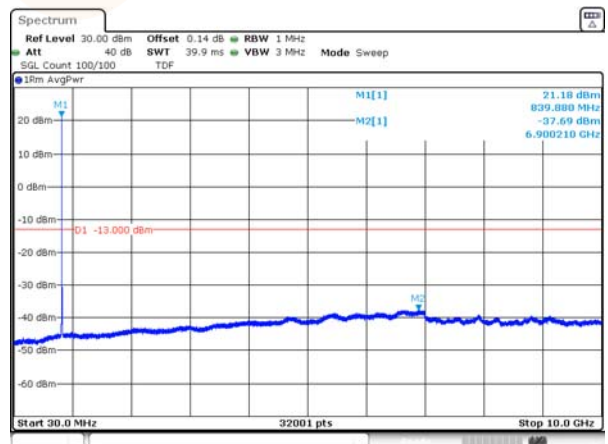

15M BW QPSK

Low channel (30 MHz ~ 10 GHz)

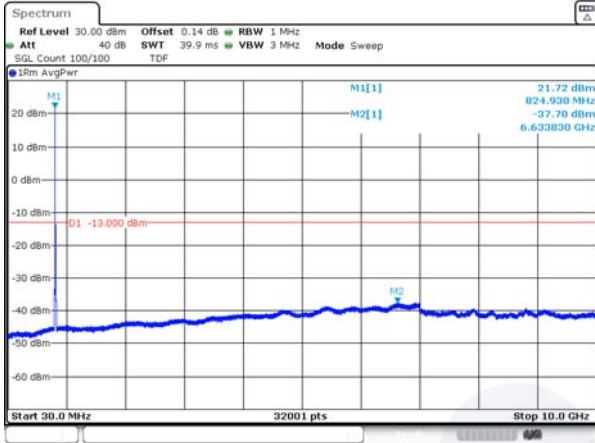

Middle channel (30 MHz ~ 10 GHz)

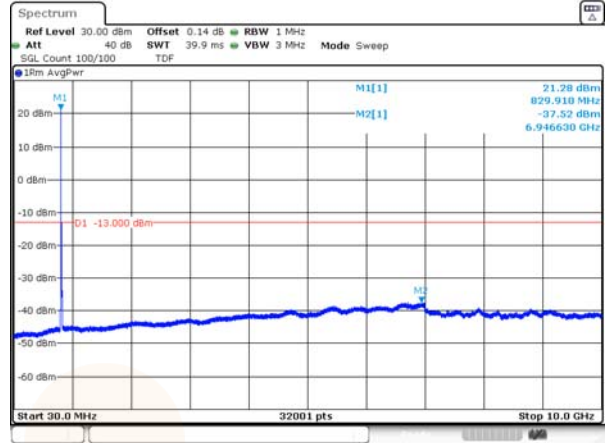

High channel (30 MHz ~ 10 GHz)

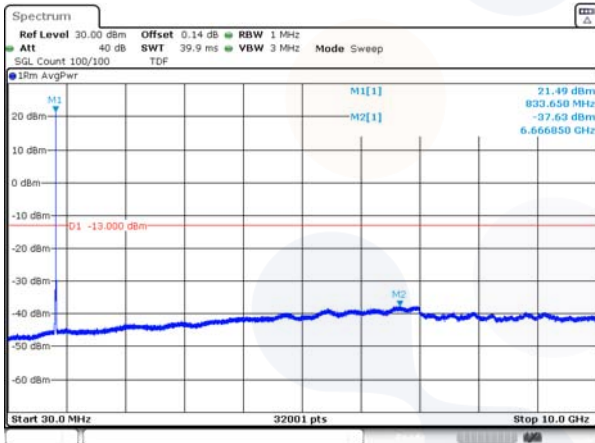

-

Blank

7.5. Peak to Average Power Ratio (PAPR)

Test setup

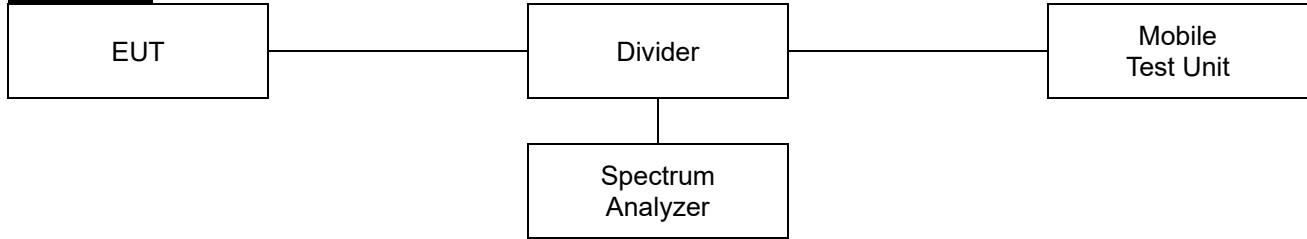

Limit

The peak-to-average ratio(PAR) of the transmission must not exceed 13 dB.

Test procedure

971168 D01 v03r01 - Section 5.7.2 or 5.7.3
971168 D02 v02r02 – Section VII
ANSI 63.26-2015 – Section 5.2.3.4 or 5.2.6

Test settings

5.2.3.4 Measurement of peak power in a broadband noise-like signal using CCDF

- 1) Set resolution/measurement Bandwidth \geq OBW or specified reference Bandwidth
- 2) Set the number of counts to a value that stabilizes the measured CCDF curve.
- 3) Set the measurement interval as follows:
 - a) For continuous transmissions, set to the greater of [10 x (number of points in sweep) x (transmission symbol period)] or 1 ms .
 - b) For burst transmissions, employ an external trigger that is synchronized with the EUT burst timing sequence, or use the internal burst trigger with a trigger level that allows the burst to stabilize. Set the measurement interval to a time that is less than or equal to the burst duration.
 - c) If there are several carriers in a single antenna port, the peak power shall be determined for each individual carrier (by disabling the other carriers while measuring the required carrier) and the total peak power calculated from the sum of the individual carrier peak powers.
- 4) Record the maximum PAPR level associated with a probability of 0.1%

5.2.6 Peak-to-average power ratio

Use one of the procedures presented in 5.2(ANSI C63.26-2015) to measure the total peak power and record as P_{PK} .

Use one of the applicable procedure presented 5.2(ANSI C63.26-2015) to measure the total average power and record as P_{AG} . Determine the P.A.P.R from:

$$PAPR(\text{dB}) = P_{PK}(\text{dBm or dBW}) - P_{AG}(\text{dBm or dBW})$$

Test results

Test mode: WCDMA 850

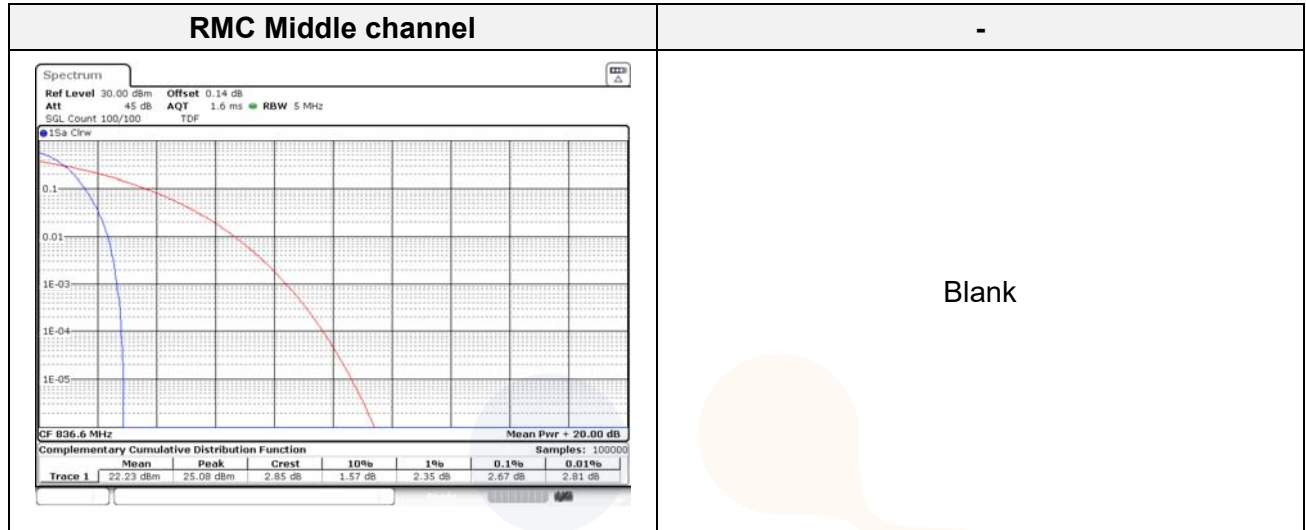

Test mode: LTE B26/5

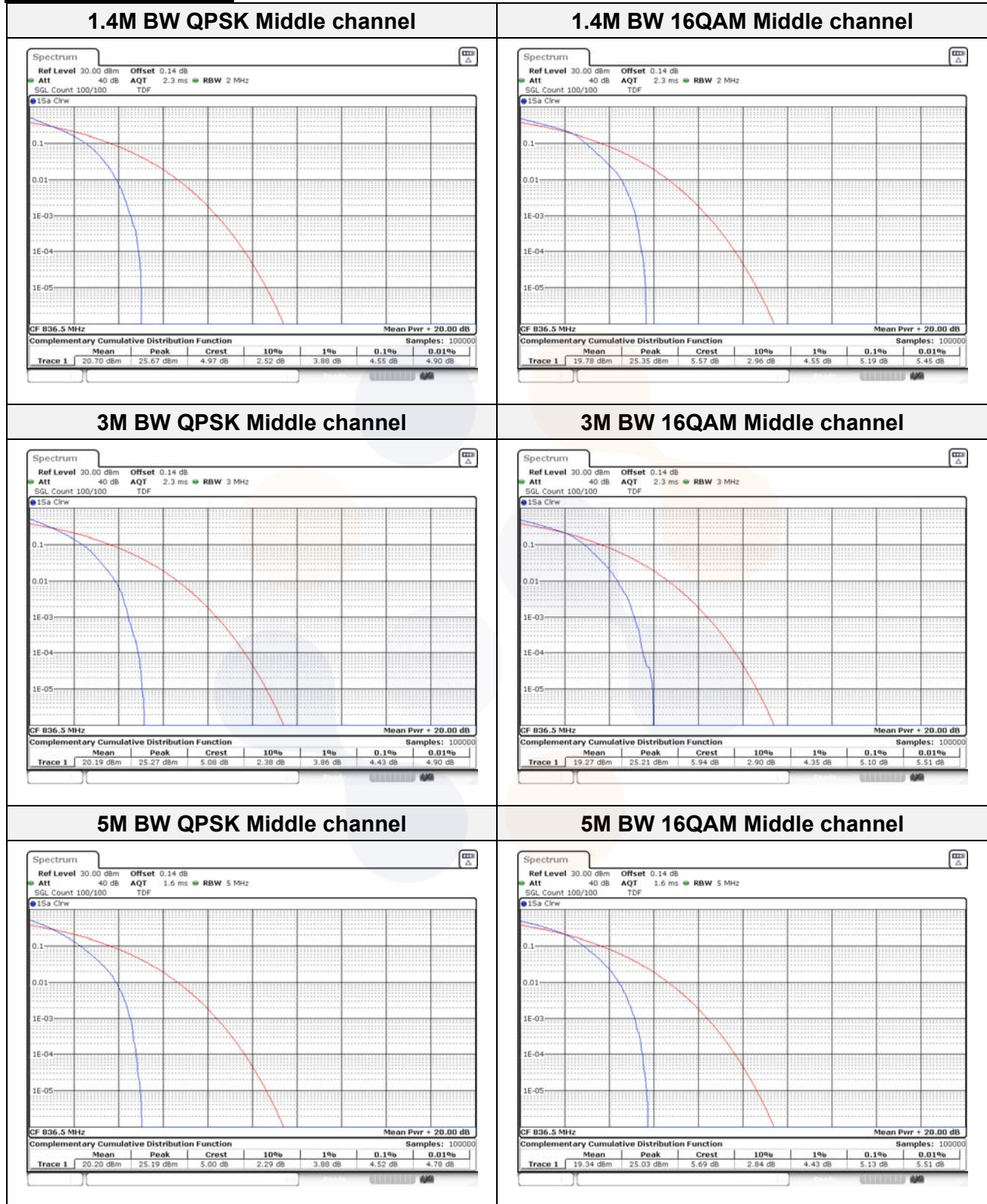

10M BW QPSK Middle channel

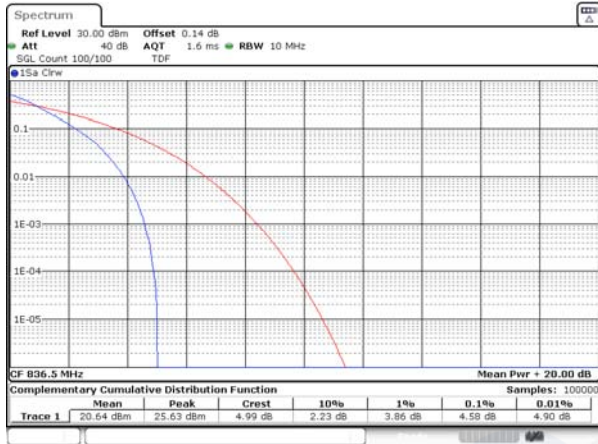

10M BW 16QAM Middle channel

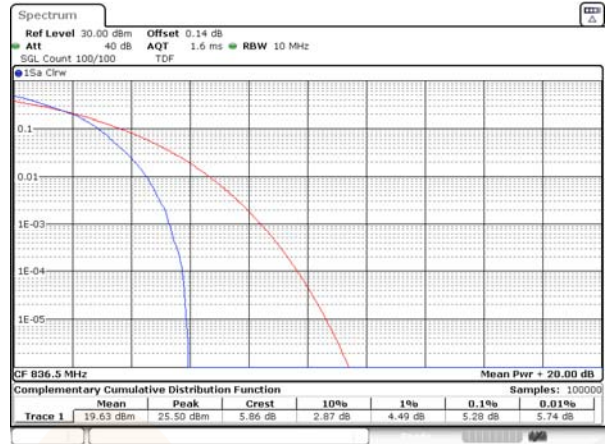

15M BW QPSK Middle channel

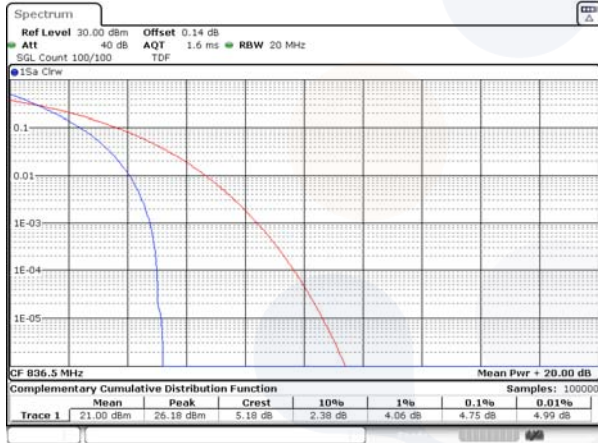

15M BW 16QAM Middle channel

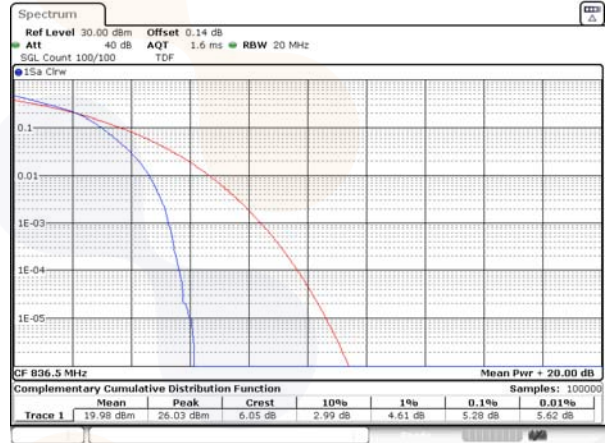

7.6. Frequency stability

Test setup

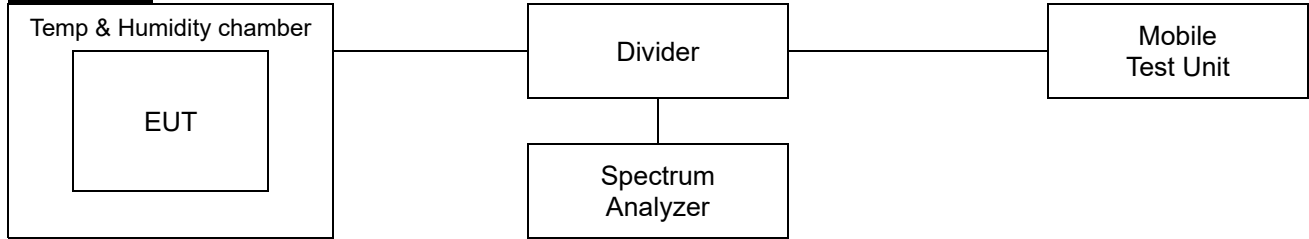

Limit

According to §2.1055(a),

The frequency stability shall be measured with variation of ambient temperature as follows:

- 1) From -30° to $+50^{\circ}$ centigrade for all equipment except that specified in paragraphs (a) (2) and (3) of this section.
- 2) From -20° to $+50^{\circ}$ centigrade for equipment to be licensed for use in the maritime services under part 80 of this chapter, except for class A, B, and S emergency position indicating radiobeacons (EPIRBS), and equipment to be licensed for use above 952 MHz at operational fixed stations in all services, stations in the local television transmission service and point-to-point microwave radio service under part 21 of this chapter, equipment licensed for use aboard aircraft in the aviation services under part 87 of this chapter, and equipment authorized for use in the family radio service under part 95 of this chapter.
- 3) From 0° to $+50^{\circ}$ centigrade for equipment to be licensed for use in the radio broadcast Services under part 73 of this chapter.

According to §2.1055(d),

The frequency stability shall be measured with variation of primary supply Voltage as follows:

- 1) Vary primary supply voltage from 85 to 115 percent of the nominal value for other than hand carried battery equipment.
- 2) For hand carried, battery powered equipment, reduce primary supply voltage to the battery operating and point which shall be specified by the manufacturer.
- 3) The supply voltage shall be measured at the input to the cable normally provided with the equipment, or at the power supply terminals if cables are not normally provided. Effects on frequency of transmitter keying (except for broadcast transmitters) and any heating element cycling at the nominal supply voltage and at each extreme also shall be shown.

According to §22.355,

The carrier frequency of each transmitter in the public mobile services must be maintained within the tolerances given in Table of this section.

For mobile devices operating in the 824 to 849 MHz B at a power level than or equal to 3 Watts, the limit specified in Table C-1 is ± 2.5 ppm.

Test procedure

ANSI 63.26-2015 – Section 5.6

Test settings

- 1) The carrier frequency of the transmitter is measured at room temperature. (20°C to provide a reference)
- 2) The equipment is turned on in a “standby” condition for one minute before applying power to the transmitter. Measurement of the carrier frequency of the transmitter is made within one minute after applying power to the transmitter.
- 3) Frequency measurements are made at 10°C intervals ranging from -30°C to +50°C. A period of at least one half-hour is provided to allow stabilization of the equipment at each Temperature level.



Test results

Test mode : WCDMA 850
 Frequency (Hz) : 836 600 000
 Channel : 4183
 Deviation limit : ±0.000 25% or 2.5 ppm

Voltage (%)	Power (V)	Temp. (°C)	Frequency (Hz)	Frequency error (Hz)	Deviation	
					(ppm)	(%)
100%	3.88	+21.5(Ref)	836,599,999	-0.76	0.0	0.000 000
		-30	836,600,000	-0.14	0.0	0.000 000
		-20	836,600,000	-0.07	0.0	0.000 000
		-10	836,600,001	1.32	0.0	0.000 000
		0	836,600,001	0.96	0.0	0.000 000
		+10	836,599,999	-0.67	0.0	0.000 000
		+20	836,599,999	-1.33	0.0	0.000 000
		+30	836,600,000	0.46	0.0	0.000 000
		+40	836,599,999	-0.71	0.0	0.000 000
		+50	836,600,001	1.14	0.0	0.000 000
115%	4.46	+21.5(Ref)	836,599,999	-1.33	0.0	0.000 000
End point	3.40	+21.5(Ref)	836,600,001	1.27	0.0	0.000 000

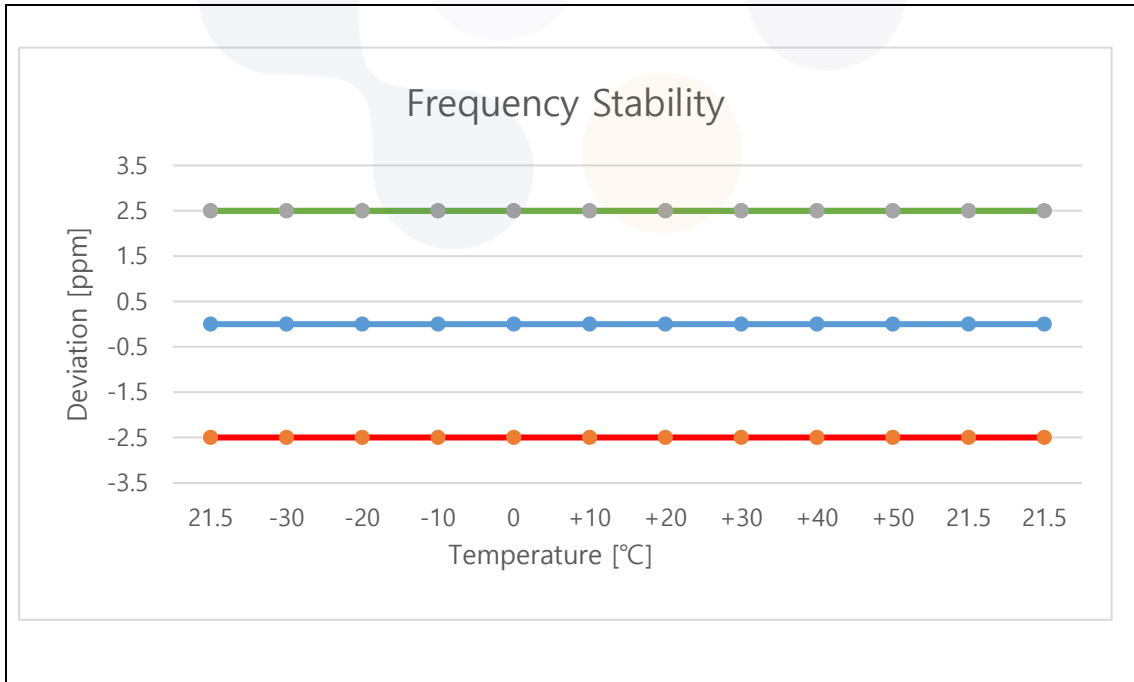

Test mode : LTE B26/5
 Frequency (Hz) : 836 500 000
 Channel : 26915
 Deviation limit : ±0.00025% or 2.5ppm

Voltage (%)	Power (V)	Temp. (°C)	Frequency (Hz)	Frequency error (Hz)	Deviation	
					(ppm)	(%)
100%	3.88	+21.5(Ref)	836,499,998	-1.83	0.0	0.000 000
		-30	836,499,997	-2.62	0.0	0.000 000
		-20	836,499,998	-1.75	0.0	0.000 000
		-10	836,499,997	-2.87	0.0	0.000 000
		0	836,499,999	-1.30	0.0	0.000 000
		+10	836,499,998	-1.94	0.0	0.000 000
		+20	836,499,998	-2.06	0.0	0.000 000
		+30	836,499,998	-1.96	0.0	0.000 000
		+40	836,499,997	-2.55	0.0	0.000 000
		+50	836,499,998	-1.93	0.0	0.000 000
115%	4.46	+21.5(Ref)	836,499,998	-2.31	0.0	0.000 000
End point	3.40	+21.5(Ref)	836,499,999	-1.41	0.0	0.000 000

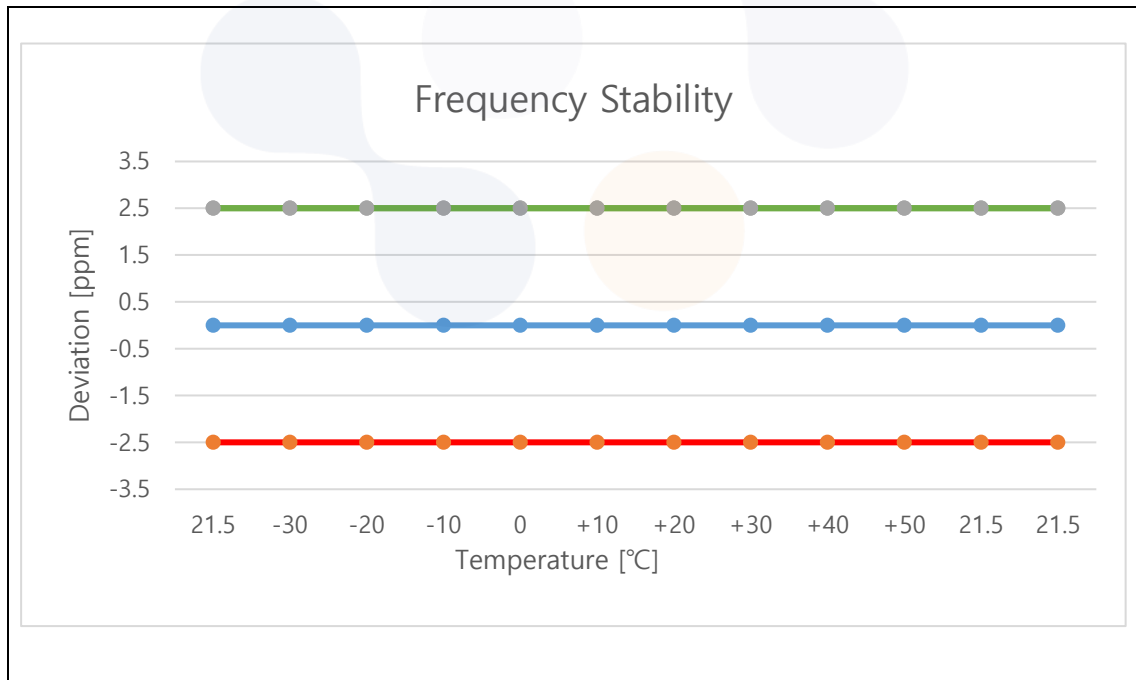

7.7. Radiated Power (ERP)

Test setup

The diagram below shows the test setup that is utilized to make the measurements for emission from 30 MHz to 1 GHz emissions.

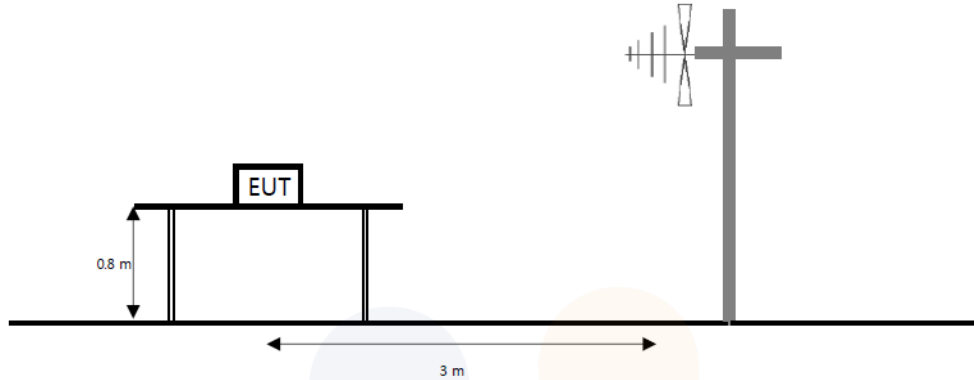

The diagram below shows the test setup that is utilized to make the measurements for emission from 1 GHz to the tenth harmonic of the highest fundamental frequency or to 40 GHz emissions, whichever is lower.

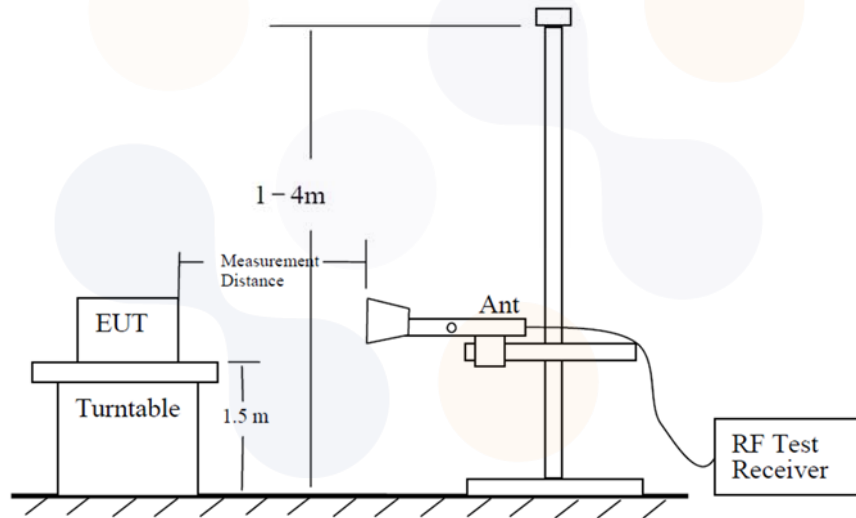

The diagram below shows the test setup for substituted method.

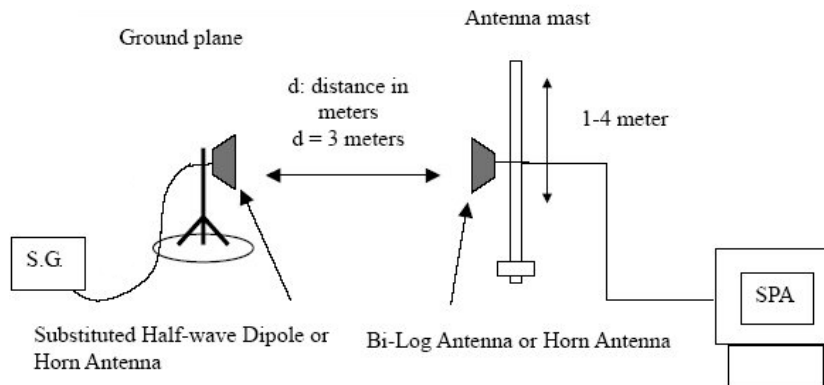

Limit

According to §22.913(a)(5),

The ERP of transmitters in the cellular radiotelephone service must not exceed the limits in this section. The ERP of mobile transmitters and auxiliary test transmitters must not exceed 7 watts.

Test procedure

412172 D01 v01r01



971168 D01 v03r01 - Section 5.2 and 5.8

ANSI 63.26-2015 – Section 5.2

ANSI/TIA-603-E-2016 - Section 2.2.17

Test settings

- 1) RBW = 1 % to 5 % of the OBW.
- 2) VBW $\geq 3 \times$ RBW.
- 3) SPAN = 2 \times to 3 \times the OBW.
- 4) Number of measurement points in sweep $\geq 2 \times$ span / RBW.
- 5) Sweep time :
 - 1) Auto couple, or
 - 2) $\geq [10 \times (\text{number of points in sweep}) \times (\text{transmission period})]$ for single sweep (automation-compatible) measurement. Transmission period is the on and off time of the transmitter.
- 6) Detector = RMS
- 7) If the EUT can be configured to transmit continuously, then set the trigger to free run.
- 8) If the EUT cannot be configured to transmit continuously, then use a sweep trigger with the level set to enable triggering only on full power bursts and configure the EUT to transmit at full power for the entire duration of each sweep. Verify that the sweep time is less than or equal to the transmission burst duration. Time gating can also be used under similar constraints (i.e., configured such that measurement data is collected only during active full-power transmissions).
- 9) Trace mode = trace averaging (RMS) over 100 sweeps.
- 10) Compute the power by integrating the spectrum across the OBW of the signal using the instrument's B or channel power measurement function, with the B/channel limits set equal to the OBW B edges. If the instrument does not have a B or channel power function, then sum the spectrum levels (in linear power units) at intervals equal to the RBW extending across the entire OBW of the spectrum.
- 11) Allow trace to fully stabilize.

<p>Eurofins KCTL Co.,Ltd. 65, Sinwon-ro, Yeongtong-gu, Suwon-si, Gyeonggi-do, 16677, Korea TEL: 82-70-5008-1021 FAX: 82-505-299-8311 www.kctl.co.kr</p>	<p>Report No.: KR24-SRF0098-A Page (55) of (62)</p>	 
--	---	---

Notes:

1. On a test site, the EUT shall be placed at 80 cm or 1.5 m height on a turn table, and in the position close to normal use as declared by the applicant.
2. The test antenna shall be oriented initially for vertical polarization located 3 m from EUT to correspond to the fundamental frequency of the transmitter.
3. The turntable is rotated through 360°, and the receiving antenna scans in order to determine the Level of the maximized emission.
4. The test antenna shall be raised and lowered again through the specified range of height until the maximum signal level is detected by the measuring receiver.
5. The maximum signal level detected by the measuring receiver shall be noted.
6. The EUT was replaced by half-wave dipole (1 GHz below) or horn antenna (1 GHz above) connected to a signal generator.
The power is calculated by the following formula;

$$Pd(\text{dBm}) = Pg(\text{dBm}) - \text{Cable loss (dB)} + \text{Antenna gain (dB)}$$
Note. Pd is the dipole equivalent power and Pg is the generator output power into the substitution antenna.
7. The test antenna shall be raised and lowered through the specified range of height to ensure that The maximum signal is received.
8. The input signal to the substitution antenna shall be adjusted to the level that produces a level Detected by the measuring corrected for the change of input attenuator setting of the measuring Receiver.
9. The input level to the substitution antenna shall be recorded as power level in dBm, corrected for Any change of input attenuator setting of the measuring receiver.
10. The measurement shall be repeated with the test antenna and the substitution antenna Orientated for horizontal polarization.

Test results

Test mode: WCDMA 850

Mode	Channel	Pol.	Antenna Gain	C.L	Substitute Level	ERP	
		[V/H]	[dBd]	[dB]	[dB m]	[dB m]	[W]
RMC	Low	H	3.41	6.10	15.40	12.71	0.019
	Middle	H	3.45	6.20	14.96	12.21	0.017
	High	H	3.25	6.26	15.21	12.20	0.017

Note.

1. $E.R.P(dBm) = \text{Substitute Level}(dB) + \text{Antenna gain}(dBd) - C.L(\text{Cable loss})(dB)$



Test mode: LTE B26/5

Bandwidth [MHz]	Modulation	Channel	Pol.	Antenna Gain	C.L	Substitute Level	ERP	
			[V/H]	[dBd]	[dB]	[dBm]	[dBm]	[W]
1.4	QPSK	Low	H	3.40	6.08	14.37	11.69	0.015
		Middle	H	3.45	6.21	14.19	11.43	0.014
		High	H	3.20	6.26	14.36	11.30	0.013
	16QAM	Low	H	3.40	6.08	13.26	10.58	0.011
		Middle	H	3.45	6.21	13.12	10.36	0.011
		High	H	3.20	6.26	13.41	10.35	0.011
3	QPSK	Low	H	3.41	6.09	14.20	11.51	0.014
		Middle	H	3.45	6.21	14.10	11.34	0.014
		High	H	3.23	6.26	14.48	11.45	0.014
	16QAM	Low	H	3.41	6.09	13.33	10.65	0.012
		Middle	H	3.45	6.21	13.21	10.45	0.011
		High	H	3.23	6.26	13.60	10.56	0.011
5	QPSK	Low	H	3.42	6.11	14.37	11.67	0.015
		Middle	H	3.45	6.21	14.08	11.32	0.014
		High	H	3.26	6.26	14.38	11.37	0.014
	16QAM	Low	H	3.42	6.11	13.30	10.60	0.011
		Middle	H	3.45	6.21	13.14	10.38	0.011
		High	H	3.26	6.26	13.38	10.37	0.011
10	QPSK	Low	H	3.44	6.11	14.21	11.54	0.014
		Middle	H	3.45	6.21	14.10	11.34	0.014
		High	H	3.33	6.21	14.50	11.62	0.015
	16QAM	Low	H	3.44	6.11	13.30	10.63	0.012
		Middle	H	3.45	6.21	13.17	10.41	0.011
		High	H	3.33	6.21	13.42	10.54	0.011
15	QPSK	Low	H	3.45	6.13	14.24	11.56	0.014
		Middle	H	3.45	6.21	14.37	11.61	0.015
		High	H	3.41	6.17	14.53	11.77	0.015
	16QAM	Low	H	3.45	6.13	13.13	10.45	0.011
		Middle	H	3.45	6.21	13.43	10.67	0.012
		High	H	3.41	6.17	13.52	10.75	0.012

Note.

1. $E.R.P(dBm) = \text{Substitute Level}(dB) + \text{Antenna gain}(dBd) - C.L(\text{Cable loss})(dB)$

7.8. Radiated Spurious Emissions

Test setup

The diagram below shows the test setup that is utilized to make the measurements for emission from 30 MHz to 1 GHz emissions.

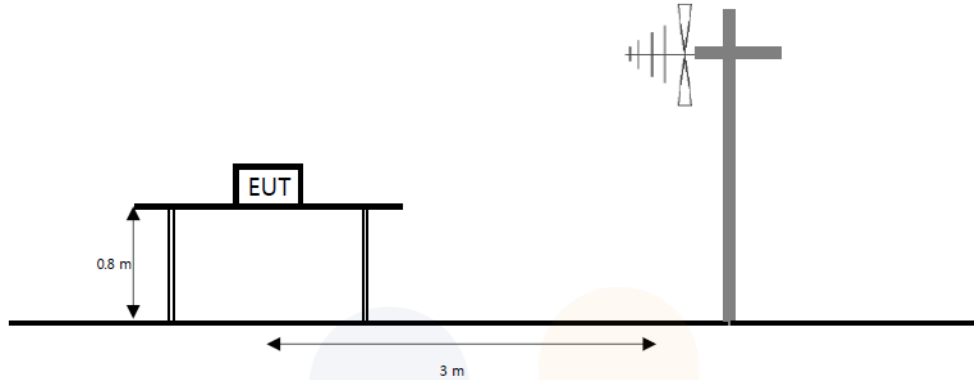

The diagram below shows the test setup that is utilized to make the measurements for emission from 1 GHz to the tenth harmonic of the highest fundamental frequency or to 40 GHz emissions, whichever is lower.

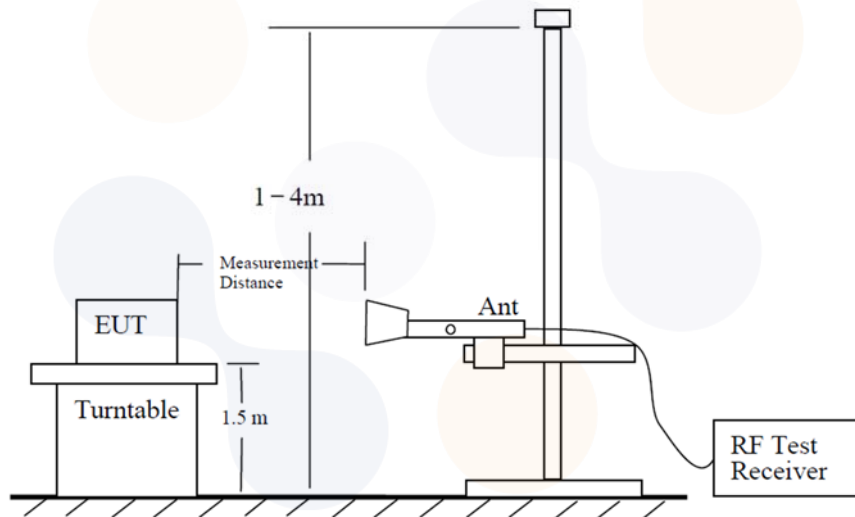

The diagram below shows the test setup for substituted method.

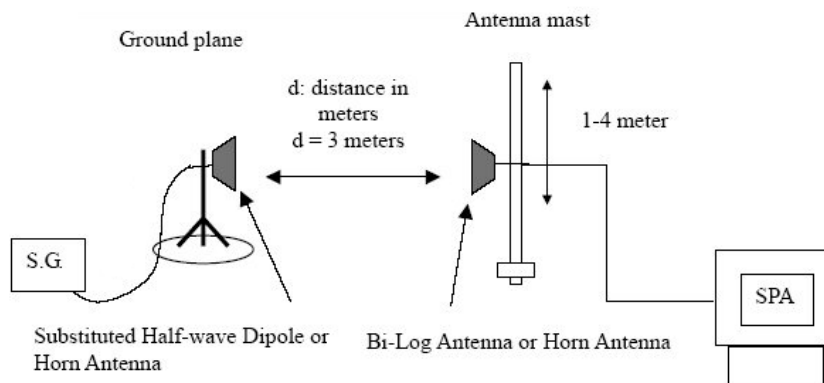

Limit

According to §22.917(a),

The power of any emission outside of the authorized operating frequency ranges must be attenuated below the transmitting power (P) by a factor of at least $43 + 10\log(P)$ dB.

Test procedure

971168 D01 v03r01 - Section 6.2

ANSI 63.26-2015 – Section 5.5

ANSI/TIA-603-E-2016 - Section 2.2.12

Test settings

- 1) RBW = 100 kHz for below 1 GHz and 1 MHz for above 1 GHz.
- 2) VBW $\geq 3 \times$ RBW.
- 3) Detector = RMS
- 4) Trace mode = Max hold
- 5) Sweep time = Auto couple
- 6) Number of sweep points $\geq 2 \times$ span / RBW
- 7) Allow trace to fully stabilize.

Notes:

1. On a test site, the EUT shall be placed at 80 cm or 1.5 m height on a turn table, and in the position close to normal use as declared by the applicant.
2. The test antenna shall be oriented initially for vertical polarization located 3 m from EUT to correspond to the fundamental frequency of the transmitter.
3. The turntable is rotated through 360°, and the receiving antenna scans in order to determine the Level of the maximized emission.
4. The test antenna shall be raised and lowered again through the specified range of height until the maximum signal level is detected by the measuring receiver.
5. The maximum signal level detected by the measuring receiver shall be noted.
6. The EUT was replaced by half-wave dipole (1 GHz below) or horn antenna (1 GHz above) connected to a signal generator.
7. The test antenna shall be raised and lowered through the specified range of height to ensure that the maximum signal is received.
8. The input signal to the substitution antenna shall be adjusted to the level that produces a level detected by the measuring corrected for the change of input attenuator setting of the measuring Receiver.
9. The input level to the substitution antenna shall be recorded as power level in dBm, corrected for any change of input attenuator setting of the measuring receiver.
10. The measurement shall be repeated with the test antenna and the substitution antenna oriented for horizontal polarization.

Test results (Above 1 000 MHz)

Test mode : WCDMA 850

Frequency(MHz) : 826.4

Channel : 4132

Mode	Frequency	Pol.	Antenna Gain	Cable loss	Substitute Level	Level	Limit	Margin
	[MHz]	[V/H]	[dBi]	[dB]	[dBm]	[dBm]	[dBm]	[dB]
RMC	1 652.75	V	5.74	8.61	-51.53	-54.40	-13.00	41.40
	2 478.23	H	5.94	10.66	-41.78	-46.50	-13.00	33.50
	3 305.76	V	7.91	12.49	-39.62	-44.20	-13.00	31.20
	4 133.29	V	9.31	14.11	-36.10	-40.90	-13.00	27.90

Test mode : WCDMA 850

Frequency(MHz) : 836.6

Channel : 4183

Mode	Frequency	Pol.	Antenna Gain	Cable loss	Substitute Level	Level	Limit	Margin
	[MHz]	[V/H]	[dBi]	[dB]	[dBm]	[dBm]	[dBm]	[dB]
RMC	1 675.32	H	5.67	8.67	-49.80	-52.80	-13.00	39.80
	2 509.82	H	6.03	10.74	-41.79	-46.50	-13.00	33.50
	3 345.15	V	7.99	12.58	-39.91	-44.50	-13.00	31.50
	4 184.16	H	9.35	13.99	-37.26	-41.90	-13.00	28.90

Test mode : WCDMA 850

Frequency(MHz) : 846.6

Channel : 4233

Mode	Frequency	Pol.	Antenna Gain	Cable loss	Substitute Level	Level	Limit	Margin
	[MHz]	[V/H]	[dBi]	[dB]	[dBm]	[dBm]	[dBm]	[dB]
RMC	1 693.37	H	5.62	8.72	-50.10	-53.20	-13.00	40.20
	2 537.72	H	6.10	10.79	-40.11	-44.80	-13.00	31.80
	3 384.12	V	8.07	12.66	-38.71	-43.30	-13.00	30.30
	4 233.81	H	9.39	14.13	-38.06	-42.80	-13.00	29.80

Note.

- E.I.R.P(dBm) = Substitute Level(dB) + Antenna gain(dBi) - C.L(Cable loss) (dB)

Test mode : LTE B26/5

Frequency(MHz) : 831.5

Channel : 26865

Bandwidth(MHz) : 15

Mode	Frequency	Pol.	Antenna Gain	Cable loss	Substitute Level	Level	Limit	Margin
	[MHz]	[V/H]	[dBi]	[dB]	[dBm]	[dBm]	[dBm]	[dB]
QPSK	1 649.88	V	5.75	8.66	-49.79	-52.70	-13.00	39.70
	2 472.08	V	5.93	10.65	-40.28	-45.00	-13.00	32.00
	3 294.27	V	7.89	12.46	-39.93	-44.50	-13.00	31.50
	4 118.93	V	9.30	14.09	-35.51	-40.30	-13.00	27.30

Test mode : LTE B26/5

Frequency(MHz) : 836.5

Channel : 26915

Bandwidth(MHz) : 15

Mode	Frequency	Pol.	Antenna Gain	Cable loss	Substitute Level	Level	Limit	Margin
	[MHz]	[V/H]	[dBi]	[dB]	[dBm]	[dBm]	[dBm]	[dB]
QPSK	1 658.50	H	5.72	8.62	-50.00	-52.90	-13.00	39.90
	2 487.67	H	5.97	10.68	-41.79	-46.50	-13.00	33.50
	3 319.71	H	7.94	12.52	-37.52	-42.10	-13.00	29.10
	4 147.65	H	9.32	14.14	-34.38	-39.20	-13.00	26.20

Test mode : LTE B26/5

Frequency(MHz) : 841.5

Channel : 26965

Bandwidth(MHz) : 15

Mode	Frequency	Pol.	Antenna Gain	Cable loss	Substitute Level	Level	Limit	Margin
	[MHz]	[V/H]	[dBi]	[dB]	[dBm]	[dBm]	[dBm]	[dB]
QPSK	1 667.93	V	5.70	8.65	-50.75	-53.70	-13.00	40.70
	2 501.62	V	6.00	10.78	-40.52	-45.30	-13.00	32.30
	3 337.76	V	7.98	12.56	-38.42	-43.00	-13.00	30.00
	4 172.27	V	9.34	13.96	-34.58	-39.20	-13.00	26.20

Note.

1. E.I.R.P(dBm) = Substitute Level(dB) + Antenna gain(dBi) - C.L(Cable loss) (dB)

8. Measurement equipment

Equipment Name	Manufacturer	Model No.	Serial No.	Next Cal. Date
Spectrum Analyzer	R&S	FSV40-N	101462	24.10.12
Spectrum Analyzer	Agilent	N9040B	US55230151	24.07.03
Divider	Marki Microwave, Inc.	PD-0040	D0006	24.07.04
DC Power Supply	AGILENT	E3632A	KR75304571	25.04.24*
Wideband Radio Communication Tester	R&S	CMW500	168683	25.02.13
Wideband Radio Communication Tester	R&S	CMW500	141780	25.01.18
Signal Generator	R&S	SMB100A	176206	25.01.18
Temp & Humid Chamber	Myeongseong R&P	CTHC-50P-DT	20150824-2	25.01.18
Bi-log Antenna	Teseq GmbH	CBL 6112D	62027	24.11.17
Bi-log Antenna	ETS-LINDGREN	3143B	00228420	25.07.20
Horn Antenna	ETS-LINDGREN	3117	00251528	25.01.26
Horn Antenna	ETS-LINDGREN	3117	00227509	24.07.12
Amplifier	SONOMA INSTRUMENT	310N	421822	24.10.12
Amplifier	B&Z Technologies	BZR-0050400-551028-252525	27736	24.07.04
High pass Filter	Wainwright Instruments GmbH	WHKX10-900-1000-15000-40SS	11	24.07.04

*This equipment was calibrated during the test period, and was used after calibration.

End of test report