



SAR EVALUATION REPORT

Applicant Name:
 Samsung Electronics Co., Ltd.
 129, Samsung-ro, Maetan dong,
 Yeongtong-gu, Suwon-si
 Gyeonggi-do, 16677, Korea

Date of Testing:
 03/20/17 - 04/20/17
Test Site/Location:
 PCTEST Lab, Columbia, MD, USA
Document Serial No.:
 1M1703230121-01-R1.A3L

FCC ID: A3LSMJ530GM

APPLICANT: SAMSUNG ELECTRONICS CO., LTD.

DUT Type: Portable Handset
Application Type: Certification
FCC Rule Part(s): CFR §2.1093
Model: SM-J530GM/DS
Additional Model(s): SM-J530GM, SM-J530YM/DS

Equipment Class	Band & Mode	Tx Frequency	SAR		
			1 gm Head (W/kg)	1 gm Body-Worn (W/kg)	1 gm Hotspot (W/kg)
PCE	GSM/GPRS/EDGE 850	824.20 - 848.80 MHz	0.20	0.35	0.41
PCE	UMTS 850	826.40 - 846.60 MHz	0.19	0.31	0.45
PCE	GSM/GPRS/EDGE 1900	1850.20 - 1909.80 MHz	0.16	0.44	0.52
PCE	UMTS 1750	1712.4 - 1752.6 MHz	0.16	0.51	0.82
PCE	UMTS 1900	1852.4 - 1907.6 MHz	0.19	0.75	0.85
PCE	LTE Band 12	699.7 - 715.3 MHz	< 0.1	0.22	0.33
PCE	LTE Band 17	706.5 - 713.5 MHz	N/A	N/A	N/A
PCE	LTE Band 5 (Cell)	824.7 - 848.3 MHz	0.21	0.42	0.58
PCE	LTE Band 4 (AWS)	1710.7 - 1754.3 MHz	0.22	0.84	0.76
PCE	LTE Band 66 (AWS)	1710.7 - 1779.3 MHz	0.12	0.33	0.52
PCE	LTE Band 2 (PCS)	1850.7 - 1909.3 MHz	0.25	0.85	0.86
PCE	LTE Band 41	2498.5 - 2687.5 MHz	< 0.1	0.27	1.07
DTS	2.4 GHz WLAN	2412 - 2462 MHz	0.79	0.18	0.41
NII	U-NII-1	5180 - 5240 MHz	N/A	N/A	N/A
NII	U-NII-2A	5260 - 5320 MHz	1.04	< 0.1	N/A
NII	U-NII-2C	5500 - 5720 MHz	0.95	< 0.1	N/A
NII	U-NII-3	5745 - 5825 MHz	0.99	< 0.1	0.90
DSS/DTS	Bluetooth	2402 - 2480 MHz		N/A	
Simultaneous SAR per KDB 690783 D01v01r03:			1.30	1.03	1.51

Note: This revised Test Report (S/N: 1M1703230121-01-R1.A3L) supersedes and replaces the previously issued test report on the same subject device for the same type of testing as indicated. Please discard or destroy the previously issued test report(s) and dispose of it accordingly.

This wireless portable device has been shown to be capable of compliance for localized specific absorption rate (SAR) for uncontrolled environment/general population exposure limits specified in ANSI/IEEE C95.1-1992 and has been tested in accordance with the measurement procedures specified in Section 1.8 of this report; for North American frequency bands only.

I attest to the accuracy of data. All measurements reported herein were performed by me or were made under my supervision and are correct to the best of my knowledge and belief. I assume full responsibility for the completeness of these measurements and vouch for the qualifications of all persons taking them. Test results reported herein relate only to the item(s) tested.

Randy Ortanez
 President





The SAR Tick is an initiative of the Mobile Manufacturers Forum (MMF). While a product may be considered eligible, use of the SAR Tick logo requires an agreement with the MMF. Further details can be obtained by emailing: sartick@mmfai.info.

FCC ID: A3LSMJ530GM		SAR EVALUATION REPORT		Approved by: Quality Manager
Document S/N: 1M1703230121-01-R1.A3L	Test Dates: 03/20/17 - 04/20/17	DUT Type: Portable Handset	Page 1 of 85	

TABLE OF CONTENTS

1	DEVICE UNDER TEST	3
2	LTE INFORMATION	11
3	INTRODUCTION	12
4	DOSIMETRIC ASSESSMENT	13
5	DEFINITION OF REFERENCE POINTS	14
6	TEST CONFIGURATION POSITIONS	15
7	RF EXPOSURE LIMITS	18
8	FCC MEASUREMENT PROCEDURES.....	19
9	RF CONDUCTED POWERS	25
10	SYSTEM VERIFICATION.....	59
11	SAR DATA SUMMARY	62
12	FCC MULTI-TX AND ANTENNA SAR CONSIDERATIONS.....	75
13	SAR MEASUREMENT VARIABILITY	80
14	EQUIPMENT LIST.....	81
15	MEASUREMENT UNCERTAINTIES.....	82
16	CONCLUSION.....	83
17	REFERENCES	84
APPENDIX A:	SAR TEST PLOTS	
APPENDIX B:	SAR DIPOLE VERIFICATION PLOTS	
APPENDIX C:	PROBE AND DIPOLE CALIBRATION CERTIFICATES	
APPENDIX D:	SAR TISSUE SPECIFICATIONS	
APPENDIX E:	SAR SYSTEM VALIDATION	
APPENDIX F:	DUT ANTENNA DIAGRAM & SAR TEST SETUP PHOTOGRAPHS	

FCC ID: A3LSMJ530GM		SAR EVALUATION REPORT		Approved by: Quality Manager
Document S/N: 1M1703230121-01-R1.A3L	Test Dates: 03/20/17 - 04/20/17	DUT Type: Portable Handset	Page 2 of 85	

1 DEVICE UNDER TEST



1.1 Device Overview

Band & Mode	Operating Modes	Tx Frequency
GSM/GPRS/EDGE 850	Voice/Data	824.20 - 848.80 MHz
UMTS 850	Voice/Data	826.40 - 846.60 MHz
GSM/GPRS/EDGE 1900	Voice/Data	1850.20 - 1909.80 MHz
UMTS 1750	Voice/Data	1712.4 - 1752.6 MHz
UMTS 1900	Voice/Data	1852.4 - 1907.6 MHz
LTE Band 12	Voice/Data	699.7 - 715.3 MHz
LTE Band 17	Voice/Data	706.5 - 713.5 MHz
LTE Band 5 (Cell)	Voice/Data	824.7 - 848.3 MHz
LTE Band 4 (AWS)	Voice/Data	1710.7 - 1754.3 MHz
LTE Band 66 (AWS)	Voice/Data	1710.7 - 1779.3 MHz
LTE Band 2 (PCS)	Voice/Data	1850.7 - 1909.3 MHz
LTE Band 41	Voice/Data	2498.5 - 2687.5 MHz
2.4 GHz WLAN	Voice/Data	2412 - 2462 MHz
U-NII-1	Voice/Data	5180 - 5240 MHz
U-NII-2A	Voice/Data	5260 - 5320 MHz
U-NII-2C	Voice/Data	5500 - 5720 MHz
U-NII-3	Voice/Data	5745 - 5825 MHz
Bluetooth	Data	2402 - 2480 MHz
NFC	Data	13.56 MHz
ANT+	Data	2402 - 2480 MHz
MST	Data	555 Hz - 8.33 kHz

1.2 Power Reduction for SAR

This device utilizes a single step power reduction mechanism for SAR compliance under portable hotspot conditions for some wireless modes and bands. All hotspot SAR evaluations for this device were performed at the maximum allowed output power when hotspot is enabled. Detailed descriptions of the power reduction mechanism are included in the operational description.

This device uses an independent fixed level power reduction mechanism for WLAN operations during voice or VoIP held to ear scenarios. Per FCC Guidance, the held-to-ear exposure conditions were evaluated at reduced power according to the head SAR positions described in IEEE 1528-2013. Detailed descriptions of the power reduction mechanism are included in the operational description.

FCC ID: A3LSMJ530GM		SAR EVALUATION REPORT		Approved by: Quality Manager
Document S/N: 1M1703230121-01-R1.A3L	Test Dates: 03/20/17 - 04/20/17	DUT Type: Portable Handset	Page 3 of 85	

1.3 Nominal and Maximum Output Power Specifications



This device operates using the following maximum and nominal output power specifications. SAR values were scaled to the maximum allowed power to determine compliance per KDB Publication 447498 D01v06.

A. Maximum PCE Target Powers

Mode / Band		Voice (dBm)	Burst Average GMSK (dBm)				Burst Average 8-PSK (dBm)			
		1 TX Slot	1 TX Slots	2 TX Slots	3 TX Slots	4 TX Slots	1 TX Slots	2 TX Slots	3 TX Slots	4 TX Slots
GSM/GPRS/EDGE 850	Maximum	33.5	33.5	32.0	30.5	29.0	28.0	26.0	24.5	23.0
	Nominal	33.0	33.0	31.5	30.0	28.5	27.5	25.5	24.0	22.5
GSM/GPRS/EDGE 1900	Maximum	30.5	30.5	28.0	26.0	24.5	26.0	24.5	23.0	21.5
	Nominal	30.0	30.0	27.5	25.5	24.0	25.5	24.0	22.5	21.0

Mode / Band		Modulated Average (dBm)			
		3GPP WCDMA	3GPP HSDPA	3GPP HSUPA	3GPP DC-HSDPA
UMTS Band 5 (850 MHz)	Maximum	24.2	23.0	23.0	23.0
	Nominal	23.7	22.5	22.5	22.5
UMTS Band 4 (1750 MHz)	Maximum	24.0	23.5	23.5	23.5
	Nominal	23.5	23.0	23.0	23.0
UMTS Band 2 (1900 MHz)	Maximum	23.5	23.5	23.5	23.5
	Nominal	23.0	23.0	23.0	23.0

Mode / Band		Modulated Average (dBm)
LTE Band 12	Maximum	24.0
	Nominal	23.5
LTE Band 17	Maximum	24.0
	Nominal	23.5
LTE Band 5 (Cell)	Maximum	24.5
	Nominal	24.0
LTE Band 4 (AWS)	Maximum	24.5
	Nominal	24.0
LTE Band 66 (AWS)	Maximum	23.2
	Nominal	22.7
LTE Band 2 (PCS)	Maximum	24.0
	Nominal	23.5
LTE Band 41	Maximum	23.5
	Nominal	23.0

FCC ID: A3LSMJ530GM		SAR EVALUATION REPORT		Approved by: Quality Manager
Document S/N: 1M1703230121-01-R1.A3L	Test Dates: 03/20/17 - 04/20/17	DUT Type: Portable Handset	Page 4 of 85	

B. Maximum WLAN Target Powers



Mode / Band		Modulated Average (dBm)
IEEE 802.11b (2.4 GHz)	Maximum	18.5
	Nominal	18.0
IEEE 802.11g (2.4 GHz)	Maximum	15.5
	Nominal	15.0
IEEE 802.11n (2.4 GHz)	Maximum	14.5
	Nominal	14.0
Bluetooth	Maximum	9.5
	Nominal	9.0
Bluetooth LE	Maximum	4.5
	Nominal	4.0

Mode / Band		Modulated Average (dBm)		
		20 MHz Bandwidth	40 MHz Bandwidth	80 MHz Bandwidth
IEEE 802.11a (5 GHz)	Maximum	14.5		
	Nominal	14.0		
IEEE 802.11n (5 GHz)	Maximum	13.5	12.5	
	Nominal	13.0	12.0	
IEEE 802.11ac (5 GHz)	Maximum	13.5	12.5	11.5
	Nominal	13.0	12.0	11.0

C. Reduced PCE Target Powers

Mode / Band		Burst Average GMSK (dBm)				Burst Average 8-PSK (dBm)			
		1 TX Slots	2 TX Slots	3 TX Slots	4 TX Slots	1 TX Slots	2 TX Slots	3 TX Slots	4 TX Slots
GSM/GPRS/EDGE 850	Maximum	31.5	30.0	28.5	27.0	28.0	26.0	24.5	23.0
	Nominal	31.0	29.5	28.0	26.5	27.5	25.5	24.0	22.5
GSM/GPRS/EDGE 1900	Maximum	28.0	26.0	24.0	22.5	26.0	24.5	23.0	21.5
	Nominal	27.5	25.5	23.5	22.0	25.5	24.0	22.5	21.0

Mode / Band		Modulated Average (dBm)			
		3GPP WCDMA	3GPP HSDPA	3GPP HSUPA	3GPP DC-HSDPA
UMTS Band 4 (1750 MHz)	Maximum	20.0	20.0	20.0	20.0
	Nominal	19.5	19.5	19.5	19.5
UMTS Band 2 (1900 MHz)	Maximum	20.5	20.5	20.5	20.5
	Nominal	20.0	20.0	20.0	20.0



FCC ID: A3LSMJ530GM		SAR EVALUATION REPORT		Approved by: Quality Manager
Document S/N: 1M1703230121-01-R1.A3L	Test Dates: 03/20/17 - 04/20/17	DUT Type: Portable Handset		Page 5 of 85

Mode / Band		Modulated Average (dBm)
LTE Band 4 (AWS)	Maximum	21.0
	Nominal	20.5
LTE Band 66 (AWS)	Maximum	20.2
	Nominal	19.7
LTE Band 2 (PCS)	Maximum	20.0
	Nominal	19.5
LTE Band 41	Maximum	21.0
	Nominal	20.5

D. Reduced WLAN Target Powers

Mode / Band		Modulated Average (dBm)
IEEE 802.11b (2.4 GHz)	Maximum	16.5
	Nominal	16.0
IEEE 802.11g (2.4 GHz)	Maximum	13.5
	Nominal	13.0
IEEE 802.11n (2.4 GHz)	Maximum	12.5
	Nominal	12.0

Mode / Band		Modulated Average (dBm)		
		20 MHz Bandwidth	40 MHz Bandwidth	80 MHz Bandwidth
IEEE 802.11a (5 GHz)	Maximum	12.5		
	Nominal	12.0		
IEEE 802.11n (5 GHz)	Maximum	11.5	10.5	
	Nominal	11.0	10.0	
IEEE 802.11ac (5 GHz)	Maximum	11.5	10.5	9.5
	Nominal	11.0	10.0	9.0

FCC ID: A3LSMJ530GM		SAR EVALUATION REPORT		Approved by: Quality Manager
Document S/N: 1M1703230121-01-R1.A3L	Test Dates: 03/20/17 - 04/20/17	DUT Type: Portable Handset		Page 6 of 85

1.4 DUT Antenna Locations

The overall dimensions of this device are > 9 x 5 cm. The overall diagonal dimension of the device is ≤160 mm and the diagonal display is ≤150 mm. A diagram showing the location of the device antennas can be found in Appendix F.

**Table 1-1
Device Edges/Sides for SAR Testing**

Mode	Back	Front	Top	Bottom	Right	Left
GPRS 850	Yes	Yes	No	Yes	Yes	Yes
UMTS 850	Yes	Yes	No	Yes	Yes	Yes
GPRS 1900	Yes	Yes	No	Yes	Yes	Yes
UMTS 1750	Yes	Yes	No	Yes	Yes	Yes
UMTS 1900	Yes	Yes	No	Yes	Yes	Yes
LTE Band 12	Yes	Yes	No	Yes	Yes	Yes
LTE Band 5 (Cell)	Yes	Yes	No	Yes	Yes	Yes
LTE Band 4 (AWS)	Yes	Yes	No	Yes	Yes	Yes
LTE Band 66 (AWS)	Yes	Yes	No	Yes	Yes	Yes
LTE Band 2 (PCS)	Yes	Yes	No	Yes	Yes	Yes
LTE Band 41	Yes	Yes	No	Yes	Yes	Yes
2.4 GHz WLAN	Yes	Yes	Yes	No	No	Yes
5 GHz WLAN	Yes	Yes	Yes	No	No	Yes

Note: Particular DUT edges were not required to be evaluated for wireless router SAR if the edges were greater than 2.5 cm from the transmitting antenna according to FCC KDB Publication 941225 D06v02r01 Section III and FCC KDB Publication 648474 D04v01r03. The distances between the transmit antennas and the edges of the device are included in the filing. When wireless router mode is enabled, U-NII-1, U-NII-2A, U-NII-2C operations are disabled. Therefore, U-NII-1, U-NII-2A, U-NII-2C operations are not considered in this section.

1.5 Near Field Communications (NFC) Antenna

This DUT has NFC operations. The NFC antenna is integrated into the device for this model. Therefore, all SAR tests were performed with the device which already incorporates the NFC antenna. A diagram showing the location of the NFC antenna can be found in Appendix F.

1.6 Simultaneous Transmission Capabilities

According to FCC KDB Publication 447498 D01v06, transmitters are considered to be transmitting simultaneously when there is overlapping transmission, with the exception of transmissions during network hand-offs with maximum hand-off duration less than 30 seconds. Possible transmission paths for the DUT are shown in Figure 1-1 and are color-coded to indicate communication modes which share the same path. Modes which share the same transmission path cannot transmit simultaneously with one another.



**Figure 1-1
Simultaneous Transmission Paths**

FCC ID: A3LSMJ530GM	PCTEST ENGINEERING LABORATORY, INC.	SAR EVALUATION REPORT	SAMSUNG	Approved by: Quality Manager
Document S/N: 1M1703230121-01-R1.A3L	Test Dates: 03/20/17 - 04/20/17	DUT Type: Portable Handset	Page 7 of 85	

This device contains multiple transmitters that may operate simultaneously, and therefore requires a simultaneous transmission analysis according to FCC KDB Publication 447498 D01v06 4.3.2 procedures.

**Table 1-2
Simultaneous Transmission Scenarios**

No.	Capable Transmit Configuration	Head	Body-Worn Accessory	Wireless Router
1	GSM voice + 2.4 GHz WI-FI	Yes	Yes	N/A
2	GSM voice + 5 GHz WI-FI	Yes	Yes	N/A
3	GSM voice + 2.4 GHz Bluetooth	N/A	Yes	N/A
4	UMTS + 2.4 GHz WI-FI	Yes	Yes	Yes
5	UMTS + 5 GHz WI-FI	Yes	Yes	Yes
6	UMTS + 2.4 GHz Bluetooth	N/A	Yes	N/A
7	LTE + 2.4 GHz WI-FI	Yes	Yes	Yes
8	LTE + 5 GHz WI-FI	Yes	Yes	Yes
9	LTE + 2.4 GHz Bluetooth	N/A	Yes	N/A
10	GPRS/EDGE + 2.4 GHz WI-FI	N/A	N/A	Yes
11	GPRS/EDGE + 5 GHz WI-FI	N/A	N/A	Yes
12	GPRS/EDGE + 2.4 GHz Bluetooth	N/A	N/A	N/A



- 2.4 GHz WLAN, 5 GHz WLAN, and 2.4 GHz Bluetooth share the same antenna path and cannot transmit simultaneously.
- All licensed modes share the same antenna path and cannot transmit simultaneously.
- When the user utilizes multiple services in UMTS 3G mode it uses multi-Radio Access Bearer or multi-RAB. The power control is based on a physical control channel (Dedicated Physical Control Channel [DPCCH]) and power control will be adjusted to meet the needs of both services. Therefore, the UMTS+WLAN scenario also represents the UMTS Voice/DATA + WLAN Hotspot scenario.
- Per the manufacturer, WIFI Direct is not expected to be used in conjunction with a held-to-ear or body-worn accessory voice call. Therefore, there are no simultaneous transmission scenarios involving WIFI direct beyond that listed in the above table.
- 5 GHz Wireless Router is only supported for the U-NII-3 by S/W, therefore U-NII-1, U-NII2A, and U-NII2C were not evaluated for wireless router conditions.
- This device supports VOLTE.
- This device supports VOWIFI

1.7 Miscellaneous SAR Test Considerations

(A) WIFI/BT

Since U-NII-1 and U-NII-2A bands have the same maximum output power and the highest reported SAR for U-NII-2A is less than 1.2 W/kg, SAR is not required for U-NII-1 band according to FCC KDB Publication 248227 D01v02r02.

Since Wireless Router operations are not allowed by the chipset firmware using U-NII-1, U-NII-2A & U-NII-2C WIFI, only 2.4 GHz and U-NII-3 WIFI Hotspot SAR tests and combinations are considered for SAR with respect to Wireless Router configurations according to FCC KDB 941225 D06v02r01.

FCC ID: A3LSMJ530GM		SAR EVALUATION REPORT		Approved by: Quality Manager
Document S/N: 1M1703230121-01-R1.A3L	Test Dates: 03/20/17 - 04/20/17	DUT Type: Portable Handset	Page 8 of 85	

Per FCC KDB 447498 D01v06, the 1g SAR exclusion threshold for distances <50mm is defined by the following equation:

$$\frac{\text{Max Power of Channel (mW)}}{\text{Test Separation Dist (mm)}} * \sqrt{\text{Frequency(GHz)}} \leq 3.0$$

Based on the maximum conducted power of Bluetooth (rounded to the nearest mW) and the antenna to user separation distance, body-worn Bluetooth SAR was not required; $[(9/15) * \sqrt{2.480}] = 0.9 < 3.0$. Per KDB Publication 447498 D01v06, the maximum power of the channel was rounded to the nearest mW before calculation.

This device supports IEEE 802.11ac with the following features:

- a) Up to 80 MHz Bandwidth only
- b) No aggregate channel configurations
- c) 1 Tx antenna output
- d) 256 QAM is supported
- e) TDWR and Band gap channels are supported

(B) Licensed Transmitter(s)

GSM/GPRS/EDGE DTM is not supported for US bands. Therefore, the GSM Voice modes in this report do not transmit simultaneously with GPRS/EDGE Data.

This device is only capable of QPSK HSUPA in the uplink. Therefore, no additional SAR tests are required beyond that described for devices with HSUPA in KDB 941225 D01v03r01.



LTE SAR for the higher modulations and lower bandwidths were not tested since the maximum average output power of all required channels and configurations was not more than 0.5 dB higher than the highest bandwidth; and the reported LTE SAR for the highest bandwidth was less than 1.45 W/kg for all configurations according to FCC KDB 941225 D05v02r04.

This device supports both LTE B12 and LTE B17. Since the supported frequency span for LTE B17 falls completely within the supported frequency span for LTE B12, both LTE bands have the same target power, and both LTE bands share the same transmission path, SAR was only assessed for LTE B12.

This device supports LTE Carrier Aggregation (CA) in the downlink only. All uplink communications are identical to Release 8 specifications. Per FCC KDB Publication 941225 D05A v01r02, SAR for LTE CA operations was not needed since the maximum average output power in LTE CA mode was not >0.25 dB higher than the maximum output power when downlink carrier aggregation was inactive.

1.8 Guidance Applied

- IEEE 1528-2013
- FCC KDB Publication 941225 D01v03r01, D05v02r04, D05Av01r02, D06v02r01 (2G/3G/4G and Hotspot)
- FCC KDB Publication 248227 D01v02r02 (SAR Considerations for 802.11 Devices)
- FCC KDB Publication 447498 D01v06 (General SAR Guidance)



FCC ID: A3LSMJ530GM	 PCTEST ENGINEERING LABORATORY, INC.	SAR EVALUATION REPORT		Approved by: Quality Manager
Document S/N: 1M1703230121-01-R1.A3L	Test Dates: 03/20/17 - 04/20/17	DUT Type: Portable Handset	Page 9 of 85	

- FCC KDB Publication 865664 D01v01r04, D02v01r02 (SAR Measurements up to 6 GHz)
- October 2013 TCB Workshop Notes (GPRS Testing Considerations)

1.9 Device Serial Numbers

Several samples with identical hardware were used to support SAR testing. The manufacturer has confirmed that the device(s) tested have the same physical, mechanical and thermal characteristics and are within operational tolerances expected for production units.



	Head Serial Number	Body-Worn Serial Number	Hotspot Serial Number
GSM/GPRS/EDGE 850	01376	01327	01467
UMTS 850	01376	01327	01327
GSM/GPRS/EDGE 1900	01319	01442	01442
UMTS 1750	01376	01319	01442
UMTS 1900	01376	01301	01442
LTE Band 12	01327	01327	01327
LTE Band 5 (Cell)	01376	01327	01327
LTE Band 4 (AWS)	01376	01327	01442
LTE Band 66 (AWS)	01376	01319	01467
LTE Band 2 (PCS)	01319	01319	01442
LTE Band 41	01319	01376	01467
2.4 GHz WLAN	74852	01392	01392
5 GHz WLAN	19228	74902	74902

FCC ID: A3LSMJ530GM		SAR EVALUATION REPORT		Approved by: Quality Manager
Document S/N: 1M1703230121-01-R1.A3L	Test Dates: 03/20/17 - 04/20/17	DUT Type: Portable Handset	Page 10 of 85	

2

LTE INFORMATION

LTE Information					
FCC ID	A3LSMJ530GM				
Form Factor	Portable Handset				
Frequency Range of each LTE transmission band	LTE Band 12 (699.7 - 715.3 MHz)				
	LTE Band 17 (706.5 - 713.5 MHz)				
	LTE Band 5 (Cell) (824.7 - 848.3 MHz)				
	LTE Band 4 (AWS) (1710.7 - 1754.3 MHz)				
	LTE Band 66 (AWS) (1710.7 - 1779.3 MHz)				
	LTE Band 2 (PCS) (1850.7 - 1909.3 MHz)				
	LTE Band 41 (2498.5 - 2687.5 MHz)				
Channel Bandwidths	LTE Band 12: 1.4 MHz, 3 MHz, 5 MHz, 10 MHz				
	LTE Band 17: 5 MHz, 10 MHz				
	LTE Band 5 (Cell): 1.4 MHz, 3 MHz, 5 MHz, 10 MHz				
	LTE Band 4 (AWS): 1.4 MHz, 3 MHz, 5 MHz, 10 MHz, 15 MHz, 20 MHz				
	LTE Band 66 (AWS): 1.4 MHz, 3 MHz, 5 MHz, 10 MHz, 15 MHz, 20 MHz				
	LTE Band 2 (PCS): 1.4 MHz, 3 MHz, 5 MHz, 10 MHz, 15 MHz, 20 MHz				
Channel Numbers and Frequencies (MHz)	Low	Low-Mid	Mid	Mid-High	High
LTE Band 12: 1.4 MHz	699.7 (23017)		707.5 (23095)		715.3 (23173)
LTE Band 12: 3 MHz	700.5 (23025)		707.5 (23095)		714.5 (23165)
LTE Band 12: 5 MHz	701.5 (23035)		707.5 (23095)		713.5 (23155)
LTE Band 12: 10 MHz	704 (23060)		707.5 (23095)		711 (23130)
LTE Band 17: 5 MHz	706.5 (23755)		710 (23790)		713.5 (23825)
LTE Band 17: 10 MHz	709 (23780)		710 (23790)		711 (23800)
LTE Band 5 (Cell): 1.4 MHz	824.7 (20407)		836.5 (20525)		848.3 (20643)
LTE Band 5 (Cell): 3 MHz	825.5 (20415)		836.5 (20525)		847.5 (20635)
LTE Band 5 (Cell): 5 MHz	826.5 (20425)		836.5 (20525)		846.5 (20625)
LTE Band 5 (Cell): 10 MHz	829 (20450)		836.5 (20525)		844 (20600)
LTE Band 4 (AWS): 1.4 MHz	1710.7 (19957)		1732.5 (20175)		1754.3 (20393)
LTE Band 4 (AWS): 3 MHz	1711.5 (19965)		1732.5 (20175)		1753.5 (20385)
LTE Band 4 (AWS): 5 MHz	1712.5 (19975)		1732.5 (20175)		1752.5 (20375)
LTE Band 4 (AWS): 10 MHz	1715 (20000)		1732.5 (20175)		1750 (20350)
LTE Band 4 (AWS): 15 MHz	1717.5 (20025)		1732.5 (20175)		1747.5 (20325)
LTE Band 4 (AWS): 20 MHz	1720 (20050)		1732.5 (20175)		1745 (20300)
LTE Band 66 (AWS): 1.4 MHz	1710.7 (131979)	1733.6 (132208)	N/A	1756.4 (132436)	1779.3 (132665)
LTE Band 66 (AWS): 3 MHz	1711.5 (131987)		1745 (132322)		1778.5 (132657)
LTE Band 66 (AWS): 5 MHz	1712.5 (131997)		1745 (132322)		1777.5 (132647)
LTE Band 66 (AWS): 10 MHz	1715 (132022)		1745 (132322)		1775 (132622)
LTE Band 66 (AWS): 15 MHz	1717.5 (132047)		1745 (132322)		1772.5 (132597)
LTE Band 66 (AWS): 20 MHz	1720 (132072)		1745 (132322)		1770 (132572)
LTE Band 2 (PCS): 1.4 MHz	1850.7 (18607)		1880 (18900)		1909.3 (19193)
LTE Band 2 (PCS): 3 MHz	1851.5 (18615)		1880 (18900)		1908.5 (19185)
LTE Band 2 (PCS): 5 MHz	1852.5 (18625)		1880 (18900)		1907.5 (19175)
LTE Band 2 (PCS): 10 MHz	1855 (18650)		1880 (18900)		1905 (19150)
LTE Band 2 (PCS): 15 MHz	1857.5 (18675)		1880 (18900)		1902.5 (19125)
LTE Band 2 (PCS): 20 MHz	1860 (18700)		1880 (18900)		1900 (19100)
LTE Band 41: 5 MHz	2506 (39750)	2549.5 (40185)	2593 (40620)	2636.5 (41055)	2680 (41490)
LTE Band 41: 10 MHz	2506 (39750)	2549.5 (40185)	2593 (40620)	2636.5 (41055)	2680 (41490)
LTE Band 41: 15 MHz	2506 (39750)	2549.5 (40185)	2593 (40620)	2636.5 (41055)	2680 (41490)
LTE Band 41: 20 MHz	2506 (39750)	2549.5 (40185)	2593 (40620)	2636.5 (41055)	2680 (41490)
UE Category	6				
Modulations Supported in UL	QPSK, 16QAM				
LTE MPR Permanently implemented per 3GPP TS 36.101 section 6.2.3-6.2.5? (manufacturer attestation to be provided)	YES				
A-MPR (Additional MPR) disabled for SAR Testing?	YES				
LTE Carrier Aggregation Possible Combinations	The technical description includes all the possible carrier aggregation combinations				
LTE Release 10 Additional Information	This device does not support full CA features on 3GPP Release 10. It supports a maximum of 2 carriers in the downlink. All uplink communications are identical to the Release 8 Specifications. Uplink communications are done on the PCC. The following LTE Release 10 Features are not supported: Relay, HetNet, Enhanced MIMO, eCIC, WIFI Offloading, MDH, eMBMS, Cross-Carrier Scheduling, Enhanced SC-FDMA.				

FCC ID: A3LSMJ530GM		SAR EVALUATION REPORT		Approved by: Quality Manager
Document S/N: 1M1703230121-01-R1.A3L	Test Dates: 03/20/17 - 04/20/17	DUT Type: Portable Handset	Page 11 of 85	

The FCC and Innovation, Science, and Economic Development Canada have adopted the guidelines for evaluating the environmental effects of radio frequency (RF) radiation in ET Docket 93-62 on Aug. 6, 1996 and Health Canada Safety Code 6 to protect the public and workers from the potential hazards of RF emissions due to FCC-regulated portable devices. [1]

The safety limits used for the environmental evaluation measurements are based on the criteria published by the American National Standards Institute (ANSI) for localized specific absorption rate (SAR) in IEEE/ANSI C95.1-1992 Standard for Safety Levels with Respect to Human Exposure to Radio Frequency Electromagnetic Fields, 3 kHz to 300 GHz [3] and Health Canada RF Exposure Guidelines Safety Code 6 [22]. The measurement procedure described in IEEE/ANSI C95.3-2002 Recommended Practice for the Measurement of Potentially Hazardous Electromagnetic Fields - RF and Microwave [4] is used for guidance in measuring the Specific Absorption Rate (SAR) due to the RF radiation exposure from the Equipment Under Test (EUT). These criteria for SAR evaluation are similar to those recommended by the International Committee for Non-Ionizing Radiation Protection (ICNIRP) in Biological Effects and Exposure Criteria for Radiofrequency Electromagnetic Fields,” Report No. Vol 74. SAR is a measure of the rate of energy absorption due to exposure to an RF transmitting source. SAR values have been related to threshold levels for potential biological hazards.

3.1 SAR Definition

Specific Absorption Rate is defined as the time derivative (rate) of the incremental energy (dU) absorbed by (dissipated in) an incremental mass (dm) contained in a volume element (dV) of a given density (ρ). It is also defined as the rate of RF energy absorption per unit mass at a point in an absorbing body (see Equation 3-1).

Equation 3-1
SAR Mathematical Equation

$$SAR = \frac{d}{dt} \left(\frac{dU}{dm} \right) = \frac{d}{dt} \left(\frac{dU}{\rho dv} \right)$$



SAR is expressed in units of Watts per Kilogram (W/kg).

$$SAR = \frac{\sigma \cdot E^2}{\rho}$$

where:

- σ = conductivity of the tissue-simulating material (S/m)
- ρ = mass density of the tissue-simulating material (kg/m³)
- E = Total RMS electric field strength (V/m)

NOTE: The primary factors that control rate of energy absorption were found to be the wavelength of the incident field in relation to the dimensions and geometry of the irradiated organism, the orientation of the organism in relation to the polarity of field vectors, the presence of reflecting surfaces, and whether conductive contact is made by the organism with a ground plane.[6]

FCC ID: A3LSMJ530GM		SAR EVALUATION REPORT		Approved by: Quality Manager
Document S/N: 1M1703230121-01-R1.A3L	Test Dates: 03/20/17 - 04/20/17	DUT Type: Portable Handset	Page 12 of 85	

4 DOSIMETRIC ASSESSMENT

4.1 Measurement Procedure

The evaluation was performed using the following procedure compliant to FCC KDB Publication 865664 D01v01r04 and IEEE 1528-2013:

1. The SAR distribution at the exposed side of the head or body was measured at a distance no greater than 5.0 mm from the inner surface of the shell. The area covered the entire dimension of the device-head and body interface and the horizontal grid resolution was determined per FCC KDB Publication 865664 D01v01r04 (See Table 4-1) and IEEE 1528-2013.
2. The point SAR measurement was taken at the maximum SAR region determined from Step 1 to enable the monitoring of SAR fluctuations/drifts during the 1g/10g cube evaluation. SAR at this fixed point was measured and used as a reference value.
3. Based on the area scan data, the peak of the region with maximum SAR was determined by spline interpolation. Around this point, a volume was assessed according to the measurement resolution and volume size requirements of FCC KDB Publication 865664 D01v01r04 (See Table 4-1) and IEEE 1528-2013. On the basis of this data set, the spatial peak SAR value was evaluated with the following procedure (see references or the DASy manual online for more details):
 - a. SAR values at the inner surface of the phantom are extrapolated from the measured values along the line away from the surface with spacing no greater than that in Table 4-1. The extrapolation was based on a least-squares algorithm. A polynomial of the fourth order was calculated through the points in the z-axis (normal to the phantom shell).
 - b. After the maximum interpolated values were calculated between the points in the cube, the SAR was averaged over the spatial volume (1g or 10g) using a 3D-Spline interpolation algorithm. The 3D-spline is composed of three one-dimensional splines with the “Not a knot” condition (in x, y, and z directions). The volume was then integrated with the trapezoidal algorithm. One thousand points (10 x 10 x 10) were obtained through interpolation, in order to calculate the averaged SAR.
 - c. All neighboring volumes were evaluated until no neighboring volume with a higher average value was found.
4. The SAR reference value, at the same location as step 2, was re-measured after the zoom scan was complete to calculate the SAR drift. If the drift deviated by more than 5%, the SAR test and drift measurements were repeated.

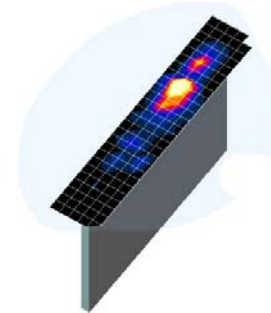

Figure 4-1 point
Sample SAR Area
Scan was

Table 4-1
Area and Zoom Scan Resolutions per FCC KDB Publication 865664 D01v01r04*

Frequency	Maximum Area Scan Resolution (mm) ($\Delta x_{\text{area}}, \Delta y_{\text{area}}$)	Maximum Zoom Scan Resolution (mm) ($\Delta x_{\text{zoom}}, \Delta y_{\text{zoom}}$)	Maximum Zoom Scan Spatial Resolution (mm)			Minimum Zoom Scan Volume (mm) (x,y,z)
			Uniform Grid	Graded Grid		
			$\Delta z_{\text{zoom}}(n)$	$\Delta z_{\text{zoom}}(1)^*$	$\Delta z_{\text{zoom}}(n>1)^*$	
≤ 2 GHz	≤ 15	≤ 8	≤ 5	≤ 4	≤ 1.5* $\Delta z_{\text{zoom}}(n-1)$	≥ 30
2-3 GHz	≤ 12	≤ 5	≤ 5	≤ 4	≤ 1.5* $\Delta z_{\text{zoom}}(n-1)$	≥ 30
3-4 GHz	≤ 12	≤ 5	≤ 4	≤ 3	≤ 1.5* $\Delta z_{\text{zoom}}(n-1)$	≥ 28
4-5 GHz	≤ 10	≤ 4	≤ 3	≤ 2.5	≤ 1.5* $\Delta z_{\text{zoom}}(n-1)$	≥ 25
5-6 GHz	≤ 10	≤ 4	≤ 2	≤ 2	≤ 1.5* $\Delta z_{\text{zoom}}(n-1)$	≥ 22

*Also compliant to IEEE 1528-2013 Table 6

FCC ID: A3LSMJ530GM		SAR EVALUATION REPORT			Approved by: Quality Manager
Document S/N: 1M1703230121-01-R1.A3L	Test Dates: 03/20/17 - 04/20/17	DUT Type: Portable Handset		Page 13 of 85	

5 DEFINITION OF REFERENCE POINTS

5.1 EAR REFERENCE POINT

Figure 5-2 shows the front, back and side views of the SAM Twin Phantom. The point “M” is the reference point for the center of the mouth, “LE” is the left ear reference point (ERP), and “RE” is the right ERP. The ERP is 15mm posterior to the entrance to the ear canal (EEC) along the B-M line (Back-Mouth), as shown in Figure 5-1. The plane passing through the two ear canals and M is defined as the Reference Plane. The line N-F (Neck-Front), also called the Reference Pivoting Line, is not perpendicular to the reference plane (see Figure 5-1). Line B-M is perpendicular to the N-F line. Both N-F and B-M lines are marked on the external phantom shell to facilitate handset positioning [5].

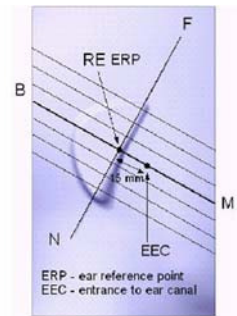

Figure 5-1
Close-Up Side view of ERP

5.2 HANDSET REFERENCE POINTS

Two imaginary lines on the handset were established: the vertical centerline and the horizontal line. The test device was placed in a normal operating position with the acoustic output located along the “vertical centerline” on the front of the device aligned to the “ear reference point” (See Figure 5-3). The acoustic output was then located at the same level as the center of the ear reference point. The test device was positioned so that the “vertical centerline” was bisecting the front surface of the handset at its top and bottom edges, positioning the “ear reference point” on the outer surface of the both the left and right head phantoms on the ear reference point.



Figure 5-2
Front, back and side view of SAM Twin Phantom

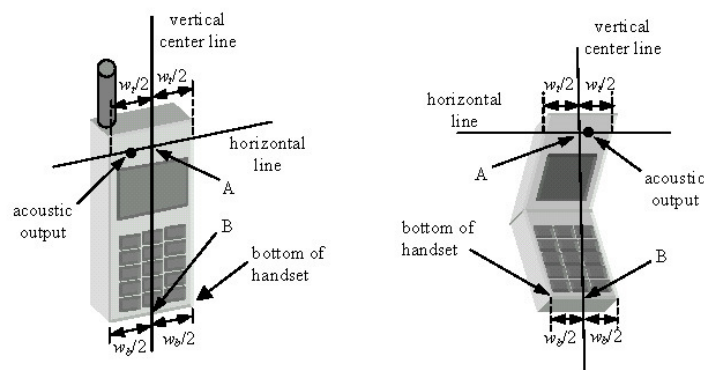

Figure 5-3
Handset Vertical Center & Horizontal Line Reference Points

FCC ID: A3LSMJ530GM		SAR EVALUATION REPORT		Approved by: Quality Manager
Document S/N: 1M1703230121-01-R1.A3L	Test Dates: 03/20/17 - 04/20/17	DUT Type: Portable Handset		Page 14 of 85

6 TEST CONFIGURATION POSITIONS

6.1 Device Holder

The device holder is made out of low-loss POM material having the following dielectric parameters: relative permittivity $\epsilon = 3$ and loss tangent $\delta = 0.02$.

6.2 Positioning for Cheek

1. The test device was positioned with the device close to the surface of the phantom such that point A is on the (virtual) extension of the line passing through points RE and LE on the phantom (see Figure 6-1), such that the plane defined by the vertical center line and the horizontal line of the phone is approximately parallel to the sagittal plane of the phantom.

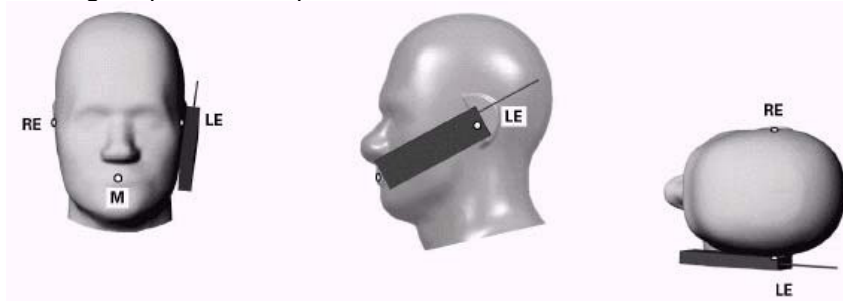



Figure 6-1 Front, Side and Top View of Cheek Position

2. The handset was translated towards the phantom along the line passing through RE & LE until the handset touches the pinna.
3. While maintaining the handset in this plane, the handset was rotated around the LE-RE line until the vertical centerline was in the reference plane.
4. The phone was then rotated around the vertical centerline until the phone (horizontal line) was symmetrical with respect to the line NF.
5. While maintaining the vertical centerline in the reference plane, keeping point A on the line passing through RE and LE, and maintaining the device contact with the ear, the device was rotated about the NF line until any point on the handset made contact with a phantom point below the ear (cheek) (See Figure 6-2).

6.3 Positioning for Ear / 15° Tilt

With the test device aligned in the “Cheek Position”:

1. While maintaining the orientation of the phone, the phone was retracted parallel to the reference plane far enough to enable a rotation of the phone by 15 degrees.
2. The phone was then rotated around the horizontal line by 15 degrees.
3. While maintaining the orientation of the phone, the phone was moved parallel to the reference plane until any part of the handset touched the head. (In this position, point A was located on the line RE-LE). The tilted position is obtained when the contact is on the pinna. If the contact was at any location other than the pinna, the angle of the phone would then be reduced. In this situation, the tilted position was obtained when any part of the phone was in contact of the ear as well as a second part of the phone was in contact with the head (see Figure 6-2).

FCC ID: A3LSMJ530GM		SAR EVALUATION REPORT		Approved by: Quality Manager
Document S/N: 1M1703230121-01-R1.A3L	Test Dates: 03/20/17 - 04/20/17	DUT Type: Portable Handset	Page 15 of 85	

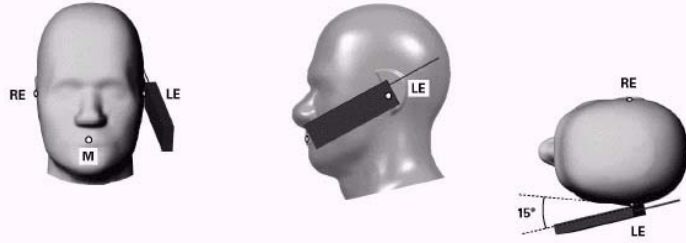

Figure 6-2 Front, Side and Top View of Ear/15° Tilt Position

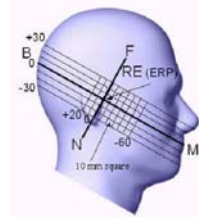

Figure 6-3 Side view w/ relevant markings

6.4 SAR Evaluations near the Mouth/Jaw Regions of the SAM Phantom

Antennas located near the bottom of a phone may require SAR measurements around the mouth and jaw regions of the SAM head phantom. This typically applies to clam-shell style phones that are generally longer in the unfolded normal use positions or to certain older style long rectangular phones. Per IEEE 1528-2013, a rotated SAM phantom is necessary to allow probe access to such regions. Both SAM heads of the TwinSAM-Chin20 are rotated 20 degrees around the NF line. Each head can be removed from the table for emptying and cleaning.

Under these circumstances, the following procedures apply, adopted from the FCC guidance on SAR handsets document FCC KDB Publication 648474 D04v01r03. The SAR required in these regions of SAM should be measured using a flat phantom. The phone should be positioned with a separation distance of 4 mm between the ear reference point (ERP) and the outer surface of the flat phantom shell. While maintaining this distance at the ERP location, the low (bottom) edge of the phone should be lowered from the phantom to establish the same separation distance between the peak SAR location identified by the truncated partial SAR distribution measured with the SAM phantom. The distance from the peak SAR location to the phone is determined by the straight line passing perpendicularly through the phantom surface. When it is not feasible to maintain 4 mm separation at the ERP while also establishing the required separation at the peak SAR location, the top edge of the phone will be allowed to touch the phantom with a separation < 4 mm at the ERP. The phone should not be tilted to the left or right while placed in this inclined position to the flat phantom.

6.5 Body-Worn Accessory Configurations

Body-worn operating configurations are tested with the belt-clips and holsters attached to the device and positioned against a flat phantom in a normal use configuration (see Figure 6-4). Per FCC KDB Publication 648474 D04v01r03, Body-worn accessory exposure is typically related to voice mode operations when handsets are carried in body-worn accessories. The body-worn accessory procedures in FCC KDB Publication 447498 D01v06 should be used to test for body-worn accessory SAR compliance, without a headset connected to it. This enables the test results for such configuration to be compatible with that required for hotspot mode when the body-worn accessory test separation distance is greater than or equal to that required for hotspot mode, when applicable. When the reported SAR for a body-worn accessory, measured without a headset connected to the handset, is > 1.2 W/kg, the highest reported SAR configuration for that wireless mode and frequency band should be repeated for that body-worn accessory with a headset attached to the handset.

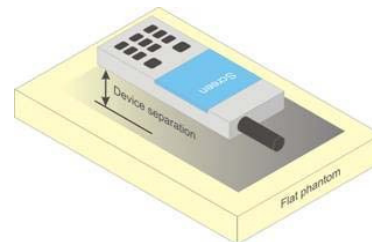

Figure 6-4 Sample Body-Worn Diagram

Accessories for Body-worn operation configurations are divided into two categories: those that do not contain metallic components and those that do contain metallic components. When multiple accessories that do not

FCC ID: A3LSMJ530GM		SAR EVALUATION REPORT		Approved by: Quality Manager
Document S/N: 1M1703230121-01-R1.A3L	Test Dates: 03/20/17 - 04/20/17	DUT Type: Portable Handset		Page 16 of 85

contain metallic components are supplied with the device, the device is tested with only the accessory that dictates the closest spacing to the body. Then multiple accessories that contain metallic components are tested with the device with each accessory. If multiple accessories share an identical metallic component (i.e. the same metallic belt-clip used with different holsters with no other metallic components) only the accessory that dictates the closest spacing to the body is tested.

Body-worn accessories may not always be supplied or available as options for some devices intended to be authorized for body-worn use. In this case, a test configuration with a separation distance between the back of the device and the flat phantom is used. Test position spacing was documented.

Transmitters that are designed to operate in front of a person's face, as in push-to-talk configurations, are tested for SAR compliance with the front of the device positioned to face the flat phantom in head fluid. For devices that are carried next to the body such as a shoulder, waist or chest-worn transmitters, SAR compliance is tested with the accessories, including headsets and microphones, attached to the device and positioned against a flat phantom in a normal use configuration.

6.6 Extremity Exposure Configurations



Devices that are designed or intended for use on extremities or mainly operated in extremity only exposure conditions; i.e., hands, wrists, feet and ankles, may require extremity SAR evaluation. When the device also operates in close proximity to the user's body, SAR compliance for the body is also required. The 1-g body and 10-g extremity SAR Exclusion Thresholds found in KDB Publication 447498 D01v06 should be applied to determine SAR test requirements.

Per KDB Publication 447498 D01v06, Cell phones (handsets) are not normally designed to be used on extremities or operated in extremity only exposure conditions. The maximum output power levels of handsets generally do not require extremity SAR testing to show compliance. Therefore, extremity SAR was not evaluated for this device.

6.7 Wireless Router Configurations

Some battery-operated handsets have the capability to transmit and receive user data through simultaneous transmission of WIFI simultaneously with a separate licensed transmitter. The FCC has provided guidance in FCC KDB Publication 941225 D06v02r01 where SAR test considerations for handsets ($L \times W \geq 9 \text{ cm} \times 5 \text{ cm}$) are based on a composite test separation distance of 10 mm from the front, back and edges of the device containing transmitting antennas within 2.5 cm of their edges, determined from general mixed use conditions for this type of devices. Since the hotspot SAR results may overlap with the body-worn accessory SAR requirements, the more conservative configurations can be considered, thus excluding some body-worn accessory SAR tests.

When the user enables the personal wireless router functions for the handset, actual operations include simultaneous transmission of both the WIFI transmitter and another licensed transmitter. Both transmitters often do not transmit at the same transmitting frequency and thus cannot be evaluated for SAR under actual use conditions due to the limitations of the SAR assessment probes. Therefore, SAR must be evaluated for each frequency transmission and mode separately and spatially summed with the WIFI transmitter according to FCC KDB Publication 447498 D01v06 procedures. The "Portable Hotspot" feature on the handset was NOT activated during SAR assessments, to ensure the SAR measurements were evaluated for a single transmission frequency RF signal at a time.

FCC ID: A3LSMJ530GM		SAR EVALUATION REPORT		Approved by: Quality Manager
Document S/N: 1M1703230121-01-R1.A3L	Test Dates: 03/20/17 - 04/20/17	DUT Type: Portable Handset	Page 17 of 85	

7 RF EXPOSURE LIMITS

7.1 Uncontrolled Environment

UNCONTROLLED ENVIRONMENTS are defined as locations where there is the exposure of individuals who have no knowledge or control of their exposure. The general population/uncontrolled exposure limits are applicable to situations in which the general public may be exposed or in which persons who are exposed as a consequence of their employment may not be made fully aware of the potential for exposure or cannot exercise control over their exposure. Members of the general public would come under this category when exposure is not employment-related; for example, in the case of a wireless transmitter that exposes persons in its vicinity.



7.2 Controlled Environment

CONTROLLED ENVIRONMENTS are defined as locations where there is exposure that may be incurred by persons who are aware of the potential for exposure, (i.e. as a result of employment or occupation). In general, occupational/controlled exposure limits are applicable to situations in which persons are exposed as a consequence of their employment, who have been made fully aware of the potential for exposure and can exercise control over their exposure. This exposure category is also applicable when the exposure is of a transient nature due to incidental passage through a location where the exposure levels may be higher than the general population/uncontrolled limits, but the exposed person is fully aware of the potential for exposure and can exercise control over his or her exposure by leaving the area or by some other appropriate means.

**Table 7-1
SAR Human Exposure Specified in ANSI/IEEE C95.1-1992 and Health Canada Safety Code 6**

HUMAN EXPOSURE LIMITS		
	UNCONTROLLED ENVIRONMENT <i>General Population</i> (W/kg) or (mW/g)	CONTROLLED ENVIRONMENT <i>Occupational</i> (W/kg) or (mW/g)
Peak Spatial Average SAR Head	1.6	8.0
Whole Body SAR	0.08	0.4
Peak Spatial Average SAR Hands, Feet, Ankle, Wrists, etc.	4.0	20

1. The Spatial Peak value of the SAR averaged over any 1 gram of tissue (defined as a tissue volume in the shape of a cube) and over the appropriate averaging time.
2. The Spatial Average value of the SAR averaged over the whole body.
3. The Spatial Peak value of the SAR averaged over any 10 grams of tissue (defined as a tissue volume in the shape of a cube) and over the appropriate averaging time.

FCC ID: A3LSMJ530GM		SAR EVALUATION REPORT		Approved by: Quality Manager
Document S/N: 1M1703230121-01-R1.A3L	Test Dates: 03/20/17 - 04/20/17	DUT Type: Portable Handset	Page 18 of 85	

Power measurements for licensed transmitters are performed using a base station simulator under digital average power.

8.1 Measured and Reported SAR

Per FCC KDB Publication 447498 D01v06, when SAR is not measured at the maximum power level allowed for production units, the results must be scaled to the maximum tune-up tolerance limit according to the power applied to the individual channels tested to determine compliance. For simultaneous transmission, the measured aggregate SAR must be scaled according to the sum of the differences between the maximum tune-up tolerance and actual power used to test each transmitter. When SAR is measured at or scaled to the maximum tune-up tolerance limit, the results are referred to as *reported* SAR. The highest *reported* SAR results are identified on the grant of equipment authorization according to procedures in KDB 690783 D01v01r03.

8.2 3G SAR Test Reduction Procedure

In FCC KDB Publication 941225 D01v03r01, certain transmission modes within a frequency band and wireless mode evaluated for SAR are defined as primary modes. The equivalent modes considered for SAR test reduction are denoted as secondary modes. When the maximum output power including tune-up tolerance specified for production units in a secondary mode is ≤ 0.25 dB higher than the primary mode or when the highest reported SAR of the primary mode, scaled by the ratio of specified maximum output power and tune-up tolerance of secondary to primary mode, is ≤ 1.2 W/kg, SAR measurements are not required for the secondary mode. These criteria are referred to as the 3G SAR test reduction procedure. When the 3G SAR test reduction procedure is not satisfied, SAR measurements are additionally required for the secondary mode.

8.3 Procedures Used to Establish RF Signal for SAR



The following procedures are according to FCC KDB Publication 941225 D01v03r01 “3G SAR Measurement Procedures.”

The device is placed into a simulated call using a base station simulator in a RF shielded chamber. Establishing connections in this manner ensure a consistent means for testing SAR and are recommended for evaluating SAR [4]. Devices under test are evaluated prior to testing, with a fully charged battery and were configured to operate at maximum output power. In order to verify that the device is tested throughout the SAR test at maximum output power, the SAR measurement system measures a “point SAR” at an arbitrary reference point at the start and end of the 1 gram SAR evaluation, to assess for any power drifts during the evaluation. If the power drift deviates by more than 5%, the SAR test and drift measurements are repeated.

8.4 SAR Measurement Conditions for UMTS

8.4.1 Output Power Verification

Maximum output power is verified on the High, Middle and Low channels according to the general descriptions in section 5.2 of 3GPP TS 34.121, using the appropriate RMC with TPC (transmit power control) set to all “1s” or applying the required inner loop power control procedures to maintain maximum output power while HSUPA is active. Results for all applicable physical channel configurations (DPCCH, DPDCHn and spreading codes, HS-DPCCH etc) are tabulated in this test report. All configurations that are not supported by the DUT or cannot be measured due to technical or equipment limitations are identified.

FCC ID: A3LSMJ530GM		SAR EVALUATION REPORT		Approved by: Quality Manager
Document S/N: 1M1703230121-01-R1.A3L	Test Dates: 03/20/17 - 04/20/17	DUT Type: Portable Handset	Page 19 of 85	

8.4.2 Head SAR Measurements

SAR for next to the ear head exposure is measured using a 12.2 kbps RMC with TPC bits configured to all “1’s”. The 3G SAR test reduction procedure is applied to AMR configurations with 12.2 kbps RMC as the primary mode. Otherwise, SAR is measured for 12.2 kbps AMR in 3.4 kbps SRB (signaling radio bearer) using the highest reported SAR configuration in 12.2 kbps RMC for head exposure.

8.4.3 Body SAR Measurements

SAR for body exposure configurations is measured using the 12.2 kbps RMC with the TPC bits all “1s”. The 3G SAR test reduction procedure is applied to other spreading codes and multiple DPDCH_n configurations supported by the handset with 12.2 kbps RMC as the primary mode. Otherwise, SAR is measured using an applicable RMC configuration with the corresponding spreading code or DPDCH_n, for the highest reported SAR configuration in 12.2 kbps RMC.

8.4.4 SAR Measurements with Rel 5 HSDPA

The 3G SAR test reduction procedure is applied to HSDPA body configurations with 12.2 kbps RMC as the primary mode. Otherwise, Body SAR for HSDPA is measured using an FRC with H-Set 1 in Sub-test 1 and a 12.2 kbps RMC configured in Test Loop Mode 1, for the highest reported SAR configuration in 12.2 kbps RMC without HSDPA. Handsets with both HSDPA and HSUPA are tested according to Release 6 HSPA test procedures.

8.4.5 SAR Measurements with Rel 6 HSUPA

The 3G SAR test reduction procedure is applied to HSPA (HSUPA/HSDPA with RMC) body configurations with 12.2 kbps RMC as the primary mode. Otherwise, Body SAR for HSPA is measured with E-DCH Sub-test 5, using H-Set 1 and QPSK for FRC and a 12.2 kbps RMC configured in Test Loop Mode 1 and power control algorithm 2, according to the highest reported body SAR configuration in 12.2 kbps RMC without HSPA.



When VOIP applies to head exposure, the 3G SAR test reduction procedure is applied with 12.2 kbps RMC as the primary mode; otherwise, the same HSPA configuration used for body SAR measurements are applied to head exposure testing.

8.4.6 SAR Measurement Conditions for DC-HSDPA

SAR is required for Rel. 8 DC-HSDPA when SAR is required for Rel. 5 HSDPA; otherwise, the 3G SAR test reduction procedure is applied to DC-HSDPA with 12.2 kbps RMC as the primary mode. Power is measured for DC-HSDPA according to the H-Set 12, FRC configuration in Table C.8.1.12 of 3GPP TS 34.121-1 to determine SAR test reduction. A primary and a secondary serving HS-DSCH Cell are required to perform the power measurement and for the results to be acceptable.

8.5 SAR Measurement Conditions for LTE

LTE modes are tested according to FCC KDB 941225 D05v02r04 publication. Establishing connections with base station simulators ensure a consistent means for testing SAR and are recommended for evaluating SAR [4]. The R&S CMW500 or Anritsu MT8820C simulators are used for LTE output power measurements and SAR testing. Closed loop power control was used so the UE transmits with maximum output power during SAR testing. SAR tests were performed with the same number of RB and RB offsets transmitting on all TTI frames (maximum TTI).

FCC ID: A3LSMJ530GM		SAR EVALUATION REPORT		Approved by: Quality Manager
Document S/N: 1M1703230121-01-R1.A3L	Test Dates: 03/20/17 - 04/20/17	DUT Type: Portable Handset		Page 20 of 85

8.5.1 Spectrum Plots for RB Configurations

A properly configured base station simulator was used for SAR tests and power measurements. Therefore, spectrum plots for RB configurations were not required to be included in this report.

8.5.2 MPR

MPR is permanently implemented for this device by the manufacturer. The specific manufacturer target MPR is indicated alongside the SAR results. MPR is enabled for this device, according to 3GPP TS36.101 Section 6.2.3 – 6.2.5 under Table 6.2.3-1.

8.5.3 A-MPR

A-MPR (Additional MPR) has been disabled for all SAR tests by setting NS=01 on the base station simulator.

8.5.4 Required RB Size and RB Offsets for SAR Testing

According to FCC KDB 941225 D05v02r04:



- a. Per Section 5.2.1, SAR is required for QPSK 1 RB Allocation for the largest bandwidth
 - i. The required channel and offset combination with the highest maximum output power is required for SAR.
 - ii. When the reported SAR is ≤ 0.8 W/kg for FDD and ≤ 0.6 W/kg for TDD, testing of the remaining RB offset configurations and required test channels is not required. Otherwise, SAR is required for the remaining required test channels using the RB offset configuration with highest output power for that channel.
 - iii. When the reported SAR for a required test channel is > 1.45 W/kg, SAR is required for all RB offset configurations for that channel.
- b. Per Section 5.2.2, SAR is required for 50% RB allocation using the largest bandwidth following the same procedures outlined in Section 5.2.1.
- c. Per Section 5.2.3, QPSK SAR is not required for the 100% allocation when the highest maximum output power for the 100% allocation is less than the highest maximum output power of the 1 RB and 50% RB allocations and the reported SAR for the 1 RB and 50% RB allocations is < 0.8 W/kg.
- d. Per Section 5.2.4 and 5.3, SAR tests for higher order modulations and lower bandwidths configurations are not required when the conducted power of the required test configurations determined by Sections 5.2.1 through 5.2.3 is less than or equal to $\frac{1}{2}$ dB higher than the equivalent configuration using QPSK modulation and when the QPSK SAR for those configurations is < 1.45 W/kg.

8.5.5 TDD

LTE TDD testing is performed using the SAR test guidance provided in FCC KDB 941225 D05v02r04. TDD is tested at the highest duty factor using UL-DL configuration 0 with special subframe configuration 6 and applying the FDD LTE procedures in KDB 941225 D05v02r04. SAR testing is performed using the extended cyclic prefix listed in 3GPP TS 36.211 Section 4.

8.5.6 Downlink Only Carrier Aggregation

Conducted power measurements with LTE Carrier Aggregation (CA) (downlink only) active are made in accordance to KDB Publication 941225 D05Av01r02. The RRC connection is only handled by one cell, the primary component carrier (PCC) for downlink and uplink communications. After making a data connection to the PCC, the UE device adds secondary component carrier(s) (SCC) on the downlink only. All uplink communications and acknowledgements remain identical to specifications when downlink

FCC ID: A3LSMJ530GM		SAR EVALUATION REPORT		Approved by: Quality Manager
Document S/N: 1M1703230121-01-R1.A3L	Test Dates: 03/20/17 - 04/20/17	DUT Type: Portable Handset	Page 21 of 85	

carrier aggregation is inactive on the PCC. For every supported combination of downlink only carrier aggregation, additional conducted output powers are measured with the downlink carrier aggregation active for the configuration with highest measured maximum conducted power with downlink carrier aggregation inactive measured among the channel bandwidth, modulation, and RB combinations in each frequency band. Per FCC KDB Publication 941225 D05Av01r02, no SAR measurements are required for carrier aggregation configurations when the average output power with downlink only carrier aggregation active is not more than 0.25 dB higher than the average output power with downlink only carrier aggregation inactive.

8.6 SAR Testing with 802.11 Transmitters

The normal network operating configurations of 802.11 transmitters are not suitable for SAR measurements. Unpredictable fluctuations in network traffic and antenna diversity conditions can introduce undesirable variations in SAR results. The SAR for these devices should be measured using chipset based test mode software to ensure the results are consistent and reliable. See KDB Publication 248227 D01v02r02 for more details.

8.6.1 General Device Setup

Chipset based test mode software is hardware dependent and generally varies among manufacturers. The device operating parameters established in test mode for SAR measurements must be identical to those programmed in production units, including output power levels, amplifier gain settings and other RF performance tuning parameters.



A periodic duty factor is required for current generation SAR systems to measure SAR. When 802.11 frame gaps are accounted for in the transmission, a maximum transmission duty factor of 92 - 96% is typically achievable in most test mode configurations. A minimum transmission duty factor of 85% is required to avoid certain hardware and device implementation issues related to wide range SAR scaling. The reported SAR is scaled to 100% transmission duty factor to determine compliance at the maximum tune-up tolerance limit.

8.6.2 U-NII-1 and U-NII-2A

For devices that operate in both U-NII-1 and U-NII-2A bands, when the same maximum output power is specified for both bands, SAR measurement using OFDM SAR test procedures is not required for U-NII-1 unless the highest reported SAR for U-NII-2A is > 1.2 W/kg. When different maximum output powers are specified for the bands, SAR measurement for the U-NII band with the lower maximum output power is not required unless the highest reported SAR for the U-NII band with the higher maximum output power, adjusted by the ratio of lower to higher specified maximum output power for the two bands, is > 1.2 W/kg. When 10-g SAR measurement is considered, a factor of 2.5 is applied to the thresholds above.

8.6.3 U-NII-2C and U-NII-3

The frequency range covered by U-NII-2C and U-NII-3 is 380 MHz (5.47 – 5.85 GHz), which requires a minimum of at least two SAR probe calibration frequency points to support SAR measurements. When Terminal Doppler Weather Radar (TDWR) restriction applies, the channels at 5.60 – 5.65 GHz in U-NII-2C band must be disabled with acceptable mechanisms and documented in the equipment certification. Unless band gap channels are permanently disabled, SAR must be considered for these channels. Each band is tested independently according to the normally required OFDM SAR measurement and probe calibration frequency points requirements.

FCC ID: A3LSMJ530GM		SAR EVALUATION REPORT		Approved by: Quality Manager
Document S/N: 1M1703230121-01-R1.A3L	Test Dates: 03/20/17 - 04/20/17	DUT Type: Portable Handset	Page 22 of 85	

8.6.4 Initial Test Position Procedure

For exposure conditions with multiple test positions, such as handset operating next to the ear, devices with hotspot mode or UMPC mini-tablet, procedures for initial test position can be applied. Using the transmission mode determined by the DSSS procedure or initial test configuration, area scans are measured for all positions in an exposure condition. The test position with the highest extrapolated (peak) SAR is used as the initial test position. When reported SAR for the initial test position is ≤ 0.4 W/kg, no additional testing for the remaining test positions is required. Otherwise, SAR is evaluated at the subsequent highest peak SAR positions until the reported SAR result is ≤ 0.8 W/kg or all test positions are measured. When 10-g SAR measurement is considered, a factor of 2.5 is applied to the thresholds above.

8.6.5 2.4 GHz SAR Test Requirements

SAR is measured for 2.4 GHz 802.11b DSSS using either the fixed test position or, when applicable, the initial test position procedure. SAR test reduction is determined according to the following:

- 1) When the reported SAR of the highest measured maximum output power channel for the exposure configuration is ≤ 0.8 W/kg, no further SAR testing is required for 802.11b DSSS in that exposure configuration.
- 2) When the reported SAR is > 0.8 W/kg, SAR is required for that position using the next highest measured output power channel. When any reported SAR is > 1.2 W/kg, SAR is required for the third channel; i.e., all channels require testing.

2.4 GHz 802.11 g/n OFDM are additionally evaluated for SAR if the highest reported SAR for 802.11b, adjusted by the ratio of the OFDM to DSSS specified maximum output power, is > 1.2 W/kg. When SAR is required for OFDM modes in 2.4 GHz band, the Initial Test Configuration Procedures should be followed. When 10-g SAR measurement is considered, a factor of 2.5 is applied to the thresholds above.



8.6.6 OFDM Transmission Mode and SAR Test Channel Selection

When the same maximum output power was specified for multiple OFDM transmission mode configurations in a frequency band or aggregated band, SAR is measured using the configuration with the largest channel bandwidth, lowest order modulation and lowest data rate. When the maximum output power of a channel is the same for equivalent OFDM configurations; for example, 802.11a, 802.11n and 802.11ac or 802.11g and 802.11n with the same channel bandwidth, modulation and data rate etc., the lower order 802.11 mode i.e., 802.11a, then 802.11n and 802.11ac or 802.11g then 802.11n, is used for SAR measurement. When the maximum output power are the same for multiple test channels, either according to the default or additional power measurement requirements, SAR is measured using the channel closest to the middle of the frequency band or aggregated band. When there are multiple channels with the same maximum output power, SAR is measured using the higher number channel.

8.6.7 Initial Test Configuration Procedure

For OFDM, an initial test configuration is determined for each frequency band and aggregated band, according to the transmission mode with the highest maximum output power specified for SAR measurements. When the same maximum output power is specified for multiple OFDM transmission mode configurations in a frequency band or aggregated band, SAR is measured using the configuration(s) with the largest channel bandwidth, lowest order modulation, lowest data rate and lowest order IEEE 802.11 mode. The channel of the transmission mode with the highest average RF output conducted power will be the initial test configuration.



When the reported SAR is ≤ 0.8 W/kg, no additional measurements on other test channels are required. Otherwise, SAR is evaluated using the subsequent highest average RF output channel until the reported SAR

FCC ID: A3LSMJ530GM		SAR EVALUATION REPORT		Approved by: Quality Manager
Document S/N: 1M1703230121-01-R1.A3L	Test Dates: 03/20/17 - 04/20/17	DUT Type: Portable Handset	Page 23 of 85	

result is ≤ 1.2 W/kg or all channels are measured. When there are multiple untested channels having the same subsequent highest average RF output power, the channel with higher frequency from the lowest 802.11 mode is considered for SAR measurements (See Section 8.6.6). When 10-g SAR measurement is considered, a factor of 2.5 is applied to the thresholds above.

8.6.8 Subsequent Test Configuration Procedures

For OFDM configurations in each frequency band and aggregated band, SAR is evaluated for initial test configuration using the fixed test position or the initial test position procedure. When the highest reported SAR (for the initial test configuration), adjusted by the ratio of the specified maximum output power of the subsequent test configuration to initial test configuration, is ≤ 1.2 W/kg, no additional SAR tests for the subsequent test configurations are required. When 10-g SAR measurement is considered, a factor of 2.5 is applied to the thresholds above.



FCC ID: A3LSMJ530GM	 SAR EVALUATION REPORT 		Approved by: Quality Manager
Document S/N: 1M1703230121-01-R1.A3L	Test Dates: 03/20/17 - 04/20/17	DUT Type: Portable Handset	Page 24 of 85

9

RF CONDUCTED POWERS

9.1 Maximum GSM Conducted Powers

Maximum Burst-Averaged Output Power										
Band	Channel	Voice	GPRS/EDGE Data (GMSK)				EDGE Data (8-PSK)			
		GSM [dBm] CS (1 Slot)	GPRS [dBm] 1 Tx Slot	GPRS [dBm] 2 Tx Slot	GPRS [dBm] 3 Tx Slot	GPRS [dBm] 4 Tx Slot	EDGE [dBm] 1 Tx Slot	EDGE [dBm] 2 Tx Slot	EDGE [dBm] 3 Tx Slot	EDGE [dBm] 4 Tx Slot
GSM 850	128	32.47	32.57	30.31	28.68	27.04	27.26	24.41	22.74	21.01
	190	32.66	32.65	30.57	28.93	27.26	27.45	24.65	22.95	21.25
	251	32.65	32.62	30.36	28.76	27.14	27.22	24.31	22.63	21.02
GSM 1900	512	29.66	29.79	26.61	25.15	23.46	25.52	23.58	22.02	20.55
	661	29.46	29.58	26.17	24.67	23.01	25.38	23.16	21.46	19.97
	810	29.52	29.45	26.48	24.87	23.19	25.47	23.53	21.66	20.13
Calculated Maximum Frame-Averaged Output Power										
Band	Channel	Voice	GPRS/EDGE Data (GMSK)				EDGE Data (8-PSK)			
		GSM [dBm] CS (1 Slot)	GPRS [dBm] 1 Tx Slot	GPRS [dBm] 2 Tx Slot	GPRS [dBm] 3 Tx Slot	GPRS [dBm] 4 Tx Slot	EDGE [dBm] 1 Tx Slot	EDGE [dBm] 2 Tx Slot	EDGE [dBm] 3 Tx Slot	EDGE [dBm] 4 Tx Slot
GSM 850	128	23.44	23.54	24.29	24.42	24.03	18.23	18.39	18.48	18.00
	190	23.63	23.62	24.55	24.67	24.25	18.42	18.63	18.69	18.24
	251	23.62	23.59	24.34	24.50	24.13	18.19	18.29	18.37	18.01
GSM 1900	512	20.63	20.76	20.59	20.89	20.45	16.49	17.56	17.76	17.54
	661	20.43	20.55	20.15	20.41	20.00	16.35	17.14	17.20	16.96
	810	20.49	20.42	20.46	20.61	20.18	16.44	17.51	17.40	17.12
GSM 850	Frame	23.97	23.97	25.48	25.74	25.49	18.47	19.48	19.74	19.49
GSM 1900	Avg. Targets:	20.97	20.97	21.48	21.24	20.99	16.47	17.98	18.24	17.99

FCC ID: A3LSMJ530GM		SAR EVALUATION REPORT		Approved by: Quality Manager
Document S/N: 1M1703230121-01-R1.A3L	Test Dates: 03/20/17 - 04/20/17	DUT Type: Portable Handset		Page 25 of 85

9.2 Reduced GSM Conducted Powers

Maximum Burst-Averaged Output Power									
Band	Channel	GPRS/EDGE Data (GMSK)				EDGE Data (8-PSK)			
		GPRS [dBm] 1 Tx Slot	GPRS [dBm] 2 Tx Slot	GPRS [dBm] 3 Tx Slot	GPRS [dBm] 4 Tx Slot	EDGE [dBm] 1 Tx Slot	EDGE [dBm] 2 Tx Slot	EDGE [dBm] 3 Tx Slot	EDGE [dBm] 4 Tx Slot
GSM 850	128	31.11	29.16	27.54	26.10	26.99	24.98	23.50	21.05
	190	31.28	29.53	27.96	26.36	27.35	25.28	23.85	21.32
	251	31.21	29.28	27.59	26.28	26.94	25.08	23.45	21.09
GSM 1900	512	27.83	24.75	23.12	21.83	25.53	23.74	21.96	20.58
	661	27.55	24.40	22.56	20.70	25.12	23.16	21.44	19.92
	810	27.98	24.95	23.25	21.68	25.86	23.49	22.05	20.26
Calculated Maximum Frame-Averaged Output Power									
Band	Channel	GPRS/EDGE Data (GMSK)				EDGE Data (8-PSK)			
		GPRS [dBm] 1 Tx Slot	GPRS [dBm] 2 Tx Slot	GPRS [dBm] 3 Tx Slot	GPRS [dBm] 4 Tx Slot	EDGE [dBm] 1 Tx Slot	EDGE [dBm] 2 Tx Slot	EDGE [dBm] 3 Tx Slot	EDGE [dBm] 4 Tx Slot
GSM 850	128	22.08	23.14	23.28	23.09	17.96	18.96	19.24	18.04
	190	22.25	23.51	23.70	23.35	18.32	19.26	19.59	18.31
	251	22.18	23.26	23.33	23.27	17.91	19.06	19.19	18.08
GSM 1900	512	18.80	18.73	18.86	18.82	16.50	17.72	17.70	17.57
	661	18.52	18.38	18.30	17.69	16.09	17.14	17.18	16.91
	810	18.95	18.93	18.99	18.67	16.83	17.47	17.79	17.25
GSM 850	Frame	21.97	23.48	23.74	23.49	18.47	19.48	19.74	19.49
GSM 1900	Avg. Targets:	18.47	19.48	19.24	18.99	16.47	17.98	18.24	17.99

Note:

- Both burst-averaged and calculated frame-averaged powers are included. Frame-averaged power was calculated from the measured burst-averaged power by converting the slot powers into linear units and calculating the energy over 8 timeslots.
- GPRS/EDGE (GMSK) output powers were measured with coding scheme setting of 1 (CS1) on the base station simulator. CS1 was configured to measure GPRS output power measurements and SAR to ensure GMSK modulation in the signal. Our investigation has shown that CS1 - CS4 settings do not have any impact on the output levels or modulation in the GPRS modes.
- EDGE (8-PSK) output powers were measured with MCS7 on the base station simulator. MCS7 coding scheme was used to measure the output powers for EDGE since investigation has shown that choosing MCS7 coding scheme will ensure 8-PSK modulation. It has been shown that MCS levels that produce 8PSK modulation do not have an impact on output power.

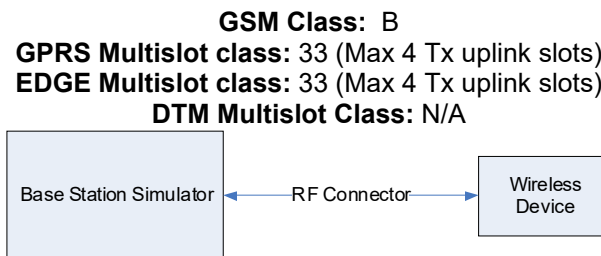



Figure 9-1
Power Measurement Setup

FCC ID: A3LSMJ530GM		SAR EVALUATION REPORT		Approved by: Quality Manager
Document S/N: 1M1703230121-01-R1.A3L	Test Dates: 03/20/17 - 04/20/17	DUT Type: Portable Handset	Page 26 of 85	



9.3 UMTS Conducted Powers

**Table 9-1
UMTS Maximum Conducted Powers**

3GPP Release Version	Mode	3GPP 34.121 Subtest	Cellular Band [dBm]			AWS Band [dBm]			PCS Band [dBm]			3GPP MPR [dB]
			4132	4183	4233	1312	1412	1513	9262	9400	9538	
99	WCDMA	12.2 kbps RMC	24.01	24.05	23.82	23.75	23.10	22.82	23.24	23.03	23.09	-
99		12.2 kbps AMR	23.93	22.34	23.68	23.84	22.11	22.80	23.17	21.51	23.05	-
6	HSDPA	Subtest 1	22.99	22.50	22.71	23.41	22.64	22.39	22.80	22.74	22.79	0
6		Subtest 2	22.13	22.18	21.95	22.66	21.94	21.82	22.30	22.00	22.22	0
6		Subtest 3	21.65	21.67	21.33	21.57	21.06	21.04	21.33	21.00	21.11	0.5
6		Subtest 4	21.65	21.66	21.39	21.27	21.03	21.00	21.31	21.00	21.14	0.5
6	HSUPA	Subtest 1	20.50	20.56	20.50	22.21	21.54	21.33	20.44	20.00	20.18	0
6		Subtest 2	18.66	18.65	19.50	20.67	20.93	20.88	18.80	18.22	18.61	2
6		Subtest 3	21.48	21.48	21.32	21.35	21.68	21.45	21.20	20.86	20.30	1
6		Subtest 4	18.79	18.83	18.71	21.60	21.00	20.80	18.59	18.19	18.45	2
6		Subtest 5	23.00	22.99	22.89	23.50	22.79	22.50	22.50	22.49	22.45	0
8	DC-HSDPA	Subtest 1	22.75	22.90	22.56	23.38	22.83	22.76	22.93	22.81	22.64	0
8		Subtest 2	22.00	21.96	21.62	22.80	21.95	22.67	22.35	22.05	22.35	0
8		Subtest 3	21.40	21.43	21.33	21.58	20.99	21.09	21.02	20.85	21.30	0.5
8		Subtest 4	21.53	21.48	21.27	20.64	21.00	21.02	21.29	21.00	21.15	0.5

**Table 9-2
UMTS Reduced Conducted Powers**

3GPP Release Version	Mode	3GPP 34.121 Subtest	AWS Band [dBm]			PCS Band [dBm]			3GPP MPR [dB]
			1312	1412	1513	9262	9400	9538	
99	WCDMA	12.2 kbps RMC	19.72	19.78	19.50	19.78	19.26	19.17	-
99		12.2 kbps AMR	19.68	19.75	19.47	19.76	19.26	19.23	-
6	HSDPA	Subtest 1	19.52	19.48	19.11	19.80	19.28	19.13	0
6		Subtest 2	19.40	19.42	19.03	19.70	19.21	19.13	0
6		Subtest 3	19.49	19.48	19.08	19.82	19.27	19.16	0.5
6		Subtest 4	19.42	19.43	19.15	19.81	19.12	19.19	0.5
6	HSUPA	Subtest 1	18.53	18.58	18.09	18.73	18.39	18.23	0
6		Subtest 2	19.45	19.49	19.00	18.79	17.84	18.10	2
6		Subtest 3	18.56	18.48	18.12	18.88	18.42	18.22	1
6		Subtest 4	19.50	19.49	19.00	18.75	17.94	18.02	2
6		Subtest 5	19.50	19.51	19.17	19.86	19.24	19.09	0
8	DC-HSDPA	Subtest 1	19.47	19.37	19.34	19.84	19.23	19.27	0
8		Subtest 2	19.65	19.36	19.40	19.82	19.13	19.25	0
8		Subtest 3	19.48	19.46	19.41	19.80	19.18	19.16	0.5
8		Subtest 4	19.37	19.49	19.32	19.89	19.16	19.19	0.5

FCC ID: A3LSMJ530GM		SAR EVALUATION REPORT		Approved by: Quality Manager
Document S/N: 1M1703230121-01-R1.A3L	Test Dates: 03/20/17 - 04/20/17	DUT Type: Portable Handset		Page 27 of 85

DC-HSDPA considerations

- 3GPP Specification 34.121-1 Release 8 Ver 8.10.0 was used for DC-HSDPA guidance
- H-Set 12 (QPSK) was confirmed to be used during DC-HSDPA measurements
- The DUT supports UE category 24 for HSDPA

It is expected by the manufacturer that MPR for some HSPA subtests may be up to 2 dB more than specified by 3GPP, but also as low as 0 dB according to the chipset implementation in this model.



Figure 9-2
Power Measurement Setup

9.4 LTE Conducted Powers

9.4.1 LTE Band 12

Table 9-3
LTE Band 12 Conducted Powers - 10 MHz Bandwidth

LTE Band 12 10 MHz Bandwidth					
Modulation	RB Size	RB Offset	Mid Channel	MPR Allowed per 3GPP [dB]	MPR [dB]
			23095 (707.5 MHz)		
			Conducted Power [dBm]		
QPSK	1	0	23.78	0	0
	1	25	23.75		0
	1	49	23.71		0
	25	0	21.85	0-1	1
	25	12	21.82		1
	25	25	21.81		1
	50	0	21.81		1
16QAM	1	0	21.80	0-1	1
	1	25	21.82		1
	1	49	21.81		1
	25	0	20.92	0-2	2
	25	12	20.90		2
	25	25	20.79		2
	50	0	20.80		2

Note: LTE Band 12 at 10 MHz bandwidth does not support three non-overlapping channels. Per KDB Publication 941225 D05v02, when a device supports overlapping channel assignment in a channel bandwidth configuration, the middle channel of the group of overlapping channels should be selected for testing.

FCC ID: A3LSMJ530GM		SAR EVALUATION REPORT		Approved by: Quality Manager
Document S/N: 1M1703230121-01-R1.A3L	Test Dates: 03/20/17 - 04/20/17	DUT Type: Portable Handset		Page 28 of 85

Table 9-4
LTE Band 12 Conducted Powers - 5 MHz Bandwidth

LTE Band 12 5 MHz Bandwidth							
Modulation	RB Size	RB Offset	Low Channel	Mid Channel	High Channel	MPR Allowed per 3GPP [dB]	MPR [dB]
			23035 (701.5 MHz)	23095 (707.5 MHz)	23155 (713.5 MHz)		
			Conducted Power [dBm]				
QPSK	1	0	23.57	23.70	23.18	0	0
	1	12	23.51	23.69	23.12		0
	1	24	23.57	23.67	23.10		0
	12	0	21.58	21.77	21.20	0-1	1
	12	6	21.59	21.72	21.33		1
	12	13	21.57	21.71	21.28		1
	25	0	21.61	21.75	21.21		1
16QAM	1	0	21.69	21.75	21.25	0-1	1
	1	12	21.67	21.74	21.41		1
	1	24	21.75	21.72	21.31		1
	12	0	20.60	20.71	20.19	0-2	2
	12	6	20.74	20.72	20.27		2
	12	13	20.73	20.70	20.22		2
	25	0	20.58	20.70	20.21		2

Table 9-5
LTE Band 12 Conducted Powers - 3 MHz Bandwidth

LTE Band 12 3 MHz Bandwidth							
Modulation	RB Size	RB Offset	Low Channel	Mid Channel	High Channel	MPR Allowed per 3GPP [dB]	MPR [dB]
			23025 (700.5 MHz)	23095 (707.5 MHz)	23165 (714.5 MHz)		
			Conducted Power [dBm]				
QPSK	1	0	23.42	23.15	23.16	0	0
	1	7	23.50	23.13	23.15		0
	1	14	23.51	23.15	23.14		0
	8	0	21.61	21.18	21.16	0-1	1
	8	4	21.74	21.20	21.19		1
	8	7	21.62	21.22	21.20		1
	15	0	21.62	21.26	21.19		1
16QAM	1	0	21.76	21.38	21.30	0-1	1
	1	7	21.77	21.24	21.27		1
	1	14	21.66	21.29	21.32		1
	8	0	20.71	20.28	20.29	0-2	2
	8	4	20.79	20.33	20.19		2
	8	7	20.65	20.41	20.26		2
	15	0	20.58	20.24	20.19		2



FCC ID: A3LSMJ530GM		SAR EVALUATION REPORT		Approved by: Quality Manager
Document S/N: 1M1703230121-01-R1.A3L	Test Dates: 03/20/17 - 04/20/17	DUT Type: Portable Handset	Page 29 of 85	

Table 9-6
LTE Band 12 Conducted Powers -1.4 MHz Bandwidth

LTE Band 12 1.4 MHz Bandwidth								
Modulation	RB Size	RB Offset	Low Channel	Mid Channel	High Channel	MPR Allowed per 3GPP [dB]	MPR [dB]	
			23017 (699.7 MHz)	23095 (707.5 MHz)	23173 (715.3 MHz)			
			Conducted Power [dBm]					
QPSK	1	0	23.73	23.18	23.16	0	0	
	1	2	23.76	23.15	23.22		0	
	1	5	23.71	23.17	23.21		0	
	3	0	23.72	23.19	23.14		0	
	3	2	23.74	23.18	23.23		0	
	3	3	23.73	23.18	23.21		0	
	6	0	21.85	21.39	21.33		0-1	1
16QAM	1	0	21.85	21.23	21.51	0-1	1	
	1	2	21.95	21.21	21.43		1	
	1	5	21.83	21.20	21.42		1	
	3	0	21.95	21.36	21.41		1	
	3	2	21.88	21.20	21.30		1	
	3	3	21.93	21.21	21.32		1	
	6	0	20.92	20.21	20.43		0-2	2

9.4.2 LTE Band 5 (Cell)

Table 9-7
LTE Band 5 (Cell) Conducted Powers - 10 MHz Bandwidth

LTE Band 5 (Cell) 10 MHz Bandwidth						
Modulation	RB Size	RB Offset	Mid Channel	MPR Allowed per 3GPP [dB]	MPR [dB]	
			20525 (836.5 MHz)			
			Conducted Power [dBm]			
QPSK	1	0	24.50	0	0	
	1	25	24.47		0	
	1	49	24.46		0	
	16QAM	25	0	23.47	0-1	1
		25	12	23.43		1
		25	25	23.39		1
		50	0	23.40		1
16QAM	1	0	23.24	0-1	1	
	1	25	23.25		1	
	1	49	23.20		1	
	16QAM	25	0	22.43	0-2	2
		25	12	22.44		2
		25	25	22.41		2
50	0	22.38	2			

Note: LTE Band 5 (Cell) at 10 MHz bandwidth does not support three non-overlapping channels. Per KDB Publication 941225 D05v02, when a device supports overlapping channel assignment in a channel bandwidth configuration, the middle channel of the group of overlapping channels should be selected for testing.



FCC ID: A3LSMJ530GM		SAR EVALUATION REPORT		Approved by: Quality Manager
Document S/N: 1M1703230121-01-R1.A3L	Test Dates: 03/20/17 - 04/20/17	DUT Type: Portable Handset		Page 30 of 85

Table 9-8
LTE Band 5 (Cell) Conducted Powers - 5 MHz Bandwidth

LTE Band 5 (Cell) 5 MHz Bandwidth							
Modulation	RB Size	RB Offset	Low Channel	Mid Channel	High Channel	MPR Allowed per 3GPP [dB]	MPR [dB]
			20425 (826.5 MHz)	20525 (836.5 MHz)	20625 (846.5 MHz)		
			Conducted Power [dBm]				
QPSK	1	0	24.26	24.32	24.03	0	0
	1	12	24.28	24.21	24.05		0
	1	24	24.21	24.26	24.02		0
	12	0	23.17	23.21	22.96	0-1	1
	12	6	23.11	23.19	22.10		1
	12	13	23.16	23.18	22.95		1
	25	0	23.17	23.23	22.90		1
16QAM	1	0	23.32	23.19	22.92	0-1	1
	1	12	23.26	23.22	22.94		1
	1	24	23.06	23.19	22.86		1
	12	0	22.18	22.15	21.94	0-2	2
	12	6	22.20	22.24	21.93		2
	12	13	22.08	22.28	21.85		2
	25	0	22.17	22.12	21.90		2

Table 9-9
LTE Band 5 (Cell) Conducted Powers - 3 MHz Bandwidth

LTE Band 5 (Cell) 3 MHz Bandwidth							
Modulation	RB Size	RB Offset	Low Channel	Mid Channel	High Channel	MPR Allowed per 3GPP [dB]	MPR [dB]
			20415 (825.5 MHz)	20525 (836.5 MHz)	20635 (847.5 MHz)		
			Conducted Power [dBm]				
QPSK	1	0	24.25	24.16	23.95	0	0
	1	7	24.26	24.19	23.94		0
	1	14	24.24	24.18	23.93		0
	8	0	23.18	23.18	22.94	0-1	1
	8	4	23.21	23.19	22.93		1
	8	7	23.20	23.23	22.90		1
	15	0	23.14	23.20	22.92		1
16QAM	1	0	23.25	23.19	22.82	0-1	1
	1	7	23.24	23.22	22.92		1
	1	14	23.21	23.15	22.94		1
	8	0	22.17	22.27	22.00	0-2	2
	8	4	22.30	22.28	22.07		2
	8	7	22.26	22.27	21.98		2
	15	0	22.25	22.29	21.97		2



FCC ID: A3LSMJ530GM		SAR EVALUATION REPORT		Approved by: Quality Manager
Document S/N: 1M1703230121-01-R1.A3L	Test Dates: 03/20/17 - 04/20/17	DUT Type: Portable Handset	Page 31 of 85	

Table 9-10
LTE Band 5 (Cell) Conducted Powers -1.4 MHz Bandwidth

LTE Band 5 (Cell) 1.4 MHz Bandwidth								
Modulation	RB Size	RB Offset	Low Channel	Mid Channel	High Channel	MPR Allowed per 3GPP [dB]	MPR [dB]	
			20407 (824.7 MHz)	20525 (836.5 MHz)	20643 (848.3 MHz)			
			Conducted Power [dBm]					
QPSK	1	0	24.14	24.10	23.75	0	0	
	1	2	24.11	24.16	23.84		0	
	1	5	24.18	24.13	23.83		0	
	3	0	24.19	24.20	23.90		0	
	3	2	24.12	24.21	23.87		0	
	3	3	24.13	24.19	23.86		0	
	6	0	23.12	23.24	22.92		0-1	1
16QAM	1	0	23.34	23.24	22.95	0-1	1	
	1	2	23.17	23.16	22.89		1	
	1	5	23.29	23.18	22.98		1	
	3	0	23.15	23.22	22.90		1	
	3	2	23.12	23.21	22.88		1	
	3	3	23.23	23.19	22.86		1	
	6	0	22.17	22.17	21.87		0-2	2

9.4.3 LTE Band 4 (AWS)

Table 9-11
LTE Band 4 (AWS) Maximum Conducted Powers - 20 MHz Bandwidth

LTE Band 4 (AWS) 20 MHz Bandwidth						
Modulation	RB Size	RB Offset	Mid Channel	MPR Allowed per 3GPP [dB]	MPR [dB]	
			20175 (1732.5 MHz)			
			Conducted Power [dBm]			
QPSK	1	0	23.44	0	0	
	1	50	23.48		0	
	1	99	23.53		0	
	16QAM	50	0	21.53	0-1	1
		50	25	21.65		1
		50	50	21.60		1
		100	0	21.61		1
16QAM	1	0	21.69	0-1	1	
	1	50	21.77		1	
	1	99	21.73		1	
	16QAM	50	0	20.62	0-2	2
		50	25	20.61		2
		50	50	20.63		2
		100	0	20.58		2

Note: LTE Band 4 (AWS) at 20 MHz bandwidth does not support three non-overlapping channels. Per KDB Publication 941225 D05v02, when a device supports overlapping channel assignment in a channel bandwidth configuration, the middle channel of the group of overlapping channels should be selected for testing.



FCC ID: A3LSMJ530GM		SAR EVALUATION REPORT		Approved by: Quality Manager
Document S/N: 1M1703230121-01-R1.A3L	Test Dates: 03/20/17 - 04/20/17	DUT Type: Portable Handset	Page 32 of 85	

Table 9-12
LTE Band 4 (AWS) Maximum Conducted Powers - 15 MHz Bandwidth

LTE Band 4 (AWS) 15 MHz Bandwidth							
Modulation	RB Size	RB Offset	Low Channel	Mid Channel	High Channel	MPR Allowed per 3GPP [dB]	MPR [dB]
			20025 (1717.5 MHz)	20175 (1732.5 MHz)	20325 (1747.5 MHz)		
			Conducted Power [dBm]				
QPSK	1	0	23.56	23.53	23.40	0	0
	1	36	23.64	23.82	23.45		0
	1	74	23.77	23.71	23.48		0
	36	0	21.74	21.59	21.62	0-1	1
	36	18	21.76	21.62	21.55		1
	36	37	21.79	21.66	21.59		1
	75	0	21.76	21.61	21.54		1
16QAM	1	0	21.51	21.54	21.50	0-1	1
	1	36	21.52	21.53	21.56		1
	1	74	21.61	21.56	21.53		1
	36	0	20.80	20.64	20.55	0-2	2
	36	18	20.84	20.61	20.52		2
	36	37	20.88	20.69	20.60		2
	75	0	20.81	20.58	20.50		2

Table 9-13
LTE Band 4 (AWS) Maximum Conducted Powers - 10 MHz Bandwidth

LTE Band 4 (AWS) 10 MHz Bandwidth							
Modulation	RB Size	RB Offset	Low Channel	Mid Channel	High Channel	MPR Allowed per 3GPP [dB]	MPR [dB]
			20000 (1715.0 MHz)	20175 (1732.5 MHz)	20350 (1750.0 MHz)		
			Conducted Power [dBm]				
QPSK	1	0	23.91	23.57	23.61	0	0
	1	25	23.96	23.61	23.67		0
	1	49	23.91	23.72	23.76		0
	25	0	21.77	21.63	21.51	0-1	1
	25	12	21.79	21.65	21.50		1
	25	25	21.81	21.67	21.53		1
	50	0	21.80	21.63	21.52		1
16QAM	1	0	21.97	21.56	21.50	0-1	1
	1	25	21.96	21.52	21.53		1
	1	49	22.02	21.63	21.54		1
	25	0	20.82	20.64	20.67	0-2	2
	25	12	20.81	20.65	20.59		2
	25	25	20.84	20.70	20.60		2
	50	0	20.85	20.66	20.54		2



FCC ID: A3LSMJ530GM		SAR EVALUATION REPORT		Approved by: Quality Manager
Document S/N: 1M1703230121-01-R1.A3L	Test Dates: 03/20/17 - 04/20/17	DUT Type: Portable Handset	Page 33 of 85	

Table 9-14
LTE Band 4 (AWS) Maximum Conducted Powers - 5 MHz Bandwidth

LTE Band 4 (AWS) 5 MHz Bandwidth							
Modulation	RB Size	RB Offset	Low Channel	Mid Channel	High Channel	MPR Allowed per 3GPP [dB]	MPR [dB]
			19975 (1712.5 MHz)	20175 (1732.5 MHz)	20375 (1752.5 MHz)		
			Conducted Power [dBm]				
QPSK	1	0	23.52	23.90	23.27	0	0
	1	12	23.55	23.95	23.26		0
	1	24	23.61	23.97	23.29		0
	12	0	21.50	21.68	21.53	0-1	1
	12	6	21.51	21.70	21.55		1
	12	13	21.54	21.72	21.54		1
	25	0	21.51	21.69	21.58		1
16QAM	1	0	21.50	21.72	21.55	0-1	1
	1	12	21.51	21.87	21.51		1
	1	24	21.58	21.83	21.57		1
	12	0	20.54	20.71	20.53	0-2	2
	12	6	20.53	20.76	20.57		2
	12	13	20.51	20.78	20.50		2
	25	0	20.55	20.76	20.51		2

Table 9-15
LTE Band 4 (AWS) Maximum Conducted Powers - 3 MHz Bandwidth

LTE Band 4 (AWS) 3 MHz Bandwidth							
Modulation	RB Size	RB Offset	Low Channel	Mid Channel	High Channel	MPR Allowed per 3GPP [dB]	MPR [dB]
			19965 (1711.5 MHz)	20175 (1732.5 MHz)	20385 (1753.5 MHz)		
			Conducted Power [dBm]				
QPSK	1	0	24.00	23.84	23.33	0	0
	1	7	24.03	23.83	23.30		0
	1	14	24.02	23.82	23.38		0
	8	0	21.84	21.52	21.50	0-1	1
	8	4	21.83	21.53	21.57		1
	8	7	21.82	21.56	21.52		1
	15	0	21.82	21.53	21.56		1
16QAM	1	0	21.90	21.55	21.67	0-1	1
	1	7	21.85	21.56	21.53		1
	1	14	21.87	21.60	21.56		1
	8	0	20.83	20.53	20.50	0-2	2
	8	4	20.84	20.54	20.57		2
	8	7	20.87	20.56	20.60		2
	15	0	20.88	20.50	20.55		2



FCC ID: A3LSMJ530GM	 PCTEST ENGINEERING LABORATORY, INC.	SAR EVALUATION REPORT		Approved by: Quality Manager
Document S/N: 1M1703230121-01-R1.A3L	Test Dates: 03/20/17 - 04/20/17	DUT Type: Portable Handset	Page 34 of 85	

Table 9-16
LTE Band 4 (AWS) Maximum Conducted Powers -1.4 MHz Bandwidth

LTE Band 4 (AWS) 1.4 MHz Bandwidth							
Modulation	RB Size	RB Offset	Low Channel	Mid Channel	High Channel	MPR Allowed per 3GPP [dB]	MPR [dB]
			19957 (1710.7 MHz)	20175 (1732.5 MHz)	20393 (1754.3 MHz)		
			Conducted Power [dBm]				
QPSK	1	0	23.87	23.67	23.29	0	0
	1	2	23.90	23.66	23.19		0
	1	5	23.89	23.69	23.16		0
	3	0	23.97	23.56	23.22		0
	3	2	24.02	23.60	23.26		0
	3	3	23.96	23.58	23.26		0
	6	0	21.89	21.51	21.50		0-1
16QAM	1	0	21.73	21.61	21.53	0-1	1
	1	2	21.81	21.63	21.56		1
	1	5	21.74	21.57	21.52		1
	3	0	21.81	21.68	21.53		1
	3	2	21.88	21.64	21.51		1
	3	3	21.91	21.59	21.53		1
	6	0	20.84	20.70	20.51		0-2

Table 9-17
LTE Band 4 (AWS) Reduced Conducted Powers - 20 MHz Bandwidth

LTE Band 4 (AWS) 20 MHz Bandwidth						
Modulation	RB Size	RB Offset	Mid Channel	MPR Allowed per 3GPP [dB]	MPR [dB]	
			20175 (1732.5 MHz)			
			Conducted Power [dBm]			
QPSK	1	0	20.43	0	0	
	1	50	20.42		0	
	1	99	20.38		0	
	QPSK	50	0	18.53	0-1	1
		50	25	18.54		1
		50	50	18.53		1
		100	0	18.50		1
16QAM	1	0	18.58	0-1	1	
	1	50	18.57		1	
	1	99	18.54		1	
	16QAM	50	0	17.50	0-2	2
		50	25	17.49		2
		50	50	17.47		2
		100	0	17.52		2

Note: LTE Band 4 (AWS) at 20 MHz bandwidth does not support three non-overlapping channels. Per KDB Publication 941225 D05v02, when a device supports overlapping channel assignment in a channel bandwidth configuration, the middle channel of the group of overlapping channels should be selected for testing.



FCC ID: A3LSMJ530GM		SAR EVALUATION REPORT		Approved by: Quality Manager
Document S/N: 1M1703230121-01-R1.A3L	Test Dates: 03/20/17 - 04/20/17	DUT Type: Portable Handset		Page 35 of 85

Table 9-18
LTE Band 4 (AWS) Reduced Conducted Powers - 15 MHz Bandwidth

LTE Band 4 (AWS) 15 MHz Bandwidth							
Modulation	RB Size	RB Offset	Low Channel	Mid Channel	High Channel	MPR Allowed per 3GPP [dB]	MPR [dB]
			20025 (1717.5 MHz)	20175 (1732.5 MHz)	20325 (1747.5 MHz)		
			Conducted Power [dBm]				
QPSK	1	0	20.22	20.31	20.16	0	0
	1	36	20.22	20.31	20.09		0
	1	74	20.27	20.29	20.05		0
	36	0	18.30	18.40	18.30	0-1	1
	36	18	18.31	18.39	18.31		1
	36	37	18.33	18.37	18.30		1
	75	0	18.30	18.39	18.32	1	
16QAM	1	0	18.32	18.54	18.39	0-1	1
	1	36	18.32	18.55	18.44		1
	1	74	18.31	18.54	18.38		1
	36	0	17.35	17.46	17.30	0-2	2
	36	18	17.34	17.50	17.30		2
	36	37	17.34	17.45	17.32		2
	75	0	17.35	17.46	17.33	2	

Table 9-19
LTE Band 4 (AWS) Reduced Conducted Powers - 10 MHz Bandwidth

LTE Band 4 (AWS) 10 MHz Bandwidth							
Modulation	RB Size	RB Offset	Low Channel	Mid Channel	High Channel	MPR Allowed per 3GPP [dB]	MPR [dB]
			20000 (1715.0 MHz)	20175 (1732.5 MHz)	20350 (1750.0 MHz)		
			Conducted Power [dBm]				
QPSK	1	0	20.19	20.38	19.99	0	0
	1	25	20.19	20.36	20.00		0
	1	49	20.22	20.36	19.98		0
	25	0	18.28	18.41	18.05	0-1	1
	25	12	18.26	18.39	18.00		1
	25	25	18.25	18.41	18.05		1
	50	0	18.26	18.40	18.07	1	
16QAM	1	0	18.28	18.44	18.00	0-1	1
	1	25	18.26	18.46	18.04		1
	1	49	18.30	18.50	18.12		1
	25	0	17.31	17.48	17.06	0-2	2
	25	12	17.31	17.47	17.15		2
	25	25	17.31	17.49	17.02		2
	50	0	17.32	17.50	17.08	2	



FCC ID: A3LSMJ530GM		SAR EVALUATION REPORT		Approved by: Quality Manager
Document S/N: 1M1703230121-01-R1.A3L	Test Dates: 03/20/17 - 04/20/17	DUT Type: Portable Handset	Page 36 of 85	

Table 9-20
LTE Band 4 (AWS) Reduced Conducted Powers - 5 MHz Bandwidth

LTE Band 4 (AWS) 5 MHz Bandwidth							
Modulation	RB Size	RB Offset	Low Channel	Mid Channel	High Channel	MPR Allowed per 3GPP [dB]	MPR [dB]
			19975 (1712.5 MHz)	20175 (1732.5 MHz)	20375 (1752.5 MHz)		
			Conducted Power [dBm]				
QPSK	1	0	20.41	20.40	20.06	0	0
	1	12	20.42	20.37	20.05		0
	1	24	20.40	20.40	20.06		0
	12	0	18.45	18.43	18.06	0-1	1
	12	6	18.43	18.43	18.07		1
	12	13	18.44	18.44	18.07		1
	25	0	18.42	18.43	18.06		1
16QAM	1	0	18.71	18.48	18.14	0-1	1
	1	12	18.73	18.47	18.07		1
	1	24	18.72	18.50	18.06		1
	12	0	17.45	17.41	17.10	0-2	2
	12	6	17.42	17.43	17.06		2
	12	13	17.43	17.44	17.06		2
	25	0	17.57	17.53	17.12		2

Table 9-21
LTE Band 4 (AWS) Reduced Conducted Powers - 3 MHz Bandwidth

LTE Band 4 (AWS) 3 MHz Bandwidth							
Modulation	RB Size	RB Offset	Low Channel	Mid Channel	High Channel	MPR Allowed per 3GPP [dB]	MPR [dB]
			19965 (1711.5 MHz)	20175 (1732.5 MHz)	20385 (1753.5 MHz)		
			Conducted Power [dBm]				
QPSK	1	0	20.33	20.40	19.92	0	0
	1	7	20.36	20.35	19.88		0
	1	14	20.32	20.37	19.83		0
	8	0	18.44	18.40	18.02	0-1	1
	8	4	18.37	18.44	18.03		1
	8	7	18.44	18.44	18.01		1
	15	0	18.45	18.41	18.02		1
16QAM	1	0	18.77	18.60	18.29	0-1	1
	1	7	18.67	18.53	18.24		1
	1	14	18.77	18.61	18.26		1
	8	0	17.42	17.65	17.11	0-2	2
	8	4	17.47	17.63	17.02		2
	8	7	17.49	17.58	17.02		2
	15	0	17.53	17.52	17.01		2



FCC ID: A3LSMJ530GM		SAR EVALUATION REPORT		Approved by: Quality Manager
Document S/N: 1M1703230121-01-R1.A3L	Test Dates: 03/20/17 - 04/20/17	DUT Type: Portable Handset		Page 37 of 85

Table 9-22
LTE Band 4 (AWS) Reduced Conducted Powers -1.4 MHz Bandwidth

LTE Band 4 (AWS) 1.4 MHz Bandwidth							
Modulation	RB Size	RB Offset	Low Channel	Mid Channel	High Channel	MPR Allowed per 3GPP [dB]	MPR [dB]
			19957 (1710.7 MHz)	20175 (1732.5 MHz)	20393 (1754.3 MHz)		
			Conducted Power [dBm]				
QPSK	1	0	20.11	20.47	19.99	0	0
	1	2	20.17	20.40	19.97		0
	1	5	20.08	20.41	20.00		0
	3	0	20.37	20.36	19.98		0
	3	2	20.38	20.40	19.95		0
	3	3	20.39	20.37	20.01		0
	6	0	18.39	18.48	18.04		0-1
16QAM	1	0	18.72	18.57	18.35	0-1	1
	1	2	18.78	18.59	18.05		1
	1	5	18.75	18.65	18.34		1
	3	0	18.58	18.47	18.07		1
	3	2	18.60	18.58	18.08		1
	3	3	18.55	18.54	18.10		1
	6	0	17.62	17.51	17.01		0-2

9.4.1 LTE Band 66 (AWS)

Table 9-23
LTE Band 66 (AWS) Maximum Conducted Powers - 20 MHz Bandwidth

LTE Band 66 (AWS) 20 MHz Bandwidth								
Modulation	RB Size	RB Offset	Low Channel	Mid Channel	High Channel	MPR Allowed per 3GPP [dB]	MPR [dB]	
			132072 (1720.0 MHz)	132322 (1745.0 MHz)	132572 (1770.0 MHz)			
			Conducted Power [dBm]					
QPSK	1	0	23.06	23.05	22.23	0	0	
	1	50	23.08	23.04	22.27		0	
	1	99	23.09	23.06	22.33		0	
	16QAM	50	0	21.42	21.23	20.39	0-1	1
		50	25	21.43	21.22	20.45		1
		50	50	21.42	21.24	20.48		1
		100	0	21.37	21.26	20.44		1
16QAM	1	0	21.13	21.13	20.37	0-1	1	
	1	50	21.19	21.11	20.34		1	
	1	99	21.18	21.12	20.38		1	
	16QAM	50	0	20.45	20.27	19.59	0-2	2
		50	25	20.44	20.22	19.51		2
		50	50	20.45	20.21	19.53		2
		100	0	20.48	20.26	19.54		2



FCC ID: A3LSMJ530GM		SAR EVALUATION REPORT		Approved by: Quality Manager
Document S/N: 1M1703230121-01-R1.A3L	Test Dates: 03/20/17 - 04/20/17	DUT Type: Portable Handset	Page 38 of 85	

Table 9-24
LTE Band 66 (AWS) Maximum Conducted Powers - 15 MHz Bandwidth

LTE Band 66 (AWS) 15 MHz Bandwidth							
Modulation	RB Size	RB Offset	Low Channel	Mid Channel	High Channel	MPR Allowed per 3GPP [dB]	MPR [dB]
			132047 (1717.5 MHz)	132322 (1745.0 MHz)	132597 (1772.5 MHz)		
			Conducted Power [dBm]				
QPSK	1	0	23.00	23.00	21.73	0	0
	1	36	23.13	23.02	21.79		0
	1	74	23.13	23.00	21.90		0
	36	0	21.26	21.10	20.25	0-1	1
	36	18	21.27	21.08	20.30		1
	36	37	21.30	21.06	20.20		1
	75	0	21.27	21.09	20.21		1
16QAM	1	0	21.13	21.03	20.25	0-1	1
	1	36	21.17	21.06	20.30		1
	1	74	21.24	21.24	20.21		1
	36	0	20.31	20.10	19.33	0-2	2
	36	18	20.30	20.02	19.27		2
	36	37	20.33	20.06	19.32		2
	75	0	20.26	20.06	19.27		2

Table 9-25
LTE Band 66 (AWS) Maximum Conducted Powers - 10 MHz Bandwidth

LTE Band 66 (AWS) 10 MHz Bandwidth							
Modulation	RB Size	RB Offset	Low Channel	Mid Channel	High Channel	MPR Allowed per 3GPP [dB]	MPR [dB]
			132022 (1715.0 MHz)	132322 (1745.0 MHz)	132622 (1775.0 MHz)		
			Conducted Power [dBm]				
QPSK	1	0	22.94	22.99	22.10	0	0
	1	25	23.00	23.00	22.11		0
	1	49	22.98	22.98	22.18		0
	25	0	21.36	21.03	20.25	0-1	1
	25	12	21.33	21.01	20.30		1
	25	25	21.36	21.00	20.24		1
	50	0	21.35	21.01	20.26		1
16QAM	1	0	21.03	21.02	20.23	0-1	1
	1	25	21.07	21.05	20.20		1
	1	49	21.14	21.00	20.21		1
	25	0	20.35	20.05	19.21	0-2	2
	25	12	20.34	20.06	19.26		2
	25	25	20.36	20.08	19.22		2
	50	0	20.35	20.04	19.24		2



FCC ID: A3LSMJ530GM		SAR EVALUATION REPORT		Approved by: Quality Manager
Document S/N: 1M1703230121-01-R1.A3L	Test Dates: 03/20/17 - 04/20/17	DUT Type: Portable Handset	Page 39 of 85	

Table 9-26
LTE Band 66 (AWS) Maximum Conducted Powers - 5 MHz Bandwidth

LTE Band 66 (AWS) 5 MHz Bandwidth							
Modulation	RB Size	RB Offset	Low Channel	Mid Channel	High Channel	MPR Allowed per 3GPP [dB]	MPR [dB]
			131997 (1712.5 MHz)	132322 (1745.0 MHz)	132647 (1777.5 MHz)		
			Conducted Power [dBm]				
QPSK	1	0	23.20	23.02	22.06	0	0
	1	12	23.12	23.03	22.10		0
	1	24	23.14	23.01	22.13		0
	12	0	21.50	21.07	20.20	0-1	1
	12	6	21.49	21.04	20.22		1
	12	13	21.52	21.06	20.28		1
	25	0	21.51	21.09	20.23		1
16QAM	1	0	21.29	21.08	20.28	0-1	1
	1	12	21.26	21.07	20.27		1
	1	24	21.44	21.03	20.20		1
	12	0	20.51	20.11	19.20	0-2	2
	12	6	20.49	20.12	19.25		2
	12	13	20.52	20.16	19.26		2
	25	0	20.53	20.11	19.31		2

Table 9-27
LTE Band 66 (AWS) Maximum Conducted Powers - 3 MHz Bandwidth

LTE Band 66 (AWS) 3 MHz Bandwidth							
Modulation	RB Size	RB Offset	Low Channel	Mid Channel	High Channel	MPR Allowed per 3GPP [dB]	MPR [dB]
			131987 (1711.5 MHz)	132322 (1745.0 MHz)	132657 (1778.5 MHz)		
			Conducted Power [dBm]				
QPSK	1	0	23.18	22.93	22.21	0	0
	1	7	23.14	22.97	22.22		0
	1	14	23.20	23.00	22.20		0
	8	0	21.50	21.02	20.27	0-1	1
	8	4	21.48	21.00	20.23		1
	8	7	21.47	21.01	20.26		1
	15	0	21.44	21.00	20.22		1
16QAM	1	0	21.55	21.18	20.27	0-1	1
	1	7	21.60	21.23	20.22		1
	1	14	21.63	21.24	20.23		1
	8	0	20.48	20.06	19.24	0-2	2
	8	4	20.47	20.04	19.27		2
	8	7	20.45	20.02	19.23		2
	15	0	20.39	20.00	19.26		2



FCC ID: A3LSMJ530GM		SAR EVALUATION REPORT		Approved by: Quality Manager
Document S/N: 1M1703230121-01-R1.A3L	Test Dates: 03/20/17 - 04/20/17	DUT Type: Portable Handset	Page 40 of 85	

Table 9-28
LTE Band 66 (AWS) Maximum Conducted Powers -1.4 MHz Bandwidth

LTE Band 66 (AWS) 1.4 MHz Bandwidth								
Modulation	RB Size	RB Offset	Low Channel	Low-Mid Channel	Mid-High	High Channel	MPR Allowed per 3GPP [dB]	MPR [dB]
			131979 (1710.7 MHz)	132208 (1733.6 MHz)	132436 (1756.4 MHz)	132665 (1779.3 MHz)		
			Conducted Power [dBm]					
QPSK	1	0	23.15	23.06	22.55	22.06	0	0
	1	2	23.14	23.14	22.57	22.05		0
	1	5	23.17	23.10	22.54	22.06		0
	3	0	23.14	23.05	22.57	22.09		0
	3	2	23.18	23.13	22.61	22.13		0
	3	3	23.15	23.09	22.58	22.12		0
16QAM	6	0	21.46	21.15	20.64	20.21	0-1	1
	1	0	21.53	21.14	20.65	20.20	0-1	1
	1	2	21.63	21.24	20.68	20.24		1
	1	5	21.57	21.20	20.61	20.22		1
	3	0	21.65	21.16	20.65	20.23		1
	3	2	21.68	21.15	20.62	20.29		1
	3	3	21.67	21.18	20.67	20.26		1
	6	0	20.53	20.15	19.64	19.20	0-2	2

Per FCC KDB Publication 447498 D01v06 Section 4.1g), 4 channels are required for LTE Band 66 with 1.4 MHz Bandwidth.

Table 9-29
LTE Band 66 (AWS) Reduced Conducted Powers - 20 MHz Bandwidth

LTE Band 66 (AWS) 20 MHz Bandwidth							
Modulation	RB Size	RB Offset	Low Channel	Mid Channel	High Channel	MPR Allowed per 3GPP [dB]	MPR [dB]
			132072 (1720.0 MHz)	132322 (1745.0 MHz)	132572 (1770.0 MHz)		
			Conducted Power [dBm]				
QPSK	1	0	19.99	19.92	19.30	0	0
	1	50	20.01	19.95	19.37		0
	1	99	20.06	19.94	19.33		0
	50	0	18.10	18.03	17.46	0-1	1
	50	25	18.15	18.05	17.51		1
	50	50	18.12	18.03	17.44		1
16QAM	100	0	18.10	18.02	17.45	0-1	1
	1	0	18.09	18.00	17.51		1
	1	50	18.14	18.02	17.47		1
	1	99	18.11	17.97	17.45	0-2	1
	50	0	17.24	17.21	16.54		2
	50	25	17.28	17.19	16.56		2
	50	50	17.29	17.23	16.60		2
100	0	17.31	17.22	16.62	2		



FCC ID: A3LSMJ530GM		SAR EVALUATION REPORT		Approved by: Quality Manager
Document S/N: 1M1703230121-01-R1.A3L	Test Dates: 03/20/17 - 04/20/17	DUT Type: Portable Handset		Page 41 of 85

Table 9-30
LTE Band 66 (AWS) Reduced Conducted Powers - 15 MHz Bandwidth

LTE Band 66 (AWS) 15 MHz Bandwidth							
Modulation	RB Size	RB Offset	Low Channel	Mid Channel	High Channel	MPR Allowed per 3GPP [dB]	MPR [dB]
			132047 (1717.5 MHz)	132322 (1745.0 MHz)	132597 (1772.5 MHz)		
			Conducted Power [dBm]				
QPSK	1	0	19.93	19.82	19.01	0	0
	1	36	19.95	19.87	19.06		0
	1	74	19.98	19.76	19.07		0
	36	0	18.01	17.95	17.37	0-1	1
	36	18	17.98	17.94	17.38		1
	36	37	18.00	17.97	17.40		1
	75	0	17.98	17.93	17.38		1
16QAM	1	0	18.07	17.87	17.20	0-1	1
	1	36	18.02	17.88	17.30		1
	1	74	18.15	17.88	17.28		1
	36	0	17.02	16.97	16.49	0-2	2
	36	18	17.01	16.97	16.58		2
	36	37	17.00	16.95	16.48		2
	75	0	16.99	16.94	16.48		2

Table 9-31
LTE Band 66 (AWS) Reduced Conducted Powers - 10 MHz Bandwidth

LTE Band 66 (AWS) 10 MHz Bandwidth							
Modulation	RB Size	RB Offset	Low Channel	Mid Channel	High Channel	MPR Allowed per 3GPP [dB]	MPR [dB]
			132022 (1715.0 MHz)	132322 (1745.0 MHz)	132622 (1775.0 MHz)		
			Conducted Power [dBm]				
QPSK	1	0	19.94	19.85	19.46	0	0
	1	25	19.92	19.79	19.46		0
	1	49	19.93	19.83	19.45		0
	25	0	17.97	17.94	17.46	0-1	1
	25	12	17.95	17.94	17.48		1
	25	25	17.96	17.94	17.54		1
	50	0	17.96	17.96	17.46		1
16QAM	1	0	17.98	18.14	17.53	0-1	1
	1	25	17.96	17.91	17.54		1
	1	49	18.00	18.12	17.62		1
	25	0	16.95	16.93	16.46	0-2	2
	25	12	16.96	16.95	16.46		2
	25	25	17.00	16.97	16.47		2
	50	0	16.99	17.00	16.46		2



FCC ID: A3LSMJ530GM		SAR EVALUATION REPORT		Approved by: Quality Manager
Document S/N: 1M1703230121-01-R1.A3L	Test Dates: 03/20/17 - 04/20/17	DUT Type: Portable Handset	Page 42 of 85	

Table 9-32
LTE Band 66 (AWS) Reduced Conducted Powers - 5 MHz Bandwidth

LTE Band 66 (AWS) 5 MHz Bandwidth							
Modulation	RB Size	RB Offset	Low Channel	Mid Channel	High Channel	MPR Allowed per 3GPP [dB]	MPR [dB]
			131997 (1712.5 MHz)	132322 (1745.0 MHz)	132647 (1777.5 MHz)		
			Conducted Power [dBm]				
QPSK	1	0	19.98	20.00	19.48	0	0
	1	12	19.95	19.97	19.47		0
	1	24	19.97	19.99	19.52		0
	12	0	18.00	18.05	17.58	0-1	1
	12	6	17.98	18.03	17.56		1
	12	13	18.00	18.06	17.54		1
	25	0	17.99	18.00	17.53		1
16QAM	1	0	18.09	18.09	17.70	0-1	1
	1	12	18.10	18.09	17.54		1
	1	24	18.09	18.13	17.58		1
	12	0	17.01	17.01	16.56	0-2	2
	12	6	16.98	17.00	16.59		2
	12	13	17.00	17.04	16.58		2
	25	0	16.98	17.00	16.61		2

Table 9-33
LTE Band 66 (AWS) Reduced Conducted Powers - 3 MHz Bandwidth

LTE Band 66 (AWS) 3 MHz Bandwidth							
Modulation	RB Size	RB Offset	Low Channel	Mid Channel	High Channel	MPR Allowed per 3GPP [dB]	MPR [dB]
			131987 (1711.5 MHz)	132322 (1745.0 MHz)	132657 (1778.5 MHz)		
			Conducted Power [dBm]				
QPSK	1	0	19.92	19.83	19.55	0	0
	1	7	19.88	19.82	19.54		0
	1	14	19.95	19.90	19.53		0
	8	0	18.09	17.98	17.55	0-1	1
	8	4	18.03	17.98	17.57		1
	8	7	18.06	17.97	17.58		1
	15	0	18.00	17.99	17.60		1
16QAM	1	0	18.49	17.93	17.91	0-1	1
	1	7	18.40	17.94	17.97		1
	1	14	18.34	17.92	18.04		1
	8	0	17.03	17.04	16.63	0-2	2
	8	4	16.98	17.09	16.69		2
	8	7	17.05	17.06	16.59		2
	15	0	17.12	17.00	16.55		2



FCC ID: A3LSMJ530GM		SAR EVALUATION REPORT		Approved by: Quality Manager
Document S/N: 1M1703230121-01-R1.A3L	Test Dates: 03/20/17 - 04/20/17	DUT Type: Portable Handset	Page 43 of 85	

Table 9-34
LTE Band 66 (AWS) Reduced Conducted Powers -1.4 MHz Bandwidth

LTE Band 66 (AWS) 1.4 MHz Bandwidth								
Modulation	RB Size	RB Offset	Low Channel	Low-Mid Channel	Mid-High	High Channel	MPR Allowed per 3GPP [dB]	MPR [dB]
			131979 (1710.7 MHz)	132208 (1733.6 MHz)	132436 (1756.4 MHz)	132665 (1779.3 MHz)		
Conducted Power [dBm]								
QPSK	1	0	19.89	20.05	19.41	19.49	0	0
	1	2	19.88	20.14	19.51	19.58		0
	1	5	19.92	20.04	19.52	19.61		0
	3	0	20.00	20.05	19.57	19.49		0
	3	2	19.99	20.11	19.55	19.51		0
	3	3	20.00	20.08	19.50	19.58		0
16QAM	6	0	18.00	18.14	17.61	17.64	0-1	1
	1	0	18.60	18.46	17.57	17.85		1
	1	2	18.68	18.53	17.61	18.00	0-1	1
	1	5	18.59	18.57	17.57	17.90		1
	3	0	18.32	18.52	17.63	17.97		1
	3	2	18.34	18.45	17.62	17.95		1
	3	3	18.28	18.45	17.60	17.98		1
	6	0	17.12	17.51	16.59	16.88		0-2

Per FCC KDB Publication 447498 D01v06 Section 4.1g), 4 channels are required for LTE Band 66 with 1.4 MHz Bandwidth.

9.4.2 LTE Band 2 (PCS)

Table 9-35
LTE Band 2 (PCS) Maximum Conducted Powers - 20 MHz Bandwidth

LTE Band 2 (PCS) 20 MHz Bandwidth								
Modulation	RB Size	RB Offset	Low Channel	Mid Channel	High Channel	MPR Allowed per 3GPP [dB]	MPR [dB]	
			18700 (1860.0 MHz)	18900 (1880.0 MHz)	19100 (1900.0 MHz)			
Conducted Power [dBm]								
QPSK	1	0	23.27	23.14	23.42	0	0	
	1	50	23.57	23.16	23.45		0	
	1	99	23.53	23.25	23.32		0	
	16QAM	50	0	21.51	21.09	21.35	0-1	1
		50	25	21.54	21.12	21.33		1
		50	50	21.53	21.13	21.34		1
100		0	21.51	21.11	21.39	1		
16QAM	1	0	21.16	21.00	21.54	0-1	1	
	1	50	21.12	21.06	21.63		1	
	1	99	21.18	21.11	21.70		1	
	16QAM	50	0	20.52	20.11	20.38	0-2	2
		50	25	20.58	20.15	20.39		2
		50	50	20.57	20.12	20.41		2
		100	0	20.54	20.10	20.42		2



FCC ID: A3LSMJ530GM		SAR EVALUATION REPORT		Approved by: Quality Manager
Document S/N: 1M1703230121-01-R1.A3L	Test Dates: 03/20/17 - 04/20/17	DUT Type: Portable Handset		Page 44 of 85

Table 9-36
LTE Band 2 (PCS) Maximum Conducted Powers - 15 MHz Bandwidth

LTE Band 2 (PCS) 15 MHz Bandwidth							
Modulation	RB Size	RB Offset	Low Channel	Mid Channel	High Channel	MPR Allowed per 3GPP [dB]	MPR [dB]
			18675 (1857.5 MHz)	18900 (1880.0 MHz)	19125 (1902.5 MHz)		
			Conducted Power [dBm]				
QPSK	1	0	23.67	23.10	23.33	0	0
	1	36	23.72	23.16	23.46		0
	1	74	23.79	23.03	23.50		0
	36	0	21.61	21.07	21.53	0-1	1
	36	18	21.65	21.08	21.51		1
	36	37	21.64	21.14	21.52		1
	75	0	21.65	21.12	21.55		1
16QAM	1	0	21.53	21.00	21.27	0-1	1
	1	36	21.52	21.05	21.44		1
	1	74	21.50	21.06	21.45		1
	36	0	20.65	20.14	20.51	0-2	2
	36	18	20.61	20.10	20.53		2
	36	37	20.65	20.18	20.59		2
	75	0	20.57	20.11	20.57		2

Table 9-37
LTE Band 2 (PCS) Maximum Conducted Powers - 10 MHz Bandwidth

LTE Band 2 (PCS) 10 MHz Bandwidth							
Modulation	RB Size	RB Offset	Low Channel	Mid Channel	High Channel	MPR Allowed per 3GPP [dB]	MPR [dB]
			18650 (1855.0 MHz)	18900 (1880.0 MHz)	19150 (1905.0 MHz)		
			Conducted Power [dBm]				
QPSK	1	0	23.53	23.13	23.32	0	0
	1	25	23.58	23.22	23.34		0
	1	49	23.60	23.28	23.43		0
	25	0	21.72	21.10	21.52	0-1	1
	25	12	21.70	21.11	21.49		1
	25	25	21.72	21.14	21.55		1
	50	0	21.69	21.13	21.56		1
16QAM	1	0	21.56	21.05	21.35	0-1	1
	1	25	21.69	21.00	21.38		1
	1	49	21.74	21.10	21.44		1
	25	0	20.71	20.20	20.61	0-2	2
	25	12	20.73	20.18	20.57		2
	25	25	20.76	20.21	20.61		2
	50	0	20.66	20.15	20.52		2



FCC ID: A3LSMJ530GM		SAR EVALUATION REPORT		Approved by: Quality Manager
Document S/N: 1M1703230121-01-R1.A3L	Test Dates: 03/20/17 - 04/20/17	DUT Type: Portable Handset	Page 45 of 85	

Table 9-38
LTE Band 2 (PCS) Maximum Conducted Powers - 5 MHz Bandwidth

LTE Band 2 (PCS) 5 MHz Bandwidth							
Modulation	RB Size	RB Offset	Low Channel	Mid Channel	High Channel	MPR Allowed per 3GPP [dB]	MPR [dB]
			18625 (1852.5 MHz)	18900 (1880.0 MHz)	19175 (1907.5 MHz)		
			Conducted Power [dBm]				
QPSK	1	0	23.88	23.15	23.51	0	0
	1	12	23.87	23.12	23.54		0
	1	24	23.91	23.16	23.60		0
	12	0	21.77	21.18	21.60	0-1	1
	12	6	21.80	21.17	21.57		1
	12	13	21.79	21.18	21.62		1
	25	0	21.74	21.19	21.58		1
16QAM	1	0	21.58	21.21	21.79	0-1	1
	1	12	21.85	21.25	21.71		1
	1	24	21.89	21.07	21.81		1
	12	0	20.84	20.11	20.66	0-2	2
	12	6	20.83	20.10	20.62		2
	12	13	20.78	20.13	20.68		2
	25	0	20.79	20.17	20.62		2

Table 9-39
LTE Band 2 (PCS) Maximum Conducted Powers - 3 MHz Bandwidth

LTE Band 2 (PCS) 3 MHz Bandwidth							
Modulation	RB Size	RB Offset	Low Channel	Mid Channel	High Channel	MPR Allowed per 3GPP [dB]	MPR [dB]
			18615 (1851.5 MHz)	18900 (1880.0 MHz)	19185 (1908.5 MHz)		
			Conducted Power [dBm]				
QPSK	1	0	23.79	23.16	23.60	0	0
	1	7	23.76	23.14	23.62		0
	1	14	23.84	23.20	23.67		0
	8	0	21.82	21.20	21.65	0-1	1
	8	4	21.81	21.18	21.62		1
	8	7	21.82	21.20	21.64		1
	15	0	21.81	21.15	21.60		1
16QAM	1	0	21.94	21.12	21.76	0-1	1
	1	7	21.88	21.11	21.67		1
	1	14	21.92	21.13	21.68		1
	8	0	20.72	20.04	20.56	0-2	2
	8	4	20.73	20.06	20.59		2
	8	7	20.76	20.00	20.51		2
	15	0	20.77	20.13	20.60		2



FCC ID: A3LSMJ530GM		SAR EVALUATION REPORT		Approved by: Quality Manager
Document S/N: 1M1703230121-01-R1.A3L	Test Dates: 03/20/17 - 04/20/17	DUT Type: Portable Handset	Page 46 of 85	

Table 9-40
LTE Band 2 (PCS) Maximum Conducted Powers -1.4 MHz Bandwidth

LTE Band 2 (PCS) 1.4 MHz Bandwidth							
Modulation	RB Size	RB Offset	Low Channel	Mid Channel	High Channel	MPR Allowed per 3GPP [dB]	MPR [dB]
			18607 (1850.7 MHz)	18900 (1880.0 MHz)	19193 (1909.3 MHz)		
QPSK	1	0	23.74	23.14	23.46	0	0
	1	2	23.75	23.01	23.52		0
	1	5	23.74	23.02	23.52		0
	3	0	23.77	23.18	23.49		0
	3	2	23.80	23.22	23.58		0
	3	3	23.81	23.20	23.56		0
	6	0	21.71	21.13	21.51		0-1
16QAM	1	0	21.74	21.15	21.50	0-1	1
	1	2	21.81	21.24	21.49		1
	1	5	21.72	21.13	21.44		1
	3	0	21.78	21.19	21.45		1
	3	2	21.80	21.26	21.56		1
	3	3	21.79	21.21	21.52		1
	6	0	20.74	20.13	20.49		0-2

Table 9-41
LTE Band 2 (PCS) Reduced Conducted Powers - 20 MHz Bandwidth

LTE Band 2 (PCS) 20 MHz Bandwidth								
Modulation	RB Size	RB Offset	Low Channel	Mid Channel	High Channel	MPR Allowed per 3GPP [dB]	MPR [dB]	
			18700 (1860.0 MHz)	18900 (1880.0 MHz)	19100 (1900.0 MHz)			
Conducted Power [dBm]								
QPSK	1	0	19.83	19.34	19.65	0	0	
	1	50	19.91	19.39	19.66		0	
	1	99	19.93	19.47	19.73		0	
	QPSK	50	0	18.12	17.49	17.83	0-1	1
		50	25	18.16	17.54	17.83		1
		50	50	18.20	17.57	17.88		1
		100	0	18.16	17.55	17.89		1
16QAM	1	0	18.18	17.15	17.68	0-1	1	
	1	50	18.29	17.28	17.76		1	
	1	99	18.32	17.29	17.85		1	
	16QAM	50	0	17.18	16.50	16.82	0-2	2
		50	25	17.18	16.55	16.87		2
		50	50	17.22	16.58	16.91		2
		100	0	17.21	16.55	16.95		2



FCC ID: A3LSMJ530GM		SAR EVALUATION REPORT		Approved by: Quality Manager
Document S/N: 1M1703230121-01-R1.A3L	Test Dates: 03/20/17 - 04/20/17	DUT Type: Portable Handset	Page 47 of 85	

Table 9-42
LTE Band 2 (PCS) Reduced Conducted Powers - 15 MHz Bandwidth

LTE Band 2 (PCS) 15 MHz Bandwidth							
Modulation	RB Size	RB Offset	Low Channel	Mid Channel	High Channel	MPR Allowed per 3GPP [dB]	MPR [dB]
			18675 (1857.5 MHz)	18900 (1880.0 MHz)	19125 (1902.5 MHz)		
			Conducted Power [dBm]				
QPSK	1	0	20.00	19.74	19.90	0	0
	1	36	20.00	19.75	19.86		0
	1	74	19.99	19.72	19.86		0
	36	0	18.27	17.80	17.92	0-1	1
	36	18	18.27	17.81	17.90		1
	36	37	18.29	17.81	17.90		1
	75	0	18.27	17.75	17.91		1
16QAM	1	0	18.35	17.88	17.91	0-1	1
	1	36	18.43	17.75	17.95		1
	1	74	18.44	18.10	17.93		1
	36	0	17.31	16.86	17.06	0-2	2
	36	18	17.32	16.84	17.03		2
	36	37	17.29	16.85	17.03		2
	75	0	17.33	16.83	16.91		2

Table 9-43
LTE Band 2 (PCS) Reduced Conducted Powers - 10 MHz Bandwidth

LTE Band 2 (PCS) 10 MHz Bandwidth							
Modulation	RB Size	RB Offset	Low Channel	Mid Channel	High Channel	MPR Allowed per 3GPP [dB]	MPR [dB]
			18650 (1855.0 MHz)	18900 (1880.0 MHz)	19150 (1905.0 MHz)		
			Conducted Power [dBm]				
QPSK	1	0	20.00	19.59	20.00	0	0
	1	25	19.98	19.57	19.90		0
	1	49	20.00	19.67	20.00		0
	25	0	18.29	17.69	18.00	0-1	1
	25	12	18.27	17.67	18.01		1
	25	25	18.28	17.67	18.03		1
	50	0	18.30	17.70	18.02		1
16QAM	1	0	18.27	18.12	18.08	0-1	1
	1	25	18.24	18.19	18.05		1
	1	49	18.24	18.19	18.03		1
	25	0	17.38	16.76	17.08	0-2	2
	25	12	17.36	16.74	17.00		2
	25	25	17.37	16.71	17.02		2
	50	0	17.30	16.73	17.01		2



FCC ID: A3LSMJ530GM		SAR EVALUATION REPORT		Approved by: Quality Manager
Document S/N: 1M1703230121-01-R1.A3L	Test Dates: 03/20/17 - 04/20/17	DUT Type: Portable Handset	Page 48 of 85	

Table 9-44
LTE Band 2 (PCS) Reduced Conducted Powers - 5 MHz Bandwidth

LTE Band 2 (PCS) 5 MHz Bandwidth							
Modulation	RB Size	RB Offset	Low Channel	Mid Channel	High Channel	MPR Allowed per 3GPP [dB]	MPR [dB]
			18625 (1852.5 MHz)	18900 (1880.0 MHz)	19175 (1907.5 MHz)		
			Conducted Power [dBm]				
QPSK	1	0	19.98	19.54	20.00	0	0
	1	12	19.90	19.57	20.00		0
	1	24	20.00	19.60	19.97		0
	12	0	18.41	17.60	18.07	0-1	1
	12	6	18.44	17.62	18.06		1
	12	13	18.45	17.61	18.02		1
	25	0	18.47	17.60	18.04		1
16QAM	1	0	18.79	17.84	18.15	0-1	1
	1	12	18.86	17.66	18.18		1
	1	24	18.85	17.62	18.17		1
	12	0	17.50	16.61	17.10	0-2	2
	12	6	17.51	16.61	17.09		2
	12	13	17.55	16.64	17.16		2
	25	0	17.47	16.67	17.15		2

Table 9-45
LTE Band 2 (PCS) Reduced Conducted Powers - 3 MHz Bandwidth

LTE Band 2 (PCS) 3 MHz Bandwidth							
Modulation	RB Size	RB Offset	Low Channel	Mid Channel	High Channel	MPR Allowed per 3GPP [dB]	MPR [dB]
			18615 (1851.5 MHz)	18900 (1880.0 MHz)	19185 (1908.5 MHz)		
			Conducted Power [dBm]				
QPSK	1	0	20.00	19.68	20.00	0	0
	1	7	19.99	19.69	19.97		0
	1	14	20.00	19.70	20.00		0
	8	0	18.46	17.71	18.12	0-1	1
	8	4	18.44	17.70	18.09		1
	8	7	18.45	17.72	18.05		1
	15	0	18.43	17.73	18.11		1
16QAM	1	0	19.00	18.04	18.27	0-1	1
	1	7	18.98	17.85	18.24		1
	1	14	18.88	17.76	18.28		1
	8	0	17.41	16.74	17.00	0-2	2
	8	4	17.42	16.74	17.08		2
	8	7	17.42	16.71	17.13		2
	15	0	17.39	16.71	17.07		2



FCC ID: A3LSMJ530GM		SAR EVALUATION REPORT		Approved by: Quality Manager
Document S/N: 1M1703230121-01-R1.A3L	Test Dates: 03/20/17 - 04/20/17	DUT Type: Portable Handset	Page 49 of 85	

Table 9-46
LTE Band 2 (PCS) Reduced Conducted Powers -1.4 MHz Bandwidth

LTE Band 2 (PCS) 1.4 MHz Bandwidth							
Modulation	RB Size	RB Offset	Low Channel	Mid Channel	High Channel	MPR Allowed per 3GPP [dB]	MPR [dB]
			18607 (1850.7 MHz)	18900 (1880.0 MHz)	19193 (1909.3 MHz)		
QPSK	1	0	20.00	19.73	19.90	0	0
	1	2	19.99	19.74	20.00		0
	1	5	20.00	19.75	19.91		0
	3	0	20.00	19.72	20.00		0
	3	2	19.98	19.74	19.98		0
	3	3	20.00	19.72	20.00		0
	6	0	18.38	17.75	18.11		0-1
16QAM	1	0	18.63	17.81	18.39	0-1	1
	1	2	18.69	17.88	18.80		1
	1	5	18.72	17.86	18.46		1
	3	0	18.54	17.78	18.25		1
	3	2	18.56	17.77	18.32		1
	3	3	18.48	17.80	18.29		1
	6	0	17.33	16.80	17.18		0-2

9.4.3 LTE Band 41

Table 9-47
LTE Band 41 Maximum Conducted Powers - 20 MHz Bandwidth

LTE Band 41 20 MHz Bandwidth										
Modulation	RB Size	RB Offset	Low Channel	Low-Mid Channel	Mid Channel	Mid-High Channel	High Channel	MPR Allowed per 3GPP [dB]	MPR [dB]	
			39750 (2506.0 MHz)	40185 (2549.5 MHz)	40620 (2593.0 MHz)	41055 (2636.5 MHz)	41490 (2680.0 MHz)			
Conducted Power [dBm]										
QPSK	1	0	21.73	22.49	22.84	21.86	22.18	0	0	
	1	50	21.75	22.45	22.71	21.73	22.03		0	
	1	99	21.80	22.42	22.61	21.59	21.96		0	
	QPSK	50	0	20.51	21.33	21.52	20.72	20.85	0-1	1
		50	25	20.50	21.31	21.50	20.67	20.78		1
		50	50	20.55	21.27	21.42	20.58	20.75		1
		100	0	20.50	21.28	21.50	20.60	20.82		1
16QAM	1	0	20.60	21.51	21.95	20.92	21.31	0-1	1	
	1	50	20.79	21.46	21.27	20.66	20.62		1	
	1	99	20.76	21.23	21.18	20.56	20.99		1	
	16QAM	50	0	19.51	20.40	20.48	19.67	19.85	0-2	2
		50	25	19.98	20.23	20.41	19.57	19.76		2
		50	50	20.12	20.21	20.35	19.52	19.74		2
		100	0	19.87	20.25	20.47	19.55	19.77		2



FCC ID: A3LSMJ530GM		SAR EVALUATION REPORT		Approved by: Quality Manager
Document S/N: 1M1703230121-01-R1.A3L	Test Dates: 03/20/17 - 04/20/17	DUT Type: Portable Handset		Page 50 of 85

Table 9-48
LTE Band 41 Maximum Conducted Powers - 15 MHz Bandwidth

LTE Band 41 15 MHz Bandwidth									
Modulation	RB Size	RB Offset	Low Channel	Low-Mid Channel	Mid Channel	Mid-High Channel	High Channel	MPR Allowed per 3GPP [dB]	MPR [dB]
			39750 (2506.0 MHz)	40185 (2549.5 MHz)	40620 (2593.0 MHz)	41055 (2636.5 MHz)	41490 (2680.0 MHz)		
			Conducted Power [dBm]						
QPSK	1	0	22.15	22.73	22.98	22.38	22.60	0	0
	1	36	22.12	22.68	22.97	22.36	22.54		0
	1	74	22.16	22.66	22.96	22.34	22.52		0
	36	0	20.80	21.51	21.68	21.05	21.38	0-1	1
	36	18	20.79	21.47	21.65	21.02	21.37		1
	36	37	20.80	21.46	21.70	21.01	21.36		1
	75	0	20.77	21.45	21.68	21.02	21.37		1
16QAM	1	0	21.33	21.67	21.97	21.32	21.34	0-1	1
	1	36	21.41	21.66	21.92	21.30	21.31		1
	1	74	21.43	21.64	21.89	21.26	21.27		1
	36	0	19.71	20.48	20.57	19.97	20.40	0-2	2
	36	18	19.73	20.46	20.60	19.98	20.37		2
	36	37	19.74	20.47	20.57	19.95	20.33		2
	75	0	19.66	20.38	20.60	19.94	20.34		2

Table 9-49
LTE Band 41 Maximum Conducted Powers - 10 MHz Bandwidth

LTE Band 41 10 MHz Bandwidth									
Modulation	RB Size	RB Offset	Low Channel	Low-Mid Channel	Mid Channel	Mid-High Channel	High Channel	MPR Allowed per 3GPP [dB]	MPR [dB]
			39750 (2506.0 MHz)	40185 (2549.5 MHz)	40620 (2593.0 MHz)	41055 (2636.5 MHz)	41490 (2680.0 MHz)		
			Conducted Power [dBm]						
QPSK	1	0	22.15	22.70	23.07	22.21	22.51	0	0
	1	25	22.28	22.69	23.03	22.16	22.50		0
	1	49	22.27	22.75	23.00	22.15	22.47		0
	25	0	20.71	21.36	21.57	20.97	21.36	0-1	1
	25	12	20.70	21.34	21.58	21.00	21.31		1
	25	25	20.64	21.35	21.60	20.97	21.30		1
	50	0	20.79	21.33	21.51	21.06	21.34		1
16QAM	1	0	20.66	21.46	21.72	21.02	21.21	0-1	1
	1	25	20.73	21.42	21.74	20.89	21.05		1
	1	49	20.65	21.39	21.68	20.98	21.09		1
	25	0	19.54	20.23	20.47	20.02	20.31	0-2	2
	25	12	19.60	20.26	20.45	19.98	20.28		2
	25	25	19.59	20.42	20.50	19.97	20.29		2
	50	0	19.57	20.25	20.51	20.01	20.32		2



FCC ID: A3LSMJ530GM		SAR EVALUATION REPORT		Approved by: Quality Manager
Document S/N: 1M1703230121-01-R1.A3L	Test Dates: 03/20/17 - 04/20/17	DUT Type: Portable Handset	Page 51 of 85	

Table 9-50
LTE Band 41 Maximum Conducted Powers - 5 MHz Bandwidth

LTE Band 41 5 MHz Bandwidth										
Modulation	RB Size	RB Offset	Low Channel	Low-Mid Channel	Mid Channel	Mid-High Channel	High Channel	MPR Allowed per 3GPP [dB]	MPR [dB]	
			39750 (2506.0 MHz)	40185 (2549.5 MHz)	40620 (2593.0 MHz)	41055 (2636.5 MHz)	41490 (2680.0 MHz)			
			Conducted Power [dBm]							
QPSK	1	0	21.97	22.53	22.77	22.22	22.56	0	0	
	1	12	21.93	22.54	22.76	22.16	22.61		0	
	1	24	21.96	22.55	22.73	22.17	22.46		0	
	QPSK	12	0	20.70	21.34	21.54	21.00	21.34	0-1	1
		12	6	20.66	21.39	21.56	21.01	21.27		1
		12	13	20.74	21.26	21.53	21.03	21.30		1
		25	0	20.76	21.30	21.57	20.96	21.33		1
1		0	20.85	21.47	21.50	21.09	21.48	0-1		1
1	12	20.79	21.43	21.47	21.03	21.42	1			
1	24	20.84	21.45	21.53	21.06	21.43	1			
16QAM	12	0	19.58	20.26	20.60	19.92	20.32	0-2	2	
	12	6	19.57	20.27	20.62	20.03	20.35		2	
	12	13	19.56	20.26	20.59	19.96	20.27		2	
	25	0	19.53	20.18	20.61	19.92	20.24	2		

Table 9-51
LTE Band 41 Reduced Conducted Powers - 20 MHz Bandwidth

LTE Band 41 20 MHz Bandwidth										
Modulation	RB Size	RB Offset	Low Channel	Low-Mid Channel	Mid Channel	Mid-High Channel	High Channel	MPR Allowed per 3GPP [dB]	MPR [dB]	
			39750 (2506.0 MHz)	40185 (2549.5 MHz)	40620 (2593.0 MHz)	41055 (2636.5 MHz)	41490 (2680.0 MHz)			
			Conducted Power [dBm]							
QPSK	1	0	19.11	19.88	20.29	19.72	20.11	0	0	
	1	50	19.04	19.77	20.10	19.58	19.95		0	
	1	99	19.06	19.74	20.02	19.44	19.85		0	
	QPSK	50	0	18.24	19.01	19.22	18.74	18.81	0-1	1
		50	25	18.24	18.98	19.18	18.69	18.78		1
		50	50	18.26	18.92	19.13	18.64	18.72		1
		100	0	18.27	18.97	19.21	18.69	18.74		1
16QAM	1	0	18.80	19.09	19.87	19.02	18.99	0-1	1	
	1	50	18.77	19.05	19.78	18.85	18.90		1	
	1	99	18.83	18.98	19.74	18.77	18.82		1	
	16QAM	50	0	17.29	17.99	18.24	17.81	17.92	0-2	2
		50	25	17.34	17.96	18.17	17.69	17.83		2
		50	50	17.30	17.95	18.15	17.66	17.85		2
		100	0	17.24	18.06	18.26	17.75	17.78		2



FCC ID: A3LSMJ530GM		SAR EVALUATION REPORT		Approved by: Quality Manager
Document S/N: 1M1703230121-01-R1.A3L	Test Dates: 03/20/17 - 04/20/17	DUT Type: Portable Handset	Page 52 of 85	

Table 9-52
LTE Band 41 Reduced Conducted Powers - 15 MHz Bandwidth

LTE Band 41 15 MHz Bandwidth										
Modulation	RB Size	RB Offset	Low Channel	Low-Mid Channel	Mid Channel	Mid-High Channel	High Channel	MPR Allowed per 3GPP [dB]	MPR [dB]	
			39750 (2506.0 MHz)	40185 (2549.5 MHz)	40620 (2593.0 MHz)	41055 (2636.5 MHz)	41490 (2680.0 MHz)			
			Conducted Power [dBm]							
QPSK	1	0	19.17	20.04	20.16	20.00	20.09	0	0	
	1	36	19.11	19.93	20.12	19.84	19.95		0	
	1	74	19.08	19.83	20.06	19.77	19.82		0	
	QPSK	36	0	18.41	18.98	19.19	18.89	18.95	0-1	1
		36	18	18.38	19.03	19.13	18.82	18.94		1
		36	37	18.34	18.95	19.08	18.78	18.86		1
		75	0	18.35	18.97	19.08	18.85	18.93		1
16QAM	1	0	18.03	18.73	19.25	18.95	18.95	0-1	1	
	1	36	18.01	18.94	19.21	18.77	18.85		1	
	1	74	18.00	18.58	19.00	18.72	18.72		1	
	16QAM	36	0	17.48	17.90	18.25	17.80	17.98	0-2	2
		36	18	17.44	17.92	18.22	17.86	17.92		2
		36	37	17.41	17.92	18.18	17.79	17.89		2
		75	0	17.40	18.00	18.23	17.88	17.97		2

Table 9-53
LTE Band 41 Reduced Conducted Powers - 10 MHz Bandwidth

LTE Band 41 10 MHz Bandwidth										
Modulation	RB Size	RB Offset	Low Channel	Low-Mid Channel	Mid Channel	Mid-High Channel	High Channel	MPR Allowed per 3GPP [dB]	MPR [dB]	
			39750 (2506.0 MHz)	40185 (2549.5 MHz)	40620 (2593.0 MHz)	41055 (2636.5 MHz)	41490 (2680.0 MHz)			
			Conducted Power [dBm]							
QPSK	1	0	19.00	19.91	20.27	19.83	19.56	0	0	
	1	25	19.12	19.85	20.16	19.74	19.78		0	
	1	49	19.03	19.86	20.13	19.66	19.65		0	
	QPSK	25	0	18.23	18.94	19.13	18.75	18.87	0-1	1
		25	12	18.14	18.85	19.16	18.69	18.66		1
		25	25	18.10	18.82	19.11	18.64	18.61		1
16QAM	50	0	18.08	18.90	19.14	18.69	18.68	0-2	1	
	1	0	18.21	18.93	19.14	18.83	18.82		1	
	1	25	18.15	18.86	19.05	18.79	18.67		1	
	1	49	18.10	18.83	19.03	18.62	18.58		1	
	25	0	17.10	17.91	18.26	17.69	17.74		2	
	25	12	17.05	17.90	18.23	17.65	17.65		2	
	25	25	17.08	17.88	18.19	17.59	17.61		2	
50	0	17.13	17.93	18.19	17.75	17.78	2			



FCC ID: A3LSMJ530GM		SAR EVALUATION REPORT		Approved by: Quality Manager
Document S/N: 1M1703230121-01-R1.A3L	Test Dates: 03/20/17 - 04/20/17	DUT Type: Portable Handset	Page 53 of 85	



Table 9-54
LTE Band 41 Reduced Conducted Powers - 5 MHz Bandwidth

LTE Band 41 5 MHz Bandwidth										
Modulation	RB Size	RB Offset	Low Channel	Low-Mid Channel	Mid Channel	Mid-High Channel	High Channel	MPR Allowed per 3GPP [dB]	MPR [dB]	
			39750 (2506.0 MHz)	40185 (2549.5 MHz)	40620 (2593.0 MHz)	41055 (2636.5 MHz)	41490 (2680.0 MHz)			
			Conducted Power [dBm]							
QPSK	1	0	19.00	20.03	20.09	19.81	19.82	0	0	
	1	12	19.10	20.07	20.06	19.77	19.80		0	
	1	24	19.01	19.94	20.02	19.70	19.76		0	
	QPSK	12	0	18.23	19.14	19.05	18.61	18.75	0-1	1
		12	6	18.10	19.00	18.90	18.59	18.59		1
		12	13	18.12	18.93	18.85	18.56	18.55		1
		25	0	18.09	18.95	18.90	18.58	18.59		1
1		0	18.12	19.20	19.04	18.75	18.64	0-1		1
1	12	18.14	19.01	18.97	18.74	18.70	1			
1	24	18.18	18.96	18.93	18.68	18.67	1			
16QAM	12	0	17.05	17.94	17.96	17.67	17.66	0-2	2	
	12	6	17.10	17.94	17.94	17.65	17.62		2	
	12	13	17.13	17.92	17.91	17.60	17.60		2	
	25	0	17.11	17.90	17.88	17.58	17.62		2	
	1	0	18.12	19.20	19.04	18.75	18.64		0-2	2
1	12	18.14	19.01	18.97	18.74	18.70	2			
1	24	18.18	18.96	18.93	18.68	18.67	2			

9.4.4 LTE Carrier Aggregation Conducted Powers

Table 9-55
LTE Carrier Aggregation Maximum Conducted Powers

PCC Band	PCC Bandwidth [MHz]	PCC (UL) Channel	PCC						SCC				Power	
			PCC (UL) Frequency [MHz]	Modulation	PCC ULI/ RB	PCC UL RB Offset	PCC (DL) Channel	PCC (DL) Frequency [MHz]	SCC Band	SCC Bandwidth [MHz]	SCC (DL) Channel	SCC (DL) Frequency [MHz]	LTE Tx. Power with DL CA Enabled (dBm)	LTE Single Carrier Tx Power (dBm)
LTE B2	5	18625	1852.5	QPSK	1	24	625	1932.5	LTE B17	10	5790	740	23.58	23.91
LTE B2	5	18625	1852.5	QPSK	1	24	625	1932.5	LTE B12	10	5095	737.5	23.51	23.91
LTE B2	5	18625	1852.5	QPSK	1	24	625	1932.5	LTE B5	10	2525	881.5	23.56	23.91
LTE B4	5	20175	1732.5	QPSK	1	24	2175	2132.5	LTE B17	10	5790	740	23.25	23.97
LTE B4	3	19965	1711.5	QPSK	1	7	1965	2111.5	LTE B12	10	5095	737.5	23.69	24.03
LTE B4	5	20175	1732.5	QPSK	1	24	2175	2132.5	LTE B5	10	2525	881.5	23.29	23.97
LTE B5	10	20525	836.5	QPSK	1	0	2525	881.5	LTE B2	20	900	1960	24.50	24.50
LTE B5	10	20525	836.5	QPSK	1	0	2525	881.5	LTE B4	20	2175	2132.5	24.49	24.50
LTE B17	10	23780	709	QPSK	1	0	5780	739	LTE B2	10	900	1960	24.00	23.78
LTE B12	10	23095	707.5	QPSK	1	0	5095	737.5	LTE B2	20	900	1960	23.91	23.78
LTE B66	5	131997	1712.5	QPSK	1	0	66461	2112.5	LTE B12	10	5095	737.5	23.19	23.20
LTE B41	10	40620	2593	QPSK	1	0	40620	2593	LTE B41	20	40470	2578	22.57	23.07
LTE B66	5	131997	1712.5	QPSK	1	0	66461	2112.5	LTE B66	15	66560	2122.4	23.19	23.20
LTE B66	5	131997	1712.5	QPSK	1	0	66461	2112.5	LTE B66	20	66584	2124.8	23.20	23.20
LTE B5	10	20525	836.5	QPSK	1	0	2525	881.5	LTE B5	5	2425	871.5	24.44	24.50
LTE B41	10	40620	2593	QPSK	1	0	40620	2593	LTE B41	5	39675	2498.5	22.66	23.07
LTE B66	5	131997	1712.5	QPSK	1	0	66461	2112.5	LTE B66	5	67311	2197.5	23.17	23.20

FCC ID: A3LSMJ530GM	 PCTEST ENGINEERING LABORATORY, INC.	SAR EVALUATION REPORT		Approved by: Quality Manager
Document S/N: 1M1703230121-01-R1.A3L	Test Dates: 03/20/17 - 04/20/17	DUT Type: Portable Handset		Page 54 of 85

**Table 9-56
LTE Carrier Aggregation Reduced Conducted Powers**



PCC									SCC				Power	
PCC Band	PCC Bandwidth [MHz]	PCC (UL) Channel	PCC (UL) Frequency [MHz]	Modulation	PCC UL# RB	PCC UL RB Offset	PCC (DL) Channel	PCC (DL) Frequency [MHz]	SCC Band	SCC Bandwidth [MHz]	SCC (DL) Channel	SCC (DL) Frequency [MHz]	LTE Tx.Power with DL CA Enabled (dBm)	LTE Single Carrier Tx Power (dBm)
LTE B2	10	18650	1855	QPSK	1	0	650	1935	LTE B17	10	5790	740	19.97	20.00
LTE B2	15	18675	1857.5	QPSK	1	0	675	1937.5	LTE B12	10	5095	737.5	19.98	20.00
LTE B2	15	18675	1857.5	QPSK	1	0	675	1937.5	LTE B5	10	2525	881.5	19.63	20.00
LTE B4	5	19975	1712.5	QPSK	1	12	1975	2112.5	LTE B17	10	5790	740	20.02	20.42
LTE B4	1.4	20175	1732.5	QPSK	1	0	2175	2132.5	LTE B12	10	5095	737.5	20.05	20.47
LTE B4	20	20175	1732.5	QPSK	1	0	2175	2132.5	LTE B5	10	2525	881.5	20.04	20.43
LTE B66	1.4	132208	1733.6	QPSK	1	2	66672	2133.6	LTE B12	10	5095	737.5	19.82	20.14
LTE B41	20	40620	2593	QPSK	1	0	40620	2593	LTE B41	20	40422	2573.2	20.33	20.29
LTE B66	5	132322	1745	QPSK	1	0	66786	2145	LTE B66	15	66687	2135.1	20.00	20.00
LTE B66	20	132072	1720	QPSK	1	99	66536	2120	LTE B66	20	66734	2139.8	20.04	20.06
LTE B41	20	40620	2593	QPSK	1	0	40620	2593	LTE B41	5	39675	2498.5	20.28	20.29
LTE B66	20	132072	1720	QPSK	1	99	66536	2120	LTE B66	5	67311	2197.5	19.97	20.06

Notes:

1. The device only supports downlink Carrier Aggregation. Uplink Carrier Aggregation is not supported. For every supported combination of downlink carrier aggregation, power measurements were performed with the downlink carrier aggregation active for the configuration with highest measured maximum conducted power with downlink carrier aggregation inactive measured among the channel bandwidth, modulation, and RB combinations in each frequency band.
2. All control and acknowledge data is sent on uplink channels that operate identical to specifications when downlink carrier aggregation is inactive.
3. For downlink carrier aggregation combinations, PCC uplink channel was selected based on section C)3)b)ii) of KBD 941225 D05 V01r02. The downlink PCC channel was paired with the selected PCC uplink channel according to normal configurations without carrier aggregation. For contiguous intra-band CA, the downlink channel spacing between the component carriers was set to multiple of 300 kHz less than the nominal channel spacing defined in section 5.4.1A of 3GPP TS 36.521. All selected downlink channels remained fully within the downlink transmission band of the respective component carrier.



**Figure 9-3
Power Measurement Setup**

FCC ID: A3LSMJ530GM		SAR EVALUATION REPORT		Approved by: Quality Manager
Document S/N: 1M1703230121-01-R1.A3L	Test Dates: 03/20/17 - 04/20/17	DUT Type: Portable Handset	Page 55 of 85	

9.5 WLAN Conducted Powers

Table 9-57
2.4 GHz WLAN Reduced Average RF Power

Freq [MHz]	Channel	2.4GHz Conducted Power [dBm]	
		IEEE Transmission Mode	
		802.11b	802.11g
2412	1	16.07	13.28
2437	6	15.79	13.06
2462	11	16.02	13.01

Table 9-58
5 GHz WLAN Reduced Average RF Power (Held-to-Ear)

Freq [MHz]	Channel	5GHz (20MHz) Conducted Power [dBm]
		IEEE Transmission Mode
		802.11a
5180	36	12.00
5200	40	11.83
5220	44	11.93
5240	48	11.82
5260	52	12.42
5280	56	12.38
5300	60	12.33
5320	64	12.27
5500	100	12.39
5600	120	12.38
5620	124	11.80
5720	144	11.71
5745	149	11.74
5785	157	11.63
5825	165	11.66





FCC ID: A3LSMJ530GM		SAR EVALUATION REPORT		Approved by: Quality Manager
Document S/N: 1M1703230121-01-R1.A3L	Test Dates: 03/20/17 - 04/20/17	DUT Type: Portable Handset	Page 56 of 85	

Table 9-59
2.4 GHz WLAN Maximum Average RF Power

Freq [MHz]	Channel	2.4GHz Conducted Power [dBm]	
		IEEE Transmission Mode	
		802.11b	802.11g
2412	1	18.01	14.79
2437	6	18.04	14.95
2462	11	17.97	14.70

Table 9-60
5 GHz WLAN Maximum Average RF Power

Freq [MHz]	Channel	5GHz (20MHz) Conducted Power [dBm]
		IEEE Transmission Mode
		802.11a
5180	36	13.74
5200	40	13.73
5220	44	13.63
5240	48	13.74
5260	52	14.23
5280	56	14.22
5300	60	14.20
5320	64	14.12
5500	100	14.08
5600	120	14.01
5620	124	13.96
5720	144	13.98
5745	149	14.21
5785	157	14.08
5825	165	14.06

FCC ID: A3LSMJ530GM		SAR EVALUATION REPORT		Approved by: Quality Manager
Document S/N: 1M1703230121-01-R1.A3L	Test Dates: 03/20/17 - 04/20/17	DUT Type: Portable Handset		Page 57 of 85

Justification for test configurations for WLAN per KDB Publication 248227 D01v02r02:

- Power measurements were performed for the transmission mode configuration with the highest maximum output power specified for production units.
- For transmission modes with the same maximum output power specification, powers were measured for the largest channel bandwidth, lowest order modulation and lowest data rate.
- For transmission modes with identical maximum specified output power, channel bandwidth, modulation and data rates, power measurements were required for all identical configurations.
- For each transmission mode configuration, powers were measured for the highest and lowest channels; and at the mid-band channel(s) when there were at least 3 channels supported. For configurations with multiple mid-band channels, due to an even number of channels, both channels were measured.
- The bolded data rate and channel above were tested for SAR.

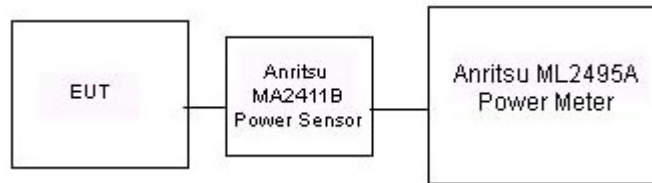

Figure 9-4

Power Measurement Setup for Bandwidths < 50 MHz

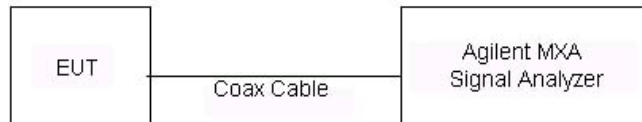



Figure 9-5

Power Measurement Setup for Bandwidths > 50 MHz



FCC ID: A3LSMJ530GM	 SAR EVALUATION REPORT 		Approved by: Quality Manager
Document S/N: 1M1703230121-01-R1.A3L	Test Dates: 03/20/17 - 04/20/17	DUT Type: Portable Handset	Page 58 of 85

10 SYSTEM VERIFICATION

10.1 Tissue Verification

**Table 10-1
Measured Head Tissue Properties**



Calibrated for Tests Performed on:	Tissue Type	Tissue Temp During Calibration (°C)	Measured Frequency (MHz)	Measured Conductivity, σ (S/m)	Measured Dielectric Constant, ϵ	TARGET Conductivity, σ (S/m)	TARGET Dielectric Constant, ϵ	% dev σ	% dev ϵ
4/10/2017	750H	19.9	700	0.867	43.266	0.889	42.201	-2.47%	2.52%
			710	0.872	43.083	0.890	42.149	-2.02%	2.22%
			740	0.896	42.707	0.893	41.994	0.34%	1.70%
			755	0.909	42.374	0.894	41.916	1.68%	1.09%
4/4/2017	835H	21.3	820	0.889	41.339	0.899	41.578	-1.11%	-0.57%
			835	0.904	41.042	0.900	41.500	0.44%	-1.10%
			850	0.921	40.908	0.916	41.500	0.55%	-1.43%
3/28/2017	1750H	20.8	1710	1.337	40.814	1.348	40.142	-0.82%	1.67%
			1750	1.388	40.558	1.371	40.079	1.24%	1.20%
			1790	1.428	40.419	1.394	40.016	2.44%	1.01%
4/4/2017	1750H	21.6	1710	1.337	40.398	1.348	40.142	-0.82%	0.64%
			1750	1.383	40.151	1.371	40.079	0.88%	0.18%
			1790	1.421	39.944	1.394	40.016	1.94%	-0.18%
3/30/2017	1900H	21.9	1850	1.385	39.991	1.400	40.000	-1.07%	-0.02%
			1880	1.417	39.880	1.400	40.000	1.21%	-0.30%
			1910	1.448	39.764	1.400	40.000	3.43%	-0.59%
4/6/2017	1900H	21.5	1850	1.387	40.453	1.400	40.000	-0.93%	1.13%
			1880	1.416	40.282	1.400	40.000	1.14%	0.70%
			1910	1.452	40.156	1.400	40.000	3.71%	0.39%
3/23/2017	2450H	22.9	2400	1.795	38.168	1.756	39.289	2.22%	-2.85%
			2450	1.854	37.914	1.800	39.200	3.00%	-3.28%
			2500	1.911	37.714	1.855	39.136	3.02%	-3.63%
4/3/2017	2600H	21.8	2550	1.934	37.833	1.909	39.073	1.31%	-3.17%
			2600	1.989	37.521	1.964	39.009	1.27%	-3.81%
			2650	2.063	37.381	2.018	38.945	2.23%	-4.02%
			2700	2.110	37.162	2.073	38.882	1.78%	-4.42%
03/27/2017	5200H-5800H	22.9	5240	4.637	35.513	4.696	35.940	-1.26%	-1.19%
			5260	4.657	35.474	4.717	35.917	-1.27%	-1.23%
			5280	4.672	35.435	4.737	35.894	-1.37%	-1.28%
			5500	4.900	35.138	4.963	35.643	-1.27%	-1.42%
			5600	5.015	34.923	5.065	35.529	-0.99%	-1.71%
			5745	5.151	34.773	5.214	35.363	-1.21%	-1.67%
			5765	5.174	34.731	5.234	35.340	-1.15%	-1.72%
			5825	5.066	35.048	5.296	35.275	-4.34%	-0.64%

FCC ID: A3LSMJ530GM		SAR EVALUATION REPORT		Approved by: Quality Manager
Document S/N: 1M1703230121-01-R1.A3L	Test Dates: 03/20/17 - 04/20/17	DUT Type: Portable Handset	Page 59 of 85	

**Table 10-2
Measured Body Tissue Properties**

Calibrated for Tests Performed on:	Tissue Type	Tissue Temp During Calibration (°C)	Measured Frequency (MHz)	Measured Conductivity, σ (S/m)	Measured Dielectric Constant, ϵ	TARGET Conductivity, σ (S/m)	TARGET Dielectric Constant, ϵ	% dev σ	% dev ϵ
4/10/2017	750B	22.1	700	0.915	54.457	0.959	55.726	-4.59%	-2.28%
			710	0.927	54.287	0.960	55.687	-3.44%	-2.51%
			740	0.955	53.999	0.963	55.570	-0.83%	-2.83%
			755	0.966	53.833	0.964	55.512	0.21%	-3.02%
4/3/2017	835B	21.2	820	0.983	55.305	0.969	55.258	1.44%	0.09%
			835	0.994	55.071	0.970	55.200	2.47%	-0.23%
			850	1.012	54.977	0.988	55.154	2.43%	-0.32%
4/17/2017	835B	20.1	820	0.967	54.920	0.969	55.258	-0.21%	-0.61%
			835	0.982	54.813	0.970	55.200	1.24%	-0.70%
			850	0.997	54.651	0.988	55.154	0.91%	-0.91%
3/30/2017	1750B	21.1	1710	1.459	51.165	1.463	53.537	-0.27%	-4.43%
			1750	1.506	51.004	1.488	53.432	1.21%	-4.54%
			1790	1.547	50.839	1.514	53.326	2.18%	-4.66%
4/10/2017	1750B	22.9	1710	1.420	52.455	1.463	53.537	-2.94%	-2.02%
			1750	1.465	52.309	1.488	53.432	-1.55%	-2.10%
			1790	1.510	52.087	1.514	53.326	-0.26%	-2.32%
4/17/2017	1750B	20.7	1710	1.442	52.306	1.463	53.537	-1.44%	-2.30%
			1750	1.492	52.133	1.488	53.432	0.27%	-2.43%
			1790	1.538	52.003	1.514	53.326	1.59%	-2.48%
4/20/2017	1750B	21.3	1710	1.461	51.882	1.463	53.537	-0.14%	-3.09%
			1750	1.508	51.762	1.488	53.432	1.34%	-3.13%
			1790	1.549	51.556	1.514	53.326	2.31%	-3.32%
4/3/2017	1900B	22.3	1850	1.516	52.396	1.520	53.300	-0.26%	-1.70%
			1880	1.552	52.269	1.520	53.300	2.11%	-1.93%
			1910	1.586	52.177	1.520	53.300	4.34%	-2.11%
4/13/2017	1900B	22.4	1850	1.509	51.442	1.520	53.300	-0.72%	-3.49%
			1880	1.541	51.484	1.520	53.300	1.38%	-3.41%
			1910	1.571	51.396	1.520	53.300	3.36%	-3.57%
4/17/2017	1900B	22.6	1850	1.508	51.287	1.520	53.300	-0.79%	-3.78%
			1880	1.547	51.158	1.520	53.300	1.78%	-4.02%
			1910	1.580	51.030	1.520	53.300	3.95%	-4.26%
3/29/2017	2450B	22.1	2400	1.948	51.178	1.902	52.767	2.42%	-3.01%
			2450	2.011	50.977	1.950	52.700	3.13%	-3.27%
			2500	2.081	50.801	2.021	52.636	2.97%	-3.49%
4/18/2017	2450B	23.3	2400	1.972	52.657	1.902	52.767	3.68%	-0.21%
			2450	2.041	52.510	1.950	52.700	4.67%	-0.36%
			2500	2.109	52.257	2.021	52.636	4.35%	-0.72%
4/10/2017	2600B	21.9	2500	2.080	50.668	2.021	52.636	2.92%	-3.74%
			2550	2.145	50.494	2.092	52.573	2.53%	-3.95%
			2600	2.220	50.230	2.163	52.509	2.64%	-4.34%
			2650	2.285	50.023	2.234	52.445	2.28%	-4.62%
			2700	2.349	49.796	2.305	52.382	1.91%	-4.94%
4/18/2017	2600B	23.3	2550	2.175	52.103	2.092	52.573	3.97%	-0.89%
			2600	2.249	51.883	2.163	52.509	3.98%	-1.19%
			2650	2.324	51.752	2.234	52.445	4.03%	-1.32%
			2700	2.389	51.486	2.305	52.382	3.64%	-1.71%
03/20/2017	5200B-5800B	20.8	5240	5.520	47.071	5.346	48.960	3.25%	-3.86%
			5260	5.528	47.004	5.369	48.933	2.96%	-3.94%
			5500	5.844	46.679	5.650	48.607	3.43%	-3.97%
			5600	6.009	46.520	5.766	48.471	4.21%	-4.03%
			5745	6.198	46.289	5.936	48.275	4.41%	-4.11%
			5765	6.219	46.283	5.959	48.248	4.36%	-4.07%
			5785	6.232	46.219	5.982	48.220	4.18%	-4.15%
03/28/2017	5200B-5800B	22.3	5745	6.141	46.567	5.936	48.275	3.45%	-3.54%
			5765	6.172	46.512	5.959	48.248	3.57%	-3.60%

The above measured tissue parameters were used in the DASY software. The DASY software was used to perform interpolation to determine the dielectric parameters at the SAR test device frequencies (per KDB Publication 865664 D01v01r04 and IEEE 1528-2013 6.6.1.2). The tissue parameters listed in the SAR test plots may slightly differ from the table above due to significant digit rounding in the software.

FCC ID: A3LSMJ530GM		SAR EVALUATION REPORT		Approved by: Quality Manager
Document S/N: 1M1703230121-01-R1.A3L	Test Dates: 03/20/17 - 04/20/17	DUT Type: Portable Handset		Page 60 of 85

10.2 Test System Verification

Prior to SAR assessment, the system is verified to $\pm 10\%$ of the SAR measurement on the reference dipole at the time of calibration by the calibration facility. Full system validation status and result summary can be found in Appendix E.

**Table 10-3
System Verification Results**

System Verification TARGET & MEASURED												
SAR System #	Tissue Frequency (MHz)	Tissue Type	Date:	Amb. Temp (°C)	Liquid Temp (°C)	Input Power (W)	Dipole SN	Probe SN	Measured SAR _{1g} (W/kg)	1 W Target SAR _{1g} (W/kg)	1 W Normalized SAR _{1g} (W/kg)	Deviation _{1g} (%)
J	750	HEAD	04/10/2017	21.1	20.0	0.200	1054	3334	1.600	8.370	8.000	-4.42%
J	835	HEAD	04/04/2017	20.5	21.3	0.200	4d133	3334	1.930	9.320	9.650	3.54%
I	1750	HEAD	03/28/2017	21.9	20.8	0.100	1008	3213	3.610	36.700	36.100	-1.63%
K	1750	HEAD	04/04/2017	23.3	21.6	0.100	1148	7409	3.600	36.200	36.000	-0.55%
K	1900	HEAD	03/30/2017	22.9	21.9	0.100	5d149	7409	3.780	40.100	37.800	-5.74%
D	1900	HEAD	04/06/2017	22.4	21.8	0.100	5d149	3288	4.010	40.100	40.100	0.00%
G	2450	HEAD	03/23/2017	21.3	22.9	0.100	797	3287	5.370	52.100	53.700	3.07%
G	2600	HEAD	04/03/2017	23.0	21.7	0.100	1126	3287	5.680	56.300	56.800	0.89%
K	5250	HEAD	03/27/2017	22.7	21.0	0.050	1237	7308	3.850	79.200	77.000	-2.78%
K	5600	HEAD	03/27/2017	22.7	21.0	0.050	1237	7308	4.090	83.300	81.800	-1.80%
K	5750	HEAD	03/27/2017	22.7	21.0	0.050	1237	7308	3.780	81.500	75.600	-7.24%
J	750	BODY	04/10/2017	23.2	22.1	0.200	1054	3334	1.690	8.610	8.450	-1.86%
H	835	BODY	04/03/2017	21.6	21.2	0.200	4d133	3318	2.030	9.500	10.150	6.84%
H	835	BODY	04/17/2017	20.0	20.1	0.200	4d133	3318	1.960	9.500	9.800	3.16%
I	1750	BODY	03/30/2017	22.5	21.1	0.100	1008	3213	3.710	37.300	37.100	-0.54%
I	1750	BODY	04/10/2017	23.5	22.9	0.100	1148	3213	3.610	37.100	36.100	-2.70%
I	1750	BODY	04/17/2017	19.2	20.1	0.100	1148	3213	3.940	37.100	39.400	6.20%
I	1750	BODY	04/20/2017	22.3	21.3	0.100	1148	3213	3.730	37.100	37.300	0.54%
G	1900	BODY	04/03/2017	24.1	22.4	0.100	5d149	3287	4.060	39.900	40.600	1.75%
K	1900	BODY	04/13/2017	22.7	22.1	0.100	5d080	7409	3.980	39.100	39.800	1.79%
K	1900	BODY	04/17/2017	22.7	21.6	0.100	5d080	7409	3.960	39.100	39.600	1.28%
E	2450	BODY	03/29/2017	23.5	22.1	0.100	981	7406	4.770	50.800	47.700	-6.10%
G	2450	BODY	04/18/2017	21.9	21.8	0.100	797	3287	5.330	50.700	53.300	5.13%
E	2600	BODY	04/10/2017	21.9	21.9	0.100	1071	3319	5.460	54.200	54.600	0.74%
G	2600	BODY	04/18/2017	21.9	21.8	0.100	1126	3287	5.490	54.500	54.900	0.73%
K	5250	BODY	03/20/2017	23.1	21.0	0.050	1237	7308	3.680	74.800	73.600	-1.60%
K	5600	BODY	03/20/2017	23.1	21.0	0.050	1237	7308	4.060	77.000	81.200	5.45%
K	5750	BODY	03/20/2017	23.1	21.0	0.050	1237	7308	3.530	75.400	70.600	-6.37%
D	5750	BODY	03/28/2017	23.5	22.3	0.050	1237	3589	3.550	75.400	71.000	-5.84%

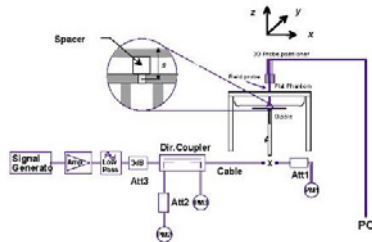

Figure 10-1

System Verification Setup Diagram



Figure 10-2

System Verification Setup Photo

FCC ID: A3LSMJ530GM		SAR EVALUATION REPORT		Approved by: Quality Manager
Document S/N: 1M1703230121-01-R1.A3L	Test Dates: 03/20/17 - 04/20/17	DUT Type: Portable Handset		Page 61 of 85

11 SAR DATA SUMMARY

11.1 Standalone Head SAR Data

**Table 11-1
GSM 850 Head SAR**



MEASUREMENT RESULTS														
FREQUENCY		Mode/Band	Service	Maximum Allowed Power [dBm]	Conducted Power [dBm]	Power Drift [dB]	Side	Test Position	Device Serial Number	Duty Cycle	SAR (1g)	Scaling Factor	Reported SAR (1g)	Plot #
MHz	Ch.										(W/kg)		(W/kg)	
836.60	190	GSM 850	GSM	33.5	32.66	-0.02	Right	Cheek	01376	1:8.3	0.161	1.213	0.195	A1
836.60	190	GSM 850	GSM	33.5	32.66	0.13	Right	Tilt	01376	1:8.3	0.071	1.213	0.086	
836.60	190	GSM 850	GSM	33.5	32.66	0.08	Left	Cheek	01376	1:8.3	0.115	1.213	0.139	
836.60	190	GSM 850	GSM	33.5	32.66	-0.18	Left	Tilt	01376	1:8.3	0.066	1.213	0.080	
ANSI / IEEE C95.1 1992 - SAFETY LIMIT Spatial Peak Uncontrolled Exposure/General Population							Head 1.6 W/kg (mW/g) averaged over 1 gram							

**Table 11-2
UMTS 850 Head SAR**

MEASUREMENT RESULTS														
FREQUENCY		Mode/Band	Service	Maximum Allowed Power [dBm]	Conducted Power [dBm]	Power Drift [dB]	Side	Test Position	Device Serial Number	Duty Cycle	SAR (1g)	Scaling Factor	Reported SAR (1g)	Plot #
MHz	Ch.										(W/kg)		(W/kg)	
836.60	4183	UMTS 850	RMC	24.2	24.05	0.06	Right	Cheek	01376	1:1	0.187	1.035	0.194	A2
836.60	4183	UMTS 850	RMC	24.2	24.05	-0.08	Right	Tilt	01376	1:1	0.076	1.035	0.079	
836.60	4183	UMTS 850	RMC	24.2	24.05	0.20	Left	Cheek	01376	1:1	0.139	1.035	0.144	
836.60	4183	UMTS 850	RMC	24.2	24.05	0.04	Left	Tilt	01376	1:1	0.075	1.035	0.078	
ANSI / IEEE C95.1 1992 - SAFETY LIMIT Spatial Peak Uncontrolled Exposure/General Population							Head 1.6 W/kg (mW/g) averaged over 1 gram							

**Table 11-3
GSM 1900 Head SAR**

MEASUREMENT RESULTS														
FREQUENCY		Mode/Band	Service	Maximum Allowed Power [dBm]	Conducted Power [dBm]	Power Drift [dB]	Side	Test Position	Device Serial Number	Duty Cycle	SAR (1g)	Scaling Factor	Reported SAR (1g)	Plot #
MHz	Ch.										(W/kg)		(W/kg)	
1880.00	661	GSM 1900	GSM	30.5	29.46	0.16	Right	Cheek	01319	1:8.3	0.127	1.271	0.161	A3
1880.00	661	GSM 1900	GSM	30.5	29.46	0.05	Right	Tilt	01319	1:8.3	0.046	1.271	0.058	
1880.00	661	GSM 1900	GSM	30.5	29.46	0.10	Left	Cheek	01319	1:8.3	0.064	1.271	0.081	
1880.00	661	GSM 1900	GSM	30.5	29.46	0.03	Left	Tilt	01319	1:8.3	0.027	1.271	0.034	
ANSI / IEEE C95.1 1992 - SAFETY LIMIT Spatial Peak Uncontrolled Exposure/General Population							Head 1.6 W/kg (mW/g) averaged over 1 gram							

FCC ID: A3LSMJ530GM		SAR EVALUATION REPORT		Approved by: Quality Manager
Document S/N: 1M1703230121-01-R1.A3L	Test Dates: 03/20/17 - 04/20/17	DUT Type: Portable Handset		Page 62 of 85

**Table 11-4
UMTS 1750 Head SAR**



MEASUREMENT RESULTS														
FREQUENCY		Mode/Band	Service	Maximum Allowed Power [dBm]	Conducted Power [dBm]	Power Drift [dB]	Side	Test Position	Device Serial Number	Duty Cycle	SAR (1g)	Scaling Factor	Reported SAR (1g)	Plot #
MHz	Ch.										(W/kg)		(W/kg)	
1712.40	1312	UMTS 1750	RMC	24.0	23.75	0.01	Right	Cheek	01376	1:1	0.126	1.059	0.133	
1712.40	1312	UMTS 1750	RMC	24.0	23.75	-0.03	Right	Tilt	01376	1:1	0.093	1.059	0.098	
1712.40	1312	UMTS 1750	RMC	24.0	23.75	0.10	Left	Cheek	01376	1:1	0.151	1.059	0.160	A4
1712.40	1312	UMTS 1750	RMC	24.0	23.75	0.07	Left	Tilt	01376	1:1	0.080	1.059	0.085	
ANSI / IEEE C95.1 1992 - SAFETY LIMIT Spatial Peak Uncontrolled Exposure/General Population							Head 1.6 W/kg (mW/g) averaged over 1 gram							

**Table 11-5
UMTS 1900 Head SAR**

MEASUREMENT RESULTS														
FREQUENCY		Mode/Band	Service	Maximum Allowed Power [dBm]	Conducted Power [dBm]	Power Drift [dB]	Side	Test Position	Device Serial Number	Duty Cycle	SAR (1g)	Scaling Factor	Reported SAR (1g)	Plot #
MHz	Ch.										(W/kg)		(W/kg)	
1880.00	9400	UMTS 1900	RMC	23.5	23.03	0.03	Right	Cheek	01376	1:1	0.173	1.114	0.193	A5
1880.00	9400	UMTS 1900	RMC	23.5	23.03	0.00	Right	Tilt	01376	1:1	0.090	1.114	0.100	
1880.00	9400	UMTS 1900	RMC	23.5	23.03	0.15	Left	Cheek	01376	1:1	0.138	1.114	0.154	
1880.00	9400	UMTS 1900	RMC	23.5	23.03	0.01	Left	Tilt	01376	1:1	0.074	1.114	0.082	
ANSI / IEEE C95.1 1992 - SAFETY LIMIT Spatial Peak Uncontrolled Exposure/General Population							Head 1.6 W/kg (mW/g) averaged over 1 gram							

**Table 11-6
LTE Band 12 Head SAR**

MEASUREMENT RESULTS																			
FREQUENCY		Mode	Bandwidth [MHz]	Maximum Allowed Power [dBm]	Conducted Power [dBm]	Power Drift [dB]	MPR [dB]	Side	Test Position	Modulation	RB Size	RB Offset	Device Serial Number	Duty Cycle	SAR (1g)	Scaling Factor	Reported SAR (1g)	Plot #	
MHz	Ch.														(W/kg)		(W/kg)		
707.50	23095	Mid	LTE Band 12	10	24.0	23.78	-0.03	0	Right	Cheek	QPSK	1	0	01327	1:1	0.077	1.052	0.081	A6
707.50	23095	Mid	LTE Band 12	10	23.0	21.85	0.08	1	Right	Cheek	QPSK	25	0	01327	1:1	0.052	1.303	0.068	
707.50	23095	Mid	LTE Band 12	10	24.0	23.78	0.17	0	Right	Tilt	QPSK	1	0	01327	1:1	0.045	1.052	0.047	
707.50	23095	Mid	LTE Band 12	10	23.0	21.85	-0.01	1	Right	Tilt	QPSK	25	0	01327	1:1	0.030	1.303	0.039	
707.50	23095	Mid	LTE Band 12	10	24.0	23.78	0.05	0	Left	Cheek	QPSK	1	0	01327	1:1	0.073	1.052	0.077	
707.50	23095	Mid	LTE Band 12	10	23.0	21.85	0.05	1	Left	Cheek	QPSK	25	0	01327	1:1	0.043	1.303	0.056	
707.50	23095	Mid	LTE Band 12	10	24.0	23.78	0.12	0	Left	Tilt	QPSK	1	0	01327	1:1	0.044	1.052	0.046	
707.50	23095	Mid	LTE Band 12	10	23.0	21.85	0.20	1	Left	Tilt	QPSK	25	0	01327	1:1	0.028	1.303	0.036	
ANSI / IEEE C95.1 1992 - SAFETY LIMIT Spatial Peak Uncontrolled Exposure/General Population										Head 1.6 W/kg (mW/g) averaged over 1 gram									

FCC ID: A3LSMJ530GM		SAR EVALUATION REPORT		Approved by: Quality Manager
Document S/N: 1M1703230121-01-R1.A3L	Test Dates: 03/20/17 - 04/20/17	DUT Type: Portable Handset	Page 63 of 85	

**Table 11-7
LTE Band 5 (Cell) Head SAR**



MEASUREMENT RESULTS																			
FREQUENCY		Mode	Bandwidth [MHz]	Maximum Allowed Power [dBm]	Conducted Power [dBm]	Power Drift [dB]	MPR [dB]	Side	Test Position	Modulation	RB Size	RB Offset	Device Serial Number	Duty Cycle	SAR (1g)	Scaling Factor	Reported SAR (1g)	Plot #	
MHz	Ch.														(W/kg)		(W/kg)		
836.50	20525	Mid	LTE Band 5 (Cell)	10	24.5	24.50	0.04	0	Right	Cheek	QPSK	1	0	01376	1:1	0.208	1.000	0.208	A7
836.50	20525	Mid	LTE Band 5 (Cell)	10	23.5	23.47	0.01	1	Right	Cheek	QPSK	25	0	01376	1:1	0.182	1.007	0.183	
836.50	20525	Mid	LTE Band 5 (Cell)	10	24.5	24.50	0.12	0	Right	Tilt	QPSK	1	0	01376	1:1	0.091	1.000	0.091	
836.50	20525	Mid	LTE Band 5 (Cell)	10	23.5	23.47	-0.02	1	Right	Tilt	QPSK	25	0	01376	1:1	0.079	1.007	0.080	
836.50	20525	Mid	LTE Band 5 (Cell)	10	24.5	24.50	0.08	0	Left	Cheek	QPSK	1	0	01376	1:1	0.160	1.000	0.160	
836.50	20525	Mid	LTE Band 5 (Cell)	10	23.5	23.47	0.12	1	Left	Cheek	QPSK	25	0	01376	1:1	0.127	1.007	0.128	
836.50	20525	Mid	LTE Band 5 (Cell)	10	24.5	24.50	-0.13	0	Left	Tilt	QPSK	1	0	01376	1:1	0.091	1.000	0.091	
836.50	20525	Mid	LTE Band 5 (Cell)	10	23.5	23.47	0.05	1	Left	Tilt	QPSK	25	0	01376	1:1	0.067	1.007	0.067	
ANSI / IEEE C95.1 1992 - SAFETY LIMIT Spatial Peak Uncontrolled Exposure/General Population										Head 1.6 W/kg (mW/g) averaged over 1 gram									

**Table 11-8
LTE Band 4 (AWS) Head SAR**

MEASUREMENT RESULTS																			
FREQUENCY		Mode	Bandwidth [MHz]	Maximum Allowed Power [dBm]	Conducted Power [dBm]	Power Drift [dB]	MPR [dB]	Side	Test Position	Modulation	RB Size	RB Offset	Device Serial Number	Duty Cycle	SAR (1g)	Scaling Factor	Reported SAR (1g)	Plot #	
MHz	Ch.														(W/kg)		(W/kg)		
1732.50	20175	Mid	LTE Band 4 (AWS)	20	24.5	23.53	0.12	0	Right	Cheek	QPSK	1	99	01376	1:1	0.141	1.250	0.176	
1732.50	20175	Mid	LTE Band 4 (AWS)	20	23.5	21.65	0.10	1	Right	Cheek	QPSK	50	25	01376	1:1	0.069	1.531	0.106	
1732.50	20175	Mid	LTE Band 4 (AWS)	20	24.5	23.53	0.02	0	Right	Tilt	QPSK	1	99	01376	1:1	0.102	1.250	0.128	
1732.50	20175	Mid	LTE Band 4 (AWS)	20	23.5	21.65	-0.01	1	Right	Tilt	QPSK	50	25	01376	1:1	0.053	1.531	0.081	
1732.50	20175	Mid	LTE Band 4 (AWS)	20	24.5	23.53	-0.03	0	Left	Cheek	QPSK	1	99	01376	1:1	0.174	1.250	0.218	A8
1732.50	20175	Mid	LTE Band 4 (AWS)	20	23.5	21.65	-0.05	1	Left	Cheek	QPSK	50	25	01376	1:1	0.083	1.531	0.127	
1732.50	20175	Mid	LTE Band 4 (AWS)	20	24.5	23.53	0.19	0	Left	Tilt	QPSK	1	99	01376	1:1	0.083	1.250	0.104	
1732.50	20175	Mid	LTE Band 4 (AWS)	20	23.5	21.65	0.05	1	Left	Tilt	QPSK	50	25	01376	1:1	0.044	1.531	0.067	
ANSI / IEEE C95.1 1992 - SAFETY LIMIT Spatial Peak Uncontrolled Exposure/General Population										Head 1.6 W/kg (mW/g) averaged over 1 gram									

**Table 11-9
LTE Band 66 (AWS) Head SAR**

MEASUREMENT RESULTS																			
FREQUENCY		Mode	Bandwidth [MHz]	Maximum Allowed Power [dBm]	Conducted Power [dBm]	Power Drift [dB]	MPR [dB]	Side	Test Position	Modulation	RB Size	RB Offset	Device Serial Number	Duty Cycle	SAR (1g)	Scaling Factor	Reported SAR (1g)	Plot #	
MHz	Ch.														(W/kg)		(W/kg)		
1720.00	132072	Low	LTE Band 66 (AWS)	20	23.2	23.09	0.14	0	Right	Cheek	QPSK	1	99	01376	1:1	0.111	1.026	0.114	
1720.00	132072	Low	LTE Band 66 (AWS)	20	22.2	21.43	0.15	1	Right	Cheek	QPSK	50	25	01376	1:1	0.060	1.194	0.072	
1720.00	132072	Low	LTE Band 66 (AWS)	20	23.2	23.09	0.16	0	Right	Tilt	QPSK	1	99	01376	1:1	0.075	1.026	0.077	
1720.00	132072	Low	LTE Band 66 (AWS)	20	22.2	21.43	-0.05	1	Right	Tilt	QPSK	50	25	01376	1:1	0.030	1.194	0.036	
1720.00	132072	Low	LTE Band 66 (AWS)	20	23.2	23.09	0.05	0	Left	Cheek	QPSK	1	99	01376	1:1	0.115	1.026	0.118	A9
1720.00	132072	Low	LTE Band 66 (AWS)	20	22.2	21.43	0.13	1	Left	Cheek	QPSK	50	25	01376	1:1	0.053	1.194	0.063	
1720.00	132072	Low	LTE Band 66 (AWS)	20	23.2	23.09	-0.06	0	Left	Tilt	QPSK	1	99	01376	1:1	0.060	1.026	0.062	
1720.00	132072	Low	LTE Band 66 (AWS)	20	22.2	21.43	-0.04	1	Left	Tilt	QPSK	50	25	01376	1:1	0.026	1.194	0.031	
ANSI / IEEE C95.1 1992 - SAFETY LIMIT Spatial Peak Uncontrolled Exposure/General Population										Head 1.6 W/kg (mW/g) averaged over 1 gram									

FCC ID: A3LSMJ530GM		SAR EVALUATION REPORT		Approved by: Quality Manager
Document S/N: 1M1703230121-01-R1.A3L	Test Dates: 03/20/17 - 04/20/17	DUT Type: Portable Handset	Page 64 of 85	

**Table 11-10
LTE Band 2 (PCS) Head SAR**



MEASUREMENT RESULTS																			
FREQUENCY		Mode	Bandwidth [MHz]	Maximum Allowed Power [dBm]	Conducted Power [dBm]	Power Drift [dB]	MPR [dB]	Side	Test Position	Modulation	RB Size	RB Offset	Device Serial Number	Duty Cycle	SAR (1g)	Scaling Factor	Reported SAR (1g)	Plot #	
MHz	Ch.														(W/kg)		(W/kg)		
1860.00	18700	Low	LTE Band 2 (PCS)	20	24.0	23.57	-0.10	0	Right	Cheek	QPSK	1	50	01319	1:1	0.227	1.104	0.251	A10
1860.00	18700	Low	LTE Band 2 (PCS)	20	23.0	21.54	-0.02	1	Right	Cheek	QPSK	50	25	01319	1:1	0.142	1.400	0.199	
1860.00	18700	Low	LTE Band 2 (PCS)	20	24.0	23.57	0.06	0	Right	Tilt	QPSK	1	50	01319	1:1	0.085	1.104	0.094	
1860.00	18700	Low	LTE Band 2 (PCS)	20	23.0	21.54	0.05	1	Right	Tilt	QPSK	50	25	01319	1:1	0.054	1.400	0.076	
1860.00	18700	Low	LTE Band 2 (PCS)	20	24.0	23.57	0.05	0	Left	Cheek	QPSK	1	50	01319	1:1	0.162	1.104	0.179	
1860.00	18700	Low	LTE Band 2 (PCS)	20	23.0	21.54	0.11	1	Left	Cheek	QPSK	50	25	01319	1:1	0.097	1.400	0.136	
1860.00	18700	Low	LTE Band 2 (PCS)	20	24.0	23.57	-0.03	0	Left	Tilt	QPSK	1	50	01319	1:1	0.045	1.104	0.050	
1860.00	18700	Low	LTE Band 2 (PCS)	20	23.0	21.54	0.12	1	Left	Tilt	QPSK	50	25	01319	1:1	0.030	1.400	0.042	
ANSI / IEEE C95.1 1992 - SAFETY LIMIT Spatial Peak Uncontrolled Exposure/General Population										Head 1.6 W/kg (mW/g) averaged over 1 gram									

**Table 11-11
LTE Band 41 Head SAR**

MEASUREMENT RESULTS																			
FREQUENCY		Mode	Bandwidth [MHz]	Maximum Allowed Power [dBm]	Conducted Power [dBm]	Power Drift [dB]	MPR [dB]	Side	Test Position	Modulation	RB Size	RB Offset	Device Serial Number	Duty Cycle	SAR (1g)	Scaling Factor	Reported SAR (1g)	Plot #	
MHz	Ch.														(W/kg)		(W/kg)		
2593.00	40620	Mid	LTE Band 41	20	23.5	22.84	-0.01	0	Right	Cheek	QPSK	1	0	01319	1:1.58	0.077	1.164	0.090	A11
2593.00	40620	Mid	LTE Band 41	20	22.5	21.52	0.19	1	Right	Cheek	QPSK	50	0	01319	1:1.58	0.061	1.253	0.076	
2593.00	40620	Mid	LTE Band 41	20	23.5	22.84	0.13	0	Right	Tilt	QPSK	1	0	01319	1:1.58	0.054	1.164	0.063	
2593.00	40620	Mid	LTE Band 41	20	22.5	21.52	-0.08	1	Right	Tilt	QPSK	50	0	01319	1:1.58	0.042	1.253	0.053	
2593.00	40620	Mid	LTE Band 41	20	23.5	22.84	0.16	0	Left	Cheek	QPSK	1	0	01319	1:1.58	0.073	1.164	0.085	
2593.00	40620	Mid	LTE Band 41	20	22.5	21.52	0.17	1	Left	Cheek	QPSK	50	0	01319	1:1.58	0.058	1.253	0.073	
2593.00	40620	Mid	LTE Band 41	20	23.5	22.84	0.13	0	Left	Tilt	QPSK	1	0	01319	1:1.58	0.036	1.164	0.042	
2593.00	40620	Mid	LTE Band 41	20	22.5	21.52	0.12	1	Left	Tilt	QPSK	50	0	01319	1:1.58	0.027	1.253	0.034	
ANSI / IEEE C95.1 1992 - SAFETY LIMIT Spatial Peak Uncontrolled Exposure/General Population										Head 1.6 W/kg (mW/g) averaged over 1 gram									

**Table 11-12
DTS Head SAR**

MEASUREMENT RESULTS																		
FREQUENCY		Mode	Service	Bandwidth [MHz]	Maximum Allowed Power [dBm]	Conducted Power [dBm]	Power Drift [dB]	Side	Test Position	Device Serial Number	Data Rate (Mbps)	Duty Cycle (%)	Peak SAR of Area Scan	SAR (1g)	Scaling Factor (Power)	Scaling Factor (Duty Cycle)	Reported SAR (1g)	Plot #
MHz	Ch.												(W/kg)	(W/kg)			(W/kg)	
2412	1	802.11b	DSSS	22	16.5	16.07	0.01	Right	Cheek	74852	1	99.8	0.764	0.652	1.104	1.002	0.721	
2412	1	802.11b	DSSS	22	16.5	16.07	0.00	Right	Tilt	74852	1	99.8	0.888	0.717	1.104	1.002	0.793	A12
2412	1	802.11b	DSSS	22	16.5	16.07	0.18	Left	Cheek	74852	1	99.8	0.520	-	1.104	1.002	-	
2412	1	802.11b	DSSS	22	16.5	16.07	0.05	Left	Tilt	74852	1	99.8	0.648	-	1.104	1.002	-	
ANSI / IEEE C95.1 1992 - SAFETY LIMIT Spatial Peak Uncontrolled Exposure/General Population										Head 1.6 W/kg (mW/g) averaged over 1 gram								

FCC ID: A3LSMJ530GM		SAR EVALUATION REPORT		Approved by: Quality Manager
Document S/N: 1M1703230121-01-R1.A3L	Test Dates: 03/20/17 - 04/20/17	DUT Type: Portable Handset		Page 65 of 85

**Table 11-13
NII Head SAR**



MEASUREMENT RESULTS																		
FREQUENCY		Mode	Service	Bandwidth [MHz]	Maximum Allowed Power [dBm]	Conducted Power [dBm]	Power Drift [dB]	Side	Test Position	Device Serial Number	Data Rate (Mbps)	Duty Cycle (%)	Peak SAR of Area Scan	SAR (1g)	Scaling Factor (Power)	Scaling Factor (Duty Cycle)	Reported SAR (1g)	Plot #
MHz	Ch.												W/kg	(W/kg)	(W/kg)	(W/kg)		
5260	52	802.11a	OFDM	20	12.5	12.42	-0.12	Right	Cheek	19228	6	98.6	1.701	0.999	1.019	1.014	1.032	
5280	56	802.11a	OFDM	20	12.5	12.38	0.05	Right	Cheek	19228	6	98.6	1.757	0.991	1.028	1.014	1.033	
5260	52	802.11a	OFDM	20	12.5	12.42	-0.01	Right	Tilt	19228	6	98.6	1.460	0.818	1.019	1.014	0.845	
5280	56	802.11a	OFDM	20	12.5	12.38	0.16	Right	Tilt	19228	6	98.6	1.462	0.812	1.028	1.014	0.846	
5260	52	802.11a	OFDM	20	12.5	12.42	0.17	Left	Cheek	19228	6	98.6	1.093	-	1.019	1.014	-	
5260	52	802.11a	OFDM	20	12.5	12.42	0.03	Left	Tilt	19228	6	98.6	1.371	0.625	1.019	1.014	0.646	
5260	52	802.11a	OFDM	20	12.5	12.42	0.20	Right	Cheek	19228	6	98.6	1.626	1.010	1.019	1.014	1.044	A13
5500	100	802.11a	OFDM	20	12.5	12.39	0.07	Right	Cheek	19228	6	98.6	1.796	0.900	1.026	1.014	0.936	
5600	120	802.11a	OFDM	20	12.5	12.38	0.08	Right	Cheek	19228	6	98.6	1.776	0.913	1.028	1.014	0.952	
5500	100	802.11a	OFDM	20	12.5	12.39	-0.07	Right	Tilt	19228	6	98.6	2.069	0.771	1.026	1.014	0.802	
5600	120	802.11a	OFDM	20	12.5	12.38	0.13	Right	Tilt	19228	6	98.6	2.234	0.887	1.028	1.014	0.925	
5500	100	802.11a	OFDM	20	12.5	12.39	-0.01	Left	Cheek	19228	6	98.6	1.288	0.590	1.026	1.014	0.614	
5500	100	802.11a	OFDM	20	12.5	12.39	-0.05	Left	Tilt	19228	6	98.6	1.052	-	1.026	1.014	-	
5600	120	802.11a	OFDM	20	12.5	12.38	-0.03	Right	Cheek	19228	6	98.6	1.673	0.805	1.028	1.014	0.839	
5745	149	802.11a	OFDM	20	12.5	11.74	0.21	Right	Cheek	19228	6	98.6	2.166	0.733	1.191	1.014	0.885	
5825	165	802.11a	OFDM	20	12.5	11.66	0.12	Right	Cheek	19228	6	98.6	1.768	0.641	1.213	1.014	0.788	
5745	149	802.11a	OFDM	20	12.5	11.74	-0.11	Right	Tilt	19228	6	98.6	2.271	0.822	1.191	1.014	0.993	
5825	165	802.11a	OFDM	20	12.5	11.66	0.17	Right	Tilt	19228	6	98.6	1.872	0.656	1.213	1.014	0.807	
5745	149	802.11a	OFDM	20	12.5	11.74	0.07	Left	Cheek	19228	6	98.6	1.121	-	1.191	1.014	-	
5745	149	802.11a	OFDM	20	12.5	11.74	0.11	Left	Tilt	19228	6	98.6	1.134	0.426	1.191	1.014	0.514	
ANSI / IEEE C95.1 1992 - SAFETY LIMIT Spatial Peak Uncontrolled Exposure/General Population								Head 1.6 W/kg (mW/g) averaged over 1 gram										

Note: Blue entry represents variability data.

11.2 Standalone Body-Worn SAR Data

**Table 11-14
GSM/UMTS Body-Worn SAR Data**

MEASUREMENT RESULTS															
FREQUENCY		Mode	Service	Maximum Allowed Power [dBm]	Conducted Power [dBm]	Power Drift [dB]	Spacing	Device Serial Number	# of Time Slots	Duty Cycle	Side	SAR (1g)	Scaling Factor	Reported SAR (1g)	Plot #
MHz	Ch.											(W/kg)		(W/kg)	
836.60	190	GSM 850	GSM	33.5	32.66	-0.01	15 mm	01327	1	1:8.3	back	0.291	1.213	0.353	A14
836.60	4183	UMTS 850	RMC	24.2	24.05	0.02	15 mm	01327	N/A	1:1	back	0.302	1.035	0.313	A16
1880.00	661	GSM 1900	GSM	30.5	29.46	0.00	15 mm	01442	1	1:8.3	back	0.349	1.271	0.444	A18
1712.40	1312	UMTS 1750	RMC	24.0	23.75	-0.01	15 mm	01319	N/A	1:1	back	0.482	1.059	0.510	A20
1880.00	9400	UMTS 1900	RMC	23.5	23.03	-0.02	15 mm	01301	N/A	1:1	back	0.674	1.114	0.751	A22
ANSI / IEEE C95.1 1992 - SAFETY LIMIT Spatial Peak Uncontrolled Exposure/General Population								Body 1.6 W/kg (mW/g) averaged over 1 gram							

FCC ID: A3LSMJ530GM		SAR EVALUATION REPORT		Approved by: Quality Manager
Document S/N: 1M1703230121-01-R1.A3L	Test Dates: 03/20/17 - 04/20/17	DUT Type: Portable Handset	Page 66 of 85	

**Table 11-15
LTE Body-Worn SAR**



MEASUREMENT RESULTS																			
FREQUENCY		Mode	Bandwidth [MHz]	Maximum Allowed Power [dBm]	Conducted Power [dBm]	Power Drift [dB]	MPR [dB]	Device Serial Number	Modulation	RB Size	RB Offset	Spacing	Side	Duty Cycle	SAR (1g) (W/kg)	Scaling Factor	Reported SAR (1g) (W/kg)	Plot #	
MHz	Ch.																		
707.50	23095	Mid	LTE Band 12	10	24.0	23.78	-0.02	0	01327	QPSK	1	0	15 mm	back	1:1	0.204	1.052	0.215	A24
707.50	23095	Mid	LTE Band 12	10	23.0	21.85	0.05	1	01327	QPSK	25	0	15 mm	back	1:1	0.134	1.303	0.175	
836.50	20525	Mid	LTE Band 5 (Cell)	10	24.5	24.50	-0.04	0	01327	QPSK	1	0	15 mm	back	1:1	0.415	1.000	0.415	A26
836.50	20525	Mid	LTE Band 5 (Cell)	10	23.5	23.47	-0.02	1	01327	QPSK	25	0	15 mm	back	1:1	0.332	1.007	0.334	
1732.50	20175	Mid	LTE Band 4 (AWS)	20	24.5	23.53	0.03	0	01327	QPSK	1	99	15 mm	back	1:1	0.675	1.250	0.844	A28
1732.50	20175	Mid	LTE Band 4 (AWS)	20	23.5	21.65	-0.01	1	01327	QPSK	50	25	15 mm	back	1:1	0.282	1.531	0.432	
1732.50	20175	Mid	LTE Band 4 (AWS)	20	23.5	21.61	0.02	1	01327	QPSK	100	0	15 mm	back	1:1	0.326	1.545	0.504	
1720.00	132072	Low	LTE Band 66 (AWS)	20	23.2	23.09	0.00	0	01319	QPSK	1	99	15 mm	back	1:1	0.318	1.026	0.326	A30
1720.00	132072	Low	LTE Band 66 (AWS)	20	22.2	21.43	-0.02	1	01319	QPSK	50	25	15 mm	back	1:1	0.178	1.194	0.213	
1860.00	18700	Low	LTE Band 2 (PCS)	20	24.0	23.57	0.02	0	01319	QPSK	1	50	15 mm	back	1:1	0.767	1.104	0.847	A32
1880.00	18900	Mid	LTE Band 2 (PCS)	20	24.0	23.25	0.01	0	01319	QPSK	1	99	15 mm	back	1:1	0.637	1.189	0.757	
1900.00	19100	High	LTE Band 2 (PCS)	20	24.0	23.45	0.06	0	01319	QPSK	1	50	15 mm	back	1:1	0.553	1.135	0.628	
1860.00	18700	Low	LTE Band 2 (PCS)	20	23.0	21.54	0.01	1	01319	QPSK	50	25	15 mm	back	1:1	0.491	1.400	0.687	
1860.00	18700	Low	LTE Band 2 (PCS)	20	23.0	21.51	0.06	1	01319	QPSK	100	0	15 mm	back	1:1	0.485	1.409	0.683	
2593.00	40620	Mid	LTE Band 41	20	23.5	22.84	-0.01	0	01376	QPSK	1	0	15 mm	back	1:1.58	0.228	1.164	0.265	A34
2593.00	40620	Mid	LTE Band 41	20	22.5	21.52	-0.03	1	01376	QPSK	50	0	15 mm	back	1:1.58	0.173	1.253	0.217	
ANSI / IEEE C95.1 1992 - SAFETY LIMIT Spatial Peak Uncontrolled Exposure/General Population										Body 1.6 W/kg (mW/g) averaged over 1 gram									

**Table 11-16
DTS Body-Worn SAR**

MEASUREMENT RESULTS																		
FREQUENCY		Mode	Service	Bandwidth [MHz]	Maximum Allowed Power [dBm]	Conducted Power [dBm]	Power Drift [dB]	Spacing	Device Serial Number	Data Rate (Mbps)	Side	Duty Cycle (%)	Peak SAR of Area Scan (W/kg)	SAR (1g) (W/kg)	Scaling Factor (Power)	Scaling Factor (Duty Cycle)	Reported SAR (1g) (W/kg)	Plot #
MHz	Ch.																	
2437	6	802.11b	DSSS	22	18.5	18.04	0.00	15 mm	01392	1	back	99.8	0.232	0.160	1.112	1.002	0.178	A36
ANSI / IEEE C95.1 1992 - SAFETY LIMIT Spatial Peak Uncontrolled Exposure/General Population										Body 1.6 W/kg (mW/g) averaged over 1 gram								

**Table 11-17
NII Body-Worn SAR**



MEASUREMENT RESULTS																		
FREQUENCY		Mode	Service	Bandwidth [MHz]	Maximum Allowed Power [dBm]	Conducted Power [dBm]	Power Drift [dB]	Spacing	Device Serial Number	Data Rate (Mbps)	Side	Duty Cycle (%)	Peak SAR of Area Scan (W/kg)	SAR (1g) (W/kg)	Scaling Factor (Power)	Scaling Factor (Duty Cycle)	Reported SAR (1g) (W/kg)	Plot #
MHz	Ch.																	
5260	52	802.11a	OFDM	20	14.5	14.23	0.20	15 mm	74902	6	back	98.6	0.090	0.044	1.064	1.014	0.047	
5500	100	802.11a	OFDM	20	14.5	14.08	-0.11	15 mm	74902	6	back	98.6	0.125	0.059	1.102	1.014	0.066	
5745	149	802.11a	OFDM	20	14.5	14.21	0.12	15 mm	74902	6	back	98.6	0.140	0.069	1.069	1.014	0.075	A38
ANSI / IEEE C95.1 1992 - SAFETY LIMIT Spatial Peak Uncontrolled Exposure/General Population										Body 1.6 W/kg (mW/g) averaged over 1 gram								

FCC ID: A3LSMJ530GM		SAR EVALUATION REPORT		Approved by: Quality Manager
Document S/N: 1M1703230121-01-R1.A3L	Test Dates: 03/20/17 - 04/20/17	DUT Type: Portable Handset	Page 67 of 85	

11.3 Standalone Hotspot SAR Data

**Table 11-18
GPRS/UMTS Hotspot SAR Data**

MEASUREMENT RESULTS															
FREQUENCY		Mode	Service	Maximum Allowed Power [dBm]	Conducted Power [dBm]	Power Drift [dB]	Spacing	Device Serial Number	# of GPRS Slots	Duty Cycle	Side	SAR (1g)	Scaling Factor	Reported SAR (1g)	Plot #
MHz	Ch.											(W/kg)		(W/kg)	
836.60	190	GSM 850	GPRS	28.5	27.96	-0.09	10 mm	01467	3	1:2.76	back	0.366	1.132	0.414	A15
836.60	190	GSM 850	GPRS	28.5	27.96	-0.03	10 mm	01467	3	1:2.76	front	0.240	1.132	0.272	
836.60	190	GSM 850	GPRS	28.5	27.96	-0.14	10 mm	01467	3	1:2.76	bottom	0.103	1.132	0.117	
836.60	190	GSM 850	GPRS	28.5	27.96	0.00	10 mm	01467	3	1:2.76	right	0.238	1.132	0.269	
836.60	190	GSM 850	GPRS	28.5	27.96	0.02	10 mm	01467	3	1:2.76	left	0.155	1.132	0.175	
836.60	4183	UMTS 850	RMC	24.2	24.05	-0.09	10 mm	01327	N/A	1:1	back	0.436	1.035	0.451	A17
836.60	4183	UMTS 850	RMC	24.2	24.05	0.04	10 mm	01327	N/A	1:1	front	0.278	1.035	0.288	
836.60	4183	UMTS 850	RMC	24.2	24.05	0.00	10 mm	01327	N/A	1:1	bottom	0.127	1.035	0.131	
836.60	4183	UMTS 850	RMC	24.2	24.05	0.15	10 mm	01327	N/A	1:1	right	0.291	1.035	0.301	
836.60	4183	UMTS 850	RMC	24.2	24.05	-0.08	10 mm	01327	N/A	1:1	left	0.162	1.035	0.168	
1909.80	810	GSM 1900	GPRS	24.0	23.25	-0.12	10 mm	01442	3	1:2.76	back	0.440	1.189	0.523	A19
1909.80	810	GSM 1900	GPRS	24.0	23.25	0.01	10 mm	01442	3	1:2.76	front	0.411	1.189	0.489	
1909.80	810	GSM 1900	GPRS	24.0	23.25	-0.09	10 mm	01442	3	1:2.76	bottom	0.434	1.189	0.516	
1909.80	810	GSM 1900	GPRS	24.0	23.25	0.16	10 mm	01442	3	1:2.76	right	0.052	1.189	0.062	
1909.80	810	GSM 1900	GPRS	24.0	23.25	0.09	10 mm	01442	3	1:2.76	left	0.070	1.189	0.083	
1732.40	1412	UMTS 1750	RMC	20.0	19.78	-0.08	10 mm	01442	N/A	1:1	back	0.580	1.052	0.610	
1732.40	1412	UMTS 1750	RMC	20.0	19.78	0.00	10 mm	01442	N/A	1:1	front	0.580	1.052	0.610	
1712.40	1312	UMTS 1750	RMC	20.0	19.72	0.02	10 mm	01442	N/A	1:1	bottom	0.353	1.067	0.377	
1732.40	1412	UMTS 1750	RMC	20.0	19.78	-0.01	10 mm	01442	N/A	1:1	bottom	0.591	1.052	0.622	
1752.60	1513	UMTS 1750	RMC	20.0	19.50	0.00	10 mm	01442	N/A	1:1	bottom	0.732	1.122	0.821	A21
1732.40	1412	UMTS 1750	RMC	20.0	19.78	0.03	10 mm	01442	N/A	1:1	right	0.081	1.052	0.047	
1732.40	1412	UMTS 1750	RMC	20.0	19.78	0.03	10 mm	01442	N/A	1:1	left	0.141	1.052	0.148	
1852.40	9262	UMTS 1900	RMC	20.5	19.78	-0.03	10 mm	01442	N/A	1:1	back	0.708	1.180	0.835	
1880.00	9400	UMTS 1900	RMC	20.5	19.26	-0.03	10 mm	01442	N/A	1:1	back	0.569	1.330	0.757	
1907.60	9538	UMTS 1900	RMC	20.5	19.17	0.05	10 mm	01442	N/A	1:1	back	0.504	1.358	0.684	
1852.40	9262	UMTS 1900	RMC	20.5	19.78	0.00	10 mm	01442	N/A	1:1	front	0.441	1.180	0.520	
1852.40	9262	UMTS 1900	RMC	20.5	19.78	-0.01	10 mm	01442	N/A	1:1	bottom	0.720	1.180	0.850	A23
1880.00	9400	UMTS 1900	RMC	20.5	19.26	-0.01	10 mm	01442	N/A	1:1	bottom	0.590	1.330	0.785	
1907.60	9538	UMTS 1900	RMC	20.5	19.17	-0.02	10 mm	01442	N/A	1:1	bottom	0.540	1.358	0.733	
1852.40	9262	UMTS 1900	RMC	20.5	19.78	0.01	10 mm	01442	N/A	1:1	right	0.083	1.180	0.098	
1852.40	9262	UMTS 1900	RMC	20.5	19.78	0.04	10 mm	01442	N/A	1:1	left	0.117	1.180	0.138	
ANSI / IEEE C95.1 1992 - SAFETY LIMIT							Body								
Spatial Peak							1.6 W/kg (mW/g)								
Uncontrolled Exposure/General Population							averaged over 1 gram								



FCC ID: A3LSMJ530GM		SAR EVALUATION REPORT		Approved by: Quality Manager
Document S/N: 1M1703230121-01-R1.A3L	Test Dates: 03/20/17 - 04/20/17	DUT Type: Portable Handset	Page 68 of 85	

**Table 11-19
LTE Band 12 Hotspot SAR**

MEASUREMENT RESULTS																			
FREQUENCY		Mode	Bandwidth [MHz]	Maximum Allowed Power [dBm]	Conducted Power [dBm]	Power Drift [dB]	MPR [dB]	Device Serial Number	Modulation	RB Size	RB Offset	Spacing	Side	Duty Cycle	SAR (1g)	Scaling Factor	Reported SAR (1g)	Plot #	
MHz	Ch.														(W/kg)		(W/kg)		
707.50	23095	Mid	LTE Band 12	10	24.0	23.78	-0.01	0	01327	QPSK	1	0	10 mm	back	1:1	0.315	1.052	0.331	A25
707.50	23095	Mid	LTE Band 12	10	23.0	21.85	-0.02	1	01327	QPSK	25	0	10 mm	back	1:1	0.205	1.303	0.267	
707.50	23095	Mid	LTE Band 12	10	24.0	23.78	-0.02	0	01327	QPSK	1	0	10 mm	front	1:1	0.214	1.052	0.225	
707.50	23095	Mid	LTE Band 12	10	23.0	21.85	-0.04	1	01327	QPSK	25	0	10 mm	front	1:1	0.140	1.303	0.182	
707.50	23095	Mid	LTE Band 12	10	24.0	23.78	0.08	0	01327	QPSK	1	0	10 mm	bottom	1:1	0.074	1.052	0.078	
707.50	23095	Mid	LTE Band 12	10	23.0	21.85	-0.02	1	01327	QPSK	25	0	10 mm	bottom	1:1	0.050	1.303	0.065	
707.50	23095	Mid	LTE Band 12	10	24.0	23.78	-0.12	0	01327	QPSK	1	0	10 mm	right	1:1	0.141	1.052	0.148	
707.50	23095	Mid	LTE Band 12	10	23.0	21.85	-0.03	1	01327	QPSK	25	0	10 mm	right	1:1	0.091	1.303	0.119	
707.50	23095	Mid	LTE Band 12	10	24.0	23.78	-0.01	0	01327	QPSK	1	0	10 mm	left	1:1	0.083	1.052	0.087	
707.50	23095	Mid	LTE Band 12	10	23.0	21.85	-0.02	1	01327	QPSK	25	0	10 mm	left	1:1	0.053	1.303	0.069	
ANSI / IEEE C95.1 1992 - SAFETY LIMIT Spatial Peak Uncontrolled Exposure/General Population								Body 1.6 W/kg (mW/g) averaged over 1 gram											

**Table 11-20
LTE Band 5 (Cell) Hotspot SAR**

MEASUREMENT RESULTS																			
FREQUENCY		Mode	Bandwidth [MHz]	Maximum Allowed Power [dBm]	Conducted Power [dBm]	Power Drift [dB]	MPR [dB]	Device Serial Number	Modulation	RB Size	RB Offset	Spacing	Side	Duty Cycle	SAR (1g)	Scaling Factor	Reported SAR (1g)	Plot #	
MHz	Ch.														(W/kg)		(W/kg)		
836.50	20525	Mid	LTE Band 5 (Cell)	10	24.5	24.50	0.00	0	01327	QPSK	1	0	10 mm	back	1:1	0.575	1.000	0.575	A27
836.50	20525	Mid	LTE Band 5 (Cell)	10	23.5	23.47	0.01	1	01327	QPSK	25	0	10 mm	back	1:1	0.458	1.007	0.461	
836.50	20525	Mid	LTE Band 5 (Cell)	10	24.5	24.50	0.03	0	01327	QPSK	1	0	10 mm	front	1:1	0.359	1.000	0.359	
836.50	20525	Mid	LTE Band 5 (Cell)	10	23.5	23.47	0.02	1	01327	QPSK	25	0	10 mm	front	1:1	0.286	1.007	0.288	
836.50	20525	Mid	LTE Band 5 (Cell)	10	24.5	24.50	-0.04	0	01327	QPSK	1	0	10 mm	bottom	1:1	0.163	1.000	0.163	
836.50	20525	Mid	LTE Band 5 (Cell)	10	23.5	23.47	-0.02	1	01327	QPSK	25	0	10 mm	bottom	1:1	0.129	1.007	0.130	
836.50	20525	Mid	LTE Band 5 (Cell)	10	24.5	24.50	-0.01	0	01327	QPSK	1	0	10 mm	right	1:1	0.335	1.000	0.335	
836.50	20525	Mid	LTE Band 5 (Cell)	10	23.5	23.47	-0.02	1	01327	QPSK	25	0	10 mm	right	1:1	0.264	1.007	0.266	
836.50	20525	Mid	LTE Band 5 (Cell)	10	24.5	24.50	0.02	0	01327	QPSK	1	0	10 mm	left	1:1	0.204	1.000	0.204	
836.50	20525	Mid	LTE Band 5 (Cell)	10	23.5	23.47	-0.08	1	01327	QPSK	25	0	10 mm	left	1:1	0.176	1.007	0.177	
ANSI / IEEE C95.1 1992 - SAFETY LIMIT Spatial Peak Uncontrolled Exposure/General Population								Body 1.6 W/kg (mW/g) averaged over 1 gram											



FCC ID: A3LSMJ530GM		SAR EVALUATION REPORT		Approved by: Quality Manager
Document S/N: 1M1703230121-01-R1.A3L	Test Dates: 03/20/17 - 04/20/17	DUT Type: Portable Handset	Page 69 of 85	

**Table 11-21
LTE Band 4 (AWS) Hotspot SAR**

MEASUREMENT RESULTS																			
FREQUENCY		Mode	Bandwidth [MHz]	Maximum Allowed Power [dBm]	Conducted Power [dBm]	Power Drift [dB]	MPR [dB]	Device Serial Number	Modulation	RB Size	RB Offset	Spacing	Side	Duty Cycle	SAR (1g)	Scaling Factor	Reported SAR (1g)	Plot #	
MHz	Ch.														(W/kg)		(W/kg)		
1732.50	20175	Mid	LTE Band 4 (AWS)	20	21.0	20.43	-0.03	0	01442	QPSK	1	0	10 mm	back	1:1	0.665	1.140	0.758	A29
1732.50	20175	Mid	LTE Band 4 (AWS)	20	20.0	18.54	-0.04	1	01442	QPSK	50	25	10 mm	back	1:1	0.498	1.400	0.697	
1732.50	20175	Mid	LTE Band 4 (AWS)	20	21.0	20.43	-0.05	0	01442	QPSK	1	0	10 mm	front	1:1	0.431	1.140	0.491	
1732.50	20175	Mid	LTE Band 4 (AWS)	20	20.0	18.54	0.01	1	01442	QPSK	50	25	10 mm	front	1:1	0.317	1.400	0.444	
1732.50	20175	Mid	LTE Band 4 (AWS)	20	21.0	20.43	-0.01	0	01442	QPSK	1	0	10 mm	bottom	1:1	0.607	1.140	0.692	
1732.50	20175	Mid	LTE Band 4 (AWS)	20	20.0	18.54	-0.01	1	01442	QPSK	50	25	10 mm	bottom	1:1	0.448	1.400	0.627	
1732.50	20175	Mid	LTE Band 4 (AWS)	20	21.0	20.43	0.10	0	01442	QPSK	1	0	10 mm	right	1:1	0.058	1.140	0.066	
1732.50	20175	Mid	LTE Band 4 (AWS)	20	20.0	18.54	0.06	1	01442	QPSK	50	25	10 mm	right	1:1	0.044	1.400	0.062	
1732.50	20175	Mid	LTE Band 4 (AWS)	20	21.0	20.43	0.01	0	01442	QPSK	1	0	10 mm	left	1:1	0.090	1.140	0.103	
1732.50	20175	Mid	LTE Band 4 (AWS)	20	20.0	18.54	0.05	1	01442	QPSK	50	25	10 mm	left	1:1	0.086	1.400	0.120	
ANSI / IEEE C95.1 1992 - SAFETY LIMIT Spatial Peak Uncontrolled Exposure/General Population								Body 1.6 W/kg (mW/g) averaged over 1 gram											

**Table 11-22
LTE Band 66 (AWS) Hotspot SAR**

MEASUREMENT RESULTS																			
FREQUENCY		Mode	Bandwidth [MHz]	Maximum Allowed Power [dBm]	Conducted Power [dBm]	Power Drift [dB]	MPR [dB]	Device Serial Number	Modulation	RB Size	RB Offset	Spacing	Side	Duty Cycle	SAR (1g)	Scaling Factor	Reported SAR (1g)	Plot #	
MHz	Ch.														(W/kg)		(W/kg)		
1720.00	132072	Low	LTE Band 66 (AWS)	20	20.2	20.06	-0.07	0	01467	QPSK	1	99	10 mm	back	1:1	0.501	1.033	0.518	A31
1720.00	132072	Low	LTE Band 66 (AWS)	20	19.2	18.15	-0.03	1	01467	QPSK	50	25	10 mm	back	1:1	0.256	1.274	0.326	
1720.00	132072	Low	LTE Band 66 (AWS)	20	20.2	20.06	-0.02	0	01467	QPSK	1	99	10 mm	front	1:1	0.335	1.033	0.346	
1720.00	132072	Low	LTE Band 66 (AWS)	20	19.2	18.15	0.03	1	01467	QPSK	50	25	10 mm	front	1:1	0.170	1.274	0.217	
1720.00	132072	Low	LTE Band 66 (AWS)	20	20.2	20.06	-0.01	0	01467	QPSK	1	99	10 mm	bottom	1:1	0.455	1.033	0.470	
1720.00	132072	Low	LTE Band 66 (AWS)	20	19.2	18.15	-0.06	1	01467	QPSK	50	25	10 mm	bottom	1:1	0.237	1.274	0.302	
1720.00	132072	Low	LTE Band 66 (AWS)	20	20.2	20.06	0.01	0	01467	QPSK	1	99	10 mm	right	1:1	0.053	1.033	0.055	
1720.00	132072	Low	LTE Band 66 (AWS)	20	19.2	18.15	0.05	1	01467	QPSK	50	25	10 mm	right	1:1	0.025	1.274	0.032	
1720.00	132072	Low	LTE Band 66 (AWS)	20	20.2	20.06	0.06	0	01467	QPSK	1	99	10 mm	left	1:1	0.065	1.033	0.067	
1720.00	132072	Low	LTE Band 66 (AWS)	20	19.2	18.15	0.02	1	01467	QPSK	50	25	10 mm	left	1:1	0.032	1.274	0.041	
ANSI / IEEE C95.1 1992 - SAFETY LIMIT Spatial Peak Uncontrolled Exposure/General Population								Body 1.6 W/kg (mW/g) averaged over 1 gram											

FCC ID: A3LSMJ530GM		SAR EVALUATION REPORT		Approved by: Quality Manager
Document S/N: 1M1703230121-01-R1.A3L	Test Dates: 03/20/17 - 04/20/17	DUT Type: Portable Handset	Page 70 of 85	

**Table 11-23
LTE Band 2 (PCS) Hotspot SAR**

MEASUREMENT RESULTS																			
FREQUENCY		Mode	Bandwidth [MHz]	Maximum Allowed Power [dBm]	Conducted Power [dBm]	Power Drift [dB]	MPR [dB]	Device Serial Number	Modulation	RB Size	RB Offset	Spacing	Side	Duty Cycle	SAR (1g)	Scaling Factor	Reported SAR (1g)	Plot #	
MHz	Ch.														(W/kg)		(W/kg)		
1860.00	18700	Low	LTE Band 2 (PCS)	20	20.0	19.93	0.00	0	01442	QPSK	1	99	10 mm	back	1:1	0.753	1.016	0.765	
1860.00	18700	Low	LTE Band 2 (PCS)	20	19.0	18.20	0.00	1	01442	QPSK	50	50	10 mm	back	1:1	0.447	1.202	0.537	
1860.00	18700	Low	LTE Band 2 (PCS)	20	20.0	19.93	0.00	0	01442	QPSK	1	99	10 mm	front	1:1	0.461	1.016	0.468	
1860.00	18700	Low	LTE Band 2 (PCS)	20	19.0	18.20	0.09	1	01442	QPSK	50	50	10 mm	front	1:1	0.272	1.202	0.327	
1860.00	18700	Low	LTE Band 2 (PCS)	20	20.0	19.93	-0.13	0	01442	QPSK	1	99	10 mm	bottom	1:1	0.845	1.016	0.859	A33
1880.00	18900	Mid	LTE Band 2 (PCS)	20	20.0	19.47	0.00	0	01442	QPSK	1	99	10 mm	bottom	1:1	0.564	1.130	0.637	
1900.00	19100	High	LTE Band 2 (PCS)	20	20.0	19.73	-0.09	0	01442	QPSK	1	99	10 mm	bottom	1:1	0.598	1.064	0.636	
1860.00	18700	Low	LTE Band 2 (PCS)	20	19.0	18.20	0.03	1	01442	QPSK	50	50	10 mm	bottom	1:1	0.486	1.202	0.584	
1860.00	18700	Low	LTE Band 2 (PCS)	20	19.0	18.16	0.00	1	01442	QPSK	100	0	10 mm	bottom	1:1	0.486	1.213	0.590	
1860.00	18700	Low	LTE Band 2 (PCS)	20	20.0	19.93	0.11	0	01442	QPSK	1	99	10 mm	right	1:1	0.087	1.016	0.088	
1860.00	18700	Low	LTE Band 2 (PCS)	20	19.0	18.20	0.19	1	01442	QPSK	50	50	10 mm	right	1:1	0.050	1.202	0.060	
1860.00	18700	Low	LTE Band 2 (PCS)	20	20.0	19.93	0.08	0	01442	QPSK	1	99	10 mm	left	1:1	0.118	1.016	0.120	
1860.00	18700	Low	LTE Band 2 (PCS)	20	19.0	18.20	0.00	1	01442	QPSK	50	50	10 mm	left	1:1	0.071	1.202	0.085	
1860.00	18700	Low	LTE Band 2 (PCS)	20	20.0	19.93	-0.04	0	01442	QPSK	1	99	10 mm	bottom	1:1	0.820	1.016	0.833	
ANSI / IEEE C95.1 1992 - SAFETY LIMIT Spatial Peak Uncontrolled Exposure/General Population								Body 1.6 W/kg (mW/g) averaged over 1 gram											

Note: Blue entry represents variability data.

**Table 11-24
LTE Band 41 Hotspot SAR**

MEASUREMENT RESULTS																			
FREQUENCY		Mode	Bandwidth [MHz]	Maximum Allowed Power [dBm]	Conducted Power [dBm]	Power Drift [dB]	MPR [dB]	Device Serial Number	Modulation	RB Size	RB Offset	Spacing	Side	Duty Cycle	SAR (1g)	Scaling Factor	Reported SAR (1g)	Plot #	
MHz	Ch.														(W/kg)		(W/kg)		
2506.00	39750	Low	LTE Band 41	20	21.0	19.11	-0.01	0	01467	QPSK	1	0	10 mm	back	1:1.58	0.693	1.545	1.071	
2549.50	40185	Low-Mid	LTE Band 41	20	21.0	19.88	-0.07	0	01467	QPSK	1	0	10 mm	back	1:1.58	0.698	1.294	0.903	A35
2593.00	40620	Mid	LTE Band 41	20	21.0	20.29	0.00	0	01467	QPSK	1	0	10 mm	back	1:1.58	0.663	1.178	0.781	
2636.50	41055	Mid-High	LTE Band 41	20	21.0	19.72	-0.06	0	01467	QPSK	1	0	10 mm	back	1:1.58	0.570	1.343	0.766	
2680.00	41490	High	LTE Band 41	20	21.0	20.11	0.02	0	01467	QPSK	1	0	10 mm	back	1:1.58	0.526	1.227	0.645	
2506.00	39750	Low	LTE Band 41	20	20.0	18.26	-0.06	1	01467	QPSK	50	50	10 mm	back	1:1.58	0.557	1.493	0.832	
2549.50	40185	Low-Mid	LTE Band 41	20	20.0	19.01	-0.03	1	01467	QPSK	50	0	10 mm	back	1:1.58	0.562	1.256	0.706	
2593.00	40620	Mid	LTE Band 41	20	20.0	19.22	0.04	1	01467	QPSK	50	0	10 mm	back	1:1.58	0.522	1.197	0.625	
2636.50	41055	Mid-High	LTE Band 41	20	20.0	18.74	-0.02	1	01467	QPSK	50	0	10 mm	back	1:1.58	0.446	1.337	0.596	
2680.00	41490	High	LTE Band 41	20	20.0	18.81	0.01	1	01467	QPSK	50	0	10 mm	back	1:1.58	0.411	1.315	0.540	
2593.00	40620	Mid	LTE Band 41	20	20.0	19.21	0.02	1	01467	QPSK	100	0	10 mm	back	1:1.58	0.520	1.199	0.623	
2593.00	40620	Mid	LTE Band 41	20	21.0	20.29	-0.03	0	01467	QPSK	1	0	10 mm	front	1:1.58	0.402	1.178	0.474	
2593.00	40620	Mid	LTE Band 41	20	20.0	19.22	0.10	1	01467	QPSK	50	0	10 mm	front	1:1.58	0.320	1.197	0.383	
2593.00	40620	Mid	LTE Band 41	20	21.0	20.29	-0.02	0	01467	QPSK	1	0	10 mm	bottom	1:1.58	0.472	1.178	0.566	
2593.00	40620	Mid	LTE Band 41	20	20.0	19.22	0.00	1	01467	QPSK	50	0	10 mm	bottom	1:1.58	0.388	1.197	0.464	
2593.00	40620	Mid	LTE Band 41	20	21.0	20.29	0.01	0	01467	QPSK	1	0	10 mm	right	1:1.58	0.069	1.178	0.081	
2593.00	40620	Mid	LTE Band 41	20	20.0	19.22	0.08	1	01467	QPSK	50	0	10 mm	right	1:1.58	0.052	1.197	0.062	
2593.00	40620	Mid	LTE Band 41	20	21.0	20.29	-0.19	0	01467	QPSK	1	0	10 mm	left	1:1.58	0.115	1.178	0.135	
2593.00	40620	Mid	LTE Band 41	20	20.0	19.22	0.08	1	01467	QPSK	50	0	10 mm	left	1:1.58	0.090	1.197	0.108	
ANSI / IEEE C95.1 1992 - SAFETY LIMIT Spatial Peak Uncontrolled Exposure/General Population								Body 1.6 W/kg (mW/g) averaged over 1 gram											

FCC ID: A3LSMJ530GM		SAR EVALUATION REPORT		Approved by: Quality Manager
Document S/N: 1M1703230121-01-R1.A3L	Test Dates: 03/20/17 - 04/20/17	DUT Type: Portable Handset		Page 71 of 85

**Table 11-25
WLAN Hotspot SAR**

MEASUREMENT RESULTS																		
FREQUENCY		Mode	Service	Bandwidth [MHz]	Maximum Allowed Power [dBm]	Conducted Power [dBm]	Power Drift [dB]	Spacing	Device Serial Number	Data Rate (Mbps)	Side	Duty Cycle (%)	Peak SAR of Area Scan	SAR (1g)	Scaling Factor (Power)	Scaling Factor (Duty Cycle)	Reported SAR (1g)	Plot #
MHz	Ch.												W/kg	(W/kg)	(1g)	(W/kg)		
2437	6	802.11b	DSSS	22	18.5	18.04	-0.10	10 mm	01392	1	back	99.8	0.489	0.340	1.112	1.002	0.379	
2437	6	802.11b	DSSS	22	18.5	18.04	0.02	10 mm	01392	1	front	99.8	0.325	-	1.112	1.002	-	
2437	6	802.11b	DSSS	22	18.5	18.04	0.18	10 mm	01392	1	top	99.8	0.568	0.372	1.112	1.002	0.414	A37
2437	6	802.11b	DSSS	22	18.5	18.04	0.14	10 mm	01392	1	left	99.8	0.076	-	1.112	1.002	-	
5745	149	802.11a	OFDM	20	14.5	14.21	-0.13	10 mm	74902	6	back	98.6	0.236	0.113	1.069	1.014	0.122	
5745	149	802.11a	OFDM	20	14.5	14.21	0.13	10 mm	74902	6	front	98.6	1.544	0.828	1.069	1.014	0.898	A39
5785	157	802.11a	OFDM	20	14.5	14.08	0.14	10 mm	74902	6	front	98.6	1.577	0.783	1.102	1.014	0.875	
5745	149	802.11a	OFDM	20	14.5	14.21	0.12	10 mm	74902	6	top	98.6	0.831	0.386	1.069	1.014	0.418	
5745	149	802.11a	OFDM	20	14.5	14.21	0.18	10 mm	74902	6	left	98.6	0.186	-	1.069	1.014	-	
5745	149	802.11a	OFDM	20	14.5	14.21	0.17	10 mm	74902	6	front	98.6	1.581	0.777	1.069	1.014	0.842	
ANSI / IEEE C95.1 1992 - SAFETY LIMIT								Body										
Spatial Peak								1.6 W/kg (mW/g)										
Uncontrolled Exposure/General Population								averaged over 1 gram										

Note: Blue entry represents variability data.



11.4 SAR Test Notes

General Notes:

- The test data reported are the worst-case SAR values according to test procedures specified in IEEE 1528-2013, and FCC KDB Publication 447498 D01v06.
- Batteries are fully charged at the beginning of the SAR measurements.
- Liquid tissue depth was at least 15.0 cm for all frequencies.
- The manufacturer has confirmed that the device(s) tested have the same physical, mechanical and thermal characteristics and are within operational tolerances expected for production units.
- SAR results were scaled to the maximum allowed power to demonstrate compliance per FCC KDB Publication 447498 D01v06.
- Device was tested using a fixed spacing for body-worn accessory testing. A separation distance of 15 mm was considered because the manufacturer has determined that there will be body-worn accessories available in the marketplace for users to support this separation distance.
- Per FCC KDB Publication 648474 D04v01r03, body-worn SAR was evaluated without a headset connected to the device. Since the standalone reported body-worn SAR was ≤ 1.2 W/kg, no additional body-worn SAR evaluations using a headset cable were required.
- Per FCC KDB 865664 D01v01r04, variability SAR tests were performed when the measured SAR results for a frequency band were greater than or equal to 0.8 W/kg. Repeated SAR measurements are highlighted in the tables above for clarity. Please see Section 13 for variability analysis.
- During SAR Testing for the Wireless Router conditions per FCC KDB Publication 941225 D06v02r01, the actual Portable Hotspot operation (with actual simultaneous transmission of a transmitter with WIFI) was not activated (See Section 6.7 for more details).

GSM Test Notes:

- Body-Worn accessory testing is typically associated with voice operations. Therefore, GSM voice was evaluated for body-worn SAR.
- Justification for reduced test configurations per KDB Publication 941225 D01v03r01 and October 2013 TCB Workshop Notes: The source-based frame-averaged output power was evaluated for all GPRS/EDGE slot configurations. The configuration with the highest target frame averaged output power was evaluated for hotspot SAR. When the maximum frame-averaged powers are equivalent across two or more slots (within 0.25 dB), the configuration with the most number of time slots was tested.

FCC ID: A3LSMJ530GM		SAR EVALUATION REPORT		Approved by: Quality Manager
Document S/N: 1M1703230121-01-R1.A3L	Test Dates: 03/20/17 - 04/20/17	DUT Type: Portable Handset	Page 72 of 85	

Per FCC KDB Publication 447498 D01v06, if the reported (scaled) SAR measured at the middle channel or highest output power channel for each test configuration is ≤ 0.8 W/kg then testing at the other channels is not required for such test configuration(s). When the maximum output power variation across the required test channels is $> \frac{1}{2}$ dB, instead of the middle channel, the highest output power channel was used.

UMTS Notes:



1. UMTS mode in was tested under RMC 12.2 kbps with HSPA Inactive per KDB Publication 941225 D01v03r01. AMR and HSPA SAR was not required per the 3G Test Reduction Procedure in KDB Publication 941225 D01v03r01.
2. Per FCC KDB Publication 447498 D01v06, if the reported (scaled) SAR measured at the middle channel or highest output power channel for each test configuration is ≤ 0.8 W/kg then testing at the other channels is not required for such test configuration(s). When the maximum output power variation across the required test channels is $> \frac{1}{2}$ dB, instead of the middle channel, the highest output power channel was used.

LTE Notes:

1. LTE Considerations: LTE test configurations are determined according to SAR Evaluation Considerations for LTE Devices in FCC KDB Publication 941225 D05v02r04. The general test procedures used for testing can be found in Section 8.5.4.
2. MPR is permanently implemented for this device by the manufacturer. The specific manufacturer target MPR is indicated alongside the SAR results. MPR is enabled for this device, according to 3GPP TS36.101 Section 6.2.3 – 6.2.5 under Table 6.2.3-1.
3. A-MPR was disabled for all SAR tests by setting NS=01 on the base station simulator. SAR tests were performed with the same number of RB and RB offsets transmitting on all TTI frames (maximum TTI).
4. Per FCC KDB Publication 447498 D01v06, when the reported (scaled) for LTE Band 41 SAR measured at the highest output power channel in a given a test configuration was > 0.6 W/kg, testing at the other channels was required for such test configurations.
5. TDD LTE was tested per the guidance provided in FCC KDB Publication 941225 D05v02r04. Testing was performed using UL-DL configuration 0 with 6 UL subframes and 2 S subframes using extended cyclic prefix only and special subframe configuration 6. SAR tests were performed at maximum output power and worst-case transmission duty factor in extended cyclic prefix. Per 3GPP 36.211 Section 4, the duty factor for special subframe configuration 6 using extended cyclic prefix is 0.633.
6. Per KDB Publication 941225 D05Av01r02, SAR for LTE CA operations was not needed since the maximum average output power in LTE CA mode was not >0.25 dB higher than the maximum output power when downlink carrier aggregation was inactive.



WLAN Notes:

1. For held-to-ear and hotspot operations, the initial test position procedures were applied. The test position with the highest extrapolated peak SAR will be used as the initial test position. When reported SAR for the initial test position is ≤ 0.4 W/kg, no additional testing for the remaining test positions was required. Otherwise, SAR is evaluated at the subsequent highest peak SAR positions until the reported SAR result is ≤ 0.8 W/kg or all test positions are measured.
2. Justification for test configurations for WLAN per KDB Publication 248227 D01v02r02 for 2.4 GHz WIFI operations, the highest measured maximum output power channel for DSSS was selected for SAR measurement. SAR for OFDM modes (2.4 GHz 802.11g/n) was not required due to the maximum allowed powers and the highest reported DSSS SAR. See Section 8.6.5 for more information.
3. Justification for test configurations for WLAN per KDB Publication 248227 D01v02r02 for 5 GHz WIFI operations, the initial test configuration was selected according to the transmission mode with the highest maximum allowed powers. Other transmission modes were not investigated since the highest reported

FCC ID: A3LSMJ530GM		SAR EVALUATION REPORT		Approved by: Quality Manager
Document S/N: 1M1703230121-01-R1.A3L	Test Dates: 03/20/17 - 04/20/17	DUT Type: Portable Handset	Page 73 of 85	

SAR for initial test configuration adjusted by the ratio of maximum output powers is less than 1.2 W/kg. See Section 8.6.6 for more information.

4. When the maximum reported 1g averaged SAR is ≤ 0.8 W/kg, SAR testing on additional channels was not required. Otherwise, SAR for the next highest output power channel was required until the reported SAR result was ≤ 1.20 W/kg or all test channels were measured.
5. When 10-g SAR measurement is considered, a factor of 2.5 is applied to the thresholds above.
6. The device was configured to transmit continuously at the required data rate, channel bandwidth and signal modulation, using the highest transmission duty factor supported by the test mode tools. The reported SAR was scaled to the 100% transmission duty factor to determine compliance. Procedures used to measure the duty factor are identical to that in the associated EMC test reports.

FCC ID: A3LSMJ530GM	 SAR EVALUATION REPORT 		Approved by: Quality Manager
Document S/N: 1M1703230121-01-R1.A3L	Test Dates: 03/20/17 - 04/20/17	DUT Type: Portable Handset	Page 74 of 85

12 FCC MULTI-TX AND ANTENNA SAR CONSIDERATIONS

12.1 Introduction

The following procedures adopted from FCC KDB Publication 447498 D01v06 are applicable to devices with built-in unlicensed transmitters such as 802.11 and Bluetooth devices which may simultaneously transmit with the licensed transmitter.

12.2 Simultaneous Transmission Procedures

This device contains transmitters that may operate simultaneously. Therefore simultaneous transmission analysis is required. Per FCC KDB Publication 447498 D01v06 4.3.2 and IEEE 1528-2013 Section 6.3.4.1.2, simultaneous transmission SAR test exclusion may be applied when the sum of the 1-g SAR for all the simultaneous transmitting antennas in a specific a physical test configuration is ≤ 1.6 W/kg. The different test positions in an exposure condition may be considered collectively to determine SAR test exclusion according to the sum of 1-g or 10-g SAR.



When standalone SAR is not required to be measured, per FCC KDB 447498 D01v06 4.3.2 b), the following equation must be used to estimate the standalone 1g SAR for simultaneous transmission assessment involving that transmitter.

$$\text{Estimated SAR} = \frac{\sqrt{f(\text{GHz})}}{7.5} * \frac{(\text{Max Power of channel, mW})}{\text{Min. Separation Distance, mm}}$$

**Table 12-1
Estimated SAR**

Mode	Frequency	Maximum Allowed Power	Separation Distance (Body)	Estimated SAR (Body)
	[MHz]	[dBm]	[mm]	[W/kg]
Bluetooth	2480	9.50	15	0.126

Note: Held-to ear configurations are not applicable to Bluetooth operations and therefore were not considered for simultaneous transmission. Per KDB Publication 447498 D01v06, the maximum power of the channel was rounded to the nearest mW before calculation.

FCC ID: A3LSMJ530GM	 PCTEST ENGINEERING LABORATORY, INC.	SAR EVALUATION REPORT		Approved by: Quality Manager
Document S/N: 1M1703230121-01-R1.A3L	Test Dates: 03/20/17 - 04/20/17	DUT Type: Portable Handset		Page 75 of 85



12.3 Head SAR Simultaneous Transmission Analysis

Table 12-2
Simultaneous Transmission Scenario with 2.4 GHz WLAN (Held to Ear)

Exposure Condition	Mode	2G/3G/4G SAR (W/kg)	2.4 GHz WLAN SAR (W/kg)	Σ SAR (W/kg)
Head SAR	GSM 850	0.195	0.793	0.988
	UMTS 850	0.194	0.793	0.987
	GSM 1900	0.161	0.793	0.954
	UMTS 1750	0.160	0.793	0.953
	UMTS 1900	0.193	0.793	0.986
	LTE Band 12	0.081	0.793	0.874
	LTE Band 5 (Cell)	0.208	0.793	1.001
	LTE Band 4 (AWS)	0.218	0.793	1.011
	LTE Band 66 (AWS)	0.118	0.793	0.911
	LTE Band 2 (PCS)	0.251	0.793	1.044
	LTE Band 41	0.090	0.793	0.883

Table 12-3
Simultaneous Transmission Scenario with 5 GHz WLAN (Held to Ear)

Exposure Condition	Mode	2G/3G/4G SAR (W/kg)	5 GHz WLAN SAR (W/kg)	Σ SAR (W/kg)
Head SAR	GSM 850	0.195	1.044	1.239
	UMTS 850	0.194	1.044	1.238
	GSM 1900	0.161	1.044	1.205
	UMTS 1750	0.160	1.044	1.204
	UMTS 1900	0.193	1.044	1.237
	LTE Band 12	0.081	1.044	1.125
	LTE Band 5 (Cell)	0.208	1.044	1.252
	LTE Band 4 (AWS)	0.218	1.044	1.262
	LTE Band 66 (AWS)	0.118	1.044	1.162
	LTE Band 2 (PCS)	0.251	1.044	1.295
	LTE Band 41	0.090	1.044	1.134

FCC ID: A3LSMJ530GM		SAR EVALUATION REPORT		Approved by: Quality Manager
Document S/N: 1M1703230121-01-R1.A3L	Test Dates: 03/20/17 - 04/20/17	DUT Type: Portable Handset	Page 76 of 85	

12.4 Body-Worn Simultaneous Transmission Analysis

Table 12-4
Simultaneous Transmission Scenario with 2.4 GHz WLAN (Body-Worn at 1.5 cm)

Exposure Condition	Mode	2G/3G/4G SAR (W/kg)	2.4 GHz WLAN SAR (W/kg)	Σ SAR (W/kg)
Body-Worn	GSM 850	0.353	0.178	0.531
	UMTS 850	0.313	0.178	0.491
	GSM 1900	0.444	0.178	0.622
	UMTS 1750	0.510	0.178	0.688
	UMTS 1900	0.751	0.178	0.929
	LTE Band 12	0.215	0.178	0.393
	LTE Band 5 (Cell)	0.415	0.178	0.593
	LTE Band 4 (AWS)	0.844	0.178	1.022
	LTE Band 66 (AWS)	0.326	0.178	0.504
	LTE Band 2 (PCS)	0.847	0.178	1.025
	LTE Band 41	0.265	0.178	0.443

Table 12-5
Simultaneous Transmission Scenario with 5 GHz WLAN (Body-Worn at 1.5 cm)

Exposure Condition	Mode	2G/3G/4G SAR (W/kg)	5 GHz WLAN SAR (W/kg)	Σ SAR (W/kg)
Body-Worn	GSM 850	0.353	0.075	0.428
	UMTS 850	0.313	0.075	0.388
	GSM 1900	0.444	0.075	0.519
	UMTS 1750	0.510	0.075	0.585
	UMTS 1900	0.751	0.075	0.826
	LTE Band 12	0.215	0.075	0.290
	LTE Band 5 (Cell)	0.415	0.075	0.490
	LTE Band 4 (AWS)	0.844	0.075	0.919
	LTE Band 66 (AWS)	0.326	0.075	0.401
	LTE Band 2 (PCS)	0.847	0.075	0.922
	LTE Band 41	0.265	0.075	0.340



FCC ID: A3LSMJ530GM		SAR EVALUATION REPORT		Approved by: Quality Manager
Document S/N: 1M1703230121-01-R1.A3L	Test Dates: 03/20/17 - 04/20/17	DUT Type: Portable Handset	Page 77 of 85	

Table 12-6
Simultaneous Transmission Scenario with Bluetooth (Body-Worn at 1.5 cm)

Exposure Condition	Mode	2G/3G/4G SAR (W/kg)	Bluetooth SAR (W/kg)	Σ SAR (W/kg)
Body-Worn	GSM 850	0.353	0.126	0.479
	UMTS 850	0.313	0.126	0.439
	GSM 1900	0.444	0.126	0.570
	UMTS 1750	0.510	0.126	0.636
	UMTS 1900	0.751	0.126	0.877
	LTE Band 12	0.215	0.126	0.341
	LTE Band 5 (Cell)	0.415	0.126	0.541
	LTE Band 4 (AWS)	0.844	0.126	0.970
	LTE Band 66 (AWS)	0.326	0.126	0.452
	LTE Band 2 (PCS)	0.847	0.126	0.973
	LTE Band 41	0.265	0.126	0.391

Note: Bluetooth SAR was not required to be measured per FCC KDB 447498. Estimated SAR results were used in the above table to determine simultaneous transmission SAR test exclusion.

12.5 Hotspot SAR Simultaneous Transmission Analysis

Table 12-7
Simultaneous Transmission Scenario with 2.4 GHz WLAN (Hotspot at 1.0 cm)

Exposure Condition	Mode	2G/3G/4G SAR (W/kg)	2.4 GHz WLAN SAR (W/kg)	Σ SAR (W/kg)
Hotspot SAR	GPRS 850	0.414	0.414	0.828
	UMTS 850	0.451	0.414	0.865
	GPRS 1900	0.523	0.414	0.937
	UMTS 1750	0.821	0.414	1.235
	UMTS 1900	0.850	0.414	1.264
	LTE Band 12	0.331	0.414	0.745
	LTE Band 5 (Cell)	0.575	0.414	0.989
	LTE Band 4 (AWS)	0.758	0.414	1.172
	LTE Band 66 (AWS)	0.518	0.414	0.932
	LTE Band 2 (PCS)	0.859	0.414	1.273
	LTE Band 41	1.071	0.414	1.485



FCC ID: A3LSMJ530GM		SAR EVALUATION REPORT		Approved by: Quality Manager
Document S/N: 1M1703230121-01-R1.A3L	Test Dates: 03/20/17 - 04/20/17	DUT Type: Portable Handset		Page 78 of 85

Table 12-8
Simultaneous Transmission Scenario with 5 GHz WLAN (Hotspot at 1.0 cm)

Exposure Condition	Mode	2G/3G/4G SAR (W/kg)	5 GHz WLAN SAR (W/kg)	Σ SAR (W/kg)
Hotspot SAR	GPRS 850	0.414	0.898	1.312
	UMTS 850	0.451	0.898	1.349
	GPRS 1900	0.523	0.898	1.421
	UMTS 1750	0.821	0.898	See Table Below
	UMTS 1900	0.850	0.898	See Table Below
	LTE Band 12	0.331	0.898	1.229
	LTE Band 5 (Cell)	0.575	0.898	1.473
	LTE Band 4 (AWS)	0.758	0.898	See Table Below
	LTE Band 66 (AWS)	0.518	0.898	1.416
	LTE Band 2 (PCS)	0.859	0.898	See Table Below
	LTE Band 41	1.071	0.898	See Table Below



Simult Tx	Configuration	UMTS 1750 SAR (W/kg)	5 GHz WLAN SAR (W/kg)	Σ SAR (W/kg)	Simult Tx	Configuration	UMTS 1900 SAR (W/kg)	5 GHz WLAN SAR (W/kg)	Σ SAR (W/kg)
		1	2	1+2			1	2	1+2
Hotspot SAR	Back	0.610	0.122	0.732	Hotspot SAR	Back	0.835	0.122	0.957
	Front	0.610	0.898	1.508		Front	0.520	0.898	1.418
	Top	-	0.418	0.418		Top	-	0.418	0.418
	Bottom	0.821	-	0.821		Bottom	0.850	-	0.850
	Right	0.047	-	0.047		Right	0.098	-	0.098
	Left	0.148	0.898*	1.046		Left	0.138	0.898*	1.036

Simult Tx	Configuration	LTE Band 4 (AWS) SAR (W/kg)	5 GHz WLAN SAR (W/kg)	Σ SAR (W/kg)	Simult Tx	Configuration	LTE Band 2 (PCS) SAR (W/kg)	5 GHz WLAN SAR (W/kg)	Σ SAR (W/kg)
		1	2	1+2			1	2	1+2
Hotspot SAR	Back	0.758	0.122	0.880	Hotspot SAR	Back	0.765	0.122	0.887
	Front	0.491	0.898	1.389		Front	0.468	0.898	1.366
	Top	-	0.418	0.418		Top	-	0.418	0.418
	Bottom	0.692	-	0.692		Bottom	0.859	-	0.859
	Right	0.066	-	0.066		Right	0.088	-	0.088
	Left	0.120	0.898*	1.018		Left	0.120	0.898*	1.018

Simult Tx	Configuration	LTE Band 41 SAR (W/kg)	5 GHz WLAN SAR (W/kg)	Σ SAR (W/kg)
		1	2	1+2
Hotspot SAR	Back	1.071	0.122	1.193
	Front	0.474	0.898	1.372
	Top	-	0.418	0.418
	Bottom	0.556	-	0.556
	Right	0.081	-	0.081
	Left	0.135	0.898*	1.033

Notes:

- For SAR summation, the highest reported SAR across all test distances was used as the most conservative evaluation for simultaneous transmission analysis for each device edge.
- (*) For test positions that were not required to be evaluated for WLAN SAR per FCC KDB Publication 248227, the worst case WLAN SAR result for applicable exposure conditions was used for simultaneous transmission analysis.
- Per FCC KDB Publication 941225 D06v02r01, the devices edges with antennas more than 2.5 cm from edge are not required to be evaluated for SAR (“-”).

FCC ID: A3LSMJ530GM		SAR EVALUATION REPORT		Approved by: Quality Manager
Document S/N: 1M1703230121-01-R1.A3L	Test Dates: 03/20/17 - 04/20/17	DUT Type: Portable Handset	Page 79 of 85	

13 SAR MEASUREMENT VARIABILITY

13.1 Measurement Variability

Per FCC KDB Publication 865664 D01v01r04, SAR measurement variability was assessed for each frequency band, which was determined by the SAR probe calibration point and tissue-equivalent medium used for the device measurements. When both head and body tissue-equivalent media were required for SAR measurements in a frequency band, the variability measurement procedures were applied to the tissue medium with the highest measured SAR, using the highest measured SAR configuration for that tissue-equivalent medium. These additional measurements were repeated after the completion of all measurements requiring the same head or body tissue-equivalent medium in a frequency band. The test device was returned to ambient conditions (normal room temperature) with the battery fully charged before it was re-mounted on the device holder for the repeated measurement(s) to minimize any unexpected variations in the repeated results.

SAR Measurement Variability was assessed using the following procedures for each frequency band:

- 1) When the original highest measured SAR is ≥ 0.80 W/kg, the measurement was repeated once.
- 2) A second repeated measurement was performed only if the ratio of largest to smallest SAR for the original and first repeated measurements was > 1.20 or when the original or repeated measurement was ≥ 1.45 W/kg (~ 10% from the 1-g SAR limit).
- 3) A third repeated measurement was performed only if the original, first or second repeated measurement was ≥ 1.5 W/kg and the ratio of largest to smallest SAR for the original, first and second repeated measurements is > 1.20 .
- 4) Repeated measurements are not required when the original highest measured SAR is < 0.80 W/kg
- 5) When 10-g SAR measurement is considered, a factor of 2.5 is applied to the thresholds above.

**Table 13-1
Head SAR Measurement Variability Results**



HEAD VARIABILITY RESULTS														
Band	FREQUENCY		Mode/Band	Service	Side	Test Position	Data Rate (Mbps)	Measured SAR (1g)	1st Repeated SAR (1g)	Ratio	2nd Repeated SAR (1g)	Ratio	3rd Repeated SAR (1g)	Ratio
	MHz	Ch.						(W/kg)	(W/kg)		(W/kg)		(W/kg)	
5250	5260.00	52	802.11a, 20 MHz Bandwidth	OFDM	Right	Cheek	6	0.999	1.010	1.01	N/A	N/A	N/A	N/A
5600	5600.00	120	802.11a, 20 MHz Bandwidth	OFDM	Right	Cheek	6	0.913	0.805	1.13	N/A	N/A	N/A	N/A
ANSI / IEEE C95.1 1992 - SAFETY LIMIT Spatial Peak Uncontrolled Exposure/General Population						Head 1.6 W/kg (mW/g) averaged over 1 gram								

**Table 13-2
Body SAR Measurement Variability Results**

BODY VARIABILITY RESULTS														
Band	FREQUENCY		Mode	Service	Data Rate (Mbps)	Side	Spacing	Measured SAR (1g)	1st Repeated SAR (1g)	Ratio	2nd Repeated SAR (1g)	Ratio	3rd Repeated SAR (1g)	Ratio
	MHz	Ch.						(W/kg)	(W/kg)		(W/kg)		(W/kg)	
1900	1860.00	18700	LTE Band 2 (PCS), 20 MHz Bandwidth	QPSK, 1 RB, 99 RB Offset	N/A	bottom	10 mm	0.845	0.820	1.03	N/A	N/A	N/A	N/A
5750	5745.00	149	802.11a, 20 MHz Bandwidth	OFDM	6	front	10 mm	0.828	0.777	1.07	N/A	N/A	N/A	N/A
ANSI / IEEE C95.1 1992 - SAFETY LIMIT Spatial Peak Uncontrolled Exposure/General Population						Body 1.6 W/kg (mW/g) averaged over 1 gram								



13.2 Measurement Uncertainty

The measured SAR was < 1.5 W/kg for all frequency bands. Therefore, per KDB Publication 865664 D01v01r04, the extended measurement uncertainty analysis per IEEE 1528-2013 was not required.

FCC ID: A3LSMJ530GM		SAR EVALUATION REPORT		Approved by: Quality Manager
Document S/N: 1M1703230121-01-R1.A3L	Test Dates: 03/20/17 - 04/20/17	DUT Type: Portable Handset	Page 80 of 85	



Manufacturer	Model	Description	Cal Date	Cal Interval	Cal Due	Serial Number
Agilent	8594A	(9kHz-2.9GHz) Spectrum Analyzer	CBT	N/A	CBT	3051A00187
Agilent	8753ES	S-Parameter Network Analyzer	6/28/2016	Annual	6/28/2017	MY40006070
Agilent	8753ES	S-Parameter Vector Network Analyzer	8/19/2016	Annual	8/19/2017	MY40003841
Agilent	E4432B	ESG-D Series Signal Generator	3/24/2017	Annual	3/24/2018	US40053896
Agilent	E4438C	ESG Vector Signal Generator	3/23/2017	Annual	3/23/2018	MY47270002
Agilent	E5515C	Wireless Communications Test Set	5/16/2015	Biennial	5/16/2017	GB43304447
Agilent	E5515C	8960 Series 10 Wireless Communications Test Set	10/5/2016	Annual	10/5/2017	GB42230325
Agilent	E8257D	(250kHz-20GHz) Signal Generator	3/22/2017	Annual	3/22/2018	MY45470194
Agilent	N5182A	MXG Vector Signal Generator	10/27/2016	Annual	10/27/2017	MY47420603
Agilent	N9020A	MXA Signal Analyzer	10/28/2016	Annual	10/28/2017	US46470561
Amplifier Research	15S1G6	Amplifier	CBT	N/A	CBT	433971
Anritsu	MA24106A	USB Power Sensor	6/2/2016	Annual	6/2/2017	1231538
Anritsu	MA24106A	USB Power Sensor	6/2/2016	Annual	6/2/2017	1231535
Anritsu	MA2411B	Pulse Power Sensor	8/18/2016	Annual	8/18/2017	1126066
Anritsu	MA2411B	Pulse Power Sensor	8/18/2016	Annual	8/18/2017	1207470
Anritsu	ML2495A	Power Meter	10/16/2015	Biennial	10/16/2017	941001
Anritsu	MT8820C	Radio Communication Analyzer	9/13/2016	Annual	9/13/2017	6201144419
COMTech	AR85729-5	Solid State Amplifier	CBT	N/A	CBT	MY55A00-009
Control Company	4352	Ultra Long Stem Thermometer	3/8/2016	Biennial	3/8/2018	160261701
Keysight	772D	Dual Directional Coupler	CBT	N/A	CBT	MY52180215
MCL	BW-N6W5+	6dB Attenuator	CBT	N/A	CBT	1139
MiniCircuits	SLP-2400+	Low Pass Filter	CBT	N/A	CBT	R8979500903
Mini-Circuits	BW-N20W5	Power Attenuator	CBT	N/A	CBT	1226
Mini-Circuits	BW-N20W5+	DC to 18 GHz Precision Fixed 20 dB Attenuator	CBT	N/A	CBT	N/A
Mini-Circuits	NLP-1200+	Low Pass Filter DC to 1000 MHz	CBT	N/A	CBT	N/A
Mini-Circuits	NLP-2950+	Low Pass Filter DC to 2700 MHz	CBT	N/A	CBT	N/A
Mitutoyo	CD-6-CSX	Digital Caliper	3/2/2016	Biennial	3/2/2018	13264162
Narda	4014C-6	4 - 8 GHz SMA 6 dB Directional Coupler	CBT	N/A	CBT	N/A
Narda	4772-3	Attenuator (3dB)	CBT	N/A	CBT	9406
Pasternack	NC-100	Torque Wrench	5/21/2015	Biennial	5/21/2017	N/A
Pasternack	PE2208-6	Bidirectional Coupler	CBT	N/A	CBT	N/A
Rohde & Schwarz	CMU200	Base Station Simulator	6/2/2016	Annual	6/2/2017	109892
Rohde & Schwarz	CMW500	Radio Communication Tester	4/26/2016	Annual	4/26/2017	112347
Rohde & Schwarz	CMW500	Wideband Radio Communication Tester	7/20/2016	Annual	7/20/2017	132885
Seekonk	NC-100	Torque Wrench 5/16", 8" lbs	3/2/2016	Biennial	3/2/2018	N/A
Seekonk	NC-100	Torque Wrench (8" lb)	9/1/2016	Biennial	9/1/2018	21053
SPEAG	D750V3	750 MHz Dipole	3/7/2017	Annual	3/7/2018	1054
SPEAG	D835V2	835 MHz SAR Dipole	7/14/2016	Annual	7/14/2017	4d133
SPEAG	D1765V2	1765 MHz SAR Dipole	5/11/2016	Annual	5/11/2017	1008
SPEAG	D1750V2	1750 MHz SAR Dipole	5/9/2016	Annual	5/9/2017	1148
SPEAG	D1900V2	1900 MHz SAR Dipole	7/15/2016	Annual	7/15/2017	5d149
SPEAG	D2450V2	2450 MHz SAR Dipole	9/13/2016	Annual	9/13/2017	797
SPEAG	D2600V2	2600 MHz SAR Dipole	7/25/2016	Annual	7/25/2017	1126
SPEAG	D5GHZV2	5 GHz SAR Dipole	8/2/2016	Annual	8/2/2017	1237
SPEAG	D1900V2	1900 MHz SAR Dipole	7/8/2016	Annual	7/8/2017	5d080
SPEAG	D2450V2	2450 MHz SAR Dipole	7/25/2016	Annual	7/25/2017	981
SPEAG	D2600V2	2600 MHz SAR Dipole	9/13/2016	Annual	9/13/2017	1071
SPEAG	ES3DV3	SAR Probe	11/15/2016	Annual	11/15/2017	3334
SPEAG	ES3DV3	SAR Probe	2/10/2017	Annual	2/10/2018	3213
SPEAG	EX3DV4	SAR Probe	5/17/2016	Annual	5/17/2017	7409
SPEAG	ES3DV3	SAR Probe	1/13/2017	Annual	1/13/2018	3288
SPEAG	ES3DV3	SAR Probe	9/19/2016	Annual	9/19/2017	3287
SPEAG	EX3DV4	SAR Probe	7/21/2016	Annual	7/21/2017	7308
SPEAG	ES3DV3	SAR Probe	2/10/2017	Annual	2/10/2018	3318
SPEAG	EX3DV4	SAR Probe	4/19/2016	Annual	4/19/2017	7406
SPEAG	ES3DV3	SAR Probe	3/14/2017	Annual	3/14/2018	3319
SPEAG	EX3DV4	SAR Probe	1/13/2017	Annual	1/13/2018	3589
SPEAG	DAE4	Dasy Data Acquisition Electronics	11/11/2016	Annual	11/11/2017	1334
SPEAG	DAE4	Dasy Data Acquisition Electronics	2/9/2017	Annual	2/9/2018	1272
SPEAG	DAE4	Dasy Data Acquisition Electronics	5/11/2016	Annual	5/11/2017	859
SPEAG	DAE4	Dasy Data Acquisition Electronics	9/14/2016	Annual	9/14/2017	1408
SPEAG	DAE4	Dasy Data Acquisition Electronics	2/9/2017	Annual	2/9/2018	665
SPEAG	DAE4	Dasy Data Acquisition Electronics	4/14/2016	Annual	4/14/2017	1407
SPEAG	DAE4	Dasy Data Acquisition Electronics	3/8/2017	Annual	3/8/2018	1368
SPEAG	DAE4	Dasy Data Acquisition Electronics	1/16/2017	Annual	1/16/2018	1466
SPEAG	DAK-12	Dielectric Assessment Kit (10MHz - 3GHz)	3/16/2017	Annual	3/16/2018	1102
SPEAG	DAK-3.5	Dielectric Assessment Kit	5/10/2016	Annual	5/10/2017	1070
SPEAG	DAKS-3.5	Portable Dielectric Assessment Kit	8/25/2016	Annual	8/25/2017	1041

Note: CBT (Calibrated Before Testing). Prior to testing, the measurement paths containing a cable, amplifier, attenuator, coupler or filter were connected to a calibrated source (i.e. a signal generator) to determine the losses of the measurement path. The power meter offset was then adjusted to compensate for the measurement system losses. This level offset is stored within the power meter before measurements are made. This calibration verification procedure applies to the system verification and output power measurements. The calibrated reading is then taken directly from the power meter after compensation of the losses for all final power measurements. Each equipment item was used solely within its respective calibration period

FCC ID: A3LSMJ530GM		SAR EVALUATION REPORT		Approved by: Quality Manager
Document S/N: 1M1703230121-01-R1.A3L	Test Dates: 03/20/17 - 04/20/17	DUT Type: Portable Handset	Page 81 of 85	

15 MEASUREMENT UNCERTAINTIES

a	c	d	e= f(d,k)	f	g	h = c x f/e	i = c x g/e	k
Uncertainty Component	Tol. (± %)	Prob. Dist.	Div.	c _i 1gm	c _i 10 gms	1gm u _i (± %)	10gms u _i (± %)	v _i
Measurement System								
Probe Calibration	6.55	N	1	1.0	1.0	6.6	6.6	∞
Axial Isotropy	0.25	N	1	0.7	0.7	0.2	0.2	∞
Hemishperical Isotropy	1.3	N	1	0.7	0.7	0.9	0.9	∞
Boundary Effect	2.0	R	1.73	1.0	1.0	1.2	1.2	∞
Linearity	0.3	N	1	1.0	1.0	0.3	0.3	∞
System Detection Limits	0.25	R	1.73	1.0	1.0	0.1	0.1	∞
Readout Electronics	0.3	N	1	1.0	1.0	0.3	0.3	∞
Response Time	0.8	R	1.73	1.0	1.0	0.5	0.5	∞
Integration Time	2.6	R	1.73	1.0	1.0	1.5	1.5	∞
RF Ambient Conditions - Noise	3.0	R	1.73	1.0	1.0	1.7	1.7	∞
RF Ambient Conditions - Reflections	3.0	R	1.73	1.0	1.0	1.7	1.7	∞
Probe Positioner Mechanical Tolerance	0.4	R	1.73	1.0	1.0	0.2	0.2	∞
Probe Positioning w/ respect to Phantom	6.7	R	1.73	1.0	1.0	3.9	3.9	∞
Extrapolation, Interpolation & Integration algorithms for Max. SAR Evaluation	4.0	R	1.73	1.0	1.0	2.3	2.3	∞
Test Sample Related								
Test Sample Positioning	2.7	N	1	1.0	1.0	2.7	2.7	35
Device Holder Uncertainty	1.67	N	1	1.0	1.0	1.7	1.7	5
Output Power Variation - SAR drift measurement	5.0	R	1.73	1.0	1.0	2.9	2.9	∞
SAR Scaling	0.0	R	1.73	1.0	1.0	0.0	0.0	∞
Phantom & Tissue Parameters								
Phantom Uncertainty (Shape & Thickness tolerances)	7.6	R	1.73	1.0	1.0	4.4	4.4	∞
Liquid Conductivity - measurement uncertainty	4.2	N	1	0.78	0.71	3.3	3.0	10
Liquid Permittivity - measurement uncertainty	4.1	N	1	0.23	0.26	1.0	1.1	10
Liquid Conductivity - Temperature Uncertainty	3.4	R	1.73	0.78	0.71	1.5	1.4	∞
Liquid Permittivity - Temperature Uncertainty	0.6	R	1.73	0.23	0.26	0.1	0.1	∞
Liquid Conductivity - deviation from target values	5.0	R	1.73	0.64	0.43	1.8	1.2	∞
Liquid Permittivity - deviation from target values	5.0	R	1.73	0.60	0.49	1.7	1.4	∞
Combined Standard Uncertainty (k=1)	RSS					11.5	11.3	60
Expanded Uncertainty (95% CONFIDENCE LEVEL)	k=2					23.0	22.6	



FCC ID: A3LSMJ530GM		SAR EVALUATION REPORT		Approved by: Quality Manager
Document S/N: 1M1703230121-01-R1.A3L	Test Dates: 03/20/17 - 04/20/17	DUT Type: Portable Handset	Page 82 of 85	

16 CONCLUSION

16.1 Measurement Conclusion



The SAR evaluation indicates that the EUT complies with the RF radiation exposure limits of the FCC and Innovation, Science, and Economic Development Canada, with respect to all parameters subject to this test. These measurements were taken to simulate the RF effects of RF exposure under worst-case conditions. Precise laboratory measures were taken to assure repeatability of the tests. The results and statements relate only to the item(s) tested.

Please note that the absorption and distribution of electromagnetic energy in the body are very complex phenomena that depend on the mass, shape, and size of the body, the orientation of the body with respect to the field vectors, and the electrical properties of both the body and the environment. Other variables that may play a substantial role in possible biological effects are those that characterize the environment (e.g. ambient temperature, air velocity, relative humidity, and body insulation) and those that characterize the individual (e.g. age, gender, activity level, debilitation, or disease). Because various factors may interact with one another to vary the specific biological outcome of an exposure to electromagnetic fields, any protection guide should consider maximal amplification of biological effects as a result of field-body interactions, environmental conditions, and physiological variables. [3]



FCC ID: A3LSMJ530GM		SAR EVALUATION REPORT		Approved by: Quality Manager
Document S/N: 1M1703230121-01-R1.A3L	Test Dates: 03/20/17 - 04/20/17	DUT Type: Portable Handset	Page 83 of 85	

17 REFERENCES

- [1] Federal Communications Commission, ET Docket 93-62, Guidelines for Evaluating the Environmental Effects of Radiofrequency Radiation, Aug. 1996.
- [2] ANSI/IEEE C95.1-2005, American National Standard safety levels with respect to human exposure to radio frequency electromagnetic fields, 3kHz to 300GHz, New York: IEEE, 2006.
- [3] ANSI/IEEE C95.1-1992, American National Standard safety levels with respect to human exposure to radio frequency electromagnetic fields, 3kHz to 300GHz, New York: IEEE, Sept. 1992.
- [4] ANSI/IEEE C95.3-2002, IEEE Recommended Practice for the Measurement of Potentially Hazardous Electromagnetic Fields - RF and Microwave, New York: IEEE, December 2002.
- [5] IEEE Standards Coordinating Committee 39 –Standards Coordinating Committee 34 – IEEE Std. 1528-2013, IEEE Recommended Practice for Determining the Peak Spatial-Average Specific Absorption Rate (SAR) in the Human Head from Wireless Communications Devices: Measurement Techniques.
- [6] NCRP, National Council on Radiation Protection and Measurements, Biological Effects and Exposure Criteria for RadioFrequency Electromagnetic Fields, NCRP Report No. 86, 1986. Reprinted Feb. 1995.
- [7] T. Schmid, O. Egger, N. Kuster, Automated E-field scanning system for dosimetric assessments, IEEE Transaction on Microwave Theory and Techniques, vol. 44, Jan. 1996, pp. 105-113.
- [8] K. Pokovic, T. Schmid, N. Kuster, Robust setup for precise calibration of E-field probes in tissue simulating liquids at mobile communications frequencies, ICECOM97, Oct. 1997, pp. 1 -124.
- [9] K. Pokovic, T. Schmid, and N. Kuster, E-field Probe with improved isotropy in brain simulating liquids, Proceedings of the ELMAR, Zadar, Croatia, June 23-25, 1996, pp. 172-175.
- [10] Schmid & Partner Engineering AG, Application Note: Data Storage and Evaluation, June 1998, p2.
- [11] V. Hombach, K. Meier, M. Burkhardt, E. Kuhn, N. Kuster, The Dependence of EM Energy Absorption upon Human Modeling at 900 MHz, IEEE Transaction on Microwave Theory and Techniques, vol. 44 no. 10, Oct. 1996, pp. 1865-1873.
- [12] N. Kuster and Q. Balzano, Energy absorption mechanism by biological bodies in the near field of dipole antennas above 300MHz, IEEE Transaction on Vehicular Technology, vol. 41, no. 1, Feb. 1992, pp. 17-23.
- [13] G. Hartsgrove, A. Kraszewski, A. Surowiec, Simulated Biological Materials for Electromagnetic Radiation Absorption Studies, University of Ottawa, Bioelectromagnetics, Canada: 1987, pp. 29-36.
- [14] Q. Balzano, O. Garay, T. Manning Jr., Electromagnetic Energy Exposure of Simulated Users of Portable Cellular Telephones, IEEE Transactions on Vehicular Technology, vol. 44, no.3, Aug. 1995.
- [15] W. Gander, Computermathematik, Birkhaeuser, Basel, 1992.
- [16] W.H. Press, S.A. Teukolsky, W.T. Vetterling, and B.P. Flannery, Numerical Recipes in C, The Art of Scientific Computing, Second edition, Cambridge University Press, 1992.
- [17] N. Kuster, R. Kastle, T. Schmid, Dosimetric evaluation of mobile communications equipment with known precision, IEEE Transaction on Communications, vol. E80-B, no. 5, May 1997, pp. 645-652.

FCC ID: A3LSMJ530GM		SAR EVALUATION REPORT		Approved by: Quality Manager
Document S/N: 1M1703230121-01-R1.A3L	Test Dates: 03/20/17 - 04/20/17	DUT Type: Portable Handset	Page 84 of 85	

- [18] CENELEC CLC/SC111B, European Prestandard (prENV 50166-2), Human Exposure to Electromagnetic Fields High-frequency: 10kHz-300GHz, Jan. 1995.
- [19] Prof. Dr. Niels Kuster, ETH, Eidgenössische Technische Hochschule Zürich, Dosimetric Evaluation of the Cellular Phone.
- [20] IEC 62209-1, Human exposure to radio frequency fields from hand-held and body-mounted wireless communication devices - Human models, instrumentation, and procedures - Part 1: Procedure to determine the specific absorption rate (SAR) for hand-held devices used in close proximity to the ear (frequency range of 300 MHz to 3 GHz), Feb. 2005.
- [21] Innovation, Science, Economic Development Canada RSS-102 Radio Frequency Exposure Compliance of Radiocommunication Apparatus (All Frequency Bands) Issue 5, March 2015.
- [22] Health Canada Safety Code 6 Limits of Human Exposure to Radio Frequency Electromagnetic Fields in the Frequency Range from 3 kHz – 300 GHz, 2015
- [23] FCC SAR Test Procedures for 2G-3G Devices, Mobile Hotspot and UMPC Devices KDB Publications 941225, D01-D07
- [24] SAR Measurement Guidance for IEEE 802.11 Transmitters, KDB Publication 248227 D01
- [25] FCC SAR Considerations for Handsets with Multiple Transmitters and Antennas, KDB Publications 648474 D03-D04
- [26] FCC SAR Evaluation Considerations for Laptop, Notebook, Netbook and Tablet Computers, FCC KDB Publication 616217 D04
- [27] FCC SAR Measurement and Reporting Requirements for 100MHz – 6 GHz, KDB Publications 865664 D01-D02
- [28] FCC General RF Exposure Guidance and SAR Procedures for Dongles, KDB Publication 447498, D01-D02
- [29] Anexo à Resolução No. 533, de 10 de Setembro de 2009.
- [30] IEC 62209-2, Human exposure to radio frequency fields from hand-held and body-mounted wireless communication devices - Human models, instrumentation, and procedures - Part 2: Procedure to determine the specific absorption rate (SAR) for wireless communication devices used in close proximity to the human body (frequency range of 30 MHz to 6 GHz), Mar. 2010.

FCC ID: A3LSMJ530GM	 SAR EVALUATION REPORT 		Approved by: Quality Manager
Document S/N: 1M1703230121-01-R1.A3L	Test Dates: 03/20/17 - 04/20/17	DUT Type: Portable Handset	Page 85 of 85

APPENDIX A: SAR TEST DATA

PCTEST ENGINEERING LABORATORY, INC.

DUT: A3LSMJ530GM; Type: Portable Handset; Serial: 01376

Communication System: UID 0, GSM; Frequency: 836.6 MHz; Duty Cycle: 1:8.3
Medium: 835 Head Medium parameters used (interpolated):
 $f = 836.6 \text{ MHz}$; $\sigma = 0.906 \text{ S/m}$; $\epsilon_r = 41.028$; $\rho = 1000 \text{ kg/m}^3$
Phantom section: Right Section

Test Date: 04-04-2017; Ambient Temp: 20.5°C; Tissue Temp: 21.3°C

Probe: ES3DV3 - SN3334; ConvF(6.49, 6.49, 6.49); Calibrated: 11/15/2016;
Sensor-Surface: 3mm (Mechanical Surface Detection)
Electronics: DAE4 Sn1334; Calibrated: 11/11/2016
Phantom: SAM with CRP v4.0; Type: QD000P40CD; Serial: TP:1800
Measurement SW: DASY52, Version 52.8 (8); SEMCAD X Version 14.6.10 (7331)

Mode: GSM 850, Right Head, Cheek, Mid.ch

Area Scan (9x15x1): Measurement grid: dx=15mm, dy=15mm

Zoom Scan (5x5x7)/Cube 0: Measurement grid: dx=8mm, dy=8mm, dz=5mm

Reference Value = 13.87 V/m; Power Drift = -0.02 dB

Peak SAR (extrapolated) = 0.202 W/kg

SAR(1 g) = 0.161 W/kg

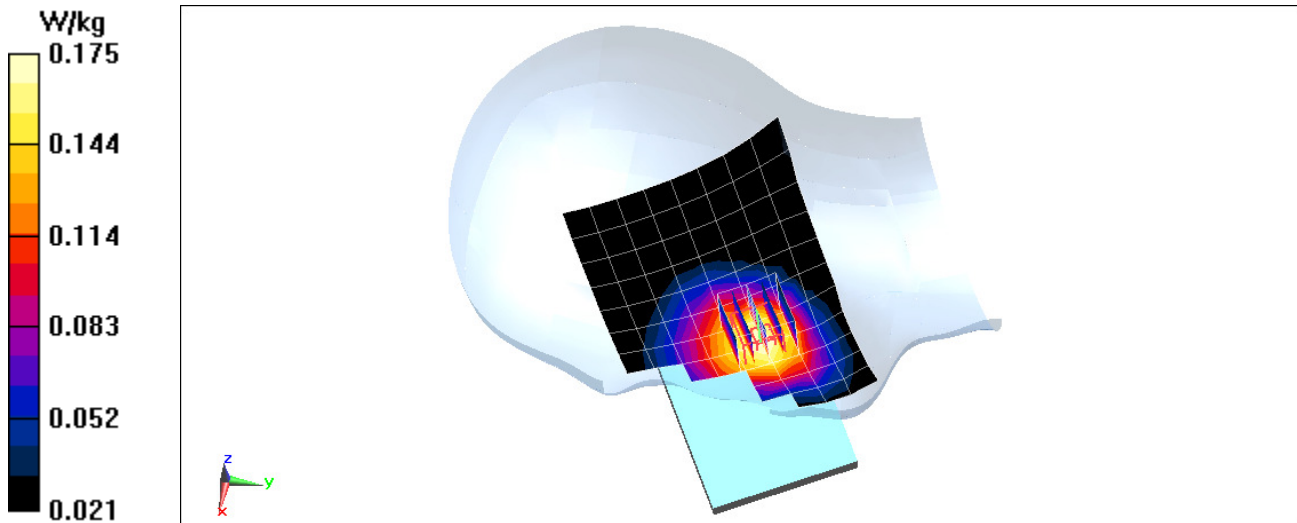

PCTEST ENGINEERING LABORATORY, INC.

DUT: A3LSMJ530GM; Type: Portable Handset; Serial: 01376

Communication System: UID 0, UMTS; Frequency: 836.6 MHz; Duty Cycle: 1:1
Medium: 835 Head Medium parameters used (interpolated):
 $f = 836.6$ MHz; $\sigma = 0.906$ S/m; $\epsilon_r = 41.028$; $\rho = 1000$ kg/m³
Phantom section: Right Section

Test Date: 04-04-2017; Ambient Temp: 20.5°C; Tissue Temp: 21.3°C

Probe: ES3DV3 - SN3334; ConvF(6.49, 6.49, 6.49); Calibrated: 11/15/2016;
Sensor-Surface: 3mm (Mechanical Surface Detection)
Electronics: DAE4 Sn1334; Calibrated: 11/11/2016
Phantom: SAM with CRP v4.0; Type: QD000P40CD; Serial: TP:1800
Measurement SW: DASY52, Version 52.8 (8); SEMCAD X Version 14.6.10 (7331)

Mode: UMTS 850, Right Head, Cheek, Mid.ch

Area Scan (9x15x1): Measurement grid: dx=15mm, dy=15mm
Zoom Scan (5x5x7)/Cube 0: Measurement grid: dx=8mm, dy=8mm, dz=5mm
Reference Value = 14.89 V/m; Power Drift = 0.06 dB
Peak SAR (extrapolated) = 0.234 W/kg
SAR(1 g) = 0.187 W/kg

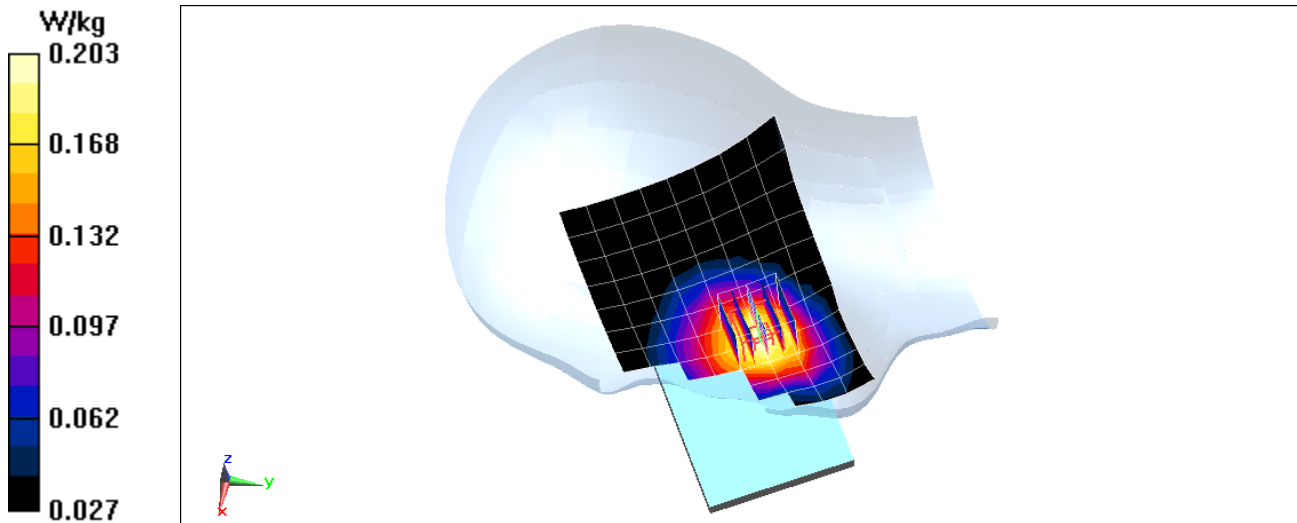

PCTEST ENGINEERING LABORATORY, INC.

DUT: A3LSMJ530GM; Type: Portable Handset; Serial: 01319

Communication System: UID 0, GSM; Frequency: 1880 MHz; Duty Cycle: 1:8.3

Medium: 1900 Head Medium parameters used:

$f = 1880 \text{ MHz}$; $\sigma = 1.417 \text{ S/m}$; $\epsilon_r = 39.88$; $\rho = 1000 \text{ kg/m}^3$

Phantom section: Right Section

Test Date: 03-30-2017; Ambient Temp: 22.9°C; Tissue Temp: 21.9°C

Probe: EX3DV4 - SN7409; ConvF(7.69, 7.69, 7.69); Calibrated: 5/17/2016;

Sensor-Surface: 1.4mm (Mechanical Surface Detection)

Electronics: DAE4 Sn859; Calibrated: 5/11/2016

Phantom: SAM Right; Type: QD000P40CD; Serial: TP:7535

Measurement SW: DASY52, Version 52.8 (8); SEMCAD X Version 14.6.10 (7331)

Mode: GSM 1900, Right Head, Cheek, Mid.ch

Area Scan (9x15x1): Measurement grid: dx=15mm, dy=15mm

Zoom Scan (5x5x7)/Cube 0: Measurement grid: dx=8mm, dy=8mm, dz=5mm

Reference Value = 9.705 V/m; Power Drift = 0.16 dB

Peak SAR (extrapolated) = 0.198 W/kg

SAR(1 g) = 0.127 W/kg

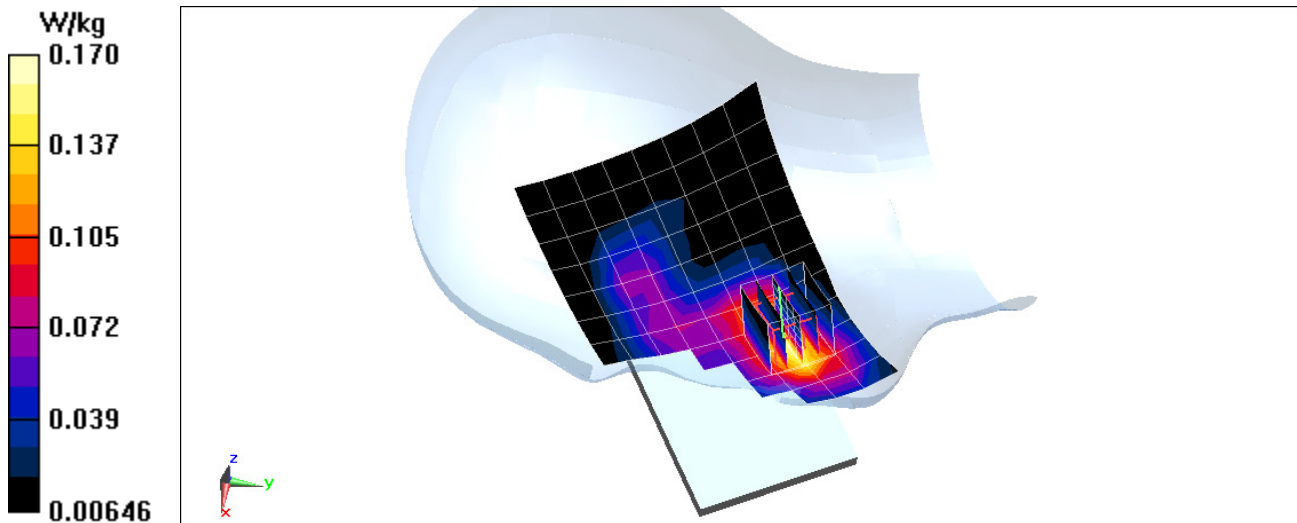

PCTEST ENGINEERING LABORATORY, INC.

DUT: A3LSMJ530GM; Type: Portable Handset; Serial: 01376

Communication System: UID 0, UMTS; Frequency: 1712.4 MHz; Duty Cycle: 1:1
Medium: 1750 Head Medium parameters used (interpolated):
 $f = 1712.4 \text{ MHz}$; $\sigma = 1.34 \text{ S/m}$; $\epsilon_r = 40.799$; $\rho = 1000 \text{ kg/m}^3$
Phantom section: Left Section

Test Date: 03-28-2017; Ambient Temp: 21.9°C; Tissue Temp: 20.8°C

Probe: ES3DV3 - SN3213; ConvF(5.49, 5.49, 5.49); Calibrated: 2/10/2017;
Sensor-Surface: 3mm (Mechanical Surface Detection)
Electronics: DAE4 Sn1272; Calibrated: 2/9/2017
Phantom: SAM Front; Type: QD000P40CD; Serial: TP:1758
Measurement SW: DASY52, Version 52.8 (8); SEMCAD X Version 14.6.10 (7331)

Mode: UMTS 1750, Left Head, Cheek, Low.ch

Area Scan (9x15x1): Measurement grid: dx=15mm, dy=15mm

Zoom Scan (5x5x7)/Cube 0: Measurement grid: dx=8mm, dy=8mm, dz=5mm

Reference Value = 11.03 V/m; Power Drift = 0.10 dB

Peak SAR (extrapolated) = 0.224 W/kg

SAR(1 g) = 0.151 W/kg

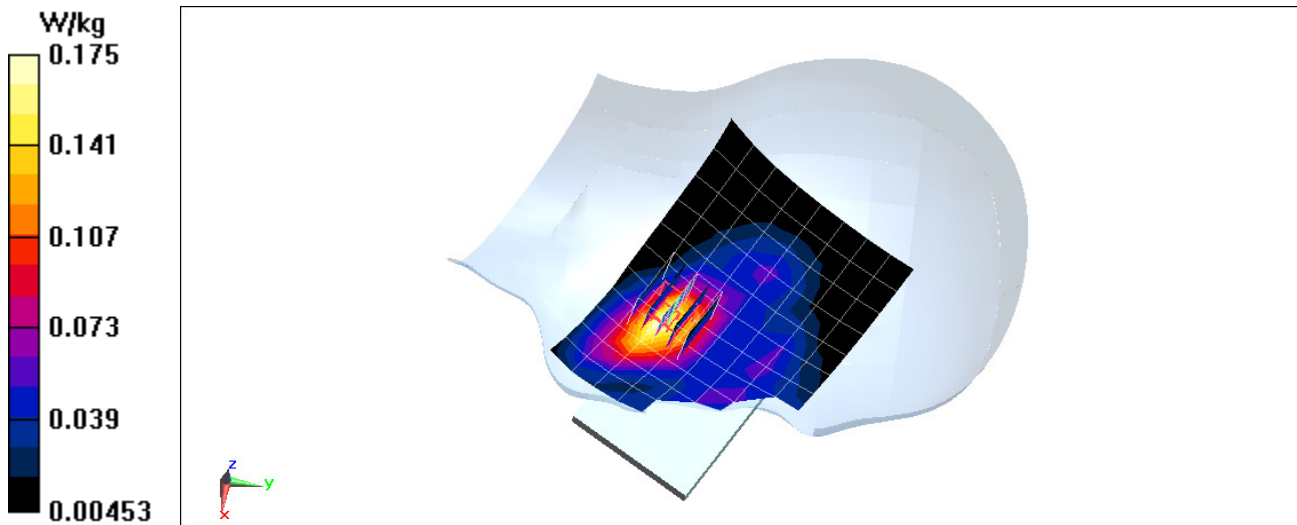

PCTEST ENGINEERING LABORATORY, INC.

DUT: A3LSMJ530GM; Type: Portable Handset; Serial: 01376

Communication System: UID 0, UMTS; Frequency: 1880 MHz; Duty Cycle: 1:1
Medium: 1900 Head Medium parameters used:
 $f = 1880 \text{ MHz}$; $\sigma = 1.416 \text{ S/m}$; $\epsilon_r = 40.282$; $\rho = 1000 \text{ kg/m}^3$
Phantom section: Right Section

Test Date: 04-06-2017; Ambient Temp: 22.4°C; Tissue Temp: 21.8°C

Probe: ES3DV3 - SN3288; ConvF(5.31, 5.31, 5.31); Calibrated: 1/13/2017;
Sensor-Surface: 3mm (Mechanical Surface Detection)
Electronics: DAE4 Sn1466; Calibrated: 1/16/2017
Phantom: SAM with CRP v5.0 Front; Type: QD000P40CD; Serial: 1646
Measurement SW: DASY52, Version 52.8 (8); SEMCAD X Version 14.6.10 (7331)

Mode: UMTS 1900, Right Head, Cheek, Mid.ch

Area Scan (9x15x1): Measurement grid: dx=15mm, dy=15mm
Zoom Scan (5x6x7)/Cube 0: Measurement grid: dx=8mm, dy=8mm, dz=5mm
Reference Value = 11.40 V/m; Power Drift = 0.03 dB
Peak SAR (extrapolated) = 0.259 W/kg
SAR(1 g) = 0.173 W/kg

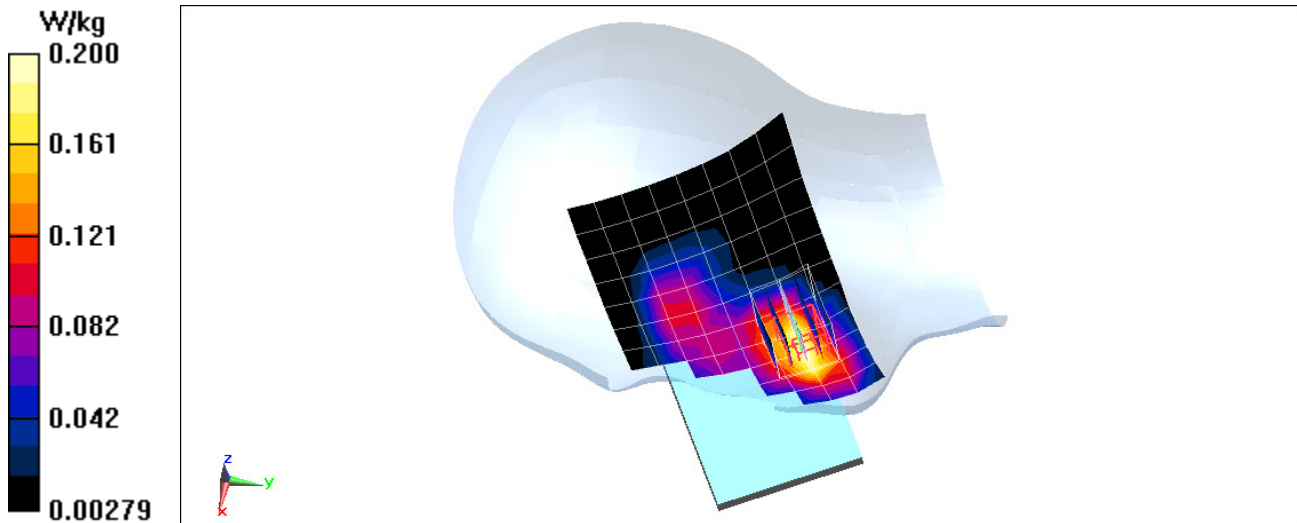

PCTEST ENGINEERING LABORATORY, INC.

DUT: A3LSMJ530GM; Type: Portable Handset; Serial: 01327

Communication System: UID 0, LTE Band 12; Frequency: 707.5 MHz; Duty Cycle: 1:1
Medium: 750 Head Medium parameters used (interpolated):
 $f = 707.5$ MHz; $\sigma = 0.871$ S/m; $\epsilon_r = 43.129$; $\rho = 1000$ kg/m³
Phantom section: Right Section

Test Date: 04-10-2017; Ambient Temp: 21.1°C; Tissue Temp: 20.0°C

Probe: ES3DV3 - SN3334; ConvF(6.76, 6.76, 6.76); Calibrated: 11/15/2016;
Sensor-Surface: 3mm (Mechanical Surface Detection)
Electronics: DAE4 Sn1334; Calibrated: 11/11/2016
Phantom: SAM with CRP v4.0; Type: QD000P40CD; Serial: TP:1800
Measurement SW: DASY52, Version 52.8 (8); SEMCAD X Version 14.6.10 (7331)

**Mode: LTE Band 12, Right Head, Cheek, Mid.ch,
10 MHz Bandwidth, QPSK, 1 RB,0 RB Offset**

Area Scan (9x14x1): Measurement grid: dx=15mm, dy=15mm

Zoom Scan (5x5x7)/Cube 0: Measurement grid: dx=8mm, dy=8mm, dz=5mm

Reference Value = 10.18 V/m; Power Drift = -0.03 dB

Peak SAR (extrapolated) = 0.0920 W/kg

SAR(1 g) = 0.077 W/kg

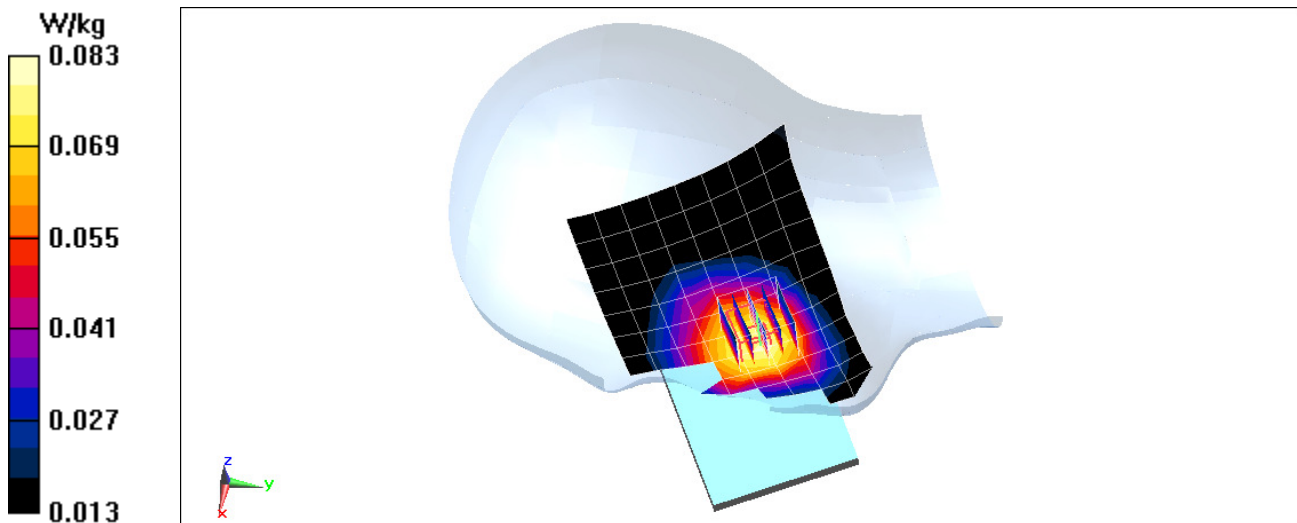

PCTEST ENGINEERING LABORATORY, INC.

DUT: A3LSMJ530GM; Type: Portable Handset; Serial: 01376

Communication System: UID 0, LTE Band 5 (Cell.); Frequency: 836.5 MHz; Duty Cycle: 1:1
Medium: 835 Head Medium parameters used (interpolated):
 $f = 836.5 \text{ MHz}$; $\sigma = 0.906 \text{ S/m}$; $\epsilon_r = 41.029$; $\rho = 1000 \text{ kg/m}^3$
Phantom section: Right Section

Test Date: 04-04-2017; Ambient Temp: 20.5°C; Tissue Temp: 21.3°C

Probe: ES3DV3 - SN3334; ConvF(6.49, 6.49, 6.49); Calibrated: 11/15/2016;
Sensor-Surface: 3mm (Mechanical Surface Detection)
Electronics: DAE4 Sn1334; Calibrated: 11/11/2016
Phantom: SAM with CRP v4.0; Type: QD000P40CD; Serial: TP:1800
Measurement SW: DASY52, Version 52.8 (8); SEMCAD X Version 14.6.10 (7331)

**Mode: LTE Band 5 (Cell.), Right Head, Cheek, Mid.ch,
10 MHz Bandwidth, QPSK, 1 RB, 0 RB Offset**

Area Scan (9x15x1): Measurement grid: dx=15mm, dy=15mm

Zoom Scan (6x5x7)/Cube 0: Measurement grid: dx=8mm, dy=8mm, dz=5mm

Reference Value = 16.29 V/m; Power Drift = 0.04 dB

Peak SAR (extrapolated) = 0.261 W/kg

SAR(1 g) = 0.208 W/kg

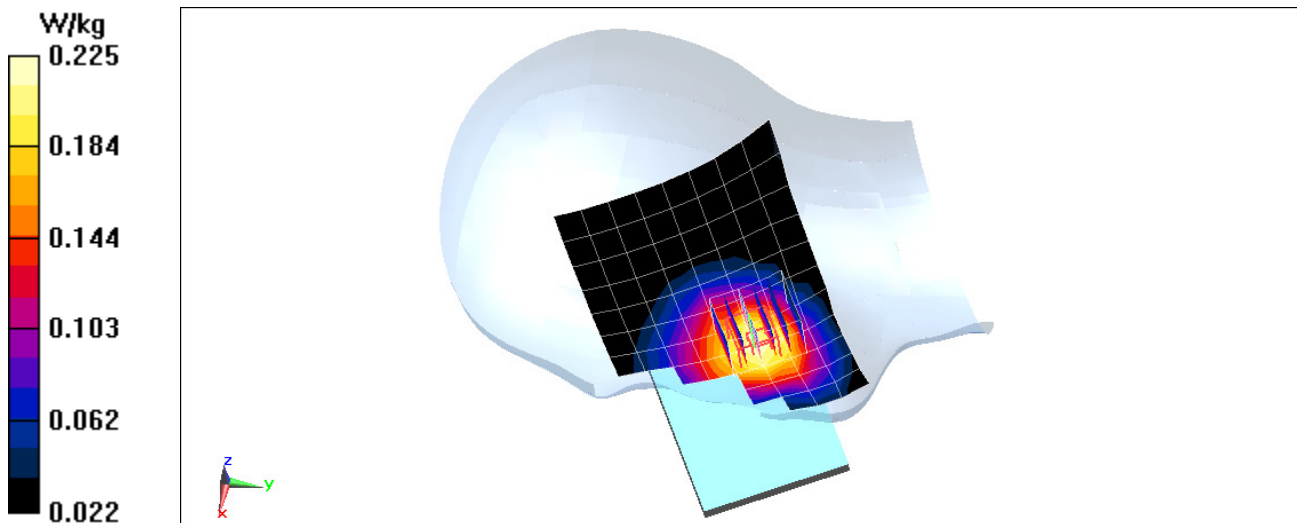

PCTEST ENGINEERING LABORATORY, INC.

DUT: A3LSMJ530GM; Type: Portable Handset; Serial: 01376

Communication System: UID 0, LTE Band 4 (AWS); Frequency: 1732.5 MHz; Duty Cycle: 1:1
Medium: 1750 Head Medium parameters used (interpolated):
 $f = 1732.5$ MHz; $\sigma = 1.366$ S/m; $\epsilon_r = 40.67$; $\rho = 1000$ kg/m³
Phantom section: Left Section

Test Date: 03-28-2017; Ambient Temp: 21.9°C; Tissue Temp: 20.8°C

Probe: ES3DV3 - SN3213; ConvF(5.49, 5.49, 5.49); Calibrated: 2/10/2017;
Sensor-Surface: 3mm (Mechanical Surface Detection)
Electronics: DAE4 Sn1272; Calibrated: 2/9/2017
Phantom: SAM Front; Type: QD000P40CD; Serial: TP:1758
Measurement SW: DASY52, Version 52.8 (8); SEMCAD X Version 14.6.10 (7331)

**Mode: LTE Band 4 (AWS), Left Head, Cheek, Mid.ch,
20 MHz Bandwidth, QPSK, 1 RB, 99 RB Offset**

Area Scan (9x15x1): Measurement grid: dx=15mm, dy=15mm
Zoom Scan (5x5x7)/Cube 0: Measurement grid: dx=8mm, dy=8mm, dz=5mm
Reference Value = 12.55 V/m; Power Drift = -0.03 dB
Peak SAR (extrapolated) = 0.257 W/kg
SAR(1 g) = 0.174 W/kg

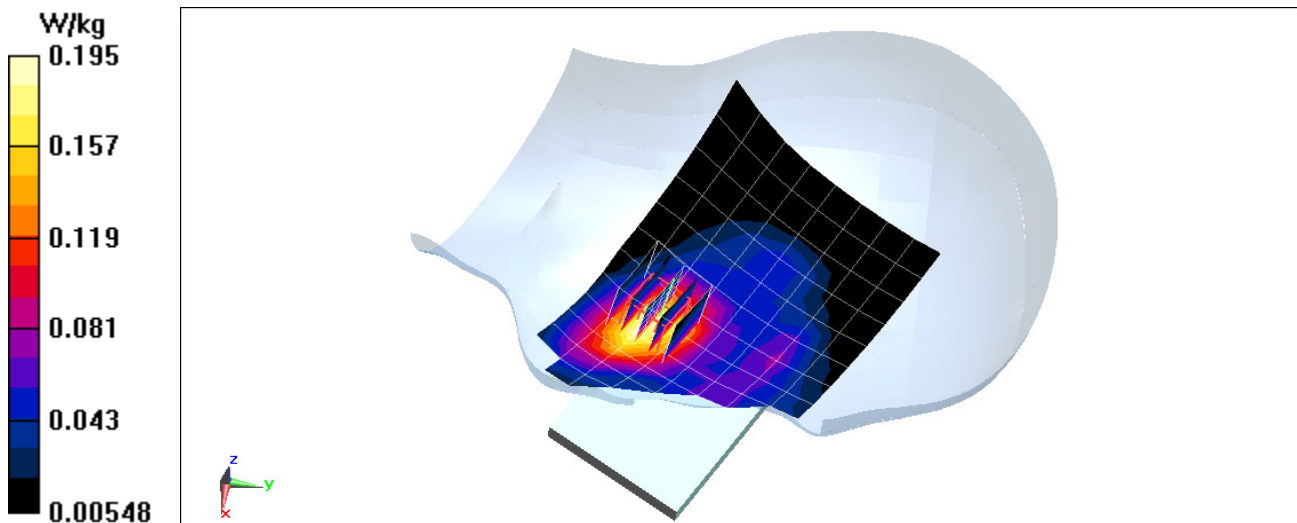

PCTEST ENGINEERING LABORATORY, INC.

DUT: A3LSMJ530GM; Type: Portable Handset; Serial: 01376

Communication System: UID 0, LTE Band 66 (AWS); Frequency: 1720 MHz; Duty Cycle: 1:1
Medium: 1750 Head Medium parameters used (interpolated):
 $f = 1720 \text{ MHz}$; $\sigma = 1.349 \text{ S/m}$; $\epsilon_r = 40.336$; $\rho = 1000 \text{ kg/m}^3$
Phantom section: Left Section

Test Date: 04-04-2017; Ambient Temp: 23.3°C; Tissue Temp: 21.6°C

Probe: EX3DV4 - SN7409; ConvF(8.05, 8.05, 8.05); Calibrated: 5/17/2016;
Sensor-Surface: 1.4mm (Mechanical Surface Detection)
Electronics: DAE4 Sn859; Calibrated: 5/11/2016
Phantom: SAM Right; Type: QD000P40CD; Serial: TP:7535
Measurement SW: DASY52, Version 52.8 (8); SEMCAD X Version 14.6.10 (7331)

**Mode: LTE Band 66 (AWS), Left Head, Cheek, Low.ch,
20 MHz Bandwidth, QPSK, 1 RB, 99 RB Offset**

Area Scan (9x15x1): Measurement grid: dx=15mm, dy=15mm
Zoom Scan (5x5x7)/Cube 0: Measurement grid: dx=8mm, dy=8mm, dz=5mm
Reference Value = 10.00 V/m; Power Drift = 0.05 dB
Peak SAR (extrapolated) = 0.178 W/kg
SAR(1 g) = 0.115 W/kg

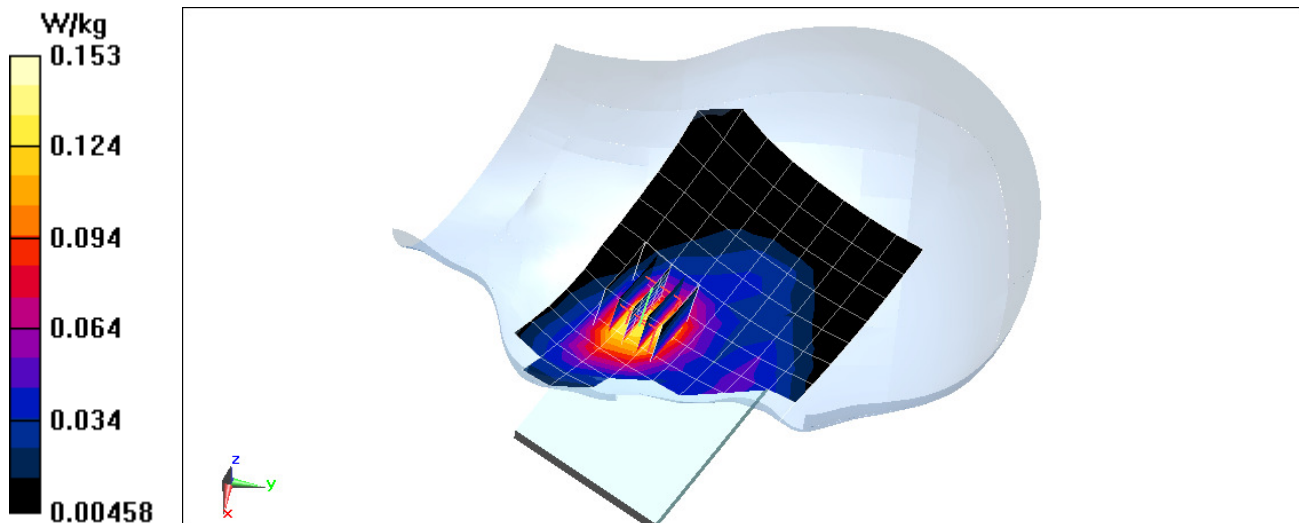

PCTEST ENGINEERING LABORATORY, INC.

DUT: A3LSMJ530GM; Type: Portable Handset; Serial: 01319

Communication System: UID 0, LTE Band 2 (PCS); Frequency: 1860 MHz; Duty Cycle: 1:1

Medium: 1900 Head Medium parameters used (interpolated):

$f = 1860$ MHz; $\sigma = 1.396$ S/m; $\epsilon_r = 39.954$; $\rho = 1000$ kg/m³

Phantom section: Right Section

Test Date: 03-30-2017; Ambient Temp: 22.9°C; Tissue Temp: 21.9°C

Probe: EX3DV4 - SN7409; ConvF(7.69, 7.69, 7.69); Calibrated: 5/17/2016;

Sensor-Surface: 1.4mm (Mechanical Surface Detection)

Electronics: DAE4 Sn859; Calibrated: 5/11/2016

Phantom: SAM Right; Type: QD000P40CD; Serial: TP:7535

Measurement SW: DASY52, Version 52.8 (8); SEMCAD X Version 14.6.10 (7331)

**Mode: LTE Band 2 (PCS), Right Head, Cheek, Low.ch,
20 MHz Bandwidth, QPSK, 1 RB, 50 RB Offset**

Area Scan (8x14x1): Measurement grid: dx=15mm, dy=15mm

Zoom Scan (5x5x7)/Cube 0: Measurement grid: dx=8mm, dy=8mm, dz=5mm

Reference Value = 13.94 V/m; Power Drift = -0.10 dB

Peak SAR (extrapolated) = 0.343 W/kg

SAR(1 g) = 0.227 W/kg

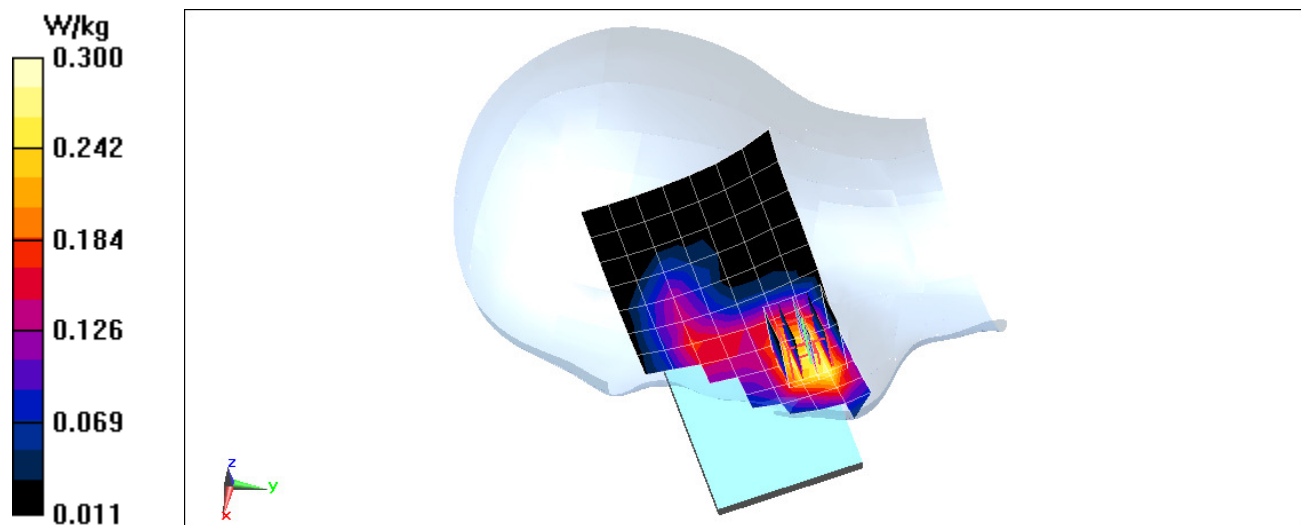

PCTEST ENGINEERING LABORATORY, INC.

DUT: A3LSMJ530GM; Type: Portable Handset; Serial: 01319

Communication System: UID 0, LTE Band 41; Frequency: 2593 MHz; Duty Cycle: 1:1.58

Medium: 2600 Head Medium parameters used (interpolated):

$f = 2593$ MHz; $\sigma = 1.981$ S/m; $\epsilon_r = 37.565$; $\rho = 1000$ kg/m³

Phantom section: Right Section

Test Date: 04-03-2017; Ambient Temp: 23.0°C; Tissue Temp: 21.7°C

Probe: ES3DV3 - SN3287; ConvF(4.41, 4.41, 4.41); Calibrated: 9/19/2016;

Sensor-Surface: 3mm (Mechanical Surface Detection)

Electronics: DAE4 Sn1408; Calibrated: 9/14/2016

Phantom: SAM Left; Type: QD000P40CA; Serial: TP:82355

Measurement SW: DASY52, Version 52.8 (8); SEMCAD X Version 14.6.10 (7331)

**Mode: LTE Band 41, Right Head, Cheek, Mid.ch,
20 MHz Bandwidth, QPSK, 1 RB, 0 RB Offset**

Area Scan (10x17x1): Measurement grid: dx=12mm, dy=12mm

Zoom Scan (7x8x7)/Cube 0: Measurement grid: dx=5mm, dy=5mm, dz=5mm

Reference Value = 7.114 V/m; Power Drift = -0.01 dB

Peak SAR (extrapolated) = 0.146 W/kg

SAR(1 g) = 0.077 W/kg

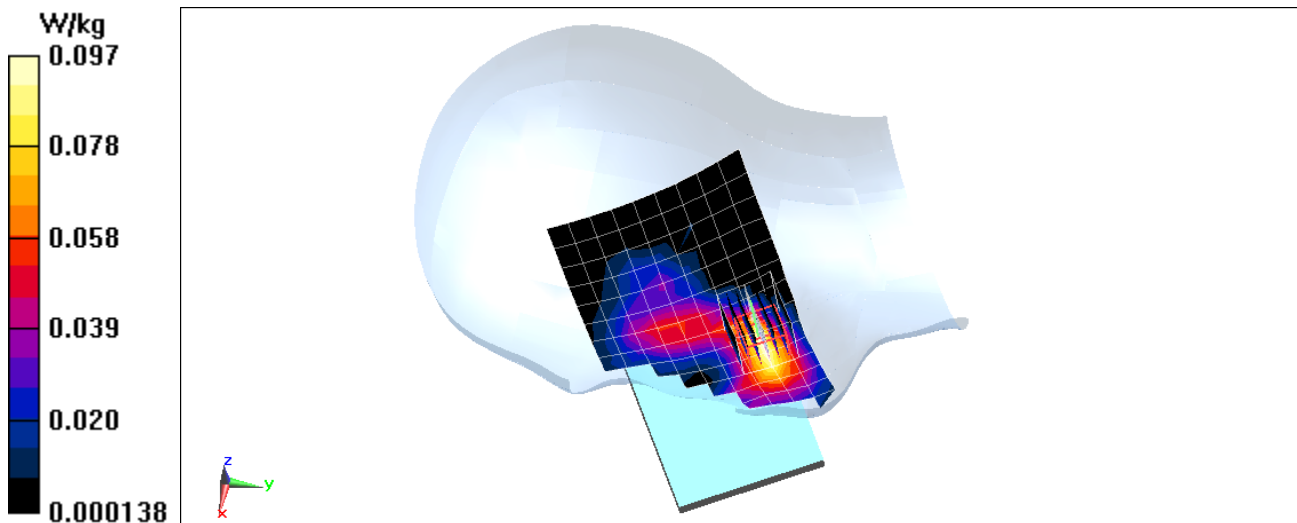

PCTEST ENGINEERING LABORATORY, INC.

DUT: A3LSMJ530GM; Type: Portable Handset; Serial: 74852

Communication System: UID 0, IEEE 802.11b; Frequency: 2412 MHz; Duty Cycle: 1:1
Medium: 2450 Head Medium parameters used (interpolated):
 $f = 2412 \text{ MHz}$; $\sigma = 1.809 \text{ S/m}$; $\epsilon_r = 38.107$; $\rho = 1000 \text{ kg/m}^3$
Phantom section: Right Section

Test Date: 03-23-2017; Ambient Temp: 21.3°C; Tissue Temp: 22.9°C

Probe: ES3DV3 - SN3287; ConvF(4.54, 4.54, 4.54); Calibrated: 9/19/2016;
Sensor-Surface: 3mm (Mechanical Surface Detection)
Electronics: DAE4 Sn1408; Calibrated: 9/14/2016
Phantom: SAM Left; Type: QD000P40CA; Serial: TP:82355
Measurement SW: DASY52, Version 52.8 (8); SEMCAD X Version 14.6.10 (7331)

Mode: IEEE 802.11b, 22 MHz Bandwidth, Right Head, Tilt, Ch 1, 1 Mbps

Area Scan (11x18x1): Measurement grid: $dx=12\text{mm}$, $dy=12\text{mm}$

Zoom Scan (8x7x7)/Cube 0: Measurement grid: $dx=5\text{mm}$, $dy=5\text{mm}$, $dz=5\text{mm}$

Reference Value = 22.14 V/m; Power Drift = 0.00 dB

Peak SAR (extrapolated) = 1.67 W/kg

SAR(1 g) = 0.717 W/kg

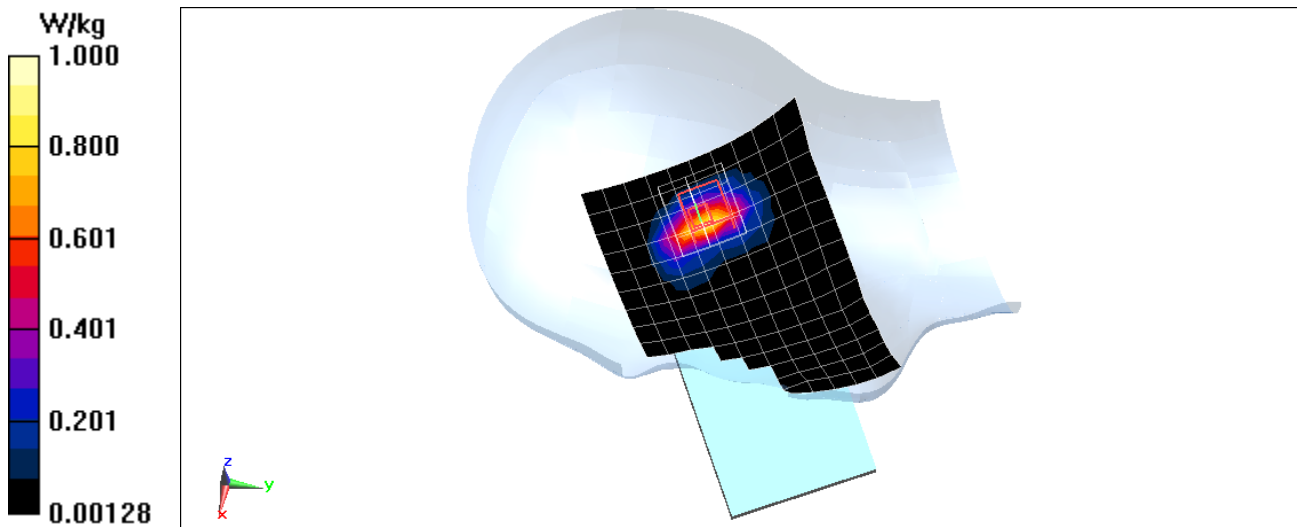

PCTEST ENGINEERING LABORATORY, INC.

DUT: A3LSMJ530GM; Type: Portable Handset; Serial: 19228

Communication System: UID 0, 802.11a 5.2-5.8 GHz Band; Frequency: 5260 MHz; Duty Cycle: 1:1

Medium: 5GHz Head Medium parameters used:

$f = 5260 \text{ MHz}$; $\sigma = 4.657 \text{ S/m}$; $\epsilon_r = 35.474$; $\rho = 1000 \text{ kg/m}^3$

Phantom section: Right Section

Test Date: 03-27-2017; Ambient Temp: 22.7°C; Tissue Temp: 21.0°C

Probe: EX3DV4 - SN7308; ConvF(5.21, 5.21, 5.21); Calibrated: 7/21/2016;

Sensor-Surface: 1.4mm (Mechanical Surface Detection)

Electronics: DAE4 Sn859; Calibrated: 5/11/2016

Phantom: SAM Left; Type: QD000P40CC; Serial: TP: 1375

Measurement SW: DASY52, Version 52.8 (8); SEMCAD X Version 14.6.10 (7331)

Mode: IEEE 802.11a, U-NII-2A, 20 MHz Bandwidth, Right Head, Cheek, Ch 52, 6 Mbps

Area Scan (12x10x1): Measurement grid: dx=10mm, dy=10mm

Zoom Scan (8x8x7)/Cube 0: Measurement grid: dx=4mm, dy=4mm, dz=1.4mm; Graded Ratio: 1.4

Reference Value = 5.086 V/m; Power Drift = 0.20 dB

Peak SAR (extrapolated) = 4.57 W/kg

SAR(1 g) = 1.01 W/kg

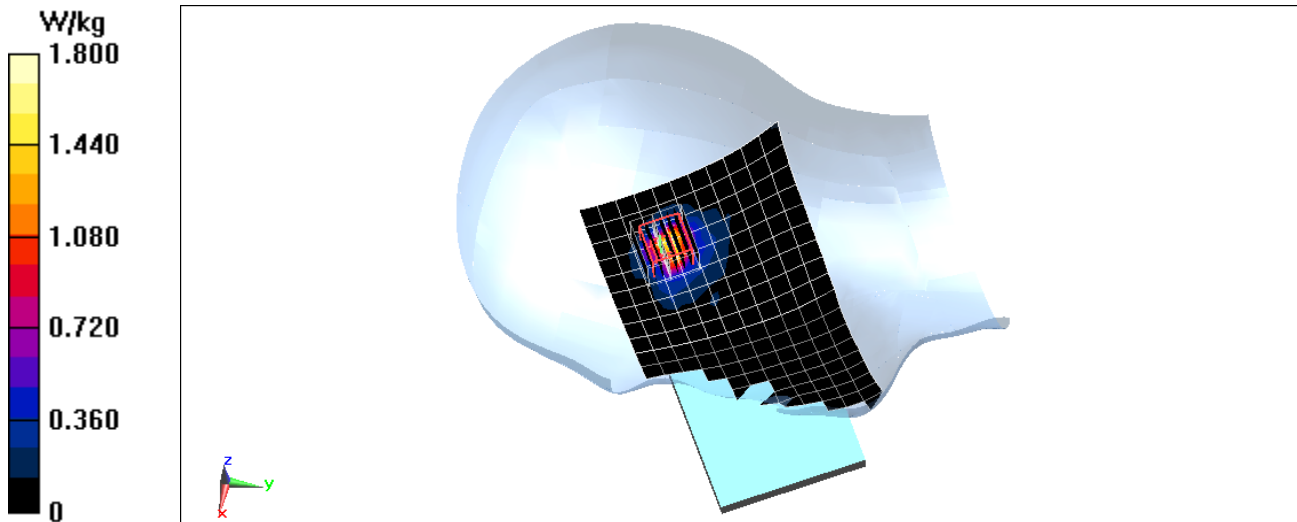

PCTEST ENGINEERING LABORATORY, INC.

DUT: A3LSMJ530GM; Type: Portable Handset; Serial: 01327

Communication System: UID 0, GSM; Frequency: 836.6 MHz; Duty Cycle: 1:8.3
Medium: 835 Body Medium parameters used (interpolated):
 $f = 836.6 \text{ MHz}$; $\sigma = 0.996 \text{ S/m}$; $\epsilon_r = 55.061$; $\rho = 1000 \text{ kg/m}^3$
Phantom section: Flat Section; Space: 1.5 cm

Test Date: 04-03-2017; Ambient Temp: 21.6°C; Tissue Temp: 21.2°C

Probe: ES3DV3 - SN3318; ConvF(6.37, 6.37, 6.37); Calibrated: 2/10/2017;
Sensor-Surface: 3mm (Mechanical Surface Detection)
Electronics: DAE4 Sn665; Calibrated: 2/9/2017
Phantom: SAM with CRP (Left); Type: SAM; Serial: 1715
Measurement SW: DASY52, Version 52.8 (8); SEMCAD X Version 14.6.10 (7331)

Mode: GSM 850, Body SAR, Back side, Mid.ch

Area Scan (9x15x1): Measurement grid: dx=15mm, dy=15mm

Zoom Scan (6x6x7)/Cube 0: Measurement grid: dx=8mm, dy=8mm, dz=5mm

Reference Value = 17.86 V/m; Power Drift = -0.01 dB

Peak SAR (extrapolated) = 0.382 W/kg

SAR(1 g) = 0.291 W/kg

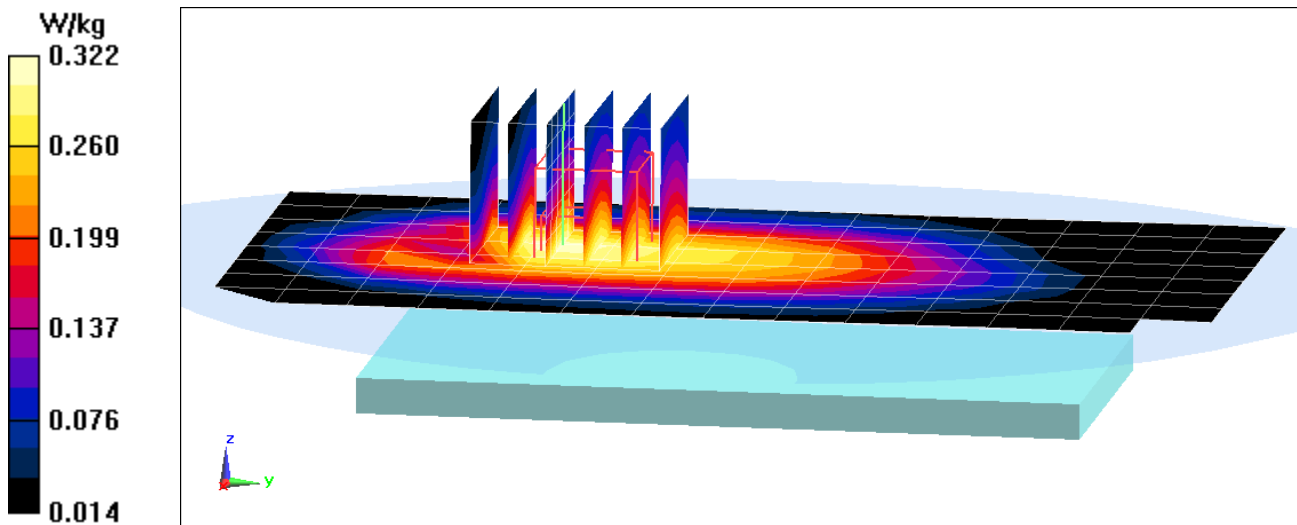

PCTEST ENGINEERING LABORATORY, INC.

DUT: A3LSMJ530GM; Type: Portable Handset; Serial: 01467

Communication System: UID 0, GSM GPRS; 3 Tx slots; Frequency: 836.6 MHz; Duty Cycle: 1:2.76
Medium: 835 Body Medium parameters used (interpolated):
 $f = 836.6 \text{ MHz}$; $\sigma = 0.984 \text{ S/m}$; $\epsilon_r = 54.796$; $\rho = 1000 \text{ kg/m}^3$
Phantom section: Flat Section; Space: 1.0 cm

Test Date: 04-17-2017; Ambient Temp: 20.0°C; Tissue Temp: 20.1°C

Probe: ES3DV3 - SN3318; ConvF(6.37, 6.37, 6.37); Calibrated: 2/10/2017;
Sensor-Surface: 3mm (Mechanical Surface Detection)
Electronics: DAE4 Sn665; Calibrated: 2/9/2017
Phantom: SAM with CRP (Left); Type: SAM; Serial: 1715
Measurement SW: DASY52, Version 52.8 (8); SEMCAD X Version 14.6.10 (7331)

Mode: GPRS 850, Body SAR, Back side, Mid.ch, 3 Tx Slots

Area Scan (9x14x1): Measurement grid: $dx=15\text{mm}$, $dy=15\text{mm}$
Zoom Scan (5x5x7)/Cube 0: Measurement grid: $dx=8\text{mm}$, $dy=8\text{mm}$, $dz=5\text{mm}$
Reference Value = 19.90 V/m; Power Drift = -0.09 dB
Peak SAR (extrapolated) = 0.660 W/kg
SAR(1 g) = 0.366 W/kg

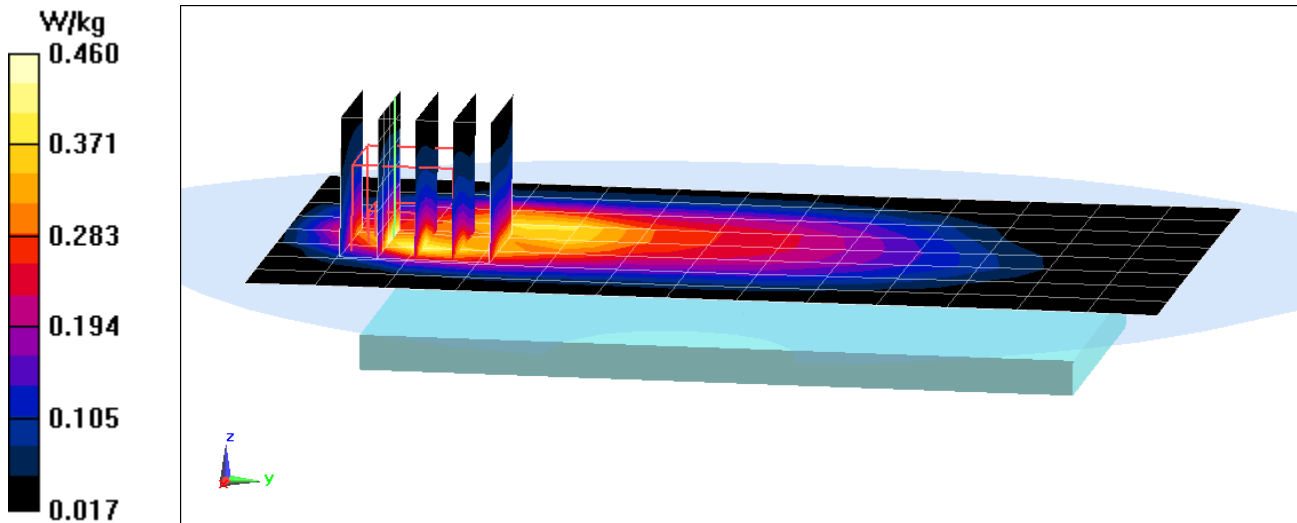

PCTEST ENGINEERING LABORATORY, INC.

DUT: A3LSMJ530GM; Type: Portable Handset; Serial: 01327

Communication System: UID 0, UMTS; Frequency: 836.6 MHz; Duty Cycle: 1:1
Medium: 835 Body Medium parameters used (interpolated):
 $f = 836.6 \text{ MHz}$; $\sigma = 0.996 \text{ S/m}$; $\epsilon_r = 55.061$; $\rho = 1000 \text{ kg/m}^3$
Phantom section: Flat Section; Space: 1.5 cm

Test Date: 04-03-2017; Ambient Temp: 21.6°C; Tissue Temp: 21.2°C

Probe: ES3DV3 - SN3318; ConvF(6.37, 6.37, 6.37); Calibrated: 2/10/2017;
Sensor-Surface: 3mm (Mechanical Surface Detection)
Electronics: DAE4 Sn665; Calibrated: 2/9/2017
Phantom: SAM with CRP (Left); Type: SAM; Serial: 1715
Measurement SW: DASY52, Version 52.8 (8); SEMCAD X Version 14.6.10 (7331)

Mode: UMTS 850, Body SAR, Back side, Mid.ch

Area Scan (9x15x1): Measurement grid: dx=15mm, dy=15mm

Zoom Scan (6x6x7)/Cube 0: Measurement grid: dx=8mm, dy=8mm, dz=5mm

Reference Value = 18.12 V/m; Power Drift = 0.02 dB

Peak SAR (extrapolated) = 0.395 W/kg

SAR(1 g) = 0.302 W/kg

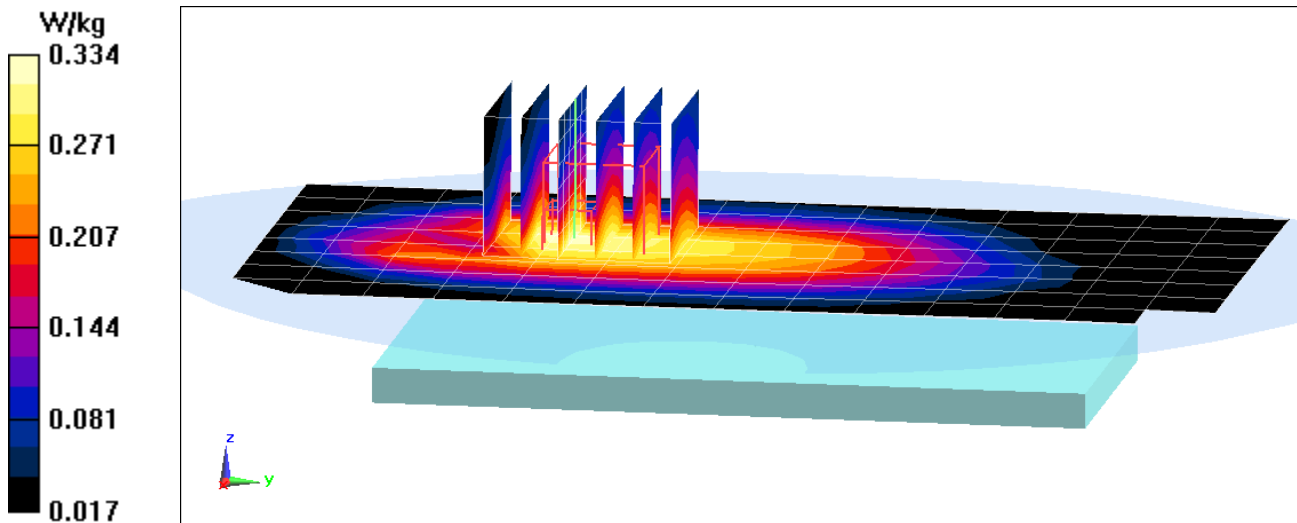

PCTEST ENGINEERING LABORATORY, INC.

DUT: A3LSMJ530GM; Type: Portable Handset; Serial: 01327

Communication System: UID 0, UMTS; Frequency: 836.6 MHz; Duty Cycle: 1:1
Medium: 835 Body Medium parameters used (interpolated):
 $f = 836.6 \text{ MHz}$; $\sigma = 0.996 \text{ S/m}$; $\epsilon_r = 55.061$; $\rho = 1000 \text{ kg/m}^3$
Phantom section: Flat Section; Space: 1.0 cm

Test Date: 04-03-2017; Ambient Temp: 21.6°C; Tissue Temp: 21.2°C

Probe: ES3DV3 - SN3318; ConvF(6.37, 6.37, 6.37); Calibrated: 2/10/2017;
Sensor-Surface: 3mm (Mechanical Surface Detection)
Electronics: DAE4 Sn665; Calibrated: 2/9/2017
Phantom: SAM with CRP (Left); Type: SAM; Serial: 1715
Measurement SW: DASY52, Version 52.8 (8); SEMCAD X Version 14.6.10 (7331)

Mode: UMTS 850, Body SAR, Back side, Mid.ch

Area Scan (9x15x1): Measurement grid: dx=15mm, dy=15mm

Zoom Scan (5x5x7)/Cube 0: Measurement grid: dx=8mm, dy=8mm, dz=5mm

Reference Value = 22.08 V/m; Power Drift = -0.09 dB

Peak SAR (extrapolated) = 0.785 W/kg

SAR(1 g) = 0.436 W/kg

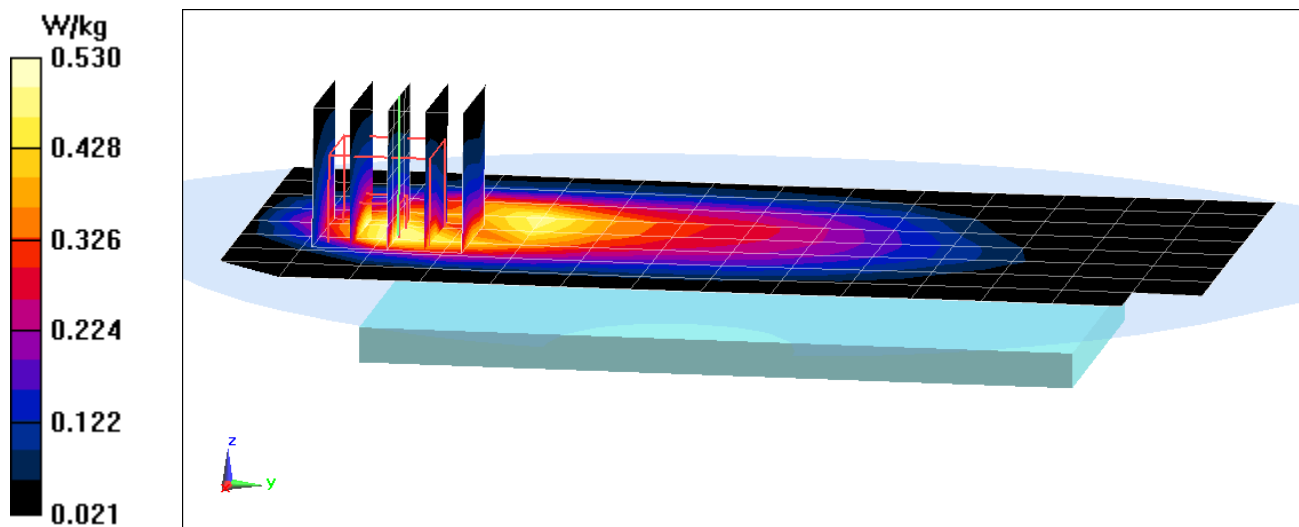

PCTEST ENGINEERING LABORATORY, INC.

DUT: A3LSMJ530GM; Type: Portable Handset; Serial: 01442

Communication System: UID 0, GSM; Frequency: 1880 MHz; Duty Cycle: 1:8.3

Medium: 1900 Body Medium parameters used:

$f = 1880 \text{ MHz}$; $\sigma = 1.547 \text{ S/m}$; $\epsilon_r = 51.158$; $\rho = 1000 \text{ kg/m}^3$

Phantom section: Flat Section; Space: 1.5 cm

Test Date: 04-17-2017; Ambient Temp: 22.7°C; Tissue Temp: 21.6°C

Probe: EX3DV4 - SN7409; ConvF(7.47, 7.47, 7.47); Calibrated: 5/17/2016;

Sensor-Surface: 1.4mm (Mechanical Surface Detection)

Electronics: DAE4 Sn859; Calibrated: 5/11/2016

Phantom: SAM Left; Type: QD000P40CC; Serial: TP: 1375

Measurement SW: DASY52, Version 52.8 (8); SEMCAD X Version 14.6.10 (7331)

Mode: GSM 1900, Body SAR, Back side, Mid.ch

Area Scan (9x13x1): Measurement grid: dx=15mm, dy=15mm

Zoom Scan (5x5x7)/Cube 0: Measurement grid: dx=8mm, dy=8mm, dz=5mm

Reference Value = 15.47 V/m; Power Drift = 0.00 dB

Peak SAR (extrapolated) = 0.587 W/kg

SAR(1 g) = 0.349 W/kg

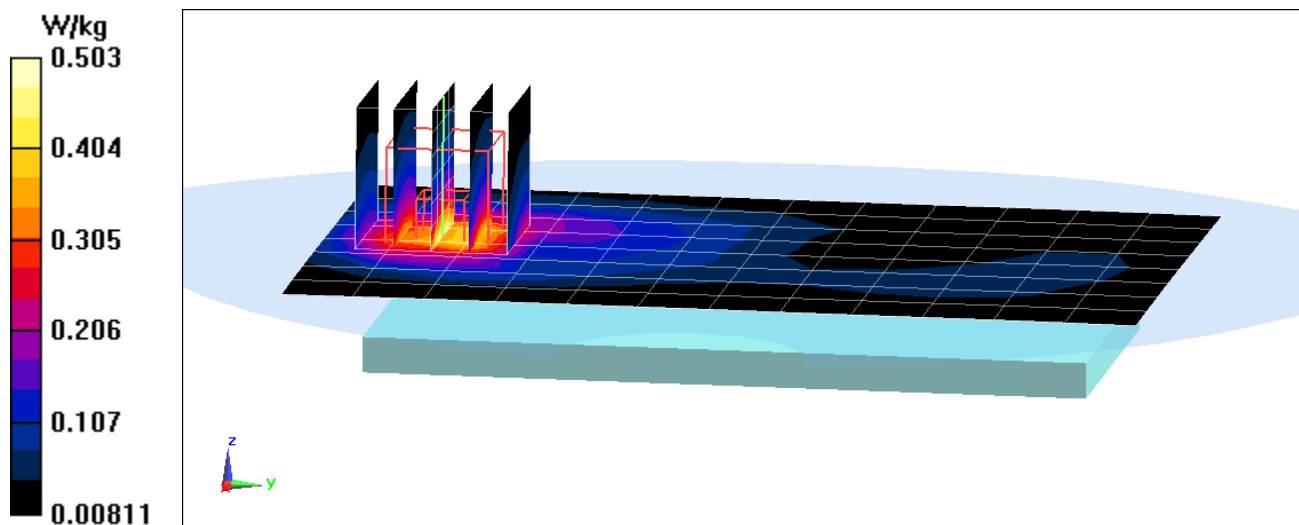

PCTEST ENGINEERING LABORATORY, INC.

DUT: A3LSMJ530GM; Type: Portable Handset; Serial: 01442

Communication System: UID 0, GSM GPRS; 3 Tx slots; Frequency: 1909.8 MHz; Duty Cycle: 1:2.76

Medium: 1900 Body Medium parameters used:

$f = 1910$ MHz; $\sigma = 1.58$ S/m; $\epsilon_r = 51.03$; $\rho = 1000$ kg/m³

Phantom section: Flat Section; Space: 1.0 cm

Test Date: 04-17-2017; Ambient Temp: 22.7°C; Tissue Temp: 21.6°C

Probe: EX3DV4 - SN7409; ConvF(7.47, 7.47, 7.47); Calibrated: 5/17/2016;

Sensor-Surface: 1.4mm (Mechanical Surface Detection)

Electronics: DAE4 Sn859; Calibrated: 5/11/2016

Phantom: SAM Left; Type: QD000P40CC; Serial: TP: 1375

Measurement SW: DASY52, Version 52.8 (8); SEMCAD X Version 14.6.10 (7331)

Mode: GPRS 1900, Body SAR, Back side, High.ch, 3 Tx Slots

Area Scan (9x13x1): Measurement grid: dx=15mm, dy=15mm

Zoom Scan (5x5x7)/Cube 0: Measurement grid: dx=8mm, dy=8mm, dz=5mm

Reference Value = 17.74 V/m; Power Drift = -0.12 dB

Peak SAR (extrapolated) = 0.782 W/kg

SAR(1 g) = 0.440 W/kg

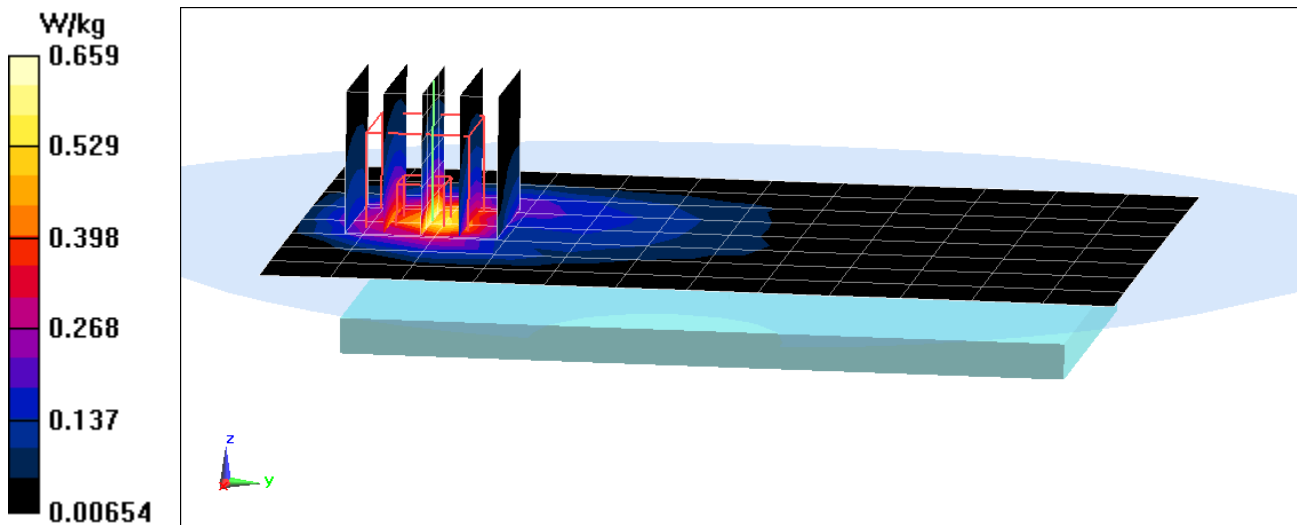

PCTEST ENGINEERING LABORATORY, INC.

DUT: A3LSMJ530GM; Type: Portable Handset; Serial: 01319

Communication System: UID 0, UMTS; Frequency: 1712.4 MHz; Duty Cycle: 1:1
Medium: 1750 Body Medium parameters used (interpolated):
 $f = 1712.4 \text{ MHz}$; $\sigma = 1.462 \text{ S/m}$; $\epsilon_r = 51.155$; $\rho = 1000 \text{ kg/m}^3$
Phantom section: Flat Section; Space: 1.5 cm

Test Date: 03-30-2017; Ambient Temp: 22.5°C; Tissue Temp: 21.1°C

Probe: ES3DV3 - SN3213; ConvF(5.09, 5.09, 5.09); Calibrated: 2/10/2017;
Sensor-Surface: 3mm (Mechanical Surface Detection)
Electronics: DAE4 Sn1272; Calibrated: 2/9/2017
Phantom: SAM Right; Type: SAM; Serial: 1757
Measurement SW: DASY52, Version 52.8 (8); SEMCAD X Version 14.6.10 (7331)

Mode: UMTS 1750, Body SAR, Back side, Low.ch

Area Scan (9x15x1): Measurement grid: dx=15mm, dy=15mm

Zoom Scan (5x5x7)/Cube 0: Measurement grid: dx=8mm, dy=8mm, dz=5mm

Reference Value = 19.35 V/m; Power Drift = -0.01 dB

Peak SAR (extrapolated) = 0.741 W/kg

SAR(1 g) = 0.482 W/kg

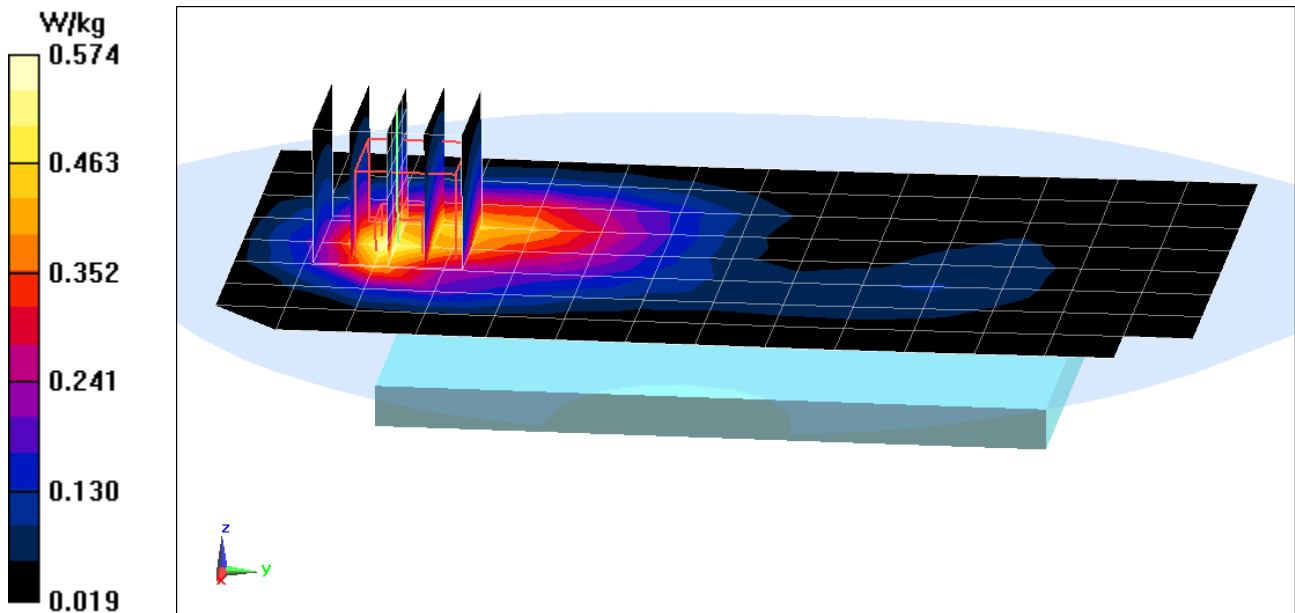

PCTEST ENGINEERING LABORATORY, INC.

DUT: A3LSMJ530GM; Type: Portable Handset; Serial: 01442

Communication System: UID 0, UMTS; Frequency: 1752.6 MHz; Duty Cycle: 1:1
Medium: 1750 Body Medium parameters used (interpolated):
 $f = 1752.6 \text{ MHz}$; $\sigma = 1.495 \text{ S/m}$; $\epsilon_r = 52.125$; $\rho = 1000 \text{ kg/m}^3$
Phantom section: Flat Section; Space: 1.0 cm

Test Date: 04-17-2017; Ambient Temp: 19.2°C; Tissue Temp: 20.1°C

Probe: ES3DV3 - SN3213; ConvF(5.09, 5.09, 5.09); Calibrated: 2/10/2017;
Sensor-Surface: 3mm (Mechanical Surface Detection)
Electronics: DAE4 Sn1272; Calibrated: 2/9/2017
Phantom: SAM Front; Type: QD000P40CD; Serial: TP:1758
Measurement SW: DASY52, Version 52.8 (8); SEMCAD X Version 14.6.10 (7331)

Mode: UMTS 1750, Body SAR, Bottom Edge, High.ch

Area Scan (10x7x1): Measurement grid: $dx=5\text{mm}$, $dy=15\text{mm}$
Zoom Scan (5x6x7)/Cube 0: Measurement grid: $dx=8\text{mm}$, $dy=8\text{mm}$, $dz=5\text{mm}$
Reference Value = 24.39 V/m; Power Drift = 0.00 dB
Peak SAR (extrapolated) = 1.21 W/kg
SAR(1 g) = 0.732 W/kg

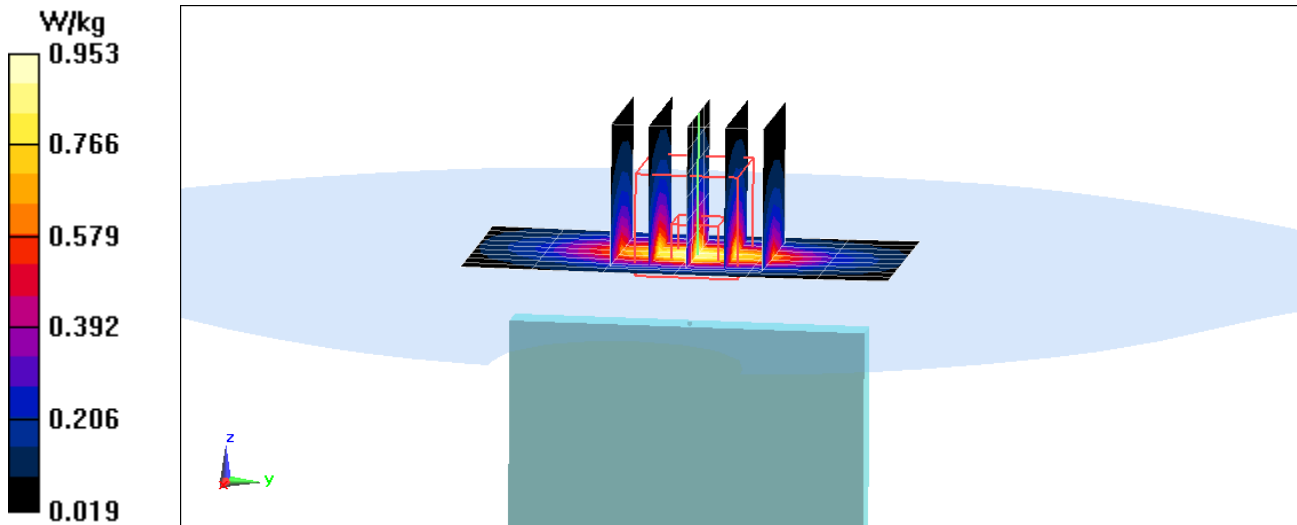

PCTEST ENGINEERING LABORATORY, INC.

DUT: A3LSMJ530GM; Type: Portable Handset; Serial: 01301

Communication System: UID 0, UMTS; Frequency: 1880 MHz; Duty Cycle: 1:1

Medium: 1900 Body Medium parameters used:

$f = 1880 \text{ MHz}$; $\sigma = 1.541 \text{ S/m}$; $\epsilon_r = 51.484$; $\rho = 1000 \text{ kg/m}^3$

Phantom section: Flat Section; Space: 1.5 cm

Test Date: 04-13-2017; Ambient Temp: 22.7°C; Tissue Temp: 22.1°C

Probe: EX3DV4 - SN7409; ConvF(7.47, 7.47, 7.47); Calibrated: 5/17/2016;

Sensor-Surface: 1.4mm (Mechanical Surface Detection)

Electronics: DAE4 Sn859; Calibrated: 5/11/2016

Phantom: SAM Left; Type: QD000P40CC; Serial: TP: 1375

Measurement SW: DASY52, Version 52.8 (8); SEMCAD X Version 14.6.10 (7331)

Mode: UMTS 1900, Body SAR, Back side, Mid.ch

Area Scan (8x14x1): Measurement grid: dx=15mm, dy=15mm

Zoom Scan (5x5x7)/Cube 0: Measurement grid: dx=8mm, dy=8mm, dz=5mm

Reference Value = 21.84 V/m; Power Drift = -0.02 dB

Peak SAR (extrapolated) = 1.14 W/kg

SAR(1 g) = 0.674 W/kg

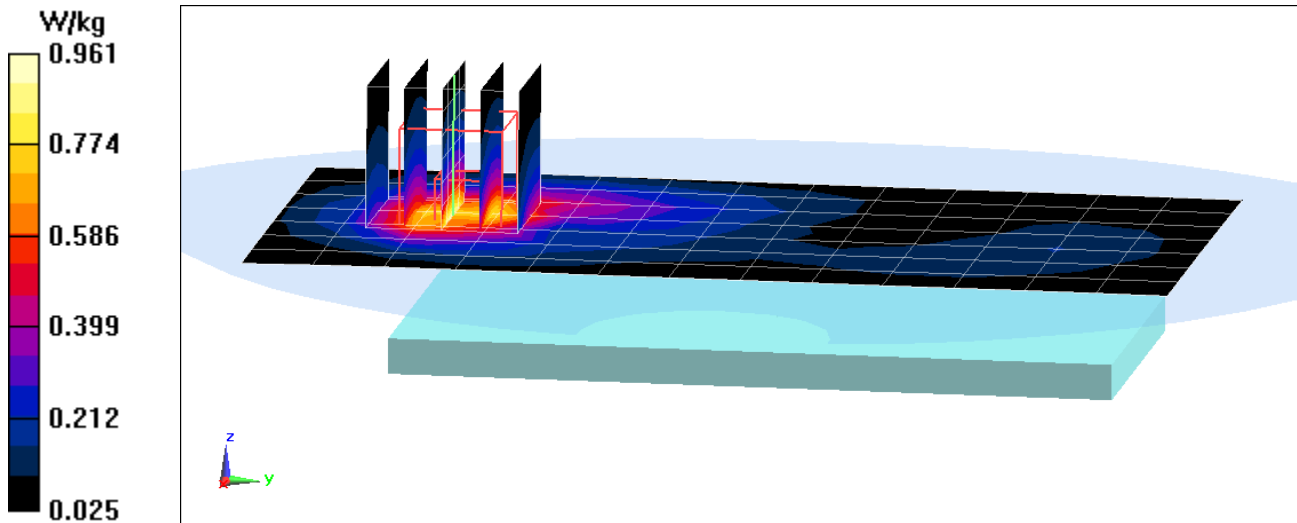

PCTEST ENGINEERING LABORATORY, INC.

DUT: A3LSMJ530GM; Type: Portable Handset; Serial: 01442

Communication System: UID 0, UMTS; Frequency: 1852.4 MHz; Duty Cycle: 1:1
Medium: 1900 Body Medium parameters used (interpolated):
 $f = 1852.4 \text{ MHz}$; $\sigma = 1.511 \text{ S/m}$; $\epsilon_r = 51.277$; $\rho = 1000 \text{ kg/m}^3$
Phantom section: Flat Section; Space: 1.0 cm

Test Date: 04-17-2017; Ambient Temp: 22.7°C; Tissue Temp: 21.6°C

Probe: EX3DV4 - SN7409; ConvF(7.47, 7.47, 7.47); Calibrated: 5/17/2016;
Sensor-Surface: 1.4mm (Mechanical Surface Detection)
Electronics: DAE4 Sn859; Calibrated: 5/11/2016
Phantom: SAM Left; Type: QD000P40CC; Serial: TP: 1375
Measurement SW: DASY52, Version 52.8 (8); SEMCAD X Version 14.6.10 (7331)

Mode: UMTS 1900, Body SAR, Bottom Edge, Low.ch

Area Scan (10x7x1): Measurement grid: dx=5mm, dy=15mm
Zoom Scan (5x5x7)/Cube 0: Measurement grid: dx=8mm, dy=8mm, dz=5mm
Reference Value = 22.94 V/m; Power Drift = -0.01 dB
Peak SAR (extrapolated) = 1.29 W/kg
SAR(1 g) = 0.720 W/kg

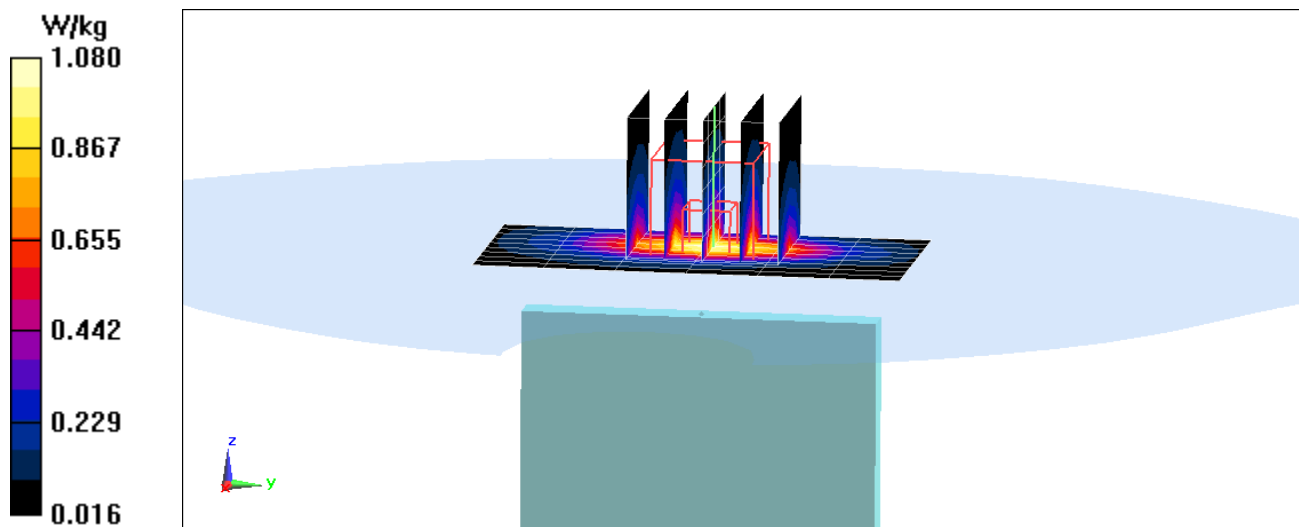

PCTEST ENGINEERING LABORATORY, INC.

DUT: A3LSMJ530GM; Type: Portable Handset; Serial: 01327

Communication System: UID 0, LTE Band 12; Frequency: 707.5 MHz; Duty Cycle: 1:1

Medium: 750 Body Medium parameters used (interpolated):

$f = 707.5 \text{ MHz}$; $\sigma = 0.924 \text{ S/m}$; $\epsilon_r = 54.329$; $\rho = 1000 \text{ kg/m}^3$

Phantom section: Flat Section; Space: 1.5 cm

Test Date: 04-10-2017; Ambient Temp: 23.2°C; Tissue Temp: 22.1°C

Probe: ES3DV3 - SN3334; ConvF(6.33, 6.33, 6.33); Calibrated: 11/15/2016;

Sensor-Surface: 3mm (Mechanical Surface Detection)

Electronics: DAE4 Sn1334; Calibrated: 11/11/2016

Phantom: SAM with CRP v4.0 Left; Type: QD000P40CD; Serial: TP:1692

Measurement SW: DASY52, Version 52.8 (8); SEMCAD X Version 14.6.10 (7331)

**Mode: LTE Band 12, Body SAR, Back side, Mid.ch,
10 MHz Bandwidth, QPSK, 1 RB, 0 RB Offset**

Area Scan (9x13x1): Measurement grid: dx=15mm, dy=15mm

Zoom Scan (6x6x7)/Cube 0: Measurement grid: dx=8mm, dy=8mm, dz=5mm

Reference Value = 15.60 V/m; Power Drift = -0.02 dB

Peak SAR (extrapolated) = 0.300 W/kg

SAR(1 g) = 0.204 W/kg

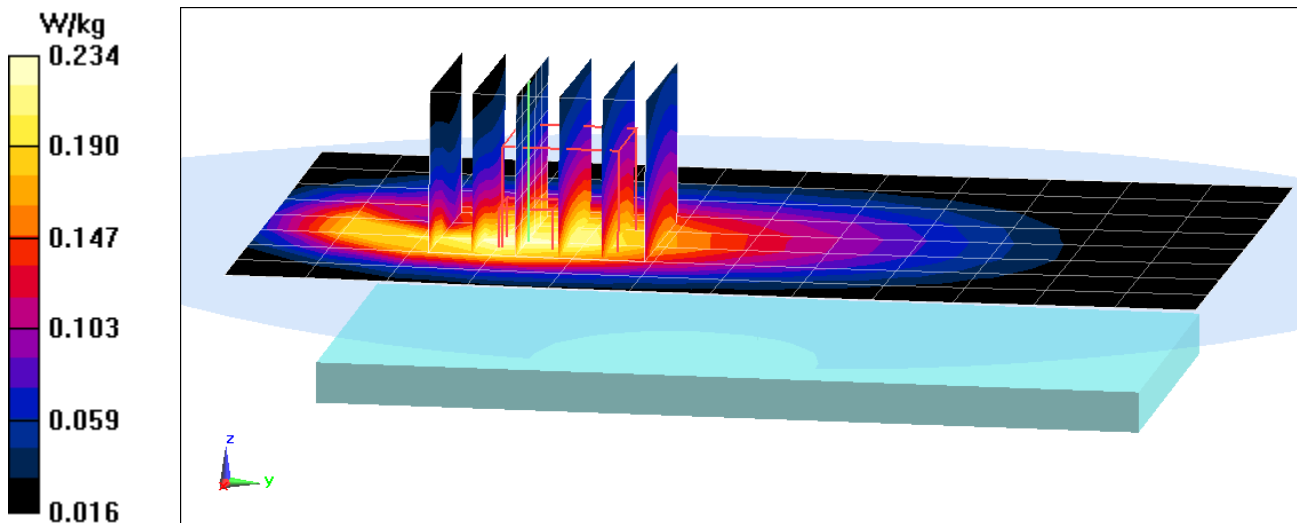

PCTEST ENGINEERING LABORATORY, INC.

DUT: A3LSMJ530GM; Type: Portable Handset; Serial: 01327

Communication System: UID 0, LTE Band 12; Frequency: 707.5 MHz; Duty Cycle: 1:1
Medium: 750 Body Medium parameters used (interpolated):
 $f = 707.5 \text{ MHz}$; $\sigma = 0.924 \text{ S/m}$; $\epsilon_r = 54.329$; $\rho = 1000 \text{ kg/m}^3$
Phantom section: Flat Section; Space: 1.0 cm

Test Date: 04-10-2017; Ambient Temp: 23.2°C; Tissue Temp: 22.1°C

Probe: ES3DV3 - SN3334; ConvF(6.33, 6.33, 6.33); Calibrated: 11/15/2016;
Sensor-Surface: 3mm (Mechanical Surface Detection)
Electronics: DAE4 Sn1334; Calibrated: 11/11/2016

Phantom: SAM with CRP v4.0 Left; Type: QD000P40CD; Serial: TP:1692
Measurement SW: DASY52, Version 52.8 (8); SEMCAD X Version 14.6.10 (7331)

**Mode: LTE Band 12, Body SAR, Back side, Mid.ch,
10 MHz Bandwidth, QPSK, 1 RB, 0 RB Offset**

Area Scan (9x13x1): Measurement grid: dx=15mm, dy=15mm

Zoom Scan (6x6x7)/Cube 0: Measurement grid: dx=8mm, dy=8mm, dz=5mm

Reference Value = 19.42 V/m; Power Drift = -0.01 dB

Peak SAR (extrapolated) = 0.582 W/kg

SAR(1 g) = 0.315 W/kg

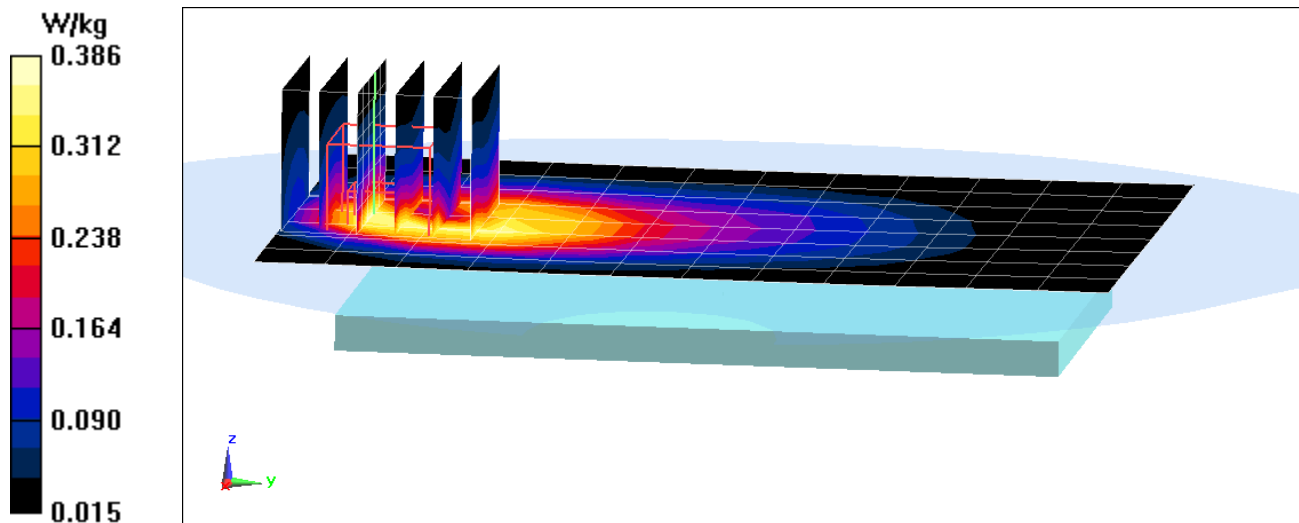

PCTEST ENGINEERING LABORATORY, INC.

DUT: A3LSMJ530GM; Type: Portable Handset; Serial: 01327

Communication System: UID 0, LTE Band 5; Frequency: 836.5 MHz; Duty Cycle: 1:1
Medium: 835 Body Medium parameters used (interpolated):
 $f = 836.5 \text{ MHz}$; $\sigma = 0.996 \text{ S/m}$; $\epsilon_r = 55.062$; $\rho = 1000 \text{ kg/m}^3$
Phantom section: Flat Section; Space: 1.5 cm

Test Date: 04-03-2017; Ambient Temp: 21.6°C; Tissue Temp: 21.2°C

Probe: ES3DV3 - SN3318; ConvF(6.37, 6.37, 6.37); Calibrated: 2/10/2017;
Sensor-Surface: 3mm (Mechanical Surface Detection)
Electronics: DAE4 Sn665; Calibrated: 2/9/2017
Phantom: SAM with CRP (Left); Type: SAM; Serial: 1715
Measurement SW: DASY52, Version 52.8 (8); SEMCAD X Version 14.6.10 (7331)

**Mode: LTE Band 5 (Cell.), Body SAR, Back side, Mid.ch,
10 MHz Bandwidth, QPSK, 1 RB, 0 RB Offset**

Area Scan (9x14x1): Measurement grid: dx=15mm, dy=15mm
Zoom Scan (5x5x7)/Cube 0: Measurement grid: dx=8mm, dy=8mm, dz=5mm
Reference Value = 21.23 V/m; Power Drift = -0.04 dB
Peak SAR (extrapolated) = 0.534 W/kg
SAR(1 g) = 0.415 W/kg

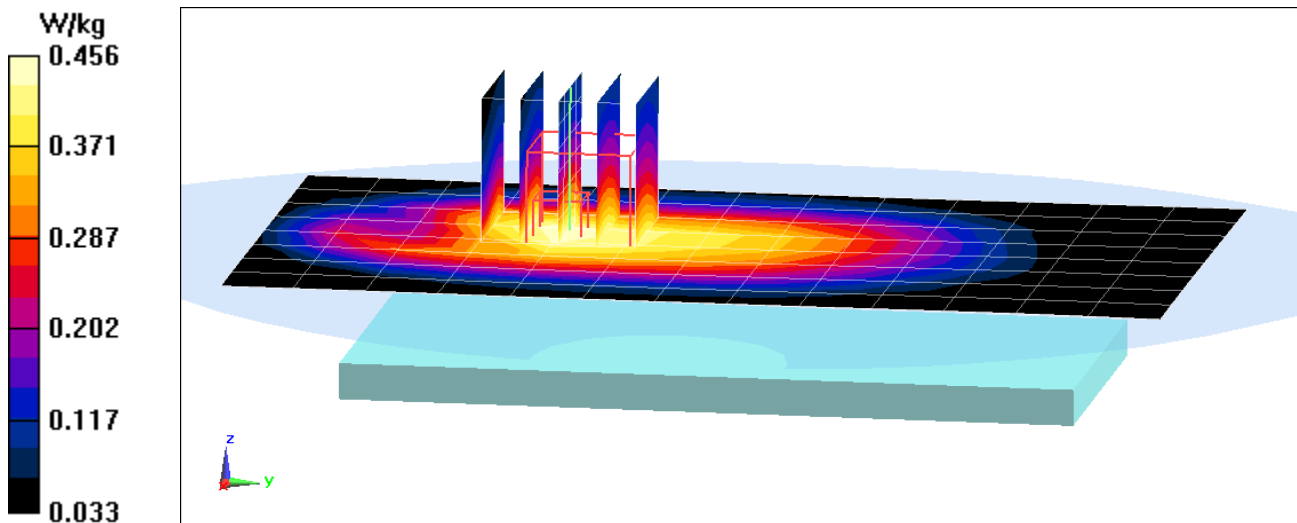

PCTEST ENGINEERING LABORATORY, INC.

DUT: A3LSMJ530GM; Type: Portable Handset; Serial: 01327

Communication System: UID 0, LTE Band 5; Frequency: 836.5 MHz; Duty Cycle: 1:1
Medium: 835 Body Medium parameters used (interpolated):
 $f = 836.5 \text{ MHz}$; $\sigma = 0.996 \text{ S/m}$; $\epsilon_r = 55.062$; $\rho = 1000 \text{ kg/m}^3$
Phantom section: Flat Section; Space: 1.0 cm

Test Date: 04-03-2017; Ambient Temp: 21.6°C; Tissue Temp: 21.2°C

Probe: ES3DV3 - SN3318; ConvF(6.37, 6.37, 6.37); Calibrated: 2/10/2017;
Sensor-Surface: 3mm (Mechanical Surface Detection)
Electronics: DAE4 Sn665; Calibrated: 2/9/2017
Phantom: SAM with CRP (Left); Type: SAM; Serial: 1715
Measurement SW: DASY52, Version 52.8 (8); SEMCAD X Version 14.6.10 (7331)

**Mode: LTE Band 5 (Cell.), Body SAR, Back side, Mid.ch,
10 MHz Bandwidth, QPSK, 1 RB, 0 RB Offset**

Area Scan (9x14x1): Measurement grid: dx=15mm, dy=15mm
Zoom Scan (5x6x7)/Cube 0: Measurement grid: dx=8mm, dy=8mm, dz=5mm
Reference Value = 25.17 V/m; Power Drift = 0.00 dB
Peak SAR (extrapolated) = 0.796 W/kg
SAR(1 g) = 0.575 W/kg

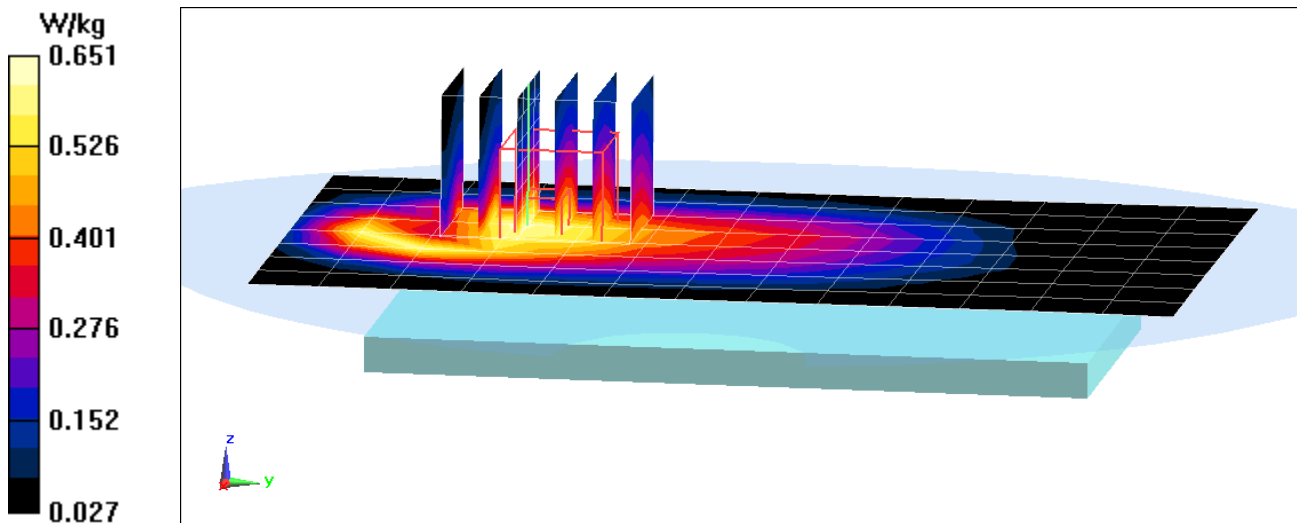

PCTEST ENGINEERING LABORATORY, INC.

DUT: A3LSMJ530GM; Type: Portable Handset; Serial: 01327

Communication System: UID 0, LTE Band 4 (AWS); Frequency: 1732.5 MHz; Duty Cycle: 1:1

Medium: 1750 Body Medium parameters used (interpolated):

$f = 1732.5$ MHz; $\sigma = 1.485$ S/m; $\epsilon_r = 51.074$; $\rho = 1000$ kg/m³

Phantom section: Flat Section; Space: 1.5 cm

Test Date: 03-30-2017; Ambient Temp: 22.5°C; Tissue Temp: 21.1°C

Probe: ES3DV3 - SN3213; ConvF(5.09, 5.09, 5.09); Calibrated: 2/10/2017;

Sensor-Surface: 3mm (Mechanical Surface Detection)

Electronics: DAE4 Sn1272; Calibrated: 2/9/2017

Phantom: SAM Right; Type: SAM; Serial: 1757

Measurement SW: DASY52, Version 52.8 (8); SEMCAD X Version 14.6.10 (7331)

**Mode: LTE Band 4 (AWS), Body SAR, Back side, Mid.ch,
20 MHz Bandwidth, QPSK, 1 RB, 99 RB Offset**

Area Scan (9x15x1): Measurement grid: dx=15mm, dy=15mm

Zoom Scan (5x5x7)/Cube 0: Measurement grid: dx=8mm, dy=8mm, dz=5mm

Reference Value = 22.77 V/m; Power Drift = 0.03 dB

Peak SAR (extrapolated) = 1.05 W/kg

SAR(1 g) = 0.675 W/kg

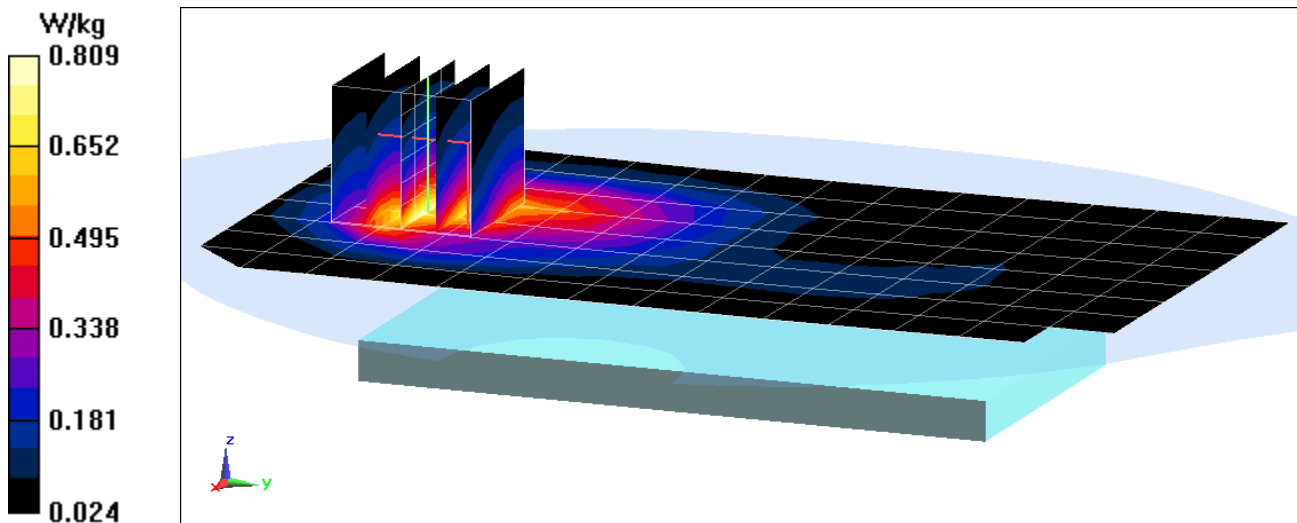

PCTEST ENGINEERING LABORATORY, INC.

DUT: A3LSMJ530GM; Type: Portable Handset; Serial: 01442

Communication System: UID 0, LTE Band 4 (AWS); Frequency: 1732.5 MHz; Duty Cycle: 1:1

Medium: 1750 Body Medium parameters used (interpolated):

$f = 1732.5$ MHz; $\sigma = 1.47$ S/m; $\epsilon_r = 52.209$; $\rho = 1000$ kg/m³

Phantom section: Flat Section; Space: 1.0 cm

Test Date: 04-17-2017; Ambient Temp: 19.2°C; Tissue Temp: 20.1°C

Probe: ES3DV3 - SN3213; ConvF(5.09, 5.09, 5.09); Calibrated: 2/10/2017;

Sensor-Surface: 3mm (Mechanical Surface Detection)

Electronics: DAE4 Sn1272; Calibrated: 2/9/2017

Phantom: SAM Front; Type: QD000P40CD; Serial: TP:1758

Measurement SW: DASY52, Version 52.8 (8); SEMCAD X Version 14.6.10 (7331)

**Mode: LTE Band 4 (AWS), Body SAR, Back side, Mid.ch,
20 MHz Bandwidth, QPSK, 1 RB, 0 RB Offset**

Area Scan (9x15x1): Measurement grid: dx=15mm, dy=15mm

Zoom Scan (5x5x7)/Cube 0: Measurement grid: dx=8mm, dy=8mm, dz=5mm

Reference Value = 22.77 V/m; Power Drift = -0.03 dB

Peak SAR (extrapolated) = 1.09 W/kg

SAR(1 g) = 0.665 W/kg

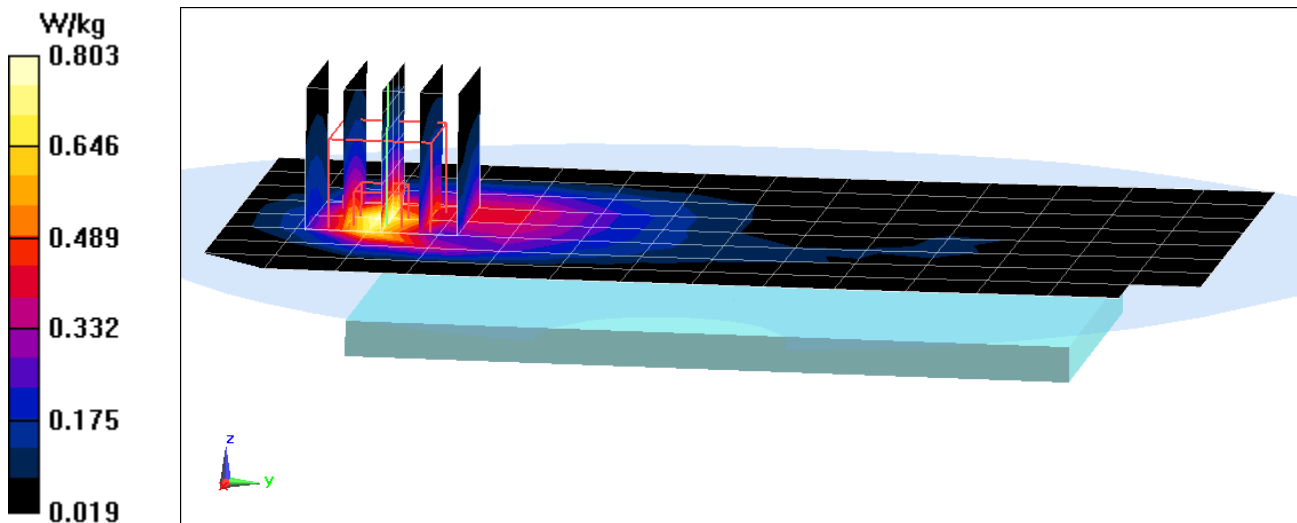

PCTEST ENGINEERING LABORATORY, INC.

DUT: A3LSMJ530GM; Type: Portable Handset; Serial: 01319

Communication System: UID 0, LTE Band 66 (AWS); Frequency: 1720 MHz; Duty Cycle: 1:1
Medium: 1750 Body Medium parameters used (interpolated):
 $f = 1720 \text{ MHz}$; $\sigma = 1.431 \text{ S/m}$; $\epsilon_r = 52.418$; $\rho = 1000 \text{ kg/m}^3$
Phantom section: Flat Section; Space: 1.5 cm

Test Date: 04-10-2017; Ambient Temp: 23.5°C; Tissue Temp: 22.9°C

Probe: ES3DV3 - SN3213; ConvF(5.09, 5.09, 5.09); Calibrated: 2/10/2017;
Sensor-Surface: 3mm (Mechanical Surface Detection)
Electronics: DAE4 Sn1272; Calibrated: 2/9/2017
Phantom: SAM Front; Type: QD000P40CD; Serial: TP:1758
Measurement SW: DASY52, Version 52.8 (8); SEMCAD X Version 14.6.10 (7331)

**Mode: LTE Band 66 (AWS), Body SAR, Back side, Low.ch,
20 MHz Bandwidth, QPSK, 1 RB, 99 RB Offset**

Area Scan (9x15x1): Measurement grid: dx=15mm, dy=15mm
Zoom Scan (5x5x7)/Cube 0: Measurement grid: dx=8mm, dy=8mm, dz=5mm
Reference Value = 15.905 V/m; Power Drift = 0.00 dB
Peak SAR (extrapolated) = 0.486 W/kg
SAR(1 g) = 0.318 W/kg

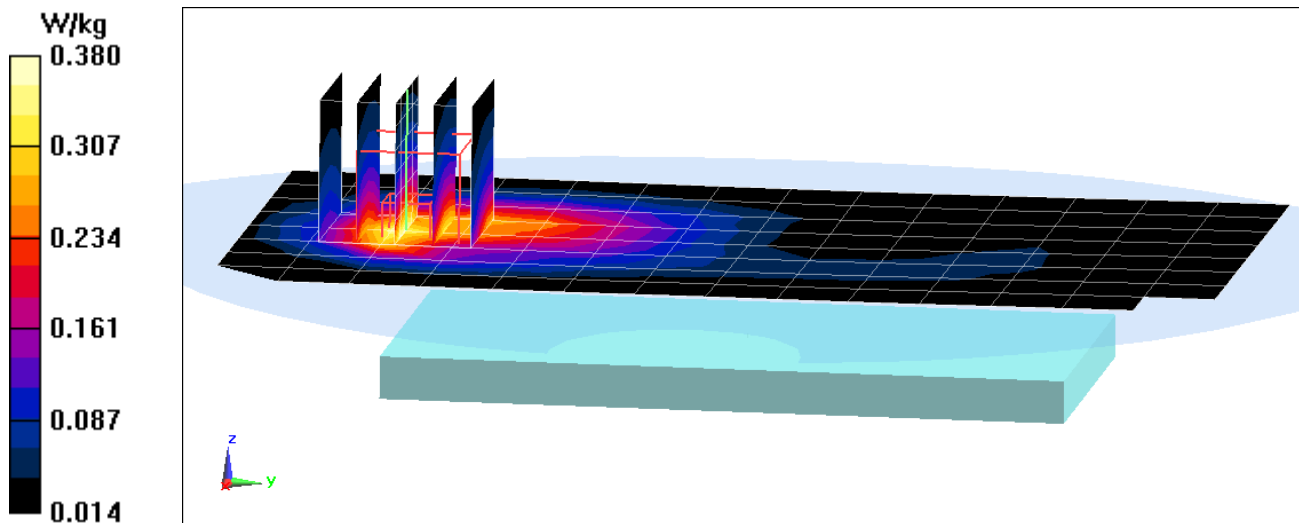

PCTEST ENGINEERING LABORATORY, INC.

DUT: A3LSMJ530GM; Type: Portable Handset; Serial: 01467

Communication System: UID 0, LTE Band 66 (AWS); Frequency: 1720 MHz; Duty Cycle: 1:1

Medium: 1750 Body Medium parameters used (interpolated):

$f = 1720 \text{ MHz}$; $\sigma = 1.473 \text{ S/m}$; $\epsilon_r = 51.852$; $\rho = 1000 \text{ kg/m}^3$

Phantom section: Flat Section; Space: 1.0 cm

Test Date: 04-20-2017; Ambient Temp: 22.3°C; Tissue Temp: 21.3°C

Probe: ES3DV3 - SN3213; ConvF(5.09, 5.09, 5.09); Calibrated: 2/10/2017;

Sensor-Surface: 3mm (Mechanical Surface Detection)

Electronics: DAE4 Sn1272; Calibrated: 2/9/2017

Phantom: SAM Front; Type: QD000P40CD; Serial: TP:1758

Measurement SW: DASY52, Version 52.8 (8); SEMCAD X Version 14.6.10 (7331)

**Mode: LTE Band 66 (AWS), Body SAR, Back side, Low.ch,
20 MHz Bandwidth, QPSK, 1 RB, 99 RB Offset**

Area Scan (9x15x1): Measurement grid: dx=15mm, dy=15mm

Zoom Scan (5x5x7)/Cube 0: Measurement grid: dx=8mm, dy=8mm, dz=5mm

Reference Value = 19.67 V/m; Power Drift = -0.07 dB

Peak SAR (extrapolated) = 0.821 W/kg

SAR(1 g) = 0.501 W/kg

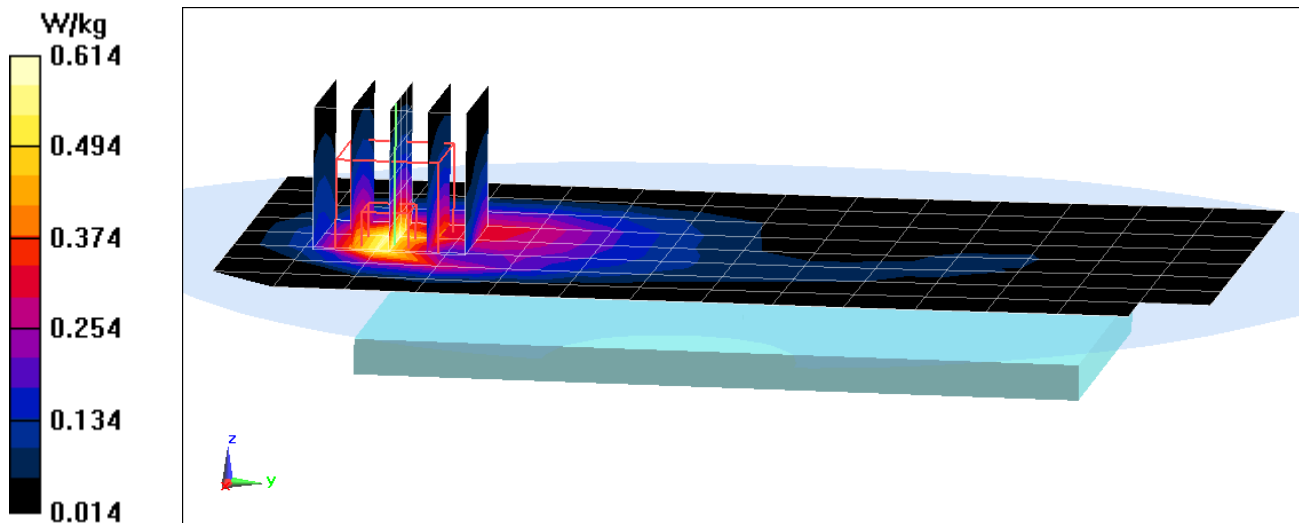

PCTEST ENGINEERING LABORATORY, INC.

DUT: A3LSMJ530GM; Type: Portable Handset; Serial: 01319

Communication System: UID 0, LTE Band 2 (PCS); Frequency: 1860 MHz; Duty Cycle: 1:1

Medium: 1900 Body Medium parameters used (interpolated):

$f = 1860 \text{ MHz}$; $\sigma = 1.528 \text{ S/m}$; $\epsilon_r = 52.354$; $\rho = 1000 \text{ kg/m}^3$

Phantom section: Flat Section; Space: 1.5 cm

Test Date: 04-03-2017; Ambient Temp: 24.1°C; Tissue Temp: 22.4°C

Probe: ES3DV3 - SN3287; ConvF(4.94, 4.94, 4.94); Calibrated: 9/19/2016;

Sensor-Surface: 3mm (Mechanical Surface Detection)

Electronics: DAE4 Sn1408; Calibrated: 9/14/2016

Phantom: SAM Front; Type: SAM; Serial: 1686

Measurement SW: DASY52, Version 52.8 (8); SEMCAD X Version 14.6.10 (7331)

**Mode: LTE Band 2 (PCS), Body SAR, Back side, Low.ch,
20 MHz Bandwidth, QPSK, 1 RB, 50 RB Offset**

Area Scan (9x14x1): Measurement grid: dx=15mm, dy=15mm

Zoom Scan (5x5x7)/Cube 0: Measurement grid: dx=8mm, dy=8mm, dz=5mm

Reference Value = 24.02 V/m; Power Drift = 0.02 dB

Peak SAR (extrapolated) = 1.20 W/kg

SAR(1 g) = 0.767 W/kg

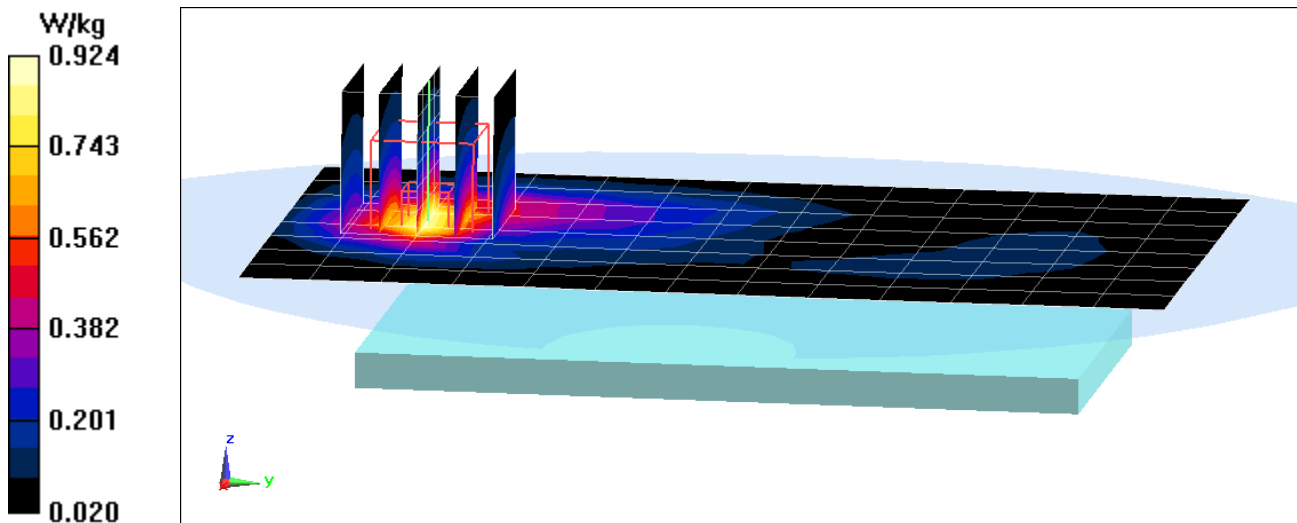

PCTEST ENGINEERING LABORATORY, INC.

DUT: A3LSMJ530GM; Type: Portable Handset; Serial: 01442

Communication System: UID 0, LTE Band 2 (PCS); Frequency: 1860 MHz; Duty Cycle: 1:1

Medium: 1900 Body Medium parameters used (interpolated):

$f = 1860$ MHz; $\sigma = 1.521$ S/m; $\epsilon_r = 51.244$; $\rho = 1000$ kg/m³

Phantom section: Flat Section; Space: 1.0 cm

Test Date: 04-17-2017; Ambient Temp: 22.7°C; Tissue Temp: 21.6°C

Probe: EX3DV4 - SN7409; ConvF(7.47, 7.47, 7.47); Calibrated: 5/17/2016;

Sensor-Surface: 1.4mm (Mechanical Surface Detection)

Electronics: DAE4 Sn859; Calibrated: 5/11/2016

Phantom: SAM Left; Type: QD000P40CC; Serial: TP: 1375

Measurement SW: DASY52, Version 52.8 (8); SEMCAD X Version 14.6.10 (7331)

**Mode: LTE Band 2 (PCS), Body SAR, Bottom Edge, Low.ch,
20 MHz Bandwidth, QPSK, 1 RB, 99 RB Offset**

Area Scan (11x9x1): Measurement grid: dx=5mm, dy=15mm

Zoom Scan (5x5x7)/Cube 0: Measurement grid: dx=8mm, dy=8mm, dz=5mm

Reference Value = 24.92 V/m; Power Drift = -0.13 dB

Peak SAR (extrapolated) = 1.52 W/kg

SAR(1 g) = 0.845 W/kg

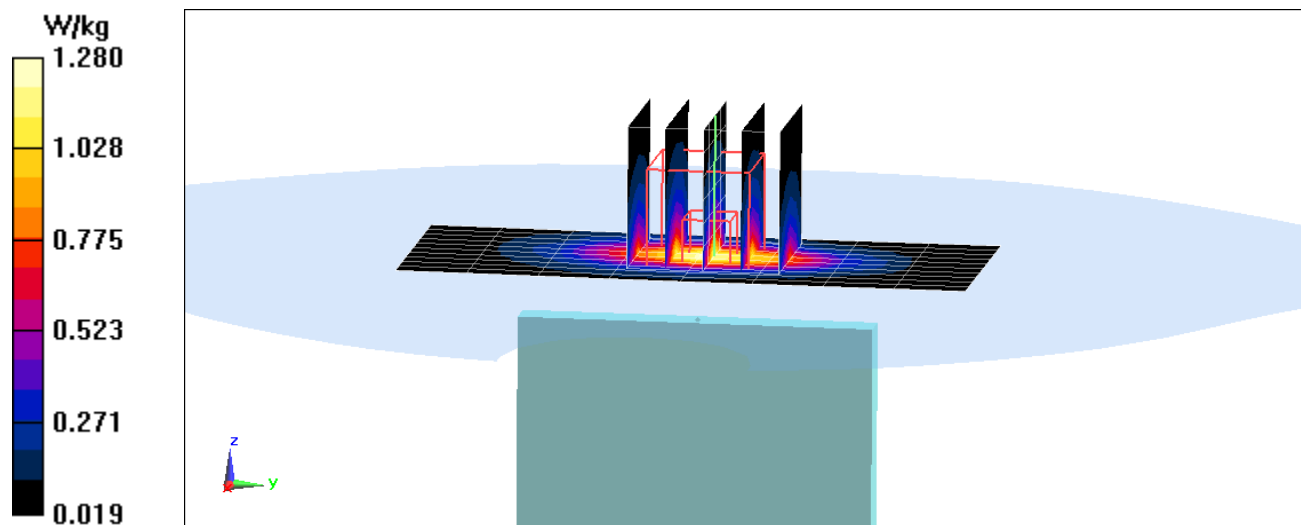

PCTEST ENGINEERING LABORATORY, INC.

DUT: A3LSMJ530GM; Type: Portable Handset; Serial: 01376

Communication System: UID 0, LTE Band 41; Frequency: 2593 MHz; Duty Cycle: 1:1.58

Medium: 2600 Body Medium parameters used (interpolated):

$f = 2593 \text{ MHz}$; $\sigma = 2.21 \text{ S/m}$; $\epsilon_r = 50.267$; $\rho = 1000 \text{ kg/m}^3$

Phantom section: Flat Section; Space: 1.5 cm

Test Date: 04-10-2017; Ambient Temp: 21.9°C; Tissue Temp: 21.9°C

Probe: ES3DV3 - SN3319; ConvF(4.18, 4.18, 4.18); Calibrated: 3/14/2017;

Sensor-Surface: 3mm (Mechanical Surface Detection)

Electronics: DAE4 Sn1368; Calibrated: 3/8/2017

Phantom: SAM 5.0 front; Type: QD000P40CD; Serial: TP:-1648

Measurement SW: DASY52, Version 52.8 (8); SEMCAD X Version 14.6.10 (7331)

**Mode: LTE Band 41, Body SAR, Back side, Mid.ch,
20 MHz Bandwidth, QPSK, 1 RB, 0 RB Offset**

Area Scan (10x16x1): Measurement grid: dx=12mm, dy=12mm

Zoom Scan (7x7x7)/Cube 0: Measurement grid: dx=5mm, dy=5mm, dz=5mm

Reference Value = 10.85 V/m; Power Drift = -0.01 dB

Peak SAR (extrapolated) = 0.442 W/kg

SAR(1 g) = 0.228 W/kg

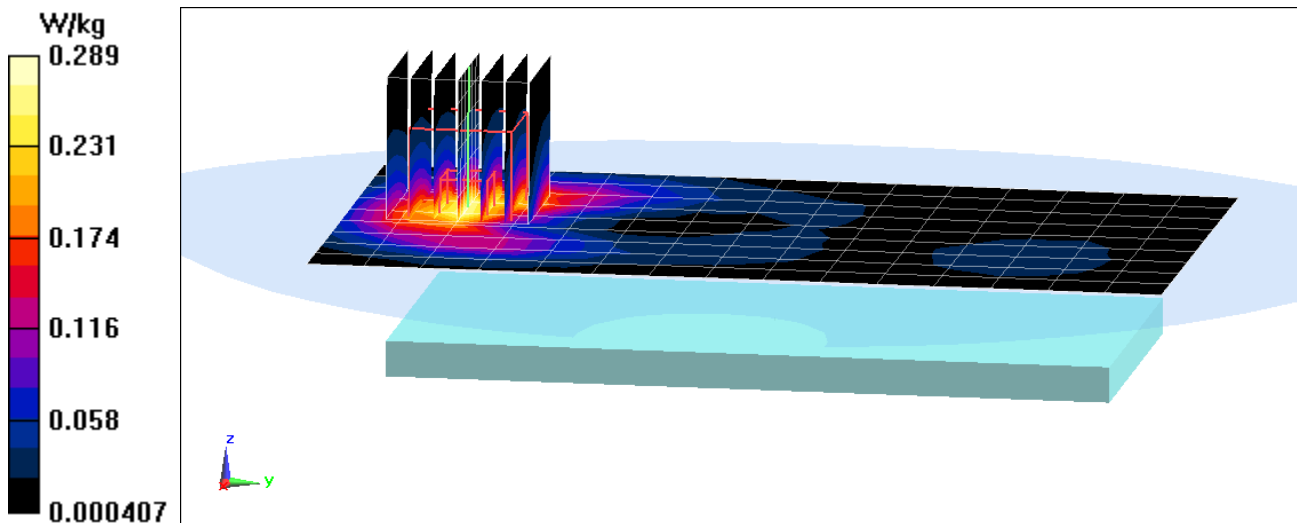

PCTEST ENGINEERING LABORATORY, INC.

DUT: A3LSMJ530GM; Type: Portable Handset; Serial: 01467

Communication System: UID 0, LTE Band 41; Frequency: 2549.5 MHz; Duty Cycle: 1:1.58

Medium: 2600 Body Medium parameters used:

$f = 2550$ MHz; $\sigma = 2.175$ S/m; $\epsilon_r = 52.103$; $\rho = 1000$ kg/m³

Phantom section: Flat Section; Space: 1.0 cm

Test Date: 04-18-2017; Ambient Temp: 21.9°C; Tissue Temp: 21.8°C

Probe: ES3DV3 - SN3287; ConvF(4.12, 4.12, 4.12); Calibrated: 9/19/2016;

Sensor-Surface: 3mm (Mechanical Surface Detection)

Electronics: DAE4 Sn1408; Calibrated: 9/14/2016

Phantom: SAM Front; Type: SAM; Serial: 1686

Measurement SW: DASY52, Version 52.8 (8); SEMCAD X Version 14.6.10 (7331)

**Mode: LTE Band 41, Body SAR, Back side, Low-Mid.ch,
20 MHz Bandwidth, QPSK, 1 RB, 0 RB Offset**

Area Scan (10x17x1): Measurement grid: dx=12mm, dy=12mm

Zoom Scan (7x7x7)/Cube 0: Measurement grid: dx=5mm, dy=5mm, dz=5mm

Reference Value = 19.12 V/m; Power Drift = -0.07 dB

Peak SAR (extrapolated) = 1.43 W/kg

SAR(1 g) = 0.698 W/kg

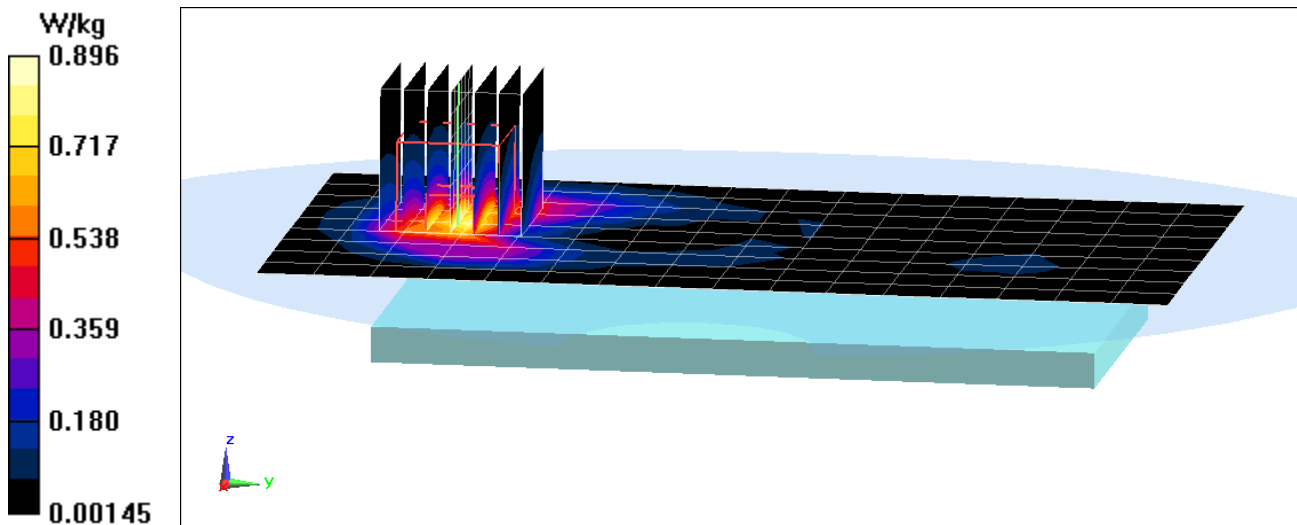

PCTEST ENGINEERING LABORATORY, INC.

DUT: A3LSMJ530GM; Type: Portable Handset; Serial: 01392

Communication System: UID 0, IEEE 802.11b; Frequency: 2437 MHz; Duty Cycle: 1:1
Medium: 2450 Body Medium parameters used (interpolated):
 $f = 2437 \text{ MHz}$; $\sigma = 1.995 \text{ S/m}$; $\epsilon_r = 51.029$; $\rho = 1000 \text{ kg/m}^3$
Phantom section: Flat Section; Space: 1.5 cm

Test Date: 03-29-2017; Ambient Temp: 23.5°C; Tissue Temp: 22.1°C

Probe: EX3DV4 - SN7406; ConvF(7.24, 7.24, 7.24); Calibrated: 4/19/2016;

Sensor-Surface: 1.4mm (Mechanical Surface Detection)

Electronics: DAE4 Sn1407; Calibrated: 4/14/2016

Phantom: SAM 5.0 front; Type: QD000P40CD; Serial: TP:-1648

Measurement SW: DASY52, Version 52.8 (8); SEMCAD X Version 14.6.10 (7331)

Mode: IEEE 802.11b, 22 MHz Bandwidth, Body SAR, Ch 06, 1 Mbps, Back Side

Area Scan (11x17x1): Measurement grid: dx=12mm, dy=12mm

Zoom Scan (7x7x7)/Cube 0: Measurement grid: dx=5mm, dy=5mm, dz=5mm

Reference Value = 9.396 V/m; Power Drift = 0.00 dB

Peak SAR (extrapolated) = 0.307 W/kg

SAR(1 g) = 0.160 W/kg

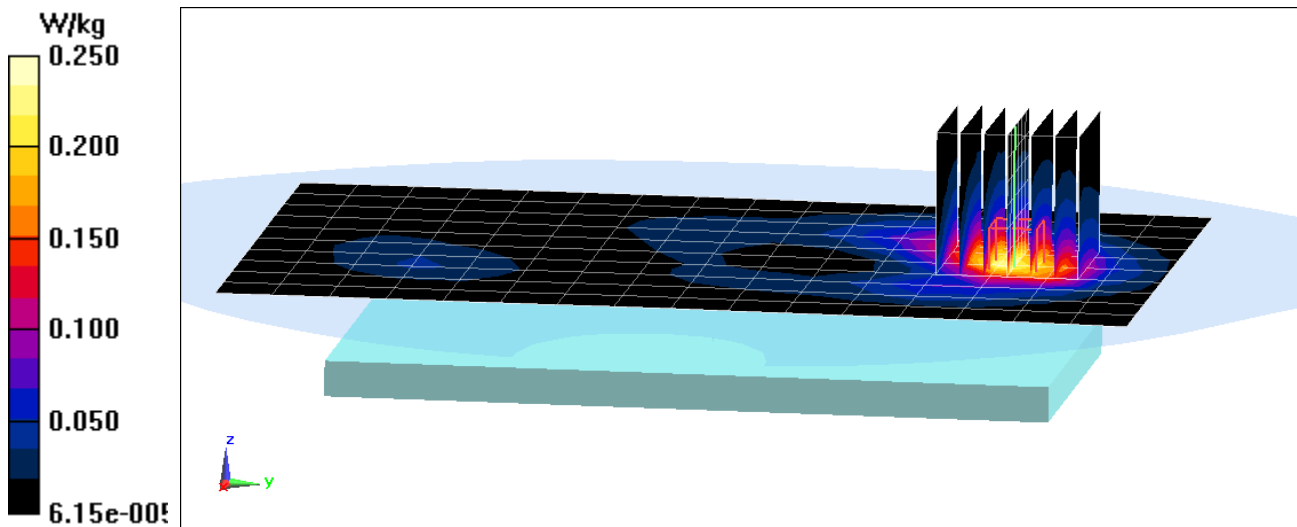

PCTEST ENGINEERING LABORATORY, INC.

DUT: A3LSMJ530GM; Type: Portable Handset; Serial: 01392

Communication System: UID 0, IEEE 802.11b; Frequency: 2437 MHz; Duty Cycle: 1:1
Medium: 2450 Body Medium parameters used (interpolated):
 $f = 2437 \text{ MHz}$; $\sigma = 1.995 \text{ S/m}$; $\epsilon_r = 51.029$; $\rho = 1000 \text{ kg/m}^3$
Phantom section: Flat Section; Space: 1.0 cm

Test Date: 03-29-2017; Ambient Temp: 23.5°C; Tissue Temp: 22.1°C

Probe: EX3DV4 - SN7406; ConvF(7.24, 7.24, 7.24); Calibrated: 4/19/2016;
Sensor-Surface: 1.4mm (Mechanical Surface Detection)
Electronics: DAE4 Sn1407; Calibrated: 4/14/2016
Phantom: SAM 5.0 front; Type: QD000P40CD; Serial: TP:-1648
Measurement SW: DASY52, Version 52.8 (8); SEMCAD X Version 14.6.10 (7331)

Mode: IEEE 802.11b, 22 MHz Bandwidth, Body SAR, Ch 6, 1 Mbps, Top Edge

Area Scan (10x9x1): Measurement grid: dx=5mm, dy=12mm

Zoom Scan (7x7x7)/Cube 0: Measurement grid: dx=5mm, dy=5mm, dz=5mm

Reference Value = 13.49 V/m; Power Drift = 0.18 dB

Peak SAR (extrapolated) = 0.736 W/kg

SAR(1 g) = 0.372 W/kg

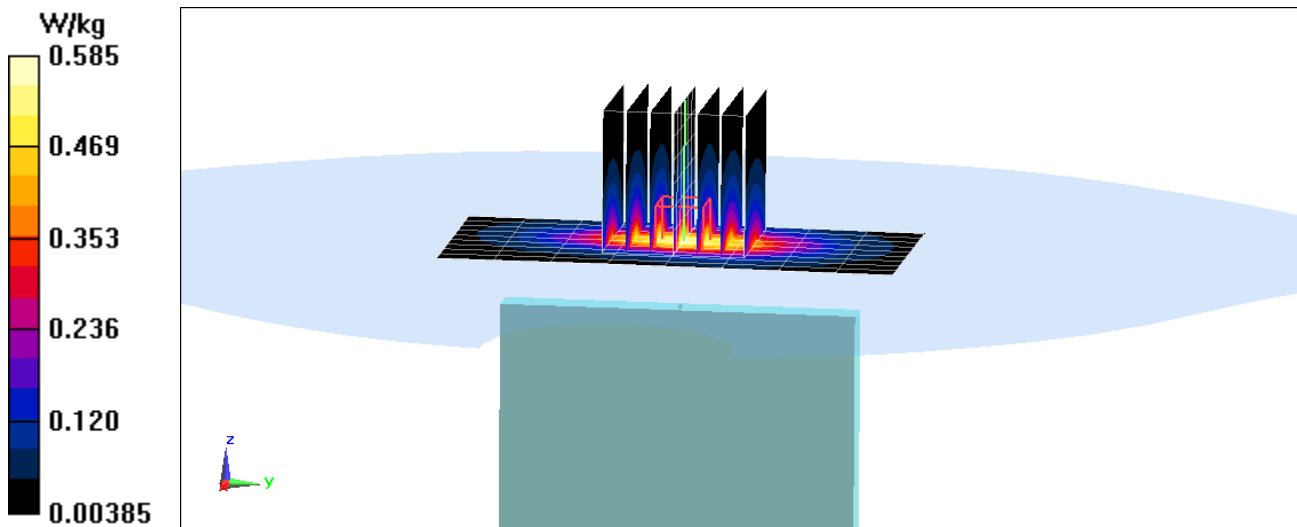

PCTEST ENGINEERING LABORATORY, INC.

DUT: A3LSMJ530GM; Type: Portable Handset; Serial: 74902

Communication System: UID 0, 802.11a 5.2-5.8 GHz Band; Frequency: 5745 MHz; Duty Cycle: 1:1

Medium: 5GHz Body Medium parameters used:

$f = 5745 \text{ MHz}$; $\sigma = 6.198 \text{ S/m}$; $\epsilon_r = 46.289$; $\rho = 1000 \text{ kg/m}^3$

Phantom section: Flat Section; Space: 1.5 cm

Test Date: 03-20-2017; Ambient Temp: 23.1°C; Tissue Temp: 21.0°C

Probe: EX3DV4 - SN7308; ConvF(4.04, 4.04, 4.04); Calibrated: 7/21/2016;

Sensor-Surface: 1.4mm (Mechanical Surface Detection)

Electronics: DAE4 Sn859; Calibrated: 5/11/2016

Phantom: SAM Left; Type: QD000P40CC; Serial: TP: 1375

Measurement SW: DASY52, Version 52.8 (8); SEMCAD X Version 14.6.10 (7331)

Mode: IEEE 802.11a, UNII-3, 20 MHz Bandwidth, Body SAR, Ch 149, 6 Mbps, Back Side

Area Scan (11x19x1): Measurement grid: dx=10mm, dy=10mm

Zoom Scan (7x7x7)/Cube 0: Measurement grid: dx=4mm, dy=4mm, dz=1.4mm; Graded Ratio: 1.4

Reference Value = 3.590 V/m; Power Drift = 0.12 dB

Peak SAR (extrapolated) = 0.243 W/kg

SAR(1 g) = 0.069 W/kg

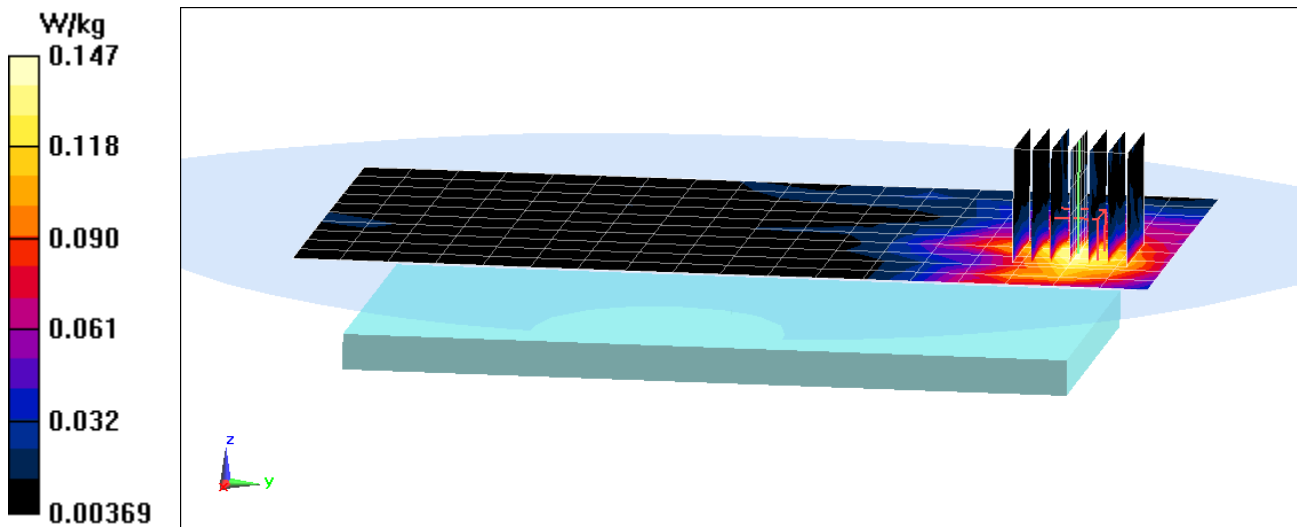

PCTEST ENGINEERING LABORATORY, INC.

DUT: A3LSMJ530GM; Type: Portable Handset; Serial: 74902

Communication System: UID 0, 802.11a 5.2-5.8 GHz Band; Frequency: 5745 MHz; Duty Cycle: 1:1

Medium: 5GHz Body Medium parameters used:

$f = 5745 \text{ MHz}$; $\sigma = 6.198 \text{ S/m}$; $\epsilon_r = 46.289$; $\rho = 1000 \text{ kg/m}^3$

Phantom section: Flat Section; Space: 1.0 cm

Test Date: 03-20-2017; Ambient Temp: 23.1°C; Tissue Temp: 21.0°C

Probe: EX3DV4 - SN7308; ConvF(4.04, 4.04, 4.04); Calibrated: 7/21/2016;

Sensor-Surface: 1.4mm (Mechanical Surface Detection)

Electronics: DAE4 Sn859; Calibrated: 5/11/2016

Phantom: SAM Left; Type: QD000P40CC; Serial: TP: 1375

Measurement SW: DASY52, Version 52.8 (8); SEMCAD X Version 14.6.10 (7331)

Mode: IEEE 802.11a, UNII-3, 20 MHz Bandwidth, Body SAR, Ch 149, 6 Mbps, Front Side

Area Scan (12x21x1): Measurement grid: dx=10mm, dy=10mm

Zoom Scan (7x7x7)/Cube 0: Measurement grid: dx=4mm, dy=4mm, dz=1.4mm; Graded Ratio: 1.4

Reference Value = 3.095 V/m; Power Drift = 0.13 dB

Peak SAR (extrapolated) = 3.31 W/kg

SAR(1 g) = 0.828 W/kg

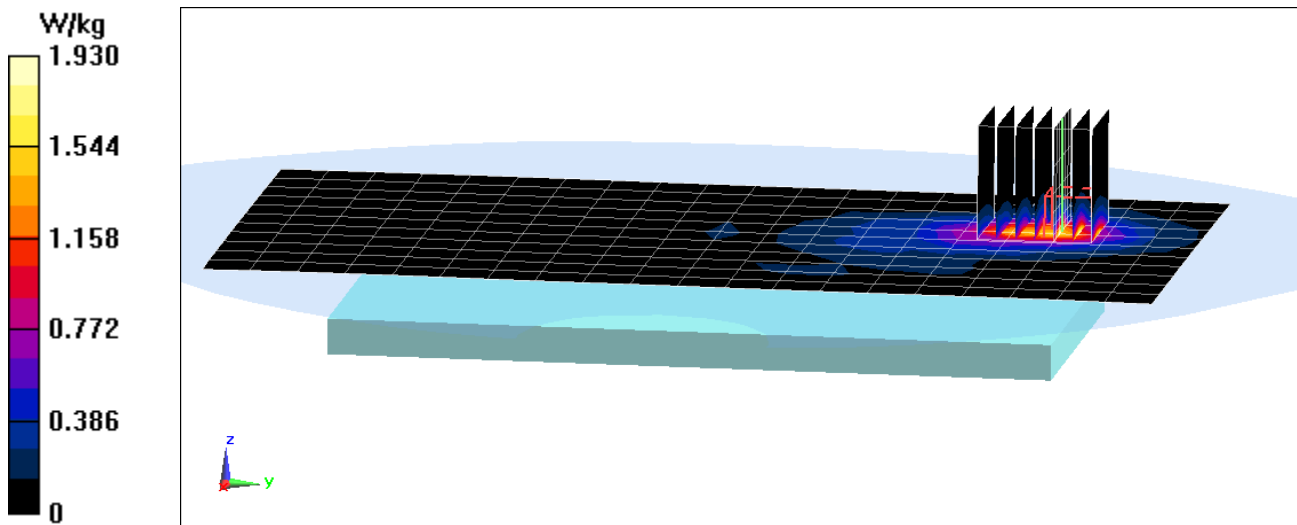

APPENDIX B: SYSTEM VERIFICATION

PCTEST ENGINEERING LABORATORY, INC.

DUT: Dipole 750 MHz; Type: D750V3; Serial: 1054

Communication System: UID 0, CW; Frequency: 750 MHz; Duty Cycle: 1:1

Medium: 750 Head Medium parameters used (interpolated):

$f = 750 \text{ MHz}$; $\sigma = 0.905 \text{ S/m}$; $\epsilon_r = 42.485$; $\rho = 1000 \text{ kg/m}^3$

Phantom section: Flat Section; Space: 1.5 cm

Test Date: 04-10-2017; Ambient Temp: 21.1°C; Tissue Temp: 20.0°C

Probe: ES3DV3 - SN3334; ConvF(6.76, 6.76, 6.76); Calibrated: 11/15/2016;

Sensor-Surface: 3mm (Mechanical Surface Detection)

Electronics: DAE4 Sn1334; Calibrated: 11/11/2016

Phantom: SAM with CRP v4.0; Type: QD000P40CD; Serial: TP:1800

Measurement SW: DASY52, Version 52.8 (8); SEMCAD X Version 14.6.10 (7331)

750 MHz System Verification at 23.0 dBm (200 mW)

Area Scan (7x15x1): Measurement grid: dx=15mm, dy=15mm

Zoom Scan (5x5x7)/Cube 0: Measurement grid: dx=8mm, dy=8mm, dz=5mm

Peak SAR (extrapolated) = 2.37 W/kg

SAR(1 g) = 1.60 W/kg

Deviation(1 g) = -4.42%

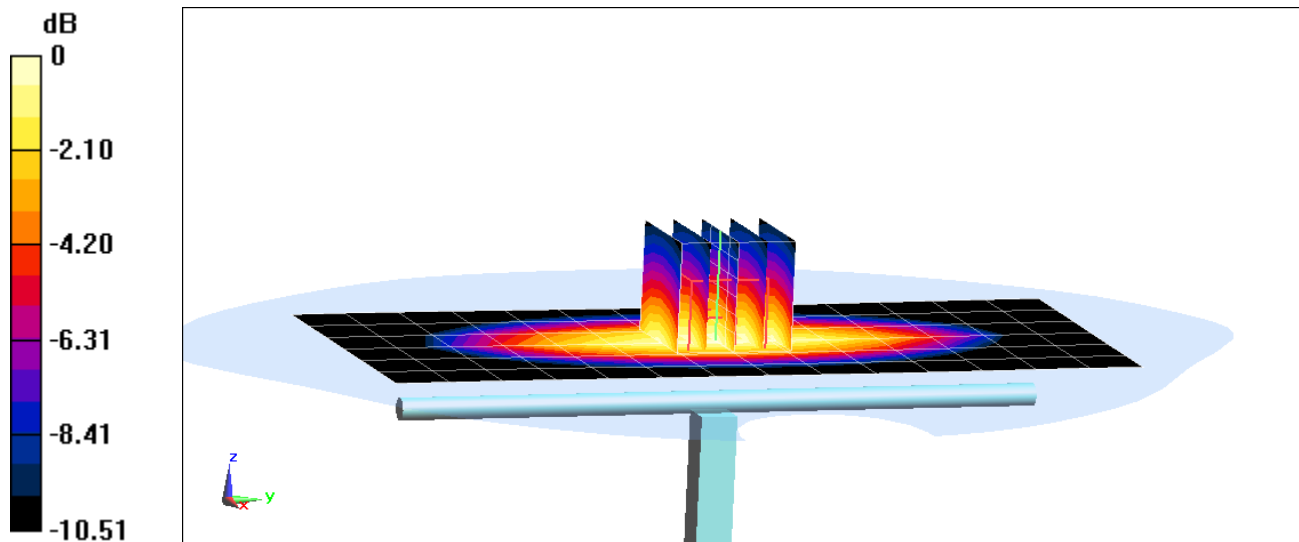

0 dB = 1.87 W/kg = 2.72 dBW/kg

PCTEST ENGINEERING LABORATORY, INC.

DUT: Dipole 835 MHz; Type: D835V2; Serial: 4d133

Communication System: UID 0, CW; Frequency: 835 MHz; Duty Cycle: 1:1

Medium: 835 Head Medium parameters used:

$f = 835 \text{ MHz}$; $\sigma = 0.904 \text{ S/m}$; $\epsilon_r = 41.042$; $\rho = 1000 \text{ kg/m}^3$

Phantom section: Flat Section; Space: 1.5 cm

Test Date: 04-04-2017; Ambient Temp: 20.5°C; Tissue Temp: 21.3°C

Probe: ES3DV3 - SN3334; ConvF(6.49, 6.49, 6.49); Calibrated: 11/15/2016;

Sensor-Surface: 3mm (Mechanical Surface Detection)

Electronics: DAE4 Sn1334; Calibrated: 11/11/2016

Phantom: SAM with CRP v4.0; Type: QD000P40CD; Serial: TP:1800

Measurement SW: DASY52, Version 52.8 (8); SEMCAD X Version 14.6.10 (7331)

835 MHz System Verification at 23.0 dBm (200 mW)

Area Scan (7x14x1): Measurement grid: dx=15mm, dy=15mm

Zoom Scan (5x5x7)/Cube 0: Measurement grid: dx=8mm, dy=8mm, dz=5mm

Peak SAR (extrapolated) = 2.83 W/kg

SAR(1 g) = 1.93 W/kg

Deviation(1 g) = 3.54%

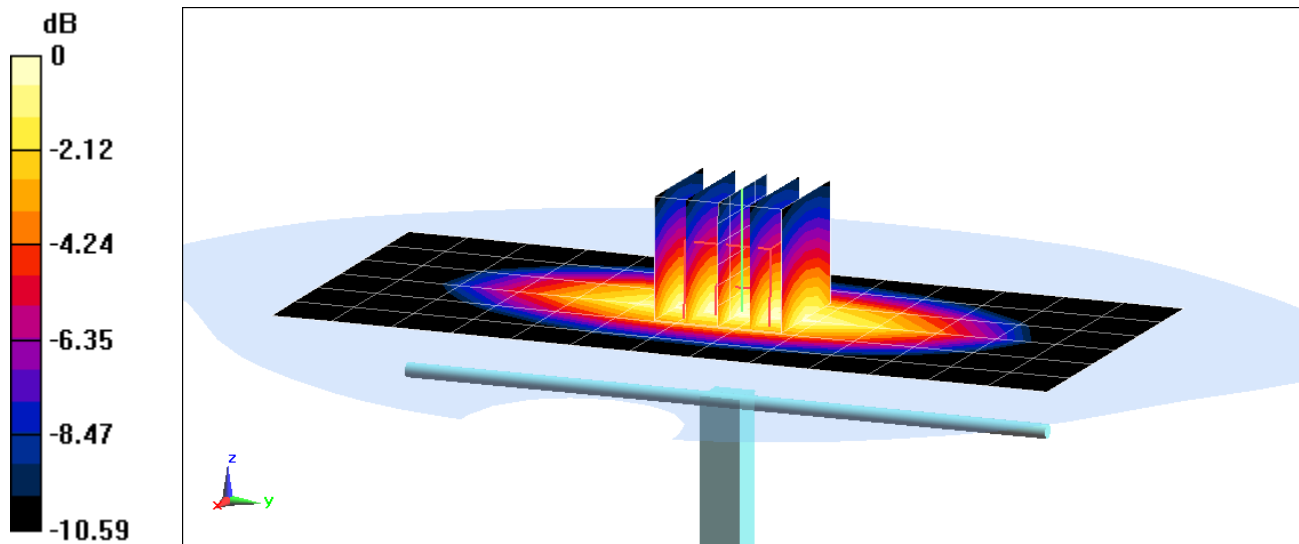

0 dB = 2.25 W/kg = 3.52 dBW/kg

PCTEST ENGINEERING LABORATORY, INC.

DUT: Dipole 1750 MHz; Type: D1765V2; Serial: 1008

Communication System: UID 0, CW; Frequency: 1750 MHz; Duty Cycle: 1:1

Medium: 1750 Head Medium parameters used:

$f = 1750 \text{ MHz}$; $\sigma = 1.388 \text{ S/m}$; $\epsilon_r = 40.558$; $\rho = 1000 \text{ kg/m}^3$

Phantom section: Flat Section Space: 1.0 cm

Test Date: 03-28-2017; Ambient Temp: 21.9°C; Tissue Temp: 20.8°C

Probe: ES3DV3 - SN3213; ConvF(5.49, 5.49, 5.49); Calibrated: 2/10/2017;

Sensor-Surface: 3mm (Mechanical Surface Detection)

Electronics: DAE4 Sn1272; Calibrated: 2/9/2017

Phantom: SAM Front; Type: QD000P40CD; Serial: TP:1758

Measurement SW: DASY52, Version 52.8 (8); SEMCAD X Version 14.6.10 (7331)

1750 MHz System Verification at 20.0 dBm (100 mW)

Area Scan (7x9x1): Measurement grid: dx=15mm, dy=15mm

Zoom Scan (5x5x7)/Cube 0: Measurement grid: dx=8mm, dy=8mm, dz=5mm

Peak SAR (extrapolated) = 6.55 W/kg

SAR(1 g) = 3.61 W/kg

Deviation(1 g) = -1.63%

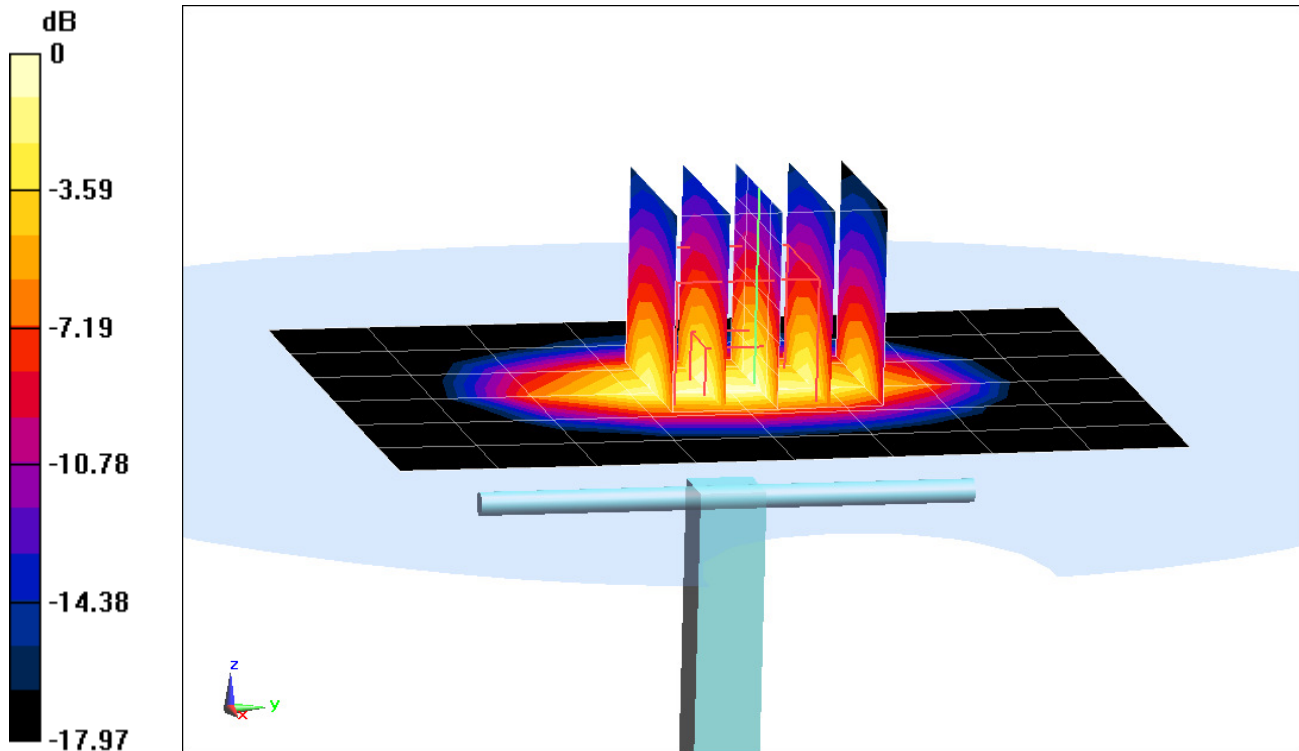

0 dB = 4.49 W/kg = 6.52 dBW/kg

PCTEST ENGINEERING LABORATORY, INC.

DUT: Dipole 1750 MHz; Type: D1750V2; Serial: 1148

Communication System: UID 0, CW; Frequency: 1750 MHz; Duty Cycle: 1:1

Medium: 1750 Head Medium parameters used:

$f = 1750 \text{ MHz}$; $\sigma = 1.383 \text{ S/m}$; $\epsilon_r = 40.151$; $\rho = 1000 \text{ kg/m}^3$

Phantom section: Flat Section; Space: 1.0 cm

Test Date: 04-04-2017; Ambient Temp: 23.3°C; Tissue Temp: 21.6°C

Probe: EX3DV4 - SN7409; ConvF(8.05, 8.05, 8.05); Calibrated: 5/17/2016;

Sensor-Surface: 1.4mm (Mechanical Surface Detection)

Electronics: DAE4 Sn859; Calibrated: 5/11/2016

Phantom: SAM Right; Type: QD000P40CD; Serial: TP:7535

Measurement SW: DASY52, Version 52.8 (8); SEMCAD X Version 14.6.10 (7331)

1750 MHz System Verification at 20.0 dBm (100 mW)

Area Scan (7x9x1): Measurement grid: dx=15mm, dy=15mm

Zoom Scan (5x5x7)/Cube 0: Measurement grid: dx=8mm, dy=8mm, dz=5mm

Peak SAR (extrapolated) = 6.79 W/kg

SAR(1 g) = 3.60 W/kg

Deviation(1 g) = -0.55%

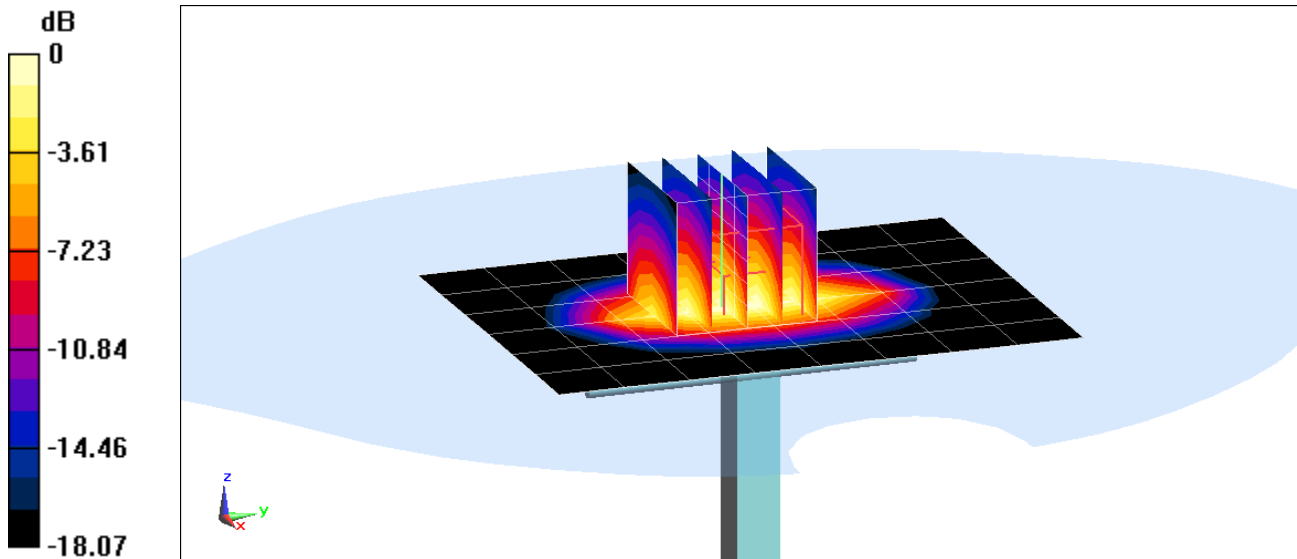

0 dB = 5.56 W/kg = 7.45 dBW/kg

PCTEST ENGINEERING LABORATORY, INC.

DUT: Dipole 1900 MHz; Type: D1900V2; Serial: 5d149

Communication System: UID 0, CW; Frequency: 1900 MHz; Duty Cycle: 1:1

Medium: 1900 Head Medium parameters used (interpolated):

$f = 1900$ MHz; $\sigma = 1.438$ S/m; $\epsilon_r = 39.803$; $\rho = 1000$ kg/m³

Phantom section: Flat Section; Space: 1.0 cm

Test Date: 03-30-2017; Ambient Temp: 22.9°C; Tissue Temp: 21.9°C

Probe: EX3DV4 - SN7409; ConvF(7.69, 7.69, 7.69); Calibrated: 5/17/2016;

Sensor-Surface: 1.4mm (Mechanical Surface Detection)

Electronics: DAE4 Sn859; Calibrated: 5/11/2016

Phantom: SAM Right; Type: QD000P40CD; Serial: TP:7535

Measurement SW: DASY52, Version 52.8 (8); SEMCAD X Version 14.6.10 (7331)

1900 MHz System Verification at 20.0 dBm (100 mW)

Area Scan (7x11x1): Measurement grid: dx=15mm, dy=15mm

Zoom Scan (5x5x7)/Cube 0: Measurement grid: dx=8mm, dy=8mm, dz=5mm

Peak SAR (extrapolated) = 7.15 W/kg

SAR(1 g) = 3.78 W/kg

Deviation(1 g) = -5.74%

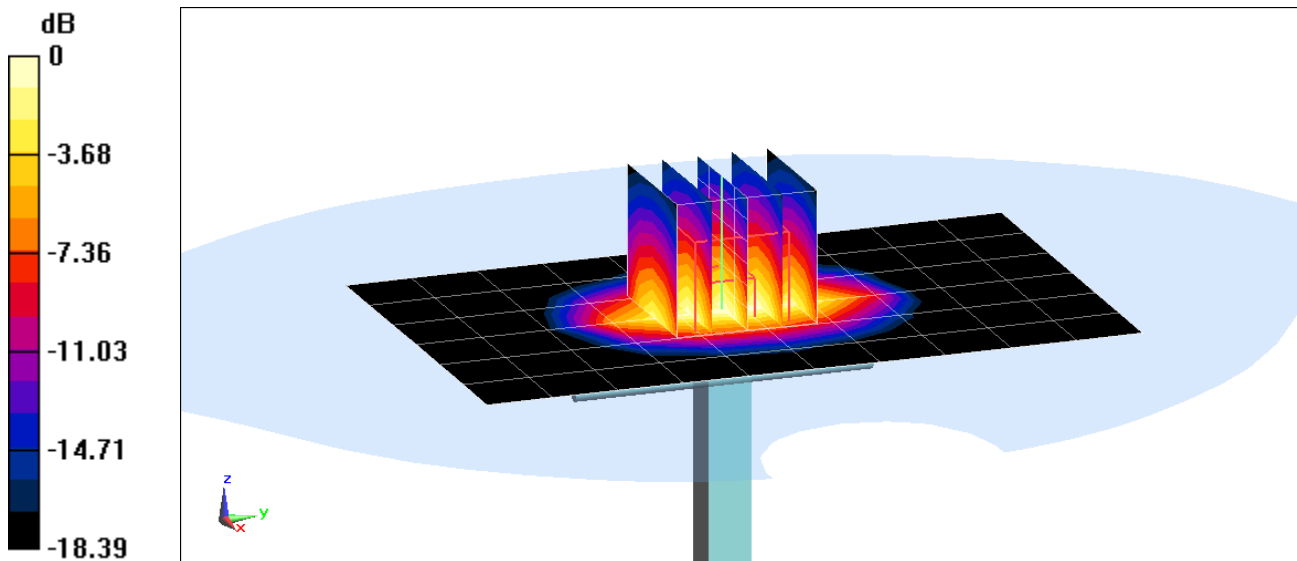

0 dB = 5.83 W/kg = 7.66 dBW/kg

PCTEST ENGINEERING LABORATORY, INC.

DUT: Dipole 1900 MHz; Type: D1900V2; Serial: 5d149

Communication System: UID 0, CW; Frequency: 1900 MHz; Duty Cycle: 1:1

Medium: 1900 Head Medium parameters used (interpolated):

$f = 1900 \text{ MHz}$; $\sigma = 1.44 \text{ S/m}$; $\epsilon_r = 40.198$; $\rho = 1000 \text{ kg/m}^3$

Phantom section: Flat Section; Space: 1.0 cm

Test Date: 04-06-2017; Ambient Temp: 22.4°C; Tissue Temp: 21.8°C

Probe: ES3DV3 - SN3288; ConvF(5.31, 5.31, 5.31); Calibrated: 1/13/2017;

Sensor-Surface: 3mm (Mechanical Surface Detection)

Electronics: DAE4 Sn1466; Calibrated: 1/16/2017

Phantom: SAM with CRP v5.0 Front; Type: QD000P40CD; Serial: 1646

Measurement SW: DASY52, Version 52.8 (8); SEMCAD X Version 14.6.10 (7331)

1900 MHz System Verification at 20.0 dBm (100 mW)

Area Scan (7x10x1): Measurement grid: dx=15mm, dy=15mm

Zoom Scan (5x5x7)/Cube 0: Measurement grid: dx=8mm, dy=8mm, dz=5mm

Peak SAR (extrapolated) = 7.35 W/kg

SAR(1 g) = 4.01 W/kg

Deviation(1 g) = 0.00%

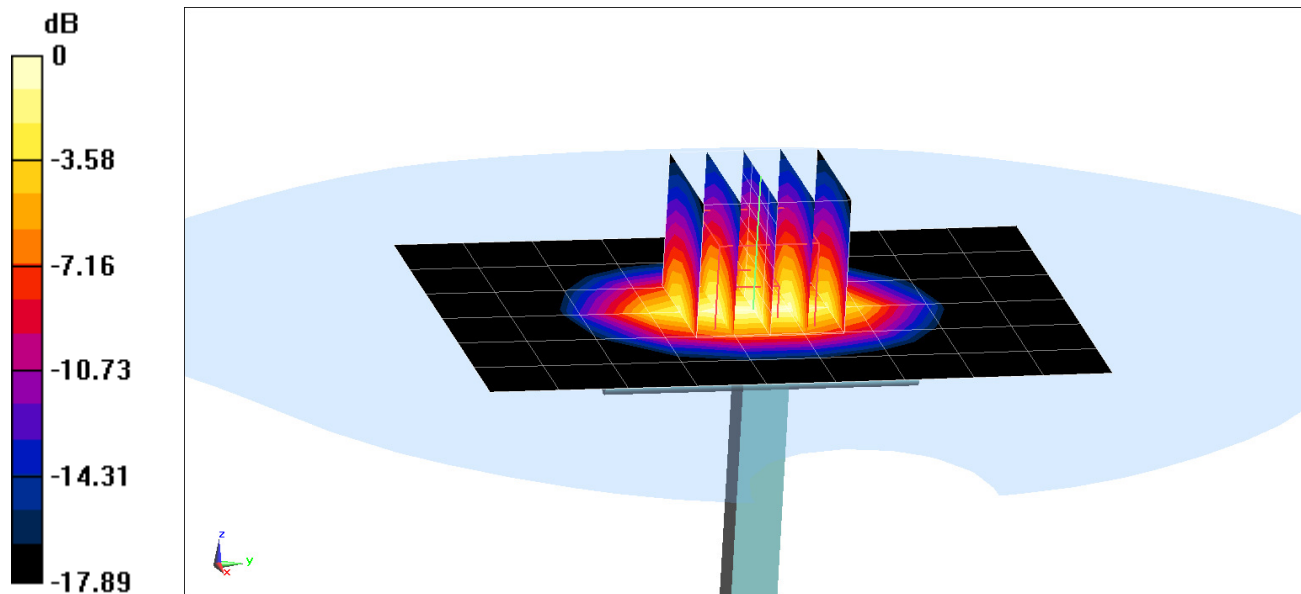

0 dB = 5.11 W/kg = 7.08 dBW/kg

PCTEST ENGINEERING LABORATORY, INC.

DUT: Dipole 2450 MHz; Type: D2450V2; Serial: 797

Communication System: UID 0, CW; Frequency: 2450 MHz; Duty Cycle: 1:1

Medium: 2450 Head Medium parameters used:

$f = 2450 \text{ MHz}$; $\sigma = 1.854 \text{ S/m}$; $\epsilon_r = 37.914$; $\rho = 1000 \text{ kg/m}^3$

Phantom section: Flat Section; Space: 1.0 cm

Test Date: 03-23-2017; Ambient Temp: 21.3°C; Tissue Temp: 22.9°C

Probe: ES3DV3 - SN3287; ConvF(4.54, 4.54, 4.54); Calibrated: 9/19/2016;

Sensor-Surface: 3mm (Mechanical Surface Detection)

Electronics: DAE4 Sn1408; Calibrated: 9/14/2016

Phantom: SAM Left; Type: QD000P40CA; Serial: TP:82355

Measurement SW: DASY52, Version 52.8 (8); SEMCAD X Version 14.6.10 (7331)

2450 MHz System Verification at 20.0 dBm (100 mW)

Area Scan (8x9x1): Measurement grid: dx=12mm, dy=12mm

Zoom Scan (7x7x7)/Cube 0: Measurement grid: dx=5mm, dy=5mm, dz=5mm

Peak SAR (extrapolated) = 11.5 W/kg

SAR(1 g) = 5.37 W/kg

Deviation(1 g) = 3.07%

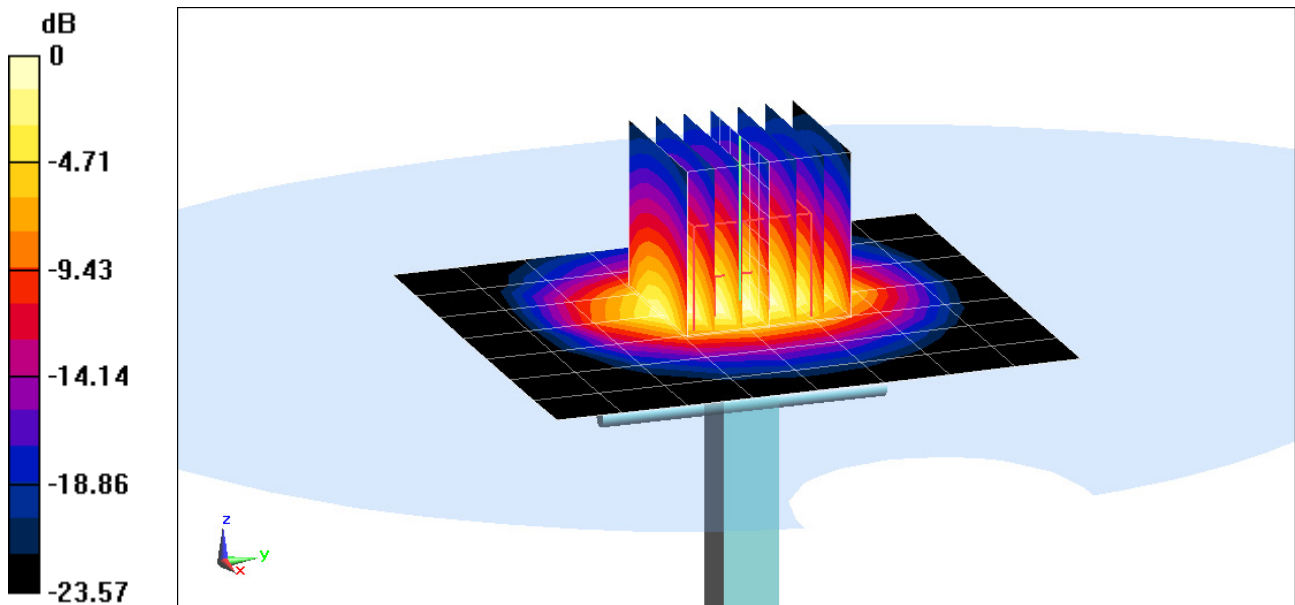

0 dB = 7.06 W/kg = 8.49 dBW/kg

PCTEST ENGINEERING LABORATORY, INC.

DUT: Dipole 2600 MHz; Type: D2600V2; Serial: 1126

Communication System: UID 0, CW; Frequency: 2600 MHz; Duty Cycle: 1:1

Medium: 2600 Head Medium parameters used:

$f = 2600 \text{ MHz}$; $\sigma = 1.989 \text{ S/m}$; $\epsilon_r = 37.521$; $\rho = 1000 \text{ kg/m}^3$

Phantom section: Flat Section; Space: 1.0 cm

Test Date: 04-03-2017; Ambient Temp: 23.0°C; Tissue Temp: 21.7°C

Probe: ES3DV3 - SN3287; ConvF(4.41, 4.41, 4.41); Calibrated: 9/19/2016;

Sensor-Surface: 3mm (Mechanical Surface Detection)

Electronics: DAE4 Sn1408; Calibrated: 9/14/2016

Phantom: SAM Left; Type: QD000P40CA; Serial: TP:82355

Measurement SW: DASY52, Version 52.8 (8); SEMCAD X Version 14.6.10 (7331)

2600 MHz System Verification at 20.0 dBm (100 mW)

Area Scan (8x9x1): Measurement grid: dx=12mm, dy=12mm

Zoom Scan (7x7x7)/Cube 0: Measurement grid: dx=5mm, dy=5mm, dz=5mm

Peak SAR (extrapolated) = 12.6 W/kg

SAR(1 g) = 5.68 W/kg

Deviation(1 g) = 0.89%

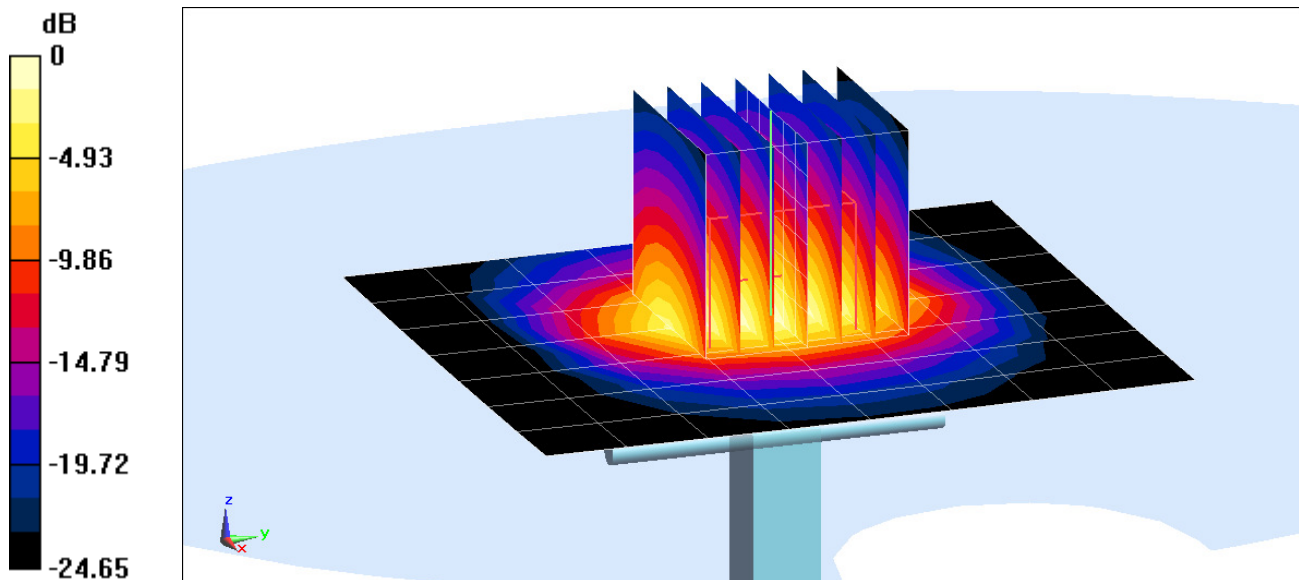

0 dB = 7.51 W/kg = 8.76 dBW/kg

PCTEST ENGINEERING LABORATORY, INC.

DUT: Dipole 5 GHz; Type: D5GHzV2; Serial: 1237

Communication System: UID 0, CW; Frequency: 5250 MHz; Duty Cycle: 1:1
Medium: 5GHz Head Medium parameters used (interpolated):
 $f = 5250 \text{ MHz}$; $\sigma = 4.647 \text{ S/m}$; $\epsilon_r = 35.493$; $\rho = 1000 \text{ kg/m}^3$
Phantom section: Flat Section; Space: 1.0 cm

Test Date: 03-27-2017; Ambient Temp: 22.7°C; Tissue Temp: 21.0°C

Probe: EX3DV4 - SN7308; ConvF(5.21, 5.21, 5.21); Calibrated: 7/21/2016;
Sensor-Surface: 1.4mm (Mechanical Surface Detection)
Electronics: DAE4 Sn859; Calibrated: 5/11/2016
Phantom: SAM Left; Type: QD000P40CC; Serial: TP: 1375
Measurement SW: DASY52, Version 52.8 (8); SEMCAD X Version 14.6.10 (7331)

5250 MHz System Verification at 17.0 dBm (50 mW)

Area Scan (7x7x1): Measurement grid: dx=10mm, dy=10mm

Zoom Scan (8x8x7)/Cube 0: Measurement grid: dx=4mm, dy=4mm, dz=1.4mm; Graded Ratio: 1.4

Peak SAR (extrapolated) = 16.9 W/kg

SAR(1 g) = 3.85 W/kg

Deviation(1 g) = -2.78%

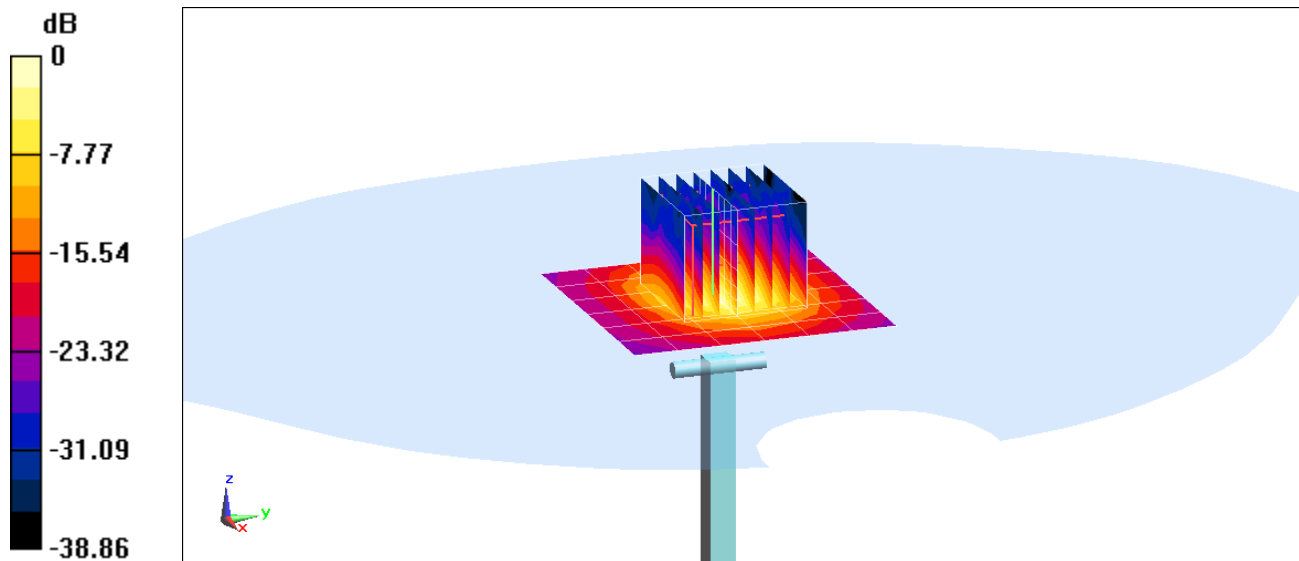

0 dB = 9.27 W/kg = 9.67 dBW/kg

PCTEST ENGINEERING LABORATORY, INC.

DUT: Dipole 5 GHz; Type: D5GHzV2; Serial: 1237

Communication System: UID 0, CW; Frequency: 5600 MHz; Duty Cycle: 1:1

Medium: 5GHz Head Medium parameters used:

$f = 5600$ MHz; $\sigma = 5.015$ S/m; $\epsilon_r = 34.923$; $\rho = 1000$ kg/m³

Phantom section: Flat Section; Space: 1.0 cm

Test Date: 03-27-2017; Ambient Temp: 22.7°C; Tissue Temp: 21.0°C

Probe: EX3DV4 - SN7308; ConvF(4.63, 4.63, 4.63); Calibrated: 7/21/2016;

Sensor-Surface: 1.4mm (Mechanical Surface Detection)

Electronics: DAE4 Sn859; Calibrated: 5/11/2016

Phantom: SAM Left; Type: QD000P40CC; Serial: TP: 1375

Measurement SW: DASY52, Version 52.8 (8); SEMCAD X Version 14.6.10 (7331)

5600 MHz System Verification at 17.0 dBm (50 mW)

Area Scan (7x7x1): Measurement grid: dx=10mm, dy=10mm

Zoom Scan (8x8x7)/Cube 0: Measurement grid: dx=4mm, dy=4mm, dz=1.4mm; Graded Ratio: 1.4

Peak SAR (extrapolated) = 18.1 W/kg

SAR(1 g) = 4.09 W/kg

Deviation(1 g) = -1.80%

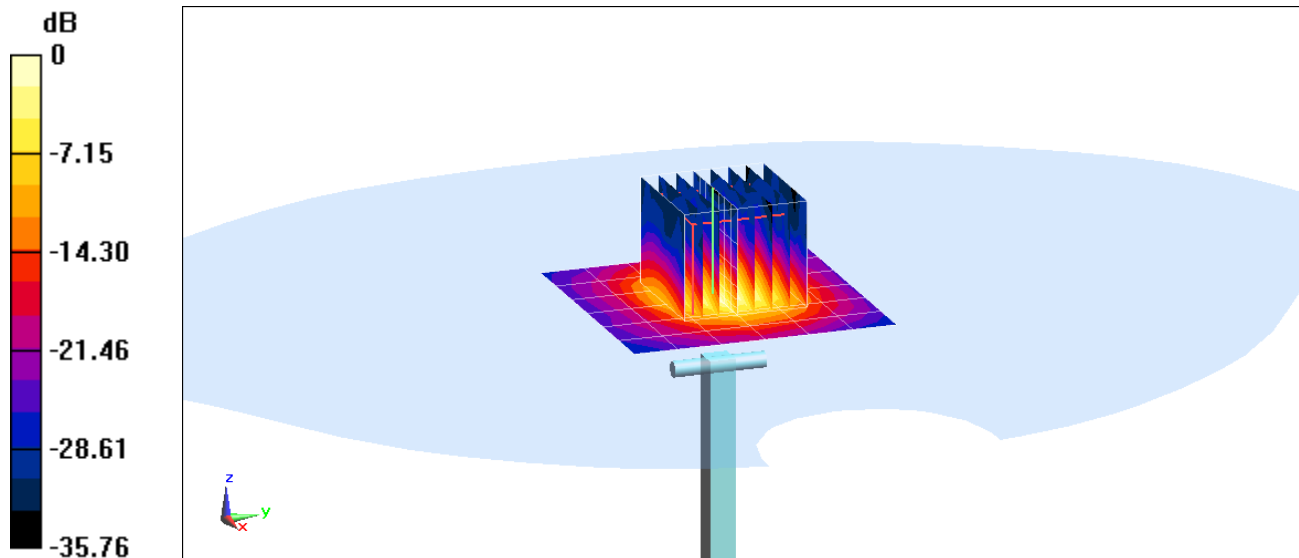

0 dB = 9.97 W/kg = 9.99 dBW/kg

PCTEST ENGINEERING LABORATORY, INC.

DUT: Dipole 5 GHz; Type: D5GHzV2; Serial: 1237

Communication System: UID 0, CW; Frequency: 5750 MHz; Duty Cycle: 1:1
Medium: 5GHz Head Medium parameters used (interpolated):
 $f = 5750 \text{ MHz}$; $\sigma = 5.157 \text{ S/m}$; $\epsilon_r = 34.763$; $\rho = 1000 \text{ kg/m}^3$
Phantom section: Flat Section; Space: 1.0 cm

Test Date: 03-27-2017; Ambient Temp: 22.7°C; Tissue Temp: 21.0°C

Probe: EX3DV4 - SN7308; ConvF(4.86, 4.86, 4.86); Calibrated: 7/21/2016;
Sensor-Surface: 1.4mm (Mechanical Surface Detection)
Electronics: DAE4 Sn859; Calibrated: 5/11/2016
Phantom: SAM Left; Type: QD000P40CC; Serial: TP: 1375
Measurement SW: DASY52, Version 52.8 (8); SEMCAD X Version 14.6.10 (7331)

5750 MHz System Verification at 17.0 dBm (50 mW)

Area Scan (7x7x1): Measurement grid: dx=10mm, dy=10mm

Zoom Scan (8x9x7)/Cube 0: Measurement grid: dx=4mm, dy=4mm, dz=1.4mm; Graded Ratio: 1.4

Peak SAR (extrapolated) = 17.0 W/kg

SAR(1 g) = 3.78 W/kg

Deviation(1 g) = -7.24%

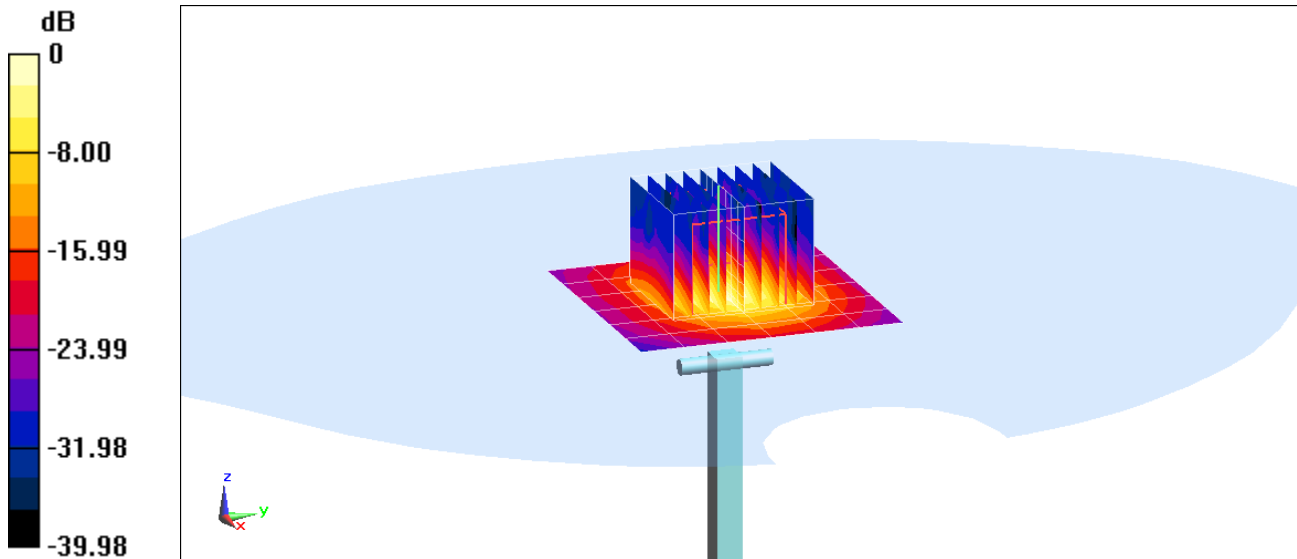

0 dB = 9.51 W/kg = 9.78 dBW/kg

PCTEST ENGINEERING LABORATORY, INC.

DUT: Dipole 750 MHz; Type: D750V3; Serial: 1054

Communication System: UID 0, CW; Frequency: 750 MHz; Duty Cycle: 1:1

Medium: 750 Body Medium parameters used (interpolated):

$f = 750 \text{ MHz}$; $\sigma = 0.962 \text{ S/m}$; $\epsilon_r = 53.888$; $\rho = 1000 \text{ kg/m}^3$

Phantom section: Flat Section; Space: 1.5 cm

Test Date: 04-10-2017; Ambient Temp: 23.2°C; Tissue Temp: 22.1°C

Probe: ES3DV3 - SN3334; ConvF(6.33, 6.33, 6.33); Calibrated: 11/15/2016;

Sensor-Surface: 3mm (Mechanical Surface Detection)

Electronics: DAE4 Sn1334; Calibrated: 11/11/2016

Phantom: SAM with CRP v4.0 Left; Type: QD000P40CD; Serial: TP:1692

Measurement SW: DASY52, Version 52.8 (8); SEMCAD X Version 14.6.10 (7331)

750 MHz System Verification at 23.0 dBm (200 mW)

Area Scan (7x15x1): Measurement grid: dx=15mm, dy=15mm

Zoom Scan (5x5x7)/Cube 0: Measurement grid: dx=8mm, dy=8mm, dz=5mm

Peak SAR (extrapolated) = 2.49 W/kg

SAR(1 g) = 1.69 W/kg

Deviation(1 g) = -1.86%

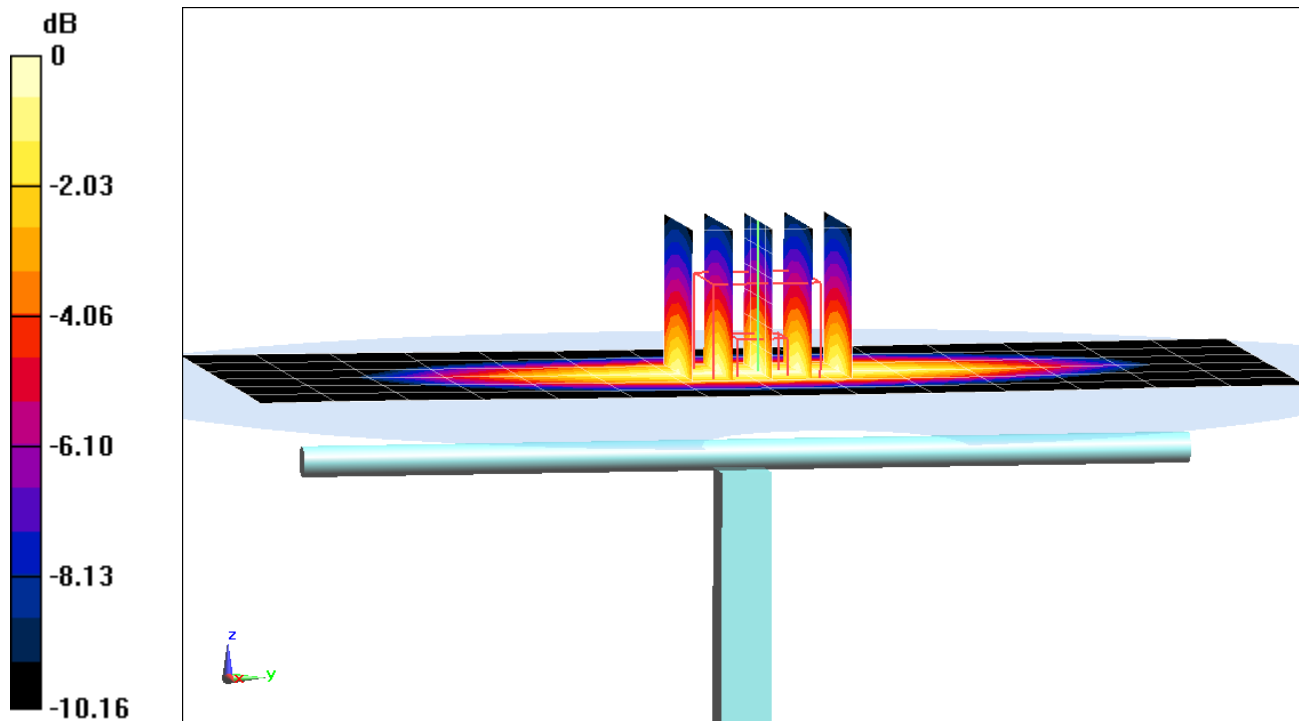

0 dB = 1.97 W/kg = 2.94 dBW/kg

PCTEST ENGINEERING LABORATORY, INC.

DUT: Dipole 835 MHz; Type: D835V2; Serial: 4d133

Communication System: UID 0, CW; Frequency: 835 MHz; Duty Cycle: 1:1

Medium: 835 Body Medium parameters used:

$f = 835 \text{ MHz}$; $\sigma = 0.994 \text{ S/m}$; $\epsilon_r = 55.071$; $\rho = 1000 \text{ kg/m}^3$

Phantom section: Flat Section; Space: 1.5 cm

Test Date: 04-03-2017; Ambient Temp: 21.6°C; Tissue Temp: 21.2°C

Probe: ES3DV3 - SN3318; ConvF(6.37, 6.37, 6.37); Calibrated: 2/10/2017;

Sensor-Surface: 3mm (Mechanical Surface Detection)

Electronics: DAE4 Sn665; Calibrated: 2/9/2017

Phantom: SAM with CRP (Left); Type: SAM; Serial: 1715

Measurement SW: DASY52, Version 52.8 (8); SEMCAD X Version 14.6.10 (7331)

835 MHz System Verification at 23.0 dBm (200 mW)

Area Scan (7x14x1): Measurement grid: dx=15mm, dy=15mm

Zoom Scan (5x5x7)/Cube 0: Measurement grid: dx=8mm, dy=8mm, dz=5mm

Peak SAR (extrapolated) = 2.96 W/kg

SAR(1 g) = 2.03 W/kg

Deviation(1 g) = 6.84%

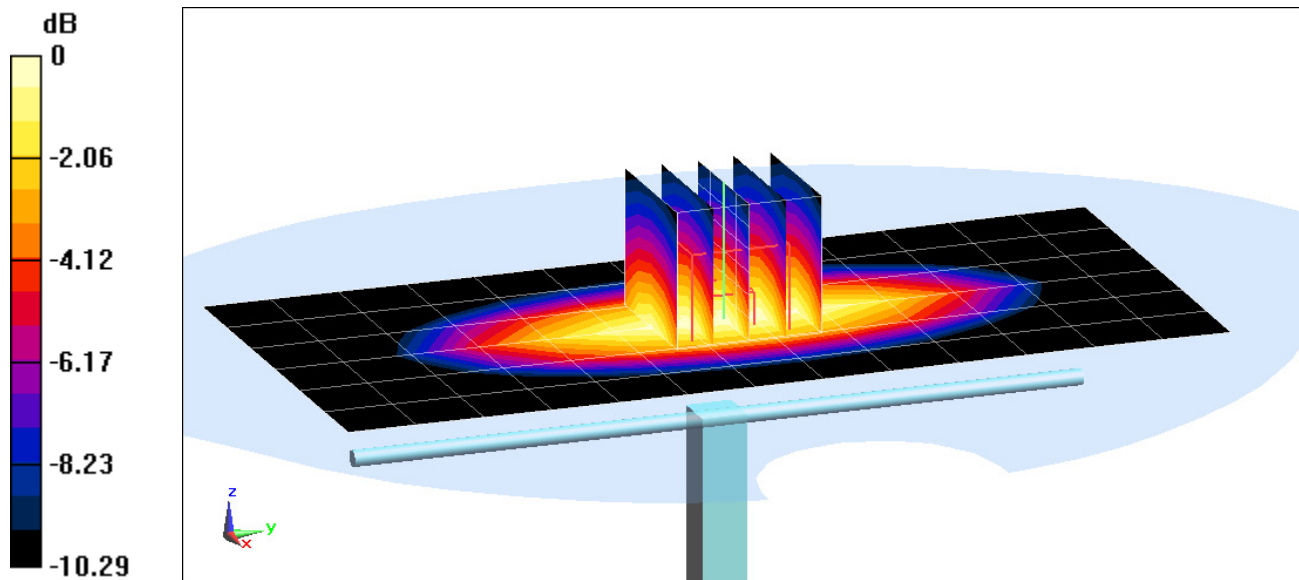

0 dB = 2.38 W/kg = 3.77 dBW/kg

PCTEST ENGINEERING LABORATORY, INC.

DUT: Dipole 1750 MHz; Type: D1765V2; Serial: 1008

Communication System: UID 0, CW; Frequency: 1750 MHz; Duty Cycle: 1:1

Medium: 1750 Body Medium parameters used:

$f = 1750$ MHz; $\sigma = 1.506$ S/m; $\epsilon_r = 51.004$; $\rho = 1000$ kg/m³

Phantom section: Flat Section; Space: 1.0 cm

Test Date: 03-30-2017; Ambient Temp: 22.5°C; Tissue Temp: 21.1°C

Probe: ES3DV3 - SN3213; ConvF(5.09, 5.09, 5.09); Calibrated: 2/10/2017;

Sensor-Surface: 3mm (Mechanical Surface Detection)

Electronics: DAE4 Sn1272; Calibrated: 2/9/2017

Phantom: SAM Right; Type: SAM; Serial: 1757

Measurement SW: DASY52, Version 52.8 (8); SEMCAD X Version 14.6.10 (7331)

1750 MHz System Verification at 20.0 dBm (100 mW)

Area Scan (7x9x1): Measurement grid: dx=15mm, dy=15mm

Zoom Scan (5x5x7)/Cube 0: Measurement grid: dx=8mm, dy=8mm, dz=5mm

Peak SAR (extrapolated) = 6.57 W/kg

SAR(1 g) = 3.71 W/kg

Deviation(1 g) = -0.54%

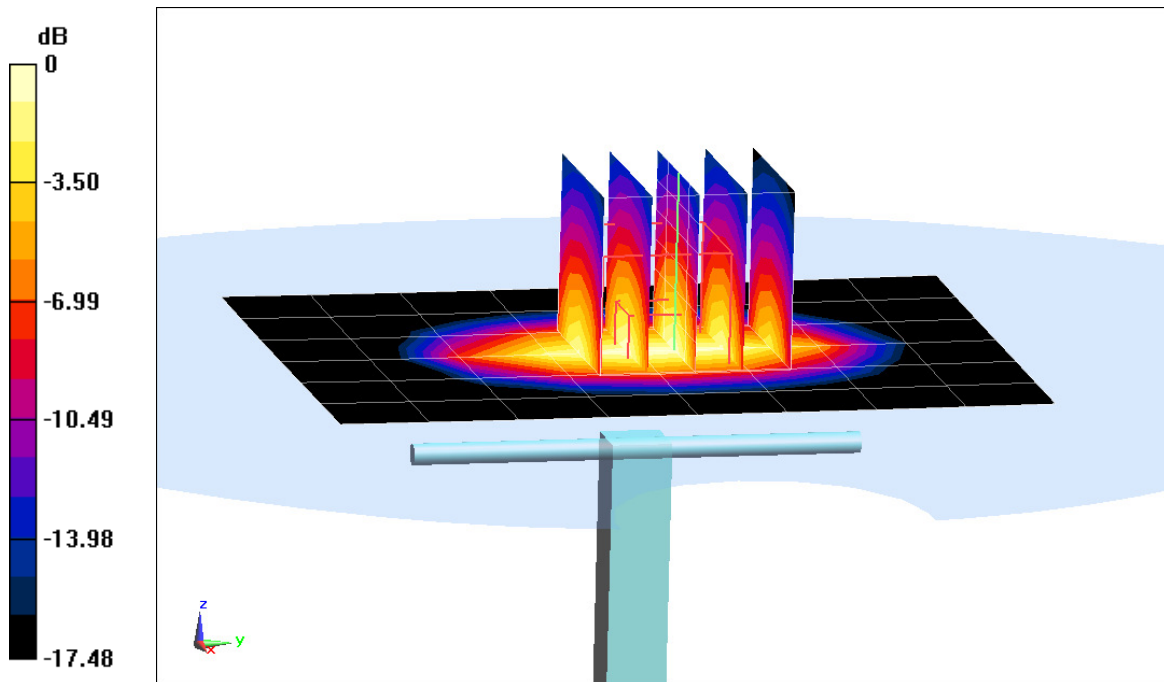

0 dB = 4.58 W/kg = 6.61 dBW/kg

PCTEST ENGINEERING LABORATORY, INC.

DUT: Dipole 1750 MHz; Type: D1750V2; Serial: 1148

Communication System: UID 0, CW; Frequency: 1750 MHz; Duty Cycle: 1:1

Medium: 1750 Body Medium parameters used:

$f = 1750 \text{ MHz}$; $\sigma = 1.492 \text{ S/m}$; $\epsilon_r = 52.133$; $\rho = 1000 \text{ kg/m}^3$

Phantom section: Flat Section; Space: 1.0 cm

Test Date: 04-17-2017; Ambient Temp: 19.2°C; Tissue Temp: 20.1°C

Probe: ES3DV3 - SN3213; ConvF(5.09, 5.09, 5.09); Calibrated: 2/10/2017;

Sensor-Surface: 3mm (Mechanical Surface Detection)

Electronics: DAE4 Sn1272; Calibrated: 2/9/2017

Phantom: SAM Front; Type: QD000P40CD; Serial: TP:1758

Measurement SW: DASY52, Version 52.8 (8); SEMCAD X Version 14.6.10 (7331)

1750 MHz System Verification at 20.0 dBm (100 mW)

Area Scan (7x9x1): Measurement grid: dx=15mm, dy=15mm

Zoom Scan (5x5x7)/Cube 0: Measurement grid: dx=8mm, dy=8mm, dz=5mm

Peak SAR (extrapolated) = 7.09 W/kg

SAR(1 g) = 3.94 W/kg

Deviation(1 g) = 6.20%

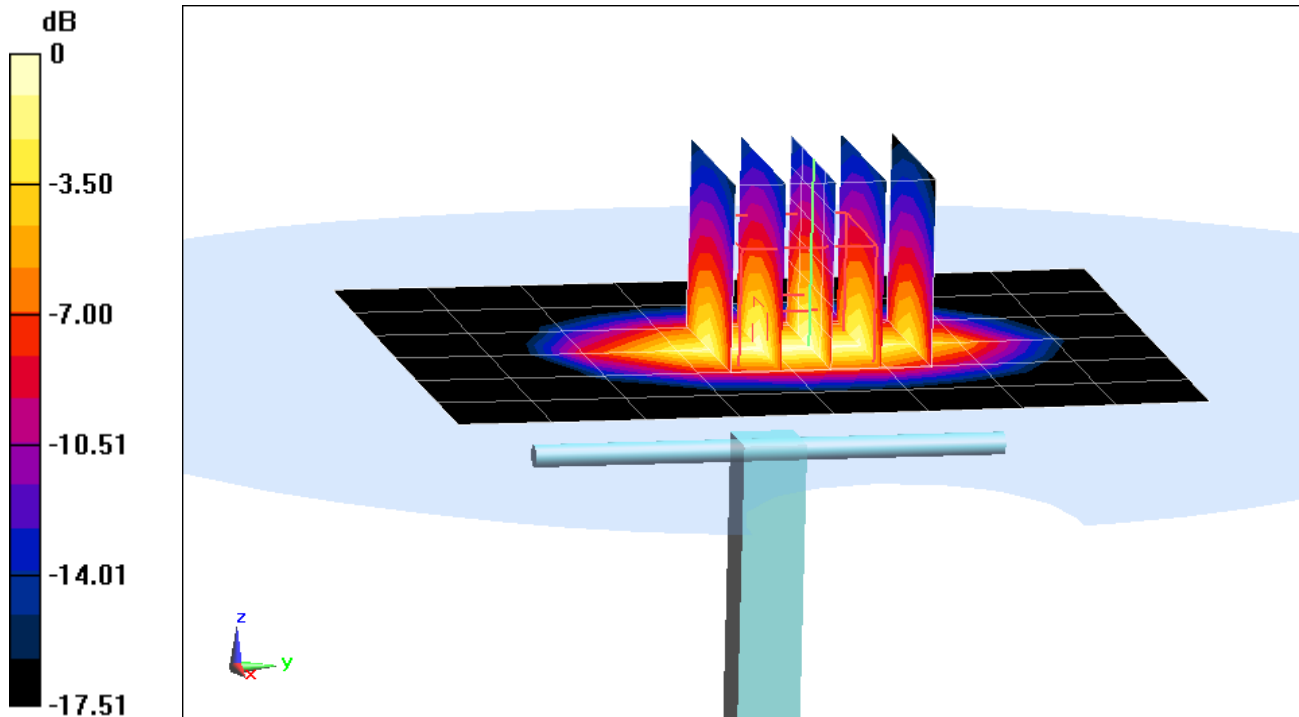

0 dB = 4.96 W/kg = 6.95 dBW/kg

PCTEST ENGINEERING LABORATORY, INC.

DUT: Dipole 1900 MHz; Type: D1900V2; Serial: 5d149

Communication System: UID 0, CW; Frequency: 1900 MHz; Duty Cycle: 1:1

Medium: 1900 Body Medium parameters used (interpolated):

$f = 1900$ MHz; $\sigma = 1.575$ S/m; $\epsilon_r = 52.208$; $\rho = 1000$ kg/m³

Phantom section: Flat Section; Space: 1.0 cm

Test Date: 04-03-2017; Ambient Temp: 24.1°C; Tissue Temp: 22.4°C

Probe: ES3DV3 - SN3287; ConvF(4.94, 4.94, 4.94); Calibrated: 9/19/2016;

Sensor-Surface: 3mm (Mechanical Surface Detection)

Electronics: DAE4 Sn1408; Calibrated: 9/14/2016

Phantom: SAM Front; Type: SAM; Serial: 1686

Measurement SW: DASY52, Version 52.8 (8); SEMCAD X Version 14.6.10 (7331)

1900 MHz System Verification at 20.0 dBm (100 mW)

Area Scan (7x10x1): Measurement grid: dx=15mm, dy=15mm

Zoom Scan (5x5x7)/Cube 0: Measurement grid: dx=8mm, dy=8mm, dz=5mm

Peak SAR (extrapolated) = 7.26 W/kg

SAR(1 g) = 4.06 W/kg

Deviation(1 g) = 1.75%

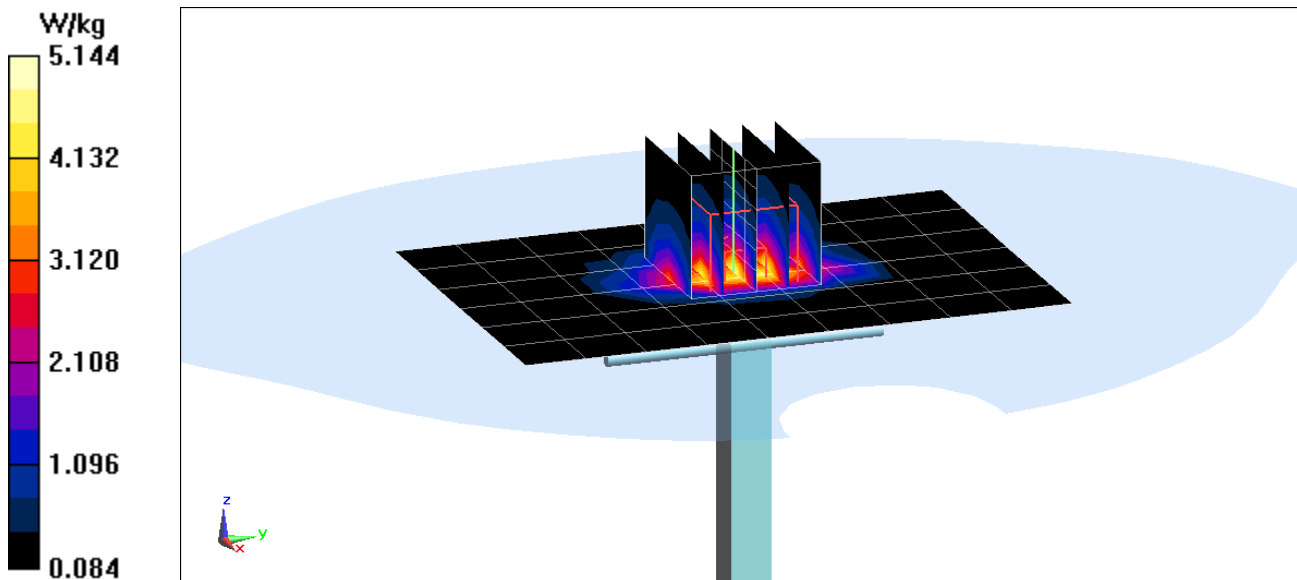

PCTEST ENGINEERING LABORATORY, INC.

DUT: Dipole 1900 MHz; Type: D1900V2; Serial: 5d080

Communication System: UID 0, CW; Frequency: 1900 MHz; Duty Cycle: 1:1

Medium: 1900 Body Medium parameters used (interpolated):

$f = 1900$ MHz; $\sigma = 1.561$ S/m; $\epsilon_r = 51.425$; $\rho = 1000$ kg/m³

Phantom section: Flat Section; Space: 1.0 cm

Test Date: 04-13-2017; Ambient Temp: 22.7°C; Tissue Temp: 22.1°C

Probe: EX3DV4 - SN7409; ConvF(7.47, 7.47, 7.47); Calibrated: 5/17/2016;

Sensor-Surface: 1.4mm (Mechanical Surface Detection)

Electronics: DAE4 Sn859; Calibrated: 5/11/2016

Phantom: SAM Left; Type: QD000P40CC; Serial: TP: 1375

Measurement SW: DASY52, Version 52.8 (8); SEMCAD X Version 14.6.10 (7331)

1900 MHz System Verification at 20.0 dBm (100 mW)

Area Scan (7x11x1): Measurement grid: dx=15mm, dy=15mm

Zoom Scan (5x5x7)/Cube 0: Measurement grid: dx=8mm, dy=8mm, dz=5mm

Peak SAR (extrapolated) = 7.72 W/kg

SAR(1 g) = 3.98 W/kg

Deviation(1 g) = 1.79%

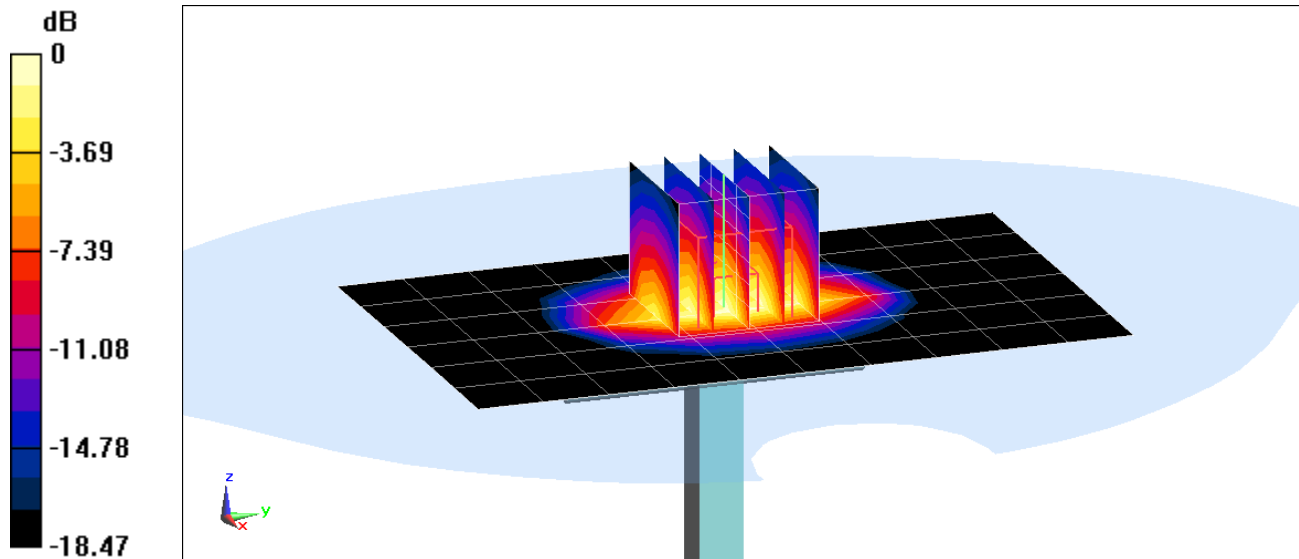

0 dB = 6.39 W/kg = 8.06 dBW/kg

PCTEST ENGINEERING LABORATORY, INC.

DUT: Dipole 2450 MHz; Type: D2450V2; Serial: 981

Communication System: UID 0, CW; Frequency: 2450 MHz; Duty Cycle: 1:1

Medium: 2450 Body Medium parameters used:

$f = 2450$ MHz; $\sigma = 2.011$ S/m; $\epsilon_r = 50.977$; $\rho = 1000$ kg/m³

Phantom section: Flat Section; Space: 1.0 cm

Test Date: 03-29-2017; Ambient Temp: 23.5°C; Tissue Temp: 22.1°C

Probe: EX3DV4 - SN7406; ConvF(7.24, 7.24, 7.24); Calibrated: 04/19/2016;

Sensor-Surface: 1.4mm (Mechanical Surface Detection)

Electronics: DAE4 Sn1407; Calibrated: 04/14/2016

Phantom: SAM 5.0 front; Type: QD000P40CD; Serial: TP:-1648

Measurement SW: DASY52, Version 52.8 (8); SEMCAD X Version 14.6.10 (7331)

2450 MHz System Verification at 20.0 dBm (100 mW)

Area Scan (8x9x1): Measurement grid: dx=12mm, dy=12mm

Zoom Scan (7x7x7)/Cube 0: Measurement grid: dx=5mm, dy=5mm, dz=5mm

Peak SAR (extrapolated) = 9.77 W/kg

SAR(1 g) = 4.77 W/kg

Deviation(1 g) = -6.10%

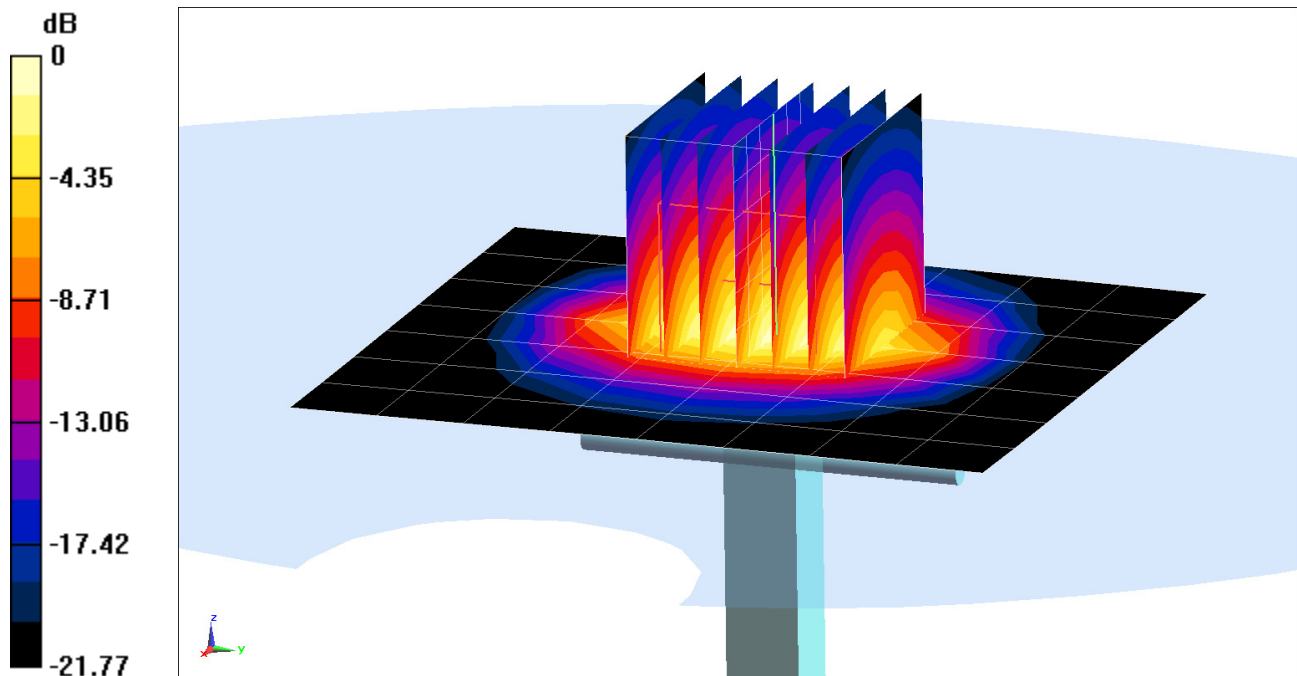

0 dB = 7.95 W/kg = 9.00 dBW/kg

PCTEST ENGINEERING LABORATORY, INC.

DUT: Dipole 2450 MHz; Type: D2450V2; Serial: 797

Communication System: UID 0, CW; Frequency: 2450 MHz; Duty Cycle: 1:1

Medium: 2450 Body Medium parameters used:

$f = 2450 \text{ MHz}$; $\sigma = 2.041 \text{ S/m}$; $\epsilon_r = 52.51$; $\rho = 1000 \text{ kg/m}^3$

Phantom section: Flat Section; Space: 1.0 cm

Test Date: 04-18-2017; Ambient Temp: 21.9°C; Tissue Temp: 21.8°C

Probe: ES3DV3 - SN3287; ConvF(4.35, 4.35, 4.35); Calibrated: 9/19/2016;

Sensor-Surface: 3mm (Mechanical Surface Detection)

Electronics: DAE4 Sn1408; Calibrated: 9/14/2016

Phantom: SAM Front; Type: SAM; Serial: 1686

Measurement SW: DASY52, Version 52.8 (8); SEMCAD X Version 14.6.10 (7331)

2450 MHz System Verification at 20.0 dBm (100 mW)

Area Scan (8x9x1): Measurement grid: dx=12mm, dy=12mm

Zoom Scan (7x7x7)/Cube 0: Measurement grid: dx=5mm, dy=5mm, dz=5mm

Peak SAR (extrapolated) = 11.5 W/kg

SAR(1 g) = 5.33 W/kg

Deviation(1 g) = 5.13%

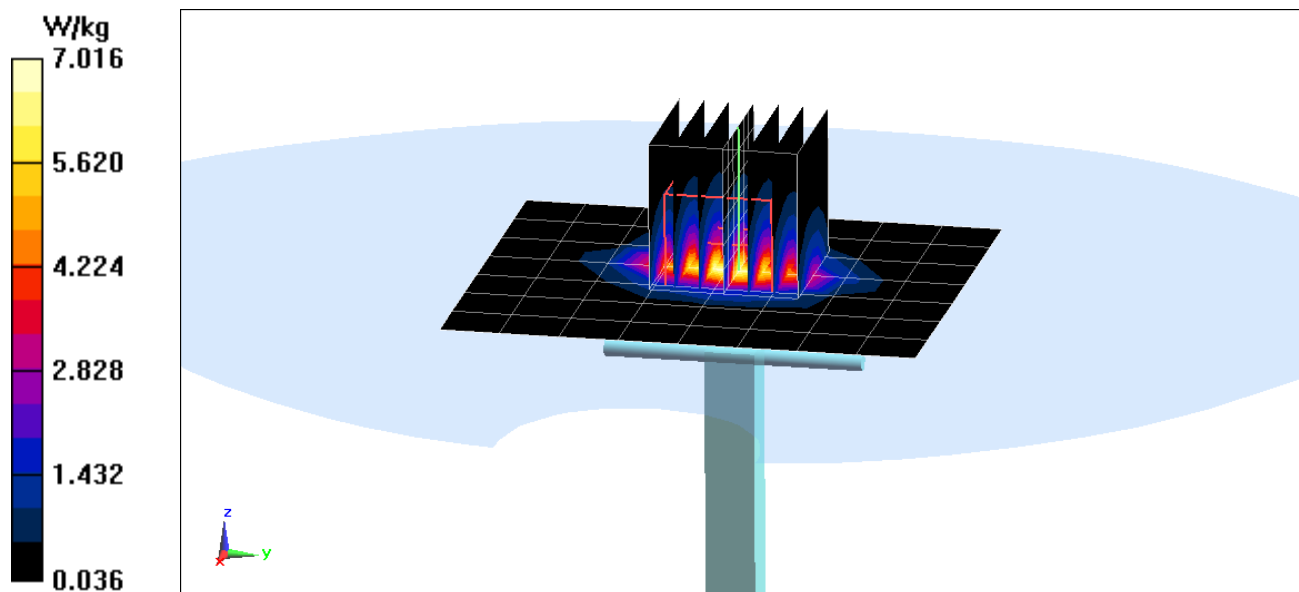

PCTEST ENGINEERING LABORATORY, INC.

DUT: Dipole 2600 MHz; Type: D2600V2; Serial: 1071

Communication System: UID 0, CW; Frequency: 2600 MHz; Duty Cycle: 1:1

Medium: 2600 Body Medium parameters used:

$f = 2600$ MHz; $\sigma = 2.22$ S/m; $\epsilon_r = 50.23$; $\rho = 1000$ kg/m³

Phantom section: Flat Section; Space: 1.0 cm

Test Date: 04-10-2017; Ambient Temp: 21.9°C; Tissue Temp: 21.9°C

Probe: ES3DV3 - SN3319; ConvF(4.18, 4.18, 4.18); Calibrated: 03/14/2017;

Sensor-Surface: 3mm (Mechanical Surface Detection)

Electronics: DAE4 Sn1368; Calibrated: 03/08/2017

Phantom: SAM 5.0 front; Type: QD000P40CD; Serial: TP:-1648

Measurement SW: DASY52, Version 52.8 (8); SEMCAD X Version 14.6.10 (7331)

2600 MHz System Verification at 20.0 dBm (100 mW)

Area Scan (8x9x1): Measurement grid: dx=12mm, dy=12mm

Zoom Scan (7x7x7)/Cube 0: Measurement grid: dx=5mm, dy=5mm, dz=5mm

Peak SAR (extrapolated) = 12.1 W/kg

SAR(1 g) = 5.46 W/kg

Deviation(1 g) = 0.74%

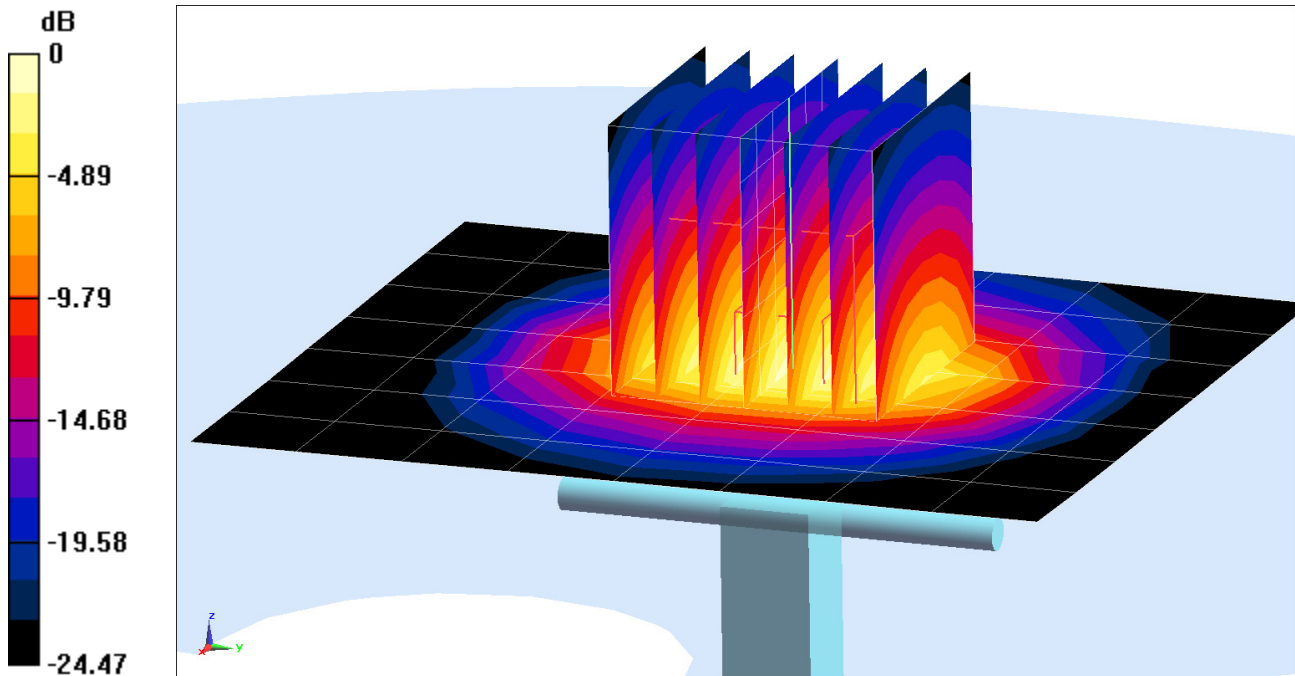

0 dB = 7.33 W/kg = 8.65 dBW/kg

PCTEST ENGINEERING LABORATORY, INC.

DUT: Dipole 2600 MHz; Type: D2600V2; Serial: 1126

Communication System: UID 0, CW; Frequency: 2600 MHz; Duty Cycle: 1:1

Medium: 2600 Body Medium parameters used:

$f = 2600 \text{ MHz}$; $\sigma = 2.249 \text{ S/m}$; $\epsilon_r = 51.883$; $\rho = 1000 \text{ kg/m}^3$

Phantom section: Flat Section; Space: 1.0 cm

Test Date: 04-18-2017; Ambient Temp: 21.9°C; Tissue Temp: 21.8°C

Probe: ES3DV3 - SN3287; ConvF(4.12, 4.12, 4.12); Calibrated: 9/19/2016;

Sensor-Surface: 3mm (Mechanical Surface Detection)

Electronics: DAE4 Sn1408; Calibrated: 9/14/2016

Phantom: SAM Front; Type: SAM; Serial: 1686

Measurement SW: DASY52, Version 52.8 (8); SEMCAD X Version 14.6.10 (7331)

2600 MHz System Verification at 20.0 dBm (100 mW)

Area Scan (8x9x1): Measurement grid: dx=12mm, dy=12mm

Zoom Scan (7x7x7)/Cube 0: Measurement grid: dx=5mm, dy=5mm, dz=5mm

Peak SAR (extrapolated) = 12.5 W/kg

SAR(1 g) = 5.49 W/kg

Deviation(1 g) = 0.73%

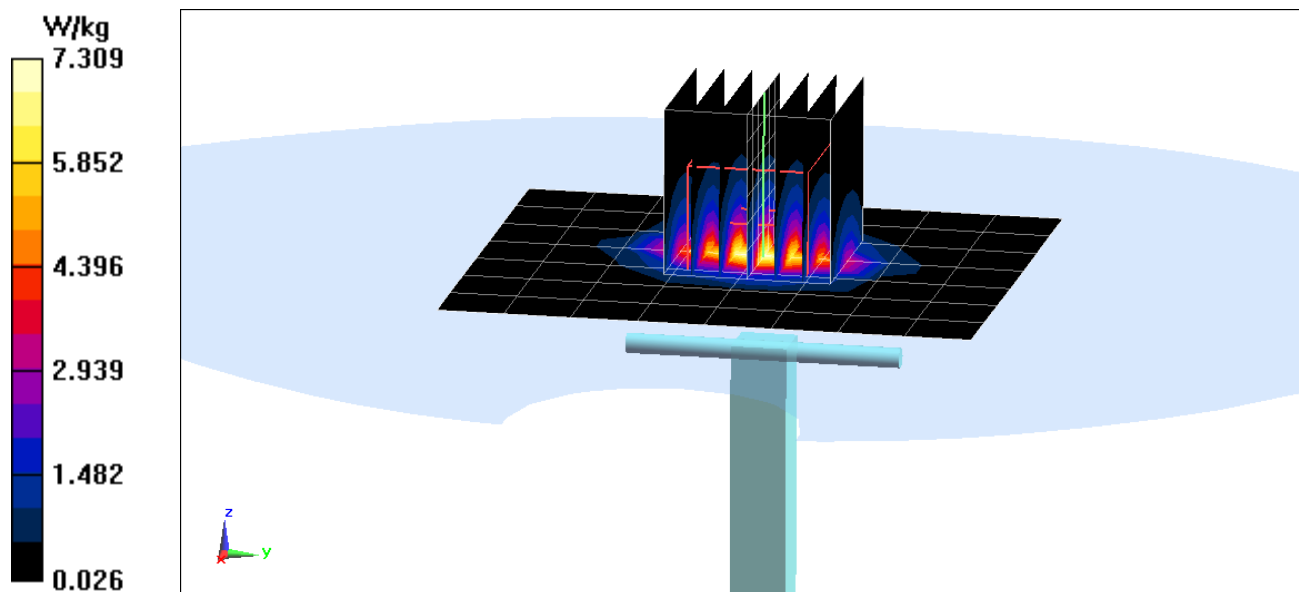

PCTEST ENGINEERING LABORATORY, INC.

DUT: Dipole 5 GHz; Type: D5GHzV2; Serial: 1237

Communication System: UID 0, CW; Frequency: 5250 MHz; Duty Cycle: 1:1

Medium: 5GHz Body Medium parameters used (interpolated):

$f = 5250 \text{ MHz}$; $\sigma = 5.524 \text{ S/m}$; $\epsilon_r = 47.038$; $\rho = 1000 \text{ kg/m}^3$

Phantom section: Flat Section; Space: 1.0 cm

Test Date: 03-20-2017; Ambient Temp: 23.1°C; Tissue Temp: 21.0°C

Probe: EX3DV4 - SN7308; ConvF(4.45, 4.45, 4.45); Calibrated: 7/21/2016;

Sensor-Surface: 1.4mm (Mechanical Surface Detection)

Electronics: DAE4 Sn859; Calibrated: 5/11/2016

Phantom: SAM Left; Type: QD000P40CC; Serial: TP: 1375

Measurement SW: DASY52, Version 52.8 (8); SEMCAD X Version 14.6.10 (7331)

5250 MHz System Verification at 17.0 dBm (50 mW)

Area Scan (7x7x1): Measurement grid: dx=10mm, dy=10mm

Zoom Scan (8x8x7)/Cube 0: Measurement grid: dx=4mm, dy=4mm, dz=1.4mm; Graded Ratio: 1.4

Peak SAR (extrapolated) = 15.1 W/kg

SAR(1 g) = 3.68 W/kg

Deviation(1 g) = -1.60%

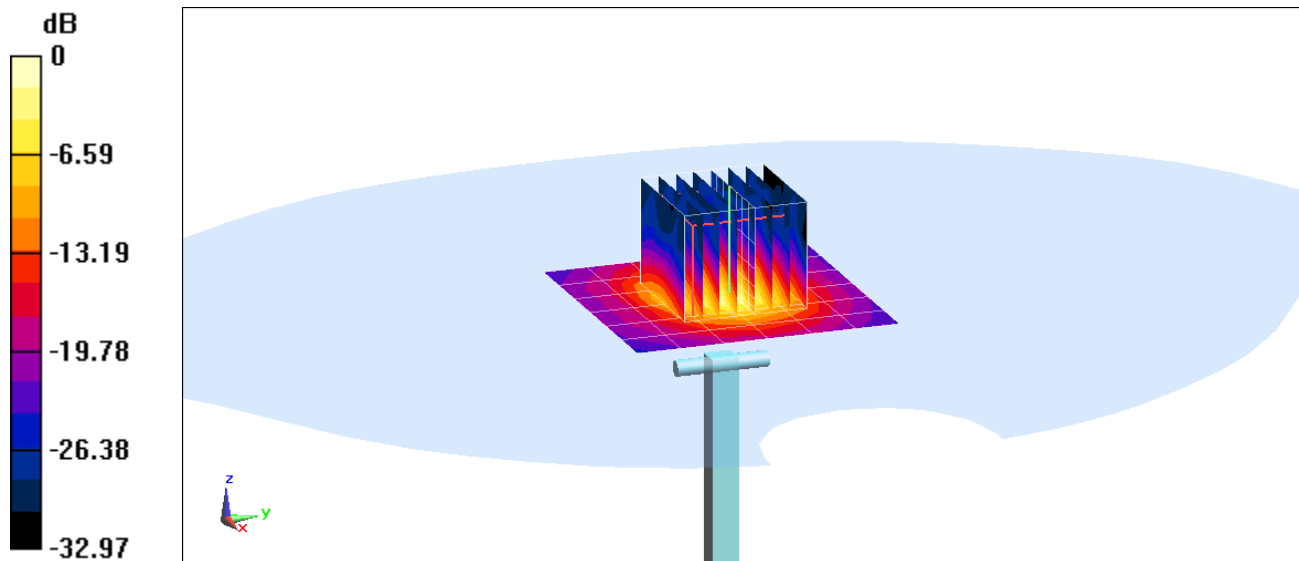

0 dB = 8.99 W/kg = 9.54 dBW/kg

PCTEST ENGINEERING LABORATORY, INC.

DUT: Dipole 5 GHz; Type: D5GHzV2; Serial: 1237

Communication System: UID 0, CW; Frequency: 5600 MHz; Duty Cycle: 1:1

Medium: 5GHz Body Medium parameters used:

$f = 5600 \text{ MHz}$; $\sigma = 6.009 \text{ S/m}$; $\epsilon_r = 46.52$; $\rho = 1000 \text{ kg/m}^3$

Phantom section: Flat Section; Space: 1.0 cm

Test Date: 03-20-2017; Ambient Temp: 23.1°C; Tissue Temp: 21.0°C

Probe: EX3DV4 - SN7308; ConvF(3.75, 3.75, 3.75); Calibrated: 7/21/2016;

Sensor-Surface: 1.4mm (Mechanical Surface Detection)

Electronics: DAE4 Sn859; Calibrated: 5/11/2016

Phantom: SAM Left; Type: QD000P40CC; Serial: TP: 1375

Measurement SW: DASY52, Version 52.8 (8); SEMCAD X Version 14.6.10 (7331)

5600 MHz System Verification at 17.0 dBm (50 mW)

Area Scan (7x7x1): Measurement grid: dx=10mm, dy=10mm

Zoom Scan (8x8x7)/Cube 0: Measurement grid: dx=4mm, dy=4mm, dz=1.4mm; Graded Ratio: 1.4

Peak SAR (extrapolated) = 16.8 W/kg

SAR(1 g) = 4.06 W/kg

Deviation(1 g) = 5.45%

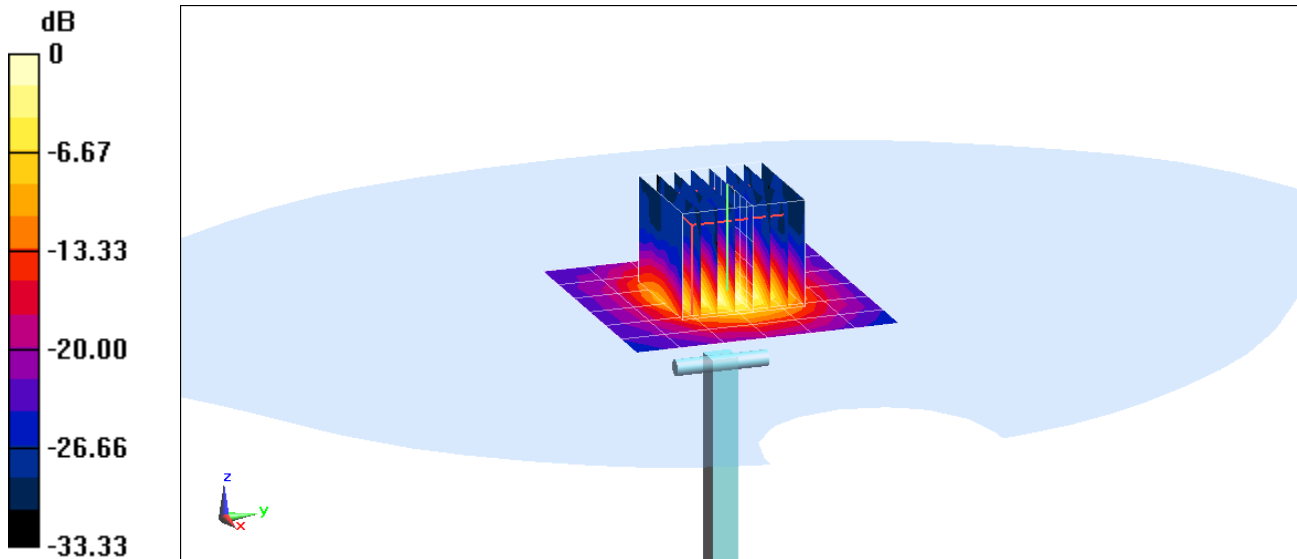

0 dB = 9.61 W/kg = 9.83 dBW/kg

PCTEST ENGINEERING LABORATORY, INC.

DUT: Dipole 5 GHz; Type: D5GHzV2; Serial: 1237

Communication System: UID 0, CW; Frequency: 5750 MHz; Duty Cycle: 1:1

Medium: 5GHz Body Medium parameters used (interpolated):

$f = 5750 \text{ MHz}$; $\sigma = 6.203 \text{ S/m}$; $\epsilon_r = 46.288$; $\rho = 1000 \text{ kg/m}^3$

Phantom section: Flat Section; Space: 1.0 cm

Test Date: 03-20-2017; Ambient Temp: 23.1°C; Tissue Temp: 21.0°C

Probe: EX3DV4 - SN7308; ConvF(4.04, 4.04, 4.04); Calibrated: 7/21/2016;

Sensor-Surface: 1.4mm (Mechanical Surface Detection)

Electronics: DAE4 Sn859; Calibrated: 5/11/2016

Phantom: SAM Left; Type: QD000P40CC; Serial: TP: 1375

Measurement SW: DASY52, Version 52.8 (8); SEMCAD X Version 14.6.10 (7331)

5750 MHz System Verification at 17.0 dBm (50 mW)

Area Scan (7x7x1): Measurement grid: dx=10mm, dy=10mm

Zoom Scan (8x8x7)/Cube 0: Measurement grid: dx=4mm, dy=4mm, dz=1.4mm; Graded Ratio: 1.4

Peak SAR (extrapolated) = 15.3 W/kg

SAR(1 g) = 3.53 W/kg

Deviation(1 g) = -6.37%

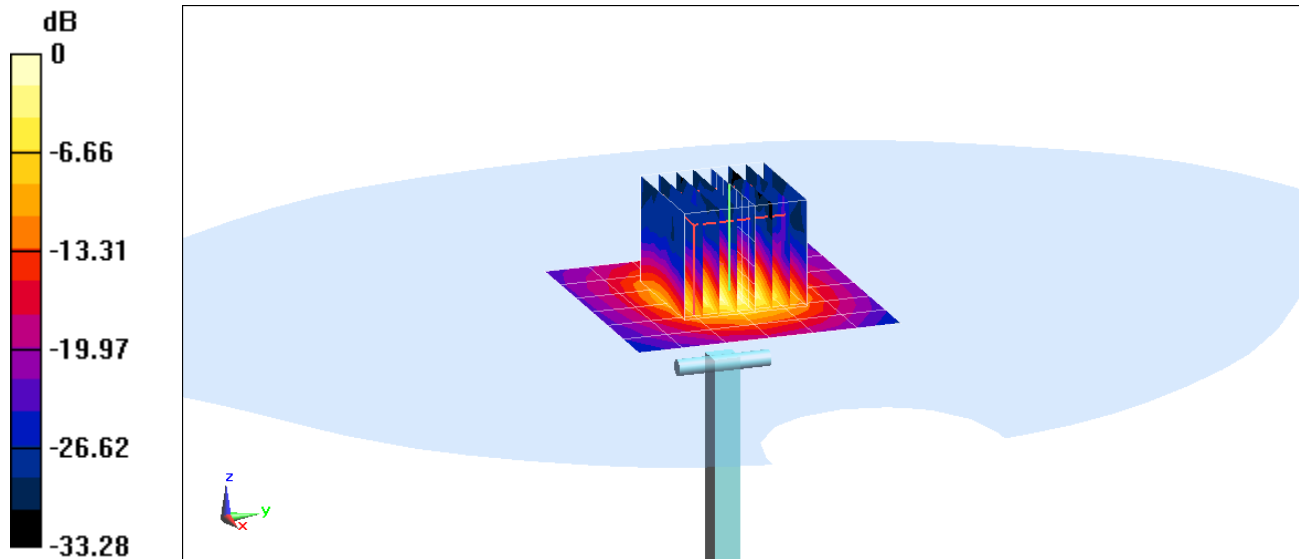

0 dB = 8.68 W/kg = 9.39 dBW/kg

PCTEST ENGINEERING LABORATORY, INC.

DUT: Dipole 5 GHz; Type: D5GHzV2; Serial: 1237

Communication System: UID 0, CW; Frequency: 5750 MHz; Duty Cycle: 1:1
Medium: 5 GHz Body Medium parameters used (interpolated):
 $f = 5750 \text{ MHz}$; $\sigma = 6.149 \text{ S/m}$; $\epsilon_r = 46.553$; $\rho = 1000 \text{ kg/m}^3$
Phantom section: Flat Section; Space: 1.0 cm

Test Date: 03-28-2017; Ambient Temp: 23.5°C; Tissue Temp: 22.3°C

Probe: EX3DV4 - SN3589; ConvF(3.83, 3.83, 3.83); Calibrated: 1/13/2017;
Sensor-Surface: 1.4mm (Mechanical Surface Detection)
Electronics: DAE4 Sn1466; Calibrated: 1/16/2017
Phantom: SAM with CRP v5.0 Front; Type: QD000P40CD; Serial: 1646
Measurement SW: DASY52, Version 52.8 (8); SEMCAD X Version 14.6.10 (7331)

5750 MHz System Verification at 17.0 dBm (50 mW)

Area Scan (7x7x1): Measurement grid: dx=10mm, dy=10mm

Zoom Scan (8x8x7)/Cube 0: Measurement grid: dx=4mm, dy=4mm, dz=1.4mm; Graded Ratio: 1.4

Peak SAR (extrapolated) = 16.5 W/kg

SAR(1 g) = 3.55 W/kg

Deviation(1 g) = -5.84%

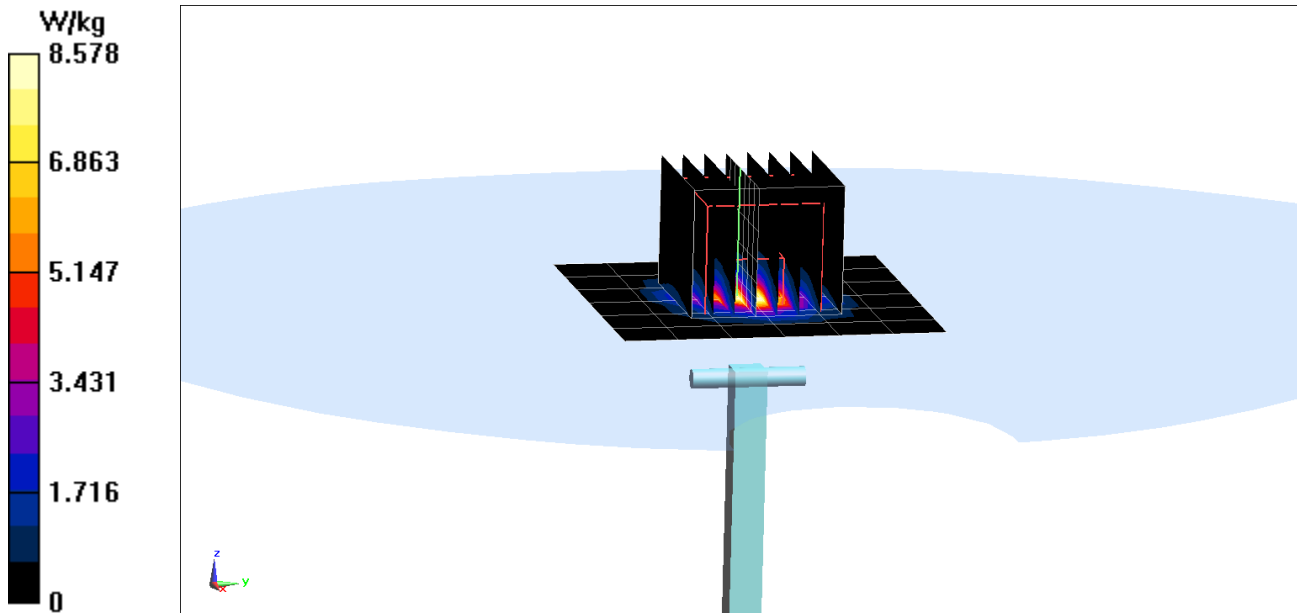

APPENDIX C: PROBE CALIBRATION



Accredited by the Swiss Accreditation Service (SAS)
The Swiss Accreditation Service is one of the signatories to the EA
Multilateral Agreement for the recognition of calibration certificates

Accreditation No.: **SCS 0108**

Client **PC Test**

Certificate No: **D750V3-1054_Mar17**

CALIBRATION CERTIFICATE

Object **D750V3 - SN:1054**

Calibration procedure(s) **QA CAL-05.v9**
Calibration procedure for dipole validation kits above 700 MHz

BNV
03-27-2017

Calibration date: **March 07, 2017**

This calibration certificate documents the traceability to national standards, which realize the physical units of measurements (SI).
The measurements and the uncertainties with confidence probability are given on the following pages and are part of the certificate.

All calibrations have been conducted in the closed laboratory facility: environment temperature (22 ± 3)°C and humidity < 70%.

Calibration Equipment used (M&TE critical for calibration)

Primary Standards	ID #	Cal Date (Certificate No.)	Scheduled Calibration
Power meter NRP	SN: 104778	06-Apr-16 (No. 217-02288/02289)	Apr-17
Power sensor NRP-Z91	SN: 103244	06-Apr-16 (No. 217-02288)	Apr-17
Power sensor NRP-Z91	SN: 103245	06-Apr-16 (No. 217-02289)	Apr-17
Reference 20 dB Attenuator	SN: 5058 (20k)	05-Apr-16 (No. 217-02292)	Apr-17
Type-N mismatch combination	SN: 5047.2 / 06327	05-Apr-16 (No. 217-02295)	Apr-17
Reference Probe EX3DV4	SN: 7349	31-Dec-16 (No. EX3-7349_Dec16)	Dec-17
DAE4	SN: 601	04-Jan-17 (No. DAE4-601_Jan17)	Jan-18

Secondary Standards	ID #	Check Date (in house)	Scheduled Check
Power meter EPM-442A	SN: GB37480704	07-Oct-15 (in house check Oct-16)	In house check: Oct-18
Power sensor HP 8481A	SN: US37292783	07-Oct-15 (in house check Oct-16)	In house check: Oct-18
Power sensor HP 8481A	SN: MY41092317	07-Oct-15 (in house check Oct-16)	In house check: Oct-18
RF generator R&S SMT-06	SN: 100972	15-Jun-15 (in house check Oct-16)	In house check: Oct-18
Network Analyzer HP 8753E	SN: US37390585	18-Oct-01 (in house check Oct-16)	In house check: Oct-17

Calibrated by: **Johannes Kurikka** Function: **Laboratory Technician**

Approved by: **Katja Pokovic** Technical Manager

Signature: *Johannes Kurikka*

Signature: *Katja Pokovic*

Issued: March 14, 2017

This calibration certificate shall not be reproduced except in full without written approval of the laboratory.



Accredited by the Swiss Accreditation Service (SAS)
The Swiss Accreditation Service is one of the signatories to the EA
Multilateral Agreement for the recognition of calibration certificates

Accreditation No.: **SCS 0108**

Glossary:

TSL	tissue simulating liquid
ConvF	sensitivity in TSL / NORM x,y,z
N/A	not applicable or not measured

Calibration is Performed According to the Following Standards:

- IEEE Std 1528-2013, "IEEE Recommended Practice for Determining the Peak Spatial-Averaged Specific Absorption Rate (SAR) in the Human Head from Wireless Communications Devices: Measurement Techniques", June 2013
- IEC 62209-1, "Procedure to measure the Specific Absorption Rate (SAR) for hand-held devices used in close proximity to the ear (frequency range of 300 MHz to 3 GHz)", February 2005
- IEC 62209-2, "Procedure to determine the Specific Absorption Rate (SAR) for wireless communication devices used in close proximity to the human body (frequency range of 30 MHz to 6 GHz)", March 2010
- KDB 865664, "SAR Measurement Requirements for 100 MHz to 6 GHz"

Additional Documentation:

- DASY4/5 System Handbook

Methods Applied and Interpretation of Parameters:

- Measurement Conditions:** Further details are available from the Validation Report at the end of the certificate. All figures stated in the certificate are valid at the frequency indicated.
- Antenna Parameters with TSL:** The dipole is mounted with the spacer to position its feed point exactly below the center marking of the flat phantom section, with the arms oriented parallel to the body axis.
- Feed Point Impedance and Return Loss:** These parameters are measured with the dipole positioned under the liquid filled phantom. The impedance stated is transformed from the measurement at the SMA connector to the feed point. The Return Loss ensures low reflected power. No uncertainty required.
- Electrical Delay:** One-way delay between the SMA connector and the antenna feed point. No uncertainty required.
- SAR measured:** SAR measured at the stated antenna input power.
- SAR normalized:** SAR as measured, normalized to an input power of 1 W at the antenna connector.
- SAR for nominal TSL parameters:** The measured TSL parameters are used to calculate the nominal SAR result.

The reported uncertainty of measurement is stated as the standard uncertainty of measurement multiplied by the coverage factor $k=2$, which for a normal distribution corresponds to a coverage probability of approximately 95%.

Measurement Conditions

DASY system configuration, as far as not given on page 1.

DASY Version	DASY5	V52.8.8
Extrapolation	Advanced Extrapolation	
Phantom	Modular Flat Phantom	
Distance Dipole Center - TSL	15 mm	with Spacer
Zoom Scan Resolution	dx, dy, dz = 5 mm	
Frequency	750 MHz ± 1 MHz	

Head TSL parameters

The following parameters and calculations were applied.

	Temperature	Permittivity	Conductivity
Nominal Head TSL parameters	22.0 °C	41.9	0.89 mho/m
Measured Head TSL parameters	(22.0 ± 0.2) °C	40.9 ± 6 %	0.91 mho/m ± 6 %
Head TSL temperature change during test	< 0.5 °C	----	----

SAR result with Head TSL

SAR averaged over 1 cm ³ (1 g) of Head TSL	Condition	
SAR measured	250 mW input power	2.14 W/kg
SAR for nominal Head TSL parameters	normalized to 1W	8.37 W/kg ± 17.0 % (k=2)

SAR averaged over 10 cm ³ (10 g) of Head TSL	condition	
SAR measured	250 mW input power	1.40 W/kg
SAR for nominal Head TSL parameters	normalized to 1W	5.50 W/kg ± 16.5 % (k=2)

Body TSL parameters

The following parameters and calculations were applied.

	Temperature	Permittivity	Conductivity
Nominal Body TSL parameters	22.0 °C	55.5	0.96 mho/m
Measured Body TSL parameters	(22.0 ± 0.2) °C	54.6 ± 6 %	0.99 mho/m ± 6 %
Body TSL temperature change during test	< 0.5 °C	----	----

SAR result with Body TSL

SAR averaged over 1 cm ³ (1 g) of Body TSL	Condition	
SAR measured	250 mW input power	2.21 W/kg
SAR for nominal Body TSL parameters	normalized to 1W	8.61 W/kg ± 17.0 % (k=2)

SAR averaged over 10 cm ³ (10 g) of Body TSL	condition	
SAR measured	250 mW input power	1.45 W/kg
SAR for nominal Body TSL parameters	normalized to 1W	5.68 W/kg ± 16.5 % (k=2)

Appendix (Additional assessments outside the scope of SCS 0108)

Antenna Parameters with Head TSL

Impedance, transformed to feed point	54.7 Ω - 0.7 j Ω
Return Loss	- 26.8 dB

Antenna Parameters with Body TSL

Impedance, transformed to feed point	50.7 Ω - 3.6 j Ω
Return Loss	- 28.7 dB

General Antenna Parameters and Design

Electrical Delay (one direction)	1.033 ns
----------------------------------	----------

After long term use with 100W radiated power, only a slight warming of the dipole near the feedpoint can be measured.

The dipole is made of standard semirigid coaxial cable. The center conductor of the feeding line is directly connected to the second arm of the dipole. The antenna is therefore short-circuited for DC-signals. On some of the dipoles, small end caps are added to the dipole arms in order to improve matching when loaded according to the position as explained in the "Measurement Conditions" paragraph. The SAR data are not affected by this change. The overall dipole length is still according to the Standard.

No excessive force must be applied to the dipole arms, because they might bend or the soldered connections near the feedpoint may be damaged.

Additional EUT Data

Manufactured by	SPEAG
Manufactured on	November 08, 2011

DASY5 Validation Report for Head TSL

Date: 07.03.2017

Test Laboratory: SPEAG, Zurich, Switzerland

DUT: Dipole 750 MHz; Type: D750V3; Serial: D750V3 - SN:1054

Communication System: UID 0 - CW ; Frequency: 750 MHz

Medium parameters used: $f = 750 \text{ MHz}$; $\sigma = 0.91 \text{ S/m}$; $\epsilon_r = 40.9$; $\rho = 1000 \text{ kg/m}^3$

Phantom section: Flat Section

Measurement Standard: DASY5 (IEEE/IEC/ANSI C63.19-2011)

DASY52 Configuration:

- Probe: EX3DV4 - SN7349; ConvF(10.17, 10.17, 10.17); Calibrated: 31.12.2016;
- Sensor-Surface: 1.4mm (Mechanical Surface Detection)
- Electronics: DAE4 Sn601; Calibrated: 04.01.2017
- Phantom: Flat Phantom 4.9 (front); Type: QD 00L P49 AA; Serial: 1001
- DASY52 52.8.8(1222); SEMCAD X 14.6.10(7331)

Dipole Calibration for Head Tissue/Pin=250 mW, d=15mm/Zoom Scan (7x7x7)/Cube 0:

Measurement grid: dx=5mm, dy=5mm, dz=5mm

Reference Value = 59.71 V/m; Power Drift = 0.01 dB

Peak SAR (extrapolated) = 3.21 W/kg

SAR(1 g) = 2.14 W/kg; SAR(10 g) = 1.4 W/kg

Maximum value of SAR (measured) = 2.85 W/kg

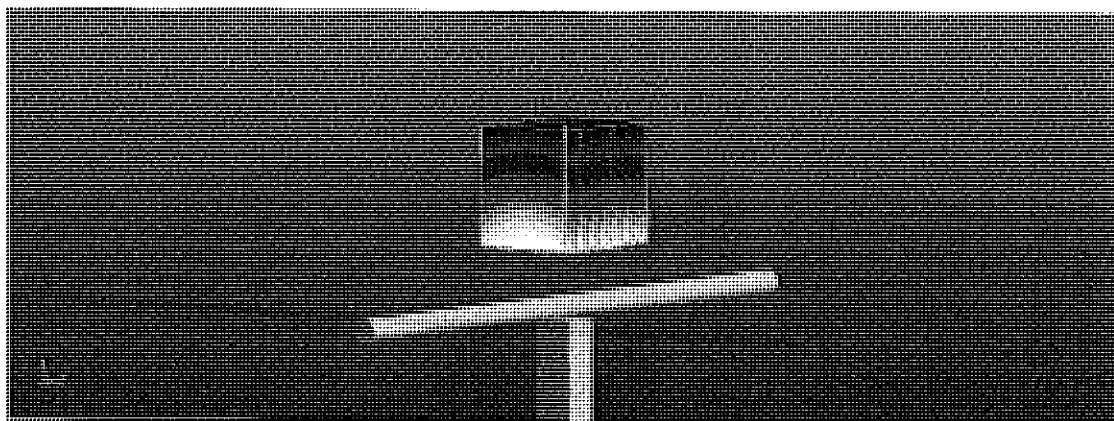
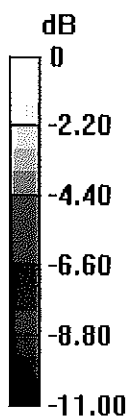

0 dB = 2.85 W/kg = 4.55 dBW/kg

Impedance Measurement Plot for Head TSL

7 Mar 2017 12:25:14

CH1 S11 1 U FS

1: 54.732 Ω -732.42 m Ω 289.73 pF

750.000 000 MHz

*
De1
Ca

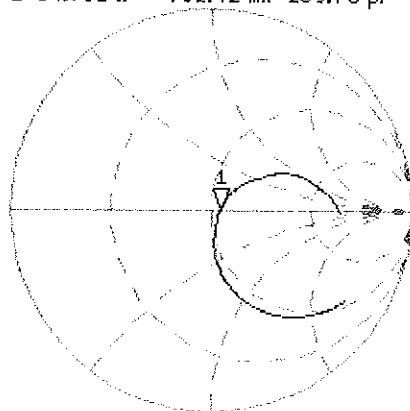

Avg
16

H1d

CH2 S11 LOG

5 dB/REF -20 dB

1:-26.788 dB

750.000 000 MHz

Ca

Avg
16

H1d

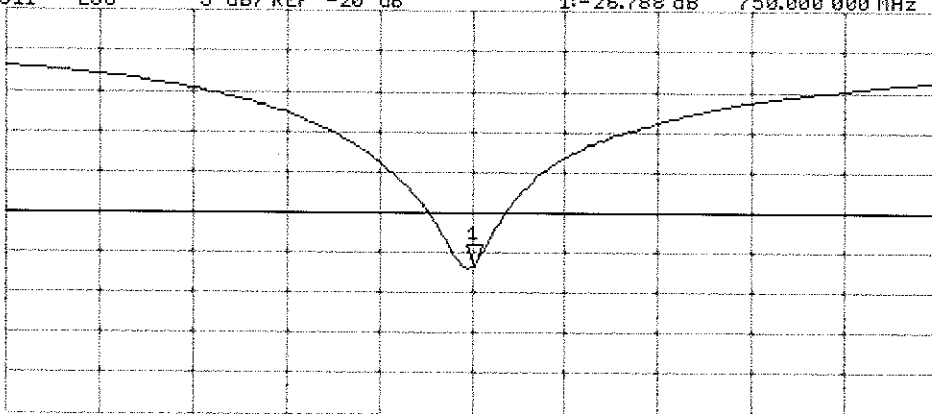

START 550.000 000 MHz

STOP 950.000 000 MHz

DASY5 Validation Report for Body TSL

Date: 07.03.2017

Test Laboratory: SPEAG, Zurich, Switzerland

DUT: Dipole 750 MHz; Type: D750V3; Serial: D750V3 - SN:1054

Communication System: UID 0 - CW ; Frequency: 750 MHz

Medium parameters used: $f = 750$ MHz; $\sigma = 0.99$ S/m; $\epsilon_r = 54.6$; $\rho = 1000$ kg/m³

Phantom section: Flat Section

Measurement Standard: DASY5 (IEEE/IEC/ANSI C63.19-2011)

DASY52 Configuration:

- Probe: EX3DV4 - SN7349; ConvF(9.99, 9.99, 9.99); Calibrated: 31.12.2016;
- Sensor-Surface: 1.4mm (Mechanical Surface Detection)
- Electronics: DAE4 Sn601; Calibrated: 04.01.2017
- Phantom: Flat Phantom 4.9 (Back); Type: QD 00R P49 AA; Serial: 1005
- DASY52 52.8.8(1222); SEMCAD X 14.6.10(7331)

Dipole Calibration for Body Tissue/Pin=250 mW, d=15mm/Zoom Scan (7x7x7)/Cube 0:

Measurement grid: dx=5mm, dy=5mm, dz=5mm

Reference Value = 57.88 V/m; Power Drift = -0.01 dB

Peak SAR (extrapolated) = 3.31 W/kg

SAR(1 g) = 2.21 W/kg; SAR(10 g) = 1.45 W/kg

Maximum value of SAR (measured) = 2.94 W/kg

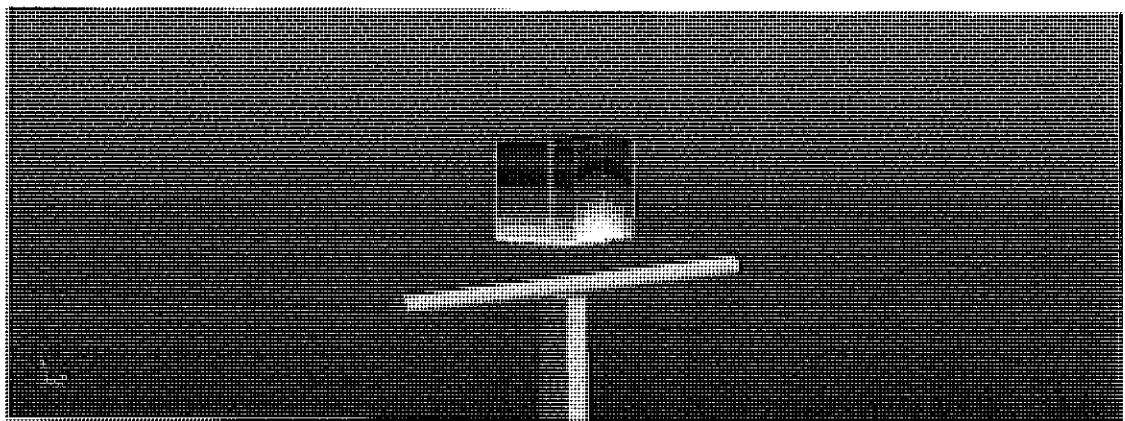
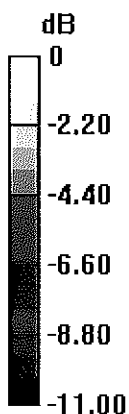

0 dB = 2.94 W/kg = 4.68 dBW/kg

Impedance Measurement Plot for Body TSL

7 Mar 2017 11:51:37
S11 1 U FS 1: 50.666 Ω -3.6309 Ω 58.445 pF 750.000 000 MHz

*
De1
CA

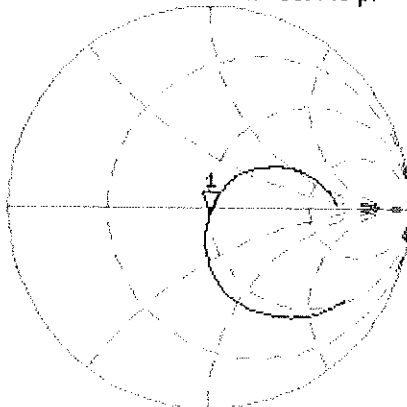

Avg
16

H1d

CH2 S11 LOG 5 dB/REF -20 dB 1: -28.716 dB 750.000 000 MHz

CA

Avg
16

H1d

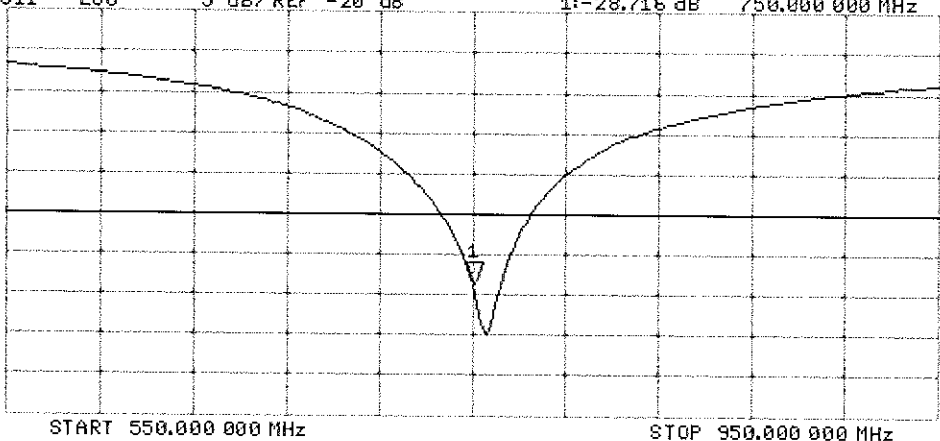



Accredited by the Swiss Accreditation Service (SAS)
The Swiss Accreditation Service is one of the signatories to the EA
Multilateral Agreement for the recognition of calibration certificates

Accreditation No.: **SCS 0108**

Client **PC Test**

Certificate No: **D835V2-4d133_Jul16**

CALIBRATION CERTIFICATE

Object **D835V2 - SN:4d133**

Calibration procedure(s) **QA CAL-05.v9**
Calibration procedure for dipole validation kits above 700 MHz

Calibration date: **July 14, 2016**

BN ✓
07/27/2016

This calibration certificate documents the traceability to national standards, which realize the physical units of measurements (SI).
The measurements and the uncertainties with confidence probability are given on the following pages and are part of the certificate.

All calibrations have been conducted in the closed laboratory facility: environment temperature (22 ± 3)°C and humidity < 70%.

Calibration Equipment used (M&TE critical for calibration)

Primary Standards	ID #	Cal Date (Certificate No.)	Scheduled Calibration
Power meter NRP	SN: 104778	06-Apr-16 (No. 217-02288/02289)	Apr-17
Power sensor NRP-Z91	SN: 103244	06-Apr-16 (No. 217-02288)	Apr-17
Power sensor NRP-Z91	SN: 103245	06-Apr-16 (No. 217-02289)	Apr-17
Reference 20 dB Attenuator	SN: 5058 (20k)	05-Apr-16 (No. 217-02292)	Apr-17
Type-N mismatch combination	SN: 5047.2 / 06327	05-Apr-16 (No. 217-02295)	Apr-17
Reference Probe EX3DV4	SN: 7349	15-Jun-16 (No. EX3-7349_Jun16)	Jun-17
DAE4	SN: 601	30-Dec-15 (No. DAE4-601_Dec15)	Dec-16
Secondary Standards	ID #	Check Date (in house)	Scheduled Check
Power meter EPM-442A	SN: GB37480704	07-Oct-15 (No. 217-02222)	In house check: Oct-16
Power sensor HP 8481A	SN: US37292783	07-Oct-15 (No. 217-02222)	In house check: Oct-16
Power sensor HP 8481A	SN: MY41092317	07-Oct-15 (No. 217-02223)	In house check: Oct-16
RF generator R&S SMT-06	SN: 100972	15-Jun-15 (in house check Jun-15)	In house check: Oct-16
Network Analyzer HP 8753E	SN: US37390585	18-Oct-01 (in house check Oct-15)	In house check: Oct-16

Calibrated by:	Name Jeton Kastrati	Function Laboratory Technician	Signature
Approved by:	Name Kalja Pokovic	Function Technical Manager	Signature

Issued: July 14, 2016

This calibration certificate shall not be reproduced except in full without written approval of the laboratory.



Accredited by the Swiss Accreditation Service (SAS)
The Swiss Accreditation Service is one of the signatories to the EA
Multilateral Agreement for the recognition of calibration certificates

Accreditation No.: **SCS 0108**

Glossary:

TSL	tissue simulating liquid
ConvF	sensitivity in TSL / NORM x,y,z
N/A	not applicable or not measured

Calibration is Performed According to the Following Standards:

- IEEE Std 1528-2013, "IEEE Recommended Practice for Determining the Peak Spatial-Averaged Specific Absorption Rate (SAR) in the Human Head from Wireless Communications Devices: Measurement Techniques", June 2013
- IEC 62209-1, "Procedure to measure the Specific Absorption Rate (SAR) for hand-held devices used in close proximity to the ear (frequency range of 300 MHz to 3 GHz)", February 2005
- IEC 62209-2, "Procedure to determine the Specific Absorption Rate (SAR) for wireless communication devices used in close proximity to the human body (frequency range of 30 MHz to 6 GHz)", March 2010
- KDB 865664, "SAR Measurement Requirements for 100 MHz to 6 GHz"

Additional Documentation:

- DASY4/5 System Handbook

Methods Applied and Interpretation of Parameters:

- Measurement Conditions:** Further details are available from the Validation Report at the end of the certificate. All figures stated in the certificate are valid at the frequency indicated.
- Antenna Parameters with TSL:** The dipole is mounted with the spacer to position its feed point exactly below the center marking of the flat phantom section, with the arms oriented parallel to the body axis.
- Feed Point Impedance and Return Loss:** These parameters are measured with the dipole positioned under the liquid filled phantom. The impedance stated is transformed from the measurement at the SMA connector to the feed point. The Return Loss ensures low reflected power. No uncertainty required.
- Electrical Delay:** One-way delay between the SMA connector and the antenna feed point. No uncertainty required.
- SAR measured:** SAR measured at the stated antenna input power.
- SAR normalized:** SAR as measured, normalized to an input power of 1 W at the antenna connector.
- SAR for nominal TSL parameters:** The measured TSL parameters are used to calculate the nominal SAR result.

The reported uncertainty of measurement is stated as the standard uncertainty of measurement multiplied by the coverage factor $k=2$, which for a normal distribution corresponds to a coverage probability of approximately 95%.

Measurement Conditions

DASY system configuration, as far as not given on page 1.

DASY Version	DASY5	V52.8.8
Extrapolation	Advanced Extrapolation	
Phantom	Modular Flat Phantom	
Distance Dipole Center - TSL	15 mm	with Spacer
Zoom Scan Resolution	dx, dy, dz = 5 mm	
Frequency	835 MHz \pm 1 MHz	

Head TSL parameters

The following parameters and calculations were applied.

	Temperature	Permittivity	Conductivity
Nominal Head TSL parameters	22.0 °C	41.5	0.90 mho/m
Measured Head TSL parameters	(22.0 \pm 0.2) °C	40.6 \pm 6 %	0.94 mho/m \pm 6 %
Head TSL temperature change during test	< 0.5 °C	----	----

SAR result with Head TSL

SAR averaged over 1 cm ³ (1 g) of Head TSL	Condition	
SAR measured	250 mW input power	2.42 W/kg
SAR for nominal Head TSL parameters	normalized to 1W	9.32 W/kg \pm 17.0 % (k=2)

SAR averaged over 10 cm ³ (10 g) of Head TSL	condition	
SAR measured	250 mW input power	1.57 W/kg
SAR for nominal Head TSL parameters	normalized to 1W	6.10 W/kg \pm 16.5 % (k=2)

Body TSL parameters

The following parameters and calculations were applied.

	Temperature	Permittivity	Conductivity
Nominal Body TSL parameters	22.0 °C	55.2	0.97 mho/m
Measured Body TSL parameters	(22.0 \pm 0.2) °C	54.9 \pm 6 %	1.01 mho/m \pm 6 %
Body TSL temperature change during test	< 0.5 °C	----	----

SAR result with Body TSL

SAR averaged over 1 cm ³ (1 g) of Body TSL	Condition	
SAR measured	250 mW input power	2.45 W/kg
SAR for nominal Body TSL parameters	normalized to 1W	9.50 W/kg \pm 17.0 % (k=2)

SAR averaged over 10 cm ³ (10 g) of Body TSL	condition	
SAR measured	250 mW input power	1.59 W/kg
SAR for nominal Body TSL parameters	normalized to 1W	6.20 W/kg \pm 16.5 % (k=2)

Appendix (Additional assessments outside the scope of SCS 0108)

Antenna Parameters with Head TSL

Impedance, transformed to feed point	50.5 Ω - 5.1 j Ω
Return Loss	- 25.7 dB

Antenna Parameters with Body TSL

Impedance, transformed to feed point	46.4 Ω - 7.5 j Ω
Return Loss	- 21.3 dB

General Antenna Parameters and Design

Electrical Delay (one direction)	1.395 ns
----------------------------------	----------

After long term use with 100W radiated power, only a slight warming of the dipole near the feedpoint can be measured.

The dipole is made of standard semirigid coaxial cable. The center conductor of the feeding line is directly connected to the second arm of the dipole. The antenna is therefore short-circuited for DC-signals. On some of the dipoles, small end caps are added to the dipole arms in order to improve matching when loaded according to the position as explained in the "Measurement Conditions" paragraph. The SAR data are not affected by this change. The overall dipole length is still according to the Standard.

No excessive force must be applied to the dipole arms, because they might bend or the soldered connections near the feedpoint may be damaged.

Additional EUT Data

Manufactured by	SPEAG
Manufactured on	July 22, 2011

DASY5 Validation Report for Head TSL

Date: 14.07.2016

Test Laboratory: SPEAG, Zurich, Switzerland

DUT: Dipole 835 MHz; Type: D835V2; Serial: D835V2 - SN:4d133

Communication System: UID 0 - CW; Frequency: 835 MHz

Medium parameters used: $f = 835$ MHz; $\sigma = 0.94$ S/m; $\epsilon_r = 40.6$; $\rho = 1000$ kg/m³

Phantom section: Flat Section

Measurement Standard: DASY5 (IEEE/IEC/ANSI C63.19-2011)

DASY52 Configuration:

- Probe: EX3DV4 - SN7349; ConvF(9.72, 9.72, 9.72); Calibrated: 15.06.2016;
- Sensor-Surface: 1.4mm (Mechanical Surface Detection)
- Electronics: DAE4 Sn601; Calibrated: 30.12.2015
- Phantom: Flat Phantom 4.9L; Type: QD000P49AA; Serial: 1001
- DASY52 52.8.8(1258); SEMCAD X 14.6.10(7372)

Dipole Calibration for Head Tissue/Pin=250 mW, d=15mm/Zoom Scan (7x7x7)/Cube 0:

Measurement grid: dx=5mm, dy=5mm, dz=5mm

Reference Value = 61.36 V/m; Power Drift = 0.03 dB

Peak SAR (extrapolated) = 3.64 W/kg

SAR(1 g) = 2.42 W/kg; SAR(10 g) = 1.57 W/kg

Maximum value of SAR (measured) = 3.23 W/kg

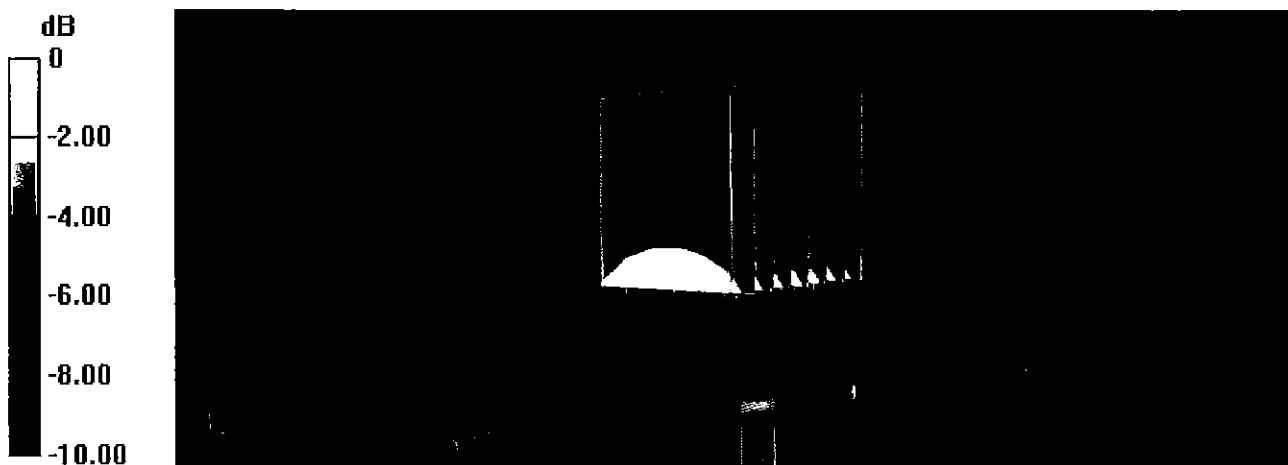

0 dB = 3.23 W/kg = 5.09 dBW/kg

Impedance Measurement Plot for Head TSL

14 Jul 2016 11:38:16
CH1 S11 1 U FS 1: 50.514 Ω -5.1445 Ω 37.050 pF 835.000 000 MHz

*
Del

CA

Avg
16

H1d

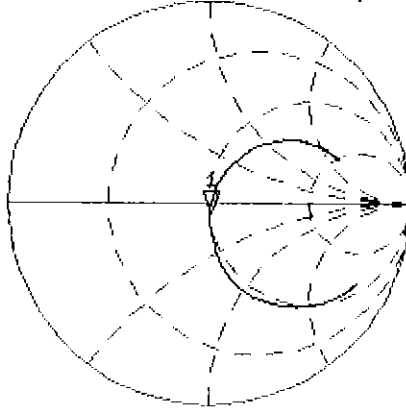

CH2 S11 LOG 5 dB/REF -20 dB 1:-25.729 dB 835.000 000 MHz

CA

H1d

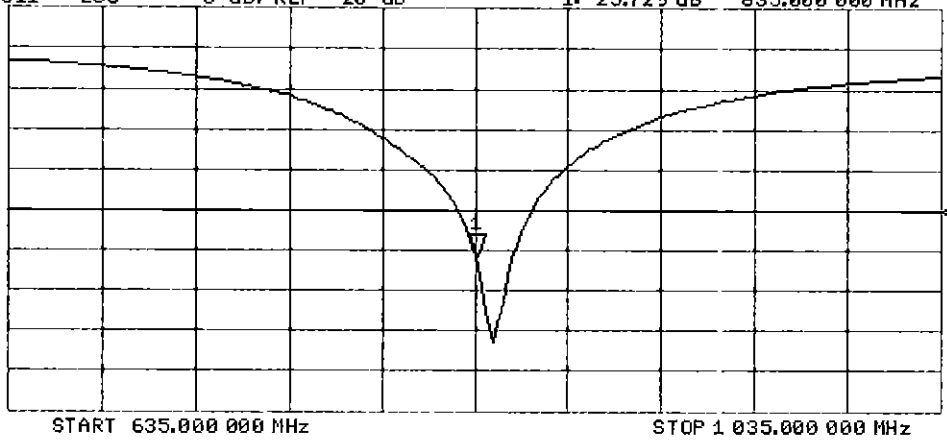

DASY5 Validation Report for Body TSL

Date: 13.07.2016

Test Laboratory: SPEAG, Zurich, Switzerland

DUT: Dipole 835 MHz; Type: D835V2; Serial: D835V2 - SN:4d133

Communication System: UID 0 - CW; Frequency: 835 MHz

Medium parameters used: $f = 835$ MHz; $\sigma = 1.01$ S/m; $\epsilon_r = 54.9$; $\rho = 1000$ kg/m³

Phantom section: Flat Section

Measurement Standard: DASY5 (IEEE/IEC/ANSI C63.19-2011)

DASY52 Configuration:

- Probe: EX3DV4 - SN7349; ConvF(9.73, 9.73, 9.73); Calibrated: 15.06.2016;
- Sensor-Surface: 1.4mm (Mechanical Surface Detection)
- Electronics: DAE4 Sn601; Calibrated: 30.12.2015
- Phantom: Flat Phantom 4.9L; Type: QD000P49AA; Serial: 1001
- DASY52 52.8.8(1258); SEMCAD X 14.6.10(7372)

Dipole Calibration for Body Tissue/Pin=250 mW, d=15mm/Zoom Scan (7x7x7)/Cube 0:

Measurement grid: dx=5mm, dy=5mm, dz=5mm

Reference Value = 59.93 V/m; Power Drift = -0.02 dB

Peak SAR (extrapolated) = 3.62 W/kg

SAR(1 g) = 2.45 W/kg; SAR(10 g) = 1.59 W/kg

Maximum value of SAR (measured) = 3.24 W/kg

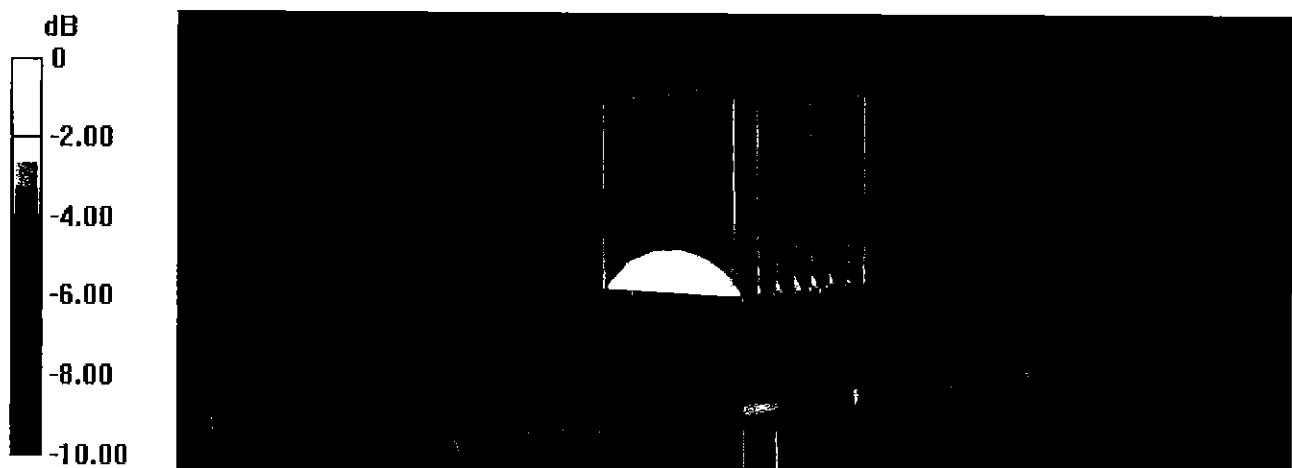

0 dB = 3.24 W/kg = 5.11 dBW/kg

Impedance Measurement Plot for Body TSL

13 Jul 2016 09:27:58
[CH1] S11 1 U FS 1: 46.404 Ω -7.4727 Ω 25.505 pF 835.000 000 MHz

*
De1

CA

Avg
16

H1d

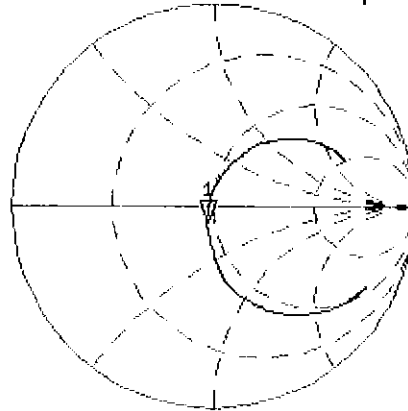

CH2 S11 LOG 5 dB/REF -20 dB 1: -21.336 dB 835.000 000 MHz

CA

Avg
16

H1d

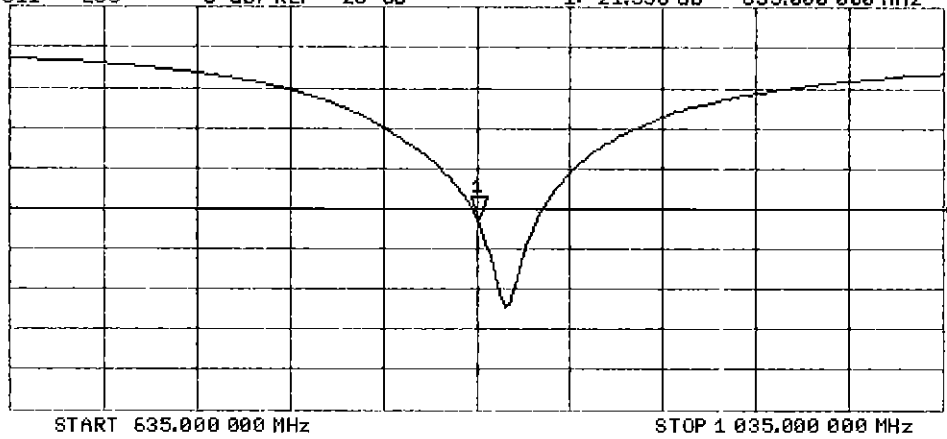



Accredited by the Swiss Accreditation Service (SAS)
The Swiss Accreditation Service is one of the signatories to the EA
Multilateral Agreement for the recognition of calibration certificates

Accreditation No.: **SCS 0108**

Client **PC Test**

Certificate No: **D1765V2-1008_May16**

CALIBRATION CERTIFICATE

Object **D1765V2 - SN:1008**

Calibration procedure(s) **QA CAL-05.v9
Calibration procedure for dipole validation kits above 700 MHz**

*BNV
05/23/16*

Calibration date: **May 11, 2016**

This calibration certificate documents the traceability to national standards, which realize the physical units of measurements (SI).
The measurements and the uncertainties with confidence probability are given on the following pages and are part of the certificate.

All calibrations have been conducted in the closed laboratory facility: environment temperature (22 ± 3)°C and humidity < 70%.

Calibration Equipment used (M&TE critical for calibration)

Primary Standards	ID #	Cal Date (Certificate No.)	Scheduled Calibration
Power meter NRP	SN: 104778	06-Apr-16 (No. 217-02288/02289)	Apr-17
Power sensor NRP-Z91	SN: 103244	06-Apr-16 (No. 217-02288)	Apr-17
Power sensor NRP-Z91	SN: 103245	06-Apr-16 (No. 217-02289)	Apr-17
Reference 20 dB Attenuator	SN: 5058 (20k)	05-Apr-16 (No. 217-02292)	Apr-17
Type-N mismatch combination	SN: 5047.2 / 06327	05-Apr-16 (No. 217-02295)	Apr-17
Reference Probe EX3DV4	SN: 7349	31-Dec-15 (No. EX3-7349_Dec15)	Dec-16
DAE4	SN: 601	30-Dec-15 (No. DAE4-601_Dec15)	Dec-16
Secondary Standards	ID #	Check Date (in house)	Scheduled Check
Power meter EPM-442A	SN: GB37480704	07-Oct-15 (No. 217-02222)	In house check: Oct-16
Power sensor HP 8481A	SN: US37292783	07-Oct-15 (No. 217-02222)	In house check: Oct-16
Power sensor HP 8481A	SN: MY41092317	07-Oct-15 (No. 217-02223)	In house check: Oct-16
RF generator R&S SMT-06	SN: 100972	15-Jun-15 (in house check Jun-15)	In house check: Oct-16
Network Analyzer HP 8753E	SN: US37390585	18-Oct-01 (in house check Oct-15)	In house check: Oct-16

Calibrated by: **Michael Weber** Name: **Michael Weber** Function: **Laboratory Technician**

Signature

M. Weber

Approved by: **Katja Pokovic** Name: **Katja Pokovic** Function: **Technical Manager**

Katja Pokovic

Issued: May 17, 2016

This calibration certificate shall not be reproduced except in full without written approval of the laboratory.



Accredited by the Swiss Accreditation Service (SAS)
The Swiss Accreditation Service is one of the signatories to the EA
Multilateral Agreement for the recognition of calibration certificates

Accreditation No.: **SCS 0108**

Glossary:

TSL	tissue simulating liquid
ConvF	sensitivity in TSL / NORM x,y,z
N/A	not applicable or not measured

Calibration is Performed According to the Following Standards:

- IEEE Std 1528-2013, "IEEE Recommended Practice for Determining the Peak Spatial-Averaged Specific Absorption Rate (SAR) in the Human Head from Wireless Communications Devices: Measurement Techniques", June 2013
- IEC 62209-1, "Procedure to measure the Specific Absorption Rate (SAR) for hand-held devices used in close proximity to the ear (frequency range of 300 MHz to 3 GHz)", February 2005
- IEC 62209-2, "Procedure to determine the Specific Absorption Rate (SAR) for wireless communication devices used in close proximity to the human body (frequency range of 30 MHz to 6 GHz)", March 2010
- KDB 865664, "SAR Measurement Requirements for 100 MHz to 6 GHz"

Additional Documentation:

- DASY4/5 System Handbook

Methods Applied and Interpretation of Parameters:

- Measurement Conditions:* Further details are available from the Validation Report at the end of the certificate. All figures stated in the certificate are valid at the frequency indicated.
- Antenna Parameters with TSL:* The dipole is mounted with the spacer to position its feed point exactly below the center marking of the flat phantom section, with the arms oriented parallel to the body axis.
- Feed Point Impedance and Return Loss:* These parameters are measured with the dipole positioned under the liquid filled phantom. The impedance stated is transformed from the measurement at the SMA connector to the feed point. The Return Loss ensures low reflected power. No uncertainty required.
- Electrical Delay:* One-way delay between the SMA connector and the antenna feed point. No uncertainty required.
- SAR measured:* SAR measured at the stated antenna input power.
- SAR normalized:* SAR as measured, normalized to an input power of 1 W at the antenna connector.
- SAR for nominal TSL parameters:* The measured TSL parameters are used to calculate the nominal SAR result.

The reported uncertainty of measurement is stated as the standard uncertainty of measurement multiplied by the coverage factor $k=2$, which for a normal distribution corresponds to a coverage probability of approximately 95%.

Measurement Conditions

DASY system configuration, as far as not given on page 1.

DASY Version	DASY5	V52.8.8
Extrapolation	Advanced Extrapolation	
Phantom	Modular Flat Phantom	
Distance Dipole Center - TSL	10 mm	with Spacer
Zoom Scan Resolution	dx, dy, dz = 5 mm	
Frequency	1750 MHz \pm 1 MHz	

Head TSL parameters

The following parameters and calculations were applied.

	Temperature	Permittivity	Conductivity
Nominal Head TSL parameters	22.0 °C	40.1	1.37 mho/m
Measured Head TSL parameters	(22.0 \pm 0.2) °C	39.8 \pm 6 %	1.36 mho/m \pm 6 %
Head TSL temperature change during test	< 0.5 °C	----	----

SAR result with Head TSL

SAR averaged over 1 cm ³ (1 g) of Head TSL	Condition	
SAR measured	250 mW input power	9.10 W/kg
SAR for nominal Head TSL parameters	normalized to 1W	36.7 W/kg \pm 17.0 % (k=2)

SAR averaged over 10 cm ³ (10 g) of Head TSL	condition	
SAR measured	250 mW input power	4.81 W/kg
SAR for nominal Head TSL parameters	normalized to 1W	19.3 W/kg \pm 16.5 % (k=2)

Body TSL parameters

The following parameters and calculations were applied.

	Temperature	Permittivity	Conductivity
Nominal Body TSL parameters	22.0 °C	53.4	1.50 mho/m
Measured Body TSL parameters	(22.0 \pm 0.2) °C	53.8 \pm 6 %	1.50 mho/m \pm 6 %
Body TSL temperature change during test	< 0.5 °C	----	----

SAR result with Body TSL

SAR averaged over 1 cm ³ (1 g) of Body TSL	Condition	
SAR measured	250 mW input power	9.30 W/kg
SAR for nominal Body TSL parameters	normalized to 1W	37.3 W/kg \pm 17.0 % (k=2)

SAR averaged over 10 cm ³ (10 g) of Body TSL	condition	
SAR measured	250 mW input power	4.94 W/kg
SAR for nominal Body TSL parameters	normalized to 1W	19.8 W/kg \pm 16.5 % (k=2)

Appendix (Additional assessments outside the scope of SCS 0108)

Antenna Parameters with Head TSL

Impedance, transformed to feed point	48.8 Ω - 6.0 j Ω
Return Loss	- 24.2 dB

Antenna Parameters with Body TSL

Impedance, transformed to feed point	45.8 Ω - 6.8 j Ω
Return Loss	- 21.6 dB

General Antenna Parameters and Design

Electrical Delay (one direction)	1.211 ns
----------------------------------	----------

After long term use with 100W radiated power, only a slight warming of the dipole near the feedpoint can be measured.

The dipole is made of standard semirigid coaxial cable. The center conductor of the feeding line is directly connected to the second arm of the dipole. The antenna is therefore short-circuited for DC-signals. On some of the dipoles, small end caps are added to the dipole arms in order to improve matching when loaded according to the position as explained in the "Measurement Conditions" paragraph. The SAR data are not affected by this change. The overall dipole length is still according to the Standard.

No excessive force must be applied to the dipole arms, because they might bend or the soldered connections near the feedpoint may be damaged.

Additional EUT Data

Manufactured by	SPEAG
Manufactured on	October 06, 2005

DASY5 Validation Report for Head TSL

Date: 11.05.2016

Test Laboratory: SPEAG, Zurich, Switzerland

DUT: Dipole 1765 MHz; Type: D1765V2; Serial: D1765V2 - SN: 1008

Communication System: UID 0 - CW; Frequency: 1750 MHz

Medium parameters used: $f = 1750$ MHz; $\sigma = 1.36$ S/m; $\epsilon_r = 39.8$; $\rho = 1000$ kg/m³

Phantom section: Flat Section

Measurement Standard: DASY5 (IEEE/IEC/ANSI C63.19-2011)

DASY52 Configuration:

- Probe: EX3DV4 - SN7349; ConvF(8.54, 8.54, 8.54); Calibrated: 31.12.2015;
- Sensor-Surface: 1.4mm (Mechanical Surface Detection)
- Electronics: DAE4 Sn601; Calibrated: 30.12.2015
- Phantom: Flat Phantom 5.0 (front); Type: QD000P50AA; Serial: 1001
- DASY52 52.8.8(1258); SEMCAD X 14.6.10(7372)

Dipole Calibration for Head Tissue/Pin=250 mW, d=10mm/Zoom Scan (7x7x7)/Cube 0:

Measurement grid: dx=5mm, dy=5mm, dz=5mm

Reference Value = 104.4 V/m; Power Drift = 0.06 dB

Peak SAR (extrapolated) = 16.7 W/kg

SAR(1 g) = 9.1 W/kg; SAR(10 g) = 4.81 W/kg

Maximum value of SAR (measured) = 13.7 W/kg

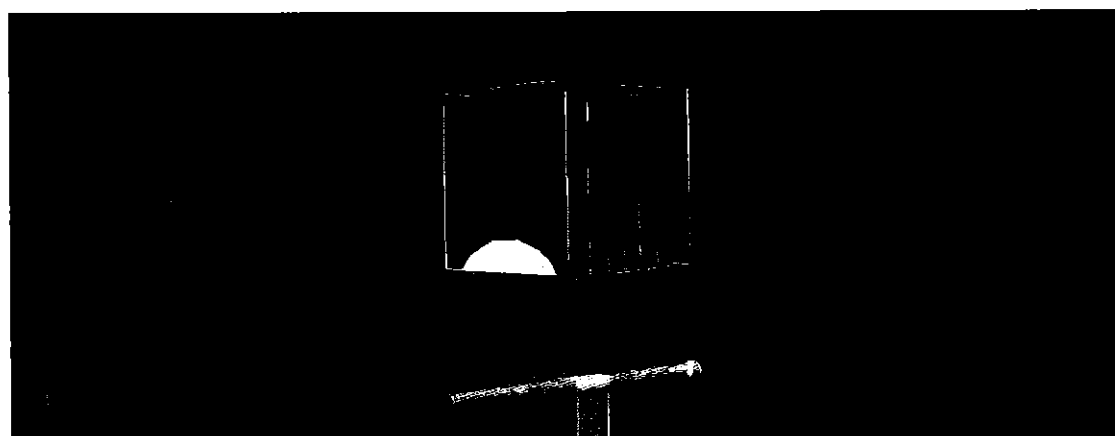

0 dB = 13.7 W/kg = 11.37 dBW/kg

Impedance Measurement Plot for Head TSL

11 May 2016 13:10:14

[CH1] S11 1 U FS 1: 48.842 Ω -6.0117 Ω 15.128 pF 1 750.000 000 MHz

*
Del
Cor
Avg
16
H1d

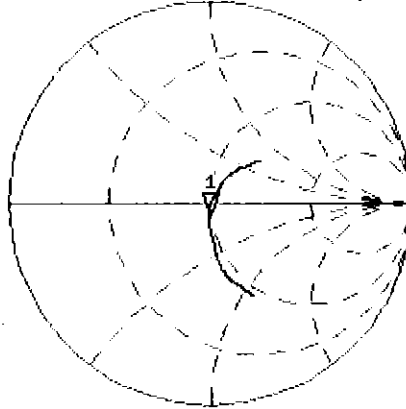

CH2 S11 LOG 5 dB/REF -20 dB 1:-24.177 dB 1 750.000 000 MHz

Del
Cor
Avg
16
H1d

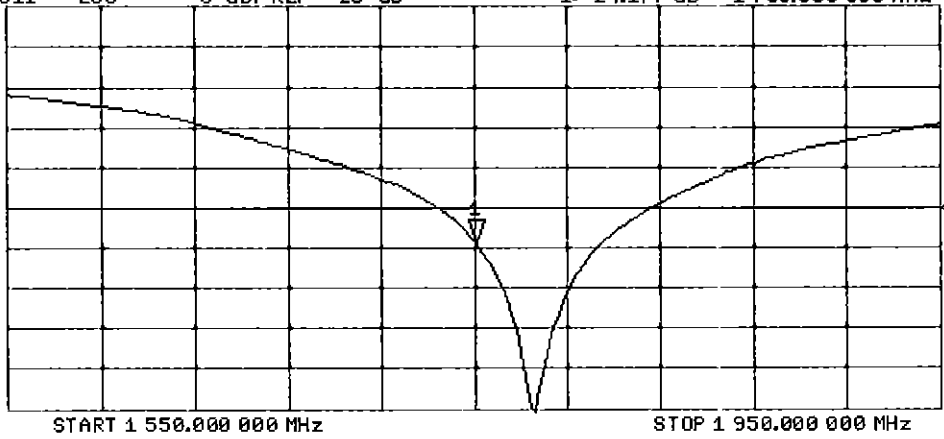

DASY5 Validation Report for Body TSL

Date: 11.05.2016

Test Laboratory: SPEAG, Zurich, Switzerland

DUT: Dipole 1765 MHz; Type: D1765V2; Serial: D1765V2 - SN: 1008

Communication System: UID 0 - CW; Frequency: 1750 MHz

Medium parameters used: $f = 1750$ MHz; $\sigma = 1.5$ S/m; $\epsilon_r = 53.8$; $\rho = 1000$ kg/m³

Phantom section: Flat Section

Measurement Standard: DASY5 (IEEE/IEC/ANSI C63.19-2011)

DASY52 Configuration:

- Probe: EX3DV4 - SN7349; ConvF(8.25, 8.25, 8.25); Calibrated: 31.12.2015;
- Sensor-Surface: 1.4mm (Mechanical Surface Detection)
- Electronics: DAE4 Sn601; Calibrated: 30.12.2015
- Phantom: Flat Phantom 5.0 (back); Type: QD000P50AA; Serial: 1002
- DASY52 52.8.8(1258); SEMCAD X 14.6.10(7372)

Dipole Calibration for Body Tissue/Pin=250 mW, d=10mm/Zoom Scan (7x7x7)/Cube 0:

Measurement grid: dx=5mm, dy=5mm, dz=5mm

Reference Value = 100.9 V/m; Power Drift = -0.01 dB

Peak SAR (extrapolated) = 16.4 W/kg

SAR(1 g) = 9.3 W/kg; SAR(10 g) = 4.94 W/kg

Maximum value of SAR (measured) = 14.0 W/kg

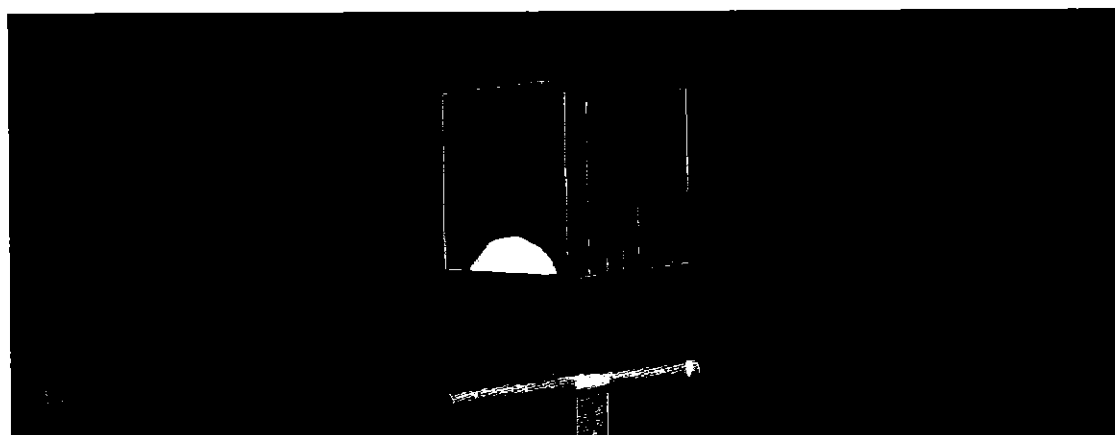

0 dB = 14.0 W/kg = 11.46 dBW/kg

Impedance Measurement Plot for Body TSL

11 May 2016 13:08:31

CH1 S11 1 U FS 1: 45.803 Ω -6.7695 Ω 13.435 pF 1 750.000 000 MHz

*
De1
Cor
Avg
16
H1d

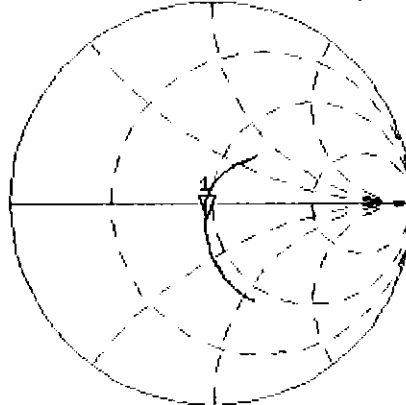

CH2 S11 LOG 5 dB/REF -20 dB 1:-21.625 dB 1 750.000 000 MHz

De1
Cor
Avg
16
H1d

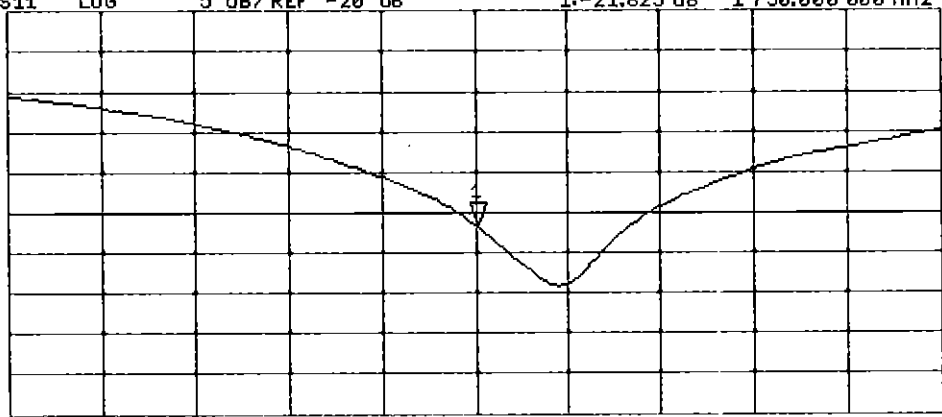

START 1 550.000 000 MHz

STOP 1 950.000 000 MHz



Accredited by the Swiss Accreditation Service (SAS)
The Swiss Accreditation Service is one of the signatories to the EA
Multilateral Agreement for the recognition of calibration certificates

Accreditation No.: **SCS 0108**

Client **PC Test**

Certificate No: **D1750V2-1148_May16**

CALIBRATION CERTIFICATE

Object **D1750V2 - SN: 1148**

Calibration procedure(s) **QA CAL-05.v9
Calibration procedure for dipole validation kits above 700 MHz**

Calibration date: **May 09, 2016**

BNV
5/17/2016

This calibration certificate documents the traceability to national standards, which realize the physical units of measurements (SI).
The measurements and the uncertainties with confidence probability are given on the following pages and are part of the certificate.

All calibrations have been conducted in the closed laboratory facility: environment temperature (22 ± 3)°C and humidity < 70%.

Calibration Equipment used (M&TE critical for calibration)

Primary Standards	ID #	Cal Date (Certificate No.)	Scheduled Calibration
Power meter NRP	SN: 104778	06-Apr-16 (No. 217-02288/02289)	Apr-17
Power sensor NRP-Z91	SN: 103244	06-Apr-16 (No. 217-02288)	Apr-17
Power sensor NRP-Z91	SN: 103245	06-Apr-16 (No. 217-02289)	Apr-17
Reference 20 dB Attenuator	SN: 5058 (20k)	05-Apr-16 (No. 217-02292)	Apr-17
Type-N mismatch combination	SN: 5047.2 / 06327	05-Apr-16 (No. 217-02295)	Apr-17
Reference Probe EX3DV4	SN: 7349	31-Dec-15 (No. EX3-7349_Dec15)	Dec-16
DAE4	SN: 601	30-Dec-15 (No. DAE4-601_Dec15)	Dec-16
Secondary Standards	ID #	Check Date (in house)	Scheduled Check
Power meter EPM-442A	SN: GB37480704	07-Oct-15 (No. 217-02222)	In house check: Oct-16
Power sensor HP 8481A	SN: US37292783	07-Oct-15 (No. 217-02222)	In house check: Oct-16
Power sensor HP 8481A	SN: MY41092317	07-Oct-15 (No. 217-02223)	In house check: Oct-16
RF generator R&S SMT-06	SN: 100972	15-Jun-15 (in house check Jun-15)	In house check: Oct-16
Network Analyzer HP 8753E	SN: US37390585	18-Oct-01 (in house check Oct-15)	In house check: Oct-16

Calibrated by: **Michael Weber** Function: **Laboratory Technician**

Signature
M. Weber

Approved by: **Katja Pokovic** Technical Manager

Katja Pokovic

Issued: May 11, 2016

This calibration certificate shall not be reproduced except in full without written approval of the laboratory.



Accredited by the Swiss Accreditation Service (SAS)
The Swiss Accreditation Service is one of the signatories to the EA
Multilateral Agreement for the recognition of calibration certificates

Accreditation No.: **SCS 0108**

Glossary:

TSL	tissue simulating liquid
ConvF	sensitivity in TSL / NORM x,y,z
N/A	not applicable or not measured

Calibration is Performed According to the Following Standards:

- IEEE Std 1528-2013, "IEEE Recommended Practice for Determining the Peak Spatial-Averaged Specific Absorption Rate (SAR) in the Human Head from Wireless Communications Devices: Measurement Techniques", June 2013
- IEC 62209-1, "Procedure to measure the Specific Absorption Rate (SAR) for hand-held devices used in close proximity to the ear (frequency range of 300 MHz to 3 GHz)", February 2005
- IEC 62209-2, "Procedure to determine the Specific Absorption Rate (SAR) for wireless communication devices used in close proximity to the human body (frequency range of 30 MHz to 6 GHz)", March 2010
- KDB 865664, "SAR Measurement Requirements for 100 MHz to 6 GHz"

Additional Documentation:

- DASY4/5 System Handbook

Methods Applied and Interpretation of Parameters:

- Measurement Conditions:* Further details are available from the Validation Report at the end of the certificate. All figures stated in the certificate are valid at the frequency indicated.
- Antenna Parameters with TSL:* The dipole is mounted with the spacer to position its feed point exactly below the center marking of the flat phantom section, with the arms oriented parallel to the body axis.
- Feed Point Impedance and Return Loss:* These parameters are measured with the dipole positioned under the liquid filled phantom. The impedance stated is transformed from the measurement at the SMA connector to the feed point. The Return Loss ensures low reflected power. No uncertainty required.
- Electrical Delay:* One-way delay between the SMA connector and the antenna feed point. No uncertainty required.
- SAR measured:* SAR measured at the stated antenna input power.
- SAR normalized:* SAR as measured, normalized to an input power of 1 W at the antenna connector.
- SAR for nominal TSL parameters:* The measured TSL parameters are used to calculate the nominal SAR result.

The reported uncertainty of measurement is stated as the standard uncertainty of measurement multiplied by the coverage factor $k=2$, which for a normal distribution corresponds to a coverage probability of approximately 95%.

Measurement Conditions

DASY system configuration, as far as not given on page 1.

DASY Version	DASY5	V52.8.8
Extrapolation	Advanced Extrapolation	
Phantom	Modular Flat Phantom	
Distance Dipole Center - TSL	10 mm	with Spacer
Zoom Scan Resolution	dx, dy, dz = 5 mm	
Frequency	1750 MHz \pm 1 MHz	

Head TSL parameters

The following parameters and calculations were applied.

	Temperature	Permittivity	Conductivity
Nominal Head TSL parameters	22.0 °C	40.1	1.37 mho/m
Measured Head TSL parameters	(22.0 \pm 0.2) °C	39.7 \pm 6 %	1.36 mho/m \pm 6 %
Head TSL temperature change during test	< 0.5 °C	----	----

SAR result with Head TSL

SAR averaged over 1 cm ³ (1 g) of Head TSL	Condition	
SAR measured	250 mW input power	9.03 W/kg
SAR for nominal Head TSL parameters	normalized to 1W	36.2 W/kg \pm 17.0 % (k=2)

SAR averaged over 10 cm ³ (10 g) of Head TSL	condition	
SAR measured	250 mW input power	4.78 W/kg
SAR for nominal Head TSL parameters	normalized to 1W	19.1 W/kg \pm 16.5 % (k=2)

Body TSL parameters

The following parameters and calculations were applied.

	Temperature	Permittivity	Conductivity
Nominal Body TSL parameters	22.0 °C	53.4	1.49 mho/m
Measured Body TSL parameters	(22.0 \pm 0.2) °C	53.8 \pm 6 %	1.50 mho/m \pm 6 %
Body TSL temperature change during test	< 0.5 °C	----	----

SAR result with Body TSL

SAR averaged over 1 cm ³ (1 g) of Body TSL	Condition	
SAR measured	250 mW input power	9.30 W/kg
SAR for nominal Body TSL parameters	normalized to 1W	37.1 W/kg \pm 17.0 % (k=2)

SAR averaged over 10 cm ³ (10 g) of Body TSL	condition	
SAR measured	250 mW input power	4.93 W/kg
SAR for nominal Body TSL parameters	normalized to 1W	19.7 W/kg \pm 16.5 % (k=2)

Appendix (Additional assessments outside the scope of SCS 0108)

Antenna Parameters with Head TSL

Impedance, transformed to feed point	49.9 Ω - 0.7 j Ω
Return Loss	- 43.3 dB

Antenna Parameters with Body TSL

Impedance, transformed to feed point	46.2 Ω - 1.4 j Ω
Return Loss	- 27.5 dB

General Antenna Parameters and Design

Electrical Delay (one direction)	1.221 ns
----------------------------------	----------

After long term use with 100W radiated power, only a slight warming of the dipole near the feedpoint can be measured.

The dipole is made of standard semirigid coaxial cable. The center conductor of the feeding line is directly connected to the second arm of the dipole. The antenna is therefore short-circuited for DC-signals. On some of the dipoles, small end caps are added to the dipole arms in order to improve matching when loaded according to the position as explained in the "Measurement Conditions" paragraph. The SAR data are not affected by this change. The overall dipole length is still according to the Standard.

No excessive force must be applied to the dipole arms, because they might bend or the soldered connections near the feedpoint may be damaged.

Additional EUT Data

Manufactured by	SPEAG
Manufactured on	September 30, 2014

DASY5 Validation Report for Head TSL

Date: 09.05.2016

Test Laboratory: SPEAG, Zurich, Switzerland

DUT: Dipole 1750 MHz; Type: D1750V2; Serial: D1750V2 - SN: 1148

Communication System: UID 0 - CW; Frequency: 1750 MHz

Medium parameters used: $f = 1750$ MHz; $\sigma = 1.36$ S/m; $\epsilon_r = 39.7$; $\rho = 1000$ kg/m³

Phantom section: Flat Section

Measurement Standard: DASY5 (IEEE/IEC/ANSI C63.19-2011)

DASY52 Configuration:

- Probe: EX3DV4 - SN7349; ConvF(8.54, 8.54, 8.54); Calibrated: 31.12.2015;
- Sensor-Surface: 1.4mm (Mechanical Surface Detection)
- Electronics: DAE4 Sn601; Calibrated: 30.12.2015
- Phantom: Flat Phantom 5.0 (front); Type: QD000P50AA; Serial: 1001
- DASY52 52.8.8(1258); SEMCAD X 14.6.10(7372)

Dipole Calibration for Head Tissue/Pin=250 mW, d=10mm/Zoom Scan (7x7x7)/Cube 0:

Measurement grid: dx=5mm, dy=5mm, dz=5mm

Reference Value = 103.5 V/m; Power Drift = 0.04 dB

Peak SAR (extrapolated) = 16.7 W/kg

SAR(1 g) = 9.03 W/kg; SAR(10 g) = 4.78 W/kg

Maximum value of SAR (measured) = 13.6 W/kg

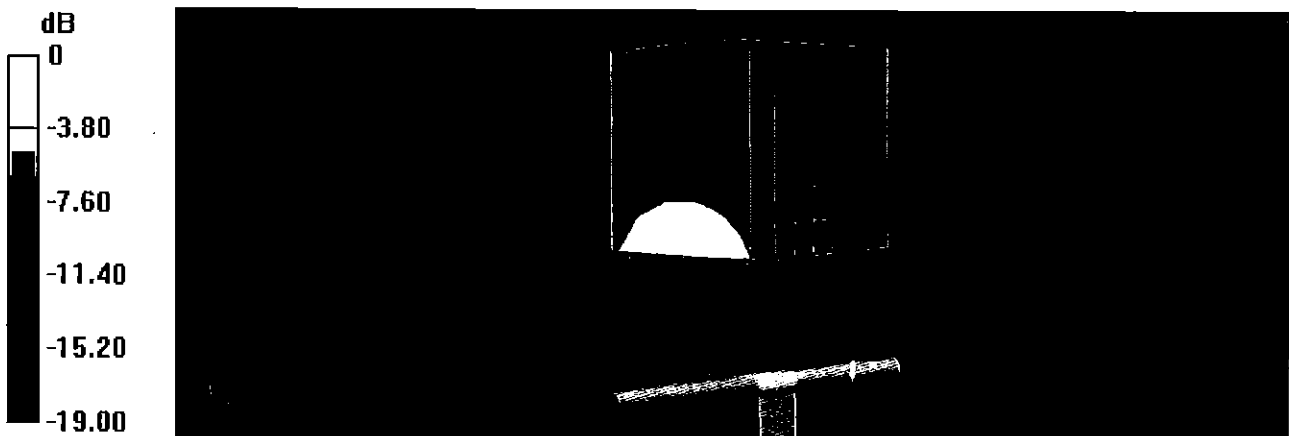

0 dB = 13.6 W/kg = 11.34 dBW/kg

Impedance Measurement Plot for Head TSL

9 May 2016 11:49:12
[CH1] S11 1 U FS 1: 49.912 Ω -679.69 m Ω 133.81 pF 1 750.000 000 MHz

*
De1
CA

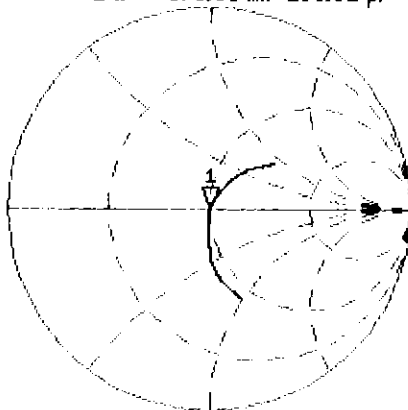

Avg
16
H1d

CH2 S11 LOG 5 dB/REF -20 dB 1: -43.269 dB 1 750.000 000 MHz

De1
CA

Avg
16
H1d

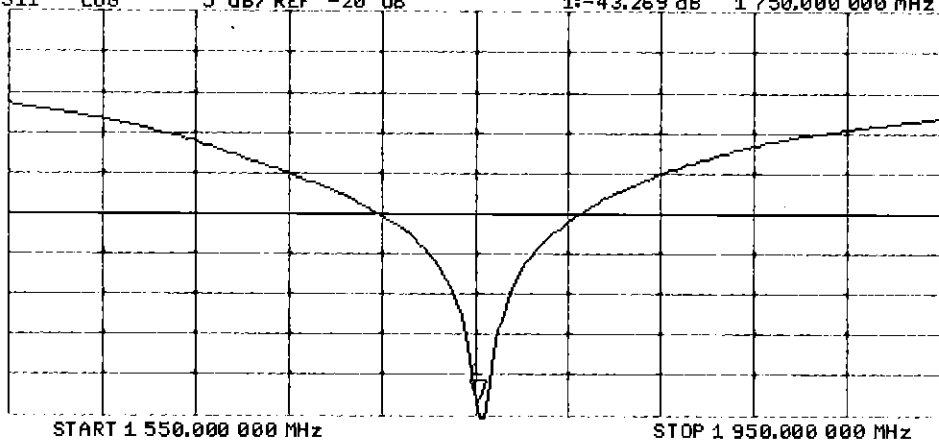

DASY5 Validation Report for Body TSL

Date: 09.05.2016

Test Laboratory: SPEAG, Zurich, Switzerland

DUT: Dipole 1750 MHz; Type: D1750V2; Serial: D1750V2 - SN: 1148

Communication System: UID 0 - CW; Frequency: 1750 MHz

Medium parameters used: $f = 1750$ MHz; $\sigma = 1.5$ S/m; $\epsilon_r = 53.8$; $\rho = 1000$ kg/m³

Phantom section: Flat Section

Measurement Standard: DASY5 (IEEE/IEC/ANSI C63.19-2011)

DASY52 Configuration:

- Probe: EX3DV4 - SN7349; ConvF(8.25, 8.25, 8.25); Calibrated: 31.12.2015;
- Sensor-Surface: 1.4mm (Mechanical Surface Detection)
- Electronics: DAE4 Sn601; Calibrated: 30.12.2015
- Phantom: Flat Phantom 5.0 (back); Type: QD000P50AA; Serial: 1002
- DASY52 52.8.8(1258); SEMCAD X 14.6.10(7372)

Dipole Calibration for Body Tissue/Pin=250 mW, d=10mm/Zoom Scan (7x7x7)/Cube 0:

Measurement grid: dx=5mm, dy=5mm, dz=5mm

Reference Value = 102.0 V/m; Power Drift = -0.08 dB

Peak SAR (extrapolated) = 16.6 W/kg

SAR(1 g) = 9.3 W/kg; SAR(10 g) = 4.93 W/kg

Maximum value of SAR (measured) = 14.1 W/kg

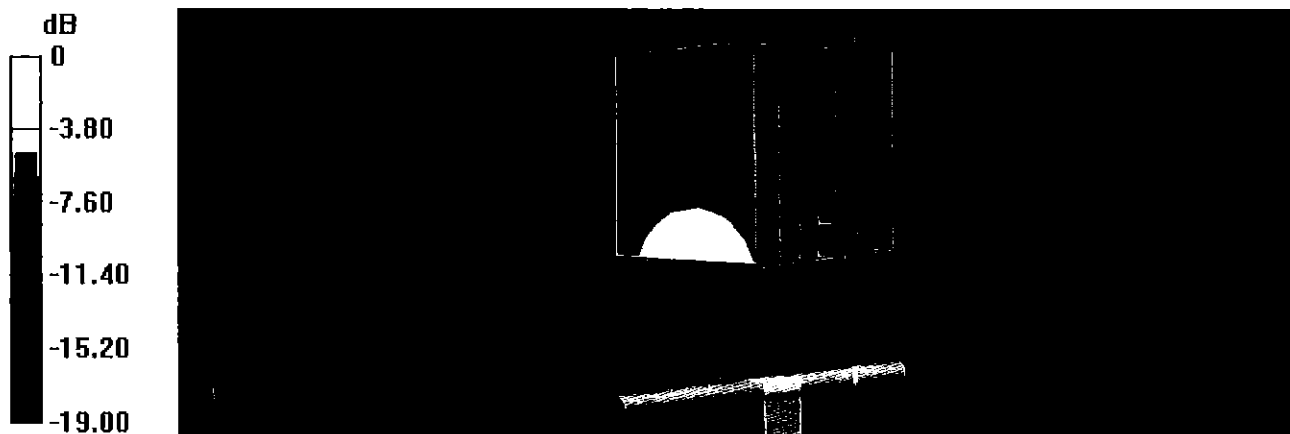

0 dB = 14.1 W/kg = 11.49 dBW/kg

Impedance Measurement Plot for Body TSL

9 May 2016 11:48:41
[CH1] S11 1 U FS 1: 46.205 Ω -1.4258 Ω 63.787 pF 1 750.000 000 MHz

*
De1

CA

Avg
16

H1d

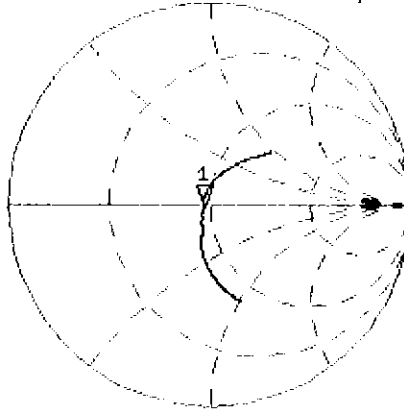

CH2 S11 LOG 5 dB/REF -20 dB 1:-27.503 dB 1 750.000 000 MHz

De1

CA

Avg
16

H1d

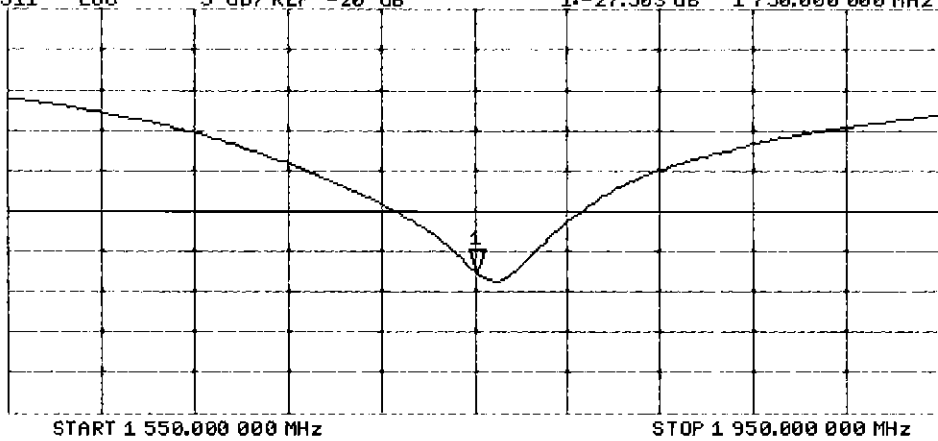



Accredited by the Swiss Accreditation Service (SAS)
The Swiss Accreditation Service is one of the signatories to the EA
Multilateral Agreement for the recognition of calibration certificates

Accreditation No.: **SCS 0108**

Client **PC Test**

Certificate No: **D1900V2-5d149_Jul16**

CALIBRATION CERTIFICATE

Object **D1900V2 - SN:5d149**

Calibration procedure(s) **QA CAL-05.v9**
Calibration procedure for dipole validation kits above 700 MHz

Calibration date: **July 15, 2016**

PNV
07/27/2016

This calibration certificate documents the traceability to national standards, which realize the physical units of measurements (SI).
The measurements and the uncertainties with confidence probability are given on the following pages and are part of the certificate.

All calibrations have been conducted in the closed laboratory facility: environment temperature (22 ± 3)°C and humidity < 70%.

Calibration Equipment used (M&TE critical for calibration)

Primary Standards	ID #	Cal Date (Certificate No.)	Scheduled Calibration
Power meter NRP	SN: 104778	06-Apr-16 (No. 217-02288/02289)	Apr-17
Power sensor NRP-Z91	SN: 103244	06-Apr-16 (No. 217-02288)	Apr-17
Power sensor NRP-Z91	SN: 103245	06-Apr-16 (No. 217-02289)	Apr-17
Reference 20 dB Attenuator	SN: 5058 (20k)	05-Apr-16 (No. 217-02292)	Apr-17
Type-N mismatch combination	SN: 5047.2 / 06327	05-Apr-16 (No. 217-02295)	Apr-17
Reference Probe EX3DV4	SN: 7349	15-Jun-16 (No. EX3-7349_Jun16)	Jun-17
DAE4	SN: 601	30-Dec-15 (No. DAE4-601_Dec15)	Dec-16

Secondary Standards	ID #	Check Date (in house)	Scheduled Check
Power meter EPM-442A	SN: GB37480704	07-Oct-15 (No. 217-02222)	In house check: Oct-16
Power sensor HP 8481A	SN: US37292783	07-Oct-15 (No. 217-02222)	In house check: Oct-16
Power sensor HP 8481A	SN: MY41092317	07-Oct-15 (No. 217-02223)	In house check: Oct-16
RF generator R&S SMT-06	SN: 100972	15-Jun-15 (in house check Jun-15)	In house check: Oct-16
Network Analyzer HP 8753E	SN: US37390585	18-Oct-01 (in house check Oct-15)	In house check: Oct-16

Calibrated by: **Claudio Leubler** Name: **Claudio Leubler** Function: **Laboratory Technician**

Approved by: **Katja Pokovic** Name: **Katja Pokovic** Function: **Technical Manager**

Signature
[Handwritten Signature]

[Handwritten Signature]

Issued: July 19, 2016

This calibration certificate shall not be reproduced except in full without written approval of the laboratory.



Accredited by the Swiss Accreditation Service (SAS)
The Swiss Accreditation Service is one of the signatories to the EA
Multilateral Agreement for the recognition of calibration certificates

Accreditation No.: **SCS 0108**

Glossary:

TSL	tissue simulating liquid
ConvF	sensitivity in TSL / NORM x,y,z
N/A	not applicable or not measured

Calibration is Performed According to the Following Standards:

- IEEE Std 1528-2013, "IEEE Recommended Practice for Determining the Peak Spatial-Averaged Specific Absorption Rate (SAR) in the Human Head from Wireless Communications Devices: Measurement Techniques", June 2013
- IEC 62209-1, "Procedure to measure the Specific Absorption Rate (SAR) for hand-held devices used in close proximity to the ear (frequency range of 300 MHz to 3 GHz)", February 2005
- IEC 62209-2, "Procedure to determine the Specific Absorption Rate (SAR) for wireless communication devices used in close proximity to the human body (frequency range of 30 MHz to 6 GHz)", March 2010
- KDB 865664, "SAR Measurement Requirements for 100 MHz to 6 GHz"

Additional Documentation:

- DASY4/5 System Handbook

Methods Applied and Interpretation of Parameters:

- Measurement Conditions:** Further details are available from the Validation Report at the end of the certificate. All figures stated in the certificate are valid at the frequency indicated.
- Antenna Parameters with TSL:** The dipole is mounted with the spacer to position its feed point exactly below the center marking of the flat phantom section, with the arms oriented parallel to the body axis.
- Feed Point Impedance and Return Loss:** These parameters are measured with the dipole positioned under the liquid filled phantom. The impedance stated is transformed from the measurement at the SMA connector to the feed point. The Return Loss ensures low reflected power. No uncertainty required.
- Electrical Delay:** One-way delay between the SMA connector and the antenna feed point. No uncertainty required.
- SAR measured:** SAR measured at the stated antenna input power.
- SAR normalized:** SAR as measured, normalized to an input power of 1 W at the antenna connector.
- SAR for nominal TSL parameters:** The measured TSL parameters are used to calculate the nominal SAR result.

The reported uncertainty of measurement is stated as the standard uncertainty of measurement multiplied by the coverage factor $k=2$, which for a normal distribution corresponds to a coverage probability of approximately 95%.

Measurement Conditions

DASY system configuration, as far as not given on page 1.

DASY Version	DASY5	V52.8.8
Extrapolation	Advanced Extrapolation	
Phantom	Modular Flat Phantom	
Distance Dipole Center - TSL	10 mm	with Spacer
Zoom Scan Resolution	dx, dy, dz = 5 mm	
Frequency	1900 MHz \pm 1 MHz	

Head TSL parameters

The following parameters and calculations were applied.

	Temperature	Permittivity	Conductivity
Nominal Head TSL parameters	22.0 °C	40.0	1.40 mho/m
Measured Head TSL parameters	(22.0 \pm 0.2) °C	39.8 \pm 6 %	1.38 mho/m \pm 6 %
Head TSL temperature change during test	< 0.5 °C	----	----

SAR result with Head TSL

SAR averaged over 1 cm ³ (1 g) of Head TSL	Condition	
SAR measured	250 mW input power	9.96 W/kg
SAR for nominal Head TSL parameters	normalized to 1W	40.1 W/kg \pm 17.0 % (k=2)

SAR averaged over 10 cm ³ (10 g) of Head TSL	condition	
SAR measured	250 mW input power	5.23 W/kg
SAR for nominal Head TSL parameters	normalized to 1W	21.0 W/kg \pm 16.5 % (k=2)

Body TSL parameters

The following parameters and calculations were applied.

	Temperature	Permittivity	Conductivity
Nominal Body TSL parameters	22.0 °C	53.3	1.52 mho/m
Measured Body TSL parameters	(22.0 \pm 0.2) °C	52.7 \pm 6 %	1.51 mho/m \pm 6 %
Body TSL temperature change during test	< 0.5 °C	----	----

SAR result with Body TSL

SAR averaged over 1 cm ³ (1 g) of Body TSL	Condition	
SAR measured	250 mW input power	9.95 W/kg
SAR for nominal Body TSL parameters	normalized to 1W	39.9 W/kg \pm 17.0 % (k=2)

SAR averaged over 10 cm ³ (10 g) of Body TSL	condition	
SAR measured	250 mW input power	5.28 W/kg
SAR for nominal Body TSL parameters	normalized to 1W	21.1 W/kg \pm 16.5 % (k=2)

Appendix (Additional assessments outside the scope of SCS 0108)

Antenna Parameters with Head TSL

Impedance, transformed to feed point	52.4 Ω + 5.5 j Ω
Return Loss	- 24.6 dB

Antenna Parameters with Body TSL

Impedance, transformed to feed point	49.6 Ω + 7.0 j Ω
Return Loss	- 23.1 dB

General Antenna Parameters and Design

Electrical Delay (one direction)	1.197 ns
----------------------------------	----------

After long term use with 100W radiated power, only a slight warming of the dipole near the feedpoint can be measured.

The dipole is made of standard semirigid coaxial cable. The center conductor of the feeding line is directly connected to the second arm of the dipole. The antenna is therefore short-circuited for DC-signals. On some of the dipoles, small end caps are added to the dipole arms in order to improve matching when loaded according to the position as explained in the "Measurement Conditions" paragraph. The SAR data are not affected by this change. The overall dipole length is still according to the Standard.

No excessive force must be applied to the dipole arms, because they might bend or the soldered connections near the feedpoint may be damaged.

Additional EUT Data

Manufactured by	SPEAG
Manufactured on	March 11, 2011

DASY5 Validation Report for Head TSL

Date: 15.07.2016

Test Laboratory: SPEAG, Zurich, Switzerland

DUT: Dipole 1900 MHz; Type: D1900V2; Serial: D1900V2 - SN:5d149

Communication System: UID 0 - CW; Frequency: 1900 MHz

Medium parameters used: $f = 1900$ MHz; $\sigma = 1.38$ S/m; $\epsilon_r = 39.8$; $\rho = 1000$ kg/m³

Phantom section: Flat Section

Measurement Standard: DASY5 (IEEE/IEC/ANSI C63.19-2011)

DASY52 Configuration:

- Probe: EX3DV4 - SN7349; ConvF(7.99, 7.99, 7.99); Calibrated: 15.06.2016;
- Sensor-Surface: 1.4mm (Mechanical Surface Detection)
- Electronics: DAE4 Sn601; Calibrated: 30.12.2015
- Phantom: Flat Phantom 5.0 (front); Type: QD000P50AA; Serial: 1001
- DASY52 52.8.8(1258); SEMCAD X 14.6.10(7372)

Dipole Calibration for Head Tissue/Pin=250 mW, d=10mm/Zoom Scan (7x7x7)/Cube 0:

Measurement grid: dx=5mm, dy=5mm, dz=5mm

Reference Value = 107.5 V/m; Power Drift = -0.02 dB

Peak SAR (extrapolated) = 18.7 W/kg

SAR(1 g) = 9.96 W/kg; SAR(10 g) = 5.23 W/kg

Maximum value of SAR (measured) = 15.5 W/kg



0 dB = 15.5 W/kg = 11.90 dBW/kg

Impedance Measurement Plot for Head TSL

15 Jul 2016 14:30:53

[CH1] S11 1 U FS 1: 52.393 Ω 5.5488 Ω 454.80 μ H 1 900.000 000 MHz

*
De1
CA
Avg
16
H1d

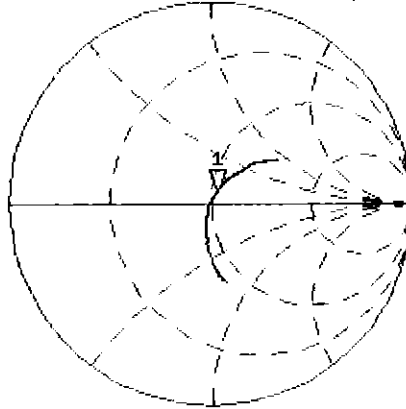

CH2 S11 LOG 5 dB/REF -20 dB 1:-24.579 dB 1 900.000 000 MHz

CA
H1d

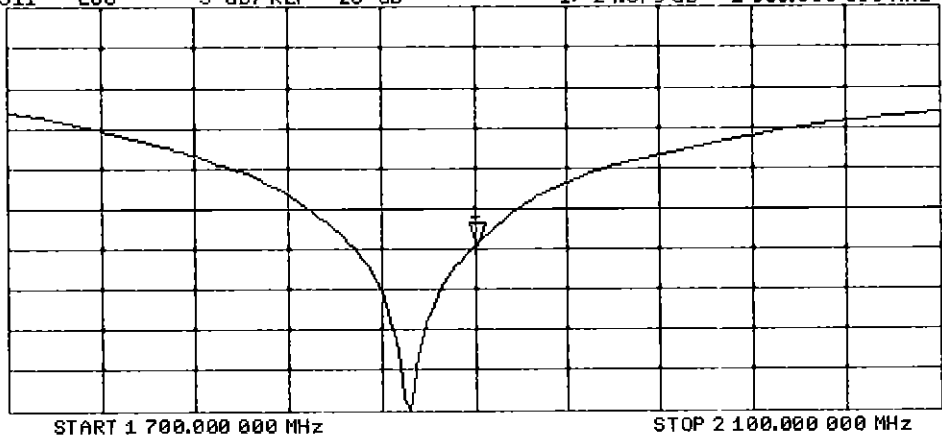

DASY5 Validation Report for Body TSL

Date: 13.07.2016

Test Laboratory: SPEAG, Zurich, Switzerland

DUT: Dipole 1900 MHz D1900V2; Type: D1900V2; Serial: D1900V2 - SN:5d149

Communication System: UID 0 - CW; Frequency: 1900 MHz

Medium parameters used: $f = 1900$ MHz; $\sigma = 1.51$ S/m; $\epsilon_r = 52.7$; $\rho = 1000$ kg/m³

Phantom section: Flat Section

Measurement Standard: DASY5 (IEEE/IEC/ANSI C63.19-2011)

DASY52 Configuration:

- Probe: EX3DV4 - SN7349; ConvF(8.03, 8.03, 8.03); Calibrated: 15.06.2016;
- Sensor-Surface: 1.4mm (Mechanical Surface Detection)
- Electronics: DAE4 Sn601; Calibrated: 30.12.2015
- Phantom: Flat Phantom 5.0 (back); Type: QD000P50AA; Serial: 1002
- DASY52 52.8.8(1222); SEMCAD X 14.6.10(7372)

Dipole Calibration for Body Tissue/Pin=250 mW, d=10mm/Zoom Scan (7x7x7)/Cube 0:

Measurement grid: dx=5mm, dy=5mm, dz=5mm

Reference Value = 103.9 V/m; Power Drift = 0.00 dB

Peak SAR (extrapolated) = 17.4 W/kg

SAR(1 g) = 9.95 W/kg; SAR(10 g) = 5.28 W/kg

Maximum value of SAR (measured) = 14.9 W/kg

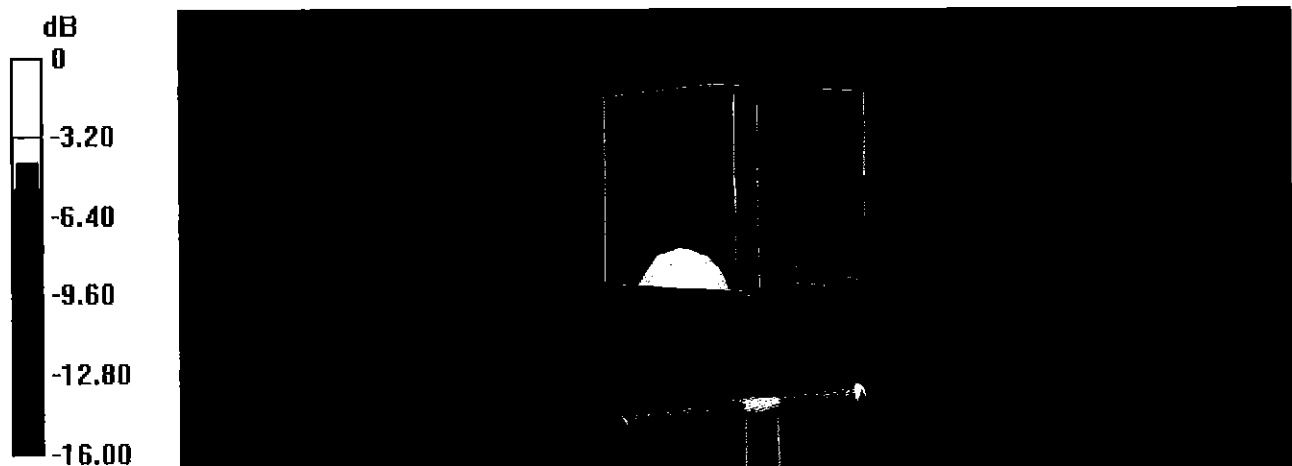

0 dB = 14.9 W/kg = 11.73 dBW/kg

Impedance Measurement Plot for Body TSL

13 Jul 2016 16:29:36

CH1 S11 1 U FS 1: 49.625 Ω 6.9922 Ω 585.71 pF 1 900,000 000 MHz

*
De1
Cor
Avg
16
H1d

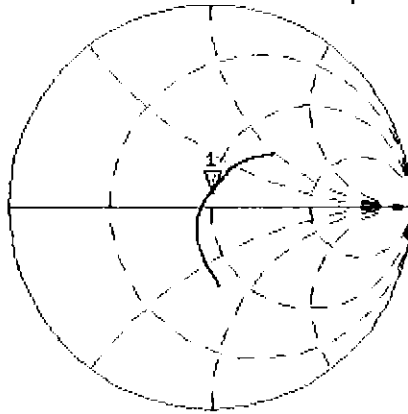

CH2 S11 LOG 5 dB/REF -20 dB 1:-23.087 dB 1 900,000 000 MHz

Cor
Avg
16
H1d

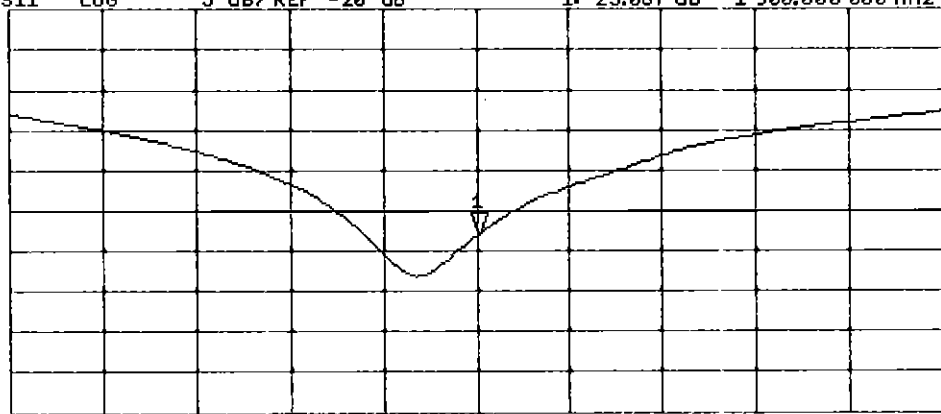

START 1 700,000 000 MHz

STOP 2 100,000 000 MHz



Accredited by the Swiss Accreditation Service (SAS)
The Swiss Accreditation Service is one of the signatories to the EA
Multilateral Agreement for the recognition of calibration certificates

Accreditation No.: **SCS 0108**

Client **PC Test**

Certificate No: **D2450V2-797_Sep16**

CALIBRATION CERTIFICATE

Object **D2450V2 - SN:797**

Calibration procedure(s) **QA CAL-05.v9**
Calibration procedure for dipole validation kits above 700 MHz

BNV
09-28-2016

Calibration date: **September 13, 2016**

This calibration certificate documents the traceability to national standards, which realize the physical units of measurements (SI).
The measurements and the uncertainties with confidence probability are given on the following pages and are part of the certificate.

All calibrations have been conducted in the closed laboratory facility: environment temperature (22 ± 3)°C and humidity < 70%.

Calibration Equipment used (M&TE critical for calibration)

Primary Standards	ID #	Cal Date (Certificate No.)	Scheduled Calibration
Power meter NRP	SN: 104778	06-Apr-16 (No. 217-02288/02289)	Apr-17
Power sensor NRP-Z91	SN: 103244	06-Apr-16 (No. 217-02288)	Apr-17
Power sensor NRP-Z91	SN: 103245	06-Apr-16 (No. 217-02289)	Apr-17
Reference 20 dB Attenuator	SN: 5058 (20k)	05-Apr-16 (No. 217-02292)	Apr-17
Type-N mismatch combination	SN: 5047.2 / 06327	05-Apr-16 (No. 217-02295)	Apr-17
Reference Probe EX3DV4	SN: 7349	15-Jun-16 (No. EX3-7349_Jun16)	Jun-17
DAE4	SN: 601	30-Dec-15 (No. DAE4-601_Dec15)	Dec-16

Secondary Standards	ID #	Check Date (in house)	Scheduled Check
Power meter EPM-442A	SN: GB37480704	07-Oct-15 (No. 217-02222)	In house check: Oct-16
Power sensor HP 8481A	SN: US37292783	07-Oct-15 (No. 217-02222)	In house check: Oct-16
Power sensor HP 8481A	SN: MY41092317	07-Oct-15 (No. 217-02223)	In house check: Oct-16
RF generator R&S SMT-06	SN: 100972	15-Jun-15 (in house check Jun-15)	In house check: Oct-16
Network Analyzer HP 8753E	SN: US37390585	18-Oct-01 (in house check Oct-15)	In house check: Oct-16

Calibrated by: **Jeton Kastrati** Function: **Laboratory Technician**

Approved by: **Katja Pokovic** Technical Manager

Signature

Issued: September 13, 2016

This calibration certificate shall not be reproduced except in full without written approval of the laboratory.



Accredited by the Swiss Accreditation Service (SAS)
The Swiss Accreditation Service is one of the signatories to the EA
Multilateral Agreement for the recognition of calibration certificates

Accreditation No.: **SCS 0108**

Glossary:

TSL	tissue simulating liquid
ConvF	sensitivity in TSL / NORM x,y,z
N/A	not applicable or not measured

Calibration is Performed According to the Following Standards:

- IEEE Std 1528-2013, "IEEE Recommended Practice for Determining the Peak Spatial-Averaged Specific Absorption Rate (SAR) in the Human Head from Wireless Communications Devices: Measurement Techniques", June 2013
- IEC 62209-1, "Procedure to measure the Specific Absorption Rate (SAR) for hand-held devices used in close proximity to the ear (frequency range of 300 MHz to 3 GHz)", February 2005
- IEC 62209-2, "Procedure to determine the Specific Absorption Rate (SAR) for wireless communication devices used in close proximity to the human body (frequency range of 30 MHz to 6 GHz)", March 2010
- KDB 865664, "SAR Measurement Requirements for 100 MHz to 6 GHz"

Additional Documentation:

- DASY4/5 System Handbook

Methods Applied and Interpretation of Parameters:

- Measurement Conditions:* Further details are available from the Validation Report at the end of the certificate. All figures stated in the certificate are valid at the frequency indicated.
- Antenna Parameters with TSL:* The dipole is mounted with the spacer to position its feed point exactly below the center marking of the flat phantom section, with the arms oriented parallel to the body axis.
- Feed Point Impedance and Return Loss:* These parameters are measured with the dipole positioned under the liquid filled phantom. The impedance stated is transformed from the measurement at the SMA connector to the feed point. The Return Loss ensures low reflected power. No uncertainty required.
- Electrical Delay:* One-way delay between the SMA connector and the antenna feed point. No uncertainty required.
- SAR measured:* SAR measured at the stated antenna input power.
- SAR normalized:* SAR as measured, normalized to an input power of 1 W at the antenna connector.
- SAR for nominal TSL parameters:* The measured TSL parameters are used to calculate the nominal SAR result.

The reported uncertainty of measurement is stated as the standard uncertainty of measurement multiplied by the coverage factor $k=2$, which for a normal distribution corresponds to a coverage probability of approximately 95%.

Measurement Conditions

DASY system configuration, as far as not given on page 1.

DASY Version	DASY5	V52.8.8
Extrapolation	Advanced Extrapolation	
Phantom	Modular Flat Phantom	
Distance Dipole Center - TSL	10 mm	with Spacer
Zoom Scan Resolution	dx, dy, dz = 5 mm	
Frequency	2450 MHz ± 1 MHz	

Head TSL parameters

The following parameters and calculations were applied.

	Temperature	Permittivity	Conductivity
Nominal Head TSL parameters	22.0 °C	39.2	1.80 mho/m
Measured Head TSL parameters	(22.0 ± 0.2) °C	37.9 ± 6 %	1.88 mho/m ± 6 %
Head TSL temperature change during test	< 0.5 °C	----	----

SAR result with Head TSL

SAR averaged over 1 cm ³ (1 g) of Head TSL	Condition	
SAR measured	250 mW input power	13.4 W/kg
SAR for nominal Head TSL parameters	normalized to 1W	52.1 W/kg ± 17.0 % (k=2)

SAR averaged over 10 cm ³ (10 g) of Head TSL	condition	
SAR measured	250 mW input power	6.26 W/kg
SAR for nominal Head TSL parameters	normalized to 1W	24.6 W/kg ± 16.5 % (k=2)

Body TSL parameters

The following parameters and calculations were applied.

	Temperature	Permittivity	Conductivity
Nominal Body TSL parameters	22.0 °C	52.7	1.95 mho/m
Measured Body TSL parameters	(22.0 ± 0.2) °C	51.6 ± 6 %	2.04 mho/m ± 6 %
Body TSL temperature change during test	< 0.5 °C	----	----

SAR result with Body TSL

SAR averaged over 1 cm ³ (1 g) of Body TSL	Condition	
SAR measured	250 mW input power	13.0 W/kg
SAR for nominal Body TSL parameters	normalized to 1W	50.7 W/kg ± 17.0 % (k=2)

SAR averaged over 10 cm ³ (10 g) of Body TSL	condition	
SAR measured	250 mW input power	6.13 W/kg
SAR for nominal Body TSL parameters	normalized to 1W	24.2 W/kg ± 16.5 % (k=2)

Appendix (Additional assessments outside the scope of SCS 0108)

Antenna Parameters with Head TSL

Impedance, transformed to feed point	53.8 Ω + 6.0 j Ω
Return Loss	- 23.3 dB

Antenna Parameters with Body TSL

Impedance, transformed to feed point	50.8 Ω + 8.0 j Ω
Return Loss	- 22.0 dB

General Antenna Parameters and Design

Electrical Delay (one direction)	1.160 ns
----------------------------------	----------

After long term use with 100W radiated power, only a slight warming of the dipole near the feedpoint can be measured.

The dipole is made of standard semirigid coaxial cable. The center conductor of the feeding line is directly connected to the second arm of the dipole. The antenna is therefore short-circuited for DC-signals. On some of the dipoles, small end caps are added to the dipole arms in order to improve matching when loaded according to the position as explained in the "Measurement Conditions" paragraph. The SAR data are not affected by this change. The overall dipole length is still according to the Standard.

No excessive force must be applied to the dipole arms, because they might bend or the soldered connections near the feedpoint may be damaged.

Additional EUT Data

Manufactured by	SPEAG
Manufactured on	January 24, 2006

DASY5 Validation Report for Head TSL

Date: 13.09.2016

Test Laboratory: SPEAG, Zurich, Switzerland

DUT: Dipole 2450 MHz; Type: D2450V2; Serial: D2450V2 - SN:797

Communication System: UID 0 - CW; Frequency: 2450 MHz

Medium parameters used: $f = 2450$ MHz; $\sigma = 1.88$ S/m; $\epsilon_r = 37.9$; $\rho = 1000$ kg/m³

Phantom section: Flat Section

Measurement Standard: DASY5 (IEEE/IEC/ANSI C63.19-2011)

DASY52 Configuration:

- Probe: EX3DV4 - SN7349; ConvF(7.72, 7.72, 7.72); Calibrated: 15.06.2016;
- Sensor-Surface: 1.4mm (Mechanical Surface Detection)
- Electronics: DAE4 Sn601; Calibrated: 30.12.2015
- Phantom: Flat Phantom 5.0 (front); Type: QD000P50AA; Serial: 1001
- DASY52 52.8.8(1258); SEMCAD X 14.6.10(7372)

Dipole Calibration for Head Tissue/Pin=250 mW, d=10mm/Zoom Scan (7x7x7)/Cube 0:

Measurement grid: dx=5mm, dy=5mm, dz=5mm

Reference Value = 113.4 V/m; Power Drift = -0.02 dB

Peak SAR (extrapolated) = 26.9 W/kg

SAR(1 g) = 13.4 W/kg; SAR(10 g) = 6.26 W/kg

Maximum value of SAR (measured) = 21.9 W/kg

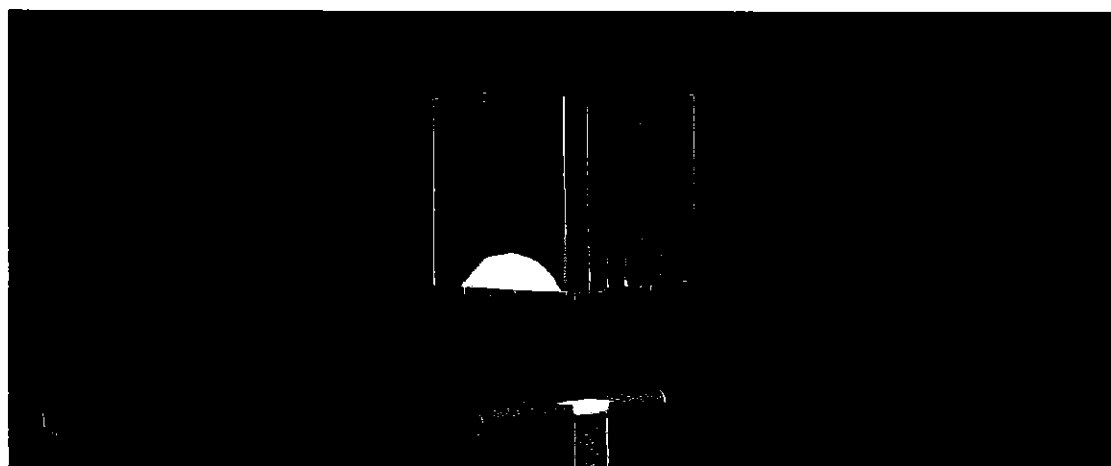
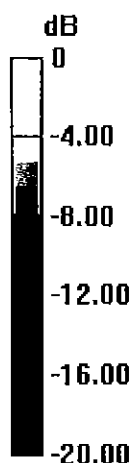

0 dB = 21.9 W/kg = 13.40 dBW/kg

Impedance Measurement Plot for Head TSL

12 Sep 2016 12:42:03

CH1 S11 1 U FS 2: 53.771 Ω 6.0234 Ω 391.29 μ H 2 450.000 000 MHz

*
De1
CA

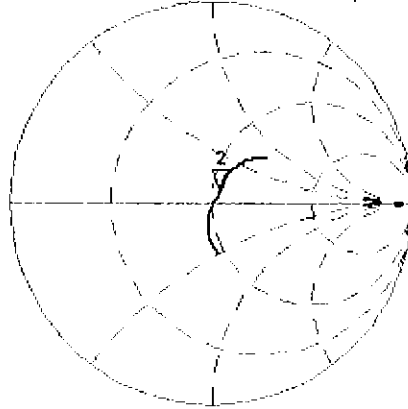

Avg
16

H1d

CH2 S11 LOG 5 dB/REF -20 dB 2:-23.300 dB 2 450.000 000 MHz

CA

Avg
16

H1d

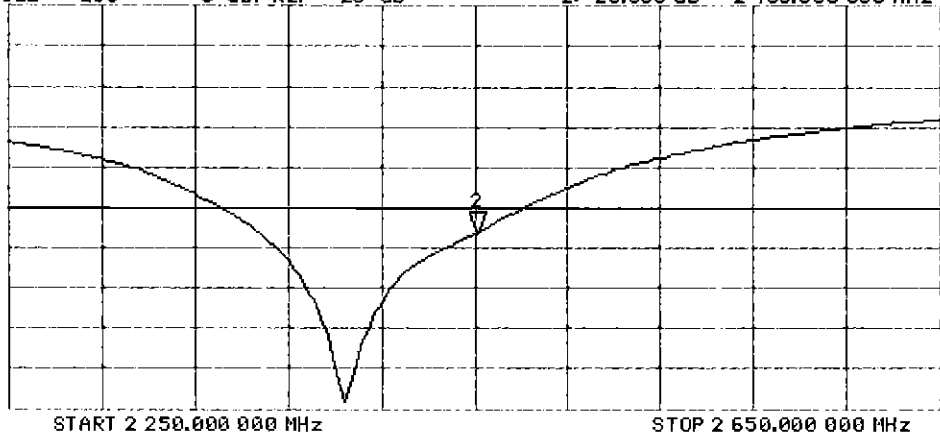

DASY5 Validation Report for Body TSL

Date: 13.09.2016

Test Laboratory: SPEAG, Zurich, Switzerland

DUT: Dipole 2450 MHz; Type: D2450V2; Serial: D2450V2 - SN:797

Communication System: UID 0 - CW; Frequency: 2450 MHz

Medium parameters used: $f = 2450$ MHz; $\sigma = 2.04$ S/m; $\epsilon_r = 51.6$; $\rho = 1000$ kg/m³

Phantom section: Flat Section

Measurement Standard: DASY5 (IEEE/IEC/ANSI C63.19-2011)

DASY52 Configuration:

- Probe: EX3DV4 - SN7349; ConvF(7.79, 7.79, 7.79); Calibrated: 15.06.2016;
- Sensor-Surface: 1.4mm (Mechanical Surface Detection)
- Electronics: DAE4 Sn601; Calibrated: 30.12.2015
- Phantom: Flat Phantom 5.0 (back); Type: QD000P50AA; Serial: 1002
- DASY52 52.8.8(1258); SEMCAD X 14.6.10(7372)

Dipole Calibration for Body Tissue/Pin=250 mW, d=10mm/Zoom Scan (7x7x7)/Cube 0:

Measurement grid: dx=5mm, dy=5mm, dz=5mm

Reference Value = 106.5 V/m; Power Drift = -0.04 dB

Peak SAR (extrapolated) = 25.6 W/kg

SAR(1 g) = 13 W/kg; SAR(10 g) = 6.13 W/kg

Maximum value of SAR (measured) = 21.2 W/kg

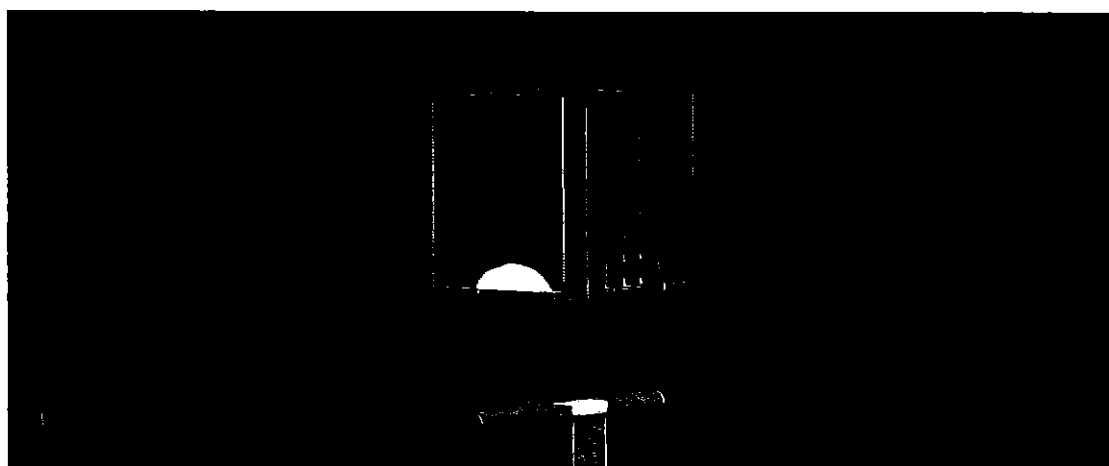
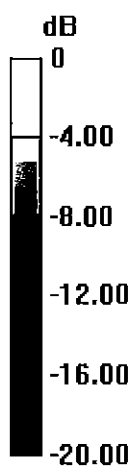

0 dB = 21.2 W/kg = 13.26 dBW/kg

Impedance Measurement Plot for Body TSL

12 Sep 2016 12:40:39

CH1 S11 1 U FS 2: 50.842 Ω 7.9531 Ω 516.64 μH 2 450.000 000 MHz

*
De1
CA

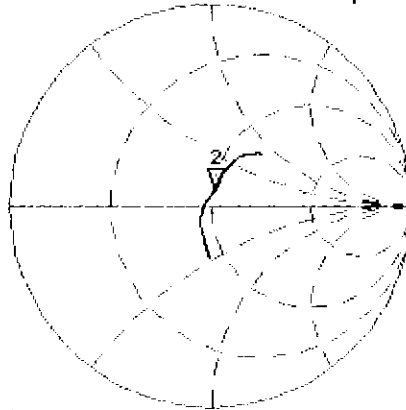

Avg
16
H1d

CH2 S11 LOG 5 dB/REF -20 dB 2:-22.037 dB 2 450.000 000 MHz

CA
Avg
16
H1d

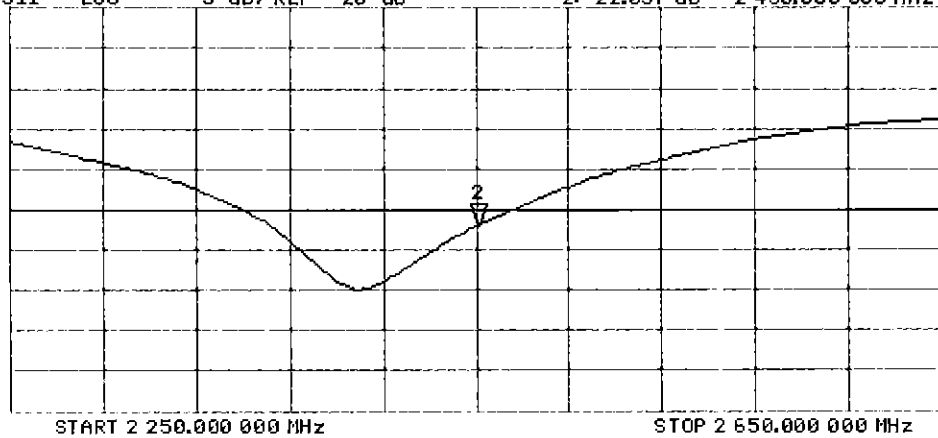



Accredited by the Swiss Accreditation Service (SAS)
The Swiss Accreditation Service is one of the signatories to the EA
Multilateral Agreement for the recognition of calibration certificates

Accreditation No.: **SCS 0108**

Client **PC Test**

Certificate No: **D2600V2-1126_Jul16**

CALIBRATION CERTIFICATE

Object **D2600V2 - SN: 1126**

Calibration procedure(s) **QA CAL-05.v9
Calibration procedure for dipole validation kits above 700 MHz**

*✓ PM
8/9/16*

Calibration date: **July 25, 2016**

This calibration certificate documents the traceability to national standards, which realize the physical units of measurements (SI).
The measurements and the uncertainties with confidence probability are given on the following pages and are part of the certificate.

All calibrations have been conducted in the closed laboratory facility: environment temperature (22 ± 3)°C and humidity < 70%.

Calibration Equipment used (M&TE critical for calibration)

Primary Standards	ID #	Cal Date (Certificate No.)	Scheduled Calibration
Power meter NRP	SN: 104778	06-Apr-16 (No. 217-02288/02289)	Apr-17
Power sensor NRP-Z91	SN: 103244	06-Apr-16 (No. 217-02288)	Apr-17
Power sensor NRP-Z91	SN: 103245	06-Apr-16 (No. 217-02289)	Apr-17
Reference 20 dB Attenuator	SN: 5058 (20k)	05-Apr-16 (No. 217-02292)	Apr-17
Type-N mismatch combination	SN: 5047.2 / 06327	05-Apr-16 (No. 217-02295)	Apr-17
Reference Probe EX3DV4	SN: 7349	15-Jun-16 (No. EX3-7349_Jun16)	Jun-17
DAE4	SN: 601	30-Dec-15 (No. DAE4-601_Dec15)	Dec-16

Secondary Standards	ID #	Check Date (in house)	Scheduled Check
Power meter EPM-442A	SN: GB37480704	07-Oct-15 (No. 217-02222)	In house check: Oct-16
Power sensor HP 8481A	SN: US37292783	07-Oct-15 (No. 217-02222)	In house check: Oct-16
Power sensor HP 8481A	SN: MY41092317	07-Oct-15 (No. 217-02223)	In house check: Oct-16
RF generator R&S SMT-06	SN: 100972	15-Jun-15 (in house check Jun-15)	In house check: Oct-16
Network Analyzer HP 8753E	SN: US37390585	18-Oct-01 (in house check Oct-15)	In house check: Oct-16

Calibrated by: **Michael Weber** Name: **Michael Weber** Function: **Laboratory Technician**

Signature: *M. Weber*

Approved by: **Katja Pokovic** Name: **Katja Pokovic** Function: **Technical Manager**

Signature: *Katja Pokovic*

Issued: July 26, 2016

This calibration certificate shall not be reproduced except in full without written approval of the laboratory.



Accredited by the Swiss Accreditation Service (SAS)
The Swiss Accreditation Service is one of the signatories to the EA
Multilateral Agreement for the recognition of calibration certificates

Accreditation No.: **SCS 0108**

Glossary:

TSL	tissue simulating liquid
ConvF	sensitivity in TSL / NORM x,y,z
N/A	not applicable or not measured

Calibration is Performed According to the Following Standards:

- IEEE Std 1528-2013, "IEEE Recommended Practice for Determining the Peak Spatial-Averaged Specific Absorption Rate (SAR) in the Human Head from Wireless Communications Devices: Measurement Techniques", June 2013
- IEC 62209-1, "Procedure to measure the Specific Absorption Rate (SAR) for hand-held devices used in close proximity to the ear (frequency range of 300 MHz to 3 GHz)", February 2005
- IEC 62209-2, "Procedure to determine the Specific Absorption Rate (SAR) for wireless communication devices used in close proximity to the human body (frequency range of 30 MHz to 6 GHz)", March 2010
- KDB 865664, "SAR Measurement Requirements for 100 MHz to 6 GHz"

Additional Documentation:

- DASY4/5 System Handbook

Methods Applied and Interpretation of Parameters:

- Measurement Conditions:** Further details are available from the Validation Report at the end of the certificate. All figures stated in the certificate are valid at the frequency indicated.
- Antenna Parameters with TSL:** The dipole is mounted with the spacer to position its feed point exactly below the center marking of the flat phantom section, with the arms oriented parallel to the body axis.
- Feed Point Impedance and Return Loss:** These parameters are measured with the dipole positioned under the liquid filled phantom. The impedance stated is transformed from the measurement at the SMA connector to the feed point. The Return Loss ensures low reflected power. No uncertainty required.
- Electrical Delay:** One-way delay between the SMA connector and the antenna feed point. No uncertainty required.
- SAR measured:** SAR measured at the stated antenna input power.
- SAR normalized:** SAR as measured, normalized to an input power of 1 W at the antenna connector.
- SAR for nominal TSL parameters:** The measured TSL parameters are used to calculate the nominal SAR result.

The reported uncertainty of measurement is stated as the standard uncertainty of measurement multiplied by the coverage factor $k=2$, which for a normal distribution corresponds to a coverage probability of approximately 95%.

Measurement Conditions

DASY system configuration, as far as not given on page 1.

DASY Version	DASY5	V52.8.8
Extrapolation	Advanced Extrapolation	
Phantom	Modular Flat Phantom	
Distance Dipole Center - TSL	10 mm	with Spacer
Zoom Scan Resolution	dx, dy, dz = 5 mm	
Frequency	2600 MHz \pm 1 MHz	

Head TSL parameters

The following parameters and calculations were applied.

	Temperature	Permittivity	Conductivity
Nominal Head TSL parameters	22.0 °C	39.0	1.96 mho/m
Measured Head TSL parameters	(22.0 \pm 0.2) °C	37.5 \pm 6 %	2.02 mho/m \pm 6 %
Head TSL temperature change during test	< 0.5 °C	----	----

SAR result with Head TSL

SAR averaged over 1 cm ³ (1 g) of Head TSL	Condition	
SAR measured	250 mW input power	14.4 W/kg
SAR for nominal Head TSL parameters	normalized to 1W	56.3 W/kg \pm 17.0 % (k=2)

SAR averaged over 10 cm ³ (10 g) of Head TSL	condition	
SAR measured	250 mW input power	6.36 W/kg
SAR for nominal Head TSL parameters	normalized to 1W	25.1 W/kg \pm 16.5 % (k=2)

Body TSL parameters

The following parameters and calculations were applied.

	Temperature	Permittivity	Conductivity
Nominal Body TSL parameters	22.0 °C	52.5	2.16 mho/m
Measured Body TSL parameters	(22.0 \pm 0.2) °C	51.4 \pm 6 %	2.20 mho/m \pm 6 %
Body TSL temperature change during test	< 0.5 °C	----	----

SAR result with Body TSL

SAR averaged over 1 cm ³ (1 g) of Body TSL	Condition	
SAR measured	250 mW input power	13.8 W/kg
SAR for nominal Body TSL parameters	normalized to 1W	54.5 W/kg \pm 17.0 % (k=2)

SAR averaged over 10 cm ³ (10 g) of Body TSL	condition	
SAR measured	250 mW input power	6.12 W/kg
SAR for nominal Body TSL parameters	normalized to 1W	24.3 W/kg \pm 16.5 % (k=2)

Appendix (Additional assessments outside the scope of SCS 0108)

Antenna Parameters with Head TSL

Impedance, transformed to feed point	48.0 Ω - 7.4 j Ω
Return Loss	- 22.1 dB

Antenna Parameters with Body TSL

Impedance, transformed to feed point	45.4 Ω - 6.2 j Ω
Return Loss	- 21.9 dB

General Antenna Parameters and Design

Electrical Delay (one direction)	1.152 ns
----------------------------------	----------

After long term use with 100W radiated power, only a slight warming of the dipole near the feedpoint can be measured.

The dipole is made of standard semirigid coaxial cable. The center conductor of the feeding line is directly connected to the second arm of the dipole. The antenna is therefore short-circuited for DC-signals. On some of the dipoles, small end caps are added to the dipole arms in order to improve matching when loaded according to the position as explained in the "Measurement Conditions" paragraph. The SAR data are not affected by this change. The overall dipole length is still according to the Standard.

No excessive force must be applied to the dipole arms, because they might bend or the soldered connections near the feedpoint may be damaged.

Additional EUT Data

Manufactured by	SPEAG
Manufactured on	October 22, 2015

DASY5 Validation Report for Head TSL

Date: 13.07.2016

Test Laboratory: SPEAG, Zurich, Switzerland

DUT: Dipole 2600 MHz; Type: D2600V2; Serial: D2600V2 - SN: 1126

Communication System: UID 0 - CW; Frequency: 2600 MHz

Medium parameters used: $f = 2600$ MHz; $\sigma = 2.02$ S/m; $\epsilon_r = 37.5$; $\rho = 1000$ kg/m³

Phantom section: Flat Section

Measurement Standard: DASY5 (IEEE/IEC/ANSI C63.19-2011)

DASY52 Configuration:

- Probe: EX3DV4 - SN7349; ConvF(7.56, 7.56, 7.56); Calibrated: 15.06.2016;
- Sensor-Surface: 1.4mm (Mechanical Surface Detection)
- Electronics: DAE4 Sn601; Calibrated: 30.12.2015
- Phantom: Flat Phantom 5.0 (front); Type: QD000P50AA; Serial: 1001
- DASY52 52.8.8(1258); SEMCAD X 14.6.10(7372)

Dipole Calibration for Head Tissue/Pin=250 mW, d=10mm/Zoom Scan (7x7x7)/Cube 0:

Measurement grid: dx=5mm, dy=5mm, dz=5mm

Reference Value = 116.2 V/m; Power Drift = 0.00 dB

Peak SAR (extrapolated) = 30.6 W/kg

SAR(1 g) = 14.4 W/kg; SAR(10 g) = 6.36 W/kg

Maximum value of SAR (measured) = 24.6 W/kg

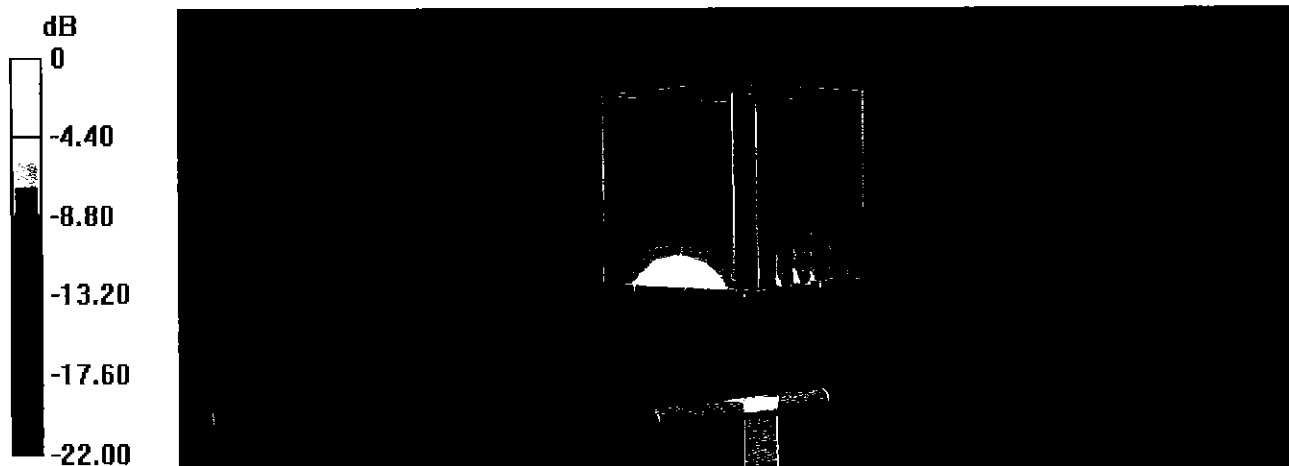

0 dB = 24.6 W/kg = 13.91 dBW/kg

Impedance Measurement Plot for Head TSL

13 Jul 2016 15:46:28

CH1 S11 1 U FS

S: 47.990 Ω -7.4297 Ω 8.2390 pF

2 600.000 000 MHz

*
De 1

CA

Avg
16

H1 d

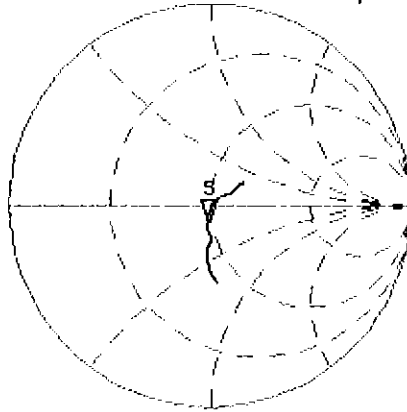

CH2 S11 LOG

5 dB/REF -20 dB

S:-22.121 dB 2 600.000 000 MHz

CA

Avg
16

H1 d

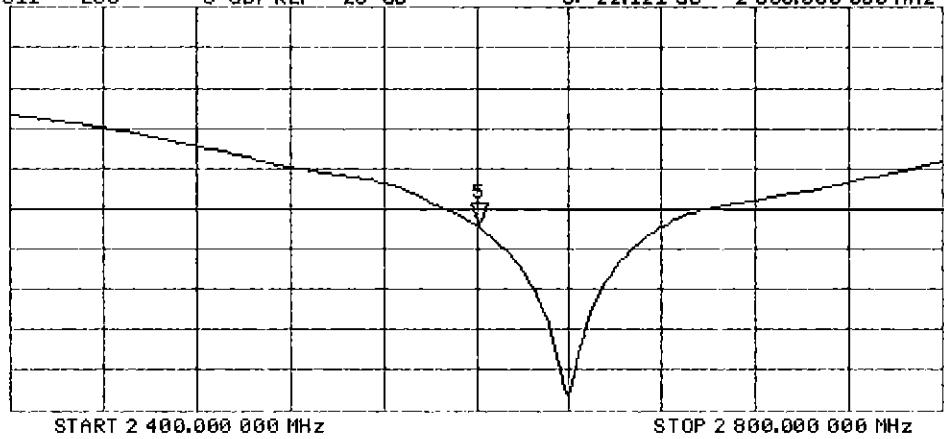

DASY5 Validation Report for Body TSL

Date: 22.07.2016

Test Laboratory: SPEAG, Zurich, Switzerland

DUT: Dipole 2600 MHz D2600V2; Type: D2600V2; Serial: D2600V2 - SN:1126

Communication System: UID 0 - CW; Frequency: 2600 MHz

Medium parameters used: $f = 2600$ MHz; $\sigma = 2.2$ S/m; $\epsilon_r = 51.4$; $\rho = 1000$ kg/m³

Phantom section: Flat Section

Measurement Standard: DASY5 (IEEE/IEC/ANSI C63.19-2011)

DASY52 Configuration:

- Probe: EX3DV4 - SN7349; ConvF(7.48, 7.48, 7.48); Calibrated: 15.06.2016;
- Sensor-Surface: 1.4mm (Mechanical Surface Detection)
- Electronics: DAE4 Sn601; Calibrated: 30.12.2015
- Phantom: Flat Phantom 5.0 (back); Type: QD000P50AA; Serial: 1002
- DASY52 52.8.8(1258); SEMCAD X 14.6.10(7372)

Dipole Calibration for Body Tissue/Pin=250 mW, d=10mm/Zoom Scan (7x7x7)/Cube 0:

Measurement grid: dx=5mm, dy=5mm, dz=5mm

Reference Value = 107.5 V/m; Power Drift = -0.04 dB

Peak SAR (extrapolated) = 28.5 W/kg

SAR(1 g) = 13.8 W/kg; SAR(10 g) = 6.12 W/kg

Maximum value of SAR (measured) = 23.0 W/kg

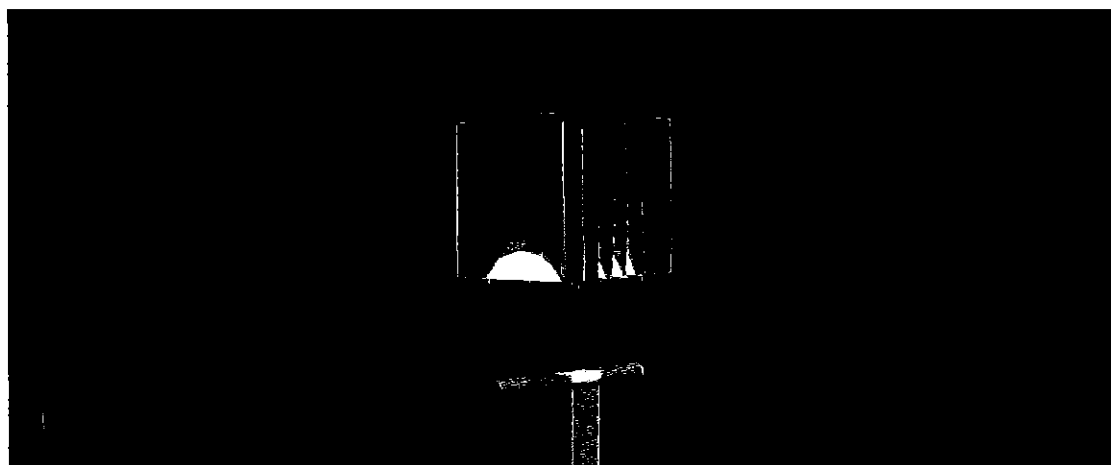
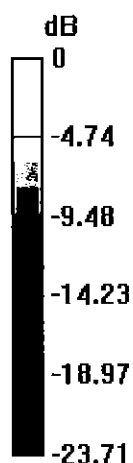

0 dB = 23.0 W/kg = 13.62 dBW/kg

Impedance Measurement Plot for Body TSL

22 Jul 2016 08:31:57

[CH1] S11 1 U FS 1: 45.354 n -6.1699 n 9.9213 pF 2 500.000 000 MHz

*
Del
CA
Avg
16
H1d

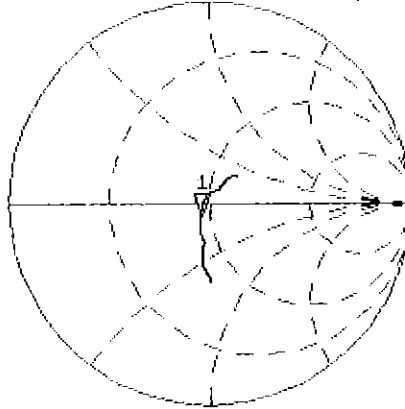

CH2 S11 LOG 5 dB/REF -20 dB 1: -21.863 dB 2 500.000 000 MHz

CA
H1d

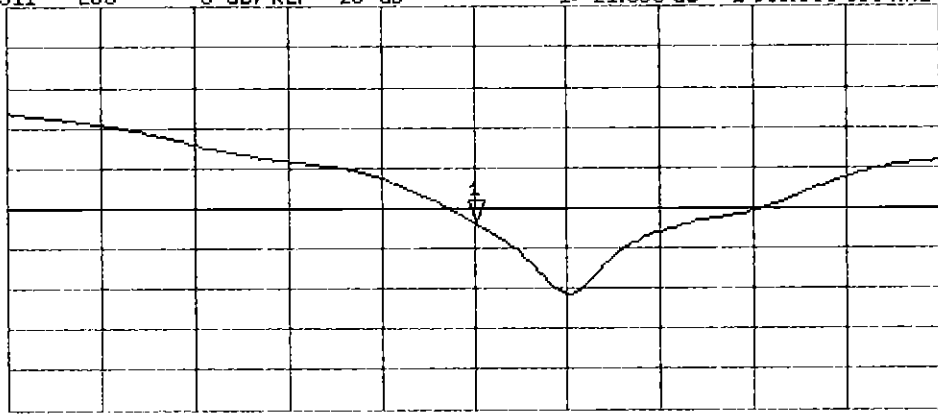

START 2 400.000 000 MHz

STOP 2 800.000 000 MHz



Accredited by the Swiss Accreditation Service (SAS)
The Swiss Accreditation Service is one of the signatories to the EA
Multilateral Agreement for the recognition of calibration certificates

Accreditation No.: **SCS 0108**

Client **PC Test**

Certificate No: **D5GHzV2-1237_Aug16**

CALIBRATION CERTIFICATE

Object **D5GHzV2 - SN:1237**

Calibration procedure(s) **QA CAL-22.v2
Calibration procedure for dipole validation kits between 3-6 GHz**

✓PT
8/9/16

Calibration date: **August 02, 2016**

This calibration certificate documents the traceability to national standards, which realize the physical units of measurements (SI).
The measurements and the uncertainties with confidence probability are given on the following pages and are part of the certificate.

All calibrations have been conducted in the closed laboratory facility: environment temperature (22 ± 3)°C and humidity < 70%.

Calibration Equipment used (M&TE critical for calibration)

Primary Standards	ID #	Cal Date (Certificate No.)	Scheduled Calibration
Power meter NRP	SN: 104778	06-Apr-16 (No. 217-02288/02289)	Apr-17
Power sensor NRP-Z91	SN: 103244	06-Apr-16 (No. 217-02288)	Apr-17
Power sensor NRP-Z91	SN: 103245	06-Apr-16 (No. 217-02289)	Apr-17
Reference 20 dB Attenuator	SN: 5058 (20k)	05-Apr-16 (No. 217-02292)	Apr-17
Type-N mismatch combination	SN: 5047.2 / 06327	05-Apr-16 (No. 217-02295)	Apr-17
Reference Probe EX3DV4	SN: 3503	30-Jun-16 (No. EX3-3503_Jun16)	Jun-17
DAE4	SN: 601	30-Dec-15 (No. DAE4-601_Dec15)	Dec-16

Secondary Standards	ID #	Check Date (in house)	Scheduled Check
Power meter EPM-442A	SN: GB37480704	07-Oct-15 (No. 217-02222)	In house check: Oct-16
Power sensor HP 8481A	SN: US37292783	07-Oct-15 (No. 217-02222)	In house check: Oct-16
Power sensor HP 8481A	SN: MY41092317	07-Oct-15 (No. 217-02223)	In house check: Oct-16
RF generator R&S SMT-06	SN: 100972	15-Jun-15 (in house check Jun-15)	In house check: Oct-16
Network Analyzer HP 8753E	SN: US37390585	18-Oct-01 (in house check Oct-15)	In house check: Oct-16

Calibrated by: **Claudio Leubler** Name: Claudio Leubler Function: Laboratory Technician

Approved by: **Katja Pokovic** Name: Katja Pokovic Function: Technical Manager

Signature

Issued: August 4, 2016

This calibration certificate shall not be reproduced except in full without written approval of the laboratory.



Accredited by the Swiss Accreditation Service (SAS)

The Swiss Accreditation Service is one of the signatories to the EA Multilateral Agreement for the recognition of calibration certificates

Glossary:

TSL	tissue simulating liquid
ConvF	sensitivity in TSL / NORM x,y,z
N/A	not applicable or not measured

Calibration is Performed According to the Following Standards:

- IEEE Std 1528-2013, "IEEE Recommended Practice for Determining the Peak Spatial-Averaged Specific Absorption Rate (SAR) in the Human Head from Wireless Communications Devices: Measurement Techniques", June 2013
- IEC 62209-2, "Procedure to determine the Specific Absorption Rate (SAR) for wireless communication devices used in close proximity to the human body (frequency range of 30 MHz to 6 GHz)", March 2010
- KDB 865664, "SAR Measurement Requirements for 100 MHz to 6 GHz"

Additional Documentation:

- DASY4/5 System Handbook

Methods Applied and Interpretation of Parameters:

- Measurement Conditions:* Further details are available from the Validation Report at the end of the certificate. All figures stated in the certificate are valid at the frequency indicated.
- Antenna Parameters with TSL:* The dipole is mounted with the spacer to position its feed point exactly below the center marking of the flat phantom section, with the arms oriented parallel to the body axis.
- Feed Point Impedance and Return Loss:* These parameters are measured with the dipole positioned under the liquid filled phantom. The impedance stated is transformed from the measurement at the SMA connector to the feed point. The Return Loss ensures low reflected power. No uncertainty required.
- Electrical Delay:* One-way delay between the SMA connector and the antenna feed point. No uncertainty required.
- SAR measured:* SAR measured at the stated antenna input power.
- SAR normalized:* SAR as measured, normalized to an input power of 1 W at the antenna connector.
- SAR for nominal TSL parameters:* The measured TSL parameters are used to calculate the nominal SAR result.

The reported uncertainty of measurement is stated as the standard uncertainty of measurement multiplied by the coverage factor $k=2$, which for a normal distribution corresponds to a coverage probability of approximately 95%.

Measurement Conditions

DASY system configuration, as far as not given on page 1.

DASY Version	DASY5	V52.8.8
Extrapolation	Advanced Extrapolation	
Phantom	Modular Flat Phantom V5.0	
Distance Dipole Center - TSL	10 mm	with Spacer
Zoom Scan Resolution	dx, dy = 4.0 mm, dz = 1.4 mm	Graded Ratio = 1.4 (Z direction)
Frequency	5250 MHz ± 1 MHz 5600 MHz ± 1 MHz 5750 MHz ± 1 MHz	

Head TSL parameters at 5250 MHz

The following parameters and calculations were applied.

	Temperature	Permittivity	Conductivity
Nominal Head TSL parameters	22.0 °C	35.9	4.71 mho/m
Measured Head TSL parameters	(22.0 ± 0.2) °C	34.4 ± 6 %	4.52 mho/m ± 6 %
Head TSL temperature change during test	< 0.5 °C	----	----

SAR result with Head TSL at 5250 MHz

SAR averaged over 1 cm ³ (1 g) of Head TSL	Condition	
SAR measured	100 mW input power	8.00 W/kg
SAR for nominal Head TSL parameters	normalized to 1W	79.2 W/kg ± 19.9 % (k=2)

SAR averaged over 10 cm ³ (10 g) of Head TSL	condition	
SAR measured	100 mW input power	2.30 W/kg
SAR for nominal Head TSL parameters	normalized to 1W	22.7 W/kg ± 19.5 % (k=2)

Head TSL parameters at 5600 MHz

The following parameters and calculations were applied.

	Temperature	Permittivity	Conductivity
Nominal Head TSL parameters	22.0 °C	35.5	5.07 mho/m
Measured Head TSL parameters	(22.0 ± 0.2) °C	33.9 ± 6 %	4.86 mho/m ± 6 %
Head TSL temperature change during test	< 0.5 °C	----	----

SAR result with Head TSL at 5600 MHz

SAR averaged over 1 cm ³ (1 g) of Head TSL	Condition	
SAR measured	100 mW input power	8.43 W/kg
SAR for nominal Head TSL parameters	normalized to 1W	83.3 W / kg ± 19.9 % (k=2)

SAR averaged over 10 cm ³ (10 g) of Head TSL	condition	
SAR measured	100 mW input power	2.42 W/kg
SAR for nominal Head TSL parameters	normalized to 1W	23.9 W/kg ± 19.5 % (k=2)

Head TSL parameters at 5750 MHz

The following parameters and calculations were applied.

	Temperature	Permittivity	Conductivity
Nominal Head TSL parameters	22.0 °C	35.4	5.22 mho/m
Measured Head TSL parameters	(22.0 ± 0.2) °C	33.7 ± 6 %	5.02 mho/m ± 6 %
Head TSL temperature change during test	< 0.5 °C	----	----

SAR result with Head TSL at 5750 MHz

SAR averaged over 1 cm ³ (1 g) of Head TSL	Condition	
SAR measured	100 mW input power	8.25 W/kg
SAR for nominal Head TSL parameters	normalized to 1W	81.5 W/kg ± 19.9 % (k=2)

SAR averaged over 10 cm ³ (10 g) of Head TSL	condition	
SAR measured	100 mW input power	2.35 W/kg
SAR for nominal Head TSL parameters	normalized to 1W	23.2 W/kg ± 19.5 % (k=2)

Body TSL parameters at 5250 MHz

The following parameters and calculations were applied.

	Temperature	Permittivity	Conductivity
Nominal Body TSL parameters	22.0 °C	48.9	5.36 mho/m
Measured Body TSL parameters	(22.0 ± 0.2) °C	47.1 ± 6 %	5.42 mho/m ± 6 %
Body TSL temperature change during test	< 0.5 °C	----	----

SAR result with Body TSL at 5250 MHz

SAR averaged over 1 cm ³ (1 g) of Body TSL	Condition	
SAR measured	100 mW input power	7.54 W/kg
SAR for nominal Body TSL parameters	normalized to 1W	74.8 W/kg ± 19.9 % (k=2)

SAR averaged over 10 cm ³ (10 g) of Body TSL	condition	
SAR measured	100 mW input power	2.12 W/kg
SAR for nominal Body TSL parameters	normalized to 1W	21.0 W/kg ± 19.5 % (k=2)

Body TSL parameters at 5600 MHz

The following parameters and calculations were applied.

	Temperature	Permittivity	Conductivity
Nominal Body TSL parameters	22.0 °C	48.5	5.77 mho/m
Measured Body TSL parameters	(22.0 ± 0.2) °C	46.5 ± 6 %	5.88 mho/m ± 6 %
Body TSL temperature change during test	< 0.5 °C	----	----

SAR result with Body TSL at 5600 MHz

SAR averaged over 1 cm ³ (1 g) of Body TSL	Condition	
SAR measured	100 mW input power	7.76 W/kg
SAR for nominal Body TSL parameters	normalized to 1W	77.0 W/kg ± 19.9 % (k=2)

SAR averaged over 10 cm ³ (10 g) of Body TSL	condition	
SAR measured	100 mW input power	2.17 W/kg
SAR for nominal Body TSL parameters	normalized to 1W	21.5 W/kg ± 19.5 % (k=2)

Body TSL parameters at 5750 MHz

The following parameters and calculations were applied.

	Temperature	Permittivity	Conductivity
Nominal Body TSL parameters	22.0 °C	48.3	5.94 mho/m
Measured Body TSL parameters	(22.0 ± 0.2) °C	46.2 ± 6 %	6.11 mho/m ± 6 %
Body TSL temperature change during test	< 0.5 °C	----	----

SAR result with Body TSL at 5750 MHz

SAR averaged over 1 cm ³ (1 g) of Body TSL	Condition	
SAR measured	100 mW input power	7.60 W/kg
SAR for nominal Body TSL parameters	normalized to 1W	75.4 W/kg ± 19.9 % (k=2)

SAR averaged over 10 cm ³ (10 g) of Body TSL	condition	
SAR measured	100 mW input power	2.11 W/kg
SAR for nominal Body TSL parameters	normalized to 1W	20.9 W/kg ± 19.5 % (k=2)

Appendix (Additional assessments outside the scope of SCS 0108)

Antenna Parameters with Head TSL at 5250 MHz

Impedance, transformed to feed point	48.6 Ω - 2.5 j Ω
Return Loss	- 30.7 dB

Antenna Parameters with Head TSL at 5600 MHz

Impedance, transformed to feed point	50.9 Ω + 1.5 j Ω
Return Loss	- 35.3 dB

Antenna Parameters with Head TSL at 5750 MHz

Impedance, transformed to feed point	53.8 Ω + 5.8 j Ω
Return Loss	- 23.5 dB

Antenna Parameters with Body TSL at 5250 MHz

Impedance, transformed to feed point	47.0 Ω - 3.9 j Ω
Return Loss	- 25.9 dB

Antenna Parameters with Body TSL at 5600 MHz

Impedance, transformed to feed point	51.5 Ω + 3.9 j Ω
Return Loss	- 27.7 dB

Antenna Parameters with Body TSL at 5750 MHz

Impedance, transformed to feed point	53.8 Ω + 0.3 j Ω
Return Loss	- 28.6 dB

General Antenna Parameters and Design

Electrical Delay (one direction)	1.193 ns
----------------------------------	----------

After long term use with 100W radiated power, only a slight warming of the dipole near the feedpoint can be measured.

The dipole is made of standard semirigid coaxial cable. The center conductor of the feeding line is directly connected to the second arm of the dipole. The antenna is therefore short-circuited for DC-signals. On some of the dipoles, small end caps are added to the dipole arms in order to improve matching when loaded according to the position as explained in the "Measurement Conditions" paragraph. The SAR data are not affected by this change. The overall dipole length is still according to the Standard.

No excessive force must be applied to the dipole arms, because they might bend or the soldered connections near the feedpoint may be damaged.

Additional EUT Data

Manufactured by	SPEAG
Manufactured on	May 04, 2015

DASY5 Validation Report for Head TSL

Date: 02.08.2016

Test Laboratory: SPEAG, Zurich, Switzerland

DUT: Dipole D5GHzV2; Type: D5GHzV2; Serial: D5GHzV2 - SN:1237

Communication System: UID 0 - CW; Frequency: 5250 MHz, Frequency: 5600 MHz, Frequency: 5750 MHz
Medium parameters used: $f = 5250$ MHz; $\sigma = 4.52$ S/m; $\epsilon_r = 34.4$; $\rho = 1000$ kg/m³
Medium parameters used: $f = 5600$ MHz; $\sigma = 4.86$ S/m; $\epsilon_r = 33.9$; $\rho = 1000$ kg/m³
Medium parameters used: $f = 5750$ MHz; $\sigma = 5.02$ S/m; $\epsilon_r = 33.7$; $\rho = 1000$ kg/m³
Phantom section: Flat Section
Measurement Standard: DASY5 (IEEE/IEC/ANSI C63.19-2011)

DASY52 Configuration:

- Probe: EX3DV4 - SN3503; ConvF(5.42, 5.42, 5.42); Calibrated: 30.06.2016; ConvF(4.89, 4.89, 4.89); Calibrated: 30.06.2016, ConvF(4.85, 4.85, 4.85); Calibrated: 30.06.2016,
- Sensor-Surface: 1.4mm (Mechanical Surface Detection)
- Electronics: DAE4 Sn601; Calibrated: 30.12.2015
- Phantom: Flat Phantom 5.0 (front); Type: QD000P50AA; Serial: 1001
- DASY52 52.8.8(1258); SEMCAD X 14.6.10(7372)

Dipole Calibration for Head Tissue/Pin=100mW, dist=10mm, f=5250 MHz/Zoom Scan, dist=1.4mm (8x8x7)/Cube 0: Measurement grid: dx=4mm, dy=4mm, dz=1.4mm
Reference Value = 74.10 V/m; Power Drift = -0.03 dB
Peak SAR (extrapolated) = 29.5 W/kg
SAR(1 g) = 8 W/kg; SAR(10 g) = 2.3 W/kg
Maximum value of SAR (measured) = 18.3 W/kg

Dipole Calibration for Head Tissue/Pin=100mW, dist=10mm, f=5600 MHz/Zoom Scan, dist=1.4mm (8x8x7)/Cube 0: Measurement grid: dx=4mm, dy=4mm, dz=1.4mm
Reference Value = 73.55 V/m; Power Drift = -0.01 dB
Peak SAR (extrapolated) = 32.9 W/kg
SAR(1 g) = 8.43 W/kg; SAR(10 g) = 2.42 W/kg
Maximum value of SAR (measured) = 19.7 W/kg

Dipole Calibration for Head Tissue/Pin=100mW, dist=10mm, f=5750 MHz/Zoom Scan, dist=1.4mm (8x8x7)/Cube 0: Measurement grid: dx=4mm, dy=4mm, dz=1.4mm
Reference Value = 72.23 V/m; Power Drift = -0.01 dB
Peak SAR (extrapolated) = 33.6 W/kg
SAR(1 g) = 8.25 W/kg; SAR(10 g) = 2.35 W/kg
Maximum value of SAR (measured) = 18.3 W/kg

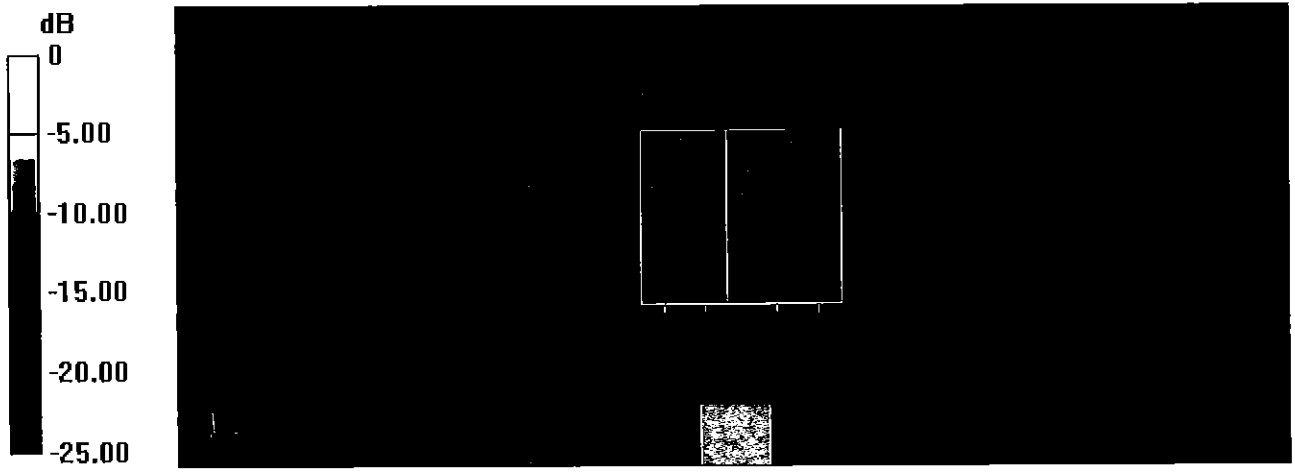

0 dB = 18.3 W/kg = 12.62 dBW/kg

Impedance Measurement Plot for Head TSL

2 Aug 2016 08:52:20

CH1 S11 1 U FS

1: 48.623 Ω -2.5332 Ω 11.967 pF

5 250.000 000 MHz

*
De1
Cor
Avg
16
H1d

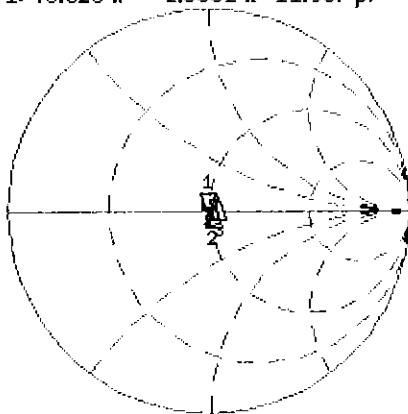

CH1 Markers
2: 50.867 Ω
1.4961 Ω
5.60000 GHz
3: 53.785 Ω
5.8164 Ω
5.75000 GHz

CH2 S11 LOG

5 dB/REF -20 dB

1: -30.691 dB 5 250.000 000 MHz

Cor
Avg
16
H1d

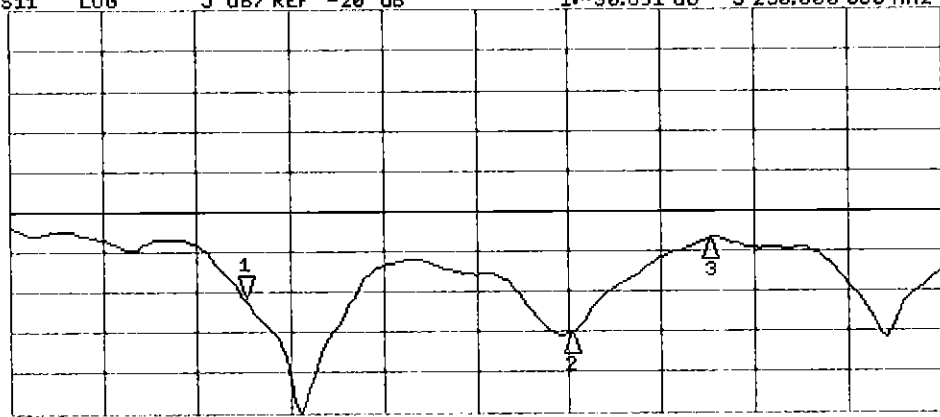

CH2 Markers
2: -35.297 dB
5.60000 GHz
3: -23.501 dB
5.75000 GHz

START 5 000.000 000 MHz

STOP 6 000.000 000 MHz

DASY5 Validation Report for Body TSL

Date: 02.08.2016

Test Laboratory: SPEAG, Zurich, Switzerland

DUT: Dipole D5GHzV2; Type: D5GHzV2; Serial: D5GHzV2 - SN:1237

Communication System: UID 0 - CW; Frequency: 5250 MHz, Frequency: 5600 MHz, Frequency: 5750 MHz

Medium parameters used: $f = 5250$ MHz; $\sigma = 5.42$ S/m; $\epsilon_r = 47.1$; $\rho = 1000$ kg/m³

Medium parameters used: $f = 5600$ MHz; $\sigma = 5.88$ S/m; $\epsilon_r = 46.5$; $\rho = 1000$ kg/m³

Medium parameters used: $f = 5750$ MHz; $\sigma = 6.11$ S/m; $\epsilon_r = 46.2$; $\rho = 1000$ kg/m³

Phantom section: Flat Section

Measurement Standard: DASY5 (IEEE/IEC/ANSI C63.19-2011)

DASY52 Configuration:

- Probe: EX3DV4 - SN3503; ConvF(4.85, 4.85, 4.85); Calibrated: 30.06.2016, ConvF(4.35, 4.35, 4.35); Calibrated: 30.06.2016, ConvF(4.3, 4.3, 4.3); Calibrated: 30.06.2016;
- Sensor-Surface: 1.4mm (Mechanical Surface Detection)
- Electronics: DAB4 Sn601; Calibrated: 30.12.2015
- Phantom: Flat Phantom 5.0 (back); Type: QD000P50AA; Serial: 1002
- DASY52 52.8.8(1222); SEMCAD X 14.6.10(7372)

Dipole Calibration for Body Tissue/Pin=100mW, dist=10mm, f=5250 MHz/Zoom Scan, dist=1.4mm (8x8x7)/Cube 0: Measurement grid: dx=4mm, dy=4mm, dz=1.4mm

Reference Value = 67.19 V/m; Power Drift = -0.04 dB

Peak SAR (extrapolated) = 28.4 W/kg

SAR(1 g) = 7.54 W/kg; SAR(10 g) = 2.12 W/kg

Maximum value of SAR (measured) = 17.3 W/kg

Dipole Calibration for Body Tissue/Pin=100mW, dist=10mm, f=5600 MHz/Zoom Scan, dist=1.4mm (8x8x7)/Cube 0: Measurement grid: dx=4mm, dy=4mm, dz=1.4mm

Reference Value = 66.80 V/m; Power Drift = -0.06 dB

Peak SAR (extrapolated) = 31.9 W/kg

SAR(1 g) = 7.76 W/kg; SAR(10 g) = 2.17 W/kg

Maximum value of SAR (measured) = 18.3 W/kg

Dipole Calibration for Body Tissue/Pin=100mW, dist=10mm, f=5750 MHz/Zoom Scan, dist=1.4mm (8x8x7)/Cube 0: Measurement grid: dx=4mm, dy=4mm, dz=1.4mm

Reference Value = 65.31 V/m; Power Drift = -0.09 dB

Peak SAR (extrapolated) = 32.6 W/kg

SAR(1 g) = 7.6 W/kg; SAR(10 g) = 2.11 W/kg

Maximum value of SAR (measured) = 18.4 W/kg

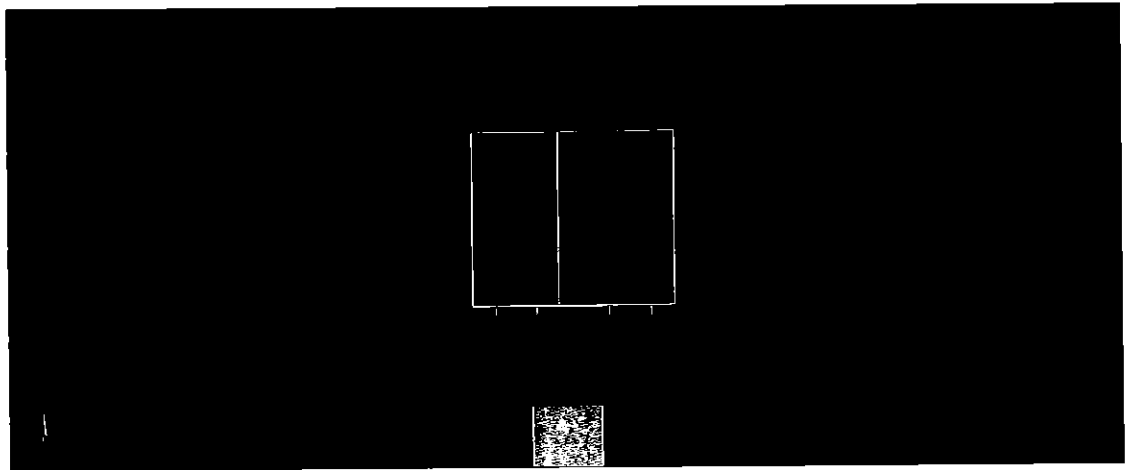
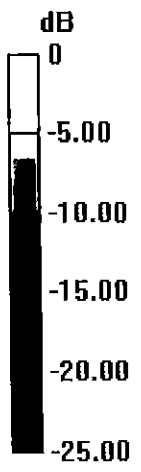

0 dB = 17.3 W/kg = 12.38 dBW/kg

Impedance Measurement Plot for Body TSL

2 Aug 2016 08:49:13

CH1 S11 1 U FS

1: 46.998 Ω -3.8984 Ω 7.7763 pF

5 250.000 000 MHz

*
Del
Cor
Avg
16
H1d

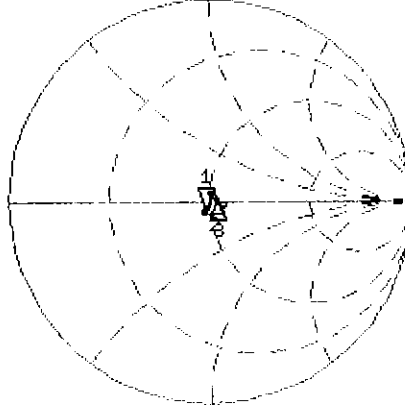

CH1 Markers
2: 51.525 Ω
3.8945 Ω
5.60000 GHz
3: 53.848 Ω
0.2930 Ω
5.75000 GHz

CH2 S11 LOG 5 dB/REF -20 dB 1:-25.900 dB 5 250.000 000 MHz

Cor
Avg
16
H1d

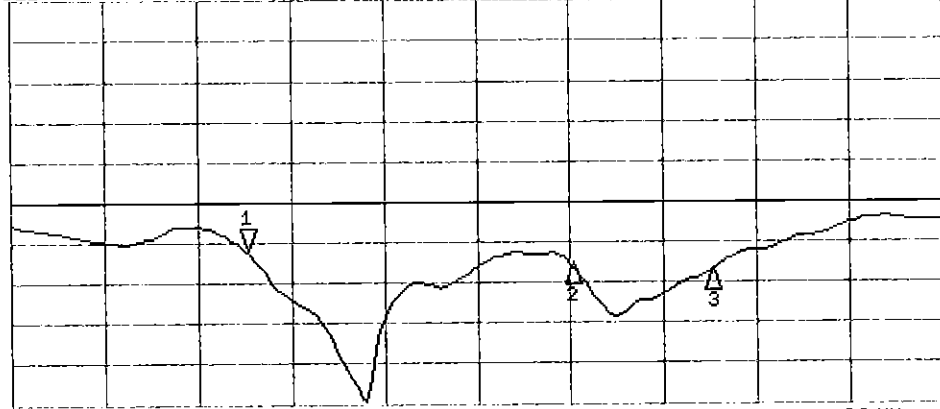

CH2 Markers
2:-27.699 dB
5.60000 GHz
3:-28.596 dB
5.75000 GHz

START 5 000.000 000 MHz

STOP 6 000.000 000 MHz



Accredited by the Swiss Accreditation Service (SAS)
The Swiss Accreditation Service is one of the signatories to the EA
Multilateral Agreement for the recognition of calibration certificates

Accreditation No.: **SCS 0108**

Client **PC Test**

Certificate No: **D1900V2-5d080_Jul16**

CALIBRATION CERTIFICATE

Object **D1900V2 - SN:5d080**

Calibration procedure(s) **QA CAL-05.v9
Calibration procedure for dipole validation kits above 700 MHz**

Calibration date: **July 08, 2016**

*BNV
7/16/2016*

This calibration certificate documents the traceability to national standards, which realize the physical units of measurements (SI).
The measurements and the uncertainties with confidence probability are given on the following pages and are part of the certificate.

All calibrations have been conducted in the closed laboratory facility: environment temperature (22 ± 3)°C and humidity < 70%.

Calibration Equipment used (M&TE critical for calibration)

Primary Standards	ID #	Cal Date (Certificate No.)	Scheduled Calibration
Power meter NRP	SN: 104778	06-Apr-16 (No. 217-02288/02289)	Apr-17
Power sensor NRP-Z91	SN: 103244	06-Apr-16 (No. 217-02288)	Apr-17
Power sensor NRP-Z91	SN: 103245	06-Apr-16 (No. 217-02289)	Apr-17
Reference 20 dB Attenuator	SN: 5058 (20k)	05-Apr-16 (No. 217-02292)	Apr-17
Type-N mismatch combination	SN: 5047.2 / 06327	05-Apr-16 (No. 217-02295)	Apr-17
Reference Probe EX3DV4	SN: 7349	15-Jun-16 (No. EX3-7349_Jun16)	Jun-17
DAE4	SN: 601	30-Dec-15 (No. DAE4-601_Dec15)	Dec-16

Secondary Standards	ID #	Check Date (in house)	Scheduled Check
Power meter EPM-442A	SN: GB37480704	07-Oct-15 (No. 217-02222)	In house check: Oct-16
Power sensor HP 8481A	SN: US37292783	07-Oct-15 (No. 217-02222)	In house check: Oct-16
Power sensor HP 8481A	SN: MY41092317	07-Oct-15 (No. 217-02223)	In house check: Oct-16
RF generator R&S SMT-06	SN: 100972	15-Jun-15 (in house check Jun-15)	In house check: Oct-16
Network Analyzer HP 8753E	SN: US37390585	18-Oct-01 (in house check Oct-15)	In house check: Oct-16

Calibrated by: **Jeton Kastrati** Name: **Jeton Kastrati** Function: **Laboratory Technician**

Approved by: **Katja Pokovic** Name: **Katja Pokovic** Function: **Technical Manager**

Signature
[Handwritten signatures]

Issued: July 13, 2016

This calibration certificate shall not be reproduced except in full without written approval of the laboratory.



Accredited by the Swiss Accreditation Service (SAS)
The Swiss Accreditation Service is one of the signatories to the EA
Multilateral Agreement for the recognition of calibration certificates

Accreditation No.: **SCS 0108**

Glossary:

TSL	tissue simulating liquid
ConvF	sensitivity in TSL / NORM x,y,z
N/A	not applicable or not measured

Calibration is Performed According to the Following Standards:

- a) IEEE Std 1528-2013, "IEEE Recommended Practice for Determining the Peak Spatial-Averaged Specific Absorption Rate (SAR) in the Human Head from Wireless Communications Devices: Measurement Techniques", June 2013
- b) IEC 62209-1, "Procedure to measure the Specific Absorption Rate (SAR) for hand-held devices used in close proximity to the ear (frequency range of 300 MHz to 3 GHz)", February 2005
- c) IEC 62209-2, "Procedure to determine the Specific Absorption Rate (SAR) for wireless communication devices used in close proximity to the human body (frequency range of 30 MHz to 6 GHz)", March 2010
- d) KDB 865664, "SAR Measurement Requirements for 100 MHz to 6 GHz"

Additional Documentation:

- e) DASY4/5 System Handbook

Methods Applied and Interpretation of Parameters:

- *Measurement Conditions:* Further details are available from the Validation Report at the end of the certificate. All figures stated in the certificate are valid at the frequency indicated.
- *Antenna Parameters with TSL:* The dipole is mounted with the spacer to position its feed point exactly below the center marking of the flat phantom section, with the arms oriented parallel to the body axis.
- *Feed Point Impedance and Return Loss:* These parameters are measured with the dipole positioned under the liquid filled phantom. The impedance stated is transformed from the measurement at the SMA connector to the feed point. The Return Loss ensures low reflected power. No uncertainty required.
- *Electrical Delay:* One-way delay between the SMA connector and the antenna feed point. No uncertainty required.
- *SAR measured:* SAR measured at the stated antenna input power.
- *SAR normalized:* SAR as measured, normalized to an input power of 1 W at the antenna connector.
- *SAR for nominal TSL parameters:* The measured TSL parameters are used to calculate the nominal SAR result.

The reported uncertainty of measurement is stated as the standard uncertainty of measurement multiplied by the coverage factor $k=2$, which for a normal distribution corresponds to a coverage probability of approximately 95%.

Measurement Conditions

DASY system configuration, as far as not given on page 1.

DASY Version	DASY5	V52.8.8
Extrapolation	Advanced Extrapolation	
Phantom	Modular Flat Phantom	
Distance Dipole Center - TSL	10 mm	with Spacer
Zoom Scan Resolution	dx, dy, dz = 5 mm	
Frequency	1900 MHz \pm 1 MHz	

Head TSL parameters

The following parameters and calculations were applied.

	Temperature	Permittivity	Conductivity
Nominal Head TSL parameters	22.0 °C	40.0	1.40 mho/m
Measured Head TSL parameters	(22.0 \pm 0.2) °C	39.8 \pm 6 %	1.38 mho/m \pm 6 %
Head TSL temperature change during test	< 0.5 °C	----	----

SAR result with Head TSL

SAR averaged over 1 cm ³ (1 g) of Head TSL	Condition	
SAR measured	250 mW input power	9.76 W/kg
SAR for nominal Head TSL parameters	normalized to 1W	39.3 W/kg \pm 17.0 % (k=2)

SAR averaged over 10 cm ³ (10 g) of Head TSL	condition	
SAR measured	250 mW input power	5.10 W/kg
SAR for nominal Head TSL parameters	normalized to 1W	20.5 W/kg \pm 16.5 % (k=2)

Body TSL parameters

The following parameters and calculations were applied.

	Temperature	Permittivity	Conductivity
Nominal Body TSL parameters	22.0 °C	53.3	1.52 mho/m
Measured Body TSL parameters	(22.0 \pm 0.2) °C	52.7 \pm 6 %	1.51 mho/m \pm 6 %
Body TSL temperature change during test	< 0.5 °C	----	----

SAR result with Body TSL

SAR averaged over 1 cm ³ (1 g) of Body TSL	Condition	
SAR measured	250 mW input power	9.75 W/kg
SAR for nominal Body TSL parameters	normalized to 1W	39.1 W/kg \pm 17.0 % (k=2)

SAR averaged over 10 cm ³ (10 g) of Body TSL	condition	
SAR measured	250 mW input power	5.17 W/kg
SAR for nominal Body TSL parameters	normalized to 1W	20.7 W/kg \pm 16.5 % (k=2)

Appendix (Additional assessments outside the scope of SCS 0108)

Antenna Parameters with Head TSL

Impedance, transformed to feed point	$52.1 \Omega + 5.3 j\Omega$
Return Loss	- 25.1 dB

Antenna Parameters with Body TSL

Impedance, transformed to feed point	$47.4 \Omega + 6.8 j\Omega$
Return Loss	- 22.6 dB

General Antenna Parameters and Design

Electrical Delay (one direction)	1.192 ns
----------------------------------	----------

After long term use with 100W radiated power, only a slight warming of the dipole near the feedpoint can be measured.

The dipole is made of standard semirigid coaxial cable. The center conductor of the feeding line is directly connected to the second arm of the dipole. The antenna is therefore short-circuited for DC-signals. On some of the dipoles, small end caps are added to the dipole arms in order to improve matching when loaded according to the position as explained in the "Measurement Conditions" paragraph. The SAR data are not affected by this change. The overall dipole length is still according to the Standard.

No excessive force must be applied to the dipole arms, because they might bend or the soldered connections near the feedpoint may be damaged.

Additional EUT Data

Manufactured by	SPEAG
Manufactured on	June 28, 2006

DASY5 Validation Report for Head TSL

Date: 08.07.2016

Test Laboratory: SPEAG, Zurich, Switzerland

DUT: Dipole 1900 MHz; Type: D1900V2; Serial: D1900V2 - SN:5d080

Communication System: UID 0 - CW; Frequency: 1900 MHz

Medium parameters used: $f = 1900$ MHz; $\sigma = 1.38$ S/m; $\epsilon_r = 39.8$; $\rho = 1000$ kg/m³

Phantom section: Flat Section

Measurement Standard: DASY5 (IEEE/IEC/ANSI C63.19-2011)

DASY52 Configuration:

- Probe: EX3DV4 - SN7349; ConvF(7.99, 7.99, 7.99); Calibrated: 15.06.2016;
- Sensor-Surface: 1.4mm (Mechanical Surface Detection)
- Electronics: DAE4 Sn601; Calibrated: 30.12.2015
- Phantom: Flat Phantom 5.0 (front); Type: QD000P50AA; Serial: 1001
- DASY52 52.8.8(1258); SEMCAD X 14.6.10(7372)

Dipole Calibration for Head Tissue/Pin=250 mW, d=10mm/Zoom Scan (7x7x7)/Cube 0:

Measurement grid: dx=5mm, dy=5mm, dz=5mm

Reference Value = 106.6 V/m; Power Drift = -0.04 dB

Peak SAR (extrapolated) = 18.4 W/kg

SAR(1 g) = 9.76 W/kg; SAR(10 g) = 5.1 W/kg

Maximum value of SAR (measured) = 15.0 W/kg

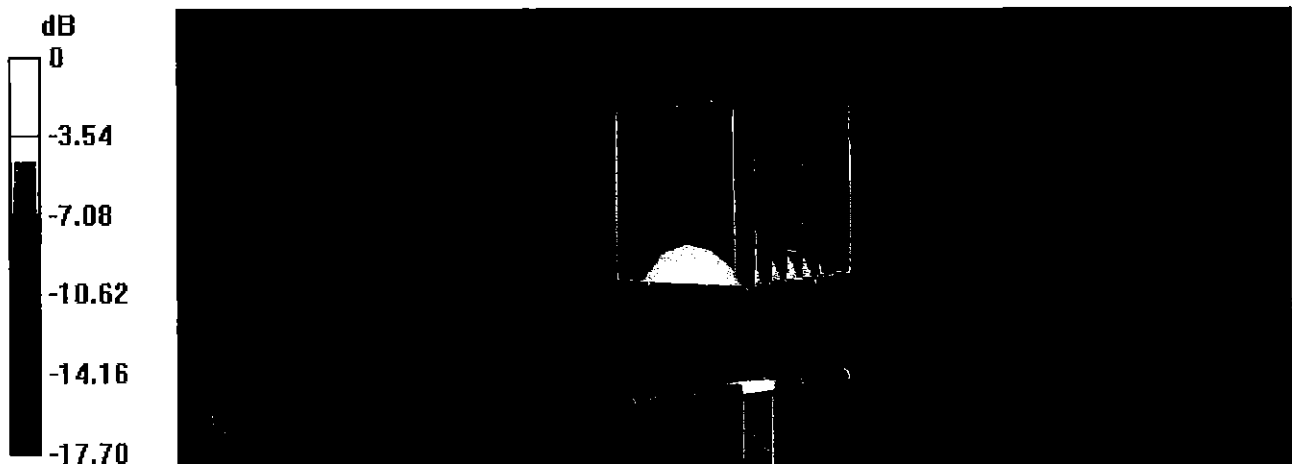

0 dB = 15.0 W/kg = 11.76 dBW/kg

Impedance Measurement Plot for Head TSL

8 Jul 2016 16:18:04

CH1 S11 1 U FS

1: 52.143 Ω 5.2500 Ω 439.78 pF

1 900.000 000 MHz

*
Del
Cor

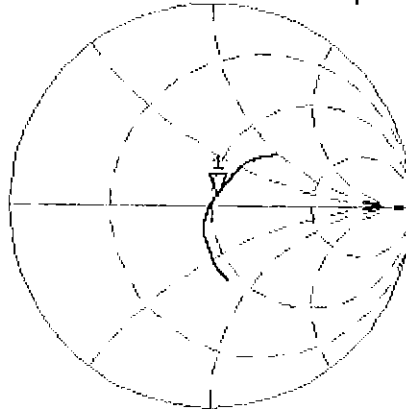

Avg
16

H1d

CH2 S11 LOG

5 dB/REF -20 dB

1:-25.118 dB

1 900.000 000 MHz

Cor

Avg
16

H1d

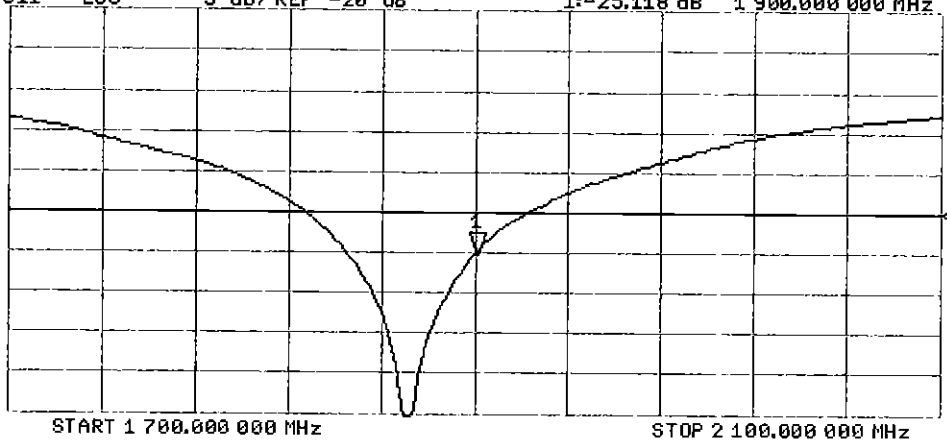

DASY5 Validation Report for Body TSL

Date: 08.07.2016

Test Laboratory: SPEAG, Zurich, Switzerland

DUT: Dipole 1900 MHz; Type: D1900V2; Serial: D1900V2 - SN:5d080

Communication System: UID 0 - CW; Frequency: 1900 MHz

Medium parameters used: $f = 1900$ MHz; $\sigma = 1.51$ S/m; $\epsilon_r = 52.7$; $\rho = 1000$ kg/m³

Phantom section: Flat Section

Measurement Standard: DASY5 (IEEE/IEC/ANSI C63.19-2011)

DASY52 Configuration:

- Probe: EX3DV4 - SN7349; ConvF(8.03, 8.03, 8.03); Calibrated: 15.06.2016;
- Sensor-Surface: 1.4mm (Mechanical Surface Detection)
- Electronics: DAE4 Sn601; Calibrated: 30.12.2015
- Phantom: Flat Phantom 5.0 (back); Type: QD000P50AA; Serial: 1002
- DASY52 52.8.8(1258); SEMCAD X 14.6.10(7372)

Dipole Calibration for Body Tissue/Pin=250 mW, d=10mm/Zoom Scan (7x7x7)/Cube 0:

Measurement grid: dx=5mm, dy=5mm, dz=5mm

Reference Value = 103.1 V/m; Power Drift = -0.02 dB

Peak SAR (extrapolated) = 17.1 W/kg

SAR(1 g) = 9.75 W/kg; SAR(10 g) = 5.17 W/kg

Maximum value of SAR (measured) = 14.7 W/kg

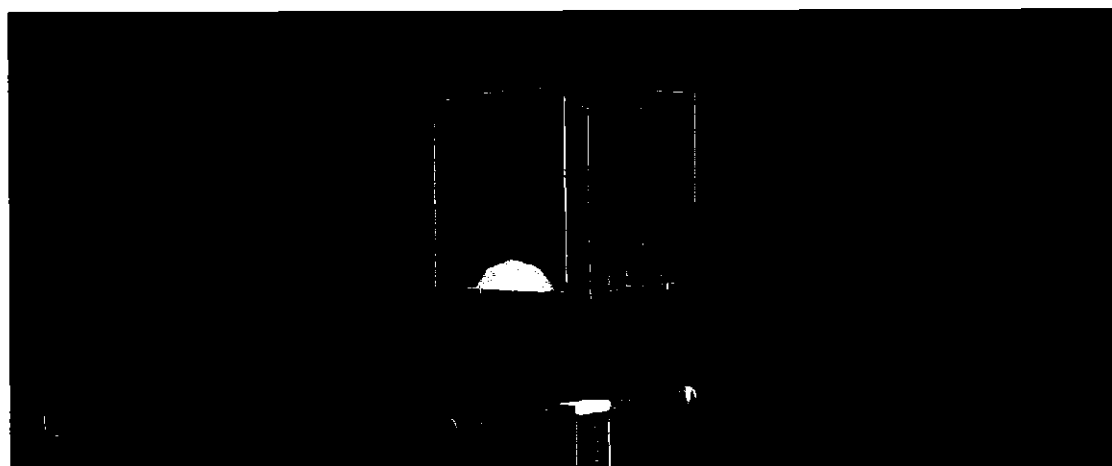
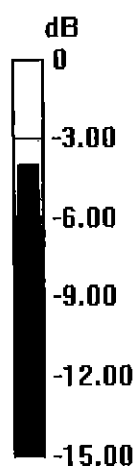

0 dB = 14.7 W/kg = 11.67 dBW/kg

Impedance Measurement Plot for Body TSL

8 Jul 2016 16:16:56

CH1 S11 1 U FS

1: 47.412 Ω 6.7422 Ω 564.78 pF

1 900.000 000 MHz

*
De1
Cor

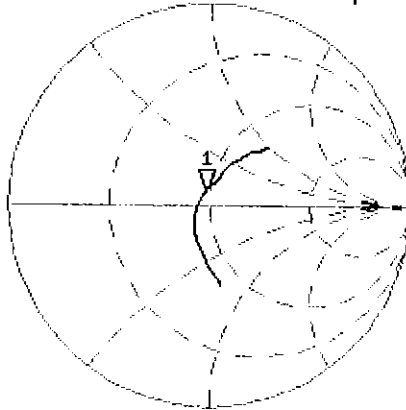

Avg
16

H1d

CH2 S11 LOG

5 dB/REF -20 dB

1:-22.620 dB

1 900.000 000 MHz

Cor

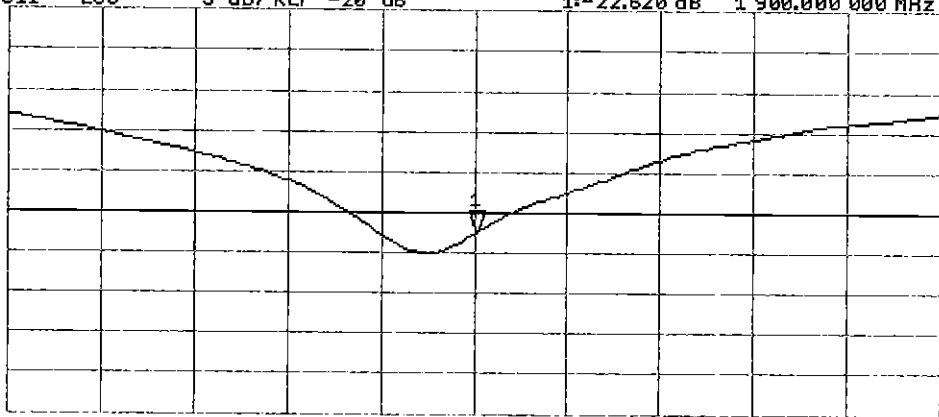

Avg
16

H1d

START 1 700.000 000 MHz

STOP 2 1 000.000 000 MHz



Accredited by the Swiss Accreditation Service (SAS)
The Swiss Accreditation Service is one of the signatories to the EA
Multilateral Agreement for the recognition of calibration certificates

Accreditation No.: **SCS 0108**

Client **PC Test**

Certificate No: **D2450V2-981_Jul16**

CALIBRATION CERTIFICATE

Object **D2450V2 - SN:981**

Calibration procedure(s) **QA CAL-05.v9
Calibration procedure for dipole validation kits above 700 MHz**

*✓ PM
8/9/16*

Calibration date: **July 25, 2016**

This calibration certificate documents the traceability to national standards, which realize the physical units of measurements (SI).
The measurements and the uncertainties with confidence probability are given on the following pages and are part of the certificate.

All calibrations have been conducted in the closed laboratory facility: environment temperature (22 ± 3)°C and humidity < 70%.

Calibration Equipment used (M&TE critical for calibration)

Primary Standards	ID #	Cal Date (Certificate No.)	Scheduled Calibration
Power meter NRP	SN: 104778	06-Apr-16 (No. 217-02288/02289)	Apr-17
Power sensor NRP-Z91	SN: 103244	06-Apr-16 (No. 217-02288)	Apr-17
Power sensor NRP-Z91	SN: 103245	06-Apr-16 (No. 217-02289)	Apr-17
Reference 20 dB Attenuator	SN: 5058 (20k)	05-Apr-16 (No. 217-02292)	Apr-17
Type-N mismatch combination	SN: 5047.2 / 06327	05-Apr-16 (No. 217-02295)	Apr-17
Reference Probe EX3DV4	SN: 7349	15-Jun-16 (No. EX3-7349_Jun16)	Jun-17
DAE4	SN: 601	30-Dec-15 (No. DAE4-601_Dec15)	Dec-16

Secondary Standards	ID #	Check Date (in house)	Scheduled Check
Power meter EPM-442A	SN: GB37480704	07-Oct-15 (No. 217-02222)	In house check: Oct-16
Power sensor HP 8481A	SN: US37292783	07-Oct-15 (No. 217-02222)	In house check: Oct-16
Power sensor HP 8481A	SN: MY41092317	07-Oct-15 (No. 217-02223)	In house check: Oct-16
RF generator R&S SMT-06	SN: 100972	15-Jun-15 (in house check Jun-15)	In house check: Oct-16
Network Analyzer HP 8753E	SN: US37390585	18-Oct-01 (in house check Oct-15)	In house check: Oct-16

Calibrated by: **Michael Weber** Name: **Michael Weber** Function: **Laboratory Technician**

Signature: *M. Weber*

Approved by: **Katja Pokovic** Name: **Katja Pokovic** Function: **Technical Manager**

Signature: *Katja Pokovic*

Issued: July 27, 2016

This calibration certificate shall not be reproduced except in full without written approval of the laboratory.



Accredited by the Swiss Accreditation Service (SAS)
The Swiss Accreditation Service is one of the signatories to the EA
Multilateral Agreement for the recognition of calibration certificates

Glossary:

TSL	tissue simulating liquid
ConvF	sensitivity in TSL / NORM x,y,z
N/A	not applicable or not measured

Calibration is Performed According to the Following Standards:

- a) IEEE Std 1528-2013, "IEEE Recommended Practice for Determining the Peak Spatial-Averaged Specific Absorption Rate (SAR) in the Human Head from Wireless Communications Devices: Measurement Techniques", June 2013
- b) IEC 62209-1, "Procedure to measure the Specific Absorption Rate (SAR) for hand-held devices used in close proximity to the ear (frequency range of 300 MHz to 3 GHz)", February 2005
- c) IEC 62209-2, "Procedure to determine the Specific Absorption Rate (SAR) for wireless communication devices used in close proximity to the human body (frequency range of 30 MHz to 6 GHz)", March 2010
- d) KDB 865664, "SAR Measurement Requirements for 100 MHz to 6 GHz"

Additional Documentation:

- e) DASY4/5 System Handbook

Methods Applied and Interpretation of Parameters:

- *Measurement Conditions:* Further details are available from the Validation Report at the end of the certificate. All figures stated in the certificate are valid at the frequency indicated.
- *Antenna Parameters with TSL:* The dipole is mounted with the spacer to position its feed point exactly below the center marking of the flat phantom section, with the arms oriented parallel to the body axis.
- *Feed Point Impedance and Return Loss:* These parameters are measured with the dipole positioned under the liquid filled phantom. The impedance stated is transformed from the measurement at the SMA connector to the feed point. The Return Loss ensures low reflected power. No uncertainty required.
- *Electrical Delay:* One-way delay between the SMA connector and the antenna feed point. No uncertainty required.
- *SAR measured:* SAR measured at the stated antenna input power.
- *SAR normalized:* SAR as measured, normalized to an input power of 1 W at the antenna connector.
- *SAR for nominal TSL parameters:* The measured TSL parameters are used to calculate the nominal SAR result.

The reported uncertainty of measurement is stated as the standard uncertainty of measurement multiplied by the coverage factor $k=2$, which for a normal distribution corresponds to a coverage probability of approximately 95%.

Measurement Conditions

DASY system configuration, as far as not given on page 1.

DASY Version	DASY5	V52.8.8
Extrapolation	Advanced Extrapolation	
Phantom	Modular Flat Phantom	
Distance Dipole Center - TSL	10 mm	with Spacer
Zoom Scan Resolution	dx, dy, dz = 5 mm	
Frequency	2450 MHz \pm 1 MHz	

Head TSL parameters

The following parameters and calculations were applied.

	Temperature	Permittivity	Conductivity
Nominal Head TSL parameters	22.0 °C	39.2	1.80 mho/m
Measured Head TSL parameters	(22.0 \pm 0.2) °C	38.0 \pm 6 %	1.86 mho/m \pm 6 %
Head TSL temperature change during test	< 0.5 °C	----	----

SAR result with Head TSL

SAR averaged over 1 cm ³ (1 g) of Head TSL	Condition	
SAR measured	250 mW input power	13.5 W/kg
SAR for nominal Head TSL parameters	normalized to 1W	52.8 W/kg \pm 17.0 % (k=2)

SAR averaged over 10 cm ³ (10 g) of Head TSL	condition	
SAR measured	250 mW input power	6.26 W/kg
SAR for nominal Head TSL parameters	normalized to 1W	24.7 W/kg \pm 16.5 % (k=2)

Body TSL parameters

The following parameters and calculations were applied.

	Temperature	Permittivity	Conductivity
Nominal Body TSL parameters	22.0 °C	52.7	1.95 mho/m
Measured Body TSL parameters	(22.0 \pm 0.2) °C	51.8 \pm 6 %	2.03 mho/m \pm 6 %
Body TSL temperature change during test	< 0.5 °C	----	----

SAR result with Body TSL

SAR averaged over 1 cm ³ (1 g) of Body TSL	Condition	
SAR measured	250 mW input power	13.0 W/kg
SAR for nominal Body TSL parameters	normalized to 1W	50.8 W/kg \pm 17.0 % (k=2)

SAR averaged over 10 cm ³ (10 g) of Body TSL	condition	
SAR measured	250 mW input power	6.04 W/kg
SAR for nominal Body TSL parameters	normalized to 1W	23.8 W/kg \pm 16.5 % (k=2)

Appendix (Additional assessments outside the scope of SCS 0108)

Antenna Parameters with Head TSL

Impedance, transformed to feed point	53.2 Ω + 3.4 j Ω
Return Loss	- 26.9 dB

Antenna Parameters with Body TSL

Impedance, transformed to feed point	50.2 Ω + 4.5 j Ω
Return Loss	- 27.0 dB

General Antenna Parameters and Design

Electrical Delay (one direction)	1.162 ns
----------------------------------	----------

After long term use with 100W radiated power, only a slight warming of the dipole near the feedpoint can be measured.

The dipole is made of standard semirigid coaxial cable. The center conductor of the feeding line is directly connected to the second arm of the dipole. The antenna is therefore short-circuited for DC-signals. On some of the dipoles, small end caps are added to the dipole arms in order to improve matching when loaded according to the position as explained in the "Measurement Conditions" paragraph. The SAR data are not affected by this change. The overall dipole length is still according to the Standard.

No excessive force must be applied to the dipole arms, because they might bend or the soldered connections near the feedpoint may be damaged.

Additional EUT Data

Manufactured by	SPEAG
Manufactured on	December 30, 2014

DASY5 Validation Report for Head TSL

Date: 13.07.2016

Test Laboratory: SPEAG, Zurich, Switzerland

DUT: Dipole 2450 MHz D2450V2; Type: D2450V2; Serial: D2450V2 - SN:981

Communication System: UID 0 - CW; Frequency: 2450 MHz

Medium parameters used: $f = 2450$ MHz; $\sigma = 1.86$ S/m; $\epsilon_r = 38$; $\rho = 1000$ kg/m³

Phantom section: Flat Section

Measurement Standard: DASY5 (IEEE/IEC/ANSI C63.19-2011)

DASY52 Configuration:

- Probe: EX3DV4 - SN7349; ConvF(7.72, 7.72, 7.72); Calibrated: 15.06.2016;
- Sensor-Surface: 1.4mm (Mechanical Surface Detection)
- Electronics: DAE4 Sn601; Calibrated: 30.12.2015
- Phantom: Flat Phantom 5.0 (front); Type: QD000P50AA; Serial: 1001
- DASY52 52.8.8(1258); SEMCAD X 14.6.10(7372)

Dipole Calibration for Head Tissue/Pin=250 mW, d=10mm/Zoom Scan (7x7x7)/Cube 0:

Measurement grid: dx=5mm, dy=5mm, dz=5mm

Reference Value = 115.8 V/m; Power Drift = 0.02 dB

Peak SAR (extrapolated) = 27.4 W/kg

SAR(1 g) = 13.5 W/kg; SAR(10 g) = 6.26 W/kg

Maximum value of SAR (measured) = 22.5 W/kg

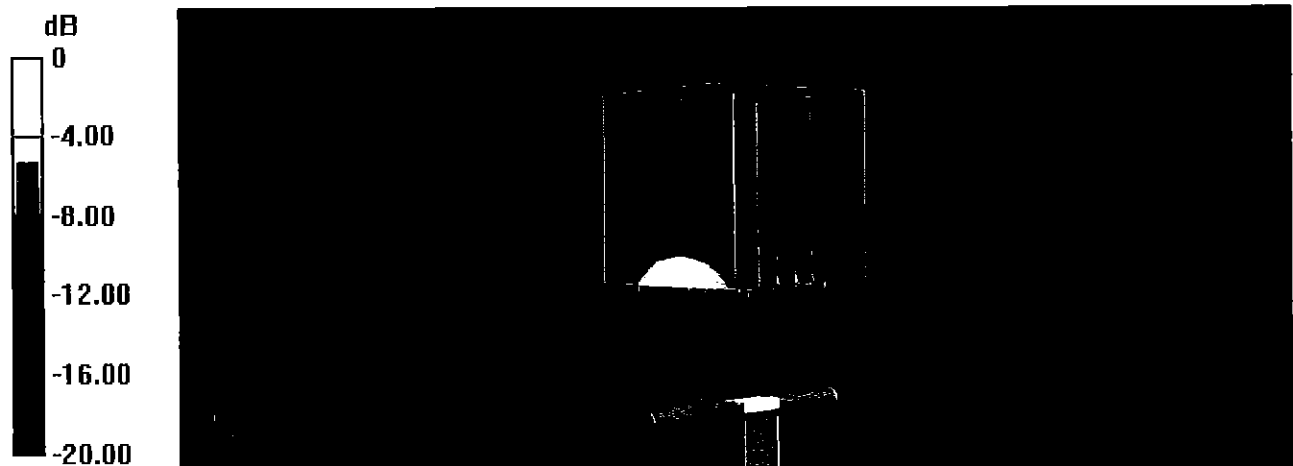

0 dB = 22.5 W/kg = 13.52 dBW/kg

Impedance Measurement Plot for Head TSL

13 Jul 2016 12:53:29

CH1 S11 1 U FS 3: 53.234 Ω 3.3633 Ω 218.48 μH 2 450.000 000 MHz

*
De l
CA
Avg
16
H1 d

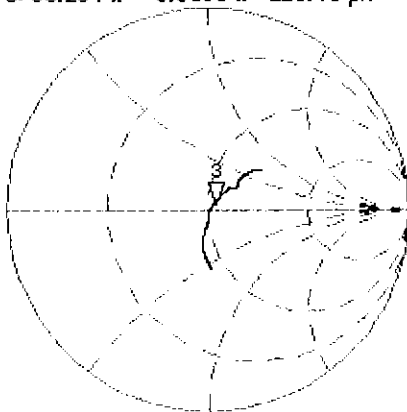

CH2 S11 LOG 5 dB/REF -20 dB 3:-26.900 dB 2 450.000 000 MHz

CA
Avg
16
H1 d

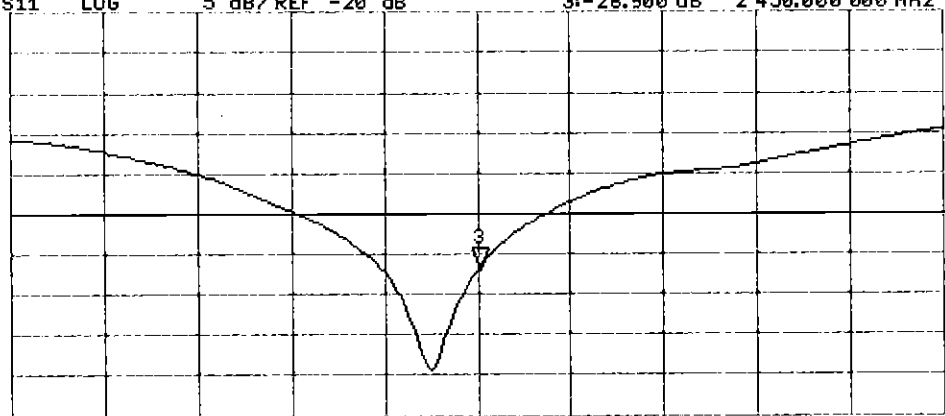

START 2 250.000 000 MHz

STOP 2 650.000 000 MHz

DASY5 Validation Report for Body TSL

Date: 25.07.2016

Test Laboratory: SPEAG, Zurich, Switzerland

DUT: Dipole 2450 MHz D2450V2; Type: D2450V2; Serial: D2450V2 - SN:981

Communication System: UID 0 - CW; Frequency: 2450 MHz

Medium parameters used: $f = 2450 \text{ MHz}$; $\sigma = 2.03 \text{ S/m}$; $\epsilon_r = 51.8$; $\rho = 1000 \text{ kg/m}^3$

Phantom section: Flat Section

Measurement Standard: DASY5 (IEEE/IEC/ANSI C63.19-2011)

DASY52 Configuration:

- Probe: EX3DV4 - SN7349; ConvF(7.79, 7.79, 7.79); Calibrated: 15.06.2016;
- Sensor-Surface: 1.4mm (Mechanical Surface Detection)
- Electronics: DAE4 Sn601; Calibrated: 30.12.2015
- Phantom: Flat Phantom 5.0 (back); Type: QD000P50AA; Serial: 1002
- DASY52 52.8.8(1258); SEMCAD X 14.6.10(7372)

Dipole Calibration for Body Tissue/Pin=250 mW, d=10mm/Zoom Scan (7x7x7)/Cube 0:

Measurement grid: dx=5mm, dy=5mm, dz=5mm

Reference Value = 107.1 V/m; Power Drift = -0.02 dB

Peak SAR (extrapolated) = 26.0 W/kg

SAR(1 g) = 13 W/kg; SAR(10 g) = 6.04 W/kg

Maximum value of SAR (measured) = 21.4 W/kg



0 dB = 21.4 W/kg = 13.30 dBW/kg

Impedance Measurement Plot for Body TSL

25 Jul 2016 10:03:11

CH1 S11 1 U FS 1: 50.184 Ω 4.4980 Ω 292.20 pF 2 450.000 000 MHz

*
De1
Ca
Avg
16
H1 d

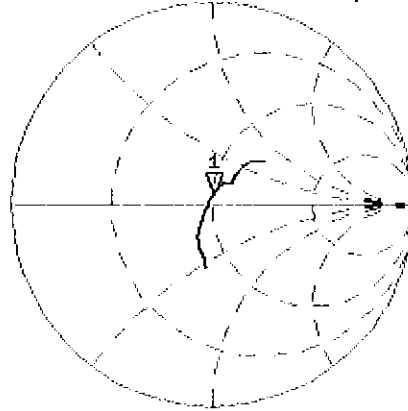

CH2 S11 LOG 5 dB/ REF -20 dB 1: -26.957 dB 2 450.000 000 MHz

Ca
H1 d

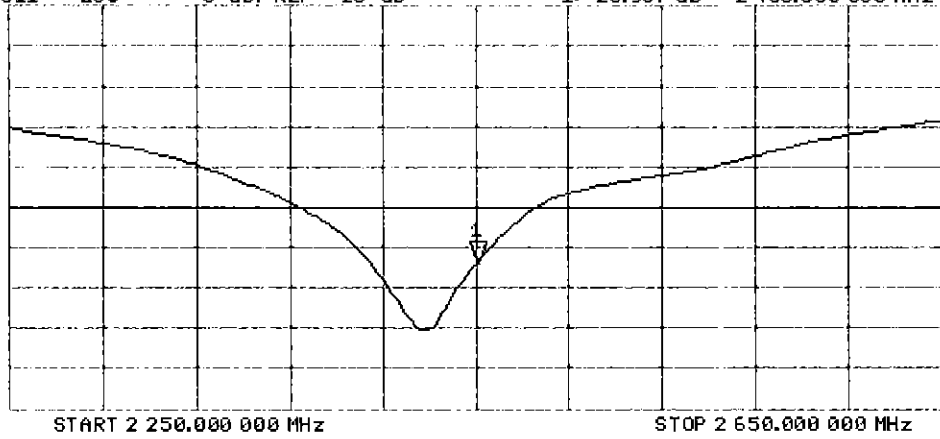



Accredited by the Swiss Accreditation Service (SAS)
The Swiss Accreditation Service is one of the signatories to the EA
Multilateral Agreement for the recognition of calibration certificates

Accreditation No.: **SCS 0108**

Client **PC Test**

Certificate No: **D2600V2-1071_Sep16**

CALIBRATION CERTIFICATE

Object **D2600V2 - SN:1071**

Calibration procedure(s) **QA CAL-05.v9
Calibration procedure for dipole validation kits above 700 MHz**

BNV
09-28-2016

Calibration date: **September 13, 2016**

This calibration certificate documents the traceability to national standards, which realize the physical units of measurements (SI).
The measurements and the uncertainties with confidence probability are given on the following pages and are part of the certificate.

All calibrations have been conducted in the closed laboratory facility: environment temperature (22 ± 3)°C and humidity < 70%.

Calibration Equipment used (M&TE critical for calibration)

Primary Standards	ID #	Cal Date (Certificate No.)	Scheduled Calibration
Power meter NRP	SN: 104778	06-Apr-16 (No. 217-02288/02289)	Apr-17
Power sensor NRP-Z91	SN: 103244	06-Apr-16 (No. 217-02288)	Apr-17
Power sensor NRP-Z91	SN: 103245	06-Apr-16 (No. 217-02289)	Apr-17
Reference 20 dB Attenuator	SN: 5058 (20k)	05-Apr-16 (No. 217-02292)	Apr-17
Type-N mismatch combination	SN: 5047.2 / 06327	05-Apr-16 (No. 217-02295)	Apr-17
Reference Probe EX3DV4	SN: 7349	15-Jun-16 (No. EX3-7349_Jun16)	Jun-17
DAE4	SN: 601	30-Dec-15 (No. DAE4-601_Dec15)	Dec-16
Secondary Standards	ID #	Check Date (in house)	Scheduled Check
Power meter EPM-442A	SN: GB37480704	07-Oct-15 (No. 217-02222)	In house check: Oct-16
Power sensor HP 8481A	SN: US37292783	07-Oct-15 (No. 217-02222)	In house check: Oct-16
Power sensor HP 8481A	SN: MY41092317	07-Oct-15 (No. 217-02223)	In house check: Oct-16
RF generator R&S SMT-06	SN: 100972	15-Jun-15 (in house check Jun-15)	In house check: Oct-16
Network Analyzer HP 8753E	SN: US37390585	18-Oct-01 (in house check Oct-15)	In house check: Oct-16

Calibrated by: **Jeton Kastrati** Function: **Laboratory Technician**

Approved by: **Katja Pokovic** Technical Manager

Signature
[Handwritten Signature]
[Handwritten Signature]

Issued: September 13, 2016

This calibration certificate shall not be reproduced except in full without written approval of the laboratory.



Accredited by the Swiss Accreditation Service (SAS)
The Swiss Accreditation Service is one of the signatories to the EA
Multilateral Agreement for the recognition of calibration certificates

Accreditation No.: **SCS 0108**

Glossary:

TSL	tissue simulating liquid
ConvF	sensitivity in TSL / NORM x,y,z
N/A	not applicable or not measured

Calibration is Performed According to the Following Standards:

- IEEE Std 1528-2013, "IEEE Recommended Practice for Determining the Peak Spatial-Averaged Specific Absorption Rate (SAR) in the Human Head from Wireless Communications Devices: Measurement Techniques", June 2013
- IEC 62209-1, "Procedure to measure the Specific Absorption Rate (SAR) for hand-held devices used in close proximity to the ear (frequency range of 300 MHz to 3 GHz)", February 2005
- IEC 62209-2, "Procedure to determine the Specific Absorption Rate (SAR) for wireless communication devices used in close proximity to the human body (frequency range of 30 MHz to 6 GHz)", March 2010
- KDB 865664, "SAR Measurement Requirements for 100 MHz to 6 GHz"

Additional Documentation:

- DASY4/5 System Handbook

Methods Applied and Interpretation of Parameters:

- Measurement Conditions:** Further details are available from the Validation Report at the end of the certificate. All figures stated in the certificate are valid at the frequency indicated.
- Antenna Parameters with TSL:** The dipole is mounted with the spacer to position its feed point exactly below the center marking of the flat phantom section, with the arms oriented parallel to the body axis.
- Feed Point Impedance and Return Loss:** These parameters are measured with the dipole positioned under the liquid filled phantom. The impedance stated is transformed from the measurement at the SMA connector to the feed point. The Return Loss ensures low reflected power. No uncertainty required.
- Electrical Delay:** One-way delay between the SMA connector and the antenna feed point. No uncertainty required.
- SAR measured:** SAR measured at the stated antenna input power.
- SAR normalized:** SAR as measured, normalized to an input power of 1 W at the antenna connector.
- SAR for nominal TSL parameters:** The measured TSL parameters are used to calculate the nominal SAR result.

The reported uncertainty of measurement is stated as the standard uncertainty of measurement multiplied by the coverage factor $k=2$, which for a normal distribution corresponds to a coverage probability of approximately 95%.

Measurement Conditions

DASY system configuration, as far as not given on page 1.

DASY Version	DASY5	V52.8.8
Extrapolation	Advanced Extrapolation	
Phantom	Modular Flat Phantom	
Distance Dipole Center - TSL	10 mm	with Spacer
Zoom Scan Resolution	dx, dy, dz = 5 mm	
Frequency	2600 MHz \pm 1 MHz	

Head TSL parameters

The following parameters and calculations were applied.

	Temperature	Permittivity	Conductivity
Nominal Head TSL parameters	22.0 °C	39.0	1.96 mho/m
Measured Head TSL parameters	(22.0 \pm 0.2) °C	37.3 \pm 6 %	2.05 mho/m \pm 6 %
Head TSL temperature change during test	< 0.5 °C	----	----

SAR result with Head TSL

SAR averaged over 1 cm ³ (1 g) of Head TSL	Condition	
SAR measured	250 mW input power	14.5 W/kg
SAR for nominal Head TSL parameters	normalized to 1W	56.3 W/kg \pm 17.0 % (k=2)

SAR averaged over 10 cm ³ (10 g) of Head TSL	condition	
SAR measured	250 mW input power	6.45 W/kg
SAR for nominal Head TSL parameters	normalized to 1W	25.3 W/kg \pm 16.5 % (k=2)

Body TSL parameters

The following parameters and calculations were applied.

	Temperature	Permittivity	Conductivity
Nominal Body TSL parameters	22.0 °C	52.5	2.16 mho/m
Measured Body TSL parameters	(22.0 \pm 0.2) °C	51.1 \pm 6 %	2.22 mho/m \pm 6 %
Body TSL temperature change during test	< 0.5 °C	----	----

SAR result with Body TSL

SAR averaged over 1 cm ³ (1 g) of Body TSL	Condition	
SAR measured	250 mW input power	13.8 W/kg
SAR for nominal Body TSL parameters	normalized to 1W	54.2 W/kg \pm 17.0 % (k=2)

SAR averaged over 10 cm ³ (10 g) of Body TSL	condition	
SAR measured	250 mW input power	6.20 W/kg
SAR for nominal Body TSL parameters	normalized to 1W	24.5 W/kg \pm 16.5 % (k=2)

Appendix (Additional assessments outside the scope of SCS 0108)

Antenna Parameters with Head TSL

Impedance, transformed to feed point	49.9 Ω - 6.7 j Ω
Return Loss	- 23.5 dB

Antenna Parameters with Body TSL

Impedance, transformed to feed point	46.1 Ω - 2.1 j Ω
Return Loss	- 26.7 dB

General Antenna Parameters and Design

Electrical Delay (one direction)	1.153 ns
----------------------------------	----------

After long term use with 100W radiated power, only a slight warming of the dipole near the feedpoint can be measured.

The dipole is made of standard semirigid coaxial cable. The center conductor of the feeding line is directly connected to the second arm of the dipole. The antenna is therefore short-circuited for DC-signals. On some of the dipoles, small end caps are added to the dipole arms in order to improve matching when loaded according to the position as explained in the "Measurement Conditions" paragraph. The SAR data are not affected by this change. The overall dipole length is still according to the Standard.

No excessive force must be applied to the dipole arms, because they might bend or the soldered connections near the feedpoint may be damaged.

Additional EUT Data

Manufactured by	SPEAG
Manufactured on	July 17, 2013

DASY5 Validation Report for Head TSL

Date: 13.09.2016

Test Laboratory: SPEAG, Zurich, Switzerland

DUT: Dipole 2600 MHz; Type: D2600V2; Serial: D2600V2 - SN:1071

Communication System: UID 0 - CW; Frequency: 2600 MHz

Medium parameters used: $f = 2600$ MHz; $\sigma = 2.05$ S/m; $\epsilon_r = 37.3$; $\rho = 1000$ kg/m³

Phantom section: Flat Section

Measurement Standard: DASY5 (IEEE/IEC/ANSI C63.19-2011)

DASY52 Configuration:

- Probe: EX3DV4 - SN7349; ConvF(7.56, 7.56, 7.56); Calibrated: 15.06.2016;
- Sensor-Surface: 1.4mm (Mechanical Surface Detection)
- Electronics: DAE4 Sn601; Calibrated: 30.12.2015
- Phantom: Flat Phantom 5.0 (front); Type: QD000P50AA; Serial: 1001
- DASY52 52.8.8(1258); SEMCAD X 14.6.10(7372)

Dipole Calibration for Head Tissue/Pin=250 mW, d=10mm/Zoom Scan (7x7x7)/Cube 0:

Measurement grid: dx=5mm, dy=5mm, dz=5mm

Reference Value = 115.1 V/m; Power Drift = -0.02 dB

Peak SAR (extrapolated) = 30.4 W/kg

SAR(1 g) = 14.5 W/kg; SAR(10 g) = 6.45 W/kg

Maximum value of SAR (measured) = 24.6 W/kg

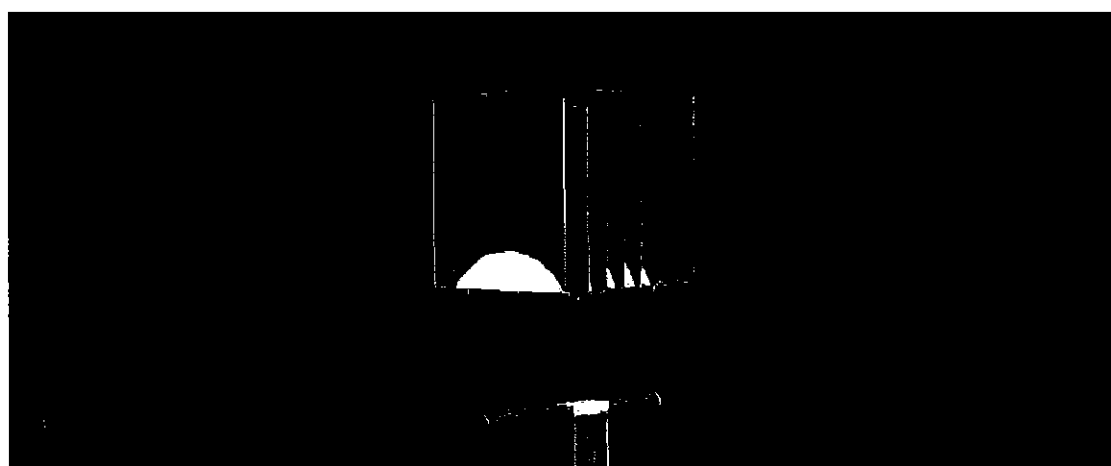
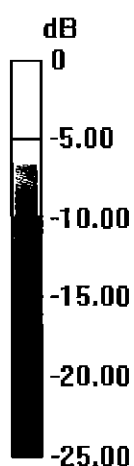

0 dB = 24.6 W/kg = 13.91 dBW/kg

Impedance Measurement Plot for Head TSL

12 Sep 2016 13:13:44

CH1 S11 1 U FS 4: 49.902 Ω -6.6523 Ω 9.2018 pF 2 600.000 000 MHz

*
De 1

CA

Avg
16

H1 d

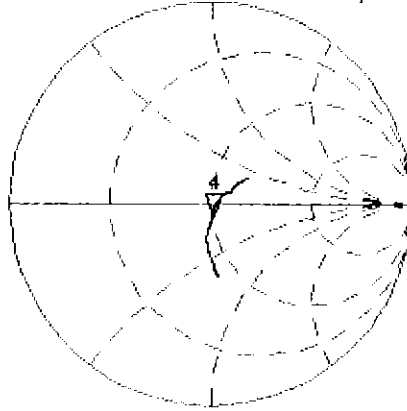

CH2 S11 LOG 5 dB/REF -20 dB 4:-23.548 dB 2 600.000 000 MHz

CA

Avg
16

H1 d

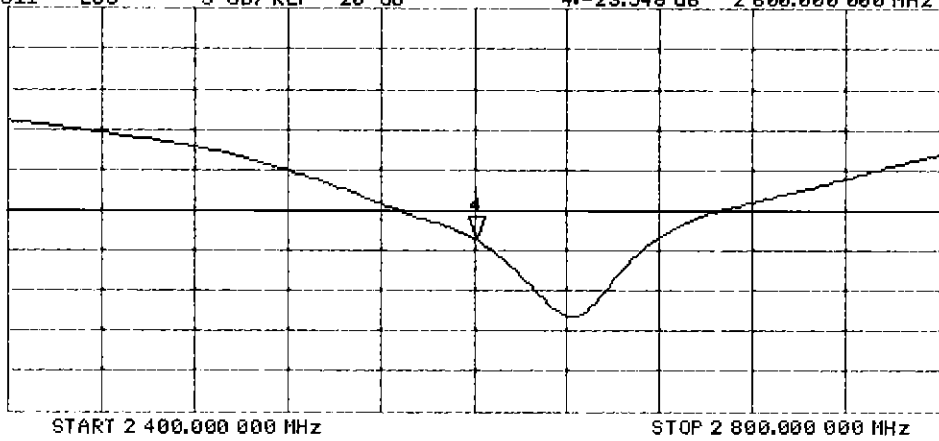

DASY5 Validation Report for Body TSL

Date: 13.09.2016

Test Laboratory: SPEAG, Zurich, Switzerland

DUT: Dipole 2600 MHz; Type: D2600V2; Serial: D2600V2 - SN:1071

Communication System: UID 0 - CW; Frequency: 2600 MHz

Medium parameters used: $f = 2600$ MHz; $\sigma = 2.22$ S/m; $\epsilon_r = 51.1$; $\rho = 1000$ kg/m³

Phantom section: Flat Section

Measurement Standard: DASY5 (IEEE/IEC/ANSI C63.19-2011)

DASY52 Configuration:

- Probe: EX3DV4 - SN7349; ConvF(7.48, 7.48, 7.48); Calibrated: 15.06.2016;
- Sensor-Surface: 1.4mm (Mechanical Surface Detection)
- Electronics: DAE4 Sn601; Calibrated: 30.12.2015
- Phantom: Flat Phantom 5.0 (back); Type: QD000P50AA; Serial: 1002
- DASY52 52.8.8(1258); SEMCAD X 14.6.10(7372)

Dipole Calibration for Body Tissue/Pin=250 mW, d=10mm/Zoom Scan (7x7x7)/Cube 0:

Measurement grid: dx=5mm, dy=5mm, dz=5mm

Reference Value = 107.7 V/m; Power Drift = -0.03 dB

Peak SAR (extrapolated) = 28.3 W/kg

SAR(1 g) = 13.8 W/kg; SAR(10 g) = 6.2 W/kg

Maximum value of SAR (measured) = 23.3 W/kg



0 dB = 23.3 W/kg = 13.67 dBW/kg

Impedance Measurement Plot for Body TSL

12 Sep 2016 13:13:09

CH1 S11 1 U FS

4: 46.078 Ω -2.0762 Ω 29.484 pF

2 600.000 000 MHz

*

De l

Ca

Avg
16

H1 d

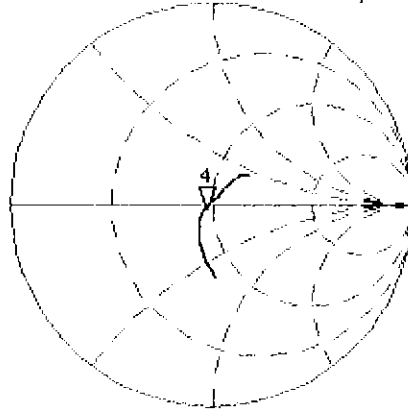

CH2 S11 LOG

5 dB/REF -20 dB

4:-26.721 dB 2 600.000 000 MHz

Ca

Avg
16

H1 d

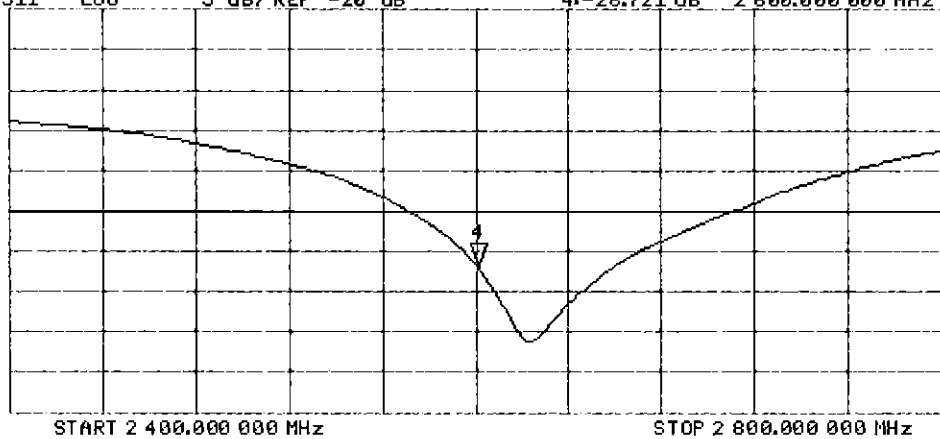



Accredited by the Swiss Accreditation Service (SAS)
The Swiss Accreditation Service is one of the signatories to the EA
Multilateral Agreement for the recognition of calibration certificates

Accreditation No.: SCS 0108

Client **PC Test**

Certificate No: **ES3-3334 Nov16**

CALIBRATION CERTIFICATE

Object **ES3DV3 - SN:3334**

Calibration procedure(s) **QA CAL-01.v9, QA CAL-12.v9, QA CAL-23.v5, QA CAL-25.v6
Calibration procedure for dosimetric E-field probes**

Calibration date: **November 15, 2016**

*BNV
11-21-2016*

This calibration certificate documents the traceability to national standards, which realize the physical units of measurements (SI).
The measurements and the uncertainties with confidence probability are given on the following pages and are part of the certificate.

All calibrations have been conducted in the closed laboratory facility: environment temperature (22 ± 3)°C and humidity < 70%.

Calibration Equipment used (M&TE critical for calibration)

Primary Standards	ID	Cal Date (Certificate No.)	Scheduled Calibration
Power meter NRP	SN: 104778	06-Apr-16 (No. 217-02288/02289)	Apr-17
Power sensor NRP-Z91	SN: 103244	06-Apr-16 (No. 217-02288)	Apr-17
Power sensor NRP-Z91	SN: 103245	06-Apr-16 (No. 217-02289)	Apr-17
Reference 20 dB Attenuator	SN: S5277 (20x)	05-Apr-16 (No. 217-02293)	Apr-17
Reference Probe ES3DV2	SN: 3013	31-Dec-15 (No. ES3-3013_Dec15)	Dec-16
DAE4	SN: 660	23-Dec-15 (No. DAE4-660_Dec15)	Dec-16
Secondary Standards	ID	Check Date (in house)	Scheduled Check
Power meter E4419B	SN: GB41293874	06-Apr-16 (in house check Jun-16)	In house check: Jun-18
Power sensor E4412A	SN: MY41498087	06-Apr-16 (in house check Jun-16)	In house check: Jun-18
Power sensor E4412A	SN: 000110210	06-Apr-16 (in house check Jun-16)	In house check: Jun-18
RF generator HP 8648C	SN: US3642U01700	04-Aug-99 (in house check Jun-16)	In house check: Jun-18
Network Analyzer HP 8753E	SN: US37390585	18-Oct-01 (in house check Oct-16)	In house check: Oct-17

	Name	Function	Signature
Calibrated by:	Jeton Kastrati	Laboratory Technician	<i>[Signature]</i>
Approved by:	Katja Pokovic	Technical Manager	<i>[Signature]</i>

Issued: November 15, 2016

This calibration certificate shall not be reproduced except in full without written approval of the laboratory.



Accredited by the Swiss Accreditation Service (SAS)

Accreditation No.: **SCS 0108**

The Swiss Accreditation Service is one of the signatories to the EA
Multilateral Agreement for the recognition of calibration certificates

Glossary:

TSL	tissue simulating liquid
NORM _{x,y,z}	sensitivity in free space
ConvF	sensitivity in TSL / NORM _{x,y,z}
DCP	diode compression point
CF	crest factor (1/duty_cycle) of the RF signal
A, B, C, D	modulation dependent linearization parameters
Polarization φ	φ rotation around probe axis
Polarization ϑ	ϑ rotation around an axis that is in the plane normal to probe axis (at measurement center), i.e., $\vartheta = 0$ is normal to probe axis
Connector Angle	information used in DASY system to align probe sensor X to the robot coordinate system

Calibration is Performed According to the Following Standards:

- IEEE Std 1528-2013, "IEEE Recommended Practice for Determining the Peak Spatial-Averaged Specific Absorption Rate (SAR) in the Human Head from Wireless Communications Devices: Measurement Techniques", June 2013
- IEC 62209-1, "Procedure to measure the Specific Absorption Rate (SAR) for hand-held devices used in close proximity to the ear (frequency range of 300 MHz to 3 GHz)", February 2005
- IEC 62209-2, "Procedure to determine the Specific Absorption Rate (SAR) for wireless communication devices used in close proximity to the human body (frequency range of 30 MHz to 6 GHz)", March 2010
- KDB 865664, "SAR Measurement Requirements for 100 MHz to 6 GHz"

Methods Applied and Interpretation of Parameters:

- NORM_{x,y,z}**: Assessed for E-field polarization $\vartheta = 0$ ($f \leq 900$ MHz in TEM-cell; $f > 1800$ MHz: R22 waveguide). NORM_{x,y,z} are only intermediate values, i.e., the uncertainties of NORM_{x,y,z} does not affect the E²-field uncertainty inside TSL (see below ConvF).
- NORM(f)_{x,y,z}** = NORM_{x,y,z} * frequency_response (see Frequency Response Chart). This linearization is implemented in DASY4 software versions later than 4.2. The uncertainty of the frequency response is included in the stated uncertainty of ConvF.
- DCP_{x,y,z}**: DCP are numerical linearization parameters assessed based on the data of power sweep with CW signal (no uncertainty required). DCP does not depend on frequency nor media.
- PAR**: PAR is the Peak to Average Ratio that is not calibrated but determined based on the signal characteristics
- A_{x,y,z}; B_{x,y,z}; C_{x,y,z}; D_{x,y,z}; VR_{x,y,z}**: A, B, C, D are numerical linearization parameters assessed based on the data of power sweep for specific modulation signal. The parameters do not depend on frequency nor media. VR is the maximum calibration range expressed in RMS voltage across the diode.
- ConvF and Boundary Effect Parameters**: Assessed in flat phantom using E-field (or Temperature Transfer Standard for $f \leq 800$ MHz) and inside waveguide using analytical field distributions based on power measurements for $f > 800$ MHz. The same setups are used for assessment of the parameters applied for boundary compensation (alpha, depth) of which typical uncertainty values are given. These parameters are used in DASY4 software to improve probe accuracy close to the boundary. The sensitivity in TSL corresponds to NORM_{x,y,z} * ConvF whereby the uncertainty corresponds to that given for ConvF. A frequency dependent ConvF is used in DASY version 4.4 and higher which allows extending the validity from ± 50 MHz to ± 100 MHz.
- Spherical isotropy (3D deviation from isotropy)**: in a field of low gradients realized using a flat phantom exposed by a patch antenna.
- Sensor Offset**: The sensor offset corresponds to the offset of virtual measurement center from the probe tip (on probe axis). No tolerance required.
- Connector Angle**: The angle is assessed using the information gained by determining the NORM_x (no uncertainty required).

Probe ES3DV3

SN:3334

Manufactured: January 24, 2012
Calibrated: November 15, 2016

Calibrated for DASY/EASY Systems
(Note: non-compatible with DASY2 system!)

DASY/EASY - Parameters of Probe: ES3DV3 - SN:3334

Basic Calibration Parameters

	Sensor X	Sensor Y	Sensor Z	Unc (k=2)
Norm ($\mu V/(V/m)^2$) ^A	1.01	1.01	0.97	± 10.1 %
DCP (mV) ^B	104.9	104.3	106.9	

Modulation Calibration Parameters

UID	Communication System Name		A dB	B dB√ μV	C	D dB	VR mV	Unc ^E (k=2)
0	CW	X	0.0	0.0	1.0	0.00	187.7	±3.3 %
		Y	0.0	0.0	1.0		186.1	
		Z	0.0	0.0	1.0		182.2	

Note: For details on UID parameters see Appendix.

Sensor Model Parameters

	C1 fF	C2 fF	α V ⁻¹	T1 ms.V ⁻²	T2 ms.V ⁻¹	T3 ms	T4 V ⁻²	T5 V ⁻¹	T6
X	70.73	504.3	35.08	31.68	3.658	5.1	1.261	0.548	1.013
Y	65.12	464.8	35.12	29.88	3.928	5.1	1.127	0.529	1.01
Z	65.17	461.4	34.69	29.79	3.402	5.1	0.804	0.54	1.01

The reported uncertainty of measurement is stated as the standard uncertainty of measurement multiplied by the coverage factor k=2, which for a normal distribution corresponds to a coverage probability of approximately 95%.

^A The uncertainties of Norm X,Y,Z do not affect the E²-field uncertainty inside TSL (see Pages 5 and 6).

^B Numerical linearization parameter: uncertainty not required.

^E Uncertainty is determined using the max. deviation from linear response applying rectangular distribution and is expressed for the square of the field value.

DASY/EASY - Parameters of Probe: ES3DV3 - SN:3334

Calibration Parameter Determined in Head Tissue Simulating Media

f (MHz) ^C	Relative Permittivity ^F	Conductivity (S/m) ^F	ConvF X	ConvF Y	ConvF Z	Alpha ^G	Depth ^G (mm)	Unc (k=2)
6	55.5	0.75	6.51	6.51	6.51	0.05	1.10	± 13.3 %
13	55.5	0.75	6.87	6.87	6.87	0.05	1.20	± 13.3 %
750	41.9	0.89	6.76	6.76	6.76	0.40	1.68	± 12.0 %
835	41.5	0.90	6.49	6.49	6.49	0.41	1.68	± 12.0 %
1750	40.1	1.37	5.45	5.45	5.45	0.51	1.46	± 12.0 %
1900	40.0	1.40	5.27	5.27	5.27	0.52	1.49	± 12.0 %
2300	39.5	1.67	4.92	4.92	4.92	0.69	1.31	± 12.0 %
2450	39.2	1.80	4.73	4.73	4.73	0.77	1.27	± 12.0 %
2600	39.0	1.96	4.51	4.51	4.51	0.80	1.27	± 12.0 %

^C Frequency validity above 300 MHz of ± 100 MHz only applies for DASY v4.4 and higher (see Page 2), else it is restricted to ± 50 MHz. The uncertainty is the RSS of the ConvF uncertainty at calibration frequency and the uncertainty for the indicated frequency band. Frequency validity below 300 MHz is ± 10, 25, 40, 50 and 70 MHz for ConvF assessments at 30, 64, 128, 150 and 220 MHz respectively. Validity of ConvF assessed at 6 MHz is 4-9 MHz, and ConvF assessed at 13 MHz is 9-19 MHz. Above 5 GHz frequency validity can be extended to ± 110 MHz

^F At frequencies below 3 GHz, the validity of tissue parameters (ϵ and σ) can be relaxed to ± 10% if liquid compensation formula is applied to measured SAR values. At frequencies above 3 GHz, the validity of tissue parameters (ϵ and σ) is restricted to ± 5%. The uncertainty is the RSS of the ConvF uncertainty for indicated target tissue parameters.

^G Alpha/Depth are determined during calibration. SPEAG warrants that the remaining deviation due to the boundary effect after compensation is always less than ± 1% for frequencies below 3 GHz and below ± 2% for frequencies between 3-6 GHz at any distance larger than half the probe tip diameter from the boundary.

DASY/EASY - Parameters of Probe: ES3DV3 - SN:3334

Calibration Parameter Determined in Body Tissue Simulating Media

f (MHz) ^C	Relative Permittivity ^F	Conductivity (S/m) ^F	ConvF X	ConvF Y	ConvF Z	Alpha ^G	Depth ^G (mm)	Unc (k=2)
750	55.5	0.96	6.33	6.33	6.33	0.45	1.54	± 12.0 %
835	55.2	0.97	6.31	6.31	6.31	0.74	1.21	± 12.0 %
1750	53.4	1.49	5.12	5.12	5.12	0.52	1.50	± 12.0 %
1900	53.3	1.52	4.91	4.91	4.91	0.41	1.81	± 12.0 %
2300	52.9	1.81	4.68	4.68	4.68	0.80	1.21	± 12.0 %
2450	52.7	1.95	4.52	4.52	4.52	0.79	1.20	± 12.0 %
2600	52.5	2.16	4.42	4.42	4.42	0.80	1.18	± 12.0 %

^C Frequency validity above 300 MHz of ± 100 MHz only applies for DASY v4.4 and higher (see Page 2), else it is restricted to ± 50 MHz. The uncertainty is the RSS of the ConvF uncertainty at calibration frequency and the uncertainty for the indicated frequency band. Frequency validity below 300 MHz is ± 10, 25, 40, 50 and 70 MHz for ConvF assessments at 30, 64, 128, 150 and 220 MHz respectively. Above 5 GHz frequency validity can be extended to ± 110 MHz.

^F At frequencies below 3 GHz, the validity of tissue parameters (ϵ and σ) can be relaxed to ± 10% if liquid compensation formula is applied to measured SAR values. At frequencies above 3 GHz, the validity of tissue parameters (ϵ and σ) is restricted to ± 5%. The uncertainty is the RSS of the ConvF uncertainty for indicated target tissue parameters.

^G Alpha/Depth are determined during calibration. SPEAG warrants that the remaining deviation due to the boundary effect after compensation is always less than ± 1% for frequencies below 3 GHz and below ± 2% for frequencies between 3-6 GHz at any distance larger than half the probe tip diameter from the boundary.

Frequency Response of E-Field (TEM-Cell:ifi110 EXX, Waveguide: R22)

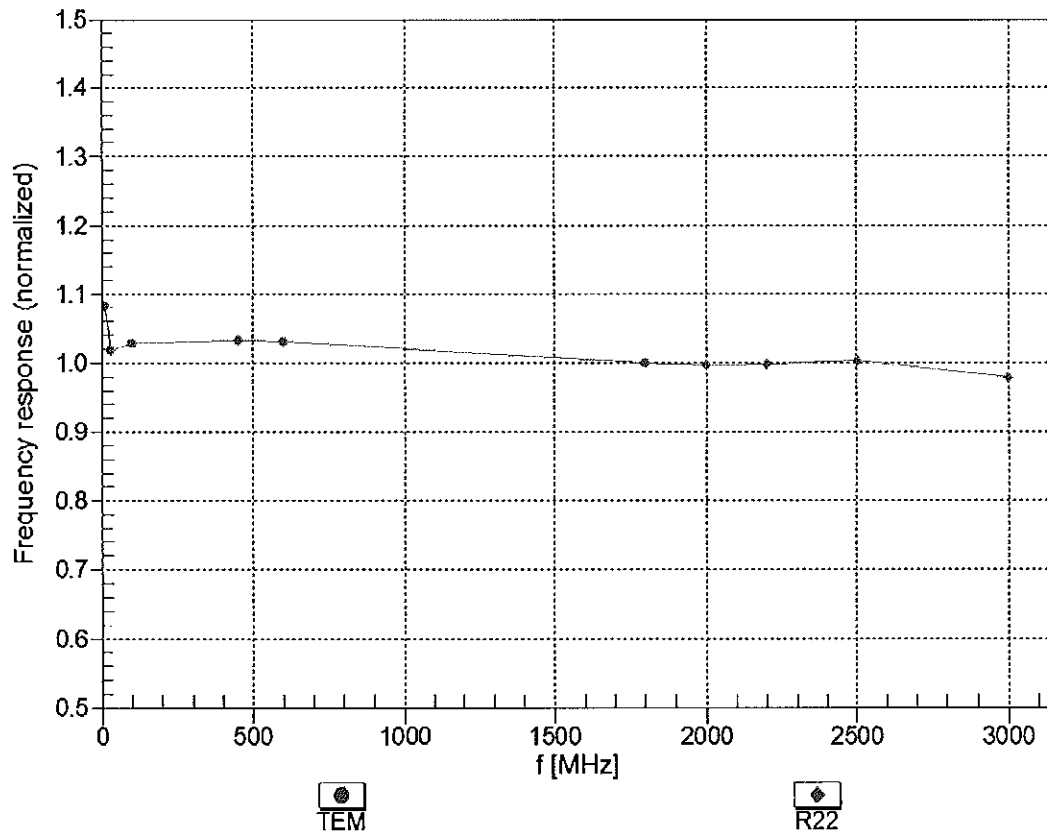

Uncertainty of Frequency Response of E-field: $\pm 6.3\%$ (k=2)

Receiving Pattern (ϕ), $\theta = 0^\circ$

f=600 MHz,TEM

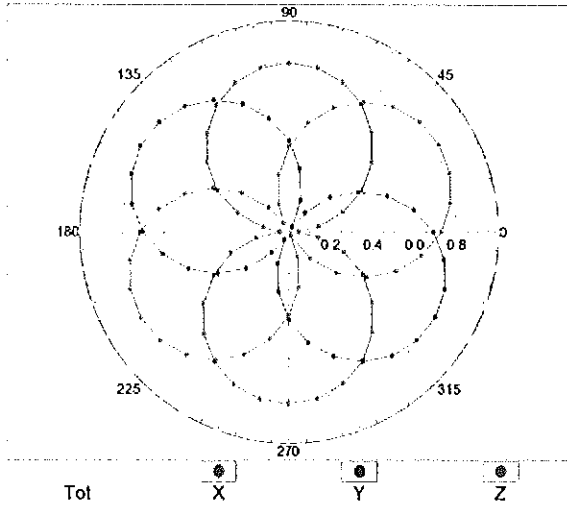

f=1800 MHz,R22

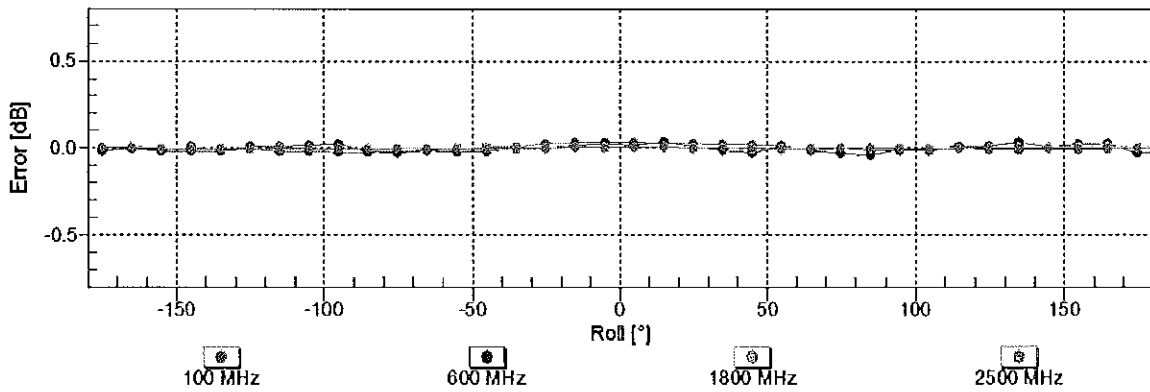
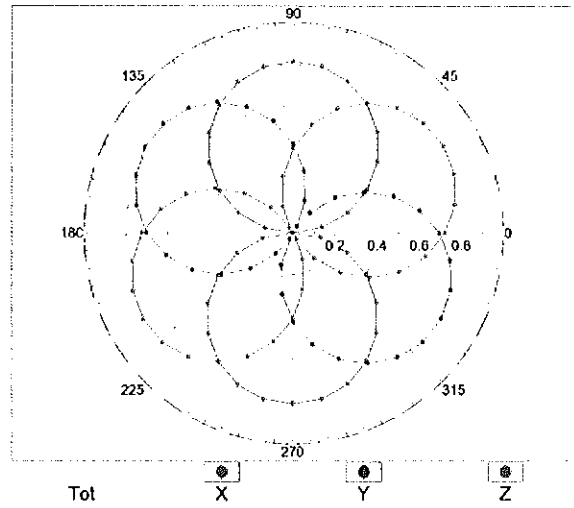

Uncertainty of Axial Isotropy Assessment: $\pm 0.5\%$ ($k=2$)

Dynamic Range $f(SAR_{head})$ (TEM cell, $f_{eval} = 1900$ MHz)

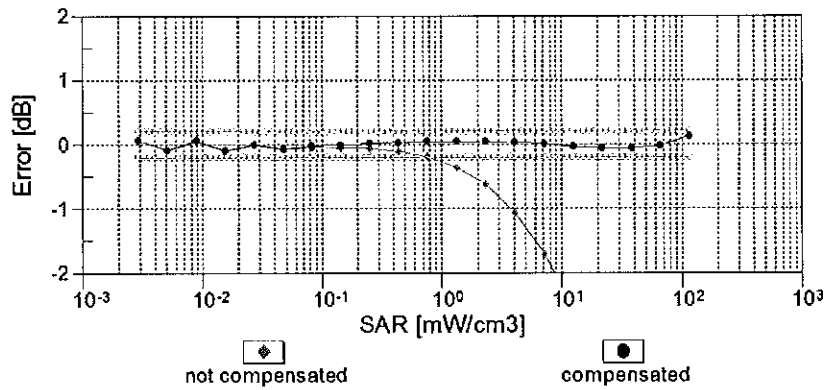
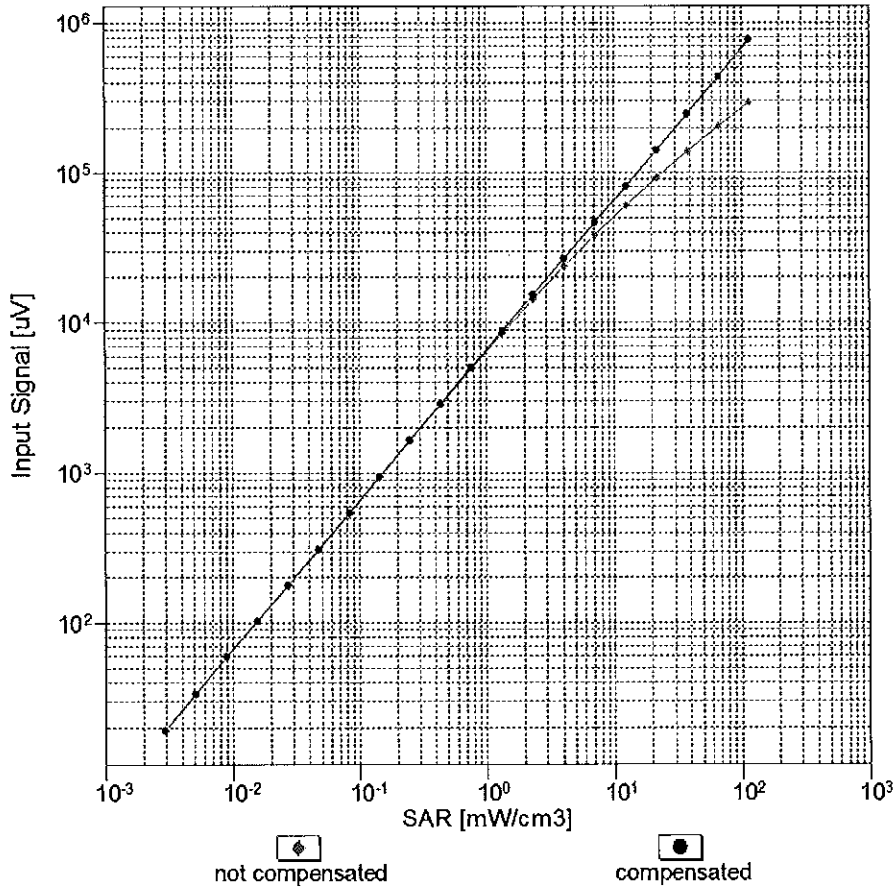

Uncertainty of Linearity Assessment: $\pm 0.6\%$ (k=2)

Conversion Factor Assessment

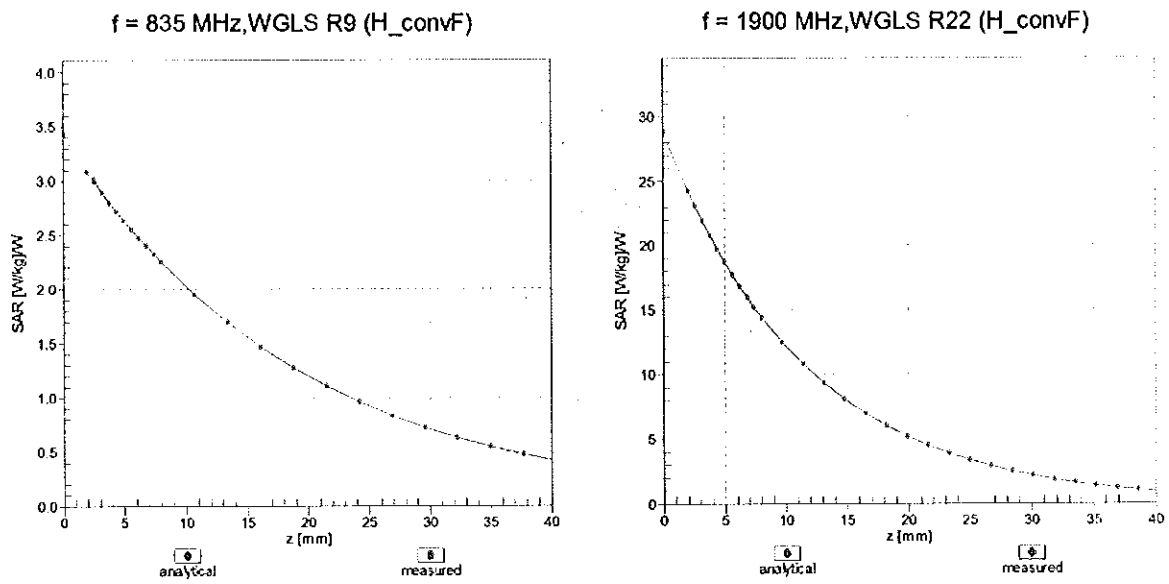

Deviation from Isotropy in Liquid Error (ϕ, ϑ), f = 900 MHz

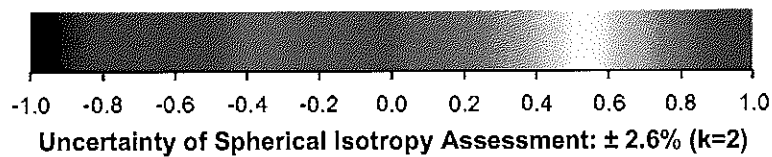
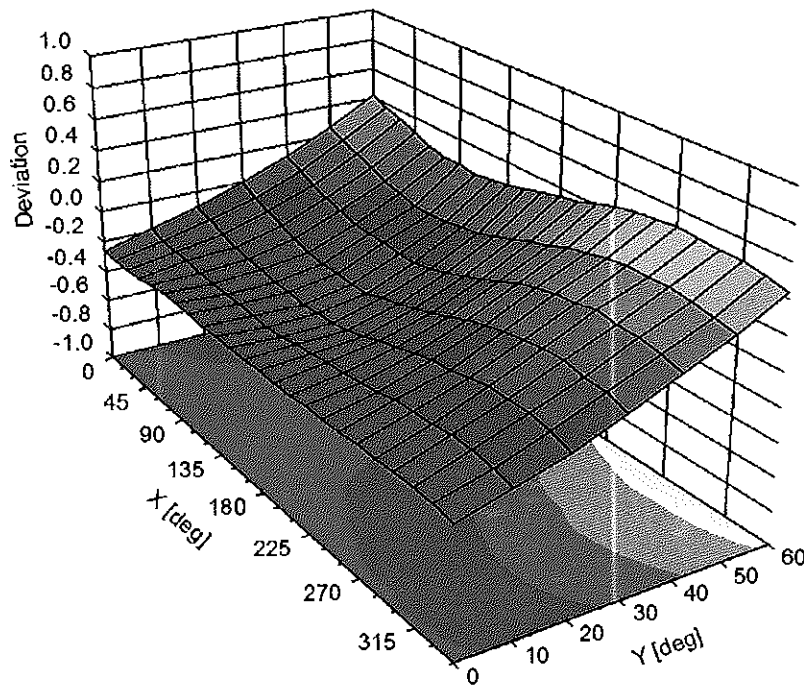

DASY/EASY - Parameters of Probe: ES3DV3 - SN:3334**Other Probe Parameters**

Sensor Arrangement	Triangular
Connector Angle (°)	14.8
Mechanical Surface Detection Mode	enabled
Optical Surface Detection Mode	disabled
Probe Overall Length	337 mm
Probe Body Diameter	10 mm
Tip Length	10 mm
Tip Diameter	4 mm
Probe Tip to Sensor X Calibration Point	2 mm
Probe Tip to Sensor Y Calibration Point	2 mm
Probe Tip to Sensor Z Calibration Point	2 mm
Recommended Measurement Distance from Surface	3 mm

Appendix: Modulation Calibration Parameters

UID	Communication System Name		A dB	B dB μ V	C	D dB	VR mV	Max Unc ^E (k=2)
0	CW	X	0.00	0.00	1.00	0.00	187.7	± 3.3 %
		Y	0.00	0.00	1.00		186.1	
		Z	0.00	0.00	1.00		182.2	
10010- CAA	SAR Validation (Square, 100ms, 10ms)	X	8.77	79.31	19.59	10.00	25.0	± 9.6 %
		Y	9.54	81.15	20.73		25.0	
		Z	9.84	81.78	20.60		25.0	
10011- CAB	UMTS-FDD (WCDMA)	X	1.16	69.33	16.31	0.00	150.0	± 9.6 %
		Y	1.10	67.90	15.63		150.0	
		Z	1.22	70.12	16.93		150.0	
10012- CAB	IEEE 802.11b WiFi 2.4 GHz (DSSS, 1 Mbps)	X	1.34	65.77	16.28	0.41	150.0	± 9.6 %
		Y	1.35	65.28	15.96		150.0	
		Z	1.37	65.99	16.52		150.0	
10013- CAB	IEEE 802.11g WiFi 2.4 GHz (DSSS-OFDM, 6 Mbps)	X	5.24	67.29	17.48	1.46	150.0	± 9.6 %
		Y	5.25	67.32	17.47		150.0	
		Z	5.24	67.39	17.55		150.0	
10021- DAB	GSM-FDD (TDMA, GMSK)	X	14.04	88.44	24.56	9.39	50.0	± 9.6 %
		Y	15.09	90.46	25.72		50.0	
		Z	17.26	92.82	26.12		50.0	
10023- DAB	GPRS-FDD (TDMA, GMSK, TN 0)	X	13.38	87.46	24.27	9.57	50.0	± 9.6 %
		Y	14.20	89.20	25.34		50.0	
		Z	16.01	91.37	25.70		50.0	
10024- DAB	GPRS-FDD (TDMA, GMSK, TN 0-1)	X	38.05	104.88	27.91	6.56	60.0	± 9.6 %
		Y	46.94	109.69	29.75		60.0	
		Z	100.00	120.75	32.11		60.0	
10025- DAB	EDGE-FDD (TDMA, 8PSK, TN 0)	X	17.81	101.01	37.92	12.57	50.0	± 9.6 %
		Y	13.12	91.27	33.89		50.0	
		Z	16.92	100.44	37.93		50.0	
10026- DAB	EDGE-FDD (TDMA, 8PSK, TN 0-1)	X	17.77	98.41	33.58	9.56	60.0	± 9.6 %
		Y	14.79	93.85	31.99		60.0	
		Z	18.16	99.88	34.34		60.0	
10027- DAB	GPRS-FDD (TDMA, GMSK, TN 0-1-2)	X	100.00	118.25	29.99	4.80	80.0	± 9.6 %
		Y	100.00	120.44	31.14		80.0	
		Z	100.00	119.61	30.56		80.0	
10028- DAB	GPRS-FDD (TDMA, GMSK, TN 0-1-2-3)	X	100.00	117.97	28.98	3.55	100.0	± 9.6 %
		Y	100.00	120.46	30.24		100.0	
		Z	100.00	119.89	29.81		100.0	
10029- DAB	EDGE-FDD (TDMA, 8PSK, TN 0-1-2)	X	13.52	92.94	30.62	7.80	80.0	± 9.6 %
		Y	11.42	89.03	29.23		80.0	
		Z	13.37	93.50	31.06		80.0	
10030- CAA	IEEE 802.15.1 Bluetooth (GFSK, DH1)	X	100.00	118.21	30.35	5.30	70.0	± 9.6 %
		Y	100.00	120.20	31.41		70.0	
		Z	100.00	119.30	30.79		70.0	
10031- CAA	IEEE 802.15.1 Bluetooth (GFSK, DH3)	X	100.00	118.75	27.66	1.88	100.0	± 9.6 %
		Y	100.00	121.92	29.18		100.0	
		Z	100.00	122.14	29.14		100.0	

10032-CAA	IEEE 802.15.1 Bluetooth (GFSK, DH5)	X	100.00	122.24	27.95	1.17	100.0	± 9.6 %
		Y	100.00	126.42	29.90		100.0	
		Z	100.00	128.02	30.44		100.0	
10033-CAA	IEEE 802.15.1 Bluetooth (PI/4-DQPSK, DH1)	X	14.25	92.44	25.75	5.30	70.0	± 9.6 %
		Y	12.48	90.39	25.26		70.0	
		Z	16.14	95.22	26.75		70.0	
10034-CAA	IEEE 802.15.1 Bluetooth (PI/4-DQPSK, DH3)	X	8.01	88.33	23.06	1.88	100.0	± 9.6 %
		Y	6.72	85.60	22.20		100.0	
		Z	9.24	90.99	24.02		100.0	
10035-CAA	IEEE 802.15.1 Bluetooth (PI/4-DQPSK, DH5)	X	4.78	82.59	20.90	1.17	100.0	± 9.6 %
		Y	4.12	80.18	20.04		100.0	
		Z	5.37	84.73	21.75		100.0	
10036-CAA	IEEE 802.15.1 Bluetooth (8-DPSK, DH1)	X	16.24	94.81	26.57	5.30	70.0	± 9.6 %
		Y	14.09	92.64	26.06		70.0	
		Z	18.84	98.03	27.68		70.0	
10037-CAA	IEEE 802.15.1 Bluetooth (8-DPSK, DH3)	X	7.84	88.03	22.91	1.88	100.0	± 9.6 %
		Y	6.49	85.11	21.99		100.0	
		Z	8.95	90.55	23.84		100.0	
10038-CAA	IEEE 802.15.1 Bluetooth (8-DPSK, DH5)	X	5.00	83.47	21.28	1.17	100.0	± 9.6 %
		Y	4.25	80.87	20.36		100.0	
		Z	5.60	85.62	22.13		100.0	
10039-CAB	CDMA2000 (1xRTT, RC1)	X	2.21	73.71	17.42	0.00	150.0	± 9.6 %
		Y	2.07	72.72	16.90		150.0	
		Z	2.43	75.47	18.19		150.0	
10042-CAB	IS-54 / IS-136 FDD (TDMA/FDM, PI/4-DQPSK, Halfrate)	X	21.10	94.61	24.99	7.78	50.0	± 9.6 %
		Y	25.53	98.75	26.74		50.0	
		Z	36.08	103.76	27.77		50.0	
10044-CAA	IS-91/EIA/TIA-553 FDD (FDMA, FM)	X	0.00	112.80	5.71	0.00	150.0	± 9.6 %
		Y	0.00	96.18	0.45		150.0	
		Z	0.00	107.58	0.68		150.0	
10048-CAA	DECT (TDD, TDMA/FDM, GFSK, Full Slot, 24)	X	10.49	80.43	23.52	13.80	25.0	± 9.6 %
		Y	10.81	81.22	24.23		25.0	
		Z	11.11	82.26	24.27		25.0	
10049-CAA	DECT (TDD, TDMA/FDM, GFSK, Double Slot, 12)	X	11.49	83.98	23.46	10.79	40.0	± 9.6 %
		Y	11.98	85.23	24.35		40.0	
		Z	12.68	86.48	24.43		40.0	
10056-CAA	UMTS-TDD (TD-SCDMA, 1.28 Mcps)	X	11.65	84.59	23.99	9.03	50.0	± 9.6 %
		Y	11.36	84.29	24.10		50.0	
		Z	12.41	86.38	24.72		50.0	
10058-DAB	EDGE-FDD (TDMA, 8PSK, TN 0-1-2-3)	X	10.62	88.69	28.41	6.55	100.0	± 9.6 %
		Y	9.13	85.32	27.18		100.0	
		Z	10.28	88.69	28.63		100.0	
10059-CAB	IEEE 802.11b WiFi 2.4 GHz (DSSS, 2 Mbps)	X	1.56	68.30	17.46	0.61	110.0	± 9.6 %
		Y	1.54	67.48	17.02		110.0	
		Z	1.58	68.47	17.70		110.0	
10060-CAB	IEEE 802.11b WiFi 2.4 GHz (DSSS, 5.5 Mbps)	X	100.00	129.94	33.28	1.30	110.0	± 9.6 %
		Y	82.67	128.45	33.38		110.0	
		Z	100.00	132.52	34.47		110.0	

10061-CAB	IEEE 802.11b WiFi 2.4 GHz (DSSS, 11 Mbps)	X	12.22	98.02	27.41	2.04	110.0	± 9.6 %
		Y	8.15	91.42	25.55		110.0	
		Z	12.67	99.62	28.21		110.0	
10062-CAB	IEEE 802.11a/h WiFi 5 GHz (OFDM, 6 Mbps)	X	4.95	67.04	16.77	0.49	100.0	± 9.6 %
		Y	4.95	67.04	16.75		100.0	
		Z	4.95	67.16	16.84		100.0	
10063-CAB	IEEE 802.11a/h WiFi 5 GHz (OFDM, 9 Mbps)	X	5.00	67.22	16.92	0.72	100.0	± 9.6 %
		Y	5.00	67.22	16.90		100.0	
		Z	5.00	67.33	16.99		100.0	
10064-CAB	IEEE 802.11a/h WiFi 5 GHz (OFDM, 12 Mbps)	X	5.37	67.60	17.20	0.86	100.0	± 9.6 %
		Y	5.35	67.58	17.17		100.0	
		Z	5.35	67.68	17.26		100.0	
10065-CAB	IEEE 802.11a/h WiFi 5 GHz (OFDM, 18 Mbps)	X	5.27	67.66	17.37	1.21	100.0	± 9.6 %
		Y	5.27	67.65	17.35		100.0	
		Z	5.25	67.74	17.44		100.0	
10066-CAB	IEEE 802.11a/h WiFi 5 GHz (OFDM, 24 Mbps)	X	5.34	67.81	17.61	1.46	100.0	± 9.6 %
		Y	5.33	67.80	17.59		100.0	
		Z	5.32	67.89	17.67		100.0	
10067-CAB	IEEE 802.11a/h WiFi 5 GHz (OFDM, 36 Mbps)	X	5.67	67.95	18.07	2.04	100.0	± 9.6 %
		Y	5.66	67.95	18.04		100.0	
		Z	5.64	68.02	18.12		100.0	
10068-CAB	IEEE 802.11a/h WiFi 5 GHz (OFDM, 48 Mbps)	X	5.84	68.42	18.48	2.55	100.0	± 9.6 %
		Y	5.84	68.39	18.44		100.0	
		Z	5.80	68.45	18.52		100.0	
10069-CAB	IEEE 802.11a/h WiFi 5 GHz (OFDM, 54 Mbps)	X	5.91	68.29	18.64	2.67	100.0	± 9.6 %
		Y	5.91	68.28	18.60		100.0	
		Z	5.88	68.35	18.68		100.0	
10071-CAB	IEEE 802.11g WiFi 2.4 GHz (DSSS/OFDM, 9 Mbps)	X	5.40	67.57	17.88	1.99	100.0	± 9.6 %
		Y	5.42	67.58	17.87		100.0	
		Z	5.39	67.65	17.94		100.0	
10072-CAB	IEEE 802.11g WiFi 2.4 GHz (DSSS/OFDM, 12 Mbps)	X	5.50	68.20	18.23	2.30	100.0	± 9.6 %
		Y	5.51	68.20	18.21		100.0	
		Z	5.48	68.27	18.29		100.0	
10073-CAB	IEEE 802.11g WiFi 2.4 GHz (DSSS/OFDM, 18 Mbps)	X	5.66	68.60	18.67	2.83	100.0	± 9.6 %
		Y	5.67	68.59	18.64		100.0	
		Z	5.63	68.66	18.73		100.0	
10074-CAB	IEEE 802.11g WiFi 2.4 GHz (DSSS/OFDM, 24 Mbps)	X	5.71	68.74	18.97	3.30	100.0	± 9.6 %
		Y	5.72	68.71	18.92		100.0	
		Z	5.68	68.77	19.01		100.0	
10075-CAB	IEEE 802.11g WiFi 2.4 GHz (DSSS/OFDM, 36 Mbps)	X	5.92	69.39	19.54	3.82	90.0	± 9.6 %
		Y	5.92	69.30	19.46		90.0	
		Z	5.87	69.36	19.56		90.0	
10076-CAB	IEEE 802.11g WiFi 2.4 GHz (DSSS/OFDM, 48 Mbps)	X	5.92	69.17	19.65	4.15	90.0	± 9.6 %
		Y	5.94	69.10	19.58		90.0	
		Z	5.88	69.15	19.67		90.0	
10077-CAB	IEEE 802.11g WiFi 2.4 GHz (DSSS/OFDM, 54 Mbps)	X	5.96	69.26	19.75	4.30	90.0	± 9.6 %
		Y	5.98	69.19	19.68		90.0	
		Z	5.92	69.25	19.77		90.0	

10081-CAB	CDMA2000 (1xRTT, RC3)	X	1.06	68.38	14.68	0.00	150.0	± 9.6 %
		Y	1.00	67.23	14.06		150.0	
		Z	1.15	69.61	15.40		150.0	
10082-CAB	IS-54 / IS-136 FDD (TDMA/FDM, PI/4-DQPSK, Fullrate)	X	2.58	65.03	9.90	4.77	80.0	± 9.6 %
		Y	2.69	65.68	10.51		80.0	
		Z	2.57	65.43	10.13		80.0	
10090-DAB	GPRS-FDD (TDMA, GMSK, TN 0-4)	X	36.90	104.46	27.83	6.56	60.0	± 9.6 %
		Y	45.21	109.15	29.65		60.0	
		Z	94.87	120.02	31.97		60.0	
10097-CAB	UMTS-FDD (HSDPA)	X	1.90	68.06	16.14	0.00	150.0	± 9.6 %
		Y	1.89	67.63	15.88		150.0	
		Z	1.96	68.55	16.47		150.0	
10098-CAB	UMTS-FDD (HSUPA, Subtest 2)	X	1.86	68.04	16.12	0.00	150.0	± 9.6 %
		Y	1.85	67.59	15.85		150.0	
		Z	1.92	68.55	16.45		150.0	
10099-DAB	EDGE-FDD (TDMA, 8PSK, TN 0-4)	X	17.69	98.25	33.53	9.56	60.0	± 9.6 %
		Y	14.75	93.74	31.95		60.0	
		Z	18.07	99.72	34.29		60.0	
10100-CAB	LTE-FDD (SC-FDMA, 100% RB, 20 MHz, QPSK)	X	3.44	71.50	17.09	0.00	150.0	± 9.6 %
		Y	3.34	70.90	16.87		150.0	
		Z	3.49	71.85	17.37		150.0	
10101-CAB	LTE-FDD (SC-FDMA, 100% RB, 20 MHz, 16-QAM)	X	3.45	68.24	16.24	0.00	150.0	± 9.6 %
		Y	3.42	67.96	16.11		150.0	
		Z	3.46	68.39	16.38		150.0	
10102-CAB	LTE-FDD (SC-FDMA, 100% RB, 20 MHz, 64-QAM)	X	3.54	68.11	16.30	0.00	150.0	± 9.6 %
		Y	3.52	67.89	16.19		150.0	
		Z	3.56	68.26	16.44		150.0	
10103-CAB	LTE-TDD (SC-FDMA, 100% RB, 20 MHz, QPSK)	X	8.66	77.35	20.84	3.98	65.0	± 9.6 %
		Y	8.46	77.01	20.81		65.0	
		Z	8.71	77.85	21.15		65.0	
10104-CAB	LTE-TDD (SC-FDMA, 100% RB, 20 MHz, 16-QAM)	X	8.88	76.70	21.45	3.98	65.0	± 9.6 %
		Y	8.67	76.23	21.29		65.0	
		Z	8.82	76.91	21.62		65.0	
10105-CAB	LTE-TDD (SC-FDMA, 100% RB, 20 MHz, 64-QAM)	X	8.13	74.97	20.97	3.98	65.0	± 9.6 %
		Y	7.88	74.31	20.72		65.0	
		Z	7.92	74.75	20.95		65.0	
10108-CAC	LTE-FDD (SC-FDMA, 100% RB, 10 MHz, QPSK)	X	3.04	70.66	16.91	0.00	150.0	± 9.6 %
		Y	2.95	70.09	16.69		150.0	
		Z	3.08	70.99	17.20		150.0	
10109-CAC	LTE-FDD (SC-FDMA, 100% RB, 10 MHz, 16-QAM)	X	3.12	68.03	16.19	0.00	150.0	± 9.6 %
		Y	3.09	67.76	16.05		150.0	
		Z	3.14	68.21	16.35		150.0	
10110-CAC	LTE-FDD (SC-FDMA, 100% RB, 5 MHz, QPSK)	X	2.50	69.68	16.63	0.00	150.0	± 9.6 %
		Y	2.43	69.09	16.36		150.0	
		Z	2.53	70.06	16.93		150.0	
10111-CAC	LTE-FDD (SC-FDMA, 100% RB, 5 MHz, 16-QAM)	X	2.81	68.48	16.49	0.00	150.0	± 9.6 %
		Y	2.78	68.30	16.36		150.0	
		Z	2.84	68.81	16.69		150.0	

10112-CAC	LTE-FDD (SC-FDMA, 100% RB, 10 MHz, 64-QAM)	X	3.24	67.90	16.20	0.00	150.0	± 9.6 %
		Y	3.21	67.68	16.09		150.0	
		Z	3.25	68.09	16.35		150.0	
10113-CAC	LTE-FDD (SC-FDMA, 100% RB, 5 MHz, 64-QAM)	X	2.97	68.50	16.56	0.00	150.0	± 9.6 %
		Y	2.94	68.37	16.47		150.0	
		Z	2.99	68.82	16.76		150.0	
10114-CAB	IEEE 802.11n (HT Greenfield, 13.5 Mbps, BPSK)	X	5.29	67.41	16.51	0.00	150.0	± 9.6 %
		Y	5.28	67.36	16.48		150.0	
		Z	5.28	67.49	16.58		150.0	
10115-CAB	IEEE 802.11n (HT Greenfield, 81 Mbps, 16-QAM)	X	5.70	67.80	16.71	0.00	150.0	± 9.6 %
		Y	5.66	67.68	16.65		150.0	
		Z	5.66	67.80	16.73		150.0	
10116-CAB	IEEE 802.11n (HT Greenfield, 135 Mbps, 64-QAM)	X	5.42	67.66	16.55	0.00	150.0	± 9.6 %
		Y	5.41	67.63	16.54		150.0	
		Z	5.42	67.76	16.63		150.0	
10117-CAB	IEEE 802.11n (HT Mixed, 13.5 Mbps, BPSK)	X	5.29	67.43	16.54	0.00	150.0	± 9.6 %
		Y	5.29	67.39	16.52		150.0	
		Z	5.29	67.52	16.61		150.0	
10118-CAB	IEEE 802.11n (HT Mixed, 81 Mbps, 16-QAM)	X	5.72	67.78	16.70	0.00	150.0	± 9.6 %
		Y	5.72	67.79	16.71		150.0	
		Z	5.72	67.90	16.79		150.0	
10119-CAB	IEEE 802.11n (HT Mixed, 135 Mbps, 64-QAM)	X	5.39	67.61	16.55	0.00	150.0	± 9.6 %
		Y	5.39	67.59	16.53		150.0	
		Z	5.39	67.71	16.62		150.0	
10140-CAB	LTE-FDD (SC-FDMA, 100% RB, 15 MHz, 16-QAM)	X	3.60	68.11	16.22	0.00	150.0	± 9.6 %
		Y	3.57	67.89	16.12		150.0	
		Z	3.61	68.26	16.36		150.0	
10141-CAB	LTE-FDD (SC-FDMA, 100% RB, 15 MHz, 64-QAM)	X	3.71	68.11	16.35	0.00	150.0	± 9.6 %
		Y	3.69	67.93	16.26		150.0	
		Z	3.72	68.27	16.48		150.0	
10142-CAC	LTE-FDD (SC-FDMA, 100% RB, 3 MHz, QPSK)	X	2.28	69.60	16.50	0.00	150.0	± 9.6 %
		Y	2.20	69.01	16.20		150.0	
		Z	2.31	70.09	16.82		150.0	
10143-CAC	LTE-FDD (SC-FDMA, 100% RB, 3 MHz, 16-QAM)	X	2.70	69.15	16.46	0.00	150.0	± 9.6 %
		Y	2.67	68.99	16.31		150.0	
		Z	2.74	69.63	16.70		150.0	
10144-CAC	LTE-FDD (SC-FDMA, 100% RB, 3 MHz, 64-QAM)	X	2.54	67.36	15.17	0.00	150.0	± 9.6 %
		Y	2.49	67.09	14.94		150.0	
		Z	2.55	67.71	15.33		150.0	
10145-CAC	LTE-FDD (SC-FDMA, 100% RB, 1.4 MHz, QPSK)	X	1.68	68.42	14.82	0.00	150.0	± 9.6 %
		Y	1.60	67.64	14.26		150.0	
		Z	1.72	69.05	15.06		150.0	
10146-CAC	LTE-FDD (SC-FDMA, 100% RB, 1.4 MHz, 16-QAM)	X	4.83	77.87	18.53	0.00	150.0	± 9.6 %
		Y	3.98	75.00	17.05		150.0	
		Z	3.89	75.00	17.12		150.0	
10147-CAC	LTE-FDD (SC-FDMA, 100% RB, 1.4 MHz, 64-QAM)	X	6.50	82.39	20.39	0.00	150.0	± 9.6 %
		Y	5.41	79.51	18.99		150.0	
		Z	5.09	78.98	18.85		150.0	

10149-CAB	LTE-FDD (SC-FDMA, 50% RB, 20 MHz, 16-QAM)	X	3.13	68.08	16.23	0.00	150.0	± 9.6 %
		Y	3.10	67.82	16.09		150.0	
		Z	3.14	68.27	16.39		150.0	
10150-CAB	LTE-FDD (SC-FDMA, 50% RB, 20 MHz, 64-QAM)	X	3.25	67.94	16.24	0.00	150.0	± 9.6 %
		Y	3.22	67.73	16.12		150.0	
		Z	3.26	68.13	16.39		150.0	
10151-CAB	LTE-TDD (SC-FDMA, 50% RB, 20 MHz, QPSK)	X	9.12	79.35	21.75	3.98	65.0	± 9.6 %
		Y	8.93	79.07	21.74		65.0	
		Z	9.26	80.07	22.14		65.0	
10152-CAB	LTE-TDD (SC-FDMA, 50% RB, 20 MHz, 16-QAM)	X	8.52	76.90	21.36	3.98	65.0	± 9.6 %
		Y	8.28	76.34	21.15		65.0	
		Z	8.47	77.14	21.53		65.0	
10153-CAB	LTE-TDD (SC-FDMA, 50% RB, 20 MHz, 64-QAM)	X	8.83	77.49	21.93	3.98	65.0	± 9.6 %
		Y	8.62	77.01	21.76		65.0	
		Z	8.79	77.75	22.10		65.0	
10154-CAC	LTE-FDD (SC-FDMA, 50% RB, 10 MHz, QPSK)	X	2.57	70.18	16.94	0.00	150.0	± 9.6 %
		Y	2.49	69.59	16.67		150.0	
		Z	2.60	70.55	17.23		150.0	
10155-CAC	LTE-FDD (SC-FDMA, 50% RB, 10 MHz, 16-QAM)	X	2.81	68.47	16.49	0.00	150.0	± 9.6 %
		Y	2.78	68.29	16.36		150.0	
		Z	2.84	68.81	16.70		150.0	
10156-CAC	LTE-FDD (SC-FDMA, 50% RB, 5 MHz, QPSK)	X	2.16	69.95	16.57	0.00	150.0	± 9.6 %
		Y	2.07	69.28	16.21		150.0	
		Z	2.20	70.51	16.91		150.0	
10157-CAC	LTE-FDD (SC-FDMA, 50% RB, 5 MHz, 16-QAM)	X	2.38	68.05	15.40	0.00	150.0	± 9.6 %
		Y	2.33	67.74	15.13		150.0	
		Z	2.41	68.51	15.61		150.0	
10158-CAC	LTE-FDD (SC-FDMA, 50% RB, 10 MHz, 64-QAM)	X	2.97	68.54	16.60	0.00	150.0	± 9.6 %
		Y	2.95	68.41	16.50		150.0	
		Z	2.99	68.87	16.80		150.0	
10159-CAC	LTE-FDD (SC-FDMA, 50% RB, 5 MHz, 64-QAM)	X	2.50	68.46	15.67	0.00	150.0	± 9.6 %
		Y	2.45	68.21	15.44		150.0	
		Z	2.53	68.95	15.89		150.0	
10160-CAB	LTE-FDD (SC-FDMA, 50% RB, 15 MHz, QPSK)	X	2.97	69.28	16.60	0.00	150.0	± 9.6 %
		Y	2.92	68.92	16.43		150.0	
		Z	3.00	69.58	16.83		150.0	
10161-CAB	LTE-FDD (SC-FDMA, 50% RB, 15 MHz, 16-QAM)	X	3.13	67.81	16.19	0.00	150.0	± 9.6 %
		Y	3.11	67.62	16.07		150.0	
		Z	3.15	68.02	16.34		150.0	
10162-CAB	LTE-FDD (SC-FDMA, 50% RB, 15 MHz, 64-QAM)	X	3.23	67.81	16.23	0.00	150.0	± 9.6 %
		Y	3.21	67.66	16.13		150.0	
		Z	3.25	68.04	16.39		150.0	
10166-CAC	LTE-FDD (SC-FDMA, 50% RB, 1.4 MHz, QPSK)	X	4.28	71.44	20.14	3.01	150.0	± 9.6 %
		Y	4.14	70.84	19.78		150.0	
		Z	4.08	70.78	19.80		150.0	
10167-CAC	LTE-FDD (SC-FDMA, 50% RB, 1.4 MHz, 16-QAM)	X	5.82	75.47	21.02	3.01	150.0	± 9.6 %
		Y	5.49	74.58	20.57		150.0	
		Z	5.34	74.36	20.53		150.0	

10168-CAC	LTE-FDD (SC-FDMA, 50% RB, 1.4 MHz, 64-QAM)	X	6.39	77.47	22.15	3.01	150.0	± 9.6 %
		Y	6.08	76.81	21.83		150.0	
		Z	5.84	76.29	21.65		150.0	
10169-CAB	LTE-FDD (SC-FDMA, 1 RB, 20 MHz, QPSK)	X	4.38	75.00	21.59	3.01	150.0	± 9.6 %
		Y	3.97	73.13	20.72		150.0	
		Z	3.86	72.93	20.71		150.0	
10170-CAB	LTE-FDD (SC-FDMA, 1 RB, 20 MHz, 16-QAM)	X	7.68	84.36	24.73	3.01	150.0	± 9.6 %
		Y	6.57	81.73	23.77		150.0	
		Z	6.11	80.75	23.47		150.0	
10171-AAB	LTE-FDD (SC-FDMA, 1 RB, 20 MHz, 64-QAM)	X	5.83	78.41	21.57	3.01	150.0	± 9.6 %
		Y	5.03	75.97	20.56		150.0	
		Z	4.85	75.79	20.60		150.0	
10172-CAB	LTE-TDD (SC-FDMA, 1 RB, 20 MHz, QPSK)	X	34.00	110.08	33.55	6.02	65.0	± 9.6 %
		Y	23.82	103.43	31.66		65.0	
		Z	27.68	107.07	32.82		65.0	
10173-CAB	LTE-TDD (SC-FDMA, 1 RB, 20 MHz, 16-QAM)	X	32.90	104.70	30.42	6.02	65.0	± 9.6 %
		Y	28.30	102.52	29.89		65.0	
		Z	30.73	104.44	30.45		65.0	
10174-CAB	LTE-TDD (SC-FDMA, 1 RB, 20 MHz, 64-QAM)	X	25.83	99.19	28.36	6.02	65.0	± 9.6 %
		Y	22.98	97.66	28.00		65.0	
		Z	24.34	99.06	28.41		65.0	
10175-CAC	LTE-FDD (SC-FDMA, 1 RB, 10 MHz, QPSK)	X	4.30	74.53	21.28	3.01	150.0	± 9.6 %
		Y	3.90	72.69	20.41		150.0	
		Z	3.80	72.54	20.44		150.0	
10176-CAC	LTE-FDD (SC-FDMA, 1 RB, 10 MHz, 16-QAM)	X	7.70	84.38	24.74	3.01	150.0	± 9.6 %
		Y	6.58	81.76	23.78		150.0	
		Z	6.11	80.77	23.48		150.0	
10177-CAE	LTE-FDD (SC-FDMA, 1 RB, 5 MHz, QPSK)	X	4.35	74.76	21.41	3.01	150.0	± 9.6 %
		Y	3.95	72.91	20.54		150.0	
		Z	3.84	72.73	20.55		150.0	
10178-CAC	LTE-FDD (SC-FDMA, 1 RB, 5 MHz, 16-QAM)	X	7.52	83.92	24.54	3.01	150.0	± 9.6 %
		Y	6.44	81.32	23.58		150.0	
		Z	6.01	80.41	23.31		150.0	
10179-CAC	LTE-FDD (SC-FDMA, 1 RB, 10 MHz, 64-QAM)	X	6.63	81.06	22.94	3.01	150.0	± 9.6 %
		Y	5.69	78.55	21.97		150.0	
		Z	5.41	78.06	21.87		150.0	
10180-CAC	LTE-FDD (SC-FDMA, 1 RB, 5 MHz, 64-QAM)	X	5.79	78.25	21.48	3.01	150.0	± 9.6 %
		Y	4.99	75.83	20.48		150.0	
		Z	4.83	75.67	20.53		150.0	
10181-CAB	LTE-FDD (SC-FDMA, 1 RB, 15 MHz, QPSK)	X	4.34	74.74	21.40	3.01	150.0	± 9.6 %
		Y	3.94	72.89	20.53		150.0	
		Z	3.83	72.71	20.54		150.0	
10182-CAB	LTE-FDD (SC-FDMA, 1 RB, 15 MHz, 16-QAM)	X	7.51	83.89	24.53	3.01	150.0	± 9.6 %
		Y	6.43	81.29	23.57		150.0	
		Z	6.00	80.39	23.30		150.0	
10183-AAA	LTE-FDD (SC-FDMA, 1 RB, 15 MHz, 64-QAM)	X	5.78	78.22	21.47	3.01	150.0	± 9.6 %
		Y	4.98	75.80	20.47		150.0	
		Z	4.82	75.64	20.52		150.0	

10184-CAC	LTE-FDD (SC-FDMA, 1 RB, 3 MHz, QPSK)	X	4.36	74.79	21.43	3.01	150.0	± 9.6 %
		Y	3.95	72.94	20.56		150.0	
		Z	3.85	72.76	20.56		150.0	
10185-CAC	LTE-FDD (SC-FDMA, 1 RB, 3 MHz, 16-QAM)	X	7.55	83.99	24.57	3.01	150.0	± 9.6 %
		Y	6.47	81.38	23.61		150.0	
		Z	6.03	80.47	23.34		150.0	
10186-AAC	LTE-FDD (SC-FDMA, 1 RB, 3 MHz, 64-QAM)	X	5.81	78.31	21.51	3.01	150.0	± 9.6 %
		Y	5.01	75.88	20.50		150.0	
		Z	4.84	75.72	20.55		150.0	
10187-CAC	LTE-FDD (SC-FDMA, 1 RB, 1.4 MHz, QPSK)	X	4.37	74.83	21.47	3.01	150.0	± 9.6 %
		Y	3.96	72.98	20.60		150.0	
		Z	3.85	72.80	20.61		150.0	
10188-CAC	LTE-FDD (SC-FDMA, 1 RB, 1.4 MHz, 16-QAM)	X	7.95	85.05	25.06	3.01	150.0	± 9.6 %
		Y	6.80	82.42	24.11		150.0	
		Z	6.29	81.33	23.77		150.0	
10189-AAC	LTE-FDD (SC-FDMA, 1 RB, 1.4 MHz, 64-QAM)	X	6.01	78.95	21.85	3.01	150.0	± 9.6 %
		Y	5.17	76.49	20.84		150.0	
		Z	4.98	76.26	20.86		150.0	
10193-CAB	IEEE 802.11n (HT Greenfield, 6.5 Mbps, BPSK)	X	4.72	66.78	16.30	0.00	150.0	± 9.6 %
		Y	4.71	66.76	16.26		150.0	
		Z	4.72	66.90	16.38		150.0	
10194-CAB	IEEE 802.11n (HT Greenfield, 39 Mbps, 16-QAM)	X	4.93	67.17	16.41	0.00	150.0	± 9.6 %
		Y	4.91	67.14	16.38		150.0	
		Z	4.92	67.28	16.49		150.0	
10195-CAB	IEEE 802.11n (HT Greenfield, 65 Mbps, 64-QAM)	X	4.97	67.17	16.41	0.00	150.0	± 9.6 %
		Y	4.95	67.14	16.38		150.0	
		Z	4.96	67.29	16.49		150.0	
10196-CAB	IEEE 802.11n (HT Mixed, 6.5 Mbps, BPSK)	X	4.74	66.90	16.34	0.00	150.0	± 9.6 %
		Y	4.73	66.86	16.30		150.0	
		Z	4.74	67.01	16.41		150.0	
10197-CAB	IEEE 802.11n (HT Mixed, 39 Mbps, 16-QAM)	X	4.94	67.19	16.42	0.00	150.0	± 9.6 %
		Y	4.93	67.16	16.39		150.0	
		Z	4.94	67.30	16.50		150.0	
10198-CAB	IEEE 802.11n (HT Mixed, 65 Mbps, 64-QAM)	X	4.97	67.18	16.41	0.00	150.0	± 9.6 %
		Y	4.96	67.16	16.39		150.0	
		Z	4.97	67.30	16.50		150.0	
10219-CAB	IEEE 802.11n (HT Mixed, 7.2 Mbps, BPSK)	X	4.69	66.91	16.31	0.00	150.0	± 9.6 %
		Y	4.68	66.88	16.27		150.0	
		Z	4.69	67.03	16.38		150.0	
10220-CAB	IEEE 802.11n (HT Mixed, 43.3 Mbps, 16-QAM)	X	4.95	67.19	16.42	0.00	150.0	± 9.6 %
		Y	4.93	67.15	16.39		150.0	
		Z	4.94	67.30	16.50		150.0	
10221-CAB	IEEE 802.11n (HT Mixed, 72.2 Mbps, 64-QAM)	X	4.98	67.12	16.41	0.00	150.0	± 9.6 %
		Y	4.96	67.09	16.38		150.0	
		Z	4.97	67.24	16.49		150.0	
10222-CAB	IEEE 802.11n (HT Mixed, 15 Mbps, BPSK)	X	5.28	67.46	16.55	0.00	150.0	± 9.6 %
		Y	5.27	67.41	16.52		150.0	
		Z	5.27	67.54	16.61		150.0	

10223-CAB	IEEE 802.11n (HT Mixed, 90 Mbps, 16-QAM)	X	5.66	67.79	16.73	0.00	150.0	± 9.6 %
		Y	5.66	67.78	16.72		150.0	
		Z	5.66	67.89	16.81		150.0	
10224-CAB	IEEE 802.11n (HT Mixed, 150 Mbps, 64-QAM)	X	5.34	67.59	16.53	0.00	150.0	± 9.6 %
		Y	5.32	67.52	16.49		150.0	
		Z	5.33	67.65	16.59		150.0	
10225-CAB	UMTS-FDD (HSPA+)	X	2.98	66.36	15.75	0.00	150.0	± 9.6 %
		Y	2.97	66.26	15.63		150.0	
		Z	2.99	66.57	15.86		150.0	
10226-CAA	LTE-TDD (SC-FDMA, 1 RB, 1.4 MHz, 16-QAM)	X	34.49	105.68	30.78	6.02	65.0	± 9.6 %
		Y	29.79	103.57	30.28		65.0	
		Z	32.28	105.46	30.82		65.0	
10227-CAA	LTE-TDD (SC-FDMA, 1 RB, 1.4 MHz, 64-QAM)	X	26.80	99.98	28.68	6.02	65.0	± 9.6 %
		Y	24.57	98.96	28.48		65.0	
		Z	25.66	100.11	28.80		65.0	
10228-CAA	LTE-TDD (SC-FDMA, 1 RB, 1.4 MHz, QPSK)	X	34.73	111.06	33.97	6.02	65.0	± 9.6 %
		Y	25.52	105.30	32.35		65.0	
		Z	30.95	109.77	33.72		65.0	
10229-CAB	LTE-TDD (SC-FDMA, 1 RB, 3 MHz, 16-QAM)	X	32.90	104.69	30.43	6.02	65.0	± 9.6 %
		Y	28.35	102.53	29.91		65.0	
		Z	30.75	104.44	30.46		65.0	
10230-CAB	LTE-TDD (SC-FDMA, 1 RB, 3 MHz, 64-QAM)	X	25.79	99.22	28.39	6.02	65.0	± 9.6 %
		Y	23.57	98.14	28.17		65.0	
		Z	24.66	99.32	28.50		65.0	
10231-CAB	LTE-TDD (SC-FDMA, 1 RB, 3 MHz, QPSK)	X	33.18	110.06	33.62	6.02	65.0	± 9.6 %
		Y	24.40	104.32	31.99		65.0	
		Z	29.56	108.76	33.36		65.0	
10232-CAB	LTE-TDD (SC-FDMA, 1 RB, 5 MHz, 16-QAM)	X	32.89	104.69	30.43	6.02	65.0	± 9.6 %
		Y	28.33	102.53	29.90		65.0	
		Z	30.74	104.44	30.46		65.0	
10233-CAB	LTE-TDD (SC-FDMA, 1 RB, 5 MHz, 64-QAM)	X	25.82	99.25	28.40	6.02	65.0	± 9.6 %
		Y	23.57	98.15	28.17		65.0	
		Z	24.67	99.34	28.51		65.0	
10234-CAB	LTE-TDD (SC-FDMA, 1 RB, 5 MHz, QPSK)	X	31.54	108.89	33.19	6.02	65.0	± 9.6 %
		Y	23.30	103.27	31.58		65.0	
		Z	28.13	107.61	32.94		65.0	
10235-CAB	LTE-TDD (SC-FDMA, 1 RB, 10 MHz, 16-QAM)	X	32.98	104.76	30.45	6.02	65.0	± 9.6 %
		Y	28.39	102.58	29.92		65.0	
		Z	30.82	104.50	30.48		65.0	
10236-CAB	LTE-TDD (SC-FDMA, 1 RB, 10 MHz, 64-QAM)	X	26.00	99.35	28.43	6.02	65.0	± 9.6 %
		Y	23.73	98.25	28.20		65.0	
		Z	24.86	99.45	28.54		65.0	
10237-CAB	LTE-TDD (SC-FDMA, 1 RB, 10 MHz, QPSK)	X	33.51	110.27	33.67	6.02	65.0	± 9.6 %
		Y	24.55	104.47	32.03		65.0	
		Z	29.82	108.95	33.42		65.0	
10238-CAB	LTE-TDD (SC-FDMA, 1 RB, 15 MHz, 16-QAM)	X	32.92	104.72	30.43	6.02	65.0	± 9.6 %
		Y	28.33	102.54	29.91		65.0	
		Z	30.76	104.46	30.46		65.0	

10239-CAB	LTE-TDD (SC-FDMA, 1 RB, 15 MHz, 64-QAM)	X	25.84	99.28	28.41	6.02	65.0	± 9.6 %
		Y	23.57	98.17	28.18		65.0	
		Z	24.68	99.36	28.51		65.0	
10240-CAB	LTE-TDD (SC-FDMA, 1 RB, 15 MHz, QPSK)	X	33.41	110.22	33.66	6.02	65.0	± 9.6 %
		Y	24.49	104.42	32.01		65.0	
		Z	29.73	108.90	33.40		65.0	
10241-CAA	LTE-TDD (SC-FDMA, 50% RB, 1.4 MHz, 16-QAM)	X	13.87	87.85	27.97	6.98	65.0	± 9.6 %
		Y	12.90	86.30	27.27		65.0	
		Z	13.00	86.99	27.62		65.0	
10242-CAA	LTE-TDD (SC-FDMA, 50% RB, 1.4 MHz, 64-QAM)	X	13.03	86.40	27.33	6.98	65.0	± 9.6 %
		Y	12.04	84.70	26.56		65.0	
		Z	12.01	85.17	26.83		65.0	
10243-CAA	LTE-TDD (SC-FDMA, 50% RB, 1.4 MHz, QPSK)	X	10.68	84.11	27.32	6.98	65.0	± 9.6 %
		Y	9.82	82.05	26.33		65.0	
		Z	9.82	82.65	26.70		65.0	
10244-CAB	LTE-TDD (SC-FDMA, 50% RB, 3 MHz, 16-QAM)	X	10.69	81.99	22.20	3.98	65.0	± 9.6 %
		Y	10.07	80.96	21.68		65.0	
		Z	10.02	81.14	21.69		65.0	
10245-CAB	LTE-TDD (SC-FDMA, 50% RB, 3 MHz, 64-QAM)	X	10.57	81.58	22.00	3.98	65.0	± 9.6 %
		Y	9.98	80.56	21.49		65.0	
		Z	9.91	80.72	21.49		65.0	
10246-CAB	LTE-TDD (SC-FDMA, 50% RB, 3 MHz, QPSK)	X	9.29	82.24	22.05	3.98	65.0	± 9.6 %
		Y	8.84	81.48	21.78		65.0	
		Z	9.57	83.17	22.39		65.0	
10247-CAB	LTE-TDD (SC-FDMA, 50% RB, 5 MHz, 16-QAM)	X	8.07	77.79	20.87	3.98	65.0	± 9.6 %
		Y	7.81	77.20	20.60		65.0	
		Z	8.04	78.08	20.96		65.0	
10248-CAB	LTE-TDD (SC-FDMA, 50% RB, 5 MHz, 64-QAM)	X	8.11	77.42	20.72	3.98	65.0	± 9.6 %
		Y	7.83	76.80	20.42		65.0	
		Z	8.05	77.65	20.78		65.0	
10249-CAB	LTE-TDD (SC-FDMA, 50% RB, 5 MHz, QPSK)	X	9.78	83.07	22.80	3.98	65.0	± 9.6 %
		Y	9.36	82.41	22.61		65.0	
		Z	10.14	84.18	23.26		65.0	
10250-CAB	LTE-TDD (SC-FDMA, 50% RB, 10 MHz, 16-QAM)	X	8.72	78.97	22.30	3.98	65.0	± 9.6 %
		Y	8.48	78.45	22.12		65.0	
		Z	8.71	79.35	22.51		65.0	
10251-CAB	LTE-TDD (SC-FDMA, 50% RB, 10 MHz, 64-QAM)	X	8.36	77.15	21.34	3.98	65.0	± 9.6 %
		Y	8.13	76.62	21.11		65.0	
		Z	8.33	77.46	21.50		65.0	
10252-CAB	LTE-TDD (SC-FDMA, 50% RB, 10 MHz, QPSK)	X	9.59	81.92	22.81	3.98	65.0	± 9.6 %
		Y	9.28	81.44	22.73		65.0	
		Z	9.85	82.90	23.29		65.0	
10253-CAB	LTE-TDD (SC-FDMA, 50% RB, 15 MHz, 16-QAM)	X	8.31	76.36	21.21	3.98	65.0	± 9.6 %
		Y	8.09	75.81	20.99		65.0	
		Z	8.25	76.57	21.35		65.0	
10254-CAB	LTE-TDD (SC-FDMA, 50% RB, 15 MHz, 64-QAM)	X	8.64	76.97	21.75	3.98	65.0	± 9.6 %
		Y	8.44	76.49	21.55		65.0	
		Z	8.59	77.21	21.89		65.0	

10255-CAB	LTE-TDD (SC-FDMA, 50% RB, 15 MHz, QPSK)	X	8.88	79.09	21.89	3.98	65.0	± 9.6 %
		Y	8.67	78.72	21.83		65.0	
		Z	8.98	79.73	22.24		65.0	
10256-CAA	LTE-TDD (SC-FDMA, 100% RB, 1.4 MHz, 16-QAM)	X	10.07	80.79	21.11	3.98	65.0	± 9.6 %
		Y	9.36	79.53	20.48		65.0	
		Z	9.27	79.61	20.43		65.0	
10257-CAA	LTE-TDD (SC-FDMA, 100% RB, 1.4 MHz, 64-QAM)	X	9.93	80.22	20.83	3.98	65.0	± 9.6 %
		Y	9.22	78.95	20.18		65.0	
		Z	9.12	79.01	20.13		65.0	
10258-CAA	LTE-TDD (SC-FDMA, 100% RB, 1.4 MHz, QPSK)	X	8.66	80.91	21.13	3.98	65.0	± 9.6 %
		Y	8.13	79.89	20.72		65.0	
		Z	8.71	81.36	21.24		65.0	
10259-CAB	LTE-TDD (SC-FDMA, 100% RB, 3 MHz, 16-QAM)	X	8.32	78.14	21.35	3.98	65.0	± 9.6 %
		Y	8.07	77.59	21.11		65.0	
		Z	8.30	78.48	21.48		65.0	
10260-CAB	LTE-TDD (SC-FDMA, 100% RB, 3 MHz, 64-QAM)	X	8.37	77.96	21.30	3.98	65.0	± 9.6 %
		Y	8.11	77.40	21.05		65.0	
		Z	8.33	78.25	21.41		65.0	
10261-CAB	LTE-TDD (SC-FDMA, 100% RB, 3 MHz, QPSK)	X	9.44	82.16	22.69	3.98	65.0	± 9.6 %
		Y	9.05	81.51	22.50		65.0	
		Z	9.69	83.12	23.12		65.0	
10262-CAB	LTE-TDD (SC-FDMA, 100% RB, 5 MHz, 16-QAM)	X	8.72	78.94	22.28	3.98	65.0	± 9.6 %
		Y	8.47	78.42	22.09		65.0	
		Z	8.71	79.32	22.48		65.0	
10263-CAB	LTE-TDD (SC-FDMA, 100% RB, 5 MHz, 64-QAM)	X	8.36	77.16	21.34	3.98	65.0	± 9.6 %
		Y	8.13	76.62	21.11		65.0	
		Z	8.33	77.46	21.50		65.0	
10264-CAB	LTE-TDD (SC-FDMA, 100% RB, 5 MHz, QPSK)	X	9.55	81.82	22.76	3.98	65.0	± 9.6 %
		Y	9.23	81.33	22.67		65.0	
		Z	9.80	82.79	23.23		65.0	
10265-CAB	LTE-TDD (SC-FDMA, 100% RB, 10 MHz, 16-QAM)	X	8.52	76.91	21.37	3.98	65.0	± 9.6 %
		Y	8.28	76.34	21.16		65.0	
		Z	8.46	77.15	21.54		65.0	
10266-CAB	LTE-TDD (SC-FDMA, 100% RB, 10 MHz, 64-QAM)	X	8.84	77.48	21.92	3.98	65.0	± 9.6 %
		Y	8.62	77.01	21.75		65.0	
		Z	8.79	77.75	22.10		65.0	
10267-CAB	LTE-TDD (SC-FDMA, 100% RB, 10 MHz, QPSK)	X	9.11	79.33	21.73	3.98	65.0	± 9.6 %
		Y	8.91	79.04	21.73		65.0	
		Z	9.25	80.04	22.13		65.0	
10268-CAB	LTE-TDD (SC-FDMA, 100% RB, 15 MHz, 16-QAM)	X	8.95	76.40	21.47	3.98	65.0	± 9.6 %
		Y	8.77	75.99	21.33		65.0	
		Z	8.89	76.60	21.62		65.0	
10269-CAB	LTE-TDD (SC-FDMA, 100% RB, 15 MHz, 64-QAM)	X	8.88	76.03	21.40	3.98	65.0	± 9.6 %
		Y	8.71	75.62	21.25		65.0	
		Z	8.81	76.21	21.54		65.0	
10270-CAB	LTE-TDD (SC-FDMA, 100% RB, 15 MHz, QPSK)	X	8.82	77.21	21.03	3.98	65.0	± 9.6 %
		Y	8.69	77.00	21.04		65.0	
		Z	8.86	77.65	21.31		65.0	

10274-CAB	UMTS-FDD (HSUPA, Subtest 5, 3GPP Rel8.10)	X	2.68	66.55	15.56	0.00	150.0	± 9.6 %
		Y	2.68	66.43	15.43		150.0	
		Z	2.71	66.85	15.73		150.0	
10275-CAB	UMTS-FDD (HSUPA, Subtest 5, 3GPP Rel8.4)	X	1.76	69.02	16.21	0.00	150.0	± 9.6 %
		Y	1.71	68.23	15.83		150.0	
		Z	1.82	69.57	16.62		150.0	
10277-CAA	PHS (QPSK)	X	6.62	71.52	15.81	9.03	50.0	± 9.6 %
		Y	6.77	71.96	16.20		50.0	
		Z	6.48	71.54	15.70		50.0	
10278-CAA	PHS (QPSK, BW 884MHz, Rolloff 0.5)	X	9.81	80.35	21.62	9.03	50.0	± 9.6 %
		Y	9.58	79.96	21.62		50.0	
		Z	9.84	80.82	21.76		50.0	
10279-CAA	PHS (QPSK, BW 884MHz, Rolloff 0.38)	X	10.00	80.57	21.71	9.03	50.0	± 9.6 %
		Y	9.73	80.14	21.69		50.0	
		Z	10.02	81.03	21.84		50.0	
10290-AAB	CDMA2000, RC1, SO55, Full Rate	X	1.82	70.77	15.90	0.00	150.0	± 9.6 %
		Y	1.72	69.89	15.40		150.0	
		Z	1.95	72.06	16.51		150.0	
10291-AAB	CDMA2000, RC3, SO55, Full Rate	X	1.03	68.06	14.52	0.00	150.0	± 9.6 %
		Y	0.98	66.97	13.92		150.0	
		Z	1.11	69.26	15.22		150.0	
10292-AAB	CDMA2000, RC3, SO32, Full Rate	X	1.32	72.62	17.03	0.00	150.0	± 9.6 %
		Y	1.20	70.85	16.19		150.0	
		Z	1.50	74.78	18.11		150.0	
10293-AAB	CDMA2000, RC3, SO3, Full Rate	X	1.86	78.12	19.78	0.00	150.0	± 9.6 %
		Y	1.66	75.88	18.82		150.0	
		Z	2.25	81.38	21.19		150.0	
10295-AAB	CDMA2000, RC1, SO3, 1/8th Rate 25 fr.	X	10.17	82.01	23.87	9.03	50.0	± 9.6 %
		Y	10.08	81.64	23.75		50.0	
		Z	10.46	83.00	24.26		50.0	
10297-AAA	LTE-FDD (SC-FDMA, 50% RB, 20 MHz, QPSK)	X	3.06	70.75	16.98	0.00	150.0	± 9.6 %
		Y	2.97	70.19	16.76		150.0	
		Z	3.09	71.09	17.26		150.0	
10298-AAB	LTE-FDD (SC-FDMA, 50% RB, 3 MHz, QPSK)	X	1.94	69.59	15.88	0.00	150.0	± 9.6 %
		Y	1.86	68.90	15.44		150.0	
		Z	2.00	70.30	16.23		150.0	
10299-AAB	LTE-FDD (SC-FDMA, 50% RB, 3 MHz, 16-QAM)	X	4.90	77.67	19.07	0.00	150.0	± 9.6 %
		Y	4.30	75.67	18.00		150.0	
		Z	4.17	75.58	18.03		150.0	
10300-AAB	LTE-FDD (SC-FDMA, 50% RB, 3 MHz, 64-QAM)	X	3.47	71.44	15.80	0.00	150.0	± 9.6 %
		Y	3.06	69.68	14.73		150.0	
		Z	3.03	69.87	14.88		150.0	
10301-AAA	IEEE 802.16e WiMAX (29:18, 5ms, 10MHz, QPSK, PUSC)	X	6.02	68.68	19.11	4.17	80.0	± 9.6 %
		Y	5.98	68.44	18.86		80.0	
		Z	5.95	68.58	19.03		80.0	
10302-AAA	IEEE 802.16e WiMAX (29:18, 5ms, 10MHz, QPSK, PUSC, 3 CTRL symbols)	X	6.59	69.62	20.04	4.96	80.0	± 9.6 %
		Y	6.48	69.09	19.63		80.0	
		Z	6.53	69.66	20.05		80.0	

10303-AAA	IEEE 802.16e WiMAX (31:15, 5ms, 10MHz, 64QAM, PUSC)	X	6.50	69.94	20.23	4.96	80.0	± 9.6 %
		Y	6.37	69.29	19.74		80.0	
		Z	6.43	69.92	20.21		80.0	
10304-AAA	IEEE 802.16e WiMAX (29:18, 5ms, 10MHz, 64QAM, PUSC)	X	6.04	68.91	19.25	4.17	80.0	± 9.6 %
		Y	5.94	68.42	18.86		80.0	
		Z	5.99	68.95	19.25		80.0	
10305-AAA	IEEE 802.16e WiMAX (31:15, 10ms, 10MHz, 64QAM, PUSC, 15 symbols)	X	8.62	79.07	24.92	6.02	50.0	± 9.6 %
		Y	11.34	86.21	27.91		50.0	
		Z	8.42	78.75	24.71		50.0	
10306-AAA	IEEE 802.16e WiMAX (29:18, 10ms, 10MHz, 64QAM, PUSC, 18 symbols)	X	7.30	73.86	22.83	6.02	50.0	± 9.6 %
		Y	6.99	72.41	21.84		50.0	
		Z	7.19	73.72	22.72		50.0	
10307-AAA	IEEE 802.16e WiMAX (29:18, 10ms, 10MHz, QPSK, PUSC, 18 symbols)	X	7.53	74.88	23.08	6.02	50.0	± 9.6 %
		Y	7.13	73.19	22.00		50.0	
		Z	7.41	74.71	22.96		50.0	
10308-AAA	IEEE 802.16e WiMAX (29:18, 10ms, 10MHz, 16QAM, PUSC)	X	7.64	75.45	23.34	6.02	50.0	± 9.6 %
		Y	7.20	73.62	22.20		50.0	
		Z	7.51	75.27	23.22		50.0	
10309-AAA	IEEE 802.16e WiMAX (29:18, 10ms, 10MHz, 16QAM, AMC 2x3, 18 symbols)	X	7.44	74.18	22.99	6.02	50.0	± 9.6 %
		Y	7.11	72.71	22.00		50.0	
		Z	7.33	74.08	22.90		50.0	
10310-AAA	IEEE 802.16e WiMAX (29:18, 10ms, 10MHz, QPSK, AMC 2x3, 18 symbols)	X	7.36	74.18	22.87	6.02	50.0	± 9.6 %
		Y	7.02	72.66	21.86		50.0	
		Z	7.24	74.05	22.76		50.0	
10311-AAA	LTE-FDD (SC-FDMA, 100% RB, 15 MHz, QPSK)	X	3.41	70.03	16.61	0.00	150.0	± 9.6 %
		Y	3.32	69.51	16.42		150.0	
		Z	3.45	70.34	16.87		150.0	
10313-AAA	IDEN 1:3	X	7.37	77.22	18.46	6.99	70.0	± 9.6 %
		Y	7.49	77.91	19.05		70.0	
		Z	7.96	79.06	19.32		70.0	
10314-AAA	IDEN 1:6	X	8.75	81.12	22.17	10.00	30.0	± 9.6 %
		Y	8.84	81.70	22.74		30.0	
		Z	9.56	83.47	23.24		30.0	
10315-AAB	IEEE 802.11b WiFi 2.4 GHz (DSSS, 1 Mbps, 96pc duty cycle)	X	1.18	65.17	15.98	0.17	150.0	± 9.6 %
		Y	1.19	64.74	15.68		150.0	
		Z	1.21	65.44	16.26		150.0	
10316-AAB	IEEE 802.11g WiFi 2.4 GHz (ERP-OFDM, 6 Mbps, 96pc duty cycle)	X	4.83	66.99	16.50	0.17	150.0	± 9.6 %
		Y	4.83	66.97	16.48		150.0	
		Z	4.83	67.11	16.58		150.0	
10317-AAB	IEEE 802.11a WiFi 5 GHz (OFDM, 6 Mbps, 96pc duty cycle)	X	4.83	66.99	16.50	0.17	150.0	± 9.6 %
		Y	4.83	66.97	16.48		150.0	
		Z	4.83	67.11	16.58		150.0	
10400-AAC	IEEE 802.11ac WiFi (20MHz, 64-QAM, 99pc duty cycle)	X	4.95	67.24	16.40	0.00	150.0	± 9.6 %
		Y	4.92	67.19	16.36		150.0	
		Z	4.94	67.35	16.49		150.0	
10401-AAC	IEEE 802.11ac WiFi (40MHz, 64-QAM, 99pc duty cycle)	X	5.53	67.22	16.43	0.00	150.0	± 9.6 %
		Y	5.54	67.25	16.44		150.0	
		Z	5.54	67.37	16.53		150.0	

10402-AAC	IEEE 802.11ac WiFi (80MHz, 64-QAM, 99pc duty cycle)	X	5.85	67.86	16.58	0.00	150.0	± 9.6 %
		Y	5.85	67.83	16.57		150.0	
		Z	5.85	67.95	16.65		150.0	
10403-AAB	CDMA2000 (1xEV-DO, Rev. 0)	X	1.82	70.77	15.90	0.00	115.0	± 9.6 %
		Y	1.72	69.89	15.40		115.0	
		Z	1.95	72.06	16.51		115.0	
10404-AAB	CDMA2000 (1xEV-DO, Rev. A)	X	1.82	70.77	15.90	0.00	115.0	± 9.6 %
		Y	1.72	69.89	15.40		115.0	
		Z	1.95	72.06	16.51		115.0	
10406-AAB	CDMA2000, RC3, SO32, SCH0, Full Rate	X	100.00	122.48	31.59	0.00	100.0	± 9.6 %
		Y	100.00	122.39	31.44		100.0	
		Z	100.00	123.91	32.06		100.0	
10410-AAA	LTE-TDD (SC-FDMA, 1 RB, 10 MHz, QPSK, UL Subframe=2,3,4,7,8,9)	X	100.00	119.39	30.70	3.23	80.0	± 9.6 %
		Y	100.00	120.18	31.03		80.0	
		Z	100.00	120.31	30.97		80.0	
10415-AAA	IEEE 802.11b WiFi 2.4 GHz (DSSS, 1 Mbps, 99pc duty cycle)	X	1.00	63.40	15.00	0.00	150.0	± 9.6 %
		Y	1.03	63.13	14.76		150.0	
		Z	1.04	63.74	15.31		150.0	
10416-AAA	IEEE 802.11g WiFi 2.4 GHz (ERP-OFDM, 6 Mbps, 99pc duty cycle)	X	4.72	66.80	16.33	0.00	150.0	± 9.6 %
		Y	4.71	66.79	16.30		150.0	
		Z	4.72	66.93	16.41		150.0	
10417-AAA	IEEE 802.11a/h WiFi 5 GHz (OFDM, 6 Mbps, 99pc duty cycle)	X	4.72	66.80	16.33	0.00	150.0	± 9.6 %
		Y	4.71	66.79	16.30		150.0	
		Z	4.72	66.93	16.41		150.0	
10418-AAA	IEEE 802.11g WiFi 2.4 GHz (DSSS-OFDM, 6 Mbps, 99pc duty cycle, Long preamble)	X	4.70	66.93	16.32	0.00	150.0	± 9.6 %
		Y	4.69	66.92	16.30		150.0	
		Z	4.70	67.07	16.41		150.0	
10419-AAA	IEEE 802.11g WiFi 2.4 GHz (DSSS-OFDM, 6 Mbps, 99pc duty cycle, Short preamble)	X	4.73	66.90	16.34	0.00	150.0	± 9.6 %
		Y	4.72	66.88	16.31		150.0	
		Z	4.73	67.03	16.42		150.0	
10422-AAA	IEEE 802.11n (HT Greenfield, 7.2 Mbps, BPSK)	X	4.86	66.91	16.35	0.00	150.0	± 9.6 %
		Y	4.85	66.90	16.33		150.0	
		Z	4.86	67.04	16.44		150.0	
10423-AAA	IEEE 802.11n (HT Greenfield, 43.3 Mbps, 16-QAM)	X	5.08	67.33	16.51	0.00	150.0	± 9.6 %
		Y	5.06	67.29	16.47		150.0	
		Z	5.07	67.43	16.58		150.0	
10424-AAA	IEEE 802.11n (HT Greenfield, 72.2 Mbps, 64-QAM)	X	4.99	67.25	16.46	0.00	150.0	± 9.6 %
		Y	4.97	67.22	16.43		150.0	
		Z	4.98	67.37	16.54		150.0	
10425-AAA	IEEE 802.11n (HT Greenfield, 15 Mbps, BPSK)	X	5.55	67.62	16.62	0.00	150.0	± 9.6 %
		Y	5.54	67.58	16.60		150.0	
		Z	5.54	67.69	16.68		150.0	
10426-AAA	IEEE 802.11n (HT Greenfield, 90 Mbps, 16-QAM)	X	5.56	67.65	16.63	0.00	150.0	± 9.6 %
		Y	5.55	67.62	16.61		150.0	
		Z	5.55	67.73	16.70		150.0	

10427-AAA	IEEE 802.11n (HT Greenfield, 150 Mbps, 64-QAM)	X	5.59	67.68	16.64	0.00	150.0	± 9.6 %
		Y	5.57	67.63	16.62		150.0	
		Z	5.58	67.75	16.70		150.0	
10430-AAA	LTE-FDD (OFDMA, 5 MHz, E-TM 3.1)	X	4.40	70.01	18.10	0.00	150.0	± 9.6 %
		Y	4.43	70.35	18.24		150.0	
		Z	4.41	70.36	18.25		150.0	
10431-AAA	LTE-FDD (OFDMA, 10 MHz, E-TM 3.1)	X	4.49	67.37	16.43	0.00	150.0	± 9.6 %
		Y	4.45	67.33	16.37		150.0	
		Z	4.47	67.52	16.51		150.0	
10432-AAA	LTE-FDD (OFDMA, 15 MHz, E-TM 3.1)	X	4.77	67.29	16.44	0.00	150.0	± 9.6 %
		Y	4.74	67.25	16.40		150.0	
		Z	4.75	67.42	16.53		150.0	
10433-AAA	LTE-FDD (OFDMA, 20 MHz, E-TM 3.1)	X	5.00	67.31	16.50	0.00	150.0	± 9.6 %
		Y	4.98	67.27	16.46		150.0	
		Z	4.99	67.42	16.57		150.0	
10434-AAA	W-CDMA (BS Test Model 1, 64 DPCH)	X	4.48	70.64	18.10	0.00	150.0	± 9.6 %
		Y	4.52	71.07	18.25		150.0	
		Z	4.50	71.08	18.27		150.0	
10435-AAA	LTE-TDD (SC-FDMA, 1 RB, 20 MHz, QPSK, UL Subframe=2,3,4,7,8,9)	X	100.00	119.25	30.64	3.23	80.0	± 9.6 %
		Y	100.00	120.04	30.96		80.0	
		Z	100.00	120.17	30.90		80.0	
10447-AAA	LTE-FDD (OFDMA, 5 MHz, E-TM 3.1, Clipping 44%)	X	3.81	67.43	16.04	0.00	150.0	± 9.6 %
		Y	3.77	67.36	15.92		150.0	
		Z	3.80	67.63	16.11		150.0	
10448-AAA	LTE-FDD (OFDMA, 10 MHz, E-TM 3.1, Clipping 44%)	X	4.29	67.14	16.28	0.00	150.0	± 9.6 %
		Y	4.27	67.10	16.23		150.0	
		Z	4.28	67.30	16.37		150.0	
10449-AAA	LTE-FDD (OFDMA, 15 MHz, E-TM 3.1, Clipping 44%)	X	4.54	67.10	16.34	0.00	150.0	± 9.6 %
		Y	4.52	67.07	16.30		150.0	
		Z	4.53	67.24	16.43		150.0	
10450-AAA	LTE-FDD (OFDMA, 20 MHz, E-TM 3.1, Clipping 44%)	X	4.71	67.05	16.35	0.00	150.0	± 9.6 %
		Y	4.70	67.01	16.31		150.0	
		Z	4.71	67.17	16.43		150.0	
10451-AAA	W-CDMA (BS Test Model 1, 64 DPCH, Clipping 44%)	X	3.76	67.73	15.85	0.00	150.0	± 9.6 %
		Y	3.70	67.65	15.70		150.0	
		Z	3.74	67.97	15.92		150.0	
10456-AAA	IEEE 802.11ac WiFi (160MHz, 64-QAM, 99pc duty cycle)	X	6.40	68.27	16.81	0.00	150.0	± 9.6 %
		Y	6.40	68.22	16.78		150.0	
		Z	6.39	68.32	16.85		150.0	
10457-AAA	UMTS-FDD (DC-HSDPA)	X	3.86	65.46	16.08	0.00	150.0	± 9.6 %
		Y	3.88	65.42	16.03		150.0	
		Z	3.88	65.58	16.16		150.0	
10458-AAA	CDMA2000 (1xEV-DO, Rev. B, 2 carriers)	X	3.55	66.84	15.36	0.00	150.0	± 9.6 %
		Y	3.51	66.84	15.20		150.0	
		Z	3.55	67.17	15.43		150.0	
10459-AAA	CDMA2000 (1xEV-DO, Rev. B, 3 carriers)	X	4.71	65.21	16.07	0.00	150.0	± 9.6 %
		Y	4.63	65.09	15.89		150.0	
		Z	4.67	65.34	16.07		150.0	

10460-AAA	UMTS-FDD (WCDMA, AMR)	X	0.99	70.26	17.25	0.00	150.0	± 9.6 %
		Y	0.94	68.45	16.37		150.0	
		Z	1.07	71.18	17.96		150.0	
10461-AAA	LTE-TDD (SC-FDMA, 1 RB, 1.4 MHz, QPSK, UL Subframe=2,3,4,7,8,9)	X	100.00	122.02	31.99	3.29	80.0	± 9.6 %
		Y	100.00	122.59	32.22		80.0	
		Z	100.00	122.98	32.28		80.0	
10462-AAA	LTE-TDD (SC-FDMA, 1 RB, 1.4 MHz, 16-QAM, UL Subframe=2,3,4,7,8,9)	X	100.00	109.85	26.14	3.23	80.0	± 9.6 %
		Y	100.00	110.36	26.33		80.0	
		Z	100.00	110.34	26.21		80.0	
10463-AAA	LTE-TDD (SC-FDMA, 1 RB, 1.4 MHz, 64-QAM, UL Subframe=2,3,4,7,8,9)	X	100.00	107.53	25.02	3.23	80.0	± 9.6 %
		Y	100.00	107.98	25.17		80.0	
		Z	100.00	107.85	25.00		80.0	
10464-AAA	LTE-TDD (SC-FDMA, 1 RB, 3 MHz, QPSK, UL Subframe=2,3,4,7,8,9)	X	100.00	120.45	31.12	3.23	80.0	± 9.6 %
		Y	100.00	121.00	31.33		80.0	
		Z	100.00	121.35	31.38		80.0	
10465-AAA	LTE-TDD (SC-FDMA, 1 RB, 3 MHz, 16-QAM, UL Subframe=2,3,4,7,8,9)	X	100.00	109.46	25.94	3.23	80.0	± 9.6 %
		Y	100.00	109.95	26.11		80.0	
		Z	100.00	109.93	25.99		80.0	
10466-AAA	LTE-TDD (SC-FDMA, 1 RB, 3 MHz, 64-QAM, UL Subframe=2,3,4,7,8,9)	X	100.00	107.15	24.83	3.23	80.0	± 9.6 %
		Y	100.00	107.57	24.97		80.0	
		Z	100.00	107.44	24.80		80.0	
10467-AAA	LTE-TDD (SC-FDMA, 1 RB, 5 MHz, QPSK, UL Subframe=2,3,4,7,8,9)	X	100.00	120.62	31.20	3.23	80.0	± 9.6 %
		Y	100.00	121.18	31.42		80.0	
		Z	100.00	121.53	31.46		80.0	
10468-AAA	LTE-TDD (SC-FDMA, 1 RB, 5 MHz, 16-QAM, UL Subframe=2,3,4,7,8,9)	X	100.00	109.57	26.00	3.23	80.0	± 9.6 %
		Y	100.00	110.07	26.17		80.0	
		Z	100.00	110.05	26.05		80.0	
10469-AAA	LTE-TDD (SC-FDMA, 1 RB, 5 MHz, 64-QAM, UL Subframe=2,3,4,7,8,9)	X	100.00	107.16	24.83	3.23	80.0	± 9.6 %
		Y	100.00	107.58	24.96		80.0	
		Z	100.00	107.45	24.80		80.0	
10470-AAA	LTE-TDD (SC-FDMA, 1 RB, 10 MHz, QPSK, UL Subframe=2,3,4,7,8,9)	X	100.00	120.64	31.20	3.23	80.0	± 9.6 %
		Y	100.00	121.21	31.42		80.0	
		Z	100.00	121.56	31.46		80.0	
10471-AAA	LTE-TDD (SC-FDMA, 1 RB, 10 MHz, 16-QAM, UL Subframe=2,3,4,7,8,9)	X	100.00	109.54	25.97	3.23	80.0	± 9.6 %
		Y	100.00	110.04	26.15		80.0	
		Z	100.00	110.01	26.03		80.0	
10472-AAA	LTE-TDD (SC-FDMA, 1 RB, 10 MHz, 64-QAM, UL Subframe=2,3,4,7,8,9)	X	100.00	107.12	24.81	3.23	80.0	± 9.6 %
		Y	100.00	107.54	24.94		80.0	
		Z	100.00	107.41	24.78		80.0	
10473-AAA	LTE-TDD (SC-FDMA, 1 RB, 15 MHz, QPSK, UL Subframe=2,3,4,7,8,9)	X	100.00	120.62	31.19	3.23	80.0	± 9.6 %
		Y	100.00	121.18	31.41		80.0	
		Z	100.00	121.53	31.45		80.0	
10474-AAA	LTE-TDD (SC-FDMA, 1 RB, 15 MHz, 16-QAM, UL Subframe=2,3,4,7,8,9)	X	100.00	109.55	25.98	3.23	80.0	± 9.6 %
		Y	100.00	110.05	26.15		80.0	
		Z	100.00	110.03	26.03		80.0	
10475-AAA	LTE-TDD (SC-FDMA, 1 RB, 15 MHz, 64-QAM, UL Subframe=2,3,4,7,8,9)	X	100.00	107.13	24.81	3.23	80.0	± 9.6 %
		Y	100.00	107.55	24.95		80.0	
		Z	100.00	107.42	24.78		80.0	

10477-AAA	LTE-TDD (SC-FDMA, 1 RB, 20 MHz, 16-QAM, UL Subframe=2,3,4,7,8,9)	X	100.00	109.42	25.91	3.23	80.0	± 9.6 %
		Y	100.00	109.91	26.09		80.0	
		Z	100.00	109.89	25.96		80.0	
10478-AAA	LTE-TDD (SC-FDMA, 1 RB, 20 MHz, 64-QAM, UL Subframe=2,3,4,7,8,9)	X	100.00	107.10	24.80	3.23	80.0	± 9.6 %
		Y	100.00	107.52	24.93		80.0	
		Z	100.00	107.38	24.76		80.0	
10479-AAA	LTE-TDD (SC-FDMA, 50% RB, 1.4 MHz, QPSK, UL Subframe=2,3,4,7,8,9)	X	15.27	94.34	26.55	3.23	80.0	± 9.6 %
		Y	13.93	92.73	25.91		80.0	
		Z	13.69	92.81	25.94		80.0	
10480-AAA	LTE-TDD (SC-FDMA, 50% RB, 1.4 MHz, 16-QAM, UL Subframe=2,3,4,7,8,9)	X	17.85	91.69	24.29	3.23	80.0	± 9.6 %
		Y	17.05	90.96	23.91		80.0	
		Z	15.74	90.05	23.61		80.0	
10481-AAA	LTE-TDD (SC-FDMA, 50% RB, 1.4 MHz, 64-QAM, UL Subframe=2,3,4,7,8,9)	X	16.05	89.42	23.31	3.23	80.0	± 9.6 %
		Y	15.20	88.58	22.88		80.0	
		Z	14.01	87.66	22.58		80.0	
10482-AAA	LTE-TDD (SC-FDMA, 50% RB, 3 MHz, QPSK, UL Subframe=2,3,4,7,8,9)	X	6.46	79.79	20.49	2.23	80.0	± 9.6 %
		Y	6.00	78.69	20.07		80.0	
		Z	6.94	81.30	21.05		80.0	
10483-AAA	LTE-TDD (SC-FDMA, 50% RB, 3 MHz, 16-QAM, UL Subframe=2,3,4,7,8,9)	X	10.64	84.45	22.26	2.23	80.0	± 9.6 %
		Y	10.00	83.37	21.70		80.0	
		Z	9.59	82.97	21.54		80.0	
10484-AAA	LTE-TDD (SC-FDMA, 50% RB, 3 MHz, 64-QAM, UL Subframe=2,3,4,7,8,9)	X	9.96	83.22	21.86	2.23	80.0	± 9.6 %
		Y	9.31	82.09	21.27		80.0	
		Z	8.95	81.72	21.12		80.0	
10485-AAA	LTE-TDD (SC-FDMA, 50% RB, 5 MHz, QPSK, UL Subframe=2,3,4,7,8,9)	X	6.59	80.11	21.11	2.23	80.0	± 9.6 %
		Y	6.08	78.90	20.69		80.0	
		Z	6.88	81.28	21.62		80.0	
10486-AAA	LTE-TDD (SC-FDMA, 50% RB, 5 MHz, 16-QAM, UL Subframe=2,3,4,7,8,9)	X	5.22	73.82	18.61	2.23	80.0	± 9.6 %
		Y	5.09	73.44	18.41		80.0	
		Z	5.33	74.50	18.88		80.0	
10487-AAA	LTE-TDD (SC-FDMA, 50% RB, 5 MHz, 64-QAM, UL Subframe=2,3,4,7,8,9)	X	5.19	73.39	18.45	2.23	80.0	± 9.6 %
		Y	5.06	73.02	18.24		80.0	
		Z	5.27	73.99	18.68		80.0	
10488-AAA	LTE-TDD (SC-FDMA, 50% RB, 10 MHz, QPSK, UL Subframe=2,3,4,7,8,9)	X	6.39	78.18	20.73	2.23	80.0	± 9.6 %
		Y	5.97	77.14	20.41		80.0	
		Z	6.48	78.88	21.13		80.0	
10489-AAA	LTE-TDD (SC-FDMA, 50% RB, 10 MHz, 16-QAM, UL Subframe=2,3,4,7,8,9)	X	5.20	72.70	18.88	2.23	80.0	± 9.6 %
		Y	5.07	72.27	18.71		80.0	
		Z	5.21	73.04	19.09		80.0	
10490-AAA	LTE-TDD (SC-FDMA, 50% RB, 10 MHz, 64-QAM, UL Subframe=2,3,4,7,8,9)	X	5.24	72.29	18.75	2.23	80.0	± 9.6 %
		Y	5.12	71.92	18.59		80.0	
		Z	5.24	72.63	18.94		80.0	
10491-AAA	LTE-TDD (SC-FDMA, 50% RB, 15 MHz, QPSK, UL Subframe=2,3,4,7,8,9)	X	6.02	75.43	19.78	2.23	80.0	± 9.6 %
		Y	5.76	74.73	19.57		80.0	
		Z	6.05	75.89	20.09		80.0	
10492-AAA	LTE-TDD (SC-FDMA, 50% RB, 15 MHz, 16-QAM, UL Subframe=2,3,4,7,8,9)	X	5.38	71.48	18.58	2.23	80.0	± 9.6 %
		Y	5.27	71.13	18.44		80.0	
		Z	5.35	71.71	18.74		80.0	

10493-AAA	LTE-TDD (SC-FDMA, 50% RB, 15 MHz, 64-QAM, UL Subframe=2,3,4,7,8,9)	X	5.42	71.24	18.51	2.23	80.0	± 9.6 %
		Y	5.32	70.91	18.38		80.0	
		Z	5.40	71.45	18.66		80.0	
10494-AAA	LTE-TDD (SC-FDMA, 50% RB, 20 MHz, QPSK, UL Subframe=2,3,4,7,8,9)	X	6.80	77.48	20.35	2.23	80.0	± 9.6 %
		Y	6.41	76.59	20.10		80.0	
		Z	6.87	78.03	20.70		80.0	
10495-AAA	LTE-TDD (SC-FDMA, 50% RB, 20 MHz, 16-QAM, UL Subframe=2,3,4,7,8,9)	X	5.50	72.14	18.82	2.23	80.0	± 9.6 %
		Y	5.37	71.71	18.66		80.0	
		Z	5.48	72.35	18.98		80.0	
10496-AAA	LTE-TDD (SC-FDMA, 50% RB, 20 MHz, 64-QAM, UL Subframe=2,3,4,7,8,9)	X	5.52	71.65	18.67	2.23	80.0	± 9.6 %
		Y	5.40	71.28	18.53		80.0	
		Z	5.49	71.85	18.82		80.0	
10497-AAA	LTE-TDD (SC-FDMA, 100% RB, 1.4 MHz, QPSK, UL Subframe=2,3,4,7,8,9)	X	5.51	77.56	19.18	2.23	80.0	± 9.6 %
		Y	5.11	76.42	18.67		80.0	
		Z	5.89	78.83	19.60		80.0	
10498-AAA	LTE-TDD (SC-FDMA, 100% RB, 1.4 MHz, 16-QAM, UL Subframe=2,3,4,7,8,9)	X	4.31	71.42	16.10	2.23	80.0	± 9.6 %
		Y	4.05	70.52	15.58		80.0	
		Z	4.34	71.77	16.11		80.0	
10499-AAA	LTE-TDD (SC-FDMA, 100% RB, 1.4 MHz, 64-QAM, UL Subframe=2,3,4,7,8,9)	X	4.27	70.94	15.80	2.23	80.0	± 9.6 %
		Y	3.98	70.00	15.24		80.0	
		Z	4.25	71.16	15.75		80.0	
10500-AAA	LTE-TDD (SC-FDMA, 100% RB, 3 MHz, QPSK, UL Subframe=2,3,4,7,8,9)	X	6.24	78.61	20.73	2.23	80.0	± 9.6 %
		Y	5.82	77.56	20.37		80.0	
		Z	6.42	79.55	21.18		80.0	
10501-AAA	LTE-TDD (SC-FDMA, 100% RB, 3 MHz, 16-QAM, UL Subframe=2,3,4,7,8,9)	X	5.18	73.19	18.64	2.23	80.0	± 9.6 %
		Y	5.05	72.81	18.45		80.0	
		Z	5.24	73.73	18.88		80.0	
10502-AAA	LTE-TDD (SC-FDMA, 100% RB, 3 MHz, 64-QAM, UL Subframe=2,3,4,7,8,9)	X	5.20	72.88	18.49	2.23	80.0	± 9.6 %
		Y	5.09	72.56	18.32		80.0	
		Z	5.26	73.41	18.72		80.0	
10503-AAA	LTE-TDD (SC-FDMA, 100% RB, 5 MHz, QPSK, UL Subframe=2,3,4,7,8,9)	X	6.31	77.98	20.65	2.23	80.0	± 9.6 %
		Y	5.89	76.94	20.32		80.0	
		Z	6.40	78.67	21.04		80.0	
10504-AAA	LTE-TDD (SC-FDMA, 100% RB, 5 MHz, 16-QAM, UL Subframe=2,3,4,7,8,9)	X	5.18	72.62	18.84	2.23	80.0	± 9.6 %
		Y	5.05	72.19	18.66		80.0	
		Z	5.18	72.96	19.04		80.0	
10505-AAA	LTE-TDD (SC-FDMA, 100% RB, 5 MHz, 64-QAM, UL Subframe=2,3,4,7,8,9)	X	5.22	72.20	18.70	2.23	80.0	± 9.6 %
		Y	5.10	71.83	18.54		80.0	
		Z	5.22	72.54	18.90		80.0	
10506-AAA	LTE-TDD (SC-FDMA, 100% RB, 10 MHz, QPSK, UL Subframe=2,3,4,7,8,9)	X	6.75	77.34	20.29	2.23	80.0	± 9.6 %
		Y	6.36	76.44	20.03		80.0	
		Z	6.81	77.88	20.63		80.0	
10507-AAA	LTE-TDD (SC-FDMA, 100% RB, 10 MHz, 16-QAM, UL Subframe=2,3,4,7,8,9)	X	5.48	72.08	18.79	2.23	80.0	± 9.6 %
		Y	5.35	71.65	18.63		80.0	
		Z	5.46	72.29	18.95		80.0	

10508-AAA	LTE-TDD (SC-FDMA, 100% RB, 10 MHz, 64-QAM, UL Subframe=2,3,4,7,8,9)	X	5.50	71.59	18.63	2.23	80.0	± 9.6 %
		Y	5.38	71.22	18.49		80.0	
		Z	5.47	71.78	18.79		80.0	
10509-AAA	LTE-TDD (SC-FDMA, 100% RB, 15 MHz, QPSK, UL Subframe=2,3,4,7,8,9)	X	6.53	74.93	19.40	2.23	80.0	± 9.6 %
		Y	6.29	74.36	19.25		80.0	
		Z	6.55	75.31	19.67		80.0	
10510-AAA	LTE-TDD (SC-FDMA, 100% RB, 15 MHz, 16-QAM, UL Subframe=2,3,4,7,8,9)	X	5.88	71.44	18.58	2.23	80.0	± 9.6 %
		Y	5.77	71.08	18.45		80.0	
		Z	5.84	71.58	18.71		80.0	
10511-AAA	LTE-TDD (SC-FDMA, 100% RB, 15 MHz, 64-QAM, UL Subframe=2,3,4,7,8,9)	X	5.87	71.05	18.47	2.23	80.0	± 9.6 %
		Y	5.77	70.72	18.36		80.0	
		Z	5.83	71.17	18.60		80.0	
10512-AAA	LTE-TDD (SC-FDMA, 100% RB, 20 MHz, QPSK, UL Subframe=2,3,4,7,8,9)	X	7.22	77.19	20.09	2.23	80.0	± 9.6 %
		Y	6.85	76.38	19.87		80.0	
		Z	7.29	77.69	20.41		80.0	
10513-AAA	LTE-TDD (SC-FDMA, 100% RB, 20 MHz, 16-QAM, UL Subframe=2,3,4,7,8,9)	X	5.86	72.04	18.79	2.23	80.0	± 9.6 %
		Y	5.72	71.59	18.64		80.0	
		Z	5.82	72.17	18.93		80.0	
10514-AAA	LTE-TDD (SC-FDMA, 100% RB, 20 MHz, 64-QAM, UL Subframe=2,3,4,7,8,9)	X	5.77	71.41	18.61	2.23	80.0	± 9.6 %
		Y	5.66	71.02	18.47		80.0	
		Z	5.73	71.53	18.74		80.0	
10515-AAA	IEEE 802.11b WiFi 2.4 GHz (DSSS, 2 Mbps, 99pc duty cycle)	X	0.97	63.64	15.09	0.00	150.0	± 9.6 %
		Y	0.99	63.32	14.82		150.0	
		Z	1.01	63.99	15.42		150.0	
10516-AAA	IEEE 802.11b WiFi 2.4 GHz (DSSS, 5.5 Mbps, 99pc duty cycle)	X	0.78	76.08	19.79	0.00	150.0	± 9.6 %
		Y	0.63	70.67	17.47		150.0	
		Z	0.88	77.61	21.01		150.0	
10517-AAA	IEEE 802.11b WiFi 2.4 GHz (DSSS, 11 Mbps, 99pc duty cycle)	X	0.85	66.24	16.04	0.00	150.0	± 9.6 %
		Y	0.85	65.35	15.50		150.0	
		Z	0.89	66.77	16.53		150.0	
10518-AAA	IEEE 802.11a/h WiFi 5 GHz (OFDM, 9 Mbps, 99pc duty cycle)	X	4.72	66.89	16.32	0.00	150.0	± 9.6 %
		Y	4.71	66.87	16.28		150.0	
		Z	4.72	67.02	16.40		150.0	
10519-AAA	IEEE 802.11a/h WiFi 5 GHz (OFDM, 12 Mbps, 99pc duty cycle)	X	4.96	67.21	16.46	0.00	150.0	± 9.6 %
		Y	4.94	67.17	16.43		150.0	
		Z	4.94	67.32	16.54		150.0	
10520-AAA	IEEE 802.11a/h WiFi 5 GHz (OFDM, 18 Mbps, 99pc duty cycle)	X	4.80	67.20	16.39	0.00	150.0	± 9.6 %
		Y	4.78	67.15	16.36		150.0	
		Z	4.79	67.31	16.47		150.0	
10521-AAA	IEEE 802.11a/h WiFi 5 GHz (OFDM, 24 Mbps, 99pc duty cycle)	X	4.73	67.21	16.38	0.00	150.0	± 9.6 %
		Y	4.71	67.16	16.34		150.0	
		Z	4.72	67.32	16.46		150.0	
10522-AAA	IEEE 802.11a/h WiFi 5 GHz (OFDM, 36 Mbps, 99pc duty cycle)	X	4.77	67.11	16.38	0.00	150.0	± 9.6 %
		Y	4.75	67.11	16.36		150.0	
		Z	4.76	67.26	16.48		150.0	

10523-AAA	IEEE 802.11a/h WiFi 5 GHz (OFDM, 48 Mbps, 99pc duty cycle)	X	4.64	67.06	16.26	0.00	150.0	± 9.6 %
		Y	4.63	67.02	16.23		150.0	
		Z	4.64	67.19	16.35		150.0	
10524-AAA	IEEE 802.11a/h WiFi 5 GHz (OFDM, 54 Mbps, 99pc duty cycle)	X	4.73	67.10	16.38	0.00	150.0	± 9.6 %
		Y	4.71	67.08	16.36		150.0	
		Z	4.72	67.24	16.48		150.0	
10525-AAA	IEEE 802.11ac WiFi (20MHz, MCS0, 99pc duty cycle)	X	4.67	66.13	15.97	0.00	150.0	± 9.6 %
		Y	4.66	66.11	15.94		150.0	
		Z	4.67	66.26	16.06		150.0	
10526-AAA	IEEE 802.11ac WiFi (20MHz, MCS1, 99pc duty cycle)	X	4.89	66.55	16.11	0.00	150.0	± 9.6 %
		Y	4.87	66.51	16.09		150.0	
		Z	4.88	66.68	16.21		150.0	
10527-AAA	IEEE 802.11ac WiFi (20MHz, MCS2, 99pc duty cycle)	X	4.80	66.53	16.08	0.00	150.0	± 9.6 %
		Y	4.78	66.49	16.04		150.0	
		Z	4.79	66.66	16.17		150.0	
10528-AAA	IEEE 802.11ac WiFi (20MHz, MCS3, 99pc duty cycle)	X	4.82	66.56	16.11	0.00	150.0	± 9.6 %
		Y	4.80	66.51	16.08		150.0	
		Z	4.81	66.68	16.20		150.0	
10529-AAA	IEEE 802.11ac WiFi (20MHz, MCS4, 99pc duty cycle)	X	4.82	66.56	16.11	0.00	150.0	± 9.6 %
		Y	4.80	66.51	16.08		150.0	
		Z	4.81	66.68	16.20		150.0	
10531-AAA	IEEE 802.11ac WiFi (20MHz, MCS6, 99pc duty cycle)	X	4.84	66.72	16.14	0.00	150.0	± 9.6 %
		Y	4.82	66.67	16.11		150.0	
		Z	4.83	66.84	16.23		150.0	
10532-AAA	IEEE 802.11ac WiFi (20MHz, MCS7, 99pc duty cycle)	X	4.69	66.61	16.10	0.00	150.0	± 9.6 %
		Y	4.66	66.54	16.05		150.0	
		Z	4.68	66.72	16.18		150.0	
10533-AAA	IEEE 802.11ac WiFi (20MHz, MCS8, 99pc duty cycle)	X	4.84	66.57	16.08	0.00	150.0	± 9.6 %
		Y	4.81	66.53	16.05		150.0	
		Z	4.83	66.70	16.17		150.0	
10534-AAA	IEEE 802.11ac WiFi (40MHz, MCS0, 99pc duty cycle)	X	5.33	66.74	16.17	0.00	150.0	± 9.6 %
		Y	5.31	66.69	16.14		150.0	
		Z	5.32	66.83	16.24		150.0	
10535-AAA	IEEE 802.11ac WiFi (40MHz, MCS1, 99pc duty cycle)	X	5.40	66.88	16.22	0.00	150.0	± 9.6 %
		Y	5.39	66.83	16.19		150.0	
		Z	5.39	66.97	16.29		150.0	
10536-AAA	IEEE 802.11ac WiFi (40MHz, MCS2, 99pc duty cycle)	X	5.26	66.87	16.20	0.00	150.0	± 9.6 %
		Y	5.25	66.82	16.17		150.0	
		Z	5.26	66.97	16.28		150.0	
10537-AAA	IEEE 802.11ac WiFi (40MHz, MCS3, 99pc duty cycle)	X	5.33	66.84	16.18	0.00	150.0	± 9.6 %
		Y	5.32	66.80	16.16		150.0	
		Z	5.33	66.94	16.26		150.0	
10538-AAA	IEEE 802.11ac WiFi (40MHz, MCS4, 99pc duty cycle)	X	5.46	66.94	16.27	0.00	150.0	± 9.6 %
		Y	5.44	66.88	16.24		150.0	
		Z	5.44	67.01	16.34		150.0	
10540-AAA	IEEE 802.11ac WiFi (40MHz, MCS6, 99pc duty cycle)	X	5.34	66.86	16.25	0.00	150.0	± 9.6 %
		Y	5.33	66.81	16.22		150.0	
		Z	5.34	66.95	16.32		150.0	

10541-AAA	IEEE 802.11ac WiFi (40MHz, MCS7, 99pc duty cycle)	X	5.34	66.83	16.23	0.00	150.0	± 9.6 %
		Y	5.32	66.74	16.19		150.0	
		Z	5.33	66.88	16.29		150.0	
10542-AAA	IEEE 802.11ac WiFi (40MHz, MCS8, 99pc duty cycle)	X	5.48	66.80	16.24	0.00	150.0	± 9.6 %
		Y	5.47	66.76	16.21		150.0	
		Z	5.47	66.89	16.31		150.0	
10543-AAA	IEEE 802.11ac WiFi (40MHz, MCS9, 99pc duty cycle)	X	5.58	66.84	16.26	0.00	150.0	± 9.6 %
		Y	5.55	66.78	16.23		150.0	
		Z	5.56	66.91	16.32		150.0	
10544-AAA	IEEE 802.11ac WiFi (80MHz, MCS0, 99pc duty cycle)	X	5.59	66.84	16.14	0.00	150.0	± 9.6 %
		Y	5.59	66.80	16.12		150.0	
		Z	5.59	66.93	16.22		150.0	
10545-AAA	IEEE 802.11ac WiFi (80MHz, MCS1, 99pc duty cycle)	X	5.80	67.23	16.27	0.00	150.0	± 9.6 %
		Y	5.81	67.21	16.27		150.0	
		Z	5.81	67.33	16.35		150.0	
10546-AAA	IEEE 802.11ac WiFi (80MHz, MCS2, 99pc duty cycle)	X	5.70	67.16	16.26	0.00	150.0	± 9.6 %
		Y	5.69	67.10	16.23		150.0	
		Z	5.70	67.23	16.32		150.0	
10547-AAA	IEEE 802.11ac WiFi (80MHz, MCS3, 99pc duty cycle)	X	5.80	67.24	16.29	0.00	150.0	± 9.6 %
		Y	5.78	67.16	16.25		150.0	
		Z	5.79	67.29	16.34		150.0	
10548-AAA	IEEE 802.11ac WiFi (80MHz, MCS4, 99pc duty cycle)	X	6.11	68.33	16.80	0.00	150.0	± 9.6 %
		Y	6.11	68.30	16.79		150.0	
		Z	6.10	68.40	16.87		150.0	
10550-AAA	IEEE 802.11ac WiFi (80MHz, MCS6, 99pc duty cycle)	X	5.72	67.09	16.23	0.00	150.0	± 9.6 %
		Y	5.71	67.04	16.21		150.0	
		Z	5.72	67.17	16.30		150.0	
10551-AAA	IEEE 802.11ac WiFi (80MHz, MCS7, 99pc duty cycle)	X	5.74	67.22	16.25	0.00	150.0	± 9.6 %
		Y	5.73	67.16	16.23		150.0	
		Z	5.74	67.28	16.32		150.0	
10552-AAA	IEEE 802.11ac WiFi (80MHz, MCS8, 99pc duty cycle)	X	5.64	66.96	16.15	0.00	150.0	± 9.6 %
		Y	5.63	66.91	16.12		150.0	
		Z	5.63	67.04	16.21		150.0	
10553-AAA	IEEE 802.11ac WiFi (80MHz, MCS9, 99pc duty cycle)	X	5.73	67.00	16.19	0.00	150.0	± 9.6 %
		Y	5.72	66.95	16.17		150.0	
		Z	5.73	67.08	16.26		150.0	
10554-AAA	IEEE 1602.11ac WiFi (160MHz, MCS0, 99pc duty cycle)	X	5.98	67.23	16.24	0.00	150.0	± 9.6 %
		Y	5.99	67.19	16.23		150.0	
		Z	5.99	67.31	16.31		150.0	
10555-AAA	IEEE 1602.11ac WiFi (160MHz, MCS1, 99pc duty cycle)	X	6.16	67.63	16.41	0.00	150.0	± 9.6 %
		Y	6.15	67.55	16.37		150.0	
		Z	6.15	67.67	16.46		150.0	
10556-AAA	IEEE 1602.11ac WiFi (160MHz, MCS2, 99pc duty cycle)	X	6.15	67.58	16.38	0.00	150.0	± 9.6 %
		Y	6.15	67.54	16.36		150.0	
		Z	6.16	67.66	16.45		150.0	
10557-AAA	IEEE 1602.11ac WiFi (160MHz, MCS3, 99pc duty cycle)	X	6.15	67.59	16.40	0.00	150.0	± 9.6 %
		Y	6.15	67.52	16.38		150.0	
		Z	6.15	67.65	16.46		150.0	

10558-AAA	IEEE 1602.11ac WiFi (160MHz, MCS4, 99pc duty cycle)	X	6.22	67.79	16.52	0.00	150.0	± 9.6 %
		Y	6.21	67.72	16.49		150.0	
		Z	6.21	67.84	16.57		150.0	
10560-AAA	IEEE 1602.11ac WiFi (160MHz, MCS6, 99pc duty cycle)	X	6.21	67.62	16.48	0.00	150.0	± 9.6 %
		Y	6.20	67.54	16.44		150.0	
		Z	6.21	67.67	16.52		150.0	
10561-AAA	IEEE 1602.11ac WiFi (160MHz, MCS7, 99pc duty cycle)	X	6.12	67.56	16.48	0.00	150.0	± 9.6 %
		Y	6.11	67.49	16.45		150.0	
		Z	6.11	67.62	16.54		150.0	
10562-AAA	IEEE 1602.11ac WiFi (160MHz, MCS8, 99pc duty cycle)	X	6.29	68.09	16.75	0.00	150.0	± 9.6 %
		Y	6.28	68.00	16.71		150.0	
		Z	6.28	68.13	16.80		150.0	
10563-AAA	IEEE 1602.11ac WiFi (160MHz, MCS9, 99pc duty cycle)	X	6.54	68.36	16.83	0.00	150.0	± 9.6 %
		Y	6.57	68.41	16.85		150.0	
		Z	6.57	68.51	16.93		150.0	
10564-AAA	IEEE 802.11g WiFi 2.4 GHz (DSSS-OFDM, 9 Mbps, 99pc duty cycle)	X	5.06	67.04	16.51	0.46	150.0	± 9.6 %
		Y	5.05	67.01	16.47		150.0	
		Z	5.06	67.15	16.59		150.0	
10565-AAA	IEEE 802.11g WiFi 2.4 GHz (DSSS-OFDM, 12 Mbps, 99pc duty cycle)	X	5.34	67.54	16.84	0.46	150.0	± 9.6 %
		Y	5.32	67.51	16.80		150.0	
		Z	5.33	67.64	16.90		150.0	
10566-AAA	IEEE 802.11g WiFi 2.4 GHz (DSSS-OFDM, 18 Mbps, 99pc duty cycle)	X	5.17	67.43	16.67	0.46	150.0	± 9.6 %
		Y	5.15	67.38	16.64		150.0	
		Z	5.16	67.53	16.75		150.0	
10567-AAA	IEEE 802.11g WiFi 2.4 GHz (DSSS-OFDM, 24 Mbps, 99pc duty cycle)	X	5.19	67.79	16.99	0.46	150.0	± 9.6 %
		Y	5.18	67.77	16.98		150.0	
		Z	5.18	67.89	17.07		150.0	
10568-AAA	IEEE 802.11g WiFi 2.4 GHz (DSSS-OFDM, 36 Mbps, 99pc duty cycle)	X	5.08	67.13	16.42	0.46	150.0	± 9.6 %
		Y	5.06	67.09	16.38		150.0	
		Z	5.07	67.25	16.51		150.0	
10569-AAA	IEEE 802.11g WiFi 2.4 GHz (DSSS-OFDM, 48 Mbps, 99pc duty cycle)	X	5.13	67.78	16.99	0.46	150.0	± 9.6 %
		Y	5.12	67.79	17.00		150.0	
		Z	5.12	67.90	17.08		150.0	
10570-AAA	IEEE 802.11g WiFi 2.4 GHz (DSSS-OFDM, 54 Mbps, 99pc duty cycle)	X	5.17	67.61	16.93	0.46	150.0	± 9.6 %
		Y	5.16	67.61	16.93		150.0	
		Z	5.16	67.74	17.02		150.0	
10571-AAA	IEEE 802.11b WiFi 2.4 GHz (DSSS, 1 Mbps, 90pc duty cycle)	X	1.39	66.83	16.76	0.46	130.0	± 9.6 %
		Y	1.39	66.19	16.38		130.0	
		Z	1.42	67.03	17.01		130.0	
10572-AAA	IEEE 802.11b WiFi 2.4 GHz (DSSS, 2 Mbps, 90pc duty cycle)	X	1.43	67.56	17.16	0.46	130.0	± 9.6 %
		Y	1.42	66.85	16.75		130.0	
		Z	1.46	67.77	17.42		130.0	
10573-AAA	IEEE 802.11b WiFi 2.4 GHz (DSSS, 5.5 Mbps, 90pc duty cycle)	X	18.61	116.47	31.43	0.46	130.0	± 9.6 %
		Y	4.07	92.61	25.14		130.0	
		Z	21.94	121.24	33.33		130.0	
10574-AAA	IEEE 802.11b WiFi 2.4 GHz (DSSS, 11 Mbps, 90pc duty cycle)	X	1.85	75.72	20.80	0.46	130.0	± 9.6 %
		Y	1.71	73.65	19.92		130.0	
		Z	1.88	76.05	21.19		130.0	

10575-AAA	IEEE 802.11g WiFi 2.4 GHz (DSSS-OFDM, 6 Mbps, 90pc duty cycle)	X	4.89	66.92	16.62	0.46	130.0	± 9.6 %
		Y	4.88	66.90	16.59		130.0	
		Z	4.88	67.03	16.69		130.0	
10576-AAA	IEEE 802.11g WiFi 2.4 GHz (DSSS-OFDM, 9 Mbps, 90pc duty cycle)	X	4.91	67.07	16.68	0.46	130.0	± 9.6 %
		Y	4.91	67.06	16.65		130.0	
		Z	4.91	67.19	16.75		130.0	
10577-AAA	IEEE 802.11g WiFi 2.4 GHz (DSSS-OFDM, 12 Mbps, 90pc duty cycle)	X	5.16	67.42	16.86	0.46	130.0	± 9.6 %
		Y	5.15	67.40	16.83		130.0	
		Z	5.15	67.52	16.93		130.0	
10578-AAA	IEEE 802.11g WiFi 2.4 GHz (DSSS-OFDM, 18 Mbps, 90pc duty cycle)	X	5.06	67.59	16.95	0.46	130.0	± 9.6 %
		Y	5.04	67.58	16.94		130.0	
		Z	5.04	67.69	17.03		130.0	
10579-AAA	IEEE 802.11g WiFi 2.4 GHz (DSSS-OFDM, 24 Mbps, 90pc duty cycle)	X	4.84	67.04	16.37	0.46	130.0	± 9.6 %
		Y	4.82	66.95	16.30		130.0	
		Z	4.83	67.12	16.43		130.0	
10580-AAA	IEEE 802.11g WiFi 2.4 GHz (DSSS-OFDM, 36 Mbps, 90pc duty cycle)	X	4.88	66.96	16.35	0.46	130.0	± 9.6 %
		Y	4.86	66.90	16.28		130.0	
		Z	4.87	67.07	16.42		130.0	
10581-AAA	IEEE 802.11g WiFi 2.4 GHz (DSSS-OFDM, 48 Mbps, 90pc duty cycle)	X	4.97	67.71	16.92	0.46	130.0	± 9.6 %
		Y	4.95	67.68	16.90		130.0	
		Z	4.95	67.80	16.99		130.0	
10582-AAA	IEEE 802.11g WiFi 2.4 GHz (DSSS-OFDM, 54 Mbps, 90pc duty cycle)	X	4.80	66.79	16.17	0.46	130.0	± 9.6 %
		Y	4.77	66.69	16.09		130.0	
		Z	4.78	66.88	16.24		130.0	
10583-AAA	IEEE 802.11a/h WiFi 5 GHz (OFDM, 6 Mbps, 90pc duty cycle)	X	4.89	66.92	16.62	0.46	130.0	± 9.6 %
		Y	4.88	66.90	16.59		130.0	
		Z	4.88	67.03	16.69		130.0	
10584-AAA	IEEE 802.11a/h WiFi 5 GHz (OFDM, 9 Mbps, 90pc duty cycle)	X	4.91	67.07	16.68	0.46	130.0	± 9.6 %
		Y	4.91	67.06	16.65		130.0	
		Z	4.91	67.19	16.75		130.0	
10585-AAA	IEEE 802.11a/h WiFi 5 GHz (OFDM, 12 Mbps, 90pc duty cycle)	X	5.16	67.42	16.86	0.46	130.0	± 9.6 %
		Y	5.15	67.40	16.83		130.0	
		Z	5.15	67.52	16.93		130.0	
10586-AAA	IEEE 802.11a/h WiFi 5 GHz (OFDM, 18 Mbps, 90pc duty cycle)	X	5.06	67.59	16.95	0.46	130.0	± 9.6 %
		Y	5.04	67.58	16.94		130.0	
		Z	5.04	67.69	17.03		130.0	
10587-AAA	IEEE 802.11a/h WiFi 5 GHz (OFDM, 24 Mbps, 90pc duty cycle)	X	4.84	67.04	16.37	0.46	130.0	± 9.6 %
		Y	4.82	66.95	16.30		130.0	
		Z	4.83	67.12	16.43		130.0	
10588-AAA	IEEE 802.11a/h WiFi 5 GHz (OFDM, 36 Mbps, 90pc duty cycle)	X	4.88	66.96	16.35	0.46	130.0	± 9.6 %
		Y	4.86	66.90	16.28		130.0	
		Z	4.87	67.07	16.42		130.0	
10589-AAA	IEEE 802.11a/h WiFi 5 GHz (OFDM, 48 Mbps, 90pc duty cycle)	X	4.97	67.71	16.92	0.46	130.0	± 9.6 %
		Y	4.95	67.68	16.90		130.0	
		Z	4.95	67.80	16.99		130.0	
10590-AAA	IEEE 802.11a/h WiFi 5 GHz (OFDM, 54 Mbps, 90pc duty cycle)	X	4.80	66.79	16.17	0.46	130.0	± 9.6 %
		Y	4.77	66.69	16.09		130.0	
		Z	4.78	66.88	16.24		130.0	

10591-AAA	IEEE 802.11n (HT Mixed, 20MHz, MCS0, 90pc duty cycle)	X	5.03	66.97	16.70	0.46	130.0	± 9.6 %
		Y	5.03	66.96	16.68		130.0	
		Z	5.03	67.08	16.78		130.0	
10592-AAA	IEEE 802.11n (HT Mixed, 20MHz, MCS1, 90pc duty cycle)	X	5.22	67.32	16.82	0.46	130.0	± 9.6 %
		Y	5.21	67.31	16.80		130.0	
		Z	5.21	67.42	16.90		130.0	
10593-AAA	IEEE 802.11n (HT Mixed, 20MHz, MCS2, 90pc duty cycle)	X	5.16	67.30	16.75	0.46	130.0	± 9.6 %
		Y	5.14	67.27	16.71		130.0	
		Z	5.14	67.40	16.82		130.0	
10594-AAA	IEEE 802.11n (HT Mixed, 20MHz, MCS3, 90pc duty cycle)	X	5.20	67.42	16.87	0.46	130.0	± 9.6 %
		Y	5.19	67.41	16.85		130.0	
		Z	5.19	67.53	16.94		130.0	
10595-AAA	IEEE 802.11n (HT Mixed, 20MHz, MCS4, 90pc duty cycle)	X	5.19	67.42	16.79	0.46	130.0	± 9.6 %
		Y	5.17	67.39	16.76		130.0	
		Z	5.17	67.51	16.86		130.0	
10596-AAA	IEEE 802.11n (HT Mixed, 20MHz, MCS5, 90pc duty cycle)	X	5.12	67.41	16.79	0.46	130.0	± 9.6 %
		Y	5.11	67.38	16.76		130.0	
		Z	5.11	67.51	16.86		130.0	
10597-AAA	IEEE 802.11n (HT Mixed, 20MHz, MCS6, 90pc duty cycle)	X	5.08	67.37	16.71	0.46	130.0	± 9.6 %
		Y	5.06	67.32	16.67		130.0	
		Z	5.06	67.46	16.78		130.0	
10598-AAA	IEEE 802.11n (HT Mixed, 20MHz, MCS7, 90pc duty cycle)	X	5.06	67.63	16.97	0.46	130.0	± 9.6 %
		Y	5.04	67.59	16.94		130.0	
		Z	5.04	67.71	17.04		130.0	
10599-AAA	IEEE 802.11n (HT Mixed, 40MHz, MCS0, 90pc duty cycle)	X	5.70	67.60	16.89	0.46	130.0	± 9.6 %
		Y	5.70	67.57	16.88		130.0	
		Z	5.69	67.67	16.95		130.0	
10600-AAA	IEEE 802.11n (HT Mixed, 40MHz, MCS1, 90pc duty cycle)	X	5.96	68.36	17.25	0.46	130.0	± 9.6 %
		Y	5.93	68.27	17.19		130.0	
		Z	5.92	68.36	17.27		130.0	
10601-AAA	IEEE 802.11n (HT Mixed, 40MHz, MCS2, 90pc duty cycle)	X	5.77	67.88	17.02	0.46	130.0	± 9.6 %
		Y	5.76	67.84	17.00		130.0	
		Z	5.76	67.94	17.07		130.0	
10602-AAA	IEEE 802.11n (HT Mixed, 40MHz, MCS3, 90pc duty cycle)	X	5.89	67.97	16.99	0.46	130.0	± 9.6 %
		Y	5.86	67.86	16.92		130.0	
		Z	5.85	67.97	17.01		130.0	
10603-AAA	IEEE 802.11n (HT Mixed, 40MHz, MCS4, 90pc duty cycle)	X	6.01	68.36	17.30	0.46	130.0	± 9.6 %
		Y	5.97	68.24	17.24		130.0	
		Z	5.97	68.34	17.32		130.0	
10604-AAA	IEEE 802.11n (HT Mixed, 40MHz, MCS5, 90pc duty cycle)	X	5.72	67.60	16.91	0.46	130.0	± 9.6 %
		Y	5.71	67.55	16.89		130.0	
		Z	5.70	67.65	16.97		130.0	
10605-AAA	IEEE 802.11n (HT Mixed, 40MHz, MCS6, 90pc duty cycle)	X	5.82	67.89	17.06	0.46	130.0	± 9.6 %
		Y	5.81	67.84	17.03		130.0	
		Z	5.81	67.95	17.12		130.0	
10606-AAA	IEEE 802.11n (HT Mixed, 40MHz, MCS7, 90pc duty cycle)	X	5.59	67.36	16.67	0.46	130.0	± 9.6 %
		Y	5.59	67.33	16.65		130.0	
		Z	5.59	67.46	16.75		130.0	

10607-AAA	IEEE 802.11ac WiFi (20MHz, MCS0, 90pc duty cycle)	X	4.86	66.24	16.30	0.46	130.0	± 9.6 %
		Y	4.85	66.24	16.28		130.0	
		Z	4.86	66.37	16.38		130.0	
10608-AAA	IEEE 802.11ac WiFi (20MHz, MCS1, 90pc duty cycle)	X	5.09	66.68	16.46	0.46	130.0	± 9.6 %
		Y	5.07	66.67	16.44		130.0	
		Z	5.08	66.80	16.54		130.0	
10609-AAA	IEEE 802.11ac WiFi (20MHz, MCS2, 90pc duty cycle)	X	4.98	66.59	16.34	0.46	130.0	± 9.6 %
		Y	4.96	66.55	16.31		130.0	
		Z	4.97	66.70	16.42		130.0	
10610-AAA	IEEE 802.11ac WiFi (20MHz, MCS3, 90pc duty cycle)	X	5.03	66.73	16.49	0.46	130.0	± 9.6 %
		Y	5.02	66.71	16.47		130.0	
		Z	5.02	66.85	16.57		130.0	
10611-AAA	IEEE 802.11ac WiFi (20MHz, MCS4, 90pc duty cycle)	X	4.96	66.60	16.37	0.46	130.0	± 9.6 %
		Y	4.94	66.56	16.33		130.0	
		Z	4.95	66.70	16.44		130.0	
10612-AAA	IEEE 802.11ac WiFi (20MHz, MCS5, 90pc duty cycle)	X	4.98	66.74	16.40	0.46	130.0	± 9.6 %
		Y	4.96	66.69	16.36		130.0	
		Z	4.97	66.85	16.48		130.0	
10613-AAA	IEEE 802.11ac WiFi (20MHz, MCS6, 90pc duty cycle)	X	5.00	66.68	16.32	0.46	130.0	± 9.6 %
		Y	4.97	66.62	16.27		130.0	
		Z	4.98	66.79	16.39		130.0	
10614-AAA	IEEE 802.11ac WiFi (20MHz, MCS7, 90pc duty cycle)	X	4.92	66.87	16.54	0.46	130.0	± 9.6 %
		Y	4.90	66.82	16.51		130.0	
		Z	4.91	66.96	16.61		130.0	
10615-AAA	IEEE 802.11ac WiFi (20MHz, MCS8, 90pc duty cycle)	X	4.96	66.40	16.15	0.46	130.0	± 9.6 %
		Y	4.94	66.35	16.10		130.0	
		Z	4.95	66.52	16.23		130.0	
10616-AAA	IEEE 802.11ac WiFi (40MHz, MCS0, 90pc duty cycle)	X	5.51	66.85	16.50	0.46	130.0	± 9.6 %
		Y	5.51	66.82	16.48		130.0	
		Z	5.51	66.93	16.57		130.0	
10617-AAA	IEEE 802.11ac WiFi (40MHz, MCS1, 90pc duty cycle)	X	5.58	66.97	16.52	0.46	130.0	± 9.6 %
		Y	5.57	66.93	16.50		130.0	
		Z	5.57	67.05	16.59		130.0	
10618-AAA	IEEE 802.11ac WiFi (40MHz, MCS2, 90pc duty cycle)	X	5.47	67.03	16.57	0.46	130.0	± 9.6 %
		Y	5.47	67.01	16.56		130.0	
		Z	5.47	67.12	16.65		130.0	
10619-AAA	IEEE 802.11ac WiFi (40MHz, MCS3, 90pc duty cycle)	X	5.49	66.84	16.42	0.46	130.0	± 9.6 %
		Y	5.48	66.81	16.40		130.0	
		Z	5.49	66.94	16.49		130.0	
10620-AAA	IEEE 802.11ac WiFi (40MHz, MCS4, 90pc duty cycle)	X	5.63	67.01	16.55	0.46	130.0	± 9.6 %
		Y	5.61	66.94	16.51		130.0	
		Z	5.61	67.06	16.60		130.0	
10621-AAA	IEEE 802.11ac WiFi (40MHz, MCS5, 90pc duty cycle)	X	5.59	67.04	16.67	0.46	130.0	± 9.6 %
		Y	5.58	67.00	16.66		130.0	
		Z	5.58	67.11	16.73		130.0	
10622-AAA	IEEE 802.11ac WiFi (40MHz, MCS6, 90pc duty cycle)	X	5.58	67.13	16.71	0.46	130.0	± 9.6 %
		Y	5.58	67.10	16.70		130.0	
		Z	5.57	67.21	16.77		130.0	

10623-AAA	IEEE 802.11ac WiFi (40MHz, MCS7, 90pc duty cycle)	X	5.50	66.83	16.46	0.46	130.0	± 9.6 %
		Y	5.47	66.72	16.39		130.0	
		Z	5.48	66.85	16.49		130.0	
10624-AAA	IEEE 802.11ac WiFi (40MHz, MCS8, 90pc duty cycle)	X	5.66	66.88	16.54	0.46	130.0	± 9.6 %
		Y	5.65	66.86	16.52		130.0	
		Z	5.65	66.97	16.61		130.0	
10625-AAA	IEEE 802.11ac WiFi (40MHz, MCS9, 90pc duty cycle)	X	6.01	67.74	17.01	0.46	130.0	± 9.6 %
		Y	6.05	67.88	17.08		130.0	
		Z	6.04	67.96	17.15		130.0	
10626-AAA	IEEE 802.11ac WiFi (80MHz, MCS0, 90pc duty cycle)	X	5.75	66.88	16.43	0.46	130.0	± 9.6 %
		Y	5.76	66.85	16.41		130.0	
		Z	5.75	66.96	16.49		130.0	
10627-AAA	IEEE 802.11ac WiFi (80MHz, MCS1, 90pc duty cycle)	X	6.01	67.38	16.62	0.46	130.0	± 9.6 %
		Y	6.02	67.40	16.64		130.0	
		Z	6.01	67.49	16.71		130.0	
10628-AAA	IEEE 802.11ac WiFi (80MHz, MCS2, 90pc duty cycle)	X	5.83	67.09	16.43	0.46	130.0	± 9.6 %
		Y	5.83	67.04	16.40		130.0	
		Z	5.83	67.16	16.49		130.0	
10629-AAA	IEEE 802.11ac WiFi (80MHz, MCS3, 90pc duty cycle)	X	5.95	67.23	16.49	0.46	130.0	± 9.6 %
		Y	5.93	67.12	16.43		130.0	
		Z	5.93	67.24	16.52		130.0	
10630-AAA	IEEE 802.11ac WiFi (80MHz, MCS4, 90pc duty cycle)	X	6.53	69.08	17.41	0.46	130.0	± 9.6 %
		Y	6.52	69.03	17.38		130.0	
		Z	6.50	69.10	17.45		130.0	
10631-AAA	IEEE 802.11ac WiFi (80MHz, MCS5, 90pc duty cycle)	X	6.39	68.76	17.42	0.46	130.0	± 9.6 %
		Y	6.37	68.68	17.39		130.0	
		Z	6.35	68.75	17.45		130.0	
10632-AAA	IEEE 802.11ac WiFi (80MHz, MCS6, 90pc duty cycle)	X	6.01	67.52	16.82	0.46	130.0	± 9.6 %
		Y	6.00	67.49	16.82		130.0	
		Z	5.99	67.58	16.88		130.0	
10633-AAA	IEEE 802.11ac WiFi (80MHz, MCS7, 90pc duty cycle)	X	5.97	67.44	16.62	0.46	130.0	± 9.6 %
		Y	5.95	67.35	16.58		130.0	
		Z	5.95	67.46	16.66		130.0	
10634-AAA	IEEE 802.11ac WiFi (80MHz, MCS8, 90pc duty cycle)	X	5.94	67.39	16.66	0.46	130.0	± 9.6 %
		Y	5.92	67.31	16.62		130.0	
		Z	5.91	67.41	16.70		130.0	
10635-AAA	IEEE 802.11ac WiFi (80MHz, MCS9, 90pc duty cycle)	X	5.81	66.73	16.09	0.46	130.0	± 9.6 %
		Y	5.79	66.63	16.02		130.0	
		Z	5.80	66.78	16.13		130.0	
10636-AAA	IEEE 1602.11ac WiFi (160MHz, MCS0, 90pc duty cycle)	X	6.15	67.27	16.52	0.46	130.0	± 9.6 %
		Y	6.16	67.25	16.52		130.0	
		Z	6.16	67.35	16.59		130.0	
10637-AAA	IEEE 1602.11ac WiFi (160MHz, MCS1, 90pc duty cycle)	X	6.36	67.74	16.73	0.46	130.0	± 9.6 %
		Y	6.35	67.67	16.70		130.0	
		Z	6.34	67.77	16.77		130.0	
10638-AAA	IEEE 1602.11ac WiFi (160MHz, MCS2, 90pc duty cycle)	X	6.33	67.63	16.65	0.46	130.0	± 9.6 %
		Y	6.34	67.61	16.65		130.0	
		Z	6.33	67.71	16.72		130.0	

10639-AAA	IEEE 1602.11ac WiFi (160MHz, MCS3, 90pc duty cycle)	X	6.35	67.70	16.74	0.46	130.0	± 9.6 %
		Y	6.35	67.65	16.72		130.0	
		Z	6.34	67.75	16.79		130.0	
10640-AAA	IEEE 1602.11ac WiFi (160MHz, MCS4, 90pc duty cycle)	X	6.39	67.82	16.74	0.46	130.0	± 9.6 %
		Y	6.38	67.74	16.71		130.0	
		Z	6.38	67.86	16.79		130.0	
10641-AAA	IEEE 1602.11ac WiFi (160MHz, MCS5, 90pc duty cycle)	X	6.37	67.50	16.60	0.46	130.0	± 9.6 %
		Y	6.36	67.44	16.57		130.0	
		Z	6.36	67.56	16.65		130.0	
10642-AAA	IEEE 1602.11ac WiFi (160MHz, MCS6, 90pc duty cycle)	X	6.45	67.86	16.94	0.46	130.0	± 9.6 %
		Y	6.43	67.79	16.91		130.0	
		Z	6.43	67.88	16.98		130.0	
10643-AAA	IEEE 1602.11ac WiFi (160MHz, MCS7, 90pc duty cycle)	X	6.27	67.55	16.69	0.46	130.0	± 9.6 %
		Y	6.26	67.47	16.66		130.0	
		Z	6.26	67.59	16.74		130.0	
10644-AAA	IEEE 1602.11ac WiFi (160MHz, MCS8, 90pc duty cycle)	X	6.53	68.33	17.11	0.46	130.0	± 9.6 %
		Y	6.51	68.21	17.05		130.0	
		Z	6.51	68.32	17.13		130.0	
10645-AAA	IEEE 1602.11ac WiFi (160MHz, MCS9, 90pc duty cycle)	X	6.77	68.56	17.17	0.46	130.0	± 9.6 %
		Y	6.81	68.62	17.19		130.0	
		Z	6.80	68.72	17.27		130.0	
10646-AAB	LTE-TDD (SC-FDMA, 1 RB, 5 MHz, QPSK, UL Subframe=2,7)	X	25.99	106.58	35.17	9.30	60.0	± 9.6 %
		Y	21.82	102.72	33.95		60.0	
		Z	27.43	108.77	35.97		60.0	
10647-AAA	LTE-TDD (SC-FDMA, 1 RB, 20 MHz, QPSK, UL Subframe=2,7)	X	27.16	108.33	35.83	9.30	60.0	± 9.6 %
		Y	22.36	104.00	34.47		60.0	
		Z	28.70	110.58	36.65		60.0	
10648-AAA	CDMA2000 (1x Advanced)	X	0.86	65.46	12.69	0.00	150.0	± 9.6 %
		Y	0.83	64.77	12.28		150.0	
		Z	0.90	66.26	13.22		150.0	

^E Uncertainty is determined using the max. deviation from linear response applying rectangular distribution and is expressed for the square of the field value.