

FCC LTE REPORT

FCC Certification

Applicant Name:
 SAMSUNG Electronics Co., Ltd.

Date of Issue:
 March 09, 2016

Address:
 129, Samsung-ro, Yeongtong-gu, Suwon-si,
 Gyeonggi-do, 16677, Rep. of Korea

Location:
 HCT CO., LTD.,
 74, Seoicheon-ro 578beon-gil, Majang-myeon,
 Icheon-si, Gyeonggi-do, 17383, Rep. of KOREA

Report No.: HCT-R-1602-F053-2
HCT FRN: 0005866421

FCC ID: A3LSMJ5108

APPLICANT: SAMSUNG Electronics Co., Ltd.

FCC Model(s): SM-J5108
EUT Type: Mobile Phone
FCC Classification: Licensed Portable Transmitter Held to Ear (PCE)
FCC Rule Part(s): §2 , §27

| Mode (MHz) | Tx Frequency (MHz) | Emission Designator | Modulation | EIRP | |
|-------------------|--------------------|---------------------|------------|----------------|------------------|
| | | | | Max. Power (W) | Max. Power (dBm) |
| LTE – Band41 (5) | 2557.5 – 2652.5 | 4M51G7D | QPSK | 0.054 | 17.35 |
| | | 4M50W7D | 16QAM | 0.041 | 16.16 |
| LTE – Band41 (10) | 2560.0 – 2650.0 | 9M01G7D | QPSK | 0.057 | 17.52 |
| | | 8M98W7D | 16QAM | 0.046 | 16.58 |
| LTE – Band41 (15) | 2562.5 – 2647.5 | 13M4G7D | QPSK | 0.057 | 17.55 |
| | | 13M5W7D | 16QAM | 0.044 | 16.44 |
| LTE – Band41 (20) | 2565.0 – 2645.0 | 18M0G7D | QPSK | 0.061 | 17.88 |
| | | 17M9W7D | 16QAM | 0.046 | 16.66 |

The measurements shown in this report were made in accordance with the procedures specified in CFR47 section §2.947. I assume full responsibility for the accuracy and completeness of these measurements, and for the qualifications of all persons taking them.

HCT CO., LTD. Certifies that no party to this application has subject to a denial of Federal benefits that includes FCC benefits pursuant to section 5301 of the Anti-Drug Abuse Act of 1998, 21 U.S. C.853(a)



Report prepared by
: Jeong Ho Kim
Test engineer of RF Team



Approved by
: Sang Jun Lee
Manager of RF Team

This report only responds to the tested sample and may not be reproduced, except in full, without written approval of the HCT Co., Ltd.

Report Revision

| TEST REPORT NO. | DATE | DESCRIPTION |
|-------------------|-------------------|--|
| HCT-R-1602-F053 | February 29, 2016 | - First Approval Report |
| HCT-R-1602-F053-1 | March 08, 2016 | - We retest the LTE 15M bandwidth Center Channel. - We revised the on page 10 |
| HCT-R-1602-F053-2 | March 09, 2016 | - Change the test date. Page on 4 |
| | | |

Table of Contents

| | |
|--|----|
| 1. GENERAL INFORMATION | 4 |
| 2. INTRODUCTION | 5 |
| 2.1. EUT DESCRIPTION..... | 5 |
| 2.2. MEASURING INSTRUMENT CALIBRATION..... | 5 |
| 2.3. TEST FACILITY | 5 |
| 3. DESCRIPTION OF TESTS | 6 |
| 3.1 EIRP RADIATED POWER AND RADIATED SPURIOUS EMISSIONS | 6 |
| 3.2 OCCUPIED BANDWIDTH..... | 7 |
| 3.3 SPURIOUS AND HARMONIC EMISSIONS AT ANTENNA TERMINAL..... | 8 |
| 3.4 FREQUENCY STABILITY / VARIATION OF AMBIENT TEMPERATURE | 9 |
| 4. LIST OF TEST EQUIPMENT | 10 |
| 5. SUMMARY OF TEST RESULTS | 11 |
| 6. SAMPLE CALCULATION..... | 12 |
| 7. TEST DATA | 14 |
| 7.1 EQUIVALENT ISOTROPIC RADIATED POWER (Band 41)..... | 14 |
| 7.2 RADIATED SPURIOUS EMISSIONS..... | 16 |
| 7.2.1 RADIATED SPURIOUS EMISSIONS (5 MHz Band 41 LTE) | 16 |
| 7.2.2 RADIATED SPURIOUS EMISSIONS (10 MHz Band 41 LTE) | 17 |
| 7.2.3 RADIATED SPURIOUS EMISSIONS (15 MHz Band 41 LTE) | 18 |
| 7.2.4 RADIATED SPURIOUS EMISSIONS (20 MHz Band 41 LTE) | 19 |
| 7.3 OCCUPIED BANDWIDTH | 20 |
| 7.4 CONDUCTED SPURIOUS EMISSIONS | 21 |
| 7.4.1 BAND EDGE..... | 22 |
| 7.5 FREQUENCY STABILITY / VARIATION OF AMBIENT TEMPERATURE | 23 |
| 7.5.1 FREQUENCY STABILITY (5 MHz Band 41 LTE) | 23 |
| 7.5.2 FREQUENCY STABILITY (10 MHz Band 41 LTE) | 24 |
| 7.5.3 FREQUENCY STABILITY (15 MHz Band 41 LTE) | 25 |
| 7.5.4 FREQUENCY STABILITY (20 MHz Band 41 LTE) | 26 |
| 8. TEST PLOTS..... | 27 |

MEASUREMENT REPORT

1. GENERAL INFORMATION

Applicant Name: SAMSUNG Electronics Co., Ltd.

Address: 129, Samsung-ro, Yeongtong-gu, Suwon-si, Gyeonggi-do, 16677, Rep. of Korea

FCC ID: A3LSMJ5108

Application Type: Certification

FCC Classification: Licensed Portable Transmitter Held to Ear (PCE)

FCC Rule Part(s): §2 , §27

EUT Type: Mobile Phone

FCC Model(s): SM-J5108

Tx Frequency: 2557.5 MHz– 2652.5 MHz (LTE – Band 41): 5 MHz
2560.0 MHz– 2650.0 MHz (LTE – Band 41): 10 MHz
2562.5 MHz– 2647.5 MHz (LTE – Band 41): 15 MHz
2565.0 MHz– 2645.0 MHz (LTE – Band 41): 20 MHz

Max. RF Output Power:

| | |
|--------------------|--|
| Band 41 (5 MHz) : | 0.054 W (QPSK) (17.35 dBm) 0.041 W (16-QAM) (16.16 dBm) |
| Band 41 (10 MHz) : | 0.057 W (QPSK) (17.52 dBm) 0.046 W (16-QAM) (16.58 dBm) |
| Band 41 (15 MHz) : | 0.057 W (QPSK) (17.55 dBm) 0.044 W (16-QAM) (16.44 dBm) |
| Band 41 (20 MHz) : | 0.061W (QPSK) (17.88 dBm) 0.046 W (16-QAM) (16.66 dBm) |

Emission Designator(s):

| | |
|--------------------|-----------------------------------|
| Band 41 (5 MHz) : | 4M51G7D (QPSK) / 4M50W7D (16-QAM) |
| Band 41 (10 MHz) : | 9M01G7D (QPSK) / 8M98W7D (16-QAM) |
| Band 41 (15 MHz) : | 13M4G7D (QPSK) / 13M5W7D (16-QAM) |
| Band 41 (20 MHz) : | 18M0G7D (QPSK) / 17M9W7D (16-QAM) |

Date(s) of Tests: January 19, 2016 ~ March 09, 2016

Antenna Specification

| | |
|---------------|--|
| Manufacturer: | Shenzhen Sunway Communication Co., Ltd |
| Antenna type: | LDS Antenna |
| Peak Gain: | Band 41 : 2.3 dBi |

2. INTRODUCTION

2.1. EUT DESCRIPTION

The SAMSUNG Electronics Co., Ltd.SM-J5108Mobile Phone consists of LTE 41.

2.2. MEASURING INSTRUMENT CALIBRATION

The measuring equipment, which was utilized in performing the tests documented herein, has been calibrated in accordance with the manufacturer's recommendations for utilizing calibration equipment, which is traceable to recognized national standards.

2.3. TEST FACILITY

The Fully-anechoic chamber and conducted measurement facility used to collect the radiated data are located at the **74, Seoicheon-ro 578beon-gil, Majang-myeon, Icheon-si, Gyeonggi-do, 17383, Rep. of KOREA.**

3. DESCRIPTION OF TESTS

3.1 EIRP RADIATED POWER AND RADIATED SPURIOUS EMISSIONS

Note: EIRP(Equivalent Isotropic Radiated Power)

Test Procedure

Radiated emission measurements are performed in the Fully-anechoic chamber. The equipment under test is placed on a non-conductive table 3-meters away from the receive antenna in accordance with ANSI/TIA-603-D-2010 Clause 2.2.17. The turntable is rotated through 360 degrees, and the receiving antenna scans in order to determine the level of the maximized emission. The level and position of the maximized emission is recorded with the spectrum analyzer using RMS detector.

A half wave dipole is then substituted in place of the EUT. For emissions above 1GHz, a horn antenna is substituted in place of the EUT. The substitute antenna is driven by a signal generator and the previously recorded signal was duplicated.

The power is calculated by the following formula;

$$P_{d(\text{dBm})} = P_{g(\text{dBm})} - \text{cable loss}_{(\text{dB})} + \text{antenna gain}_{(\text{dB})}$$

Where: P_d is the dipole equivalent power and P_g is the generator output power into the substitution antenna.

The maximum EIRP is calculated by adding the forward power to the calibrated source plus its appropriate gain value. These steps are repeated with the receiving antenna in both vertical and horizontal polarization. the difference between the gain of the horn and an isotropic antenna are taken into consideration

Radiated spurious emissions

1. Frequency Range : 30 MHz ~ 10th Harmonics of highest channel fundamental frequency.
2. Measured distance : 30 MHz ~ 11 GHz at 3 m
11 GHz ~ 27 GHz at 1m
3. The EUT was setup to maximum output power.
4. The high, low and a middle channel were tested for out of band measurements.

3.2 OCCUPIED BANDWIDTH.

Test set-up

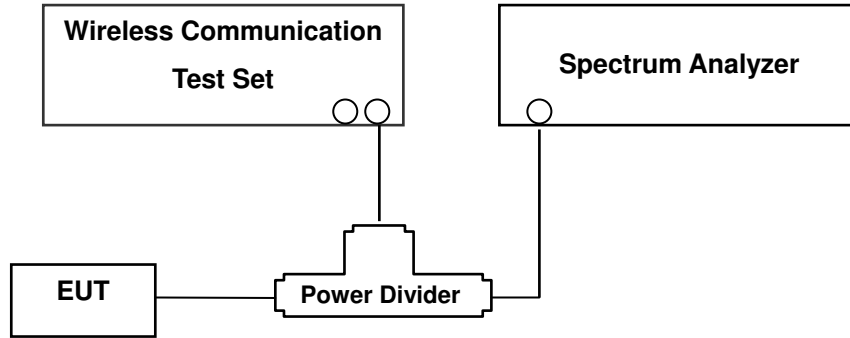

(Configuration of conducted Emission measurement)

The width of a frequency band such that, below the lower and above the upper frequency limits, the mean powers emitted are each equal to a specified percentage 0.5 % of the total mean power of a given emission.

Test Procedure

OBW is tested in accordance with KDB971168 D01 Power Meas License Digital Systems v02r02, October 17, 2014, Section 4.2.

The EUT makes a call to the communication simulator. The power was measured with R&S Spectrum Analyzer. All measurements were done at 3 channels(low, middle and high operational range.)

The conducted occupied bandwidth used the power splitter via EUT RF power connector between simulation base station and spectrum analyzer.

The communication simulator station system controlled a EUT to export maximum output power under transmission mode and specific channel frequency. Use OBW measurement function of Spectrum analyzer to measure 99 % occupied bandwidth

3.3 SPURIOUS AND HARMONIC EMISSIONS AT ANTENNA TERMINAL.

Test Procedure

Spurious and harmonic emissions at antenna terminal is tested in accordance with KDB971168 D01 Power Meas License Digital Systems v02r02, October 17, 2014, Section 6.0.

The level of the carrier and the various conducted spurious and harmonic frequencies is measured by means of a calibrated spectrum analyzer.

The EUT was setup to maximum output power. The 1 MHz RBW was used to scan from 30 MHz to 26.5 GHz. And limit is -25 dBm. The high, low and a middle channel were tested for out of band measurements.

- Channel Edge Requirement : In the 1MHz bands immediately outside and adjacent to the channel, a resolution bandwidth of at least 2% of the emission bandwidth of the fundamental emission of the transmitter may be employed to measure the out of band Emissions. Limit is -10 dBm on all frequencies between the channel edge and 5 MHz from the channel edge, -13 dBm on all frequencies between 5 MHz and X MHz from the channel edge, -25 dBm on all frequencies more than X MHz from channel edge, where X is the greater of 6 MHz or the actual emission bandwidth. In addition, the attenuation factor shall not be less than -13 dBm on all frequencies between 2490.5 MHz and 2496 MHz and -25 dBm at below 2490.5 MHz.

NOTES: The analyzer plot offsets were determined by below conditions.

- For LTE Band 41, total offset 27.9 dBm = 20 dBm attenuator + 6 dBm Divider + 1.9 dBm RF cables.

3.4 FREQUENCY STABILITY / VARIATION OF AMBIENT TEMPERATURE

Test Set-up

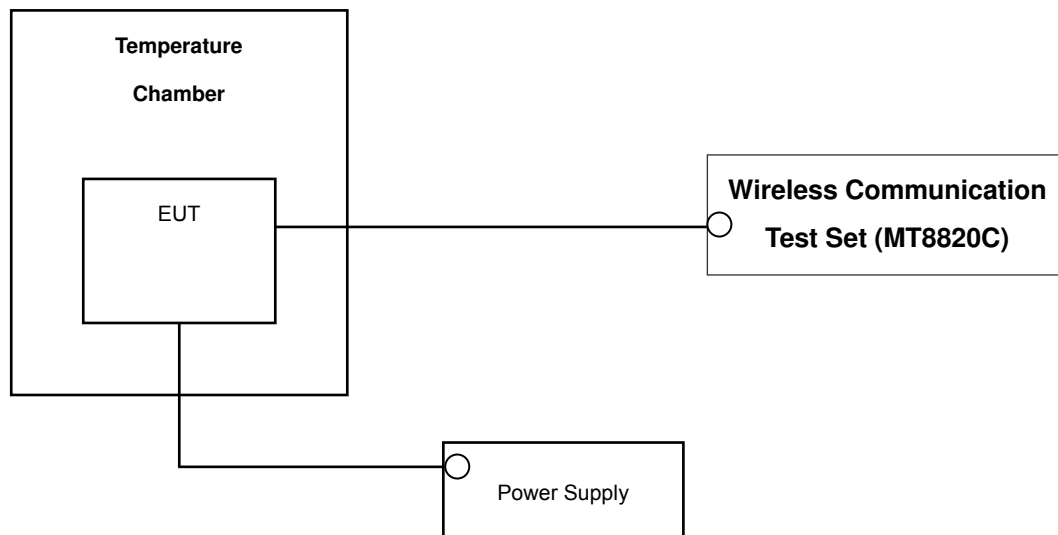

* Nominal Operating Voltage

Test Procedure

Frequency stability is tested in accordance with ANSI/TIA-603-D-2010 section 2.2.2.

The frequency stability of the transmitter is measured by:

- a.) **Temperature:** The temperature is varied from - 30 °C to + 50 °C using an environmental chamber.
- b.) **Primary Supply Voltage:** The primary supply voltage is varied from battery end point to 100 % of the voltage normally at the input to the device or at the power supply terminals if cables are not normally supplied.

Specification — the frequency stability shall be sufficient to ensure that the fundamental emission stays within the authorized frequency block.

Time Period and Procedure:

The carrier frequency of the transmitter is measured at room temperature (20°C to provide a reference).

1. The equipment is turned on in a “standby” condition for one minute before applying power to the transmitter. Measurement of the carrier frequency of the transmitter is made within one minute after applying power to the transmitter.
2. Frequency measurements are made at 10°C intervals ranging from -30°C to +50°C. A period of at least one half-hour is provided to allow stabilization of the equipment at each temperature level.

NOTE: The EUT is tested down to the battery endpoint.

4. LIST OF TEST EQUIPMENT

| Manufacture | Model/ Equipment | Serial Number | Calibration Interval | Calibration Due |
|-----------------|---|------------------------|----------------------|-----------------|
| Agilent | N1921A/ Power Sensor | MY45241059 | Annual | 07/09/2016 |
| Agilent | N1911A/ Power Meter | MY45100523 | Annual | 07/09/2016 |
| CERNEX | CBLU1183540/ POWER AMP | 24612 | Annual | 05/21/2016 |
| Wainwright | WHKX 10-900-1000-15000-40SS/H.P.F | 5 | Annual | 08/11/2016 |
| Wainwright | WHKX10-2700-3000-18000-40SS/H.P.F | 3 | Annual | 08/05/2016 |
| Hewlett Packard | 11667B / Power Splitter | 10545 | Annual | 02/15/2017 |
| Hewlett Packard | 11667B / Power Splitter | 11275 | Annual | 04/29/2016 |
| ITECH | IT6720/ Power Supply | 0100215626700119 | Annual | 11/02/2016 |
| Schwarzbeck | UHAP/ Dipole Antenna | 557 | Biennial | 03/23/2017 |
| Schwarzbeck | UHAP/ Dipole Antenna | 558 | Biennial | 03/23/2017 |
| EXP | EX-TH400/ Chamber | None | Annual | 05/29/2016 |
| Schwarzbeck | BBHA 9120D/ Horn Antenna | 9210D-1298 | Biennial | 10/16/2016 |
| Schwarzbeck | BBHA 9120D/ Horn Antenna | 9210D-1299 | Biennial | 10/16/2016 |
| Schwarzbeck | BBHA 9170/ Horn Antenna(15~40GHz) | BBHA9170342 | Biennial | 04/30/2017 |
| Schwarzbeck | BBHA 9170/ Horn Antenna(15~35GHz) | BBHA9170124 | Biennial | 04/30/2017 |
| Agilent | N9020A/Signal Analyzer | MY51110063 | Annual | 04/29/2016 |
| Hewlett Packard | 8493C/ATTENUATOR | 17280 | Annual | 06/29/2016 |
| REOHDE&SCHWARZ | FSV40-N/Signal Analyzer | 101068-SZ | Annual | 09/23/2016 |
| REOHDE&SCHWARZ | FSV40/Spectrum Analyzer | 1307.9002K40-100931-NK | Annual | 06/04/2016 |
| Agilent | 8960 (E5515C)/ Base Station | MY48360800 | Annual | 10/30/2016 |
| Anritsu Corp. | MT8820C/Wideband Radio Communication Tester | 6200863156 | Annual | 02/26/2017 |
| Anritsu Corp. | MT8820C/Wideband Radio Communication Tester | 6201026545 | Annual | 02/16/2017 |

5. SUMMARY OF TEST RESULTS

| FCC Part Section(s) | Test Description | Test Limit | Test Condition | Test Result |
|------------------------|--|--|----------------|-------------|
| 2.1049 | Occupied Bandwidth | N/A | CONDUCTED | PASS |
| 2.1051, 27.53(m)(4) | Band Edge / Conducted Spurious Emissions. | < 40 + 10log10 (P[Watts]) at Channel edges < 43 + 10log10 (P[Watts]) between 5 and X MHz from Channel edges <55 + 10log10 (P[Watts]) beyond X MHz beyond from Channel edges | | PASS |
| *2.1046 | Conducted Output Power | N/A | | PASS |
| 2.1055, 27.54 | Frequency stability | Emission must remain in band | | PASS |
| 27.50(h)(2) | Equivalent Isotropic Radiated Power | < 2 Watts max. EIRP | RADIATED | PASS |
| 2.1053, 27.53(m)(4) | Undesirable Emissions | < 40 + 10log10 (P[Watts]) at Channel edges < 43 + 10log10 (P[Watts]) between 5 and X MHz from Channel edges <55 + 10log10 (P[Watts]) beyond X MHz beyond from Channel edges | | PASS |

*See SAR Report

6. SAMPLE CALCULATION

A. EIRP Sample Calculation

| Mode | Ch./ Freq. | | Measured Level(dBm) | Substitute LEVEL(dBm) | Ant. Gain (dBi) | C.L | Pol. | EIRP | |
|----------------|------------|------------|---------------------|-----------------------|-----------------|------|------|-------|-------|
| | channel | Freq.(MHz) | | | | | | W | dBm |
| LTE Band 41 | 40740.0 | 2605.0 | -25.64 | 7.97 | 11.04 | 1.74 | H | 0.053 | 17.27 |

EIRP = Substitute LEVEL(dBm) + Ant. Gain – CL(Cable Loss)

- 1) The EUT mounted on a wooden tripod is 2.5 meter above test site ground level.
- 2) During the test , the turn table is rotated until the maximum signal is found.
- 3) Record the field strength meter's level.
- 4) Replace the EUT with dipole/Horn antenna that is connected to a calibrated signal generator.
- 5) Increase the signal generator output till the field strength meter's level is equal to the item (3).
- 6) The signal generator output level with Ant. Gain and cable loss are the rating of Equivalent Isotropic Radiated Power (**EIRP**).

B. Emission Designator

QPSK Modulation

5 MHz Bandwidth

Emission Designator = 4M50G7D

LTE BW = 4.50 MHz

G = Phase Modulation

7 = Quantized/Digital Info

D = Data transmission; telemetry; telecommand

10MHz Bandwidth

Emission Designator = 8M95G7D

LTE BW = 8.95 MHz

G = Phase Modulation

7 = Quantized/Digital Info

D = Data transmission; telemetry; telecommand

15MHz Bandwidth

Emission Designator = 13M5G7D

LTE BW = 13.47 MHz

G = Phase Modulation

7 = Quantized/Digital Info

D = Data transmission; telemetry; telecommand

20MHz Bandwidth

Emission Designator = 18M0G7D

LTE BW = 18.03 MHz

G = Phase Modulation

7 = Quantized/Digital Info

D = Data transmission; telemetry; telecommand

16QAM Modulation

5 MHz Bandwidth

Emission Designator = 4M51W7D

LTE BW = 4.51 MHz

W = main carrier modulated in a combination of two or more of the following modes; amplitude, angle, pulse

7 = Quantized/Digital Info

D = Data transmission; telemetry; telecommand

10MHz Bandwidth

Emission Designator = 8M94W7D

LTE BW = 8.94 MHz

W = main carrier modulated in a combination of two or more of the following modes; amplitude, angle, pulse

7 = Quantized/Digital Info

D = Data transmission; telemetry; telecommand

15MHz Bandwidth

Emission Designator = 13M5W7D

LTE BW = 13.47MHz

W = main carrier modulated in a combination of two or more of the following modes; amplitude, angle, pulse

7 = Quantized/Digital Info

D = Data transmission; telemetry; telecommand

20MHz Bandwidth

Emission Designator = 18M0W7D

LTE BW = 18.03 MHz

W = main carrier modulated in a combination of two or more of the following modes; amplitude, angle, pulse

7 = Quantized/Digital Info

D = Data transmission; telemetry; telecommand

7. TEST DATA

7.1 EQUIVALENT ISOTROPIC RADIATED POWER (Band 41)

| Freq (MHz) | Bandwidth | Modulation | Measured Level (dBm) | Substitute Level (dBm) | Ant. Gain(dBi) | C.L | Pol | EIRP | |
|------------|-----------|------------|----------------------|------------------------|----------------|------|-----|-------|-------|
| | | | | | | | | W | dBm |
| 2557.5 | 5 MHz | QPSK | -25.86 | 7.75 | 11.00 | 1.72 | H | 0.050 | 17.03 |
| | | 16-QAM | -26.92 | 6.69 | 11.00 | 1.72 | H | 0.040 | 15.97 |
| 2605.0 | | QPSK | -25.56 | 8.05 | 11.04 | 1.74 | H | 0.054 | 17.35 |
| | | 16-QAM | -26.75 | 6.86 | 11.04 | 1.74 | H | 0.041 | 16.16 |
| 2652.5 | | QPSK | -26.10 | 7.84 | 11.07 | 1.74 | H | 0.052 | 17.17 |
| | | 16-QAM | -27.13 | 6.81 | 11.07 | 1.74 | H | 0.041 | 16.14 |

Equivalent Isotropic Radiated Power Data (5 MHz Band 41 LTE)

Note: All of RB size has been tested for emissions and EIRP, with the 1RB configuration observed as the worst case

| Freq (MHz) | Bandwidth | Modulation | Measured Level (dBm) | Substitute Level (dBm) | Ant. Gain(dBi) | C.L | Pol | EIRP | |
|------------|-----------|------------|----------------------|------------------------|----------------|------|-----|-------|-------|
| | | | | | | | | W | dBm |
| 2560.0 | 10 MHz | QPSK | -25.47 | 8.13 | 11.00 | 1.71 | H | 0.055 | 17.42 |
| | | 16-QAM | -26.47 | 7.13 | 11.00 | 1.71 | H | 0.044 | 16.42 |
| 2605.0 | | QPSK | -25.39 | 8.22 | 11.04 | 1.74 | H | 0.057 | 17.52 |
| | | 16-QAM | -26.33 | 7.28 | 11.04 | 1.74 | H | 0.046 | 16.58 |
| 2650.0 | | QPSK | -26.11 | 7.81 | 11.07 | 1.74 | H | 0.052 | 17.14 |
| | | 16-QAM | -26.84 | 7.08 | 11.07 | 1.74 | H | 0.044 | 16.41 |

Equivalent Isotropic Radiated Power Data (10 MHz Band 41 LTE)

Note: All of RB size has been tested for emissions and EIRP, with the 1RB configuration observed as the worst case

| Freq (MHz) | Bandwidth | Modulation | Measured Level (dBm) | Substitute Level (dBm) | Ant. Gain(dBi) | C.L | Pol | EIRP | |
|------------|-----------|------------|----------------------|------------------------|----------------|------|-----|-------|-------|
| | | | | | | | | W | dBm |
| 2562.5 | 15 MHz | QPSK | -25.50 | 8.11 | 11.00 | 1.71 | H | 0.055 | 17.40 |
| | | 16-QAM | -26.46 | 7.15 | 11.00 | 1.71 | H | 0.044 | 16.44 |
| 2593.0 | | QPSK | -25.82 | 7.79 | 11.03 | 1.72 | H | 0.051 | 17.10 |
| | | 16-QAM | -26.82 | 6.79 | 11.03 | 1.72 | H | 0.041 | 16.10 |
| 2647.5 | | QPSK | -25.73 | 8.22 | 11.07 | 1.74 | H | 0.057 | 17.55 |
| | | 16-QAM | -27.08 | 6.87 | 11.07 | 1.74 | H | 0.042 | 16.20 |

Equivalent Isotropic Radiated Power Data (15 MHz Band 41 LTE)

Note: All of RB size has been tested for emissions and EIRP, with the 1RB configuration observed as the worst case

| Freq (MHz) | Bandwidth | Modulation | Measured Level (dBm) | Substitute Level (dBm) | Ant. Gain(dBi) | C.L | Pol | EIRP | |
|------------|-----------|------------|----------------------|------------------------|----------------|------|-----|-------|-------|
| | | | | | | | | W | dBm |
| 2565.0 | 20 MHz | QPSK | -25.04 | 8.58 | 11.01 | 1.71 | H | 0.061 | 17.88 |
| | | 16-QAM | -26.26 | 7.36 | 11.01 | 1.71 | H | 0.046 | 16.66 |
| 2605.0 | | QPSK | -25.60 | 8.01 | 11.04 | 1.74 | H | 0.054 | 17.31 |
| | | 16-QAM | -26.76 | 6.85 | 11.04 | 1.74 | H | 0.041 | 16.15 |
| 2645.0 | | QPSK | -25.57 | 8.41 | 11.07 | 1.75 | H | 0.059 | 17.73 |
| | | 16-QAM | -26.81 | 7.17 | 11.07 | 1.75 | H | 0.045 | 16.49 |

Equivalent Isotropic Radiated Power Data (20 MHz Band 41 LTE)

Note: All of RB size has been tested for emissions and EIRP, with the 1RB configuration observed as the worst case

NOTES:

Equivalent Isotropic Radiated Power Measurements by Substitution Method

according to ANSI/TIA/EIA-603-D-2010 June 24, 2010:

The EUT was placed on a non-conductive styrofoam resin table 3-meters from the receive antenna. Turntable rotation was adjusted for the highest reading on the receive spectrum analyzer. For LTE signals, RBW = 1-5% of the OBW, not to exceed 1MHz, VBW ≥ 3 x RBW, Detector = RMS. A Horn antenna was substituted in place of the EUT. This Horn antenna was driven by a signal generator and the level of the signal generator was adjusted to obtain the same receive spectrum analyzer reading. The conducted power at the terminals of the Horn antenna is measured. The difference between the gain of the horn and an isotropic antenna is taken into consideration and the EIRP is recorded.

Also, we have done x, y, z planes in EUT and horizontal and vertical polarization in detecting antenna. The worst case of the EUT is y plane in LTE mode. Also worst case of detecting Antenna is horizontal polarization in LTE mode.

7.2 RADIATED SPURIOUS EMISSIONS

7.2.1 RADIATED SPURIOUS EMISSIONS (5 MHz Band 41 LTE)

- ▣ OPERATING FREQUENCY : 2605.00 MHz
- ▣ MEASURED OUTPUT POWER: 17.35 dBm = 0.054 W
- ▣ MODULATION SIGNAL: 5 MHz QPSK
- ▣ DISTANCE: 3 meters
- ▣ LIMIT: $55 + 10 \log_{10}(W) =$ 42.35 dBc

| Ch | Freq (MHz) | Measured Level (dBm) | Ant. Gain (dBi) | Substitute Level (dBm) | C.L | Pol | EIRP (dBm) | dBc |
|---------------------|------------|----------------------|-----------------|------------------------|------|-----|------------|-------|
| 40265.0 (2557.5) | 5,115.0 | -44.94 | 13.57 | -53.00 | 2.43 | H | -41.86 | 59.21 |
| | 7,672.5 | -42.83 | 11.94 | -44.30 | 2.96 | H | -35.32 | 52.67 |
| | 10,230.0 | -43.02 | 11.76 | -37.50 | 3.66 | H | -29.40 | 46.75 |
| 40740.0 (2605.0) | 5,210.0 | -43.37 | 13.72 | -51.75 | 2.45 | H | -40.48 | 57.83 |
| | 7,815.0 | -44.14 | 11.76 | -45.53 | 3.07 | H | -36.84 | 54.19 |
| | 10,420.0 | -48.73 | 11.68 | -43.14 | 3.64 | H | -35.10 | 52.45 |
| 41215.0 (2652.5) | 5,305.0 | -43.65 | 13.87 | -52.11 | 2.47 | V | -40.71 | 58.06 |
| | 7,957.5 | -47.55 | 11.58 | -47.45 | 3.01 | V | -38.88 | 56.23 |
| | 10,610.0 | -42.76 | 11.60 | -37.02 | 3.67 | V | -29.09 | 46.44 |

- NOTES:**
1. Radiated Spurious Emission Measurements at 1 meter and 3 meters by Substitution Method according to ANSI/TIA/EIA-603-D-2010 June 24, 2010:
 2. We are performed all frequency to 10th harmonics from 30 MHz. Measurements above show only up to 3 maximum emissions noted, or would be lesser if no specific emissions from the EUT are recorded (ie: margin > 20 dB from the applicable limit) and considered that's already beyond the background noise floor.
 3. We have done x, y, z planes in EUT and horizontal and vertical polarization in detecting antenna.
 4. All of RB size has been tested for emissions and EIRP, with the 1RB configuration observed as the worst case
 5. We are performed 16QAM and QPSK modulations. The worst case data are reported in the table above.

7.2.2 RADIATED SPURIOUS EMISSIONS (10 MHz Band 41 LTE)

- ▣ OPERATING FREQUENCY : 2605.00 MHz
- ▣ MEASURED OUTPUT POWER: 17.52 dBm = 0.057 W
- ▣ MODULATION SIGNAL: 10 MHz QPSK
- ▣ DISTANCE: 3 meters
- ▣ LIMIT: $55 + 10 \log_{10}(W) =$ 42.52 dBc

| Ch | Freq (MHz) | Measured Level (dBm) | Ant. Gain (dBi) | Substitute Level (dBm) | C.L | Pol | EIRP (dBm) | dBc |
|---------------------|------------|----------------------|-----------------|------------------------|------|-----|------------|-------|
| 40290.0 (2560.0) | 5,120.0 | -44.24 | 13.58 | -52.20 | 2.43 | H | -41.05 | 58.57 |
| | 7,680.0 | -42.13 | 11.93 | -43.69 | 2.97 | H | -34.73 | 52.25 |
| | 10,240.0 | -42.86 | 11.76 | -37.56 | 3.49 | H | -29.29 | 46.81 |
| 40740.0 (2605.0) | 5,210.0 | -43.72 | 13.72 | -52.10 | 2.45 | H | -40.83 | 58.35 |
| | 7,815.0 | -39.99 | 11.76 | -41.38 | 3.07 | H | -32.69 | 50.21 |
| | 10,420.0 | -49.30 | 11.68 | -43.71 | 3.64 | H | -35.67 | 53.19 |
| 41190.0 (2650.0) | 5,300.0 | -43.30 | 13.86 | -51.75 | 2.47 | H | -40.36 | 57.88 |
| | 7,950.0 | -47.47 | 11.59 | -47.34 | 3.02 | H | -38.77 | 56.29 |
| | 10,600.0 | -43.59 | 11.61 | -37.66 | 3.77 | H | -29.82 | 47.34 |

- NOTES:**
1. Radiated Spurious Emission Measurements at 1 meter and 3 meters by Substitution Method according to ANSI/TIA/EIA-603-D-2010 June 24, 2010:
 2. We are performed all frequency to 10th harmonics from 30 MHz. Measurements above show only up to 3 maximum emissions noted, or would be lesser if no specific emissions from the EUT are recorded (ie: margin > 20 dB from the applicable limit) and considered that's already beyond the background noise floor.
 3. We have done x, y, z planes in EUT and horizontal and vertical polarization in detecting antenna.
 4. All of RB size has been tested for emissions and EIRP, with the 1RB configuration observed as the worst case
 5. We are performed 16QAM and QPSK modulations. The worst case data are reported in the table above.

7.2.3 RADIATED SPURIOUS EMISSIONS (15 MHz Band 41 LTE)

- ▣ OPERATING FREQUENCY : 2647.50 MHz
- ▣ MEASURED OUTPUT POWER: 17.55 dBm = 0.057 W
- ▣ MODULATION SIGNAL: 15 MHz QPSK
- ▣ DISTANCE: 3 meters
- ▣ LIMIT: $55 + 10 \log_{10}(W) =$ 42.55 dBc

| Ch | Freq (MHz) | Measured Level (dBm) | Ant. Gain (dBi) | Substitute Level (dBm) | C.L | Pol | EIRP (dBm) | dBc |
|---------------------|------------|----------------------|-----------------|------------------------|------|-----|------------|-------|
| 40315.0 (2562.5) | 5,125.0 | -43.71 | 13.59 | -51.52 | 2.44 | H | -40.37 | 57.92 |
| | 7,687.5 | -42.61 | 11.92 | -44.29 | 3.00 | H | -35.37 | 52.92 |
| | 10,250.0 | -42.07 | 11.75 | -36.36 | 3.53 | H | -28.14 | 45.69 |
| 40620.0 (2593.0) | 5,186.0 | -48.12 | 13.68 | -56.68 | 2.46 | H | -45.46 | 63.01 |
| | 7,779.0 | -47.22 | 11.80 | -48.07 | 3.05 | H | -39.32 | 56.87 |
| | 10,372.0 | -47.14 | 11.70 | -41.51 | 3.62 | H | -33.43 | 50.98 |
| 41165.0 (2647.5) | 5,295.0 | -43.61 | 13.85 | -52.21 | 2.48 | H | -40.84 | 58.39 |
| | 7,942.5 | -47.14 | 11.60 | -47.09 | 3.02 | H | -38.51 | 56.06 |
| | 10,590.0 | -44.88 | 11.61 | -38.53 | 3.71 | H | -30.63 | 48.18 |

- NOTES:**
1. Radiated Spurious Emission Measurements at 1 meter and 3 meters by Substitution Method according to ANSI/TIA/EIA-603-D-2010 June 24, 2010:
 2. We are performed all frequency to 10th harmonics from 30 MHz. Measurements above show only up to 3 maximum emissions noted, or would be lesser if no specific emissions from the EUT are recorded (ie: margin > 20 dB from the applicable limit) and considered that's already beyond the background noise floor.
 3. We have done x, y, z planes in EUT and horizontal and vertical polarization in detecting antenna.
 4. All of RB size has been tested for emissions and EIRP, with the 1RB configuration observed as the worst case
 5. We are performed 16QAM and QPSK modulations. The worst case data are reported in the table above.

7.2.4 RADIATED SPURIOUS EMISSIONS (20 MHz Band 41 LTE)

- ▣ OPERATING FREQUENCY : 2565.00 MHz
- ▣ MEASURED OUTPUT POWER: 17.88 dBm = 0.061 W
- ▣ MODULATION SIGNAL: 20 MHz QPSK
- ▣ DISTANCE: 3 meters
- ▣ LIMIT: $55 + 10 \log_{10}(W) =$ 42.88 dBc

| Ch | Freq (MHz) | Measured Level (dBm) | Ant. Gain (dBi) | Substitute Level (dBm) | C.L | Pol | EIRP (dBm) | dBc |
|---------------------|------------|----------------------|-----------------|------------------------|------|-----|------------|-------|
| 40340.0 (2565.0) | 5,130.0 | -44.16 | 13.60 | -51.83 | 2.44 | H | -40.67 | 58.55 |
| | 7,695.0 | -42.64 | 11.92 | -44.29 | 3.02 | H | -35.39 | 53.27 |
| | 10,260.0 | -42.42 | 11.75 | -36.84 | 3.48 | H | -28.57 | 46.45 |
| 40740.0 (2605.0) | 5,210.0 | -44.69 | 13.72 | -53.07 | 2.45 | H | -41.80 | 59.68 |
| | 7,815.0 | -44.26 | 11.76 | -45.65 | 3.07 | H | -36.96 | 54.84 |
| | 10,420.0 | -49.43 | 11.68 | -43.84 | 3.64 | H | -35.80 | 53.68 |
| 41140.0 (2645.0) | 5,290.0 | -43.69 | 13.84 | -52.45 | 2.48 | H | -41.09 | 58.97 |
| | 7,935.0 | -46.57 | 11.61 | -46.59 | 3.02 | H | -38.00 | 55.88 |
| | 10,580.0 | -45.09 | 11.61 | -38.50 | 3.81 | H | -30.70 | 48.58 |

- NOTES:**
1. Radiated Spurious Emission Measurements at 1 meter and 3 meters by Substitution Method according to ANSI/TIA/EIA-603-D-2010 June 24, 2010:
 2. We are performed all frequency to 10th harmonics from 30 MHz. Measurements above show only up to 3 maximum emissions noted, or would be lesser if no specific emissions from the EUT are recorded (ie: margin > 20 dB from the applicable limit) and considered that's already beyond the background noise floor.
 3. We have done x, y, z planes in EUT and horizontal and vertical polarization in detecting antenna.
 4. All of RB size has been tested for emissions and EIRP, with the 1RB configuration observed as the worst case
 5. We are performed 16QAM and QPSK modulations. The worst case data are reported in the table above.

7.3 OCCUPIED BANDWIDTH

| Band | Band Width | Frequency (MHz) | Modulation | Resource Block Size | Resource Block Offset | Data (dB) |
|---------|------------|-----------------|------------|---------------------|-----------------------|-------------|
| Band 41 | 5 MHz | 2605.0 | QPSK | 25 | 0 | 4.5070 |
| | | | 16-QAM | 25 | 0 | 4.4992 |
| | 10 MHz | 2605.0 | QPSK | 50 | 0 | 9.0053 |
| | | | 16-QAM | 50 | 0 | 8.9770 |
| | 15 MHz | 2593.0 | QPSK | 75 | 0 | 13.431 |
| | | | 16-QAM | 75 | 0 | 13.498 |
| | 20 MHz | 2605.0 | QPSK | 100 | 0 | 17.955 |
| | | | 16-QAM | 100 | 0 | 17.927 |

- Plots of the EUT's Occupied Bandwidth are shown Page 28 ~31.

7.4 CONDUCTED SPURIOUS EMISSIONS

■FACTORS FOR FREQUENCY

| Frequency Range (GHz) | Factor [dB] |
|-----------------------|-------------|
| 0.03 – 1 | 27.145 |
| 1 – 5 | 26.960 |
| 5 – 10 | 27.542 |
| 10 – 15 | 28.439 |
| 15 – 20 | 29.144 |
| Above 20 | 30.148 |

NOTES:

Factor(dB) = Cable Loss + Attenuator +Power Splitter

| Band | Band Width (MHz) | Frequency (MHz) | Frequency of Maximum Harmonic (GHz) | Factor (dB) | Measurement Maximum Data (dBm) | Result (dBm) |
|---------|------------------|-----------------|-------------------------------------|-------------|--------------------------------|--------------|
| Band 41 | 5 | 2557.5 | 26.31808 | 30.148 | -59.788 | -29.640 |
| | | 2605.0 | 25.79172 | 30.148 | -59.761 | -29.613 |
| | | 2652.5 | 26.11265 | 30.148 | -59.944 | -29.796 |
| | 10 | 2560.0 | 25.87298 | 30.148 | -60.039 | -29.891 |
| | | 2605.0 | 25.33507 | 30.148 | -59.854 | -29.706 |
| | | 2650.0 | 26.44307 | 30.148 | -59.070 | -28.922 |
| | 15 | 2562.5 | 26.12874 | 30.148 | -59.943 | -29.795 |
| | | 2593.0 | 26.35310 | 30.148 | -59.724 | -29.576 |
| | | 2647.5 | 26.25208 | 30.148 | -59.559 | -29.411 |
| | 20 | 2565.0 | 25.78058 | 30.148 | -59.761 | -29.613 |
| | | 2605.0 | 26.17824 | 30.148 | -59.472 | -29.324 |
| | | 2645.0 | 25.73191 | 30.148 | -60.006 | -29.858 |

NOTES:

1. Conducted Spurious Emissions was Tested QPSK Modulation, Resource Block Size 1 and Resource Block Offset 0
2. Result (dBm) = Measurement Maximum Data (dBm) + Factor (dB)

- Plots of the EUT's Conducted Spurious Emissions are shown Page 38 ~ 49.

7.4.1 BAND EDGE

| Band | Band Width (MHz) | Frequency (MHz) | Modulation | Resource Block Size | Resource Block Offset | Channel Edge Data [dBm] | | | | | |
|---------|------------------|-----------------|------------|---------------------|-----------------------|-------------------------------|--------|---|--------|--|--------|
| | | | | | | Channel Edge (Limit: -10 dBm) | | 5MHz ~ X MHz from the Channel Edge (Limit: -13 dBm) | | X MHz ~ from the Channel Edge (Limit: -25 dBm) | |
| | | | | | | Lower | Upper | Lower | Upper | Lower | Upper |
| Band 41 | 5 | 2557.5 | QPSK | 25 | 0 | -20.53 | -19.57 | -37.89 | -37.60 | -39.11 | -38.55 |
| | | 2605.0 | | 25 | 0 | -21.95 | -23.49 | -37.17 | -36.95 | -39.78 | -39.86 |
| | | 2652.5 | | 25 | 0 | -20.01 | -21.50 | -37.50 | -37.91 | -36.87 | -38.77 |
| | 10 | 2560.0 | | 50 | 0 | -22.13 | -20.91 | -34.32 | -34.79 | -44.64 | -42.43 |
| | | 2605.0 | | 50 | 0 | -22.38 | -21.81 | -32.00 | -34.64 | -42.12 | -40.65 |
| | | 2650.0 | | 50 | 0 | -21.54 | -22.61 | -26.50 | -30.31 | -39.08 | -38.48 |
| | 15 | 2562.5 | | 75 | 0 | -26.15 | -24.09 | -33.14 | -33.58 | -46.07 | -41.94 |
| | | 2593.0 | | 75 | 0 | -22.32 | -24.97 | -30.12 | -32.87 | -41.79 | -40.10 |
| | | 2647.5 | | 75 | 0 | -21.27 | -26.40 | -26.08 | -28.67 | -38.59 | -39.50 |
| | 20 | 2565.0 | | 100 | 0 | -25.52 | -22.98 | -33.58 | -33.17 | -49.90 | -42.05 |
| | | 2605.0 | | 100 | 0 | -24.52 | -23.29 | -31.46 | -32.92 | -42.66 | -41.83 |
| | | 2645.0 | | 100 | 0 | -23.07 | -27.15 | -27.67 | -29.62 | -37.84 | -41.53 |

- Plots of the EUT's Band Edge are shown Page 32 ~ 37.

7.5 FREQUENCY STABILITY / VARIATION OF AMBIENT TEMPERATURE

7.5.1 FREQUENCY STABILITY (5 MHz Band 41 LTE)

- ▣ OPERATING FREQUENCY: 2605.000,000 Hz
- ▣ CHANNEL: 40740 (5 MHz)
- ▣ REFERENCE VOLTAGE: 3.85 VDC
- ▣ DEVIATION LIMIT: Emission must remain in band

| Voltage (%) | Power (VDC) | Temp. (°C) | Frequency (Hz) | Frequency Error (Hz) | Deviation (%) | ppm |
|----------------|-------------|------------|----------------|----------------------|---------------|--------|
| 100% | 3.85 | +20(Ref) | 2605 000 005 | 0.0 | 0.000 000 | 0.0000 |
| 100% | | -30 | 2605 000 017 | 11.6 | 0.000 000 | 0.0045 |
| 100% | | -20 | 2605 000 020 | 14.5 | 0.000 001 | 0.0056 |
| 100% | | -10 | 2605 000 014 | 8.9 | 0.000 000 | 0.0034 |
| 100% | | 0 | 2605 000 015 | 10.0 | 0.000 000 | 0.0038 |
| 100% | | +10 | 2605 000 015 | 9.8 | 0.000 000 | 0.0038 |
| 100% | | +30 | 2605 000 014 | 9.0 | 0.000 000 | 0.0035 |
| 100% | | +40 | 2605 000 013 | 8.1 | 0.000 000 | 0.0031 |
| 100% | | +50 | 2605 000 010 | 5.4 | 0.000 000 | 0.0021 |
| Batt. Endpoint | 3.60 | +20 | 2605 000 018 | 12.9 | 0.000 000 | 0.0050 |

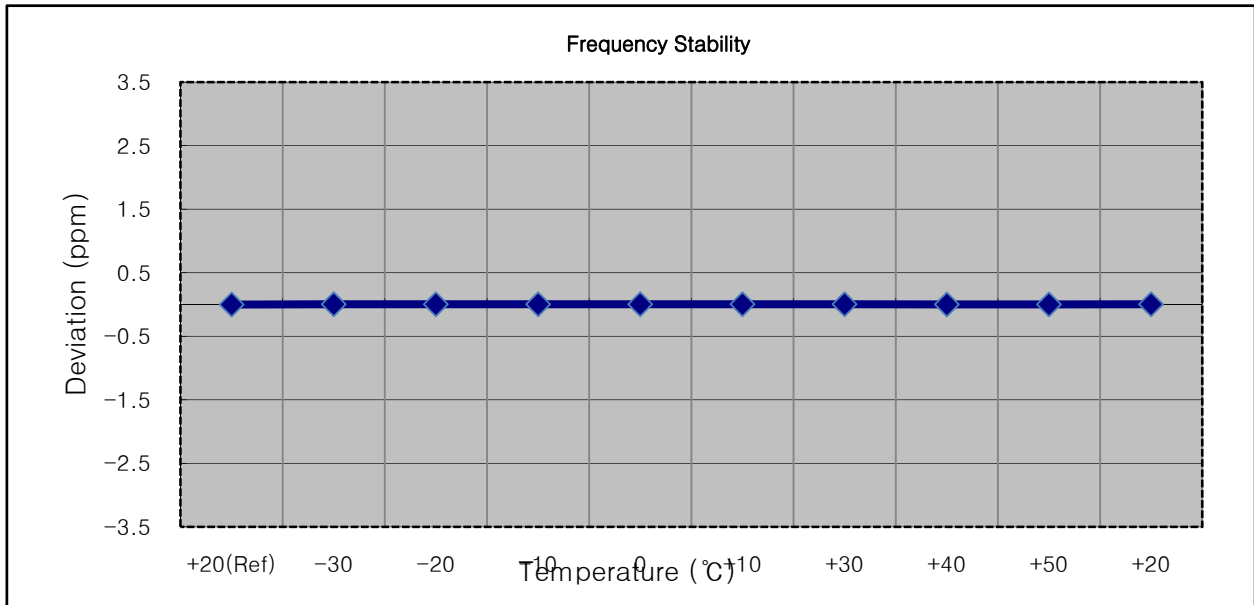

7.5.2 FREQUENCY STABILITY (10 MHz Band 41 LTE)

- ▣ OPERATING FREQUENCY: 2605.000,000 Hz
- ▣ CHANNEL: 40740 (10 MHz)
- ▣ REFERENCE VOLTAGE: 3.85 VDC
- ▣ DEVIATION LIMIT: Emission must remain in band

| Voltage (%) | Power (VDC) | Temp. (°C) | Frequency (Hz) | Frequency Error (Hz) | Deviation (%) | ppm |
|----------------|-------------|------------|----------------|----------------------|---------------|---------|
| 100% | 3.85 | +20(Ref) | 2604 999 991 | 0.0 | 0.000 000 | 0.0000 |
| 100% | | -30 | 2604 999 987 | -4.9 | 0.000 000 | -0.0019 |
| 100% | | -20 | 2604 999 999 | 7.2 | 0.000 000 | 0.0028 |
| 100% | | -10 | 2604 999 997 | 5.6 | 0.000 000 | 0.0021 |
| 100% | | 0 | 2604 999 997 | 5.4 | 0.000 000 | 0.0021 |
| 100% | | +10 | 2604 999 997 | 5.4 | 0.000 000 | 0.0021 |
| 100% | | +30 | 2604 999 998 | 6.1 | 0.000 000 | 0.0023 |
| 100% | | +40 | 2604 999 986 | -5.9 | 0.000 000 | -0.0023 |
| 100% | | +50 | 2604 999 997 | 5.4 | 0.000 000 | 0.0021 |
| Batt. Endpoint | 3.60 | +20 | 2604 999 998 | 6.3 | 0.000 000 | 0.0024 |

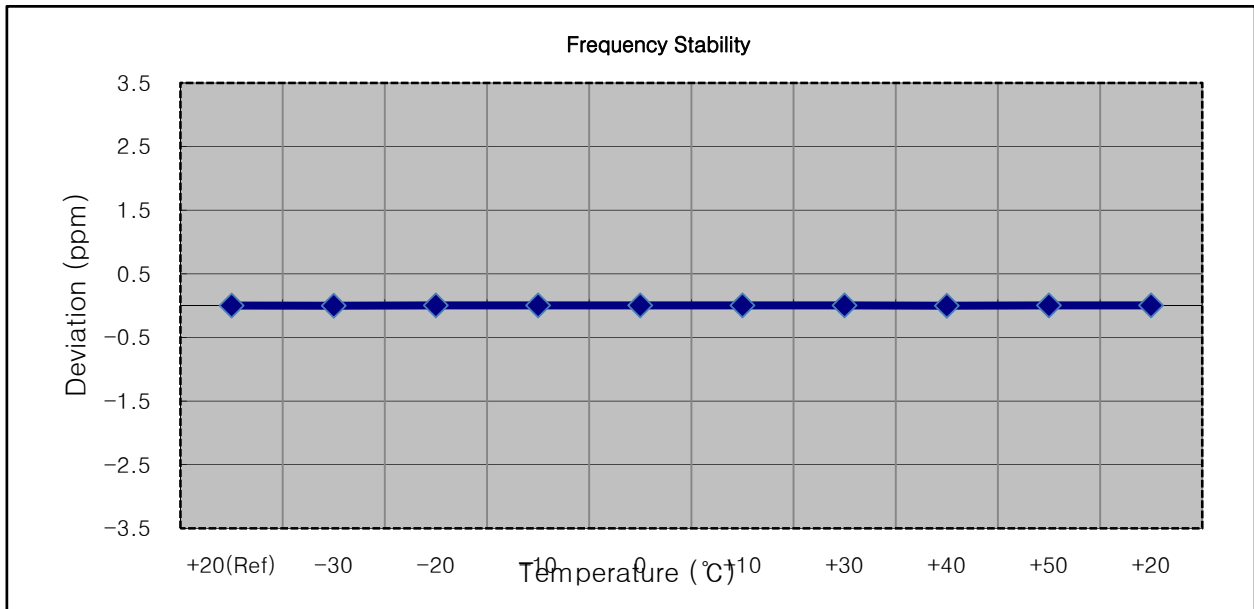

7.5.3 FREQUENCY STABILITY (15 MHz Band 41 LTE)

- ▣ OPERATING FREQUENCY: 2593.000,000 Hz
- ▣ CHANNEL: 40620 (15 MHz)
- ▣ REFERENCE VOLTAGE: 3.85 VDC
- ▣ DEVIATION LIMIT: Emission must remain in band

| Voltage (%) | Power (VDC) | Temp. (°C) | Frequency (Hz) | Frequency Error (Hz) | Deviation (%) | ppm |
|----------------|-------------|------------|----------------|----------------------|---------------|--------|
| 100% | 3.85 | +20(Ref) | 2593 000 005 | 0.0 | 0.000 000 | 0.000 |
| 100% | | -30 | 2593 000 011 | 6.2 | 0.000 000 | 0.002 |
| 100% | | -20 | 2592 999 999 | -5.1 | 0.000 000 | -0.002 |
| 100% | | -10 | 2593 000 001 | -3.2 | 0.000 000 | -0.001 |
| 100% | | 0 | 2593 000 012 | 7.8 | 0.000 000 | 0.003 |
| 100% | | +10 | 2592 999 998 | -6.8 | 0.000 000 | -0.003 |
| 100% | | +30 | 2592 999 998 | -6.5 | 0.000 000 | -0.003 |
| 100% | | +40 | 2593 000 015 | 10.2 | 0.000 000 | 0.004 |
| 100% | | +50 | 2593 000 013 | 8.5 | 0.000 000 | 0.003 |
| Batt. Endpoint | 3.60 | +20 | 2593 000 010 | 5.4 | 0.000 000 | 0.002 |

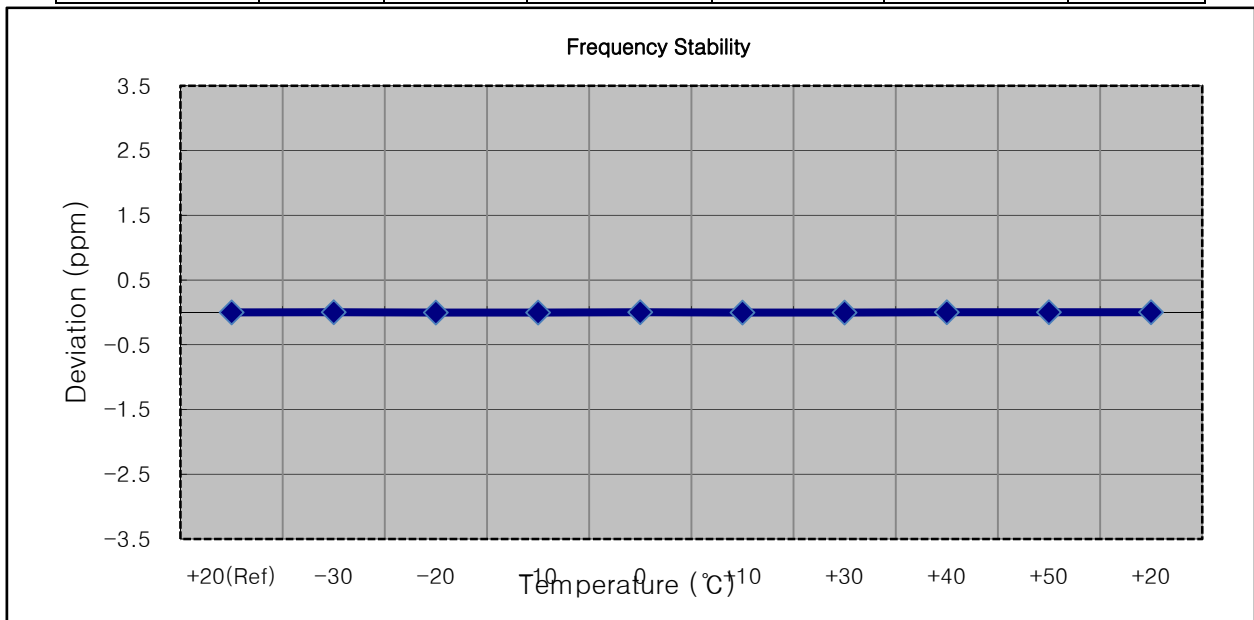

7.5.4 FREQUENCY STABILITY (20 MHz Band 41 LTE)

- ▣ OPERATING FREQUENCY: 2605.000,000 Hz
- ▣ CHANNEL: 40740 (20 MHz)
- ▣ REFERENCE VOLTAGE: 3.85 VDC
- ▣ DEVIATION LIMIT: Emission must remain in band

| Voltage (%) | Power (VDC) | Temp. (°C) | Frequency (Hz) | Frequency Error (Hz) | Deviation (%) | ppm |
|----------------|-------------|------------|----------------|----------------------|---------------|-----------|
| 100% | 3.85 | +20(Ref) | 2605 000 005 | 0.0 | 0.000 000 | 0.000 |
| 100% | | -30 | 2605 000 011 | 6.2 | 0.000 000 | 0.002 |
| 100% | | -20 | 2605 000 011 | 6.7 | 0.000 000 | 0.003 |
| 100% | | -10 | 2605 000 012 | 7.6 | 0.000 000 | 0.003 |
| 100% | | 0 | 2605 000 011 | 6.7 | 0.000 000 | 0.003 |
| 100% | | +10 | 2604 999 998 | -6.9 | 0.000 000 | -0.003 |
| 100% | | +30 | 2605 000 015 | 10.1 | 0.000 000 | 0.004 |
| 100% | | +40 | 2605 000 001 | -4.1 | 0.000 000 | -0.002 |
| 100% | | +50 | 2605 000 009 | 4.2 | 0.000 000 | 0.002 |
| Batt. Endpoint | | 3.60 | +20 | 2605 000 013 | 8.2 | 0.000 000 |

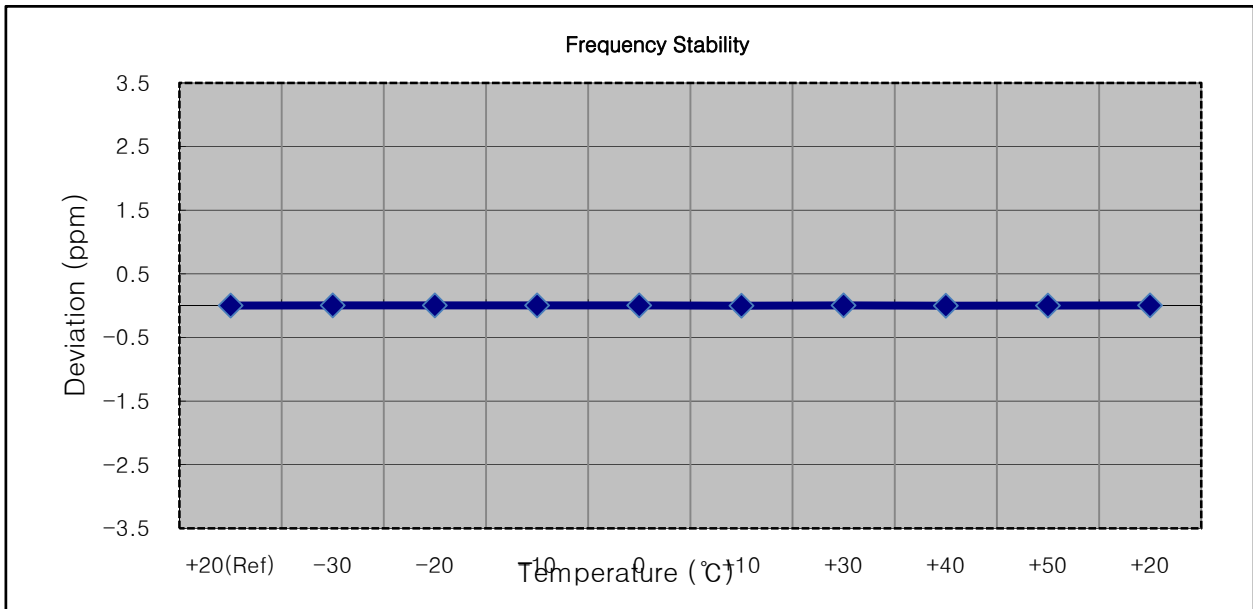

8. TEST PLOTS

BAND 41. Occupied Bandwidth Plot (5 MHz Ch.40740 QPSK RB 25)

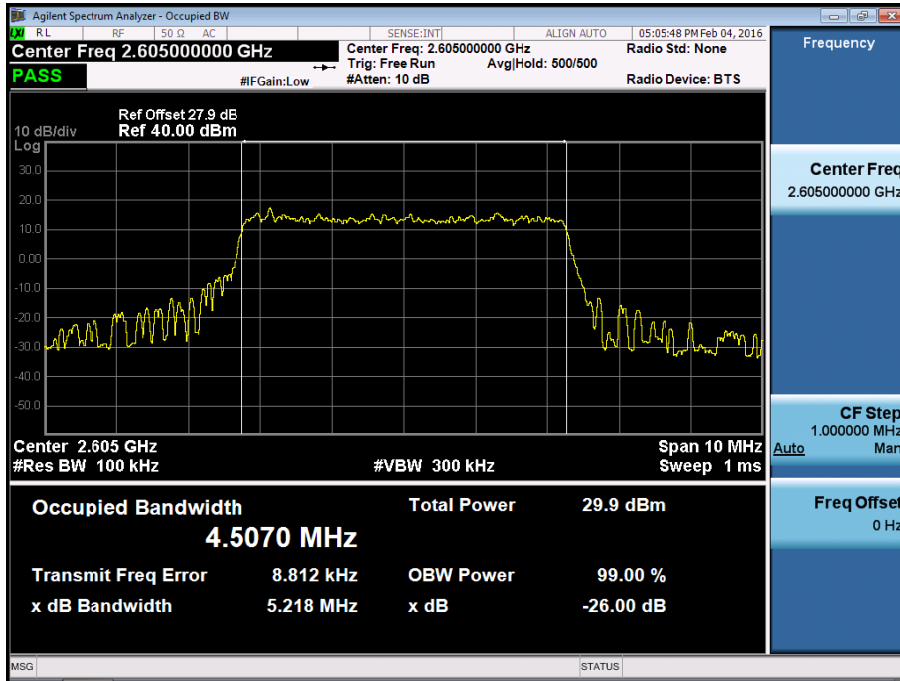

BAND 41. Occupied Bandwidth Plot (5 MHz Ch.40740 16-QAM RB 25)

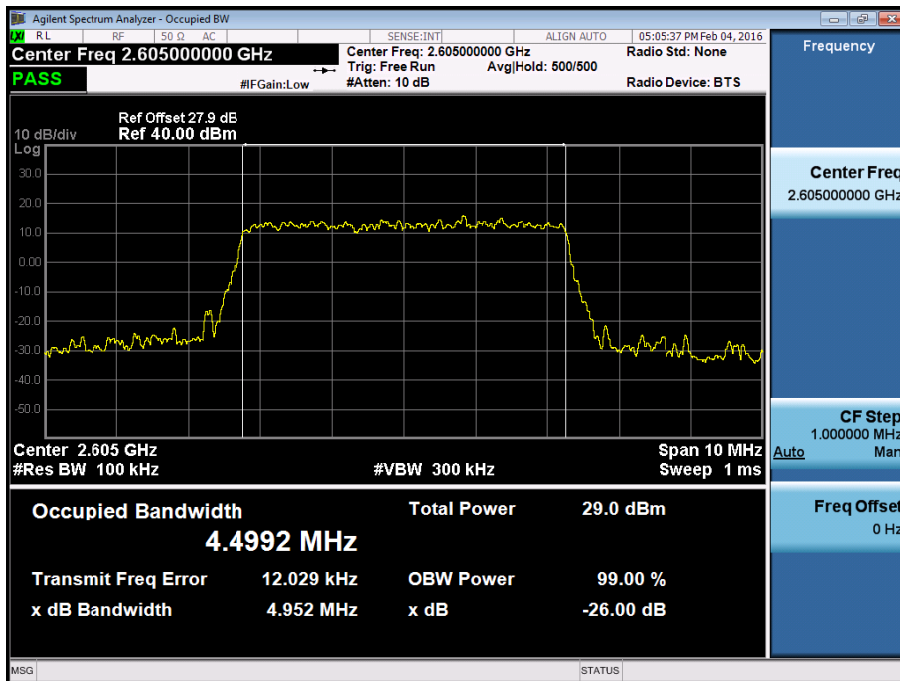

BAND 41. Occupied Bandwidth Plot (10 MHz Ch.40740 QPSK RB 50)

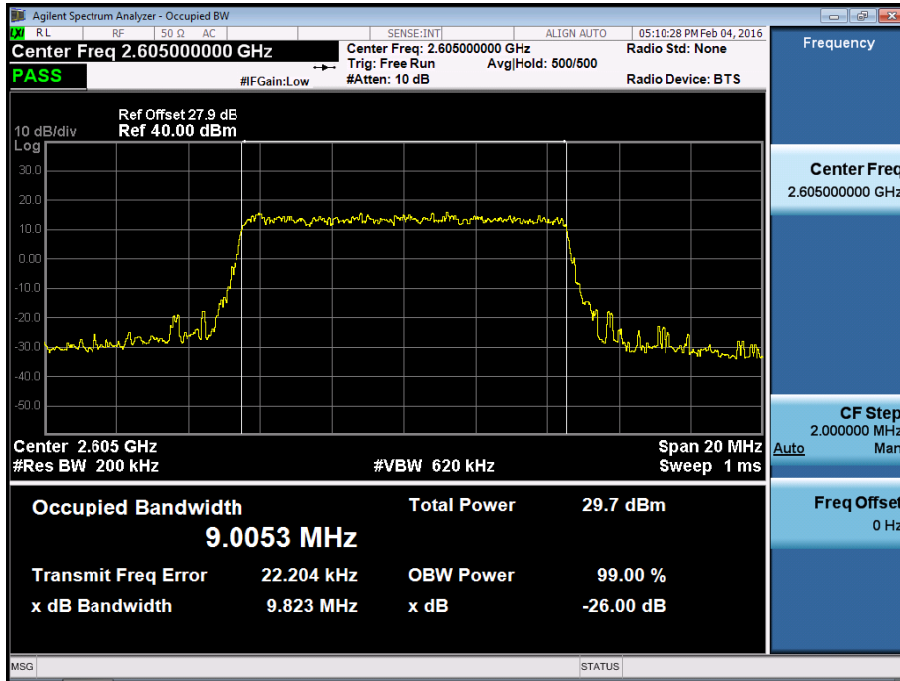

BAND 41. Occupied Bandwidth Plot (10 MHz Ch.40740 16-QAM RB 50)

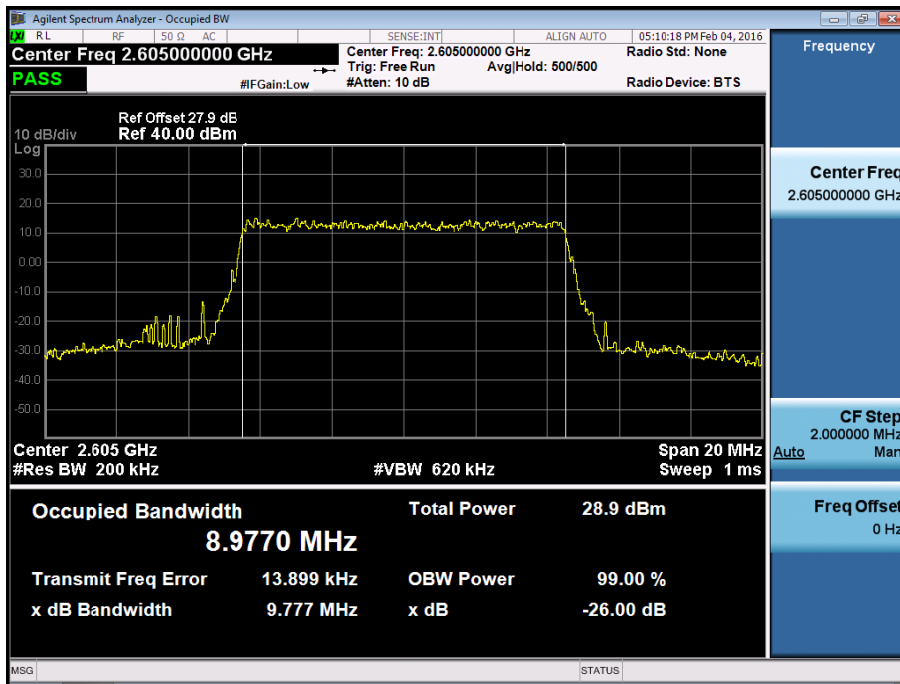

BAND 41. Occupied Bandwidth Plot (15 MHz Ch.40620 QPSK RB 75)

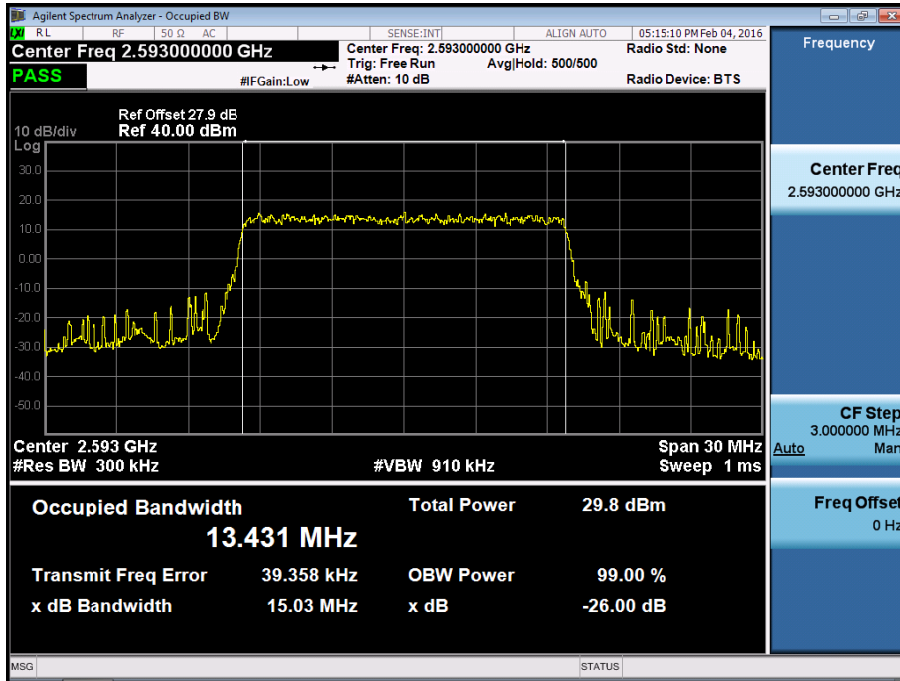

BAND 41. Occupied Bandwidth Plot (15 MHz Ch.40620 16-QAM RB 75)

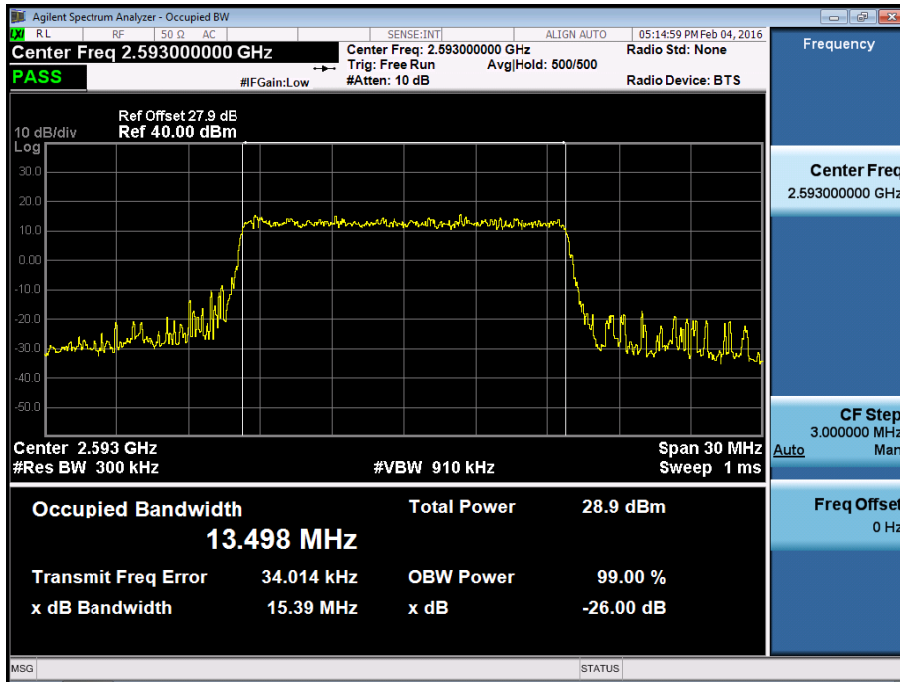

BAND 41. Occupied Bandwidth Plot (20 MHz Ch.40740 QPSK RB 100)

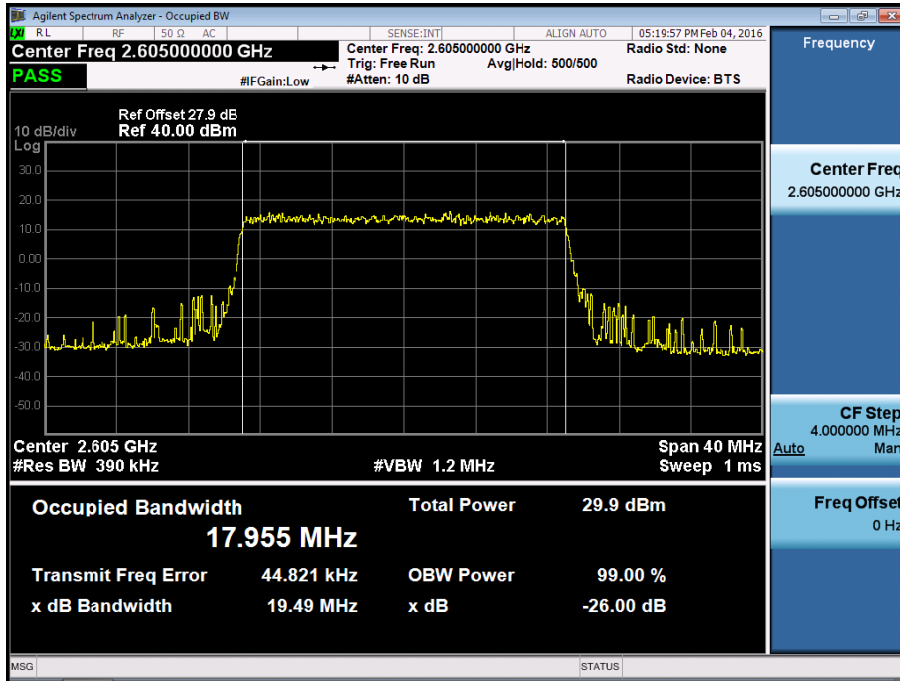

BAND 41. Occupied Bandwidth Plot (20 MHz Ch.40740 16-QAM RB 100)

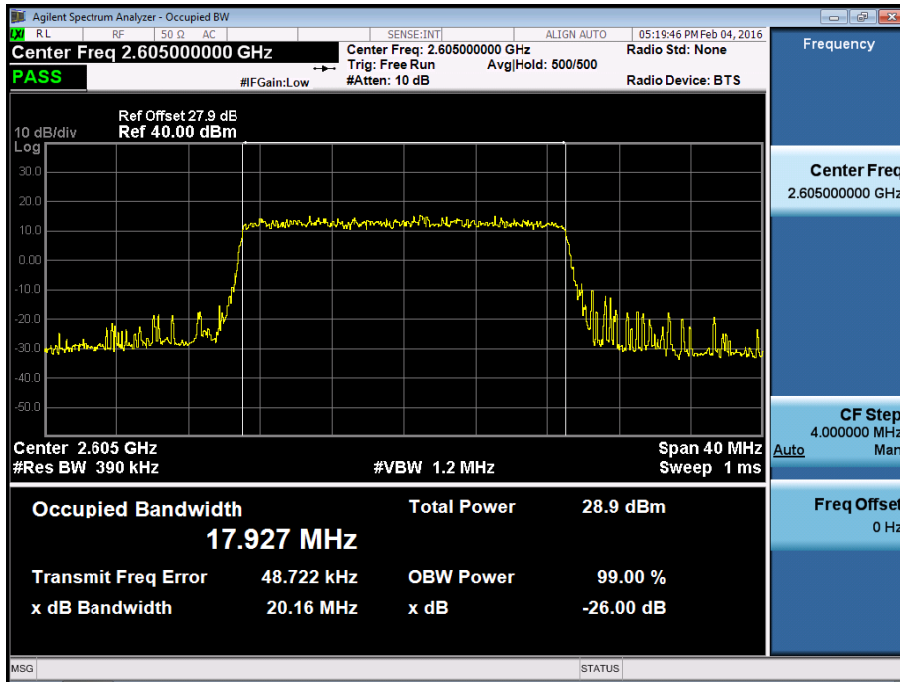

BAND 41. Low Channel Edge Plot (5 MHz Ch.40265 QPSK RB 25)

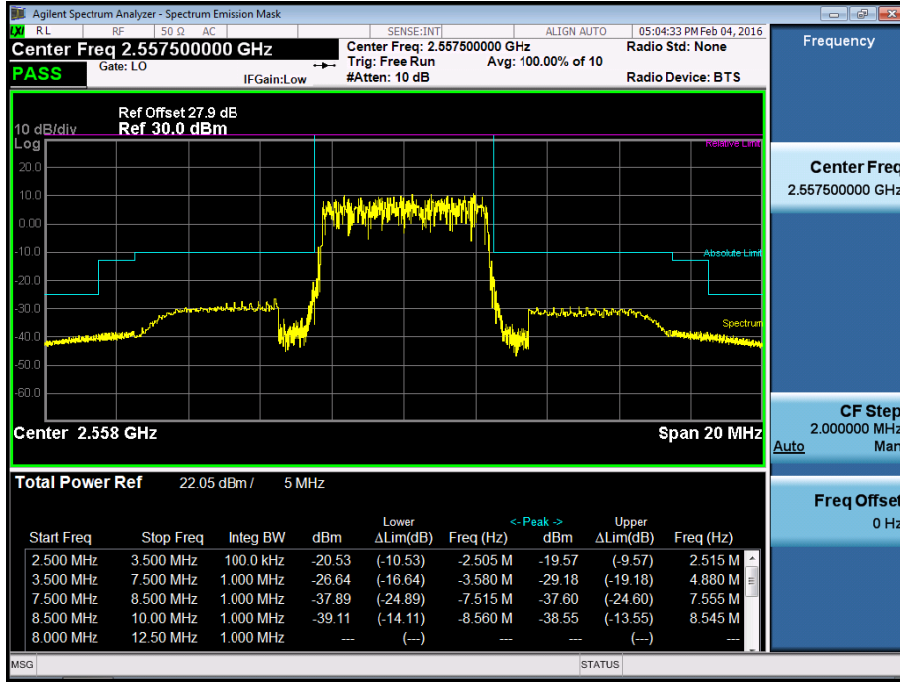

BAND 41. Mid Channel Edge Plot (5 MHz Ch.40740 QPSK RB 25)

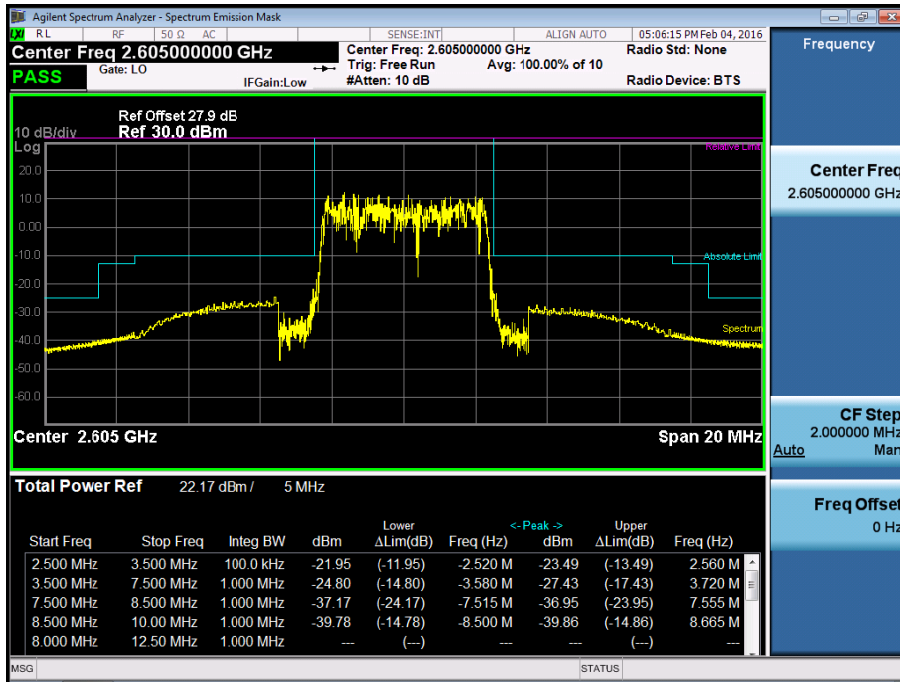

BAND 41. High Channel Edge Plot (5 MHz Ch.41215 QPSK RB 25)

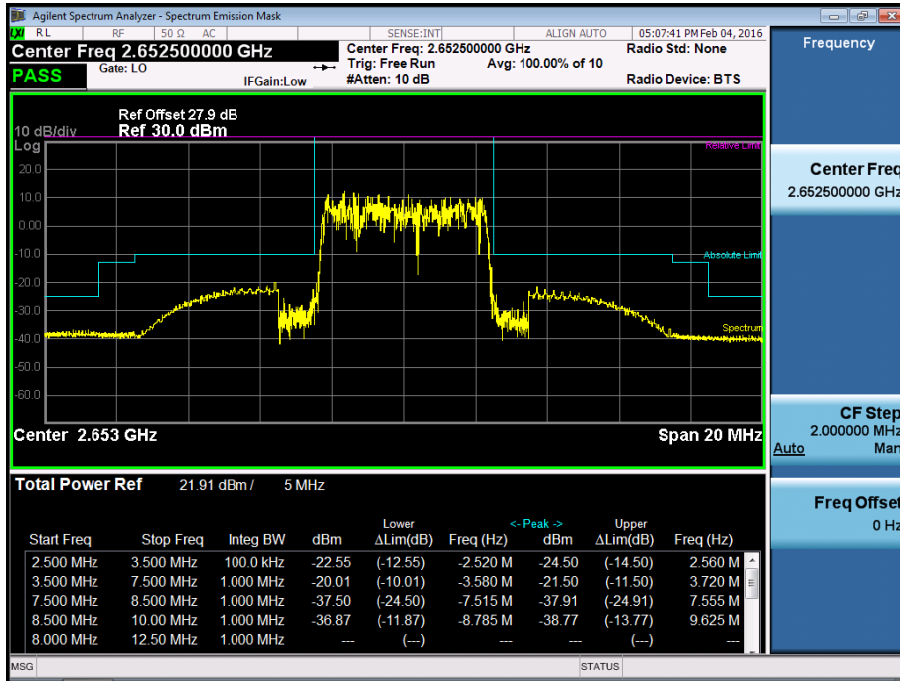

BAND 41. Low Channel Edge Plot (10 MHz Ch.40290 QPSK RB 50)

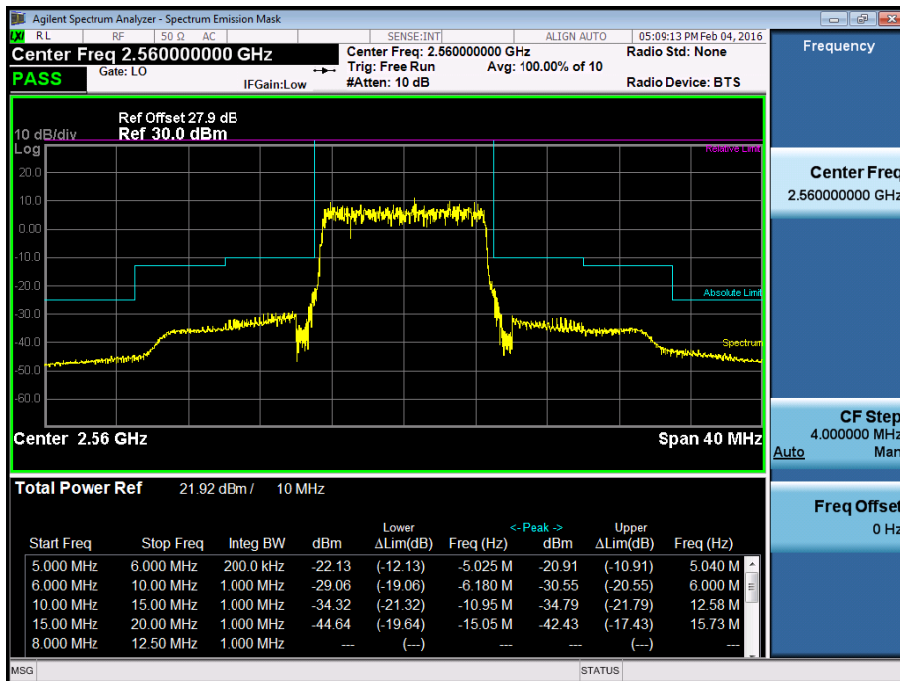

BAND 41. Mid Channel Edge Plot (10 MHz Ch.40740 QPSK RB 50)

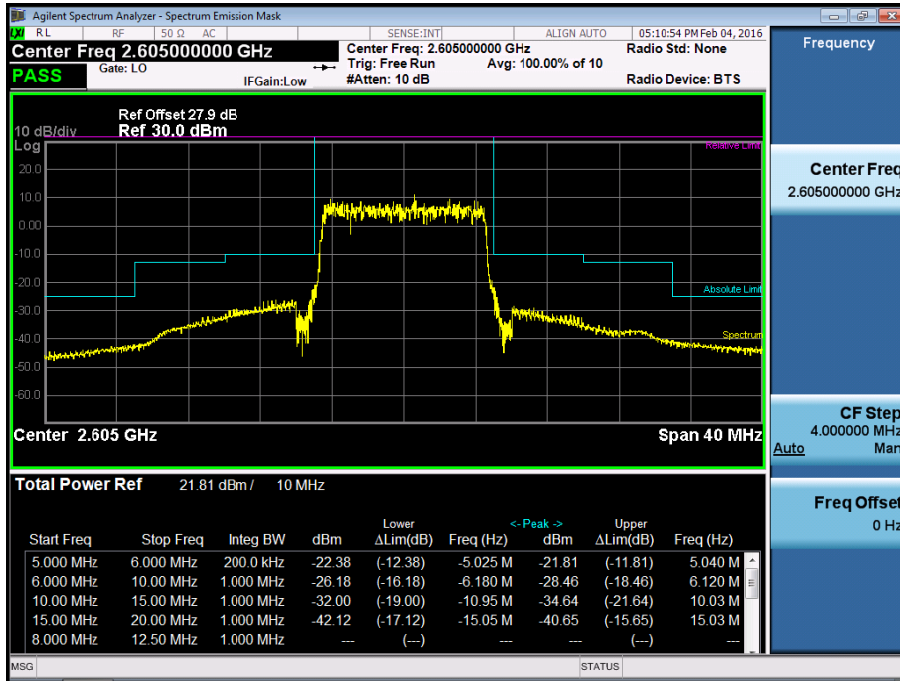

BAND 41. High Channel Edge Plot (10 MHz Ch.41190 QPSK RB 50)

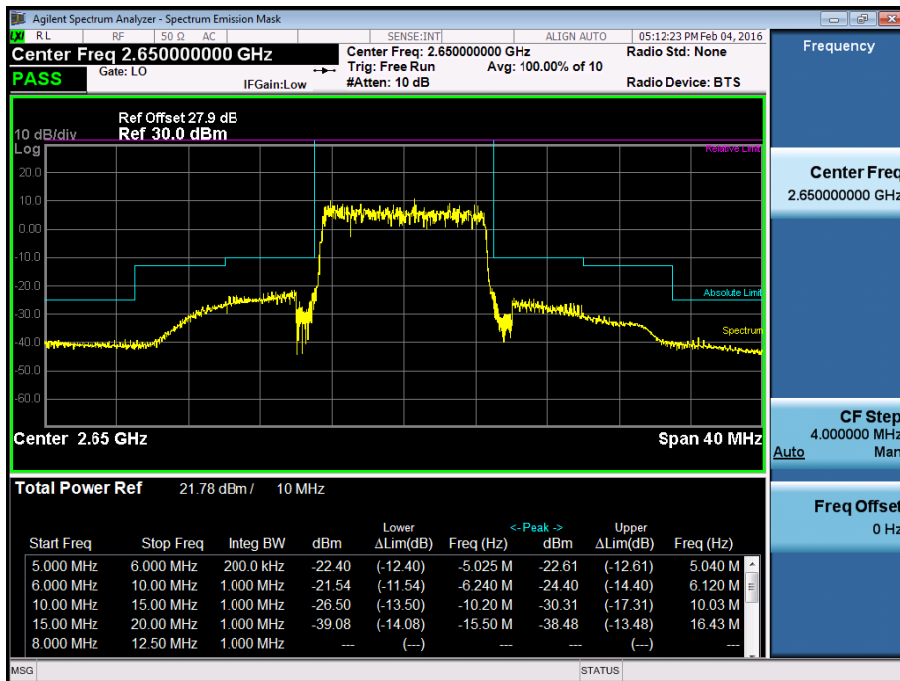

BAND 41. Low Channel Edge Plot (15 MHz Ch.40315 QPSK RB 75)

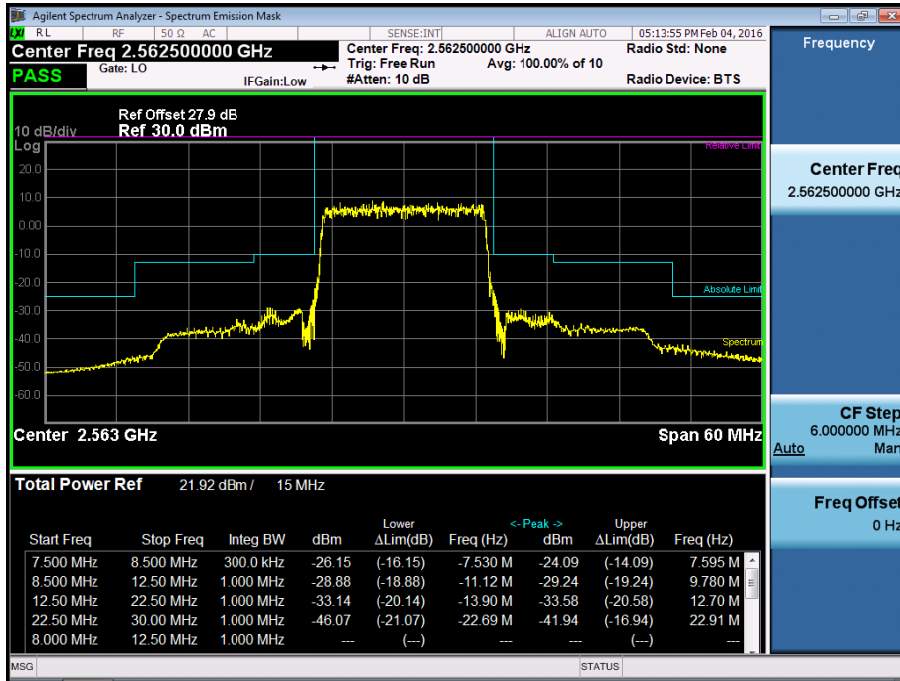

BAND 41. Mid Channel Edge Plot (15 MHz Ch.40620 QPSK RB 75)

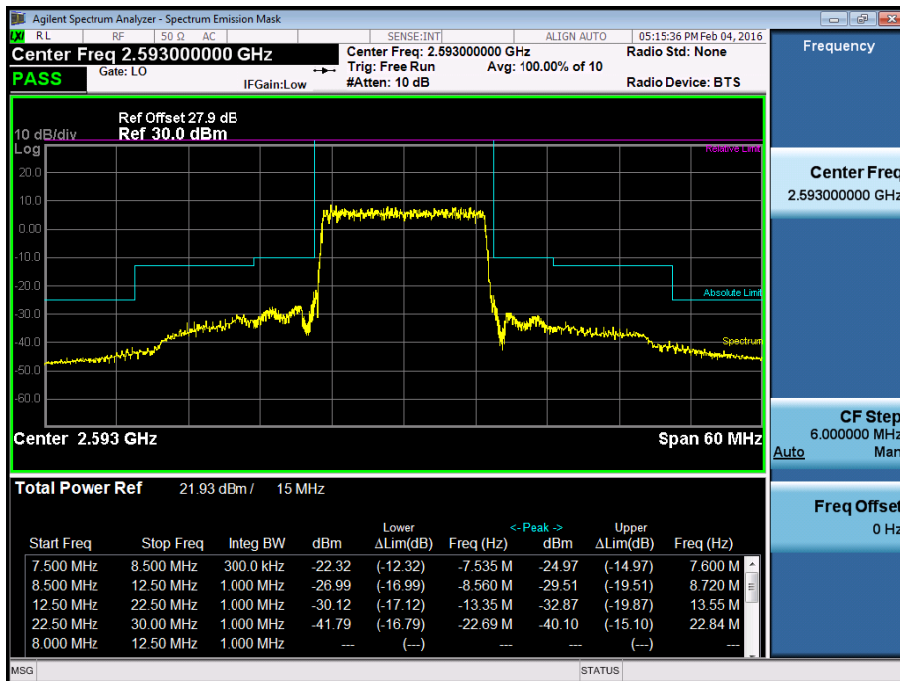

BAND 41. High Channel Edge Plot (15 MHz Ch.41165 QPSK RB 75)

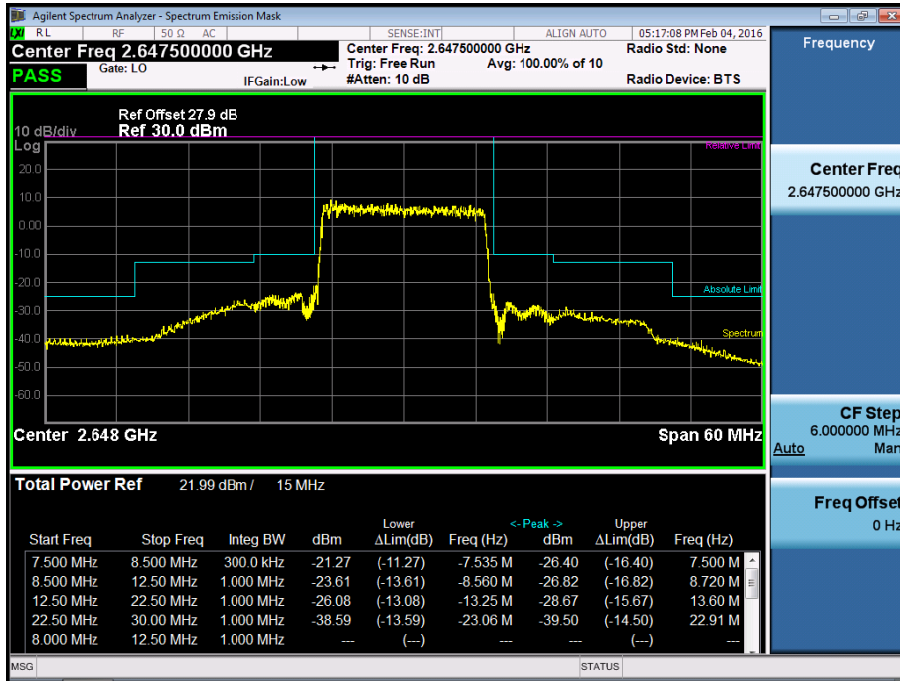

BAND 41. Low Channel Edge Plot (20 MHz Ch.40340 QPSK RB 100)

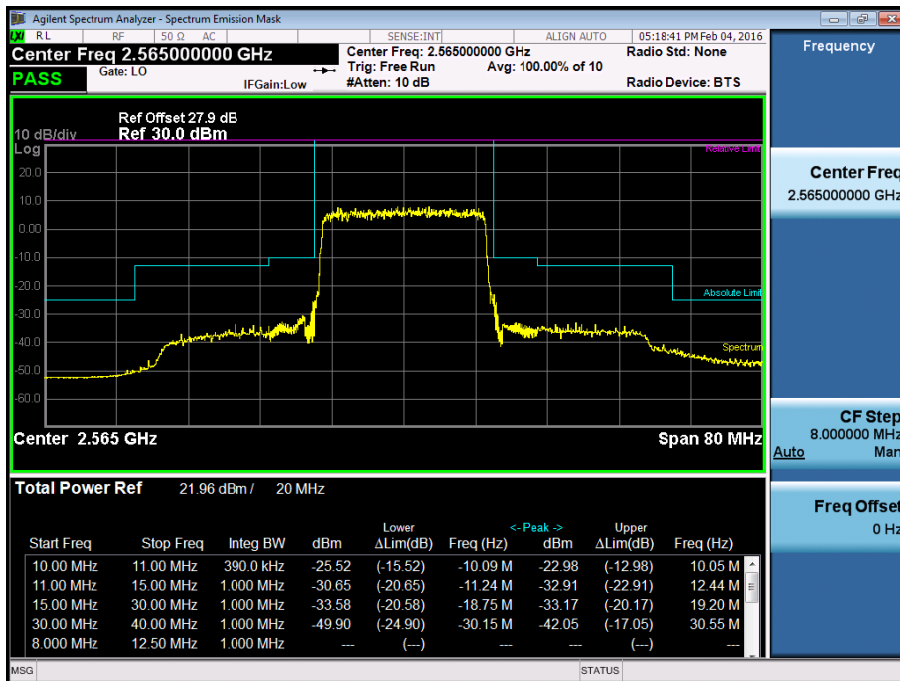

BAND 41. Mid Channel Edge Plot (20 MHz Ch.40740 QPSK RB 100)

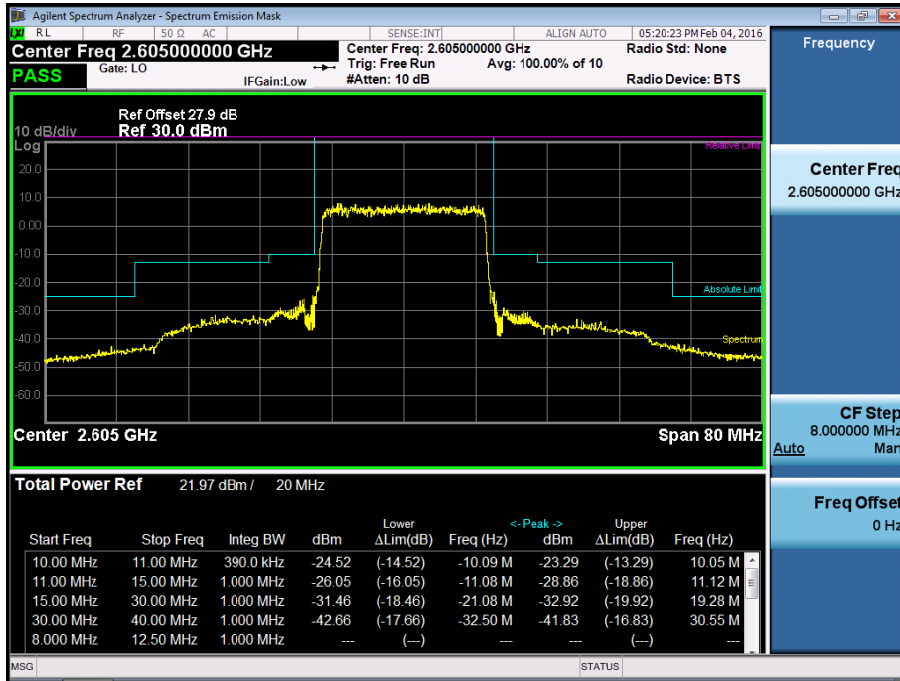

BAND 41. High Channel Edge Plot (20 MHz Ch.41140 QPSK RB 100)

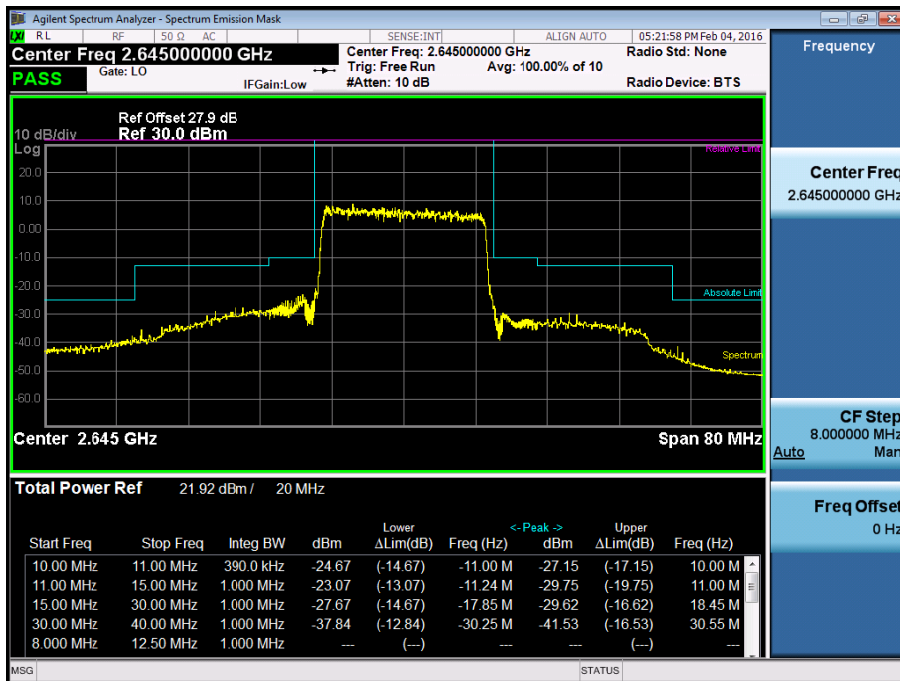

BAND 41. Conducted Spurious Plot 1 (5 MHz Ch.40265 QPSK RB 1, Offset 0)

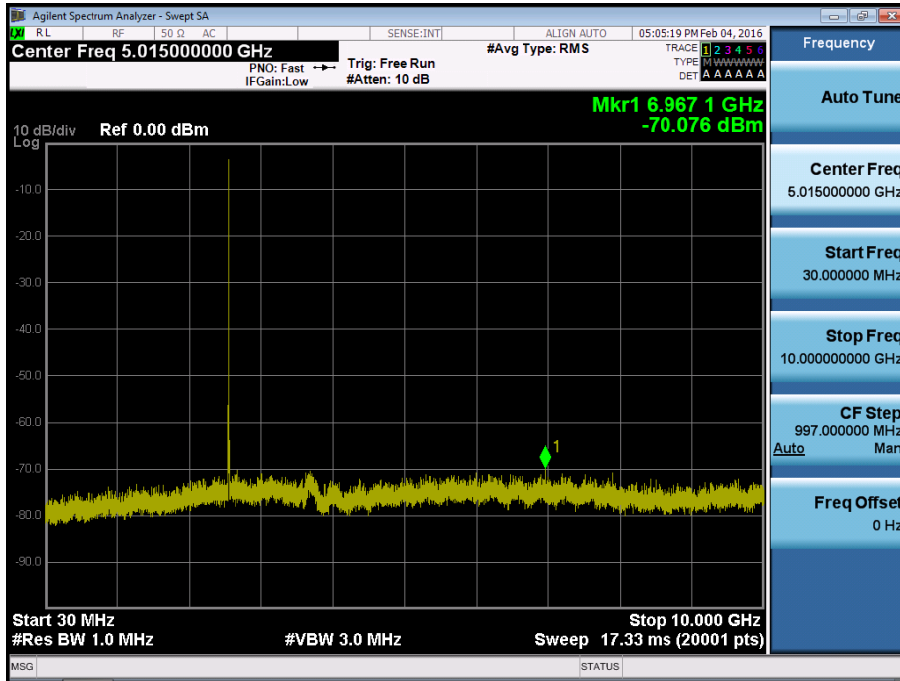

BAND 41. Conducted Spurious Plot 2 (5 MHz Ch. 40265 QPSK RB 1, Offset 0)

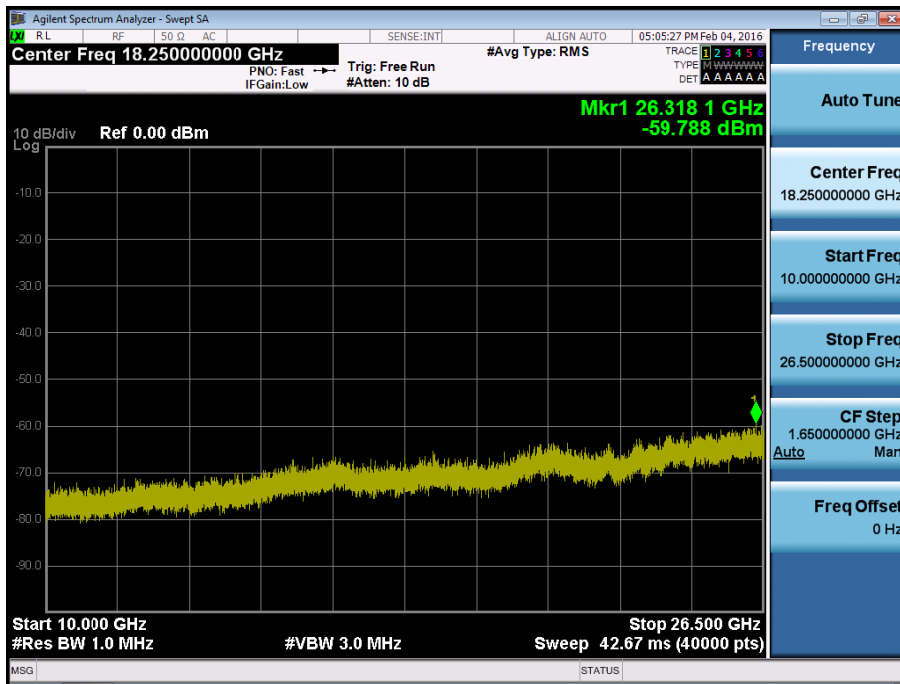

BAND 41. Conducted Spurious Plot 1 (5 MHz Ch.40740 QPSK RB 1, Offset 0)

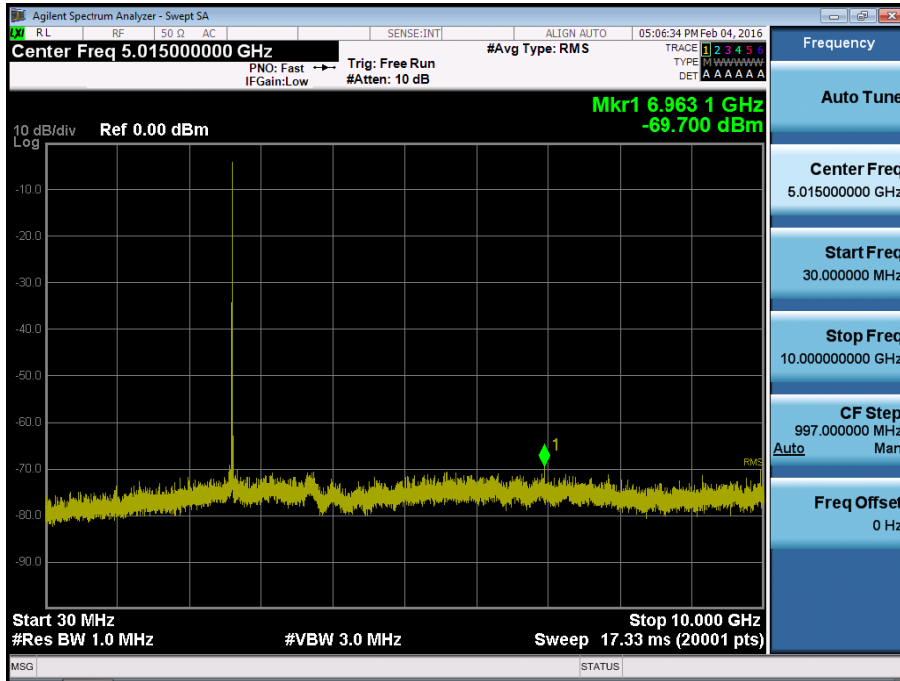

BAND 41. Conducted Spurious Plot 2 (5 MHz Ch. 40740 QPSK RB 1, Offset 0)

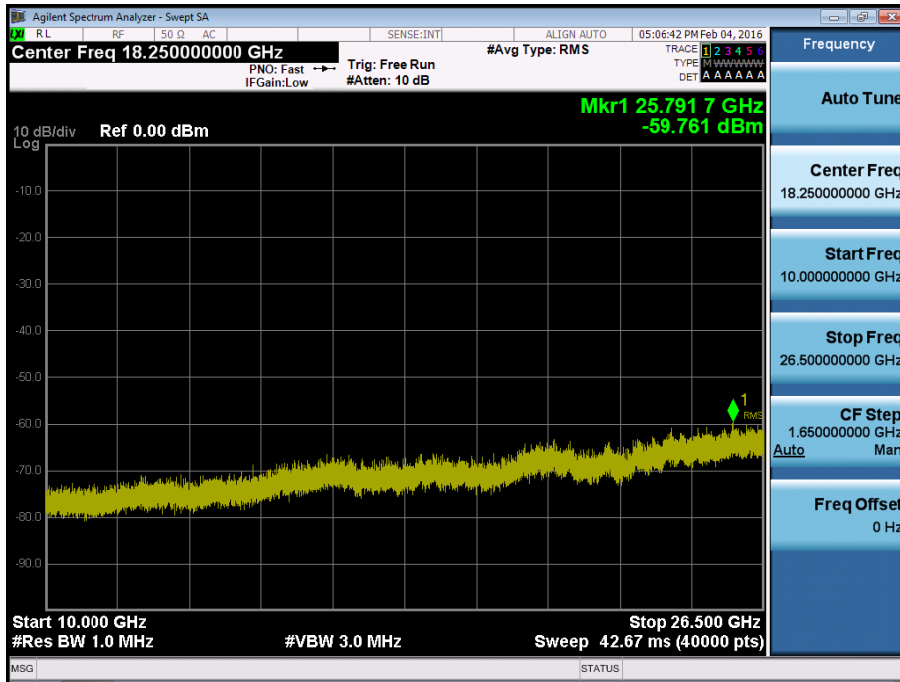

BAND 41. Conducted Spurious Plot 1 (5 MHz Ch.41215 QPSK RB 1, Offset 0)

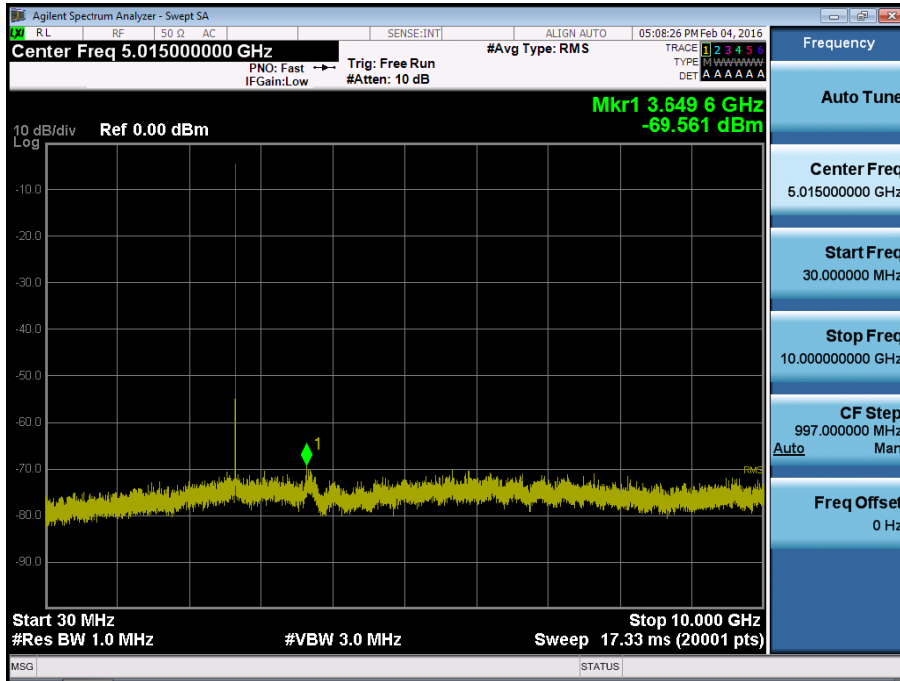

BAND 41. Conducted Spurious Plot 2 (5 MHz Ch. 41215 QPSK RB 1, Offset 0)

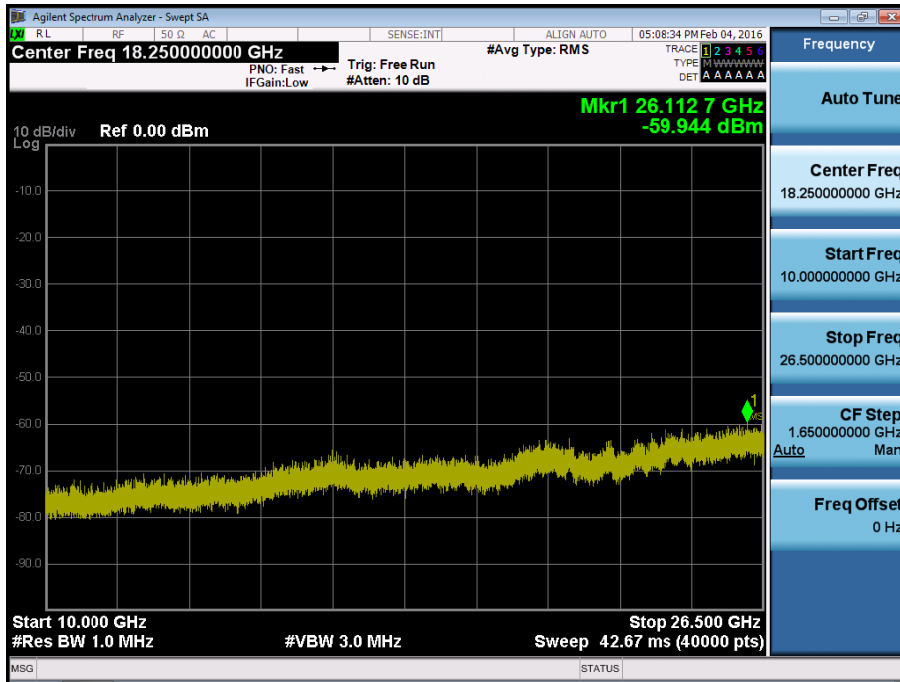

BAND 41. Conducted Spurious Plot 1 (10 MHz Ch.40290 QPSK RB 1, Offset 0)

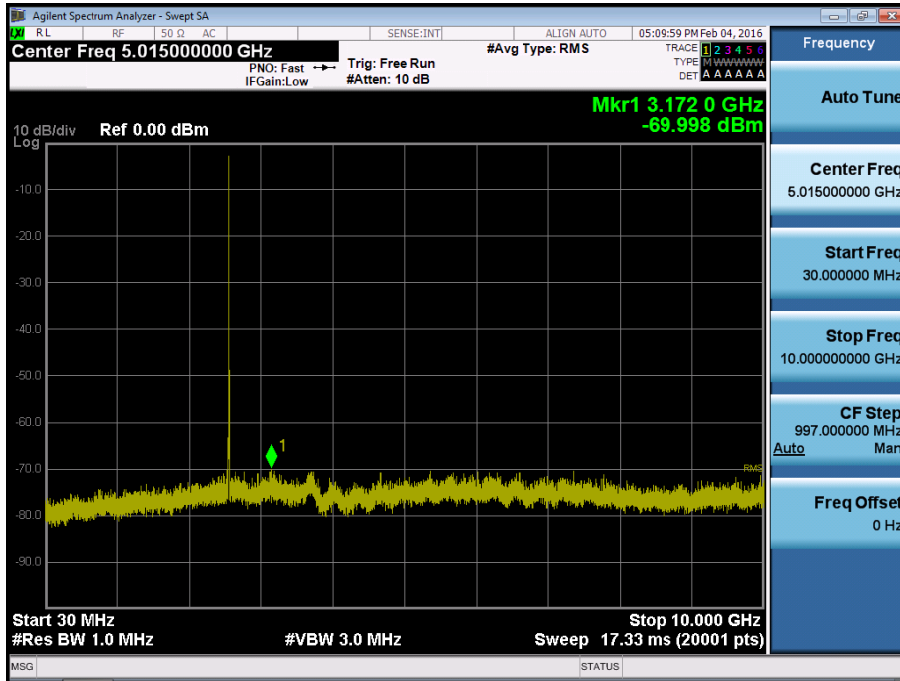

BAND 41. Conducted Spurious Plot 2 (10 MHz Ch. 40290 QPSK RB 1, Offset 0)

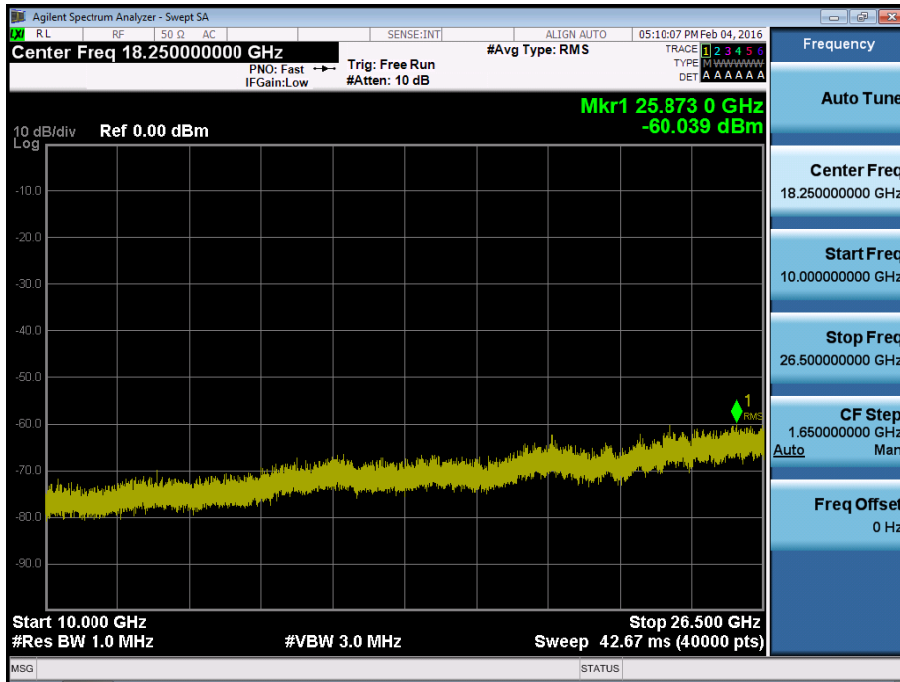

BAND 41. Conducted Spurious Plot 1 (10 MHz Ch.40740 QPSK RB 1, Offset 0)

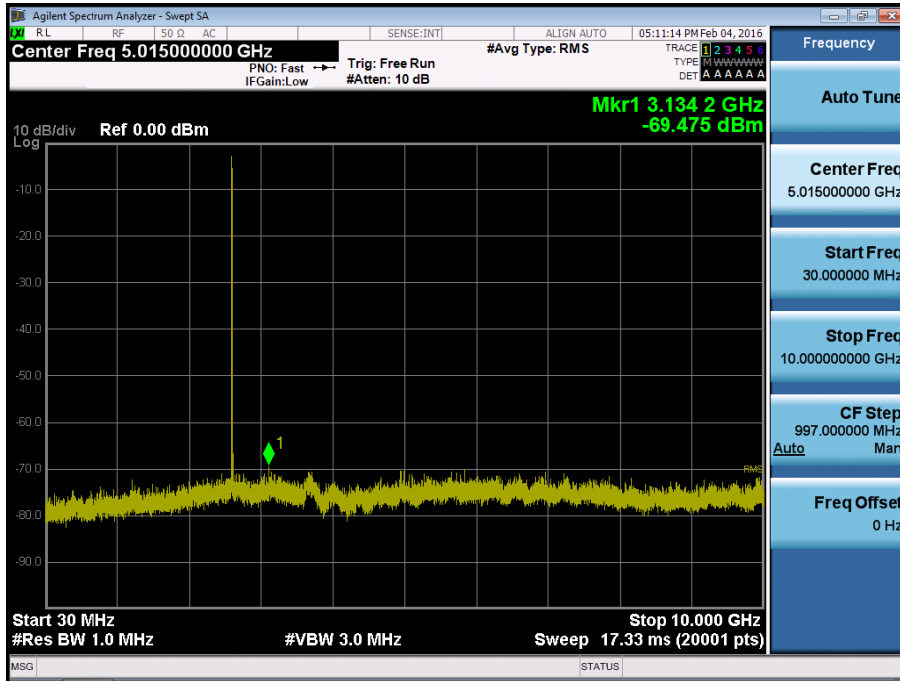

BAND 41. Conducted Spurious Plot 2 (10 MHz Ch. 40740 QPSK RB 1, Offset 0)

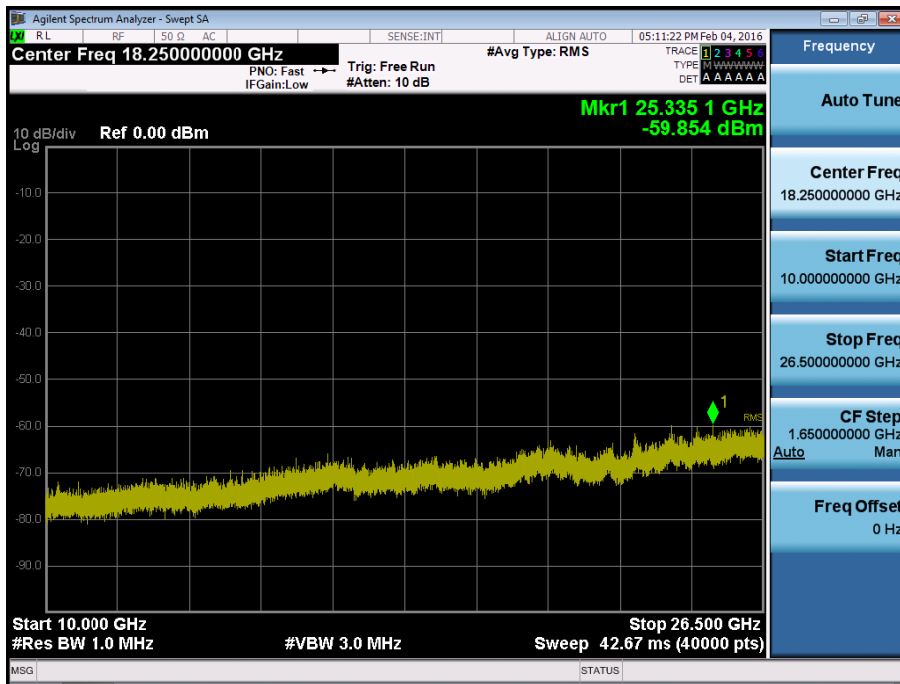

BAND 41. Conducted Spurious Plot 1 (10 MHz Ch.41190 QPSK RB 1, Offset 0)

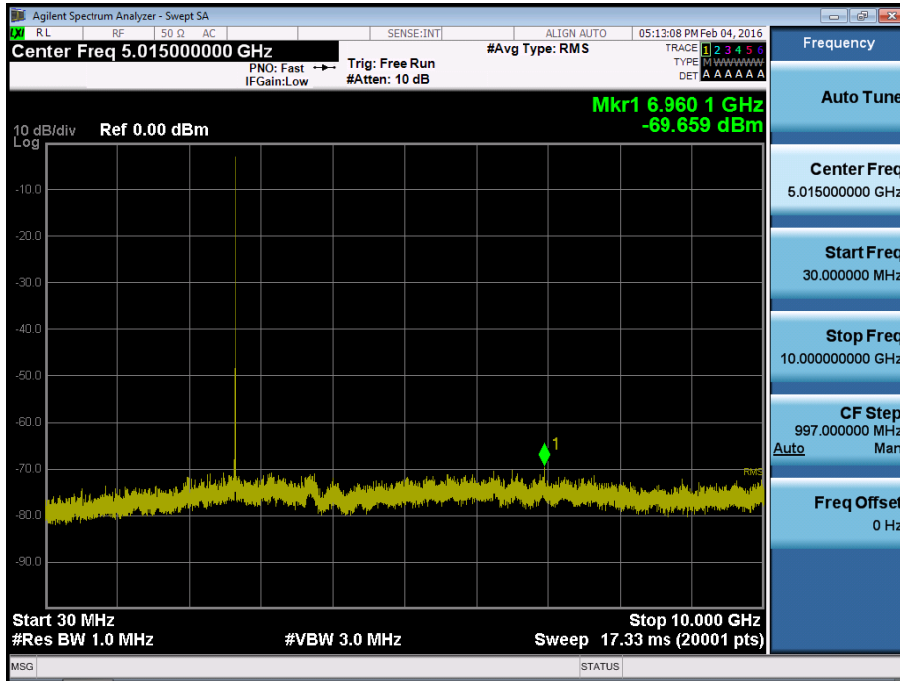

BAND 41. Conducted Spurious Plot 2 (10 MHz Ch. 41190 QPSK RB 1, Offset 0)

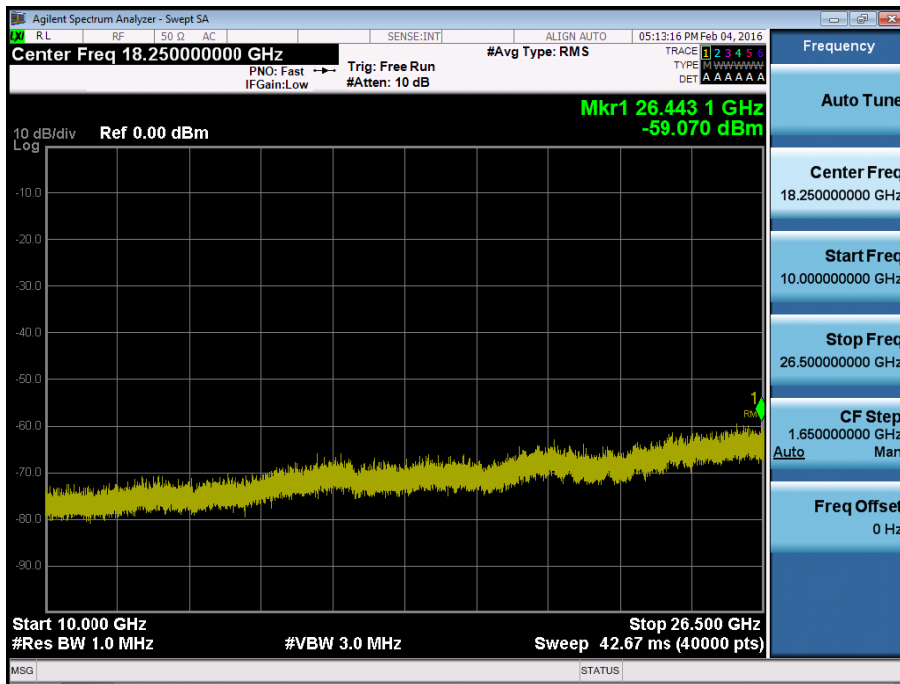

BAND 41. Conducted Spurious Plot 1 (15 MHz Ch.40315 QPSK RB 1, Offset 0)

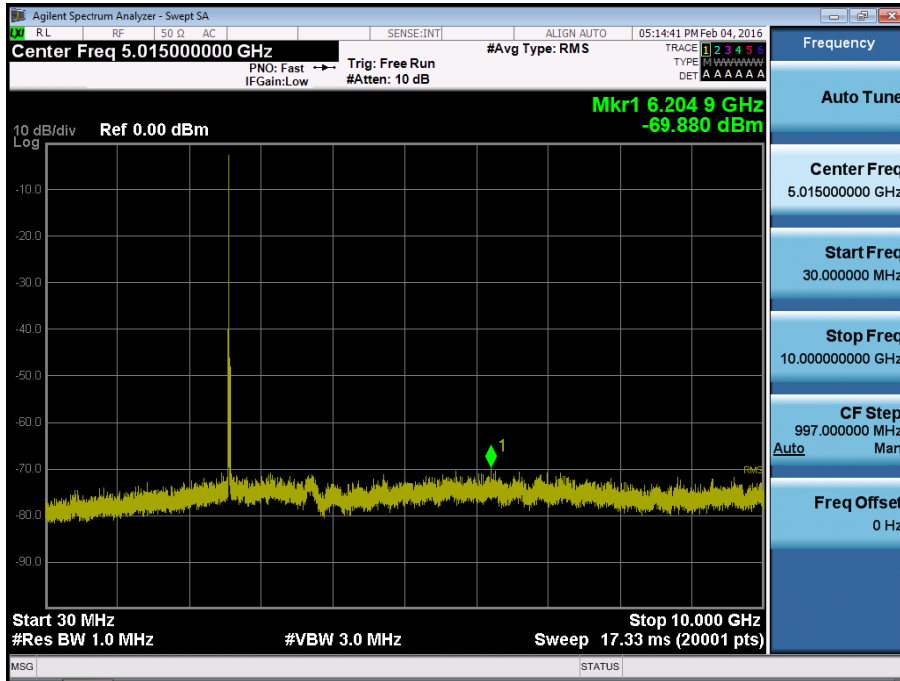

BAND 41. Conducted Spurious Plot 2 (15 MHz Ch. 40315 QPSK RB 1, Offset 0)

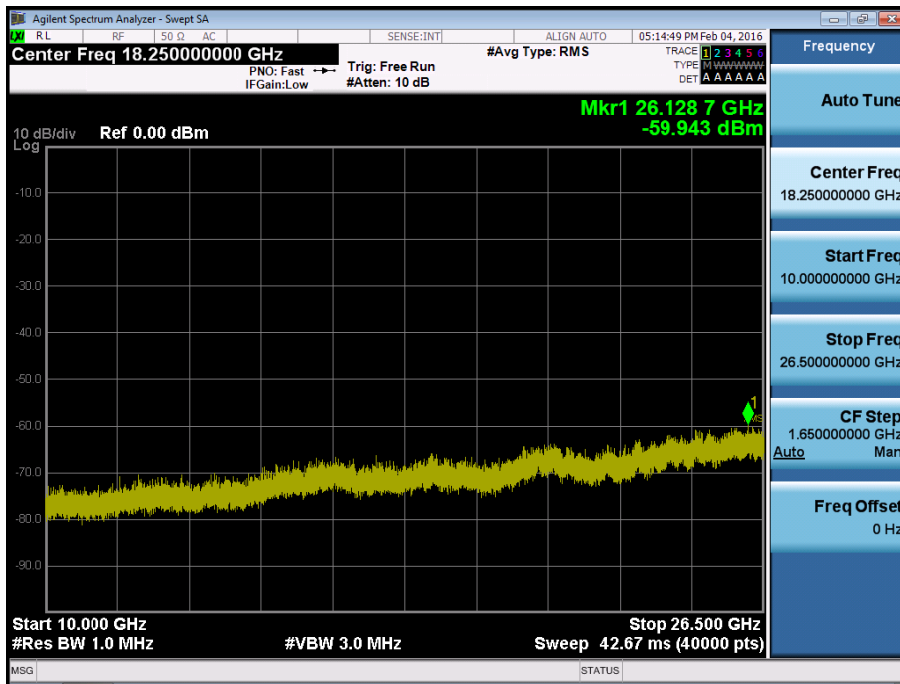

BAND 41. Conducted Spurious Plot 1 (15 MHz Ch.40620 QPSK RB 1, Offset 0)

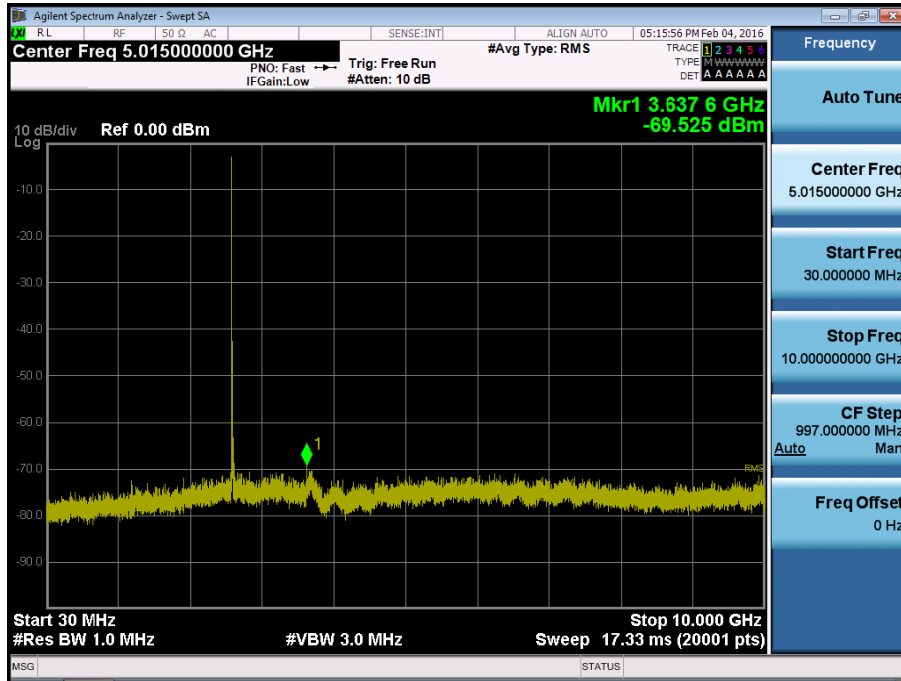

BAND 41. Conducted Spurious Plot 2 (15 MHz Ch. 40620 QPSK RB 1, Offset 0)

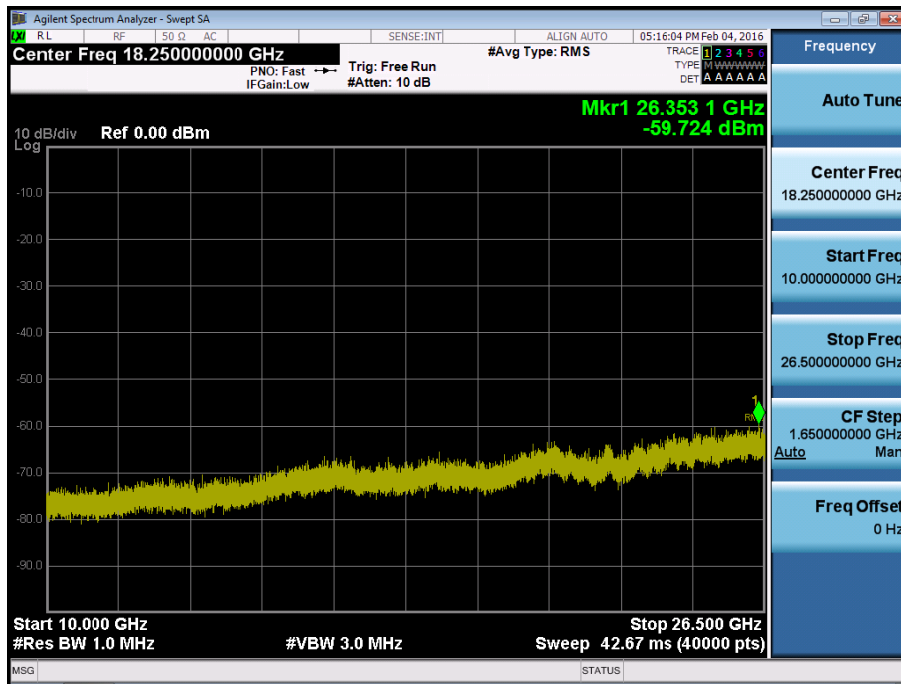

BAND 41. Conducted Spurious Plot 1 (15 MHz Ch.41165 QPSK RB 1, Offset 0)

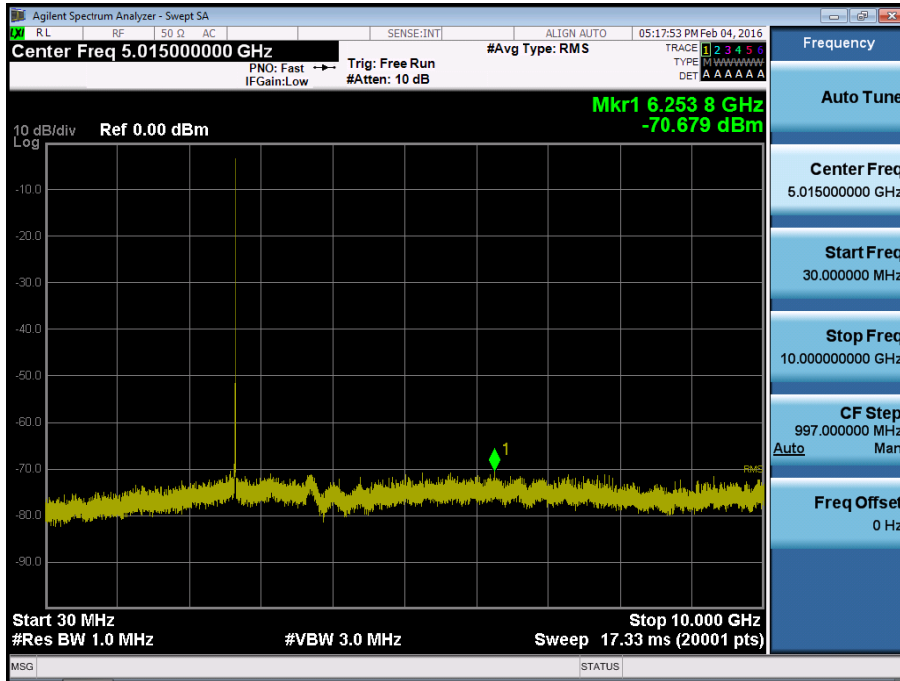

BAND 41. Conducted Spurious Plot 2 (15 MHz Ch. 41165 QPSK RB 1, Offset 0)

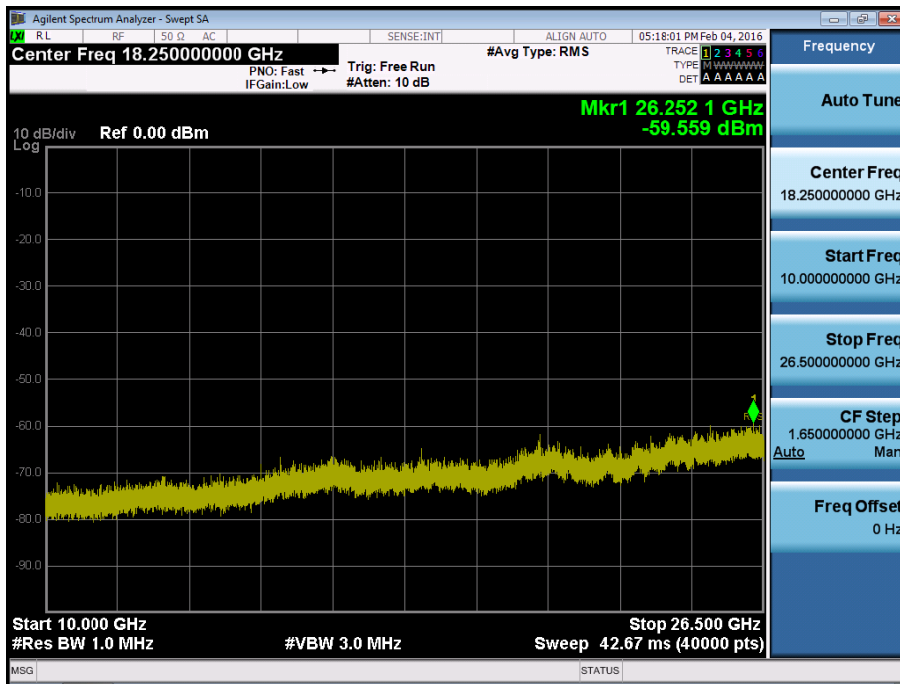

BAND 41. Conducted Spurious Plot 1 (20 MHz Ch.40340 QPSK RB 1, Offset 0)

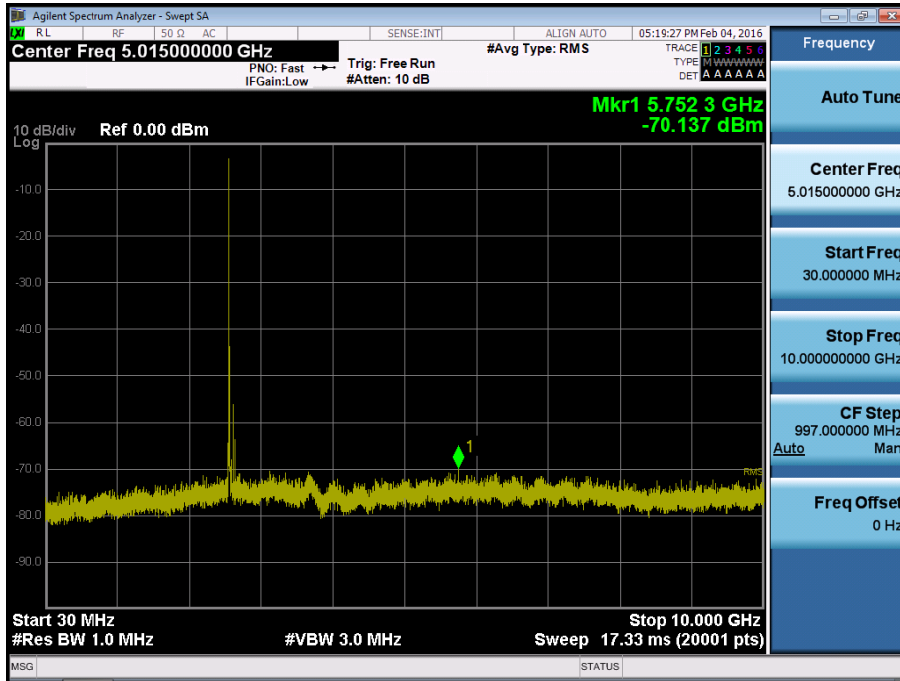

BAND 41. Conducted Spurious Plot 2 (20 MHz Ch. 40340 QPSK RB 1, Offset 0)

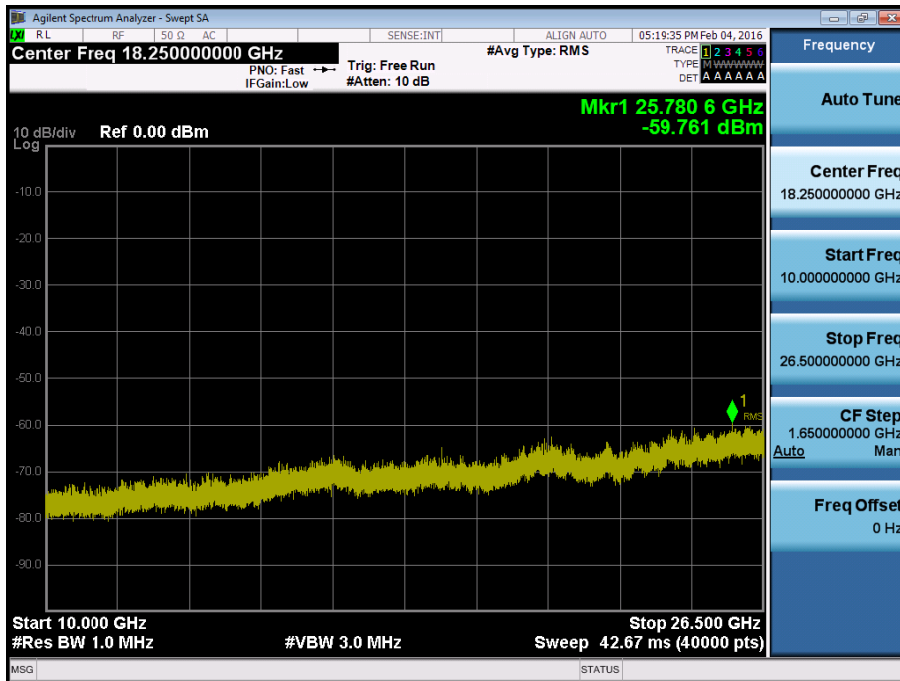

BAND 41. Conducted Spurious Plot 1 (20 MHz Ch.40740 QPSK RB 1, Offset 0)

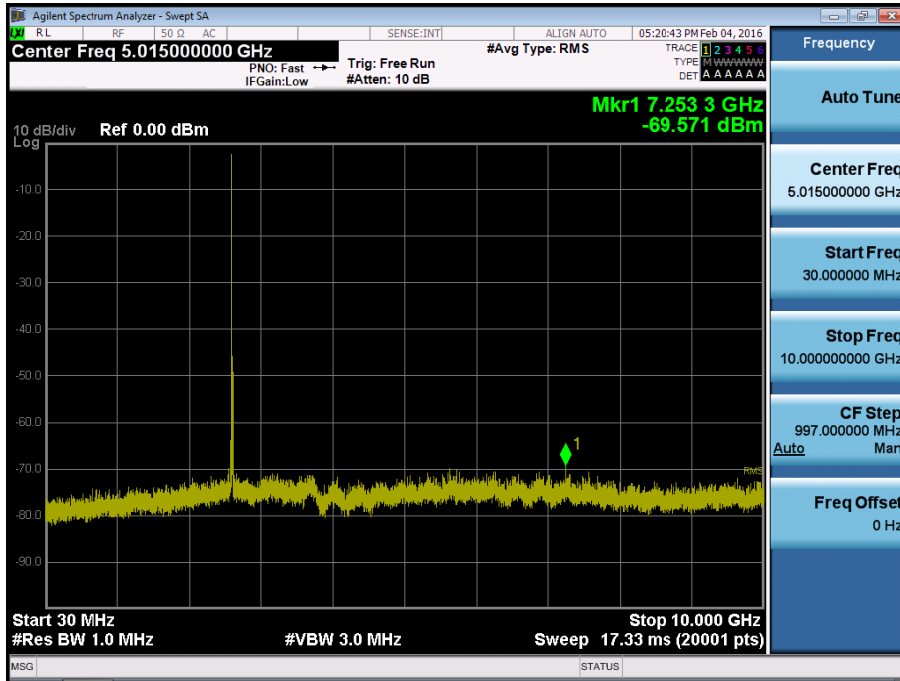

BAND 41. Conducted Spurious Plot 2 (20 MHz Ch. 40740 QPSK RB 1, Offset 0)

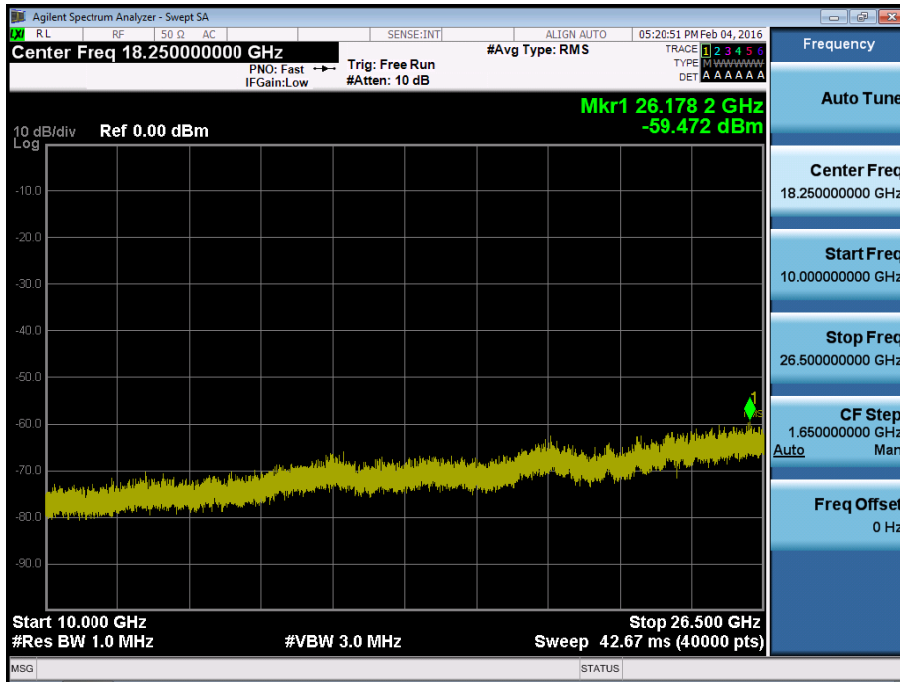

BAND 41. Conducted Spurious Plot 1 (20 MHz Ch.41140 QPSK RB 1, Offset 0)

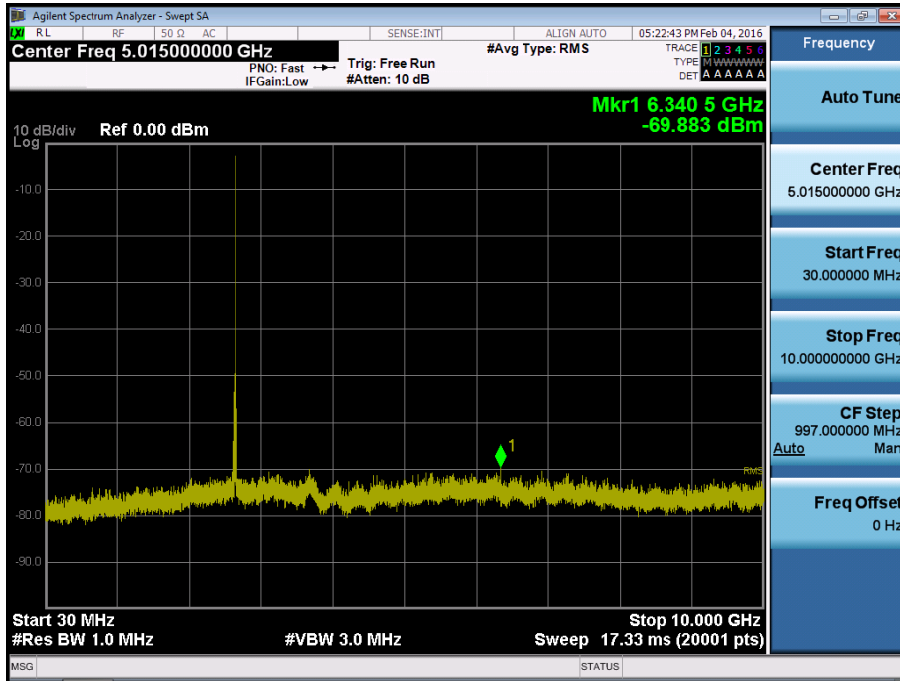

BAND 41. Conducted Spurious Plot 2 (20 MHz Ch. 41140 QPSK RB 1, Offset 0)

