

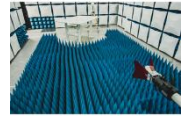

PCTEST ENGINEERING LABORATORY, INC.

7185 Oakland Mills Road, Columbia, MD 21046 USA
Tel. 410.290.6652 / Fax 410.290.6654
http://www.pctest.com



MEASUREMENT REPORT FCC PART 15.247 WLAN 802.11b/g/n

Applicant Name:
Samsung Electronics Co., Ltd.
129, Samsung-ro,
Yeongtong-gu, Suwon-si
Gyeonggi-do, 16677, Korea

Date of Testing:
3/9-4/25/2018
Test Site/Location:
PCTEST Lab. Columbia, MD, USA
Test Report Serial No.:
1M1805160106-05.A3L

FCC ID:	A3LSMJ337R4
APPLICANT:	Samsung Electronics Co., Ltd.

Application Type:	Certification
Model:	SM-J337R4
EUT Type:	Portable Handset
Frequency Range:	2412 – 2462MHz
Classification:	Digital Transmission System (DTS)
FCC Rule Part(s):	Part 15 Subpart C (15.247)
Test Procedure(s):	ANSI C63.10-2013, KDB 558074 D01 v04

This equipment has been shown to be capable of compliance with the applicable technical standards as indicated in the measurement report and was tested in accordance with the measurement procedures specified in ANSI C63.10-2013 and KDB 558074 D01 v04. Test results reported herein relate only to the item(s) tested.

I attest to the accuracy of data. All measurements reported herein were performed by me or were made under my supervision and are correct to the best of my knowledge and belief. I assume full responsibility for the completeness of these measurements and vouch for the qualifications of all persons taking them.

Randy Ortanez
President



FCC ID: A3LSMJ337R4		MEASUREMENT REPORT (CERTIFICATION)		Approved by: Quality Manager
Test Report S/N: 1M1805160106-05.A3L	Test Dates: 3/9-4/25/2018	EUT Type: Portable Handset		Page 1 of 54

TABLE OF CONTENTS

1.0	INTRODUCTION.....	4
1.1	Scope	4
1.2	PCTEST Test Location.....	4
1.3	Test Facility / Accreditations.....	4
2.0	PRODUCT INFORMATION	5
2.1	Equipment Description	5
2.2	Device Capabilities	5
2.3	Test Configuration	6
2.4	EMI Suppression Device(s)/Modifications	6
3.0	DESCRIPTION OF TESTS	7
3.1	Evaluation Procedure	7
3.2	AC Line Conducted Emissions	7
3.3	Radiated Emissions.....	8
3.4	Environmental Conditions.....	8
4.0	ANTENNA REQUIREMENTS	9
5.0	MEASUREMENT UNCERTAINTY.....	10
6.0	TEST EQUIPMENT CALIBRATION DATA.....	11
7.0	TEST RESULTS.....	12
7.1	Summary	12
7.2	6dB Bandwidth Measurement	13
7.3	Output Power Measurement.....	19
7.4	Power Spectral Density	21
7.5	Conducted Emissions at the Band Edge	27
7.6	Conducted Spurious Emissions.....	31
7.7	Radiated Spurious Emission Measurements – Above 1 GHz.....	36
7.7.1	Radiated Spurious Emission Measurements	40
7.7.2	Radiated Restricted Band Edge Measurements	44
7.8	Radiated Spurious Emissions Measurements – Below 1GHz	47
7.9	Line-Conducted Test Data.....	51
8.0	CONCLUSION	54

FCC ID: A3LSMJ337R4		MEASUREMENT REPORT (CERTIFICATION)		Approved by: Quality Manager
Test Report S/N: 1M1805160106-05.A3L	Test Dates: 3/9-4/25/2018	EUT Type: Portable Handset	Page 2 of 54	

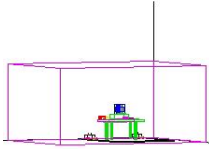

MEASUREMENT REPORT

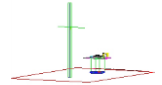

Mode	Tx Frequency (MHz)	Conducted Power			
		Avg Conducted		Peak Conducted	
		Max. Power (mW)	Max. Power (dBm)	Max. Power (mW)	Max. Power (dBm)
802.11b	2412 - 2462	73.790	18.68	125.603	20.99
802.11g	2412 - 2462	36.644	15.64	133.968	21.27
802.11n	2412 - 2462	34.754	15.41	132.130	21.21

EUT Overview

FCC ID: A3LSMJ337R4	 MEASUREMENT REPORT (CERTIFICATION)			Approved by: Quality Manager
Test Report S/N: 1M1805160106-05.A3L	Test Dates: 3/9-4/25/2018	EUT Type: Portable Handset	Page 3 of 54	

1.0 INTRODUCTION

1.1 Scope

Measurement and determination of electromagnetic emissions (EMC) of radio frequency devices including intentional and/or unintentional radiators for compliance with the technical rules and regulations of the Federal Communications Commission and the Innovation, Science and Economic Development Canada.

1.2 PCTEST Test Location

These measurement tests were conducted at the PCTEST Engineering Laboratory, Inc. facility located at 7185 Oakland Mills Road, Columbia, MD 21046. The measurement facility is compliant with the test site requirements specified in ANSI C63.4-2014.

1.3 Test Facility / Accreditations

Measurements were performed at PCTEST Engineering Lab located in Columbia, MD 21046, U.S.A.

- PCTEST is an ISO 17025-2005 accredited test facility under the American Association for Laboratory Accreditation (A2LA) with Certificate number 2041.01 for Specific Absorption Rate (SAR), Hearing Aid Compatibility (HAC) testing, where applicable, and Electromagnetic Compatibility (EMC) testing for and Innovation, Science, and Economic Development Canada rules.
- PCTEST TCB is a Telecommunication Certification Body (TCB) accredited to ISO/IEC 17065-2012 by A2LA (Certificate number 2041.03) in all scopes of Rules and ISED Standards (RSS).
- PCTEST facility is a registered (2451B) test laboratory with the site description on file with ISED.

FCC ID: A3LSMJ337R4	 MEASUREMENT REPORT (CERTIFICATION)		Approved by: Quality Manager
Test Report S/N: 1M1805160106-05.A3L	Test Dates: 3/9-4/25/2018	EUT Type: Portable Handset	Page 4 of 54

2.0 PRODUCT INFORMATION

2.1 Equipment Description

The Equipment Under Test (EUT) is the **Samsung Portable Handset FCC ID: A3LSMJ337R4**. The test data contained in this report pertains only to the emissions due to the EUT's WLAN (DTS) transmitter.

Test Device Serial No.: 05814, 58087, 05813, 22535

2.2 Device Capabilities

This device contains the following capabilities:

850/1900 CDMA (BC0, BC1), 850/1900 GSM/GPRS/EDGE, 850/1900 WCDMA/HSPA, Multi-band LTE, 802.11b/g/n WLAN, 802.11a/n UNII, Bluetooth (LE)

Ch.	Frequency (MHz)	Ch.	Frequency (MHz)
1	2412	7	2442
2	2417	8	2447
3	2422	9	2452
4	2427	10	2457
5	2432	11	2462
6	2437		

Table 2-1. Frequency/ Channel Operations

Note: The maximum achievable duty cycles for all modes were determined based on measurements performed on a spectrum analyzer in zero-span mode with RBW = 8MHz, VBW = 50MHz, and detector = peak per the guidance of Section 6.0 b) of ANSI C63.10-2013 and KDB 558074 D01 v04. The RBW and VBW were both greater than 50/T, where T is the minimum transmission duration, and the number of sweep points across T was greater than 100. The duty cycles are as follows:

Maximum Achievable Duty Cycles		
802.11 Mode/Band	Duty Cycle [%]	
2.4GHz	b	99.0
	g	97.5
	n	92.9

Table 2-2. Measured Duty Cycles

FCC ID: A3LSMJ337R4		MEASUREMENT REPORT (CERTIFICATION)		Approved by: Quality Manager
Test Report S/N: 1M1805160106-05.A3L	Test Dates: 3/9-4/25/2018	EUT Type: Portable Handset	Page 5 of 54	

Data Rates Supported: 1Mbps, 2Mbps, 5.5Mbps, 11Mbps (b)
 6Mbps, 9Mbps, 12Mbps, 18Mbps, 24Mbps, 36Mbps, 48Mbps, 54Mbps (g)
 6.5/7.2Mbps, 13/14.4Mbps, 19.5/21.7Mbps, 26/28.9Mbps, 39/43.3Mbps,
 52/57.8Mbps, 58.5/65Mbps, 65/72.2Mbps (n)

2.3 Test Configuration

The EUT was tested per the guidance of KDB 558074 D01 v04. ANSI C63.10-2013 was used to reference the appropriate EUT setup for radiated spurious emissions testing and AC line conducted testing. See Sections 3.2 for AC line conducted emissions test setups, 3.3 for radiated emissions test setups, and 7.2, 7.3, 7.4, 7.5, and 7.6 for antenna port conducted emissions test setups.

2.4 EMI Suppression Device(s)/Modifications

No EMI suppression device(s) were added and/or no modifications were made during testing.

FCC ID: A3LSMJ337R4	 MEASUREMENT REPORT (CERTIFICATION) 		Approved by: Quality Manager
Test Report S/N: 1M1805160106-05.A3L	Test Dates: 3/9-4/25/2018	EUT Type: Portable Handset	Page 6 of 54

3.0 DESCRIPTION OF TESTS

3.1 Evaluation Procedure

The measurement procedures described in the American National Standard of Procedures for Compliance Testing of Unlicensed Wireless Devices (ANSI C63.10-2013) and the guidance provided in KDB 558074 D01 v04 were used in the measurement of the EUT.

Deviation from measurement procedure.....None

3.2 AC Line Conducted Emissions

The line-conducted facility is located inside a 10'x16'x9' shielded enclosure. The shielded enclosure is manufactured by ETS Lindgren RF Enclosures. The shielding effectiveness of the shielded room is in accordance with MIL-Std-285 or NSA 65-5. A 1m x 1.5m wooden table 80cm high is placed 40cm away from the vertical wall and 80cm away from the sidewall of the shielded room. Two 10kHz-30MHz, 50Ω/50μH Line-Impedance Stabilization Networks (LISNs) are bonded to the shielded room floor. Power to the LISNs is filtered by external high-current high-insertion loss power line filters. The external power line filter is an ETS Lindgren Model LPRX-4X30 (100dB Attenuation, 14kHz-18GHz) and the two EMI/RFI filters are ETS Lindgren Model LRW-2030-S1 (100dB Minimum Insertion Loss, 14kHz – 10GHz). These filters attenuate ambient signal noise from entering the measurement lines. These filters are also bonded to the shielded enclosure.

The EUT is powered from one LISN and the support equipment is powered from the second LISN. If the EUT is a DC-powered device, power will be derived from the source power supply it normally will be powered from and this supply line(s) will be connected to the second LISN. All interconnecting cables more than 1 meter were shortened to a 1 meter length by non-inductive bundling (serpentine fashion) and draped over the back edge of the test table. All cables were at least 40cm above the horizontal reference groundplane. Power cables for support equipment were routed down to the second LISN while ensuring that that cables were not draped over the second LISN.

Sufficient time for the EUT, support equipment, and test equipment was allowed in order for them to warm up to their normal operating condition. The RF output of the LISN was connected to the spectrum analyzer and exploratory measurements were made to determine the frequencies producing the maximum emission from the EUT. The spectrum was scanned from 150kHz to 30MHz with a spectrum analyzer. The detector function was set to peak mode for exploratory measurements while the bandwidth of the analyzer was set to 10kHz. The EUT, support equipment, and interconnecting cables were arranged and manipulated to maximize each emission. Once the worst case emissions have been identified, the one EUT cable configuration/arrangement and mode of operation that produced these emissions is used for final measurements on the same test site. The analyzer is set to CISPR quasi-peak and average detectors with a 9kHz resolution bandwidth for final measurements.

Line conducted emissions test results are shown in Section 7.9. The EMI Receiver mode of the Agilent MXE was used to perform AC line conducted emissions testing.

FCC ID: A3LSMJ337R4		MEASUREMENT REPORT (CERTIFICATION)		Approved by: Quality Manager
Test Report S/N: 1M1805160106-05.A3L	Test Dates: 3/9-4/25/2018	EUT Type: Portable Handset	Page 7 of 54	

3.3 Radiated Emissions

The radiated test facilities consisted of an indoor 3 meter semi-anechoic chamber used for final measurements and exploratory measurements, when necessary. The measurement area is contained within the semi-anechoic chamber which is shielded from any ambient interference. The test site inside the chamber is a 6m x 5.2m elliptical, obstruction-free area in accordance with Figure 5.7 of Clause 5 in ANSI C63.4-2014. Absorbers are arranged on the floor between the turn table and the antenna mast in such a way so as to maximize the reduction of reflections for measurements above 1GHz. An 80cm tall test table made of Styrodur is placed on top of the turn table. For measurements above 1GHz, an additional Styrodur pedestal is placed on top of the test table to bring the total table height to 1.5m.

For all measurements, the spectrum was scanned through all EUT azimuths and from 1 to 4 meter receive antenna height using a broadband antenna from 30MHz up to the upper frequency shown in 15.33(b)(1) depending on the highest frequency generated or used in the device or on which the device operates or tunes. For frequencies above 1GHz, linearly polarized double ridge horn antennas were used. For frequencies below 30MHz, a calibrated loop antenna was used. When exploratory measurements were necessary, they were performed at 1 meter test distance inside the semi-anechoic chamber using broadband antennas, broadband amplifiers, and spectrum analyzers to determine the frequencies and modes producing the maximum emissions. Sufficient time for the EUT, support equipment, and test equipment was allowed in order for them to warm up to their normal operating condition. The test set-up was placed on top of the 1 x 1.5 meter table. The EUT, support equipment, and interconnecting cables were arranged and manipulated to maximize each emission. Appropriate precaution was taken to ensure that all emissions from the EUT were maximized and investigated. The system configuration, mode of operation, turntable azimuth, and receive antenna height was noted for each frequency found.

Final measurements were made in the semi-anechoic chamber using calibrated, linearly polarized broadband and horn antennas. The test setup was configured to the setup that produced the worst case emissions. The spectrum analyzer was set to investigate all frequencies required for testing to compare the highest radiated disturbances with respect to the specified limits. The turntable containing the EUT was rotated through 360 degrees and the height of the receive antenna was varied 1 to 4 meters and stopped at the azimuth and height producing the maximum emission. Each emission was maximized by changing the orientation of the EUT through three orthogonal planes and changing the polarity of the receive antenna, whichever produced the worst-case emissions.

3.4 Environmental Conditions

The temperature is controlled within range of 15°C to 35°C. The relative humidity is controlled within range of 10% to 75%. The atmospheric pressure is monitored within the range 86-106kPa (860-1060mbar).

FCC ID: A3LSMJ337R4		MEASUREMENT REPORT (CERTIFICATION)		Approved by: Quality Manager
Test Report S/N: 1M1805160106-05.A3L	Test Dates: 3/9-4/25/2018	EUT Type: Portable Handset	Page 8 of 54	

4.0 ANTENNA REQUIREMENTS

Excerpt from §15.203 of the Rules/Regulations:

“An intentional radiator antenna shall be designed to ensure that no antenna other than that furnished by the responsible party can be used with the device. The use of a permanently attached antenna or of an antenna that uses a unique coupling to the intentional radiator shall be considered sufficient to comply with the provisions of this section.”

- The antennas of the EUT are **permanently attached**.
- There are no provisions for connections to an external antenna.

Conclusion:

The EUT unit complies with the requirement of §15.203.

FCC ID: A3LSMJ337R4	 MEASUREMENT REPORT (CERTIFICATION) 		Approved by: Quality Manager
Test Report S/N: 1M1805160106-05.A3L	Test Dates: 3/9-4/25/2018	EUT Type: Portable Handset	Page 9 of 54

5.0 MEASUREMENT UNCERTAINTY

The measurement uncertainties shown below were calculated in accordance with the requirements of ANSI C63.10-2013. All measurement uncertainty values are shown with a coverage factor of $k = 2$ to indicate a 95% level of confidence. The measurement uncertainty shown below meets or exceeds the U_{CISPR} measurement uncertainty values specified in CISPR 16-4-2 and, thus, can be compared directly to specified limits to determine compliance.

Contribution	Expanded Uncertainty (\pm dB)
Conducted Bench Top Measurements	1.13
Line Conducted Disturbance	3.09
Radiated Disturbance (<1GHz)	4.98
Radiated Disturbance (>1GHz)	5.07
Radiated Disturbance (>18GHz)	5.09

FCC ID: A3LSMJ337R4	 MEASUREMENT REPORT (CERTIFICATION)			Approved by: Quality Manager
Test Report S/N: 1M1805160106-05.A3L	Test Dates: 3/9-4/25/2018	EUT Type: Portable Handset	Page 10 of 54	

6.0 TEST EQUIPMENT CALIBRATION DATA

Test Equipment Calibration is traceable to the National Institute of Standards and Technology (NIST). Measurements antennas used during testing were calibrated in accordance to the requirements of ANSI C63.5-2017.

Manufacturer	Model	Description	Cal Date	Cal Interval	Cal Due	Serial Number
-	RE1	Radiated Emissions Cable Set (UHF/EHF)	6/21/2017	Annual	6/21/2018	RE1
-	WL25-1	Conducted Cable Set (25GHz)	6/14/2017	Annual	6/14/2018	WL25-1
Agilent	N9038A	MXE EMI Receiver	4/26/2017	Annual	4/26/2018	MY51210133
Com-Power	AL-130	9kHz - 30MHz Loop Antenna	10/10/2017	Biennial	10/10/2019	121034
EMCO	3160-09	Small Horn (18 - 26.5GHz)	8/23/2016	Biennial	8/23/2018	135427
Rohde & Schwarz	SFUNIT-Rx	Shielded Filter Unit	7/3/2017	Annual	7/3/2018	102135
Rohde & Schwarz	SFUNIT-Rx	Shielded Filter Unit	7/3/2017	Annual	7/3/2018	102134
Rohde & Schwarz	FSW67	Signal / Spectrum Analyzer	8/11/2017	Annual	8/11/2018	103200
Rohde & Schwarz	ESU26	EMI Test Receiver (26.5GHz)	4/19/2017	Annual	4/19/2018	100342
Rohde & Schwarz	ESU40	EMI Test Receiver (40GHz)	7/31/2017	Annual	7/31/2018	100348
Rohde & Schwarz	TS-PR26	18-26.5 GHz Pre-Amplifier	5/11/2017	Annual	5/11/2018	100040
Rohde & Schwarz	SFUNIT-Rx	Shielded Filter Unit	7/3/2017	Annual	7/3/2018	102133
Solar Electronics	8012-50-R-24-BNC	Line Impedance Stabilization Network	8/14/2017	Biennial	8/14/2019	310233
Sunol	DRH-118	Horn Antenna (1-18 GHz)	8/11/2017	Biennial	8/11/2019	A042511
Sunol	JB6	Bi-Log Antenna (30M - 6GHz)	9/27/2016	Biennial	9/27/2018	A082816
Sunol	DRH-118	Horn Antenna (1-18GHz)	8/11/2017	Biennial	8/11/2019	A050307

Table 6-1. Annual Test Equipment Calibration Schedule

Note:

For equipment listed above that has a calibration date or calibration due date that falls within the test date range, care was taken to ensure that this equipment was used after the calibration date and before the calibration due date.

FCC ID: A3LSMJ337R4	 MEASUREMENT REPORT (CERTIFICATION) 		Approved by: Quality Manager
Test Report S/N: 1M1805160106-05.A3L	Test Dates: 3/9-4/25/2018	EUT Type: Portable Handset	Page 11 of 54

7.0 TEST RESULTS

7.1 Summary

Company Name: Samsung Electronics Co., Ltd.
 FCC ID: A3LSMJ337R4
 Classification: Digital Transmission System (DTS)

Part Section(s)	RSS Section(s)	Test Description	Test Limit	Test Condition	Test Result	Reference
15.247(a)(2)	RSS-247 [5.2]	6dB Bandwidth	> 500kHz	CONDUCTED	PASS	Section 7.2
15.247(b)(3)	RSS-247 [5.4]	Transmitter Output Power	< 1 Watt		PASS	Sections 7.3
15.247(e)	RSS-247 [5.2]	Transmitter Power Spectral Density	< 8dBm / 3kHz Band		PASS	Section 7.4
15.247(d)	RSS-247 [5.5]	Band Edge / Out-of-Band Emissions	≥ 20dBc		PASS	Sections 7.5, 7.6
15.205 15.209	RSS-Gen [8.9]	General Field Strength Limits (Restricted Bands and Radiated Emission Limits)	Emissions in restricted bands must meet the radiated limits detailed in 15.209 (RSS-Gen [8.9])	RADIATED	PASS	Sections 7.7, 7.8
15.207	RSS-Gen [8.8]	AC Conducted Emissions 150kHz – 30MHz	< 15.207 limits (RSS-Gen[8.8])	LINE CONDUCTED	PASS	Section 7.9

Table 7-1. Summary of Test Results

Notes:

- 1) All modes of operation and data rates were investigated. The test results shown in the following sections represent the worst case emissions.
- 2) The analyzer plots shown in this section were all taken with a correction table loaded into the analyzer. The correction table was used to account for the losses of the cables and attenuators used as part of the system to connect the EUT to the analyzer at all frequencies of interest.
- 3) All antenna port conducted emissions testing was performed on a test bench with the antenna port of the EUT connected to the spectrum analyzer through calibrated cables and attenuators.
- 4) For conducted spurious emissions, automated test software was used to measure emissions and capture the corresponding plots necessary to show compliance. The measurement software utilized is PCTEST “WLAN Automation,” Version 3.5.
- 5) For radiated band edge, automated test software was used to measure emissions and capture the corresponding plots necessary to show compliance. The measurement software utilized is PCTEST “Chamber Automation,” Version 0.2.8.

FCC ID: A3LSMJ337R4		MEASUREMENT REPORT (CERTIFICATION)		Approved by: Quality Manager
Test Report S/N: 1M1805160106-05.A3L	Test Dates: 3/9-4/25/2018	EUT Type: Portable Handset	Page 12 of 54	

7.2 6dB Bandwidth Measurement

§15.247(a.2); RSS-247 [5.2]

Test Overview and Limit

The bandwidth at 6dB down from the highest in-band spectral density is measured with a spectrum analyzer connected to the transmitter antenna terminal of the EUT while the EUT is operating at its maximum duty cycle, at maximum power, and at the appropriate frequencies. All data rates were investigated and the worst case configuration results are reported in this section.

The minimum permissible 6dB bandwidth is 500 kHz.

Test Procedure Used

ANSI C63.10-2013 – Section 11.8.2 Option 2
KDB 558074 D01 v04 – Section 8.2 Option 2

Test Settings

1. The signal analyzer's automatic bandwidth measurement capability was used to perform the 6dB bandwidth measurement. The "X" dB bandwidth parameter was set to X = 6. The bandwidth measurement was not influenced by any intermediate power nulls in the fundamental emission.
2. RBW = 100kHz
3. VBW $\geq 3 \times$ RBW
4. Detector = Peak
5. Trace mode = max hold
6. Sweep = auto couple
7. The trace was allowed to stabilize

Test Setup

The EUT and measurement equipment were set up as shown in the diagram below.



Figure 7-1. Test Instrument & Measurement Setup

Test Notes

None

FCC ID: A3LSMJ337R4		MEASUREMENT REPORT (CERTIFICATION)		Approved by: Quality Manager
Test Report S/N: 1M1805160106-05.A3L	Test Dates: 3/9-4/25/2018	EUT Type: Portable Handset		Page 13 of 54

Frequency [MHz]	Channel No.	802.11 Mode	Data Rate [Mbps]	Measured Bandwidth [MHz]	Minimum Bandwidth [MHz]
2412	1	b	1	8.142	0.500
2437	6	b	1	8.137	0.500
2462	11	b	1	8.131	0.500
2412	1	g	6	15.72	0.500
2437	6	g	6	15.83	0.500
2462	11	g	6	15.78	0.500
2412	1	n	6.5/7.2 (MCS0)	15.51	0.500
2437	6	n	6.5/7.2 (MCS0)	15.13	0.500
2462	11	n	6.5/7.2 (MCS0)	15.35	0.500

Table 7-2. Conducted Bandwidth Measurements

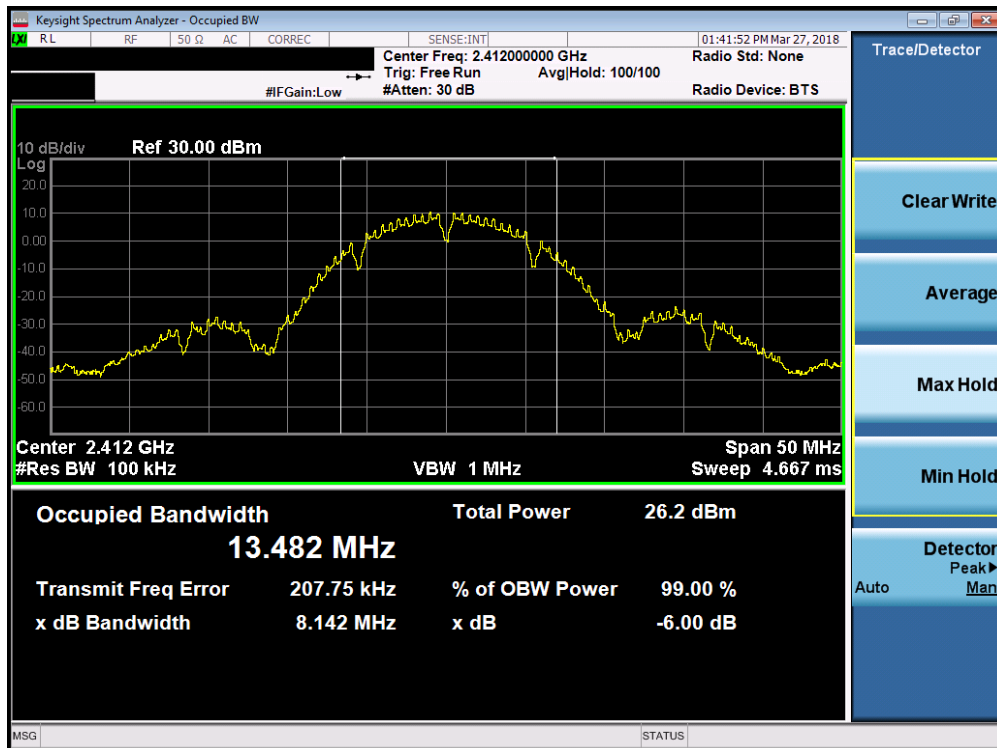

Plot 7-1. 6dB Bandwidth Plot (802.11b – Ch. 1)

FCC ID: A3LSMJ337R4		MEASUREMENT REPORT (CERTIFICATION)		Approved by: Quality Manager
Test Report S/N: 1M1805160106-05.A3L	Test Dates: 3/9-4/25/2018	EUT Type: Portable Handset		Page 14 of 54

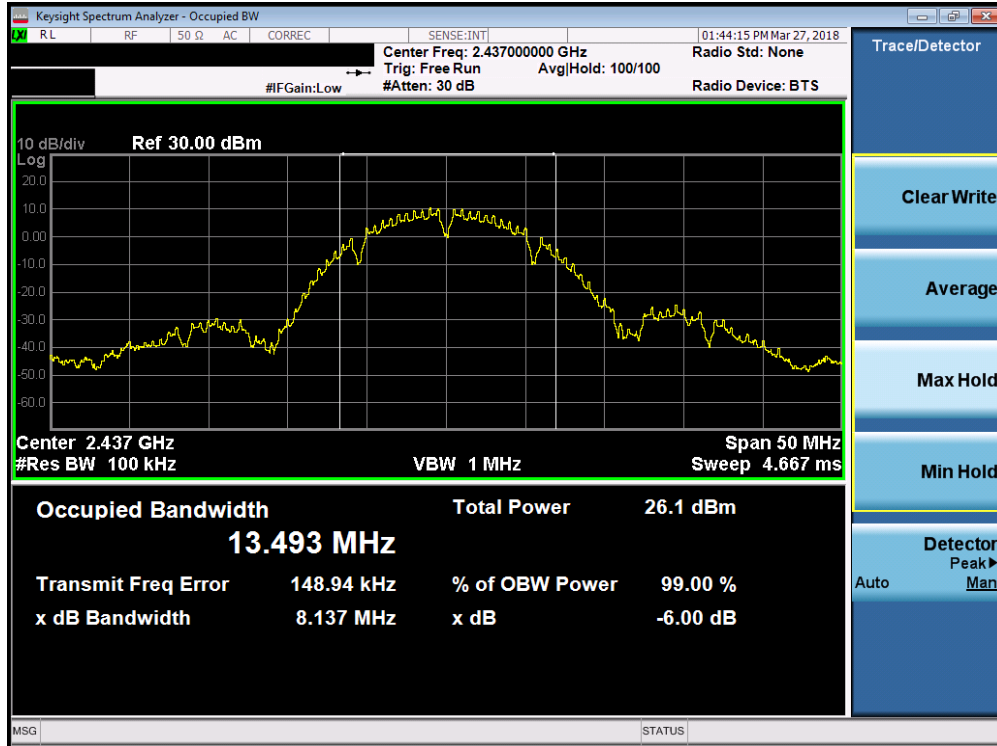

Plot 7-2. 6dB Bandwidth Plot (802.11b – Ch. 6)

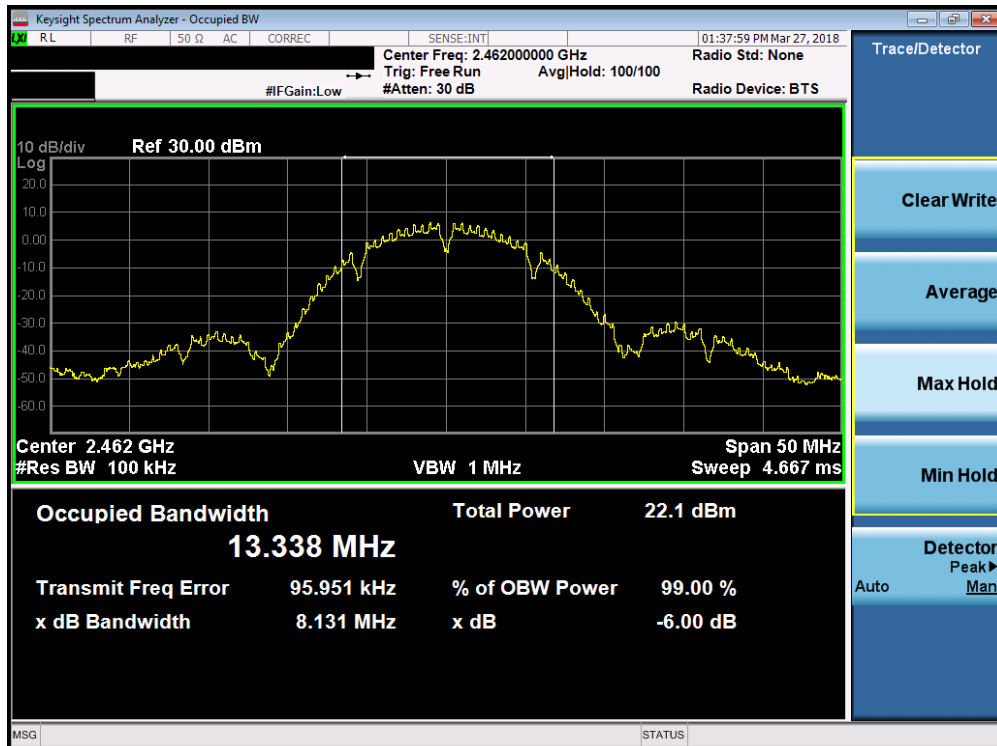

Plot 7-3. 6dB Bandwidth Plot (802.11b – Ch. 11)

FCC ID: A3LSMJ337R4	PCTEST ENGINEERING LABORATORY, INC.	MEASUREMENT REPORT (CERTIFICATION)		Approved by: Quality Manager
Test Report S/N: 1M1805160106-05.A3L	Test Dates: 3/9-4/25/2018	EUT Type: Portable Handset		Page 15 of 54

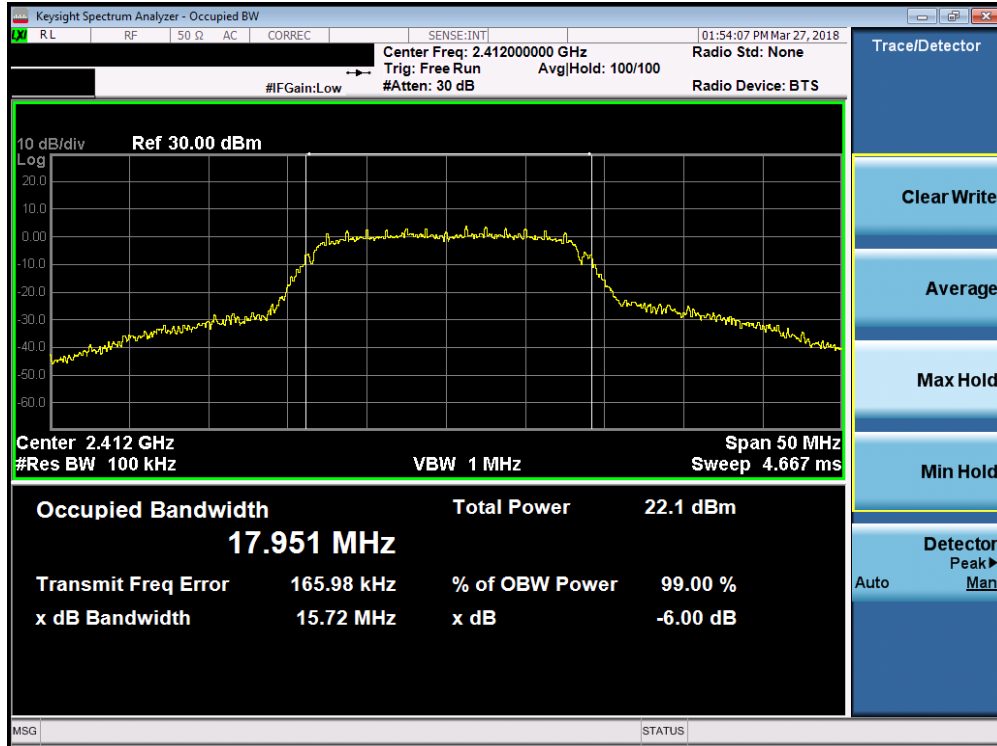

Plot 7-4. 6dB Bandwidth Plot (802.11g – Ch. 1)

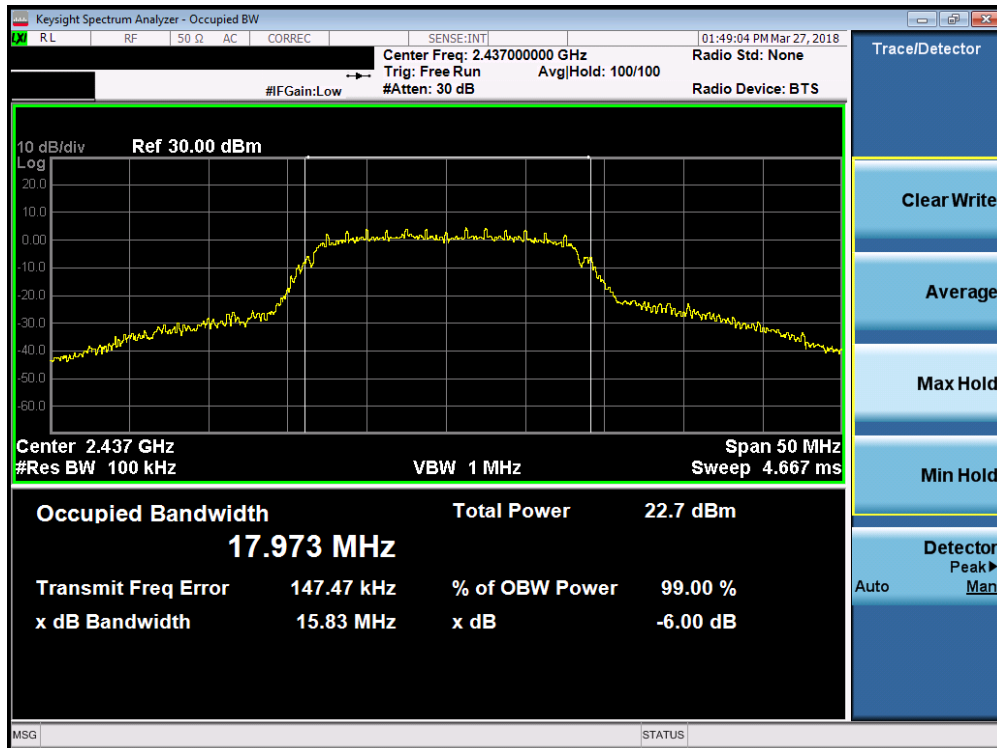

Plot 7-5. 6dB Bandwidth Plot (802.11g – Ch. 6)

FCC ID: A3LSMJ337R4	PCTEST ENGINEERING LABORATORY, INC.	MEASUREMENT REPORT (CERTIFICATION)	SAMSUNG	Approved by: Quality Manager
Test Report S/N: 1M1805160106-05.A3L	Test Dates: 3/9-4/25/2018	EUT Type: Portable Handset		Page 16 of 54

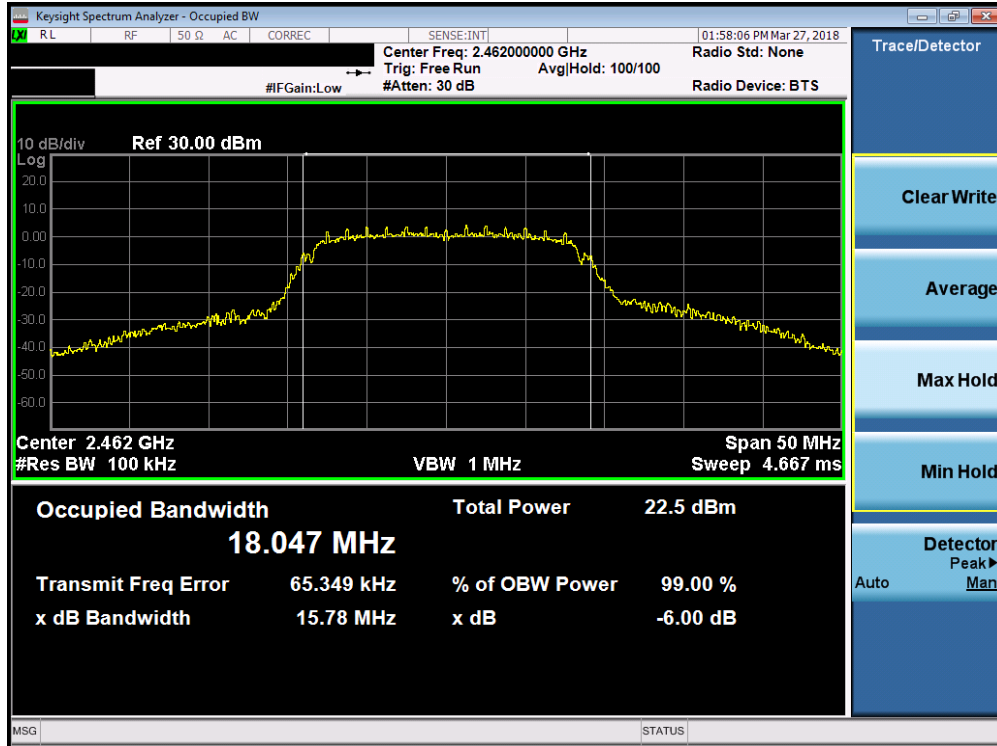

Plot 7-6. 6dB Bandwidth Plot (802.11g – Ch. 11)

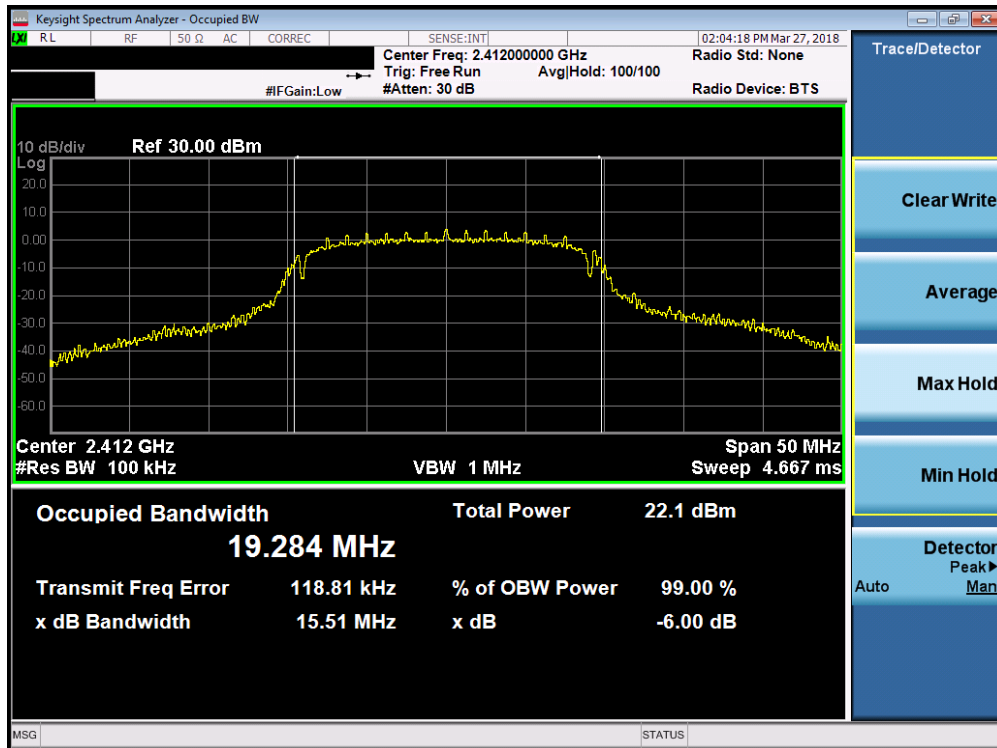

Plot 7-7. 6dB Bandwidth Plot (802.11n (2.4GHz) – Ch. 1)

FCC ID: A3LSMJ337R4	PCTEST ENGINEERING LABORATORY, INC.	MEASUREMENT REPORT (CERTIFICATION)	SAMSUNG	Approved by: Quality Manager
Test Report S/N: 1M1805160106-05.A3L	Test Dates: 3/9-4/25/2018	EUT Type: Portable Handset		Page 17 of 54

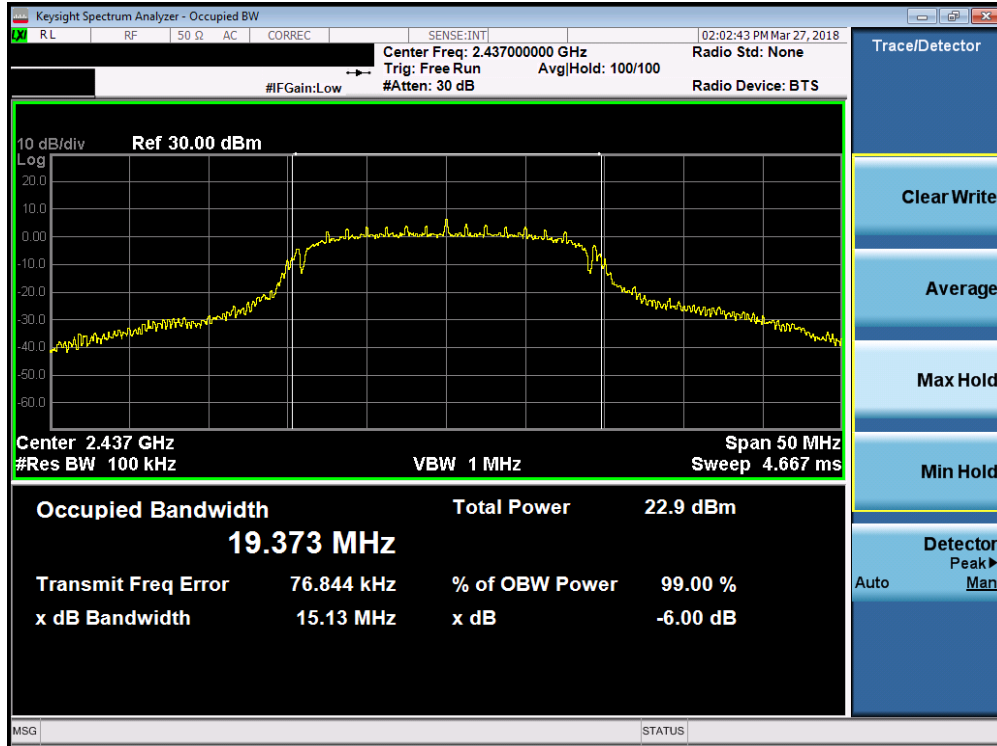

Plot 7-8. 6dB Bandwidth Plot (802.11n (2.4GHz) – Ch. 6)

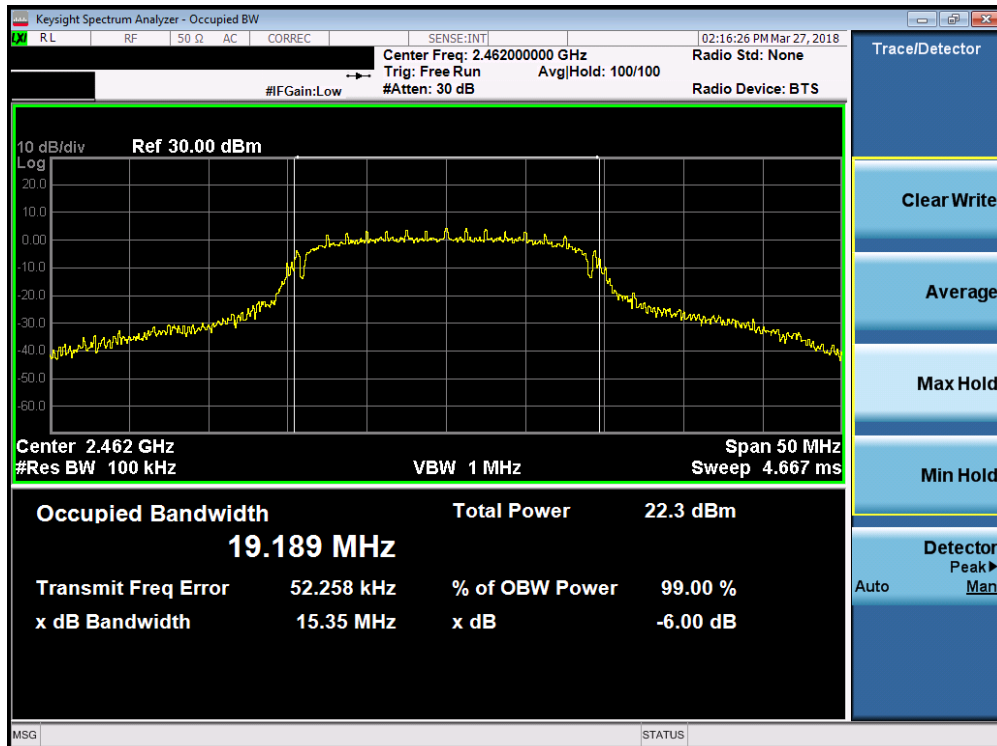

Plot 7-9. 6dB Bandwidth Plot (802.11n (2.4GHz) – Ch. 11)

FCC ID: A3LSMJ337R4	PCTEST ENGINEERING LABORATORY, INC.	MEASUREMENT REPORT (CERTIFICATION)	SAMSUNG	Approved by: Quality Manager
Test Report S/N: 1M1805160106-05.A3L	Test Dates: 3/9-4/25/2018	EUT Type: Portable Handset		Page 18 of 54

7.3 Output Power Measurement

§15.247(b.3); RSS-247 [5.4]

Test Overview and Limits

A transmitter antenna terminal of EUT is connected to the input of an RF power sensor. Measurement is made using a broadband power meter capable of making peak and average measurements while the EUT is operating at its maximum duty cycle, at maximum power, and at the appropriate frequencies.

The maximum permissible conducted output power is 1 Watt.

Test Procedure Used

ANSI C63.10-2013 – Section 11.9.1.3 PKPM1 Peak Power Method
 KDB 558074 D01 v04 – Section 9.1.3 PKPM1 Peak Power Method
 ANSI C63.10-2013 – Section 11.9.2.3.2 Method AVGPM-G
 KDB 558074 D01 v04 – Section 9.2.3.2 Method AVGPM-G

Test Settings

Method PKPM1 (Peak Power Measurement)

Peak power measurements were performed only when the EUT was transmitting at its maximum power control level using a broadband power meter with a pulse sensor. The pulse sensor employs a VBW = 50MHz so this method was only used for signals whose DTS bandwidth was less than or equal to 50MHz.

Method AVGPM-G (Average Power Measurement)

Average power measurements were performed only when the EUT was transmitting at its maximum power control level using a broadband power meter with a pulse sensor. The power meter implemented triggering and gating capabilities which were set up such that power measurements were recorded only during the ON time of the transmitter. The trace was averaged over 100 traces to obtain the final measured average power.

Test Setup

The EUT and measurement equipment were set up as shown in the diagrams below.



Figure 7-2. Test Instrument & Measurement Setup for Power Meter Measurements

Test Notes

None

FCC ID: A3LSMJ337R4		MEASUREMENT REPORT (CERTIFICATION)		Approved by: Quality Manager
Test Report S/N: 1M1805160106-05.A3L	Test Dates: 3/9-4/25/2018	EUT Type: Portable Handset		Page 19 of 54

Freq [MHz]	Channel	Detector	IEEE Transmission Mode			Conducted Power Limit [dBm]	Conducted Power Margin [dB]
			802.11b	802.11g	802.11n		
2412	1	AVG	18.67	15.35	15.11	30.00	-11.33
		PEAK	20.99	21.26	21.16	30.00	-8.74
2437	6	AVG	18.68	15.64	15.41	30.00	-11.32
		PEAK	20.96	21.27	21.21	30.00	-8.73
2457	10	AVG	17.63	14.47	13.39	30.00	-12.37
		PEAK	19.81	20.39	19.71	30.00	-9.61
2462	11	AVG	18.31	10.73	10.44	30.00	-11.69
		PEAK	20.44	17.69	17.24	30.00	-9.56

Table 7-3. Conducted Output Power Measurements

FCC ID: A3LSMJ337R4	 MEASUREMENT REPORT (CERTIFICATION)			Approved by: Quality Manager
Test Report S/N: 1M1805160106-05.A3L	Test Dates: 3/9-4/25/2018	EUT Type: Portable Handset	Page 20 of 54	

7.4 Power Spectral Density

§15.247(e); RSS-247 [5.2]

Test Overview and Limit

The peak power density is measured with a spectrum analyzer connected to the antenna terminal of the EUT while the EUT is operating at its maximum duty cycle, at maximum power, and at the appropriate frequencies. All data rates were investigated and the worst case configuration results are reported in this section.

The maximum permissible power spectral density is 8 dBm in any 3 kHz band.

Test Procedure Used

ANSI C63.10-2013 – Section 11.10.2 Method PKPSD
KDB 558074 D01 v04 – Section 10.2 Method PKPSD

Test Settings

1. Analyzer was set to the center frequency of the DTS channel under investigation
2. Span = 1.5 times the DTS channel bandwidth
3. RBW = 10kHz
4. VBW = 1MHz
5. Detector = peak
6. Sweep time = auto couple
7. Trace mode = max hold
8. Trace was allowed to stabilize

Test Setup

The EUT and measurement equipment were set up as shown in the diagram below.



Figure 7-3. Test Instrument & Measurement Setup

Test Notes

None

FCC ID: A3LSMJ337R4	 MEASUREMENT REPORT (CERTIFICATION)			Approved by: Quality Manager
Test Report S/N: 1M1805160106-05.A3L	Test Dates: 3/9-4/25/2018	EUT Type: Portable Handset	Page 21 of 54	

Frequency [MHz]	Channel No.	802.11 Mode	Data Rate [Mbps]	Measured Power Spectral Density [dBm]	Maximum Permissible Power Density [dBm / 3kHz]	Margin [dB]	Pass / Fail
2412	1	b	1	1.12	8.00	-6.88	Pass
2437	6	b	1	1.21	8.00	-6.79	Pass
2462	11	b	1	0.67	8.00	-7.33	Pass
2412	1	g	6	-3.63	8.00	-11.63	Pass
2437	6	g	6	-2.52	8.00	-10.52	Pass
2462	11	g	6	-2.75	8.00	-10.75	Pass
2412	1	n	6.5/7.2 (MCS0)	-4.75	8.00	-12.75	Pass
2437	6	n	6.5/7.2 (MCS0)	-4.15	8.00	-12.15	Pass
2462	11	n	6.5/7.2 (MCS0)	-4.34	8.00	-12.34	Pass

Table 7-4. Conducted Power Density Measurements

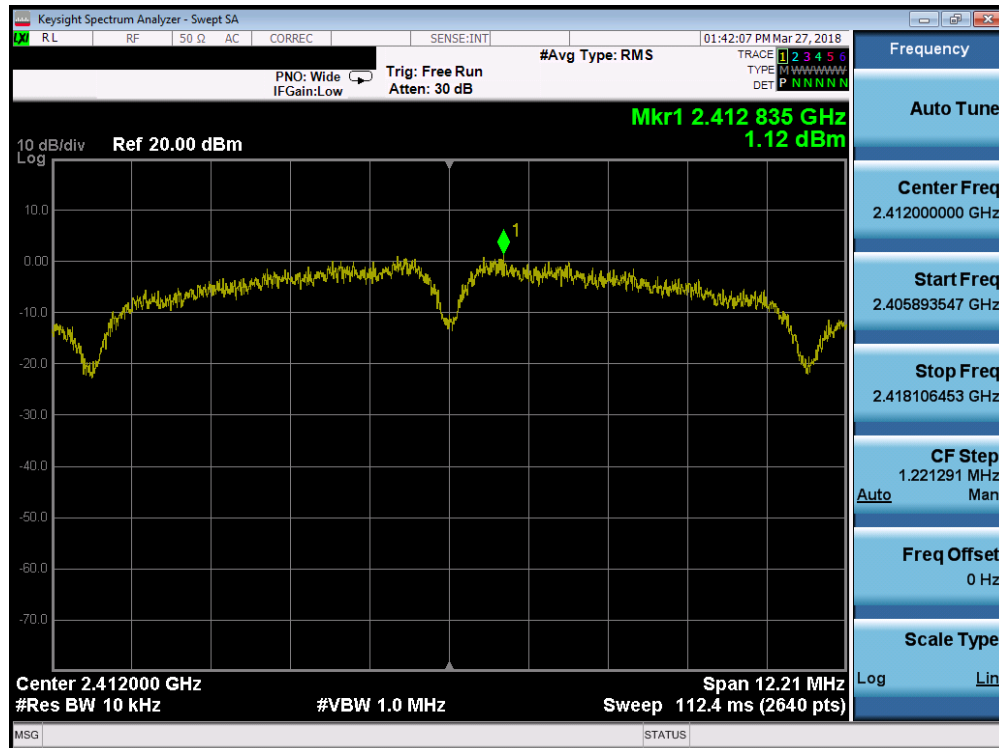

Plot 7-10. Power Spectral Density Plot (802.11b – Ch. 1)

FCC ID: A3LSMJ337R4		MEASUREMENT REPORT (CERTIFICATION)		Approved by: Quality Manager
Test Report S/N: 1M1805160106-05.A3L	Test Dates: 3/9-4/25/2018	EUT Type: Portable Handset		Page 22 of 54

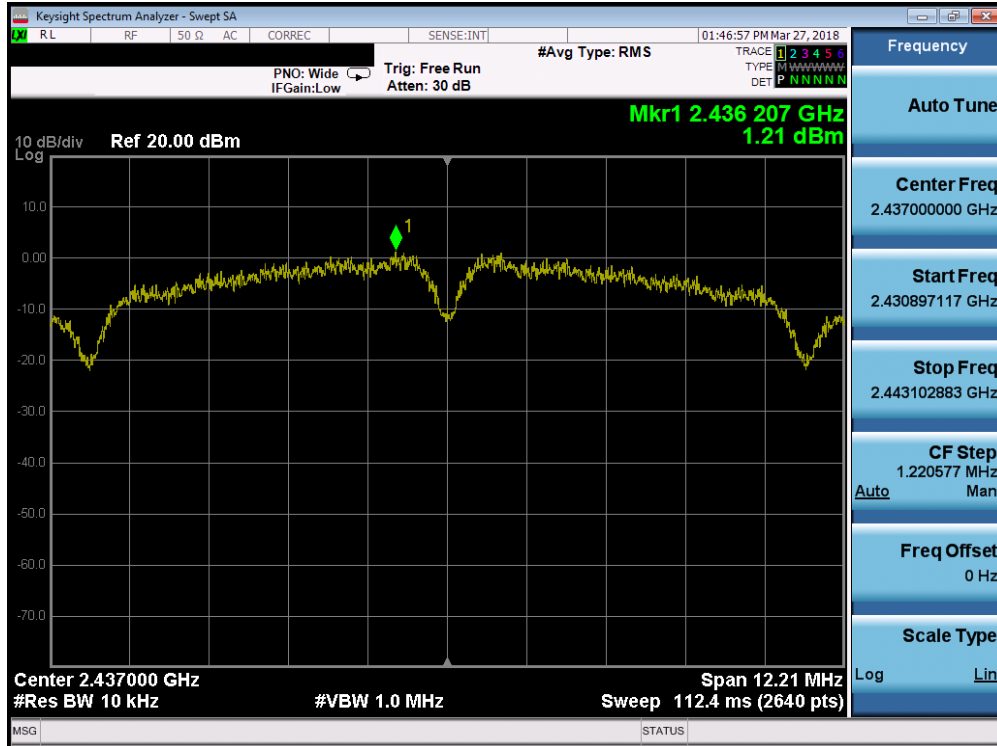

Plot 7-11. Power Spectral Density Plot (802.11b – Ch. 6)

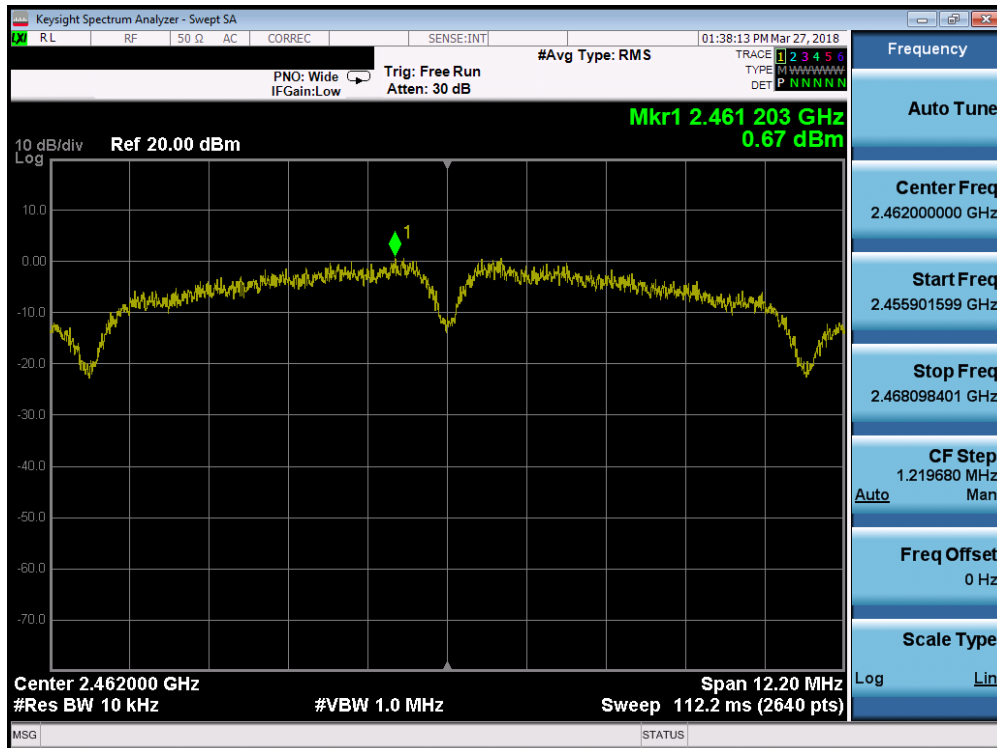

Plot 7-12. Power Spectral Density Plot (802.11b – Ch. 11)

FCC ID: A3LSMJ337R4	PCTEST ENGINEERING LABORATORY, INC.	MEASUREMENT REPORT (CERTIFICATION)	SAMSUNG	Approved by: Quality Manager
Test Report S/N: 1M1805160106-05.A3L	Test Dates: 3/9-4/25/2018	EUT Type: Portable Handset		Page 23 of 54

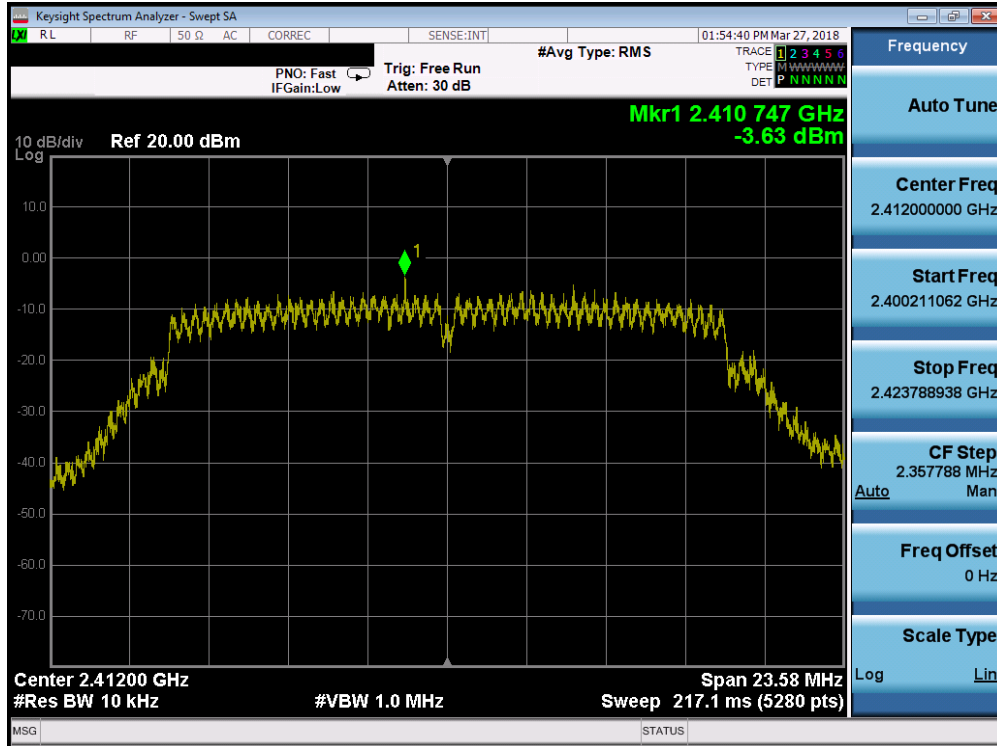

Plot 7-13. Power Spectral Density Plot (802.11g – Ch. 1)

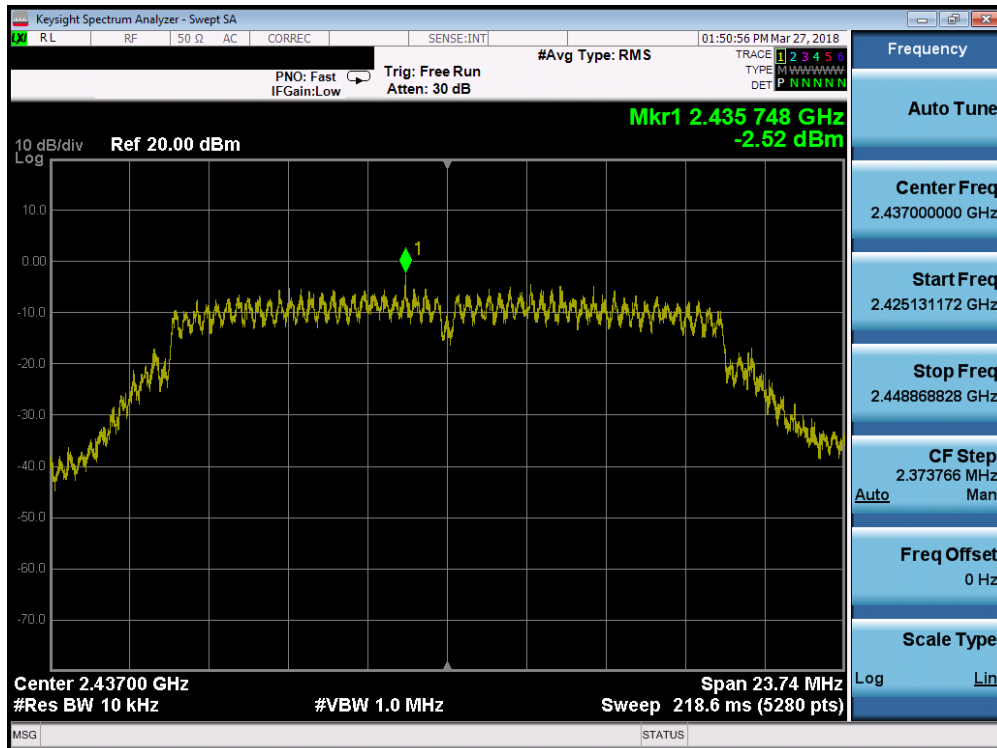

Plot 7-14. Power Spectral Density Plot (802.11g – Ch. 6)

FCC ID: A3LSMJ337R4		MEASUREMENT REPORT (CERTIFICATION)		Approved by: Quality Manager
Test Report S/N: 1M1805160106-05.A3L	Test Dates: 3/9-4/25/2018	EUT Type: Portable Handset		Page 24 of 54

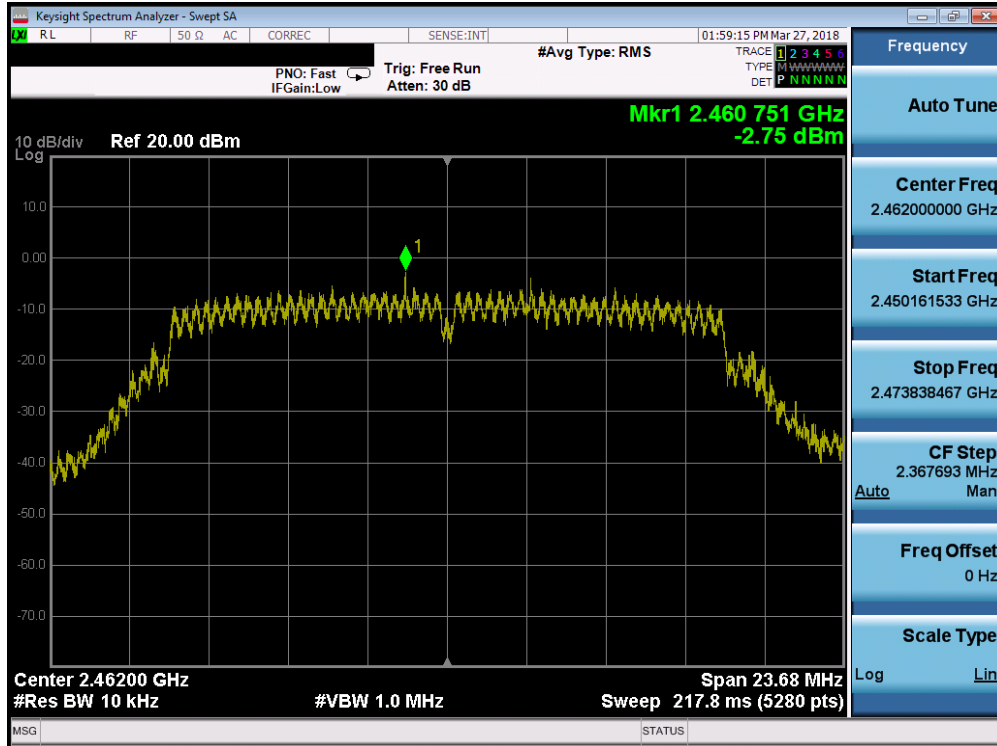

Plot 7-15. Power Spectral Density Plot (802.11g – Ch. 11)

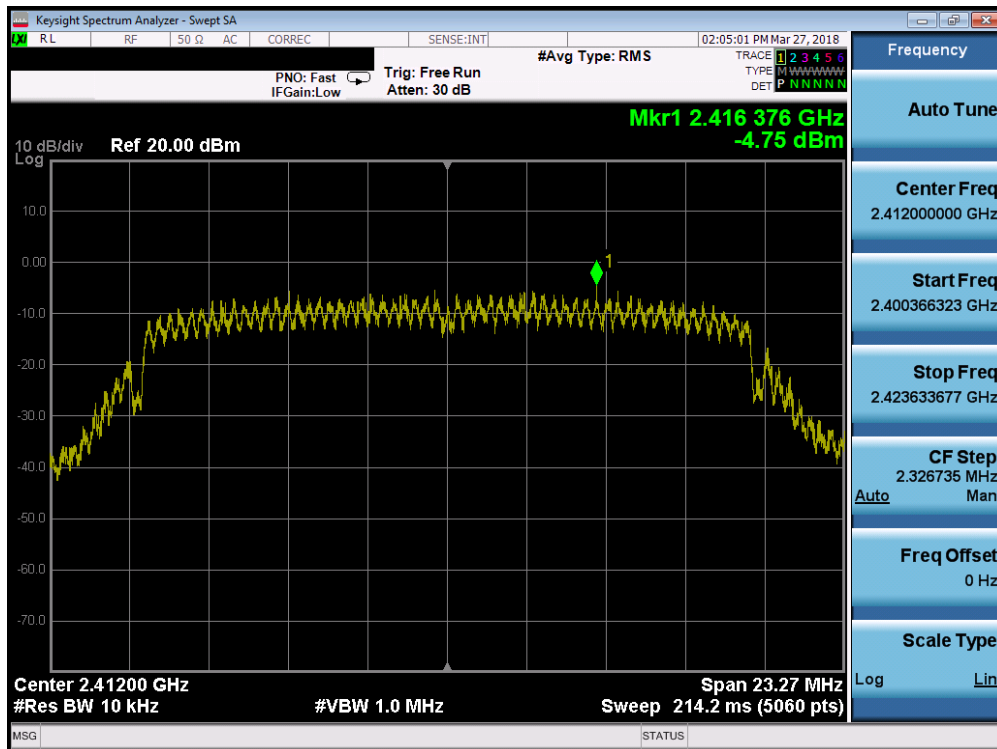

Plot 7-16. Power Spectral Density Plot (802.11n (2.4GHz) – Ch. 1)

FCC ID: A3LSMJ337R4	PCTEST ENGINEERING LABORATORY, INC.	MEASUREMENT REPORT (CERTIFICATION)		Approved by: Quality Manager
Test Report S/N: 1M1805160106-05.A3L	Test Dates: 3/9-4/25/2018	EUT Type: Portable Handset		Page 25 of 54

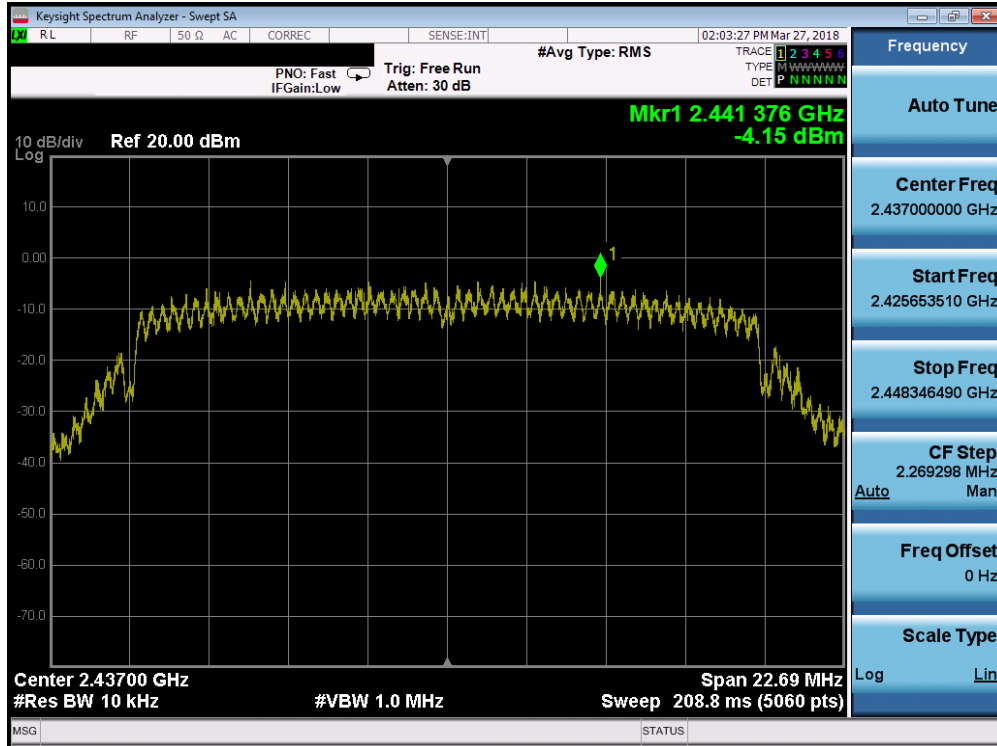

Plot 7-17. Power Spectral Density Plot (802.11n (2.4GHz) – Ch. 6)

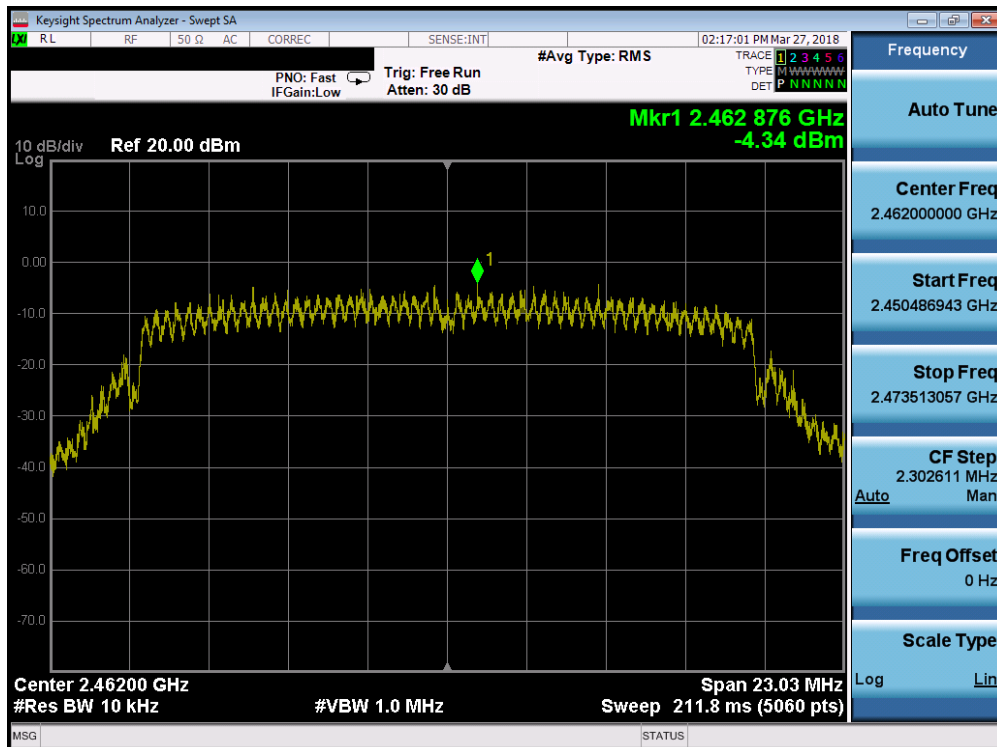

Plot 7-18. Power Spectral Density Plot (802.11n (2.4GHz) – Ch. 11)

FCC ID: A3LSMJ337R4	PCTEST ENGINEERING LABORATORY, INC.	MEASUREMENT REPORT (CERTIFICATION)		Approved by: Quality Manager
Test Report S/N: 1M1805160106-05.A3L	Test Dates: 3/9-4/25/2018	EUT Type: Portable Handset		Page 26 of 54

7.5 Conducted Emissions at the Band Edge

§15.247(d); RSS-247 [5.5]

Test Overview and Limit

All out of band emissions are measured with a spectrum analyzer connected to the antenna terminal of the EUT while the EUT is operating at its maximum duty cycle, at maximum power, and at the appropriate frequencies. All data rates were investigated to determine the worst case configuration. For the following out of band conducted spurious emissions plots at the band edge, the EUT was set at a data rate of 1Mbps for “b” mode, 6 Mbps for “g” mode, and 6.5/7.2Mbps for “n” mode as these settings produced the worst-case emissions.

The limit for out-of-band spurious emissions at the band edge is 30dB below the fundamental emission level, as determined from the in-band power measurement of the DTS channel performed in a 100kHz bandwidth per the PSD procedure (Section 7.4).

Test Procedure Used

ANSI C63.10-2013 – Section 11.11.3
KDB 558074 D01 v04 – Section 11.3

Test Settings

1. Start and stop frequency were set such that the band edge would be placed in the center of the plot
2. Span was set large enough so as to capture all out of band emissions near the band edge
3. RBW = 100kHz
4. VBW = 1MHz
5. Detector = Peak
6. Number of sweep points $\geq 2 \times \text{Span/RBW}$
7. Trace mode = max hold
8. Sweep time = auto couple
9. The trace was allowed to stabilize

Test Setup

The EUT and measurement equipment were set up as shown in the diagram below.

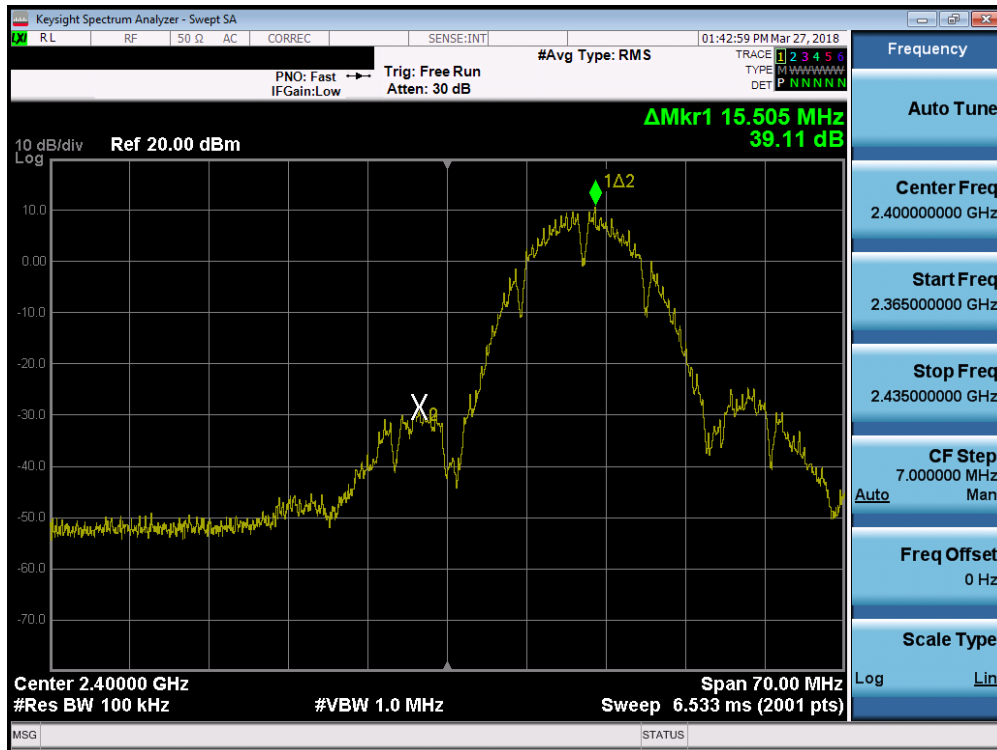

Figure 7-4. Test Instrument & Measurement Setup

Test Notes

None

FCC ID: A3LSMJ337R4		MEASUREMENT REPORT (CERTIFICATION)		Approved by: Quality Manager
Test Report S/N: 1M1805160106-05.A3L	Test Dates: 3/9-4/25/2018	EUT Type: Portable Handset		Page 27 of 54



Plot 7-19. Band Edge Plot (802.11b – Ch. 1)

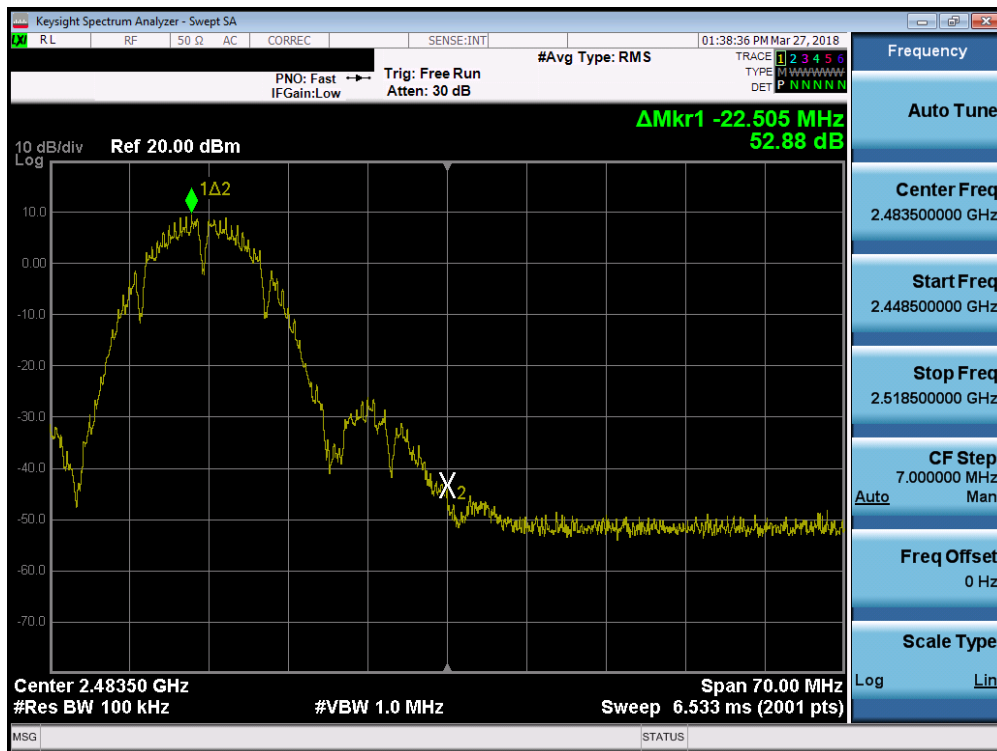

Plot 7-20. Band Edge Plot (802.11b – Ch. 11)

FCC ID: A3LSMJ337R4		MEASUREMENT REPORT (CERTIFICATION)		Approved by: Quality Manager
Test Report S/N: 1M1805160106-05.A3L	Test Dates: 3/9-4/25/2018	EUT Type: Portable Handset		Page 28 of 54

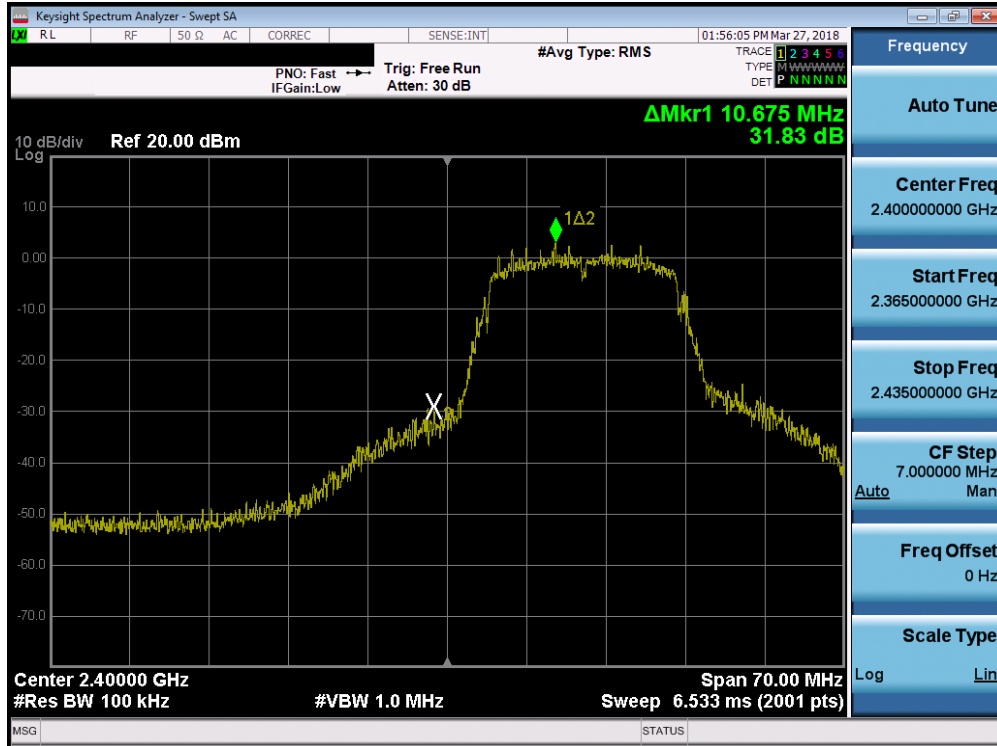

Plot 7-21. Band Edge Plot (802.11g– Ch. 1)



Plot 7-22. Band Edge Plot (802.11g – Ch. 11)

FCC ID: A3LSMJ337R4	PCTEST ENGINEERING LABORATORY, INC.	MEASUREMENT REPORT (CERTIFICATION)		Approved by: Quality Manager
Test Report S/N: 1M1805160106-05.A3L	Test Dates: 3/9-4/25/2018	EUT Type: Portable Handset		Page 29 of 54

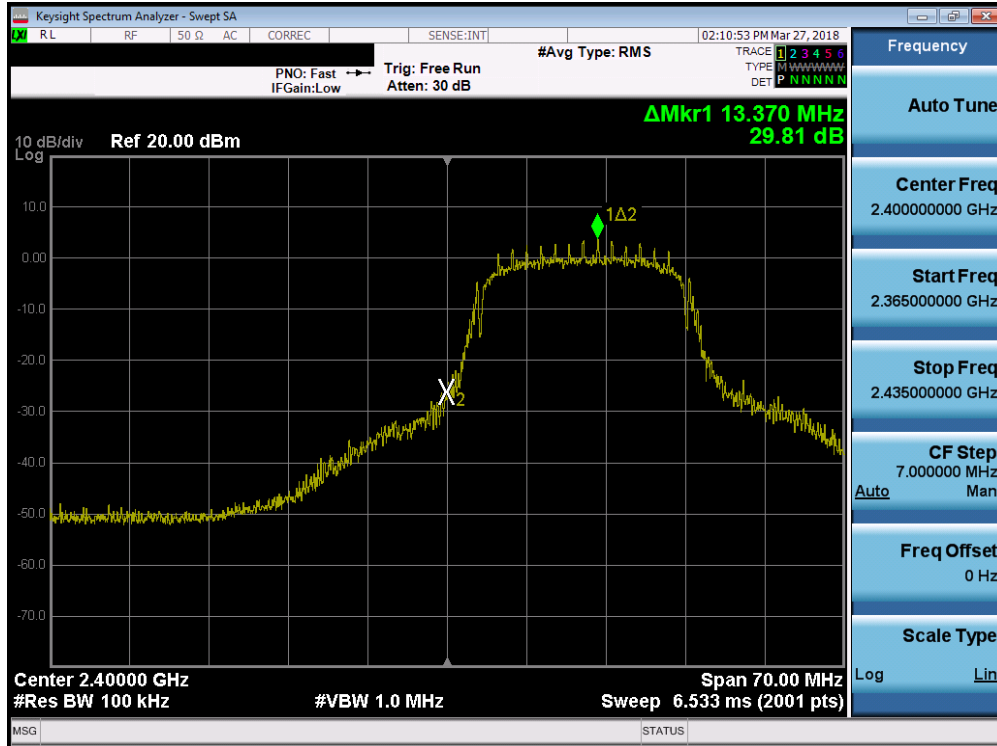

Plot 7-23. Band Edge Plot (802.11n (2.4GHz) – Ch. 1)

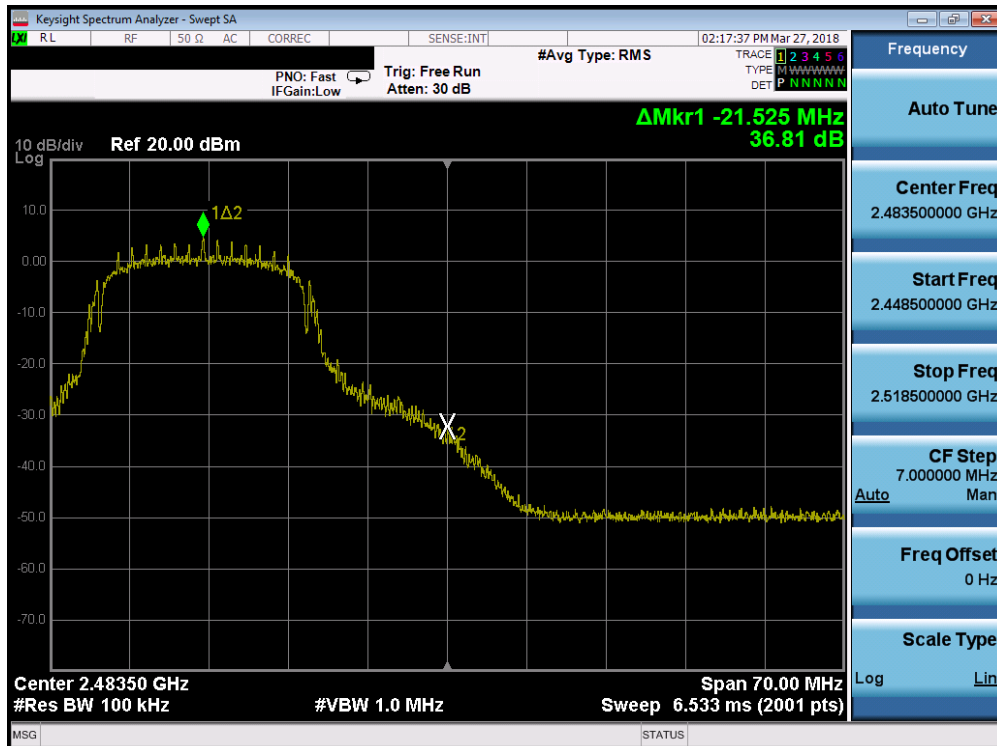

Plot 7-24. Band Edge Plot (802.11n (2.4GHz) – Ch. 11)

FCC ID: A3LSMJ337R4		MEASUREMENT REPORT (CERTIFICATION)		Approved by: Quality Manager
Test Report S/N: 1M1805160106-05.A3L	Test Dates: 3/9-4/25/2018	EUT Type: Portable Handset		Page 30 of 54

7.6 Conducted Spurious Emissions

§15.247(d); RSS-247 [5.5]

Test Overview and Limit

All out of band emissions are measured with a spectrum analyzer connected to the antenna terminal of the EUT while the EUT is operating at its maximum duty cycle, at maximum power, and at the appropriate frequencies. All data rates were investigated to determine the worst case configuration. For the following out of band conducted spurious emissions plots, the EUT was investigated in all available data rates for “b”, “g”, and “n” modes. The worst case spurious emissions for the 2.4GHz band were found while transmitting in “b” mode at 1 Mbps and are shown in the plots below.

The limit for out-of-band spurious emissions at the band edge is 30dB below the fundamental emission level, as determined from the in-band power measurement of the DTS channel performed in a 100kHz bandwidth per the procedure in Section 11.1 of ANSI C63.10-2013 and KDB 558074 D01 v04.

Test Procedure Used

ANSI C63.10-2013 – Section 11.11.3
KDB 558074 D01 v04 – Section 11.3

Test Settings

1. Start frequency was set to 30MHz and stop frequency was set to 25GHz (separated into two plots per channel)
2. RBW = 1MHz
3. VBW = 3MHz
4. Detector = Peak
5. Trace mode = max hold
6. Sweep time = auto couple
7. The trace was allowed to stabilize

Test Setup

The EUT and measurement equipment were set up as shown in the diagram below.



Figure 7-5. Test Instrument & Measurement Setup

FCC ID: A3LSMJ337R4		MEASUREMENT REPORT (CERTIFICATION)		Approved by: Quality Manager
Test Report S/N: 1M1805160106-05.A3L	Test Dates: 3/9-4/25/2018	EUT Type: Portable Handset		Page 31 of 54

Test Notes

1. RBW was set to 1MHz rather than 100kHz in order to increase the measurement speed.
2. The display line shown in the following plots denotes the limit at 30dB below the fundamental emission level measured in a 100kHz bandwidth. However, since the traces in the following plots are measured with a 1MHz RBW, the display line may not necessarily appear to be 30dB below the level of the fundamental in a 1MHz bandwidth.
3. For plots showing conducted spurious emissions near the limit, the frequencies were investigated with a reduced RBW to ensure that no emissions were present.

FCC ID: A3LSMJ337R4	 MEASUREMENT REPORT (CERTIFICATION) 		Approved by: Quality Manager
Test Report S/N: 1M1805160106-05.A3L	Test Dates: 3/9-4/25/2018	EUT Type: Portable Handset	Page 32 of 54

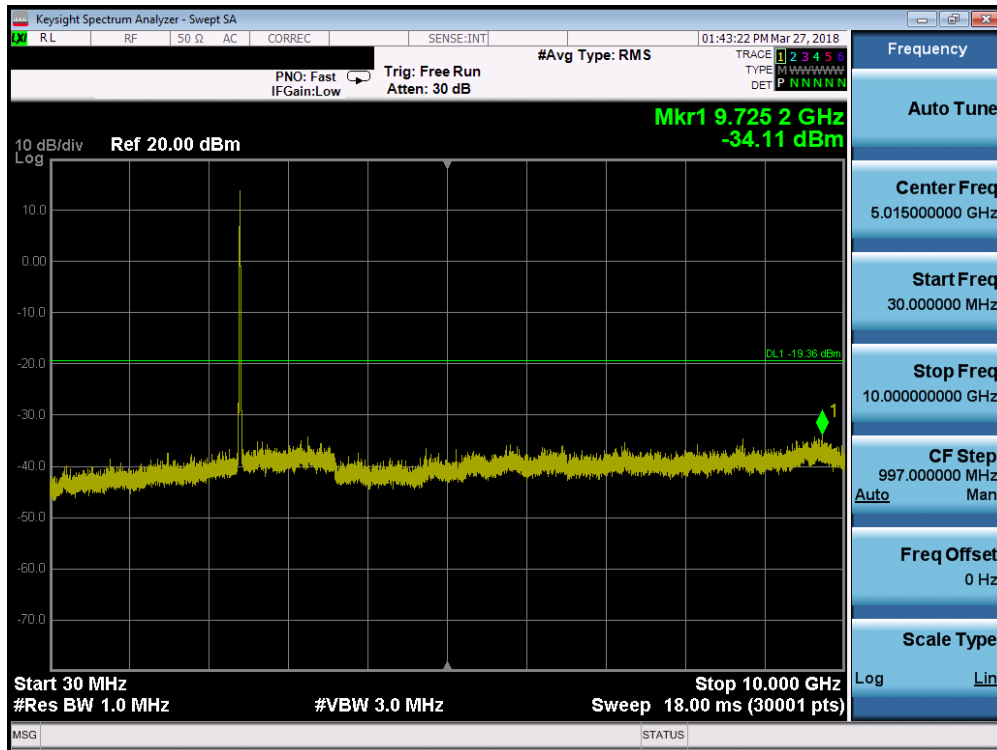

Plot 7-25. Conducted Spurious Plot (802.11b – Ch. 1)

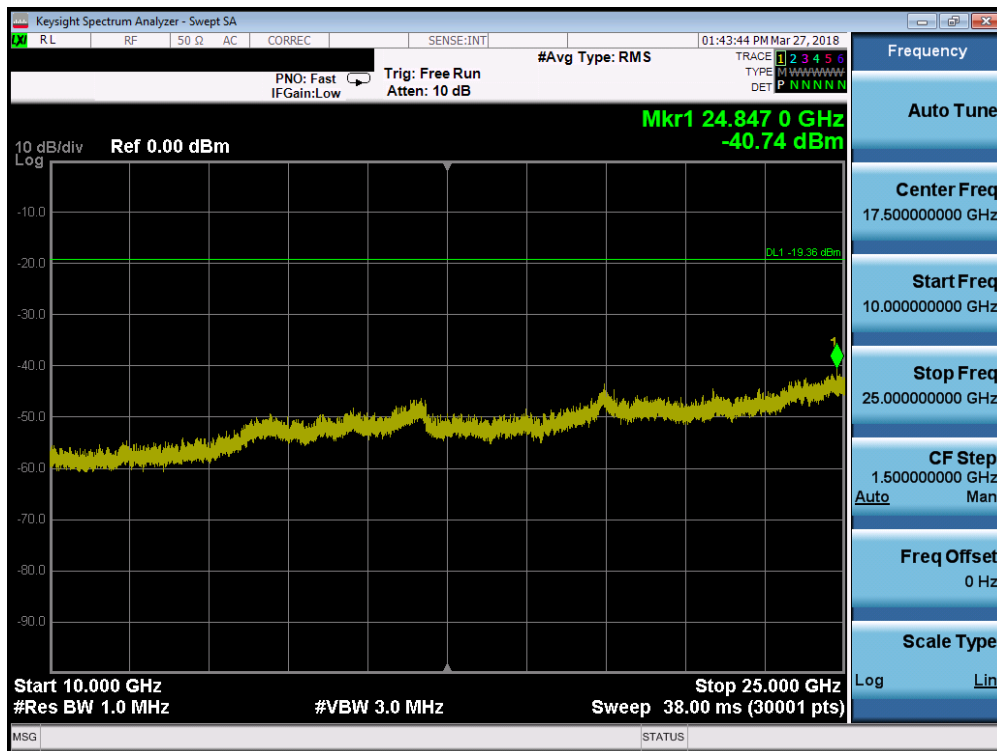

Plot 7-26. Conducted Spurious Plot (802.11b – Ch. 1)

FCC ID: A3LSMJ337R4		MEASUREMENT REPORT (CERTIFICATION)		Approved by: Quality Manager
Test Report S/N: 1M1805160106-05.A3L	Test Dates: 3/9-4/25/2018	EUT Type: Portable Handset		Page 33 of 54

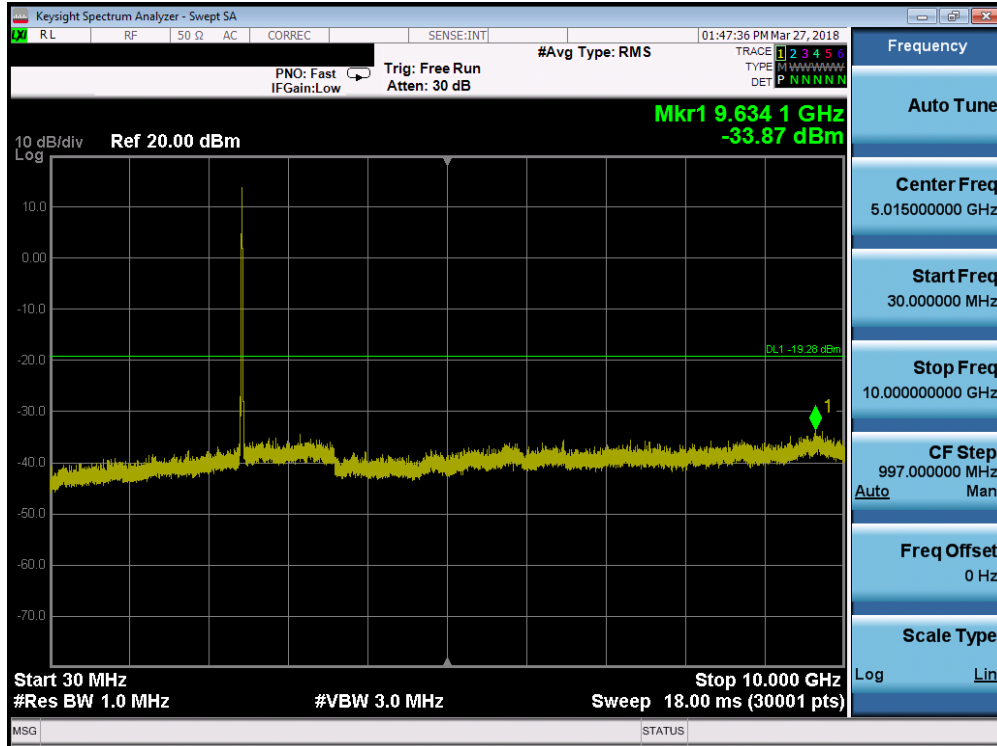

Plot 7-27. Conducted Spurious Plot (802.11b – Ch. 6)

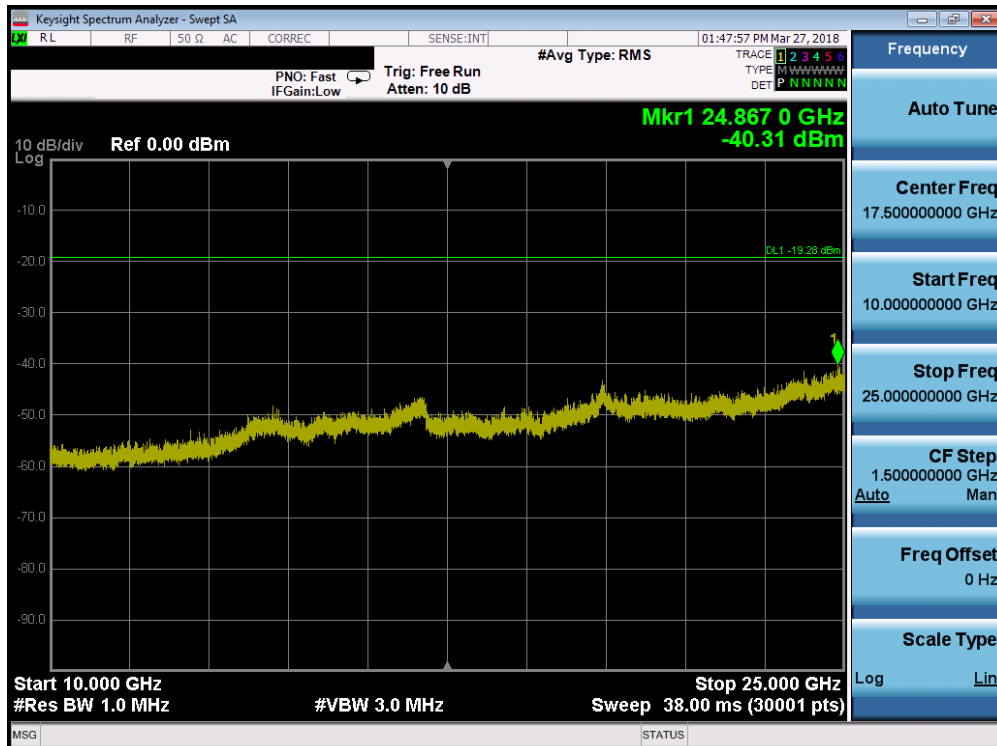

Plot 7-28. Conducted Spurious Plot (802.11b – Ch. 6)

FCC ID: A3LSMJ337R4		MEASUREMENT REPORT (CERTIFICATION)		Approved by: Quality Manager
Test Report S/N: 1M1805160106-05.A3L	Test Dates: 3/9-4/25/2018	EUT Type: Portable Handset		Page 34 of 54

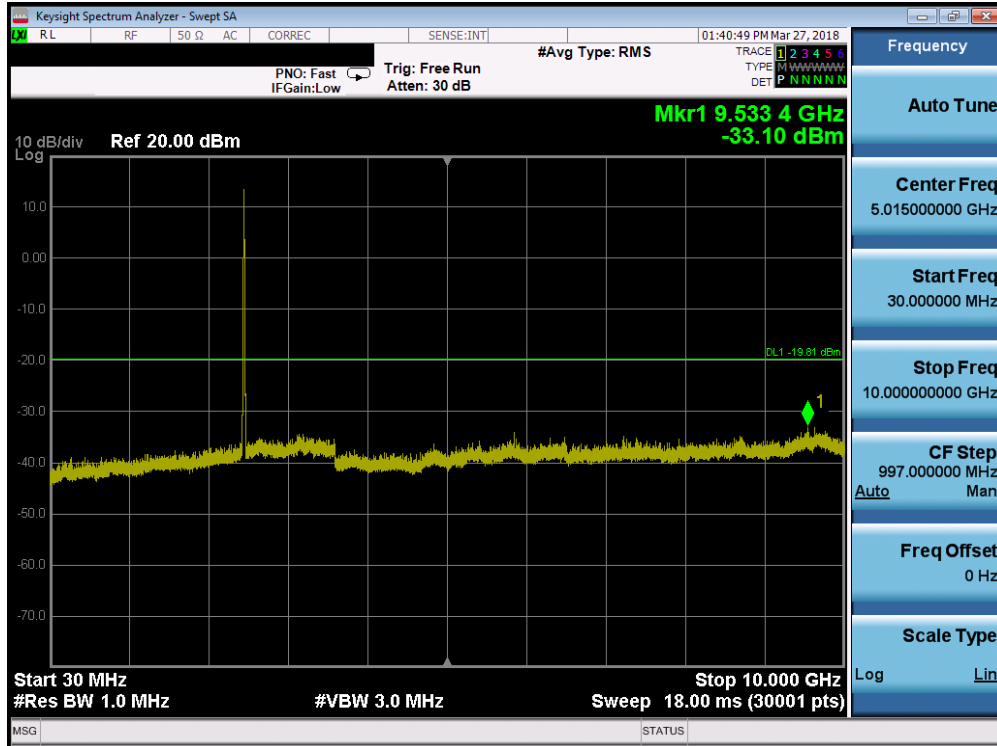

Plot 7-29. Conducted Spurious Plot (802.11b – Ch. 11)

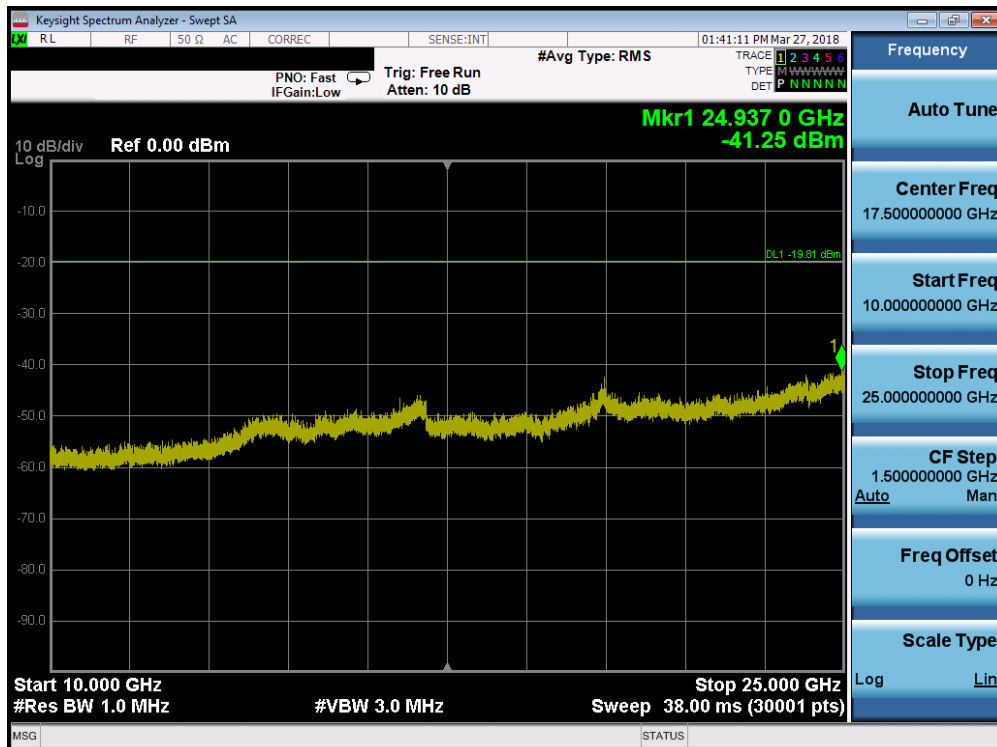

Plot 7-30. Conducted Spurious Plot (802.11b – Ch. 11)

FCC ID: A3LSMJ337R4		MEASUREMENT REPORT (CERTIFICATION)		Approved by: Quality Manager
Test Report S/N: 1M1805160106-05.A3L	Test Dates: 3/9-4/25/2018	EUT Type: Portable Handset		Page 35 of 54

7.7 Radiated Spurious Emission Measurements – Above 1 GHz

§15.247(d) §15.205 & §15.209; RSS-Gen [8.9]

Test Overview and Limit

All out of band radiated spurious emissions are measured with a spectrum analyzer connected to a receive antenna while the EUT is operating at its maximum duty cycle, at maximum power, and at the appropriate frequencies. All data rates and modes were investigated for radiated spurious emissions. Only the radiated emissions of the configuration that produced the worst case emissions are reported in this section.

All out of band emissions appearing in a restricted band as specified in Section 15.205 of the Title 47 CFR and Table 6 of RSS-Gen (8.10) must not exceed the limits shown in Table 7-5 per Section 15.209 and RSS-Gen (8.9).

Frequency	Field Strength [$\mu\text{V/m}$]	Measured Distance [Meters]
Above 960.0 MHz	500	3

Table 7-5. Radiated Limits

Test Procedures Used

ANSI C63.10-2013 – Section 6.6.4.3
KDB 558074 D01 v04 – Section 12.1, 12.2.7

Test Settings

Average Field Strength Measurements

1. Analyzer center frequency was set to the frequency of the radiated spurious emission of interest
2. RBW = 1MHz
3. VBW = 3MHz
4. Detector = power average (RMS)
5. Number of measurement points = 1001 (Number of points must be $\geq 2 \times \text{span/RBW}$)
6. Sweep time = auto
7. Trace (RMS) averaging was performed over at least 100 traces

Peak Field Strength Measurements

1. Analyzer center frequency was set to the frequency of the radiated spurious emission of interest
2. RBW = 1MHz
3. VBW = 3MHz
4. Detector = peak
5. Sweep time = auto couple
6. Trace mode = max hold
7. Trace was allowed to stabilize

FCC ID: A3LSMJ337R4		MEASUREMENT REPORT (CERTIFICATION)		Approved by: Quality Manager
Test Report S/N: 1M1805160106-05.A3L	Test Dates: 3/9-4/25/2018	EUT Type: Portable Handset	Page 36 of 54	

FCC ID: A3LSMJ337R4	 MEASUREMENT REPORT (CERTIFICATION)		 Approved by: Quality Manager
Test Report S/N: 1M1805160106-05.A3L	Test Dates: 3/9-4/25/2018	EUT Type: Portable Handset	Page 37 of 54

Test Setup

The EUT and measurement equipment were set up as shown in the diagram below.

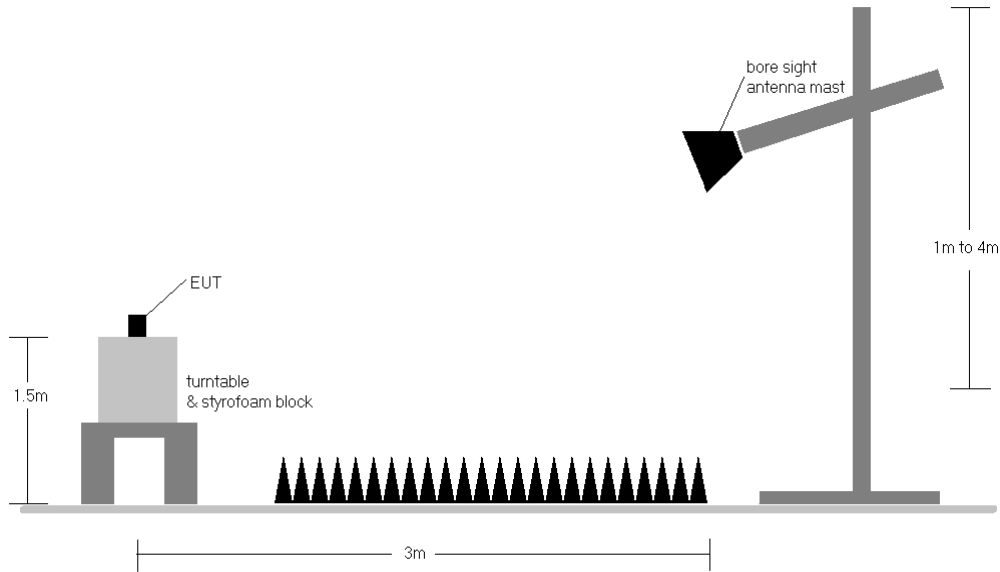

Figure 7-6. Test Instrument & Measurement Setup

Test Notes

1. The optional test procedures for antenna port conducted measurements of unwanted emissions per the guidance of KDB 558074 D01 v04 were not used to evaluate this device for compliance to radiated limits. All radiated spurious emissions levels were measured in a radiated test setup.
2. All emissions lying in restricted bands specified in Section 15.205 and Section 8.10 of RSS-Gen are below the limit shown in Table 7-5.
3. The antenna is manipulated through typical positions, polarity and length during the tests. The EUT is manipulated through three orthogonal planes.
4. This unit was tested with its standard battery.
5. The spectrum is measured from 9kHz to the 10th harmonic of the fundamental frequency of the transmitter using CISPR quasi peak detector below 1GHz. Above 1 GHz, average and peak measurements were taken using linearly polarized horn antennas. The worst-case emissions are reported however emissions whose levels were not within 20dB of the respective limits were not reported.
6. Emissions below 18GHz were measured at a 3 meter test distance while emissions above 18GHz were measured at a 1 meter test distance with the application of a distance correction factor.
7. The wide spectrum spurious emissions plots shown on the following pages are used only for the purpose of emission identification. Any emissions found to be within 20dB of the limit are fully investigated and the results are shown in this section.
8. The "-" shown in the following RSE tables are used to denote a noise floor measurement.

FCC ID: A3LSMJ337R4		MEASUREMENT REPORT (CERTIFICATION)		Approved by: Quality Manager
Test Report S/N: 1M1805160106-05.A3L	Test Dates: 3/9-4/25/2018	EUT Type: Portable Handset		Page 38 of 54

Sample Calculations

Determining Spurious Emissions Levels

- Field Strength Level $_{[dB\mu V/m]} = \text{Analyzer Level }_{[dBm]} + 107 + \text{AFCL }_{[dB/m]}$
- $\text{AFCL }_{[dB/m]} = \text{Antenna Factor }_{[dB/m]} + \text{Cable Loss }_{[dB]}$
- $\text{Margin }_{[dB]} = \text{Field Strength Level }_{[dB\mu V/m]} - \text{Limit }_{[dB\mu V/m]}$

Radiated Band Edge Measurement Offset

- The amplitude offset shown in the radiated restricted band edge plots in Section 7.7 was calculated using the formula:

$$\text{Offset (dB)} = (\text{Antenna Factor} + \text{Cable Loss} + \text{Attenuator}) - \text{Preamplifier Gain}$$

FCC ID: A3LSMJ337R4	 MEASUREMENT REPORT (CERTIFICATION)			Approved by: Quality Manager
Test Report S/N: 1M1805160106-05.A3L	Test Dates: 3/9-4/25/2018	EUT Type: Portable Handset		Page 39 of 54

7.7.1 Radiated Spurious Emission Measurements

§15.247(d) §15.205 & §15.209; RSS-Gen [8.9]

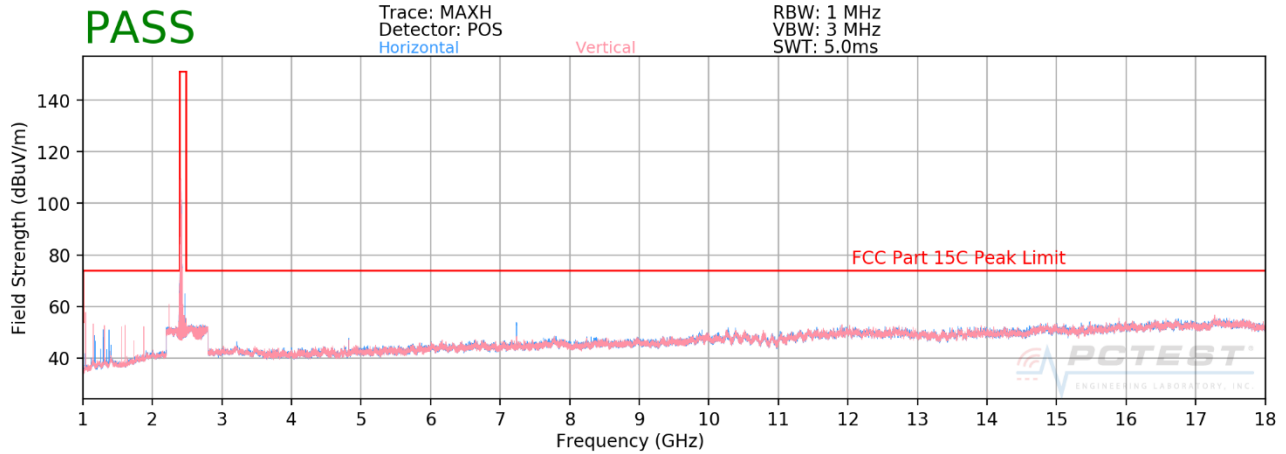

Plot 7-31. Radiated Spurious Plot above 1GHz (802.11b – Ch. 1)

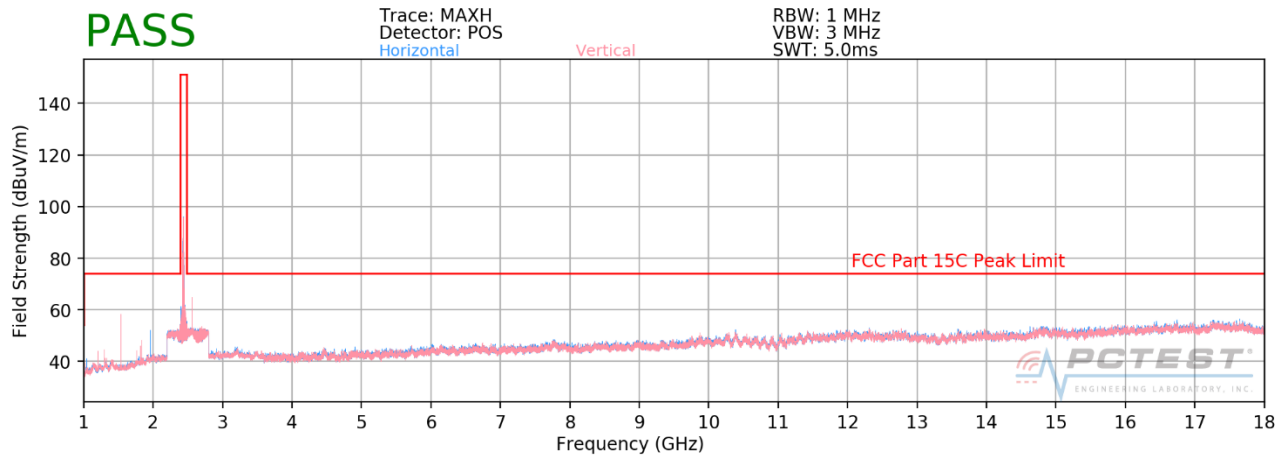

Plot 7-32. Radiated Spurious Plot above 1GHz (802.11b – Ch. 6)

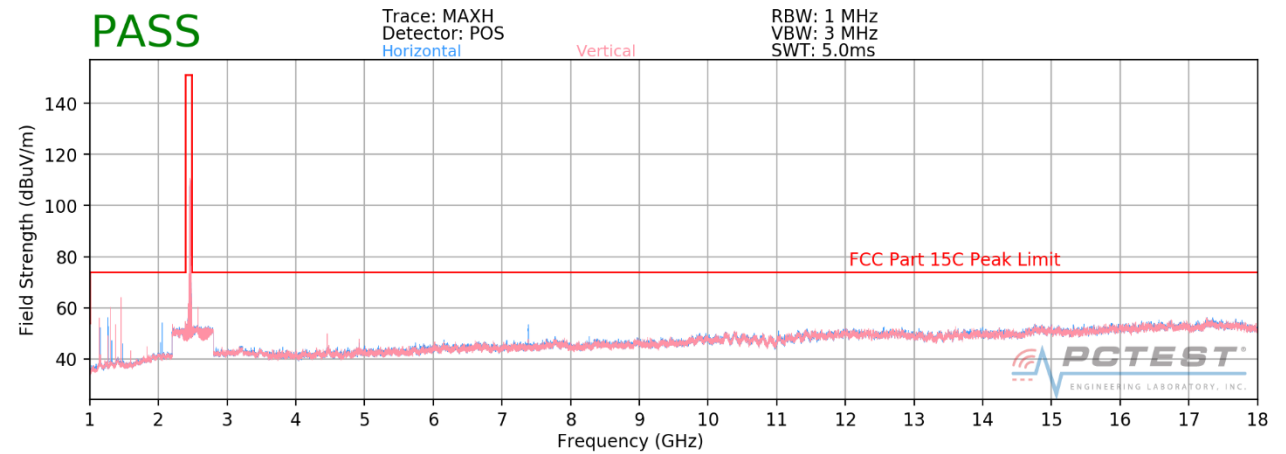

Plot 7-33. Radiated Spurious Plot above 1GHz (802.11b – Ch. 11)

FCC ID: A3LSMJ337R4		MEASUREMENT REPORT (CERTIFICATION)		Approved by: Quality Manager
Test Report S/N: 1M1805160106-05.A3L	Test Dates: 3/9-4/25/2018	EUT Type: Portable Handset		Page 40 of 54

Radiated Spurious Emissions Measurements (Above 18GHz)
§15.209; RSS-Gen [8.9]

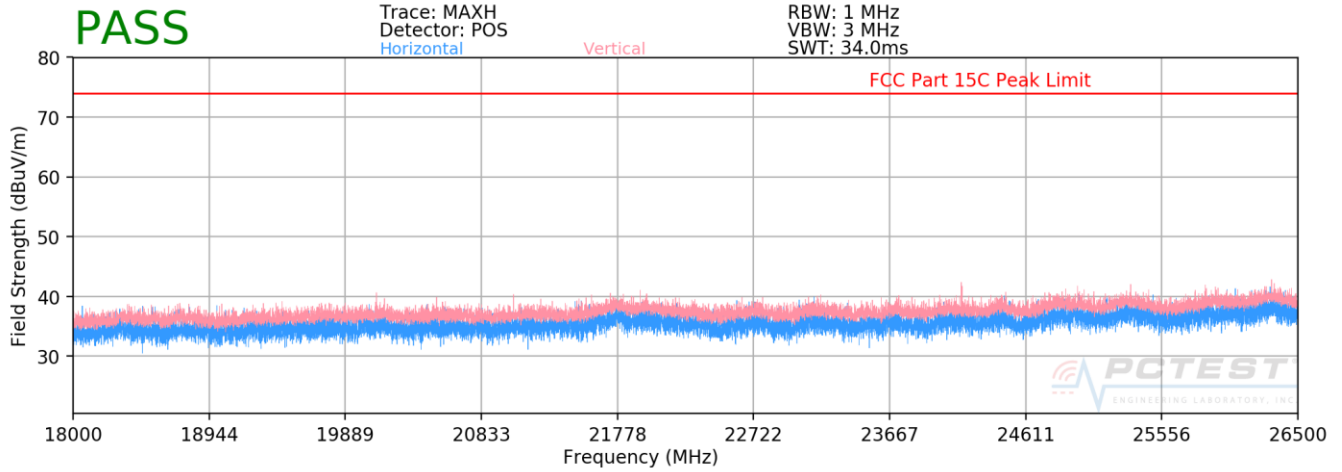

Plot 7-34. Radiated Spurious Plot above 18GHz

FCC ID: A3LSMJ337R4	 MEASUREMENT REPORT (CERTIFICATION)			Approved by: Quality Manager
Test Report S/N: 1M1805160106-05.A3L	Test Dates: 3/9-4/25/2018	EUT Type: Portable Handset	Page 41 of 54	

Radiated Spurious Emission Measurements

§15.247(d) §15.205 & §15.209; RSS-Gen [8.9]

Worst Case Mode: 802.11b
 Worst Case Transfer Rate: 1 Mbps
 Distance of Measurements: 3 Meters
 Operating Frequency: 2412MHz
 Channel: 01

Frequency [MHz]	Detector	Ant. Pol. [H/V]	Antenna Height [cm]	Turntable Azimuth [degree]	Analyzer Level [dBm]	AFCL [dB/m]	Field Strength [dBµV/m]	Limit [dBµV/m]	Margin [dB]
4824.00	Avg	V	109	254	-58.08	1.88	50.80	53.98	-3.18
4824.00	Peak	V	109	254	-64.22	1.88	44.66	73.98	-29.32
12060.00	Avg	V	-	-	-73.47	13.40	46.93	53.98	-7.05
12060.00	Peak	V	-	-	-62.19	13.40	58.21	73.98	-15.77

Table 7-6. Radiated Measurements

Worst Case Mode: 802.11b
 Worst Case Transfer Rate: 1 Mbps
 Distance of Measurements: 3 Meters
 Operating Frequency: 2437MHz
 Channel: 06

Frequency [MHz]	Detector	Ant. Pol. [H/V]	Antenna Height [cm]	Turntable Azimuth [degree]	Analyzer Level [dBm]	AFCL [dB/m]	Field Strength [dBµV/m]	Limit [dBµV/m]	Margin [dB]
4874.00	Avg	V	109	275	-64.55	2.91	45.36	53.98	-8.62
4874.00	Peak	V	109	275	-57.37	2.91	52.54	73.98	-21.44
7311.00	Avg	V	113	79	-70.86	9.10	45.24	53.98	-8.74
7311.00	Peak	V	113	79	-60.67	9.10	55.43	73.98	-18.55
12185.00	Avg	V	-	-	-73.64	12.89	46.25	53.98	-7.73
12185.00	Peak	V	-	-	-61.70	12.89	58.19	73.98	-15.79

Table 7-7. Radiated Measurements

FCC ID: A3LSMJ337R4		MEASUREMENT REPORT (CERTIFICATION)		Approved by: Quality Manager
Test Report S/N: 1M1805160106-05.A3L	Test Dates: 3/9-4/25/2018	EUT Type: Portable Handset	Page 42 of 54	

Worst Case Mode: 802.11b
 Worst Case Transfer Rate: 1 Mbps
 Distance of Measurements: 3 Meters
 Operating Frequency: 2462MHz
 Channel: 11

Frequency [MHz]	Detector	Ant. Pol. [H/V]	Antenna Height [cm]	Turntable Azimuth [degree]	Analyzer Level [dBm]	AFCL [dB/m]	Field Strength [dBμV/m]	Limit [dBμV/m]	Margin [dB]
4924.00	Avg	V	100	276	-64.57	2.37	44.80	53.98	-9.18
4924.00	Peak	V	100	276	-57.59	2.37	51.78	73.98	-22.20
7386.00	Avg	V	100	76	-71.33	9.38	45.05	53.98	-8.93
7386.00	Peak	V	100	76	-60.85	9.38	55.53	73.98	-18.45
12310.00	Avg	V	-	-	-73.78	13.36	46.58	53.98	-7.40
12310.00	Peak	V	-	-	-62.55	13.36	57.81	73.98	-16.17

Table 7-8. Radiated Measurements

FCC ID: A3LSMJ337R4	 MEASUREMENT REPORT (CERTIFICATION)			Approved by: Quality Manager
Test Report S/N: 1M1805160106-05.A3L	Test Dates: 3/9-4/25/2018	EUT Type: Portable Handset	Page 43 of 54	

7.7.2 Radiated Restricted Band Edge Measurements

§15.205 §15.209; RSS-Gen [8.9]

The radiated restricted band edge measurements are measured with an EMI test receiver connected to the receive antenna while the EUT is transmitting.

Worst Case Mode:	802.11n
Worst Case Transfer Rate:	MCS0
Distance of Measurements:	3 Meters
Operating Frequency:	2412MHz
Channel:	1

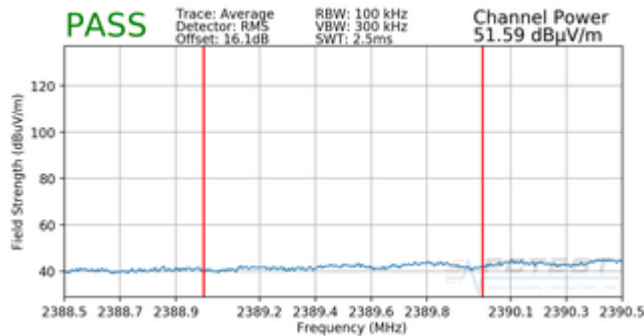

Plot 7-35. Radiated Restricted Lower Band Edge Measurement (Average)

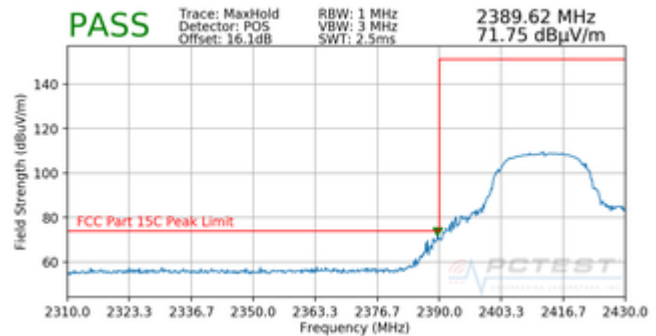

Plot 7-36. Radiated Restricted Lower Band Edge Measurement (Peak)

FCC ID: A3LSMJ337R4	 MEASUREMENT REPORT (CERTIFICATION)			Approved by: Quality Manager
Test Report S/N: 1M1805160106-05.A3L	Test Dates: 3/9-4/25/2018	EUT Type: Portable Handset	Page 44 of 54	

Worst Case Mode: 802.11n
 Worst Case Transfer Rate: MCS0
 Distance of Measurements: 3 Meters
 Operating Frequency: 2457MHz
 Channel: 10

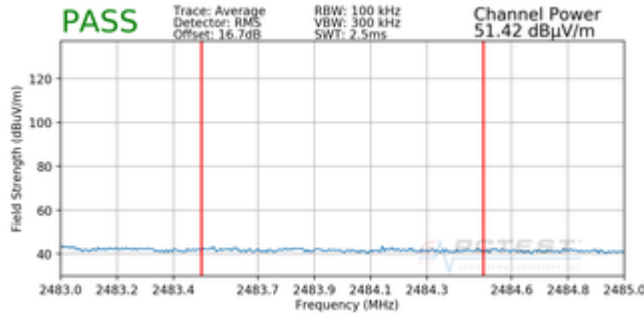

Plot 7-37. Radiated Restricted Upper Band Edge Measurement (Average)

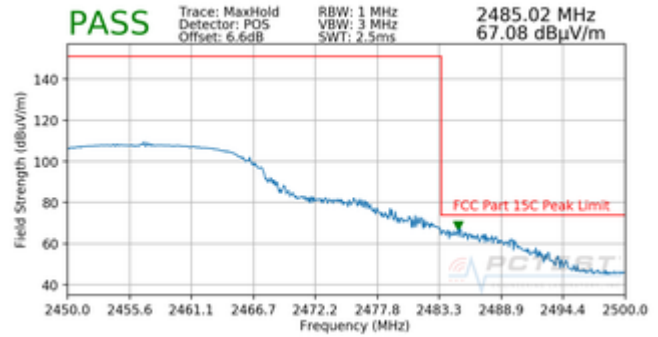

Plot 7-38. Radiated Restricted Upper Band Edge Measurement (Peak)

FCC ID: A3LSMJ337R4	 MEASUREMENT REPORT (CERTIFICATION) 		Approved by: Quality Manager
Test Report S/N: 1M1805160106-05.A3L	Test Dates: 3/9-4/25/2018	EUT Type: Portable Handset	Page 45 of 54

Worst Case Mode: 802.11n
 Worst Case Transfer Rate: MCS0
 Distance of Measurements: 3 Meters
 Operating Frequency: 2462MHz
 Channel: 11

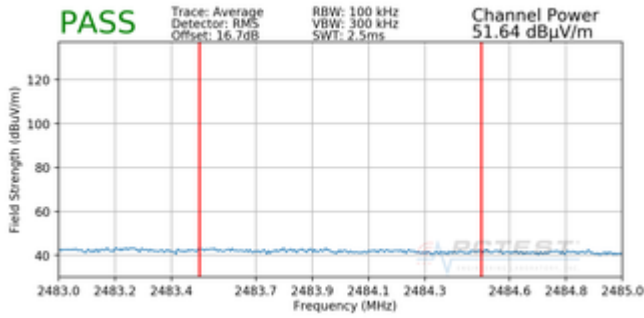

Plot 7-39. Radiated Restricted Upper Band Edge Measurement (Average)

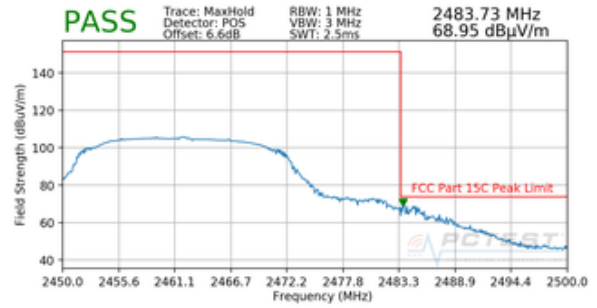

Plot 7-40. Radiated Restricted Upper Band Edge Measurement (Peak)

FCC ID: A3LSMJ337R4	MEASUREMENT REPORT (CERTIFICATION)			Approved by: Quality Manager
Test Report S/N: 1M1805160106-05.A3L	Test Dates: 3/9-4/25/2018	EUT Type: Portable Handset	Page 46 of 54	

7.8 Radiated Spurious Emissions Measurements – Below 1GHz §15.209; RSS-Gen [8.9]

Test Overview and Limit

All out of band radiated spurious emissions are measured with a spectrum analyzer connected to a receive antenna while the EUT is operating at its maximum duty cycle, at maximum power, and at the appropriate frequencies. All data rates and modes were investigated for radiated spurious emissions. Only the radiated emissions of the configuration that produced the worst case emissions are reported in this section.

All out of band emissions appearing in a restricted band as specified in Section 15.205 of the Title 47 CFR and Table 6 of RSS-Gen (8.10) must not exceed the limits shown in Table 7-9 per Section 15.209 and RSS-Gen (8.9).

Frequency	Field Strength [$\mu\text{V/m}$]	Measured Distance [Meters]
0.009 – 0.490 MHz	2400/F (kHz)	300
0.490 – 1.705 MHz	24000/F (kHz)	30
1.705 – 30.00 MHz	30	30
30.00 – 88.00 MHz	100	3
88.00 – 216.0 MHz	150	3
216.0 – 960.0 MHz	200	3
Above 960.0 MHz	500	3

Table 7-9. Radiated Limits

Test Procedures Used

ANSI C63.10-2013

Test Settings

Quasi-Peak Field Strength Measurements

1. Analyzer center frequency was set to the frequency of the radiated spurious emission of interest
2. RBW = 120kHz (for emissions from 30MHz – 1GHz)
3. Detector = quasi-peak
4. Sweep time = auto couple
5. Trace mode = max hold
6. Trace was allowed to stabilize

FCC ID: A3LSMJ337R4	 MEASUREMENT REPORT (CERTIFICATION)			Approved by: Quality Manager
Test Report S/N: 1M1805160106-05.A3L	Test Dates: 3/9-4/25/2018	EUT Type: Portable Handset	Page 47 of 54	

Test Setup

The EUT and measurement equipment were set up as shown in the diagrams below.

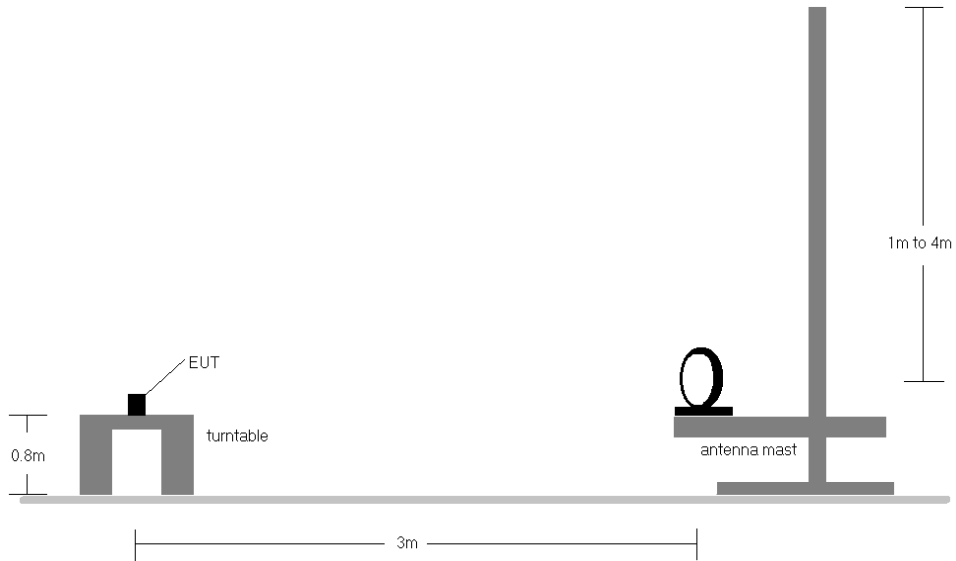

Figure 7-7. Radiated Test Setup < 30Mhz

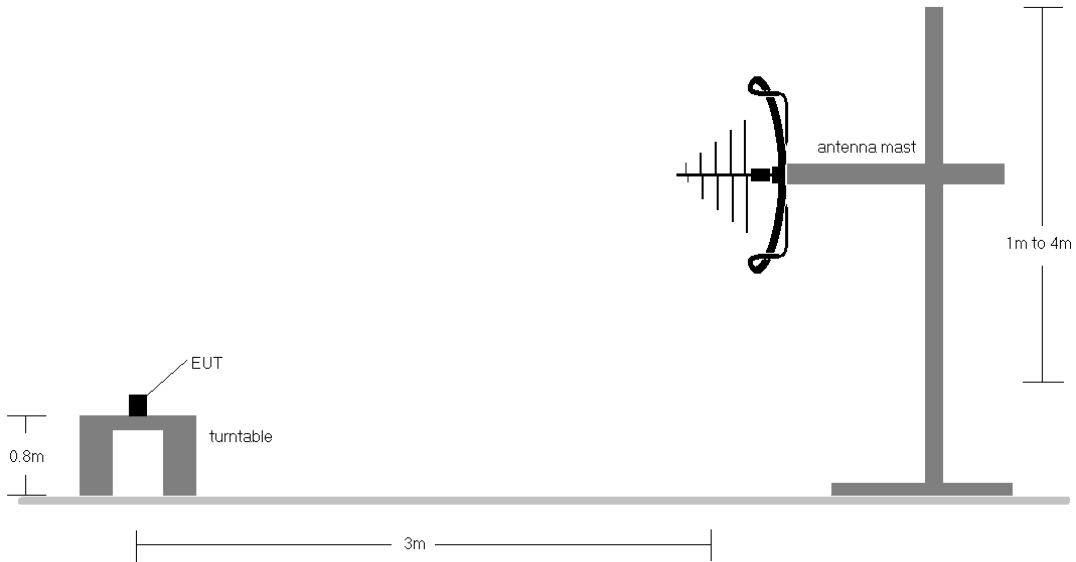

Figure 7-8. Radiated Test Setup < 1GHz

<p>FCC ID: A3LSMJ337R4</p>		<p>MEASUREMENT REPORT (CERTIFICATION)</p>	 <p>Approved by: Quality Manager</p>
<p>Test Report S/N: 1M1805160106-05.A3L</p>	<p>Test Dates: 3/9-4/25/2018</p>	<p>EUT Type: Portable Handset</p>	<p>Page 48 of 54</p>

Test Notes

1. All emissions lying in restricted bands specified in §15.205 and RSS-Gen(8.10) are below the limit shown in Table 7-9.
2. The broadband receive antenna is manipulated through vertical and horizontal polarizations during the tests. The EUT is manipulated through three orthogonal planes.
3. This unit was tested with its standard battery.
4. The spectrum is investigated using a peak detector and final measurements are recorded using CISPR quasi peak detector. The worst-case emissions are reported however emissions whose levels were not within 20dB of the respective limits were not reported.
5. Emissions were measured at a 3 meter test distance.
6. Emissions are investigated while operating on the center channel of the mode, band, and modulation that produced the worst case results during the transmitter spurious emissions testing.
7. No spurious emissions were detected within 20dB of the limit below 30MHz.
8. The results recorded using the broadband antenna is known to correlate with the results obtained by using a tuned dipole with an acceptable degree of accuracy. The VSWR for the measurement antenna was found to be less than 2:1.
9. The wide spectrum spurious emissions plots shown on the following pages are used only for the purpose of emission identification. There were no emissions detected in the 30MHz – 1GHz frequency range, as shown in the subsequent plots.

FCC ID: A3LSMJ337R4	 MEASUREMENT REPORT (CERTIFICATION) 		Approved by: Quality Manager
Test Report S/N: 1M1805160106-05.A3L	Test Dates: 3/9-4/25/2018	EUT Type: Portable Handset	Page 49 of 54

Radiated Spurious Emissions Measurements (Below 1GHz)
§15.209; RSS-Gen [8.9]

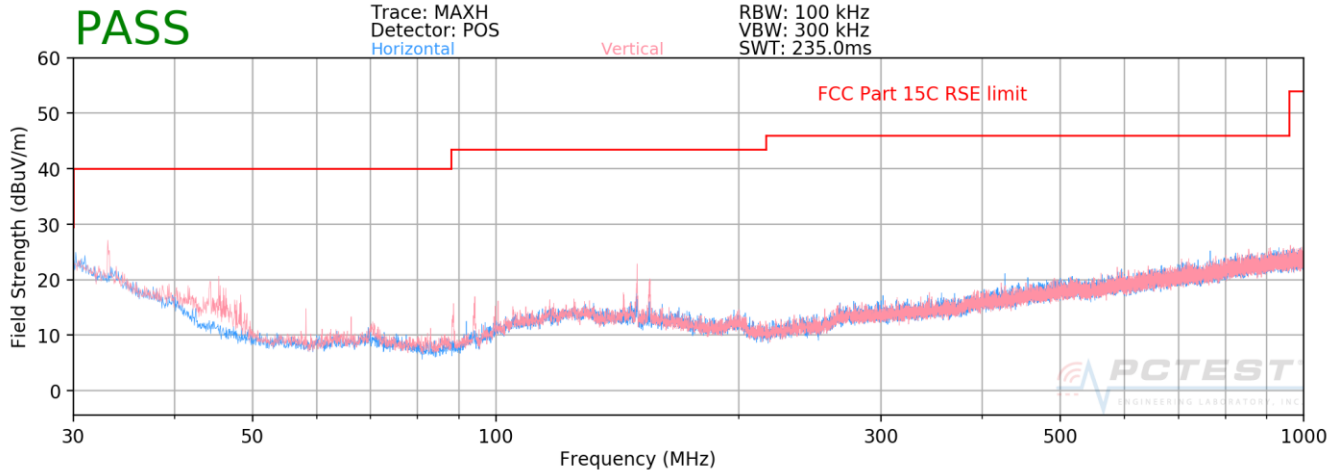

Plot 7-41. Radiated Spurious Plot below 1GHz ANT1

FCC ID: A3LSMJ337R4	 MEASUREMENT REPORT (CERTIFICATION) 		Approved by: Quality Manager
Test Report S/N: 1M1805160106-05.A3L	Test Dates: 3/9-4/25/2018	EUT Type: Portable Handset	Page 50 of 54

7.9 Line-Conducted Test Data

§15.207; RSS-Gen [8.8]

Test Overview and Limit

All AC line conducted spurious emissions are measured with a receiver connected to a grounded LISN while the EUT is operating at its maximum duty cycle, at maximum power, and at the appropriate frequencies. All data rates and modes were investigated for conducted spurious emissions. Only the conducted emissions of the configuration that produced the worst case emissions are reported in this section.

All conducted emissions must not exceed the limits shown in the table below, per Section 15.207 and RSS-Gen (8.8).

Frequency of emission (MHz)	Conducted Limit (dBµV)	
	Quasi-peak	Average
0.15 – 0.5	66 to 56*	56 to 46*
0.5 – 5	56	46
5 – 30	60	50

Table 7-10. Conducted Limits

*Decreases with the logarithm of the frequency.

Test Procedures Used

ANSI C63.10-2013, Section 6.2

Test Settings

Quasi-Peak Field Strength Measurements

1. Analyzer center frequency was set to the frequency of the spurious emission of interest
2. RBW = 9kHz (for emissions from 150kHz – 30MHz)
3. Detector = quasi-peak
4. Sweep time = auto couple
5. Trace mode = max hold
6. Trace was allowed to stabilize

Average Field Strength Measurements

1. Analyzer center frequency was set to the frequency of the spurious emission of interest
2. RBW = 9kHz (for emissions from 150kHz – 30MHz)
3. Detector = RMS
4. Sweep time = auto couple
5. Trace mode = max hold
6. Trace was allowed to stabilize

FCC ID: A3LSMJ337R4		MEASUREMENT REPORT (CERTIFICATION)		Approved by: Quality Manager
Test Report S/N: 1M1805160106-05.A3L	Test Dates: 3/9-4/25/2018	EUT Type: Portable Handset	Page 51 of 54	

Test Setup

The EUT and measurement equipment were set up as shown in the diagram below.

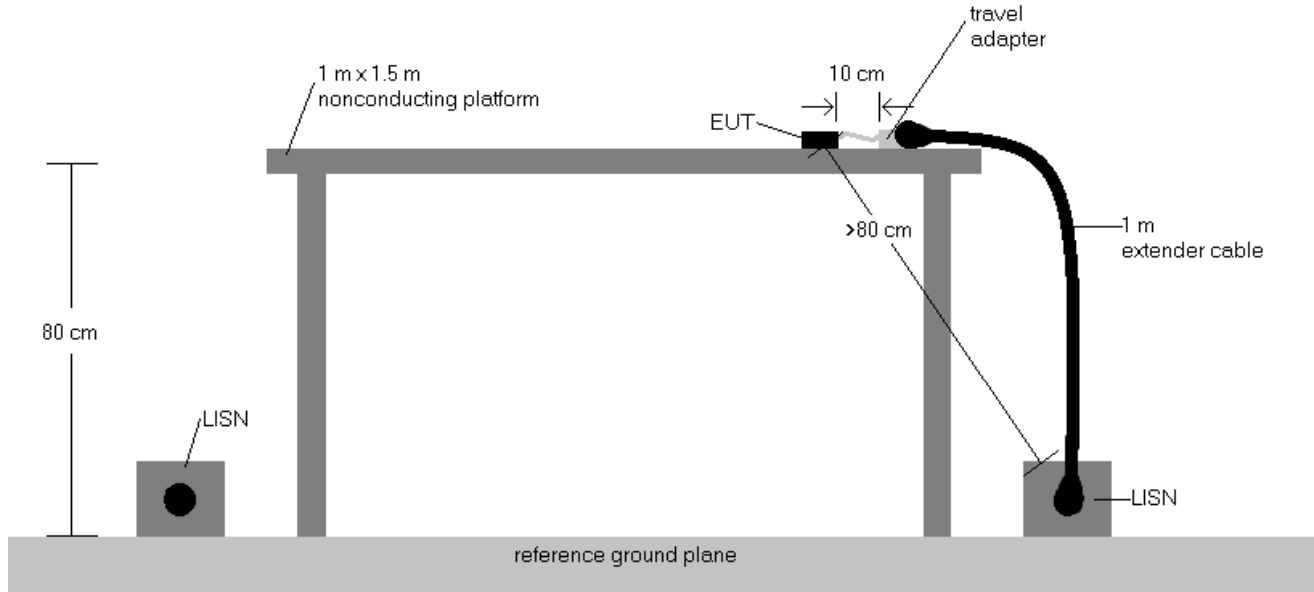
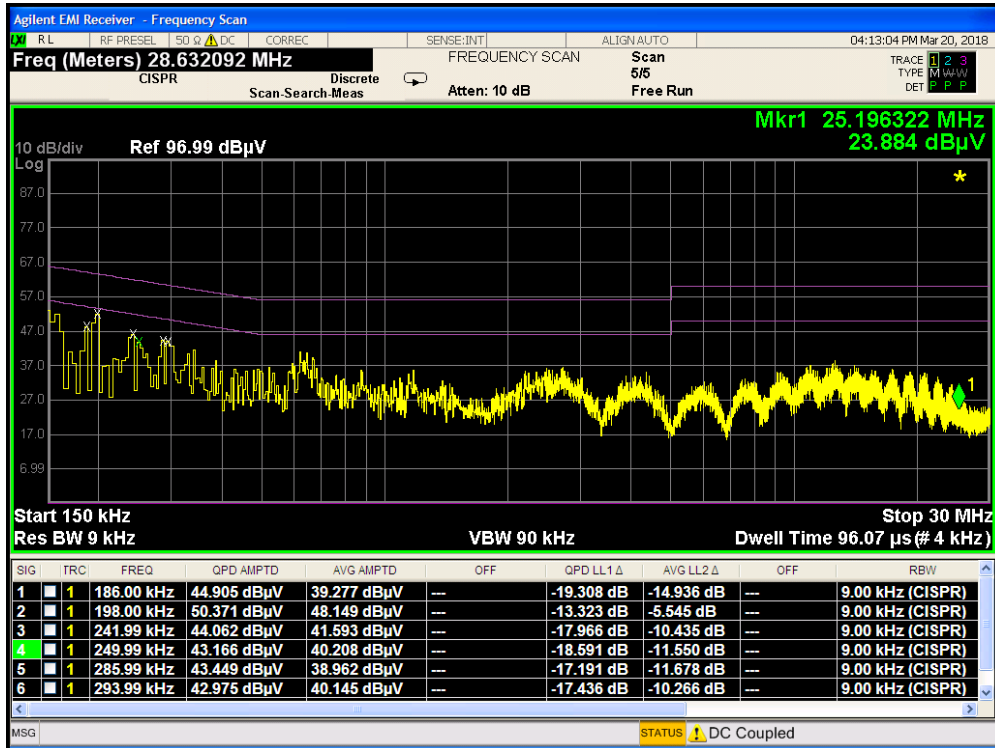

Figure 7-9. Test Instrument & Measurement Setup

Test Notes

1. All modes of operation were investigated and the worst-case emissions are reported using mid channel. The emissions found were not affected by the choice of channel used during testing.
2. The limit for an intentional radiator from 150kHz to 30MHz are specified in Part 15.207 and RSS-Gen(8.8).
3. $\text{Corr. (dB)} = \text{Cable loss (dB)} + \text{LISN insertion factor (dB)}$
4. $\text{QP/AV Level (dB}\mu\text{V)} = \text{QP/AV Analyzer/Receiver Level (dB}\mu\text{V)} + \text{Corr. (dB)}$
5. $\text{Margin (dB)} = \text{QP/AV Limit (dB}\mu\text{V)} - \text{QP/AV Level (dB}\mu\text{V)}$
6. Traces shown in plot are made using a peak detector.
7. Deviations to the Specifications: None.

FCC ID: A3LSMJ337R4		MEASUREMENT REPORT (CERTIFICATION)		Approved by: Quality Manager
Test Report S/N: 1M1805160106-05.A3L	Test Dates: 3/9-4/25/2018	EUT Type: Portable Handset		Page 52 of 54



Plot 7-42. Line Conducted Plot with 802.11b (L1)

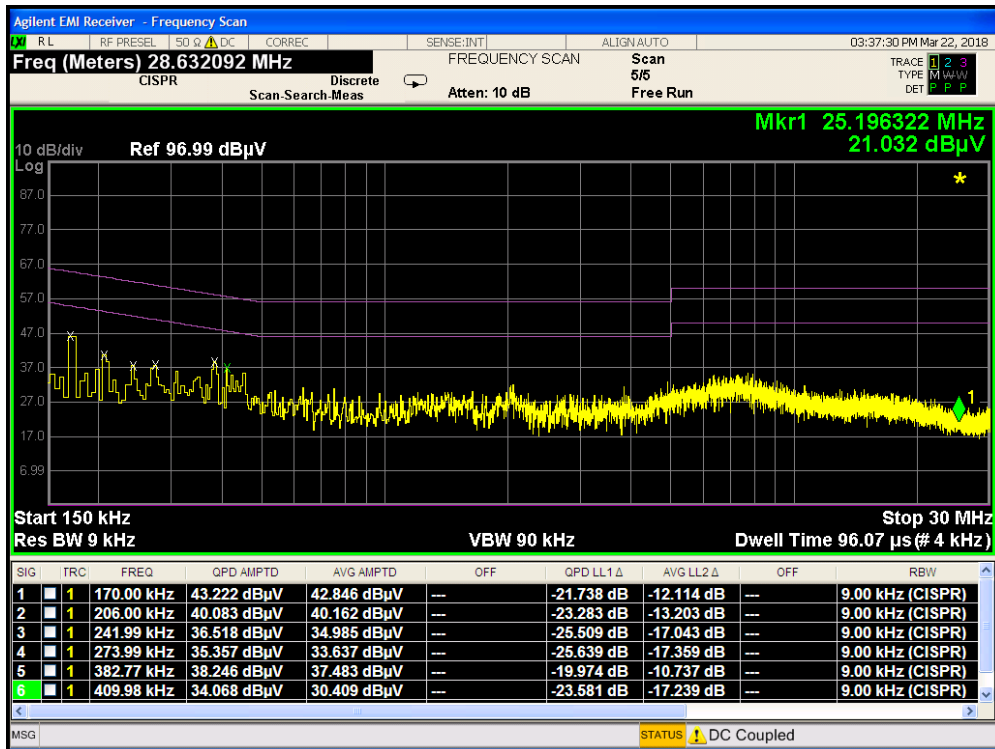

Plot 7-43. Line Conducted Plot with 802.11b (N)

FCC ID: A3LSMJ337R4		MEASUREMENT REPORT (CERTIFICATION)		Approved by: Quality Manager
Test Report S/N: 1M1805160106-05.A3L	Test Dates: 3/9-4/25/2018	EUT Type: Portable Handset		Page 53 of 54

8.0 CONCLUSION

The data collected relate only the item(s) tested and show that the **Samsung Portable Handset FCC ID: A3LSMJ337R4** is in compliance with Part 15 Subpart C (15.247) of the FCC Rules.

FCC ID: A3LSMJ337R4	 MEASUREMENT REPORT (CERTIFICATION)		Approved by: Quality Manager
Test Report S/N: 1M1805160106-05.A3L	Test Dates: 3/9-4/25/2018	EUT Type: Portable Handset	Page 54 of 54