



**FCC CFR47 PART 22 SUBPART H
FCC CFR47 PART 24 SUBPART E**

WWAN

CERTIFICATION TEST REPORT

FOR

GSM/WCDMA/LTE Phone + BT/BLE, DTS b/g/n and NFC

MODEL NUMBER : SM-J320ZN, SM-J320N0

FCC ID: A3LSMJ320ZN

REPORT NUMBER: 16K23140-E4V1

ISSUE DATE: APR 06, 2016

Prepared for
**SAMSUNG ELECTRONICS CO., LTD.
129 SAMSUNG-RO, YEONGTONG-GU, SUWON-SI,
GYEONGGI-DO, 16677, KOREA**

Prepared by
**UL Korea, Ltd. Suwon Laboratory
218 Maeyeong-ro, Yeongtong-gu,
Suwon-si, Gyeonggi-do, 16675, Korea
TEL: (031) 337-9902
FAX: (031) 213-5433**



Revision History

<u>Rev.</u>	<u>Issue Date</u>	<u>Revisions</u>	<u>Revised By</u>
V1	04/06/16	Initial issue	Junwhan Lee

TABLE OF CONTENTS

1. ATTESTATION OF TEST RESULTS	5
2. TEST METHODOLOGY	6
3. FACILITIES AND ACCREDITATION	6
4. CALIBRATION AND UNCERTAINTY	6
4.1. <i>MEASURING INSTRUMENT CALIBRATION</i>	6
4.2. <i>SAMPLE CALCULATION</i>	6
4.3. <i>MEASUREMENT UNCERTAINTY</i>	6
5. EQUIPMENT UNDER TEST	7
5.1. <i>DESCRIPTION OF EUT</i>	7
5.2. <i>MAXIMUM OUTPUT POWER (GSM)</i>	7
5.3. <i>MAXIMUM OUTPUT POWER (WCDMA)</i>	7
5.4. <i>MAXIMUM OUTPUT POWER (LTE)</i>	8
5.5. <i>DESCRIPTION OF TEST SETUP</i>	9
6. TEST AND MEASUREMENT EQUIPMENT	11
7. Summary Table	12
8. RF POWER OUTPUT VERIFICATION	13
8.1. <i>GSM/GPRS/EDGE</i>	13
8.1.1. <i>GSM OUTPUT POWER RESULT</i>	14
8.2. <i>UMTS REL 99</i>	15
8.2.1. <i>WCDMA OUTPUT POWER RESULT</i>	19
8.3. <i>LTE OUTPUT VERIFICATION</i>	21
8.3.1. <i>LTE OUTPUT POWER RESULT</i>	22
9. PEAK TO AVERAGE RATIO	23
9.1. <i>CONDUCTED PEAK TO AVERAGE RESULT</i>	23
9.2. <i>CONDUCTED PEAK TO AVERAGE PLOTS</i>	24
10. LIMITS AND CONDUCTED RESULTS	26
10.1. <i>OCCUPIED BANDWIDTH</i>	26
10.1.1. <i>OCCUPIED BANDWIDTH RESULTS</i>	26
10.1.2. <i>OCCUPIED BANDWIDTH PLOTS</i>	28
10.2. <i>BAND EDGE EMISSIONS</i>	35
10.2.1. <i>BAND EDGE PLOTS</i>	37
10.3. <i>OUT OF BAND EMISSIONS</i>	43
10.3.1. <i>OUT OF BAND EMISSIONS RESULT</i>	44

10.3.2.	OUT OF BAND EMISSIONS PLOTS	46
10.4.	<i>FREQUENCY STABILITY</i>	53
10.4.1.	FREQUENCY STABILITY RESULTS.....	54
11.	RADIATED TEST RESULTS	56
11.1.	<i>RADIATED POWER (ERP & EIRP)</i>	56
11.1.1.	ERP/EIRP Results	57
11.1.2.	ERP/EIRP DATA	59
11.2.	<i>FIELD STRENGTH OF SPURIOUS RADIATION</i>	66
11.2.1.	SPURIOUS RADIATION PLOTS.....	67
12.	SETUP PHOTOS.....	74

1. ATTESTATION OF TEST RESULTS

COMPANY NAME: SAMSUNG ELECTRONICS CO., LTD.
EUT DESCRIPTION: GSM/WCDMA/LTE Phone + BT/BLE, DTS b/g/n and NFC
MODEL NUMBER: SM-J320ZN, SM-J320N0
SERIAL NUMBER: R38H308DJWH (RADIATED);
R37H308DM3E, R38H308DWDA (CONDUCTED)
DATE TESTED: MAR18, 2016 - MAR 30, 2016

APPLICABLE STANDARDS	
STANDARD	TEST RESULTS
FCC PART 22H, 24E	Pass

UL Korea, Ltd. tested the above equipment in accordance with the requirements set forth in the above standards. All indications of Pass/Fail in this report are opinions expressed by UL Korea, Ltd. based on interpretations and/or observations of test results. Measurement Uncertainties were not taken into account and are published for informational purposes only. The test results show that the equipment tested is capable of demonstrating compliance with the requirements as documented in this report.

Note: The results documented in this report apply only to the tested sample, under the conditions and modes of operation as described herein. This document may not be altered or revised in any way unless done so by UL Korea, Ltd. and all revisions are duly noted in the revisions section. Any alteration of this document not carried out by UL Korea, Ltd. will constitute fraud and shall nullify the document. This report must not be used by the client to claim product certification, approval, or endorsement by IAS, any agency of the Federal Government, or any agency of any government.

Approved & Released For
UL Korea, Ltd. By:



CY Choi
Suwon Lab Engineer
UL Korea, Ltd.

Tested By:



Junwhan Lee
Suwon Lab Engineer
UL Korea, Ltd.

2. TEST METHODOLOGY

The tests documented in this report were performed in accordance with TIA-603-D, FCC CFR 47 Part 22 and FCC CFR Part 24.

3. FACILITIES AND ACCREDITATION

The test sites and measurement facilities used to collect data are located at 218 Maeyeong-ro, Yeongtong-gu, Suwon-si, Gyeonggi-do, 16675, Korea. Line conducted emissions are measured only at the 218 address. The following table identifies which facilities were utilized for radiated emission measurements documented in this report. Specific facilities are also identified in the test results sections.

218 Maeyeong-ro	
<input type="checkbox"/>	Chamber 1
<input checked="" type="checkbox"/>	Chamber 2

UL Korea, Ltd. is accredited by IAS, Laboratory Code TL-637. The full scope of accreditation can be viewed at <http://www.iasonline.org/PDF/TL/TL-637.pdf>.

4. CALIBRATION AND UNCERTAINTY

4.1. MEASURING INSTRUMENT CALIBRATION

The measuring equipment utilized to perform the tests documented in this report has been calibrated in accordance with the manufacturer's recommendations, and is traceable to recognized national standards.

4.2. SAMPLE CALCULATION

Where relevant, the following sample calculation is provided:

EIRP = PSA reading with EUT worst orientation (dBm) + Path loss (dB) – cable loss(between the SG and substitution antenna) + Substitution Antenna Factor (dBi)

ERP = PSA reading with EUT worst orientation (dBm) + Path loss (dB) – cable loss(between the SG and substitution antenna)

(Path loss = Signal generator output – PSA reading with substitution antenna)

4.3. MEASUREMENT UNCERTAINTY

Where relevant, the following measurement uncertainty levels have been estimated for tests performed on the apparatus:

PARAMETER	UNCERTAINTY
Conducted Disturbance, 0.15 to 30 MHz	2.32 dB
Radiated Disturbance, Below 1GHz	4.14 dB
Radiated Disturbance, Above 1 GHz	5.97 dB

Uncertainty figures are valid to a confidence level of 95%.

5. EQUIPMENT UNDER TEST

5.1. DESCRIPTION OF EUT

The EUT is a GSM/WCDMA/LTE Phone + BT/BLE, DTS b/g/n and NFC.

SM-J320ZN and SM-J320N0 are same hardware and only difference is existence of non-USA LTE band. SM-J320ZN supports LTE band 28/40. SM-J320N0 did not support LTE band 28/40. SM-J320ZN was used for the test.

5.2. MAXIMUM OUTPUT POWER (GSM)

The transmitter has a maximum peak conducted and radiated ERP / EIRP output powers as follows:

FCC Part 22/24						
Band	Frequency Range	Modulation	Conducted		Radiated	
	[MHz]		Peak	Avg [dBm]	Avg [mW]	Avg [dBm]
GSM1900	1850~1910	GMSK	28.58	721.11		
		GPRS	28.61	726.11	27.84	608.14
		EGPRS	25.20	331.13	25.73	374.11

5.3. MAXIMUM OUTPUT POWER (WCDMA)

The transmitter has a maximum peak conducted and radiated ERP / EIRP output powers as follows:

FCC Part 22/24						
Band	Frequency Range	Modulation	Conducted		Radiated	
	[MHz]		Peak	Avg [dBm]	Avg [mW]	Avg [dBm]
Band 5	824~849	REL99	22.89	194.54	19.88	97.27
		HSDPA	22.84	192.31	19.35	86.10
		HSUPA	22.90	194.98		
Band 2	1850~1910	REL99	22.87	193.64	22.93	196.34
		HSDPA	22.17	164.82	21.96	157.04
		HSUPA	21.87	153.82		

5.4. MAXIMUM OUTPUT POWER (LTE)

The transmitter has a maximum peak conducted and radiated ERP / EIRP output powers as follows:

LTE Band 5

FCC Part 22							
Band	Frequency Range [MHz]	BandWidth [MHz]	Modulation Peak	Conducted		Radiated	
				Avg [dBm]	Avg [mW]	Avg [dBm]	Avg [mW]
Band 5	824 ~ 849	10	QPSK	24.08	255.86	17.86	61.09
			16QAM	23.50	223.87	17.94	62.23
		5	QPSK	24.19	262.42	19.12	81.66
			16QAM	23.18	207.97	19.23	83.75
		3	QPSK	24.26	266.69	19.41	87.30
			16QAM	23.50	223.87	19.44	87.90
		1.4	QPSK	24.21	263.63	17.23	52.84
			16QAM	23.50	223.87	17.25	53.09

DESCRIPTION OF AVAILABLE ANTENNAS

The radio utilizes a FPCB antenna for the [List the bands supported with a maximum peak gain as follow:

Frequency (MHz)	Peak Gain (dBi)
WCDMA Band 5 / LTE Band 5 824 ~ 849 MHz	1.6
GSM 1900 / WCDMA Band 2 1850 ~ 1910 MHz	3.4

5.5. DESCRIPTION OF TEST SETUP

SUPPORT EQUIPMENT

Support Equipment List				
Description	Manufacturer	Model	Serial Number	FCC ID
Charger	SAMSUNG	ETA0U83HWE	DW2H226DS/A-E	N/A
Data Cable	SAMSUNG	ECB-DU68WE	N/A	N/A
Earphone	SAMSUNG	EHS61ASFWE	N/A	N/A

I/O CABLES

I/O Cable List						
Cable No	Port	# of identical ports	Connector Type	Cable Type	Cable Length (m)	Remarks
1	DC Power	1	Mini-USB	Shielded	0.8m	N/A
2	Audio	1	Mini-Jack	Unshielded	1.0m	N/A

TEST SETUP

The EUT is continuously communicated to the call box during the tests.

SETUP DIAGRAM FOR TESTS (CONDUCTED TEST SETUP)

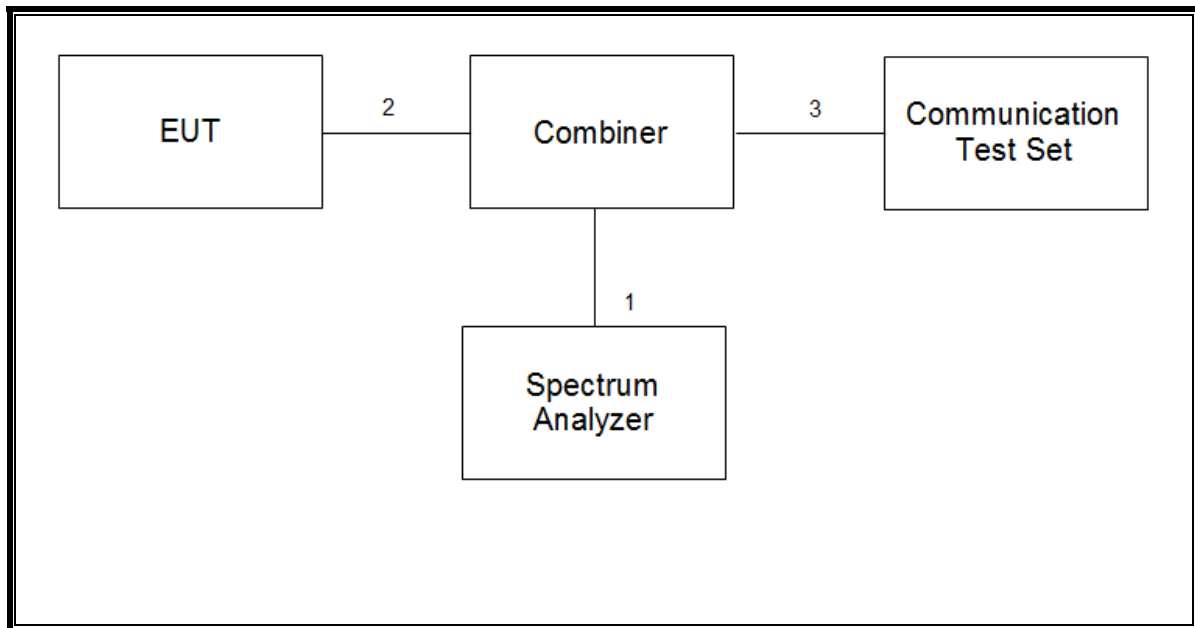

SETUP DIAGRAM FOR TESTS (RADIATED TEST SETUP)

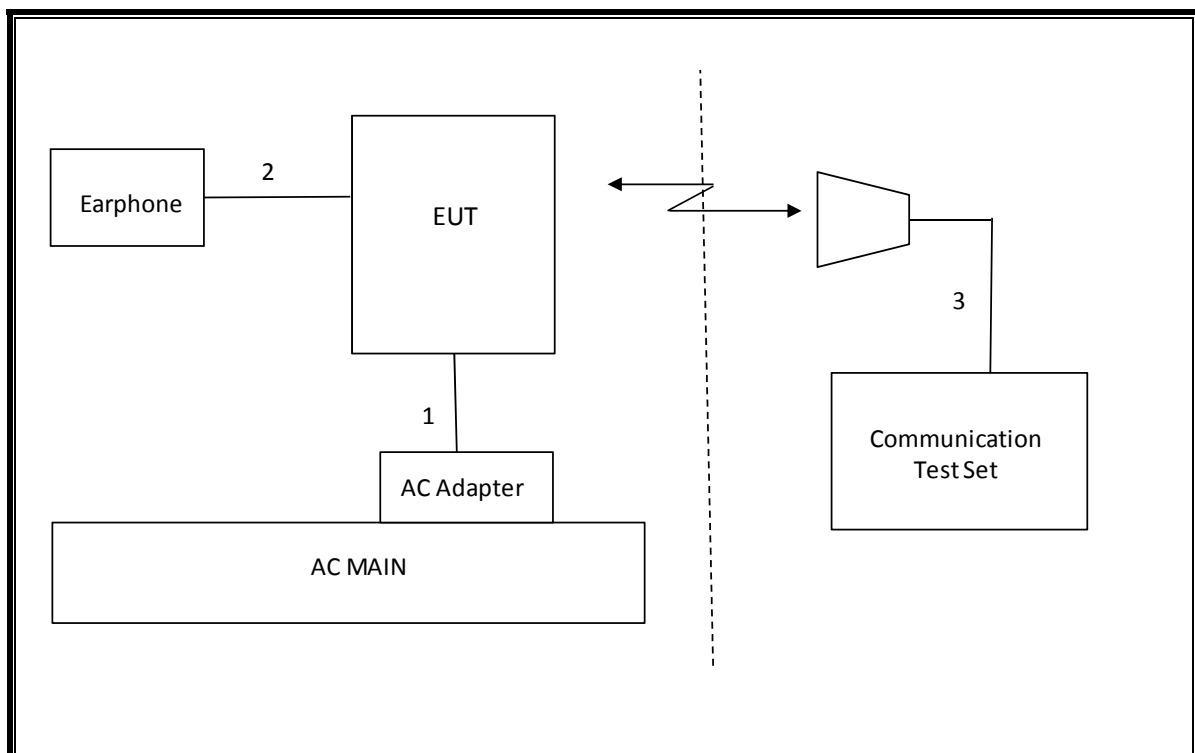

6. TEST AND MEASUREMENT EQUIPMENT

The following test and measurement equipment was utilized for the tests documented in this report:

Test Equipment List				
Description	Manufacturer	Model	S/N	Cal Due
Antenna, Tuned Dipole 400~1000 MHz	ETS	3121D DB4	00164753	07-28-16
Antenna, Horn, 40 GHz	ETS	3116C	00166155	09-23-16
Antenna, Horn, 40 GHz	ETS	3116C-PA	00168841	08-24-17
Antenna, Bilog, 30MHz-1GHz	SCHWARZBECK	VULB9163	750	11-17-16
Antenna, Bilog, 30MHz-1GHz	SCHWARZBECK	VULB9163	749	04-25-17
Antenna, Horn, 18 GHz	ETS	3115	00167211	09-20-16
Antenna, Horn, 18 GHz	ETS	3115	00161451	05-17-17
Antenna, Horn, 18 GHz	ETS	3117	00168724	06-17-17
Antenna, Horn, 18 GHz	ETS	3117	00168717	06-17-17
Combiner	WEINSCHTEL	1575	2151	08-20-16
Communications Test Set	R&S	CMW500	150312	08-18-16
Communications Test Set	R&S	CMW500	115331	08-18-16
Communications Test Set	R&S	CMW500	102271	08-18-16
DC Power Supply	Agilent / HP	E3640A	MY54226395	08-18-16
Preamplifier, 1000 MHz	Sonoma	310N	341282	08-18-16
Preamplifier, 1000 MHz	Sonoma	310N	351741	08-18-16
Preamplifier, 18 GHz	Miteq	AFS42-00101800-25-S-42	1876511	08-18-16
Preamplifier, 18 GHz	Miteq	AFS42-00101800-25-S-42	1896138	08-18-16
Spectrum Analyzer, 44 GHz	Agilent / HP	N9030A	MY54170614	08-19-16
Spectrum Analyzer, 44 GHz	Agilent / HP	N9030A	MY54490312	08-19-16
Bluetooth Tester	TESCOM	TC-3000C	3000C000546	08-18-16
Average Power Sensor	R&S	NRZ-Z91	102681	08-18-16
Average Power Sensor	Agilent / HP	U2000	MY54270007	08-18-16
EMI Test Receive, 40 GHz	R&S	ESU40	100439	08-19-16
EMI Test Receive, 40 GHz	R&S	ESU40	100457	08-19-16
EMI Test Receive, 3 GHz	R&S	ESR3	101832	08-19-16
Attenuator / Switch driver	HP	11713A	3748A04272	N/A
Low Pass Filter 3GHz	Micro-Tronics	LPS17541	009	08-18-16
Low Pass Filter 3GHz	Micro-Tronics	LPS17541	015	08-18-16
High Pass Filter 5GHz	Micro-Tronics	HPS17542	009	08-18-16
High Pass Filter 6GHz	Micro-Tronics	HPM17543	010	08-18-16
High Pass Filter 5GHz	Micro-Tronics	HPS17542	016	08-18-16
High Pass Filter 6GHz	Micro-Tronics	HPM17543	015	08-18-16
LISN	R&S	ENV-216	101836	08-19-16
LISN	R&S	ENV-216	101837	08-19-16

7. Summary Table

FCC Part Section	Test Description	Test Limit	Test Condition	Test Result	Note
2.1049	Occupied Band width (99%)	N/A	Conducted	Pass	8.9779 MHz
22.917(a) 24.238(a)	Band Edge / Conducted Spurious Emission	-13dBm		Pass	-14.562dBm
2.1046	Conducted output power	N/A		Pass	28.61 dBm
22.355 24.235	Frequency Stability	2.5PPM		Pass	-0.01PPM
22.913(a)(2)	Effective Radiated Power	38 dBm	Radiated	Pass	19.88 dBm
24.232(c)	Equivalent Isotropic Radiated Power	33dBm		Pass	27.84 dBm
22.917(a) 24.238(a)	Radiated Spurious Emission	-13dBm		Pass	-27.6 dBm

FCC Rule Part	Frequency Range [MHz]	Output Power [W]	Frequency Tolerance	Emission Designator	Emission Bandwidth	Communication Type
GSM						
24E	1850.2 - 1909.8	0.608	2.5 ppm	248KGXW		GSM1900
	1850.2 - 1909.8	0.374	2.5 ppm	249KG7W		EGSM1900
WCDMA						
22H	826.4 - 846.6	0.097	2.5 ppm	4M17F9W		WCDMA BAND5
24E	1852.4 - 1907.6	0.196	2.5 ppm	4M18F9W		WCDMA BAND2
LTE Band 5						
22H	829.0 - 844.0	0.061	2.5 ppm	8M98G7W	10	QPSK
22H	829.0 - 844.0	0.062	2.5 ppm	8M97D7W	10	16QAM
22H	825.5 - 847.5	0.087	2.5 ppm	2M70G7W	3	QPSK
22H	825.5 - 847.5	0.088	2.5 ppm	2M70D7W	3	16QAM

8. RF POWER OUTPUT VERIFICATION

8.1. GSM/GPRS/EDGE

Function: Menu select > GSM Mobile Station > GSM 850/900/1800/1900
Press Connection control to choose the different menus
Press RESET > choose all to reset all settings
Connection Press Signal Off to turn off the signal and change settings
Network Support > GSM+GPRS or GSM+EGPRS
Main Service > Packet Data
Service selection > Test Mode A – Auto Slot Config. off
MS Signal Press Slot Config bottom on the right twice to select and change the number of time slots and power setting
 > Slot configuration > Uplink/Gamma
 > 33 dBm for GPRS 850/900
 > 30 dBm for GPRS1800/1900
BS Signal Enter the same channel number for TCH channel (test channel) and BCCH channel
Frequency Offset > + 0 Hz
Mode > BCCH and TCH
BCCH Level > -85 dBm (May need to adjust if link is not stable)
BCCH Channel > choose desire test channel [Enter the same channel number for TCH channel (test channel) and BCCH channel]
Channel Type > Off
P0 > 4 dB
Slot Config > Unchanged (if already set under MS Signal)
TCH > choose desired test channel
Hopping > Off
Main Timeslot > 3 (Default)
Network Coding Scheme > CS4 (GPRS) and MCS5 ~ MCS9 (EGPRS)
Bit Stream > 2E9-1PSR Bit Pattern
AF/RF Enter appropriate offsets for Ext. Att. Output and Ext. Att. Input
Connection Press Signal On to turn on the signal and change settings

8.1.1. GSM OUTPUT POWER RESULT

GSM1900 Measured Results

Band	Mode	Coding Scheme	Time Slots	Ch No.	Freq. [MHz]	Max. Power		
						Burst Pwr [dBm]	Frame Pwr [dBm]	
1900	GSM (Voice)	CS1	1	512	1850.2	28.39	19.36	
				661	1880.0	28.51	19.48	
				810	1909.8	28.58	19.55	
	GPRS (GMSK)	CS1	1	1	512	1850.2	28.38	19.35
					661	1880.0	28.61	19.58
					810	1909.8	28.58	19.55
					512	1850.2	26.62	20.60
					661	1880.0	26.86	20.84
					810	1909.8	26.67	20.65
			2	1	512	1850.2	26.62	20.60
					661	1880.0	26.86	20.84
					810	1909.8	26.67	20.65
			3	1	512	1850.2	23.89	19.63
					661	1880.0	24.14	19.88
					810	1909.8	24.03	19.77
	4	1	512	1850.2	22.57	19.56		
			661	1880.0	22.78	19.77		
			810	1909.8	22.57	19.56		
	EGPRS (8PSK)	MCS5	1	1	512	1850.2	24.91	15.88
					661	1880.0	25.19	16.16
					810	1909.8	25.00	15.97
			2	1	512	1850.2	24.94	18.92
					661	1880.0	25.20	19.18
					810	1909.8	25.10	19.08
3			1	512	1850.2	24.42	20.16	
				661	1880.0	24.67	20.41	
				810	1909.8	24.55	20.29	
4			1	512	1850.2	23.40	20.39	
				661	1880.0	23.63	20.62	
				810	1909.8	23.50	20.49	

8.2. UMTS REL 99

Release 99 Setup Procedures used to establish the test signals

The following tests were completed according to the test requirements outlined in section 5.2 of the 3GPP TS34.121-1 specification. The DUT supports power Class 3, which has a nominal maximum output power of 24 dBm (+1.7/-3.7).

Mode	Subtest	Rel99
WCDMA General Settings	Loopback Mode	Test Mode 2
	Rel99 RMC	12.2kbps RMC
	Power Control Algorithm	Algorithm2
	β_c/β_d	8/15

HSDPA Setup Procedures used to establish the test signals

The following 4 Sub-tests were completed according to Release 7 procedures in section 5.2 of 3GPP TS34.121. A summary of these settings are illustrated below:

	Mode	HSDPA	HSDPA	HSDPA	HSDPA
	Subtest	1	2	3	4
W-CDMA General Settings	Loopback Mode	Test Mode 1			
	Rel99 RMC	12.2kbps RMC			
	HSDPA FRC	H-Set 1			
	Power Control Algorithm	Algorithm 2			
	β_c	2/15	11/15	15/15	15/15
	β_d	15/15	15/15	8/15	4/15
	Bd (SF)	64			
	β_c/β_d	2/15	12/15	15/8	15/4
	β_{hs}	4/15	24/15	30/15	30/15
MPR (dB)	0	0	0.5	0.5	
HSDPA Specific Settings	D_{ACK}	8			
	D_{NAK}	8			
	DCQI	8			
	Ack-Nack repetition factor	3			
	CQI Feedback (Table 5.2B.4)	4ms			
	CQI Repetition Factor (Table 5.2B.4)	2			
	$A_{hs}=\beta_{hs}/\beta_c$	30/15			

HSPA (HSDPA & HSUPA) Setup Procedures used to establish the test signals

The following 5 Sub-tests were completed according to Release 6 procedures in section 5.2 of 3GPP TS34.121. A summary of these settings are illustrated below:

Mode	HSPA					
	Subtest	1	2	3	4	5
WCDMA General Settings	Loopback Mode	Test Mode 1				
	Rel99 RMC	12.2 kbps RMC				
	HSDPA FRC	H-Set 1				
	HSUPA Test	HSPA				
	Power Control Algorithm	Algorithm 2				Algorithm 1
	β_c	11/15	6/15	15/15	2/15	15/15
	β_d	15/15	15/15	9/15	15/15	0
	β_{ec}	209/225	12/15	30/15	2/15	5/15
	β_c/β_d	11/15	6/15	15/9	2/15	15/1
	β_{hs}	22/15	12/15	30/15	4/15	5/15
	β_{ed}	1309/225	94/75	47/15	56/75	47/15
CM (dB)	1	3	2	3	1	
MPR (dB)	0	2	1	2	0	
HSDPA Specific Settings	DACK	8				0
	DNAK	8				0
	DCQI	8				0
	Ack-Nack repetition factor	3				
	CQI Feedback (Table 5.2B.4)	4ms				
	CQI Repetition Factor (Table 5.2B.4)	2				
	$A_{hs} = \beta_{hs}/\beta_c$	30/15				
HSUPA Specific Settings	E-DPDCCH	6	8	8	5	7
	DHARQ	0	0	0	0	0
	AG Index	20	12	15	17	21
	ETFCI (from 34.121 Table C.11.1.3)	75	67	92	71	81
	Associated Max UL Data Rate kbps	242.1	174.9	482.8	205.8	308.9
	Reference E-TFCIs	5	5	2	5	1
	Reference E-TFCI	11	11	11	11	67
	Reference E-TFCI PO	4	4	4	4	18
	Reference E-TFCI	67	67	92	67	67
	Reference E-TFCI PO	18	18	18	18	18
	Reference E-TFCI	71	71	71	71	71
	Reference E-TFCI PO	23	23	23	23	23
	Reference E-TFCI	75	75	75	75	75
	Reference E-TFCI PO	26	26	26	26	26
	Reference E-TFCI	81	81	81	81	81
Reference E-TFCI PO	27	27	27	27	27	
Maximum Channelisation Codes	2xSF2				SF4	

DC-HSDPA Setup Procedures used to establish the test signals

The following tests were completed according to procedures in section 7.3.13 of 3GPP TS34.108 v9.5.0. A summary of these settings are illustrated below:

Downlink Physical Channels are set as per 3GPP TS34.121-1 v9.0.0 E.5.0

Table E.5.0: Levels for HSDPA connection setup

Parameter	Unit	Value
During Connection setup		
P-CPICH_Ec/Ior	dB	-10
P-CCPCH and SCH_Ec/Ior	dB	-12
PICH_Ec/Ior	dB	-15
HS-PDSCH	dB	off
HS-SCCH_1	dB	off
DPCH_Ec/Ior	dB	-5
OCNS_Ec/Ior	dB	-3.1

Call is set up as per 3GPP TS34.108 v9.5.0 sub clause 7.3.13

The configurations of the fixed reference channels for HSDPA RF tests are described in 3GPP TS 34.121, annex C for FDD and 3GPP TS 34.122.

Table C.8.1.12: Fixed Reference Channel H-Set 12

Parameter	Unit	Value
Nominal Avg. Inf. Bit Rate	kbps	60
Inter-TTI Distance	TTI's	1
Number of HARQ Processes	Processes	6
Information Bit Payload (N_{INF})	Bits	120
Number Code Blocks	Blocks	1
Binary Channel Bits Per TTI	Bits	960
Total Available SML's in UE	SML's	19200
Number of SML's per HARQ Proc.	SML's	3200
Coding Rate		0.15
Number of Physical Channel Codes	Codes	1
Modulation		QPSK
Note 1: The RMC is intended to be used for DC-HSDPA mode and both cells shall transmit with identical parameters as listed in the table. Note 2: Maximum number of transmission is limited to 1, i.e., retransmission is not allowed. The redundancy and constellation version 0 shall be used.		

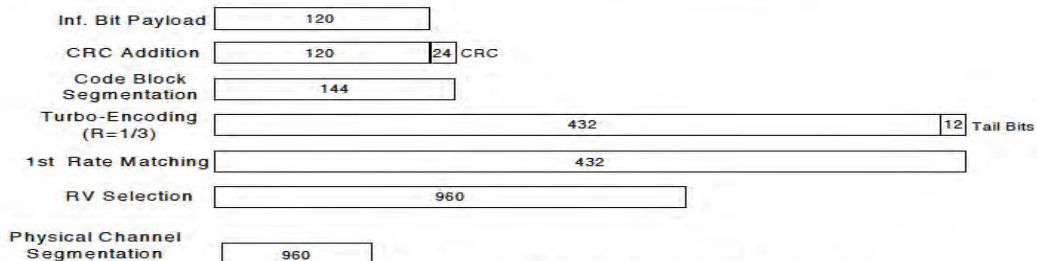

Figure C.8.19: Coding rate for Fixed reference Channel H-Set 12 (QPSK)

The following 4 Sub-tests for HSDPA were completed according to Release 8 procedures in section 5.2 of 3GPP TS34.121. A summary of subtest settings are illustrated below:

Mode	HSDPA	HSDPA	HSDPA	HSDPA	
Subtest	1	2	3	4	
WCDMA General Settings	Loopback Mode	Test Mode 1			
	Rel99 RMC	12.2kbps RMC			
	HSDPA FRC	H-Set 1			
	Power Control Algorithm	Algorithm2			
	β_c	2/15	11/15	15/15	15/15
	β_d	15/15	15/15	8/15	4/15
	β_d (SF)	64			
	β_c/β_d	2/15	11/15	15/8	15/4
	β_{hs}	4/15	24/15	30/15	30/15
MPR (dB)	0	0	0.5	0.5	
HSDPA Specific Settings	DACK	8			
	DNAK	8			
	DCQI	8			
	Ack-Nack Repetition factor	3			
	CQI Feedback	4ms			
	CQI Repetition Factor	2			
	$A_{hs} = \beta_{hs} / \beta_c$	30/15			

HSPA+

Since 16QAM is not used for uplink, the uplink Category and release is same as HSUPA, i.e., CAT 6 Rel 6. Therefore, the RF conducted power is not measured.

8.2.1. WCDMA OUTPUT POWER RESULT

WCDMA Band 5 Measured Results

Band	Mode		UL Ch No.	Freq. [MHz]	MPR [dB]	Avg Pwr [dBm]	
W-CDMA Band V	Rel 99	RMC, 12.2 kbps	4132	826.4	0	23.89	
			4183	836.6	0	23.68	
			4233	846.6	0	23.65	
	HSDPA	Subtest 1	4132	826.4	0	22.84	
			4183	836.6	0	22.63	
			4233	846.6	0	22.64	
		Subtest 2	4132	826.4	0	22.38	
			4183	836.6	0	22.14	
			4233	846.6	0	22.40	
		Subtest 3	4132	826.4	0.5	22.37	
			4183	836.6	0.5	21.98	
			4233	846.6	0.5	22.20	
		Subtest 4	4132	826.4	0.5	22.34	
			4183	836.6	0.5	22.02	
			4233	846.6	0.5	22.16	
		HSUPA	Subtest 1	4132	826.4	0	22.61
				4183	836.6	0	22.72
				4233	846.6	0	22.86
	Subtest 2		4132	826.4	2	21.55	
			4183	836.6	2	21.56	
			4233	846.6	2	21.67	
	Subtest 3		4132	826.4	1	21.90	
			4183	836.6	1	21.65	
			4233	846.6	1	21.91	
	Subtest 4		4132	826.4	2	21.95	
			4183	836.6	2	21.70	
			4233	846.6	2	21.66	
	Subtest 5		4132	826.4	0	22.89	
			4183	836.6	0	22.50	
			4233	846.6	0	22.90	

WCDMA Band 2 Measured Results

Band	Mode		UL Ch No.	Freq. [MHz]	MPR [dB]	Avg Pwr [dBm]	
W-CDMA Band II	Rel 99	RMC, 12.2 kbps	9262	1852.4	0	22.87	
			9400	1880.0	0	22.70	
			9538	1907.6	0	22.78	
	HSDPA	Subtest 1	9262	1852.4	0	22.17	
			9400	1880.0	0	21.86	
			9538	1907.6	0	21.99	
		Subtest 2	9262	1852.4	0	21.77	
			9400	1880.0	0	21.70	
			9538	1907.6	0	21.89	
		Subtest 3	9262	1852.4	0.5	21.66	
			9400	1880.0	0.5	21.23	
			9538	1907.6	0.5	21.45	
		Subtest 4	9262	1852.4	0.5	21.71	
			9400	1880.0	0.5	21.44	
			9538	1907.6	0.5	21.45	
		HSUPA	Subtest 1	9262	1852.4	0	21.54
				9400	1880.0	0	21.50
				9538	1907.6	0	21.87
	Subtest 2		9262	1852.4	2	20.82	
			9400	1880.0	2	20.51	
			9538	1907.6	2	20.59	
	Subtest 3		9262	1852.4	1	20.86	
			9400	1880.0	1	20.68	
			9538	1907.6	1	20.79	
	Subtest 4		9262	1852.4	2	20.96	
			9400	1880.0	2	20.37	
			9538	1907.6	2	20.29	
	Subtest 5		9262	1852.4	0	21.81	
			9400	1880.0	0	21.60	
			9538	1907.6	0	21.61	

8.3. LTE OUTPUT VERIFICATION

The following tests were conducted according to the test requirements outlined in section 6.2 of the 3GPP TS36.101 specification.

UE Power Class: 3 (23 +/- 2dBm). The allowed Maximum Power Reduction (MPR) for the maximum output power due to higher order modulation and transmit bandwidth configuration (resource blocks) is specified in Table 6.2.3-1 of the 3GPP TS36.101.

Table 6.2.3-1: Maximum Power Reduction (MPR) for Power Class 3

Modulation	Channel bandwidth / Transmission bandwidth (RB)						MPR (dB)
	1.4 MHz	3.0 MHz	5 MHz	10 MHz	15 MHz	20 MHz	
QPSK	> 5	> 4	> 8	> 12	> 16	> 18	≤ 1
16 QAM	≤ 5	≤ 4	≤ 8	≤ 12	≤ 16	≤ 18	≤ 1
16 QAM	> 5	> 4	> 8	> 12	> 16	> 18	≤ 2

The allowed A-MPR values specified below in Table 6.2.4.-1 of 3GPP TS36.101 are in addition to the allowed MPR requirements. All the measurements below were performed with A-MPR disabled, by using Network Signalling Value of "NS_01".

Table 6.2.4-1: Additional Maximum Power Reduction (A-MPR)

Network Signalling value	Requirements (sub-clause)	E-UTRA Band	Channel bandwidth (MHz)	Resources Blocks (N_{RB})	A-MPR (dB)
NS_01	6.6.2.1.1	Table 5.5-1	1.4, 3, 5, 10, 15, 20	Table 5.6-1	NA
NS_03	6.6.2.2.1	2, 4, 10, 23, 25, 35, 36	3	>5	≤ 1
			5	>6	≤ 1
			10	>6	≤ 1
			15	>8	≤ 1
			20	>10	≤ 1
NS_04	6.6.2.2.2	41	5	>6	≤ 1
			10, 15, 20	See Table 6.2.4-4	
NS_05	6.6.3.3.1	1	10, 15, 20	≥ 50	≤ 1
NS_06	6.6.2.2.3	12, 13, 14, 17	1.4, 3, 5, 10	Table 5.6-1	n/a
NS_07	6.6.2.2.3	13	10	Table 6.2.4-2	Table 6.2.4-2
	6.6.3.3.2				
NS_08	6.6.3.3.3	19	10, 15	> 44	≤ 3
NS_09	6.6.3.3.4	21	10, 15	> 40	≤ 1
				> 55	≤ 2
NS_10		20	15, 20	Table 6.2.4-3	Table 6.2.4-3
NS_11	6.6.2.2.1	23 ¹	1.4, 3, 5, 10	Table 6.2.4-5	Table 6.2.4-5
..					
NS_32	-	-	-	-	-

Note 1: Applies to the lower block of Band 23, i.e. a carrier placed in the 2000-2010 MHz region.

8.3.1. LTE OUTPUT POWER RESULT

LTE Band 5 Measured Results

Band	BW (MHz)	Mode	RB Allocation	RB offset	Target MPR	Avg Pwr [dBm]		
						Max. Power		
						829 MHz	836.5 MHz	844 MHz
LTE Band 5	10	QPSK	1	0	0	23.94	24.08	24.03
			1	25	0	24.08	23.88	23.96
			1	49	0	23.94	24.08	24.01
			25	0	1	21.97	22.09	21.98
			25	12	1	22.07	21.95	22.03
			25	25	1	22.09	21.88	21.96
		16QAM	50	0	1	22.03	22.08	22.12
			1	0	1	23.48	23.06	23.14
			1	25	1	23.38	23.17	23.06
			1	49	1	23.50	23.24	23.16
			25	0	2	21.17	21.12	21.10
			25	12	2	21.09	21.11	21.17
			25	25	2	21.11	21.12	21.07
			50	0	2	21.18	21.15	21.04
Band	BW (MHz)	Mode	RB Allocation	RB offset	Target MPR	Avg Pwr [dBm]		
						Max. Power		
						826.5 MHz	836.5 MHz	846.5 MHz
LTE Band 5	5	QPSK	1	0	0	23.79	24.17	23.84
			1	12	0	24.19	23.88	24.13
			1	24	0	24.05	23.93	23.83
			12	0	1	21.92	22.01	22.03
			12	7	1	21.84	21.95	21.95
			12	13	1	21.88	21.96	21.91
		16QAM	25	0	1	21.88	22.03	21.97
			1	0	1	22.72	22.91	23.18
			1	12	1	22.67	22.88	22.98
			1	24	1	22.84	22.90	23.18
			12	0	2	20.99	21.10	21.11
			12	7	2	20.98	20.97	20.90
			12	13	2	21.08	21.14	20.91
			25	0	2	21.13	21.13	21.06
Band	BW (MHz)	Mode	RB Allocation	RB offset	Target MPR	Avg Pwr [dBm]		
						Max. Power		
						825.5 MHz	836.5 MHz	847.5 MHz
LTE Band 5	3	QPSK	1	0	0	23.78	24.01	23.97
			1	8	0	24.26	23.73	24.05
			1	14	0	24.13	23.91	23.91
			8	0	1	21.98	22.06	22.01
			8	4	1	21.93	21.95	22.05
			8	7	1	21.91	21.91	22.05
			15	0	1	22.00	22.01	21.93
		16QAM	1	0	1	23.42	23.15	23.47
			1	8	1	23.11	23.16	23.47
			1	14	1	23.14	23.09	23.50
			8	0	2	21.03	21.27	21.30
			8	4	2	21.01	21.19	21.04
			8	7	2	20.98	21.16	20.90
			15	0	2	21.18	21.07	21.00
Band	BW (MHz)	Mode	RB Allocation	RB offset	Target MPR	Avg Pwr [dBm]		
						Max. Power		
						824.7 MHz	836.5 MHz	848.3 MHz
LTE Band 5	1.4	QPSK	1	0	0	23.90	23.75	23.94
			1	3	0	23.92	24.08	23.89
			1	5	0	23.97	23.93	23.92
			3	0	0	24.10	24.08	24.11
			3	1	0	24.21	23.96	24.08
			3	3	0	24.11	23.94	24.15
		16QAM	6	0	1	22.08	21.93	22.15
			1	0	1	23.50	23.15	23.15
			1	3	1	23.50	23.20	23.29
			1	5	1	23.50	23.14	23.17
			3	0	1	23.35	22.98	23.40
			3	1	1	23.00	22.92	23.45
			3	3	1	22.73	23.00	23.34
			6	0	2	20.87	21.04	21.24

9. PEAK TO AVERAGE RATIO

Test Procedure

Per KDB 971168 D01 Power Meas License Digital Systems v02r02;

The transmitter output was connected to a CMW500 Test Set and configured to operate at maximum power. The PAR were measured on the Spectrum Analyzer.

Test Spec

In addition, when the transmitter power is measured in terms of average value, the peak-to-average ratio of the power shall not exceed 13 dB.

9.1. CONDUCTED PEAK TO AVERAGE RESULT

GSM

Band	Channel	f [MHz]	Mode	Ratio [dB]	Limit [dB]
GSM1900	661	1880.0	GPRS	2.84	13.00
			EGPRS	5.85	

WCDMA

Band	Channel	f [MHz]	Mode	Ratio [dB]	Limit [dB]
Band 5	4183	836.6	REL99	2.77	13.00
			HSDPA	3.04	
Band 2	9400	1880.0	REL99	2.98	
			HSDPA	3.09	

LTE Band 5

Band	BW [MHz]	Channel	f [MHz]	Mode	Ratio [dB]	Limit [dB]
Band 5	10	20525	836.5	QPSK	3.66	13.00
				16QAM	4.10	
	5			QPSK	3.68	
				16QAM	4.55	
	3			QPSK	3.71	
				16QAM	4.21	
	1.4			QPSK	3.64	
				16QAM	4.20	

9.2. CONDUCTED PEAK TO AVERAGE PLOTS

GSM

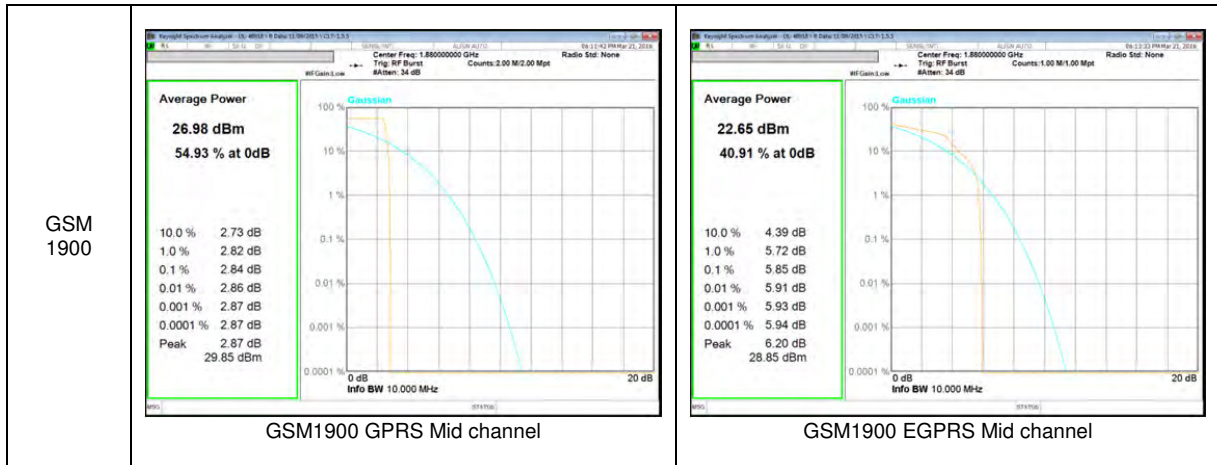

WCDMA

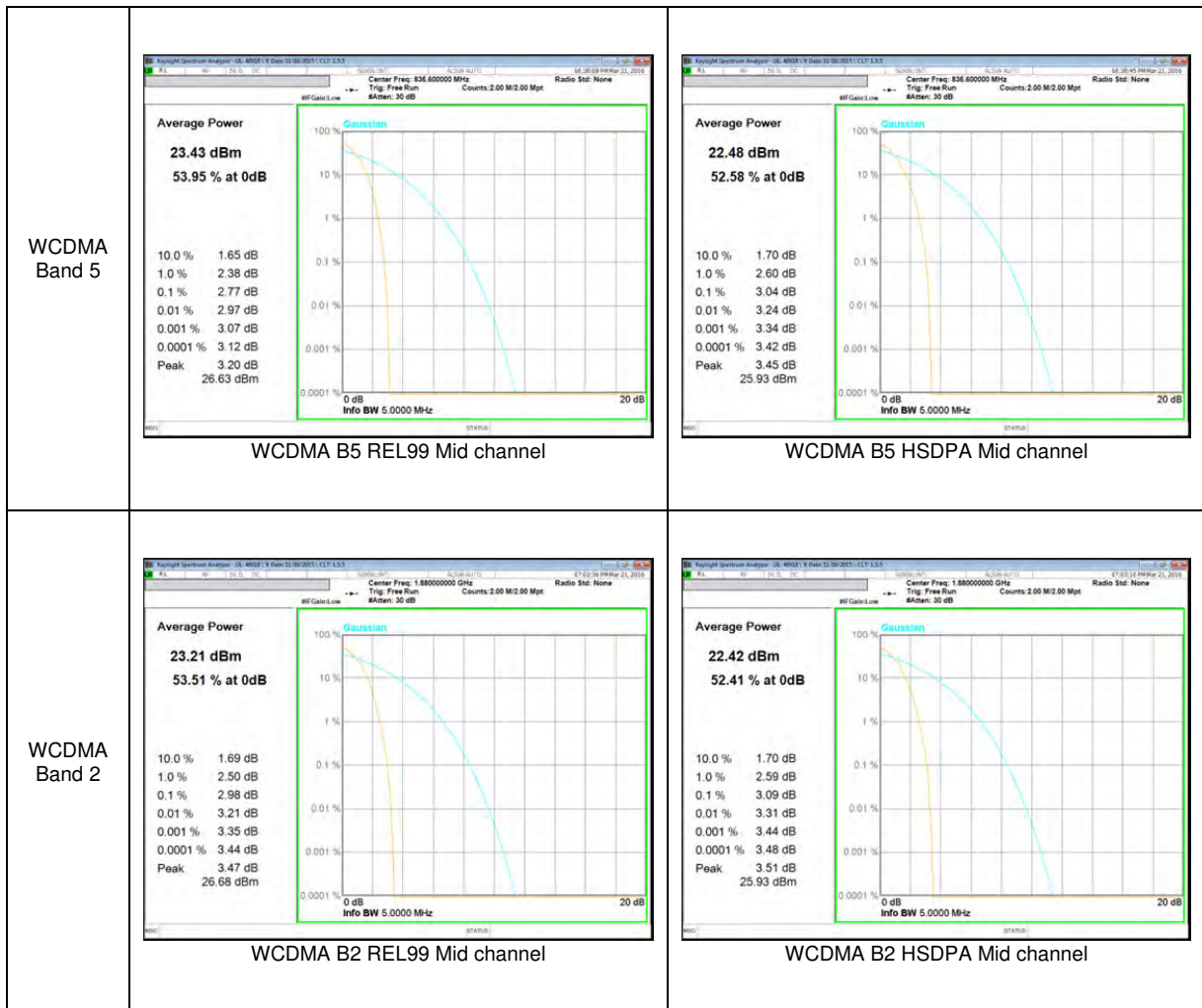

LTE Band 5

<p>LTE Band 5 10 MHz</p>	<p>Average Power 23.71 dBm 49.72 % at 0dB</p> <p>10.0 % 2.59 dB 1.0 % 3.59 dB 0.1 % 3.66 dB 0.01 % 3.70 dB 0.001 % 3.72 dB 0.0001 % 3.73 dB Peak 3.73 dB 27.44 dBm</p> <p>Info BW 10.000 MHz</p>	<p>Average Power 23.70 dBm 46.55 % at 0dB</p> <p>10.0 % 2.84 dB 1.0 % 4.04 dB 0.1 % 4.10 dB 0.01 % 4.12 dB 0.001 % 4.13 dB 0.0001 % 4.14 dB Peak 4.21 dB 27.91 dBm</p> <p>Info BW 10.000 MHz</p>
	<p>LTE B5 10MHz QPSK Mid channel</p>	<p>LTE B5 10MHz 16QAM Mid channel</p>
<p>LTE Band 5 5 MHz</p>	<p>Average Power 23.58 dBm 49.93 % at 0dB</p> <p>10.0 % 2.50 dB 1.0 % 3.61 dB 0.1 % 3.68 dB 0.01 % 3.71 dB 0.001 % 3.72 dB 0.0001 % 3.73 dB Peak 3.74 dB 27.32 dBm</p> <p>Info BW 10.000 MHz</p>	<p>Average Power 22.72 dBm 44.35 % at 0dB</p> <p>10.0 % 2.99 dB 1.0 % 4.48 dB 0.1 % 4.55 dB 0.01 % 4.58 dB 0.001 % 4.70 dB 0.0001 % 4.73 dB Peak 4.80 dB 27.52 dBm</p> <p>Info BW 10.000 MHz</p>
	<p>LTE B5 5MHz QPSK Mid channel</p>	<p>LTE B5 5MHz 16QAM Mid channel</p>
<p>LTE Band 5 3 MHz</p>	<p>Average Power 23.59 dBm 49.50 % at 0dB</p> <p>10.0 % 2.60 dB 1.0 % 3.66 dB 0.1 % 3.71 dB 0.01 % 3.72 dB 0.001 % 3.74 dB 0.0001 % 3.75 dB Peak 3.77 dB 27.36 dBm</p> <p>Info BW 10.000 MHz</p>	<p>Average Power 23.30 dBm 45.84 % at 0dB</p> <p>10.0 % 2.88 dB 1.0 % 4.17 dB 0.1 % 4.21 dB 0.01 % 4.24 dB 0.001 % 4.26 dB 0.0001 % 4.29 dB Peak 4.30 dB 27.60 dBm</p> <p>Info BW 10.000 MHz</p>
	<p>LTE B5 3MHz QPSK Mid channel</p>	<p>LTE B5 3MHz 16QAM Mid channel</p>
<p>LTE Band 5 1.4 MHz</p>	<p>Average Power 23.70 dBm 50.57 % at 0dB</p> <p>10.0 % 2.54 dB 1.0 % 3.58 dB 0.1 % 3.64 dB 0.01 % 3.66 dB 0.001 % 3.67 dB 0.0001 % 3.68 dB Peak 3.73 dB 27.43 dBm</p> <p>Info BW 10.000 MHz</p>	<p>Average Power 23.58 dBm 45.91 % at 0dB</p> <p>10.0 % 2.88 dB 1.0 % 4.15 dB 0.1 % 4.20 dB 0.01 % 4.22 dB 0.001 % 4.24 dB 0.0001 % 4.24 dB Peak 4.31 dB 27.89 dBm</p> <p>Info BW 10.000 MHz</p>
	<p>LTE B5 1.4MHz QPSK Mid channel</p>	<p>LTE B5 1.4MHz 16QAM Mid channel</p>

10. LIMITS AND CONDUCTED RESULTS

10.1. OCCUPIED BANDWIDTH

RULE PART(S)

FCC: §2.1049

LIMITS

For reporting purposes only

TEST PROCEDURE

The transmitter output was connected to a calibrated coaxial cable and coupler, the other end of which was connected to a spectrum analyzer. The occupied bandwidth was measured with the spectrum analyzer at the low, middle and high channel in each band. The -26dB bandwidth was also measured and recorded.

(KDB 971168 D01 Power Meas License Digital Systems v02r02)

10.1.1. OCCUPIED BANDWIDTH RESULTS

GSM

Band	Mode	Channel	f [MHz]	99% BW [KHz]	26dB BW [KHz]
GSM1900	GPRS	512	1850.2	243.52	310.9
		661	1880.0	248.48	313.0
		810	1909.8	244.86	316.5
	EGPRS	512	1850.2	246.13	317.4
		661	1880.0	249.41	316.4
		810	1909.8	241.62	305.6

WCDMA

Band	Mode	Channel	f [MHz]	99% BW [MHz]	26dB BW [MHz]
Band 5	REL99	4132	826.4	4.1627	4.621
		4183	836.6	4.1685	4.645
		4233	846.6	4.1549	4.637
	HSDPA	4132	826.4	4.1598	4.613
		4183	836.6	4.1600	4.624
		4233	846.6	4.1544	4.617
Band 2	REL99	9262	1852.4	4.1724	4.645
		9400	1880.0	4.1758	4.625
		9538	1907.6	4.1694	4.640
	HSDPA	9262	1852.4	4.1794	4.622
		9400	1880.0	4.1565	4.615
		9538	1907.6	4.1781	4.636

LTE Band 5

Band	BW [MHz]	Channel	f [MHz]	Mode	99% BW [MHz]	26dB BW [MHz]
Band 5	10	20450	829.0	QPSK	8.9779	9.815
				16QAM	8.9607	9.866
		20524	836.5	QPSK	8.9673	9.834
				16QAM	8.9711	9.834
		20599	844.0	QPSK	8.9760	9.793
				16QAM	8.9566	9.857
	5	20425	826.5	QPSK	4.4980	4.925
				16QAM	4.4984	4.964
		20524	836.5	QPSK	4.4981	5.021
				16QAM	4.5035	5.004
		20624	846.5	QPSK	4.4843	4.905
				16QAM	4.5057	5.038
	3	20415	825.5	QPSK	2.6883	2.945
				16QAM	2.6967	2.985
		20524	836.5	QPSK	2.6880	2.980
				16QAM	2.6980	2.986
		20634	847.5	QPSK	2.6993	2.984
				16QAM	2.6946	2.998
	1.4	20407	824.7	QPSK	1.0793	1.275
				16QAM	1.0861	1.295
		20524	836.5	QPSK	1.0858	1.282
				16QAM	1.0872	1.335
		20624	848.3	QPSK	1.0808	1.280
				16QAM	1.0878	1.369

10.1.2. OCCUPIED BANDWIDTH PLOTS

GSM 1900

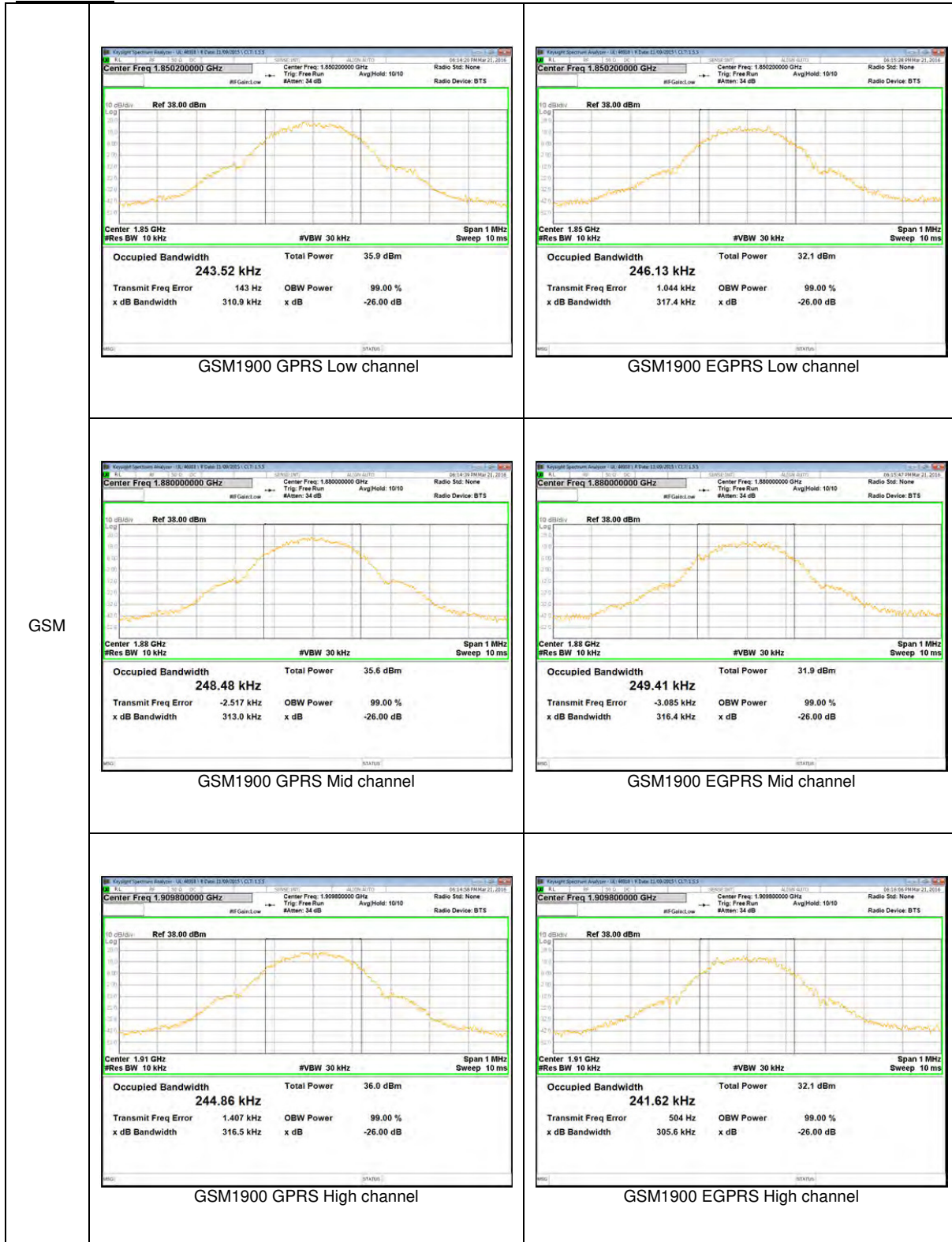

WCDMA Band 5

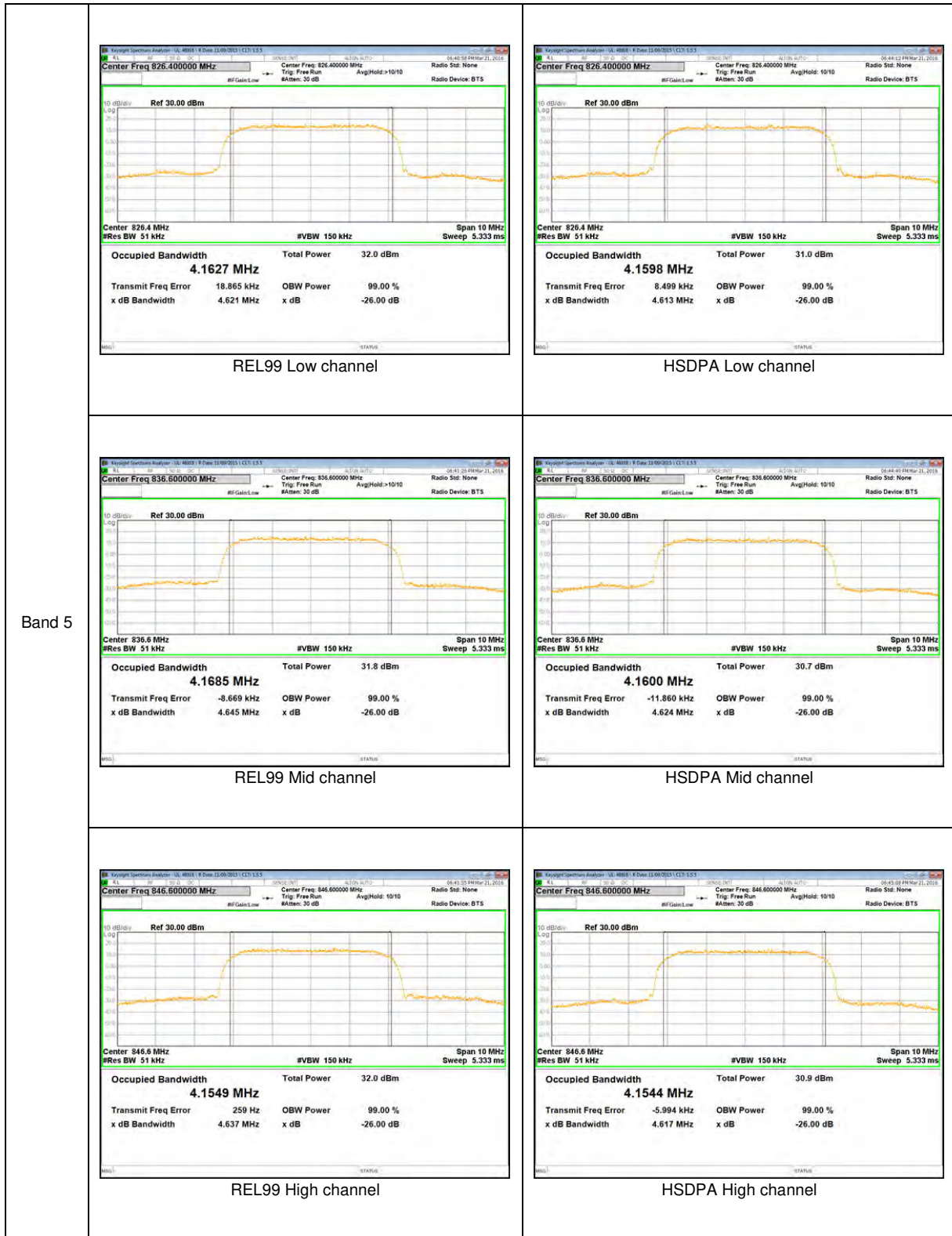

WCDMA Band 2

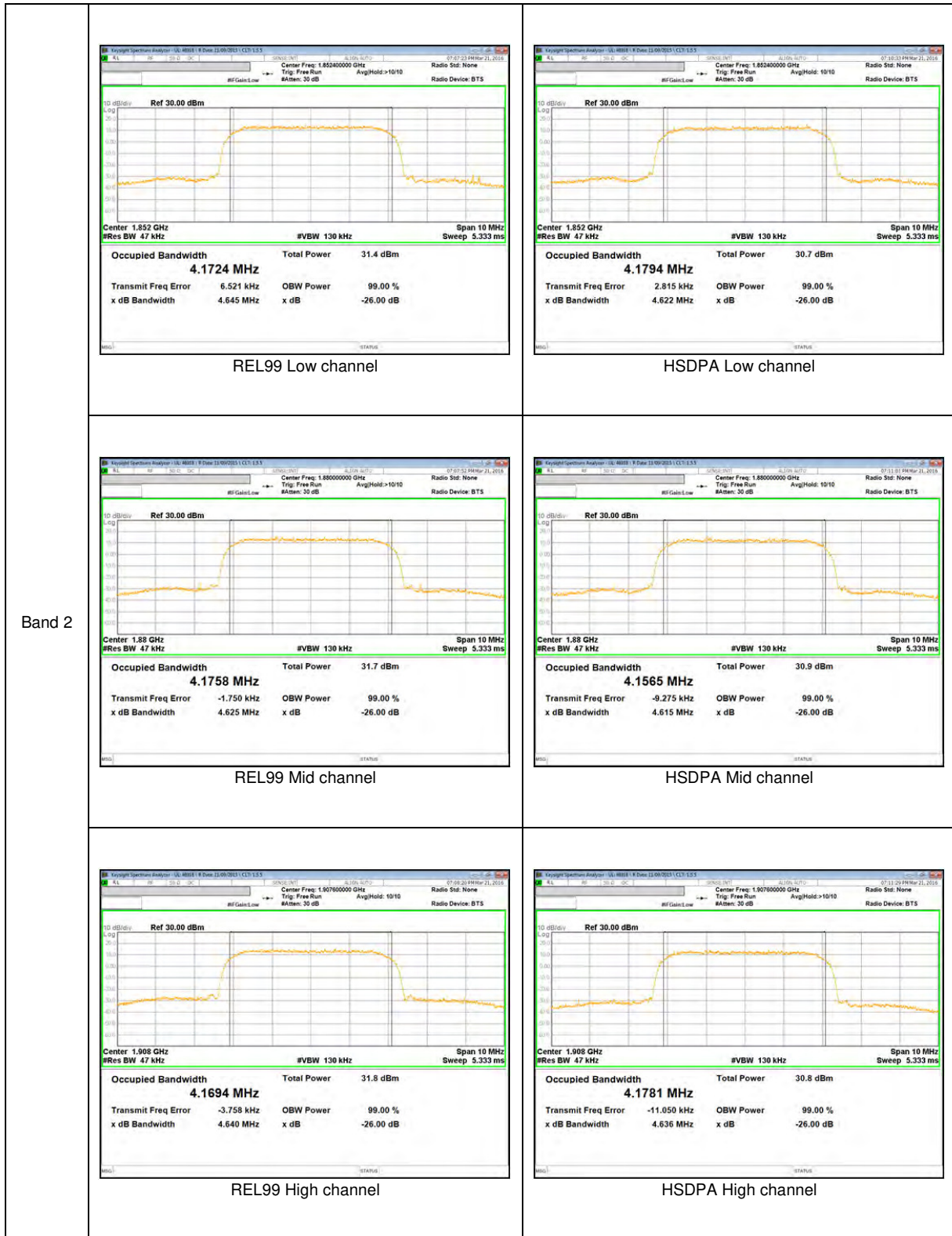

LTE Band 5



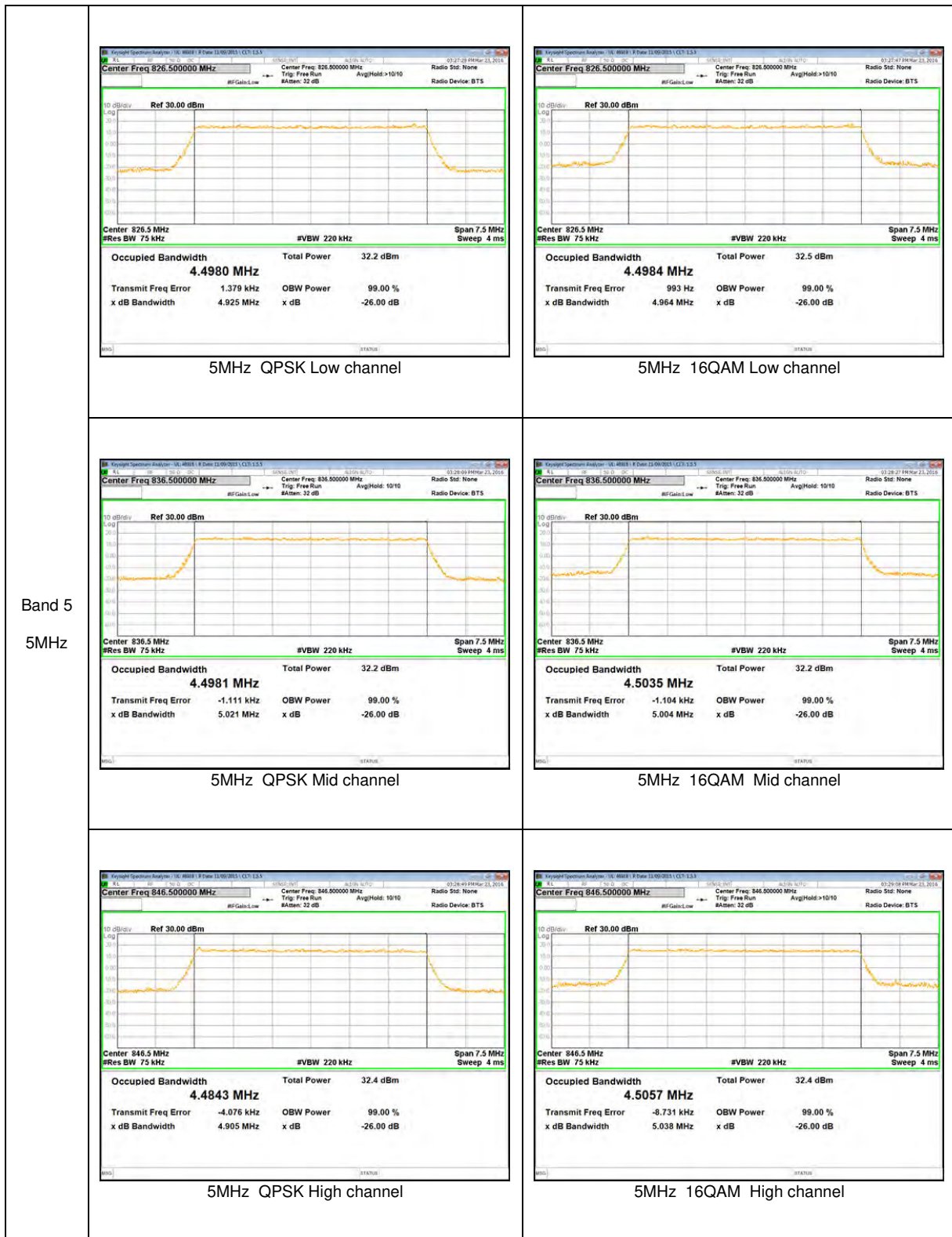





10.2. BAND EDGE EMISSIONS

RULE PART(S)

FCC: §22.359, §24.238

LIMITS

The power of any emission outside of the authorized operating frequency ranges must be attenuated below the transmitting power (P) by a factor of at least $43 + 10 \log (P)$ dB.

TEST PROCEDURE

Per KDB 971168 D01 Power Meas License Digital Systems v02r02

The transmitter output was connected to a CMW500 Test Set and configured to operate at maximum power. The band edge emissions were measured at the required operating frequencies in each band on the Spectrum Analyzer.

RESULTS

GSM

Band	Mode	Side	f [MHz]	Level [dBm]	Limit [dBm]
GSM1900	GPRS	Lower	1849.997	-17.811	-13.00
		Upper	1910.018	-18.214	
	EGPRS	Lower	1849.972	-25.105	
		Upper	1910.018	-24.406	

WCDMA

Band	Mode	Side	f [MHz]	Level [dBm]	Limit [dBm]
Band 5	REL99	Lower	824	-32.260	-13.00
		Upper	849	-33.773	
	HSDPA	Lower	824	-33.803	
		Upper	849	-37.310	
Band 2	REL99	Lower	1850	-35.158	
		Upper	1910	-35.996	
	HSDPA	Lower	1850	-34.980	
		Upper	1910	-38.125	

LTE 5

Bandwidth	Mode	Side	RB Status	f [MHz]	Level [dBm]	Limit [dBm]
10 MHz	QPSK	Lower	1RB	824.000	-28.606	-13.00
			FRB	824.000	-26.917	
		Upper	1RB	849.000	-27.008	
			FRB	849.000	-30.112	
	16QAM	Lower	1RB	824.000	-25.744	
			FRB	824.000	-28.892	
		Upper	1RB	849.000	-29.399	
			FRB	849.000	-31.779	
5 MHz	QPSK	Lower	1RB	824.000	-18.325	
			FRB	824.000	-24.520	
		Upper	1RB	849.000	-18.453	
			FRB	849.000	-24.831	
	16QAM	Lower	1RB	824.000	-17.658	
			FRB	824.000	-22.484	
		Upper	1RB	849.000	-18.686	
			FRB	849.000	-23.590	
3 MHz	QPSK	Lower	1RB	824.000	-16.921	
			FRB	824.000	-22.690	
		Upper	1RB	849.000	-15.568	
			FRB	849.000	-22.724	
	16QAM	Lower	1RB	824.000	-14.562	
			FRB	824.000	-21.820	
		Upper	1RB	849.000	-15.376	
			FRB	849.000	-19.445	
1.4 MHz	QPSK	Lower	1RB	824.000	-21.051	
			FRB	824.000	-25.674	
		Upper	1RB	849.000	-20.732	
			FRB	849.000	-22.634	
	16QAM	Lower	1RB	824.000	-21.449	
			FRB	824.000	-23.693	
		Upper	1RB	849.000	-17.303	
			FRB	849.000	-18.455	

10.2.1. BAND EDGE PLOTS

GSM

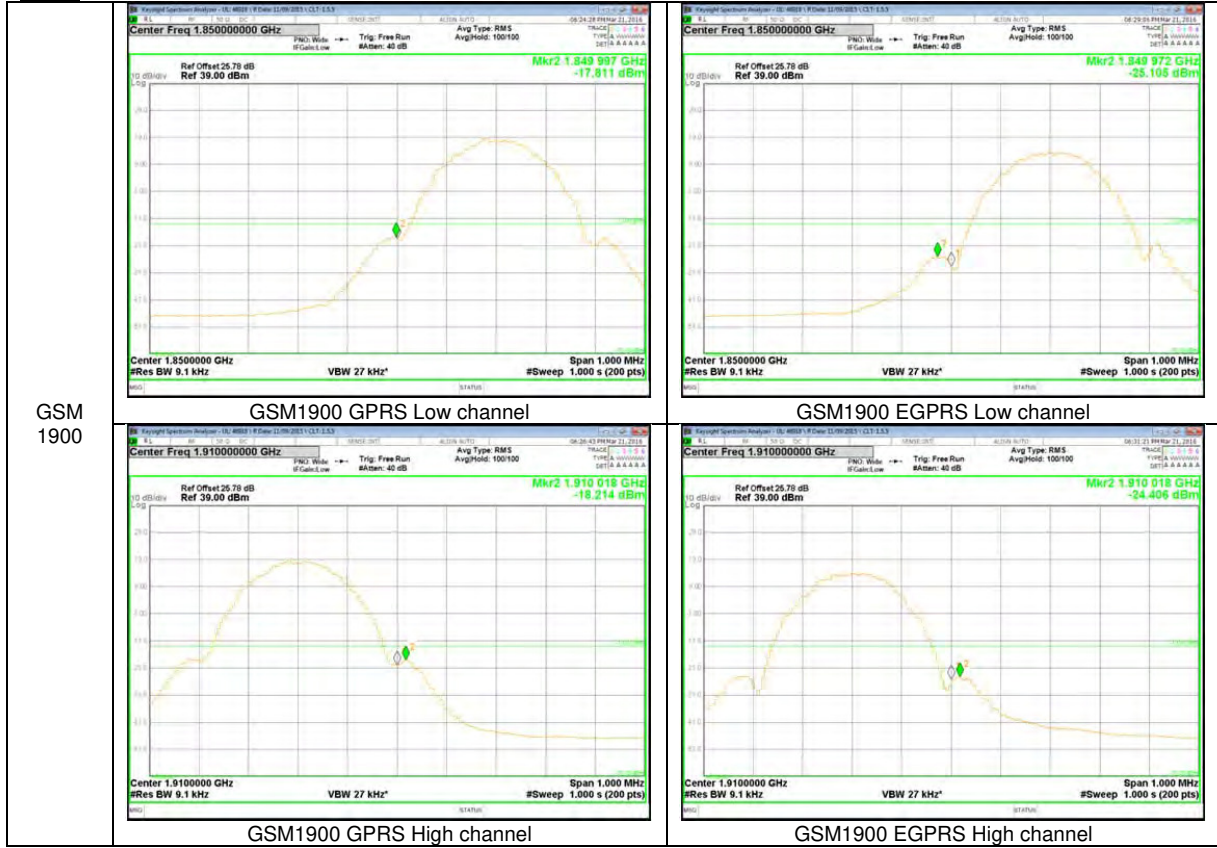

WCDMA

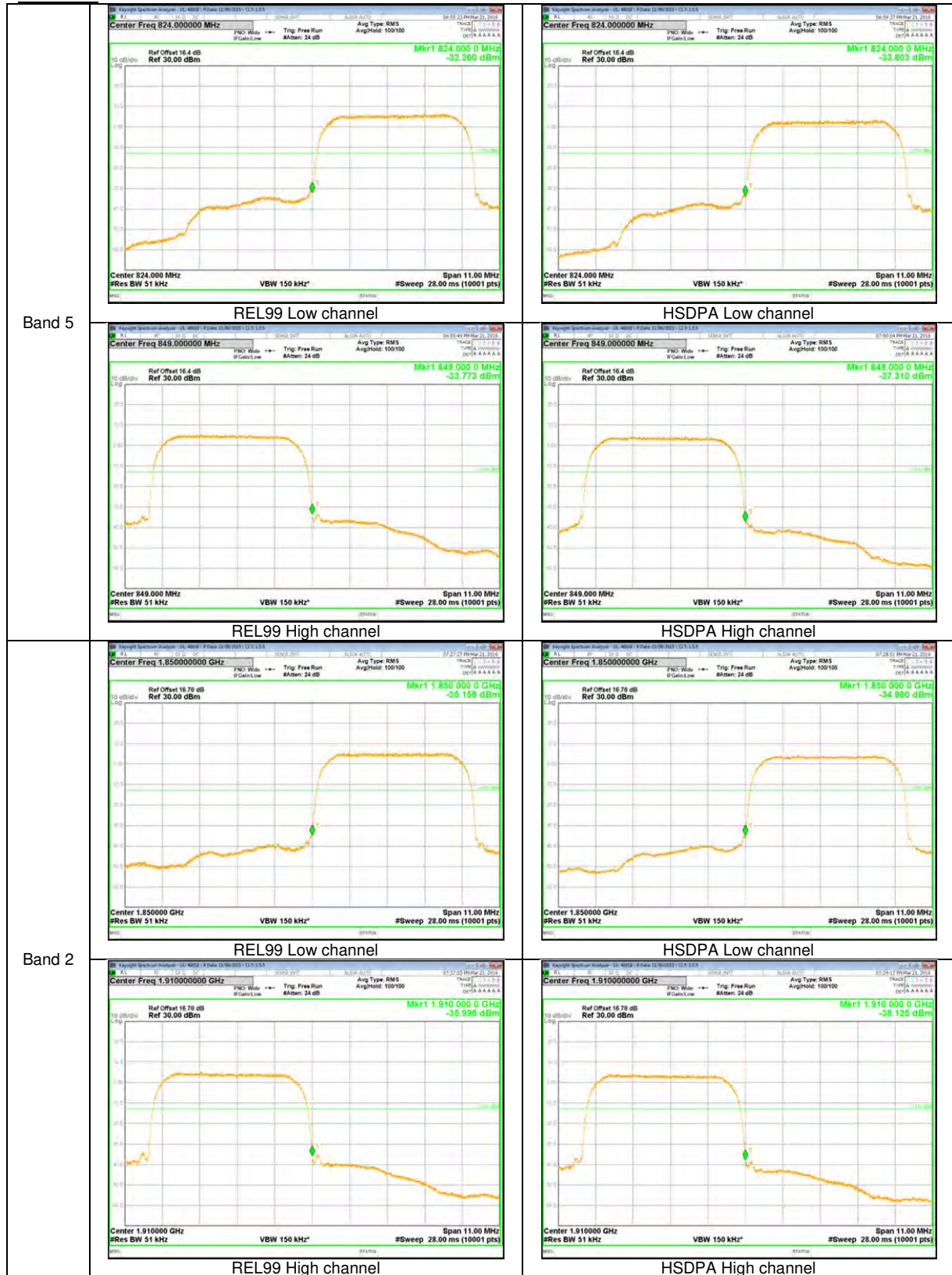

LTE Band 5

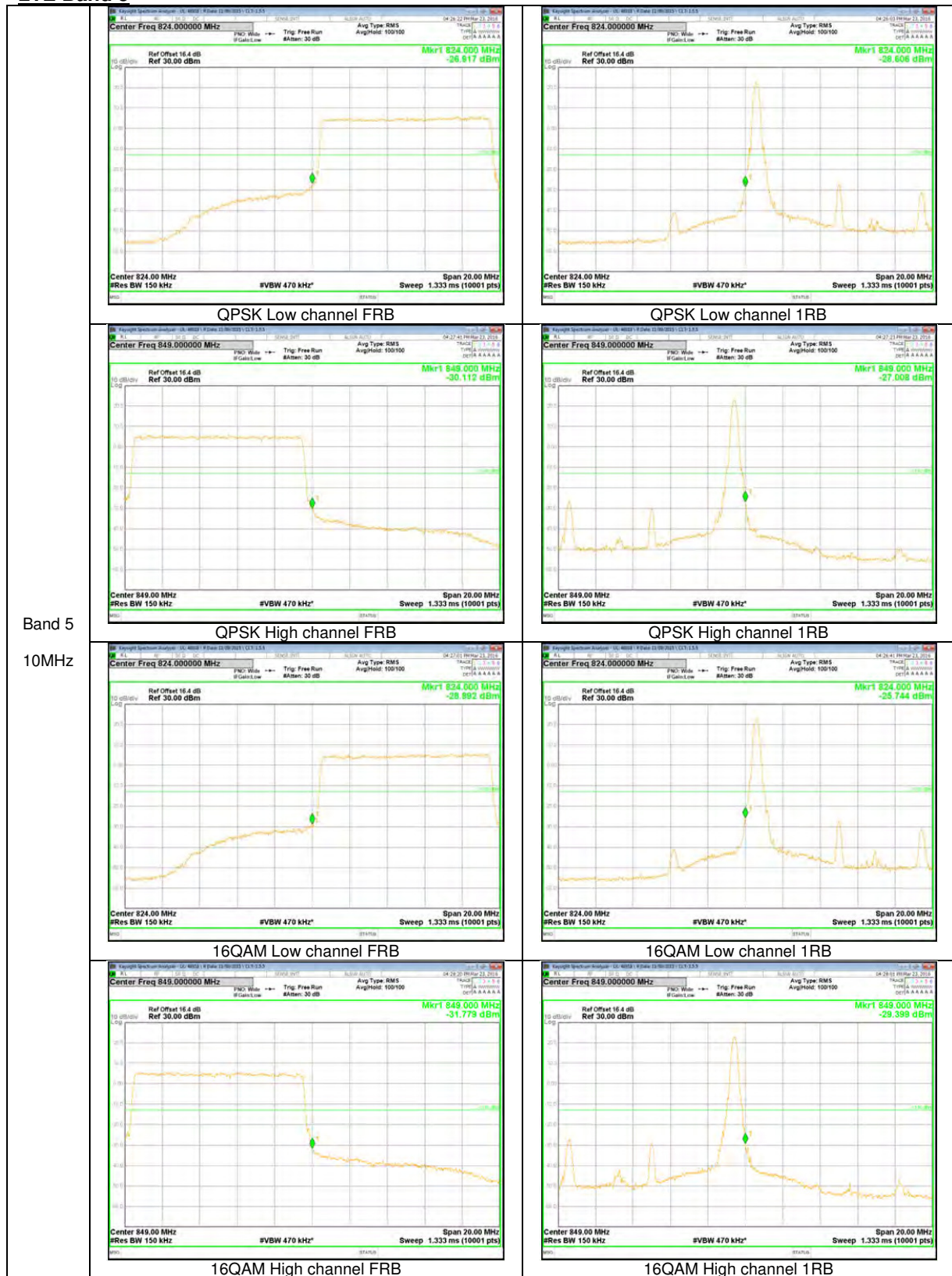

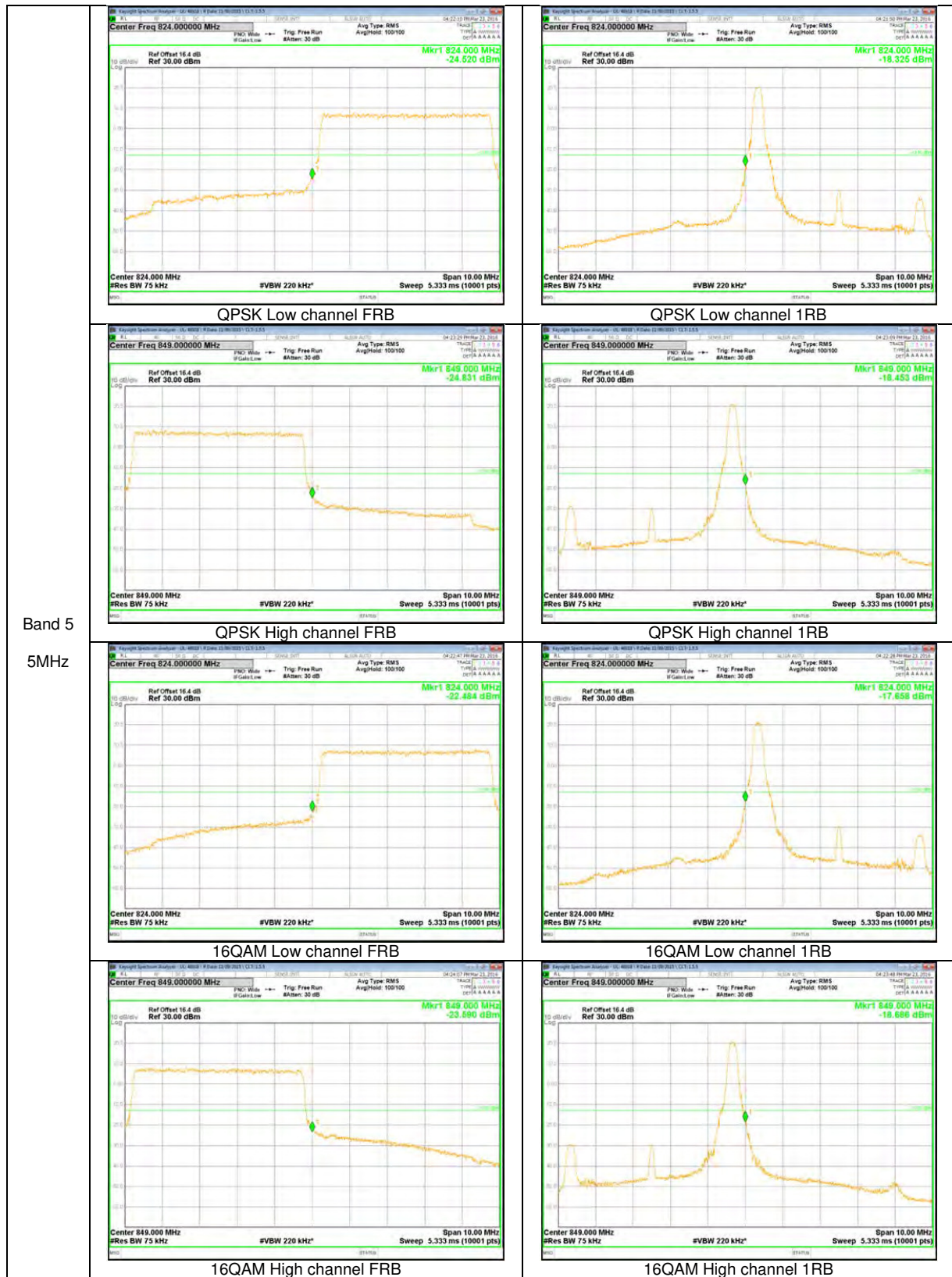

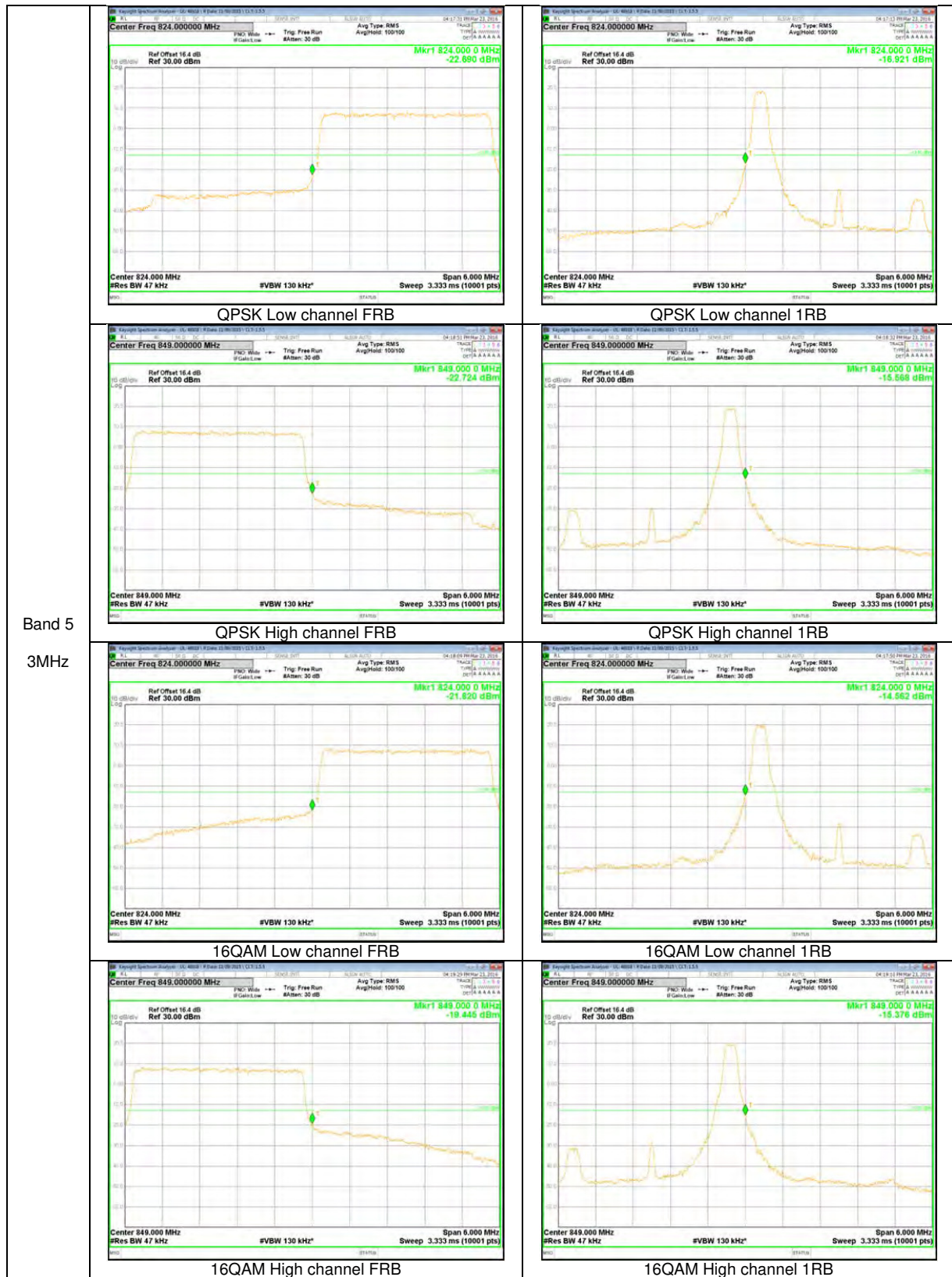

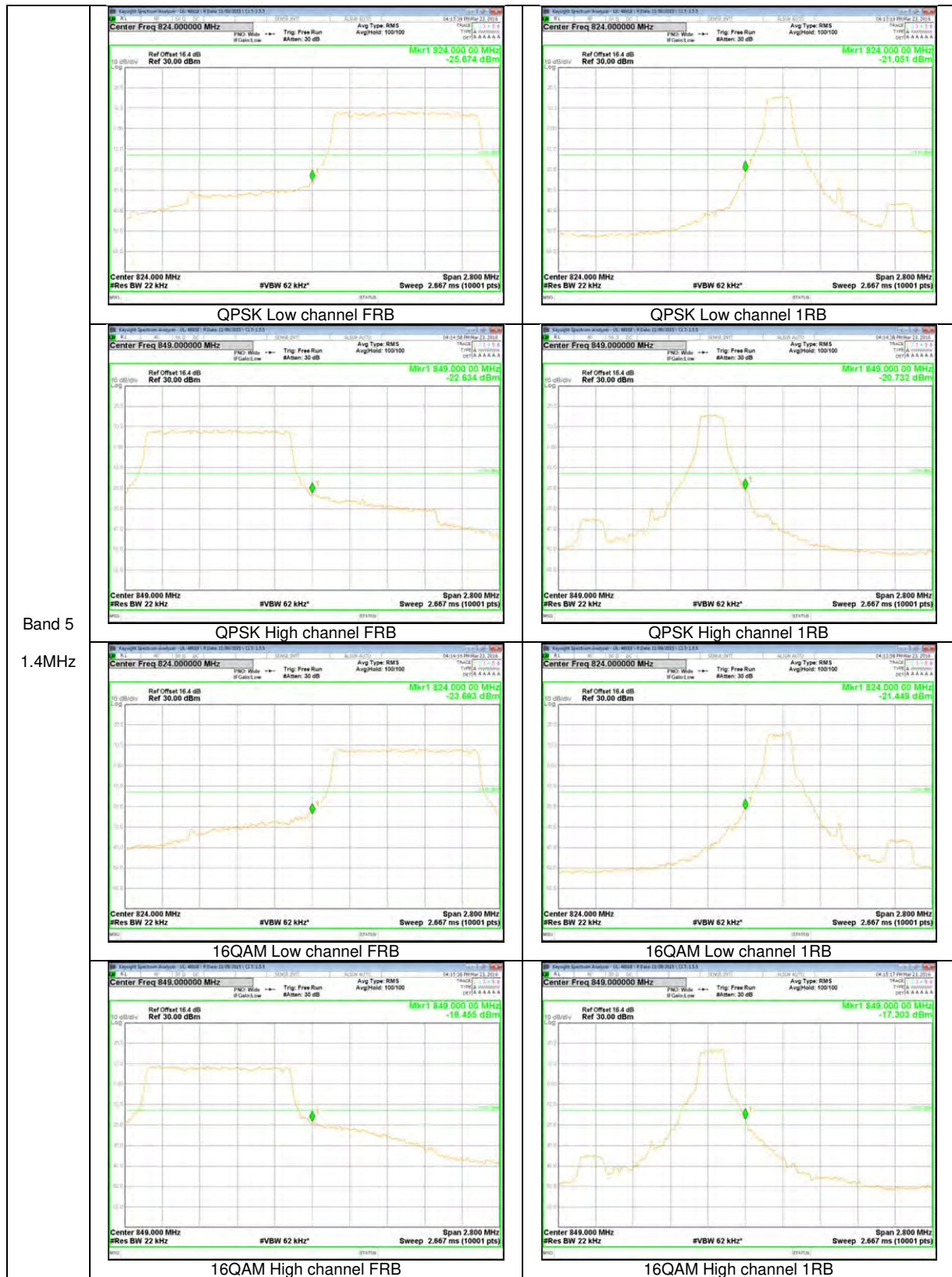

10.3. OUT OF BAND EMISSIONS

RULE PART(S)

FCC: §2.1051, §22.901, §22.917, §24.238

LIMITS

The power of any emission outside of the authorized operating frequency ranges must be attenuated below the transmitting power (P) by a factor of at least $43 + 10 \log (P)$ dB.

TEST PROCEDURE

Per KDB 971168 D01 Power Meas License Digital Systems v02r02

The RF output of the transmitter was connected to a spectrum analyzer through a calibrated coaxial cable. Sufficient scans were taken to show the out-of-band Emissions, if any, up to 10th harmonic. Multiple sweeps were recorded in maximum hold mode using a peak detector to ensure that the worst-case emissions were caught.

RESULTS

10.3.1. OUT OF BAND EMISSIONS RESULT

GSM

Band	Mode	f [MHz]	Spurious [dBm]	Limit [dBm]	Margin [dB]
GSM1900	GPRS	1850.2	-21.69	-13.00	8.69
		1880.0	-22.77		9.77
		1909.8	-22.40		9.4
	EGPRS	1850.2	-22.42		9.42
		1880.0	-22.22		9.22
		1909.8	-22.94		9.94

WCDMA

Band	Mode	f [MHz]	Spurious [dBm]	Limit [dBm]	Margin [dB]
Band 5	REL99	826.4	-32.79	-13.00	19.79
		836.6	-32.70		19.7
		846.6	-32.00		19
	HSDPA	826.4	-32.81		19.81
		836.6	-32.69		19.69
		846.6	-32.74		19.74
Band 2	REL99	1852.4	-33.14	-13.00	20.14
		1880.0	-32.72		19.72
		1907.6	-32.58		19.58
	HSDPA	1852.4	-32.48		19.48
		1880.0	-33.00		20
		1907.6	-32.67		19.67

LTE 5

Bandwidth	Mode	f [MHz]	Spurious [dBm]	Limit [dBm]	Margin [dB]
10 MHz	QPSK	829.0	-26.49	-13.00	13.49
		836.5	-27.04		14.04
		844.0	-27.56		14.56
	16QAM	829.0	-28.08		15.08
		836.5	-26.59		13.59
		844.0	-26.55		13.55
5 MHz	QPSK	826.5	-27.28		14.28
		836.5	-26.51		13.51
		846.5	-26.83		13.83
	16QAM	826.5	-26.96		13.96
		836.5	-26.15		13.15
		846.5	-26.70		13.7
3 MHz	QPSK	825.5	-26.37	13.37	
		836.5	-27.20	14.2	
		847.5	-26.69	13.69	
	16QAM	825.5	-26.80	13.8	
		836.5	-27.04	14.04	
		847.5	-26.80	13.8	
1.4 MHz	QPSK	824.7	-26.44	13.44	
		836.5	-27.29	14.29	
		848.3	-26.36	13.36	
	16QAM	824.7	-26.44	13.44	
		836.5	-26.82	13.82	
		848.3	-27.02	14.02	

10.3.2. OUT OF BAND EMISSIONS PLOTS
GSM 1900

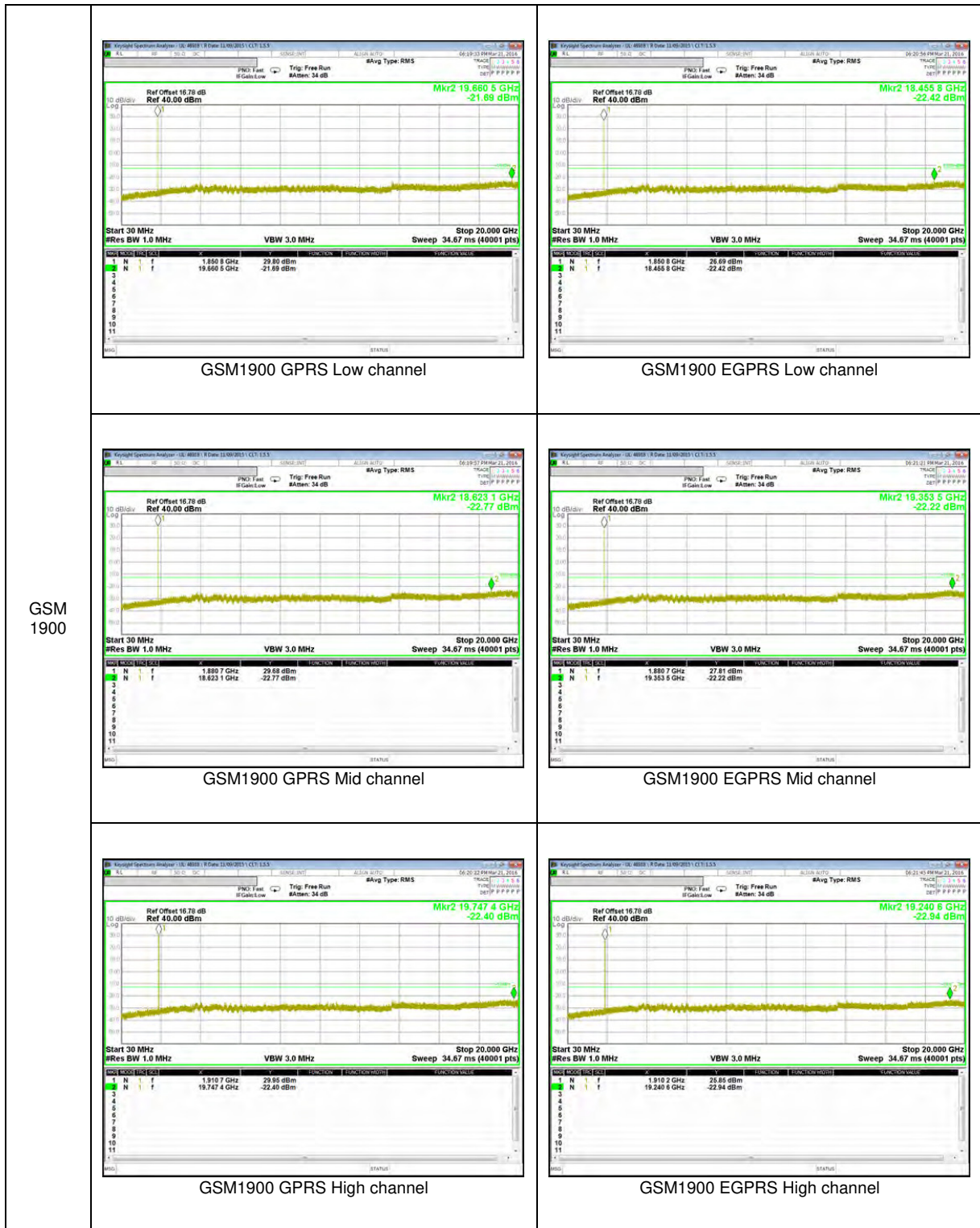

WCDMA Band 5

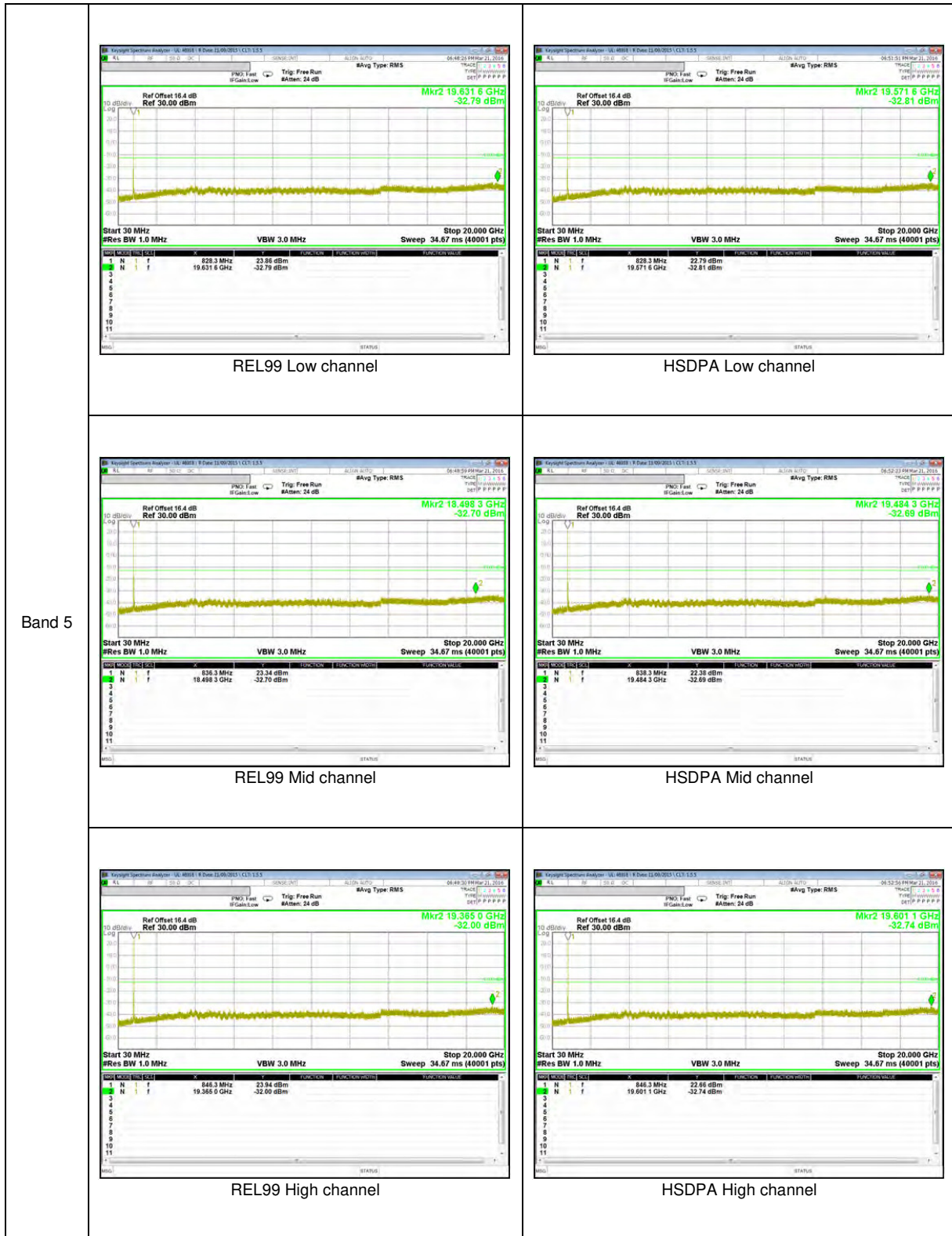

Band 5

WCDMA Band 2

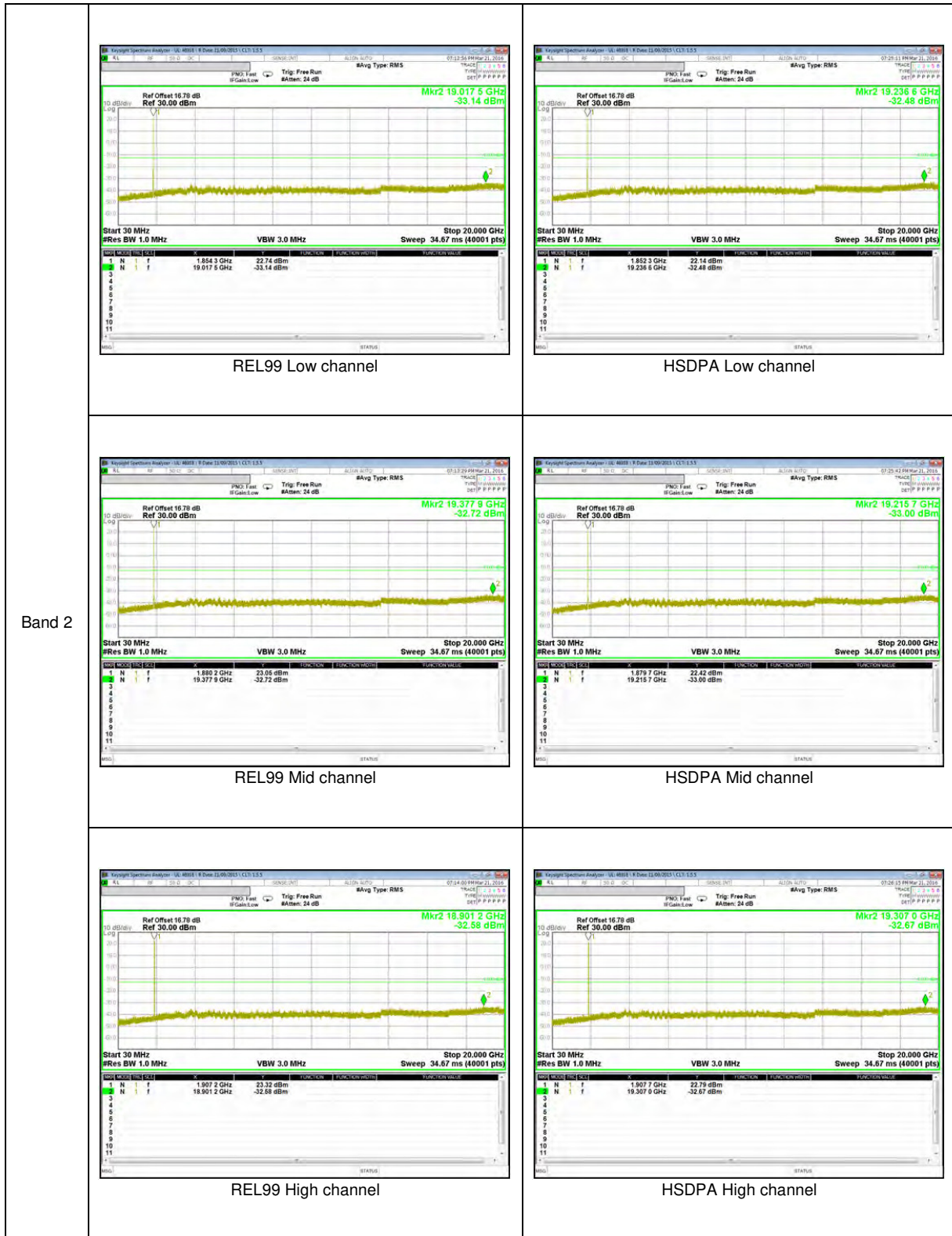

LTE Band 5

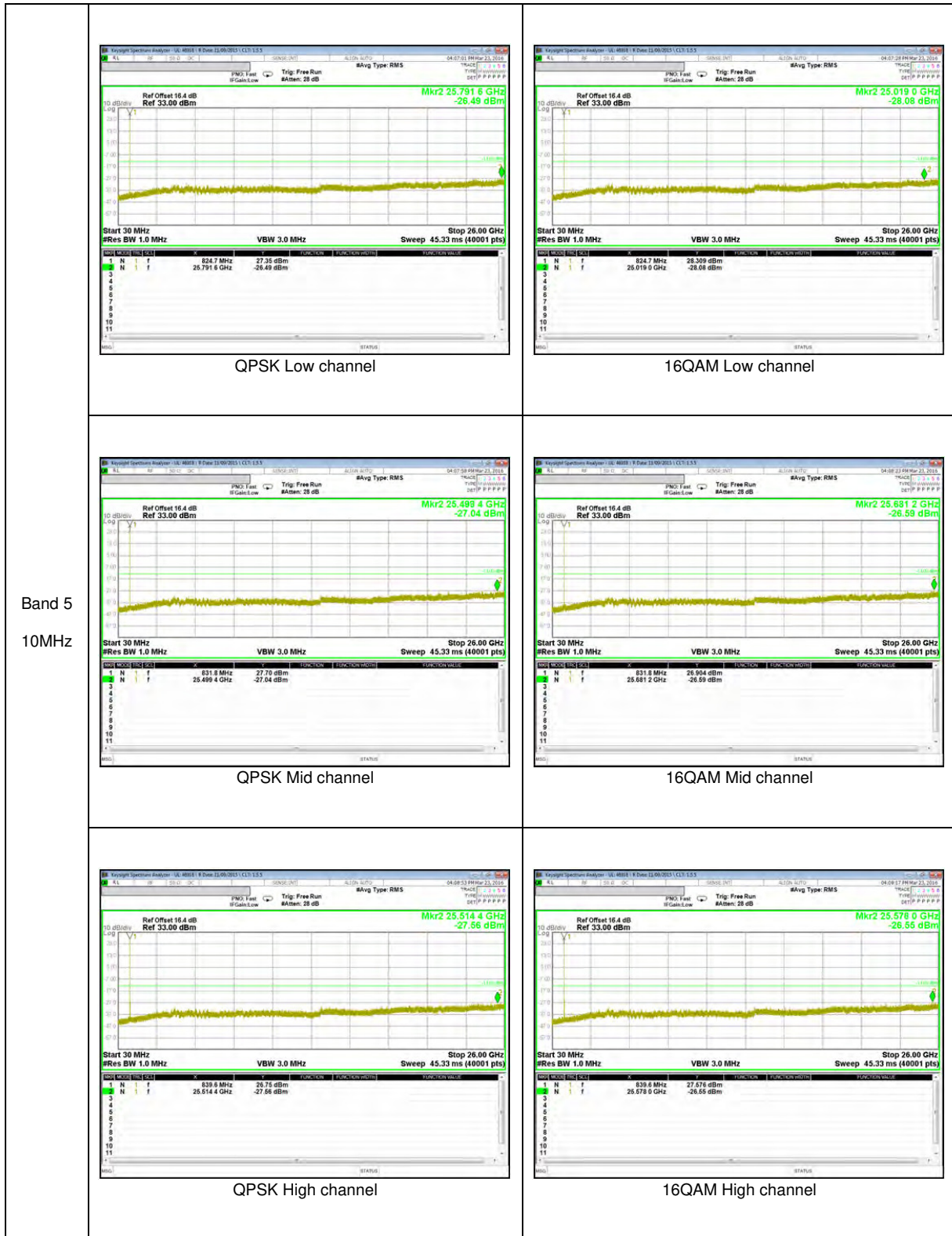

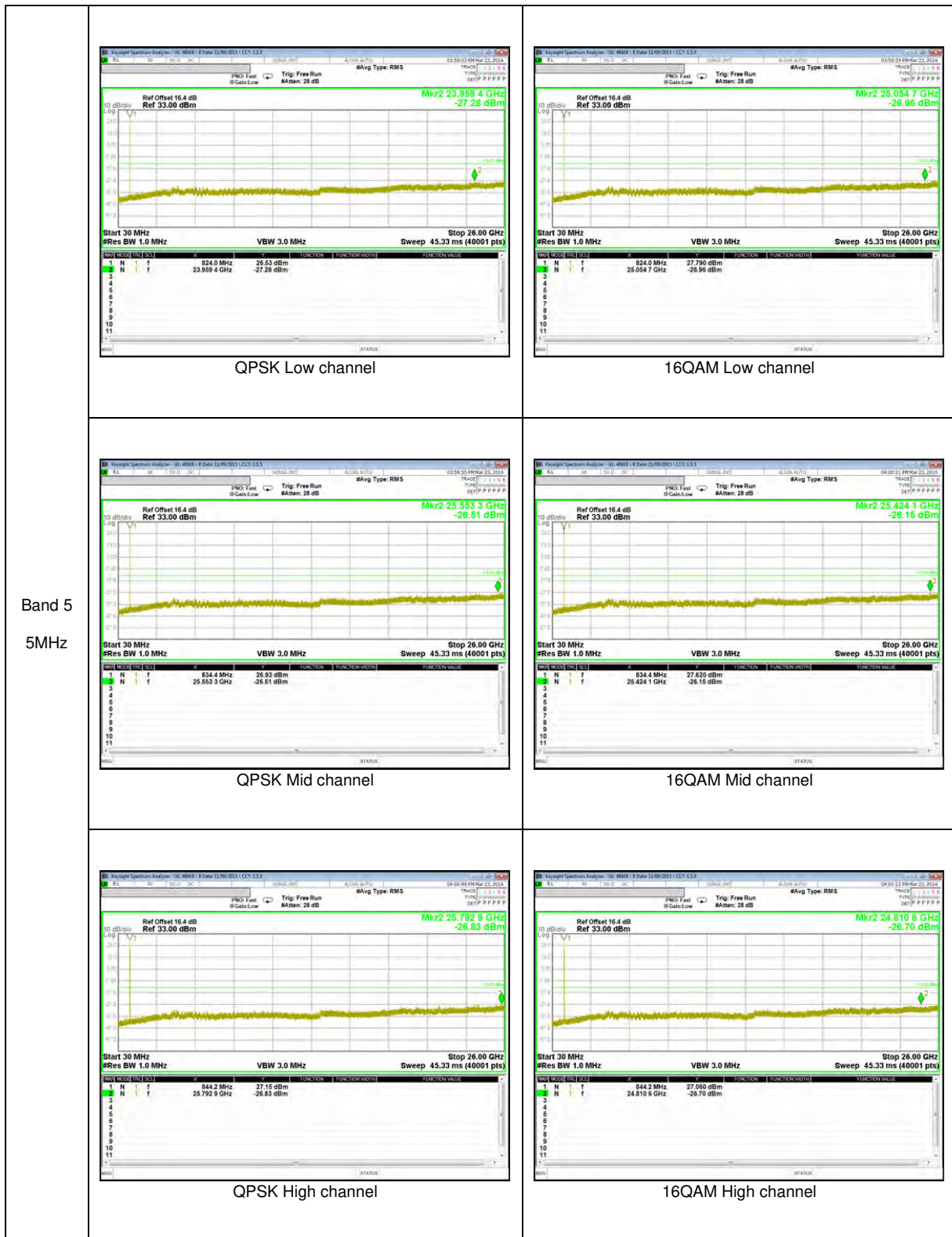

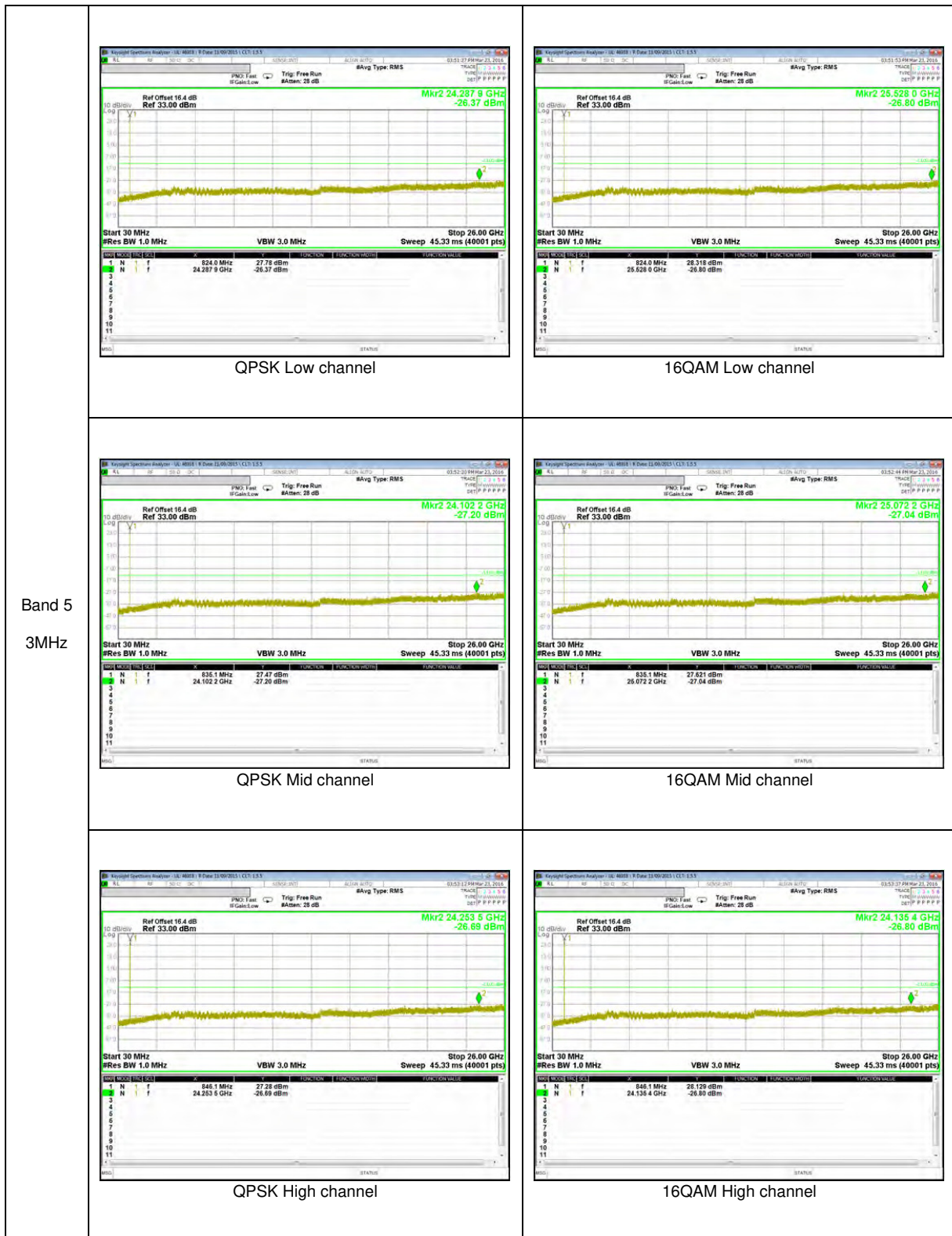

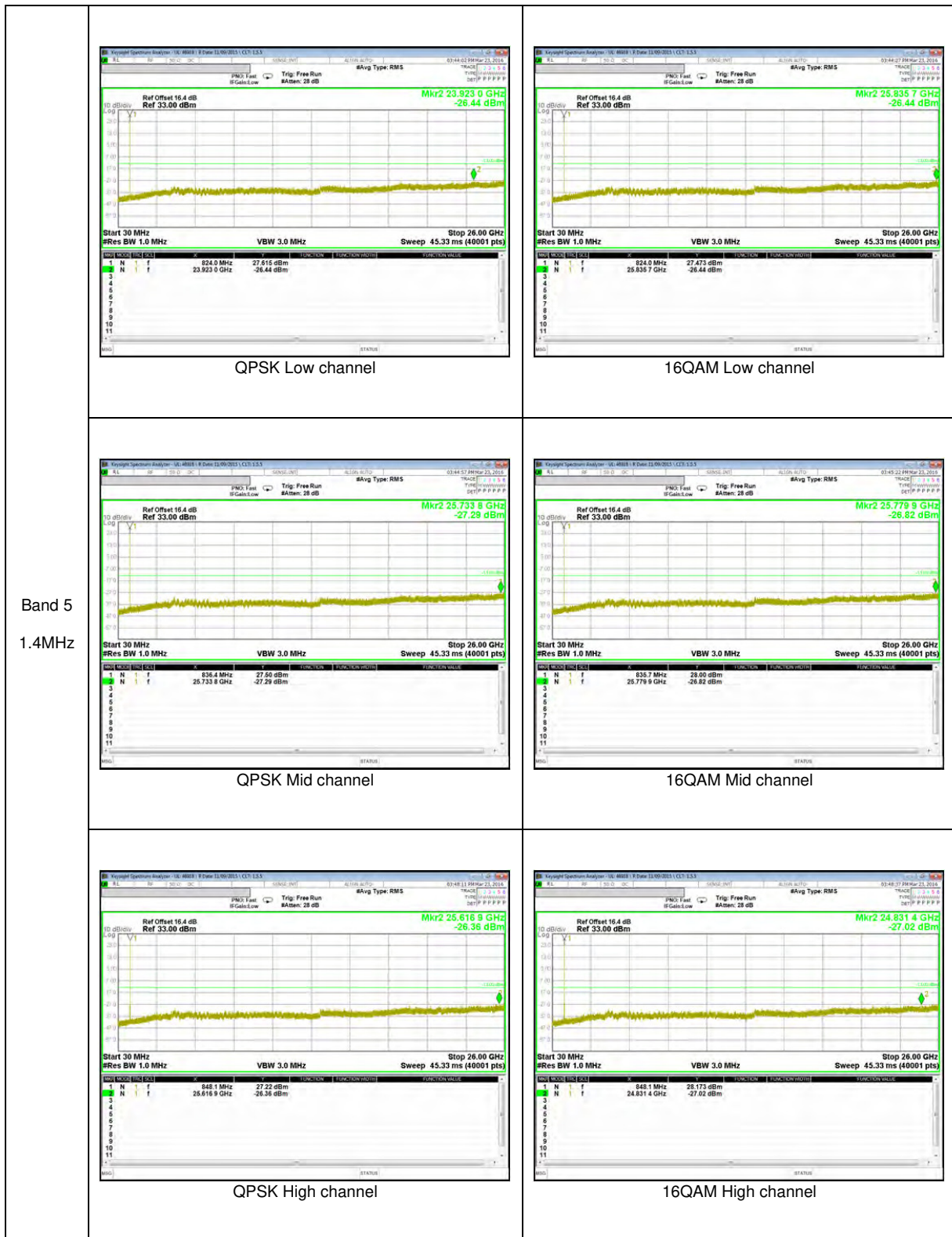

10.4. FREQUENCY STABILITY

RULE PART(S)

FCC: §2.1055, §22.355, §24.235

LIMITS

§22.355 - The carrier frequency shall not depart from the reference frequency in excess of ± 2.5 ppm for mobile stations.

§24.235 - The frequency stability shall be sufficient to ensure that the fundamental emission stays within the authorized frequency block.

TEST PROCEDURE

Per KDB 971168 D01 Power Meas License Digital Systems v02r02

RESULTS

See the following pages.

10.4.1. FREQUENCY STABILITY RESULTS

LTE Band 5, Channel 20524, Frequency 836.5 MHz

WCDMA Band 5, Channel 4183, Frequency 836.6 MHz

Reference Frequency: Cellular Mid Channel 836.5 MHz @ 20°C				
Limit: +/- 2.5 ppm = 2091.250 Hz				
Power Supply [Vdc]	Environment Temperature [°C]	Frequency Deviation Measured with Time Elapse		
		[MHz]	Delta [ppm]	Limit [ppm]
3.80	50	836.49999560	0.002	2.5
3.80	40	836.49999399	0.004	2.5
3.80	30	836.49999401	0.004	2.5
3.80	20	836.49999750	0	2.5
3.80	10	836.49999403	0.004	2.5
3.80	0	836.50000262	-0.006	2.5
3.80	-10	836.49999765	0.000	2.5
3.80	-20	836.50000574	-0.010	2.5
3.80	-30	836.50000350	-0.007	2.5

Reference Frequency: Cellular Mid Channel 836.5 MHz @ 20°C				
Limit: +/- 2.5 ppm = 2091.250 Hz				
Power Supply [Vdc]	Environment Temperature [°C]	Frequency Deviation Measured with Time Elapse		
		[MHz]	Delta [ppm]	Limit [ppm]
3.80	20	836.49999750	0	2.5
4.20	20	836.50000227	-0.006	2.5
3.40	20	836.49999838	-0.001	2.5

WCDMA Band 2, Channel 9400, Frequency 1880.0 MHz

GSM 1900, Channel 661, Frequency 1880.0 MHz

Reference Frequency: PCS Mid Channel 1880.0 MHz @ 20°C				
Limit: +/- 2.5 ppm = 4700.000 Hz				
Power Supply [Vdc]	Environment Temperature [°C]	Frequency Deviation Measured with Time Elapse		
		[MHz]	Delta [ppm]	Limit [ppm]
3.80	50	1879.99999576	0.000	2.5
3.80	40	1879.99998831	0.004	2.5
3.80	30	1879.99998524	0.005	2.5
3.80	20	1879.99999557	0	2.5
3.80	10	1879.99999483	0.000	2.5
3.80	0	1879.99998873	0.004	2.5
3.80	-10	1879.99999624	0.000	2.5
3.80	-20	1879.99999556	0.000	2.5
3.80	-30	1880.00000433	-0.005	2.5

Reference Frequency: PCS Mid Channel 1880.0 MHz @ 20°C				
Limit: +/- 2.5 ppm = 4700.000 Hz				
Power Supply [Vdc]	Environment Temperature [°C]	Frequency Deviation Measured with Time Elapse		
		[MHz]	Delta [ppm]	Limit [ppm]
3.80	20	1879.99999557	0	2.5
4.20	20	1879.99998783	0.004	2.5
3.40	20	1879.99999556	0.000	2.5

11. RADIATED TEST RESULTS

11.1. RADIATED POWER (ERP & EIRP)

RULE PART(S)

FCC: §2.1046, §22.913, §24.232

LIMITS

22.913(a) - The ERP of mobile transmitters and auxiliary test transmitters must not exceed 7 Watts.

24.232(c) - Mobile/portable stations are limited to 2 watts e.i.r.p. peak power and the equipment must employ means to limit the power to the minimum necessary for successful communications.

In addition, when the transmitter power is measured in terms of average value, the peak-to-average ratio of the power shall not exceed 13dB.

TEST PROCEDURE

ANSI / TIA / EIA 603D Clause 2.2.17; MXA setting reference to 971168 D01 v02r02

For peak power measurement with a MXA:

a) Set the RBW \geq OBW; b) Set VBW \geq 3 \times RBW; c) Set span \geq 2 \times RBW; d) Sweep time = auto couple; e) Detector = peak; f) Ensure that the number of measurement points \geq span/RBW; g) Trace mode = max hold;

For average power measurement with a MXA:

a) Set span to at least 1.5 times the OBW; b) Set RBW = 1-5% of the OBW, not to exceed 1 MHz; c) Set VBW \geq 3 \times RBW; d) Set number of points in sweep \geq 2 \times span / RBW; e) Sweep time = auto-couple; f) Detector = RMS (power averaging); g) Use free run trigger If burst duty cycle \geq 98; h) Use trigger to capture bursts If burst duty cycle < 98; i) Trace average at least 100 traces in power averaging (*i.e.*, RMS) mode. j) Compute the power by integrating the spectrum across the OBW of the signal using the instrument's band power measurement function.

TEST RESULTS

11.1.1. ERP/EIRP Results

GSM

Band	Mode	Channel	f [MHz]	ERP / EIRP	
				[dBm]	[mW]
GSM1900	GPRS	512	1850.2	27.84	608.14
		661	1880.0	27.47	558.47
		810	1909.8	27.55	568.85
	EGPRS	512	1850.2	25.73	374.11
		661	1880.0	25.62	364.75
		810	1909.8	25.23	333.43

WCDMA

Band	Mode	Channel	f [MHz]	ERP / EIRP	
				[dBm]	[mW]
Band 5	REL99	4132	826.4	19.88	97.27
		4183	836.6	19.20	83.18
		4233	846.6	18.55	71.61
	HSDPA	4132	826.4	19.35	86.10
		4183	836.6	18.60	72.44
		4233	846.6	18.07	64.12
Band 2	REL99	9262	1852.4	22.93	196.34
		9400	1880.0	22.35	171.79
		9538	1907.6	22.54	179.47
	HSDPA	9262	1852.4	21.96	157.04
		9400	1880.0	21.30	134.90
		9538	1907.6	21.58	143.88

LTE Band 5

Band	BW [MHz]	Mode	RB/RB Size	f [MHz]	ERP / EIRP	
			Full RB		[dBm]	[mW]
Band 5	10	QPSK	50/0	829.0	17.86	61.09
			50/0	836.5	16.28	42.46
			50/0	844.0	16.74	47.21
		16QAM	50/0	829.0	17.94	62.23
			50/0	836.5	16.34	43.05
			50/0	844.0	16.48	44.46
	5	QPSK	25/0	826.5	19.12	81.66
			25/0	836.5	19.10	81.28
			25/0	846.5	17.27	53.33
		16QAM	25/0	826.5	19.23	83.75
			25/0	836.5	18.99	79.25
			25/0	846.5	17.84	60.81
	3	QPSK	15/0	825.5	19.41	87.30
			15/0	836.5	18.89	77.45
			15/0	847.5	18.26	66.99
		16QAM	15/0	825.5	19.44	87.90
			15/0	836.5	18.85	76.74
			15/0	847.5	18.55	71.61
	1.4	QPSK	6/0	824.7	17.19	52.36
			6/0	836.5	17.23	52.84
			6/0	848.3	15.09	32.28
		16QAM	6/0	824.7	17.04	50.58
			6/0	836.5	17.25	53.09
			6/0	848.3	15.62	36.48

11.1.2. ERP/EIRP DATA

GSM 1900

GSM GSM1900 GPRS		High Frequency Substitution Measurement UL Korea, Ltd. Suwon Laboratory Chamber 2										
		f GHz	SG reading (dBm)	Ant. Pol. (H/V)	Cable Loss (dB)	Antenna Gain (dBi)	EIRP (dBm)	Limit (dBm)	Delta (dB)	Notes		
GSM GSM1900 EGPRS		Company: Samsung Project #: 16K23140 Date: 03-18-16 Test Engineer: Steven Kim Configuration: EUT ONLY, X Position Mode: GPRS 1900MHz <u>Test Equipment:</u> Receiving: 3117[00168724] and Chamber 1 SMA Cables Substitution: 3115[00161451] Substitution, 3m SMA Cable Warehouse										
		Low Ch										
		1850.20	18.6	V	1.60	8.80	25.75	33.0	-7.3			
		1850.20	20.6	H	1.60	8.80	27.84	33.0	-5.2			
		Mid Ch										
		1880.00	20.5	V	1.62	8.62	27.47	33.0	-5.5			
		1880.00	20.3	H	1.62	8.62	27.34	33.0	-5.7			
		High Ch										
		1909.80	20.2	V	1.63	8.44	27.04	33.0	-6.0			
		1909.80	20.7	H	1.63	8.44	27.55	33.0	-5.4			
		Rev. 3.17.11										
		GSM GSM1900 EGPRS		Company: Samsung Project #: 16K23140 Date: 03-18-16 Test Engineer: Steven Kim Configuration: EUT ONLY, X Position Mode: EGPRS 1900MHz <u>Test Equipment:</u> Receiving: 3117[00168724] and Chamber 1 SMA Cables Substitution: 3115[00161451] Substitution, 3m SMA Cable Warehouse								
				Low Ch								
				1850.20	16.8	V	1.60	8.80	23.98	33.0	-9.0	
1850.20	18.5			H	1.60	8.80	25.73	33.0	-7.3			
Mid Ch												
1880.00	18.6			V	1.62	8.62	25.62	33.0	-7.4			
1880.00	18.5			H	1.62	8.62	25.45	33.0	-7.5			
High Ch												
1909.80	18.0			V	1.63	8.44	24.78	33.0	-8.2			
1909.80	18.4			H	1.63	8.44	25.23	33.0	-7.8			
Rev. 3.17.11												

WCDMA Band 5

WCDMA Band 5 REL99	<p align="center">High Frequency Substitution Measurement UL Korea, Ltd. Suwon Laboratory Chamber 2</p> <p>Company: Samsung Project #: 16K23140 Date: 03-21-16 Test Engineer: Steven Kim Configuration: EUT ONLY, Z Position Mode: Rel 99_850 MHz</p> <p>Test Equipment: Receiving: VULB9163-749, and 3m Chamber N-type Cable (Setup this one for testing EUT) Substitution: Dipole S/N: 00164753, 3m SMA Cable Warehouse.</p> <table border="1"> <thead> <tr> <th>f MHz</th> <th>SG reading (dBm)</th> <th>Ant. Pol. (H/V)</th> <th>Cable Loss (dB)</th> <th>Antenna Gain (dBd)</th> <th>ERP (dBm)</th> <th>Limit (dBm)</th> <th>Margin (dB)</th> <th>Notes</th> </tr> </thead> <tbody> <tr> <td colspan="9">Low Ch</td> </tr> <tr> <td>826.40</td> <td>22.49</td> <td>V</td> <td>1.1</td> <td>-1.5</td> <td>19.88</td> <td>38.5</td> <td>-18.6</td> <td></td> </tr> <tr> <td>826.40</td> <td>6.69</td> <td>H</td> <td>1.1</td> <td>-1.5</td> <td>4.08</td> <td>38.5</td> <td>-34.4</td> <td></td> </tr> <tr> <td colspan="9">Mid Ch</td> </tr> <tr> <td>836.60</td> <td>21.69</td> <td>V</td> <td>1.1</td> <td>-1.4</td> <td>19.20</td> <td>38.5</td> <td>-19.3</td> <td></td> </tr> <tr> <td>836.60</td> <td>7.16</td> <td>H</td> <td>1.1</td> <td>-1.4</td> <td>4.67</td> <td>38.5</td> <td>-33.8</td> <td></td> </tr> <tr> <td colspan="9">High Ch</td> </tr> <tr> <td>846.60</td> <td>20.93</td> <td>V</td> <td>1.1</td> <td>-1.3</td> <td>18.55</td> <td>38.5</td> <td>-19.9</td> <td></td> </tr> <tr> <td>846.60</td> <td>10.16</td> <td>H</td> <td>1.1</td> <td>-1.3</td> <td>7.78</td> <td>38.5</td> <td>-30.7</td> <td></td> </tr> </tbody> </table> <p>Rev. 3.17.11</p>	f MHz	SG reading (dBm)	Ant. Pol. (H/V)	Cable Loss (dB)	Antenna Gain (dBd)	ERP (dBm)	Limit (dBm)	Margin (dB)	Notes	Low Ch									826.40	22.49	V	1.1	-1.5	19.88	38.5	-18.6		826.40	6.69	H	1.1	-1.5	4.08	38.5	-34.4		Mid Ch									836.60	21.69	V	1.1	-1.4	19.20	38.5	-19.3		836.60	7.16	H	1.1	-1.4	4.67	38.5	-33.8		High Ch									846.60	20.93	V	1.1	-1.3	18.55	38.5	-19.9		846.60	10.16	H	1.1	-1.3	7.78	38.5	-30.7	
	f MHz	SG reading (dBm)	Ant. Pol. (H/V)	Cable Loss (dB)	Antenna Gain (dBd)	ERP (dBm)	Limit (dBm)	Margin (dB)	Notes																																																																																		
Low Ch																																																																																											
826.40	22.49	V	1.1	-1.5	19.88	38.5	-18.6																																																																																				
826.40	6.69	H	1.1	-1.5	4.08	38.5	-34.4																																																																																				
Mid Ch																																																																																											
836.60	21.69	V	1.1	-1.4	19.20	38.5	-19.3																																																																																				
836.60	7.16	H	1.1	-1.4	4.67	38.5	-33.8																																																																																				
High Ch																																																																																											
846.60	20.93	V	1.1	-1.3	18.55	38.5	-19.9																																																																																				
846.60	10.16	H	1.1	-1.3	7.78	38.5	-30.7																																																																																				
WCDMA Band 5 HSDPA	<p align="center">High Frequency Substitution Measurement UL Korea, Ltd. Suwon Laboratory Chamber 2</p> <p>Company: Samsung Project #: 16K23140 Date: 03-21-16 Test Engineer: Steven Kim Configuration: EUT ONLY, Z Position Mode: HSDPA_850 MHz</p> <p>Test Equipment: Receiving: VULB9163-749, and 3m Chamber N-type Cable (Setup this one for testing EUT) Substitution: Dipole S/N: 00164753, 3m SMA Cable Warehouse.</p> <table border="1"> <thead> <tr> <th>f MHz</th> <th>SG reading (dBm)</th> <th>Ant. Pol. (H/V)</th> <th>Cable Loss (dB)</th> <th>Antenna Gain (dBd)</th> <th>ERP (dBm)</th> <th>Limit (dBm)</th> <th>Margin (dB)</th> <th>Notes</th> </tr> </thead> <tbody> <tr> <td colspan="9">Low Ch</td> </tr> <tr> <td>826.40</td> <td>21.96</td> <td>V</td> <td>1.1</td> <td>-1.5</td> <td>19.35</td> <td>38.5</td> <td>-19.1</td> <td></td> </tr> <tr> <td>826.40</td> <td>6.03</td> <td>H</td> <td>1.1</td> <td>-1.5</td> <td>3.42</td> <td>38.5</td> <td>-35.0</td> <td></td> </tr> <tr> <td colspan="9">Mid Ch</td> </tr> <tr> <td>836.60</td> <td>21.09</td> <td>V</td> <td>1.1</td> <td>-1.4</td> <td>18.60</td> <td>38.5</td> <td>-19.9</td> <td></td> </tr> <tr> <td>836.60</td> <td>6.19</td> <td>H</td> <td>1.1</td> <td>-1.4</td> <td>3.70</td> <td>38.5</td> <td>-34.8</td> <td></td> </tr> <tr> <td colspan="9">High Ch</td> </tr> <tr> <td>846.60</td> <td>20.45</td> <td>V</td> <td>1.1</td> <td>-1.3</td> <td>18.07</td> <td>38.5</td> <td>-20.4</td> <td></td> </tr> <tr> <td>846.60</td> <td>7.07</td> <td>H</td> <td>1.1</td> <td>-1.3</td> <td>4.69</td> <td>38.5</td> <td>-33.8</td> <td></td> </tr> </tbody> </table> <p>Rev. 3.17.11</p>	f MHz	SG reading (dBm)	Ant. Pol. (H/V)	Cable Loss (dB)	Antenna Gain (dBd)	ERP (dBm)	Limit (dBm)	Margin (dB)	Notes	Low Ch									826.40	21.96	V	1.1	-1.5	19.35	38.5	-19.1		826.40	6.03	H	1.1	-1.5	3.42	38.5	-35.0		Mid Ch									836.60	21.09	V	1.1	-1.4	18.60	38.5	-19.9		836.60	6.19	H	1.1	-1.4	3.70	38.5	-34.8		High Ch									846.60	20.45	V	1.1	-1.3	18.07	38.5	-20.4		846.60	7.07	H	1.1	-1.3	4.69	38.5	-33.8	
f MHz	SG reading (dBm)	Ant. Pol. (H/V)	Cable Loss (dB)	Antenna Gain (dBd)	ERP (dBm)	Limit (dBm)	Margin (dB)	Notes																																																																																			
Low Ch																																																																																											
826.40	21.96	V	1.1	-1.5	19.35	38.5	-19.1																																																																																				
826.40	6.03	H	1.1	-1.5	3.42	38.5	-35.0																																																																																				
Mid Ch																																																																																											
836.60	21.09	V	1.1	-1.4	18.60	38.5	-19.9																																																																																				
836.60	6.19	H	1.1	-1.4	3.70	38.5	-34.8																																																																																				
High Ch																																																																																											
846.60	20.45	V	1.1	-1.3	18.07	38.5	-20.4																																																																																				
846.60	7.07	H	1.1	-1.3	4.69	38.5	-33.8																																																																																				

WCDMA Band 2

		High Frequency Substitution Measurement UL Korea, Ltd. Suwon Laboratory Chamber 2							
WCDMA Band 2 REL99	Company:		Samsung						
	Project #:		16K23140						
	Date:		03-18-16						
	Test Engineer:		Steven.Kim						
	Configuration:		EUT ONLY, X Position						
	Mode:		REL99_1900 MHz						
	<u>Test Equipment:</u>		Receiving: 3117[00168724] and Chamber 1 SMA Cables Substitution: 3115[00161451] Substitution, 3m SMA Cable Ware house						
	f MHz	SG reading (dBm)	Ant. Pol. (H/V)	Cable Loss (dB)	Antenna Gain (dBi)	EIRP (dBm)	Limit (dBm)	Margin (dB)	Notes
	Low Ch								
	1852.40	12.43	V	1.60	8.79	19.62	33.0	-13.4	
	1852.40	15.74	H	1.60	8.79	22.93	33.0	-10.1	
	Mid Ch								
	1880.00	13.67	V	1.62	8.62	20.67	33.0	-12.3	
	1880.00	15.35	H	1.62	8.62	22.35	33.0	-10.6	
	High Ch								
1907.60	13.70	V	1.63	8.45	20.52	33.0	-12.5		
1907.60	15.72	H	1.63	8.45	22.54	33.0	-10.5		
Rev. 3.17.11 Note: For Band 4 EIRP limit is 30dBm									
WCDMA Band 2 HSDPA	Company:		Samsung						
	Project #:		16K23140						
	Date:		03-18-16						
	Test Engineer:		Steven.Kim						
	Configuration:		EUT ONLY, X Position						
	Mode:		HSDPA_1900 MHz						
	<u>Test Equipment:</u>		Receiving: 3117[00168724] and Chamber 1 SMA Cables Substitution: 3115[00161451] Substitution, 3m SMA Cable Ware house						
	f MHz	SG reading (dBm)	Ant. Pol. (H/V)	Cable Loss (dB)	Antenna Gain (dBi)	EIRP (dBm)	Limit (dBm)	Margin (dB)	Notes
	Low Ch								
	1852.40	11.74	V	1.60	8.79	18.93	33.0	-14.1	
	1852.40	14.77	H	1.60	8.79	21.96	33.0	-11.0	
	Mid Ch								
	1880.00	12.80	V	1.62	8.62	19.80	33.0	-13.2	
	1880.00	14.30	H	1.62	8.62	21.30	33.0	-11.7	
	High Ch								
1907.60	12.71	V	1.63	8.45	19.53	33.0	-13.5		
1907.60	14.76	H	1.63	8.45	21.58	33.0	-11.4		
Rev. 3.17.11 Note: For Band 4 EIRP limit is 30dBm									

LTE Band 5

		High Frequency Substitution Measurement UL Korea, Ltd. Suwon Laboratory Chamber 2							
LTE Band 5 10MHz QPSK	Company:	Samsung							
	Project #:	16K23140							
	Date:	03-21-16							
	Test Engineer:	Steven.Kim							
	Configuration:	EUT ONLY, Z Position							
	Mode:	TX, LTE BAND 5, 10MHz BW,QPSK							
	Test Equipment:								
	Receiving: VULB9163-749, and 3m Chamber N-type Cable (Setup this one for testing EUT)								
	Substitution: Dipole S/N: 00164753, 3m SMA Cable Warehouse.								
	f MHz	SG reading (dBm)	Ant. Pol. (H/V)	Cable Loss (dB)	Antenna Gain (dBd)	ERP (dBm)	Limit (dBm)	Margin (dB)	Notes
	Low Ch								
	829.00	20.44	V	1.1	-1.5	17.86	38.5	-20.6	
	829.00	-1.80	H	1.1	-1.5	-4.38	38.5	-42.8	
	Mid Ch								
	836.50	18.77	V	1.1	-1.4	16.28	38.5	-22.2	
836.50	4.76	H	1.1	-1.4	2.27	38.5	-36.2		
High Ch									
844.00	19.13	V	1.1	-1.3	16.74	38.5	-21.7		
844.00	6.03	H	1.1	-1.3	3.61	38.5	-34.8		
Rev. 3.17.11 Note: For Band 13/17 ERP limit is 34.77dBm; For Band 26 limit is 50dBm									
LTE Band 5 10MHz 16QAM	High Frequency Substitution Measurement UL Korea, Ltd. Suwon Laboratory Chamber 2								
	Company:	Samsung							
	Project #:	16K23140							
	Date:	03-21-16							
	Test Engineer:	Steven.Kim							
	Configuration:	EUT ONLY, Z Position							
	Mode:	LTE5 10MHz FUND 16QAM							
	Test Equipment:								
	Receiving: VULB9163-749, and 3m Chamber N-type Cable (Setup this one for testing EUT)								
	Substitution: Dipole S/N: 00164753, 3m SMA Cable Warehouse.								
	f MHz	SG reading (dBm)	Ant. Pol. (H/V)	Cable Loss (dB)	Antenna Gain (dBd)	ERP (dBm)	Limit (dBm)	Margin (dB)	Notes
	Low Ch								
	829.00	20.52	V	1.1	-1.5	17.94	38.5	-20.5	
	829.00	-1.77	H	1.1	-1.5	-4.35	38.5	-42.8	
	Mid Ch								
836.50	18.85	V	1.1	-1.4	16.34	38.5	-22.1		
836.50	4.66	H	1.1	-1.4	2.15	38.5	-36.3		
High Ch									
844.00	18.90	V	1.1	-1.3	16.48	38.5	-22.0		
844.00	6.02	H	1.1	-1.3	3.60	38.5	-34.8		
Rev. 3.17.11 Note: For Band 13/17 ERP limit is 34.77dBm; For Band 26 limit is 50dBm									

LTE Band 5 5MHz QPSK	<p align="center">High Frequency Substitution Measurement UL Korea, Ltd. Suwon Laboratory Chamber 2</p> <p>Company: Samsung Project #: 16K23140 Date: 03-21-16 Test Engineer: Steven.Kim Configuration: EUT ONLY, Z Position Mode: LTE5 5MHz FUND QPSK</p> <p>Test Equipment: Receiving: VULB9163-749, and 3m Chamber N-type Cable (Setup this one for testing EUT) Substitution: Dipole S/N: 00164753, 3m SMA Cable Warehouse.</p> <table border="1"> <thead> <tr> <th>f MHz</th> <th>SG reading (dBm)</th> <th>Ant. Pol. (H/V)</th> <th>Cable Loss (dB)</th> <th>Antenna Gain (dBd)</th> <th>ERP (dBm)</th> <th>Limit (dBm)</th> <th>Margin (dB)</th> <th>Notes</th> </tr> </thead> <tbody> <tr><td colspan="9">Low Ch</td></tr> <tr><td>826.50</td><td>21.72</td><td>V</td><td>1.1</td><td>-1.5</td><td>19.12</td><td>38.5</td><td>-19.3</td><td></td></tr> <tr><td>826.50</td><td>2.43</td><td>H</td><td>1.1</td><td>-1.5</td><td>-0.17</td><td>38.5</td><td>-38.6</td><td></td></tr> <tr><td colspan="9">Mid Ch</td></tr> <tr><td>836.50</td><td>21.59</td><td>V</td><td>1.1</td><td>-1.4</td><td>19.10</td><td>38.5</td><td>-19.4</td><td></td></tr> <tr><td>836.50</td><td>4.51</td><td>H</td><td>1.1</td><td>-1.4</td><td>2.02</td><td>38.5</td><td>-36.4</td><td></td></tr> <tr><td colspan="9">High Ch</td></tr> <tr><td>846.50</td><td>20.15</td><td>V</td><td>1.6</td><td>-1.3</td><td>17.27</td><td>38.5</td><td>-21.2</td><td></td></tr> <tr><td>846.50</td><td>7.07</td><td>H</td><td>1.6</td><td>-1.3</td><td>4.19</td><td>38.5</td><td>-34.3</td><td></td></tr> </tbody> </table> <p>Rev. 3.17.11 Note: For Band 13/17 ERP limit is 34.77dBm; For Band 26 limit is 50dBm</p>									f MHz	SG reading (dBm)	Ant. Pol. (H/V)	Cable Loss (dB)	Antenna Gain (dBd)	ERP (dBm)	Limit (dBm)	Margin (dB)	Notes	Low Ch									826.50	21.72	V	1.1	-1.5	19.12	38.5	-19.3		826.50	2.43	H	1.1	-1.5	-0.17	38.5	-38.6		Mid Ch									836.50	21.59	V	1.1	-1.4	19.10	38.5	-19.4		836.50	4.51	H	1.1	-1.4	2.02	38.5	-36.4		High Ch									846.50	20.15	V	1.6	-1.3	17.27	38.5	-21.2		846.50	7.07	H	1.6	-1.3	4.19	38.5	-34.3	
	f MHz	SG reading (dBm)	Ant. Pol. (H/V)	Cable Loss (dB)	Antenna Gain (dBd)	ERP (dBm)	Limit (dBm)	Margin (dB)	Notes																																																																																										
Low Ch																																																																																																			
826.50	21.72	V	1.1	-1.5	19.12	38.5	-19.3																																																																																												
826.50	2.43	H	1.1	-1.5	-0.17	38.5	-38.6																																																																																												
Mid Ch																																																																																																			
836.50	21.59	V	1.1	-1.4	19.10	38.5	-19.4																																																																																												
836.50	4.51	H	1.1	-1.4	2.02	38.5	-36.4																																																																																												
High Ch																																																																																																			
846.50	20.15	V	1.6	-1.3	17.27	38.5	-21.2																																																																																												
846.50	7.07	H	1.6	-1.3	4.19	38.5	-34.3																																																																																												
LTE Band 5 5MHz 16QAM	<p align="center">High Frequency Substitution Measurement UL Korea, Ltd. Suwon Laboratory Chamber 2</p> <p>Company: Samsung Project #: 16K23140 Date: 03-21-16 Test Engineer: Steven.Kim Configuration: EUT ONLY, Z Position Mode: LTE5 5MHz FUND 16QAM</p> <p>Test Equipment: Receiving: VULB9163-749, and 3m Chamber N-type Cable (Setup this one for testing EUT) Substitution: Dipole S/N: 00164753, 3m SMA Cable Warehouse.</p> <table border="1"> <thead> <tr> <th>f MHz</th> <th>SG reading (dBm)</th> <th>Ant. Pol. (H/V)</th> <th>Cable Loss (dB)</th> <th>Antenna Gain (dBd)</th> <th>ERP (dBm)</th> <th>Limit (dBm)</th> <th>Margin (dB)</th> <th>Notes</th> </tr> </thead> <tbody> <tr><td colspan="9">Low Ch</td></tr> <tr><td>826.50</td><td>21.83</td><td>V</td><td>1.1</td><td>-1.5</td><td>19.23</td><td>38.5</td><td>-19.2</td><td></td></tr> <tr><td>826.50</td><td>2.46</td><td>H</td><td>1.1</td><td>-1.5</td><td>-0.14</td><td>38.5</td><td>-38.6</td><td></td></tr> <tr><td colspan="9">Mid Ch</td></tr> <tr><td>836.50</td><td>21.48</td><td>V</td><td>1.1</td><td>-1.4</td><td>18.99</td><td>38.5</td><td>-19.5</td><td></td></tr> <tr><td>836.50</td><td>4.46</td><td>H</td><td>1.1</td><td>-1.4</td><td>1.97</td><td>38.5</td><td>-36.5</td><td></td></tr> <tr><td colspan="9">High Ch</td></tr> <tr><td>846.50</td><td>20.22</td><td>V</td><td>1.1</td><td>-1.3</td><td>17.84</td><td>38.5</td><td>-20.6</td><td></td></tr> <tr><td>846.50</td><td>7.25</td><td>H</td><td>1.1</td><td>-1.3</td><td>4.87</td><td>38.5</td><td>-33.6</td><td></td></tr> </tbody> </table> <p>Rev. 3.17.11 Note: For Band 13/17 ERP limit is 34.77dBm; For Band 26 limit is 50dBm</p>									f MHz	SG reading (dBm)	Ant. Pol. (H/V)	Cable Loss (dB)	Antenna Gain (dBd)	ERP (dBm)	Limit (dBm)	Margin (dB)	Notes	Low Ch									826.50	21.83	V	1.1	-1.5	19.23	38.5	-19.2		826.50	2.46	H	1.1	-1.5	-0.14	38.5	-38.6		Mid Ch									836.50	21.48	V	1.1	-1.4	18.99	38.5	-19.5		836.50	4.46	H	1.1	-1.4	1.97	38.5	-36.5		High Ch									846.50	20.22	V	1.1	-1.3	17.84	38.5	-20.6		846.50	7.25	H	1.1	-1.3	4.87	38.5	-33.6	
f MHz	SG reading (dBm)	Ant. Pol. (H/V)	Cable Loss (dB)	Antenna Gain (dBd)	ERP (dBm)	Limit (dBm)	Margin (dB)	Notes																																																																																											
Low Ch																																																																																																			
826.50	21.83	V	1.1	-1.5	19.23	38.5	-19.2																																																																																												
826.50	2.46	H	1.1	-1.5	-0.14	38.5	-38.6																																																																																												
Mid Ch																																																																																																			
836.50	21.48	V	1.1	-1.4	18.99	38.5	-19.5																																																																																												
836.50	4.46	H	1.1	-1.4	1.97	38.5	-36.5																																																																																												
High Ch																																																																																																			
846.50	20.22	V	1.1	-1.3	17.84	38.5	-20.6																																																																																												
846.50	7.25	H	1.1	-1.3	4.87	38.5	-33.6																																																																																												

LTE Band 5 3MHz QPSK	High Frequency Substitution Measurement UL Korea, Ltd. Suwon Laboratory Chamber 2								
	Company:		Samsung						
	Project #:		16K23140						
	Date:		03-21-16						
	Test Engineer:		Steven.Kim						
	Configuration:		EUT ONLY, Z Position						
	Mode:		LTE5 3MHz FUND QPSK						
	Test Equipment:								
	Receiving: VULB9163-749, and 3m Chamber N-type Cable (Setup this one for testing EUT)								
	Substitution: Dipole S/N: 00164753, 3m SMA Cable Warehouse.								
	f	SG reading	Ant. Pol.	Cable Loss	Antenna Gain	ERP	Limit	Margin	Notes
	MHz	(dBm)	(H/V)	(dB)	(dBd)	(dBm)	(dBm)	(dB)	
	Low Ch								
	825.50	22.01	V	1.1	-1.5	19.41	38.5	-19.0	
825.50	1.85	H	1.1	-1.5	-0.75	38.5	-39.2		
Mid Ch									
836.50	21.38	V	1.1	-1.4	18.89	38.5	-19.6		
836.50	6.33	H	1.1	-1.4	3.84	38.5	-34.6		
High Ch									
847.50	21.14	V	1.6	-1.3	18.26	38.5	-20.2		
847.50	8.49	H	1.6	-1.3	5.61	38.5	-32.8		
Rev. 3.17.11 Note: For Band 13/17 ERP limit is 34.77dBm; For Band 26 limit is 50dBm									
LTE Band 5 3MHz 16QAM	High Frequency Substitution Measurement UL Korea, Ltd. Suwon Laboratory Chamber 2								
	Company:		Samsung						
	Project #:		16K23140						
	Date:		03-21-16						
	Test Engineer:		Steven.Kim						
	Configuration:		EUT ONLY, X Position						
	Mode:		LTE5 3MHz FUND 16QAM						
	Test Equipment:								
	Receiving: VULB9163-749, and 3m Chamber N-type Cable (Setup this one for testing EUT)								
	Substitution: Dipole S/N: 00164753, 3m SMA Cable Warehouse.								
	f	SG reading	Ant. Pol.	Cable Loss	Antenna Gain	ERP	Limit	Margin	Notes
	MHz	(dBm)	(H/V)	(dB)	(dBd)	(dBm)	(dBm)	(dB)	
	Low Ch								
	825.50	22.04	V	1.1	-1.5	19.44	38.5	-19.0	
825.50	1.83	H	1.1	-1.5	-0.77	38.5	-39.2		
Mid Ch									
836.50	21.34	V	1.1	-1.4	18.85	38.5	-19.6		
836.50	6.39	H	1.1	-1.4	3.90	38.5	-34.6		
High Ch									
847.50	20.93	V	1.1	-1.3	18.55	38.5	-19.9		
847.50	8.52	H	1.1	-1.3	6.14	38.5	-32.3		
Rev. 3.17.11 Note: For Band 13/17 ERP limit is 34.77dBm; For Band 26 limit is 50dBm									

		High Frequency Substitution Measurement UL Korea, Ltd. Suwon Laboratory Chamber 2								
LTE Band 5 1.4MHz QPSK	Company:		Samsung							
	Project #:		16K23140							
	Date:		03-21-16							
	Test Engineer:		Steven.Kim							
	Configuration:		EUT ONLY, Z Position							
	Mode:		LTE5 1.4MHz FUND QPSK							
	Test Equipment:									
	Receiving:		VULB9163-749, and 3m Chamber N-type Cable (Setup this one for testing EUT)							
	Substitution:		Dipole S/N: 00164753, 3m SMA Cable Warehouse.							
			f MHz	SG reading (dBm)	Ant. Pol. (H/V)	Cable Loss (dB)	Antenna Gain (dBd)	ERP (dBm)	Limit (dBm)	Margin (dB)
Low Ch										
824.70		19.79	V	1.1	-1.5	17.19	38.5	-21.3		
824.70		2.74	H	1.1	-1.5	0.14	38.5	-38.3		
Mid Ch										
836.50		19.72	V	1.1	-1.4	17.23	38.5	-21.2		
836.50		4.03	H	1.1	-1.4	1.54	38.5	-36.9		
High Ch										
848.30		17.97	V	1.6	-1.3	15.09	38.5	-23.4		
848.30		5.90	H	1.6	-1.3	3.02	38.5	-35.4		
		Rev. 3.17.11 Note: For Band 13/17 ERP limit is 34.77dBm; For Band 26 limit is 50dBm								
		High Frequency Substitution Measurement UL Korea, Ltd. Suwon Laboratory Chamber 2								
LTE Band 5 1.4MHz 16QAM	Company:		Samsung							
	Project #:		16K23140							
	Date:		03-21-16							
	Test Engineer:		Steven.Kim							
	Configuration:		EUT ONLY, Z Position							
	Mode:		LTE5 1.4MHz FUND 16QAM							
	Test Equipment:									
	Receiving:		VULB9163-749, and 3m Chamber N-type Cable (Setup this one for testing EUT)							
	Substitution:		Dipole S/N: 00164753, 3m SMA Cable Warehouse.							
			f MHz	SG reading (dBm)	Ant. Pol. (H/V)	Cable Loss (dB)	Antenna Gain (dBd)	ERP (dBm)	Limit (dBm)	Margin (dB)
Low Ch										
824.70		19.64	V	1.1	-1.5	17.04	38.5	-21.4		
824.70		2.50	H	1.1	-1.5	-0.10	38.5	-38.6		
Mid Ch										
836.50		19.74	V	1.1	-1.4	17.25	38.5	-21.2		
836.50		4.80	H	1.1	-1.4	2.31	38.5	-36.1		
High Ch										
848.30		18.00	V	1.1	-1.3	15.62	38.5	-22.8		
848.30		5.99	H	1.1	-1.3	3.61	38.5	-34.8		
		Rev. 3.17.11 Note: For Band 13/17 ERP limit is 34.77dBm; For Band 26 limit is 50dBm								

11.2. FIELD STRENGTH OF SPURIOUS RADIATION

RULE PART(S)

FCC: §2.1053, §22.917, §24.238

LIMIT

Part 22.917(a) & Part 24.238(a) The power of any emission outside of the authorized operating frequency ranges must be attenuated below the transmitting power (P) by a factor of at least $43 + 10 \log (P)$ dB.

TEST PROCEDURE

For Cellular equipment - Compliance with these rules is based on the use of measurement instrumentation employing a resolution bandwidth of 100 kHz or greater. In the 1 MHz bands immediately outside and adjacent to the frequency block a resolution bandwidth of at least one percent of the emission bandwidth of the fundamental emission of the transmitter may be employed. A narrower resolution bandwidth is permitted in all cases to improve measurement accuracy provided the measured power is integrated over the full required measurement bandwidth (i.e. 100 kHz or 1 percent of emission bandwidth, as specified). The emission bandwidth is defined as the width of the signal between two points, one below the carrier center frequency and one above the carrier center frequency, outside of which all emissions are attenuated at least 26 dB below the transmitter power.

For PCS equipment - Compliance with these rules is based on the use of measurement instrumentation employing a resolution bandwidth of 1 MHz or greater. However, in the 1 MHz bands immediately outside and adjacent to the frequency block a resolution bandwidth of at least one percent of the emission bandwidth of the fundamental emission of the transmitter may be employed. A narrower resolution bandwidth is permitted in all cases to improve measurement accuracy provided the measured power is integrated over the full required measurement bandwidth (i.e. 1 MHz or 1 percent of emission bandwidth, as specified). The emission bandwidth is defined as the width of the signal between two points, one below the carrier center frequency and one above the carrier center frequency, outside of which all emissions are attenuated at least 26 dB below the transmitter power.

RESULTS

11.2.1. SPURIOUS RADIATION PLOTS

GSM 1900

GSM GSM1900 GPRS	UL Korea, Ltd Suwon Laboratory Above 1GHz High Frequency Substitution Measurement																																																																																																																																																																																																																												
	Company: Samsung Project #: 16K23140 Date: 03-18-16 Test Engineer: Steven Kim Configuration: EUT / AC Adapter / Earphone, X Position Mode: GPRS 1900																																																																																																																																																																																																																												
	Chamber: Chamber 2 Pre-amplifier: AFS42 Filter: Filter 1 Limit: Part 24																																																																																																																																																																																																																												
	<table border="1"> <thead> <tr> <th>f GHz</th> <th>SG reading (dBm)</th> <th>Ant. Pol. (H/V)</th> <th>Distance (m)</th> <th>Preamp (dB)</th> <th>Filter (dB)</th> <th>EIRP (dBm)</th> <th>Limit (dBm)</th> <th>Delta (dB)</th> <th>Notes</th> </tr> </thead> <tbody> <tr><td colspan="10">Low Ch, 1850.2MHz</td></tr> <tr><td>3.7004</td><td>-0.1</td><td>V</td><td>3.0</td><td>40.5</td><td>1.0</td><td>-39.5</td><td>-13.0</td><td>-26.5</td><td></td></tr> <tr><td>5.5506</td><td>-4.9</td><td>V</td><td>3.0</td><td>40.8</td><td>1.0</td><td>-44.7</td><td>-13.0</td><td>-31.7</td><td></td></tr> <tr><td>7.4008</td><td>10.7</td><td>V</td><td>3.0</td><td>40.8</td><td>1.0</td><td>-29.1</td><td>-13.0</td><td>-16.1</td><td></td></tr> <tr><td>3.7000</td><td>-5.8</td><td>H</td><td>3.0</td><td>40.5</td><td>1.0</td><td>-45.2</td><td>-13.0</td><td>-32.2</td><td></td></tr> <tr><td>5.5506</td><td>-4.8</td><td>H</td><td>3.0</td><td>40.8</td><td>1.0</td><td>-44.6</td><td>-13.0</td><td>-31.6</td><td></td></tr> <tr><td>7.4008</td><td>7.3</td><td>H</td><td>3.0</td><td>40.8</td><td>1.0</td><td>-32.5</td><td>-13.0</td><td>-19.5</td><td></td></tr> <tr><td colspan="10">Mid Ch, 1880.0MHz</td></tr> <tr><td>3.7600</td><td>-1.0</td><td>V</td><td>3.0</td><td>40.5</td><td>1.0</td><td>-40.5</td><td>-13.0</td><td>-27.5</td><td></td></tr> <tr><td>5.6400</td><td>-6.0</td><td>V</td><td>3.0</td><td>40.8</td><td>1.0</td><td>-45.8</td><td>-13.0</td><td>-32.8</td><td></td></tr> <tr><td>7.5200</td><td>8.8</td><td>V</td><td>3.0</td><td>40.7</td><td>1.0</td><td>-30.9</td><td>-13.0</td><td>-17.9</td><td></td></tr> <tr><td>3.7600</td><td>-8.0</td><td>H</td><td>3.0</td><td>40.5</td><td>1.0</td><td>-47.5</td><td>-13.0</td><td>-34.5</td><td></td></tr> <tr><td>5.6400</td><td>-5.3</td><td>H</td><td>3.0</td><td>40.8</td><td>1.0</td><td>-45.1</td><td>-13.0</td><td>-32.1</td><td></td></tr> <tr><td>7.5200</td><td>5.8</td><td>H</td><td>3.0</td><td>40.7</td><td>1.0</td><td>-34.0</td><td>-13.0</td><td>-21.0</td><td></td></tr> <tr><td colspan="10">High Ch, 1909.8 MHz</td></tr> <tr><td>3.8196</td><td>-0.8</td><td>V</td><td>3.0</td><td>40.6</td><td>1.0</td><td>-40.4</td><td>-13.0</td><td>-27.4</td><td></td></tr> <tr><td>5.7294</td><td>-3.8</td><td>V</td><td>3.0</td><td>40.8</td><td>1.0</td><td>-43.6</td><td>-13.0</td><td>-30.6</td><td></td></tr> <tr><td>7.6392</td><td>6.4</td><td>V</td><td>3.0</td><td>40.7</td><td>1.0</td><td>-33.2</td><td>-13.0</td><td>-20.2</td><td></td></tr> <tr><td>3.8196</td><td>-6.3</td><td>H</td><td>3.0</td><td>40.6</td><td>1.0</td><td>-45.9</td><td>-13.0</td><td>-32.9</td><td></td></tr> <tr><td>5.7294</td><td>-2.9</td><td>H</td><td>3.0</td><td>40.8</td><td>1.0</td><td>-42.7</td><td>-13.0</td><td>-29.7</td><td></td></tr> <tr><td>7.6392</td><td>3.5</td><td>H</td><td>3.0</td><td>40.7</td><td>1.0</td><td>-36.1</td><td>-13.0</td><td>-23.1</td><td></td></tr> </tbody> </table> Rev. 03.03.09 Note: No other emissions were detected above the system noise floor.	f GHz	SG reading (dBm)	Ant. Pol. (H/V)	Distance (m)	Preamp (dB)	Filter (dB)	EIRP (dBm)	Limit (dBm)	Delta (dB)	Notes	Low Ch, 1850.2MHz										3.7004	-0.1	V	3.0	40.5	1.0	-39.5	-13.0	-26.5		5.5506	-4.9	V	3.0	40.8	1.0	-44.7	-13.0	-31.7		7.4008	10.7	V	3.0	40.8	1.0	-29.1	-13.0	-16.1		3.7000	-5.8	H	3.0	40.5	1.0	-45.2	-13.0	-32.2		5.5506	-4.8	H	3.0	40.8	1.0	-44.6	-13.0	-31.6		7.4008	7.3	H	3.0	40.8	1.0	-32.5	-13.0	-19.5		Mid Ch, 1880.0MHz										3.7600	-1.0	V	3.0	40.5	1.0	-40.5	-13.0	-27.5		5.6400	-6.0	V	3.0	40.8	1.0	-45.8	-13.0	-32.8		7.5200	8.8	V	3.0	40.7	1.0	-30.9	-13.0	-17.9		3.7600	-8.0	H	3.0	40.5	1.0	-47.5	-13.0	-34.5		5.6400	-5.3	H	3.0	40.8	1.0	-45.1	-13.0	-32.1		7.5200	5.8	H	3.0	40.7	1.0	-34.0	-13.0	-21.0		High Ch, 1909.8 MHz										3.8196	-0.8	V	3.0	40.6	1.0	-40.4	-13.0	-27.4		5.7294	-3.8	V	3.0	40.8	1.0	-43.6	-13.0	-30.6		7.6392	6.4	V	3.0	40.7	1.0	-33.2	-13.0	-20.2		3.8196	-6.3	H	3.0	40.6	1.0	-45.9	-13.0	-32.9		5.7294	-2.9	H	3.0	40.8	1.0	-42.7	-13.0	-29.7		7.6392	3.5	H	3.0	40.7	1.0	-36.1	-13.0	-23.1	
f GHz	SG reading (dBm)	Ant. Pol. (H/V)	Distance (m)	Preamp (dB)	Filter (dB)	EIRP (dBm)	Limit (dBm)	Delta (dB)	Notes																																																																																																																																																																																																																				
Low Ch, 1850.2MHz																																																																																																																																																																																																																													
3.7004	-0.1	V	3.0	40.5	1.0	-39.5	-13.0	-26.5																																																																																																																																																																																																																					
5.5506	-4.9	V	3.0	40.8	1.0	-44.7	-13.0	-31.7																																																																																																																																																																																																																					
7.4008	10.7	V	3.0	40.8	1.0	-29.1	-13.0	-16.1																																																																																																																																																																																																																					
3.7000	-5.8	H	3.0	40.5	1.0	-45.2	-13.0	-32.2																																																																																																																																																																																																																					
5.5506	-4.8	H	3.0	40.8	1.0	-44.6	-13.0	-31.6																																																																																																																																																																																																																					
7.4008	7.3	H	3.0	40.8	1.0	-32.5	-13.0	-19.5																																																																																																																																																																																																																					
Mid Ch, 1880.0MHz																																																																																																																																																																																																																													
3.7600	-1.0	V	3.0	40.5	1.0	-40.5	-13.0	-27.5																																																																																																																																																																																																																					
5.6400	-6.0	V	3.0	40.8	1.0	-45.8	-13.0	-32.8																																																																																																																																																																																																																					
7.5200	8.8	V	3.0	40.7	1.0	-30.9	-13.0	-17.9																																																																																																																																																																																																																					
3.7600	-8.0	H	3.0	40.5	1.0	-47.5	-13.0	-34.5																																																																																																																																																																																																																					
5.6400	-5.3	H	3.0	40.8	1.0	-45.1	-13.0	-32.1																																																																																																																																																																																																																					
7.5200	5.8	H	3.0	40.7	1.0	-34.0	-13.0	-21.0																																																																																																																																																																																																																					
High Ch, 1909.8 MHz																																																																																																																																																																																																																													
3.8196	-0.8	V	3.0	40.6	1.0	-40.4	-13.0	-27.4																																																																																																																																																																																																																					
5.7294	-3.8	V	3.0	40.8	1.0	-43.6	-13.0	-30.6																																																																																																																																																																																																																					
7.6392	6.4	V	3.0	40.7	1.0	-33.2	-13.0	-20.2																																																																																																																																																																																																																					
3.8196	-6.3	H	3.0	40.6	1.0	-45.9	-13.0	-32.9																																																																																																																																																																																																																					
5.7294	-2.9	H	3.0	40.8	1.0	-42.7	-13.0	-29.7																																																																																																																																																																																																																					
7.6392	3.5	H	3.0	40.7	1.0	-36.1	-13.0	-23.1																																																																																																																																																																																																																					
GSM GSM1900 EGPRS	UL Korea, Ltd Suwon Laboratory Above 1GHz High Frequency Substitution Measurement																																																																																																																																																																																																																												
	Company: Samsung Project #: 16K23140 Date: 03-18-16 Test Engineer: Steven Kim Configuration: EUT / AC Adapter / Earphone, X Position Mode: EGPRS 1900 MHz																																																																																																																																																																																																																												
	Chamber: Chamber 2 Pre-amplifier: AFS42 Filter: Filter 1 Limit: Part 24																																																																																																																																																																																																																												
	<table border="1"> <thead> <tr> <th>f GHz</th> <th>SG reading (dBm)</th> <th>Ant. Pol. (H/V)</th> <th>Distance (m)</th> <th>Preamp (dB)</th> <th>Filter (dB)</th> <th>EIRP (dBm)</th> <th>Limit (dBm)</th> <th>Delta (dB)</th> <th>Notes</th> </tr> </thead> <tbody> <tr><td colspan="10">Low Ch, 1850.2MHz</td></tr> <tr><td>3.7004</td><td>1.1</td><td>V</td><td>3.0</td><td>40.5</td><td>1.0</td><td>-38.3</td><td>-13.0</td><td>-25.3</td><td></td></tr> <tr><td>5.5506</td><td>-3.5</td><td>V</td><td>3.0</td><td>40.8</td><td>1.0</td><td>-43.4</td><td>-13.0</td><td>-30.4</td><td></td></tr> <tr><td>7.4008</td><td>12.2</td><td>V</td><td>3.0</td><td>40.8</td><td>1.0</td><td>-27.6</td><td>-13.0</td><td>-14.6</td><td></td></tr> <tr><td>3.7000</td><td>-4.8</td><td>H</td><td>3.0</td><td>40.5</td><td>1.0</td><td>-44.3</td><td>-13.0</td><td>-31.3</td><td></td></tr> <tr><td>5.5500</td><td>-3.8</td><td>H</td><td>3.0</td><td>40.8</td><td>1.0</td><td>-43.6</td><td>-13.0</td><td>-30.6</td><td></td></tr> <tr><td>7.4000</td><td>8.6</td><td>H</td><td>3.0</td><td>40.8</td><td>1.0</td><td>-31.2</td><td>-13.0</td><td>-18.2</td><td></td></tr> <tr><td colspan="10">Mid Ch, 1880.0MHz</td></tr> <tr><td>3.7600</td><td>-0.2</td><td>V</td><td>3.0</td><td>40.5</td><td>1.0</td><td>-39.7</td><td>-13.0</td><td>-26.7</td><td></td></tr> <tr><td>5.6400</td><td>-5.0</td><td>V</td><td>3.0</td><td>40.8</td><td>1.0</td><td>-44.8</td><td>-13.0</td><td>-31.8</td><td></td></tr> <tr><td>7.5200</td><td>10.0</td><td>V</td><td>3.0</td><td>40.7</td><td>1.0</td><td>-29.8</td><td>-13.0</td><td>-16.8</td><td></td></tr> <tr><td>3.7600</td><td>-6.8</td><td>H</td><td>3.0</td><td>40.5</td><td>1.0</td><td>-46.3</td><td>-13.0</td><td>-33.3</td><td></td></tr> <tr><td>5.6400</td><td>-4.1</td><td>H</td><td>3.0</td><td>40.8</td><td>1.0</td><td>-43.9</td><td>-13.0</td><td>-30.9</td><td></td></tr> <tr><td>7.5200</td><td>7.0</td><td>H</td><td>3.0</td><td>40.7</td><td>1.0</td><td>-32.8</td><td>-13.0</td><td>-19.8</td><td></td></tr> <tr><td colspan="10">High Ch, 1909.8 MHz</td></tr> <tr><td>3.8196</td><td>0.3</td><td>V</td><td>3.0</td><td>40.6</td><td>1.0</td><td>-39.3</td><td>-13.0</td><td>-26.3</td><td></td></tr> <tr><td>5.7294</td><td>-2.6</td><td>V</td><td>3.0</td><td>40.8</td><td>1.0</td><td>-42.4</td><td>-13.0</td><td>-29.4</td><td></td></tr> <tr><td>7.6392</td><td>7.5</td><td>V</td><td>3.0</td><td>40.7</td><td>1.0</td><td>-32.2</td><td>-13.0</td><td>-19.2</td><td></td></tr> <tr><td>3.8196</td><td>-7.6</td><td>H</td><td>3.0</td><td>40.6</td><td>1.0</td><td>-47.2</td><td>-13.0</td><td>-34.2</td><td></td></tr> <tr><td>5.7294</td><td>-4.0</td><td>H</td><td>3.0</td><td>40.8</td><td>1.0</td><td>-43.8</td><td>-13.0</td><td>-30.8</td><td></td></tr> <tr><td>7.6392</td><td>2.4</td><td>H</td><td>3.0</td><td>40.7</td><td>1.0</td><td>-37.3</td><td>-13.0</td><td>-24.3</td><td></td></tr> </tbody> </table> Rev. 03.03.09 Note: No other emissions were detected above the system noise floor.	f GHz	SG reading (dBm)	Ant. Pol. (H/V)	Distance (m)	Preamp (dB)	Filter (dB)	EIRP (dBm)	Limit (dBm)	Delta (dB)	Notes	Low Ch, 1850.2MHz										3.7004	1.1	V	3.0	40.5	1.0	-38.3	-13.0	-25.3		5.5506	-3.5	V	3.0	40.8	1.0	-43.4	-13.0	-30.4		7.4008	12.2	V	3.0	40.8	1.0	-27.6	-13.0	-14.6		3.7000	-4.8	H	3.0	40.5	1.0	-44.3	-13.0	-31.3		5.5500	-3.8	H	3.0	40.8	1.0	-43.6	-13.0	-30.6		7.4000	8.6	H	3.0	40.8	1.0	-31.2	-13.0	-18.2		Mid Ch, 1880.0MHz										3.7600	-0.2	V	3.0	40.5	1.0	-39.7	-13.0	-26.7		5.6400	-5.0	V	3.0	40.8	1.0	-44.8	-13.0	-31.8		7.5200	10.0	V	3.0	40.7	1.0	-29.8	-13.0	-16.8		3.7600	-6.8	H	3.0	40.5	1.0	-46.3	-13.0	-33.3		5.6400	-4.1	H	3.0	40.8	1.0	-43.9	-13.0	-30.9		7.5200	7.0	H	3.0	40.7	1.0	-32.8	-13.0	-19.8		High Ch, 1909.8 MHz										3.8196	0.3	V	3.0	40.6	1.0	-39.3	-13.0	-26.3		5.7294	-2.6	V	3.0	40.8	1.0	-42.4	-13.0	-29.4		7.6392	7.5	V	3.0	40.7	1.0	-32.2	-13.0	-19.2		3.8196	-7.6	H	3.0	40.6	1.0	-47.2	-13.0	-34.2		5.7294	-4.0	H	3.0	40.8	1.0	-43.8	-13.0	-30.8		7.6392	2.4	H	3.0	40.7	1.0	-37.3	-13.0	-24.3	
f GHz	SG reading (dBm)	Ant. Pol. (H/V)	Distance (m)	Preamp (dB)	Filter (dB)	EIRP (dBm)	Limit (dBm)	Delta (dB)	Notes																																																																																																																																																																																																																				
Low Ch, 1850.2MHz																																																																																																																																																																																																																													
3.7004	1.1	V	3.0	40.5	1.0	-38.3	-13.0	-25.3																																																																																																																																																																																																																					
5.5506	-3.5	V	3.0	40.8	1.0	-43.4	-13.0	-30.4																																																																																																																																																																																																																					
7.4008	12.2	V	3.0	40.8	1.0	-27.6	-13.0	-14.6																																																																																																																																																																																																																					
3.7000	-4.8	H	3.0	40.5	1.0	-44.3	-13.0	-31.3																																																																																																																																																																																																																					
5.5500	-3.8	H	3.0	40.8	1.0	-43.6	-13.0	-30.6																																																																																																																																																																																																																					
7.4000	8.6	H	3.0	40.8	1.0	-31.2	-13.0	-18.2																																																																																																																																																																																																																					
Mid Ch, 1880.0MHz																																																																																																																																																																																																																													
3.7600	-0.2	V	3.0	40.5	1.0	-39.7	-13.0	-26.7																																																																																																																																																																																																																					
5.6400	-5.0	V	3.0	40.8	1.0	-44.8	-13.0	-31.8																																																																																																																																																																																																																					
7.5200	10.0	V	3.0	40.7	1.0	-29.8	-13.0	-16.8																																																																																																																																																																																																																					
3.7600	-6.8	H	3.0	40.5	1.0	-46.3	-13.0	-33.3																																																																																																																																																																																																																					
5.6400	-4.1	H	3.0	40.8	1.0	-43.9	-13.0	-30.9																																																																																																																																																																																																																					
7.5200	7.0	H	3.0	40.7	1.0	-32.8	-13.0	-19.8																																																																																																																																																																																																																					
High Ch, 1909.8 MHz																																																																																																																																																																																																																													
3.8196	0.3	V	3.0	40.6	1.0	-39.3	-13.0	-26.3																																																																																																																																																																																																																					
5.7294	-2.6	V	3.0	40.8	1.0	-42.4	-13.0	-29.4																																																																																																																																																																																																																					
7.6392	7.5	V	3.0	40.7	1.0	-32.2	-13.0	-19.2																																																																																																																																																																																																																					
3.8196	-7.6	H	3.0	40.6	1.0	-47.2	-13.0	-34.2																																																																																																																																																																																																																					
5.7294	-4.0	H	3.0	40.8	1.0	-43.8	-13.0	-30.8																																																																																																																																																																																																																					
7.6392	2.4	H	3.0	40.7	1.0	-37.3	-13.0	-24.3																																																																																																																																																																																																																					

WCDMA Band 5

		UL Korea, Ltd Suwon Laboratory Above 1GHz High Frequency Substitution Measurement																																																																																																																																																																																																																																					
WCDMA Band 5 REL99	Company: Samsung Project #: 16K23140 Date: 03-21-16 Test Engineer: Steven.Kim Configuration: EUT / AC Adapter / Earphone, Z Position Mode: Tx, REL99,850MHz	<div style="display: flex; justify-content: space-around;"> <div style="border: 1px solid black; padding: 2px;">Chamber Chamber 2</div> <div style="border: 1px solid black; padding: 2px;">Pre-amplifier AFS42</div> <div style="border: 1px solid black; padding: 2px;">Filter Filter 1</div> <div style="border: 1px solid black; padding: 2px;">Limit Part 22</div> </div> <table border="1" style="width: 100%; border-collapse: collapse;"> <thead> <tr> <th>f GHz</th> <th>SG reading (dBm)</th> <th>Ant. Pol. (H/V)</th> <th>Distance (m)</th> <th>Preamp (dB)</th> <th>Filter (dB)</th> <th>EIRP (dBm)</th> <th>Limit (dBm)</th> <th>Delta (dB)</th> <th>Notes</th> </tr> </thead> <tbody> <tr><td colspan="10">Low Ch, 826.40MHz</td></tr> <tr><td>1.6520</td><td>-13.9</td><td>V</td><td>3.0</td><td>39.1</td><td>1.0</td><td>-52.0</td><td>-13.0</td><td>-39.0</td><td></td></tr> <tr><td>2.4790</td><td>-17.8</td><td>V</td><td>3.0</td><td>39.5</td><td>1.0</td><td>-56.4</td><td>-13.0</td><td>-43.4</td><td></td></tr> <tr><td>3.3056</td><td>-15.8</td><td>V</td><td>3.0</td><td>40.1</td><td>1.0</td><td>-54.9</td><td>-13.0</td><td>-41.9</td><td></td></tr> <tr><td>1.6520</td><td>-9.8</td><td>H</td><td>3.0</td><td>39.1</td><td>1.0</td><td>-47.9</td><td>-13.0</td><td>-34.9</td><td></td></tr> <tr><td>2.4790</td><td>-18.5</td><td>H</td><td>3.0</td><td>39.5</td><td>1.0</td><td>-57.0</td><td>-13.0</td><td>-44.0</td><td></td></tr> <tr><td>3.3056</td><td>-16.1</td><td>H</td><td>3.0</td><td>40.1</td><td>1.0</td><td>-55.2</td><td>-13.0</td><td>-42.2</td><td></td></tr> <tr><td colspan="10">Mid Ch, 836.6MHz</td></tr> <tr><td>1.6732</td><td>-15.1</td><td>V</td><td>3.0</td><td>39.1</td><td>1.0</td><td>-53.2</td><td>-13.0</td><td>-40.2</td><td></td></tr> <tr><td>2.5098</td><td>-17.8</td><td>V</td><td>3.0</td><td>39.5</td><td>1.0</td><td>-56.4</td><td>-13.0</td><td>-43.4</td><td></td></tr> <tr><td>3.3464</td><td>-15.8</td><td>V</td><td>3.0</td><td>40.1</td><td>1.0</td><td>-54.9</td><td>-13.0</td><td>-41.9</td><td></td></tr> <tr><td>1.6732</td><td>-14.7</td><td>H</td><td>3.0</td><td>39.1</td><td>1.0</td><td>-52.8</td><td>-13.0</td><td>-39.8</td><td></td></tr> <tr><td>2.5098</td><td>-18.3</td><td>H</td><td>3.0</td><td>39.5</td><td>1.0</td><td>-56.8</td><td>-13.0</td><td>-43.8</td><td></td></tr> <tr><td>3.3464</td><td>-16.2</td><td>H</td><td>3.0</td><td>40.1</td><td>1.0</td><td>-55.3</td><td>-13.0</td><td>-42.3</td><td></td></tr> <tr><td colspan="10">High Ch, 846.6MHz</td></tr> <tr><td>1.6932</td><td>-13.3</td><td>V</td><td>3.0</td><td>39.1</td><td>1.0</td><td>-51.5</td><td>-13.0</td><td>-38.5</td><td></td></tr> <tr><td>2.5390</td><td>-17.9</td><td>V</td><td>3.0</td><td>39.6</td><td>1.0</td><td>-56.4</td><td>-13.0</td><td>-43.4</td><td></td></tr> <tr><td>3.3860</td><td>-15.9</td><td>V</td><td>3.0</td><td>40.2</td><td>1.0</td><td>-55.1</td><td>-13.0</td><td>-42.1</td><td></td></tr> <tr><td>1.6932</td><td>-12.6</td><td>H</td><td>3.0</td><td>39.1</td><td>1.0</td><td>-50.7</td><td>-13.0</td><td>-37.7</td><td></td></tr> <tr><td>2.5390</td><td>-18.1</td><td>H</td><td>3.0</td><td>39.6</td><td>1.0</td><td>-56.6</td><td>-13.0</td><td>-43.6</td><td></td></tr> <tr><td>3.3860</td><td>-16.3</td><td>H</td><td>3.0</td><td>40.2</td><td>1.0</td><td>-55.4</td><td>-13.0</td><td>-42.4</td><td></td></tr> </tbody> </table> <p>Rev. 03.03.09 Note: No other emissions were detected above the system noise floor.</p>									f GHz	SG reading (dBm)	Ant. Pol. (H/V)	Distance (m)	Preamp (dB)	Filter (dB)	EIRP (dBm)	Limit (dBm)	Delta (dB)	Notes	Low Ch, 826.40MHz										1.6520	-13.9	V	3.0	39.1	1.0	-52.0	-13.0	-39.0		2.4790	-17.8	V	3.0	39.5	1.0	-56.4	-13.0	-43.4		3.3056	-15.8	V	3.0	40.1	1.0	-54.9	-13.0	-41.9		1.6520	-9.8	H	3.0	39.1	1.0	-47.9	-13.0	-34.9		2.4790	-18.5	H	3.0	39.5	1.0	-57.0	-13.0	-44.0		3.3056	-16.1	H	3.0	40.1	1.0	-55.2	-13.0	-42.2		Mid Ch, 836.6MHz										1.6732	-15.1	V	3.0	39.1	1.0	-53.2	-13.0	-40.2		2.5098	-17.8	V	3.0	39.5	1.0	-56.4	-13.0	-43.4		3.3464	-15.8	V	3.0	40.1	1.0	-54.9	-13.0	-41.9		1.6732	-14.7	H	3.0	39.1	1.0	-52.8	-13.0	-39.8		2.5098	-18.3	H	3.0	39.5	1.0	-56.8	-13.0	-43.8		3.3464	-16.2	H	3.0	40.1	1.0	-55.3	-13.0	-42.3		High Ch, 846.6MHz										1.6932	-13.3	V	3.0	39.1	1.0	-51.5	-13.0	-38.5		2.5390	-17.9	V	3.0	39.6	1.0	-56.4	-13.0	-43.4		3.3860	-15.9	V	3.0	40.2	1.0	-55.1	-13.0	-42.1		1.6932	-12.6	H	3.0	39.1	1.0	-50.7	-13.0	-37.7		2.5390	-18.1	H	3.0	39.6	1.0	-56.6	-13.0	-43.6		3.3860	-16.3	H	3.0	40.2	1.0	-55.4	-13.0	-42.4		
	f GHz	SG reading (dBm)	Ant. Pol. (H/V)	Distance (m)	Preamp (dB)	Filter (dB)	EIRP (dBm)	Limit (dBm)	Delta (dB)	Notes																																																																																																																																																																																																																													
	Low Ch, 826.40MHz																																																																																																																																																																																																																																						
	1.6520	-13.9	V	3.0	39.1	1.0	-52.0	-13.0	-39.0																																																																																																																																																																																																																														
	2.4790	-17.8	V	3.0	39.5	1.0	-56.4	-13.0	-43.4																																																																																																																																																																																																																														
	3.3056	-15.8	V	3.0	40.1	1.0	-54.9	-13.0	-41.9																																																																																																																																																																																																																														
	1.6520	-9.8	H	3.0	39.1	1.0	-47.9	-13.0	-34.9																																																																																																																																																																																																																														
	2.4790	-18.5	H	3.0	39.5	1.0	-57.0	-13.0	-44.0																																																																																																																																																																																																																														
	3.3056	-16.1	H	3.0	40.1	1.0	-55.2	-13.0	-42.2																																																																																																																																																																																																																														
	Mid Ch, 836.6MHz																																																																																																																																																																																																																																						
	1.6732	-15.1	V	3.0	39.1	1.0	-53.2	-13.0	-40.2																																																																																																																																																																																																																														
	2.5098	-17.8	V	3.0	39.5	1.0	-56.4	-13.0	-43.4																																																																																																																																																																																																																														
	3.3464	-15.8	V	3.0	40.1	1.0	-54.9	-13.0	-41.9																																																																																																																																																																																																																														
	1.6732	-14.7	H	3.0	39.1	1.0	-52.8	-13.0	-39.8																																																																																																																																																																																																																														
	2.5098	-18.3	H	3.0	39.5	1.0	-56.8	-13.0	-43.8																																																																																																																																																																																																																														
	3.3464	-16.2	H	3.0	40.1	1.0	-55.3	-13.0	-42.3																																																																																																																																																																																																																														
	High Ch, 846.6MHz																																																																																																																																																																																																																																						
	1.6932	-13.3	V	3.0	39.1	1.0	-51.5	-13.0	-38.5																																																																																																																																																																																																																														
	2.5390	-17.9	V	3.0	39.6	1.0	-56.4	-13.0	-43.4																																																																																																																																																																																																																														
	3.3860	-15.9	V	3.0	40.2	1.0	-55.1	-13.0	-42.1																																																																																																																																																																																																																														
	1.6932	-12.6	H	3.0	39.1	1.0	-50.7	-13.0	-37.7																																																																																																																																																																																																																														
	2.5390	-18.1	H	3.0	39.6	1.0	-56.6	-13.0	-43.6																																																																																																																																																																																																																														
	3.3860	-16.3	H	3.0	40.2	1.0	-55.4	-13.0	-42.4																																																																																																																																																																																																																														
	WCDMA Band 5 HSDPA	Company: Samsung Project #: 16K23140 Date: 03-21-16 Test Engineer: Steven.Kim Configuration: EUT / AC Adapter / Earphone, Z Position Mode: Tx, HSDPA,850MHz	<div style="display: flex; justify-content: space-around;"> <div style="border: 1px solid black; padding: 2px;">Chamber Chamber 2</div> <div style="border: 1px solid black; padding: 2px;">Pre-amplifier AFS42</div> <div style="border: 1px solid black; padding: 2px;">Filter Filter 1</div> <div style="border: 1px solid black; padding: 2px;">Limit Part 22</div> </div> <table border="1" style="width: 100%; border-collapse: collapse;"> <thead> <tr> <th>f GHz</th> <th>SG reading (dBm)</th> <th>Ant. Pol. (H/V)</th> <th>Distance (m)</th> <th>Preamp (dB)</th> <th>Filter (dB)</th> <th>EIRP (dBm)</th> <th>Limit (dBm)</th> <th>Delta (dB)</th> <th>Notes</th> </tr> </thead> <tbody> <tr><td colspan="10">Low Ch, 826.40MHz</td></tr> <tr><td>1.6520</td><td>-15.1</td><td>V</td><td>3.0</td><td>39.1</td><td>1.0</td><td>-53.2</td><td>-13.0</td><td>-40.2</td><td></td></tr> <tr><td>2.4790</td><td>-17.9</td><td>V</td><td>3.0</td><td>39.5</td><td>1.0</td><td>-56.4</td><td>-13.0</td><td>-43.4</td><td></td></tr> <tr><td>3.3056</td><td>-15.8</td><td>V</td><td>3.0</td><td>40.1</td><td>1.0</td><td>-54.9</td><td>-13.0</td><td>-41.9</td><td></td></tr> <tr><td>1.6520</td><td>-10.8</td><td>H</td><td>3.0</td><td>39.1</td><td>1.0</td><td>-48.9</td><td>-13.0</td><td>-35.9</td><td></td></tr> <tr><td>2.4790</td><td>-18.4</td><td>H</td><td>3.0</td><td>39.5</td><td>1.0</td><td>-56.9</td><td>-13.0</td><td>-43.9</td><td></td></tr> <tr><td>3.3056</td><td>-16.1</td><td>H</td><td>3.0</td><td>40.1</td><td>1.0</td><td>-55.2</td><td>-13.0</td><td>-42.2</td><td></td></tr> <tr><td colspan="10">Mid Ch, 836.6MHz</td></tr> <tr><td>1.6732</td><td>-16.6</td><td>V</td><td>3.0</td><td>39.1</td><td>1.0</td><td>-54.7</td><td>-13.0</td><td>-41.7</td><td></td></tr> <tr><td>2.5098</td><td>-17.9</td><td>V</td><td>3.0</td><td>39.5</td><td>1.0</td><td>-56.4</td><td>-13.0</td><td>-43.4</td><td></td></tr> <tr><td>3.3464</td><td>-16.0</td><td>V</td><td>3.0</td><td>40.1</td><td>1.0</td><td>-55.1</td><td>-13.0</td><td>-42.1</td><td></td></tr> <tr><td>1.6732</td><td>-16.3</td><td>H</td><td>3.0</td><td>39.1</td><td>1.0</td><td>-54.4</td><td>-13.0</td><td>-41.4</td><td></td></tr> <tr><td>2.5098</td><td>-18.3</td><td>H</td><td>3.0</td><td>39.5</td><td>1.0</td><td>-56.8</td><td>-13.0</td><td>-43.8</td><td></td></tr> <tr><td>3.3464</td><td>-16.1</td><td>H</td><td>3.0</td><td>40.1</td><td>1.0</td><td>-55.3</td><td>-13.0</td><td>-42.3</td><td></td></tr> <tr><td colspan="10">High Ch, 846.6MHz</td></tr> <tr><td>1.6932</td><td>-14.5</td><td>V</td><td>3.0</td><td>39.1</td><td>1.0</td><td>-52.6</td><td>-13.0</td><td>-39.6</td><td></td></tr> <tr><td>2.5390</td><td>-17.8</td><td>V</td><td>3.0</td><td>39.6</td><td>1.0</td><td>-56.4</td><td>-13.0</td><td>-43.4</td><td></td></tr> <tr><td>3.3860</td><td>-15.9</td><td>V</td><td>3.0</td><td>40.2</td><td>1.0</td><td>-55.1</td><td>-13.0</td><td>-42.1</td><td></td></tr> <tr><td>1.6932</td><td>-13.9</td><td>H</td><td>3.0</td><td>39.1</td><td>1.0</td><td>-52.1</td><td>-13.0</td><td>-39.1</td><td></td></tr> <tr><td>2.5390</td><td>-18.2</td><td>H</td><td>3.0</td><td>39.6</td><td>1.0</td><td>-56.7</td><td>-13.0</td><td>-43.7</td><td></td></tr> <tr><td>3.3860</td><td>-16.2</td><td>H</td><td>3.0</td><td>40.2</td><td>1.0</td><td>-55.4</td><td>-13.0</td><td>-42.4</td><td></td></tr> </tbody> </table> <p>Rev. 03.03.09 Note: No other emissions were detected above the system noise floor.</p>									f GHz	SG reading (dBm)	Ant. Pol. (H/V)	Distance (m)	Preamp (dB)	Filter (dB)	EIRP (dBm)	Limit (dBm)	Delta (dB)	Notes	Low Ch, 826.40MHz										1.6520	-15.1	V	3.0	39.1	1.0	-53.2	-13.0	-40.2		2.4790	-17.9	V	3.0	39.5	1.0	-56.4	-13.0	-43.4		3.3056	-15.8	V	3.0	40.1	1.0	-54.9	-13.0	-41.9		1.6520	-10.8	H	3.0	39.1	1.0	-48.9	-13.0	-35.9		2.4790	-18.4	H	3.0	39.5	1.0	-56.9	-13.0	-43.9		3.3056	-16.1	H	3.0	40.1	1.0	-55.2	-13.0	-42.2		Mid Ch, 836.6MHz										1.6732	-16.6	V	3.0	39.1	1.0	-54.7	-13.0	-41.7		2.5098	-17.9	V	3.0	39.5	1.0	-56.4	-13.0	-43.4		3.3464	-16.0	V	3.0	40.1	1.0	-55.1	-13.0	-42.1		1.6732	-16.3	H	3.0	39.1	1.0	-54.4	-13.0	-41.4		2.5098	-18.3	H	3.0	39.5	1.0	-56.8	-13.0	-43.8		3.3464	-16.1	H	3.0	40.1	1.0	-55.3	-13.0	-42.3		High Ch, 846.6MHz										1.6932	-14.5	V	3.0	39.1	1.0	-52.6	-13.0	-39.6		2.5390	-17.8	V	3.0	39.6	1.0	-56.4	-13.0	-43.4		3.3860	-15.9	V	3.0	40.2	1.0	-55.1	-13.0	-42.1		1.6932	-13.9	H	3.0	39.1	1.0	-52.1	-13.0	-39.1		2.5390	-18.2	H	3.0	39.6	1.0	-56.7	-13.0	-43.7		3.3860	-16.2	H	3.0	40.2	1.0	-55.4	-13.0	-42.4	
		f GHz	SG reading (dBm)	Ant. Pol. (H/V)	Distance (m)	Preamp (dB)	Filter (dB)	EIRP (dBm)	Limit (dBm)	Delta (dB)	Notes																																																																																																																																																																																																																												
Low Ch, 826.40MHz																																																																																																																																																																																																																																							
1.6520		-15.1	V	3.0	39.1	1.0	-53.2	-13.0	-40.2																																																																																																																																																																																																																														
2.4790		-17.9	V	3.0	39.5	1.0	-56.4	-13.0	-43.4																																																																																																																																																																																																																														
3.3056		-15.8	V	3.0	40.1	1.0	-54.9	-13.0	-41.9																																																																																																																																																																																																																														
1.6520		-10.8	H	3.0	39.1	1.0	-48.9	-13.0	-35.9																																																																																																																																																																																																																														
2.4790		-18.4	H	3.0	39.5	1.0	-56.9	-13.0	-43.9																																																																																																																																																																																																																														
3.3056		-16.1	H	3.0	40.1	1.0	-55.2	-13.0	-42.2																																																																																																																																																																																																																														
Mid Ch, 836.6MHz																																																																																																																																																																																																																																							
1.6732		-16.6	V	3.0	39.1	1.0	-54.7	-13.0	-41.7																																																																																																																																																																																																																														
2.5098		-17.9	V	3.0	39.5	1.0	-56.4	-13.0	-43.4																																																																																																																																																																																																																														
3.3464		-16.0	V	3.0	40.1	1.0	-55.1	-13.0	-42.1																																																																																																																																																																																																																														
1.6732		-16.3	H	3.0	39.1	1.0	-54.4	-13.0	-41.4																																																																																																																																																																																																																														
2.5098		-18.3	H	3.0	39.5	1.0	-56.8	-13.0	-43.8																																																																																																																																																																																																																														
3.3464		-16.1	H	3.0	40.1	1.0	-55.3	-13.0	-42.3																																																																																																																																																																																																																														
High Ch, 846.6MHz																																																																																																																																																																																																																																							
1.6932		-14.5	V	3.0	39.1	1.0	-52.6	-13.0	-39.6																																																																																																																																																																																																																														
2.5390		-17.8	V	3.0	39.6	1.0	-56.4	-13.0	-43.4																																																																																																																																																																																																																														
3.3860		-15.9	V	3.0	40.2	1.0	-55.1	-13.0	-42.1																																																																																																																																																																																																																														
1.6932		-13.9	H	3.0	39.1	1.0	-52.1	-13.0	-39.1																																																																																																																																																																																																																														
2.5390		-18.2	H	3.0	39.6	1.0	-56.7	-13.0	-43.7																																																																																																																																																																																																																														
3.3860		-16.2	H	3.0	40.2	1.0	-55.4	-13.0	-42.4																																																																																																																																																																																																																														

WCDMA Band 2

		UL Korea, Ltd Suwon Laboratory Above 1GHz High Frequency Substitution Measurement											
WCDMA Band 2 REL99	Company: Samsung Project #: 16K23140 Date: 03-18-16 Test Engineer: Steven.Kim Configuration: EUT / AC Adapter / Earphone / X Position Mode: Tx, REL99,1900MHz		Chamber: Chamber 2 Pre-amplifier: AFS42 Filter: Filter 1 Limit: Part 24										
			f GHz	SG reading (dBm)	Ant. Pol. (H/V)	Distance (m)	Preamp (dB)	Filter (dB)	EIRP (dBm)	Limit (dBm)	Delta (dB)	Notes	
			Low Ch, 1852.4MHz										
			3.7048	-11.9	V	3.0	40.5	1.0	-51.4	-13.0	-38.4		
			5.5572	-10.5	V	3.0	40.8	1.0	-50.3	-13.0	-37.3		
			7.4096	1.5	V	3.0	40.8	1.0	-38.3	-13.0	-25.3		
			3.7048	-11.1	H	3.0	40.5	1.0	-50.6	-13.0	-37.6		
			5.5572	-11.0	H	3.0	40.8	1.0	-50.8	-13.0	-37.8		
			7.4096	-3.9	H	3.0	40.8	1.0	-43.7	-13.0	-30.7		
			Mid Ch, 1880MHz										
			3.7600	-11.3	V	3.0	40.5	1.0	-50.8	-13.0	-37.8		
			5.6400	-10.4	V	3.0	40.8	1.0	-50.2	-13.0	-37.2		
			7.5200	2.0	V	3.0	40.7	1.0	-37.7	-13.0	-24.7		
			3.7600	-11.0	H	3.0	40.5	1.0	-50.5	-13.0	-37.5		
			5.6400	-10.8	H	3.0	40.8	1.0	-50.6	-13.0	-37.6		
		7.5200	-3.7	H	3.0	40.7	1.0	-43.4	-13.0	-30.4			
		High Ch, 1907.6MHz											
		3.8152	-11.5	V	3.0	40.6	1.0	-51.1	-13.0	-38.1			
		5.7228	-10.2	V	3.0	40.8	1.0	-50.0	-13.0	-37.0			
		7.6304	2.3	V	3.0	40.7	1.0	-37.3	-13.0	-24.3			
		3.8152	-10.5	H	3.0	40.6	1.0	-50.1	-13.0	-37.1			
		5.7228	-10.6	H	3.0	40.8	1.0	-50.4	-13.0	-37.4			
		7.6304	-3.6	H	3.0	40.7	1.0	-43.2	-13.0	-30.2			
		Rev. 03.03.09 Note: No other emissions were detected above the system noise floor.											
WCDMA Band 2 HSDPA	Company: Samsung Project #: 16K23140 Date: 03-18-16 Test Engineer: Steven.Kim Configuration: EUT / AC Adapter / Earphone / X Position Mode: Tx, HSDPA,1900MHz		Chamber: Chamber 2 Pre-amplifier: AFS42 Filter: Filter 1 Limit: Part 24										
			f GHz	SG reading (dBm)	Ant. Pol. (H/V)	Distance (m)	Preamp (dB)	Filter (dB)	EIRP (dBm)	Limit (dBm)	Delta (dB)	Notes	
			Low Ch, 1852.4MHz										
			3.7048	-11.0	V	3.0	40.5	1.0	-50.5	-13.0	-37.5		
			5.5572	-10.3	V	3.0	40.8	1.0	-50.1	-13.0	-37.1		
			7.4096	2.4	V	3.0	40.8	1.0	-37.3	-13.0	-24.3		
			3.7048	-10.3	H	3.0	40.5	1.0	-49.8	-13.0	-36.8		
			5.5572	-10.8	H	3.0	40.8	1.0	-50.7	-13.0	-37.7		
			7.4096	-3.1	H	3.0	40.8	1.0	-42.9	-13.0	-29.9		
			Mid Ch, 1880MHz										
			3.7600	-10.5	V	3.0	40.5	1.0	-50.0	-13.0	-37.0		
			5.6400	-10.2	V	3.0	40.8	1.0	-50.0	-13.0	-37.0		
			7.5200	3.0	V	3.0	40.7	1.0	-36.7	-13.0	-23.7		
			3.7600	-10.0	H	3.0	40.5	1.0	-49.6	-13.0	-36.6		
			5.6400	-10.7	H	3.0	40.8	1.0	-50.5	-13.0	-37.5		
		7.5200	-2.8	H	3.0	40.7	1.0	-42.5	-13.0	-29.5			
		High Ch, 1907.6MHz											
		3.8152	-10.5	V	3.0	40.6	1.0	-50.0	-13.0	-37.0			
		5.7228	-9.9	V	3.0	40.8	1.0	-49.7	-13.0	-36.7			
		7.6304	3.1	V	3.0	40.7	1.0	-36.5	-13.0	-23.5			
		3.8152	-9.5	H	3.0	40.6	1.0	-49.1	-13.0	-36.1			
		5.7228	-10.4	H	3.0	40.8	1.0	-50.2	-13.0	-37.2			
		7.6304	-2.6	H	3.0	40.7	1.0	-42.2	-13.0	-29.2			
		Rev. 03.03.09 Note: No other emissions were detected above the system noise floor.											

LTE Band 5

LTE Band 5 10MHz QPSK	UL Korea, Ltd Suwon Laboratory Above 1GHz High Frequency Substitution Measurement									
	Company: Samsung Project #: 16K23140 Date: 03-21-16 Test Engineer: Steven.Kim Configuration: EUT / AC Adapter / Earphone, Z Position Mode: TX, LTE BAND 5, 10MHz BW,QPSK									
<div style="display: flex; justify-content: space-around;"> <div style="border: 1px solid black; padding: 2px;">Chamber Chamber 2</div> <div style="border: 1px solid black; padding: 2px;">Pre-amplifier AFS42</div> <div style="border: 1px solid black; padding: 2px;">Filter Filter 1</div> <div style="border: 1px solid black; padding: 2px;">Limit Part 22</div> </div>										
f GHz	SG reading (dBm)	Ant. Pol. (H/V)	Distance (m)	Preamp (dB)	Filter (dB)	EIRP (dBm)	Limit (dBm)	Delta (dB)	Notes	
Low Channel (829MHz)										
1.6580	-15.8	V	3.0	39.1	1.0	-53.9	-13.0	-40.9		
2.4870	-20.0	V	3.0	39.5	1.0	-58.5	-13.0	-45.5		
3.3160	-17.0	V	3.0	40.1	1.0	-56.1	-13.0	-43.1		
1.6580	-11.6	H	3.0	39.1	1.0	-49.8	-13.0	-36.8		
2.4870	-23.6	H	3.0	39.5	1.0	-62.2	-13.0	-49.2		
3.3160	-20.7	H	3.0	40.1	1.0	-59.9	-13.0	-46.9		
Mid Channel (836.5MHz)										
1.6730	-17.8	V	3.0	39.1	1.0	-56.0	-13.0	-43.0		
2.5090	-24.6	V	3.0	39.5	1.0	-63.1	-13.0	-50.1		
3.3460	-21.9	V	3.0	40.1	1.0	-61.0	-13.0	-48.0		
1.6730	-13.9	H	3.0	39.1	1.0	-52.0	-13.0	-39.0		
2.5090	-24.8	H	3.0	39.5	1.0	-63.3	-13.0	-50.3		
3.3460	-23.2	H	3.0	40.1	1.0	-62.3	-13.0	-49.3		
High Channel (844MHz)										
1.6880	-17.2	V	3.0	39.1	1.0	-55.4	-13.0	-42.4		
2.5320	-22.7	V	3.0	39.5	1.0	-61.2	-13.0	-48.2		
3.3760	-20.1	V	3.0	40.2	1.0	-59.2	-13.0	-46.2		
1.6880	-9.7	H	3.0	39.1	1.0	-47.9	-13.0	-34.9		
2.5320	-23.4	H	3.0	39.5	1.0	-61.9	-13.0	-48.9		
3.3760	-20.4	H	3.0	40.2	1.0	-59.6	-13.0	-46.6		
Rev. 03.03.09 Note: No other emissions were detected above the system noise floor.										
LTE Band 5 10MHz 16QAM	UL Korea, Ltd Suwon Laboratory Above 1GHz High Frequency Substitution Measurement									
	Company: Samsung Project #: 16K23140 Date: 03-21-16 Test Engineer: Steven.Kim Configuration: EUT / AC Adapter / Earphone, Z Position Mode: TX, LTE BAND 5, 10MHz BW, 16QAM									
<div style="display: flex; justify-content: space-around;"> <div style="border: 1px solid black; padding: 2px;">Chamber Chamber 2</div> <div style="border: 1px solid black; padding: 2px;">Pre-amplifier AFS42</div> <div style="border: 1px solid black; padding: 2px;">Filter Filter 1</div> <div style="border: 1px solid black; padding: 2px;">Limit Part 22</div> </div>										
f GHz	SG reading (dBm)	Ant. Pol. (H/V)	Distance (m)	Preamp (dB)	Filter (dB)	EIRP (dBm)	Limit (dBm)	Delta (dB)	Notes	
Low Channel (829MHz)										
1.6580	-15.8	V	3.0	39.1	1.0	-53.9	-13.0	-40.9		
2.4870	-19.7	V	3.0	39.5	1.0	-58.2	-13.0	-45.2		
3.3160	-17.2	V	3.0	40.1	1.0	-56.3	-13.0	-43.3		
1.6580	-11.9	H	3.0	39.1	1.0	-50.0	-13.0	-37.0		
2.4870	-23.0	H	3.0	39.5	1.0	-61.5	-13.0	-48.5		
3.3160	-20.6	H	3.0	40.1	1.0	-59.7	-13.0	-46.7		
Mid Channel (836.5MHz)										
1.6730	-16.9	V	3.0	39.1	1.0	-55.0	-13.0	-42.0		
2.5090	-24.8	V	3.0	39.5	1.0	-63.3	-13.0	-50.3		
3.3460	-22.1	V	3.0	40.1	1.0	-61.2	-13.0	-48.2		
1.6730	-13.3	H	3.0	39.1	1.0	-51.4	-13.0	-38.4		
2.5090	-24.9	H	3.0	39.5	1.0	-63.4	-13.0	-50.4		
3.3460	-23.3	H	3.0	40.1	1.0	-62.4	-13.0	-49.4		
High Channel (844MHz)										
1.6880	-17.5	V	3.0	39.1	1.0	-55.6	-13.0	-42.6		
2.5320	-22.5	V	3.0	39.5	1.0	-61.1	-13.0	-48.1		
3.3760	-20.1	V	3.0	40.2	1.0	-59.3	-13.0	-46.3		
1.6880	-10.5	H	3.0	39.1	1.0	-48.6	-13.0	-35.6		
2.5320	-23.2	H	3.0	39.5	1.0	-61.7	-13.0	-48.7		
3.3760	-20.8	H	3.0	40.2	1.0	-59.9	-13.0	-46.9		
Rev. 03.03.09 Note: No other emissions were detected above the system noise floor.										

		UL Korea, Ltd Suwon Laboratory Above 1GHz High Frequency Substitution Measurement																																																																																																																																																																																																																																				
LTE Band 5 5MHz QPSK	Company: Samsung Project #: 16K23140 Date: 03-21-16 Test Engineer: Steven.Kim Configuration: EUT / AC Adapter / Earphone, Z Position Mode: TX, LTE BAND 5, 5MHz BW, QPSK	<div style="display: flex; justify-content: space-around;"> <div style="border: 1px solid black; padding: 2px;">Chamber Chamber 2</div> <div style="border: 1px solid black; padding: 2px;">Pre-amplifier AFS42</div> <div style="border: 1px solid black; padding: 2px;">Filter Filter 1</div> <div style="border: 1px solid black; padding: 2px;">Limit Part 22</div> </div> <table border="1"> <thead> <tr> <th>f GHz</th> <th>SG reading (dBm)</th> <th>Ant. Pol. (H/V)</th> <th>Distance (m)</th> <th>Preamp (dB)</th> <th>Filter (dB)</th> <th>EIRP (dBm)</th> <th>Limit (dBm)</th> <th>Delta (dB)</th> <th>Notes</th> </tr> </thead> <tbody> <tr><td colspan="10">Low Channel (826.5MHz)</td></tr> <tr><td>1.6530</td><td>-11.4</td><td>V</td><td>3.0</td><td>39.1</td><td>1.0</td><td>-49.5</td><td>-13.0</td><td>-36.5</td><td></td></tr> <tr><td>2.4790</td><td>-19.7</td><td>V</td><td>3.0</td><td>39.5</td><td>1.0</td><td>-58.2</td><td>-13.0</td><td>-45.2</td><td></td></tr> <tr><td>3.3060</td><td>-14.3</td><td>V</td><td>3.0</td><td>40.1</td><td>1.0</td><td>-53.4</td><td>-13.0</td><td>-40.4</td><td></td></tr> <tr><td>1.6530</td><td>-8.3</td><td>H</td><td>3.0</td><td>39.1</td><td>1.0</td><td>-46.4</td><td>-13.0</td><td>-33.4</td><td></td></tr> <tr><td>2.4790</td><td>-23.7</td><td>H</td><td>3.0</td><td>39.5</td><td>1.0</td><td>-62.2</td><td>-13.0</td><td>-49.2</td><td></td></tr> <tr><td>3.3060</td><td>-19.5</td><td>H</td><td>3.0</td><td>40.1</td><td>1.0</td><td>-58.6</td><td>-13.0</td><td>-45.6</td><td></td></tr> <tr><td colspan="10">Mid Channel (836.5MHz)</td></tr> <tr><td>1.6730</td><td>-16.9</td><td>V</td><td>3.0</td><td>39.1</td><td>1.0</td><td>-55.0</td><td>-13.0</td><td>-42.0</td><td></td></tr> <tr><td>2.5090</td><td>-24.6</td><td>V</td><td>3.0</td><td>39.5</td><td>1.0</td><td>-63.2</td><td>-13.0</td><td>-50.2</td><td></td></tr> <tr><td>3.3460</td><td>-22.8</td><td>V</td><td>3.0</td><td>40.1</td><td>1.0</td><td>-61.9</td><td>-13.0</td><td>-48.9</td><td></td></tr> <tr><td>1.6730</td><td>-12.7</td><td>H</td><td>3.0</td><td>39.1</td><td>1.0</td><td>-50.8</td><td>-13.0</td><td>-37.8</td><td></td></tr> <tr><td>2.5090</td><td>-25.0</td><td>H</td><td>3.0</td><td>39.5</td><td>1.0</td><td>-63.6</td><td>-13.0</td><td>-50.6</td><td></td></tr> <tr><td>3.3460</td><td>-23.2</td><td>H</td><td>3.0</td><td>40.1</td><td>1.0</td><td>-62.3</td><td>-13.0</td><td>-49.3</td><td></td></tr> <tr><td colspan="10">High Channel (846.5MHz)</td></tr> <tr><td>1.6930</td><td>-15.9</td><td>V</td><td>3.0</td><td>39.1</td><td>1.0</td><td>-54.0</td><td>-13.0</td><td>-41.0</td><td></td></tr> <tr><td>2.5390</td><td>-23.4</td><td>V</td><td>3.0</td><td>39.6</td><td>1.0</td><td>-61.9</td><td>-13.0</td><td>-48.9</td><td></td></tr> <tr><td>3.3860</td><td>-21.1</td><td>V</td><td>3.0</td><td>40.2</td><td>1.0</td><td>-60.3</td><td>-13.0</td><td>-47.3</td><td></td></tr> <tr><td>1.6930</td><td>-15.7</td><td>H</td><td>3.0</td><td>39.1</td><td>1.0</td><td>-53.8</td><td>-13.0</td><td>-40.8</td><td></td></tr> <tr><td>2.5390</td><td>-23.3</td><td>H</td><td>3.0</td><td>39.6</td><td>1.0</td><td>-61.8</td><td>-13.0</td><td>-48.8</td><td></td></tr> <tr><td>3.3860</td><td>-21.4</td><td>H</td><td>3.0</td><td>40.2</td><td>1.0</td><td>-60.6</td><td>-13.0</td><td>-47.6</td><td></td></tr> </tbody> </table> <p>Rev. 03.03.09 Note: No other emissions were detected above the system noise floor.</p>									f GHz	SG reading (dBm)	Ant. Pol. (H/V)	Distance (m)	Preamp (dB)	Filter (dB)	EIRP (dBm)	Limit (dBm)	Delta (dB)	Notes	Low Channel (826.5MHz)										1.6530	-11.4	V	3.0	39.1	1.0	-49.5	-13.0	-36.5		2.4790	-19.7	V	3.0	39.5	1.0	-58.2	-13.0	-45.2		3.3060	-14.3	V	3.0	40.1	1.0	-53.4	-13.0	-40.4		1.6530	-8.3	H	3.0	39.1	1.0	-46.4	-13.0	-33.4		2.4790	-23.7	H	3.0	39.5	1.0	-62.2	-13.0	-49.2		3.3060	-19.5	H	3.0	40.1	1.0	-58.6	-13.0	-45.6		Mid Channel (836.5MHz)										1.6730	-16.9	V	3.0	39.1	1.0	-55.0	-13.0	-42.0		2.5090	-24.6	V	3.0	39.5	1.0	-63.2	-13.0	-50.2		3.3460	-22.8	V	3.0	40.1	1.0	-61.9	-13.0	-48.9		1.6730	-12.7	H	3.0	39.1	1.0	-50.8	-13.0	-37.8		2.5090	-25.0	H	3.0	39.5	1.0	-63.6	-13.0	-50.6		3.3460	-23.2	H	3.0	40.1	1.0	-62.3	-13.0	-49.3		High Channel (846.5MHz)										1.6930	-15.9	V	3.0	39.1	1.0	-54.0	-13.0	-41.0		2.5390	-23.4	V	3.0	39.6	1.0	-61.9	-13.0	-48.9		3.3860	-21.1	V	3.0	40.2	1.0	-60.3	-13.0	-47.3		1.6930	-15.7	H	3.0	39.1	1.0	-53.8	-13.0	-40.8		2.5390	-23.3	H	3.0	39.6	1.0	-61.8	-13.0	-48.8		3.3860	-21.4	H	3.0	40.2	1.0	-60.6	-13.0	-47.6	
	f GHz	SG reading (dBm)	Ant. Pol. (H/V)	Distance (m)	Preamp (dB)	Filter (dB)	EIRP (dBm)	Limit (dBm)	Delta (dB)	Notes																																																																																																																																																																																																																												
Low Channel (826.5MHz)																																																																																																																																																																																																																																						
1.6530	-11.4	V	3.0	39.1	1.0	-49.5	-13.0	-36.5																																																																																																																																																																																																																														
2.4790	-19.7	V	3.0	39.5	1.0	-58.2	-13.0	-45.2																																																																																																																																																																																																																														
3.3060	-14.3	V	3.0	40.1	1.0	-53.4	-13.0	-40.4																																																																																																																																																																																																																														
1.6530	-8.3	H	3.0	39.1	1.0	-46.4	-13.0	-33.4																																																																																																																																																																																																																														
2.4790	-23.7	H	3.0	39.5	1.0	-62.2	-13.0	-49.2																																																																																																																																																																																																																														
3.3060	-19.5	H	3.0	40.1	1.0	-58.6	-13.0	-45.6																																																																																																																																																																																																																														
Mid Channel (836.5MHz)																																																																																																																																																																																																																																						
1.6730	-16.9	V	3.0	39.1	1.0	-55.0	-13.0	-42.0																																																																																																																																																																																																																														
2.5090	-24.6	V	3.0	39.5	1.0	-63.2	-13.0	-50.2																																																																																																																																																																																																																														
3.3460	-22.8	V	3.0	40.1	1.0	-61.9	-13.0	-48.9																																																																																																																																																																																																																														
1.6730	-12.7	H	3.0	39.1	1.0	-50.8	-13.0	-37.8																																																																																																																																																																																																																														
2.5090	-25.0	H	3.0	39.5	1.0	-63.6	-13.0	-50.6																																																																																																																																																																																																																														
3.3460	-23.2	H	3.0	40.1	1.0	-62.3	-13.0	-49.3																																																																																																																																																																																																																														
High Channel (846.5MHz)																																																																																																																																																																																																																																						
1.6930	-15.9	V	3.0	39.1	1.0	-54.0	-13.0	-41.0																																																																																																																																																																																																																														
2.5390	-23.4	V	3.0	39.6	1.0	-61.9	-13.0	-48.9																																																																																																																																																																																																																														
3.3860	-21.1	V	3.0	40.2	1.0	-60.3	-13.0	-47.3																																																																																																																																																																																																																														
1.6930	-15.7	H	3.0	39.1	1.0	-53.8	-13.0	-40.8																																																																																																																																																																																																																														
2.5390	-23.3	H	3.0	39.6	1.0	-61.8	-13.0	-48.8																																																																																																																																																																																																																														
3.3860	-21.4	H	3.0	40.2	1.0	-60.6	-13.0	-47.6																																																																																																																																																																																																																														
LTE Band 5 5MHz 16QAM	Company: Samsung Project #: 16K23140 Date: 03-21-16 Test Engineer: Steven.Kim Configuration: EUT / AC Adapter / Earphone, Z Position Mode: TX, LTE BAND 5, 5MHz BW, 16QAM	<div style="display: flex; justify-content: space-around;"> <div style="border: 1px solid black; padding: 2px;">Chamber Chamber 2</div> <div style="border: 1px solid black; padding: 2px;">Pre-amplifier AFS42</div> <div style="border: 1px solid black; padding: 2px;">Filter Filter 1</div> <div style="border: 1px solid black; padding: 2px;">Limit Part 22</div> </div> <table border="1"> <thead> <tr> <th>f GHz</th> <th>SG reading (dBm)</th> <th>Ant. Pol. (H/V)</th> <th>Distance (m)</th> <th>Preamp (dB)</th> <th>Filter (dB)</th> <th>EIRP (dBm)</th> <th>Limit (dBm)</th> <th>Delta (dB)</th> <th>Notes</th> </tr> </thead> <tbody> <tr><td colspan="10">Low Channel (826.5MHz)</td></tr> <tr><td>1.6530</td><td>-11.5</td><td>V</td><td>3.0</td><td>39.1</td><td>1.0</td><td>-49.6</td><td>-13.0</td><td>-36.6</td><td></td></tr> <tr><td>2.4790</td><td>-19.8</td><td>V</td><td>3.0</td><td>39.5</td><td>1.0</td><td>-58.3</td><td>-13.0</td><td>-45.3</td><td></td></tr> <tr><td>3.3060</td><td>-14.4</td><td>V</td><td>3.0</td><td>40.1</td><td>1.0</td><td>-53.5</td><td>-13.0</td><td>-40.5</td><td></td></tr> <tr><td>1.6530</td><td>-7.9</td><td>H</td><td>3.0</td><td>39.1</td><td>1.0</td><td>-46.0</td><td>-13.0</td><td>-33.0</td><td></td></tr> <tr><td>2.4790</td><td>-22.9</td><td>H</td><td>3.0</td><td>39.5</td><td>1.0</td><td>-61.4</td><td>-13.0</td><td>-48.4</td><td></td></tr> <tr><td>3.3060</td><td>-19.2</td><td>H</td><td>3.0</td><td>40.1</td><td>1.0</td><td>-58.3</td><td>-13.0</td><td>-45.3</td><td></td></tr> <tr><td colspan="10">Mid Channel (836.5MHz)</td></tr> <tr><td>1.6730</td><td>-16.8</td><td>V</td><td>3.0</td><td>39.1</td><td>1.0</td><td>-55.0</td><td>-13.0</td><td>-42.0</td><td></td></tr> <tr><td>2.5090</td><td>-24.7</td><td>V</td><td>3.0</td><td>39.5</td><td>1.0</td><td>-63.2</td><td>-13.0</td><td>-50.2</td><td></td></tr> <tr><td>3.3460</td><td>-22.9</td><td>V</td><td>3.0</td><td>40.1</td><td>1.0</td><td>-62.0</td><td>-13.0</td><td>-49.0</td><td></td></tr> <tr><td>1.6730</td><td>-12.3</td><td>H</td><td>3.0</td><td>39.1</td><td>1.0</td><td>-50.5</td><td>-13.0</td><td>-37.5</td><td></td></tr> <tr><td>2.5090</td><td>-25.0</td><td>H</td><td>3.0</td><td>39.5</td><td>1.0</td><td>-63.6</td><td>-13.0</td><td>-50.6</td><td></td></tr> <tr><td>3.3460</td><td>-23.1</td><td>H</td><td>3.0</td><td>40.1</td><td>1.0</td><td>-62.3</td><td>-13.0</td><td>-49.3</td><td></td></tr> <tr><td colspan="10">High Channel (846.5MHz)</td></tr> <tr><td>1.6930</td><td>-16.1</td><td>V</td><td>3.0</td><td>39.1</td><td>1.0</td><td>-54.2</td><td>-13.0</td><td>-41.2</td><td></td></tr> <tr><td>2.5390</td><td>-22.9</td><td>V</td><td>3.0</td><td>39.6</td><td>1.0</td><td>-61.5</td><td>-13.0</td><td>-48.5</td><td></td></tr> <tr><td>3.3860</td><td>-21.0</td><td>V</td><td>3.0</td><td>40.2</td><td>1.0</td><td>-60.1</td><td>-13.0</td><td>-47.1</td><td></td></tr> <tr><td>1.6930</td><td>-15.8</td><td>H</td><td>3.0</td><td>39.1</td><td>1.0</td><td>-53.9</td><td>-13.0</td><td>-40.9</td><td></td></tr> <tr><td>2.5390</td><td>-23.2</td><td>H</td><td>3.0</td><td>39.6</td><td>1.0</td><td>-61.8</td><td>-13.0</td><td>-48.8</td><td></td></tr> <tr><td>3.3860</td><td>-21.3</td><td>H</td><td>3.0</td><td>40.2</td><td>1.0</td><td>-60.5</td><td>-13.0</td><td>-47.5</td><td></td></tr> </tbody> </table> <p>Rev. 03.03.09 Note: No other emissions were detected above the system noise floor.</p>									f GHz	SG reading (dBm)	Ant. Pol. (H/V)	Distance (m)	Preamp (dB)	Filter (dB)	EIRP (dBm)	Limit (dBm)	Delta (dB)	Notes	Low Channel (826.5MHz)										1.6530	-11.5	V	3.0	39.1	1.0	-49.6	-13.0	-36.6		2.4790	-19.8	V	3.0	39.5	1.0	-58.3	-13.0	-45.3		3.3060	-14.4	V	3.0	40.1	1.0	-53.5	-13.0	-40.5		1.6530	-7.9	H	3.0	39.1	1.0	-46.0	-13.0	-33.0		2.4790	-22.9	H	3.0	39.5	1.0	-61.4	-13.0	-48.4		3.3060	-19.2	H	3.0	40.1	1.0	-58.3	-13.0	-45.3		Mid Channel (836.5MHz)										1.6730	-16.8	V	3.0	39.1	1.0	-55.0	-13.0	-42.0		2.5090	-24.7	V	3.0	39.5	1.0	-63.2	-13.0	-50.2		3.3460	-22.9	V	3.0	40.1	1.0	-62.0	-13.0	-49.0		1.6730	-12.3	H	3.0	39.1	1.0	-50.5	-13.0	-37.5		2.5090	-25.0	H	3.0	39.5	1.0	-63.6	-13.0	-50.6		3.3460	-23.1	H	3.0	40.1	1.0	-62.3	-13.0	-49.3		High Channel (846.5MHz)										1.6930	-16.1	V	3.0	39.1	1.0	-54.2	-13.0	-41.2		2.5390	-22.9	V	3.0	39.6	1.0	-61.5	-13.0	-48.5		3.3860	-21.0	V	3.0	40.2	1.0	-60.1	-13.0	-47.1		1.6930	-15.8	H	3.0	39.1	1.0	-53.9	-13.0	-40.9		2.5390	-23.2	H	3.0	39.6	1.0	-61.8	-13.0	-48.8		3.3860	-21.3	H	3.0	40.2	1.0	-60.5	-13.0	-47.5	
	f GHz	SG reading (dBm)	Ant. Pol. (H/V)	Distance (m)	Preamp (dB)	Filter (dB)	EIRP (dBm)	Limit (dBm)	Delta (dB)	Notes																																																																																																																																																																																																																												
Low Channel (826.5MHz)																																																																																																																																																																																																																																						
1.6530	-11.5	V	3.0	39.1	1.0	-49.6	-13.0	-36.6																																																																																																																																																																																																																														
2.4790	-19.8	V	3.0	39.5	1.0	-58.3	-13.0	-45.3																																																																																																																																																																																																																														
3.3060	-14.4	V	3.0	40.1	1.0	-53.5	-13.0	-40.5																																																																																																																																																																																																																														
1.6530	-7.9	H	3.0	39.1	1.0	-46.0	-13.0	-33.0																																																																																																																																																																																																																														
2.4790	-22.9	H	3.0	39.5	1.0	-61.4	-13.0	-48.4																																																																																																																																																																																																																														
3.3060	-19.2	H	3.0	40.1	1.0	-58.3	-13.0	-45.3																																																																																																																																																																																																																														
Mid Channel (836.5MHz)																																																																																																																																																																																																																																						
1.6730	-16.8	V	3.0	39.1	1.0	-55.0	-13.0	-42.0																																																																																																																																																																																																																														
2.5090	-24.7	V	3.0	39.5	1.0	-63.2	-13.0	-50.2																																																																																																																																																																																																																														
3.3460	-22.9	V	3.0	40.1	1.0	-62.0	-13.0	-49.0																																																																																																																																																																																																																														
1.6730	-12.3	H	3.0	39.1	1.0	-50.5	-13.0	-37.5																																																																																																																																																																																																																														
2.5090	-25.0	H	3.0	39.5	1.0	-63.6	-13.0	-50.6																																																																																																																																																																																																																														
3.3460	-23.1	H	3.0	40.1	1.0	-62.3	-13.0	-49.3																																																																																																																																																																																																																														
High Channel (846.5MHz)																																																																																																																																																																																																																																						
1.6930	-16.1	V	3.0	39.1	1.0	-54.2	-13.0	-41.2																																																																																																																																																																																																																														
2.5390	-22.9	V	3.0	39.6	1.0	-61.5	-13.0	-48.5																																																																																																																																																																																																																														
3.3860	-21.0	V	3.0	40.2	1.0	-60.1	-13.0	-47.1																																																																																																																																																																																																																														
1.6930	-15.8	H	3.0	39.1	1.0	-53.9	-13.0	-40.9																																																																																																																																																																																																																														
2.5390	-23.2	H	3.0	39.6	1.0	-61.8	-13.0	-48.8																																																																																																																																																																																																																														
3.3860	-21.3	H	3.0	40.2	1.0	-60.5	-13.0	-47.5																																																																																																																																																																																																																														

LTE Band 5 3MHz QPSK	<p style="text-align: center;">UL Korea, Ltd Suwon Laboratory Above 1GHz High Frequency Substitution Measurement</p> <p>Company: Samsung Project #: 16K23140 Date: 03-21-16 Test Engineer: Steven.Kim Configuration: EUT / AC Adapter / Earphone, Z Position Mode: TX LTE BAND 5, 3MHz BW,QPSK</p> <p style="text-align: center;"> Chamber Pre-amplifier Filter Limit Chamber 2 AFS42 Filter 1 Part 22 </p> <table border="1"> <thead> <tr> <th>f GHz</th> <th>SG reading (dBm)</th> <th>Ant. Pol. (H/V)</th> <th>Distance (m)</th> <th>Preamp (dB)</th> <th>Filter (dB)</th> <th>EIRP (dBm)</th> <th>Limit (dBm)</th> <th>Delta (dB)</th> <th>Notes</th> </tr> </thead> <tbody> <tr><td colspan="10">Low Channel (825.5MHz)</td></tr> <tr><td>1.6510</td><td>-13.1</td><td>V</td><td>3.0</td><td>39.1</td><td>1.0</td><td>-51.2</td><td>-13.0</td><td>-38.2</td><td></td></tr> <tr><td>2.4765</td><td>-21.7</td><td>V</td><td>3.0</td><td>39.5</td><td>1.0</td><td>-60.3</td><td>-13.0</td><td>-47.3</td><td></td></tr> <tr><td>3.3020</td><td>-15.7</td><td>V</td><td>3.0</td><td>40.1</td><td>1.0</td><td>-54.8</td><td>-13.0</td><td>-41.8</td><td></td></tr> <tr><td>1.6510</td><td>-8.2</td><td>H</td><td>3.0</td><td>39.1</td><td>1.0</td><td>-47.3</td><td>-13.0</td><td>-34.3</td><td></td></tr> <tr><td>2.4765</td><td>-24.3</td><td>H</td><td>3.0</td><td>39.5</td><td>1.0</td><td>-62.9</td><td>-13.0</td><td>-49.9</td><td></td></tr> <tr><td>3.3020</td><td>-19.9</td><td>H</td><td>3.0</td><td>40.1</td><td>1.0</td><td>-59.0</td><td>-13.0</td><td>-46.0</td><td></td></tr> <tr><td colspan="10">Mid Channel (836.5MHz)</td></tr> <tr><td>1.6730</td><td>-16.4</td><td>V</td><td>3.0</td><td>39.1</td><td>1.0</td><td>-54.5</td><td>-13.0</td><td>-41.5</td><td></td></tr> <tr><td>2.5090</td><td>-23.4</td><td>V</td><td>3.0</td><td>39.5</td><td>1.0</td><td>-61.9</td><td>-13.0</td><td>-48.9</td><td></td></tr> <tr><td>3.3460</td><td>-21.3</td><td>V</td><td>3.0</td><td>40.1</td><td>1.0</td><td>-60.4</td><td>-13.0</td><td>-47.4</td><td></td></tr> <tr><td>1.6730</td><td>-14.6</td><td>H</td><td>3.0</td><td>39.1</td><td>1.0</td><td>-52.8</td><td>-13.0</td><td>-39.8</td><td></td></tr> <tr><td>2.5090</td><td>-24.4</td><td>H</td><td>3.0</td><td>39.5</td><td>1.0</td><td>-62.9</td><td>-13.0</td><td>-49.9</td><td></td></tr> <tr><td>3.3460</td><td>-22.3</td><td>H</td><td>3.0</td><td>40.1</td><td>1.0</td><td>-61.4</td><td>-13.0</td><td>-48.4</td><td></td></tr> <tr><td colspan="10">High Channel (847.5MHz)</td></tr> <tr><td>1.6950</td><td>-13.8</td><td>V</td><td>3.0</td><td>39.1</td><td>1.0</td><td>-51.9</td><td>-13.0</td><td>-38.9</td><td></td></tr> <tr><td>2.5425</td><td>-23.2</td><td>V</td><td>3.0</td><td>39.6</td><td>1.0</td><td>-61.8</td><td>-13.0</td><td>-48.8</td><td></td></tr> <tr><td>3.3900</td><td>-21.7</td><td>V</td><td>3.0</td><td>40.2</td><td>1.0</td><td>-60.9</td><td>-13.0</td><td>-47.9</td><td></td></tr> <tr><td>1.6950</td><td>-16.8</td><td>H</td><td>3.0</td><td>39.1</td><td>1.0</td><td>-54.9</td><td>-13.0</td><td>-41.9</td><td></td></tr> <tr><td>2.5425</td><td>-23.3</td><td>H</td><td>3.0</td><td>39.6</td><td>1.0</td><td>-61.9</td><td>-13.0</td><td>-48.9</td><td></td></tr> <tr><td>3.3900</td><td>-21.5</td><td>H</td><td>3.0</td><td>40.2</td><td>1.0</td><td>-60.7</td><td>-13.0</td><td>-47.7</td><td></td></tr> </tbody> </table> <p>Rev. 03.03.09 Note: No other emissions were detected above the system noise floor.</p>	f GHz	SG reading (dBm)	Ant. Pol. (H/V)	Distance (m)	Preamp (dB)	Filter (dB)	EIRP (dBm)	Limit (dBm)	Delta (dB)	Notes	Low Channel (825.5MHz)										1.6510	-13.1	V	3.0	39.1	1.0	-51.2	-13.0	-38.2		2.4765	-21.7	V	3.0	39.5	1.0	-60.3	-13.0	-47.3		3.3020	-15.7	V	3.0	40.1	1.0	-54.8	-13.0	-41.8		1.6510	-8.2	H	3.0	39.1	1.0	-47.3	-13.0	-34.3		2.4765	-24.3	H	3.0	39.5	1.0	-62.9	-13.0	-49.9		3.3020	-19.9	H	3.0	40.1	1.0	-59.0	-13.0	-46.0		Mid Channel (836.5MHz)										1.6730	-16.4	V	3.0	39.1	1.0	-54.5	-13.0	-41.5		2.5090	-23.4	V	3.0	39.5	1.0	-61.9	-13.0	-48.9		3.3460	-21.3	V	3.0	40.1	1.0	-60.4	-13.0	-47.4		1.6730	-14.6	H	3.0	39.1	1.0	-52.8	-13.0	-39.8		2.5090	-24.4	H	3.0	39.5	1.0	-62.9	-13.0	-49.9		3.3460	-22.3	H	3.0	40.1	1.0	-61.4	-13.0	-48.4		High Channel (847.5MHz)										1.6950	-13.8	V	3.0	39.1	1.0	-51.9	-13.0	-38.9		2.5425	-23.2	V	3.0	39.6	1.0	-61.8	-13.0	-48.8		3.3900	-21.7	V	3.0	40.2	1.0	-60.9	-13.0	-47.9		1.6950	-16.8	H	3.0	39.1	1.0	-54.9	-13.0	-41.9		2.5425	-23.3	H	3.0	39.6	1.0	-61.9	-13.0	-48.9		3.3900	-21.5	H	3.0	40.2	1.0	-60.7	-13.0	-47.7	
	f GHz	SG reading (dBm)	Ant. Pol. (H/V)	Distance (m)	Preamp (dB)	Filter (dB)	EIRP (dBm)	Limit (dBm)	Delta (dB)	Notes																																																																																																																																																																																																																			
Low Channel (825.5MHz)																																																																																																																																																																																																																													
1.6510	-13.1	V	3.0	39.1	1.0	-51.2	-13.0	-38.2																																																																																																																																																																																																																					
2.4765	-21.7	V	3.0	39.5	1.0	-60.3	-13.0	-47.3																																																																																																																																																																																																																					
3.3020	-15.7	V	3.0	40.1	1.0	-54.8	-13.0	-41.8																																																																																																																																																																																																																					
1.6510	-8.2	H	3.0	39.1	1.0	-47.3	-13.0	-34.3																																																																																																																																																																																																																					
2.4765	-24.3	H	3.0	39.5	1.0	-62.9	-13.0	-49.9																																																																																																																																																																																																																					
3.3020	-19.9	H	3.0	40.1	1.0	-59.0	-13.0	-46.0																																																																																																																																																																																																																					
Mid Channel (836.5MHz)																																																																																																																																																																																																																													
1.6730	-16.4	V	3.0	39.1	1.0	-54.5	-13.0	-41.5																																																																																																																																																																																																																					
2.5090	-23.4	V	3.0	39.5	1.0	-61.9	-13.0	-48.9																																																																																																																																																																																																																					
3.3460	-21.3	V	3.0	40.1	1.0	-60.4	-13.0	-47.4																																																																																																																																																																																																																					
1.6730	-14.6	H	3.0	39.1	1.0	-52.8	-13.0	-39.8																																																																																																																																																																																																																					
2.5090	-24.4	H	3.0	39.5	1.0	-62.9	-13.0	-49.9																																																																																																																																																																																																																					
3.3460	-22.3	H	3.0	40.1	1.0	-61.4	-13.0	-48.4																																																																																																																																																																																																																					
High Channel (847.5MHz)																																																																																																																																																																																																																													
1.6950	-13.8	V	3.0	39.1	1.0	-51.9	-13.0	-38.9																																																																																																																																																																																																																					
2.5425	-23.2	V	3.0	39.6	1.0	-61.8	-13.0	-48.8																																																																																																																																																																																																																					
3.3900	-21.7	V	3.0	40.2	1.0	-60.9	-13.0	-47.9																																																																																																																																																																																																																					
1.6950	-16.8	H	3.0	39.1	1.0	-54.9	-13.0	-41.9																																																																																																																																																																																																																					
2.5425	-23.3	H	3.0	39.6	1.0	-61.9	-13.0	-48.9																																																																																																																																																																																																																					
3.3900	-21.5	H	3.0	40.2	1.0	-60.7	-13.0	-47.7																																																																																																																																																																																																																					
LTE Band 5 3MHz 16QAM	<p style="text-align: center;">UL Korea, Ltd Suwon Laboratory Above 1GHz High Frequency Substitution Measurement</p> <p>Company: Samsung Project #: 16K23140 Date: 03-21-16 Test Engineer: Steven.Kim Configuration: EUT / AC Adapter / Earphone, Z Position Mode: TX LTE BAND 5, 3MHz BW,16QAM</p> <p style="text-align: center;"> Chamber Pre-amplifier Filter Limit Chamber 2 AFS42 Filter 1 Part 22 </p> <table border="1"> <thead> <tr> <th>f GHz</th> <th>SG reading (dBm)</th> <th>Ant. Pol. (H/V)</th> <th>Distance (m)</th> <th>Preamp (dB)</th> <th>Filter (dB)</th> <th>EIRP (dBm)</th> <th>Limit (dBm)</th> <th>Delta (dB)</th> <th>Notes</th> </tr> </thead> <tbody> <tr><td colspan="10">Low Channel (825.5MHz)</td></tr> <tr><td>1.6510</td><td>-12.6</td><td>V</td><td>3.0</td><td>39.1</td><td>1.0</td><td>-50.7</td><td>-13.0</td><td>-37.7</td><td></td></tr> <tr><td>2.4675</td><td>-21.5</td><td>V</td><td>3.0</td><td>39.5</td><td>1.0</td><td>-60.0</td><td>-13.0</td><td>-47.0</td><td></td></tr> <tr><td>3.3020</td><td>-15.6</td><td>V</td><td>3.0</td><td>40.1</td><td>1.0</td><td>-54.7</td><td>-13.0</td><td>-41.7</td><td></td></tr> <tr><td>1.6510</td><td>-8.7</td><td>H</td><td>3.0</td><td>39.1</td><td>1.0</td><td>-46.8</td><td>-13.0</td><td>-33.8</td><td></td></tr> <tr><td>2.4675</td><td>-24.3</td><td>H</td><td>3.0</td><td>39.5</td><td>1.0</td><td>-62.9</td><td>-13.0</td><td>-49.9</td><td></td></tr> <tr><td>3.3020</td><td>-19.8</td><td>H</td><td>3.0</td><td>40.1</td><td>1.0</td><td>-58.9</td><td>-13.0</td><td>-45.9</td><td></td></tr> <tr><td colspan="10">Mid Channel (836.5MHz)</td></tr> <tr><td>1.6730</td><td>-16.1</td><td>V</td><td>3.0</td><td>39.1</td><td>1.0</td><td>-54.2</td><td>-13.0</td><td>-41.2</td><td></td></tr> <tr><td>2.5090</td><td>-23.3</td><td>V</td><td>3.0</td><td>39.5</td><td>1.0</td><td>-61.8</td><td>-13.0</td><td>-48.8</td><td></td></tr> <tr><td>3.3460</td><td>-21.3</td><td>V</td><td>3.0</td><td>40.1</td><td>1.0</td><td>-60.4</td><td>-13.0</td><td>-47.4</td><td></td></tr> <tr><td>1.6730</td><td>-13.7</td><td>H</td><td>3.0</td><td>39.1</td><td>1.0</td><td>-51.9</td><td>-13.0</td><td>-38.9</td><td></td></tr> <tr><td>2.5090</td><td>-24.3</td><td>H</td><td>3.0</td><td>39.5</td><td>1.0</td><td>-62.8</td><td>-13.0</td><td>-49.8</td><td></td></tr> <tr><td>3.3460</td><td>-22.2</td><td>H</td><td>3.0</td><td>40.1</td><td>1.0</td><td>-61.3</td><td>-13.0</td><td>-48.3</td><td></td></tr> <tr><td colspan="10">High Channel (847.5MHz)</td></tr> <tr><td>1.6950</td><td>-13.3</td><td>V</td><td>3.0</td><td>39.1</td><td>1.0</td><td>-51.4</td><td>-13.0</td><td>-38.4</td><td></td></tr> <tr><td>2.5425</td><td>-22.9</td><td>V</td><td>3.0</td><td>39.6</td><td>1.0</td><td>-61.5</td><td>-13.0</td><td>-48.5</td><td></td></tr> <tr><td>3.3900</td><td>-21.6</td><td>V</td><td>3.0</td><td>40.2</td><td>1.0</td><td>-60.8</td><td>-13.0</td><td>-47.8</td><td></td></tr> <tr><td>1.6950</td><td>-16.5</td><td>H</td><td>3.0</td><td>39.1</td><td>1.0</td><td>-54.7</td><td>-13.0</td><td>-41.7</td><td></td></tr> <tr><td>2.5425</td><td>-23.1</td><td>H</td><td>3.0</td><td>39.6</td><td>1.0</td><td>-61.7</td><td>-13.0</td><td>-48.7</td><td></td></tr> <tr><td>3.3900</td><td>-21.5</td><td>H</td><td>3.0</td><td>40.2</td><td>1.0</td><td>-60.7</td><td>-13.0</td><td>-47.7</td><td></td></tr> </tbody> </table> <p>Rev. 03.03.09 Note: No other emissions were detected above the system noise floor.</p>	f GHz	SG reading (dBm)	Ant. Pol. (H/V)	Distance (m)	Preamp (dB)	Filter (dB)	EIRP (dBm)	Limit (dBm)	Delta (dB)	Notes	Low Channel (825.5MHz)										1.6510	-12.6	V	3.0	39.1	1.0	-50.7	-13.0	-37.7		2.4675	-21.5	V	3.0	39.5	1.0	-60.0	-13.0	-47.0		3.3020	-15.6	V	3.0	40.1	1.0	-54.7	-13.0	-41.7		1.6510	-8.7	H	3.0	39.1	1.0	-46.8	-13.0	-33.8		2.4675	-24.3	H	3.0	39.5	1.0	-62.9	-13.0	-49.9		3.3020	-19.8	H	3.0	40.1	1.0	-58.9	-13.0	-45.9		Mid Channel (836.5MHz)										1.6730	-16.1	V	3.0	39.1	1.0	-54.2	-13.0	-41.2		2.5090	-23.3	V	3.0	39.5	1.0	-61.8	-13.0	-48.8		3.3460	-21.3	V	3.0	40.1	1.0	-60.4	-13.0	-47.4		1.6730	-13.7	H	3.0	39.1	1.0	-51.9	-13.0	-38.9		2.5090	-24.3	H	3.0	39.5	1.0	-62.8	-13.0	-49.8		3.3460	-22.2	H	3.0	40.1	1.0	-61.3	-13.0	-48.3		High Channel (847.5MHz)										1.6950	-13.3	V	3.0	39.1	1.0	-51.4	-13.0	-38.4		2.5425	-22.9	V	3.0	39.6	1.0	-61.5	-13.0	-48.5		3.3900	-21.6	V	3.0	40.2	1.0	-60.8	-13.0	-47.8		1.6950	-16.5	H	3.0	39.1	1.0	-54.7	-13.0	-41.7		2.5425	-23.1	H	3.0	39.6	1.0	-61.7	-13.0	-48.7		3.3900	-21.5	H	3.0	40.2	1.0	-60.7	-13.0	-47.7	
f GHz	SG reading (dBm)	Ant. Pol. (H/V)	Distance (m)	Preamp (dB)	Filter (dB)	EIRP (dBm)	Limit (dBm)	Delta (dB)	Notes																																																																																																																																																																																																																				
Low Channel (825.5MHz)																																																																																																																																																																																																																													
1.6510	-12.6	V	3.0	39.1	1.0	-50.7	-13.0	-37.7																																																																																																																																																																																																																					
2.4675	-21.5	V	3.0	39.5	1.0	-60.0	-13.0	-47.0																																																																																																																																																																																																																					
3.3020	-15.6	V	3.0	40.1	1.0	-54.7	-13.0	-41.7																																																																																																																																																																																																																					
1.6510	-8.7	H	3.0	39.1	1.0	-46.8	-13.0	-33.8																																																																																																																																																																																																																					
2.4675	-24.3	H	3.0	39.5	1.0	-62.9	-13.0	-49.9																																																																																																																																																																																																																					
3.3020	-19.8	H	3.0	40.1	1.0	-58.9	-13.0	-45.9																																																																																																																																																																																																																					
Mid Channel (836.5MHz)																																																																																																																																																																																																																													
1.6730	-16.1	V	3.0	39.1	1.0	-54.2	-13.0	-41.2																																																																																																																																																																																																																					
2.5090	-23.3	V	3.0	39.5	1.0	-61.8	-13.0	-48.8																																																																																																																																																																																																																					
3.3460	-21.3	V	3.0	40.1	1.0	-60.4	-13.0	-47.4																																																																																																																																																																																																																					
1.6730	-13.7	H	3.0	39.1	1.0	-51.9	-13.0	-38.9																																																																																																																																																																																																																					
2.5090	-24.3	H	3.0	39.5	1.0	-62.8	-13.0	-49.8																																																																																																																																																																																																																					
3.3460	-22.2	H	3.0	40.1	1.0	-61.3	-13.0	-48.3																																																																																																																																																																																																																					
High Channel (847.5MHz)																																																																																																																																																																																																																													
1.6950	-13.3	V	3.0	39.1	1.0	-51.4	-13.0	-38.4																																																																																																																																																																																																																					
2.5425	-22.9	V	3.0	39.6	1.0	-61.5	-13.0	-48.5																																																																																																																																																																																																																					
3.3900	-21.6	V	3.0	40.2	1.0	-60.8	-13.0	-47.8																																																																																																																																																																																																																					
1.6950	-16.5	H	3.0	39.1	1.0	-54.7	-13.0	-41.7																																																																																																																																																																																																																					
2.5425	-23.1	H	3.0	39.6	1.0	-61.7	-13.0	-48.7																																																																																																																																																																																																																					
3.3900	-21.5	H	3.0	40.2	1.0	-60.7	-13.0	-47.7																																																																																																																																																																																																																					

		UL Korea, Ltd Suwon Laboratory Above 1GHz High Frequency Substitution Measurement									
LTE Band 5 1.4MHz QPSK		Company: Samsung									
		Project #: 16K23140									
		Date: 03-21-16									
		Test Engineer: Steven.Kim									
		Configuration: EUT / AC Adapter / Earphone, Z Position									
		Mode: TX, LTE BAND 5, 1.4MHz BW, QPSK									
		Chamber: Chamber 2		Pre-amplifier: AFS42		Filter: Filter 1		Limit: Part 22			
		f GHz	SG reading (dBm)	Ant. Pol. (H/V)	Distance (m)	Preamp (dB)	Filter (dB)	EIRP (dBm)	Limit (dBm)	Delta (dB)	Notes
		Low Channel (824.7MHz)									
		1.6494	-13.6	V	3.0	39.1	1.0	-51.7	-13.0	-38.7	
		2.4741	-22.2	V	3.0	39.5	1.0	-60.7	-13.0	-47.7	
		3.2988	-16.3	V	3.0	40.1	1.0	-55.4	-13.0	-42.4	
		1.6494	-8.6	H	3.0	39.1	1.0	-47.7	-13.0	-34.7	
		2.4741	-24.7	H	3.0	39.5	1.0	-63.2	-13.0	-50.2	
		3.2988	-20.4	H	3.0	40.1	1.0	-59.5	-13.0	-46.5	
		Mid Channel (836.5MHz)									
		1.6730	-16.8	V	3.0	39.1	1.0	-54.9	-13.0	-41.9	
		2.5090	-23.8	V	3.0	39.5	1.0	-62.4	-13.0	-49.4	
		3.3460	-21.6	V	3.0	40.1	1.0	-60.7	-13.0	-47.7	
		1.6730	-15.0	H	3.0	39.1	1.0	-53.2	-13.0	-40.2	
		2.5090	-24.8	H	3.0	39.5	1.0	-63.3	-13.0	-50.3	
		3.3460	-22.7	H	3.0	40.1	1.0	-61.9	-13.0	-48.9	
		High Channel (848.3MHz)									
		1.6966	-14.4	V	3.0	39.1	1.0	-52.6	-13.0	-39.6	
		2.5449	-23.8	V	3.0	39.6	1.0	-62.4	-13.0	-49.4	
		3.3932	-22.3	V	3.0	40.2	1.0	-61.5	-13.0	-48.5	
		1.6966	-17.1	H	3.0	39.1	1.0	-55.2	-13.0	-42.2	
		2.5449	-23.7	H	3.0	39.6	1.0	-62.3	-13.0	-49.3	
		3.3932	-21.9	H	3.0	40.2	1.0	-61.1	-13.0	-48.1	
		Rev. 03.03.09 Note: No other emissions were detected above the system noise floor.									
LTE Band 5 1.4MHz 16QAM		UL Korea, Ltd Suwon Laboratory Above 1GHz High Frequency Substitution Measurement									
		Company: Samsung									
		Project #: 16K23140									
		Date: 03-21-16									
		Test Engineer: Steven.Kim									
		Configuration: EUT / AC Adapter / Earphone, Z Position									
		Mode: TX, LTE BAND 5, 1.4MHz BW, 16QAM									
		Chamber: Chamber 2		Pre-amplifier: AFS42		Filter: Filter 1		Limit: Part 22			
		f GHz	SG reading (dBm)	Ant. Pol. (H/V)	Distance (m)	Preamp (dB)	Filter (dB)	EIRP (dBm)	Limit (dBm)	Delta (dB)	Notes
		Low Channel (824.7MHz)									
		1.6494	-13.3	V	3.0	39.1	1.0	-51.4	-13.0	-38.4	
		2.4741	-21.7	V	3.0	39.5	1.0	-60.2	-13.0	-47.2	
		3.2988	-15.7	V	3.0	40.1	1.0	-54.8	-13.0	-41.8	
		1.6494	-9.0	H	3.0	39.1	1.0	-47.1	-13.0	-34.1	
		2.4741	-24.2	H	3.0	39.5	1.0	-62.7	-13.0	-49.7	
		3.2988	-19.8	H	3.0	40.1	1.0	-58.9	-13.0	-45.9	
		Mid Channel (836.5MHz)									
		1.6730	-16.3	V	3.0	39.1	1.0	-54.4	-13.0	-41.4	
		2.5090	-23.3	V	3.0	39.5	1.0	-61.8	-13.0	-48.8	
		3.3460	-21.2	V	3.0	40.1	1.0	-60.3	-13.0	-47.3	
		1.6730	-14.7	H	3.0	39.1	1.0	-52.8	-13.0	-39.8	
		2.5090	-24.4	H	3.0	39.5	1.0	-63.0	-13.0	-50.0	
		3.3460	-22.3	H	3.0	40.1	1.0	-61.4	-13.0	-48.4	
		High Channel (848.3MHz)									
		1.6966	-13.9	V	3.0	39.1	1.0	-52.0	-13.0	-39.0	
		2.5449	-23.2	V	3.0	39.6	1.0	-61.8	-13.0	-48.8	
		3.3932	-21.8	V	3.0	40.2	1.0	-61.0	-13.0	-48.0	
		1.6966	-16.7	H	3.0	39.1	1.0	-54.8	-13.0	-41.8	
		2.5449	-23.1	H	3.0	39.6	1.0	-61.7	-13.0	-48.7	
		3.3932	-21.4	H	3.0	40.2	1.0	-60.5	-13.0	-47.5	
		Rev. 03.03.09 Note: No other emissions were detected above the system noise floor.									