



# PCTEST ENGINEERING LABORATORY, INC.

7185 Oakland Mills Road, Columbia, MD 21046 USA  
Tel. +1.410.290.6652 / Fax +1.410.290.6654  
http://www.pctestlab.com



## SAR EVALUATION REPORT

**Applicant Name:**  
Samsung Electronics Co., Ltd.  
129, Samsung-ro, Maetan dong,  
Yeongtong-gu, Suwon-si  
Gyeonggi-do, 16677, Korea

**Date of Testing:**  
11/17/2015 – 01/28/2016  
**Test Site/Location:**  
PCTEST Lab, Columbia, MD, USA  
**Document Serial No.:**  
OY1511191972-R2.A3L

**FCC ID:** A3LSMJ320A

**APPLICANT:** SAMSUNG ELECTRONICS CO., LTD.

**DUT Type:** Portable Handset  
**Application Type:** Certification  
**FCC Rule Part(s):** CFR §2.1093  
**Model(s):** SM-J320A

Equipment Class	Band & Mode	Tx Frequency	SAR		
			1 gm Head (W/kg)	1 gm Body-Worn (W/kg)	1 gm Hotspot (W/kg)
PCE	GSM/GPRS/EDGE 850	824.20 - 848.80 MHz	0.40	0.76	1.10
PCE	UMTS 850	826.40 - 846.60 MHz	0.41	0.60	0.60
PCE	UMTS 1750	1712.4 - 1752.6 MHz	0.66	0.84	0.87
PCE	GSM/GPRS/EDGE 1900	1850.20 - 1909.80 MHz	0.37	0.31	0.38
PCE	UMTS 1900	1852.4 - 1907.6 MHz	0.74	0.28	0.72
PCE	LTE Band 12	699.7 - 715.3 MHz	0.50	0.60	0.60
PCE	LTE Band 5 (Cell)	824.7 - 848.3 MHz	0.56	0.84	0.84
PCE	LTE Band 4 (AWS)	1710.7 - 1754.3 MHz	0.74	0.70	0.74
PCE	LTE Band 2 (PCS)	1850.7 - 1909.3 MHz	0.75	0.35	0.58
DTS	2.4 GHz WLAN	2412 - 2462 MHz	0.50	0.38	0.46
DSS/DTS	Bluetooth	2402 - 2480 MHz	N/A		
<b>Simultaneous SAR per KDB 690783 D01v01r03:</b>			1.24	1.22	1.56

Note: This revised Test Report (S/N: OY1511191972-R2.A3L) supersedes and replaces the previously issued test report on the same subject device for the same type of testing as indicated. Please discard or destroy the previously issued test report(s) and dispose of it accordingly.

This wireless portable device has been shown to be capable of compliance for localized specific absorption rate (SAR) for uncontrolled environment/general population exposure limits specified in ANSI/IEEE C95.1-1992 and has been tested in accordance with the measurement procedures specified in Section 1.7 of this report; for North American frequency bands only.

I attest to the accuracy of data. All measurements reported herein were performed by me or were made under my supervision and are correct to the best of my knowledge and belief. I assume full responsibility for the completeness of these measurements and vouch for the qualifications of all persons taking them. Test results reported herein relate only to the item(s) tested.

Randy Ortanez  
President





The SAR Tick is an initiative of the Mobile Manufacturers Forum (MMF). While a product may be considered eligible, use of the SAR Tick logo requires an agreement with the MMF. Further details can be obtained by emailing: sartick@mmfai.info.

FCC ID A3LSMJ320A		SAR EVALUATION REPORT		<b>Reviewed by:</b> Quality Manager
<b>Document S/N:</b> OY1511191972-R2.A3L	<b>Test Dates:</b> 11/17/2015 - 01/28/2016	<b>DUT Type:</b> Portable Handset	Page 1 of 63	

# T A B L E O F C O N T E N T S

1	DEVICE UNDER TEST .....	3
2	LTE INFORMATION .....	10
3	INTRODUCTION .....	11
4	DOSIMETRIC ASSESSMENT .....	12
5	DEFINITION OF REFERENCE POINTS .....	13
6	TEST CONFIGURATION POSITIONS FOR HANDSETS .....	14
7	RF EXPOSURE LIMITS .....	17
8	FCC MEASUREMENT PROCEDURES.....	18
9	RF CONDUCTED POWERS.....	23
10	SYSTEM VERIFICATION.....	43
11	SAR DATA SUMMARY .....	46
12	FCC MULTI-TX AND ANTENNA SAR CONSIDERATIONS.....	55
13	SAR MEASUREMENT VARIABILITY .....	58
14	EQUIPMENT LIST.....	59
15	MEASUREMENT UNCERTAINTIES .....	60
16	CONCLUSION.....	61
17	REFERENCES .....	62
APPENDIX A:	SAR TEST PLOTS	
APPENDIX B:	SAR DIPOLE VERIFICATION PLOTS	
APPENDIX C:	PROBE AND DIPOLE CALIBRATION CERTIFICATES	
APPENDIX D:	SAR TISSUE SPECIFICATIONS	
APPENDIX E:	SAR SYSTEM VALIDATION	
APPENDIX F:	DUT ANTENNA DIAGRAM & SAR TEST SETUP PHOTOGRAPHS	

FCC ID A3LSMJ320A		SAR EVALUATION REPORT		Reviewed by: Quality Manager
Document S/N: OY1511191972-R2.A3L	Test Dates: 11/17/2015 - 01/28/2016	DUT Type: Portable Handset		Page 2 of 63

# 1 DEVICE UNDER TEST

## 1.1 Device Overview



Band & Mode	Operating Modes	Tx Frequency
GSM/GPRS/EDGE 850	Voice/Data	824.20 - 848.80 MHz
UMTS 850	Voice/Data	826.40 - 846.60 MHz
UMTS 1750	Voice/Data	1712.4 - 1752.6 MHz
GSM/GPRS/EDGE 1900	Voice/Data	1850.20 - 1909.80 MHz
UMTS 1900	Voice/Data	1852.4 - 1907.6 MHz
LTE Band 12	Voice/Data	699.7 - 715.3 MHz
LTE Band 5 (Cell)	Voice/Data	824.7 - 848.3 MHz
LTE Band 4 (AWS)	Voice/Data	1710.7 - 1754.3 MHz
LTE Band 2 (PCS)	Voice/Data	1850.7 - 1909.3 MHz
2.4 GHz WLAN	Data	2412 - 2462 MHz
Bluetooth	Data	2402 - 2480 MHz

## 1.2 Power Reduction for SAR

This device utilizes a single step power reduction mechanism for SAR compliance under portable hotspot conditions for some wireless modes and bands. All hotspot SAR evaluations for this device were performed at the maximum allowed output power when hotspot is enabled. Detailed descriptions of the power reduction mechanism are included in the operational description.

This device uses an independent single-step fixed level power reduction mechanism for WLAN operations during voice or VoIP held to ear scenarios. Per FCC Guidance, the held-to-ear exposure conditions were evaluated at reduced power according to the head SAR positions described in IEEE 1528.

The reduced powers for the power reduction mechanisms were confirmed via conducted power measurements at the RF port (See Section 9). Detailed descriptions of the mechanisms are included in the operational description.

FCC ID A3LSMJ320A		SAR EVALUATION REPORT		Reviewed by: Quality Manager
Document S/N: OY1511191972-R2.A3L	Test Dates: 11/17/2015 - 01/28/2016	DUT Type: Portable Handset	Page 3 of 63	

### 1.3 Nominal and Maximum Output Power Specifications



This device operates using the following maximum and nominal output power specifications. SAR values were scaled to the maximum allowed power to determine compliance per KDB Publication 447498 D01v05r02.

#### A. Maximum Power:

Mode / Band		Voice (dBm)	Burst Average GMSK (dBm)		Burst Average 8-PSK (dBm)	
			1 TX Slot	1 TX Slots	2 TX Slots	1 TX Slots
GSM/GPRS/EDGE 850	Maximum	<b>33.5</b>	<b>33.5</b>	<b>32.5</b>	<b>28.0</b>	<b>26.0</b>
	Nominal	<b>33.0</b>	<b>33.0</b>	<b>32.0</b>	<b>27.5</b>	<b>25.5</b>
GSM/GPRS/EDGE 1900	Maximum	<b>30.5</b>	<b>30.5</b>	<b>28.0</b>	<b>27.0</b>	<b>25.0</b>
	Nominal	<b>30.0</b>	<b>30.0</b>	<b>27.5</b>	<b>26.5</b>	<b>24.5</b>

Mode / Band		Modulated Average (dBm)		
		3GPP WCDMA	3GPP HSDPA	3GPP HSUPA
UMTS Band 5 (850 MHz)	Maximum	<b>24.3</b>	<b>23.0</b>	<b>23.0</b>
	Nominal	<b>23.8</b>	<b>22.5</b>	<b>22.5</b>
UMTS Band 4 (1750 MHz)	Maximum	<b>23.2</b>	<b>23.0</b>	<b>23.0</b>
	Nominal	<b>22.7</b>	<b>22.5</b>	<b>22.5</b>
UMTS Band 2 (1900 MHz)	Maximum	<b>24.0</b>	<b>24.0</b>	<b>24.0</b>
	Nominal	<b>23.5</b>	<b>23.5</b>	<b>23.5</b>

Mode / Band		Modulated Average (dBm)
LTE Band 12	Maximum	<b>24.5</b>
	Nominal	<b>24.0</b>
LTE Band 5 (Cell)	Maximum	<b>24.5</b>
	Nominal	<b>24.0</b>
LTE Band 4 (AWS)	Maximum	<b>24.5</b>
	Nominal	<b>24.0</b>
LTE Band 2 (PCS)	Maximum	<b>24.3</b>
	Nominal	<b>23.8</b>

FCC ID A3LSMJ320A	 <b>PCTEST</b> Engineering Laboratory, Inc.	<b>SAR EVALUATION REPORT</b>		Reviewed by: Quality Manager
Document S/N: OY1511191972-R2.A3L	Test Dates: 11/17/2015 - 01/28/2016	DUT Type: Portable Handset		Page 4 of 63

**BT/WLAN – Maximum Power:**

Mode / Band		Modulated Average (dBm)
IEEE 802.11b (2.4 GHz)	Maximum	<b>16.5</b>
	Nominal	<b>16.0</b>
IEEE 802.11g (2.4 GHz)	Maximum	<b>15.0</b>
	Nominal	<b>14.5</b>
IEEE 802.11n (2.4 GHz)	Maximum	<b>14.0</b>
	Nominal	<b>13.5</b>
Bluetooth	Maximum	<b>9.0</b>
	Nominal	<b>8.5</b>
Bluetooth LE	Maximum	<b>8.5</b>
	Nominal	<b>8.0</b>

**B. Reduced Power:**

Mode / Band		Modulated Average (dBm)		
		3GPP WCDMA	3GPP HSDPA	3GPP HSUPA
UMTS Band 2 (1900 MHz)	Maximum	<b>23.0</b>	<b>23.0</b>	<b>23.0</b>
	Nominal	<b>22.5</b>	<b>22.5</b>	<b>22.5</b>

Mode / Band		Modulated Average (dBm)
LTE Band 4 (AWS)	Maximum	<b>22.5</b>
	Nominal	<b>22.0</b>
LTE Band 2 (PCS)	Maximum	<b>22.3</b>
	Nominal	<b>21.8</b>

**WLAN- Reduced Power- Held to Ear:**

Mode / Band		Modulated Average (dBm)
IEEE 802.11b (2.4 GHz)	Maximum	<b>10.5</b>
	Nominal	<b>10.0</b>
IEEE 802.11g (2.4 GHz)	Maximum	<b>11.5</b>
	Nominal	<b>11.0</b>
IEEE 802.11n (2.4 GHz)	Maximum	<b>11.5</b>
	Nominal	<b>11.0</b>

FCC ID A3LSMJ320A	 <b>SAR EVALUATION REPORT</b> 		Reviewed by: Quality Manager
Document S/N: OY1511191972-R2.A3L	Test Dates: 11/17/2015 - 01/28/2016	DUT Type: Portable Handset	Page 5 of 63



## 1.4 DUT Antenna Locations

The overall dimensions of this device are  $\geq 9 \times 5$  cm. The overall diagonal dimension of the device is  $\leq 160$  mm and the diagonal display is  $\leq 150$  mm. A diagram showing the location of the device antennas can be found in Appendix F.

**Table 1-1  
Device Edges/Sides for SAR Testing**

Mode	Back	Front	Top	Bottom	Right	Left
GPRS 850	Yes	Yes	No	Yes	Yes	Yes
UMTS 850	Yes	Yes	No	Yes	Yes	Yes
UMTS 1750	Yes	Yes	No	Yes	Yes	Yes
GPRS 1900	Yes	Yes	No	Yes	Yes	Yes
UMTS 1900	Yes	Yes	No	Yes	Yes	Yes
LTE Band 12	Yes	Yes	No	Yes	Yes	Yes
LTE Band 5 (Cell)	Yes	Yes	No	Yes	Yes	Yes
LTE Band 4 (AWS)	Yes	Yes	No	Yes	Yes	Yes
LTE Band 2 (PCS)	Yes	Yes	No	Yes	Yes	Yes
2.4 GHz WLAN	Yes	Yes	Yes	No	Yes	No

Note: Particular DUT edges were not required to be evaluated for wireless router SAR if the edges were greater than 2.5 cm from the transmitting antenna according to FCC KDB Publication 941225 D06v02 guidance, page 2. The distances between the transmit antennas and the edges of the device are included in the filing.

FCC ID A3LSMJ320A		SAR EVALUATION REPORT		Reviewed by: Quality Manager
Document S/N: OY1511191972-R2.A3L	Test Dates: 11/17/2015 - 01/28/2016	DUT Type: Portable Handset	Page 6 of 63	

## 1.5 Simultaneous Transmission Capabilities

According to FCC KDB Publication 447498 D01v05r02, transmitters are considered to be transmitting simultaneously when there is overlapping transmission, with the exception of transmissions during network hand-offs with maximum hand-off duration less than 30 seconds. Possible transmission paths for the DUT are shown in Figure 1-1 and are color-coded to indicate communication modes which share the same path. Modes which share the same transmission path cannot transmit simultaneously with one another.

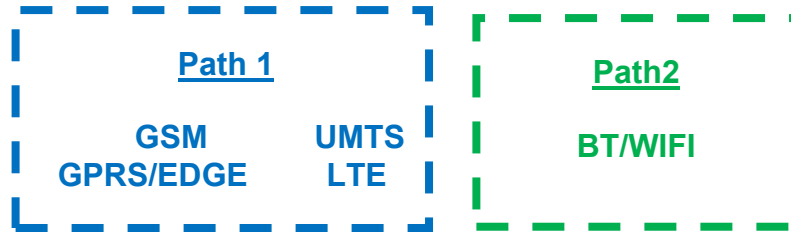



**Figure 1-1**  
**Simultaneous Transmission Paths**

This device contains multiple transmitters that may operate simultaneously, and therefore requires a simultaneous transmission analysis according to FCC KDB Publication 447498 D01v05r02 3) procedures.

**Table 1-2**  
**Simultaneous Transmission Scenarios**

No.	Capable Transmit Configuration	Head	Body-Worn Accessory	Wireless Router
1	GSM voice + 2.4 GHz WI-FI	Yes	Yes	N/A
2	GSM voice + 2.4 GHz Bluetooth	N/A	Yes	N/A
3	UMTS + 2.4 GHz WI-FI	Yes	Yes	Yes
4	UMTS + 2.4 GHz Bluetooth	N/A	Yes	N/A
5	LTE + 2.4 GHz WI-FI	Yes	Yes	Yes
6	LTE + 2.4 GHz Bluetooth	N/A	Yes	N/A
7	GPRS/EDGE + 2.4 GHz WI-FI	N/A	N/A	Yes

- 2.4 GHz WLAN, and 2.4 GHz Bluetooth share the same antenna path and cannot transmit simultaneously.
- All licensed modes share the same antenna path and cannot transmit simultaneously.
- When the user utilizes multiple services in UMTS 3G mode it uses multi-Radio Access Bearer or multi-RAB. The power control is based on a physical control channel (Dedicated Physical Control Channel [DPCCCH]) and power control will be adjusted to meet the needs of both services. Therefore, the UMTS+WLAN scenario also represents the UMTS Voice/DATA + WLAN Hotspot scenario.
- Per the manufacturer, WIFI Direct is not expected to be used in conjunction with a held-to-ear or body-worn accessory voice call. Therefore, there are no simultaneous transmission scenarios involving WIFI direct beyond that listed in the above table.
- This device supports VoLTE.

FCC ID A3LSMJ320A		SAR EVALUATION REPORT		Reviewed by: Quality Manager
Document S/N: OY1511191972-R2.A3L	Test Dates: 11/17/2015 - 01/28/2016	DUT Type: Portable Handset	Page 7 of 63	

## 1.6 Miscellaneous SAR Test Considerations

### (A) WIFI/BT

Per FCC KDB 447498 D01v05r02, the 1g SAR exclusion threshold for distances <50mm is defined by the following equation:

$$\frac{\text{Max Power of Channel (mW)}}{\text{Test Separation Dist (mm)}} * \sqrt{\text{Frequency(GHz)}} \leq 3.0$$

Based on the maximum conducted power of Bluetooth (rounded to the nearest mW) and the antenna to user separation distance, body-worn Bluetooth SAR was not required;  $[(8/15) * \sqrt{2.480}] = 0.8 < 3.0$ . Per KDB Publication 447498 D01v05r02, the maximum power of the channel was rounded to the nearest mW before calculation.

### (B) Licensed Transmitter(s)

GSM/GPRS/EDGE DTM is not supported for US bands. Therefore, the GSM Voice modes in this report do not transmit simultaneously with GPRS/EDGE Data.



This device is only capable of QPSK HSUPA in the uplink. Therefore, no additional SAR tests are required beyond that described for devices with HSUPA in KDB 941225 D01v03.

LTE SAR for the higher modulations and lower bandwidths were not tested since the maximum average output power of all required channels and configurations was not more than 0.5 dB higher than the highest bandwidth; and the reported LTE SAR for the highest bandwidth was less than 1.45 W/kg for all configurations according to FCC KDB 941225 D05v02r03.

This device supports LTE Carrier Aggregation (CA) in the downlink only. All uplink communications are identical to Release 8 specifications. Per FCC KDB Publication 941225 D05A v01r01, SAR for LTE CA operations was not needed since the maximum average output power in LTE CA mode was not >0.25 dB higher than the maximum output power when downlink carrier aggregation was inactive.

## 1.7 Guidance Applied



- IEEE 1528-2013
- FCC KDB Publication 941225 D01v03, D05v02r03, D05Av01r01, D06v02 (2G/3G/4G and Hotspot)
- FCC KDB Publication 248227 D01v02r01 (SAR Considerations for 802.11 Devices)
- FCC KDB Publication 447498 D01v05r02 (General SAR Guidance)
- FCC KDB Publication 865664 D01v01r04, D02v01r01 (SAR Measurements up to 6 GHz)
- October 2013 TCB Workshop Notes (GPRS Testing Considerations)

FCC ID A3LSMJ320A		SAR EVALUATION REPORT		Reviewed by: Quality Manager
Document S/N: OY1511191972-R2.A3L	Test Dates: 11/17/2015 - 01/28/2016	DUT Type: Portable Handset		Page 8 of 63

## 1.8 Device Serial Numbers

Several samples with identical hardware were used to support SAR testing. The manufacturer has confirmed that the device(s) tested have the same physical, mechanical and thermal characteristics and are within operational tolerances expected for production units.



	Head Serial Number	Body-Worn Serial Number	Hotspot Serial Number
GSM/GPRS/EDGE 850	03061	08102	08102
UMTS 850	62364	62364	62364
UMTS 1750	56721	08102	08102
GSM/GPRS/EDGE 1900	03061	03061	03061
UMTS 1900	62364	08102	03384
LTE Band 12	56721	56721	56721
LTE Band 5 (Cell)	62364	62364	62364
LTE Band 4 (AWS)	08102	08102	03087
LTE Band 2 (PCS)	62364	08102	03087
2.4 GHz WLAN	08102	08102	08102

FCC ID A3LSMJ320A	 <b>PCTEST</b> ENGINEERING LABORATORY, INC.	<b>SAR EVALUATION REPORT</b>		<b>Reviewed by:</b> Quality Manager
<b>Document S/N:</b> OY1511191972-R2.A3L	<b>Test Dates:</b> 11/17/2015 - 01/28/2016	<b>DUT Type:</b> Portable Handset		Page 9 of 63

## 2

## LTE INFORMATION

LTE Information			
<b>FCC ID</b>	<b>A3LSMJ320A</b>		
Form Factor	Portable Handset		
Frequency Range of each LTE transmission band	LTE Band 12 (699.7 - 715.3 MHz)		
	LTE Band 5 (Cell) (824.7 - 848.3 MHz)		
	LTE Band 4 (AWS) (1710.7 - 1754.3 MHz)		
	LTE Band 2 (PCS) (1850.7 - 1909.3 MHz)		
Channel Bandwidths	LTE Band 12: 1.4 MHz, 3 MHz, 5 MHz, 10 MHz		
	LTE Band 5 (Cell): 1.4 MHz, 3 MHz, 5 MHz, 10 MHz		
	LTE Band 4 (AWS): 1.4 MHz, 3 MHz, 5 MHz, 10 MHz, 15 MHz, 20 MHz		
	LTE Band 2 (PCS): 1.4 MHz, 3 MHz, 5 MHz, 10 MHz, 15 MHz, 20 MHz		
Channel Numbers and Frequencies (MHz)	Low	Mid	High
LTE Band 12: 1.4 MHz	699.7 (23017)	707.5 (23095)	715.3 (23173)
LTE Band 12: 3 MHz	700.5 (23025)	707.5 (23095)	714.5 (23165)
LTE Band 12: 5 MHz	701.5 (23035)	707.5 (23095)	713.5 (23155)
LTE Band 12: 10 MHz	704 (23060)	707.5 (23095)	711 (23130)
LTE Band 5 (Cell): 1.4 MHz	824.7 (20407)	836.5 (20525)	848.3 (20643)
LTE Band 5 (Cell): 3 MHz	825.5 (20415)	836.5 (20525)	847.5 (20635)
LTE Band 5 (Cell): 5 MHz	826.5 (20425)	836.5 (20525)	846.5 (20625)
LTE Band 5 (Cell): 10 MHz	829 (20450)	836.5 (20525)	844 (20600)
LTE Band 4 (AWS): 1.4 MHz	1710.7 (19957)	1732.5 (20175)	1754.3 (20393)
LTE Band 4 (AWS): 3 MHz	1711.5 (19965)	1732.5 (20175)	1753.5 (20385)
LTE Band 4 (AWS): 5 MHz	1712.5 (19975)	1732.5 (20175)	1752.5 (20375)
LTE Band 4 (AWS): 10 MHz	1715 (20000)	1732.5 (20175)	1750 (20350)
LTE Band 4 (AWS): 15 MHz	1717.5 (20025)	1732.5 (20175)	1747.5 (20325)
LTE Band 4 (AWS): 20 MHz	1720 (20050)	1732.5 (20175)	1745 (20300)
LTE Band 2 (PCS): 1.4 MHz	1850.7 (18607)	1880 (18900)	1909.3 (19193)
LTE Band 2 (PCS): 3 MHz	1851.5 (18615)	1880 (18900)	1908.5 (19185)
LTE Band 2 (PCS): 5 MHz	1852.5 (18625)	1880 (18900)	1907.5 (19175)
LTE Band 2 (PCS): 10 MHz	1855 (18650)	1880 (18900)	1905 (19150)
LTE Band 2 (PCS): 15 MHz	1857.5 (18675)	1880 (18900)	1902.5 (19125)
LTE Band 2 (PCS): 20 MHz	1860 (18700)	1880 (18900)	1900 (19100)
UE Category	4		
Modulations Supported in UL	QPSK, 16QAM		
LTE MPR Permanently implemented per 3GPP TS 36.101 section 6.2.3~6.2.5? (manufacturer attestation to be provided)	YES		
A-MPR (Additional MPR) disabled for SAR Testing?	YES		
LTE Carrier Aggregation Possible Combinations	The technical description includes all the possible carrier aggregation combinations		
LTE Release 10 Additional Information	This device does not support full CA features on 3GPP Release 10. It supports a maximum of 2 carriers in the downlink. All uplink communications are identical to the Release 8 Specifications. Uplink communications are done on the PCC. The following LTE Release 10 Features are not supported: Relay, HetNet, Enhanced MIMO, eICl, WIFI Offloading, MDH, eMBMA, Cross-Carrier Scheduling, Enhanced SC-FDMA.		

FCC ID A3LSMJ320A		<b>SAR EVALUATION REPORT</b>		<b>Reviewed by:</b> Quality Manager
<b>Document S/N:</b> OY1511191972-R2.A3L	<b>Test Dates:</b> 11/17/2015 - 01/28/2016	<b>DUT Type:</b> Portable Handset	Page 10 of 63	

### 3 INTRODUCTION

The FCC and Industry Canada have adopted the guidelines for evaluating the environmental effects of radio frequency (RF) radiation in ET Docket 93-62 on Aug. 6, 1996 and Health Canada Safety Code 6 to protect the public and workers from the potential hazards of RF emissions due to FCC-regulated portable devices. [1]

The safety limits used for the environmental evaluation measurements are based on the criteria published by the American National Standards Institute (ANSI) for localized specific absorption rate (SAR) in IEEE/ANSI C95.1-1992 Standard for Safety Levels with Respect to Human Exposure to Radio Frequency Electromagnetic Fields, 3 kHz to 300 GHz [3] and Health Canada RF Exposure Guidelines Safety Code 6 [22]. The measurement procedure described in IEEE/ANSI C95.3-2002 Recommended Practice for the Measurement of Potentially Hazardous Electromagnetic Fields - RF and Microwave [4] is used for guidance in measuring the Specific Absorption Rate (SAR) due to the RF radiation exposure from the Equipment Under Test (EUT). These criteria for SAR evaluation are similar to those recommended by the International Committee for Non-Ionizing Radiation Protection (ICNIRP) in Biological Effects and Exposure Criteria for Radiofrequency Electromagnetic Fields,” Report No. Vol 74. SAR is a measure of the rate of energy absorption due to exposure to an RF transmitting source. SAR values have been related to threshold levels for potential biological hazards.

#### 3.1 SAR Definition

Specific Absorption Rate is defined as the time derivative (rate) of the incremental energy (dU) absorbed by (dissipated in) an incremental mass (dm) contained in a volume element (dV) of a given density (ρ). It is also defined as the rate of RF energy absorption per unit mass at a point in an absorbing body (see Equation 3-1).

**Equation 3-1  
SAR Mathematical Equation**

$$SAR = \frac{d}{dt} \left( \frac{dU}{dm} \right) = \frac{d}{dt} \left( \frac{dU}{\rho dv} \right)$$



**SAR is expressed in units of Watts per Kilogram (W/kg).**

$$SAR = \frac{\sigma \cdot E^2}{\rho}$$

where:

- σ = conductivity of the tissue-simulating material (S/m)
- ρ = mass density of the tissue-simulating material (kg/m<sup>3</sup>)
- E = Total RMS electric field strength (V/m)

NOTE: The primary factors that control rate of energy absorption were found to be the wavelength of the incident field in relation to the dimensions and geometry of the irradiated organism, the orientation of the organism in relation to the polarity of field vectors, the presence of reflecting surfaces, and whether conductive contact is made by the organism with a ground plane.[6]

FCC ID A3LSMJ320A		SAR EVALUATION REPORT		Reviewed by: Quality Manager
Document S/N: 0Y1511191972-R2.A3L	Test Dates: 11/17/2015 - 01/28/2016	DUT Type: Portable Handset	Page 11 of 63	

## 4 DOSIMETRIC ASSESSMENT

### 4.1 Measurement Procedure

The evaluation was performed using the following procedure compliant to FCC KDB Publication 865664 D01v01r04 and IEEE 1528-2013:

1. The SAR distribution at the exposed side of the head or body was measured at a distance no greater than 5.0 mm from the inner surface of the shell. The area covered the entire dimension of the device-head and body interface and the horizontal grid resolution was determined per FCC KDB Publication 865664 D01v01r04 (See Table 4-1) and IEEE 1528-2013.
2. The point SAR measurement was taken at the maximum SAR region determined from Step 1 to enable the monitoring of SAR fluctuations/drifts during the 1g/10g cube evaluation. SAR at this fixed point was measured and used as a reference value.
3. Based on the area scan data, the peak of the region with maximum SAR was determined by spline interpolation. Around this point, a volume was assessed according to the measurement resolution and volume size requirements of FCC KDB Publication 865664 D01v01r04 (See Table 4-1) and IEEE 1528-2013. On the basis of this data set, the spatial peak SAR value was evaluated with the following procedure (see references or the DASy manual online for more details):
  - a. SAR values at the inner surface of the phantom are extrapolated from the measured values along the line away from the surface with spacing no greater than that in Table 4-1. The extrapolation was based on a least-squares algorithm. A polynomial of the fourth order was calculated through the points in the z-axis (normal to the phantom shell).
  - b. After the maximum interpolated values were calculated between the points in the cube, the SAR was averaged over the spatial volume (1g or 10g) using a 3D-Spline interpolation algorithm. The 3D-spline is composed of three one-dimensional splines with the “Not a knot” condition (in x, y, and z directions). The volume was then integrated with the trapezoidal algorithm. One thousand points (10 x 10 x 10) were obtained through interpolation, in order to calculate the averaged SAR.
  - c. All neighboring volumes were evaluated until no neighboring volume with a higher average value was found.
4. The SAR reference value, at the same location as step 2, was re-measured after the zoom scan was complete to calculate the SAR drift. If the drift deviated by more than 5%, the SAR test and drift measurements were repeated.

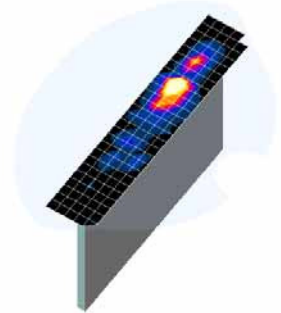



**Figure 4-1**  
Sample SAR Area Scan

**Table 4-1**  
Area and Zoom Scan Resolutions per FCC KDB Publication 865664 D01v01r04\*

Frequency	Maximum Area Scan Resolution (mm) ( $\Delta x_{\text{area}}, \Delta y_{\text{area}}$ )	Maximum Zoom Scan Resolution (mm) ( $\Delta x_{\text{zoom}}, \Delta y_{\text{zoom}}$ )	Maximum Zoom Scan Spatial Resolution (mm)			Minimum Zoom Scan Volume (mm) (x, y, z)
			Uniform Grid $\Delta z_{\text{zoom}}(n)$	Graded Grid		
				$\Delta z_{\text{zoom}}(1)^*$	$\Delta z_{\text{zoom}}(n>1)^*$	
≤ 2 GHz	≤ 15	≤ 8	≤ 5	≤ 4	≤ 1.5* $\Delta z_{\text{zoom}}(n-1)$	≥ 30
2-3 GHz	≤ 12	≤ 5	≤ 5	≤ 4	≤ 1.5* $\Delta z_{\text{zoom}}(n-1)$	≥ 30
3-4 GHz	≤ 12	≤ 5	≤ 4	≤ 3	≤ 1.5* $\Delta z_{\text{zoom}}(n-1)$	≥ 28
4-5 GHz	≤ 10	≤ 4	≤ 3	≤ 2.5	≤ 1.5* $\Delta z_{\text{zoom}}(n-1)$	≥ 25
5-6 GHz	≤ 10	≤ 4	≤ 2	≤ 2	≤ 1.5* $\Delta z_{\text{zoom}}(n-1)$	≥ 22

\*Also compliant to IEEE 1528-2013 Table 6

FCC ID A3LSMJ320A		SAR EVALUATION REPORT		Reviewed by: Quality Manager
Document S/N: OY1511191972-R2.A3L	Test Dates: 11/17/2015 - 01/28/2016	DUT Type: Portable Handset		Page 12 of 63

# 5 DEFINITION OF REFERENCE POINTS

## 5.1 EAR REFERENCE POINT

Figure 5-2 shows the front, back and side views of the SAM Twin Phantom. The point “M” is the reference point for the center of the mouth, “LE” is the left ear reference point (ERP), and “RE” is the right ERP. The ERP is 15mm posterior to the entrance to the ear canal (EEC) along the B-M line (Back-Mouth), as shown in Figure 5-1. The plane passing through the two ear canals and M is defined as the Reference Plane. The line N-F (Neck-Front), also called the Reference Pivoting Line, is not perpendicular to the reference plane (see Figure 5-1). Line B-M is perpendicular to the N-F line. Both N-F and B-M lines are marked on the external phantom shell to facilitate handset positioning [5].

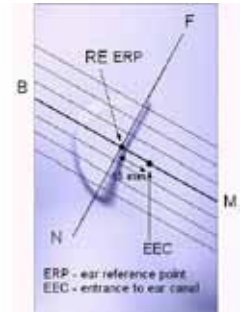

**Figure 5-1**  
Close-Up Side view of ERP

## 5.2 HANDSET REFERENCE POINTS



Two imaginary lines on the handset were established: the vertical centerline and the horizontal line. The test device was placed in a normal operating position with the acoustic output located along the “vertical centerline” on the front of the device aligned to the “ear reference point” (See Figure 5-3). The acoustic output was then located at the same level as the center of the ear reference point. The test device was positioned so that the “vertical centerline” was bisecting the front surface of the handset at its top and bottom edges, positioning the “ear reference point” on the outer surface of the both the left and right head phantoms on the ear reference point.

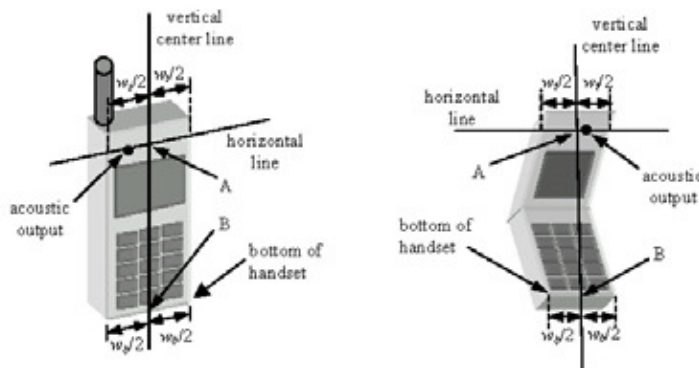

**Figure 5-2**  
Front, back and side view of SAM Twin Phantom



**Figure 5-3**  
Handset Vertical Center & Horizontal Line Reference Points

FCC ID A3LSMJ320A		SAR EVALUATION REPORT		Reviewed by: Quality Manager
Document S/N: OY1511191972-R2.A3L	Test Dates: 11/17/2015 - 01/28/2016	DUT Type: Portable Handset		Page 13 of 63

## 6 TEST CONFIGURATION POSITIONS FOR HANDSETS

### 6.1 Device Holder

The device holder is made out of low-loss POM material having the following dielectric parameters: relative permittivity  $\epsilon = 3$  and loss tangent  $\delta = 0.02$ .

### 6.2 Positioning for Cheek

1. The test device was positioned with the device close to the surface of the phantom such that point A is on the (virtual) extension of the line passing through points RE and LE on the phantom (see Figure 6-1), such that the plane defined by the vertical center line and the horizontal line of the phone is approximately parallel to the sagittal plane of the phantom.

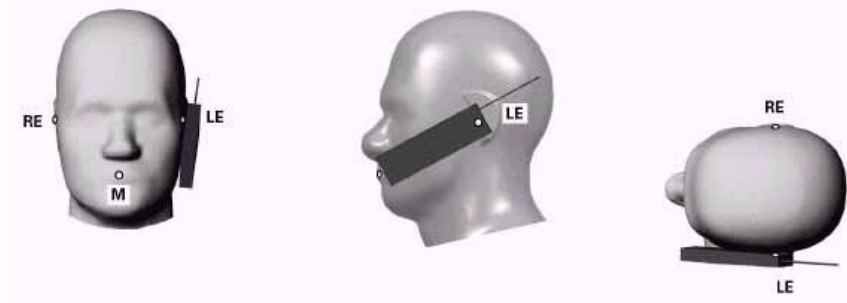



Figure 6-1 Front, Side and Top View of Cheek Position

2. The handset was translated towards the phantom along the line passing through RE & LE until the handset touches the pinna.
3. While maintaining the handset in this plane, the handset was rotated around the LE-RE line until the vertical centerline was in the reference plane.
4. The phone was then rotated around the vertical centerline until the phone (horizontal line) was symmetrical with respect to the line NF.
5. While maintaining the vertical centerline in the reference plane, keeping point A on the line passing through RE and LE, and maintaining the device contact with the ear, the device was rotated about the NF line until any point on the handset made contact with a phantom point below the ear (cheek) (See Figure 6-2).

### 6.3 Positioning for Ear / 15° Tilt

With the test device aligned in the “Cheek Position”:

1. While maintaining the orientation of the phone, the phone was retracted parallel to the reference plane far enough to enable a rotation of the phone by 15 degrees.
2. The phone was then rotated around the horizontal line by 15 degrees.
3. While maintaining the orientation of the phone, the phone was moved parallel to the reference plane until any part of the handset touched the head. (In this position, point A was located on the line RE-LE). The tilted position is obtained when the contact is on the pinna. If the contact was at any location other than the pinna, the angle of the phone would then be reduced. In this situation, the tilted position was obtained when any part of the phone was in contact of the ear as well as a second part of the phone was in contact with the head (see Figure 6-2).

FCC ID A3LSMJ320A		SAR EVALUATION REPORT		Reviewed by: Quality Manager
Document S/N: OY1511191972-R2.A3L	Test Dates: 11/17/2015 - 01/28/2016	DUT Type: Portable Handset		Page 14 of 63



**Figure 6-2 Front, Side and Top View of Ear/15° Tilt Position**

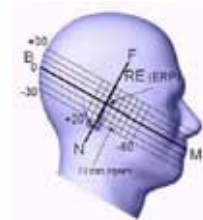

**Figure 6-3 Side view w/ relevant markings**

## 6.4 Body-Worn Accessory Configurations

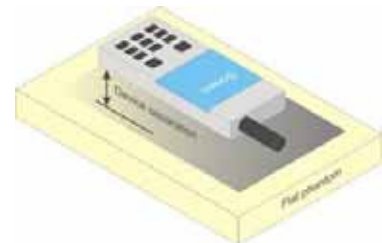

Body-worn operating configurations are tested with the belt-clips and holsters attached to the device and positioned against a flat phantom in a normal use configuration (see Figure 6-4). Per FCC KDB Publication 648474 D04v01r02, Body-worn accessory exposure is typically related to voice mode operations when handsets are carried in body-worn accessories. The body-worn accessory procedures in FCC KDB Publication 447498 D01v05r02 should be used to test for body-worn accessory SAR compliance, without a headset connected to it. This enables the test results for such configuration to be compatible with that required for hotspot mode when the body-worn accessory test separation distance is greater than or equal to that required for hotspot mode, when applicable. When the reported SAR for a body-worn accessory, measured without a headset connected to the handset, is  $> 1.2 \text{ W/kg}$ , the highest reported SAR configuration for that wireless mode and frequency band should be repeated for that body-worn accessory with a headset attached to the handset.



**Figure 6-4 Sample Body-Worn Diagram**

Accessories for Body-worn operation configurations are divided into two categories: those that do not contain metallic components and those that do contain metallic components. When multiple accessories that do not contain metallic components are supplied with the device, the device is tested with only the accessory that dictates the closest spacing to the body. Then multiple accessories that contain metallic components are tested with the device with each accessory. If multiple accessories share an identical metallic component (i.e. the same metallic belt-clip used with different holsters with no other metallic components) only the accessory that dictates the closest spacing to the body is tested.

Body-worn accessories may not always be supplied or available as options for some devices intended to be authorized for body-worn use. In this case, a test configuration with a separation distance between the back of the device and the flat phantom is used. Test position spacing was documented. Transmitters that are designed to operate in front of a person's face, as in push-to-talk configurations, are tested for SAR compliance with the front of the device positioned to face the flat phantom in head fluid. For devices that are carried next to the body such as a shoulder, waist or chest-worn transmitters, SAR compliance is tested with the accessories, including headsets and microphones, attached to the device and positioned against a flat phantom in a normal use configuration.

FCC ID A3LSMJ320A		SAR EVALUATION REPORT		Reviewed by: Quality Manager
Document S/N: OY1511191972-R2.A3L	Test Dates: 11/17/2015 - 01/28/2016	DUT Type: Portable Handset		Page 15 of 63

## 6.5 Extremity Exposure Configurations



Devices that are designed or intended for use on extremities or mainly operated in extremity only exposure conditions; i.e., hands, wrists, feet and ankles, may require extremity SAR evaluation. When the device also operates in close proximity to the user's body, SAR compliance for the body is also required. The 1-g body and 10-g extremity SAR Exclusion Thresholds found in KDB Publication 447498 D01v05r02 should be applied to determine SAR test requirements.

Per KDB Publication 447498 D01v05r02, Cell phones (handsets) are not normally designed to be used on extremities or operated in extremity only exposure conditions. The maximum output power levels of handsets generally do not require extremity SAR testing to show compliance. Therefore, extremity SAR was not evaluated for this device.

## 6.6 Wireless Router Configurations

Some battery-operated handsets have the capability to transmit and receive user data through simultaneous transmission of WIFI simultaneously with a separate licensed transmitter. The FCC has provided guidance in FCC KDB Publication 941225 D06v02 where SAR test considerations for handsets ( $L \times W \geq 9 \text{ cm} \times 5 \text{ cm}$ ) are based on a composite test separation distance of 10 mm from the front, back and edges of the device containing transmitting antennas within 2.5 cm of their edges, determined from general mixed use conditions for this type of devices. Since the hotspot SAR results may overlap with the body-worn accessory SAR requirements, the more conservative configurations can be considered, thus excluding some body-worn accessory SAR tests.

When the user enables the personal wireless router functions for the handset, actual operations include simultaneous transmission of both the WIFI transmitter and another licensed transmitter. Both transmitters often do not transmit at the same transmitting frequency and thus cannot be evaluated for SAR under actual use conditions due to the limitations of the SAR assessment probes. Therefore, SAR must be evaluated for each frequency transmission and mode separately and spatially summed with the WIFI transmitter according to FCC KDB Publication 447498 D01v05r02 procedures. The "Portable Hotspot" feature on the handset was NOT activated during SAR assessments, to ensure the SAR measurements were evaluated for a single transmission frequency RF signal at a time.

FCC ID A3LSMJ320A	 <b>SAR EVALUATION REPORT</b> 		<b>Reviewed by:</b> Quality Manager
Document S/N: OY1511191972-R2.A3L	Test Dates: 11/17/2015 - 01/28/2016	DUT Type: Portable Handset	Page 16 of 63

# 7 RF EXPOSURE LIMITS

## 7.1 Uncontrolled Environment

UNCONTROLLED ENVIRONMENTS are defined as locations where there is the exposure of individuals who have no knowledge or control of their exposure. The general population/uncontrolled exposure limits are applicable to situations in which the general public may be exposed or in which persons who are exposed as a consequence of their employment may not be made fully aware of the potential for exposure or cannot exercise control over their exposure. Members of the general public would come under this category when exposure is not employment-related; for example, in the case of a wireless transmitter that exposes persons in its vicinity.



## 7.2 Controlled Environment

CONTROLLED ENVIRONMENTS are defined as locations where there is exposure that may be incurred by persons who are aware of the potential for exposure, (i.e. as a result of employment or occupation). In general, occupational/controlled exposure limits are applicable to situations in which persons are exposed as a consequence of their employment, who have been made fully aware of the potential for exposure and can exercise control over their exposure. This exposure category is also applicable when the exposure is of a transient nature due to incidental passage through a location where the exposure levels may be higher than the general population/uncontrolled limits, but the exposed person is fully aware of the potential for exposure and can exercise control over his or her exposure by leaving the area or by some other appropriate means.

**Table 7-1  
SAR Human Exposure Specified in ANSI/IEEE C95.1-1992 and Health Canada Safety Code 6**

HUMAN EXPOSURE LIMITS		
	UNCONTROLLED ENVIRONMENT <i>General Population</i> (W/kg) or (mW/g)	CONTROLLED ENVIRONMENT <i>Occupational</i> (W/kg) or (mW/g)
<b>Peak Spatial Average SAR</b> Head	1.6	8.0
<b>Whole Body SAR</b>	0.08	0.4
<b>Peak Spatial Average SAR</b> Hands, Feet, Ankle, Wrists, etc.	4.0	20

1. The Spatial Peak value of the SAR averaged over any 1 gram of tissue (defined as a tissue volume in the shape of a cube) and over the appropriate averaging time.
2. The Spatial Average value of the SAR averaged over the whole body.
3. The Spatial Peak value of the SAR averaged over any 10 grams of tissue (defined as a tissue volume in the shape of a cube) and over the appropriate averaging time.

FCC ID A3LSMJ320A		SAR EVALUATION REPORT		Reviewed by: Quality Manager
Document S/N: OY1511191972-R2.A3L	Test Dates: 11/17/2015 - 01/28/2016	DUT Type: Portable Handset	Page 17 of 63	

# 8

# FCC MEASUREMENT PROCEDURES



Power measurements for licensed transmitters are performed using a base station simulator under digital average power.

## 8.1 Measured and Reported SAR

Per FCC KDB Publication 447498 D01v05r02, when SAR is not measured at the maximum power level allowed for production units, the results must be scaled to the maximum tune-up tolerance limit according to the power applied to the individual channels tested to determine compliance. For simultaneous transmission, the measured aggregate SAR must be scaled according to the sum of the differences between the maximum tune-up tolerance and actual power used to test each transmitter. When SAR is measured at or scaled to the maximum tune-up tolerance limit, the results are referred to as *reported* SAR. The highest *reported* SAR results are identified on the grant of equipment authorization according to procedures in KDB 690783 D01v01r03.

## 8.2 3G SAR Test Reduction Procedure

In FCC KDB Publication 941225 D01v03, certain transmission modes within a frequency band and wireless mode evaluated for SAR are defined as primary modes. The equivalent modes considered for SAR test reduction are denoted as secondary modes. When the maximum output power including tune-up tolerance specified for production units in a secondary mode is

FCC ID A3LSMJ320A		SAR EVALUATION REPORT		Reviewed by: Quality Manager
Document S/N: 0Y1511191972-R2.A3L	Test Dates: 11/17/2015 - 01/28/2016	DUT Type: Portable Handset		Page 18 of 63

## 8.4 SAR Measurement Conditions for UMTS

### 8.4.1 Output Power Verification

Maximum output power is verified on the High, Middle and Low channels according to the general descriptions in section 5.2 of 3GPP TS 34.121, using the appropriate RMC with TPC (transmit power control) set to all "1s" or applying the required inner loop power control procedures to maintain maximum output power while HSUPA is active. Results for all applicable physical channel configurations (DPCCH, DPDCH<sub>n</sub> and spreading codes, HS-DPCCH etc) are tabulated in this test report. All configurations that are not supported by the DUT or cannot be measured due to technical or equipment limitations are identified.

### 8.4.2 Head SAR Measurements

SAR for next to the ear head exposure is measured using a 12.2 kbps RMC with TPC bits configured to all "1's". The 3G SAR test reduction procedure is applied to AMR configurations with 12.2 kbps RMC as the primary mode. Otherwise, SAR is measured for 12.2 kbps AMR in 3.4 kbps SRB (signaling radio bearer) using the highest reported SAR configuration in 12.2 kbps RMC for head exposure.

### 8.4.3 Body SAR Measurements

SAR for body exposure configurations is measured using the 12.2 kbps RMC with the TPC bits all "1s". The 3G SAR test reduction procedure is applied to other spreading codes and multiple DPDCH<sub>n</sub> configurations supported by the handset with 12.2 kbps RMC as the primary mode. Otherwise, SAR is measured using an applicable RMC configuration with the corresponding spreading code or DPDCH<sub>n</sub>, for the highest reported SAR configuration in 12.2 kbps RMC.



### 8.4.4 SAR Measurements with Rel 5 HSDPA

The 3G SAR test reduction procedure is applied to HSDPA body configurations with 12.2 kbps RMC as the primary mode. Otherwise, Body SAR for HSDPA is measured using an FRC with H-Set 1 in Sub-test 1 and a 12.2 kbps RMC configured in Test Loop Mode 1, for the highest reported SAR configuration in 12.2 kbps RMC without HSDPA. Handsets with both HSDPA and HSUPA are tested according to Release 6 HSPA test procedures.

### 8.4.5 SAR Measurements with Rel 6 HSUPA

The 3G SAR test reduction procedure is applied to HSPA (HSUPA/HSDPA with RMC) body configurations with 12.2 kbps RMC as the primary mode. Otherwise, Body SAR for HSPA is measured with E-DCH Sub-test 5, using H-Set 1 and QPSK for FRC and a 12.2 kbps RMC configured in Test Loop Mode 1 and power control algorithm 2, according to the highest reported body SAR configuration in 12.2 kbps RMC without HSPA.

When VOIP applies to head exposure, the 3G SAR test reduction procedure is applied with 12.2 kbps RMC as the primary mode; otherwise, the same HSPA configuration used for body SAR measurements are applied to head exposure testing.

FCC ID A3LSMJ320A		SAR EVALUATION REPORT		Reviewed by: Quality Manager
Document S/N: OY1511191972-R2.A3L	Test Dates: 11/17/2015 - 01/28/2016	DUT Type: Portable Handset		Page 19 of 63

## 8.5 SAR Measurement Conditions for LTE

LTE modes are tested according to FCC KDB 941225 D05v02r03 publication. Establishing connections with base station simulators ensure a consistent means for testing SAR and are recommended for evaluating SAR [4]. The R&S CMW500 or Anritsu MT8820C simulators are used for LTE output power measurements and SAR testing. Closed loop power control was used so the UE transmits with maximum output power during SAR testing. SAR tests were performed with the same number of RB and RB offsets transmitting on all TTI frames (maximum TTI).

### 8.5.1 Spectrum Plots for RB Configurations

A properly configured base station simulator was used for SAR tests and power measurements. Therefore, spectrum plots for RB configurations were not required to be included in this report.

### 8.5.2 MPR

MPR is permanently implemented for this device by the manufacturer. The specific manufacturer target MPR is indicated alongside the SAR results. MPR is enabled for this device, according to 3GPP TS36.101 Section 6.2.3 – 6.2.5 under Table 6.2.3-1.



### 8.5.3 A-MPR

A-MPR (Additional MPR) has been disabled for all SAR tests by setting NS=01 on the base station simulator.

### 8.5.4 Required RB Size and RB Offsets for SAR Testing

According to FCC KDB 941225 D05v02r03:

- a. Per Section 4.2.1, SAR is required for QPSK 1 RB Allocation for the largest bandwidth
  - i. The required channel and offset combination with the highest maximum output power is required for SAR.
  - ii. When the reported SAR is  $\leq 0.8$  W/kg, testing of the remaining RB offset configurations and required test channels is not required. Otherwise, SAR is required for the remaining required test channels using the RB offset configuration with highest output power for that channel.
  - iii. When the reported SAR for a required test channel is  $> 1.45$  W/kg, SAR is required for all RB offset configurations for that channel.
- b. Per Section 4.2.2, SAR is required for 50% RB allocation using the largest bandwidth following the same procedures outlined in Section 4.2.1.
- c. Per Section 4.2.3, QPSK SAR is not required for the 100% allocation when the highest maximum output power for the 100% allocation is less than the highest maximum output power of the 1 RB and 50% RB allocations and the reported SAR for the 1 RB and 50% RB allocations is  $< 0.8$  W/kg.
- d. Per Section 4.2.4 and 4.3, SAR tests for higher order modulations and lower bandwidths configurations are not required when the conducted power of the required test configurations determined by Sections 4.2.1 through 4.2.3 is less than or equal to  $\frac{1}{2}$  dB higher than the equivalent configuration using QPSK modulation and when the QPSK SAR for those configurations is  $< 1.45$  W/kg.

FCC ID A3LSMJ320A	 PCTEST Engineering Laboratory, Inc.	SAR EVALUATION REPORT	 SAMSUNG	Reviewed by: Quality Manager
Document S/N: OY1511191972-R2.A3L	Test Dates: 11/17/2015 - 01/28/2016	DUT Type: Portable Handset		Page 20 of 63

### 8.5.5 Downlink Carrier Aggregation

LTE Carrier Aggregation (CA) measurements are made in accordance to 3GPP TS 36.521-1 V10.4.0 (2012-12). The RRC connection is only handled by one cell, the Primary component carrier (PCC) for downlink and uplink communications. After making a data connection to the PCC, the UE device adds the Secondary component carrier (SCC) on the downlink only. All uplink communications and acknowledgements remain identical to release 8 specifications on the PCC. Additional output powers are measured using two carriers in the downlink for the release 8 configurations with the highest output power among all channels, RB configurations and bandwidths for each uplink band. Per FCC KDB Publication 941225 D05A v01r01, no SAR measurements are required when the average output power with downlink carrier aggregation active is not more than 0.25 dB higher than the average output power with downlink carrier aggregation inactive.

### 8.6 SAR Testing with 802.11 Transmitters

The normal network operating configurations of 802.11 transmitters are not suitable for SAR measurements. Unpredictable fluctuations in network traffic and antenna diversity conditions can introduce undesirable variations in SAR results. The SAR for these devices should be measured using chipset based test mode software to ensure the results are consistent and reliable. See KDB Publication 248227 D01v02r01 for more details.



#### 8.6.1 General Device Setup

Chipset based test mode software is hardware dependent and generally varies among manufacturers. The device operating parameters established in test mode for SAR measurements must be identical to those programmed in production units, including output power levels, amplifier gain settings and other RF performance tuning parameters.

A periodic duty factor is required for current generation SAR systems to measure SAR. When 802.11 frame gaps are accounted for in the transmission, a maximum transmission duty factor of 92 - 96% is typically achievable in most test mode configurations. A minimum transmission duty factor of 85% is required to avoid certain hardware and device implementation issues related to wide range SAR scaling. The reported SAR is scaled to 100% transmission duty factor to determine compliance at the maximum tune-up tolerance limit.

#### 8.6.2 Initial Test Position Procedure

For exposure conditions with multiple test positions, such as handset operating next to the ear, devices with hotspot mode or UMPC mini-tablet, procedures for initial test position can be applied. Using the transmission mode determined by the DSSS procedure or initial test configuration, area scans are measured for all positions in an exposure condition. The test position with the highest extrapolated (peak) SAR is used as the initial test position. When reported SAR for the initial test position is  $\leq 0.4$  W/kg, no additional testing for the remaining test positions is required. Otherwise, SAR is evaluated at the subsequent highest peak SAR positions until the reported SAR result is  $\leq 0.8$  W/kg or all test positions are measured.

FCC ID A3LSMJ320A	 PCTEST Engineering Laboratory, Inc.	SAR EVALUATION REPORT		Reviewed by: Quality Manager
Document S/N: OY1511191972-R2.A3L	Test Dates: 11/17/2015 - 01/28/2016	DUT Type: Portable Handset		Page 21 of 63

### 8.6.3 2.4 GHz SAR Test Requirements

SAR is measured for 2.4 GHz 802.11b DSSS using either the fixed test position or, when applicable, the initial test position procedure. SAR test reduction is determined according to the following:

- 1) When the reported SAR of the highest measured maximum output power channel for the exposure configuration is  $\leq 0.8$  W/kg, no further SAR testing is required for 802.11b DSSS in that exposure configuration.
- 2) When the reported SAR is  $> 0.8$  W/kg, SAR is required for that position using the next highest measured output power channel. When any reported SAR is  $> 1.2$  W/kg, SAR is required for the third channel; i.e., all channels require testing.

2.4 GHz 802.11 g/n OFDM are additionally evaluated for SAR if the highest reported SAR for 802.11b, adjusted by the ratio of the OFDM to DSSS specified maximum output power, is  $> 1.2$  W/kg. When SAR is required for OFDM modes in 2.4 GHz band, the Initial Test Configuration Procedures should be followed.

### 8.6.4 OFDM Transmission Mode and SAR Test Channel Selection

For the 2.4 GHz, when the same maximum output power was specified for multiple OFDM transmission mode configurations in a frequency band or aggregated band, SAR is measured using the configuration with the largest channel bandwidth, lowest order modulation and lowest data rate. When the maximum output power of a channel is the same for equivalent OFDM configurations; for example, 802.11g and 802.11n with the same channel bandwidth, modulation and data rate etc., the lower order 802.11 mode i.e., 802.11g then 802.11n, is used for SAR measurement. When the maximum output power are the same for multiple test channels, either according to the default or additional power measurement requirements, SAR is measured using the channel closest to the middle of the frequency band or aggregated band. When there are multiple channels with the same maximum output power, SAR is measured using the higher number channel.



### 8.6.5 Initial Test Configuration Procedure

For OFDM, in both 2.4 Ghz bands, an initial test configuration is determined for each frequency band and aggregated band, according to the transmission mode with the highest maximum output power specified for SAR measurements. When the same maximum output power is specified for multiple OFDM transmission mode configurations in a frequency band or aggregated band, SAR is measured using the configuration(s) with the largest channel bandwidth, lowest order modulation, lowest data rate and lowest order IEEE 802.11 mode. The channel of the transmission mode with the highest average RF output conducted power will be the initial test configuration.

When the reported SAR is  $\leq 0.8$  W/kg, no additional measurements on other test channels are required. Otherwise, SAR is evaluated using the subsequent highest average RF output channel until the reported SAR result is  $\leq 1.2$  W/kg or all channels are measured. When there are multiple untested channels having the same subsequent highest average RF output power, the channel with higher frequency from the lowest 802.11 mode is considered for SAR measurements (See Section 8.6.4).

### 8.6.6 Subsequent Test Configuration Procedures

For OFDM configurations in each frequency band and aggregated band, SAR is evaluated for initial test configuration using the fixed test position or the initial test position procedure. When the highest reported SAR (for the initial test configuration), adjusted by the ratio of the specified maximum output power of the subsequent test configuration to initial test configuration, is  $\leq 1.2$  W/kg, no additional SAR tests for the subsequent test configurations are required.

FCC ID A3LSMJ320A		SAR EVALUATION REPORT		Reviewed by: Quality Manager
Document S/N: OY1511191972-R2.A3L	Test Dates: 11/17/2015 - 01/28/2016	DUT Type: Portable Handset		Page 22 of 63

# 9 RF CONDUCTED POWERS

## 9.1 GSM Conducted Powers

		Maximum Burst-Averaged Output Power				
		Voice	GPRS/EDGE Data (GMSK)		EDGE Data (8-PSK)	
Band	Channel	GSM [dBm] CS (1 Slot)	GPRS [dBm] 1 Tx Slot	GPRS [dBm] 2 Tx Slot	EDGE [dBm] 1 Tx Slot	EDGE [dBm] 2 Tx Slot
GSM 850	128	32.88	32.96	<b>31.95</b>	27.36	25.37
	190	32.82	32.89	<b>31.90</b>	27.11	25.13
	251	32.86	32.95	<b>31.85</b>	27.28	25.44
GSM 1900	512	29.34	29.67	<b>27.35</b>	26.28	24.34
	661	29.38	29.71	<b>27.39</b>	26.31	24.29
	810	29.41	29.76	<b>27.37</b>	26.41	24.23
GSM 850	Targets:	33.0	33.0	<b>32.0</b>	27.5	25.5
GSM 1900		30.0	30.0	<b>27.5</b>	26.5	24.5
		Calculated Maximum Frame-Averaged Output Power				
		Voice	GPRS/EDGE Data (GMSK)		EDGE Data (8-PSK)	
Band	Channel	GSM [dBm] CS (1 Slot)	GPRS [dBm] 1 Tx Slot	GPRS [dBm] 2 Tx Slot	EDGE [dBm] 1 Tx Slot	EDGE [dBm] 2 Tx Slot
GSM 850	128	23.85	23.93	<b>25.93</b>	18.33	19.35
	190	23.79	23.86	<b>25.88</b>	18.08	19.11
	251	23.83	23.92	<b>25.83</b>	18.25	19.42
GSM 1900	512	20.31	20.64	<b>21.33</b>	17.25	18.32
	661	20.35	20.68	<b>21.37</b>	17.28	18.27
	810	20.38	20.73	<b>21.35</b>	17.38	18.21
GSM 850	Frame Avg. Targets:	23.97	23.97	<b>25.98</b>	18.47	19.48
GSM 1900		20.97	20.97	<b>21.48</b>	17.47	18.48



Note:

- Both burst-averaged and calculated frame-averaged powers are included. Frame-averaged power was calculated from the measured burst-averaged power by converting the slot powers into linear units and calculating the energy over 8 timeslots.
- GPRS/EDGE (GMSK) output powers were measured with coding scheme setting of 1 (CS1) on the base station simulator. CS1 was configured to measure GPRS output power measurements and SAR to ensure GMSK modulation in the signal. Our Investigation has shown that CS1 - CS4 settings do not have any impact on the output levels or modulation in the GPRS modes.
- EDGE (8-PSK) output powers were measured with MCS7 on the base station simulator. MCS7 coding scheme was used to measure the output powers for EDGE since investigation has shown that choosing MCS7 coding scheme will ensure 8-PSK modulation. It has been shown that MCS levels that produce 8PSK modulation do not have an impact on output power.

**GSM Class: B**  
**GPRS Multislot class: 10 (Max 2 Tx uplink slots)**  
**EDGE Multislot class: 10 (Max 2 Tx uplink slots)**  
**DTM Multislot Class: N/A**



**Figure 9-1**  
**Power Measurement Setup**

FCC ID A3LSMJ320A		SAR EVALUATION REPORT		Reviewed by: Quality Manager
Document S/N: OY1511191972-R2.A3L	Test Dates: 11/17/2015 - 01/28/2016	DUT Type: Portable Handset	Page 23 of 63	

## 9.2 UMTS Conducted Powers

### A. Maximum UMTS Conducted Powers

Mode	3GPP 34.121 Subtest	Cellular Band [dBm]			AWS Band [dBm]			PCS Band [dBm]			3GPP MPR [dB]
		4132	4183	4233	1312	1412	1513	9262	9400	9538	
WCDMA	12.2 kbps RMC	23.52	23.48	23.41	22.29	22.35	22.28	23.11	22.94	22.96	-
	12.2 kbps AMR	23.33	23.26	23.31	22.28	22.36	22.27	22.99	22.95	22.94	-
HSDPA	Subtest 1	22.81	22.79	22.67	22.28	22.32	22.20	23.09	22.94	22.79	0
	Subtest 2	22.56	22.72	22.73	22.09	22.03	22.09	22.76	22.87	22.66	0
	Subtest 3	21.04	21.09	21.06	22.08	22.07	22.16	21.79	21.85	21.67	0.5
	Subtest 4	22.09	22.26	22.21	21.61	21.58	21.63	22.31	22.33	22.19	0.5
HSUPA	Subtest 1	21.61	21.63	21.49	21.57	21.61	21.50	22.47	22.22	22.38	0
	Subtest 2	20.37	20.42	20.24	20.26	20.25	20.29	21.17	21.33	21.15	2
	Subtest 3	20.89	20.99	20.90	21.63	21.69	21.56	22.31	22.24	22.21	1
	Subtest 4	20.13	20.19	20.23	20.37	20.34	20.39	21.26	21.40	21.22	2
	Subtest 5	22.88	22.86	22.71	22.50	22.48	22.42	23.24	23.10	23.13	0

### B. Reduced UMTS Conducted Powers- Hotspot Mode Active



Mode	3GPP 34.121 Subtest	PCS Band [dBm]			3GPP MPR [dB]
		9262	9400	9538	
WCDMA	12.2 kbps RMC	22.78	22.47	22.49	-
	12.2 kbps AMR	22.69	22.50	22.53	-
HSDPA	Subtest 1	22.40	22.18	22.20	0
	Subtest 2	21.33	21.21	21.14	0
	Subtest 3	21.90	21.74	21.65	0.5
	Subtest 4	20.87	20.73	20.65	0.5
HSUPA	Subtest 1	22.04	21.94	21.98	0
	Subtest 2	20.93	20.81	20.72	2
	Subtest 3	21.48	21.27	21.34	1
	Subtest 4	20.98	20.78	20.71	2
	Subtest 5	22.41	22.19	22.24	0

This device does not support DC-HSDPA.

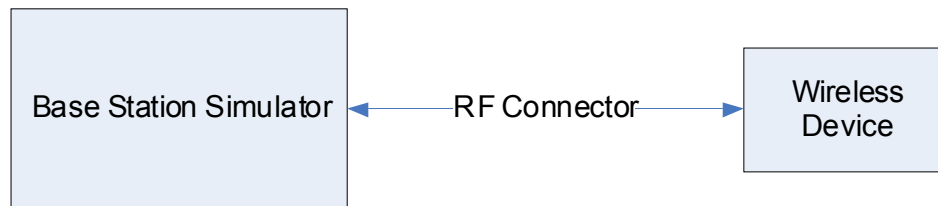
It is expected by the manufacturer that MPR for some HSPA subtests may be up to 2 dB more than specified by 3GPP, but also as low as 0 dB according to the chipset implementation in this model.



**Figure 9-2**  
**Power Measurement Setup**

FCC ID A3LSMJ320A		SAR EVALUATION REPORT		Reviewed by: Quality Manager
Document S/N: OY1511191972-R2.A3L	Test Dates: 11/17/2015 - 01/28/2016	DUT Type: Portable Handset		Page 24 of 63

## 9.3 LTE Conducted Powers

### 9.3.1 LTE Band 12



**Table 9-1  
LTE Band 12 Conducted Powers - 10 MHz Bandwidth**

LTE Band 12 10 MHz Bandwidth					
Modulation	RB Size	RB Offset	Mid Channel	MPR Allowed per 3GPP [dB]	MPR [dB]
			23095 (707.5 MHz)		
			Conducted Power [dBm]		
QPSK	1	0	23.57	0	0
	1	25	23.48		0
	1	49	23.49		0
	25	0	22.79	0-1	1
	25	12	22.72		1
	25	25	22.72		1
	50	0	22.77		1
16QAM	1	0	22.18	0-1	1
	1	25	22.09		1
	1	49	22.10		1
	25	0	21.76	0-2	2
	25	12	21.73		2
	25	25	21.68		2
	50	0	21.77		2

Note: LTE Band 12 at 10 MHz bandwidth does not support three non-overlapping channels. Per KDB Publication 941225 D05v02, when a device supports overlapping channel assignment in a channel bandwidth configuration, the middle channel of the group of overlapping channels should be selected for testing.

**Table 9-2  
LTE Band 12 Conducted Powers - 5 MHz Bandwidth**

LTE Band 12 5 MHz Bandwidth							
Modulation	RB Size	RB Offset	Low Channel	Mid Channel	High Channel	MPR Allowed per 3GPP [dB]	MPR [dB]
			23035 (701.5 MHz)	23095 (707.5 MHz)	23155 (713.5 MHz)		
			Conducted Power [dBm]	Conducted Power [dBm]	Conducted Power [dBm]		
QPSK	1	0	23.51	23.47	23.65	0	0
	1	12	23.58	23.42	23.53		0
	1	24	23.56	23.41	23.52		0
	12	0	22.65	22.68	22.70	0-1	1
	12	6	22.76	22.59	22.63		1
	12	13	22.72	22.60	22.60		1
	25	0	22.66	22.63	22.74		1
16QAM	1	0	22.04	22.13	21.91	0-1	1
	1	12	22.00	22.08	21.82		1
	1	24	22.03	22.06	21.83		1
	12	0	21.59	21.70	21.67	0-2	2
	12	6	21.68	21.61	21.58		2
	12	13	21.64	21.65	21.64		2
	25	0	21.60	21.66	21.67		2



FCC ID A3LSMJ320A		SAR EVALUATION REPORT		Reviewed by: Quality Manager
Document S/N: OY1511191972-R2.A3L	Test Dates: 11/17/2015 - 01/28/2016	DUT Type: Portable Handset		Page 25 of 63

**Table 9-3**  
**LTE Band 12 Conducted Powers - 3 MHz Bandwidth**

LTE Band 12 3 MHz Bandwidth							
Modulation	RB Size	RB Offset	Low Channel	Mid Channel	High Channel	MPR Allowed per 3GPP [dB]	MPR [dB]
			23025 (700.5 MHz)	23095 (707.5 MHz)	23165 (714.5 MHz)		
			Conducted Power [dBm]				
QPSK	1	0	23.68	23.46	23.61	0	0
	1	7	23.69	23.49	23.64		0
	1	14	23.74	23.45	23.47		0
	8	0	22.73	22.70	22.79	0-1	1
	8	4	22.75	22.61	22.81		1
	8	7	22.77	22.57	22.78		1
	15	0	22.62	22.66	22.81		1
16QAM	1	0	22.31	22.28	22.07	0-1	1
	1	7	22.27	22.14	22.11		1
	1	14	22.30	22.17	22.08		1
	8	0	21.63	21.66	21.81	0-2	2
	8	4	21.76	21.57	21.82		2
	8	7	21.80	21.56	21.82		2
	15	0	21.69	21.66	21.78		2

**Table 9-4**  
**LTE Band 12 Conducted Powers -1.4 MHz Bandwidth**

LTE Band 12 1.4 MHz Bandwidth							
Modulation	RB Size	RB Offset	Low Channel	Mid Channel	High Channel	MPR Allowed per 3GPP [dB]	MPR [dB]
			23017 (699.7 MHz)	23095 (707.5 MHz)	23173 (715.3 MHz)		
			Conducted Power [dBm]				
QPSK	1	0	23.63	23.61	23.67	0	0
	1	2	23.63	23.58	23.65		0
	1	5	23.72	23.66	23.48		0
	3	0	23.28	23.28	23.49		0
	3	2	23.37	23.23	23.46		0
	3	3	23.34	23.22	23.38		0
	6	0	22.76	22.60	22.74	0-1	1
16QAM	1	0	22.08	22.04	22.36	0-1	1
	1	2	22.06	22.06	22.31		1
	1	5	22.03	22.03	22.32		1
	3	0	21.81	21.72	21.86		1
	3	2	21.79	21.71	21.89		1
	3	3	21.80	21.69	21.82		1
	6	0	21.68	21.58	21.69	0-2	2

FCC ID A3LSMJ320A	 <b>PCTEST</b> <small>ENGINEERING LABORATORY, INC.</small>	<b>SAR EVALUATION REPORT</b>		<b>Reviewed by:</b> Quality Manager
<b>Document S/N:</b> OY1511191972-R2.A3L	<b>Test Dates:</b> 11/17/2015 - 01/28/2016	<b>DUT Type:</b> Portable Handset		Page 26 of 63

### 9.3.2 LTE Band 5 (Cell)



**Table 9-5  
LTE Band 5 (Cell) Conducted Powers - 10 MHz Bandwidth**

LTE Band 5 (Cell) 10 MHz Bandwidth					
Modulation	RB Size	RB Offset	Mid Channel	MPR Allowed per 3GPP [dB]	MPR [dB]
			20525 (836.5 MHz)		
			Conducted Power [dBm]		
QPSK	1	0	23.50	0	0
	1	25	<b>23.51</b>		0
	1	49	23.31		0
	25	0	<b>22.71</b>	0-1	1
	25	12	22.62		1
	25	25	22.61		1
16QAM	50	0	22.63	0-1	1
	1	0	22.46		1
	1	25	22.40		1
	1	49	22.31	0-2	1
	25	0	21.60		2
	25	12	21.52		2
	25	25	21.52		2
	50	0	21.63	2	

Note: LTE Band 5 (Cell) at 10 MHz bandwidth does not support three non-overlapping channels. Per KDB Publication 941225 D05v02, when a device supports overlapping channel assignment in a channel bandwidth configuration, the middle channel of the group of overlapping channels should be selected for testing.

**Table 9-6  
LTE Band 5 (Cell) Conducted Powers - 5 MHz Bandwidth**

LTE Band 5 (Cell) 5 MHz Bandwidth								
Modulation	RB Size	RB Offset	Low Channel	Mid Channel	High Channel	MPR Allowed per 3GPP [dB]	MPR [dB]	
			20425 (826.5 MHz)	20525 (836.5 MHz)	20625 (846.5 MHz)			
			Conducted Power [dBm]					
QPSK	1	0	23.48	23.48	23.53	0	0	
	1	12	23.47	23.49	23.54		0	
	1	24	23.53	23.40	22.94		0	
	QPSK	12	0	22.75	22.58	22.42	0-1	1
		12	6	22.66	22.61	22.57		1
		12	13	22.68	22.55	22.41		1
		25	0	22.80	22.57	22.57		1
16QAM	1	0	22.57	22.46	22.29	0-1	1	
	1	12	22.56	22.42	22.16		1	
	1	24	22.61	22.38	22.11		1	
	16QAM	12	0	21.63	21.55	21.51	0-2	2
		12	6	21.56	21.49	21.56		2
		12	13	21.53	21.47	21.47		2
		25	0	21.64	21.57	21.53		2



FCC ID A3LSMJ320A		SAR EVALUATION REPORT		Reviewed by: Quality Manager
Document S/N: OY1511191972-R2.A3L	Test Dates: 11/17/2015 - 01/28/2016	DUT Type: Portable Handset		Page 27 of 63

**Table 9-7**  
**LTE Band 5 (Cell) Conducted Powers - 3 MHz Bandwidth**

LTE Band 5 (Cell) 3 MHz Bandwidth							
Modulation	RB Size	RB Offset	Low Channel	Mid Channel	High Channel	MPR Allowed per 3GPP [dB]	MPR [dB]
			20415 (825.5 MHz)	20525 (836.5 MHz)	20635 (847.5 MHz)		
			Conducted Power [dBm]				
QPSK	1	0	23.74	23.52	23.42	0	0
	1	7	23.68	23.58	23.37		0
	1	14	23.76	23.55	22.83		0
	8	0	22.77	22.70	22.51	0-1	1
	8	4	22.66	22.64	22.44		1
	8	7	22.65	22.60	22.45		1
	15	0	22.77	22.62	22.59		1
16QAM	1	0	22.62	22.63	22.60	0-1	1
	1	7	22.55	22.61	22.46		1
	1	14	22.53	22.53	22.37		1
	8	0	21.64	21.58	21.54	0-2	2
	8	4	21.53	21.65	21.40		2
	8	7	21.63	21.61	21.45		2
	15	0	21.77	21.64	21.49		2

**Table 9-8**  
**LTE Band 5 (Cell) Conducted Powers -1.4 MHz Bandwidth**

LTE Band 5 (Cell) 1.4 MHz Bandwidth							
Modulation	RB Size	RB Offset	Low Channel	Mid Channel	High Channel	MPR Allowed per 3GPP [dB]	MPR [dB]
			20407 (824.7 MHz)	20525 (836.5 MHz)	20643 (848.3 MHz)		
			Conducted Power [dBm]				
QPSK	1	0	23.72	23.53	23.44	0	0
	1	2	23.64	23.58	23.36		0
	1	5	23.66	23.58	23.02		0
	3	0	23.41	23.27	23.22		0
	3	2	23.39	23.33	23.07		0
	3	3	23.31	23.28	23.08		0
	6	0	22.84	22.65	22.57	0-1	1
16QAM	1	0	22.73	22.61	22.38	0-1	1
	1	2	22.67	22.51	22.27		1
	1	5	22.72	22.66	22.33		1
	3	0	22.26	22.16	22.08		1
	3	2	22.23	22.24	21.93		1
	3	3	22.21	22.21	21.94		1
	6	0	21.74	21.61	21.51	0-2	2

FCC ID A3LSMJ320A	 <b>PCTEST</b> Engineering Laboratory, Inc.	<b>SAR EVALUATION REPORT</b>		<b>Reviewed by:</b> Quality Manager
<b>Document S/N:</b> OY1511191972-R2.A3L	<b>Test Dates:</b> 11/17/2015 - 01/28/2016	<b>DUT Type:</b> Portable Handset		Page 28 of 63

### 9.3.3 LTE Band 4 (AWS)



**Table 9-9  
LTE Band 4 (AWS) Maximum Conducted Powers - 20 MHz Bandwidth**

LTE Band 4 (AWS) 20 MHz Bandwidth					
Modulation	RB Size	RB Offset	Mid Channel	MPR Allowed per 3GPP [dB]	MPR [dB]
			20175 (1732.5 MHz)		
			Conducted Power [dBm]		
QPSK	1	0	23.63	0	0
	1	50	<b>23.81</b>		0
	1	99	23.59		0
	50	0	22.03	0-1	1
	50	25	<b>22.18</b>		1
	50	50	22.05		1
	100	0	22.15		1
16QAM	1	0	22.35	1	1
	1	50	22.28		1
	1	99	22.33		1
	50	0	21.08	0-2	2
	50	25	21.11		2
	50	50	21.00		2
	100	0	21.06		2

Note: LTE Band 4 (AWS) at 20 MHz bandwidth does not support three non-overlapping channels. Per KDB Publication 941225 D05v02, when a device supports overlapping channel assignment in a channel bandwidth configuration, the middle channel of the group of overlapping channels should be selected for testing.

**Table 9-10  
LTE Band 4 (AWS) Maximum Conducted Powers - 15 MHz Bandwidth**

LTE Band 4 (AWS) 15 MHz Bandwidth							
Modulation	RB Size	RB Offset	Low Channel	Mid Channel	Frequency [MHz]	MPR Allowed per 3GPP [dB]	MPR [dB]
			20025 (1717.5 MHz)	20175 (1732.5 MHz)	20325 (1747.5 MHz)		
			Conducted Power [dBm]				
QPSK	1	0	23.50	23.52	23.24	0	0
	1	36	23.61	23.60	23.32		0
	1	74	23.49	23.50	23.34		0
	36	0	22.04	22.01	22.05	0-1	1
	36	18	22.20	22.12	22.05		1
	36	37	22.08	22.06	22.04		1
	75	0	22.07	22.04	22.04		1
16QAM	1	0	22.54	22.46	22.26	0-1	1
	1	36	22.60	22.60	22.36		1
	1	74	22.51	22.52	22.29		1
	36	0	21.01	21.00	20.95	0-2	2
	36	18	21.05	21.01	20.92		2
	36	37	21.04	20.98	20.91		2
	75	0	20.94	20.92	21.00		2



FCC ID A3LSMJ320A		<b>SAR EVALUATION REPORT</b>		Reviewed by: Quality Manager
Document S/N: OY1511191972-R2.A3L	Test Dates: 11/17/2015 - 01/28/2016	DUT Type: Portable Handset		Page 29 of 63

**Table 9-11**  
**LTE Band 4 (AWS) Maximum Conducted Powers - 10 MHz Bandwidth**

LTE Band 4 (AWS) 10 MHz Bandwidth							
Modulation	RB Size	RB Offset	Low Channel	Mid Channel	High Channel	MPR Allowed per 3GPP [dB]	MPR [dB]
			20000 (1715.0 MHz)	20175 (1732.5 MHz)	20350 (1750.0 MHz)		
			Conducted Power [dBm]				
QPSK	1	0	23.53	23.53	23.27	0	0
	1	25	23.70	23.59	23.42		0
	1	49	23.59	23.52	23.43		0
	25	0	22.01	22.03	22.10	0-1	1
	25	12	22.12	22.17	22.02		1
	25	25	22.11	22.06	21.95		1
	50	0	22.05	22.07	22.07		1
16QAM	1	0	22.43	22.56	22.30	0-1	1
	1	25	22.51	22.48	22.26		1
	1	49	22.40	22.53	22.34		1
	25	0	21.04	20.88	21.08	0-2	2
	25	12	21.13	21.02	21.10		2
	25	25	21.14	20.93	21.03		2
	50	0	21.03	20.99	21.05		2

**Table 9-12**  
**LTE Band 4 (AWS) Maximum Conducted Powers - 5 MHz Bandwidth**

LTE Band 4 (AWS) 5 MHz Bandwidth							
Modulation	RB Size	RB Offset	Low Channel	Mid Channel	High Channel	MPR Allowed per 3GPP [dB]	MPR [dB]
			19975 (1712.5 MHz)	20175 (1732.5 MHz)	20375 (1752.5 MHz)		
			Conducted Power [dBm]				
QPSK	1	0	23.45	23.64	23.26	0	0
	1	12	23.58	23.67	23.20		0
	1	24	23.60	23.62	23.31		0
	12	0	22.09	22.11	21.97	0-1	1
	12	6	22.14	22.09	21.91		1
	12	13	22.17	22.11	21.91		1
	25	0	22.08	22.09	21.94		1
16QAM	1	0	22.68	22.38	22.21	0-1	1
	1	12	22.70	22.39	22.27		1
	1	24	22.72	22.42	22.28		1
	12	0	20.98	21.14	20.79	0-2	2
	12	6	20.99	21.13	20.72		2
	12	13	21.03	21.17	20.71		2
	25	0	20.93	20.97	20.89		2



FCC ID A3LSMJ320A		<b>SAR EVALUATION REPORT</b>		<b>Reviewed by:</b> Quality Manager
<b>Document S/N:</b> OY1511191972-R2.A3L	<b>Test Dates:</b> 11/17/2015 - 01/28/2016	<b>DUT Type:</b> Portable Handset		Page 30 of 63

**Table 9-13**  
**LTE Band 4 (AWS) Maximum Conducted Powers - 3 MHz Bandwidth**

LTE Band 4 (AWS) 3 MHz Bandwidth							
Modulation	RB Size	RB Offset	Frequency [MHz]	Frequency [MHz]	Frequency [MHz]	MPR Allowed per 3GPP [dB]	MPR [dB]
			19965 (1711.5 MHz)	20175 (1732.5 MHz)	20385 (1753.5 MHz)		
			Conducted Power [dBm]				
QPSK	1	0	23.57	23.67	23.39	0	0
	1	7	23.61	23.59	23.33		0
	1	14	23.69	23.67	23.43		0
	8	0	22.10	22.11	22.00	0-1	1
	8	4	22.08	22.07	21.93		1
	8	7	22.17	22.11	21.96		1
16QAM	15	0	22.11	22.10	21.98	0-1	1
	1	0	22.71	22.54	22.27		1
	1	7	22.73	22.49	22.21		1
	1	14	22.77	22.53	22.23	0-2	1
	8	0	21.02	21.01	20.89		2
	8	4	21.04	20.96	20.83		2
	8	7	21.12	21.01	20.84		2
15	0	20.96	20.94	20.97	2		

**Table 9-14**  
**LTE Band 4 (AWS) Maximum Conducted Powers -1.4 MHz Bandwidth**

LTE Band 4 (AWS) 1.4 MHz Bandwidth								
Modulation	RB Size	RB Offset	Low Channel	Mid Channel	Frequency [MHz]	MPR Allowed per 3GPP [dB]	MPR [dB]	
			19957 (1710.7 MHz)	20175 (1732.5 MHz)	20393 (1754.3 MHz)			
			Conducted Power [dBm]					
QPSK	1	0	23.62	23.62	23.43	0	0	
	1	2	23.55	23.57	23.42		0	
	1	5	23.67	23.58	23.43		0	
	3	0	23.29	23.25	23.26	0-1	0	
	3	2	23.32	23.28	23.24		0	
	3	3	23.33	23.26	23.23		0	
16QAM	6	0	22.10	22.15	22.10	0-1	1	
	1	0	22.64	22.64	22.47		0-1	1
	1	2	22.61	22.60	22.52			1
	1	5	22.57	22.66	22.56	1		
	3	0	22.20	22.37	22.06	1		
	3	2	22.23	22.40	22.09	1		
	3	3	22.24	22.35	22.06	1		
6	0	21.08	21.07	20.95	0-2	2		

FCC ID A3LSMJ320A		<b>SAR EVALUATION REPORT</b>		Reviewed by: Quality Manager
Document S/N: OY1511191972-R2.A3L	Test Dates: 11/17/2015 - 01/28/2016	DUT Type: Portable Handset		Page 31 of 63



**Table 9-15**  
**LTE Band 4 (AWS) Conducted Powers - 20 MHz Bandwidth- Hotspot Mode Active**

LTE Band 4 (AWS) 20 MHz Bandwidth					
Modulation	RB Size	RB Offset	Mid Channel	MPR Allowed per 3GPP [dB]	MPR [dB]
			20175 (1732.5 MHz)		
			Conducted Power [dBm]		
QPSK	1	0	21.68	0	0
	1	50	<b>21.81</b>		0
	1	99	21.72		0
	50	0	20.46	0-1	1
	50	25	<b>20.52</b>		1
	50	50	20.46		1
	100	0	20.45		1
16QAM	1	0	20.71	0-2	1
	1	50	20.76		1
	1	99	20.82		1
	50	0	19.33	0-2	2
	50	25	19.39		2
	50	50	19.46		2
	100	0	19.47		2

Note: LTE Band 4 (AWS) at 20 MHz bandwidth does not support three non-overlapping channels. Per KDB Publication 941225 D05v02, when a device supports overlapping channel assignment in a channel bandwidth configuration, the middle channel of the group of overlapping channels should be selected for testing.

**Table 9-16**  
**LTE Band 4 (AWS) Conducted Powers - 15 MHz Bandwidth- Hotspot Mode Active**

LTE Band 4 (AWS) 15 MHz Bandwidth							
Modulation	RB Size	RB Offset	Low Channel	Mid Channel	Frequency [MHz]	MPR Allowed per 3GPP [dB]	MPR [dB]
			20025 (1717.5 MHz)	20175 (1732.5 MHz)	20325 (1747.5 MHz)		
			Conducted Power [dBm]				
QPSK	1	0	21.40	21.46	21.36	0	0
	1	36	21.48	21.53	21.45		0
	1	74	21.46	21.50	21.37		0
	36	0	20.15	20.22	20.25	0-1	1
	36	18	20.17	20.31	20.18		1
	36	37	20.13	20.31	20.14		1
	75	0	20.06	20.20	20.12		1
16QAM	1	0	20.39	20.46	20.41	0-1	1
	1	36	20.42	20.45	20.47		1
	1	74	20.47	20.51	20.51		1
	36	0	19.06	19.11	19.14	0-2	2
	36	18	19.10	19.20	19.27		2
	36	37	19.05	19.22	19.05		2
	75	0	18.98	19.11	19.12		2



FCC ID A3LSMJ320A		<b>SAR EVALUATION REPORT</b>		Reviewed by: Quality Manager
Document S/N: OY1511191972-R2.A3L	Test Dates: 11/17/2015 - 01/28/2016	DUT Type: Portable Handset		Page 32 of 63

**Table 9-17**  
**LTE Band 4 (AWS) Conducted Powers - 10 MHz Bandwidth- Hotspot Mode Active**

LTE Band 4 (AWS) 10 MHz Bandwidth							
Modulation	RB Size	RB Offset	Low Channel	Mid Channel	High Channel	MPR Allowed per 3GPP [dB]	MPR [dB]
			20000 (1715.0 MHz)	20175 (1732.5 MHz)	20350 (1750.0 MHz)		
			Conducted Power [dBm]				
QPSK	1	0	21.41	21.49	21.49	0	0
	1	25	21.48	21.61	21.53		0
	1	49	21.49	21.62	21.52		0
	25	0	20.07	20.24	20.15	0-1	1
	25	12	20.15	20.30	20.18		1
	25	25	20.06	20.28	20.18		1
	50	0	20.05	20.25	20.23		1
16QAM	1	0	20.52	20.52	20.63	0-1	1
	1	25	20.43	20.46	20.60		1
	1	49	20.44	20.60	20.57		1
	25	0	19.09	19.11	19.23	0-2	2
	25	12	19.18	19.20	19.25		2
	25	25	19.11	19.18	19.14		2
	50	0	19.02	19.16	19.13		2

**Table 9-18**  
**LTE Band 4 (AWS) Conducted Powers - 5 MHz Bandwidth- Hotspot Mode Active**

LTE Band 4 (AWS) 5 MHz Bandwidth							
Modulation	RB Size	RB Offset	Low Channel	Mid Channel	High Channel	MPR Allowed per 3GPP [dB]	MPR [dB]
			19975 (1712.5 MHz)	20175 (1732.5 MHz)	20375 (1752.5 MHz)		
			Conducted Power [dBm]				
QPSK	1	0	21.44	21.50	21.56	0	0
	1	12	21.45	21.56	21.49		0
	1	24	21.58	21.62	21.56		0
	12	0	20.04	20.17	20.14	0-1	1
	12	6	20.15	20.19	20.07		1
	12	13	20.19	20.27	20.14		1
	25	0	20.04	20.18	20.17		1
16QAM	1	0	20.37	20.44	20.31	0-1	1
	1	12	20.38	20.41	20.27		1
	1	24	20.41	20.47	20.37		1
	12	0	19.08	19.06	19.17	0-2	2
	12	6	19.07	19.14	19.10		2
	12	13	19.14	19.23	19.08		2
	25	0	19.01	19.18	19.09		2



FCC ID A3LSMJ320A		<b>SAR EVALUATION REPORT</b>		Reviewed by: Quality Manager
Document S/N: OY1511191972-R2.A3L	Test Dates: 11/17/2015 - 01/28/2016	DUT Type: Portable Handset		Page 33 of 63

**Table 9-19**  
**LTE Band 4 (AWS) Conducted Powers - 3 MHz Bandwidth- Hotspot Mode Active**

LTE Band 4 (AWS) 3 MHz Bandwidth							
Modulation	RB Size	RB Offset	Frequency [MHz]	Frequency [MHz]	Frequency [MHz]	MPR Allowed per 3GPP [dB]	MPR [dB]
			19965 (1711.5 MHz)	20175 (1732.5 MHz)	20385 (1753.5 MHz)		
			Conducted Power [dBm]				
QPSK	1	0	21.62	21.57	21.50	0	0
	1	7	21.63	21.57	21.43		0
	1	14	21.69	21.65	21.51		0
	8	0	20.14	20.15	20.14	0-1	1
	8	4	20.21	20.16	20.09		1
	8	7	20.20	20.21	20.10		1
	15	0	20.11	20.16	20.12		1
16QAM	1	0	20.79	20.51	20.57	0-1	1
	1	7	20.82	20.54	20.50		1
	1	14	20.86	20.51	20.61		1
	8	0	19.03	19.23	19.08	0-2	2
	8	4	19.11	19.25	19.04		2
	8	7	19.20	19.30	19.03		2
	15	0	19.09	19.20	19.08		2

**Table 9-20**  
**LTE Band 4 (AWS) Conducted Powers - 1.4 MHz Bandwidth- Hotspot Mode Active**

LTE Band 4 (AWS) 1.4 MHz Bandwidth							
Modulation	RB Size	RB Offset	Low Channel	Mid Channel	Frequency [MHz]	MPR Allowed per 3GPP [dB]	MPR [dB]
			19957 (1710.7 MHz)	20175 (1732.5 MHz)	20393 (1754.3 MHz)		
			Conducted Power [dBm]				
QPSK	1	0	21.70	21.59	21.41	0	0
	1	2	21.73	21.65	21.39		0
	1	5	21.70	21.71	21.44		0
	3	0	21.36	21.44	21.29		0
	3	2	21.44	21.37	21.31		0
	3	3	21.44	21.35	21.26		0
	6	0	20.29	20.25	20.12	0-1	1
16QAM	1	0	20.83	20.80	20.59	0-1	1
	1	2	20.77	20.72	20.54		1
	1	5	20.69	20.77	20.24		1
	3	0	20.21	20.13	20.11		1
	3	2	20.21	20.19	20.14		1
	3	3	20.18	20.14	20.10		1
	6	0	19.10	19.09	19.15	0-2	2

FCC ID A3LSMJ320A		<b>SAR EVALUATION REPORT</b>		Reviewed by: Quality Manager
Document S/N: OY1511191972-R2.A3L	Test Dates: 11/17/2015 - 01/28/2016	DUT Type: Portable Handset		Page 34 of 63



### 9.3.4 LTE Band 2 (PCS)

**Table 9-21**  
**LTE Band 2 (PCS) Maximum Conducted Powers - 20 MHz Bandwidth**

LTE Band 2 (PCS) 20 MHz Bandwidth								
Modulation	RB Size	RB Offset	Low Channel	Mid Channel	High Channel	MPR Allowed per 3GPP [dB]	MPR [dB]	
			18700 (1860.0 MHz)	18900 (1880.0 MHz)	19100 (1900.0 MHz)			
			Conducted Power [dBm]					
QPSK	1	0	23.77	23.62	23.83	0	0	
	1	50	23.91	23.76	<b>23.95</b>		0	
	1	99	23.83	23.83	23.35		0	
	QPSK	50	0	22.65	22.50	22.69	0-1	1
		50	25	22.62	22.49	<b>22.80</b>		1
		50	50	22.63	22.45	22.75		1
		100	0	22.70	22.57	22.78		1
16QAM	1	0	22.91	22.73	23.00	0-1	1	
	1	50	22.94	22.76	22.98		1	
	1	99	22.95	22.83	22.28		1	
	16QAM	50	0	21.59	21.35	21.64	0-2	2
		50	25	21.61	21.47	21.66		2
		50	50	21.56	21.38	21.61		2
		100	0	21.57	21.59	21.72		2

**Table 9-22**  
**LTE Band 2 (PCS) Maximum Conducted Powers - 15 MHz Bandwidth**

LTE Band 2 (PCS) 15 MHz Bandwidth								
Modulation	RB Size	RB Offset	Low Channel	Mid Channel	Frequency [MHz]	MPR Allowed per 3GPP [dB]	MPR [dB]	
			18675 (1857.5 MHz)	18900 (1880.0 MHz)	19125 (1902.5 MHz)			
			Conducted Power [dBm]					
QPSK	1	0	23.98	23.73	23.82	0	0	
	1	36	24.00	23.84	23.96		0	
	1	74	23.99	23.83	23.80		0	
	QPSK	36	0	22.64	22.46	22.66	0-1	1
		36	18	22.73	22.50	22.66		1
		36	37	22.61	22.42	22.64		1
		75	0	22.64	22.50	22.55		1
16QAM	1	0	22.71	22.76	22.97	0-1	1	
	1	36	22.90	22.82	23.00		1	
	1	74	22.82	22.91	22.98		1	
	16QAM	36	0	21.50	21.38	21.53	0-2	2
		36	18	21.59	21.44	21.56		2
		36	37	21.57	21.35	21.49		2
		75	0	21.53	21.42	21.55		2



FCC ID A3LSMJ320A		<b>SAR EVALUATION REPORT</b>		<b>Reviewed by:</b> Quality Manager
<b>Document S/N:</b> OY1511191972-R2.A3L	<b>Test Dates:</b> 11/17/2015 - 01/28/2016	<b>DUT Type:</b> Portable Handset	Page 35 of 63	

**Table 9-23**  
**LTE Band 2 (PCS) Maximum Conducted Powers - 10 MHz Bandwidth**

LTE Band 2 (PCS) 10 MHz Bandwidth							
Modulation	RB Size	RB Offset	Low Channel	Frequency [MHz]	Frequency [MHz]	MPR Allowed per 3GPP [dB]	MPR [dB]
			18650 (1855.0 MHz)	18900 (1880.0 MHz)	19150 (1905.0 MHz)		
			Conducted Power [dBm]				
QPSK	1	0	23.98	23.72	23.91	0	0
	1	25	24.00	23.88	23.96		0
	1	49	23.99	23.86	23.57		0
	25	0	22.67	22.44	22.70	0-1	1
	25	12	22.78	22.45	22.56		1
	25	25	22.78	22.35	22.54		1
16QAM	50	0	22.71	22.42	22.74	0-1	1
	1	0	22.97	22.87	23.00		1
	1	25	23.00	22.90	22.99		1
	1	49	23.00	22.96	22.95	0-2	1
	25	0	21.62	21.46	21.67		2
	25	12	21.73	21.48	21.63		2
	25	25	21.64	21.28	21.55	2	
	50	0	21.61	21.30	21.61	2	

**Table 9-24**  
**LTE Band 2 (PCS) Maximum Conducted Powers - 5 MHz Bandwidth**

LTE Band 2 (PCS) 5 MHz Bandwidth							
Modulation	RB Size	RB Offset	Low Channel	Mid Channel	Frequency [MHz]	MPR Allowed per 3GPP [dB]	MPR [dB]
			18625 (1852.5 MHz)	18900 (1880.0 MHz)	19175 (1907.5 MHz)		
			Conducted Power [dBm]				
QPSK	1	0	23.99	23.70	23.98	0	0
	1	12	24.00	23.73	24.00		0
	1	24	24.00	23.78	23.97		0
	12	0	22.75	22.51	22.72	0-1	1
	12	6	22.81	22.39	22.63		1
	12	13	22.86	22.41	22.62		1
16QAM	25	0	22.74	22.43	22.71	0-1	1
	1	0	22.99	22.82	22.96		1
	1	12	23.00	22.79	22.98		1
	1	24	23.00	22.83	22.99	0-2	1
	12	0	21.60	21.41	21.62		2
	12	6	21.67	21.28	21.51		2
	12	13	21.73	21.30	21.54	2	
	25	0	21.70	21.32	21.59	2	



FCC ID A3LSMJ320A	 <b>PCTEST</b> <small>ENGINEERING LABORATORY, INC.</small>	<b>SAR EVALUATION REPORT</b>		<b>Reviewed by:</b> Quality Manager
<b>Document S/N:</b> OY1511191972-R2.A3L	<b>Test Dates:</b> 11/17/2015 - 01/28/2016	<b>DUT Type:</b> Portable Handset		Page 36 of 63

**Table 9-25**  
**LTE Band 2 (PCS) Maximum Conducted Powers - 3 MHz Bandwidth**

LTE Band 2 (PCS) 3 MHz Bandwidth							
Modulation	RB Size	RB Offset	Low Channel	Mid Channel	High Channel	MPR Allowed per 3GPP [dB]	MPR [dB]
			18615 (1851.5 MHz)	18900 (1880.0 MHz)	19185 (1908.5 MHz)		
			Conducted Power [dBm]				
QPSK	1	0	23.96	23.98	23.98	0	0
	1	7	23.98	23.99	23.95		0
	1	14	24.00	24.00	23.94		0
	8	0	22.86	22.41	22.72	0-1	1
	8	4	22.88	22.43	22.58		1
	8	7	22.88	22.46	22.59		1
	15	0	22.80	22.47	22.74		1
16QAM	1	0	22.94	22.78	22.97	0-1	1
	1	7	22.96	22.72	22.93		1
	1	14	22.99	22.76	22.99		1
	8	0	21.71	21.34	21.62	0-2	2
	8	4	21.72	21.24	21.50		2
	8	7	21.74	21.29	21.52		2
	15	0	21.66	21.35	21.64		2

**Table 9-26**  
**LTE Band 2 (PCS) Maximum Conducted Powers -1.4 MHz Bandwidth**

LTE Band 2 (PCS) 1.4 MHz Bandwidth							
Modulation	RB Size	RB Offset	Low Channel	Mid Channel	High Channel	MPR Allowed per 3GPP [dB]	MPR [dB]
			18607 (1850.7 MHz)	18900 (1880.0 MHz)	19193 (1909.3 MHz)		
			Conducted Power [dBm]				
QPSK	1	0	23.95	23.97	23.96	0	0
	1	2	23.99	23.84	23.98		0
	1	5	24.00	23.91	23.95		0
	3	0	23.94	23.68	23.85		0
	3	2	23.95	23.66	23.81		0
	3	3	23.97	23.64	23.76		0
	6	0	22.85	22.48	22.71	0-1	1
16QAM	1	0	23.00	22.63	23.00	0-1	1
	1	2	22.97	22.57	22.97		1
	1	5	23.00	22.62	22.99		1
	3	0	22.78	22.41	22.62		1
	3	2	22.72	22.39	22.57		1
	3	3	22.73	22.38	22.58		1
	6	0	21.74	21.43	21.54		0-2



FCC ID A3LSMJ320A		<b>SAR EVALUATION REPORT</b>		Reviewed by: Quality Manager
Document S/N: OY1511191972-R2.A3L	Test Dates: 11/17/2015 - 01/28/2016	DUT Type: Portable Handset		Page 37 of 63

**Table 9-27**  
**LTE Band 2 (PCS) Conducted Powers - 20 MHz Bandwidth- Hotspot Mode Active**

LTE Band 2 (PCS) 20 MHz Bandwidth							
Modulation	RB Size	RB Offset	Low Channel	Mid Channel	High Channel	MPR Allowed per 3GPP [dB]	MPR [dB]
			18700 (1860.0 MHz)	18900 (1880.0 MHz)	19100 (1900.0 MHz)		
			Conducted Power [dBm]				
QPSK	1	0	21.50	21.26	21.56	0	0
	1	50	21.66	21.41	21.67		0
	1	99	21.65	21.48	21.58		0
	50	0	20.34	20.28	20.46	0-1	1
	50	25	20.40	20.30	20.51		1
	50	50	20.47	20.32	20.36		1
	100	0	20.35	20.34	20.43		1
16QAM	1	0	20.56	20.57	20.53	0-1	1
	1	50	20.64	20.74	20.67		1
	1	99	20.77	20.83	20.63		1
	50	0	19.29	19.18	19.43	0-2	2
	50	25	19.43	19.21	19.42		2
	50	50	19.42	19.26	19.30		2
	100	0	19.41	19.30	19.39		2

**Table 9-28**  
**LTE Band 2 (PCS) Conducted Powers - 15 MHz Bandwidth- Hotspot Mode Active**

LTE Band 2 (PCS) 15 MHz Bandwidth							
Modulation	RB Size	RB Offset	Low Channel	Mid Channel	Frequency [MHz]	MPR Allowed per 3GPP [dB]	MPR [dB]
			18675 (1857.5 MHz)	18900 (1880.0 MHz)	19125 (1902.5 MHz)		
			Conducted Power [dBm]				
QPSK	1	0	21.49	21.18	21.30	0	0
	1	36	21.47	21.29	21.27		0
	1	74	21.51	21.28	21.26		0
	36	0	20.24	20.07	20.20	0-1	1
	36	18	20.31	20.10	20.23		1
	36	37	20.32	20.04	20.05		1
	75	0	20.18	20.04	20.16		1
16QAM	1	0	20.57	20.14	20.30	0-1	1
	1	36	20.64	20.17	20.29		1
	1	74	20.61	20.03	20.30		1
	36	0	19.20	18.99	19.12	0-2	2
	36	18	19.25	19.10	19.05		2
	36	37	19.26	19.06	19.08		2
	75	0	19.23	19.05	19.06		2



FCC ID A3LSMJ320A		<b>SAR EVALUATION REPORT</b>		Reviewed by: Quality Manager
Document S/N: OY1511191972-R2.A3L	Test Dates: 11/17/2015 - 01/28/2016	DUT Type: Portable Handset		Page 38 of 63

**Table 9-29**  
**LTE Band 2 (PCS) Conducted Powers - 10 MHz Bandwidth- Hotspot Mode Active**

LTE Band 2 (PCS) 10 MHz Bandwidth							
Modulation	RB Size	RB Offset	Low Channel	Frequency [MHz]	Frequency [MHz]	MPR Allowed per 3GPP [dB]	MPR [dB]
			18650 (1855.0 MHz)	18900 (1880.0 MHz)	19150 (1905.0 MHz)		
			Conducted Power [dBm]				
QPSK	1	0	21.46	21.18	21.26	0	0
	1	25	21.50	21.28	21.39		0
	1	49	21.56	21.34	21.32		0
	25	0	20.23	20.04	20.17	0-1	1
	25	12	20.23	20.06	20.00		1
	25	25	20.24	19.96	20.02		1
16QAM	50	0	20.20	19.98	20.14	0-1	1
	1	0	20.49	20.29	20.33		1
	1	25	20.55	20.21	20.39		1
	1	49	20.62	20.32	20.31	0-2	1
	25	0	19.22	19.06	19.11		2
	25	12	19.31	19.07	19.04		2
	25	25	19.23	18.99	19.07	2	
	50	0	19.22	18.95	19.05	2	

**Table 9-30**  
**LTE Band 2 (PCS) Conducted Powers - 5 MHz Bandwidth- Hotspot Mode Active**

LTE Band 2 (PCS) 5 MHz Bandwidth							
Modulation	RB Size	RB Offset	Low Channel	Mid Channel	Frequency [MHz]	MPR Allowed per 3GPP [dB]	MPR [dB]
			18625 (1852.5 MHz)	18900 (1880.0 MHz)	19175 (1907.5 MHz)		
			Conducted Power [dBm]				
QPSK	1	0	21.56	21.24	21.41	0	0
	1	12	21.55	21.23	21.34		0
	1	24	21.62	21.25	21.33		0
	12	0	20.35	20.01	20.10	0-1	1
	12	6	20.30	19.97	20.04		1
	12	13	20.32	19.97	20.01		1
16QAM	25	0	20.31	19.94	20.13	0-1	1
	1	0	20.35	20.31	20.17		1
	1	12	20.33	20.33	20.16		1
	1	24	20.38	20.34	20.15	0-2	1
	12	0	19.30	18.97	18.98		2
	12	6	19.23	18.91	18.91		2
	12	13	19.26	18.88	18.90	2	
	25	0	19.21	18.98	19.03	2	



FCC ID A3LSMJ320A		<b>SAR EVALUATION REPORT</b>		Reviewed by: Quality Manager
Document S/N: OY1511191972-R2.A3L	Test Dates: 11/17/2015 - 01/28/2016	DUT Type: Portable Handset		Page 39 of 63

**Table 9-31**  
**LTE Band 2 (PCS) Conducted Powers - 3 MHz Bandwidth- Hotspot Mode Active**

LTE Band 2 (PCS) 3 MHz Bandwidth							
Modulation	RB Size	RB Offset	Low Channel	Mid Channel	High Channel	MPR Allowed per 3GPP [dB]	MPR [dB]
			18615 (1851.5 MHz)	18900 (1880.0 MHz)	19185 (1908.5 MHz)		
Conducted Power [dBm]							
QPSK	1	0	21.75	21.29	21.30	0	0
	1	7	21.71	21.31	21.35		0
	1	14	21.75	21.33	21.32		0
	8	0	20.34	20.10	20.11	0-1	1
	8	4	20.29	20.06	20.06		1
	8	7	20.32	20.08	20.02		1
	15	0	20.33	20.08	20.08		1
16QAM	1	0	20.87	20.20	20.58	0-1	1
	1	7	20.86	20.17	20.43		1
	1	14	20.91	20.17	20.52		1
	8	0	19.31	19.10	19.07	0-2	2
	8	4	19.25	19.14	19.03		2
	8	7	19.28	19.18	19.01		2
	15	0	19.33	18.97	19.07		2

**Table 9-32**  
**LTE Band 2 (PCS) Conducted Powers -1.4 MHz Bandwidth- Hotspot Mode Active**

LTE Band 2 (PCS) 1.4 MHz Bandwidth							
Modulation	RB Size	RB Offset	Low Channel	Mid Channel	High Channel	MPR Allowed per 3GPP [dB]	MPR [dB]
			18607 (1850.7 MHz)	18900 (1880.0 MHz)	19193 (1909.3 MHz)		
Conducted Power [dBm]							
QPSK	1	0	21.71	21.36	21.38	0	0
	1	2	21.63	21.30	21.34		0
	1	5	21.64	21.33	21.36		0
	3	0	21.51	21.14	21.27		0
	3	2	21.52	21.15	21.20		0
	3	3	21.49	21.11	21.14	0	
	6	0	20.40	20.05	20.12	0-1	1
16QAM	1	0	20.67	20.28	20.41	0-1	1
	1	2	20.63	20.17	20.43		1
	1	5	20.66	20.21	20.47		1
	3	0	20.32	20.03	20.16		1
	3	2	20.34	20.07	20.14		1
	3	3	20.29	20.01	20.09	1	
	6	0	19.25	19.17	19.15	0-2	2

FCC ID A3LSMJ320A		<b>SAR EVALUATION REPORT</b>		Reviewed by: Quality Manager
Document S/N: OY1511191972-R2.A3L	Test Dates: 11/17/2015 - 01/28/2016	DUT Type: Portable Handset		Page 40 of 63

## 9.3.5 LTE Carrier Aggregation Conducted Powers

Table 9-33  
LTE Carrier Aggregation Maximum Conducted Powers

PCC								SCC				Power	
PCC Band	PCC Bandwidth [MHz]	PCC (UL) Channel	PCC (UL) Frequency [MHz]	PCC UL# RB	PCC UL RB Offset	PCC (DL) Channel	PCC (DL) Frequency [MHz]	SCC Band	SCC Bandwidth [MHz]	SCC (DL) Channel	SCC (DL) Frequency [MHz]	LTE Rel 10 Tx.Power (dBm)	LTE Rel. 8 Tx.Power (dBm)
LTE B2	10	18650	1855	1	25	650	1935	LTE B5	10	2525	881.5	23.61	24.00
LTE B2	10	18650	1855	1	25	650	1935	LTE B12	10	5095	737.5	23.97	24.00
LTE B12	3	23025	700.5	1	14	730	5025	LTE B2	10	900	1960	23.64	23.74
LTE B5	5	20625	846.5	1	12	2625	891.5	LTE B2	10	900	1960	23.26	23.54
LTE B5	5	20625	846.5	1	12	2625	891.5	LTE B4	10	2175	2132.5	23.31	23.54
LTE B4	10	20000	1715	1	25	2000	2115	LTE B12	10	5095	737.5	23.22	23.70
LTE B4	10	20000	1715	1	25	2000	2115	LTE B5	10	2525	881.5	23.24	23.70

Table 9-34  
LTE Carrier Aggregation Reduced Conducted Powers- Hotspot Mode Active

PCC								SCC				Power	
PCC Band	PCC Bandwidth [MHz]	PCC (UL) Channel	PCC (UL) Frequency [MHz]	PCC UL# RB	PCC UL RB Offset	PCC (DL) Channel	PCC (DL) Frequency [MHz]	SCC Band	SCC Bandwidth [MHz]	SCC (DL) Channel	SCC (DL) Frequency [MHz]	LTE Rel 10 Tx.Power (dBm)	LTE Rel. 8 Tx.Power (dBm)
LTE B2	3	18615	1851.5	1	0	615	1931.5	LTE B5	10	2525	881.5	21.61	21.75
LTE B2	3	18615	1851.5	1	0	650	1935	LTE B12	10	5095	737.5	21.48	21.75
LTE B4	10	20175	1732.5	1	49	2175	2132.5	LTE B12	10	5095	737.5	21.47	21.62
LTE B4	10	20175	1732.5	1	49	2175	2132.5	LTE B5	10	2525	881.5	21.44	21.62

Notes:

1. The device does not support all Rel. 10 Carrier Aggregation features due to modem chipset limitation.
2. The device only supports downlink Carrier Aggregation. Uplink Carrier Aggregation is not supported. Power measurements were performed with two DL carriers for the Release 8 configuration that had the highest output power (across all bandwidths, channels and RB Configurations) for each band
3. All control and acknowledge data is sent on uplink channels that operate identical to release 8 specifications.

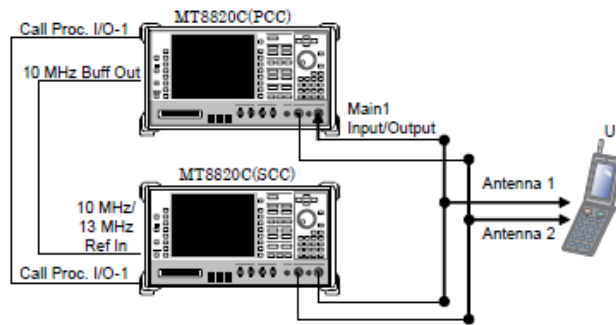

Figure 9-3  
Power Measurement Setup

FCC ID A3LSMJ320A	PCTEST Engineering Laboratory, Inc.	SAR EVALUATION REPORT	SAMSUNG	Reviewed by: Quality Manager
Document S/N: OY1511191972-R2.A3L	Test Dates: 11/17/2015 - 01/28/2016	DUT Type: Portable Handset		Page 41 of 63

## 9.4 Maximum WLAN Conducted Powers

Table 9-35  
2.4 GHz WLAN Average RF Power

Freq [MHz]	Channel	2.4GHz Conducted Power [dBm]	
		IEEE Transmission Mode	
		802.11b	802.11g
2412	1	15.66	14.49
2437	6	15.71	14.41
2462	11	<b>15.76</b>	14.62

## 9.5 Reduced WLAN Conducted Powers – Held to Ear

Table 9-23  
2.4 GHz WLAN Held to Ear Average RF Power

Freq [MHz]	Channel	2.4GHz Conducted Power [dBm]		
		IEEE Transmission Mode		
		802.11b	802.11g	802.11n
2412	1	10.28	10.37	10.16
2437	6	10.36	10.40	10.21
2462	11	<b>10.46</b>	10.42	10.33

Justification for test configurations for WLAN per KDB Publication 248227 D01v02r01:

- Power measurements were performed for the transmission mode configuration with the highest maximum output power specified for production units.
- For transmission modes with the same maximum output power specification, powers were measured for the largest channel bandwidth, lowest order modulation and lowest data rate.
- For transmission modes with identical maximum specified output power, channel bandwidth, modulation and data rates, power measurements were required for all identical configurations.
- For each transmission mode configuration, powers were measured for the highest and lowest channels; and at the mid-band channel(s) when there were at least 3 channels supported. For configurations with multiple mid-band channels, due to an even number of channels, both channels were measured.
- The bolded data rate and channel above were tested for SAR.

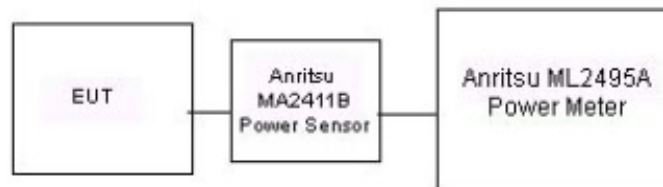



Figure 9-4  
Power Measurement Setup

FCC ID A3LSMJ320A		SAR EVALUATION REPORT		Reviewed by: Quality Manager
Document S/N: OY1511191972-R2.A3L	Test Dates: 11/17/2015 - 01/28/2016	DUT Type: Portable Handset		Page 42 of 63



# 10 SYSTEM VERIFICATION

## 10.1 Tissue Verification

**Table 10-1  
Measured Head Tissue Properties**

Calibrated for Tests Performed on:	Tissue Type	Tissue Temp During Calibration (C°)	Measured Frequency (MHz)	Measured Conductivity, $\sigma$ (S/m)	Measured Dielectric Constant, $\epsilon$	TARGET Conductivity, $\sigma$ (S/m)	TARGET Dielectric Constant, $\epsilon$	% dev $\sigma$	% dev $\epsilon$
11/19/2015	750H	21.8	700	0.880	44.105	0.889	42.201	-1.01%	4.51%
			710	0.889	43.986	0.890	42.149	-0.11%	4.36%
			740	0.916	43.588	0.893	41.994	2.58%	3.80%
			755	0.930	43.391	0.894	41.916	4.03%	3.52%
11/17/2015	835H	21.5	820	0.904	42.178	0.899	41.578	0.56%	1.44%
			835	0.918	41.991	0.900	41.500	2.00%	1.18%
			850	0.933	41.786	0.916	41.500	1.86%	0.69%
1/18/2016	835H	21.2	820	0.879	40.405	0.899	41.578	-2.22%	-2.82%
			835	0.892	40.219	0.900	41.500	-0.89%	-3.09%
			850	0.906	40.031	0.916	41.500	-1.09%	-3.54%
11/23/2015	1750H	20.8	1710	1.285	39.721	1.348	40.142	-4.67%	-1.05%
			1750	1.331	39.496	1.371	40.079	-2.92%	-1.45%
			1790	1.366	39.382	1.394	40.016	-2.01%	-1.58%
1/19/2016	1750H	21.2	1710	1.346	40.467	1.348	40.142	-0.15%	0.81%
			1750	1.390	40.283	1.371	40.079	1.39%	0.51%
			1790	1.423	40.064	1.394	40.016	2.08%	0.12%
11/18/2015	1900H	22.0	1850	1.375	39.156	1.400	40.000	-1.79%	-2.11%
			1880	1.405	39.037	1.400	40.000	0.36%	-2.41%
			1910	1.435	38.879	1.400	40.000	2.50%	-2.80%
1/18/2016	1900H	21.2	1850	1.367	38.996	1.400	40.000	-2.36%	-2.51%
			1880	1.397	38.877	1.400	40.000	-0.21%	-2.81%
			1910	1.428	38.740	1.400	40.000	2.00%	-3.15%
1/19/2016	2450H	21.0	2400	1.786	38.449	1.756	39.289	1.71%	-2.14%
			2450	1.840	38.234	1.800	39.200	2.22%	-2.46%
			2500	1.896	38.069	1.855	39.136	2.21%	-2.73%



The above measured tissue parameters were used in the DASY software. The DASY software was used to perform interpolation to determine the dielectric parameters at the SAR test device frequencies (per KDB Publication 865664 D01v01r04 and IEEE 1528-2013 6.6.1.2). The tissue parameters listed in the SAR test plots may slightly differ from the table above due to significant digit rounding in the software.

FCC ID A3LSMJ320A		SAR EVALUATION REPORT		Reviewed by: Quality Manager
Document S/N: OY1511191972-R2.A3L	Test Dates: 11/17/2015 - 01/28/2016	DUT Type: Portable Handset		Page 43 of 63

**Table 10-2  
Measured Body Tissue Properties**

Calibrated for Tests Performed on:	Tissue Type	Tissue Temp During Calibration (C°)	Measured Frequency (MHz)	Measured Conductivity, $\sigma$ (S/m)	Measured Dielectric Constant, $\epsilon$	TARGET Conductivity, $\sigma$ (S/m)	TARGET Dielectric Constant, $\epsilon$	% dev $\sigma$	% dev $\epsilon$
11/23/2015	750B	23.7	700	0.912	54.202	0.959	55.726	-4.90%	-2.73%
			710	0.921	54.115	0.960	55.687	-4.06%	-2.82%
			740	0.945	53.763	0.963	55.570	-1.87%	-3.25%
			755	0.958	53.520	0.964	55.512	-0.62%	-3.59%
11/22/2015	835B	21.1	820	0.971	53.750	0.969	55.258	0.21%	-2.73%
			835	0.986	53.623	0.970	55.200	1.65%	-2.86%
			850	1.001	53.494	0.988	55.154	1.32%	-3.01%
1/25/2016	835B	21.3	820	0.989	53.615	0.969	55.258	2.06%	-2.97%
			835	1.004	53.454	0.970	55.200	3.51%	-3.16%
			850	1.020	53.300	0.988	55.154	3.24%	-3.36%
1/18/2016	1750B	22.1	1710	1.419	51.788	1.463	53.537	-3.01%	-3.27%
			1750	1.462	51.662	1.488	53.432	-1.75%	-3.31%
			1790	1.502	51.550	1.514	53.326	-0.79%	-3.33%
1/28/2016	1750B	22.5	1710	1.451	52.030	1.463	53.537	-0.82%	-2.81%
			1750	1.492	51.897	1.488	53.432	0.27%	-2.87%
			1790	1.534	51.719	1.514	53.326	1.32%	-3.01%
1/18/2016	1900B	22.5	1850	1.466	52.557	1.520	53.300	-3.55%	-1.39%
			1880	1.496	52.560	1.520	53.300	-1.58%	-1.39%
			1910	1.530	52.464	1.520	53.300	0.66%	-1.57%
1/21/2016	1900B	21.6	1850	1.501	51.831	1.520	53.300	-1.25%	-2.76%
			1880	1.534	51.759	1.520	53.300	0.92%	-2.89%
			1910	1.565	51.653	1.520	53.300	2.96%	-3.09%
1/25/2016	1900B	23.5	1850	1.501	51.647	1.520	53.300	-1.25%	-3.10%
			1880	1.532	51.569	1.520	53.300	0.79%	-3.25%
			1910	1.564	51.449	1.520	53.300	2.89%	-3.47%
1/19/2016	2450B	21.5	2400	1.928	51.750	1.902	52.767	1.37%	-1.93%
			2450	1.992	51.567	1.950	52.700	2.15%	-2.15%
			2500	2.058	51.286	2.021	52.636	1.83%	-2.56%

The above measured tissue parameters were used in the DASY software. The DASY software was used to perform interpolation to determine the dielectric parameters at the SAR test device frequencies (per KDB Publication 865664 D01v01r04 and IEEE 1528-2013 6.6.1.2). The tissue parameters listed in the SAR test plots may slightly differ from the table above due to significant digit rounding in the software.

FCC ID A3LSMJ320A		SAR EVALUATION REPORT		Reviewed by: Quality Manager
Document S/N: OY1511191972-R2.A3L	Test Dates: 11/17/2015 - 01/28/2016	DUT Type: Portable Handset		Page 44 of 63

## 10.2 Test System Verification

Prior to SAR assessment, the system is verified to  $\pm 10\%$  of the SAR measurement on the reference dipole at the time of calibration by the calibration facility. Full system validation status and result summary can be found in Appendix E.

**Table 10-3**  
**System Verification Results**

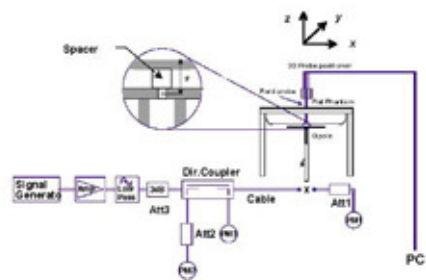

System Verification TARGET & MEASURED												
SAR System #	Tissue Frequency (MHz)	Tissue Type	Date:	Amb. Temp (°C)	Liquid Temp (°C)	Input Power (W)	Dipole SN	Probe SN	Measured SAR <sub>1g</sub> (W/kg)	1 W Target SAR <sub>1g</sub> (W/kg)	1 W Normalized SAR <sub>1g</sub> (W/kg)	Deviation <sub>1g</sub> (%)
K	750	HEAD	11/19/2015	23.2	21.8	0.200	1054	3022	1.740	8.280	8.700	5.07%
E	835	HEAD	11/17/2015	22.7	21.1	0.200	4d119	3351	1.770	9.380	8.850	-5.65%
G	835	HEAD	01/18/2016	24.0	22.1	0.200	4d119	3334	1.950	9.380	9.750	3.94%
J	1750	HEAD	11/23/2015	20.3	20.8	0.100	1051	3319	3.460	36.200	34.600	-4.42%
H	1750	HEAD	01/19/2016	22.3	21.2	0.100	1051	3263	3.690	36.200	36.900	1.93%
J	1900	HEAD	11/18/2015	21.2	22.0	0.100	5d141	3319	3.720	39.900	37.200	-6.77%
D	1900	HEAD	01/18/2016	21.1	21.1	0.100	5d149	3209	4.220	40.700	42.200	3.69%
E	2450	HEAD	01/19/2016	22.3	21.0	0.100	719	3351	5.060	54.200	50.600	-6.64%
I	750	BODY	11/23/2015	22.0	23.7	0.200	1003	3333	1.740	8.460	8.700	2.84%
E	835	BODY	11/22/2015	20.7	20.7	0.200	4d119	3351	2.000	9.200	10.000	8.70%
E	835	BODY	01/25/2016	21.9	21.0	0.200	4d119	3351	1.910	9.200	9.550	3.80%
K	1750	BODY	01/18/2016	23.5	22.7	0.100	1051	3022	3.750	37.100	37.500	1.08%
H	1750	BODY	01/28/2016	24.3	23.9	0.100	1051	3263	3.940	37.100	39.400	6.20%
I	1900	BODY	01/18/2016	21.1	22.5	0.100	5d141	3333	4.060	40.000	40.600	1.50%
J	1900	BODY	01/21/2016	22.1	21.6	0.100	5d149	3319	3.960	40.400	39.600	-1.98%
I	1900	BODY	01/25/2016	21.5	23.5	0.100	5d141	3333	4.070	40.000	40.700	1.75%
J	2450	BODY	01/19/2016	21.7	21.5	0.100	797	3319	4.990	51.500	49.900	-3.11%



**Figure 10-1**  
**System Verification Setup Diagram**



**Figure 10-2**  
**System Verification Setup Photo**

FCC ID A3LSMJ320A		SAR EVALUATION REPORT		Reviewed by: Quality Manager
Document S/N: OY1511191972-R2.A3L	Test Dates: 11/17/2015 - 01/28/2016	DUT Type: Portable Handset		Page 45 of 63

# 11 SAR DATA SUMMARY

## 11.1 Standalone Head SAR Data

**Table 11-1  
GSM 850 Head SAR**



MEASUREMENT RESULTS														
FREQUENCY		Mode/Band	Service	Maximum Allowed Power [dBm]	Conducted Power [dBm]	Power Drift [dB]	Side	Test Position	Device Serial Number	Duty Cycle	SAR (1g)	Scaling Factor	Reported SAR (1g)	Plot #
MHz	Ch.										(W/kg)		(W/kg)	
836.60	190	GSM 850	GSM	33.5	32.82	-0.13	Right	Cheek	03061	1:8.3	0.336	1.169	0.393	
836.60	190	GSM 850	GSM	33.5	32.82	0.07	Right	Tilt	03061	1:8.3	0.212	1.169	0.248	
836.60	190	GSM 850	GSM	33.5	32.82	-0.01	Left	Cheek	03061	1:8.3	0.343	1.169	0.401	A1
836.60	190	GSM 850	GSM	33.5	32.82	0.05	Left	Tilt	03061	1:8.3	0.215	1.169	0.251	
ANSI / IEEE C95.1 1992 - SAFETY LIMIT Spatial Peak Uncontrolled Exposure/General Population								Head 1.6 W/kg (mW/g) averaged over 1 gram						

**Table 11-2  
UMTS 850 Head SAR**

MEASUREMENT RESULTS														
FREQUENCY		Mode/Band	Service	Maximum Allowed Power [dBm]	Conducted Power [dBm]	Power Drift [dB]	Side	Test Position	Device Serial Number	Duty Cycle	SAR (1g)	Scaling Factor	Reported SAR (1g)	Plot #
MHz	Ch.										(W/kg)		(W/kg)	
836.60	4183	UMTS 850	RMC	24.3	23.48	0.04	Right	Cheek	62364	1:1	0.335	1.208	0.405	A2
836.60	4183	UMTS 850	RMC	24.3	23.48	0.01	Right	Tilt	62364	1:1	0.224	1.208	0.271	
836.60	4183	UMTS 850	RMC	24.3	23.48	0.02	Left	Cheek	62364	1:1	0.323	1.208	0.390	
836.60	4183	UMTS 850	RMC	24.3	23.48	0.03	Left	Tilt	62364	1:1	0.222	1.208	0.268	
ANSI / IEEE C95.1 1992 - SAFETY LIMIT Spatial Peak Uncontrolled Exposure/General Population								Head 1.6 W/kg (mW/g) averaged over 1 gram						

**Table 11-3  
UMTS 1750 Head SAR**

MEASUREMENT RESULTS														
FREQUENCY		Mode/Band	Service	Maximum Allowed Power [dBm]	Conducted Power [dBm]	Power Drift [dB]	Side	Test Position	Device Serial Number	Duty Cycle	SAR (1g)	Scaling Factor	Reported SAR (1g)	Plot #
MHz	Ch.										(W/kg)		(W/kg)	
1732.40	1412	UMTS 1750	RMC	23.2	22.35	-0.04	Right	Cheek	56721	1:1	0.311	1.216	0.378	
1732.40	1412	UMTS 1750	RMC	23.2	22.35	-0.04	Right	Tilt	56721	1:1	0.116	1.216	0.141	
1732.40	1412	UMTS 1750	RMC	23.2	22.35	0.08	Left	Cheek	56721	1:1	0.543	1.216	0.660	A3
1732.40	1412	UMTS 1750	RMC	23.2	22.35	0.07	Left	Tilt	56721	1:1	0.144	1.216	0.175	
ANSI / IEEE C95.1 1992 - SAFETY LIMIT Spatial Peak Uncontrolled Exposure/General Population								Head 1.6 W/kg (mW/g) averaged over 1 gram						

FCC ID A3LSMJ320A			SAR EVALUATION REPORT				Reviewed by: Quality Manager
Document S/N: OY1511191972-R2.A3L	Test Dates: 11/17/2015 - 01/28/2016	DUT Type: Portable Handset		Page 46 of 63			

**Table 11-4  
GSM 1900 Head SAR**



MEASUREMENT RESULTS														
FREQUENCY		Mode/Band	Service	Maximum Allowed Power [dBm]	Conducted Power [dBm]	Power Drift [dB]	Side	Test Position	Device Serial Number	Duty Cycle	SAR (1g)	Scaling Factor	Reported SAR (1g)	Plot #
MHz	Ch.										(W/kg)		(W/kg)	
1880.00	661	GSM 1900	GSM	30.5	29.38	0.03	Right	Cheek	03061	1:8.3	0.130	1.294	0.168	
1880.00	661	GSM 1900	GSM	30.5	29.38	0.11	Right	Tilt	03061	1:8.3	0.048	1.294	0.062	
1880.00	661	GSM 1900	GSM	30.5	29.38	-0.08	Left	Cheek	03061	1:8.3	0.282	1.294	0.365	A4
1880.00	661	GSM 1900	GSM	30.5	29.38	0.04	Left	Tilt	03061	1:8.3	0.078	1.294	0.101	
ANSI / IEEE C95.1 1992 - SAFETY LIMIT Spatial Peak Uncontrolled Exposure/General Population							Head 1.6 W/kg (mW/g) averaged over 1 gram							

**Table 11-5  
UMTS 1900 Head SAR**

MEASUREMENT RESULTS														
FREQUENCY		Mode/Band	Service	Maximum Allowed Power [dBm]	Conducted Power [dBm]	Power Drift [dB]	Side	Test Position	Device Serial Number	Duty Cycle	SAR (1g)	Scaling Factor	Reported SAR (1g)	Plot #
MHz	Ch.										(W/kg)		(W/kg)	
1880.00	9400	UMTS 1900	RMC	24.0	22.94	0.07	Right	Cheek	62364	1:1	0.408	1.276	0.521	
1880.00	9400	UMTS 1900	RMC	24.0	22.94	0.04	Right	Tilt	62364	1:1	0.128	1.276	0.163	
1880.00	9400	UMTS 1900	RMC	24.0	22.94	-0.06	Left	Cheek	62364	1:1	0.583	1.276	0.744	A5
1880.00	9400	UMTS 1900	RMC	24.0	22.94	-0.02	Left	Tilt	62364	1:1	0.173	1.276	0.221	
ANSI / IEEE C95.1 1992 - SAFETY LIMIT Spatial Peak Uncontrolled Exposure/General Population							Head 1.6 W/kg (mW/g) averaged over 1 gram							

**Table 11-6  
LTE Band 12 Head SAR**

MEASUREMENT RESULTS																			
FREQUENCY		Mode	Bandwidth [MHz]	Maximum Allowed Power [dBm]	Conducted Power [dBm]	Power Drift [dB]	MPR [dB]	Side	Test Position	Modulation	RB Size	RB Offset	Device Serial Number	Duty Cycle	SAR (1g)	Scaling Factor	Reported SAR (1g)	Plot #	
MHz	Ch.														(W/kg)		(W/kg)		
707.50	23095	Mid	LTE Band 12	10	24.5	23.57	0.11	0	Right	Cheek	QPSK	1	0	56721	1:1	0.391	1.239	0.484	
707.50	23095	Mid	LTE Band 12	10	23.5	22.79	-0.02	1	Right	Cheek	QPSK	25	0	56721	1:1	0.298	1.178	0.351	
707.50	23095	Mid	LTE Band 12	10	24.5	23.57	-0.03	0	Right	Tilt	QPSK	1	0	56721	1:1	0.234	1.239	0.290	
707.50	23095	Mid	LTE Band 12	10	23.5	22.79	0.04	1	Right	Tilt	QPSK	25	0	56721	1:1	0.176	1.178	0.207	
707.50	23095	Mid	LTE Band 12	10	24.5	23.57	-0.10	0	Left	Cheek	QPSK	1	0	56721	1:1	0.400	1.239	0.496	A6
707.50	23095	Mid	LTE Band 12	10	23.5	22.79	-0.20	1	Left	Cheek	QPSK	25	0	56721	1:1	0.299	1.178	0.352	
707.50	23095	Mid	LTE Band 12	10	24.5	23.57	-0.01	0	Left	Tilt	QPSK	1	0	56721	1:1	0.267	1.239	0.331	
707.50	23095	Mid	LTE Band 12	10	23.5	22.79	0.15	1	Left	Tilt	QPSK	25	0	56721	1:1	0.185	1.178	0.218	
ANSI / IEEE C95.1 1992 - SAFETY LIMIT Spatial Peak Uncontrolled Exposure/General Population							Head 1.6 W/kg (mW/g) averaged over 1 gram												

FCC ID A3LSMJ320A		SAR EVALUATION REPORT		Reviewed by: Quality Manager
Document S/N: OY1511191972-R2.A3L	Test Dates: 11/17/2015 - 01/28/2016	DUT Type: Portable Handset	Page 47 of 63	

**Table 11-7  
LTE Band 5 (Cell) Head SAR**



MEASUREMENT RESULTS																			
FREQUENCY		Mode	Bandwidth [MHz]	Maximum Allowed Power [dBm]	Conducted Power [dBm]	Power Drift [dB]	MPR [dB]	Side	Test Position	Modulation	RB Size	RB Offset	Device Serial Number	Duty Cycle	SAR (1g) (W/kg)	Scaling Factor	Reported SAR (1g) (W/kg)	Plot #	
MHz	Ch.																		
836.50	20525	Mid	LTE Band 5 (Cell)	10	24.5	23.51	0.01	0	Right	Cheek	QPSK	1	25	62364	1:1	0.406	1.256	0.510	
836.50	20525	Mid	LTE Band 5 (Cell)	10	23.5	22.71	0.08	1	Right	Cheek	QPSK	25	0	62364	1:1	0.294	1.199	0.353	
836.50	20525	Mid	LTE Band 5 (Cell)	10	24.5	23.51	-0.06	0	Right	Tilt	QPSK	1	25	62364	1:1	0.280	1.256	0.352	
836.50	20525	Mid	LTE Band 5 (Cell)	10	23.5	22.71	0.03	1	Right	Tilt	QPSK	25	0	62364	1:1	0.190	1.199	0.228	
836.50	20525	Mid	LTE Band 5 (Cell)	10	24.5	23.51	0.05	0	Left	Cheek	QPSK	1	25	62364	1:1	0.448	1.256	0.563	A7
836.50	20525	Mid	LTE Band 5 (Cell)	10	23.5	22.71	0.14	1	Left	Cheek	QPSK	25	0	62364	1:1	0.301	1.199	0.361	
836.50	20525	Mid	LTE Band 5 (Cell)	10	24.5	23.51	-0.03	0	Left	Tilt	QPSK	1	25	62364	1:1	0.308	1.256	0.387	
836.50	20525	Mid	LTE Band 5 (Cell)	10	23.5	22.71	-0.10	1	Left	Tilt	QPSK	25	0	62364	1:1	0.202	1.199	0.242	
ANSI / IEEE C95.1 1992 - SAFETY LIMIT Spatial Peak Uncontrolled Exposure/General Population									Head 1.6 W/kg (mW/g) averaged over 1 gram										

**Table 11-8  
LTE Band 4 (AWS) Head SAR**

MEASUREMENT RESULTS																			
FREQUENCY		Mode	Bandwidth [MHz]	Maximum Allowed Power [dBm]	Conducted Power [dBm]	Power Drift [dB]	MPR [dB]	Side	Test Position	Modulation	RB Size	RB Offset	Device Serial Number	Duty Cycle	SAR (1g) (W/kg)	Scaling Factor	Reported SAR (1g) (W/kg)	Plot #	
MHz	Ch.																		
1732.50	20175	Mid	LTE Band 4 (AWS)	20	24.5	23.81	0.01	0	Right	Cheek	QPSK	1	50	08102	1:1	0.379	1.172	0.444	
1732.50	20175	Mid	LTE Band 4 (AWS)	20	23.5	22.18	-0.09	1	Right	Cheek	QPSK	50	25	08102	1:1	0.282	1.355	0.382	
1732.50	20175	Mid	LTE Band 4 (AWS)	20	24.5	23.81	-0.18	0	Right	Tilt	QPSK	1	50	08102	1:1	0.141	1.172	0.165	
1732.50	20175	Mid	LTE Band 4 (AWS)	20	23.5	22.18	-0.09	1	Right	Tilt	QPSK	50	25	08102	1:1	0.101	1.355	0.137	
1732.50	20175	Mid	LTE Band 4 (AWS)	20	24.5	23.81	-0.05	0	Left	Cheek	QPSK	1	50	08102	1:1	0.630	1.172	0.738	A8
1732.50	20175	Mid	LTE Band 4 (AWS)	20	23.5	22.18	0.01	1	Left	Cheek	QPSK	50	25	08102	1:1	0.493	1.355	0.668	
1732.50	20175	Mid	LTE Band 4 (AWS)	20	24.5	23.81	-0.01	0	Left	Tilt	QPSK	1	50	08102	1:1	0.234	1.172	0.274	
1732.50	20175	Mid	LTE Band 4 (AWS)	20	23.5	22.18	0.05	1	Left	Tilt	QPSK	50	25	08102	1:1	0.172	1.355	0.233	
ANSI / IEEE C95.1 1992 - SAFETY LIMIT Spatial Peak Uncontrolled Exposure/General Population									Head 1.6 W/kg (mW/g) averaged over 1 gram										

**Table 11-9  
LTE Band 2 (PCS) Head SAR**

MEASUREMENT RESULTS																			
FREQUENCY		Mode	Bandwidth [MHz]	Maximum Allowed Power [dBm]	Conducted Power [dBm]	Power Drift [dB]	MPR [dB]	Side	Test Position	Modulation	RB Size	RB Offset	Device Serial Number	Duty Cycle	SAR (1g) (W/kg)	Scaling Factor	Reported SAR (1g) (W/kg)	Plot #	
MHz	Ch.																		
1900.00	19100	High	LTE Band 2 (PCS)	20	24.3	23.95	0.09	0	Right	Cheek	QPSK	1	50	62364	1:1	0.332	1.084	0.360	
1900.00	19100	High	LTE Band 2 (PCS)	20	23.3	22.80	0.14	1	Right	Cheek	QPSK	50	25	62364	1:1	0.244	1.122	0.274	
1900.00	19100	High	LTE Band 2 (PCS)	20	24.3	23.95	-0.03	0	Right	Tilt	QPSK	1	50	62364	1:1	0.133	1.084	0.144	
1900.00	19100	High	LTE Band 2 (PCS)	20	23.3	22.80	0.02	1	Right	Tilt	QPSK	50	25	62364	1:1	0.118	1.122	0.132	
1900.00	19100	High	LTE Band 2 (PCS)	20	24.3	23.95	-0.10	0	Left	Cheek	QPSK	1	50	62364	1:1	0.688	1.084	0.746	A9
1900.00	19100	High	LTE Band 2 (PCS)	20	23.3	22.80	-0.11	1	Left	Cheek	QPSK	50	25	62364	1:1	0.555	1.122	0.623	
1900.00	19100	High	LTE Band 2 (PCS)	20	24.3	23.95	0.11	0	Left	Tilt	QPSK	1	50	62364	1:1	0.174	1.084	0.189	
1900.00	19100	High	LTE Band 2 (PCS)	20	23.3	22.80	-0.03	1	Left	Tilt	QPSK	50	25	62364	1:1	0.135	1.122	0.151	
ANSI / IEEE C95.1 1992 - SAFETY LIMIT Spatial Peak Uncontrolled Exposure/General Population									Head 1.6 W/kg (mW/g) averaged over 1 gram										

FCC ID A3LSMJ320A		SAR EVALUATION REPORT		Reviewed by: Quality Manager
Document S/N: OY1511191972-R2.A3L	Test Dates: 11/17/2015 - 01/28/2016	DUT Type: Portable Handset		Page 48 of 63

**Table 11-10  
WLAN Head SAR**

MEASUREMENT RESULTS																		
FREQUENCY		Mode	Service	Bandwidth [MHz]	Maximum Allowed Power [dBm]	Conducted Power [dBm]	Power Drift [dB]	Side	Test Position	Device Serial Number	Data Rate (Mbps)	Duty Cycle (%)	Peak SAR of Area Scan	SAR (1g)	Scaling Factor (Power)	Scaling Factor (Duty Cycle)	Reported SAR (1g)	Plot #
MHz	Ch.												(W/kg)	(W/kg)	(W/kg)	(W/kg)		
2462	11	802.11b	DSSS	22	10.5	10.46	-	Right	Cheek	08102	1	99.9	0.355	-	1.009	1.001	-	
2462	11	802.11b	DSSS	22	10.5	10.46	-	Right	Tilt	08102	1	99.9	0.262	-	1.009	1.001	-	
2462	11	802.11b	DSSS	22	10.5	10.46	0.08	Left	Cheek	08102	1	99.9	0.582	0.494	1.009	1.001	0.498	A10
2462	11	802.11b	DSSS	22	10.5	10.46	0.01	Left	Tilt	08102	1	99.9	0.442	0.382	1.009	1.001	0.385	
ANSI / IEEE C95.1 1992 - SAFETY LIMIT Spatial Peak Uncontrolled Exposure/General Population										Head 1.6 W/kg (mW/g) averaged over 1 gram								

**11.2 Standalone Body-Worn SAR Data**

**Table 11-11  
GSM/UMTS Body-Worn SAR Data**



MEASUREMENT RESULTS															
FREQUENCY		Mode	Service	Maximum Allowed Power [dBm]	Conducted Power [dBm]	Power Drift [dB]	Spacing	Device Serial Number	# of Time Slots	Duty Cycle	Side	SAR (1g)	Scaling Factor	Reported SAR (1g)	Plot #
MHz	Ch.											(W/kg)	(W/kg)	(W/kg)	
836.60	190	GSM 850	GSM	33.5	32.82	-0.01	10 mm	08102	1	1.8.3	back	0.649	1.169	0.759	A11
836.60	4183	UMTS 850	RMC	24.3	23.48	-0.03	10 mm	62364	N/A	1:1	back	0.496	1.208	0.599	A13
1712.40	1312	UMTS 1750	RMC	23.2	22.29	0.03	10 mm	08102	N/A	1:1	back	0.677	1.233	0.835	
1732.40	1412	UMTS 1750	RMC	23.2	22.35	0.01	10 mm	08102	N/A	1:1	back	0.678	1.216	0.824	A14
1752.60	1513	UMTS 1750	RMC	23.2	22.28	-0.01	10 mm	08102	N/A	1:1	back	0.601	1.236	0.743	
1880.00	661	GSM 1900	GSM	30.5	29.38	-0.07	10 mm	03061	1	1.8.3	back	0.238	1.294	0.308	A16
1880.00	9400	UMTS 1900	RMC	24.0	22.94	-0.03	15 mm	08102	N/A	1:1	back	0.217	1.276	0.277	A18
ANSI / IEEE C95.1 1992 - SAFETY LIMIT Spatial Peak Uncontrolled Exposure/General Population										Body 1.6 W/kg (mW/g) averaged over 1 gram					

**Table 11-12  
LTE Body-Worn SAR**

MEASUREMENT RESULTS																			
FREQUENCY		Mode	Bandwidth [MHz]	Maximum Allowed Power [dBm]	Conducted Power [dBm]	Power Drift [dB]	MPR [dB]	Device Serial Number	Modulation	RB Size	RB Offset	Spacing	Side	Duty Cycle	SAR (1g)	Scaling Factor	Reported SAR (1g)	Plot #	
MHz	Ch.														(W/kg)	(W/kg)	(W/kg)		
707.50	23095	Mid	LTE Band 12	10	24.5	23.57	-0.06	0	56721	QPSK	1	0	10 mm	back	1:1	0.487	1.239	0.603	A20
707.50	23095	Mid	LTE Band 12	10	23.5	22.79	0.03	1	56721	QPSK	25	0	10 mm	back	1:1	0.376	1.178	0.443	
836.50	20525	Mid	LTE Band 5 (Cell)	10	24.5	23.51	0.00	0	62364	QPSK	1	25	10 mm	back	1:1	0.668	1.256	0.839	A21
836.50	20525	Mid	LTE Band 5 (Cell)	10	23.5	22.71	-0.09	1	62364	QPSK	25	0	10 mm	back	1:1	0.456	1.199	0.547	
836.50	20525	Mid	LTE Band 5 (Cell)	10	23.5	22.63	0.01	1	62364	QPSK	50	0	10 mm	back	1:1	0.443	1.222	0.541	
1732.50	20175	Mid	LTE Band 4 (AWS)	20	24.5	23.81	-0.06	0	08102	QPSK	1	50	15 mm	back	1:1	0.598	1.172	0.701	A22
1732.50	20175	Mid	LTE Band 4 (AWS)	20	23.5	22.18	-0.06	1	08102	QPSK	50	25	15 mm	back	1:1	0.450	1.355	0.610	
1900.00	19100	High	LTE Band 2 (PCS)	20	24.3	23.95	-0.12	0	08102	QPSK	1	50	15 mm	back	1:1	0.324	1.084	0.351	A24
1900.00	19100	High	LTE Band 2 (PCS)	20	23.3	22.80	-0.02	1	08102	QPSK	50	25	15 mm	back	1:1	0.232	1.122	0.260	
ANSI / IEEE C95.1 1992 - SAFETY LIMIT Spatial Peak Uncontrolled Exposure/General Population										Body 1.6 W/kg (mW/g) averaged over 1 gram									

**Table 11-13  
DTS Body-Worn SAR**

MEASUREMENT RESULTS																		
FREQUENCY		Mode	Service	Bandwidth [MHz]	Maximum Allowed Power [dBm]	Conducted Power [dBm]	Power Drift [dB]	Spacing	Device Serial Number	Data Rate (Mbps)	Side	Duty Cycle (%)	Peak SAR of Area Scan	SAR (1g)	Scaling Factor (Power)	Scaling Factor (Duty Cycle)	Reported SAR (1g)	Plot #
MHz	Ch.												(W/kg)	(W/kg)	(W/kg)	(W/kg)		
2462	11	802.11b	DSSS	22	16.5	15.76	-0.09	10 mm	08102	1	back	99.9	0.404	0.324	1.186	1.001	0.384	A26
ANSI / IEEE C95.1 1992 - SAFETY LIMIT Spatial Peak Uncontrolled Exposure/General Population										Body 1.6 W/kg (mW/g) averaged over 1 gram								



FCC ID A3LSMJ320A		<b>SAR EVALUATION REPORT</b>		<b>Reviewed by:</b> Quality Manager
<b>Document S/N:</b> OY1511191972-R2.A3L	<b>Test Dates:</b> 11/17/2015 - 01/28/2016	<b>DUT Type:</b> Portable Handset	Page 49 of 63	

# 11.3 Standalone Wireless Router SAR Data

Table 11-14  
GPRS/UMTS Hotspot SAR Data

MEASUREMENT RESULTS															
FREQUENCY		Mode	Service	Maximum Allowed Power [dBm]	Conducted Power [dBm]	Power Drift [dB]	Spacing	Device Serial Number	# of GPRS Slots	Duty Cycle	Side	SAR (1g)	Scaling Factor	Reported SAR (1g)	Plot #
MHz	Ch.											(W/kg)		(W/kg)	
824.20	128	GSM 850	GPRS	32.5	31.95	-0.03	10 mm	08102	2	1:4.15	back	0.967	1.135	1.098	A12
836.60	190	GSM 850	GPRS	32.5	31.90	0.04	10 mm	08102	2	1:4.15	back	0.955	1.148	1.096	
848.80	251	GSM 850	GPRS	32.5	31.85	0.00	10 mm	08102	2	1:4.15	back	0.759	1.161	0.881	
824.20	128	GSM 850	GPRS	32.5	31.95	-0.02	10 mm	08102	2	1:4.15	front	0.778	1.135	0.883	
836.60	190	GSM 850	GPRS	32.5	31.90	0.02	10 mm	08102	2	1:4.15	front	0.735	1.148	0.844	
848.80	251	GSM 850	GPRS	32.5	31.85	0.03	10 mm	08102	2	1:4.15	front	0.577	1.161	0.670	
836.60	190	GSM 850	GPRS	32.5	31.90	0.04	10 mm	08102	2	1:4.15	bottom	0.131	1.148	0.150	
836.60	190	GSM 850	GPRS	32.5	31.90	-0.06	10 mm	08102	2	1:4.15	right	0.623	1.148	0.715	
836.60	190	GSM 850	GPRS	32.5	31.90	-0.04	10 mm	08102	2	1:4.15	left	0.620	1.148	0.712	
824.20	128	GSM 850	GPRS	32.5	31.95	-0.03	10 mm	08102	2	1:4.15	back	0.926	1.135	1.051	
836.60	4183	UMTS 850	RMC	24.3	23.48	-0.03	10 mm	62364	N/A	1:1	back	0.496	1.208	0.599	A13
836.60	4183	UMTS 850	RMC	24.3	23.48	0.02	10 mm	62364	N/A	1:1	front	0.412	1.208	0.498	
836.60	4183	UMTS 850	RMC	24.3	23.48	-0.01	10 mm	62364	N/A	1:1	bottom	0.102	1.208	0.123	
836.60	4183	UMTS 850	RMC	24.3	23.48	-0.02	10 mm	62364	N/A	1:1	right	0.386	1.208	0.466	
836.60	4183	UMTS 850	RMC	24.3	23.48	0.00	10 mm	62364	N/A	1:1	left	0.319	1.208	0.385	
1712.40	1312	UMTS 1750	RMC	23.2	22.29	0.03	10 mm	08102	N/A	1:1	back	0.677	1.233	0.835	
1732.40	1412	UMTS 1750	RMC	23.2	22.35	0.01	10 mm	08102	N/A	1:1	back	0.678	1.216	0.824	
1752.60	1513	UMTS 1750	RMC	23.2	22.28	-0.01	10 mm	08102	N/A	1:1	back	0.601	1.236	0.743	
1712.40	1312	UMTS 1750	RMC	23.2	22.29	0.06	10 mm	08102	N/A	1:1	front	0.705	1.233	0.869	A15
1732.40	1412	UMTS 1750	RMC	23.2	22.35	0.03	10 mm	08102	N/A	1:1	front	0.696	1.216	0.846	
1752.60	1513	UMTS 1750	RMC	23.2	22.28	0.05	10 mm	08102	N/A	1:1	front	0.626	1.236	0.774	
1732.40	1412	UMTS 1750	RMC	23.2	22.35	0.02	10 mm	08102	N/A	1:1	bottom	0.220	1.216	0.268	
1732.40	1412	UMTS 1750	RMC	23.2	22.35	0.01	10 mm	08102	N/A	1:1	right	0.076	1.216	0.092	
1732.40	1412	UMTS 1750	RMC	23.2	22.35	-0.07	10 mm	08102	N/A	1:1	left	0.293	1.216	0.356	
1880.00	661	GSM 1900	GPRS	28.0	27.39	-0.05	10 mm	03061	2	1:4.15	back	0.278	1.151	0.320	
1880.00	661	GSM 1900	GPRS	28.0	27.39	-0.05	10 mm	03061	2	1:4.15	front	0.326	1.151	0.375	A17
1880.00	661	GSM 1900	GPRS	28.0	27.39	0.02	10 mm	03061	2	1:4.15	bottom	0.095	1.151	0.109	
1880.00	661	GSM 1900	GPRS	28.0	27.39	0.10	10 mm	03061	2	1:4.15	right	0.036	1.151	0.041	
1880.00	661	GSM 1900	GPRS	28.0	27.39	0.01	10 mm	03061	2	1:4.15	left	0.177	1.151	0.204	
1880.00	9400	UMTS 1900	RMC	23.0	22.47	-0.08	10 mm	03384	N/A	1:1	back	0.500	1.130	0.565	
1880.00	9400	UMTS 1900	RMC	23.0	22.47	0.06	10 mm	03384	N/A	1:1	front	0.635	1.130	0.718	A19
1880.00	9400	UMTS 1900	RMC	23.0	22.47	0.02	10 mm	03384	N/A	1:1	bottom	0.187	1.130	0.211	
1880.00	9400	UMTS 1900	RMC	23.0	22.47	0.06	10 mm	03384	N/A	1:1	right	0.079	1.130	0.089	
1880.00	9400	UMTS 1900	RMC	23.0	22.47	-0.01	10 mm	03384	N/A	1:1	left	0.399	1.130	0.451	
ANSI / IEEE C95.1 1992 - SAFETY LIMIT Spatial Peak Uncontrolled Exposure/General Population							Body 1.6 W/kg (mW/g) averaged over 1 gram								

Note: Blue entry represents variability measurement.



FCC ID A3LSMJ320A		SAR EVALUATION REPORT		Reviewed by: Quality Manager
Document S/N: OY1511191972-R2.A3L	Test Dates: 11/17/2015 - 01/28/2016	DUT Type: Portable Handset	Page 50 of 63	

**Table 11-15  
LTE Band 12 Hotspot SAR**

MEASUREMENT RESULTS																			
FREQUENCY		Mode	Bandwidth [MHz]	Maximum Allowed Power [dBm]	Conducted Power [dBm]	Power Drift [dB]	MPR [dB]	Device Serial Number	Modulation	RB Size	RB Offset	Spacing	Side	Duty Cycle	SAR (1g) (W/kg)	Scaling Factor	Reported SAR (1g) (W/kg)	Plot #	
MHz	Ch.																		
707.50	23095	Mid	LTE Band 12	10	24.5	23.57	-0.06	0	56721	QPSK	1	0	10 mm	back	1:1	0.487	1.239	0.603	A20
707.50	23095	Mid	LTE Band 12	10	23.5	22.79	0.03	1	56721	QPSK	25	0	10 mm	back	1:1	0.376	1.178	0.443	
707.50	23095	Mid	LTE Band 12	10	24.5	23.57	0.08	0	56721	QPSK	1	0	10 mm	front	1:1	0.408	1.239	0.506	
707.50	23095	Mid	LTE Band 12	10	23.5	22.79	0.02	1	56721	QPSK	25	0	10 mm	front	1:1	0.309	1.178	0.364	
707.50	23095	Mid	LTE Band 12	10	24.5	23.57	0.02	0	56721	QPSK	1	0	10 mm	bottom	1:1	0.074	1.239	0.092	
707.50	23095	Mid	LTE Band 12	10	23.5	22.79	0.01	1	56721	QPSK	25	0	10 mm	bottom	1:1	0.057	1.178	0.067	
707.50	23095	Mid	LTE Band 12	10	24.5	23.57	-0.01	0	56721	QPSK	1	0	10 mm	right	1:1	0.336	1.239	0.416	
707.50	23095	Mid	LTE Band 12	10	23.5	22.79	0.06	1	56721	QPSK	25	0	10 mm	right	1:1	0.269	1.178	0.317	
707.50	23095	Mid	LTE Band 12	10	24.5	23.57	0.04	0	56721	QPSK	1	0	10 mm	left	1:1	0.310	1.239	0.384	
707.50	23095	Mid	LTE Band 12	10	23.5	22.79	0.09	1	56721	QPSK	25	0	10 mm	left	1:1	0.242	1.178	0.285	
ANSI / IEEE C95.1 1992 - SAFETY LIMIT Spatial Peak Uncontrolled Exposure/General Population								Body 1.6 W/kg (mW/g) averaged over 1 gram											

**Table 11-16  
LTE Band 5 (Cell) Hotspot SAR**

MEASUREMENT RESULTS																			
FREQUENCY		Mode	Bandwidth [MHz]	Maximum Allowed Power [dBm]	Conducted Power [dBm]	Power Drift [dB]	MPR [dB]	Device Serial Number	Modulation	RB Size	RB Offset	Spacing	Side	Duty Cycle	SAR (1g) (W/kg)	Scaling Factor	Reported SAR (1g) (W/kg)	Plot #	
MHz	Ch.																		
836.50	20525	Mid	LTE Band 5 (Cell)	10	24.5	23.51	0.00	0	62364	QPSK	1	25	10 mm	back	1:1	0.668	1.256	0.839	A21
836.50	20525	Mid	LTE Band 5 (Cell)	10	23.5	22.71	-0.09	1	62364	QPSK	25	0	10 mm	back	1:1	0.456	1.199	0.547	
836.50	20525	Mid	LTE Band 5 (Cell)	10	23.5	22.63	0.01	1	62364	QPSK	50	0	10 mm	back	1:1	0.443	1.222	0.541	
836.50	20525	Mid	LTE Band 5 (Cell)	10	24.5	23.51	-0.03	0	62364	QPSK	1	25	10 mm	front	1:1	0.562	1.256	0.706	
836.50	20525	Mid	LTE Band 5 (Cell)	10	23.5	22.71	0.03	1	62364	QPSK	25	0	10 mm	front	1:1	0.382	1.199	0.458	
836.50	20525	Mid	LTE Band 5 (Cell)	10	24.5	23.51	0.06	0	62364	QPSK	1	25	10 mm	bottom	1:1	0.125	1.256	0.157	
836.50	20525	Mid	LTE Band 5 (Cell)	10	23.5	22.71	-0.01	1	62364	QPSK	25	0	10 mm	bottom	1:1	0.091	1.199	0.109	
836.50	20525	Mid	LTE Band 5 (Cell)	10	24.5	23.51	0.02	0	62364	QPSK	1	25	10 mm	right	1:1	0.423	1.256	0.531	
836.50	20525	Mid	LTE Band 5 (Cell)	10	23.5	22.71	0.08	1	62364	QPSK	25	0	10 mm	right	1:1	0.292	1.199	0.350	
836.50	20525	Mid	LTE Band 5 (Cell)	10	24.5	23.51	-0.09	0	62364	QPSK	1	25	10 mm	left	1:1	0.515	1.256	0.647	
836.50	20525	Mid	LTE Band 5 (Cell)	10	23.5	22.71	0.05	1	62364	QPSK	25	0	10 mm	left	1:1	0.366	1.199	0.439	
ANSI / IEEE C95.1 1992 - SAFETY LIMIT Spatial Peak Uncontrolled Exposure/General Population								Body 1.6 W/kg (mW/g) averaged over 1 gram											



FCC ID A3LSMJ320A		<b>SAR EVALUATION REPORT</b>		<b>Reviewed by:</b> Quality Manager
<b>Document S/N:</b> OY1511191972-R2.A3L	<b>Test Dates:</b> 11/17/2015 - 01/28/2016	<b>DUT Type:</b> Portable Handset	Page 51 of 63	

**Table 11-17  
LTE Band 4 (AWS) Hotspot SAR**

MEASUREMENT RESULTS																			
FREQUENCY		Mode	Bandwidth [MHz]	Maximum Allowed Power [dBm]	Conducted Power [dBm]	Power Drift [dB]	MPR [dB]	Device Serial Number	Modulation	RB Size	RB Offset	Spacing	Side	Duty Cycle	SAR (1g) (W/kg)	Scaling Factor	Reported SAR (1g) (W/kg)	Plot #	
MHz	Ch.																		
1732.50	20175	Mid	LTE Band 4 (AWS)	20	22.5	21.81	0.08	0	03087	QPSK	1	50	10 mm	back	1:1	0.631	1.172	0.740	A23
1732.50	20175	Mid	LTE Band 4 (AWS)	20	21.5	20.52	0.02	1	03087	QPSK	50	25	10 mm	back	1:1	0.493	1.253	0.618	
1732.50	20175	Mid	LTE Band 4 (AWS)	20	22.5	21.81	-0.05	0	03087	QPSK	1	50	10 mm	front	1:1	0.623	1.172	0.730	
1732.50	20175	Mid	LTE Band 4 (AWS)	20	21.5	20.52	-0.02	1	03087	QPSK	50	25	10 mm	front	1:1	0.480	1.253	0.601	
1732.50	20175	Mid	LTE Band 4 (AWS)	20	22.5	21.81	0.09	0	03087	QPSK	1	50	10 mm	bottom	1:1	0.205	1.172	0.240	
1732.50	20175	Mid	LTE Band 4 (AWS)	20	21.5	20.52	0.00	1	03087	QPSK	50	25	10 mm	bottom	1:1	0.144	1.253	0.180	
1732.50	20175	Mid	LTE Band 4 (AWS)	20	22.5	21.81	-0.04	0	03087	QPSK	1	50	10 mm	right	1:1	0.074	1.172	0.087	
1732.50	20175	Mid	LTE Band 4 (AWS)	20	21.5	20.52	0.03	1	03087	QPSK	50	25	10 mm	right	1:1	0.055	1.253	0.069	
1732.50	20175	Mid	LTE Band 4 (AWS)	20	22.5	21.81	0.04	0	03087	QPSK	1	50	10 mm	left	1:1	0.317	1.172	0.372	
1732.50	20175	Mid	LTE Band 4 (AWS)	20	21.5	20.52	0.12	1	03087	QPSK	50	25	10 mm	left	1:1	0.244	1.253	0.306	
ANSI / IEEE C95.1 1992 - SAFETY LIMIT Spatial Peak Uncontrolled Exposure/General Population							Body 1.6 W/kg (mW/g) averaged over 1 gram												

**Table 11-18  
LTE Band 2 (PCS) Hotspot SAR**

MEASUREMENT RESULTS																			
FREQUENCY		Mode	Bandwidth [MHz]	Maximum Allowed Power [dBm]	Conducted Power [dBm]	Power Drift [dB]	MPR [dB]	Device Serial Number	Modulation	RB Size	RB Offset	Spacing	Side	Duty Cycle	SAR (1g) (W/kg)	Scaling Factor	Reported SAR (1g) (W/kg)	Plot #	
MHz	Ch.																		
1900.00	19100	High	LTE Band 2 (PCS)	20	22.3	21.67	-0.01	0	03087	QPSK	1	50	10 mm	back	1:1	0.415	1.156	0.480	
1900.00	19100	High	LTE Band 2 (PCS)	20	21.3	20.51	0.06	1	03087	QPSK	50	25	10 mm	back	1:1	0.325	1.199	0.390	
1900.00	19100	High	LTE Band 2 (PCS)	20	22.3	21.67	0.05	0	03087	QPSK	1	50	10 mm	front	1:1	0.497	1.156	0.575	A25
1900.00	19100	High	LTE Band 2 (PCS)	20	21.3	20.51	-0.03	1	03087	QPSK	50	25	10 mm	front	1:1	0.379	1.199	0.454	
1900.00	19100	High	LTE Band 2 (PCS)	20	22.3	21.67	0.03	0	03087	QPSK	1	50	10 mm	bottom	1:1	0.140	1.156	0.162	
1900.00	19100	High	LTE Band 2 (PCS)	20	21.3	20.51	-0.01	1	03087	QPSK	50	25	10 mm	bottom	1:1	0.113	1.199	0.135	
1900.00	19100	High	LTE Band 2 (PCS)	20	22.3	21.67	0.03	0	03087	QPSK	1	50	10 mm	right	1:1	0.079	1.156	0.091	
1900.00	19100	High	LTE Band 2 (PCS)	20	21.3	20.51	0.06	1	03087	QPSK	50	25	10 mm	right	1:1	0.059	1.199	0.071	
1900.00	19100	High	LTE Band 2 (PCS)	20	22.3	21.67	-0.02	0	03087	QPSK	1	50	10 mm	left	1:1	0.352	1.156	0.407	
1900.00	19100	High	LTE Band 2 (PCS)	20	21.3	20.51	0.05	1	03087	QPSK	50	25	10 mm	left	1:1	0.269	1.199	0.323	
ANSI / IEEE C95.1 1992 - SAFETY LIMIT Spatial Peak Uncontrolled Exposure/General Population							Body 1.6 W/kg (mW/g) averaged over 1 gram												

FCC ID A3LSMJ320A		SAR EVALUATION REPORT		Reviewed by: Quality Manager
Document S/N: OY1511191972-R2.A3L	Test Dates: 11/17/2015 - 01/28/2016	DUT Type: Portable Handset	Page 52 of 63	

**Table 11-19  
WLAN Hotspot SAR**

MEASUREMENT RESULTS																		
FREQUENCY		Mode	Service	Bandwidth [MHz]	Maximum Allowed Power [dBm]	Conducted Power [dBm]	Power Drift [dB]	Spacing	Device Serial Number	Data Rate (Mbps)	Side	Duty Cycle (%)	Peak SAR of Area Scan	SAR (1g)	Scaling Factor (Power)	Scaling Factor (Duty Cycle)	Reported SAR (1g)	Plot #
MHz	Ch.												W/kg	(W/kg)			(W/kg)	
2462	11	802.11b	DSSS	22	16.5	15.76	-0.09	10 mm	08102	1	back	99.9	0.404	0.324	1.186	1.001	0.384	
2462	11	802.11b	DSSS	22	16.5	15.76	0.12	10 mm	08102	1	front	99.9	0.455	0.387	1.186	1.001	0.459	A27
2462	11	802.11b	DSSS	22	16.5	15.76	-	10 mm	08102	1	top	99.9	0.288	-	1.186	1.001	-	
2462	11	802.11b	DSSS	22	16.5	15.76	-	10 mm	08102	1	right	99.9	0.116	-	1.186	1.001	-	
ANSI / IEEE C95.1 1992 - SAFETY LIMIT									Body									
Spatial Peak									1.6 W/kg (mW/g)									
Uncontrolled Exposure/General Population									averaged over 1 gram									



## 11.4 SAR Test Notes

### General Notes:

1. The test data reported are the worst-case SAR values according to test procedures specified in IEEE 1528-2013, and FCC KDB Publication 447498 D01v05r02.
2. Batteries are fully charged at the beginning of the SAR measurements.
3. Liquid tissue depth was at least 15.0 cm for all frequencies.
4. The manufacturer has confirmed that the device(s) tested have the same physical, mechanical and thermal characteristics and are within operational tolerances expected for production units.
5. SAR results were scaled to the maximum allowed power to demonstrate compliance per FCC KDB Publication 447498 D01v05r02.
6. Device was tested using a fixed spacing for body-worn accessory testing. A separation distance of 15 mm was considered because the manufacturer has determined that there will be body-worn accessories available in the marketplace for users to support this separation distance.
7. Per FCC KDB Publication 648474 D04v01r02, body-worn SAR was evaluated without a headset connected to the device. Since the standalone reported body-worn SAR was  $\leq 1.2$  W/kg, no additional body-worn SAR evaluations using a headset cable were required.
8. Per FCC KDB 865664 D01v01r04, variability SAR tests were performed when the measured SAR results for a frequency band were greater than 0.8 W/kg. Repeated SAR measurements are highlighted in the tables above for clarity. Please see Section 13 for variability analysis.
9. During SAR Testing for the Wireless Router conditions per FCC KDB Publication 941225 D06v02, the actual Portable Hotspot operation (with actual simultaneous transmission of a transmitter with WIFI) was not activated (See Section 6.6 for more details).

### GSM Test Notes:

1. Body-Worn accessory testing is typically associated with voice operations. Therefore, GSM voice was evaluated for body-worn SAR.
2. Justification for reduced test configurations per KDB Publication 941225 D01v03 and October 2013 TCB Workshop Notes: The source-based frame-averaged output power was evaluated for all GPRS/EDGE slot configurations. The configuration with the highest target frame averaged output power was evaluated for hotspot SAR. When the maximum frame-averaged powers are equivalent across two or more slots (within 0.25 dB), the configuration with the most number of time slots was tested.
3. Per FCC KDB Publication 447498 D01v05r02, if the reported (scaled) SAR measured at the middle channel or highest output power channel for each test configuration is  $\leq 0.8$  W/kg then testing at the other channels is not required for such test configuration(s). When the maximum output power variation across the required test channels is  $> \frac{1}{2}$  dB, instead of the middle channel, the highest output power channel was used.

FCC ID A3LSMJ320A		SAR EVALUATION REPORT		Reviewed by: Quality Manager
Document S/N: OY1511191972-R2.A3L	Test Dates: 11/17/2015 - 01/28/2016	DUT Type: Portable Handset		Page 53 of 63

UMTS Notes:



1. UMTS mode in was tested under RMC 12.2 kbps with HSPA Inactive per KDB Publication 941225 D01v03. AMR and HSPA SAR was not required per the 3G Test Reduction Procedure in KDB Publication 941225 D01v03.
2. Per FCC KDB Publication 447498 D01v05r02, if the reported (scaled) SAR measured at the middle channel or highest output power channel for each test configuration is  $\leq 0.8$  W/kg then testing at the other channels is not required for such test configuration(s). When the maximum output power variation across the required test channels is  $> \frac{1}{2}$  dB, instead of the middle channel, the highest output power channel was used.

LTE Notes:

1. LTE Considerations: LTE test configurations are determined according to SAR Evaluation Considerations for LTE Devices in FCC KDB Publication 941225 D05v02r03. The general test procedures used for testing can be found in Section 8.5.4.
2. MPR is permanently implemented for this device by the manufacturer. The specific manufacturer target MPR is indicated alongside the SAR results. MPR is enabled for this device, according to 3GPP TS36.101 Section 6.2.3 – 6.2.5 under Table 6.2.3-1.
3. A-MPR was disabled for all SAR tests by setting NS=01 on the base station simulator. SAR tests were performed with the same number of RB and RB offsets transmitting on all TTI frames (maximum TTI).
4. Per KDB Publication 941225 D05Av01r01, SAR for LTE CA operations was not needed since the maximum average output power in LTE CA mode was not  $>0.25$  dB higher than the maximum output power when downlink carrier aggregation was inactive.

WLAN Notes:

1. For held-to-ear and hotspot operations, the initial test position procedures were applied. The test position with the highest extrapolated peak SAR will be used as the initial test position. When reported SAR for the initial test position is  $\leq 0.4$  W/kg, no additional testing for the remaining test positions was required. Otherwise, SAR is evaluated at the subsequent highest peak SAR positions until the reported SAR result is  $\leq 0.8$  W/kg or all test positions are measured.
2. Justification for test configurations for WLAN per KDB Publication 248227 D01v02r01 for 2.4 GHz WIFI operations, the highest measured maximum output power channel for DSSS was selected for SAR measurement. SAR for OFDM modes (2.4 GHz 802.11g/n) was not required due to the maximum allowed powers and the highest reported DSSS SAR. See Section 8.6.3 for more information.
3. When the maximum reported 1g averaged SAR is  $\leq 0.8$  W/kg, SAR testing on additional channels was not required. Otherwise, SAR for the next highest output power channel was required until the reported SAR result was  $\leq 1.20$  W/kg or all test channels were measured.
4. The device was configured to transmit continuously at the required data rate, channel bandwidth and signal modulation, using the highest transmission duty factor supported by the test mode tools. The reported SAR was scaled to the 100% transmission duty factor to determine compliance. Procedures used to measure the duty factor are identical to that in the associated EMC test reports.

FCC ID A3LSMJ320A	 <b>SAR EVALUATION REPORT</b> 		Reviewed by: Quality Manager
Document S/N: OY1511191972-R2.A3L	Test Dates: 11/17/2015 - 01/28/2016	DUT Type: Portable Handset	Page 54 of 63

## 12 FCC MULTI-TX AND ANTENNA SAR CONSIDERATIONS

### 12.1 Introduction

The following procedures adopted from FCC KDB Publication 447498 D01v05r02 are applicable to devices with built-in unlicensed transmitters such as 802.11 and Bluetooth devices which may simultaneously transmit with the licensed transmitter.

### 12.2 Simultaneous Transmission Procedures

This device contains transmitters that may operate simultaneously. Therefore simultaneous transmission analysis is required. Per FCC KDB 447498 D01v05r02 IV.C.1.iii and IEEE 1528-2013 Section 6.3.4.1.2, simultaneous transmission SAR test exclusion may be applied when the sum of the 1-g SAR for all the simultaneous transmitting antennas in a specific physical test configuration is  $\leq 1.6$  W/kg. The different test positions in an exposure condition may be considered collectively to determine SAR test exclusion according to the sum of 1-g or 10-g SAR.



When standalone SAR is not required to be measured, per FCC KDB 447498 D01v05r02 4.3.2 2), the following equation must be used to estimate the standalone 1g SAR for simultaneous transmission assessment involving that transmitter.

$$\text{Estimated SAR} = \frac{\sqrt{f(\text{GHz})}}{7.5} * \frac{(\text{Max Power of channel, mW})}{\text{Min. Separation Distance, mm}}$$

**Table 12-1  
Estimated SAR**

Mode	Frequency	Maximum Allowed Power	Separation Distance (Body)	Estimated SAR (Body)
	[MHz]	[dBm]	[mm]	[W/kg]
Bluetooth	2480	9.00	15	0.112

Note: Held-to ear configurations are not applicable to Bluetooth operations and therefore were not considered for simultaneous transmission. Per KDB Publication 447498 D01v05r02, the maximum power of the channel was rounded to the nearest mW before calculation.

FCC ID A3LSMJ320A		SAR EVALUATION REPORT		Reviewed by: Quality Manager
Document S/N: OY1511191972-R2.A3L	Test Dates: 11/17/2015 - 01/28/2016	DUT Type: Portable Handset		Page 55 of 63

### 12.3 Head SAR Simultaneous Transmission Analysis

**Table 12-2**  
Simultaneous Transmission Scenario with 2.4 GHz WLAN (Held to Ear)



Exposure Condition	Mode	2G/3G/4G SAR (W/kg)	2.4 GHz WLAN SAR (W/kg)	Σ SAR (W/kg)
Head SAR	GSM 850	0.401	0.498	0.899
	UMTS 850	0.405	0.498	0.903
	UMTS 1750	0.660	0.498	1.158
	GSM 1900	0.365	0.498	0.863
	UMTS 1900	0.744	0.498	1.242
	LTE Band 12	0.496	0.498	0.994
	LTE Band 5 (Cell)	0.563	0.498	1.061
	LTE Band 4 (AWS)	0.738	0.498	1.236
	LTE Band 2 (PCS)	0.746	0.498	<b>1.244</b>

### 12.4 Body-Worn Simultaneous Transmission Analysis

**Table 12-3**  
Simultaneous Transmission Scenario with 2.4 GHz WLAN (Body-Worn at 1.5 cm)

Exposure Condition	Mode	2G/3G/4G SAR (W/kg)	2.4 GHz WLAN SAR (W/kg)	Σ SAR (W/kg)
Body-Worn	GSM 850	0.759	0.384	1.143
	UMTS 850	0.599	0.384	0.983
	UMTS 1750	0.835	0.384	1.219
	GSM 1900	0.308	0.384	0.692
	UMTS 1900	0.277	0.384	0.661
	LTE Band 12	0.603	0.384	0.987
	LTE Band 5 (Cell)	0.839	0.384	<b>1.223</b>
	LTE Band 4 (AWS)	0.701	0.384	1.085
	LTE Band 2 (PCS)	0.351	0.384	0.735

Note: For SAR summation for body-worn back side at 1.5 cm, the SAR values at 1.0 cm for some transmission modes were used since the 1.0 cm test distance was more conservative.

FCC ID A3LSMJ320A	 PCTEST Engineering Laboratory, Inc.	SAR EVALUATION REPORT		Reviewed by: Quality Manager
Document S/N: OY1511191972-R2.A3L	Test Dates: 11/17/2015 - 01/28/2016	DUT Type: Portable Handset		Page 56 of 63

**Table 12-4**  
**Simultaneous Transmission Scenario with Bluetooth (Body-Worn at 1.5 cm)**

Exposure Condition	Mode	2G/3G/4G SAR (W/kg)	Bluetooth SAR (W/kg)	Σ SAR (W/kg)
Body-Worn	GSM 850	0.759	0.112	0.871
	UMTS 850	0.599	0.112	0.711
	UMTS 1750	0.835	0.112	0.947
	GSM 1900	0.308	0.112	0.420
	UMTS 1900	0.277	0.112	0.389
	LTE Band 12	0.603	0.112	0.715
	LTE Band 5 (Cell)	0.839	0.112	<b>0.951</b>
	LTE Band 4 (AWS)	0.701	0.112	0.813
	LTE Band 2 (PCS)	0.351	0.112	0.463

Note:

1. Bluetooth SAR was not required to be measured per FCC KDB 447498. Estimated SAR results were used in the above table to determine simultaneous transmission SAR test exclusion.
2. For SAR summation for body-worn back side at 1.5 cm, the SAR values at 1.0 cm for some transmission modes were used since the 1.0 cm test distance was more conservative.



## 12.5 Hotspot SAR Simultaneous Transmission Analysis

**Table 12-5**  
**Simultaneous Transmission Scenario (2.4 GHz Hotspot at 1.0 cm)**

Exposure Condition	Mode	2G/3G/4G SAR (W/kg)	2.4 GHz WLAN SAR (W/kg)	Σ SAR (W/kg)
Hotspot SAR	GPRS 850	1.098	0.459	<b>1.557</b>
	UMTS 850	0.599	0.459	1.058
	UMTS 1750	0.869	0.459	1.328
	GPRS 1900	0.375	0.459	0.834
	UMTS 1900	0.718	0.459	1.177
	LTE Band 12	0.603	0.459	1.062
	LTE Band 5 (Cell)	0.839	0.459	1.298
	LTE Band 4 (AWS)	0.740	0.459	1.199
	LTE Band 2 (PCS)	0.575	0.459	1.034

## 12.6 Simultaneous Transmission Conclusion

The above numerical summed SAR results for all the worst-case simultaneous transmission conditions were below the SAR limit. Therefore, the above analysis is sufficient to determine that simultaneous transmission cases will not exceed the SAR limit and therefore no measured volumetric simultaneous SAR summation is required per FCC KDB Publication 447498 D01v05r02 and IEEE 1528-2013 Section 6.3.4.1.2.

FCC ID A3LSMJ320A		SAR EVALUATION REPORT		Reviewed by: Quality Manager
Document S/N: OY1511191972-R2.A3L	Test Dates: 11/17/2015 - 01/28/2016	DUT Type: Portable Handset		Page 57 of 63

## 13 SAR MEASUREMENT VARIABILITY

### 13.1 Measurement Variability

Per FCC KDB Publication 865664 D01v01r04, SAR measurement variability was assessed for each frequency band, which was determined by the SAR probe calibration point and tissue-equivalent medium used for the device measurements. When both head and body tissue-equivalent media were required for SAR measurements in a frequency band, the variability measurement procedures were applied to the tissue medium with the highest measured SAR, using the highest measured SAR configuration for that tissue-equivalent medium. These additional measurements were repeated after the completion of all measurements requiring the same head or body tissue-equivalent medium in a frequency band. The test device was returned to ambient conditions (normal room temperature) with the battery fully charged before it was re-mounted on the device holder for the repeated measurement(s) to minimize any unexpected variations in the repeated results.

SAR Measurement Variability was assessed using the following procedures for each frequency band:



- 1) When the original highest measured SAR is  $\geq 0.80$  W/kg, the measurement was repeated once.
- 2) A second repeated measurement was performed only if the ratio of largest to smallest SAR for the original and first repeated measurements was  $> 1.20$  or when the original or repeated measurement was  $\geq 1.45$  W/kg (~ 10% from the 1-g SAR limit).
- 3) A third repeated measurement was performed only if the original, first or second repeated measurement was  $\geq 1.5$  W/kg and the ratio of largest to smallest SAR for the original, first and second repeated measurements is  $> 1.20$ .
- 4) Repeated measurements are not required when the original highest measured SAR is  $< 0.80$  W/kg

**Table 13-1  
Body SAR Measurement Variability Results**

BODY VARIABILITY RESULTS													
Band	FREQUENCY		Mode	Service	Side	Spacing	Measured SAR (1g)	1st Repeated SAR (1g)	Ratio	2nd Repeated SAR (1g)	Ratio	3rd Repeated SAR (1g)	Ratio
835	824.20	128	GSM 850	GPRS	back	10 mm	0.967	0.926	1.04	N/A	N/A	N/A	N/A
ANSI / IEEE C95.1 1992 - SAFETY LIMIT Spatial Peak Uncontrolled Exposure/General Population						Body 1.6 W/kg (mW/g) averaged over 1 gram							

### 13.2 Measurement Uncertainty

The measured SAR was  $< 1.5$  W/kg for all frequency bands. Therefore, per KDB Publication 865664 D01v01r04, the extended measurement uncertainty analysis per IEEE 1528-2013 was not required.

FCC ID A3LSMJ320A		SAR EVALUATION REPORT		Reviewed by: Quality Manager
Document S/N: OY1511191972-R2.A3L	Test Dates: 11/17/2015 - 01/28/2016	DUT Type: Portable Handset		Page 58 of 63



# 14 EQUIPMENT LIST

Manufacturer	Model	Description	Cal Date	Cal Interval	Cal Due	Serial Number
Agilent	8594A	(9kHz-2.9GHz) Spectrum Analyzer	N/A	N/A	N/A	3051A00187
Agilent	8648D	(9kHz-4GHz) Signal Generator	3/15/2015	Annual	3/15/2016	3629U00687
Agilent	8753ES	Network Analyzer	3/20/2015	Annual	3/20/2016	MY40001472
Agilent	E4438C	ESG Vector Signal Generator	3/12/2015	Annual	3/12/2016	MY45090700
Agilent	E5515C	Wireless Communications Test Set	3/19/2014	Biennial	3/19/2016	GB45360985
Agilent	E8257D	(250kHz-20GHz) Signal Generator	3/15/2015	Annual	3/15/2016	MY45470194
Agilent	N5182A	MXG Vector Signal Generator	3/16/2015	Annual	3/16/2016	MY47420800
Amplifier Research	15S1G6	Amplifier	N/A	CBT	N/A	433971
Amplifier Research	15S1G6	Amplifier	N/A	CBT	N/A	433972
Anritsu	MA24106A	USB Power Sensor	3/2/2015	Annual	3/2/2016	1344555
Anritsu	MA24106A	USB Power Sensor	3/2/2015	Annual	3/2/2016	1344556
Anritsu	MA2411B	Pulse Power Sensor	8/3/2015	Annual	8/3/2016	1126066
Anritsu	MA2481A	Power Sensor	3/10/2015	Annual	3/10/2016	5821
Anritsu	ML2495A	Power Meter	10/16/2015	Biennial	10/16/2017	1328004
Anritsu	ML2496A	Power Meter	3/13/2015	Annual	3/13/2016	1306009
Anritsu	MT8820C	Radio Communication Analyzer	6/12/2015	Annual	6/12/2016	6201240328
Anritsu	MT8820C	Radio Communication Analyzer	7/24/2015	Annual	7/24/2016	6200901190
COMTech	AR85729-5	Solid State Amplifier	N/A	CBT	N/A	M155A00-009
Control Company	4040	Digital Thermometer	3/18/2015	Biennial	3/18/2017	150194896
Control Company	4353	Long Stem Thermometer	1/22/2015	Biennial	1/22/2017	150053081
Keysight	772D	Dual Directional Coupler	N/A	CBT	N/A	MY52180215
MCL	BW-N6W5+	6dB Attenuator	N/A	CBT	N/A	1139
MiniCircuits	SLP-2400+	Low Pass Filter	N/A	CBT	N/A	R8979500903
Mini-Circuits	BW-N20W5	Power Attenuator	N/A	CBT	N/A	1226
Mini-Circuits	BW-N20W5+	DC to 18 GHz Precision Fixed 20 dB Attenuator	N/A	CBT	N/A	N/A
Mini-Circuits	NLP-1200+	Low Pass Filter DC to 1000 MHz	N/A	CBT	N/A	N/A
Mini-Circuits	NLP-2950+	Low Pass Filter DC to 2700 MHz	N/A	CBT	N/A	N/A
Mitutoyo	CD-6"CSX	Digital Caliper	5/8/2014	Biennial	5/8/2016	13264162
Narda	4014C-6	4 - 8 GHz SMA 6 dB Directional Coupler	N/A	CBT	N/A	N/A
Narda	4772-3	Attenuator (3dB)	N/A	CBT	N/A	9406
Pasternack	PE2209-10	Bidirectional Coupler	N/A	CBT	N/A	N/A
Pasternack	NC-100	Torque Wrench	5/21/2015	Biennial	5/21/2017	N/A
Pasternack	PE2208-6	Bidirectional Coupler	N/A	CBT	N/A	N/A
Rohde & Schwarz	CMU200	Base Station Simulator	6/3/2015	Annual	6/3/2016	109892
SPEAG	DAK-3.5	Dielectric Assessment Kit	10/20/2015	Annual	10/20/2016	1091
Rohde & Schwarz	CMW500	Radio Communication Tester	3/18/2015	Annual	3/18/2016	128633
Seekonk	NC-100	Torque Wrench 5/16", 8" lbs	3/18/2014	Biennial	3/18/2016	N/A
Seekonk	NC-100	Torque Wrench	3/18/2014	Biennial	3/18/2016	N/A
SPEAG	D750V3	750 MHz Dipole	3/11/2015	Annual	3/11/2016	1054
SPEAG	D835V2	835 MHz SAR Dipole	4/13/2015	Annual	4/13/2016	4d119
SPEAG	D1750V2	1750 MHz SAR Dipole	4/15/2015	Annual	4/15/2016	1051
SPEAG	D1900V2	1900 MHz SAR Dipole	4/14/2015	Annual	4/14/2016	5d141
SPEAG	D1900V2	1900 MHz SAR Dipole	7/14/2015	Annual	7/14/2016	5d149
SPEAG	D2450V2	2450 MHz SAR Dipole	8/20/2015	Annual	8/20/2016	719
SPEAG	D750V3	750 MHz SAR Dipole	1/16/2015	Annual	1/16/2016	1003
SPEAG	D2450V2	2450 MHz SAR Dipole	1/15/2015	Annual	1/15/2016	797
SPEAG	DAE4	Dasy Data Acquisition Electronics	2/18/2015	Annual	2/18/2016	665
SPEAG	DAE4	Dasy Data Acquisition Electronics	8/24/2015	Annual	8/24/2016	1322
SPEAG	DAE4	Dasy Data Acquisition Electronics	11/11/2015	Annual	11/11/2016	1415
SPEAG	DAE4	Dasy Data Acquisition Electronics	3/13/2015	Annual	3/13/2016	1368
SPEAG	DAE4	Dasy Data Acquisition Electronics	6/17/2015	Annual	6/17/2016	859
SPEAG	DAE4	Dasy Data Acquisition Electronics	3/13/2015	Annual	3/13/2016	1334
SPEAG	DAE4	Dasy Data Acquisition Electronics	10/27/2015	Annual	10/27/2016	1333
SPEAG	ES3DV2	SAR Probe	8/26/2015	Annual	8/26/2016	3022
SPEAG	ES3DV3	SAR Probe	6/22/2015	Annual	6/22/2016	3351
SPEAG	ES3DV3	SAR Probe	11/17/2015	Annual	11/17/2016	3334
SPEAG	ES3DV3	SAR Probe	3/19/2015	Annual	3/19/2016	3319
SPEAG	ES3DV3	SAR Probe	5/20/2015	Annual	5/20/2016	3263
SPEAG	ES3DV3	SAR Probe	3/19/2015	Annual	3/19/2016	3209
SPEAG	ES3DV3	SAR Probe	10/29/2015	Annual	10/29/2016	3333



**Note:**

- CBT (Calibrated Before Testing). Prior to testing, the measurement paths containing a cable, amplifier, attenuator, coupler or filter were connected to a calibrated source (i.e. a signal generator) to determine the losses of the measurement path. The power meter offset was then adjusted to compensate for the measurement system losses. This level offset is stored within the power meter before measurements are made. This calibration verification procedure applies to the system verification and output power measurements. The calibrated reading is then taken directly from the power meter after compensation of the losses for all final power measurements.

- All equipment was used solely within its calibration period.

FCC ID A3LSMJ320A		<b>SAR EVALUATION REPORT</b>		<b>Reviewed by:</b> Quality Manager
<b>Document S/N:</b> OY1511191972-R2.A3L	<b>Test Dates:</b> 11/17/2015 - 01/28/2016	<b>DUT Type:</b> Portable Handset	Page 59 of 63	

a	c	d	e= f(d,k)	f	g	h = c x f/e	i = c x g/e	k
Uncertainty Component	Tol. (± %)	Prob. Dist.	Div.	c <sub>i</sub> 1gm	c <sub>i</sub> 10 gms	1gm u <sub>i</sub> (± %)	10gms u <sub>i</sub> (± %)	v <sub>i</sub>
<b>Measurement System</b>								
Probe Calibration	6.55	N	1	1.0	1.0	6.6	6.6	∞
Axial Isotropy	0.25	N	1	0.7	0.7	0.2	0.2	∞
Hemishperical Isotropy	1.3	N	1	0.7	0.7	0.9	0.9	∞
Boundary Effect	2.0	R	1.73	1.0	1.0	1.2	1.2	∞
Linearity	0.3	N	1	1.0	1.0	0.3	0.3	∞
System Detection Limits	0.25	R	1.73	1.0	1.0	0.1	0.1	∞
Readout Electronics	0.3	N	1	1.0	1.0	0.3	0.3	∞
Response Time	0.8	R	1.73	1.0	1.0	0.5	0.5	∞
Integration Time	2.6	R	1.73	1.0	1.0	1.5	1.5	∞
RF Ambient Conditions - Noise	3.0	R	1.73	1.0	1.0	1.7	1.7	∞
RF Ambient Conditions - Reflections	3.0	R	1.73	1.0	1.0	1.7	1.7	∞
Probe Positioner Mechanical Tolerance	0.4	R	1.73	1.0	1.0	0.2	0.2	∞
Probe Positioning w/ respect to Phantom	6.7	R	1.73	1.0	1.0	3.9	3.9	∞
Extrapolation, Interpolation & Integration algorithms for Max. SAR Evaluation	4.0	R	1.73	1.0	1.0	2.3	2.3	∞
<b>Test Sample Related</b>								
Test Sample Positioning	2.7	N	1	1.0	1.0	2.7	2.7	35
Device Holder Uncertainty	1.67	N	1	1.0	1.0	1.7	1.7	5
Output Power Variation - SAR drift measurement	5.0	R	1.73	1.0	1.0	2.9	2.9	∞
SAR Scaling	0.0	R	1.73	1.0	1.0	0.0	0.0	∞
<b>Phantom &amp; Tissue Parameters</b>								
Phantom Uncertainty (Shape & Thickness tolerances)	7.6	R	1.73	1.0	1.0	4.4	4.4	∞
Liquid Conductivity - measurement uncertainty	4.2	N	1	0.78	0.71	3.3	3.0	10
Liquid Permittivity - measurement uncertainty	4.1	N	1	0.23	0.26	1.0	1.1	10
Liquid Conductivity - Temperature Uncertainty	3.4	R	1.73	0.78	0.71	1.5	1.4	∞
Liquid Permittivity - Temperature Uncertainty	0.6	R	1.73	0.23	0.26	0.1	0.1	∞
Liquid Conductivity - deviation from target values	5.0	R	1.73	0.64	0.43	1.8	1.2	∞
Liquid Permittivity - deviation from target values	5.0	R	1.73	0.60	0.49	1.7	1.4	∞
<b>Combined Standard Uncertainty (k=1)</b>	RSS					11.5	11.3	60
<b>Expanded Uncertainty</b> (95% CONFIDENCE LEVEL)	k=2					23.0	22.6	



FCC ID A3LSMJ320A		SAR EVALUATION REPORT		Reviewed by: Quality Manager
Document S/N: OY1511191972-R2.A3L	Test Dates: 11/17/2015 - 01/28/2016	DUT Type: Portable Handset		Page 60 of 63

# 16 CONCLUSION

## 16.1 Measurement Conclusion



The SAR evaluation indicates that the EUT complies with the RF radiation exposure limits of the FCC and Industry Canada, with respect to all parameters subject to this test. These measurements were taken to simulate the RF effects of RF exposure under worst-case conditions. Precise laboratory measures were taken to assure repeatability of the tests. The results and statements relate only to the item(s) tested.

Please note that the absorption and distribution of electromagnetic energy in the body are very complex phenomena that depend on the mass, shape, and size of the body, the orientation of the body with respect to the field vectors, and the electrical properties of both the body and the environment. Other variables that may play a substantial role in possible biological effects are those that characterize the environment (e.g. ambient temperature, air velocity, relative humidity, and body insulation) and those that characterize the individual (e.g. age, gender, activity level, debilitation, or disease). Because various factors may interact with one another to vary the specific biological outcome of an exposure to electromagnetic fields, any protection guide should consider maximal amplification of biological effects as a result of field-body interactions, environmental conditions, and physiological variables. [3]



FCC ID A3LSMJ320A	 <b>PCTEST</b> ENGINEERING LABORATORY, INC.	<b>SAR EVALUATION REPORT</b>		<b>Reviewed by:</b> Quality Manager
<b>Document S/N:</b> 0Y1511191972-R2.A3L	<b>Test Dates:</b> 11/17/2015 - 01/28/2016	<b>DUT Type:</b> Portable Handset	Page 61 of 63	

## 17 REFERENCES

- [1] Federal Communications Commission, ET Docket 93-62, Guidelines for Evaluating the Environmental Effects of Radiofrequency Radiation, Aug. 1996.
- [2] ANSI/IEEE C95.1-2005, American National Standard safety levels with respect to human exposure to radio frequency electromagnetic fields, 3kHz to 300GHz, New York: IEEE, 2006.
- [3] ANSI/IEEE C95.1-1992, American National Standard safety levels with respect to human exposure to radio frequency electromagnetic fields, 3kHz to 300GHz, New York: IEEE, Sept. 1992.
- [4] ANSI/IEEE C95.3-2002, IEEE Recommended Practice for the Measurement of Potentially Hazardous Electromagnetic Fields - RF and Microwave, New York: IEEE, December 2002.
- [5] IEEE Standards Coordinating Committee 39 –Standards Coordinating Committee 34 – IEEE Std. 1528-2013, Recommended Practice for Determining the Peak Spatial-Average Specific Absorption Rate (SAR) in the Human Head Due to Wireless Communications Devices: Measurement Techniques.
- [6] NCRP, National Council on Radiation Protection and Measurements, Biological Effects and Exposure Criteria for RadioFrequency Electromagnetic Fields, NCRP Report No. 86, 1986. Reprinted Feb. 1995.
- [7] T. Schmid, O. Egger, N. Kuster, Automated E-field scanning system for dosimetric assessments, IEEE Transaction on Microwave Theory and Techniques, vol. 44, Jan. 1996, pp. 105-113.
- [8] K. Pokovic, T. Schmid, N. Kuster, Robust setup for precise calibration of E-field probes in tissue simulating liquids at mobile communications frequencies, ICECOM97, Oct. 1997, pp. 1 -124.
- [9] K. Pokovic, T. Schmid, and N. Kuster, E-field Probe with improved isotropy in brain simulating liquids, Proceedings of the ELMAR, Zadar, Croatia, June 23-25, 1996, pp. 172-175.
- [10] Schmid & Partner Engineering AG, Application Note: Data Storage and Evaluation, June 1998, p2.
- [11] V. Hombach, K. Meier, M. Burkhardt, E. Kuhn, N. Kuster, The Dependence of EM Energy Absorption upon Human Modeling at 900 MHz, IEEE Transaction on Microwave Theory and Techniques, vol. 44 no. 10, Oct. 1996, pp. 1865-1873.
- [12] N. Kuster and Q. Balzano, Energy absorption mechanism by biological bodies in the near field of dipole antennas above 300MHz, IEEE Transaction on Vehicular Technology, vol. 41, no. 1, Feb. 1992, pp. 17-23.
- [13] G. Hartsgrrove, A. Kraszewski, A. Surowiec, Simulated Biological Materials for Electromagnetic Radiation Absorption Studies, University of Ottawa, Bioelectromagnetics, Canada: 1987, pp. 29-36.
- [14] Q. Balzano, O. Garay, T. Manning Jr., Electromagnetic Energy Exposure of Simulated Users of Portable Cellular Telephones, IEEE Transactions on Vehicular Technology, vol. 44, no.3, Aug. 1995.
- [15] W. Gander, Computermathematick, Birkhaeuser, Basel, 1992.
- [16] W.H. Press, S.A. Teukolsky, W.T. Vetterling, and B.P. Flannery, Numerical Recipes in C, The Art of Scientific Computing, Second edition, Cambridge University Press, 1992.
- [17] N. Kuster, R. Kastle, T. Schmid, Dosimetric evaluation of mobile communications equipment with known precision, IEEE Transaction on Communications, vol. E80-B, no. 5, May 1997, pp. 645-652.

FCC ID A3LSMJ320A		SAR EVALUATION REPORT		Reviewed by: Quality Manager
Document S/N: OY1511191972-R2.A3L	Test Dates: 11/17/2015 - 01/28/2016	DUT Type: Portable Handset	Page 62 of 63	

- [18] CENELEC CLC/SC111B, European Prestandard (prENV 50166-2), Human Exposure to Electromagnetic Fields High-frequency: 10kHz-300GHz, Jan. 1995.
- [19] Prof. Dr. Niels Kuster, ETH, Eidgenössische Technische Hochschule Zürich, Dosimetric Evaluation of the Cellular Phone.
- [20] IEC 62209-1, Human exposure to radio frequency fields from hand-held and body-mounted wireless communication devices - Human models, instrumentation, and procedures - Part 1: Procedure to determine the specific absorption rate (SAR) for hand-held devices used in close proximity to the ear (frequency range of 300 MHz to 3 GHz), Feb. 2005.
- [21] Industry Canada RSS-102 Radio Frequency Exposure Compliance of Radiocommunication Apparatus (All Frequency Bands) Issue 4, March 2010.
- [22] Health Canada Safety Code 6 Limits of Human Exposure to Radio Frequency Electromagnetic Fields in the Frequency Range from 3 kHz – 300 GHz, 2009
- [23] FCC SAR Test Procedures for 2G-3G Devices, Mobile Hotspot and UMPC Devices KDB Publications 941225, D01-D07
- [24] SAR Measurement Guidance for IEEE 802.11 Transmitters, KDB Publication 248227 D01v02r01
- [25] FCC SAR Considerations for Handsets with Multiple Transmitters and Antennas, KDB Publications 648474 D03-D04
- [26] FCC SAR Evaluation Considerations for Laptop, Notebook, Netbook and Tablet Computers, FCC KDB Publication 616217 D04
- [27] FCC SAR Measurement and Reporting Requirements for 100MHz – 6 GHz, KDB Publications 865664 D01-D02
- [28] FCC General RF Exposure Guidance and SAR Procedures for Dongles, KDB Publication 447498, D01-D02
- [29] Anexo à Resolução No. 533, de 10 de Setembro de 2009.
- [30] IEC 62209-2, Human exposure to radio frequency fields from hand-held and body-mounted wireless communication devices - Human models, instrumentation, and procedures - Part 2: Procedure to determine the specific absorption rate (SAR) for wireless communication devices used in close proximity to the human body (frequency range of 30 MHz to 6 GHz), Mar. 2010.

FCC ID A3LSMJ320A	 <b>SAR EVALUATION REPORT</b> 		<b>Reviewed by:</b> Quality Manager
Document S/N: OY1511191972-R2.A3L	Test Dates: 11/17/2015 - 01/28/2016	DUT Type: Portable Handset	Page 63 of 63

## APPENDIX A: SAR TEST DATA

# PCTEST ENGINEERING LABORATORY, INC.

**DUT: A3LSMJ320A; Type: Portable Handset; Serial: 03061**

Communication System: UID 0, GSM; Frequency: 836.6 MHz; Duty Cycle: 1:8.3  
Medium: 835 Head, Medium parameters used (interpolated):  
 $f = 836.6 \text{ MHz}$ ;  $\sigma = 0.893 \text{ S/m}$ ;  $\epsilon_r = 40.199$ ;  $\rho = 1000 \text{ kg/m}^3$   
Phantom section: Left Section

Test Date: 01-18-2016; Ambient Temp: 24.0°C; Tissue Temp: 22.1°C

Probe: ES3DV3 - SN3334; ConvF(6.37, 6.37, 6.37); Calibrated: 11/17/2015;  
Sensor-Surface: 3mm (Mechanical Surface Detection)  
Electronics: DAE4 Sn1415; Calibrated: 11/11/2015  
Phantom: SAM Front; Type: SAM; Serial: 1686  
Measurement SW: DASY52, Version 52.8 (8); SEMCAD X Version 14.6.10 (7331)

**Mode: GSM 850, Left Head, Cheek, Mid.ch**

**Area Scan (9x14x1):** Measurement grid: dx=15mm, dy=15mm

**Zoom Scan (5x5x7)/Cube 0:** Measurement grid: dx=8mm, dy=8mm, dz=5mm

Reference Value = 20.29 V/m; Power Drift = -0.01 dB

Peak SAR (extrapolated) = 0.433 W/kg

**SAR(1 g) = 0.343 W/kg**

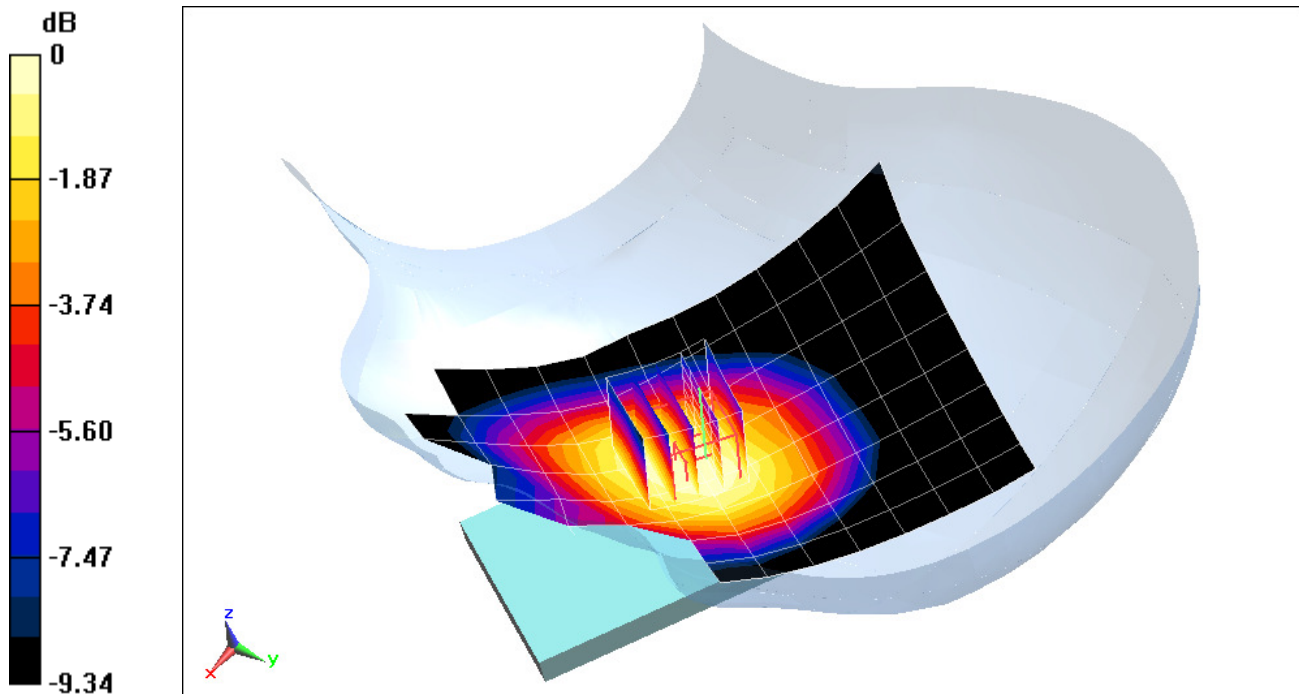

0 dB = 0.374 W/kg = -4.27 dBW/kg

# PCTEST ENGINEERING LABORATORY, INC.

**DUT: A3LSMJ320A; Type: Portable Handset; Serial: 62364**

Communication System: UID 0, UMTS; Frequency: 836.6 MHz; Duty Cycle: 1:1  
Medium: 835 Head, Medium parameters used (interpolated):  
 $f = 836.6 \text{ MHz}$ ;  $\sigma = 0.92 \text{ S/m}$ ;  $\epsilon_r = 41.969$ ;  $\rho = 1000 \text{ kg/m}^3$   
Phantom section: Right Section

Test Date: 11-17-2015; Ambient Temp: 22.7°C; Tissue Temp: 21.1°C

Probe: ES3DV3 - SN3351; ConvF(6.17, 6.17, 6.17); Calibrated: 6/22/2015;  
Sensor-Surface: 3mm (Mechanical Surface Detection)  
Electronics: DAE4 Sn1322; Calibrated: 8/24/2015  
Phantom: SAM V5.0 Right; Type: QD000P40CD; Serial: 1647  
Measurement SW: DASY52, Version 52.8 (8); SEMCAD X Version 14.6.10 (7331)

**Mode: UMTS 850, Right Head, Cheek, Mid.ch**

**Area Scan (9x15x1):** Measurement grid: dx=15mm, dy=15mm  
**Zoom Scan (5x5x7)/Cube 0:** Measurement grid: dx=8mm, dy=8mm, dz=5mm  
Reference Value = 19.51 V/m; Power Drift = 0.04 dB  
Peak SAR (extrapolated) = 0.408 W/kg  
**SAR(1 g) = 0.335 W/kg**

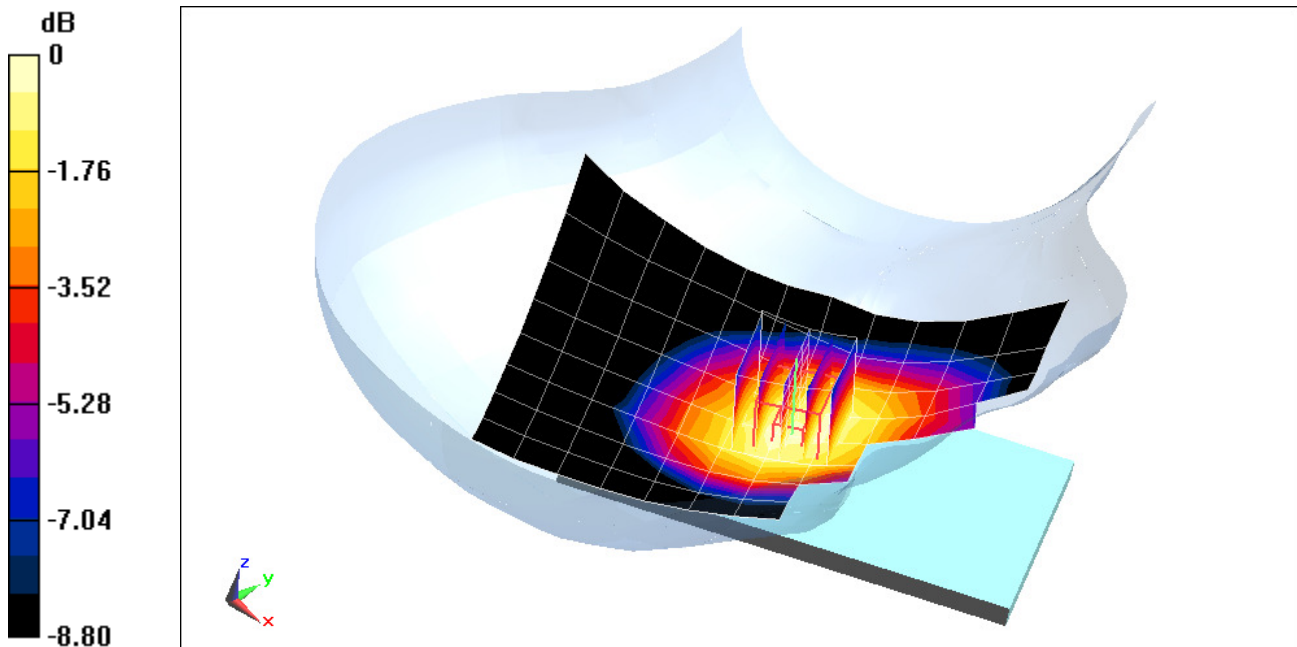

0 dB = 0.368 W/kg = -4.34 dBW/kg

# PCTEST ENGINEERING LABORATORY, INC.

**DUT: A3LSMJ320A; Type: Portable Handset; Serial: 56721**

Communication System: UID 0, UMTS; Frequency: 1732.4 MHz; Duty Cycle: 1:1  
Medium: 1750 Head, Medium parameters used (interpolated):  
 $f = 1732.4 \text{ MHz}$ ;  $\sigma = 1.311 \text{ S/m}$ ;  $\epsilon_r = 39.595$ ;  $\rho = 1000 \text{ kg/m}^3$   
Phantom section: Left Section

Test Date: 11-23-2015; Ambient Temp: 20.3°C; Tissue Temp: 20.8°C

Probe: ES3DV3 - SN3319; ConvF(5.29, 5.29, 5.29); Calibrated: 3/19/2015;  
Sensor-Surface: 3mm (Mechanical Surface Detection)  
Electronics: DAE4 Sn1368; Calibrated: 3/13/2015  
Phantom: SAM with CRP v4.0; Type: QD000P40CD; Serial: TP:1800  
Measurement SW: DASY52, Version 52.8 (8); SEMCAD X Version 14.6.10 (7331)

**Mode: AWS UMTS, Left Head, Cheek, Mid.ch**

**Area Scan (9x15x1):** Measurement grid: dx=15mm, dy=15mm  
**Zoom Scan (5x5x7)/Cube 0:** Measurement grid: dx=8mm, dy=8mm, dz=5mm  
Reference Value = 20.15 V/m; Power Drift = 0.08 dB  
Peak SAR (extrapolated) = 0.839 W/kg  
**SAR(1 g) = 0.543 W/kg**

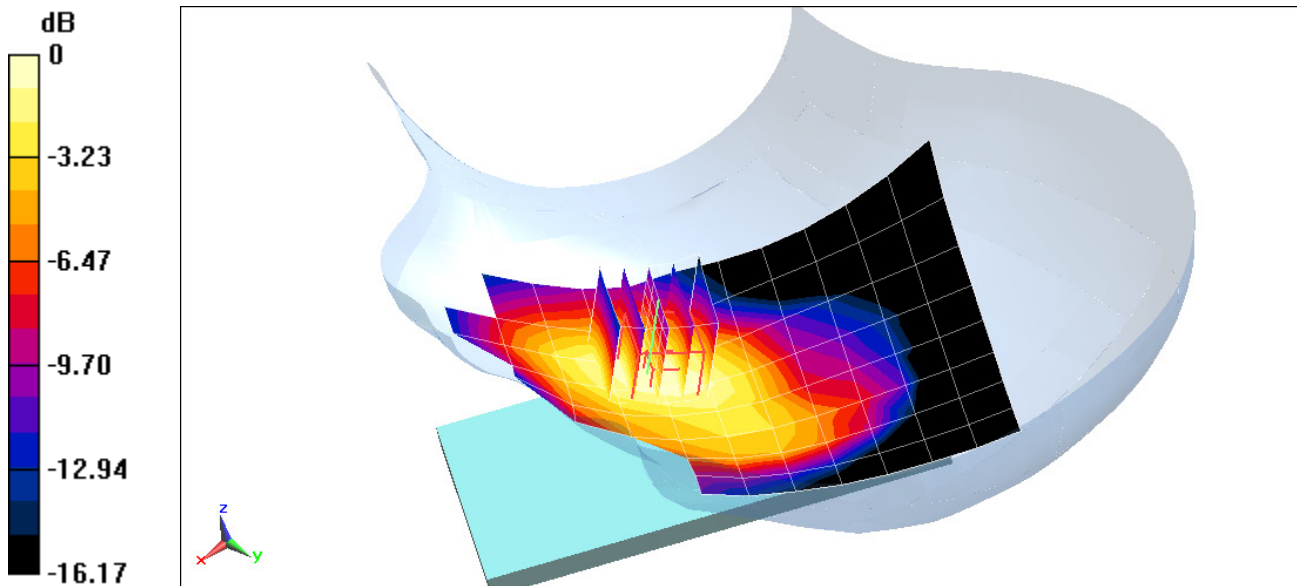

0 dB = 0.633 W/kg = -1.99 dBW/kg

# PCTEST ENGINEERING LABORATORY, INC.

**DUT: A3LSMJ320A; Type: Portable Handset; Serial: 03061**

Communication System: UID 0, GSM; Frequency: 1880 MHz; Duty Cycle: 1:8.3  
Medium: 1900 Head, Medium parameters used:  
 $f = 1880 \text{ MHz}$ ;  $\sigma = 1.397 \text{ S/m}$ ;  $\epsilon_r = 38.877$ ;  $\rho = 1000 \text{ kg/m}^3$   
Phantom section: Left Section

Test Date: 01-18-2016; Ambient Temp: 21.1°C; Tissue Temp: 21.1°C

Probe: ES3DV3 - SN3209; ConvF(5.05, 5.05, 5.05); Calibrated: 3/19/2015;  
Sensor-Surface: 3mm (Mechanical Surface Detection)  
Electronics: DAE4 Sn1407; Calibrated: 4/20/2015  
Phantom: SAM v5.0 front; Type: QD000P40CD; Serial: TP-1646  
Measurement SW: DASY52, Version 52.8 (8); SEMCAD X Version 14.6.10 (7331)

**Mode: GSM 1900, Left Head, Cheek, Mid.ch**

**Area Scan (9x15x1):** Measurement grid: dx=15mm, dy=15mm  
**Zoom Scan (5x5x7)/Cube 0:** Measurement grid: dx=8mm, dy=8mm, dz=5mm  
Reference Value = 14.25 V/m; Power Drift = -0.08 dB  
Peak SAR (extrapolated) = 0.471 W/kg  
**SAR(1 g) = 0.282 W/kg**

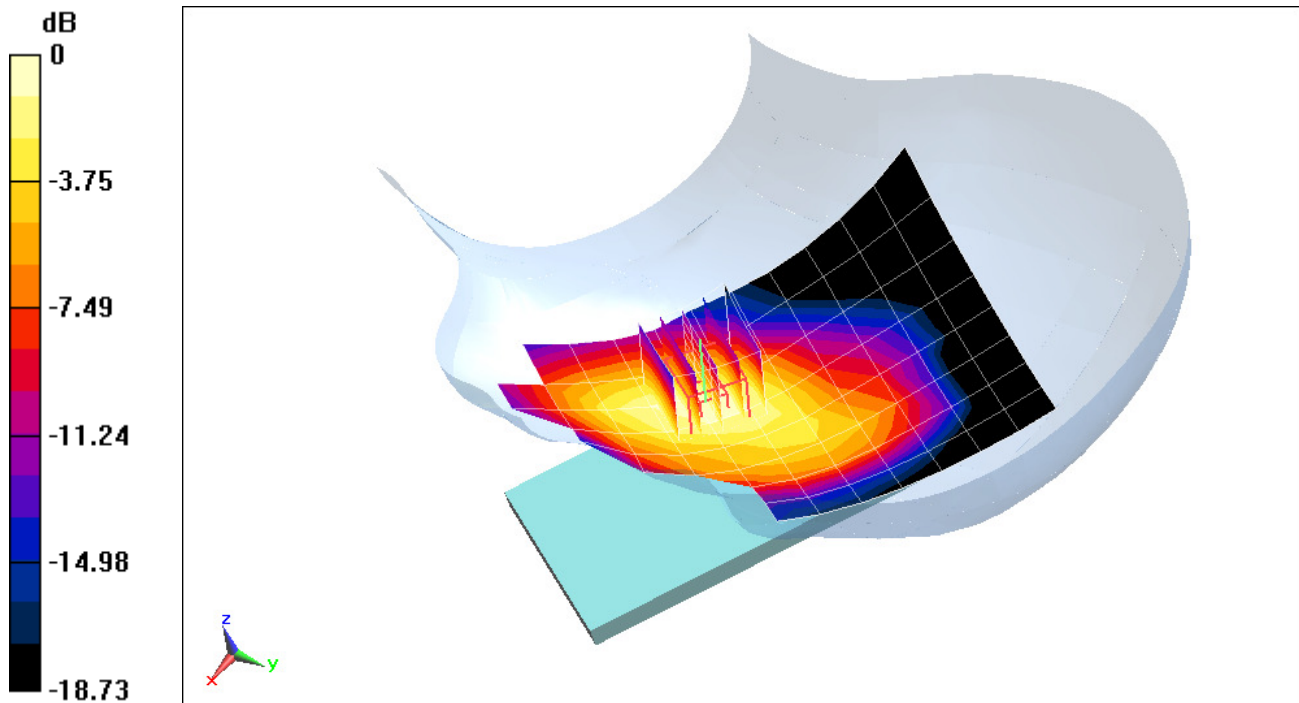

0 dB = 0.339 W/kg = -4.70 dBW/kg

# PCTEST ENGINEERING LABORATORY, INC.

**DUT: A3LSMJ320A; Type: Portable Handset; Serial: 62364**

Communication System: UID 0, UMTS; Frequency: 1880 MHz; Duty Cycle: 1:1

Medium: 1900 Head, Medium parameters used:

$f = 1880 \text{ MHz}$ ;  $\sigma = 1.405 \text{ S/m}$ ;  $\epsilon_r = 39.037$ ;  $\rho = 1000 \text{ kg/m}^3$

Phantom section: Left Section

Test Date: 11-18-2015; Ambient Temp: 21.2°C; Tissue Temp: 22.0°C

Probe: ES3DV3 - SN3319; ConvF(5.1, 5.1, 5.1); Calibrated: 3/19/2015;

Sensor-Surface: 3mm (Mechanical Surface Detection)

Electronics: DAE4 Sn1368; Calibrated: 3/13/2015

Phantom: SAM with CRP v4.0; Type: QD000P40CD; Serial: TP:1800

Measurement SW: DASY52, Version 52.8 (8); SEMCAD X Version 14.6.10 (7331)

**Mode: UMTS 1900, Left Head, Cheek, Mid.ch**

**Area Scan (9x15x1):** Measurement grid: dx=15mm, dy=15mm

**Zoom Scan (5x5x7)/Cube 0:** Measurement grid: dx=8mm, dy=8mm, dz=5mm

Reference Value = 21.10 V/m; Power Drift = -0.06 dB

Peak SAR (extrapolated) = 0.909 W/kg

**SAR(1 g) = 0.583 W/kg**

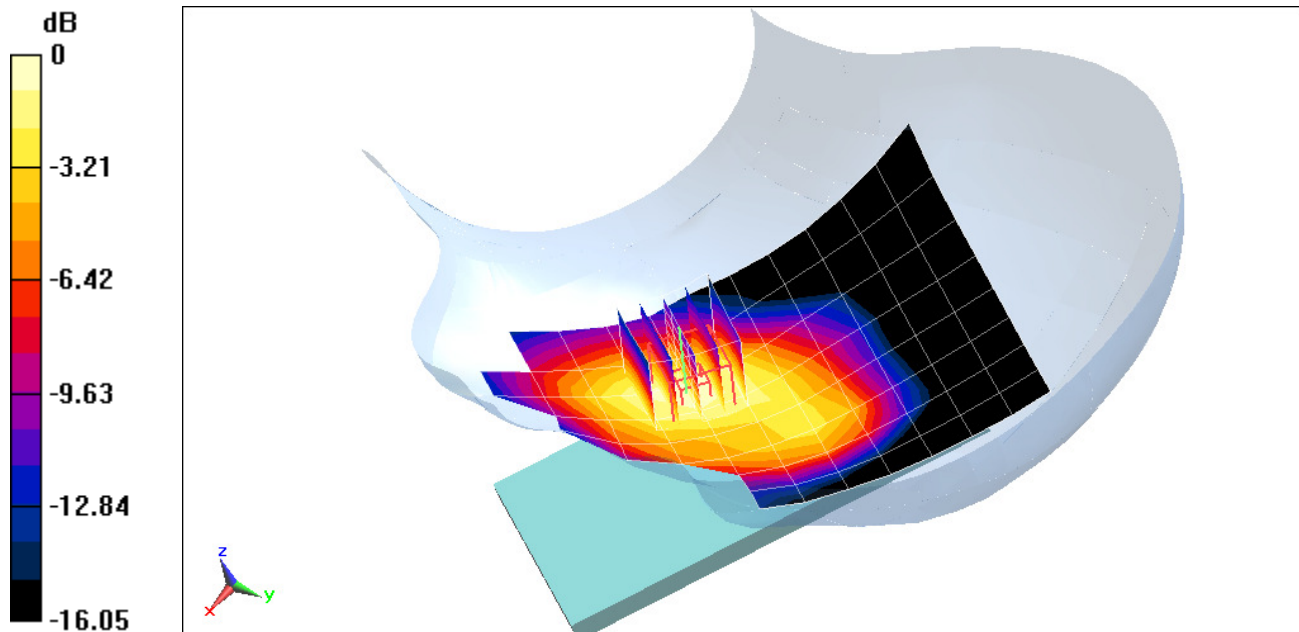

0 dB = 0.692 W/kg = -1.60 dBW/kg

# PCTEST ENGINEERING LABORATORY, INC.

**DUT: A3LSMJ320A; Type: Portable Handset; Serial: 56721**

Communication System: UID 0, LTE Band 12; Frequency: 707.5 MHz; Duty Cycle: 1:1  
Medium: 750 Head, Medium parameters used (interpolated):  
 $f = 707.5 \text{ MHz}$ ;  $\sigma = 0.887 \text{ S/m}$ ;  $\epsilon_r = 44.016$ ;  $\rho = 1000 \text{ kg/m}^3$   
Phantom section: Left Section

Test Date: 11-19-2015; Ambient Temp: 23.2°C; Tissue Temp: 21.8°C

Probe: ES3DV2 - SN3022; ConvF(6.33, 6.33, 6.33); Calibrated: 8/26/2015;  
Sensor-Surface: 3mm (Mechanical Surface Detection)  
Electronics: DAE4 Sn665; Calibrated: 2/18/2015  
Phantom: SAM with CRP v4.0; Type: QD000P40CD; Serial: TP:1797  
Measurement SW: DASY52, Version 52.8 (8); SEMCAD X Version 14.6.10 (7331)

**Mode: LTE Band 12, Left Head, Cheek, Mid.ch,  
QPSK, 10 MHz Bandwidth, 1 RB, 0 RB Offset**

**Area Scan (7x14x1):** Measurement grid:  $dx=15\text{mm}$ ,  $dy=15\text{mm}$   
**Zoom Scan (5x5x7)/Cube 0:** Measurement grid:  $dx=8\text{mm}$ ,  $dy=8\text{mm}$ ,  $dz=5\text{mm}$   
Reference Value = 22.31 V/m; Power Drift = -0.10 dB  
Peak SAR (extrapolated) = 0.487 W/kg  
**SAR(1 g) = 0.400 W/kg**

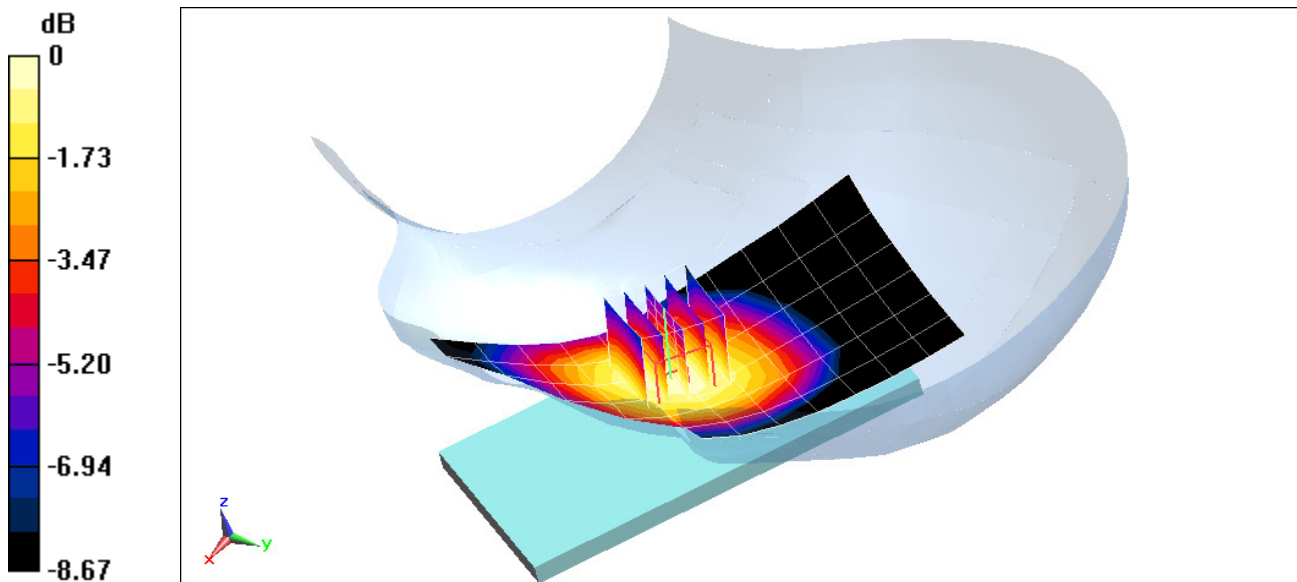

0 dB = 0.437 W/kg = -3.60 dBW/kg

# PCTEST ENGINEERING LABORATORY, INC.

**DUT: A3LSMJ320A; Type: Portable Handset; Serial: 62364**

Communication System: UID 0, LTE Band 5 (Cell.); Frequency: 836.5 MHz; Duty Cycle: 1:1  
Medium: 835 Head, Medium parameters used (interpolated):  
 $f = 836.5 \text{ MHz}$ ;  $\sigma = 0.919 \text{ S/m}$ ;  $\epsilon_r = 41.971$ ;  $\rho = 1000 \text{ kg/m}^3$   
Phantom section: Left Section

Test Date: 11-17-2015; Ambient Temp: 22.7°C; Tissue Temp: 21.1°C

Probe: ES3DV3 - SN3351; ConvF(6.17, 6.17, 6.17); Calibrated: 6/22/2015;  
Sensor-Surface: 3mm (Mechanical Surface Detection)  
Electronics: DAE4 Sn1322; Calibrated: 8/24/2015  
Phantom: SAM V5.0 Right; Type: QD000P40CD; Serial: 1647  
Measurement SW: DASY52, Version 52.8 (8); SEMCAD X Version 14.6.10 (7331)

**Mode: LTE Band 5 (Cell.), Left Head, Cheek, Mid.ch,  
10 MHz Bandwidth, QPSK, 1 RB, 25 RB Offset**

**Area Scan (9x15x1):** Measurement grid:  $dx=15\text{mm}$ ,  $dy=15\text{mm}$

**Zoom Scan (5x5x7)/Cube 0:** Measurement grid:  $dx=8\text{mm}$ ,  $dy=8\text{mm}$ ,  $dz=5\text{mm}$

Reference Value = 23.58 V/m; Power Drift = 0.05 dB

Peak SAR (extrapolated) = 0.575 W/kg

**SAR(1 g) = 0.448 W/kg**

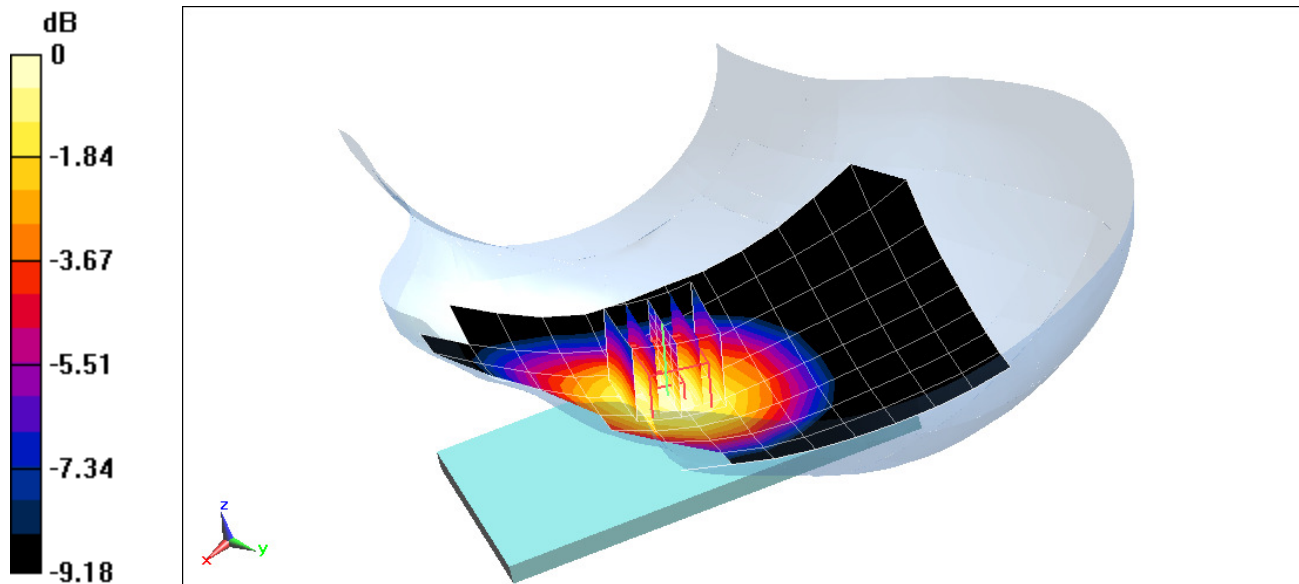

0 dB = 0.497 W/kg = -3.04 dBW/kg

# PCTEST ENGINEERING LABORATORY, INC.

**DUT: A3LSMJ320A; Type: Portable Handset; Serial: 08102**

Communication System: UID 0, LTE Band 4 (AWS); Frequency: 1732.5 MHz; Duty Cycle: 1:1  
Medium: 1750 Head, Medium parameters used (interpolated):  
 $f = 1732.5$  MHz;  $\sigma = 1.371$  S/m;  $\epsilon_r = 40.364$ ;  $\rho = 1000$  kg/m<sup>3</sup>  
Phantom section: Left Section

Test Date: 01-19-2016; Ambient Temp: 22.3°C; Tissue Temp: 21.2°C

Probe: ES3DV3 - SN3263; ConvF(5.27, 5.27, 5.27); Calibrated: 5/20/2015;  
Sensor-Surface: 3mm (Mechanical Surface Detection)  
Electronics: DAE4 Sn859; Calibrated: 6/17/2015  
Phantom: SAM with CRP v5.0 (Right); Type: QD000P40CD; Serial: TP:1759  
Measurement SW: DASY52, Version 52.8 (8); SEMCAD X Version 14.6.10 (7331)

**Mode: LTE Band 4 (AWS), Left Head, Cheek, Mid.ch,  
20 MHz Bandwidth, QPSK, 1 RB, 50 RB Offset**

**Area Scan (9x15x1):** Measurement grid: dx=15mm, dy=15mm  
**Zoom Scan (5x5x7)/Cube 0:** Measurement grid: dx=8mm, dy=8mm, dz=5mm  
Reference Value = 24.25 V/m; Power Drift = -0.05 dB  
Peak SAR (extrapolated) = 0.929 W/kg  
**SAR(1 g) = 0.630 W/kg**

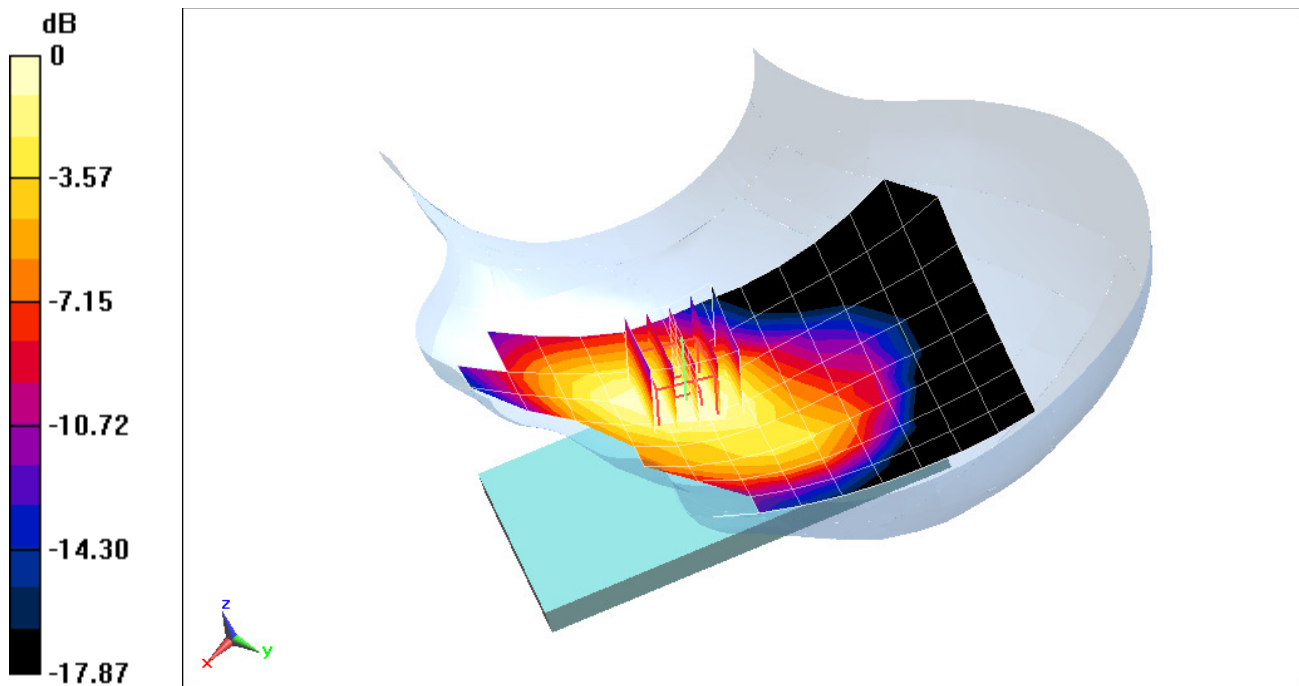

0 dB = 0.735 W/kg = -1.34 dBW/kg

# PCTEST ENGINEERING LABORATORY, INC.

**DUT: A3LSMJ320A; Type: Portable Handset; Serial: 62364**

Communication System: UID 0, LTE Band 2 (PCS); Frequency: 1900 MHz; Duty Cycle: 1:1  
Medium: 1900 Head, Medium parameters used (interpolated):  
 $f = 1900 \text{ MHz}$ ;  $\sigma = 1.425 \text{ S/m}$ ;  $\epsilon_r = 38.932$ ;  $\rho = 1000 \text{ kg/m}^3$   
Phantom section: Left Section

Test Date: 11-18-2015; Ambient Temp: 21.2°C; Tissue Temp: 22.0°C

Probe: ES3DV3 - SN3319; ConvF(5.1, 5.1, 5.1); Calibrated: 3/19/2015;  
Sensor-Surface: 3mm (Mechanical Surface Detection)

Electronics: DAE4 Sn1368; Calibrated: 3/13/2015

Phantom: SAM with CRP v4.0; Type: QD000P40CD; Serial: TP:1800

Measurement SW: DASY52, Version 52.8 (8); SEMCAD X Version 14.6.10 (7331)

**Mode: LTE Band 2 (PCS), Left Head, Cheek, High.ch,  
20 MHz Bandwidth, QPSK, 1 RB, 50 RB Offset**

**Area Scan (9x15x1):** Measurement grid:  $dx=15\text{mm}$ ,  $dy=15\text{mm}$

**Zoom Scan (5x5x7)/Cube 0:** Measurement grid:  $dx=8\text{mm}$ ,  $dy=8\text{mm}$ ,  $dz=5\text{mm}$

Reference Value = 24.02 V/m; Power Drift = -0.10 dB

Peak SAR (extrapolated) = 1.06 W/kg

**SAR(1 g) = 0.688 W/kg**

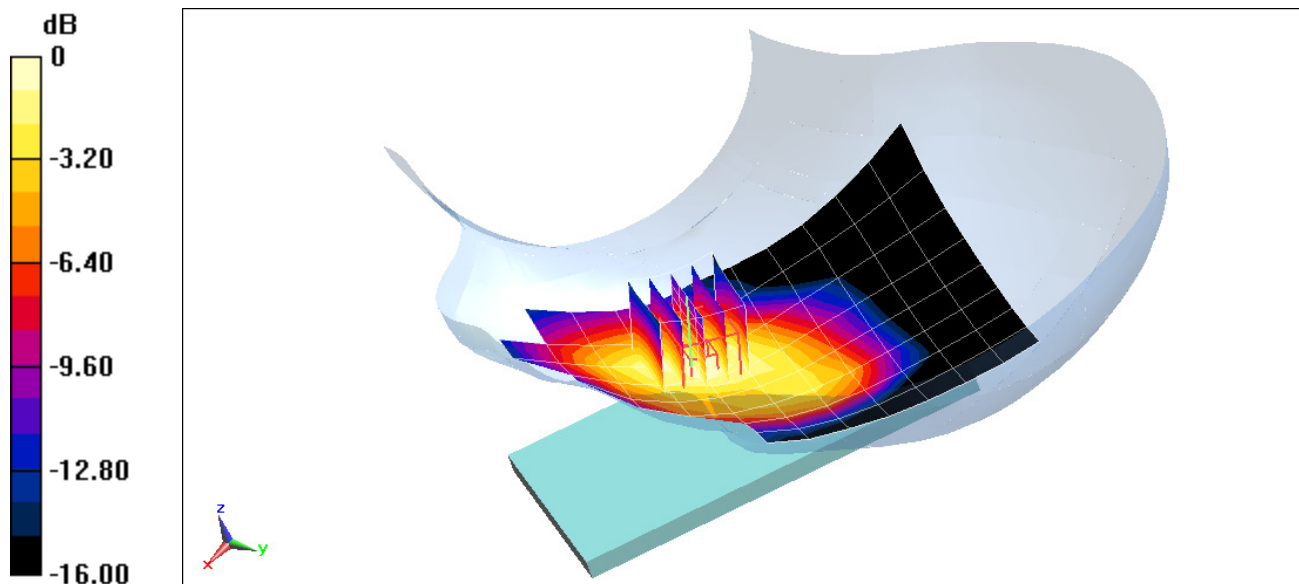

0 dB = 0.817 W/kg = -0.88 dBW/kg

# PCTEST ENGINEERING LABORATORY, INC.

**DUT: A3LSMJ320A; Type: Portable Handset; Serial: 08102**

Communication System: UID 0, IEEE 802.11b (0); Frequency: 2462 MHz; Duty Cycle: 1:1  
Medium: 2450 Head, Medium parameters used (interpolated):  
 $f = 2462 \text{ MHz}$ ;  $\sigma = 1.853 \text{ S/m}$ ;  $\epsilon_r = 38.194$ ;  $\rho = 1000 \text{ kg/m}^3$   
Phantom section: Left Section

Test Date: 01-19-2016; Ambient Temp: 22.3°C; Tissue Temp: 21.0°C

Probe: ES3DV3 - SN3351; ConvF(4.46, 4.46, 4.46); Calibrated: 6/22/2015;  
Sensor-Surface: 3mm (Mechanical Surface Detection)  
Electronics: DAE4 Sn1322; Calibrated: 8/24/2015  
Phantom: SAM V5.0 Right; Type: QD000P40CD; Serial: 1647  
Measurement SW: DASY52, Version 52.8 (8); SEMCAD X Version 14.6.10 (7331)

**Mode: IEEE 802.11b, 22 MHz Bandwidth, Left Head, Cheek, Ch 11, 1 Mbps**

**Area Scan (11x18x1):** Measurement grid: dx=12mm, dy=12mm  
**Zoom Scan (7x8x7)/Cube 0:** Measurement grid: dx=5mm, dy=5mm, dz=5mm  
Reference Value = 17.38 V/m; Power Drift = 0.08 dB  
Peak SAR (extrapolated) = 1.11 W/kg  
**SAR(1 g) = 0.494 W/kg**

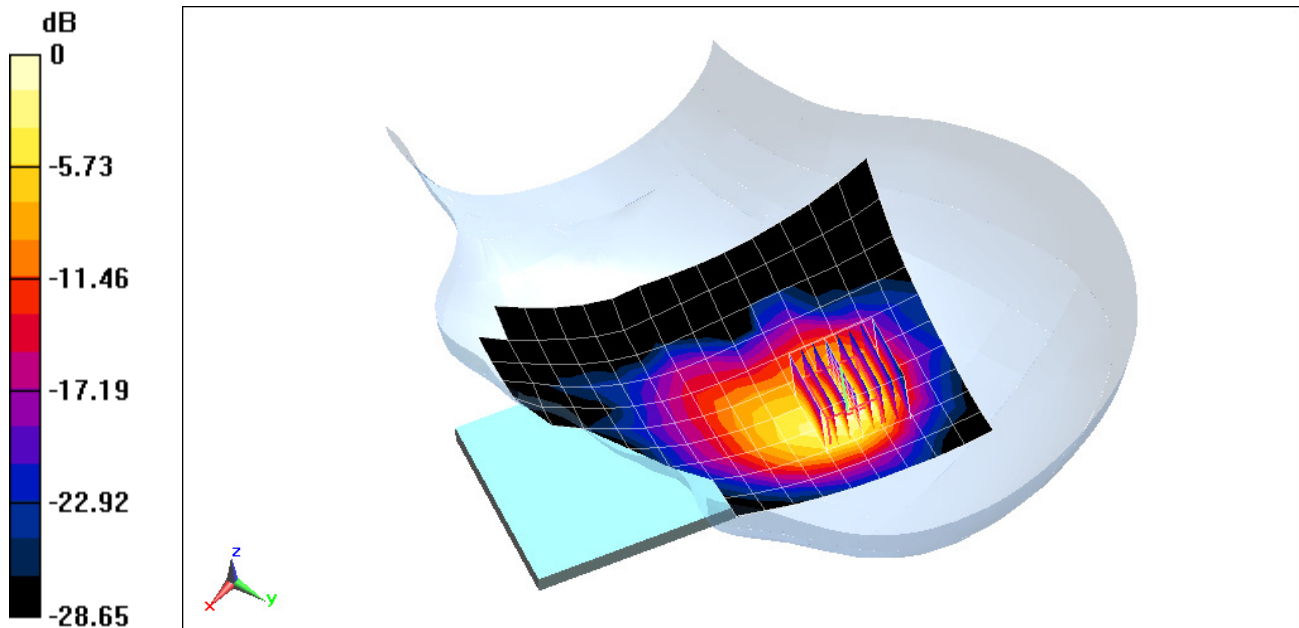

0 dB = 0.652 W/kg = -1.86 dBW/kg

# PCTEST ENGINEERING LABORATORY, INC.

**DUT: A3LSMJ320A; Type: Portable Handset; Serial: 08102**

Communication System: UID 0, GSM; Frequency: 836.6 MHz; Duty Cycle: 1:8.3  
Medium: 835 Body, Medium parameters used (interpolated):  
 $f = 836.6 \text{ MHz}$ ;  $\sigma = 1.006 \text{ S/m}$ ;  $\epsilon_r = 53.438$ ;  $\rho = 1000 \text{ kg/m}^3$   
Phantom section: Flat Section; Space: 1.0 cm

Test Date: 01-25-2016; Ambient Temp: 21.9°C; Tissue Temp: 21.0°C

Probe: ES3DV3 - SN3351; ConvF(6.11, 6.11, 6.11); Calibrated: 6/22/2015;  
Sensor-Surface: 3mm (Mechanical Surface Detection)  
Electronics: DAE4 Sn1322; Calibrated: 8/24/2015  
Phantom: SAM 5.0 front; Type: QD000P40CD; Serial: TP:-1648  
Measurement SW: DASY52, Version 52.8 (8); SEMCAD X Version 14.6.10 (7331)

**Mode: GSM 850, Body SAR, Back side, Mid.ch**

**Area Scan (9x15x1):** Measurement grid: dx=15mm, dy=15mm  
**Zoom Scan (5x5x7)/Cube 0:** Measurement grid: dx=8mm, dy=8mm, dz=5mm  
Reference Value = 26.36 V/m; Power Drift = -0.01 dB  
Peak SAR (extrapolated) = 0.804 W/kg  
**SAR(1 g) = 0.649 W/kg**

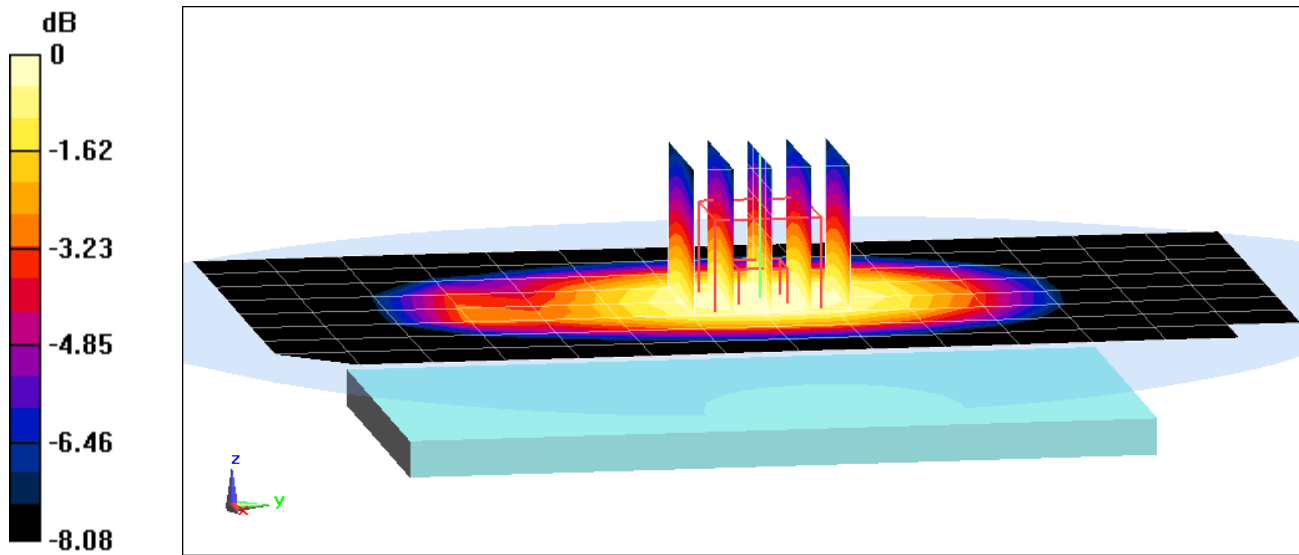

0 dB = 0.710 W/kg = -1.49 dBW/kg

# PCTEST ENGINEERING LABORATORY, INC.

**DUT: A3LSMJ320A; Type: Portable Handset; Serial: 08102**

Communication System: UID 0, GSM GPRS; 2 Tx slots; Frequency: 824.2 MHz; Duty Cycle: 1:4.15

Medium: 835 Body, Medium parameters used (interpolated):

$f = 824.2 \text{ MHz}$ ;  $\sigma = 0.993 \text{ S/m}$ ;  $\epsilon_r = 53.57$ ;  $\rho = 1000 \text{ kg/m}^3$

Phantom section: Flat Section; Space: 1.0 cm

Test Date: 01-25-2016; Ambient Temp: 21.9°C; Tissue Temp: 21.0°C

Probe: ES3DV3 - SN3351; ConvF(6.11, 6.11, 6.11); Calibrated: 6/22/2015;

Sensor-Surface: 3mm (Mechanical Surface Detection)

Electronics: DAE4 Sn1322; Calibrated: 8/24/2015

Phantom: SAM 5.0 front; Type: QD000P40CD; Serial: TP:-1648

Measurement SW: DASY52, Version 52.8 (8); SEMCAD X Version 14.6.10 (7331)

**Mode: GPRS 850, Body SAR, Back side, Low.ch, 2 Tx Slots**

**Area Scan (9x15x1):** Measurement grid: dx=15mm, dy=15mm

**Zoom Scan (5x5x7)/Cube 0:** Measurement grid: dx=8mm, dy=8mm, dz=5mm

Reference Value = 32.57 V/m; Power Drift = -0.03 dB

Peak SAR (extrapolated) = 1.18 W/kg

**SAR(1 g) = 0.967 W/kg**

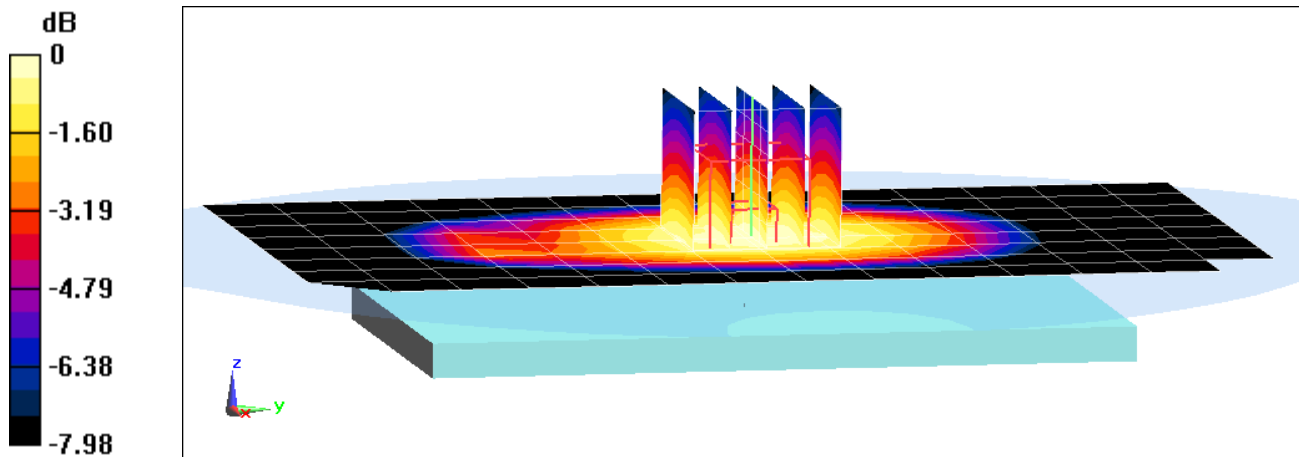

0 dB = 1.06 W/kg = 0.25 dBW/kg

# PCTEST ENGINEERING LABORATORY, INC.

**DUT: A3LSMJ320A; Type: Portable Handset; Serial: 62364**

Communication System: UID 0, UMTS; Frequency: 836.6 MHz; Duty Cycle: 1:1  
Medium: 835 Body, Medium parameters used (interpolated):  
 $f = 836.6 \text{ MHz}$ ;  $\sigma = 0.988 \text{ S/m}$ ;  $\epsilon_r = 53.609$ ;  $\rho = 1000 \text{ kg/m}^3$   
Phantom section: Flat Section; Space: 1.0 cm

Test Date: 11-22-2015; Ambient Temp: 20.7°C; Tissue Temp: 20.7°C

Probe: ES3DV3 - SN3351; ConvF(6.11, 6.11, 6.11); Calibrated: 6/22/2015;  
Sensor-Surface: 3mm (Mechanical Surface Detection)  
Electronics: DAE4 Sn1322; Calibrated: 8/24/2015  
Phantom: SAM 5.0 front; Type: QD000P40CD; Serial: TP:-1648  
Measurement SW: DASY52, Version 52.8 (8); SEMCAD X Version 14.6.10 (7331)

**Mode: UMTS 850, Body SAR, Back side, Mid.ch**

**Area Scan (9x15x1):** Measurement grid: dx=15mm, dy=15mm  
**Zoom Scan (5x5x7)/Cube 0:** Measurement grid: dx=8mm, dy=8mm, dz=5mm  
Reference Value = 22.85 V/m; Power Drift = -0.03 dB  
Peak SAR (extrapolated) = 0.654 W/kg  
**SAR(1 g) = 0.496 W/kg**

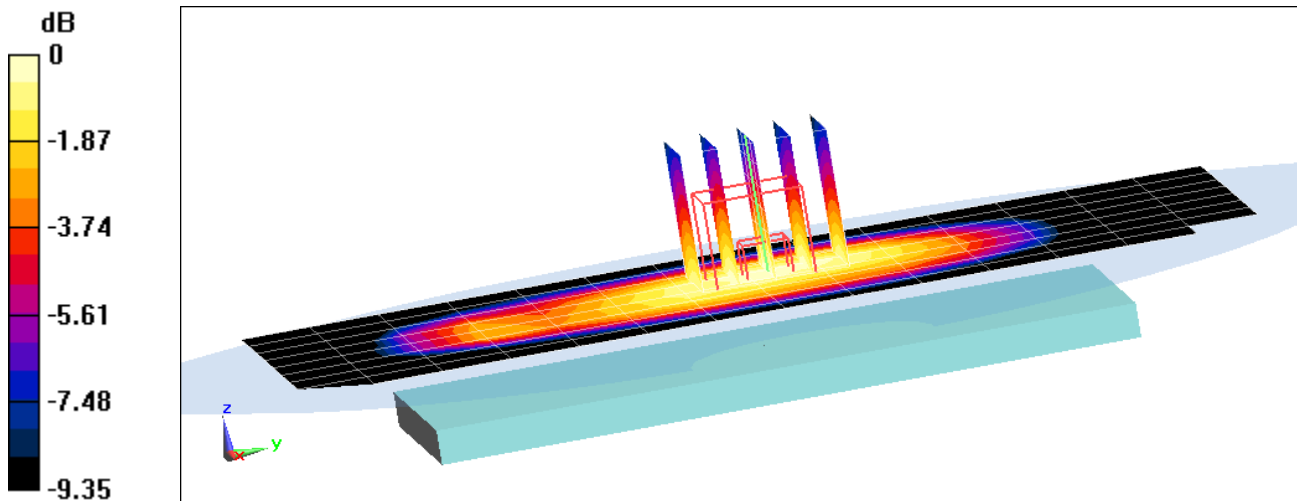

0 dB = 0.555 W/kg = -2.56 dBW/kg

# PCTEST ENGINEERING LABORATORY, INC.

**DUT: A3LSMJ320A; Type: Portable Handset; Serial: 08102**

Communication System: UID 0, UMTS (0); Frequency: 1732.4 MHz; Duty Cycle: 1:1  
Medium: 1750 Body, Medium parameters used (interpolated):  
 $f = 1732.4 \text{ MHz}$ ;  $\sigma = 1.443 \text{ S/m}$ ;  $\epsilon_r = 51.717$ ;  $\rho = 1000 \text{ kg/m}^3$   
Phantom section: Flat Section; Space: 1.0 cm

Test Date: 01-18-2016; Ambient Temp: 23.5°C; Tissue Temp: 22.7°C

Probe: ES3DV2 - SN3022; ConvF(4.79, 4.79, 4.79); Calibrated: 8/26/2015;  
Sensor-Surface: 3mm (Mechanical Surface Detection)  
Electronics: DAE4 Sn665; Calibrated: 2/18/2015  
Phantom: ELI v5.0; Type: QDOVA001BB; Serial: 1229  
Measurement SW: DASY52, Version 52.8 (8); SEMCAD X Version 14.6.10 (7331)

**Mode: AWS UMTS, Body SAR, Back side, Mid.ch**

**Area Scan (9x13x1):** Measurement grid: dx=15mm, dy=15mm  
**Zoom Scan (5x5x7)/Cube 0:** Measurement grid: dx=8mm, dy=8mm, dz=5mm  
Reference Value = 22.10 V/m; Power Drift = 0.01 dB  
Peak SAR (extrapolated) = 1.05 W/kg  
**SAR(1 g) = 0.678 W/kg**

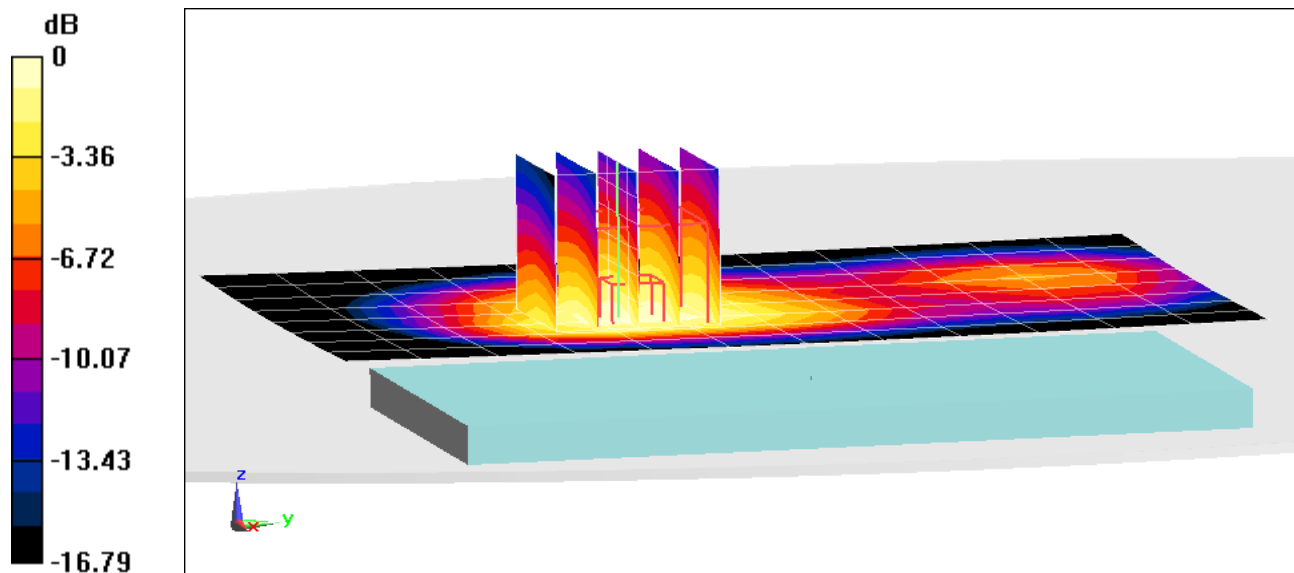

# PCTEST ENGINEERING LABORATORY, INC.

**DUT: A3LSMJ320A; Type: Portable Handset; Serial: 08102**

Communication System: UID 0, UMTS (0); Frequency: 1712.4 MHz; Duty Cycle: 1:1  
Medium: 1750 Body, Medium parameters used (interpolated):  
 $f = 1712.4 \text{ MHz}$ ;  $\sigma = 1.422 \text{ S/m}$ ;  $\epsilon_r = 51.78$ ;  $\rho = 1000 \text{ kg/m}^3$   
Phantom section: Flat Section; Space: 1.0 cm

Test Date: 01-18-2016; Ambient Temp: 23.5°C; Tissue Temp: 22.7°C

Probe: ES3DV2 - SN3022; ConvF(4.79, 4.79, 4.79); Calibrated: 8/26/2015;  
Sensor-Surface: 3mm (Mechanical Surface Detection)  
Electronics: DAE4 Sn665; Calibrated: 2/18/2015  
Phantom: ELI v5.0; Type: QDOVA001BB; Serial: 1229  
Measurement SW: DASY52, Version 52.8 (8); SEMCAD X Version 14.6.10 (7331)

**Mode: AWS UMTS, Body SAR, Front side, Low.ch**

**Area Scan (9x13x1):** Measurement grid: dx=15mm, dy=15mm  
**Zoom Scan (7x7x7)/Cube 0:** Measurement grid: dx=8mm, dy=8mm, dz=5mm  
Reference Value = 22.26 V/m; Power Drift = 0.06 dB  
Peak SAR (extrapolated) = 1.08 W/kg  
**SAR(1 g) = 0.705 W/kg**

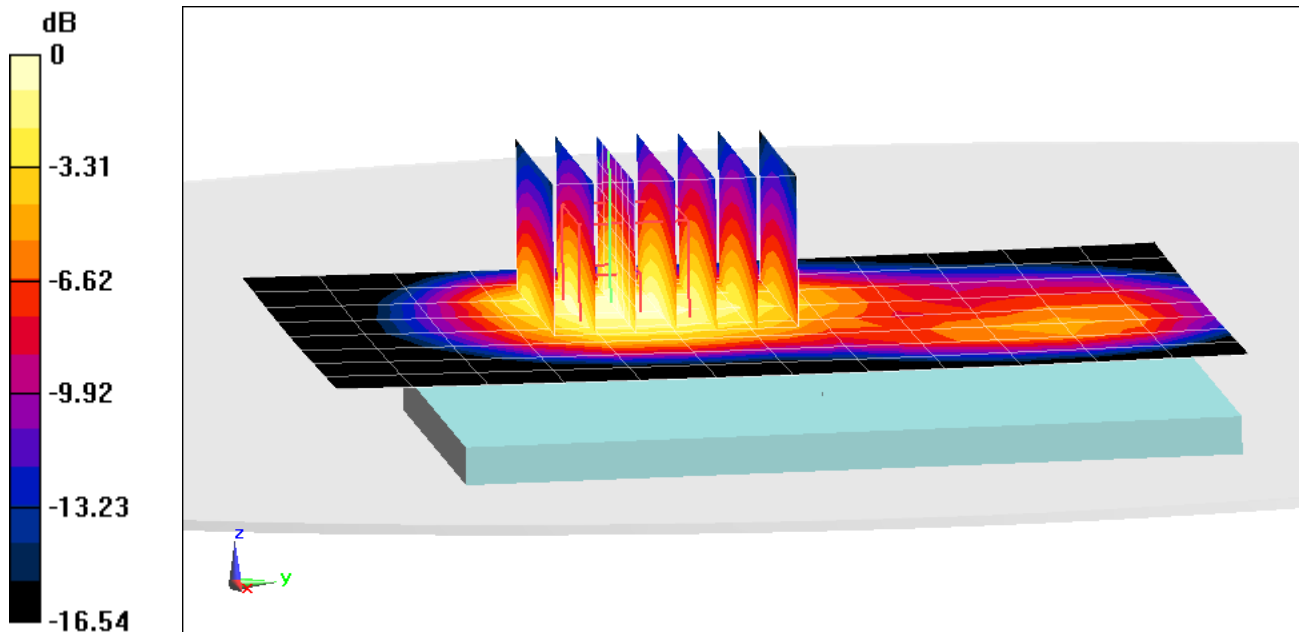

0 dB = 0.821 W/kg = -0.86 dBW/kg

# PCTEST ENGINEERING LABORATORY, INC.

**DUT: A3LSMJ320A; Type: Portable Handset; Serial: 03061**

Communication System: UID 0, GSM; Frequency: 1880 MHz; Duty Cycle: 1:8.3  
Medium: 1900 Body, Medium parameters used:  
 $f = 1880 \text{ MHz}$ ;  $\sigma = 1.496 \text{ S/m}$ ;  $\epsilon_r = 52.56$ ;  $\rho = 1000 \text{ kg/m}^3$   
Phantom section: Flat Section; Space: 1.0 cm

Test Date: 01-18-2016; Ambient Temp: 21.1°C; Tissue Temp: 22.5°C

Probe: ES3DV3 - SN3333; ConvF(4.7, 4.7, 4.7); Calibrated: 10/29/2015;  
Sensor-Surface: 3mm (Mechanical Surface Detection)  
Electronics: DAE4 Sn1333; Calibrated: 10/27/2015  
Phantom: SAM Front; Type: QD000P40CD; Serial: TP:1758  
Measurement SW: DASY52, Version 52.8 (8); SEMCAD X Version 14.6.10 (7331)

**Mode: GSM 1900, Body SAR, Back side, Mid.ch**

**Area Scan (9x15x1):** Measurement grid: dx=15mm, dy=15mm  
**Zoom Scan (5x5x7)/Cube 0:** Measurement grid: dx=8mm, dy=8mm, dz=5mm  
Reference Value = 12.80 V/m; Power Drift = -0.07 dB  
Peak SAR (extrapolated) = 0.411 W/kg  
**SAR(1 g) = 0.238 W/kg**

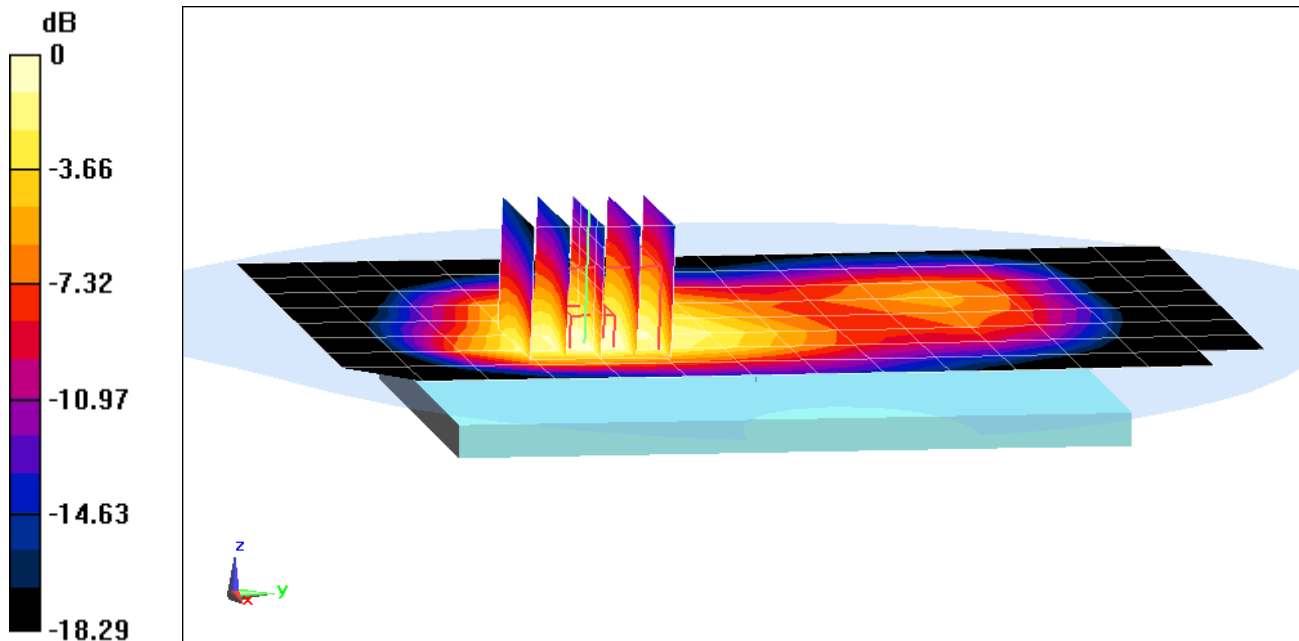

0 dB = 0.287 W/kg = -5.42 dBW/kg

# PCTEST ENGINEERING LABORATORY, INC.

**DUT: A3LSMJ320A; Type: Portable Handset; Serial: 03061**

Communication System: UID 0, GSM GPRS; 2 Tx slots; Frequency: 1880 MHz; Duty Cycle: 1:4.15

Medium: 1900 Body, Medium parameters used:

$f = 1880 \text{ MHz}$ ;  $\sigma = 1.496 \text{ S/m}$ ;  $\epsilon_r = 52.56$ ;  $\rho = 1000 \text{ kg/m}^3$

Phantom section: Flat Section; Space: 1.0 cm

Test Date: 01-18-2016; Ambient Temp: 21.1°C; Tissue Temp: 22.5°C

Probe: ES3DV3 - SN3333; ConvF(4.7, 4.7, 4.7); Calibrated: 10/29/2015;

Sensor-Surface: 3mm (Mechanical Surface Detection)

Electronics: DAE4 Sn1333; Calibrated: 10/27/2015

Phantom: SAM Front; Type: QD000P40CD; Serial: TP:1758

Measurement SW: DASY52, Version 52.8 (8); SEMCAD X Version 14.6.10 (7331)

**Mode: GPRS 1900, Body SAR, Front side, Mid.ch, 2 Tx Slots**

**Area Scan (9x15x1):** Measurement grid: dx=15mm, dy=15mm

**Zoom Scan (6x6x7)/Cube 0:** Measurement grid: dx=8mm, dy=8mm, dz=5mm

Reference Value = 15.08 V/m; Power Drift = -0.05 dB

Peak SAR (extrapolated) = 0.526 W/kg

**SAR(1 g) = 0.326 W/kg**

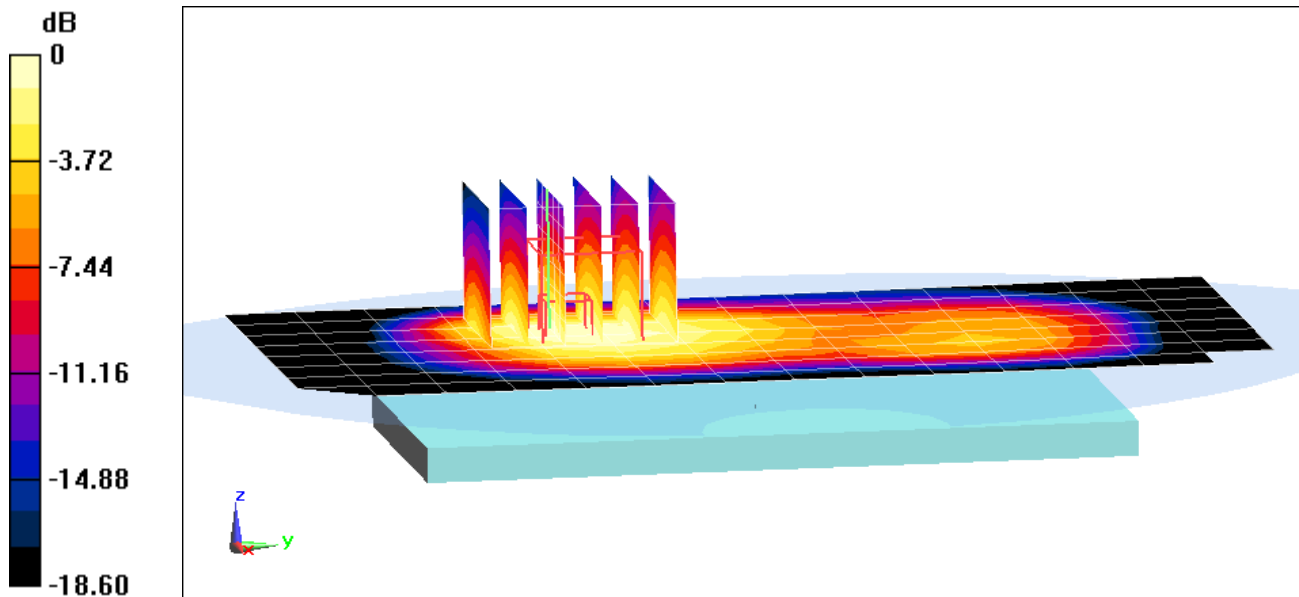

0 dB = 0.383 W/kg = -4.17 dBW/kg

# PCTEST ENGINEERING LABORATORY, INC.

**DUT: A3LSMJ320A; Type: Portable Handset; Serial: 08102**

Communication System: UID 0, UMTS; Frequency: 1880 MHz; Duty Cycle: 1:1  
Medium: 1900 Body, Medium parameters used:  
 $f = 1880 \text{ MHz}$ ;  $\sigma = 1.532 \text{ S/m}$ ;  $\epsilon_r = 51.569$ ;  $\rho = 1000 \text{ kg/m}^3$   
Phantom section: Flat Section; Space: 1.5 cm

Test Date: 01-25-2016; Ambient Temp: 21.5°C; Tissue Temp: 23.5°C

Probe: ES3DV3 - SN3333; ConvF(4.7, 4.7, 4.7); Calibrated: 10/29/2015;  
Sensor-Surface: 3mm (Mechanical Surface Detection)  
Electronics: DAE4 Sn1333; Calibrated: 10/27/2015  
Phantom: SAM Front; Type: QD000P40CD; Serial: TP:1758  
Measurement SW: DASY52, Version 52.8 (8); SEMCAD X Version 14.6.10 (7331)

**Mode: UMTS 1900, Body SAR, Back side, Mid.ch**

**Area Scan (9x15x1):** Measurement grid: dx=15mm, dy=15mm  
**Zoom Scan (6x6x7)/Cube 0:** Measurement grid: dx=8mm, dy=8mm, dz=5mm  
Reference Value = 12.31 V/m; Power Drift = -0.03 dB  
Peak SAR (extrapolated) = 0.350 W/kg  
**SAR(1 g) = 0.217 W/kg**

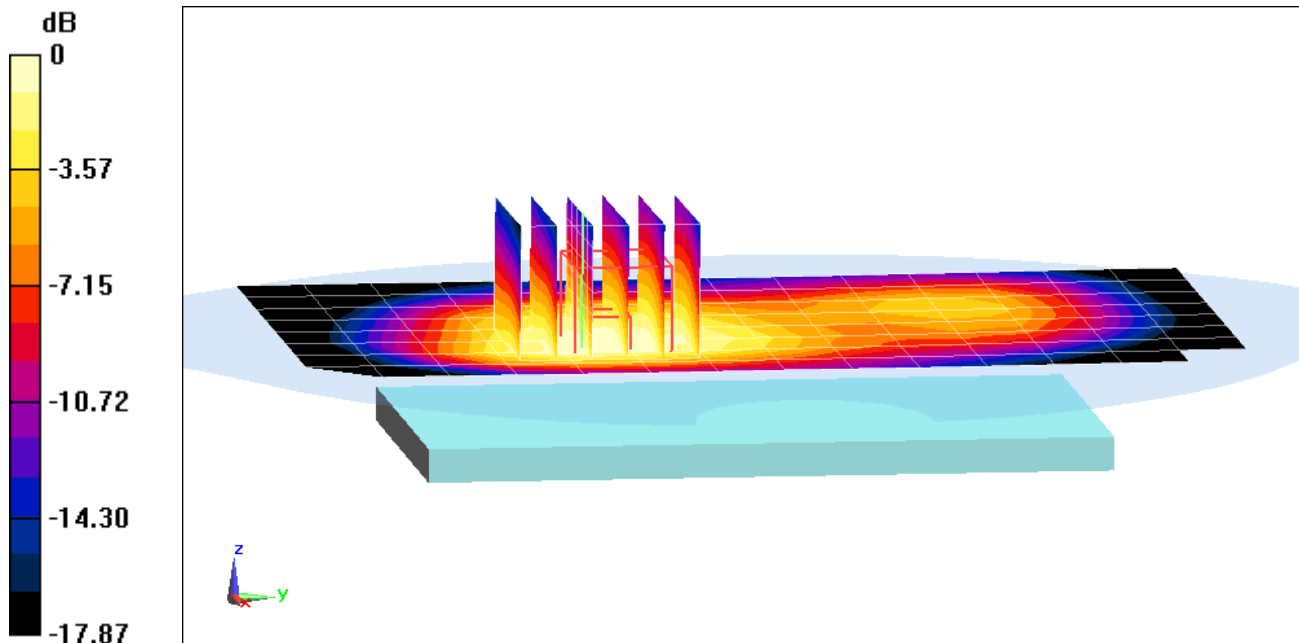

# PCTEST ENGINEERING LABORATORY, INC.

**DUT: A3LSMJ320A; Type: Portable Handset; Serial: 03384**

Communication System: UID 0, UMTS; Frequency: 1880 MHz; Duty Cycle: 1:1  
Medium: 1900 Body, Medium parameters used:  
 $f = 1880 \text{ MHz}$ ;  $\sigma = 1.532 \text{ S/m}$ ;  $\epsilon_r = 51.569$ ;  $\rho = 1000 \text{ kg/m}^3$   
Phantom section: Flat Section; Space: 1.0 cm

Test Date: 01-25-2016; Ambient Temp: 21.5°C; Tissue Temp: 23.5°C

Probe: ES3DV3 - SN3333; ConvF(4.7, 4.7, 4.7); Calibrated: 10/29/2015;  
Sensor-Surface: 3mm (Mechanical Surface Detection)  
Electronics: DAE4 Sn1333; Calibrated: 10/27/2015  
Phantom: SAM Front; Type: QD000P40CD; Serial: TP:1758  
Measurement SW: DASY52, Version 52.8 (8); SEMCAD X Version 14.6.10 (7331)

**Mode: UMTS 1900, Body SAR, Front side, Mid.ch**

**Area Scan (9x15x1):** Measurement grid: dx=15mm, dy=15mm  
**Zoom Scan (6x6x7)/Cube 0:** Measurement grid: dx=8mm, dy=8mm, dz=5mm  
Reference Value = 20.61 V/m; Power Drift = 0.06 dB  
Peak SAR (extrapolated) = 1.04 W/kg  
**SAR(1 g) = 0.635 W/kg**

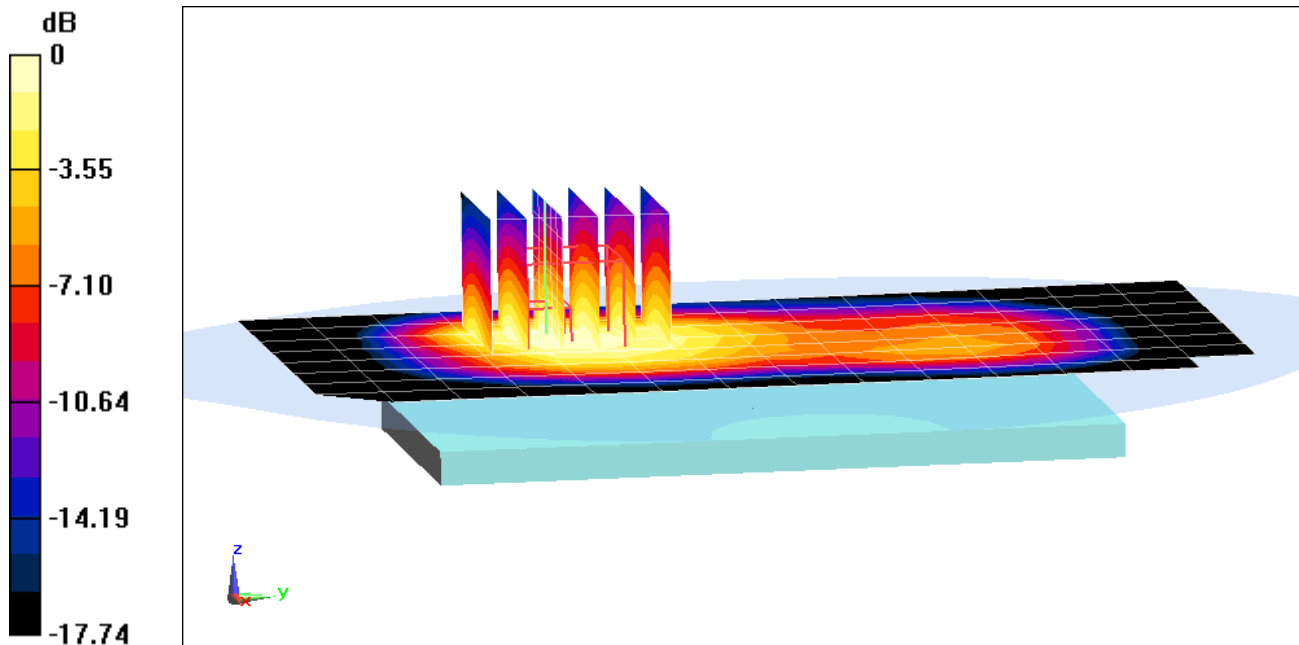

0 dB = 0.748 W/kg = -1.26 dBW/kg

# PCTEST ENGINEERING LABORATORY, INC.

**DUT: A3LSMJ320A; Type: Portable Handset; Serial: 56721**

Communication System: UID 0, LTE Band 12; Frequency: 707.5 MHz; Duty Cycle: 1:1  
Medium: 750 Body, Medium parameters used (interpolated):  
 $f = 707.5 \text{ MHz}$ ;  $\sigma = 0.919 \text{ S/m}$ ;  $\epsilon_r = 54.137$ ;  $\rho = 1000 \text{ kg/m}^3$   
Phantom section: Flat Section; Space: 1.0 cm

Test Date: 11-23-2015; Ambient Temp: 22.0°C; Tissue Temp: 23.7°C

Probe: ES3DV3 - SN3333; ConvF(6.31, 6.31, 6.31); Calibrated: 10/29/2015;  
Sensor-Surface: 3mm (Mechanical Surface Detection)  
Electronics: DAE4 Sn1333; Calibrated: 10/27/2015  
Phantom: SAM Front; Type: QD000P40CD; Serial: TP:1758  
Measurement SW: DASY52, Version 52.8 (8); SEMCAD X Version 14.6.10 (7331)

**Mode: LTE Band 12, Body SAR, Back side, Mid.ch,  
10 MHz Bandwidth, QPSK, 1 RB, 0 RB Offset**

**Area Scan (9x13x1):** Measurement grid: dx=15mm, dy=15mm  
**Zoom Scan (5x5x7)/Cube 0:** Measurement grid: dx=8mm, dy=8mm, dz=5mm  
Reference Value = 23.94 V/m; Power Drift = -0.06 dB  
Peak SAR (extrapolated) = 0.599 W/kg  
**SAR(1 g) = 0.487 W/kg**

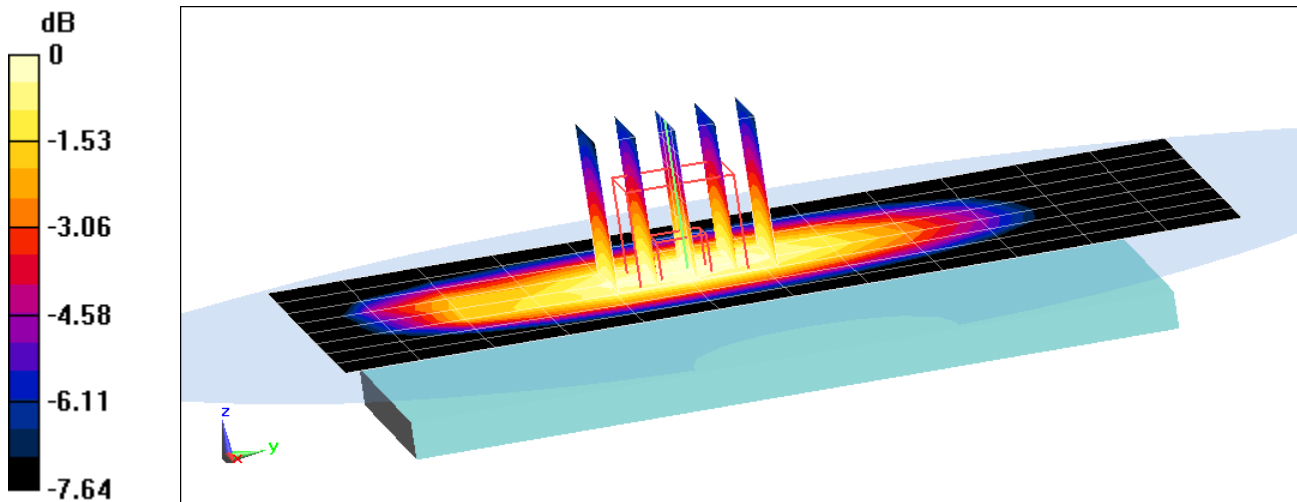

0 dB = 0.531 W/kg = -2.75 dBW/kg

# PCTEST ENGINEERING LABORATORY, INC.

**DUT: A3LSMJ320A; Type: Portable Handset; Serial: 62364**

Communication System: UID 0, LTE Band 5; Frequency: 836.5 MHz; Duty Cycle: 1:1

Medium: 835 Body, Medium parameters used (interpolated):

$f = 836.5 \text{ MHz}$ ;  $\sigma = 0.988 \text{ S/m}$ ;  $\epsilon_r = 53.61$ ;  $\rho = 1000 \text{ kg/m}^3$

Phantom section: Flat Section; Space: 1.0 cm

Test Date: 11-22-2015; Ambient Temp: 20.7°C; Tissue Temp: 20.7°C

Probe: ES3DV3 - SN3351; ConvF(6.11, 6.11, 6.11); Calibrated: 6/22/2015;

Sensor-Surface: 3mm (Mechanical Surface Detection)

Electronics: DAE4 Sn1322; Calibrated: 8/24/2015

Phantom: SAM 5.0 front; Type: QD000P40CD; Serial: TP:-1648

Measurement SW: DASY52, Version 52.8 (8); SEMCAD X Version 14.6.10 (7331)

**Mode: LTE Band 5 (Cell.), Body SAR, Back side, Mid.ch,  
10 MHz Bandwidth, QPSK, 1 RB, 25 RB Offset**

**Area Scan (9x15x1):** Measurement grid: dx=15mm, dy=15mm

**Zoom Scan (5x5x7)/Cube 0:** Measurement grid: dx=8mm, dy=8mm, dz=5mm

Reference Value = 26.36 V/m; Power Drift = 0.00 dB

Peak SAR (extrapolated) = 0.881 W/kg

**SAR(1 g) = 0.668 W/kg**

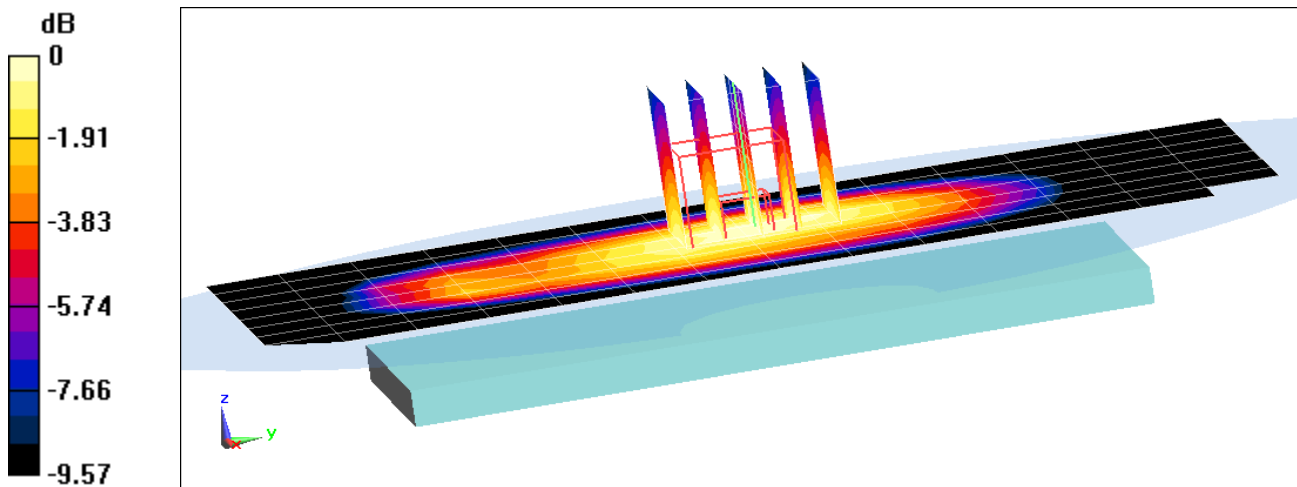

0 dB = 0.746 W/kg = -1.27 dBW/kg

# PCTEST ENGINEERING LABORATORY, INC.

**DUT: A3LSMJ320A; Type: Portable Handset; Serial: 08102**

Communication System: UID 0, LTE Band 4 (AWS); Frequency: 1732.5 MHz; Duty Cycle: 1:1  
Medium: 1750 Body, Medium parameters used (interpolated):  
 $f = 1732.5 \text{ MHz}$ ;  $\sigma = 1.443 \text{ S/m}$ ;  $\epsilon_r = 51.717$ ;  $\rho = 1000 \text{ kg/m}^3$   
Phantom section: Flat Section; Space: 1.5 cm

Test Date: 01-18-2016; Ambient Temp: 23.5°C; Tissue Temp: 22.7°C

Probe: ES3DV2 - SN3022; ConvF(4.79, 4.79, 4.79); Calibrated: 8/26/2015;  
Sensor-Surface: 3mm (Mechanical Surface Detection)  
Electronics: DAE4 Sn665; Calibrated: 2/18/2015  
Phantom: ELI v5.0; Type: QDOVA001BB; Serial: 1229  
Measurement SW: DASY52, Version 52.8 (8); SEMCAD X Version 14.6.10 (7331)

**Mode: LTE Band 4 (AWS), Body SAR, Back side, Mid.ch,  
20 MHz Bandwidth, QPSK, 1 RB, 50 RB Offset**

**Area Scan (9x14x1):** Measurement grid:  $dx=15\text{mm}$ ,  $dy=15\text{mm}$   
**Zoom Scan (6x6x7)/Cube 0:** Measurement grid:  $dx=8\text{mm}$ ,  $dy=8\text{mm}$ ,  $dz=5\text{mm}$   
Reference Value = 20.69 V/m; Power Drift = -0.06 dB  
Peak SAR (extrapolated) = 0.897 W/kg  
**SAR(1 g) = 0.598 W/kg**

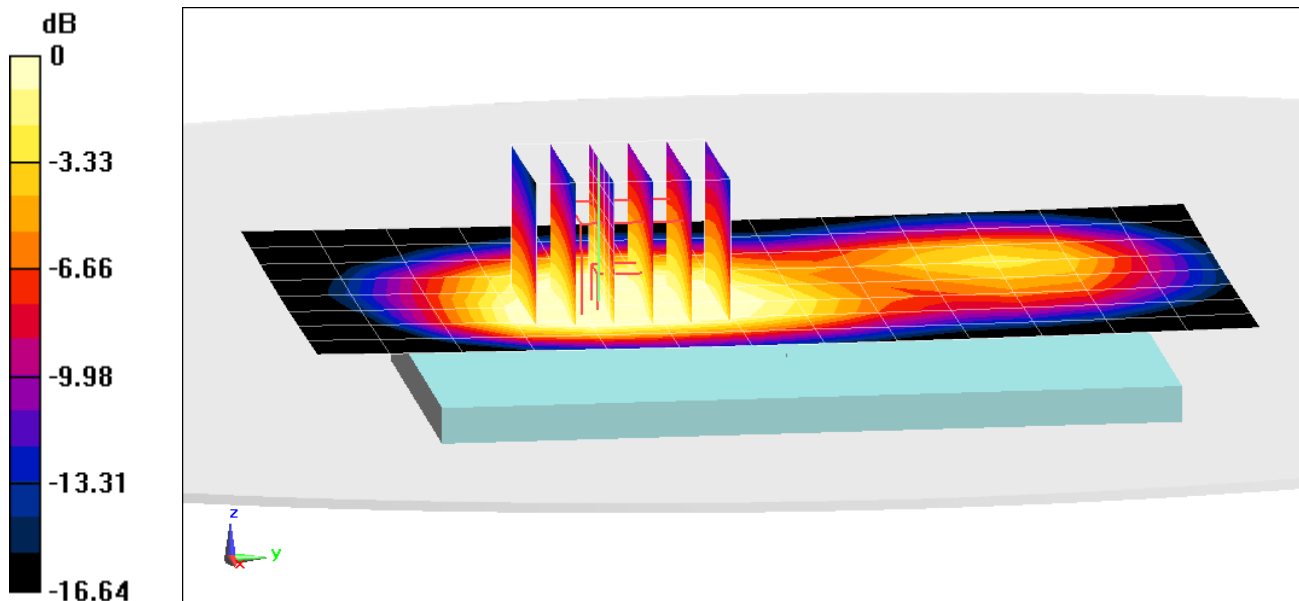

0 dB = 0.688 W/kg = -1.62 dBW/kg

# PCTEST ENGINEERING LABORATORY, INC.

**DUT: A3LSMJ320A; Type: Portable Handset; Serial: 03087**

Communication System: UID 0, LTE Band 4 (AWS); Frequency: 1732.5 MHz; Duty Cycle: 1:1

Medium: 1750 Body Medium parameters used (interpolated):

$f = 1732.5$  MHz;  $\sigma = 1.474$  S/m;  $\epsilon_r = 51.955$ ;  $\rho = 1000$  kg/m<sup>3</sup>

Phantom section: Flat Section; Space: 1.0 cm

Test Date: 01-28-2016; Ambient Temp: 24.3°C; Tissue Temp: 23.9°C

Probe: ES3DV3 - SN3263; ConvF(4.88, 4.88, 4.88); Calibrated: 5/20/2015;

Sensor-Surface: 3mm (Mechanical Surface Detection)

Electronics: DAE4 Sn859; Calibrated: 6/17/2015

Phantom: SAM with CRP v5.0 (Right); Type: QD000P40CD; Serial: TP:1759

Measurement SW: DASY52, Version 52.8 (8); SEMCAD X Version 14.6.10 (7331)

**Mode: LTE Band 4 (AWS), Body SAR, Back side, Mid.ch,  
20 MHz Bandwidth, QPSK, 1 RB, 50 RB Offset**

**Area Scan (9x15x1):** Measurement grid: dx=15mm, dy=15mm

**Zoom Scan (5x5x7)/Cube 0:** Measurement grid: dx=8mm, dy=8mm, dz=5mm

Reference Value = 21.76 V/m; Power Drift = 0.08 dB

Peak SAR (extrapolated) = 0.977 W/kg

**SAR(1 g) = 0.631 W/kg**

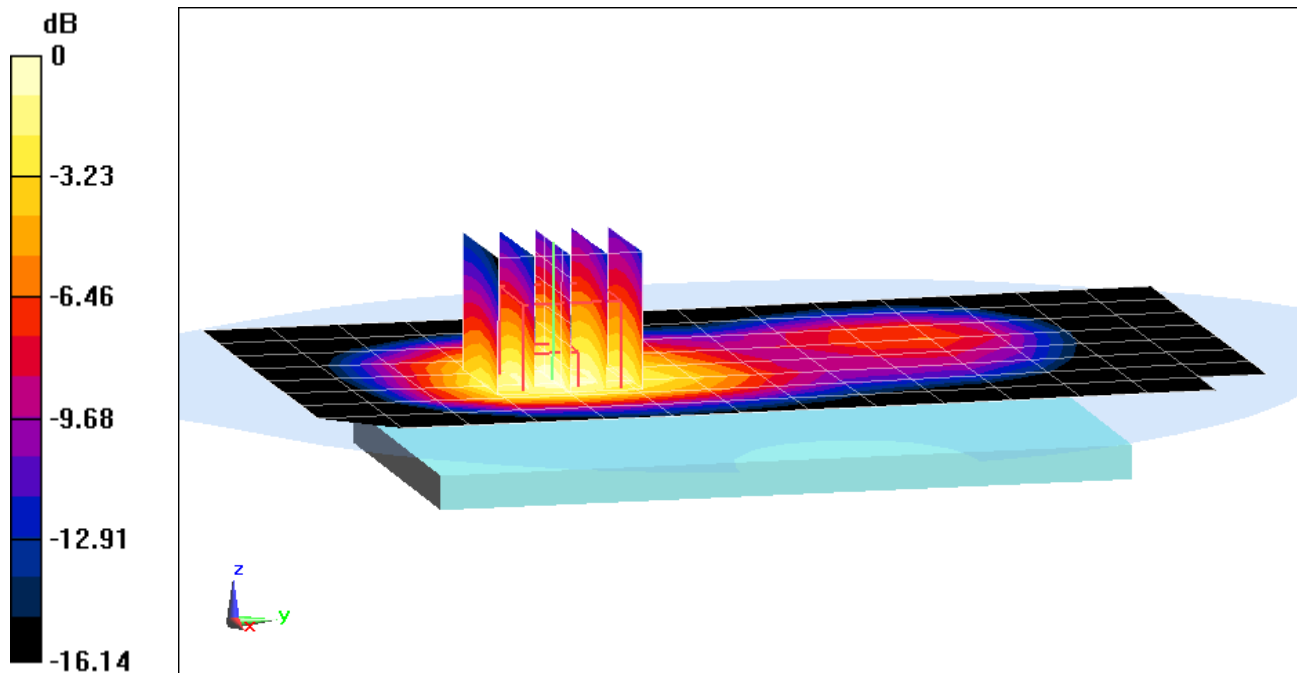

0 dB = 0.741 W/kg = -1.30 dBW/kg

# PCTEST ENGINEERING LABORATORY, INC.

**DUT: A3LSMJ320A; Type: Portable Handset; Serial: 08102**

Communication System: UID 0, LTE Band 2 (PCS); Frequency: 1900 MHz; Duty Cycle: 1:1

Medium: 1900 Body, Medium parameters used (interpolated):

$f = 1900 \text{ MHz}$ ;  $\sigma = 1.553 \text{ S/m}$ ;  $\epsilon_r = 51.489$ ;  $\rho = 1000 \text{ kg/m}^3$

Phantom section: Flat Section; Space: 1.5 cm

Test Date: 01-25-2016; Ambient Temp: 21.5°C; Tissue Temp: 23.5°C

Probe: ES3DV3 - SN3333; ConvF(4.7, 4.7, 4.7); Calibrated: 10/29/2015;

Sensor-Surface: 3mm (Mechanical Surface Detection)

Electronics: DAE4 Sn1333; Calibrated: 10/27/2015

Phantom: SAM Front; Type: QD000P40CD; Serial: TP:1758

Measurement SW: DASY52, Version 52.8 (8); SEMCAD X Version 14.6.10 (7331)

**Mode: LTE Band 2 (PCS), Body SAR, Back side, High.ch,  
20 MHz Bandwidth, QPSK, 1 RB, 50 RB Offset**

**Area Scan (9x15x1):** Measurement grid: dx=15mm, dy=15mm

**Zoom Scan (7x6x7)/Cube 0:** Measurement grid: dx=8mm, dy=8mm, dz=5mm

Reference Value = 15.05 V/m; Power Drift = -0.12 dB

Peak SAR (extrapolated) = 0.518 W/kg

**SAR(1 g) = 0.324 W/kg**

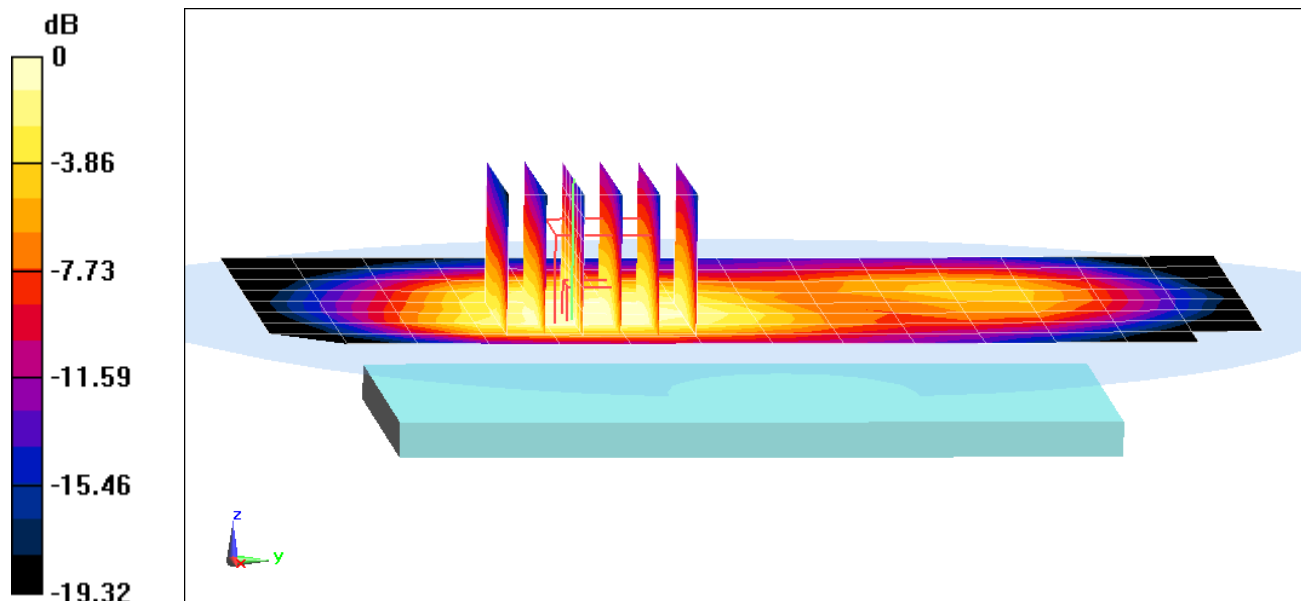

0 dB = 0.378 W/kg = -4.23 dBW/kg

# PCTEST ENGINEERING LABORATORY, INC.

**DUT: A3LSMJ320A; Type: Portable Handset; Serial: 03087**

Communication System: UID 0, LTE Band 2 (PCS) (0); Frequency: 1900 MHz; Duty Cycle: 1:1  
Medium: 1900 Body, Medium parameters used (interpolated):  
 $f = 1900 \text{ MHz}$ ;  $\sigma = 1.555 \text{ S/m}$ ;  $\epsilon_r = 51.688$ ;  $\rho = 1000 \text{ kg/m}^3$   
Phantom section: Flat Section; Space: 1.0 cm

Test Date: 01-21-2016; Ambient Temp: 22.1°C; Tissue Temp: 21.6°C

Probe: ES3DV3 - SN3319; ConvF(4.53, 4.53, 4.53); Calibrated: 3/19/2015;  
Sensor-Surface: 3mm (Mechanical Surface Detection)  
Electronics: DAE4 Sn1368; Calibrated: 3/13/2015  
Phantom: SAM with CRP v4.0; Type: QD000P40CD; Serial: TP:1800  
Measurement SW: DASY52, Version 52.8 (8); SEMCAD X Version 14.6.10 (7331)

**Mode: LTE Band 2 (PCS), Body SAR, Front side, High.ch,  
20 MHz Bandwidth, QPSK, 1 RB, 50 RB Offset**

**Area Scan (9x15x1):** Measurement grid: dx=15mm, dy=15mm  
**Zoom Scan (5x5x7)/Cube 0:** Measurement grid: dx=8mm, dy=8mm, dz=5mm  
Reference Value = 18.07 V/m; Power Drift = 0.05 dB  
Peak SAR (extrapolated) = 0.809 W/kg  
**SAR(1 g) = 0.497 W/kg**

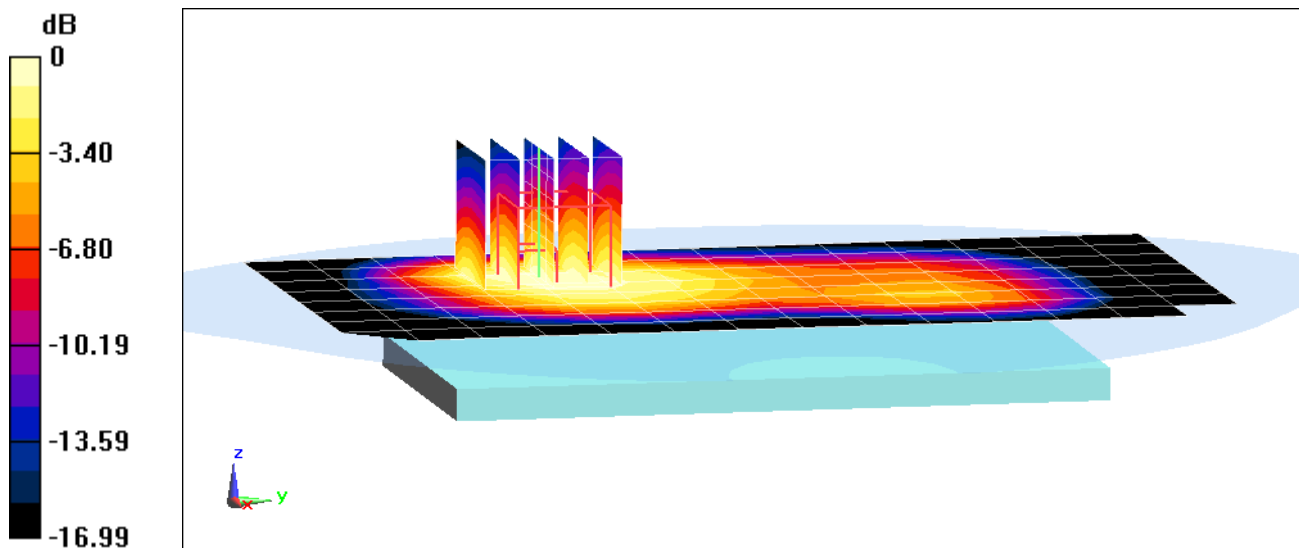

0 dB = 0.587 W/kg = -2.31 dBW/kg

# PCTEST ENGINEERING LABORATORY, INC.

**DUT: A3LSMJ320A; Type: Portable Handset; Serial: 08102**

Communication System: UID 0, IEEE 802.11b (0); Frequency: 2462 MHz; Duty Cycle: 1:1

Medium: 2450 Body, Medium parameters used (interpolated):

$f = 2462 \text{ MHz}$ ;  $\sigma = 2.008 \text{ S/m}$ ;  $\epsilon_r = 51.5$ ;  $\rho = 1000 \text{ kg/m}^3$

Phantom section: Flat Section; Space: 1.0 cm

Test Date: 01-19-2016; Ambient Temp: 21.7°C; Tissue Temp: 21.5°C

Probe: ES3DV3 - SN3319; ConvF(4.11, 4.11, 4.11); Calibrated: 3/19/2015;

Sensor-Surface: 3mm (Mechanical Surface Detection)

Electronics: DAE4 Sn1368; Calibrated: 3/13/2015

Phantom: SAM with CRP v4.0; Type: QD000P40CD; Serial: TP:1800

Measurement SW: DASY52, Version 52.8 (8); SEMCAD X Version 14.6.10 (7331)

**Mode: IEEE 802.11b, 22 MHz Bandwidth, Body SAR, Ch 11, 1 Mbps, Back Side**

**Area Scan (11x17x1):** Measurement grid: dx=12mm, dy=12mm

**Zoom Scan (7x7x7)/Cube 0:** Measurement grid: dx=5mm, dy=5mm, dz=5mm

Reference Value = 13.36 V/m; Power Drift = -0.09 dB

Peak SAR (extrapolated) = 0.706 W/kg

**SAR(1 g) = 0.324 W/kg**

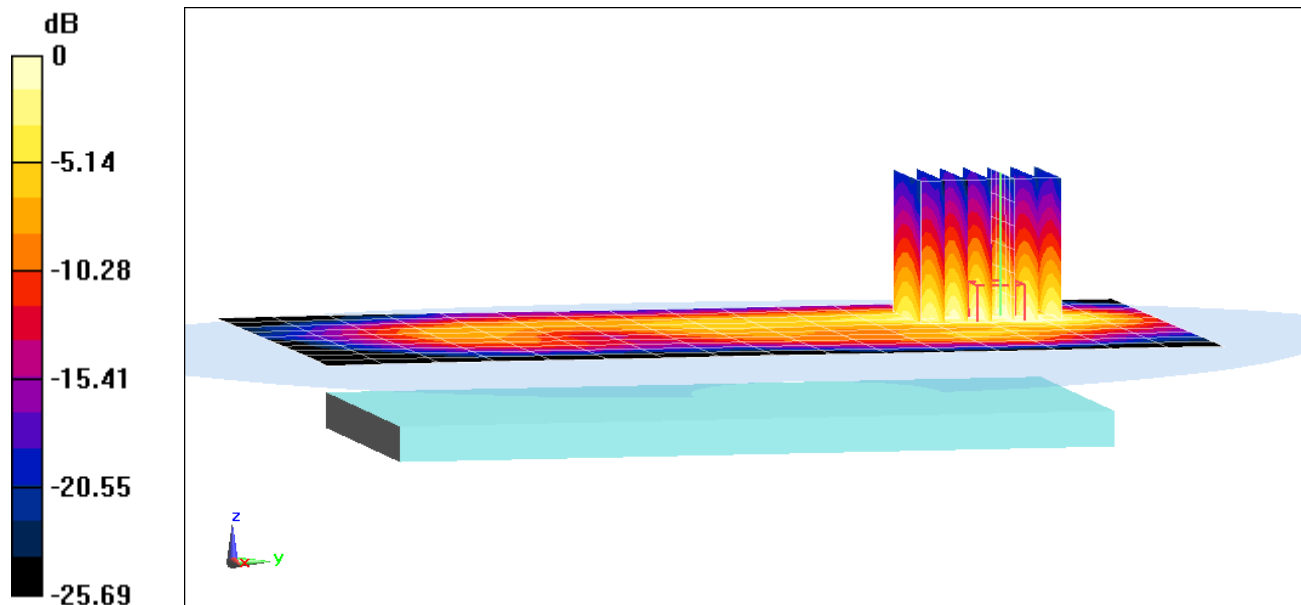

0 dB = 0.412 W/kg = -3.85 dBW/kg

# PCTEST ENGINEERING LABORATORY, INC.

**DUT: A3LSMJ320A; Type: Portable Handset; Serial: 08102**

Communication System: UID 0, IEEE 802.11b (0); Frequency: 2462 MHz; Duty Cycle: 1:1  
Medium: 2450 Body, Medium parameters used (interpolated):  
 $f = 2462 \text{ MHz}$ ;  $\sigma = 2.008 \text{ S/m}$ ;  $\epsilon_r = 51.5$ ;  $\rho = 1000 \text{ kg/m}^3$   
Phantom section: Flat Section; Space: 1.0 cm

Test Date: 01-19-2016; Ambient Temp: 21.7°C; Tissue Temp: 21.5°C

Probe: ES3DV3 - SN3319; ConvF(4.11, 4.11, 4.11); Calibrated: 3/19/2015;  
Sensor-Surface: 3mm (Mechanical Surface Detection)  
Electronics: DAE4 Sn1368; Calibrated: 3/13/2015  
Phantom: SAM with CRP v4.0; Type: QD000P40CD; Serial: TP:1800  
Measurement SW: DASY52, Version 52.8 (8); SEMCAD X Version 14.6.10 (7331)

**Mode: IEEE 802.11b, 22 MHz Bandwidth, Body SAR, Ch 11, 1 Mbps, Front Side**

**Area Scan (11x17x1):** Measurement grid: dx=12mm, dy=12mm  
**Zoom Scan (7x7x7)/Cube 0:** Measurement grid: dx=5mm, dy=5mm, dz=5mm  
Reference Value = 14.24 V/m; Power Drift = 0.12 dB  
Peak SAR (extrapolated) = 0.845 W/kg  
**SAR(1 g) = 0.387 W/kg**

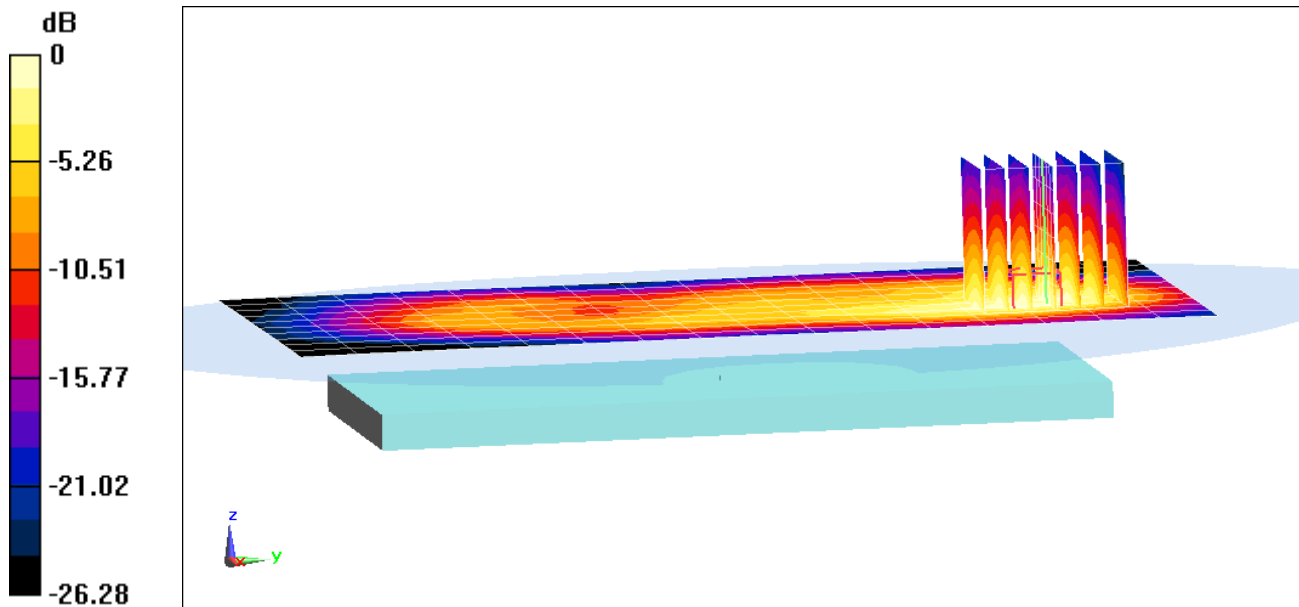

0 dB = 0.501 W/kg = -3.00 dBW/kg

## APPENDIX B: SYSTEM VERIFICATION

# PCTEST ENGINEERING LABORATORY, INC.

**DUT: Dipole 750 MHz; Type: D750V3; Serial: 1054**

Communication System: UID 0, CW; Frequency: 750 MHz; Duty Cycle: 1:1

Medium: 750 Head, Medium parameters used (interpolated):

$f = 750 \text{ MHz}$ ;  $\sigma = 0.925 \text{ S/m}$ ;  $\epsilon_r = 43.457$ ;  $\rho = 1000 \text{ kg/m}^3$

Phantom section: Flat Section; Space: 1.5 cm

Test Date: 11-19-2015; Ambient Temp: 23.2°C; Tissue Temp: 21.8°C

Probe: ES3DV2 - SN3022; ConvF(6.33, 6.33, 6.33); Calibrated: 8/26/2015;

Sensor-Surface: 3mm (Mechanical Surface Detection)

Electronics: DAE4 Sn665; Calibrated: 2/18/2015

Phantom: SAM with CRP v4.0; Type: QD000P40CD; Serial: TP:1797

Measurement SW: DASY52, Version 52.8 (8);SEMCAD X Version 14.6.10 (7331)

## 750 MHz System Verification at 23.0 dBm (200 mW)

**Area Scan (7x15x1):** Measurement grid: dx=15mm, dy=15mm

**Zoom Scan (5x5x7)/Cube 0:** Measurement grid: dx=8mm, dy=8mm, dz=5mm

Peak SAR (extrapolated) = 2.59 W/kg

**SAR(1 g) = 1.74 W/kg**

Deviation(1 g) = 5.07%

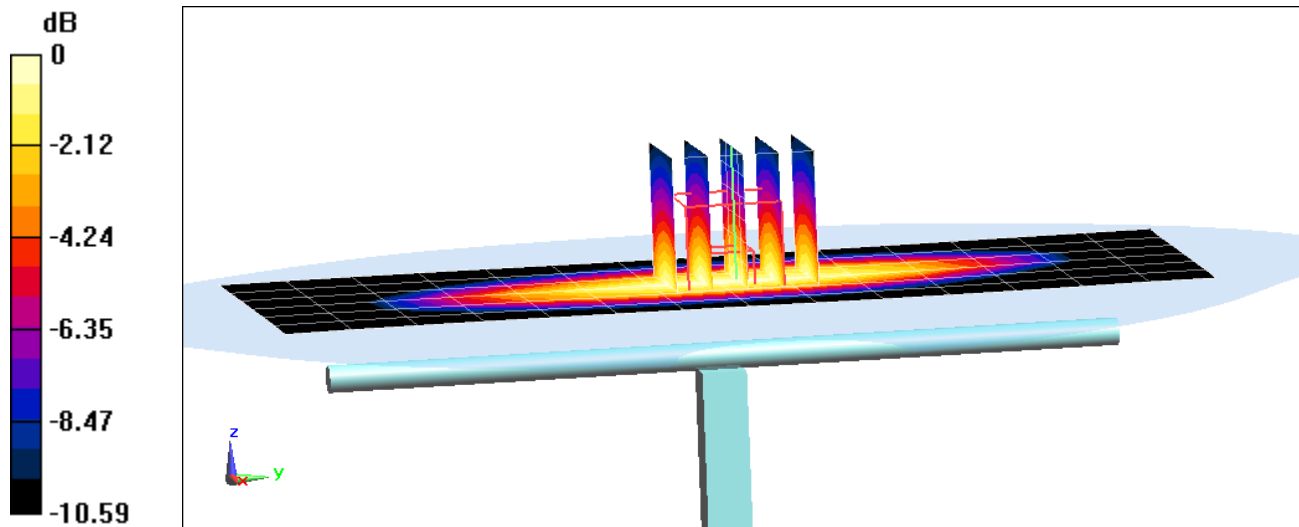

0 dB = 2.03 W/kg = 3.07 dBW/kg

# PCTEST ENGINEERING LABORATORY, INC.

**DUT: Dipole 835 MHz; Type: D835V2; Serial: 4d119**

Communication System: UID 0, CW; Frequency: 835 MHz; Duty Cycle: 1:1

Medium: 835 Head, Medium parameters used:

$f = 835 \text{ MHz}$ ;  $\sigma = 0.918 \text{ S/m}$ ;  $\epsilon_r = 41.991$ ;  $\rho = 1000 \text{ kg/m}^3$

Phantom section: Flat Section; Space: 1.5 cm

Test Date: 11-17-2015; Ambient Temp: 22.7°C; Tissue Temp: 21.1°C

Probe: ES3DV3 - SN3351; ConvF(6.17, 6.17, 6.17); Calibrated: 6/22/2015;

Sensor-Surface: 3mm (Mechanical Surface Detection)

Electronics: DAE4 Sn1322; Calibrated: 8/24/2015

Phantom: SAM V5.0 Right; Type: QD000P40CD; Serial: 1647

Measurement SW: DASY52, Version 52.8 (8);SEMCAD X Version 14.6.10 (7331)

## 835 MHz System Verification at 23.0 dBm (200 mW)

**Area Scan (7x14x1):** Measurement grid: dx=15mm, dy=15mm

**Zoom Scan (5x5x7)/Cube 0:** Measurement grid: dx=8mm, dy=8mm, dz=5mm

Peak SAR (extrapolated) = 2.62 W/kg

**SAR(1 g) = 1.77 W/kg**

Deviation(1 g) = -5.65%

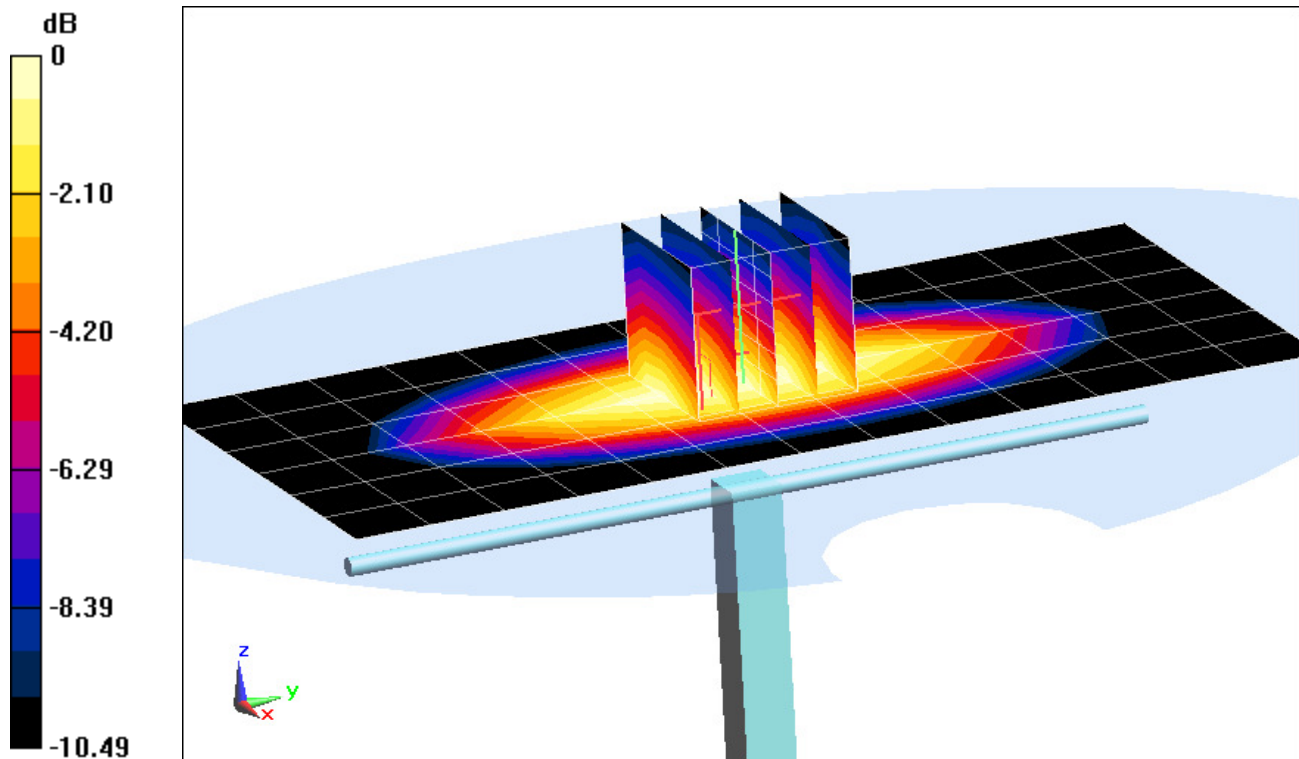

# PCTEST ENGINEERING LABORATORY, INC.

**DUT: Dipole 835 MHz; Type: D835V2; Serial: 4d119**

Communication System: UID 0, CW; Frequency: 835 MHz; Duty Cycle: 1:1

Medium: 835 Head Medium parameters used:

$f = 835 \text{ MHz}$ ;  $\sigma = 0.892 \text{ S/m}$ ;  $\epsilon_r = 40.219$ ;  $\rho = 1000 \text{ kg/m}^3$

Phantom section: Flat Section ; Space: 1.5 cm

Test Date: 01-18-2016; Ambient Temp: 24.0°C; Tissue Temp: 22.1°C

Probe: ES3DV3 - SN3334; ConvF(6.37, 6.37, 6.37); Calibrated: 11/17/2015;

Sensor-Surface: 3mm (Mechanical Surface Detection)

Electronics: DAE4 Sn1415; Calibrated: 11/11/2015

Phantom: SAM Front; Type: SAM; Serial: 1686

Measurement SW: DASY52, Version 52.8 (8);SEMCAD X Version 14.6.10 (7331)

## 835 MHz System Verification at 23.0 dBm (200 mW)

**Area Scan (7x14x1):** Measurement grid: dx=15mm, dy=15mm

**Zoom Scan (5x5x7)/Cube 0:** Measurement grid: dx=8mm, dy=8mm, dz=5mm

Peak SAR (extrapolated) = 2.87 W/kg

**SAR(1 g) = 1.95 W/kg**

Deviation(1 g) = 3.94%

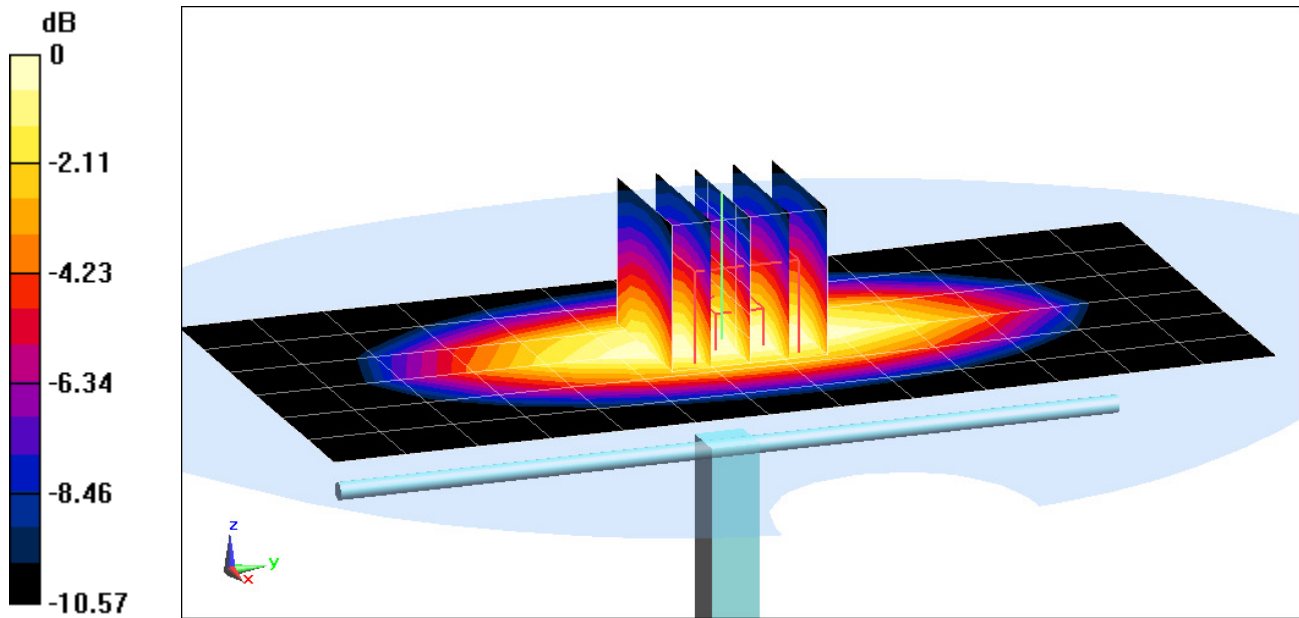

0 dB = 2.27 W/kg = 3.56 dBW/kg

# PCTEST ENGINEERING LABORATORY, INC.

**DUT: Dipole 1750 MHz; Type: D1750V2; Serial: 1051**

Communication System: UID 0, CW; Frequency: 1750 MHz; Duty Cycle: 1:1

Medium: 1750 Head, Medium parameters used:

$f = 1750 \text{ MHz}$ ;  $\sigma = 1.331 \text{ S/m}$ ;  $\epsilon_r = 39.496$ ;  $\rho = 1000 \text{ kg/m}^3$

Phantom section: Flat Section; Space: 1.0 cm

Test Date: 11-23-2015; Ambient Temp: 20.3°C; Tissue Temp: 20.8°C

Probe: ES3DV3 - SN3319; ConvF(5.29, 5.29, 5.29); Calibrated: 3/19/2015;

Sensor-Surface: 3mm (Mechanical Surface Detection)

Electronics: DAE4 Sn1368; Calibrated: 3/13/2015

Phantom: SAM with CRP v4.0; Type: QD000P40CD; Serial: TP:1800

Measurement SW: DASY52, Version 52.8 (8); SEMCAD X Version 14.6.10 (7331)

## 1750 MHz System Verification at 20.0 dBm (100 mW)

**Area Scan (7x9x1):** Measurement grid: dx=15mm, dy=15mm

**Zoom Scan (5x5x7)/Cube 0:** Measurement grid: dx=8mm, dy=8mm, dz=5mm

Peak SAR (extrapolated) = 6.28 W/kg

**SAR(1 g) = 3.46 W/kg**

Deviation(1 g) = -4.42%

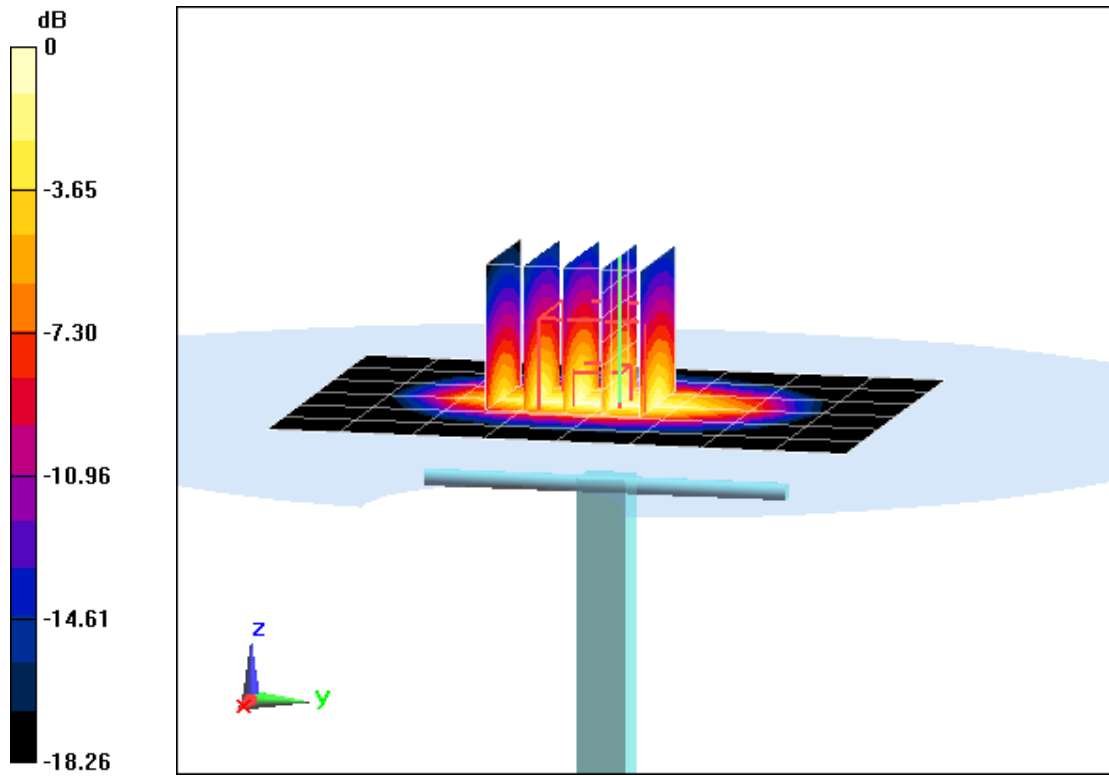

0 dB = 4.32 W/kg = 6.35 dBW/kg

# PCTEST ENGINEERING LABORATORY, INC.

**DUT: Dipole 1750 MHz; Type: D1750V2; Serial: 1051**

Communication System: UID 0, CW; Frequency: 1750 MHz; Duty Cycle: 1:1

Medium: 1750 Head Medium parameters used:

$f = 1750 \text{ MHz}$ ;  $\sigma = 1.39 \text{ S/m}$ ;  $\epsilon_r = 40.283$ ;  $\rho = 1000 \text{ kg/m}^3$

Phantom section: Flat Section; Space: 1.0 cm

Test Date: 01-19-2016; Ambient Temp: 22.3°C; Tissue Temp: 21.2°C

Probe: ES3DV3 - SN3263; ConvF(5.27, 5.27, 5.27); Calibrated: 5/20/2015;

Sensor-Surface: 3mm (Mechanical Surface Detection)

Electronics: DAE4 Sn859; Calibrated: 6/17/2015

Phantom: SAM with CRP v5.0 (Right); Type: QD000P40CD; Serial: TP:1759

Measurement SW: DASY52, Version 52.8 (8);SEMCAD X Version 14.6.10 (7331)

## 1750 MHz System Verification at 20.0 dBm (100 mW)

**Area Scan (7x9x1):** Measurement grid: dx=15mm, dy=15mm

**Zoom Scan (5x5x7)/Cube 0:** Measurement grid: dx=8mm, dy=8mm, dz=5mm

Peak SAR (extrapolated) = 6.62 W/kg

**SAR(1 g) = 3.69 W/kg**

Deviation(1 g) = 1.93%

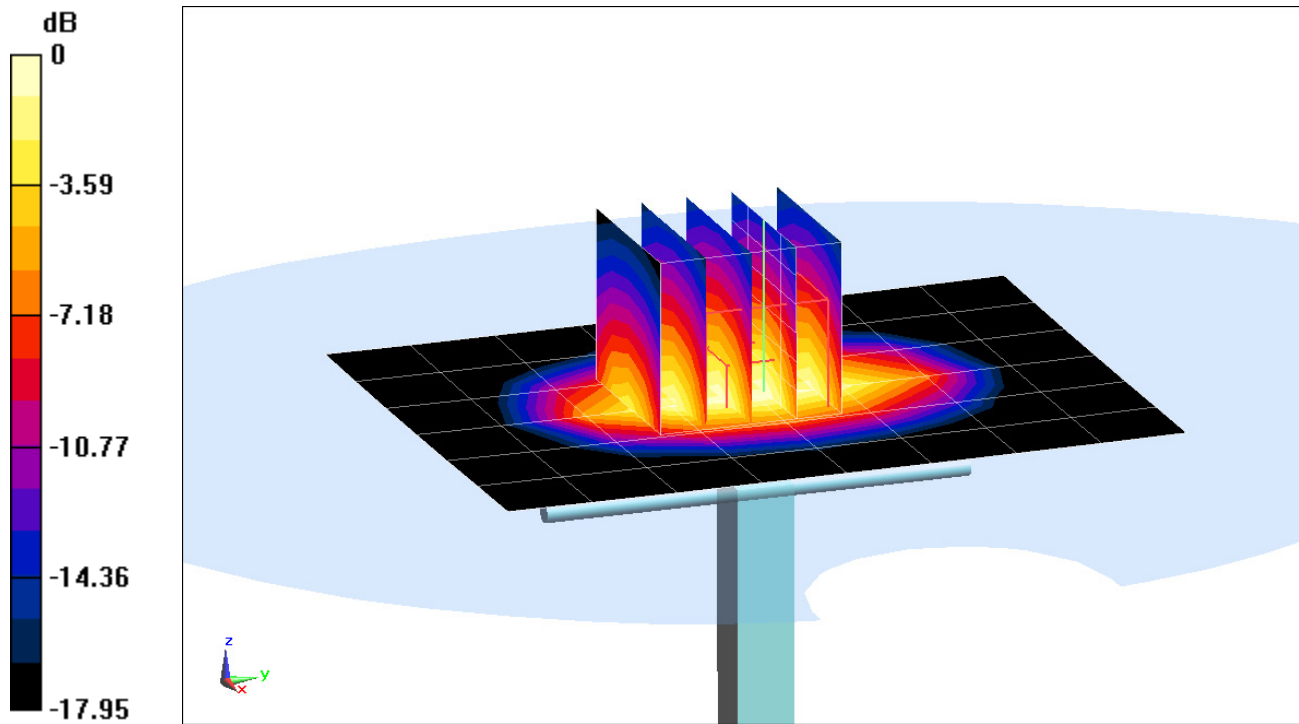

0 dB = 4.60 W/kg = 6.63 dBW/kg

# PCTEST ENGINEERING LABORATORY, INC.

**DUT: Dipole 1900 MHz; Type: D1900V2; Serial: 5d141**

Communication System: UID 0, CW; Frequency: 1900 MHz; Duty Cycle: 1:1

Medium: 1900 Head, Medium parameters used (interpolated):

$f = 1900 \text{ MHz}$ ;  $\sigma = 1.425 \text{ S/m}$ ;  $\epsilon_r = 38.932$ ;  $\rho = 1000 \text{ kg/m}^3$

Phantom section: Flat Section; Space: 1.0 cm

Test Date: 11-18-2015; Ambient Temp: 21.2°C; Tissue Temp: 22.0°C

Probe: ES3DV3 - SN3319; ConvF(5.1, 5.1, 5.1); Calibrated: 3/19/2015;

Sensor-Surface: 3mm (Mechanical Surface Detection)

Electronics: DAE4 Sn1368; Calibrated: 3/13/2015

Phantom: SAM with CRP v4.0; Type: QD000P40CD; Serial: TP:1800

Measurement SW: DASY52, Version 52.8 (8); SEMCAD X Version 14.6.10 (7331)

## 1900 MHz System Verification at 20.0 dBm (100 mW)

**Area Scan (7x10x1):** Measurement grid: dx=15mm, dy=15mm

**Zoom Scan (5x5x7)/Cube 0:** Measurement grid: dx=8mm, dy=8mm, dz=5mm

Peak SAR (extrapolated) = 6.72 W/kg

**SAR(1 g) = 3.72 W/kg**

Deviation(1 g) = -6.77%

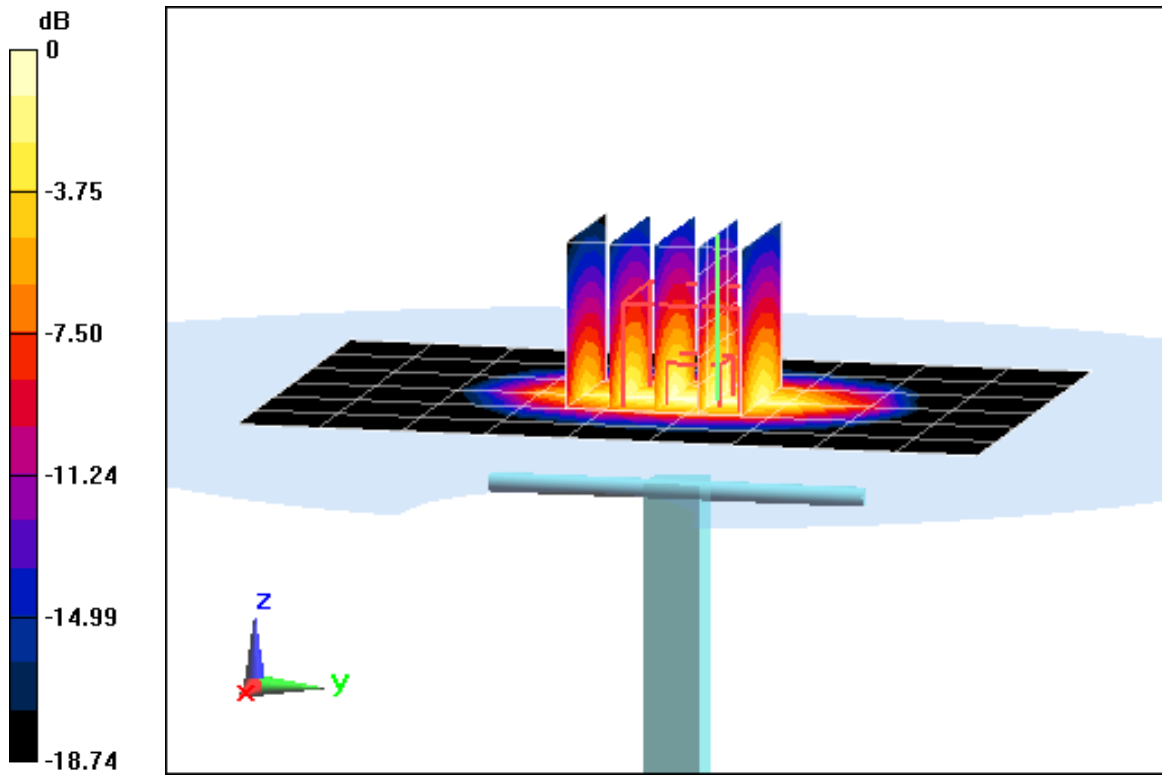

0 dB = 4.64 W/kg = 6.67 dBW/kg

# PCTEST ENGINEERING LABORATORY, INC.

**DUT: Dipole 1900 MHz; Type: D1900V2; Serial: 5d149**

Communication System: UID 0, CW; Frequency: 1900 MHz; Duty Cycle: 1:1  
Medium: 1900 Head Medium parameters used (interpolated):  
 $f = 1900 \text{ MHz}$ ;  $\sigma = 1.418 \text{ S/m}$ ;  $\epsilon_r = 38.786$ ;  $\rho = 1000 \text{ kg/m}^3$   
Phantom section: Flat Section; Space: 1.0 cm

Test Date: 01-18-2016; Ambient Temp: 21.1°C; Tissue Temp: 21.1°C

Probe: ES3DV3 - SN3209; ConvF(5.05, 5.05, 5.05); Calibrated: 3/19/2015;  
Sensor-Surface: 3mm (Mechanical Surface Detection)  
Electronics: DAE4 Sn1407; Calibrated: 4/20/2015  
Phantom: SAM v5.0 front; Type: QD000P40CD; Serial: TP-1646  
Measurement SW: DASY52, Version 52.8 (8);SEMCAD X Version 14.6.10 (7331)

## 1900 MHz System Verification at 20.0 dBm (100 mW)

**Area Scan (7x10x1):** Measurement grid: dx=15mm, dy=15mm  
**Zoom Scan (5x5x7)/Cube 0:** Measurement grid: dx=8mm, dy=8mm, dz=5mm  
Peak SAR (extrapolated) = 8.21 W/kg  
**SAR(1 g) = 4.22 W/kg**  
Deviation (1g) = 3.69 %

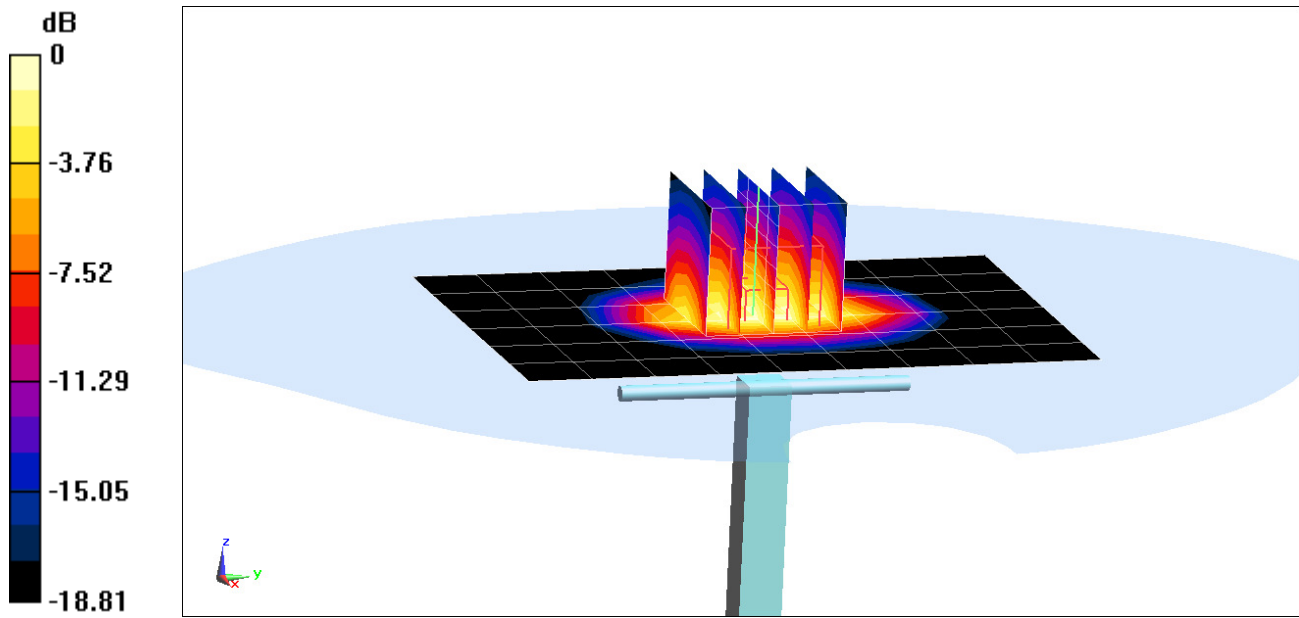

0 dB = 5.36 W/kg = 7.29 dBW/kg

# PCTEST ENGINEERING LABORATORY, INC.

**DUT: Dipole 2450 MHz; Type: D2450V2; Serial: 719**

Communication System: UID 0, CW; Frequency: 2450 MHz; Duty Cycle: 1:1

Medium: 2300 Head Medium parameters used:

$f = 2450 \text{ MHz}$ ;  $\sigma = 1.84 \text{ S/m}$ ;  $\epsilon_r = 38.234$ ;  $\rho = 1000 \text{ kg/m}^3$

Phantom section: Flat Section ; Space: 1.0 cm

Test Date: 01-19-2016; Ambient Temp: 22.3°C; Tissue Temp: 21.0°C

Probe: ES3DV3 - SN3351; ConvF(4.46, 4.46, 4.46); Calibrated: 6/22/2015;

Sensor-Surface: 3mm (Mechanical Surface Detection)

Electronics: DAE4 Sn1322; Calibrated: 8/24/2015

Phantom: SAM V5.0 Right; Type: QD000P40CD; Serial: 1647

Measurement SW: DASY52, Version 52.8 (8);SEMCAD X Version 14.6.10 (7331)

## 2450 MHz System Verification at 20.0 dBm (100 mW)

**Area Scan (8x9x1):** Measurement grid: dx=12mm, dy=12mm

**Zoom Scan (7x7x7)/Cube 0:** Measurement grid: dx=5mm, dy=5mm, dz=5mm

Peak SAR (extrapolated) = 10.5 W/kg

**SAR(1 g) = 5.06 W/kg**

Deviation(1 g) = -6.64%

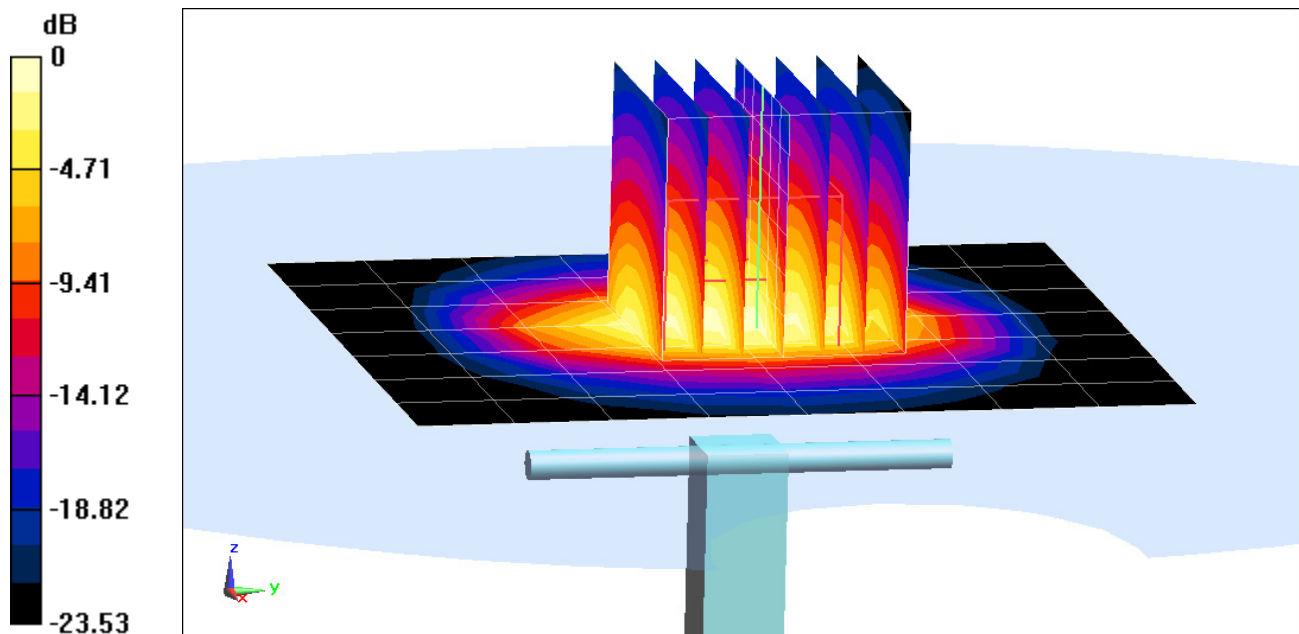

0 dB = 6.60 W/kg = 8.20 dBW/kg

# PCTEST ENGINEERING LABORATORY, INC.

**DUT: Dipole 750 MHz; Type: D750V3; Serial: 1003**

Communication System: UID 0, CW; Frequency: 750 MHz; Duty Cycle: 1:1

Medium: 750 Body, Medium parameters used (interpolated):

$f = 750 \text{ MHz}$ ;  $\sigma = 0.954 \text{ S/m}$ ;  $\epsilon_r = 53.601$ ;  $\rho = 1000 \text{ kg/m}^3$

Phantom section: Flat Section; Space: 1.5 cm

Test Date: 11-23-2015; Ambient Temp: 22.0°C; Tissue Temp: 23.7°C

Probe: ES3DV3 - SN3333; ConvF(6.31, 6.31, 6.31); Calibrated: 10/29/2015;

Sensor-Surface: 3mm (Mechanical Surface Detection)

Electronics: DAE4 Sn1333; Calibrated: 10/27/2015

Phantom: SAM Front; Type: QD000P40CD; Serial: TP:1758

Measurement SW: DASY52, Version 52.8 (8);SEMCAD X Version 14.6.10 (7331)

## 750 MHz System Verification at 23.0 dBm (200 mW)

**Area Scan (7x15x1):** Measurement grid: dx=15mm, dy=15mm

**Zoom Scan (5x5x7)/Cube 0:** Measurement grid: dx=8mm, dy=8mm, dz=5mm

Peak SAR (extrapolated) = 2.53 W/kg

**SAR(1 g) = 1.74 W/kg**

Deviation(1 g) = 2.84%

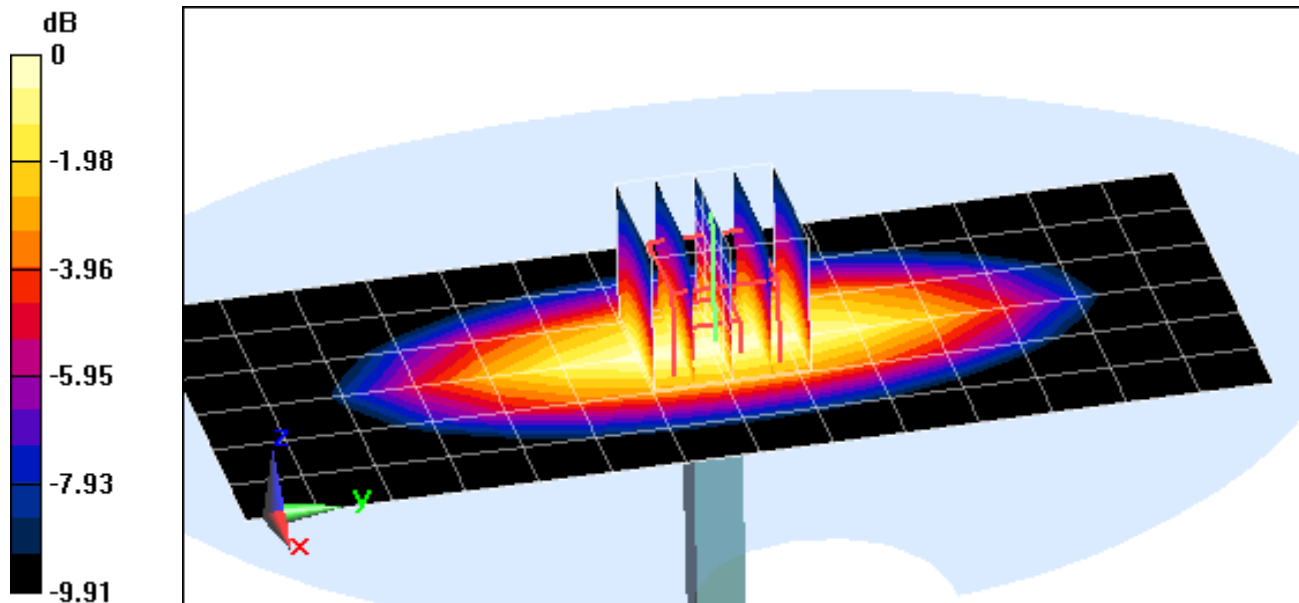

0 dB = 2.02 W/kg = 3.05 dBW/kg

# PCTEST ENGINEERING LABORATORY, INC.

**DUT: Dipole 835 MHz; Type: D835V2; Serial: 4d119**

Communication System: UID 0, CW; Frequency: 835 MHz; Duty Cycle: 1:1

Medium: 835 Body, Medium parameters used:

$f = 835 \text{ MHz}$ ;  $\sigma = 0.986 \text{ S/m}$ ;  $\epsilon_r = 53.623$ ;  $\rho = 1000 \text{ kg/m}^3$

Phantom section: Flat Section; Space: 1.5 cm

Test Date: 11-22-2015; Ambient Temp: 20.7°C; Tissue Temp: 20.7°C

Probe: ES3DV3 - SN3351; ConvF(6.11, 6.11, 6.11); Calibrated: 6/22/2015;

Sensor-Surface: 3mm (Mechanical Surface Detection)

Electronics: DAE4 Sn1322; Calibrated: 8/24/2015

Phantom: SAM 5.0 front; Type: QD000P40CD; Serial: TP:-1648

Measurement SW: DASY52, Version 52.8 (8);SEMCAD X Version 14.6.10 (7331)

## 835 MHz System Verification at 23.0 dBm (200 mW)

**Area Scan (7x14x1):** Measurement grid: dx=15mm, dy=15mm

**Zoom Scan (5x5x7)/Cube 0:** Measurement grid: dx=8mm, dy=8mm, dz=5mm

Peak SAR (extrapolated) = 2.90 W/kg

**SAR(1 g) = 2.00 W/kg**

Deviation(1 g) = 8.70%

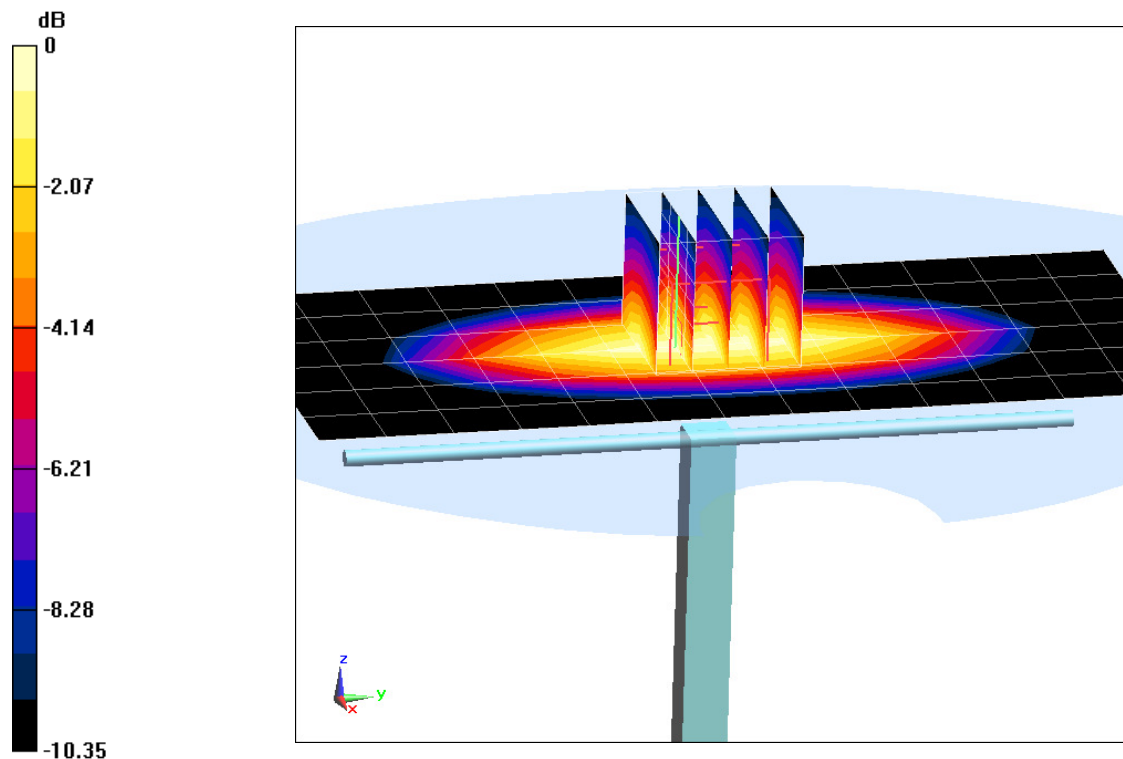

0 dB = 2.32 W/kg = 3.65 dBW/kg

# PCTEST ENGINEERING LABORATORY, INC.

**DUT: Dipole 1750 MHz; Type: D1750V2; Serial: 1051**

Communication System: UID 0, CW; Frequency: 1750 MHz; Duty Cycle: 1:1  
Medium: 1750 Body Medium parameters used:  
 $f = 1750 \text{ MHz}$ ;  $\sigma = 1.462 \text{ S/m}$ ;  $\epsilon_r = 51.662$ ;  $\rho = 1000 \text{ kg/m}^3$   
Phantom section: Flat Section ; Space: 1.0 cm

Test Date: 01-18-2016; Ambient Temp: 23.5°C; Tissue Temp: 22.7°C

Probe: ES3DV2 - SN3022; ConvF(4.79, 4.79, 4.79); Calibrated: 8/26/2015;  
Sensor-Surface: 3mm (Mechanical Surface Detection)  
Electronics: DAE4 Sn665; Calibrated: 2/18/2015  
Phantom: ELI v5.0; Type: QDOVA001BB; Serial: 1229  
Measurement SW: DASY52, Version 52.8 (8);SEMCAD X Version 14.6.10 (7331)

## 1750 MHz System Verification at 20.0 dBm (100 mW)

**Area Scan (7x9x1):** Measurement grid: dx=15mm, dy=15mm  
**Zoom Scan (5x5x7)/Cube 0:** Measurement grid: dx=8mm, dy=8mm, dz=5mm  
Peak SAR (extrapolated) = 6.57 W/kg  
**SAR(1 g) = 3.75 W/kg**  
Deviation(1 g) = 1.08%

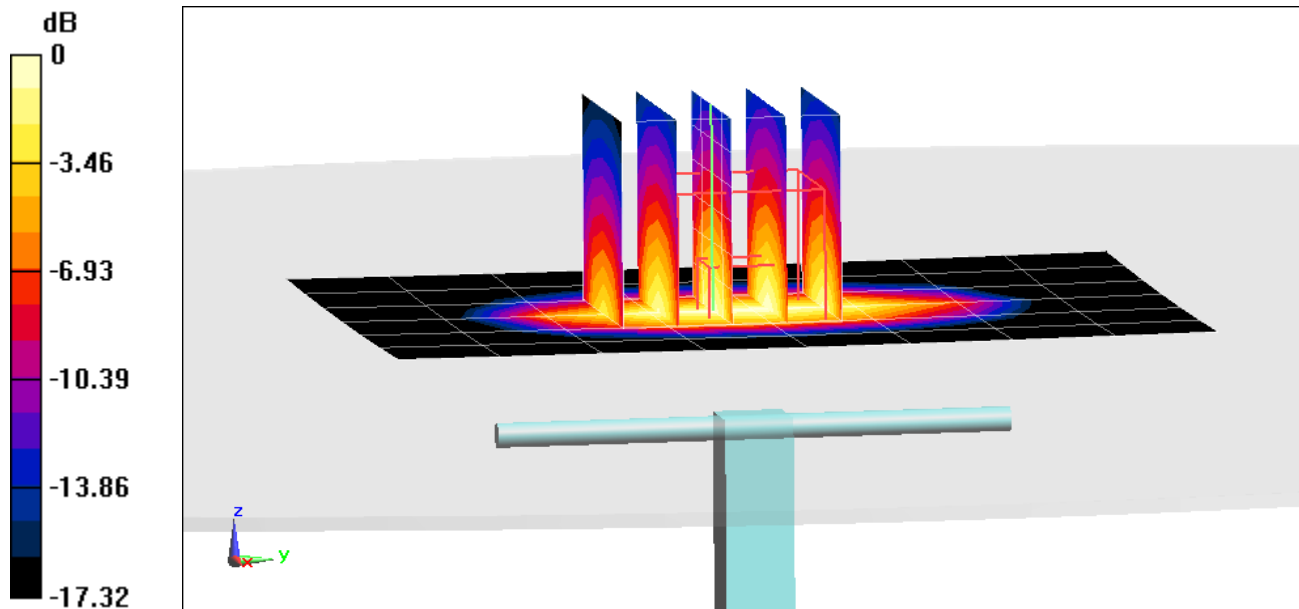

0 dB = 4.64 W/kg = 6.67 dBW/kg

# PCTEST ENGINEERING LABORATORY, INC.

**DUT: Dipole 1750 MHz; Type: D1750V2; Serial: 1051**

Communication System: UID 0, CW; Frequency: 1750 MHz; Duty Cycle: 1:1

Medium: 1750 Body Medium parameters used:

$f = 1750 \text{ MHz}$ ;  $\sigma = 1.492 \text{ S/m}$ ;  $\epsilon_r = 51.897$ ;  $\rho = 1000 \text{ kg/m}^3$

Phantom section: Flat Section; Space: 1.0 cm

Test Date: 01-28-2016; Ambient Temp: 24.3°C; Tissue Temp: 23.9°C

Probe: ES3DV3 - SN3263; ConvF(4.88, 4.88, 4.88); Calibrated: 5/20/2015;

Sensor-Surface: 3mm (Mechanical Surface Detection)

Electronics: DAE4 Sn859; Calibrated: 6/17/2015

Phantom: SAM with CRP v5.0 (Right); Type: QD000P40CD; Serial: TP:1759

Measurement SW: DASY52, Version 52.8 (8);SEMCAD X Version 14.6.10 (7331)

## 1750 MHz System Verification at 20.0 dBm (100 mW)

**Area Scan (7x9x1):** Measurement grid: dx=15mm, dy=15mm

**Zoom Scan (5x5x7)/Cube 0:** Measurement grid: dx=8mm, dy=8mm, dz=5mm

Peak SAR (extrapolated) = 6.83 W/kg

**SAR(1 g) = 3.94 W/kg**

Deviation(1 g) = 6.20%

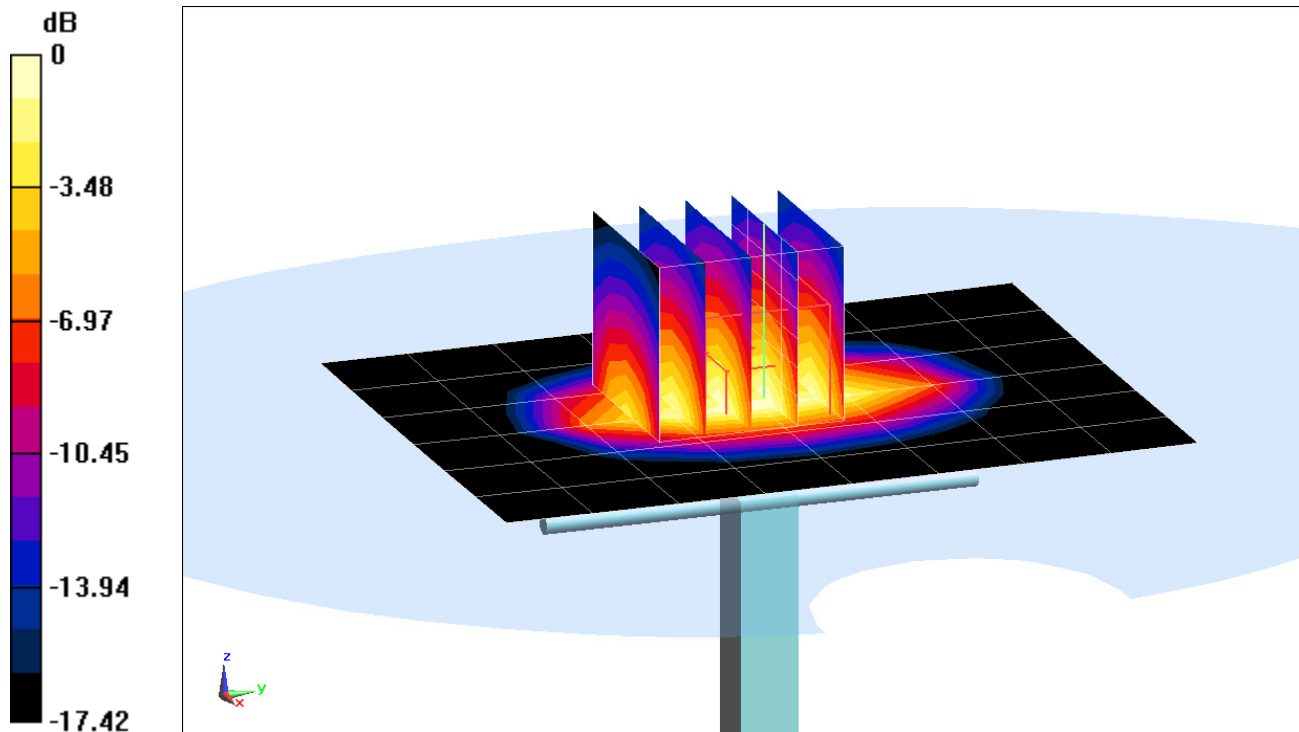

0 dB = 4.89 W/kg = 6.89 dBW/kg

# PCTEST ENGINEERING LABORATORY, INC.

**DUT: Dipole 1900 MHz; Type: D1900V2; Serial: 5d149**

Communication System: UID 0, CW; Frequency: 1900 MHz; Duty Cycle: 1:1

Medium: 1900 Body Medium parameters used (interpolated):

$f = 1900$  MHz;  $\sigma = 1.555$  S/m;  $\epsilon_r = 51.688$ ;  $\rho = 1000$  kg/m<sup>3</sup>

Phantom section: Flat Section; Space: 1.0 cm

Test Date: 01-21-2016; Ambient Temp: 22.1°C; Tissue Temp: 21.6°C

Probe: ES3DV3 - SN3319; ConvF(4.53, 4.53, 4.53); Calibrated: 3/19/2015;

Sensor-Surface: 3mm (Mechanical Surface Detection)

Electronics: DAE4 Sn1368; Calibrated: 3/13/2015

Phantom: SAM with CRP v4.0; Type: QD000P40CD; Serial: TP:1800

Measurement SW: DASY52, Version 52.8 (8);SEMCAD X Version 14.6.10 (7331)

## 1900 MHz System Verification at 20.0 dBm (100 mW)

**Area Scan (7x10x1):** Measurement grid: dx=15mm, dy=15mm

**Zoom Scan (5x5x7)/Cube 0:** Measurement grid: dx=8mm, dy=8mm, dz=5mm

Peak SAR (extrapolated) = 7.03 W/kg

**SAR(1 g) = 3.96 W/kg**

Deviation(1 g) = -1.98%

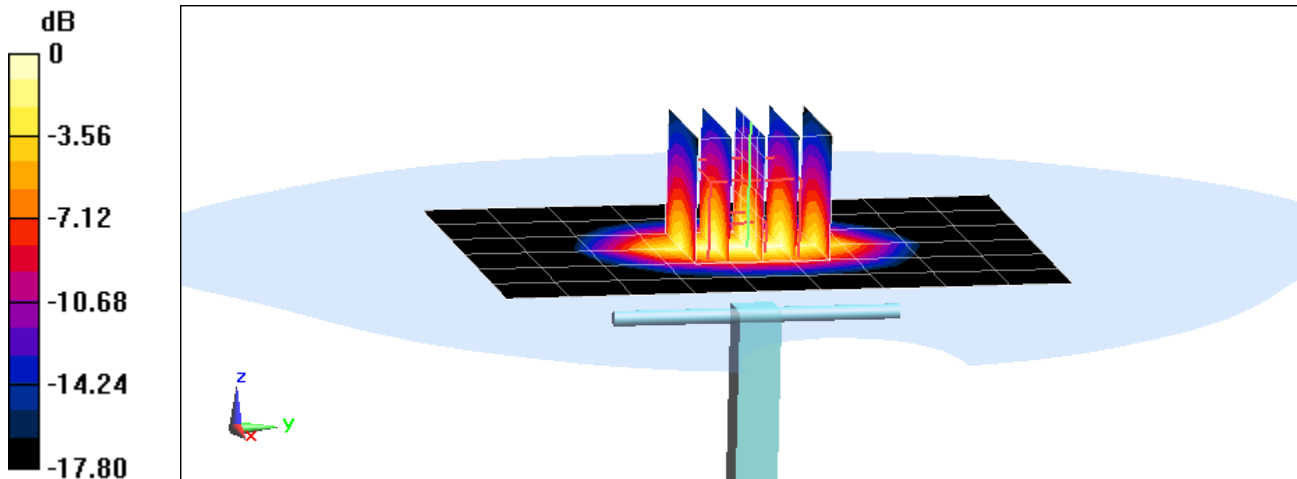

0 dB = 5.03 W/kg = 7.02 dBW/kg

# PCTEST ENGINEERING LABORATORY, INC.

**DUT: Dipole 1900 MHz; Type: D1900V2; Serial: 5d141**

Communication System: UID 0, CW; Frequency: 1900 MHz; Duty Cycle: 1:1

Medium: 1900 Body Medium parameters used (interpolated):

$f = 1900 \text{ MHz}$ ;  $\sigma = 1.553 \text{ S/m}$ ;  $\epsilon_r = 51.489$ ;  $\rho = 1000 \text{ kg/m}^3$

Phantom section: Flat Section; Space: 1.0 cm

Test Date: 01-25-2016; Ambient Temp: 21.5°C; Tissue Temp: 23.5°C

Probe: ES3DV3 - SN3333; ConvF(4.7, 4.7, 4.7); Calibrated: 10/29/2015;

Sensor-Surface: 3mm (Mechanical Surface Detection)

Electronics: DAE4 Sn1333; Calibrated: 10/27/2015

Phantom: SAM Front; Type: QD000P40CD; Serial: TP:1758

Measurement SW: DASY52, Version 52.8 (8);SEMCAD X Version 14.6.10 (7331)

## 1900 MHz System Verification at 20.0 dBm (100 mW)

**Area Scan (7x10x1):** Measurement grid: dx=15mm, dy=15mm

**Zoom Scan (5x5x7)/Cube 0:** Measurement grid: dx=8mm, dy=8mm, dz=5mm

Peak SAR (extrapolated) = 7.52 W/kg

**SAR(1 g) = 4.07 W/kg**

Deviation(1 g) = 1.75%

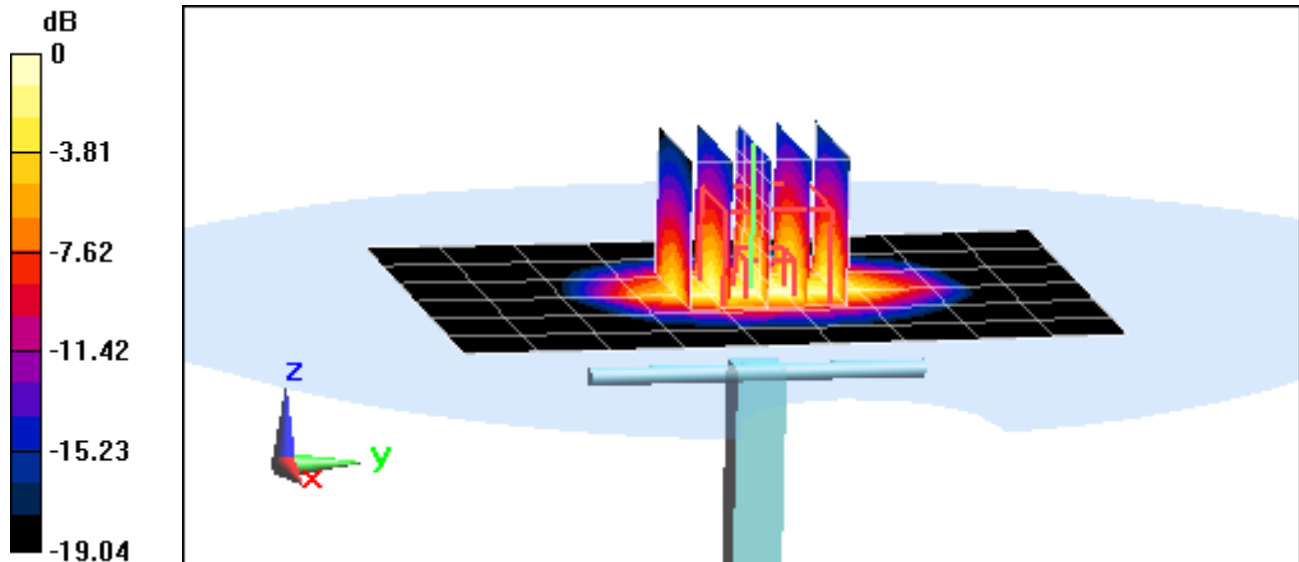

0 dB = 5.14 W/kg = 7.11 dBW/kg

# PCTEST ENGINEERING LABORATORY, INC.

**DUT: Dipole 2450 MHz; Type: D2450V2; Serial: 797**

Communication System: UID 0, CW; Frequency: 2450 MHz; Duty Cycle: 1:1

Medium: 2450 Body Medium parameters used:

$f = 2450$  MHz;  $\sigma = 1.992$  S/m;  $\epsilon_r = 51.567$ ;  $\rho = 1000$  kg/m<sup>3</sup>

Phantom section: Flat Section; Space: 1.0 cm

Test Date: 01-19-2016; Ambient Temp: 21.7°C; Tissue Temp: 21.5°C

Probe: ES3DV3 - SN3319; ConvF(4.11, 4.11, 4.11); Calibrated: 3/19/2015;

Sensor-Surface: 3mm (Mechanical Surface Detection)

Electronics: DAE4 Sn1368; Calibrated: 3/13/2015

Phantom: SAM with CRP v4.0; Type: QD000P40CD; Serial: TP:1800

Measurement SW: DASY52, Version 52.8 (8);SEMCAD X Version 14.6.10 (7331)

## 2450 MHz System Verification at 20.0 dBm (100 mW)

**Area Scan (8x9x1):** Measurement grid: dx=12mm, dy=12mm

**Zoom Scan (7x7x7)/Cube 0:** Measurement grid: dx=5mm, dy=5mm, dz=5mm

Peak SAR (extrapolated) = 11.3 W/kg

**SAR(1 g) = 4.99 W/kg**

Deviation(1 g) = -3.11%

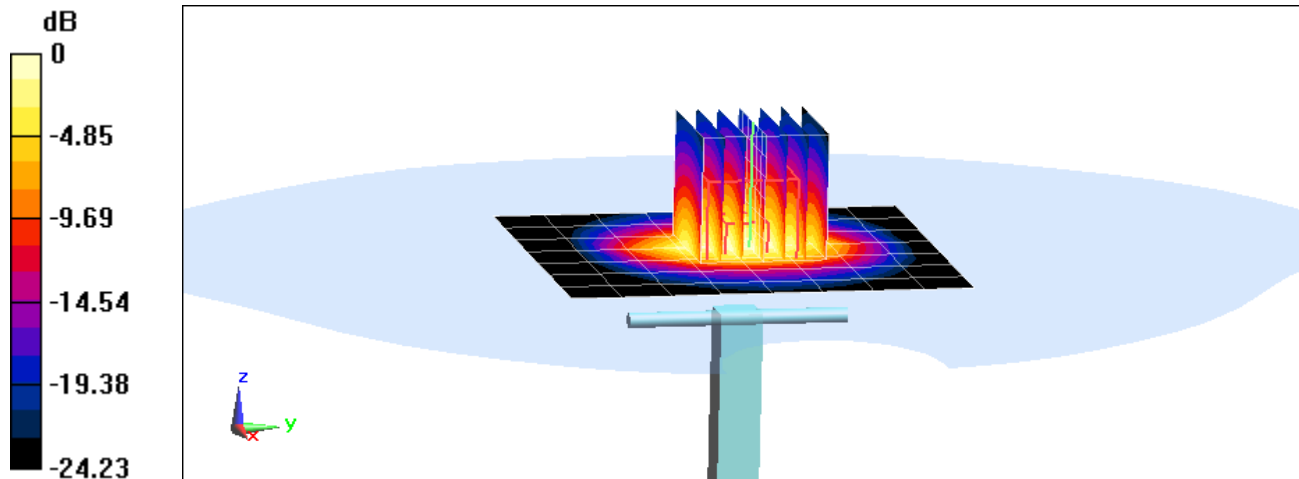

0 dB = 6.65 W/kg = 8.23 dBW/kg

## APPENDIX C: PROBE CALIBRATION



Accreditation No.: **SCS 0108**

Accredited by the Swiss Accreditation Service (SAS)  
The Swiss Accreditation Service is one of the signatories to the EA  
Multilateral Agreement for the recognition of calibration certificates

Client **PC Test**

Certificate No: **D750V3-1054\_Mar15**

## CALIBRATION CERTIFICATE

Object **D750V3 - SN:1054**

Calibration procedure(s) **QA CAL-05.v9  
Calibration procedure for dipole validation kits above 700 MHz**

*CCV  
3/26/15*

Calibration date: **March 11, 2015**

This calibration certificate documents the traceability to national standards, which realize the physical units of measurements (SI).  
The measurements and the uncertainties with confidence probability are given on the following pages and are part of the certificate.

All calibrations have been conducted in the closed laboratory facility: environment temperature (22 ± 3)°C and humidity < 70%.

Calibration Equipment used (M&TE critical for calibration)

Primary Standards	ID #	Cal Date (Certificate No.)	Scheduled Calibration
Power meter EPM-442A	GB37480704	07-Oct-14 (No. 217-02020)	Oct-15
Power sensor HP 8481A	US37292783	07-Oct-14 (No. 217-02020)	Oct-15
Power sensor HP 8481A	MY41092317	07-Oct-14 (No. 217-02021)	Oct-15
Reference 20 dB Attenuator	SN: 5058 (20k)	03-Apr-14 (No. 217-01918)	Apr-15
Type-N mismatch combination	SN: 5047.2 / 06327	03-Apr-14 (No. 217-01921)	Apr-15
Reference Probe ES3DV3	SN: 3205	30-Dec-14 (No. ES3-3205_Dec14)	Dec-15
DAE4	SN: 601	18-Aug-14 (No. DAE4-601_Aug14)	Aug-15
Secondary Standards	ID #	Check Date (in house)	Scheduled Check
RF generator R&S SMT-06	100005	04-Aug-99 (in house check Oct-13)	In house check: Oct-16
Network Analyzer HP 8753E	US37390585 S4206	18-Oct-01 (in house check Oct-14)	In house check: Oct-15

Calibrated by: **Name** Michael Weber **Function** Laboratory Technician

**Signature**  
*M. Weber*

Approved by: **Name** Katja Pokovic **Function** Technical Manager

*K. Pokovic*

Issued: March 11, 2015

This calibration certificate shall not be reproduced except in full without written approval of the laboratory.



Accredited by the Swiss Accreditation Service (SAS)  
The Swiss Accreditation Service is one of the signatories to the EA  
Multilateral Agreement for the recognition of calibration certificates

Accreditation No.: **SCS 0108**

**Glossary:**

TSL	tissue simulating liquid
ConvF	sensitivity in TSL / NORM x,y,z
N/A	not applicable or not measured

**Calibration is Performed According to the Following Standards:**

- IEEE Std 1528-2013, "IEEE Recommended Practice for Determining the Peak Spatial-Averaged Specific Absorption Rate (SAR) in the Human Head from Wireless Communications Devices: Measurement Techniques", June 2013
- IEC 62209-1, "Procedure to measure the Specific Absorption Rate (SAR) for hand-held devices used in close proximity to the ear (frequency range of 300 MHz to 3 GHz)", February 2005
- KDB 865664, "SAR Measurement Requirements for 100 MHz to 6 GHz"

**Additional Documentation:**

- DASY4/5 System Handbook

**Methods Applied and Interpretation of Parameters:**

- Measurement Conditions:* Further details are available from the Validation Report at the end of the certificate. All figures stated in the certificate are valid at the frequency indicated.
- Antenna Parameters with TSL:* The dipole is mounted with the spacer to position its feed point exactly below the center marking of the flat phantom section, with the arms oriented parallel to the body axis.
- Feed Point Impedance and Return Loss:* These parameters are measured with the dipole positioned under the liquid filled phantom. The impedance stated is transformed from the measurement at the SMA connector to the feed point. The Return Loss ensures low reflected power. No uncertainty required.
- Electrical Delay:* One-way delay between the SMA connector and the antenna feed point. No uncertainty required.
- SAR measured:* SAR measured at the stated antenna input power.
- SAR normalized:* SAR as measured, normalized to an input power of 1 W at the antenna connector.
- SAR for nominal TSL parameters:* The measured TSL parameters are used to calculate the nominal SAR result.

The reported uncertainty of measurement is stated as the standard uncertainty of measurement multiplied by the coverage factor  $k=2$ , which for a normal distribution corresponds to a coverage probability of approximately 95%.

## Measurement Conditions

DASY system configuration, as far as not given on page 1.

<b>DASY Version</b>	DASY5	V52.8.8
<b>Extrapolation</b>	Advanced Extrapolation	
<b>Phantom</b>	Modular Flat Phantom	
<b>Distance Dipole Center - TSL</b>	15 mm	with Spacer
<b>Zoom Scan Resolution</b>	dx, dy, dz = 5 mm	
<b>Frequency</b>	750 MHz $\pm$ 1 MHz	

## Head TSL parameters

The following parameters and calculations were applied.

	Temperature	Permittivity	Conductivity
<b>Nominal Head TSL parameters</b>	22.0 °C	41.9	0.89 mho/m
<b>Measured Head TSL parameters</b>	(22.0 $\pm$ 0.2) °C	40.8 $\pm$ 6 %	0.90 mho/m $\pm$ 6 %
<b>Head TSL temperature change during test</b>	< 0.5 °C	----	----

## SAR result with Head TSL

<b>SAR averaged over 1 cm<sup>3</sup> (1 g) of Head TSL</b>	Condition	
SAR measured	250 mW input power	2.10 W/kg
SAR for nominal Head TSL parameters	normalized to 1W	<b>8.28 W/kg <math>\pm</math> 17.0 % (k=2)</b>

<b>SAR averaged over 10 cm<sup>3</sup> (10 g) of Head TSL</b>	condition	
SAR measured	250 mW input power	1.37 W/kg
SAR for nominal Head TSL parameters	normalized to 1W	<b>5.42 W/kg <math>\pm</math> 16.5 % (k=2)</b>

## Body TSL parameters

The following parameters and calculations were applied.

	Temperature	Permittivity	Conductivity
<b>Nominal Body TSL parameters</b>	22.0 °C	55.5	0.96 mho/m
<b>Measured Body TSL parameters</b>	(22.0 $\pm$ 0.2) °C	54.7 $\pm$ 6 %	0.99 mho/m $\pm$ 6 %
<b>Body TSL temperature change during test</b>	< 0.5 °C	----	----

## SAR result with Body TSL

<b>SAR averaged over 1 cm<sup>3</sup> (1 g) of Body TSL</b>	Condition	
SAR measured	250 mW input power	2.19 W/kg
SAR for nominal Body TSL parameters	normalized to 1W	<b>8.53 W/kg <math>\pm</math> 17.0 % (k=2)</b>

<b>SAR averaged over 10 cm<sup>3</sup> (10 g) of Body TSL</b>	condition	
SAR measured	250 mW input power	1.45 W/kg
SAR for nominal Body TSL parameters	normalized to 1W	<b>5.68 W/kg <math>\pm</math> 16.5 % (k=2)</b>

## Appendix (Additional assessments outside the scope of SCS 0108)

### Antenna Parameters with Head TSL

Impedance, transformed to feed point	54.8 $\Omega$ - 0.6 j $\Omega$
Return Loss	- 26.7 dB

### Antenna Parameters with Body TSL

Impedance, transformed to feed point	48.8 $\Omega$ - 2.6 j $\Omega$
Return Loss	- 30.6 dB

### General Antenna Parameters and Design

Electrical Delay (one direction)	1.033 ns
----------------------------------	----------

After long term use with 100W radiated power, only a slight warming of the dipole near the feedpoint can be measured.

The dipole is made of standard semirigid coaxial cable. The center conductor of the feeding line is directly connected to the second arm of the dipole. The antenna is therefore short-circuited for DC-signals. On some of the dipoles, small end caps are added to the dipole arms in order to improve matching when loaded according to the position as explained in the "Measurement Conditions" paragraph. The SAR data are not affected by this change. The overall dipole length is still according to the Standard.

No excessive force must be applied to the dipole arms, because they might bend or the soldered connections near the feedpoint may be damaged.

### Additional EUT Data

Manufactured by	SPEAG
Manufactured on	November 08, 2011

## DASY5 Validation Report for Head TSL

Date: 11.03.2015

Test Laboratory: SPEAG, Zurich, Switzerland

**DUT: Dipole 750 MHz; Type: D750V3; Serial: D750V3 - SN:1054**

Communication System: UID 0 - CW; Frequency: 750 MHz

Medium parameters used:  $f = 750$  MHz;  $\sigma = 0.9$  S/m;  $\epsilon_r = 40.8$ ;  $\rho = 1000$  kg/m<sup>3</sup>

Phantom section: Flat Section

Measurement Standard: DASY5 (IEEE/IEC/ANSI C63.19-2011)

DASY52 Configuration:

- Probe: ES3DV3 - SN3205; ConvF(6.44, 6.44, 6.44); Calibrated: 30.12.2014;
- Sensor-Surface: 3mm (Mechanical Surface Detection)
- Electronics: DAE4 Sn601; Calibrated: 18.08.2014
- Phantom: Flat Phantom 4.9L; Type: QD000P49AA; Serial: 1001
- DASY52 52.8.8(1222); SEMCAD X 14.6.10(7331)

### **Dipole Calibration for Head Tissue/Pin=250 mW, d=15mm/Zoom Scan (7x7x7)/Cube 0:**

Measurement grid: dx=5mm, dy=5mm, dz=5mm

Reference Value = 54.06 V/m; Power Drift = -0.01 dB

Peak SAR (extrapolated) = 3.16 W/kg

**SAR(1 g) = 2.1 W/kg; SAR(10 g) = 1.37 W/kg**

Maximum value of SAR (measured) = 2.46 W/kg

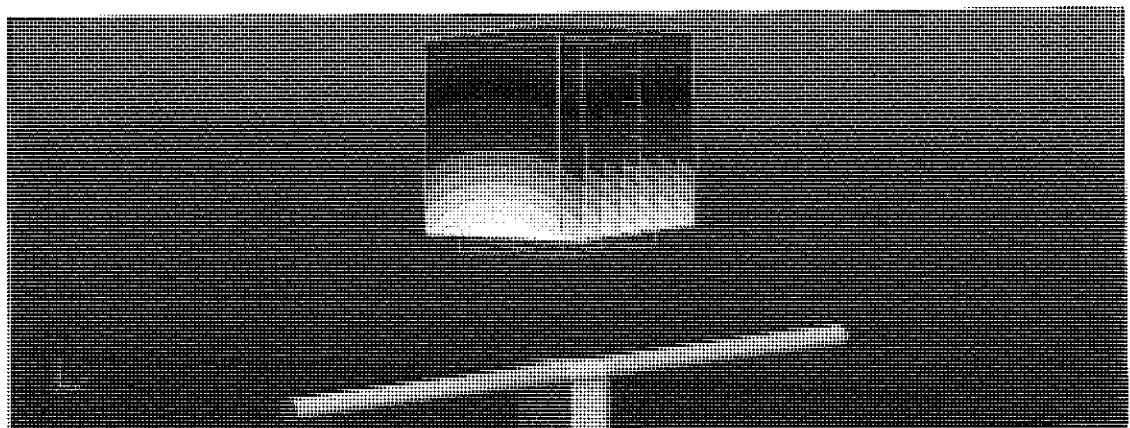
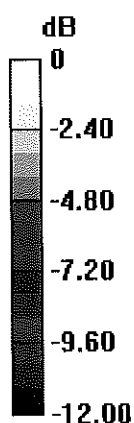

0 dB = 2.46 W/kg = 3.91 dBW/kg

# Impedance Measurement Plot for Head TSL

11 Mar 2015 12:42:05  
CH1 S11 1 U FS 1: 54.844  $\Omega$  -552.73 m $\Omega$  383.92 pF 750.000 000 MHz

\*  
Del  
CA  
Avg  
16  
H1d

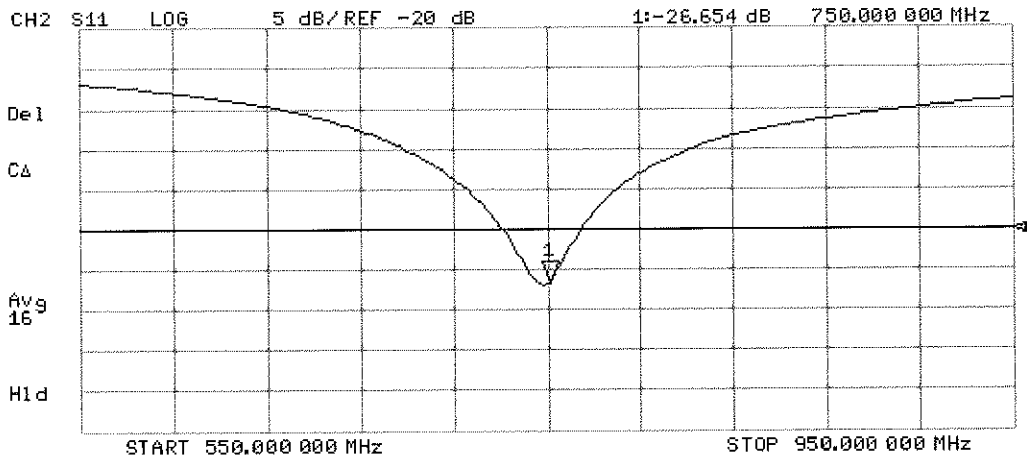
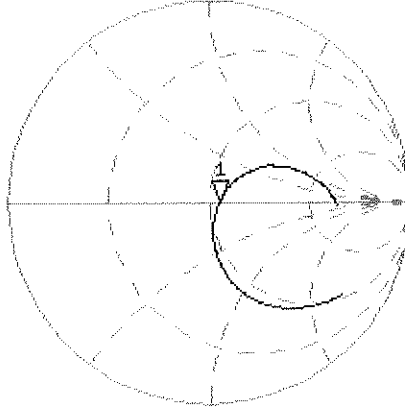

## DASY5 Validation Report for Body TSL

Date: 11.03.2015

Test Laboratory: SPEAG, Zurich, Switzerland

**DUT: Dipole 750 MHz; Type: D750V3; Serial: D750V3 - SN:1054**

Communication System: UID 0 - CW; Frequency: 750 MHz

Medium parameters used:  $f = 750$  MHz;  $\sigma = 0.99$  S/m;  $\epsilon_r = 54.7$ ;  $\rho = 1000$  kg/m<sup>3</sup>

Phantom section: Flat Section

Measurement Standard: DASY5 (IEEE/IEC/ANSI C63.19-2011)

DASY52 Configuration:

- Probe: ES3DV3 - SN3205; ConvF(6.21, 6.21, 6.21); Calibrated: 30.12.2014;
- Sensor-Surface: 3mm (Mechanical Surface Detection)
- Electronics: DAE4 Sn601; Calibrated: 18.08.2014
- Phantom: Flat Phantom 4.9L; Type: QD000P49AA; Serial: 1001
- DASY52 52.8.8(1222); SEMCAD X 14.6.10(7331)

### Dipole Calibration for Body Tissue/Pin=250 mW, d=15mm/Zoom Scan (7x7x7)/Cube 0:

Measurement grid: dx=5mm, dy=5mm, dz=5mm

Reference Value = 52.35 V/m; Power Drift = 0.03 dB

Peak SAR (extrapolated) = 3.20 W/kg

**SAR(1 g) = 2.19 W/kg; SAR(10 g) = 1.45 W/kg**

Maximum value of SAR (measured) = 2.54 W/kg

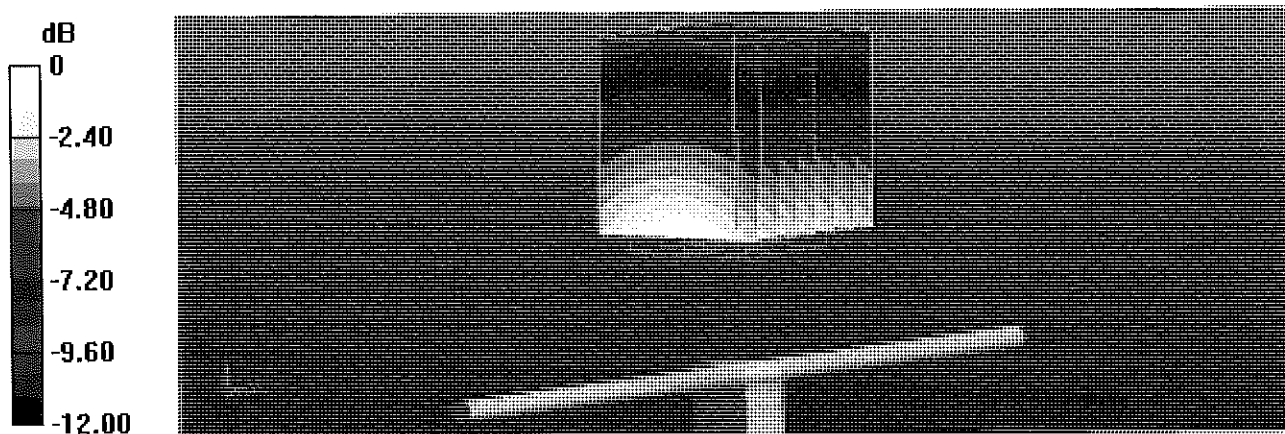

0 dB = 2.54 W/kg = 4.05 dBW/kg

# Impedance Measurement Plot for Body TSL

11 Mar 2015 11:49:08  
[CH1] S11 1 U FS 1: 48.779  $\Omega$  -2.6426  $\Omega$  80.303 pF 750.000 000 MHz

\*  
De1

CA

Avg  
16

H1d

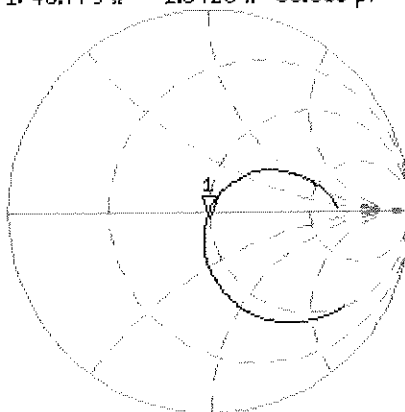

CH2 S11 LOG 5 dB/REF -20 dB 1: -30.614 dB 750.000 000 MHz

De1

CA

Avg  
16

H1d

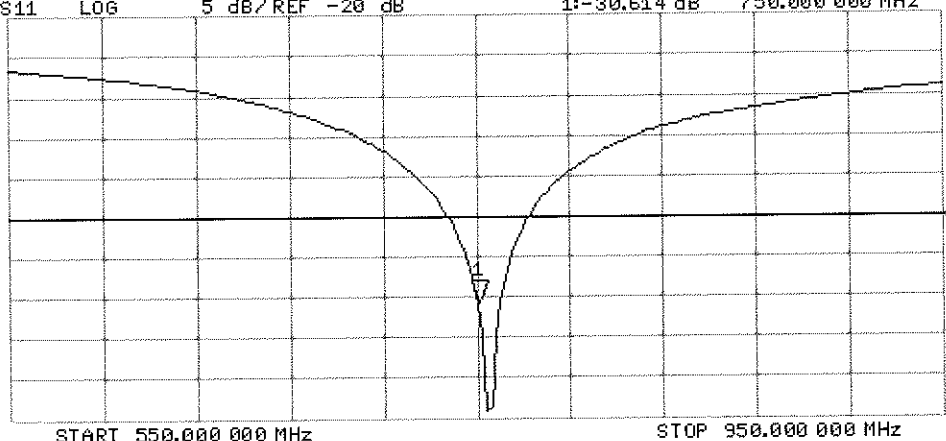



Accredited by the Swiss Accreditation Service (SAS)  
The Swiss Accreditation Service is one of the signatories to the EA  
Multilateral Agreement for the recognition of calibration certificates

Accreditation No.: **SCS 0108**

Client **PC Test**

Certificate No: **D835V2-4d119\_Apr15**

## CALIBRATION CERTIFICATE

Object **D835V2 - SN:4d119**

Calibration procedure(s) **QA CAL-05.v9**  
**Calibration procedure for dipole validation kits above 700 MHz**

Calibration date: **April 13, 2015**

*RY ✓*  
*4/29/15*

This calibration certificate documents the traceability to national standards, which realize the physical units of measurements (SI).  
The measurements and the uncertainties with confidence probability are given on the following pages and are part of the certificate.

All calibrations have been conducted in the closed laboratory facility: environment temperature (22 ± 3)°C and humidity < 70%.

Calibration Equipment used (M&TE critical for calibration)

Primary Standards	ID #	Cal Date (Certificate No.)	Scheduled Calibration
Power meter EPM-442A	GB37480704	07-Oct-14 (No. 217-02020)	Oct-15
Power sensor HP 8481A	US37292783	07-Oct-14 (No. 217-02020)	Oct-15
Power sensor HP 8481A	MY41092317	07-Oct-14 (No. 217-02021)	Oct-15
Reference 20 dB Attenuator	SN: 5058 (20k)	01-Apr-15 (No. 217-02131)	Mar-16
Type-N mismatch combination	SN: 5047.2 / 06327	01-Apr-15 (No. 217-02134)	Mar-16
Reference Probe ES3DV3	SN: 3205	30-Dec-14 (No. ES3-3205_Dec14)	Dec-15
DAE4	SN: 601	18-Aug-14 (No. DAE4-601_Aug14)	Aug-15
Secondary Standards	ID #	Check Date (in house)	Scheduled Check
RF generator R&S SMT-06	100005	04-Aug-99 (in house check Oct-13)	In house check: Oct-16
Network Analyzer HP 8753E	US37390585 S4206	18-Oct-01 (in house check Oct-14)	In house check: Oct-15

Calibrated by: **Israe Elnaouq** (Name) / **Laboratory Technician** (Function) / *[Signature]* (Signature)

Approved by: **Katja Pokovic** (Name) / **Technical Manager** (Function) / *[Signature]* (Signature)

Issued: April 13, 2015

This calibration certificate shall not be reproduced except in full without written approval of the laboratory.



Accredited by the Swiss Accreditation Service (SAS)  
The Swiss Accreditation Service is one of the signatories to the EA  
Multilateral Agreement for the recognition of calibration certificates

Accreditation No.: **SCS 0108**

**Glossary:**

TSL	tissue simulating liquid
ConvF	sensitivity in TSL / NORM x,y,z
N/A	not applicable or not measured

**Calibration is Performed According to the Following Standards:**

- IEEE Std 1528-2013, "IEEE Recommended Practice for Determining the Peak Spatial-Averaged Specific Absorption Rate (SAR) in the Human Head from Wireless Communications Devices: Measurement Techniques", June 2013
- IEC 62209-1, "Procedure to measure the Specific Absorption Rate (SAR) for hand-held devices used in close proximity to the ear (frequency range of 300 MHz to 3 GHz)", February 2005
- KDB 865664, "SAR Measurement Requirements for 100 MHz to 6 GHz"

**Additional Documentation:**

- DASY4/5 System Handbook

**Methods Applied and Interpretation of Parameters:**

- Measurement Conditions:* Further details are available from the Validation Report at the end of the certificate. All figures stated in the certificate are valid at the frequency indicated.
- Antenna Parameters with TSL:* The dipole is mounted with the spacer to position its feed point exactly below the center marking of the flat phantom section, with the arms oriented parallel to the body axis.
- Feed Point Impedance and Return Loss:* These parameters are measured with the dipole positioned under the liquid filled phantom. The impedance stated is transformed from the measurement at the SMA connector to the feed point. The Return Loss ensures low reflected power. No uncertainty required.
- Electrical Delay:* One-way delay between the SMA connector and the antenna feed point. No uncertainty required.
- SAR measured:* SAR measured at the stated antenna input power.
- SAR normalized:* SAR as measured, normalized to an input power of 1 W at the antenna connector.
- SAR for nominal TSL parameters:* The measured TSL parameters are used to calculate the nominal SAR result.

The reported uncertainty of measurement is stated as the standard uncertainty of measurement multiplied by the coverage factor  $k=2$ , which for a normal distribution corresponds to a coverage probability of approximately 95%.

## Measurement Conditions

DASY system configuration, as far as not given on page 1.

DASY Version	DASY5	V52.8.8
Extrapolation	Advanced Extrapolation	
Phantom	Modular Flat Phantom	
Distance Dipole Center - TSL	15 mm	with Spacer
Zoom Scan Resolution	dx, dy, dz = 5 mm	
Frequency	835 MHz $\pm$ 1 MHz	

## Head TSL parameters

The following parameters and calculations were applied.

	Temperature	Permittivity	Conductivity
Nominal Head TSL parameters	22.0 °C	41.5	0.90 mho/m
Measured Head TSL parameters	(22.0 $\pm$ 0.2) °C	40.9 $\pm$ 6 %	0.94 mho/m $\pm$ 6 %
Head TSL temperature change during test	< 0.5 °C	----	----

## SAR result with Head TSL

SAR averaged over 1 cm <sup>3</sup> (1 g) of Head TSL	Condition	
SAR measured	250 mW input power	2.43 W/kg
SAR for nominal Head TSL parameters	normalized to 1W	<b>9.38 W/kg <math>\pm</math> 17.0 % (k=2)</b>

SAR averaged over 10 cm <sup>3</sup> (10 g) of Head TSL	condition	
SAR measured	250 mW input power	1.57 W/kg
SAR for nominal Head TSL parameters	normalized to 1W	<b>6.11 W/kg <math>\pm</math> 16.5 % (k=2)</b>

## Body TSL parameters

The following parameters and calculations were applied.

	Temperature	Permittivity	Conductivity
Nominal Body TSL parameters	22.0 °C	55.2	0.97 mho/m
Measured Body TSL parameters	(22.0 $\pm$ 0.2) °C	55.4 $\pm$ 6 %	1.01 mho/m $\pm$ 6 %
Body TSL temperature change during test	< 0.5 °C	----	----

## SAR result with Body TSL

SAR averaged over 1 cm <sup>3</sup> (1 g) of Body TSL	Condition	
SAR measured	250 mW input power	2.37 W/kg
SAR for nominal Body TSL parameters	normalized to 1W	<b>9.20 W/kg <math>\pm</math> 17.0 % (k=2)</b>

SAR averaged over 10 cm <sup>3</sup> (10 g) of Body TSL	condition	
SAR measured	250 mW input power	1.55 W/kg
SAR for nominal Body TSL parameters	normalized to 1W	<b>6.06 W/kg <math>\pm</math> 16.5 % (k=2)</b>

## Appendix (Additional assessments outside the scope of SCS 0108)

### Antenna Parameters with Head TSL

Impedance, transformed to feed point	50.2 $\Omega$ - 2.2 j $\Omega$
Return Loss	- 33.3 dB

### Antenna Parameters with Body TSL

Impedance, transformed to feed point	47.7 $\Omega$ - 4.9 j $\Omega$
Return Loss	- 25.1 dB

### General Antenna Parameters and Design

Electrical Delay (one direction)	1.386 ns
----------------------------------	----------

After long term use with 100W radiated power, only a slight warming of the dipole near the feedpoint can be measured.

The dipole is made of standard semirigid coaxial cable. The center conductor of the feeding line is directly connected to the second arm of the dipole. The antenna is therefore short-circuited for DC-signals. On some of the dipoles, small end caps are added to the dipole arms in order to improve matching when loaded according to the position as explained in the "Measurement Conditions" paragraph. The SAR data are not affected by this change. The overall dipole length is still according to the Standard.

No excessive force must be applied to the dipole arms, because they might bend or the soldered connections near the feedpoint may be damaged.

### Additional EUT Data

Manufactured by	SPEAG
Manufactured on	June 29, 2010

# DASY5 Validation Report for Head TSL

Date: 13.04.2015

Test Laboratory: SPEAG, Zurich, Switzerland

**DUT: Dipole 835 MHz; Type: D835V2; Serial: D835V2 - SN:4d119**

Communication System: UID 0 - CW; Frequency: 835 MHz

Medium parameters used:  $f = 835 \text{ MHz}$ ;  $\sigma = 0.94 \text{ S/m}$ ;  $\epsilon_r = 40.9$ ;  $\rho = 1000 \text{ kg/m}^3$

Phantom section: Flat Section

Measurement Standard: DASY5 (IEEE/IEC/ANSI C63.19-2011)

DASY52 Configuration:

- Probe: ES3DV3 - SN3205; ConvF(6.2, 6.2, 6.2); Calibrated: 30.12.2014;
- Sensor-Surface: 3mm (Mechanical Surface Detection)
- Electronics: DAE4 Sn601; Calibrated: 18.08.2014
- Phantom: Flat Phantom 4.9L; Type: QD000P49AA; Serial: 1001
- DASY52 52.8.8(1222); SEMCAD X 14.6.10(7331)

## Dipole Calibration for Head Tissue/Pin=250 mW, $d=15\text{mm}$ /Zoom Scan (7x7x7)/Cube 0:

Measurement grid:  $dx=5\text{mm}$ ,  $dy=5\text{mm}$ ,  $dz=5\text{mm}$

Reference Value = 56.77 V/m; Power Drift = 0.01 dB

Peak SAR (extrapolated) = 3.64 W/kg

**SAR(1 g) = 2.43 W/kg; SAR(10 g) = 1.57 W/kg**

Maximum value of SAR (measured) = 2.85 W/kg

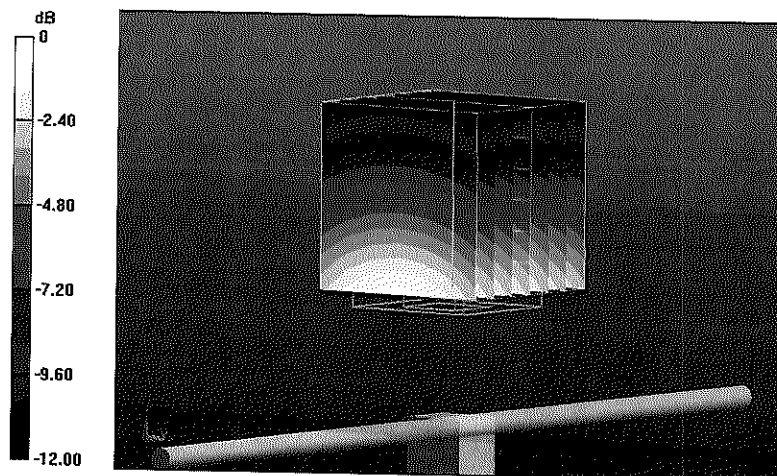

0 dB = 2.85 W/kg = 4.55 dBW/kg

# Impedance Measurement Plot for Head TSL

CH1 S11 1 U FS 13 Apr 2015 13:42:59  
 2: 50.213  $\Omega$  -2.1602  $\angle$  88.237  $\mu$ F 835.000 000 MHz

\*  
 Del  
 CA  
 Avg  
 16  
 H1 d

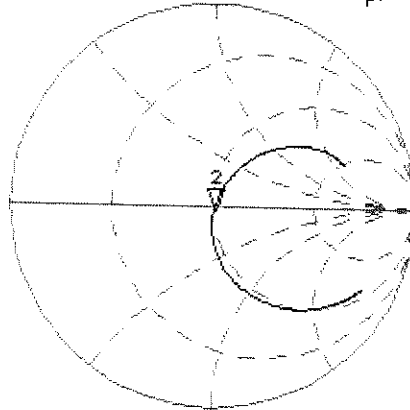

CH2 S11 LOG 5 dB/REF -20 dB 2: -33.275 dB 835.000 000 MHz

CA  
 Avg  
 16  
 H1 d

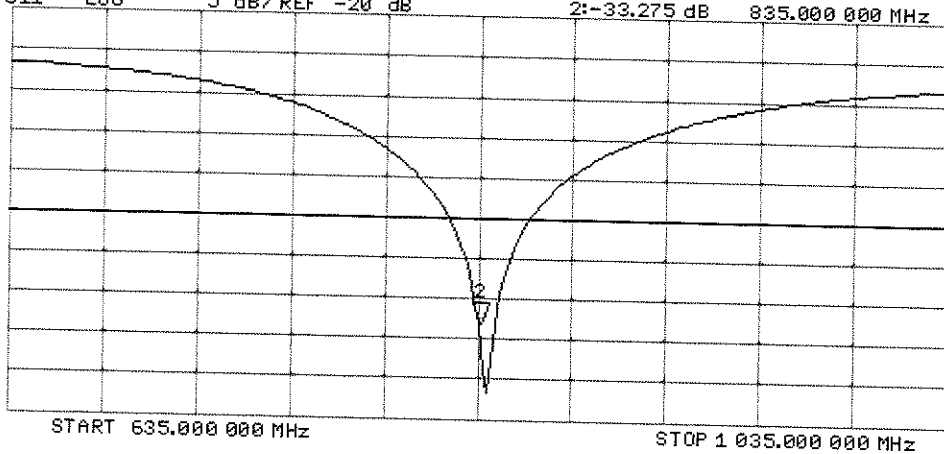

# DASY5 Validation Report for Body TSL

Date: 13.04.2015

Test Laboratory: SPEAG, Zurich, Switzerland

**DUT: Dipole 835 MHz; Type: D835V2; Serial: D835V2 - SN:4d119**

Communication System: UID 0 - CW; Frequency: 835 MHz

Medium parameters used:  $f = 835$  MHz;  $\sigma = 1.01$  S/m;  $\epsilon_r = 55.4$ ;  $\rho = 1000$  kg/m<sup>3</sup>

Phantom section: Flat Section

Measurement Standard: DASY5 (IEEE/IEC/ANSI C63.19-2011)

DASY52 Configuration:

- Probe: ES3DV3 - SN3205; ConvF(6.17, 6.17, 6.17); Calibrated: 30.12.2014;
- Sensor-Surface: 3mm (Mechanical Surface Detection)
- Electronics: DAE4 Sn601; Calibrated: 18.08.2014
- Phantom: Flat Phantom 4.9L; Type: QD000P49AA; Serial: 1001
- DASY52 52.8.8(1222); SEMCAD X 14.6.10(7331)

## Dipole Calibration for Body Tissue/Pin=250 mW, d=15mm/Zoom Scan (7x7x7)/Cube 0:

Measurement grid: dx=5mm, dy=5mm, dz=5mm

Reference Value = 54.44 V/m; Power Drift = -0.06 dB

Peak SAR (extrapolated) = 3.52 W/kg

**SAR(1 g) = 2.37 W/kg; SAR(10 g) = 1.55 W/kg**

Maximum value of SAR (measured) = 2.77 W/kg

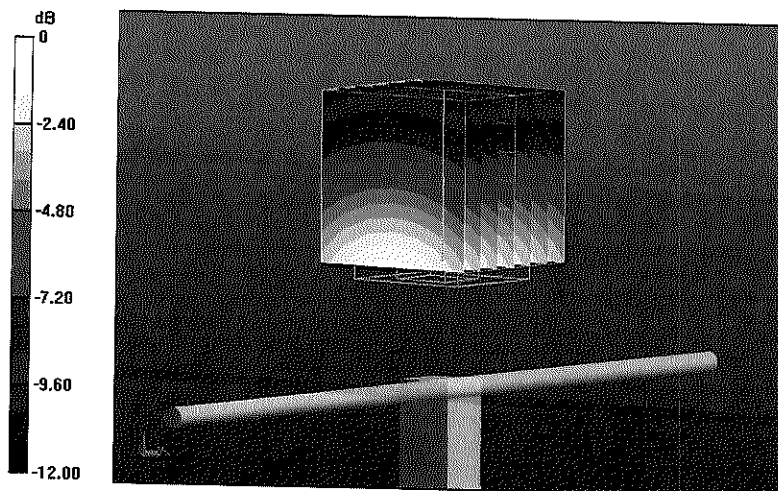

0 dB = 2.77 W/kg = 4.42 dBW/kg

# Impedance Measurement Plot for Body TSL

CH1 S11 1 U FS 13 Apr 2015 10:53:33  
 2: 47.658  $\Omega$  -4.9043  $\Omega$  38.865 pF 835.000 000 MHz

\*  
 Del  
 CA  
 Avg  
 16  
 H1 d

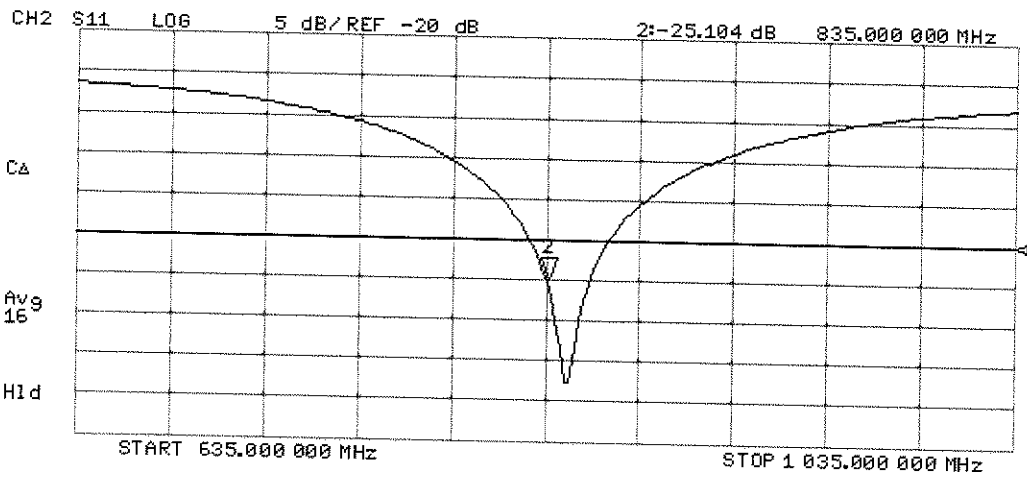
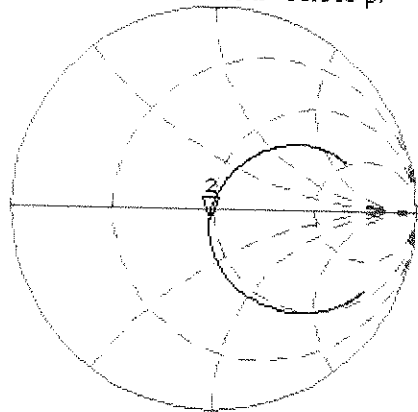



Accredited by the Swiss Accreditation Service (SAS)  
The Swiss Accreditation Service is one of the signatories to the EA  
Multilateral Agreement for the recognition of calibration certificates

Accreditation No.: **SCS 0108**

Client **PC Test**

Certificate No: **D1750V2-1051\_Apr15**

## CALIBRATION CERTIFICATE

Object **D1750V2 - SN:1051**

Calibration procedure(s) **QA CAL-05.v9  
Calibration procedure for dipole validation kits above 700 MHz**

PM ✓  
4/29/15

Calibration date: **April 15, 2015**

This calibration certificate documents the traceability to national standards, which realize the physical units of measurements (SI).  
The measurements and the uncertainties with confidence probability are given on the following pages and are part of the certificate.

All calibrations have been conducted in the closed laboratory facility: environment temperature (22 ± 3)°C and humidity < 70%.

Calibration Equipment used (M&TE critical for calibration)

Primary Standards	ID #	Cal Date (Certificate No.)	Scheduled Calibration
Power meter EPM-442A	GB37480704	07-Oct-14 (No. 217-02020)	Oct-15
Power sensor HP 8481A	US37292783	07-Oct-14 (No. 217-02020)	Oct-15
Power sensor HP 8481A	MY41092317	07-Oct-14 (No. 217-02021)	Oct-15
Reference 20 dB Attenuator	SN: 5058 (20k)	01-Apr-15 (No. 217-02131)	Mar-16
Type-N mismatch combination	SN: 5047.2 / 06327	01-Apr-15 (No. 217-02134)	Mar-16
Reference Probe ES3DV3	SN: 3205	30-Dec-14 (No. ES3-3205_Dec14)	Dec-15
DAE4	SN: 601	18-Aug-14 (No. DAE4-601_Aug14)	Aug-15
Secondary Standards	ID #	Check Date (in house)	Scheduled Check
RF generator R&S SMT-06	100005	04-Aug-99 (in house check Oct-13)	In house check: Oct-16
Network Analyzer HP 8753E	US37390585 S4206	18-Oct-01 (in house check Oct-14)	In house check: Oct-15

Calibrated by: **Jeton Kastrati**      **Function: Laboratory Technician**      **Signature:**

Approved by: **Katja Pokovic**      **Technical Manager**

Issued: April 15, 2015

This calibration certificate shall not be reproduced except in full without written approval of the laboratory.



Accredited by the Swiss Accreditation Service (SAS)  
The Swiss Accreditation Service is one of the signatories to the EA  
Multilateral Agreement for the recognition of calibration certificates

Accreditation No.: **SCS 0108**

**Glossary:**

TSL	tissue simulating liquid
ConvF	sensitivity in TSL / NORM x,y,z
N/A	not applicable or not measured

**Calibration is Performed According to the Following Standards:**

- IEEE Std 1528-2013, "IEEE Recommended Practice for Determining the Peak Spatial-Averaged Specific Absorption Rate (SAR) in the Human Head from Wireless Communications Devices: Measurement Techniques", June 2013
- IEC 62209-1, "Procedure to measure the Specific Absorption Rate (SAR) for hand-held devices used in close proximity to the ear (frequency range of 300 MHz to 3 GHz)", February 2005
- KDB 865664, "SAR Measurement Requirements for 100 MHz to 6 GHz"

**Additional Documentation:**

- DASY4/5 System Handbook

**Methods Applied and Interpretation of Parameters:**

- Measurement Conditions:* Further details are available from the Validation Report at the end of the certificate. All figures stated in the certificate are valid at the frequency indicated.
- Antenna Parameters with TSL:* The dipole is mounted with the spacer to position its feed point exactly below the center marking of the flat phantom section, with the arms oriented parallel to the body axis.
- Feed Point Impedance and Return Loss:* These parameters are measured with the dipole positioned under the liquid filled phantom. The impedance stated is transformed from the measurement at the SMA connector to the feed point. The Return Loss ensures low reflected power. No uncertainty required.
- Electrical Delay:* One-way delay between the SMA connector and the antenna feed point. No uncertainty required.
- SAR measured:* SAR measured at the stated antenna input power.
- SAR normalized:* SAR as measured, normalized to an input power of 1 W at the antenna connector.
- SAR for nominal TSL parameters:* The measured TSL parameters are used to calculate the nominal SAR result.

The reported uncertainty of measurement is stated as the standard uncertainty of measurement multiplied by the coverage factor  $k=2$ , which for a normal distribution corresponds to a coverage probability of approximately 95%.

## Measurement Conditions

DASY system configuration, as far as not given on page 1.

DASY Version	DASY5	V52.8.8
Extrapolation	Advanced Extrapolation	
Phantom	Modular Flat Phantom	
Distance Dipole Center - TSL	10 mm	with Spacer
Zoom Scan Resolution	dx, dy, dz = 5 mm	
Frequency	1750 MHz ± 1 MHz	

## Head TSL parameters

The following parameters and calculations were applied.

	Temperature	Permittivity	Conductivity
Nominal Head TSL parameters	22.0 °C	40.1	1.37 mho/m
Measured Head TSL parameters	(22.0 ± 0.2) °C	38.9 ± 6 %	1.35 mho/m ± 6 %
Head TSL temperature change during test	< 0.5 °C	----	----

## SAR result with Head TSL

SAR averaged over 1 cm <sup>3</sup> (1 g) of Head TSL	Condition	
SAR measured	250 mW input power	9.04 W/kg
SAR for nominal Head TSL parameters	normalized to 1W	<b>36.2 W/kg ± 17.0 % (k=2)</b>

SAR averaged over 10 cm <sup>3</sup> (10 g) of Head TSL	condition	
SAR measured	250 mW input power	4.80 W/kg
SAR for nominal Head TSL parameters	normalized to 1W	<b>19.2 W/kg ± 16.5 % (k=2)</b>

## Body TSL parameters

The following parameters and calculations were applied.

	Temperature	Permittivity	Conductivity
Nominal Body TSL parameters	22.0 °C	53.4	1.49 mho/m
Measured Body TSL parameters	(22.0 ± 0.2) °C	51.5 ± 6 %	1.48 mho/m ± 6 %
Body TSL temperature change during test	< 0.5 °C	----	----

## SAR result with Body TSL

SAR averaged over 1 cm <sup>3</sup> (1 g) of Body TSL	Condition	
SAR measured	250 mW input power	9.32 W/kg
SAR for nominal Body TSL parameters	normalized to 1W	<b>37.1 W/kg ± 17.0 % (k=2)</b>

SAR averaged over 10 cm <sup>3</sup> (10 g) of Body TSL	condition	
SAR measured	250 mW input power	5.01 W/kg
SAR for nominal Body TSL parameters	normalized to 1W	<b>20.0 W/kg ± 16.5 % (k=2)</b>

## Appendix (Additional assessments outside the scope of SCS 0108)

### Antenna Parameters with Head TSL

Impedance, transformed to feed point	51.3 $\Omega$ - 0.2 j $\Omega$
Return Loss	- 37.5 dB

### Antenna Parameters with Body TSL

Impedance, transformed to feed point	46.9 $\Omega$ + 0.3 j $\Omega$
Return Loss	- 29.9 dB

### General Antenna Parameters and Design

Electrical Delay (one direction)	1.221 ns
----------------------------------	----------

After long term use with 100W radiated power, only a slight warming of the dipole near the feedpoint can be measured.

The dipole is made of standard semirigid coaxial cable. The center conductor of the feeding line is directly connected to the second arm of the dipole. The antenna is therefore short-circuited for DC-signals. On some of the dipoles, small end caps are added to the dipole arms in order to improve matching when loaded according to the position as explained in the "Measurement Conditions" paragraph. The SAR data are not affected by this change. The overall dipole length is still according to the Standard.

No excessive force must be applied to the dipole arms, because they might bend or the soldered connections near the feedpoint may be damaged.

### Additional EUT Data

Manufactured by	SPEAG
Manufactured on	February 19, 2010

# DASY5 Validation Report for Head TSL

Date: 15.04.2015

Test Laboratory: SPEAG, Zurich, Switzerland

**DUT: Dipole 1750 MHz; Type: D1750V2; Serial: D1750V2 - SN:1051**

Communication System: UID 0 - CW; Frequency: 1750 MHz

Medium parameters used:  $f = 1750$  MHz;  $\sigma = 1.35$  S/m;  $\epsilon_r = 38.9$ ;  $\rho = 1000$  kg/m<sup>3</sup>

Phantom section: Flat Section

Measurement Standard: DASY5 (IEEE/IEC/ANSI C63.19-2011)

DASY52 Configuration:

- Probe: ES3DV3 - SN3205; ConvF(5.2, 5.2, 5.2); Calibrated: 30.12.2014;
- Sensor-Surface: 3mm (Mechanical Surface Detection)
- Electronics: DAE4 Sn601; Calibrated: 18.08.2014
- Phantom: Flat Phantom 5.0 (front); Type: QD000P50AA; Serial: 1001
- DASY52 52.8.8(1222); SEMCAD X 14.6.10(7331)

## Dipole Calibration for Head Tissue/Pin=250 mW, d=10mm/Zoom Scan (7x7x7)/Cube 0:

Measurement grid: dx=5mm, dy=5mm, dz=5mm

Reference Value = 94.99 V/m; Power Drift = 0.06 dB

Peak SAR (extrapolated) = 16.3 W/kg

**SAR(1 g) = 9.04 W/kg; SAR(10 g) = 4.8 W/kg**

Maximum value of SAR (measured) = 11.5 W/kg

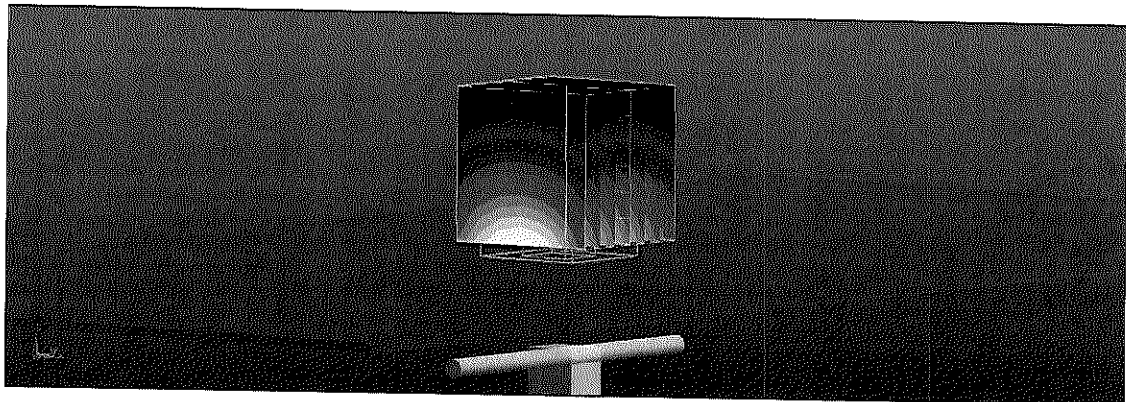
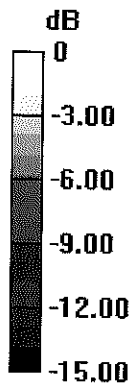

0 dB = 11.5 W/kg = 10.61 dBW/kg

# Impedance Measurement Plot for Head TSL

**[CH1] S11 1 U FS**      15 Apr 2015 12:25:31  
 3: 51.330  $\Omega$     -248.05 m $\Omega$     366.65 pF      1 750.000 000 MHz

\*  
 Del  
 C $\Delta$   
 Avg  
 16  
 H1d

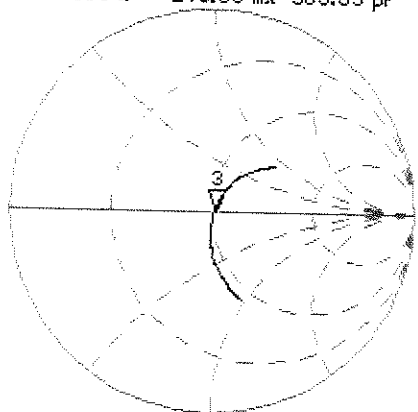

**CH2 S11 LOG 5 dB/REF -20 dB**      3: -37.470 dB    1 750.000 000 MHz

C $\Delta$   
 Avg  
 16  
 H1d

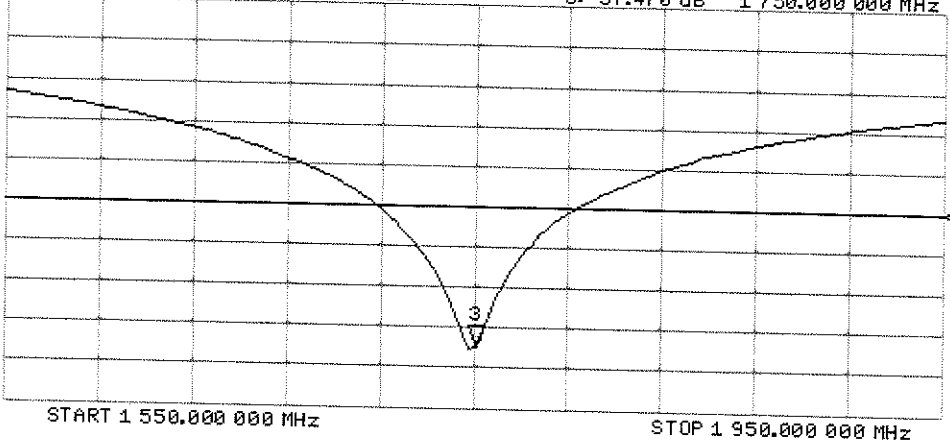

# DASY5 Validation Report for Body TSL

Date: 15.04.2015

Test Laboratory: SPEAG, Zurich, Switzerland

**DUT: Dipole 1750 MHz; Type: D1750V2; Serial: D1750V2 - SN:1051**

Communication System: UID 0 - CW; Frequency: 1750 MHz

Medium parameters used:  $f = 1750$  MHz;  $\sigma = 1.48$  S/m;  $\epsilon_r = 51.5$ ;  $\rho = 1000$  kg/m<sup>3</sup>

Phantom section: Flat Section

Measurement Standard: DASY5 (IEEE/IEC/ANSI C63.19-2011)

DASY52 Configuration:

- Probe: ES3DV3 - SN3205; ConvF(4.88, 4.88, 4.88); Calibrated: 30.12.2014;
- Sensor-Surface: 3mm (Mechanical Surface Detection)
- Electronics: DAE4 Sn601; Calibrated: 18.08.2014
- Phantom: Flat Phantom 5.0 (back); Type: QD000P50AA; Serial: 1002
- DASY52 52.8.8(1222); SEMCAD X 14.6.10(7331)

## Dipole Calibration for Body Tissue/Pin=250 mW, d=10mm/Zoom Scan (7x7x7)/Cube 0:

Measurement grid: dx=5mm, dy=5mm, dz=5mm

Reference Value = 92.87 V/m; Power Drift = 0.01 dB

Peak SAR (extrapolated) = 16.0 W/kg

**SAR(1 g) = 9.32 W/kg; SAR(10 g) = 5.01 W/kg**

Maximum value of SAR (measured) = 11.7 W/kg

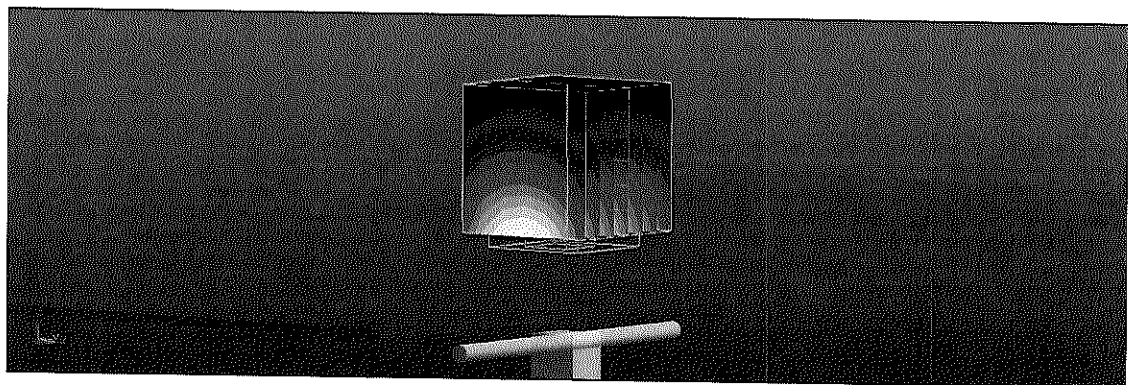
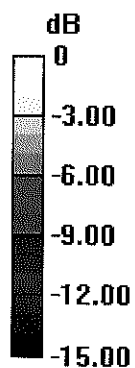

0 dB = 11.7 W/kg = 10.68 dBW/kg

# Impedance Measurement Plot for Body TSL

CH1 S11 1 U FS 3: 46.930  $\Omega$  0.3242  $\Omega$  29.486 pF 15 Apr 2015 12:23:57  
 1 750.000 000 MHz

\*  
 De1  
 Ca  
 Avg  
 16  
 H1 d

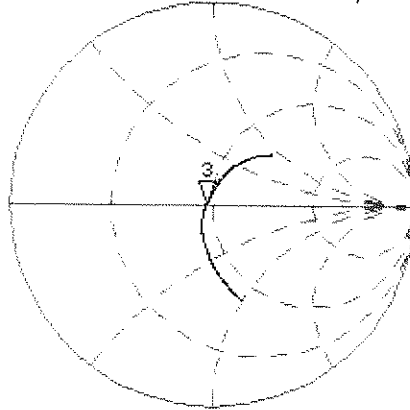

CH2 S11 LOG 5 dB/REF -20 dB 3:-29.939 dB 1 750.000 000 MHz

Ca  
 Avg  
 16  
 H1 d

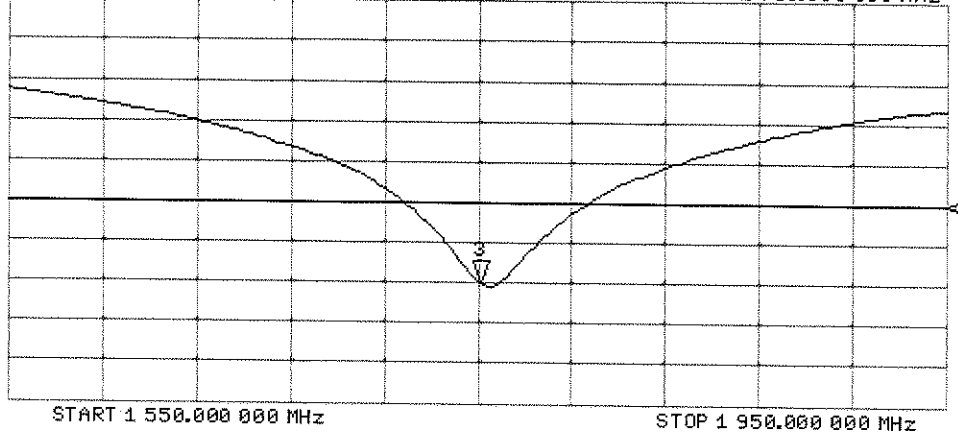



Accredited by the Swiss Accreditation Service (SAS)  
The Swiss Accreditation Service is one of the signatories to the EA  
Multilateral Agreement for the recognition of calibration certificates

Accreditation No.: **SCS 0108**

Client **PC Test**

Certificate No: **D1900V2-5d141\_Apr15**

## CALIBRATION CERTIFICATE

Object **D1900V2 - SN:5d141**

Calibration procedure(s) **QA CAL-05.v9  
Calibration procedure for dipole validation kits above 700 MHz**

Calibration date: **April 14, 2015**

This calibration certificate documents the traceability to national standards, which realize the physical units of measurements (SI).  
The measurements and the uncertainties with confidence probability are given on the following pages and are part of the certificate.

All calibrations have been conducted in the closed laboratory facility: environment temperature (22 ± 3)°C and humidity < 70%.

Calibration Equipment used (M&TE critical for calibration)

Primary Standards	ID #	Cal Date (Certificate No.)	Scheduled Calibration
Power meter EPM-442A	GB37480704	07-Oct-14 (No. 217-02020)	Oct-15
Power sensor HP 8481A	US37292783	07-Oct-14 (No. 217-02020)	Oct-15
Power sensor HP 8481A	MY41092317	07-Oct-14 (No. 217-02021)	Oct-15
Reference 20 dB Attenuator	SN: 5058 (20k)	01-Apr-15 (No. 217-02131)	Mar-16
Type-N mismatch combination	SN: 5047.2 / 06327	01-Apr-15 (No. 217-02134)	Mar-16
Reference Probe ES3DV3	SN: 3205	30-Dec-14 (No. ES3-3205_Dec14)	Dec-15
DAE4	SN: 601	18-Aug-14 (No. DAE4-601_Aug14)	Aug-15
Secondary Standards	ID #	Check Date (in house)	Scheduled Check
RF generator R&S SMT-06	100005	04-Aug-99 (in house check Oct-13)	In house check: Oct-16
Network Analyzer HP 8753E	US37390585 S4206	18-Oct-01 (in house check Oct-14)	In house check: Oct-15

Calibrated by: **Name** Claudio Leubler **Function** Laboratory Technician **Signature**

Approved by: **Name** Katja Pokovic **Function** Technical Manager **Signature**

Issued: April 14, 2015

This calibration certificate shall not be reproduced except in full without written approval of the laboratory.

PM ✓  
4/29/15



Accredited by the Swiss Accreditation Service (SAS)

The Swiss Accreditation Service is one of the signatories to the EA  
Multilateral Agreement for the recognition of calibration certificates

Accreditation No.: **SCS 0108**

### Glossary:

TSL	tissue simulating liquid
ConvF	sensitivity in TSL / NORM x,y,z
N/A	not applicable or not measured

### Calibration is Performed According to the Following Standards:

- IEEE Std 1528-2013, "IEEE Recommended Practice for Determining the Peak Spatial-Averaged Specific Absorption Rate (SAR) in the Human Head from Wireless Communications Devices: Measurement Techniques", June 2013
- IEC 62209-1, "Procedure to measure the Specific Absorption Rate (SAR) for hand-held devices used in close proximity to the ear (frequency range of 300 MHz to 3 GHz)", February 2005
- KDB 865664, "SAR Measurement Requirements for 100 MHz to 6 GHz"

### Additional Documentation:

- DASY4/5 System Handbook

### Methods Applied and Interpretation of Parameters:

- Measurement Conditions:* Further details are available from the Validation Report at the end of the certificate. All figures stated in the certificate are valid at the frequency indicated.
- Antenna Parameters with TSL:* The dipole is mounted with the spacer to position its feed point exactly below the center marking of the flat phantom section, with the arms oriented parallel to the body axis.
- Feed Point Impedance and Return Loss:* These parameters are measured with the dipole positioned under the liquid filled phantom. The impedance stated is transformed from the measurement at the SMA connector to the feed point. The Return Loss ensures low reflected power. No uncertainty required.
- Electrical Delay:* One-way delay between the SMA connector and the antenna feed point. No uncertainty required.
- SAR measured:* SAR measured at the stated antenna input power.
- SAR normalized:* SAR as measured, normalized to an input power of 1 W at the antenna connector.
- SAR for nominal TSL parameters:* The measured TSL parameters are used to calculate the nominal SAR result.

The reported uncertainty of measurement is stated as the standard uncertainty of measurement multiplied by the coverage factor  $k=2$ , which for a normal distribution corresponds to a coverage probability of approximately 95%.

## Measurement Conditions

DASY system configuration, as far as not given on page 1.

DASY Version	DASY5	V52.8.8
Extrapolation	Advanced Extrapolation	
Phantom	Modular Flat Phantom	
Distance Dipole Center - TSL	10 mm	with Spacer
Zoom Scan Resolution	dx, dy, dz = 5 mm	
Frequency	1900 MHz ± 1 MHz	

## Head TSL parameters

The following parameters and calculations were applied.

	Temperature	Permittivity	Conductivity
Nominal Head TSL parameters	22.0 °C	40.0	1.40 mho/m
Measured Head TSL parameters	(22.0 ± 0.2) °C	38.6 ± 6 %	1.37 mho/m ± 6 %
Head TSL temperature change during test	< 0.5 °C	----	----

## SAR result with Head TSL

SAR averaged over 1 cm <sup>3</sup> (1 g) of Head TSL	Condition	
SAR measured	250 mW input power	9.93 W/kg
SAR for nominal Head TSL parameters	normalized to 1W	<b>39.9 W/kg ± 17.0 % (k=2)</b>

SAR averaged over 10 cm <sup>3</sup> (10 g) of Head TSL	condition	
SAR measured	250 mW input power	5.20 W/kg
SAR for nominal Head TSL parameters	normalized to 1W	<b>20.9 W/kg ± 16.5 % (k=2)</b>

## Body TSL parameters

The following parameters and calculations were applied.

	Temperature	Permittivity	Conductivity
Nominal Body TSL parameters	22.0 °C	53.3	1.52 mho/m
Measured Body TSL parameters	(22.0 ± 0.2) °C	52.8 ± 6 %	1.50 mho/m ± 6 %
Body TSL temperature change during test	< 0.5 °C	----	----

## SAR result with Body TSL

SAR averaged over 1 cm <sup>3</sup> (1 g) of Body TSL	Condition	
SAR measured	250 mW input power	9.94 W/kg
SAR for nominal Body TSL parameters	normalized to 1W	<b>40.0 W/kg ± 17.0 % (k=2)</b>

SAR averaged over 10 cm <sup>3</sup> (10 g) of Body TSL	condition	
SAR measured	250 mW input power	5.29 W/kg
SAR for nominal Body TSL parameters	normalized to 1W	<b>21.2 W/kg ± 16.5 % (k=2)</b>

## Appendix (Additional assessments outside the scope of SCS 0108)

### Antenna Parameters with Head TSL

Impedance, transformed to feed point	53.0 $\Omega$ + 4.6 j $\Omega$
Return Loss	- 25.5 dB

### Antenna Parameters with Body TSL

Impedance, transformed to feed point	48.2 $\Omega$ + 5.6 j $\Omega$
Return Loss	- 24.5 dB

### General Antenna Parameters and Design

Electrical Delay (one direction)	1.198 ns
----------------------------------	----------

After long term use with 100W radiated power, only a slight warming of the dipole near the feedpoint can be measured.

The dipole is made of standard semirigid coaxial cable. The center conductor of the feeding line is directly connected to the second arm of the dipole. The antenna is therefore short-circuited for DC-signals. On some of the dipoles, small end caps are added to the dipole arms in order to improve matching when loaded according to the position as explained in the "Measurement Conditions" paragraph. The SAR data are not affected by this change. The overall dipole length is still according to the Standard.

No excessive force must be applied to the dipole arms, because they might bend or the soldered connections near the feedpoint may be damaged.

### Additional EUT Data

Manufactured by	SPEAG
Manufactured on	March 11, 2011

# DASY5 Validation Report for Head TSL

Date: 14.04.2015

Test Laboratory: SPEAG, Zurich, Switzerland

**DUT: Dipole 1900 MHz; Type: D1900V2; Serial: D1900V2 - SN:5d141**

Communication System: UID 0 - CW; Frequency: 1900 MHz

Medium parameters used:  $f = 1900$  MHz;  $\sigma = 1.37$  S/m;  $\epsilon_r = 38.6$ ;  $\rho = 1000$  kg/m<sup>3</sup>

Phantom section: Flat Section

Measurement Standard: DASY5 (IEEE/IEC/ANSI C63.19-2011)

DASY52 Configuration:

- Probe: ES3DV3 - SN3205; ConvF(5, 5, 5); Calibrated: 30.12.2014;
- Sensor-Surface: 3mm (Mechanical Surface Detection)
- Electronics: DAE4 Sn601; Calibrated: 18.08.2014
- Phantom: Flat Phantom 5.0 (front); Type: QD000P50AA; Serial: 1001
- DASY52 52.8.8(1222); SEMCAD X 14.6.10(7331)

## Dipole Calibration for Head Tissue/Pin=250 mW, d=10mm/Zoom Scan (7x7x7)/Cube 0:

Measurement grid: dx=5mm, dy=5mm, dz=5mm

Reference Value = 98.18 V/m; Power Drift = 0.04 dB

Peak SAR (extrapolated) = 18.2 W/kg

**SAR(1 g) = 9.93 W/kg; SAR(10 g) = 5.2 W/kg**

Maximum value of SAR (measured) = 12.5 W/kg

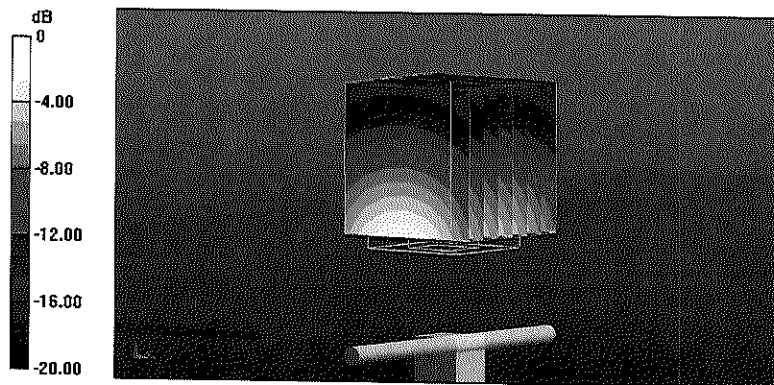

0 dB = 12.5 W/kg = 10.97 dBW/kg

# Impedance Measurement Plot for Head TSL

14 Apr 2015 13:39:53

CH1 S11 1 U FS 1: 53.010  $\Omega$  4.5664  $\Omega$  382.51 pF 1 900.000 000 MHz

\*  
De1  
CA  
Avg  
16  
H1d

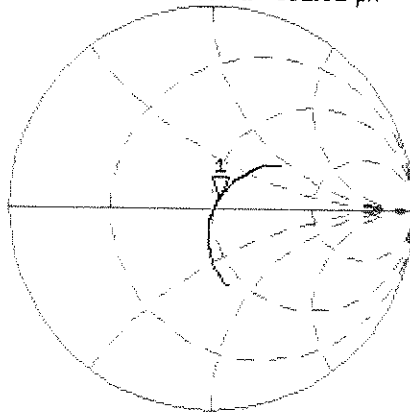

CH2 S11 LOG 5 dB/REF -20 dB 1:-25.507 dB 1 900.000 000 MHz

CA  
Avg  
16  
H1d

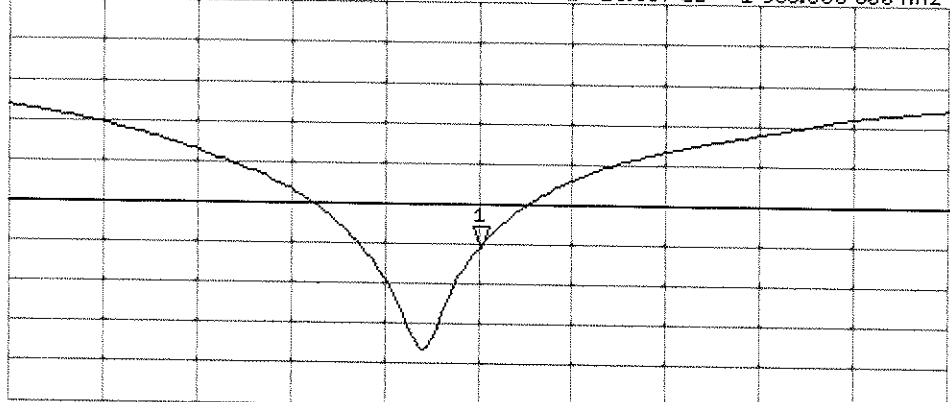

START 1 700.000 000 MHz STOP 2 100.000 000 MHz

# DASY5 Validation Report for Body TSL

Date: 14.04.2015

Test Laboratory: SPEAG, Zurich, Switzerland

**DUT: Dipole 1900 MHz; Type: D1900V2; Serial: D1900V2 - SN:5d141**

Communication System: UID 0 - CW; Frequency: 1900 MHz

Medium parameters used:  $f = 1900$  MHz;  $\sigma = 1.5$  S/m;  $\epsilon_r = 52.8$ ;  $\rho = 1000$  kg/m<sup>3</sup>

Phantom section: Flat Section

Measurement Standard: DASY5 (IEEE/IEC/ANSI C63.19-2011)

DASY52 Configuration:

- Probe: ES3DV3 - SN3205; ConvF(4.65, 4.65, 4.65); Calibrated: 30.12.2014;
- Sensor-Surface: 3mm (Mechanical Surface Detection)
- Electronics: DAE4 Sn601; Calibrated: 18.08.2014
- Phantom: Flat Phantom 5.0 (back); Type: QD000P50AA; Serial: 1002
- DASY52 52.8.8(1222); SEMCAD X 14.6.10(7331)

**Dipole Calibration for Body Tissue/Pin=250 mW, d=10mm/Zoom Scan (7x7x7)/Cube 0:**

Measurement grid: dx=5mm, dy=5mm, dz=5mm

Reference Value = 95.73 V/m; Power Drift = 0.01 dB

Peak SAR (extrapolated) = 16.9 W/kg

**SAR(1 g) = 9.94 W/kg; SAR(10 g) = 5.29 W/kg**

Maximum value of SAR (measured) = 12.5 W/kg

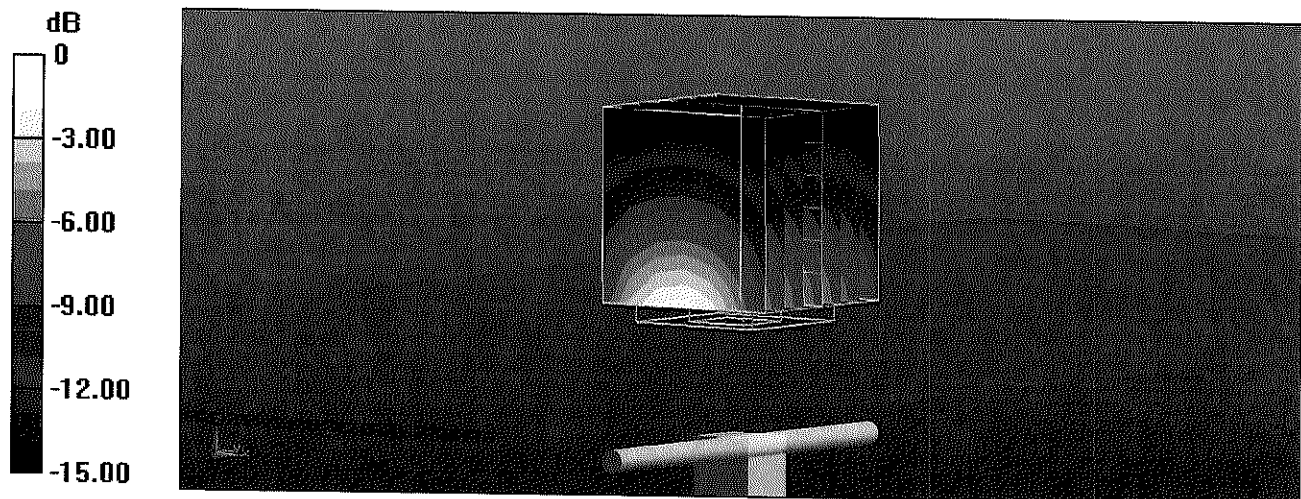

# Impedance Measurement Plot for Body TSL

14 Apr 2015 13:39:04

CH1 S11 1 U FS

1: 48.211  $\Omega$  5.5664  $\Omega$  466.27 pF

1 900.000 000 MHz

\*  
Del  
CA

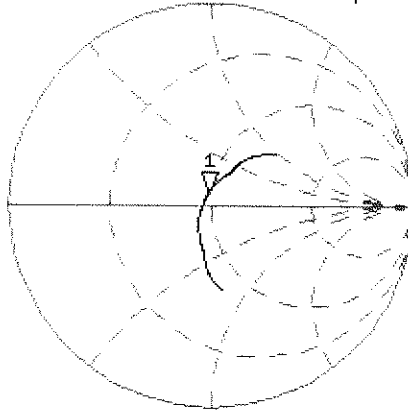

Avg  
16

H1d

CH2 S11 LOG 5 dB/REF -20 dB 1:-24,520 dB 1 900.000 000 MHz

CA

Avg  
16

H1d

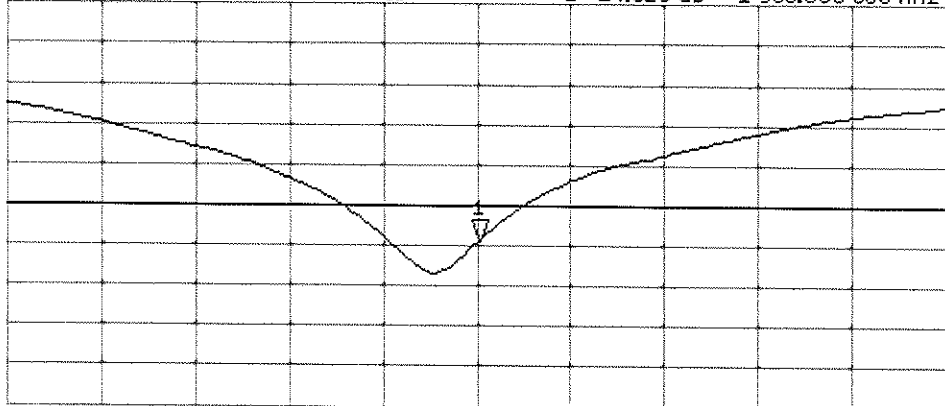

START 1 700.000 000 MHz

STOP 2 100.000 000 MHz



Accredited by the Swiss Accreditation Service (SAS)  
The Swiss Accreditation Service is one of the signatories to the EA  
Multilateral Agreement for the recognition of calibration certificates

Accreditation No.: **SCS 0108**

Client **PC Test**

Certificate No: **D1900V2-5d149\_Jul15**

## CALIBRATION CERTIFICATE

Object **D1900V2 - SN:5d149**

Calibration procedure(s) **QA CAL-05.v9  
Calibration procedure for dipole validation kits above 700 MHz**

Calibration date: **July 14, 2015**

CCV  
8/4/15

This calibration certificate documents the traceability to national standards, which realize the physical units of measurements (SI).  
The measurements and the uncertainties with confidence probability are given on the following pages and are part of the certificate.

All calibrations have been conducted in the closed laboratory facility: environment temperature (22 ± 3)°C and humidity < 70%.

Calibration Equipment used (M&TE critical for calibration)

Primary Standards	ID #	Cal Date (Certificate No.)	Scheduled Calibration
Power meter EPM-442A	GB37480704	07-Oct-14 (No. 217-02020)	Oct-15
Power sensor HP 8481A	US37292783	07-Oct-14 (No. 217-02020)	Oct-15
Power sensor HP 8481A	MY41092317	07-Oct-14 (No. 217-02021)	Oct-15
Reference 20 dB Attenuator	SN: 5058 (20k)	01-Apr-15 (No. 217-02131)	Mar-16
Type-N mismatch combination	SN: 5047.2 / 06327	01-Apr-15 (No. 217-02134)	Mar-16
Reference Probe ES3DV3	SN: 3205	30-Dec-14 (No. ES3-3205_Dec14)	Dec-15
DAE4	SN: 601	18-Aug-14 (No. DAE4-601_Aug14)	Aug-15
Secondary Standards	ID #	Check Date (in house)	Scheduled Check
RF generator R&S SMT-06	100005	04-Aug-99 (in house check Oct-13)	In house check: Oct-16
Network Analyzer HP 8753E	US37390585 S4206	18-Oct-01 (in house check Oct-14)	In house check: Oct-15

Calibrated by: **Leif Klysner** (Name) / **Laboratory Technician** (Function) / *[Signature]* (Signature)

Approved by: **Katja Pokovic** (Name) / **Technical Manager** (Function) / *[Signature]* (Signature)

Issued: July 14, 2015

This calibration certificate shall not be reproduced except in full without written approval of the laboratory.



Accredited by the Swiss Accreditation Service (SAS)

The Swiss Accreditation Service is one of the signatories to the EA Multilateral Agreement for the recognition of calibration certificates

**Glossary:**

TSL	tissue simulating liquid
ConvF	sensitivity in TSL / NORM x,y,z
N/A	not applicable or not measured

**Calibration is Performed According to the Following Standards:**

- IEEE Std 1528-2013, "IEEE Recommended Practice for Determining the Peak Spatial-Averaged Specific Absorption Rate (SAR) in the Human Head from Wireless Communications Devices: Measurement Techniques", June 2013
- IEC 62209-1, "Procedure to measure the Specific Absorption Rate (SAR) for hand-held devices used in close proximity to the ear (frequency range of 300 MHz to 3 GHz)", February 2005
- IEC 62209-2, "Procedure to determine the Specific Absorption Rate (SAR) for wireless communication devices used in close proximity to the human body (frequency range of 30 MHz to 6 GHz)", March 2010
- KDB 865664, "SAR Measurement Requirements for 100 MHz to 6 GHz"

**Additional Documentation:**

- DASY4/5 System Handbook

**Methods Applied and Interpretation of Parameters:**

- Measurement Conditions:* Further details are available from the Validation Report at the end of the certificate. All figures stated in the certificate are valid at the frequency indicated.
- Antenna Parameters with TSL:* The dipole is mounted with the spacer to position its feed point exactly below the center marking of the flat phantom section, with the arms oriented parallel to the body axis.
- Feed Point Impedance and Return Loss:* These parameters are measured with the dipole positioned under the liquid filled phantom. The impedance stated is transformed from the measurement at the SMA connector to the feed point. The Return Loss ensures low reflected power. No uncertainty required.
- Electrical Delay:* One-way delay between the SMA connector and the antenna feed point. No uncertainty required.
- SAR measured:* SAR measured at the stated antenna input power.
- SAR normalized:* SAR as measured, normalized to an input power of 1 W at the antenna connector.
- SAR for nominal TSL parameters:* The measured TSL parameters are used to calculate the nominal SAR result.

The reported uncertainty of measurement is stated as the standard uncertainty of measurement multiplied by the coverage factor  $k=2$ , which for a normal distribution corresponds to a coverage probability of approximately 95%.

## Measurement Conditions

DASY system configuration, as far as not given on page 1.

<b>DASY Version</b>	DASY5	V52.8.8
<b>Extrapolation</b>	Advanced Extrapolation	
<b>Phantom</b>	Modular Flat Phantom	
<b>Distance Dipole Center - TSL</b>	10 mm	with Spacer
<b>Zoom Scan Resolution</b>	dx, dy, dz = 5 mm	
<b>Frequency</b>	1900 MHz $\pm$ 1 MHz	

## Head TSL parameters

The following parameters and calculations were applied.

	Temperature	Permittivity	Conductivity
<b>Nominal Head TSL parameters</b>	22.0 °C	40.0	1.40 mho/m
<b>Measured Head TSL parameters</b>	(22.0 $\pm$ 0.2) °C	39.7 $\pm$ 6 %	1.38 mho/m $\pm$ 6 %
<b>Head TSL temperature change during test</b>	< 0.5 °C	----	----

## SAR result with Head TSL

<b>SAR averaged over 1 cm<sup>3</sup> (1 g) of Head TSL</b>	Condition	
SAR measured	250 mW input power	10.1 W/kg
SAR for nominal Head TSL parameters	normalized to 1W	<b>40.7 W/kg <math>\pm</math> 17.0 % (k=2)</b>

<b>SAR averaged over 10 cm<sup>3</sup> (10 g) of Head TSL</b>	condition	
SAR measured	250 mW input power	5.34 W/kg
SAR for nominal Head TSL parameters	normalized to 1W	<b>21.5 W/kg <math>\pm</math> 16.5 % (k=2)</b>

## Body TSL parameters

The following parameters and calculations were applied.

	Temperature	Permittivity	Conductivity
<b>Nominal Body TSL parameters</b>	22.0 °C	53.3	1.52 mho/m
<b>Measured Body TSL parameters</b>	(22.0 $\pm$ 0.2) °C	52.7 $\pm$ 6 %	1.54 mho/m $\pm$ 6 %
<b>Body TSL temperature change during test</b>	< 0.5 °C	----	----

## SAR result with Body TSL

<b>SAR averaged over 1 cm<sup>3</sup> (1 g) of Body TSL</b>	Condition	
SAR measured	250 mW input power	10.2 W/kg
SAR for nominal Body TSL parameters	normalized to 1W	<b>40.4 W/kg <math>\pm</math> 17.0 % (k=2)</b>

<b>SAR averaged over 10 cm<sup>3</sup> (10 g) of Body TSL</b>	condition	
SAR measured	250 mW input power	5.49 W/kg
SAR for nominal Body TSL parameters	normalized to 1W	<b>21.8 W/kg <math>\pm</math> 16.5 % (k=2)</b>

## Appendix (Additional assessments outside the scope of SCS 0108)

### Antenna Parameters with Head TSL

Impedance, transformed to feed point	51.4 $\Omega$ + 5.6 j $\Omega$
Return Loss	- 24.9 dB

### Antenna Parameters with Body TSL

Impedance, transformed to feed point	47.7 $\Omega$ + 6.1 j $\Omega$
Return Loss	- 23.5 dB

### General Antenna Parameters and Design

Electrical Delay (one direction)	1.197 ns
----------------------------------	----------

After long term use with 100W radiated power, only a slight warming of the dipole near the feedpoint can be measured.

The dipole is made of standard semirigid coaxial cable. The center conductor of the feeding line is directly connected to the second arm of the dipole. The antenna is therefore short-circuited for DC-signals. On some of the dipoles, small end caps are added to the dipole arms in order to improve matching when loaded according to the position as explained in the "Measurement Conditions" paragraph. The SAR data are not affected by this change. The overall dipole length is still according to the Standard.

No excessive force must be applied to the dipole arms, because they might bend or the soldered connections near the feedpoint may be damaged.

### Additional EUT Data

Manufactured by	SPEAG
Manufactured on	March 11, 2011

## DASY5 Validation Report for Head TSL

Date: 14.07.2015

Test Laboratory: SPEAG, Zurich, Switzerland

**DUT: Dipole 1900 MHz; Type: D1900V2; Serial: D1900V2 - SN:5d149**

Communication System: UID 0 - CW; Frequency: 1900 MHz

Medium parameters used:  $f = 1900$  MHz;  $\sigma = 1.38$  S/m;  $\epsilon_r = 39.7$ ;  $\rho = 1000$  kg/m<sup>3</sup>

Phantom section: Flat Section

Measurement Standard: DASY5 (IEEE/IEC/ANSI C63.19-2011)

DASY52 Configuration:

- Probe: ES3DV3 - SN3205; ConvF(5, 5, 5); Calibrated: 30.12.2014;
- Sensor-Surface: 3mm (Mechanical Surface Detection)
- Electronics: DAE4 Sn601; Calibrated: 18.08.2014
- Phantom: Flat Phantom 5.0 (front); Type: QD000P50AA; Serial: 1001
- DASY52 52.8.8(1222); SEMCAD X 14.6.10(7331)

### **Dipole Calibration for Head Tissue/Pin=250 mW, d=10mm/Zoom Scan (7x7x7)/Cube 0:**

Measurement grid: dx=5mm, dy=5mm, dz=5mm

Reference Value = 99.22 V/m; Power Drift = 0.02 dB

Peak SAR (extrapolated) = 18.3 W/kg

**SAR(1 g) = 10.1 W/kg; SAR(10 g) = 5.34 W/kg**

Maximum value of SAR (measured) = 12.9 W/kg

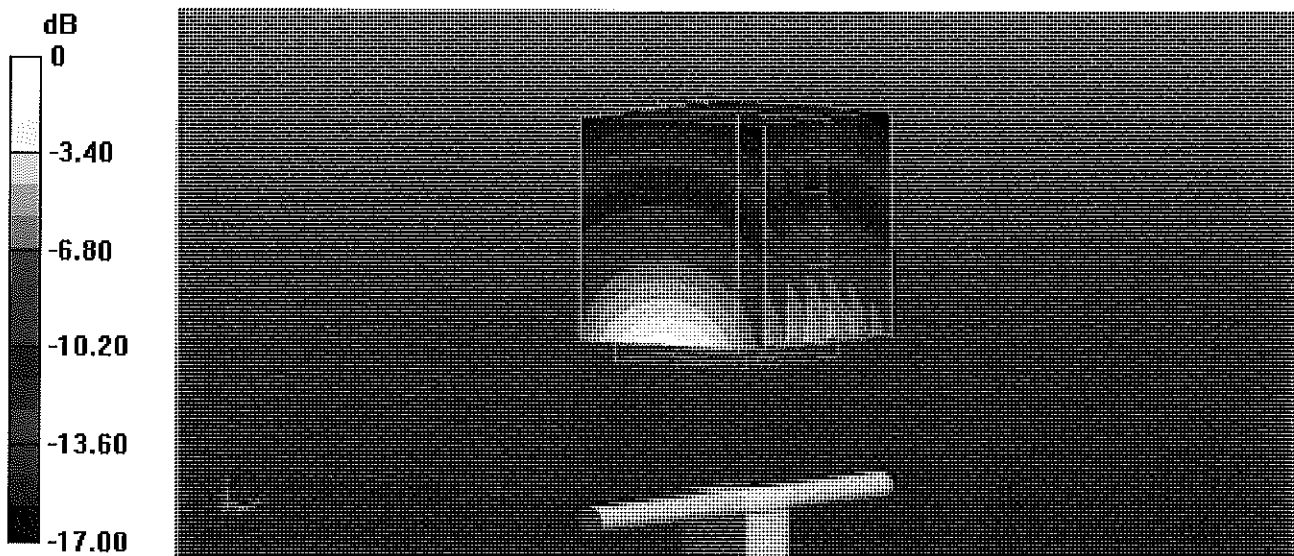

0 dB = 12.9 W/kg = 11.11 dBW/kg

# Impedance Measurement Plot for Head TSL

14 Jul 2015 09:20:59

CH1 S11 1 U FS 1: 51.447  $\Omega$  5.5664  $\Omega$  466.27  $\mu$ H 1 900.000 000 MHz

\*  
De1  
CA  
Avg  
16  
H1d

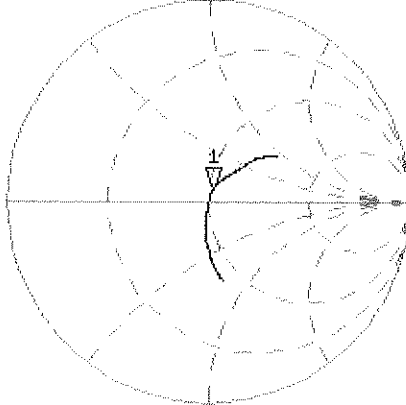

CH2 S11 LOG 5 dB/REF -20 dB 1: -24.943 dB 1 900.000 000 MHz

De1  
CA  
Avg  
16  
H1d

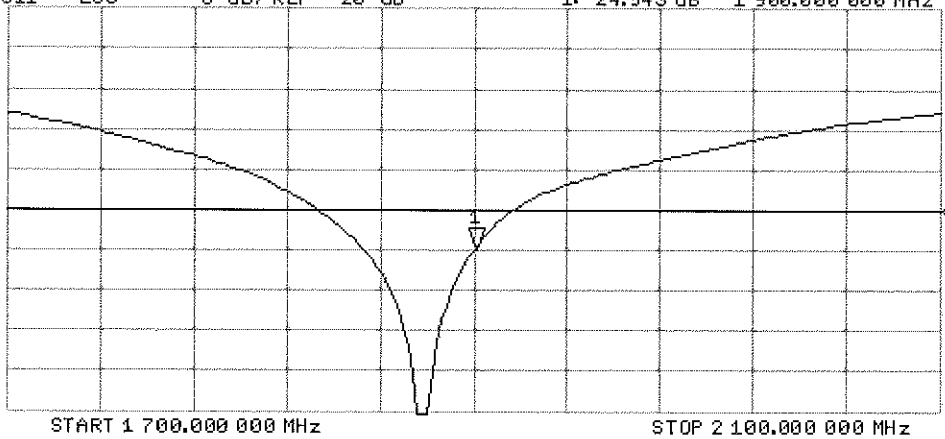

# DASY5 Validation Report for Body TSL

Date: 14.07.2015

Test Laboratory: SPEAG, Zurich, Switzerland

**DUT: Dipole 1900 MHz; Type: D1900V2; Serial: D1900V2 - SN:5d149**

Communication System: UID 0 - CW; Frequency: 1900 MHz

Medium parameters used:  $f = 1900$  MHz;  $\sigma = 1.54$  S/m;  $\epsilon_r = 52.7$ ;  $\rho = 1000$  kg/m<sup>3</sup>

Phantom section: Flat Section

Measurement Standard: DASY5 (IEEE/IEC/ANSI C63.19-2011)

DASY52 Configuration:

- Probe: ES3DV3 - SN3205; ConvF(4.65, 4.65, 4.65); Calibrated: 30.12.2014;
- Sensor-Surface: 3mm (Mechanical Surface Detection)
- Electronics: DAE4 Sn601; Calibrated: 18.08.2014
- Phantom: Flat Phantom 5.0 (back); Type: QD000P50AA; Serial: 1002
- DASY52 52.8.8(1222); SEMCAD X 14.6.10(7331)

## Dipole Calibration for Body Tissue/Pin=250 mW, d=10mm/Zoom Scan (7x7x7)/Cube 0:

Measurement grid: dx=5mm, dy=5mm, dz=5mm

Reference Value = 95.96 V/m; Power Drift = 0.01 dB

Peak SAR (extrapolated) = 17.2 W/kg

**SAR(1 g) = 10.2 W/kg; SAR(10 g) = 5.49 W/kg**

Maximum value of SAR (measured) = 12.9 W/kg

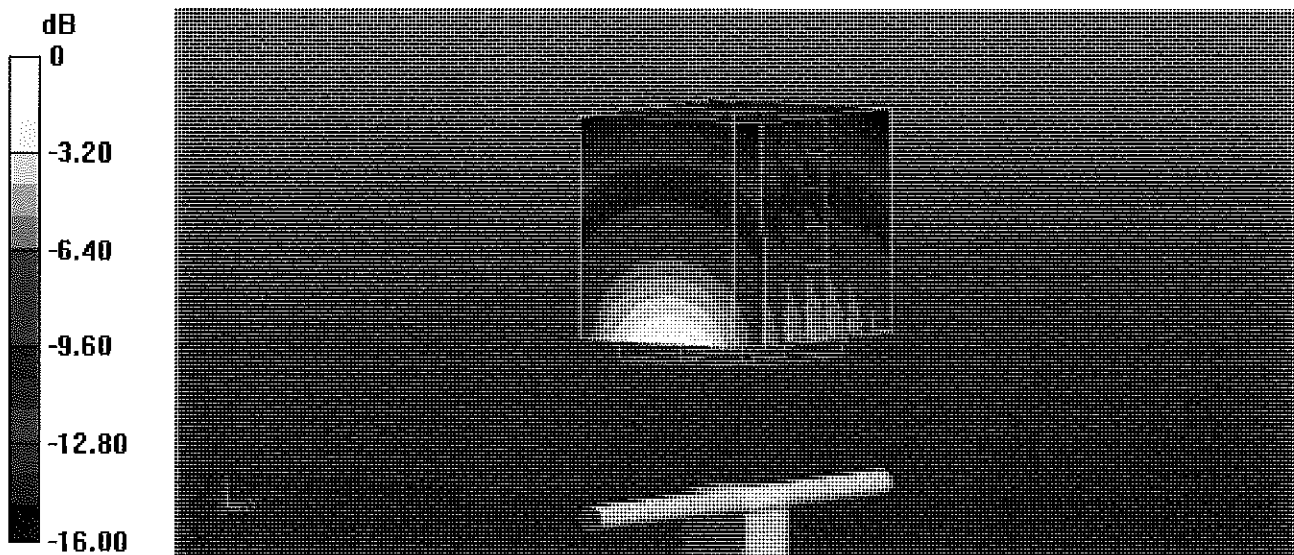

0 dB = 12.9 W/kg = 11.11 dBW/kg

# Impedance Measurement Plot for Body TSL

14 Jul 2015 09:20:09

CH1 S11 1 U FS 1: 47.723  $\omega$  6.1406  $\omega$  514.37 pF 1 900.000 000 MHz

\*  
De1  
CA

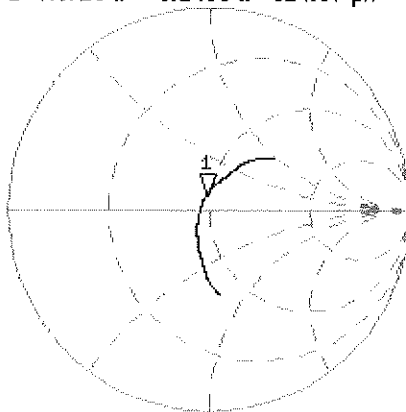

Avg  
16

H1d

CH2 S11 LOG 5 dB/REF -20 dB 1:-23.490 dB 1 900.000 000 MHz

De1

CA

Avg  
16

H1d

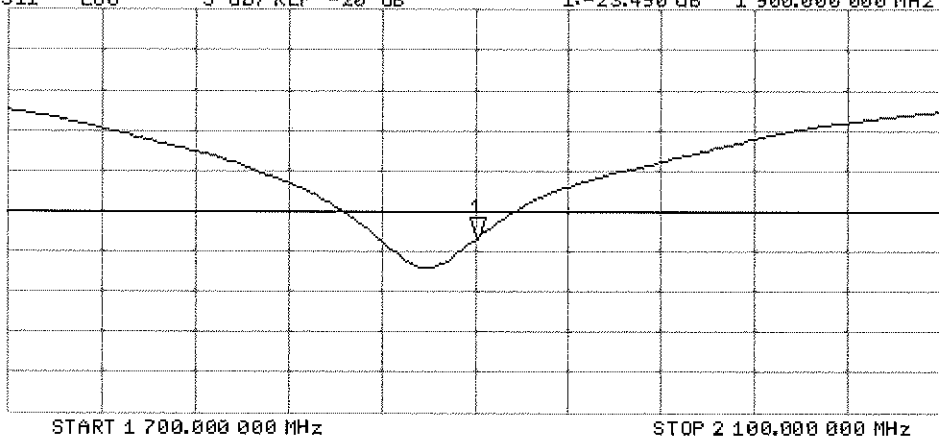



Accredited by the Swiss Accreditation Service (SAS)  
The Swiss Accreditation Service is one of the signatories to the EA  
Multilateral Agreement for the recognition of calibration certificates

Accreditation No.: **SCS 0108**

Client **PC Test**

Certificate No: **D2450V2-719\_Aug15**

## CALIBRATION CERTIFICATE

Object **D2450V2 - SN: 719**

Calibration procedure(s) **QA CAL-05.v9**  
**Calibration procedure for dipole validation kits above 700 MHz**

Calibration date: **August 20, 2015**

*BN ✓*  
*9/3/15*

This calibration certificate documents the traceability to national standards, which realize the physical units of measurements (SI).  
The measurements and the uncertainties with confidence probability are given on the following pages and are part of the certificate.

All calibrations have been conducted in the closed laboratory facility: environment temperature (22 ± 3)°C and humidity < 70%.

Calibration Equipment used (M&TE critical for calibration)

Primary Standards	ID #	Cal Date (Certificate No.)	Scheduled Calibration
Power meter EPM-442A	GB37480704	07-Oct-14 (No. 217-02020)	Oct-15
Power sensor HP 8481A	US37292783	07-Oct-14 (No. 217-02020)	Oct-15
Power sensor HP 8481A	MY41092317	07-Oct-14 (No. 217-02021)	Oct-15
Reference 20 dB Attenuator	SN: 5058 (20k)	01-Apr-15 (No. 217-02131)	Mar-16
Type-N mismatch combination	SN: 5047.2 / 06327	01-Apr-15 (No. 217-02134)	Mar-16
Reference Probe ES3DV3	SN: 3205	30-Dec-14 (No. ES3-3205_Dec14)	Dec-15
DAE4	SN: 601	17-Aug-15 (No. DAE4-601_Aug15)	Aug-16
Secondary Standards	ID #	Check Date (in house)	Scheduled Check
RF generator R&S SMT-06	100005	04-Aug-99 (in house check Oct-13)	In house check: Oct-16
Network Analyzer HP 8753E	US37390585 S4206	18-Oct-01 (in house check Oct-14)	In house check: Oct-15

Calibrated by: **Name** Michael Weber **Function** Laboratory Technician

**Signature**  
*M. Weber*

Approved by: **Name** Katja Pokovic **Function** Technical Manager

*[Signature]*

Issued: August 21, 2015

This calibration certificate shall not be reproduced except in full without written approval of the laboratory.



Accredited by the Swiss Accreditation Service (SAS)

The Swiss Accreditation Service is one of the signatories to the EA  
Multilateral Agreement for the recognition of calibration certificates

Accreditation No.: **SCS 0108**

### Glossary:

TSL	tissue simulating liquid
ConvF	sensitivity in TSL / NORM x,y,z
N/A	not applicable or not measured

### Calibration is Performed According to the Following Standards:

- IEEE Std 1528-2013, "IEEE Recommended Practice for Determining the Peak Spatial-Averaged Specific Absorption Rate (SAR) in the Human Head from Wireless Communications Devices: Measurement Techniques", June 2013
- IEC 62209-1, "Procedure to measure the Specific Absorption Rate (SAR) for hand-held devices used in close proximity to the ear (frequency range of 300 MHz to 3 GHz)", February 2005
- IEC 62209-2, "Procedure to determine the Specific Absorption Rate (SAR) for wireless communication devices used in close proximity to the human body (frequency range of 30 MHz to 6 GHz)", March 2010
- KDB 865664, "SAR Measurement Requirements for 100 MHz to 6 GHz"

### Additional Documentation:

- DASY4/5 System Handbook

### Methods Applied and Interpretation of Parameters:

- Measurement Conditions:** Further details are available from the Validation Report at the end of the certificate. All figures stated in the certificate are valid at the frequency indicated.
- Antenna Parameters with TSL:** The dipole is mounted with the spacer to position its feed point exactly below the center marking of the flat phantom section, with the arms oriented parallel to the body axis.
- Feed Point Impedance and Return Loss:** These parameters are measured with the dipole positioned under the liquid filled phantom. The impedance stated is transformed from the measurement at the SMA connector to the feed point. The Return Loss ensures low reflected power. No uncertainty required.
- Electrical Delay:** One-way delay between the SMA connector and the antenna feed point. No uncertainty required.
- SAR measured:** SAR measured at the stated antenna input power.
- SAR normalized:** SAR as measured, normalized to an input power of 1 W at the antenna connector.
- SAR for nominal TSL parameters:** The measured TSL parameters are used to calculate the nominal SAR result.

The reported uncertainty of measurement is stated as the standard uncertainty of measurement multiplied by the coverage factor  $k=2$ , which for a normal distribution corresponds to a coverage probability of approximately 95%.

## Measurement Conditions

DASY system configuration, as far as not given on page 1.

<b>DASY Version</b>	DASY5	V52.8.8
<b>Extrapolation</b>	Advanced Extrapolation	
<b>Phantom</b>	Modular Flat Phantom	
<b>Distance Dipole Center - TSL</b>	10 mm	with Spacer
<b>Zoom Scan Resolution</b>	dx, dy, dz = 5 mm	
<b>Frequency</b>	2450 MHz ± 1 MHz	

## Head TSL parameters

The following parameters and calculations were applied.

	Temperature	Permittivity	Conductivity
<b>Nominal Head TSL parameters</b>	22.0 °C	39.2	1.80 mho/m
<b>Measured Head TSL parameters</b>	(22.0 ± 0.2) °C	39.2 ± 6 %	1.87 mho/m ± 6 %
<b>Head TSL temperature change during test</b>	< 0.5 °C	----	----

## SAR result with Head TSL

<b>SAR averaged over 1 cm<sup>3</sup> (1 g) of Head TSL</b>	Condition	
SAR measured	250 mW input power	13.8 W/kg
SAR for nominal Head TSL parameters	normalized to 1W	<b>54.2 W/kg ± 17.0 % (k=2)</b>

<b>SAR averaged over 10 cm<sup>3</sup> (10 g) of Head TSL</b>	condition	
SAR measured	250 mW input power	6.48 W/kg
SAR for nominal Head TSL parameters	normalized to 1W	<b>25.7 W/kg ± 16.5 % (k=2)</b>

## Body TSL parameters

The following parameters and calculations were applied.

	Temperature	Permittivity	Conductivity
<b>Nominal Body TSL parameters</b>	22.0 °C	52.7	1.95 mho/m
<b>Measured Body TSL parameters</b>	(22.0 ± 0.2) °C	53.2 ± 6 %	2.00 mho/m ± 6 %
<b>Body TSL temperature change during test</b>	< 0.5 °C	----	----

## SAR result with Body TSL

<b>SAR averaged over 1 cm<sup>3</sup> (1 g) of Body TSL</b>	Condition	
SAR measured	250 mW input power	13.1 W/kg
SAR for nominal Body TSL parameters	normalized to 1W	<b>51.9 W/kg ± 17.0 % (k=2)</b>

<b>SAR averaged over 10 cm<sup>3</sup> (10 g) of Body TSL</b>	condition	
SAR measured	250 mW input power	6.11 W/kg
SAR for nominal Body TSL parameters	normalized to 1W	<b>24.3 W/kg ± 16.5 % (k=2)</b>

## Appendix (Additional assessments outside the scope of SCS 0108)

### Antenna Parameters with Head TSL

Impedance, transformed to feed point	54.5 $\Omega$ + 5.3 j $\Omega$
Return Loss	- 23.5 dB

### Antenna Parameters with Body TSL

Impedance, transformed to feed point	50.1 $\Omega$ + 6.5 j $\Omega$
Return Loss	- 23.7 dB

### General Antenna Parameters and Design

Electrical Delay (one direction)	1.149 ns
----------------------------------	----------

After long term use with 100W radiated power, only a slight warming of the dipole near the feedpoint can be measured.

The dipole is made of standard semirigid coaxial cable. The center conductor of the feeding line is directly connected to the second arm of the dipole. The antenna is therefore short-circuited for DC-signals. On some of the dipoles, small end caps are added to the dipole arms in order to improve matching when loaded according to the position as explained in the "Measurement Conditions" paragraph. The SAR data are not affected by this change. The overall dipole length is still according to the Standard.

No excessive force must be applied to the dipole arms, because they might bend or the soldered connections near the feedpoint may be damaged.

### Additional EUT Data

Manufactured by	SPEAG
Manufactured on	September 10, 2002

# DASY5 Validation Report for Head TSL

Date: 20.08.2015

Test Laboratory: SPEAG, Zurich, Switzerland

**DUT: Dipole 2450 MHz; Type: D2450V2; Serial: D2450V2 - SN: 719**

Communication System: UID 0 - CW; Frequency: 2450 MHz

Medium parameters used:  $f = 2450 \text{ MHz}$ ;  $\sigma = 1.87 \text{ S/m}$ ;  $\epsilon_r = 39.2$ ;  $\rho = 1000 \text{ kg/m}^3$

Phantom section: Flat Section

Measurement Standard: DASY5 (IEEE/IEC/ANSI C63.19-2011)

DASY52 Configuration:

- Probe: ES3DV3 - SN3205; ConvF(4.54, 4.54, 4.54); Calibrated: 30.12.2014;
- Sensor-Surface: 3mm (Mechanical Surface Detection)
- Electronics: DAE4 Sn601; Calibrated: 17.08.2015
- Phantom: Flat Phantom 5.0 (front); Type: QD000P50AA; Serial: 1001
- DASY52 52.8.8(1222); SEMCAD X 14.6.10(7331)

## Dipole Calibration for Head Tissue/Pin=250 mW, d=10mm/Zoom Scan (7x7x7)/Cube 0:

Measurement grid:  $dx=5\text{mm}$ ,  $dy=5\text{mm}$ ,  $dz=5\text{mm}$

Reference Value = 102.2 V/m; Power Drift = -0.01 dB

Peak SAR (extrapolated) = 28.1 W/kg

**SAR(1 g) = 13.8 W/kg; SAR(10 g) = 6.48 W/kg**

Maximum value of SAR (measured) = 18.2 W/kg

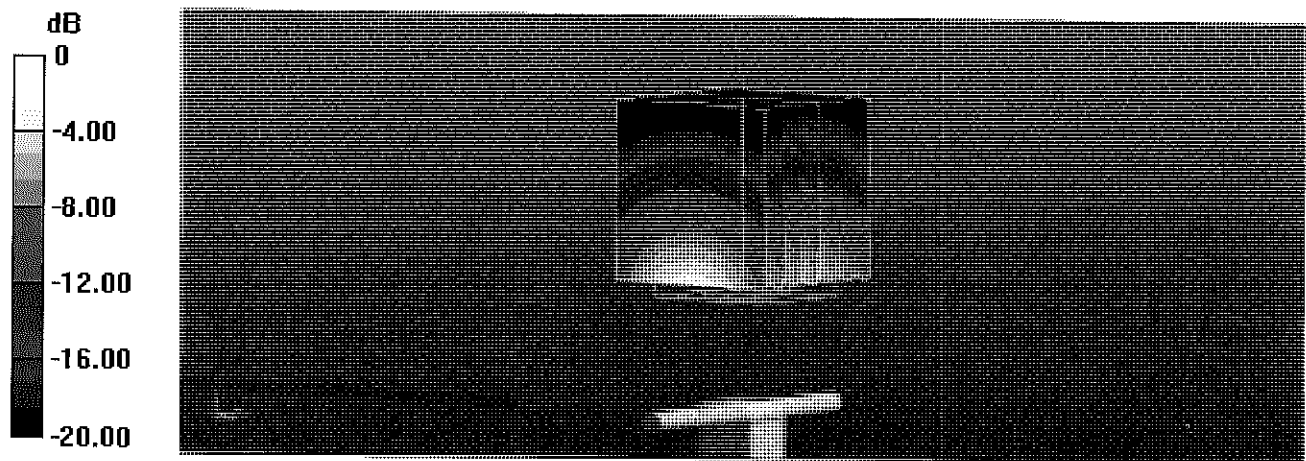

# Impedance Measurement Plot for Head TSL

CH1 S11 1 U FS 19 Aug 2015 12:34:37  
4: 54.510  $\Omega$  5.3223  $\Omega$  345.74  $\mu$ H 2 450.000 000 MHz

\*  
De1  
CA  
Avg  
16  
H1d

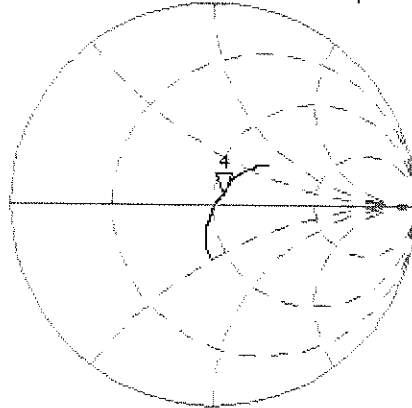

CH2 S11 LOG 5 dB/REF -20 dB 4: -23.517 dB 2 450.000 000 MHz

CA  
Avg  
16  
H1d

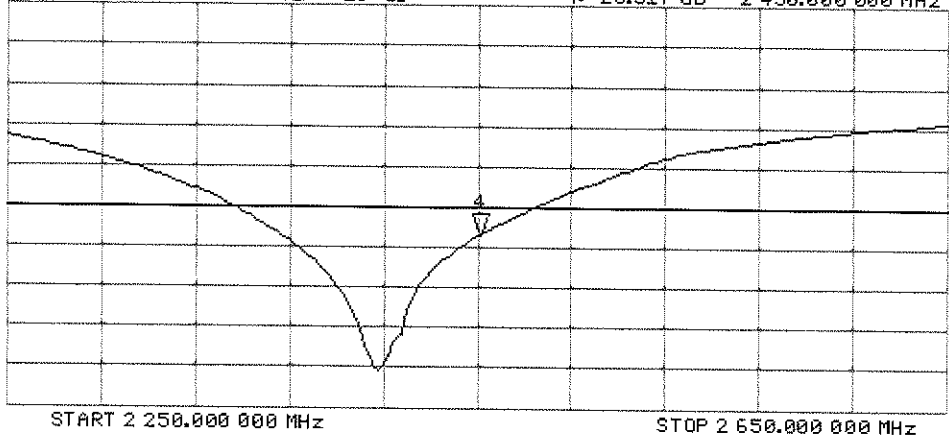

# DASY5 Validation Report for Body TSL

Date: 19.08.2015

Test Laboratory: SPEAG, Zurich, Switzerland

**DUT: Dipole 2450 MHz; Type: D2450V2; Serial: D2450V2 - SN: 719**

Communication System: UID 0 - CW; Frequency: 2450 MHz

Medium parameters used:  $f = 2450$  MHz;  $\sigma = 2$  S/m;  $\epsilon_r = 53.2$ ;  $\rho = 1000$  kg/m<sup>3</sup>

Phantom section: Flat Section

Measurement Standard: DASY5 (IEEE/IEC/ANSI C63.19-2011)

DASY52 Configuration:

- Probe: ES3DV3 - SN3205; ConvF(4.32, 4.32, 4.32); Calibrated: 30.12.2014;
- Sensor-Surface: 3mm (Mechanical Surface Detection)
- Electronics: DAE4 Sn601; Calibrated: 17.08.2015
- Phantom: Flat Phantom 5.0 (back); Type: QD000P50AA; Serial: 1002
- DASY52 52.8.8(1222); SEMCAD X 14.6.10(7331)

## Dipole Calibration for Body Tissue/Pin=250 mW, d=10mm/Zoom Scan (7x7x7)/Cube 0:

Measurement grid: dx=5mm, dy=5mm, dz=5mm

Reference Value = 95.73 V/m; Power Drift = 0.01 dB

Peak SAR (extrapolated) = 26.9 W/kg

**SAR(1 g) = 13.1 W/kg; SAR(10 g) = 6.11 W/kg**

Maximum value of SAR (measured) = 17.3 W/kg

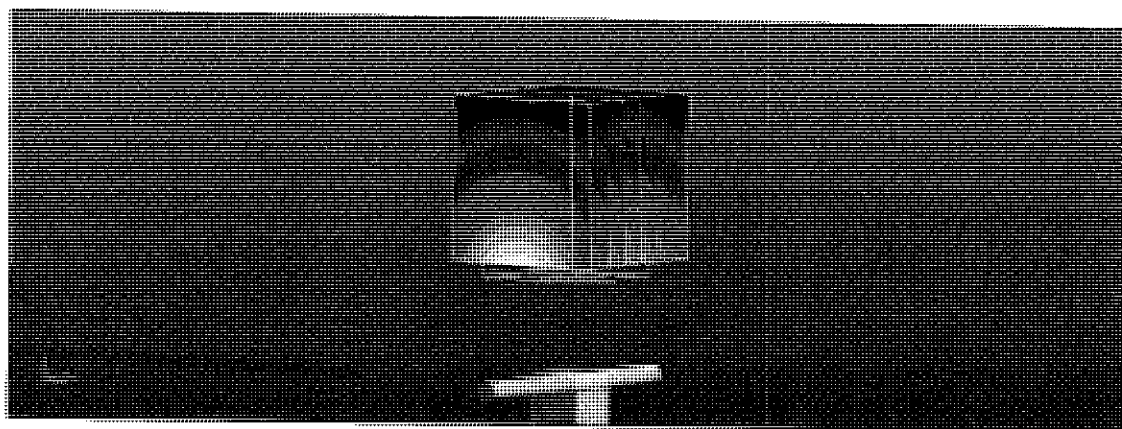
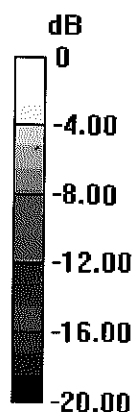

0 dB = 17.3 W/kg = 12.38 dBW/kg

# Impedance Measurement Plot for Body TSL

CH1 S11 1 U FS 19 Aug 2015 12:33:47  
4: 50.098  $\Omega$  6.5195  $\mu$  423.52 pF 2 450.000 000 MHz

\*  
De1  
C $\Delta$   
Avg  
16  
H1d

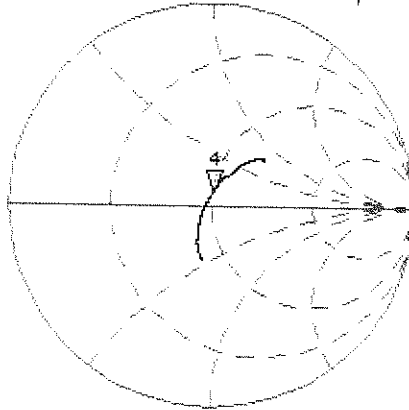

CH2 S11 LOG 5 dB/REF -20 dB 4: -23.742 dB 2 450.000 000 MHz

C $\Delta$   
Avg  
16  
H1d

